

BUILD A ONE-TUBE FM TUNER

POPULAR ELECTRONICS

AUGUST
1960

35
CENTS

HI-FI • HAM & CITIZENS RADIO • SWL

Complete Plans For:

Miniaturized Oscilloscope

see page 39

All About:

- **Unlicensed 2-Way Radio**
- **Vacuum-Tube Testers**
- **Rebuilding Short-Wave Receivers**

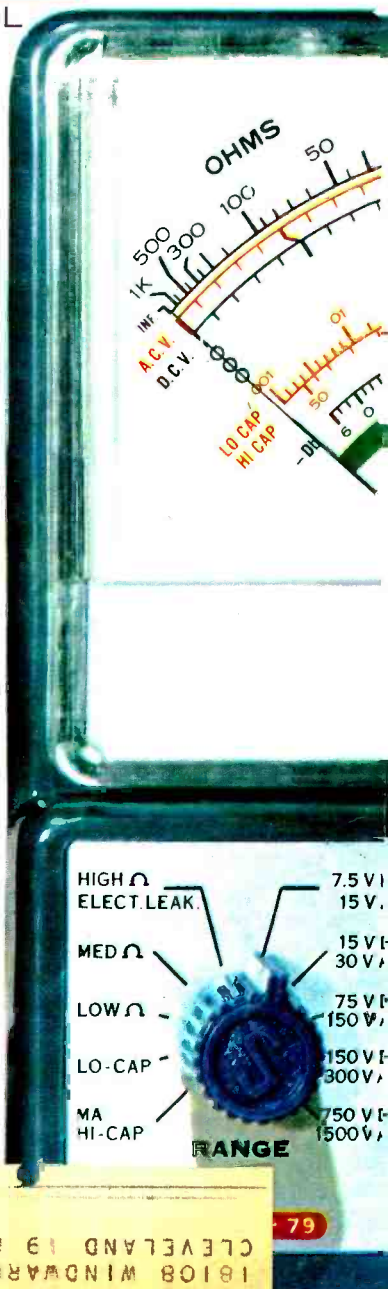
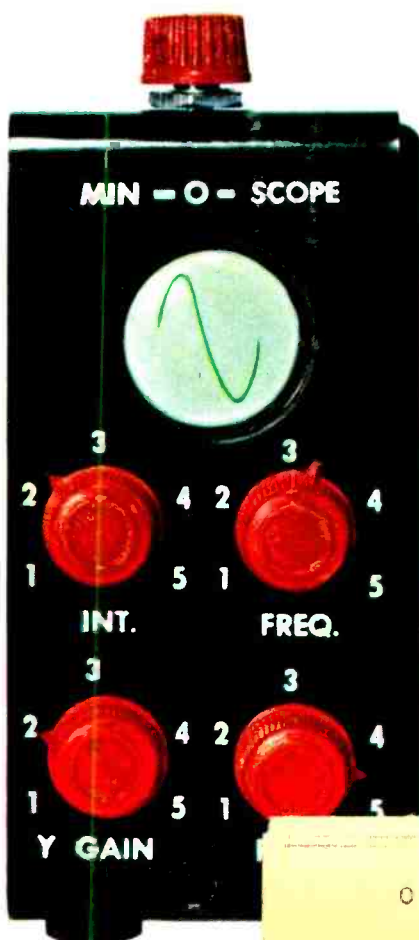

Special:

The How and Why of

20S106811
 LOUIS HOFFART
 18108 WINDWARD
 CLEVELAND 19 OHIO

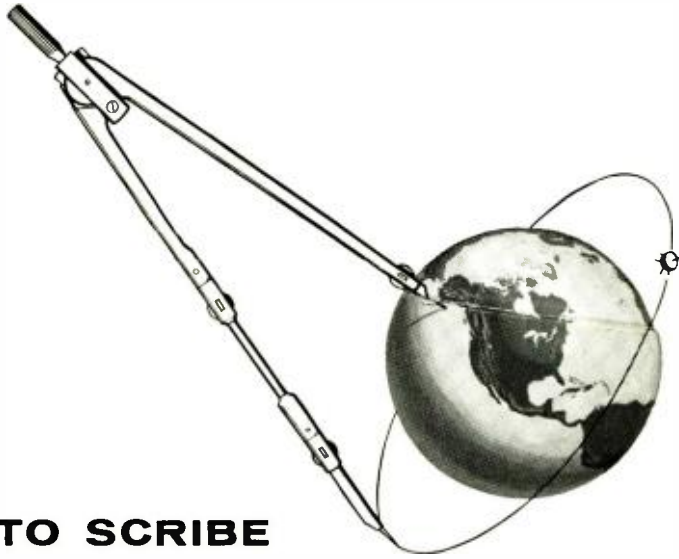

HOW TO SCRIBE A "PERFECT" CIRCLE IN OUTER SPACE

Bell Laboratories guidance system achieves unprecedented accuracy in steering Tiros weather satellite into orbit

Equipped with TV cameras, tape recorders, solar cells and antennas, the world's most advanced weather satellite, the NASA Tiros I, had to be placed in a precisely circular orbit at a specified altitude to do its job well.

The "shot" was a virtual bull's-eye. The mean altitude was within *one mile* of that

planned. And the deviation from this mean was less than $\frac{1}{2}$ per cent, making it the most-nearly-perfect circular orbit ever achieved with a space vehicle by either the United States or Russia.

The dependability and accuracy of Bell Laboratories' ground-controlled Command Guidance System has been proven before—in the successful test flights of the Air Force Titan intercontinental ballistic missile, and in last year's Air Force Thor-Able re-entry test shots from which the first nose-cone recoveries were made at ICBM distance. Now, with Tiros, the system contributes to a dramatic *non-military* project. Other uses are in the offing.

This achievement in precise guidance again illustrates the versatility of Bell Laboratories' research and development capabilities—directed primarily toward improving your Bell telephone service.



Two Bell Laboratories engineers, T. J. Grieser and D. R. Hagner, look over the second-stage section of the Air Force Thor-Able missile used to launch the NASA Tiros weather satellite.

BELL TELEPHONE LABORATORIES

World center of communications research and development



NOW READY

The NEW NRI Home Study Course in ELECTRONICS

PRINCIPLES — PRACTICES — MAINTENANCE

SPECIAL TRAINING EQUIPMENT

No extra cost. In NRI Electronics training especially developed training kits bring to life theory you learn in easy, illustrated lessons. You get practical experience with Thyatron Tube circuits, Multivibrators, Capacitors, Diodes, Transistors, Telemetry, Computer Circuits and other basic circuits and components.



KIT 1 Get practical experience measuring voltage, current, building circuits.

KIT 2 Build d'Arsonval type Vacuum Tube Voltmeter. Test power line frequencies, high audio, radio frequency signals, resistances.

KIT 3 Practice with resistors, capacitors, coils. Work with half, full-wave, bridge, voltage doubler and pi-type filter circuits.

KIT 4 Build circuits with pentode tubes, selenium resistors, transistors. Build oscillator, check signal phase shift with oscilloscope.

KIT 5 Experiment with thyatron tube circuits, Lissajous patterns. Study basic amplitude detector circuits, modulation, demodulation.

KIT 6 Get practical experience with magnetic amplifiers, learn to use modified Prony brake; determine motor torque. Use strobe disc to measure motor speed.

KIT 7 Learn effects of positive and negative feedbacks (used in analog computers). Practice varying polarizing voltage and illumination.

KIT 8 Experiment with multivibrators used as timing generators in binary counters, and as frequency dividers. Learn to use blocking oscillators, thermistors.

KIT 9 Practical experience in telemetry circuits used in earth satellites, remote control devices. Work with basic circuits used in digital and analog computers.

KIT 10 Assemble circuits in electrical and electro-mechanical systems, make valuable practical electronic circuits.

MAIL COUPON—New 64-Page Catalog pictures and describes Training Kits, explains what you learn.

NRI is America's oldest, largest home study Radio-Television-Electronics school. For over 45 years NRI has been training men without previous experience for success in Radio-Television Servicing and Communications. Now, expanded uses of Electronics in industry, business and defense are increasing the demand for Electronic Technicians. Four to seven Technicians are needed for every engineer. To meet this demand NRI announces a complete, comprehensive course in ELECTRONICS—Principles, Practices, Maintenance.

This training stresses basic fundamentals because so many Electronic devices are built around identical Electronic principles. It is for beginners, or for Technicians who wish to expand their knowledge.



This is the Electronic Age. Electronic Equipment is already being used to count, weigh, control flow of liquids, solids, gases. Control exposure in photography, detect fumes, or fire. Inspect at remote points. Supervise traffic. Survey land areas and ocean contours. Search for oil, miles beneath the surface. Measure radiation and control power levels in atomic installations. Control air traffic. Translate one language into another. The MILITARY applications of Electronics . . . particularly in space rockets and missiles, tracking devices, etc., . . . probably equal all of the uses above. Electronic equipment is used to machine parts through complex cycles. It is used in business to process data, control inventory, prepare payrolls, post, calculate, and in medicine for electrodiagnosis, measure body characteristics, electro-surgery.

This is the Electronic Age. Electronic Equipment is already being used to count, weigh, control flow of liquids, solids, gases. Control exposure in photography, detect fumes, or fire. Inspect at remote points. Supervise traffic. Survey land areas and ocean contours. Search for oil, miles beneath the surface. Measure radiation and control power levels in atomic installations. Control air traffic. Translate one language into another. The MILITARY applications of Electronics . . . particularly in space rockets and missiles, tracking devices, etc., . . . probably equal all of the uses above. Electronic equipment is used to machine parts through complex cycles. It is used in business to process data, control inventory, prepare payrolls, post, calculate, and in medicine for electrodiagnosis, measure body characteristics, electro-surgery.



Job Counselors Recommend
Right today a career in Electronics offers

unlimited opportunity. Job Counselors know the pay is high, jobs interesting, advancement opportunities great. They advise ambitious, aggressive men who want higher pay now and a better future. "For an interesting career, get into Electronics."

Learn More to Earn More

Simply waiting and wishing for a better job won't get you ahead. You have to decide you want to succeed and *you must act*. NRI can provide the training you need at home in spare time. No need to go away to school. You don't need a high school diploma or previous Electronic experience. This course is planned to meet the needs of beginners. You work and train with components and circuits you will meet throughout your Electronics career. You get especially developed training kits for practical experience that make Electronics easy, simple to learn.

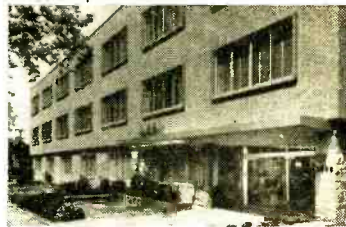

Oldest and Largest School

Training men to succeed, is the National Radio Institute's *only* business. The NRI Diploma is respected and recognized. NRI graduates are everywhere throughout U.S. and Canada. Mail the coupon today. New, FREE 64-page Catalog gives facts, opportunities about careers in Industrial and Military Electronics, also shows what you learn, facts about NRI's other courses in Radio-Television Servicing and Radio-Television Communications. Monthly payments available.

OLDEST & LARGEST HOME STUDY RADIO-TV SCHOOL
National Radio Institute

WASHINGTON 16, D. C. ESTABLISHED 1914

MAIL THIS COUPON NOW

NATIONAL RADIO INSTITUTE
Washington 16, D. C. OHD4

Send me full information without cost or obligation. No salesmen will call.
(Please print.)

Name Age

Address

City Zone State

ACCREDITED MEMBER NATIONAL HOME STUDY COUNCIL

POPULAR ELECTRONICS

AUGUST

1960

VOLUME 13

NUMBER 2



Special Construction Features

- Build the Min-O-Scope.....*Charles J. Schauers, W6QLV* 39
One of the finest tube-operated oscilloscopes ever designed,
the Min-O-Scope can be constructed for less than \$30.00.
- One-Tube FM Tuner.....*Robert E. Devine, W6AYW* 49
Easy to build and a cinch to operate, this simple tuner's
performance approaches that of far more elaborate sets.

Other Construction Projects

- High-Power Crystal Set.....*Walter B. Ford* 63
Combination Radio-Intercom..... 66
Low-Cost Black Light.....*Louis E. Garner, Jr.* 83
Transinjector Probe.....*C. L. Henry* 90

Audio and High Fidelity

- Inside the Hi-Fi Microphone (Part 2).....*Joseph Marshall* 55
How to Get the Most from Your Tapes.....*John Milder* 71
Dual 20-watt Stereo Amplifier..... 85
Experimenter's Test Speaker.....*E. G. Louis* 97

Electronic Features and New Developments

- Notes from the Editor: Glad Tidings.....*Oliver Read, W1ETI* 6
Unlicensed Two-Way Radio.....*Lee Craig* 45
World's Largest Capacitor..... 48
Russian-English Translating Machine.....*Ken Gilmore* 59
How the Translator Works.....*Ken Gilmore* 60
The How and Why of Solder (After Class Feature).....*Lou Garner* 67
Electronics in the News..... 75
Test Instruments—The Tube Tester (Part 1).....*G. H. Harrison* 80
Transistor Topics.....*Lou Garner* 92
Crossword Puzzle.....*James J. Porten* 98
Electronic Analogy Quiz.....*Robert P. Balin* 99
Carl & Jerry: Electronic Lifeline.....*John T. Frye, W9EGY* 100

Amateur, CB and SWL

- FCC Report: Citizens Band Clubs.....*Robert E. Tall* 8
How to Get DX.....*Fred E. Ebel, W9PXA* 53
On the Citizens Band.....*Tom Kneitel, 2W1965* 70
Rebuild the Relics for SWL'ing.....*A. A. Wicks* 76
Across the Ham Bands: The Ham Station Log....*Herb S. Brier, W9EGQ* 87
Short-Wave Report.....*Hank Bennett, W2PNA* 95
Short-Wave Monitor Registration..... 96

Departments

- Letters from Our Readers..... 12
New Products..... 16
POP'tronics Bookshelf..... 22
Tips and Techniques..... 28

Cover photo by Bruce Pendleton

Copyright © 1960 by ZIFF-DAVIS PUBLISHING COMPANY. All rights reserved.

YOU be the judge of *knight-kit* value

A PRODUCT OF ALLIED RADIO



FREE examination privilege

More and more people are finding out how easy it is to build exciting Knight-Kits, how satisfying they are to own, and how much they save.

If you haven't yet enjoyed the experience and fun of building and owning a Knight-Kit, we invite you to take advantage of our free examination offer. Order any Knight-Kit. Examine it on arrival. Inspect the

quality of the components, the circuitry, the easy-assembly manual. We're so confident you'll want the kit, we can make this offer: If you're not COMPLETELY SATISFIED, just return the kit for full refund.

Order a Knight-Kit now. Know the thrill of the most satisfying build-your-own experience in electronics.

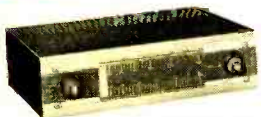

Y-731 Deluxe FM-AM Stereo Hi-Fi Tuner (Multiplex add-in) \$87.50
only \$5 down



Y-774 Deluxe 40-Watt Stereo Amplifier (with Center Channel) \$79.50
only \$5 down

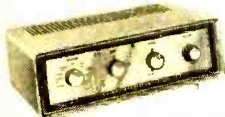

Y-773 Super-Value 20-Watt Stereo Hi-Fi Amplifier... \$44.50
only \$2 down

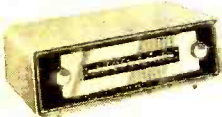

Y-787 FM-AM Hi-Fi Tuner (with Multiplex jack) \$49.95
only \$2 down



Y-713 Best-selling Citizens Band Transceiver. Tunable 22-channel super-regen receiver... \$39.95
only \$2 down



Y-258 4-Band "Span Master" Receiver (with cabinet) \$25.95
only \$2 down



R-100 Amateur Communications Receiver (Hi-gain, with built-in Q-Multiplier)... \$104.50
only \$5 down



Y-708 1000 Ohm/Volt Pocket Volt-Ohm-Milliammeter \$9.95

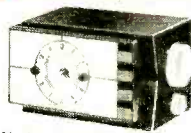

Y-737 "Ranger" Clock-Radio with "sleep" switch... \$24.95
only \$2 down

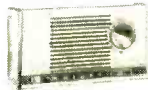

Y-771 5-Transistor Superhet Portable Radio (less battery) \$25.95
only \$2 down



Y-125 General-purpose VTVM (11 meg. input res.) \$25.75
only \$2 down

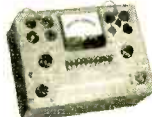

Y-143 Model "600" Tube Checker (checks over 700 types) \$32.95
only \$2 down

easiest to build...
satisfying to own...
...money-saving

ONLY \$2 DOWN
on orders up to \$50;
\$5 down on orders
up to \$200...

see scores of
other *knight-kits*

HI-FI KITS

Stereo Preamplifier
60-W Stereo Amplifier
Monaural Amplifiers
Hi-Fi Tuners
Speaker Systems
and others

HOBBYIST KITS

"Space-Spanner" Radio
"Ranger" Radios
Transistor Radios
2-Way Intercom
Electronic Lab Kits
and many others

INSTRUMENT KITS

Lab AC VTVM
VOM's
5" Scopes
Tube Checkers
Signal Tracer
Audio Generator
Sweep Generator
plus many others

AMATEUR KITS

50-Watt Transmitter
Self-Powered VFO
100 kc Crystal Calibrator
Code Practice Oscillator
Grid Dip Oscillator

there's a money-saving *knight-kit*
for every need... see them all in the

ALLIED CATALOG

Describes the complete KNIGHT-KIT line in detail. Order the kit of your choice—judge quality and value for yourself under our Free examination privilege!

FREE

send
for it!



ALLIED RADIO

ALLIED RADIO, Dept. 23-H
100 N. Western Ave., Chicago 80, Ill.

Send FREE Catalog featuring Knight-Kits.

Name _____

Address _____

City _____ Zone _____ State _____

Editor & Publisher
OLIVER READ, W1ETI

Managing Editor
JULIAN M. SIENKIEWICZ, WA2CQL

Feature Editor
FURMAN HEBB

Art Director
ALFONS J. REICH

Associate Editors
RICHARD A. FLANAGAN
MARGARET MAGNA
PERRY WINTER, K2VLR

Editorial Assistant
DOLORES GIMBEL

Contributing Editors
H. BENNETT, W2PNA
H. S. BRIER, W9EGQ
J. T. FRYE, W9EGV
L. E. GARNER, JR.
T. KNEITEL, 2W1965

Art Associate
J. A. ROTH

Art and Drafting Dept.
K. W. PAUL, JR.
W. K. VAHSING, WV2GYL

Advertising Director
JOHN A. RONAN, Jr.

Advertising Manager
WILLIAM G. McROY, 2W4144

POPULAR ELECTRONICS

World's Largest-Selling Electronics Magazine

Average Net Paid Circulation Over 320,000

COMING NEXT MONTH

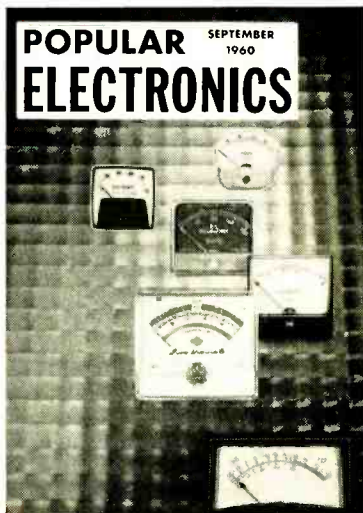

(ON SALE AUGUST 25)

ZIFF-DAVIS PUBLISHING COMPANY,
One Park Ave., New York 16, N. Y.
William B. Ziff, Chairman of the Board
(1946-1953); William Ziff, President;
W. Bradford Briggs, Executive Vice
President; Michael Michaelson, Vice
President and Circulation Director; Hersh-
el B. Sorbin, Vice President; J. Leonard
O'Donnell, Treasurer.



BRANCH OFFICES: Midwestern Office,
434 S. Wabash Ave., Chicago 5, Ill.;
Jim Weakley, Advertising Manager;
Western Office, 9025 Wilshire Blvd.,
Beverly Hills, Calif., Don Ceno, Western
Manager.

Foreign Advertising Representatives:
D. A. Goodall Ltd., London; Albert Mil-
hodo & Co., Antwerp and Dusseldorf.

SUBSCRIPTION SERVICE: Forms 3579 and all subscription correspondence should be addressed to Circulation Department, 434 South Wabash Avenue, Chicago 5, Illinois. Please allow at least four weeks for change of address. Include your old address as well as new—enclosing if possible an address label from a recent issue.

CONTRIBUTORS: Contributors are advised to retain a copy of their manuscripts and illustrations. Contributions should be mailed to the New York Editorial Office and must be accompanied by return postage. Contributions will be handled with reasonable care, but this magazine assumes no responsibility for their safety. Any copy accepted is subject to whatever adaptations and revisions are necessary to meet the requirements of this publication. Payment covers all author's, contributor's and contestant's rights, titles, and interest in and to the material accepted and will be made at our current rates upon acceptance. All photos and drawings will be considered as part of material purchased.

● METERS

All about the various types of meters—how they are made and how they work

● HI-FI OUTPUT TRANSFORMERS

A hi-fi amplifier can be no better than its output transformer. Learn what's involved in the design of output transformers for the highest fi

● IONIZED AIR

Recent investigations indicate that electrically charged air may have a beneficial effect on human health. This article discusses ion therapy and how it may become an important medical tool

● CARRIER-CURRENT INTERCOM

Complete plans for an easy-to-build intercom that sends messages over your house wiring

**GET FULL FACTS
FREE!**

Prepare for a
Profitable, Exciting Future

as an **Electronics
Technician!**

**No Previous Technical Experience
Required!**

Opportunities were never greater for the man who wants to get someplace and be somebody than they are today in the fast-expanding, profitable field of Electronics.

Let us tell you without cost or obligation how you may prepare for a real career in one or more branches of Electronics, either in our well-equipped Chicago or Toronto laboratories—or at home without interfering with your present job. Send coupon for **FREE** facts today!

**AN EXCELLENT OPPORTUNITY
FOR MEN 17-55!**

Even if you haven't an advanced education, find out how you may prepare in your spare time at home, to enter the **BIG OPPORTUNITY** field of Electronics. Mail coupon **TODAY!**

FREE! Sample Booklet!

We'll give you a free copy of an interesting booklet, "Electronics and YOU." See for yourself how you may take advantage of the opportunities in this growing field.



**NO ADVANCED
EDUCATION NEEDED!**

Prepare now for Electronic job opportunities in —

Radar
Guided Missile
Control
Computers
Radio
Television
Broadcasting
Communications

Remote Control
Systems
Automation
Electronics
Industrial
Electronics
Your Own
Service Shop

Free Employment Service

DeVry Tech's Placement Department is in contact with some of the best-known employers in the Electronics field. The service is free to all graduates — and DeVry Tech's record in helping to place men has been outstanding.

Draft Age?

We have valuable information for every man of draft age; so if you are subject to military service, be sure to check the coupon.

Accredited Member of National Home Study Council



"One of North America's
Fore-most Electronics
Training Centers"

**DeVRY TECHNICAL
INSTITUTE**
4141 Belmont Avenue • Chicago 41, Illinois

MAIL COUPON TODAY!

DeVRY TECHNICAL INSTITUTE
4141 Belmont Ave., Chicago 41, Ill., Dept. **PE-8-Q**

Please give me your **FREE** booklet, "Electronics and Space Travel," and tell me how I may prepare to enter one or more branches of Electronics as listed above.

Name _____ Age _____

Please Print _____

Street _____ Apt. _____

City _____ Zone _____ State _____

Check here if subject to Military Training.

Canadian residents address: DeVry Tech of Canada, Ltd.
2032 970 Lawrence Avenue West, Toronto, Ontario

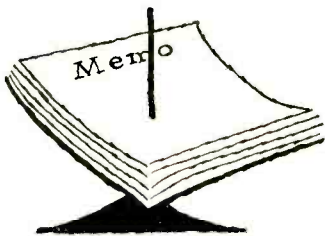

Notes from the Editor

GLAD TIDINGS. For the first time in several years, the general situation in the broadcasting field looks encouraging. At long last, it seems that the federal government is taking steps to solve some of the broadcasting industry's most vexing long-range problems.

Perhaps the most important development is a bill before Congress that would provide the FCC with a practical means of punishing radio and television stations for improper operation. Until now, the FCC's only punitive measure has been to revoke the license of the offending station. This step was so drastic that it was never put into practice, and it was consequently of little value for bringing wayward stations into line. The bill under consideration would give the FCC more flexibility in dealing with offending stations. In addition to revoking licenses, the FCC would be authorized to suspend a station's license or to levy sizable fines for improper operation. Reprehensible actions by the station would include the acceptance of payola, fixing quizzes, making false statements in the license application form, and failing to operate substantially as set forth in the license.

The second encouraging sign is that FCC Chairman Frederick W. Ford has asked Congress for an appropriation to create a 25-member monitoring group to check television programming on a regular basis. Mr. Ford has made it clear that the group would not engage in censorship. Instead, it would investigate complaints and check on how well broadcasters were meeting their obligation to operate "in the public interest." Implicit in the FCC's action is the suggestion that the agency is now determined to assume its rightful regulatory place in the broadcasting field after many years of relative inactivity.

Also worth noting is a proposal now before Congress to authorize a two-year test of u.h.f. television in New York City. If this goes through, it could have far-reaching effects on the future of television. Since there are more applicants for TV station licenses than there are channels available on the v.h.f. band (Channels 2 through 13), the logical answer has always been to utilize the 70 available u.h.f. channels. But the technical efficiency of the u.h.f. channels is a matter of much dispute. The New York test would determine this efficiency once and for all. Should they be proven satisfactory, the next step might be to require all manufacturers of TV sets to include provisions on future models for both v.h.f. and u.h.f. reception. After about 10 years, virtually everyone would have a combination v.h.f.-u.h.f. set. Programming on v.h.f. could then begin in earnest, thus easing the congestion on the v.h.f. band.

Oliver Read

Through
HOME STUDY
 or in
RESIDENT CLASSES

ELECTRONICS

— field of opportunity —

the Grantham Communications
 Electronics Course prepares you
 for your first class commercial
F.C.C. LICENSE

The Grantham home study course teaches you principles of electronics in a simple "easy-to-grasp" manner. Each new principle is explained first in *everyday language* and then, after you understand it, is associated with the proper *technical language*. You learn and remember more, because the emphasis is on *understanding* rather than on memorizing.

This correspondence course is directed toward two major objectives — (1) to *teach* you a great deal about electronics, and (2) to prepare you to *pass* all of the F. C. C. examinations required for a first class commercial operator's license. We teach you step by step and have you practice with FCC-type tests which you send to the School for grading and comment. You prepare for your F. C. C. examinations under the watchful direction of an instructor who is especially qualified in this field.

Grantham training is the easy way to learn more quickly — to prepare more thoroughly — for F. C. C. examinations. And your first class license is the quick, easy way to prove to your employer that you are worth more money.

Get details concerning *how* we can prepare you for your F. C. C. license and *how* that license can help you advance in electronics. Mail the coupon below to the home office of Grantham School of Electronics in Hollywood, Calif., and our free catalog will be sent to you promptly.

offers

interesting and profitable careers in

RADIO AND TV BROADCASTING • TWO-WAY RADIO COMMUNICATIONS • RESEARCH AND DEVELOPMENT • RELAY STATION MAINTENANCE • AUTOMATION ELECTRONICS • TECHNICAL WRITING IN ELECTRONICS • INDUSTRIAL ELECTRONICS • ELECTRONIC COMPUTERS • MILITARY ELECTRONICS • INSTRUMENTATION • TELEMETERING • AERONAUTICAL ELECTRONICS • SPACE ELECTRONICS

and many other

interesting and profitable fields of the present and future

To get ahead in electronics, you must have the proper training and your employer must know that you have that training. Your F. C. C. license is a "diploma" in communications electronics granted by the U. S. Government, and it is recognized as such by employers. Grantham School of Electronics specializes in preparing you to earn this diploma.

HERE'S PROOF... that Grantham students prepare for F. C. C. examinations in a minimum of time. Here is a list of a few of our recent graduates, the class of license they got, and how long it took them:

	License	Weeks
Edgar T. Phelps, 931 Hickory Street, Poplar Bluff, Mo.	1st	12
Wayne Hogg, 4830 San Fernando Rd., Glendale, Calif.	1st	20
Robert Watson, Star Route, Box 24, Renovo, Pa.	1st	12
William H. Patchin, 3865 Westview Ave., NW, Canton, Ohio	1st	12
V. Dean DeVore, 309 Bess Street, Washington, Ill.	1st	16
Edward T. Wall, Box 184, Kenly, N. C.	1st	12
James W. Wranich, 4236 Michigan Street, Kansas City, Mo.	1st	20
Robert E. Sullivan, 2475 E. Douglas, Des Moines, Iowa	1st	12
Nelson S. Kibler, 1413 Patrick Henry Dr., Falls Church, Va.	1st	18
Barry L. Ulrich, 1110 Chestnut Ave., Barnesboro, Pa.	1st	14
Jerry E. Milligan, 707 Ragsdale Dr., Milan, Tenn.	1st	12
Robert S. Davis, 2100 - 10 Ave., So., Apt. 12, Birmingham, Ala.	1st	13

If you are interested in details concerning our training, indicate in the coupon below whether you prefer home study or resident classes, and mail the coupon to the School's home office in Hollywood, California — to the address given in the coupon — for free details.

GRANTHAM SCHOOL OF ELECTRONICS

HOLLYWOOD

SEATTLE

KANSAS CITY

WASHINGTON

FIRST CLASS F.C.C. LICENSE IN 12 WEEKS

Grantham resident schools are located in four major cities — Hollywood, Seattle, Kansas City, and Washington, D. C. Regularly scheduled classes in F. C. C. license preparation are offered at all locations. New day classes begin every three months, and new evening classes begin four times a year. The day classes meet 5 days a week and prepare you for a first class F. C. C. license in 12 weeks. The evening classes meet 3 nights a week and prepare you for a first class license in 20 weeks. For more information about the Grantham resident schools, indicate in the coupon the city of your choice and then mail the coupon to the School's home office in Hollywood, Calif. Free details will be mailed to you promptly.

GRANTHAM SCHOOL OF ELECTRONICS
 1505 N. Western Ave., Hollywood 27, Calif.



(Mail in envelope or paste on postal card)

To: **GRANTHAM SCHOOL OF ELECTRONICS**
 1505 N. WESTERN AVE., HOLLYWOOD 27, CALIF.

Gentlemen:

Please send me your free booklet telling how I can get my commercial F. C. C. license quickly. I understand there is no obligation and no salesman will call.

Name _____ Age _____

Address _____

City _____ State _____

I am interested in: Home Study Kansas City classes
 Hollywood classes Seattle classes Washington classes

03M

MAIL COUPON FOR FREE DETAILS — NO SALESMAN WILL CALL →

New Sylvania
**"Transistor Circuit
 Handbook for the
 Hobbyist"** gives you
 30 performance-tested
 circuits using
 low-cost transistors!

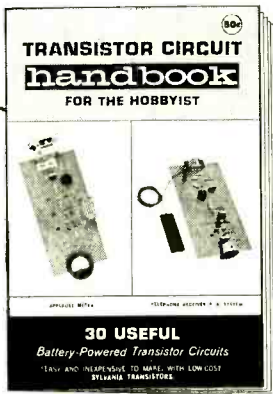

Interesting new "gadgets" and useful equipment for every electronic experimenter, "ham" or student. Handbook is divided into four circuit-packed chapters.

- I Test Equipment Circuits
- II High Frequency Circuits
- III Audio Frequency Circuits
- IV Utility Circuits

**NOW AT YOUR LOCAL
 SYLVANIA SEMICONDUCTOR
 DISTRIBUTOR'S. Only 50¢.**

Get a copy today!

Sylvania Semiconductor Division, Woburn, Mass.

SYLVANIA
 Subsidiary of GENERAL TELEPHONE & ELECTRONICS



FCC Report

By **ROBERT E. TALL**
 Washington Correspondent

Citizens Band Clubs

INQUIRING Citizens Banders are being told by the Federal Communications Commission that the FCC rules neither specifically permit nor prohibit Citizens Band clubs. While such clubs "have no official status with the Commission," the FCC adds that a properly organized and well-run club "may render a valuable service" to everyone. Actually, the Commission seems to be pretty happy with CB clubs on the whole, and FCC staff officials like the way most of the clubs are developing.

The FCC believes that CB clubs—like present amateur radio organizations—can help solve interference problems within the Citizens Radio Service and between other radio services, notably broadcast and television stations. One FCC official looks forward to CB clubs doing more "self-policing" than they are at present. He cautions, however, that a CB club should not take part in or encourage any activity that would foster a hobby-type interest in CB radio. Those who are interested in radio experimentation or in communications for hobby purposes should obtain amateur licenses.

Some CB clubs are apparently being formed to get around the new rule which limits transmissions to five minutes each. If CB units are actually licensed to a club, this limit may be exceeded, but the operators are heading for trouble if they attempt to use such units for messages not relating to club activities.

Petitions filed by CB clubs in Ohio and Colorado asked the FCC to reconsider the February rule change which clearly prohibits random contacts with unknown stations. The Commission denied these petitions since this type of communications tends to monopolize the Citizens Band fre-

want to
double
your pay?

MOVE AHEAD IN
ELECTRONICS

Get All
3 Free!



FIND OUT what the FCC license means.

Your FCC license is recognized by employers as proof of your technical ability.

FIND OUT how the FCC license helps you get a better job or increase your pay on your present job.

"Investment in training really pays off."
"I am now employed by the Western Electric Company as an electronic tester. My status as a student of Cleveland Institute was an important factor in my being employed. Knowledge gained through the course has proved amazingly helpful and affords me a feeling of complete confidence."

T. E. Spence, Greensboro, N. C.



MAIL COUPON TODAY

Cleveland Institute of Electronics

Desk PE-67, 4900 Euclid Avenue, Cleveland 3, Ohio

Please send Free Booklets prepared to help me get ahead in Electronics. I have had training or experience in Electronics as indicated below:

- | | |
|---|---|
| <input type="checkbox"/> Military | <input type="checkbox"/> Broadcasting |
| <input type="checkbox"/> Radio TV Servicing | <input type="checkbox"/> Home Experimenting |
| <input type="checkbox"/> Manufacturing | <input type="checkbox"/> Telephone Company |
| <input type="checkbox"/> Amateur Radio | <input type="checkbox"/> Other _____ |

FIND OUT how we guarantee your FCC license.

The Master Course in Electronics will provide you with the mental tools of the electronics technician and prepare you for a First Class FCC license (Commercial) with a radar endorsement. When you successfully complete the Master Course, if you fail to pass the FCC examination, you will receive a full refund of all tuition payments.

FIND OUT how employers make job offers like this to our graduates every month.

RCA has positions for technicians, field engineers and instructor technicians to install, maintain, and teach military radar, communications, and fire control equipment. Company benefits.

-You'll Be Glad You Did!

Accredited by the National Home Study Council

In what kind of work are you now engaged? _____
In what branch of Electronics are you interested? _____

Name _____ Age _____

Address _____ PE-67

City _____ Zone _____ State _____

DYNAKITS

Look Best — Test Best — Sound Best

NEW STEREO PREAMP KIT

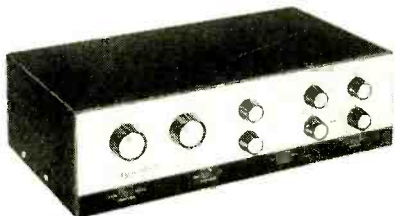

- ★ The unique "no distortion" performance initiated by the famous DYNAKIT Pre-amplifier.
- ★ 7 stereo inputs, DC heaters, built-in power supply, DYNA's exclusive "blend" control.
- ★ Highest gain, lowest noise, greatest channel separation, and the easiest to use.
- ★ The ultimate in simplicity—2 pre-assembled printed circuit boards cut assembly time to 8 hours.
- ★ Complete with cover \$59.95* net.

NEW STEREO 70 KIT



- ★ Dual 35 watt super-quality Amplifiers—70 watt continuous monophonic rating—160 watt peak.
- ★ All critical parts on prefabricated printed circuit assembly reduces wiring time to five hours.
- ★ Premium quality parts conservatively operated permit one-year guarantee.
- ★ Uncompromised design for finest performance—usable with *all* speakers.
- ★ Only \$99.95* net including all parts, instructions, and protective cover.

Available from leading Hi-Fi dealers everywhere.
Descriptive brochure available on request.

*Slightly higher in West

DYNACO, INC.

Dept. PE, 3916 Powelton Ave., Phila. 4, Pa.

quencies and is more appropriate in amateur radio.

Furthermore, violation notices issued before the February rule change will "remain in the official files of the stations concerned," despite protests by the CB groups. The cry "ex post facto" can still be heard. "Because there may have existed a possibility for misinterpretation of the scope of permissible communications," the Commission said, the earlier violation notices "will not be considered in connection with any possible future rules violations by the same licensees."

The Commission has asked that all organizations concerned with the sale, maintenance, or use of Citizens Radio equipment help bring about a prompt cessation of unlicensed operation. In particular, the FCC noted an increasing number of reports on CB equipment suppliers who advise their customers that their equipment may be operated before a license is issued by the Commission. The FCC said that the orderly development of the Citizens Radio Service is hampered by this illegal practice. A salesman who engages in such activity, warned the FCC, in addition to subjecting himself to a year in prison, a \$10,000 fine, or both, may be sacrificing the long-range good will of a misadvised customer who will be operating an unlicensed transmitter.

Telephone answering services are now requesting permission to use the Citizens Radio Service—the FCC has already received a considerable number of such applications. These answering services want to employ CB radio for incidental communications such as dispatching vehicles and messengers for the purpose of carrying messages to their clients. Also, they would like to use CB to inform customers of telephone calls received.

The transmission of actual messages over CB radio would be a direct violation of Section 19.61(b) of the CB rules, which clearly state that CB radio should be used to provide a service on a "strictly voluntary and no-charge basis" only. According to the FCC, however, the customer may install his own duly licensed transmitter on the answering service's premises so that the answering service can relay the licensee's calls to him. Such operation is subject to the condition that the licensee (customer) retain control of his CB radio system even though it would be, in part, operated by the answering service personnel.

—30—

These men are getting practical training in **NEW Shop-Labs of**

ELECTRICITY

COYNE

ELECTRONICS ON REAL

Motors—Generators—
Switchboards—
Controls—Modern
Appliances—
Automatic
Electronic
Control Units

in Chicago—prepare for today's TOP OPPORTUNITY FIELD. Train on real full-size equipment at COYNE where thousands of successful men have trained for over 60 years—largest, oldest, best equipped school of its kind. Professional and experienced instructors show you how, then do practical jobs yourself. No previous experience or advanced education needed. Employment Service to Graduates.

START NOW—PAY LATER—Liberal Finance and Payment Plans. Part-time employment help for students. **GET FREE BOOK**—"Guide to Careers" which describes all training offered in ELECTRICITY and TELEVISION-RADIO ELECTRONICS—no obligation; NO SALESMAN WILL CALL.

TELEVISION

RADIO ELECTRONICS ON REAL

TV Receivers—
Black and White
and Color
AM-FM and
Auto Radios
Transistors
Printed Circuits
Test Equipment

Coyne Electrical School, 1501 W. Congress Parkway
Chartered Not For Profit • Chicago 7, Dept. CO-2C

MAIL COUPON OR WRITE TO ADDRESS BELOW

COYNE ELECTRICAL SCHOOL
Dept. CO-2C—New Coyne Building
1501 W. Congress Pkwy., Chicago 7, Ill.

Send BIG FREE book and details of all the training you offer. However, I am especially interested in:

Electricity Television Both Fields

Name _____

Address _____

City _____ State _____

COYNE offers
LOW COST

TELEVISION RADIO - COLOR TV

Training in
Spare Time AT HOME



The future is YOURS in TELEVISION!
A fabulous field—good pay—fascinating work—a prosperous future in a good job, or independence in your own business!

Send Coupon or write to address below
for Free Book

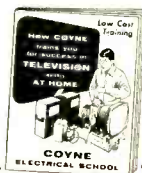

Coyne brings you MODERN-QUALITY Television Home Training; training designed to meet Coyne standards at truly lowest cost—you pay for training only—no costly "put together kits." Not an old Radio Course with Television "tacked on." Here is MODERN TELEVISION TRAINING including Radio, UHF and Color TV. No Radio background or previous experience needed. Personal guidance by Coyne Staff. Practical Job Guides to show you how to do actual servicing jobs—make money early in course. Free Life-time Employment Service to Graduates.

and full details, including easy Payment Plan. No obligation, no salesman will call.

COYNE Television
Home Training Division
Dept. CO-H2, New Coyne Building
1501 W. Congress Pkwy., Chicago 7, Ill.

Send Free Book and details on how I can get Coyne Quality Television Home Training at low cost and easy terms.

Name _____

Address _____

City _____ State _____

COYNE ELECTRICAL SCHOOL

CHARTERED AS AN EDUCATIONAL INSTITUTION
NOT FOR PROFIT

1501 W. Congress Parkway • Chicago 7, Dept. CO-H2



B. W. COOKE, Jr., President
Coyne—the Institution behind this training... the largest, oldest, best equipped residential school of its kind. Founded 1899.

Letters

from our

readers

Storm-Window Antenna

■ I thought you might be interested in a "no-cost" TV antenna system I'm trying out. I have been getting excellent results on the u.h.f. channels from an antenna which consists merely of two aluminum storm windows wired together—recep-

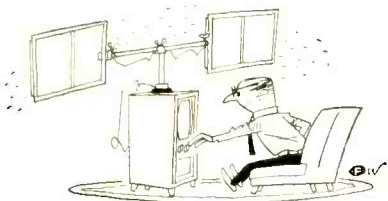

tion is good up to about 60 miles at night. A little experimentation with multiple storm windows might make this system work on the v.h.f. bands.

DR. MARTIN APPELBAUM
Hazleton, Pa.

TV Techniques

■ I enjoyed your May 1960 issue very much, just as I've enjoyed each issue you have published for the past six years. However, I would like to point out a misleading statement in the article entitled "TV's Trick Techniques," i.e., "it took the invention of the color television camera to make such a fancy effect [insetting a live actor into a background provided by another camera] possible."

Early in 1950, Wayne Johnson of KFI-TV, Los Angeles, demonstrated this effect to the SMPTE, using only black-and-white equipment. Shortly thereafter, Rolf Drucker, David Fee, and George Gould designed a montage amplifier for use on "Tom Corbett, Space Cadet," again employing only monochrome equipment. Each of these systems used a keying signal produced by the actor's silhouette. The silhouette was created by taking part of the signal from the camera which picked up the actor and increasing the contrast until only a black-and-white silhouette remained.

DONALD G. WYLIE
Television Station WMSB
Michigan State University
East Lansing, Mich.

■ In reference to "TV's Trick Techniques" in your May issue, I would like to point out to your readers that they may have been fooled a good deal longer than they realize.

It's not generally known, but during the nominating conventions four years ago, CBS reporter Walter Cronkite saw hardly any of the doings on the convention floor (in the flesh, that is). Although Mr. Cronkite appeared to be in a broadcast booth that overlooked the floor of the con-

vention hall, he was actually in a temporary studio located near the auditorium. The side shots that showed Mr. Cronkite looking out over the convention floor were produced by a remote camera and electronic blanking.

It is possible to do insets with monochrome, but this process is very tricky. Suppose an actress is to be shown dancing down an "inset" street. The technical arrangement might have the actress dancing against a black background so that the pickup from the background camera would be keyed in whenever the subject camera scanned the background. But if the director wanted to move in for a close-up of the actress and she opened her mouth to sing, the dark area in her mouth could also key in the background. Thus, Dinah Shore *could* find herself with a Chevrolet in her mouth!

ROY H. TRUMBULL
Downey, Calif.

Our thanks go to readers Wylie and Trumbull for providing the above information. The statement that reader Wylie criticizes, quite rightly, should have said that the color camera made insets practical, not possible. Reader Trumbull's illustration of the difficulties of monochrome insets serves to point up the fact that such insets were indeed possible—but not fully practical—with the earlier systems.

Absolute Zero

■ I would like to bring to your attention an error which appeared in the April issue in your article

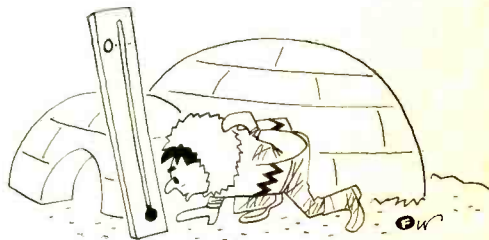

about the maser. The text states that absolute zero on the Fahrenheit scale is -473° . The correct temperature is -459.69° F.

ROBERT BARI
Bergenfield, N. J.

Views on Compatible Records

■ After reading your "Notes from the Editor" concerning a compatible stereo record in the May 1960 issue of POPULAR ELECTRONICS, I would like to make the following remarks:

- Let us not confuse the record industry and the customer any further. Let us improve the system we already have.

- Let us press records on material that will not create surface noise.

- Let us press only one half as many records from a single "stamper."

- Let us increase the output from stereo records enough to eliminate hum problems.

- Let us provide more inter-channel separation. It's easier to take care of the hole in the middle than it is to get additional separation when the original record doesn't have it to begin with.

These are the ways to increase the sales of stereo

For serious-minded men desiring higher income and status-

CREI has developed a program of home study that is comparable in technological content to advanced residence courses in electronics. The program was developed hand-in-hand with leading companies and Government agencies contributing to the Nation's efforts in electronics, communications, missiles, and space exploration.

This CREI program in Electronics Engineering Technology may be completed in 2 to 4 years, depending on how much of your spare time you can devote to study. The courses are presented in easy-to-understand form. Our instructors will give you personal attention and assist you when you need help.

To qualify CREI graduates for advancement to key technical positions, CREI offers a complete program in electronics, including—

- Automation • Instrumentation • Industrial Electronics
 Aeronautical Electronics • Guided Missiles • Radar
 Servo-mechanisms • Computers • Astronautics • Telemetering • Communications • Electronics Manufacturing • Field Engineering

A COLLEGE-LEVEL EXTENSION PROGRAM IN ELECTRONICS

There is a drastic need in the electronics industry for well-educated engineers and technical personnel. Although the great majority of students find ample opportunity for advancement with their present companies, CREI maintains a Placement Bureau to assist graduates and advanced students in finding more desirable positions. For many years, the demand for CREI graduates and advanced students has far exceeded the supply.

A few of the private companies and government agencies whose officials approve CREI for their own personnel:

- | | |
|--|---------------------------|
| U. S. Navy (5,240 enrolled in extension program) | Florida Power & Light |
| Army, Air Force, Marine Corps, Coast Guard | Pan American Airways |
| Columbia Broadcasting System | United Airlines |
| National Broadcasting Company | The Martin Company |
| Federal Electric Corporation | All America Cable & Radio |
| | Voice of America |
| | ... and many others |

CREI's Extension Division offers you a college-level home study program in electronics comparable in technological content to advanced residence courses.

QUALIFICATIONS FOR CREI. You qualify if you have a high school diploma or equivalent, and if you have had basic electronic training and practical experience in electronics. Available to Veterans.

Mail this coupon . . . today!

CAPITOL RADIO ENGINEERING INSTITUTE
 ECPD Accredited Technical Institute Curricula • Founded 1927
 Dept. 1208-G, 3224 16th St., N.W., Washington 10, D.C.

Please send me your course outline and FREE 44-Page Book "Insurance for Your Future in the New World of Electronics" . . . describing opportunities and CREI home study courses in Advanced Electronic Engineering Technology.

Check field of greatest interest

- Radar, Servo and Computer Engineering Technology
- Electronic Engineering Technology
- Communications Engineering Technology
- Television Engineering Technology
- Aeronautical Electronic Engineering Technology
- Automation and Industrial Electronics Engineering Technology

Name _____ Age _____
 Street _____
 City _____ Zone _____ State _____

Check: Home Study Residence School Korean Veteran



To obtain fast, immediate service and to avoid delay, it is necessary that the following information be filled in:

Employed by _____

 Type of Present Work _____
 Education: _____
 Years of High School _____
 Other _____
 Electronics Experience _____

TIME TO CLEAN UP
YOUR SYSTEM . . .

Norelco®

T-7 LOUDSPEAKERS
with voice coil magnets of
Ticonal-7 steel (30% more
efficient* than Alnico V)

* . . . 30% more efficient
response to the full signal range
of your amplifier . . . WHETHER
ITS RATED OUTPUT is
10 WATTS or a HUNDRED . . .
at any listening level from a
whisper to a shout!

GUILD-CRAFTED BY PHILIPS OF
THE NETHERLANDS TO GIVE YOU

THE CLEANEST SOUND AROUND



Ask for a
demonstration
wherever
good sound is
sold or write to:

**NORTH
AMERICAN
PHILIPS
CO., INC.**

High Fidelity Products Division,
230 Duffy Avenue,
Hicksville, L. I., N. Y.

Letters

(Continued from page 12)

records, in my opinion, not by new records produced by Design or any other company.

CARL E. JENSEN
Randolph, Mass.

■ My answer to the question in your editorial, "how many stereo records did you buy?" is: only half as many as I would have liked to. And my reason is plain and simple: stereo records are too expensive. If the record companies will lower their prices, they will sell more stereo records.

A compatible record is not the answer—especially for the real hi-fi fan. In a compatible record, too much of the fidelity will be lost. I'm sure the hi-fi fan doesn't want this as a solution.

I wouldn't mind paying extra for a stereo record if the manufacturers would give me something for my money—preferably in the form of better, quieter surfaces. And what about those bubbles in the present stereo discs? Are they what we're paying extra for?

No, compatible records are not the answer. Better records at lower prices may be the answer . . . or at the very least, better records at the same price. I, for one, am not buying any more stereo records until their quality improves.

PAUL SAFCHICK
Monroeville, Pa.

We certainly concur with readers Jensen and Safchick when they say that better and cheaper stereo records are needed. But this still wouldn't solve the compatibility problem. In reference to the Design compatible record, we can only restate the concluding point made in the article in our June issue which discussed the compatible record at length: ". . . if the new technique is practicable, the other manufacturers will gradually switch over to compatible records." If the technique does not measure up, the compatible record will probably go the way of the Edsel.

Eel-lectricity

■ A friend and I differ on a point which I hope the editors of POPULAR ELECTRONICS can clear up. I contend that the South American electric



eel can develop enough electricity to kill large animals. My friend says it's all native superstition. Who is right?

JERRY FUCHS
Brooklyn, N. Y.

Electric eels can produce about one ampere of current at over 600 volts. This is enough wattage to stun or paralyze a man or a large animal (such as a horse) long enough for him to drown. Incidentally, although an electric eel can light up a light bulb, the power companies are happy it's not suitable for powering motors, etc.

-30-



Looking for quality in Citizens Radio Equipment?

International's 2-way Communication power packages will solve your need.

The International Traveler . . . a new ALL transistor portable transceiver especially engineered to meet the most demanding requirements where "truly" portable short range communication is required. Compact: 4" x 6" x 7 $\frac{3}{4}$ ". Weighs less than 5 lbs.

The Traveler's 15 transistors provide maximum "talk power" and "reception." Built-in speaker plus separate phones jack. Dual con-

version receiver. Truly effective noise limiter and squelch. Two channel crystal controlled receiver and transmitter. Push-to-talk operation. Powered by built-in nickel cadmium battery and charger.

Complete with battery, charger, microphone, 2 sets crystals, whip antenna, carrying strap, and mobile mounting bracket. .only **\$249.50**

Write for International's Complete Catalog.



The EXECUTIVE, complete with one channel 9 transmit crystal, AC power cord, microphone, and operating instructions

. . . .only **\$169.95.**

The International Executive . . . ideal for a fixed base station or mobile use.

Push-to-talk operation, 3 crystal controlled transmit positions, two crystal controlled receive positions, dual conversion super-heterodyne receiver tuning all 23 channels.

Five watts plate input. Series Gated automatic noise limiter. Fifteen tube performance. The Executive has 10 tubes and 1 diode. Four tubes are multi-purpose.

Universal built-in power supply for 6 VDC, 12 VDC, and 115 VAC. Size: 5 $\frac{1}{2}$ " x 8 $\frac{1}{2}$ " x 9". Weighs 12 lbs.

**INTERNATIONAL
CRYSTAL MFG. CO. INC.**

18 NORTH LEE — OKLA. CITY, OKLA.

**RESIDENT SCHOOL COURSES
IN LOS ANGELES AND NEW YORK CITY**

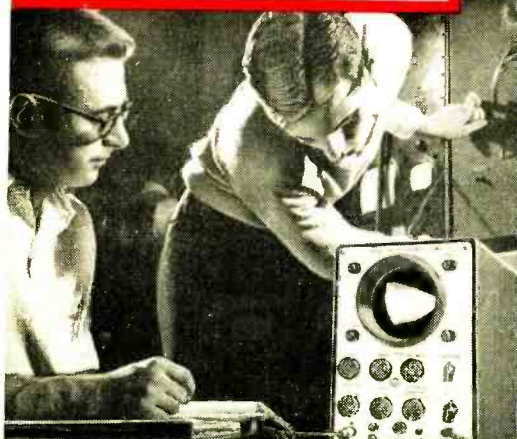

Industry needs Electronic Technologists!

LET RCA TRAIN YOU IN General Electronics Technical Writing TV, Communications

Countless career opportunities are open to you in such fields as automation, guided missiles, radar, television, computers, and other industrial electronic applications.

RCA Institutes Resident Schools in New York City and Los Angeles offer you comprehensive courses that prepare you for the field of electronics you may choose. No previous technical training required. Introductory courses in Math and Physics available.

Coeducational Day and Evening classes. Free placement service. Applications now being accepted.



The Most Trusted Name
in Electronics

© RADIO CORPORATION OF AMERICA

Send to the school nearest you

RCA Institutes, Inc., Dept. PER-80.

350 West Fourth Street
New York 14, N. Y.

Pacific Electric Building
610 S. Main St., L.A. 14, Calif.

Please send me your FREE catalog of Resident School courses.

Name _____

(PLEASE PRINT)

Address _____

City _____ Zone _____ State _____

For Home Study Courses See Ad On Opposite Page

NEW products

STEREO TUNER KIT

The Heathkit Model AJ-10 is a new AM-FM stereo tuner with provisions for adding an FM multiplex adapter. The FM section features a sensitivity of 2 microvolts for



20 db quieting, a 3-position a.f.c. switch, and a separate tuning indicator. The AM section has a "narrow-broad" bandwidth switch and a built-in rod antenna. Price, in kit form, \$59.95. (Heath Company, Benton Harbor, Mich.)

A.C. VTVM KIT

Featured on the new a.c. VTVM Knight-Kit is an automatic motor-driven range selector that sets the VTVM to the correct range when the probe is touched to the circuit under test. Voltage ranges are .003, .010, .030, 0.1, 0.3, 1, 3, 10, 30, 100, and 300 volts. Decibels are measured from -62 to +52 in eleven ranges.



Frequency response is from 20 cps to 2.5 mc. ± 1 db, with flat response from 50 to 500 kc. Unit employs 10 tubes plus rectifier. \$99.50. (Allied Radio Corp., 100 N. Western Ave., Chicago 80, Ill.)

FM CAR RADIO

Scheduled to be introduced in September, the Granco FM car radio features the latest in transistorized circuitry. The tuner section uses automatic frequency control to



LET RCA TRAIN YOU IN ELECTRONICS

RCA Institutes, one of the world's leading electronic technical schools, offers a Home Study Course in . . .

ELECTRONICS FOR AUTOMATION

. . . Now you have four comprehensive courses for your electronic training . . . from basic electronic theory to the more advanced principles of color TV and Automation.

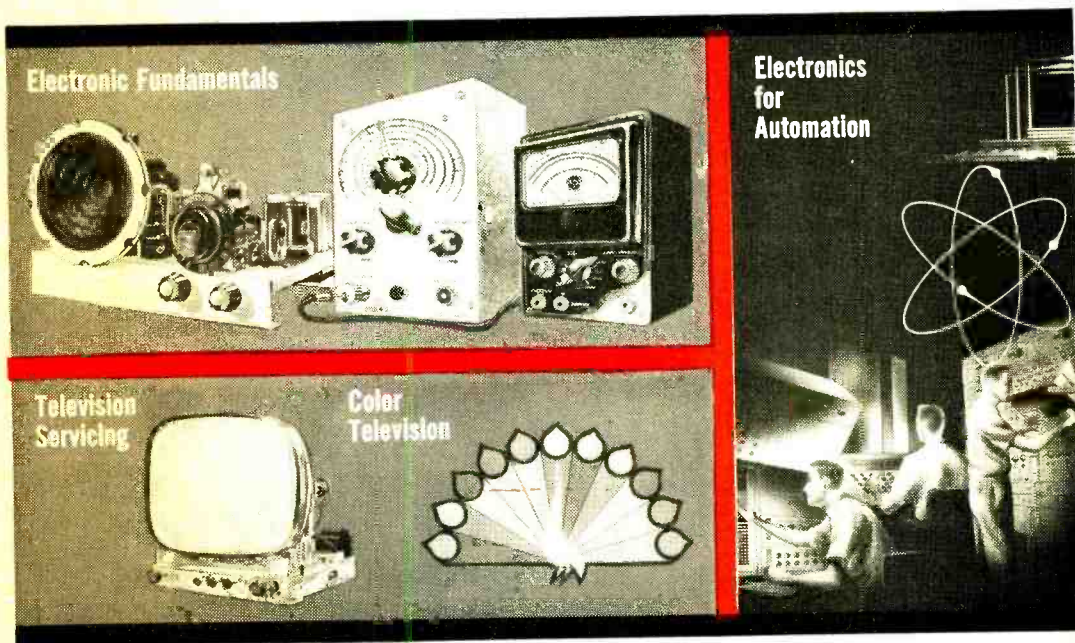

Send for our
64 page Home
Study Catalog

FREE!

For
**RESIDENT SCHOOL
COURSES**

see ad on opposite page.



Practical work with the very first lesson. Pay-as-you-learn. You need pay for only one study group at a time.

RCA INSTITUTES, Inc. Home Study School, Dept. PE-80

A Service of Radio Corporation of America

350 West Fourth Street, New York 14, N. Y.

Please rush me your FREE illustrated 64-page book "Your Career in Electronics," describing your home training programs. No obligation. No salesman will call.

Name Age

Please print

Address

City Zone State

Veterans: Enter discharge date

CANADIANS — Take advantage of these same RCA courses at no additional cost. No postage, no customs, no delay. Send coupon to: RCA Victor Company, Ltd., 5581 Royalmount Ave., Montreal 9, Quebec
To save time, paste coupon on postcard.

NEW 4-WAY POCKET TOOL

a real "working partner" for removing backs of TV sets and installing antennas



1 It's a 1/4" nut driver!
Fits Parker Kalon screws.

Genuine Xcelite plastic handle.
Equipped with pocket clip.

2 It's a 7/16" nut driver!
Ideal for antenna
installations.

3 It's a No. 1
Phillips
screwdriver!

Double-end blade
inserts in 7/16"
hex opening.

4 It's a 3/16"
slotted
screwdriver!

XCELITE

XCELITE, INC. • ORCHARD PARK, N. Y.
Canada: Charles W. Pointon, Ltd., Toronto, Ont.

See "No. 600" next
time you pick up parts.

Enjoy your HI-FI OUTDOORS

PATIO, GARDEN, TERRACE, POOL

with the new WT-6

ATLAS HI-FI

COAX-PROJECTOR

all-weather construction... install it, forget it...
or take it with you wherever you listen.



True hi-fi TWO-WAY system—
not just a "compromise." The
WT-6 comprises a weather-
proof cone type driver (with
6-inch throat) coupled to its
individual woofer horn; a sep-
arate pressure-type driver
loaded to its separate tweeter
horn; and built-in electronic
crossover filter.

For all indoor and outdoor
uses... universally adjustable
"U" type rugged steel mount-
ing... finished in high-tem-
perature baked modern beige
enamel.

Power Rating 15 watts contin-
uous. Freq. Resp. 125-15,000
cps. Impedance 8 ohms. Dis-
persion 120°. Bell opening
15", overall depth 12".

See the WT-6 at
your local dis-
tributor. Send
for catalog 560.

Net \$34.50

ATLAS SOUND CORP.
Dept. PE-8, 1449 - 39th St., Brooklyn 18, N. Y.



products

(Continued from page 16)

lock stations in tune, making it unnecessary for the driver to divert his attention from the road for dial-twisting. The unit will

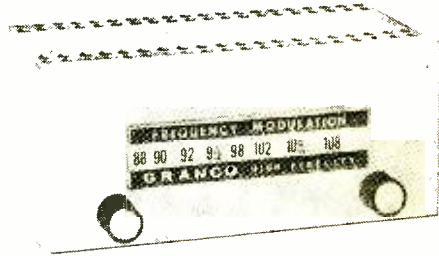

cost only about \$75.00 installed, and will be suitable for use in any car having a 12-volt ignition system. (Granco Products, Inc., 83-30 Kew Gardens Rd., Kew Gardens, N. Y.)

CODE PRACTICE OSCILLATOR

A transistorized battery-operated code practice oscillator has been announced by EICO, 33-00 Northern Blvd., Long Island City 1, N. Y. The Model 706 has a built-in

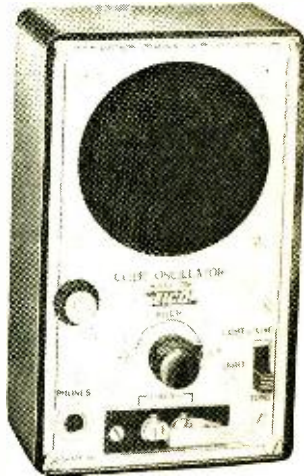

3" speaker and a flashing light for visual use. A headphone output jack and a pitch control are also included. Price: in kit form, \$8.95; factory-wired, \$12.95.

STEREO TONE ARM

Designed for easy installation, the new "Professional" tone arm manufactured by Shure Brothers, Inc., 222 Hartrey Ave., Evanston, Ill., mounts entirely from the top of the turntable motorboard and requires no soldering. Other features include

NEW!

MADE IN U.S.A.



LAFAYETTE HE-15 CITIZENS BAND 11 METER SUPERHETERODYNE TRANSCIVER

Not Superregenerative but SUPERHET

COMPLETELY
WIRED
NOT
A KIT

64.50
ONLY 5.00 DOWN

- 5 Crystal Controlled Transmitting Positions: Operates at a maximum FCC legal power input of 5 watts fully modulated.
- Superheterodyne Tuneable Receiver Over Full 22 Channel Band: RF stage in both Transmitter and receiver, 3 watts audio output plus large 4" speaker.
- Complete with Transmitting Crystal: Removable front plate for easy accessibility of crystals. Channel 9 crystal supplied.
- 4 Dual Function Tubes, plus 2 Single Function Tubes, plus 2 Rectifiers for 12 Tube Performance: Compares with units costing 3 times as much. Unexcelled reception on land and sea with coverage up to 20 or more miles depending on antenna height and terrain.

- Planetary Vernier Tuning: Controls include 3 position function switch (transmit, receive, plus transmit with spring return) and automatic noise limiting switch.
 - High Output Crystal Microphone: 2 position push to talk slide switch; especially designed for sustained transmit operation with a minimum of background noise.
 - Adapts for Use Anywhere: Modern compact styling. Brackets are supplied for easy mounting of unit in auto, truck or boat. Addition of 6 or 12 volt power supply (separately supplied) adapts transceiver for mobile operation. Only 4 1/2"D x 6"W x 4"H.
- Anyone Can Operate: No examination or technical knowledge required—Any citizen 18 years or older is eligible for a license. Simply fill out FCC application supplied with HE-15 Transceiver.
- | | |
|---|-----------|
| HE-15 Factory Wired and Tested (Less antenna) | |
| 5.00 Down | Net 64.50 |
| HE-19 Whip Antenna | Net 3.95 |
| HE-16 Power Supply For 12 Volts | Net 11.95 |
| HE-18 Power Supply For 6 Volts | Net 11.95 |



Use in the Home



Boating — Ship to Shore



On the Farm



Business — Trucking

NEW! LAFAYETTE TELESCOPIC CITIZENS BAND WHIP ANTENNA

3.95 • Chrome Plated • Telescopes From 16 1/2" to 40" • Mounts Vertically or Right Angle

An outstanding antenna value. This high quality three section telescoping antenna is designed for attachment directly to your citizens band transceiver. Ideal for point to point service over short distances. Molded base loading coil has a threaded stud with a PL-259 plug—connector for vertical or right angle mounting. Shpg. wt. HE-19 Net 3.95

NEW! LAFAYETTE RADIO FIELD INDICATOR

A Must For All Ham and Citizens Band

- Provides a Continuous Indication **7.95** of Transmitter Output
- Rugged 200ua Meter Movement with Variable Sensitivity Control
- Requires no Electricity, Batteries or Transmitter Connection

Measures the RF field generated by any marine, mobile or fixed transmitter. Rear phone jack accepts earphones. Antenna extends from 3 1/4" to 10 3/4". Bottom plate magnet allows mounting on any metal surface. Measures 3 1/8"W x 2 1/4" H x 2"D (less antenna). Shpg wt., 2 lbs.



TM-14 Net 7.95

LAFAYETTE "Tiny" 6-Transistor Radio

Sensational Performance In a Small Package!

- 6 Transistors Plus a Germanium Diode
- Superheterodyne Circuit
- Vest Pocket Size—Only 4"H x 2 1/2"W x 1 1/4"D
- Built In Earphone Jack For Private Listening
- Trouble-Free Printed Circuit
- Built-In Ferrite Bar Antenna
- Economical—Uses Only One 9 Volt Battery



ONLY **19.95**

Complete with battery, carrying case and earphone. Shpg wt. 2 lbs.

FS-208 "Tiny" 6-Transistor Radio Net 19.95

PLEASE RUSH ITEMS CHECKED

- HE-15 Citizens Band Transceiver TM-14 Radio Field Indicator
 FS-206 "Tiny" 6 Transistor Radio HE-19 Whip Antenna
 Free 308 Page Catalog 600

Enclosed Find \$.....
Please include postage to cover shipping

FREE 308 Giant Size Pages

Name.....
Address.....
City..... Zone..... State.....

LAFAYETTE RADIO • P.O. BOX 222, Jamaica 33, N.Y. • Dept. IH-6

products

(Continued from page 18)

a direct-reading stylus-pressure gauge, provisions for maintaining proper stylus overhang with various cartridges, interchangeable lock-on heads, and adjustable height. Ball bearings are used in all pivot points. Price: Model M232 (12" arm), \$29.95; Model M236 (16" arm), \$31.95.

HAM TRANSMITTER

Designed for 90 watts c.w. and 75 watts phone input power, the "Globe Scout Deluxe" is a 6-80 meter bandswitching transmitter. It has a self-contained power sup-



ply, a pi-net output on 10-80 meters, and a tuned link-coupled output on 6 meters. The cabinet measures 15 1/4" x 6 1/4" x 11 1/4" and features an aluminum panel with burnished rotary switches. Price, \$149.95. (Globe Electronics, 22-30 South 34th St., Council Bluffs, Iowa.)

WIRELESS INTERCOM

The Vocatron CC-60 wireless intercom is a self-contained master station capable of originating and receiving calls. Features include a squelch circuit to filter out unwanted noise and a "press-to-talk" switch that can be locked in place. Power consumption is only 30 watts. The Vocatron measures 3" x 8" x 6". Price, per pair: \$109. Additional units are \$54.50 each. (Vocaline Company of America, Inc., Old Saybrook, Conn.)



SEMI-KIT SPEAKER SYSTEM

The bookshelf-type semi-kit speaker system announced by PACO Electronics Co.,

70-31 84th St., Glendale, L. I., N. Y., includes a 10" Jensen long-excursion woofer, a horn-loaded compression tweeter, and a preassembled enclosure of 3/4" furniture-grade plywood. Overall response is from 45 to



14,000 cps, and a control is provided to adjust the output level from the tweeter. Impedance is 8 ohms. Size: 23 1/2" x 13" x 12". Price: Model L2-U (unfinished), \$59.95; Model L2-W (walnut finish), \$69.95.

HIGH-OUTPUT LANTERN

A battery-operated lantern with over twice the light output of a new automobile headlight has recently been introduced by Burgess Battery Co., Freeport, Ill. Powered by a compact 12-volt battery, the Radar-Lite lantern projects an 80,000 - candle-power beam, providing nearly a full mile of visibility. The 4 1/2" light-head attaches to the battery with insulated screw caps and can be tilted up or down 135 degrees. Price, complete with battery, \$10.95.

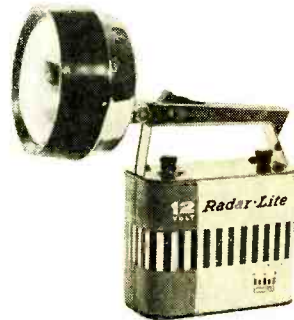

PORTABLE TAPE RECORDER

A transistorized portable tape recorder that weighs less than five pounds is being marketed by the Radio Shack Corp., 167 Washington St., Boston 8, Mass. The Realistic TR-730 is a 2-track, 2-speed (3 3/4 and 1 1/2 ips) recorder which operates on batteries. Measuring only 2 1/2" x 5 1/2" x 7 1/2", the unit has a built-in VU meter, an amplifier, and a speaker. Frequency response is from 200 to 5000 cps. Price, complete with batteries, mike, and one reel of tape, \$89.50. -30-

Now available at electronics parts stores, hi-fi salons, and record shops!

Stereo-Monophonic
Test Record

Specially packaged
at only

\$1.59

(\$1.98 in Canada)



As a man who is seriously interested in hi-fi, you will certainly want to take advantage of this new and important test record, now on sale at electronics parts stores, hi-fi salons, and record shops. It will enable you to know your system inside-out. As a result, your listening enjoyment will be even greater than ever before.

This Stereo-Monophonic Test Record is the *most complete test record* of its kind—containing the widest range of essential check-points ever incorporated into *one* test disc! And, best of all, you need no expensive test equipment when you use this record! Just listen and get the thorough results you want—all checks can be made by ear!

Here are some of the questions this record will answer for you!

- ✓ How good is my stylus? Is it worn? Will it damage my records?
- ✓ What about my stereo cartridge? Does it have enough vertical compliance so that it won't ruin my expensive stereo records?
- ✓ Is my turntable running at the right speed? Is it free of rumble, wow, and flutter?
- ✓ What sort of standing waves do I get in my listening room?
- ✓ Are my speakers hooked up correctly? Are they phased properly, and is the correct speaker connected to the right stereo channel?
- ✓ How perfectly is my system equalized?
- ✓ What about separation? Is it adequate?

This special test record brings you an extraordinary 2-way value. First, it guides you in evaluating the quality of reproduction your equipment now produces. Second, it specifies the adjustments necessary to get the best recorded sound you have ever heard! This is easily the best value of the year for everyone who owns a hi-fi system—either monophonic or stereo!

NOW ON SALE EXCLUSIVELY AT ELECTRONICS PARTS STORES, HI-FI SALONS AND RECORD SHOPS!

You can be sure this Stereo-Monophonic test record comes as close to perfection as is humanly possible, because the editors of *ELECTRONICS WORLD*—leading technical magazine in the field of electronics—have poured their accumulated know-how into this record. Purchase your record today! (If you find your dealer does not yet have a supply available, ask him to order them for you.)

SPECIAL NOTE TO DEALERS: for information on ordering your supply of records, contact Ziff-Davis Publishing Company, Direct Sales Division, One Park Avenue, New York 16, N. Y.

Complete Training

FOR BETTER RADIO-TV SERVICE JOBS



Let these two great Ghirardi training books teach you to handle all types of AM, FM and TV service jobs by approved professional methods—and watch your efficiency and earnings soar!

Each book is a complete service training guide. Each contains complete data on modern methods and equipment—NOT a re-hash of old, out-of-date material. Each is co-authored by A. A. Ghirardi whose famous RADIO PHYSICS COURSE and MODERN RADIO SERVICING were, for 20 years, more widely used for military, school and home study training than any other books of their type!

THE NEW Ghirardi RADIO-TV SERVICE LIBRARY

Almost 1500 pages and over 800 clear illustrations show step-by-step how to handle every phase of troubleshooting and servicing.

1—Radio and Television Receiver TROUBLESHOOTING AND REPAIR

A complete guide to profitable professional methods. For the beginner, it is a comprehensive training course. For the experienced serviceman, it is a quick way to "brush up" on specific jobs, to develop improved techniques or to find fast answers to puzzling service problems. Includes invaluable "step-by-step" service charts, 820 pages, 417 illus., price \$7.50 separately.

2—Radio and Television Receiver CIRCUITRY AND OPERATION

This 660-page volume is the ideal guide for servicemen who realize it pays to know what really makes modern radio-TV receivers "tick" and why. Gives a complete understanding of basic circuits and circuit variations; how to recognize them at a glance; how to eliminate guesswork and useless testing in servicing them. 417 illus., Price separately \$6.75.

Special low price . . . you save \$1.25

If broken into lesson form and sent to you as a "course," you'd regard these two great books as a bargain at \$50 or more!

Under this new offer, you save \$1.25 on the price of the two books—and have the privilege of paying in easy installments while you use them! No lessons to wait for. You learn fast—and right!

STUDY 10 DAYS FREE!

Dept. PE-80, RINEHART & CO., Inc.
232 Madison Ave., New York 16, N. Y.

Send books below for 10-day FREE EXAMINATION. In 10 days I will either remit price indicated (plus postage) or return books postpaid and owe you nothing.

Radio & TV Receiver TROUBLESHOOTING & REPAIR (Price \$7.50 separately)

Radio & TV CIRCUITRY & OPERATION (Price \$6.75)

Check here for MONEY-SAVING COMBINATION OFFER. Save \$1.25. Send both of above big books at special price of only \$13.00 for the two. (Regular price \$14.25 . . . you save \$1.25!). Payable at rate of \$4 plus postage after 10 days if you decide to keep books, and \$3 a month for 3 months until the total of \$13.00 has been paid.

SAVE! Send money with order and we pay postage. 10-day return privilege with money refunded.

Name

Address

City, Zone, State

Outside U.S.A.—\$8.00 for TROUBLESHOOTING & REPAIR; \$7.25 for CIRCUITRY & OPERATION; \$14.00 for both. Cash only, but money refunded if you return books in 10 days.

POP'tronics Bookshelf

"PRINCIPLES OF FREQUENCY MODULATION" by B. S. Camies. Published by John F. Rider Publisher, Inc., 116 W. 14th St., New York 11, N. Y. 147 pages. Soft cover. \$3.50.

A comprehensive account of the principles of frequency modulation, this book provides detailed coverage—including many mathematical analyses—of FM theory and practice. The author, a well-known English engineer, handles the subject very well, but American readers should be prepared to translate British words into American, e.g., "valves" into "tubes." This is a minor problem, however; all in all, the volume should prove useful as a text or as a reference work to both students and radio engineers.

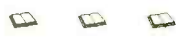

"ELECTROMAGNETIC WAVES" by Robert Irving. Published by Alfred A. Knopf, Inc., 501 Madison Ave., New York, N. Y. 141 pages. \$3.00.

This very handsomely designed book is an introduction to the subject of electromagnetic waves. It is meant for young people, being simply and clearly written, and it would be a good "first" book for a child who has shown interest in the field of electronics. Topics covered include light, radio waves, infrared waves, ultraviolet waves, X-rays, microwaves, and gamma rays. Although coverage is not very thorough in any single area, the book generally accomplishes what it sets out to do.



"BASICS OF INDUCTION HEATING" (Vols. 1 and 2) by Chester A. Tudbury. Published by John F. Rider Publisher, Inc., 116 West 14th St., New York, N. Y. Volume 1, 140 pages; Volume 2, 144 pages. Soft



... symbol of
RAD-TEL
FIRST QUALITY

INSIST ON RAD-TEL FOR EVERY
 TELEVISION AND RADIO TUBE NEED

Super-Special!
KIT OF 100
Bi-Pass
CONDENSERS
 Over 50%
 Are 600V
 at LESS
 THAN 4¢ each
 Goodall
 Semi-Molded
 Paper and MYLAR
 Made up of approx.
 16-200V, 20-400V
 and 64-600V.
 Values .001 to 1 mf

\$3.95

GUARANTEED
ONE FULL
YEAR!

Up to 75% OFF on BRAND NEW TUBES

You Can Rely On Rad-Tel's Speedy One Day Service!

Not Used — Not Pulled Out Of Old Sets • Each Tube Individually and Attractively Boxed!

Qty.	Type	Price	Qty.	Type	Price	Qty.	Type	Price	Qty.	Type	Price	Qty.	Type	Price	Qty.	Type	Price
—	024M	.79	—	4B27	.96	—	6AV6	.40	—	6DE6	.58	—	12AE6	.43	—	12CR6	.54
—	1AX2	.62	—	4CS6	.61	—	6AW8	.89	—	6DG6	.59	—	12AF3	.73	—	12CU5	.58
—	1B3GT	.79	—	4DE6	.62	—	6AX4	.65	—	6DQ6	1.10	—	12AF6	.49	—	12CUG	1.06
—	1DN5	.55	—	4DK6	.60	—	6AX7	.64	—	6DT5	.76	—	12AJ6	.46	—	12CX6	.54
—	1G3	.73	—	4OT6	.55	—	6BA6	.49	—	6DT6	.53	—	12AL5	.45	—	12DB5	.69
—	1J3	.73	—	5AM8	.79	—	6BC5	.54	—	6EU8	.79	—	12AL8	.95	—	12DE8	.75
—	1K3	.73	—	5AN8	.86	—	6BC7	.94	—	6EA8	.79	—	12AQ5	.52	—	12DL8	.85
—	1L6	1.05	—	5AQ5	.52	—	6BC8	.97	—	6H6GT	.58	—	12AT6	.43	—	12DM7	.67
—	1LN5	.59	—	5AT8	.80	—	6BD6	.51	—	6J5GT	.51	—	12AT7	.76	—	12DQ6	1.04
—	1R5	.62	—	5BK7A	.82	—	6BE6	.55	—	6J6	.67	—	12AU6	.50	—	12DS7	.79
—	1S5	.51	—	5BQ7	.97	—	6BF6	.44	—	6K6	.79	—	12AU7	.60	—	12DZ6	.56
—	1T4	.58	—	5BR8	.79	—	6BG6	1.66	—	6S4	.48	—	12AV5	.97	—	12EL6	.50
—	1U4	.57	—	5CG8	.76	—	6BF6	.65	—	6SA7GT	.76	—	12AV6	.41	—	12EG6	.54
—	1U5	.50	—	5CL8	.76	—	6BF8	.87	—	6SK7GT	.74	—	12AV7	.75	—	12EZ6	.53
—	1X2B	.82	—	5EA8	.80	—	6BJ6	.62	—	6SL7	.80	—	12AX4	.67	—	12F5	.66
—	2AF4	.96	—	5EU8	.80	—	6BK7	.85	—	6SN7	.65	—	12AX7	.63	—	12F8	.66
—	2CY5	.71	—	5F6	.68	—	6BL7	1.00	—	6SQ7	.73	—	12AZ7	.86	—	12FM6	.45
—	3AL5	.42	—	5T8	.81	—	6BN4	.57	—	6T4	.99	—	12B4	.63	—	12K5	.65
—	3AU6	.51	—	5U4	.60	—	6BN6	.74	—	6U8	.78	—	12BA6	.50	—	12SA7M	.86
—	3AV6	.41	—	5U8	.81	—	6BQ5	.65	—	6V6GT	.54	—	12BD6	.50	—	12SK7GT	.74
—	3BA6	.51	—	5V6	.56	—	6BQ6GT	1.05	—	6W4	.75	—	12BE6	.53	—	12SN7	.67
—	3BC5	.54	—	5X8	.78	—	6BQ7	.95	—	6W6	.69	—	12BF6	.44	—	12SQ7M	.73
—	3BE6	.52	—	5Y3	.46	—	6BF8	.78	—	6X4	.39	—	12BH7	.73	—	12U7	.62
—	3BN6	.76	—	6AB4	.46	—	6BU8	.70	—	6X5GT	.77	—	12BL6	.56	—	12V6GT	.53
—	3BU8	.78	—	6AC7	.96	—	6BY6	.54	—	6X8	.53	—	12BQ6	1.06	—	12W6	.69
—	3BY6	.55	—	6AF3	.73	—	6BZ6	.54	—	7AU7	.61	—	12BZ7	.75	—	12X4	.38
—	3BZ6	.55	—	6AF4	.97	—	6BZ7	.97	—	7A8	.68	—	12C5	.56	—	17AX4	.67
—	3CB6	.54	—	6AG5	.65	—	6C4	.43	—	7B6	.69	—	12CA5	.59	—	17BQ6	1.09
—	3CF6	.60	—	6AH6	.99	—	6CB6	.54	—	7Y4	.69	—	12CA5	.59	—	17C5	.58
—	3CS6	.52	—	6AK5	.95	—	6CD6	1.42	—	8AU8	.83	—	12CA5	.56	—	17CA5	.62
—	3CY5	.71	—	6AL5	.47	—	6CF6	.64	—	8AW8	.93	—	—	—	—	—	—
—	30K6	.60	—	6AM8	.78	—	6CG7	.60	—	8BQ5	.60	—	—	—	—	—	—
—	30T6	.50	—	6AN4	.95	—	6CG8	.77	—	8CG7	.62	—	—	—	—	—	—
—	3Q5	.80	—	6AN8	.85	—	6CM7	.66	—	8CM7	.68	—	—	—	—	—	—
—	3S4	.61	—	6AQ5	.50	—	6CM7	.65	—	8CN7	.97	—	—	—	—	—	—
—	3V4	.58	—	6AR5	.55	—	6CF6	.51	—	8CX8	.93	—	—	—	—	—	—
—	4BC5	.56	—	6AS5	.60	—	6CS6	.57	—	8EB8	.94	—	—	—	—	—	—
—	4BC8	.96	—	6AT6	.43	—	6CU5	.58	—	10DA7	.71	—	—	—	—	—	—
—	4BN6	.75	—	6AT8	.79	—	6CU6	1.08	—	11CY7	.75	—	—	—	—	—	—
—	4BQ7	.96	—	6AU4	.82	—	6CY5	.70	—	12A4	.60	—	—	—	—	—	—
—	4BS8	.98	—	6AU6	.50	—	6CY7	.71	—	12A55	.55	—	—	—	—	—	—
—	4BU8	.71	—	6AU7	.61	—	6DA4	.68	—	12AC6	.49	—	—	—	—	—	—
—	4BZ6	.58	—	6AU8	.87	—	6DB5	.69	—	12AD6	.57	—	—	—	—	—	—

TRANSISTORS

ICBO ≈ 6V IEBO ≈ 3V hfe ckt A
 10 pa max. 10 pa max. 25 min.

IN LOTS OF 10

29¢ EA.

CIRCUIT A

General Purpose Type

SEND FOR FREE TROUBLE SHOOTER GUIDE AND NEW TUBE & PARTS CATALOG.

RAD-TEL TUBE CO.

55 Chambers St
 Newark 5, N. J.

PE-860

TERMS: 25% deposit must accompany all orders — balance C. O. D. **Not Affiliated With**
 \$1 HANDLING CHARGE FOR ORDERS UNDER \$5. Subject to prior sale. **Any Other Mail**
 Please add postage. No C. O. D.'s outside continental U. S. A. **Order Tube Co.**

The TRUTH About ELECTRONICS JOBS!

High-pay positions await you in Electronics—fastest-growing major industry in U. S. 1,500,000 employed—more needed! Huge demand for trained men in missiles, rockets, electronics, outer-space projects. Also in Radio-TV service, broadcasting studios, communications. Real opportunity if you prepare now, this easy, low-cost way. FREE book tells all!

Get this valuable book now . . .



Your Chance for High-Pay Career:

I would like to send you my FREE book shown above. It will tell you all about the Electronics-Radio-Television field . . . show you the many high-pay careers open to trained men . . . and explain how you can qualify yourself in a minimum of time, at a minimum of cost. Home study or resident training. Demand for electronics specialists greatly exceeds the supply. Just check the positions held by these recent Central Graduates picked at random from our files:

Garry Sheley, ELECTRONIC TECHNICIAN, Convair Astronautics; Jack Frazier, STUDIO ENGINEER, Station KMTV-TV; Alvin Brazda, STAFF ASSISTANT, Sandia Corporation; David Winkler, PUBLICATIONS ENGINEER, Martin Company. Over 50,000 successful graduates since 1931!

P. L. Foster C. L. Foster, President

Clip and Mail Today!

ELECTRONICS DIVISION—Central Technical Institute
Dept. A-80, 1644 Wyandotte St., Kansas City 8, Mo.

(Offering engineering technician curricula accredited by Engineers Council for Professional Development.)

Please tell me more about how your training can qualify ME for a high-pay Electronics career. (Check specific field(s) of interest below, if you wish.)

- | | | |
|--------------------------------------|---|---|
| <input type="checkbox"/> Radio | <input type="checkbox"/> Guided Missile | <input type="checkbox"/> Tech. Drafting |
| <input type="checkbox"/> Television | <input type="checkbox"/> Nuclear Power | <input type="checkbox"/> Armed Forces |
| <input type="checkbox"/> Color TV | <input type="checkbox"/> Radar | <input type="checkbox"/> Civil Service |
| <input type="checkbox"/> Electronics | <input type="checkbox"/> Aviation | <input type="checkbox"/> Your Business |
| <input type="checkbox"/> Other | | |



ACCREDITED by
National Home
Study Council
Member National
Council of
Technical Schools

Name _____
Address _____
City _____ Zone _____
State _____ County _____
Age _____ Education _____

Bookshelf

(Continued from page 22)

cover editions. \$3.90 per volume; cloth-bound set, \$8.90.

These two volumes present the principles underlying the art of induction heating. Since the author starts at a rather basic level, anyone with a knowledge of electronic theory will be able to follow along without difficulty. Numerous illustrations in the now-familiar style previously used in "Basic Electronics" and other Rider publications help the reader to understand the subject. There are review questions at the end of each chapter.



"TWO-WAY MOBILE RADIO HANDBOOK" by Jack Helmi. Published by Howard W. Sams and Co., Inc., 2201 E. 46th St., Indianapolis 5, Ind. 208 pages. Soft cover. \$3.95.

Here is the first really comprehensive treatment of the rapidly expanding mobile radio field. This book is packed with information, and should be invaluable to the service technician who works in this field or who plans to enter it. Covered in detail are receiver and transmitter circuits, power supplies, control systems, and antenna systems. Servicing tips and instructions for setting up a service business in mobile radio are included, as are circuit diagrams and illustrations of many commercial units.



"OFFICIAL REGISTRY OF TRANSPORTATION RADIO SYSTEMS," 1960 Edition. Published by Milton B. Sleeper, Communications Engineering Book Co., Monterey, Mass. 72 pages. \$4.00.

Just as the Amateur and Citizens Radio Services have their own "call books," so do the various commercial services. This book lists the thousands of two-way radio sta-

Always say you saw it in—POPULAR ELECTRONICS

We'd like to send you these important new books for a 7-DAY FREE TRIAL EXAMINATION

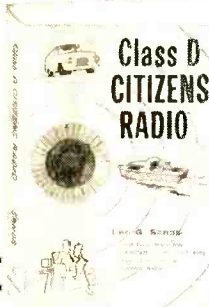

CLASS D CITIZENS RADIO

Leo G. Sands

Here is the first complete book on Citizens Radio Operation. Ever since the initial use of 2-way radiotelephone by police departments, this field has been growing in importance and application. Now, with more than a million vehicles equipped for its use, Citizens Radio is a major phase of the electronics field. This important new volume covers every aspect of the field—its history, rules, and everything about how it works—in seven big chapters with one hundred major sections. You'll learn exactly what Citizens Radio is, its applications, what equipment you need, the full story on receiver circuits and transmitters, antennas, installation, and maintenance, full FCC rulings, how to apply for licenses, etc. Many illustrations.

\$4.95

COMPUTERS AND HOW THEY WORK

by James Fahnestock

Here is a fact-filled exciting guidebook to the wonderworld of electronic computers, with more than 120 illustrations and easy-to-follow tables in 10 big chapters. Step by step, you'll see and understand the workings of every type of computer ever used. This important new book illustrates the basic principles of computers in methods that require no knowledge of electronics. You'll learn all about computer memories, flip-flops and the binary counting system. You'll learn the mathematical language of computers where $1 + 1 = 10$. Other chapters show you how computers use tubes and transistors to make complex logical decisions in thousandths of a second. **COMPUTERS AND HOW THEY WORK** is must reading for career minded students and for electronics pros who want a more complete knowledge of this field.

\$4.95

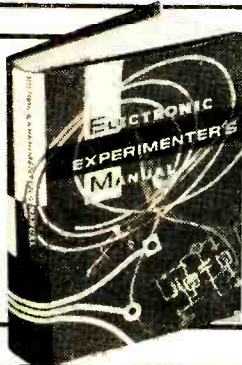
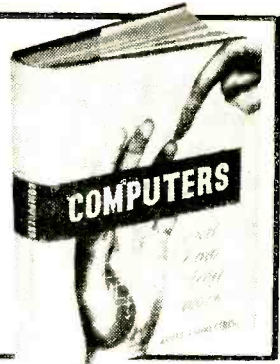

THE ELECTRONIC EXPERIMENTER'S MANUAL

by David A. Findlay

With a few dollars worth of basic tools, and this book to guide you, you can explore the magic of electronics experimentation more completely than ever before. In a few short hours, you'll start your first project. You'll learn about every component used in experimentation, every tool, its function and why it is used. There are 10 big sections, each covering a specific phase of construction. There's a giant section of projects you can build, test equipment you'll construct and use in your future work. **THE ELECTRONIC EXPERIMENTER'S MANUAL** will give you the professional know-how you must have no matter what phase of electronics is your specialty.

\$4.95

7 DAY FREE EXAMINATION

When your books arrive, read and enjoy their diversity of contents, the thoroughness of their coverage. Then after seven days examination, if you decide that they are not everything you want, send them back and receive a complete refund of the purchase price.

USE THIS CERTIFICATE FOR 7 DAY FREE EXAMINATION

ELECTRONICS BOOK SERVICE •

434 S. Wabash Ave., Chicago 5, Ill.



Please send me copies of **CLASS D CITIZENS RADIO** and bill me at only \$4.95 a copy plus a few cents postage.

Please send me copies of **COMPUTERS AND HOW THEY WORK**, and bill me at only \$4.95 a copy plus a few cents postage.

Please send me copies of **THE ELECTRONIC EXPERIMENTER'S MANUAL**, and bill me at only \$4.95 a copy plus a few cents postage.

If I don't agree that this is one of the best electronics investments I've ever made, I may return the book(s) within seven days and get a full refund.

\$ enclosed. (SAVE MONEY! Enclose payment with Your order and we'll pay the postage.)

Name

Address

City Zone State

7FE80

find new
adventure in
amateur
radio...

with
Viking
1st choice of
amateurs the
world over!

loaded with features... kit or wired!



ADVENTURER—50 watts CW input 80 through 10 meters. 240-181-1... Kit Am. Net... \$54.95	RANGER—75 watts : CW input; 65 watts : phone—160 through : 10 meters. 240-161-2... Kit : Am. Net... \$229.50 : 240 161-1... Wired : Am. Net... \$329.50	VALIANT—275 watts : CW and 55B; 200 : watts AM—160 : through 10 meters. 240-104-2... Kit : Am. Net... \$349.50 240-104-2... Wired : Am. Net... \$439.50
--	--	--



Complete specifications and schematics on all Johnson transmitters, amplifiers, station accessories, keys and practice sets!



E. F. JOHNSON CO.

1233 2nd Ave. S.W. • Waseca, Minn.

NAME _____
ADDRESS _____
CITY _____ STATE _____

**BUILD THE
PROJECTS
DESCRIBED
IN THIS
ISSUE OF**

**POPULAR
ELECTRONICS**

WITH THESE



PRODUCTS

"Low Cost Black Light"

Use BUD CU-2104A—95¢

"Experimenter's Test Speakers"

Use BUD CU-2107A—\$1.50

"Unlicensed Two-Way Radio"

Use BUD WO-6—\$12.05

"Across the Ham Bands"

Use BUD CU 2117A—78¢

All Bud products are available for immediate delivery from your Authorized Bud Distributor. They are the best for applications described in these projects.

WATCH FOR THESE LISTINGS EVERY MONTH
IN POPULAR ELECTRONICS

BUD RADIO, INC.

2118 East 55th Street Cleveland 3, Ohio
Dept. P.E.

Bookshelf

(Continued from page 24)

tions in the transportation radio services: taxicab companies, railroads, auto emergency, motor carrier, highway trucks, etc. It contains full information on call letters, operating frequencies, location, licenses, and equipment used at every fixed and mobile station operating in these industries. A valuable reference guide for the industrial communications engineer, this book is very handy to have around the SWL shack, too.



"HANDBOOK OF TV TROUBLES" by Sol Heller. Published by Holt, Rinehart and Winston, Inc., 383 Madison Ave., New York 17, N. Y. 302 pages. \$5.95.

Attractively bound and produced, this book is an excellent guide to television receiver repair. Intended primarily for the service technician, it will also be of value to the less specialized electronics enthusiast. Virtually every video problem that could arise is covered, with recommendations for its cure. The inclusion of many photographs taken of the picture tubes in improperly operating television sets is a worthwhile feature.

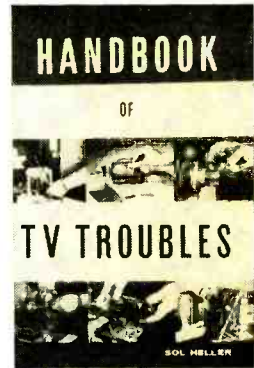

Miscellaneous Literature

■ "TV Servicing Short Cuts," by Milton S. Kiver, is a 104-page soft-covered booklet that relates 69 case histories of TV service problems. A second edition, it is available for \$1.50 from electronic parts distributors or from Howard W. Sams & Co., Inc., 1720 East 38th St., Indianapolis 6, Ind.

■ A new series of publications for the electronic experimenter is being issued free of charge by the J. W. Miller Co., 5917 S. Main St., Los Angeles 3, Calif. The first issue of "The Coil Forum" is now available and is devoted to construction plans for a transistorized FM receiver.

—30—

NOW!
at a price
you can afford!

MAKE MORE MONEY in TELEVISION RADIO-ELECTRONICS

**BETTER...MORE COMPLETE...LOWER COST...
WITH NATIONAL SCHOOLS SHOP-METHOD
HOME TRAINING!**

BETTER... Training that is proved and tested in Resident School shops and laboratories, by a School that is the **OLDEST** and **LARGEST** of its kind in the world.

MORE COMPLETE... You learn **ALL PHASES** of *Television-Radio-Electronics*.

LOWER COST... Other schools make several courses out of the material in our **ONE MASTER COURSE**... and you pay more for less training than you get in *our course* at **ONE LOW TUITION!**



These two FREE books will show you how!

You get all information by mail... You make your own decision... at home! **NO SALESMAN WILL CALL**

TOP PAY... UNLIMITED OPPORTUNITIES LIFETIME SECURITY CAN BE YOURS!

You are needed in the Television, Radio, and Electronics industry! Trained technicians are in growing demand at excellent pay—in **ALL PHASES**, including Servicing, Manufacturing, Broadcasting and Communications, Automation, Radar, Government Missile Projects.

NATIONAL SCHOOLS SHOP-METHOD HOME TRAINING, with newly added lessons and equipment, trains you in your spare time at home, for these unlimited opportunities, including many technical jobs leading to supervisory positions.

YOU LEARN BY BUILDING EQUIPMENT WITH KITS AND PARTS WE SEND YOU. Your National Schools course includes thorough *Practical* training—**YOU LEARN BY DOING!** We send you complete standard equipment of professional quality for building various experimental and test units. You advance step by step, perform more than 100 experiments, and you build a complete TV set from the ground up, that is yours to keep! A big, new TV picture tube is included at no extra charge.

EARN AS YOU LEARN. We'll show you how to earn extra money right from the start. Many of our students pay for their course—and more—while studying. So can you!

LESSONS AND INSTRUCTION MATERIAL ARE UP-TO-DATE, PRACTICAL, INTERESTING. Every National Schools Shop-Method lesson is made easy to understand by numerous illustrations and diagrams. All instruction material has been developed and tested in our own Resident School Shops, Laboratories and Studios.

SEND FOR INFORMATION TODAY... it can mean the difference between **SUCCESS** and failure for you! Send for your **FREE BOOK** "Your Future in Television-Radio-Electronics" and **FREE Sample Lesson**. Do it **TODAY**, while you are thinking about your future. It doesn't cost you anything to investigate!

GET THE BENEFITS OF OUR OVER 50 YEARS EXPERIENCE

Approved for
GI Training



NATIONAL SCHOOLS
Los Angeles 37, Calif.

YOU GET...

- 19 Big Kits—**YOURS TO KEEP!**
- Friendly Instruction and Guidance
- Job Placement Service
- Unlimited Consultation
- Diploma—Recognized by Industry
- **EVERYTHING YOU NEED FOR SUCCESS!**

SHOP-METHOD HOME TRAINING COVERS ALL PHASES OF INDUSTRY

1. Television, including Color TV
2. Radio AM & FM
3. Electronics for Guided Missiles
4. Sound Recording and Hi-Fidelity
5. FCC License
6. Automation and Computers
7. Radar & Micro-Waves
8. Broadcasting and Communications

RESIDENT TRAINING AT LOS ANGELES

If you wish to take your training in our Resident School at Los Angeles, the world's TV capital, start **NOW** in our big, modern Shops, Labs and Radio-TV Studios. Here you work with latest Electronic equipment—professionally installed—finest, most complete facilities offered by any school. Expert, friendly instructors. Personal attention. Graduate Employment Service. Help in finding home near school... and part time job while you learn. Check box in coupon for full information.

NATIONAL TECHNICAL SCHOOLS

WORLD-WIDE TRAINING SINCE 1905

MAIL NOW TO
NATIONAL TECHNICAL SCHOOLS, Dept. R2G-80
4000 S FIGUEROA ST LOS ANGELES 37, CALIF.
Rush free TV-Radio "Opportunity" Book and sample lesson. No salesman will call.

NAME _____ AGE _____
ADDRESS _____
CITY _____ ZONE _____ STATE _____
 Check if interested ONLY in Resident School training at Los Angeles
VETERANS Give date of Discharge _____

$H^2 = A^2 + B^2$

NOW Science
shows you how to
Learn by "EAR"
ladies & gentlemen...



NOW YOU CAN LEARN WHILE YOU SLEEP

Just think what it can mean to you in dollars and cents, confidence, success, fun to learn a language, speech, statistics, facts, figures, bridge, music, *anything*—OVERNIGHT . . . while you sleep . . . and learn it FASTER—RETAIN IT BETTER.

That's what *really* happens when scientifically proved **Dorniphone** trains your memory for you awake and asleep . . . and what's more the Dorniphone not only puts your sleeping time to use, but helps you sleep more soundly as well. In addition, this amazing, versatile instrument "plays" for you, too, provides fine entertainment with high quality reproduction of sound—both voice and music for greater enjoyment.

Get the scientific evidence about Dorniphone TODAY. Write, call for FREE Book, FREE Demonstration.

MODERNOPHONE, INC. Circle 7-0830
292-080 Radio City, N. Y. 20, N. Y.

Gentlemen: Please send me your FREE Book. I am interested in learning more about the DORNIPHONE and what it can do for me. No obligation—no salesman will call.

NAME.....

ADDRESS.....

CITY..... ZONE..... STATE.....

My main interest in Dorniphones is for:

- | | |
|--|---|
| <input type="checkbox"/> Language Learning | <input type="checkbox"/> Speech Improvement |
| <input type="checkbox"/> Memorization | <input type="checkbox"/> Sleep Inducement |
| <input type="checkbox"/> Habit Correction | <input type="checkbox"/> School or College Work |
| <input type="checkbox"/> Bridge Rules | |

Tips and Techniques



CAMERA TRIPOD AS MIKE STAND

Select a nut that will fit your camera tripod mounting stud and cement it securely to the back of your tape recorder mike. Simply screw the mike onto the camera tripod stud and you will have a nifty mike



stand. You can use it on the floor or on a table top.—Charles Lang, San Francisco, Calif.

NEON LAMP FLASHER

Neon lamps normally require up to 90 volts d.c., but you can make a small neon lamp flash using only a 1.5-volt flashlight cell for power. Hook up a NE-2 or similar neon lamp across the primary of any output or filament transformer, or across a choke of 1 henry or more, as shown. The flashlight cell and push-button switch are connected in parallel with the winding. Press the but-

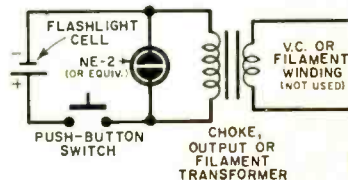

ton for an instant, then release it. The lamp will flash on the release. The secret of the flasher? When the button is pressed, a weak electromagnet is created. When it is released, the collapsing field generates a voltage of opposite polarity in the coil
(Continued on page 33)

To build the projects in this issue of

POPULAR ELECTRONICS

Use these
STANCOR TRANSFORMERS

High Power Crystal Set
T1—Output Transformer
Use Stancor A-3856, \$2.90 net

Build the Min-O-Scope
T1—Power Transformer
Use Stancor PS8416, \$2.85 net

One-tube FM Tuner
T1—Power Transformer
Use Stancor PS8415, \$2.37 net

Experimenter's Test Speaker
T1—Output Transformer
Use Stancor A-3856, \$2.90 net

They are available from any Stancor Distributor . . . and have been verified for their application in the construction projects listed.

LOOK FOR this helpful listing every month. It appears regularly in Popular Electronics.

CHICAGO STANDARD TRANSFORMER CORPORATION
3501 W. Addison St. Chicago, Illinois

POPULAR ELECTRONICS ANNOUNCES A
**SPECIAL SUMMER
 SALE OF 57
 ELECTRONICS
 BOOKS**

The publishers of POPULAR ELECTRONICS invite you to choose any of these wonderfully informative electronics books, on a 7-day free trial basis. Here are important books for radio and TV servicemen, electronics professionals, students and hobbyists—books on exciting electronic construction, communications, theory, hi-fi and tape—plus many more subjects that will show you how to save money and get more profit and satisfaction from electronics.

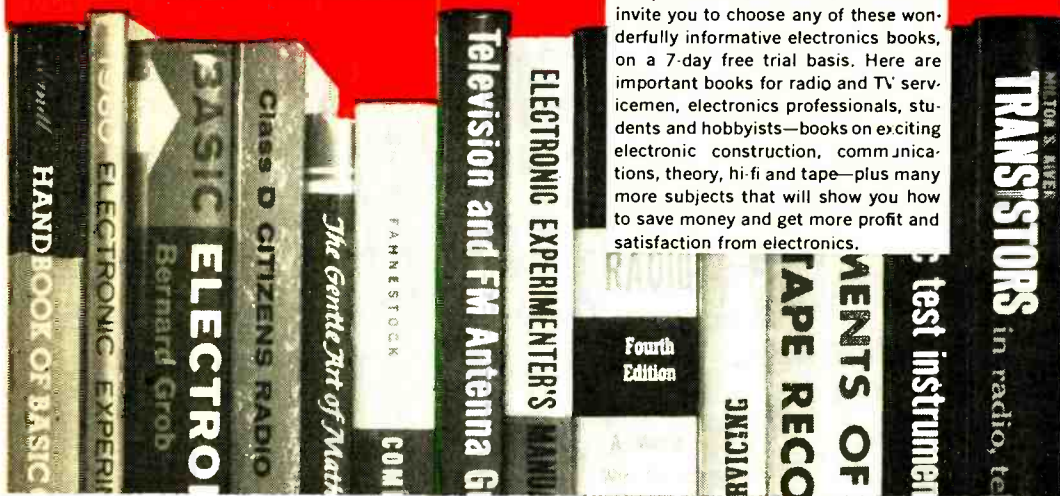

THEORY AND INSTRUCTION

Get started in radio, TV, communications, by using these simple basic guides to electronic principles, functions, and operations!



2500. BASIC ELECTRONICS, Grob

An introductory text on the fundamentals of electricity and electronics for technicians in radio, television and industrial electronics. \$9.25

2512. PRIMER OF ELECTRONICS AND RADIANT ENERGY, Caverly

Clear and simple explanation of electronics and electronic tubes and circuits for all concerned with the manufacture, application, operation of household or industrial electronic devices. \$7.50



2521. BASIC ELECTRONICS, Daly and Greenfield

Here in twelve chapters is a complete general introduction to electronics for technicians who make use of complex electronic equipment in modern laboratories. \$9.00

2501. ELEMENTS OF ELECTRONICS, Hikey and Villines

This basic electronics text offers an excellent course for training radio and electronics technicians and for students in television, radar and sonar. \$6.95



2511. UNDERSTANDING RADIO, Watson, Welch and Eby

For those with little or no technical knowledge who wish to know the fundamentals of radio theory and servicing. \$7.95

2412. TELEVISION AND FM ANTENNA GUIDE, Noll & Mandl

Two antenna experts tell you their secrets of antenna choice and installation for best reception in any area. Loaded with useful tips on improving reception in fringe and difficult areas. \$5.25



2519. HANDBOOK OF BASIC CIRCUITS, Mandl

A basic guide to circuitry combining comprehensive coverage of major circuits with detailed information on circuits used in TV, FM and AM. Simply written and easy-to-understand. \$7.95

2522. ELEMENTS OF RADIO, Hellman

A thorough grounding in all basic principles of radio, radio communication, with a review of electricity and magnetism. Also includes chapter on transistors. \$5.50



2502. ELEMENTS OF RADIO, Marcus & Marcus

Now in its 4th edition. More than a million copies sold! Follows proved method of exposition, proceeds from the simple to the complex. \$7.00

HI-FI AND TAPE

Special references for the sound enthusiast to help him select, build, and improve his hi-fi and stereo recording system.



2000/60. STEREO-HI-FI GUIDE, Ziff-Davis Publishing Company

Just published! 1960 edition features 60-page exclusive by Joseph Marshall on components and how they work. \$1.00

2004/60. HI-FI ANNUAL & AUDIO HANDBOOK, Ziff-Davis Publishing Company

1960 edition. Prepared by the editors of Electronics World. An excellent advanced guide to theory, construction and circuitry. \$1.00



2753. LOW-COST HI-FI, Hoefler

Hundreds of hints for budget hi-fi will be found in these fourteen chapters with over 300 detailed photographs, drawings and diagrams. \$2.50

2757. RIBBONS OF SOUND, Barleben

A perfect introduction to tape recording principles and practices. Paper. \$2.50; 2757C Cloth. \$3.50

2760. HI-FI STEREO FOR YOUR HOME, Whitman

Tells what stereo is, how it works, affects home listening habits, and how to install and maintain it. \$3.50

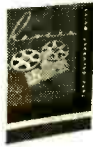

42. REVERE TAPE RECORDER GUIDE, Tydings

The first non-technical book to provide useful information on the Revere Tape Recorder. Also a basic guide to the entire field of tape. Will show you new uses and add to your enjoyment of tape recording. \$1.95

49. TAPE RECORDING GUIDE, Marshall

Designed to help you get the most out of your tape recorder, whether for business, pleasure or professional use. A handy guide to have around, no matter what type of equipment you own or plan to purchase. \$1.95



2750. ELEMENTS OF MAGNETIC TAPE RECORDING, Haynes

All aspects of this recording medium are described in easy-to-understand detail. 416 pages. \$7.95

2005/60. HI-FI DIRECTORY & BUYERS' GUIDE, Ziff-Davis Publishing Company

1960 edition. World's only complete listing of all hi-fi and stereo equipment, components and accessories. Five big sections. Over 1,000 illustrations. \$1.00



2752. HIGH QUALITY SOUND REPRODUCTION, Moir

A perfect manual for both the professional engineer and the serious amateur in high fidelity. Complete coverage of sound reproduction in 591 pages. \$15.00

Save time and labor in radio and TV maintenance by referring to professional handbooks!

RADIO AND TV SERVICING



2415. MANDL'S TELEVISION SERVICING, Mandl

This standard text book in the T.V. servicing field provides clear descriptions of the fundamentals of T.V., and practical instruction on the diagnosis and correction of typical troubles. \$6.95

2416. LABORATORY MANUAL FOR BASIC TELEVISION AND TELEVISION RECEIVER SERVICING, Zbar and Schildkraut

55 experiments covering fundamental skills in T.V. receivers and T.V. receiver servicing. \$4.50

2422. HANDBOOK OF TV REPAIR, Hertzberg

A basic guide to do-it-yourself T.V. repairs for the amateur. \$2.50

2429. TELEVISION RECEIVER SERVICING, Kiver

New (fourth) edition is a carefully written complete handbook for the television serviceman. New chapter discusses color T.V.—operation and servicing. \$5.95



2425. ELEMENTS OF TELEVISION SERVICING FOR BENCH AND FIELD, Marcus and Gendler

Up to date discussion of installation, servicing and repair of T.V. receivers, designed for the practicing serviceman. \$8.15

2400. PROFITABLE RADIO TROUBLESHOOTING, Marcus and Levy

Explains in easy-to-understand manner the use of simple and advanced test instruments, opening a radio servicing business, pitfalls, and successful procedures for a full-grown business. \$5.95

2408. ESSENTIALS OF ELECTRICITY FOR RADIO AND TELEVISION, Slurzberg and Osterheld

Provides necessary background of principles for understanding T.V., FM and radio circuits. \$8.00

2407. HOW TO GET AHEAD IN THE TELEVISION AND RADIO SERVICING BUSINESS, Marcus

Shows the easy way to get started as a TV-Radio repairman, how to earn while you learn, how to get and keep customers. \$3.50



2404. FM RADIO SERVICING HANDBOOK, King

A practical guide to FM V.H.F. receivers, their design, construction, alignment and repair. \$5.00



2442. BASIC ELECTRONIC TEST INSTRUMENTS, Turner

Over 60 instruments described, their uses fully explained, and valuable work-saving short-cuts outlined. \$4.95

ELECTRICITY AND APPLIANCES

Brush up on electrical theory, repair any electrical appliance by using these simple manuals!

2651. MAJOR APPLIANCE SERVICING, Brockwell



Gives essential, overall information for a career in major-appliance servicing, explaining methods of repairing appliances, organizing and managing a service business. \$5.95

2653. PRACTICAL ELECTRICITY, Croft

What electricity is, how it is generated and how it is used. Simply written with many graphic examples. \$8.50

2667. ELECTRIC MOTOR REPAIR, Rosenberg

All details of modern motor repair work. Actual demonstrations of what to do and why. Designed for bench use with a duospiral binding that lies flat. \$6.95

2660. BEGINNING ELECTRICITY, Eaton

Principles, construction and operation of basic electrical devices and appliances. A thorough foundation of electricity. \$6.00

2652. HOW TO REPAIR HOME APPLIANCES, Campbell

For the do-it-yourselfer, a handy, easy-to-read reference book. \$2.50

Be eligible for the higher paying jobs by mastering math needed in electronics — quickly and easily.

MATHEMATICS

2802. MATHEMATICS FOR ELECTRICIANS, Kuehn

A review of the fundamental processes of arithmetic, logarithms, and alternating current work. Includes chapter on the concept of work and horsepower. Material is arranged to provide a logical teaching sequence. \$6.75



2807. THE GENTLE ART OF MATHEMATICS, Pedoe

A fresh slant on things mathematical, a stimulating glimpse into the fascinating world of numbers. You will read and enjoy this diverting as well as instructive book. \$3.95

2803. BASIC MATHEMATICS FOR ELECTRICITY, RADIO AND TELEVISION, Singer

Here, mathematical principles are presented as dynamic tools for solving electrical problems. A practical course for students as well as an excellent refresher course for skilled technicians. \$8.25

TRANSISTORS AND TUBES

Keep abreast of the latest designs and concepts in both transistors and tubes by using the charts, diagrams, and photographs in these practical books!



2600. TRANSISTORS, Gillie

Describes and analyzes semi-conductors and transistors and how they behave. 300 pages, illustrated. \$7.95

2602. TRANSISTOR AUDIO AMPLIFIERS, Shea

Fundamental considerations, transistor parameters, basic amplifier design, coupled stages, preamps, Class A and Class B power amplifiers, examples of practical design and much more. \$7.00

2603. VACUUM-TUBE AND SEMICONDUCTOR ELECTRONICS, Millman

The first book to integrate vacuum tubes and transistors. Teaches electronic circuit theory to provide an intimate understanding of the vacuum-tube and semiconductor device as a circuit element. \$10.00

2604. BASIC ELECTRON TUBES, Geppert

A text for a first course in electronics. It covers the tubes themselves, not the circuit applications. Basic principles governing operation of specialized tubes are explained. \$7.50

2607. TRANSISTORS, Coblenz & Owens

Treats theory, practical applications and manufacture of transistors in a way useful to technicians, engineers and advanced workers. Silicon and germanium transistors—how they are made, used, how they work. \$6.50



2601. TRANSISTORS IN RADIO, TELEVISION AND ELECTRONICS, Kiver

A descriptive, non-mathematical text for radio, television, electronics technicians and for those who need to gain a working knowledge of transistors and transistor circuits. \$7.95

2605. FUNDAMENTALS OF VACUUM TUBES, Eastman

A text midway between the purely descriptive and the purely mathematical. Discusses the principal types of vacuum tubes. \$10.50

2606. ELECTRON-TUBE CIRCUITS, Seely

A clear analytical method in the study of electron-tube circuits. Provides a broad background in preparing for work in radio and electronic engineering. \$10.50

**Construction
and
Experimentation**

Wonderful "how-to" books to help you build and enjoy practical electronic devices simply and easily.



2006. ELECTRONIC EXPERIMENTER'S MANUAL, Findlay

With a few dollars worth of basic tools and this book to guide you, you can explore electronics experimentation more completely than ever before. 10 big sections. \$4.95

2002/60. ELECTRONIC KITS DIRECTORY, Ziff-Davis Publishing Company

New 1960 edition lists over 750 kits, latest models, prices and features for hi-fi, ham radio, SWL, shop improvement, Citizen's Band, fun and education. \$1.00

235L. RADIO PROJECTS, Marcus

10 easy to construct radios described in this book cover the field thoroughly and completely, progressing in difficulty from the simple crystal detector to the superheterodyne receiver. \$3.85

2001/60. ELECTRONIC EXPERIMENTER'S HANDBOOK, Ziff-Davis Publishing Company

40 projects for home and shop, 20 of which are transistorized. Special section on understanding transistor circuits. \$1.00; 2001C, cloth \$1.95

**Communications
and
Broadcasting**

Here are books which simplify basic and advanced theory — and open new horizons to you in the field of communications!

2901. HAM RADIO, Hertzberg

Tells exactly how to become a "ham" — how to obtain a ham "ticket", how to learn code, how to select receivers and transmitters — everything you need to know is between the covers of this handy guidebook. \$2.50

2900. BROADCASTING TELEVISION AND RADIO, Kingson, Cowgill, Levy

A simple, practical introduction to broadcasting, dealing with performance before the microphone and camera. \$8.65



2008. CLASS D CITIZENS RADIO, Sands

First complete book on Citizens Radio operation. Covers Class D history, rules, applications, how it works. Many illustrations. \$4.95

2907. RADIO OPERATING QUESTIONS AND ANSWERS, Hornung & McKenzie

Presents specific information on radio law, operating practices and theory for those studying to pass the FCC commercial radio operator exams of the various license grades. \$6.00

Special Topics

Choose any of these practical books—to take advantage of the growing opportunities in the exciting field of electronics!



2007. COMPUTERS AND HOW THEY WORK, Fahnestock

A fact-filled guidebook to electronic computers. Explains the workings of every major computer system. Must reading for all who want a more complete knowledge of this important field. \$4.95

2003/60. YOUR CAREER IN ELECTRONICS, Ziff-Davis Publishing Company

Tells where you fit in, how to program your future, test your electronics aptitude, advance in your job or career. \$1.00

2301. ELECTRONICS DICTIONARY, Cooke & Markus

An authoritative dictionary containing accurate, understandable definitions of nearly 6500 terms used in radio, television, industrial electronics, facsimile, sound recording, etc. \$6.50

2914. THE RADAR POCKET BOOK, Boulding

A clear and concise handbook of information on basic electrical principles and formulae applicable to radar, together with data on the various parts of a radar installation. \$3.85

*See Your
Parts Jobber
Or Use This
Coupon Today!*

Leading radio and electronics parts jobbers, hi-fi dealers and salons are making their stores headquarters for books on every electronics subject. You can take this list to your favorite dealer for immediate purchase.

If your local parts jobber or dealer does not carry books, use the coupon for prompt delivery from ELECTRONICS BOOK SERVICE, on a 7-day free trial basis.

ELECTRONICS BOOK SERVICE

434 South Wabash Avenue, Chicago 5, Illinois



Please send me the book(s) I have listed below for a FREE 7-day Trial Examination. I understand that if I am not completely satisfied, I may return my selection(s) and I'll owe you nothing. Otherwise, I will send you payment for the book(s) of my choice, plus postage and handling.

NUMBER	TITLE	PRICE

*TOTAL

*New York City Residents, please add 3% sales tax.

(If you need more space to list additional titles, attach a sheet of paper with additional list.)

SAVE MONEY! Enclose payment in full for the book(s) of your choice and we will pay shipping charges. Same return privileges and prompt refund guaranteed. **ZE860**

Please send me FREE CATALOG, when published.

NAME _____ PLEASE PRINT CLEARLY

ADDRESS _____

CITY _____ ZONE _____ STATE _____

Tips

(Continued from page 28)

which is high enough to fire the lamp.—*Carl Wright, Tucson, Arizona.*

TRANSISTOR BREADBOARD CONNECTOR

Tired of soldering and unsoldering components in transistor breadboard circuits?

A simple hook-up arrangement can be made from a standard Jonesstrip. Such strips are available in several sizes and lengths—for even greater flexibility, a pair of them can be mounted side by side. Their screw connections make for easy circuit changes. This setup is good for vacuum-tube circuits as well.—*Jason Scheckley, New York, N. Y.*

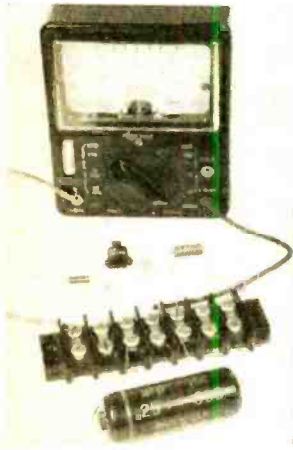

REPAIR TRIMMERS WITH TAPE

When the transparent dielectric insulation between the plates of a compression-type trimmer capacitor wears away or



punctures, replace it with cellophane tape. Usually, one or two thicknesses will provide the correct dielectric constant for near-normal capacitance and voltage breakdown rating.—*James Clifford, Detroit, Mich.*

TAPE SERVES AS WRENCH

Having trouble starting nuts on screws in those tight corners? There's often no room for a wrench, but your finger wrapped with friction or cellophane tape, sticky side out,

prepare for your career in

ELECTRONICS ELECTRICAL ENGINEERING RADIO-TV COMPUTERS

At MSOE, you can equip yourself for a career in many exciting, growing fields:
**MISSILES • RADAR • AVIONICS
AUTOMATION • RESEARCH
DEVELOPMENT • ELECTRICAL
POWER • ROCKETRY**

When you graduate from the Milwaukee School of Engineering, you are prepared for a dynamic career as an Electrical Engineer or Engineering Technician. Under a faculty of specialists, you gain a sound technical education in modern, completely equipped laboratories and classrooms. As a result, MSOE graduates are in great demand and highly accepted by industries nationally.

At MSOE, you will meet men from all walks of life and all parts of the country—some fresh out of high school or prep school, others in their twenties—veterans and non-veterans.

You can start school in any one of four quarters and begin specializing immediately. Engineering technicians graduate in 2 years with an Associate in Applied Science degree. For a Bachelor of Science degree in Engineering, you attend 4 years. A 3-month preparatory course also is available.



FREE CAREER BOOKLET!

If you're interested in any phase of electronics, radio or television, be sure to look into the programs of study offered by the Milwaukee School of Engineering. Just mail the coupon.

MILWAUKEE SCHOOL OF ENGINEERING

Dept. PE 860 1025 N. Milwaukee St.
Milwaukee, Wisconsin

Please send FREE Career Booklet. I'm interested in
 Electronics Electrical Power Television
 Mechanical Engineering Radio Computers
 Electrical Engineering Industrial Electronics

PLEASE PRINT

Name _____ Age _____

Address _____

City _____ Zone _____ State _____

I'm eligible for veterans education benefits

MS-125

QUICKLY CUT HOLES

in metal, plastics,
hard rubber...



GREENLEE CHASSIS PUNCHES

Make smooth, accurate openings in 1½ minutes or less... for sockets, plugs, controls, meters, panel lights, etc. Easy to use... simply turn with wrench.

Many sizes and models.

Write for literature.

GREENLEE

GREENLEE TOOL CO., 1915 Columbia Ave., Rockford Illinois

WHO NEEDS MILES OF WIRE?

GET HOME ELECTRICITY
ANYWHERE
WITH A

terado POWER
CONVERTER

Change 6 or 12 volt D.C. to 110 volt, 60 cycle A.C.

No installation—just plug into cigarette lighter of car, truck, or boat, and it's ready to go!

Operate lights, electric shavers, dictation machines, record players, small electric tools, portable TV, and testing equipment.

Models from 15 to 200 watts,
priced as low as \$12.95

See Your Electronic Parts
Dealer or Jobber

TERADO COMPANY

1057 RAYMOND AVE., ST. PAUL 8, MINNESOTA
In Canada: ATLAS RADIO CORPORATION LTD., ONTARIO



Tips

(Continued from page 33)

will do the trick. Just press the nut firmly against the tape, and start it on its way.—*Frank Harazin, New York, N. Y.*

TAPE INDEX CUE

If your recorder doesn't have an index counter, there's still a way to find the selection you want on a reel of recording tape. You can make an index cue by cutting a small piece of cellophane tape and sticking

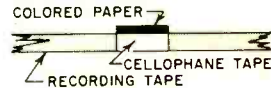

it on the recording tape so that it extends ¼" beyond the tape. Then stick a ¼" piece of colored paper on the protruding portion of the cellophane—this will enable you to find the cue easily when the tape is moving. Be sure to put the cue on the uncoated (shiny) side of the tape.—*Jay Willever, Indianapolis, Ind.*

RAPID WIRE-TINNING TRICK

You can tin a number of leads quickly with a device made from window screen. Clamp a doubled-up piece of the screen in your vise and pass the leads to be tinned

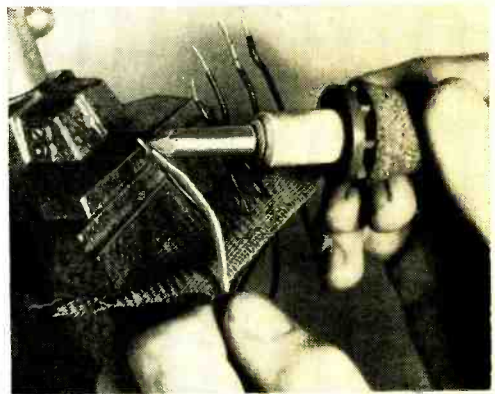

through it. Don't use too much solder or you'll find it hard to pull out the wires.—*John A. Comstock, Wellsboro, Pa.*

SAFETY SWITCH DEVICE

An arm added to the end of a lever-actuated snap-action Microswitch makes a convenient holder for safety glasses and a safety device as well. The switch can be wired into the start-button circuit of grind-

POPULAR ELECTRONICS

SEPTEMBER
1960

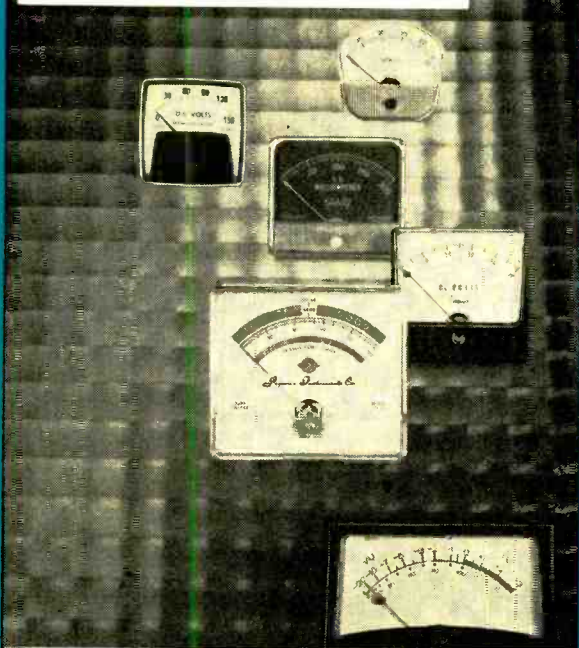

MONTH AFTER MONTH, POPULAR ELECTRONICS RETAINS ITS POSITION AS THE WORLD'S LEADING ELECTRONICS MAGAZINE. THAT'S BECAUSE IT'S EASY TO READ, INFORMATIVE AND ENTERTAINING! FOR EXAMPLE, TAKE THESE FEATURES—COMING UP IN THE SEPTEMBER ISSUE:

THE HOW AND WHY OF METERS

Do you know how meters are designed? What goes into their construction? Or how a 50-microamp meter differs from a 1-amp one? The answers are all here—along with some tips on how you can make use of meters in more ways!

GOING MOBILE ON THE CITIZENS BAND

This intriguing "how to" feature offers you complete instructions and plans for installing a Citizens Band transceiver in your car. It's great for calling the office or home while en route!

ELECTRICALLY CHARGED AIR AND YOUR HEALTH

Ever wonder why you felt better after a thunderstorm? Applying the same principles, scientists have found that ionized air can be used to fight such ailments as the all-too-common cold, sore throats, hay fever, and the like. And the fascinating thing about the whole subject is that how and why ions speed the healing process is not understood—but tests indicate they do!

INSIDE THE HI-FI OUTPUT TRANSFORMER

The output transformer is the heart of a hi-fi amplifier—and this feature shows you how the heart beats! It's full of valuable information on the design and manufacture of this important element in good listening.

And you'll find every issue of POPULAR ELECTRONICS jam packed with this kind of varied reading! That's why it's smart to make sure that you don't miss reading even one issue. A subscription guarantees that your copy will be delivered to your doorstep every month. If you haven't already done so, why not subscribe right now!

CURRENT SUBSCRIPTION RATES:

one year, \$4

two years, \$7

three years, \$10

POPULAR ELECTRONICS

434 South Wabash Avenue

Chicago 5, Illinois

August, 1960

35

Tips

(Continued from page 34)

ers, drill presses, and the like, so that it is impossible to start the machines with the glasses on the arm. Remember that one

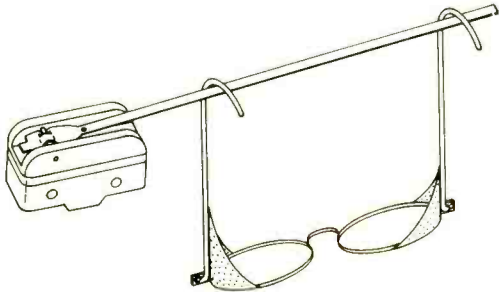

small fleck of emery can cause the loss of an eye.—*Courtesy Minneapolis-Honeywell Regulator Co.*

PLASTIC PROTECTS METER FACE

Many small multimeters have a plastic meter face that is easily scratched. To prevent such scratching, stretch a large plastic bowl cover over the meter. This is a partic-



ularly good practice if you store your meter in a tool box.—*Charles Lang, San Francisco, Calif.*

TIPS WANTED

Are you aware that POPULAR ELECTRONICS is very much interested in receiving your *Tips and Techniques* hints? If you know of any shop or circuit short-cut or innovation, tell us about it and you may receive up to ten dollars for your trouble. Just send us a short typewritten description plus a sharp photograph or circuit drawing. Unused items will be returned only if they are accompanied by a stamped, self-addressed envelope. Why keep your pet ideas to yourself? Let everyone else in on them.

Build the Best CITIZENS BAND TRANSCEIVER ... **EICO**

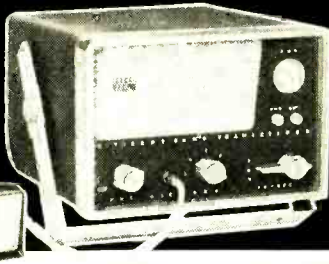

#760 (117 VAC) less bracket:
#761 (117 VAC & 6 VDC):
#762 (117 VAC & 12 VDC):

Kit \$59.95, Wired \$89.95
Kit \$69.95, Wired \$99.95
Kit \$69.95, Wired \$99.95

Highly reliable; exemplary electronic, mechanical, industrial design. Powerful 5-watt (as defined by FCC) crystal-controlled transmitter & extremely sensitive, selective superhet receiver with RF stage & noise limiter. Built-in speaker, detachable ceramic mike. Pre-set & sealed crystal oscillator circuit elements. To change channels, just change crystals — no adjustments needed. Built-in variable "pi" network matches most popular antennas. Portable whip & roof antennas available. No exams or special skill needed — any citizen 18 years or older may obtain station license by submitting FCC form, supplied free by EICO.



Build the Best 6-TRANSISTOR RADIO RA-6
Kit \$29.95 Wired \$49.95
includes FET, less 9V battery

High sensitivity & selectivity. New plug-in type transistors. Big-set volume & tone: 4" x 6" speaker; push-pull audio. Built-in ferrite rod antenna. Pre-aligned RF & IF transformers. Planetary vernier tuning. Earphone jack for private listening. Attractive tan leatherette case, retractable handle. Compact: 8½" w, 4½" h, 2½" d. Only 3 lbs.

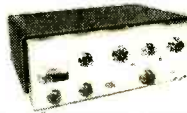

90-WATT CW TRANSMITTER* #720
Kit \$79.95 Wired \$119.95

*U.S. Pat No. D-184,776

"Top quality" — ELECTRONIC KITS GUIDE. Ideal for veteran or novice. 90W CW, 65W external plate modulation. 80 through 100 meters.



HIGH-LEVEL UNIVERSAL
MODULATOR-DRIVER #730
Kit \$49.95 Wired \$79.95

Cover E-5 \$4.50
Delivers 50W undistorted audio. Modulates transmitters having RF inputs up to 100W. Unique over-modulation indicator.



New Code Practice Oscillator #706
Kit \$8.95 Wired \$12.95

Rugged battery-operated transistor oscillator circuit, built-in speaker. Front panel has flashing light, phone jack, pitch control (500-2000 cps), external key terminals, "temporary" key. Panel switch selects Tone, Light, or both Tone & Light. 6½" h, 3¾" w, 2¾" d.



GRID DIP METER #710
Kit \$29.95 Wired \$49.95

Includes complete set of coils for full band coverage. Continuous coverage 400 kc to 250 mc. 500 ua meter.

Compare — judge for yourself — at your neighborhood EICO dealer. For FREE catalog on over 70 models of easy-to-build professional test instruments, hi-fi and ham gear, fill out coupon on Page 38

EICO

Add 5% in the West. ©1960

3300 N. Blvd., L. I. C. 1, N. Y.

BUILD YOUR OWN 16 RADIO CIRCUITS AT HOME

Reg. U. S. Pat. Off

ONLY \$295
with the New
PROGRESSIVE RADIO "EDU-KIT"®
A Practical Home Radio Course



- Now Includes**
- ★ 12 RECEIVERS
 - ★ TRANSMITTER
 - ★ SIGNAL TRACER
 - ★ SIGNAL INJECTOR
 - ★ CODE OSCILLATOR
 - ★ No Knowledge of Radio Necessary
 - ★ No Additional Parts or Tools Needed
 - ★ EXCELLENT BACKGROUND FOR TV
 - ★ School Inquiries Invited
 - ★ Sold in 79 Countries

YOU DON'T HAVE TO SPEND HUNDREDS OF DOLLARS FOR A RADIO COURSE

The "Edu-Kit" offers you an outstanding PRACTICAL HOME RADIO COURSE at a rock-bottom price. Our Kit is designed to train Radio & Electronics Technicians, making use of the most modern methods of home training. You will learn radio theory, construction practice and servicing. THIS IS A COMPLETE RADIO COURSE IN EVERY DETAIL. You will learn how to build radios using regular schematics; how to wire and solder in a professional manner; how to service radios. You will work with the standard type of Punched metal chassis as well as the latest development of Printed Circuit chassis. You will learn the basic principles of radio. You will construct, study and work with RF and AF amplifiers and oscillators, detectors, rectifiers, test equipment. You will learn and practice code, using the Progressive Code Oscillator. You will learn and practice trouble-shooting using the Progressive Signal Tracer, Progressive Signal Injector, Progressive Dynamic Radio & Electronics Tester and the accompanying instructional material. You will receive training for the Novice, Technician and General Classes of F.C.C. Radio Amateur License and will build 16 Receiver, Transmitter, Code Oscillator, Signal Tracer and Signal Injector circuits, and learn how to operate them. You will receive an excellent background for television, Hi-Fi and Electronics. Absolutely no previous knowledge of radio or science is required. The "Edu-Kit" is the product of many years of teaching and engineering experience. The "Edu-Kit" will provide you with a basic education in Electronics and Radio, worth many times the complete price of \$22.95. The Signal Tracer alone is worth more than the price of the entire Kit.

FREE EXTRAS

- SET OF TOOLS
- SOLDERING IRON
- ELECTRONICS TESTER
- PLIERS-CUTTERS
- ALIGNMENT TOOL
- WRENCH SET
- VALUABLE DISCOUNT CARD
- CERTIFICATE OF MERIT
- TESTER INSTRUCTION MANUAL
- HIGH FIDELITY GUIDE & QUIZZES
- TELEVISION BOOK & RADIO TROUBLE-SHOOTING BOOK
- MEMBERSHIP IN RADIO-TV CLUB
- CONSULTATION SERVICE & FCC AMATEUR LICENSE TRAINING
- PRINTED CIRCUITRY

SERVICING LESSONS

You will learn trouble-shooting and servicing in a progressive manner. You will practice repairs on the sets that you construct. You will learn symptoms and causes of trouble in home, portable and car radios. You will learn how to use the professional Signal Tracer, the unique Signal Injector and the dynamic Radio & Electronics Tester. While you are learning in this practical way, you will be able to do many a repair job for your friends and neighbors, and charge fees which will far exceed the price of the "Edu-Kit." Our Consultation Service will help you with any technical problems you may have. J. Stataitis, of 25 Poplar Pl., Waterbury, Conn., writes: "I have repaired several sets for my friends, and made money. The "Edu-Kit" paid for itself. I was ready to spend \$240 for a course, but I found your ad and sent for your Kit."

FROM OUR MAIL BAG

Ben Valerio, P. O. Box 21, Magna, Utah: "The Edu-Kits are wonderful. Here I am sending you the questions and also the circuits for them. I have been in Radio for the last seven years, but like to work with Radio Kits, and like to build Radio Testing Equipment. I enjoyed every minute I worked with the different kits; the Signal Tracer works fine. Also like to let you know that I feel proud of becoming a member of your Radio-TV Club."

Robert L. Shuff, 1534 Monroe Ave., Huntington, W. Va.: "Thought I would drop you a few lines to say that I received my Edu-Kit, and was really amazed that such a bargain can be had at such a low price. I have already started repairing radios and phonographs. My friends were really surprised to see me get into the swing of it so quickly. The Troubleshooting Tester that comes with the Kit is really swell, and finds the trouble, if there is any to be found."

THE KIT FOR EVERYONE

You do not need the slightest background in radio or science. Whether you are interested in Radio & Electronics because you want an interesting hobby, a well paying business or a job with a future, you will find the "Edu-Kit" worth-while investment. Many thousands of individuals of all

ages and backgrounds have successfully used the "Edu-Kit" in more than 79 countries of the world. The "Edu-Kit" has been carefully designed, step by step, so that you cannot make a mistake. The "Edu-Kit" allows you to teach yourself at your own rate. No instructor is necessary.

PROGRESSIVE TEACHING METHOD

The Progressive Radio "Edu-Kit" is the foremost educational radio kit in the world, and is universally accepted as the standard in the field of electronics training. The "Edu-Kit" uses the modern educational principle of "Learn by Doing." Therefore you construct, learn schematics, study theory, practice trouble-shooting—all in a closely integrated program designed to develop an easily-learned thorough and interesting background in radio. You begin by examining the various radio parts of the "Edu-Kit." You then learn the function, theory and wiring of these parts. Then you build a simple radio. With this first set you will enjoy listening to regular broadcast stations, learn theory, practice testing and trouble-shooting. Then you build a more advanced radio, learn more advanced theory and techniques. Gradually, in a progressive manner, and at your own rate, you will find yourself constructing more advanced multi-tube radio circuits, and doing work like a Professional Radio Technician. Included in the "Edu-Kit" course are sixteen Receiver, Transmitter, Code Oscillator, Signal Tracer, and Signal Injector circuits. These are not unprofessional "breadboard" experiments, but genuine radio circuits constructed by means of professional wiring and soldering on metal chassis, plus the new method of radio construction known as "Printed Circuitry." These circuits operate on your regular AC or DC house current.

THE "EDU-KIT" IS COMPLETE

You will receive all parts and instructions necessary to build 16 different radio and electronics circuits, each guaranteed to operate. Our Kits contain tubes, tube sockets, variable, electrolytic, mica, ceramic and paper dielectric condensers, resistors, tie strips, coils, hardware, tubing, punched metal chassis, Instruction Manuals, hook-up wire, solder, etc. In addition, you receive Printed Circuit materials, including Printed Circuit chassis, special tube sockets, hardware and instructions. You also receive a useful set of tools, a professional electric soldering iron and a self-powered Dynamic Radio and Electronics Tester. The "Edu-Kit" also includes Code Instructions and the Progressive Code Oscillator. In addition to F.C.C.-type Questions and Answers for Radio Amateur License training. You receive Signal Injector, a High Fidelity Guide and a Quiz Book. You receive Membership in Radio-TV Club, Free Consultation Service, Certificate of Merit and Discount Privileges. You receive all parts, tools, instructions, etc. Everything is yours to keep.

PRINTED CIRCUITRY

At no increase in price, the "Edu-Kit" now includes Printed Circuitry. You build a Printed Circuit Signal Injector, a unique servicing instrument that can detect many Radio and TV troubles. This revolutionary new technique of radio construction is now becoming popular in commercial radio and TV sets. A Printed Circuit is a special insulated chassis on which has been deposited a conducting material which takes the place of wiring. The various parts are merely plugged in and soldered to terminals.

Printed Circuitry is the basis of modern Automation Electronics. A knowledge of this subject is a necessity today for anyone interested in Electronics.

UNCONDITIONAL MONEY-BACK GUARANTEE

ORDER DIRECT FROM AD—RECEIVE FREE BONUS RESISTOR AND CONDENSER KITS WORTH \$7

- Send "Edu-Kit" postpaid. I enclose full payment of \$22.95.
- I enclose \$5. Send "Edu-Kit" C.O.D. for balance plus postage.
- Rush me FREE descriptive literature concerning "Edu-Kit."

Name
Address

PROGRESSIVE "EDU-KITS" INC.

1186 Broadway, Dept. 571D, Hewlett, N. Y.

the experts say
your BEST BUY
 is **EICO**®...

EICO, 3300 N. Blvd., L.I.C. 1, N.Y. PE-8

Show me HOW TO SAVE 50% on 70 models of top-quality: HI-FI TEST INSTRUMENTS
 "HAM" GEAR Send FREE Stereo Hi-Fi Guide. Send FREE Short Course for Novice License. Send FREE Catalog & name of neighborhood EICO dealer.

Name:
 Address:
 City: Zone: State:

ADD 5% IN THE WEST

... in
STEREO and MONO HI-FI



STEREO Dual Amplifier-Preamplifier HF81
 Kit \$69.95. Wired \$109.95.
 "Excellent" — SATURDAY REVIEW: HI-FI MUSIC AT HOME.



NEW! STEREO Automatic Changer/Player 1007 (.7 mil diamond, 3 mil sapph dual styli)
 \$59.75 incl. F.E.T.

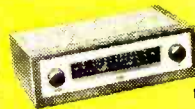

FM Tuner HFT90
 Kit \$39.95*. Wired \$65.95*. Cover \$3.95.
 "One of the best buys" AUDIOCRAFT



STEREO Dual Preamplifier HF85
 Kit \$39.95. Wired \$64.95.
 "Extreme flexibility" — HI-FI REVIEW a bargain"



Mono Power Amplifiers (60, 50, 35, 30, 22, 14-Watt; use 2 for Stereo) from Kit \$23.50. Wired \$41.50.



AM Tuner HFT94
 Kit \$39.95. Wired \$65.95, incl. Cover & F.E.T.
2-Way Bookshelf Speaker System HFS1 complete with factory-built cabinet: Kit \$39.95. Wired \$47.95



STEREO Dual Power Amplifiers: New 100W HF89: Kit \$99.50. Wired \$139.50.
 70W HF87: Kit \$74.95. Wired \$114.95.
 28W HF86: Kit \$43.95. Wired \$74.95.



Mono Integrated Amplifiers: (50, 30, 20, 12-Watt; use 2 for Stereo) from Kit \$34.95. Wired \$57.95.



TRUE Hi-Fi quality to drive hi efficiency speakers to concert volume.

NEW! COMPLETE STEREO DUAL AMPLIFIER AF-4
 Kit \$38.95. Wired \$64.95

... and in
TEST INSTRUMENTS



New Transistorized Power & Bias Supply #1020
 Kit \$19.95. Wired \$27.95.



Miniaturized Multi-Signal Tracer #145A
 Kit \$19.95. Wired \$28.95.



Vacuum Tube Voltmeter #221
 Kit \$25.95. Wired \$39.95.



Peak-to-Peak VTVM #232 & Uni-Probe (pat. pend.)
 Kit \$29.95. Wired \$49.95.



New Battery-Powered Filament Continuity Tester #612
 Kit \$3.95. Wired \$5.95.



1000 Ohms/Volt V-O-M #536
 Kit \$12.90. Wired \$14.90.



5" Push-Pull Scope #425
 Kit \$44.95. Wired \$79.95.



DC-5 MC 5" Scope #460
 Kit \$79.95. Wired \$129.50.

Tube Tester #625
 Kit \$34.95. Wired \$49.95.



RF Signal Generator #324
 Kit \$26.95. Wired \$39.95.



Series/Parallel R-C Combination Box #1140
 Kit \$13.95. Wired \$19.95. 1350 Combinations!



6V & 12V Battery Eliminator & Charger #1050
 Kit \$29.95. Wired \$38.95. Extra-filtered for transistor equip. #1060. Kit \$38.95. Wired \$47.95.



R-C Bridge & R-C-L Comparator #950B
 Kit \$19.95. Wired \$29.95.

IN STOCK! Compare, take them home — right "off the shelf" — from 2000 neighborhood dealers. Over 2 MILLION EICO instruments in use throughout the world.

© 1960 ELECTRONIC INSTRUMENT CO., INC., 33-00 N. BLVD., L.I.C. 1, N.Y.

Build the MIN-O-SCOPE

*Compact, self-contained
oscilloscope-in-miniature
is ideal for on-the-spot
checks, tests, adjustments*

By
CHARLES J. SCHAUERS
W6QLV

ALTHOUGH preliminary adjustments on mobile radio equipment can be made on the bench, they're best done under actual operating conditions. The little scope to be described here is small enough and light enough to allow just that. In fact, because of its extreme portability and ease of operation, the Min-O-Scope has few equals for on-the-spot checking and adjusting. It's ideal for viewing television circuit waveforms and tracking down audio system troubles.

August, 1960



A true oscilloscope-in-miniature, this tiny unit can be built for less than \$30.00. In performance, it offers nearly as much as some larger scopes, yet it measures only $7\frac{1}{8}'' \times 4\frac{3}{4}'' \times 2\frac{1}{4}''$ —about the size of a book. And although it requires 117 volts a.c. for

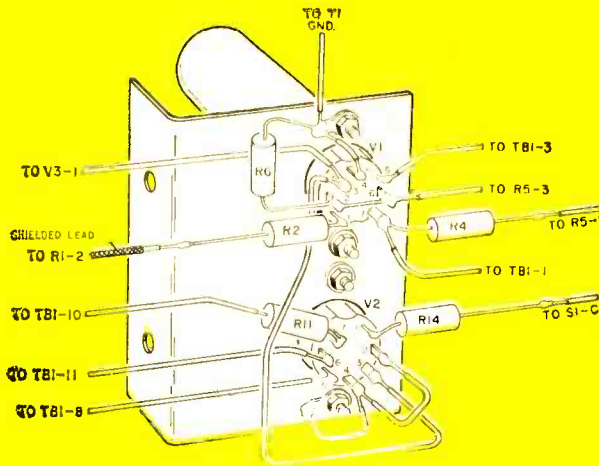

Subassemblies are built separately and wired into circuit. Chassis for V1 and V2 measures 2" x 2 1/2" and has 3/4" lip; terminal board TBI has 11 pairs of solder lugs and measures 1/2" x 3 1/2" overall.

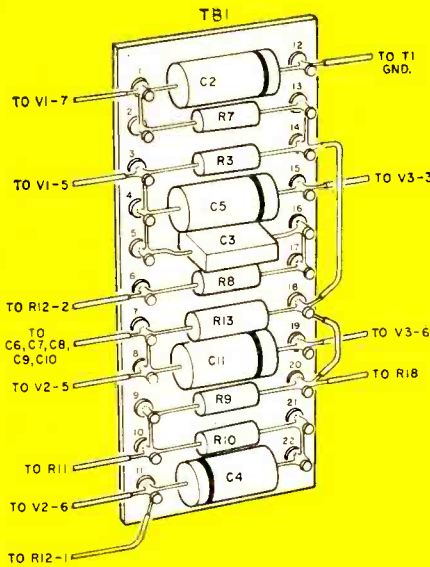

operation, it uses so little current that a small d.c.-to-a.c. converter (such as the one described on page 53 of the May *POPULAR ELECTRONICS*) will power it very effectively for mobile use.

Like any scope, this one is designed around a cathode-ray tube (CRT). Made by Electronic Tubes Ltd., the 1CP1 cathode-ray tube used in the Min-O-Scope is only 4 1/2" long and fits a standard octal socket.

More important, it will operate at voltages from 350 to 600 volts.

One of the most intriguing features of this little CRT is its ability to operate without centering or focusing controls—these operations are taken care of in its design. Of course, such controls could be added, but the resistor values specified result in good centering with no adjustment whatever.

Circuit Details. Potentiometer *R1* controls the height of the displayed pattern on the CRT. As little as 1.5 volts r.m.s. applied to the vertical amplifier input will result in full vertical deflection. Considering the size of the overall instrument, this sensitivity is astonishing!

Measurements made with the gain control wide open indicate that the upper limit of flat frequency response is near 55 kc. At half gain it approaches 18 kc. The gain falls off about 30% (of 1 kc. reference) at around 300 kc. at full gain and around 82 kc. at half gain.

Five ranges of sweep speed are provided. By using potentiometer *R19*, fine-frequency control can be obtained with a range variability of about 10 to 1. Thus, the minimum frequency-repetition rate of the time-base circuit is about 20 cps (*S1*, position 1); the maximum frequency-repetition rate for this same switch setting is about 200 cps. Likewise, the highest minimum frequency-repetition rate of 3500 cycles has a maximum repetition rate of approximately 35 kc. (*S1*, position 5).

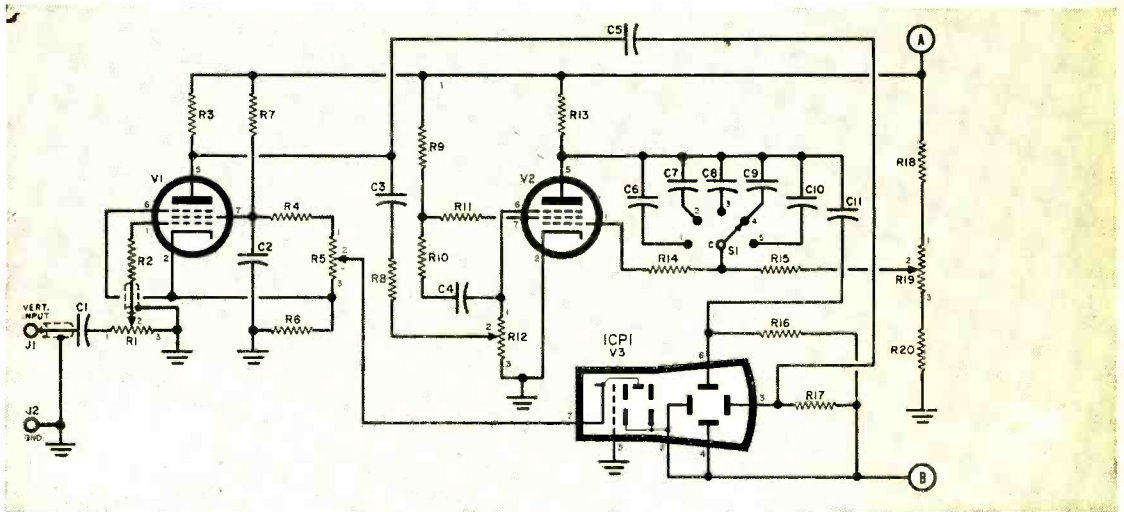

Vertical amplifier (V1), sweep generator (V2), and cathode-ray tube (V3) sections of oscilloscope.

PARTS LIST

- | | | |
|---|-------------|---|
| C1—1- μ t., 600-volt paper | | R8, R15—220,000 ohms |
| C2, C5, C11—1- μ t. paper | | R9—27,000 ohms |
| C3—.001- μ t. mica | all ceramic | R10, R13—47,000 ohms |
| C4—.01- μ t. paper | and paper | R12—50,000-ohm potentiometer (Mallory U35 or |
| C6—.00015- μ t. mica | capacitors | equivalent) |
| C7—.001- μ t. ceramic | 400 volts | R16—330,000 ohms |
| C8—.005- μ t. ceramic | unless | R18—100,000 ohms |
| C9—.02- μ t. ceramic | otherwise | R21—22,000 ohms |
| C10—.05- μ t. ceramic | specified | R23, R24—4700 ohms |
| C12, C13—.01- μ t. ceramic | | R25, R27—1 megohm |
| C14a/C14b—8/8 μ t., 450 volt electrolytic | | R26—470,000 ohms |
| C15—20- μ t., 450-volt electrolytic | | S1—S.p.s.t. switch, on R12 (Mallory US26 or |
| C16, C17—25- μ t. paper | | equivalent) |
| D1, D2—150-ma. silicon diode (Sarkes Tarzian | | S2—Miniature 5-position tap switch (Grayhill |
| M-150 or equivalent) | | 5001-5 or equivalent) |
| F1, F2—1/4-amp., 3AG fuse (in power plug) | | T1—Power transformer; primary, 117 volts a.c.; |
| NE1—Neon bulb (General Electric NE-2E or | | secondaries, 250 volts @ 25 ma., 6.3 volts @ |
| equivalent) | | 1 amp. (Knight 62G008 or equivalent) |
| P1—Fused power plug (Elmenco) | | TB1—Terminal board (Lafayette Type MS-304 or |
| R1, R5, R19—1-megohm potentiometer (Mallory | | equivalent) |
| U54 or equivalent) | | V1, V2—6AM6 or 6AU6 tube |
| R2, R11, R14, R22—47 ohms | all fixed | V3—ICP1 tube (available from Electronic Tubes |
| R3—33,000 ohms | resistor | Ltd., High Wycombe, Bucks., England, for S8.40, |
| R4, R17—2.2 megohms | 1/2 watt | postpaid) |
| R6—220 ohms | | 1—7 1/8" x 4 3/4" x 2 1/4" Bakelite case |
| R7, R20—68,000 ohms | | Misc.—Hardware, magnetic foil, wire, etc. |

Power supply of Min-O-Scope. Points "A" and "B" connect to matching symbols in the diagram above.

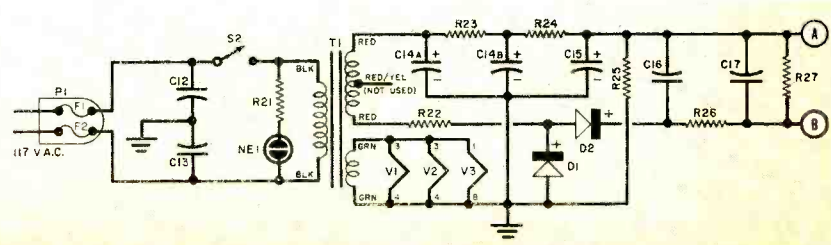

HOW IT WORKS

The Min-O-Scope is composed of three tubes and a common power supply. Tube *V3*, the cathode-ray tube and heart of the Min-O-Scope circuit, graphically shows fluctuations in the voltage applied to input jack *J1*. Principal components needed for *V3*'s operation are a sweep oscillator (*V2*), a voltage amplifier (*V1*), and a power supply.

In operation, electrons emitted by *V3*'s cathode are focused into a narrow beam of very high velocity. This beam, controlled both horizontally and vertically by the inputs from *V2* and *V1* respectively, is allowed to strike a fluorescent screen, where it causes the screen to glow. The sweep voltage—or time-base voltage, as it is sometimes called—from sweep oscillator *V2* is applied to *V3*'s horizontal deflecting plate, and the amplified output from *V1* is delivered to *V3*'s vertical deflecting plate. Current flow—and thus "brightness" or "intensity"—in *V3* is controlled by the setting of potentiometer *R5*.

Vertical deflection amplifier *V1* is a con-

played pattern. The output from *V1* is coupled to *V3*'s vertical deflecting plate through capacitor *C5*; the omission of the usual cathode-bypass capacitor from *V1* introduces degenerative feedback into the stage and thus extends frequency response.

Sweep oscillator *V2* generates the sawtooth waveform required by *V3*. Although *V2* appears to be another conventional class A amplifier, the stage is actually a modified Miller integrator circuit. Its sawtooth output is chiefly a result of the placement of capacitors *C6* through *C10*, which are individually switched between *V2*'s plate and grid. The input to the tube's suppressor (controlled by the setting of *R12*) governs the charging and discharging of the selected capacitor by altering *V2*'s effective plate and screen voltages; potentiometer *R19* varies sweep speed over a 10 to 1 ratio by adjusting the voltage applied to the grid of *V2* in its class A state and thus the discharge rate of the selected capacitor.

The power supply uses two silicon recti-

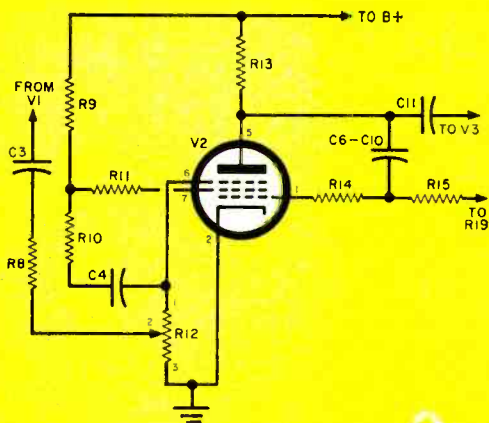

Sweep oscillator (*V2*) supplies time-base voltage for cathode-ray tube. Oscillation results from coupling between plate and grid.

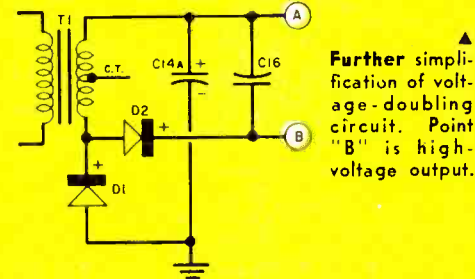
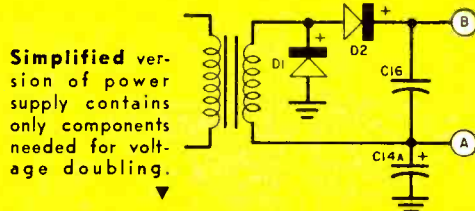

ventional, resistance-capacitance-coupled amplifier. The input signal from *J1* is fed through d.c. blocking capacitor *C1* to potentiometer *R1*, which controls the gain of the stage and thus the height of *V3*'s dis-

fiers in a voltage-doubling circuit to provide high voltage for the CRT. Diode *D1* also serves as a half-wave rectifier to supply plate voltage for the voltage amplifier and sweep voltage circuits.

Although the amplifier section (*V1*) isn't really needed for tests in which there is 100 volts or more available for direct application to the CRT's vertical and horizontal plates—checking AM modulation percentages is one example—no binding posts are provided for this purpose. But it's a simple

matter to use clip leads for direct connection to the CRT.

Construction. A Bakelite instrument case was selected to house the scope because it provided an easy means to mount parts without insulation worries. Be very careful when drilling holes in the case—

always use a small drill to get the hole started, and avoid applying much drill pressure or you may chip the Bakelite. Use a sharp punch to lay out the holes.

First drill the front-panel hole for the CRT, the four potentiometers, and the neon indicating lamp. Then drill the holes for the handle and switch *S1*.

Transformer *T1* is mounted in the upper left-hand corner of the case. One terminal of *T1* is used to fasten it to the case with a 6-32 screw; the other terminal is cut off to save space. The two binding posts (one red and one black) should then be installed on the rear of the case for vertical and ground inputs. Drill a hole for the 117-volt a.c. line cord in the rear before mounting the rectifiers and filter capacitors.

Solder the lugs of the two four-terminal mounting strips to the transformer case; the strips hold the resistors associated with the power supply. Mount diodes *D1* and *D2* in clips in the lower-left rear corner of the case. Then install the clamp which supports the CRT.

A dual 11-terminal mounting board is used to hold a number of capacitors and resistors. Wire leads about 9" long are connected to the terminals as shown and then the board is mounted to the closed side of the case with one screw. This board simplifies wiring considerably.

With the tube chassis installed, wiring should proceed from the terminal board to the tube chassis; then to the pots; and on to the CRT socket, switch *S2*, and the power supply. Leads on the CRT socket as well as on the terminal board should be color-coded to make connections easy.

Operation. Before testing the Min-O-Scope, install fuses *F1* and *F2* in the fused plug and carefully check all wiring against the diagrams. Now turn *S2* on. The neon bulb should light immediately and the tubes' heaters should begin to glow.

A word of caution at this point: do not attempt to operate the CRT at less than 350 volts—to do so may damage it. If you have difficulty getting the CRT spot to come to the center, vary the values of *R16* and *R17*; potentiometers rated at 2½ megohms can be used in place of these fixed resistors if you wish.

After the tubes have warmed up, a horizontal line should appear on the face of the CRT. If it is not exactly horizontal, twist the CRT in its socket until the line is perfectly aligned across the center of the tube

face. Make certain that the CRT is not mounted too closely to transformer *T1*. To shield the CRT from the power transformer, some Netic magnetic foil (made by the Magnetic Shield Division of the Perfection Mica Co., 1322 North Elston Ave., Chicago 22, Ill.) can be wrapped around it and secured with two turns of small copper wire.

Next, with *R1* at minimum, connect the output from a 6-volt filament transformer between the vertical amplifier input and ground. Now rotate *R1* very slowly until a waveform is produced. Switch *S1* to posi-



Completed scope is compact and fully portable. Rubber feet on bottom protect case; holes on side were added for ventilation.

tion 2, rotate *R5* to feed a little voltage to *V2*, and adjust fine frequency control *R19* to produce a stationary pattern. A little juggling of *R5* and *R19* should produce a well-defined wave.

With no CRT focusing or centering to worry about, the Min-O-Scope is about the simplest scope in the world to operate. You'll find it useful for AM modulation checking; SSB equipment alignment; receiver monitoring; checking power supply ripple; as a null indicator in bridge measurements; checking key-click filters and audio amplifier operation; and dozens of other tests and adjustments. —30—

UNLICENSED

FCC Form 660 Rev. June 1958
STATION CALL SIGN

UNITED STATES OF AMERICA
FEDERAL COMMUNICATIONS COMMISSION
WASHINGTON, D. C.
AMATEUR RADIO LICENSE
Fixed transmitter location, and remote control position when authorized.

EXPIRES 3 a. m.

NOT TRANSFERABLE

Licensee and P. O. Address

(This license is subject to conditions shown on reverse side)

Operator Privileges

Class	CLUB STA.	Issuing Officer	Effective Date
Class		C. B. Plummer	6-18-59

SEE UPPER RIGHT CORNER FOR EXPIRATION DATE

Countersigned

Secretary
May Jean Moran

Two-Way Radio

You can go on the air legally without a license by making your phono oscillator double as a tiny broadcast station

By **LEE CRAIG**

IF YOU'RE FAMILIAR with ham radio, you probably know that hams need a license before they can go on the air. But there's a way you can go on the air—legally—with no license at all. The secret is to keep your transmitter's power within the limits specified by the Federal Communications Commission. Under present regulations, you can broadcast voice, music, or code without a license if you keep the radiated power from your transmitter low.

Any phono oscillator—actually a small AM transmitter—can be used as a "flea-power" broadcasting station. These oscillators are available ready-made or in kit form for as little as \$4.50. Plug a microphone into the oscillator phono jack, connect a 10' piece of wire as an antenna, turn the oscillator on, tune it to a clear spot on the AM band, and you're ready to go on the air.

What You Need. For two-way communication between stations, each station must be equipped with a transmitter (phono

oscillator) and a conventional AM broadcast receiver.

Usually not designed with a press-to-talk circuit, a phono oscillator radiates continuously when turned on. But you can have



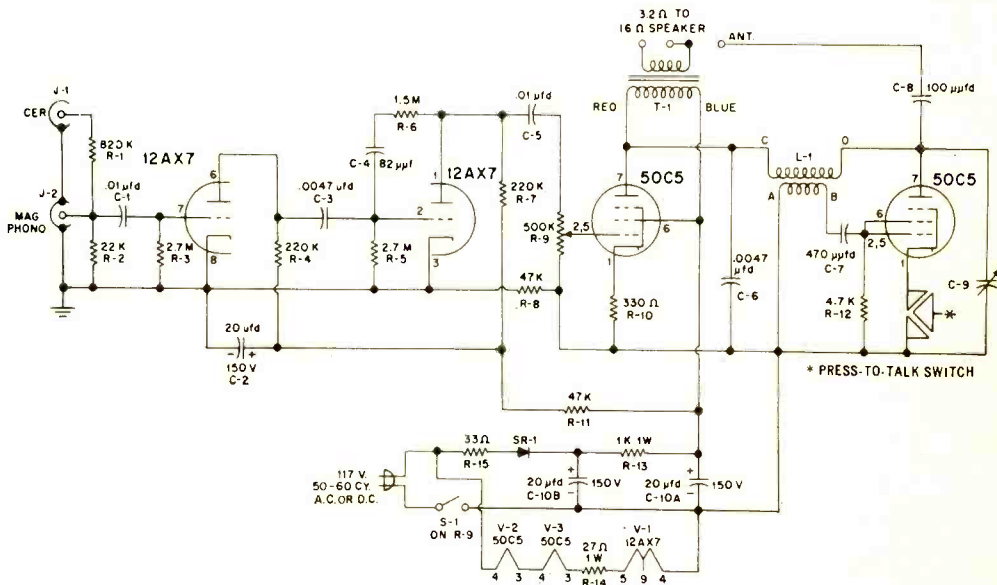

Versatile Knight-Kit wireless broadcaster/amplifier can be used with almost any phono pickup or microphone. Signals can be broadcast or fed directly to a speaker.

"simplex" (press-to-talk) communication in mobile-radio style by adding a push button to your transmitter. This generally requires little more than connecting a push button in series with the cathode of the oscillator tube. When the button is pressed, the transmitter is on. When it is released, the transmitter is off. The schematic shows where to add a press-to-talk switch to the Knight-Kit wireless broadcaster/amplifier.

Phono oscillators are intended for very short range operation, on the order of 50' to 100', but they can be heard much farther when connected to an antenna. The signal radiated by the Knight wireless broadcaster, for example, can be heard 200' away with a pocket-size transistor receiver, and up to half-a-mile away with a good auto radio.

There's another trick to increasing a phono oscillator's range. The FCC limits the length of the transmitting antenna to minimize radiation, but there's no limitation on the receiving antenna's length. Using a good antenna at the receiving end will boost any phono oscillator's range for two-way communication.

Receivers with built-in loop antennas can be made more sensitive by connecting them to an outside antenna. Many receivers have an antenna jack for this purpose. If your set doesn't have one, you can still increase



its sensitivity by coupling an antenna system to it inductively (see photo on next page).

Mobile Operation. A simple transmitter of this sort can also be installed in a car, using a vibrator or transistor-type converter to furnish the required 117 volts a.c. from the car battery. The antenna can be one of the conventional telescoping car radio antennas.

Instead of the usual shielded lead, you can use a piece of ordinary insulated wire for connecting the transmitter to the antenna. But remember that the overall length of the lead-in and the telescoping an-

tenna must not exceed 10 feet. And don't forget to ground the transmitter chassis to the frame of the car.

The car radio is used as the receiving device in such a two-way station. Don't expect much range—you'll be doing well if you get 1000 feet. This range, however, is adequate for talking to your family by radio when passing your house, or for two or



▲ You can add an antenna to your radio even though it lacks an antenna jack. Reception can often be improved by simply unplugging a floor lamp and wrapping the lead cord around the radio as shown.

◀ Wired and ready for use, Bud Radio's WO-6 phono oscillator has a terminal strip at bottom for easy connection to input and antenna.



erodyne beat that will interfere with reception of that particular station by nearby listeners.

Most factory-made oscillators have already been certified by the manufacturer and meet FCC requirements. FCC regulations allow you to operate your transmitter on any frequency between 510 and 1600 kc. Input power to your transmitter's final stage (plate voltage \times plate current in amperes, plus screen voltage \times screen current in amperes) must be kept below 100 milliwatts (0.1 watt), and your antenna and its transmission line must be less than 10' long, overall. In addition, spurious radiations (harmonics) must be at least 20 db (1/10th the voltage) below the level of the unmodulated carrier at the operating frequency.

It's a good idea to get a copy of Part 15 of the FCC Rules before attempting to use a transmitter without a license. You can obtain a copy from the U. S. Government Printing Office, Washington 25, D. C., for \$1.25, including postage. Armed with this information and a phono oscillator or two, you're in for lots of fun.

more cars in a convoy. You can also communicate between a car and a house trailer.

Setting Up. Tune an AM broadcast receiver to a clear spot in the band where no station is heard. Then, with the 10' antenna connected, adjust the transmitting tuning knob or adjusting screw until the radio receiver's background noise drops. Plug a mike into the oscillator's phono jack and check for your voice on the radio.

Make sure that the transmitter isn't tuned to within 10 kc. of a broadcast station that can be heard in the neighborhood. Otherwise, signals from your transmitter and the broadcast station will form a het-

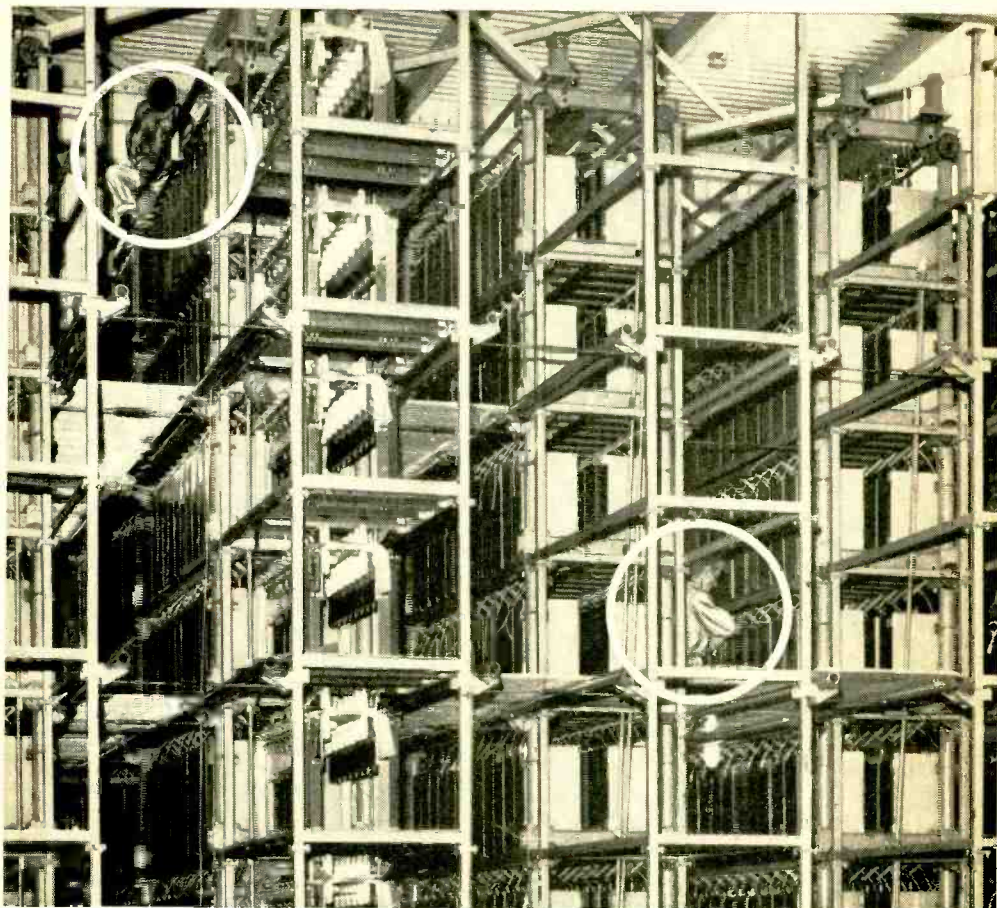

Giant capacitor bank at Los Alamos discharges 40 million amperes in 10 microseconds. Circled workmen give some idea of overall size of unit, only one-third of which is shown here.

World's Largest Capacitor

NOW being completed at the Los Alamos Scientific Laboratory in New Mexico is the world's largest capacitor. Called *Zeus* after the ancient god who hurled thunderbolts, the device is capable of delivering a 40-million-ampere jolt—equal to the entire electrical output of the United States—for a period of 10 microseconds. The power is used for experiments in connection with *Project Sherwood*, our research program for harnessing thermonuclear energy.

Zeus is composed of 12 racks, each measuring 20' high, 3' wide, and 28' long. A total of 4032 capacitors—336 for each rack—offers a capacity of 60,000 microfarads, or .06 farad. With a charging current of 3.5 amperes at 2500 volts d.c., only about 85

seconds is required to charge all 12 racks to 20,000 volts.

The output power is handled by 1343 ignitron switches and their firing systems which feed into 1343 output cables. Complex output facilities permit four experiments to be conducted independently.

Since just a fraction of *Zeus'* power could cook a man to a crisp, elaborate safety precautions are observed. All experiments are carried out behind interlocked doors. Warning alarms, automatic shut-off circuits, and remote-control systems also contribute to the safety of the device.

The entire system was designed by the Los Alamos Scientific Lab in cooperation with the Sandria Corporation. —30—

ONE-TUBE FM TUNER



HERE'S a one-tube FM tuner that's inexpensive, easy-to-build, and remarkably good-sounding to boot. Naturally, the set's sensitivity doesn't compare with that of commercially available tuners, but it will pull in most stations within a range of approximately 10 miles. Parts for the tuner, including power supply, will cost about \$11.

Because it's built around a superregenerative detector, the set is comparatively insensitive to pulse interference—auto ignition noise, for example. Another inherent characteristic of a superregenerative detector is its tendency to hang on to a signal; this gives the set a sort of automatic frequency control action.

August, 1960



Superregenerative circuit provides FM reception at rock-bottom price, incorporates features of more elaborate sets

By **ROBERT E. DEVINE**, W6AYW

Although the tuner circuit isn't much more complicated than some fancy crystal sets, bear in mind that its operating frequency is measured in *megacycles*, not *kilocycles*. A good many sets will get by with long, sloppy leads at broadcast frequencies, but things just won't perk at 100 mc. unless the wiring is as short and direct as possible. For this reason, it's best to follow closely the general layout shown.

Construction. The tuner and power supply were assembled on a 3½" x 6½" x ½"

piece of plywood. End pieces are $3\frac{1}{2}$ " x $3\frac{1}{2}$ " x $\frac{1}{4}$ " plywood; the cover is a $10\frac{1}{2}$ " x 7" piece of perforated metal bent into a "U" shape. If you have trouble with body-capacity effects, try mounting a $3\frac{1}{2}$ " x $2\frac{1}{2}$ " piece of sheet metal on the back of the front panel to isolate tuning capacitor $C2$; ground the metal plate.

Since pins 2 and 5 on socket $SO1$ were not needed in wiring, they were removed. The metal grounding post in the center of the socket was also removed and replaced with a wood screw to mount the socket on the board. A $\frac{1}{4}$ -40 nut placed under $SO1$ acts as a spacer to keep the remaining pins from being pushed out flat as the socket is tightened down.

Choke $RFC1$ was wound on a $\frac{1}{2}$ " dowel, then coated with polystyrene dope to make it easier to handle. If you don't have No. 23 enameled wire on hand, but do have No. 22

holes slightly undersized to grip the leads firmly.

Note that transformer $T1$'s mounting strap is grounded. One red lead from $T1$ is soldered to a lug under one of $T1$'s mounting screws; another lug is used under the other mounting screw. Be sure to scrape off the paint around $T1$'s mounting holes to insure good electrical contact.

One last construction tip—don't fudge on the values of resistor $R3$ and capacitors $C3$ and $C4$. The total cost of these three parts is relatively small, and their values are quite critical. Capacitor $C3$ must be a silver mica unit as specified.

Operation. With the a.c. power cord plugged in, an outside antenna attached (a TV antenna will work well), and the audio output lead plugged into an amplifier, you should hear either a hiss or a station. Now all you have to do is adjust $C4$ or $L1$ for

Circuitry of the FM tuner is extremely simple, as the schematic diagram shows. A single triode ($V1$) is connected in a superregenerative hookup; power for the tube is furnished by rectifier $D1$.

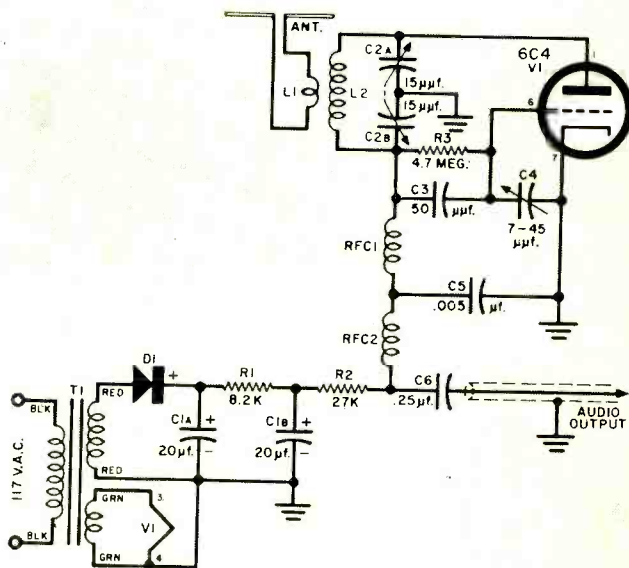

or 24, use it instead. Choke $RFC2$ isn't overly critical, either—any 7- to 10-mh. r.f. choke should be satisfactory.

The B+, ground, and heater leads are terminated on a three-terminal mounting strip; $RFC2$ and $L1$ are soldered to brass screws driven into the plywood. The a.c. cord, the shielded audio output cable, and the 300-ohm twin lead can be passed through holes in the rear panel; make these

best performance, and expand or compress $L2$ so that the tuning capacitor covers the 88- to 108-mc. range.

Capacitor $C4$ is properly set when its capacitance has been increased as much as possible with the detector still oscillating over the entire frequency range. With $C4$ at maximum, the receiver will be dead over part or all of the FM band. Too tight a coupling between $L1$ and $L2$ will also stop

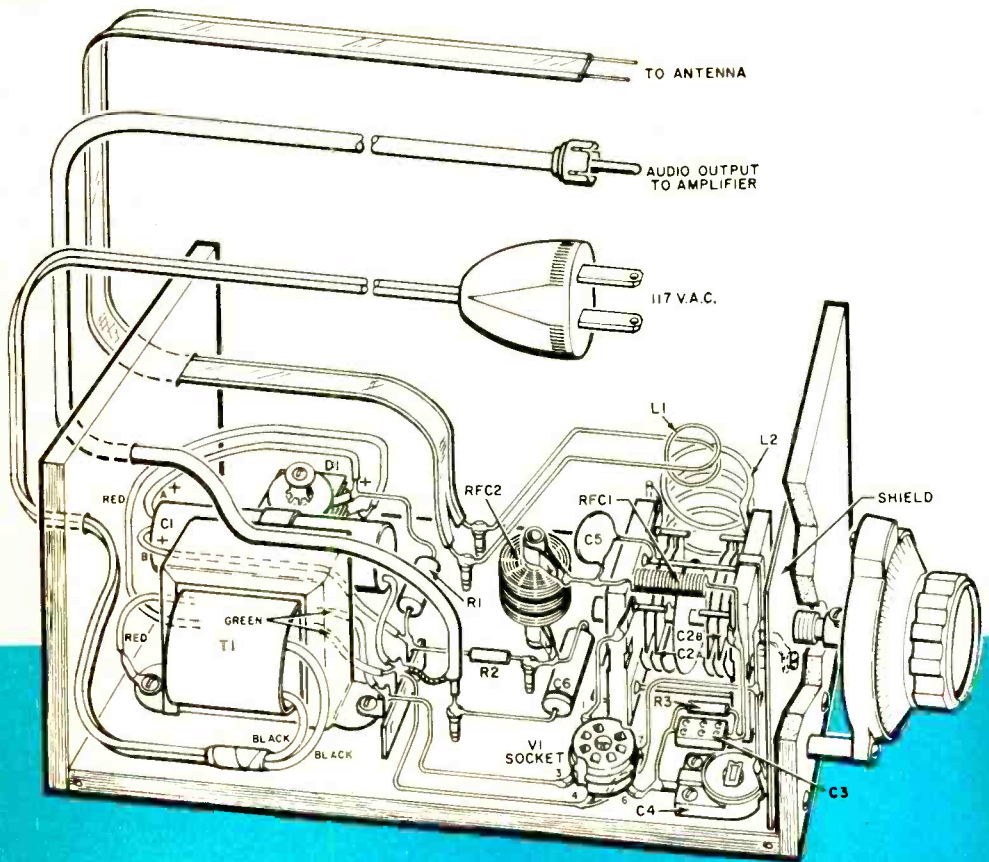

PARTS LIST

- C1a/C1b**—20-20 μ l., 150-volt electrolytic capacitor
C2a/C2b—15- μ l. dual variable capacitor (Bud LC 1660 or equivalent)
C3—50- μ l. silver mica capacitor
C4—7.45 μ l. trimmer capacitor (Centralab Type 833 or equivalent)
C5—.005- μ l. disc capacitor
C6—.25- μ l., 400-volt capacitor
D1—50-ma., 130-volt selenium rectifier
L1—1½ turns of #14 enameled wire, ¼" long, ⅜" in diameter
L2—4½ turns of #12 enameled wire, ¾" long, ½" in diameter
R1—8200-ohm, 1-watt resistor
R2—27,000-ohm, ½-watt resistor
R3—4.7-megohm, ½-watt resistor
RFC1—30" length of #23 enameled wire wound on ¼" form
RFC2—8-mh. r.f. choke
SO1—7-pin miniature socket
T1—Power transformer; primary, 1.7 volts a.c.; secondaries, 125 volts at 15 ma., 6.3 volts at 0.6 amp. (Stancor PS-8415 or equivalent)
VI—6C4 tube
 1—3½" x 6½" x ½" sheet of plywood
 2—3½" x 3½" x ¼" sheets of plywood
 1—10½" x 7" piece of perforated metal
Misc.—Tuning knob, a.c. cord and plug, shielded wire and phono pin plug, 300-ohm twin lead, three-terminal mounting strip, wire, solder, etc.

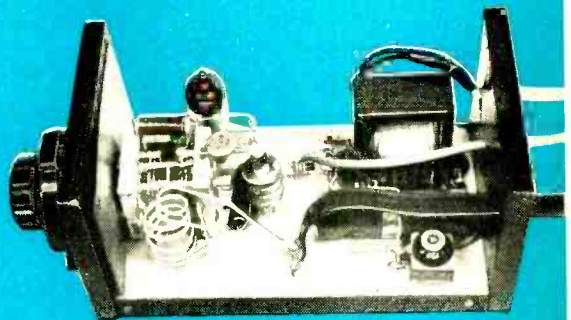

Parts are assembled in breadboard fashion on a 3½" x 6½" plywood base; slightly undersized holes in rear panel hold 300-ohm twin-lead, line cord, and audio output cable securely. Shield behind front panel is optional.

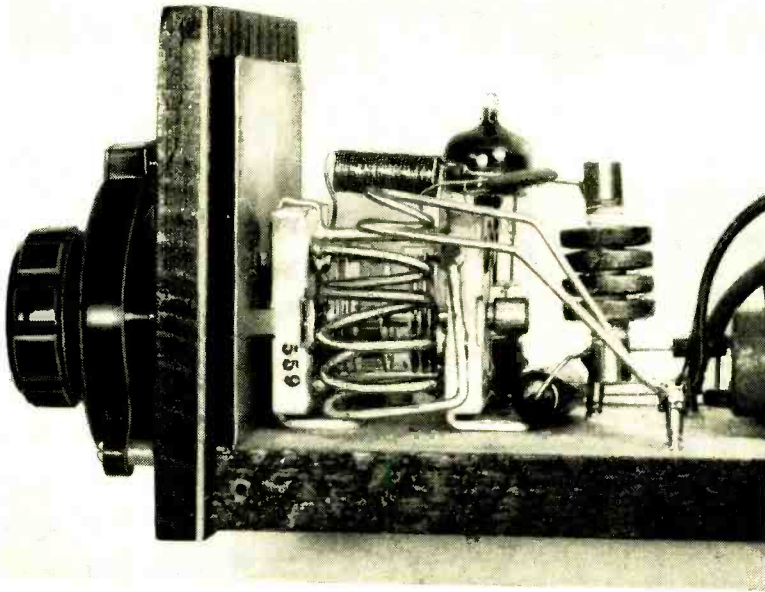

L1
1/2 TURNS #14
WIRE, 3/8" DIA.

L2
4 1/2" TURNS
#12 WIRE,
3/4" LONG,
1/2" DIA.

Coils L1 and L2 are hand-wound from No. 14 and No. 12 wire respectively and held in place by their own leads. Although the coils should be as close together as possible, they should not touch each other. Spacing of L2 can be varied until the tuner covers the entire 88-108 mc. FM band.

HOW IT WORKS

A single triode is used as a superregenerative detector in the familiar Colpitts circuit. Incoming signals from the TV or FM antenna pass through the 300-ohm twin-lead to L1. Since coils L1-L2 act as a transformer, voltage is induced into L2 with specific stations selected by tuned circuit L2-C2. The signal passes to the grid of V1 through grid leak resistor-capacitor combination R3-C3. Since both grid and plate circuits of V1 are tuned to the same frequency by L2-C2, oscillation takes place at that frequency.

Because of the presence of R3-C3, oscillations occur simultaneously at another and lower frequency. This second or "quenched" frequency throws the detector in and out of oscillation at its main frequency some 20 to 30 thousand times a second. Since sensitivity in a regenerative detector is maximum when the detector is about to go into oscillation, throwing the detector in and out of oscillation at a ultrasonic rate results in sensitivity so great that thermal noise can be heard as a hiss between stations.

The a.f. component in the output from the detector is filtered by the r.f. chokes and capacitor C5, then fed to an external amplifier through d.c. blocking capacitor C6. Power for the detector is furnished by transformer T1 working in conjunction with half-wave rectifier D1 and filter C1-R1.

the oscillation, but the coupling here should be as close as possible to bring in stations strongly and eliminate hiss. You can also try grounding one side of L1; make the connection permanent if it results in a stronger signal.

If you can't get stations on the high end of the band, unsolder L2, expand it slightly, re-solder it in place, and see if the high end of the band comes in. If it does not, repeat this procedure until it does. On the other hand, if the tuning capacitor becomes fully enmeshed before you get to the lower-frequency stations, unsolder L2 as above, but compress it before replacing it. If this doesn't work, add one turn to the coil—you'll have to make a new coil to do so, but this should take only a few minutes.

Prepare to be pleasantly surprised if you have a hi-fi rig to feed the tuner into. Many people are astounded at the quality of sound that emanates from this ultra-simple unit. In fact, you're likely to be swamped with friends by the bushel who want you to whip up one for them.

-30-



How to Get DX

By FRED E. EBEL, W9PXA

A MUSICAL QRM from the door chimes interrupted my vain attempts to raise a ZS2. A small, round, middle-aged man and a girl stood at my door.

"May we have a minute?" he asked, sliding past me with the young lady when I did not answer immediately. They sat down side by side on the couch. In the strong light, I judged the girl to be about 18 and exceedingly plain—to put it mildly.

"You're wondering what this is all about," he began, a curved slice of a smile on his pumpkin face. "Well, my daughter and I are SWL's. We listen in to your DX attempts quite a bit, living just in the next block as we do. And we know you have a problem. May we be frank?"

"A problem? Well, if you say so. Go ahead."

"Yes, a problem—namely, your difficulty in making DX contacts despite high power and a 75' four-element beam. In short, your many CQ's rarely result in a contact."

I blushed, then bristled, the short hairs on my neck standing up as though charged by a rubbed comb.

He lifted a hand in remonstrance. "You said I could be frank."

"Go on." I tried to sound pleasant, but this guy was beginning to get my goat. This SWL! What did he know about ham radio? And his daughter—why was *she* here?

"All right, so I don't make many DX con-

tacts. I even have trouble making nighttime ground-wave rag-chew QSO's. There could be any number of reasons."

He shook his head. "There is only one reason—you!"

I advanced on my guest, chin jutting out. I weigh 210 and recently graduated from the Flexor School of Muscle Building. The little guy made for the door with his daughter.

"Very well, young man. If we can't be frank, we can't help you."

"Wait . . . I'm sorry." He had me hooked. Now I was curious. "Just what is wrong with me? Be as frank as you like."

He sank down into an easy chair, leaned forward, and almost whispered: "It's your voice."

"What do you mean? Wha-what's wrong with my voice?" I steeled myself for the answer.

"It's lousy!"

I bristled again, then remembered the frankness bit. "Explain," I demanded.

He extracted a reel of tape from his pocket and motioned toward my tape recorder. "This will explain, if you play it."

IT was my voice—a "CQ DX" call I'd made the week before, which, like the rest, had resulted in a big nothing. It was the first time I'd heard my voice. I'd recorded a lot of hams, but I'd never listened to myself before. And, my voice really *was* lousy! Even with the help of a 15" woofer, it was like the shrill piping of a three-year-old. I'd heard squeaking gates that sounded better.

Suddenly I felt sorry for all the hams

that had to put up with my voice, and I knew why my CQ's were followed by dead air. But how did my strange visitor fit into this dismal picture? A light flared in my head.

"If—if this is blackmail, I'll—I'll not give you more than ten dollars to get rid of that tape!"

He seemed genuinely offended. "Sir, if you're thinking in terms of blackmail, then our—ah, arrangement is off."

"Arrangement? What's this about an arrangement?"

He coughed, and for the first time appeared nervous. "Sir, now I'll be frank about myself and daughter. I have a meager income and my daughter has—well, you can see that she would have difficulty getting work, even as an office girl."

Too many Marilyn Monroe's nowadays, I thought. "Go on," I prodded, wondering what the hooker was.

"Well, Gertie's got to do something. She's expressed an interest in welding. They wear a mask, you know and—" He left the words unsaid in respect for his daughter. "She'd like to go to this welding school, but"—his head fell—"we're short about fifty dollars."

I thought this one over. Was it worth fifty dollars to be told that your voice is lousy and be given audible proof? True, I now knew why my CQ's had fallen on deaf ears. But touched as I was by this display of parent-to-daughter affection, fifty dollars was fifty dollars.

"I could give you ten," I said. "Maybe the other neighbors would—"

"Please!" he pleaded. "No charity. We have a service."

"A service?"

"Yes, my daughter, Gertie. She could do your CQ's, serve as a sort of bait. Then, when your DX contact is hooked, you could take over. She would perform this service for a nominal fee—say, three dollars an hour."

THIS was nothing new. I'd been hooked lots of times by feminine CQ's. But Gertie! He saw the skepticism on my face, drew out what appeared to be a script, and handed it to his daughter.

"Close your eyes while Gertie reads this," he commanded.

I obeyed and Gertie intoned a "CQ DX," signing my call letters. I had never heard such a voice. Each word—nay, each syllable—was like a loving caress, petal smooth,



intoxicatingly sweet. I was floating on a sea of fragrant roses, conjuring up an image of the creature endowed with this lovely voice—heart-shaped face, peaches-and-cream complexion, and full, red lips pouted provocatively. Instinctively, I pursed my lips.

My pumpkin-headed visitor brought me back to grim reality with a hearty: "Nice voice, isn't it?"

I opened my eyes. "Say something—anything!" I demanded, looking intently at Gertie.

"I am very pleased to meet you," she responded.

Again I was thrilled. But my enthusiasm quickly wilted as Gertie's painfully plain features came back into focus. Still, I was interested. With a voice like that as CQ bait, I *could* rack up plenty of rare DX—the kind of fierce, competitive DX where the distant ham chooses one of the many hams calling on his frequency. A siren voice like Gertie's would be irresistible.

"Okay," I agreed. "We'll try it. Tomorrow's Saturday. See you at 9 in the morning, Gertie."

Her father coughed discreetly. "I'll be with her." Then noticing my slight frown, "Don't worry, I'll be quiet as a mouse, reading my bird book. You—ah—understand why."

I understood. But as far as I was concerned, Gertie had a chaperone with her at all times—her face. So I agreed.

Gertie, posing as a "friend of the family," belted out some terrific CQ's that figuratively melted the insulation off coax trans-

(Continued on page 118)

INSIDE the Hi-Fi Microphone

PART 2 of two parts

AS we discussed last month, each type of microphone has its own special advantages. This means that no one microphone is "better" than any other—it all depends on what you want the microphone to do.

From the user's point of view, the most important characteristics are: (1) *frequency response*, (2) *pickup pattern*, (3) *sensitivity*, and (4) *impedance*. For every application, there is an optimum combination of these characteristics. Let's look at each of them in turn and see how they enter into the overall picture.

Frequency Response. Broadcasting and recording are two fields where a microphone is often called upon to cover the widest possible frequency range. Although this is far easier said than done, there are several high-quality (and expensive) microphones which come close to managing it—among them the Neumann (formerly Telefunken) U-47, the Sony C37A, and the Capps CM-2001 capacitor mikes, as well as one or two ribbon mikes.

The super fidelity that these mikes offer, however, can frequently be too much of a good thing. For example, too much response in the very low bass region can result in unwanted pickup from street traffic, subways, air conditioners, etc. This problem is so serious that recordings in European concert halls are often made in the dead of night when such disturbances are at their lowest level. An "ultra-fidelity" mike, therefore, while ideally suited for recording original master tapes, is of limited use to the average recordist.

Less expensive, but still quite suitable for most amateur uses, is a microphone with a slightly less extended frequency response. In fact, for most amateur hi-fi purposes, a microphone whose response slopes off below 50 cps is preferable to a microphone that is flat down to 30 cps. There are a number of microphones that provide a flat re-

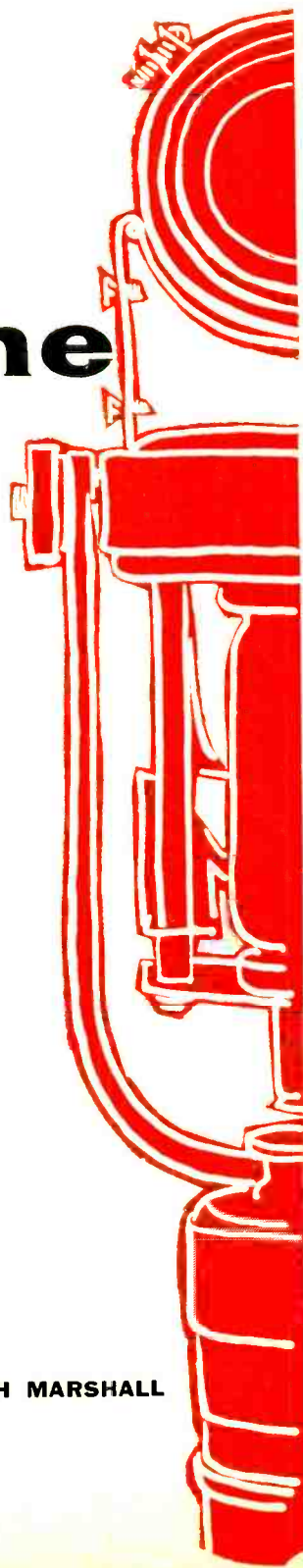

By
JOSEPH MARSHALL



"Ultra-fidelity" microphones such as the Neumann U-47, above, are somewhat tricky to operate and are designed for use by professionals.



Recommended for "live" amateur hi-fi recordings is a good-quality microphone in the medium-price range, such as the Turner Model 57.

response between about 50 and 15,000 cps, but which roll off the extremely low frequencies. Among these are the Electro-Voice 635, the Shure "Unidyne," and the Turner 57.

For home recording and for high-fidelity public address systems, the high-end response can slope off beyond 10,000 cycles. Many microphones with frequency response from roughly 50 to 10,000 cps are available at very reasonable prices.

For communications work, a microphone with a wide frequency response is definitely a disadvantage. One which covers the range between 300 and 4000 cycles will provide higher efficiency and better intelligibility under high-noise conditions than will a higher-quality mike. Carbon microphones were once used almost exclusively for this purpose, but today there are both dynamic and crystal mikes designed specifically for limited-bandwidth voice work.

Since it is obvious that differing applications call for microphones with different frequency-response characteristics, it is logical to suppose that a microphone with variable response would be useful. A number of microphones provide this facility. The most common type has a built-in switch which produces either a flat response for music or a sloping bass response for voice. Perhaps the most versatile mike

in this respect is the Electro-Voice 667. It comes with a preamplifier which has controls for varying both the treble and bass response and for adding a "presence" peak at around 4000 cycles.

Pickup Pattern. We noted last month that microphones can have omni-directional, bi-directional, or uni-directional patterns, or even a combination of the three. In many applications, the microphone's pickup pattern is more important than its frequency response.

Since an omni-directional microphone is similar to the human ear—both pick up sound equally well from all directions—it might seem that it could easily duplicate the sound heard by human ears. Up to a point, this is true. For example, it is generally desirable to use an omni-directional mike to record a concert because it will pick up not only the direct musical waves but also the reverberation of the auditorium.

But even though human ears are omni-directional, the "mind-ear" combination can disregard sounds it does not want to hear. At a noisy cocktail party, for instance, the ear hears the overall clamor, but the mind can filter out the talk of a single person. On the other hand, if an omni-directional mike were used in such circumstances, it would be exceedingly dif-



General-purpose microphones can be used for recordings, paging, public address, etc. This is American Microphone Co.'s Model D-10.

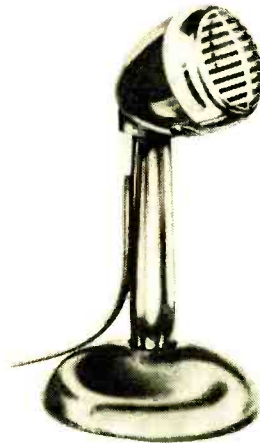

Designed for single-sideband transmission, Shure's Model 400 emphasizes the 300-3000 cps range to maximize speech intelligibility.

difficult to pick out a single voice from the resulting pickup.

When the program material and extraneous noises can be controlled, however, an omni-directional mike is a good choice. Such mikes are widely used for home recording because they aren't critical as to placement, and they produce a "natural-sounding" recording. In broadcast work, the omni-directional mike is preferred for interviews in quiet surroundings because it does not have to be moved around so much. And, as we have noted, it is preferred for music recordings in concert halls and auditoriums because it picks up the room reverberation, thus enhancing the recording.

Whenever there is likely to be interference from undesired sounds, a directional mike should be used.

In public-address work, a cardioid, or uni-directional mike, is almost a necessity to avoid acoustic feedback. The cardioid mike attenuates the pickup from its rear by a factor of 10 or more, and therefore minimizes feedback.

Uni-directional mikes are also preferred for use in rooms which have excessive reverberation or echo. Since they favor the direct sound and attenuate the reflected sound, they reduce the amount of reverberation pickup.

The bi-directional mike has special ap-

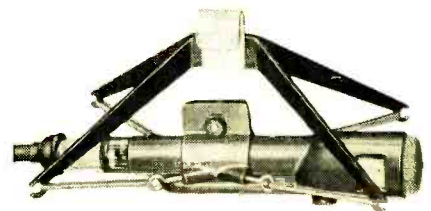
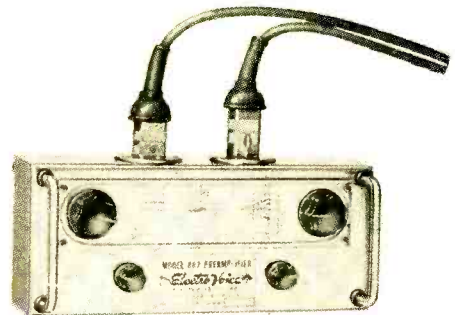

Variable frequency response and vibration-proof suspension is offered by the Electro-Voice Model 667, which comes with a preamplifier. Chart shows response curves at various tone-control settings.

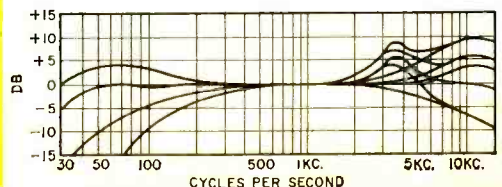

plications. In recording or broadcast work, an orchestra can be divided into two halves, and the bi-directional mike put in between so that both halves are picked up equally. The nulls in the pickup pattern at the sides of a bi-directional mike can be used to minimize noise pickup.

It is possible to design a microphone that offers variable pickup patterns, and a few years ago several mikes offering this feature were available. Today, however, it is usually cheaper to buy two separate mikes with different characteristics, and variable-pattern mikes are rather scarce.

Sensitivity. Since a microphone is essentially a tiny loudspeaker in reverse, it has poor coupling to the air, and is therefore a rather insensitive device. In fact, the average microphone produces only about one to five millivolts output.

The sensitivity of microphones is still rated by an old broadcast standard which gives the output level in db below 1 volt—-60 db or -54 db, for example. The *smaller*

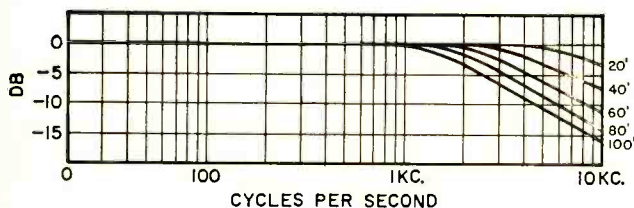

This chart shows attenuation effect of cable length on high frequencies when high-impedance (25,000-ohm) mikes are used.

the number, the *more sensitive* the microphone. If you keep in mind that -60 db is equivalent to 1 millivolt and that a change of 6 db indicates either doubling or halving the output, you can translate the ratings into millivolts. Thus a mike with a sensitivity of -54 db is twice as sensitive as a -60 db mike and delivers 2 millivolts.

Microphone sensitivity doesn't become much of a problem until it gets below -60 db. Generally speaking, the medium-priced crystal and dynamic mikes suitable for p.a., amateur, and home recording use deliver 2 millivolts or more. The high-fidelity mikes range around 1 millivolt, and it is generally only the super-fidelity mikes which have outputs below 1 millivolt.

Impedance. The output impedance of a microphone is an important consideration for a purchaser. Since crystal and ceramic

mikes are high-impedance devices, they can be fed directly into the high-impedance input of a preamplifier. Thus, they require no matching transformer. On the debit side, crystal and ceramic microphones fall victim to the two troubles that afflict any high-impedance devices: susceptibility to hum pickup, and loss of high-frequency response.

When a crystal or a ceramic mike is used with more than 25 feet of cable, an annoyingly high hum level may well result. Long cables also adversely affect the high-frequency response of a high-impedance microphone. Even a 20' cable will produce a drop of around 3 db at 10,000 cycles. The diagram on this page shows how cable lengths in excess of 20 feet attenuate the response of a typical high-impedance mike. It will be noticed that a cable run of 100 feet will result in a severe loss of high frequencies.

On the whole, high-impedance microphones are still quite popular because they are fairly inexpensive. And if they are used with short cables, they are satisfactory for most amateur, p.a., and home-recording applications.

Although low-impedance microphones have the disadvantage of requiring a matching transformer, they have the advantage of being far less susceptible to hum pickup. Also, they are almost immune to high-frequency attenuation

caused by long connecting cables. Consequently, when long cable runs are involved, the low-impedance microphone is the preferred choice.

The necessary impedance-matching transformers are sometimes built into the microphone. A few microphones offer a switch-controlled choice of either high- or low-impedance output so they can be used to best advantage with either short or long cables.

In choosing a microphone, it would be foolish to pick a model—as many people do—solely on the basis of frequency response. As we have seen, sensitivity, pickup patterns, and output impedance are equally important. Also to be carefully considered is the use to which the microphone will be put and, in addition, the type of equipment with which it will be employed.



RUSSIAN-ENGLISH TRANSLATING MACHINE

New computer developed by IBM for the Air Force is expected to translate all important Russian publications into English



TAKE an article from a Russian scientific paper or from *Pravda*, or even the original text of *Dr. Zhivago*; feed it into a new Air Force electronic translator; and out comes an English version. The grammar might horrify an English professor and the words may be a little scrambled, but the meaning is usually clear. This new machine, first of its kind, will soon buckle down to the gigantic task of translating the tons of scientific material which flow out of the Soviet Union every year. At present, much of this material goes unread by U. S. scientists for want of translation. The new translator was developed and built for the Air Force by IBM. It works on a relatively simple principle, although

Pravda - December 30, 1959 Article No. 2
 Will Open New Secret Universe
 Academician V. Ambartsumyan
 Sixth decade XX century represents one of the most stirring pages history humanity. Socialist country Europe and Asia, population that constitute more billion man, successfully move along the way of

the actual electronic gadgetry needed to do the job is pretty complex. In effect, the machine is an electronic computer with a dictionary of some 55,000 Russian words and their English equivalents built into its "memory." The dictionary itself is a 10" glass disc on which the words are written in "binary" form.
 (Continued on page 114)

See next page for "how-it-works" information

How the Translator Works...

OPERATION of the electronic translator can be compared to someone looking through a regular Russian-English dictionary. First he thumbs through the pages, scanning a word here and there, until he finds the right page. Then he looks over each word until he finds the one he wants. Finally, he reads its English equivalent.

The translator does pretty much the same thing. Here, briefly, is the overall picture of the translator's operation.

An operator types the Russian word on a Flexowriter, a special typewriter which codes the word as a series of holes in a paper tape. The tape is fed into a reading circuit where the holes are translated into a series of electrical pulses representing the word. The input register sends these pulses on to the comparator where they are stored.

Now a light beam scans the bands on the dictionary disc until it finds the one containing the sought-after word. It then reads off each word of this band and sends them—one at a time—to the comparator, which compares them to the input word. When the comparator finds an exact match, it signals the disc reader to send the very next word—which will be the English translation of the Russian word just located—to the output buffer. This circuit punches a tape which can then be fed to an output Flexowriter where the English word will be automatically typed out.

Holes Represent Numbers. Let's examine how this works in more detail. Figure 1 shows a sample of the punched tape that is fed into the input register. Each vertical column of six holes or spaces across the tape represents a number. (The center row of small holes is for a sprocket drive.) Each number stands for one Russian character (a letter, number, or punctuation mark) or for some instruction to the computer (space, start a new paragraph, make the next letter a capital, start or stop printing, etc.).

The tape uses the *binary*, rather than the *decimal*, system; i.e., *two*, rather than *ten*, is the key number in the system. Each hole represents the number *two* raised to a dif-

ferent power. Thus, Row One signifies *two* to the zero power (or 1), Row Two stands for *two* to the first power (or 2), Row Three is *two* squared (4), and so on. Row Four is 2^3 , or 8, Row Five is 2^4 , or 16, and Row Six is 2^5 , or 32. Now let's read the columns.

Column 1 is punched in Row One; since Row One signifies 2^0 , the first hole has a numerical value of 1. Moving up the rows, we also find holes in Row Two (2^1 , or 2), Row Three (2^2 , or 4), Row Four (2^3 , or 8), and Row Six (2^5 , or 32). Adding all the rows together, we get 47, the number represented by Column 1. Similarly, Column 2 adds up to 37, and the holes in Column 3

THE EDITORS

ferent power. Thus, Row One signifies *two* to the zero power (or 1), Row Two stands for *two* to the first power (or 2), Row Three is *two* squared (4), and so on. Row Four is 2^3 , or 8, Row Five is 2^4 , or 16, and Row Six is 2^5 , or 32. Now let's read the columns.

Column 1 is punched in Row One; since Row One signifies 2^0 , the first hole has a numerical value of 1. Moving up the rows, we also find holes in Row Two (2^1 , or 2), Row Three (2^2 , or 4), Row Four (2^3 , or 8), and Row Six (2^5 , or 32). Adding all the rows together, we get 47, the number represented by Column 1. Similarly, Column 2 adds up to 37, and the holes in Column 3

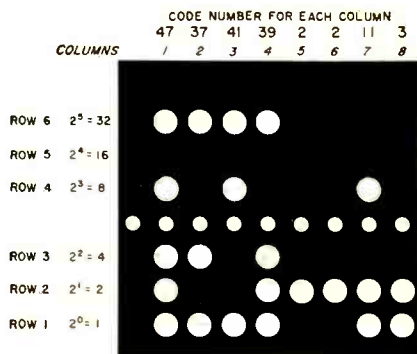

Fig. 1. Section of punched paper tape is shown double size. Each vertical column of holes represents a Russian character.

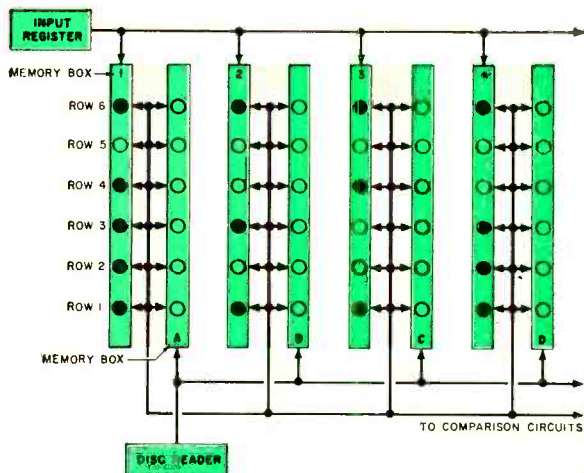

Fig. 2. Representation of the comparator circuit. Each numbered memory box stores a coded character in exactly the same pattern as shown on the punched tape in Fig. 1. When a coded word from the glass-disc dictionary is fed into the lettered boxes, its pattern is compared with that of the numbered boxes.

add up to 41, and so on. Each of these numbers stands for a Russian character or for some instruction to the machine.

A series of numbers which represents one word is fed into the comparator. Each number—or letter—of the word goes into a separate “memory box” as shown in Fig. 2, with the 47 of the first column on the tape going into Box 1, the 37 into Box 2, etc. As can be seen, the patterns on these boxes correspond exactly to the patterns of the holes in the tape: if there is a hole in Row 1 on the tape, Row 1 in the box will be “on.” The six indicators appearing in each box represent six circuits, each of which can be either “on” or “off.”

Thus, the input word is “stored” in binary language; i.e., the code number for each letter is expressed in a series of “on’s” and “off’s” rather than by conventional digits (1, 2, 3, 4, etc.). Binary language is used because a circuit for handling such information is very simple: a control pulse to the circuit will flip it either on or off (conducting or non-conducting).

At this point—with the input word safely stored away—we will turn our attention to the “dictionary,” the spinning glass disc that supplies words in binary form to be compared with the input word.

Binary-Coded Dictionary. The disc dictionary uses a similar code of “on’s” and “off’s,” but the coded material is arranged in 700 concentric tracks which are photographically printed on the outer area of the disc. The pattern formed by the binary-coded words, enlarged about 150 times, is shown in Fig. 3.

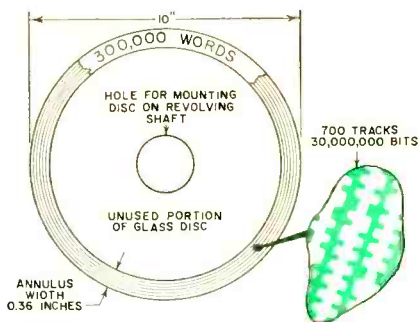
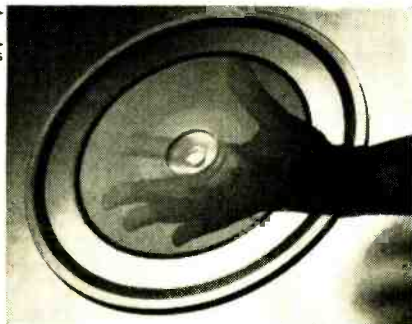

Fig. 3. Glass-disc dictionary stores words in binary-coded form. Immediately following each coded Russian word is its coded English equivalent.

Each “bit” of information, which corresponds to a *single* hole in the punched tape, is represented by the simple relationship between black squares and adjacent white areas. If the bit is to signify “0” or “no-hole,” it is coded so that the black square comes before the white area. If it is to signify “1” or “hole,” the white area comes before the black square. Thus, we can read off the numbers from the disc code as shown in Fig. 4, on page 62.

Each series of six “0’s” or “1’s” (which

represents a single character or letter) can be read just like the six "no holes" and "holes" on the paper tape, and in the same order; i.e., as though you were reading Rows 1 through 6 on the tape. The first series of six digits on the memory track adds up to 48, just as do the holes on the tape shown for comparison.

As a light source for reading the disc, the translator uses the spot on the face of a cathode-ray tube, focused by a standard microscope lens into a very small beam. A light-sensitive photo-multiplier tube on the other side of the disc records the series of "on's" and "off's" (or "0's" and "1's") as the disc rotates, and sends them to the *lettered* memory boxes (Fig. 2). There they form the pattern which is compared with the coded input word.

If the binary coding of the input word matches the coding of the word from the dictionary, the comparison circuit signals the disc reader to send to the output stage the coded information that follows the coded Russian word. This information represents the English translation of the Russian word that was just matched. It is punched out on tape in binary form and sent to the Flexowriter to be typed out in English. Both memory boxes are then erased, and the input register is notified to send in the next word.

If at any point during the comparison process a coded character from the dictionary does not match the information in the *numbered* memory box, the comparison circuit detects a difference voltage between the two and erases all the *lettered* boxes. Then, one after another, words from the dictionary are compared in the same fashion until the matching word is found.

Searching for Words. Since the technique used to scan the glass-disc dictionary largely determines the computer's speed, let's examine it more closely.

The disc scanner uses a relatively simple system to keep the light beam centered on the track being read out. When the beam is tracking properly, it passes over an equal number of black and white areas. Thus, the *average* brightness of the beam as measured by the photo-multiplier tube would be the equivalent of a grey tone. An intensity-measuring circuit interprets this grey level as zero.

But if the spot begins to drift toward the

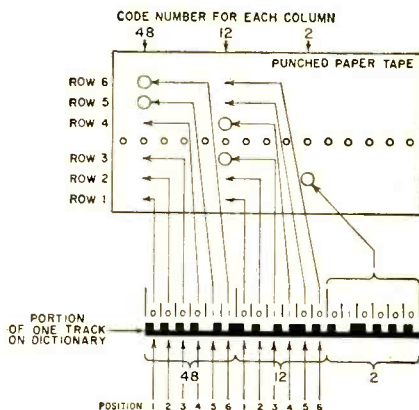

Fig. 4. Comparison of code used by the dictionary disc with that of a punched tape. Each system can be converted to the other.

clear area between the tracks, more light gets through. The intensity-measuring circuit immediately generates a voltage of a specified polarity, applies it to a servo system which controls the positions of the spot on the scope face, and moves the spot back to the equilibrium position.

If the beam drifts toward the solid black area, the same thing happens, but the correction is in the opposite direction. In either case, the beam is "locked in" the center of the track. So sensitive and fast is this circuit that the beam will even follow an eccentric track with the disc revolving at its normal speed of 1200 rpm.

Since about 700 tracks are used to store the words in the machine's vocabulary, the beam must search from one to the other to find the proper match. Instead of the words being arranged in alphabetical order like a regular dictionary, they are arranged in numerical order. This means that a word whose binary code number is low will appear early in the dictionary, and that one whose number is high will be nearer the end.

Suppose the scanner has just located a match on Band 325, and the next word it will have to find is on Band 550. When the number representing the first letter of the new word is fed in, the scanner samples a word on Band 325 where it happens to be at the moment. Since the code number of the new word starts with a higher

(Continued on page 115)

HERE'S a pint-sized crystal radio with enough oomph to drive a 2½" speaker. This little unit's selectivity is far better than you'd expect to find in a crystal receiver and volume is equal to that obtained with sets using a transistor. No external power source is required.

The unusual selectivity of this radio is due to its special double-tuned circuit. A pair of diodes connected as a voltage-doubler provides the extra kick to operate the small speaker. An output jack is provided for headphone listening and for connecting the set to an amplifier.

Construction. The model was built on a 2½" x 4½" wooden chassis with a 3½" x 4½" metal front panel. However, size is not critical, and other materials can be substituted if desired.

Two standard ferrite loopsticks, *L2* and *L3*, are used. Both must be modified by the addition of a second winding, *L1* and *L4*, respectively. Each of the added windings consists of 22 turns of No. 24 cotton-covered wire wound on a small cardboard tube as shown on the pictorial. (Actually, any wire size from No. 22 to No. 28 with cotton or enamel insulation will do the job.) The

High-Power Crystal Set

Voltage-doubler circuit drives miniature speaker

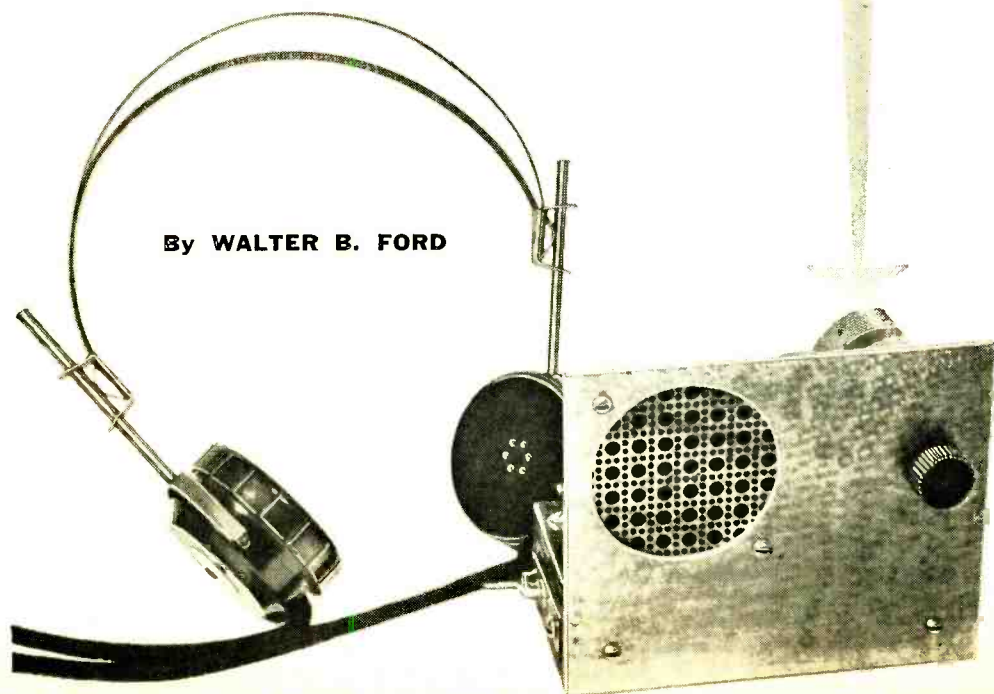

Layout is not critical but L2 and L3 should be mounted at right angles to each other.

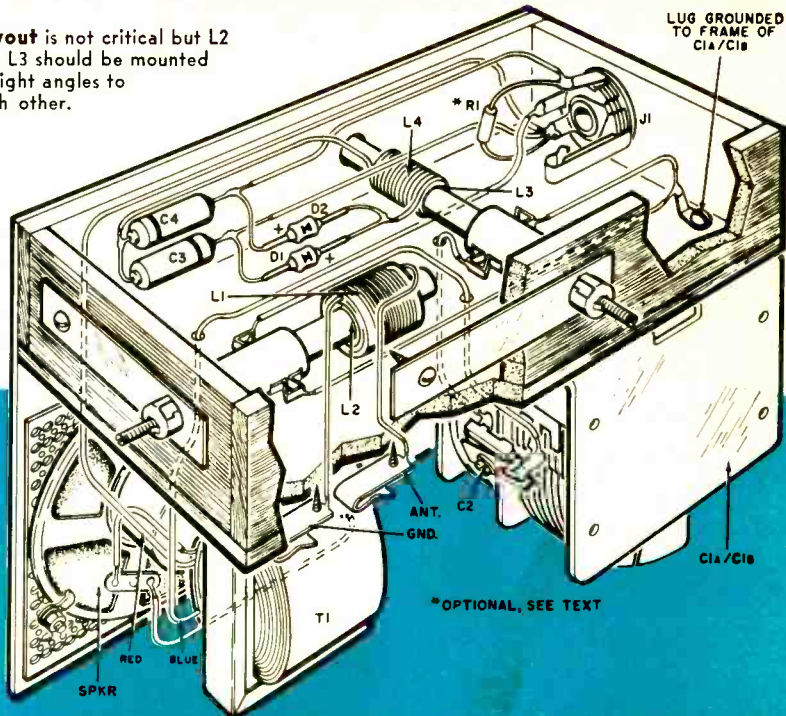

The crystal set shown was built on a wooden chassis. If a metal chassis is used, be sure to insulate the Fahnestock clips (antenna and ground) from the chassis.

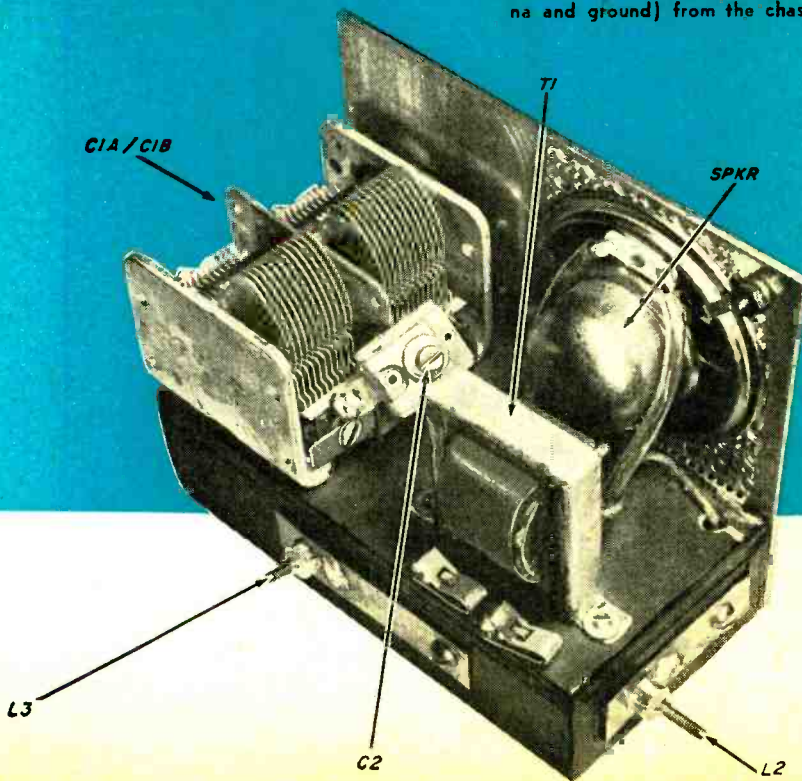

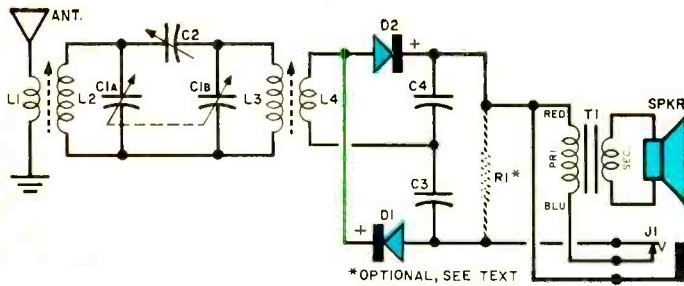

For phone operation only, the speaker, transformer, and resistor R1 can be omitted. In this case, connect high-impedance phones in place of R1.

diameter of the cardboard tube should be slightly larger than L2 and L3 so that L1 and L4 will slip over L2 and L3 easily.

Resistor R1 is used only for feeding the set into an amplifier; it should be omitted for both earphone and loudspeaker operation. Trimmer capacitor C2 should be soldered across the stator terminals of two-gang variable capacitor C1a/C1b, as shown. The speaker and output transformer can be mounted wherever convenient.

After all of the parts have been mounted on the chassis, wire them together following the schematic and pictorial diagrams. Be sure that diodes D1 and D2 and capacitors C3 and C4 are correctly polarized.

Alignment and Operation. To align the receiver, first connect it to an antenna and ground. (The optimum length of the antenna varies with location, but 50 feet will usually be suitable in areas serviced by several broadcast stations.) Next, plug in a high-impedance earphone at jack J1. Tune in a station near the high-frequency end of the broadcast band—say 1500 kc.—and adjust the trimmer capacitors on variable capacitor C1a/C1b for the loudest signal.

Trimmer capacitor C2 should then be adjusted for the best selectivity and volume over the entire broadcast band. Finally, coils L1 and L4 can be optimally positioned by sliding them back and forth over coils L2 and L3. If a nearby station interferes with reception of a weaker one, tune the slug on L2 for minimum interference.

For loudspeaker operation, simply unplug the earphone from J1—strong local stations should come in with fair volume. To operate the set as an AM tuner, wire R1 in place and connect J1 to the crystal-phono input of a preamplifier or integrated amplifier. The set should give excellent results with a quality hi-fi system.

-30-

PARTS LIST

- C1a/C1b—2-gang, 365- μ f. variable capacitor (Lafayette MS-142 or equivalent)
- C2—180- μ f. compression-type trimmer capacitor
- C3, C4—.005- μ f. fixed capacitor
- D1, D2—1N34A diode
- J1—Closed-circuit phone jack
- L1, L4—22 turns of No. 24 cotton-covered wire (see text)
- L2, L3—Ferrite antenna coil (Miller 6300 or equivalent)
- R1—47,000-ohm, 1/2-watt resistor (see text)
- T1—Replacement-type output transformer; 3000- to 10,000-ohm primary; 4-ohm secondary
- Spkr.—2 1/2" speaker, 4-ohm voice coil (Lafayette SK-65 or equivalent)
- Misc.—Hardware, wood, aluminum sheet, Fahnestock clips, etc.

HOW IT WORKS

The receiver employs a double-tuned circuit feeding a crystal-diode voltage-doubler/detector which drives a small speaker. In operation, r.f. signals picked up by the antenna system are induced into coil L2 from coil L1. The desired signal is selected by tuned circuit C1a-L2 and coupled through capacitor C2 to a second tuned circuit, C1b-L3, which improves the selectivity by narrowing the r.f. bandpass. The twice-tuned r.f. signal is then induced into coil L4 from coil L3.

The positive half of the r.f. signal appearing across L4 passes through diode D2 to charge capacitor C4; the negative half of the signal passes through diode D1 to charge capacitor C3. Polarities of the charges on C3 and C4 are such that the effective voltage is doubled. This voltage appears across the primary of output transformer T1, which changes the high impedance at the output of diodes D1 and D2 to the low impedance required by the speaker.

When high-impedance earphones are plugged into closed-circuit jack J1, the speaker is disconnected and the output from the diodes feeds directly into the earphones. Optional load resistor R1 is placed across the output of the diodes when the receiver is used with an amplifier.

Combination Radio-Intercom

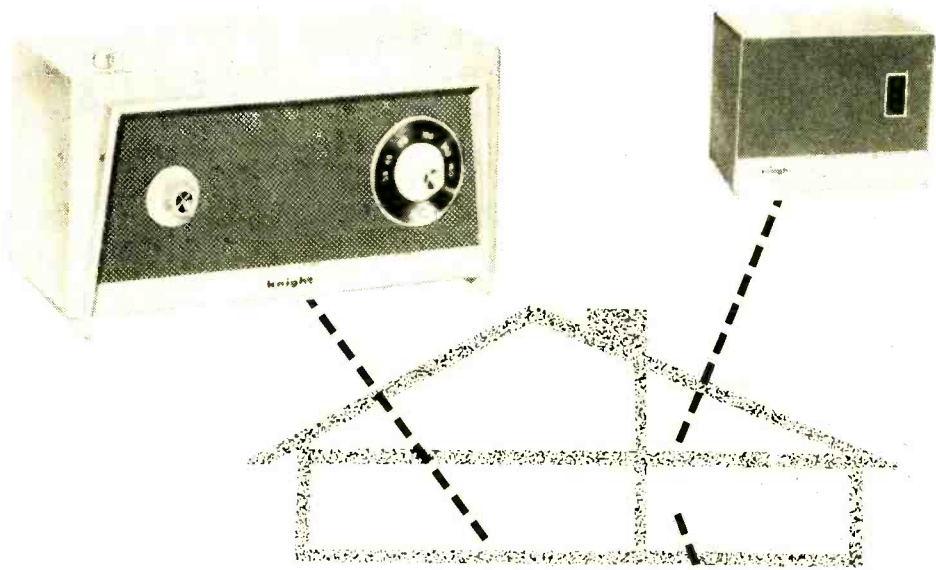

***Knight-Kit "Ranger" superhet doubles as an intercom,
accepts up to three remote stations***

THINKING about getting an intercom? Or maybe you're considering an extra radio for the kitchen. If so, hold off buying either until you've had a chance to investigate the Knight-Kit "Ranger" radio-intercom. This dual-function unit serves both as a standard broadcast-band radio (five-tube superhet design) and as an intercom.

Up to three remote stations can be connected in parallel with the "master" station, with remote stations located as much as 50' apart—in a bedroom and a basement workshop, for example, while the master station is in the kitchen. What's more, the remote stations can receive broadcasts, call the master station (automatically muting broadcasts as the call is made), and—in the case of two or more remotes—talk with each other as well as with the master station. The master and remote units are all housed in ivory-colored styrene cabinets with contrasting dark-brown speaker grilles.

Use of printed circuits and a detailed construction manual make construction easy—the only tools you'll need are a pair of long-nose pliers, some diagonal cutters, a screwdriver, and a soldering iron. The complete kit, including one remote station, is available from Allied Radio Corp., 100 N. Western Ave., Chicago 80, Ill., for \$27.50. Extra remote stations are \$3.95 each.

-30-

the how and why of

Solder

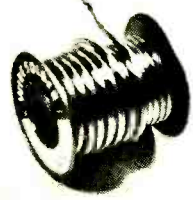

By **LOU GARNER**

ORIGINATING in the dim recesses of history, soldering is one of the oldest arts known to the metal worker. At the same time, however, this ages-old process is of prime importance to our modern world of electronic controls, long-range communications, and space exploration. Soldered electrical connections are used in all types of electrical and electronic equipment, from the simplest pocket receivers to the most complex computers. They are found in the electronics gear used in vessels which explore the bottom of the sea as well as in satellites probing the depths of space.

Solder is an alloy, that is, a homogenous mixture of two or more elemental metals. The most popular solder is a mixture of lead and tin in varying proportions. Other elements may be present, such as cadmium, zinc, bismuth or antimony, but generally in very low percentages and, as often as not, as undesired impurities. A few special-purpose solders are made in which a third or fourth metal is added to the basic tin-lead alloy, but these solders are seldom encountered in day-to-day work.

Pure lead has a melting point of approximately 621°F; tin's melting point is 450°F. But the two metals blended together result in an alloy with a melting point lower than that of either metal alone. The exact melting point of the alloy depends on the ratio of tin to lead; generally, the more tin, the lower the melting point. See Fig. 1.

The lowest temperature at which solder will melt—361°F—can be attained only when the alloy contains 63% tin and 37% lead. This combination is known as an "eutectic" alloy—from the Greek word meaning "easily melted." If the alloy con-

tains a higher percentage of either tin or lead, it passes through an intermediate semi-molten or *plastic* state as it is heated, becoming a liquid at a higher temperature.

When the solder is composed of more than 37% lead—such as 40/60 solder (40% tin, 60% lead)—the lead starts to crystallize out of the solution first as the heated liquid cools. Similarly, if the tin content is above 63%, the tin starts to crystallize first. In either case, the remaining liquid portion of the alloy approaches closer and closer to the 63/37 ratio until the temperature drops to 361°F, at which time the entire mass solidifies. This is the reason solder appears to solidify slowly when it first cools, and then seems to harden instantaneously at a certain point.

Bonding Action. When solder is applied to a metal for which it has an affinity—such as copper—the molten solder actually dissolves some of the surface metal. A new alloy is formed between the metal and the solder, producing a direct metallic chemical bond between the solder and the base metal. It is this characteristic of solder that makes it so valuable in electronic work, for such a bond has very low electrical resistance and is quite resistant to mechanical shocks, vibration, or stress. The strength of the

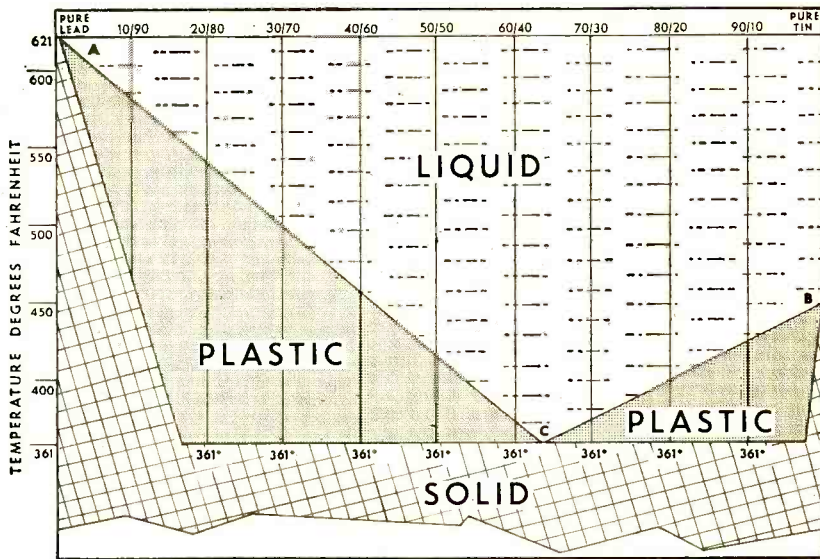

Fig. 1. Solder's melting point can be controlled by varying its tin/lead ratio, since a tin and lead alloy has a lower melting point than either pure lead or pure tin. The melting point shown by lines AC and BC reaches its lowest level with a 63/37 ratio between tin and lead. All non-eutectic alloys pass through a plastic state as they melt.

solder joint depends on the ratio of the solder's tin-lead content, with maximum strength occurring when the tin content is from about 40% to 65% (see Fig. 2).

If a soldered joint will be subjected to severe mechanical stress, it's a good idea to make a strong mechanical connection before you solder. For most purposes, however, this is not necessary. Most experimenters make the mechanical connection just tight enough to hold the wires together while soldering them, allowing the connection to be easily "unsoldered" if necessary.

In order for the all-important metallic bond to be formed, it is essential that the solder alloy contact the surface of the base metal. Dirt, grease, or paint will prevent such contact and result in an improperly soldered joint. For a good job, the metal surfaces to be soldered must be clean.

Another hindrance to good solder-to-base contact is caused by oxygen in the air. Thin oxide crusts which have high electrical resistances and poor heat conduction form on the metal's surface. This oxide film will keep the molten solder away from the base metal and must be removed before proper bonding can take place.

Use of Fluxes. Oxide films are commonly broken up with a corrosive chemical known as a flux. As far as general work is

concerned, soldering fluxes are of two basic types: the highly corrosive "acid" flux employed in heavy work and the familiar "rosin" flux used extensively in electrical and electronic soldering.

An acid flux leaves a residue on the joined surfaces. Since this residue has a strong affinity for water, it absorbs water from the air, liquefying and running over the soldered connection. Because it retains its corrosive properties, it can cause damage. In addition, because it is electrically conductive, it can cause shorts.

Rosin flux leaves a residue which is not corrosive and which has high electrical resistance—in fact, it's a pretty good insulator. *Only* rosin-type fluxes should be used to make electrical connections. This point can't be stressed too strongly—most manufacturers of electronic kits automatically void all guarantees if the assembler uses an acid flux for soldering.

Although flux is necessary, it is easy to apply too much or too little. If too little is applied, a poorly soldered connection will result. Too much flux may result in excessive spreading of the solder and an excessive residue. In order that the proper amount of flux may always be used, solders with self-contained fluxes have been developed. The flux is held within a hollow core in the solder wire. Some manufactur-

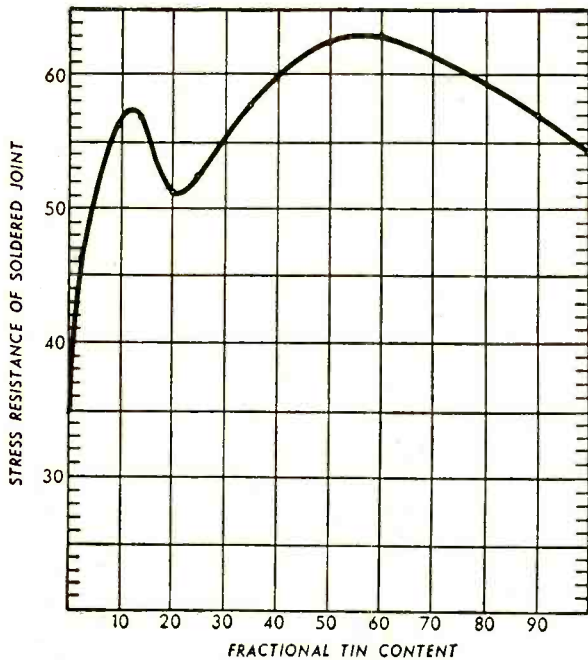

Fig. 2. Effect of increasing tin content on the strength of a solder joint. (Diagrams courtesy Kester Solder Co.)

ers use more than one flux core, with three or five cores being the most popular.

Commercially manufactured solder is available in a variety of types, depending on (1) the tin/lead ratio, (2) the diameter and/or shape of the solder, (3) the percentage of flux, if used, (4) the type of flux, and (5) whether it is single- or multi-cored. For radio and electronics work, the most popular kinds are the wire-type, rosin-cored solders, in 40/60, 50/50, or 60/40 alloys, with diameters of from $\frac{1}{16}$ to $\frac{1}{8}$ inches. The finer-wired solders are used for miniature equipment, such as hearing aids, pocket radios, and so on, while the larger-diameter solder is used for heavier operations such as power connections in transmitters, soldering to metal chassis, etc.

Soldering Tips. Once we know how solder works, it's easy to figure out the best technique to use in soldering—we just apply common sense. First, we know that the surface to be soldered must be clean of dirt or grease. We know, too, that a good mechanical connection must be made before soldering if the joint will be subjected to mechanical stress. And we know that a suitable flux (rosin-type for electronic work) must be used.

The function of the soldering iron is simply to heat the work to the melting point of the solder used. To do this job

effectively, the soldering iron tip must be clean, because dirt and corrosion act as heat insulators. Loose dirt and grease can be wiped off a hot soldering tip with a clean damp rag. Corrosion can be removed with the aid of a piece of steel wool or a file.

In addition to being clean, the soldering iron tip must be "tinned." This simply means that there should be a thin coating of molten solder on the tip surface. Tinning prevents an oxide film from forming on the
(Continued on page 112)

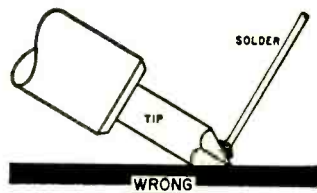
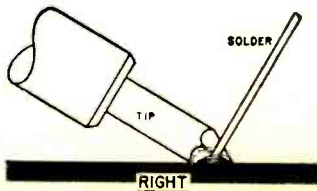

Fig. 3. Good soldering technique calls for the solder to be applied at the junction of the tip of the soldering iron and the joint to be soldered.



On the Citizens Band



By TOM KNEITEL, 2W1965

IN the March issue, we requested your help in compiling a list of the most-used "personal communications" channels in each of the Citizens Band call areas. The response was excellent, and the information in the table below is the result.

You will note that there are some channels and some call areas not represented

tions: Channel 9—National Calling Frequency and Marine Frequency (commercial); Channel 13—Marine Frequency (non-commercial); and Channel 15—National Transportation Services. The Channel 15 allocation is a new one and should come in handy—it is hoped that this will be the "motorists" channel, with motels, hotels, restaurants, service stations, and highway police monitoring it.

Business use of CB is making tremendous strides. We have even heard of several commercial outfits who have abandoned their regular complex FM equipment to take advantage of CB operation. A company can talk directly to its customers on CB, and easy licensing, low equipment cost, and relatively simple maintenance are other important considerations.

One CBusinessman who is putting the band to work for him is Felix Gutkowsky, 1W3536, of Uncasville, Conn.—his matchbook cover speaks for itself. We look forward to increasing use of this type of direct customer-dealer communications.

You can dress up your mobile installation with an inexpensive (and almost indestructible) 3½" x 8½" Lamicoid plastic call plaque. Large white call letters (yours) are deeply etched into either red or black backgrounds (your choice). Over the call, you can have 17 characters in smaller letters—a swell

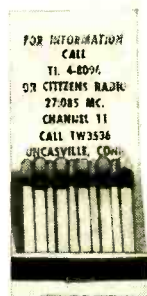

Channels	Call Areas
1	1, 17, 13, 18
2	1, 18, 24
4	8, 9, 10, 12, 13, 18
5	12, 18
7	1, 2, 7, 10, 12, 24
8	7, 9, 18
9	all
10	12
11	all
12	3, 19, 20, 24
15	10
16	7, 12, 24
17	4
20	1, 2, 6, 7, 11
21	12, 13
22	1, 4
23	4



in the table. We didn't forget about them—there just wasn't a significant concentration of stations in any area on some of the channels, and stations in other areas didn't seem to utilize any group of channels in preference to others.

Don't fail to take advantage of the three nation-wide unofficial CB channel alloca-

place for your club's name, your channels, etc. The plaques are \$2.95 each, and for 50 cents more you can have 17 characters etched *beneath* the call letters. If you order one—from J. F. Giglio, % E. M. Fay Co., 12 Witt St., Lynn, Mass.—specify whether you want it drilled with two or four mounting holes, or undrilled. —50—

How to get the most from your tapes

SOME of the biggest news in the audio world lately has been about magnetic tape. In addition to its many other attributes, tape has become a really economical medium, thanks to the new four-track tape system. Prerecorded four-track stereo tapes are now on dealers' shelves in healthy numbers and at reasonable prices. And since the four-track machines have doubled playing time, home recordists now have two extra tracks for mono or stereo recording.

With more FM stations taking to the airwaves all across the country, there's more music in the air than ever before—free for the taping. So if you own a tape recorder (or plan to buy one), this is a good time to explore the ways of getting the tops in quality, convenience, and enjoyment from your tapes. There are a few simple but important tricks for putting—and keeping—good sound on every reel.

Recording Techniques. Your skill in recording will not only determine how well your tapes sound when they are played back for the first time, but it will also influence the way they stand up in the future. The two big enemies of clean-sounding tapes—noise and print-through (the transfer of sound from one layer of tape to another)—usually are the result of improper recording technique. Their effects become more annoying with each playback.

One of the secrets of avoiding noise and print-through is in finding the right record-

It's easy to make good recordings— if you know how. Here is a guide to improving the quality of your tapes

By JOHN MILDER

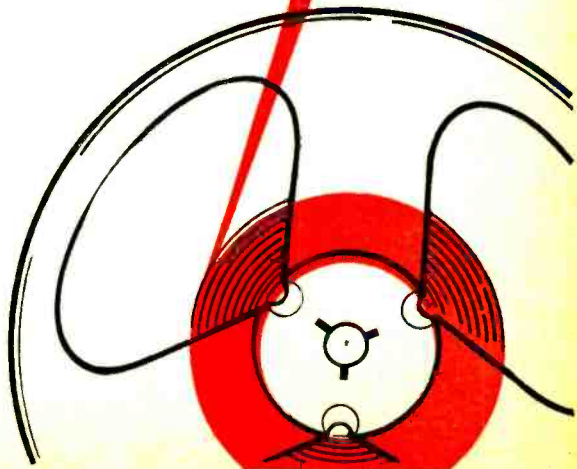

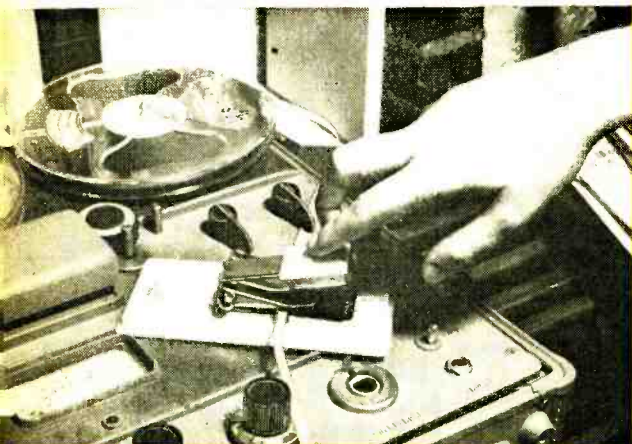

Probably the most useful accessory for your tape recorder is a tape splicer. The one above, "Gibson Girl Standard," is marketed by Robins Industries.



Bulk erasers are handy, too. They are simple to use and they contribute to better tapes. This is the Audiotex "Taperaser."



Partially magnetized recording heads can cause noisy tapes. A head demagnetizer, such as the Audio Devices unit at right, will remedy this condition.

ing level. If you set your recording level too low, you'll get too much noise in playback. Too high a recording level, on the other hand, will put more sound on your tapes than they can handle, making them leak sound from one layer to the next, thus causing print-through.

Your main guide for the right recording volume is your recorder's level indicator. If you're a really critical listener, a VU meter is the only kind of level indicator you'll be happy with. Magic-eye and neon indicators can give you a fair indication of the volume level that's going on the tape, but they aren't as accurate as a VU meter. If your recorder doesn't have a VU meter, you might consider having a service technician install one for you.

No matter what type of level indicator your recorder has, always make a "dry run" before you actually start to record. Set your recording level before you start taping, and then stick to it. Even a slight increase in noise level caused by too low

a recording level is usually easier on your ears than the sudden jumps and drops in volume that result from constantly readjusting the level control.

Choosing a Tape. You can find tapes of different thickness, base material, and reel size to suit just about any purpose you can dream up, and it will pay you to match the tape to the job. Let's look for a moment at the different playing times now available on various types of tape.

If you have a four-track recorder, a standard 7" reel of 1½-mil tape recorded at 7½ ips will give you two solid hours of monophonic listening. "Long-play" tape on the same reel size will play over three hours, and ½-mil "double-play" tape still another hour. A whole evening's worth of sound can thus be put on a single tape. And when you record at 3¾ ips, all of these times are doubled—a standard reel of tape can give you over four hours of listening for about a three-dollar investment.

Since you can get such a tremendous



Tape head life can be extended by bypassing the heads during rewind and by lubricating the tape occasionally with a suitable lubricating cloth.

Removing the accumulation of oxide on tape heads is easy with a commercial tape-head cleaner. Alternatively, an alcohol-soaked "Q-Tip" will do the job.



Speedwinders cut rewinding time. This one, the Heath SW-1, handles 10½" reels and rewinds 1200' of tape in 40 seconds.



amount of sound on a 7" reel, the smaller 3" and 5" reels will frequently be more convenient to use. The shorter reels make it easier to locate a particular program that you've put on tape. If you match the length of the material you want to record to the appropriate reel size, you'll find that it pays off both in convenience and in less wasted tape per reel.

Incidentally, you may be interested in a booklet that lists the playing times for most classical music. Entitled "Time Table for the Classical Repertoire," it's available from William Colbert, 153-21 Hillside Ave., Jamaica 32, N. Y., for \$2.75. It's not fancy, but it does have the necessary information.

Unless you want to record a real marathon program, you'll usually get best results by sticking to standard 1½-mil or 1-mil tape. While the frequency response and other characteristics of double-play (½-mil) tape are up to par, print-through is harder to avoid, and the tape requires

fairly gentle handling by your recorder to avoid being stretched.

For those "immortal" recordings that you'd like to hand down to your grandchildren, pick a Mylar-based tape. Mylar stands up better than acetate backing against the effects of temperature variations and humidity in your home, and under most circumstances it will last indefinitely. A bit later, though, we'll see how you can help your acetate-based tapes give Mylar a run for its money.

Accessories. For continuing top quality from your tapes, it's a good idea to start collecting some inexpensive but important accessories for your recorder. At the top of the list is a tape splicer. A good splicer will allow you to take care of tape breaks in a jiffy without leaving any audible trace of your mending job. It will also make it easy for you to reclaim lengths of unused tape ends by splicing them together.

If you notice that your tapes seem to be getting noisier, it's probably because your

tape heads have become magnetized. During the recording process, a loud bass transient (like the wallop of a bass drum) can cause magnetization, and the cumulative effects of switching the recorder from record to play can bring it on, too. The cure, properly enough, is a head demagnetizer. It's a neat little gadget that looks like a cross between a signal probe and a soldering iron, and it does its job in a few seconds. Like the VU meter, it will pay back its cost in listening pleasure.

Next in line is a bulk eraser. This device is useful because the erase circuits on most recorders just can't wipe away all the sound on your tapes. They leave behind a slight sonic residue roughly equal to a mild case of print-through, raising the noise level on subsequent recordings. Some tape users also claim that this sound residue causes the material which is recorded over it to sound slightly distorted. A bulk eraser will clear off your tapes quickly and more efficiently than will the erase circuit in your recorder. All you do is plug it in, put the reel of tape on it, and it brings the noise level down at least to that of virgin tape. Be careful, though, to keep the eraser a safe distance away from tapes you want to save.

Always a serious and potentially expensive problem is tape head wear. Friction from tape moving over the heads, particularly during rewind and fast forward, can wear open the micro-sized gaps in recording and playback heads. As the gaps widen, the heads lose their high-frequency response and the sparkle begins to disappear from your tapes. The only cure is replacement of the heads—a costly proposition.

One way to get the most mileage from your tape heads is to keep the tape away from the heads during rewind and fast forward. On most machines it's possible to re-route the tape so it doesn't contact the heads, and this should be done if it is practical. Another way to save wear on the heads is to get a tapewinder. This is a device that rewinds tapes independently of the recorder. Heath has one in kit form (Model SW-1).

Since a tapewinder is a bit more expensive than most accessories, you'll have to weigh its value for your particular needs. If there's no other way to keep your tapes away from your recorder's heads during rewind, a tapewinder is a good investment.

Like your automobile, your tapes will

profit from a periodic lubrication job. You can do your tapes and your tape heads a big favor by buying a special cloth which lubricates them with silicone. It's easy to give your tapes a silicone treatment during rewind, and if you do it only once a year, your acetate-based tapes won't get brittle with age. You'll also cut down on the friction against the heads and, in addition, you'll get rid of the loose oxide particles on the tape that might otherwise clog up the head gaps. There are several silicone cloths now on the market, but make sure that the one you buy is designed specifically for tapes rather than records. Occasional lubrication will help your acetate tapes take on some of the long-wearing properties of Mylar.

There is a raft of other accessories worth investigating. Audio Devices makes a unit called an "Echoraser" which can decrease print-through up to 10 db. If you're a do-it-yourself'er, you'll be interested in the special tapes for checking frequency response and head alignment. Even if you don't know a capstan from a take-up reel, you should clean the heads on your recorder every month or so; this is an easy job, and there are a number of products designed for it—ranging from special cleaning tapes and liquids to ordinary alcohol and Q-tips available from your local drug store. Complete kits for keeping your tapes and recorder in top shape are now being supplied by some manufacturers—notably Audiotex and Robins.

Tape Storage. With the proper care and the proper storage, you can extend the life and fidelity of your tapes almost indefinitely. If it's feasible, you should keep your tapes in the coolest and least humid spot in your house. You can't quite match the storage facilities of the big recording companies—they keep their master tapes in metal cans in rooms that look like bomb shelters—but you'll be rewarded for any pains you take by longer tape life and less print-through.

Compared to records—which often take beatings from dust, rough handling, and uncompliant cartridges—your tapes have a pretty easy life. They can't be scratched or ruined by a worn stylus. To continue to enjoy the quality and fidelity that are the trademarks of tape, all you have to do is try out the tricks and accessories outlined here. It'll be more than worth the little effort it will require.

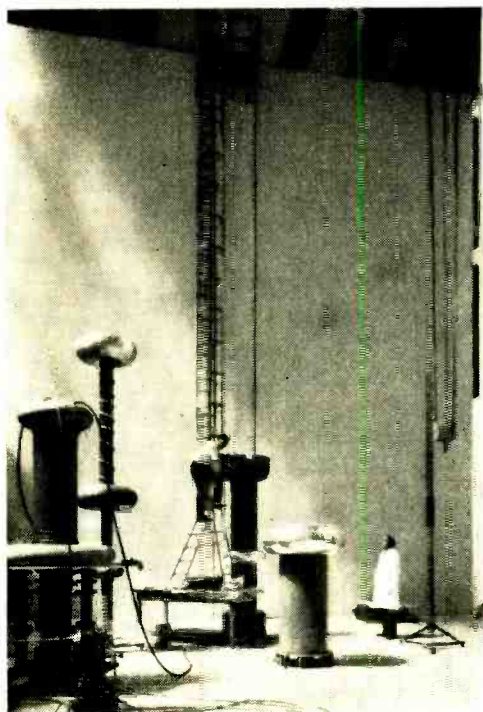

FRENCH NUCLEAR RESEARCH LABORATORY

SOMETHING from an old Frankenstein movie? Not at all. It's a French particle accelerator being constructed in Grenoble, France. It will be used to investigate the chemical behavior of substances under radiation. (*French Embassy photo*)



MINIATURE TRANSMITTER PINPOINTS GROUSE

MINIATURE radio transmitters attached to six wild grouse at University of Minnesota's Forest Research Center provide scientists with information on feeding, roosting, and mating habits of these birds. The transmitters were designed by Minneapolis-Honeywell. Hood over bird's head is temporary.



HOME-BUILT ATOM SMASHER

YOUNG Joseph B. Tate, a student at the Normandy Senior High School in St. Louis, Mo., designed and built this 1,000,000-volt cyclotron. Working under the supervision of his physics teacher, Louis Deall (at right in photo), Joseph labored for three years on the project. The cyclotron weighs 10,000 pounds and is valued at \$20,000. (*UPI photo*)

WOULD you like to have an 8- to 12-tube short-wave receiver for five or ten dollars—or perhaps even free? This may sound fantastic but it is not impossible. In attics, barns, and radio-TV repair shop basements across the nation, such receivers are gathering dust, just waiting to hit the megacycle trail again.

These radios, manufactured in the thirties and early forties when short-wave listening was the rage, are some of the most solidly designed receivers ever produced for the SWL'er. They were sold under the pre-war sales pitch, "the world at your fingertips." And they can still put the world at your fingertips. All you need is a little know-how in picking up a bargain.

Where and What to Buy. Obtaining one of these sets is no problem. There may even be one in your own attic or basement. If not, many of them are piled up in the rear of radio repair shops. Look for dealers who have been in business for ten or more years, since these sets would have been traded in about 1947-51. Try several dealers, explain that you are an experimenter, and ask to look at their old "junk" sets. Most dealers are glad to get rid of these old sets because they take up valuable storage space.

Try to get a name-brand set, such as Philco, RCA, Westinghouse, General Electric, Crosley, etc. These sets are usually consoles (floor models) or large table models. Look for a big circular or slide-rule dial and a variety of controls.

Pay particular attention to the receiver's frequency ranges. Some of the old two-band models have, in addition to the broadcast band, a 7-to-18 mc. band. Others are three-banders with a 1.7-to-8 mc. band and an 8- to 18- or 22-mc. range in addition to the BC band. If you're lucky, you may even discover a four-band model with an additional range of 200 to 400 kc.—the low frequency marine and aircraft wavelengths.

Now look in the back of the set. Don't be concerned if you see an inch of dust. It can be cleaned off. Check the number of tubes and look for a three-gang variable capacitor; the third gang is an r.f. stage and indicates quality design.

Rebuild the Relics for SWL'ing

*... and put those vintage
short-wave sets back
on the megacycle trail*

When you find a receiver that looks good to you, buy it—if the price is right. As a rule, you shouldn't pay more than fifteen or twenty dollars for one of these sets. The author recently bought five of them and didn't have to go above ten dollars—one was only fifty cents! The smaller the investment, the less you need be concerned about a bad buy. Even if you get a lemon, you can "cannibalize" it for its speaker, power transformer, and other parts. But there is obviously no point in wasting any time on a set whose components are clearly damaged.

Cleaning it Up. Once you have brought your "find" home, the best thing to do is to give it a thorough cleaning with a vacuum cleaner and a small dry paint brush. You will be pleasantly surprised at the

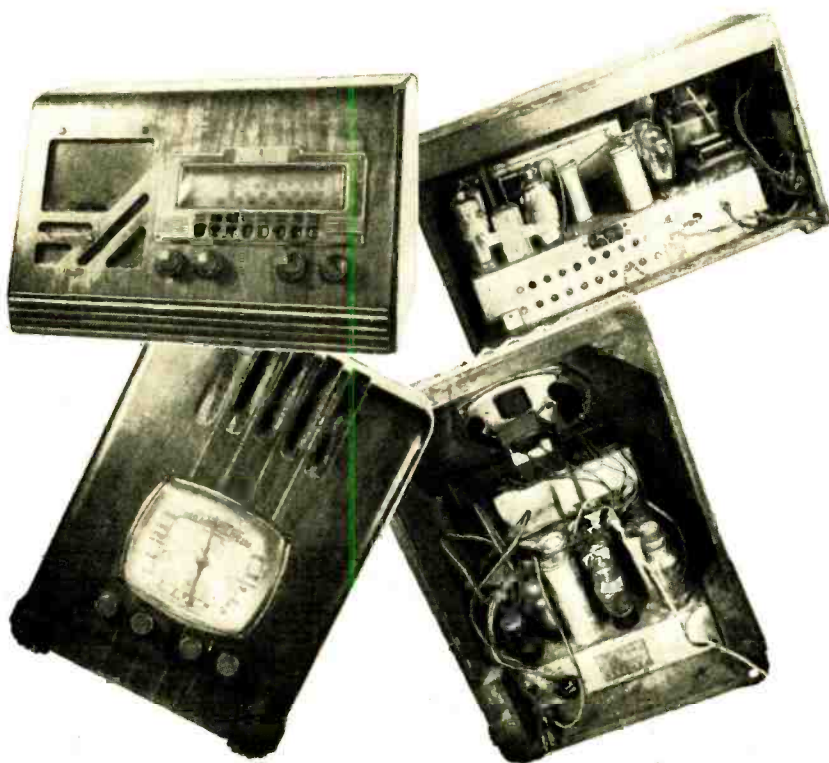

By A. A. WICKS

difference this makes. Before cleaning it, however, remove the chassis from the cabinet and, if possible, unplug the speaker and set it aside. Remove the tubes, also, first making a chart of their correct positions if a tube-placement guide is not already glued to the inside or bottom of the cabinet.

After the chassis and speaker are cleaned, don't be too anxious to turn on the power. Rather, look the chassis over carefully for burned insulation, charred resistors, or poor solder joints. Note down what you find. Don't poke or probe around the wires since the insulation is likely to be brittle; it is desirable to replace such wiring piece-by-piece as required.

Getting the Schematic. If possible, get a circuit diagram of the unit. The correct model and chassis number will either be

stamped on the chassis or marked on the inside of the cabinet. Often the dealer who sold you the set can lend you a schematic and you can have a photostat made of it. Or you may be able to find the schematic in one of the Rider or Sams manuals.

Supreme Publications, Highland Park, Ill., puts out several volumes of circuit schematics for these old sets; a complete index of these published circuits is available for 25 cents. And if all else fails, a courteous letter to the manufacturer of the radio will sometimes be successful.

Tests with Power Off. Test the tubes and replace any that are defective or missing. Some of the older tube types may be difficult to obtain, but there are a number of possible substitutions. Here are some of the typical tubes found in these sets, and

their present-day equivalents: for the 6A7, you can substitute a 6SA7 or a 6SB7Y; for the 6Q7 or 75, a 6SQ7; for the 41, a 6K6; for the 42, a 6F6; and for the 80, a 5Y3. If you don't want to replace the tube socket, you can use a plug-in adapter.

Next, a couple of ohmmeter checks are in order. Check for continuity across the set's a.c. plug, first with on-off switch open, then closed. With the switch "off," no continuity should exist; when it is "on," a low-resistance reading should be obtained which indicates a good power transformer primary. Make another continuity check between each prong of the a.c. plug and the chassis to test for a shorted line capacitor, if one is used.

If everything is satisfactory, remove all tubes and check for a low resistance across the two plate pins on the rectifier socket. One-half the resistance from each rectifier plate to ground or to the transformer center tap indicates a good high-voltage winding on the transformer. Then test for a low resistance across the filament pins of the rectifier socket and across the filament of any other tube socket; this checks out the power transformer filament windings.

Now test all of the electrolytic filter capacitors and replace any that read less than one-half megohm after a few seconds on the ohmmeter. As a matter of fact, it's a good idea to replace all the capacitors in the set since they are likely to be leaky. Replace can-type electrolytics with tubular units and use the vacant chassis space for the beat-frequency oscillator to be described later.

Replace paper capacitors with the new plastic or ceramic units. The small cost of



this replacement pays off in better operation and less trouble from intermittents. In addition, many hard-to-locate faults will be eliminated.

Older sets use the speaker field coil for a power supply filter choke. If the field coil is open, replace it with a filter choke of the same d.c. resistance and use a permanent-magnet speaker in place of the original unit.

Powering the Set. Plug in all the tubes and turn on the power. Look for sparks inside the rectifier tube or for evidences of overheating. The receiver should show some signs of life at this point.

If the receiver works, but is not sensitive, try a good antenna, preferably an outside one. (These sets are extremely well shielded and rely on a good antenna for good reception.) Also, the receiver could be badly misaligned; a careful alignment may be in order. During alignment, make certain that you use the correct intermediate frequency—these receivers use various intermediate frequencies, such as 465, 455, 265 and 175 kc.

If the set does not work, or works poorly, voltage or resistance checks and signal-tracing are in order. The B+ voltage at the output of the power supply should be within the limits specified in the service brochure or schematic—about 300 volts d.c.

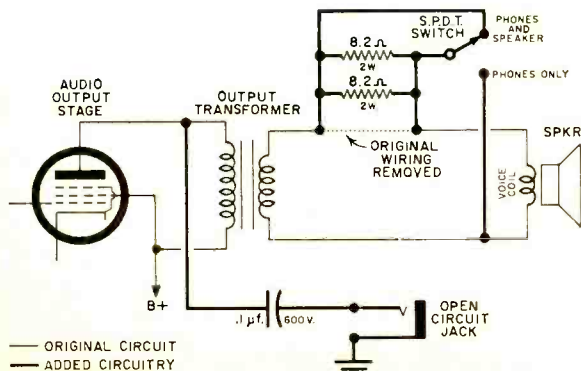
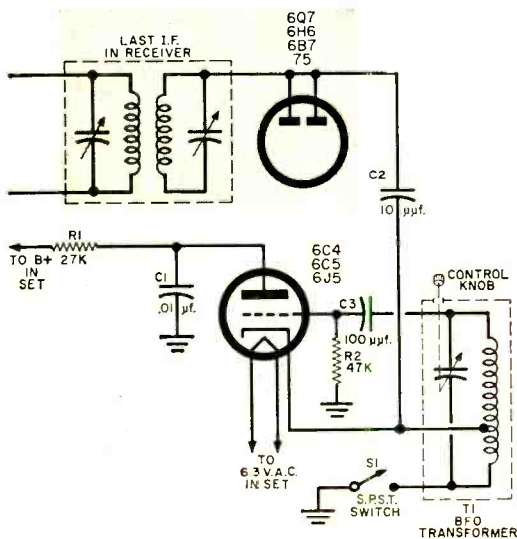

Fig. 1. Adding an output jack to a receiver will enable you to use it with high-impedance headphones or a tape recorder.

Fig. 2. A BFO circuit can be added for code reception and to help locate stations. Capacitor C2 connects to plates of diode detector.



BFO PARTS LIST

- C1— $.01\text{-}\mu\text{f.}$, 600-volt paper capacitor
- C2— $10\text{-}\mu\text{f.}$ mica capacitor
- C3— $100\text{-}\mu\text{f.}$ mica capacitor
- R1—27,000-ohm, $\frac{1}{2}$ -watt resistor
- R2—47,000-ohm, $\frac{1}{2}$ -watt resistor
- S1—S.p.s.t. toggle or slide switch
- T1—290-650 kc. BFO transformer (Meissner 17-6074, Allied Radio 60H230, or equivalent)

for the average set. If the voltage is abnormally low, make voltage checks at the plate and screen of each tube. Any tube with a very low plate or screen voltage probably is draining excessive current and all components in the stage should be tested.

Tape or Phone Jack. Once the receiver is operating well, you can add an output jack to it for headphone operation or for feeding a tape recorder. With the circuit shown in Fig. 1, you have the option of either simultaneous headphone-speaker operation or headphone operation alone. The open-circuit phone jack and the s.p.d.t. tog-

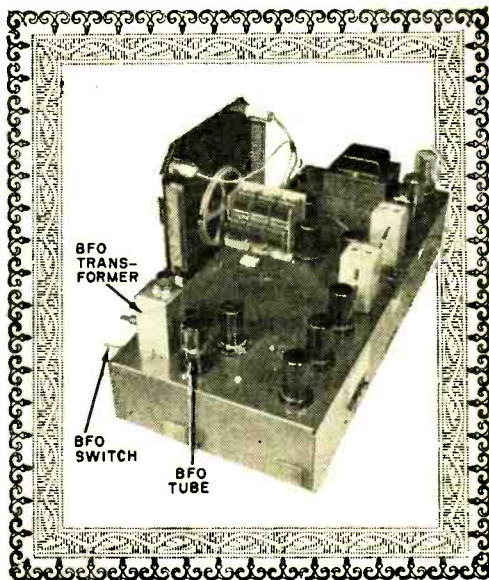

gle or slide switch can be mounted at any convenient place on the chassis.

Be sure to use a 600-volt capacitor for the $.1\text{-}\mu\text{f.}$ unit shown; lower-voltage units are not safe. The two 8.2-ohm, 2-watt resistors may get slightly warm on the "phones only" position of the s.p.d.t. switch. Use higher-wattage units for push-pull output stages and connect the capacitor to the plate of either output tube.

Adding a BFO. For code reception, a single-tube beat-frequency oscillator (BFO) can be added to the set. (See Fig. 2.) Current drain for the BFO is so low that all necessary power can be taken from the set. A single triode such as a 6J5, 6C5, or 6C4 can be used—mount it in a vacant space on the chassis.

Locate the BFO transformer ($T1$) on the chassis in a place where its tuning knob will be available for adjustment. Adjust the BFO transformer to the frequency that corresponds with the i.f. frequency of your receiver. Connect capacitor $C2$ to the "top" of the secondary on the last i.f. transformer which is usually connected to a diode detector, such as the 6B7, 6H6, 6Q7, or 75. To operate the BFO, switch on $S1$ and adjust $T1$'s control until a whistle is heard on every station received. Leave the control where the pitch of the whistle suits you. Now even the weakest station will show up as a "peep" when you're scanning the band.

the

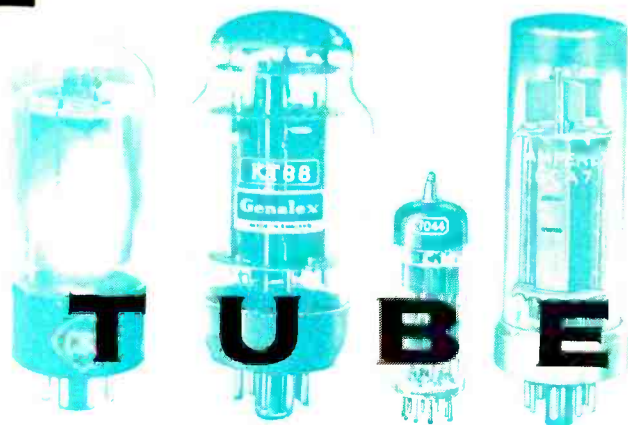

TUBE TESTER

*Here's the inside story on the devices
designed to gauge the vacuum tube's basic health*

PART 1 — Checking for Shorts and for Noise

By G. H. HARRISON

THE vacuum tube—delicate heart of most electronic equipment—is understandably subject to many ills. Its elements can become shorted together, disconnected from their pins, or loose on their mountings. Its filament or heater can burn out, just like a light bulb. Its cathode, intended to supply a steady stream of electrons to be shaped and molded by the tube's other elements, can partially “dry up” and refuse to part with enough electrons. Or its grid or some other element can begin acting like a cathode and start spurting out an electron stream of its own.

Then, too, the tube itself can become gassy or noisy. Or it can just get “tired out”—no specific trouble may show up, but the tube simply doesn't have the “oomph” to do its job properly any longer.

Some of these troubles can be tracked down without a tube tester. A simple filament continuity tester, such as the EICO

Model 612 shown in Fig. 1, will quickly reveal open filaments. Alternatively, an open filament or inter-element short circuit can be located with an ohmmeter. Tubes suspected of other troubles can be yanked out and replaced with new ones to see if this makes any difference—if, that is, you happen to have a spare of the right type on hand or don't mind buying one.

But these methods have their shortcomings. A continuity tester or ohmmeter provides only the crudest type of test. And the replacement method is subject to error because other circuit elements, in addition to a defective tube, might be faulty. Thus, plugging in a new tube in such cases might make no difference, and the troubleshooter might conclude that the original tube was okay.

For these reasons, service technicians and electronic experimenters look to their tube testers for quick, accurate information

about the condition of the tubes they use. Tube testers are equipped to probe every aspect of a tube's "state of health." Most testers, in addition to giving some general indication of tube quality, also check for shorts, loose elements, and other possible sources of trouble.

Types of Testers. Tube testers are divided into two general types, depending on the method used to test overall quality. Some, called emission testers, have the plate and all grids tied together. A positive voltage is applied to the plate and grids, and the current in the cathode circuit is measured. In other words, such testers show just how many electrons the cathode is capable of emitting under given conditions of plate voltage.

But since the primary purpose of a tube is to *amplify* (except for diodes and other special-purpose tubes which are always given simple emission tests), the most accurate and revealing test is to see how efficiently a tube operates as an amplifier. This is called mutual-conductance testing. Mutual conductance is simply a measure of the effect small variations in grid voltage have on plate current. To put it another way, mutual-conductance testers measure how well amplifier tubes work under actual operating conditions. Since they are more complex than emission testers, they naturally cost more.

Let's run through the normal tube-testing procedure to see what you should and should *not* do when using a tube tester. We'll digress from time to time in order to examine some tube-tester circuitry in detail.

Testing for Shorts. First, turn on the instrument and adjust the line-voltage cali-

Fig. 1. A continuity checker, such as the EICO Model 612, is among the simplest types of tube testers. Helpful in tracking down tube troubles, it has a pilot lamp which will light if tube filaments or heaters are okay.

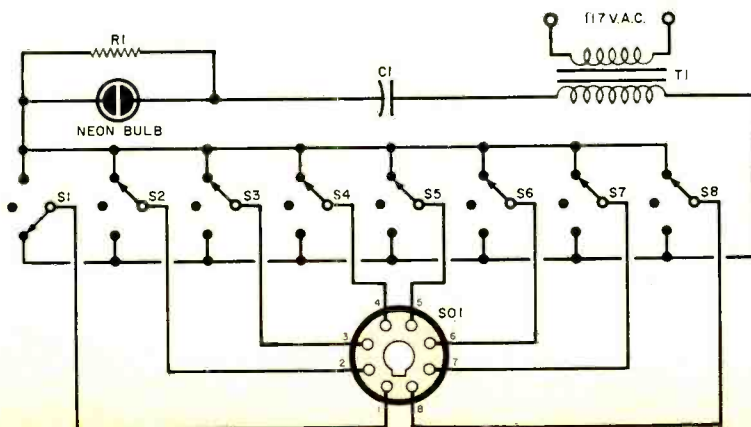
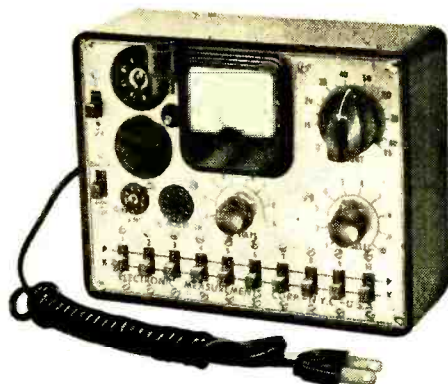
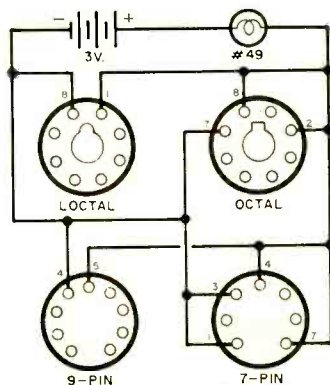

Fig. 2. Inter-element shorts can be quickly and easily located with tube testers such as the EMC Model 211. For simplicity, this diagram of a portion of the 211's circuitry shows only one of the unit's tube sockets.



side of the same circuit. If a short exists between the isolated element and any other tube element, the circuit is completed and the bulb flashes on.

In testing for shorts with the EMC 211, as with most other testers, disregard momentary flashes of the neon bulb when you throw one of the switches. These flashes are caused by the discharge of inter-electrode and stray circuit capacitances. It's also a good idea to tap the tube under test gently with your finger throughout the

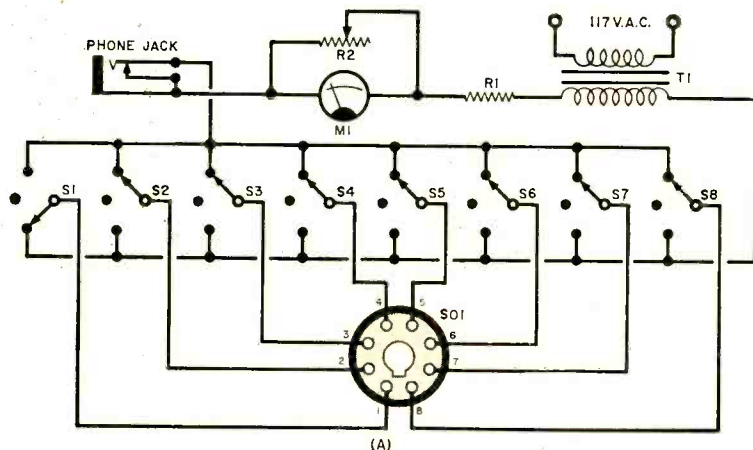
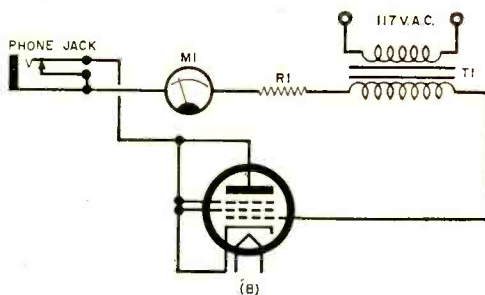

Fig. 3. Simplified schematic (A) of noise-testing circuit in Superior Model TW-11 tube tester (see photo above left). Further simplification of this circuit (B) shows the tube under test for grid noise; the remaining elements are connected in parallel.

bration control. Most testers provide this adjustment—it simply insures consistent indications by cancelling out normal line-voltage variations. Next, locate the tube type to be checked on the tester's tube chart, and set all of the dials and levers as specified for that particular tube. Make sure that they are all accurately set, and that you haven't confused two tubes on the chart with similar designations—a 6J5 for a 6J6, for instance. Now plug in the tube. Wait about 30 seconds for the tube to warm up, then test for shorts according to directions in the tester's instruction manual.

Figure 2 shows how the EMC Model 211 tube tester checks for shorts. Each element in the tube under test is connected to the center arm of a s.p.d.t. switch as shown in this simplified diagram. Next, each switch is thrown to the test position, one at a time, then returned to "normal." When one switch is in the test position and the others "normal," all elements except the one being tested are hooked to one side of a circuit containing a power source and a neon bulb. The isolated element is hooked to the other



test; this will reveal any loose elements which might short out under vibration.

While testing for shorts, make sure that the indicator bulb does not glow even faintly, except for flashes when you throw the switches. A very weak glow, if continuous, can indicate a high-resistance leakage path, even though no direct short exists. Most tube testers are not equipped to make sensitive leakage tests—such tests were not usually necessary until FM and TV came along. Some AM radios and amplifiers operate unimpaired with a leaky tube, but sensitive FM and TV circuits gen-

(Continued on page 113)

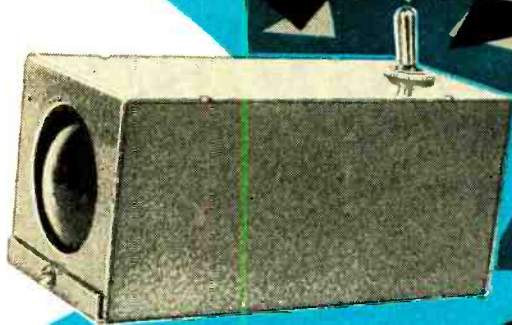

Low-Cost

BLACK LIGHT

ULTRAVIOLET or "black light" is used extensively in criminal investigation work, prospecting, and chemical analysis. Under the pale-purple light of the ultraviolet lamp, many minerals, dyes, greases, and even familiar household substances glow in weird colors.

This characteristic glow—known as fluorescence—is the secret of many commercial products. It is found in the familiar fluorescent lamp; in dyes and inks which seems to "glow" in sunlight; and even in a popular laundry detergent—a fluorescent additive makes clothes appear whiter and brighter than normal in sunlight.

You can assemble your own low-power "black light" source from readily available components at a total cost of less than five dollars. Unless you're a slowpoke, you should be able to complete the job in less than two hours.

Construction and Testing. The circuit is extremely simple and requires only wiring a switch in series with an argon lamp. The lamp is mounted in a light-proof box to protect the eyes from direct exposure to it. Since the ultraviolet output of the

By LOUIS E. GARNER, JR.

*This simple "black light" source
can be built in a couple of hours,
and it promises loads of fun*

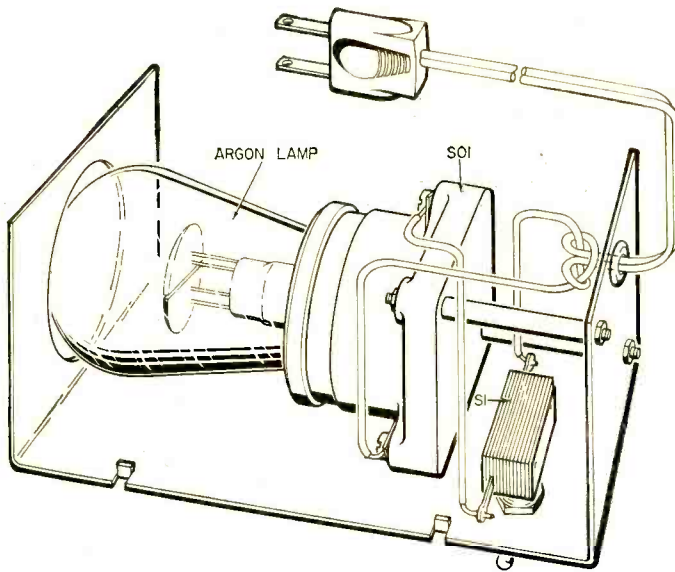

PARTS LIST

- SI—S.p.s.t toggle switch
- SO1—Edison-base lamp socket (Allied Radio 52E850)
- 1—Type AR-1 two-watt argon lamp (Allied Radio 52E810)
- 1—5" x 2 1/4" x 2 1/4" aluminum box (Bud CU-2104A or equivalent)
- Misc.—Hardware, line cord and plug, etc.

Space lamp socket from box with two bushings. Bulb must be inserted before socket is mounted.



lamp is harmful to the retina, the lighted bulb should not be viewed directly unless you wear glasses. Even then, it's best not to expose your eyes to the lighted argon lamp unnecessarily.

After you complete the wiring, plug the unit into a wall outlet (either a.c. or d.c.) and close the on-off switch. The half-moon electrodes of the argon bulb should glow with a faint purplish light. (If you obtain an orange glow, someone has slipped you a neon bulb in error; there is a neon-filled bulb which is externally and internally identical to the argon bulb, and the two

types of bulbs are sometimes mixed in the stockroom.)

For best results, carry out your experiments in a darkened room. Use the completed instrument to examine minerals, powders, detergents, oils, greases, and other common substances. Often, you'll find a substance that is one color under normal room light will glow an entirely different color when viewed under "black light."

Visible and Invisible. The argon lamp gives off energy in both the visible and the invisible (ultraviolet) region of the spectrum. The visible light is a deep purple color. The invisible output from the lamp is spread over a number of wavelengths in the ultraviolet region but is concentrated mainly in the long-wave portion (see the spectrum diagram below). Although ultraviolet rays are invisible to the eye, a visible light is produced when they strike some substances. This phenomenon is called "fluorescence."

-30-

Chart shows the relative position of ultraviolet radiation in the electromagnetic spectrum.

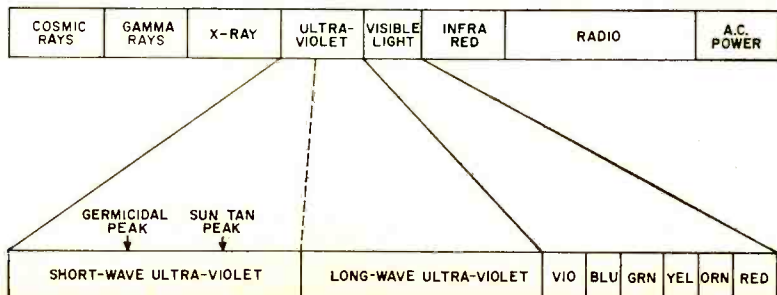



IN the last few years, audiophiles have come to expect something special from the Sherwood company. Sherwood originally broke into the hi-fi market with a medium-priced FM tuner that compared favorably with some of the most expensive units then available. This success was followed by several mono tuners and amplifiers and—with the coming of stereo—by stereophonic tuners and amplifiers. One of the latest additions to the line is the Model S-5000 dual 20-watt integrated amplifier, which more than lives up to the high standards set by its predecessors.

Priced at \$189.50, the S-5000 is obviously not an inexpensive amplifier but, in the long run, it might be a better buy than many a "bargain-priced" unit. It is well designed and constructed, and seems to have facilities to take care of all future program sources. These qualities suggest that here is an amplifier that will give years of satisfactory service.

Thoughtful Design. When you first take the S-5000 out of its packing case, you immediately get the impression that it is *quality* merchandise. The front panel is beautifully finished in white and gold, the controls and switches operate smoothly, and the weight of the unit (just under 30 pounds) is a good indication that there has

Dual 20-Watt Stereo Amplifier

Sherwood S-5000 offers high-quality performance

been no skimping on the quality of the output transformers.

Although the basic circuits of the S-5000 follow somewhat conventional design precepts—the output circuit has a pair of fixed-bias 7189's operating into a distributed-load output transformer—it's the little things about the S-5000 that will be most appreciated. The tape-head inputs, for instance, can be converted for use with a second magnetic phono pickup (RIAA equalization) simply by snipping two wires and making a couple of easy connections. Another nice touch is a special circuit which

Rear view of the S-5000 with cover of preamplifier section removed. Transformers are good-sized units, accounting for most of the S-5000's total weight of almost 30 pounds.

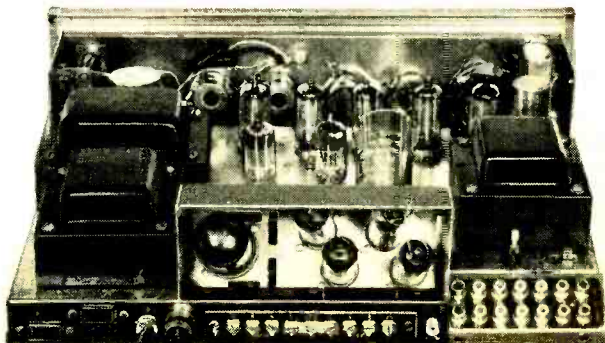

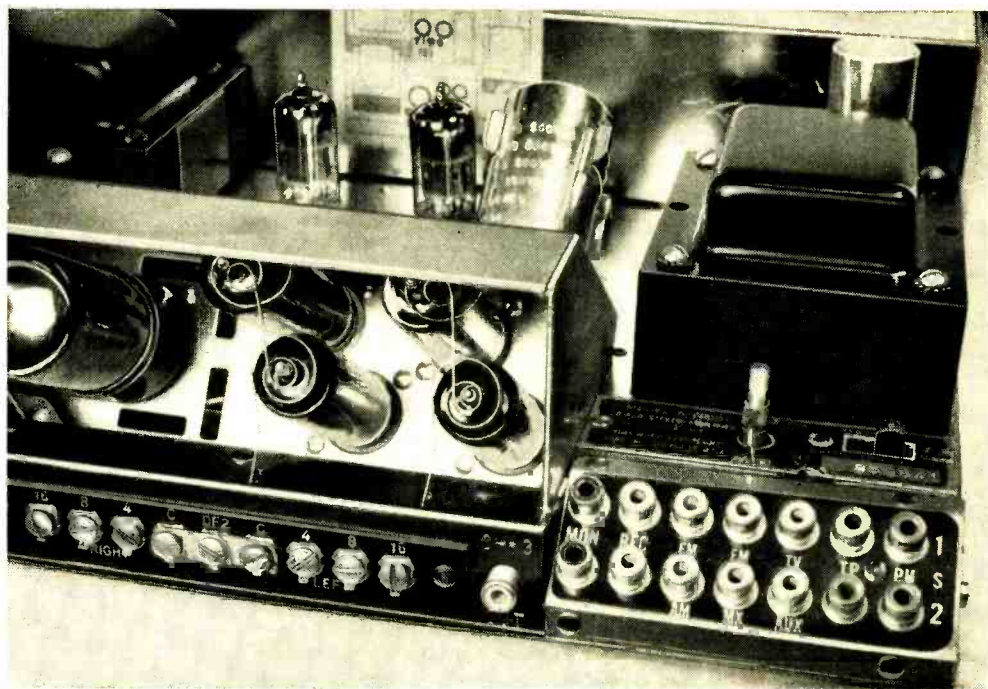

Close-up of the S-5000's input and output facilities. Control shafts over the dual row of inputs allow the user to adjust each channel's output-tube balance by ear.

makes it possible to adjust the balance of the output tubes by ear. (Each channel is adjusted separately).

As evidence that the Sherwood engineers stay abreast of developments in circuit components, "packaged" circuits are used in the bass-control section and in the rumble and scratch filter circuits. The rumble and scratch filters, by the way, have very sharp cutoffs and hinge at 100 and 5000 cps respectively.

Additional Features. Other refinements include a phase-reversal switch for one channel, a presence-rise circuit which provides a 6-db boost at 2600 cps, and a third-channel output for feeding an additional amplifier-speaker combination.

The volume control functions as a loudness control when the loudness-compensation network is switched in. This network provides bass and treble boost to compensate for the ear's deficiencies at low listening levels. The S-5000 has one of the better-sounding loudness circuits: the sound doesn't take on the muddy quality that characterizes many loudness controls.

Laboratory tests prove that the S-5000 is a good performer as well as a "good looker."

The measurements so nearly correspond with those claimed by the manufacturer that any differences are inconsequential.

Summing up, the S-5000 is a well-engineered amplifier that should have a long and useful life. Complete information about the unit is available from *Sherwood Electronics Laboratories, Inc.*, 4300 North California Ave., Chicago 18, Ill. —30—

POPULAR ELECTRONICS TEST REPORT

Power Output (per channel): 20.8 watts (r.m.s.) with no clipping

Frequency Response: 20-30,000 cps \pm 1 db
IM Distortion: 1.78% at 10 watts (60c: 7030c/4:1)

Tone Control Position for Flat Response: Treble, -7 db; Bass, +2 db (calibrated on front panel)

Square-Wave Response:



50 C.P.S.

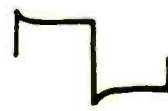

1000 C.P.S.

POPULAR ELECTRONICS



Across the Ham Bands

By
HERB S. BRIER
W9EGQ

THE HAM STATION LOG

WHAT would you do if you received a notice from the Canadian Government stating that your c.w. signals had clobbered one of their vital aircraft channels? Could you prove your innocence? Ray Smith, K9DWI, faced this problem recently when he received such a report via the FCC.

Ray immediately thumbed through his ham shack log. His entries showed that he was on the air at the time of the interference, but that he was participating in a SSB (single-sideband) "round table." Ray informed the FCC of this fact, and, to further his cause, he supplied the call letters of the stations he had worked. Thus, be-

cause he had made the proper entries in his log, Ray was able to clear his record.

"What's so unusual about that?" you may ask. "FCC amateur regulation #12.136 requires every ham to keep an accurate log." True, but a good many hams fall down on the job. Here's a check list you can use to see if your station's log is fulfilling all the FCC requirements.

- ✓ Your signature, station call letters, fixed-station location, and time zone used (GMT, EST, etc.) should be recorded on the log cover or first page.
- ✓ The date and time of each transmission should be recorded. The date need be



Ham of the Month

Forty-four years ago, Frank Matejka, W2BB, put his first ham transmitter on the air. It consisted of a homemade battery, an oatmeal box wound with wire, and a Ford spark coil. Frank continued to use home-built ham equipment until two years ago, at which time he installed a Collins trans-

mitter and receiver in his ham shack. He works the world with them, but still feels that there is no thrill like hamming with equipment you build yourself.

Now Project Manager for the St. Lawrence Power Project at Massena, N. Y., Frank's profession as a civil engineer has taken him all over the United States and abroad. He has helped organize many radio clubs and was director of the Rocky Mountain Division of the A.R.R.L. for four terms. An Extra Class ham, he is affiliated with so many radio organizations that he has lost track of their number, just as he has the vast number of countries he's worked. One of Frank's chief delights is to attend ham gatherings and meet the friends he has made over the air; he often speaks before such groups.

W2BB's first experience in supplying emergency communications was gained in Brownsville, Texas, in 1933. A hurricane tore the roof off his home, but his ham equipment was not damaged—he had carefully covered it with mattresses! This was lucky, as his ham station eventually became the only means of communication to get help for the stricken city. Frank received an official government citation for his work during this disaster.



Ken Schaffer, WA2BQK, now 12, has been a General for two years. He has worked over 70 countries.



This station belongs to **Gerald Dewell, K4CCT**, Oxford, Ala. The "operator" is his 3-year-old nephew.

entered only once for each day's transmissions; the time should be entered at the beginning and end of each transmission. In the case of an uninterrupted sequence of transmissions, however, only the beginning time of the first contact and the sign-off time of the last contact need be entered in the log.

- ✓ If a ham other than yourself operates your station, he should sign your log alongside the transmission entry.
- ✓ If someone without a license speaks into your microphone while he is under your supervision, you should record the non-amateur's name in the log at the time of transmission.
- ✓ You should record the call sign for every station called. When repeated calls are made to the same station in uninterrupted sequence, the call sign need be recorded only once.
- ✓ The input power to the final stage should be recorded—but only once as long as the power is not changed.
- ✓ The frequency band should be recorded. If just one band is used or a sequence of calls is made on the same band, only one entry need be made. As added insurance—although not required by law—you can record the actual frequency of each call.
- ✓ The type of emission should be recorded. If only one type is used, or if you make a sequence of calls using the same type of emission, an entry need be made just once.
- ✓ Whenever a fixed station is moved to a new location, this fact should be recorded in the log. Mobile station operators should record the type and identity of the

vehicle (auto, boat, plane, etc.) in which the station is operated. Moreover, mobile stations are required to give the approximate geographical location of the station at the time of each call; when a sequence of calls is made from the same place, the location need be entered only once.

- ✓ If message traffic is handled, a copy of each message sent or received should be entered in the log or retained on file at the station for at least one year.
- ✓ The station log should be retained for a period of one year after the date of the last entry.

If your log meets all the requirements in this check list, you won't have to worry about false violation reports. If not, copy the check list on the last page of your log. Read it before every series of transmissions and after you close down for the day. It won't be long before you can be sure that your log contains an accurate record of your station's activities.

ECONOMY T-R "SWITCH"

Here is an electronic device that permits instantaneous "switching" of a single antenna from your receiver to your transmitter. It's as simple as they come, is completely electronic in operation, and requires no external power supply. It will safely handle the output of a 200-watt transmitter on AM phone, 300 watts on c.w., and 500 watts on single sideband. Although it does attenuate received signals slightly, this is not important when the unit is fed with a 50- or 72-ohm antenna system and when the receiver has adequate gain.

The transmit-receive "switch" is built in

a 3¼" x 2⅛" x 1⅛" Minibox (Bud CU-2117A or equivalent) as shown. All components are mounted in the "cover" half of the box. Coax connectors *J1* and *J2* are mounted on one end, and coax connector *J3* is mounted on the 3¼" x 2⅛" side. All three connectors are Amphenol Type 83-1R or their equivalents.

Scrape the paint off the box around the connector mounting holes to insure good contact between the connectors and the box which serves as a shield and common ground. Wire together the center lugs of *J1* and *J2* with a short busbar jumper and solder the center base pin of the 6-watt,

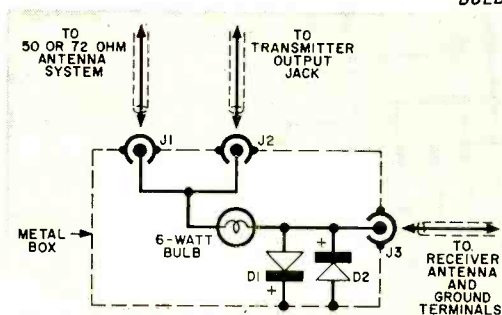
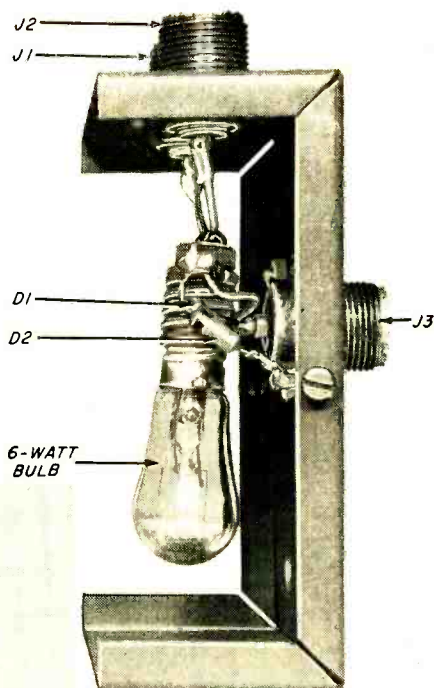

Instantaneous "switching" of an antenna from transmitter to receiver is possible with this simple T-R "switch." Requiring only six inexpensive parts, the unit is mounted in a small metal box as shown. Keep leads very short for best results.

117-volt bulb (GE S6 or equivalent) to the middle of the jumper. The other bulb terminal (the screw base) is connected to the center lug of *J3* with a short piece of busbar.

Finally, hook up diodes *D1* and *D2* (1N34 or equivalent) in parallel, with polarities opposed (plus to minus), and solder them between the center lug of connector *J3* and a ground lug under one of *J3*'s mounting screws. Be sure to use a heat sink when soldering the diodes and mount them as close to *J3* as possible.

In operation, connect *J1* to a 50- or 72-ohm antenna feed line. Connect *J2* to the transmitter using a short length of RG-58/U (50 ohms impedance) or RG-59/U (72 ohms impedance) coaxial cable. Use a similar length of coax between *J3* and your receiver. Both coax jumpers should be terminated on each end with Amphenol 83-851 plugs or their equivalents. However, one plug may be omitted if your receiver has screw-type antenna and ground terminals.

When receiving, signals picked up by the antenna pass through the filament of the

6-watt bulb directly to the receiver antenna and ground terminals. There is little loss of incoming signal strength since the resistance of the bulb is very low when it is cold. And although diodes *D1* and *D2* are shunted across the receiver antenna-ground terminals, they do not attenuate low-level signals much.

When transmitting, the r.f. voltage from the transmitter passes to ground through the filament of the bulb and diodes *D1* and *D2*. The resistance of the bulb's filament is thereby raised to over 2500 ohms. This effectively puts only a fraction of a volt across the diodes and prevents the transmitted signal from damaging the receiver. To avoid annoying "howl" in the receiver's speaker when transmitting, flip the receiver's "send-receive" or "standby-receive" switch to "send" or "standby" in order to silence the set.

(Continued on page 123)



Build the TRANSINJECTOR PROBE

TROUBLE-SHOOTING radios or amplifiers is easy with the signal-injection method, but signal generators are rather expensive. The "Transinjector" is a rocket-like probe that generates all the signals you need, yet costs less than six dollars to build. It doesn't have to be aligned or adjusted, and its transistorized circuit will run for about 500 hours on a single four-volt battery.

Construction. The Transinjector is housed in a plunger-operated cake decora-

tor which you can buy at your local hardware or five-and-dime store. Choose one that is at least 1½" in diameter and about 5" to 6" long.

The electronic portion of the probe is built on a 1" square of perforated phenolic board as shown in the pictorial. Use transistor sockets and connect the resistors and capacitors to the socket terminals by their leads. Don't plug in the transistors until all wiring and soldering is completed.

Note that only three connections are made to the circuit board—at points *A*, *B*, and *C* on the diagrams. Cut two 6" lengths of stranded hook-up wire and connect them to points *A* and *B* as shown. Connect a 6" lead to each terminal of switch *S1* (one of these leads will later be connected to point *C*), and mount the switch as close to the probe end as possible.

Next, mount the probe tip on the front cover of the decorator. Use a standard miniature phone plug for the probe tip, and cement it to the cover with an epoxy resin such as Plastic-Alum or Eccobond.

Now, remove the cake decorator plunger and mount the battery holder on the rear cover of the decorator. Before you mount it, remove the negative terminal of the battery holder. This will leave a hole in the battery holder which will allow it to be

fastened to the rear decorator cover with a short machine screw and nut. Locate the mounting nut on the inside of the cover; it serves as the negative battery terminal as well.

Assembly and Testing. Connect either lead from *S1* to point *C* on the phenolic board. Then mount the board inside the shell of the probe near *S1*. After the board is in place, solder the lead from point *B* to the shell of the battery holder; the remaining lead from *S1* is connected to the

HOW IT WORKS

The "Transinector" is a multivibrator operating at a fundamental frequency of approximately 5000 cps. It produces an output waveform very rich in harmonics which are usable up to 2 mc. The fundamental frequency is determined by the values of resistor-capacitor combinations R_4-C_1 and R_3-C_2 . Resistors R_1 and R_2 serve as collector and emitter loads (respectively) for transistor Q_1 , and resistors R_5 and R_6 are the corresponding loads for Q_2 . The output signal is taken from the collector of Q_2 through coupling capacitor C_3 ; battery B_1 supplies power for Q_1 and Q_2 through switch S_1 .

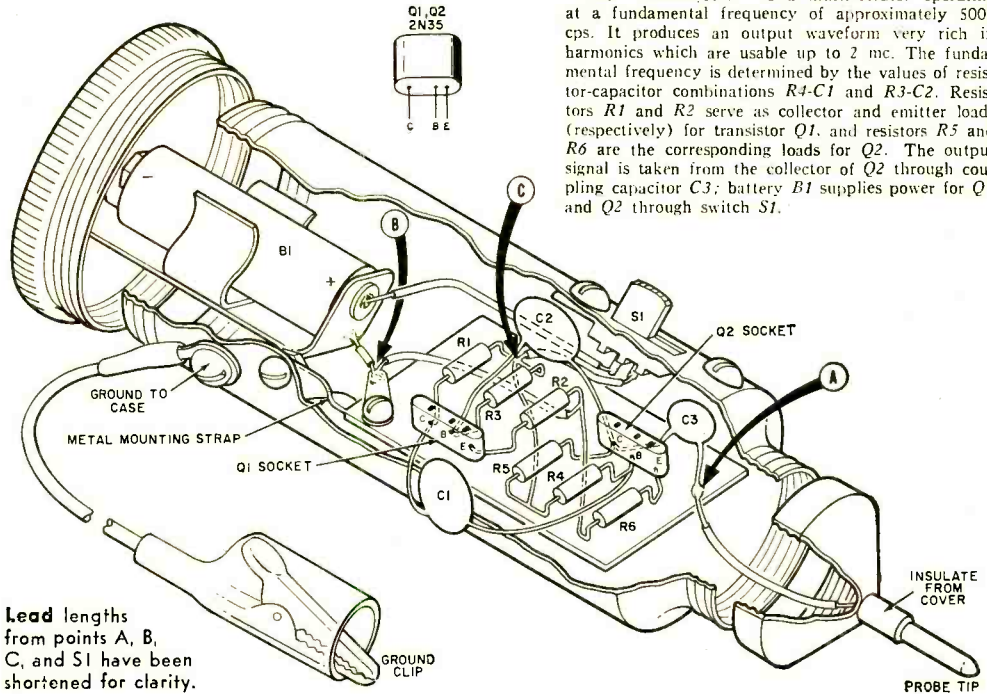

Lead lengths from points A, B, C, and S1 have been shortened for clarity.

PARTS LIST

- B_1 —4-volt battery (Mallory TR-133R or equivalent)
 C_1, C_2 — $.005\text{-}\mu\text{f.}$, 200-volt disc capacitor
 C_3 — $100\text{-}\mu\text{f.}$, 1000-volt mica capacitor
 Q_1, Q_2 —2N35 transistor
 R_1, R_5 —1800 ohms All resistors
 R_2, R_6 —39 ohms $\frac{1}{2}$ watt carbon
 R_3, R_4 —33,000 ohms
 S_1 —S.p.s.t. slide switch (Latayette SW-14 or equivalent)
 1—1" x 1" perforated phenolic board
 1—Cake decorator (see text)
 1—Battery holder (Latayette MS-173 or equivalent)
 1—Miniature phone plug
 Misc.—Transistor sockets, alligator clip, stranded hookup wire, machine screws, etc.

positive battery terminal. Now connect the lead from point A to the probe tip.

A second solder lug is mounted with another machine screw on the outside of the probe. Connect about two feet of test prod wire to this lug and terminate the lead in an alligator clip. Insert the battery, screw on the front and rear covers, and your probe is ready for action.

To check out the probe, connect a 1000- to 5000-ohm earphone across the probe tip and alligator clip. When you switch on S_1 , you should hear a rough 5000-cps tone. If you do not, recheck the battery polarity and circuit wiring.

Operation. To use the Transinector for trouble-shooting either radios or amplifiers, first connect the probe's alligator clip to the defective set's chassis or ground bus. Then, starting with the last stage, touch the probe tip to each vacuum-tube grid, or transistor base, and work toward the input or first stage. You will hear an output signal if the stage is operating.

When you reach the grid (or base) that gives no output signal, you have found the defective stage. To find the defective component, make voltage and resistance checks in the faulty stage.

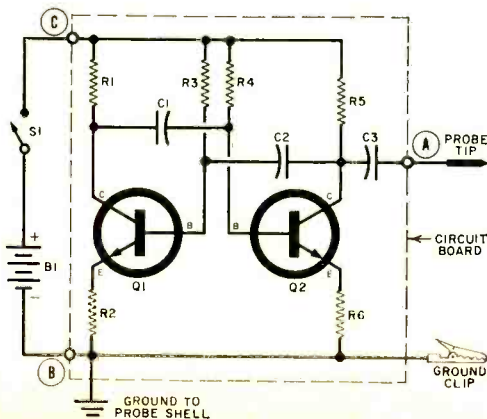

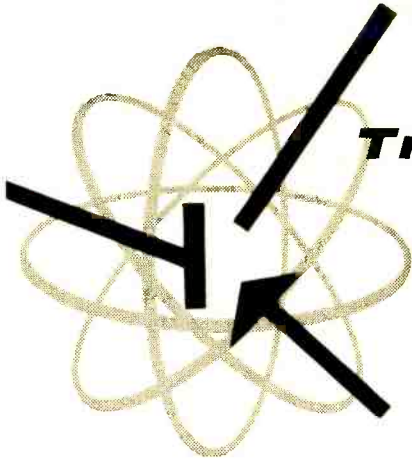

Transistor Topics

By **LOU GARNER**

EVER wonder why some diodes are "Zener" diodes and some are not? Basically, almost any "standard" diode—the popular 1N34A, for instance—can be used as a Zener diode. But they seldom are, because their "Zener" characteristics vary too much from one unit to another.

Like conventional diodes, Zener diodes are two-electrode devices made from similar materials (germanium or silicon, for instance). But a Zener diode has been specially manufactured and selected to have specific characteristics.

To understand what we mean by a Zener diode, refer to the two basic circuits given in Fig. 1 and to the corresponding graph of diode current vs. applied voltage. This graph applies to virtually any Zener diode.

Suppose we apply d.c. voltage to the diode, such that the cathode is negative and its anode positive. See Fig. 1(A). Then, suppose we gradually increase this voltage from zero to a predetermined maximum value. Since the cathode is negative, the diode junction is biased in its "forward" or "conducting" direction. With zero voltage applied, the current through the diode, as indicated by the series current meter will be zero. As the voltage is increased, the current through the junction increases rapidly until the point of maximum continuous forward current is reached. This

increase in current is shown on the right-hand side of the graph.

Now, let's reverse the polarity of the d.c. voltage, applying a positive voltage to the cathode and a negative voltage to the anode. See Fig. 1(B). Here, the diode is biased in its "reverse" or "non-conducting" direction. Unless the diode is defective, little or no current should flow. As we gradually increase the reverse voltage, a small "leakage" current may start to flow. If the diode is good, this will be but a tiny fraction of the forward current for a corresponding voltage applied to the diode in its conducting direction.

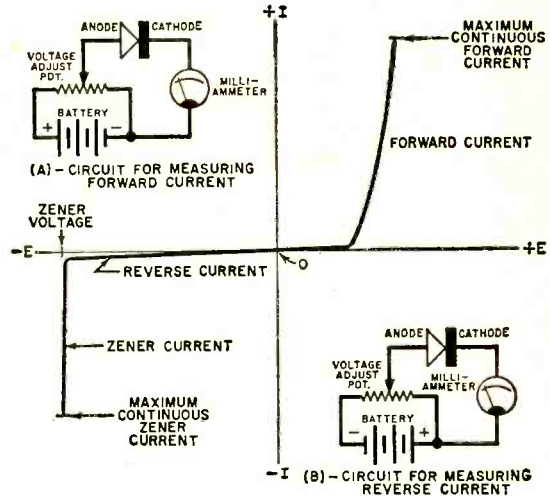

Fig. 1. Zener diode's forward and reverse currents can be measured with simple circuits; reverse current increases slowly until the "Zener" voltage is reached. See text.

As the reverse voltage is increased, we will eventually reach a point at which the junction "breaks down" and a sudden increase in reverse current flow occurs, as shown on the left-hand side of the graph. This point is the diode's "Zener" voltage. Unless there is something to limit the reverse current flow (such as a series re-

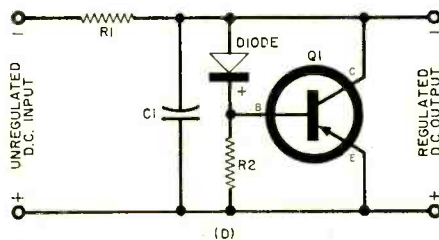
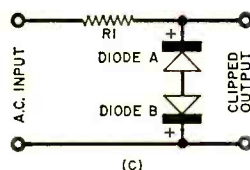
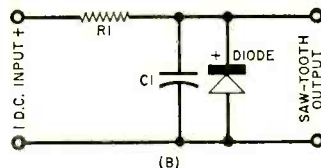
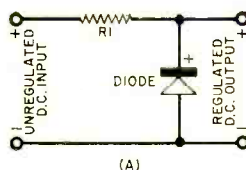

Fig. 2. Typical circuits utilizing Zener diodes include: (A) simple voltage-regulator circuit, (B) relaxation oscillator, (C) peak limiter, and (D) improved regulator circuit.

sistor), the diode current will increase past the maximum continuous Zener current until the junction is destroyed.

A Zener diode, then, is simply a diode primarily designed for operation at the point on its conduction curve where reverse current increases suddenly. The characteristics of a Zener diode are more or less analogous to those of a gas-filled diode tube, such as a neon bulb or voltage regulator tube, and the Zener diode is used in similar applications.

Basic schematic diagrams illustrating a few of the many possible applications for Zener diodes are given in Fig. 2.

A simple voltage-regulator circuit is shown in Fig. 2(A). Here, an unregulated d.c. supply serves as a power source. Series resistor $R1$ limits circuit current to safe values and acts in conjunction with the diode to maintain a regulated output voltage with changes in both source voltage and external loading. If less current is drawn by the load or if the input voltage increases, the output voltage normally tends to rise. Such a rise in voltage, however, causes a swing past the diode's Zener voltage, resulting in heavy conduction and a corresponding increased voltage drop across $R1$, restoring the output voltage to its regulated value.

The circuit in Fig. 2(B) should be familiar to you—mentally replace the diode with a neon bulb and you have a relaxation

oscillator. Except for the lower voltages involved, this circuit's operation is much like its neon-bulb counterpart.

In the circuit of Fig. 2(C), two Zener diodes are connected in series back-to-back across an a.c. source. Series resistor $R1$ serves to limit current flow to within the diodes' maximum ratings. In operation, one diode conducts on the positive half-cycles, the other acting as an open (or high-resistance) circuit until its Zener voltage is exceeded, at which time it conducts heavily. The diodes interchange their roles on the negative half-cycles. Such a circuit can be used as a peak limiter, a square-wave generator, a pulse shaper, or in similar applications, depending on the choice of diodes, input signal waveform and amplitude, series resistor value, and so on.

The circuit in Fig. 2(D) is basically simi-

lar to that in Fig. 2(A), but with a power transistor ($Q1$) added to "amplify" the Zener diode's power-handling capacity. In operation, this circuit maintains the output voltage at a constant value regardless of changes in external loading or input voltage amplitude.

If you are interested in delving further into the subject, there are two excellent books on Zener diodes. The "Silicon Zener Diode Handbook" is available from Motorola, Inc., Semiconductor Products Div., 5005

kilowatt—which is more than enough for small- to medium-sized transmitters, large fans, or even a standard portable TV set!

As shown in Fig. 3, the inverter circuit uses a push-pull switching oscillator, with a single transformer, $T1$, serving both to step up the a.c. signal to the desired 117-volt output and to provide the base feedback signal necessary to maintain switching. High power is obtained through $p-n-p$ power transistors $Q1$, $Q2$, $Q3$, and $Q4$, in a push-pull parallel arrangement. Base bias

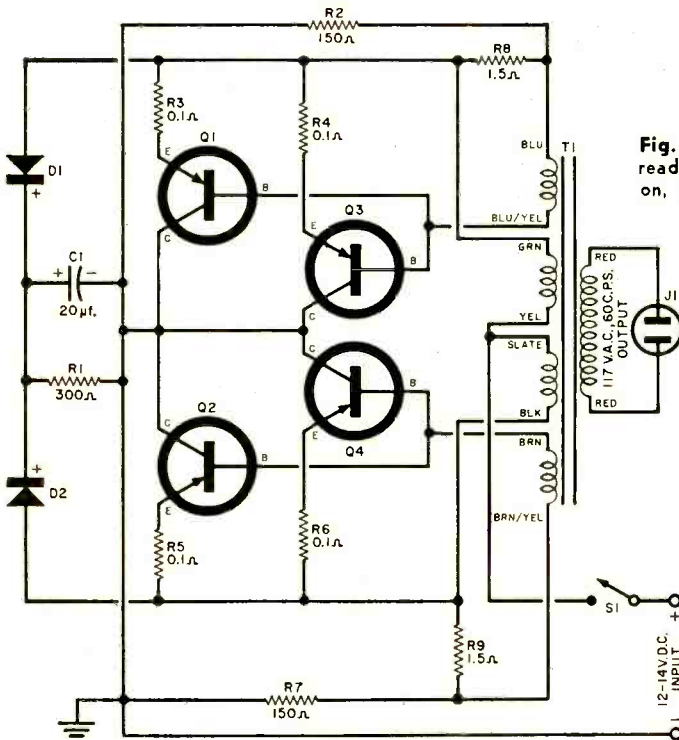

Fig. 3. Inverter circuit designed by reader/author E. G. Louis of Wheaton, Md., will handle up to 250 watts.

East McDonald Rd., Phoenix, Arizona, for \$1.00; and the "Zener Diode Handbook" is available from International Rectifier, 1521 East Grand Ave., El Segundo, Calif., for \$2.00.

Reader's Circuit. During the summer months, there is more than an average amount of interest in d.c.-to-a.c. inverters—units for converting the 12 volts d.c. supplied by car and boat batteries to 117 volts a.c. The inverter circuit designed by reader/author E. G. Louis of Wheaton, Md., uses a standard transformer and other readily available components. This unit puts out a husky 250 watts—a quarter of a

is provided by voltage dividers $R2-R8$ and $R7-R9$. Emitter resistors $R3, R4, R5, R6$ serve to stabilize circuit operation and to minimize differences in the individual characteristics of the transistors used.

In operation, damper diodes $D1$ and $D2$, together with resistor $R1$ and bypass capacitor $C1$, reduce the amplitude of switching transients, protecting the transistors from excessive voltage peaks. A modified common-collector arrangement permits the transistors to be mounted directly on a heavy heat sink. Note that all collectors are connected to circuit ground.

(Continued on page 116)

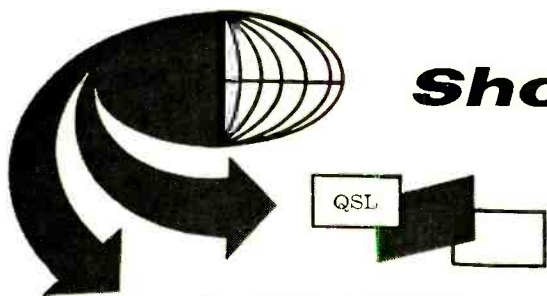

Short-Wave Report

By **HANK BENNETT**
W2PNA/WPE2FT

OFFICIALLY inaugurated on February 25, 1945, the International Service of the Canadian Broadcasting Corporation (*Radio Canada*) now broadcasts in 16 languages with a total weekly "on the air" time of 100 hours.

The studios and headquarters are located in Montreal in a well-equipped building which also houses studios for the CBC domestic services. Equipment in the studios includes 6 disc recorders and 14 tape recorders. The "nerve center" is a one-man control board which covers the various studios, transmitter feeds, and both incoming and outgoing network presentations.

Transmitters for the International Serv-

ice are installed at Sackville, New Brunswick, some 600 miles east of Montreal, a location favorable for transmissions to Europe. There are two 50,000-watt short-wave transmitters which can be operated on any band from 6 mc. to 21 mc., and a 50,000-watt medium-wave transmitter operating on 1070 kc. The latter unit bears the call-sign CBA and is frequently heard in Eastern areas; it usually identifies simply as *CBA, Maritime*.

All antennas are of the "curtain" type, consisting of stacked horizontal radiators with similar reflectors which are hung from steel towers. The arrays can all be directed by remote control. With the exception of the 6-mc. array, two transmitters can feed the same antenna through a common transmission line. So-called "diplexing" filters

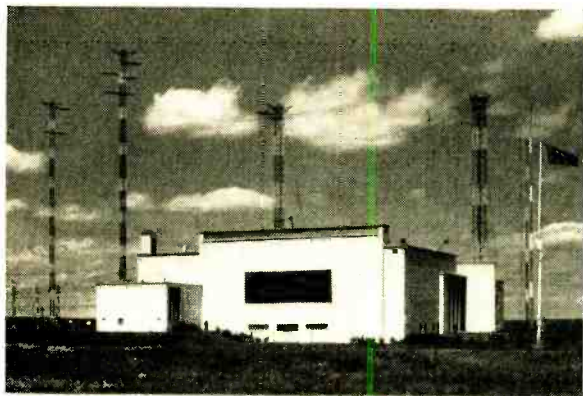

Radio Canada's headquarters in Montreal (right) are shared by the CBC's domestic services. The transmitters and antennas (above) are located at Sackville, New Brunswick.



are used to reduce the power flow from one transmitter to the other; these filters are made up of lengths of transmission line which prevent cross-modulation.

Radio Canada receives about 30,000 letters yearly, and all reports are welcomed. The address is *Radio Canada*, International Service, Box 6000, Montreal, Quebec.

KFRN, Dallas, Texas. A new station which is expected to be on the air some time in October is KFRN, Dallas, Texas. Co-owner A. L. Crain says that it will operate on 15,180 kc. and the schedule will be as follows: 1700-1800 and 2100-2300 in English; 1800-2100 in Spanish. The station will beam programs to Central and South America as well as to stateside listeners.

Plans for KFRN indicate that some of the programs will be educational, a number of which will be locally produced. There will be programs of good music, and some non-denominational religious dramatizations—as well as sponsored religious broadcasts. The usual standards, such as newscasts, will also be aired. One program which should have high listener appeal will be "The Educational Aspects of Short-Wave Listening," in which Mr. Crain plans to have taped interviews with officers of various clubs. Keep a watch on 15,180 kc. later this year.

Our thanks go to Earl Kinmonth, WPE9AGB, for his assistance in the preparation of the material on *Radio Canada*,

and to Jim Cumbie, WPE5AC, in connection with KFRN.

S.W. Monitor Program. If you haven't yet applied for your Short-Wave Monitor Certificate, you'll want to send in the registration form below.

POPULAR ELECTRONICS, as you probably know, awards individual short-wave station letters to each qualified monitor who applies. This means you can have your own station letters prominently displayed on an attractive 8½" x 11" certificate. Once your certificate has been issued, your registration form and station letters are kept on permanent file at POPULAR ELECTRONICS. Station letters are assigned according to the equivalent amateur radio call areas (WPE-1AA, WPE4BB, WPE9CC, etc.).

Here's what you do to become a POPULAR ELECTRONICS' registered Short-Wave Monitor:

1. Complete the Monitor Registration form below to prove that you are a serious short-wave listener.

2. Mail the registration form together with ten cents in coin and a *stamped, self-addressed, business envelope* to Monitor Registration, POPULAR ELECTRONICS, One Park Ave., New York 16, N. Y.

If you live outside the United States, send two International Reply Coupons (IRC) in place of the stamped, self-addressed envelope.

(Continued on page 119)

Short-Wave Monitor Registration

(Please Print)		
Name		
Address	City	State
Receiver	Make	Model
	Make	Model
Principal SW Bands Monitored		Number of QSL Cards Received
Type of Antenna Used		
Signature		Date

Experimenter's Test Speaker

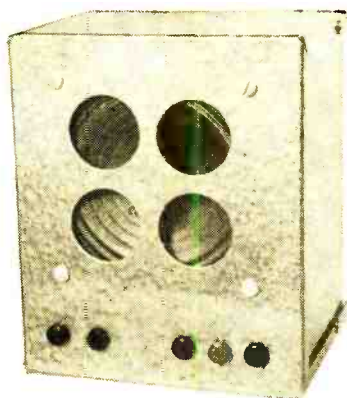

By E. G. LOUIS

TAKE a small PM speaker, a metal or wooden box, a universal output transformer, and a few test jacks. Add a little over an hour's pleasant work, and you've got a handy unit that combines a test or extension speaker, a dynamic microphone, and a test output transformer.

You can use the device as an extension speaker for your TV or radio set, or you can hook it up as a test speaker for checking home-built gear. The test output transformer is fine for substitution in service work, and the unit will also work as a dynamic microphone when you hook it up to your hi-fi or p.a. system.

All parts are readily available and should cost five dollars or less, depending on the quality of the speaker and transformer chosen.

Construction. Assemble and wire the unit following the pictorial diagram. Use insulating washers for mounting jacks *J1* through *J5* if you build the unit in a metal box. The speaker grille pattern shown was made by punching four large holes in the metal box with a standard chassis punch; you can punch or cut a fancier pattern if you wish.

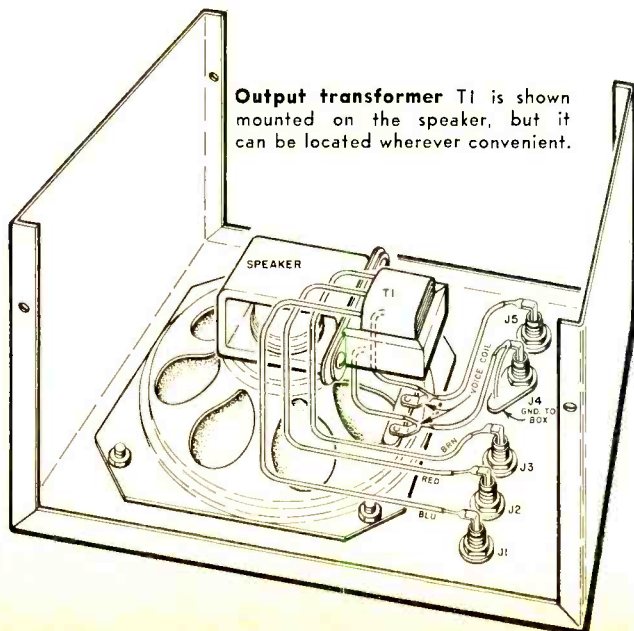

The output transformer in the parts list has several secondary taps to match loads of various impedances. Taps 1 and 4 were selected in the author's model because they seemed to offer a good "compromise" impedance—on the order of 2000 to 3000 ohms. You may want to select other taps, depending on your requirements—simply follow the printed instructions furnished with the transformer. Actually, you can use almost any transformer or speaker since these impedances are really not very critical.

Hooking It Up. For a test or extension loudspeaker,

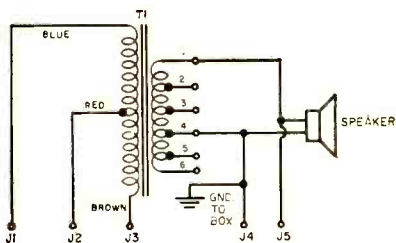

PARTS LIST

- J1, J3—Tip jack (blue)
- J2—Tip jack (red)
- J4, J5—Tip jack (black)
- T1—Universal output transformer, push-pull plates to voice coil (Stancor A-3856, Knight 62G023, or equivalent)
- 1—4" speaker (Quam 4A06 or equivalent)
- 1—4" x 5" x 6" aluminum box (Bud CU-2107A or equivalent)
- Misc.—Hardware, wire, etc.

Speaker and transformer should be selected to have approximately the same wattage rating. Connect speaker to secondary tap that matches the voice-coil impedance.

connect the voice coil of the test unit's speaker (jacks *J4* and *J5*) in parallel with the voice coil of the speaker in the set under test. If you hook it up to an amplifier that has several output impedances, select the one that gives the best results.

For a dynamic microphone, connect the voice coil of the test unit's speaker (jacks *J4* and *J5*) to the low-impedance input of the amplifier or p.a. system (low-impedance inputs such as are usually found in transistorized amplifiers). For high-impedance inputs (usually found in vacuum-tube amplifiers), connect jacks *J1* and *J3* to the amplifier input. If you're not sure about

the input impedance, try both connections, and use the one that works best.

For a test output transformer, connect the test unit's transformer to the output stage in the defective set; the exact connections will depend on the type of output stage under test. For "single-ended" outputs, disconnect the lead to the plate of the output tube and connect the plate to *J1*. Next, connect either *J2* or *J3* to the B+ in the set under test. For push-pull stages, disconnect the leads to the plates of both output tubes, and connect one plate to *J1*, the other to *J3*. Jack *J2* should then be connected to the set's B+. Be sure that the push-pull stage doesn't draw more current than the transformer can handle. It's also wise to run the push-pull stage at low volume to protect the test unit's speaker. —30—

CROSSWORD PUZZLE

By James J. Porten

ACROSS

- 1 Grid voltage
- 5 Summit
- 10 _____: mechanical servo
- 13 Old man (c.w.)
- 15 _____ convex lens
- 16 Thulium (symbol)
- 17 Atomic Energy Commission
- 19 Inhabitants of Far East
- 20 _____ element beam
- 21 Commonly used in converters (abbrev.)
- 22 _____ sink
- 23 Joule (dimensions)
- 24 Toddler
- 27 Element necessary for reception
- 28 End of message
- 29 Doctrine
- 31 Element used in rectifiers
- 32 "C" in R/C
- 34 Continuity (abbrev.)
- 35 Average

DOWN

- 2 Watt (units)
- 3 High mountain
- 4 Vend
- 5 Atomic number
- 6 Cathode-ray oscilloscope
- 7 Master oscillator
- 9 Having a common axis
- 11 Federal agency
- 12 Function of cathode

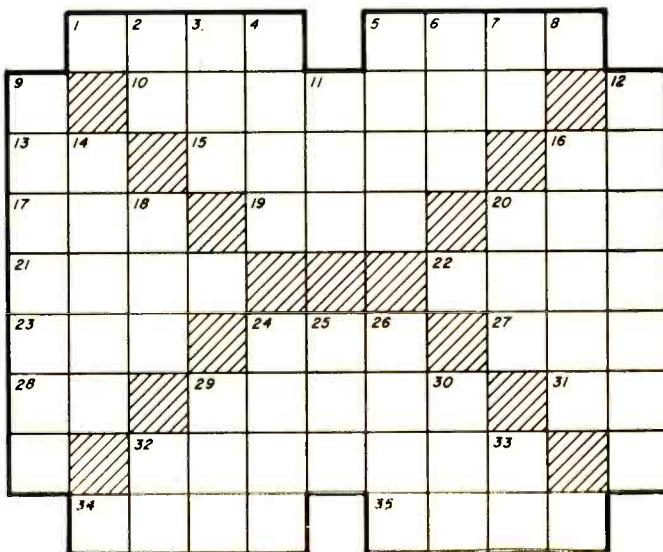

- 14 Unit of measurement
- 16 Impedance-matching device (abbrev.)
- 18 _____ whisker detector
- 20 Beverage
- 24 Canvas shelter
- 25 Smallest of Great Lakes (abbrev.)

- 26 Function of soldering lug (abbrev.)
 - 29 32,000 oz. (avoird.)
 - 30 Pedal digit
 - 32 Cobalt (symbol)
 - 33 Norway (Ham prefix)
- (See page 109 for solution)

Electronic Analogy Quiz

By ROBERT P. BALIN

Analogies—or comparisons—between electrical and mechanical phenomena are widely used to explain many electronic principles. See if you can match the lettered objects to the numbered symbols in the boxes below. The correct match in each case, and a complete explanation of the principles involved, will be found on page 110.

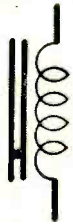

1.



2.



3.



4.

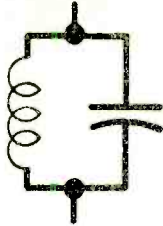

5.

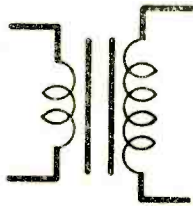

6.



7.



8.

A.

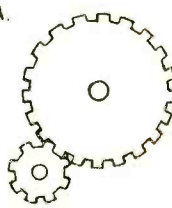

B.

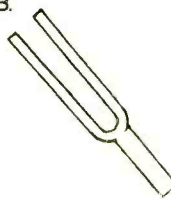

C.



D.

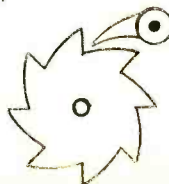

E.

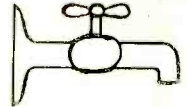

F.

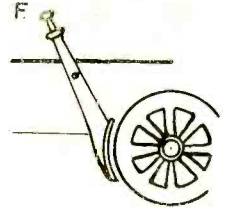

G.

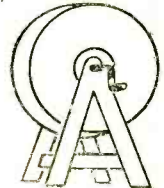

H.



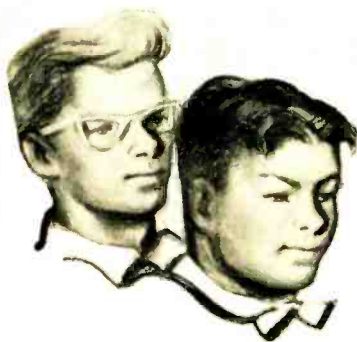

By
JOHN T. FRYE
W9EGV

Carl and Jerry

Electronic Lifeline

“WE BETTER pull off here and ice up,” Jerry’s uncle said as he turned the pickup truck off the highway and stopped in front of a small, windowless building.

Carl and Jerry hopped out of the truck into the blazing Florida sunshine and watched curiously as Uncle George placed some coins into two different slots in the side of the building. Then Uncle George reached inside an opening at the bottom of the building and pulled out a paper bag of crushed ice which he dumped into their huge thermos jug of drinking water. From another opening he pulled a small cake of ice and placed it in the ice chest in the back of the truck; this was to preserve the fish they were going to catch!

“All I’ve got to say,” Carl commented, “is that you’ve got lots more confidence in catching fish down here than we have in Indiana. Back there we wait to see if we’re going to catch anything. If we do, *then* we worry about the ice.”

“We’ll catch fish,” Uncle George said with a confident smile wrinkling his tanned face. He checked over the trim little white cabin cruiser with powerful twin outboards mounted on its stern that was being towed on a sturdy trailer behind the truck, then cried, “All aboard for Sebastian Inlet!”

The two boys were spending a couple of weeks of their vacation with Jerry’s uncle in Orlando. This morning they were going on an all-day fishing trip to Sebastian Inlet on Florida’s east coast, nearly a hundred miles from Orlando.

“M-m-m-m, smell that salt breeze!” Jerry exclaimed as they rolled down Highway A1A with the Intercoastal Indian River Waterway on their right and the open sea on their left.

“Yep,” Uncle George said. “Either you like that smell or it makes you sick.”

“I don’t see how anyone could help liking it,” Carl remarked as he breathed deeply of the air rushing in the open windows of the truck. “Hey, Jer, look at that tri-band beam!” he exclaimed, pointing to a 10/15/20-meter trapped-beam antenna that stood out against the blue sky above a cottage built on a dune near the sea.

“Okay, boys!” Uncle George admonished with mock sternness. “Let’s have none of that electronic jazz today. This is a vacation—remember?”

“Roger, Uncle G.,” Jerry agreed with a grin; but a few minutes later it was he who was calling attention to an elaborate cubical quad antenna installation at another house beside the ocean.

“Boy-oh-boy-oh-boy!” he groaned. “If this isn’t a ham’s dream of an antenna farm, I never saw one. Just think: no wires or trees to foul up the beam pattern; a perfect salt-water ground practically underneath the tower; and not a thing between you and Europe or Africa but an ocean of salt water. No wonder so many DX stations I call come back to W4’s.”

“Yeah,” Carl consoled him, “but think what a job it must be to maintain those antenna systems, what with the salt spray chewing on the metal parts and coating the insulators and feedline with a low-resistance film. And look how the wind is tugging at them right now.”

“We could do without that breeze,” Uncle George said with a frown. “This place we’re going to fish gets pretty tricky when the wind blows hard.”

Before he could amplify this statement they ran out of road; Highway A1A ended abruptly in a small parking area overlooking a little boat basin. Uncle George drove confidently off the blacktop to the left along a sand road that wound among

the trees and cottages. Suddenly he stopped the truck and began to back rapidly along a twisting path that zig-zagged back and forth down to the edge of the boat basin. Soon the wheels of the boat trailer rode smoothly down a boat ramp into the water until the little cruiser was almost afloat.

"Here, Jerry, you go up to the bait house and get us a hundred shrimp to start with," Uncle George said as he handed a bait bucket out of the truck. "Just tell the man who they're for and say we'll settle up when we leave. You, Carl, roll up your britches and help me get the boat off the trailer. I saw by the tide-clock up at the camp that the tide will still be coming in for another hour, and quite often the fish bite best just as the tide turns. Time's awastin'!"

BY THE TIME Jerry returned the boat was in the water, the truck and trailer had been parked out of the way of others wanting to use the ramp, and a single idling motor was holding the prow against the bank. Jerry took time only to get a zippered bag from behind the seat of the truck and hand it carefully to Carl before he climbed into the boat. Still using only one of the two motors, Uncle George sent the cruiser through an opening in the jetty that protected the boat basin from the rougher water of the inlet.

As they passed through this narrow opening, the boys could see that the inlet was simply a wide trench the sea had battered across the strip of sand separating the ocean from the broad, salty reaches of the Indian River. The inlet was possibly three-quarters of a mile in length and of varying width, but it was not more than a couple of hundred yards across at the sea end. Here the "lips" and "throat" of the inlet were protected from the eroding effect of the pounding waves by a lining of huge blocks of black granite, piled from deep down in the water to a height of twenty feet or so. Even the jetty that walled off the boat basin from waves entering the inlet was made of these sharp-edged rocks.

Uncle George turned to the right and cruised down the inlet for about half a mile. The water was dotted with other fishermen, all in smaller boats. He steered clear of them and kept the cruiser moving at a slow pace so as to produce as small waves as possible. Finally he dropped the anchor. Under the combined influence of

the stiff breeze and the incoming tide, the cruiser swung around and pointed its bow back toward the sea end of the inlet.

No time was lost in baiting up with the shrimp and getting the lines overboard. Almost at once Carl's rod tip jerked down sharply and he reeled in a sea trout that would weigh at least a pound and a half. This was the auspicious beginning for the most exciting fishing Carl and Jerry had ever done.

For the next couple of hours all three of them caught fish after fish. There were more trout, a couple of flounder, three big



drum fish, a bluefish, some whiting, and even a sand-shark a couple of feet long. Both Carl and Jerry hooked into fish that never stopped going but snapped their lines and took hooks, sinkers, and all with them.

Then the tide turned and swung the boat around in spite of the breeze from the east that was growing stronger all the time. Shortly afterward the large fish stopped biting, except spasmodically, and a school of smaller fish that Uncle George called "Sailor's Choice" moved in around the boat. They proved most adept at shelling the meat out of the shrimp and leaving only the empty husk on the hook.

"Boys, we gotta get more bait," Uncle George said as he peered down into the bait bucket. "I certainly hate to leave this spot, though. The snook should start hitting any minute now, and I know from experience that we're anchored in the best snook-catching spot in the inlet. If we leave, those other boats that haven't been doing nearly so well as we have will surely move in. Maybe I'd better get out on the bank and walk back to camp for some bait."

"Let me go," Jerry volunteered eagerly.

"Well, okay," Uncle George said as he gave his nephew a puzzled look. Jerry was

not noted for his fondness for exercise, and it was a bit strange to hear him volunteer so readily for a long, hot walk through the sand-gnat infested palmettos. "Get us fifty more shrimp and about three dozen large minnows."

JERRY laid down his rod and carefully unzipped the bag he had handed to Carl back at the landing. He removed two identical metal boxes about the size and shape of milk cartons. Both boxes had telephone-type microphones and earphones fastened to one side. As Uncle George watched silently, and a little disapprovingly, the boys connected together the pieces of two short center-loaded whip antennas and fastened one to each of the two boxes.

"Aw, Uncle G., you wouldn't expect us to forget about electronics entirely," Jerry said in wheedling tones. "These are transistorized ten-meter transceivers we finished building just before we left. They're low-power short-range jobs, and we've been aching to see how they'll work. I'll take this one with me and talk back to Carl."

"I might have known you two couldn't even go fishing without lugging some electronic junk along," Uncle George said in resignation.

They reeled in and put Jerry ashore, then went back and anchored in their lucky spot. Jerry trudged along a path that wound in and out of the palmettos toward the fish camp at the head of the inlet. As he walked, he kept up a running conversation with Carl, interrupted now and then as Carl had to lay down the transceiver to reel in a fish. The transceivers worked to perfection, putting in strong and steady signals in spite of the flea-power drain on their batteries.

When he reached the fish camp, Jerry noticed that the waves were running much higher than before. Wind and tide were locked in a furious struggle at the mouth of the inlet; the water there was a swirling, heaving maelstrom of mountainous swells and breaking waves that even ran into the inlet and broke over the top of the jetty protecting the boat basin. Most of the boats were fishing far down in the inlet in quiet water, but one small boat was anchored in the center of the inlet opposite the boat basin opening. The loud sports shirts and the sunburned faces of the two occupants proclaimed them tourists.

"That's a poor place for those Yankees to

be fishing," the bait-seller muttered to Jerry as he stared with a worried frown at the little boat bobbing around like a cork in the rough water. "The undertow here is bad, and that tide is really running. With this wind—oh oh!" he broke off sharply. The boat had suddenly started moving rapidly backward toward the boiling water at the mouth of the inlet. For a few seconds the men, intent on their fishing, did not notice the movement. When they did, the man in the bow snatched at the anchor rope and brought up a frayed end. The rope had snapped.

The other man tugged at the starting rope of the motor; it broke into a roar and abruptly stopped the backward motion of the boat. The little craft moved rapidly



away from the mouth of the inlet for a few yards, then the motor sputtered and quit.

"Oh, the fools!" the bait-seller groaned. "Fishing in a spot like that with an empty gas tank!"

The man in the stern of the boat frantically tried to pour gasoline from a big red can into the motor, but by now the boat was pitching and tossing so hard that this was impossible. Suddenly a huge wave caught the boat broadside and flipped it over. As the people on the bank watched in horror, one of the men popped to the

(Continued on page 108)

LEKTRON'S WORLD FAMOUS POLY PAKS®

AT FACTORY-TO-YOU PRICES

NOW for the FIRST TIME

A NEW PRICE



91¢

each in LOTS of 12

LIMITED TIME ONLY

96¢ each in Lots of 6—88¢ each in Lots of 24

FREE! CHOOSE ANY ITEM \$1 OR LESS WITH ANY \$10.00 ORDER! SEE LISTING BELOW

3 FERRITE LOOPSTICKS
Adjustable; 540 to 1600 kcs. Worth \$2. **\$1**

"POLY" WIRE PAK
Asst. colors, 6—25 ft. rolls; plastic ins. ±18 thru ±24. Worth \$4. **\$1**

40 TRANSISTOR RESISTORS
Asst. to 3 megs. 1/5 watt rating. Color-coded. Worth \$5. **\$1**

SOLDERING IRON
115V AC/DC; with cord & plug. Nifty hobby unit. Worth \$3. **\$1**

20-PC. TWIST DRILL SET
In case, 1/16 thru 1/4". For all types of drills. **\$1**

2000 OHM PHONE
With cord & plug. Hearing-aid type, with ear loop. Worth \$3. **\$1**

24 ARTISTS BRUSHES
100% pure bristles. Sizes 1 to 5. **\$1**

CRYSTAL PHONE
Sensitive! 100's transistor pro. w/ cord & plug. **\$1**

\$25 SURPRISE PAK
Wide variety of usable radio-hobby parts. **\$1**

TRANSISTOR RADIO BASIC
Incl. transistor, socket, loopstick, diode, case. Worth \$3. **\$1**

CRYSTAL RADIO SET
Incl. diode, loopstick, wire, condenser, etc.; diagram & cabinet. **\$1**

50 PRECISION RESISTORS
1/2 watt. values. 1/2W to 2W. **\$1**

8 NEON INDICATORS
For 110 VAC; mini. bay. types. **\$1**

100 HALF WATT RESISTORS
Asst. values. Some 1/2W. Worth \$18. **\$1**

10 3-SEC. TIMERS
Precision geared. Worth \$5 ea. **\$1**

10 INSTRUMENT KNOBS
Pointer types, black, brass insert & set screws. **\$1**

8-PC. NUTDRIVER SET
Plastic handle; 3 thru 7/16 nutdrivers in handy case. Worth \$8. **\$1**

35 POWER RESISTORS
Asst. 5 to 50W to 10,000 ohms. Various types too. Worth \$12. **\$1**

70 MICA CONDENSERS
INCL. silvers too! .00025 to .01 to 600V. Worth \$20. **\$1**

10 ELECTROLYTIC COND'N'RS
Incl. can & paper types. Duals too! To 1000 mfd to 450V. Worth \$12. **\$1**

80 TUBULAR CONDENSERS
Papers, molded, oils, ceramic! .0001 to 1 mfd to 600V. Worth \$16. **\$1**

40 SILVER MICAS
1 & 5¢ asst. values. Finest made. Worth \$8. **\$1**

300-FT. HOOKUP WIRE
Asst. colors, insulation, sizes. Worth \$6. **\$1**

60 RADIO 'N' TV KNOBS
Asst. colors, sizes, shapes; some \$1 ea. **\$1**

1500 PCS. HARDWARE
Nuts, bolts, etc.; wide variety. Handy shop asst. **\$1**

30 MOLDED CONDENSERS
Oils too! Lasts for life. Worth \$8. **\$1**

40 TWO-WATT RESISTORS
Incl. 1/2 watt. Asst. values. **\$1**

8 SILICON 'N' XTAL DIODES
1N21, 1N24, etc. Some worth \$10. **\$1**

4 1N34 DIODES
Or equal; glass-sealed. New mini. types. **\$1**

50 DISC CONDENSERS
Asst. .0001 to .01 to 1000V. Worth \$10. **\$1**

4 OUTPUT TRANSFORMERS
50L6, etc. Open frame types. Worth \$8. **\$1**

6 115VAC PANEL SWITCHES
Toggle type; SPST, DPDT, etc. A shop must. **\$1**

70 INSULATED RESISTORS
IRC, Allen Bradley, Stackpole makers. 1/2, 1W, 100 ohms to 1 meg. 1/2, 5/72 too. Worth \$15. **\$1**

10 PANEL SWITCHES
Asst. micros, power, rotary types. Exc. variety. Worth \$12. **\$1**

25 PANEL PILOT LITES
Mini bay & screw types. Worth \$5. **\$1**

60 RESISTOR SPECIAL
Carbons, precision, hi-Q. W/V. carbon-films, to 50W, 1/2 watt too. Worth \$10. **\$1**

10 VOLUME CONTROLS
Asst. to 1 meg. Some with switch. Worth \$15. **\$1**

3 HOBBY TRANSISTORS
PNP's, etc. Similar to CK 722. Worth \$6. **\$1**

125 RESISTORS
Asst. values, incl 1/2 watt too! To 1 meg. Worth \$10. **\$1**

15 "POLY" BOXES
Snap-top covers; sizes to 4". For parts, etc. Worth \$3. **\$1**

4 I.F. TRANSFORMERS
45¢ kes. Only 1/2" sq. Transistor cks. Worth \$3. **\$1**

60 PLUGS & RECEPTACLES
Incl. power, audio, battery, etc. Worth \$8. **\$1**

125 CERAMIC CONDENSERS
Incl. discs too! Wide variety of types & values. Worth \$10. **\$1**

12 GERMANIUM DIODES
Glass-sealed, similar to 1N48; hobbyists note! **\$1**

3 AC-DC RECTIFIERS
SELENITE, 110V; 65 & 700 mA; half wave. Worth \$3. **\$1**

NEEDLE & STAMP CHECKER
Battery-operated. Checks needles, stamps, etc. Worth \$3. **\$1**

10 RCA PLUG 'N' JACK SETS
For amps, tuners, recorders, etc. **\$1**

13-IN-1 PAK
Diodes; carbon, W/V., precision, hi-Q resistors; disc, ceramic, molded, oil, paper, mica condensers; socket, coils. Worth \$8. **\$1**

40 TUBE SOCKETS
4 to 12 prongs, mica filled too! & mini types. Worth \$8. **\$1**

7 SILICON DIODES
1N21, 1N22, 1N23, etc. Some worth \$10 ea. **\$1**

4 AC & DC CHOKES
Power & radio types; to 300 mfd. Open frame types. Worth \$10. **\$1**

50-FT. 'ZIP' CORD
For spike, ext's, ins., AC/DC, 2-con. parallel. Worth \$3. **\$1**

60 TERMINAL STRIPS
1 to 10 tie points. Used in every type of proj. Worth \$5. **\$1**

70 COILS & CHOKES
RF, ant., osc., slug-tuned, I.F. Wonderful shop asst. Worth \$16. **\$1**

70 ONE-WATT RESISTORS
Incl. precision, W/V., carbon-films, 1 & 1/2 watt too. **\$1**

60 CONDENSER SPECIAL
Incl. discs, ceramics, molded, mica, papers, oils, etc. Worth \$11. **\$1**

15 ROTARY SWITCHES
Asst. gears, contacts! Worth \$17. **\$1**

6 TRANSISTOR* RADIO

KIT! *Basic 20 pcs. incl. I.F.'s, osc. coils, var. cond., in-and-out trans., sockets, instructions **\$5.88**

GIANT TUBE SALE

70% to 90% OFF! NAMED BRAND TUBES—YEAR GUARANTEE!

TYPE	SALE	TYPE	SALE	TYPE	SALE	TYPE	SALE	TYPE	SALE	TYPE	SALE	TYPE	SALE	TYPE	SALE
024	\$.09	3V4	.69	6AH6	1.29	6BE6	.63	6CU6	1.19	6S17	.89	6X8	.89	12L6	.67
1B3	.89	4BQ7	1.14	6AL5	.29	6BG6G	1.89	6DE6	.69	6SN7	.79	12AT7	.49	12SA7	.99
1R5	.89	4BZ7	1.12	6AL5	.53	6BH6	.79	6D6E	1.14	6S07	.79	12AT7	.84	12SK7	.89
154	.89	5AM8	.95	6AM8	.89	6BK5	.94	6J5	.69	6T4	1.19	12AU6	.61	12SN7	.79
155	.69	5AN8	.95	6AN8	.89	6BK7A	.94	6J6	.79	6T8	1.05	12AU7	.79	12SQ7	.89
174	.64	5AB5	.63	6BQ5	.62	6BL7	1.09	6K6	.79	6U8	.99	12AV6	.69	12V6	.59
1V4	.69	5AT8	.89	6A55	.69	6BN6	.84					12AV7	.93	12X4	.49
1V2	.59	5BK7A	.99	6AT6	.53	6BQ6	1.29					12AX4	.75	25BQ6	1.29
1U5	.87	516	.81	6AT8	.57	6BL7	1.09					12AX5	.69		
1X2A	.99	5T8	.98	6AU4	.96	6BZ6	.63					12AY7	.99		
3AL5	.54	5U4	.69	6AU6	.99	6BZ7	1.19					12AZ7	.74		
3AU6	.66	5U8	.94	6AU8	.99	6C8	1.49					12B4	.74		
3C85	.69	5X8	.93	6AV6	.49	6CB6	.66					12BE6	.69		
3BE6	.63	5Y3	.52	6AW8	.99	6CD6	1.69					12BE6	.59		
3N6	.86	5AB4	.89	6AX4	.79	6CES	.66					12B7	.85		
3BY6	.69	6AC7	.59	6AT8	.57	6C7	.72					12B7	.85		
3BZ6	.65	6AF4	1.06	6B88	1.04	6CC7	.69					12B7	.85		
3CB6	.63	6AG5	.79	6BC5	.65	6CL6	1.04					12B7	.85		
3C6	.68	6BQ7	1.19	6BD6	1.16	6CN7	.79					12B7	.85		
354	.69	6AH4	.89	6BD6	.65	6CS6	.64					12B7	.85		

BUY 20 TUBES TAKE AN ADDITIONAL 10% OFF

TUBE TESTER
Check 400 tubes
Wired **\$2.49**

HOW TO ORDER

ORDER BY "BLACK-TYPE" HEADLINES
i.e. 10 VOLUME CONTROLS—\$1

MINIMUM ORDER \$2

LEKTRON

135 EVERETT AVE.
CHELSEA 50, MASS.

AVG. WT. 1 lb. per pak. State price with each item. Send check or M.O. including sufficient postage; excess returned. C.O.D. orders, 25% down; paid, net 30 days. Include Postal Zone No. in address. (Canada postage, 18¢ 1st lb.; 28¢ ea. add'l lb.)

August, 1960

FROM HEATH...

14 NEW KITS

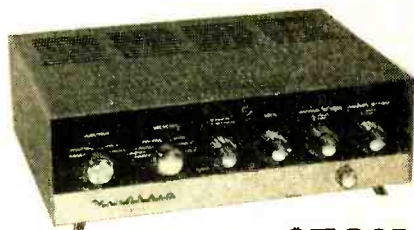

AA-50 \$79⁹⁵

HI-FI RATED 25/25 WATT STEREO AMPLIFIER-PREAMPLIFIER KIT

A complete 25/25 watt stereo power and control center (50 watts mono) . . . 5 switch-selected inputs for each channel . . . new mixed center speaker output . . . stereo reverse and balance controls . . . special channel separation control . . . separate tone controls for each channel with ganged volume controls . . . all of these deluxe features in a single, compact and handsomely styled unit! Five inputs for each 25 watt channel are provided: stereo channel for magnetic phono cartridge (RIAA equalized); tape head input; three high level auxiliary inputs for tuners, TV, etc. There is also an input for monophonic magnetic phono cartridge, so switched that monophonic records can be played through either or both amplifiers. The automatically mixed center speaker output lets you fill in the "hole-in-the-middle" found in some stereo recordings, or add extra monophonic speakers in other locations. Nearly all of the components are mounted on three circuit boards, simplifying assembly and minimizing possibility of wiring errors. 30 lbs.

New Heathkit Stereo Hi-Fi Components . . .

plus Exciting New Kits for the Ham, Technician,

Boating Fan and Hobbyist



AD-10

\$33⁹⁵

MANUAL STEREO RECORD PLAYER KIT

Made by famous Garrard of England, the AD-10 is a compact 4-speed player designed to provide trouble-free performance with low rumble, flutter and wow figures. "Plug-in" cartridge feature. Rubber matted heavy turntable is shock-mounted, and idler wheels retract when turned off to prevent flat spots. Powered by a line-filtered, four-pole induction motor at 16, 33 $\frac{1}{2}$, 45 and 78 rpm. Supplied with Sonotone STA4-SD ceramic stereo turn-over cartridge with .7 mil diamond and 3 mil sapphire styli. Mechanism and vinyl covered mounting base preassembled, arm pre-wired; just attach audio and power cables, install cartridge and mount on base. With 12" record on table, requires approximately 15" W. x 13" D. x 6" H. Color styled in cocoa brown and beige. 10 lbs.



a subsidiary of
DAYSTROM, INCORPORATED



AA-20 \$34⁹⁵

ECONOMY STEREO PREAMPLIFIER KIT

Although these two new Heathkit models are designed as companion pieces, either one can be used with your present stereo system. The preamplifier (AA-20) features 4 inputs in each stereo channel and gives you a choice of 6 functions. It will accommodate a magnetic phonograph (RIAA equalized), a crystal or ceramic phonograph, and two auxiliary sources (AM-FM tuners, TV, tape recorders, etc.) and is completely self-powered. The six-position function selector switch gives you instant selection of "Amplifier A" or "Amplifier B" for single channel monophonic; "Monophonic A" or "Monophonic B" for dual channel monophonic using both amplifiers and either preamplifier; "Stereo" and "Stereo Reverse". 8 lbs.



AA-30 \$45⁹⁵

HI-FI RATED 14/14 WATT BASIC STEREO AMPLIFIER KIT

Two 14-watt high fidelity amplifiers, one for each stereo channel, are packaged in the single, compact, handsomely styled amplifier (AA-30). Suitable for use with any stereo preamplifier or with a pair of monophonic preamplifiers, it features individual amplifier gain controls and speaker phase reversal switch. Output terminals accommodate 4, 8 and 16 ohm speakers. 21 lbs.



SA-2 \$54⁹⁵

HI-FI RATED 14/14 WATT STEREO AMPLIFIER KIT

A tremendous dollar value in the medium power class, this top-quality stereo amplifier-preamplifier combination delivers full 14 watts per stereo channel (28 watts monophonic) to drive your stereo system with ease, while versatile controls give you fingertip command of its every function. In addition to "stereo" and "stereo reverse" functions, the SA-2 provides for complete monophonic operation. Inputs on each stereo channel accommodate "magnetic phono" (RIAA equalized), "crystal phono", "tuner" and high level auxiliary input for tape recorder, TV, etc. Other features include a speaker phase-reversal switch, clutched volume controls, ganged tone controls, filament balance controls, and two AC outlets to accommodate accessory equipment. Handsomely styled in black with inlaid gold design. 23 lbs.



SA-3 \$29⁹⁵

UTILITY RATED 3/3 WATT STEREO AMPLIFIER KIT

Your least expensive route to stereo, the SA-3 delivers 3 watts per stereo channel (6 watts monophonic), adequate for average living-room listening. The high level preamplifier has two separate inputs for each channel and is designed for use with ceramic or crystal cartridge record players, tuners, tape recorders, etc. Featured are ganged bass and treble tone controls, clutched volume controls, channel reversing switch, speaker phase reversal switch and mono-stereo function selector switch. Attractively styled with satin-black cabinet. 13 lbs.

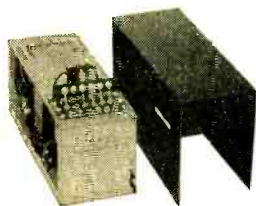

AN-10 \$19⁹⁵

MIXED LOWS STEREO CROSSOVER NETWORK KIT

The AN-10 makes it possible for you to convert to stereo or improve your present stereo system by using just one bass "woofer"; saves buying a second bass speaker, permits using more economical "wing" speakers, improves the bass response of any stereo system. Delivers the non-direction bass frequencies of both channels below 250 cps to a single woofer and passes the higher frequency stereo channels to a pair of wing speakers. Rated at 25 watts per channel. Matches 8 or 16 ohm woofers, 8 ohm high frequency speakers, or Heathkit SS-1-2-3 speaker systems. 10 lbs.

TURN PAGE FOR MORE HIGH QUALITY DO-IT-YOURSELF KITS



HEATHKIT® GIVES YOU MORE IN THESE TEN WAYS:

1. **Building a Heathkit is easy**—Check-by-step instruction manuals make it virtually impossible for you to fail.
2. **Building a Heathkit is quick**—No complicated, technical jargon for you to decipher; at most, a Heathkit takes only a few evenings to assemble.
3. **Building a Heathkit is economical**—Mass production and purchasing economies are passed directly along to you, our customers.
4. **Building a Heathkit is educational**—As you build, you learn . . . more about electronics, more about the component units and when and where to add them.
5. **Building a Heathkit is fun**—Nothing quite equals the sense of achievement you receive when you successfully complete a Heathkit unit and "tune-in" for the first time.
6. **Your Heathkit is Guaranteed**—Every Heathkit unit is guaranteed to meet advertised performance specifications . . . or your money will be cheerfully refunded.
7. **Your Heathkit is available on Convenient Credit**—Our time payment plan makes it possible for you to order now . . . pay later.
8. **Your Heathkit is Tops in Quality**—The very finest in electronic equipment comes to you in kit form from the Heath Company.
9. **Heathkit Dealers can Serve you Locally**—Carefully selected Heathkit representatives are available in most localities.
10. **Heathkit Service is Customer Service**—Our staff of technical experts is always ready to answer your questions or help you if you have any difficulty.



GC-1
\$109⁹⁵

\$11.00 dn., \$10.00 mo.



XR-2P
\$29⁹⁵

(6 lbs.)



XR-2L
\$34⁹⁵

(7 lbs.)

TEN-TRANSISTOR "MOHICAN" GENERAL COVERAGE RECEIVER KIT (GC-1)

An excellent portable or fixed station receiver. Many firsts in receiver design, ten transistor circuit, flashlight battery power supply and new ceramic IF transmitters. The amazing miniature transmitters used in the GC-1 replace transformer, inductive and capacitive elements used in conventional circuits for shaping bandpass; offer superior time and temperature stability, never need alignment, provide excellent selectivity. Telescoping 54" whip antenna, tuning meter, fly-wheel tuning and large slide-rule dial also featured. Covers 550 kc to 30 mc in five bands. Electrical handsbread on five additional bands cover amateur frequencies from 80 through 10 meters. Operates up to 400 hours on 8 standard size "C" batteries. Sensitivity: 10 uv, broadcast band; 2 uv, amateur bands, for 10 db signal-to-noise ratio. Selectivity: 3 kc wide at 6 db down. Measures 6½" x 12" x 10", 20 lbs.

HEATHKIT XP-2. Plug-in power supply for 110 VAC operation of GC-1. 2 lbs. \$9.95



HD-19
\$34⁹⁵



HD-20
\$14⁹⁵

6-TRANSISTOR PORTABLE RADIO KIT (XR-2 Series)

Unsurpassed quality and styling are combined in these handsome sets to provide you with superb and dependable portable entertainment wherever you are—wherever you go! Choose the gleaming, two-tone molded plastic model or the handsome simulated leather-and-plastic combination—both feature a gracefully curved grille in smart beige plastic. The XR-2P complements the handsome grille with a mocha colored case of high-impact plastic, while the XR-2L encases the beige grille in suntan color Sur-U-Lon simulated leather. Vernier tuning control gives you smooth, precise station selection. Six Texas Instrument transistors are used for quality performance and long life; a large 4" x 6" PM speaker with heavy magnet provides "big set" richness of tone. Ready to play after simple assembly—transformers prealigned. Six flashlight batteries used for power (500—1,000 hrs.) (Batteries not included).



HW-19 (10 meter)
HW-29 (6 meter)

\$39⁹⁵
each

ORDERING INSTRUCTIONS

Fill out the order blank below, giving us your name and address in the space provided at right. Include charges for parcel post according to weights shown. Express orders are shipped delivery charges collect. All prices F.O.B. Benton Harbor, Mich. A 20% deposit is required on all C.O.D. orders. Prices subject to change without notice. Dealers and export prices slightly higher.

QUAN.	ITEM	MODEL NO.	PRICE

Ship via Parcel Post Express C.O.D. Best Way

FREE CATALOG!

Over 150 items of stereo, marine, amateur and test equipment are illustrated and described in the complete Heathkit Catalog.



HEATH COMPANY Benton Harbor 10, Mich.
Please send my free copy of your complete catalog.

NAME _____

ADDRESS _____

CITY _____ ZONE _____ STATE _____

New! One switch operation

"HYBRID" PHONE PATCH KIT (HD-19)

Transfer calls from ham rig to telephone by flipping a single switch! Allows voice control (VOX) or manual operation. VU meter monitors output to 600 ohm line and serves as null depth indicator. Separate receiver and transmitter gain controls. Provides better than 30 db isolation between receive and transmit circuits. All leads filtered to minimize RF feedback. Matches receivers with 3 to 16 ohms impedance. 4 lbs.

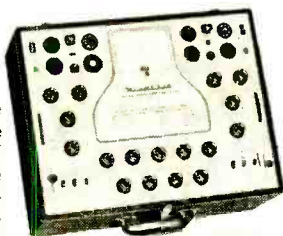

TT-1
\$13495

\$13.50 dn., \$12.00 mo.

NEW 100 KC CRYSTAL CALIBRATOR KIT (HD-20)

This versatile ham aid provides marker frequencies every 100 kc between 100 kc and 54 mc. Use to align all types of communications equipment. Features transistor circuit dependability, battery power portability, and crystal control accuracy. .005% crystal supplied. 1 lb.



Two brand new models

HEATHKIT 10 & 6 METER TRANSCEIVERS

Complete ham facilities at low cost! Ideal for beginning and veteran hams for local net operations. Transmitter and receiver are combined in one easy-to-use instrument. Features neat, modern styling, press-to-talk transmit/receive switch, built-in AC power supply, variable receiver tuning, variable gain control, and amplifier metering jack. Operates mobile using vibrator power supply. Microphone and two power cables included. Handsomely styled in two-tone mocha and beige. Less crystal.

VIBRATOR POWER SUPPLIES: VP-1-6 (6 volt), VP-1-12 (12 volt). 4 lbs. Kit; **\$8.95** each. Wired; **\$12.95** each.



EK-1
\$1995

MUTUAL CONDUCTANCE TUBE TESTER (TT-1)

The impressive list of its features make this tube tester a fine value. Tests Gm (amplifiers) from 0-24,000 micromhos, Emission, Leakage, Grid current ($\frac{1}{4}$ microampere sensitivity). Voltage regulators (built-in variable DC power supply), Low power Thyratron and Eye tubes. Features 300, 450, and 600 ma constant current heater supplies, life test, Hybrid tube test, built-in switch operated calibration circuit. Large easy-to-read meter, and constant tension free-rolling roll chart mechanism. Individual selector switches allow testing any tube type, regardless of basepin connections, protecting against obsolescence. Assembly simplified by 7 wiring harnesses and transformer terminal board. Assembly skill of technician or higher recommended, time 40 hours average. Black leatherette case with white trim, nylon feet, removable top. 27 lbs.

EDUCATIONAL KIT (EK-1)

Teaches, as you build, the basic "yardsticks" of electronics—opens up fascinating areas of study for youngsters and adults alike. The combination kit and text-workbook gives you a practical demonstration of the principles of voltage, current and resistance; the theory and construction of direct current series and parallel circuits, voltmeter, ammeter and ohmmeter circuits and the application of ohms law to these circuits. The completed meter is used to verify ohms law and the maximum power transfer theorem, one of the most important theorems in electronics. The finished kit, a practical volt-ohm-milliammeter, may be used in a variety of applications. Procedures for checking home appliances and automobile circuits included with the kit. The EK-1 will serve as a prerequisite to following Heathkit Educational kits. Get started NOW in this new and exciting series of "learn-by-doing" educational kits. 4 lbs.

See Your Heathkit® Dealer*

*The convenience of Local Heathkit Sales and Service costs but a few dollars more.

Carl and Jerry

(Continued from page 102)

surface still clinging to the red gasoline can to keep himself afloat. The other man could be seen trying to hang on to the overturned boat. Every few seconds a wave would tear him loose or even tumble the boat over him, but each time he would swim back to it and hang on desperately.

"Can't they swim to the shore?" Jerry asked.

"Those waves would beat a man to a



bloody pulp against the rocks before he could ever get a foothold," the bait man said. "If we only had a boat big enough to go out there and get them!"

Without a word Jerry raced to the top of a rickety wooden tower that overlooked the mouth of the inlet and began talking earnestly into the microphone of the transceiver. In a few panting sentences he explained the situation to Carl, who relayed the information to Uncle George.

"Keep them in sight if you can. We're on our way!" he heard Carl's excited voice coming from the earphone.

IT SEEMED a long time, although it was really only a matter of minutes, until Jerry heard the throbbing snarl of the twin outboards and saw the white prow of the little cruiser coming straight down the center of the inlet. Under the powerful thrust of the two motors going at full throttle, the cruiser was coming like a rock skipped over the surface. Uncle George was steering with one hand and holding the transceiver to his ear with the other. Carl had crawled out on the deck at the bow with a life preserver attached to a rope.

Without hesitating, the little cruiser ploughed straight ahead into the boiling,

surging water. "Off to the left, off to the left!" Jerry shouted into the transceiver mike as he caught a glimpse of the bobbing red can on the top of a wave far out from the mouth of the inlet. Obediently the cruiser turned in that direction.

The man grasped the life preserver Carl threw to him, released the gasoline can, and let Carl pull him over to the cruiser. Carl helped him up over the bow away from the dangerous propellers that kept the boat headed into the wind.

Then the cruiser turned and came back to the nearly-submerged boat and its human barnacle. The boat was floating so low in the water that it couldn't be seen at all from the cruiser wallowing amid the deep waves, but Jerry steered them to it from his vantage point high above the water. The second man was so crazed with fear that he wouldn't let go of the boat and swim a few strokes to the life preserver tossed near him. But when another wave knocked him loose from the boat, he hooked an arm blindly through the preserver and was pulled to the tossing cruiser.

Carl got the man by the arms and pulled the upper part of his exhausted body across the bow. Then the boy held him there with his feet still dangling as the cruiser ploughed back through the seething water at the mouth of the inlet and turned into the quiet of the boat basin. The rescued men were helped into a nearby cabin and given stimulating cups of hot coffee.

THE TWO BOYS and Uncle George decided they had enough excitement for one day, so they backed the trailer into the water and quietly loaded the boat. The fish were placed in the ice chest, the gear was

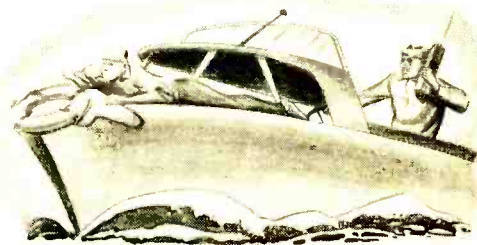

put into the truck, and in a matter of minutes they were on the highway.

"Boys, it was mighty lucky for those two fellows back there that you had your radio gadgets along with you today," Uncle

George suddenly commented. "I'm thinking that a little radio in my boat might be a darned good thing. Looks like I'm going to have to get a ham license."

"Not necessarily, Uncle G.," Jerry answered. "I think a Citizens Band installation would be just the ticket for talking from a fellow's boat to his car, his cottage, or to a fish camp. Maybe it would be a good idea for a boat livery owner to equip his boats with Citizen-Band transceivers. Boats with big outboard motors have a starting battery that could power the sets. And people who already have a transceiver could rent a crystal that would put them on the frequency of the base station at the fish camp where they put their boat in. Then they could call in if their motor conked out, if the boat operator became ill, or just to ask about bait, the weather, or what the fish were biting."

For a few miles they rode along thinking about the interesting possibilities of this idea. Then Carl broke the silence: "You know that salt breeze still smells good to me, and it doesn't make me sick; but somehow it smells kinda different than it did before. It's like the smell of gunpowder or the ozone odor you get around a high-tension arc. It's pleasing, but there's an air of danger about it, too," he finished with a shiver inside his damp clothing.

"That's good," Uncle George said with sudden seriousness. "This afternoon you boys learned respect for the sea. Lack of such respect nearly cost those two men their lives, and it does take the lives of many people every year. Never forget that there are very few careless old men around salt water."

-30-

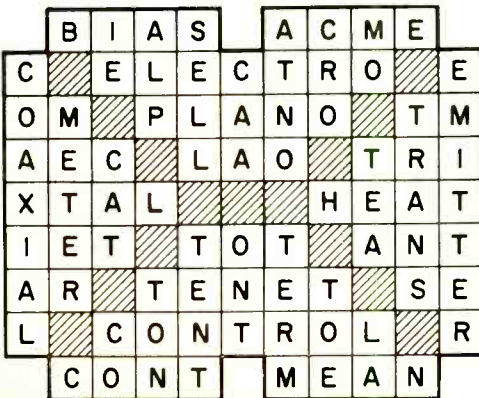

Answer to crossword puzzle appearing on page 98.

August, 1960

Attention



YOUNG MEN AND WOMEN

An Avionics career can give you Money — Security — Respect. Two World Renowned names PHILCO and SPARTAN bring you the finest training on the newest and most modern equipment available today. Radar - Radio - Transistors - Television - Modulars and Solid State Computers.

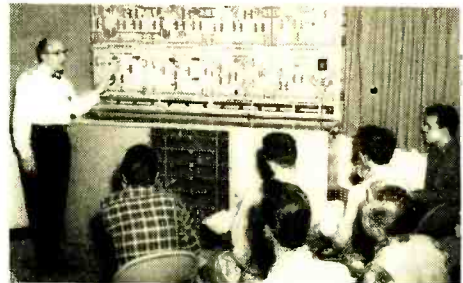

You Must Act NOW!

WHICH CAREER INTERESTS YOU

- New Avionics
- Jet Mechanic
- Co-Pilot Engineer
- Commercial Pilot
- Link Trainer
- Instrument Mechanic



Director of Admissions
Spartan School of Aeronautics
Municipal Airport • Tulsa, Okla.

Name.....

Address.....

City..... Age.....

Zone..... State.....

Spartan Alumni • Write George Goodhead
P. O. Box 15852 • Tulsa 9, Oklahoma

MOBILE-FIXED CONVERTER

POLICE • FIRE • CITIZENS' BAND

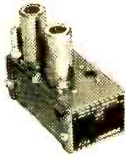

For Use with
12 V. Transistor Type
Car Radios
26-50 MC

#331B—Complete with crystal and tubes. Requires no high voltage supply. Operates on 12 V. DC. Self installed in seconds. **\$24.95**
Other models for 108-162 MC available.

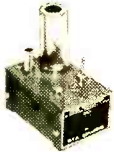

#315A is a practical converter for emergency use. Easily installed. Tuning range approximately 12 MC in the 26-50 MC band—30 MC in the 108-174 MC band. Designed for mobile or home use. **\$13.95**

Available crystal controlled up to 54 MC. **\$19.95**
Also available crystal controlled up to 165 MC. **\$22.95**



#316A VARIABLE CONVERTER. Front panel tuning permits rapid change between separated signals over 10 MC range in 26-54 or 108-174 MC bands. **\$19.95**

#341A CITIZENS BAND TUNEABLE CONVERTER. This universal converter covers the entire Citizens Band and is designed for use with home, car or communications sets—AC-DC or standard models. Also available: 200-400 KC Aircraft, 2-3 MC Marine, 4.5 MC-CAP. or 2-174 MC. **\$24.95**

Full line of converters and receivers for every application.

ORDER TODAY or WRITE for LITERATURE

KUHN ELECTRONICS

20 GLENWOOD CINCINNATI 17, OHIO

GET
INTO

ELECTRONICS

V. T. I. training leads to success as technicians, field engineers, specialists in communications, guided missiles, computers, radar, automation. Basic & advanced courses in theory & laboratory. Assoc. degree in 29 mos. B. S. obtainable. ECPD accredited, G.I. approved. Graduates with major companies. Start Sept. Feb. Dorms. campus. H. S. graduates or equivalent. Catalog

VALPARAISO TECHNICAL INSTITUTE

Dept. PE VALPARAISO, INDIANA

OFFICIAL U.S. GOV'T. WEATHER REPORTS
ON YOUR CAR RADIO!

Be a weather expert! TC-1 Weather Radio receives 24 hour aircraft weather reports (200-400 K.C.) on your car radio. Minutes to install, no electrical connections, won't interfere with AM reception. Nationwide reception. 3 year guarantee. Send check or money order, \$35.50, postpaid.

Boulevard Electronics, 1229 W.
Washington, Chicago Ill. Dept. PE-8



Send for free
illustrated brochure



LOOK

NO FURTHER . . . IF YOU'RE
UNHAPPY WITH "HI" HI-FI
PRICES. WRITE FOR OUR
UNUSUAL AUDIO CATALOG.

KEY ELECTRONICS CO.
120-B Liberty St., N. Y. 6

Analogy Quiz Answers

(Quiz appears on page 99)

1. **G.** Because of its magnetic field, an inductor has the ability to resist any change in the amount or direction of the current flowing through it—we call this property "electrical inertia." A heavy grinding wheel, because of its mass, has mechanical inertia and tends to resist any change in its speed or direction of rotation.
2. **D.** A rectifier in an electrical circuit permits electron flow in only one direction. A ratchet wheel and check pawl likewise permit rotation in only one direction.
3. **C.** A capacitor stores electrical energy in its dielectric when it is charged, and the energy is recovered when you provide a discharge path for it. The coil spring in a jack-in-the-box stores mechanical energy in its stressed turns when the spring is compressed; this energy is recovered when you open the box.
4. **H.** A fuse element can carry little more than the normal current for its circuit; when an overload occurs, it is the first thing to burn in two and thereby open the circuit. The fuse may be compared, then, to the weakest link in a chain.
5. **B.** A resonant circuit will oscillate at a frequency determined by the inductance and capacitance present. A tuning fork oscillates as well, but at a frequency determined by its mechanical construction.
6. **A.** A transformer takes electrical energy supplied to its primary winding as a large current at low voltage and provides us with virtually the same amount of energy delivered as a small current at high voltage from its secondary winding. A gear train receives mechanical energy at high speed and low torque and converts it for use by a device requiring the same amount of power supplied at low speed and high torque.
7. **E.** An open switch stops electron flow in the same manner as a closed faucet stops the flow of water.
8. **F.** A resistor limits the current in a circuit, but converts some of the electrical energy into heat while doing so. The brake shoe on the wagon wheel limits the speed of its rotation, and changes some of the mechanical energy into heat.

ELECTRONIC KITS 1960 DIRECTORY



500 ELECTRONIC KITS

WHAT THEY ARE!

WHAT THEY COST!

WHAT THEY DO!

Yours in the brand new 1960

ELECTRONIC KITS 1960 DIRECTORY

Here it is—the only complete, comprehensive directory covering the exciting world of electronic kits! It's yours in the 1960 ELECTRONIC

KITS DIRECTORY — over 160 pages — listing over 500 kits of all kinds. Each listing gives you manufacturers, specifications, prices, everything you need to know about kits!

You'll find such informative features as:

- **GIANT KIT BUILDERS GUIDE**

Gives you the latest improvements, and innovations in kits...helps you select the right kit...identifies parts for you, too!

- **COMPLETE SURVEY AND DIRECTORY OF:**

Kits for HI-FI—make your own amplifiers, preamps, speakers, turntables, stereo control units, and tone arms.

Kits for COMMUNICATIONS—Rundowns on kits for oscilloscopes, tube testers, power

supplies, transmitters, receivers, transceivers. Kits for EDUCATION—Coverage of radio kits and many other special projects.

NOW ON SALE AT YOUR FAVORITE
NEWSSTAND OR ELECTRONIC PARTS
STORE **ONLY \$1.00**

Don't miss 1960 ELECTRONIC KITS DIRECTORY. Now on sale at newsstands, electronic parts stores and hi-fi salons! Buy your copy today, or order by using the handy coupon at right. Only \$1.00.

August, 1960

Ziff-Davis Publishing Company
Department PE-86
434 S. Wabash Ave., Chicago 5, Illinois
Please send me a copy of the 1960
ELECTRONIC KITS DIRECTORY. I enclose
\$1.00 plus 10¢ to cover mailing and handling
charges. (Canada and Foreign \$1.25 plus 10¢
postage).

Name _____

Address _____

City _____ Zone _____ State _____



Olson

FREE



Fill in coupon for a FREE One Year Subscription to OLSON RADIO'S Fantastic Bargain Packed Catalog — Unheard of LOW, LOW, WHOLESALE PRICES on Brand Name Speakers, Changers, Tubes, Tools, Hi-Fi's, Stereo Amps, Tuners and other Bargains.

NAME _____

ADDRESS _____

CITY _____ ZONE _____ STATE _____

If you have a friend interested in electronics send his name and address for a FREE subscription also.

OLSON RADIO CORPORATION

810 S. Forge St. Akron 8, Ohio

\$1 ELECTRONIC SALE

Buy one at the low price listed and get the second for only \$1.00 more. Price includes postage and insurance.

All merchandise is new, tested, guaranteed, and meets FCC specifications where required. Tubes, transistors, and crystals are included. Power supplies and cabinets are not.

- TRANSMITTER**, Code #253275, 5 watt, 27 mc. crystal controlled citizens band. \$14.99 ea. 2 for \$15.99.
- TRANSMITTER**, Code #253505, 5 watt, 50 to 54 mc., crystal controlled, amateur band. \$14.99 ea. 2 for \$15.99.
- TRANSMITTER**, Code #925327, 100 milliwatt, 27 mc., crystal controlled, citizens band, completely transistorized. Shirt pocket size. \$14.99 ea. 2 for \$15.99.
- CONVERTER**, Code #260270, adapts any broadcast radio to 27 mc. citizens band. Tunes all 22 channels. \$14.99 ea. 2 for \$15.99.
- CONVERTER**, Code #926027, similar to above except uses 3 high frequency transistors in place of tube. Operates on 6 or 12 volts. \$24.99 ea. 2 for \$25.99.
- NOISE SILENCER**, Code #113300, for superhet radio receivers. A superior circuit using 2 dual tubes which provides the most effective noise clipping and adjustable squeel without audio distortion or loss of gain. \$14.99 ea. 2 for \$15.99.
- RECEIVER**, Code #715271, frequency range 27 to 29 mc. citizens band and 10 meter amateur band. Sensitivity better than 4 microvolts. Battery operated. \$9.99 ea. 2 for \$10.99.
- RECEIVER**, Code #971527, 27 mc. citizens band. Pocket size, completely transistorized. Operates on 4 pen-light cells. \$16.99 ea. 2 for \$17.99.

Limited Quantity—no catalogs or literature available. All merchandise on display at our retail store at 196-23 Jamaica Ave., Hollis 23, N. Y.

Mail your order direct to our factory below.

VANGUARD ELECTRONIC LABS, Dept. E-8
190-48 99 Ave., Hollis 23, N. Y.

How and Why of Solder

(Continued from page 69)

soldering tip and retarding heat transfer.

"Right" and "wrong" soldering techniques are illustrated in Fig. 3. The iron's tip is held flat against the work and the solder is applied at the junction of the tip and the wire to be soldered. Once the solder is applied, the joint must be held stationary while the iron is removed and until the soldered connection cools sufficiently for the solder to solidify. If the connection is disturbed while the solder is in a "plastic" state, the bond may be broken or the solder may solidify in small, high-resistance crystals, giving the joint a "frosty" appearance.

A special soldering technique, often used for soldering aluminum, is illustrated in Fig. 4. Here, a special "aluminum solder" alloy is employed, and the work is heated with a torch flame. A fiberglass brush,

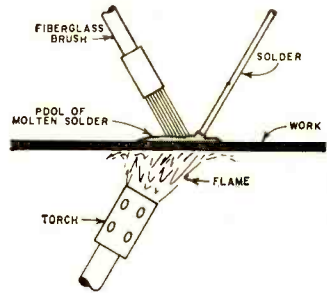

Fig. 4. Special technique often employed in soldering aluminum.

rather than a chemical flux, is used to break up the oxide film on the work's surface. Suitable brushes and aluminum solder are available at most hardware stores.

In practice, the torch flame is applied to the *back* of the work, for the flame itself can serve as a strong oxidizing agent. The solder is melted in a pool, and the fiberglass brush is rapidly rubbed back and forth across the metal surfaces. If two pieces of aluminum are to be joined together, each is "tinned" individually using this technique. Afterwards, the tinned surfaces are clamped together and the torch flame applied to "sweat" the joint together.

Good soldering is absolutely essential to top performance in electronic equipment. And you don't have to be a genius to do an expert job—it's simply a matter of a little knowledge and a little practice.

Test Instruments

(Continued from page 82)

erally react adversely to even the slightest leakage. For this reason, many manufacturers are now turning out highly sensitive leakage testers, both as separate units and as part of regular testers. More about this next month.

Incidentally, "shorts" will show up across the filament or heater terminals, and in cases where single elements are connected internally to more than one pin. A "short" indication here, of course, is perfectly normal, and the tube-tester chart will indicate where these normal "shorts" should appear.

If shorts other than normal ones show up during testing, the tube should be discarded. A shorted tube can, under certain conditions, damage a tube tester if the tube is tested for emission or mutual conductance. For this reason, tubes should *always* be tested for shorts first, and thrown out immediately if shorted.

Testing for Noise. Many testers provide a circuit for testing noisy or potentially noisy tubes, and this is a logical test to make next. Loose tube elements fre-

quently cause noise. These elements tend to vibrate, changing inter-electrode spacing and hence capacitance and other circuit constants.

Figure 3(A) shows a simplified diagram of the noise-testing circuit of the Superior Model TW-11 tube tester. Using a switching circuit similar to that used for short testing, one element at a time is hooked through a pair of magnetic headphones (crystal phones won't do here) to one side of a transformer. The other tube elements—all shorted together—are hooked to the other side. Figure 3(B) shows a still further simplified diagram with the grid under test, and the switching circuits eliminated for clarity. Tap the tube lightly with your finger during the test; if there are any loose elements, they will vibrate and cause a ringing or "pinging" in the headphones.

At this point, we are ready to test emission or mutual conductance—depending on your tester—and run checks for open elements and gas. Next month, we'll examine these functions in detail, and look over the field of "quick" testers, cathode-ray testers, transistor testers, and other special-purpose instruments.

-30-

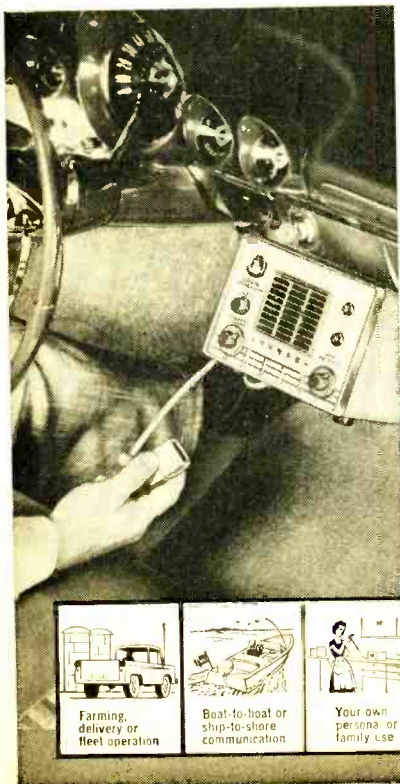

"More than Citizens' Radio" ...
a complete, fully engineered "industrial-type" transceiver!

VIKING *Messenger*

Anyone can operate—license issued by the FCC on request

from **\$129⁷⁵**

- Complete 23 channel Citizens' Band coverage—choose 1 of any 5 channels by the flip of a switch.
- Maximum legal power—excellent range—meets all FCC requirements.
- Excellent receiver sensitivity and selectivity—full fidelity voice reproduction.

"More than just 2-way Citizens' Radio equipment"—the Viking "Messenger" will deliver the finest performance of any equipment available in the field. Designed throughout for 10 watt power level—limited to 5 watts for Citizens' Radio. Easy to install anywhere in your home, business location, car, truck or boat . . . offers many unique features found only on more expensive communications systems. Built-in Squelch, Automatic Volume Control, and Automatic Noise Limiter. Compact, modern styling—only 5 3/8" high, 7" wide, and 11 3/8" deep. Complete with tubes, push-to-talk microphone, and crystals for one channel.



Available from authorized Johnson Electronic or Marine Distributors. Installation and service coast-to-coast at all General Electric Communications Service Stations.



Farming, delivery or fleet operation



Boat-to-boat or ship-to-shore communication



Your own personal or family use



Construction or "off-the-road" equipment

FREE
Color Brochure



WRITE TODAY

E. F. JOHNSON COMPANY

125 Second Ave. S. W. • Waseca, Minnesota
• Please rush me your full color brochure describing the Viking "Messenger" Citizens' Transceiver.

NAME _____

ADDRESS _____

CITY _____ STATE _____

Manufacturers of the world's most widely used personal communications transmitters

Russian-English Translator

(Continued from page 59)

When a Russian word is fed in, the computer translates it into its "binary" language—a series of light and dark spots in a certain order. Then a light beam searches through the words recorded on the disc until it finds a word in binary form that is identical to the one just fed in. Recorded immediately after the word is its English equivalent, also in binary form. The beam "reads" this word, then signals the proper keys on an electric typewriter, and the word is typed out in English. (A more detailed description of the computer's operation begins on page 60.)

Because of the wide differences between English and Russian grammar and sentence structure, the English translation is usually far from a literary masterpiece. For example, the Russian title of a recent *Pravda* article used to test the machine was "New Secrets of the Universe to be Revealed." It came out of the translator, "Will Open New Secret Universe."

Fed by Hand. The machine now operates at only about 40 words a minute, since the text to be translated must be fed in by a human typist. But the translating circuits which compare the incoming words with those on the machine's dictionary are capable of finding some 1800 words per minute. With several typists preparing tapes, the translator will operate at this faster speed—the equivalent of about one full-length book per hour.

In the future, the tedious task of hand typing will be entirely eliminated. Baird Atomic, Incorporated, of Cambridge, Mass., is working on a high-speed Russian print scanner that will read printed Russian words electronically and feed them into the translator.

Also in an advanced stage of development is a device which will give the translator a few pointers on the English language. This gadget, called a word analyzer, will check each sentence coming out of the machine and make any necessary grammatical corrections before sending the translation to the printer.

More Words, Less Cost. The new translator will be tremendously useful not only to scientists, but to government officials, scholars, and others vitally interested in the wealth of information contained in Russian publications. At this time, several

billion words on scientific subjects alone flow from Soviet presses each year. The U. S. Government currently spends about \$1,500,000 translating some 80 million words, a small fraction of the Soviet output. Because of the time and expense involved, the rest—no matter how important—must go untranslated.

The Air Force estimates that its entire machine-translation project will cost something over \$5,000,000. Since Uncle Sam now spends about a third that amount every year for translation and gets only a fraction of Soviet output, the machine is expected to pay for itself in a short time. Even more important, virtually all Russian publications of importance will be translated.

In Russia, over 2600 full-time translators and 26,000 part-time scientist-translators publish 500,000 abstracts of English technical books and articles each year. Several years ago it became clear that the U. S. would never be able to translate a comparable amount of Russian into English by conventional methods. It was then that the idea of developing a translating machine was born.

Project Near Completion. The Air Force program got under way in 1955 and is expected to be completed in 1961. By that time, the automatic scanner will have been added to eliminate manual typing, and the English translation will flow continuously from one or more high-speed automatic printers. The machine's vocabulary will probably have been expanded tenfold to about 500,000 words, including virtually every existing word in both English and Russian. The word analyzer will also be in operation, so the machine will not talk like an illiterate.

When will it go into day-by-day use? A new transistorized version is now being built for the government by IBM at its Kingston, N. Y., plant. The new unit, based on the experience gained during the construction of the first model, will be faster, ultra-reliable, and much more compact. Scientists say it will be able to handle all of the government's translation needs. But since improvements are still being incorporated almost daily, the specific date when the new computer will begin earning its keep has not been set.

Although the machines will be used first to translate Russian technical and scientific documents needed by our scientists and engineers, they will find many other uses

as well. Economists, psychologists, physicians, geologists, scholars, and specialists in almost every field of human knowledge are anxious to find out what the Russians are doing in their fields.

Similar machines for translating other languages are also on the way. For example, IBM has developed a French translator which has about 23,000 words in its vocabulary and is already being used to translate mathematical papers. Dr. Gilbert King of IBM, inventor of the Russian-English translator, sees no reason why the same principles could not be applied to any language—even oriental ones. His machine, he says, "is a major breakthrough towards the automatic translation of all languages." -30-

How the Translator Works

(Continued from page 62)

number, a difference voltage will be generated and applied to the beam-controlling servo. This signal develops just enough force to make the beam jump one track in the right direction, where it locks in again.

The beam samples the first word it comes to. If the number is again not high enough, the voltage is developed to make it jump once more. The beam continues to jump until it has gone one band *past* the proper one. At this point, a voltage of the opposite polarity is developed. This voltage drives the beam *back* one band, and there it locks in and begins to search for the matching word.

Incidentally, the search circuit is so fast that even if the beam has to travel across all 700 tracks before finding a match—a rare occurrence—the total time of the search will be less than 1/1200 of a second. A cathode-ray tube is employed as the light source because its moving spot of light can be easily and quickly moved about during the search procedure.

Using only refinements of current techniques—no breakthroughs would be needed—a translator could be made in which the tracks would be only one-third their present size, and the disc would spin at three times its present speed. This would mean that the same amount of disc surface would hold 10 times as much material, and could be read out many times faster. -30-

TRU-VAC 1-YEAR GUARANTEED RADIO and TV TUBES

Factory Used or Factory Second Tubes! TRU-VAC will replace FREE any tube that becomes defective in use within 1 year from date of purchase!

ALL TUBES INDIVIDUALLY BOXED, CODE DATED & BRANDED "TRU-VAC"
 Partial Listing Only . . . Thousands More Tubes in Stock!

SPECIAL!		65N7GT 30¢		6W4GT 30¢					
024	48Q7A	6AH6	6BD6	6CF6	6N7	6X8	7X6	12BD6	12W6GT
1A7GT	48S8	6AK5	6BE6	6CG8	6Q7	6Y6G	7X7	12BE6	12X4
1B3T	48Z7	6AL5	6BF5	6CH8	6S4	7AA	XXL7X4	12BH7	19AU4GT
1H5GT	4C96	6AW8	6BG6G	6CL6	658GT	7A5	7Z4	12BQ6	19B6GG
1R5	5AMR	6AN8	6BH6	6CM6	65D7G	7A6	12A8	12BR7	19T8
1S5	5ANR	6AQ5	6BJ6	6CW7	65F5	7B4	12A85	12B7	2526GT
1T4	5AT8	6A06	6BK5	6CN7	65G7	7B5	12AQS	12CA5	35A5
1U4	5AV8	6A07	6BK7	6CQ8	65H7	7B6	12AT6	12D4	35B5
1U5	5A24	6AR5	6BL7GT	6CR6	65J7	7B7	12AT7	12K7	35C5
1V2	5C08	6AS5	6BN6	6CU6	65K7	7B8	12AUG	12L6	35W4
1X2	5R4	6AT6	6BQ6GT	6CV6	65L7	7C6	12AV6	12Q7	35Z5
2A4F	5T8	6AU4GT	6BQ7	6D6	65M7	7C7	12AW7	12S7	50A5
2B4M	5U4	6AUSGT	6BR8	6DE6	65N7	7C7	12AX7	125J7	50B5
2C15	5U8	6AUR	6BS8	6DG6GT	6T4	7E6	12AX7	125K7	50C5
3A15	5V4G	6AV5GT	6BY5G	6DQ6	6T8	7E7	12A27	125N7	50L6
3BC5	5V6GT	6AV6G	6BZ6	6F6	6U5	7F7	12B86	125Q7	117Z3
3RN6	5X8	6AW8	6BZ7	6H6	6U8	7F8	12BA6	125R7	127Z3
3RZ5	5Y3	6AX5GT	6C4	6J5	6V6GT	7G7	12BA7		
3CB6	6AB4	6BB	6CA8	6J6	6W6GT	7H7			
3S4	6AF4	6BC5	6CB6	6J7	6X4	7Q7			
3V4	6AH4GT	6BC8	6CD6G	6K7	6X5GT	7S7			

BRAND NEW 1-YEAR GUARANTEED TV PICTURE TUBES

Below listed prices do not include dot. Add Additional \$5.00 Deposit on tube sizes to 20" on 21" and 24" tubes—\$7.50. Deposit refunded immediately when dot is returned unopened. Unwarranted tubes—\$4.00 extra. Picture tubes shipped only to continental USA and Canada—All tubes F.O.B. Harrison, N. J.

103P4	7.99	17CP4	16.99	21AMP4	17.99	21KP4	18.39
16CP4	16.09	17TP4	16.39	21VP4	18.79	21YP4	18.39
16RP4	11.99	20CP4	15.89	21WP4	17.49	21XP4	17.49
17VP4	15.49	20HP4	17.89	21EP4	17.29	21YF4	18.39
17BP4	12.49	21ALP4	18.73	21P4	16.39	24CP4	27.79

ATTENTION QUANTITY USERS! Big Discounts Are Yours . . . Call or Write For Our 1000 Tube "Private Label" Special!

Money cheerfully refunded within five (5) days if not satisfied!

SHIPPING INSTRUCTIONS: TRU-VAC PAYS YOUR POSTAGE on orders of \$5 or more in USA and Territories. Send approximate postage on Canadian and foreign orders. Any order less than \$5 requires 25¢ handling charge. Send 25¢ on C.O.D.'s.

ANY TUBE NOT LISTED ALSO AVAILABLE AT 35¢ EACH!

1 Month Only!
TRU-VAC 1-YEAR GUARANTEED RADIO & TV TUBES GET 2 TUBES FOR THE PRICE OF 1—PLUS A PENNY!
35¢ EACH TUBE! PER 100 TUBES
 • Buy all the tubes you want for 35¢ each, and get extra tubes for leech dollars and get 100 extra tubes for 35¢.
 Take your pick now the tubes! . . . types
6AC7 6CS7 7N7
6AG5 6AGT 12AU7
6AU6 6SA7 12BF6
6AX4GT 7A7 12CN5
6BA6 7C4 12KS
6CG7 7C5 12RS

TRU-VAC

Harrison Avenue • Box 107 • Harrison, N. J. Humboldt 4-9770

35¢

\$33

Per 100 TUBES

16 INCH Used TV CONSOLES
 • RCA, EMERSON, ADMIRAL Other Famous Makes! All in excellent condition! Worth much more!
 All sets shipped in double cartons to prevent breakage. Shipped express in continental USA & Canada. P.O.B. Harrison, N.J.
FREE BONUS OF RABBIT EARS ANTENNA (REG. \$1.95)
 Sent FREE with each set!

BUILD YOUR OWN Concert Quality ELECTRONIC ORGAN SAVE 50%



- Step by step instructions
- Pay as you build
- Over 14 models

THE *Artisan* ELECTRONIC ORGAN

Send for free literature

ELECTRONIC ORGAN ARTS

4949 YORK BLVD., LOS ANGELES 42, CALIF.

Please send me free information



NAME _____
ADDRESS _____
CITY _____ ZONE _____
STATE _____
P-8.

FREE



Full year's subscription to RADIO SHACK'S Sensational ELECTRONICS CATALOGS

Send coupon at once! See world's largest and best line of electronic equipment. Stereo, hi-fi, ham radio, tapes—over 100,000 items for pro or amateur—all at money-saving prices. 15-day no-risk home trial on any item.

MAIL COUPON NOW!

Radio Shack Corp., 730 Commonwealth Ave., Boston 17, Mass. Dept. 60-H7
Without further request, send latest catalog plus every new issue for one full year—all FREE and POSTPAID.

Name _____
Address _____
Post Office _____
or City _____ Zone _____ State _____

SCIENCE ENGINEERING

Bachelor's degree in 27 or 36 months

Accelerated year-round program: Aero, Chemical, Civil, Elec., Mech., Metallurgical, Mathematics, Chemistry, Physics. Modest rate. Earn board. New classes start Sept., Jan., Mar., June. Catalog. 2380 E. Washington Blvd., Fort Wayne 2, Indiana.

INDIANA TECHNICAL COLLEGE

Transistor Topics

(Continued from page 94)

Duplicating this project is not too difficult, but be sure to use properly rated components. Silicon rectifiers *D1* and *D2* are 500-ma. units (International Rectifier Type SD500 or equivalent); the transistors are all Delco Type 2N278; and *C1* is a 20- μ f., 100-volt tubular electrolytic capacitor. All the resistors are 5-watt units except *R2* and *R7*, which are 20-watt wire-wounds. Jack *J1* is a standard female receptacle (Amphenol Type MIP or equivalent), and *S1* is a heavy-duty power switch. (A good trick is to use a d.p.s.t. switch instead of the s.p.s.t. type needed, wiring both poles in parallel to double current-carrying capacity.) Finally, *T1* is a Thordarson Type TR-72 power transformer.

When wiring the unit, use a fairly heavy chassis, mounting the transistors directly against the chassis to insure good heat-sinking. Use at least No. 12 gauge wire for all internal connections, and either No. 6 or No. 8 for connection to the 12-volt d.c. source—the heavier the wire, the better. If you install the completed unit in a car, check on battery polarity to make sure the negative side of the battery is grounded. If the positive terminal is grounded, insulate the inverter chassis from the car's frame.

One further tip: note that there is no fuse in the secondary circuit. But a short circuit across the output or a severe decrease in load resistance will cause the oscillator to shut off, protecting its internal components as well as the external a.c. circuit.

Incidentally, a gremlin got into the works last month and reversed the connecting lines in the block diagram of the Heath

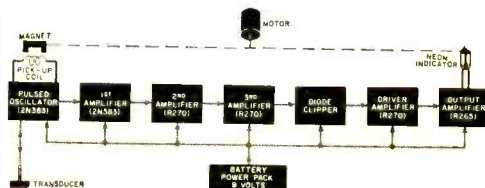

DS-1A depth sounder (page 85). We're happy to report that the gremlin has since been cornered—see correct version above.

Product News. Texas Instruments (Box 312, Dallas, Texas) is now producing the first of a series of solid circuit networks, the Type 502 binary counter. Achieving a

100:1 size reduction as compared to conventional "microminiature" circuits, the 502 assembly measures only 0.25" long by a little over 0.1" wide.

From the General Electric Company (Syracuse, N. Y.) comes word of a new manual on applications of silicon-controlled rectifiers. Running to 255 pages, the "Controlled Rectifier Manual" contains 13 chapters written by five members of G.E.'s application engineering organization. In addition to basic design data, the manual contains information on controlled rectifier characteristics, tables, charts, design nomographs, and many circuit diagrams. Priced at one dollar per copy, it is available through all G.E. semiconductor distributors.

Tiny transistorized transmitters that can be swallowed by patients are now being built by the National Institute of Medical Research, Hampstead, London, England. Once swallowed, they transmit information on internal body temperatures, acidity, and other conditions.

A new *double-emitter* transistor has been developed by RCA. A *p-n-p* drift-field type, it permits simplified design of mixer-oscillator circuits for portable and auto radio receivers; it also has potential application in small transmitters and other types of electronic equipment. Since the unit is still a developmental type, characteristics are not available at this time.

Hams will welcome the recent announcement by Pacific Semiconductors, Inc. (10451 W. Jefferson Blvd., Culver City, Calif.) that it is producing two types of triple-diffused high-frequency *n-p-n* power transistors. With maximum ratings of 140 volts for the Type PT900 and 80 volts for the PT901, both transistors have a 15-ampere peak collector current and can dissipate 125 watts. Each has an alpha cutoff frequency of (hold your breath) 50 mc.

A new line of low-current, silicon-controlled rectifiers has been introduced by General Electric Company. Eight models are available, differing only in their peak inverse voltage ratings (from 25 volts for Type C10U to 400 volts for Type C10D). Capable of handling peak surge currents of 125 amperes, these units are priced under \$10.00 each in small quantities.

That's the transistor story to date. I'll be back next month with more news and circuits.

—Low



Leo I. Meyerson, WØGFQ, Says
pay only 10% down
on these
Citizens Band Radios

GLOBE ELECTRONICS

NEW
Pocketphone

only \$12⁵⁰ down
\$7.50 Per Mo.

GIVES
YOU



NOW AT "the house
the hams built!"

- Actual Size 1 1/4 x 2 3/8 x 6 1/4
- Range 1/2 to 1 Mile
- Handy Paging System
- Requires No License

New portable high styled two-way radio that actually fits into your pocket. Exclusive "power-pak" rechargeable battery lasts a year or more. For factory, surveying, construction, department stores, stock-yards, hospitals, firemen, policemen, golf, office, and home.

\$125.00 Each

the CB-200 Broadcaster Deluxe

Especially designed for the commercial user and consumer desiring a more rugged unit. Five crystal controlled channels for transmitting. Four crystal channel receiving plus one tunable position over entire band. Adapted for selective calling system. Dual conversion eliminates interference. Absolutely quiet.

Size: 3 7/8 x 12 x 10 1/4, \$179.95 each.

the CB-100 Citizens Broadcaster

Complete 3-channel, 2-way station for permanent installation or travel. Only 3 1/2 x 10 1/2 x 13. Easy to install, operate. Only 3 controls. Range 5 - 15 miles. Complete with one set crystals, push-to-talk microphone, \$129.95 each.

WRL

WORLD RADIO LABORATORIES

3415 W. BROADWAY • PHONE 32 8-1851
COUNCIL BLUFFS, IOWA

LEO: PLEASE SEND () TALKABILITY
FOLDER ON THE GLOBE CITIZENS BAND
RADIOS.

NAME: _____

ADDRESS: _____

CITY & STATE: _____

PE-8

TV PICTURE TUBES AT LOWEST PRICES

10BP4	\$ 7.95	16WP4	\$12.00	17TP4	\$17.00	21EP4	\$13.50
12LP4	8.50	16PT4	9.95	19AP4	16.00	21FP4	14.50
14B/CP4	9.95	17AVP4	12.50	20CP4	13.50	21WP4	14.00
16DP4	12.00	17BP4	9.95	20HP4	14.50	21YP4	14.50
16EP4	12.75	17CP4	17.00	21AP4	22.10	21ZP4	13.50
16GP4	14.50	17GP4	17.60	21ALP4	15.75	24CP4	23.50
16KP4	9.95	17HP4	12.50	21AMP4	15.75	24DP4	24.50
16LP4	10.95	17LP4	11.50	21ATP4	15.75	27EP4	39.95
16RP4	9.95	17QP4	9.95	21AUP4	15.75	27RP4	39.95

1 YEAR WARRANTY

Aluminized tubes \$3.00 for 21"; \$5.00 for 24" and 27" additional. Prices include the return of an acceptable similar tube under vacuum. These tubes are manufactured from reprocessed used glass bulbs. All materials including the electron gun are brand new.

ALL PRICES FOB CHICAGO, ILLINOIS. Deposit required, when old tube is not returned, refundable at time of return. 25% deposit required on COD shipments. Old tubes must be returned prepaid. Tubes shipped Rail Express. We ship to the Continental U. S. and Canada, only.

WRITE FOR COMPLETE LIST

—PICTURE TUBE OUTLET—
2922 MILWAUKEE AVE., CHICAGO 18, ILLINOIS
Dickens 2-2048

CODE

TELEPLEX METHOD trains you to hear Code signals just as you hear spoken words—because it teaches Code SOUNDS and not dots and dashes. Thirty words with ease... fifty words not unreasonable! Starts beginner or advances your present speed. Try it for yourself and compare with anything else. 40 years experience teaching Code have made the Teleplex Method far superior to all the cheap "gimmicks" on the market. Write today for details and free trial. You be the judge! (Improved cabinet allows new low cost.)



TELEPLEX CO.

739-C Kazmir Court, Modesto, Calif.

Canadian Representative: THE HAM SHACK
1269 Granville St.—Vancouver, B. C.

**BEFORE YOU BUY...
GET THIS CATALOG
FREE!**

Send postcard today for your free G-C Catalog 158... 80 pages of valuable service aids available at your distributor.



G-C ELECTRONICS CO.

division of Textron Electronics, Inc. Western Plant: Los Angeles 18, Calif.
Main Plant: ROCKFORD, ILLINOIS, U.S.A.

engineering degree in 27 months

Grasp your chance for a better life. Rapid advancement. Better income. BACHELOR OF SCIENCE DEGREE IN 27 MONTHS in Elect. (Electronics or Power major), Mech., Civil, Aero., Chem., Engineering. IN 36 MONTHS in Business Administration (General Business, Acctg., Major Transport Mkt. majors). Small classes. More professional class hours. Well-equipped labs, Campus, Dorms. Modest costs. Year-round operation. Founded 1884. Enter Sept., Jan., Mar., July. Write J. D. McCarthy, Director of Admissions, for Catalog and "Your Career in Engineering and Commerce" Book.

TRI-STATE COLLEGE

3680 College Avenue
Angola, Indiana

118

How to Get DX

(Continued from page 54)

mission lines. No matter where I oriented the beam, Gertie's CQ's netted big ones—VK's, ZL's, HS's, VP8's, EQ's, AC4's—you name it and we got it!

What happened afterwards was inevitable. Every unmarried male operator wanted to meet Gertie, begged me for her picture and QTH. To save both parties from embarrassment, I invented some fiction about Gertie being engaged. It satisfied all but one persistent rajah in India who would not give up. He would marry her unseen, give her jewels, elephants, the works.

I told Gertie about the rajah after one of those delightful lunches she'd been making from the contents of my messy refrigerator. She laughed, (her laugh is like those tiny silver bells you hang on Christmas trees), and said, "Wouldn't I look silly on an elephant!"

I walked her home that night, her OM tagging behind us like a contented dachshund. The next evening I took her out mobiling. We had a couple of very successful QSO's and then just parked and talked.

I HAD a serious talk with Gertie's OM soon after that. "You're not *really* going to send Gertie to welding school, are you?" I demanded.

He lowered his paper. "Welding school?" He furrowed his brow. "I don't seem to recall anything about welding school."

He lifted the newspaper. I could tell without looking that there was a smile on that round face. The old coot knew all the time.

Why don't you listen for our CQ on 20 meters one of these nights? We usually come on about 8 p.m.—after the kiddies are asleep.

—30—

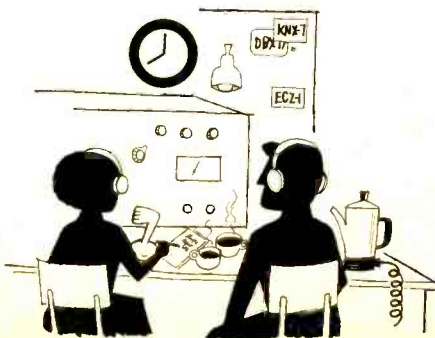

Always say you saw it in—POPULAR ELECTRONICS

Short-Wave Report

(Continued from page 96)

The following is a resume of the current station reports. All times shown are Eastern Standard and the 24-hour system is used. At time of compilation all reports are correct. The stations reserve the right to change frequency and/or schedules with little or no advance notice. Please send all reports to P. O. Box 254, Haddonfield, N. J., in time to reach Your Editor by the eighth of each month.

Albania—R. Tirana is noted on 7155 kc. at 1730-1800 with Eng. talks and music. (WPE1BY)

Andorra—R. Andorre is heard well on 5978 kc. from 0045 s/on Monday through Saturday in French and Spanish. They verified promptly with a card. (WPE8MS)

Argentina—LRA, Buenos Aires, continues to have Eng. to Europe on 15,345 kc. at 1800-1900 and to Eastern N.A. on 9690 kc. at 2200-2300. The West Coast period remains at 0002-0102, also on 9690 kc. (WPE1AGM, WPE2EG, WPE2GM, WPE5AG, WPE9BR)

Brazil—ZYF23, Radiodifusora do Maranhao, 4735 kc., has increased power to 5 kw. and wants reports. The schedule: 0350-0600, 0800-1100, and 1400-2100. Reports go to Cx. Postal 152, Sao Luiz, Maranhao, Brazil. (WPE2AXS)

Burma—"You are listening to Myanma Athan, the Burma B/C Service" is tuned on 9540 kc. at 0200 with Eng. news and classical music from 0220 to 0240 s/off. (WPE4RC/KH6)

Canada—CHNX, Halifax, 6130 kc., relays the programs of CHNS, 960 kc., at 0400-2315 (Sundays from 0800). The power is 500 watts. Reports go to Box 400, Halifax, N. S. CFRX, Toronto, 6070 kc., relays the programs of CFRB, 1010 kc., 24 hours daily, with 1000 watts power. (WPE2BJI, WPE4BFY, WPE9AGB, WPE0ADY, CS)

There have been many reports on the new voice transmission of CHU, Dominion Observatory, Ottawa, which operates on 3330, 7335, and 14,670 kc. The announcements read: "CHU, Dominion Observatory, Canada; Eastern Standard Time — hours — minutes."

Colombia—La Voz del Cauca has been noted on 6145 kc., possibly a move from 4915 kc. (or a new parallel channel), at 2149-2210 with Latin American music. (WPE2AXS)

Costa Rica—TIFC, Faro del Caribe (The Lighthouse of the Caribbean), San Jose, operates on 9645 and 6037 kc. at 1900-2300 in Spanish and from 2300 to 0000 s/off (Sundays from 2230, also at 1500-1800) in English. Reports go to TIFC, Box 2710, San Jose. (WPE6ATY, WPE6UD, WPE8WT, WPE9ADW, WPE9AGB)

TIHGB, R. Reloj, San Jose, is fair from 1900 to 0700. The schedule calls for 24-hour operations daily. Programs are basically music and time checks with commercials between records; however, news is given at 0330, 1830, and 2100. Presumably this is all Spanish. (WPE3HP)

Dominican Republic—A station thought to be R. Deportiva Tangica is actually R. De-

MICRO

ELECTRON TUBE

INTRODUCES FOR THE FIRST TIME
ANYWHERE A SELECT STOCK OF USED
TUBES AT A FABULOUS LOW PRICE

37¢

ea.

\$35

PER
HUNDRED
ASSTD.

FOR any TUBE LISTED

Jan Surplus Tubest!

ALL TUBES SENT POSTAGE PAID
Please send 25¢ handling for orders under \$5. Send 25% deposit on C.O.D. orders. Send approximate postage on Canadian and foreign orders.

MICRO

ELECTRON TUBE CO

P. O. Box 55, Dept. PE8, Park Sta., Paterson 3, N. J.

- Each and every tube is tested in our own laboratory for mutual conductance and life test.
- We guarantee FREE replacement for one year of any tube purchased from us which fails to function efficiently under any or all operating conditions. Prompt refunds; are made on any defective merchandise.
- The advertised tubes are not necessarily new, but may be electrically perfect factory seconds or used tubes—each is clearly so marked.

0A2	6X8	6BH6	6SF5	7Z4	19BG6G
02A	6Y3GT	6BJ6	6SF7	7A8	19J6
1A7GT	6Y4G	6BK5	6S17	12A05	19T8
1B3GT	6A7	6BK7	6SK7	12AT6	2A4
1H4G	6A8	6BL7GT	6SN7GT	12AT7	25A5
1H5GT	6A8A	6BN6	6S07	12AU6	25B06
1L4	6AC7	6BQ6GT	6S57	12AU7	25ON6
1L6	6AF4	6B7	6S7	12AV7	25L6GT
1N3GT	6AC5	6BY5G	6S7	12AV8	25W4GT
1Q5GT	6AG7	6BZ6	6T4	12A7	25Z5
1R5	6AM4GT	6BZ7	6U8	12AX4GT	25Z6
1S5	6AN6	6C4	6V6	12A7	25Z6
1T4	6AK5	6C5	6W4GT	12B4	26
1U4	6AL5	6C5	6W6GT	12B6	35A5
1U5	6AL7	6C6	6X4	12B7	35B5
1V2	6AM6	6C8B	6X5	12B8	35C5
1X2	6AN8	6CD6G	6C7	12B8E	35LGT
2A3	6AG5	6CF6	6K5	12B9	35S4
2A4	6AG6	6CG7	6X8	12B9E	35V4
2F4	6AG7GT	6CL6	6V8G	12BR7	35ZGT
3B3C5	6AR5	6CM6	7A4XXL	12BR7	37
3B8B	6AQ7GT	6CM7	7A5	12CA5	39/44
3B28	6AR5	6CN7	7A6	12J5	42
3CB8	6AS5	6CS6	7A7	12K7	43
3CF6	6AT6	6CS8	7A8	12L6	45
3CS8	6AT6	6C6G	7A8	12M7	50A5
3JF4	6AU4GT	6D6	7B4	12S47	50B8
3Q4	6AUSGT	6D8	7B5	12S67	50C5
354	6AU8	6D8	7B6	12S7	50LGT
3V4	6AU8	6E6	7C7	12S7GT	50X6
4B07A	6AV5GT	6H6	7B7	12S7GT	57
4B27	6AV6	6J4	7B8	12V6GT	58
5A58	6AW6	6J5	7C4	12W6GT	71A
5A78	6AX4GT	6J7	7C5	12W6GT	78
5A78	6AX5GT	6K7	7C6	12Z3	78
5AV8	6B	6K6GT	7C7	12Z3	78
5AV4	6BA6	6K7	7C7	1466	80
5B7A	6BC5	6K8	7C7	1407	80
5J8	6BC6	6L7	7E7	19	84/624
5T8	6BD8	6N7	7F7	19AU4GT	11723
5U4	6BE6	6Q7	7F8	11726	11726
5U8	6BF5	6S4	7H7	1223	78
5V4G	6BF6	6SRGT	7N7	147/1287	78
5V6GT	6BC6G	6SA7	7Q7	1466	80
		6S7	7X7/XXFM	1407	80
		6S7	7Y4	19	84/624

WRITE DEPT. PE8, FOR OUR FREE COMPLETE LIST OF TUBES & SPECIAL PURPOSE TUBES

POPULAR ELECTRONICS
AUGUST 1950



Send
POPULAR ELECTRONICS

Every
Month

name _____

address _____

city _____ zone _____ state _____

3 years for \$10

Check one: 2 years for \$7

1 year for \$4

Payment Enclosed Bill Me

In the U. S., its possessions and Canada.
Foreign rates: Pan American Union countries, add .50 per year; all other foreign countries, add \$1 per year.

Mail to: **POPULAR ELECTRONICS**
Dept. PE-86, 434 S. Wabash Ave., Chicago 5, Ill.

PURCHASING A HI-FI SYSTEM?

Send Us
Your List of
Components
For A
Package
Quotation

WE WON'T BE
UNDERSOLD

All merchandise is brand new,
factory fresh and guaranteed.

**AIREX
RADIO
CORPORATION**

64-PE Cortlandt St., N. Y. 7

CO 7-2137

PARTIAL LIST OF BRANDS IN STOCK

Jim Lansing*
Altec Lansing
Electrovoice
Jensen • Hartley
University • Stephens
Acoustic Research
Janszen
Wharfedale
Karlson Cabinets
Viking
Concertone
Bell • G.E.
Weathers
Harman-Kardon
Eico • Pilot • Fisher
Uher Recorder
Acrosound • Roberts
Bogen • Leak
Dynakit • H. H. Scott
Thorens* • Sherwood*
Artizan Cabinets
Dual Changer*
Ampex • DeWald
Sany • Challenger
Wallensak • Pentron
Garrard • Quad*
Miracord • Pickering
Glaser-Steers
Components
Rek-O-Kut • Tandberg*
Audio Tape
Norelco • Magnecord*
Fairchild • Gray
Rockford Cabinets
*Fair Traded

portiva Handicap. Apartado 81. Ciudad Trujillo. HI2LR, 1000 watts, was noted on 6205 kc. (a move from 6250 kc.) nightly from around 1730 with an occasional American pop record. (WPE1BM)

Ecuador—HCJB, Quito, carries "Morning In The Mountains" to the Americas at 0900-1130 daily on 17,890 and 15,115 kc. "Quito Calling" is beamed to Europe on the same channels at 1400-1900 daily except Mondays. "Ecuadorian Echoes" is broadcast at 2100-0000 daily to the Americas on 15,115, 11,915, and 9745 kc. Letters are answered on Sundays. (WPE1NC, WPE2BJI, WPE2BWC, WPE9AGB, WPE9BFQ)

England—A station operating on 4900 kc. from 1715 to 1730 s/off with talks in a Slavic language has been identified as being a BBC outlet operating in the European Service. It has also been noted at 1450 in German. (BB)

Formosa—The Voice of Free China, Taipei, has been found at 2030-2045 to N.A. on a new channel, 17,786 kc. (WPE9KM)

French Guiana—Cayenne is heard well on 6170 kc. at 0515 s/on and from 1730 to 1800 s/off. Most programs are in French. (WPE2-BFB, WPE8MS)

Guatemala—TGQB, R. Nacional de Quetzaltenango, Quetzaltenango, 11,700 kc., is a new station noted at 1200-1415, 1745-1830, 1930, and from 2230 to 2303 s/off with mostly L.A. music; news in Spanish at 1245, 1345; chimes, announcements, and acknowledgment of DX reports at 1830. (WPE4BC, WPE4HJ, WPE5AC, WPE9KM, WPE0AE, SH)

TGJA, Guatemala City, 5990 kc., has been noted with an Eng. xmsn from 2315 to 0000, with news and sports to 2330, talks and music to 0000. (WPE1BM, WPE9KM, WPE9MS)

India—All India Radio is heard well on 11,710 and 17,790 kc. to Europe and West Africa at 1445-1545; on 21,605 kc. to S. E. Asia at 0830-0930; the 17,830-kc. broadcast at 2130-2145 with Eng. news is part of the Home Service from Delhi "B" and is also directed to S. E. Asia; on 15,105, 11,830, and 9530 kc. to S. E. Asia for Indians overseas in Hindi at 1815-1915, and on 17,705 and 15,105 kc. in Tamil at 1915-2015. (WPE8MS, WPE0AE)

Jordan—Amman has been tuned on 11,812 kc. in Arabic and English from 2300. The schedule runs to 0330 and also from 0600 to 0800 and 1000 to 1700. (WPE1BY)

Kenya—The Eng. program from Nairobi is now noted on 4934 kc. whereas 4885 kc. carries Swahili around 2230, a swap of channels. Both have a weather report at 2230. The Coast Regional Service from Mombasa, 4965 kc., has native chanting at 2230-2300. The West Kenya Regional at Kisumu is fair on 4804 kc. at 2224 with a native religious program. (WPE3NF)

Liberia—ELWA, Monrovia, now operates to N.A. at 2000-2300 (1815-1945 has been dropped) on 11,986, 15,180, and 21,535 kc. (21,515 kc. has been dropped). The new IS is a series of rapidly beating drums. (WPE1ARV, WPE1BY, WPE1QJ, WPE5CN, WPE6ACE, WPE8AEJ, WPE8ASF, WPE9AWW)

Netherlands—Hilversum currently has Eng. to N.A. at 1415-1505 on 17,775 and 15,220 kc. (also on 6020 kc. to Europe) and at 2030-2120 on 11,950 and 9590 kc; Dutch to N.A. at 1600-1730 (Sundays only) on 11,915 and 15,445 kc.,

and at 2030-2220 on 11,730 and 9715 kc. English is beamed to Australia, New Zealand, and the Pacific area at 0500-0550 on 21,480 and 17,775 kc., and to S. Asia and Africa at 0900-0950 on 21,565 and 25,610 kc. The *Happy Station* Program is aired to Europe, Asia and S. Pacific areas at 0530-0700, and to Africa and the Mid-East at 1100-1230 on 21,565, 17,775, and 6020 kc.; to S. America at 1600-1730 on 15,220 and 11,730 kc.; and to N.A. at 2100-2230 on 11,950 and 9590 kc. This program is on Sundays only. The Monday DX program has been shifted to Tuesdays and expanded to 2045-2115. The "Letterbox," "Announcer's Choice," and "From The Amsterdam Archives" programs were moved to Wednesday. "Window On Holland" is now heard on Saturdays only; the Wednesday edition has been deleted. (WPE1HV, WPE3ADI, WPE3-ATR, WPE4BFY, WPE6SK, WPE8MS, WPE-9AOP, WPE9NY, WPEOEX, VE1PE2U, VE2-PE3W, VE7PE1R, JD, AS)

Nicaragua—A partially-identified station in Managua giving the call-sign YN-S (or YN-F) was noted on 1775 kc. from 2200 s/on to 2218 s/off with Spanish pop records. (DC)

North Borneo—R. Sabah, Jesselton, operates on 5980 kc. at 2300-0100 (Saturdays from 2200) and 0400-0900; in Kadazan at 0000 and 0500; in Chinese at 2300 and 0400; in Malay at 0030 and 0615; in Eng. at 2200 (Saturdays only), 2330. 0600 (BBC news and local news) and 0730. (WPE8MS)

Philippines—The Far East B/C Corp., Manila, carries Eng. at 1600-1830 on 17,805 and 21,515 kc., at 1830-1930 on 9730. 11,920, 15,385, 17,805, and 21,515 kc., at 0400-0500 on 6030, 11,855, and 21,515 kc., and at 0500-0730 on 11,920 and 21,515 kc. Reports go to P. O. Box 2041, Manila. (WPE7QN, VE7PE1R, JR)

Poland—Warsaw is scheduled as follows: 0630-0700, 0730-0800, and 0800-0830 on 17,800, 15,275, and 15,120 kc.; 1930-2000, 2000-2030, 2130-2200, and 2200-2230 on 15,275, 11,815, and 9775 kc. This is in Eng. to N.A. The Mailbag is scheduled on Mondays at 1930 and the Stamp Club on the second and fourth Wednesday of the month at 1930. Other Eng. xmsns: 1330-1400 on 9540 kc.; 1430-1500 on 7125 and 5950 kc.; 1530-1600 on 7315 and 9775 kc.; and 1630-1700 on 9540 and 5950 kc. (WPE1BD, WPE1-HV, WPE4BFY, WPE9AOP, WPEOSN, VE7-PE1R)

Rhodesia—The African Service from Lusaka, 4826 kc., is noted at 2320 with jazz music and an Eng. ID at 2330. (WPE3NF)

South Korea—Seoul operates on the following schedule: to N.A. at 0030-0130 on 11,925 and 15,410 kc. in Eng. and Korean; to Hawaii at 0230-0330 on 15,410 kc., and at 1100-1200 on 11,925 kc. in Eng. and Korean; to Japan at 0800-0830 on 9640 kc. in Japanese; to S.E. Asia at 0900-1000 on 15,410 and 9640 kc. in Eng. and French; to Europe at 1645-1800 on 11,925 kc. in Eng., French, and Korean; and in the General Overseas Service at 0530-0600 on 9640 kc. in English. (WPE1CR)

Spain—Madrid is heard on 9360 and 11,815 kc. to Brazil at 1715-1745, to N.A. at 1745-1840, and to Latin America at 1900-2200. The N.A. xmsn is also beamed to Australia on 15,420 kc. Other N.A. periods can be noted at

August, 1960



Now you can master

BASIC ELECTRICITY BASIC ELECTRONICS

The Rider 'picture-book' way

Fabulous illustrated training course now used by
U. S. Navy—No Other Books Like Them!

A Complete Idea on Every Page

Here's how this easy, illustrated course work: *every page* covers one complete idea! There's at least one big illustration on that same page to explain it! What's more, an imaginary instructor stands figuratively at your elbow, doing "demonstrations" that make it even easier for you to understand. Then, at the end of every section, you'll find *review pages* that highlight the important topics you've just covered. You build a thorough, step-by-step knowledge at your own pace—as fast as you yourself want to go! Sponsored by the Navy to turn out trained technicians in record time, this modern course presents Basic Electricity and Basic Electronics in a simple way that everyone can grasp—regardless of previous education!

10 Complete Volumes

BASIC ELECTRICITY—Volumes 1 and 2 cover DC components and circuits; Volumes 3 and 4 cover AC components and circuits; Volume 5 covers AC and DC motors and machinery.

BASIC ELECTRONICS—Volume 1 covers Diodes and Power Supplies; Volumes 2 and 3 cover Amplifiers and Oscillators; Volumes 4 and 5 cover Transmitters and Receivers.

Home Study Without Correspondence

This course is so different, so complete—there's no need for the usual letter writing, question and answer correspondence! Learn at home—at your own pace!

10 Day Examination — Money Back Guarantee

Send today for these exciting new training courses—*you risk nothing!* When you receive the volumes, examine them in your own home for 10 full days. If, at the end of that time, you're not completely satisfied, simply return the books to us and we'll gladly refund your full purchase price! Total cost for either 5-volume course is only \$10.00!

BASIC ELECTRICITY #169, 5-vols. soft covers, \$10.00; #169H, all 5 vols. in one cloth binding, \$11.50.

BASIC ELECTRONICS #170, 5-vols. soft cover, \$10.00; #170H, all 5 vols. in one cloth binding, \$11.50.

JUST PUBLISHED

VOLUME 6 BASIC ELECTRONICS by Van Valkenburgh, Nooger & Neville Inc. We are pleased to announce the publication of Volume 6, BASIC ELECTRONICS by Van Valkenburgh, Nooger & Neville. Volume 6 is a companion volume to the present five volume course on Basic Electronics by the above authors. It is intended to enable you to expand into the areas of semiconductors, transistors and frequency modulation after the content of the first five volumes has been completed. Volume 6 utilizes the same famous "picture-book" technique used in the present highly successful five volume course.

The original five volume course in BASIC ELECTRONICS is available as heretofore as five individual volumes in paper covers and as all five volumes in one cloth binding.

Vol. 6 #170-6 paper cover, \$2.90; #170-6H, cloth \$3.60.

at electronics parts jobbers or bookstores, or order direct:
DEPT. PE-8



JOHN F. RIDER PUBLISHER INC.
116 West 14th Street, New York 11, N. Y.
Canadian prices same as U.S.

add city & state taxes. All prices subject to revision.

2215, 2315, and 0015 on 9360 and 6130 kc. (WPE1AGM, WPE1ARV, WPE4BFY, WPE8-MS, WPE9ADP)

Sweden—Stockholm's revised Eng. schedule reads: to the Far East at 0730-0800 on 9620 and 15.240 kc.; to Eastern N.A. at 0900-0930

broadcast every Monday (WPE2BBN, WPE-2BRH, WPE2FK, WPE3ATR, WPE4BFY, WPE4FB, WPE9AGB)

Switzerland—Here are a few changes in Berne's schedule: 15,315 kc. (HEU6) replaces 6165 kc. (HER3) to N.A. at 2030-2115; 15,315 kc. also replaces 15,305 kc. (HER6) to East Australia and New Zealand at 0215-0400, to West Australia and Far East at 0400-0445, to Japan and S.E. Asia at 0745-0930, to India and Pakistan at 0945-1130, and to the Mid East at 1145-1330; 9545 kc. (HED5) replaces 9665 kc. (HEU3) to Ireland and the United Kingdom at 1345-1530 and to Spain and Portugal at 1545-1730. The DX program has been moved to Tuesdays and extended to 15 minutes. They want single-track tapes (any recognized speed) of four minutes duration from listeners, to be broadcast on future programs; the tapes will be returned after being used. Written

SHORT-WAVE CONTRIBUTORS

James Silk (WPE1AGM), Madison, Conn.
 John Rushton (WPE1ARV), S. Providence, R. I.
 Anson Boice (WPE1BD), New Britain, Conn.
 Jerry Berg (WPE1BM), W. Hartford, Conn.
 Alan Roth (WPE1BY), Bridgeport, Conn.
 Jim O'Mara (WPE1CR), S. Boston, Mass.
 Robert Dilzer (WPE1HV), Woodbridge, Conn.
 Thomas Stanley (WPE1NC), Springfield, Vt.
 Joseph Urbanski, Jr. (WPE1QJ), E. Bridgewater, Mass.
 Robert Newhart (WPE2AXS), Merchantville, N. J.
 D. Lorenzini (WPE2BBN), Landisville, N. J.
 Myron Smith (WPE2BFB), Rochester, N. Y.
 Gregory Hensas (WPE2BJI), Jericho, N. Y.
 Jim Teeling (WPE2BMO), Orange, N. J.
 Al Mencher (WPE2BRH), Bayside, N. Y.
 Carlton Ellis (WPE2BWC), Penn Yan, N. Y.
 John Harvey (WPE2EG), Lewiston, N. Y.
 Steven Meltzer (WPE2FK), New York, N. Y.
 David Butler (WPE2GM), Point Pleasant Beach, N. J.
 Allen Eiermann (WPE3ADI), Baltimore, Md.
 Lewis Hankins (WPE3ATR), Smyrna, Del.
 Joseph E. Clawson, Jr. (WPE3BAR), Tarentum, Pa.
 Richard Morcroft (WPE3HP), Pittsburgh, Pa.
 George Cox (WPE3NF), New Castle, Del.
 Gale Whitton (WPE3TF), Tionesta, Pa.
 Grady Ferguson (WPE4BC), Charlotte, N. C.
 Richard P. Lane (WPE4BFY), Memphis, Tenn.
 Maxey Irwin (WPE4FB), Sparta, Tenn.
 Alan Knapp (WPE4HI), Roanoke, Va.
 Thomas Snyder (WPE4RC/KH6), Kahului, Hawaii
 Jim Cumbie (WPE5AC), Dallas, Texas
 William Bing (WPE5AG), New Orleans, La.
 Arno J. M. Feltner (WPE5CN), New Braunfels, Texas
 Richard McGlew (WPE6ACE), San Francisco, Calif.
 Chuck Adams (WPE6ATY), San Jose, Calif.
 Raymond Grace, Jr. (WPE6SK), Torrance, Calif.
 James Saindon (WPE6UD), Coronado, Calif.
 Richard Jordan (WPE7QN), Seattle, Wash.
 Charles Reti (WPE8AEI), Detroit, Mich.
 Paul Petosky (WPE8ASF), Trout Lake, Mich.
 Charles Sutton (WPE8BGF), Toledo, Ohio
 Mike Kander (WPE8MS), Dayton, Ohio
 Mark Lewis (WPE8WV), Avon Lake, Ohio
 Lee Lannoye (WPE9ADP), Green Bay, Wis.
 Dale Dettmer (WPE9ADW), Fort Wayne, Ind.
 Earl Kinmonth (WPE9AGB), Joliet, Ill.
 Bob Driuz (WPE9AOP), Chicago, Ill.
 George Ullrich (WPE9AWW), Hammond, Ind.
 Mitchell F. Stevens (WPE9BFQ), Danville, Ill.
 Mike Rossman (WPE9BR), Joliet, Ill.
 A. R. Niblack (WPE9KMI), Vincennes, Ind.
 Al Hovey (WPE9MS), Bonduel, Wis.
 Mike Nielsen (WPE9NY), Park Ridge, Ill.
 Richard Olson (WPE9ADY), Rochester, Minn.
 John Beaver, Sr. (WPE9OAE), Pueblo, Colo.
 W. D. Rodgers (WPE9EAX), St. Louis, Mo.
 Allyn M. Lamb (WPE9SV), Wichita, Kansas
 George Buchanan (WPE9VB), Webster Groves, Mo.
 George Fenerty (VE1PE2U), Halifax, N. S.
 Burton Lang (VE2PE3W), Howick, Quebec
 David Bennett (VE7PE1R), Richmond, B. C.
 Bernard Brown (BB), Derby, England
 Drayton Cooper (DC), Edisto Island, S. C.
 Jackie Darden (JD), Fort Worth, Texas
 Shaler Hanisch (SH), Pasadena, Calif.
 Charles Krabek (CK), E. Weymouth, Mass.
 Joseph Russo (JR), Tom's River, N. J.
 Alan Smith, Jr. (AS), Versailles, Ind.
 Carl Sexton (CS), Newport, Tenn.

SHORT-WAVE ABBREVIATIONS

annt—Announcement	kw.—Kilowatts
BBC—British B/C Corp.	N.A.—North America
B/C—Broadcasting	R.—Radio
Eng.—English	s/off—Sign-off
ID—Identification	s/on—Sign-on
IS—Interval signal	xmsn—Transmission
kc.—Kilocycles	

DX items are also welcomed. (WPE1ARV, WPE1BM, WPE1HV, WPE2BMO, WPE2BRH, WPE8MS, VE2PE3W)

Syria—The only Eng. service on the short waves from Damascus is at 1500-1530 on 15,165 kc. beamed to Europe. A new outlet on 5675 kc. has been noted from 1652 to 1800/close, Arabic and classical music, French news. (WPE1CR, WPE3NF, WPE0VB, CK)

Tahiti—Papeete is audible on 11,815 kc. at 1140-1210 with records and anmts in French; news at 1200. (WPEOAE)

Tchad Republic—Fort Lamy, 9585 kc., is heard from 0700 s/on to 0800; French news is given at 0730. The IS is several notes on a lute. (WPE8BGF)

Tunisia—Tunis has changed its frequency from 9630 kc. to 6105 kc., where it is heard at 0000 and 1800. (WPE3NF)

USA—The Maritime Trades Department operates Sundays at 1120-1130 with maritime news on WFK39, 19,850 kc. (Caribbean, East Coast of S. America, S. Atlantic areas, and Eastern USA); on WFL65, 15,850 kc. (Gulf of Mexico, Caribbean, Western coasts of USA, Mexico, and South America); on WFK95, 15,700 kc. (N. Atlantic, Mediterranean, Europe, and East Coast of N.A.). Reports in Morse code are given at 1415 Sundays on WCO, 13,020, 16,908.8, and 22,407 kc., and at 2215 Sundays on WMM25, 15,607 kc., and WMM81, 11,037.5 kc. Reports go to M.T.D., Box 525, G.P.O., Brooklyn, N. Y. (WPE3BAR)

Vatican City—The Vatican Radio has Eng. daily at 1000 and 1315 on 9646, 11,685, and 15,120 kc. to Europe; at 0530 on Monday, Wednesday, and Friday on 17,735 and 21,740 kc. to Central and South Africa; at 1100 on Monday, Wednesday, and Saturday at 17,840 and 21,515 kc. to India, Pakistan, and Ceylon. (WPE3TF, WPE0VB)

and 2045-2115 and to Western N.A. at 2215-2245 on 17,840 and 11,810 kc.; to S. Asia at 0945-1015 on 17,840 and 15,240 kc.; to the Mid East at 1115-1145 on 15,240 and 11,705 kc.; to Africa at 1245-1315 on 15,240 kc. and at 1445-1515 on 11,705 kc.; and to Europe at 1530-1600 on 12,710 kc. The DX program is

Across the Ham Bands

(Continued from page 89)

News and Views

Before he got his General, **Glen Spears, K5WTB**, 3102 Garland, Texarkana, Ark., was on the air as a Novice for 4½ months. He racked up 44 states, all confirmed. All work was on 15 and 40 meters, and he used a Globe Chief 90 transmitter and a National NC-300 receiver. In two weeks as a General, he has added four states, already confirmed, and is looking for skeds with Nevada and Idaho to complete his WAS. Glen's new transmitter is a Heathkit Apache, and he will schedule any-one needing an Arkansas contact. . . . Another General, **Jon M. Schumacker, K9REE**, 5505 Winnequah Trail, Madison 4, Wis., is still using his Novice transmitter, a Heathkit AT-1 running 20 to 25 watts. And why not? It has knocked off 46 states for him, including Hawaii and Alaska, on 15 and 40 meters, his favorite bands. Jon has also worked Canada, Puerto Rico, and Costa Rica. His antenna is a 40-meter dipole about 25' high, and his receiver is a Hallicrafters S-85, souped up with the simple one-tube Q-Multiplier which was described on page 90 of the February 1959 *Among the Novice Hams*.

Tommy, WPE7VU, reports that **Pat Bailey, KN7KBN**, 711 S. 6th, Las Vegas, Nev., is now waiting for his Conditional license. Pat worked 40 states and has 38 confirmed. He uses a Globe Chief Deluxe transmitter to feed a Hy-Gain 12-AV, 10-, 15-, and 20-meter vertical antenna; his receiver is a Hallicrafters SX-99. Pat's best DX is KC4USN at the Geographic South Pole and UD6AS, Azerbaijan—and he has the cards to prove it! . . . **Don Daves, KN8OYQ**, 827 Chalker St., Akron 10, Ohio, runs a Johnson Viking I transmitter, a RME-4500 receiver, and a Heathkit QF-1 Q-Multiplier on the 80-, 40-, and 15-meter Novice bands. He likes to rag-chew, especially on 80 meters, and would like to be nominated for the Rag Chewers Club. . . . **Dana G. McCarthy, WV2KAR**, 32 Wendt Ave., Larchmont, N. Y., was thrilled to have worked WH6DIG in Honolulu at 0600, EST, on 40 meters the other morning. He runs about 40 watts to his Heathkit DX-40 transmitter, which feeds a 40-meter dipole antenna. He receives on a Hallicrafters S-38E aided by a QF-1 Q-Multiplier.

Dave Sumner, K4FXG, R.F.D. 3, Box 184, Dade City, Fla., was a Novice for three months but has been a General for a year now. His station uses a DX-40 transmitter and a Hammarlund HQ-110C receiver. Although Dave has a Hornet 3-element, tri-band antenna for 10, 15, and 20 meters, his favorite bands are 80-meter c.w. and 75-meter phone. He has worked 32 states on 80 c.w., out of a total of 45 worked on all bands. Dave serves as Net Control Station for the Tropical Phone Net on 3945 kc. on Thursdays; the net meets daily at 1730 EDST. . . . **Kenneth J. Becker, WV6JMH**, 5113 W. 116th St., Los Angeles 45,

TELTRON - Leading Values in Tubes and Parts

All Tubes Individually Boxed • Unconditionally Guaranteed for One Year. Send for Free Complete Tube List & Order Blank. Your Inquiry Will Put You on Our Mailing List

FREE BONUS ONE (1) YEAR FREE subscription to ELECTRONICS WORLD or POPULAR ELECTRONICS PLUS ONE (1) SCHEMATIC DIAGRAM of Your Choice With Every Receiving Tube Order of \$30 Or More. NOTE! If you already are a subscriber to either magazine, one (1) year will be added to your subscription. FREE. If Your Receiving Tube Order is \$30 Or More, Fill In This Coupon

TELTRON ELECTRIC CO.
 428 Harrison Ave., Harrison, N. J.
 Send me one (1) year FREE subscription to _____ (state magazine desired) PLUS ONE (1) FREE Schematic Diagram _____ (State model No. of radio or TV) _____
 Name _____
 Address _____
 City _____ State _____



Model 625K
FREE
 Eico Tube Tester
 This brand new EICO tube tester is yours absolutely FREE with every receiving tube order of \$100 or more within 60 days. Includes all new tubes and six tubes. May be purchased from TELTRON for \$34.95.

SAVE ON ALL TUBES Here's a Partial List of Most Often Used Tubes

02A	.45	5CL8	.65	6BH6	.51	6DE5	.43	12AB5	.44	12SA7	.45
1B3GT	.62	5C08	.59	6BJ6	.51	6DG6	.50	12AF6	.44	12SB7	.45
1DN5	.60	5J6	.61	6BJ8	.64	6DQ6	.69	12AJ6	.46	12SN7G	.36
1R5	.55	5U5	.52	6BK5	.75	6DS5	.69	12AT6	.37	12SQ7	.58
1T4	.51	5L8	.59	6K7	.78	6E8	.63	12B7	.47	12VGT	.43
1U4	.51	5V4G	.49	6L7GT	.78	6H6	.47	12AU6	.43	12W	.43
1U5	.43	5X8	.55	6BN4	.44	6J5	.49	12AU7	.58	6GT	.43
1X2	.62	5YGT	.57	6R6G	.50	6J5	.51	12AV6	.62	17A6	.66
2AF4	1.02	6A84	.43	6Q5	.74	6K6GT	.39	12AV7	.73	4GT	.50
2A5	.50	6AC7	.65	6R0GT	.83	6S4	.41	12AX	.74	17D4	.50
3AF4	1.02	6F4	.65	6C6G1	.63	6T8	.45	12C7	.60	17DE6	.68
3AU6	.43	6AG3	.52	6BY5G	.75	6C7	.54	12AX7	.61	19A4	.60
3BC5	.58	6AH6	.47	6BZ6	.45	6K7	.45	12AZ7	.65	19B6C61	.48
3B5	.90	6AL5	.43	6BZ7	.95	6S1GT	.60	12B4	.62	25B0	.33
3BZ6	.45	6AM8	.59	6C4	.41	6S7GT	.60	12BA6	.46	6GT	.42
3CB6	.51	6AN8	.64	6C6	.51	6S7	.38	12BE6	.46	25D6C1	.19
3DT6	.51	6AQ5	.58	6C6G1	.63	6T8	.71	12B4	.60	25D6	.62
3V4	.48	6AS5	.52	6C6G1	.63	6U8	.76	12BQ6	.63	25L6	.62
4B8C	.69	6AU4GT	.50	6C8	.59	6G7	.48	12BY7	.65	25W4GT	.43
4B9	.68	6AUSGT	.60	6C7F6	.45	6W4GT	.42	12C7	.64	25Z6GT	.36
4BQ7	.75	6AU6	.43	6C7T	.44	6W6GT	.32	12C6	.63	25Z6	.36
4CB6	.51	6AV6	.37	6C8	.54	6X4	.37	12C6	.44	35C5	.48
4DE4	.55	6AW5	.46	6CMT	.48	6X8	.75	12D85	.59	35L6GT	.41
4D76	.59	6AX4GT	.60	6CQ4	.59	7AU7	.37	12D7	.59	35Z5GT	.33
5AM8	.59	6BA8	.56	6C56	.45	8AW8	.75	12DM7	.59	35Z5GT	.33
5A4	.64	6BA8	.59	6C6U8	.98	8C7	.54	12DQ6	.63	50B5	.48
5AQ5	.48	6BC8	.48	6X8	.84	8CMT	.54	12E6	.48	50C5	.48
5AT8	.54	6BC8	.59	6CV5	.49	8C8	.50	12E6	.49	50EHS	.59
5AV6	.54	6B8	.44	6C7F	.66	9U8	.79	12FM6	.43	50L6GT	.50
5BK7	.68	6BF5	.68	6D4	.59	10D7	.59	12G5	.43	50L6GT	.50
5BR6	.66	6BG6G	1.18	6DB5	.59	11CV7	.74	12J6	.43	117Z6GT	.65

Send for FREE complete list of most often used tube types

Self-Service Tube Checkers
 Reconditioned console model 22 socket tube checkers proved to repair signal. Let your tube customers test their own—your investment will be returned in one week with little effort. COMPLETE WITH KEY FOR BOTTOM DOOR AND NEON LIGHTED HEAD. \$39.95 F.O.B. our warehouse.

Heavy Duty Solder Gun
 With Extra Tip & Solder Free \$5.95
 FIBER FUSE CLIPPS 15c each pzd. 12 for \$1.65 pzd.
CHANNEL MASTER CONSOLE ANTENNA \$6.95 F.O.B. Harrison, N.J.
SWITCH-TYPE INDOOR ANTENNA \$2.99 pzd. Buy 6, \$2.49
PARALLEL PICTURE TUBE
BRIGHTENER 95c
 Series type \$1.39

All Transistor Portable Radio Kits
 Amazing. No bigger than a pack of cigarettes! Assembles easily in 30 minutes! Kit includes cabinet, transistors, printed circuit, ear piece, resistors, capacitors, antenna, instructions. Money back if not as advertised. List Value \$15.95. \$6.95 Shipped PPD

"USED TV" 500 TRADE-IN TV'S
 All expensive console models with little or no tube replacement. Excellent for resale or second set. Sizes: 10", 17", 19". Now any similar shipped F.O.B. Harrison, N.J. \$14.95 as is

Auto Vibrators
 6 Volt 4 Prong Universal \$1.59
 12 Volt 4 Prong Standard \$1.79
 12 Volt 4 Prong Standard \$1.99

New Price Schedule of Television PICTURE TUBES

PICTURE GUARANTEED FOR ONE (1) YEAR

8DP4	* 16RPA	11.95	20DP5	15.75	
10ABP4	* 16TPA	11.95	20HP4	17.75	
10BP4	7.95	17AP4	15.75	21ACP4	21.95
12LP4	10.75	17AVP4	15.75	21AP4	19.65
14BP4	11.75	17P4	13.25	21AMP4	18.75
14CP4	11.95	17P4	17.25	21MP4	21.25
14DP4	13.25	17P4	17.95	21ATP4	19.65
14RP4	14.25	17P4	16.49	21AUP4	19.25
16AP4	16.45	17P4	16.49	21AVP4	19.25
16BP4	12.45	17P4	17.45	21AWP4	18.75
16DP4	11.99	17P4	13.25	21EP4	17.25
16EP4	15.99	17P4	16.49	21FP4	19.25
16GP4	15.99	17P4	16.49	21MP4	21.25
16HP4	12.49	17P4	16.49	21WPA	18.75
16KP4	11.95	19AP4	18.25	21XP4	18.75
16LP4	11.95	20CP4	15.75	21YP4	18.75

Amplified on Any Tube \$4.00 Extra.
 All Picture Tubes require a deposit on your dud. Please add an additional \$5.00 on tube sizes 17". Add \$7.00 on sizes 19", 20", 21" and 24". Your cash deposit will be refunded immediately upon receipt of your dud receipt. Picture Tubes are shipped promptly from our warehouse (the US Continent and Canada only), Harrison, N. J. *Price upon request.

Complete Stock of SPECIAL PURPOSE TUBES AND DEMI-CONDUCTORS. Write for Free List.
NEW LIBERAL TERMS.
 No min. order. Free postage on tube & parts orders over \$5.00 U.S.A. 10% Terra. 25% depend on C.O.D.'s. Send postage on Canadian, foreign shipments. Excess refunded. Pic. tubes & outdoor antennas. 1918 Harrison, N.J. Tubes may be factory 2nds or used, clearly marked.

TELTRON ELECTRIC COMPANY

PE-8
 428 HARRISON AVE., HARRISON, N. J. Humboldt 4-9848

Calif., is getting out on "The Nifty Novice Transmitter" described in the April 1959 POPULAR ELECTRONICS. Ken built it and has worked 22 states feeding it into a 15-meter dipole. He receives on a National NC-57 receiver. Try Ken if you need a California contact on 15. . . . **Bob Saltzman, WA2BWC**, One Vista Drive, Great Neck, N. Y., worked 20 countries and 48 states, all states confirmed, in a year as a Novice. As a General, he has added a few more countries to his total. Bob runs 50 watts to a 6146 on phone and c.w. on 80 through 10 meters. He uses a Heathkit VF-1 VFO in the General bands but sticks to crystal control in the Novice bands. Bob offers to help prospective amateurs obtain their licenses.

Gerald Sewell, K4CCT, 2003 Hwy 21, Oxford, Ala., plugged a 6AC7 tube into the r.f. amplifier socket of his Hallicrafters S-108 receiver in place of the original 6SG7 as suggested in our March column with "remarkable results even on 80 and 40 meters." He uses a Johnson Adventurer transmitter running 50 watts to agitate the ionosphere via folded dipole an-

tennas on 80 and 40 meters and straight dipoles on 15 and 20 meters. Gerald likes to DX on the low end of 40 meters between 2:00 and 4:30 a.m., but he doesn't hear enough 7's to satisfy him. . . . **Kenneth Schaffer, WA2BQK** 222 E. 202 St., Bronx 58, N. Y., has had his General ticket for almost two years. And when the time limit expires, he is going for his Extra Class license. His code speed is 45 wpm in his head and 30 to 35 wpm on paper! Kenneth also boasts a whale of an antenna—a 40-meter doublet, 200 feet above the ground! It is fed with a Heathkit DX-20, modified so much that the Heath Company probably wouldn't recognize it. But it works well, if working all states and over 70 countries on 20 and 40 meters with 50 watts input is any evidence. His BC-342 receiver has also been through the WA2BQK modification center.

That does it for another month. Send your ham shack pictures, news, and construction projects to: Herb Brier, W9EGQ, C/O POPULAR ELECTRONICS, One Park Ave., New York 16, N. Y. 73,

Herb, W9EGQ

POPULAR ELECTRONICS BARGAIN BASEMENT

SAVE ON THESE SPECIAL BUYS OF THE MONTH

ALL BAND TRAP ANTENNA!



Reduces Interference and Noise on All Makes Short Wave Receivers, Makes World Wide Reception Stronger, Clearer on All Bands!

For ALL Amateur Transmitters. Guaranteed for 500 Watt Power for Pi-Net or Link Direct Feed. Light, Neat, Weatherproof

Complete as shown total length 102 ft., with 87 ft. of 72 ohm balanced feeding line. Hi-impact molded sealed automatic frequency resonant traps (W 3 ea. 1" x 3" x 3" long). You just tune to desired band for beamlike results. Excellent for ALL world wide short wave receivers and amateur transmitters. For NOVICE AND ALL CLASS AMATEURS! See an Inverted V for All Band power and performance. 5 separate antennas with better performance guaranteed. NO HAYWIRE HOUSE APPEARANCE! EASY INSTALLATION!

80-40-20-15-10 meter bands. Complete.	\$14.95
40-20-15-10 meter bands. 24 ft. antenna (best for worldwide sw't)	\$13.95
20-15-10 meter bands. Dual Trap. 24 ft. Antenna	\$19.95

SEND ONLY \$3.00 (cash, c.k., m.o.) and pay postman balance COD plus postage on arrival or send bill prior for postpaid delivery. Available only from:

WESTERN RADIO Dept. AEL-8 Kearney, Nebraska

ONE CENT SALE Buy One At Our Regular Low Price And Get The Second For Only 1c More

CITIZENS BAND TRANSMITTER (27 MC) 5 watt chassis, complete with crystal \$14.99 each, two for \$15.00

CITIZENS BAND RECEIVER chassis tunable through all 22 channels. Complete with audio amplifier. \$9.99 ea., two for \$10.00

AMATEUR BAND TRANSCEIVER (144-148 MC) chassis with dual VHF triodes for satellite radio transmission. \$9.99 ea., two for \$10.00

SIGNAL BOOSTER chassis for 27 MC. High gain (20DB) double tuned RF pentode amplifier. Improves performance of any Citizens Band receiver. Complete with tube \$11.99 each, 2 for \$12.00

KIT OF PARTS for AM-FM-VHF radio receiver. Tunable from 80-200 mc. which includes U.S. satellite frequencies. \$6.99 ea., two for \$7.00

CONVERTER (Crystal Controlled) for 27 MC Citizens Band. Adapts any standard broadcast radio to 27 MC band. Tunes all 22 channels. Complete with tubes and crystal. \$14.99 each, 2 for \$15.00

LIMITED QUANTITY—NO LITERATURE OR CATALOG
Remit in full! Include sufficient postage. No C.O.D.'s.

VANGUARD ELECTRONIC LABS. Dept. E-8
Factory & Mail Order: 190-48 99th Ave., Hollis 23, N. Y.
Retail Store: 196-23 Jamaica Ave., Hollis 23, N. Y.

Experimenters • Amateurs • Hobbyists

Extraordinary values await you in government surplus electronic components. Don't buy anything until you have our "Bargain Bulletin"; new material for mere dimes on the loilar. Remember, everything is brand new; here are typical v lues:

Fil xfmr. 115/60. 12.6/3.25. et sec. potted. 6 lbs.	\$1.95
Choke. 12 hy/150 mhs. 190 ohms. 400 volt test. 5 lbs.	1.39
CIW filter. 600 ohm. 1105 v.c. / 100 eye down 20 db. 4 lbs.	6.95
Electrolytic. 30 mfd/450 volts. Cornell-Dubilier. 8 oz.	33c
5 MC IF. single slug tuned, only 2" high. 2 oz.	3.95c
6 volt dynamotor. 600 volts/1500 mhs. Eicon. 10 lbs.	\$6.95
Antenna relay. Advance 1004A-3A. 13 vac. D1/D2-SP. 12 oz.	2.89
Thordarson line to voice coil TS60548. 10 watt. 1 lbs.	1.39
HV "scope xfmr. 115/60. 1500 v.c. mhs. potted. 10 lbs.	\$3.60
Sprague 2538-6 oil capacitor. 1 mfd/1000 volts. 1 lb.	.95c

WRITE TODAY FOR FREE GOVERNMENT SURPLUS BARGAIN BULLETIN

JOE PALMER P.O. Box 6188 CCC, Sacramento, California

NEW SILICON 750MA RECTIFIERS*

GENERAL PURPOSE SPECIAL 2 FOR \$1 400 PIV AT 250 MA 25 FOR \$10

rms/ piv 35 50 25c	rms/ piv 70 100 35c	rms/ piv 140 200 45c	rms/ piv 210 300 55c
rms/ piv 280 400 65c	rms/ piv 350 500 85c	rms/ piv 420 600 \$1.10	rms/ piv 490 700 \$1.35
rms/ piv 560 800 \$1.50	rms/ piv 630 900 \$1.70	rms/ piv 700 1000 \$2.00	rms/ piv 770 1100 \$2.50

Use in F.W.Bridge or F.W.C.T. up to 1A DC or mtg 2 sq Fins for 1.5Amp (Orders \$3 or more we pay postage 48 states.) *Derate 20% for Capacitor Input. Send 25c for Catalogue

"TAB" 1111 Liberty St. N. Y. 6, N. Y.

WALKIE TALKIE RADIO SENDING SET

YOUR OWN POCKET SIZE RADIO STATION

Talk to any house or car radio without wires or hookups of any kind! We only 1 1/2 lbs. Size 1 1/2" x 8" x 8" 1 1/2" Built-in antenna "Break-in" on regular radio broadcasts with "dial setter" and "Push-to-Talk" switch. Self-contained flashlight batteries—Power transistor! Talk to radios in the same building and to cars or between cars up to one block or more away—depending on local conditions. No license or permit needed! Practical and real fun in a million ways. Guaranteed to work—1 year service guaranteed.

SEND ONLY \$3.00 (cash, ck., m.o.) and pay postman only \$1.95 plus C.O.D. postage or send \$12.99 for postpaid delivery. Shipped complete ready to operate with instructions for all kinds of operation. New 1961 Model Radio Talkie is now Super-powered! Order yours now—Today! Available only from:

WESTERN RADIO, Dept. TEL-8 Kearney, Nebr.

NEVER FAIL— ZONE YOUR MAIL

The Post Office has divided 106 cities into postal delivery zones to speed mail delivery. Be sure to include zone number when writing to these cities; be sure to include your zone number in your return address—after the city, before the state.



ELECTRONICS MARKET PLACE

RATE: 50¢ per word. Minimum 10 words prepaid. October issue closes August 8th. Send order and remittance to Martin Lincoln, POPULAR ELECTRONICS, 1 Park Ave., New York 16, N. Y.

FOR SALE

SOMETHING for sale? Place a classified ad in this section. Low-cost, fast results. It's easy.

TELEVISION Sets \$11.95 plus Shipping—Jones T.V., Sanatoga, Pa.

GOVERNMENT Sells! Surplus Electronics: Test equipment; Oscilloscopes; Transceivers; Jeeps; Boats; Aircrafts; Misc.—Send for U. S. Depot Directory & Procedure \$1.25—"Brody Surplus," Box 425 PE, Nanuet, N. Y.

WPE-SWL-CB-QSL Cards—Samples 10¢—"Brownie" W3CJ1, 3110A Lehigh, Allentown, Penna.

RADIO & TV Tubes at Manufacturer's prices! 100% Guaranteed! Brand New! No re-brands or pulls! United Radio, Box 1000-E, Newark, N. J.

GOVERNMENT Surplus Receivers, Transmitters, Snooperscopes, Parabolic Reflectors, Picture Catalog 10¢. Meshna, Malden 48, Mass.

DIAGRAMS for repairing radios \$1.00, Television \$2.00. Give make, model. Diagram Service, Box 672-PE, Hartford 1, Conn.

AUTO Radio Distributor Selling, Servicing, Becker Blaupunkt, FM-AM, other European, American Sets. Save 30% + Square Electronics, 150-60 Northern Blvd., Flushing, New York.

REPAIR Instructions, Schematics, Radios, T.V's, Hi-Fi's, 99¢ Model? "Coop" Box 5938, Kansas City 11, Missouri.

NEW! Electric soldering gun with internal solder feed. Leaves one hand free for manipulating work. Low price. Free literature. Arnies Electronics, McNeal, Arizona.

NEW U. S. Motors Chain Drive Garage Door Operators, push button control \$59.95. ARF Radio Control, \$40.00. Refund including shipping charges unless delighted. Operates doors to 20 feet wide, 8 feet high. Specify flat or sectional door, automobile voltage. Closeout opportunity. Last chance! Demco, Box 110, Sebring 10, Ohio.

CONDENSER checker—opens, shorts, intermittents. Accurate, reliable. Ready to use. Guaranteed! \$4.98. Mesco, Box 4521, Kansas City 24, Mo.

CITIZENS Banders. Assure yourself of maximum power output. Read "True Speech Power" on Monitor Meter. Free literature. Pelzer Electronics, 51-07 90th St., Elmhurst, N. Y.

CITIZEN Band Antennas. Heavy duty ground plane built to last. Cast aluminum hub, heavy tempered aluminum elements will withstand strong winds. Reversible mounting permits cable to be run inside or outside mast. Maximum all-around performance in hilly terrain. Buy direct from manufacturer. \$24.95 PPD. in U. S. E. Van Riper, P. O. Box 172, Dover, N. J.

CITIZENS Band! Add a Hushpuppy noise Suppressor to your Heathkit Transceiver! Squelch Action! Completely Wired. Guaranteed. \$4.98. Western Mass. Electronics, Great Barrington, Mass.

NEW Tubes, 50% off, Top Brands, Top Performance, List Free. Lukacs, Dept. F, Box 353, Jersey City, N. J.

10 DISTANCE Crystal set plans—25¢; 20 different 50¢, with Transistor experiments. catalog. Laboratories, 1131-L Valota, Redwood City, California.

TUBE Tester. Even Picture Tube. Deluxe Model \$4.98. Tubes and parts, up to % 80 % off. Free list. Tes-Tronic Co., Box 97, Uleta, Fla.

CAPACITOR leakage tester. Checks shorted, leaky condensers quickly, easily. Guaranteed. Send \$14.95 to: Bob's Radio & TV Supply. P. O. Box 149, Wayland, Mass.

SHORTWAVE attachment receives 6 to 12 megacycles through superheterodyne radios. Complete \$2.98 postpaid. John Ditch, 247-44 76th Avenue, Bellerose 26, New York.

THREE Transistor wrist radio. Clear reception, 35 miles away. \$7.98. Send \$6.98. Mickey DelBello, Manvel, Texas.

CITIZENS Band Call monitor decal for automobile. Colorful, Neat. Four for dollar. Clubs inquire. Harris, 114 Danray Drive, Richmond 27, Virginia.

WANTED

WANT to buy good equipment and accessories? Place a low-cost classified ad in this space.

CYLINDER and old disc phonographs. Edison Conqueror, Idelia, and Oratorio models. Berliner Gramophones and Zono-o-phones, Columbia cylinder Graphophones, and Coin-operated cylinder Phonos. Want old catalogues and literature on early phonos prior to 1919. Will pay cash or trade late hi-fi components. Popular Electronics, Box 50, 1 Park Ave., New York 16, N. Y.

CASH for used short-wave Ham Receivers, Transmitters and Accessories. Treger, W9IVJ, 2023 N. Harlem Ave., Chicago 35B, TXedo 9-6429.

HIGH-FIDELITY



PRICES? The Best! Factory-sealed Hi-Fi Components? Yes! Send for free catalog. Audion, 25P Oxford Road., Massapequa, N. Y.

DISGUSTED with "HI" Hi-Fi Prices? Unusual discounts on your High Fidelity Requirements. Write Key Electronics, 120 Liberty St., New York 6, N. Y. CLoverdale 8-4288.

INDUCTORS For Crossover Networks. 118 types in stock. Send for brochure. C & M Coils, 3016 Holmes Avenue N. W., Huntsville, Ala.

TREMENDOUS savings! Sherwood, Dual AR, all others! Immediate reply to your correspondence. Sound Room, 1509 Bedford Avenue, Brooklyn, N. Y.

RECORDERS, Components. Free Wholesale Catalogue. Carston, 125-P East 88, New York City 28.

TAPE & RECORDERS

TAPE Recorders, Hi-Fi components, Sleep Learning Equipment, tapes. Unusual Values. Free Catalog. Dressner, 69-02F, 174 St., Flushing 65, N. Y.

AMPEX, Concertone, Magnecord, Presto, Bogen, Tandberg, Pentron, Sherwood, Rek-O-Kut, Scott, Shure, Dynakit, others, Trades. Boynton Studio, Dept. PE, 10 Pennsylvania Ave., Tuckahoe, N. Y.

RENT Stereo Tapes—over 1,000 different—all major labels—free catalog. Stereo-Parti, 811-P Centinela Ave., Inglewood 3, California.

LOW Quotes on everything HiFi & Stereo Tapes. Bargain List: HiFi, Dept. E3, Roslyn, Pa.

INSTRUCTION

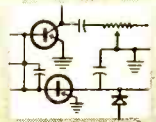

WRITE Martin Lincoln, Popular Electronics, 1 Park Avenue, New York 16, N. Y. for information on how to place a classified ad in this section.

CALCULUS or Algebra, Easy Practical Lessons. First four \$1. Mathco, 4256-8 Minnor, Cincinnati 17, Ohio.

LEARN Code. Quality for Amateur or Commercial License. Free Book. Candier System, Dept. PE-8, Box 9226, Denver 20, Colo.

INVENTIONS WANTED

INVENTIONS wanted. Patented: unpatented. Global Marketing Service, 2420-P 77th, Oakland 5, Calif.

INVENTIONS Wanted, patented: unpatented. J. T. Invention Sales Company, 25 Fayette St., Brooklyn 6, N. Y.

PLASTICS

NEW Liquid Casting Plastic, clear, colors. Embed real flowers, butterflies, photos, coins. Send 25¢ for two handbooks "How to Cast Liquid Plastics" and "How to Make Extra Money at Home." Castolite, Dept. J-108, Woodstock, Illinois.

MISCELLANEOUS

MAKE Huge Profits—Below Wholesale Prices—Bankrupt, close-out, and imported merchandise—sporting goods, jewelry, auto accessories, novelties, linen, hardware, etc. Big merchandise lists printed 6 times yearly—\$2.00 per year (refundable). Barnards, 1081 Gilwood Ave., La Puente, California.

INTERCEPT a conversation more than 100 yards away. Low-cost transistorized unit. Requires no external connections, no hidden microphones, picks sound out of the air. Complete diagram and plans, \$2.00. F. D'Imperio, P. O. Box 4281, Philadelphia 44, Pa.

MYSTIC Antenna reveals secrets of nature's electronics! Locate hidden springs, water, gas, sewer lines, buried treasure! Works indoors; outdoors. Saves work, money! Easy to use. Fun for experiments! Details free. Stillwater, Box W-337, Morris Plains, New Jersey.

SHOPPING GUIDE

Classified

A HANDY REFERENCE TO PRODUCTS AND SERVICES NOT NECESSARILY ELECTRONIC, BUT OF WIDE GENERAL INTEREST.

LEATHERCRAFT

FREE "Do-It-Yourself" Leathercraft Catalog. Tandy Leather Company, Box 791—R-36, Fort Worth, Texas.

MUSIC

SONGPOEMS And Lyrics Wanted! Mail to: Tin Pan Alley, Inc., 1650 Broadway, New York 19, N. Y.

POEMS Wanted for musical setting and recording. Send poems. Free examination. Crown Music, 49-TM West 32, New York 1.

SONGS into Dollars! Share 33 million dollars yearly for New Songwriters, Songpoets. Any subject, songs composed. Published, promoted by largest firm. Information, appraisal Free. Send Nordyke Music Publishers, 6000 Sunset, Hollywood 283, California.

BUSINESS OPPORTUNITIES

GROW Mushrooms. Cellar, shed and outdoors. Spare, full time, year round. We pay \$4.50 lb. dried. We have 29,000 customers. Free Book. Mushrooms, Dept. 334, 2954 Admiral Way. Seattle. Wash.

VENDING Machines—No Selling. Operate a route of coin machines and earn amazing profits. 32-page catalog free. Parkway Machine Corporation, Dept. 12, 715 Ensor St., Baltimore 2, Md.

MAKE \$25-\$50 Week, clipping newspaper items for publishers. Some clippings worth \$5.00 each. Particulars free. National, 81-DG, Knickerbocker Station, New York.

EMPLOYMENT INFORMATION

HIGH Pay Overseas, Domestic Jobs. Men, Women. Generous benefits. Companies pay transportation. For info, write: World Wide, Dept. E1, 149 N. Franklin St., Hempstead, N. Y.

OVERSEAS Employment. American firms and United States Government. Comprehensive job information \$2.00. Foreign Opportunities, Box 172, Columbus 16, Ohio.

WORK—live in Southern California. We sell up to date list of missile and electronic companies which employ engineers, technicians, draftsmen, etc. Send for additional information. Box 866, Whittier, California.

EARN Extra money selling advertising book matches. Free samples furnished. Matchcorp, Dept. MD-80, Chicago 32, Illinois.

PHOTOGRAPHY—FILM EQUIPMENT, SERVICES

FREE every month—Blackhawk's newspaper-size catalog 8mm. 16mm. movies, 2"x2" color slides. Biggest selection in USA. Bargains in used 16mm. sound films, projectors. Blackhawk Films, Davenport 24, Iowa.

OPTICAL Science Math Bargains Request Free Giant Catalog "C1" — 128 pages — Astronomical Telescopes, Microscopes, Lenses, Binoculars, Kits, Parts. Amazing war surplus bargains. Edmund Scientific Co., Barrington, New Jersey.

AMAZING Folding Binoculars! 2.5x25mm. Only \$3.00 postpaid: Dave Donovan, 7 E. Wilmot Ave., Havertown, Pa.

FREE! New 1960 catalog of all photographic books available for your copy. Send postcard with name and address to Catalog, Popular Photography Book Service, One Park Ave., New York 16, N. Y.

STAMPS & COINS

OVER 320,000 buyers and sellers will read your ad when placed in this space. It costs only 50¢ per word; minimum of 10 words including your name and address.

100 DIFFERENT U. S. Commemoratives 50¢, Approvals included. Shelron, Box 907-J, New York 8, N. Y.

GIGANTIC Collection Free! Includes triangles, early United States, animals, commemoratives, British Colonies, high value pictorials, etc. Complete collection plus big illustrated magazine all free. Send 5¢ for postage. Gray Stamp Company, Dept. 72, Toronto, Canada.

50 WORLD Wide Stamps, many exciting commemoratives, for only 10¢ and stamped self-addressed envelope. No approvals will be sent. Popular Electronics, Box 105, 1 Park Ave., New York 16, N. Y.

Always say you saw it in—POPULAR ELECTRONICS

MISCELLANEOUS

WHATEVER your needs, Popular Electronics classified can solve them. Simply place an ad in these columns and watch your results pour in.

KEY chains, personalized ashtrays, smoke sets—Novelties for home, office and gifts. Inexpensive items. Send 10¢ for illustrated brochure. House of Brand, Dept. PE-4, 3458 Fish Avenue, New York 69, New York.

BUY direct from factories—Appliances, Cameras, Watches! Free details! Cam Co., 6810PE—20th Ave., Brooklyn 4, N. Y.

EXCLUSIVE formula cleans, lubricates and extends life of all phonograph records, \$2.00. Peck's—A80, 103 Citizens Avenue, Waterbury 10, Conn.

WINEMAKING, Beer, Ale Brewing, Cider. Methods, illustrated, \$3.00. Eaton Bookstore, Box 1242-C, Santa Rosa, California.

DIESEL Injector Parts and Fuel Pumps Wanted. GM51-53-71-110. 2093 East 19 Street, Cleveland 15, Ohio.

PEGLESS, holeless Cribbage Board, \$2.95. Peck's—A80, 103 Citizens Avenue, Waterbury 10, Conn.

BUSINESS Cards \$3.75 Thousand postpaid. Free samples. Imagination, Box 761, Hollywood 28, Calif.

HOMEBREW. Make it yourself. Complete instructions \$1.75. Homecrafts, Box 587-A, Bellevue, Nebraska.

EMBOSS Business Cards \$3.95 per 1000. Edward Printing Service, 7430 Selwick Dr., Parma 28, Ohio.

PEN-PAL Specialty Service, 221 West Maple, Viroqua, Wisconsin. Scientific interests Matched—25¢. Free information.

REMAILS—Prompt, Confidential, 50¢. Also Monthly Rates. Box 1533, Tallahassee, Fla.

POPULAR ELECTRONICS

Advertisers' Index—August 1960

ADVERTISER	PAGE	ADVERTISER	PAGE
Airex Radio Corporation	120	Modernaphone, Inc.	28
Allied Radio	3	Moss Electronic Inc.	3rd, 4th Cover, 128
Atlas Sound Corp.	18	National Radio Institute	1
Bell Telephone Laboratories	2nd Cover	National Technical Schools	27
Boulevard Electronics	110	North American Philips Co., Inc.	14
Bud Radio	26	Olson Radio Corporation	112
Capitol Radio Engineering Institute	13	Palmer, Joe	124
Central Technical Institute	24	Picture Tube Outlet	118
Chicago Standard Transformer Corporation	28	Popular Electronics Book Division	25
Cleveland Institute of Electronics	9	Popular Electronics Book Division Listing	29, 30, 31, 32
Coyne Electrical School	11	Progressive "Edu-Kits" Inc.	37
DeVry Technical Institute	5	RCA Institutes, Inc.	16, 17
Dynaco, Inc.	10	Rad-Tel Tube Co.	23
EICO	36, 38	Radio Shack Corp.	116
Electronic Organ Arts, Inc.	116	Rider Publishing, Inc., John F.	121
G C Electronics Co.	118	Rinehart & Co., Inc.	22
Grantham School of Electronics	7	Spartan School of Aeronautics	109
Greenlee Tool Co.	34	Sylvania Semiconductor Division	8
Heath Company	104, 105, 106, 107	"TAB"	124
Indiana Technical College	116	Teleplex Co.	118
International Crystal Mfg. Co., Inc.	15	Teltron Electric Co.	123
Johnson Co., E. F.	113, 26	Terado Company	34
Key Electronics Co.	110	Tri-State College	118
Kuhn Electronics	110	Tru-vac Electric Company	115
Lafayette Radio	19	Valparaiso Technical Institute	110
Lektron	103	Vanguard Electric Labs.	124, 112
Micro Electron Tube Co.	119	Western Radio	124
Milwaukee School of Engineering	33	World Radio Laboratories	117
		Xcelite, Inc.	18

EXAMINE ANY OF THESE TESTERS

BEFORE YOU BUY!!

Yes, we offer to ship at our risk one or more of the testers described on these pages.

Superior's New Model 70 UTILITY TESTER®

FOR REPAIRING ALL ELECTRICAL APPLIANCES and AUTOMOBILE CIRCUITS

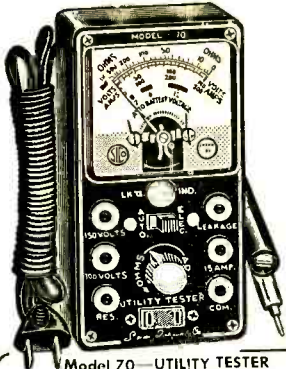

Model 70—UTILITY TESTER
Total Price \$15.85—

Terms: \$3.85 after 10 day trial, then \$4.00 monthly for 3 months, if satisfactory. Otherwise return, no explanation necessary.

As an electrical trouble shooter the Model 70:

- Will test Toasters, Irons, Broilers, Heating Pads, Clocks, Fans, Vacuum Cleaners, Refrigerators, Lamps, Fluorecents, Switches, Thermostats, etc.
- Measures A.C. and D.C. Voltages, A.C. and D.C. Current, Resistances, Leakages, etc.
- Will measure current consumption while the appliance under test is in operation.
- Incorporates a sensitive direct-reading resistance range which will measure all resistances commonly used in electrical appliances, motors, etc.
- Leakage detecting circuit will indicate continuity from zero ohms to 5 megohms (5,000,000 ohms).

As an Automotive Tester the Model 70 will test:

- Both 6 Volt and 12 Volt Storage Batteries • Generators • Starters • Distributors • Ignition Coils • Regulators • Relays • Circuit Breakers • Cigarette Lighters • Stop Lights • Condensers • Directional Signal Systems • All Lamps and Bulbs • Fuses • Heating Systems • Horns • Also will locate poor grounds, breaks in wiring, poor connections, etc.



INCLUDED FREE This 64-page book—practically a condensed course in electricity. Learn by doing.

Just read the following partial list of contents: What is electricity? • Simplified version of Ohms Law • What is wattage? • Simplified wattage charts • How to measure voltage, current, resistance and leakage • How to test all electrical appliances and motors using a simplified trouble-shooting technique. • How to trace trouble in the electrical circuits and parts in automobiles and trucks.

Model 70 comes complete with 64 page book and test leads

\$15.85
Only

Superior's New Model TV-50A GENOMETER

7 Signal Generators in One!

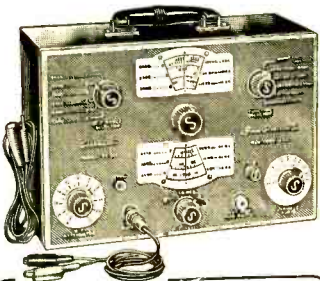

Model TV-50A GENOMETER...
Total Price \$47.50
Terms: \$11.50 after 10 day trial, then \$6.00 monthly for 6 months if satisfactory. Otherwise return, no explanation necessary.

- ✓ R.F. Signal Generator for A.M. ✓ Bar Generator ✓ Marker Generator
- ✓ R.F. Signal Generator for F.M. ✓ Cross Hatch Generator
- ✓ Audio Frequency Generator ✓ Color Dot Pattern Generator

This versatile All-Inclusive GENERATOR Provides ALL the Outputs for Servicing:
A.M. Radio • F.M. Radio • Amplifiers • Black and White TV • Color TV

R. F. SIGNAL GENERATOR: The Model TV-50A Genometer provides complete coverage for A.M. and F.M. alignment. Generates Radio Frequencies from 100 Kilocycles to 60 Megacycles on fundamentals and from 60 Megacycles to 180 Megacycles on powerful harmonics.

VARIABLE AUDIO FREQUENCY GENERATOR: In addition to a fixed 400 cycle sine-wave audio, the Model TV-50A Genometer provides a variable 300 cycle to 20,000 cycle peaked wave audio signal.

MARKER GENERATOR: The Model TV-50A includes all the most frequently needed marker points. The following markers are provided: 180 Kc., 262.5 Kc., 450 Kc., 600 Kc., 1000 Kc., 1400 Kc., 1600 Kc., 2000 Kc., 2500 Kc., 3579 Kc., 4.5 Mc., 5 Mc., 10.7 Mc., (3579 Kc. is the color burst frequency).

BAR GENERATOR: The Model TV-50A projects an actual Bar Pattern on any TV Receiver Screen. Patterns will consist of 4 to 16 horizontal bars or 7 to 20 vertical bars.

DOT PATTERN GENERATOR (FOR COLOR TV): Although you will be able to use most of your regular standard equipment for servicing Color TV, the one addition which is a "must" is a Dot Pattern Generator. The Dot Pattern projected on any color TV Receiver tube by the Model TV-50A will enable you to adjust for proper color convergence.

The Model TV-50A comes absolutely complete with shielded leads and operating instructions. Only

\$47.50

DID YOU EVER?

Order merchandise by mail, including deposit or payment in full, then wait and write . . . wait and write?

Purchase anything on time and sign a lengthy complex contract written in small difficult-to-read type?

Purchase an item by mail or in a retail store then experience frustrating delay and red tape when you applied for a refund?

Obviously prompt shipment and attention to orders is an essential requirement in our business . . . We ship at our risk!

PRINTED IN U.S.A.

NO

CONTRACT TO SIGN CO-MAKERS EMPLOYER NOTIFICATION

The simple order authorization included in this offer is all you sign. We ask only that you promise to pay for or return the goods we ship in good faith.

EXAMINE ANY ITEM YOU SELECT IN THE PRIVACY OF YOUR OWN HOME

Then if completely satisfied pay on the interest-free terms plainly specified. When we say interest-free we mean not one penny added for "interest" for "finance" for "credit-checking" or for "carrying charges." The net price of each tester is plainly marked in our ads—that is all you pay except for parcel post or other transportation charges we may prepay.

Superior's New
Model 82A

A truly do-it-yourself type TUBE TESTER

TEST ANY TUBE IN 10 SECONDS FLAT!



Model 82A—Tube Tester
Total Price **\$34.50**
Terms: \$6.50 after 10 day trial, then \$6.00 monthly for 5 months if satisfactory. Otherwise return, no explanation necessary.

- ① Turn the filament selector switch to position specified.
- ② Insert it into a numbered socket as designated on our chart (over 600 types included).
- ③ Press down the quality button—

THAT'S ALL! Read emission quality direct on bad-good meter scale.

FEATURES:

- Tests over 600 tube types.
- Tests OZ4 and other gas-filled tubes.
- Employs new 4" meter with sealed air-damping chamber resulting in accurate vibrationless readings.
- Use of 22 sockets permits testing all popular tube types and prevents possible obsolescence.
- Dual Scale meter permits testing of low current tubes.
- 7 and 9 pin straighteners mounted on panel.
- All sections of multi-element tubes tested simultaneously.
- Ultra-sensitive leakage test circuit will indicate leakage up to 5 megohms.

Production of this Model was delayed a full year pending careful study by Superior's engineering staff of this new method of testing tubes. Don't let the low price mislead you! We claim Model 82A will outperform similar looking units which sell for much more—and as proof, we offer to ship it on our examine before you buy policy.

Model 82A comes housed in handsome, portable, Saddle-Stitched Texon case. Only... **\$36⁵⁰** Net

SUPERIOR'S
NEW
MODEL 82

C.R.T. TESTER

Tests and Rejuvenates ALL PICTURE TUBES

ALL BLACK AND WHITE TUBES ALL COLOR TUBES

From 50 degree to 110 degree types—from 8", to 30" types.

Test ALL picture tubes—in the carton—out of the carton—in the set!

- Model 83 is not simply a rehashed black and white C.R.T. Tester with a color adapter added. Model 83 employs a new improved circuit designed specifically to test the older type black and white tubes and the newer type black and white tubes and all color picture tubes.
- Model 83 provides separate filament operating voltages for the older 6.3 types and the newer 8.4 types.
- Model 83 employs a 4" air-damped meter with quality and calibrated scales.
- Model 83 properly tests the red, green and blue sections of color tubes individually—for each section of a color tube contains its own filament, plate, grid and cathode.
- Model 83 will detect tubes which are apparently good but require rejuvenation. Such tubes will provide a picture seemingly good

- but lacking in proper definition, contrast and focus. To test for such malfunctions you simply press the red, green and blue sections of the meter reading will indicate the condition.
- Rejuvenation of picture tubes is not simply a matter of applying a high voltage to the filament. Such voltages improperly applied can strip the cathode of the oxide coating essential for proper emission. The Model 83 applies a selective low voltage uniformly to assure increased life with no danger of cathode damage.

Housed in handsome portable Saddle Stitches Texon case—complete with sockets for all black and white tubes and all color tubes. Only **\$38⁵⁰**



Model 83—C.R.T. Tube Tester
Total Price **\$38.50**
Terms: \$8.50 after 10 day trial, then \$6.00 monthly for 5 months if satisfactory. Otherwise return, no explanation necessary.

We invite you to try before you buy any of the models described on this page, the preceding page and the following pages. If after a 10 day trial you are completely satisfied and decide to keep the Tester, you need send us only the down payment and agree to pay the balance due at the monthly indicated rate.

NO INTEREST OR FINANCE CHARGES ADDED!

If not completely satisfied, you are privileged to return the Tester to us, cancelling any further obligation.

SEE OTHER SIDE

CUT OUT AND MAIL TODAY! ▶

MOSS ELECTRONIC, INC.
Dept. D-778 3849 Tenth Ave., New York 34, N. Y.

Please send me the units checked on approval. If completely satisfied I will pay on the terms specified with no interest or finance charges added. Otherwise, I will return after a 10 day trial positively cancelling all further obligation.

- | | |
|---|--|
| <input type="checkbox"/> Model 77 Total Price \$42.50
\$12.50 within 10 days. Balance \$6.00 monthly for 5 months. | <input type="checkbox"/> Model 83 Total Price \$38.50
\$8.50 within 10 days. Balance \$6.00 monthly for 5 months. |
| <input type="checkbox"/> Model TV-50A Total Price \$47.50
\$11.50 within 10 days. Balance \$6.00 monthly for 6 months. | <input type="checkbox"/> Model 70 Total Price \$15.85
\$3.85 within 10 days. Balance \$4.00 monthly for 3 months. |
| <input type="checkbox"/> Model 82A Total Price \$36.50
\$6.50 within 10 days. Balance \$6.00 monthly for 5 months. | <input type="checkbox"/> Model 79 Total Price \$38.50
\$8.50 within 10 days. Balance \$6.00 monthly for 5 months. |

Name
Address
City Zone State

All prices net. F.O.B., N. Y. C.

SHIPPED ON APPROVAL 10 MONEY WITH ORDER — NO C. O. D.



Model 77—VACUUM TUBE VOLT-METER. Total Price . . . \$42.50
Terms: \$12.50 after 10 day trial, then \$6.00 monthly for 5 months if satisfactory. Otherwise return, no explanation necessary.

Superior's New Model 77 **VACUUM TUBE VOLTMETER** WITH NEW 6" FULL-VIEW METER

Compare it to any peak-to-peak V. T. V. M. made by any other manufacturer at any price!

- Extra large meter scale enables us to print all calibrations in large easy-to-read type.
- Employs a 12AU7 as D. C. amplifier and two 9006's as peak-to-peak voltage rectifiers to assure maximum stability. • Meter is virtually burn-out proof. The sensitive 400

As A DC VOLTMETER: The Model 77 is indispensable in Hi-Fi Amplifier servicing and a must for Black and White and color TV Receiver servicing where circuit loading cannot be tolerated.

As AN ELECTRONIC OHMMETER: Because of its wide range of measurement leaky capacitors show up glaringly. Because of its sensitivity and low loading, Intermittents are easily found, isolated and repaired.

As AN AC VOLTMETER: Measures RMS values if sine wave, and peak-to-peak value if complex wave. Pedestal voltages that determine the "black" level in TV receivers are easily read.

micro-ampere meter is isolated from the measuring circuit by a balanced push-pull amplifier. • Uses selected 1/2% zero temperature coefficient resistors as multipliers. This assures unchanging accurate readings on all ranges.

SPECIFICATIONS

- DC VOLTS—0 to 3/15/75/150/300/750/1,500
- AC VOLTS—0 to 3/15/75/150/300/750/1,500 volts. • 0 to 3/15/75/150/300/750/1,500 VAC (Peak to Peak)
- ELECTRONIC OHMMETER—0 to 1,000 ohms/10,000 ohms/100,000 ohms/1 meg-ohm/10 megohms/100 megohms/1,000 megohms
- DECIBELS—-10 db to +38 db, -10 db to +38 db, +30 db to +58 db. All based on 0 db = .006 watt (6 mw) into a 500 ohm line (1.73v).
- ZERO CENTER METER—For discrimination alignment with full scale range of 0 to 1.5/7.5/37.5/75/150/375/750 volts as 11 megohms input resistance.

Comes complete with operating instructions, probe leads, and streamlined carrying case. Operates on 110-120 volt 60 cycle. Only **\$42.50**



Model 79—Super Meter
Total Price . . . \$38.50
Terms: \$8.50 after 10 day trial, then \$6.00 monthly for 5 months if satisfactory. Otherwise return, no explanation necessary.

SUPERIOR'S NEW MODEL 79 **SUPER-METER** WITH NEW 6" FULL-VIEW METER

A Combination VOLT-OHM MILLIAMMETER

Plus CAPACITY, REACTANCE, INDUCTANCE & DECIBEL MEASUREMENTS
Also Tests SELENIUM & SILICON RECTIFIERS, SILICON & GERMANIUM DIODES

The Model 79 represents 20 years of continuous experience in the design and production of SUPER-METERS, an exclusive SICO development. It includes not only every circuit improvement perfected in 20 years of specialization but, in addition includes those services which are "musts" for properly servicing the ever-increasing number of new components used in all phases of today's electronic pro-

duction. For example with the Model 79 SUPER-METER you can measure the quality of selenium and silicon rectifiers and all types of diodes—components which have come into common use only within the past five years, and because this latest SUPER-METER necessarily required extra meter scale, SICO used its new full-view 6-inch meter.

SPECIFICATIONS:

- D.C. VOLTS: 0 to 7.5/15/75/150/750/1,500.
- A.C. VOLTS: 0 to 15/30/150/300/1,500/3,000
- D.C. CURRENT: 0 to 1.5/15/150 Ma. 0 to 1.5/15 Amperes
- RESISTANCE: 0 to 1,000/100,000 Ohms. 0 to 10 Megohms.
- CAPACITY: .001 to 1 Mfd., 1 to 50 Mfd.
- REACTANCE: 50 to 2,500 Ohms, 2,500 Ohms to 2.5 Megohms.
- INDUCTANCE: .15 to 7 Henries, 7 to 7,000 Henries.
- DECIBELS: -6 to +18, +14 to +38, +34 to +58. The following components are all tested for QUALITY at appropriate test po-

tentials. Two separate BAD-GOOD scales on the meter are used for direct readings. All Electrolytic Condensers from 1 MFD to 1000 MFD. All Germanium Diodes. All Selenium Rectifiers. All Silicon Diodes. All Silicon Rectifiers.

Model 79 comes complete with operating instructions, test leads, and streamlined carrying case. Use it on the bench—use it on calls. Only **\$38.50**

TRY FOR 10 DAYS BEFORE you buy! THEN if satisfactory

pay in easy, interest free, monthly payments. See coupon inside.

We invite you to try before you buy any of the models described on this and the preceding pages. If after a 10 day trial you are completely satisfied and decide to keep the Tester, you need send us only the down payment and agree to pay the balance due at the monthly indicated rate. (See other side for time payment schedule details.)

**NO INTEREST
OR FINANCE
CHARGES ADDED!**

If not completely satisfied, you are privileged to return the Tester to us, cancelling any further obligation.

**SEE OTHER
SIDE**

CUT OUT AND MAIL TODAY!

FIRST CLASS

Permit No. 61430

New York, N. Y.

BUSINESS REPLY CARD

No Postage Stamp Necessary if Mailed in the U. S.

POSTAGE WILL BE PAID BY —

MOSS ELECTRONIC, INC.

3849 TENTH AVENUE

NEW YORK 34, N. Y.