

BUILD YOUR OWN BURGLAR ALARM

POPULAR ELECTRONICS

JULY
1960

35
CENTS

HI-FI • HAM & CITIZEN RADIO • SWL

Complete Plans For:

- Reflex Pocket Radio
- Building a Radioman's Lamp

All About:

- Ship-Shaping Marine Radio
- Microphones for Hi-Fi

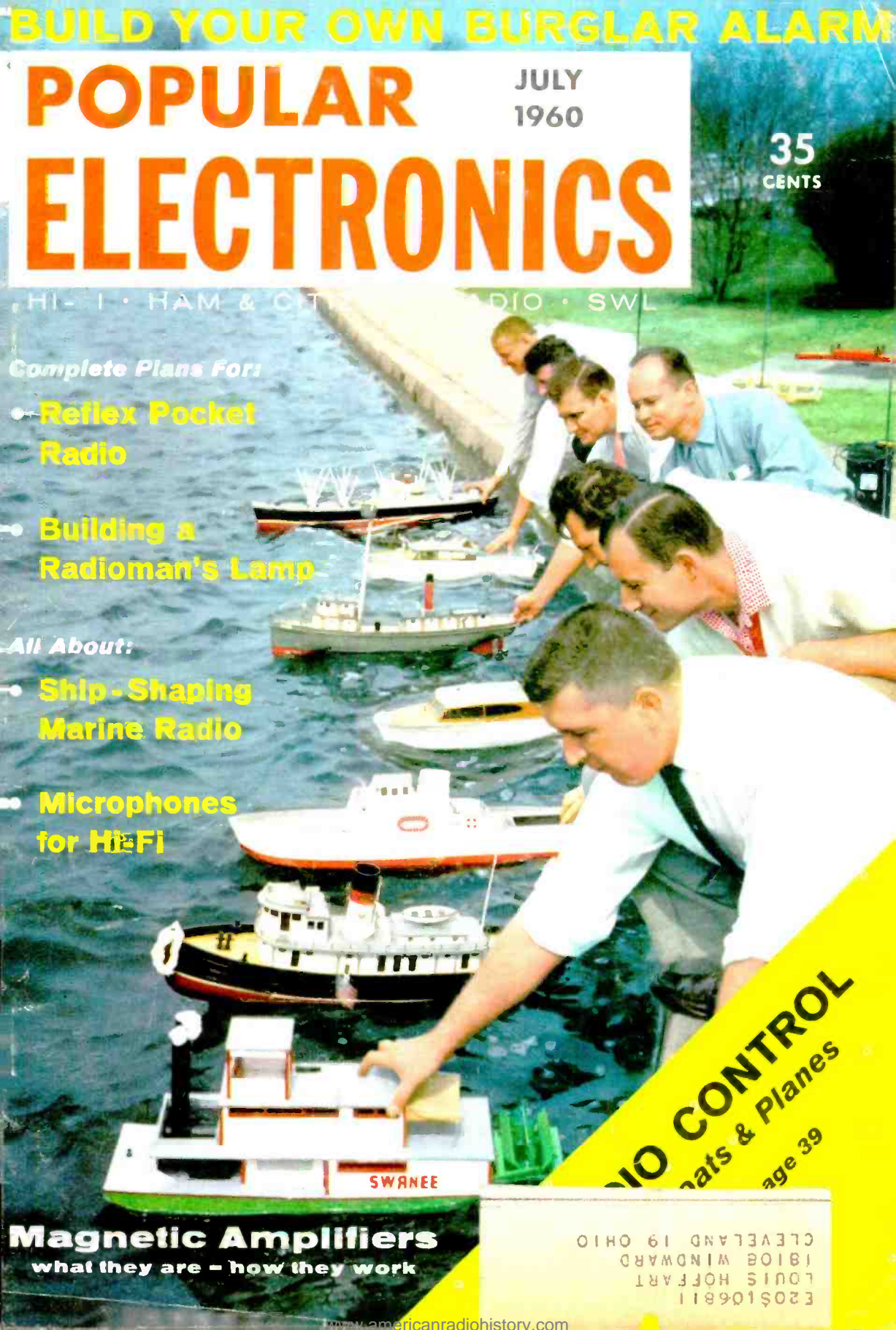

NO CONTROL
 at & Planes
 age 39

Magnetic Amplifiers
 what they are - how they work

2205 106811
 LOUIS HOFFART
 18108 WINDWARD
 CLEVELAND 19 OHIO

PRICES CUT ALMOST $\frac{1}{3}$

on Audiotape on 1½-mil **MYLAR***

THAT'S RIGHT! Audio Devices has cut at least 31% off the price of its premium-quality Audiotape on 1½-mil "Mylar." Now you can enjoy all the advantages of DuPont's fabulous "Mylar" for little more than the cost of ordinary plastic-base tape.

Audiotape on 1½-mil "Mylar" is the finest tape in the Audiotape line. Its tough, durable "Mylar" base and professional-quality oxide make it the perfect tape for schools, recording studios, radio and TV stations, military users—as well as discriminating home recordists.

See your Audiotape dealer as soon as possible. At the new low prices, his stock will move fast. (Similar price reductions have also been made on Master "Low Print-through" Audiotape on 1½-mil "Mylar.")

* "Mylar" is DuPont's trademark for its polyester film—the toughest, most durable recording tape base material known to man. "Mylar" cannot dry out or become brittle with age. Radical differences in temperature and humidity have no effect on it. Recording tapes on "Mylar" can't break or stretch in normal use, regardless of temperature or humidity. Most importantly, "Mylar" is a known, tested base material—proven by years of use in telemetry, automation and electronic computing applications. Millions of feet have been recorded by professional and amateur sound recordists, too.

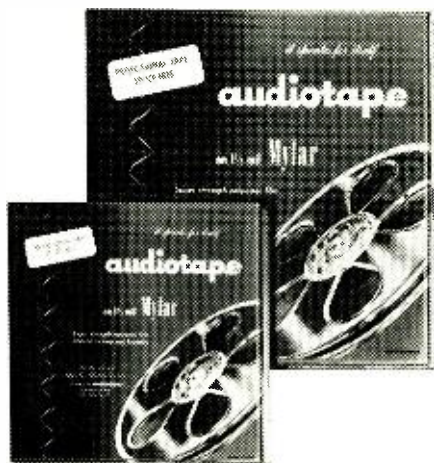

audiotape
TRADE MARK

AUDIO DEVICES, INC., 444 Madison Ave., N. Y. 22, N. Y.

In Hollywood: 840 N. Fairfax Ave. • In Chicago: 5428 N. Milwaukee Ave.



YOU BUILD Broadcasting Transmitter

As part of N.R.I. Communications Course you build this low power Transmitter; use it to learn methods required of commercial broadcasting operators, train for FCC license.

YOU BUILD Signal Generator

N.R.I. sends kits of parts to build this Signal Generator. You get practical experience, conduct tests to compensate Radio frequency amplifiers, practice aligning a typical I.F. video amplifier in TV circuit, many other experiments.

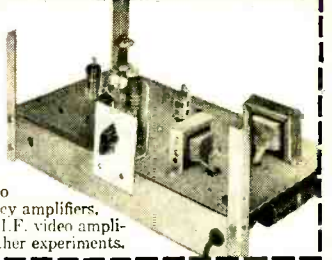

YOU BUILD Vacuum Tube Voltmeter

Use it to get practical experience, earn extra cash fixing neighbors, sets in spare time, gain knowledge to help you work in Radio, Television, Color TV. With N.R.I. training you work on circuits common to both Radio and TV. Equipment you build "brings to life" things you learn in N.R.I.'s easy-to-understand lessons. 64 page Catalog FREE, shows all equipment you get.

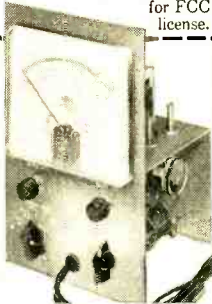

YOU BUILD AC-DC Superhet Receiver

N.R.I. servicing training supplies all parts, everything is yours to keep. Nothing takes the place of practical experience. You get actual servicing experience by practicing with this modern receiver; you learn-by-doing.

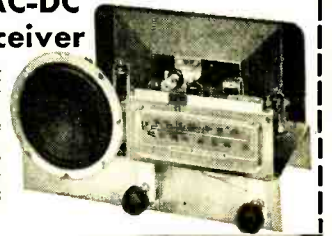

Learn RADIO TELEVISION ELECTRONICS *by Practicing at Home*

WHAT GRADUATES DO AND SAY

Chief Engineer

"I am Chief Engineer of Station KCCU in Mandan, N. D. I also have my own spare time business servicing high frequency two-way communications systems." R. BARNETT, Bismarek, North Dakota.



Paid for Instruments

"I am doing very well in spare time TV and Radio. Sometimes have three TV jobs waiting and also fix car Radios for garages. I paid for instruments out of earnings." G. F. SEAMAN, Has Own TV Business



Has Own TV Business

"We have an appliance store with our Radio and TV servicing, and get TV repairs. During my Army service, NRI training helped get me a top rated job." W. M. WEIDNER, Fairfax, South Dakota.



NEED FOR TECHNICIANS INCREASING Fast Growing Field Offers Good Pay, Bright Future

Today's OPPORTUNITY field is Radio-Television. Over 125 million home Radios plus 30 million sets in cars and 40,000,000 Television sets mean big money for trained Radio-TV Technicians. More than 4,000 Radio and TV Broadcasting stations offer interesting and important positions for technicians, operators. Color television, portable TV sets, Hi-Fi, other developments assure future growth.

It's the trained man who gets ahead. The fellow who uses his spare time to develop knowledge and skill gets the better job, drives a better car, lives in a better home, is respected for what he knows

and can do. So plan now to get into Radio-TV.

Keep your job while training with N.R.I. You learn at home in your spare time. N.R.I. is oldest and largest home study Radio-TV School. Our methods have proved successful for more than 40 years, provide practical experience.

Soon after enrolling, many N.R.I. students start to earn \$10, \$15 a week extra in spare time fixing sets. Many open their own full time Radio-TV shops after getting N.R.I. Diploma. Find out more. Mail Coupon. Cost is low, terms easy; includes all equipment. Address: **National Radio Institute, Dept. OGD-4, Washington, D. C.**

Send for
**LESSON
and CATALOG
FREE**

VETERANS
Available under
G.I. Bills



MAIL COUPON NOW

NATIONAL RADIO INSTITUTE
Dept. OGD-4 Washington 16, D. C.

Mail me Sample Lesson and 64-Page Catalog, FREE. (No Salesman will call. Please write plainly.)

Name: _____ Age: _____

Address: _____

City: _____ Zone: _____ State: _____

ACCREDITED MEMBER, NATIONAL HOME STUDY COUNCIL

POPULAR ELECTRONICS

JULY

1960

VOLUME 13

NUMBER 1



Electronic Construction Projects

One-Transistor Pocket Radio.....	Alvin Mason	43
Earphone Booster Amplifier.....	Louis E. Garner, Jr.	46
Electronic Burglar Alarm.....	Ed Duda	62
Radioman's Lamp.....	Charles Caringella, W6NJY	69
D.P.D.T. Switches in Power Circuits.....	Kenneth Richardson	98

Audio and High Fidelity

Build a Picnic Speaker.....	Luis Vicens	54
Inside the Hi-Fi Microphone.....	Joseph Marshall	55
How to Extend the Life of Your Records.....	John Milder	77
Communicating Through the Earth.....	J. C. Fischesser	87
Stereo Amplifier-Preamplifier.....		90

Electronic Features and New Developments

Operation Radio Control.....		39
TV Explores Deep Wells.....	Harry J. Miller	48
New Developments in Product Design.....		50
Ship-Shaping Marine Radios.....	Leo G. Sands	59
Magnetic Amplifiers—How They Work, What They Do.....	Ken Gilmore	71
Test Instruments—The Sweep Generator.....	G. H. Harrison	80
Transistor Topics.....	Lou Garner	84
Carl and Jerry: Tussle with a Tachometer.....	John T. Frye, W9EGY	94

Amateur and SWL

Notes from the Editor: SWL Registration.....	Oliver Read, W1ETI	6
FCC Report: Computers for FCC.....	Robert E. Tall	8
DX'ing Down Below.....	Tom Kneitel, WPE2AB	51
The Strange Inhabitants of 75-Meter Phone... James F. Van Detta, WA2FQZ		66
On the Citizens Band.....	Tom Kneitel, 2W1965	76
Across the Ham Bands: Putting Up Antennas.....	Herb S. Brier, W9EGQ	91
Short-Wave Report.....	Hank Bennett, W2PNA	97

Departments

Letters from Our Readers.....		12
POP'tronics Bookshelf.....		18
New Products.....		24
Tips and Techniques.....		34

Cover photo courtesy ITT Laboratories

Copyright © 1960 by ZIFF-DAVIS PUBLISHING COMPANY. All rights reserved.

POPULAR ELECTRONICS

“All personnel . . .
 clear the firing area . . .
 stand by for
 countdown . . .
 minus 10 . . .
 . . . 9 . . . 8
 7 . . . 6 . . .
 . 5 . . . 4 . . .
 3 . . . 2 . . .
 . . . 1 . . .”

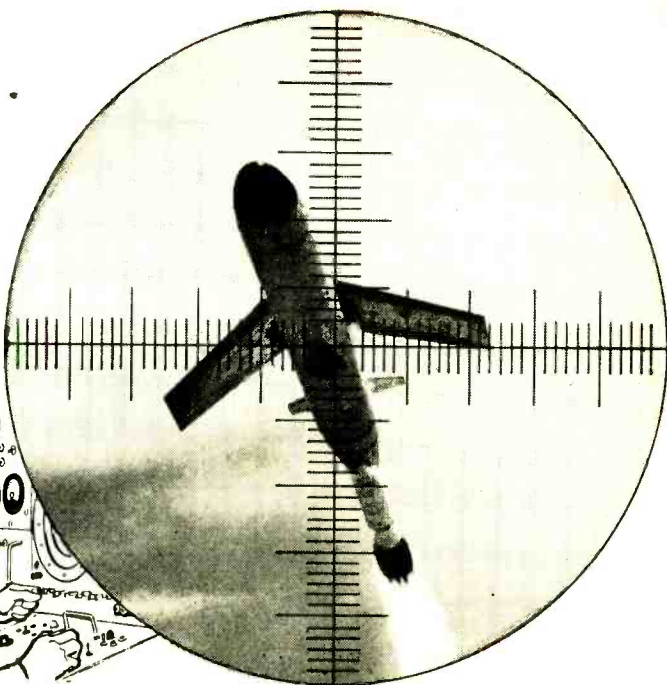
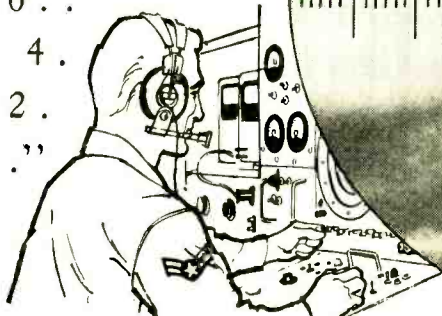

YOU MAY HANDLE A SITUATION LIKE THIS...

If you measure up to the Aerospace Team

A man in this situation requires cool judgment and an aptitude for advanced technical training. This is the kind of man who can measure up to the qualifications of the U. S. Air Force. He is the kind of man who can build a career in the Aerospace Age that will be meaningful and rewarding.

Are you that man? As a trained and experienced Air Force technical specialist, you

will have the opportunity to work with the intricate equipment of the Aerospace Age—the age of air and space travel. You will enjoy steady advancement and solid security. And you will be superbly prepared for the future.

If you would like to learn more about the many unique advantages that go with a career in Air Force blue, fill in and mail this coupon today.

U.S. AIR FORCE

There's a place for tomorrow's leaders on the Aerospace Team

PASTE COUPON ON POSTCARD AND MAIL TO:

Airman Information, Dept. MPO7, Box 7608, Washington 4, D. C.

Please send me more information on my opportunities in the U.S. Air Force. I am between the ages of 17-34 and reside in U.S.A. or possessions.

Name _____

Address _____

City _____ Zone _____ County _____ State _____

Editor & Publisher
OLIVER READ, W1ETI

Managing Editor
JULIAN M. SIENKIEWICZ, WA2CQL

Feature Editor
FURMAN HEBB

Art Director
ALFONS J. REICH

Associate Editors
RICHARD A. FLANAGAN
MARGARET MAGNA
PERRY WINTER, K2VLR

Editorial Assistant
DOLORES GIMBEL

Contributing Editors
H. BENNETT, W2PNA
H. S. BRIER, W9EGQ
J. T. FRYE, W9EGV
L. E. GARNER, JR.
T. KNEITEL, 2W1963

Art Associate
J. A. ROTH

Art and Drafting Dept.
K. W. PAUL, JR.
W. K. VAHSING, WV2GYL

Advertising Director
JOHN A. RONAN, Jr.

Advertising Manager
WILLIAM G. McROY, 2W4144

ZIFF-DAVIS PUBLISHING COMPANY,
One Park Ave., New York 16, N. Y.
William B. Ziff, Chairman of the Board
(1946-1953); William Ziff, President;
W. Bradford Briggs, Executive Vice
President; Michael Michaelson, Vice
President and Circulation Director; Her-
shel B. Sarbin, Vice President; J. Leonard
O'Donnell, Treasurer.



BRANCH OFFICES: Midwestern Office,
434 S. Wabash Ave., Chicago 5, Ill.,
Jim Weakley, Advertising Manager;
Western Office, 9025 Wilshire Blvd.,
Beverly Hills, Calif., Dan Cena, Western
Manager.

Foreign Advertising Representatives:
D. A. Goodall Ltd., London; Albert Mil-
hado & Co., Antwerp and Dusseldorf.

SUBSCRIPTION SERVICE: Forms 3579 and all subscription correspondence should be addressed to Circulation Department, 434 South Wabash Avenue, Chicago 5, Illinois. Please allow at least four weeks for change of address. Include your old address as well as new—enclosing if possible an address label from a recent issue.

CONTRIBUTORS: Contributors are advised to retain a copy of their manuscripts and illustrations. Contributions should be mailed to the New York Editorial Office and must be accompanied by return postage. Contributions will be handled with reasonable care, but this magazine assumes no responsibility for their safety. Any copy accepted is subject to whatever adaptations and revisions are necessary to meet the requirements of this publication. Payment covers all author's, contributor's and contestant's rights, titles, and interest in and to the material accepted and will be made at our current rates upon acceptance. All photos and drawings will be considered as part of material purchased.

POPULAR ELECTRONICS

World's Largest-Selling Electronics Magazine

Average Net Paid Circulation 295,979

COMING NEXT MONTH

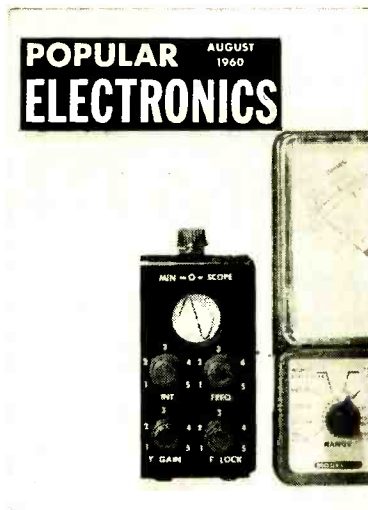

(ON SALE JULY 26)

● **BUILD THE MIN-O-SCOPE**

An oscilloscope that's actually dwarfed by an ordinary VTVM (see photo above), the Min-O-Scope is the ultimate in portability—and it costs only about \$30.00 to construct

● **ONE-TUBE FM TUNER**

For less than \$10.00, you can build an ultra-simple FM tuner offering amazing sensitivity and fidelity

● **TAPE TECHNIQUES**

If you own—or plan to buy—a tape recorder, you'll want to read this article on how to get the most from your tapes

● **TUBE TESTERS**

The first of two articles on how tube testers work and what to look for when buying one

Now! Work Over
300 PRACTICAL
PROJECTS with these
PARTS AT HOME!

to help You learn

ELECTRONICS

RADIO - TELEVISION - RADAR

NOW . . . at home in your spare time you can get the very kind of training and subsequent Employment Service you need to get started toward real earnings in one of today's brightest opportunity fields—TELEVISION-RADIO-ELECTRONICS. Now that Electronics is entering so many new fields, here is a chance of a lifetime to prepare to cash in on its remarkable growth.

DeVry Tech's amazingly practical home method enables you to set up your own HOME LABORATORY. You spend minimum time to get maximum knowledge from over 300 practical projects, using the same type of basic equipment used in our modern Chicago and Toronto Training Centers!

DeVry Tech Provides EVERYTHING YOU NEED . . .

—to help you master TV-ELECTRONICS. In addition to the home laboratory and easy-to-read lessons, you even use HOME MOVIES—an exclusive DeVry Tech advantage. You watch hidden actions . . . see electrons on the march. Movies help you to learn faster . . . easier . . . better.

LABORATORY TRAINING

Full time day and evening training programs in our modern Chicago and Toronto Laboratories are also available. MAIL COUPON TODAY for facts.

BUILD and KEEP Valuable TEST EQUIPMENT

As part of your training, you build and keep a fine Jewel-Bearing Vacuum Tube VOLTMETER and a 5-inch COLOR OSCILLOSCOPE—both high quality, needed test instruments.

EFFECTIVE EMPLOYMENT SERVICE

Get the same Employment Service that has helped so many DeVry Tech graduates get started in this fast-growing field.

EARN WHILE YOU LEARN

DeVry Tech's practical training helps you toward spare time income servicing Radio and Television sets.

CHECK
These Exciting
Job
Opportunities!



TV-Radio Broadcast Technician
Color Television Specialist
Radar Operator
Laboratory Technician
Airline Radio Man
Computer Specialist
Quality Control Manager
Your Own Sales & Service Shop
. . . PLUS MANY OTHERS

"One of North America's Foremost Electronics Training Centers"

Accredited Member
of National Home
Study Council



DeVRY TECHNICAL INSTITUTE
CHICAGO 41, ILLINOIS

MAIL COUPON TODAY!

DeVry TECHNICAL INSTITUTE
4141 Belmont Ave., Chicago 41, Ill., Dept. FE-7-Q

Please give me your FREE booklet, "Electronics in Space Travel," and tell me how I may prepare to enter one or more branches of Electronics.

Name _____ Age _____

Street _____ PLEASE PRINT _____ Apt. _____

City _____ Zone _____ State _____

2045 Canadian residents address: DeVry Tech of Canada, Ltd.
970 Lawrence Avenue West, Toronto, Ontario

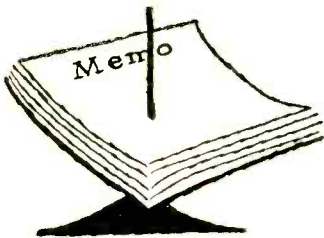

Notes from the Editor

SWL REGISTRATION. Just the other day we received a tabulated report on the Short-Wave Monitor Registration Program that was sponsored by POPULAR ELECTRONICS last year. Here are some of the statistics from the report which I think will interest you. The tabulation, incidentally, was based on 12,948 registration forms received up to January 1, 1960.

First of all, let me fill you in on the purpose of the registration program itself. There had long been a need for the "SWL" to have some individuality. Unlike hams, who are licensed by the government and assigned their own call letters, short-wave listeners had no one to turn to and were "lost in the shuffle." We decided to do something about this situation--it was high time each DX'er had his own "call sign" to use on his QSL cards rather than the anonymous "W5-SWL" type of identification. We then devised the now-famous "WPE" call signs, cleared them with the FCC, and began issuing them to DX'ers.

The most striking bit of information extracted from the tabulated report was that 41.2% of the registering short-wave monitors own more than one receiver. These receivers are not home-brew one-tube regen sets but top-notch-quality all-band receivers that would make the average ham turn green with envy. Manufacturers whose receivers were listed the most times were--in order--Hallicrafters, National, Allied Radio (Knight and Knight-Kit), and Heath. All together, these manufacturers accounted for 65% of the receivers owned by the registrants. The most frequently listed receiver was--you guessed it--the Hallicrafters S-38. Various models of the S-38 are being used by almost 10% of the registrants--quite an endorsement of this old favorite. The second most-used receiver was the Heath AR-3, a unit which has started many an SWL on the road to this rewarding hobby.

The most popular bands monitored are 20, 25, 31, and 40 meters --more than 20% of the registrants reported that they listen to these bands regularly. Over 55% of the monitors use a long-wire antenna; however, many prefer a high-gain beam antenna of some kind--with a few using antenna rotators. One last statistic points out the degree of interest that most of the registrants have in short-wave listening: almost one out of ten reported that he had already obtained over 100 QSL cards.

The overwhelming number of applicants for the certificates made the registration project worthwhile and helped us gain a great deal of valuable information about our SWL readers in addition to reaffirming our belief that DX'ing is a serious and vital electronics hobby. We hope to translate this information into better, more interesting coverage of the SWL field.

Oliver Read

NOW!
at a price
you can afford!

MAKE MORE MONEY in TELEVISION RADIO-ELECTRONICS

**BETTER...MORE COMPLETE...LOWER COST...
WITH NATIONAL SCHOOLS SHOP-METHOD
HOME TRAINING!**

BETTER... Training that is proved and tested in Resident School shops and laboratories, by a School that is the **OLDEST** and **LARGEST** of its kind in the world.

MORE COMPLETE... You learn **ALL PHASES** of *Television-Radio-Electronics*.

LOWER COST... Other schools make several courses out of the material in our **ONE MASTER COURSE** . . . and you pay more for less training than you get in *our course* at **ONE LOW TUITION!**



These
two FREE books will
show you how!

You get all information
by mail . . . You make
your own decision . . . at
home! **NO SALESMAN
WILL CALL**

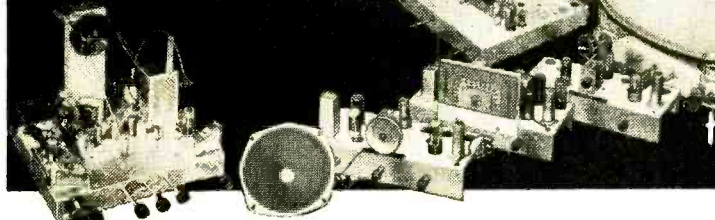

TOP PAY... UNLIMITED OPPORTUNITIES LIFETIME SECURITY CAN BE YOURS!

You are needed in the Television, Radio, and Electronics industry! Trained technicians are in growing demand at excellent pay—in **ALL PHASES**, including Servicing, Manufacturing, Broadcasting and Communications, Automation, Radar, Government Missile Projects.

NATIONAL SCHOOLS SHOP-METHOD HOME TRAINING, with newly added lessons and equipment, trains you in your spare time at home, for these unlimited opportunities, including many technical jobs leading to supervisory positions.

YOU LEARN BY BUILDING EQUIPMENT WITH KITS AND PARTS WE SEND YOU. Your National Schools course includes thorough *Practical training—YOU LEARN BY DOING!* We send you complete standard equipment of professional quality for building various experimental and test units. You advance step by step, perform more than 100 experiments, and you build a complete TV set from the ground up, that is yours to keep! A big, new TV picture tube is included at no extra charge.

EARN AS YOU LEARN. We'll show you how to earn extra money right from the start. Many of our students pay for their course—and more—while studying. So can you!

LESSONS AND INSTRUCTION MATERIAL ARE **UP-TO-DATE, PRACTICAL, INTERESTING.** Every National Schools Shop-Method lesson is made easy to understand by numerous illustrations and diagrams. All instruction material has been developed and tested in our own Resident School Shops, Laboratories and Studios.

SEND FOR INFORMATION TODAY . . . it can mean the difference between **SUCCESS** and failure for you! Send for your **FREE BOOK** "Your Future in Television-Radio-Electronics" and **FREE Sample Lesson.** Do it **TODAY**, while you are thinking about your future. It doesn't cost you anything to investigate!

GET THE BENEFITS OF OUR OVER 50 YEARS EXPERIENCE

Approved for
GI Training



NATIONAL SCHOOLS

Los Angeles 37, Calif.

YOU GET...

- 19 Big Kits—**YOURS TO KEEP!**
- Friendly Instruction and Guidance
- Job Placement Service
- Unlimited Consultation
- Diploma—Recognized by Industry
- **EVERYTHING YOU NEED FOR SUCCESS!**

SHOP-METHOD HOME TRAINING COVERS ALL PHASES OF INDUSTRY

1. Television, including Color TV
2. Radio AM & FM
3. Electronics for Guided Missiles
4. Sound Recording and Hi-Fidelity
5. FCC License
6. Automation and Computers
7. Radar & Micro-Waves
8. Broadcasting and Communications

RESIDENT TRAINING AT LOS ANGELES

If you wish to take your training in our Resident School at Los Angeles, the world's TV capital, start **NOW** in our big, modern Shops, Labs and Radio-TV Studios. Here you work with latest Electronic equipment . . . professionally installed . . . finest, most complete facilities offered by any school. Expert, friendly instructors. Personal attention. Graduate Employment Service. Help in finding home near school . . . and part time job while you learn. Check box in coupon for full information.

NATIONAL TECHNICAL SCHOOLS

WORLD-WIDE TRAINING SINCE 1905

MAIL NOW TO
NATIONAL TECHNICAL SCHOOLS, Dept. R2G-70
4000 S. FIGUEROA ST. LOS ANGELES 37, CALIF.
Rush free TV-Radio "Opportunity" Book and sample lesson. No salesman will call.

NAME _____ AGE _____

ADDRESS _____

CITY _____ ZONE _____ STATE _____

Check if interested **ONLY** in Resident School training at Los Angeles.
VETERANS: Give date of Discharge _____

TIME TO CLEAN UP
YOUR SYSTEM...

Norelco[®]

T-7 LOUDSPEAKERS
with voice coil magnets of
Ticonal-7 steel (30% more
efficient* than Alnico V)

*... 30% more efficient
response to the full signal range
of your amplifier... WHETHER
ITS RATED OUTPUT is
10 WATTS or a HUNDRED...
at any listening level from a
whisper to a shout!

GUILD-CRAFTED BY PHILIPS OF
THE NETHERLANDS TO GIVE YOU

THE CLEANEST SOUND AROUND



Ask for a
demonstration
wherever
good sound is
sold or write to:

**NORTH
AMERICAN
PHILIPS
CO., INC.**

High Fidelity Products Division,
230 Duffy Avenue,
Hicksville, L. I., N. Y.



FCC Report

☆☆☆☆☆ ☆☆☆☆☆☆☆☆☆☆☆☆☆☆☆☆☆☆☆☆☆

By **ROBERT E. TALL**
Washington Correspondent

Computers for FCC

THE electronic data processing bug has bitten the FCC. At the moment, chances look good that the Commission will be blipping out your Citizens Band licenses by machine in a few more years. Studies are already being made by the National Bureau of Standards to see which parts of the FCC's activities can be fitted into computer operation, but it will probably take until early 1963 for the Commission to make the necessary decisions and get the program into full swing.

Word on the computer plans was passed to the House Interstate & Foreign Commerce Communications Subcommittee when the Commission went up for its annual quizzing in connection with appropriations for the year starting July 1. Several of the Congressmen briefed on the plans expressed quick support.

FCC Executive Officer Robert W. Cox told the subcommittee that both the Bureau of Standards and the Commission feel it is "premature" to say how much money can be saved or how much faster work can be done by a computerized operation. However, both agencies are "very optimistic" about the possibilities.

The big question concerning the Citizens Band and other two-way radio fields administered by the FCC is not whether the machines can handle license processing, but whether they can do the work more economically. A decision as to whether or not to swing into a full data processing program will probably be made by the FCC this fall. If the agency goes the computer route, another complete overhauling of application and license forms is indicated.

Chairman Albert Thomas (D., Tex.) of the House Subcommittee said the work of the FCC's Safety & Special Radio Services

Always say you saw it in—POPULAR ELECTRONICS

These men are getting practical training in **NEW Shop-Labs of**

ELECTRICITY

COYNE

ELECTRONICS ON REAL

Motors—Generators
—Switchboards—
Controls—Modern
Appliances—
Automatic
Electronic
Control Units

in Chicago—prepare for today's TOP OPPORTUNITY FIELD. Train on real full-size equipment at COYNE where thousands of successful men have trained for over 60 years—largest, oldest, best equipped school of its kind. Professional and experienced instructors show you how, then do practical jobs yourself. No previous experience or advanced education needed. Employment Service to Graduates.

START NOW—PAY LATER—Liberal Finance and Payment Plans. Part-time employment help for students. **GET FREE BOOK**—"Guide to Careers" which describes all training offered in **ELECTRICITY** and **TELEVISION-RADIO ELECTRONICS**—no obligation; **NO SALESMAN WILL CALL.**

TELEVISION

RADIO ELECTRONICS ON REAL

TV Receivers—
Black and White
and Color
AM-FM and
Auto Radios
Transistors
Printed Circuits
Test Equipment

Coyne Electrical School, 1501 W. Congress Parkway
Chartered Not For Profit • Chicago 7, Dept. BO-2C

MAIL COUPON OR WRITE TO ADDRESS BELOW

COYNE ELECTRICAL SCHOOL
Dept. BO-2C—New Coyne Building
1501 W. Congress Pkwy., Chicago 7, Ill.

Send **BIG FREE** book and details of all the training you offer. However, I am especially interested in:

Electricity Television Both Fields

Name _____

Address _____

City _____ State _____



COYNE offers
LOW COST

TELEVISION RADIO - COLOR TV

Training in
Spare Time **AT HOME**



The future is **YOURS** in **TELEVISION!**
A fabulous field—good pay—fascinating work—a prosperous future in a good job, or independence in your own business!

Send Coupon or write to address below
for Free Book

Coyne brings you **MODERN-QUALITY** Television Home Training; training designed to meet Coyne standards at truly lowest cost—you pay for training only—**no costly "put together kits."** Not an old Radio Course with Television "tacked on." Here is **MODERN TELEVISION TRAINING** including **Radio, UHF and Color TV.** No Radio background or previous experience needed. Personal guidance by Coyne Staff. **Practical Job Guides** to show you how to do actual servicing jobs—**make money early in course.** Free Life-time Employment Service to Graduates.

and full details, including easy Payment Plan. **No obligation, no salesman will call.**



**COYNE Television
Home Training Division**
Dept. BO-H2, New Coyne Building
1501 W. Congress Pkwy., Chicago 7, Ill.

Send Free Book and details on how I can get Coyne Quality Television: Home Training at low cost and easy terms.

Name _____

Address _____

City _____ State _____

COYNE ELECTRICAL SCHOOL

CHARTERED AS AN EDUCATIONAL INSTITUTION
NOT FOR PROFIT

1501 W. Congress Parkway • Chicago 7, Dept. BO-H2



B. W. COOKE, Jr., President
Coyne—the Institution behind this training... the largest, oldest, best equipped residential school of its kind. Founded 1909.

 <p>1 Model T-61 New "Speed Check" Tube Tester Kit Kit Net Price.....\$49.95 Factory-wired Net Price. \$69.95</p>	 <p>Model C-25 New "In Circuit" Capacitor Tester Kit Kit Net Price.....\$19.95 Factory-wired Net Price. \$29.95</p>
---	--

<p>3 Model T-5 New Rapid Filament Tester Kit Kit Net Price.....\$4.50 Factory-wired Net Price. \$6.50</p>	<p>4 Model SC-1 New Condenser Substitution Box Kit Kit Net Price.....\$8.95 Factory-wired Net Price. \$11.95</p>
--	---

...and now **PRECISION** adds **10** more value-packed kits to the **PACO** Line

<p>5 Model CD-3 New Decade Condenser Kit Kit Net Price.....\$19.95 Factory-wired Net Price. \$24.95</p>	<p>6 Model SR-2 New Resistance Substitution Box Kit Kit Net Price.....\$8.95 Factory-wired Net Price. \$11.95</p>
--	--

<p>7 Model RD-5 New Decade Resistor/Divider Kit Kit Net Price.....\$23.95 Factory-wired Net Price. \$29.95</p>	<p>8 Model ST-45 New AM-FM Stereo Tuner Kit Kit Net Price.....\$84.95 Semi-kit Net Price.....\$99.95 Factory-wired Net Price \$134.95</p>
---	--

<p>9 Model ST-35 New FM Tuner Kit Kit Net Price.....\$59.95 Semi-kit Net Price.....\$69.95 Factory-wired Net Price. \$89.95</p>	<p>10 Model L2-U New Wide-Range Two-Way Speaker System Semi-Kit Semi-kit, unfinished Net Price \$59.95 Semi-kit, walnut finish Net Price \$69.95</p>
--	---

SEE THESE KITS ON DISPLAY AT ANY LEADING ELECTRONIC PARTS DISTRIBUTOR



PACO Test Equipment and Hi Fi Kits are produced under the auspices of **PRECISION Apparatus Company, Inc.**, world-famous manufacturer of industrial electronic test instruments and stereo high fidelity components for over a quarter of a century. Write to Dept. P for the new complete 1960 PACO Catalog, just off the press. You'll keep it for permanent reference.
PACO ELECTRONICS COMPANY, INC.
70-31 84th STREET, GLENDALE 27, L. I., N. Y.
Kit Division of **PRECISION Apparatus Co., Inc.**

Bureau, which includes the Citizens Band activities, should fit into computer operation "just like it is made to order." If the program is undertaken, it very definitely should mean much quicker application processing.

Citizens Band applications were being received by the FCC at a rate of more than 10,000 a month, and the FCC told the House members that since "an estimated 50 firms are making or planning to make the relatively inexpensive Citizens Band equipment, a steady rise in receipts can be expected as sales promotion plans get under way and competition results in lowered prices." The Congressmen sitting in on the sessions did not raise many questions when they were told that the Commission expects the Citizens Radio Service to grow to an estimated 200,000 licensees this year, and that the blossoming service has required enforcement action "leading to the issuance of at least 100 citations per month" for violations.

The FCC asked for money for added enforcement personnel to handle problems involving class D licensees, which will "undoubtedly increase as the band becomes saturated." Individual CB enforcement cases continue to involve primarily off-frequency operation and failure to answer FCC violation notices.

Amateur radio, meanwhile, got a large national publicity boost when a live broadcast account of the annual meeting of President Eisenhower's Committee on Employment of the Physically Handicapped was transmitted to physically handicapped and other radio enthusiasts throughout the world.

Accounts of the May 5-6 meeting in Washington were put on the amateur airways by Miss Margaret Cauffield (W3UTR) and Gordon Walker. Miss Cauffield is a wheelchair-bound "ham" employed by the Office of Vocational Rehabilitation of the Department of Health, Education & Welfare; Mr. Walker is also confined to a wheelchair and is an electronics engineer with the Navy's Bureau of Ships.

The station they used was loaned for the venture by a Washington electronics and radio parts firm. It was operated with a power of about 145 watts, with a 55' x 35' antenna supplied by the Naval Research Laboratory on the roof of the Departmental Auditorium in Washington where the meeting was held.

Do you WISH you were EMPLOYED in ELECTRONICS?

F.C.C. LICENSE—THE KEY TO BETTER JOBS

An F.C.C. *commercial* (not amateur) license is your ticket to higher pay and more interesting employment. This license is Federal Government evidence of your qualifications in electronics. Employers are eager to hire *licensed* technicians.

WHICH LICENSE FOR WHICH JOB?

The **THIRD CLASS** radiotelephone license is of value primarily in that it qualifies you to take the second class examination. The scope of authority covered by a third class license is extremely limited.

The **SECOND CLASS** radiotelephone license qualifies you to install, maintain and operate most all radiotelephone equipment except commercial broadcast station equipment.

The **FIRST CLASS** radio telephone license qualifies you to install, maintain and operate every type of radiotelephone equipment (except amateur) including all radio and television stations in the United States, its territories and possessions. This is the highest class of radiotelephone license available.

GRANTHAM TRAINING PREPARES YOU

The Grantham course covers the required subject matter completely. Even though it is planned primarily to lead directly to a first class FCC license, it does this by **TEACHING** you electronics. Some of the subjects covered in detail are: Basic Electricity for Beginners, Basic Mathematics, Ohm's and Kirchoff's Laws, Alternating Current, Frequency and Wavelength, Inductance, Capacitance, Impedance, Resonance, Vacuum Tubes, Transistors, Basic Principles of Amplification, Classes of Amplifiers, Oscillators, Power Supplies, AM Transmitters and Receivers, FM Transmitters and Receivers, Antennas and Transmission Lines, Measuring Instruments, FCC Rules and Regulations, and extensive theory and mathematical calculations associated with all the above subjects explained simply and in detail.

OUR GUARANTEE

If you should fail the F. C. C. exam after finishing our course, we guarantee to give additional training at **NO ADDITIONAL COST**. Read details in our free booklet.

Get Your First Class Commercial F.C.C. LICENSE QUICKLY!

Learn by Correspondence or in Resident Classes

Grantham training is offered by correspondence or in resident classes. Either way, we train you quickly and thoroughly---teach you a great deal of electronics and prepare you to pass the F. C. C. examination for a first class license. Get details now. Mail coupon below.

This booklet **FREE!**

This free booklet gives details of our training and explains what an F. C. C. license can do for your future. Send for your copy today.

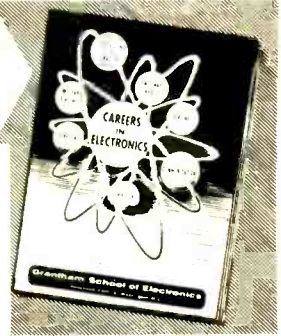

HERE'S PROOF...

that Grantham students prepare for F.C.C. examinations in a minimum of time. Here is a list of a few of our recent graduates, the class of license they got, and how long it took them:

	License	Weeks
Mario Bidese, 342 Alexander Avenue, Greensburg, Pa.	1st	12
Richard M. Wilhoit, 2104 Santa Paula, Las Vegas, Nev.	1st	12
Larry R. Perrine, 7 Normandy Place, Champaign, Ill.	1st	15
Emerson F. Lawson, 111 Excelsior Ave., Union, S.C.	1st	12
Marion Woolsey, 3746 Warwick, Kansas City, Mo.	1st	12
Harold W. Johnson, 5070 Hermosa Ave., Los Angeles, Calif.	1st	15
Arthur W. Hardy, 66 Dresser Ave., Great Barrington, Mass.	1st	12
Ralph Frederick Beisner, 2126 Grand, Joplin, Mo.	1st	12
N. B. Mills, II, 110 So. Race St., Statesville, N.C.	1st	12
Dean A. Darling, 403 S. Chase Ave., Columbus 4, Ohio	1st	12
Paul O. Bernard, 408 First Ave., N.E., Watertown, S.D.	1st	18
Gerald L. Chopp, 518 Aubudon Road, Kohler, Wis.	1st	12

Grantham School of Electronics

HOLLYWOOD CALIF.

SEATTLE WASH.

KANSAS CITY MO.

WASHINGTON D.C.

RESIDENT CLASSES HELD IN FOUR CITIES

If you are interested in attending day or evening classes mail the coupon for free information to our home office in Hollywood, Calif.



(Mail in envelope or paste on postal card)

To: **GRANTHAM SCHOOL OF ELECTRONICS**
1505 N. WESTERN AVE., HOLLYWOOD 27, CALIF.

Gentlemen:

Please send me your free booklet telling how I can get my commercial F.C.C. license quickly. I understand there is no obligation and no salesman will call.

Name _____ Age _____

Address _____

City _____ State _____

I am interested in: Home Study. Seattle classes
 Hollywood classes, Kansas City classes, Washington classes

03-K

MAIL COUPON NOW—NO SALESMAN WILL CALL →

IMPORTANT: For the man who wants to make big money in Radio-Television!

ONLY SPRAYBERRY TRAINING IN RADIO and TELEVISION

**OFFERS YOU ALL OF THESE VITAL NEW ADVANTAGES
TO HELP YOU EARN MORE MONEY FROM THE START!**

NEW BUSINESS BUILDERS

... through these practical proven plans and ideas we help you make plenty of extra money in spare time while training.

NEW TRAINING EQUIPMENT

... the famous Sprayberry Training kits have been newly engineered by our staff to offer you the latest in Radio-TV Service Techniques!

NEW TRANSISTOR COURSE

... literally millions of new transistor radios are being used. We show you how to make money fixing them!

NEW HIGH FIDELITY

... there's big money to be made installing and servicing Hi-Fi units. Your Sprayberry training now offers you this valuable and profitable preparation!

TRAIN AT HOME—SPARE TIME

WITH THESE **25 BIG COMPLETE KITS of PARTS & EQUIPMENT**

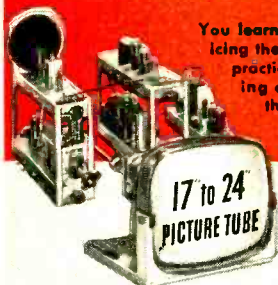

You learn Radio-TV Servicing the best way... the practical way... testing and assembling these modern kits of equipment.

◀ The new Sprayberry Training Television Receiver, built and tested in 5 sections.

Now offered... this fine modern oscilloscope.

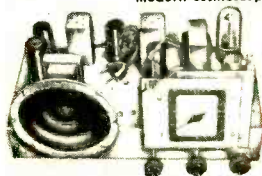

◀ You build this powerful two-band superheterodyne radio receiver.

You build the new Sprayberry tester—a complete 18-range Volt-Ohm-Milliammeter test meter.

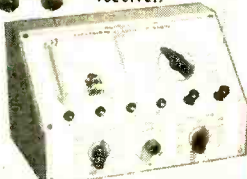

FREE These two big new books are yours free! Find out what Radio-Television offers you... and let us show you how easily you can learn, even without previous experience of any kind. Rush COUPON today!

The field of Radio-Television Servicing is such a fast moving industry that the best jobs and biggest incomes always go first to the man with the most modern, complete and up-to-date training. Thanks to constant revision and improvement... Sprayberry Training helps you earn more from the start... and keeps you earning more in the months and years ahead!

Make no mistake! All radio-television training is not alike. The basic purpose behind Sprayberry Training is to prepare you as rapidly and as surely as possible... to make top money servicing Radio and Television sets and equipment. This is where the big money has been for years... and will continue to be in the years ahead.

It's important for you to know that for over 30 years... Sprayberry Training has been preparing ambitious men for success in this interesting and profitable kind of work. Our school has helped hundreds to qualify for the best jobs... or to get started in profitable businesses of their own. Today our student rolls are the largest in our school's history... because the need and demand for Radio-Television Service Technicians has never been more urgent.

Just \$6.00 Starts You

To encourage more men to enter Radio-Television at once... to help fill the great need for trained men... we're making it easier than ever before to start training. Just \$6.00 enrolls you. This liberal offer is naturally limited. Get the facts now

and consider enrollment while these favorable terms are available to you.

KEEP YOUR JOB... while learning

Under the Sprayberry Plan you train entirely at home in spare time. You combine the most modern lesson training with fascinating and invaluable practical work with 25 big kits of parts and equipment that we supply. You get the equivalent of years of shop practice... and you can train as fast or as slowly as you wish. We help you make excellent spare time money while learning... and everything you receive—lessons, books, manuals, equipment—all yours to keep!

This is the Radio-Television industry's most modern and up-to-the-minute training. Sprayberry is the one school that gives you personalized attention and takes a real interest in your progress. Remember... just \$6 starts you! Mail the coupon today. Let the facts speak for themselves. Let us send you our new catalog and sample lesson... and prove the kind of opportunity that Sprayberry training can open up for you.



MAIL COUPON—No Salesman Will Call

SPRAYBERRY ACADEMY OF RADIO-TELEVISION
Dept. 105-N, 1512 W. Jarvis Ave., Chicago 26, Ill.

Please rush all information on your ALL NEW Radio-Television Training Plan. I understand this does not obligate me and that no salesman will call upon me. Include New Catalog and Sample Lesson FREE.

NAME _____ AGE _____

ADDRESS _____

CITY _____ ZONE _____ STATE _____

SPRAYBERRY ACADEMY OF RADIO-TELEVISION
Dept. 105-N, 1512 West Jarvis Ave., Chicago 26, Ill.

MOBILE-FIXED CONVERTER

POLICE • FIRE • CITIZENS' BAND

For Use with
12 V. Transistor Type
Car Radios
26-50 MC



#331B—Complete with crystal and tubes. Requires no high voltage supply. Operates on 12 V. DC. Self installed in seconds. **\$24.95**
Other models for 108-162 MC available.



#315A is a practical converter for emergency use. Easily installed. Tuning range approximately 12 MC in the 26-50 MC band—30 MC in the 108-174 MC band. Designed for mobile or home use. **\$13.95**
Available crystal controlled up to 54 MC. **\$19.95**
Also available crystal controlled up to 165 MC. **\$22.95**



#316A VARIABLE CONVERTER. Front panel tuning permits rapid change between separated signals over 10 MC range in 26-54 or 108-174 MC bands. **\$19.95**

#341A CITIZENS BAND TUNEABLE CONVERTER. This universal converter covers the entire Citizens Band and is designed for use with home, car or communications sets—AC-DC or standard models. Also available: 200-400 KC Aircraft, 2-3 MC Marine, 4.5 MC-CAP, or Amateur 2-30 MC. **\$24.95**

Full line of converters and receivers for every application.

ORDER TODAY or WRITE for LITERATURE

KUHN ELECTRONICS
20 GLENWOOD CINCINNATI 17, OHIO

Letters

(Continued from page 12)

the subject anywhere. It was not only a refresher for old-timers, but an education in itself for any newcomer to the electronics field. In almost five

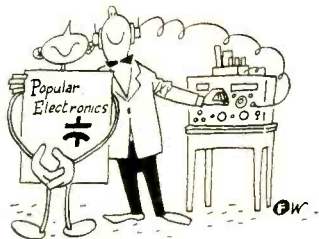

years of hamming, I had never been able to find a good, clear article on capacitors before.

BRUCE W. WALLACE, K8OIG/AFA8OIG
Rochester, Mich.

Canadian Novices

■ I would like to start a move to have Novice licenses issued in Canada. Any Canadian SWL's who are interested in becoming Novices are invited to send me their signatures so I can forward them, along with our arguments, to the Department of Transport.

DAVID A. GRANGER
73 Sunninghill Ave.
Hamilton, Ontario, Canada

Information Please

■ I recently bought a surplus receiver called a "R2/ARR 3." It works well but I can only pick up channel 4. Can you tell me how to convert it

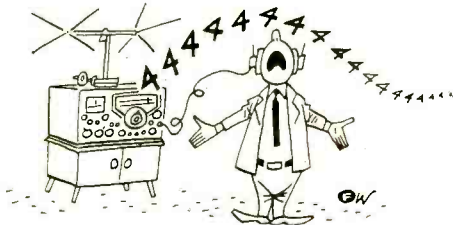

to the FM broadcast band, or where I could get the necessary information?

JOHN BECKETT
338 Inverness Ave. East
Hamilton, Ont., Canada

Can anyone out there give Reader Beckett a helping hand?

BC DX'ing

■ I was glad to read Mr. Leitch's letter in the April issue concerning BC'ing, for I would like to see broadcast-band listening come into its own. Although I am also a short-wave enthusiast (I've logged 35 countries, 12 verified to date), listening on the broadcast band with my Hallicrafters S-38E provides a bigger thrill—I've been doing it for about a year now, and short-wave listening was never so much fun.

On the BC-band I have thus far logged 244 stations, covering 27 U. S. states, three Canadian

Always say you saw it in—POPULAR ELECTRONICS



LEADS AGAIN WITH
CITIZENS BAND
"RADIO-PHONE"
TR-800 TRANSCEIVER



ONLY
99.95
LIST

Furnished with Ceramic
Microphone and one
Transmitting Crystal

For Communication on the move!

- Superhet Trans-Receiver
- 5 Channel Transmit
- 22 Channel Vernier-Tuned Receiving
- 5 Watts Input-Plate Modulated R. F. Amplifier
- On-Off & R. F. Indicators
- Noise-Limiter Control
- Mobile Mounting Brackets Included
- Power Supply Available For 6 and 12 Volt Operation

Write for Brochure and Name of Your Nearest Dealer

UNITED SCIENTIFIC LABORATORIES, INC.

35-09 37th AVE., LONG ISLAND CITY I, N. Y.

Also Mfr's of DeWald HI-FI Stereo Components and FM Radio



**FINE
DYNAMIC MICROPHONES
YOU CAN DEPEND ON ...
ALWAYS**

"How stable?" is the question asked most often about a microphone. Once the type of installation is determined, it is essential that frequency response and directional sensitivity characteristics remain unaffected. This is *stability*—and should remain constant. It is a clue to the wide acceptance and universal use of the Electro-Voice family of dynamic microphones—a family comprising 35 different models, each designed for a specific application. Highly developed precision tooling, extensive research, and functional design have created instruments of outstanding ruggedness and durability. All internal parts nest or interlock to prevent any movement of the reproducing mechanism even when the case is subjected to severe shock. In addition, the exclusive Acoustalloy diaphragm assures smooth response and reliability far surpassing ordinary demands. This vital moving element has no equal in withstanding high humidity, temperature extremes, corrosion and mechanical impact. Laboratory tests reveal only two ways to damage Acoustalloy: heat the microphone so hot it can't be handled, or actually puncture or tear the diaphragm. Each microphone type is field-tested prior to acceptance for manufacture and, when in production, every model is evaluated for exact frequency response, level and pos-

sible distortion, or mechanical imperfections prior to shipment. Such care in manufacturing and testing assures maximum reliability, all-important stability, and remarkable uniformity within dynamic types.

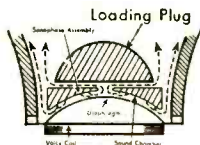

**HORN-LOADED TWEETERS
PROVIDE CLARITY WITHOUT
DISTORTION**

Electro-Voice Tweeters are noted for clarity and low distortion. But obtaining that clarity was a critical problem until E-V's development of the Avedon Sonophase Throat Design.

VHF tweeters handle the widest range of response—from 3500 to 20,000 cps. E-V tweeters function as a true piston in the lower range, but at the critical point (about 12 kc) sound must be taken from the center of the diaphragm and from the periphery at the same time. Without some way to prevent it, sound cancellation occurs because of diaphragm deformation at and above this critical frequency. This deformation causes phase shift to occur between the center and periphery of the diaphragm. Increasingly higher frequencies cause the phase shift to be more pronounced because of an ever increasing deformation of the diaphragm.

The Avedon Sonophase Throat Design accomplishes the vital restoration of phase relationship and level by incorporating a compression driver with unique loading plugs which properly phase upper

frequencies while leaving lower frequencies unaffected. The loading plugs force the sound to travel a circuitous path, producing in-phase sound regardless of the frequency of the signal.

Coupled to the Avedon Sonophase Throat Design is the Hoodwin Diffraction Horn, designed to insure sound dispersion throughout the listening area. This is especially important in stereo application to prevent the "beamed" or directional nature of most high frequencies.



**NEW HAM
RECEIVER PASSES THE
TOUGHEST TEST OF ALL**

An interesting story lies behind the recent performance testing of the first RME 6900 Communications Receiver. After final inspection of the first unit, one of the RME executives (W9IOP), decided to use this new receiver in the 1960 Radio Amateur Sweepstakes. This contest, sponsored each year by the Amateur Radio Relay League, determines which amateur operator can establish the most radio contacts in a given 40 hour period.

The receiver was delivered to W9IOP only three hours before the contest began. In spite of his lack of familiarity with the receiver, W9IOP not only won the contest, but logged a record-breaking 1,369 contacts to establish a new national Sweepstakes record.

The RME 6900 Communications Receiver is the product of over 30 years of high-frequency receiver design. Engineered by radio amateurs — for radio amateurs — it incorporates every conceivable operating feature to facilitate working today's busy ham bands.

For more information write
Dept. 70P



RESIDENT SCHOOL COURSES IN
LOS ANGELES AND NEW YORK CITY

START YOUR CAREER IN ELECTRONICS NOW AT RCA INSTITUTES... Choose from this list

	Course	Qualifications	Length of Course
A	Advanced Electronic Technology (T-3)	High School grad, with Algebra, Physics or Science	Day 2¼ yrs. Eve. 6¾ yrs.
B	TV and General Electronics (V-7)	2 yrs. High School, with Algebra, Physics or Science	Day 1½ yrs. Eve. 4½ yrs.
C	Radio & TV Servicing (V-3)	2 yrs. High School	Day 9 mos. Eve. 2¼ yrs.
D	Transistors*	V-3 or equivalent	Eve. 3 mos.
E	Electronic Drafting (V-9)*	2 yrs. High School, with Algebra, Physics or Science	Eve. 3 yrs.
F	Color TV	V-3 or equivalent	Day 3 mos. Eve. 3 mos.
G	Audio-Hi Fidelity*	V-3 or equivalent	Eve. 3 mos.
H	Video Tape*	V-3 or equivalent	Eve. 3 mos.
I	Technical Writing (V-10)	V-3 or equivalent	Eve. 3-18 mos.
J	Radio Telegraph Operating (V-5)*	2 yrs. High School, with Algebra, Physics or Science	Day 9 mos. Eve. 2¼ yrs.
K	Radio Code (V-4)*	8th Grade	Eve. as desired
L	Preparatory Math & Physics (P-0)	1 yr. High School	Day 3 mos.
M	Preparatory Mathematics (P-0A)	1 yr. High School	Eve. 3 mos.

*Courses to be added to Los Angeles Curriculum

RCA Institutes is one of the largest technical institutes in the United States devoted exclusively to electronics. Coeducational Day and Evening classes. Free placement service. Applications now being accepted.



The Most Trusted Name
in Electronics
RADIO CORPORATION OF AMERICA



Send to the school nearest you!

RCA Institutes, Inc., Dept. PER-70
350 West Fourth Street Pacific Electric Building
New York 14, N. Y. 610 S. Main St., L.A. 14, Calif.

Please send me your FREE catalog. I am interested in the courses circled below.

A B C D E F G H I J K L M

Name _____ (please print)

Address _____

City _____ Zone _____ State _____

For Home Study Courses See Ad On Opposite Page

Letters

(Continued from page 14)

provinces, and nine Mexican states. In addition, I have picked up two Cuban stations but have not yet been able to enter them in my log for lack of adequate identification.

I am hoping that the hobby of logging in the broadcast band will soon begin to interest more and more fans of the airwaves. I sincerely believe that BC'ing deserves a great deal of attention, for it is most fascinating.

DONALD BURLESON
Wichita Falls, Texas

Readers interested in joining a BC DX'ing club should contact the National Radio Club, Box 63, Kensington Station, Buffalo 15, N. Y., or the DX'ers Radio Club % Jim Ernst, Mahone Bay, Nova Scotia.

Car Radio Conversion

■ Thank you for the fine article on "How to Convert a Car Radio for Home Use." by E. G. Louis in the February issue. I bought a used car radio just like the author's for \$2.50. I used a Stancor PM8419 transformer for the conversion and the radio works swell—no hum or noise of any kind. I haven't put it in a cabinet yet, but it really pulls in the stations.

ELDRIDGE BRANDON
Hazel, Ky.

Manual Wanted

■ I urgently need a copy of War Department Manual TM11-300AF for Frequency Meter BC-221 (SCR-211-AF), frequency coverage 125 kc. to 20,000 kc. I will gladly forward an International Money Order for the cost involved.

RON D. YOUNG
3 Bell Hill
Danbury, Chelmsford,
Essex, England

Young Mexican Fan

■ I thought you might like to see a picture of my son, Enrique, shortly after he went to sleep read-



ing a copy of POPULAR ELECTRONICS. Enrique is only four years old, but he enjoys your magazine very much.

MANUEL MENDEZ
Jalapa, Mexico

Then how come it put him to sleep?

—50—

Always say you saw it in—POPULAR ELECTRONICS

RCA INSTITUTES OFFERS YOU THE FINEST OF HOME STUDY TRAINING

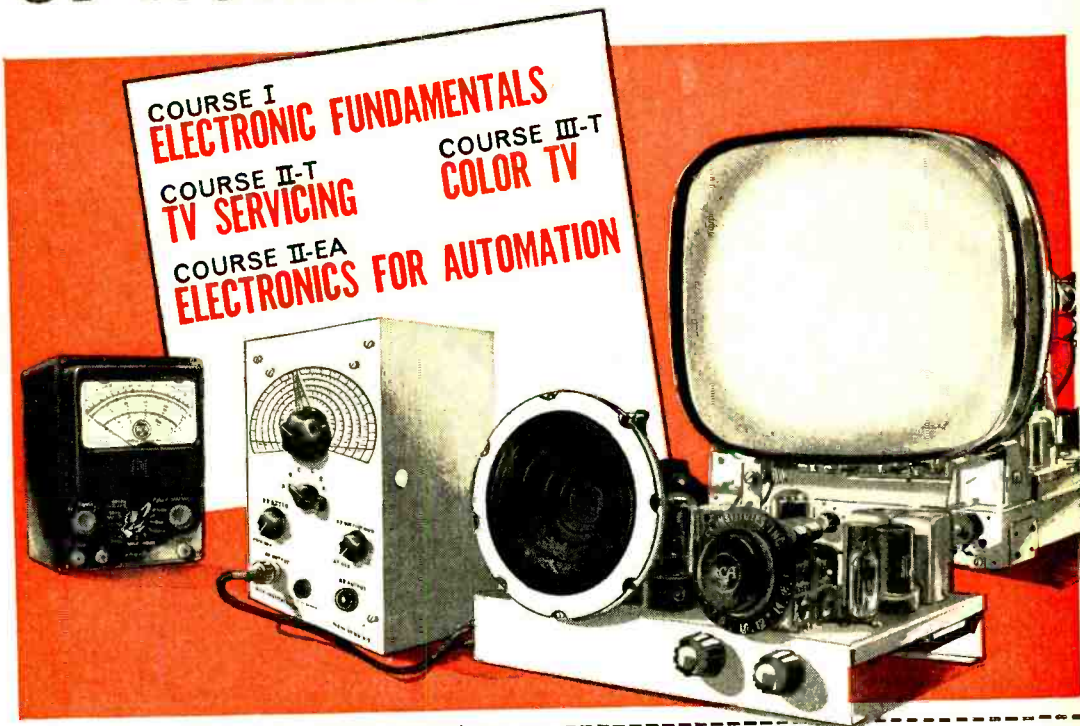

The equipment illustrated and text material you get with each course is yours to keep. Practical work with very first lesson. Courses for the beginner and the advanced student. Pay-as-you-learn. You need pay for only one study group at a time.

RCA INSTITUTES, Inc. Home Study School DEPT. PE-70

A Service of Radio Corporation of America

350 West Fourth Street, New York 14, N. Y.

Without obligation, send me **FREE 64-page CATALOG** on Home Study Courses. No salesman will call.

Name Age
Please print

Address

City Zone State

Korean Vets! Enter discharge date

CANADIANS — Take advantage of these same RCA courses at no additional cost. No postage, no customs, no delay. Send coupon to:

RCA VICTOR COMPANY, LTD.

5575 Royalmount Avenue, Montreal 9, Que.

To save time, paste coupon on postcard



SEND FOR THIS FREE BOOK NOW

For Resident School courses, see ad on opposite page.

POPtronics Bookshelf

"APPLICATIONS OF ELECTRONICS" by Bernard Grob and Milton S. Kiver. Published by McGraw-Hill Book Company, 330 W. 42nd St., New York 36, N. Y. 628 pages. Hard cover. \$7.00.

Intended as the second volume of a two-volume set, this book takes up where Mr. Grob's previous book, "Basic Electronics," left off. It can be used alone, however, by anyone who has a basic knowledge of electronics. Topics include vacuum-tube amplifiers, transistor amplifiers, receivers, test instruments, industrial electronics, military electronics, and electronic navigational aids. Recommended as a text or reference.

"101 WAYS TO USE YOUR HAM TEST EQUIPMENT" by Robert G. Middleton. Published by Howard W. Sams & Co., Inc.

2201 E. 46th St., Indianapolis, Ind. 168 pages. Soft cover. \$2.50.

One of the best substitutes for actual bench experience is Bob Middleton's series of "101 Ways" books. This latest volume, which discusses the use of test equipment generally associated with amateur radio operation, is a worthy addition to the series. The specific equipment covered includes the grid-dip meter, the antenna impedance meter, the VOM and VTVM, the oscilloscope, reflected-power and SWR meters, plus bridges and some other miscellaneous equipment used to perform various types of measurements.

This book is well worth careful study since the diagrams and explanations of the testing procedures illustrate many aspects of electronic theory. Consequently, it is recommended not just for hams but for



to use your...

By ROBERT G. MIDDLETON



PHOTOFACT PUBLICATION

ALL TUBES INDIVIDUALLY
BOXED - UNCONDITIONALLY
GUARANTEED FOR ONE YEAR

Send for Free Complete Tube List &
Order Blank. Your inquiry will
Put you on Our Mailing List

FREE

EICO TUBE
TESTER
Eico - 625K Free
with Purchase of
\$100. - Recv. Tubes
in 60 Days. Buy it for
\$34.95 ppd.

FREE

68GBG with \$10.
order!

FREE

\$7.50 pkg. inc. 3-65N7
plus 25 ass'd tubes with
\$25. - order!

CHANNEL MASTER ANTENNA
KIT, COMPLETE WITH 8 ELEM-
ENT ANTENNA - CHIMNEY
STRAPS, 50 FT. 300 OHM LEAD
IN, ALUMINUM MAST, STAND
OFFS AND INSULATORS. \$7.99

LOTS OF THREE - \$7.49

FOB HARRISON, N.J. IM. DLV.

HEAVY DUTY SOLDER GUN.

PREPAID \$4.95 - 3 for \$14.29

CHANNEL MASTER SWITCH

TYPE RABBIT EARS - \$2.99

LOTS OF 6 \$2.49 - PPD.

6V 4 pr. VIBRATORS - \$1.59

12V 3 pr. - \$1.79

12V 4 pr. - \$1.99

DURABLE ALUMINUM

RABBIT EARS - \$1.69

PARALLEL TUBE

BRIGHTENERS - \$3.99

New Price Schedule of TELEVISION PICTURE TUBES

121PA	10.75	17CP4	17.25	21AP4	21.25	21VP4	17.25
148P4	11.75	121P4	17.45	21AUP4	19.25	21VP4	18.75
18AP4	16.45	19AP4	18.25	21AVP4	19.25	21ZP4	17.25
16CP4	15.99	20CP4	15.75	21AWP4	18.75	24ADP4	-
169P4	11.95	20HP4	17.75	21EP4	17.25	24AP4	-
16LP4	11.95	21ALP4	18.75	21KP4	19.25	24CP4	27.25
18AP4	11.95	21AMP4	18.75	21MP4	21.25	24DP4	28.75
17AVP4	15.75						

Aluminized on any tube \$4.00 extra. All picture tubes require a deposit on your bid. Please add an additional \$5.00 on tube sizes to 17". Add \$7.00 on sizes 19", 20", 21" and 24". Your cash deposit will be refunded immediately upon receipt of your bid. Prepaid. Picture tubes are shipped promptly from our warehouse (the US Continent and Canada only). FOB: Harrison, New Jersey.

PICTURE GUARANTEED FOR ONE (1) YEAR

"USED TVs" 500 TRADE IN TVs
FOR QUICK SALE

We have purchased from a huge appliance store a quantity of used TVs. The sets are in excellent condition and most are Standard Brands. Sizes run from 12" to 24" - Excellent for second set or for experimenters. SETS SHIPPED RAILWAY EXPRESS FOB our warehouse.

\$14.95 as is (continental USA & Canada only)

SELF-SERVICE TUBE CHECKERS

These reconditioned console model 22 socket tube checkers have proven their worth in busy repair shops. Let your tube customers test their own tubes. Your investment will be returned in one week with little effort on your part. COMPLETE WITH KEY FOR BOTTOM DOOR AND NEON LIGHTED HEAD.

\$39.95 FOB OUR WAREHOUSE

NEW CATALOGUE: No. 1000 - 1000 tubes. Low price on all tube & component orders. Send in U.S.A. APO's & Territories. 25% deposit required on 4010's. Please send approximate amount on Canadian and foreign shipments. (Books will be refunded.)

Send for FREE complete list of most often used tube types

SMASHES PRICES ON TUBES for '60

SAVE ON ALL TUBES

PARTIAL LIST OF MOST OFTEN USED TUBES

021	45	6AC7	65	6CY5	49	12BA4	46
180GT	60	6AF4	102	6CV7	66	12BK6	46
10N3	60	6AG5	102	6DA6	66	12BE6	46
180	70	6AH6	47	6DE5	59	12BH7	61
180	70	6AL5	42	6DG6T	59	12C6A	63
180	70	6AM8	42	6DE6	43	12BY7	61
180	70	6AN8	59	6DQ6	60	12CR6	63
114	51	6AS5	52	6EAB	69	12C6B	63
114	51	6AS5	52	6EAB	69	12C6C	63
114	51	6AS5	52	6EAB	69	12C6D	63
114	51	6AS5	52	6EAB	69	12C6E	63
114	51	6AS5	52	6EAB	69	12C6F	63
114	51	6AS5	52	6EAB	69	12C6G	63
114	51	6AS5	52	6EAB	69	12C6H	63
114	51	6AS5	52	6EAB	69	12C6I	63
114	51	6AS5	52	6EAB	69	12C6J	63
114	51	6AS5	52	6EAB	69	12C6K	63
114	51	6AS5	52	6EAB	69	12C6L	63
114	51	6AS5	52	6EAB	69	12C6M	63
114	51	6AS5	52	6EAB	69	12C6N	63
114	51	6AS5	52	6EAB	69	12C6O	63
114	51	6AS5	52	6EAB	69	12C6P	63
114	51	6AS5	52	6EAB	69	12C6Q	63
114	51	6AS5	52	6EAB	69	12C6R	63
114	51	6AS5	52	6EAB	69	12C6S	63
114	51	6AS5	52	6EAB	69	12C6T	63
114	51	6AS5	52	6EAB	69	12C6U	63
114	51	6AS5	52	6EAB	69	12C6V	63
114	51	6AS5	52	6EAB	69	12C6W	63
114	51	6AS5	52	6EAB	69	12C6X	63
114	51	6AS5	52	6EAB	69	12C6Y	63
114	51	6AS5	52	6EAB	69	12C6Z	63
114	51	6AS5	52	6EAB	69	12C6A1	63
114	51	6AS5	52	6EAB	69	12C6A2	63
114	51	6AS5	52	6EAB	69	12C6A3	63
114	51	6AS5	52	6EAB	69	12C6A4	63
114	51	6AS5	52	6EAB	69	12C6A5	63
114	51	6AS5	52	6EAB	69	12C6A6	63
114	51	6AS5	52	6EAB	69	12C6A7	63
114	51	6AS5	52	6EAB	69	12C6A8	63
114	51	6AS5	52	6EAB	69	12C6A9	63
114	51	6AS5	52	6EAB	69	12C6A10	63
114	51	6AS5	52	6EAB	69	12C6A11	63
114	51	6AS5	52	6EAB	69	12C6A12	63
114	51	6AS5	52	6EAB	69	12C6A13	63
114	51	6AS5	52	6EAB	69	12C6A14	63
114	51	6AS5	52	6EAB	69	12C6A15	63
114	51	6AS5	52	6EAB	69	12C6A16	63
114	51	6AS5	52	6EAB	69	12C6A17	63
114	51	6AS5	52	6EAB	69	12C6A18	63
114	51	6AS5	52	6EAB	69	12C6A19	63
114	51	6AS5	52	6EAB	69	12C6A20	63
114	51	6AS5	52	6EAB	69	12C6A21	63
114	51	6AS5	52	6EAB	69	12C6A22	63
114	51	6AS5	52	6EAB	69	12C6A23	63
114	51	6AS5	52	6EAB	69	12C6A24	63
114	51	6AS5	52	6EAB	69	12C6A25	63
114	51	6AS5	52	6EAB	69	12C6A26	63
114	51	6AS5	52	6EAB	69	12C6A27	63
114	51	6AS5	52	6EAB	69	12C6A28	63
114	51	6AS5	52	6EAB	69	12C6A29	63
114	51	6AS5	52	6EAB	69	12C6A30	63
114	51	6AS5	52	6EAB	69	12C6A31	63
114	51	6AS5	52	6EAB	69	12C6A32	63
114	51	6AS5	52	6EAB	69	12C6A33	63
114	51	6AS5	52	6EAB	69	12C6A34	63
114	51	6AS5	52	6EAB	69	12C6A35	63
114	51	6AS5	52	6EAB	69	12C6A36	63
114	51	6AS5	52	6EAB	69	12C6A37	63
114	51	6AS5	52	6EAB	69	12C6A38	63
114	51	6AS5	52	6EAB	69	12C6A39	63
114	51	6AS5	52	6EAB	69	12C6A40	63
114	51	6AS5	52	6EAB	69	12C6A41	63
114	51	6AS5	52	6EAB	69	12C6A42	63
114	51	6AS5	52	6EAB	69	12C6A43	63
114	51	6AS5	52	6EAB	69	12C6A44	63
114	51	6AS5	52	6EAB	69	12C6A45	63
114	51	6AS5	52	6EAB	69	12C6A46	63
114	51	6AS5	52	6EAB	69	12C6A47	63
114	51	6AS5	52	6EAB	69	12C6A48	63
114	51	6AS5	52	6EAB	69	12C6A49	63
114	51	6AS5	52	6EAB	69	12C6A50	63
114	51	6AS5	52	6EAB	69	12C6A51	63
114	51	6AS5	52	6EAB	69	12C6A52	63
114	51	6AS5	52	6EAB	69	12C6A53	63
114	51	6AS5	52	6EAB	69	12C6A54	63
114	51	6AS5	52	6EAB	69	12C6A55	63
114	51	6AS5	52	6EAB	69	12C6A56	63
114	51	6AS5	52	6EAB	69	12C6A57	63
114	51	6AS5	52	6EAB	69	12C6A58	63
114	51	6AS5	52	6EAB	69	12C6A59	63
114	51	6AS5	52	6EAB	69	12C6A60	63
114	51	6AS5	52	6EAB	69	12C6A61	63
114	51	6AS5	52	6EAB	69	12C6A62	63
114	51	6AS5	52	6EAB	69	12C6A63	63
114	51	6AS5	52	6EAB	69	12C6A64	63
114	51	6AS5	52	6EAB	69	12C6A65	63
114	51	6AS5	52	6EAB	69	12C6A66	63
114	51	6AS5	52	6EAB	69	12C6A67	63
114	51	6AS5	52	6EAB	69	12C6A68	63
114	51	6AS5	52	6EAB	69	12C6A69	63
114	51	6AS5	52	6EAB	69	12C6A70	63
114	51	6AS5	52	6EAB	69	12C6A71	63
114	51	6AS5	52	6EAB	69	12C6A72	63
114	51	6AS5	52	6EAB	69	12C6A73	63
114	51	6AS5	52	6EAB	69	12C6A74	63
114	51	6AS5	52	6EAB	69	12C6A75	63
114	51	6AS5	52	6EAB	69	12C6A76	63
114	51	6AS5	52	6EAB	69	12C6A77	63
114	51	6AS5	52	6EAB	69	12C6A78	63
114	51	6AS5	52	6EAB	69	12C6A79	63
114	51	6AS5	52	6EAB	69	12C6A80	63
114	51	6AS5	52	6EAB	69	12C6A81	63
114	51	6AS5	52	6EAB	69	12C6A82	63
114	51	6AS5	52	6EAB	69	12C6A83	63
114	51	6AS5	52	6EAB	69	12C6A84	63
114	51	6AS5	52	6EAB	69	12C6A85	63
114	51	6AS5	52	6EAB	69	12C6A86	63
114	51	6AS5	52	6EAB	69	12C6A87	63
114	51	6AS5	52	6EAB	69	12C6A88	63
114	51	6AS5	52	6EAB	69	12C6A89	63
114	51	6AS5	52	6EAB	69	12C6A90	63
114	51	6AS5	52	6EAB	69	12	

YOU be the judge of **knight-kit**® value

A PRODUCT OF ALLIED RADIO



FREE examination privilege

More and more people are finding out how easy it is to build exciting Knight-Kits, how satisfying they are to own, and how much they save.

If you haven't yet enjoyed the experience and fun of building and owning a Knight-Kit, we invite you to take advantage of our free examination offer. Order any Knight-Kit. Examine it on arrival. Inspect the

quality of the components, the circuitry, the easy-assembly manual. We're so confident you'll want the kit, we can make this offer: If you're not COMPLETELY SATISFIED, just return the kit for full refund.

Order a Knight-Kit now. Know the thrill of the most satisfying build-your-own experience in electronics.



Y-731 Deluxe FM-AM Stereo Hi-Fi Tuner (Multiplex add-in) \$87.50
only \$2 down



Y-774 Deluxe 40-Watt Stereo Amplifier (with Center Channel) \$79.50
only \$5 down



Y-773 Super-Value 20-Watt Stereo Hi-Fi Amplifier... \$44.50
only \$2 down



Y-787 FM-AM Hi-Fi Tuner (with Multiplex jack) \$49.95
only \$2 down



Y-713 Best-selling Citizens Band Transceiver. Tunable 22-channel super-regen receiver... \$39.95
only \$2 down

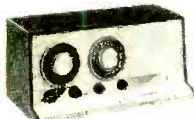

Y-258 4-Band "Span Master" Receiver (with cabinet) \$25.95
only \$2 down



R-100 Amateur Communications Receiver (Hi-gain, with built-in Q-Multiplier). \$104.50
only \$5 down



Y-708 1000 Ohm/Volt Pocket Volt-Ohm-Milliammeter \$9.95



Y-737 "Ranger" Clock-Radio with "sleep" switch... \$24.95
only \$2 down



Y-771 5-Transistor Superhet Portable Radio (less battery) \$25.95
only \$2 down



Y-125 General-purpose VTVM (11 meg. input res.) \$25.75
only \$2 down

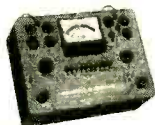

Y-143 Model "600" Tube Checker (checks over 700 types) \$32.95
only \$2 down

easiest to build ...
satisfying to own ...
money-saving

ONLY \$2 DOWN
on orders up to \$50;
\$5 down on orders
up to \$200...

see scores of
other **knight-kits**

HI-FI KITS

Stereo Preamplifier
60-W Stereo Amplifier
Monaural Amplifiers
Hi-Fi Tuners
Speaker Systems
and others

HOBBYIST KITS

"Space-Spanner" Radio
"Ranger" Radios
Transistor Radios
2-Way Intercom
Electronic Lab Kits
and many others

INSTRUMENT KITS

Lab AC VTVM
VOM's
5" Scales
Tube Checkers
Signal Tracer
Audio Generator
Sweep Generator
plus many others

AMATEUR KITS

50-Watt Transmitter
Self-Powered VFO
100 kc Crystal Calibrator
Code Practice Oscillator
Grid Dip Oscillator

there's a money-saving **knight-kit** for every need... see them all in the

ALLIED CATALOG

Describes the complete KNIGHT-KIT line in detail. Order the kit of your choice—judge quality and value for yourself under our Free examination privilege!

FREE

send for it!



ALLIED RADIO

ALLIED RADIO, Dept. 23-G
100 N. Western Ave., Chicago 80, Ill.

Send FREE Catalog featuring Knight-Kits.

Name _____

Address _____

City _____ Zone _____ State _____

THE VERY FINEST CITIZENS' RADIO...



Farming,
delivery or
fleet operation



Car-to-office
or home
communication



Boat-to-boat or
ship-to-shore
communication

FREE
Color Brochure
WRITE TODAY

Messenger from **\$129⁷⁵**

- Anyone can operate—license issued by FCC on request!
- 23 channel Class "D" Band coverage—choose 1 of 5 channels by flip of switch!

Designed for 10 watts—limited to 5 for Citizens' Radio. Excellent receiver sensitivity and selectivity. Built-in Squelch, Automatic Volume Control, and Automatic Noise Limiter. With tubes, microphone, and crystals for 1 channel.

Available from authorized Johnson Distributors—installation and service at all General Electric Communications Service Stations.



E. F. JOHNSON CO

126 Second Ave. S.W. • Waseca, Minn.

- Please rush me your full color brochure describing the Viking "Messenger" Citizens' Transceiver.

NAME _____

ADDRESS _____

CITY _____

STATE _____

Enjoy your HI-FI OUTDOORS

PATIO, GARDEN, TERRACE, POOL

with the new WT-6 **ATLAS HI-FI** COAX-PROJECTOR

all-weather construction... install it, forget it...
or take it with you wherever you listen.



True hi-fi TWO-WAY system—not just a "compromise." The WT-6 comprises a weather-proof cone type driver (with 6-inch throat) with its individual woofer horn; a separate pressure-type driver loaded to its separate tweeter horn; and built-in electronic crossover filter.

For all indoor and outdoor uses... universally adjustable "U" type rugged steel mounting... finished in high-temperature baked modern beige enamel.

Power Rating 15 watts continuous. Freq. Resp. 125-15,000 cps. Impedance 8 ohms. Dispersion 120°. Bell opening 15", overall depth 12".

See the WT-6 at your local distributor. Send for catalog 560.

Net \$34.50



ATLAS SOUND CORP.
Dept. PE 7, 1449 - 39th St., Brooklyn 18, N. Y.

Bookshelf

(Continued from page 18)

anyone who would like to have a fuller and more detailed understanding of all phases of electronics.



"RADIO CONTROL FOR MODEL BUILDERS" by William Winter. Published by John F. Rider Publisher, Inc., 116 W. 14 St. New York 11, N. Y. 220 pages. Soft cover. \$4.25.

Here is a complete guide for the radio-control fan. The author is the editor of *Model Airplane News* and he knows his subject intimately. Starting at a basic level, he gradually works his way up to more advanced topics. Following an excellent introductory chapter on how to get started in radio control, he discusses transmitters, receivers, actuators, power supplies, meters, relays, the radio-controlled boat, and advanced systems. Highly recommended as a most useful source of information about radio control.

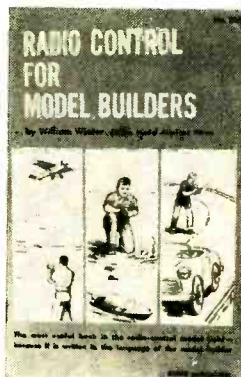

"ABC'S OF HAM RADIO" by Howard S. Pyle. Published by Howard W. Sams & Co., Inc., 2201 E. 46th St., Indianapolis 6, Ind. 112 pages. Soft cover. \$1.50.

This simply written introduction to ham radio covers the subject from the standpoint of the complete newcomer. It discusses how to go about getting a license and how to learn code. In addition, it provides a brief course in basic electricity and electronics. Recommended to anyone interested in becoming a radio amateur, it would be a fine gift for a youngster.



"PRINCIPLES OF GUIDED MISSILES AND NUCLEAR WEAPONS," prepared by the U. S. Navy Training Publications Center. Available from Superintendent of Docu-

LAFAYETTE HE-15 CITIZENS BAND 11 METER SUPERHETERODYNE TRANSCEIVER

Not Superregenerative but SUPERHET

- Planetary Vernier Tuning: Controls include 3 position function switch (transmit, receive, plus transmit with spring return) and automatic noise limiting switch.
- High Output Crystal Microphone: 2 position push to talk slide switch; especially designed for sustained transmit operation with a minimum of background noise.
- Adapts for Use Anywhere: Modern compact styling. Brackets are supplied for easy mounting of unit in auto, truck or boat. Addition of 6 or 12 volt power supply (separately supplied) adapts transceiver for mobile operation. Only 4 1/2" D x 6" W x 4" H.

Anyone Can Operate: No examination or technical knowledge required—Any citizen 18 years or older is eligible for a license. Simply fill out FCC application supplied with HE-15 Transceiver.

HE-15 Factory Wired and Tested (Less antenna)	5.00 Down	Net 64.50
HE-19 Whip Antenna		Net 3.95
HE-16 Power Supply For 12 Volts		Net 11.95
HE-18 Power Supply For 6 Volts		Net 11.95



COMPLETELY
WIRED
NOT
A KIT

64.50

ONLY 5.00 DOWN

- 5 Crystal Controlled Transmitting Positions: Operates at a maximum FCC legal power input of 5 watts fully modulated.
- Superheterodyne Tuneable Receiver Over Full 22 Channel Band: RF stage in both Transmitter and receiver, 3 watts audio output plus large 4" speaker.
- Complete with Transmitting Crystal: Removable front plate for easy accessibility of crystals. Channel 9 crystal supplied.
- 4 Dual Function Tubes, plus 2 Single Function Tubes, plus 2 Rectifiers for 12 Tube Performance: Compares with units costing 3 times as much. Unexcelled reception on land and sea with coverage up to 20 or more miles depending on antenna height and terrain.



Use In the Home



Boating — Ship to Shore



On the Farm



Business — Trucking

NEW! LAFAYETTE TELESCOPIC CITIZENS BAND WHIP ANTENNA

3.95 • Chrome Plated • Telescopes From 16 1/2" to 40" • Mounts Vertically or Right Angle

An outstanding antenna value. This high quality three section telescoping antenna is designed for attachment directly to your citizens band transceiver. Ideal for point to point service over short distances. Molded base loading coil has a threaded stud with a PL-259 plug—connector for vertical or right angle mounting. Shpg. wt: HE-19 Net 3.95



NEW! LAFAYETTE RADIO FIELD INDICATOR

A Must For All Ham and Citizens Band

- Provides a Continuous Indication of Transmitter Output **7.95**
- Rugged 200ua Meter Movement with Variable Sensitivity Control
- Requires no Electricity, Batteries or Transmitter Connection

Measures the RF field generated by any marine, mobile or fixed transmitter. Rear phone jack accepts earphones. Antenna extends from 3 1/4" to 10 3/4". Bottom plate magnet allows mounting on any metal surface. Measures 3 1/8" W x 2 1/4" H x 2" D (less antenna). Shpg wt., 2 lbs.



TM-14 Net 7.95

PLEASE RUSH ITEMS CHECKED

- | | |
|---|--|
| <input type="checkbox"/> HE-15 Citizens Band Transceiver | <input type="checkbox"/> TM-14 Radio Field Indicator |
| <input type="checkbox"/> FS-206 "Tiny" 6 Transistor Radio | <input type="checkbox"/> HE-19 Whip Antenna |
| <input type="checkbox"/> Free 308 Page Catalog 600 | |

Enclosed Find \$.....
Please include postage to cover shipping

FREE 308 Giant Size Pages

Name.....
Address.....
City.....Zone.....State.....

LAFAYETTE RADIO • P.O. BOX 222, Jamaica 33, N.Y. • Dept. IG-6

LAFAYETTE "Tiny" 6-Transistor Radio

Sensational Performance In a Small Package!

- 6 Transistors Plus a Germanium Diode Superheterodyne Circuit
- Vest Pocket Size—Only 4" H x 2 1/2" W x 1 1/4" D
- Built In Earphone Jack For Private Listening
- Trouble-Free Printed Circuit
- Built-In Ferrite Bar Antenna
- Economical—Uses Only One 9 Volt Battery



ONLY **19.95**

Complete with battery, carrying case and earphone. Shpg wt. 2 lbs.
FS-208 "Tiny" 6-Transistor Radio Net 19.95

Bookshelf

(Continued from page 20)

ments. U. S. Government Printing Office, Washington 25, D. C. 284 pages. Soft cover. \$2.00.

Like many U. S. Government publications, this book is notable both for the amount of information it provides and for the clear way in which it is presented. Much of the text is devoted to explaining the principles of guided missiles, including systems for propulsion, control, and guidance. This part of the book is jam-packed with information that should interest anyone with a mechanical or electronic turn of mind.

The remainder of the work is concerned with nuclear weapons. The section on their destructive effects is absolutely spine-chilling; if anyone still believes that nuclear war is feasible, let him read this book.

"DIRECT CURRENT ELECTRICITY" by Alexander Efron. Published by John F. Rider Publisher, Inc., 116 West 14th St.,

New York, N. Y. Soft cover. 100 pages. \$2.25.

This is a very interesting book about the fundamentals of direct current electricity in terms of the Franklinian Approach—or from the point of view that current flows from plus to minus. The illustrations effectively complement the text, adding interest and clarifying the presentation. Considerable attention is paid to electrochemistry, voltage drop, and the magnetic effects of electric current. Recommended as rewarding reading for anyone with a basic knowledge of electronics.

Miscellaneous Literature

■ A complete catalog of Lafayette audio and electronic kits has recently been announced. Write to Lafayette Electronics Mfg. Corp., 104-46 Dunkirk St., Jamaica 12, N. Y. for this attractive 20-page booklet.

■ "Tape Recording Head Reference Guide," a 16-page booklet containing specifications and illustrations of tape recorder heads, is available for 50 cents from Robins Industries, 36-27 Prince St., Flushing, N. Y. —30—

REMARKABLE TUBE VALUES AT 1950 PRICES

ALL TUBES IND. BOXED, CODE DATED AND BRANDED "TRU-VAC®"

Typical TRU-VAC® Bargains! THIS IS A PARTIAL LIST Thousands More Always In Stock

6SN7GT		ALWAYS 30c		6W4GT		ALWAYS 30c					
OY4	2C35	5R4	4A55	4BK7	6C58	6SD7GT	784	724	12B7	1916	50C5
O24	3A4	5U4	4A16	6R7GT	4C58	65F5	785	12A8	12CA5	1918	5016
1A7GT	3A5	5UR	6AU6GT	6B8A	4C6U	65F7	786	12A85	12CM5	24A	56
183GT	3A15	5V4GT	6AUSGT	6B06GT	6D6	45C7	787	12A25	12D4	2516GT	57
1C6	38C5	5V6GT	6AU6	6B07	6D6E	65H7	788	12A16	12F5	24	58
1C7	38N6	5X8	6AU8	6B8R	6D6AGT	6517	7C4	12A17	12K7	27	71A
1F4	38Z6	5Y3	6AV5GT	6B58	6D06	65K7	7C5	12A06	12L6	35	75
1F5	3C86	6A6	6AV6	6B75G	6F5	6517	7C6	12A07	12O7	35A5	76
1G4	3Q4	6A8A	6AW8	6B26	6F6	65Q7	7C7	12A06	12P7	35B5	77
1H5GT	354	6AC7	6AX6GT	6B27	6H6	65R7	7E5	12A07	12S7	35C5	78
114	3V4	6A7A	6AX5GT	6C4	6J4	614	7E6	12AX4GT	12SK7	35W4	80
116	48Q7A	6AG5	6B2	4CB6	6J5	608	7E7	12A07	12SN7GT	35Z5	84/624
1N5GT	4B58	6AH4GT	6BA6	6CD6G	6J6	6V6GT	7F7	12A27	12SO7	36	112Z3
1R5	4B27	6AH6	6BC5	6CF6	6J7	6W6GT	7F8	12A8	12V6GT	38	
155	4C86	6AK5	6BC8	6CG7	6K6GT	6X4	7G7	12B8A	12W6GT	39/44	
174	4AM8	6AL5	6BD6	6CH8	6K7	6X5GT	7H7	12B87	12X4	41	
174	5AN8	6AM8	6BE6	6CL6	6N7	6X8	7H7	12B06	14A7/12B7		
1U2	5A18	6AN8	6BF5	6CM6	6O7	6Y6G	7Q7	12B6	14B6	42	
1V2	5AV8	6AQ5	6BG5G	6CM7	654	7A4/XXL	757	12B6	14Q7	43	
1X2	5A24	6A06	6BH6	6CN7	657	7A5	7X6	12B87	19	45	
2A4	5BR8	6A07	6B16	6C08	658GT	7A6	7X7	12B06	19AU4GT	50A5	
2B4	516	6AR5	6BK5	6C8A	65A7	7A7	7Y4	12B87	19B6G	50B5	

1 YEAR GUARANTEED PICTURE TUBES

Brand New* Allied A-1 Tubes Brand New
Below Listed prices do not include dud. Add Additional 55.00 Deposit on tube sizes to 20" on 21" and 24" tubes—\$7.50. Deposit refunded immediately when dud is returned prepaid.

Aluminized tubes—\$4.00 extra.
Picture tubes shipped only to continental USA and Canada—All tubes F.O.B. Harrison, N. J.

10P4	799	16P4	1219	12CP4	1600	19A7A	1830	21A1P4	1878	21P4	1830	21P4	1830
12P4	1049	16P4	1199	17CP4	1780	20CP4	1580	21AMP4	1799	21R4	1830	21P4	1749
14P4	1199	16P4	1219	17CP4	1899	20CP4	1580	21A1P4	1878	21MP4	2230	24P4	3949
16A4	1409	16P4	1199	17CP4	1699	20HP4	1780	21AMP4	1878	21P4	1830	24CP4	2730
20P4	1219	17A1P4	1549	17CP4	1280	21A1P4	2149	21AWP4	1749	21P4	1749	24P4	2930
24P4	1609	17B1P4	1349	17CP4	1699	21A1P4	1878	21P4	1730	21P4	1749		

ATTENTION QUANTITY USERS! Big Discounts Are Yours! Call or Write For Our 1000 Tube "Private Label" Special Attention Handling Dept. MGR. Money cheerfully refunded within five (5) days, if not completely satisfied! TRU-VAC® PAYS YOUR POSTAGE on orders of \$5 or more in U.S.A. and Territories. Send approximate postage on Canadian and foreign orders. Any order less than \$5 requires 25¢ handling charge. Send 25¢ on C.O.D.'s. All orders subject to prior sale. (Complying with Federal regulations, the following statement appears in all Tru-Vac advertising: Tubes appearing in this ad may be FACTORY SECONDS or USED tubes and are clearly marked.)

Your best buy.

TRU-VAC

35¢
33¢ PER HUNDRED

For any used or factory second tube!

USED TV CONSOLES

Guaranteed to Work When You Receive Them

10" & 12"	\$29	17"	\$45
14" & 16"	\$37	19"	\$59
20" & 21"			\$70

All sets shipped in two cartons to avoid breakage. Sets shipped express to continental U.S.A. and Canada only. F.O.B. Harrison, New Jersey.

FREE BONUS—RABBIT EARS

FREE with each set purchased

Value \$7.95

GUARANTEE

Only TRU-VAC guarantees to replace any tube which becomes defective in use within one year of date of purchase.

FREE FUSE CLIP

Sent With Any Order Of \$5 Or More

TRU-VAC Electric Company

Visit Our Huge Testing Dept. In The Heart Of Harrison, N. J.'s Electronics Industry

Harrison Avenue Box 107 Harrison, New Jersey Humboldt 4-9770

CONVERT YOUR CAR RADIO FOR SHORT WAVE RECEPTION WITH...

MOBILETTE



INTERNATIONAL'S ALL TRANSISTOR, CRYSTAL CONTROLLED CONVERTER

Now, in a matter of minutes, your standard broadcast car radio becomes a short wave receiver . . . bringing in stations from coast-to-coast as well as the four corners of the globe.

Designed by International for AMATEURS, CITIZEN LICENSEES, SHORT WAVE LISTENERS, HOBBYIST.

Available in SEVEN frequency ranges covering the Amateur bands, 75 through 10 meters, the Citizens band, and WWV National Bureau of Standards Time Broadcasts.

Three simple steps to install. (1) Remove antenna lead from car radio and plug into input of Mobilette. (2) Plug jumper wire from Mobilette into antenna connection of car radio. (3) Plug power connector into cigarette lighter socket. It's that easy!

Works on either 6 or 12 volts without change. Miniature size.

International Mobilettes cover these short wave bands.

Catalog No.	Frequency
630 — 105	75 meters (Amateur)
630 — 104	40 meters (Amateur)
630 — 106	10 MC (WWV Time Broadcasts)
630 — 103	20 meters (Amateur)
630 — 102	15 meters (Amateur)
630 — 101	11 meters (Citizens)
630 — 100	10 meters (Amateur)
	28.5 — 29.5 MC

Available soon for 6 and 2 meters at slightly higher price.



Complete, ready to plug in and operate . . . only **\$19.95**

Order direct from International. Terms F. O. B. Okla. City. Include postage. Shipping Weight 2 lbs.



18 NORTH LEE — OKLA. CITY, OKLA.

INTERNATIONAL CRYSTAL MFG. CO., INC., 18 NO. LEE
OKLAHOMA CITY, OKLAHOMA

GENTLEMEN: PLEASE SHIP THE FOLLOWING MOBILETTES @ \$19.95 EACH.

CATALOG NO.	FREQ.	QUANTITY
_____	_____	_____
_____	_____	_____

SHIP TO — NAME _____
AMOUNT ENCLOSED ADDRESS _____

INCLUDE POSTAGE WITH ORDER.

CITIZEN BAND CLASS "D" CRYSTALS



3rd Overtone: Hermetically Sealed
.005% tolerance—Meet F C C require-
ments, $\frac{1}{32}$ pin spacing—.050 pin diam-
eters; (.093 pins avail-
able, add 15c per crys-
tal.)
ALL 22 FREQUENCIES \$2.95 EACH
IN STOCK!

(add 5c per crystal for postage and handling)

The following Class "D" Citizen Band frequencies in stock (frequencies listed in megacycles): 26.965, 26.975, 26.985, 27.005, 27.015, 27.025, 27.035, 27.055, 27.065, 27.075, 27.085, 27.105, 27.115, 27.125, 27.135, 27.155, 27.165, 27.175, 27.185, 27.205, 27.215, 27.225.

Matched crystal sets for Globe, Conset, Citi-Pone and Hallcrafters Units . . . \$5.90 per set. Specify equipment make.

RADIO CONTROL CRYSTALS in HC6/U HOLDERS—SIX FREQUENCIES

In stock for immediate delivery (frequencies listed in mega-
cycles): tolerance .005%, $\frac{1}{32}$ pin spacing, .050 pin diameter,
.093 pins available, add 15c per crystal.) Specify frequency
desired!

26.995, 27.045, 27.095, 27.145, 27.195, 27.255 **\$2.95 EACH**

(add 5c per crystal for postage and handling)

Send for **FREE CRYSTAL CATALOG #860**
WITH OSCILLATOR CIRCUITS

ASK YOUR PARTS DEALER FOR TEXAS CRYSTALS

See big red display . . . If he doesn't stock them, send us his name and order direct from factory.

All Orders Shipped From Our
New Florida Plant 1st Class Mail
Rush your order to:

TEXAS CRYSTALS

Dept. P-70, 1000 Crystal Drive, Fort Myers, Fla.
For even faster service, Phone WE 6-2100

PURCHASING A HI-FI SYSTEM? NOW YOU CAN CHARGE IT!

If you are an International credit card holder,
Up to 10 months to pay. No down payment necessary.

Send Us
Your List of
Components
For A Package
Quotation

WE WON'T BE
UNDERSOLD

All merchandise is brand new,
factory fresh and guaranteed.

AIREX RADIO CORPORATION

64-PE Cortlandt St., N. Y. 7

CO 7-2137

- Altec Lansing
- Electrovoice
- Jensen • Hartley
- University • Stephens
- Acoustic Research
- Janzen
- Wharfedale
- Karlson Cabinets
- Viking
- Concertone
- Bell • G. E.
- Weathers
- Harman-Kardon
- Eico • Pilot
- Uher Recorder
- Acrosound • Roberts
- Fisher
- Bogen • Leak
- Dynakit • H. M. Scott
- Thorens • Sherwood
- (Fair Traded)
- Dual Changer
- Ampex • DeWald
- Sony • Challenger
- Wollensak • Pentron
- Garrard • Quad
- Miracord • Pickering
- Glaser-Steers
- Components
- Rek-O-Kut
- Audio Tape
- Norelco • Magnecord
- Fairchild • Gray

NEW products

STEREO CARTRIDGE

The Norelco Model AG3400 stereo cartridge employs the moving magnet principle and features high vertical compliance (3.5×10^{-9} cm/dyne) and high output (30 millivolts per channel). Frequency response is virtually flat from 50 cps to 18,000 cps, according to the manufacturer. Channel separation is more than 22 db at 1000 cps, and the moving mass of the stylus tip is 2 milligrams. Price, complete with replaceable stylus, \$29.95. (North American Philips Co., Inc., High Fidelity Products Div., 230 Duffy Ave., Hicksville, L. I., N. Y.)



MINIATURE TUBE TESTER

Measuring only $6\frac{3}{4}'' \times 5\frac{1}{4}'' \times 2\frac{1}{4}''$, the Model 211 tube tester checks all octal, loctal, seven- and nine-pin miniature tubes for shorts, leakages, opens, and intermit-



tents. Emission is indicated directly on a two-color meter dial. Magic-eye tubes and voltage regulator tubes can also be tested. Shipping weight is 3 pounds. Price, \$22.90 wired, \$14.90 in kit form. (Electronic Meas-

Always say you saw it in—POPULAR ELECTRONICS



Accredited by the National Home Study Council

good training
doesn't cost . . .
if pays!

How To Get an



FCC License (Commercial)

Get Your FCC
License Quickly

We Guarantee to train you **Your FCC License**
until you receive

Get all 3 FREE

We guarantee
to train you until you receive
Your FCC License

—or your money back

The Master Course in Electronics will provide you with the mental tools of the electronics technician and prepare you for a First Class FCC License (Commercial) with a radar endorsement. When you successfully complete the Master Course, if you fail to pass the FCC examination, you will receive a full refund of all tuition payments.

GET THIS HANDY POCKET
ELECTRONICS DATA GUIDE

Free . . .

Puts all the commonly used conversion factors, formulas, tables, and color codes at your fingertips. Yours absolutely free if you mail the coupon in 30 days. No further obligation!

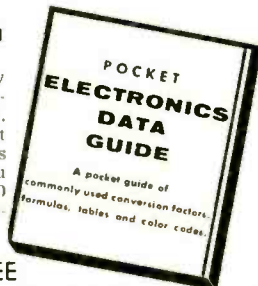

TO GET THIS FREE
GIFT, MAIL COUPON Within 30 Days!

Cleveland Institute of Electronics

4900 Euclid Ave. Desk PE-66 Cleveland 3, Ohio

July, 1960

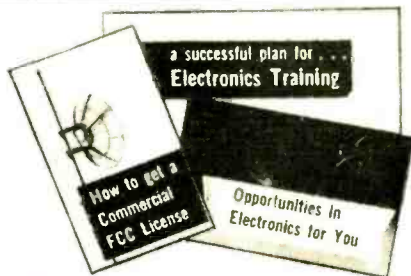

Cleveland Institute of Electronics

4900 Euclid Ave., Desk PE-66, Cleveland 3, Ohio

Please send Free Booklets prepared to help me get ahead in Electronics and a free copy of your "Pocket Electronics Data Guide." I have had training or experience in Electronics as indicated below:

- | | |
|---|---|
| <input type="checkbox"/> Military | <input type="checkbox"/> Broadcasting |
| <input type="checkbox"/> Radio-TV Servicing | <input type="checkbox"/> Home Experimenting |
| <input type="checkbox"/> Manufacturing | <input type="checkbox"/> Telephone Company |
| <input type="checkbox"/> Amateur Radio | <input type="checkbox"/> Other _____ |

In what kind of work
are you now engaged?

In what branch of
Electronics are you
interested?

Name _____ Age _____

Address _____

City _____ Zone _____ State _____

PE-66

IT'S TRANSISTORIZED

to provide a new high in reliability—units can be left in operation indefinitely without damage from overheating. Practically eliminates need for service calls.

IT'S TRANSISTORIZED

to reduce operating costs—low power drain makes operating costs negligible. Draws only 2% of the power required to operate a vacuum tube amplifier with comparable gain. Also has battery plug for 22 volt DC supply.

IT'S TRANSISTORIZED

to achieve performance previously impossible—new circuitry (pat. pend.) provides maximum gain and minimum noise, high output capabilities. Can be used with low input signals. Insures top performance for color and black-and-white TV, plus coverage of the FM radio band.

BLONDER-TONGUE BT-3

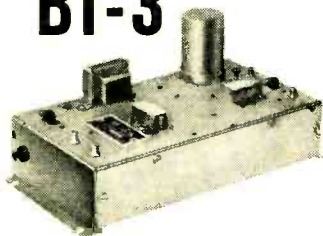

transistorized broadband tv/fm amplifier

GAIN: 18—15 db (channel 2-6); 19 db (7-13); 15—9 db (88-108 mc.) **List 99.50**

Available at parts distributors. For further information write Dept. PE-7

BLONDER-TONGUE LABS., INC.

9 Alling Street, Newark 2, New Jersey

In Canada: Tequipment Mfg. Co., Ltd., London, Ont.

Export: Morhan Export Corp., N. Y. 13, N. Y.



products

(Continued from page 24)

ments Corp., 625 Broadway, New York 12, N. Y.)

CB TRANSCEIVER KIT

The new Heath Citizens Band transceiver kit features a superhet receiver that provides for either crystal-controlled or continuously variable tuning. Other circuit refinements include a noise limiter, an adjustable squelch control, and a crystal-con-



trolled transmitter. Available in either a.c. or d.c. models, the GW-10 is supplied with a press-to-talk microphone, hardware for under-the-dash mounting in mobile installations, and FCC license application forms. Price, \$62.95. (Heath Company, Benton Harbor, Mich.)

STEREO TUNER

Features of the Model S-2200 AM-FM-Multiplex stereo tuner announced by *Sherwood Electronic Laboratories, Inc.*, 4300 N. California Ave., Chicago 18, Ill., include

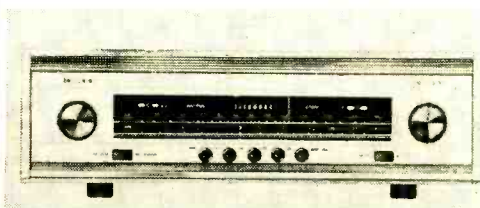

push-button operation, .95-microvolt sensitivity on FM, and an interstation noise elimination circuit. The AM section offers a choice of either 15-kc. or 5-kc. bandwidth. Price, \$179.50, less case. Also available is a plug-in adapter, the Model AMX, for receiving FM multiplex stereo transmissions: price, \$49.50.

SOLDERING PENCIL HOLDER

A soldering pencil holder that stays cool after 100 hours of continuous use is being

Always say you saw it in—POPULAR ELECTRONICS

BUILD 16 RADIO

CIRCUITS AT HOME

with the New **PROGRESSIVE RADIO "EDU-KIT"®** ONLY \$22.95

A Practical Home Radio Course

- Now Includes**
- ★ 12 RECEIVERS
 - ★ TRANSMITTER
 - ★ SIGNAL TRACER
 - ★ SIGNAL INJECTOR
 - ★ CODE OSCILLATOR
 - ★ No Knowledge of Radio Necessary
 - ★ No Additional Parts or Tools Needed
 - ★ EXCELLENT BACKGROUND FOR TV
 - ★ School Inquiries Invited
 - ★ Sold in 79 Countries

YOU DON'T HAVE TO SPEND HUNDREDS OF DOLLARS FOR A RADIO COURSE

The "Edu-Kit" offers you an outstanding PRACTICAL HOME RADIO COURSE at a rock-bottom price. Our Kit is designed to train Radio & Electronics Technicians, making use of the most modern methods of home training. You will learn radio theory, construction practice and servicing. THIS IS THE COMPLETE RADIO COURSE IN EVERY DETAIL. You will learn how to build radios, using regular schematics; how to wire and solder in a professional manner; how to service radios. You will work with the standard type of punched metal chassis as well as the latest development of Printed Circuit chassis. You will learn the basic principles of radio. You will construct, study and work with RF and AF amplifiers and oscillators, detectors, rectifiers, test equipment. You will learn and practice code, using the Progressive Code Oscillator. Progressive Signal Tracer, Progressive Dynamic Radio & Electronics Tester and the accompanying instructional material. You will receive training for the Novice, Technician and General Classes of C.C. Radio Amateur License, build 16 Receiver, Transmitter, Code Oscillator, Signal Tracer and Signal Injector circuits, and learn how to operate them. You will receive an excellent background for television, Hi-Fi and Electronics. Absolutely no previous knowledge of radio or electronics science is required. The "Edu-Kit" is the product of many years of teaching and engineering experience. The "Edu-Kit" will provide you with a basic education in Electronics and Radio, worth many times the complete price of \$22.95. The Signal Tracer alone is worth more than the price of the entire Kit.

THE KIT FOR EVERYONE

You do not need the slightest background in radio or science. Whether you are interested in Radio & Electronics because you want an interesting hobby, a well paying business or a job with a future, you will find the "Edu-Kit" a worth-while investment. Many thousands of individuals of all ages and backgrounds have successfully used the "Edu-Kit" in more than 79 countries of the world. The "Edu-Kit" has been carefully designed, step by step, so that you cannot make a mistake. The "Edu-Kit" allows you to teach yourself at your own rate. No instructor is necessary.

PROGRESSIVE TEACHING METHOD

The Progressive Radio "Edu-Kit" is the foremost educational radio kit in the world, and is universally accepted as the standard in the field of electronics training. The "Edu-Kit" uses the modern educational principle of "Learn by Doing." Therefore you construct, learn schematics, study theory, practice trouble-shooting—all in a closely integrated program designed to provide an easy-to-learn, thorough and interesting background in radio. You begin by examining the various radio parts of the "Edu-Kit." You then learn the function, theory and wiring of these parts. Then you build a simple radio. With this first set you will enjoy listening to regular broadcast stations, learn theory, practice testing and trouble-shooting. Then you build a more advanced radio, learn more advanced theory and techniques. Gradually, in a progressive manner, and at your own rate, you will find yourself more advanced multi-tube radio circuits, and doing work like a professional Radio Technician. Included in the "Edu-Kit" course are sixteen Receiver, Transmitter, Code Oscillator, Signal Tracer, and Signal Injector circuits. These are not unprofessional "breadboard" experiments, but genuine radio circuits, constructed by means of professional wiring and soldering on metal chassis, plus the new method of radio construction known as "Printed Circuitry." These circuits operate on your regular AC or DC house current.

THE "EDU-KIT" IS COMPLETE

You will receive all parts and instructions necessary to build 16 different radio and electronics circuits, each guaranteed to operate. Our Kits contain tubes, tube sockets, variable, electrolytic, mica, ceramic and paper dielectric condensers, resistors, tie strips, coils, hardware, tubing, punched metal chassis, Instruction Manuals, hook-up wire, solder, etc. In addition, you receive Printed Circuit materials, including Printed Circuit chassis, special tube sockets, hardware and instructions. You also receive a useful set of tools, a professional electric soldering iron, and a self-powered Dynamic Radio and Electronics Tester. The "Edu-Kit" also includes Code Instructions and the Progressive Code Oscillator, in addition to, F.C.C.-type Questions and Answers for Radio Amateur License training. You will also receive lessons for servicing with the Progressive Signal Tracer and the Progressive Signal Injector, a High Fidelity Guide and a Quiz Book. You receive Membership in Radio-TV Club. Free Consultation Service, Certificate of Merit and Discount Privileges. You receive all parts, tools, instructions, etc. Everything is yours to keep.

PRINTED CIRCUITRY

At no increase in price, the "Edu-Kit" now includes Printed Circuitry. You build a Printed Circuit Signal Injector, a unique servicing instrument that can detect many Radio and TV troubles. This revolutionary new technique of radio construction is now becoming popular in commercial radio and TV sets.

A Printed Circuit is a special insulated chassis on which has been deposited a conducting material which takes the place of wiring. The various parts are merely plugged in and soldered to terminals.

Printed Circuitry is the basis of modern Automation Electronics. A knowledge of this subject is a necessity today for anyone interested in Electronics.

UNCONDITIONAL MONEY-BACK GUARANTEE

ORDER DIRECT FROM AD—RECEIVE FREE BONUS RESISTOR AND CONDENSER KITS WORTH \$7

Send "Edu-Kit" postpaid. I enclose full payment of \$22.95.

Send "Edu-Kit" C.O.D. I will pay \$22.95 plus postage.

Rush me FREE descriptive literature concerning "Edu-Kit."

Name

Address

PROGRESSIVE "EDU-KITS" INC.

1186 Broadway, Dept. 570D, Hewlett, N. Y.



Reg. U. S. Pat. Off.

FREE EXTRAS

- SET OF TOOLS
- SOLDERING IRON
- ELECTRONICS TESTER
- PLIERS-CUTTERS
- ALIGNMENT TOOL
- WRENCH SET
- VARIABLE DISCOUNT CARD
- CERTIFICATE OF MERIT
- TESTER INSTRUCTION MANUAL
- HIGH FIDELITY GUIDE & QUIZZES
- TELEVISION BOOK & RADIO TROUBLE-SHOOTING BOOK
- MEMBERSHIP IN RADIO-TV CLUB: CONSULTATION SERVICE & FCC AMATEUR LICENSE TRAINING
- PRINTED CIRCUITRY

SERVICING LESSONS

You will learn trouble-shooting and servicing in a progressive manner. You will practice repairs on the sets that you construct. You will learn symptoms and causes of trouble in home, portable and car radios. You will learn how to use the professional Signal Tracer, the unique Signal Injector and the dynamic Radio & Electronics Tester. While you will be able to do many a repair job for your friends and neighbors, and charge fees which will far exceed the price of the "Edu-Kit." Our Consultation Service will help you with any technical problems you may have.

J. Slatkis, of 25 Poplar Pl., Waterbury, Conn., writes: "I have repaired several sets for my friends, and made money. The "Edu-Kit" paid for itself. I was ready to spend \$240 for a Course, but I found your ad and sent for your Kit."

FROM OUR MAIL BAG

Bon Valerio, P. O. Box 21, Manna, Utah: "The Edu-Kits are wonderful. Here I am sending you the questions and also the answers for them. I have been in Radio for the last seven years, but like to work with Radio Kits, and like to build Radio Testing Equipment. I enjoyed every minute I worked with the different kits; the Signal Tracer works fine. Also like to let you know that I feel proud of becoming a member of your Radio-TV Club."

Robert L. Shuff, 1534 Monroe Ave., Huntington, W. Va.: "Thought I would drop you a few lines to say that I received my Edu-Kit, and was really amazed that such a bargain can be had at such a low price. I have already started repairing radios and phonographs. My friends were really surprised to see me get into the swing of it so quickly. The Troubleshooting Tester that comes with the Kit is really swell, and finds the trouble, if there is any to be found."



Olson

*** FREE ***

Fill in coupon for a FREE One Year Subscription to OLSON RADIO'S Fantastic Bargain Packed Catalog — Unheard of LOW, LOW, WHOLESALE PRICES on Brand Name Speakers, Changers, Tubes, Tools, Hi-Fi's, Stereo Amps, Tuners and other Bargains.

NAME _____
 ADDRESS _____
 CITY _____ ZONE _____ STATE _____

If you have a friend interested in electronics send his name and address for a FREE subscription also.

OLSON RADIO CORPORATION
 809 S. Forge St. Akron 8, Ohio

ASSEMBLE YOUR OWN

WALKIE-TALKIE RADIOPHONES

New Improved Model for
 27 mc Citizens Band

Electronic Chassis ONLY **\$24⁹⁸** post-paid

- Meets FCC requirements for new class "D" citizens band radio-telephone.
- License easily obtained on application by any U. S. citizen 18 years or over. No tests to take.
- Transmits and receives one to several miles depending on obstructions and elevation.
- Assembled unit is completely portable and requires no external connections. Operates from self contained batteries obtainable at your local radio store.
- Electronic chassis is wired, tested, guaranteed and includes crystal controlled oscillator, R.F. power amplifier, audio modulator, receiver with R.F. stage, and a new transistorized audio booster stage for extra loud reception plus a complete set of tubes and transistor.
- Radio receiver is tunable to any of the 22 channels by a single control knob. Features ultra-high amplification, automatic volume control and noise clipping.
- Instructions and photographs are supplied with each chassis for completing the walkie-talkie as illustrated. Accessories are not included but are available at low cost.

FREE R.F. power indicator kit with each order.
 SEND YOUR ORDER TODAY. INCLUDE POSTAL MONEY ORDER FOR FAST DELIVERY. C.O.D.'s REQUIRE \$5.00 DEPOSIT.
 N. Y. City residents add sales tax.

SPRINGFIELD ENTERPRISES
 Box 54-E-7 Springfield Gardens 13, N. Y.

products

(Continued from page 26)

marketed by Sidco, Box 312, Venice, Calif. Constructed of nylon, the handle is air-cooled and does not require a cork grip;

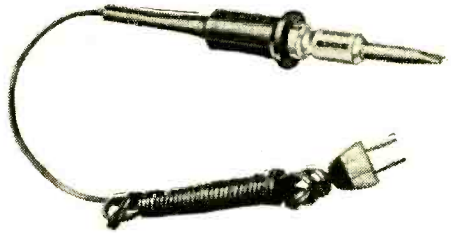

interchangeable tips are held firmly in place by a device in the handle. Price, less tip, \$2.50.

LINE-OPERATED VTVM

In addition to their battery-operated VTVM, *Century Electronics Co., Inc.*, 111 Roosevelt Ave., Mineola, N. Y., has now made available a line-operated unit, the Model VT-10. A multi-function probe can be set to operate as a d.c. probe, an a.c. probe, a "Lo-Cap" probe, or an r.f. probe.

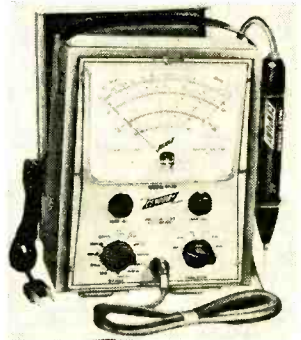

The 6" 100-microamp meter has four multi-color scales. Price, \$58.50.

RECORD CHANGER

A record changer is being marketed by *Arkay International*, 88-06 Van Wyck Expressway, Jamaica, N. Y., in both kit and



factory-assembled form. Called the "Human Brain" record changer, it will play records of all sizes, mixed in any order. Additional information can be obtained from the manufacturer.

-30-

POPULAR ELECTRONICS ANNOUNCES A
**SPECIAL SUMMER
 SALE OF 57
 ELECTRONICS
 BOOKS**

The publishers of POPULAR ELECTRONICS invite you to choose any of these wonderfully informative electronics books, on a 7-day free trial basis. Here are important books for radio and TV servicemen, electronics professionals, students and hobbyists—books on exciting electronic construction, communications, theory, hi-fi and tape—plus many more subjects that will show you how to save money and get more profit and satisfaction from electronics.

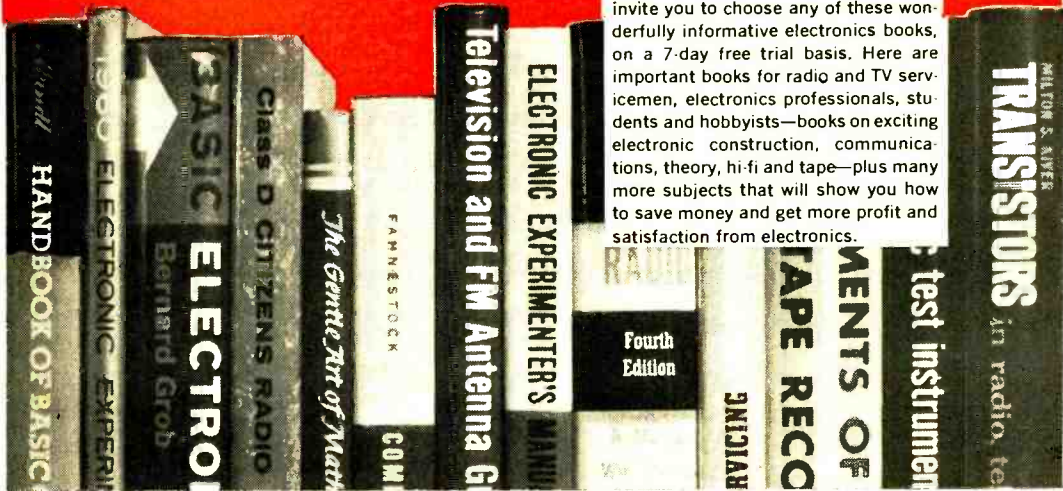

THEORY AND INSTRUCTION

Get started in radio, TV, communications, by using these simple basic guides to electronic principles, functions, and operations!



2500. BASIC ELECTRONICS, Grob
 An introductory text on the fundamentals of electricity and electronics for technicians in radio, television and industrial electronics. \$9.25

2501. ELEMENTS OF ELECTRONICS, Hikey and Villines
 This basic electronics text offers an excellent course for training radio and electronics technicians and for students in television, radar and sonar. \$6.95



2519. HANDBOOK OF BASIC CIRCUITS, Mandl
 A basic guide to circuitry combining comprehensive coverage of major circuits with detailed information on circuits used in TV, FM and AM. Simply written and easy-to-understand. \$7.95

2512. PRIMER OF ELECTRONICS AND RADIANT ENERGY, Caverly

Clear and simple explanation of electronics and electronic tubes and circuits for all concerned with the manufacture, application, operation of household or industrial electronic devices. \$7.50



2511. UNDERSTANDING RADIO, Watson, Welch and Eby
 For those with little or no technical knowledge who wish to know the fundamentals of radio theory and servicing. \$7.95

2522. ELEMENTS OF RADIO, Hellman
 A thorough grounding in all basic principles of radio, radio communication, with a review of electricity and magnetism. Also includes chapter on transistors. \$5.50



2521. BASIC ELECTRONICS, Daly and Greenfield
 Here in twelve chapters is a complete general introduction to electronics for technicians who make use of complex electronic equipment in modern laboratories. \$9.00

2412. TELEVISION AND FM ANTENNA GUIDE, Noll & Mandl

Two antenna experts tell you their secrets of antenna choice and installation for best reception in any area. Loaded with useful tips on improving reception in fringe and difficult areas. \$5.25



2502. ELEMENTS OF RADIO, Marcus & Marcus
 Now in its 4th edition. More than a million copies sold! Follows proved method of exposition, proceeds from the simple to the complex. \$7.00

HI-FI AND TAPE

Special references for the sound enthusiast to help him select, build, and improve his hi-fi and stereo recording system.



2000/60. STEREO-HI-FI GUIDE, Ziff-Davis Publishing Company

Just published! 1960 edition features 60-page exclusive by Joseph Marshall on components and how they work. \$1.00

2757. RIBBONS OF SOUND, Barleben

A perfect introduction to tape recording principles and practices. Paper. \$2.50; 2757C Cloth. \$3.50

2760. HI-FI STEREO FOR YOUR HOME, Whitman

Tells what stereo is, how it works, affects home listening habits, and how to install and maintain it. \$3.50



2750. ELEMENTS OF MAGNETIC TAPE RECORDING, Haynes

All aspects of this recording medium are described in easy-to-understand detail. 416 pages, \$7.95

2004/60. HI-FI ANNUAL & AUDIO HANDBOOK, Ziff-Davis Publishing Company

1960 edition. Prepared by the editors of Electronics World. An excellent advanced guide to theory, construction and circuitry. \$1.00



42. REVERSE TAPE RECORDER GUIDE, Tydings

The first non-technical book to provide useful information on the Reverse Tape Recorder. Also a basic guide to the entire field of tape. Will show you new uses and add to your enjoyment of tape recording. \$1.95

2005/60. HI-FI DIRECTORY & BUYERS' GUIDE, Ziff-Davis Publishing Company

1960 edition. World's only complete listing of all hi-fi and stereo equipment, components and accessories. Five big sections. Over 1,000 illustrations. \$1.00



2753. LOW-COST HI-FI, Hoefler

Hundreds of hints for budget hi-fi will be found in these fourteen chapters with over 300 detailed photographs, drawings and diagrams. \$2.50

49. TAPE RECORDING GUIDE, Marshall

Designed to help you get the most out of your tape recorder, whether for business, pleasure or professional use. A handy guide to have around, no matter what type of equipment you own or plan to purchase. \$1.95



2752. HIGH QUALITY SOUND REPRODUCTION, Moir

A perfect manual for both the professional engineer and the serious amateur in high fidelity. Complete coverage of sound reproduction in 591 pages, \$15.00

Save time and labor in radio and TV maintenance by referring to professional handbooks!

RADIO AND TV SERVICING



2415. MANDL'S TELEVISION SERVICING, Mandl

This standard text book in the T.V. servicing field provides clear descriptions of the fundamentals of T.V., and practical instruction on the diagnosis and correction of typical troubles. \$6.95

2429. TELEVISION RECEIVER SERVICING, Kiver

New (fourth) edition is a carefully written complete handbook for the television serviceman. New chapter discusses color T.V.—operation and servicing. \$5.95



2442. BASIC ELECTRONIC TEST INSTRUMENTS, Turner

Over 60 instruments described, their uses fully explained, and valuable work-saving short-cuts outlined. \$4.95

2416. LABORATORY MANUAL FOR BASIC TELEVISION AND TELEVISION RECEIVER SERVICING, Zbar and Schildkraut

55 experiments covering fundamental skills in T.V. receivers and T.V. receiver servicing. \$4.50

2422. HANDBOOK OF TV REPAIR, Hertzberg

A basic guide to do-it-yourself T.V. repairs for the amateur. \$2.50

2400. PROFITABLE RADIO TROUBLESHOOTING, Marcus and Levy

Explains in easy-to-understand manner the use of simple and advanced test instruments, opening a radio servicing business, pitfalls, and successful procedures for a full-grown business. \$5.95

2408. ESSENTIALS OF ELECTRICITY FOR RADIO AND TELEVISION, Slurberg and Osterheld

Provides necessary background of principles for understanding T.V., FM and radio circuits. \$8.00



2425. ELEMENTS OF TELEVISION SERVICING FOR BENCH AND FIELD, Marcus and Gendler

Up to date discussion of installation, servicing and repair of T.V. receivers, designed for the practicing serviceman. \$8.15

2407. HOW TO GET AHEAD IN THE TELEVISION AND RADIO SERVICING BUSINESS, Marcus

Shows the easy way to get started as a TV-Radio repairman, how to earn while you learn, how to get and keep customers. \$3.50



2404. FM RADIO SERVICING HANDBOOK, King

A practical guide to FM V.H.F. receivers, their design, construction, alignment and repair. \$5.00

ELECTRICITY AND APPLIANCES

Brush up on electrical theory, repair any electrical appliance by using these simple manuals!

2651. MAJOR APPLIANCE SERVICING, Brockwell

Gives essential, overall information for a career in major-appliance servicing, explaining methods of repairing appliances, organizing and managing a service business. \$5.95

2653. PRACTICAL ELECTRICITY, Croft
What electricity is, how it is generated and how it is used. Simply written with many graphic examples. \$8.50

2667. ELECTRIC MOTOR REPAIR, Rosenberg

All details of modern motor repair work. Actual demonstrations of what to do and why. Designed for bench use with a duospiral binding that lies flat. \$6.95

2660. BEGINNING ELECTRICITY, Eaton

Principles, construction and operation of basic electrical devices and appliances. A thorough foundation of electricity. \$6.00

2652. HOW TO REPAIR HOME APPLIANCES, Campbell

For the do-it-yourselfer, a handy, easy-to-read reference book. \$2.50



Be eligible for the higher paying jobs by mastering math needed in electronics — quickly and easily.

MATHEMATICS

2802. MATHEMATICS FOR ELECTRICIANS, Kuehn

A review of the fundamental processes of arithmetic, logarithms, and alternating current work. Includes chapter on the concept of work and horsepower. Material is arranged to provide a logical teaching sequence. \$6.75



2807. THE GENTLE ART OF MATHEMATICS, Pedoe

A fresh slant on things mathematical, a stimulating glimpse into the fascinating world of numbers. You will read and enjoy this diverting as well as instructive book. \$3.95

2803. BASIC MATHEMATICS FOR ELECTRICITY, RADIO AND TELEVISION, Singer

Here, mathematical principles are presented as dynamic tools for solving electrical problems. A practical course for students as well as an excellent refresher course for skilled technicians. \$8.25

TRANSISTORS AND TUBES

Keep abreast of the latest designs and concepts in both transistors and tubes by using the charts, diagrams, and photographs in these practical books!

2600. TRANSISTORS, Gillie

Describes and analyzes semi-conductors and transistors and how they behave. 300 pages, illustrated. \$7.95

2602. TRANSISTOR AUDIO AMPLIFIERS, Shea

Fundamental considerations, transistor parameters, basic amplifier design, coupled stages, preamps, Class A and Class B power amplifiers, examples of practical design and much more. \$7.00

2603. VACUUM-TUBE AND SEMICONDUCTOR ELECTRONICS, Millman

The first book to integrate vacuum tubes and transistors. Teaches electronic circuit theory to provide an intimate understanding of the vacuum-tube and semiconductor device as a circuit element. \$10.00

2604. BASIC ELECTRON TUBES, Geppert

A text for a first course in electronics. It covers the tubes themselves, not the circuit applications. Basic principles governing operation of specialized tubes are explained. \$7.50

2607. TRANSISTORS, Coblenz & Owens

Treats theory, practical applications and manufacture of transistors in a way useful to technicians, engineers and advanced workers. Silicon and germanium transistors—how they are made, used, how they work. \$6.50

2605. FUNDAMENTALS OF VACUUM TUBES, Eastman

A text midway between the purely descriptive and the purely mathematical. Discusses the principal types of vacuum tubes. \$10.50

2606. ELECTRON-TUBE CIRCUITS, Seely

A clear analytical method in the study of electron-tube circuits. Provides a broad background in preparing for work in radio and electronic engineering. \$10.50

2601. TRANSISTORS IN RADIO, TELEVISION AND ELECTRONICS, Kiver

A descriptive, non-mathematical text for radio, television, electronics technicians and for those who need to gain a working knowledge of transistors and transistor circuits. \$7.95





... symbol of
RAD-TEL
FIRST QUALITY

INSIST ON RAD-TEL FOR EVERY
 TELEVISION AND RADIO TUBE NEED

Super-Special!
KIT OF 100
Bi-Pass
CONDENSERS

Over 50%
 Are 600V
 at LESS
 THAN 4¢ each
 Goodall
 Semi-Molded
 Paper and MYLAR
 Made up of approx.
 16-200V, 20-400V
 and 64-600V.
 Values .001 to 1mf

\$3.95

GUARANTEED ONE FULL YEAR! **70% OFF on BRAND NEW TUBES**
 You Can Rely On Rad-Tel's Speedy One Day Service!

Not Used — Not Pulled Out Of Old Sets • Each Tube Individually and Attractively Boxed!

Qty.	Type	Price	Qty.	Type	Price	Qty.	Type	Price	Qty.	Type	Price	Qty.	Type	Price	Qty.	Type	Price
—	024M	.79	—	4B27	.96	—	6AV6	.40	—	6DE6	.58	—	12AE6	.43	—	12CR6	.54
—	1AX2	.62	—	4C56	.61	—	6AW8	.89	—	6DG6	.59	—	12AF3	.73	—	12CU5	.58
—	1B3GT	.79	—	4DE6	.62	—	6AX4	.65	—	6DQ6	1.10	—	12AF6	.49	—	12CU6	1.06
—	1DN5	.55	—	4DK6	.60	—	6AX7	.64	—	6DT5	.76	—	12A16	.46	—	12CX6	.54
—	1G3	.73	—	4DT6	.55	—	6BA6	.49	—	6DT6	.53	—	12A15	.45	—	12DB5	.69
—	1J3	.73	—	5AM8	.79	—	6BC5	.54	—	6E08	.79	—	12A18	.95	—	12DE8	.75
—	1K3	.73	—	5AN8	.86	—	6BC7	.94	—	6EA8	.79	—	12AQ5	.52	—	12DL8	.85
—	1L6	1.05	—	5AQ5	.52	—	6BC8	.97	—	6H6GT	.58	—	12AT6	.43	—	12DM7	.67
—	1LN5	.59	—	5AT8	.80	—	6BD6	.51	—	6J5GT	.51	—	12AT7	.76	—	12DQ6	1.04
—	1R5	.62	—	5BK7A	.82	—	6BE6	.55	—	6J6	.67	—	12AU6	.50	—	12DS7	.79
—	1S5	.51	—	5BQ7	.97	—	6BF6	.44	—	6K6	.79	—	12AU7	.60	—	12DZ6	.56
—	1T4	.58	—	5BR8	.79	—	6BG6	1.66	—	6S4	.48	—	12AV5	.97	—	12EL6	.50
—	1U4	.57	—	5CG8	.76	—	6BH6	.65	—	6SA7GT	.76	—	12AV6	.41	—	12EG6	.54
—	1U5	.50	—	5CL8	.76	—	6BH8	.87	—	6SK7GT	.74	—	12AV7	.75	—	12EZ6	.53
—	1X2B	.82	—	5EA8	.80	—	6BJ6	.62	—	6SL7	.80	—	12AX4	.67	—	12F5	.66
—	2AF4	.96	—	5E08	.80	—	6BK7	.85	—	6SN7	.65	—	12AX7	.63	—	12F8	.66
—	2CY5	.71	—	5I6	.68	—	6BL7	1.00	—	6SQ7	.73	—	12AZ7	.86	—	12FM6	.45
—	3AL5	.42	—	5T8	.81	—	6BN4	.57	—	6T4	.99	—	12B4	.63	—	12K5	.65
—	3AU6	.51	—	5U4	.60	—	6BN6	.74	—	6U8	.78	—	12BA6	.50	—	12SA7M	.86
—	3AV6	.41	—	5U8	.81	—	6B05	.65	—	6V6GT	.54	—	12B06	.50	—	12SK7GT	.74
—	3BA6	.51	—	5V6	.56	—	6B06GT	1.05	—	6W4	.75	—	12BE6	.53	—	12SN7	.67
—	3BC5	.54	—	5X8	.78	—	6BQ7	.95	—	6W6	.69	—	12BF6	.44	—	12SQ7M	.73
—	3BE6	.52	—	5Y3	.46	—	6BR8	.78	—	6X4	.39	—	12BH7	.73	—	12T7	.62
—	3BN6	.76	—	6AB4	.46	—	6BU8	.70	—	6X5GT	.53	—	12BL6	.56	—	12V6GT	.53
—	3BU8	.78	—	6AC7	.96	—	6BY6	.54	—	6X8	.77	—	12BQ6	1.06	—	12W6	.69
—	3BY6	.55	—	6AF3	.73	—	6BZ6	.54	—	7AU7	.61	—	12B7	.74	—	12X4	.38
—	3BZ6	.55	—	6AF4	.97	—	6BZ7	.97	—	7A8	.68	—	12BZ7	.75	—	17AX4	.67
—	3CB6	.54	—	6AG5	.65	—	6C4	.43	—	7B6	.69	—	12C5	.56	—	17BQ6	1.09
—	3CF6	.60	—	6AH6	.99	—	6CB6	.54	—	7Y4	.69	—	12CA5	.59	—	17C5	.58
—	3CS6	.52	—	6AK5	.95	—	6CD6	1.42	—	8AU8	.83	—	12CN5	.56	—	17CA5	.62
—	3CY5	.71	—	6AL5	.47	—	6CF6	.64	—	8AW8	.93	TRANSISTORS ICBO ± 6V IEBQ ± 3V hfe ckt A 10 pa max. 10 pa max. 25 min. IN LOTS OF 10 29¢ EA General Purpose Type 					
—	3DK6	.60	—	6AM8	.78	—	6CG7	.60	—	8BQ5	.60						
—	3DT6	.50	—	6AN4	.95	—	6CG8	.77	—	8CG7	.62						
—	3Q5	.80	—	6AN8	.85	—	6CM7	.66	—	8CM7	.68						
—	3S4	.61	—	6AQ5	.50	—	6CN7	.65	—	8CN7	.97						
—	3V4	.58	—	6AR5	.55	—	6CR6	.51	—	8CX8	.93						
—	4BC5	.56	—	6AS5	.60	—	6CS6	.57	—	8EB8	.94						
—	4BC8	.96	—	6AT6	.43	—	6CU5	.58	—	10DA7	.71						
—	4BN6	.75	—	6AT8	.79	—	6CU6	1.08	—	11CY7	.75						
—	4BQ7	.96	—	6AU4	.82	—	6CY5	.70	—	12A4	.60						
—	4BS8	.98	—	6AU6	.50	—	6CY7	.71	—	12A5	.55						
—	4BU8	.71	—	6AU7	.61	—	6DA4	.68	—	12AC6	.49						
—	4BZ6	.58	—	6AU8	.87	—	6DB5	.69	—	12AD6	.57						

SEND FOR FREE TROUBLE SHOOTER GUIDE AND NEW TUBE & PARTS CATALOG.

RAD-TEL TUBE CO.

55 Chambers St
 Newark 5, N. J.

PE-760

TERMS: 25% deposit must accompany all orders — balance C. O. D.
 \$1 HANDLING CHARGE FOR ORDERS UNDER \$5. Subject to prior sale.
 Please add postage. No C. O. D.'s outside continental U. S. A.

Not Affiliated With
 Any Other Mail
 Order Tube Co.

Tips and Techniques

TAPE MOUNTS CAPACITOR

Need a mounting bracket for an electrolytic capacitor? A band of electrician's plastic tape will serve the purpose. Wrap

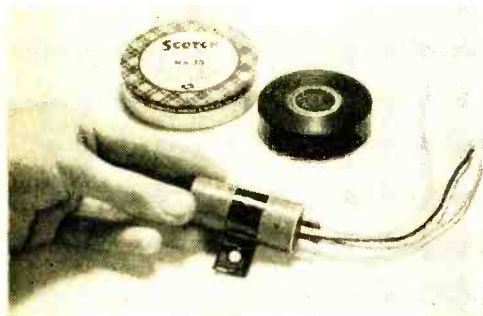

a short length of tape around the capacitor, and leave a small tab extending from the body of the unit. Punch a hole in the tab and mount the capacitor with a screw and nut.—*John A. Comstock, Wellsboro, Pa.*

SPOOL HOLDS WIRES FOR SOLDERING

Your solder spool flange can be used to hold wires and parts while you solder them. Hacksaw a couple of "V" shaped slots on

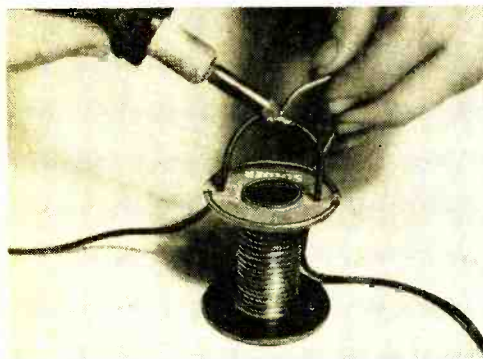

opposite sides of one flange. File off any burrs or sharp corners on the cut edges and slip in the wires to be soldered.—*Joseph Carroll, Brooklyn, N. Y.*

PROTECTING SUN BATTERY LEADS

Sun battery leads are fragile and often break off during experiments. Since they are difficult or impossible to repair, try

mounting the batteries on a small wooden base with thumb tacks, wood screws, or cellulose tape. Make the leads more compact by curling them around a stiff wire and then withdrawing the wire. Solder each lead to a medium-size ($\frac{3}{4}$ "-long) Fahnestock clip screwed to the wooden base. The

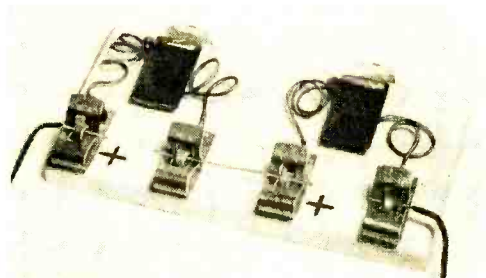

positive (red) terminals can be labeled with a ball-point pen.—*Art Trauffer, Council Bluffs, Iowa.*

MAKE YOUR OWN QSL CARDS

You can make an inexpensive and artistic QSL by drawing a sample of the desired card to size, in India ink, on a sheet of white paper or cardboard. Take this black and white "master copy" to a photo-finishing shop and have a negative made. Prints can then be ordered on heavy postcard size paper imprinted with a standard postcard form on the reverse side. (The negative can be copied at home if you have printing equipment.) Color the finished postcard prints with photo-tinting solution.—*Glenn P. Pittsley, Fayetteville, N. C.*

WALL SWITCH SAFETY LOCK

When working on electrical equipment controlled by a distant switch—basement lights and attic fans, for instance—you can use this safety "lock" to protect yourself from accidental electric shock. Take an ordinary $1\frac{1}{4}$ "-wide spring-action paper clip and attach a "hands off" sign to it as shown. Clip it on the switch lever controlling the device you are about to work on. This makes it impossible for

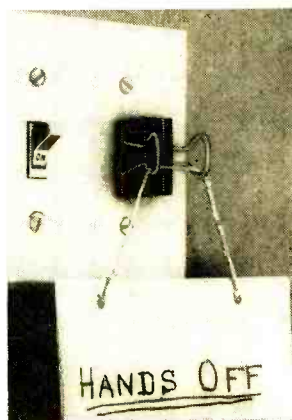

POPULAR ELECTRONICS

For serious-minded men desiring higher income and status-

CREI has developed a program of home study that is comparable in technological content to advanced residence courses in electronics. The program was developed hand-in-hand with leading companies and Government agencies contributing to the Nation's efforts in electronics, communications, missiles, and space exploration.

This CREI program in Electronics Engineering Technology may be completed in 2 to 4 years, depending on how much of your spare time you can devote to study. The courses are presented in easy-to-understand form. Our instructors will give you personal attention and assist you when you need help.

To qualify CREI graduates for advancement to key technical positions, CREI offers a complete program in electronics, including—

- Automation • Instrumentation • Industrial Electronics
- Aeronautical Electronics • Guided Missiles • Radar
- Servo-mechanisms • Computers • Astronautics • Telemetering • Communications • Electronics Manufacturing • Field Engineering

A COLLEGE-LEVEL EXTENSION PROGRAM IN ELECTRONICS

There is a drastic need in the electronics industry for well-educated engineers and technical personnel. Although the great majority of students find ample opportunity for advancement with their present companies, CREI maintains a Placement Bureau to assist graduates and advanced students in finding more desirable positions. For many years, the demand for CREI graduates and advanced students has far exceeded the supply.

A few of the private companies and government agencies whose officials approve CREI for their own personnel:

- | | |
|--|---------------------------|
| U. S. Navy (5,240 enrolled in extension program) | Florida Power & Light |
| Army, Air Force, Marine Corps, Coast Guard | Pan American Airways |
| Columbia Broadcasting System | United Airlines |
| National Broadcasting Company | The Martin Company |
| Federal Electric Corporation | All America Cable & Radio |
| | Voice of America |
| | ... and many others |

QUALIFICATIONS FOR CREI. You qualify if you have a high school diploma or equivalent, and if you have had basic electronic training and practical experience in electronics. Available to Veterans.

CREI's Extension Division offers you a college-level home study program in electronics comparable in technological content to advanced residence courses.

Mail this coupon . . . today!

CAPITOL RADIO ENGINEERING INSTITUTE

ECPD Accredited Technical Institute Curricula • Founded 1927
 Dept. 1207-G, 3224 16th St., N.W., Washington 10, D.C.

Please send me your course outline and FREE 44-Page Book "Insurance for Your Future in the New World of Electronics" . . . describing opportunities and CREI home study courses in Advanced Electronic Engineering Technology.



Check field of greatest interest

- Radar, Servo and Computer Engineering Technology
- Electronic Engineering Technology
- Communications Engineering Technology
- Television Engineering Technology
- Aeronautical Electronic Engineering Technology
- Automation and Industrial Electronics Engineering Technology

Name _____ Age _____

Street _____

City _____ Zone _____ State _____

Check: Home Study Residence School Korean Veteran

To obtain fast, immediate service and to avoid delay, it is necessary that the following information be filled in:

Employed by _____

Type of Present Work _____

Education: _____

Years of High School _____

Other _____

Electronics Experience _____

Tips

(Continued from page 34)

anyone to snap on the circuit accidentally without first removing the paper clip.—
George P. Pearce, Albuquerque, N. M.

TRANSFORMER SELECTS DRILL SPEEDS

To obtain a variety of speeds from your electric drill, use an isolation transformer with adjustable output voltages. By setting

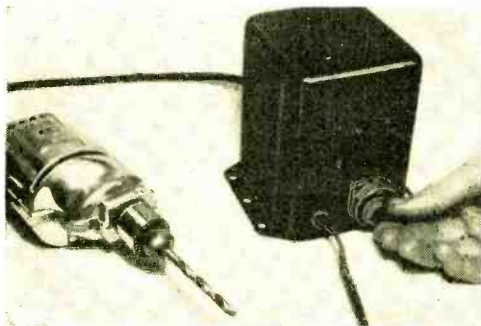

the transformer switch for an output above or below the normal line voltage, drill speed can be changed several hundred rpm, up or down. Be certain the transformer has

sufficient wattage rating to handle the drill's current safely. To obtain the wattage rating of your drill, multiply its current rating by 117 volts. Don't operate your drill on higher line voltages continuously for any extended periods as this might damage the motor.—*Jerome Cunningham, Chicago, Ill.*

DON'T "VISE" THAT DRILL

Never clamp your electric drill directly in a vise in an effort to replace a horizontal drill stand. You could very easily tighten the vise enough to crack or cave-in the drill's case and cause it to rub against the motor armature. Instead, take a thin piece of scrap aluminum, about 2" x 12", and wrap it tightly around the drill. Clamp the ends of the aluminum strip in the vise.—*Charles Lang, San Francisco, Calif.*

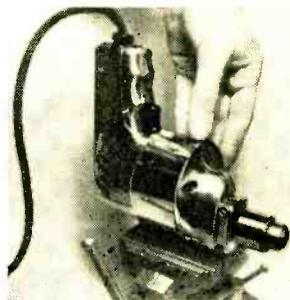

-50-

Build the Best CITIZENS BAND TRANSCEIVER ...



#760 (117 VAC) less bracket:
#761 (117 VAC & 6 VDC):
#762 (117 VAC & 12 VDC):

Kit \$59.95. Wired \$89.95
Kit \$69.95. Wired \$99.95
Kit \$69.95. Wired \$99.95

Highly reliable; exemplary electronic, mechanical, industrial design. Powerful 5-watt (as defined by FCC) crystal-controlled transmitter & extremely sensitive, selective superhet receiver with RF stage & noise limiter. Built-in speaker, detachable ceramic mike. Pre-set & sealed crystal oscillator circuit elements. To change channels, just change crystals -- no adjustments needed. Built-in variable "pi" network matches most popular antennas. Portable whip & roof antennas available. No exams or special skill needed -- any citizen 18 years or older may obtain station license by submitting FCC form, supplied free by EICO.

Build the Best 6-TRANSISTOR RADIO RA-6
Kit \$29.95 Wired \$49.95
includes FET, less 9V battery



High sensitivity & selectivity. New plug-in type transistors. Big-set volume & tone. 4" x 6" speaker; push-pull audio. Built-in Ferrite rod antenna. Pre-aligned RF & IF transformers. Planetary vernier tuning. Earphone jack for private listening. Attractive tan leatherette case, retractable handle. Compact: 8 1/2" w, 4 1/2" h, 2 1/2" d. Only 3 lbs.

Build the Best Ham Gear

New Code Practice Oscillator #706
Kit \$8.95 Wired \$12.95



Rugged battery-operated transistor oscillator circuit, built-in speaker. Front panel has flashing light, phone jack, pitch control (500-2000 cps), external key terminals, "temporary" key. Panel switch selects Tone, Light, or both Tone & Light. 6 1/2" h, 3 3/4" w, 2 3/4" d.



90-WATT CW TRANSMITTER* #720
Kit \$79.95 Wired \$119.95

*U.S. Pat No. D-184,776

"Top quality" — ELECTRONIC KITS GUIDE. Ideal for veteran or novice. 90W CW, 65W external plate modulation. 80 through 10 meters.



HIGH-LEVEL UNIVERSAL
MODULATOR-DRIVER #730
Kit \$49.95 Wired \$79.95

Cover E-5 \$4.50
Delivers 50W undistorted audio. Modulates transmitters having RF inputs up to 100W. Unique over-modulation indicator.



GRID DIP METER #710
Kit \$29.95 Wired \$49.95

Includes complete set of coils for full band coverage. Continuous coverage 400 kc to 250 mc. 500 ua meter.

Compare — judge for yourself — at your neighborhood EICO dealer. For FREE catalog on over 70 models of easy-to-build professional test instruments, hi-fi and ham gear, fill out coupon on Page 38

Add 5% in the West. ©1960

3300 N. Blvd., L. I. C. I., N. Y.



from stand



to hand . . . instantly



introducing the
world's smallest
cardioid dynamic
microphone

UNIDYNE III
by

SHURE

\$50⁰⁰

Professional Net

**EVERYTHING YOU WANT IN A
QUALITY CARDIOID MICROPHONE
. . . AND THEN SOME!**

Compact size . . . modern design . . . wide response . . . superior feedback suppression . . . uniform cardioid pattern . . . ruggedness . . . reliability; you name it, SHURE has designed it into the dramatic new Unidyne III.

50% SMALLER — Less than 6" x 1 1/4", 0.6 lb.!

PERFECTION IN PERFORMANCE — moving coil design with truly uniform cardioid pick-up pattern. Response: 50 to 15,000 cps. Up to 75% greater distances from sound source. Impressive feedback suppression.

MAXIMUM VERSATILITY — unobtrusive size, dual impedance, light weight, instant change from stand to hand, and wide-range response make it ideal for faithful reproduction of voice or music, indoors or out, for P.A., tape recording . . . anywhere fine quality is required.

RUGGED AND RELIABLE — Famous SHURE quality. Takes 6-foot drop-tests and still performs according to specifications!

Literature available:

SHURE BROTHERS, INC.
222 Hartrey Ave., Evanston, Ill.

the experts say
your BEST BUY
 is **EICO**...

EICO, 3300 N. Blvd., L.I.C. 1, N.Y. PE-7

Show me HOW TO SAVE 50% on 70 models of top-quality:
 HI-FI TEST INSTRUMENTS
 "HAM" GEAR Send FREE Stereo Hi-Fi Guide.
 Send FREE Short Course for Novice License.
 Send FREE Catalog & name of neighborhood EICO dealer.

Name: _____
 Address _____
 City _____ Zone _____ State _____

ADD 5% IN THE WEST

... in
STEREO and MONO HI-FI



STEREO Dual Amplifier-Preamplifier HF81
 Kit \$69.95.
 Wired \$109.95.
 "Excellent" — SATURDAY REVIEW: HI-FI MUSIC AT HOME.



NEW! STEREO Automatic Changer/Player 1007 (.7 mil diamond, 3 mil sapph dual styli)
 \$59.75 incl. FET.



FM Tuner HFT90
 Kit \$39.95*.
 Wired \$65.95*.
 Cover \$3.95.
 "One of the best buys" AUDIOCRAFT



STEREO Dual Preamplifier HF85
 Kit \$39.95.
 Wired \$64.95.
 "Extreme flexibility" — HI-FI REVIEW
 a bargain!



Mono Power Amplifiers (60, 50, 35, 30, 22, 14-Watt; use 2 for Stereo)
 from Kit \$23.50.
 Wired \$41.50.

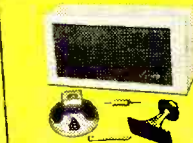

AM Tuner HFT94
 "Less Cover, F.E.T. incl." Kit \$39.95.
 Wired \$65.95.
 incl. Cover & F.E.T.
 2-Way Bookshelf Speaker System HFS1 complete with factory-built cabinet:
 Kit \$39.95
 Wired \$47.95



STEREO Dual Power Amplifiers: New 100W HF89: Kit \$99.50
 Wired \$139.50.
 70W HF87: Kit \$74.95. Wired \$114.95.
 28W HF86: Kit \$43.95. Wired \$74.95.



Mono Integrated Amplifiers: (50, 30, 20, 12-Watt; use 2 for Stereo)
 from Kit \$34.95.
 Wired \$57.95.



NEW! COMPLETE STEREO DUAL AMPLIFIER AF-4
 Kit \$38.95
 Wired \$64.95

TRUE Hi-Fi quality to drive hi efficiency speakers to concert volume.

... and in
TEST INSTRUMENTS



New Transistorized Power & Bias Supply #1020
 Kit \$19.95.
 Wired \$27.95.



Miniaturized Multi-Signal Tracer #145A
 Kit \$19.95.
 Wired \$28.95.



Vacuum Tube Voltmeter #221
 Kit \$25.95.
 Wired \$39.95.



New Battery-Powered Filament Continuity Tester #612. Kit \$3.95.
 Wired \$5.95.



1000 Ohms/Volt V.O.M. #536
 Kit \$12.90.
 Wired \$14.90.



5" Push-Pull Scope #425
 Kit \$44.95
 Wired \$79.95.



Peak-to-Peak VTVM #232 & Uni-Probe
 Kit \$29.95.
 Wired \$49.95.



RF Signal Generator #324
 Kit \$26.95.
 Wired \$39.95.



Series/Parallel R-C Combination Box #1140
 Kit \$13.95. Wired \$19.95
 1350 Combinations!



6V & 12V Battery Eliminator & Charger #1050
 Kit \$29.95. Wired \$38.95.
 Extra-filtered for transistor equip. #1060
 Kit \$38.95. Wired \$47.95



Tube Tester #625
 Kit \$34.95.
 Wired \$49.95.



R-C Bridge & R-C-L Comparator #950B
 Kit \$19.95.
 Wired \$29.95.

IN STOCK! Compare, take them home — right "off the shelf" — from 2000 neighborhood dealers. Over 2 MILLION EICO instruments in use throughout the world.

© 1960 ELECTRONIC INSTRUMENT CO., INC., 3300 N. BLVD., L.I.C. 1, N.Y.

See Page 36 for the BEST BUYS in CITIZENS TRANSCEIVERS, "HAM" GEAR and TRANSISTOR RADIOS.

Operation Radio Control

**Engineers at ITT
relax and have fun
with radio-controlled
model boats and planes**

ON a lake near Nutley, New Jersey, a model aircraft carrier backs slowly out from shore, swings around, and majestically sails away. Accurately detailed down to the planes on its landing deck, the miniature craft responds to every electronic command from shore.

A few miles away, a model plane climbs into the air. It circles, goes through a series of acrobatic maneuvers, and finally comes in for a perfect landing. Again, its every action is controlled electronically from the ground.

These scenes are duplicated countless times on any sunny weekend from Maine to California. But the enthusiastic electronic hobbyists that control their models near Nutley, N. J., are unique in at least one way. During working hours, they design and develop some of Uncle Sam's most complex electronic hardware. All of these men are employed in International Telephone and Telegraph's electronic defense research laboratory. Their

July, 1960

COVER STORY

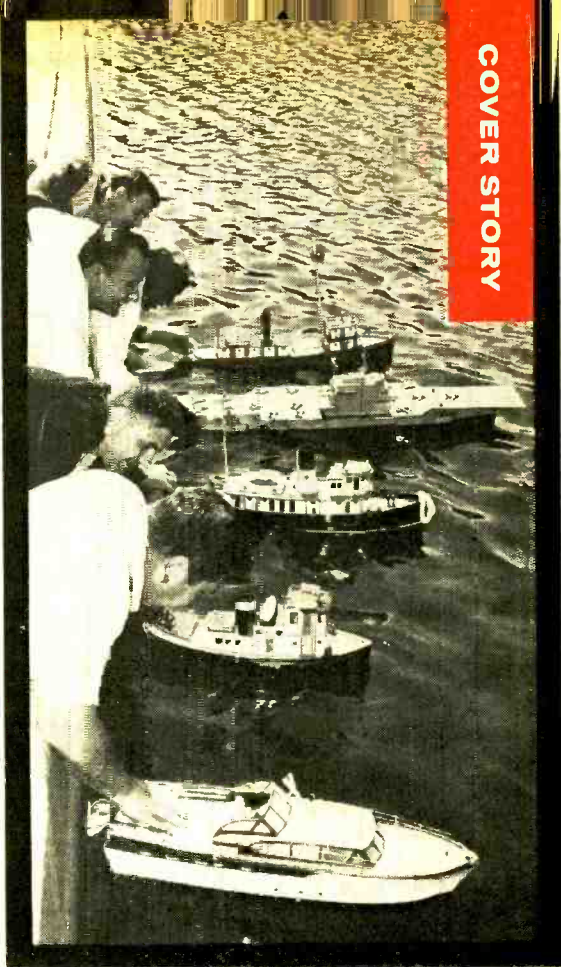

Technician William Hadson puts his beautifully detailed aircraft carrier through its paces.

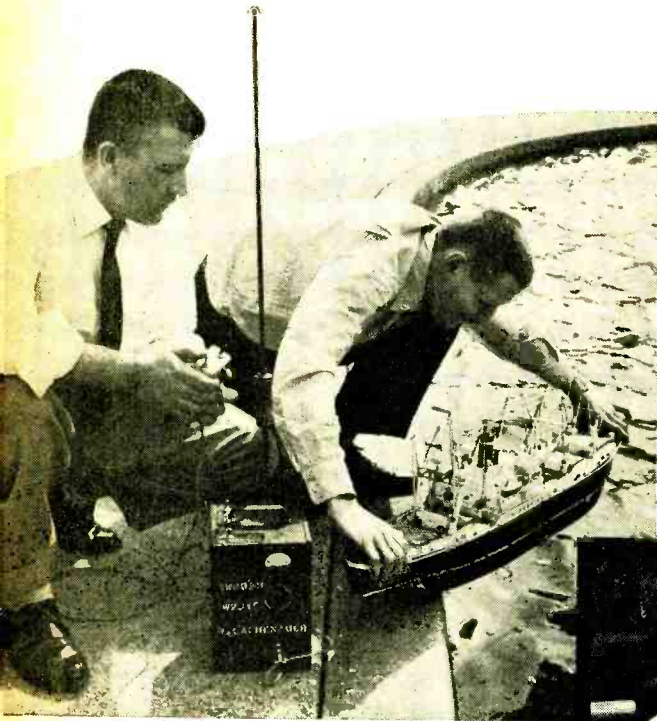

Designer Seymour Glassner has a mighty serious look on his face when he's behind his drafting board (below), but when he prepares to launch his model freighter (left), he breaks out in smiles. The freighter's hull, by the way, sports 15 alternating layers of lacquer and elbow grease. Although the ship looks almost perfect, Seymour says he will put another year's work into it. In the meantime, it's fully seaworthy, and Seymour enjoys sailing it.



jobs entail work on radar, satellite tracking and communications equipment, navigation aids, and hush-hush electronic counter-measures gear.

Since they are engineers, technicians, and designers, most of the ITT modelers have greater technical knowledge than other hobbyists. But they still run into problems with their R/C boats and planes.

One day last summer, for example, technician Dick Lachenauer wished he had never heard of radio control. It all began when he tried to be helpful. A small boy's boat had drifted out into the middle of a lake, and Dick sent his radio-controlled tug out to nudge it back in to shore. Apparently the tug nudged it a little too hard, because the boat sank! Dick ended by rolling up his trousers and going wading.

But, as with most modelers—and particularly with those who have been bitten by the radio-control bug—such minor difficulties are quickly forgotten. Not long ago we went out with the ITT radio-controllers and came back with these pictures—which prove that electronic hobbyists, be they amateur or pro, have more fun than the proverbial barrel of monkeys!

model boats ...

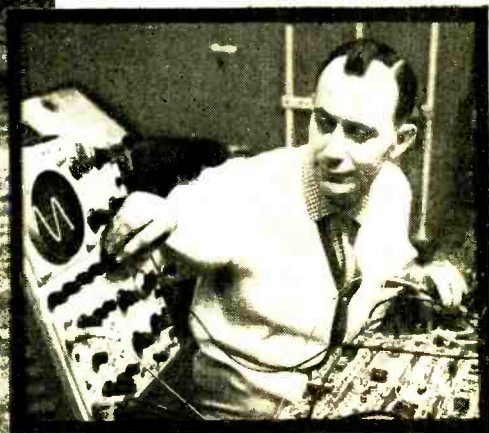

Senior technician Richard Lachenauer—called "Cap'n Dick" by the boys—is equally at home when checking out a Loran-C navigations simulator in ITT's avionics laboratory or designing control systems for model boats.

After making some control adjustments, John DiCiccio carefully fits the superstructure back onto his sleek model cruiser. If you look closely, you'll see scale-sized passengers on the deck. This cruiser, like most model boats, is driven by an electric motor. But at least one craft in the ITT fleet is powered by a gasoline engine, and one goes still further toward realism with a miniature steam engine.



...and model planes, too!



1 Engine's revving up just right . . . the radio gear's all checked out . . . so . . .



2 . . . off she goes! Chuck does the launching himself; a friend handles the controls until Chuck can get back and take over.



3 The launch was successful ▲ and the plane is climbing steadily now. Looks like it's going to be a good flight.

4 A few minutes later, Chuck ► takes over the controls and puts the plane through a series of fancy aerial acrobatics.



KINGPIN of the ITT modelers' "airborne division" is veteran radio-control enthusiast Chuck Kenny. The possessor of college degrees in both electrical and mechanical engineering, Chuck specializes in packaging—that is, cramming more and more parts into less and less space. Like most of the other ITT modelers, Chuck designs and builds most of the 27.25-mc. control gear used in his planes. Here are some recent shots of Chuck and one of his planes in action.

*Reflex and
regenerative circuits
are combined
in this sensitive
and stable . . .*

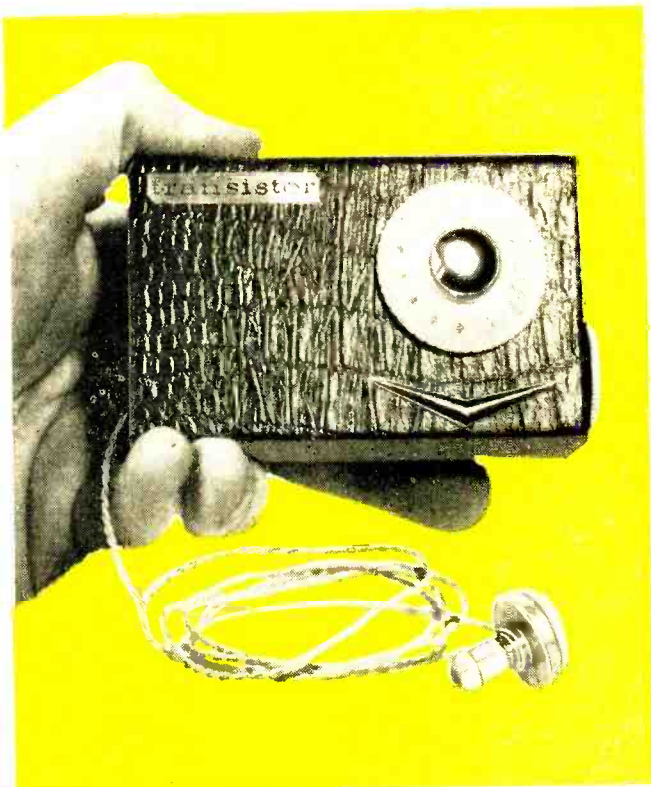

ONE TRANSISTOR POCKET RADIO

**By
ALVIN MASON**

DESIGNING and constructing a one-transistor pocket receiver is a challenge to any experimenter. A good many "pocket" receivers are either too large or too bulky for true "pocket" operation. Or they simply don't possess enough sensitivity and gain to pull in stations without an external antenna.

The little receiver described here gets around both of these weaknesses. It uses a combination of reflex and regenerative action to cut size and components to a minimum and increase sensitivity to striking proportions. The complete unit measures only 4" x 2½" x ¾". And it's powerful enough to pull in every local station on the dial with no external antenna at all!

Reflex Circuit. Because of the "reflex" action of the circuit, a single transistor is made to amplify the signal twice—once at radio frequencies and again, after detection, at audio frequencies (see "How It Works"). To simplify the circuit, a diode is used as a detector, leaving

the transistor free to do nothing but amplify.

Also acting to increase the circuit's simplicity and stability is the regeneration hookup. The circuit is designed so that the amount of positive feedback or regeneration doesn't control the overall sensitivity as is usually the case with regenerative detectors. What's more, there is no regeneration control or annoying oscillation to contend with.

Since the remarkable efficiency of this little set doesn't depend on regeneration alone, only a limited amount of regeneration is used. Its stability is evidenced by

the fact that, once adjusted, the set is as stable as most non-regenerative detectors.

Although a Philco r.f. transformer was used as *T1* in the model, this particular transformer is available only from authorized Philco distributors and may prove hard to get. However, *T1* is in no way critical—a number of transformers were substituted for the Philco unit, and most of them worked satisfactorily.

The Argonne AR-162 (available from Lafayette Radio, 165-08 Liberty Ave., Jamaica 33, N. Y., for \$2.95) seems to be a good substitution. A miniature output transformer measuring only 1" x 3/4" x 3/4", the AR-162 has identical center-tapped primary and secondary windings of 500 ohms with a d.c. resistance of 18 ohms. You'll have to remove the transformer's strap and laminations to fit the unit in the small plastic box specified in the parts list. But you'll find that this bit of disassembling proves no problem (see illustration on next page). The windings are light enough to be held in place with a strip of transparent tape. The center-taps are not used.

Construction. The chassis is a piece of Formica or phenolic board about 4" x 2 1/2" x 1/16". Depending on the size of the components, the chassis should fit into a small plastic box measuring about 4" x 2 1/2" x 3/4". Homemade printed circuitry was used on the model, but standard wiring will do just as well. Most of the component leads are long enough to permit point-to-point

PARTS LIST

- B1—15-volt battery (two Eveready 404E's or equivalent in parallel)
- C1—365- μ f. variable capacitor (Lafayette MS-445 or equivalent)
- C2—10- μ f., 25-volt miniature electrolytic capacitor
- C3—30- μ f., 25-volt miniature electrolytic capacitor
- C4—.0005- μ f. ceramic capacitor
- C5—.01- μ f. ceramic capacitor
- C6—Gimmick capacitor (see text)
- D1—1N60 diode
- L1—Antenna coil for C1 (Superex 2004 or equivalent)
- L2—Six turns of #20 insulated wire wound on L1 (see text)
- Q1—2N78 transistor
- R1—10,000 ohms
- R2—22,000 ohms
- R3—560 ohms
- R4—10,000-ohm volume control with s.p.s.t. switch S1 (Lafayette VC-28 or equivalent)
- S1—S.p.s.t. switch (on R4)
- T1—Coupling transformer (Philco 32-4763-2 or equivalent—see text)
- 1—2000-ohm impedance earphone (Lafayette MS-368 or equivalent)
- 1—Transistor socket
- 1—4" x 2 1/2" x 3/4" plastic box
- 1—4" x 2 1/2" x 1/16" phenolic board
- Misc.—Tuning dial, knob for volume control, wire, solder, etc.

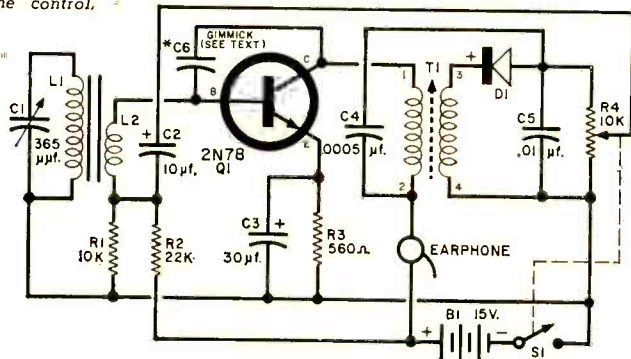

One transistor does the work of two in this highly efficient circuit. The signal is amplified twice—once at radio frequencies and, after detection, at audio frequencies.

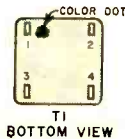
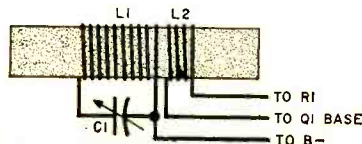

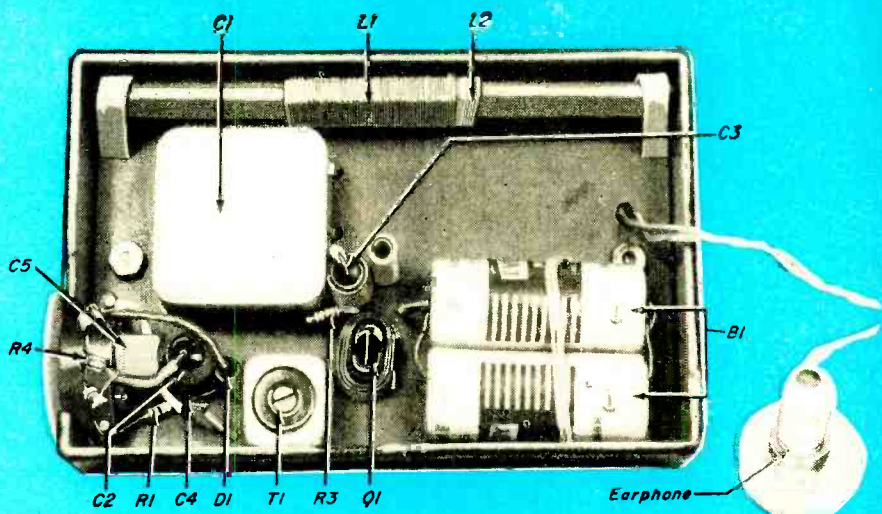

Parts are mounted on a phenolic board; R2 and C6 are on reverse side.

wiring, but a transistor socket was used to prevent possible damage to the transistor when soldering.

Coil *L2* consists of six to nine turns of No. 26 insulated hookup wire wound on the "ground" end of *L1* and spaced $\frac{1}{16}$ " from it. "Gimmick" capacitor *C6* is made up of two $\frac{1}{2}$ " lengths of insulated hookup wire twisted together several times to form a small capacitor.

It's a good idea to lay out all parts and drill most of the holes in the chassis before starting assembly. Since the wiring is relatively simple, you should be able to take your time and do a good job. As with any construction project, time spent in careful wiring will pay off in the long run.

Operation. After all parts have been mounted and soldered in place, double-check all connections. Now, with the switch off and battery *B1* in place, plug in the transistor. Turn on the set and rotate the volume control to full on. Select a station, preferably the strongest one on the dial. Listen for distortion. If necessary, either loosen the coupling in capacitor *C6* by untwisting the leads slightly or by snipping off the leads bit by bit until the distortion disappears.

Once adjusted, the set should be nearly as stable as the superhet in your living room. And it's a safe bet that in sensitivity and portability this little unit will have few equals.

-30-

HOW IT WORKS

One transistor and one diode are employed in a circuit that combines the advantages of both reflex and regenerative action. Because the signal passes through transistor *Q1* twice—once as r.f. and once as a.f.—the transistor is properly described as operating in a "reflex" circuit. Adding to the already high efficiency of this circuit is the regeneration furnished by gimmick capacitor *C6*.

In operation, the r.f. signal picked up by antenna coil *L1* is tuned by coil-capacitor combination *L1-C1* and induced into secondary coil *L2*. Fed directly into the base of transistor *Q1*, the r.f. signal is amplified and passed to transformer *T1*. A portion of the signal from *Q1*'s collector is returned to *Q1*'s base by capacitor *C6* to provide additional gain through regeneration. The signal induced in *T1*'s secondary is detected by diode *D1*, smoothed by capacitor *C5*, and returned to the base of *Q1* through volume-control *R4* and coupling capacitor *C2*.

Transistor *Q1* again amplifies the signal, this time at audio frequencies. The audio signal from *Q1*'s collector is fed through the primary of *T1* to the earphone.

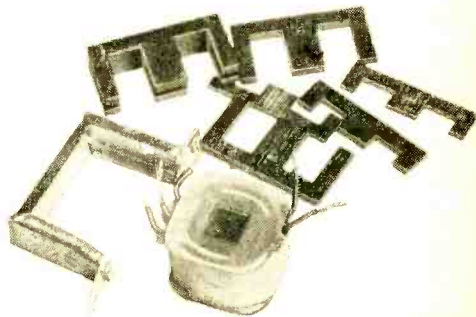

Coupling transformer *T1* must be a miniature unit. If Argonne Type AR-162 is used, it can be reduced in size by removing the strap and laminations.

Build an

Earphone Booster Amplifier



By LOUIS E. GARNER, JR.

Self-powered device steps up earphone volume

MAGNETIC earphones are a familiar item in the experimenter's world. Beginners use them with crystal sets, one- and two-tube radios, and small transistor receivers. More advanced hobbyists use them with signal tracers, short-wave sets, and dozens of other units.

This little transistorized earphone "booster-amplifier" will increase the sensitivity of any standard magnetic earphone. Inexpensive and easy-to-build, it is one of the most useful accessories the experimenter can own. Only standard



components available through both local and mail order supply houses are incorporated.

Construction. Use a clean, hot, well-tinned soldering iron and rosin-core solder for all connections. The transistor leads should be soldered as quickly as possible to avoid overheating; use your long-nose pliers as a heat sink by gripping the transistor lead between the joint to be soldered and the transistor case, and insulate all bare leads with spaghetti tubing.

Resistor *R1* should be selected to match the output impedance of the unit used with the earphone booster. Transistor portables will probably re-

quire a 470-ohm, $\frac{1}{2}$ -watt resistor for *R1*; crystal radios about 47,000 ohms, $\frac{1}{2}$ watt; vacuum-tube receivers about 100,000 ohms, $\frac{1}{2}$ watt.

Make the battery connections last—note that the terminal strip lug connected to the positive battery terminal is grounded. Because battery life is quite long, the battery can be soldered permanently into the circuit. Avoid heating the battery excessively when soldering, since heat may damage it.

With the wiring completed, double-check all connections for possible errors, poorly soldered joints, and accidental shorts. And pay particular attention to battery polarity.

Operation. To use the completed instrument, plug standard magnetic earphones (units from 500 to 6000 ohms impedance will work with the booster) into output jacks *J1* and *J2*. Next, plug input tip plugs *P1* and *P2* into the earphone jacks of the unit whose output you want to boost—a crystal receiver, for example.

The earphone booster goes on the instant phones are plugged into it; so be sure to unplug the phone from the booster when it's not in use to conserve the battery. —30—

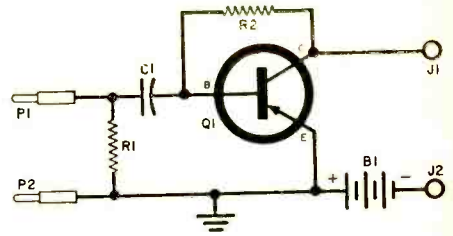

HOW IT WORKS

A one-stage resistance-coupled amplifier, the earphone booster uses a *p-n-p* transistor in the common-emitter arrangement. The input signal applied across *R1* is coupled through d.c. blocking capacitor *C1* to *Q1*'s base. Amplified output from *Q1* appears across the magnetic earphones serving as *Q1*'s collector load. Operating current is supplied from a single 15-volt battery, *B1*; base bias is obtained from the collector circuit through resistor *R2* which also introduces inverse feedback to improve transistor interchangeability.

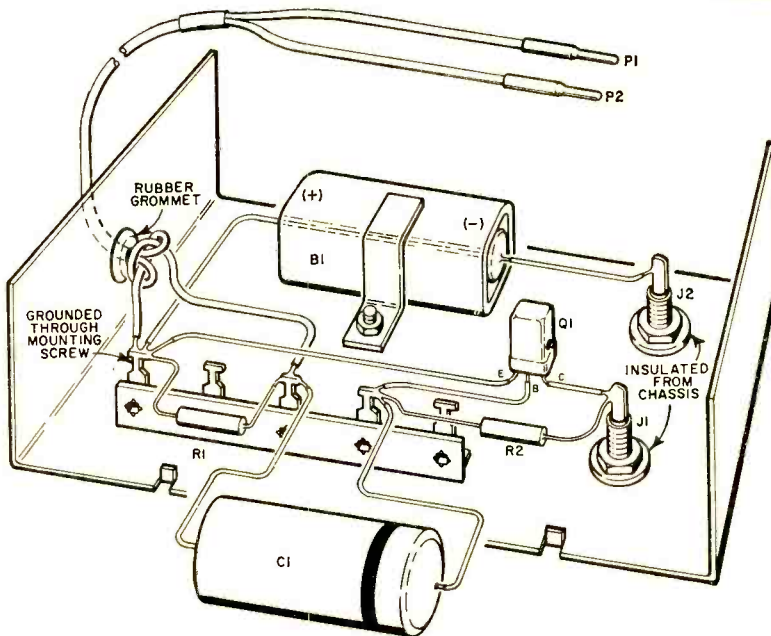
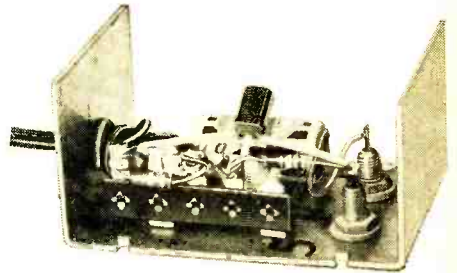

PARTS LIST

- B1*—15-volt battery (Burgess Y10 or equivalent)
- C1*—0.1- μ f., 200-volt capacitor
- J1, J2*—Phone tip jack
- P1, P2*—Phone tip plug
- Q1*—CK722 transistor
- R1*—See text
- R2*—270,000-ohm, $\frac{1}{2}$ -watt resistor
- 1— $3\frac{1}{4}$ " x $2\frac{1}{8}$ " x $1\frac{1}{8}$ " aluminum box (Bud CU-3001A or equivalent)
- Misc.—Hardware, S-lug terminal strip, small bracket, grommet, etc.

TV Explores Deep Wells

**Watertight TV camera
provides "inside" pictures
from 1500 feet down**

CLOSED-CIRCUIT TV, already at work in factories, banks, hotels, and garages, is now being used to explore the watery depths of wells. A Los Angeles company, Hallamore Electronics, in conjunction with Layne and Bowler Pump Co., has designed a special watertight TV camera that can be lowered into well shafts up to 1500 feet deep.

The TV camera is cylindrical in shape and measures about 4" in diameter and 20" in length. It carries its own lighting—three tiny 150-watt filament-type bulbs, each with a quartz envelope. Lighting intensity is variable, being controlled at the surface by a Variac.

Whatever the camera sees down in the well is viewed on a 17" monitor receiver. During a well survey, photos can be taken of the monitor screen, thus providing a permanent record of the well's condition. The sweep waveforms for the camera are supplied by circuitry in the monitor and are carried down to the camera by a multi-conductor cable.

The new system has already proven its worth many times. In one well, for example, the bottom part of a pump had fallen off as it was being pulled out of the shaft and had become tightly wedged. The camera quickly showed exactly how the part was stuck, providing the workmen with enough information to retrieve it.

In another instance, a well was not delivering as much water as had been anticipated. When the camera was lowered to the level at which water had first been located during the drilling operation, a flow of water could be clearly determined by watching the movement of particles floating past the camera. The problem was solved when the camera also showed that layers of white limestone were impeding a full flow of water.

Since the system has been in operation only a relatively short time, well drillers expect this new electronic underwater eye to disclose many more deep secrets. —50—



This is the custom-built TV camera that sends back pictures from the bottoms of deep wells.

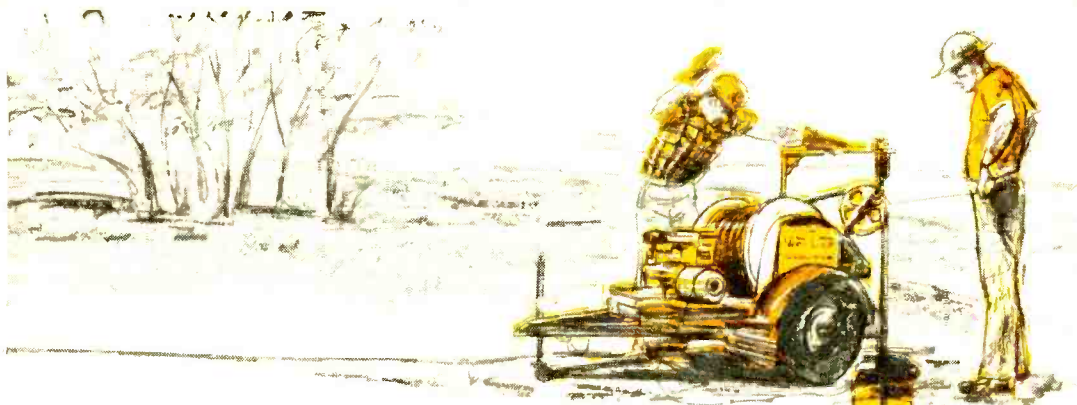

By **HARRY J. MILLER**

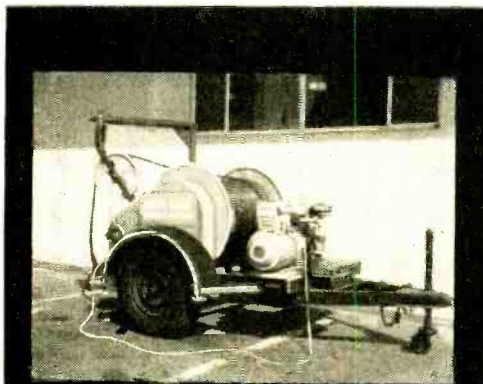

Gasoline-operated generator makes the TV system independent of power lines.



Photo taken off monitor shows the metal screening at the bottom of a 200' well.

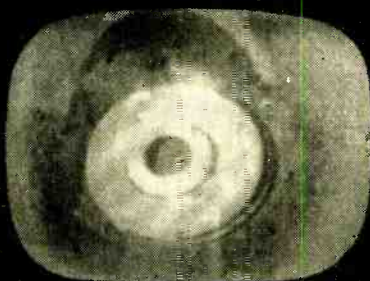

Here, the impeller of a pump lies at the bottom of a well and impedes water flow.

NEW DEVELOPMENTS IN PRODUCT DESIGN



Large-Screen Portable TV

THE Motorola "Astronaut" is the first large-screen battery-operated portable TV set to be offered for sale. Completely transistorized, the forty-pound "Astronaut" features a 19" picture tube. A silver-cadmium battery which can be recharged overnight from an a.c. outlet powers the set for five or six hours of operation. Price: around \$360.00, including battery.

Swedish Hi-Fi Speaker

ONE of the most unconventional loud-speaker systems ever to reach these shores, the Swedish-made Lund 1001 is a two-way speaker with a built-in bass-treble bi-amplifying system. The frequency response of the amplifiers—which operate without output transformers—is adjusted to complement the response of the speakers. The Lund 1001 will be priced for sale in this country at approximately \$395.00.

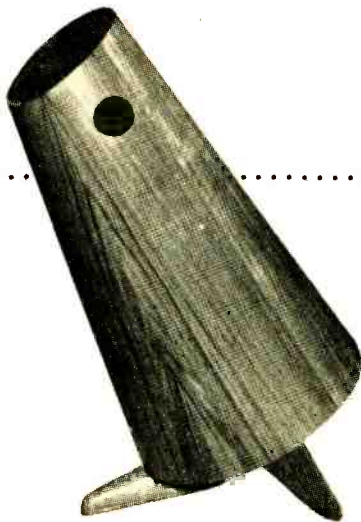

..... *Radio Hearing Aid*



A NEW concept in eyeglass hearing aids, the Telex "Radiant" is a two-piece unit, with a five-transistor miniature radio transmitter built into the earpiece and a one-transistor receiver incorporated into a separate dime-sized earphone. The design of the "Radiant" eliminates all external wires and mechanical connections and reduces acoustical feedback. Price: about \$330.00.

DX'ing

EVER wonder what goes on "down below" the standard broadcast band? Most of us think of short-wave listening when we think of DX, but there are many diligent and adventurous DX'ers who find excitement in a different world of communications. They DX from 540 kc. down to 10 kc.—otherwise known as the long-wave band.

The special "gimmick" on this band is something called "ground wave." Short-wave stations have it too, but on a small scale compared to long-wave stations. Ground-wave signals travel along the surface of the earth from the transmitting antenna. The intensity tends to drop with distance, but if you blast out with enough power at low frequencies, you can cover the globe on a ground wave 24 hours a day.

Huge antennas are required for long-wave transmission. And tremendous transmitting power is needed to push the ground-wave signal around the earth. One long-wave station, operated by the U. S. Navy in Jim Creek, Wash., puts out a million watts, pumping its signal into an antenna that has its supporting wires strung between several mountain tops; its signal packs such a wallop that it can be heard by submarines 90 feet below the surface of the water, wherever they may be.

The long-wave band is only a half-megacycle wide, compared with over 26 mc. for the international short-wave bands. Half a megacycle is close quarters in any man's band. But there are many stations that must operate on these low frequencies, stations which comprise the delicacies of "down below" DX'ing.

The "rock bottom" of the radio spectrum—below 20 kc.—chatters away with c.w. stations of the U. S. Navy, the British Post Office, the Swedish Telecommunications Dept., the German Post Office, and about 101 other outfits. These stations extend upwards in frequency to 90 kc. Here they are joined by many of the world's coastal telegraph stations that contact ships on international routes. The ships themselves start showing up on 130 kc. They soon become intermixed with over 85 European and Asian broadcasting stations, beginning at 150 kc.

The next group of stations is by far the most popular with long-wave DX'ers. They are the zillions of radio navigational stations throughout the world which start popping up around 200 kc. These aeronautical and marine beacons and ranges, operated by commercial, government, and military interests, send their identifications

down below

***Listen to hundreds of fascinating stations all over the world
on the little-known v.l.f. band***

By TOM KNEITEL, WPE2AB

TYPICAL LONG-WAVE STATIONS HEARD IN U.S.A.

Kc.	Call	Location	Kc.	Call	Location
14.5	CNM	Casablanca, Morocco	98.5	XPM50	Thule, Greenland
15.3	NHR	Kodiak, Alaska	98.5	TAB	Ankara, Turkey
15.3	NPN	Guam, Marianas Is.	99.55	OEV33	D. Altenburg, Austria
15.3	NLK	Jim Creek, Wash.	99.7	DIU	Potsdam, E. Germany
15.5	NSS	Annapolis, Md.	100.0	CCS	Santiago, Chile
15.7	NPL	San Diego, Calif.	103.4	NAU	San Juan, P.R.
16.0	GBR	Rugby, England	103.4	NAU3	St. Thomas, V.I.
16.4	DMA	Bonames, W. Germany	108.0	RKA76	Moscow, U.S.S.R.
16.6	NPM	Honolulu, Hawaii	110.05	GYP	Hong Kong
17.0	NDT	Tokyo, Japan	110.15	CQX	S. Tome Is., S. Atlantic
17.2	SAQ	Varberg, Sweden	110.15	CQZ	Lobito, Angola
18.0	NBA	Balboa, Canal Zone	112.0	NHY	Pt. Lyutey, Morocco
18.0	NPQ	San Francisco, Calif.	112.85	GYS	Singapore
20.27	IDR	Rome, Italy	115.3	CFH	Halifax, N.S., Canada
33.95	LCA	Jeloey, Norway	119.15	NAM	Norfolk, Va.
39.35	JJC	Tokyo, Japan	119.15	ZSL	Capetown, U. of S. Africa
44.0	VHB	Belconnen, Australia	121.0	UBP	* U.S.S.R.
44.8	GYU2	Gibraltar	122.65	CQF	Bissau, Port. Guinea
51.7	XDA	Mexico City, Mex.	124.75	CTF	Flores, Azores Is.
53.0	NUD	Adak Is., Alaska	124.75	CTQ	Funchal, Madeira
55.5	NPO	Manila, Phil. Is.	125.0	HRC	Tela, Honduras
58.0	NPC	Keyport, Wash.	125.0	STP	Pt. Sudan, Egyptian U.A.R.
60.0	KK2XEI	Boulder, Colo.	125.0	VPC	Pt. Stanley, Falkland Is.
60.0	MSF	Rugby, England	125.0	XXA	Goa, Port. India
62.0	GIZ20	Rugby, England	125.0	YQI	Costanta, Roumania
62.1	ORL48	Ruiselede, Belgium	126.0	UDL3	* U.S.S.R.
62.45	SOA71	Radom, Poland	127.0	UCJ	Vanavara, U.S.S.R.
63.1	HAB	Szekesfehervar, Hungary	131.0	UNA	Kherson, U.S.S.R.
63.85	FYO3	Paris, France	132.0	RFSO	* U.S.S.R.
65.95	NAW	Guantanamo Bay, Cuba	132.0	ULV	Faizabad, U.S.S.R.
65.95	PEW	Koolwijk, Netherlands	135.0	PGU	Pt. Barrios, Guatemala
72.45	EAA	Aranjuez, Spain	142.0	UOX	Chamidta Mys, U.S.S.R.
75.6	OXE21	Skamlebaek, Denmark	142.86	UBJ	Baku, U.S.S.R.
78.2	GYC	Whitehall, England	142.86	UIX	Tcheliuskin, U.S.S.R.
78.55	LOF	Mar del Plata, Argentina	147.5	WCC	Chatham, Mass.
79.0	RET	Leningrad, U.S.S.R.	150.0	ZBH	S. Georgia Is., S. Atlantic
83.1	OFA83	Nummela, Finland	152.0	YNNA	Managua, Nicaragua
85.7	OAZ	Lima, Peru	153.0	WVCS	Madras, India
96.05	HBB	Berne, Switzerland	182.0	TFU	Reykjavik, Iceland
97.45	GYZ	Malta	194.0	ASK	Karachi, Pakistan

*Location unknown

so slowly that, even if you don't read c.w., you can log them with one ear tied behind your back. All you have to do is jot the actual "dots" and "dashes" down on a piece of paper and later decipher them from a list of Morse code characters.

Many of the aeronautical stations send weather transmissions in voice at 15 minutes before and after each hour. There are also many airport control towers to be heard which use voice. At 405 kc., the navigational stations end and the maritime communications stations again take over.

If you can copy c.w. at any respectable speed, you might find more excitement during a few hours of listening on 500 kc. than you'd get from a week of watching TV. This is the "International Calling and Distress" channel, used by every commercial coastal telegraph station, every Coast Guard and Navy station, and every ocean-going commercial and military ship in the

world. Many planes flying international routes also operate on this frequency.

In the remaining portion of the "down below" band—510 through 535 kc.—there are numerous government beacon stations, familiar to the many DX'ers who have wandered off the beaten path with regular "communications receivers."

DX'ploring receivers that tune down to the 15-kc. sub-basement are inexpensive and plentiful in the used and military surplus market. They include the U. S. Navy's RAK and RBL models and RCA's AR-8510. The soldering-gun crowd can build a sensitive 13-to-550 kc. receiver from plans in the December 1958 POPULAR ELECTRONICS. For receiving, any long-wire antenna will give dandy results in this range.

If, like many, you are interested in the beacon stations—200 to 400 kc.—you have a still wider selection of sets to choose from. If you stick with the low-priced sur-

plus gear, you'll find the U. S. Army's low-frequency beacon receivers quite good. They include the BC 344, 348, 433, and 1206. The Navy has its own models: the ARB, ARN, RAL, RAO, and RAX. There are also available many used commercial long-wave receivers: the Bendix MN-26; Hallicrafters S-51 and S-72L; and National's HRO and NC-200.

New commercial receivers for the beacon frequencies are currently manufactured by Admiral, Heath, LT Labs, Motorola, National, Nova-Tech, Sonar, Zenith, and a host of others. In addition, European manufacturers normally include a long-wave

International Telecommunications Union, Palais Wilson, Geneva, Switzerland. Write directly to Geneva for details and prices of their many lists.

Many easily heard U. S. aero beacons and ranges are listed in the bi-weekly booklet called "Airman's Guide," sold by the Superintendent of Documents, U. S. Government Printing Office, Washington 25, D. C. Prices vary from issue to issue—usually ranging between 50 cents and \$1.00.

Canadian aero beacons and ranges are

▶ The author's listening post. His long-wave receiver, an RBL-2, is second from the bottom on the left.



▲ U. S. Coast Guard radio operators "stand watch" on 500 kc., the International Calling and Distress Frequency, which is monitored by all marine stations and ships at sea.

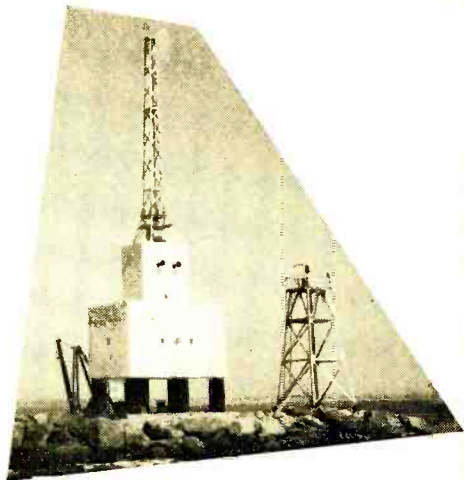
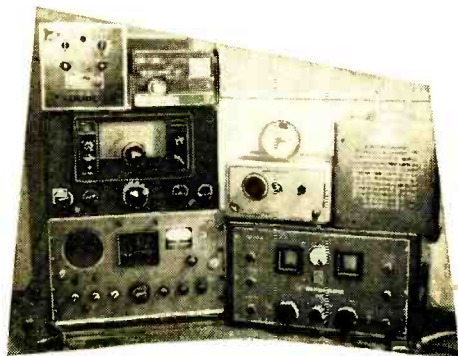

▲ This three-way navigational aid at Long Beach Harbor, Calif., transmits a low-frequency radio beacon in addition to flashing a 140,000-candle-power light and blasting on its fog-horn. (U. S. Coast Guard photo)

band in the majority of "home-type" receivers they turn out.

Of particular interest to the dollar-conscious DX'er is an efficient and inexpensive low-frequency converter, the TC-1, recently developed by Boulevard Electronics (1229 W. Washington Blvd., Chicago 7, Ill.). It can be connected to the antenna of any good communications receiver or car radio. Battery-operated and transistorized, it tunes from 200 to 400 kc.

QSL's from v.i.f. stations are something to try for. Station information is plentiful, especially from the Secretary General,

given in "Air Navigational Radio Aids," available for 25 cents (in Canadian funds) from the Queen's Printer, Department of Public Printing and Stationery, Ottawa, Ont., Canada. Make checks and money

(Continued on page 108)

Build a Picnic Speaker

By LUIS VICENS

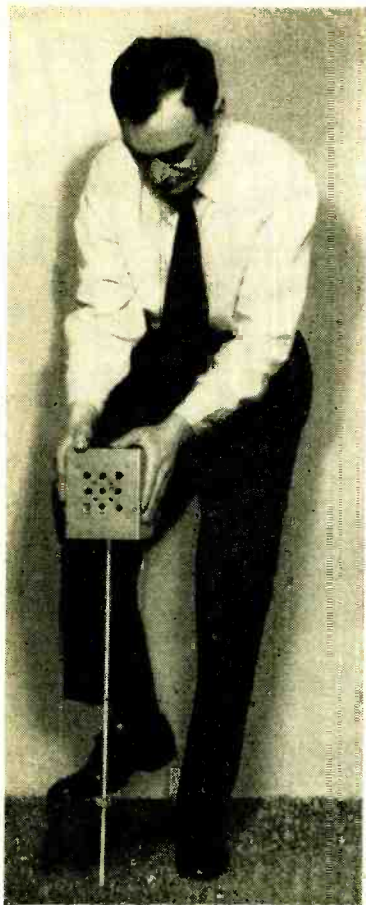

Hook up the extension speaker assembly to your car radio as shown, then mount it near your picnic area by driving the aluminum spike into the ground.

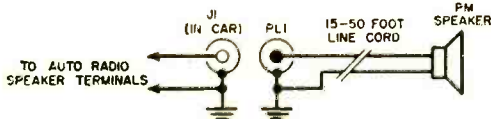

JUST "pipe" the output of your car radio into this extension loudspeaker, and you can have pleasant background music at picnics and beach parties. The complete assembly costs only a few dollars and takes an hour or so to put together.

Basically, the unit is a small PM loudspeaker (about 4") mounted in a box. You'll also need a length of connecting line, a carrying handle, and a sharpened spike for mounting the assembly in the ground near your picnic spread. The extension speaker is hooked up in parallel with the speaker on your car radio.

Mount the picnic speaker in an aluminum chassis box about 4" x 5" x 6" or larger (Bud CU-2107A or equivalent). Cut a baffle opening in the box and cover it with grille cloth or screen-door netting to keep careless fingers out. If you prefer to work with wood, you can use a cigar box, lacquered to make it weatherproof.

The spike is made from a 28" to 32" length of $\frac{3}{8}$ " aluminum rod. File one end to a point and thread the other end to accept a mounting nut. A small bracket can be attached part-way down the spike to provide a toe grip for driving the spike into hard-packed soil.

Connect the picnic speaker's voice-coil terminals to the car radio with about 15 to 50 feet of 117-volt rubber-insulated "zip" cord. Attach an RCA phono plug (PLI) to the end of the cord, and bring the car radio's voice coil terminals out to a matching RCA phono jack (J1) which can be mounted on a bracket under the car's dashboard.

-30-

Metal cleat bolted to rear of unit holds cord in place when the picnic speaker is not in use.

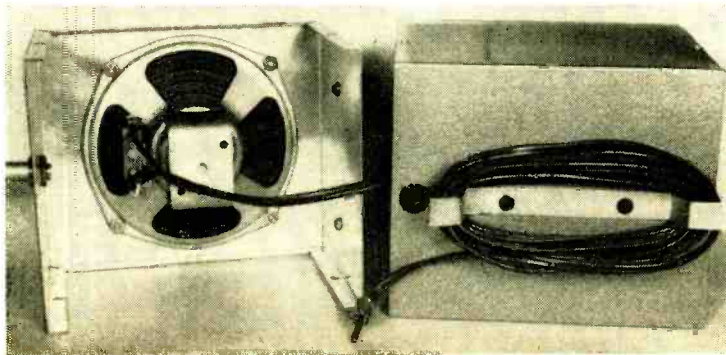

INSIDE the Hi-Fi Microphone

PART 1 of two parts

MICROPHONES are transducers—they convert mechanical energy (sound waves) into electrical energy, just as loudspeakers convert electrical energy into mechanical. As a matter of fact, these two transducers—microphones and loudspeakers—are so closely related that, given the right conditions, any dynamic speaker can be used as a microphone and vice-versa. This dual-function use is utilized in intercom systems and is one reason intercoms can be produced so cheaply.

There are many different types of microphones. Some are rough-and-tough customers that you can drop on the floor with no ill effects. Others are prima donnas that will refuse to work if you so much as sneeze at them (this is literally true in the case of the ribbon microphone). To see why the various types of microphones have the specific advantages and disadvantages that they do, let's start by discussing the dynamic mike, a versatile performer which can be found in use all the way from ham shacks to recording studios.

Dynamic Microphones. Since dynamic microphones are similar to loudspeakers in basic theory, they present some of the same design problems. (See Fig. 1.) Somewhat like a loudspeaker, a dynamic microphone tends to have a peak in its mid range because of resonance in its suspension system. This peak, however, can be controlled by providing an empty space behind the diaphragm. The air cavity works to reduce resonant peaks in the same way a properly designed enclosure damps out a loudspeaker's resonances. Several other small air chambers behind the diaphragm—carefully proportioned to emphasize or attenuate certain frequencies—are generally included in the microphone's design.

The bass response of a dynamic microphone is sometimes extended by building a "ducted port" into the case. This is a hollow tube which permits

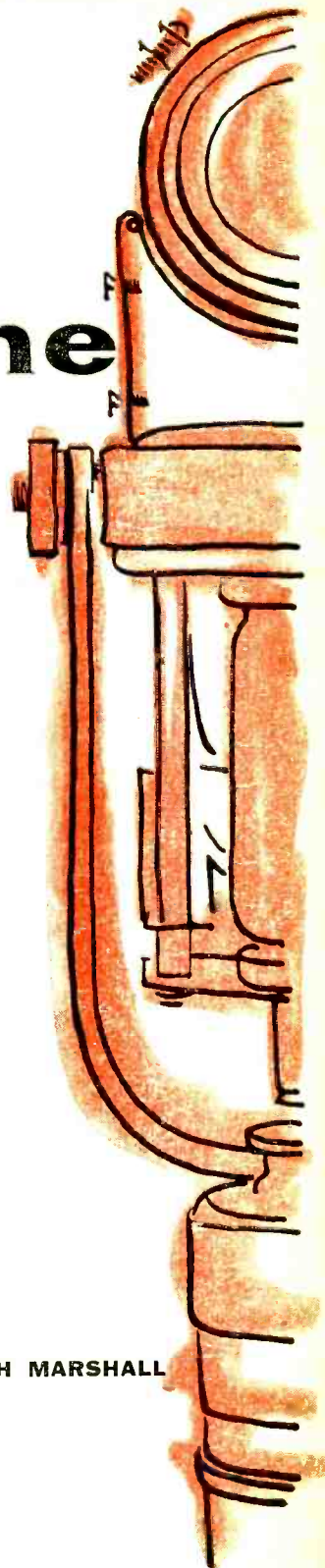

By
JOSEPH MARSHALL

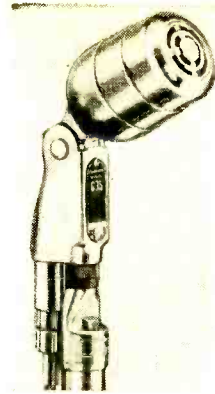
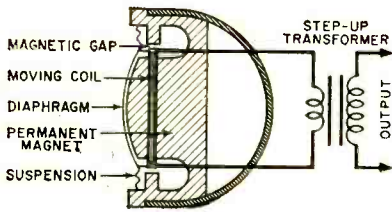
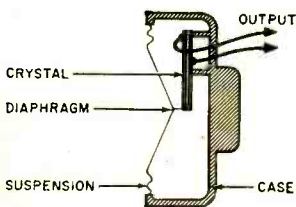

Fig. 1. Construction of a typical dynamic microphone is shown at upper left. Examples of dynamic microphones include the Shure 530 (at left) and the Electro-Voice 635 (above).

Fig. 2. Basic design of a bimorphic crystal microphone is shown below. At right is the Sonotone CM-10 ceramic microphone.



the sound to excite a resonant chamber, vibrating the back of the cone in phase with the front and thus producing a greater movement of the diaphragm at frequencies near the chamber's natural resonance. This boost can be removed by closing the duct.

The dynamic mike has several advantageous features. If it is well designed and carefully constructed, it can provide a very wide and smooth frequency response. In addition, it is quite sturdy and can take its share of hard knocks without damage.

One of the most important characteristics of a dynamic microphone is its low output impedance. This is a valuable feature since it allows long cables to be run from the mike to the amplifier without excessive hum pickup. But this low output impedance necessitates the use of a special step-up transformer at the amplifier to match it to a high-impedance input.

The polar pattern of a dynamic mike is normally omni-directional—that is, it picks up sound from any direction equally well. It is possible, however, to modify this pickup pattern, as we shall see.

Crystal and Ceramic Mikes. Some crystalline materials such as Rochelle salts and barium titanate produce electric voltages when they are bent. This phenomenon is the basis for the operation of both the crystal microphone and the crystal phono pickup.

There are two types of crystal mikes: the

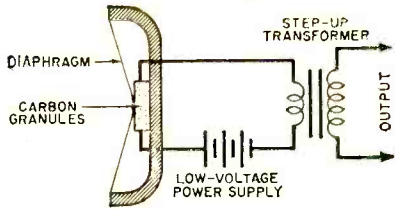

Fig. 3. Diagram of a carbon microphone with its associated power supply and transformer.

granules are attached to a diaphragm so that the carbon is compressed "in tune" with the variations of the sound waves as the diaphragm moves. The resistance of the carbon varies at an audio rate as the carbon is compressed. When the carbon "button" is connected to a battery, its varying resistance causes the current going through it to vary also. These current variations are delivered to an amplifier through a transformer. (See Fig. 3.)

A carbon mike delivers high output voltages and consequently needs little amplification. But its frequency response is limited, and, because of the changing con-

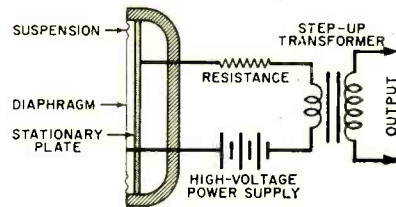
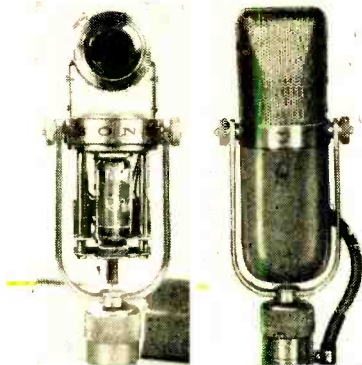

Fig. 4. Elements of a capacitor mike are shown above. At upper left are internal and external views of the Sony C37A capacitor microphone. Immediately at left is the Altec Lansing 21D "Lipstick" mike.

bimorphic and the sound-cell. In the bimorphic type, a crystal is connected by a lever to a diaphragm so that the movement of the diaphragm bends the crystal and generates a voltage. (See Fig. 2.) In the sound-cell type, there is no diaphragm: sound waves hit the face of a bank of crystals and bend them directly. Bimorphic crystal mikes are inexpensive and produce a response up to around 7000 cps. Sound-cell types are more expensive but they go up to 10,000 cps and beyond.

Crystal mikes are omni-directional and have relatively high output at very high impedances—from 500,000 ohms to 5 megohms. For this reason, they can be connected directly to the input of an amplifier without using a transformer. The characteristic high impedance of crystal mikes makes them highly susceptible to hum pickup, however, unless a short interconnecting cable is used.

Ceramic mikes are very similar to crystal mikes in general characteristics, price, and performance. They are much less susceptible to heat and humidity, however.

Carbon Mikes. The oldest and cheapest microphone is the carbon mike. Carbon

tact resistance of the carbon granules, it is quite noisy. Carbon microphones are used in telephones and in the simpler types of voice communications where price is an important consideration; they are not suited for high-fidelity applications.

Capacitor Mikes. The moving diaphragm of a capacitor microphone is one plate of a two-plate variable capacitor. When a fixed high voltage is applied to the two plates and a resistor is placed in series with this polarizing voltage, a movement of the diaphragm will cause the capacitance between the plates to vary, thus varying

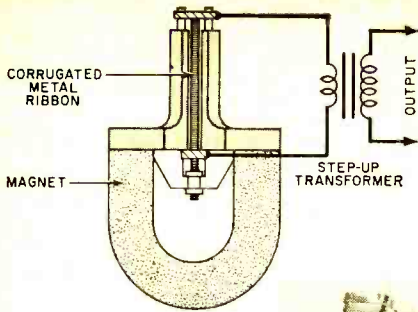
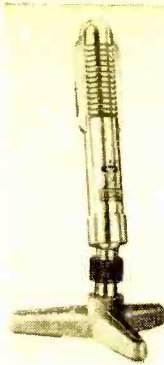

Fig. 5. Construction of a ribbon microphone is detailed above. Commercially available ribbon mikes include Shure 330 (at right) and the Dynaco B&O 50 (upper right).



the current flow through the resistor. (See Fig. 4.)

Because the current variation is very small, however, the resistor must be quite large to produce a useful voltage drop. This results in a high-impedance circuit which would be susceptible to hum and noise pick-up if a long shielded cable leading to the amplifier were used. For this reason, the preamplifier is built right into the microphone; the preamp is designed to have a low output impedance so that cable length is not critical.

In the old days, the physical size of capacitor microphones made them unsuitable for most purposes. Recently, however, the techniques of miniaturization have helped the capacitor mike come back with a bang. One example, the Altec Lansing "Lipstik" microphone, is even smaller than most dynamic and crystal mikes, being only $\frac{5}{8}$ " in diameter and 6" long, complete with a built-in preamplifier, but less the power supply which is in a separate box a few feet away.

The new capacitor mikes approach the ideal in frequency response and dynamic range characteristics, covering the entire audio range with an unprecedented evenness and lack of coloration. For this reason, they are widely used today in professional

recording. Since capacitor mikes are largely handcrafted, they are expensive—around \$400.00 apiece.

Ribbon Mikes. A less expensive type of microphone that approaches the capacitor type in overall performance is the ribbon mike. This design consists of a narrow ribbon of corrugated Duralumin supported at its ends in a magnetic gap. As the ribbon vibrates in response to sound waves, it cuts the gap's magnetic field and generates a voltage. (See Fig. 5.) Because it has no diaphragm and complex suspension system, a ribbon mike's resonance can be kept below 20 cycles. The ribbon mike is also free from cavity resonances and pressure doubling.

Ribbon microphones have extremely low output impedances and thus have built-in transformers to match them to the line (usually 600 ohms). Frequency response in less expensive models can extend to beyond 13,000 cycles, and some broadcast and recording ribbon mikes go from 20 to 20,000 cycles.

The main disadvantage of the ribbon mike is that the ribbon itself is very fragile and will not stand up to rough treatment. To avoid damage to the ribbon, it should not be used outdoors if there is a wind. Also, a ribbon mike has a tendency to over-accentuate the bass end when picking up a voice at close range. This effect has been reduced in many models, however, by the addition of damping pads or electrical networks to roll off the low end.

The ribbon mike differs from the others we have discussed so far in that it is bi-directional. A sound that comes from the side will not move the ribbon and there is no voltage generated. Sounds from the

(Continued on page 107)



By
LEO G. SANDS

COMMON complaints about marine radiotelephones are noisy reception, inadequate range, and interference from other vessels. More often than not, however, the boat owner doesn't really understand how to get the most from his equipment. Actually, much can be done to improve the operation of boat radios.

First, consider the fact that very low power systems are involved. An AM broadcasting station's signal, for example, comes from a transmitter as powerful as 50,000 watts. But a boat radio radiates only 2-5 watts. Even a telephone company shore station radiates only about 100 watts. Yet there are users who expect greater range from a boat radio than from a broadcasting station!

Typical boat radios are rated at 20 to 150

Ship-Shaping Marine Radios

*Good installation and operating techniques improve
the seaworthiness of any marine radiotelephone*

watts input. Since power rating is based on power *input* rather than *output*, a "20-watt" set doesn't actually deliver 20 watts. Its final r.f. power amplifier tube *consumes* 20 watts, a figure derived by multiplying its plate voltage by its plate current in amperes. Most transmitters are about 50% efficient, so a 20-watt transmitter will deliver about 10 watts of honest-to-goodness r.f. energy to the antenna.

To go one step further, the transmitting range is determined by the power radiated by the antenna, not the power that it consumes. When a 20-watt transmitter is fed into an antenna of 20 - 25% efficiency, the effective radiated power is on the order of 2 - 2½ watts. This is low power indeed compared to a 50,000-watt AM broadcasting station or a TV transmitter with an effective radiated power in excess of 100,000 watts.

Antenna/Ground System. No boat radio is better than its antenna system. And a good boat antenna is rarely more than 25% efficient because it simply isn't as long as it should be. For best results, the antenna should be one-half wavelength long, which, at 2 mc., would mean an antenna 230 feet in length! A quarter-wave vertical antenna about 115' long would be an efficient radiator, but even a quarter-wave antenna is far too long for small-craft use.

Consequently, a compromise must be made. This compromise usually takes the form of a loaded antenna consisting of two rods joined in the middle by a loading coil. The loading coil "stretches" the rods so that the antenna takes on some of the electrical characteristics of a long-wire. While this is not a very efficient scheme, it is the best answer engineers have come up with to date.

Many boat owners are unaware that the actual antenna is only *half* of an antenna system. Without an effective *ground*, even a good antenna will function poorly. A metal hull is an excellent ground, but good electrical contact must be made with it. A bolt through the hull is one safe bet, with the hull scraped clean so that good electrical contact can be made with a piece of flat metal braid (½" or larger) connected to the radio ground terminal. Both the metal braid and the antenna lead-in should be as short as possible.

To obtain a good ground on a boat with a wooden or plastic hull, a large (12' x 12', if possible) copper plate on the outside of the



hull is best. If this isn't feasible, brass or copper strips about 3" - 4" wide can be fastened to the inside or outside of the hull, securely bonded together by copper braid soldered or bolted to each strip. In addition, the engine and all large metal parts should be bonded to the ground system to obtain as much ground area as possible.

Recently, special grounding devices of porous metal have been developed which are less than a square foot or so in area. These devices are sponge-like in construction, and their makers claim that water seeping through their pores helps make them effective grounds.

But regardless of the installation, the proof of the antenna "pudding" is in its performance. A radio technician can determine the antenna ground system efficiency by noting how well the transmitter loads into its antenna. And the boat owner himself can check antenna ground efficiency by noting how far he can talk.

Modulation. Most modern transmitters are designed so that modulation cannot exceed 100%. But if modulation is less than 80%, range will be impaired.

In most transmitters, a modulation limiter is included to prevent overmodulation and to maintain a higher average level of modulation. Weaker sounds picked up by the microphone are boosted and louder sounds are prevented from being amplified

◀ **A handset** is often better than an ordinary microphone for marine use. Inexperienced users find it hard to hold a telephone-type handset improperly. Also, the handset's directional properties cut noise pickup from wind, rough weather and the boat's motor.



Microphones are sometimes a source of trouble for the uninformed boat-owner. Used correctly, they should be held two to three inches from the lips in order to deliver enough output for good modulation.

to a level that would produce overmodulation.

The percentage of modulation achieved depends to some extent upon how the microphone is used. Talking too softly into a microphone at an excessive distance usually results in insufficient modulation. And, because of the action of the modulation limiter, background noises picked up by the microphone may be too loud, making it difficult for a distant listener to separate the voice from the noise.

By talking into the microphone at a distance of 2 - 3 inches, in a normal voice, adequate modulation and good range should be

attainable. Talking more loudly than required to obtain maximum modulation won't increase range and can actually cause distortion.

Input Voltage. Transmitting range is also determined in part by the input voltage applied to the transmitter. On small craft, power is usually obtained from a 12-volt storage battery, but the actual voltage across the battery terminals will vary. What's more, there is a loss in the wires leading from the battery to the equipment.

This loss is determined by the size and length of the wires as well as by any elec-

(Continued on page 104)



Build an Electronic

Inexpensive unit protects your boat, car,

NOW THAT the boating season is in full swing, you'll want to take steps to protect your shipboard gear from burglary and vandalism. Here's an inexpensive and simple burglar alarm that can turn on a warning light, a horn, or even a siren, if any unauthorized persons attempt to remove equipment from the craft. It can also be used to protect ham gear in your car, or guard your home while you're away on vacation. This electronic watchman will make your summer holiday more carefree and enjoyable.

The alarm uses only a few parts and will operate for months on its self-contained battery—standby current is only 50 microamperes. Due to the low operating voltage and current, there is no danger of shock. Even so, the relay in the alarm can carry up to 2 amps at 125 volts, enough to operate most bells and sirens.

Construction. The model was built into a 6" x 3 1/8" x 1 1/2" plastic box with a hinged top, as shown in the pictorial. The accompanying test unit was built into a 2 7/8" x 1 1/4" x 1 1/8" plastic box and is designed to plug into the burglar alarm. Other con-

tainers or layouts can be used, if you wish, since the circuit is not critical.

Relay *K1* plugs into a standard octal tube socket and transistor *Q1* into a transistor socket. All other parts are supported by their leads except "five-way" binding posts *BP1*, *BP2*, *BP3*, and *BP4*, which are mounted at one end of the box. Be sure to position *BP1* and *BP2* exactly 3/4" apart in order to match the spacing of banana plugs *P1* and *P2* on the test unit. If desired, potentiometer *R1* and transistor *Q1* can be mounted in a separate plastic box as shown.

The relay should be waterproofed before it is installed in the alarm. To do so, remove the four screws from the relay's plastic cover. Then, using lacquer or clear nail polish, coat the area between the octal base and the metal flange, both inside and outside the relay. Replace the cover and screws, and coat the mating area between the relay cover and the metal flange. Use plenty of lacquer around each of the four screws.

Adjustment. Before adjusting the alarm, be sure that the relay and transistor are firmly seated in the sockets and that the



Burglar Alarm

or home while you're away

By ED DUDA

18-volt battery is properly connected. Wrong battery polarity can ruin the transistor.

Next, plug *P1* and *P2* of the test unit into binding posts *BP1* and *BP2* of the burglar alarm; lamp *PL1* on the test unit should light. Connect binding posts *BP3* and *BP4* with a length of wire and adjust potentiometer *R1* until the lamp goes out. When you remove the jumper wire, the lamp should light once more. The burglar

alarm should now be ready for installation.

Be sure to keep a jumper wire across *BP3* and *BP4* when the unit is not connected to an alarm circuit. This keeps current drain on battery *B1* at a minimum.

Installation. One of the most important considerations in any burglar-alarm system is to prevent the burglar from disabling the alarm. Once a convenient hiding place has been selected for the alarm, the next step is to hook up binding posts *BP3* and

Simple test unit (at right) checks out the alarm. Binding posts are hooked up to the warning and sensing circuits.

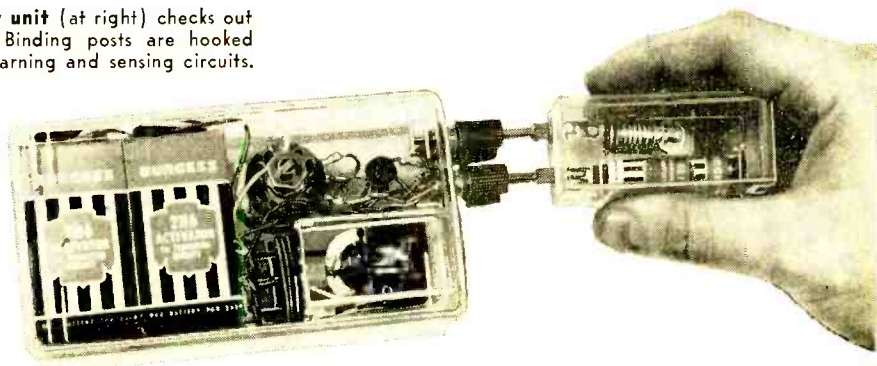

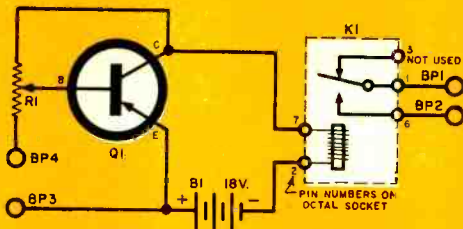

Single transistor (Q1) energizes relay K1 when circuit across BP3 and BP4 is opened. Test unit plugs into BP1 and BP2; lamp PL1 lights when K1 is energized.

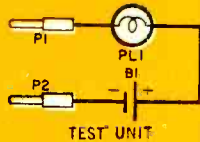

PARTS LIST

- B1—18-volt battery (two Burgess 2N6 9-volt batteries or equivalent in series)
- B2—1.5-volt penlight cell (test unit)
- BP1, BP2, BP3, BP4—Five-way binding post (Lafayette MS-566 or equivalent)
- K1—S.p.d.t. relay, 4000-ohm coil; 2-amp., 125-volt contacts; 1.9-ma. operating current (Kurman 23DB42 or equivalent)
- P1, P2—Banana plug
- PL1—1.5-volt flashlight lamp (test unit)
- Q1—2N188A transistor
- R1—250,000-ohm, 2-watt potentiometer (Ohmite CLU-254) or equivalent
- I—Octal tube socket
- 1—Transistor socket
- Misc.—Hardware, plastic boxes, battery clips, penlight cell holder, penlight bulb socket, etc.

BP4 to a "sensing" circuit at the property requiring protection. The sensing circuit is nothing more than a switch that is inadvertently operated by the burglar when he attempts to remove equipment or open a window or door. Typical sensing circuits, one for each of these three cases, are shown at left.

The final step is to connect binding posts BP1 and BP2 to the warning circuit, which can be any of a number of electrical signaling devices. Two typical warning circuits are shown at right. On your car or boat, you can use your horn for an alarm. To do this, connect one lead from binding post BP1 to one horn-button terminal and another lead from BP2 to the other horn-button terminal. In other installations, BP1 and BP2 can be connected to an alarm gong, flashing light, siren or even to a door bell.

If the equipment to be protected is a piece of mobile electronic gear housed in a metal cabinet, attach leads from BP3 and BP4 to separate metal plates underneath the cabinet. Should the cabinet be lifted off the metal plates, the circuit through the cabinet will be broken and the alarm set off.

This same technique can be used with the front or rear door of your home. A movable switch contact should be mounted on the door and a fixed contact on the door jamb; one contact is connected to BP3 and the other to BP4. If anyone opens the door, the alarm will go off. Be sure to use a sensing switch that will remain open once the door has been opened; otherwise the thief could close the door after him and thus silence the alarm.

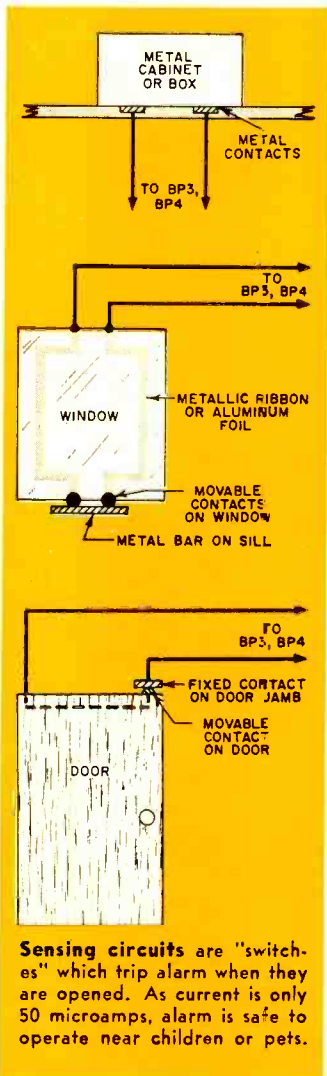

Sensing circuits are "switches" which trip alarm when they are opened. As current is only 50 microamps, alarm is safe to operate near children or pets.

Layout is not critical. The author mounted potentiometer $R1$ and transistor $Q1$ in a small plastic box inside main box. Relay $K1$ plugs into octal tube socket.

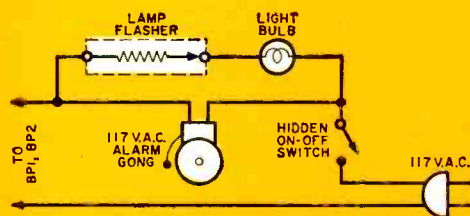
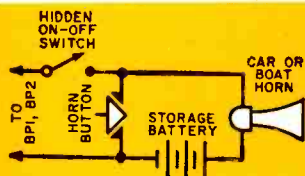
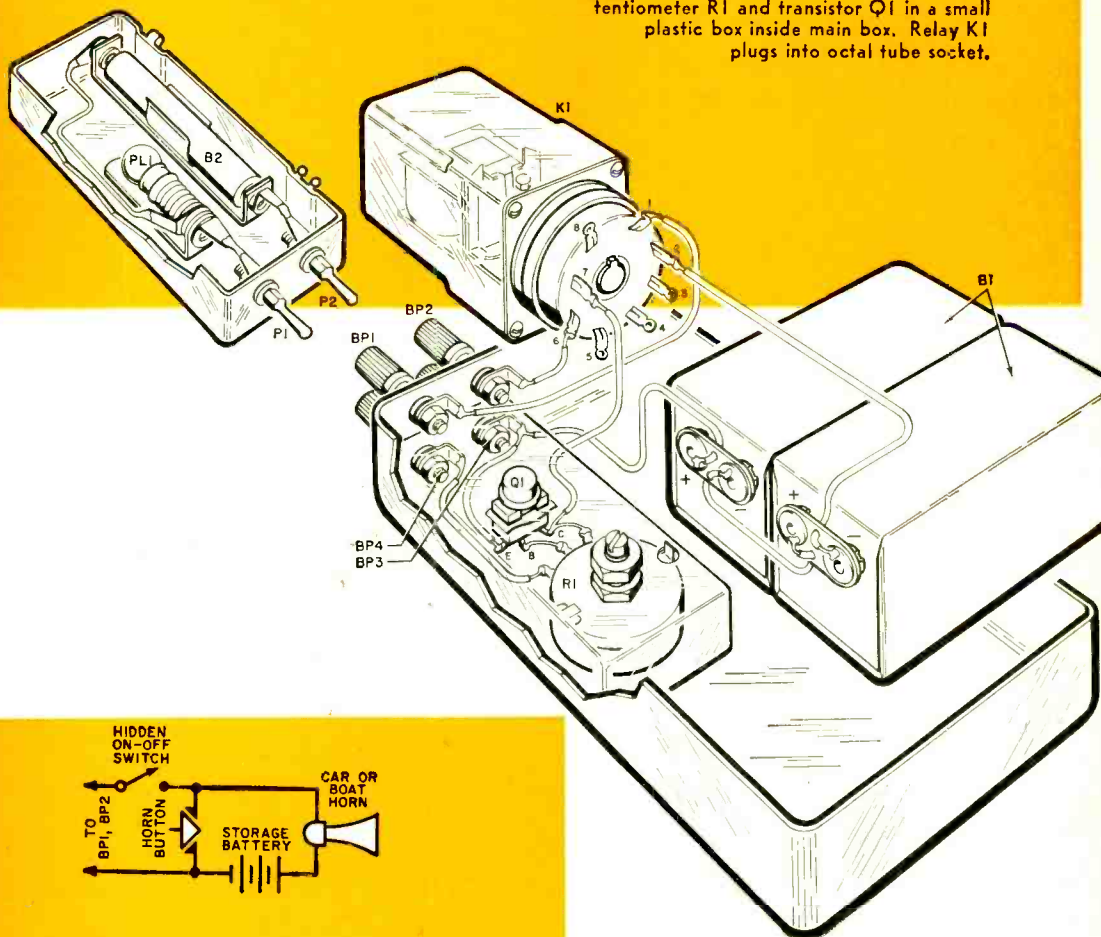

Warning circuit on boat or car can use horn to sound the alarm. Installations in homes or stores can operate a 117-volt a.c. system. Open hidden switch to silence alarm after it has been tripped.

HOW IT WORKS

The burglar alarm employs a single transistor ($Q1$) with a relay ($K1$) as its collector load. In operation, $BP3$ and $BP4$ are connected to each other at the equipment under protection. Potentiometer $R1$ acts as a voltage divider in series with battery $B1$ and relay $K1$.

The arm of $R1$ is set to a point where the base of $Q1$ is only slightly less positive than $Q1$'s emitter. This setting of $R1$ keeps $Q1$ in the non-conductive state; insufficient current flows to energize relay $K1$. When the circuit across $BP3$ and $BP4$ is opened, the base of $Q1$ goes very negative and $Q1$ conducts heavily, energizing $K1$. With $K1$ energized, normally open contacts 1 and 6 of $K1$ close and connect binding posts $BP1$ and $BP2$. This switches on the warning device and thus sounds an alarm.

When plugs $P1$ and $P2$ of the test unit are plugged into $BP1$ and $BP2$, battery $B2$ will light warning lamp $PL1$ if there is a break in the circuit connecting $BP3$ and $BP4$. In actual use, a bell, siren, or other warning device is substituted for the test unit.

The Strange Inhabitants of

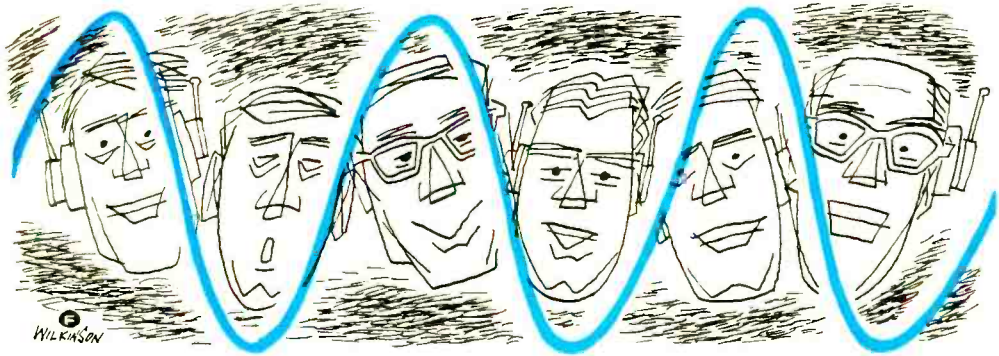

75-Meter Phone

There's no lack of unusual characters on 75-meter phone. How many of the operators described here have you come across?

By

JAMES F. VAN DETTA, WA2FQZ

ONE of the most popular meeting places for hams is the 75-meter phone band. Although the propagation characteristics of this band aren't particularly conducive to exotic DX, evening time finds the frequencies between 3800 and 4000 kc. buzzing with activity.

Most of the operators that work this band turn up night after night to talk about anything and everything under the sun. The great majority of them are fine, considerate gentlemen; a few are miserable clods. In between are all kinds imaginable. Here are some of the stranger types you'll meet on 75-meter phone.

FIRST, let's consider the lovable character who calls CQ, gets you to answer his call, transmits for half an hour, and then signs off because he has to run some urgent errand. As he signs off, he asks you to give him your handle quickly because he "can't even hang around for your final." "My final!" you weep pitifully, "I haven't even had my *initial!*"

Then there's the fellow who just won't sign off. He's more difficult to disengage than a Novice after his first DX contact. This verbose chap comes back for a "final final," then for a "short final final final," and so it goes. After a half hour or so of this kind of thing, you begin to flush with the excitement of the challenge. As time slips by, an earnest duel evolves. If you're fortunate, QRM renders the official decision: a draw.

Perhaps you've run into the guy who leaves you to "tie the ribbons on it" while he sneaks off the frequency to find another QSO. He doesn't even wait to hear your final transmission before scampering off in search of another contact. After you sign off with him and tune up about 30 kc., there



Waiting for the fellow who continually has to search for words can be a harrowing experience. His best bet might be to try a written script.

he is, already in another QSO. It gives you a nice warm feeling to know you have been talking to the frequency instead of to another human being.

Did you ever meet the fellow who doesn't seem to know the name of anything? He makes you want to break into his transmission and supply him with the appropriate word. "At last my *ah-uh-oh* my *ah-uh* trans *uh-ah* mit *ah-oh* ter is working fine now, but my *uh-ah-oh* . . ." The poor guy just seems to be noun-less.

Worse than being noun-less is the operator who is thought-less. "Yessiree. Now



Transmit-receive switching can be complex, but this guy carries things too far. If he goofos his switching sequence, your ears will be the losers.

you wanted to know about . . . (long pause) . . . Say, did you ever hear about that idea to have all . . . (pause) . . . I wonder if my SWR will . . . (long pause) . . . When I tell you . . ." This fellow seems determined never to finish a thought.

Since we all can't afford the kind of transmit-receive switching we would like, sometimes you'll find a ham who has to throw a dozen switches before he turns it back over to you. Once in a while, he will get his switch-throwing sequence mixed up and his signal will howl and screech until he completes his switching operations. As your eardrums vibrate against your chattering molars, you'll have the unforgettable experience of knowing what a sound engineer means when he talks about the "threshold of pain."

Your nerves can also be quickly worn to a frazzle by the fellow who has an electronic voice control circuit that isn't functioning properly. After he mutters each phrase, his carrier snaps off with a thump and the

background noise smashes into your ears. "Well, I *ROAR-ROAR* hope you *ROAR-ROAR* can copy me *ROAR-ROAR* over there *ROAR-ROAR-ROAR*." This situation has to be experienced to be appreciated.

"A lot can still be said in favor of a hand-operated T-R switch," you explain to the nice man in the white coat as he adjusts your snug-fitting jacket.

THE independent fellow with his own phonetics often confuses more than he informs. If his name is Pat, for example, his phonetics might be "psychological; Aetna; tsetse." If the QRM is pretty rough, you get only the last word of phonetics. So when you come back at him with, "Well, Fifi, the QRM is pretty bad here. . . ," it hits him where it hurts most—in his phonetics!

The operator who avoids "I," "me," and "mine" like the plague is apparently unaware that "I" and its various forms are perfectly respectable. "We have enjoyed the



Racks of home-brew equipment fill the ham shack of the self-styled "electronic designer." You'll recognize him on the air by his 60-cycle hum.

QSO, OM. It has been a pleasure for *us* to meet up with you." You wonder if perhaps he is a pair of Siamese Twins.

Then there's the fanatic single-sidebander who scornfully refers to AM as "ancient modulation." Following his wobbly signal as it wanders around the band requires an alert pair of hands on the receiver controls. As he recites his enthusiastic praises of SSB, he also remarks that the reason you're having trouble receiving him must be faulty operational technique on your part, or maybe a design defect in your 75A4.

And who hasn't met the operator with a homebrew rig who fancies himself an elec-

tronic designer? This character is easy to recognize because his signal features a healthy 60-cycle hum. He joyfully spends three times the cost of a commercial kit to get one-third its performance and sneers disdainfully at anyone who buys a kit. If he only knew how much his performance could be improved!

Closely allied in spirit to the "electronic designer" is the self-appointed "electronic genius." You'll find him to be a generous fellow when you are experiencing some trouble with your rig. With unmatched swiftness, he will offer a diagnosis of your difficulty.

Your problem, he will tell you with an air of condescension, is due to *one or more* of



The amateur comedian really breaks himself up with his own corn-ball jokes. His attempts at humor are usually met with cold silence at the other end.

the following: (1) bad tubes, (2) bad components, (3) shorts, (4) improper transmitter tuning, (5) faulty design, (6) faulty wiring, (7) something wrong with antenna system, (8) something wrong with a.c. line.

And wonder of wonders, when you do find your trouble, it is almost invariably one or more of the causes suggested by the helpful diagnostician! Are there any others? How quickly this wizard can pinpoint troubles is an endless source of amazement.

A CHARACTER we could do without is the fellow who tunes up his transmitter without checking to see if the frequency is clear. Listening to his variable-pitched whistling, one becomes quite convinced that he must be a cross between a parrot and an intoxicated canary. However, he dispels this assumption to some extent by his "count-ups" and "count-downs." He usually counts up to about 100 and then back down to 1 . . . by 1's, as if he were training to become count-down officer at Cape Canaveral.

When he finally comes back to some of the stations that have been calling him, this guy says, "Thanks for the shout, fellows. I was just tuning up the ole rig here. Wanted to make sure it was socking out the ole soup. You know, I've been on the air umpteen years, and I never yet called a CQ. Don't believe in it. No need for all this CQ'ing."

Occasionally you run into a would-be comedian. He has a new joke every day. A sample of his refreshing humor goes like this:

"Did you hear the one about the two balun coils? There was these two balun coils and one says to the other, 'Social security'." Here he breaks into riotous laughter as he turns it over to you.

"I don't get it," you admit.

He comes back howling with hilarity, "You won't—ha ha ha—until you're 65!"

TRAFFIC NETS are a distinct plus for ham radio. You always feel your shoulders go back a little in pride as you hear the net begin to pass messages.

"Being discharged on April 5th.

Bake a cake, Mom. Warm up the car,

Dad. See you both soon. Love."

So goes a message from a soldier who is shortly to join his parents. You slowly break into a smile of vicarious satisfaction. Then it hits you. This is the 28th of April! The message is over three weeks old! The poor ex-GI will probably receive his own message at home. Or maybe it will be received by one of his descendants.

For a first-hand course in the torments of frustration, try a QSO with the joker who has a one-track mind. Regardless of your comments or questions, he will ignore your transmissions. If he's a hi-fi buff, for example, he will come back to you with, "Yeah, OK there, OM. Well, today I got this new speaker system for the hi-fi. Complete absence of coloration with acoustical suspension, you know? Say, when you compare it with the old system I had . . ." and on he rambles.

Finally, to complete our cast of characters on 75-meter phone, there is, as you may have suspected, the unlikely individual who makes notes on some of the other inhabitants of 75-meter phone and sends in an article to POPULAR ELECTRONICS describing them. His only additional words are, "BCNU on 75!"

—30—

By
CHARLES CARINGELLA,
W6NJY

RADIOMAN'S LAMP

LAMPS have been made using everything from abalone shells to zebra hides. For the electronics enthusiast, what could be more appropriate than a lamp made from a large transmitting tube? Such a lamp can be built for less than ten dollars and completed in one evening. The only tools you'll need for the project are an ice pick, a drill, a screwdriver, and a soldering iron.

Your best source for one of the big transmitting tubes is an electronic surplus store. These tubes come in a variety of sizes and usually sell anywhere from a dollar up. Size isn't critical, but the one you choose must have a plate cap.

The Western Electric 701A tube used here costs about \$8 (\$16 for two, if you want to make a pair of matching lamps). It's especially well suited for use in a lamp because its pins are actually hollow lengths of $\frac{3}{16}$ " tubing—this makes passing leads through the pins a comparatively simple matter. Then, too, one pin is located at the top of the tube and four at the bottom, which gives the 701A the necessary top cap and base connections required for the lamp.

To start the actual construction,

make a small hole in the end of one pin to release the vacuum. This can be done with any sharp instrument, such as an ice pick, since the copper pins are very soft. Play it safe by wrapping the tube in several layers of rags until it is completely covered except for the pins. The rags will absorb any accidental shocks and offer some degree of

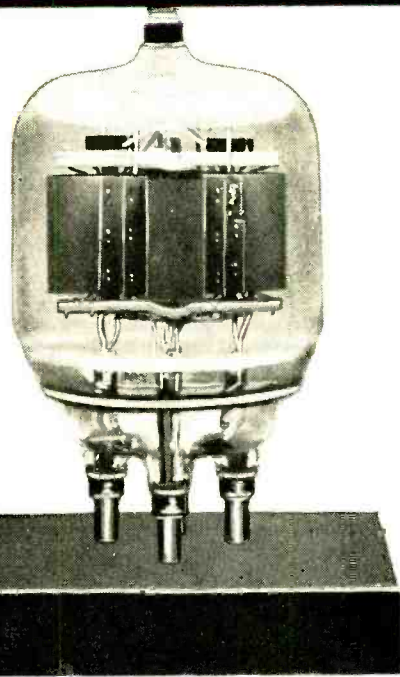

**High-power transmitting tube
makes attractive table lamp**

protection in the event the tube should break.

Next, drill a $\frac{1}{8}$ " hole in each of the four bottom pins and a $\frac{3}{16}$ " hole in the top pin. Be careful when drilling—and don't attempt to drill before the vacuum has been released.

Two leads of insulated No. 20 hookup

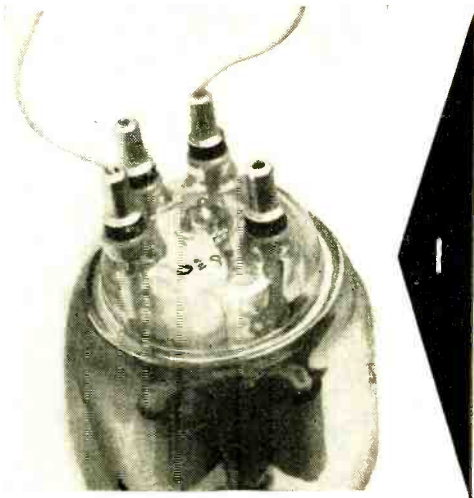

1 First step in wiring lamp is to pass two insulated leads, one at a time, through top pin, inside tube, and out bottom pins.

2 Self-tapping screws inserted in unused tube pins hold tube on chassis base. Terminal strip is tie-point for leads and line cord.

3 Socket and switch assembly attached to top pin completes lamp. QSL's or circuitry applied to shade imparts electronic "touch."

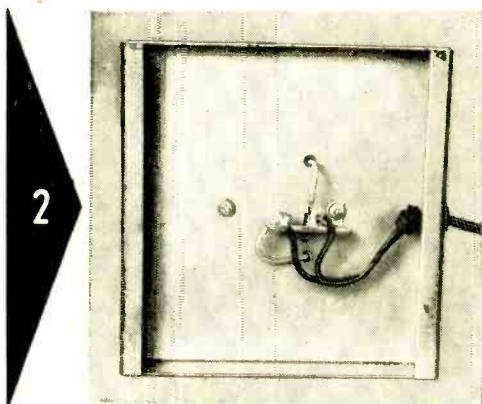

2

wire are required to supply power to the light bulb. Each lead is fed through the top pin, one at a time, and passed through the tube and out separate bottom pins. (The other two bottom pins are used to mount the tube to the base with a couple of self-tapping screws.) This is the critical point in the wiring—all in all, it takes a little patience and about 15 minutes to work the wires through. When this is done, fasten a standard lamp socket-switch fixture to the top pin and connect the wires to it.

Now prepare the base, which is a standard 5" x 7" x 2" aluminum chassis (Bud AC-402 or equivalent). If you wish, you can use any other size chassis or mounting base that suits your decor.

First drill four $\frac{1}{8}$ " holes through the top side of the chassis to match the location of the tube's bottom pins. Next, drill a $\frac{3}{4}$ " hole at the rear apron of the chassis to accommodate the power cord.

After all the holes are drilled, apply three or four coats of quick-drying enamel to the chassis and let it dry thoroughly. Then mount the tube to the base by inserting self-tapping screws through the appropriate holes in the chassis and into the remaining two tube pins.

Install a $\frac{3}{8}$ " rubber grommet in the power cord hole and connect the cord to the leads coming from the tube. A two-lug terminal strip can be used as a tie-point; if a terminal strip is not used, twist the leads together and carefully insulate them with electrical tape.

Add any lamp shade your heart desires, and your "transmitting tube" lamp is ready for operation.

—50—

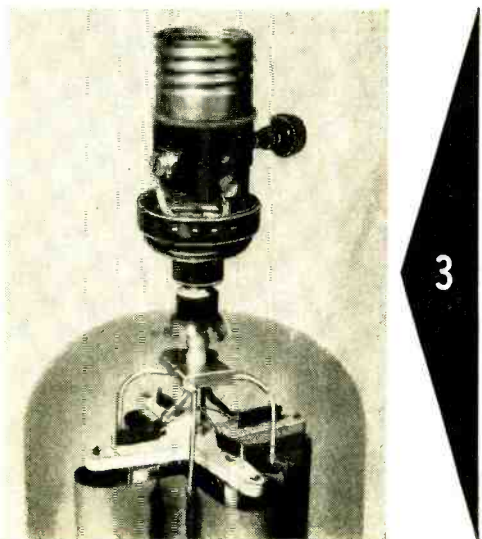

3

MAGNETIC AMPLIFIERS

how they work and what they do

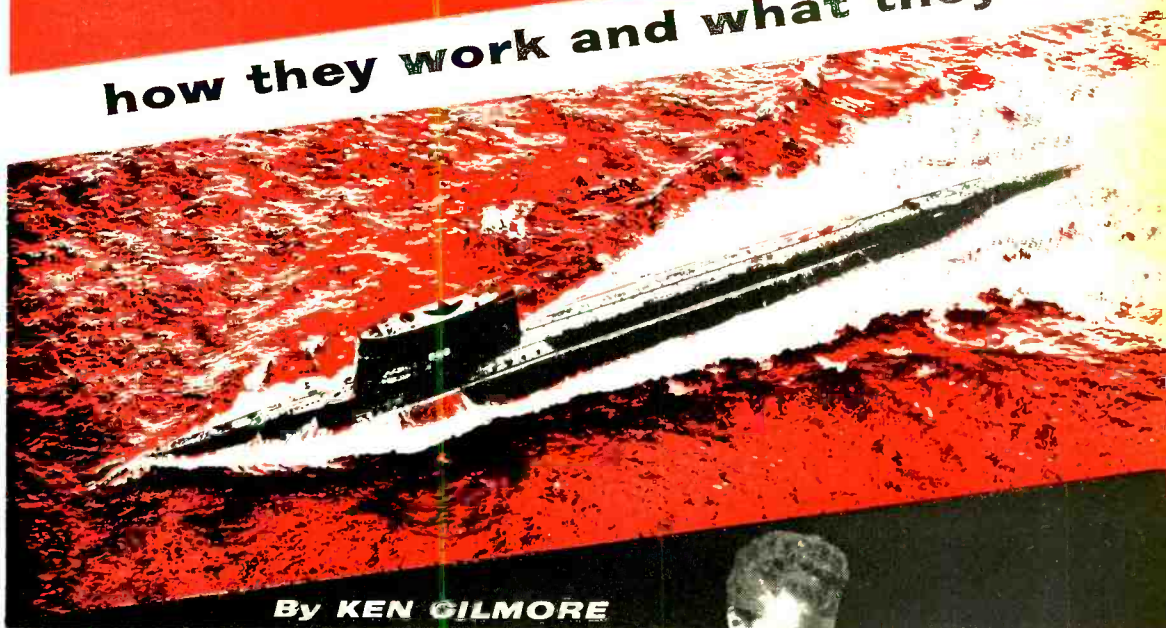

By KEN GILMORE

THE ATOMIC SUBMARINE Triton glides swiftly and silently through the deep. As its power plant purrs steadily, scores of electronic watchdogs probe every part of the sub's powerful reactor. Suddenly the pressure in a reaction chamber begins to rise over the allowable amount. One of the electronic guardians instantly notes the rise and applies a corrective signal—before a human operator could know that anything had begun to go wrong.

The electronic watchdogs that keep the Triton's powerful nuclear plant operating without a hitch are magnetic amplifiers—

July, 1960



Scores of magnetic amplifiers in the world-circling Triton control its atomic reactor. Above, finishing touches are put on the General Electric "magnetic" that monitors the reactor's temperature.

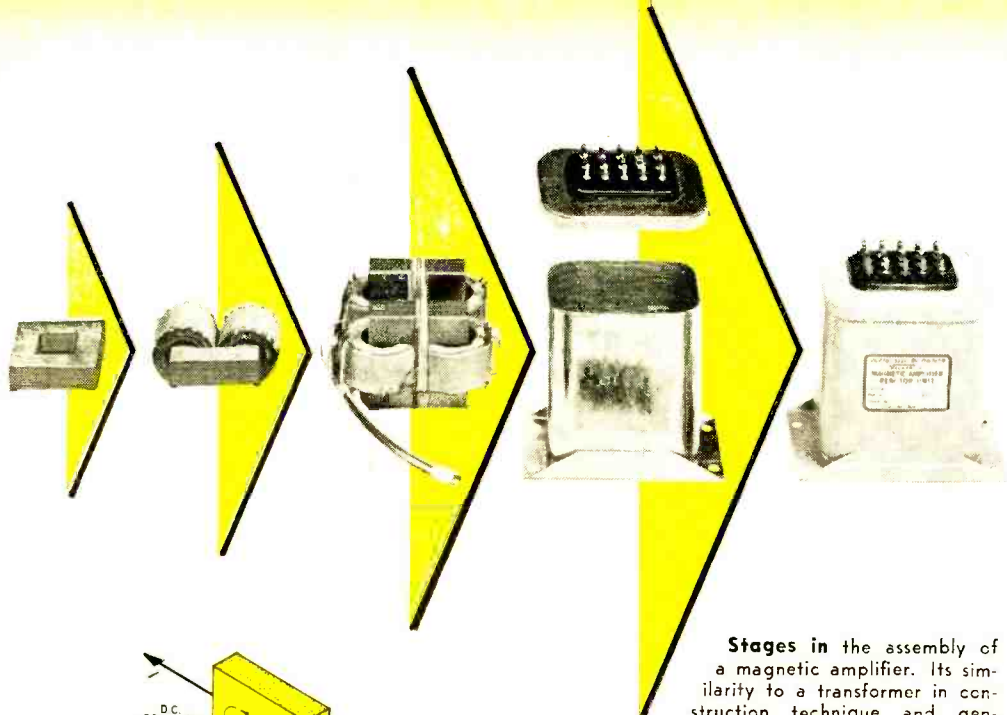

Stages in the assembly of a magnetic amplifier. Its similarity to a transformer in construction technique and general appearance is striking.

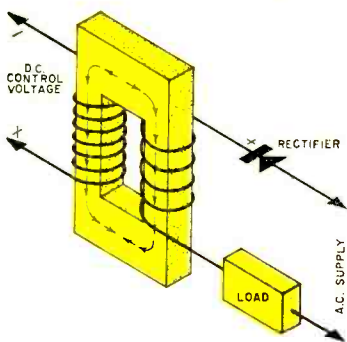

Fig. 1. Basic circuit for half-wave magnetic amplifier.

almost a hundred of them are used for this critical job. Yet these same magnetic amplifiers—the heart of the control system of one of the world's most up-to-the-minute fighting machines—are straight out of the horse-and-buggy era.

Forgotten and Rediscovered. Magnetic amplifiers came into being when the century was just one year old. It would be six years—in 1907—before a youngster named Lee DeForest would make news with his audion, the world's first vacuum-tube amplifier. And the transistor was still 47 years in the future.

For a while, it looked as though the magnetic amplifier would hold its own against that upstart, the audion. In 1916, E. F. W. Alexanderson, the electronic pioneer, employed magnetic amplifiers to modulate his early transmitters and many World War I

transmitting stations used his circuits. By the early 20's, however, the flashy vacuum tube had taken over, and the "magnetic" was almost forgotten in this country.

It was not forgotten in Germany, however, as we found out when World War II started. In the years between the wars, the Germans had brought the magnetic amplifier to a high state of development. Wartime found them using magnetics for reliable, accurate, and trouble-free control of everything from gun turrets to automatic pilot systems, and they even used them in the V2 rockets.

Awakened to the possibilities inherent in this design, Allied scientists began to push the development of magnetic amplifiers. Before much progress had been made, though, the war was over. But the spark had been kindled, and a few years later Vickers Inc. (now a division of Sperry Rand) came out with the first commercially produced magnetics.

By that time, interest had been aroused all over the world. In the following decade, hundreds of other firms, including all the big names in electrical and electronic equipment, have added magnetics to their product lines. And almost no branch of industry now operates without them.

Flux Controls Current. A modern-day magnetic amplifier is, essentially, nothing



Magnetic amplifiers like the Vickers unit above allow fingertip control of elaborate lighting systems in TV studios. (NBC photo)

more than an iron core with two or more coils of wire wound around it. In construction and appearance, it is similar to a transformer. But there the similarity ends.

A magnetic amplifier—or saturable reactor, as it is sometimes called—is a true amplifier. Like a vacuum tube, it uses a small signal to control a large one. But there are sharp differences. Where the vacuum tube controls a current flowing to a d.c. power supply, the magnetic amplifier controls an a.c. flow. While the vacuum tube is primarily a voltage amplifier, the magnetic is a power amplifier. And where the vacuum tube uses voltage variations to control a flow of electrons, the magnetic amplifier controls current flow through a coil by varying magnetic flux.

Magnetics come in half-wave and full-wave types, as do a.c. power supplies.

First, let's look at the basic half-wave circuit shown in Fig. 1.

A d.c. current flowing through the control winding will cause a build-up of magnetic flux in the iron core. The greater the flux, the lower will be the impedance of the output winding. With a lower impedance in the circuit, more current will flow from the a.c. power supply through the output winding and the load.

When the current in the control winding reaches a certain point, the core is said to be *saturated*, which means that it has all the flux it can hold. At this point, the impedance of the output winding is very low, and the current through the load is very high. On the other hand, when there is *no* control current flowing, and consequently no flux in the core, the output impedance is extremely high, and practically no current flows through the output winding or the load. Thus, by controlling the current through the control winding, the output winding impedance, and consequently the current through the load, is made continuously variable.

A rectifier in series with the output winding keeps the constantly reversing polarity

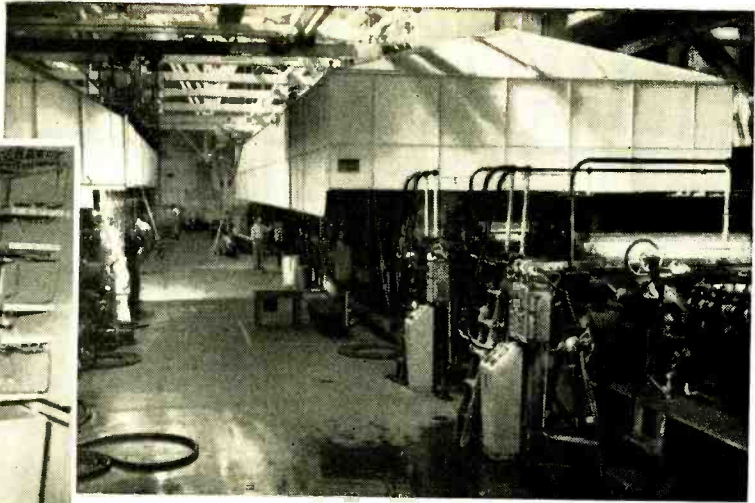

Thanks to magnetic amplifiers, this paper-making machine at West Tacoma Newsprint Corporation in Tacoma, Washington, can operate at 5000 feet per second, many times faster than previously possible. Magnetics continuously adjust the speed of the take-up rollers, slowing them down as the roll of paper gets larger. Control room is at left.

Fig. 2. Basic circuit for a full-wave magnetic amplifier.

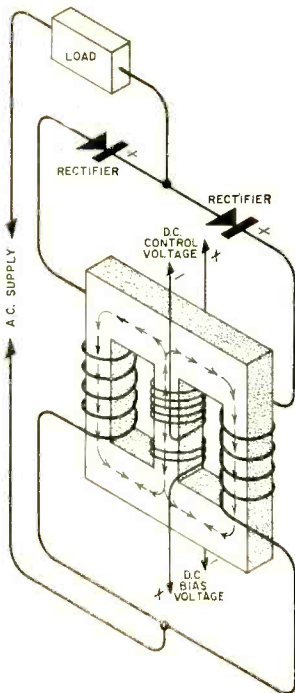

of the a.c. supply from cancelling out the control winding flux. The direction of the current flow through the secondary is arranged so that the magnetic fluxes created by the two windings reinforce each other rather than cancel each other out.

A full-wave circuit is shown in Fig. 2. It works like the circuit in Fig. 1, except that it makes use of both half cycles of the a.c. supply current. The two halves of the output winding are wound so that the direction of the magnetic flux created by both of them in the center leg of the core is the same as the direction of the flux created by the control winding.

The bias winding can be used to control the general range of the amplifier's operation, just as the bias on a vacuum tube causes the tube to operate on a certain part of its characteristic curve. In a magnetic amplifier, when a small bias current flows, a certain amount of flux is continuously present in the core, even with no control voltage supplied. Thus, the impedance of the output winding will never reach its maximum value, nor will the current through the load reach its minimum.

Many magnetic amplifiers have an additional control winding which is used for feedback. This winding taps a certain amount of the output circuit's current and applies it back as a control current. As with a vacuum tube, the feedback can be

either negative or positive. In general, negative feedback improves the linearity of the amplifier while positive feedback increases its gain.

Single-stage magnetics can be built with gains of about 200,000, far beyond the capabilities of the vacuum tube. With a gain on this order, a few milliwatts of power in the control winding—an amount that could be supplied by one or two flashlight cells—

the field of entertainment, too. NBC's two big color television studios—one in Burbank, California, the other in Brooklyn, N. Y.—have magnetic amplifier lighting-control systems. With this setup, the lighting man has fingertip control over each of the hundreds of lights throughout the studio. He can control them individually or in banks, as he desires, working from a small keyboard that looks something like an organ

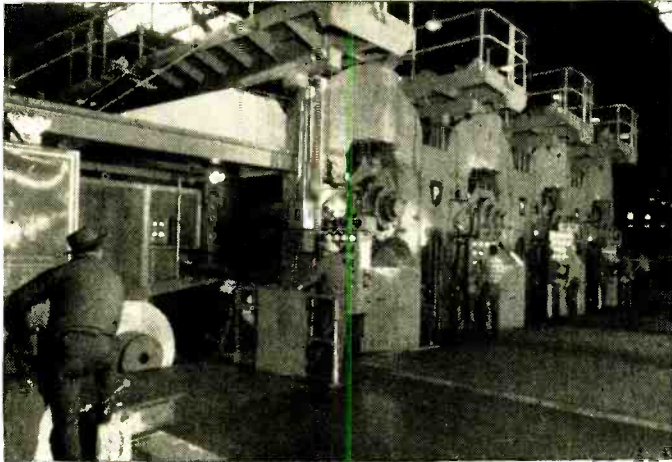

Steel-rolling mills use magnetic amplifiers, too. Because the steel gets longer as it is rolled, each set of rollers must turn at a slightly different speed. Magnetics keep all the rollers operating at the proper speed relationship regardless of how fast the steel is fed in. (*Pittsburgh Steel photo*)

may control a load of 25,000 watts in the output circuit.

Rugged and Reliable. Magnetics are extremely rugged. They can be—and frequently are—completely potted and sealed in airtight containers. They thrive on extremes of heat, dust, moisture, vibration, and other adverse conditions that would put vacuum tubes and transistors out of operation. Their efficiency is high, as with transformers and other magnetic devices. In addition, no filament current is required. So little heat is generated by magnetics that they can be packed into extremely small containers which need practically no ventilation or cooling.

Because magnetics can handle large amounts of current easily, they are a natural choice for electric furnace control. A Reynolds Aluminum Company furnace in Corpus Christi, Texas, uses such a control system. Precise furnace control by magnetics also helps to “grow” transistors in the latest types of transistor-manufacturing processes.

Magnetics have recently begun to invade

console. Unlike older types of theatre lighting devices—autotransformers and rheostats—magnetics present no fire hazard.

Since magnetic amplifiers have no moving parts and no delicate components, they last for years with virtually no maintenance. For this reason, they are used in such critical applications as the control of the atomic pile in nuclear subs and in missile-guidance systems, where reliability under adverse conditions of vibration, heat, and acceleration is vital.

Reliability is also the reason magnetics were chosen to monitor and control the critical voltages and currents of the transatlantic cable. If a voltage begins to change, a magnetic compensates for the change, and, at the same time, sounds an alarm so an operator can check to find the reason for the change. If the current drawn by the underwater repeater amplifier tubes begins to rise, once again the alarm is given, and corrective action is taken automatically. By insuring that the current does not rise to dangerous levels, the magnetics pro-

(Continued on page 109)

On the Citizens Band



By TOM KNEITEL, 2W1965

ANYONE who has spent five minutes listening on the 11-meter Citizens Band will agree that some "rules of the road" are badly needed to guide operators along the path to proper, courteous, and efficient operation. The POPULAR ELECTRONICS CB Courtesy Code" (below) sets forth some basic operating policies for CB'ers.

- 1 Do not transmit on a channel without first listening to see if it is clear. If the channel is in use, stand by until it is clear.
- 2 Keep calls down to a minimum ("2W4887, 2W4887, this is 2W4580" should be sufficient). If the called station doesn't reply, try again in 30 seconds. If there is still no answer, wait 10 minutes before you call again.
- 3 Say "over" at the end of each transmission so the operator you are contacting will know that you expect him to transmit.
- 4 If you hear a station being called which you know has cleared the channel, inform the calling station.
- 5 Always help in an emergency, even if the extent of your help is to cease transmissions and keep the channel open.
- 6 If a station accidentally interferes with your communications, request that the station stand by for a few moments until your communications are completed. You should then finish your contact as soon as possible.
- 7 Never work cross-channel unless it is the only way to send an extremely important message. If you must work cross-channel, ask the other station to give your channel a quick check to see if it is clear.

Does your station abide by the POP'ronics "CB Courtesy Code?" It should. But these pointers are only a few of the more

obvious table manners that CB'ers should observe. If you have any to add, send a post card to this column with your suggestions (keep them brief). We'll incorporate them into our code if they are applicable.

A CB Log Book is being issued by "H" Enterprises, P.O. Box 867, Brooklyn 1, N. Y. Even though the FCC doesn't require logs for CB stations, you might find it useful to keep a record of communications from your station. If you are a businessman, you will probably find that keeping track of orders and dispatches is a must. The book sells for \$1.98 (\$1.50 to members of the Five-Watt Wizards National CB Club).

We finally found out what a Hush-Puppy is. It's an automatic squelch adapter designed for the Heath CB-1 (although it will work on many other CB and non-CB receivers, too). Taking only about four minutes to attach, it really silences the receiver until an incoming signal activates it. Write to Western Massachusetts Electronics, Great Barrington, Mass., about this adapter if you're interested.

A pocket-size field-strength meter is now available from Quaker Electronic Co. of Plymouth, Pa., for \$7.95. Weighing only 1½ pounds, it shows the maximum power radiated by your transmitter. This unit comes in two models—all-band or for your specified frequency.

Canadians who want to have a Citizens Band should get in touch with Larry D. Whiting of Strathroy, Ontario. Larry is spearheading the cause and has already received a huge response to his letter on Canadian CB which appeared in our March issue.

Larry was informed recently that the Department of Transport is conducting a survey into the practicability of Canadian CB. That's a start, and we wish Larry and his group the best of luck. CB would certainly be a boon to the many people living in Canada's wide-open spaces where land-line communications don't exist.

-30-

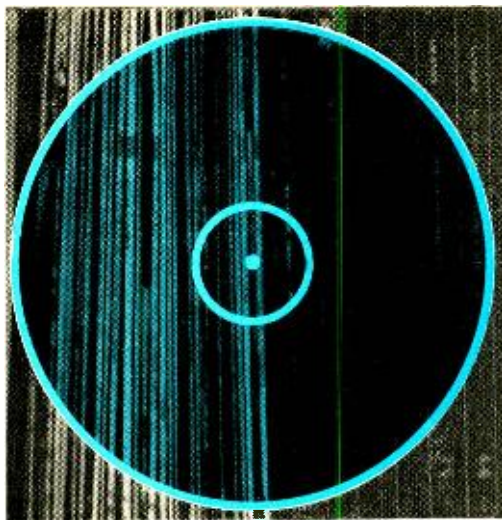

how to extend the life of your records

*Here's what you should know
about record wear and care*

By
JOHN MILDER

WHEN the time comes to show off your hi-fi rig, you frequently find that your favorite records just don't have the sparkle they once had. Annoying pops and clicks, distortion, and muffled highs supply the all-too-audible evidence of record wear. To make your system sound its best, you reach for that brand-new record fresh from your dealer's stock.

There's no denying that record wear will take the fine edge off your listening enjoyment unless you take active measures to prevent it. Fortunately, there are many ways to save your records from unnecessary punishment. With a little help from you, they can continue to sound brand-new even when they should be eligible for an old-age pension. Let's look at the inside story on record wear and see how it can be prevented.

Stylus Condition. Since the tip of your stylus is in constant contact with your records, it has a crucial influence on record wear. The first rule is: keep it clean—and

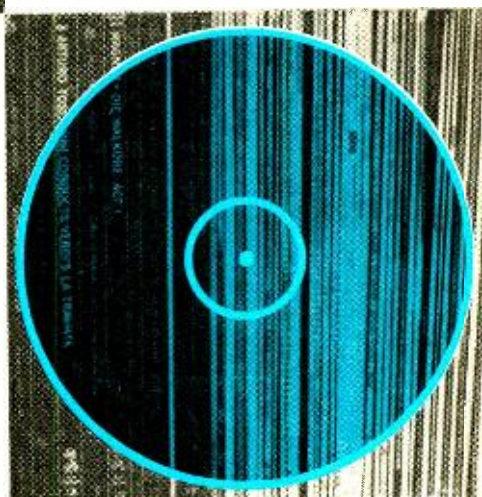

not with your finger, either. A camel's hair brush is just about ideal; it will clean off the dust and dirt, but it won't damage the stylus' delicate suspension system.

There's no way to predict just how long your particular stylus will last. It depends on how much listening you do, the kind of record player you use, and the amount of pressure on the stylus. In any event, don't wait until your records begin to sound fuzzy before you have your stylus checked. By the time you can hear the effects of a worn stylus, it has already been at work damaging your records.

If you don't use a diamond tip, you should have your stylus checked at least once a month. A diamond should last a year or more, but if your record playing is a daily

Camel's hair brushes are ideal for keeping the tip of a stylus clean. Don't use your fingers—you may damage the pickup.



habit, it's a good idea to start checking at the six-month mark and every month or so thereafter.

When it's time for stylus replacement, buy a completely new assembly. A few companies will still re-tip your old stylus bar, but the small saving involved isn't worth the disadvantage of keeping a stylus assembly which has probably lost most of its original compliance. A replacement made or approved by the manufacturer of your cartridge is the best way to make sure that your records get the treatment they deserve.

Cartridge Compliance. Probably the next most important factor in record wear is the design of the cartridge itself. The battle between a poorly designed cartridge and your record grooves will always result in your records coming out on the losing end. A good cartridge, though, can bring your records safely past the hundred-play mark.

The key to your cartridge's behavior is its compliance—the freedom of its stylus to move from side to side and up and down when following the twisting trail of a record groove. Cartridges vary in their compliances mainly because of differences in their mechanical innards. The more work the generating element inside the cartridge has to perform, the stiffer and less compliant the stylus assembly will be.

For stereo records, the cartridge's vertical compliance is particularly important. But mono records, too—despite the fact that their grooves are modulated laterally—demand a cartridge that has good vertical compliance. If the stylus has trouble moving vertically, it won't be able to cope with

Tracking pressure is easily checked with the assistance of a good pressure gauge.



“pinch effect”—which requires that the stylus move up slightly when highly modulated sections of the groove reduce the effective groove diameter. A mono cartridge with poor vertical compliance will plow straight ahead through the modulation instead of moving upward. Damage to the grooves is the result. In the case of stereo records, poor vertical compliance will in time demolish the separation between the channels.

You can get a good clue to a cartridge's compliance by using test equipment no more elaborate than your own ears. A monophonic record is your best listening source, since stereo tends to divide your attention. On a mono record, a pickup with good lateral compliance will produce a smooth and wide frequency response, with a solid and well-defined bass. At normal listening volume, the loudest recorded passages (ex-

Loose dust can be cleaned off records by wiping them with a damp cloth. Don't use a dry cloth, however, because it will create static electricity, causing more dust to be attracted.



"Billow" the record jacket when sliding a record in or out of it to prevent the record surfaces from rubbing against it.



Dirt that has found its way deep into the record grooves can be removed by gently washing the records in lukewarm water.

cept at the innermost record grooves) should come through with no sense of strain and with no extraneous noise superimposed. Also, with the volume control of your amplifier all the way down, you shouldn't be able to hear much, if any, sound coming from the cartridge itself when you stand more than two or three feet away from your record player.

If your cartridge seems to flunk these tests, have it checked to see if its stylus assembly has reached the end of the road. If the stylus seems to be in good condition but it still won't fill the bill, you should think about stepping up to a better cartridge. Even if you don't have a super-duper system with all-out frequency response, both your system and your records will benefit from a better cartridge. A pickup with really good compliance will surprise you by "finding" music down in the grooves

of mono records that have been damaged by less considerate cartridges.

Record-Handling Tips. Although your cartridge and its stylus have first say in the treatment of your records, you yourself are next in line. Your record-playing habits can extend—or cut short—the life of your records. Here's how to make sure that they will stay new for a long time.

Stylus pressure is of primary importance and should be checked from time to time. The important thing here is to follow the recommendations of the cartridge manufacturer. Don't make the tracking pressure either heavier or lighter than the manufacturer suggests. While it's easy to visualize record wear caused by too much stylus pressure, too little pressure can do just as much damage; it prevents good contact between the stylus and the record groove, causing the stylus to rattle around in the groove. This adds a fuzzy quality to the sound and encourages groove-skipping. Unless your cartridge and tone arm are specifically designed for ultra-low tracking pressures, don't try to get down into the one- or two-gram region.

If you use a record changer, don't pile too many records on it at once. A thick stack of records makes it tough for most

(Continued on page 110)

Test Instruments

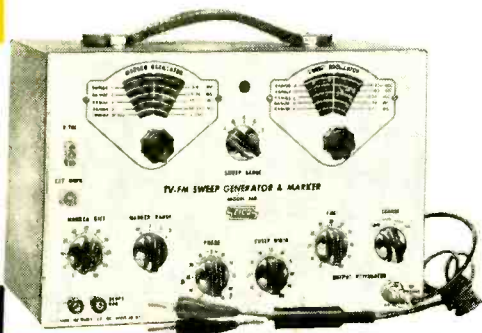

the

Sweep Generator

By G. H. HARRISON

How it works and how it is used

UNTIL RECENTLY, it was a rare service shop or experimenter's bench that boasted a sweep generator. But the coming of FM and TV has made this valuable test instrument an absolute necessity for the serviceman. At the same time, the ham and electronic experimenter have learned that the sweep generator can be a versatile tool in servicing and aligning a wide variety of electronic equipment.

Basically, a sweep generator is nothing more than a frequency-modulated signal generator. In other words, instead of producing a steady signal at one frequency, it *sweeps* rapidly back and forth over a selected band of frequencies, just like an FM broadcast station. Its output frequency might start at 50 mc., for example, rise swiftly to 55 mc., dip back to 45, go up again to 55, and so on. The generator would repeat this frequency sweep from 45 to 55 mc. and back 60 times each second. Such a unit would have a *sweep rate* of 60 cycles, a *sweep width* or *bandwidth* of 10 mc. ($55 - 45 = 10$), a *center frequency* of 50 mc.

What is the purpose of a sweep generator? Simply this—with a sweep generator and oscilloscope, you can actually *see* an overall response curve of an electronic circuit, rather than simply measuring volt-

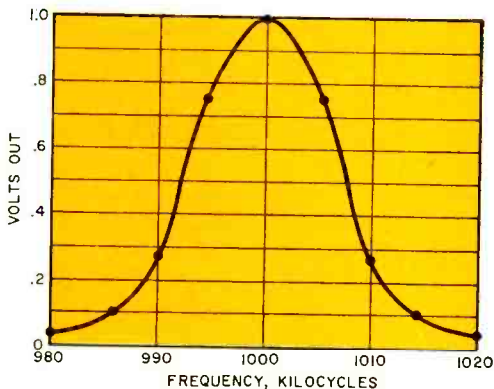

Fig. 1. A standard signal generator can be used to plot the bandwidth of an AM receiver, but the procedure is time-consuming. A sweep generator shows this complete curve instantly.

ages, currents, and other variables, and then figuring out what is happening.

General Applications. To get a better idea of how a sweep generator works, let's examine the way it can be used in checking the bandwidth of an AM receiver. This job *could* be done with a regular AM signal generator and voltmeter by taking a series of output measurements at different frequencies. With the receiver tuned to 1000

kc., for example, you could take output readings while tuning the signal generator to frequencies from 980 to 1020 kc. in 5-kc. steps and plotting the output curve on graph paper. The result would probably look something like Fig. 1. But a sweep generator can be set to sweep through the same band of frequencies. Then, with an oscilloscope hooked to the receiver's output, the frequency response curve will appear instantaneously on the scope tube.

While such a procedure is merely helpful when checking AM radios, it is essential for TV and FM. This is because the wide bandpass characteristics of TV and FM circuits necessitate the use of a sweep generator. Figure 2 shows two typical curves. For the associated circuits involved to operate properly, the *shape* as well as the amplitude of these curves must be accurate. The only practical way to align such cir-

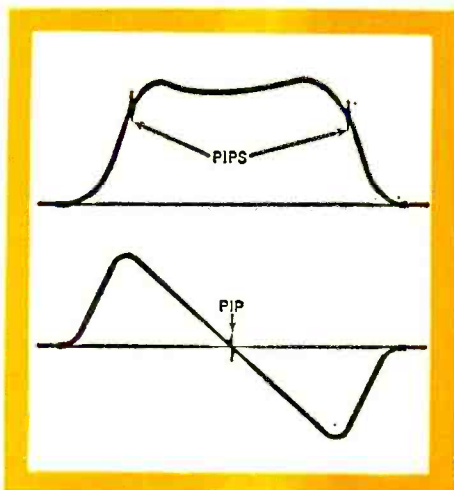

Fig. 2. Sweep generators are essential for the proper alignment of FM and TV circuits, since the curve shape is important. Pips are injected to aid in alignment.

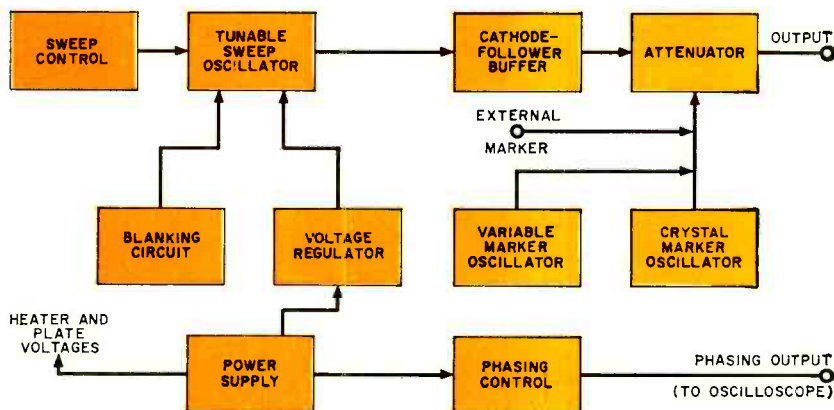

Fig. 3. Heart of a typical sweep generator is the tunable sweep oscillator. It varies its output frequency continuously back and forth around a center frequency.

cuits is to actually see the waveforms on an oscilloscope and note how the shapes change as the alignment controls are adjusted.

Sweep "Oscillators." The block diagram of a typical sweep generator is shown in Fig. 3. Note that a "tunable sweep oscillator" has replaced the simple r.f. oscillator found in the AM signal generator. Actually, however, there isn't a great difference between the two. If you were to take an ordinary AM signal generator and turn the tuning knob back and forth, the output frequency would vary continuously as you turned the knob—you would be *sweeping* the generator through a band of frequencies. A small motor attached to the knob could be used to drive the tuning knob back and forth automatically. With the motor

running, the frequency of the generator's output signal would continuously sweep through a band of frequencies.

Early sweep generators were made in exactly this way. A small, specially designed motor-driven capacitor (Fig. 4) was connected across the main oscillator's resonant tank circuit. Today's sweep generator accomplishes the same thing but generally uses more modern sweep circuits.

There are several all-electronic sweep methods in current use. The Heath TS-4A sweep generator, for example, employs the

"Increductor," a transformer-like device in which the inductance of one coil is controlled by the amount of current flowing in the other. Figure 5 shows a simplified diagram of the Heath circuit.

The a.c. current flowing through the primary winding of the Increductor creates a magnetic field in the common core. The higher the current, the less the permeability of the core, and, consequently, the lower the inductance of the secondary coil (which

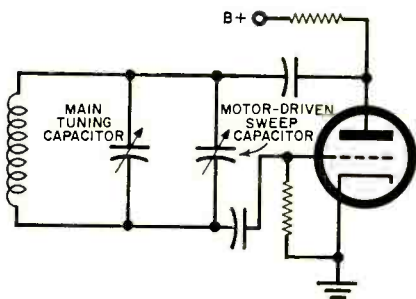

Fig. 4. Motors once turned capacitors to provide sweep, but most sweep generators today have electronic sweep circuits.

Fig. 5. Heath TS-4A sweep generator uses an Increductor to provide electronic sweep from Colpitts oscillator circuit.

forms part of the oscillator tank circuit). Thus, the oscillator frequency sweeps back and forth with the 60-cycle current applied to the primary of the Increductor; the greater the current, the wider the frequency swing.

The small rectifier in the Increductor primary circuit keeps just enough d.c. current flowing so that the tank inductance is maintained about halfway between its maximum and minimum values with no a.c. current applied. When the sweep circuit is turned on, the oscillator's frequency swings about equally above and below the center frequency, rather than in just one direction as would be the case if the rectifier weren't used.

Another popular method of sweep modulation is the reactance tube, shown in Fig. 6. Briefly, the oscillator "sees" the reactance-tube circuit connected across its tank circuit as a capacitor. As the reactance-tube control voltage varies, the circuit

capacitance appearing across the tank circuit also varies, and so does the oscillator frequency.

Tunable Swept Oscillators. There are two common methods of controlling the output frequency of the sweep generator. Some units have a tunable swept oscillator—that is, the frequency-modulated oscillator can be tuned through the entire range of the instrument with the main tuning control.

This circuit has the important advantage of simplicity, but it has one drawback, too. There is some variation in the sweep width as the center frequency is changed. To overcome this, some generators operate on a somewhat different principle, using the basic circuit shown in Fig. 7. The swept oscillator operates at a constant 100 mc.; the

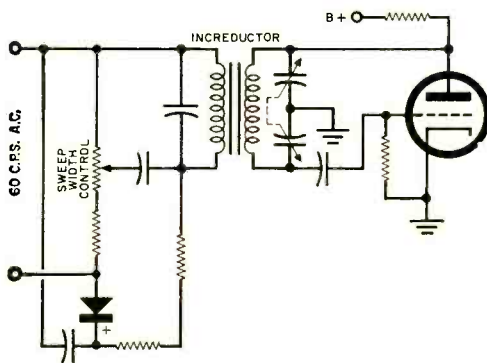

tunable oscillator has two bands—100-200 mc. and 200-300 mc. The outputs of the two oscillators are heterodyned to give any sum or difference frequency between 0 and 400 mc. (In practice, the output would probably be used only up to 300 mc., as shown in the diagram.) Since the frequency of the swept oscillator is fixed, the sweep width is absolutely constant over the entire range of the instrument.

Other Controls. Most sweep generators also contain one or more *marker oscillators* (see Fig. 3). These oscillators generate small markers or "pips" which can be seen on the output waveform (see Fig. 2). Since the frequency of the marker pip is known from the marker dial setting, an operator can adjust the waveform until the pips appear on exactly the proper part of the curve. He then knows that the waveform is accurately aligned. Many generators have two marker oscillators: one crystal-controlled, the other tunable. The

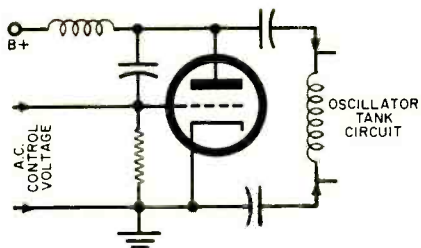
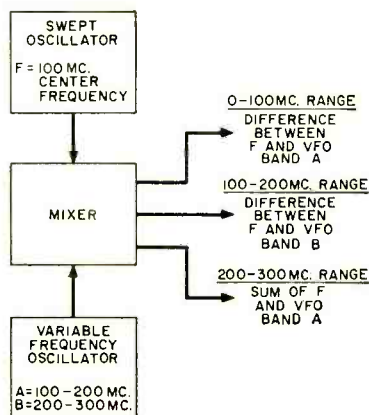

Fig. 6. Reactance tube varies oscillator frequency electrically by altering capacitance in the oscillator tank circuit.

Fig. 7. A fixed center frequency for the swept oscillator increases stability; oscillator outputs are heterodyned.



crystal oscillator is used both to produce a fixed-frequency pip and to calibrate all of the other ranges of the instrument.

Sweep generators also usually have an input which will accommodate an external marker oscillator. An ordinary signal generator can be used as an external marker. With this arrangement, it is possible for an operator to have three separate, individually controllable pips on the sweep—two from the generator's own oscillators, and one from an external oscillator. (A skillful operator can have even more pips by mixing the outputs of the various oscillators to produce a series of harmonics at proper frequencies.) Simpler generators may not have an internal tunable marker oscillator at all; instead, they may merely incorporate an input jack for an external marker.

Sweep generators usually provide a *blanking circuit*. This circuit makes the output waveform appearing on the oscilloscope face easier to read by blanking out the generator's return sweep. For example, if the generator were set to sweep from 45 to 55 mc. and back again, the blanking circuit would let the rising sweep from 45 to 55 mc. go through but would "blank out" the return sweep from 55 back down to 45 mc. Although TV or FM receivers can be aligned without this feature, the scope face in most cases is a little easier to read and interpret with the sweep showing in one direction only.

There is one more control on most sweep generators—the *phasing control* which is used to synchronize the generator's sweep

with the oscilloscope's trace. As the generator sweeps from 45 to 55 mc., for example, the scope trace will travel from left to right across the face of the scope in exact synchronism, if the phasing control is properly adjusted.

Aligning Receivers. The actual procedure for aligning a television receiver is quite complex, and varies considerably from one set to another depending on the circuits used by the manufacturer. Therefore, even experienced servicemen usually find it necessary to have the manufacturer's alignment instructions on hand before undertaking this job. Although the alignment of an FM receiver is considerably simpler, it helps to have the manufacturer's instructions here, too.

Television and FM circuits operate at higher frequencies than AM circuits and are therefore much more critical. Consequently, these 10 general rules will help you get best results when using a sweep generator with these receivers:

1. Follow the manufacturer's instructions exactly. Use only recommended tools, and set the controls exactly as indicated.

2. Grounding is important. Connect the sweep generator ground lead as close to the hot input as possible. If grasping the leads causes any change in waveform, try to get better grounding. Use heavy straps (hook-up wire is usually not suitable) to connect the chassis of the various pieces of equipment together. A metal-surfaced work bench is ideal for this purpose.

(Continued on page 113)

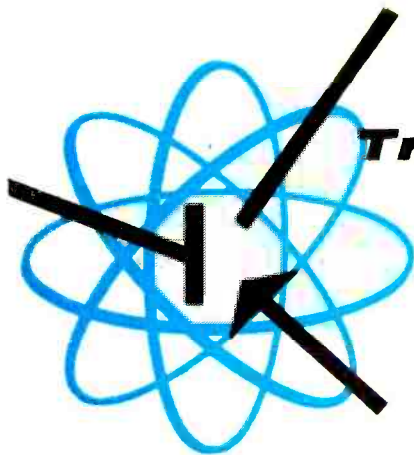

Transistor Topics

By LOU GARNER

BOATING, with its allied sports of fishing, water skiing, and skin diving, is among the nation's fastest-growing hobbies. And paralleling this increasing interest in boating is a strong demand for economical, reliable, and easy-to-use marine electronic equipment. As we might expect, the transistor's chief attributes—high efficiency, light weight, small size, low power requirements, and good reliability—make it ideal for use in most types of marine electronic gear.

One of the most interesting electronic devices available to boating enthusiasts is the echo-type depth sounder. Heath's Model DS-1A, available as a comparatively low-cost, easy-to-assemble kit, is typical of commercial depth sounders. Its basic principle of operation is illustrated in Fig. 1; the block diagram (Fig. 2) shows the important circuit functions.

In operation, the DS-1A projects a "beam" of sharp, accurately spaced, high-frequency (185-kc.) ultrasonic pulses through the water from a barium titanate ceramic transducer mounted on the boat's hull. These pulse-like signals are reflected or "bounced back" from the bottom as well as from submerged objects, fish, or other obstacles beneath the boat—in much the same way that an echo is reflected from the side of a building or from a distant canyon wall.

Water depths are measured by determining the time required for a single pulse to be bounced back to the boat. This time lapse is equal to *twice* the time required for

the pulse to reach the reflecting surface. If the velocity of ultrasonic energy in water is assumed constant, then the lapsed time is directly proportional to the distance to the bottom (or to the submerged object).

The signal's velocity in water is approximately 4800 feet per second. Reducing this to unit length, it requires .000208 second for the signal to travel one foot. Suppose, now, that we send out a pulse and receive an echo exactly .0208 second later. Since this represents *twice* the time required for the signal to reach the target (half going to target, half returning as echo), we divide in half, giving .0104 second. Dividing .000208 into .0104, we find that the target, be it the bottom or a submerged object, is exactly 50 feet away from our signal source.

The heart of the DS-1A is a governor-controlled, battery-powered motor driving a rotor which carries a small magnet and a neon indicator lamp (see Fig. 2). The motor speed is held accurately at 1440 rpm. so that the time required for a single revolution (.0416 second) exactly equals the time required for a pulse to travel 100 feet

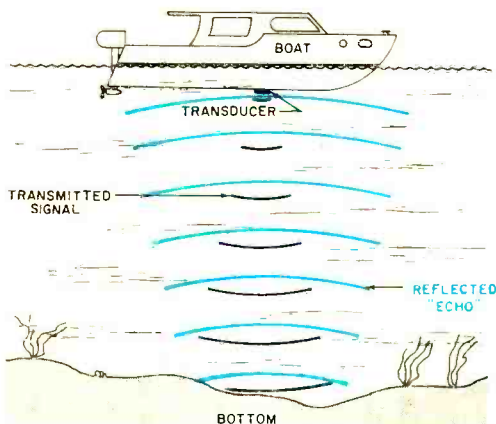

Fig. 1. Depth sounders determine the distance to underwater objects by sending out a pulse and then measuring how long it takes for the echo to return.

through water and to return as an echo.

As the rotor spins, the magnet is aligned once in every revolution with a small pick-up coil. Passing the coil, the magnet generates a sharp electrical pulse. This pulse, in turn, triggers a 185-kc. transistorized oscillator, turning it "on" for a few cycles of operation. The high-frequency energy developed is fed simultaneously to the ceramic transducer and to a five-stage transistorized amplifier.

The electrical energy coupled to the

cause an echo, multiple flashes may occur. These flashes vary somewhat in intensity, depending on the strength of the reflected signal and hence, to some extent, on the size of the object. With experience, the depth sounder operator can tell the nature of submerged objects (fish, sunken wreck, or what have you) and the type of bottom over which the boat is traveling.

Readers' Circuits. Robert Palladino, 34 Aspen Rd., West Orange, N. J., sent in the simple receiver circuit shown in Fig. 3,

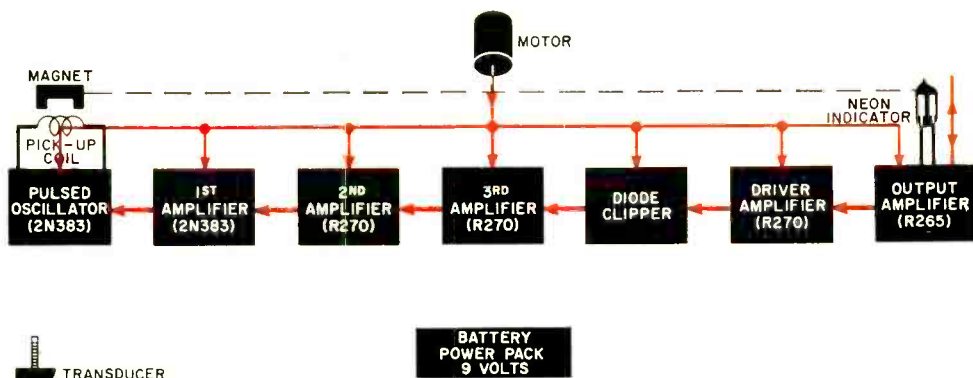
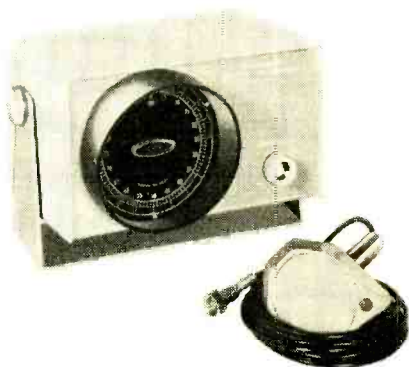

Fig. 2. Heath's DS-1A depth sounder is an all-transistorized device for small boat owners. The R270 and R265 transistors are produced by Texas Instruments.

transducer is converted into sound energy and projected as an ultrasonic pulse through the water. The reflected pulse or "echo," returning when the oscillator is inactive, is detected by the transducer and coupled to the five-stage amplifier. Of course, the reflected pulse is much weaker than the original signal, due to loss of energy and dispersion in the water.

Both the original pulse and the echo signal are amplified and clipped to similar levels. The two signals are then used to drive the neon indicator attached to the motor's rotor arm. Each pulse causes the neon lamp to flash. The original pulse flashes the lamp when the magnet is lined up with the pickup coil; this represents "zero" depth. The echo pulse flashes the lamp at some point during its rotation, with the angle of rotation directly proportional to the distance to the object causing the echo. Thus, the dial scale behind which the neon lamp rotates can be calibrated in feet.

Since any object under the water can



and the audio level meter circuit in Fig. 4 comes from Robert Bari, 207 N. Washington Ave., Bergenfield, N. J.

Referring first to Fig. 3, this two-transistor broadcast-band receiver is a relatively high-gain, low-cost set requiring a minimum of components. Coil *L1* is standard Superex ferrite loopstick, *C1* a 365- μf . variable capacitor. Almost any diode can be used for *D1*; types 1N34, 1N69, and CK705 are suitable. Transistor *Q1* is a 2N35 (*n-p-n*) unit, *Q2* a CK722 (*p-n-p*) unit; other transistors with similar characteristics could be used equally well.

Aside from a pair of moderate impedance

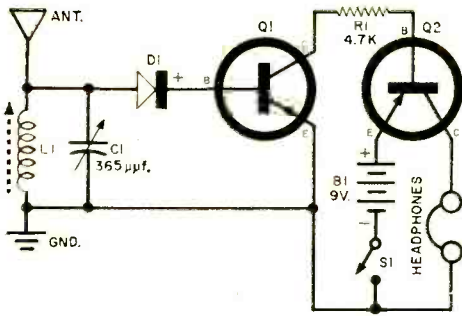

Fig. 3. Two-transistor broadcast-band receiver designed by Robert Palladino. Diode *D1* is the detector; audio amplification is furnished by the transistors.

(1000- to 4000-ohm) magnetic earphones, a s.p.s.t. on-off switch, and a battery power pack, resistor *R1* is the only other electrical part required. The power pack, *B1*, can be a single transistor battery (such as an RCA Type VS309A) or it can be made up by connecting six penlight or flashlight cells in series.

In operation, r.f. signals picked up by the antenna-ground system are selected by

relative sound levels and can serve as an applause meter for amateur theatricals. This unit is also useful as a noise level meter or as a balance meter for adjusting stereo installations.

A miniature PM loudspeaker (Argonne No. AR-95) serves as a microphone. Signals picked up by the speaker are coupled to a common-emitter amplifier stage though impedance-matching transformer *T1* (Argonne Type AR-96). Capacitor *C1* is a d.c. blocking capacitor which prevents *Q1*'s base bias from passing through *T1*'s secondary winding; bias current is furnished through *R1*.

The amplified audio signal supplied by *Q1* is coupled through interstage transformer *T2* (Lafayette Type TR-98) to *Q2*, a type 2N170 *n-p-n* transistor in the common-emitter arrangement. Base bias for *Q2* is furnished through a voltage divider made up of *R2* and *T2*'s secondary winding. Resistor *R3* serves as *Q2*'s collector load.

From the second stage, the signal appearing across *R3* is coupled through capacitor *C2* to resistor *R4*. The audio signal is then rectified by diode *D1* which develops

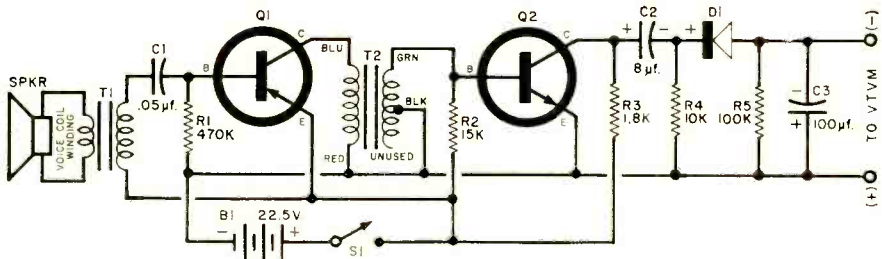

Fig. 4. The transistorized audio level meter submitted by reader Robert Bari measures sound levels. Miniature speaker serves as an inexpensive microphone.

tuned circuit *L1-C1* and detected by diode *D1*. From here, the detected audio signal is amplified by a two-stage amplifier (*Q1-Q2*) using *n-p-n* and *p-n-p* in a complementary arrangement. A common-emitter circuit is employed, with *R1* serving to limit *Q2*'s base current.

Bob indicates that best results are obtained with an external antenna, although strong local stations can be received with *L1*'s pickup alone.

The transistorized audio level meter (Fig. 4) is designed to operate with a d.c. VTVM on the 0-3 or 0-15 volt scales. It measures

a d.c. voltage across output load resistor *R5*. Capacitor *C3* serves as an output filter. Operating power is furnished by 22½-volt battery *B1* (Burgess Type U15), controlled by s.p.s.t. toggle or slide switch *S1*.

As long as standard construction practice is followed, the audio level meter's layout and lead dress shouldn't be too critical. Care must be taken to observe electrolytic, diode, and battery polarities, of course. To minimize the possibility of external hum or noise pickup, the assembled circuit should be mounted in a small metal cabinet.

Sun-Powered Car. From the International Rectifier Corporation in sunny California (1521 E. Grand Ave., El Segundo) comes news of a sun-powered automobile.

(Continued on page 112)



Communicating

T h r o u g h

The Earth

IT ALL STARTED on a very hot day last summer. I was sprawled in a chair in my basement workshop—the coolest spot I could find—and was in the middle of a beautiful dream about the day I would get my ham ticket when the phone rang. It was Frank, and he sounded as if he had just won the Irish sweepstakes.

“Joe,” he blurted, “I’m on the air in the ground.”

“Frank,” I said, “I know it’s hot, but you can live with it. Just calm down and start over.”

“It’s the truth. I *am* on the air in the ground,” he repeated. “Go out in your back yard and drive a ground rod at the back of your lot. Run an insulated wire from the rod into your basement, and then hook a set of headphones in series between the wire and a cold water pipe.”

A few questions convinced me that Frank had not flipped his lid, but he still wouldn’t tell me the whole story, so I dug out an old copper ground rod and followed his instructions. When I hooked some phones between the wire from the ground rod and the cold water pipe, I heard a 60-cycle hum, a whine or two of some higher frequency, and a few clicks and pops. This was mildly interesting, but it got old fast, and I was just about to doff the phones when I heard something

*You can go on the air
through the ground with this
ultra-simple system*

By J. C. FISCHER



else. Code signals, bearing the unmistakable stamp of Frank's shaky fist, were coming out of the phones! Sure enough, he was on the air in the ground.

I made it over to Frank's house—a distance of four blocks—in record time. He and I both have a common interest in electronics and a common struggle to master the code for our ham tests, but he always seems to be ahead of me when it comes to dreaming up some new experiment. This time he really had me guessing.

I found him in his workshop. He had a telegraph key, a code practice oscillator, and an audio amplifier sitting on the bench. But there was nothing new in this. I had seen those gadgets hundreds of times.

"Okay, Marconi," I said. "Explain."

"Did you hear me?" he asked.

"Yeah, I heard you. How did you do it?"

"Simplest thing in the world, Joe. I plugged the code practice oscillator into the amplifier and connected the amplifier to a couple of grounds; and, presto—I had a transmitter."

"You mean to tell me I heard the grounded output of that amplifier? How much power does that thing put out, anyway?"

"Only ten watts," Frank beamed. "I tried it out first only a couple of blocks away, and it was so loud I felt sure you would be able to hear it at your house."

"Say," I exclaimed, "you know what this means?"

"I sure do," he grinned. "It means you and I are going to breathe some new life into that old, dull code practice. We're going to have our own communication circuit through the earth."

And so we did. In fact, we found two more fellows in the neighborhood who wanted to learn the code, and we soon had a four-station net going. In the course of setting up the net, we learned a few things that might help others who want to try the same system.

The Ground System. First of all, we found that the two grounds should be as far apart as possible. Most fellows won't be able to locate the ground rod more than a hundred feet away from the point where the water pipe enters the earth, but that's good enough, and even shorter distances will work okay.

Also, the grounds should be as good as possible. You won't need to improve the water pipe ground—it's pretty good already

—but the other ground should have as much metal as deep into the soil as is practical. Several ground rods bonded together are better than one, and a piece or two of scrap sheet metal buried along with the rods won't do any harm. Don't make the mistake of using the water pipes of two different houses as the two grounds. The water pipe grounds are shorted together by the neutral circuit of the power lines.

An ohmmeter can be used to check the quality of the ground system. Our best system measured 20 ohms between the two grounds, and the poorest measured 200 ohms. In measuring the resistance, always switch the meter leads and take the average of the two readings. The readings will probably differ because there will usually be a small direct current between the two grounds, which will add to or buck the meter current, depending upon the polarity of the meter connections. There is also an a.c. voltage between grounds which is usually large enough to show up on the low-voltage scale of a multimeter.

Matching Impedances. Once the ground system is installed and the resistance determined, the amplifier must be matched to that resistance. Most amplifiers have a variety of output impedances, and this makes it easy if your ground resistance falls close to one of the impedances. For example, the 16-ohm output on Frank's 10-watter worked very nicely into the 20-ohm ground at his station.

If you end up with some odd value that your amplifier won't feed, you'll have to use a matching transformer between the amplifier and the grounds. This doesn't need to be a drain on your wallet, though, since any transformer in the junk box with the proper turns ratio and power rating will work fine.

For example, one of the fellows in our net used a modulator as his audio amplifier. It was a 30-watt job that gave him a nice signal, but the lowest impedance he could match was 500 ohms. Since his ground resistance was approximately 20 ohms, he needed a transformer with an impedance step-down ratio of 25. Knowing that the turns ratio is equal to the square root of the impedance ratio, he looked around the junk box for a transformer with a turns ratio of 5 to 1. He found just what he needed in an old power transformer with a 600-volt secondary. By hooking the modulator's 500-ohm output to the high-voltage

secondary winding of the power transformer and the 117-volt primary winding to the two grounds, he got a good match from the modulator to the load.

When improvising matching transformers, it is useful to check the actual power developed across the load to be sure the match is right. We did this by measuring the a.c. voltage across the two grounds while the key was closed. In the case of the

are still higher-frequency noise components which ride through with the signal. We did *not* try supersonic signal frequencies with appropriate filters and amplifiers at the receiving end, however; this might be an interesting field for experiment.

Incidentally, hooking a mike instead of an audio oscillator to the amplifier gave us an easy way to use voice to compare notes on code practice. Phone signals were fair

Block diagram of the "through-the-earth" communication system.

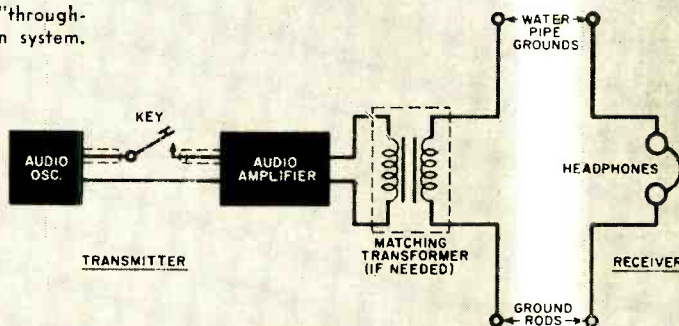

modulator, we measured 25 volts across the 20-ohm grounds. Ohm's law (power equals voltage squared divided by resistance) indicated that the amplifier was developing full power (31 watts) across the load.

Installation Tips. There is very little that can be said about the receiver setup since it is so simple. Any set of headphones will do. The same grounds that are used for transmitting will serve for receiving, provided that a send-receive d.p.d.t. switch is employed. However, we found it better to use two separate ground systems. This method assures that the amplifier will always be loaded, eliminating the risk of ruining an output transformer by operating into an open circuit.

Also, a separate ground system for receiving permits monitoring your own sending and the use of break-in, which is a lot of fun in net rag-chews. The receiving grounds need not be as elaborate as those for the transmitter. We use single rods located some distance from the transmitting "antenna" so that our own signals are not deafening in the headphones.

We experimented with receiving amplifiers, but they don't help since the noise in the earth is amplified along with the signal. Filters to discriminate against the 60-cycle noise are not fully effective, either, as there

but naturally not as strong as c.w., and only stations close to each other could use this mode of operation.

Operational Range. We learned that the idea of communicating through the earth was not a new one. In fact, the French used a similar scheme with spark coils rather than audio amplifiers during World War I, and hams used the method to a limited extent when they were forced to leave the air during World War II. Nevertheless, the principle has not been used widely enough to be familiar to a large number of experimenters. Perhaps this is due to the limited communication range of the system.

The question of how much range can be covered with an earth communication system is hard to answer because there are so many variables. Based upon our experience with moderate power and simple ground systems, I would say that a mile radius is the outside limit with only headphones as a receiver. We copied a weak signal at this distance with 50 watts of transmitter power in soil which was predominantly clay. On the other hand, with improvement in the signal-to-noise ratio through the use of supersonic frequencies, amplifiers, and filters, it might be possible to extend the range to several miles.

SEEREO Amplifier-Preamplifier

SEEREO



Lafayette KT-250A delivers 25 watts per channel, provides equalized inputs for phono, tape, or tuner

If you haven't yet "gone stereo"—or if you're looking for a "best buy" to replace your present stereo amplifier—the Lafayette KT-250A kit is a good bet. An integrated stereo amplifier-preamplifier, it has equalized inputs for magnetic or crystal phono and tape head, as well as inputs for a tuner and an "auxiliary" source. Its output matches 4-, 8-, and 16-ohm speakers, and there's a third-channel output which furnishes a monophonic blend of both stereo channels. If you really want to raise the roof, you can feed this third output to an auxiliary monophonic amplifier.

With a pair of fixed-biased EL86's in the output of each channel, the KT-250A provides 25 watts stereophonically or 50 watts monophonically. Simple switching allows four different modes of operation—reproduction of either channel through both amplifiers, normal stereo, reverse channel, and reverse phase.

Each channel has its own bass and treble controls. Corresponding controls for the two channels are concentrically mounted, and the volume controls can be clutched to serve as a master gain control for both channels. A touch of a switch and the volume controls become loudness controls for low-level listening.

The measured frequency response of the unit was within 1.5 db from 20 to 20,000 cps and IM distortion was 1.3% at 20 watts output per channel. Hum and noise was down 72 db on the tuner input and 48 db on phono. Sensitivity for full output was .5 volt on tuner and 3 millivolts on phono. The KT-250A is available from Lafayette Radio, 165-08 Liberty Ave., Jamaica 33, N. Y., for \$74.50; a fully wired model (LA-250A) is available for \$99.50.

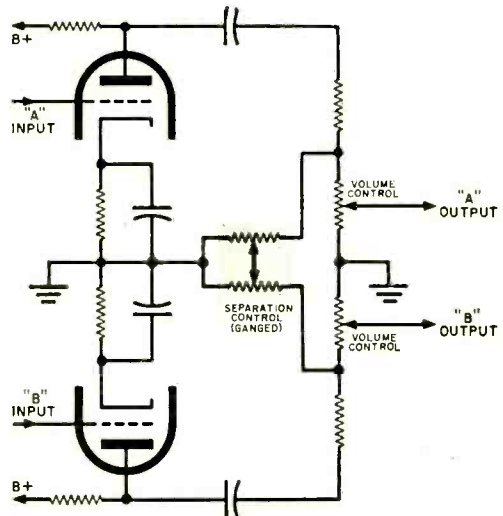

Ganged "separation control" varies the amount of cross-coupling between "A" and "B" amplifiers to reduce exaggerated stereo effects.



Across the Ham Bands

By
HERB S. BRIER
W9EGQ

PUTTING UP ANTENNAS

MOST hams quickly learn the importance of a good antenna system in getting more than mediocre results from a ham station. But some don't learn until too late that putting up an antenna improperly can be the most dangerous thing they ever do. The following items which appeared in midwestern newspapers in recent weeks tell the story.

"South Bend, Ind. Two teen-age brothers, one of whom had just received his new ham license, were killed last night when the antenna they were erecting fell against a 12,000-volt power line. A witness said, 'It was like a dozen Roman candles going off all at once.'"

"Chicago. Two 16-year-old boys, pals since grade school, were electrocuted last night while stringing a ham antenna between two trees. They tied a wrench to one end of the wire and threw it over a power line. One boy held on one end of it, and the other boy grabbed the other end of the wire to pull it."

High-Voltage Power Lines. Do not discount the chances of getting tangled up with 12,000 volts because you think there are no high-voltage power lines in your neighborhood. You may be right, but don't bet your life on it. There are a lot more high voltages floating around the utility lines along our streets and alleys than most people suspect. The average utility pole has at least three power lines with about 4000 volts between them and 2300 volts between each one and ground.

What's more, to satisfy the constantly increasing demand for electrical power to operate air conditioners, electric stoves, and the like, power companies are replacing these 4000-volt distribution systems with 12,000-volt lines (7200 volts to ground). In addition, there are often high-voltage lines on the poles for street lights and other special services.

With such high voltages around the utility lines, there is just no safe way to erect an antenna over or near them. Even if you did manage to put an antenna up without getting killed, the antenna would land in a maze of high

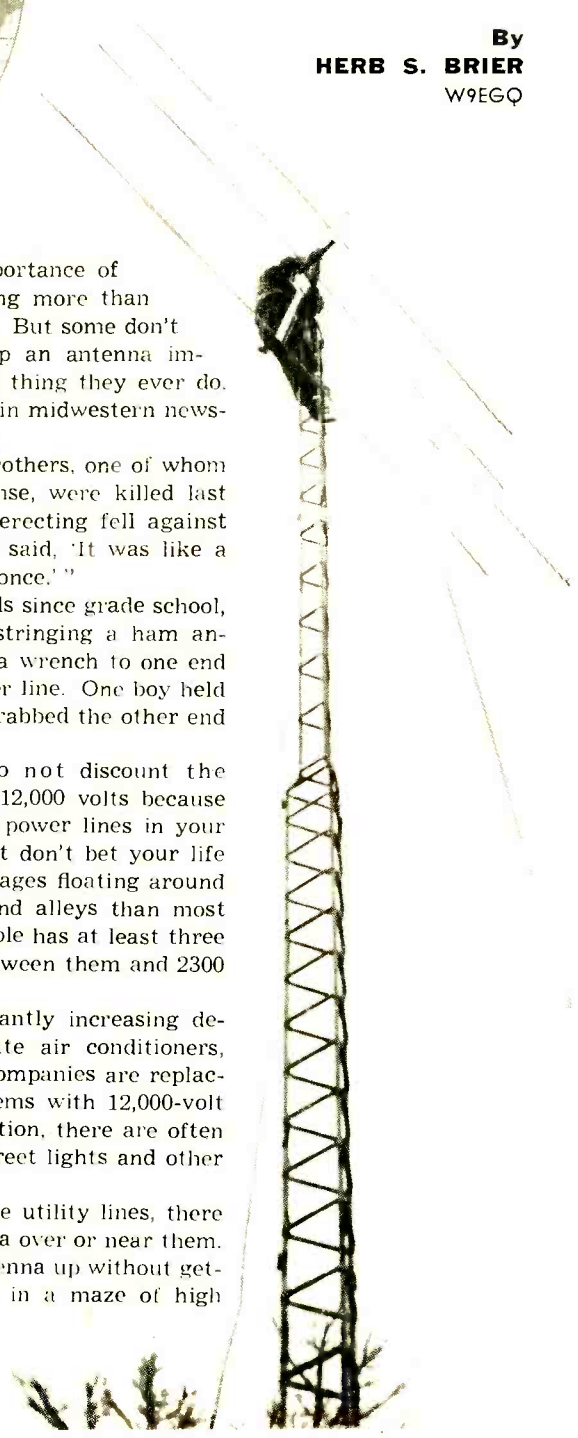

voltage if it ever fell, and this voltage would be brought right into your ham station via the antenna feed system.

A Safe Installation. For absolute safety, no antenna should ever be erected over a power line. However, if we followed this rule, few of us would have any antennas at all, since there aren't many backyards without at least one set of power lines carrying 115 or 230 volts to our homes. Fortunately, you can still put up a safe antenna system, in spite of power lines, by exercising elementary precautions—and by making sure not to string an antenna over a line carrying more than 230 volts.

It's best to have a plan of operation before you start climbing. Your antenna should be measured and preassembled with its insulators and feed line attached. Then you won't have to measure it and put it together while hanging precariously on the top of a pole with the antenna wire draped over a couple of power lines.

Wear heavy work gloves, preferably of rubber. Their insulating qualities may save your life if you should accidentally touch

a live wire. Never depend on the insulation on outside power lines; after years of being exposed to varying weather conditions, it just can't be trusted.

If the power lines across your yard make your antenna problem difficult to solve, don't hesitate to discuss the problem with a representative of the power company. You will probably be pleasantly surprised at the help and cooperation you receive.

Keeping the Antenna Up. Just as important as getting your antenna up is keeping it up. This is not too difficult. Use at least No. 14 copper-clad steel or No. 12 copper wire (enameled) for the antenna proper in conjunction with antenna insulators strong enough to stand the strain. Usually you have to contend with a lot more than merely the combined weights of the antenna and feed lines, especially when they are covered with ice or snow and the wind is blowing.

Twist all connections tightly and solder them carefully. When the antenna is supported by a tree, place a strong coil spring between the antenna insulator and the tree

Tom Moss, W4HYW, is a c.w. and radioteletype operator for the Third Army at Fort McPherson near Atlanta, Ga. As a ham, he has held practically all A.R.R.L. offices and is now Vice-Director of the Southeastern Division. He is also active in R.A.C.E.S., having served as Deputy Director of the Atlanta C. D.

W4HYW covers all ham bands from 1.8 to 148 mc. He uses separate amplifiers capable of a maximum power input of 750 watts on each band, driven by a variety of low-power transmitters. He also runs a separate 500-watt phone transmitter; the modulator on this rig doubles as a modulator for the v.h.f. finals. The equipment in his shack is rounded out with an SSB exciter, an electronic keyer, and RTTY and test gear. Tom's antennas include a Mosley 20/15/10 meter tri-bander, an "all-band" doublet and a vertical for the lower frequencies, plus separate rotaries for the v.h.f. bands.

Since 1951, Tom's major ham activity has been as manager of the K4/W4 QSL Bureau. Each month he handles a barrage of DX cards. He manages to keep them flowing to their destinations as long as the "4's" keep him supplied with stamped and addressed envelopes. However, he constantly has a backlog of several thousand unclaimed DX cards on file.

Tom is something of a DX man himself and an award chaser as well. Top man in the world-wide "Award Hunter's Club," he has over 107 recognized amateur awards to his credit.



Ham of the Month

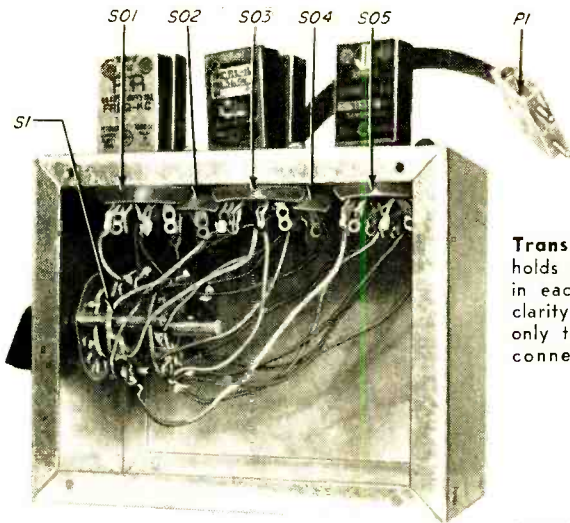

Transmitter crystal selector (left) holds up to ten crystals, two fitting in each of five octal sockets. For clarity, the schematic below shows only two of the sockets and their connections to switch *S1a/S1b*.

to absorb excessive strain on the antenna as the tree sways. And use heavy weatherproof rope or strong rustproof wire for your antenna halcyards.

CRYSTAL SELECTOR

A crystal-controlled transmitter can be frustrating when you want to be able to change frequency quickly to get "on top" of that "rare one" calling CQ. With the plug-in adapter shown here, you can select any one of ten crystals by just turning a knob. In effect, this gives you a sort of crystal-controlled VFO.

The unit is built on a standard 3" x 4" x 5" aluminum box (Bud AU-1028 or equivalent). Standard octal tube sockets (*SO1-SO5*) are used as crystal sockets; each one accepts two crystals. Note that octal sockets *SO3*, *SO4*, and *SO5* and their connections to switch terminals 5 through 10 have been left off the schematic diagram for clarity.

Two circuits are possible, depending on the type of transmitter you have. Switch *S1a/S1b* is a double-pole, 11-position switch (Centralab PA-1005 or equivalent) which can be used for both circuits. If neither side of the crystal socket in your transmitter is grounded (as is the case with the Johnson "Adventurer" or the Knight T-50, for example), use the circuit as shown without the ground.

If one side of your transmitter's crystal

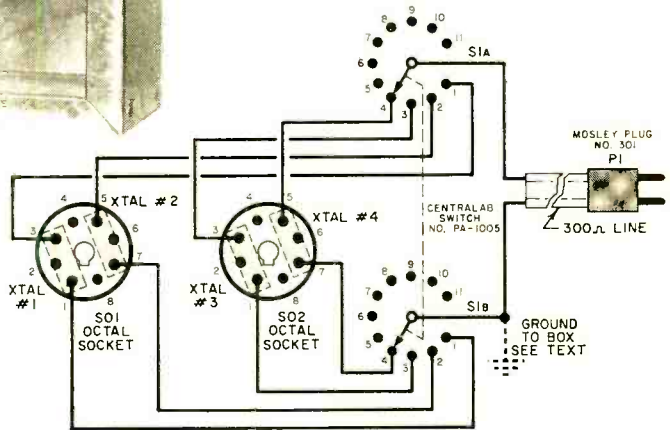

socket is grounded (as in the Globe Chief 90A or the Heathkit DX-20), then ground the rotor of *S1b*. Alternately, you can use a single-pole, 11-position switch (Centralab PA-1001 or equivalent) instead of the double-pole unit. If you decide on the single-pole switch, ground one lead from the 300-ohm line and pins 1 and 7 on each octal socket; but keep in mind that this limits the adapter for use only with transmitters having one side of the crystal socket grounded.

Connect a short length (about 12") of 300-ohm line to the rotors of *S1a* and *S1b*, or to the rotor of *S1a* and ground, depending on the circuit used. This line is terminated in crystal socket plug *P1* (Mosley 301 or equivalent). Mark the ground pin on *P1* and the ground pin on the transmitter's crystal socket if your particular transmitter requires it.

To operate the unit, plug *P1* into the transmitter crystal socket, plug crystals into the octal sockets, and use switch *S1* to select the desired crystal.

(Continued on page 115)



Carl and Jerry

Tussle With A Tachometer

"HERE ARE TWO electronic tachometers we can build for our car," Jerry said as he spread a magazine and a little yellow booklet on the bench in front of his pal, Carl. "This one uses an 884 thyatron powered by a vibrator power supply. As you can see, it's a detailed construction article, and the gadget uses a relatively inexpensive 1-ma. meter as an indicator.

"The other one, in this booklet published by Sylvania, has two 2N233 transistors connected in a one-shot multivibrator circuit. Power is taken directly from either a six- or twelve-volt car battery. However, about all we have to go on here is the diagram and a very limited description. And this tachometer uses a fairly expensive and delicate 50- μ a. meter."

"Do both work on the same principle?"

"Actually, yes. Whenever a selected spark plug fires, the thyatron is triggered into firing or the multivibrator circuit into flip-flopping. Each 'firing' or 'flip-flop' sends a pulse of current through the meter which has a large capacitor connected across it. This meter-capacitor combination responds to the average current produced by the pulses. Since these pulses are equal in amplitude and are uniformly spaced, the average current indicated by the meter goes up in linear fashion with the frequency of the pulses. That means the meter can be calibrated to show the rpm of the motor."

"I say we build the transistor job," Carl decided, as he finished looking over the two articles. "We have the transistors and the meter, and we should know enough about electronics not to need step-by-step instructions."

"Okay, but before we start, suppose you tell me once more why we need a tachome-

ter. Remember we resolved that anything we put on the car had to be functional."

"A tachometer is functional," Carl insisted. "Knowing exactly how fast the motor is turning over is important in many cases. For instance, take 'boxwork,' as we hoity-toity motorists call gear-shifting. There is one proper engine speed for each shift, and working with a tachometer permits you to find and use those speeds. Also, we can log the oil pressure for a particular engine speed and use that as a reference later to see if we're losing pressure. We can note at what engine speed our generator begins to charge the battery and use this as a check on the generator's operation. With a little math that takes into account the rear-axle ratio and the rear-wheel circumference, we can convert rpm into mph and check on the accuracy of our speedometer."

"Enough!" Jerry interrupted. "I'm convinced. All that bothers me now is how we're going to calibrate the tachometer."

"Well, just remember that a particular cylinder of a four-cycle engine fires only once every two revolutions," Carl pointed out. "When the engine is turning over at



4000 rpm, our tachometer will be receiving 2000 pulses per minute—”

“I’ve got it!” Jerry suddenly interrupted. “Let’s get busy and build the thing. Then I’ll show you an easy way to calibrate it.”

IT DIDN’T TAKE the boys long to collect the parts they needed. But Carl and Jerry prided themselves on making their electronic equipment as compact and well-arranged as possible, so they spent considerable time on layout. Since they realized that the tachometer would be subjected to intense vibration in the car, they anchored all parts for the multivibrator circuit solidly on a small perforated board of insulated material, and then fastened this board securely inside a small metal cabinet. Two 10,000-volt capacitors, a neon bulb, and a fixed and variable resistor for attenuating and limiting the high-voltage pulses from the spark plug were similarly mounted in another metal box. Phono jacks on the boxes allowed them to be connected together by a short piece of RG-58/U coaxial cable. Another length of cable connected the multivibrator unit to the meter, which was shock-mounted on a bracket designed to clamp on the steering column.

“Well,” Carl said as he surveyed the completed tachometer, “I guess we’re ready to mount it in the car and calibrate it.”

“We calibrate it first and *then* mount it in the car,” Jerry corrected him. “Trot out the sine- and square-wave generator and connect it to the input of the multivibrator circuit while I set up the ‘scope.”

Carl did as instructed, then watched as Jerry ran leads from the output of the audio generator to the vertical input terminals of the oscilloscope and connected the 60-cycle test voltage terminal on the ‘scope to the ungrounded horizontal input terminal.

“Here’s my idea—double-check me and see if I’m wrong,” Jerry said. “Our 0-50 μ a. meter will indicate 0-5000 rpm. That means 48 μ a. must correspond to 4800 rpm. This reading should be produced when the multivibrator is receiving 2400 pulses per minute, or 40 pulses per second.

“Our square-wave generator should put out a pulse that will trigger the multivibrator in the same fashion that the attenuated pulse from a spark plug does,” he continued. “All we have to do is adjust the calibrating resistor of the tachometer so

that the meter reads 48 μ a. when the multivibrator is being fed a square-wave signal of 40 cps. We can double-check the linearity with square waves of 30 and 20 cps. They should produce readings of 3600 and 2400 rpm respectively.”

“Sounds okay to me,” Carl agreed, “but how are you going to be sure you have exactly 40 cycles from the generator? The dial calibration is reasonably accurate, but you can’t depend on it down to the cycle.”

“That’s where the ‘scope comes in. We’ll

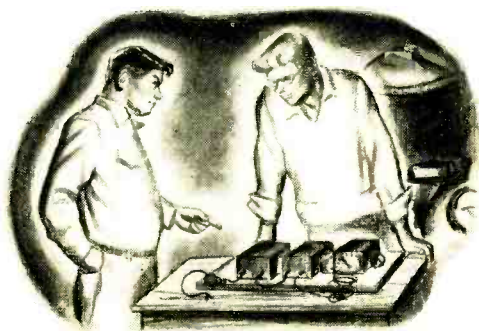

compare the 40-, 30-, and 20-cycle output of the generator with the 60-cycle line frequency with Lissajous figures. Watch.”

Jerry turned on the ‘scope and switched on the audio generator, set for sine-wave output. As he approached the 40-cycle mark on the dial, the rapidly revolving pattern of interlaced curving lines slowed down and finally stopped.

“See,” Jerry said; “a line along the left side of the pattern would touch three of the loops while a line across the top would touch two. That means the ratio of the signal generator frequency to the line frequency is 2:3 or 40:60.”

When the generator was putting out exactly 30 cycles, two loops of the pattern touched the imaginary vertical line and only one touched the horizontal line. At 20 cycles, only one loop still touched the horizontal line, but three loops touched the vertical line.

Jerry went back to the 40-cycle frequency and switched the generator over to square-wave output. As he did so, the distorted pattern began to wiggle, showing that the change in output had caused the generator frequency to shift slightly. A touch of the generator tuning knob stopped the pattern again. Jerry reduced the generator output until the meter indication began to fall off and move erratically; then he increased the

output until the reading was stationary.

"Okay, now set the calibrate control for a 48- μ a. reading," he instructed Carl. When this was done and the generator set exactly for a 30-cycle output, the meter read 36 μ a. When the frequency was reduced to 20 cycles, the reading dropped to 24 μ a.

"Right on the money!" Jerry gloated as he grinned across at his pal. "The thing is certainly linear over the top half of the scale at any rate. Disconnect that six-volt lantern battery, and let's install the gadget in the car."

THE MULTIVIBRATOR UNIT was bolted to the metal body of the car up under the dash, the attenuator unit was mounted on the front of the fire-wall in the engine compartment, and the connecting coax cable was run through a small hole in the partition. Connections were made to the rear spark plug and to the cold side of the ignition switch so that the tachometer would be switched on with the ignition. When everything was connected, the boys started the motor. Then they adjusted the variable resistor in the attenuator unit until the



meter gave a steady and unvarying indication at a constant engine speed, and moved up and down smoothly as the motor was speeded up and slowed down.

"Well, it seems to be all right, but I still would like to be sure the indication is accurate at slow speeds," Jerry fretted. "We both know bottom-of-the-scale meter readings are often less dependable than those shown in the top half of the scale."

"Maybe so, but since our square-wave

generator won't go below 20 cycles, it looks as though 2400 rpm is the lowest engine speed we *know* is accurate," Carl observed.

"Wait a doggoned minute!" Jerry suddenly exclaimed, clapping an open palm to his forehead. "When the engine is running 400 rpm, the tachometer is receiving 200 shots a minute from a single spark plug. And since all six plugs fire once every two revolutions, the coil is putting out 6 x 200 or 1200 shots a minute, right?"

"Right."

"And when the tachometer is receiving 1200 pulses per minute, it reads 2400 rpm. Can you see where I'm heading?"

"Yeah, I sure can. All we have to do is connect the pickup of the tachometer to the hot lead from the ignition coil and adjust the idle until we get an indication of 2400 rpm. Then we reconnect the pickup to a single spark plug, and if the meter action is linear we should get a reading of 400 rpm."

"And 400 rpm is very close to the slowest speed we'll need to read. So if the meter indicates correctly there, we can depend on it over the whole scale."

The lead from the coil to the distributor was arranged so that a temporary connection could be made to it. Then Jerry adjusted the idle screw until 2400 rpm was indicated on the meter. Next, he used a pair of plastic photography tongs to transfer the input connection of the tachometer from the high-tension terminal of the coil to a spark plug.

"What does it read?" he called to Carl.

"It might be just a freckle low," Carl said slowly as he peered closely at the meter, "but it's so close to 4 μ a. that you can't tell the difference."

"Good!" Jerry said with satisfaction.

"WE CERTAINLY went to a lot of trouble to make sure this thing was telling us the truth," Carl observed, turning off the ignition.

"When it comes to test equipment of any kind, either you have confidence in it or it's no good," Jerry remarked. "The time a technician takes to make sure his instruments are accurate is never wasted. Working with a meter whose readings you're not sure of is like using a rubber ruler to build a house. But now I've got the connection back on the spark plug, so what say we taxi around a bit with our tachometer?"

"Be my guest!" Carl said, and he opened the car door for his friend.

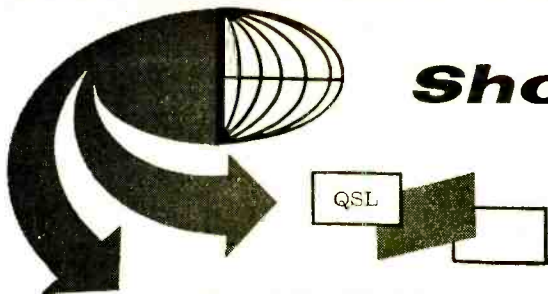

Short-Wave Report

By **HANK BENNETT**

W2PNA/WPE2FT

MINISTER, high-school teacher, freelance newspaper and magazine writer—our featured DX'er this month is all of these things—and an amateur radio operator, licensed broadcast engineer, and short-wave monitor as well.

Primarily a Presbyterian minister, Drayton Cooper, Edisto Island, S. C., doubles as a high-school teacher specializing in higher mathematics. He also worked in broadcast radio for several years, winding up at WSB, Atlanta, as associate news editor.

Drayton developed an interest in radio at the tender age of six (he's now 27 and married). He did some SWL'ing for a while, then got his ham license (in 1955) and became known on the airways as K4KSY. He is currently one of our outstanding SWL monitors in the southern states.

Edisto Island is an ideal location for DX'ing; a semi-tropical island off the extreme lower South Carolina coast between Savannah, Georgia, and Charleston, S. C., it is right in the middle of "Hurricane Alley." Drayton frequently provides the only means of communication between the island and the mainland, especially when the local police net is unable to get through on their channel. During hurricane "Gracie" last fall, for example, K4KSY stayed on the air for 44 continuous hours. Watch for him on the 75-meter phone band during the hurricane season.

Included in Drayton's listening post is a

Scott RCH receiver (Navy surplus; 12 tubes), an RME DB-20 preselector, a six-meter Gonset converter, and, for transmitting, a Globe Scout 680-A. His "antenna farm" contains 70' and 140' dipoles and a 225' long-wire. Incidentally, Drayton's RCH receiver, which dates from World War II days, provides continuous coverage from 50 kc. to 24 mc.

Since Drayton returned to short-wave listening, he has collected a total of 35 veries, covering 20 of 45 countries heard. (Previously he had a total of 100 countries with 98 verified). He considers his best veri



Drayton Cooper, K4SKY, has a minimum of equipment in his SWL corner but he makes good use of it. Radio enthusiast from the age of six, Drayton is a full-time minister and part-time writer.

to be one from HI7T, Santiago, Dom. Rep., on 90 meters. Preferring to DX the lower bands because they "present more of a challenge," his favorite listening for all-around good programming includes stations in Denmark, Switzerland, Australia, and Germany. He would like to hear from other DX-minded ministers.

(Continued on page 117)

D.P.D.T. Switches in Power Circuits

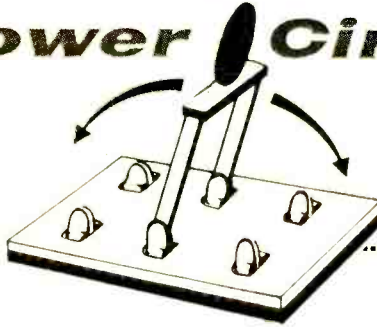

By **KENNETH RICHARDSON**

The common double-pole double-throw (d.p.d.t.) switch has a number of novel applications unknown to the average experimenter. By properly connecting one or more of these switches, you can achieve control over lamp brightness, transformer voltage output, and electromagnet strength.

Photoflood lamps have a comparatively short life span when used on normal line voltage, but connecting two of these lamps in series will greatly lengthen their life. A quick changeover from parallel (normal) to series connection can be accomplished through use of a 10-amp switch. The series connection furnishes sufficient light to perform preliminary focusing adjustments; switching to the parallel connection delivers full illumination for exposure of the film.

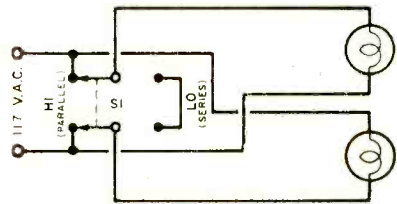

A filament transformer with two 6.3-volt secondary windings can be used in an experimenter's power supply to provide either 6.3 volts or 12.6 volts at the flip of a d.p.d.t. switch. Maximum current output for the 6.3-volt output is the sum of the maximum currents of both 6.3-volt windings; the 12.6-volt output current is limited by the lower current rating of either winding. If voltage output is zero, the secondary windings are bucking each other, and the connections to one of the 6.3-volt windings should be reversed.

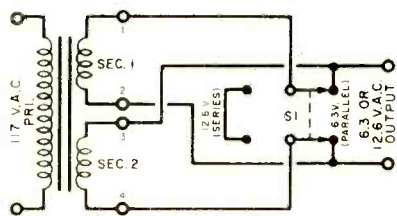

A d.c. electromagnet with two identical coils can be varied in strength and polarity by using two d.p.d.t. switches. Switch S1 selects either parallel or series connections for the coils. More current flows in the parallel setup, creating a more powerful magnet. Switch S2 reverses current flow, switching the magnetic poles. Reverse the connections to one coil if the magnet is weak.

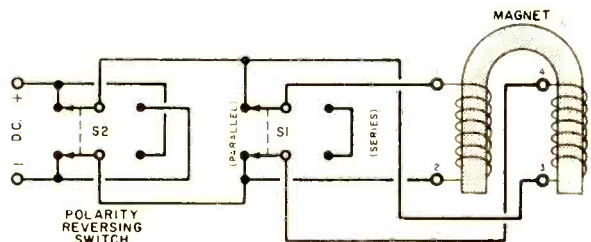

Citizen's Band Radio Operators!

For improved reception,
quality and range, use

Sarkes Tarzian Full Wave Silicon Rectifiers

S5347—replaces 6BW4 or 12BW4

S5017—replaces OZ4

\$13.00
user's
price

Tarzian silicon rectifiers are available to replace
over 95% of all popular vacuum tube rectifiers



ADVANTAGES:

- Improved performance
- Cooler operation
- More reliability
- Less power drain (batteries last longer)
- Longer life for components
- Better regulation

Sarkes Tarzian's new Full Wave Silicon Rectifiers are ultra-high performance replacement tubes that give you the very maximum in reception, quality and range. Cool operation improves reliability and long life of all components.

Ask your repairman for a Sarkes Tarzian Full Wave Rectifier replacement, or see your nearest Sarkes Tarzian distributor. For additional information about Sarkes Tarzian tube replacement silicon rectifiers, write Section 5101E.



SARKES TARZIAN, INC.

World's Leading Manufacturers of TV and FM Tuners • Closed Circuit TV Systems • Broadcast Equipment • Air Trimmers • FM Radios • Magnetic Recording Tape • Semiconductor Devices

SEMICONDUCTOR DIVISION • BLOOMINGTON, INDIANA

In Canada: 700 Weston Rd., Toronto 9 • Export: Ad Auriema, Inc., New York

FROM
HEATH...

14 NEW KITS



AA-50 \$79⁹⁵

HI-FI RATED 25/25 WATT STEREO AMPLIFIER-PREAMPLIFIER KIT

A complete 25/25 watt stereo power and control center (50 watts mono) . . . 5 switch-selected inputs for each channel . . . new mixed center speaker output . . . stereo reverse and balance controls . . . special channel separation control . . . separate tone controls for each channel with ganged volume controls . . . all of these deluxe features in a single, compact and handsomely styled unit! Five inputs for each 25 watt channel are provided: stereo channel for magnetic phono cartridge (RIAA equalized); tape head input; three high level auxiliary inputs for tuners, TV, etc. There is also an input for monophonic magnetic phono cartridge, so switched that monophonic records can be played through either or both amplifiers. The automatically mixed center speaker output lets you fill in the "hole-in-the-middle" found in some stereo recordings, or add extra monophonic speakers in other locations. Nearly all of the components are mounted on three circuit boards, simplifying assembly and minimizing possibility of wiring errors. 30 lbs.

New Heathkit Stereo Hi-Fi Components . . .

plus Exciting New Kits for the Ham, Technician,

Boating Fan and Hobbyist



AD-10
\$33⁹⁵

MANUAL STEREO RECORD PLAYER KIT

Made by famous Garrard of England, the AD-10 is a compact 4-speed player designed to provide trouble-free performance with low rumble, flutter and wow figures. "Plug-in" cartridge feature. Rubber matted heavy turntable is shock-mounted, and idler wheels retract when turned off to prevent flat spots. Powered by a line-filtered, four-pole induction motor at 16, 33 $\frac{1}{3}$, 45 and 78 rpm. Supplied with Sonotone STA4-SD ceramic stereo turn-over cartridge with .7 mil diamond and 3 mil sapphire styli. Mechanism and vinyl covered mounting base preassembled, arm pre-wired; just attach audio and power cables, install cartridge and mount on base. With 12" record on table, requires approximately 15" W. x 13" D. x 6" H. Color styled in cocoa brown and beige. 10 lbs.



a subsidiary of
DAYSTROM, INCORPORATED

ECONOMY STEREO PREAMPLIFIER KIT

Although these two new Heathkit models are designed as companion pieces, either one can be used with your present stereo system. The preamplifier (AA-20) features 4 inputs in each stereo channel and gives you a choice of 6 functions. It will accommodate a magnetic phonograph (RIAA equalized), a crystal or ceramic phonograph, and two auxiliary sources (AM-FM tuners, TV, tape recorders, etc.) and is completely self-powered. The six-position function selector switch gives you instant selection of "Amplifier A" or "Amplifier B" for single channel monophonic; "Monophonic A" or "Monophonic B" for dual channel monophonic using both amplifiers and either preamplifier; "Stereo" and "Stereo Reverse". 8 lbs.

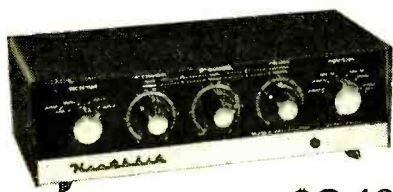

AA-20 \$34⁹⁵

HI-FI RATED 14/14 WATT BASIC STEREO AMPLIFIER KIT

Two 14-watt high fidelity amplifiers, one for each stereo channel, are packaged in the single, compact, handsomely styled amplifier (AA-30). Suitable for use with any stereo preamplifier or with a pair of monophonic preamplifiers, it features individual amplifier gain controls and speaker phase reversal switch. Output terminals accommodate 4, 8 and 16 ohm speakers. 21 lbs.



AA-30 \$45⁹⁵

HI-FI RATED 14/14 WATT STEREO AMPLIFIER KIT

A tremendous dollar value in the medium power class, this top-quality stereo amplifier-preamplifier combination delivers full 14 watts per stereo channel (28 watts monophonic) to drive your stereo system with ease, while versatile controls give you fingertip command of its every function. In addition to "stereo" and "stereo reverse" functions, the SA-2 provides for complete monophonic operation. Inputs on each stereo channel accommodate "magnetic phono" (RIAA equalized), "crystal phono", "tuner" and high level auxiliary input for tape recorder, TV, etc. Other features include a speaker phase-reversal switch, clutched volume controls, ganged tone controls, filament balance controls, and two AC outlets to accommodate accessory equipment. Handsomely styled in black with inlaid gold design. 23 lbs.



SA-2 \$54⁹⁵

UTILITY RATED 3/3 WATT STEREO AMPLIFIER KIT

Your least expensive route to stereo, the SA-3 delivers 3 watts per stereo channel (6 watts monophonic), adequate for average living-room listening. The high level preamplifier has two separate inputs for each channel and is designed for use with ceramic or crystal cartridge record players, tuners, tape recorders, etc. Featured are ganged bass and treble tone controls, clutched volume controls, channel reversing switch, speaker phase reversal switch and mono-stereo function selector switch. Attractively styled with satin-black cabinet. 13 lbs.



SA-3 \$29⁹⁵

MIXED LOWS STEREO CROSSOVER NETWORK KIT

The AN-10 makes it possible for you to convert to stereo or improve your present stereo system by using just one bass "woofer"; saves buying a second bass speaker, permits using more economical "wing" speakers, improves the bass response of any stereo system. Delivers the non-direction bass frequencies of both channels below 250 cps to a single woofer and passes the higher frequency stereo channels to a pair of wing speakers. Rated at 25 watts per channel. Matches 8 or 16 ohm woofers, 8 ohm high frequency speakers, or Heathkit SS-1-2-3 speaker systems. 10 lbs.

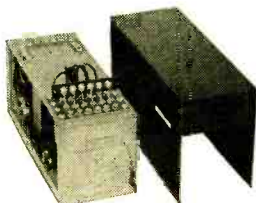

AN-10 \$19⁹⁵

TURN PAGE FOR MORE HIGH QUALITY DO-IT-YOURSELF KITS



HEATHKIT® GIVES YOU MORE IN THESE TEN WAYS:

- 1. Building a Heathkit is easy**—Check-by-step instruction manuals make it virtually impossible for you to fail.
- 2. Building a Heathkit is quick**—No complicated, technical jargon for you to decipher; at most, a Heathkit takes only a few evenings to assemble.
- 3. Building a Heathkit is economical**—Mass production and purchasing economies are passed directly along to you, our customers.
- 4. Building a Heathkit is educational**—As you build, you learn . . . more about electronics, more about the component units and when and where to add them.
- 5. Building a Heathkit is fun**—Nothing quite equals the sense of achievement you receive when you successfully complete a Heathkit unit and "tune-in" for the first time.
- 6. Your Heathkit is Guaranteed**—Every Heathkit unit is guaranteed to meet advertised performance specifications . . . or your money will be cheerfully refunded.
- 7. Your Heathkit is available on Convenient Credit**—Our time payment plan makes it possible for you to order now . . . pay later.
- 8. Your Heathkit is Tops in Quality**—The very finest in electronic equipment comes to you in kit form from the Heath Company.
- 9. Heathkit Dealers can Serve you Locally**—Carefully selected Heathkit representatives are available in most localities.
- 10. Heathkit Service is Customer Service**—Our staff of technical experts is always ready to answer your questions or help you if you have any difficulty.

TEN-TRANSISTOR "MOHICAN" GENERAL COVERAGE RECEIVER KIT (GC-1)

An excellent portable or fixed station receiver. Many firsts in receiver design, ten transistor circuit, flashlight battery power supply and new ceramic IF transformers. The amazing miniature transistors used in the GC-1 replace transformer, inductive and capacitive elements used in conventional circuits for shaping bandpass; offer superior time and temperature stability, never need alignment, provide excellent selectivity. Telescoping 54" whip antenna, tuning meter, fly-wheel tuning and large slide-rule dial also featured. Covers 550 kc to 30 mc in five bands. Electrical bandspread on five additional bands cover amateur frequencies from 80 through 10 meters. Operates up to 400 hours on 8 standard size "C" batteries. Sensitivity: 10 uv, broadcast band; 2 uv, amateur bands, for 10 db signal-to-noise ratio. Selectivity: 3 kc wide at 6 db down. Measures 6½" x 12" x 10". 20 lbs.

HEATHKIT XP-2 Plug-in power supply for 110 VAC operation of GC-1. 2 lbs. \$9.95



GC-1
\$109.95
\$11.00 dn., \$10.00 mo.



HD-19
\$34.95



HD-20
\$14.95

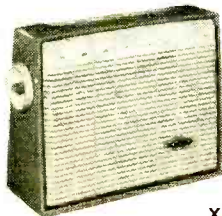

XR-2P
\$29.95
(6 lbs.)



XR-2L
\$34.95
(7 lbs.)

6-TRANSISTOR PORTABLE RADIO KIT (XR-2 Series)

Unsurpassed quality and styling are combined in these handsome sets to provide you with superb and dependable portable entertainment wherever you are—wherever you go! Choose the gleaming, two-tone molded plastic model or the handsome simulated leather-and-plastic combination—both feature a gracefully curved grille in smart beige plastic. The XR-2P complements the handsome grille with a mocha colored case of high-impact plastic, while the XR-2L encases the beige grille in suntan color Sur-U-Lon simulated leather. Vernier tuning control gives you smooth, precise station selection. Six Texas Instrument transistors are used for quality performance and long life; a large 4" x 6" PM speaker with heavy magnet provides "big set" richness of tone. Ready to play after simple assembly—transformers prealigned. Six flashlight batteries used for power (500—1,000 hrs.) (Batteries not included).



HR-19 (10 meter)
HW-29 (6 meter)

\$39.95
each

a subsidiary of
DAYSTROM, INCORPORATED.

Order Direct by Mail or

Always say you saw it in—POPULAR ELECTRONICS

ORDERING INSTRUCTIONS

Fill out the order blank below, giving us your name and address in the space provided at right. Include charges for parcel post according to weights shown. Express orders are shipped delivery charges collect. All prices F.O.B. Benton Harbor, Mich. A 20% deposit is required on all C.O.D. orders. Prices subject to change without notice. Dealers and export prices slightly higher.

QUAN.	ITEM	MODEL NO.	PRICE

Ship via Parcel Post Express C.O.D. Best Way

FREE CATALOG!

Over 150 items of stereo, marine, amateur and test equipment are illustrated and described in the complete Heathkit Catalog.



HEATH COMPANY Benton Harbor 10, Mich.
Please send my free copy of your complete catalog.

NAME _____

ADDRESS _____

CITY _____

ZONE _____

STATE _____

New! One switch operation

"HYBRID" PHONE PATCH KIT (HD-19)

Transfer calls from ham rig to telephone by flipping a single switch! Allows voice control (VOX) or manual operation. VU meter monitors output to 600 ohm line and serves as null depth indicator. Separate receiver and transmitter gain controls. Provides better than 30 db isolation between receive and transmit circuits. All leads filtered to minimize RF feedback. Matches receivers with 3 to 16 ohms impedance. 4 lbs.

NEW 100 KC CRYSTAL CALIBRATOR KIT (HD-20)

This versatile ham aid provides marker frequencies every 100 kc between 100 kc and 54 mc. Use to align all types of communications equipment. Features transistor circuit dependability, battery power portability, and crystal control accuracy. .005% crystal supplied. 1 lb.

Two brand new models

HEATHKIT 10 & 6 METER TRANSCEIVERS

Complete ham facilities at low cost! Ideal for beginning and veteran hams for local net operations. Transmitter and receiver are combined in one easy-to-use instrument. Features neat, modern styling, press-to-talk transmit/receive switch, built-in AC power supply, variable receiver tuning, variable gain control, and amplifier metering jack. Operates mobile using vibrator power supply. Microphone and two power cables included. Handsomely styled in two-tone mocha and beige. Less crystal.

VIBRATOR POWER SUPPLIES: VP-1-6 (6 volt), VP-1-12 (12 volt). 4 lbs. Kit; \$8.95 each. Wired; \$12.95 each.

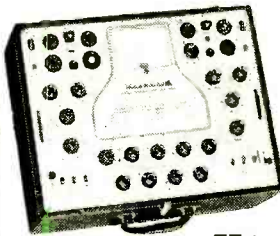

TT-1

\$134.95

\$13.50 dn., \$12.00 mo.

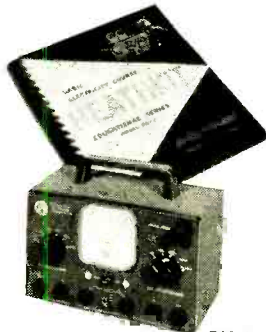

EK-1

\$19.95

MUTUAL CONDUCTANCE TUBE TESTER (TT-1)

The impressive list of its features make this tube tester a fine value. Tests Gm (amplifiers) from 0-24,000 micromhos, Emission, Leakage, Grid current ($\frac{1}{4}$ microampere sensitivity), Voltage regulators (built-in variable DC power supply). Low power Thyatron and Eye tubes. Features 300, 450, and 600 ma constant current heater supplies, life test, Hybrid tube test, built-in switch operated calibration circuit. Large easy-to-read meter, and constant tension free-rolling roll chart mechanism. Individual selector switches allow testing any tube type, regardless of basepin connections, protecting against obsolescence. Assembly simplified by 7 wiring harnesses and transformer terminal board. Assembly skill of technician or higher recommended, time 40 hours average. Black leatherette case with white trim, nylon feet, removable top. 27 lbs.

EDUCATIONAL KIT (EK-1)

Teaches, as you build, the basic "yardsticks" of electronics—opens up fascinating areas of study for youngsters and adults alike. The combination kit and text-workbook gives you a practical demonstration of the principles of voltage, current and resistance; the theory and construction of direct current series and parallel circuits, voltmeter, ammeter and ohmmeter circuits and the application of ohms law to these circuits. The completed meter is used to verify ohms law and the maximum power transfer theorem, one of the most important theorems in electronics. The finished kit, a practical volt-ohm-milliammeter, may be used in a variety of applications. Procedures for checking home appliances and automobile circuits included with the kit. The EK-1 will serve as a prerequisite to following Heathkit Educational kits. Get started NOW in this new and exciting series of "learn-by-doing" educational kits. 4 lbs.

See Your Heathkit® Dealer*

*The convenience of Local Heathkit Sales and Service costs but a few dollars more.

Ship-Shaping Marine Radio

(Continued from page 61)

trical resistances at the connections. A total resistance of only 0.1 ohm in the joints and wires combined can cause a 1-volt drop in a 10-ampere circuit. And, in a 12-volt system, even a 1-volt drop can cause a significant loss in transmitter power output and in receiver sensitivity. The wires should be as short and heavy as possible, and connections should be tight.

Ignition. Receiving range is determined mainly by the level of man-made noise in the vicinity of the receiver. In an automobile, it's easy to control ignition noise because the engine is enclosed in a metallic compartment which acts as a shield. On a boat, it is far more of a problem because the engine and its high-voltage wiring are usually exposed.

A commercial suppressor inserted at the spark-plug end of each high-voltage line between the distributor and the spark plugs should do much toward reducing noise. In the case of a single-cylinder engine, a suppressor inserted in the lead between the ignition coil and the spark plugs is required. Sometimes it's necessary to use shielded cable (with the shield grounded to the engine head or block) between the spark plugs and the distributor or ignition coil.

A special ignition-noise-suppression capacitor, consisting simply of a capacitor inside a metal can, can be installed between the input to the ignition coil and the nearest grounded point. Since even the lighting circuits pick up and re-radiate ignition impulses, it may be necessary to install similar capacitors at switches, lamp sockets, and other points along the vessel's wiring system to bypass ignition impulses to ground. Noise caused by the sparking of generator brushes can be eliminated by connecting a capacitor across the armature of the generator.

If noise persists after all of these precautionary measures have been tried, a portable transistor radio held close to the wiring will usually pin-point sources of interference.

Other Interference Cures. Poor contacts between metal surfaces will sometimes cause metallic objects to act as a rectifier or detector, allowing noise and even radio signals to mix and form a maze of interference. Vibrating wires also contribute noise and sometimes interfere with the

transmitted as well as the received signals. Bonding all metallic objects together is usually the answer, although a poor bond can aggravate the problem.

To obtain maximum range and minimum noise, every channel of your receiver should be tuned as close as possible to the correct frequency. When you're having trouble on a particular channel, the cure is to replace that channel's crystal with one specifically designed for the make and model receiver you are using. You may have trouble if the crystal was designed for another type of set, even if the frequency stamped on it is correct. If all channels are consistently noisy, the trouble could be caused by defective components in the receiver's i.f. or audio amplifiers.

Many marine radiotelephones are equipped with squelch control. The receiving range will be cut drastically if the squelch is improperly adjusted. With some settings, only very strong signals will be heard; with others, very weak signals will be heard, but the noise that accompanies them will be excessive. By varying squelch settings, you can learn to regulate the effective sensitivity and signal-to-noise ratio of your receiver to meet your requirements. Too often, a receiver is blamed when it is the squelch setting itself that is at fault. Some noise is unavoidable in receivers equipped with automatic volume control. Strong stations will have little background noise; but since sensitivity is automatically increased on weak signals, the noise level is boosted as well.

Proper Maintenance. The performance of a marine radiotelephone depends upon the kind of maintenance it is given. Both the transmitter and receiver should be checked thoroughly every few months. Tubes and vibrators should be tested and replaced when indicated. All transmit and receive frequencies should be measured with a frequency meter. Receiver sensitivity should be measured, and if found to be below par, the receiver should be realigned.

No license is required to repair or tune a transmitter as long as it's connected to a non-radiating dummy antenna. When connected to a "live" antenna, however, a transmitter can be tuned only by someone possessing a valid first- or second-class radiotelephone operator license. In all cases, it is the transmitter's licensee (station license holder) who is responsible to the FCC for its proper operation and use.

-30-

LEKTRON—WORLD'S ONLY POLY PAK[®] PRODUCER

FREE

1,000,000
RADIO-TV PARTS
BOUGHT FOR THIS
EXCLUSIVE SALE



It's like having Christmas in July

\$50.00 WORTH OF Over 150 pcs. **RADIO-TV PARTS** **\$1** **POLY PAK[®]**
 OF YOUR CHOICE LISTED BELOW
 ADD 25¢ for handling You'll be satisfied when you receive it
 Sale ends August 15, 1960

BOTH FREE WITH EVERY \$10.00 ORDER

- 3 FERRITE LOOPSTICKS**
Adjustable, 540 to 1600 kc's. Worth \$2. **\$1**
- 3 AC-DC RECTIFIERS**
Scientific, 110V; 65 & 100 ma; half wave. Worth \$4. **\$1**
- NEEDLE & STAMP CHECKER**
Handy-operated. Checks needles, stamps, etc. Worth \$3. **\$1**
- 10 RCA PLUG-IN JACK SETS**
For amps, tuners, recorders, etc. Worth \$2. **\$1**
- 13-IN-1 PAK**
Diodes; carbon, W.V., precision, hi-Q resistors; disc, ceramic, molded, silk, paper; mica condensers; socket; coils. Worth \$8. **\$1**
- 40 TUBE SOCKETS**
4 to 12 prongs, some ceramic & mica filled, & mini types. Worth \$8. **\$1**
- 7 SILICON DIODES**
1N21, 1N22, 1N23, etc. Some worth \$10 ea. **\$1**
- 4 AC & DC CHOKES**
Power & radio types; to 300 mhs. Open frame types. Worth \$10. **\$1**
- 2 TRANSISTOR TRANSFORMERS**
For citizens band & transistor circuits, 100 ohm to 100K imp. Worth \$10. **\$1**
- \$30 RELAY SURPRISE**
Popular shop & lab asst. **\$1**
- 50-FT. 'ZIP' CORD**
For speaker extensions, AC/DC, 2-cond. parallel. Worth \$3. **\$1**
- 60 TERMINAL STRIPS**
1 to 10 tie points. Used in every type of proj. Worth \$5. **\$1**
- 70 COILS & CHOKES**
RP, ant. use, slug-tuned, I.F. Wonderful shop asst. Worth \$4. **\$1**
- 70 ONE-WATT RESISTORS**
Incl. precisions, W.V., carbon-films, 1 & 5% too. Worth \$20. **\$1**
- 65 CONDENSER SPECIAL**
Incl. discs, ceramics, molded, mica, papers, oils, etc. Worth \$12. **\$1**

- 15 ROTARY SWITCHES**
Asst grans, contacts; for power & circuit chang'ng. Worth \$17. **\$1**
- "POLY" WIRE PAK**
Asst colors; 6-25 ft. rolls; plastic ins.; ±18 thru ±24. Worth \$4. **\$1**
- 8 SILICON/CRYST. DIODES**
1N21, 1N34, etc. Some worth \$10. **\$1**
- 4 1N34 DIODES**
Or equal; glass-sealed. New mini. types. **\$1**
- 40 DISC CONDENSERS**
Asst. 0.001 to .01 to 1000V. Worth \$10. **\$1**
- 4 OUTPUT TRANSFORMERS**
50L6, etc. Open frame. **\$1**
- 6 115VAC PANEL SWITCHES**
Toggle type. SPST, DPDT. **\$1**
- TRANSISTOR RADIO BASIC**
Incl. transistor, socket, loopstick, diode, case. Worth \$3. **\$1**
- CRYSTAL RADIO SET**
Incl. diode, loopstick, wire, condenser, etc.; diagram & cabinet. **\$1**
- 1 ELECTRIC MOTOR**
115 VAC, 3000 rpm, 100's Shop uses. Worth \$5. **\$1**
- 2 SAPPHIRE NEEDLES**
4-speed, for genl. purp. cartridges, 10,000 plays. Worth \$2. **\$1**
- 70 INSULATED RESISTORS**
IRC, Allen Bradley, Stackpole makers. 1/2, 1W, 100 ohms to 1 meg. 1%, 5%. Worth \$15. **\$1**
- 10 PANEL SWITCHES**
Micros, power, rotary types. Exc. variety. Worth \$10. **\$1**
- 30 PANEL PILOT LITES**
Mini bay & screw types. Worth \$5. **\$1**
- 65 RESISTOR SPECIAL**
Carbons, precisions, hi-Q, W.V., carbon-films, to 50W, 1% too. Worth \$10. **\$1**
- 10 VOLUME CONTROLS**
Asst to 1 meg. Some with switch. Worth \$15. **\$1**

- 3 HOBBY TRANSISTORS**
PNP's, etc. Similar to CK-722. Worth \$8. **\$1**
 - 125 RESISTORS**
30 values, incl 1% too, carbons! To 1 meg. 1/2, 1W. Worth \$10. **\$1**
 - 15 "POLY" BOXES**
Snap-top covers; sizes to 4". For parts & radio basics. Worth \$3. **\$1**
 - 4 I.F. TRANSFORMERS**
456 kc's. Only 1/2" sq. base for trans. cases. Worth \$4. **\$1**
 - 60 PLUGS & RECEPTACLES**
Incl. power, audio, battery, etc. Worth \$8. **\$1**
 - 125 CERAMIC CONDENSERS**
Incl. discs too! Wide variety of types & values. Worth \$10. **\$1**
 - 12 GERMANIUM DIODES**
Glass-sealed, similar to 1N48; hobbyists' need! **\$1**
- \$5.00 ORDERS**
WE WILL GIVE YOU
\$500 WORTH OF
RADIO
PARTS
FREE
- VEEDER ROOT COUNTER**
Counts 000 to 999. Exc. for tape revolvers & coil makers. Worth \$5. **\$1**
 - 100 HALF WATT RESISTORS**
Pop. asst values. Some 1% too. Worth \$18. **\$1**
 - 10 3-SEC. TIMERS**
Precision geared. Worth \$5 ea. **\$1**
 - 10 INSTRUMENT KNOBS**
Pointer types, black, brass insert & set screws. **\$1**
 - 8-PC. NUTDRIVER SET**
Plastic handle, 3/16 thru 7/16 nutdrivers in handy case. Worth \$3. **\$1**
 - 35 POWER RESISTORS**
Asst. 5 to 30W to 10,000 ohms. Vitreous types too. Worth \$12. **\$1**

- 70 MICA CONDENSERS**
Incl. silvered too! 0.0025 to .01 to 600V. Worth \$20. **\$1**
- 10 ELECTROLYTIC CND'N'RS**
Incl. can & paper types. Units too! To 1000 mfd to 450 V. Worth \$12. **\$1**
- 80 TUBULAR CONDENSERS**
Paper, molded, silk, ceramic! .0001 to 1 mfd to 600V. Worth \$10. **\$1**
- 30 SILVER MICAS**
1 & 2% asst values. Finest mica made. Worth \$8. **\$1**
- 300-FT. HOOKUP WIRE**
Asst. colors, insulation, sizes. Worth \$5. **\$1**
- 60 RADIO 'N' TV KNOBS**
Asst. colors, sizes, shapes; some worth \$1 ea. **\$1**
- 1500 PCS. HARDWARE**
Nuts, bolts, etc. Wide variety. Handy shop asst. **\$1**
- 30 MOLDED CONDENSERS**
Pop. values, black beauties, oils, etc. Lasts for life! Worth \$8. **\$1**
- 40 TWO-WATT RESISTORS**
Incl. 1% too. Asst. values. **\$1**
- 40 TRANSISTOR RESISTORS**
Asst. to 3 megs. 1/5 watt rating. Color coded. Worth \$5. **\$1**
- SOLDERING IRON**
115V AC/DC; with cord & plug. Nifty hobby unit. Worth \$8. **\$1**
- 20-PC TWIST DRILL SET**
In case, 1/16 thru 1/4". For all types of drills. **\$1**
- 2000 OHM PHONE**
With cord & plug. Hearing-aid type, with ear loop. Worth \$8. **\$1**
- 24 ARTISTS BRUSHES**
100% pure bristles. Sizes 1 to 4. **\$1**
- CRYSTAL PHONE**
Sensitive! 100's transistor proj.-asst. & plug. **\$1**
- \$25 SURPRISE PAK**
Wide variety of usable radio-TV/hobby parts. **\$1**

GIANT TUBE—SALE! 70% to 90% OFF! NAMED BRAND TUBES—YEAR GUARANTEE!

TYPE	SALE	TYPE	SALE	TYPE	SALE	TYPE	SALE	TYPE	SALE	TYPE	SALE	TYPE	SALE		
024	\$.59	3V4	\$.69	6AH6	1.29	6BE6	.63	6CUG	1.19	6E5L	.89	6X8	\$.89	12L6	\$.67
1B3	\$.89	4BQ7	1.14	6AK5	\$.49	6BG6G	1.89	6D6E	\$.69	6SN7	\$.79	12AT7	\$.89	12SA7	\$.99
1B4	\$.89	5AR5	1.12	6AL5	\$.53	6BH6	\$.79	6DQ6	1.14	6SQ7	\$.79	12AU6	\$.61	12SK7	\$.79
154	\$.89	5AW8	\$.95	6AM8	\$.89	6BK6	\$.99	6E6	\$.69	6T8	1.19	12AV6	\$.79	12SQ7	\$.89
155	\$.69	5AN8	\$.99	6AN8	\$.99	6BK7A	\$.94	6J6	\$.79	G18	1.19	12AV6	\$.49	12TV6	\$.59
1T4	\$.64	5AQ5	\$.63	6AQ5	\$.62	6BL7	1.09	6K6	\$.79	G8	1.19	12AV7	\$.69	12X4	1.49
1U4	\$.69	5AT8	\$.89	6AS8	\$.69	6BL7	1.09	6K6	\$.79	G8	1.19	12AX7	\$.69	25BQ6	1.29
1U5	\$.59	5BK7A	\$.99	6AT6	\$.53	6BQ6	1.29								
1V2	\$.57	516	\$.81	6AT8	\$.53	6BQ7	1.09								
1X2	\$.99	518	\$.98	6AU4	\$.96	6BZ6	\$.63								
3AL5	\$.54	5U4	\$.69	6AU6	\$.96	6C6	1.19								
3AU6	\$.64	5V8	\$.94	6AU8	\$.99	6C4	\$.49								
3B5	\$.69	5Y4	\$.92	6AV6	\$.49	6CB6	\$.66								
3BE6	\$.63	5Y3	\$.93	6AW8	\$.99	6CG7	1.69								
3BN6	\$.86	6AB4	\$.59	6AX4	\$.79	6C6E	\$.66								
3C5	\$.69	6AC7	\$.99	6BA6	\$.57	6CF6	\$.72	654	\$.59	6V6	\$.69	12BK5	\$.99	35C5	\$.59
3BZ6	\$.65	6AF4	1.06	6BA8	1.04	6CG7	\$.69	65A7	\$.89	6W4	\$.74	12BK6	1.29	35W4	\$.49
3CB6	\$.63	6AG5	\$.79	6BC5	\$.65	6CL6	1.04	65C7	\$.85	6W6	\$.79	12B7	\$.85	35Z5	\$.55
3C56	\$.68	6AQ7	1.19	6BC8	1.19	6CN7	\$.74	65J7	\$.79	6X4	\$.48	12BZ7	\$.85	50C5	\$.59
354	\$.69	6AH4	\$.89	6BD6	\$.65	6CS6	\$.64	65K7	\$.84	6X5	\$.59	12DQ6	1.15	50L6	\$.89

HOW TO ORDER

ORDER BY "BLACK-TYPE" HEADLINES
 i.e. 60 TERMINAL STRIPS—\$1

MINIMUM ORDER \$2

LEKTRON

135 EVERETT AVE.
 CHELSEA 50, MASS.

AVG. WT. 1 lb. per pak. State price with each item. Send check or M.O. including sufficient postage; excess returned. C.O.D. orders, 25% down; rated, net 30 days. Include Postal Zone No. in address. (Canada postage, 48¢ 1st lb.; 28¢ ea. add'l lb.)

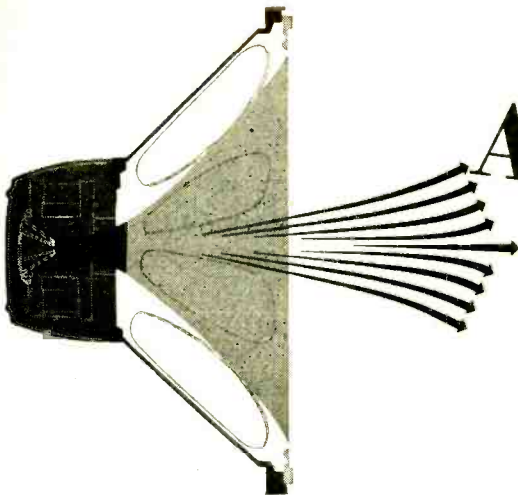

Announcing

*The most
Complete
Guide to Hi-Fi
and Stereo
Ever Published!*

STEREO • HI-FI GUIDE 1960

In this compact, handy reference, you'll find the answers to nearly any question on hi-fi, plus details and data on trends, components, speakers, stereo, audio theory. Prepared by the Editors of POPULAR ELECTRONICS, the 1960 STEREO • HI-FI GUIDE is easy to understand—complete with diagrams, illustrations, and clear explanations.

Here's what you'll find in the five big sections of the 1960 STEREO • HI-FI GUIDE:

I. YEARBOOK

- Trends and New Products
- Multiplex—an analysis and forecast

II. INSIDE THE COMPONENTS

- Detailed analysis of preamps, stereo preamps, power amps, tuners, turntables, and stereo cartridges

III. SPEAKERS AND ACOUSTICS

- Inside the HiFi Loudspeakers and Enclosure
- Electrostatic and Cone Type Speakers
- Does Shrinking Size Mean Shrinking Sound?
- Between Speaker and Ear
- Custom-Built Equipment Enclosure

IV. STEREO

- Stereo Standards
- What You Should Know Before Buying Stereo
- Stereo Simplexing Simplified
- Stereo Tape is Back to Stay
- Balancing Your Stereo System
- Stereo Cartridge Directory
- Stereo Records—Fad or Fulfillment?

V. AUDIO THEORY AND APPLICATION

- Maintaining and Testing Your HiFi
- Harmonic Distortion
- Filter and Crossover Networks

DON'T DELAY—NOW ON SALE at your favorite newsstand or Electronic Parts Store, or order by coupon today. Only \$1.00.

NOW
On Sale
or order by
coupon today!
Only \$1.00



Ziff-Davis Publishing Company
Department PE-760
434 S. Wabash Avenue,
Chicago 5, Illinois

Please send me a copy of the 1960 STEREO® HI-FI GUIDE. I enclose \$1.00, the cost of the GUIDE, plus 10¢ to cover mailing and handling charges. (Foreign \$1.25, plus 25¢ handling charges.)

Name _____

Address _____

City _____ Zone _____ State _____

Inside the Hi-Fi Microphone

(Continued from page 58)

front or back produce an output that depends on how accurately the sound source is centered either at the back or the front. The result is an overall pickup pattern having the shape of a figure eight.

Under some circumstances, the bi-directional pickup pattern has great advantages. Unwanted sounds can be minimized simply by facing the mike in a different direction. The balance between sections of an orchestra can thus be varied quite easily.

Single-Direction Mikes. Designers worked for a long time to develop uni-directional mikes and they eventually succeeded using some highly ingenious methods. One of the curious facts of geometry is that the sum of a circle and a figure eight is a figure called a cardioid—a heart-shaped pattern. Combining an omni-directional mike with a bi-directional mike results in a cardioid pattern which is a reasonable approximation to the uni-directional pattern desired. This can be done by building two microphones into the same case and then combining their outputs. (See Fig. 6.) A potentiometer which mixes the outputs of the two mikes in different proportions allows the pickup pattern to be varied.

Another type of dual-element cardioid microphone is made up of two ribbon transducers. One ribbon is open on both sides and has the typical figure-eight pattern. The back of the other ribbon, however, is totally enclosed in an acoustic labyrinth, and has an omni-directional pattern. When the outputs are combined, a cardioid pattern results.

In the RCA 77 dual-ribbon microphone, the directional pattern can be changed by adjusting the opening which leads from the back of the second ribbon to an acoustic labyrinth. When the aperture is all the way open, the back of the ribbon is also effectively open, causing the second ribbon

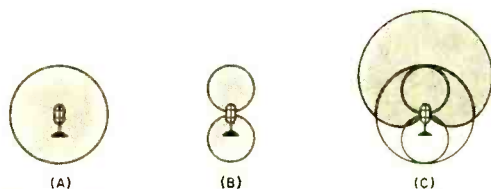
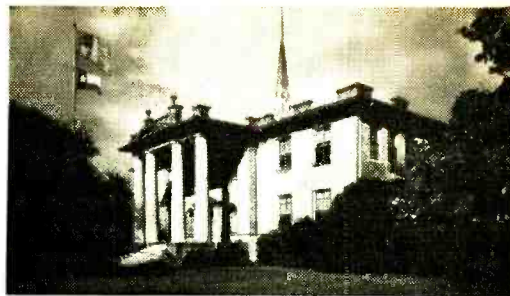

Fig. 6. The most common microphone pickup patterns are omni-directional (A), bi-directional (B), and uni-directional, or cardioid (C). When (A) and (B) are added algebraically, they produce (C).

July, 1960



PORT ARTHUR COLLEGE

ELECTRONICS • COMMUNICATIONS
RESIDENT • CO-EDUCATIONAL
AM-FM RADIO • TV STATIONS
MARINE RADIO

TRAINING Is the finest. Well equipped college classrooms and laboratories with AM, FM transmitters, radar and marine equipment, color fundamentals, transistors, television, camera chain, experimental laboratory test equipment, etc. used as standard part of curriculum.

PRACTICAL On-the-job-training program. College operates Radio Station KPAC, co-owner of KPAC-TV. You learn the interesting way. You learn by doing.

G.I. APPROVED

CO-EDUCATIONAL You enjoy the personal growth and cultural advantages that only the American co-educational college system can provide.

LOW COST Being a non-profit vocational institution explains our low tuition rates . . . \$36 per month. Room and board at campus dormitory only \$52 per month. Monthly payments accepted.

FREE PLACEMENT SERVICE Our graduates are in demand at good salaries. We have trained men from all 49 states and abroad.

INVESTIGATE Write for illustrated booklet P-48 for further details. Classes now forming. Non high school graduates must pass entrance examination. Persons 21 years or older may be accepted on individual approval.

PORT ARTHUR COLLEGE

PORT ARTHUR, P-1182, TEXAS

Founded in 1909

to have a figure-eight pattern. When the aperture is closed, the pattern of the second ribbon is omni-directional. This pattern combines with the figure-eight of the first mike to make the cardioid pattern. Other pickup patterns can be obtained by adjusting the opening.

The omni-directional pickup pattern of a dynamic mike can be converted into a cardioid shape by controlling out-of-phase pickup and by adjusting various acoustical impedances in the microphone case. There are two general ways of doing this. The first is to put one or more resonators at the back of the case which vibrate out of phase with the diaphragm, thus tending to prevent the diaphragm from responding to sounds from the side and back. The other technique is to provide several small openings at the back air chamber to permit the acoustical impedances to be varied and thus change the pickup pattern. Some manufacturers prefer to manipulate the characteristics of an omni-directional mike when they design a cardioid microphone rather than build two microphones into one case and then combine their outputs. -30-

DX'ing Down Below

(Continued from page 53)

orders payable to the Receiver General of Canada.

Hundreds of other long-wave stations are included in "Radio Navigational Aids, H.O. 205," which can be had for \$5.00 from the U. S. Navy Hydrographic Office, Washington 25, D. C.

If you'd like a "sneak preview" of DX'ing on the 200- to 400-kc. aero beacon band, you can listen to a fascinating new LP record that was made aboard an aircraft in flight. It's called "On Course, On the Glide Path," and is produced by Aero-Progress, Inc., 10493 Santa Monica Blvd., Los Angeles 25, Calif. It's complete with an illustrated brochure, and should make an ideal reference guide for any DX'er. It sells for \$5.98 plus 25¢ postage.

Why don't you put on your electronic diving helmet and plunge into the kilocycle depths? As you pass that last standard broadcasting station at the bottom of the dial, you'll enter a new world. Come on in, the DX is fine! -30-

How You Can "GET ON THE AIR" —Without An EXAM!

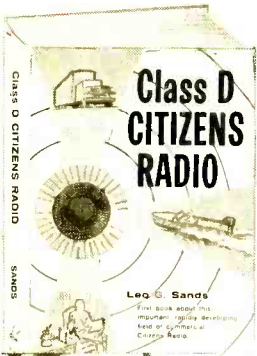

NEW Class "D" Citizens Radio Handbook Answers ALL Your Questions About: How to use two-way radios for business and pleasure—to talk from car to car, ship to shore, office to mobile unit, between farm buildings, on hunting trips, and dozens of other useful applications.

HERE's how to get the most out of your Class D Citizens Band Radio Set—how to buy and use equipment for the ultimate in fun and practicality! This new, fully illustrated, easy-to-read book tells you, in layman's language, EVERYTHING the Citizens Banders needs to know. Contents include what to buy and how much it will cost...which set will suit your needs best...how to apply for your free license (no FCC examination required). Discusses

transmitters, receivers, antennas, power requirements, and gives you full instructions for installation and maintenance. Tells you how and where you can use your set and includes complete FCC rules and regulations. Contains 180 clear simply-written pages and 72 informative illustrations; only \$4.95 plus few cents for shipping. FREE 7 Day Trial—Send no money! Mail coupon at once.

Mail Coupon TODAY for 7 DAY FREE TRIAL Examination!



ELECTRONICS BOOK SERVICE

A Division of the Ziff-Davis Publishing Co. CRE760
434 South Wabash Avenue, Chicago 5, Ill.

Please send me copies of CLASS D CITIZENS RADIO and bill me only \$4.95 per copy plus a few cents postage. If I am not pleased with the book, I may return it within 7 days and I will owe you nothing.

CHECK HERE AND SAVE MONEY. I enclose payment for book(s) herewith, and you will pay the postage. (Same 7-day return privilege.)

PRINT NAME.....

ADDRESS.....

CITY.....ZONE.....STATE.....

N.Y.C. Residents, Please add 3% Sales Tax.

Magnetic Amplifiers

(Continued from page 75)

long the lives of the submerged tubes. This is important because lifting the cable to replace a damaged tube costs thousands of dollars.

Long-Life Switching. Basic magnetic amplifier circuits can be modified to give special effects. For example, a magnetic to which excessive positive feedback has been applied becomes "bistable." This means that it is stable in only two states of operation: maximum output or minimum output. There is no in-between. The amplifier is adjusted so that the core is normally in a non-saturated state. But even the tiniest input signal—perhaps only a few microamperes—will throw it into complete saturation. Thus it becomes the equivalent of an extremely sensitive switch, or relay.

But a magnetic amplifier is a switch without moving parts or contacts, and it is virtually indestructible. The bistable magnetic is beginning to find widespread use as a replacement for relays where long, reliable service is of great importance.

Several automotive companies—the Ford Motor Co., for example are now using magnetics to control the flow of parts in the engine assembly line. First, proximity switches containing magnetic amplifiers sense the presence or absence of necessary parts on an automated line. Other magnetics, cued by the proximity switch, supply the parts as needed. Since there are no moving components and no contacts, these magnetics show no signs of wear after millions upon millions of operations—long after normal relay contacts would have worn out. Another series of magnetics controls the speed of the engine assembly conveyor, to determine the proper production rate.

The uses for magnetic amplifiers are almost limitless. They serve as memory units in computers and as speed regulators in steel, paper, and textile mills; they control gun turrets and radar antennas on navy ships; they regulate the voltage output of huge turbine generators; they control automatic elevators, mine hoists, power shovels, cranes, and printing presses. In short, wherever the considerations of precise, reliable, trouble-free control are important—from jet aircraft to atomic submarines—you'll find magnetic amplifiers working silently and efficiently.

The TRUTH About ELECTRONICS JOBS!

High-pay positions await you in Electronics—fastest-growing major industry in U. S. 1,500,000 employed—more needed! Huge demand for trained men in missiles, rockets, electronics, outer-space projects. Also in Radio-TV service, broadcasting studios, communications. Real opportunity if you prepare now, this easy, low-cost way. FREE book tells all!

Get this valuable book now . . .



Approved for Veterans

Your Chance for High-Pay Career:

I would like to send you my FREE book shown above. It will tell you all about the Electronics-Radio-Television field . . . show you the many high-pay careers open to trained men . . . and explain how you can qualify yourself in a minimum of time, at a minimum of cost. Home study or resident training. Demand for electronics specialists greatly exceeds the supply. Just check the positions held by these recent Central Graduates picked at random from our files:

Garry Sheley, ELECTRONIC TECHNICIAN, Convair Astronautics; Jack Frazier, STUDIO ENGINEER, Station KMTV-TV; Alvin Brazda, STAFF ASSISTANT, Sandia Corporation; David Winkler, PUBLICATIONS ENGINEER, Martin Company. Over 50,000 successful graduates since 1931!

P. L. Foster C. L. Foster, President

Clip and Mail Today!

**ELECTRONICS DIVISION—Central Technical Institute
Dept. A-70, 1644 Wyandotte St., Kansas City 8, Mo.**

(Offering engineering technician curricula accredited by Engineers Council for Professional Development.)

Please tell me more about how your training can qualify ME for a high-pay Electronics career. (Check specific field(s) of interest below, if you wish.)

- | | | |
|--|---|---|
| <input type="checkbox"/> Radio | <input type="checkbox"/> Guided Missile | <input type="checkbox"/> Tech. Drafting |
| <input type="checkbox"/> Television | <input type="checkbox"/> Nuclear Power | <input type="checkbox"/> Armed Forces |
| <input type="checkbox"/> Color TV | <input type="checkbox"/> Radar | <input type="checkbox"/> Civil Service |
| <input type="checkbox"/> Electronics | <input type="checkbox"/> Aviation | <input type="checkbox"/> Your Business |
| <input type="checkbox"/> Other | | |



ACCREDITED BY
National Home
Study Council
Member National
Councils of
Technical Schools

Name
Address
City Zone
State County
Age Education

**BUILD THE
PROJECTS
DESCRIBED
IN THIS
ISSUE OF**

WITH THESE



PRODUCTS

**POPULAR
ELECTRONICS**

"Build a Picnic Speaker"

Use BUD CU-2107A—\$1.50

"Crystal Selector"

Use BUD AU-1028—\$1.37

"Unlicensed Two-Way Radio"

Use BUD WO-6—\$12.05

"Radioman's Lamp"

Use BUD AC-402—\$1.17

"Build an Earphone Booster"

Use BUD CU-3001A—61¢

All Bud products are available for immediate delivery from your Authorized Bud Distributor. They are the best for applications described in these projects.

WATCH FOR THESE LISTINGS EVERY MONTH
IN POPULAR ELECTRONICS

BUD RADIO, INC.

2118 East 55th Street

Cleveland 3, Ohio

Dept. P.E.

To build the
projects in
this
issue
of

Use these
STANCOR
TRANSFORMERS

POPULAR
ELECTRONICS

Sorry

Nothing This Month

Transformers are specified *only* when they have been verified for their application in the construction projects listed in this issue.

LOOK FOR this helpful listing every month. It appears regularly in Popular Electronics.

CHICAGO STANDARD
TRANSFORMER CORPORATION
3501 W. Addison St. Chicago, Illinois

Extend Life of Records

(Continued from page 79)

changer arms to track at a uniform stylus pressure and playing angle, and there's also a greater chance for your records to do themselves damage by grinding dust and grit into each other's grooves.

Regardless of whether you play your records on a turntable or a changer, bring the unit to a complete stop before you put records on it. Don't grind those delicate record grooves against the moving surface of the table. Also try to get into the habit of slipping the records you've played back into their jackets before you settle down for more listening.

The Dust Problem. No matter how careful you are in handling your records, you still have to cope with the problem of keeping them free of dust. Records start to collect dust almost from the moment they leave the stamper at the factory, mainly because they bristle with static electricity which attracts airborne dust with tremendous speed and efficiency. Recently some of the record manufacturers have started to add a static-eliminating agent to the record "mix," but the great majority of records reach your living room with a good static charge on their surfaces.

The time to attack the problem of static electricity is before you play the record for the first time. If you wait until it has been played a few times, the dust attracted by its static charge will already be partially ground into the grooves.

Simply brushing the record off with a rag won't get rid of the dust attracted by static electricity. On the contrary, it will probably build up the static charge even more. A damp, soft cloth will usually do a satisfactory job, but for best results you need one of the products specifically designed for static elimination.

Anti-static products include treated cloths, sprays, and even mildly radioactive capsules which clip on to your tone arm and de-staticize the surface of the record as it plays. Both cloths and sprays do the job pretty well, but their effects are not permanent. Sprays have their disadvantages, too; an overenthusiastic user can apply such a healthy layer of spray that it will gum up the record grooves and the stylus as well.

Probably the easiest anti-static products to use are the radioactive types, either at-

tached to the tone arm or imbedded in a special record brush. With these gadgets, your records can be conveniently de-staticized at each playing, and you can count on a year or two of use before having to replace the radioactive element.

Incidentally, you should always "billow" the record jacket when you're sliding a record in or out of it to prevent the surfaces of the record from rubbing against the inside of the jacket—and thus increasing the amount of static electricity build-up. Also, the glassine-type inner covers are very efficient static electricity generators and should be deposited in a nearby waste basket.

Once you've licked the static problem, you'll find it much easier to keep your records free of dust, and those pops and clicks from your loudspeaker will be few and far between. For even better listening, though, you should give your records a bath every year or two. This will get rid of the abrasive grit that's managed to find its way deep down into the grooves.

All you have to do is give your records a very gentle scrubbing with a soft sponge in some lukewarm water that contains a little sudsless detergent. A quick rinse under the faucet and a wipe with a clear sponge—plus a few seconds exposure to the air—and your records will be clean as a whistle. Try this treatment on one of your older records to see just how easy and effective it is. The only precaution here concerns the record label itself. On a few brands, the ink will run when it is wet. Although this is the exception, it's wise to check and see if the ink is color-fast before you dunk it into the wash water.

Record Storage. Storing your records is quite simple and involves only a few rules of common sense. Keep the records away from radiators and sunny windows to avoid warping, and store them on end on a shelf or in a cabinet. Don't stack them horizontally because the ones on the bottom will suffer from too much pressure and those on top are likely to warp. Plastic sleeves for your records will help seal out dust, particularly when your record jackets start to crack open with age.

If you follow the techniques for record care outlined above, your records should provide like-new performance for a long time. And the slight effort you spend to keep your records in tip-top shape will pay dividends in listening pleasure. —30—

July, 1960

FREE CAREER BOOKLET

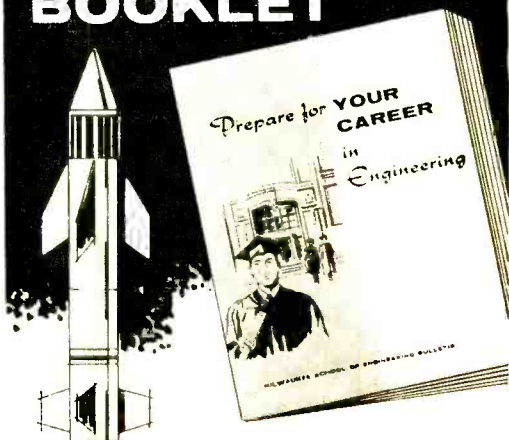

To guide you to a successful future in

ELECTRONICS RADIO-TV COMPUTERS ELECTRICAL ENGINEERING

This interesting pictorial booklet tells you how you can prepare for a dynamic career as an Electrical Engineer or Engineering Technician in many exciting, growing fields:

**MISSILES • AVIONICS • AUTOMATION
SALES • DEVELOPMENT
ELECTRICAL POWER • ROCKETRY
RADAR • RESEARCH**

Get all the facts about job opportunities, length of study, courses offered, degrees you can earn, scholarships, part-time work — as well as pictures of the Milwaukee School of Engineering's educational and recreational facilities. No obligation — it's yours free.

MILWAUKEE SCHOOL OF ENGINEERING

MAIL COUPON TODAY!

Milwaukee School of Engineering
Dept. PE-760 1025 N. Milwaukee St., Milwaukee, Wis.

Please send FREE "Your Career" booklet
I'm interested in

Electronics Radio-TV Computers
 Electrical Engineering Mechanical Engineering

Name _____ Age _____

PLEASE PRINT

Address _____

City _____ Zone _____ State _____

I'm eligible for veterans education benefits.
Discharge date _____

MS-117

**YOUR COPIES OF
POPULAR
ELECTRONICS
ARE VALUABLE**

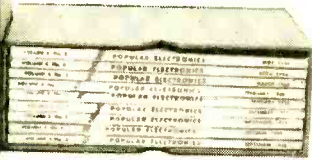

**KEEP THEM NEAT . . . CLEAN . . .
READY FOR INSTANT REFERENCE!**

Now you can keep a year's copies of POPULAR ELECTRONICS in a rich-looking leatherette file that makes it easy to locate any issue for ready reference. Specially designed for POPULAR ELECTRONICS, this handy file—with its distinctive, washable Kivar cover and 16-carat gold leaf lettering—not only looks good but keeps every issue neat, clean and orderly. So don't risk tearing and soiling your copies of POPULAR ELECTRONICS—always a ready source of valuable information. Order several of these POPULAR ELECTRONICS volume files today. They are \$2.50 each, postpaid—3 for \$7.00, or 6 for \$13.00. Satisfaction guaranteed or your money back. Order direct from:

JESSE JONES BOX CORP. Dept. PE
(Established 1843)
Box 5120 Philadelphia 41, Pa.

YOURS FREE—
**THIS BIG WALSCO
ELECTRONICS PRODUCTS
CATALOG!**

Send postcard today for your free copy of Walco's 64-page Catalog 59 . . . or ask for one at your distributor.

WALSCO ELECTRONICS MFG. CO.
Division of Tectron Inc.
Western Plant: Los Angeles 18, California
Main Plant: **ROCKFORD, ILLINOIS, U.S.A.**
In Canada: Atlas Radio Corporation

MASTER ELECTRONICS

Intensive, high-level training at this recognized public college prepares you for a successful career in electronics. Fine equipment—experienced instructors—small classes—personal attention—all college advantages provide excellent learning opportunities. Associate in Applied Science Degree in 18 months. Engineering option. Low tuition and living costs. College housing for single and married students. Established 1925. FREE catalog. Write

TRINIDAD STATE JUNIOR COLLEGE
Trinidad Dept. PE-7 Colorado

engineering degree in 27 months

Grasp your chance for a better life. Rapid advancement. Better income. **BACHELOR OF SCIENCE DEGREE IN 27 MONTHS** in Elect. (Electronics or Power major), Mech., Civil, Aero., Chem. Engineering, **IN 36 MONTHS** in Business Administration (General Business, Acctg., Motor Transport Mgt. majors). Small classes. More professional class hours. Well-equipped labs. Campus. Dorms. Modest costs. Year-round operation. Founded 1884. Enter Sept., Jan., Mar., July. Write J. D. McCarthy, Director of Admissions, for Catalog and "Your Career in Engineering and Commerce" Book.

TRI-STATE COLLEGE 3670 College Avenue
Angola, Indiana

Transistor Topics

(Continued from page 86)

Company engineers made up the car by combining the old and the new—a 1912 *Baker Electric* teamed with a roof-mounted panel of 10,000 silicon solar cells connected in a series-parallel arrangement to charge the storage batteries of the car's 72-volt electrical system. The panel, covering 26 square feet, can charge the batteries in 10 hours. Powered by a 3-hp. electric motor, the car is capable of speeds up to 20 mph.

But don't rush out to buy your own sun-powered car—this unit is one of a kind, and the power panels are not yet in mass production.

Product News. Sylvania's new Type D-4121 silicon diode has the highest switching rate of any commercially manufactured unit—it's capable of performing up to 500,000,000 logic functions in a fraction of a second when used in computer circuits. It has a switching speed of 0.3 μ sec.—three-tenths of one thousandth-millionth of a second. And man, that's fast!

The tunnel diode continues to make news. Here in the U. S., RCA is producing these units in pilot plant quantities. And from Tokyo comes news that the world-famous Sony plant has started producing them.

The International Rectifier Corporation (El Segundo, Calif.) has introduced a new series of low-cost Zener diodes. Featuring a new sealing technique, these units are made in standard RETMA voltage steps from 5.6 to 27 volts. Rated at 10 watts, they sell for under \$6.00 each.

Thermoelectric cooling units designed to maintain constant operating temperatures for transistors have been put on the commercial market. Manufactured by Westinghouse Electric Corporation (Youngwood, Pa.), they use the Peltier effect (see *Transistor Topics*, May, 1960).

From the General Electric Company (Syracuse, N. Y.) comes news of a series of high-speed germanium *n-p-n* switching transistors, Types 2N1288 and 2N1289. Under development for over two years, these units operate up to 60 mc. With maximum ratings of 20 volts, they have *betas* up to 150. Selling price, in large quantities, is under five dollars per unit.

That about covers the semiconductor story for now. I'll be back next month with more news and circuits.

Lou

Test Instruments

(Continued from page 83)

3. Use an isolation transformer if the receiver under test is of the transformerless type.

4. Use only the output lead furnished with the sweep generator. Extending the lead with extra wire can change the waveform drastically.

5. Keep the leads as clear as possible of stages other than those under test.

6. Use the lowest sweep generator output that gives a usable waveform. A generator output even slightly too high can distort the curve.

7. Marker pips should also be kept as small as possible to avoid waveform distortion.

8. Generally, a better i.f. alignment will result if the local oscillator is disabled while i.f. is being aligned.

9. Be sure that both receiver and test equipment are warmed up for at least 30 minutes before you begin.

10. Exact bias, as called for in the manufacturer's alignment instructions, is important. If dry cells are specified for bias voltage, make certain you use fresh ones.

Various Models. Sweep generators offer many different features, and naturally come in a wide range of prices. Some instruments have variable internal marker oscillators, for example; others do not. If you already have an AM signal generator that can be used as a marker oscillator, you may not need a sweep generator with an internal tunable marker.

Some generators have a wider sweep bandwidth than others. There are even a few generators designed for servicing FM receivers only, but most cover the FM and TV bands with room to spare on either end—some are even tunable down through the broadcast band.

Excellent sweep generators can be built from kits. They run from around \$35 for the simpler models to about \$75 for the more complex units. Wired models cost from almost \$100 to several hundred dollars. There are also combination signal and sweep generators which can perform all the functions of both; these, naturally, are a little more expensive. Other special units can be bought with especially high- or especially low-frequency ranges, high output, or other unique features.

-30-

July, 1960

Attention

YOUNG MEN AND WOMEN



Electronics is the key to your future. Money - Security - Respect. Two World Renowned names PHILCO and SPARTAN bring you the finest electronics training on the newest and most modern equipment available today. Radar - Sonar - Radio - Transistors - Television - Modulars and Solid State Computers.

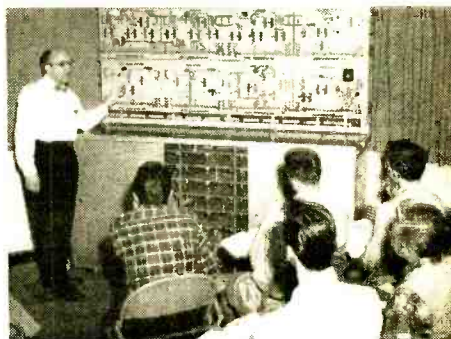

You Must Act NOW!

WHICH CAREER INTERESTS YOU

- New Electronics
- Jet Mechanic
- Co-Pilot Engineer
- Commercial Pilot
- Link Trainer
- Instrument Mechanic



Director of Admissions
Spartan School of Aeronautics
Municipal Airport • Tulsa, Okla.

Name

Address

City Age

Zone State

Spartan Alumni • Write George Goodhead
P. O. Box 15852 • Tulsa 9, Oklahoma

IN AUGUST

**POPULAR
ELECTRONICS**



**COMPLETE PLANS
FOR BUILDING THIS**

MINIATURE OSCILLOSCOPE!

Complete your test-equipment line-up with this highly-portable oscilloscope that you can build for less than \$25.00! It's perfect for fixing TV sets... tracing hum in your hi-fi rig... checking your newly designed circuits. Get complete, easy-to-follow diagrams and illustrations in the pages of August POPULAR ELECTRONICS.

In addition, you'll enjoy these features:

• **A ONE-TUBE FM TUNER FOR LESS THAN \$10.00**

This one-tube FM tuner is so easy to build at such a small price! You'll be amazed at its remarkable sound.

• **INSIDE THE HI-FI MICROPHONE—Part II**

Here's Part II of this important series on hi-fi mikes. August POPULAR ELECTRONICS will give you additional facts on how to choose and use a hi-fi mike that's perfect for your needs.

These features are typical of the coverage you'll enjoy month after month in POPULAR ELECTRONICS... world's leading electronic hobbyist magazine. Take advantage of the present low subscription rates to bring POPULAR ELECTRONICS to your door every month. Subscribe now!

• **THE HOW AND WHY OF SOLDER**

What kind of solder has the lowest melting point? What type is the strongest? When should acid flux be used? You'll find out the answers to these and many other questions in August POPULAR ELECTRONICS.



SUBSCRIPTION RATES

One year \$4

Two years \$7

Three years \$10

POPULAR ELECTRONICS • 434 South Wabash Avenue • Chicago 5, Illinois

Across the Ham Bands

(Continued from page 93)

News and Views

Jack Hurray, K3GRE, 1601 Indiana Ave., Monaca, Pa., runs 25 watts to a Heathkit AT-1 transmitter. He added the VFO described in "Across The Ham Bands," June, 1959, to escape the QRM of the 40-meter Novice band. Now he does most of his operating between 7000 and 7150 kc., c.w., although he modulates the AT-1 about 50% with his tape-recorder amplifier and occasionally gets on 20 meters to chat with a few locals. Jack worked only 11 states as a Novice, but his total is soaring now. He receives with a Hallicrafters SX-17, and his antenna is a 40-meter dipole. . . . In the April "Letters from Our Readers," **Jim, W5UJN**, objects to using a hi-fi amplifier as a ham modulator (described in our January column) on the grounds that its frequency response would cause the signal to take up too much room in the ham bands. But a series capacitor-potentiometer high-frequency attenuator at the output of the amplifier should make it perfectly suitable for ham use. Trial and error while on the air will give you the right values for the attenuator components.

Incidentally, reader Frederic J. Mohr in Bayville, N. J., has called our attention to a typographical error in the May *Across the Ham Bands*. The parts list for the 80-meter harmonic filter on page 93 gives 0.0003- μ mf. values for C1 and C3. These capacitors should be 0.0003-microfarad units.

Howie Lawrence, KN1MFA, 8 Fermoy Heights Ave., Dorchester, Mass., has worked 130 stations in 23 states, Canada, and Puerto Rico in two months on the air. He started on 80 meters, worked his way to 40, and then to 15, where he worked 12 new states in two days. A Heathkit DX-20 heats his 40-meter dipole, and Howie receives on a Hallicrafters S-38E.

. . . **Rich, KN0YCP**, of St. Louis, Mo., works 40 meters most of the time with his Heathkit DX-40 and Knight R-100 receiver. He asked some questions about two meters and a vertical antenna but did not include his address. If he will furnish it, we will be glad to answer



Alan Richards, WA2EGA, operates in Flushing, N. Y. July, 1960

for
CITIZENS BAND
marine
radio

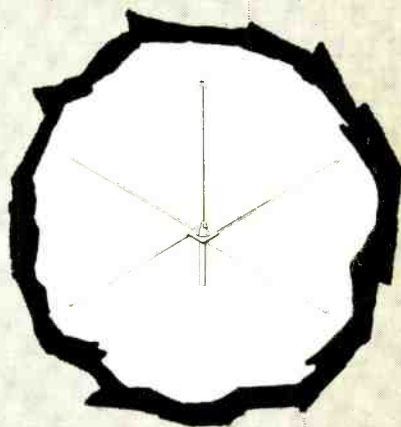

MOSLEY V-27-GP

100% RUST PROOF Vertical Antenna for the 11 meter Citizens Band. 360° radiation pattern for effective communication at any heading when antenna is mounted clear of interacting objects.

Radiator and radials are of heavy gauge 61ST6 aluminum. Fittings and hardware are brass, copper and stainless steel. Vertical and radials are each 9' long. Heavy duty base mount with coax connector fits 1¼" ID pipe mast. Supplied with Mosley Antenna Coat for protection against salt corrosion. Model V-27-GP, less mast & RG-8/U coax.

Net Price, \$34.95

Available from most electronic equipment distributors—coast-to-coast.

Mosley
Electronics, Inc.

4610 N. Lindbergh • Bridgeton, Missouri

his letter. . . . **Fred G. Leisen, WV6HEI**, 2674 Friedell Dr., San Diego 10, Calif., in 10 months as a Novice worked 34 states, three Canadians, and Ivor, VK3XB, using a DX-40 transmitter and a National NC-300 receiver. His General license is now on the way.

Dudley H. Cahn, K8QEX, 3408 Mulhern Ave., Kalamazoo, Mich., really ran up a record as a Novice with his Heathkit DX-40, Hammarlund HQ-129X receiver, home-built 15-meter beam, 40-meter dipole, and 80-meter long-

SIX-METER RULE CHANGE

The FCC has moved the 100-kc. segment of the six-meter band which is reserved for A1 (c.w. telegraphy) emission only. The authorized segment is now 50.0—50.1 mc., rather than 50.9—51.0 mc. The ruling permitting A1 emission only on 147.9—148.0 mc. in the two-meter band remains unchanged.

wire. "Worked All Continents," "Worked All States," and a 20-wpm code certificate decorate his shack wall. He has 44 countries worked with 24 confirmed. Now that he is a General, Dudley finds the competition a bit rougher. But he logged UJ8GG on the low end of 40 meters the other day. . . . **Doug Price, WV2IRW**, 59 Mill Spring Road, Manhasset, N. Y., feeds his DX-20 into a vertical on 40 meters and into a 2-element beam on



Ham shack of Fred Leisen, WV6HEI, in San Diego.

15, with the vertical and a folded dipole serving as alternate 15-meter antennas. Doug receives with a National NC-109. He has worked 24 states and considers California on 40 meters his best DX. After just spending an extra \$2.00 for postage on duplicate QSL cards, Doug's pet peeve is the non-QSL gang.

G. W. Grove, W1WHL, better known as "The Old Connecticut Squire," informs us that the Fifth Annual Graveyard Net Picnic will be held on July 9 and 10 at Jamestown, Virginia. Highlights of the event will be "Eyeball" QSO's, QSL and mobile judging contests, drawings by the dozens, equipment auctions and swaps, a beauty contest for the ladies, and games for the children. Facilities are available for camping, fishing, swimming, and boating. For more information and literature on the event, write to Norm Reynolds, K4GKN, 36 N. Lawson Rd., Poquoson, Va.

Steve Richmond, K1JAW, 115 Franklin, Reading, Mass., started as a Novice in 1958 at the age of 14. He has made the "Brass Pounder's League" for his message-handling, has a 30-wpm code certificate and a pretty fair 40-meter DX record. With his Heathkit DX-20, Knight, VFO, and 40-meter dipole, Steve has worked Russia, Poland, Sweden, Germany, Czechoslovakia, and 47 states. He will be glad to help the would-be hams in his immediate area get their tickets. . . . **Thomas**

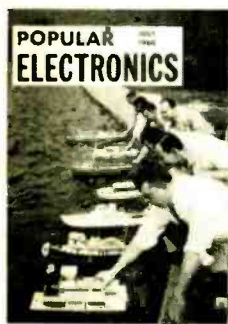

Send
**POPULAR
ELECTRONICS**
Every
Month

name _____

address _____

city _____ zone _____ state _____

3 years for \$10

Check one: 2 years for \$7

1 year for \$4

Payment Enclosed

Bill Me

In the U. S., its possessions and Canada. Foreign rates: Pan American Union countries, add .50 per year; all other foreign countries, add \$1 per year.

Mail to: **POPULAR ELECTRONICS**
Dept. PE-76, 434 S. Wabash Ave., Chicago 5, Ill.

ELUSIVE HARMONIC

In the May issue of POPULAR ELECTRONICS, two errors crept into the article entitled "The Case of the Elusive Harmonic." One was permitting Bob, a Novice ham, to use a VFO. Well, Bob is now back on crystals and working hard for that General ticket. The other occurred in the schematic on page 71; the 2.5-mhy. r.f. choke connected across the antenna terminals should be wired from the right-hand junction of L2-R5 to the 150-ma. meter's top terminal. In the original schematic, the only DX Bob could get was from his power supply. Many thanks to our readers who pointed out these mistakes.

M. Gooding, K4LHB/WPE4YW, P. O. Box 91, Oakton, Va., has been running five watts to a 6AQ5 on 7175 kc., and working such areas as Florida, California, and Indiana. Tom's regular transmitter is a Globe Scout-65 driving an 813, and his receiver is a Hallicrafters SX-28. He would like to compare notes with other experimenters who have low-power transmitters. . . .

Howard W. Epley, KN7KPM, Route 2, Box 263, Winlock, Wash., asks: "What's this about a 'Where are the sevens club?'" He will sked anyone on 15 meters for his first "7" or Washington contact. In two months on the air, Howard has worked 46 states, Canada, Wales, Sweden, Southern Rhodesia, Japan, and Puerto Rico. His tools are a Johnson Adventurer transmitter, a Hallicrafters SX-100 receiver, and a home-built two-element beam.

Carl O. Baptiste, HH2BC, Jacmel, Haiti, W. I., reports that his friend, **Jean Sorel**, P. O. Box 555, Port-au-Prince, Haiti, W. I., would like to correspond with sightless amateurs. Mr. Sorel, who is a successful lawyer, linguist, and teacher, would like to become a ham himself and then help other blind people join our hobby. . . . **Jeff Speiser, K1LDD**, 254 W. 234 St., New York 63, N. Y., a student at M.I.T., is interested in contacting anyone with information on the CRP-46ADA radar receiver. He also wants to locate persons in the New York or Boston areas interested in the 3- and 10-cm. ham bands—radio astronomy, moon bounce, etc.

How about *your* letter, pictures, and comments for next month? 73,

Herb, W9EGQ

Short-Wave Report

(Continued from page 97)

The following is a resume of the current reports. All times shown are Eastern Standard and the 24-hour system is used. At time of compilation all schedules given are correct. Stations often change frequency and/or schedule with little or no advance notice. Please send all reports to P. O. Box 254, Had-donfield, N. J., in time to reach your Short-Wave Editor by the eighth of each month.

Albania—ZAA, Tirana, has been carrying an English segment at 1730-1758 on 7157 kc. French precedes this at 1700. (WPE1AAC, WPE3NF)

Antigua—Radio Antigua, British West Indies, has been found on 3255 kc. from 1758 with tuning signal and s/on at 1800 in English. A recorded music period with some request numbers followed to 1845 when the signal faded. Does anyone know the power? (WPE0AE)

Argentina—LRA, Radio Nacional, Buenos Aires, is beamed to Central Europe on 15,345 kc. at 1400 in Spanish, 1500 in German, 1600 in Italian, 1700 in French, 1800 in English, and 1900 in Portuguese, to Eastern N.A. on 9690 kc. at 2100 in Spanish and 2200 in English, and to Western N.A. on 9690 kc. at 2302 in Spanish and 0002 in English. All xmsns are one hour



Leo I. Meyerson, W0GFQ, Says
pay only 10% down
on these
Citizens Band Radios

GLOBE ELECTRONICS

NEW
Pocketphone
only \$12.50 down

\$7.50 Per Mo.

GIVES
YOU

NOW AT "the house
the hams built!"

- Actual Size 1 1/4 x 2 3/8 x 6 1/4
- Range 1/2 to 1 Mile
- Handy Paging System
- Requires No License

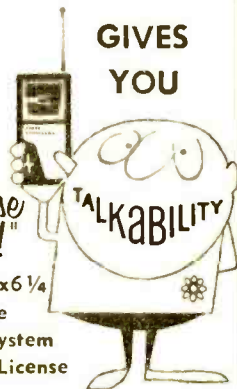

New portable high styled two-way radio that actually fits into your pocket. Exclusive "power-pak" rechargeable battery lasts a year or more. For factory, surveying, construction, department stores, stock-yards, hospitals, firemen, policemen, golf, office, and home.

\$125.00 Each

the CB-200 Broadcaster Deluxe

Especially designed for the commercial user and consumer desiring a more rugged unit. Five crystal controlled channels for transmitting. Four crystal channel receiving plus one tunable position over entire band. Adapted for selective calling system. Dual conversion eliminates interference. Absolutely quiet.

Size: 37x12x10 1/4. \$179.95 each.

the CB-100 Citizens Broadcaster

Complete 3-channel, 2-way station for permanent installation or travel. Only 3 1/2 x 10 1/4 x 13. Easy to install, operate. Only 3 controls. Range 5-15 miles. Complete with one set crystals, push-to-talk microphone, \$129.95 each.

WRL

WORLD RADIO LABORATORIES

3415 W. BROADWAY • PHONE 32 8-1851
COUNCIL BLUFFS, IOWA

LEO: PLEASE SEND () TALKABILITY
FOLDER ON THE GLOBE CITIZENS BAND
RADIOS.

NAME: _____

ADDRESS: _____

CITY & STATE: _____

PE-7



**SELL YOUR USED
EQUIPMENT Through
POPULAR ELECTRONICS'
Classified Columns!**

The 320,000 purchasers of POPULAR ELECTRONICS are always interested in good used equipment or components. So, if you have something to sell, let PE readers know about it through our classified columns. It costs very little: just 50¢ a word, including name and address. Minimum message: 10 words.

For
further
information
write:

Martin Lincoln
POPULAR ELECTRONICS
One Park Avenue
New York 16, N. Y.

long. (WPE1AMW, WPE1BD, WPE3EX, WPE9AHC)

Australia—Here is the latest schedule from *R. Australia* (all English except where noted). To S. and S.E. Asia: 1714-0900 on 25,735 kc.; 1714-0415 on 21,540 kc. (Indonesian at 0100-0230); 2130-0230 on 21,600 kc. (Saturdays only—sports service); 1714-0230 on 17,840 kc. (Indonesian at 1714-1815, French at 1815-1915, Indonesian at 0100-0230); 1714-1915 on 15,210 kc.; 1714-1930 on 15,320 kc. (Indonesian at 1714-1815, French to 1915); 0100-0445 on 15,160 kc.; 0429-1230 on 11,740 kc. (Indonesian at 0429-0600, Chinese to 0800, Thai at 0830-0930); 0829-1000 on 11,760 kc.; 0459-1230 on 9580 kc.; 0429-1230 on 7220 kc. (Indonesian at 0429-0600, Chinese to 0800, Thai at 0830-0930). In the East Asia and N. Pacific Islands Service: 1559-1800 on 15,240 kc., 0244-0700 on 11,760 kc., and 0459-0900 on 9630 kc. To Mid-Pacific Islands: 1500-1700 on 15,315 kc., 1930-2030 on 17,710 kc. (French), 1930-2030 on 15,160 kc. (French), and 0100-0445 on 11,810 kc. (Saturdays at 0244-0445). To S. Pacific Islands: 1500-1700 on 11,840 kc., 1815-1915 on 21,680 kc. (French), and 0100-0415 on 11,710 kc. To N.A.: 0714-0815 on 11,710 kc. (East Coast) and 1014-1115 on 11,810 kc. (West Coast). To United Kingdom and Europe: 0100-0230 on 11,710 kc. To Africa: 2329-0045 on 21,680 kc. The DX program is aired Saturdays at 1700, Sundays at 0030, 0215, 0800, and 1100. (WPE4BC, WPE0AE)

Bahamas—If you have never logged these islands, look for ZNS, Nassau, in the broadcast band at 1540 kc. DX'ers along the East Coast should have little trouble finding this one during evening hours. (WPE4JP)

Bolivia—A new station is *R. Guavira*, Santa Cruz, 9200 kc. It was noted at 1858-1930 with Spanish anmts, good music, and frequent ID's. (WPE0AE)

CP27, 9444 kc., La Paz, has two English programs: "At Close of Day" at 2105 on Thursdays and a religious program daily except Tuesday and Sunday at 2100. This station, now powered at 400 watts, is expected to increase to 10 kw., according to Harold Hill, Director. (FB)

Brazil—ZYN31, *R. Soc. da Bahia*, Salvador, 1525 kc., is noted at 1500-2300, replacing 11,875 kc. There is severe QRM from Lisbon (beamed to Brazil) until 2100. (WPE4FI, WPE9KM)

The best time to log the experimental college station on 17,725 kc. is around 1800 on Saturdays or Sundays. Otherwise, this station is on an irregular schedule. (WPE9KM)

PRN9, *La Voz da Policia Federal*, Rio de Janeiro, is to have an English DX program put on by the Brazilian DX Club. Dates and times have not been given as yet but the frequency should be 9295 kc. Pennants will be awarded for correct reports. (WPE1BY)

Canary Islands—Two stations currently being heard are *R. Atlantico*, Las Palmas, 9490 kc., with English on Saturdays at 1800-1900, and EA8AB, Tenerife, 7295 kc., at 1724-1820 with talks in Spanish and some jazz music. Contrary to schedule given in *World Radio Handbook*, the broadcasting definitely runs past 1800. (WPE3NF, WPE8BGF)

Cook Islands—ZK1ZA, Rarotonga, 4965 kc.,

Always say you saw it in—POPULAR ELECTRONICS

is on the air Wednesdays only as 2327-0030 with native music. The IS is island drum beats. (WPE6EZ)

Curacao—Here is another country that few have logged. Look for *R. Curom*, Willemstad, 9654 kc., at 2000-2230. This is all-Dutch but you may be able to log it by carefully listening for the ID. (WPE4FI)

Dominican Republic—A new station is *R. Deportiva Tangica*, 6250 kc. Previously heard on 6200 kc., it has been noted at 1730-2100 and later. (WPE3NF, WPE9KM)

El Salvador—A letter from YSEB, San Salvador, states that its affiliate, YSDR, Santa Ana, has a new outlet on 4800 kc. with slogan of *R. Tropical*. Reports go to Apartado Postal 1006, San Salvador. (WPE3HP)

Finland—*Oy Yleisradio Ab*, Helsinki, operates to Europe at 0400-0600 on 6120 kc. and at 1100-1330 on 6120, 15,190, and 17,800 kc.; to N.A. Sept. 23 to March 20 at 0630-0900 (DX program Saturdays at 0630-0700), March 21 to Sept. 22 at 1530-1800 (DX program Fridays at 1530-1600) on 15,190 and 17,800 kc. The DX program alternates weekly with "Musical Mailbag." (WPE9ADY, WPEOSS)

Formosa—*The Voice of Free China* has Eng. daily at 2030-2045 and 0505-0550 on BED7, 7320 kc., BED6, 11,815 kc., BED57, 15,345 kc., BED58, 17,755 kc. (WPE1BD, ET)

France—Paris is strong on 7280 kc. at 0100-0145, beamed to the Pacific Islands and dual to 9560, 17,765, and 21,580 kc. (WPE6EZ)

Germany—Cologne operates to Eastern N.A. at 1900-2200 and to Western N.A. at 2200-0100 on 11,795 and 9640 kc.; to Eastern N.A. at 1715-1845 on 15,375 and 11,795 kc. and to Western N.A. at 0000-0130 on 9735 and 11,945 kc. German lessons are given at 1815 on 11,795 and 15,375 kc., and at 0100 on 9735 and 11,945 kc. Test programs have recently been heard to West Africa at 1300-1400 on 15,275 and 17,875 kc. (Eng. news at 1330); to So. America at 1620-1630 on 15,275 kc.; and to Central America at 1920-2000 on 9605 kc. The latter two xmsns are in German and Spanish. (WPE2AXS, WPE2BFB, WPE2BMO)



Allyn M. Lamb, WPE0SN, does his DX'ing in Wichita, Kansas, with a Hallicrafters S-85 receiver, a 100-kc. calibrator, and a Heath QF-1 multiplier.

July, 1960

COMPLETE SERVICE TRAINING

... written so you can understand it!



Only \$13
for the complete
2-volume course

3 MONTHS TO PAY

Fix any TV or Radio Ever Made

EASIER-BETTER-FASTER!

No complicated theory or mathematics! These famous Ghirardi books get right down to brass tacks in showing you how to handle all types of AM, FM, and TV service work by approved professional methods. Almost 1500 pages and over 800 clear illustrations show how to handle every phase of troubleshooting and servicing. Each book is co-authored by A. A. Ghirardi whose manuals have helped train more servicemen than any other books or courses of their kind!

1—Radio and Television Receiver TROUBLESHOOTING AND REPAIR

A complete guide to profitable professional methods. For the beginner, it is a comprehensive training course. For the experienced serviceman, it is a quick way to "brush up" on specific jobs, to develop improved techniques or to find fast answers to puzzling service problems. Includes invaluable "step-by-step" troubleshooting charts that show what to look for and where. 820 pages, 417 illustrations, price \$7.50 separately.

2—Radio and Television Receiver CIRCUITRY AND OPERATION

This 660-page volume is the ideal guide for servicemen who realize it pays to know what really makes modern radio-TV receivers "tick" and why. Gives a complete understanding of basic circuits and circuit variations; how to recognize them at a glance; how to eliminate guesswork and useless testing in servicing them. 417 illus. Price separately \$6.75.

Special low price . . . you save \$1.25

If broken into lessons and sent to you as a "course," you'd regard these two great books as a bargain at \$75 or more!

Under this new offer, you buy both books for only \$13.00 . . . you save \$1.25—and have the privilege of paying in easy installments while you use them! No lessons to wait for. You learn fast—and right!

STUDY 10 DAYS FREE!

Dept. PE-70, RINEHART & CO., Inc.
232 Madison Ave., New York 16, N. Y.

Send books below for 10-day FREE EXAMINATION. In 10 days I will either remit price indicated (plus postage) or return books postpaid and owe you nothing.

Radio & TV Receiver **TROUBLESHOOTING & REPAIR** (Price \$7.50 separately)

Radio & TV **CIRCUITRY & OPERATION** (Price \$6.75)

Check here for **MONEY-SAVING COMBINATION OFFER**
Save \$1.25. Send both of above big books at special price of only \$13.00 for the two. (Regular price \$14.25 you save \$1.25.) Available at rate of \$3 plus postage after 10 days if you decide to keep books and \$3 a month for 3 months until the total of \$13.00 has been paid.

SAVE! Send cash with order and we pay postage. Same return privilege with money promptly refunded.

Name

Address

City, Zone, State

Outside U.S.A.—\$8.00 for **TROUBLESHOOTING & REPAIR**; \$7.25 for **CIRCUITRY & OPERATION**; \$14.00 for both. Cash only, but money refunded if you return books in 10 days.

CODE

I have been teaching Code for forty years and I know that before you can read Code you must first learn the Code alphabet according to SOUND. Dotteddash is not A. The SOUND resulting from dotteddash is A.

Regardless of discouraging experience to the contrary learning Code is extremely easy and fascinating. It does not have to be third degree punishment. My automatic transmitter is really automatic. In a matter of seconds you select just a few letters, an entire lesson, any number of lessons or entire record of seven lessons engraved in copper and your selection will be automatically transmitted over and over with no stopping or changing anything. Let me send you the full story.



R. G. Miller, TELEPLEX COMPANY
739 Kazmer Court Modesto, California

VACATION Special Bargains!

TRANSISTOR PORTABLE

COMPLETELY WIRED

Reg. \$24.95
\$12.88 (plus postage)

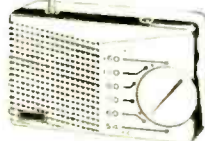

• With Built-in Speaker!
Complete with 9-volt battery, carrying case, earphone, speaker, built-in antenna for suburbs (telescopic for rural).

Satisfaction Guaranteed
Send cash, check or M. O.
(plus postage)

6 TRANSISTOR * RADIO
KIT, Phase 20 per. incl. I.F.'s, osc. coils, var. cond., in-and-out transistors, sockets, instructions. **\$5.88**

LEKTRON See our full page ad.
135 Everett Ave., Chelsea 50, Mass.

GET INTO ELECTRONICS

V.T.I. training leads to success as technicians, field engineers, specialists in communications, radar, missiles, computers, radar automation, Basic & advanced courses in theory & laboratory. Assoc. degree in 20 mos. B. S. obtainable. ECPI accredited. G.E.I. approved. Graduates with major companies. Start Stud. Fee. Dorms, campus. U. S. graduates or equivalent. Catalog.

VALPARAISO TECHNICAL INSTITUTE
Dept. PE VALPARAISO, INDIANA



LOOK

NO FURTHER . . . IF YOU'RE UNHAPPY WITH "HI" HI-FI PRICES. WRITE FOR OUR UNUSUAL AUDIO CATALOG. KEY ELECTRONICS CO. 120-B Liberty St., N. Y. 6

SCIENCE ENGINEERING

Bachelor's degree in 27 or 36 months

Accelerated year-round program: Aero, Chemical, Civil, Elec., Mech., Metallurgical, Mathematics, Chemistry, Physics. Modest rate. Earn board. New classes start Sept., Jan., Mar., June. Catalog. 2370 E. Washington Blvd., Fort Wayne 2, Indiana.

INDIANA TECHNICAL COLLEGE

WPE2YK, WPE3AJC, WPE3BBM, WPE3DS, WPE4BC, WPE4MF, WPE6PG, WPE9KM, WPEOTA, VE3PE6Y, EC, WK)

Greece—Athens is good on 11.718 kc. with s/on at 1800. It can also be heard on 11.718 and 15.345 kc. with English news at 1230. (WPE8BGF, WPE9KM)

Honduras—A new outlet may be *La Voz de Suyapa*, 4940 kc. Good from 2100, it should not be confused with the Suyapa outlet on 6125 kc. (WPE9KM)

Iceland—A letter from TFJ gives the schedule as 1600-1700 daily and 0815-0915 on Sundays on 12,175 kc. Reports, accompanied by an IRC, should be sent to Iceland State B/C Service, Reykjavik, Iceland. (WPE1AAC, WPE1HY)

India—All India Radio, Delhi, has replaced 15,105 kc. with 15,180 kc. in the 1445-1545 xmsn to the Middle East. The 15,280-kc. channel is noted well at 0730 with IS, Eng. ID, and opening with news. (WPE1CE, WPE3NF, WPE8HF)

Israel—4XB31, *Voice of Jerusalem*, 9009 kc., has extended the Eng. xmsn to 1515-1600, an increase of 15 minutes. (WPE0EH, VE2PE1H)

Japan—The latest schedule from R. Japan reads as follows: to S. Asia at 1000-1130 on 11,965 and 15,325 kc. in Hindi, Urdu, Japanese and English; to Middle East at 145-1345 on 11,705, 15,325 and 9675 kc. in Arabic, French, English and Japanese; Europe II at 1400-1600 on 11,705, 15,325 and 9675 kc. in Russian, German, French, Italian, Swedish, English, and Japanese; to N.A. at 1930-2030 on 17,855 and 15,325 kc. in English and Japanese; Latin

SHORT-WAVE ABBREVIATIONS

annt	Announcement	kw	Kilowatts
B/C	Broadcasting	N.A.	North America
Eng.	English	QRM	Station interference
ID	Identification	R	Radio
IRC	International Reply Coupon	s/off	Sign-off
IS	Interval signal	s/on	Sign-on
kc.	Kilocycles	xmsn	Transmission

America I at 2200-2300 on 17,855 and 15,325 kc. in Spanish and Japanese; N.A. and Hawaii at 0000-0200 on 11,705, 15,325 and 17,825 kc. in English and Japanese; Europe I at 0230-0330 on 17,855 and 21,620 kc. in English and Japanese; Latin America II at 0400-0530 on 11,705 and 9525 kc. in Portuguese, Japanese and Spanish; Australia and New Zealand at 0430-0530 on 11,800 and 15,235 kc. in English and Japanese; East Asia at 0500-0730 on 11,940 kc. in Japanese; Asian Continent at 0545-0745 on 11,705 and 9525 kc. in Chinese, Japanese, Russian and English; Philippine Islands and Indonesia at 0630-0800 on 17,855 and 15,325 kc. in Indonesian and English; Korea at 0800-0900 on 9525 kc. in Korean and Japanese; S.E. Asia at 0800-1100 on 11,705 and 9675 kc. in Chinese, Fukinese, Cantonese, Thai, French, English, and Japanese. General Asian Service at 1900-1930, 2100-2130, 2300-2330, 0100-0200, 0300-0330, 0400-0430, 0500-0530, 0600-0630, 0700-0730, and 0800-0900 on 15,135 kc. in English and Japanese. (WPE1BD, WPE4BFY, UN, Radio Japan News)

Jordan—A station believed to be in Amman

ELECTRONIC KITS 1960 DIRECTORY

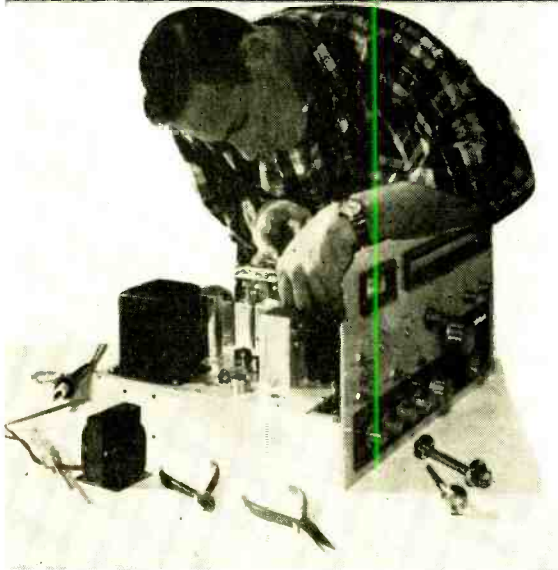

500 ELECTRONIC KITS

WHAT THEY ARE!
WHAT THEY COST!
WHAT THEY DO!

Yours in the brand new 1960

ELECTRONIC KITS 1960 DIRECTORY

Here it is—the only complete, comprehensive directory covering the exciting world of electronic kits! It's yours in the 1960 ELECTRONIC

KITS DIRECTORY—over 160 pages—listing over 500 kits of all kinds. Each listing gives you manufacturers, specifications, prices, everything you need to know about kits!

You'll find such informative features as:

- **GIANT KIT BUILDERS GUIDE**

Gives you the latest improvements, and innovations in kits...helps you select the right kit...identifies parts for you, too!

- **COMPLETE SURVEY AND DIRECTORY OF:**

Kits for HI-FI—make your own amplifiers, preamps, speakers, turntables, stereo control units, and tone arms.

Kits for COMMUNICATIONS—Run-downs on kits for oscilloscopes, tube testers, power supplies, transmitters, receivers, transceivers. Kits

for EDUCATION—Coverage of radio kits and many other special projects.

NOW ON SALE AT YOUR FAVORITE
NEWSSTAND OR ELECTRONIC PARTS
STORE **ONLY \$1.00**

Don't miss 1960 ELECTRONIC KITS DIRECTORY. Now on sale at newsstands, electronic parts stores and hi-fi salons! Buy your copy today, or order by using the handy coupon at right. Only \$1.00.

Ziff-Davis Publishing Company
Department PE 76
434 S. Wabash Ave., Chicago 5, Illinois
Please send me a copy of the 1960 ELECTRONIC KITS DIRECTORY. I enclose \$1.00 plus 10¢ to cover mailing and handling charges. (Canada and Foreign \$1.25 plus 10¢ postage).

Name _____

Address _____

City _____ Zone _____ State _____

TV PICTURE TUBES AT LOWEST PRICES

10BP4	\$ 7.95	16WP4	\$12.00	17TP4	\$17.00	21EP4	\$13.50
12LP4	8.50	16PT4	9.95	19AP4	16.00	21FP4	14.50
14B/CP4	9.95	17AVP4	12.50	20CP4	13.50	21WP4	14.00
16DP4	12.00	17BP4	9.95	20HP4	14.50	21YP4	14.50
16EP4	12.75	17CP4	17.00	21AP4	22.10	21ZP4	13.50
16GP4	14.50	17GP4	17.60	21ALP4	15.75	24CP4	23.50
16KP4	9.95	17HP4	12.50	21AMP4	15.75	24DP4	24.50
16LP4	10.95	17LP4	11.50	21ATP4	15.75	27EP4	39.95
16RP4	9.95	17QP4	9.95	21AUP4	15.75	27RP4	39.95

1 YEAR WARRANTY

Aluminized tubes \$3.00 for 21"; \$5.00 for 24" and 27" additional. Prices include the return of an acceptable similar tube under vacuum. These tubes are manufactured from reprocessed used glass bulbs. All materials including the electron gun are brand new.

ALL PRICES FOB CHICAGO, ILLINOIS. Deposit required, when old tube is not returned, refundable at time of return. 25% deposit required on COD shipments. Old tubes must be returned prepaid. Tubes shipped Rail Express. We ship to the Continental U. S. and Canada, only.

WRITE FOR COMPLETE LIST

—PICTURE TUBE OUTLET—
2922 MILWAUKEE AVE., CHICAGO 18, ILLINOIS
Dickens 2-2048

FREE



Full year's subscription to RADIO SHACK'S Sensational ELECTRONICS CATALOGS

Send coupon at once! See world's largest and best line of electronic equipment. Stereo, hi-fi, ham radio, tapes—over 100,000 items for pro or amateur—all at money-saving prices. 15-day no-risk home trial on any item.

MAIL COUPON NOW!

Radio Shack Corp., 730 Commonwealth Ave., Boston 17, Mass. Dept. 60-67
Without further request, send latest catalog plus every new issue for one full year—all FREE and POSTPAID.

Name _____

Address _____

Post Office _____

or City _____

Zone _____ State _____

FREE 5" PLASTIC EXTENDER

Push Button Assembly
Pin-Point Application & Won't Cause Shorts

"No-Noise"
VOLUME CONTROL and
CONTACT RESTORER

2 oz. Btl. Cleans 6 oz. can
Lubricates Protects
\$1.00 \$2.25

"No-Noise"
TUNER-TONIC

With Perma-Film
"A little does a lot!"
6 oz. aerosol can
\$3.25

Insist On Genuine "No-Noise" Products

ELECTRONIC CHEMICAL CORP. At Your Dist. Only
813 Communipaw Ave., Jersey City 4, N. J.

NOW—AVIATION WEATHER REPORTS, IN YOUR CAR

Be a weather expert! TC-1 Weather Radio receives 24 hour aircraft weather reports (200-400 K.C.) on your car radio. Minutes to install, no electrical connections, won't interfere with AM reception. Nationwide reception. 3 year guarantee. Send check or money order \$35.50, postpaid.



Send for free illustrated brochure

Boulevard Electronics, 1229 W. Washington, Chicago Ill, Dept PE-7

ESSCOIZED... A new term not found in Webster's... Denotes ULTIMATE PERFORMANCE in CB radio gear.

EXCLUSIVELY AVAILABLE, the unique super sensitive & selective dual conversion superhet receiver adapter as described in 40M KNEELES column in the May POPULAR ELECTRONICS. Factory wired-aligned for simple installation in your Heathkit CB-1 Transceiver case. Includes effective noise switch. \$39.95
ESSCOIZED CB-1 transmitter section. A unique conversion includes additional HI OUTPUT (4W) class C stage & PL Network. It results in fabulous performance, strongest signals on CB band. Factory installation only. Includes crystal checker. \$29.95
THE ESSCO DUAL GROUND PLANE ANTENNA will extend your XTR range because of its 3db gain. Sturdy longlasting elements. \$27.95
ESSCO CB HQTS. 58 Walker Street N. Y. C. 13, N. Y.

has been noted testing on 11,812 kc. at 0000-0100 in Arabic. Further checks are being made. (WPE3NF)

Middle Congo Republic—Brazzaville carries English at 0015 on 21,500, 15,440, 11,725, 9730, and 5970 kc., at 0300 on 15,440 and 21,500 kc., at 0600 on 15,440 kc., at 0700 on 15,420 kc., at 0930 on 17,720 and 21,500 kc., at 1200 on 11,725.

SHORT-WAVE CONTRIBUTORS

Stanley Schwartz (WPE1AIC), Bridgeport, Conn.
Donald Brison (WPE1AMH), Edgewood, R. I.
C. W. Green (WPE1ARL), Pittsfield, Mass.
Anson Boice (WPE1BD), New Britain, Conn.
Alan Roth (WPE1B1), Bridgeport, Conn.
David Gerns (WPE1CE), Concord, Mass.
Peter Lukesh (WPE1DS), Sudbury, Mass.
Steve Ewing (WPE1HY), Aikinson, N. H.
Robert Newhart (WPE2ANS), Merchantville, N. J.
Myron Smith (WPE2BFB), Rochester, N. Y.
Jim Teeling (WPE2BMO), Orange, N. J.
Albert Mencher (WPE2BRH), Bayside, N. Y.
Danny Katcher (WPE2CNI), South Orange, N. J.
Allan Tannenbaum (WPE2CPP), Passaic, N. J.
John Lounsbury (WPE2YK), Brooktondale, N. Y.
Ed MacDonald (WPE3AJC), Maivern, Pa.
Walter Schulz (WPE3AYB), Philadelphia, Pa.
C. Small (WPE3BBM), Washington, D. C.
Donald Campbell (WPE3BCE), Washington, D. C.
Dan Metro (WPE3DS), McKeesport, Pa.
Rene Reixach (WPE3EX), Washington, D. C.
Richard Morcroft (WPE3HP), Pittsburgh, Pa.
George Cox (WPE3NF), New Castle, Del.
Grady Ferguson (WPE4BC), Charlotte, N. C.
Richard Lane (WPE4BF), Memphis, Tenn.
Roger Legge (WPE4FI), McLean, Va.
Bill Bruner (WPE4JP), Key West, Fla.
Jim Miller (WPE4MF), Dickson, Tenn.
Pedro Vasquez (WPE5RB), Trumagawa, Japan (temporary)

Jack Stanley (WPE6BR), Lomita, Calif.
J. Art Russell (WPE6EZ), San Diego, Calif.
Gerhard Kmeth (WPE6PG), Bakersfield, Calif.
Ron Russell (WPE6TY), Stockton, Calif.
Charles Sutton (WPE8BGF), Toledo, Ohio
Dan Wilt (WPE5HF), Akron, Ohio
Dan Watts (WPE5HS), Greenwich, Ohio
John Gomochak (WPE5RE), Struthers, Ohio
Hank Zabielski (WPE5V), Taylor, Mich.
Richard Olson (WPE9AD), Rochester, Minn.
Earl Kinmonth (WPE9AGB), Joliet, Ill.
Thomas Savage (WPE9AIC), Bloomington, Ill.
Robert Klein (WPE9ARA), Beaver Dam, Wis.
A. R. Niblock (WPE9KM), Vincennes, Ind.
John Beaver, Sr. (WPE9AE), Pueblo, Colo.
Donald Mackison (WPE9AJP), Denver, Colo.
Dick Schreiber (WPE9EH), Wheat Ridge, Colo.
Jerry McMahan (WPE9SS), Barnes City, Iowa
Gerhardt Martens (WPE9TA), Frazee, Minn.
K. Kerber (VE1PE3L), Halifax, N. S.
Donald Druck (VE2PE1H), Montreal, Que.
Bruce Lawton (VE3PE6Y), Don Mills, Ont.
Richard Bendall (VE4PEU), Winnipeg, Man.
Fred Baines (FB), New Glasgow, N. S.
Edward Colby (EC), Lynn, Mass.
Doug Eggen (DE), Edmonton, Alta.
Charles Krabek (CK), E. Weymouth, Mass.
John Kennedy (JK), Shelby, Ohio
William Kosek (WK), Washington, Pa.
Halvor Leifer (HL), Navarre, Ohio
Julia Maldonado de Loebel (JL), River Forest, Ill.
Edward Tilbury (ET), Anchorage, Alaska
Ulrich Jaop (UN), Kelsterbach, Germany
Radio News News

5970, and 21,500 kc., at 1310 on 11,725 and 5970 kc., at 1430 on 9540 kc., at 2015 and 2145 on 11,725 kc. The 21,500-kc. channel is used on Sundays only. (WPE2CPP, WPE3AJC, WPE6BAR, WPE8VS, WPE9AJP, VE4PEU, DE, JK, HL)

Morocco—Rabat is heard on 7115 kc. at 1600-2200, all-Arabic, and on 7226 kc. at 1740-1800 with French news at 1750 and Spanish

Always say you saw it in—POPULAR ELECTRONICS

We'd like to send you these important new books for a 7-DAY FREE TRIAL EXAMINATION

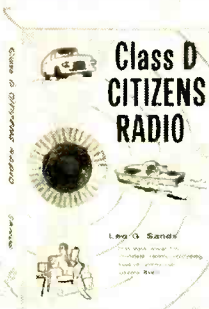

CLASS D CITIZENS RADIO

Leo G. Sands

Here is the first complete book on Citizens Radio Operation. Ever since the initial use of 2-way radiotelephone by police departments, this field has been growing in importance and application. Now, with more than a million vehicles equipped for its use, Citizens Radio is a major phase of the electronics field. This important new volume covers every aspect of the field—its history, rules, and everything about how it works—in seven big chapters with one hundred major sections. You'll learn exactly what Citizens Radio is, its applications, what equipment you need, the full story on receiver circuits and transmitters, antennas, installation, and maintenance, full FCC rulings, how to apply for licenses, etc. Many illustrations.

\$4.95

COMPUTERS AND HOW THEY WORK by James Fahnstock

Here is a fact-filled exciting guidebook to the wonderworld of electronic computers, with more than 120 illustrations and easy-to-follow tables in 10 big chapters. Step by step, you'll see and understand the workings of every type of computer ever used. This important new book illustrates the basic principles of computers in methods that require no knowledge of electronics. You'll learn all about computer memories, flip-flops and the binary counting system. You'll learn the mathematical language of computers where $1 + 1 = 10$. Other chapters show you how computers use tubes and transistors to make complex logical decisions in thousandths of a second. **COMPUTERS AND HOW THEY WORK** is must reading for career minded students and for electronics pros who want a more complete knowledge of this field.

\$4.95

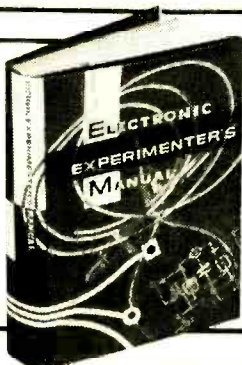
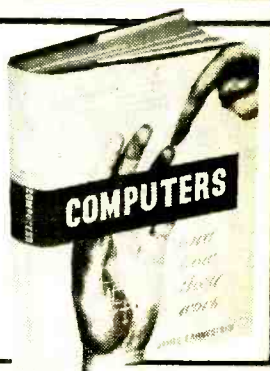

THE ELECTRONIC EXPERIMENTER'S MANUAL

by David A. Findlay

With a few dollars worth of basic tools, and this book to guide you, you can explore the magic of electronics experimentation more completely than ever before. In a few short hours, you'll start your first project. You'll learn about every component used in experimentation, every tool, its function and why it is used. There are 10 big sections, each covering a specific phase of construction. There's a giant section of projects you can build, test equipment you'll construct and use in your future work. **THE ELECTRONIC EXPERIMENTER'S MANUAL** will give you the professional know-how you must have no matter what phase of electronics is your specialty.

\$4.95

USE THIS CERTIFICATE FOR 7 DAY FREE EXAMINATION

7 DAY FREE EXAMINATION

When your books arrive, read and enjoy their diversity of contents, the thoroughness of their coverage. Then after seven days examination, if you decide that they are not everything you want, send them back and receive a complete refund of the purchase price.

ELECTRONICS BOOK SERVICE •

434 S. Wabash Ave., Chicago 5, Ill.



Please send me copies of **CLASS D CITIZENS RADIO** and bill me at only \$4.95 a copy plus a few cents postage.

Please send me copies of **COMPUTERS AND HOW THEY WORK**, and bill me at only \$4.95 a copy plus a few cents postage.

Please send me copies of **THE ELECTRONIC EXPERIMENTER'S MANUAL**, and bill me at only \$4.95 a copy plus a few cents postage.

If I don't agree that this is one of the best electronics investments I've ever made, I may return the book(s) within seven days and get a full refund.

\$ enclosed. (SAVE MONEY! Enclose payment with your order and we'll pay the postage.)

Name

Address

City Zone State

ZPE70

news starting at 1800. (WPE1BD, WPE3NF)

Netherlands—Hilversum is now on 11,755 kc., replacing 11,915 kc., to N.A. at 2030-2120 (Sundays at 2100-2230). (WPE1ARL, WPE1CE, WPE1DS, WPE2BRH, WPE2YK, WPE3AJC, WPE3NF, WPE4FI, WPE5RB, WPE9KM)

Norway—Norsk Rikskringkasting, Oslo, operates to N.A., North Atlantic, and Caribbean areas at 2000-2120 ("Norway This Week" on Sundays at 2105-2125) and to the North Atlantic, West N.A., Pacific areas, and E. Africa at 2300-0020 ("Norway This Week" on Mondays at 0005-0025) on LLM, 15,175 kc., LLK, 11,850 kc., LLG, 9610 kc., and LKJ, 6130 kc. (WPE3CE, WPE0TA)

Peru—Try for R. Continental, 9350 kc., at 2155-2215; dual to R. America on 9455 kc. only for Spanish news at 2200-2205. Another station noted well at times is R. Loreto on 9530 kc. from 2330 to 0000 s/off. (WPE6EZ, JL)

Philippines—Far East B/C Service, Manila, has English at 2300-2330 on 9730, 11,855, 15,300, 17,805, and 21,515 kc., at 0915-1045 on 9730, 15,300, and 17,805 kc., at 0800-0830 and 1000-1130 on 11,920 and 21,515 kc. English news

is given at 1645, 1830, 2300, 0430, 0700, 0800, 1000, and 1045. Call letters: 9730 kc., DZH7; 11,855 kc., DZH8; 11,920 kc., DZF2; 15,300 kc., DZH9; 17,805 kc., DZI6; 21,515 kc., DZI8. (WPE3DS, WPE5RB, WPE6TY, WPE9ARA)

Senegal—R. Senegal, Dakar, 4893 kc., has English news from its own station sources, not a Brazzaville relay. Try for it at 1730 on Saturdays. (WPE3NF)

Sudan—R. Omdurman, Khartoum, has a new schedule that reads: Arabic at 2315-0030 (except Fridays), 2315-0600 (Fridays), and 0930-1600 daily. To Southern Sudan at 0900-0930 daily, 0300-0400 (Sundays). English at 0730-0800 daily. Frequencies are 5039 kc. (20 kw.), 9600 kc. (7.5 kw.), and 11,855 kc. (20 kw.). (WPE1BY)

Turkey—R. Ankara, has Eng. news and music to N.A. daily at 1815-1900 on 9515 kc. A "Mailbag" is given Sundays at 1825-1840. Other xmsns noted from Ankara include: 0830-0915 on 17,820 kc.; 1330-1415 on 7285 and 9745 kc.; and 1600-1645 on 15,160 kc. (WPE2CNI, WPE3AYB, WPE4BFY, WPE8HS, WPE8RE, WPE9AGB, VEIPE2L, CK, JK) -30-

POPULAR ELECTRONICS

BARGAIN BASEMENT
SAVE ON THESE SPECIAL BUYS OF THE MONTH

WALKIE TALKIE RADIO SENDING SET



YOUR OWN POCKET SIZE RADIO STATION
Talk to any house or car radio without wires or hookups of any kind! Wt. only 1/2 lb. Size 1 1/2" x 2 1/2" x 1 1/2". Built-in antenna. "Break-in" on regular radio broadcasts with "Dist. Select" and "Push-to-Talk" switch. Self-contained flashlight batteries—Power transistor! Talk to radios in the same building and to cars or between cars up to one block or more away—depending on local conditions. No license or permit needed! Practical and real fun in a million ways. Guaranteed to work—1 year service guaranteed.
SEND ONLY \$3.00—(cash, ck, mo) and pay postman only \$9.95 plus COD postage or send \$12.00 for postpaid delivery. Shipped complete ready to operate with instructions for all kinds of operation. New 1961 Model Radio Talkie is now Super-powered! Order yours now—Today! Available only from:
WESTERN RADIO, Dept. TEL-7 Kearney, Nebr.

ONE CENT SALE Buy One At Our Regular Low Price And Get The Second For Only 1c More

CITIZENS BAND TRANSMITTER (27 MC) 5 watt chassis, complete with crystal \$14.99 each, two for \$15.00
CITIZENS BAND RECEIVER chassis tunable through all 22 channels. Complete with audio amplifier. \$9.99 ea., two for \$10.00
AMATEUR BAND TRANSCIVER 144-148 MC chassis with dual VHF triodes for walkie-talkie radiophone. \$9.99 ea., two for \$10.00.
SIGNAL BOOSTER chassis for 27 MC. High gain (20dB) double tuned RF pentode amplifier. Improves performance of any Citizen Band receiver. Complete with tube \$14.99 each, 2 for \$15.00.
KIT OF PARTS for AM-FM-VHF radio receiver. Tunable from 80-200 mc. which includes U.S. satellite frequencies. \$6.99 ea., two for \$7.00.
CONVERTER (Crystal Controlled) for 27 MC Citizen Band. Adapts any standard broadcast radio to 27 MC band. Tunes all 22 channels. Complete with tubes and crystal. \$14.99 each, 2 for \$15.00.
LIMITED QUANTITY—NO LITERATURE OR CATALOG
Remit in full. Includes postage. No C.O.D.'s.
VANGUARD ELECTRONIC LABS. Dept. E-7
Factory & Mail Order, 190-48 99th Ave., Hollis 23, N. Y.
Retail Store, 196-23 Jamaica Ave., Hollis 23, N. Y.

Experimenters • Amateurs • Hobbyists

Extraordinary values await you in government surplus electronic components. Don't buy anything until you have our "Bargain Bulletin"; new material for mere dimes on the dollar. Remember, everything is brand new; here are typical values:
Stanco choke, 5.3 hy/450 mils, 50 ohms, 3 KV... 12 lbs. \$3.89
Pwr xfmr 115/60, 490 var/130, 5.2 & 6.3/3 pot, 9 lbs. 3.19
40 meter coil for RC-610—15 ea. 65c
Mallory oil cond, 8 mfd/660 AC (1750 DC okay)... 3 lbs. 2.39
Cathode ray tube, Type 2A1P—2 lbs. \$1.45... 75 lbs. 24/18.95
Fil xfmr, 115/60 pri, 27 amps of 6.3 volts... 3 lbs. 3.29
Jennings type VC vacuum cond, 100 mmfd/20 KV, 2 lbs. 6.95
4.5-5 MC 1Fs, dual cond (tuned-7 oz. 22c... 3/ .95
Tone arm, Webster Adl replacement arm—1 lbs. \$1.69... 2/2.95
Sil-Bio fuses, type 3AG, 1/32 amp, box of 100... 2 lbs. 2.95
WRITE TODAY FOR FREE GOVERNMENT SURPLUS BARGAIN BULLETIN
JOE PALMER P.O. Box 6188 CCC, Sacramento, California

NEW SILICON 500MA RECTIFIERS*

GENERAL PURPOSE 400 PIV AT 250 MA
SPECIAL 2 FOR \$1 25 FOR \$10

rms/div 35 50 25c	rms/div 70/100 35c	rms/div 140/200 45c	rms/div 210/300 55c
rms/div 280/400 65c	rms/div 350/500 85c	rms/div 420/600 \$1.10	rms/div 490/700 \$1.35
rms/div 560/800 \$1.50	rms/div 630/900 \$1.70	rms/div 700/1000 \$2.00	rms/div 770/1100 \$2.50

Use in F.W.Bridge or F.W.C.T. up to 750ma DC or mtg 2" sq Fins for 1.5Amp. (Orders \$5 or more we pay postage 48 states.)
*Rate 20% for Capacitor Input. Send 25c for Catalogue
"TAB" I I I K Liberty St. N. Y. 6, N. Y.

ALL BAND TRAP ANTENNA!

Reduces interference and noise on all makes Short Wave Receivers. Makes World Wide Reception Stronger, Clearer on All Bands!
For ALL Amateur Transmitters. Guaranteed for 500 Watts Power for Pi-Net or Link Direct Feed, Light, Neat, Weatherproof.
Complete as shown total length 102 ft. with 87 ft. of 7/16 ohm balanced feedline. Hi-imped milled steel automatic frequency resonant trap. Wt. 3 oz. (1 1/2" x 5" long). You just tune to desired band for harmonic route. Excellent for ALL world wide short wave receivers and amateur transmitters. For NOVICE AND ALL CLASS AMATEURS! Use as Invented 1 for All Band power gain! Eliminates 5 separate antennas with better performance guaranteed. NO HAYWIRE HOUSE APPLIANCE! EASY INSTALLATION!
40-40-20-15-10 meter bands, complete... \$14.95
40-20-15-10 meter bands, 54 ft. antenna (best for worldwide swl's)... \$13.95
20-15-10 meter bands, Dual Trap, 24 ft. Antenna... \$19.95
SEND ONLY \$3.00 (cash, ck, mo) and pay postman balance COD plus postage on arrival or send full price for postpaid delivery. Available only from:
WESTERN RADIO Dept. AEL-7 Kearney, Nebraska

NEVER FAIL—ZONE YOUR MAIL

The Post Office has divided 106 cities into postal delivery zones to speed mail delivery. Be sure to include zone number when writing to these cities; be sure to include your zone number in your return address—after the city, before the state.



ELECTRONICS MARKET PLACE

RATE: 50c per word. Minimum 10 words prepaid. September issue closes July 7th. Send order and remittance to Martin Lincoln, POPULAR ELECTRONICS, 1 Park Ave., New York 16, N. Y.

FOR SALE

ELECTRONICS Kits wired and tested. Cost, 20% kit price. Work guaranteed. Ten years kit building experience assures top results. Write, E. McCann, 52 Summer, Haverhill, Mass.

FOLDING Pocket Binoculars—2.5x25 mm. Amazing Price, \$3.00. Dave Donovan, 7 E. Wilmot, Havertown, Pa.

10 DISTANCE Crystal set plans—25¢; 20 different 50¢, with Transistor experiments, catalog. Laboratories, 1131-L Valota, Redwood City, California.

RADIO and Television Tubes—Brand New, 1st Quality. Top Name Brands in original boxes, 60% off list, Free Bonus with orders, Prompt Deliveries; U T C—Box 306, Syosset, N. Y.

TELEVISION Sets \$9.95 plus Shipping—Jones T.V., Sanatoga, Pa.

DIAGRAMS for repairing radios \$1.00, Television \$2.00. Give make, model. Diagram Service, Box 672-PE, Hartford 1, Conn.

GOVERNMENT Surplus Receivers, Transmitters, Snooperscopes, Parabolic Reflectors, Picture Catalog 10¢. Meshna, Malden 48, Mass.

AUTO Radio Distributor Selling, Servicing, Becker Blaupunkt, FM-AM, other European, American Sets. Save 30%, + Square Electronics, 150-60 Northern Blvd., Flushing, New York.

GOVERNMENT Sells! Surplus Electronics; Test equipment; Oscilloscopes, Transceivers, Jeeps, Boats, Aircrafts, Misc—Send for U. S. Depot Directory & Procedure \$1.00—"Government Surplus Sales," Box 425 PE, Nanuet, N. Y.

WPE-SWL-CB-QSL Cards—Samples 10¢—"Brownie" W3CJI, 3110A Lehigh, Allentown, Penna.

RADIO & TV Tubes at Manufacturer's prices! 100% Guaranteed! Brand New! No re-brands or pulls! United Radio, Box 1000-E, Newark, N. J.

REPAIR Instructions, Schematics, Radios, T.V.'s, HiFi's, 99¢ Model? "Coop" Box 5938, Kansas City 11, Missouri.

CONDENSER checker—opens, shorts intermittents. Accurate, reliable. Ready to use. Guaranteed! Mesco, Box 4521, K. C. 24, Mo.

CITIZEN Banders increase coverage 100% R. F. cascode amplifier kit \$4.95. Wired \$6.95. I. F. Amplifier kit \$4.95 wired \$6.95. Specify, Make, Model. Money back guarantee. Todd Radio 9417-3 Ave., Brooklyn 9, N. Y.

CITIZEN'S Band! Add a Hushpuppy noise suppressor to your Heathkit transceiver! Squelch Action. Completely Wired. Guaranteed. \$4.98. Western Mass. Electronics, Great Barrington, Mass.

CITIZEN'S Band. Preamplifier Kit, printed circuit, high sensitivity \$12.95 complete. \$22.95 wired. Capri Electronics, 3118 W. 48th, Los Angeles 43, Calif.

CAPACITOR Leakage Tester. Checks Shorted, Leaky condensers quickly, easily. Guaranteed. Send \$14.95 to: Bob's Radio & TV Supply, P. O. Box 149, Wayland, Mass.

CHEMICALS and Apparatus Catalog 25¢. Nu-Age Laboratories, Box 232, Bellmore, N. Y.

WANTED

CASH for used short-wave Ham Receivers, Transmitters and Accessories. Treger, W9IVJ. 2023 N. Harlem Ave., Chicago 35B, TXuded 9-6429.

WANT to buy good equipment and accessories? Place a low-cost classified ad in this space.

July, 1960

CYLINDER and old disc phonographs. Edison Conqueror, Idelia, and Oratorio models. Berliner Gramophones and Zono-o-phones, Columbia cylinder Graphophones, and Coin-operated cylinder Phonos. Want old catalogues and literature on early phonos prior to 1919. Will pay cash or trade late hi-fi components. Popular Electronics, Box 50, 1 Park Ave., New York 16, N. Y.

HIGH-FIDELITY



PRICES? The Best! Factory-sealed Hi-Fi Components? Yes! Send for free catalog. Audion, 25P Oxford Road., Massapequa, N. Y.

DISGUSTED with "HI" Hi-Fi Prices? Unusual discounts on your High Fidelity Requirements. Write Key Electronics, 120 Liberty St., New York 6, N. Y. CLOverdale 8-4288.

AUDIO Accessories—best prices—free catalog. Audiotone Recording Services, P. O. Box 9, Port Washington, N. Y.

TREMENDOUS savings! Sherwood, Dual AR, all others! Immediate reply to your correspondence. Sound Room, 1509 Bedford Avenue, Brooklyn, N. Y.

KITS Assembled: Hi-Fi, Amateur, Test Equipment, Etc. Workmanship Guaranteed. For Details Write Remco, Box 475, Knoxville, Illinois.

TAPE & RECORDERS

TAPE Recorders, Hi-Fi components, Sleep Learning Equipment, tapes. Unusual Values. Free Catalog. Dressner, 69-02P, 174 St., Flushing 65, N. Y.

AMPEX, Concertone, Magnecord, Presto, Bogen, Tandberg, Pentron, Sherwood, Rek-O-Kut, Scott, Shure, Dynakit, others, Trades, Boynton Studio, Dept. PE, 10 Pennsylvania Ave., Tuckahoe, N. Y.

RENT Stereo Tapes—over 1,000 different—all major labels—free catalog, Stereo-Parti, 811-P Centinela Ave., Inglewood 3, California.

RECORDERS, Components Free wholesale catalogue. Carston, 125-P East 88, N. Y. C. 28.

LOW Quotes on everything HiFi & Stereo Tapes. Bargain Lists. HiFi, Dept. P2, Roslyn, Pa.

SAVE Over 100% Tape-Recorder 2-speed 7 1/2"/sec. 3 3/4"/sec. 5 in. speaker \$49.95 8-transistor 2-Band w/battery, earphone leather case \$28.85 6-transistor w/battery, earphone leather case \$17.85. Check or money order, guaranteed. P. O. Box 2404, Memphis 2, Tenn.

NEW Patented Tape Threader. Simply attach to end of tape. Eliminates pigtail threading. Automatically releases at end of reel. Holds loaded reel from spilling. A boon to every tape recordist. Send \$1 for 5 threaders. Tunetime Recording Enterprises, Box 652, Adelaide St. Postal Stn., Toronto, Ontario, Canada.

INSTRUCTION

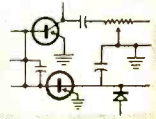

TRANSISTORIZE your automobile ignition system. Complete plans and instructions: \$2.50. Technical Services Institute, 5699-24th Terrace North, St. Petersburg 10, Florida.

COMPLETE your high school at home in spare time with 63-year-old school. Texts furnished. No classes. Diploma. Information booklet free. American School, Dept. XB63—Drexel at 58th, Chicago 37, Illinois.

WRITE Martin Lincoln, Popular Electronics, 1 Park Avenue, New York 16, N. Y. for information on how to place a classified ad in this section.

POLICE Radar Detector. Stop before those radar speed traps. Fool proof, legal system. Complete diagrams and instructions \$2.75. C. Carrier Co., 5880 Hollywood Blvd., Hollywood 28, Calif.

BE A Spy! Correspondence course on wire tapping, bugging, telescopic sound pickup, recording techniques, microphotography, invisible and remote photography, telescopic and aerial photography. Lessons in surveillance, tailing, and use of equipment. Complete course \$22.50. C. Carrier Co., 5880 Hollywood Blvd., Hollywood 28, Calif.

ELECTRONIC Hypnotizer. Simplifies the art of Hypnosis. Diagrams and operating instructions \$3.00. C. Carrier Co., 5880 Hollywood Blvd., Hollywood 28, Calif.

2 MAN Submarine. Jet powered. Cheap and easy to build. Construction plans and instructions. \$4.25. Seaway Electronics, 5880 Hollywood Blvd., Hollywood 28, Calif.

2 WAY Wrist Radio with auxiliary Long Distance Booster. Complete construction details \$3.00. C. Carrier Co., 5880 Hollywood Blvd., Hollywood 28, Calif.

JUNK Your Distributor and Voltage Regulator.: Improve automobile mileage and performance. Construction details for transistorized distributor and voltage regulator. No moving parts. \$4.75. DB Enterprises, 8959 Wonderland Ave., Hollywood 46, Calif.

COLOR TV. Convert your black and white TV to color. Completely Electronic. No mechanical gadgets. Costs about \$35. Complete construction details \$4.75. DB Enterprises, 8959 Wonderland Ave., Hollywood 46, Calif.

ELECTRONICS By sleep teaching. The thorough way to train. Catalog 24¢. Electra-Sleep, 8959 Wonderland Ave., Hollywood 46, Calif.

EXPERIMENT with nature's electronics! Instructions—Stillwater, Box 337 W. Morris Plains, New Jersey.

CALCULUS or Algebra. Easy Lessons. First Four \$1. Matchco, 4256-8 Minnor, Cincinnati 17, Ohio.

HIGHLY Effective Home-study Review For FCC Commercial Phone Exams. Free Literature. Write: Chief Instructor, Cook's School of Electronics, PE7, Box 10634, Jackson 9, Miss.

INVENTIONS WANTED

INVENTIONS wanted. Patented: unpatented. Global Marketing Service, 2420-P 77th, Oakland 5, Calif.

INVENTIONS Wanted, patented: unpatented. J. T. Invention Sales Company, 25 Fayette St., Brooklyn 6, N. Y.

TURN Your Ideas—Inventions into cash, royalty. Ketchum's Advertising, B-1058-I, Springfield, Illinois.

MISCELLANEOUS

BIRTHDAY, Graduation Gifts for Hams. Brochure. K9TVA, 6429C Glenwood, Chicago 26.

VOLTAGE Tester Screw Driver Combination \$1.00. Naelco, Box 182, Mercer Island, Washington.

SHOPPING GUIDE

Classified

A HANDY REFERENCE TO PRODUCTS AND SERVICES NOT NECESSARILY ELECTRONIC, BUT OF WIDE GENERAL INTEREST.

BUSINESS OPPORTUNITIES

VENDING Machines—No Selling. Operate a route of coin machines and earn amazing profits. 32-page catalog free. Parkway Machine Corporation, Dept. 12, 715 Ensor St., Baltimore 2, Md.

BUY direct from factories—Appliances. Cameras. Watches! Free details! Cam Company, 6810 PE—20th Ave., Brooklyn 4, N. Y.

GROW Mushrooms. Cellar, shed and outdoors. Spare, full time, year round. We pay \$4.50 lb. dried. We have 29,000 customers. Free Book. Mushrooms, Dept. 334, 2954 Admiral Way, Seattle, Wash.

RADIO Parts Stores & Hi-Fi Salons: Someone "borrowing" your personal copy of Popular Electronics each month? You ought to be taking advantage of Popular Electronics' convenient re-sale plan. Sell copies in your store . . . perform a good service for your customers . . . with no risk involved. For details, write: Direct Sales Department, Popular Electronics, One Park Avenue, New York 16, New York.

MAKE \$25-\$50 Week, clipping newspaper items for publishers. Some clippings worth \$5.00 each. Particulars free. National, 81-DG, Knickerbocker Station, New York City.

MUSIC

SONGPOEMS And Lyrics Wanted! Mail to: Tin Pan Alley, Inc., 1650 Broadway, New York 19, N. Y.

POEMS Wanted for musical setting and recording. Send poems. Free examination. Crown Music, 49-TM West 32, New York 1.

EMPLOYMENT INFORMATION

OVERSEAS Employment. American firms and United States Government. Comprehensive job information \$2.00. Foreign Opportunities, Box 172, Columbus 16, Ohio.

EARN extra money selling advertising book matches. Free samples furnished. Matchcorp., Dept. MD-70, Chicago 32, Illinois.

HIGH Pay Overseas, Domestic Jobs, Men, Women. Generous Benefits. Companies Pay Transportation. For info, write: World Wide, Dept. E, 149 N. Franklin St., Hempstead, N. Y.

PHOTOGRAPHY—FILM EQUIPMENT, SERVICES

OPTICAL Science Math Bargains Request Free Giant Catalog "CJ"—128 pages—Astronomical Telescopes, Microscopes, Lenses, Binoculars, Kits, Parts. Amazing war surplus bargains. Edmund Scientific Co., Barrington, New Jersey.

STAMPS & COINS

105 DIFFERENT U. S. stamps 25¢, Approvals included. Shelron, Box 907-J, New York 8, N. Y.

50 ALL Different stamps—Free with approvals. Wm. Rice, 87 Washington Avenue, Kingston 42, N. Y.

LEATHERCRAFT

FREE "Do-It-Yourself" Leathercraft Catalog. Tandy Leather Company, Box 791—M-34, Fort Worth, Texas.

MISCELLANEOUS

FREE! New 1960 catalog of all photographic books available for your copy. Send postcard with name and address to Catalog, Popular Photography Book Service, One Park Ave., New York 16, N. Y.

Always say you saw it in—POPULAR ELECTRONICS

WINEMAKING. Beer, Ale Brewing, Cider. Methods, illustrated, \$3.00. Eaton Bookstore, Box 1242-C, Santa Rosa, California.

WHATEVER your needs. Popular Electronics classified can solve them. Simply place an ad in these columns and watch your results pour in.

PEN-PAL Specialty Service, 221 West Maple, Viroqua, Wis. Scientific Interests Matched—25¢ Free Information.

NEW Mothers' Names! \$1.00 per 100. M.A.M., P. O. Box #8213, Honolulu, Hawaii (Waikiki Branch).

KEY chains, personalized ashtrays, smoke sets—Novelties for home, office and gifts. Inexpensive items. Send 10¢ for illustrated brochure. House of Brand, Dept. PE-3, 3458 Fish Avenue, New York 69, New York.

HOMEBREWED Wines, Beers, Complete instructions—\$1.00. Dean's, Box 40-EL, Elberton, Georgia.

HOW to pick locks! Illustrated. \$9.95 Wilford Publications, 7400 Benjamin Franklin Station, Washington 4, D. C.

BUSINESS Cards \$3.75 Thousand postpaid. Free samples. Imagination, Box 761, Hollywood 28, Calif.

GOLF Clubs Wholesale. Free Price List. Crystal Golf Sales, Crystal, Mich.

HOMEBREW. Make it yourself. Complete instructions \$1.75. Homecrafts, Box 587-A, Bellevue, Nebraska.

OVER 320,000 buyers and sellers will read your ad when placed in this space. It costs only 50¢ per word; minimum of 10 words including your name and address.

SENDING A BILL?

It'll get there quicker if you give your postal delivery zone number with your address.

The Post Office has divided 106 cities into postal delivery zones to speed mail delivery. Be sure to include zone number when writing to these cities; be sure to include **your** zone number in **your** return address — after the city, before the state.

Advertisers' Index JULY 1960—POPULAR ELECTRONICS

ADVERTISER	PAGE	ADVERTISER	PAGE
Airex Radio Corporation	24	National Technical Schools	7
Allied Radio	19	North American Philips Company, Inc.	8
Atlas Sound Corp.	20	Olson Radio Corporation	28
Audio Devices, Inc.	2nd Cover	Paco Electronics Company, Inc.	10
Blonder-Tongue Laboratories, Inc.	26	Palmer, Joe	124
Boulevard Electronics	122	Picture Tube Outlet	122
Bud Radio	110	Popular Electronics Book Division	108, 123
Capitol Radio Engineering Institute	35	Popular Electronics Book Division Listing	29, 30, 31, 32
Central Technical Institute	109	Port Arthur College	107
Chicago Standard Transformer Corporation	110	Progressive "Edu-Kits" Inc.	27
Cleveland Institute of Electronics	25	RCA Institutes, Inc.	16, 17
Coyne Electrical School	9	Rad-Tel Tube Co.	33
DeVry Technical Institute	5	Radio Shack Corp.	122
EICO	36, 38	Rinehart & Co., Inc.	119
Electro-Voice	15	Sarkes Tarzian	99
Electronic Chemical Corp.	122	Shure Brothers Inc.	37
ESSCO	122	Spartan School of Aeronautics	113
Grantham School of Electronics	11	Sprayberry Academy of Radio-Television	13
Heath Company	100, 101, 102, 103	Springfield Enterprises	28
Indiana Technical College	120	"TAB"	124
International Crystal Mfg. Co., Inc.	23	Teltron Electric Co.	18
Johnson Company, E. F.	20	Texas Crystals	24
Key Electronics Co.	120	Tri-State College	112
Kuhn Electronics	14	Trinidad College	112
Lafayette Radio	21	Tru-Vac Electric Company	22
Lektron	105, 120	U. S. Air Force	3
Micro Electron Tube Co.	12	United Scientific Laboratories, Inc.	14
Miller, R. G.	120	Valparaiso Technical Institute	120
Milwaukee School of Electronics	111	Vanguard Electronic Labs.	124
Mosley Electronics, Inc.	115	Walsco Electronics Mfg. Co.	112
Moss Electronic Inc.	3rd, 4th Cover, 128	Western Radio	124
National Radio Institute	1	World Radio Laboratories	117

SHIPPED ON APPROVAL NO MONEY WITH ORDER - NO C.O.D.

Superior's New Model 76

ALL PURPOSE BRIDGE

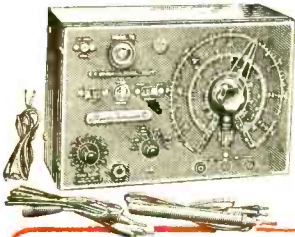

Model 76 ALL PURPOSE BRIDGE
Total Price \$26.95
Terms: \$6.95 after 10 day trial, then \$5.00 per month for 4 months if satisfactory. Otherwise return, no explanation necessary.

IT'S A **CONDENSER BRIDGE**
IT'S A **RESISTANCE BRIDGE**

- ✓ **CAPACITY BRIDGE SECTION**
4 Ranges: .00001 Microfarad to .005 Microfarad; .001 Microfarad to .5 Microfarad; .1 Microfarad to 50 Microfarads; 20 Microfarads to 1000 Microfarads. Will also measure the power factor of all condensers from .1 to 1000 Microfarads.
- ✓ **RESISTANCE BRIDGE SECTION**
2 Ranges: 100 ohms to 50,000 ohms; 10,000 ohms to 5 megohms.
- ✓ **SIGNAL TRACER SECTION**
With the use of the R.F. and A.F. Probes included with the Model 76, you can

IT'S A **SIGNAL TRACER**
IT'S A **TV ANTENNA TESTER**

- make stage gain measurements, locate signal loss in R.F. and Audio stages, localize faulty stages, locate distortion and hum, etc.
- ✓ **TV ANTENNA TESTER SECTION**
Loss of sync., snow and instability are only a few of the faults which may be due to a break in the antenna, so why not check the TV antenna first? Locates a break in any TV antenna and measures the location of the break in feet from the set terminals.

Complete with R.F. and A.F. probes and test leads **\$26⁹⁵ Net**

Superior's New Model TV-50A GENOMETER

7 Signal Generators in One!

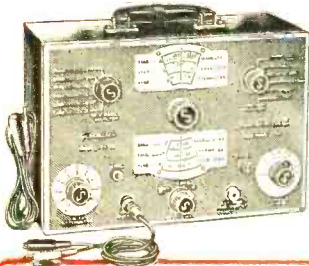

Model TV-50A GENOMETER . . .
Total Price \$47.50
Terms: \$11.50 after 10 day trial, then \$6.00 monthly for 6 months if satisfactory. Otherwise return, no explanation necessary.

- ✓ R.F. Signal Generator for A.M.
- ✓ R.F. Signal Generator for F.M.
- ✓ Audio Frequency Generator
- ✓ Bar Generator
- ✓ Cross Hatch Generator
- ✓ Color Dot Pattern Generator
- ✓ Marker Generator

This versatile All-Inclusive GENERATOR Provides ALL the Outputs for Servicing:

A.M. Radio • F.M. Radio • Amplifiers • Black and White TV • Color TV

R. F. SIGNAL GENERATOR: The Model TV-50A Genometer provides complete coverage for A.M. and F.M. alignment. Generates Radio Frequencies from 100 Kilocycles to 60 Megacycles on fundamentals and from 60 Megacycles to 180 Megacycles on powerful harmonics.

VARIABLE AUDIO FREQUENCY GENERATOR: In addition to a fixed 400 cycle sine-wave audio, the Model TV-50A Genometer provides a variable 300 cycle to 20,000 cycle peaked wave audio signal.

BAR GENERATOR: The Model TV-50A projects an actual Bar Pattern on any TV Receiver Screen. Patterns will consist of 4 to 16 horizontal bars or 7 to 20 vertical bars.

CROSS HATCH GENERATOR: The Model TV-50A Genometer will project a cross-hatch pattern on any TV picture tube. The pattern will consist of non-shifting, horizontal and vertical lines interlaced to provide a stable cross-hatch effect.

DOT PATTERN GENERATOR (FOR COLOR TV)
Although you will be able to use most of your regular standard equipment for servicing Color TV, the one addition which is a "must" is a Dot Pattern Generator. The Dot Pattern projected on any color TV Receiver tube by the Model TV-50A will enable you to adjust for proper color convergence.

MARKER GENERATOR: The Model TV-50A includes all the most frequently needed marker points. The following markers are provided: 189 Kc., 262.5 Kc., 456 Kc., 600 Kc., 1000 Kc., 1400 Kc., 1600 Kc., 2000 Kc., 2500 Kc., 3579 Kc., 4.5 Mc., 5 Mc., 10.7 Mc., (3579 Kc. is the color burst frequency).

The Model TV-50A comes absolutely complete with shielded leads and operating instructions. Only **\$47⁵⁰**

APPROVAL FORM ON NEXT PAGE ▶

NO INTEREST OR FINANCE CHARGES ADDED!

before you buy any of the models described on the following pages. If after a 10 day trial you are not completely satisfied and decide to keep the model, you are only the down payment and agree to pay the balance at the monthly indicated rate.

If not completely satisfied, you are privileged to return the model to us, cancelling any further obligation.

POPULAR ELECTRONICS, INC.

Dept. D-765 3849 Tenth Avenue, New York 34, N. Y.

PRINTED IN U.S.A.

POPULAR ELECTRONICS

TRY FOR 10 DAYS

before you buy! **then** if satisfactory pay in easy, interest free, monthly payments. See coupon below.

Superior's New
Model 82A

A truly do-it-yourself type **TUBE TESTER**

TEST ANY TUBE IN 10 SECONDS FLAT!



- ① Turn the filament selector switch to position specified.
- ② Insert it into a numbered socket as designated on our chart (over 600 types included).
- ③ Press down the quality button—

THAT'S ALL! Read emission quality direct on bad-good meter scale.

FEATURES:

- Tests over 600 tube types.
- Tests OZ4 and other gas-filled tubes.
- Employs new 4" meter with sealed air-damping chamber resulting in accurate vibrationless readings.
- Use of 22 sockets permits testing all popular tube types and prevents possible obsolescence.
- Dual Scale meter permits testing of low current tubes.
- 7 and 9 pin straighteners mounted on panel.
- All sections of multi-element tubes tested simultaneously.
- Ultra-sensitive leakage test circuit will indicate leakage up to 5 megohms.

Production of this Model was delayed a full year pending careful study by Superior's engineering staff of this new method of testing tubes. Don't let the low price mislead you! We claim Model 82A will outperform similar looking units which sell for much more—and as proof, we offer to ship it on our examine before you buy policy.

Model 82A comes housed in handsome, portable, Saddle-Stitched Texon case. Only....

\$36.50
Net

Model 82A—Tube Tester
Total Price **\$36.50**
Terms: \$6.50 after 10 day trial, then \$6.00 monthly for 5 months if satisfactory. Otherwise return, no explanation necessary.

SUPERIOR'S
NEW
MODEL 83

C.R.T. TESTER

Tests and Rejuvenates **ALL PICTURE TUBES**

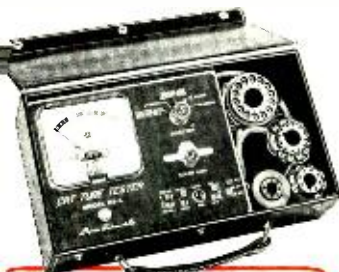

ALL BLACK AND WHITE TUBES **ALL COLOR TUBES**

From 5C degree to 110 degree types
—from 3" to 30" types.

Test ALL picture tubes—in the carton—out of the carton—in the set!

Model 83—C.R.T. Tube Tester
Total Price **\$38.50**
Terms: \$8.50 after 10 day trial, then \$6.00 monthly for 5 months if satisfactory. Otherwise return, no explanation necessary.

- Model 83 is not simply a rehashed black and white C.R.T. Tester with a color adaptor added. Model 83 employs a new improved circuit designed specifically to test the older type black and white tubes, the newer type black and white tubes and all color picture tubes.
- Model 83 provides separate filament operating voltages for the older 6.3 types and the newer 8.4 types.
- Model 83 employs a 4" air-damped meter with quality and calibrated scales.
- Model 83 properly tests the red, green and blue sections of color tubes individually—for each section of a color tube contains its own filament, plate, grid and cathode.
- Model 83 will detect tubes which are apparently good but require rejuvenation. Such tubes will provide a picture seemingly good

but lacking in proper definition, contrast and focus. To test for such malfunction, you simply press the red switch of Model 83. If the tube is weakening, the meter reading will indicate the condition. Rejuvenation of picture tubes is not simply a matter of applying a high voltage to the filament. Such voltages improperly applied can strip the cathode of the oxide coating essential for proper emission. The Model 83 applies a selective low voltage uniformly to assure increased life with no danger of cathode damage.

Housed in handsome portable Saddle Stitches Texon case—complete with sockets for all black and white tubes and all color tubes. Only

\$38.50

We invite you to try before you buy any of the models described on this page, the preceding page and the following pages. If after a 10 day trial you are completely satisfied and decide to keep the Tester, you need send us only the down payment and agree to pay the balance due at the monthly indicated rate.

NO INTEREST OR FINANCE CHARGES ADDED!

If not completely satisfied, you are privileged to return the Tester to us, cancelling any further obligation.

**SEE OTHER
SIDE**

CUT OUT AND MAIL TODAY! ▶

MOSS ELECTRONIC, INC.

Dept. D-765, 3849 Tenth Ave., New York 34, N. Y.

Please send me the units checked on approval. If completely satisfied I will pay on the terms specified with no interest or finance charges added. Otherwise, I will return after a 10 day trial positively cancelling all further obligation.

- | | |
|--|--|
| <input type="checkbox"/> Model 76 .. Total Price \$26.95
\$6.95 within 10 days. Balance \$5.00 monthly for 4 months. | <input type="checkbox"/> Model 83 .. Total Price \$38.50
\$8.50 within 10 days. Balance \$6.00 monthly for 5 months. |
| <input type="checkbox"/> Model TV-50A .. Total Price \$47.50
\$11.50 within 10 days. Balance \$6.00 monthly for 6 months. | <input type="checkbox"/> Model 70... Total Price \$15.85
\$3.85 within 10 days. Balance \$4.00 monthly for 3 months. |
| <input type="checkbox"/> Model 82A... Total Price \$36.50
\$6.50 within 10 days. Balance \$6.00 monthly for 5 months. | <input type="checkbox"/> Model 80 .. Total Price \$42.50
\$12.50 within 10 days. Balance \$6.00 monthly for 5 months. |

Name

Address

City Zone State

All prices net, F.O.B., N. Y. C.

PLUGGED ON APPROVAL NO MONEY WITH ORDER — NO C. O. D.

Superior's New Model 70 UTILITY TESTER®

FOR REPAIRING ALL ELECTRICAL APPLIANCES and AUTOMOBILE CIRCUITS



As an electrical trouble shooter the Model 70:

- Will test Toasters, Irons, Broilers, Heating Pads, Clocks, Fans, Vacuum Cleaners, Refrigerators, Lamps, Fluorescents, Switches, Thermostats, etc.
- Measures A.C. and D.C. Voltages, A.C. and D.C. Current, Resistances, Leakages, etc.
- Will measure current consumption while the appliance under test is in operation.
- Incorporates a sensitive direct-reading resistance range which will measure all resistances commonly used in electrical appliances, motors, etc.
- Leakage detecting circuit will indicate continuity from zero ohms to 5 megohms (5,000,000 ohms).

As an Automotive Tester the Model 70 will test:

- Both 6 Volt and 12 Volt Storage Batteries • Generators • Starters • Distributors • Ignition Coils • Regulators • Relays • Circuit Breakers • Cigarette Lighters • Stop Lights • Condensers • Directional Signal Systems • All Lamps and Bulbs • Fuses • Heating Systems • Horns • Also will locate poor grounds, breaks in wiring, poor connections, etc.

INCLUDED FREE This 64-page book—practically a condensed course in electricity. Learn by doing.

Just read the following partial list of contents: What is electricity? • Simplified version of Ohms Law • What is wattage? • Simplified wattage charts • How to measure voltage, current, resistance and leakage • How to test all electrical appliances and motors using a simplified trouble-shooting technique. • How to trace trouble in the electrical circuits and parts in automobiles and trucks.

Model 70 comes complete with 64 page book and test leads

\$15⁸⁵
Only

Model 70—UTILITY TESTER
Total Price...\$15.85—

Terms: \$3.85 after 10 day trial, then \$4.00 monthly for 3 months, if satisfactory. Otherwise return, no explanation necessary.



SUPERIOR'S NEW MODEL 80

20,000 OHMS PER VOLT ALLMETER

THE ONLY 20,000 OHMS PER VOLT V.O.M. SELLING FOR LESS THAN \$50 WHICH PROVIDES ALL THE FOLLOWING FEATURES:

- ✓ 6 INCH FULL-VIEW METER provides large easy-to-read calibrations. No squinting or guessing when you use Model 80.
 - ✓ MIRROR SCALE permits fine accurate measurements where fractional readings are important.
 - ✓ CAPACITY RANGES permit you to accurately measure all condensers from .00025 MFD to 30 MFD in addition to the standard volt, current, resistance and decibel ranges.
 - ✓ HANDSOME SADDLE-STITCHED CARRYING CASE included with Model 80 Allmeter at no extra charge enables you to use this fine instrument on outside calls as well as on the bench in your shop.
- 7 D.C. VOLTAGE RANGES: (At a sensitivity of 20,000 Ohms per Volt) 0 to 15/75/150/300/750/1500/7500 Volts.
 - 6 A.C. VOLTAGE RANGES: (At a sensitivity of 5,000 Ohms per Volt) 0 to 15/75/150/300/750/1500 Volts.
 - 3 RESISTANCE RANGES: 0 to 2,000/200,000 Ohms. 0-20 Megohms.
 - 2 CAPACITY RANGES: .00025 Mfd. to 3 Mfd., .05 Mfd. to 30 Mfd.
 - 5 D.C. CURRENT RANGES: 0-75 Microamperes, 0 to 7.5/75/750 Milliampers, 0 to 15 Amperes.
 - 3 DECIBEL RANGES: - 6 db to + 18 db, + 14 db to + 38 db, + 34 db to + 58 db

Model 80 Allmeter comes complete with operating instructions, test leads and portable carrying case. Only **\$42⁵⁰**

TRY FOR 10 DAYS BEFORE you buy! THEN if satisfactory

pay in easy, interest free, monthly payments. See coupon inside.

We invite you to try before you buy any of the models described on this and the preceding pages. If after a 10 day trial you are completely satisfied and decide to keep the Tester, you need send us only the down payment and agree to pay the balance due at the monthly indicated rate. (See other side for time payment schedule details.)

NO INTEREST OR FINANCE CHARGES ADDED!

If not completely satisfied, you are privileged to return the Tester to us, cancelling any further obligation.

SEE OTHER SIDE

CUT OUT AND MAIL TODAY!

FIRST CLASS

Permit No. 61430

New York, N. Y.

VIA AIR MAIL



BUSINESS REPLY CARD

No Postage Stamp Necessary if Mailed in the U. S.

POSTAGE WILL BE PAID BY —

MOSS ELECTRONIC, INC.

3849 TENTH AVENUE

NEW YORK 34, N. Y.