

THE IDEA THAT GREW FOR 100 YEARS

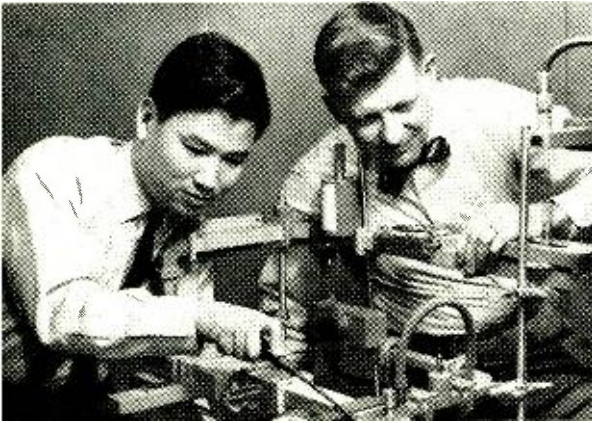

At Bell Laboratories, M. Uenohara (left) adjusts his reactance amplifier, assisted by A. E. Bakanowski. Extremely low "noise" is achieved when certain diodes are cooled in liquid nitrogen.

This is the first practical diode for amplifier as developed by A. E. Bakanowski and A. Uhler.

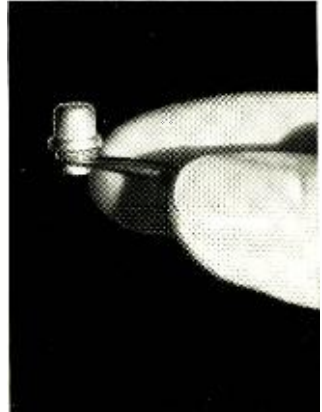

How basic scientific ideas develop in the light of expanding knowledge is strikingly illustrated by the development of Bell Laboratories' new "parametric" or "reactance" amplifier.

Over 100 years ago, scientists experimenting with vibrating strings observed that vibrations could be amplified by giving them a push at strategic moments, using properly synchronized tuning forks. This is done in much the same way a child on a swing "pumps" in new energy by shifting his center of gravity in step with his motion.

At the turn of the century, scientists theorized that *electrical* vibrations, too, could be amplified by synchronously varying the *reactance* of a capacitor. Later amplifiers were made to work on this principle but none at microwave frequencies.

Then came the middle 50's. Bell Telephone Laboratories scientists, by applying their new transistor technology, developed semiconductor diodes of greatly improved capabilities. They determined theoretically *how* the electrical capacitance of these new diodes could be utilized to amplify at *microwave* frequencies. They created a new microwave amplifier with far less "noise" than conventional amplifiers.

The new reactance amplifier has a busy future in the battle with "noise." At present, it is being developed for applications in tropospheric transmission and radar. But it has many other possible applications. It can be used, for instance, in the reception of signals reflected from satellites. It is still another example of the continuing efforts to improve your Bell System communications.

BELL TELEPHONE LABORATORIES

WORLD CENTER OF COMMUNICATIONS RESEARCH AND DEVELOPMENT



Learn Radio-Television Electronics

by Practicing at Home in Your Spare Time

WITHOUT EXTRA CHARGE YOU GET special NRI kits developed to give you actual practice with Radio-TV receiver or broadcasting circuits and equipment. All equipment is yours to keep.

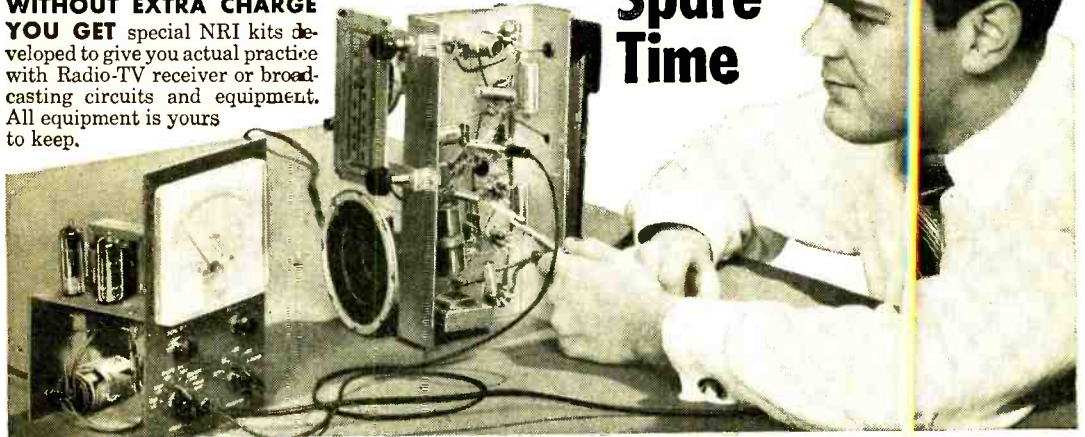

Fast Growing Field Offers You Good Pay, Success, Bright Future



RADIO-TV BROADCASTING (see above) offers important positions as Operators and Technicians. **RADIO-TV SERVICING** Technicians (see below) needed in every community. Their services are respected, their skill appreciated.



J. E. SMITH
Founder

Bigger than ever and still growing fast. That's why Radio-TV has special appeal to ambitious men not satisfied with their job and earnings. Training PLUS opportunity is the ideal combination for success. The technical man is looked up to. He does important work, gets good pay for it. NRI can supply training quickly. Keep your job while training. You learn at home in your spare time.

Added Income Soon—\$10, \$15 a Week in Spare Time

Soon after enrolling, many NRI students start to earn \$10, \$15 a week in spare time fixing sets. Some pay for their training and enjoy extra pleasures this way. Some who start in spare time build their own full time Radio-TV servicing business. NRI training is practical—gets quick results. Easy to understand, well illustrated lessons teach you basic principles.

And you **LEARN-BY-DOING** by practicing with kits of equipment NRI furnishes. NRI methods are tested, proven. NRI has trained thousands for successful careers in Radio-TV.

Find Out What NRI Offers

Mail coupon now. *Actual lesson free.* Also 64 page catalog that shows opportunities in Radio-TV, things you learn, equipment you get. Cost of NRI courses low. Easy terms. **NATIONAL RADIO INSTITUTE.** Dept. OFD4, Washington 16, D.C.

No Stamp? USE THIS

PASTE OR SCOTCH TAPE ON ENVELOPE



BUSINESS REPLY MAIL NO POSTAGE STAMP NECESSARY IF MAILED IN U.S.A.	FIRST CLASS PERMIT NO. 208 WASHINGTON, D.C.
POSTAGE WILL BE PAID BY	
NATIONAL RADIO INSTITUTE	
WASHINGTON 16, D.C.	

N.R.I. TRAINED THESE MEN FOR SUCCESS



"I was repairing Radios by 10th lesson. Now have good TV job." **M. R. LINDEMUTH,** Fort Wayne, Ind.



"Doing spare time repairs on Radio and TV. Soon servicing full time." **CLYDE HIGGINS,** Waltham, Mass.

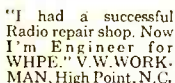

"I had a successful Radio repair shop. Now I'm Engineer for WHPE." **V.W. WORKMAN,** High Point, N.C.



"There are a number of NRI graduates here. I can thank NRI for this job." **JACK WAGNER,** Lexington, N.C.



VETERANS Approved Under G.I. Bills

SEND FOR BOTH FREE

National Radio Institute

Dept. OFD4 Washington 16, D. C.

Mail me Sample Lesson and 64-Page Catalog FREE. (No salesman will call. Please write plainly.)

Name _____ Age _____

Address _____

City _____ Zone _____ State _____

Accredited Member National Home Study Council



POPULAR ELECTRONICS is published monthly by Ziff-Davis Publishing Company, William B. Ziff, Chairman of the Board (1946-1953), at 134 S. Wabash Ave., Chicago 5, Ill. Second-class postage paid at Chicago, Illinois. Authorized by Post Office Department, Ottawa, Canada, as second-class matter. **SUBSCRIPTION RATES:** One year U.S. and possessions, and Canada \$4.00; Pan-American Union Countries \$4.50; all other foreign countries, \$5.00.

POPULAR ELECTRONICS

JUNE

1960

VOLUME 12

NUMBER 6



Cover Story

Let's Build the "Tiny Mite".....Forrest H. Frantz, Sr. 73

Other Construction Projects

Volt/Ammeter Kit..... 49
R.F. Power Meter.....Joseph Tartas, W2YKT 52
Black Box Magic.....Kenneth Richardson 57
Low-Cost Transistor Tester.....Martin H. Patrick 68

Audio and High Fidelity

CBS Tape Cartridge (Notes from the Editor).....Oliver Read, W1ETI 8
Inside the Hi-Fi Tape Recorder:
Bias, Erase and Equalization Circuits.....Joseph Marshall 46
A Compatible Stereo Record.....Robert Angus 65
How to Place Stereo Speakers.....John Milder 82

Electronic Features and New Developments

Eavesdropping on Outer Space.....Ken Gilmore 41
Electronics Adds a New Angle to Angling.....Robert P. Hammond 50
Test Instruments—The Signal Generator (Part 3).....G. H. Harrison 62
Transistor Topics.....Lou Garner 77
Pay TV's First Battle.....John D. Lenk 79
The Language of Vectors (After Class Feature—
Part 2 of two parts).....Saunders Harris 85
Carl & Jerry: Two Tough Customers.....John T. Frye, W9EGV 89

Amateur and SWL

FCC Report: Citizens Band Applications.....Robert E. Tall 10
DX'ing on TV.....King Schafer 54
Across the Ham Bands: How to Prevent Trouble with the FCC
Herb S. Brier, W9EGQ 71
Short-Wave Report: QSL Bureaus.....Hank Bennett, W2PNA 76
On the Citizens Band.....Tom Kneitel, 2W1965 88

Departments

Letters from Our Readers..... 14
POP'tronics Bookshelf..... 22
Tips and Techniques..... 28
New Products..... 34

Index to Volume 12 (Jan.-June, 1960)..... 124

Cover pictorial by Bruce Aldrich

Copyright © 1960 by ZIFF-DAVIS PUBLISHING COMPANY. All rights reserved.

POPULAR ELECTRONICS



the
tape
that
cost **\$9,000,000** to perfect!

Soundcraft Tape with the new **FA-4** frequency adjusted formula-tion. Designed to meet the unlimited challenge of the most exciting new era in recording history!

Only years of research... and the most modern and advanced tape manufacturing facilities in the world... could have perfected this tape! Soundcraft's new **FA-4 FORMULATION** is frequency adjusted to provide the superlative sound reproduction demanded in this exciting era of new discoveries and innovations in tape recording. You'll hear "highs" as never

before... the full frequency spectrum for perhaps the very first time!

Insist on Soundcraft Tape with the new **FA-4 FORMULATION** before you run another reel through your recorder... you'll never settle for inferior sound reproduction again!

REEVES SOUNDCRAFT CORP.

Great Pasture Rd., Danbury, Conn. • Chicago: 28 E. Jackson Blvd.
Los Angeles: 342 N. LaBrea • Toronto: 700 Weston Rd. R104

POPULAR ELECTRONICS

World's Largest-Selling Electronics Magazine

Average Net Paid Circulation 295,979

Editor & Publisher
OLIVER READ, W1ETI

Managing Editor
JULIAN M. SIENKIEWICZ, WA2CQL

Feature Editor
FURMAN HEBB

Art Director
ALFONS J. REICH

Associate Editors
RICHARD A. FLANAGAN
MARGARET MAGNA
PERRY WINTER, K2VLR

Editorial Assistant
DOLORES GIMBEL

Contributing Editors
H. BENNETT, W2PNA
H. S. BRIER, W9EGQ
J. T. FRYE, W9EGV
L. E. GARNER, JR.
T. KNEITEL, 2W1965

Art Associate
J. A. ROTH

Art and Drafting Dept.
K. W. PAUL, JR.
W. K. VAHLSING, WV2GYL

Advertising Director
JOHN A. RONAN, Jr.

Advertising Manager
WILLIAM G. McROY, 2W4144

ZIFF-DAVIS PUBLISHING COMPANY,
One Park Ave., New York 16, N. Y.
William B. Ziff, Chairman of the Board
(1946-1953); William Ziff, President;
W. Bradford Briggs, Executive Vice
President; Michael Michaelson, Vice
President and Circulation Director; Hersh-
el B. Sarbin, Vice President; J. Leonard
O'Donnell, Treasurer.



BRANCH OFFICES: Midwestern Office,
434 S. Wabash Ave., Chicago 5, Ill.,
Jim Weakley, advertising manager;
Western Office, 9025 Wilshire Blvd.,
Beverly Hills, Calif., Dan Cena, Western
Manager.

Foreign Advertising Representatives:
D. A. Goodall Ltd., London; Albert Mil-
hado & Co., Antwerp and Dusseldorf.

SUBSCRIPTION SERVICE: Forms 3579 and all subscription correspondence should be addressed to Circulation Department, 434 South Wabash Avenue, Chicago 5, Illinois. Please allow at least four weeks for change of address. Include your old address as well as new—enclosing if possible an address label from a recent issue.

CONTRIBUTORS: Contributors are advised to retain a copy of their manuscripts and illustrations. Contributions should be mailed to the New York Editorial Office and must be accompanied by return postage. Contributions will be handled with reasonable care, but this magazine assumes no responsibility for their safety. Any copy accepted is subject to whatever adaptations and revisions are necessary to meet the requirements of this publication. Payment covers all author's, contributor's and contestant's rights, titles, and interest in and to the material accepted and will be made at our current rates upon acceptance. All photos and drawings will be considered as part of material purchased.

COMING NEXT MONTH

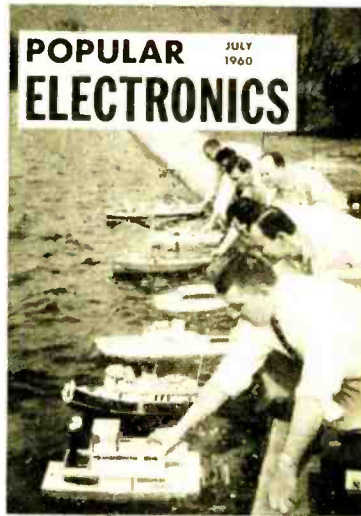

(ON SALE JUNE 28)

● OPERATION RADIO CONTROL

The fascinating story of how some of our most brilliant engineers design radio-controlled model boats and planes for their own enjoyment

● MAGNETIC AMPLIFIERS

Recently "rediscovered," magnetic amplifiers now have a new lease on life. Learn how they work and what they're used for

● ONE-TRANSISTOR RECEIVER

Complete construction plans for building a tiny vest-pocket receiver that makes use of a single transistor for both r.f. and a.f. amplification

● LOW-DOWN ON MICROPHONES

A quick survey of the advantages and disadvantages of five different types of microphones

**NOW...GET
EVERYTHING
YOU NEED TO
PREPARE TO EARN
REAL MONEY IN**

ELECTRONICS

**From RADIO • TELEVISION • RADAR
To GUIDED MISSILE CONTROL, etc.**

One of
Today's
BRIGHTEST
Opportunity Fields!



Today's great Electronics field offers you a chance of a lifetime to prepare for highly interesting work and a wonderfully promising future! With so many new developments coming up in Electronics, opportunities for trained men were never brighter. Send coupon for details.

Right in your own home you may now get one of today's most interesting . . . **PRACTICAL WAYS** to prepare for a good job or your own business in Electronics. No previous technical experience or advanced education are needed! DeVry Tech brings you a unique **3-WAY COMBINATION** of texts, home movies and real equipment—the same type of basic equipment as found in our well-equipped Chicago and Toronto Laboratories.

EMPLOYMENT SERVICE

. . . helps you get started toward a good job, or toward advancement in the company you now work for. **FREE** to all graduates.

EARN WHILE YOU LEARN

DeVry Tech's practical program helps you to earn **EXTRA MONEY** in your spare time, servicing Radio and TV sets.

Your Guide

to PROFITABLE JOB OPPORTUNITIES

See how YOU may get ready for Jobs as:

TV-Radio Broadcast Technician
Color Television Specialist
Radar Operator • Laboratory Technician
Airline Radio Man • Computer Specialist
Quality Control Manager

Your Own Sales & Service Shop . . . **PLUS MANY OTHERS**

SEND FOR FREE BOOKLET!

"One of North America's Foremost Electronics Training Centers"



Accredited Member of
National Home
Study Council

DeVRY TECHNICAL INSTITUTE
CHICAGO 41, ILLINOIS

300 EXPERIMENTS

Build over 300 practical projects from many shipments of Radio-Electronic parts. You build and operate TV-Radio circuits . . . wireless microphone . . . and many other major projects—all designed to provide outstanding practical experience at home.



HOME MOVIES

Thanks to this exclusive home training aid, many important fundamentals quickly become "movie clear." Now you can actually see electrons on the march and other "hidden actions"—a wonderful advantage that is almost like having a teacher at your side.



BUILD YOUR OWN TEST EQUIPMENT

As part of your home laboratory projects, you **BUILD** and **KEEP** a fine quality 5-inch **COLOR OSCILLOSCOPE** and a Jewel Bearing **VACUUM TUBE VOLTMETER**. You will find this equipment ideal for helping you earn in your spare time while a student—and later when working full time in the field.



BUILD AND KEEP A BIG 21-INCH TV SET

For added practical experience, you can also build and keep this quality 21-inch **TV SET** that provides TV reception at its finest (DeVry Tech also offers another home training without the TV set).

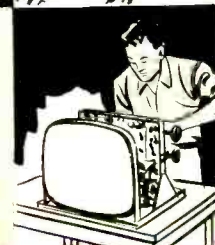

MAIL COUPON TODAY!

DeVRY TECHNICAL INSTITUTE
4141 Belmont Avenue, Chicago 41, Ill., Dept. PE-6-Q

Please give me your **FREE** booklet, "Electronics in Space Travel," and tell me how I may prepare to enter one or more branches of Electronics.

Name _____ Age _____

Street _____ Apt. _____

City _____ Zone _____ State _____

2046 Canadian residents address DeVry Tech of Canada, Ltd.
626 Roselawn Ave., Toronto 12, Ont.

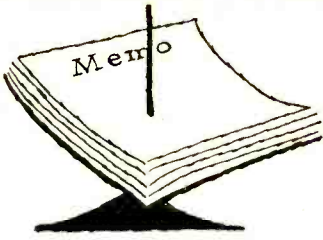

Notes from the Editor

CBS TAPE CARTRIDGE. It was on this page in our April issue that I mentioned the forthcoming appearance of the CBS tape-cartridge system. At that time I had a strong hunch that CBS might pull a rabbit out of its hat and come up with a significant advance in hi-fi/stereo. Well, the magicians at CBS, led by Peter Goldmark, the inventor of the LP record, have apparently done just that. The new system was demonstrated in New York during the recent I.R.E. show, and it made a profound impression on virtually everyone who heard it.

By any standard of comparison, the quality of the system is exceptional. And when you consider that the system uses tape which is 150 mils wide (about 1/7") moving at the speed of only 1 7/8 ips, it is well-nigh unbelievable. Very good high-frequency response (to 15,000 cps) is achieved through the use of narrow-gap heads and a new tape developed by Minnesota Mining and Manufacturing Co. This tape has smaller magnetizable particles than standard tape, thus permitting higher frequencies to be recorded on it. In addition, its oxide coating does not rub off on the heads.

Other features worthy of note include the tape cartridge itself, which is only 3½" square and contains slightly over an hour's stereo playing time; a third channel recorded down the center of the tape that provides a "delayed" sum signal for optional use with a third amplifier-speaker system to increase the amount of reverberation in the listening room; and provisions for automatic operation whereby five cartridges can be played in sequence without touching the machine.

Production models of the new system are now under development by Zenith, and the first commercial units will probably be available next year. Prices are indefinite as yet, but a pre-recorded one-hour tape cartridge will probably be under \$5.95, the average cost of a stereo record.

JAPANESE TV SETS. The long-expected influx of Japanese television receivers into this country is about to begin. Sony has already demonstrated a 13½-lb., battery-powered transistorized portable to be imported in quantity very soon. Unlike the portable announced by Philco last year, the Sony set has a direct-view picture tube, 8" in diagonal measurement. Retail price will be about \$250.00.

Perhaps even more interesting is the news that Hitachi is getting ready to produce color TV sets for the American market. Plans aren't certain yet as to whether Hitachi will assemble the units completely or just build the chassis. In any case, lower-priced color sets may be on the way!

Olin Read

Through HOME STUDY or in RESIDENT CLASSES

ELECTRONICS

— field of opportunity —

the Grantham Communications
Electronics Course prepares you
for your first class commercial

F.C.C. LICENSE

The Grantham home study course teaches you principles of electronics in a simple "easy-to-grasp" manner. Each new principle is explained first in *everyday language* and then, after you understand it, is associated with the proper *technical language*. You learn and remember more, because the emphasis is on *understanding* rather than on memorizing.

This correspondence course is directed toward two major objectives — (1) to *teach* you a great deal about electronics, and (2) to prepare you to *pass* all of the F. C. C. examinations required for a first class commercial operator's license. We teach you step by step and have you practice with FCC-type tests which you send to the School for grading and comment. You prepare for your F. C. C. examinations under the watchful direction of an instructor who is especially qualified in this field.

Grantham training is the easy way to learn more quickly — to prepare more thoroughly — for F. C. C. examinations. And your first class license is the quick, easy way to prove to your employer that you are worth more money.

Get details concerning *how* we can prepare you for your F. C. C. license and *how* that license can help you advance in electronics. Mail the coupon below to the home office of Grantham School of Electronics in Hollywood, Calif., and our free catalog will be sent to you promptly.

offers

interesting and profitable careers in

RADIO AND TV BROADCASTING • TWO-WAY RADIO COMMUNICATIONS • RESEARCH AND DEVELOPMENT • RELAY STATION MAINTENANCE • AUTOMATION ELECTRONICS • TECHNICAL WRITING IN ELECTRONICS • INDUSTRIAL ELECTRONICS • ELECTRONIC COMPUTERS • MILITARY ELECTRONICS • INSTRUMENTATION • TELEMETERING • AERONAUTICAL ELECTRONICS • SPACE ELECTRONICS

and many other

interesting and profitable fields of the present and future

To get ahead in electronics, you must have the proper training and your employer must know that you have that training. Your F. C. C. license is a "diploma" in communications electronics granted by the U. S. Government, and it is recognized as such by employers. Grantham School of Electronics specializes in preparing you to earn this diploma.

HERE'S PROOF... that Grantham students prepare for F. C. C. examinations in a minimum of time. Here is a list of a *few* of our recent graduates, the class of license they got, and how long it took them:

	License	Weeks
Edgar T. Phelps, 931 Hickory Street, Poplar Bluff, Mo.	1st	12
Wayne Hogg, 4830 San Fernando Rd., Glendale, Calif.	1st	20
Robert Watson, Star Route, Box 24, Renovo, Pa.	1st	12
William H. Patchin, 3865 Westview Ave., NW, Canton, Ohio	1st	12
V. Dean DeVore, 309 Bess Street, Washington, Ill.	1st	16
Edward T. Wall, Box 184, Kenly, N. C.	1st	12
James W. Wranich, 4236 Michigan Street, Kansas City, Mo.	1st	20
Robert E. Sullivan, 2475 E. Douglas, Des Moines, Iowa	1st	12
Nelson S. Kibler, 1413 Patrick Henry Dr., Falls Church, Va.	1st	18
Barry L. Ulrich, 1110 Chestnut Ave., Barnesboro, Pa.	1st	14
Jerry E. Milligan, 707 Ragsdale Dr., Milan, Tenn.	1st	12
Robert S. Davis, 2100 - 10 Ave., So., Apt. 12, Birmingham, Ala.	1st	13

If you are interested in details concerning our training, indicate in the coupon below whether you prefer home study or resident classes, and mail the coupon to the School's home office in Hollywood, California — to the address given in the coupon — for free details.

GRANTHAM SCHOOL OF ELECTRONICS

HOLLYWOOD

SEATTLE

KANSAS CITY

WASHINGTON

FIRST CLASS F.C.C. LICENSE IN 12 WEEKS

Grantham resident schools are located in four major cities — Hollywood, Seattle, Kansas City, and Washington, D.C. Regularly scheduled classes in F. C. C. license preparation are offered at all locations. New day classes begin every three months, and new evening classes begin four times a year. The day classes meet 5 days a week and prepare you for a first class F. C. C. license in 12 weeks. The evening classes meet 3 nights a week and prepare you for a first class license in 20 weeks. For more information about the Grantham resident schools, indicate in the coupon the city of your choice and then mail the coupon to the School's home office in Hollywood, Calif. Free details will be mailed to you promptly.

GRANTHAM SCHOOL OF ELECTRONICS
1505 N. Western Ave., Hollywood 27, Calif.



(Mail in envelope or paste on postal card)

To: **GRANTHAM SCHOOL OF ELECTRONICS**
1505 N. WESTERN AVE., HOLLYWOOD 27, CALIF.

Gentlemen:

Please send me your free booklet telling how I can get my commercial F.C.C. license quickly. I understand there is no obligation and no salesman will call.

Name _____ Age _____

Address _____

City _____ State _____

I am interested in: Home Study Kansas City classes

Hollywood classes Seattle classes Washington classes

03G

MAIL COUPON FOR FREE DETAILS — NO SALESMAN WILL CALL →

New Sylvania
**"Transistor Circuit
 Handbook for the
 Hobbyist"** gives you
 30 performance-tested
 circuits using
 low-cost transistors!



Interesting new "gadgets" and useful equipment for every electronic experimenter, "ham" or student. Handbook is divided into four circuit-packed chapters.

- I Test Equipment Circuits
- II High Frequency Circuits
- III Audio Frequency Circuits
- IV Utility Circuits

**NOW AT YOUR LOCAL
 SYLVANIA SEMICONDUCTOR
 DISTRIBUTOR'S. Only 50¢.**

Get a copy today!

Sylvania Semiconductor Division, Woburn, Mass.

SYLVANIA
 Subsidiary of GENERAL TELEPHONE & ELECTRONICS



FCC Report

By **ROBERT E. TALL**
 Washington Correspondent

Citizens Band Applications

WHILE the pot continues to bubble at the Federal Communications Commission on enforcement of the new Citizens Band restrictions, other developments keep popping up.

For one thing, CB'ers can look forward to a new application form being adopted by the Commission, possibly within the next several months. The new form, designed for processing by a method which makes more use of machine stamping than is possible with the present application form, is expected to permit considerable speed-up in handling.

In the present stages of planning, the new form would apply to the Class B, C and D Citizens Radio categories.

Meanwhile, the need for more "understandable" explanations on the present application form is being emphasized by FCC officials. The Commission feels that the licensee should be more specific about what he plans to do with his Citizens Band unit. A survey by the Commission shows that 63% of the Citizens Band applications being returned without action are classed as "defective" because of incomplete statements as to the intended use of the radio units. The FCC explains that the statements do not have to be elaborate, but that it does definitely want to know the intended use.

Another 12% of the applications being returned are classed as defective because the potential Citizens Bander has failed to have his application notarized. In one of his first official duties as new Chairman of the FCC, Frederick W. Ford strongly supported a legislative proposal being studied by the House Interstate & Foreign Commerce Committee that would knock out this re-

These men are getting practical training in **NEW Shop-Labs of**

ELECTRICITY

COYNE

ELECTRONICS

ON REAL

Motors—Generators
—Switchboards—
Controls—Modern
Appliances—
Automatic
Electronic
Control Units

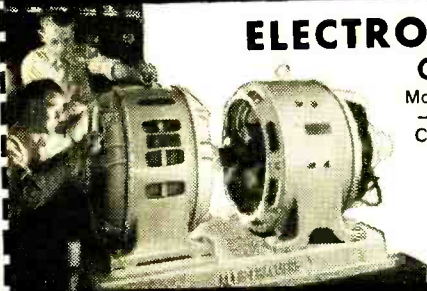

TELEVISION

RADIO ELECTRONICS

ON REAL

TV Receivers—
Black and White
and Color
AM-FM and
Auto Radios
Transistors
Printed Circuits
Test Equipment



in Chicago—prepare for today's TOP OPPORTUNITY FIELD. Train on real full-size equipment at COYNE where thousands of successful men have trained for over 60 years—largest, oldest, best equipped school of its kind. Professional and experienced instructors show you how, then do practical jobs yourself. No previous experience or advanced education needed. Employment Service to Graduates.

START NOW—PAY LATER—Liberal Finance and Payment Plans. Part-time employment help for students. **GET FREE BOOK**—"Guide to Careers" which describes all training offered in ELECTRICITY and TELEVISION—**RADIO ELECTRONICS**—no obligation; **NO SALESMAN WILL CALL.**

Coyne Electrical School, 1501 W. Congress Parkway
Chartered Not For Profit • Chicago 7, Dept. AO-2C

MAIL COUPON OR WRITE TO ADDRESS BELOW

COYNE ELECTRICAL SCHOOL
Dept. AO-2C—New Coyne Building
1501 W. Congress Pkwy., Chicago 7, Ill.

Send BIG FREE book and details of all the training you offer. However, I am especially interested in:

Electricity Television Both Fields

Name _____

Address _____

City _____ State _____



COYNE offers

LOW COST

TELEVISION RADIO - COLOR TV

**Training in
Spare Time AT HOME**

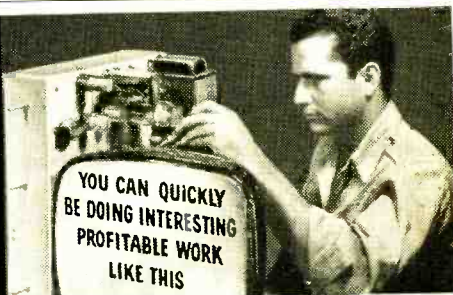

The future is **YOURS** in **TELEVISION!**

A fabulous field—good pay—fascinating work—a prosperous future in a good job, or independence in your own business!

Coyne brings you **MODERN-QUALITY** Television Home Training; training designed to meet Coyne standards at truly lowest cost—you pay for training only—*no costly "put together kits."* Not an old Radio Course with Television "tacked on." Here is **MODERN TELEVISION TRAINING** including **Radio, UHF and Color TV.** No Radio background or previous experience needed. Personal guidance by Coyne Staff. **Practical Job Guides** to show you how to do actual servicing jobs—*make money early in course.* Free Life-time Employment Service to Graduates.

COYNE
ELECTRICAL SCHOOL

CHARTERED AS AN EDUCATIONAL INSTITUTION
NOT FOR PROFIT

1501 W. Congress Parkway • Chicago 7, Dept. AO-H2



B.W. COOKE, Jr., President

Coyne—the Institution behind this training... the largest, oldest, best equipped residential school of its kind. Founded 1899.

**Send Coupon or write to address below
for Free Book**

and full details,
including easy
Payment Plan.

**No obligation, no
salesman will call.**



COYNE Television
Home Training Division
Dept. AO-H2, New Coyne Building
1501 W. Congress Pkwy., Chicago 7, Ill.

Send Free Book and details on how I can get Coyne Quality Television Home Training at low cost and easy terms.

Name _____

Address _____

City _____ State _____

SHURE
PROFESSIONAL

tone arm

for any cartridge . . . stereo or monophonic



new safety

for records. Surface wear is held to absolute minimum through flawless tracking made possible by an ingenious and unprecedented combination of adjustments. Optimum static and dynamic balance, precise height, correct cartridge "overhang," and incredibly accurate stylus force are quickly achieved and easily maintained without guesswork.



new sound

from records. Modern high-compliance, light tracking cartridges (Shure M3D compliance is 4.0×10^{-6} cm/dyne; 3 gm. tracking) require arm balance of a high order in all planes to deliver ALL the sound, undistorted. The Shure arm pivots on drag-free precision bearings. Precision adjustments assure optimum suspension and permanent balance, regardless of cartridge characteristics.



new simplicity

in installation and operation. Installs completely from top side of motorboard — without solder. Lock-on heads are instantly interchangeable. Direct-reading stylus force gauge with counterweight assembly permit visual static balance checks at any time.

M232 for 12" records	\$2995 net
M232 with Shure M7D	\$53.95 net
M232 with Shure M3D	\$74.95 net

SHURE BROTHERS, INC.
222 Hartrey Avenue, Evanston, Illinois

quirement. A bill along the same lines was put through the Senate last year.

The FCC told the Congressional Committee that the requirement for notarization imposes an unnecessary burden on the public, and hampers the Commission's processing work. The FCC feels that the U. S. Code already provides for fine or imprisonment if false statements are included on an application form, and the Commission can revoke licenses later if applicants prove to be untruthful.

However, FCC officials caution that the deletion of the notarization requirement will be in the future, and that any Citizens Bander who wants his license from the Commission before the change is completed must have his application notarized in the usual manner.

On a more cheerful note, Citizens Banders interested in organizing specific-purpose CB operations, such as channels for marine, motel, garage, or other types of use, have been given the green light by the FCC.

Most of the original operations along this line have been in the marine field, and in the unofficial establishing of Channel 9 as the "National Calling Frequency." But FCC officials point out that there is "no reason why" CB'ers in a given area cannot agree among themselves to use one or two, or possibly even more, of the CB channels for communications to and from transient motorists seeking information.

A high-ranking FCC official says he feels such cooperative common-channel usage is an "excellent idea," but he adds quickly that the Commission has no plans at the moment to set aside any channels on a nation-wide basis for any of the specific-purpose operations. He emphasizes that it would not be "appropriate" for the FCC to take such a step at the present time. If these unofficial nets do spring up, the FCC will watch them closely and will be guided in part by their effectiveness when the time comes to legislate on the subject of allocating channels for specific-use purposes.

One of the many petitions filed with the Commission since the latest rule revisions looks toward increased power input to the final stage, possibly an increase to 15 or 25 watts. Also, additional authorized types of emission are being considered for FCC-type accepted equipment. In the near future, CB'ers may be able to use single sideband, double sideband and/or FM.

—50—

Always say you saw it in—POPULAR ELECTRONICS

NOW!
at a price
you can afford!

MAKE MORE MONEY in TELEVISION RADIO-ELECTRONICS

**BETTER...MORE COMPLETE...LOWER COST...
WITH NATIONAL SCHOOLS SHOP-METHOD
HOME TRAINING!**

BETTER... Training that is proved and tested in Resident School shops and laboratories, by a School that is the **OLDEST** and **LARGEST** of its kind in the world.

MORE COMPLETE... You learn **ALL PHASES** of *Television-Radio-Electronics*.

LOWER COST... Other schools make several courses out of the material in our **ONE MASTER COURSE**... and you pay more for less training than you get in our course at **ONE LOW TUITION!**

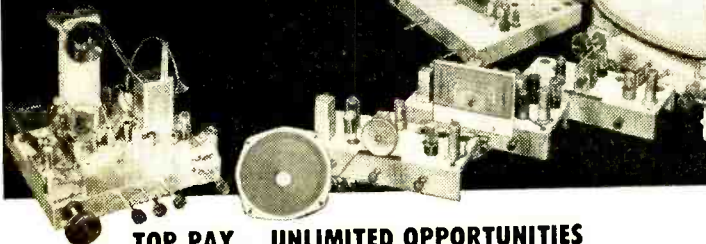

These
two FREE books will
show you how!

You get all information
by mail... You make
your own decision... at
home! **NO SALESMAN
WILL CALL**

TOP PAY... UNLIMITED OPPORTUNITIES LIFETIME SECURITY CAN BE YOURS!

You are needed in the Television, Radio, and Electronics industry! Trained technicians are in growing demand at excellent pay—in **ALL PHASES**, including Servicing, Manufacturing, Broadcasting and Communications, Automation, Radar, Government Missile Projects.

NATIONAL SCHOOLS SHOP-METHOD HOME TRAINING, with newly added lessons and equipment, trains you in your spare time at home, for these unlimited opportunities, including many technical jobs leading to supervisory positions.

YOU LEARN BY BUILDING EQUIPMENT WITH KITS AND PARTS WE SEND YOU. Your National Schools course includes thorough *Practical* training—**YOU LEARN BY DOING!** We send you complete standard equipment of professional quality for building various experimental and test units. You advance step by step, perform more than 100 experiments, and you build a complete TV set from the ground up, that is yours to keep! A big, new TV picture tube is included at no extra charge.

EARN AS YOU LEARN. We'll show you how to earn extra money right from the start. Many of our students pay for their course—and more—while studying. So can you!

RESIDENT TRAINING AT LOS ANGELES

If you wish to take your training in our Resident School at Los Angeles, the world's TV capital, start **NOW** in our big, modern Shops, Labs and Radio-TV Studios. Here you work with latest Electronic equipment - professionally installed - finest, most complete facilities offered by any school. Expert, friendly instructors. Personal attention. Graduate Employment Service. Help in finding home near school - and part time job while you learn. Check box in coupon for full information.

LESSONS AND INSTRUCTION MATERIAL ARE UP-TO-DATE, PRACTICAL, INTERESTING. Every National Schools Shop-Method lesson is made easy to understand by numerous illustrations and diagrams. All instruction material has been developed and tested in our own Resident School Shops, Laboratories and Studios.

SEND FOR INFORMATION TODAY... it can mean the difference between **SUCCESS** and failure for you! Send for your **FREE BOOK** "Your Future in Television-Radio-Electronics" and **FREE Sample Lesson**. Do it **TODAY**, while you are thinking about your future. It doesn't cost you anything to investigate!

GET THE BENEFITS OF OUR OVER 50 YEARS EXPERIENCE

Approved for
GI Training



NATIONAL SCHOOLS
Los Angeles 37, Calif.

YOU GET...

- 19 Big Kits—**YOURS TO KEEP!**
- Friendly Instruction and Guidance
- Job Placement Service
- Unlimited Consultation
- Diploma—Recognized by Industry
- **EVERYTHING YOU NEED FOR SUCCESS!**

SHOP-METHOD HOME TRAINING COVERS ALL PHASES OF INDUSTRY

1. Television, including Color TV
2. Radio AM & FM
3. Electronics for Guided Missiles
4. Sound Recording and Hi-Fidelity
5. FCC License
6. Automation and Computers
7. Radar & Micro-Waves
8. Broadcasting and Communications

NATIONAL TECHNICAL SCHOOLS

WORLD-WIDE TRAINING SINCE 1905

MAIL NOW TO
NATIONAL TECHNICAL SCHOOLS, Dept. R2G-60
4000 S. FIGUEROA ST. LOS ANGELES 37, CALIF.
Rush free TV-Radio "Opportunity" Book and sample
lesson. No salesman will call.

NAME _____ AGE _____
ADDRESS _____
CITY _____ ZONE _____ STATE _____

Check if interested **ONLY** in Resident School training at Los Angeles.
VETERANS Give date of Discharge _____

DYNAKITS

Look Best — Test Best — Sound Best

NEW STEREO PREAMP KIT



- ★ The unique "no distortion" performance initiated by the famous DYNAKIT Pre-amplifier.
- ★ 7 stereo inputs, DC heaters, built-in power supply, DYNA's exclusive "blend" control.
- ★ Highest gain, lowest noise, greatest channel separation, and the easiest to use.
- ★ The ultimate in simplicity—2 pre-assembled printed circuit boards cut assembly time to 8 hours.
- ★ Complete with cover \$59.95* net.

NEW STEREO 70 KIT



- ★ Dual 35 watt super-quality Amplifiers—70 watt continuous monophonic rating—160 watt peak.
- ★ All critical parts on prefabricated printed circuit assembly reduces wiring time to five hours.
- ★ Premium quality parts conservatively operated permit one-year guarantee.
- ★ Uncompromised design for finest performance—usable with *all* speakers.
- ★ Only \$99.95* net including all parts, instructions, and protective cover.

Available from leading Hi-Fi dealers everywhere.
Descriptive brochure available on request.
*Slightly higher in West

DYNACO, INC.

Dept. PE, 3916 Powelton Ave., Phila. 4, Pa.

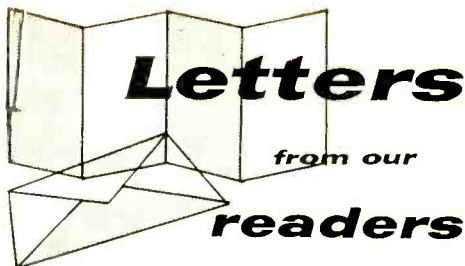

Car Radio Conversion

■ I converted a car radio for home use as per Mr. Louis' article in the February issue and am very pleased with the results. In fact, the performance of the converted car radio now rivals that of my expensive table radio.

Incidentally, I installed a ferrite antenna in place of the original antenna and a 12" speaker instead of the smaller car speaker. Many thanks to you and Mr. Louis for the fine article.

JONATHAN SHAPIRO
New York, N. Y.

Bouquets

■ Please allow an "outsider" to the electronics field (I'm a mechanical engineer) to congratulate you on putting out such an interesting, readable magazine. Largely through your efforts, I'm beginning to

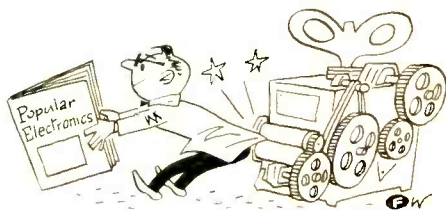

think I may someday understand the realm of the electron.

Thanks particularly for the insert feature, "Understanding Transistor Circuits," in the August, 1959 issue. I will always cherish this article as being the first real light shed on transistor circuit design for me.

Bouquets also to Lou Garner for his brief analyses of readers' circuits in his *Transistor Topics* column. They are always clearly written and understandable.

And thanks for remembering that every reader is not an electronic genius.

CHARLES H. DAVIS
Westbury, N. Y.

Foreign Vs. Domestic Watts

■ Recently while I was in a radio shop exchanging yarns with my serviceman friend, I noticed that the British-made speaker he was installing in a cabinet was marked "British rating 15 watts/American rating 30 watts." This seemed to indicate that an American watt is half a British watt, possibly also explaining why so many American amplifiers have advertised outputs of 40, 50, and even 70 watts.

However, I have always understood that wattage was calculated by multiplying the current

Always say you saw it in—POPULAR ELECTRONICS

ANOTHER WAY RCA
SERVES EDUCATION
THROUGH
ELECTRONICS



6 REASONS WHY RCA TRAINING IN ELECTRONICS

can be the smartest investment
you'll make in your *entire lifetime!*

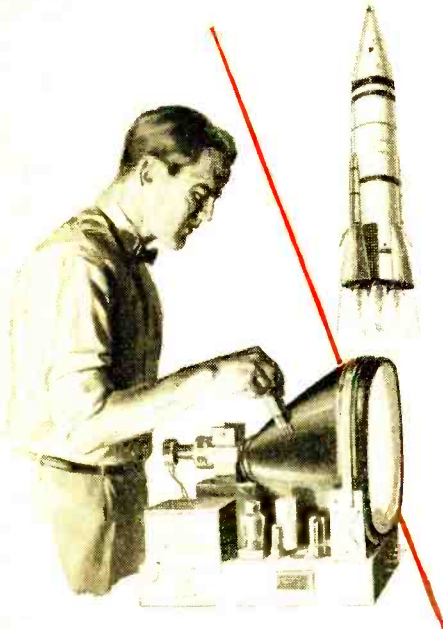

1. You get the finest training-at-home under the supervision of the RCA INSTITUTES, experts in technical training for over 50 years. The very name "RCA" means dependability, integrity, and scientific advance.

2. You get comprehensive training in your choice of four complete, up-to-date Courses . . . from basic electronics theory to Color TV and Automation.

3. You get Theory, Experiment, and Service Practice starting with the very first lesson . . . a complete training package throughout the course. No special technical background is required.

4. You get prime quality equipment as a regular part of your Course . . . equipment that you keep and use on the job. You never have to take apart one piece to build another.

5. You get each study group on a pay-as-you-go basis. Should you wish to interrupt your training at any time, you will not owe RCA Institutes a penny more, unless and until you decide to resume the Course.

6. You get top recognition — worldwide. Graduates of RCA Institutes now work for leaders in the electronics field; many have their own businesses. This record is true tribute to the high quality of RCA Institutes training.

Send for this
64-page Home
Study Catalog
FREE!



RESIDENT SCHOOL Courses in New York City and Los Angeles offer comprehensive training in Television and Electronics. Day and Evening classes start four times each year. Detailed information on request.

RCA INSTITUTES, Inc. Home Study School Dept. PE-50

A Service of Radio Corporation of America

350 West Fourth Street, New York 14, N. Y.

Please rush me your FREE illustrated 64-page book "Your Career in Electronics," describing your home training programs. No obligation. No salesman will call.

Name Age
please print

Address

City Zone State

Korean Vets! Enter discharge date

CANADIANS— Take advantage of these same RCA courses at no additional cost. No postage, no customs, no delay. Send coupon to: RCA Victor Company, Ltd., 5001 Cote de Liesse Rd., Montreal 9, Quebec
To save time, paste coupon on postcard.

Letters (Continued from page 14)

through a load by the voltage across it. How, then, can a British watt be double an American watt? Or is this discrepancy simply traceable to overenthusiastic advertising copy writers?

J. R. H. BELL
Harvey House, Collegiate Sch.
Wanganui, New Zealand

A watt is still a watt regardless of which side of the ocean it's measured on. Reader Bell's confusion lies in the fact that there is no universally accepted method of measuring the power output of an amplifier. Generally speaking, the greater the output, the greater the distortion. This means that an amplifier's output will vary, depending upon how much harmonic distortion you are willing to allow—0.1%, 1%, 2%, or more. You can also rate the power output at a certain percentage of intermodulation distortion—2% for example. Or you can do your measuring at the point where the output waveform as observed on an oscilloscope begins to clip.

To explain the specific question raised by Mr. Bell, British manufacturers generally rate the power output of their amplifiers at lower distortion levels than do American manufacturers. For example, the Leak "Point One" series of amplifiers and preamplifiers is so named because their output is measured at 0.1% harmonic distortion.

It is fairly obvious, therefore, that any power output claim is virtually meaningless unless the manufacturer also states the distortion level at

which the power output was measured. This is the general point of the new IHFM standards for measuring amplifiers: a statement of power output should always be accompanied by the distortion level at which the measurement was made.

Wireless Metronome

■ I recently completed the wireless metronome described in your January issue. Other readers who plan to build this unit may be interested to know that instead of winding coil L1 myself, I used a standard Vari-Loopstick. This arrangement seems to work very well.

MICHAEL AXELRAD
Uniontown, Pa.

Young Experimenter

■ My son George, who is twelve years old and a novice electronic experimenter, performed some modifications on the "Sensitive Diode Transistor Radio" described by Art Trauffer in your January issue. I think these changes will be of interest to your readers.

Instead of the antenna coil recommended by Mr. Trauffer, George used a four-contact antenna coil that he salvaged from an old radio. In addition, he connected the set to an outside antenna. By trying various connections on the antenna coil and by attaching the outside antenna alternately to the stator and the rotor of the variable capacitor, George was able to receive short-wave stations as well as broadcast-band stations.

During the week of March 20th to 26th, Radio (Continued on page 20)

REMARKABLE TUBE VALUES AT 1950 PRICES
ALL TUBES IND. BOXED, CODE DATED AND BRANDED "TRU-VAC®"
Typical TRU-VAC® Bargains! THIS IS A PARTIAL LIST

6SN7GT				6W4GT			
ALWAYS 30c				ALWAYS 30c			
OY4	2CY5	5R4	6A55	6BK7	6CS6	6SD7GT	784
OZ4	3A4	5U4	6AT6	6BL7GT	6CUG5	6F55	785
1A7GT	2A5	5U8	6AU4GT	6BN6	6CUG6	6F57	786
1B3GT	2AL5	5V4G	6AUSGT	6BQAQGT	6D6	6G57	787
1C7	2BC5	5V6GT	6AU6	6BQ7	6D6E	6SHT	788
1C7	2BN6	5XB	6AU8	6B88	6D6G	6G57	7C4
1F4	2B26	5Y3	6AV5GT	6B5B	6D6G	6SHT	7C5
1F5	1CB6	6A6	6AV6	6B5G	6D6	6S17	7C6
1G4	3Q4	4AB4	6AW8	6B26	6F6	6SQ7	7C7
1G5GT	354	6AC7	6AX4GT	6B27	6H6	6SR7	7E5
114	3V4	6AF4	6AX5GT	6C4	6J4	6T4	7E6
116	4807A	6AG5	6B8	6CB6	6J5	6U8	7E7
1MSGT	4B5B	6AH4GT	6BA6	6CD6G	6J6	6V6GT	7F7
1B5	4B27	6AH6	6BC5	6CF6	6J7	6W6GT	7F8
155	4CB6	6AK5	6BCB	6CG7	6K6GT	6X4	7G7
114	5AN8	6AL5	6BD6	6C8	6N7	6X5GT	7H7
1U4	5AN8	6AM8	6BE6	6C16	6N7	6X8	7H7
1U5	5A7B	6AN8	6BF5	6CMA	6O7	6Y6G	7O7
1V2	5AV8	6AOS	6BG6G	6CM7	654	7A4/XXL	757
1X2	5A24	6A06	6BH6	6CN7	657	7A5	7X6
2A14	5BR8	6A07	6BJ6	6AQB	658GT	7A6	7X7
2BN4	5J6	6AR5	6BK5	6CR6	65A7	7A7	7Y4

Thousands More Always In Stock

Your best buy

TRU-VAC

35¢

33¢

For any used or factory second tube!

USED TV CONSOLES

Guaranteed to Work When You Receive Them

10" & 12" \$29

14" & 16" \$37

17" \$45

20" & 21" \$59

All sets shipped in two cartons to avoid breakage. Sets shipped express to continental U.S.A. and Canada only. F.O.B. Harrison, New Jersey.

FREE BONUS—RABBIT EARS

FREE with each set purchased

\$7.95 Value

GUARANTEE

Only TRU-VAC guarantee to replace antec to replace free any tube which becomes defective in use within one year of date of purchase.

FREE FUSE CLIP

Sent With Any Order Of \$5 Or More

1 YEAR GUARANTEED PICTURE TUBES

Brand New* Allied A-1 Tubes Brand New
Below Listed prices do not include dud. Add Additional \$5.00 Deposit on tube sizes to 20" on 21" and 24" tubes—\$7.50. Deposit refunded immediately when dud is returned prepaid. Aluminized tubes—\$4.00 extra.

Picture tubes shipped only to continental U.S. and Canada—All tubes F.O.B. Harrison, N. J.

105P4	99	10AP4	12 19	17CP4	16 99	19AP4	18 39	21AP4	18 39	21PP4	18 39	21TP4	17 49
125P4	10 49	16KP4	11 99	17CP4	12 89	20C5	15 89	21AP4	17 99	21PP4	18 39	21TP4	17 49
14B/CP4	11 99	16LP4	12 19	17MP4	16 99	20DP4	15 89	21AU4	18 39	21MP4	21 39	24AP4	29 49
16AD4	16 09	16AP4	11 99	17IP4	16 99	20PP4	17 89	21AP4	18 39	21TP4	18 39	24CP4	27 79
16DP4	12 19	17AP4	15 49	17CP4	13 89	21AP4	21 49	21AP4	17 49	21PP4	17 49	24DP4	27 79
16CP4	16 09	17BP4	13 49	17PP4	16 99	21AP4	18 39	21PP4	17 49	21TP4	17 49		

ATTENTION QUANTITY USERS! Big Discounts Are Yours... Call or Write For Our 1000 Tube "Private Label" Special! Attention Branding Dept. MGR.

Money cheerfully refunded within five (5) days, if not completely satisfied!

TRU-VAC® PAYS YOUR POSTAGE on orders of \$5 or more in U.S.A. and Territories. Send approximate postage on Canadian and foreign orders. Any order less than \$5 requires 25¢ handling charge. Send 25¢ on C.O.D.'s. All orders subject to prior sale.

Consulting with Federal regulations, the following statement appears in all Tru-Vac advertising: Tubes advertising in this ad may be FACTORY SECONDS or USED tubes and are clearly marked.

TRU-VAC Electric Company

Harrison Avenue Box 107 Harrison, New Jersey Humboldt 4-9770

Visit Our Huge Testing Dept. In The Heart Of Harrison, N. J.'s Electronics Industry

Always say you saw it in—POPULAR ELECTRONICS

PRICES CUT ALMOST $\frac{1}{3}$

on Audiotape on 1½-mil **MYLAR***

THAT'S RIGHT! Audio Devices has cut at least 31% off the price of its premium-quality Audiotape on 1½-mil "Mylar." Now you can enjoy all the advantages of DuPont's fabulous "Mylar" for little more than the cost of ordinary plastic-base tape.

Audiotape on 1½-mil "Mylar" is the finest tape in the Audiotape line. Its tough, durable "Mylar" base and professional-quality oxide make it the perfect tape for schools, recording studios, radio and TV stations, military users—as well as discriminating home recordists.

See your Audiotape dealer as soon as possible. At the new low prices, his stock will move fast. (Similar price reductions have also been made on Master "Low Print-through" Audiotape on 1½-mil "Mylar.")

*"Mylar" is DuPont's trademark for its polyester film—the toughest, most durable recording tape base material known to man. "Mylar" cannot dry out or become brittle with age. Radical differences in temperature and humidity have no effect on it. Recording tapes on "Mylar" can't break or stretch in normal use, regardless of temperature or humidity. Most importantly, "Mylar" is a known, tested base material—proven by years of use in telemetry, automation and electronic computing applications. Millions of feet have been recorded by professional and amateur sound recordists, too.

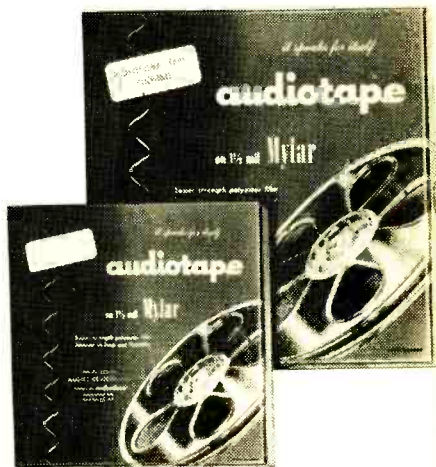

audiotape
TRADE MARK

AUDIO DEVICES, INC., 444 Madison Ave., N. Y. 22, N. Y.

In Hollywood: 840 N. Fairfax Ave. * In Chicago: 5428 N. Milwaukee Ave.

ELECTRONICS
BOOK SERVICE

will send you your choice of the world's greatest electronics books with a **7-DAY MONEY-BACK GUARANTEE**

Here are some of the world's greatest electronics books...chosen carefully by the editors of the Ziff-Davis Electronics Division as among the best in their fields. You'll find top-notch texts and manuals on theory and instruction...important volumes covering every aspect of high fidelity and tape recording...reference books to help you understand such fields as computers, citizens band and electronics experimentation. Each volume is designed to help you get more

know-how, greater enjoyment from your electronics specialty—and each is sent to you with this guarantee: If you are not completely satisfied after reading and studying your books for seven full days, return them and you will receive a complete refund, with no questions asked! Here is the perfect way to build the library every man in electronics must have. A perfect way, incidentally, to solve gift problems too. Simply use the coupon below to indicate your choices and to place your order!

THEORY AND INSTRUCTION

2015. BASIC ELECTRONICS BY BERNARD GROB. An introductory text on the fundamentals of electricity and electronics for technicians in radio, television and industrial electronics. Exceptionally clear style makes this book ideal for home study. \$9.25



2018. ELEMENTS OF RADIO BY A. MARCUS & WM. MARCUS. Employing a unique "spiral" method of instruction, this is an excellent one-volume course on the essentials of radio. Over 500 diagrams and drawings. \$7.00

2016. ELECTRONICS DICTIONARY BY COOKE & MARCUS. Definitions of almost 6,500 terms, abbreviations. An essential volume. \$6.50

2014. BASIC ELECTRONICS BY J. DALY & R. A. GREENFIELD. Here, in twelve chapters, is a complete general introduction to electronics for technicians who make use of complex electronic equipment in modern laboratories. \$9.00

2009. TELEVISION AND FM ANTENNA GUIDE BY EDWARD M. NOLL & MATTHEW MANDL. Two antenna experts tell you their secrets of antenna choice and

installation for best reception in any area. Loaded with useful tips on improving reception in fringe and difficult areas. \$5.25

2004. FM RADIO SERVICING HANDBOOK. A practical guide to frequency modulated VHF radio receivers, their design, construction, alignment and repair; with chapters on adaptors, aerials and hi-fi audio equipment. \$5.00

2025. UNDERSTANDING RADIO BY WATSON, WELCH & EBY. Here is the perfect volume for those with little or no technical knowledge who wish to know the fundamentals of radio theory and servicing. Complete explanations of 24 major areas of radio. \$7.95.

ZIFF-DAVIS ELECTRONICS ANNUALS



2044. HI-FI ANNUAL & AUDIO HANDBOOK (1960 edition—Paper). \$1.00

2045. HI-FI DIRECTORY & BUYERS' GUIDE (1960 edition—Paper). \$1.00

2047. YOUR CAREER IN ELECTRONICS (1960 edition—Paper). \$1.00

2048. ELECTRONICS EXPERIMENTER'S HANDBOOK (1960 edition—Paper). \$1.00
2048C—cloth, \$1.95

2043. STEREO-HI-FI GUIDE (1960 edition—Paper). \$1.00
2043C—cloth, \$1.95

2043/59. HI-FI GUIDE & YEARBOOK (1959 edition—Paper). \$1.00

for

LOWEST
microphonics...

hum...

noise

in a high- μ
dual triode



the

Amperex

ECC83 A PLUG-IN

REPLACEMENT FOR THE 12AX7

MICROPHONICS:

Negligible in amplifiers requiring an input voltage of at least 50 mv for an output of 5 watts. No special precautions against microphonics necessary even though the tube is mounted in the near vicinity of a loudspeaker with 5% acoustical efficiency.

HUM AND NOISE LEVEL:

Better than -60 db relative to 50 mv when the grid circuit impedance is no greater than 0.5 megohms (at 60 cps), the center tap of the heater is grounded and the cathode resistor is by-passed by a capacitor of at least 100 mfd.

OTHER Amperex TUBES FOR HIGH-FIDELITY AUDIO APPLICATIONS:

- EL84/6BQ5** 9-pin power pentode; 17 W PP
- 6CA7/EL34** High-power pentode; 100 W PP
- EF86/6Z6** Low-noise high- μ pentode
- ECC81/12AT7** Low-noise medium- μ dual triode
- ECC82/12AU7** Low-noise low- μ dual triode
- ECC85/6AQ8** High- μ dual triode for FM tuners
- GZ34/5AR4** Cathode-type rectifier; 250 ma.
- EZ80/6V4** 9-pin rectifier; cathode; 90 ma.
- EZ81/6CA4** 9-pin rectifier; cathode; 150 ma.

At All Leading Electronic Parts Distributors



Amperex
ELECTRONIC CORP.
230 Duffy Ave., Hicksville, Long Island, N.Y.

Letters

(Continued from page 16)

Moscow came in consistently to the degree that 90% of the programs were understandable. George also logged Geneva, Sofia, London, and some Spanish-speaking stations. Selectivity was not good, and the foreign stations did not come in strong until after six in the evening.

George and I think that articles such as Mr. Trauffer's, which leave something to the imagination, are more worthwhile than those that tell the "complete" story. We were certainly amazed at our ability to pick up stations on the other side of the world with a 1½-volt radio you can hide in your hand.

JOSEPH E. FINEGAN
Rumson, N. J.

Metal Locator

■ If any of your readers have built and used the transistorized metal locator described in the June, 1959 issue, I would appreciate hearing from them. Could it possibly locate an outboard motor in



about eight feet of water? Does anyone have any suggestions?

S. GRZYNSKI
Box 266, Fisher Branch
Manitoba, Canada

The metal locator you mention won't operate through eight feet of water, but perhaps one of our readers has made a modification to increase its range. Our suggestion is that you tie the motor to the boat from now on!

Dry Cell Rejuvenator

■ I have just finished building the dry cell tester and rejuvenator described in your January issue by James E. Murphy. Although I am a novice who doesn't know a milliampere from a watt, the gadget is perking right along charging the little dry cells, and, incidentally, making my nine-year-old daughter very happy.

Would it be possible to extend the usefulness of this device so that it could charge six-volt lantern-type batteries and the 22½-volt batteries used in flash guns?

F. E. BLAINE
Hamburg, N. Y.

We can't give you any tried-and-tested information, but a transformer with a 12- or 14-volt secondary—rather than the 6-volt secondary specified by Mr. Murphy—might do the trick. The problem is in getting enough reverse current flow through the battery. If a second transformer proves to be satisfactory with higher-voltage batteries, some type of a switch will have to be installed to allow the original transformer to be used for rejuvenating 1½-volt batteries.

-30-

IMPORTANT: For the man who wants to make big money in Radio-Television!

ONLY SPRAYBERRY TRAINING IN RADIO and TELEVISION

**OFFERS YOU ALL OF THESE VITAL NEW ADVANTAGES
TO HELP YOU EARN MORE MONEY FROM THE START!**

NEW BUSINESS BUILDERS

... through these practical proven plans and ideas we help you make plenty of extra money in spare time while training.

NEW TRAINING EQUIPMENT

... the famous Sprayberry Training kits have been newly engineered by our staff to offer you the latest in Radio-TV Service Techniques!

NEW TRANSISTOR COURSE

... literally millions of new transistor radios are being used. We show you how to make money fixing them!

NEW HIGH FIDELITY

... there's big money to be made installing and servicing Hi-Fi units. Your Sprayberry training now offers you this valuable and profitable preparation!

TRAIN AT HOME—SPARE TIME

WITH THESE **25 BIG COMPLETE KITS of PARTS & EQUIPMENT**

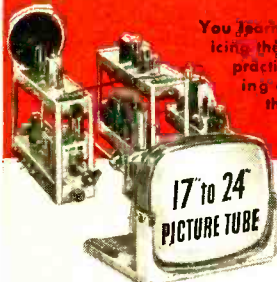

You learn Radio-TV Servicing the best way... the practical way... testing and assembling these modern kits of equipment.

◆ The new Sprayberry Training Television Receiver, built and tested in 5 sections.

Now offered... this fine modern oscilloscope.

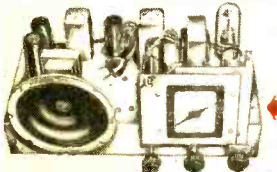

◆ You build this powerful two-band super-heterodyne radio receiver.

You build the new Sprayberry tester — a complete 18-range Volt-Ohm-Milliammeter test meter.

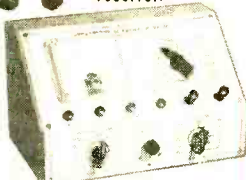

FREE These two big new books are yours free! Find out what Radio-Television offers you... and let us show you how easily you can learn, even without previous experience of any kind. Rush **COUPON** today!

The field of Radio-Television Servicing is such a fast moving industry that the best jobs and biggest incomes always go first to the man with the most modern, complete and up-to-date training. Thanks to constant revision and improvement... Sprayberry Training helps you earn more from the start... and keeps you earning more in the months and years ahead!

Make no mistake! All radio-television training is not alike. The basic purpose behind Sprayberry Training is to prepare you as rapidly and as surely as possible... to make top money servicing Radio and Television sets and equipment. This is where the big money has been for years... and will continue to be in the years ahead.

It's important for you to know that for over 30 years... Sprayberry Training has been preparing ambitious men for success in this interesting and profitable kind of work. Our school has helped hundreds to qualify for the best jobs... or to get started in profitable businesses of their own. Today our student rolls are the largest in our school's history... because the need and demand for Radio-Television Service Technicians has never been more urgent.

Just \$6.00 Starts You

To encourage more men to enter Radio-Television at once... to help fill the great need for trained men... we're making it easier than ever before to start training. Just \$6.00 enrolls you. This liberal offer is naturally limited. Get the facts now

and consider enrollment while these favorable terms are available to you.

KEEP YOUR JOB... while learning

Under the Sprayberry Plan you train entirely at home in spare time. You combine the most modern lesson training with fascinating and invaluable practical work with 25 big kits of parts and equipment that we supply. You get the equivalent of years of shop practice... and you can train as fast or as slowly as you wish. We help you make excellent spare time money while learning... and everything you receive—lessons, books, manuals, equipment—all yours to keep!

This is the Radio-Television industry's most modern and up-to-the-minute training. Sprayberry is the one school that gives you personalized attention and takes a real interest in your progress. Remember... just \$6 starts you! Mail the coupon today. Let the facts speak for themselves. Let us send you our new catalog and sample lesson... and prove the kind of opportunity that Sprayberry training can open up for you.

MAIL COUPON—No Salesman Will Call

SPRAYBERRY ACADEMY OF RADIO-TELEVISION
Dept. 105-M, 1512 W. Jarvis Ave., Chicago 26, Ill.

Please rush all information on your ALL-NEW Radio-Television Training Plan. I understand this does not obligate me and that no salesman will call upon me. Include New Catalog and Sample Lesson FREE.

NAME _____ AGE _____

ADDRESS _____

CITY _____ ZONE _____ STATE _____



SPRAYBERRY ACADEMY OF RADIO-TELEVISION
Dept. 105-M, 1512 West Jarvis Ave., Chicago 26, Ill.

POP'tronics Bookshelf

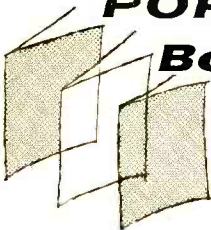

"HOW TO TROUBLESHOOT TV SYNC CIRCUITS" by Ira Remer. Published by John F. Rider Publisher, Inc., 116 West 14th St., New York, N. Y. Soft cover. 128 pages. \$2.90.

Well organized and clearly written, this volume offers a wealth of information on the why's and wherefore's of sync circuits. The picture-tube photos that illustrate sync-circuit faults are excellent. Fundamentals of the subject are covered in detail, and a

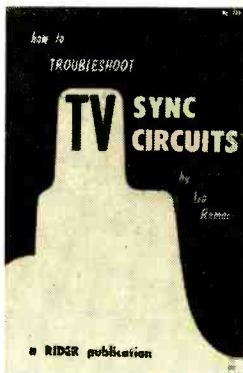

section is included which analyzes the various sync troubles encountered in color receivers. Fruitful reading for the television trouble-shooter.

"TRIPLE PINDEX," published by Radio Corporation of America, Electron Tube Division, Harrison, N. J. Soft cover. \$1.75.

This useful book presents base diagrams for over 1500 tubes *in triplicate*. Every page is split into three horizontal sections, each showing the base diagram of the same tube. By flipping page segments, the user can have as many as three different tube diagrams in front of him at one time. This arrangement should prove a big time-saver in working on unfamiliar radios or TV receivers.

"SERVICING HI-FI AM-FM TUNERS" published by Howard W. Sams and Co., Inc., 1720 East 38th St., Indianapolis 6, Ind. Soft cover. 160 pages. \$2.95.

This is a collection of "PHOTOFACT"

3 Great New Kits for Stereo by PACO

...with the famous specially-prepared giant-size diagrams and super-simple step-by-step instructions for fool-proof assembly and wiring. Crafted by PACO, Kit Division of **PRECISION** Apparatus Company, Inc., world-famous manufacturers of laboratory electronic test equipment for over a quarter of a century.



The PACO SA-40 40 WATT STEREO PREAMP-AMPLIFIER
The Last Preamp-Amplifier You'll Ever Have to Buy

Model SA-40—Kit, complete with gold and satin black cabinet.

Net Price: \$79.95

Model SA-40W—Factory-wired, complete with gold and satin black cabinet.

Net Price: \$129.95



The PACO ST-45 AM-FM STEREO TUNER
A Truly Unusual Engineering Achievement of Stability and Sensitivity

AVAILABLE THREE WAYS:

Model ST-45—KIT, with factory-prealigned transformers, complete with gold and satin black cabinet.

Net Price: \$84.95

Model ST-45PA—SEMI-KIT, with both FM and AM tuner sections factory-wired and completely prealigned and calibrated for hairline sensitivity, complete with gold and satin black cabinet.

Net Price: \$99.95

Model ST-45W—FACTORY-WIRED, aligned, calibrated and assembled, complete with gold and black satin cabinet.

Net Price: \$134.95



The PACO ST-35 FM TUNER
AVAILABLE THREE WAYS:

Model ST-35—KIT, with factory-prealigned transformers, complete with gold and satin black cabinet.

Net Price: \$59.95

Model ST-35PA—SEMI-KIT, with tuner section factory-wired and completely prealigned for hairline sensitivity, complete with gold and satin black cabinet.

Net Price: \$69.95

Model ST-35W—FACTORY-WIRED, aligned, calibrated and assembled, complete with gold and satin black cabinet.

Net Price: \$89.95



NEW PACO 2-WAY SPEAKER SYSTEM SEMI-KIT
featuring Jensen Mid-Range-Woofer and Horn-Type Tweeter

Model L2-U—Semi-Kit, with unfinished, sanded cabinet.

Net Price: \$59.95

Model L2-F—Semi-Kit, with walnut-finished cabinet.

Net Price: \$69.95



AVAILABLE AT ALL LEADING ELECTRONIC PARTS DISTRIBUTORS

You'll want much more data . . . the performance specifications will amaze you . . . write for complete, illustrated brochure to:

PACO ELECTRONICS COMPANY, INC.
70-31 84th Street, Glendale 27, L. I., N. Y.
Kit Division of **PRECISION** Apparatus Company, Inc.

Why be satisfied with less when:

this College-level program of home study in Electronic Engineering Technology

—can help you achieve new levels of income and success



Mail This Coupon Today

CAPITOL RADIO ENGINEERING INSTITUTE
ECPD Accredited Technical Institute Curricula • Founded 1927
Dept. 1206-G, 3224 16th St., N.W., Washington 10, D. C.

Please send me your course outline and FREE 44-Page Book "Insurance for Your Future in the New World of Electronics" describing opportunities and CREI home study courses in Advanced Electronic Engineering Technology.

- Check field of greatest interest**
- Radar, Servo and Computer Engineering Technology
 - Electronic Engineering Technology
 - Communications Engineering Technology
 - Television Engineering Technology
 - Aeronautical Electronic Engineering Technology
 - Automation and Industrial Electronics Engineering Technology

Name _____ Age _____
Street _____
City _____ Zone _____ State _____

Check: Home Study Residence School Korean Veteran

CREI OFFERS COLLEGE-LEVEL OPPORTUNITY to the man who wisely realizes that the recognition and rewards in electronics are now going to other men—especially the man with modern advanced education.

WITHIN TWO TO FOUR YEARS, depending on the courses selected and amount of stick-to-itiveness brought to bear, you can complete this program in electronics, which is comparable in technological content to advanced residence courses. You study during hours chosen by you. You have plenty of time to do your best.

THIS ADVANCED PROGRAM IS THE CULMINATION of 33 years of working closely with leading companies and Government agencies in the critical field of electronics, where demand for engineering and technical personnel far exceeds the supply. The courses are presented in easy-to-understand form, and our experienced instructors guide your progress step by step.

YOU QUALIFY FOR CREI if you have a high school diploma or equivalent, and if you have had basic electronic training and practical experience in electronics.

PLEASE WRITE US NOW FOR DETAILED, ILLUSTRATED, 44-PAGE CATALOGUE, which gives complete information on home study program and registration procedure. CREI also offers a Residence School Program, where graduates earn AAS degree. Day and evening classes start at regular intervals. Electronics experience is not required for admittance to the Residence School.

CREI PROFESSIONAL STANDING

U.S. Office of Education lists CREI as "an institution of higher education."

CREI was a co-founder of the National Council of Technical Schools.

CREI was among the first three technical institutes whose curricula were accredited by the Engineers' Council for Professional Development.

More than 20,500 students are enrolled in CREI Home Study and Resident Programs.

America's leading electronics, communications, missiles and space exploration companies and Government agencies recognize CREI. Many of these organizations actually pay the tuition for their employees studying with CREI.



To obtain fast, immediate service and to avoid delay, it is necessary that the following information be filled in:

Employed by _____
Type of Present Work _____
Education: _____
Years of High School _____
Other _____
Electronics Experience _____

What do you need in Battery Power?

ZINC-CARBON? NICKEL-CADMIUM?
WATER-ACTIVATED? MERCURY?

**MORE THAN 5,000
BURGESS BATTERY TYPES**

each with the highest measure of uniform dependability! This is why 2 of 3 electronic engineers specify

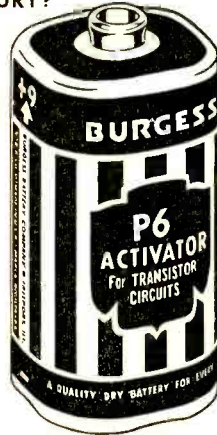

BURGESS BATTERIES

Here are **5 reasons** why Burgess leads in the electronics market.

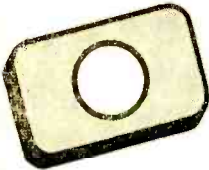

1. EXCLUSIVE WAFER CELL CONSTRUCTION

... offers compactness, long shelf life, exceptional service life. A 30% increase in battery life at no increase in size.

2. TRANSISTOR ACTIVATORS

Burgess Transistor Activator Batteries are smaller! Yet they deliver 30% more power because of the patented "Wafer-Cell" construction! Activators give compact power, uniform performance, longer shelf life.



3. RESERVE BATTERIES

High energy output in compact form. Can be stored dry for years!



Activated by immersing in water. No spilling or leaking! Wide range of efficient operating temperatures. Designed for your specific applications.

4. MERCURY ACTIVATORS

Burgess exclusive patents offer sealed-in-steel protection, wide temperature range efficiency, controlled venting, patented inner cell connector, and flat discharge curve.



5. SEALED NICKEL-CADMIUM BATTERIES

A secondary rechargeable battery system which delivers high energy output from a small package! Hermetically sealed-in-steel cells eliminate annoying maintenance and addition of liquids. Can be recharged many times.



See your local radio serviceman—dealer for more information.

BURGESS BATTERY COMPANY
DIVISION OF SERVEL, INC.

FREEPORT, ILLINOIS NIAGARA FALLS, CANADA

Bookshelf (Continued from page 22)

folders on AM-FM tuners and receivers produced in 1958-1959. Manufacturers represented are Altec Lansing, Challenger, Chapman, Bogen, Fisher, Grommes, Harman-Kardon, Knight, Madison Fielding, Masco, Newcomb, Pilot, Scott, Sherwood, and Stromberg-Carlson. Information on each model includes a schematic, resistance charts, photos, parts list, dial-stringing guide, etc. A special section covers speaker design and theory. Recommended to the service technician and to the hi-fi fan who likes to keep up to date on circuitry.



"**FUNDAMENTALS OF ELECTRONICS**" by Matthew Mandl. Published by Prentice-Hall, Inc., 70 Fifth Ave., New York 11, N. Y. 574 pages. \$10.60.

Although this book covers some very familiar ground, it should not be considered just another volume on basic electronics. It has been written with unusual care; the author presumably kept the reader

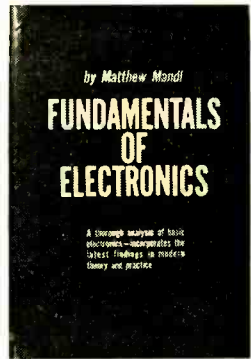

in mind at every step. Each new term is explained in such a logical manner that the reader can move on to new concepts without feeling that they are unfamiliar or difficult. Any possible points of confusion are cleared up almost before they can arise. The usual organization pattern for a text on basic electronics is followed—electron theory, magnetism, d.c., a.c., vacuum tubes, transistors, basic circuits, etc. Highly recommended as a text for the beginner and as a good reference book for the more experienced reader.



"**HOW TO USE METERS**," Second Edition, by John F. Rider and Sol D. Prensky. Published by John F. Rider Publisher, Inc., 116 West 14th St., New York 11, N. Y. 216 pages. Soft cover. \$3.50.

Brought completely up to the minute, the new edition of this book covers the field of

Always say you saw it in—POPULAR ELECTRONICS

Opportunities in Electronics

- Radar
- Guided Missiles
- Broadcasting
- Aeronautical Electronics
- Computers
- Automation
- Industrial Electronics
- Home Electronics

Are you interested in learning how you can have a profitable career in any or all of the above fields?

Find out how modern technical training and a Government License (FCC) can lead to profitable employment in any branch of electronics.



Send for these
3 FREE Booklets

Thousands of interesting well-paid jobs in electronics must be filled. To fill such jobs, you need sound technical training. An FCC license is convincing proof of technical skill. Send for the three Cleveland Institute booklets offered here. They explain how you can prepare for an interesting and profitable career in electronics. Mail the coupon today—no obligation.

good training doesn't cost—it pays!

Cleveland Institute of Electronics

Desk PE-65 4900 Euclid Ave. Cleveland 3, Ohio

Accredited by
the National
Home Study
Council



Please send FREE Booklets prepared to help me get ahead in Electronics. I have had training or experience in Electronics as indicated below:

- | | |
|---|---|
| <input type="checkbox"/> Military | <input type="checkbox"/> Broadcasting |
| <input type="checkbox"/> Radio-TV Servicing | <input type="checkbox"/> Home Experimenting |
| <input type="checkbox"/> Manufacturing | <input type="checkbox"/> Telephone Company |
| <input type="checkbox"/> Amateur Radio | <input type="checkbox"/> Other..... |

In what kind of work are you now engaged?.....

In what branch of Electronics are you interested?.....

Name..... Age.....

Address.....

City..... Zone..... State.....

Desk PE-65



Now you can master
BASIC ELECTRICITY
BASIC ELECTRONICS
The Rider 'picture-book' way

Fabulous illustrated training course now used by
U. S. Navy—No Other Books Like Them!

A Complete Idea on Every Page

Here's how this easy, illustrated course work: *every page covers one complete idea!* There's at least one big illustration on that same page to explain it! What's more, an imaginary instructor stands figuratively at your elbow, doing "demonstrations" that make it even easier for you to understand. Then, at the end of every section, you'll find *review pages* that highlight the important topics you've just covered. You build a thorough, step-by-step knowledge at your own pace—as fast as you yourself want to go! Sponsored by the Navy to turn out trained technicians in record time, this modern course presents Basic Electricity and Basic Electronics in a simple way that everyone can grasp—regardless of previous education!

10 Complete Volumes

BASIC ELECTRICITY—Volumes 1 and 2 cover DC components and circuits; Volumes 3 and 4 cover AC components and circuits; Volume 5 covers AC and DC motors and machinery.

BASIC ELECTRONICS—Volume 1 covers Diodes and Power Supplies; Volumes 2 and 3 cover Amplifiers and Oscillators; Volumes 4 and 5 cover Transmitters and Receivers.

Home Study Without Correspondence

This course is so different, so complete—there's no need for the usual letter writing, question and answer correspondence! Learn at home—at your own pace!

10 Day Examination — Money Back Guarantee

Send today for these exciting new training courses—*you risk nothing!* When you receive the volumes, examine them in your own home for 10 full days. If, at the end of that time, you're not completely satisfied, simply return the books to us and we'll gladly refund your full purchase price! Total cost for either 5-volume course is only \$10.00! In Canada, prices approximately 5% higher.

BASIC ELECTRICITY #169, 5-vols. soft covers, \$10.00; #169H, all 5 vols. in one cloth binding, \$11.50.

BASIC ELECTRONICS #170, 5-vols. soft cover, \$10.00; #170H, all 5 vols. in one cloth binding, \$11.50.

JUST PUBLISHED

VOLUME 6 BASIC ELECTRONICS by Van Valkenburgh, Nooger & Neville Inc. We are pleased to announce the publication of Volume 6, **BASIC ELECTRONICS** by Van Valkenburgh, Nooger & Neville. Volume 6 is a companion volume to the present five volume course on Basic Electronics by the above authors. It is intended to enable you to expand into the areas of semiconductors, transistors and frequency modulation after the content of the first five volumes has been completed. Volume 6 utilizes the same famous "picture-book" technique used in the present highly successful five volume course.

The original five volume course in **BASIC ELECTRONICS** is available as heretofore as five individual volumes in paper covers and as all five volumes in one cloth binding.

Vol. 6 #170-6 paper cover, \$2.90; #170-6H, cloth \$3.60.

at electronics parts jobbers or bookstores, or order direct: DEPT. PE-6



JOHN F. RIDER PUBLISHER INC.
116 West 14th Street, New York 11, N. Y.
Canadian prices same as U.S.
add city & state taxes. All prices subject to revision.

Bookshelf (Continued from page 24)

meters—how they work and how to use them—in admirable fashion. The text is complete, and, as the greatest amount of space is devoted to the design of meters, the reader should obtain a solid grounding in this subject. Recommended as an excellent study and reference work.



"F-M SIMPLIFIED," Third Edition, by Milton S. Kiver. Published by D. Van Nostrand Co., Inc., 120 Alexander St., Princeton, N. J. 384 pages. \$7.50.

Probably a great many **POPULAR ELECTRONICS** readers cut their FM eyeteeth on the earlier editions of this book. Those that did will remember that Mr. Kiver deals with his subject clearly and thoroughly. In this expanded and up-to-date edition, the basics of FM theory, analyses of circuits, alignment, and the fundamentals of FM transmitters are covered in detail. Although the treatment is not as simplified as the title might lead one to expect, this book provides an excellent introduction to FM for anyone who wants a thorough grounding in FM theory and operation.



Miscellaneous Literature

A new commercial sound catalog for use by architects, engineers, sound men, and consumers has been issued by Electro-Voice, Inc., Buchanan, Mich. Recommendations for public address, home recording, communications and other applications for microphones and loudspeakers are included. Ask for your copy of "Commercial Sound Catalogue No. 132."

Radio amateurs will be interested in the new "Rider Global Time Conversion Simplifier." This 17" x 22" color chart tells you the time anywhere in the world at a glance. It is available from John F. Rider Publisher, Inc., 116 West 14th St., New York, N. Y., for \$1.00.

Now available at electronics parts stores, hi-fi salons, and record shops!

Stereo-Monophonic
Test Record

Specially packaged
at only

\$1.59

(\$1.98 in Canada)



As a man who is seriously interested in hi-fi, you will certainly want to take advantage of this new and important test record, now on sale at electronics parts stores, hi-fi salons, and record shops. It will enable you to know your system inside-out. As a result, your listening enjoyment will be even greater than ever before.

This Stereo-Monophonic Test Record is the *most complete test record* of its kind—containing the widest range of essential check-points ever incorporated into *one* test disc! And, best of all, you need no expensive test equipment when you use this record! Just listen and get the thorough results you want—all checks can be made by ear!

This special test record brings you an extraordinary 2-way value. First, it guides you in evaluating the quality of reproduction your equipment now produces. Second, it specifies the adjustments necessary to get the best recorded sound you have ever heard! This is easily the best value of the year for everyone who owns a hi-fi system—either monophonic or stereo!

NOW ON SALE EXCLUSIVELY AT ELECTRONICS PARTS STORES, HI-FI SALONS AND RECORD SHOPS!

You can be sure this Stereo-Monophonic test record comes as close to perfection as is humanly possible, because the editors of *ELECTRONICS WORLD*—leading technical magazine in the field of electronics—have poured their accumulated know-how into this record. Purchase your record today! (If you find your dealer does not yet have a supply available, ask him to order them for you.)

SPECIAL NOTE TO DEALERS: for information on ordering your supply of records, contact Ziff-Davis Publishing Company, Direct Sales Division, One Park Avenue, New York 16, N. Y.

Here are some of the questions this record will answer for you!

- ✓ How good is my stylus? Is it worn? Will it damage my records?
- ✓ What about my stereo cartridge? Does it have enough vertical compliance so that it won't ruin my expensive stereo records?
- ✓ Is my turntable running at the right speed? Is it free of rumble, wow, and flutter?
- ✓ What sort of standing waves do I get in my listening room?
- ✓ Are my speakers hooked up correctly? Are they phased properly, and is the correct speaker connected to the right stereo channel?
- ✓ How perfectly is my system equalized?
- ✓ What about separation? Is it adequate?

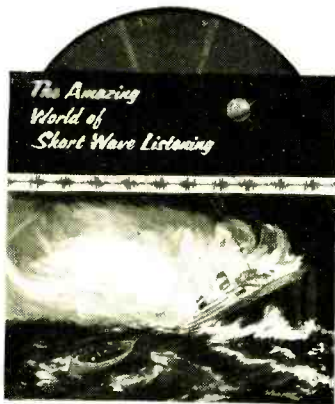

SPECIAL OFFER

25¢

Hear these authentic recordings of dramatic events from

"The Amazing World of Short Wave Listening"

narrated by Alex Dreier, Radio-TV "Man on the Go"

- President's voice from outer space!
- Actual capture of a desperate criminal!
- Radio amateur at Little America!
- Ships at sea . . . aircraft in action!



S-38E receiver
\$59.95

3 short wave bands plus standard broadcast. Built-in speaker, headset output.

MAIL COUPON TODAY!

h hallicrafters...
DEPT. 36 CHICAGO 11, ILL.

Gentlemen: Please rush by return mail my recording, "The Amazing World of Short Wave Listening." I enclose 25¢.

NAME _____

ADDRESS _____

CITY _____

STATE _____

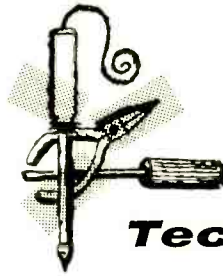

Tips and Techniques

SAVE YOUR RECORDER MOTOR

If you frequently use your tape recorder's audio section as a utility amplifier, you can cut wear on the motor by installing an s.p.s.t. switch in series with one of the motor power leads. Most recorders are vented adequately enough to cool the en-

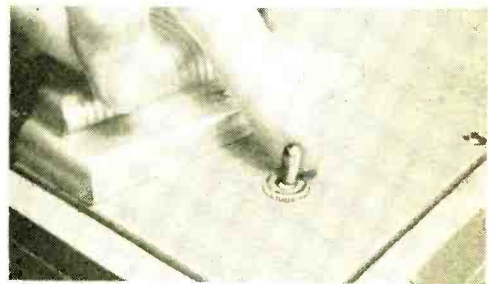

closure without the help of the motor's fan. If your recorder does appear to heat up with the motor off, turn it on occasionally.—*John A. Comstock, Wellsboro, Pa.*

ROUND-JAWED ALLIGATOR CLIPS

Alligator clips have a habit of slipping off phono plugs, dial lamp bases, or other round objects. Bending the jaws of a clip

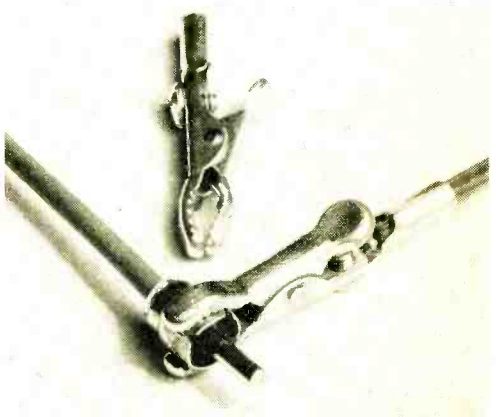

will enable them to get a firmer grip on such objects. Use a pair of long-nose pliers and carefully bend each jaw as shown. Re-

Always say you saw it in—POPULAR ELECTRONICS

BECOME A RADIO TECHNICIAN For Only \$22.95

BUILD 16 RADIO

Reg. U. S. Pat. Off.



CIRCUITS AT HOME

PRACTICAL HOME RADIO COURSE only **\$22.95**

All Guaranteed to Work!
Progressive Radio "Edu-Kit" ®

NOW INCLUDES

- ★ 12 RECEIVERS
- ★ TRANSMITTER
- ★ SIGNAL TRACER
- ★ SIGNAL INJECTOR
- ★ CODE OSCILLATOR
- ★ No Knowledge of Radio Necessary
- ★ No Additional Parts or Tools Needed

Unconditional Money-Back Guarantee

It is understood and agreed that should the Progressive Radio "Edu-Kit" be returned to Progressive "Edu-Kits" Inc. for any reason whatever, the purchase price will be refunded in full, without quibble or question, and without delay.

The high recognition which Progressive "Edu-Kits" Inc. has earned through its many years of service to the public is due to its unconditional insistence upon the maintenance of perfect engineering, the highest instructional standards and 100% adherence to its Unconditional Money-Back Guarantee. As a result, we do not have a single dissatisfied customer throughout the entire world.

YOU DON'T HAVE TO SPEND HUNDREDS OF DOLLARS FOR A RADIO COURSE

The "Edu-Kit" offers you an outstanding PRACTICAL HOME RADIO COURSE at a rock-bottom price. Our kit is designed to train Radio & Electronics Technicians, making use of the most modern methods of home training. You will learn radio theory, construction practice and servicing. **THIS IS A COMPLETE RADIO COURSE IN EVERY DETAIL.**

You will learn how to build radios, using regular schematics; how to wire and solder in a professional manner; how to service radios. You will work with the standard type of punched metal chassis as well as the latest development of Printed Circuit chassis.

You will learn the basic principles of radio. You will construct, study and work with RF and AF amplifiers and oscillators, detectors, rectifiers, test equipment. You will learn and practice code, using the Progressive Code Oscillator. You will learn and practice troubleshooting, using the Progressive Signal Tracer, Progressive Signal Injector, Progressive Dynamic Radio & Electronics Tester and the accompanying instructional material.

You will receive training for the Novice, Technician and General Classes of F.C.C. Radio Amateur Licenses. You will build 16 Receiver, Transmitter, Code Oscillator, Signal Tracer and Signal Injector circuits, and learn how to operate them. You will receive an excellent background for television, Hi-Fi and Electronics.

Absolutely no previous knowledge of radio or science is required. The "Edu-Kit" is the product of many years of teaching and engineering experience. The "Edu-Kit" will provide you with a basic education in Electronics and Radio, worth many times the complete price of \$22.95. The Signal Tracer alone is worth more than the price of the entire Kit.

THE KIT FOR EVERYONE

You do not need the slightest background in radio or science. Whether you are interested in Radio & Electronics because you want an interesting hobby, a well paying business or a job with a future, you will find the "Edu-Kit" a worth-while investment. Many thousands of individuals of all

ages and backgrounds have successfully used the "Edu-Kit" in more than 79 countries of the world. The "Edu-Kit" has been carefully designed, step by step, so that you cannot make a mistake. The "Edu-Kit" allows you to teach yourself at your own rate. No instructor is necessary.

PROGRESSIVE TEACHING METHOD

The Progressive Radio "Edu-Kit" is the foremost educational radio kit in the world, and is universally accepted as the standard in the field of electronics training. The "Edu-Kit" uses the modern educational principle of "Learn by Doing." Therefore you construct, learn schematics, study theory, practice trouble-shooting—all in a closely integrated program designed to provide an easily-learned thorough and interesting background in radio.

You begin by examining the various radio parts of the "Edu-Kit." You then learn the function, theory and wiring of these parts. Then you build a simple radio. With this first set you will enjoy listening to regular broadcast stations, learn theory, practice testing and trouble-shooting. Then you build a more advanced radio, learn more advanced theory and techniques. Gradually, in a progressive manner, and at your own rate, you will find yourself constructing more advanced multi-tube radio circuits, and doing work like a professional Radio Technician.

Included in the "Edu-Kit" course are sixteen Receiver, Transmitter, Code Oscillator, Signal Tracer, and Signal Injector circuits. These are not unprofessional "breadboard" experiments, but genuine radio circuits, constructed by means of professional wiring and soldering on metal chassis, plus the new method of radio construction known as "Printed Circuitry." These circuits operate on your regular AC or DC house current.

THE "EDU-KIT" IS COMPLETE

You will receive all parts and instructions necessary to build 16 different radio and electronics circuits, each guaranteed to operate. Our Kits contain tubes, tube sockets, variable electrolytic, mica ceramic and paper dielectric condensers, resistors, tie strips, coils, hardware, tubes, punched metal chassis, Instruction Manuals, hook-up wire, solder, etc.

In addition, you receive Printed Circuit materials, including Printed Circuit chassis, special tube sockets, hardware and instructions. You also receive a useful set of tools, a professional electric soldering iron, and a self-powered Dynamic Radio and Electronics Tester. The "Edu-Kit" also includes Code Instructions and the Progressive Code Oscillator, in addition to F.C.C.-type Questions and Answers for Radio Amateur License training. You will also receive lessons for working with the Progressive Signal Tracer and the Progressive Signal Injector, a High Fidelity Guide and a Quiz Book. You receive Membership in Radio-TV Club, Free Consultation Service, Certificate of Merit and Discount Privileges. You receive all parts, tools, instructions, etc. Everything is yours to keep.

FREE EXTRAS

SET OF TOOLS

- SOLDERING IRON
- ELECTRONICS TESTER
- PLIERS-CUTTERS
- ALIGNMENT TOOL
- WRENCH SET
- VALUABLE DISCOUNT CARD
- CERTIFICATE OF MERIT
- TESTER INSTRUCTION MANUAL
- HIGH FIDELITY GUIDE + QUIZZES
- TELEVISION BOOK + RADIO TROUBLE-SHOOTING BOOK
- MEMBERSHIP IN RADIO-TV CLUB: CONSULTATION SERVICE + FCC AMATEUR LICENSE TRAINING
- PRINTED CIRCUITRY

SERVICING LESSONS

You will learn trouble-shooting and servicing in a progressive manner. You will practice repairs on the sets that you construct. You will learn symptoms and causes of trouble in home, portable and car radios. You will learn how to use the professional Signal Tracer, the unique Signal Injector and the dynamic Radio & Electronics Tester. While you are learning in this practical way, you will be able to do many a repair job for your friends and neighbors, and charge fees which will far exceed the price of the "Edu-Kit." Our Consultation Service will help you with any technical problems you may have.

J. Statialis, of 25 Poplar Pl., Waterbury, Conn., writes: "I have repaired several sets for my friends and made money. The "Edu-Kit" paid for itself. I was ready to spend \$240 for a Course, but I found your ad and sent for your Kit."

FROM OUR MAIL BAG

Ben Valerio, P. O. Box 21, Magna, Utah: "The Edu-Kits are wonderful. Here I am sending you the questions and also the answers for them. I have been in Radio for the last seven years, but like to work with Radio Kits, and like to build Radio Testing Equipment. I enjoyed every minute I worked with the different kits, the Signal Tracer works fine. Also like to let you know that I feel proud of becoming a member of your Radio-TV Club."

Robert L. Shuff, 1534 Monroe Ave., Huntington, W. Va.: "Thought I would drop you a few lines to say that I received my Edu-Kit, and was really amazed that such a bargain can be had at such a low price. I have already started repairing radios and phonographs. My friends were really surprised to see me get into the swing of it so quickly. The Troubleshooting Tester that comes with the Kit is really swell, and finds the trouble, if there is any to be found."

PRINTED CIRCUITRY

At no increase in price, the "Edu-Kit" now includes Printed Circuitry. You build a Printed Circuit Signal Injector, a unique servicing instrument that can detect many Radio and TV troubles. This revolutionary new technique of radio construction is now becoming popular in commercial radio and TV sets.

A Printed Circuit is a special insulated chassis on which has been deposited a conducting material which takes the place of wiring. The various parts are merely plugged in and soldered to terminals.

Printed Circuitry is the basis of modern Automation Electronics. A knowledge of this subject is a necessity today for anyone interested in Electronics.

ORDER DIRECT FROM AD—RECEIVE FREE BONUS RESISTOR AND CONDENSER KITS WORTH \$7

- Send "Edu-Kit" postpaid. I enclose full payment of \$22.95.
- Send "Edu-Kit" C.O.D. I will pay \$22.95 plus postage.
- Rush me FREE descriptive literature concerning "Edu-Kit."

Name

Address

PROGRESSIVE "EDU-KITS" INC.

Progressive Building, Dept. 569D, 1184-86 Broadway, Hewlett, N. Y.

Tips

(Continued from page 28)

inforce the bends with a small pool of solder on the outside of the jaw directly over the bend. The thumb tab on the clip can also be bent upward a bit to allow the jaws to open wider.—*Art Trauffer, Council Bluffs, Iowa.*

CLIP-ON SOLDERING-IRON HOLDER

An old tin-can lid can serve as a handy clip-on soldering-iron holder. Bend the lid

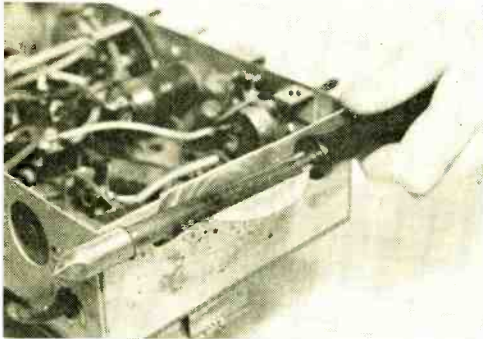

into the shape shown—a "V" with ears—and clip it over the edge of the chassis by

bending one ear down. This holder is especially useful when you are working on the underside of a set.—*James Clifford, Detroit, Mich.*

REPAIR "RABBIT-EARS" ANTENNAS

A telescoping "rabbit-ears" antenna often becomes worn after much use, with poor electrical contact between sections. You can tighten the loose sections and eliminate resistive contact between them by simply extending the ears and tinning about a half-inch of the lower portion of each section with a very thin layer of solder.—*Charles Lang, San Francisco, Calif.*

AMPLIFY YOUR WATCH TICKS

You can "play" the ticks of a watch or alarm clock over your hi-fi set by placing your crystal phono pickup on top of the watch as shown and turning the amplifier gain control full on. How does it work? The ticking of the watch vibrates the generating mechanism in the pickup, the loudness of the reproduced ticks depends on the sensitivity of your pickup, the gain of your amplifier, and the efficiency of your speaker. Better results can be obtained with the

ALL TUBES INDIVIDUALLY BOXED - UNCONDITIONALLY GUARANTEED FOR ONE YEAR
Send for Free Complete Tube List & Order Blank. Your Inquiry Will Put You on Our Mailing List

TELTRON SMASHES PRICES ON TUBES for '60

SAVE ON ALL TUBES HERE'S A PARTIAL LIST OF MOST OF OUR USED TUBES

FREE EICO TUBE TESTER
Eico 625K Free with Purchase of \$100. — Recv. Tubes in 60 Days. Buy it for \$34.95 ppd.

New Price Schedule of TELEVISION PICTURE TUBES

121P4	10.75	17CP4	17.25	21AP4	21.25	21WP4	17.25
14BP4	11.75	171P4	17.45	21AUP4	19.25	21YP4	18.75
16AP4	16.45	18AP4	18.25	21AUP4	19.25	21ZP4	17.25
16CP4	15.95	20CP4	15.75	21AP4	18.75	24AP4	-
16KP4	11.95	20HP4	17.75	21EP4	17.25	24AP4	27.25
16LP4	11.95	21AP4	18.75	21KP4	19.25	24CP4	27.25
16OP4	11.95	21AMP4	18.75	21MP4	21.25	24DP4	28.75
17AP4	12.75						

PICTURE GUARANTEED FOR ONE (1) YEAR

Aluminized on one tube, \$4.00 extra. All picture tubes require a deposit on your duct. Please add an additional \$5.00 on tube sizes to 17". Add \$7.00 on sizes 19", 20", 21" and 24". Your cash deposit will be refunded immediately upon receipt of your duct prepaid. Picture tubes are shipped promptly from our warehouse (the US Continent and Canada only). P.O.B. Harrison, New Jersey

FREE 6BG6 with \$10. order!
FREE \$7.50 pkg. inc. 3-65N7 plus 25 asstd. tubes with \$25. order!

"NEW AND HARD TO GET" "USED TVs" 500 TRADE IN TVs FOR QUICK SALE

We have purchased from a huge appliance store a quantity of used TVs. The sets are in excellent condition and most are Standard Brands. Sizes run from 12" to 24" — Excellent for second set or for experimenters. SETS SHIPPED RAILWAY EXPRESS FOB our warehouse.

\$14.95 as is (continental USA & Canada only)

"SELDOM USED" 25 ONLY... SELF SERVICING VICE TUBE CHECKERS

These reconditioned console model 22 socket tube checkers have proven their worth in busy repair shops. Let your tube customers test their own tubes. Your investment will be returned in one week with little effort on your part. COMPLETE WITH KEY FOR BOTTOM DOOR AND NEON LIGHTED HEAD.

\$39.95 FOB OUR WAREHOUSE

NEW LIBERAL TERMS. No minimum order. Free postage on all tube & parts orders over \$2.00 in U.S.A. A.P.O. & Territories. 25% deposit required on C.O.D.s. Please send approximate postage on Canadian and Foreign shipments. Returns will be refunded. All picture tubes and outdoor antenna shipped FOB Harrison, New Jersey

02X	45	6AC7	65	6CY5	49	12BA6	46
18G7	42	6AF4	103	6CY7	66	12B16	46
1DNG	60	6AG5	52	6D4A	59	12BH7	61
1G3GT	47	6AH6	47	6D6A	59	12BG6	63
1R5	51	6AL5	43	6D6GT	59	12BR7	65
1S5	43	6AN8	59	6DGGT	50	12CR6	43
1R2	70	6AM8	64	6DQ6	69	12CU6	44
1U4	51	6AS5	48	6D5S	59	12DA6	43
1U5	42	6AU6GT	52	6E6B	65	12D85	59
1R2	42	6AU8GT	40	6J5	47	12D18	59
2AFA	102	6AU8	37	6AG7	69	12D16	64
2BN4	55	6AV6	43	6J6	61	12D47	59
2C75	50	6AW8	50	654	59	12D66	63
2AF4	102	6AX6GT	60	657	41	12D57	64
3AU6	43	6BA8	60	65A7	45	12EK6	59
2B5	90	6BA8	58	65C7	54	12E26	49
3B8	65	6BC8	49	65K7	65	12F66	43
3B26	45	6BE6	46	65TGT	60	12K5	43
3C6A	51	6B5	39	65WGT	60	12L6GT	43
3D16	51	6B6G	48	6E8	28	12S67	44
3V4	48	6B86	51	6V6GT	76	12SK7	55
4A6	43	6B96	64	6W6GT	50	12S2P	46
4BC8	69	6B8	51	6W6GT	43	12W6GT	38
4R6	68	6B85	73	6X6GT	52	12W6GT	42
4R07	75	6B87	73	6X6	37	12X6GT	42
4C86	51	6B7GT	78	6X8	75	17D4	50
4D6	55	6B94	44	6AW8	33	17D6A	50
4D16	59	6B96	74	6B8	60	19A24	50
3AM8	59	6C7A	90	6C7	54	19B6G	60
3AN8	64	6B0GT	83	6C8	54	25B0GT	82
3A05	68	6B2A	85	9U8	90	25D6G	119
3AT8	54	6B87	85	9U8	29	25C16	42
3AV8	54	6B24	45	10D7	59	25L6GT	41
3BR8	66	6B27	95	12A85	44	25W6GT	43
3C18	66	6C8A	51	12AF6	44	35B5	48
3C0B	59	6C8B	54	12AG7	50	50B5	48
316	41	6C6G	163	12A17	71	35W4	33
3U4	49	6C7A	45	12A17	71	35W4	33
3U8	59	6C7B	44	12AV6	42	50C5	48
3V4G	49	6C8	43	12AX7	73	50H5	59
5X8	55	6C8B	59	12AX7	61	117Z3	33
5YGT	30	6C16	95	12AX7	61	117Z3	33
6AB4	43	6C8A	64	12B4	85	117Z6GT	65

Send for FREE complete list of most often used tube types.

TELTRON ELECTRIC CO.
428 HARRISON AVE., HARRISON, N. J.

PE-6 Humboldt 4-9848

Tubes listed may be in circuit of other used tubes and are clearly marked.

YOU be the judge of *knight-kit* value

A PRODUCT OF ALLIED RADIO



FREE examination privilege

More and more people are finding out how easy it is to build exciting Knight-Kits, how satisfying they are to own, and how much they save.

If you haven't yet enjoyed the experience and fun of building and owning a Knight-Kit, we invite you to take advantage of our free examination offer. Order any Knight-Kit. Examine it on arrival. Inspect the

quality of the components, the circuitry, the easy-assembly manual. We're so confident you'll want the kit, we can make this offer: If you're not COMPLETELY SATISFIED, just return the kit for full refund.

Order a Knight-Kit now. Know the thrill of the most satisfying build-your-own experience in electronics.



Y-731 Deluxe FM-AM Stereo Hi-Fi Tuner (Multiplex add-in) \$87.50
only \$5 down



Y-774 Deluxe 40-Watt Stereo Amplifier (with Center Channel) \$79.50
only \$5 down

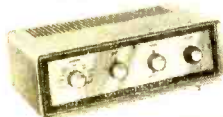

Y-773 Super-Value 20-Watt Stereo Hi-Fi Amplifier... \$44.50
only \$2 down

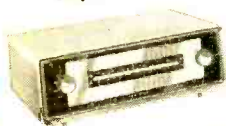

Y-787 FM-AM Hi-Fi Tuner (with Multiplex jack) \$49.95
only \$2 down



Y-713 Best-selling Citizens Band Transceiver. Tunable 22-channel super-regen receiver... \$39.95
only \$2 down

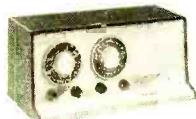

Y-258 4-Band "Span Master" Receiver (with cabinet) \$25.95
only \$2 down



R-100 Amateur Communications Receiver (Hi-gain, with built-in Q-Multiplier) \$104.50
only \$5 down



Y-708 1000 Ohm/Volt Pocket Volt-Ohm-Milliammeter \$9.95



Y-737 "Ranger" Clock-Radio with "sleep" switch... \$24.95
only \$2 down



Y-771 5-Transistor Superhet Portable Radio (less battery) \$25.95
only \$2 down



Y-125 General-purpose VTVM (1 meg. input res.) \$25.75
only \$2 down



Y-143 Model "600" Tube Checker (checks over 700 types) \$32.95
only \$2 down

easiest to build...
satisfying to own...
money-saving

ONLY \$2 DOWN
on orders up to \$50;
\$5 down on orders up to \$200...

see scores of other *knight-kits*

HI-FI KITS

Stereo Preamplifier
60-W Stereo Amplifier
Monaural Amplifiers
Hi-Fi Tuners
Speaker Systems
and others

HOBBYIST KITS

"Space-Spanner" Radio
"Ranger" Radios
Transistor Radios
2-Way Intercom
Electronic Lab Kits
and many others

INSTRUMENT KITS

Lab AC VTVM
VOM's
5" Scopes
Tube Checkers
Signal Tracer
Audio Generator
Sweep Generator
plus many others

AMATEUR KITS

50-Watt Transmitter
Self-Powered VFO
100 kc Crystal Calibrator
Code Practice Oscillator
Grid Dip Oscillator

there's a money-saving *knight-kit* for every need... see them all in the **ALLIED CATALOG**

Describes the complete KNIGHT-KIT line in detail. Order the kit of your choice—judge quality and value for yourself under our Free examination privilege!

FREE

send for it!

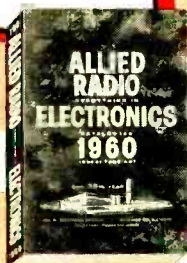

ALLIED RADIO

ALLIED RADIO, Dept. 23-F
100 N. Western Ave., Chicago 80, Ill.

Send FREE Catalog featuring Knight-Kits.

Name _____

Address _____

City _____ Zone _____ State _____

Tips

(Continued from page 30)

pickup on the back of the watch. Caution: don't try this experiment with magnetic

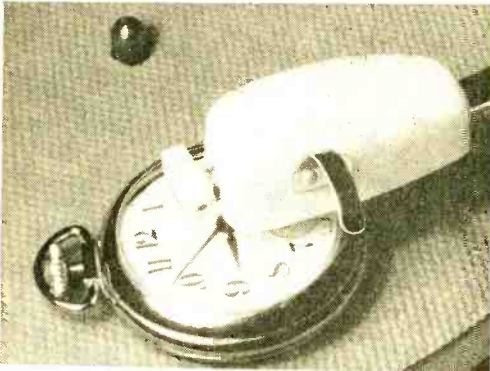

pickups since their internal magnets may detrimentally affect small watches.—*Carl Dunant, Council Bluffs, Iowa.*

INTERMITTENT TUBES

Battery radios or three-way portables that go dead may be suffering from oscillator-tube voltages that are either too low because of weak batteries or too high be-

cause of aging tubes. Some sets will operate for a time after a brief rest and then go dead again. The obvious remedy is a set of fresh batteries, even though the old ones still meet the demands of the other tubes.

Other sets that have been playing at reduced volume with relatively weak batteries will not operate at all with fresh batteries. In this case, the trouble may be a breakdown of aging elements in the oscillator tubes under the higher voltages from the new batteries. The remedy, of course, is to replace the faulty tubes—usually a 1A7-GT or a 1R5.—*Lt. Col. Eugene F. Coriell, Wright Patterson A.F.B., Ohio.* —50—

TIPS WANTED

Are you aware that POPULAR ELECTRONICS is very much interested in receiving your *Tips and Techniques* hints? If you know of any shop or circuit short-cut or innovation, tell us about it and you may receive up to ten dollars for your trouble. Just send us a short typewritten description plus a sharp photograph or circuit drawing. Unused items will be returned only if they are accompanied by a stamped, self-addressed envelope. Why keep your pet ideas to yourself? Let everyone else in on them.

MICRO ELECTRON TUBE

INTRODUCES FOR THE FIRST TIME ANYWHERE A SELECT STOCK OF USED TUBES AT A FABULOUS LOW PRICE

37¢ ea.

FOR any TUBE LISTED

\$35 PER HUNDRED ASSTD.

ALL TUBES SENT POSTAGE PAID
Please send 25c handling for orders under \$5. Send 25% deposit on C.O.D. orders. Send approximate postage on Canadian and foreign orders.

MICRO ELECTRON TUBE CO.

P.O. Box 55, Dept. PE6, Park Sta., Paterson 3, N. J.

- Each and every tube is tested in our own laboratory for mutual conduction and life test.
- We guarantee FREE replacement for one year of any tube purchased from us which fails to function efficiently under any or all operating conditions. Prompt refunds are made on any defective merchandise.
- The advertised tubes are not necessarily new, but may be electrically perfect factory seconds or used tubes—each is clearly so marked.

0A2	5X8	6BH6	6SF5	724	19BG6G
024	5Y3GT	6BJ6	6SF7	12A8	1916
1A7GT	6Y4Q	6BK5	6S17	12A05	1918
1B30T	6A7	6BK7	6SK7	12AT6	2A4
1W4C	6AB	6BL7CT	6SL7GT	12AT7	25AV5
1NSGT	6AB8	6BN8	6SN7GT	12AU6	25BQ6
1L4	6AC7	6BQ6GT	6SQ7	12AU7	25DM6
1L4	6AC7	6BQ6GT	6SQ7	12AV6	25L6GT
1NSGT	6AF4	6BQ7	6S57	12AV7	25W4GT
1QS7	6AG5	6B7	6S7	12AX7	25Z5
1R5	6AG7	6B7Z	6T4	12AX4GT	25Z6
155	6AH4GT	6BZ6	6U6	12AX7	26
1T4	6AH6	6BZ7	6V6	12B4	35A5
1U4	6A8	6C4	6W6	12B7	35B5
1U5	6AL5	6C5	6W6GT	12B8	35C5
1V2	6AM8	6C6	6W6GT	12B9	35L6GT
2A3	6AN8	6C8B	6X4	12BE6	35Y4
2AF4	6A05	6C06Q	6CF8	12BF6	35Z5GT
3B0C5	6A06	6C6M5	6CM7	12B87	37
3B8E	6A07GT	6C6M7	6C7	12B96	39/44
3BZ6	6A85	6C7	6E	12BR7	42
3CB6	6AT8	6C8	6F8	12BY7	43
3CF6	6A8T	6C85	6G7	12C45	50A5
3CS6	6A8T	6C85	6H7	12C57	50B5
3FL4	6A8GT	6C85	6J7	12D7	50C5
3Q4	6A8GT	6D6E	6K7	12E6	50L6GT
3S4	6A8	6D6E	6L7	12F6	50X6
3V4	6A8	6E	6M7	12G7	56
4B07A	6AV5GT	6H6	6N7	12H7	57
4BZ7A	6AV6	6J4	6P7	12I6GT	71A
5A58	6AV6	6J5	6Q7	12J6GT	75
5A78	6AX6GT	6J7	6R7	12K6GT	76
5AV8	6AX6GT	6K6GT	6S7	12L6GT	77
5AW4	6B6	6K7	6T7	12M6GT	78
5B7	6B6	6K8	6U7	12N7GT	80
5J8	6BC5	6L7	6V7	12P6GT	84/624
5T8	6BC8	6M7	6W7	12Q6GT	117Z6
5U4G	6BE6	6N7	6X7	12R6GT	
5U8	6BE6	6O7	6Y7	12S6GT	
5V4C	6BF5	6P7	6Z7	12T6GT	
5V6GT	6BF6	6Q7	6A8	12U6GT	
	6BG6G	6R7	6B8	12V6GT	
		6S7	6C8	12W6GT	
			6D8	12X6GT	
			6E8	12Y6GT	
			6F8	12Z6GT	
			6G8	13A6GT	
			6H8	13B6GT	
			6I8	13C6GT	
			6J8	13D6GT	
			6K8	13E6GT	
			6L8	13F6GT	
			6M8	13G6GT	
			6N8	13H6GT	
			6O8	13I6GT	
			6P8	13J6GT	
			6Q8	13K6GT	
			6R8	13L6GT	
			6S8	13M6GT	
			6T8	13N6GT	
			6U8	13O6GT	
			6V8	13P6GT	
			6W8	13Q6GT	
			6X8	13R6GT	
			6Y8	13S6GT	
			6Z8	13T6GT	
			7A8	13U6GT	
			7B8	13V6GT	
			7C8	13W6GT	
			7D8	13X6GT	
			7E8	13Y6GT	
			7F8	13Z6GT	
			7G8	14A6GT	
			7H8	14B6GT	
			7I8	14C6GT	
			7J8	14D6GT	
			7K8	14E6GT	
			7L8	14F6GT	
			7M8	14G6GT	
			7N8	14H6GT	
			7O8	14I6GT	
			7P8	14J6GT	
			7Q8	14K6GT	
			7R8	14L6GT	
			7S8	14M6GT	
			7T8	14N6GT	
			7U8	14O6GT	
			7V8	14P6GT	
			7W8	14Q6GT	
			7X8	14R6GT	
			7Y8	14S6GT	
			7Z8	14T6GT	
			8A8	14U6GT	
			8B8	14V6GT	
			8C8	14W6GT	
			8D8	14X6GT	
			8E8	14Y6GT	
			8F8	14Z6GT	
			8G8	15A6GT	
			8H8	15B6GT	
			8I8	15C6GT	
			8J8	15D6GT	
			8K8	15E6GT	
			8L8	15F6GT	
			8M8	15G6GT	
			8N8	15H6GT	
			8O8	15I6GT	
			8P8	15J6GT	
			8Q8	15K6GT	
			8R8	15L6GT	
			8S8	15M6GT	
			8T8	15N6GT	
			8U8	15O6GT	
			8V8	15P6GT	
			8W8	15Q6GT	
			8X8	15R6GT	
			8Y8	15S6GT	
			8Z8	15T6GT	
			9A8	15U6GT	
			9B8	15V6GT	
			9C8	15W6GT	
			9D8	15X6GT	
			9E8	15Y6GT	
			9F8	15Z6GT	
			9G8	16A6GT	
			9H8	16B6GT	
			9I8	16C6GT	
			9J8	16D6GT	
			9K8	16E6GT	
			9L8	16F6GT	
			9M8	16G6GT	
			9N8	16H6GT	
			9O8	16I6GT	
			9P8	16J6GT	
			9Q8	16K6GT	
			9R8	16L6GT	
			9S8	16M6GT	
			9T8	16N6GT	
			9U8	16O6GT	
			9V8	16P6GT	
			9W8	16Q6GT	
			9X8	16R6GT	
			9Y8	16S6GT	
			9Z8	16T6GT	
			10A8	16U6GT	
			10B8	16V6GT	
			10C8	16W6GT	
			10D8	16X6GT	
			10E8	16Y6GT	
			10F8	16Z6GT	
			10G8	17A6GT	
			10H8	17B6GT	
			10I8	17C6GT	
			10J8	17D6GT	
			10K8	17E6GT	
			10L8	17F6GT	
			10M8	17G6GT	
			10N8	17H6GT	
			10O8	17I6GT	
			10P8	17J6GT	
			10Q8	17K6GT	
			10R8	17L6GT	
			10S8	17M6GT	
			10T8	17N6GT	
			10U8	17O6GT	
			10V8	17P6GT	
			10W8	17Q6GT	
			10X8	17R6GT	
			10Y8	17S6GT	
			10Z8	17T6GT	
			11A8	17U6GT	
			11B8	17V6GT	
			11C8	17W6GT	
			11D8	17X6GT	
			11E8	17Y6GT	
			11F8	17Z6GT	
			11G8	18A6GT	
			11H8	18B6GT	
			11I8	18C6GT	
			11J8	18D6GT	
			11K8	18E6GT	
			11L8	18F6GT	
			11M8	18G6GT	
			11N8	18H6GT	
			11O8	18I6GT	
			11P8	18J6GT	
			11Q8	18K6GT	
			11R8	18L6GT	
			11S8	18M6GT	
			11T8	18N6GT	
			11U8	18O6GT	
			11V8	18P6GT	
			11W8	18Q6GT	
			11X8	18R6GT	
			11Y8	18S6GT	
			11Z8	18T6GT	
			12A8	18U6GT	
			12B8	18V6GT	
			12C8	18W6GT	
			12D8	18X6GT	
			12E8	18Y6GT	
			12F8	18Z6GT	
			12G8	19A6GT	
			12H8	19B6GT	
			12I8	19C6GT	
			12J8	19D6GT	
			12K8	19E6GT	
			12L8	19F6GT	
			12M8	19G6GT	
			12N8	19H6GT	
			12O8	19I6GT	
			12P8	19J6GT	
			12Q8	19K6GT	
			12R8	19L6GT	
			12S8	19M6GT	
			12T8	19N6GT	
			12U8	19O6GT	

NEW!

MADE IN U.S.A.



LAFAYETTE HE-15 CITIZENS BAND 11 METER SUPERHETERODYNE TRANSCEIVER

Not Superregenerative but **SUPERHET**

COMPLETELY
WIRED
NOT
A KIT

64.50

ONLY 5.00 DOWN

- 5 Crystal Controlled Transmitting Positions: Operates at a maximum FCC legal power input of 5 watts fully modulated.
- Superheterodyne Tuneable Receiver Over Full 22 Channel Band: RF stage in both Transmitter and receiver, 3 watts audio output plus large 4" speaker.
- Complete with Transmitting Crystal: Removable front plate for easy accessibility of crystals. Channel 9 crystal supplied.
- 4 Dual Function Tubes, plus 2 Single Function Tubes, plus 2 Rectifiers for 12 Tube Performance: Compares with units costing 3 times as much. Unexcelled reception on land and sea with coverage up to 20 or more miles depending on antenna height and terrain.

- Planetary Vernier Tuning: Controls include 3 position function switch (transmit, receive, plus transmit with spring return) and automatic noise limiting switch.
 - High Output Crystal Microphone: 2 position push to talk slide switch; especially designed for sustained transmit operation with a minimum of background noise.
 - Adapts for Use Anywhere: Modern compact styling. Brackets are supplied for easy mounting of unit in auto, truck or boat. Addition of 6 or 12 volt power supply (separately supplied) adapts transceiver for mobile operation. Only 4 1/2" D x 6" W x 4" H.
- Anyone Can Operate: No examination or technical knowledge required—Any citizen 18 years or older is eligible for a license. Simply fill out FCC application supplied with HE-15 Transceiver.
- | | | |
|---|-----------|----------------|
| HE-15 Factory Wired and Tested (Less antenna) | 5.00 Down |Net 64.50 |
| HE-19 Whip Antenna | | Net 3.95 |
| HE-16 Power Supply For 12 Volts | | Net 11.95 |
| HE-18 Power Supply For 6 Volts | | Net 11.95 |



Use in the Home



Boating — Ship to Shore



On the Farm



Business — Trucking

NEW! LAFAYETTE TELESCOPIC CITIZENS BAND WHIP ANTENNA

3.95

- Chrome Plated • Telescopes From 16 1/2" to 40" • Mounts Vertically or Right Angle

An outstanding antenna value. This high quality three section telescoping antenna is designed for attachment directly to your citizens band transceiver. Ideal for point to point service over short distances. Molded base loading coil has a threaded stud with a PL-25S plug—connector for vertical or right angle mounting. Shpg. wt; HE-19 Net 3.95

NEW! LAFAYETTE RADIO FIELD INDICATOR

A Must For All Ham and Citizens Band

7.95

- Provides a Continuous Indication of Transmitter Output
- Rugged 200ua Meter Movement with Variable Sensitivity Control
- Requires no Electricity, Batteries or Transmitter Connection

Measures the RF field generated by any marine, mobile or fixed transmitter. Rear phone jack accepts earphones. Antenna extends from 3 1/4" to 10 3/4". Bottom plate magnet allows mounting on any metal surface. Measures 3 1/8" W x 2 1/4" H x 2" D (less antenna). Shpg wt., 2 lbs.



TM-14 Net 7.95

PLEASE RUSH ITEMS CHECKED

- | | |
|---|--|
| <input type="checkbox"/> HE-15 Citizens Band Transceiver | <input type="checkbox"/> TM-14 Radio Field Indicator |
| <input type="checkbox"/> FS-206 "Tiny" 6 Transistor Radio | <input type="checkbox"/> HE-19 Whip Antenna |
| <input type="checkbox"/> Free 308 Page Catalog 600 | |

Enclosed Find \$.....
Please include postage to cover shipping

FREE 308 Giant Size Pages

Name.....
Address.....
City.....Zone.....State.....

LAFAYETTE RADIO • P.O. BOX 222, Jamaica 33, N.Y. • Dept. 1F-6

LAFAYETTE "Tiny" 6-Transistor Radio

Sensational Performance In a Small Package!

- 6 Transistors Plus a Germanium Diode
- Superheterodyne Circuit
- Vest Pocket Size—Only 4" H x 2 1/2" W x 1 1/4" D
- Built In Earphone Jack For Private Listening
- Trouble-Free Printed Circuit
- Built-In Ferrite Bar Antenna
- Economical—Uses Only One 9 Volt Battery



ONLY **19.95**

Complete with battery, carrying case and earphone. Shpg wt. 2 lbs.

FS-206 "Tiny" 6-Transistor Radio.....Net 19.95

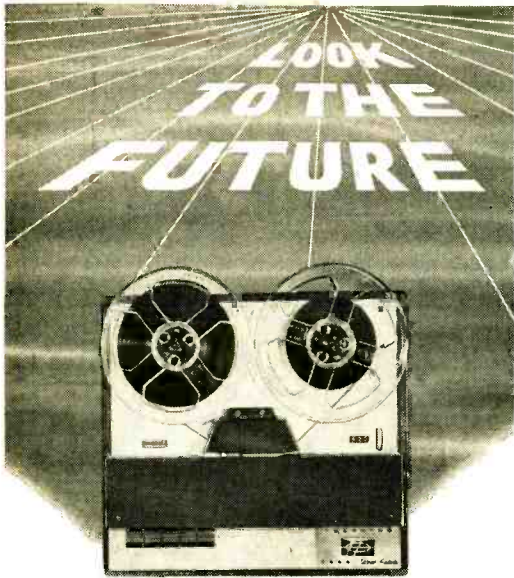

Experts agree that repeated playings will soon deteriorate the total quality of a disc recording. Yet, fifteen, fifty, five hundred playings from now, you can still enjoy the same sweet, clean highs, the same rich velvety lows that you cherished in your recordings today with a

TELECTRO SERIES 900 STEREO TAPE DECK

Telectro's low, low price . . . as low as **\$89.95** . . . makes tape recording your most economical as well as your most satisfactory program source. Yet, in spite of its low price, a Telectro tape deck offers the quality and versatility demanded by the finest monaural and stereophonic high fidelity systems.

CHECK THESE TOP QUALITY FEATURES

4-track head for all stereo and monaural tapes • Interchangeable head assemblies • Stereo and monaural record/playback • Unique pushbutton controls • 3 speed versatility: 7½ ips, 3¾ ips, and the extra convenience of ultra long-play 17½ ips • Solenoid-operated automatic shutoff • Digital tape counter • Rotary speed selector for easy speed choice • Unique brake design permits easy reel rotation • Fast wind—fast rewind, with no spillage or breakage • Pushbutton interlocks fulfill professional requirements.

Make your high fidelity system complete with a
TELECTRO
Stereo Tape Deck



a product of
TELECTROSONIC CORPORATION
35-18 37th St., Long Island City 1, N. Y.

Ask to see the five great TELECTRO tape decks and the complete line of Telectro design-mated tape preamplifiers at your high fidelity dealer, or write for full information Dept. EL6

NEW products

"S" METER

A smart-looking "S" meter, the Model ME-63, is calibrated in microvolts ("S" units from 1-10 and 1-5) and in decibels from S-9 to 30 db. It is housed in a 4" x



2½" x 2½" gold box with a 1¼" meter and zero-adjust control. The ME-63 can be used with any receiver that has an a.v.c. circuit. Price, \$5.88. (Olson Radio Corp., 260 South Forge St., Akron, Ohio.)

GADY TUBE TESTER

A compact tube caddy with a built-in tube tester is being manufactured by Mercury Electronics Corp., 77 Searing Ave., Mineola, N. Y. The Model 102-C can carry a stock of 125 tubes; has a drawer for tools.

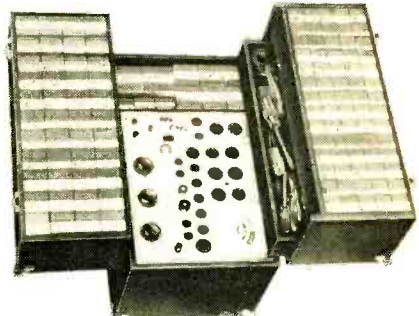

test leads, etc.; and tests over 700 tube types. Its 21 sockets are made of phosphor bronze, its panel of etched aluminum. Price, \$74.50.

REMOTE TV TUNER

Essentially a TV set without sweep circuits and a picture tube, the Tech-Master

Always say you saw it in—POPULAR ELECTRONICS

CONVERT YOUR CAR RADIO FOR SHORT WAVE RECEPTION WITH ...

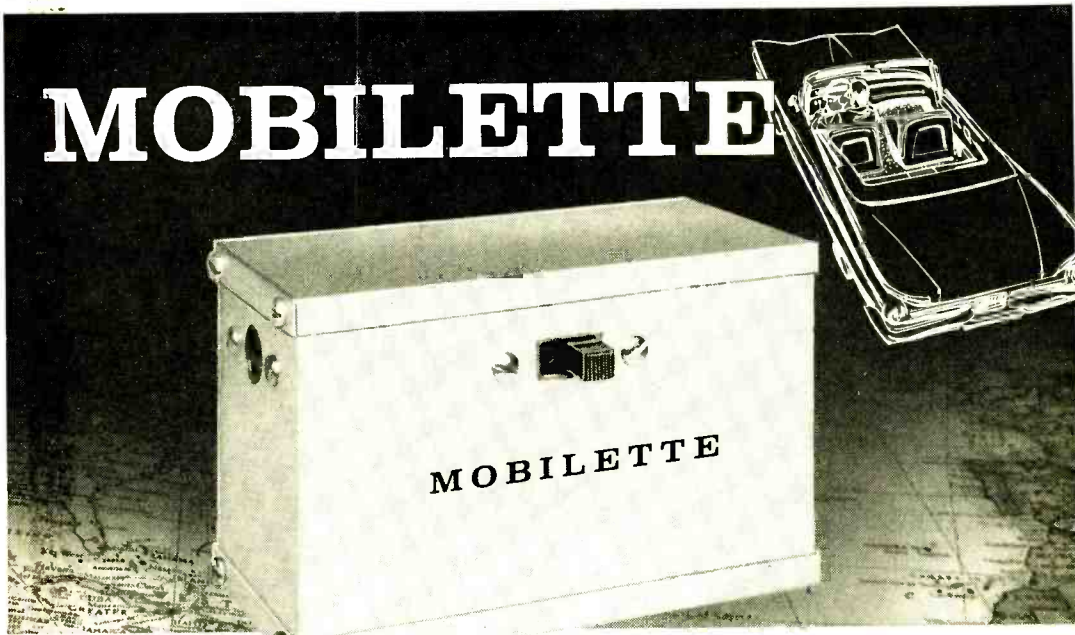

INTERNATIONAL'S ALL TRANSISTOR, CRYSTAL CONTROLLED CONVERTER

Now, in a matter of minutes, your standard broadcast car radio becomes a short wave receiver . . . bringing in stations from coast-to-coast as well as the four corners of the globe.

Designed by International for AMATEURS, CITIZEN LICENSEES, SHORT WAVE LISTENERS, HOBBYIST.

Available in SEVEN frequency ranges covering the Amateur bands, 75 through 10 meters, the Citizens band, and WWV National Bureau of Standards Time Broadcasts.

Three simple steps to install. (1) Remove antenna lead from car radio and plug into input of Mobilette. (2) Plug jumper wire from Mobilette into antenna connection of car radio. (3) Plug power connector into cigarette lighter socket. It's that easy!

Works on either 6 or 12 volts without change. Miniature size.

International Mobilettes cover these short wave bands.

Catalog No.	Frequency
630 — 105	75 meters (Amateur)
630 — 104	40 meters (Amateur)
630 — 106	10 MC (WWV Time Broadcasts)
630 — 103	20 meters (Amateur)
630 — 102	15 meters (Amateur)
630 — 101	11 meters (Citizens)
630 — 100	10 meters (Amateur)
	28.5 — 29.5 MC

Available soon for 6 and 2 meters at slightly higher price.



Complete, ready to plug in and operate . . . only **\$19.95**

Order direct from International. Terms F. O. B. Okla. City. Include postage. Shipping Weight 2 lbs.

**INTERNATIONAL
CRYSTAL MFG. CO. INC.**

18 NORTH LEE — OKLA. CITY, OKLA.

INTERNATIONAL CRYSTAL MFG. CO., INC., 18 NO. LEE
OKLAHOMA CITY, OKLAHOMA
GENTLEMEN: PLEASE SHIP THE FOLLOWING MOBILETTES @
\$19.95 EACH.

CATALOG NO. _____ FREQ. _____ QUANTITY _____

SHIP TO — NAME _____
AMOUNT ENCLOSED _____ ADDRESS _____

INCLUDE POSTAGE WITH ORDER.

The Taming Of The Shrill

Shakespeare tamed the shrew. Sonotone tames shrill noises — turntable rumbles!

With monophonic cartridges, distorting vertical vibrations may pass unnoticed. But in stereo, vertical rumblings can sound like elephants doing the cha-cha.

That's why Sonotone's model "8TA" stereo ceramic cartridge has an exclusive suppressor that reduces turntable rumble to an absolute minimum for highest fidelity. You'll hear the difference when you get a Sonotone!

Price \$14.50...others from \$5.45 to \$29.50 (including mounting bracket).

FREE "Stereo Simplified" booklet — tells you how stereo operates. Write to:

Sonotone

Electronic Applications Division, Dept. C3-60
ELMSFORD, NEW YORK

QUICKLY CUT HOLES

in metal, plastics,
hard rubber...



ROUND



SQUARE



KEY



"D"



GREENLEE CHASSIS PUNCHES

Make smooth, accurate openings in 1½ minutes or less... for sockets, plugs, controls, meters, panel lights, etc. Easy to use...

simply turn with wrench.

Many sizes and models.

Write for literature.



GREENLEE TOOL CO., 1915 Columbia Ave., Rockford Illinois

products

(Continued from page 34)

Model 23A remote-control tuner can be used with any standard TV receiver. It has an r.f. stage, three i.f. stages, two audio stages,



a built-in speaker, and an output for a tape recorder or hi-fi set. The video output of the Model 23A "Duo-Master" is fed into the video detector stage of the TV set by a coaxial cable up to 60 feet in length. Price, \$79.50. (Tech-Master Corp., 75 Front St., Brooklyn 1, N. Y.)

TRANSISTORIZED CONVERTERS

Two "Transipower" transistorized d.c.-to-d.c. converters are being offered by Cornell-

Dubilier Electric Corp., South Plainfield, N. J. The Model 12TP12 is a transmitter power supply which converts 12 volts d.c. to 500 volts d.c. at 240 ma. (120 watts) or to 500 volts



d.c. at 150 ma. and 250 volts d.c. at 100 ma. The Model 12TP3 is a receiver power supply which converts 12 volts d.c. to 300 volts d.c. at 100 ma. (30 watts) or to 300 volts d.c. at 70 ma. and 150 volts d.c. at 60 ma. Both units are miniaturized and light in weight. Prices: Model 12TP12, \$60.00; Model 12TP3, \$45.00.

TRANSISTOR INVERTER

The Arkay Model 2-120W transistor inverter converts 12 volts d.c. into 117 volts a.c. A two-transistor unit with a power capacity of 125 watts, it weighs 5½ pounds and measures approximately 10" x 4" x 5";

Always say you saw it in—POPULAR ELECTRONICS

FEATURED
IN JULY

POPULAR ELECTRONICS

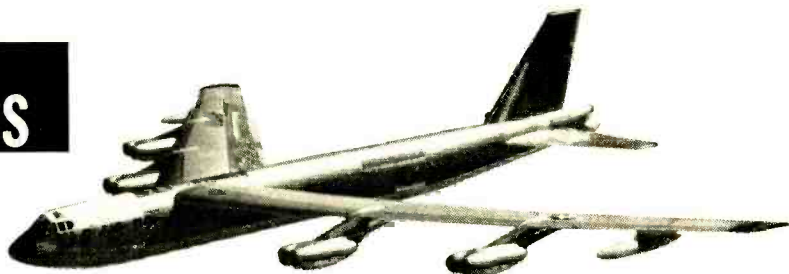

FROM **SEA TO SKY...**



MAGNETIC AMPLIFIERS CARRY THE LOAD!

Because magnetic amplifiers use no tubes and thus have virtually unlimited current capacity, they are utilized wherever demands are the most critical: jet bombers, atomic submarines, and industry. You can find out exactly what magnetic amplifiers are... what they do... how they work... in this special feature in July **POPULAR ELECTRONICS**!

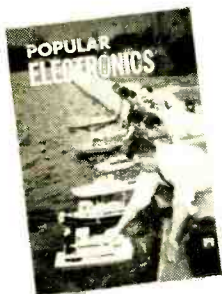

SUBSCRIPTION RATES

ONE YEAR \$4

TWO YEARS \$7

THREE YEARS \$10

POPULAR ELECTRONICS

434 South Wabash Avenue,
Chicago 5, Illinois

YOU'LL ALSO ENJOY THESE INFORMATIVE JULY POPULAR ELECTRONICS FEATURES:

- **HI-FI MICROPHONES**

Want to know how to choose the hi-fi mike for your needs... how to use it to best advantage... learn all about pick-up patterns? July **POPULAR ELECTRONICS** brings you the first of a two-part series that gives you a complete rundown on hi-fi microphones.

- **BUILD A ONE-TRANSISTOR VEST-POCKET RADIO!**

Just one evening of work and you have yourself a personal receiver that provides amazingly good reception—without external antenna. Very simple to build... and it costs under \$10.00.

- **DX'ING DOWN BELOW**

There are some rare DX'ing delicacies down below—below the broadcast band, that is! You can find many interesting stations on longwave that start at frequencies as low as 15,000 cycles. This article tells you where to find them... how to receive them... what kind of receiver you need.

These features are typical of the coverage you'll enjoy month after month in **POPULAR ELECTRONICS**... world's leading electronic hobbyist magazine. Take advantage of the present low subscription rates to bring **POPULAR ELECTRONICS** to your door every month. Subscribe now!

products

(Continued from page 36)

price, \$35.95 wired, \$29.95 in kit form. (Arkay International, Inc., 88-06 Van Wyck Expressway, Jamaica, N. Y.)

THIN PANEL METER

The Parker panel meter with printed-circuit movement has been announced by Interlab, Inc., 437 Fifth Ave., New York 16, N. Y. The entire meter is contained in a

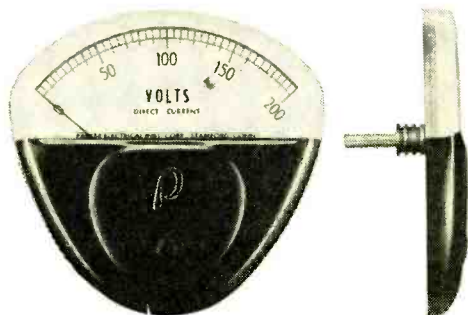

housing only 1/2" thick and the mounting screws do double-duty as electrical connectors. According to the manufacturer, an

electrical overload of 1000% for one second will not disturb the accuracy of the meter.

SUPER TWEETER

Response within ± 2 db to 40,000 cps is possible with the "Sphericon" Model T-202 tweeter produced by University Loudspeakers, Inc., 80 S. Kensico Ave., White Plains, N. Y. A domed phenolic diaphragm is acoustically loaded by a conoidal ring to give a 120° dispersion pattern in all directions.

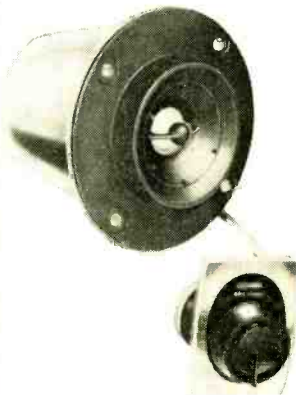

Highly efficient, the tweeter comes complete with built-in 3000-cps crossover network, volume control, and 36" cable. Power-handling capacity is 30 watts of integrated material; nominal impedance is 8 ohms. Size: 4 3/8" in diameter, 4" deep. Price, \$24.94.

-30-

Build the Best CITIZENS BAND TRANSCEIVER... **EICO**

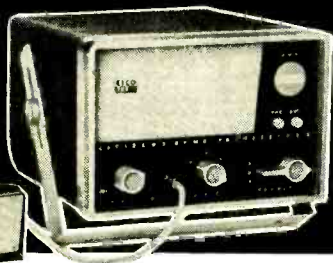

Highly reliable; exemplary electronic, mechanical, industrial design. Powerful 5-watt (as defined by FCC) crystal-controlled transmitter & extremely sensitive, selective superhet receiver with RF stage & noise limiter. Built-in speaker, detachable ceramic mike. Pre-set & sealed crystal oscillator circuit elements. To change channels, just change crystals — no adjustments needed. Built-in variable "pi" network matches most popular antennas. Portable whip & roof antennas available. No exams or special skill needed — any citizen 18 years or older may obtain station license by submitting FCC form, supplied free by EICO.



Build the Best 6-TRANSISTOR RADIO RA-6

Kit \$29.95 Wired \$49.95
includes FET, less 9V battery

High sensitivity & selectivity. New plug-in type transistors. Big-set volume & tone. 4" x 6" speaker; push-pull audio. Built-in Ferrite rod antenna. Pre-aligned RF & IF transformers. Planetary vernier tuning. Earphone jack for private listening. Attractive tan leatherette case, retractable handle. Compact: 8 1/2" w, 4 1/2" h, 2 1/2" d. Only 3 lbs.



90-WATT CW TRANSMITTER* #720

Kit \$79.95 Wired \$119.95
*U.S. Pat No. D-184,776
"Top quality" — ELECTRONIC KITS GUIDE. Ideal for veteran or novice. 90W CW, 65W external plate modulation. 80 through 100 meters.



HIGH-LEVEL UNIVERSAL MODULATOR-DRIVER #730

Kit \$49.95 Wired \$79.95
Cover E-5 \$4.50
Delivers 50W undistorted audio. Modulates transmitters having RF inputs up to 100W. Unique over-modulation indicator.



New Code Practice Oscillator #706

Kit \$8.95 Wired \$12.95
Rugged battery-operated transistor oscillator circuit, built-in speaker. Front panel has flashing light, phone jack, pitch control (500-2000 cps), external key terminals, "temporary" key. Panel switch selects Tone, Light, or both Tone & Light. 6 1/2" h, 3 3/4" w, 2 3/4" d.



GRID DIP METER #710

Kit \$29.95 Wired \$49.95
Includes complete set of coils for full band coverage. Continuous coverage 400 kc to 250 mc. 500 ua meter.

Compare — judge for yourself — at your neighborhood EICO dealer. For FREE catalog on over 70 models of easy-to-build professional test instruments, hi-fi and ham gear, fill out coupon on Page 40

EICO

Add 5% in the West. © 1960

3300 N. Blvd., L. I. C. 1, N. Y.



... symbol of
RAD-TEL
FIRST QUALITY

INSIST ON RAD-TEL FOR EVERY
 TELEVISION AND RADIO TUBE NEED

**GUARANTEED
 ONE FULL
 YEAR!**

70% OFF on BRAND NEW TUBES

You Can Rely On Rad-Tel's Speedy One Day Service!

Not Used — Not Pulled Out Of Old Sets • Each Tube Individually and Attractively Boxed!

Qty.	Type	Price	Qty.	Type	Price	Qty.	Type	Price	Qty.	Type	Price	Qty.	Type	Price	Qty.	Type	Price
—	0Z4M	.79	—	4BC5	.56	—	6AQ5	.50	—	6CG8	.77	—	8AW8	.93	—	12BH7	.73
—	1AX2	.62	—	4BC8	.96	—	6AR5	.55	—	6CM7	.66	—	8BQ5	.60	—	12BK5	.70
—	1B3GT	.79	—	4BE6	.54	—	6AS5	.60	—	6CN7	.65	—	8CG7	.62	—	12BL6	.56
—	1DN5	.55	—	4BN6	.75	—	6AT6	.43	—	6CR6	.51	—	8CM7	.68	—	12BQ6	1.06
—	1G3	.73	—	4BQ7	.96	—	6AT8	.79	—	6CS6	.57	—	8CN7	.97	—	12BY7	.74
—	1J3	.73	—	4BS8	.98	—	6AU4	.82	—	6CU5	.58	—	8CX8	.93	—	12BZ7	.75
—	1K3	.73	—	4BU8	.71	—	6AU6	.50	—	6CU6	1.08	—	8EB8	.94	—	12C5	.56
—	1L6	1.05	—	4BZ6	.58	—	6AU7	.61	—	6CY5	.70	—	10DA7	.71	—	12CA5	.59
—	1LA6	.69	—	4B27	.96	—	6AU8	.87	—	6CY7	.71	—	11CY7	.75	—	12CN5	.56
—	1LC6	.79	—	4CB6	.59	—	6AV6	.40	—	6DA4	.68	—	12A4	.60	—	12CR6	.54
—	1LN5	.59	—	4CS6	.61	—	6AW8	.89	—	6DB5	.69	—	12AB5	.55	—	12CU5	.58
—	1R5	.62	—	4DE6	.62	—	6AX4	.65	—	6DE6	.58	—	12AC6	.49	—	12CU6	1.06
—	1S5	.51	—	4DK6	.60	—	6AX7	.64	—	6DG6	.59	—	12AD6	.57	—	12CX6	.54
—	1T4	.58	—	4DT6	.55	—	6BA6	.49	—	6DQ6	1.10	—	12AE6	.43	—	12DB5	.69
—	1U4	.57	—	5AM8	.79	—	6BC5	.54	—	6DT5	.76	—	12AF3	.73	—	12DE8	.75
—	1U5	.50	—	5AN8	.86	—	6BC7	.94	—	6DT6	.53	—	12AF6	.49	—	12DL8	.85
—	1X2B	.82	—	5AQ5	.52	—	6BC8	.97	—	6EUB	.79	—	12A16	.46	—	12DM7	.67
—	2AF4	.96	—	5AT8	.80	—	6BD6	.51	—	6EA8	.79	—	12A15	.45	—	12DQ6	1.04
—	2BN4	.60	—	5BK7A	.82	—	6BE6	.55	—	6EB8	.94	—	12A18	.95	—	12DS7	.79
—	2CY5	.71	—	5BQ7	.97	—	6BF6	.44	—	6HG6T	.58	—	12AQ5	.52	—	12DZ6	.56
—	3AL5	.42	—	5BR8	.79	—	6BG6	1.66	—	6J5GT	.51	—	12AT6	.43	—	12EL6	.50
—	3AU6	.51	—	5CG8	.76	—	6BH6	.65	—	6J6	.67	—	12AT7	.76	—	12EG6	.54
—	3AV6	.41	—	5CL8	.76	—	6BH8	.87	—	6K6	.79	—	12AUG	.50	—	12EK6	.56
—	3BA6	.51	—	5EA8	.80	—	6BJ6	.62	—	6S4	.48	—	12AU7	.60	—	12EZ6	.53
—	3BC5	.54	—	5EU8	.80	—	6BK5	.80	—	6SA7GT	.76	—	12AV5	.97	—	12F5	.66
—	3BE6	.52	—	5J6	.68	—	6BK7	.85	—	6SK7GT	.74	—	12AV6	.41	—	12F8	.66
—	3BN4	.63	—	5T8	.81	—	6BL7	1.00	—	6SL7	.80	—	12AV7	.75	—	12FM6	.45
—	3BN6	.76	—	5U4	.60	—	6BN4	.57	—	6SN7	.65	—	12AX4	.67	—	12K5	.65
—	3BU8	.78	—	5U8	.81	—	6BN6	.74	—	6SQ7	.73	—	12AX7	.63	—	12SA7M	.86
—	3BY6	.55	—	5V6	.56	—	6BQ5	.65	—	6T4	.99	—	12AZ7	.86	—	12SK7GT	.74
—	3BZ6	.55	—	5X8	.78	—	6BQ6GT	1.05	—	6T8	.80	—	12B4	.63	—	12SN7	.67
—	3CB6	.54	—	5Y3	.46	—	6BQ7	.95	—	6U8	.78	—	12BA6	.50	—	12SQ7M	.73
—	3CF6	.60	—	6AB4	.46	—	6BR8	.78	—	6V6GT	.54	—	12B06	.50	—	12U7	.62
—	3CS6	.52	—	6AC7	.96	—	6BS8	.90	—	6W4	.75	—	12BE6	.53	—	12V6GT	.53
—	3CY5	.71	—	6AF3	.73	—	6BU8	.70	—	6W6	.69	—	12BF6	.44	—	12W6	.69
—	3DE6	.62	—	6AF4	.97	—	6BY6	.54	—	6X4	.39	—					
—	30K6	.60	—	6AG5	.65	—	6BZ6	.54	—	6X5GT	.53	—					
—	30T6	.50	—	6AH6	.99	—	6BZ7	.97	—	6X8	.77	—					
—	3Q5	.80	—	6AK5	.95	—	6C4	.43	—	7AU7	.61	—					
—	3S4	.61	—	6AL5	.47	—	6CB6	.54	—	7A8	.68	—					
—	3V4	.58	—	6AM8	.78	—	6CD6	1.42	—	7B6	.69	—					
—	4AU6	.54	—	6AN4	.95	—	6CF6	.64	—	7Y4	.69	—					
—	4BA6	.51	—	6AN8	.85	—	6CG7	.60	—	8AU8	.83	—					

PLEASE PRINT PLAINLY

Name

Address

City

SEND FOR FREE TROUBLE SHOOTER GUIDE AND NEW TUBE & PARTS CATALOG.

RAD-TEL TUBE CO.

55 Chambers St.
 Newark 5, N. J.

Dept. PE-660

TERMS: 25% deposit must accompany all orders — balance C. O. D. Not Affiliated With
 \$1 HANDLING CHARGE FOR ORDERS UNDER \$5. Subject to prior sale. Any Other Mail
 Please add postage. No C. O. D.'s outside continental U. S. A. Order Tube Co.

the experts say
your BEST BUY
 is **EICO**...

EICO, 3300 N. Blvd., L.I.C. 1, N.Y. PE-6

Show me HOW TO SAVE 50% on 70 models of top-quality: HI-FI TEST INSTRUMENTS
 "HAM" GEAR Send FREE Stereo Hi-Fi Guide. Send FREE Short Course for Novice License. Send FREE Catalog & name of neighborhood EICO dealer.

Name:
 Address:
 City: Zone: State:

ADD 5% IN THE WEST

...in
STEREO and MONO HI-FI



STEREO Dual Amplifier-Preamp HF81
 Kit \$69.95.
 Wired \$109.95.
 "Excellent!" — SATURDAY REVIEW: HI-FI MUSIC AT HOME.



NEW! STEREO Automatic Changer/Player 1007 (.7 mil diamond, 3 mil sapph dual styli)
 \$59.75 incl. FET.



FM Tuner HFT90 Kit \$39.95*.
 Wired \$65.95*.
 Cover \$3.95.
 "One of the best buys" AUDIOCRAFT

*Less Cover, F.E.T. incl.

AM Tuner HFT94 Kit \$39.95.
 Wired \$65.95, incl. Cover & F.E.T.



STEREO Dual Preamp HF85
 Kit \$39.95
 Wired \$64.95.
 "Extreme flexibility" — HI-FI REVIEW
 a bargain!



Mono Power Amplifiers (60, 50, 35, 30, 22, 14-Watt; use 2 for Stereo)
 from Kit \$23.50.
 Wired \$41.50.



2-Way Bookshelf Speaker System HFS1 complete with factory-built cabinet:
 Kit \$39.95
 Wired \$47.95



70W HF87: Kit \$74.95. Wired \$114.95.
28W HF86: Kit \$43.95. Wired \$74.95.



Mono Integrated Amplifiers: (50, 30, 20, 12-Watt; use 2 for Stereo)
 from Kit \$34.95.
 Wired \$57.95.



NEW! COMPLETE STEREO DUAL AMPLIFIER AF-4
 Kit \$38.95
 Wired \$64.95

TRUE Hi-Fi quality to drive hi efficiency speakers to concert volume.

...and in
TEST INSTRUMENTS



New Transistorized Power & Bias Supply #1020
 Kit \$19.95.
 Wired \$27.95.



Miniaturized Multi-Signal Tracer #145A
 Kit \$19.95.
 Wired \$28.95.



Vacuum Tube Voltmeter #221
 Kit \$25.95.
 Wired \$39.95.



Peak-to-Peak VTVM #232 & Uni-Probe (pat. pend.)
 Kit \$29.95.
 Wired \$49.95.



New Battery-Powered Filament Continuity Tester #612.
 Kit \$3.95.
 Wired \$5.95.



1000 Ohms/Volt V.O.M.-#536
 Kit \$12.90.
 Wired \$14.90.



5" Push-Pull Scope #425
 Kit \$44.95
 Wired \$79.95.
DC-5 MC 5" Scope #460
 Kit \$79.95.
 Wired \$129.50.



Tube Tester #625
 Kit \$34.95.
 Wired \$49.95.



RF Signal Generator #324
 Kit \$26.95.
 Wired \$39.95.



Series/Parallel R-C Combination Box #1140
 Kit \$13.95. Wired \$19.95
 1350 Combinations!



6V & 12V Battery Eliminator & Charger #1050
 Kit \$29.95. Wired \$38.95.
 Extra-filtered for transistor equip. #1060
 Kit \$38.95. Wired \$47.95



R-C Bridge & R-C-L Comparator #950B
 Kit \$19.95.
 Wired \$29.95.

IN STOCK! Compare, take them home — right "off the shelf" — from 2000 neighborhood dealers. Over 2 MILLION EICO instruments in use throughout the world.

© 1960 ELECTRONIC INSTRUMENT CO., INC., 33-00 N. BLVD., L.I.C. 1, N.Y.

See Page 38 for the BEST BUYS in CITIZENS TRANSCEIVERS, "HAM" GEAR and TRANSISTOR RADIOS.

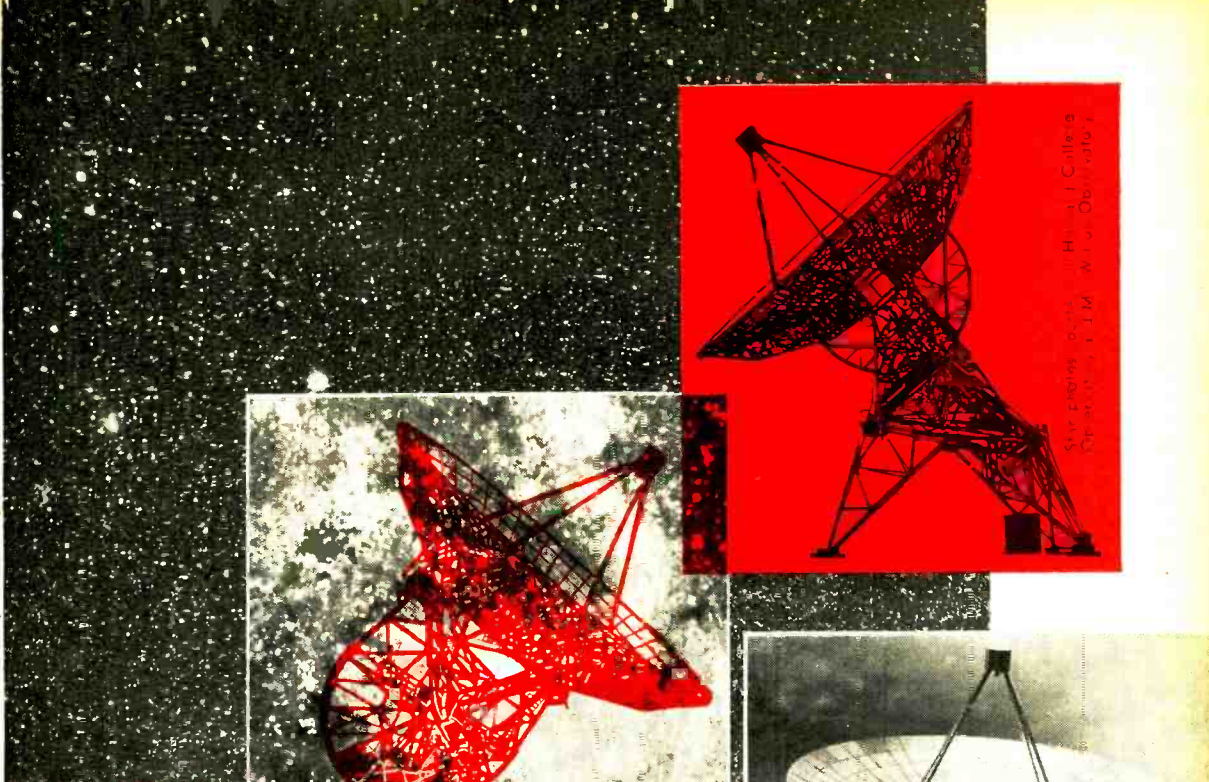

See photograph on p. 11. Howard J. Callender
Department of A.E.M., University of California

eavesdropping on OUTER SPACE

THE YEAR was 1931. The place: an abandoned farm near Holmdel, New Jersey. A brilliant young scientist from Bell Laboratories—Karl Jansky—had been assigned the job of tracking down mysterious noises that were interfering with radio communications. Suddenly, he picked up a disturbance he had never heard before: screaming between a whoosh, a crackle, and a frying sound. The next night the noise was there again and the next night, and the next—always from the same direction.

Several months later, as Jansky sat reviewing his carefully kept records, an astonishing fact

Radio astronomy, one of man's youngest sciences, seeks to solve two of man's oldest questions: 'What is the origin of the universe' and 'is there life on other planets?'

By KEN GILMORE

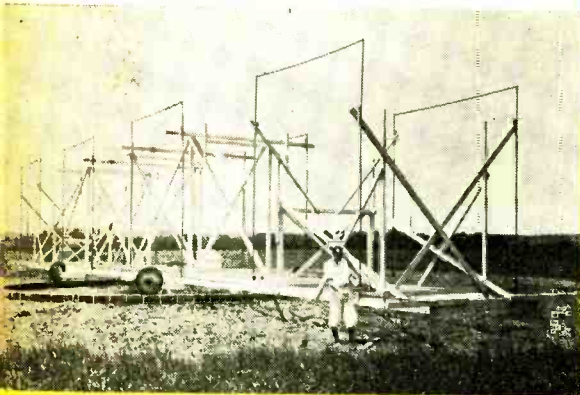

▲ **Karl Jansky**, pioneer radio astronomer, is shown here with the rotating antenna he used in the early 1930's when he discovered that radio waves from outer space could be received on earth. Jansky's work was done at the Bell Telephone Labs in Holmdel, N. J.

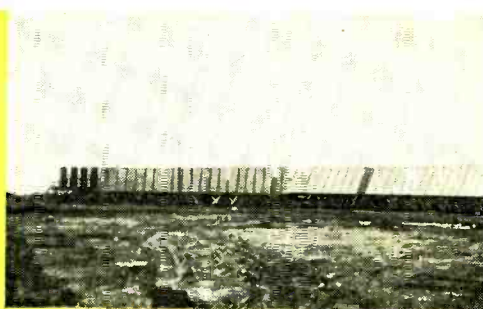

▲ **Aerial view of the Mills Cross radio telescope** near Sidney, Australia. Each arm of the antenna is one-third of a mile in length. The antenna's great size enables it to be used in the study of wavelengths longer than those that can be picked up by a conventional parabolic antenna.

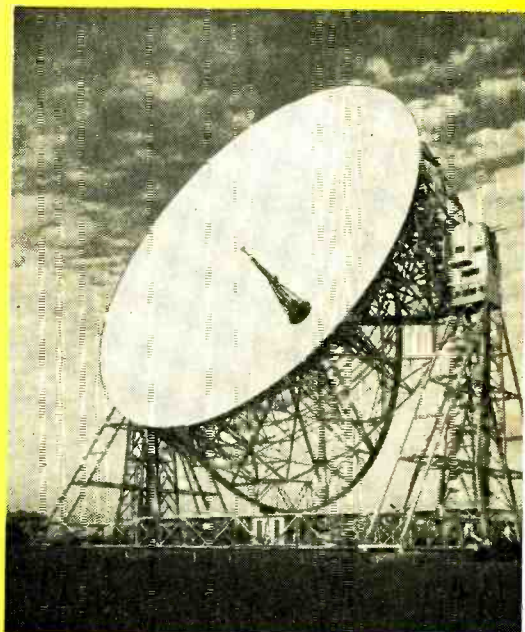

▶ **The twin 90' antennas** at the California Institute of Technology provide the highest resolution of any radio telescope now in operation or under construction. Within two months after the pair was first put to work, they established the locations of nine radio stars outside the Milky Way, thereby exceeding the total of all the extra-galactic radio sources previously identified.

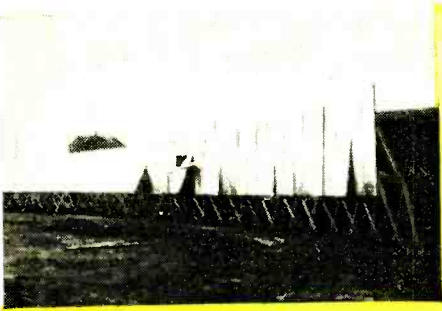

▲
Primary reflector of radio telescope at the Pulkovo Observatory in Russia looks more like a board fence than a scientific instrument. Each panel is about 4' by 10' and can be adjusted individually. The 425' multi-paneled reflector directs all energy it receives into a much smaller secondary reflector located 200' away at the focus of the primary reflector.

◀
The largest fully steerable radio telescope in the world, the Jodrell Bank installation in England, has a reflector bowl 250' in diameter. Although the telescope is used extensively in tracking man-made satellites, its main job is to receive and record radio waves that originate in outer space at distances up to a billion light-years away. The giant installation was designed by the radio astronomy department of Manchester University.

struck him. The strange noise had appeared exactly four minutes earlier every night. Quickly checking an astronomy textbook, he felt a wild excitement as his hunch was confirmed: because of the earth's rotation around the sun, the stars rise four minutes earlier every night. The weird sound was coming from outer space!

Karl Jansky's discoveries were reported in a scientific paper, but his fellow engineers failed to see their significance. Jansky's boss told him to continue his studies on regular static; reluctantly, he did so. He died a few years later, before the world began to appreciate the importance of his work.

But Jansky's discoveries had fascinated a young engineer who was living in Wheaton, Ill. In his spare time, Grote Reber built a 30' dish antenna and began to search the heavens. He made the first radio map of the sky, isolating the now well-known "hot spots"—sources of strong radio signals from outer space. Before anyone else became interested in Reber's research, however, along came World War II, bringing with it rapid advances in the entire field of electronics—among them, radar.

In February, 1942, while the English were waiting apprehensively for a German attack, British radar was suddenly jammed by a blast of hissing, crackling noise. The British, certain that the Germans had found a way to disable their radar, prepared for the attack they thought was coming. It never came. Later, physicist J. Stanley Hey determined that the noise had come not from across the channel, but from across the universe! Similar experiences were reported by other radar operators around the world.

After the war, the first radio telescopes began sprouting here and there. These early telescopes were made from radar sets because radar was the most sensitive equipment available, and besides, surplus radar could be had for a song. As demand grew for better and more powerful equipment, a new branch of electronics began to evolve—radio astronomy!

The Edge of Space. Until the radio telescope came along, astronomers could only look at stars within range of optical telescopes. The rest were hidden by interstellar dust clouds. But radio telescopes can hear signals from behind this dust. Thus, radio astronomy has revealed whole systems of previously undiscovered stars. In addition, radio telescopes have allowed man to probe space over seven billion light-years away—more than three times as far as the most powerful optical telescope can "see." Bigger radio telescopes now under construction will extend the range to perhaps 40 billion light-years, *to the very edge of space!*

These new instruments should allow scientists to settle a long-standing argument about the beginning of the universe. Did it—as backers of the so-called "steady-state" theory hold—have no beginning, but always exist as it is now? Or is the "expanding-universe" theory correct? Supporters of the latter view believe that all matter was once a single, vast, super-dense

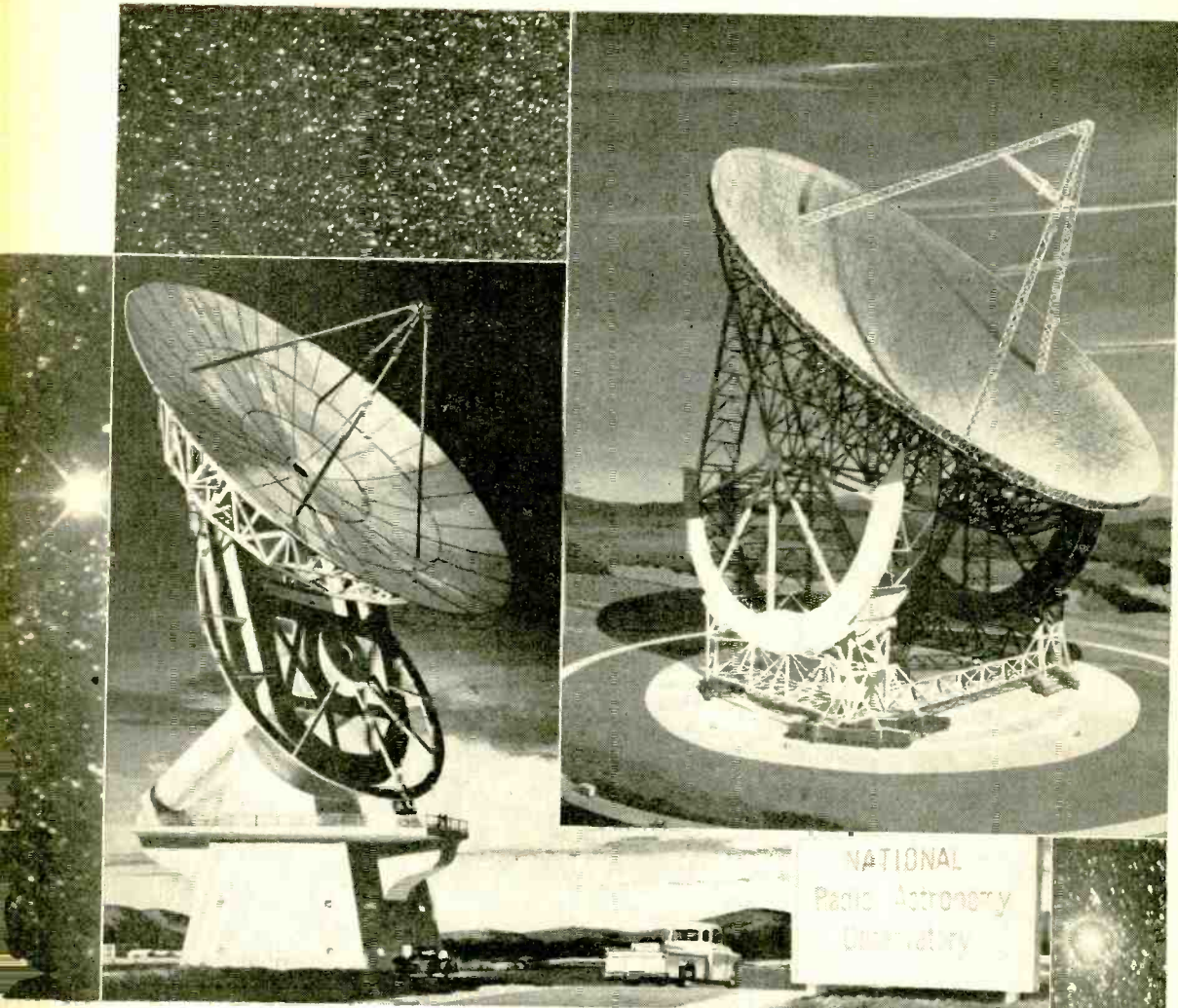

▲
Under construction at the National Radio Astronomy Observatory in Green Bank, W. Va., is this 140' precision telescope. The surface of the reflector will be more than one-third of an acre in area and is designed to be accurate within a quarter of an inch. When completed, the 210'-high instrument should be the most highly accurate radio telescope in the world.





◀ **This giant** radio telescope is being built for the U. S. Naval Research Laboratory in Sugar Grove, W. Va. The huge reflector will be 600' wide, twice the length of a football field. The entire 20,000-ton installation will rotate on rollers which ride circular tracks on the ground, allowing the dish to be aimed at any point in the sky above the horizon.

body. But, eons ago, something caused it to explode. The present planets and galaxies speeding through space, they say, are the result of that explosion.

Which theory is right? The radio telescope may uncover valuable clues. If, for example, the galaxies farthest out seem bunched more closely together than those nearest the center, then the universe is probably expanding. The reasoning goes like this. Since it takes billions of years for light from the edge of the universe to reach us, galaxies at the outer edge will be seen not as they are today, but as they were several billion years ago. On the other hand, should radio telescopes show that galaxies are distributed fairly evenly throughout space, this would be strong evidence that the steady-state theory is correct.

Life On Other Planets. Radio telescopes are also being used to search for intelligent life on distant planets, in a quest known as *Project Ozma*. It began on April 11th when two young scientists, Dr. Frank Drake and William Walton of the National Radio Astronomy Observatory in Green Bank, W. Va., pointed the 85' dish antenna shown on page 41 at two nearby stars—Tau Ceti and Epsilon Eridani—and listened for patterns of artificial signals mixed in with the natural noise.

Dr. Drake—at 29 one of the world's leading radio astronomers—feels the chances are good that eventually we will "tune in" on life in outer space. We know that at least some—probably many—stars have habitable planets similar to ours. The odds are overwhelming that life developed on some of them just as it did on earth. Some of these beings have probably progressed as far or further than we have, and should be capable of sending radio signals.

Are we close enough to pick up these transmissions? It's pretty much a matter of what size radio telescopes we use. Dr. Drake calculates that the 85' antenna he is now using should be able to pick up artificial signals from as far away as 10 or 12 light-years. A 600' antenna—such as the one now being built about 30 miles away from Dr. Drake's present instrument—should be able to detect signals that originate 100 light-years away. Within that range are 10,000 stars, and astronomers think the odds are good that there are technically advanced civilizations on some of them.

Ironically, if and when we do hear signals from outer planets, we will probably not know it for months. An incoming signal would be so weak that it would be lost in background noise (it took computers almost a year to confirm our radar contact with Venus in 1958). Eventually, however, high-speed computers which analyze all signals received will isolate any transmission that cannot be accounted for by natural background noise.

Could we break the language barrier between us and an alien civilization? Scientists working on the problem think so. They theorize that races seeking radio contact in space would transmit pulses coded by some

(Continued on page 110)



◀ **Over three** football fields across, this 1000'-wide antenna is being built into a natural bowl of coral limestone in Puerto Rico for use by Cornell University's Radio-physics and Space Research Center. One of its first tasks will be to study the under-surface of the planet Jupiter.

INSIDE

the

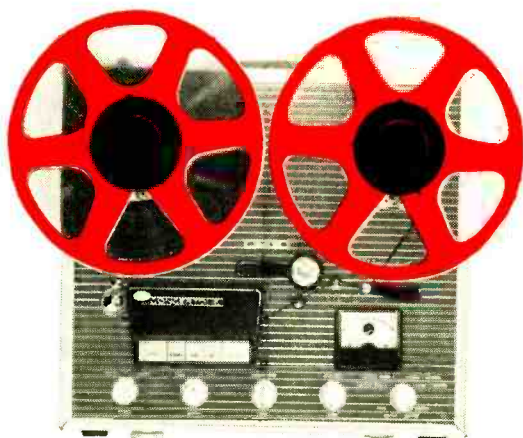

Hi-Fi Tape Recorder

Bias, erase and equalization circuits

RECORDING signals on magnetic tape necessitates some specialized, but important, electronic circuits. Bias current for the record and erase heads must be generated by an oscillator circuit. Equalization for both record and playback must be provided by other circuits. Still other circuits are required to amplify input signals until they are of sufficient amplitude to drive the record head.

Bias Current. One of the keys to successful magnetic recording is bias current. "Bias," here, has an entirely different meaning than its usual one with amplifiers. In tape-recorder terminology, bias refers to high-frequency oscillations which are fed to the recording head along with the input signal. The bias current decreases distortion and increases signal output. Interestingly enough, experts don't agree on how bias works—but it does. It is perhaps most convenient to imagine that the bias "shakes up" the magnetic fields on the tape, making it easier for them to be modulated.

Frequency stability of the bias oscillator isn't critical, but its frequency should be at least four times the highest signal frequency to be recorded to avoid beat notes.

By **JOSEPH MARSHALL**

Thus, most bias oscillators operate at from 40 to 100 kc. Typical oscillator circuits include the single-ended Colpitts, the Hartley, the tuned plate, and the push-pull Colpitts circuit.

Because any harmonic distortion generated by the oscillator will cause noise to be transferred to the tape, the push-pull design (which cancels out the even-order harmonics) is found in the better recorders, such as the Ampex 910 (Fig. 1). Ampex even goes so far as to include a control to balance the currents through the oscillator tubes, thus minimizing harmonic distortion. This control is called "Noise Balance."

For simplicity and economy, some recorders have a single tube operating as oscillator in the record mode and audio output in playback. The Telectro 320 employs a 6AQ5 for audio output during playback; switching an LC network into the grid circuit enables the same tube to function as an oscillator during record.

A push-pull audio output stage is even simpler to convert. It will function as a push-pull oscillator stage if the control

ratio) must be made. Increased bias reduces distortion and boosts signal output, but it causes the frequency response at the high end to drop off. In general, the best compromise for the bias is a level 2 db below the point that gives maximum output at 1000 cps.

Some recorders provide a small variable capacitor in series with the bias oscillator and the record head for adjusting the amount of bias. More commonly, a fixed ca-

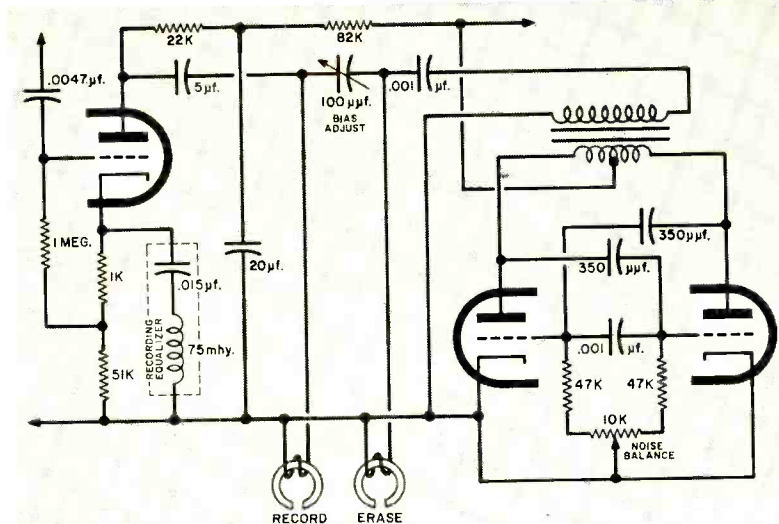

Fig. 1. Recording circuit of the Ampex 910. The 10,000-ohm potentiometer allows the push-pull oscillator to be balanced for minimum harmonics. Erase current is supplied through the .001- μ f. capacitor, and bias for the record head can be adjusted by the 100- μ f. capacitor. Network in cathode circuit of driver tube boosts high frequencies in recording process.

grids of the output tubes are switched to small capacitors which terminate at the plates of the opposite tubes. The output transformer serves as the tank. This arrangement is used in the Telectro 300.

Erase Current. As we have seen, bias is a high-frequency alternating current. When recorded or magnetized tape is brought through the field created by an alternating current and then is slowly removed from the field, it will be demagnetized. This is how the erase head works. It produces a fluctuating magnetic field which demagnetizes, or erases, the tape.

Although the same oscillator usually supplies current for both bias and erase, the two functions require different amounts of current, with the erase head demanding roughly 20 times more than the playback head. The amount of bias for the record head is rather critical because a compromise between distortion, high-frequency response, and output (or signal-to-noise

pacitor is employed to adjust the bias to the desired current value.

Coupling the record and erase heads to the bias oscillator is a little tricky because they require different amounts of current, and, in addition, the oscillator circuit should not be loaded down by the heads. Usually a transformer is included in the frequency-determining tank to isolate the heads from the oscillator and to provide good impedance matching.

The circuit used in the Bell recorders has the record head fed from the secondary of the transformer, while the erase head is coupled directly to the oscillator through a capacitor. In the Pentron recorders, the erase and record heads are fed by different taps on the output transformer. Ampex couples the record head to the oscillator by means of a variable capacitor in series with the capacitor feeding the erase head.

Record Equalization. As pointed out in a previous article in this series, an unequal-

ized tape recording produces a response that rises at a 6-db-per-octave slope until it reaches a maximum at some frequency between 2500 and 10,000 cycles, depending on the head and the speed of the tape. Above this upper frequency, there is a downward slope due to losses in the head. Figure 2 gives the unequalized recording curves of a high-quality head operating at 15 and 7½ ips. Obviously, to obtain a flat response, we need to flatten out these

curves as much as possible in the recording process. The extreme high end should be boosted at least enough to make up for the recording losses. Unfortunately, it is not easy to do this because the high-frequency roll-off is greater than 6 db per octave. To compen-

sate for such a sharp roll-off, some fairly elaborate networks are required. In the Ampex 900 series, a tuned circuit in the cathode of the tube that drives the record head peaks the high-frequency response to make up for the roll-off. In the Concertone, a feedback loop is run from the recording head to an early stage; because the inductance of the head is included in the feedback loop, a sharp boost is possible. In home-type recorders, such expensive and elaborate measures are not justified. Simple RC networks, in either interstage coupling or feedback networks, are used to obtain partial compensation of the high-end roll-off during recording. If the recorder is used at two or more speeds, the compensation has to be changed also. Usually extra treble boost is switched in at the lower speeds.

It will be noted from the curve of Fig. 2 that the response at 30 cycles is fully 30 db below the

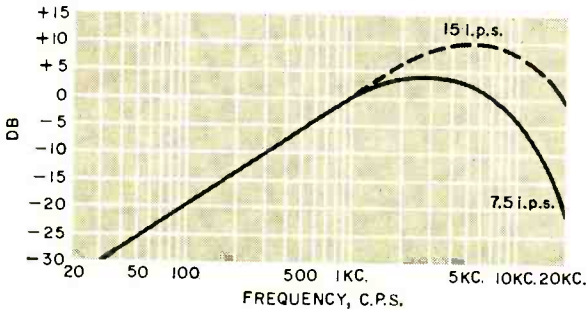

Fig. 2. Unequalized recording curves for a high-quality head.

Fig. 3. Recording equalization curve used by Ampex at 7½ ips.

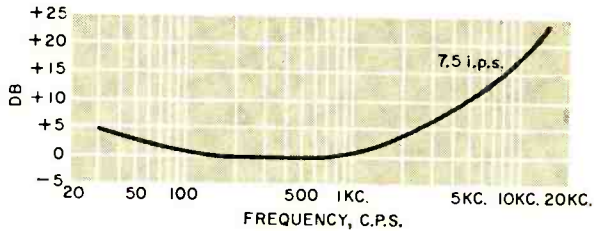
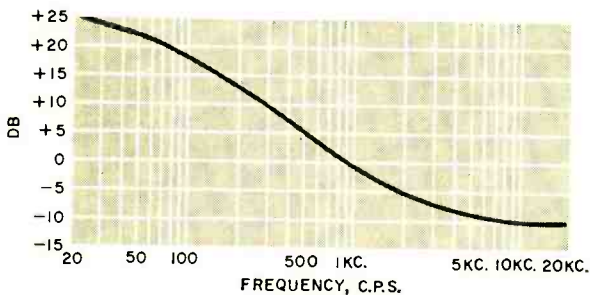

Fig. 4. NAB playback equalization curve for 7½-ips tapes.



curves as much as possible in the recording process.

The extreme high end should be boosted at least enough to make up for the recording losses. Unfortunately, it is not easy to do this because the high-frequency roll-off is greater than 6 db per octave. To compen-

response at 1000 cycles. Since a 30-db boost in playback would raise serious hum problems, it is desirable to provide a little low-bass boost in the recording process to simplify the problem of playback equalization. Thus, for best overall performance, the equalized recording curve should look something like the Ampex 7½-ips curve in Fig. 3, where we have a boost at both ends. The more elaborate recorders provide boost at both the high and low ends, but, to minimize hum troubles, home-type machines usually do not include low-end boost.

Playback Equalization. Frequency response equalization for playback is obtained in the same way as record equaliza-

(Continued on page 116)

Volt // Ammeter Kit

New Knight-Kit checks charge-discharge current and battery voltage on the spot

SINCE the day that car manufacturers began to do away with ammeters, many car owners have had only a single red warning light to tell them what's going on in the car's electrical system. The warning light goes on when the battery is putting out more current than the generator is pumping into it. But the light doesn't indicate *rate* of discharge—a 30-amp or a 1-amp discharge results in the same glowing red light. What's more, the light gives virtually no indication of the battery's condition.

The Knight 83 Y 711 ammeter-voltmeter kit supplies the missing ammeter and gives you a matching voltmeter to boot. You can see the actual rate of charge or discharge on the ammeter, and the voltmeter gives you a rough indication of the condition of your battery. The ammeter scale ranges over 30-0-30 amperes and the voltmeter scale from 9 to 15 volts.

Both meters are mounted side-by-side on a chrome-plated, rubber-trimmed panel. In-

stallation of the "twin" meters is simplified by universal under-the-dash mounting brackets and solderless terminals.

This ammeter-voltmeter will work with any 12-volt electrical system, car or boat, with either positive or negative grounds. Wiring diagrams supplied show how to connect the unit to systems of either ground polarity. The kit is available from Allied Radio Corporation (100 N. Western Ave., Chicago 80, Ill.) for \$10.75. —30—

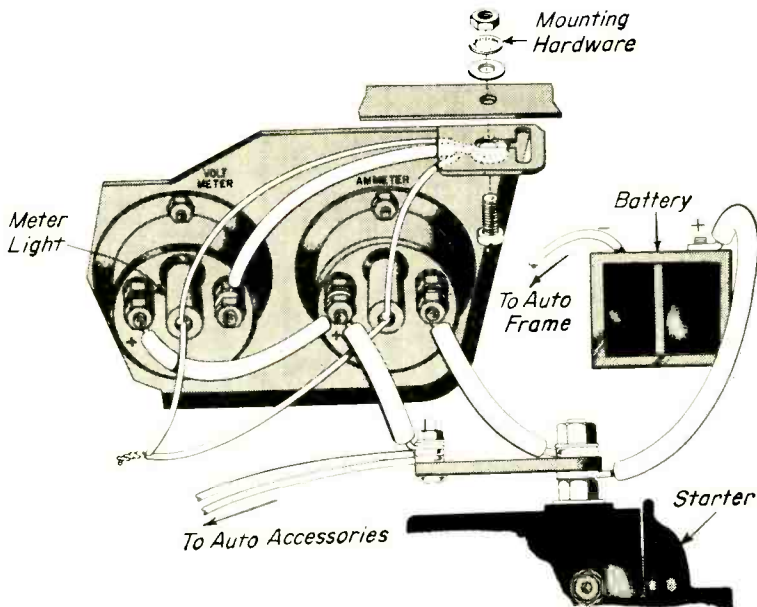
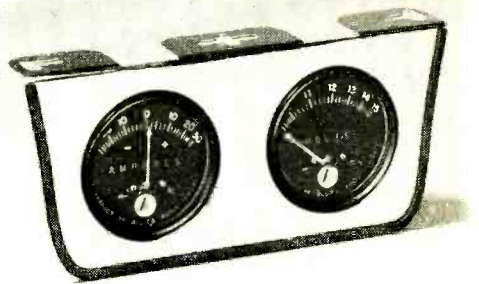

Illuminated meters show battery charge-discharge current and voltage at a glance.

Wiring diagrams provided make kit easy to install. Meter panel mounts under dash.



Electronics Adds a New Angle to Angling

Portable pulsing system stuns fish,

THIS summer some unusual fishermen will be drifting down country streams in the vicinity of Seattle, Washington. To the uninformed, they'll appear to be fitted out only with dip nets; yet they'll bring in up to 1200 fish in an hour. The secret of their angling success will be a piece of electronic gear that gives nearby fish a jolt of electricity, causing them to surface near the waiting nets.

Invented at the U. S. Fish and Wildlife Service, this amazing gadget is used by scientists to collect samples of fish in streams where nets and other fishing implements are impractical. Its results are enough to put any fisherman into ecstasy. On a recent field trip, quarter-mile drifts down a stream were made, and 50 to 60 fish were pulled in on each drift.

Electronic fishing is not a new idea, but this is the first truly portable system that has been devised. It consists of a 230-volt gasoline-powered generator, a transistorized square-wave pulsing unit, and two electrodes. The positive electrode is an expanded grid about 15" x 24" mounted at the end of a pole. The bottom of the fishing boat, which is aluminum, serves as the negative electrode.

Stunning Effect. Fish are not killed by this device, but merely stunned. The pulsing unit radiates high-voltage d.c. pulses into the water, setting up a charged field

POPULAR ELECTRONICS



Photos from Three Lions

Biologist Ben Patten displays a 5¼-lb bass which he caught with the aid of an electronic fishing system. He holds in his left hand an electronic "fishing pole," or, more accurately, the system's positive electrode.

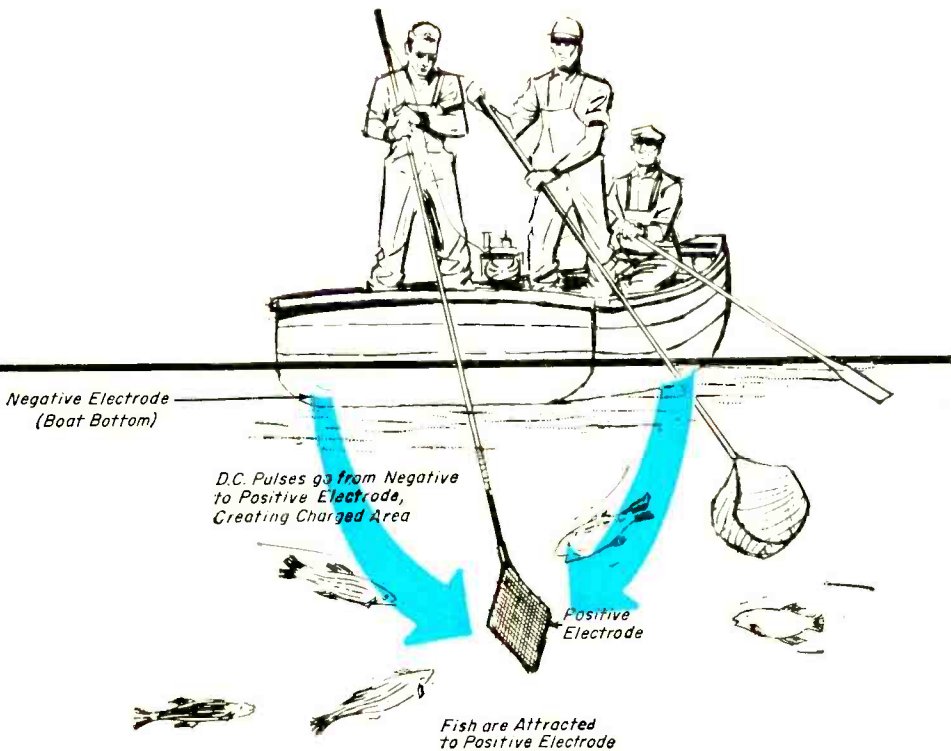

then brings them to the surface

By **ROBERT P. HAMMOND**

Portable pulsing system developed by the U. S. Fish and Wildlife Service is powered by a 230-volt gasoline generator. Unit employs transistorized circuitry and is less than 2' wide.

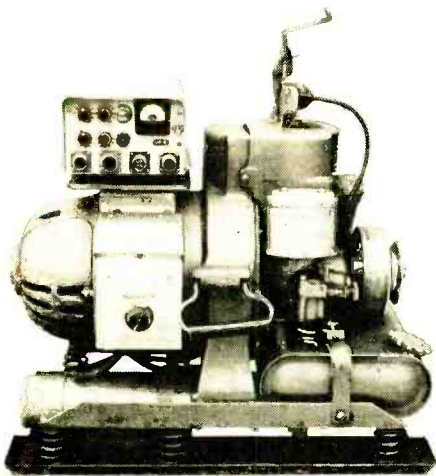

that extends about 12 feet from each electrode. Fish coming into this field are captured by the "electrotaxic effect" and herded toward the positive electrode. As they approach the electrode, the increased intensity of the current stuns them and they turn on their sides and float to the surface. Then they are scooped up in nets.

The electrotaxic effect is one of the most interesting features of the operation. It is present only when d.c. current is used, and the reaction of the fish is involuntary. For reasons still unknown, a fish immediately faces the positive electrode when it enters the charged field. Each time the electric pulse is sent, the fish twitches, then swims inexorably toward the positive electrode. Scientists believe this to be strictly a muscular reaction. Fish that have had their heads removed behave exactly the same as live fish, twitching and moving straight toward the positive electrode.

Researchers have found that different
(Continued on page 103)

Build an R.F.

This inexpensive instrument doubles as a

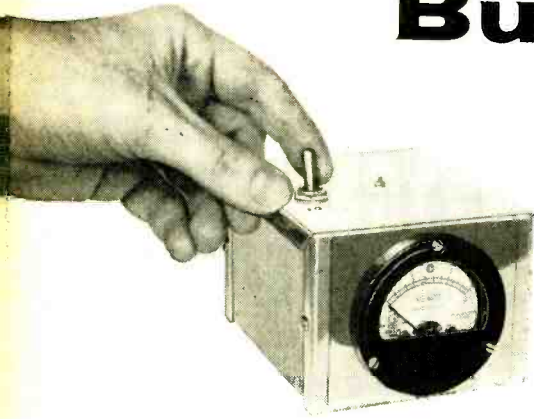

ALTHOUGH many amateurs use an ordinary light bulb to "measure" r.f. power output, this is a hit-and-miss method at best. A 150-watt bulb operating at "half-brilliance" doesn't necessarily indicate 75 watts output—the bulb's impedance doesn't match the transmitter output impedance,

and "half-brilliance" is little more than a crude guess. The only accurate method of measuring r.f. power output is to use a calibrated r.f. power meter.

Here's a two-in-one unit that's both an r.f. power meter and a dummy load in one compact aluminum case. It's capable of handling 40 watts continuously and up to 100 watts for very short intervals. It can also be used to test a transmitter's low-pass harmonic filter.

This little unit has an effective input impedance of about 50 ohms to match the out-

Standard Minibox serves as chassis for power meter. For best results, use a single insulated tie-point and ground lug when wiring, as shown in pictorial diagram.

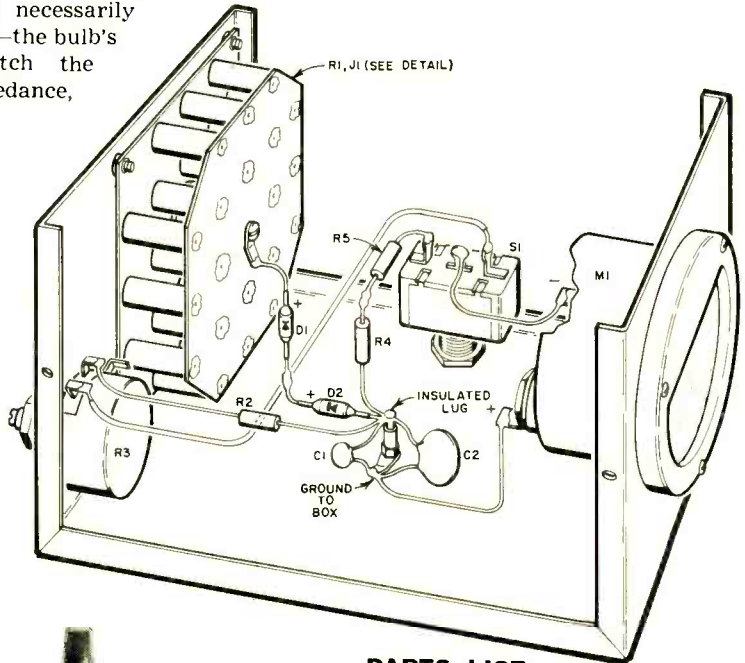

PARTS LIST

- C1— $.001\text{-}\mu\text{l.}$, 600-volt ceramic disc capacitor
- C2— $.01\text{-}\mu\text{l.}$, 600-volt ceramic disc capacitor
- D1, D2—1N38B diode
- J1—Coax connector
- M1—200- $\mu\text{a.}$ d.c. meter (Triplett 221T, or equivalent)
- R1—50-ohm, 40-watt resistor (see text)
- R2—330,000-ohm, $\frac{1}{2}$ -watt, 5% resistor
- R3—250,000-ohm, 2-watt potentiometer, linear taper (Ohmite CLU1041 or equivalent)
- R4—33,000-ohm, $\frac{1}{2}$ -watt, 5% resistor
- R5—100,000-ohm, $\frac{1}{2}$ -watt, 5% resistor
- S1—S.p.d.t. toggle switch
- 1—3" x 4" x 5" Minibox
- Misc.—Hardware, brass plates, etc.

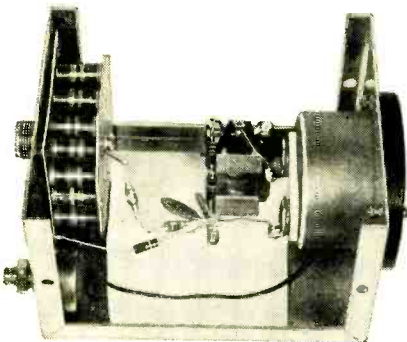

Power Meter

dummy load in your ham shack

By JOSEPH TARTAS, W2YKT

put impedance of most transmitters. It operates on frequencies up to 200 mc. with a voltage-standing-wave-ratio (VSWR) of only 2:1 on the upper limit. Using standard components, you can build it for \$20 or less, depending on the meter used.

Construction. The 3" x 4" x 5" Minibox which serves as a cabinet also acts as a heat sink for load resistor $R1$. Drill the mounting holes for input jack $J1$ and potentiometer $R3$ at one end of the box; you'll need a hole for the meter on the opposite end. Switch $S1$ mounts on top.

Load resistor $R1$ consists of twenty 1000-ohm, 2-watt, 5% composition resistors soldered in parallel to a pair of brass or copper plates as shown in the pictorial detail. Cut the two load-resistor plates at the same time from two copper or brass sheets. Each plate should be 2 3/8" square; the thickness isn't important. When the plates are cut, mark one for drilling, clamp them together, and drill both at the same time. This will insure alignment of holes and make assembly easier. Cut off the corners of the back plate to allow access to the nuts on the mounting screws.

To assemble the load resistor, pass a lead from each 1000-ohm resistor through a hole in the front plate, bending over each lead

(Continued on page 104)

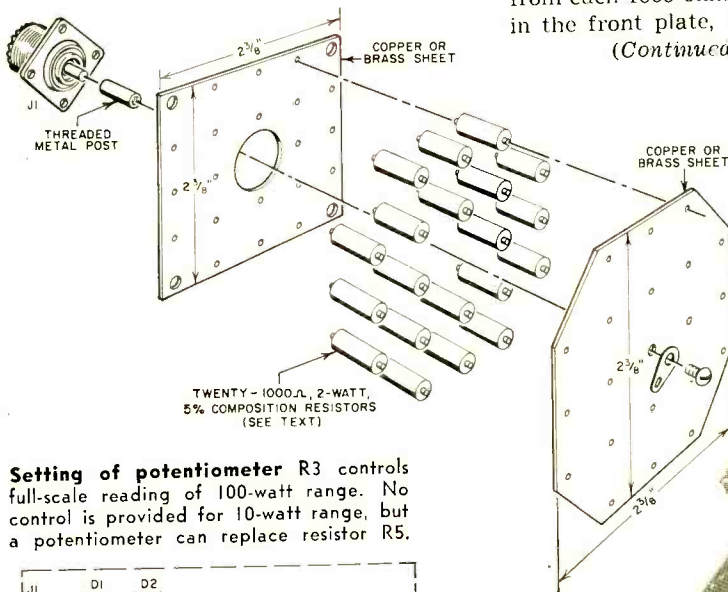

Metal plates for load resistor $R1$ should be clamped together and drilled at the same time to insure proper alignment of holes.

Setting of potentiometer $R3$ controls full-scale reading of 100-watt range. No control is provided for 10-watt range, but a potentiometer can replace resistor $R5$.

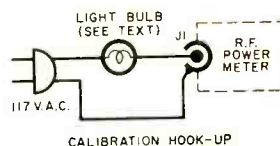
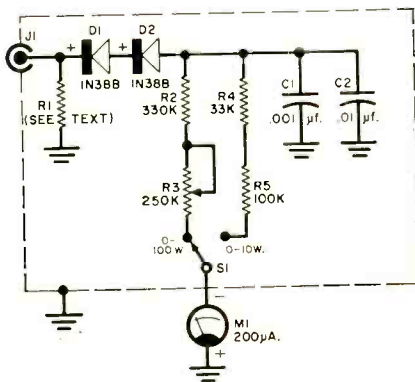

June and July are the peak months for long-distance TV reception.

Here's what you should know to get started in this exciting hobby

DX'ing on TV

By KING SCHAFER

THIS June and July, a scattered group of enthusiasts will be watching television screens all over the country. But they won't be viewing regular video programs. Instead, their entire efforts will be directed towards picking up TV stations that are hundreds, even thousands, of miles away!

Long-distance television reception (TV DX) is an exciting hobby where the unexpected often happens. A DX'er in Ohio, for example, may come across anything from a Cuban beer commercial to a Texas weather report—all while waiting for an "ID" (station identification). The peak months for this unusual activity—June and July—are just beginning, so a good time for any prospective DX'er to get started is now!

Reflecting the Signal. As you probably know, TV signals tend to go out into space unless they are reflected back to earth. Various types of atmospheric "reflectors" exist at different times of the year.

In the early summer, for instance, a section of the ionosphere called the "E-layer" is ionized by the sun. The areas of ionization act as a reflector of sorts to bend the television signals back to earth.

Reception by "E-skip" (DX slang for "E-layer" reflections) is confined chiefly to the low-band v.h.f. channels (2 through 6). The average distance covered is about 1200





200 miles

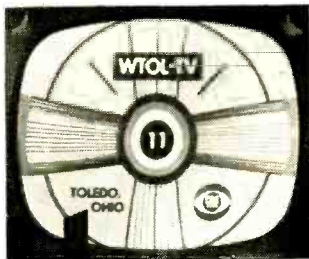

275 miles



700 miles

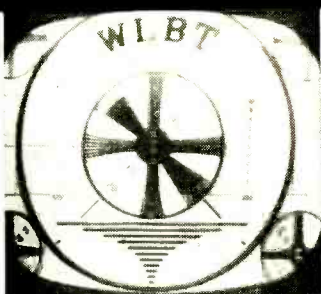

950 miles



1000 miles

miles, but DX'ers have noted stations as far away as 6000 miles and as close as 450 miles via "E-skip." Reception beyond 2000 miles is probably the result of signals bouncing back and forth between the "E-layer" and the earth's surface.

Many outstanding examples of "E-skip" reception are on record, among them the July 1957 logging by Robert Seybold in Dunkirk, N. Y., of KENI-TV in Anchorage, Alaska, and KFAR-TV in Fairbanks, Alaska. The time duration of the "E-skip" sessions is anywhere from five minutes to several hours.

"Trops." As summer and the "E-layer" begin to fade away, the depressing thought may arise that all those beautiful visions of far-away test patterns will likewise disappear. Not at all, for with early autumn

Long-distance pickups above were logged by author near Buffalo, N. Y. Longest DX was from Pensacola, Fla.

comes what DX'ers call the "Trops" season, named after a lower section of the ionosphere called the "troposphere."

As large weather fronts of high- and low-pressure areas move rapidly across the land, ducts or paths are formed which force television signals down to lower levels. This condition is usually first noticed when stations about 70 miles away begin to increase in signal strength. Later, the reception range may extend a good 300 to 600 miles, or even

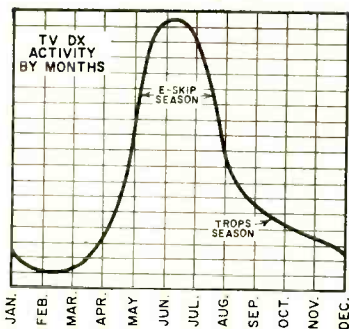

Chart of TV DX activity shows that the months from late Spring to early Fall are the best for TV DX'ing.

1000 miles plus in some areas. As opposed to "E-skip," however, it's the high-band v.h.f. channels (7 through 13) that are affected most by "Trops."

Even channels 14 - 83 on the u.h.f. band produce some amazing results during September and October. Again, the time duration may be several hours, or a scant half hour, with varying degrees of picture quality. A "Trops" record that still stands was set five years ago by DX'er Barney Raunch of Peoria, Ill., when he logged high-band stations from both coasts.

Meteors and Sunspots. With the collapse of the "Trops" season in late October, and the approach of the "lag" period, diligent DX'ers are still not downhearted. Their attentions are merely shifted to a highly elusive form of DX referred to as "MS," the abbreviation for "meteor scatter."

As meteors from outer space enter the earth's dense atmosphere, friction is created which causes them to burn up. Ionization results from this burning action, but it lasts only for a second or two. The ionized

areas reflect television signals back to earth, but only in ratio to the duration of ionization. This "on-off" ionization produces the odd effect of "light-switch" reception, where a picture may "burst" in and then out again at the bat of an eye! During peak meteor activity, however, the overlapping effects of numerous meteor burn-ups greatly extend the length of time a signal can be received.

The low-band channels are the ones to watch for "MS," as high-band receptions are rare. Actually "MS" is only one aspect of the scatter-propagation mode, but DX'ers use it as a general term to cover all burst-type observations. Distances covered by "MS" have ranged all the way from 70 miles to a strapping 3000 miles! DX'er Bill Nieman of Buffalo, N. Y., almost hit the 3000-mile mark when KNXT (Channel 2) in Los Angeles, Calif., flashed on his screen in the spring of 1959.

The most complex and exacting form of TV DX, usually attempted only by experts, is "F2" reception. This refers to the "F2" layer of the ionosphere. Anything observed by "F2" is outstanding because the "F2" layer is activated only intermittently by sunspots. Reception from the "F2" layer is possible from 2000 to 15,000 miles away!

Sad to say, however, there are some difficulties that prevent many U. S. DX'ers from making an "F2" pickup. First, most of the stations from 2000 to 15,000 miles distant are in Europe. Because these stations employ different technical standards than ours, it is necessary to convert receivers to satisfy the differences—a highly involved ordeal. Secondly, with 2000 miles the minimum pickup possible with "F2" reception, the received signal is consequently very weak and exceedingly difficult to tune in.

Receiving Equipment. The average person might think that the equipment needed to pull in far-off TV stations would be based around 200' towers and ultra-expensive receivers. Few DX'ers are equipped in this costly fashion, however.

The most important piece of equipment is the television receiver itself. No matter how extensive your antenna installation may be, a receiver that is not operating at top efficiency will severely limit your chances of making any worthwhile DX. It is of prime importance, therefore, to see to it that your TV set is in the best condition

(Continued on page 102)



Station verifications such as this postcard are sought and collected by TV DX'ers as evidence of their skill.

BLACK BOX Magic



By **KENNETH RICHARDSON**

Complete construction plans for a box that talks back

WHAT makes this black box talk? It's a safe bet that guests at your next party will be stumped. Close inspection makes it obvious that the box is empty. Yet it tells fortunes, brings back voices from the past, and asks questions that reveal rare insight and intelligence.

There's some trickery involved, of course. The black box is actually part of a huge air-core transformer. The transformer's

"primary" is a large coil of wire hidden under the carpet in the room where your guests are seated. Its "secondary" is a coil of wire hidden in the base of the black box itself.

You'll need an accomplice to make it work, but he needn't be a ventriloquist—the black box is entirely electronic in operation. Unknown to your guests, your accomplice is seated in an adjoining room

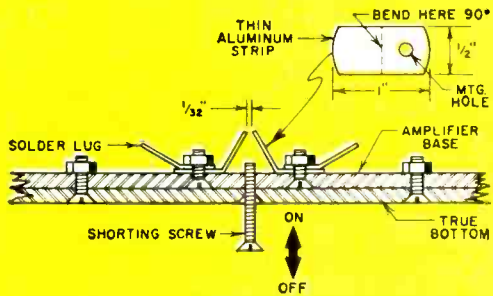
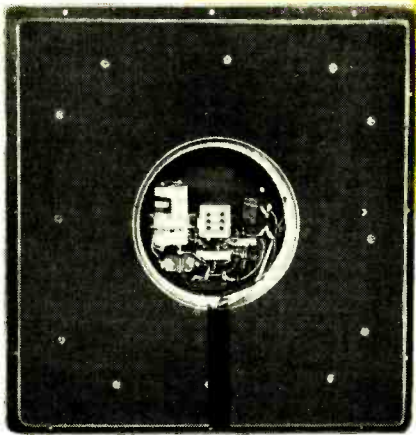
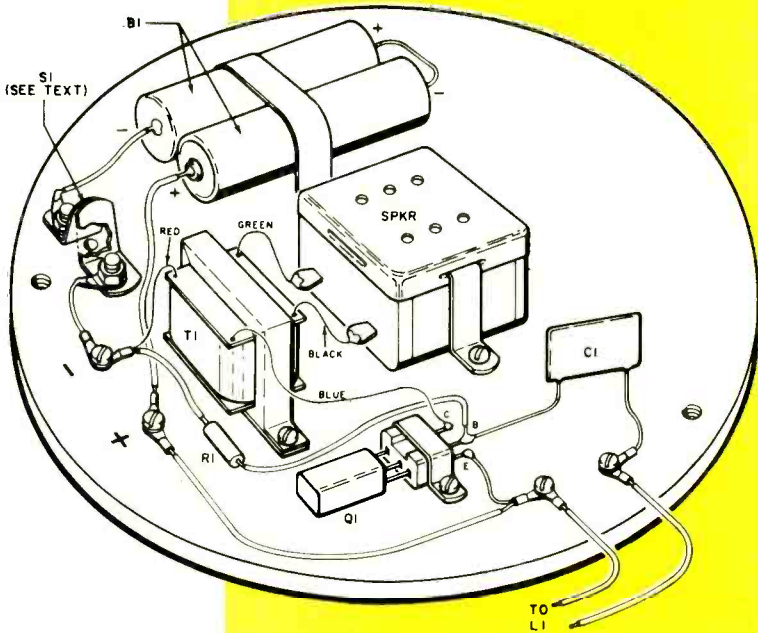

Transistor amplifier for black box is built on disc cut from plastic or Masonite sheet and attached to larger sheet. (See pictorial above and exploded view at right.) "Screw-switch" S1 (detail above) is optional; batteries can be wired permanently into circuit.

with a pair of amplifiers: a "talk" amplifier and a "listen" amplifier. A microphone concealed near your guests brings him their questions through the "listen" amplifier; his answers are returned through a second microphone plugged into the "talk" amplifier. A radio could serve as one of the amplifiers, if convenient.

The concealed "primary" coil of wire is connected to the output of the "talk" am-

plifier. The "secondary" coil in the black box picks up the signal from the "primary" and feeds it to a tiny, one-transistor amplifier and subminiature speaker (also hidden in the box), thus allowing your accomplice's voice to emanate from the apparently empty box.

Construction. Make the black box from 1/2" plywood. It should measure from 12" to 14" on a side, and from 6" to 8" high.

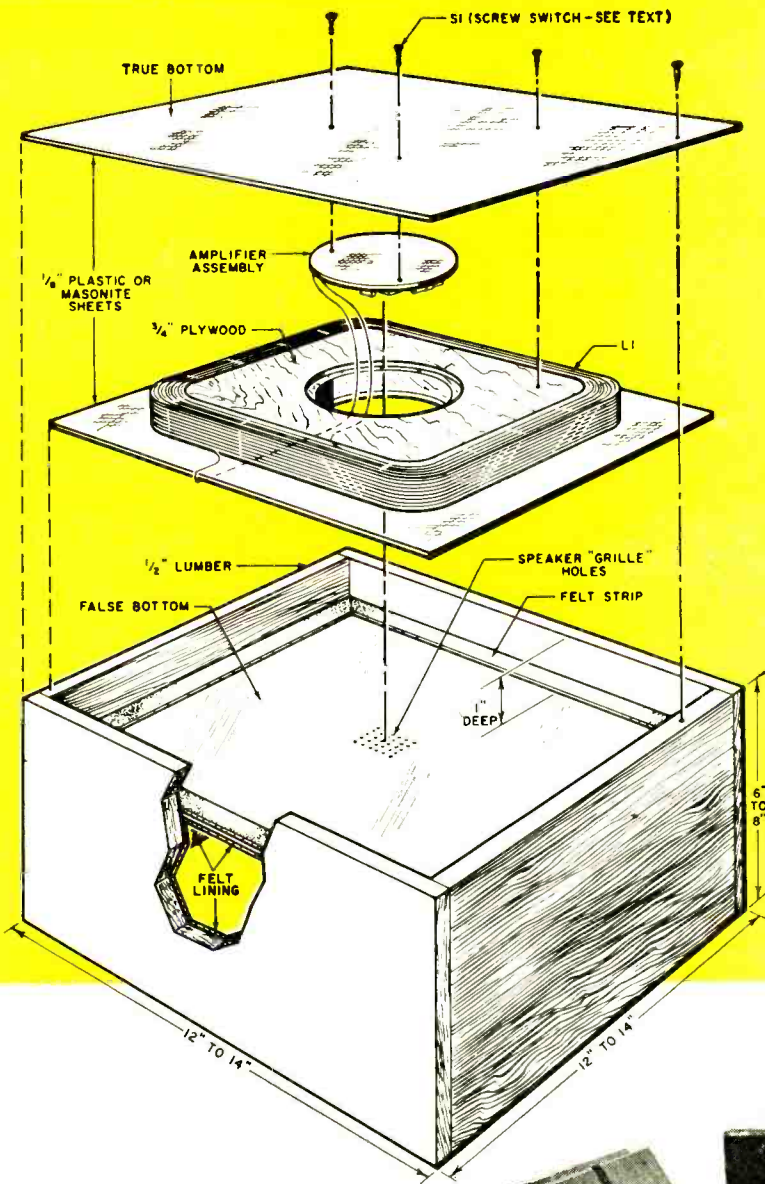

The box is open on one end and sealed with a false bottom about 1" from the opposite end (see exploded view above). Perforate about 1 sq. in. of the false bottom in its exact center—the holes will act as a speaker grille. The entire inside of the box can be lined with felt or other cloth to conceal the grille holes and to give the box an "empty" look.

Inserted in the false-bottom cavity is a

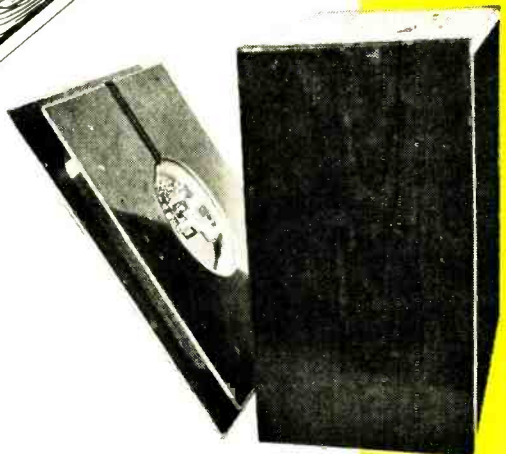

ACCOMPLICE'S HIDEOUT

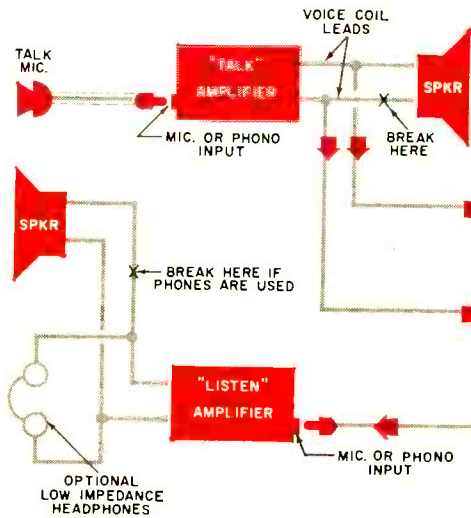

DEMONSTRATION ROOM

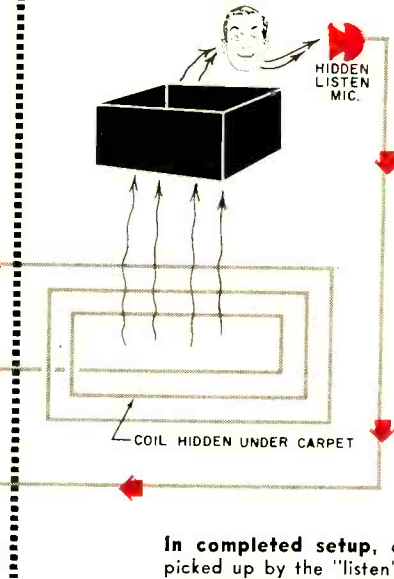

In completed setup, questions are picked up by the "listen" microphone and fed to the accomplice's hideout. The "talk" amplifier sends his answers back to the demonstration room where hidden coils transfer them electrical-ly to the amplifier in the black box.

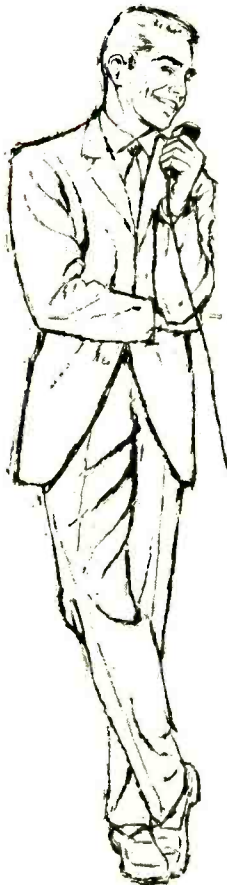

"sandwich" made of two $\frac{1}{8}$ " plastic or Masonite sheets separated by a $11\frac{1}{2}$ " x $11\frac{1}{2}$ " (for a 14" x 14" box) square of $\frac{3}{4}$ " plywood with rounded corners. Cut the inside plastic sheet the same size as the false bottom; the outside sheet is the true bottom and is cut to fit the bottom of the box. Cut a 5"-diameter hole in the center of the inside sheet and in the plywood.

After assembling the plastic and plywood sandwich, wind pickup coil *L1*—about 700 turns of No. 30 to 34 enameled wire—around the inside of the sandwich on the $\frac{3}{4}$ " plywood. To facilitate winding, mount the sandwich in a homemade jig so it can be turned like a wheel as this "secondary" coil is wound.

The one-transistor amplifier and speaker are mounted on the plastic or Masonite disc cut from the inner sheet of the sandwich. Reduce the disc diameter by about $\frac{1}{2}$ " so it will fit in the false-bottom cavity.

A "screw-switch" (*S1*) can be made for the amplifier as shown in the pictorial detail. Simply bend two thin strips of aluminum and mount them about $\frac{1}{4}$ " apart; then bend them until they are $\frac{1}{32}$ " apart. Drill a hole in the disc between the strips and in the corresponding place in the true bottom. Threading a machine screw through this

hole and screwing it flush with the true bottom shorts the strips and closes the switch.

If desired, the switch can be eliminated and battery *B1* wired directly to the amplifier. No-signal current drain is about 2 ma., so the battery will last for some time before replacement is necessary.

Using the Black Box. The "primary" coil to be hidden under the carpet is made up of several turns of No. 20 to 30 wire. Experiment with the coil diameter and the number of turns for best results.

Place the "primary" coil under the edge of the carpet. If your demonstration room has wall-to-wall carpeting, or if the coil proves to be too bulky under the carpet, wind it on the baseboard or ceiling molding instead.

Then disconnect the speaker voice coil from your accomplice's "talk" amplifier and connect the secondary of its output transformer to the "primary" coil. Ordinary lamp cord is ideal for use as interconnecting wire.

Connect the concealed "listen" microphone to the "listen" amplifier, or use a wireless mike if you wish. Your accomplice can listen with headphones or through the loudspeaker of the "listen" amplifier if its level is not too high.

To bring back voices from the past, simply have your accomplice play a suitable phonograph record through the "talk" amplifier at the appropriate time. —30—

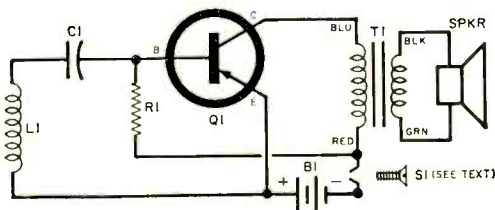
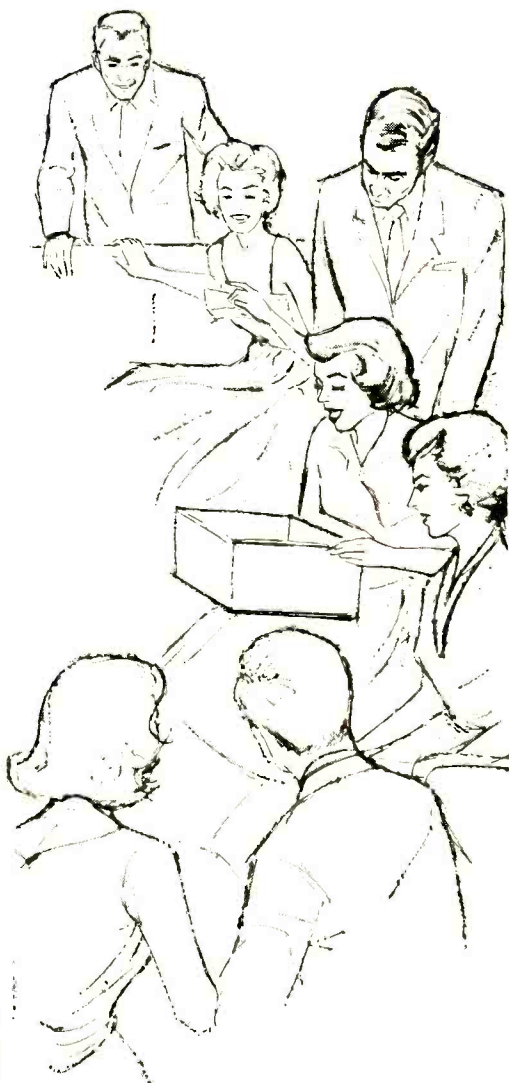

PARTS LIST

- B1*—3-volt battery (two penlight cells in series)
- C1*—0.1- μ t., 50-volt capacitor
- L1*—Pickup coil, 2000 feet of \pm 30 to 34 enameled wire (see text)
- Q1*—CK721 transistor (or equivalent)
- R1*—47,000-ohm, $\frac{1}{2}$ -watt resistor
- S1*—S.p.s.t. "on-off" switch (see text)
- T1*—Miniature output transformer; 2000-ohm primary, 11-ohm secondary (Argonne AR-114 or equivalent)
- Spkr.*—Subminiature loudspeaker (Telex 9155 "Mini-Mike" or equivalent)
- 1*—Length of \pm 20 to 30 covered wire (see text)
- 2*— $\frac{1}{8}$ " plastic or Masonite sheets (see text)
- Misc.*— $\frac{1}{2}$ " and $\frac{3}{4}$ " plywood, felt, hardware, etc.

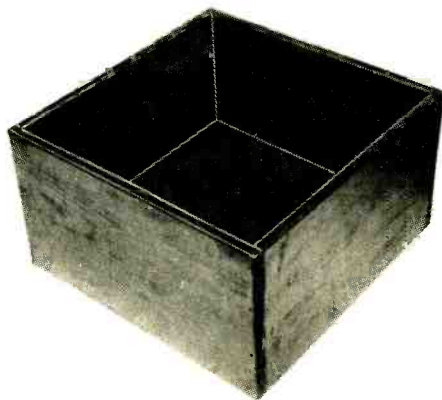

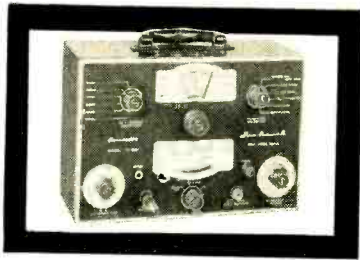

**Test
Instruments**

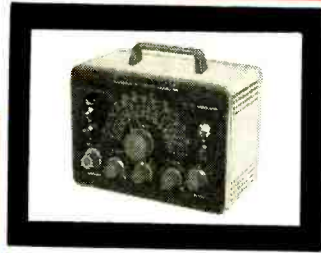

the **Signal Generator**

Part 3 *Trouble-Shooting and Other Uses*

By G. H. HARRISON

TO BECOME better acquainted with the versatile r.f. signal generator, let's put it to work as a trouble-shooter. That five-tube a.c.-d.c. receiver that's been gathering dust in the closet ever since it went on the blink back in 1953 should make a good test subject.

Take the receiver out of its case, plug it in, and turn on the switch. You guessed it: nothing happens! Since the set isn't going to fix itself, let's begin our trouble-shooting by checking first the filaments, then the B+ voltage. (See POPULAR ELECTRONICS, March, 1959, p. 69, for details on this part of the procedure.)

When the set still refuses to produce so much as a squeak even with all the tubes lit and the B+ normal, the time has come to put the signal generator into action. We'll trouble-shoot by working "backwards" through the set, starting with the speaker stage and ending with the antenna.

First, clip the generator's ground lead to the receiver chassis and connect the generator's *A. F. Out* to the grid of the audio output tube (Fig. 1, point *A*). With the receiver volume at maximum, turn the generator's a.f. output control up slowly. If a

400-cps tone can be heard in the speaker, the audio output stage and speaker are working properly.

Next, move the test lead to the grid of the first audio tube (point *B*). If no sound comes from the speaker, the trouble must lie between points *B* and *A*. Either the circuit of *V3* isn't working, or coupling capacitor *C1* is open. To eliminate one suspect, connect the signal generator output to the plate circuit (point *C*). If there is still no sound from the speaker, *C1* must be causing the trouble. Let's replace it with a new one.

Success! When the signal generator is connected to either point *C* or *B*, sound comes out of the speaker. (Note: even with a defective coupling capacitor, a very weak signal will probably be heard with the signal generator connected as above, due to stray capacitances. Under normal conditions, however, the signal from the speaker should be at about the same level regardless of which side of the capacitor is connected to the generator.)

Perhaps the radio will play with the new capacitor in the circuit. Disconnect the signal generator entirely and try to tune in a station. If the speaker remains silent, something else is wrong.

Set the generator to the receiver's intermediate frequency—probably 455 or 456 kc. Turn the signal generator's modulation selector to *Internal* and connect the test lead from the *R.F. Out* terminal to the grid of the i.f. tube (point *D*). Slowly turn up the output level. If nothing happens, the trouble must lie between points *D* and *B*.

Let's narrow down the possibilities. Move the probe to the plate circuit of *V2* (point *E*)—still no sound. Next, touch it to the output of the i.f. transformer (point *F*). Now a signal comes out of the speaker. Obviously, the difficulty is between points *E*

to your hi-fi setup match the rest of the system? Your signal generator—in connection with other test instruments—can tell you.

To measure frequency response, hook up the instruments as shown in Fig. 2. Connect the audio oscillator's output to the *Ext. Mod.* terminals of the signal generator; then connect the output of the generator to the tuner's antenna terminals. Set the audio oscillator frequency to 400 cps and adjust its output to give approximately 30% modulation. (The signal generator instruction book should contain adjustment details.) Set the controls on the signal generator and the tuner to the same frequency—around 1000 kc.—and adjust the output levels to give a moderate indication on the output meter.

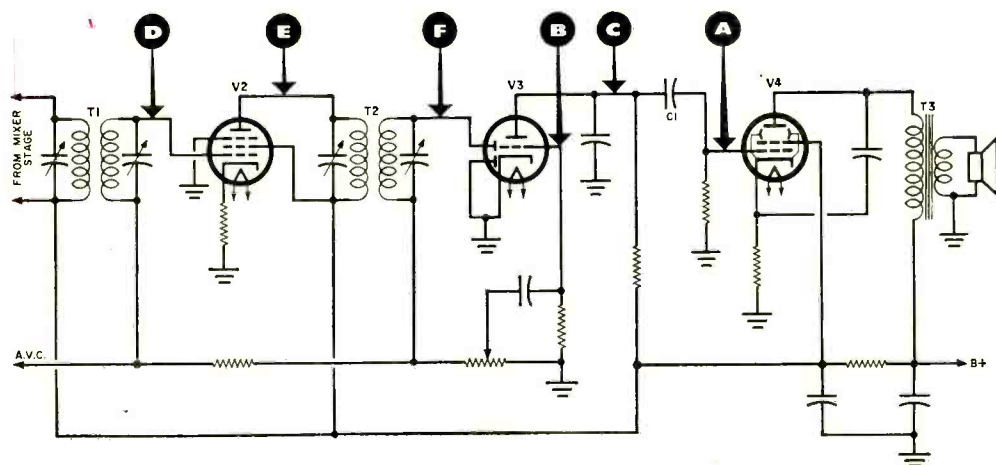

Fig. 1. Trouble-shooting a typical a.c.-d.c. receiver is easy with a signal generator. Injecting generator output at points A through F quickly isolates faulty components.

and *F*, which means that i.f. transformer *T2* is probably at fault. A quick ohmmeter check will show if its secondary is open. Let's assume that it is.

When the transformer has been replaced, the receiver will have low sensitivity because the new transformer isn't aligned properly. Align it (see May 1960 issue, p. 83). Assuming there's nothing else wrong, the receiver should now operate perfectly. Here's one set that will be doing more than gather dust for a while!

Frequency Response. The signal generator can do more than help put an ailing receiver on the road to recovery. It can also show how efficiently a receiver or tuner is operating. For example, how does the performance of that AM tuner you just added

Jot down the output meter reading at 400 cps. Now tune the oscillator to 300 cps. (Note: Measure the output of the oscillator at point *A* in Fig. 2, and adjust if necessary.) Write down the 300-cps reading. Adjust to 200, 150, 100, 90, 80, 70, 60, 50, 40, 30, and 20 cps, and note each reading.

Now tune back to 400 cps, and start in the other direction. Following the same procedure, take output readings at 500, 600, 700, 800, 900, 1000, 1500, 2000, 3000, 4000, 5000, 6000, 7000, 8000, 9000, 10,000, 15,000 and 20,000 cps. Plot the values recorded on graph paper and you will have the tuner's frequency-response curve (see Fig. 3).

Checking Sensitivity. The instruction book that came with your hi-fi tuner or ham receiver probably gives sensitivity

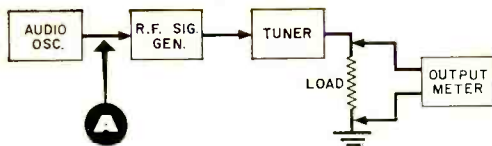

Fig. 2. Setup for measuring tuner's frequency response; "A" is point at which output level of audio oscillator is checked.

specifications. It's a good idea to check them occasionally to insure that the overall operation of the receiver is up to par.

You'll need a signal generator with an accurate indicator to measure the output level. Connect it as in Fig. 4(A). When you work with the broadcast-band frequencies, a simple dummy antenna such as that in Fig. 4(B) can be used; Fig. 4(C) is the recommended Institute of Radio Engineers dummy antenna for multi-band receivers. A

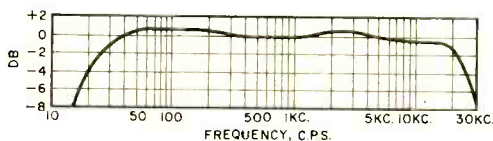

Fig. 3. Frequency response curve of typical tuner. Voltage readings can be converted into decibels and plotted as shown.

dummy antenna *must* be used in making sensitivity measurements to insure accurate input voltage levels.

When you are checking the sensitivity of a tuner, the output meter should be connected across a dummy output load resistor. If you are measuring the sensitivity of a complete receiver, connect the meter across the speaker voice coil or a load resistor substituted for the voice coil.

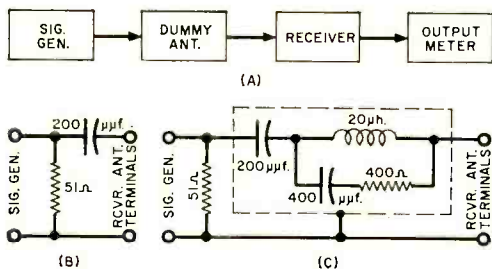

Fig. 4. Hookup for measuring sensitivity (A), simple dummy antenna (B), and dummy antenna recommended by I.R.E. (C).

Now set the signal generator and the receiver carefully to the same frequency. Open the receiver's volume control to its loudest position. Adjust the signal generator's output level until the meter reads the output voltage specified in the instruction manual; then note the output level of the signal generator. The amount of signal required to give a predetermined output is the sensitivity of the tuner expressed in microvolts. A typical tuner may require 100 μv . to produce a specified output—such as 1.0 volt. More sensitive tuners might require only 4 or 5 μv . or even less.

Complete receivers are rated as requiring so many μv . to produce a certain output power. If you do not have a meter which reads output power, you can use the formula $E = \sqrt{PR}$ to figure out what voltage reading on the output meter will give the desired power. For example, if your load is a 16-ohm voice coil or load resistor and the receiver's instruction manual specifies that sensitivity should be measured with 1.0 watt of output power, the formula would work out as follows: $E = \sqrt{1 \times 16} = \sqrt{16} = 4$ volts.

Measuring Selectivity. As many receivers and some hi-fi tuners have variable selectivity, the receiver instruction book may give selectivity ratings in such terms as "bandwidth at 10 times down is 18 kc." To understand what this means, consider a typical tuner that produces a one-volt output when 5 μv . are applied to its input at a frequency of 1000 kc. But when the signal generator is tuned 9 kc. to either side of 100 kc., the output drops to 0.1 volt. In other words, with the receiver remaining tuned to 1000 kc., the output at 1009 and 991 kc. (a spread of 18 kc.) is one-tenth as much as it was at 1000 kc., or "10 times down at 18 kc." (see Fig. 5).

To measure selectivity, use the setup shown in Fig. 4(A). Tune the signal generator and receiver very carefully to a frequency about mid-band (1000 kc. or so on the broadcast band). With the signal generator's attenuator set at "X1," adjust the fine control and receiver gain to some convenient reading—say 1.0 volt—on the output meter. Be sure the signal generator output is as low as possible to avoid overloading the receiver.

Turn the attenuator to "X10" and slowly raise the frequency of the signal generator until the output meter again reads

(Continued on page 98)

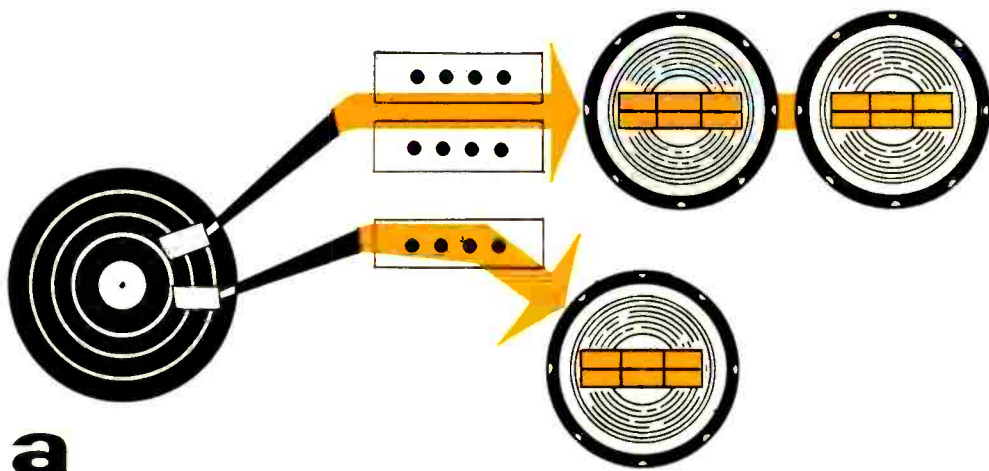

a

COMPATIBLE STEREO RECORD

ONE of the most hotly debated subjects among record manufacturers today is a new type of stereo record which its proponents claim is completely compatible. That is, it can be played on either stereophonic or standard monophonic equipment without fear of undue damage to the record grooves.

Design Records, a small company in comparison to the giants in the field, is the force behind this new system. The Design people feel that disappointing record sales are largely traceable to the public's confusion about being offered two different types of records—mono and stereo. If a single compatible record could serve both markets, they maintain, such confusion would be eliminated.

The question of compatibility, it must be remembered, was one reason why the Westrex 45-45 stereo cutting system was adopted in the first place. It featured a V-shaped groove containing a sound channel on each wall. As a needle bumped up and down and from side to side, it picked up

Here is a special report on a new type of record that can be played on either stereo or mono equipment **By ROBERT ANGUS**

parts of each signal—in the lateral plane, the sum of the two channels, and in the vertical, their difference. When a record was played on monophonic equipment, it was argued, the cartridge would pick up only the lateral or sum signal.

Most early stereo disc manufacturers played up the compatibility feature in their advertising, saying that the records would play equally well on monophonic or stereo equipment. Gradually it developed that stereo cartridges would track more satisfactorily if the stylus tip were smaller than the 1-mil tip used for monophonic records. It also became evident that mono cartridges had a tendency to plow right through the groove's vertical modulation, destroying the stereo effect after repeated playings. Soon the experts warned that the compatibility of stereo only went one way—that stereo equipment could be used to play mono

Comparing the grooves of a standard Westrex stereo record with grooves of Design's compatible record (opposite page) shows the compatible record to have less vertical modulation, thereby more closely approximating a monophonic cut.

records. If, on the other hand, you played your stereo records on mono equipment, you were taking their lives in your hands.

Cutting Techniques. The secret of the new compatible record is that there is some "tampering" with the stereo signals before they're fed into the cutter. Instead of producing a sum and difference on the record by cutting the two sound channels at an angle, the new process does the adding and subtracting at a point before the signals reach the cutter. This results in a vertical-lateral cut, with the sum signal engraved laterally and the difference signal contained in the vertical modulation. In playback, a standard stereo cartridge adds and subtracts the vertical-lateral information and recreates the two stereo channels.

In addition to manipulating the two channels before they reach the cutter, the system also reduces the bass response in the vertical component—the "difference" channel—so the dips and rises in the groove will be less sharp.

According to Sidney Feldman of Master-tone Recording Studios, one of the men who has experimented with the new process, the effects of attenuating the bass are less noticeable if you work with sum and difference channels than if you tamper with the left and right channels separately. The result is a record without steep hills and deep valleys, in which the needle rides along in relative serenity.

Engineers such as Feldman and John Mosely, who was formerly head engineer at Audio Fidelity Records, explain that it's the vertical modulation that tends to make the regular stereo record non-compatible. Mono cartridges tend to level the hills and valleys, wiping out the "difference" channel. By reducing their amplitude, the engineers reasoned, it should also be possible to reduce vertical wear, and, incidentally, make the records easier to stamp out on pressing machines.

To evaluate the process, the following

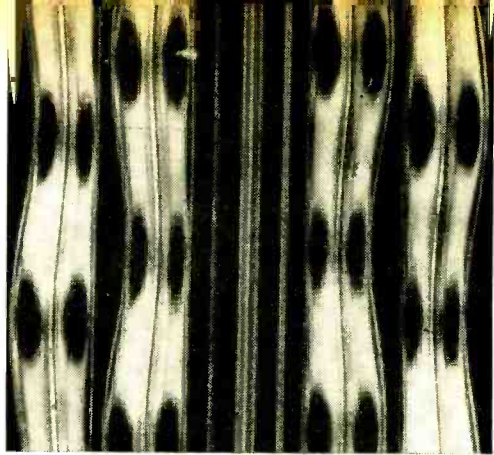

Design compatible discs were tested: "Porgy and Bess," "Ray Eberle Sings," "Flower Drum Song," and "Ray Bohr at the Radio City Music Hall Organ." In addition, Design supplied mono and conventional 45-45 stereo copies of "Flower Drum Song" for comparison purposes. Equipment used in evaluating the records consisted of a Glaser-Steers GS-77 record changer, a Fairchild SM-1 stereo cartridge (tracking at 3.5 grams) and a General Electric VR-II mono cartridge (tracking at six grams). All listening tests were made with Koss earphones to minimize external distractions.

Test Results. In subjective listening tests, it was discovered that "Flower Drum Song" in Design's compatible version was virtually indistinguishable from the company's regular stereo version. Design's stereo, however, has some peculiarities which most other manufacturers have avoided. On neither the conventional stereo disc nor on the compatible record was there enough bass to tell what sort of low-frequency reproduction the new disc was capable of. Both records featured extreme separation, with a vocalist relegated entirely to one speaker, and the bulk of the orchestra to the other.

When the compatible stereo disc was played monophonically, the reproduction was, if anything, superior to the mono pressing. Both soloist and orchestra emerged more clearly, and there was no audible distortion (except for the weak bass, which appeared on both records).

The next question concerned wear. The GS-77 changer was set up so it would go through its changing cycle every 3½ minutes. Then, the entire last track of a Design compatible stereo record was played over and over again for an eight-hour period with the VR-II mono cartridge. At the

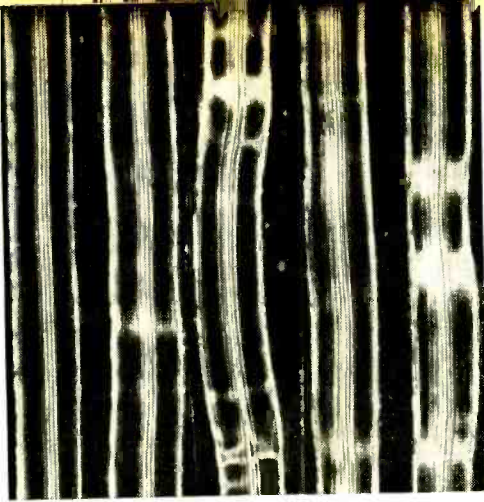

end of that time (approximately 140 plays later), the record was played with the Fairchild stereo cartridge. There were visible and audible signs of wear on the record, but there was no audible loss of the stereo effect.

As a check, the mono version of the same record was put through a similar wear test using the VR-II. Again, the changer went through approximately 140 plays. Although the mono disc showed visible signs of deterioration, it seemed to stand up better under this sort of punishment than did the compatible stereo disc.

Surprisingly enough, conventional 45-45 stereo records don't come off too badly in this sort of testing. A section of a regular stereo record was played over and over with the VR-II mono cartridge, and after every ten plays the record was played stereophonically. After 20 mono plays, there was no audible loss of stereo quality. By 30 plays, however, some highs were lost and distortion was noticeable. After 40 plays, distortion increased markedly and the stereo effect also began to disappear.

Summing up, it was found that surface noise increases markedly at a point somewhere around 30 plays when a non-compatible stereo disc is played with a mono cartridge. The same amount of surface noise from a mono or a compatible stereo record played with a mono cartridge occurs at about 50 plays. Channel separation tends to be wiped out much earlier in the 45-45 stereo disc, again starting at a point somewhere between 20 and 30 plays. In the case of the compatible disc, channel separation was not lost after 140 monophonic plays. High frequencies—those upwards of 10,000 cycles—tended to disappear somewhere below 20 plays for the conventional stereo record and somewhere under 60

plays with a compatible or a mono record. After 140 plays, both the compatible stereo and the mono discs still reproduced the range from 100 cycles to about 9000 cycles fairly clean.

Evaluation. Does the compatible record work? The answer is yes—at least in the case of these records. Is there a sacrifice in quality? Again, with these records, there is none. Both 45-45 stereo records and compatible stereo versions were checked against master tapes, a test which revealed no more loss of quality than does any disc-to-master-tape comparison. What the test did demonstrate was the superiority of tape over disc.

The bass on compatible discs apparently loses its directionality. When asked about this, Don Plunkett, the president of Fairchild Recording Equipment Company, said, "There is serious doubt today regarding the contribution of the lowest frequencies—particularly frequencies below 200 cps—to the spatial feeling so important for stereo reproduction. The reduced separation (at the lower frequencies), caused by reducing the vertical component, permits a higher *lateral* bass level for the same groove space. Thus, when the record is played back with both a stereo cartridge and a mono cartridge, it will produce bass response superior to that possible if full separation had been maintained down to the lowest frequencies."

Objections to the new process have been both loud and heated. One of the leading critics has been Sidney Frey, whose Audio Fidelity label produced the first commercial stereo record. "The customer pays hard-earned bucks for that bass," says Frey. "To deprive him of it would be a crime." In answer, the Design people state that compromises are constantly made in record-making, and that the new record is no more of a compromise than is the RIAA recording curve. Even if, theoretically, there is a slight loss of bass in the compatible method, the supporters of the process say, the record is still quite acceptable psychologically.

Design's compatible stereo records are now on the market. At this writing, however, no other company has indicated that it plans to use the compatible process. It seems logical to assume that if the new technique is practicable, the other manufacturers in the field will gradually switch over to compatible records. If the system is truly an advance, the consumer will reap the benefits.



LOW COST Transistor Tester

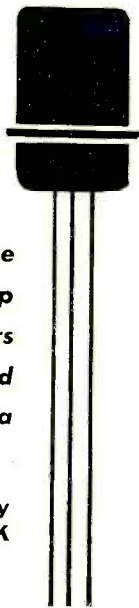

**Direct-reading device
checks both p-n-p
and n-p-n transistors
for leakage and
comparative beta**

**By
MARTIN H. PATRICK**

TRANSISTOR leakage and comparative *beta* can be checked in one operation with this direct-reading *beta* comparator. "Creepers" and "leakers" show up quickly, and the problem of matching transistors in push-pull circuits becomes extremely simple. Leakage current can be read immediately by plugging either an *n-p-n* or *p-n-p* low-power transistor into the proper socket. Pressing a button shows the *beta* value on the meter.

This little device makes use of the fact that many manufacturers recommend transistor emitter-to-collector leakage be no more than 0.125 ma. Most transistors with no more than this amount of static leakage will draw about 10 μ a., emitter-to-base,

when supplied by a 1½-volt source through a 127,000-ohm resistance. With this unit, it's a simple matter to read the comparative *beta* directly from a milliammeter scale.

Construction. The tester is housed in an ordinary metal filing box, 4" x 3" x 5", with all parts except *R5* mounted on a wooden baseboard which fits snugly into the top of the box (see pictorial). Attach the meter, face up, to the left side of the baseboard; then mount the sockets on the right.

Resistor pairs *R1-R3* and *R2-R4* should be selected so that their values are identical; the parts list recommends $\pm 5\%$ tolerances, but $\pm 1\%$ resistors would be even better. Mount the dry cells on the bottom of the baseboard, or, if space doesn't permit, fasten them to the bottom of the filing box; if you prefer not to solder directly to the batteries, obtain a two-cell battery holder.

Make the special shorting plug by soldering a small piece of metal to a "U"-shaped length of wire. Two small holes can be drilled in the base to hold the shorting plug when it's not in use, or a third transistor socket can be used as a holder. It's best to wire the sockets before fastening them to the baseboard; note that the collector of one socket is connected to the emitter of the other. Although you can manage without it, spaghetti on the base leads of both tran-

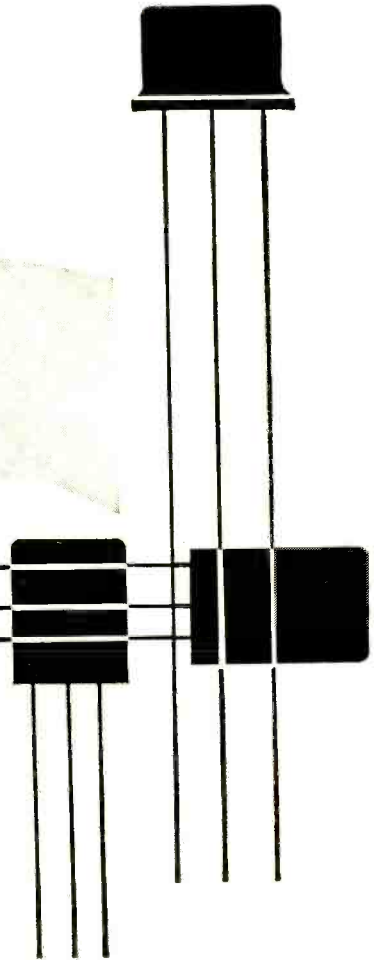
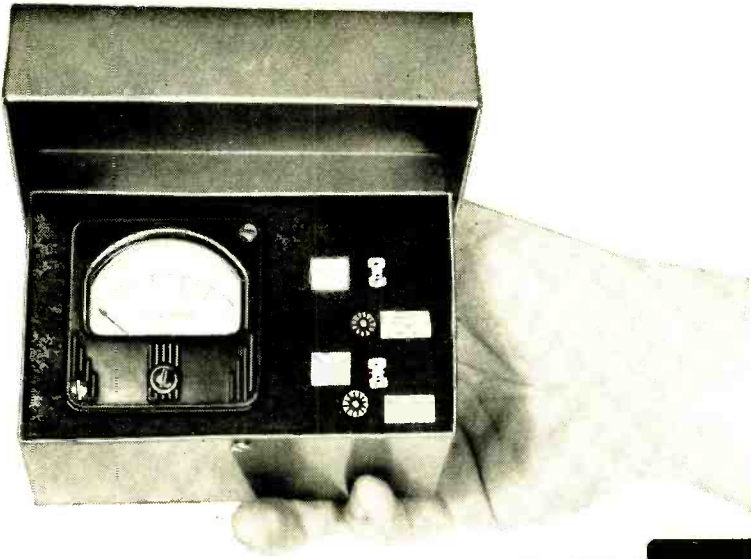

Special switches used in model for S1 and S2 were made from the contact points of an old relay, but standard miniature push-button switches can be used instead.

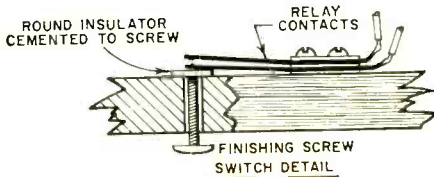
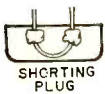
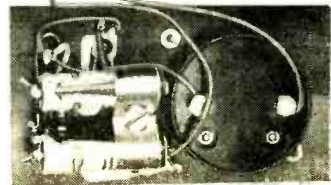
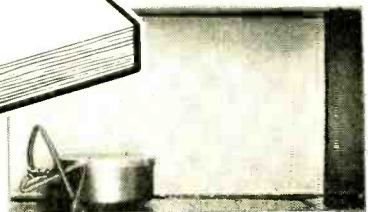
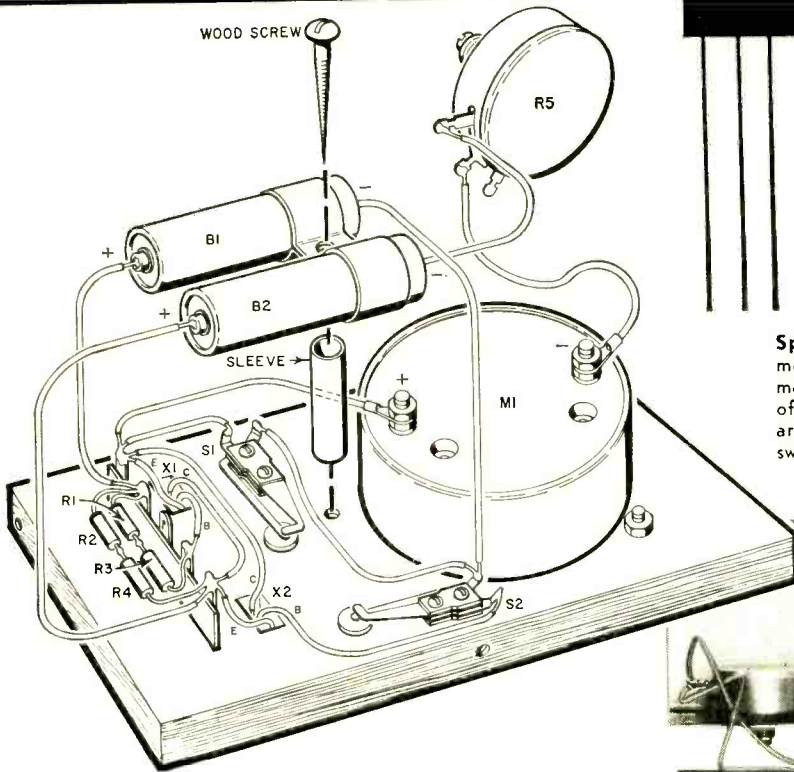

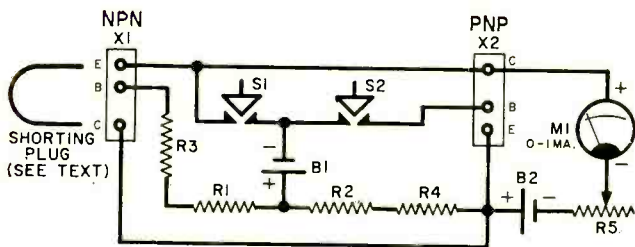

PARTS LIST

- R1, R2—100,000-ohm, 1/2-watt carbon resistor, $\pm 5\%$
- R3, R4—27,000-ohm, 1/2-watt carbon resistor, $\pm 5\%$
- R5—5000-ohm wire-wound potentiometer (Mallory M5MPK or equivalent)
- S1, S2—Miniature push-button switch (Lafayette MS-449 or equivalent)
- B1, B2—1 1/2-volt penlight cell (Burgess Type "Z" or equivalent)
- M1—0-1 ma. milliammeter
- 1—"U"-shaped wire clip (see text)
- 1—4" x 3" x 5" metal filing box
- 1—3" x 5" x 1/2" wooden baseboard (see text)
- Misc.—Five-terminal mounting strip, transistor sockets, wire, screws, etc.

Resistor pairs R1-R3 and R2-R4 must be of equal value; use an ohmmeter to check values. Homemade shunting plug is used for adjusting meter to full-scale reading.

Transistor pin connections vary somewhat with the manufacturer. A colored line or dot rather than additional spacing is sometimes a means of denoting the collector.

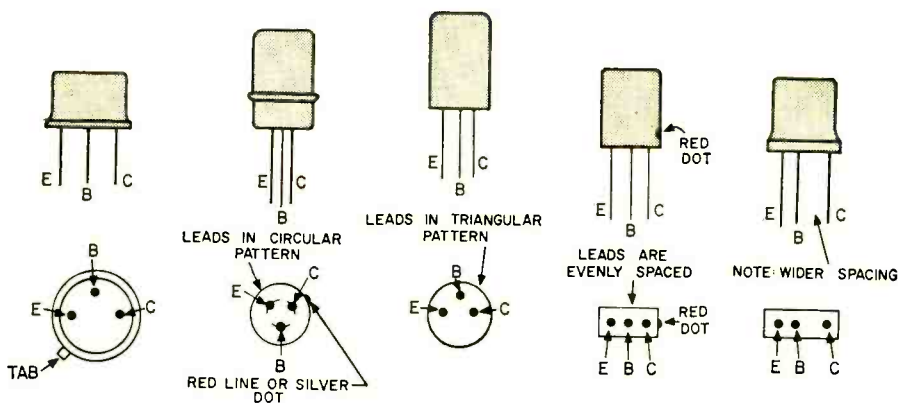

sistor sockets is the surest way of preventing accidental shorts when plugging in and unplugging transistors.

Using the Tester. Adjust the meter to read full scale before using the comparator. To do this, insert the "U"-shaped shunting plug across the emitter and collector terminals on either socket, and adjust R5. Once the meter is set, it need be checked only periodically.

Simply insert the transistor under test into the *n-p-n* or *p-n-p* socket, depending on the type of transistor. The meter will indicate the leakage. If it is above 0.125 ma., in all probability it exceeds that recommended by the manufacturer. If you're not certain, check the manufacturer's specification sheets or a transistor manual.

If the transistor has low leakage, press

the appropriate push-button switch and note the meter reading. Mentally move the decimal point two places to the right to determine the comparative *beta*. For example, a milliammeter reading of 0.34 is equal to a *beta* of 34, a reading of 0.23 is equal to a *beta* of 23, and so on.

To arrive at a more accurate comparative *beta* reading, subtract the leakage from the final reading. For example, if the leakage is 0.10 and the final reading is 0.45, subtracting the leakage from the final reading and moving the decimal point two places to the right gives a comparative *beta* of 35.

Transistors showing creeping or drift should be questioned, since a good transistor will give the same reading consistently no matter how often the switch is opened or closed.



Across the Ham Bands

By
HERB S. BRIER
W9EGQ

HOW TO PREVENT TROUBLE WITH THE FCC

ONE of ham radio's proudest traditions is its ability to police itself. If one ham violates an amateur regulation, intentionally or not, other hams immediately call the violation to his attention, and the matter is ordinarily settled without official action by the FCC. A perfect example of how this system works occurred only recently.

A Novice friend of mine got up early one Sunday to make a few contacts on 80 meters. He called CQ and raised Rex, W8PCY, Grandville, Mich. Rex gave him an RST599 report.

"You have a very fine signal," said Rex. "The only trouble is that I am listening to you on 7440 kc., the second harmonic of 3720 kc., the frequency you think you are on. You better close down and find out what the trouble is before you get a discrepancy report from the FCC."

Of course, my friend immediately left the air. Later in the day, with the aid of an-

other ham, he discovered that his transmitter was actually tuned to the second harmonic of his crystal frequency. This is easily done with the multi-band output tank circuits incorporated in most low-power ham transmitters, especially when they feed a makeshift antenna.

When Rex's QSL card arrived, it was accompanied by a letter. In it Rex said that he often worked 80-meter Novices with his receiver tuned to their second harmonics and his transmitter on 80 meters. He keeps them out of trouble with the FCC.

Monitoring Harmonics. If other experienced hams would follow W8PCY's example, it would go a long way towards solv-

Ham of the Month

Dr. Henry L. Richter, Jr., W6VZA, is an outstanding ham, scientist, and private citizen. Born in 1927, he obtained his first ham license when he was 16. After service in the Navy, he entered California Technical Institute, earning a B.S. degree in Chemistry in 1952 and a Ph.D. in Chemistry in 1955. He was married in 1947, and he and his wife, Marilyn, have five children.

Dr. Richter joined the Cal Tech Jet Propulsion Laboratories in 1955 and is now chief of its Space Instruments Section. He was active in the development and launching of the "Explorer" series of earth satellites and was instrumental in selecting sites for U. S. space-probe tracking stations abroad. In addition, he was coordinator for U. S. radio participation in the International Geophysical Year satellite tracking program, and a member of the American delegation to the IGY steering committee meeting held in Moscow in 1958.

W6VZA has a six-meter station in his car and a two-meter station in his home. A Johnson "Ranger" transmitter and a rebuilt BC-348 receiver take care of the lower frequencies. He is active in civilian defense work and the San Gabriel Valley Radio Club, a member of both the A.R.R.L. and I.R.E., and an honorary Deputy Sheriff of Los Angeles County.



ing a most difficult Novice problem. The only equipment you need for this kind of monitoring is your transmitter and a receiver capable of tuning the harmonic "shadows" of the 80- and 40-meter ham bands.

Actually, it is frequently easier to hear the harmonics than the fundamental signals. This is due to the longer "skip" and lower interference on the harmonic frequencies. For example, I often hear strong harmonics of east-coast 40-meter hams be-



majority of hams, who take pride in emitting clean, sharp signals.

Did you ever stop to think that you may be partly responsible for keeping such signals on the air? How? By following the common practice of giving better reports than their signals deserve to the stations you work.

When was the last time you gave anyone less than T9 on c.w.? Didn't you give a T8 report to that DX station with a signal like a rhinoceros with the colic, for fear he wouldn't send you a QSL card if you gave him an honest tone report? His own mother wouldn't have given him better than T2. And do you add "C" for chirp or "K" for clicks after your RST reports when warranted? On phone, do you give reports like, "Your signals are 30 db over nine," and ig-

Two young Novices. Richard Foster, KN9SBV, of Oxford, Ind. (left), and Dudley Cahn, KN8QEX, Kalamazoo, Mich. (below), both use Heath transmitters. Richard keys a DX-20, and Dudley a DX-40.

tween 14,350 and 14,600 kc. when it is difficult to copy their fundamental signals because of the heavy interference from closer stations.

As soon as you tell the average Novice that he is radiating a harmonic, he will install an antenna coupler such as that described on page 133 of December, 1959, POPULAR ELECTRONICS, and a harmonic filter as described on page 93 last month. And don't be too smug about Novice harmonics. A little listening between 7500 and 8000 kc. (the harmonic "shadow" of the 80-meter band) will quickly convince you that General Class hams have their harmonic problems too.

Honest Reports. Less serious than out-of-band radiation, but more annoying to other hams, are the substandard signals put out by a small percentage of all operators. On c.w., such signals are rough and unsteady, chirpy and full of clicks. On phone, they spatter and they drift. They have hum and frequency modulation. Phone or c.w., they occupy more than their fair share of our crowded bands. Consequently, they cause unnecessary interference to the



more excessive broadness, hum, distortion, or other signal defects?

How can you blame a ham with a poor signal for believing that his signal is perfectly okay when the great majority of his reports confirm it? Do you believe the reports you receive? Admittedly, you may feel a little mean when you give an unflattering report to a ham whose signal leaves something to be desired, but what is the value of a dishonest report?

Role of the FCC. Don't get the idea that I recommend cruising up and down the ham bands like a policeman on a motorcycle looking for things to complain about in other hams' signals. Leave that to the ARRL "Official Observers" and to the FCC

(Continued on page 108)

LET'S BUILD the "TINY MITE"

By FORREST H. FRANTZ, Sr.

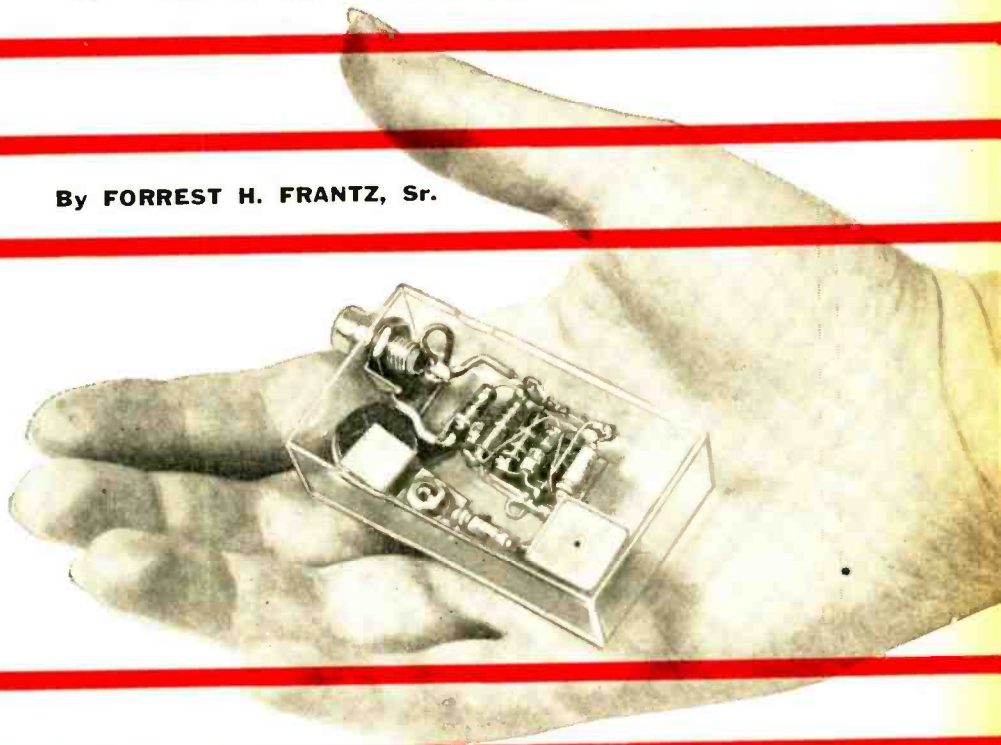

Footsteps on a carpet come through loud and clear

with a peewee amplifier no bigger than a postage stamp

WANT an amplifier that's smaller than a postage stamp? Here are construction details for the "Tiny Mite," one of the tiniest three-transistor amplifiers you'll be able to build for some time to come. The reason? Parts are getting smaller all the time, but those available to experimenters at reasonable prices won't get much smaller than the parts in this amplifier.

The "Tiny Mite" is so compact that it has considerable novelty value. For one thing, you can use it to show your friends just

what miniaturization in electronic components really means. You'll also find it handy for surveillance and "eavesdropping" purposes, since it's easy to conceal. An ear-phone extension cord is all you'll need to listen to conversations at remote locations.

All in all, the "fun" possibilities of this unusually small amplifier are extremely large! Time and money expenditures are pretty much in line with the size of the unit—you can wire the entire amplifier in less than two hours, using parts that should

cost you less than \$10. For operation, you'll need a microphone and an earphone, but these are components you may already have on hand.

Construction. One of the secrets of the amplifier's size is the construction technique employed. Parts are cemented to a thin plastic strip, then connected to one another by their pigtail leads.

Mount and wire all components as shown in the pictorial diagram, leaving room for

have to be unsoldered later when the amplifier is installed in its box. Use clip leads to connect a 50,000-ohm potentiometer into the circuit as R_4 . Adjust the potentiometer for best tone with reasonable volume, then disconnect it and measure its resistance on an ohmmeter. Cement and connect the nearest value fixed carbon resistor into the circuit as R_4 .

If you want to include a volume control, the Lafayette VC-43 or another 10,000-ohm

PARTS LIST

$B1$ —1½-volt battery (RCA VS074 penlight cell, Mallory RM-625RT hearing-aid cell, or equivalent)

$C1, C2$ —1.0- μ t., 6-volt ultraminiature electrolytic capacitor (Lafayette P6-1 or equivalent)

$J1$ —Earphone jack
 $Q1, Q2, Q3$ —2N207 transistor (Philco)

$R1$ —5600-ohm resistor

$R2$ —3300-ohm resistor

$R3$ —2700-ohm resistor

$R4$ —10,000- to 50,000-ohm selected resistor (see text)

$R5$ —10,000-ohm potentiometer with switch $S1$ (Lafayette VC-43 or equivalent—see text)

$S1$ —S.p.s.t. switch (on $R5$)

Mic.—½" x ½" miniature magnetic microphone (Shure MC-30 or equivalent)

1—Magnetic earphone, 1000-2000 ohms impedance (Lafayette MS 368, or equivalent)

1—Plastic box (see text)

* A low-noise type 2N207B can be substituted for $Q1$ if desired

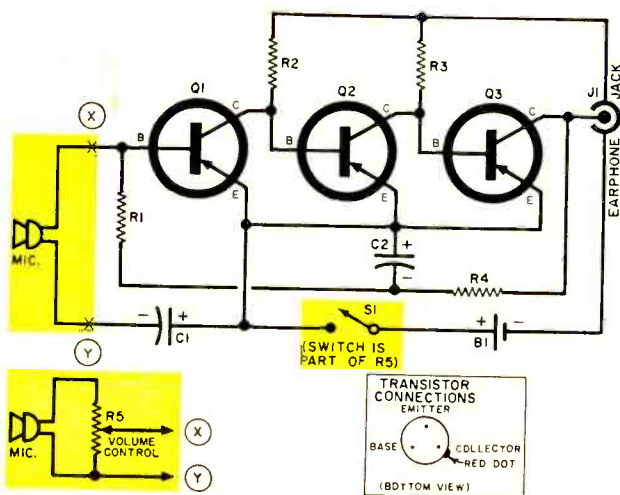

"Tiny Mite" utilizes three transistors in a direct-coupled circuit. Battery can connect directly to $Q1$'s emitter if switch is not used.

resistor R_4 so that it can be mounted later. Keep all leads as short as possible. Be sure to use a heat sink when soldering transistor leads; gripping each lead with a pair of long-nose pliers will prevent soldering-iron heat from damaging the transistor. You'll need a tiny soldering iron for this tiny unit—a soldering pencil is ideal if you happen to have one handy.

The value of R_4 should be determined experimentally; it will probably fall between 10,000 and 50,000 ohms. To find the best value, connect the microphone, capacitor $C1$, earphone and battery $B1$ to the amplifier as shown in the pictorial. A temporary soldering job will do, since these parts will

potentiometer can be used. The compact VC-43 incorporates a switch that will serve to control battery power; refer to the schematic diagram for circuit details.

The amplifier circuit is now ready for mounting in a small box. In the model, a Walsco plastic hardware box was used—such boxes, full of hardware, are available from local parts distributors for about 33 cents each.

Drill a hole in the box to mount the earphone plug. Mount the amplifier circuit, earphone plug, battery, microphone, and capacitor $C1$ in the box, using cement to hold loose parts in place. Wire all parts together and solder. Now slide the box cover

in place and scratch an outline of the microphone on the cover. Remove the cover, cut out the scratched section, then slide the cover back in place.

Operation. Plugging in the earphone connects the power supply and energizes the circuit. Current drain on this miniature unit is extremely low: the model draws less than 2.0 ma. Either a 1.5-volt penlight cell or a miniature hearing-aid cell such as the Mallory RM-625RT will power the amplifier

HOW IT WORKS

Three 2N207 transistors are employed in an amplifier circuit that is direct-coupled to eliminate capacitors and/or transformers between transistors. Direct coupling permits use of lower operating voltages, with a resulting reduction in the input-stage noise figure.

Resistors *R1* and *R4* furnish base bias for transistor *Q1*. Resistor *R4* is connected to the collector of output transistor *Q3* to provide d.c. feedback to *Q1* and thus insure good temperature stability for all three transistors. Resistor *R2* serves as collector load for *Q1* and base bias resistor for *Q2*; *R3* performs the same functions for *Q2* and *Q3*. Capacitor *C1* isolates the d.c. base bias for *Q1* from the microphone circuit; *C2* bypasses audio that would otherwise be fed from *Q3* to *Q1*.

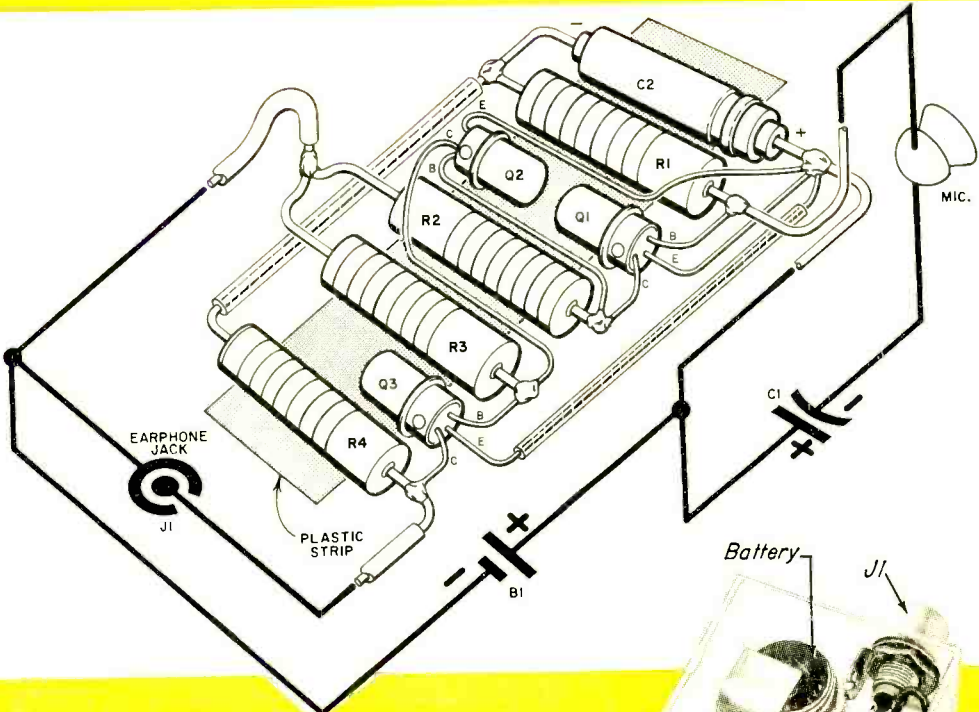

nicely. The penlight cell will furnish power continuously for several weeks, the physically smaller hearing-aid cell for five days or more.

While this is one of the smallest amplifiers ever, it's also a "Tiny Mite" of the first order. In fact, the gain of the unit is so great that you'll be able to hear someone walking on a rug. If you're looking for a practical application, you might try using it as a hearing aid. But bear in mind that it isn't compensated for individual hearing characteristics—hearing-aid sales agencies usually sell standard amplifiers but choose earphones with characteristics to meet individual needs.

-30-

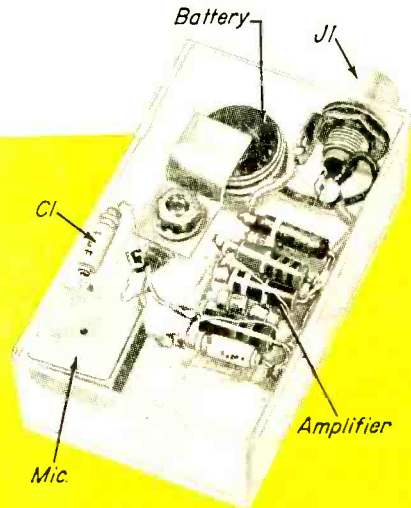

Amplifier, microphone, battery, and earphone jack are mounted in a plastic hardware box. Miniaturization can be carried still further through the use of ultraminiature resistors.

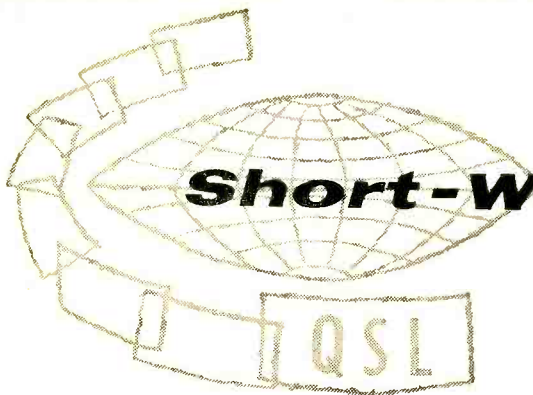

Short-Wave Report

By **HANK BENNETT**
W2PNA/WPE2FT

QSL BUREAUS

WHEN listening on the amateur frequencies, especially the higher bands where DX is prevalent, you will often hear a state-side station tell a foreign amateur to "QSL via ARRL." Likewise, you may hear an amateur from the United Kingdom request that his card be sent through the "RSGB." What are the ARRL and the RSGB? And why should cards be sent through those channels rather than to home addresses?

The ARRL is the American Radio Relay League and the RSGB is the Radio Society of Great Britain. These two organizations are the largest clubs devoted basically to the amateur operator. They sponsor their own "QSL Bureaus" whereby incoming QSL cards can be received through a central receiving point. For example, there is one ARRL QSL Bureau for each call area.

Imagine a ham trying to give his home

address on the air to another operator in Afghanistan, New Zealand, or Peru. Errors would probably result. Instead, he simply asks that his card be sent "via ARRL," and the operator on the foreign end has merely to check his Call Book for the address of the proper QSL Bureau.

Hams and SWL's send a supply of No. 10 stamped, self-addressed envelopes to the QSL Bureau in their particular call area. When cards come in for them, they are usually filed in one of these envelopes until a certain number of cards are received; then the envelope is forwarded. Few cards are lost in the mails when they are channeled through the QSL Bureaus.

Unfortunately, large-scale QSL Bureaus exclusively for SWL's who want to receive cards from hams do not exist. Usually, a ham will send in a batch of QSL cards to an ARRL QSL Bureau destined for SWL's

(Continued on page 117)

Individual (PE) call letters are rapidly replacing impersonal SWL prefixes on cards. QSL Bureaus can sometimes be of assistance in delivering QSL cards from hams to SWL's.

SAO PAULO, S.P. — BRAZIL			
P Y 2 P E 1 A			
Also PY2-13335 (LABRE)			
AT	GMT	ON	CLG/WKG
	EST	KCB	
		M	
<input type="checkbox"/> I'D LIKE TO RECEIVE YOUR QSL-CARD + PROGRAM SCHEDULE			
SWL — CIRO SAITO QTH: RUA IPEROIG, 328 — PERDIZES SAO PAULO, S.P. BRAZIL (OF THE LABRE) P. T. O.			

REGISTERED SHORT WAVE MONITOR STATION	
WPE9-AIW	
Indianapolis 21, Indiana 742 So. Hiatt Street	
Radio.....	Hrd u call/work.....
on Mc, fone/cw,	19.....
at EST. Ur sigs R... S... T...	
Revrt:.....	Ant:.....
Remarks:.....	
Ed. 73, Robert McTeely C. Fritz, Joliet, Illinois	

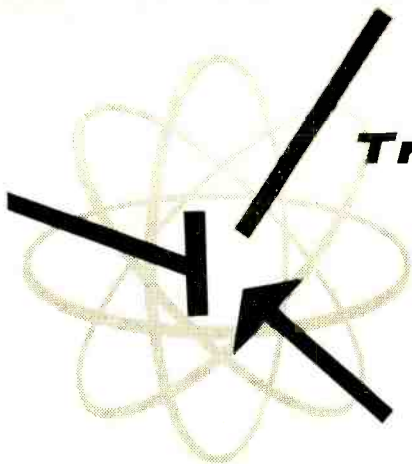

Transistor Topics

By **LOU GARNER**

IN a test instrument intended for field or portable applications, the primary advantages of transistorized over tube circuitry are ruggedness, lower weight, and almost minute power requirements. Less obvious, but no less important, are the transistor's other characteristics: smaller physical size, lack of an extended "warm-up" time, and the fact that it develops a negligible amount of internal heat.

This last item is particularly important in test instruments, for excessive heat can lead to a gradual deterioration of capacitors and other components, and it can cause changes in calibration as well. When you use vacuum-tube-operated equipment, for example, it is customary to allow several minutes "warm-up" to permit temperatures and circuit performance to stabilize.

These advantages have resulted in a growing trend towards transistorized test instruments. In some cases, manufacturers have simply "transistorized" older models. In others, the transistor has made possible the development of completely new types of test gear.

A few years back, transistorized circuits were adopted by the smaller and newer test instrument manufacturers. Recently, the Cubic Corporation of San Diego, Calif., which started operations in 1951, intro-

duced an extended line of transistorized instruments, some intended for bench as well as field use. Included in this line are pulse generators, waveform generators, and curve tracers. Another relatively new firm, Universal Transistor Products Corporation, New York, N. Y., has specialized in developing instruments for atomic work, such as transistorized Geiger counters, dosimeters, and so on.

Today, more and more "old-line" firms are introducing transistorized test instruments, including such respected names as Hewlett-Packard, General Radio, and Boonton Radio. DuMont is producing a tran-

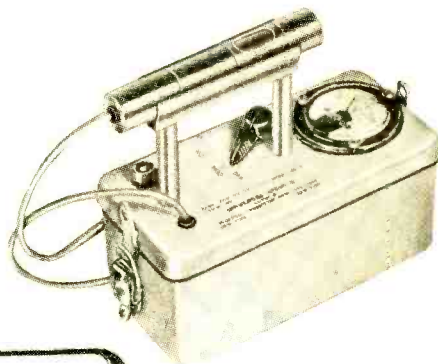

Test instruments are becoming more and more transistorized. Cubic Corporation's pulse generator and Universal Transistor Products' Geiger counter (top photo) are examples of this trend.

sistorized r.f. frequency meter. The Narda Microwave Corporation produces a transistorized VSWR amplifier-meter. Tektronix has developed a fully transistorized (except for the CRT) cathode-ray oscilloscope. And Motorola has announced a fully transistorized a.c. voltmeter.

Nor is this trend towards transistorized circuitry confined solely to U. S. manufacturers. Firms in Japan, England, Germany, France, and Switzerland are discovering the advantages of transistorized designs. One of the recent developments overseas is a six-transistor colorimeter by Pyror S. A. of Switzerland. If the trend continues, the day may come when most test instruments are transistorized. And that day may be sooner than we think!

Readers' Circuits. The overwhelming majority of small transistorized receiver circuits specify magnetic earphones. Not so the circuit submitted by reader Tom Rehm, KN9PIQ, 2947 N. Farwell Ave., Milwaukee 11, Wis. His circuit (Fig. 1) permits the use of one of the low-cost crystal earsets now offered by major parts distributors.

Referring to the schematic, *L1* is a Superex Type VL Vari-Loopstick and *C1* a 365- μf . tuning capacitor. Diode *D1* is a

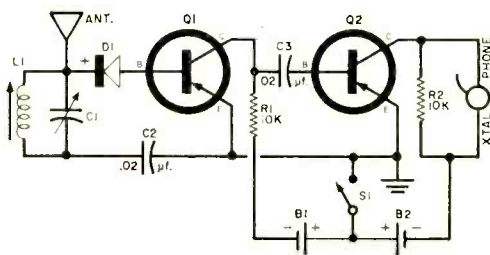
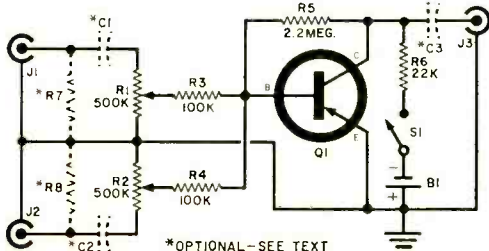

Fig. 1. Transistorized receiver circuit submitted by reader Tom Rehm utilizes inexpensive crystal earphone.

Fig. 2. Audio mixer designed by Darrel Newell permits mixing two audio signals in broadcast-studio fashion.



*OPTIONAL—SEE TEXT

type 1N65; *Q1* and *Q2* are G.E. Type 2N107 transistors. Either paper or ceramic capacitors can be used for *C2* and *C3*; values from 0.02 to 0.1 μf . at a working voltage of 25 volts or higher should be suitable. Resistors *R1* and *R2* are 10,000-ohm, $\frac{1}{2}$ -watt units. Operating power is furnished by a pair of penlight cells, *B1* and *B2*, controlled by a s.p.s.t. toggle or slide switch, *S1*.

In operation, r.f. signals picked up by the antenna (*Ant.*) are selected by tuned circuit *L1-C1* and detected by diode *D1*. The resulting audio signal is coupled to a two-stage resistance-coupled amplifier, *Q1-Q2*, using *p-n-p* transistors in the common-emitter arrangement. Resistor *R1* serves as *Q1*'s collector load, while *R2* in parallel with the high-impedance crystal earset acts as *Q2*'s output load. Capacitor *C2* serves as a bypass, while *C3* provides interstage coupling. Separate batteries are provided for each stage to minimize coupling through the power supply.

Note that Tom operates his transistors *without* externally applied base bias, relying on their small internal leakage currents to establish optimum operation.

Build the set on either a Bakelite board or a conventional chassis. Mount the chassis in a plastic or wooden case. After assembly, adjust *L1*'s core for 1600-ke. signals with *C1* set at minimum capacity. You may find it worthwhile to experiment with higher supply voltages in some cases—try a 3.0-volt (two penlight cells in series) or a 6.0-volt supply. Tom suggests a 32" whip antenna for reception of strong local stations.

The circuit in Fig. 2 should be of interest to audiophiles and recording enthusiasts. Submitted by Darrel Newell (Beltrami, Minn.), the unit is a transistorized *audio mixer*. He suggests its use for mixing signals from a phonograph and a microphone to simulate broadcast studio operation.

Jacks *J1*, *J2*, and *J3* should be chosen to match your other audio gear. Potentiometers *R1* and *R2* are 500,000-ohm carbon units, *R5* a 2.2-megohm resistor, and *R6* a 22,000-ohm resistor; all fixed resistors are $\frac{1}{2}$ -watt size. Transistor *Q1* is a Raytheon Type CK722. Operating power is supplied by a 1.5-volt size "D" flashlight cell, controlled by s.p.s.t. toggle or slide switch *S1*.

In operation, *Q1* serves as a single-stage common-emitter amplifier. Input signals are applied through *J1* and *J2*, appearing

(Continued on page 100)

Pay TV's First Battle



Pat Boone appears on Canadian pay TV in "Journey to the Center of the Earth." A whole family of six watches for the price of one.

THE FIRST major battle of "Pay" vs. "Free" TV started at 7 p.m., Friday, February 26, 1960. Coins began dropping into boxes attached to TV sets in Toronto's suburban community of Etobicoke. Subscription television for Canada was on the road.

Contrary to popular opinion, the Canadians were not paying for something they could previously have had free. For one dollar, subscribers could use their TV sets to watch one of two motion pictures currently being shown in Toronto's neighborhood theaters: 20th Century-Fox's "Journey to the Center of the Earth" and Warner's "The Nun's Story." These films—which will probably not appear on free TV for at least 10 years—were repeated on following days at the same charge. Alternately, a subscriber could pay a dollar for a

A wired pay-TV system is already in operation in Canada. Since no FCC approval is required, installations will be made in the USA this year

By JOHN D. LENK

live telecast of a hockey game between the Toronto "Maple Leafs" and the New York "Rangers" from Madison Square Garden in New York.

Three Channels Added. Three different programs are simultaneously delivered to the TV receiver by means of a compact attachment mounted on or near the set. The subscriber has his choice of which

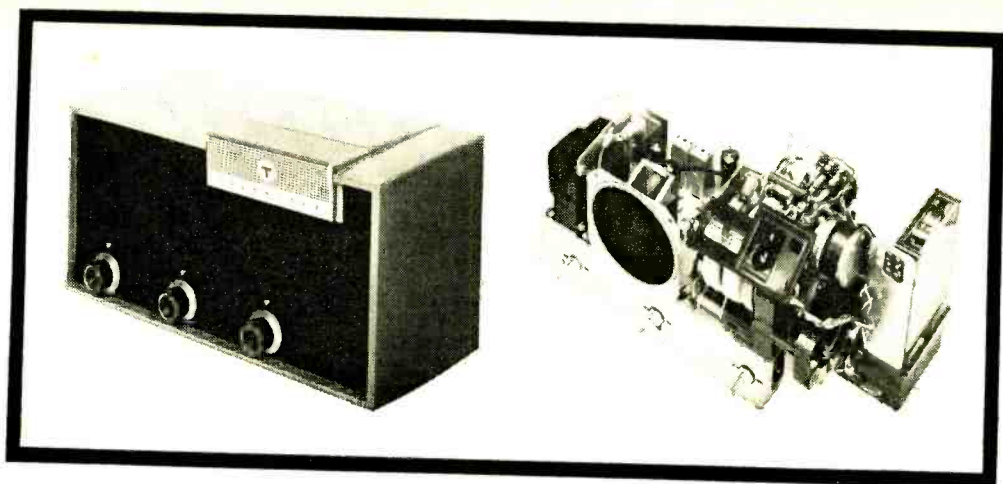

External and internal views of the Telemeter attachment. It connects to the antenna terminals of a TV set.

program—if any—he wishes to see. The system does not require the approval of governmental broadcasting agencies because the programs are transmitted by wire and thus do not take up valuable frequency space.

After the subscriber pays an initial five-dollar installation charge, it's strictly a pay-as-you-see proposition. There is no monthly service charge or "minimum." Prices for programs vary from "free" to \$2.00. Shown during the first month of operation were such films as "North by Northwest," "Room at the Top," "Gigi," and "Cash McCall."

Being wired for the toll system is a residential area which includes 13,000 homes. As of March 1, some 1000 hookups had been completed, and another 3000 subscribers were waiting for the installation crews. By July, a total of 5000 subscribers is expected to be watching first-run movies, sports events, and stage plays in the comfort of their living rooms.

Viewer's Choice. When the subscriber turns on his set, he hears a recording announce the programs being offered and the prices of each. A price window on the attachment also indicates the charge for each program. Assume that Channel A is offering a current motion picture, Channel B is featuring a live stage play, and Channel C has a sporting event. If the subscriber elects to watch the sports event, he tunes the program selector on the attachment to Channel C. When he does this, the price of the program immediately appears in the price window.

After coins are inserted in the coin slot, the attachment feeds the program into the set on an unused channel (because Channels 5 and 6 are not allocated in the same community, one of these channels is always open). Upon receipt of the coins, a magnetic tape recorder in the attachment makes a record of the "transaction." The tape is collected every month or two along with the cash.

Lack of correct change is no problem. The subscriber simply puts in more money than is indicated on the price window. He can then apply the overpayment to a future program. Or, if desired, a refund will be made at collection time.

Should the subscriber decide that nothing is worth paying for that particular night, he simply turns a knob, restoring his normal TV service—without charge, of course. Incidentally, throughout the day, subscribers receive a free bonus in the form of virtually continuous hi-fi background music.

Initial reactions of subscribers to the toll system were enthusiastic. Especially praised was the picture quality of the televised movies. The direct-wire system eliminates any picture defects caused by poor reception—"snow," "ghosts," etc. In addition, because the motion pictures are televised from 35-mm. prints, the larger film size—in comparison with the 16-mm. movie prints now standard on commercial

TV—results in better detail, improved tonal gradation, and generally superior image quality.

Backed by Paramount. Trans-Canada Telemeter, a company backed by Paramount Pictures, is running the Canadian operation. Paramount has invested over ten million dollars in a parent organization, International Telemeter, since 1951 and has more than one million tied up in the Toronto installation. As far as the companies involved are concerned, the installation is not an experiment; it is for keeps.

The basic philosophy behind the Toronto project is to recapture lost movie audiences and to develop new ones. There is considerable evidence that many people do not

go to the movies because it is too much trouble; hiring a baby sitter, driving to the theater, parking the car, driving home—all are factors that tend to reduce the movie audience. Telemeter figures that if the people won't go to the movies, it will take the movies to them.

The economics of the operation are rather interesting. The per-home cost of an installation runs Telemeter about \$100. Studies that compare this expense with the per-seat cost of a movie theater indicate that a pay-TV installation is far cheaper. The annual income from a pay-TV installation is also calculated to be more than that from a single theater seat.

(Continued on page 126)

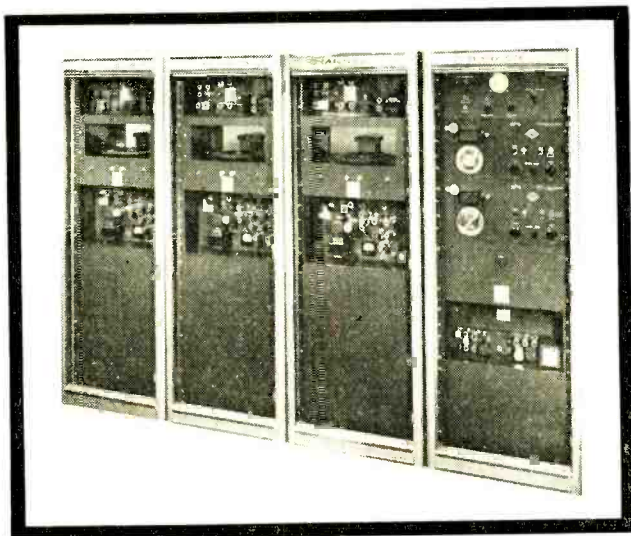

◀ **Transmitter racks** for the wired pay-TV system. Each of three channels (A, B, and C) carries not only a program, but also the price information and code numbers to identify the program. The fourth ("Barker") transmitter carries a recorded message which announces up-coming programs.

▼ **Custom-built control** console for the toll-TV operation in West Toronto. The operator can monitor all three channels at once.

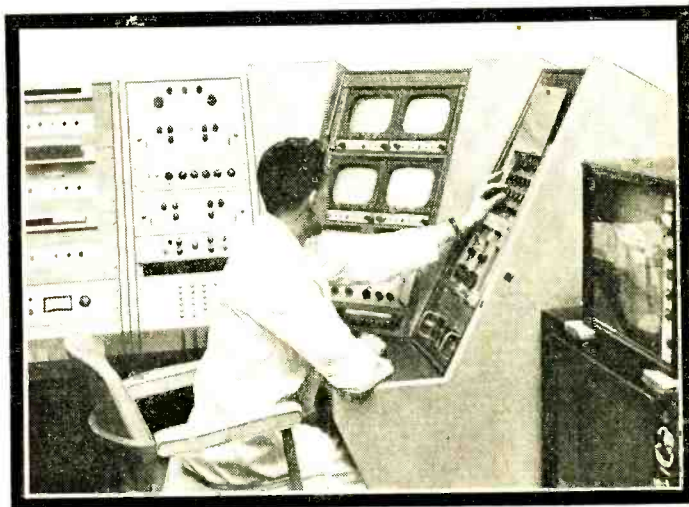

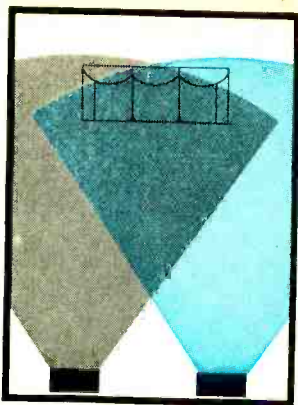

Putting the speakers along one of the shorter walls of the listening room is a common and usually successful arrangement.

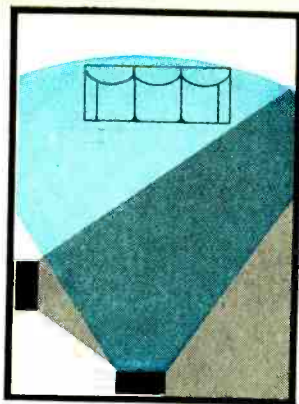

"Listening corner" placement cannot be recommended because stereo's directionality and overall perspective are lost.

How to place

Many stereo systems don't sound right

simply because the speakers are placed incorrectly.

Here's how to set up your stereo speakers for full effectiveness

WHEN stereo is at its best, it can break down the invisible barrier between the listener and the performer, bringing the Modern Jazz Quartet or the New York Philharmonic into your living room. But despite the tremendous improvement of stereo records and tapes, many stereo systems fall far short of their sonic potentialities.

For example, a friend of mine recently invited me over to hear his spanking-new stereo system. One of the speakers was located near the floor in the living room; the other was about twenty feet away, on top of a cabinet in the dining room. Although the equipment was some of the finest available, a good table-model radio would have sounded better. With the speakers located as they were, the system was capable of producing neither good stereo nor good sound of any kind.

Perhaps the most important reason for the disappointing performance of some stereo systems is that their owners seem to have no firm idea of how stereo *should* sound. As long as a cymbal clash comes from one side of a room and the blare of a trumpet from the other, many listeners assume that the full potential of stereo is being delivered. If you are one of those who think directionality is the key to stereo's realism, go to a concert and hear what "real" music sounds like. The purpose of stereo is to duplicate—not exaggerate—an original unity of sound.

Although the ultimate enjoyment of stereo depends on the listener's knowledge of how it should sound (so he can adjust the various controls accordingly), the basic techniques for achieving good stereo sound are not complicated. By paying attention to a few simple rules for the care, feeding,

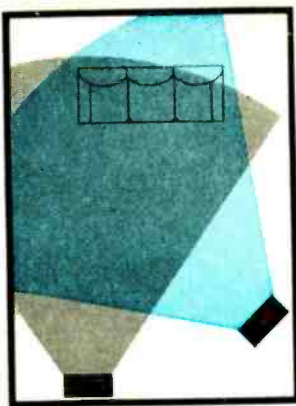

Placing one speaker near and one far can provide good coverage, but arrival-time differences garble acoustic phasing.

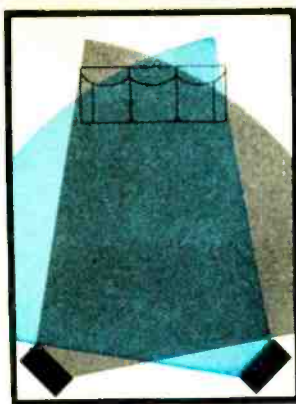

Corner placement provides fair coverage and good bass, but it can create standing waves and excessive channel separation.

Stereo Speakers

By JOHN MILDER

and placement of stereo speakers, you can figuratively invite a jazz combo or symphony orchestra into your living room.

Phasing Problems. The "care and feeding" of stereo speakers involves getting and keeping them in phase with each other. When speakers are correctly phased, the resulting sound seems to come from the space between them, rather than from one or the other. Out-of-phase systems produce sound with a rough or uncertain quality—and an exaggerated directionality that has no relation to the sonic characteristics of a live performance. In addition, out-of-phase stereo usually seems to jump back and forth at random between the two speaker systems.

Putting two speakers in phase initially is usually an easy job—a matter of connecting both pairs of speaker leads so that the cones of both speakers will move back and

forth in unison. Many speaker systems have coded terminals that facilitate proper phasing, and others can be put in phase by means of a short listening test with a monophonic source—the sound should seem to originate between the two speakers. A special test record devised by *Electronics World* provides an easy way to check speaker phasing.

After the speakers are initially phased, it's necessary to keep them in phase. This is not as obvious as it may seem. In the long chain of events between the recording session and the playback in your living room, there are many chances for the two stereo channels to move out of phase with each other. Most amplifier manufacturers provide a phasing switch to cope with this possibility. If your amplifier doesn't have a phasing switch, you can install a double-pole, double-throw switch on one speaker

to reverse the connection of the wires. In any case, it's always a good idea to try flipping the phasing switch when things don't seem to sound right.

Reversed Channels. In addition to problems of phase reversal, it's also possible for the two stereo channels to become reversed. This makes the right-channel material come out of the left speaker and vice

effectiveness is complicated because the recording industry has not standardized stereo recording techniques, particularly with regard to microphone placement. The engineer's understandable willingness to experiment with microphone placement should prompt you to experiment with speaker placement. In practice, this does not mean that you should put your speak-



Home furnishings magazines give some of the poorest advice for placing stereo speakers. One of the best-known publications suggested the above arrangement. Only the person who sat precisely in the center of the couch would hear stereo.

versa. Although this situation isn't as common as phase-reversal, manufacturers of stereo amplifiers supply a channel-reverse switch to take care of it.

Listening to either reversed-channel or out-of-phase stereo material can be a strange experience, but a combination of both can produce a really zany sound. Musical instruments seem to jump back and forth between speakers, and strange reverberations fill your living room. While the overall sound is definitely unlike anything you've ever heard on a monophonic system, don't mistake it for true stereo. On first listening, you might actually like this spectacularly strange kind of sound. After a few hours, however, you'll be much happier if you straighten out the stereo with the phase- and channel-reversal switches.

Speaker Placement. Deciding where to place the stereo speakers for maximum

ers on hand trucks and shift them around the living room to accommodate different kinds of recording, but it does indicate that installing stereo speakers permanently—particularly in walls—is not a good idea because a decision on recording standards could obsolete a custom installation.

Experimenting for a few hours with speaker placement will pay big dividends in listening pleasure. Probably within the first few minutes, you will discover that really significant changes in sound quality can result from moving one speaker even a few inches. In the case of "bookshelf" speaker systems, a change from horizontal to vertical positioning will usually produce a very audible difference, and moving the speaker from a bookshelf or mantelpiece to an on-the-floor location will often provide a startling change.

(Continued on page 106)



The Language of **VECTORS**

**Ken and Larry conclude their discussion
on vectors this month and uncover more information
about the language that engineers use**

Part 2

By SAUNDER HARRIS

KEN was deep in the innards of a transmitter when Larry entered his attic ham shack. He put down his still-smoking soldering gun and greeted his friend.

"Hi, Larry. What brings you to the inner sanctum this Saturday morn?"

"My! For an electronic genius you're pretty forgetful," Larry replied with a grin. "Remember our last discussion on vectors? I'm back to have a go at them again . . . by invitation, of course."

Ken laughed. "I do remember the invitation, believe it or not, and I'm chock full of vectors just waiting for you. Pull up a chair while I untangle this mess of wires. Where were we when the last session ended?"

"Well, you had finally gotten it through my thick skull that vectors were lines that had direction and length, and that both their direction and length meant something electrically. In the cases we discussed, the direction of the vector indicated the phase angle of the voltage or current; the length of the vector showed the strength of the voltage or current. Then we drew some curves that showed leading and lagging currents and also the vector diagrams for each curve." Larry stopped for breath.

"I don't mind telling you, Ken," he went on, "that it was a darned sight more interesting than I thought it would be. As a matter of fact, I think I learned a lot in our

last session. Now I'm anxious to see how you apply all this vector stuff to actual circuits."

"I'm glad you're interested in the serious study of electronics, Larry. That's the only way you're going to keep up with all the new theories being worked out by engineers."

"**T**ODAY, for a start," Ken said, "we'll look at the way circuit elements affect the voltage and current relationships in an electronic circuit. Then we'll express what we learn in terms of vectors. Can you, by chance, rattle off the elements of a circuit in your gay, inimitable manner?"

Larry hesitated for a moment. "When you say circuit elements, do you mean things like coils, capacitors, and resistors?" he asked.

"That's the answer . . . almost," Ken replied. "The electrical elements in any circuit are resistance, inductance, and capacitance. They are put into the circuit by means of resistors, coils, and capacitors."

"At least I was close," said Larry.

"Well, let's get down to work with vectors, then. First we'll see what happens to the voltage and current curves of a circuit consisting of a resistance only, plus an a.c. power source." Ken took a pencil and some paper from the work table and made a rapid sketch.

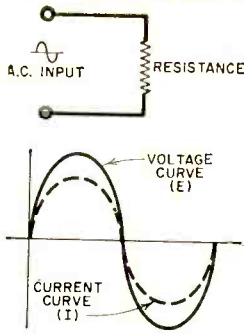

Larry had watched Ken closely as he drew. Finally he blurted out, "I get it, Ken. When there's a pure resistance in the circuit, the voltage and current rise and fall together and there's no phase angle between them. That's why you said a while ago that circuit elements were important. How about letting me draw the vector diagram for this set of curves?"

He took the paper and pencil from Ken and in a moment the diagram was drawn. He passed the sketch back across the table. "How's that, professor?" he asked.

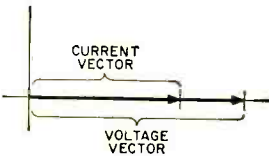

"Swell, Larry. Now, are you sure you understand why you drew the two vectors on one line? Are they really one vector or two?"

"Hey, now, Ken! Don't ask embarrassing questions. But I can answer the first one . . . I think. The two vectors are drawn on the same line because there's no phase angle between them. And they're two separate vectors, all right. I think one is longer than the other because you showed the voltage curve to be higher than the current curve on your drawing . . ."

"Actually, you do understand, Larry," Ken said. "But you're not sure of yourself. While the two vectors you drew—one for the current and one for the voltage—look like one line, in reality they are two lines, one lying on top of the other. It's like the hands of a clock at noon. The two hands seem to be one at first glance, with the minute hand extending beyond the hour hand."

Larry got the point, so Ken went on.

"With regard to the length of each vec-

tor, you are the one who sets up the scale for that. It becomes nothing more than a matter of convenience—your drawing has to be easy to work with and not too large or too small. For example, if you're dealing with voltages on the order of 100 volts, it would be murder to let an inch equal a volt. But if you let one inch equal 50 volts, a 100-volt vector would be two inches long and your vector diagram would be in reasonable scale."

Larry nodded. "The way you explain it, Ken, I can set up two scales, one for amperes and one for volts. They don't really have anything to do with each other. Right?"

"You're on the beam, Larry," Ken said. "Now let's look into another case where there is pure capacitance in the circuit."

KEN made another drawing and said, "Here's the circuit and the curves involved. Let's see what you can do about translating this into a vector diagram."

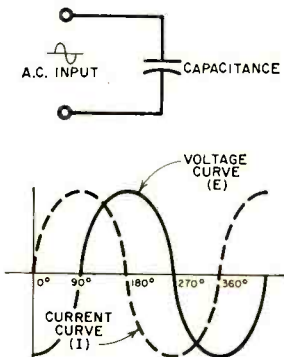

This time Larry was a little slower on the uptake. He studied the curves Ken had drawn and scratched his head in puzzlement.

"What's the matter, friend—stuck?" Ken asked. "Here, let me give you a little hint. Study the two curves and figure out which one started first—that's the one that's leading. Then show them that way on your diagram and show the amount of lead in degrees."

"I see it now!" Larry shouted. "This isn't tough at all." He began to draw and talk at the same time. "The curves you drew show that the current starts to flow first. When it reaches the 90° point, the voltage starts to build up. It should look like this in vector form."

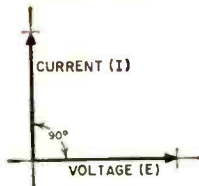

"That's 100% correct," said Ken. "You show the current leading the voltage by 90° . That happens in every circuit where there's pure capacitance. See how the use of a vector diagram brings this point out? That's why it's so important to be able to read them, and why they're used so often in engineering texts.

"Let me ask you this question, though, just to see how bright you really are. What's going on in the circuit that causes the voltage to lead the current? See if the diagram can give you any clue."

Larry's jolly look rapidly dissolved into chagrin. "I don't even know what you're talking about, Ken."

"Sure you do, Larry. You're just not thinking along the right lines. Let me ask you this: what sort of a voltage is there across the capacitor before the a.c. input is fed to the circuit?"

"None," Larry promptly replied, perking up a little.

"Right. Now, what's the first thing that happens when the a.c. is applied?"

"Well, I guess the current starts to flow," Larry answered.

"You guess! Current sure does flow. And what is current? Electrons, right? And where do these electrons flow to? And what . . ."

"Whoa there, mighty mentor!" exclaimed Larry. "I've got it. The picture is as clear as a wide-screen vectorscope. The current, or rather the electrons, must flow and pile up on the capacitor plates before a voltage can be built up across the capacitor. That's why the current leads the voltage in this case."

Larry looked proud and continued explaining. "Then, when enough electrons have piled up so that the voltage across the capacitor equals the applied voltage, no more current flows and the current curve drops down to zero."

He flipped through the papers to Ken's diagram of the curves for the capacitor circuit. "Here," he said, pointing to the 180° spot on the base line. "This is the point where the capacitor is fully charged to the

potential of the applied voltage and the current stops flowing."

"Nice going, Larry," Ken replied. "I think you *have* got it. With the explaining you just did, the next step in vector analysis should be a cinch for you."

ONCE AGAIN Ken took pencil in hand. "This time we'll see what goes on in a circuit that has pure inductance. Then we'll finish up in a blaze of glory with a circuit that combines all three elements."

Ken then drew the curves for the voltage and current flow through a circuit that contained a pure inductance.

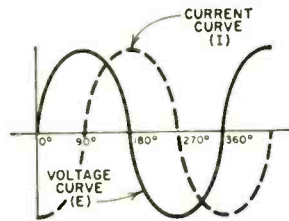
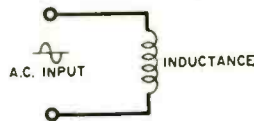

"Without getting long-winded about it, Larry, I'll tell you that the inductive circuit acts directly opposite to that of the pure capacitance," Ken said. "The reason for this goes back to the basic laws of magnetism."

"Could you give me a brief explanation?" Larry asked. "Not that I don't know what's what. I just want to see if you do." He ducked as Ken threatened him with a friendly poke.

"Okay, Larry. Here goes. When a current flows through a coil, a magnetic field is built up around the coil. Now, as this current varies—as it has to in an a.c. circuit—the magnetic field also varies and cuts across the coil. When it does this, it introduces a voltage in the circuit that acts to oppose the change in the current. This opposing voltage reaches its maximum value at the same time the current is at a minimum. For this reason it is said to lead the current by 90° . Was the explaining okay, wise guy?"

"Yes, sir, you did very well. I'll see that a good mark is entered for you," snickered

(Continued on page 112)

On the Citizens Band



By TOM KNEITEL, 2W1965

ONE of the newest rigs out, the Lafayette HE-15 transceiver shown in the photo below, marks a major breakthrough in the CB price-vs.-quality war.

On the "quality" side of the ledger, the HE-15 features a tunable superhet receiver with vernier tuning across all CB channels, an on/off noise limiter switch, r.f. stages in the transmitter and receiver, and five transmit channels. Now, without looking in your Lafayette catalog, take a guess at the price.

If you said \$64.50, you're right, but you probably peeked because the HE-15 has all the features of sets going for more than a hundred dollars.

Forty members of the Bronx-Westchester CB Association (New York) are becoming part of the Disaster Patrol Division of the Mt. Vernon, N. Y., Civil Defense organization. The Disaster Patrol Chief gave CB a field test in which club members supplied automobiles and CB equipment for 25 patrol cadets. The idea was to check reliability of CB coverage over wide areas, give the cadets training in reporting to the control, and check the coordination of teams acting under orders from a mobile control center.

Some thirty automobiles with CB rigs will now be made available to the Disaster Patrol as a result of the affiliation with the club. Anybody else hooked up with Civil Defense yet?

If you're thinking about modifying your license, Richie Seidenberg has some interesting news for you. Richie, 2W2933, filed for some additional mobile units and received his license back with the call "2W4887" typed on top. When he asked the FCC about it, they told him that modified licenses receive new calls because it's easier for their records. The old calls are cancelled. Furthermore, Richie was told that when his present 2W4887 license expires in

five years a third call will probably replace the second one on his new license.

Several months ago, you may remember, we told you not to assume that any "0.005" crystal would automatically place you "on frequency," because a crystal will only function properly when operating within the circuit for which it was designed. Texas Crystals recently announced that guaranteed-accurate CB crystals can now



be delivered for any unit made. Be sure to specify the make and model number of your rig when ordering.

The "Five-Watt Wizards" club, which we discussed in the March column, has had a fantastic number of requests for membership information. Applications have been received from as far away as Hawaii.

As a result of the increasing interest in this club, its members have now decided to solicit membership actively from CB'ers throughout the nation. If you want to belong to a national organization for the advancement of CB, drop a card to "The Five-Watt Wizards," 137-27A 68th Drive, Kew Garden Hills 67, N. Y.

-30-



Carl and Jerry

Two Tough Customers

YOU MIGHT HAVE expected to find Carl and Jerry outside on such a wonderful, warm June evening. But they were perched on the workbench of their basement laboratory instead, looking questioningly across at their respective fathers seated side by side on a leather-covered couch.

"No doubt you boys are wondering why we called this conference," Mr. Bishop, Jerry's father, began; "so let me say right off that you can quit looking so serious and guilty. You're not in any trouble—at least none that we've caught you in."

"That's right," Mr. Anderson agreed with a smile. "To end the suspense, boys . . . we've decided it's time you two had a car."

"Yippe-e-e-e!!" Carl shouted as he bounded off the bench and began skipping around the lab. Jerry, who seldom permitted himself to waste any energy, stayed put; but the big grin wreathing his round face showed that he shared his chum's feelings.

"We think you should know how and why we reached this decision," Mr. Bishop continued as Carl settled back on the bench. "Both of us have kept sharp eyes on you as you took drivers' training in school, as you passed your drivers' tests and got your licenses, and as you herded the family buses around these past few weeks. You still have a lot to learn about handling and maintaining a car, but we think you'll learn much faster in a car for which you're solely responsible."

"I might add that your mothers don't agree," Mr. Anderson said with a wry smile; "and you should keep in mind that your old dads have stuck their collective necks way out for you on this one. If you get hurt or hurt anyone else with your car, not only will we be the two sorriest fathers in town, but we're going to hear 'I told you so' for the rest of our lives."

"Along that line," Mr. Bishop went on, "we can't have you buying a worn-out, dangerous junker. But a good, sound used car still costs a sizable chunk of cash. Now that we're preparing to send you two characters through college, neither family has much money to spare—at least not enough to put out the whole cost of a good car."

"That's why we decided to split the expense and buy you two a partnership car," Mr. Anderson chimed in. "We know this arrangement wouldn't work in many cases, but we think you two are an exception. You practically live together, anyway; so we have a hunch you won't mind sharing a car."

"We'd rather!" Carl and Jerry chorused.

"Fine," Mr. Bishop said happily. "Then here's the dope: we looked around quite a



bit and decided a careful shopper can get a good, safe used car for around six hundred dollars. A careless shopper can get an awful stinging for twice that amount. At any rate, we're each putting three hundred dollars into a car-buying fund. You boys are to shop around until you're sure you've found the car you want costing six hundred dollars or less. Then we'll go down and buy

it for you. The choice will be solely yours. We're hoping you'll take your time, use good judgment, and get a real bargain; but if you buy a lemon, there'll be no one to blame but yourselves."

FOR A LITTLE WHILE no one spoke. Then Jerry said hoarsely, "Dad, and Mr. Anderson, I want you to know I really appreciate what you're doing. I know you're taking a chance on us, and I'm sure going to try and deserve your confidence."

"Me, too," Carl added; "and maybe we can set your mind at ease on one point. Jer and I have talked it over, and we've decided teen-age drivers fall roughly into three groups. The *Hot-Rodders* are the fellows who try to squeeze every bit of speed and acceleration possible out of a car. They're interested in what we hams would call the automobile's maximum peak power output. A few of them fail to use good judgment about where and when they try out their souped-up 'irons,' and they bring the bad name of reckless drivers to the whole group, which really isn't fair."

"Then there are the *Show-Offs*," Jerry continued. "These fellows are more concerned with the car's appearance than with its snap or top speed. They are the ones who go in for customizing the body, lowering the silhouette, dual-exhausts, chrome trim, etc. They want their car to be noticed, and sometimes they try to attract attention by childish actions like squealing the tires, using straight pipes, unnecessary blowing of special horns, and so on."

"Finally," Carl concluded, "there are the *Mechs*. These are the boys who pride themselves on keeping their automobiles in tip-top mechanical condition and treating them with respect. Their cars are spic and span, but they put no money into chrome gadgets, dummy radio antennas, or other things that don't contribute to the car's performance. They would as soon kick a dog as abuse their car's mechanism with jack-rabbit starts or tire-screaming stops. They know just as much about what makes a car tick as do the Hot-Rodders, but they're interested in the car's overall, long-time performance instead of its short-burst peak performance. They are just as proud of their cars as are the Show-Offs, but their satisfaction comes from a motor that purrs as smoothly and quietly as a kitten, a body that is tight and free from squeaks and rattles, and a smooth driving technique that wrings the maxi-

mum mileage out of every drop of oil or gasoline. Jer and I have decided that, as future engineers, we belong with the *Mechs*."

"Well," Mr. Anderson said casually, trying hard not to reveal how pleased he was with what he had just heard. "I know a pair of future *Mechs* who had better be scampering off to bed so they can get up bright and early tomorrow morning and start car-hunting. Come along, son; let's go home."

LATE AFTERNOON three days later found Carl and Jerry, rather dispirited, standing in front of Sam's Used Car Sales.

"Well, we may as well go in," Carl said. "This is the very last dealer in town."

"I suppose so," Jerry agreed; "but would you have believed it was so hard to buy a car? In the last three days I've been under more cars than a cross-walk, and we haven't found a thing we want at our price."

At this point a short, fat little man wearing a broad-brimmed Stetson hat and puffing at a thin, crooked cigar sauntered out of the office of the car lot. "If you young punks are thinking of trying to sell me

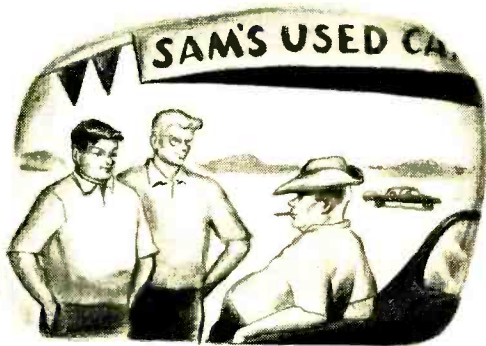

some hub caps you've stolen, you can forget it," he said with a scowl as he flipped the ashes from his cigar with a little finger.

"We don't want to sell you anything, mister," Carl said politely. "We want to buy a car."

"Not from me you don't," the little man asserted. "I've been through that jazz. You want to give me about a bill and a half for a clunker that will run fast enough and hold together just long enough to splash you all over the landscape. Go buy your suicide weapon elsewhere. Plenty of guys will take your money."

"Now, hold on," Jerry said indignantly. "We're not looking for a car to hot-rod. We want a good, sound, safe used car at a reasonable price. We're more interested in how long it will run than in how fast it will go."

Sam cocked his cigar up at a jaunty angle and looked shrewdly at the two boys. "So maybe I went off half-cocked," he said gruffly, "but your pitch is new to me. How much dough you got?" he demanded.

Carl and Jerry exchanged glances. Then Jerry flung caution to the winds and gulped, "Exactly six hundred dollars. Our dads are putting it up."

"How come your folks don't do the shopping?"

"They think if we've got sense enough to drive a car we ought to have sense enough to buy one."

"Hm-m-m, that's an interesting theory most folks prefer to apply in reverse," Sam said with a broad grin that crinkled his eyes almost closed. "Come along and I'll show you something."

The boys followed the waddling little man until he stopped in front of a very clean-looking 1954 model four-door sedan of a popular make. "Now, there," Sam said proudly, "is a real cream-puff if I ever saw one. The guy who owned it had one of those little foreign cars that took almost all the short-trip driving. At least three-fourths of the miles on that speedometer were put on during vacations and other long trips. The rest of the time that car sat in the garage. I've been holding it for my wife's kid brother, but when he found out that the six-cylinder motor only develops 115 horsepower, he lost interest. That bird-brain thinks anything under a couple of hundred horsepower is only for running tinker-toys."

Carl and Jerry had been eagerly going over the car while Sam was talking. He watched them examine the brake and clutch pedals of the straight-stick job for wear. He saw them look at the mileage and date on the door-edge lube sticker and compare this with the 32,000 odd miles on the speedometer. With difficulty he concealed a grin as they solemnly ran all the door windows up and down, opened and closed all four doors, and examined the paint on the door edges for evidence of a repaint job. Then they methodically checked the tread on all four tires and carefully examined the frame for any signs that it had been heated and

straightened after an accident. Finally they raised the hood and took out the dipstick. The oil was clean and of a viscosity that checked with the #20 shown on the lube sticker.

"Don't you want to hear it run?" Sam asked curiously. "That's the first thing a teen-ager usually does: start the motor and wind it up before the oil has a chance to circulate. We call this 'tightening the bearings'."

Sam wedged himself under the wheel and started the motor. The starter turned slowly, but once started the motor hummed smoothly.

"What's that little clicking sound?" Carl asked.

"Tappets of the overhead valves," Sam explained as he shut off the motor and got out of the car. "They always make a little noise. But say: I've got to close up now and meander on home. We're having company tonight, and the little woman will flatten me if I'm late. You boys come back tomorrow and finish looking the car over. I won't be surprised if we do business. I like the way you two go at things."

Reluctantly the boys closed the hood and took off for home, excitedly planning further checks.

WHEN Sam unlocked the door of his office the next morning, Carl and Jerry were right on his heels. He had to do some book work, but he gave the boys the keys to the car and suggested they take it for a trial drive. When he walked out of the office an hour later, the boys were back and had the front end of the car jacked up. Jerry was wearing a pair of earphones

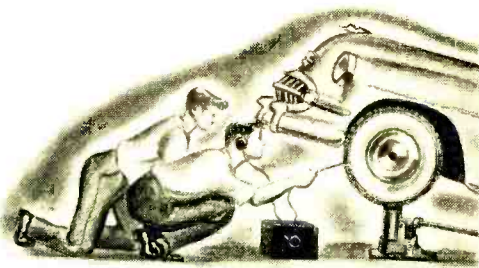

plugged into a small black box. He was pressing a little rod sticking out of this box against an exposed front axle as he slowly turned the wheel.

"I think there's a bad bearing in this

wheel," Jerry announced. "I can hear it grinding through this contact mike working into the transistor amplifier. I don't hear it on the other wheel."

"We'll soon find out," Sam said indulgently as he pulled a crescent wrench and a pair of pliers from his hip pocket and started taking off the wheel. "I was a garage mechanic for many years," he explained, "but they kept making cars lower and lower, and I kept getting thicker and thicker. Finally, even with lowering blocks on my creeper, I couldn't slide under 'em any more; so I stopped doctoring them and started selling them. Well! I'll be darned! This bearing is a little rough. We'll put in a new one."

"And how about relining the brakes?" Carl asked. "Those bands are almost down to the iron."

"Okay," Sam groaned; "but you boys are going to have me on the street with a tin cup and pencils. Don't forget I'm letting you steal this sweet little buggy for only six bills."

Jerry got into the car and hit the starter. The motor revolved very slowly but did not start.

"Don't tell me I'm going to have to throw in a new battery!" Sam groaned.

Carl picked up the volt-ohmmeter that had been placed for safe-keeping in the rear seat and connected it across the battery terminals as Jerry twisted the starting key again.

"It's not the battery," Carl announced. "The voltage only drops to 5.5 volts with the starter load."

"Better the battery than the starter," Sam said, as he nervously took out one of his crooked little cigars and lit it.

"I've hooked the meter between the grounded battery terminal and the starter case. Hit the starter again," Carl instructed Jerry. "Hold it!" he exclaimed as soon as the starter began its sluggish turning. "That's it. There's a volt or so drop right there. Must be a poor ground connection on the battery cable. Can I borrow that wrench a minute?"

"Be my guest," Sam replied, holding out the tool.

Carl's lanky frame slid easily under the car, and he did some high-powered grunting and wrench-tugging. "Now try her," he called. The starter whirred rapidly, and the motor started instantly.

A pleased smile spread over Sam's face.

"Boys," he said impulsively, "I've taken a shine to you; so let's quit horsing around. I like to see a good car go to someone who appreciates and takes care of it. You two have convinced me you will do just that. I'll stake my reputation as a mechanic—of which I'm pretty proud—that this car will give years of satisfaction. It's a real bargain at six bills just as it stands, but I'll put in the new bearing and the brakes and check it all over. You can have it at eight tonight if you want it. What do you say to that?"

Carl and Jerry looked at each other and then said in chorus, "We'll take it!"

IT SEEMED to the boys that eight o'clock would never come, but finally they and their fathers started on foot for Sam's place. Their pride-and-joy, freshly washed and polished, was ready and waiting right in front of the office. They looked it over lovingly as their fathers went into the office with Sam to conclude the deal. As the men came out, Carl flipped a quarter into the air and Jerry called out, "Heads!"

"Tails it is," Carl revealed, and he slid

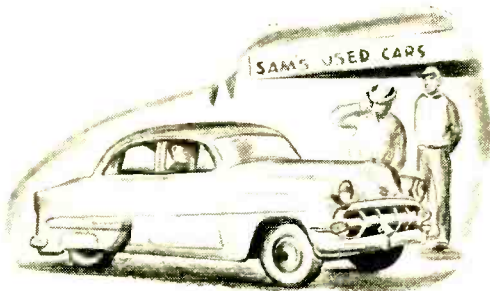

behind the wheel while Jerry got in beside him.

"Pilot to co-pilot," Carl called in a singsong voice, "ready for take-off?"

"Blast off," Jerry instructed.

The car rolled smoothly out into the street, and as Sam watched the gleaming tail lights disappear around a corner, he took off his big hat and held it against his chest as he looked up into the star-studded June sky.

"Boss," he said reverently, "there goes my good deed for the day, and I feel real good about it. But if it's not too much to ask, could you maybe send me a few tire-kicking, door-slamming suckers now just to sort of even things up?"

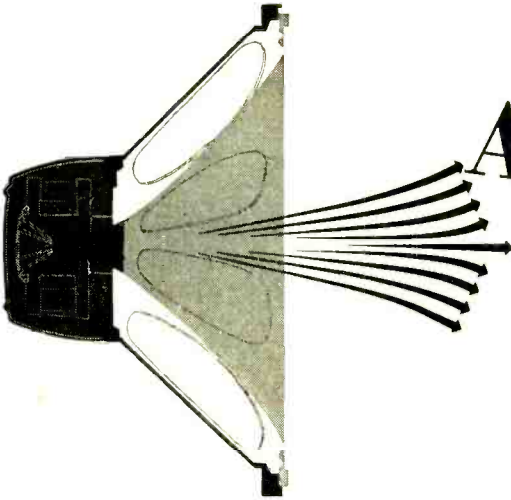

Announcing

*The most
Complete
Guide to Hi-Fi
and Stereo
Ever Published!*

STEREO • HI-FI GUIDE 1960

In this compact, handy reference, you'll find the answers to nearly any question on hi-fi, plus details and data on trends, components, speakers, stereo, audio theory. Prepared by the Editors of POPULAR ELECTRONICS, the 1960 STEREO • HI-FI GUIDE is easy to understand—complete with diagrams, illustrations, and clear explanations.

Here's what you'll find in the five big sections of the 1960 STEREO • HI-FI GUIDE:

I. YEARBOOK

- Trends and New Products
- Multiplex—an analysis and forecast

II. INSIDE THE COMPONENTS

- Detailed analysis of preamps, stereo preamps, power amps, tuners, turntables, and stereo cartridges

III. SPEAKERS AND ACOUSTICS

- Inside the HiFi Loudspeakers and Enclosure
- Electrostatic and Cone Type Speakers
- Does Shrinking Size Mean Shrinking Sound?
- Between Speaker and Ear
- Custom-Built Equipment Enclosure

IV. STEREO

- Stereo Standards
- What You Should Know Before Buying Stereo
- Stereo Simplexing Simplified
- Stereo Tape is Back to Stay
- Balancing Your Stereo System
- Stereo Cartridge Directory
- Stereo Records—Fad or Fulfillment?

V. AUDIO THEORY AND APPLICATION

- Maintaining and Testing Your HiFi
- Harmonic Distortion
- Filter and Crossover Networks

DON'T DELAY—NOW ON SALE at your favorite newsstand or Electronic Parts Store, or order by coupon today. Only \$1.00.

NOW

On Sale

or order by

coupon today!

Only \$1.00



Ziff-Davis Publishing Company
Department PE-660
434 S. Wabash Avenue,
Chicago 5, Illinois

Please send me a copy of the 1960 STEREO® HI-FI GUIDE. I enclose \$1.00, the cost of the GUIDE, plus 10¢ to cover mailing and handling charges. (Foreign \$1.25, plus 25¢ handling charges.)

Name _____

Address _____

City _____ Zone _____ State _____

FROM HEATH...

14 NEW KITS



AA-50 \$79⁹⁵

HI-FI RATED 25/25 WATT STEREO AMPLIFIER-PREAMPLIFIER KIT

A complete 25/25 watt stereo power and control center (50 watts mono) . . . 5 switch-selected inputs for each channel . . . new mixed center speaker output . . . stereo reverse and balance controls . . . special channel separation control . . . separate tone controls for each channel with ganged volume controls . . . all of these deluxe features in a single, compact and handsomely styled unit! Five inputs for each 25 watt channel are provided: stereo channel for magnetic phono cartridge (RIAA equalized); tape head input; three high level auxiliary inputs for tuners, TV, etc. There is also an input for monophonic magnetic phono cartridge, so switched that monophonic records can be played through either or both amplifiers. The automatically mixed center speaker output lets you fill in the "hole-in-the-middle" found in some stereo recordings, or add extra monophonic speakers in other locations. Nearly all of the components are mounted on three circuit boards, simplifying assembly and minimizing possibility of wiring errors. 30 lbs.

New Heathkit Stereo Hi-Fi Components . . .

plus Exciting New Kits for the Ham, Technician,

Boating Fan and Hobbyist



AD-10
\$33⁹⁵

MANUAL STEREO RECORD PLAYER KIT

Made by famous Garrard of England, the AD-10 is a compact 4-speed player designed to provide trouble-free performance with low rumble, flutter and wow figures. "Plug-in" cartridge feature. Rubber matted heavy turntable is shock-mounted, and idler wheels retract when turned off to prevent flat spots. Powered by a line-filtered, four-pole induction motor at 16, 33 $\frac{1}{3}$, 45 and 78 rpm. Supplied with Sonotone STA4-SD ceramic stereo turn-over cartridge with .7 mil diamond and 3 mil sapphire styli. Mechanism and vinyl covered mounting base preassembled, arm pre-wired; just attach audio and power cables, install cartridge and mount on base. With 12" record on table, requires approximately 15" W. x 13" D. x 6" H. Color styled in cocoa brown and beige. 10 lbs.



a subsidiary of
DAYSTROM, INCORPORATED



AA-20 \$34⁹⁵

ECONOMY STEREO PREAMPLIFIER KIT

Although these two new Heathkit models are designed as companion pieces, either one can be used with your present stereo system. The preamplifier (AA-20) features 4 inputs in each stereo channel and gives you a choice of 6 functions. It will accommodate a magnetic phonograph (RIAA equalized), a crystal or ceramic phonograph, and two auxiliary sources (AM-FM tuners, TV, tape recorders, etc.) and is completely self-powered. The six-position function selector switch gives you instant selection of "Amplifier A" or "Amplifier B" for single channel monophonic; "Monophonic A" or "Monophonic B" for dual channel monophonic using both amplifiers and either preamplifier; "Stereo" and "Stereo Reverse". 8 lbs.



AA-30 \$45⁹⁵

HI-FI RATED 14/14 WATT BASIC STEREO AMPLIFIER KIT

Two 14-watt high fidelity amplifiers, one for each stereo channel, are packaged in the single, compact, handsomely styled amplifier (AA-30). Suitable for use with any stereo preamplifier or with a pair of monophonic preamplifiers, it features individual amplifier gain controls and speaker phase reversal switch. Output terminals accommodate 4, 8 and 16 ohm speakers. 21 lbs.



SA-2 \$54⁹⁵

HI-FI RATED 14/14 WATT STEREO AMPLIFIER KIT

A tremendous dollar value in the medium power class, this top-quality stereo amplifier-preamplifier combination delivers full 14 watts per stereo channel (28 watts monophonic) to drive your stereo system with ease, while versatile controls give you fingertip command of its every function. In addition to "stereo" and "stereo reverse" functions, the SA-2 provides for complete monophonic operation. Inputs on each stereo channel accommodate "magnetic phono" (RIAA equalized), "crystal phono", "tuner" and high level auxiliary input for tape recorder, TV, etc. Other features include a speaker phase-reversal switch, clutched volume controls, ganged tone controls, filament balance controls, and two AC outlets to accommodate accessory equipment. Handsomely styled in black with inlaid gold design. 23 lbs.



SA-3 \$29⁹⁵

UTILITY RATED 3/3 WATT STEREO AMPLIFIER KIT

Your least expensive route to stereo, the SA-3 delivers 3 watts per stereo channel (6 watts monophonic), adequate for average living-room listening. The high level preamplifier has two separate inputs for each channel and is designed for use with ceramic or crystal cartridge record players, tuners, tape recorders, etc. Featured are ganged bass and treble tone controls, clutched volume controls, channel reversing switch, speaker phase reversal switch and mono-stereo function selector switch. Attractively styled with satin-black cabinet. 13 lbs.

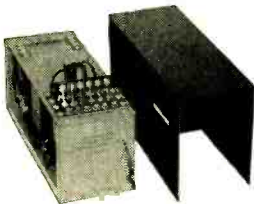

AN-10 \$19⁹⁵

MIXED LOWS STEREO CROSSOVER NETWORK KIT

The AN-10 makes it possible for you to convert to stereo or improve your present stereo system by using just one bass "woofer"; saves buying a second bass speaker, permits using more economical "wing" speakers, improves the bass response of any stereo system. Delivers the non-direction bass frequencies of both channels below 250 cps to a single woofer and passes the higher frequency stereo channels to a pair of wing speakers. Rated at 25 watts per channel. Matches 8 or 16 ohm woofers, 8 ohm high frequency speakers, or Heathkit SS-1-2-3 speaker systems. 10 lbs.

TURN PAGE FOR MORE HIGH QUALITY DO-IT-YOURSELF KITS



HEATHKIT® GIVES YOU MORE IN THESE TEN WAYS:

1. **Building a Heathkit is easy**—Check-by-step instruction manuals make it virtually impossible for you to fail.
2. **Building a Heathkit is quick**—No complicated, technical jargon for you to decipher; at most, a Heathkit takes only a few evenings to assemble.
3. **Building a Heathkit is economical**—Mass production and purchasing economies are passed directly along to you, our customers.
4. **Building a Heathkit is educational**—As you build, you learn . . . more about electronics, more about the component units and when and where to add them.
5. **Building a Heathkit is fun**—Nothing quite equals the sense of achievement you receive when you successfully complete a Heathkit unit and "tune-in" for the first time.
6. **Your Heathkit is Guaranteed**—Every Heathkit unit is guaranteed to meet advertised performance specifications . . . or your money will be cheerfully refunded.
7. **Your Heathkit is available on Convenient Credit**—Our time payment plan makes it possible for you to order now . . . pay later.
8. **Your Heathkit is Tops in Quality**—The very finest in electronic equipment comes to you in kit form from the Heath Company.
9. **Heathkit Dealers can Serve you Locally**—Carefully selected Heathkit representatives are available in most localities.
10. **Heathkit Service is Customer Service**—Our staff of technical experts is always ready to answer your questions or help you if you have any difficulty.



GC-1
\$109.95
\$11.00 dn., \$10.00 mo.

TEN-TRANSISTOR "MOHICAN" GENERAL COVERAGE RECEIVER KIT (GC-1)

An excellent portable or fixed station receiver. Many firsts in receiver design, ten transistor circuit, flashlight battery power supply and new ceramic IF transfilters. The amazing miniature transfilters used in the GC-1 replace transformer, inductive and capacitive elements used in conventional circuits for shaping bandpass; offer superior time and temperature stability, never need alignment, provide excellent selectivity. Telescoping 54" whip antenna, tuning meter, fly-wheel tuning and large slide-rule dial also featured. Covers 550 kc to 30 mc in five bands. Electrical bandspread on five additional bands cover amateur frequencies from 80 through 10 meters. Operates up to 400 hours on 8 standard size "C" batteries. Sensitivity: 10 uv, broadcast band; 2 uv, amateur bands, for 10 db signal-to-noise ratio. Selectivity: 3 kc wide at 6 db down. Measures 6 1/2" x 12" x 10". 20 lbs.

HEATHKIT XP-2 Plug-in power supply for 110 VAC operation of GC-1. 2 lbs. \$9.95



HD-19
\$34.95



HD-20
\$14.95

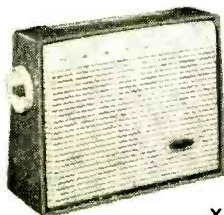

XR-2P
\$29.95
(6 lbs.)

6-TRANSISTOR PORTABLE RADIO KIT (XR-2 Series)

Unsurpassed quality and styling are combined in these handsome sets to provide you with superb and dependable portable entertainment wherever you go—wherever you go! Choose the gleaming, two-tone molded plastic model or the handsome simulated leather-and-plastic combination—both feature a gracefully curved grille in smart beige plastic. The XR-2P complements the handsome grille with a mocha colored case of high-impact plastic, while the XR-2L encases the beige grille in suntan color Sur-U-Lon simulated leather. Vernier tuning control gives you smooth, precise station selection. Six Texas Instrument transistors are used for quality performance and long life; a large 4" x 6" PM speaker with heavy magnet provides "big set" richness of tone. Ready to play after simple assembly—transformers prealigned. Six flashlight batteries used for power (500—1,000 hrs.) (Batteries not included).



XR-2L
\$34.95
(7 lbs.)



HW-19 (10 meter)
HW-29 (6 meter)

\$39.95
each

a subsidiary of
DAYSTROM, INCORPORATED

Order Direct by Mail or

Always say you saw it in—POPULAR ELECTRONICS

ORDERING INSTRUCTIONS

Fill out the order blank below, giving us your name and address in the space provided at right. Include charges for parcel post according to weights shown. Express orders are shipped delivery charges collect. All prices F.O.B. Benton Harbor, Mich. A 20% deposit is required on all C.O.D. orders. Prices subject to change without notice. Dealers and export prices slightly higher.

QUAN.	ITEM	MODEL NO.	PRICE

Ship via Parcel Post Express C.O.D. Best Way

FREE CATALOG!

Over 150 items of stereo, marine, amateur and test equipment are illustrated and described in the complete Heathkit Catalog.

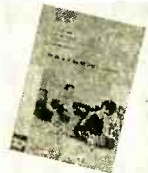

HEATH COMPANY Benton Harbor 10, Mich.
Please send my free copy of your complete catalog.

NAME _____

ADDRESS _____

CITY _____ ZONE _____ STATE _____

New! One switch operation

"HYBRID" PHONE PATCH KIT (HD-19)

Transfer calls from ham rig to telephone by flipping a single switch! Allows voice control (VOX) or manual operation. VU meter monitors output to 600 ohm line and serves as null depth indicator. Separate receiver and transmitter gain controls. Provides better than 30 db isolation between receive and transmit circuits. All leads filtered to minimize RF feedback. Matches receivers with 3 to 16 ohms impedance. 4 lbs.

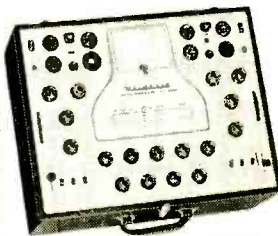

TT-1

\$134.95

\$13.50 dn., \$12.00 mo.

NEW 100 KC CRYSTAL CALIBRATOR KIT (HD-20)

This versatile ham aid provides marker frequencies every 100 kc between 100 kc and 54 mc. Use to align all types of communications equipment. Features transistor circuit dependability, battery power portability, and crystal control accuracy. .005% crystal supplied. 1 lb.



Two brand new models

HEATHKIT 10 & 6 METER TRANSCEIVERS

Complete ham facilities at low cost! Ideal for beginning and veteran hams for local net operations. Transmitter and receiver are combined in one easy-to-use instrument. Features neat, modern styling, press-to-talk transmit/receive switch, built-in AC power supply, variable receiver tuning, variable gain control, and amplifier metering jack. Operates mobile using vibrator power supply. Microphone and two power cables included. Handsomely styled in two-tone mocha and beige. Less crystal.

VIBRATOR POWER SUPPLIES: VP-1-6 (6 volt), VP-4-12 (12 volt), 4 lbs. Kit; \$8.95 each. Wired; \$12.95 each.



EK-1

\$19.95

MUTUAL CONDUCTANCE TUBE TESTER (TT-1)

The impressive list of its features make this tube tester a fine value. Tests Gm (amplifiers) from 0-21,000 micromhos, Emission, Leakage, Grid current (1/4 microampere sensitivity). Voltage regulators (built-in variable DC power supply), Low power Thyatron and Eye tubes. Features 300, 450, and 600 ma constant current heater supplies, life test, Hybrid tube test, built-in switch operated calibration circuit. Large easy-to-read meter, and constant tension free-rolling roll chart mechanism. Individual selector switches allow testing any tube type, regardless of basepin connections, protecting against obsolescence. Assembly simplified by 7 wiring harnesses and transformer terminal board. Assembly skill of technician or higher recommended, time 40 hours average. Black leatherette case with white trim, nylon feet, removable top. 27 lbs.

EDUCATIONAL KIT (EK-1)

Teaches, as you build, the basic "yardsticks" of electronics—opens up fascinating areas of study for youngsters and adults alike. The combination kit and text-workbook gives you a practical demonstration of the principles of voltage, current and resistance; the theory and construction of direct current series and parallel circuits, voltmeter, ammeter and ohmmeter circuits and the application of ohms law to these circuits. The completed meter is used to verify ohms law and the maximum power transfer theorem, one of the most important theorems in electronics. The finished kit, a practical volt-ohm-milliammeter, may be used in a variety of applications. Procedures for checking home appliances and automobile circuits included with the kit. The EK-1 will serve as a prerequisite to following Heathkit Educational kits. Get started NOW in this new and exciting series of "learn-by-doing" educational kits. 4 lbs.

See Your Heathkit® Dealer*

*The convenience of Local Heathkit Sales and Service costs but a few dollars more.

Test Instruments

(Continued from page 64)

1.0 volt. Write down the signal generator frequency. Turn the output control to "X100" and raise the frequency once more. If the signal generator has an "X1000" position, increase the frequency still more until the meter again reads 1.0 volt.

Reduce the output control to "X10" again and tune the signal generator to slightly below the receiver frequency until the meter reads 1.0 volt. Raise the output to "X100" and "X1000," each time tuning lower until the 1.0-volt reading is obtained, and noting the frequency. Selectivity curves can then be plotted as shown in Fig. 5. Incidentally, you can expect selectivity to vary somewhat with frequency, with the lower end of the band tending to be more sharply selective than the upper end.

Examine the typical selectivity curves in

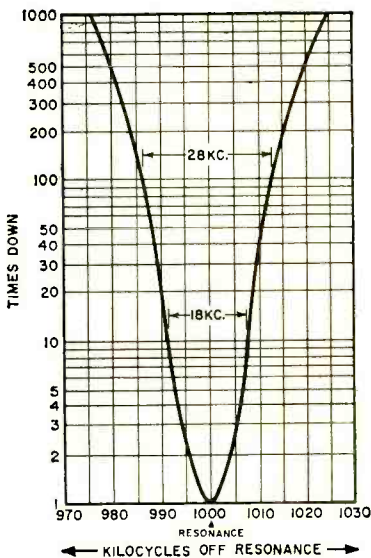

Fig. 5. Selectivity curves of receiver measured with setup in Fig. 4(A). Chart shows receiver 100 times down at 28 kc.

Fig. 5. If the receiver is tuned to 1000 kc., a station broadcasting at 1010 kc. would be approximately 20 times weaker than the 1000-kc. station; a station at 1030 kc. would be more than 1000 times weaker, or completely inaudible.

Maintenance. Signal generators are subject to most of the troubles suffered by other electronic equipment—troubles due to

aging, dust, corrosion, and vibration. A regular program of preventive maintenance will assure accurate readings and long service from your generator.

Defective tubes, shorted capacitors, open resistors, and other simple difficulties can be checked and corrected by conventional means. Screws should be tightened from time to time, if necessary.

Signal generators also need occasional frequency calibration. Fortunately, local broadcast stations make good frequency standards. To calibrate a generator, tune in a local station, and set the dial of the signal generator near the same frequency. Place the signal generator's "hot" lead near the receiver antenna and you'll probably hear a high-pitched whistle from the radio speaker. Tune the signal generator so that the frequency of the whistle gets lower and lower. Eventually you'll find a spot where the whistle stops completely—tuning the signal generator in either direction from this spot will cause the whistle to start again. This is known as the "zero beat" point—the point at which the signal generator and radio station are tuned to exactly the same frequency.

You can check high-frequency bands on the signal generator by zero-beating with short-wave and FM stations. If the signal generator dial doesn't read the same as the broadcast-station frequency, adjust the oscillator trimmer until it reads accurately. On signal generators which do not have oscillator trimmers, you may be able to adjust the dial pointer until it indicates the proper frequency. If neither of the adjustments is available, make a calibration chart to show the amount of error on the various bands. It's a good idea to check each band in several places to see if the error is about the same throughout.

One final tip: most signal generator bands overlap slightly. For example, if Band 1 tunes from 100 to 290 kc., Band 2 will probably begin at 280 kc. Since tuning errors are more likely to occur at the high end of any band, use the low-end reading wherever possible.

There are many "tricks" connected with the use of individual generators—no two models are exactly alike, or have precisely similar characteristics. As you become increasingly familiar with your generator, you'll find more and more ways in which it can be helpful in solving your particular problems.

LEKTRON SHOPPERS SAVE...SAVE...

DURING OUR GIANT, ANNUAL PENNY SALE!



10 of LEKTRON'S Best-Sellers - Get the Extra PAK For 1¢

FREE
PICK ANY \$1.00 PAK FREE with any \$10 order
 Your choice of any Poly Pak® (including double paks) FREE from \$1.00 listings.

- | | | |
|---|------------|-----------------------|
| <input type="checkbox"/> Panel Light Bulbs | 20 for \$1 | 40 for \$1.01 |
| <input type="checkbox"/> Carbon Resistors | 60 for \$1 | 120 for \$1.01 |
| <input type="checkbox"/> Lucite Boxes | 10 for \$1 | 20 for \$1.01 |
| <input type="checkbox"/> Transistor IFs | 3 for \$1 | 6 for \$1.01 |
| <input type="checkbox"/> Plugs & Receptacles | 60 for \$1 | 120 for \$1.01 |
| <input type="checkbox"/> \$15 Geiger Counter Tube | 1 for \$1 | 2 for \$1.01 |
| <input type="checkbox"/> 60 Ceramic Condensers | 60 for \$1 | 120 for \$1.01 |
| <input type="checkbox"/> Tubular Condensers | 50 for \$1 | 100 for \$1.01 |
| <input type="checkbox"/> Germanium Diodes | 12 for \$1 | 24 for \$1.01 |
| <input type="checkbox"/> Tube Sockets | 30 for \$1 | 60 for \$1.01 |

ORDER BY BLACK-TYPE HEADLINES . . . PICK FREE \$1 ITEMS FROM BELOW

THIS OFFER IS GOOD UNTIL JULY 15, 1960

- | | | | | |
|---|--|---|---|---|
| <input type="checkbox"/> For 365mmf variables Broadcast band. \$1 | <input type="checkbox"/> 2 HI-Q LOOPSTICKS | <input type="checkbox"/> 60 CONDENSER SPEC. Molded, mica, ceramic, paper, discs. \$15 val. \$1 | <input type="checkbox"/> 10 PANEL SWITCHES Sensitive, rotary power, slide, micro. Reg. \$5. \$1 | <input type="checkbox"/> \$25 SURPRISE PAK Wide variety of radio popular electronic parts. \$1 |
| <input type="checkbox"/> 3 AC-DC SELENIUMS Rectifiers. 110 VAC/DC. Strong adhesive. \$5-val. \$1 | <input type="checkbox"/> 3 AC-DC SELENIUMS | <input type="checkbox"/> \$15 ROTARY PAK Circuit changers, power transfer types. \$1 | <input type="checkbox"/> 60 PRECISION RES'T'RS 1%, ass'd. values. 1/2 W to 2 W. \$1 | <input type="checkbox"/> 70 TUBULAR COND'RS 20 Values, 0001 to 5 mfd to 1000 VDC. Reg. \$14. \$1 |
| <input type="checkbox"/> ELECTRIC MAGNIFIER W/ on-off switch, & bulb for precision checks. \$1 | <input type="checkbox"/> "POLY" WIRE PAK 6 25-11, rolls, plastic ins. ±20 to 30, ass't colors. \$1 | <input type="checkbox"/> 40 SUBMINI RESIST'RS For transistor circuits. Ass't to 3 meg. \$1 | <input type="checkbox"/> \$25 TRANSFORMER SPEC. Handy transformer ass't for hobbyists, repairmen. \$1 | <input type="checkbox"/> TRANS. RADIO BASIC Has transistor, socket, diode, loopstick. \$1 |
| <input type="checkbox"/> 8 NEON GLO LAMPS Type NE-16 fits in socket. \$1 | <input type="checkbox"/> 8 SIL. XTAL DIODES 1N21, 1N22, etc. Some worth \$5.00 ea. \$1 | <input type="checkbox"/> 4 IN34 DIODES Or equal. Color-coded. For 1000's of uses. \$1 | <input type="checkbox"/> 60 RESISTOR SPECIAL W.W., carbon, precision, vari., to 50W. \$1 | <input type="checkbox"/> 40 "SILVER" MICAS 1 & 5%. Ass't values. Finest made. \$1 |
| <input type="checkbox"/> 8 RCA PLUG-IN JACK SETS Matched pairs. For tuners, amps, recorders. \$1 | <input type="checkbox"/> 2 500-MILL RECT'FRS Silicon, "hi-hat." Reg \$1.50 ea. \$1 | <input type="checkbox"/> GIANT SUN BATTERY 1 1/2" long. 100's of sunray & life bulb projects. \$1 | <input type="checkbox"/> 12 VOL. CONTROLS Some w/switch, carbon & W.W., for vol., 10 types. \$1 | <input type="checkbox"/> 300-FT. HOOK-UP WIRE 16 thru 24. Glass, plastic insul.; colors, tinned. \$1 |
| <input type="checkbox"/> 125 HALF WATERS Carbon resistors. 30 values. 1% too. \$1 | <input type="checkbox"/> 40 TRANSISTOR DISCS Condensers incl. .02 and .05 mfd. Points too. \$1 | <input type="checkbox"/> 2 HOBBY TRANSISTORS Mini types. Similar to CK-722, 2N107. \$1 | <input type="checkbox"/> 20 TWIST DRILL SET In estimated cases: 1/16 thru 1/4". Elec. drills. \$1 | <input type="checkbox"/> 60 RADIO-TV KNOBS Colored, set screw types too! 1/2" to 3/4". Some \$1. \$1 |
| <input type="checkbox"/> 10-IN-1 PAKETTE Diodes, resistors, electros, sockets, lites, wire, etc. \$1 | <input type="checkbox"/> 7 TRANSISTOR SOCKETS For all transistors & submini tubes. \$1 | <input type="checkbox"/> 40 POWER RESISTORS Vitreous, enamel, porcelain types. 100's of uses. \$1 | <input type="checkbox"/> SUPER POWERED PHONE SENS. For transistor work. 2000 ohms, cord & plug. \$1 | <input type="checkbox"/> 1500 PCS. HARDWARE Nuts, bolts, brackets, screws, etc. in shop pak. \$1 |
| <input type="checkbox"/> 50 TUBE SOCKETS Wide variety. Includes NPO's, and tubulars, too. \$1 | <input type="checkbox"/> 4 OUTPUT TRANSFORM'RS 501B, etc. Open cased. Some \$2.50 ea. \$1 | <input type="checkbox"/> 2 HOBBY TRANSISTORS Mini types. Similar to CK-722, 2N107. \$1 | <input type="checkbox"/> 24 PAINT BRUSHES 6" handles, 100% pure bristles. 100's of uses. \$1 | <input type="checkbox"/> WORLD'S SMALLEST RADIO Germanium kit, lasts for life. All parts, instructions. \$1 |
| <input type="checkbox"/> 6 SILICON DIODES 1N21, 1N23, etc. Some worth \$10. \$1 | <input type="checkbox"/> SOLDERING IRON 115 VAC/DC; with cord set. For hobbyists, etc. \$1 | <input type="checkbox"/> 40 POWER RESISTORS Vitreous, enamel, porcelain types. 100's of uses. \$1 | <input type="checkbox"/> 75 MICA COND'S'RS Silvers & 17c. 20 vals. .00025 to 0.1 mf to 1000V. \$1 | <input type="checkbox"/> 40 MOLDED COND'N'RS 0001 to 1 to 1000 VDC. Oils, pure; reg. \$30. \$1 |
| <input type="checkbox"/> MIKE TRANSFORM'RS Mini size. Sealed. 100 ohms to 100,000 ohms. \$1 | <input type="checkbox"/> 6 SLIDE SWITCHES Toggle action. For 115 VAC/DC. Incl. SPST, DPDT. \$1 | <input type="checkbox"/> 2 PAINT BRUSHES 6" handles, 100% pure bristles. 100's of uses. \$1 | <input type="checkbox"/> 30 ELECTRO PAK 10mf to 1000mf & 450V. Duals & triples too. \$1 | <input type="checkbox"/> 10 "GRAIN-O-WHEAT" Lamps; by GE, 1.5VDC; mini work. Worth 25c ea. \$1 |
| <input type="checkbox"/> \$30 RELAY SURPRISE Popular relay assortment. Guar. satisfaction. \$1 | <input type="checkbox"/> 2 SAPPHIRE NEEDLES 5000 plays. All speed. Fits Asiatic cartridges. \$1 | <input type="checkbox"/> 2 PAINT BRUSHES 6" handles, 100% pure bristles. 100's of uses. \$1 | <input type="checkbox"/> HEARING AID PHONE Crystal. With cord & plug. Use as mike too. \$1 | <input type="checkbox"/> 40 TWO WATERS 10 Radio-TV val; 100 ohms to 500K. 5% too. \$1 |
| <input type="checkbox"/> 6 ROLLS VINYL TAPE In handy pak, 1000 uses. Strong adhesive; \$5-val. \$1 | <input type="checkbox"/> 2 POWER TRANSISTORS 10 types. For audio circuits in cars, etc. Reg. \$10. \$1 | <input type="checkbox"/> 75 MICA COND'S'RS Silvers & 17c. 20 vals. .00025 to 0.1 mf to 1000V. \$1 | <input type="checkbox"/> ELECTRIC MOTOR 1 1/2" VDC; 3000 rpm; Perm. magnet. 100's of uses. \$1 | <input type="checkbox"/> 1" SQ. CRYSTAL MIKE 100 to 7000 cps. Sensitive. For hiway, etc. \$1 |
| <input type="checkbox"/> 50-FT. POWER CABLE For intercoms, spkrs. etc. 2 cond., #18 rubber. \$1 | <input type="checkbox"/> 70 INSULATED RES'T'RS 1/2, 1, 2W. Finest carbons made. 1 & 5% too. \$1 | <input type="checkbox"/> 30 ELECTRO PAK 10mf to 1000mf & 450V. Duals & triples too. \$1 | | |
| <input type="checkbox"/> 60 TERMINAL STRIPS Solder lug type; 1 to 10 lugs. Used in elec. proj. \$1 | | | | |
| <input type="checkbox"/> 70 COILS & CHOKES RF, ant. osc. slp-tuned & IF. 15 types. Reg. \$22. \$1 | | | | |
| <input type="checkbox"/> 75 ONE-WATERS Resistors incl precision 1%. \$1 | | | | |

FREE GIANT BARGAIN CATALOG WRITE FOR YOURS!

- | |
|---|
| <input type="checkbox"/> 6 Transistor* Radio KIT! *Basic 20 pcs. incl. IF's, osc. coils, var. cond., in-and-out trans. sockets, instruc- tions \$4.99 |
| <input type="checkbox"/> TUBE TESTER Checks 400 tubes. Complete, wired \$2.49 |

EXCLUSIVE LEKTRON SALE RADIO-TV PARTS BY the POUND!!!

Reg. ONE POUND Precision Resistors . . . \$65	\$3 per pound
ONE POUND Disc Condensers . . . \$50	
ONE POUND Disc & Ceramics . . . \$45	
ONE POUND Ceramic Condensers . \$100	

★ QUANTITIES: 500-1000 PCS. SATISFACTION GUARANTEED.

HOW TO ORDER
 Minimum Orders—\$2

- Avg. wt. 1 lb. per Poly Pak
- Each Poly Pak guaranteed

State Price with each item. Send check or M.O. including sufficient postage; excess returned. C.O.D. orders, 25% down; rated, net 30 days. INCLUDE POSTAL ZONE in address. (Canada postage, 48c 1st lb.; 28c ea. add'l lb.)

LEKTRON 135 EVERETT AVE. CHELSEA 50, MASS.

IT'S FUN TO BE AN ARMCHAIR ADVENTURER

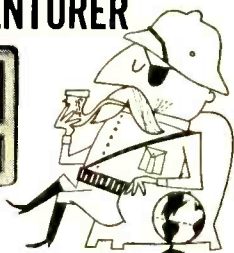

With a NATIONAL NC-60 SPECIAL Shortwave Radio Receiver you can cross the six continents in the comfort of your favorite chair, visit foreign lands, eavesdrop on aircraft, ships at sea and radio hams. Enjoy standard broadcast too, with this powerful new radio receiver. Suggested price only \$59.95. Write for literature and name of nearest dealer.

JOIN THE NATIONAL ASSOCIATION OF ARMCHAIR ADVENTURERS

SEND 50c for membership certificate and exciting new book on Shortwave Listening. Tells when, where, how to listen, provides log for listing countries you hear. SEND 50c to:

National RADIO CO., INC.

MELROSE 76, MASS.

A wholly owned subsidiary of National Co., Inc.



Export: AD AURIEMA, INC. 85 Broad St., New York, N.Y., U.S.A.
In Canada: CANADIAN MARCONI CO., Toronto 17

ASSEMBLE YOUR OWN

WALKIE-TALKIE RADIOPHONES



New Improved Model for
27 mc Citizens Band

Electronic
Chassis
ONLY

\$24⁹⁸
post-paid

- Meets FCC requirements for new class "D" citizens band radio-telephone.
- License easily obtained on application by any U. S. citizen 18 years or over. No tests to take.
- Transmits and receives one to several miles depending on obstructions and elevation.
- Assembled unit is completely portable and requires no external connections. Operates from self contained batteries obtainable at your local radio store.
- Electronic chassis is wired, tested, guaranteed and includes crystal controlled oscillator, R.F. power amplifier, audio modulator, receiver with R.F. stage, and a new transistorized audio booster stage for extra loud reception plus a complete set of tubes and transistor.
- Radio receiver is tunable to any of the 22 channels by a single control knob. Features ultra-high amplification, automatic volume control and noise clipping.
- Instructions and photographs are supplied with each chassis for completing the walkie-talkie as illustrated. Accessories are not included but are available at low cost.

FREE R.F. power indicator kit with each order.

SEND YOUR ORDER TODAY. INCLUDE POSTAL MONEY ORDER FOR FAST DELIVERY. C.O.D.'S REQUIRE \$5.00 DEPOSIT. N. Y. City residents add sales tax.

SPRINGFIELD ENTERPRISES

Box 54-E-6

Springfield Gardens 13, N. Y.

Transistor Topics

(Continued from page 78)

across individual "fader" controls $R1$ and $R2$. Resistors $R3$ and $R4$ isolate the input signals. Base bias current is supplied through $R5$, while $R6$ serves as $Q1$'s collector load. The amplified output signal is supplied through $J3$.

If you decide to duplicate Darrel's circuit, you'll find it worthwhile to assemble the audio mixer in a small aluminum cabinet to minimize external hum pickup. Use shielded leads for all inter-equipment connections. Note that Darrel has omitted coupling capacitors in order to keep the circuit simple and the cost low; these are needed *only* if the instrument is used with equipment not having built-in d.c. isolation. Where needed, use 0.1- to 0.5- μ f., 200- to 600-volt units ($C1$, $C2$, $C3$) for coupling between the equipment and jacks $J1$, $J2$, and $J3$. Proper load resistors ($R7$, $R8$) for the phono or mike cartridges used should also be connected as shown.

Help Wanted! Here are several requests from readers looking for special circuits. If you can help, write directly to the reader.

Ray Henning, Box 1244, Cal Poly, San Luis Obispo, Calif., is looking for an intercom circuit suitable for use in light airplanes.

W. J. Locke, 124 Dillon St., Houston 17, Texas, wants a fully transistorized, low-cost "walkie talkie" circuit with an operating range of approximately one mile.

Richard S. Swain, 13557 Douglas St., Yucaipa, Calif., needs a good circuit for a transistorized recording amplifier.

T. F. X. Carroll, 287 Avenue C, New York 9, N. Y., would like a compact semiconductor power supply suitable for use with a BC611.

Product News. General Motors Research Laboratories (Warren, Mich.) has developed a cadmium sulphide transistor. Although still experimental, this transistor has been used in oscillators, multivibrators, amplifiers, and radiation detectors. It has photosensitive as well as conventional transistor characteristics and thus is suitable for many special-purpose applications.

General Electric (Liverpool, N. Y.) is now producing sample quantities of a gallium arsenide tunnel diode. According to G.E., these new units have performance characteristics somewhat superior to those of the more familiar germanium tunnel

diode, although upper frequency limits are a bit lower.

A Swiss firm has developed—of all things—a transistorized pneumatic hammer! In operation, a free-running multivibrator operates the hammer by controlling solenoid valves. A potentiometer permits continuous adjustment of operating frequency up to 17 cps. These hammers, incidentally, are not of the high-power variety for tearing up city streets, but miniature units for use in the watch-making industry!

RCA (Somerville, N. J.) has announced a new semiconductor device designed to improve the sound quality of transistor radios while extending potential battery life. Basically a "compensating diode," the device is used in transistor amplifier circuits to compensate for changes in operating characteristics due to temperature variations.

The Lansdale Tube Company (Division of Philco) has announced price reductions for many of its transistors. These cuts range from 15% to 35% on 19 different types, reflecting higher demand and production improvements.

Minneapolis-Honeywell too, has issued a new rate schedule indicating lower prices for several transistors. Cuts range up to 20% for Types 2N538 and 2N538A, both high-quality power transistors designed for general-purpose use in amplifiers, power converters, switching circuits, and voltage regulators.

From International Rectifier Corporation (El Segundo, Calif.) comes news of a Zener diode handbook. Price is \$2.00 per copy, and it is available either by mail order or through local distributors.

That does it for now. Looking at the calendar, I see that vacation time is upon us . . . have fun!

Lou

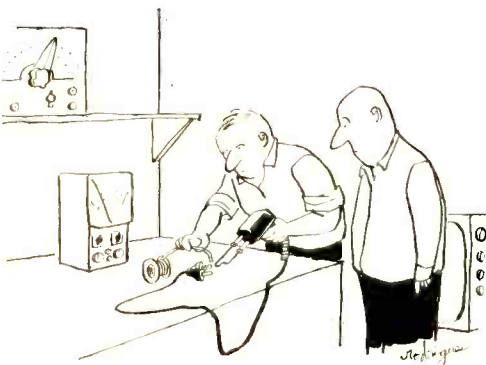

100 TIMES MORE TRANSISTOR RADIO BATTERY LIFE

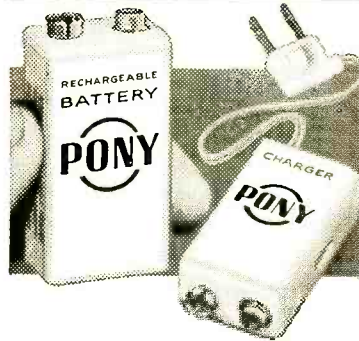

NEW
B&K
Rechargeable
BATTERY
AND
PLUG-IN
CHARGER

Revolutionary new idea gives you long-life, ready-to-use battery power for playing transistor radios, or for servicing them, or for other handy power needs. *Saves money*—stops frequent dry battery replacements. Improves tone quality. Recharges anytime, even while you sleep. Foolproof. Cannot overcharge. Directly interchangeable with the miniature 9-volt batteries used in transistor radios.

Complete Battery and Charger, both for only **\$4⁹⁵**
(slightly higher west of Rockies)

See your Parts Distributor or Send for Bulletin ST-9B

B & K MANUFACTURING CO.
1801 W. BELLE PLAINE AVE • CHICAGO 13, ILL.

SENDING A BILL?

It'll get there quicker if you give your postal delivery zone number with your address.

The Post Office has divided 106 cities into postal delivery zones to speed mail delivery. Be sure to include zone number when writing to these cities; be sure to include **your** zone number in **your** return address — after the city, before the state.

DX'ing on TV

(Continued from page 56)

possible. Here are the main considerations:

- The more a television receiver is used, the more its efficiency decreases. If possible, a second set should be used for program viewing, and the DX set employed for hobby purposes only.
- Heat is the set's prime enemy. Always keep it away from heaters and in an area of free air circulation. For best ventilation, the back of the set should be left off (unless small children or pets are about).
- Dust is the side-kick of heat. The chassis should be cleaned by hand or with a blower every three months. Caution: discharge the high-voltage section before cleaning the set.
- Tuner contacts should be inspected and cleaned at least once a year. Constant channel-switching in DX operation makes this necessary.
- All tubes should be tested every four months. Any tube found to be operating at less than 60% of maximum should be replaced.
- High-gain r.f. tubes such as the 6BZ8 and the 6922 are available to soup up the set's front-end performance. Good results can be obtained with them, but you should consult data on their application to your set's circuit before installing them.
- Realignment of the set is usually not necessary. If you feel that the set would profit from realignment, however, have it done only by a highly skilled technician who has considerable alignment experience.

It should be mentioned that some receivers are more successful at DX'ing than others. A model with a high-gain cascode tuner, three or four i.f. stages, and wired circuitry is highly desirable. The Zenith line is popular among TV DX'ers, as are the Du Mont and Andrea receivers.

Snagging the Signal. Almost any roof-mounted antenna can be employed for TV DX'ing, but the higher the gain and the more directional the antenna, the better it is for DX'ing. For v.h.f., a large percentage of DX'ers find that the Channel 2 - 13 Yagi is tops in all-around performance. Cut-to-channel Yagis do provide higher signal pickup for given channels, but installing several of these on one roof or tower is highly impractical (especially when one considers that couplers and switches can attenuate the signals). Stacking any antenna will provide higher gain, but in-

creasing the height is easier and better.

No matter what type your antenna, use a good grade lead-in such as the popular v.h.f. / u.h.f. foam variety. It's also wise to take your antenna down once a year for a thorough cleaning and check-up.

Another important aid to TV DX'ing is a good rotator. Since most antennas deliver the best signal when "pointed" directly toward the sending station, the advantage of 360° coverage is obvious. And for critical u.h.f. - DX, a rotator is a must.

A good signal booster can be used in every DX rig. Boosters come in two general types: the antenna-top and the set-top model. Both can pep up weak signals, but the antenna-top unit has the edge because incoming signals are amplified *before* transfer to the lead-in. Although the set-top unit amplifies noise collected in the lead-in process, most DX'ers use it because of its lower cost. Various models are available, and any receiver can be equipped with a set-top booster in a matter of minutes.

The cheapest "booster-like" device is a 7" x 4" sheet of metal foil. You wrap the foil on the lead-in about three feet from the receiver's input terminals, tune to a weak high-band or u.h.f. station, and slide the foil about six inches in either direction until the best picture is obtained. When changing channels, the adjustment is repeated. This impedance-matching technique is helpful to FM DX'ers also.

Why TV DX? There are two questions the layman usually asks a TV DX'er. First: why do you do it? Second: what proof is there you've actually seen the stations you claim to have seen?

The second question is not so hard to answer. Proof of reception is established by a photograph, by a "veri" (verification) card or letter from the station, or even by a tape recording of the station's "ID."

The first question is tougher. Why people will sit for hours in front of a TV set, switching from one blank channel to another is beyond me. But they do. And I do. And chances are, once you get started, you will, too!

-30-

Readers who would like further information about TV DX'ing should write to the American Ionospheric Propagation Association, c/o Art Collins, 68 Amber St., Buffalo, N. Y. This TV DX club publishes a monthly bulletin with reports and data of interest to serious DX'ers.

New Angle to Angling

(Continued from page 51)

pulsing rates affect fish of various sizes differently. Pulse rates of from 45 to 50 pulses per second are most effective on fish from 4" to 7" long and rates from 85 to 90 pulses per second work best with larger fish. A compromise rate of 50 pulses per second is adequate for most operations, however.

By the way, don't start getting any ideas about building your own electronic fishing system. Electronic fishing by other than scientists is illegal on most waterways in the United States.

Foreign Experiments. Europeans have done considerable work in developing commercially practical electronic fishing gear. Dr. Konrad O. Kreutzer, a German, has been especially active in this field. In one of his early experiments, he adapted a German minesweeper for the purpose, using a 60' span between electrodes. More recently, the efficiency of his system has been increased sufficiently to pay development costs.

Dr. Kreutzer also experimented with an electrical fish hook. A fish would be shocked and knocked unconscious when it bit the hook, and the fisherman could then pull in a dead weight rather than a fighting fish. This device was designed with the tuna industry in mind because the average tuna weighs more than 100 pounds and fights the line with great vigor. It has never had wide application, however.

The Russians, too, have experimented with electronic fishing gear, combining it with a giant vacuum cleaner that sucks the fish into the boat when they come near the positive electrode. As an added touch for night fishing, the Russians suspend lights over the vacuum pump inlet.

A similar system that operates in salt water has recently been announced by a West German electronics company, International Electronics Laboratories of Hamburg. Because of salt water's high conductivity, it was thought that electronic fishing in sea water would not be practical. However, tests indicate that this new system is quite satisfactory for sea-water applications. A 3'-wide flexible tube with an electric light to attract the fish is lowered into the water. As the fish approach the lower end of the tube, they are drawn up it toward the positive electrode at the upper

prepare for your career in

ELECTRONICS ELECTRICAL ENGINEERING RADIO-TV COMPUTERS

At MSOE, you can equip yourself for a career in many exciting, growing fields:
**MISSILES • RADAR • AVIONICS
AUTOMATION • RESEARCH
DEVELOPMENT • ELECTRICAL
POWER • ROCKETRY**

When you graduate from the Milwaukee School of Engineering, you are prepared for a dynamic career as an Electrical Engineer or Engineering Technician. Under a faculty of specialists, you gain a sound technical education in modern, completely equipped laboratories and classrooms. As a result, MSOE graduates are in great demand and highly accepted by industries nationally.

At MSOE, you will meet men from all walks of life and all parts of the country — some fresh out of high school or prep school, others in their twenties — veterans and non-veterans.

You can start school in any one of four quarters and begin specializing immediately. Engineering technicians graduate in 2 years with an Associate in Applied Science degree. For a Bachelor of Science degree in Engineering, you attend 4 years. A 3-month preparatory course also is available.



FREE CAREER BOOKLET!

If you're interested in any phase of electronics, radio or television, be sure to look into the programs of study offered by the Milwaukee School of Engineering. Just mail the coupon.

MILWAUKEE SCHOOL OF ENGINEERING

Dept. PE 660 1025 N. Milwaukee St.
Milwaukee, Wisconsin

Please send FREE Career Booklet. I'm interested in

- Electronics Electrical Power Television
 Mechanical Engineering Radio Computers
 Electrical Engineering Industrial Electronics

PLEASE PRINT

Name..... Age.....

Address.....

City..... Zone..... State.....

I'm eligible for veterans education benefits

MS-125

setup, calculate the power for a given meter reading as follows:

$$\text{Power (watts)} = \frac{\text{Voltage}^2 \text{ (across } R1)}{50}$$

This formula is valid only if the voltage scale on the VTVM is calibrated in r.m.s. Use *extreme caution* when calibrating, since one side of the 117-volt line is connected directly to the power meter case.

The full-scale reading on the 100-watt range can be changed to read approximately 20% higher or lower by adjusting pot. *R3*. The 10-watt range need not be calibrated and should read 10 watts full-scale with the values of *R4* and *R5* shown. If desired, the 100,000-ohm resistor used for *R5* can be changed to a 2-watt potentiometer of the same value. This would allow you to vary the full-scale reading with switch *S1* in its "10-watt" position.

Operation. To operate the unit as a power meter, connect *J1* to the output jack of the transmitter under test. Set the range switch to the 100-watt position to start. If the meter reads 10 watts or less, you can safely switch *S1* to the 10-watt range for a more accurate reading.

To test a transmitter's low-pass harmonic filter, connect *J1* to the output of the filter with the transmitter output connected to the filter input. Record the wattage at the filter output jack. Next, remove the filter and connect *J1* directly to the transmitter output. A much higher reading without the filter indicates that the filter elements need readjustment or that the transmitter has a high harmonic output.

As a dummy load, the r.f. power meter can be operated continuously at 40 watts or less. Higher transmitter outputs should be applied only momentarily to prevent damage to load resistor *R1*.

-30-

HOW IT WORKS

The r.f. power meter determines the power output of a transmitter by measuring the voltage across fixed load resistor *R1*, which is connected to the transmitter output. Meter *M1* is calibrated in watts according to Ohm's law.

In operation, diodes *D1* and *D2* rectify the r.f. voltage across *R1*. The rectified voltage appears across resistors *R2*, *R3*, and meter *M1* in the 100-watt range, and across resistors *R4*, *R5*, and meter *M1* in the 10-watt range. In each range (selected by *S1*), a current flows through the meter in proportion to the rectified voltage present.

Two bypass capacitors (*C1* and *C2*) are used to maintain the linearity of the meter. At self-resonance, each capacitor becomes ineffective as a bypass device. But since the two capacitors are self-resonant at different frequencies, one always functions as an r.f. bypass.

COMPLETE SERVICE TRAINING

... written so you can understand it!



Fix any TV or Radio Ever Made

EASIER-BETTER-FASTER!

No complicated theory or mathematics! These famous Ghirardi books get right down to brass tacks in showing you how to handle all types of AM, FM, and TV service work by approved professional methods. Almost 1500 pages and over 800 clear illustrations show how to handle every phase of troubleshooting and servicing. Each book is co-authored by A. A. Ghirardi whose manuals have helped train more servicemen than any other books or courses of their kind!

1—Radio and Television Receiver TROUBLESHOOTING AND REPAIR

A complete guide to profitable professional methods. For the beginner, it is a comprehensive training course. For the experienced serviceman, it is a quick way to "brush up" on specific jobs, to develop improved techniques or to find fast answers to puzzling service problems. Includes invaluable "step-by-step" troubleshooting charts that show what to look for and where. 820 pages, 417 illustrations, price \$7.50 separately.

2—Radio and Television Receiver CIRCUITRY AND OPERATION

This 669-page volume is the ideal guide for servicemen who realize it pays to know what really makes modern radio-TV receivers "tick," and why. Gives a complete understanding of basic circuits and circuit variations; how to recognize them at a glance; how to eliminate guesswork and useless testing in servicing them. 417 illus. Price separately \$6.75.

Special low price . . . you save \$1.25

If broken into lessons and sent to you as a "course," you'd regard these two great books as a bargain at \$7.50 or more! Under this new offer, you buy both books for only \$13.00 . . . you save \$1.25—and have the privilege of having in easy installments while you use them! No lessons to wait for. You learn fast—and right!

STUDY 10 DAYS FREE!

Dept. PE-60, RINEHART & CO., Inc.
232 Madison Ave., New York 16, N. Y.

Send books below for 10-day FREE EXAMINATION. In 10 days I will either return price indicated (plus postage) or return books postpaid and owe you nothing.

Radio & TV Receiver TROUBLESHOOTING & REPAIR (Price \$7.50 separately)

Radio & TV CIRCUITRY & OPERATION (Price \$6.75)

Check here for MONEY-SAVING COMBINATION OFFER. Save \$1.25. Send both of above big books at special price of only \$13.00 for the two. (Regular price \$14.25 . . . you save \$1.25.) Payable at rate of \$4 plus postage after 10 days if you decide to keep books and \$3 a month for 3 months until the total of \$13.00 has been paid.

SAVE! Send cash with order and we pay postage. Same return privilege with money promptly refunded.

Name

Address

City, Zone, State

Outside U.S.A. \$8.00 for TROUBLESHOOTING & REPAIR; \$7.25 for CIRCUITRY & OPERATION; \$14.00 for both. Cash only, but money refunded if you return books in 10 days.

find new
adventure in
amateur
radio...

with

Viking
1st choice of
amateurs the
world over!

loaded with features... kit or wired!



ADVENTURER —50 watts CW input 80 through 10 meters. 240-181-1... Kit Am. Net... \$54.95	RANGER —75 watts CW input; 65 watts phone—160 through 10 meters. 240-161-2... Kit Am. Net... \$229.50	VALIANT —275 watts CW and SSB; 200 watts AM—160 through 10 meters. 240-104-2... Kit Am. Net... \$349.50
	240-161-1... Wired Am. Net... \$329.50	240-104-1... Wired Am. Net... \$439.50



FREE CATALOG



E. F. JOHNSON CO.

1233 2nd Ave. S.W. • Waseca, Minn.

Complete specifications and schematics on all Johnson transmitters, amplifiers, station accessories, keys and practice sets!

NAME _____

ADDRESS _____

CITY _____ STATE _____

PURCHASING A HI-FI SYSTEM? NOW YOU CAN CHARGE IT!

If you are an International credit card holder. Up to 10 months to pay. No down payment necessary.

Send Us
Your List of
Components
For A Package
Quotation

WE WON'T BE UNDERSOLD

All merchandise is brand new, factory fresh and guaranteed.

AIREX RADIO CORPORATION

64-PE Cortlandt St., N. Y. 7

CO 7-2137

Altec Lansing
Electrovoice
Jensen • Hartley
University • Stephens
Acoustic Research
Janszen
Wharfedale
Karlsen Cabinets
Viking
Concertone
Bell • G.E.
Weathers
Harman-Kardon
Eico • Pilot
Sherwood
Acrosound • Roberts
Fisher • Ferrograph
Bogen • Leak
Dynakit • H. H. Scott
Thorens
(Fair Traded)
Dual Changer
Ampex • DeWald
Sony • Challenger
Wollensak • Pentron
Garrard • Quad
Miracord • Pickering
Glaser-Steers
Components
Rek-O-Kut
Audio Tape
Norelco • Magnecord
Fairchild • Gray

How to Place Stereo Speakers

(Continued from page 84)

In any room it's necessary to strike a balance between the best stereo illusion and the most comfortable overall sound. The optimum positions for each purpose sometimes don't coincide. The best listening coverage for stereo is usually attained when the speakers are positioned along one of the shorter walls of a room. Corner placement generally provides the best bass response, but the space separating two corner speakers will often be too extreme for effective stereo.

After you outgrow a possible mania for ping-pong effects, your main consideration will be listening ease. In your first hour of experimenting, you will find that certain locations produce reflections and concentrations of sound (standing waves) which amplify one particular frequency range tremendously. At almost any point in the frequency scale, standing waves make for extreme listening fatigue, and at very low frequencies they produce a general feeling of uneasiness which is hard to pinpoint at first. Square rooms are usually the worst offenders in standing-wave production, particularly when speakers are positioned in corners.

Because of the variations in recording techniques, there are no rigid rules about how far the speakers should be spaced apart, although today's stereo speakers are usually not placed as far apart as in the earliest days of stereo. The ideal, of course, is to duplicate the original separation of the microphones used in recording. This is an elusive goal at the moment, still waiting for the last word from the recording engineer. In general, though, a bottom limit of three to four feet of speaker separation is necessary even in the smallest listening room to allow sorting out the separate impressions which give stereo its impact.

As you test speaker locations in your living room, the problem of speaker phasing reappears in another form. This time the consideration is acoustical—rather than electrical—phasing. For maximum stereo effect, the sound from both speakers should reach your ears at precisely the same instant. This means that both speakers should be approximately the same distance from your listening position. While it's not always possible to be exact in placing speakers for this purpose, putting one

significantly closer than the other to your favorite listening spot will partially destroy one of the most carefully calculated aspects of stereo sound.

The Decor Conflict. While you have considerable choice in the positioning of speakers, a few things are (or should be) taboo for the true stereophile. Almost all of them are related to room decor. Many wives, encouraged by pictures in home furnishing magazines, are adept at placing stereo speakers to score a decorative triumph. Unfortunately, sound values are usually lost in the esthetic shuffle.

A favorite decorative gambit is the placing of speakers in a "listening corner" at right angles to each other. While speakers can often be placed facing slightly toward or away from each other, the ninety-degree placement usually means misery for the stereophile. Carefully planned phase relationships disappear and the perspective which stereo offers—both in directionality and depth—is largely lost. Less serious but even more common is the installation of bookshelf speaker systems at staggered distances from the floor. The alert stereophile should be prepared to cope with his wife's decorative instinct and keep it within bounds.

Interior decorators are to be regarded with particular caution—some will stop at nothing in their efforts to "harmonize" decor and stereo. One of the more outrageous concepts involves the use of a circular rug to match the "round" sound of stereo.

Also to be avoided is the intrusion of a piece of furniture directly between you and either of the speakers. If high frequencies are obstructed and muffled by a well-stuffed sofa inherited from Aunt Minnie, much of the impact of stereo will disappear. Highs are responsible for supplying most of the subtle details in the make-up of musical instruments, and their absence leaves you listening to unsatisfactory reproduction.

Finally, it's worthwhile to remember that stereo was intended to supply the depth and perspective you feel at a live performance, rather than a super-directionality of sound which you seldom notice at a concert. If you concentrate too much on hearing the drums from the left and the trumpets from the right, you may wind up with out-of-phase or otherwise inferior sound which is a long way from the realism that stereo, at its best, can offer.

-30-

June, 1960

only for those who want the *ultimate*

SHERWOOD

"TOP RATED"

again and again

-and NOW AGAIN!



Model S-530, 20-watt "stereo"
Dual Amplifier-Preamplifier, Fair Trade Price—\$189.50



Model S-2200, FM-AM-MX Stereo Tuner,
Fair Trade Price—\$179.50

AMERICAN AUDIO INSTITUTE

314 EAST 116th ST. CHICAGO 4, ILL.

October 27, 1959

Sherwood Electronic Labs., Inc.
4300 North California Avenue
Chicago 18, Illinois

Gentlemen:

We find that the incorporation of a center-channel output and a damping auto-selector in July 1959 increases the "Summary Rating" of the Sherwood S-530A to the highest of all FM-AM Stereo Amplifier-Tuners in the ARI Evaluation Test Report.

Sincerely,

AMERICAN AUDIO INSTITUTE

Telix R. Brown
Telix R. Brown
Executive Director

The "Most honored of them all" S-5000 stereo amplifier-preamplifier is joined by the S-2200 stereo tuner. As with its "Top Rated" predecessors, the S-2200 features FM "Inter-channel Hush" plus push button selector, internal plug-in adaptor for Stereo FM Multiplex, 2 "Acro-beam" tuning indicators, simulcast FM/AM stereo. All Sherwood tuners feature FM sensitivity below 0.05 microvolts and 1/3% distortion @ 100% FM. For further details write: Sherwood Electronic Laboratories, Inc., 4300 N. California Avenue, Chicago 18, Illinois.

For complete specifications write Dept. PE-6

107

USE THE CONNECTORS
THE PROFESSIONALS
USE

E-Z-HOOKs

Make Testing — Substituting — Trouble Shooting
EASY — FAST — SAFE!

Electronic experts want connectors that grip — and *WON'T* slip.

The exclusive E-Z-HOOK design grips test spots positively . . . eliminates intermittents . . . leaves your hands free. A sliding nylon insulator protects against adjacent shorts.

Add new convenience to your test equipment. Have more fun — more confidence in experimenting and trouble shooting. Get E-Z-HOOKs at your favorite parts distributor today.



2/3
Actual
Size

- No. 61-1 E-Z-HOOK CLIP*
For Jumper and equipment leads, etc. \$.49 net
- No. 71-1 E-Z-HOOK SUB
For substituting parts without soldering69 net
- No. 59-4 E-Z-HOOK TIP
Adapter for Banana test probe.69 net
- No. 56-1 E-Z-HOOK TIP
Adapter for Standard .060" test probe.89 net
- No. 55-0 E-Z-HOOK TIP
Adapter for Needlepoint .060" test probe.89 net
- No. 54-1 E-Z-HOOK CUSTOM PROBE*
For special probe assemblies and replacements 1.39 net

*Also available with gold plated hookwire for Guid-d Missile work and other special projects.

All feature 6 colors for easy lead identification.

EVERY E-Z-HOOK IS GUARANTEED



E-Z-HOOK TEST PRODUCTS

1536 Woodburn Avenue Covington, Ky.
Canadian Rep.: Len Finkler, Ltd., Toronto 12, Ontario

TRAIN for SUCCESS with CENTRAL

Electronics TV and RADIO

Airlines

Read about opportunities for electronic technicians in giant aero-space industry, radar, television, computers, atomic energy, etc. Published by leading midwestern technical institute — offering resident and home study courses.

- Learn how to qualify as
- Airline Station Agent,
- Reservationist, Passenger
- Agent, Radio Operator, etc.
- Fly the jets.
- Nation-wide placement service.

FREE BOOK

FREE BOOK

ACCREDITED BY NHSC

CENTRAL TECHNICAL INSTITUTE (Est. 1931)
Dept. A-60. 1644 Wyandotte Street, Kansas City 8, Missouri

Across the Ham Bands

(Continued from page 72)

monitoring stations. Instead, try to give true reports to the stations you work to the best of your ability and equipment. And if anybody disputes their accuracy, don't waste your time in fruitless argument. Simply admit the possibility that you might be wrong.

In turn, if you receive an unflattering report, don't argue with the ham who gives it to you. If your signal is bad, why be the only one on the band not to know it? When you know it, you can do something about it.

A local ham called a short time ago to tell me that he had just received an official FCC discrepancy report. Although his carrier frequency was 2.1 kc. inside the 20-meter phone band, he was cited because his *sidebands* extended 2 kc. into the c.w. band. The FCC *does* monitor the ham bands.

News and Views

You've heard about "cooking on the front burner." Well, **Nick, W9YQP**, Springfield, Ill., beats that. His wife cooks on that burner and the rest of the burners on her electric stove, but she listens to Nick on the front burner. That's the one he comes out of "loud and clear" when he's on the air. Can anybody explain it? . . . **Arnaldo Coro, Jr., CO2DL**, 62 #3310 Marianao, Cuba, works 50.1 and 50.4 mc., running 15 watts to a 6146 feeding a five-element beam. He and CO2's MW, ZX, XZ, RR, GX, and QY would like to arrange skeds with U.S. six-meter hams for propagation research. Arnaldo is interested in working 40-meter Novices, but he needs a 40-meter Novice crystal, which is not obtainable in Cuba—currency restrictions. . . . **Joe Burch, KN3JLS**, 556 Continental Rd., Hatboro, Pa., started his ham career with an old Stromberg-Carlson receiver, minus BFO. After chalking up a record of two contacts, he decided to give his Heathkit DX-20 transmitter a little help and got a Hallicrafters S-85 receiver and a Heathkit QF-1 Q-multiplier. His antenna is a Windom, fed through balun coils. With this combination, he has 18 states worked, 16 confirmed. Joe will help prospective hams get their licenses.

Larry McKay, K5RRG, P.O. Box 98, Madison, Miss., uses a Heathkit DX-40 to feed 10- and 40-meter dipoles, both 40' high, and receives with a Hammarlund HQ-110C. He has worked 50 states and 18 countries, but moans because he cannot pry a QSL card out of Hawaii. His country total is 18. Check with Larry if you need a Mississippi card. Forty-meter c.w. and 10-meter phone are his favorites. . . . **Larry Aldrich, KN3HJQ**, RD #3, Corry, Pa., works 40 and 80 meters, using a Globe Scout 680-A transmitter. Its r.f. leaps into space from a 125' "long-wire" antenna, and his signal trapper is a converted "surplus" ARC-5. In fact,

free

RADIO SHACK CORPORATION

ELECTRONICS CATALOG plus every new issue for 1 year

Yours free if you act now! Radio Shack's big 312-page catalog featuring the newest and best in electronic equipment! Stereo, hi-fi, ham radio, tapes and scores more items for amateur, pro. Also receive FREE subscription to all new issues for year!

MAIL COUPON NOW

Radio Shack Corp., 730 Commonwealth Ave., Boston 17, Mass., Dept. 60F7
Send FREE Catalog—Also every new issue for 12 months, a year's subscription Free.

Name _____
Address _____
Post Office _____
or City _____ Zone _____ State _____

he must have two of them to work both 80 and 40. In four months on the air, his total is 101 contacts. . . . **Donald E. Lampkin, WY2HMB**, 187—29 Mangin Ave., St. Albans 12, L. I., N. Y., passed his Technician exam in December and plans to take his General exam this summer. He uses a home-built 6L6 transmitter running 25 watts and receives with a Hallicrafters S-40A receiver. . . . **Don Lewis, KN4MQT**, 1860 Audubon Dr., N. E., Atlanta 6, Ga., also sticks to home-built transmitters. His 40-meter rig runs 35 to 40 watts, and he has a 25-watt for 15 meters. He receives on a Hallicrafters S-38B. Don's record is 19 states, 14 confirmed, but he works under a dire handicap: if his school grades drop to "C," he goes off the air until they come back up again.

Dave Grant, WL7DEM, P.O. Box 190, Nome, Alaska, has heard many Novices miss choice DX stations calling them because they don't tune off their own frequencies. Being only 150 miles from UAØ (Russia), Dave rates as pretty good DX for most other U.S. hams himself—really "far out," in fact. In eight months, he has worked 12 states, plus Russia, Midway, Guam, Okinawa, Japan, and New Zealand.

. . . **Richard Stewart, Jr., K3ITH**, 2504 Prescott Rd., Haverton, Pa., uses his 40-meter dipole antenna on all bands from 10 to 80 meters, feeding it with a DX-20. He uses a separate antenna for his Hallicrafters S-38E receiver. QSO's with 26 states prove that he gets out. Dick is president of the Haverford Junior High Radio Club and a member of the

Rag Chewer's Club. . . . **Gordon Pastor, KN8RMN** (17), 3090 Hillier Rd., Barberton, Ohio, likes 15 and 40 meters. In three months, he has worked 10 countries on five continents. A three-element 15-meter beam, 45' high, helps his DX-40 do the job, and an RME DB-22A preselector assists his old Hallicrafters SX-28 receiver. Gordie grinds his own crystals for the transmitter. Between 15 and 40 meters, he has worked 45 states.

Don Wright, VE6AAM, 4707 Coronation Dr., and **Brian Credico, VE6EX**, 1928 29 St., S.W., both in Calgary, Alberta, Canada, make a joint report. Don prefers 15-meter c.w. but drops down to 80 meters occasionally. His EICO transmitter feeds a five-element G4ZU beam. He has two receivers—a Hallicrafters SX-99 and a Hammarlund HQ-100. He has worked all states but needs cards from New Mexico and Montana. DX: 38 countries, 18 confirmed. Brian VE6EX, needs Utah, Vermont, and South Dakota. He has 23 countries, 13 confirmed. His transmitter is "home-brew," running 45 watts on phone and 80 watts on c.w. Twenty meters is his favorite phone band, but he works a lot of c.w. on 15, 20, and 40 meters. Brian has a three-element 20-meter beam, a "ground plane," and a 40-meter dipole. His receiver is a Hammarlund HQ-110. Both boys work as many Novices as they can and QSL 100% on receipt of cards.

Until next month, when I hope to have your letter, picture, and suggestions, 73.

Herb, W9EGQ

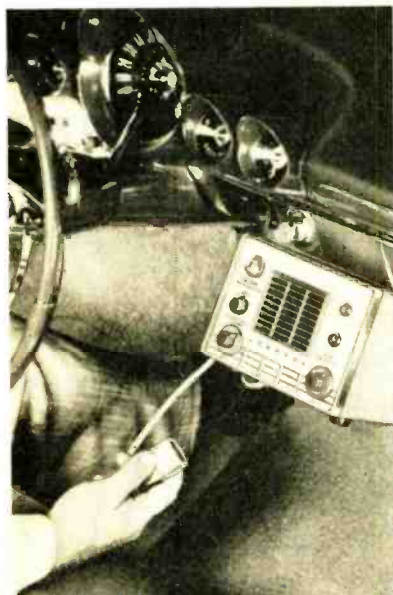

"More than Citizens' Radio"...

a complete, fully engineered "industrial-type" transceiver!

VIKING *Messenger*

Anyone can operate—license issued by the FCC on request

from **\$129⁷⁵**

- Complete 23 channel Citizens' Band coverage—choose 1 of any 5 channels by the flip of a switch.
- Maximum legal power—excellent range—meets all FCC requirements.
- Excellent receiver sensitivity and selectivity—full fidelity voice reproduction.

"More than just 2-way Citizens' Radio equipment"—the Viking "Messenger" will deliver the finest performance of any equipment available in the field. Designed throughout for 10 watt power level—limited to 5 watts for Citizens' Radio. Easy to install anywhere in your home, business location, car, truck or boat . . . offers many unique features found only on more expensive communications systems. Built-in Squelch, Automatic Volume Control, and Automatic Noise Limiter. Compact, modern styling—only 5 3/4" high, 7" wide, and 11 3/4" deep. Complete with tubes, push-to-talk microphone, and crystals for one channel.



Available from authorized Johnson Electronic or Marine Distributors. Installation and service coast-to-coast at all General Electric Communications Service Stations.



FREE
Color Brochure

E. F. JOHNSON COMPANY

125 Second Ave. S.W. • Waseca, Minnesota
• Please rush me your full color brochure describing the Viking "Messenger" Citizens' Transceiver.

NAME _____

ADDRESS _____

CITY _____

STATE _____

WRITE TODAY

Manufacturers of the world's most widely used personal communications transmitters

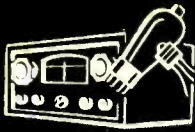

**SELL YOUR USED
EQUIPMENT Through
POPULAR ELECTRONICS'
Classified Columns!**

The 320,000 purchasers of **POPULAR ELECTRONICS** are always interested in good used equipment or components. So, if you have something to sell, let PE readers know about it through our classified columns. It costs very little: just 50¢ a word, including name and address. Minimum message: 10 words.

For
further
information
write:

Martin Lincoln
POPULAR ELECTRONICS
One Park Avenue
New York 16, N. Y.

GET INTO ELECTRONICS

V.T.I. training leads to success as technicians, field engineers, specialists in communications, guided missiles, computers, radar, automation. Basic & advanced courses in theory & laboratory. Assoc. degree in 29 mos. B. S. obtainable. ECPD accredited, G.I. approved. Graduates with major companies. Start Sept., Feb. Durans, campus. H. S. graduates or equivalent. Catalog.

VALPARAISO TECHNICAL INSTITUTE
Dept. PE VALPARAISO, INDIANA

CITIZENS RADIO!

SAVE MONEY! Read these all-new Handbooks!

HOW TO OBTAIN YOUR CITIZENS RADIO LICENSE

License form and full data. No examination! Includes "Part 19" rules. Book #107. Price: \$1.00.

ANTENNAS FOR CITIZENS RADIO SERVICE

Low cost build-it-yourself antennas will make you "top signal". Book #108. Price: \$1.00.

OPERATION OF YOUR CITIZENS RADIO STATION

Installation and operation data. Cure of TV interference. Non-technical. Book #109 (Ready July 1). Price: \$1.00.

At your radio dealer. Add 15c on mail orders to: Radio Publications, Inc., Dept. E, Wilton, Conn.

Eavesdropping on Outer Space

(Continued from page 45)

logical system to represent natural physical constants, such as the speed of light. Our computers would make quick work of breaking a code based on such logical concepts.

But deciphering signals is just one problem to be encountered in this, man's strangest adventure in communications. Even if signals come from the nearest stars, the distances involved are so great that it would take almost 20 years to answer a single question. If, as is more likely, life is found at a distance of 50 light-years, it would take 100 years to get our first answer.

Elaborate Installations. The equipment now being used in radio astronomy would seem like a dream-come-true to Karl Jansky. Today's receivers can detect signals millions of times weaker than could his home-built rig. Masers and other super-sensitive devices are actually capable of hearing signals that are a millionth of a millionth of a millionth of a watt!

Ingenious devices isolate, identify, and measure minute signals completely buried in the cacophony of squeals, crackles, and wails that fill the ether. Where yesterday's radio astronomer listened on a headset, or watched a moving pen scratch a wavy line on a graph, today's scientist sits in his office figuring out new exercises for his giant telescope to run through.

The telescope itself, meanwhile, peers into its assigned sector of the heavens, translates what it sees into digital form, and feeds the result into an electronic brain for analysis and evaluation. Like the Venus radar contact mentioned earlier, today's received signals are far too complex for a human operator to recognize, let alone analyze. So computers have moved in to do the job.

Certainly the most eye-catching feature of any modern radio telescope is its antenna. It may take any one of a weird variety of forms. The University of Ohio telescope, for example, looks like a giant upside-down rake with each 12' tooth wrapped in a steel coil. Near Sydney, Australia, there is a space ear in the form of a giant cross with arms a third of a mile long. A Russian instrument at the University of Leningrad looks like a huge board fence, with each board individually adjustable.

Today's largest radio telescope is at Jod-

rell Bank, not far from Manchester, England. It is a giant dish, 250' in diameter, as tall as a 30-story building. It is tilted by battleship gun turrets and mounted on locomotive wheels riding a circular track.

Future Telescopes. The world's most impressive telescope—and the largest scientific instrument ever built—will be the U. S. Navy's 600' dish telescope already under construction at Green Bank, W. Va. This mammoth space ear will tower 66 stories. Its giant dish will be as big as Yankee Stadium, yet the entire seven acres of its aluminum-mesh reflecting surface will be accurate to within a fraction of an inch. Since thermal contraction and expansion—and distortion caused by wind pressure and gravity—would normally stretch the reflector out of shape by several inches, engineers have worked out a scheme to keep the surface absolutely true at all times. They've arranged this by dividing the face into a number of small sections and installing individual servo motors on each one. In the finished dish, each section will adjust automatically for the slightest misalignment.

Bigger and more powerful radiosopes are coming. Not long after the 600' antenna

goes into operation in 1962, Cornell University's 1000' giant in Puerto Rico is expected to be ready for action. This monster will not be steerable—its huge bowl will be hollowed out of a mountain valley. But its great range will push back the frontier of space still further.

Even this huge reflector will suffer from limitations that no earthbound telescope can overcome, however. Radio noise created by the decay of radioactive substances in the earth's crust has long been a source of trouble. Unavoidable, too, is the interference generated by the layer of ionized gas that covers our planet several hundred miles above its surface.

But radio astronomers think they already have the answer: a telescope in space! Not only would such a telescope get away from the earth's noise, but it would also be free from gravity, wind, and changing temperatures. When will such an instrument be built? Not for a long time, surely. But when it is, it will be another valuable tool in man's never-ending quest for knowledge of outer space—a quest that began with Karl Jansky's startling discoveries less than 30 years ago.

-30-

SCIENCE ENGINEERING

Bachelor's degree in 27 or 36 months

Accelerated year-round program: Aero., Chemical, Civil, Electrical, Mechanical, Metallurgical, Mathematics, Chemistry, Physics, Molest rate. Earn board. New classes start June, September, January, March. Catalog, 2360 E. Washington Boulevard, Fort Wayne 2, Indiana.

INDIANA TECHNICAL COLLEGE



LOOK

NO FURTHER... IF YOU'RE UNHAPPY WITH "HI" HI-FI PRICES, WRITE FOR OUR UNUSUAL AUDIO CATALOG. KEY ELECTRONICS CO. 120-B Liberty St., N. Y. 6

BEFORE YOU BUY... GET THIS CATALOG FREE!

Send postcard today for your free G-C Catalog 158... 80 pages of valuable service aids available at your distributor.



G-C ELECTRONICS CO.
division of Textron Electronics, Inc. Western Plant: Los Angeles 18, Calif.
Main Plant: ROCKFORD, ILLINOIS, U.S.A.

IMPROVE YOUR SWL/DX-ABILITY WITH LOW COST TD-3 Jr. ANTENNA

(10-15-20 or 10-15-40 meters)

You'll add more hard-to-get stations to your log with this "Ham-Quality" Mosley Antenna. Factory assembled—easy to install (just tie the ends to any convenient support). Weatherproof—weighs only 1 3/4 lb. Overall length—24 ft.

WRITE FOR NAME OF NEAREST DISTRIBUTOR

Mosley Electronics, Inc. 4610 N. Lindbergh
Bridgeton, Missouri

ONLY
\$12.50
COMPLETE

SERVICE MASTER . . . EVERY TOOL YOU NEED 99% OF THE TIME

Complete 23-piece kit for radio, TV, and electronic service calls. Includes 2 interchangeable handles (Regular and Stubby), 9 snap-in regular nutdrivers . . . 3 stubby, 3 screwdrivers (2 slotted, 1 Phillips), 2 reamers, 7" extension. Plus "Cushion Grip" long nose plier, diagonals, and adjustable wrench. Durable, plastic-coated case.

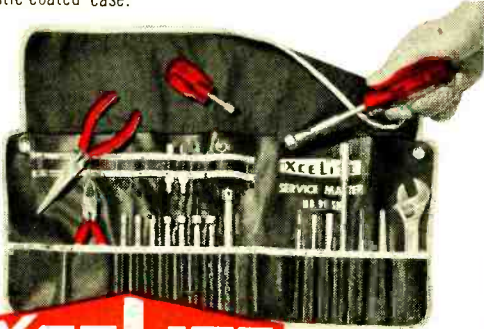

XCELITE

XCELITE, INC., ORCHARD PARK, N. Y.
Canada: Charles W. Pointon, Ltd., Toronto, Ont.

ask your distributor to show you Kit 99 SM.

CITIZEN BAND CLASS "D" CRYSTALS



3rd Overtone: Hermetically Sealed .005% tolerance—Meets F. C. C. requirements, 1/2" pin spacing—.050 pin diameter. (.093 pins available, add 15¢ per crystal.)
\$2.95 EACH
ALL 22 FREQUENCIES IN STOCK!

(add 5¢ per crystal for postage and handling)

The following Class "D" Citizen Band frequencies in stock (frequencies listed in megacycles): 26.965, 26.975, 26.985, 27.005, 27.015, 27.025, 27.035, 27.055, 27.065, 27.075, 27.085, 27.105, 27.115, 27.125, 27.135, 27.155, 27.165, 27.175, 27.185, 27.205, 27.215, 27.225.

Matched crystal sets for Globe, Conset, Cit-Fone and Hallier-afters Units . . . \$5.90 per set. Specify equipment make.

RADIO CONTROL CRYSTALS in HC6/U HOLDERS—SIX FREQUENCIES

In stock for immediate delivery (frequencies listed in megacycles): tolerance .005%, 1/2" pin spacing, .050 pin diameter. (.093 pins available, add 15¢ per crystal.) Specify frequency desired.

26.995, 27.045, 27.095, 27.145, 27.195, 27.255 **\$2.95 EACH**

(add 5¢ per crystal for postage and handling)

Send for **FREE CRYSTAL CATALOG #860 WITH OSCILLATOR CIRCUITS**

ASK YOUR PARTS DEALER FOR TEXAS CRYSTALS

See big red display . . . if he doesn't stock them, send us his name and order direct from factory.

All Orders Shipped From Our
New Florida Plant 1st Class Mail
Rush your order to:

TEXAS CRYSTALS

Dept. P-60, 1000 Crystal Drive, Fort Myers, Fla.
For even faster service, Phone WE 6-2100

The Language of Vectors

(Continued from page 87)

Larry. "Now let me draw the vector diagram for an inductive circuit." Larry made a rapid sketch.

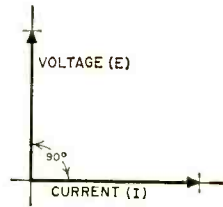

"That's it," said Ken approvingly. "Now let's get serious, Larry, and put all the things we've discussed together in one piece. I'm going to draw a very simple circuit that has all three elements—resistance, inductance, and capacitance. Then I'll draw the complete set of curves for the circuit. When you see it, I think you'll really understand why vectors are important. Remember, what I'm drawing is just about as simple a situation as you can find in an electronics circuit."

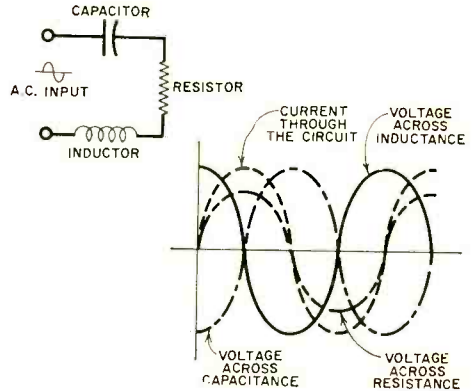

"Wow!" Larry smacked his hand loudly against his forehead and stood up. "That does it, pal. You said it would be a simple circuit. I'm leaving. See you around."

"Steady, old boy," said Ken with a laugh. "This is the test that will separate the man vectors from the boy vectors. Actually, all you have to do is plot each curve as its own vector on a set of coordinate axes. Draw the coordinates, take the curves one at a time, and see how you make out."

Note to the reader: This can be your test as well as Larry's. Before you read on, why not try and draw the vector diagram for

Always say you saw it in—POPULAR ELECTRONICS

We'd like to send you these important new books for a 7-DAY FREE TRIAL EXAMINATION

CITIZENS RADIO Leo G. Sands



Here is the first complete book on Citizens Radio Operation. Ever since the initial use of 2-way radiotelephone by police departments, this field has been growing in importance and application. Now, with more than a million vehicles equipped for its use, Citizens Radio is a major phase of the electronics field. This important new volume covers every aspect of the field—its history, rules, and everything about how it works—in seven big chapters with one hundred major sections. You'll learn exactly what Citizens Radio is, its applications, what equipment you need, the full story on receiver circuits and transmitters, antennas, installation, and maintenance, full FCC rulings, how to apply for licenses, etc. Many illustrations. **\$4.95**

COMPUTERS AND HOW THEY WORK by James Fahnstock

Here is a fact-filled exciting guidebook to the wonderworld of electronic computers, with more than 120 illustrations and easy-to-follow tables in 10 big chapters. Step by step, you'll see and understand the workings of every type of computer ever used. This important new book illustrates the basic principles of computers in methods that require no knowledge of electronics. You'll learn all about computer memories, flip-flops and the binary counting system. You'll learn the mathematical language of computers where $1 + 1 = 10$. Other chapters show you how computers use tubes and transistors to make complex logical decisions in thousandths of a second. **COMPUTERS AND HOW THEY WORK** is must reading for career minded students and for electronics pros who want a more complete knowledge of this field. **\$4.95**

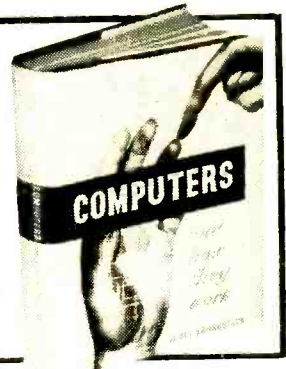

THE ELECTRONIC EXPERIMENTER'S MANUAL by David A. Findlay

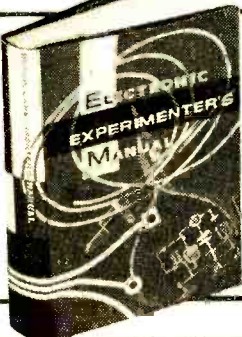

With a few dollars worth of basic tools, and this book to guide you, you can explore the magic of electronics experimentation more completely than ever before. In a few short hours, you'll start your first project. You'll learn about every component used in experimentation, every tool, its function and why it is used. There are 10 big sections, each covering a specific phase of construction. There's a giant section of projects you can build, test equipment you'll construct and use in your future work. **THE ELECTRONIC EXPERIMENTER'S MANUAL** will give you the professional know-how you must have no matter what phase of electronics is your specialty. **\$4.95**

USE THIS CERTIFICATE FOR 7 DAY FREE EXAMINATION

7 DAY FREE EXAMINATION

When your books arrive, read and enjoy their diversity of contents, the thoroughness of their coverage. Then after seven days examination, if you decide that they are not everything you want, send them back and receive a complete refund of the purchase price.

ELECTRONICS BOOK SERVICE • A Division of the Ziff-Davis Publishing Co.
434 S. Wabash Ave., Chicago 5, Ill.

Please send me _____ copies of **CITIZENS RADIO** and bill me at only \$4.95 a copy plus a few cents postage.

Please send me _____ copies of **COMPUTERS AND HOW THEY WORK**, and bill me at only \$4.95 a copy plus a few cents postage.

Please send me _____ copies of **THE ELECTRONIC EXPERIMENTER'S MANUAL**, and bill me at only \$4.95 a copy plus a few cents postage.

If I don't agree that this is one of the best electronics investments I've ever made, I may return the book(s) within seven days and get a full refund.

\$ _____ enclosed. (SAVE MONEY! Enclose payment with your order and we'll pay the postage.)

Name _____

Address _____

City _____ Zone _____ State _____

ZPFCO

Enjoy your HI-FI OUTDOORS

PATIO, GARDEN, TERRACE, POOL

with the new WT-6 ATLAS HI-FI COAX-PROJECTOR

all-weather construction... install it, forget it!...
or take it with you wherever you listen.



True hi-fi TWO-WAY system—
not just a "compromise." The
WT-6 comprises a weather-
proof cone type driver (with
6-inch throat) coupled to its
individual woofer horn; a sepa-
rate pressure-type driver
loaded to its separate tweeter
horn; and built-in electronic
crossover filter.

For all indoor and outdoor
uses... universally adjustable
"U" type rugged steel mount-
ing... finished in high-tem-
perature baked modern beige
enamel.

Power Rating 15 watts contin-
uous. Freq. Resp. 125-15,000
cps. Impedance 8 ohms. Dis-
persion 120°. Bell opening
15", overall depth 12".

See the WT-6 at
your local dis-
tributor. Send
for catalog 560.

Net \$34.50



ATLAS SOUND CORP.
Dept. PE-6, 1449 - 39th St., Brooklyn 18, N. Y.

CODE

I have been teaching Code
for forty years and I know
that before you can read Code
you must first learn the Code
alphabet according to SOUND.
Dottedash is not A. The SOUND
resulting from dottedash is A.

Regardless of discouraging
experience to the contrary learning Code is extremely
easy and fascinating. It does not have to be third
degree punishment. My automatic transmitter is really
automatic. In a matter of seconds you select just a
few letters, an entire lesson, any number of lessons
or entire record of seven lessons engraved in copper
and your selection will be automatically transmitted
over and over with no stopping or changing anything.
Let me send you the full story.



R. G. Miller, TELEPLEX COMPANY
739 Kazmer Court Modesto, California

MASTER ELECTRONICS

Intensive, high-level training at this recognized public college
prepares you for a successful career in electronics. Fine equip-
ment—experienced instructors—small classes—personal attention—
all college advantages provide excellent learning opportunities.
Associate in Applied Science Degree in 18 months. Engineering
option. Low tuition and living costs. College housing for single
and married students. Established 1925. FREE catalog. Write

TRINIDAD STATE JUNIOR COLLEGE
Trinidad, Colorado
Dept. PE-6

these curves yourself? Remember Ken's
advice: take the curves one at a time and
set up a vector for each one. If one vector
falls on top of another, that's okay—just
think each curve out for itself.

LARRY began to draw with some hesita-
tion. "First I'll draw in the vector for
the current because it's the same for the
whole series circuit," he said. "Then I'll
draw the vector for the voltage across the
resistor. Say... these two are in phase
with each other, so they would come out on
the same line... like so. How's this, Ken?"

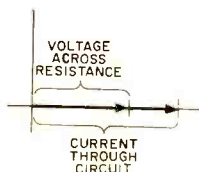

"That's the way to use the old noggin,
Larry. Now you have two more curves to
consider, the voltage across the inductance
and the voltage across the capacitance—
which leads which, and by how much. Draw
that in and there's your vector diagram."

With sudden inspiration, Larry began to
pencil in the two additional vectors. "First
off," he said as he drew, "the voltage across
the inductance is at a maximum point when
the current curve is at zero. That means it
leads the current by 90°, so I'll show it this
way."

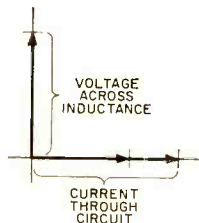

"Good boy," said Ken enthusiastically.
"Now finish it off."

"Lemme see, now," murmured Larry.
"The only vector left to put in is one to
represent the voltage across the capacitor.
From what I know, and from the looks of
the curve, that voltage is 90° behind the
current, so its vector would fit in here."
Larry drew in this final vector. "Double-
checking against your curves, Ken, I can
see that the capacitor voltage is at a min-
imum at the points where the current curve

crosses the base line of the coordinate axis. That means I must be right when I show this vector lagging behind the current vector by 90°."

He passed his complete drawing across to Ken.

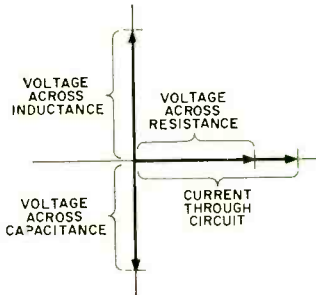

"That's it, Larry. The diagram is right and you've done a fine job. Now, if you'll look at the mess of curves that represent the same circuit as the vector diagram you just drew, I'll bet you can see why engineers like to work with vectors."

"Boy, do I ever get the point, Ken! The vector diagram sure does simplify things . . . once you understand what it means. I really want to thank you for teaching me all about using vectors."

"Wait one sec, chum. Did I read you right? Do you think you know all about vectors?" When Larry nodded, Ken started to laugh.

"All I've done, Larry, is show you the ABC's of the subject. Remember this: vector algebra takes up a full college course and gets pretty deep. If you remember what we did discuss, though, you'll be able to understand enough about vectors to follow most discussions you come across in technical books and articles.

"If I were you I'd get a text on the mathematics of electronics — *Mathematics for Electricians and Radiomen*, by Nelson M. Cooke, is a good one. Study the sections on vectors in it and you'll be surprised how much you can learn in a short time. All you need is high-school math, and you'll be on your way.

"Speaking of being on your way," Ken added, "it's time for me to close up shop here."

"Thanks loads, Ken," said Larry. "I really appreciate the help. From now on vectors will hold no fears for me, and I'm sure going to dig into them a little deeper as you suggested."

-30-

June, 1960

GLOBE ELECTRONICS

3-Channel, 2-Way Radio CB-100

Citizens Broadcaster

- ★ High Styled
- ★ Ranges up to 15 Miles
- ★ Requires No Tests for License

GIVES YOU



CB-100—Complete 3-channel, 2-way station for permanent installation or travel. Only 31¢ x 101¢ x 113¢. Easy to install, operate. Only 3 controls. Range 10-15 miles. Complete with one set crystals, push-to-talk microphone, \$129.95 each.

Just \$13.00 Down
\$760 Per Mo.



and you get **"LISTENABILITY"**
WITH THE HALLICRAFTERS S-38E



Net: \$59.95

\$600 Down

\$500 Per Mo.

Excellent receiver for world wide short wave reception covering standard broadcast band 540-1650kc, three short wave bands 1650kc-32mc, and intermediate frequency 455kc. Two section tuning gang with electrical band-spread. Oscillator for code reception. Easy-to-read side rule dial. Built-in 5" speaker. Four tubes plus rectifier. Size 12 7/8" x 7" x 9 1/4".

We Stock the Complete Line of Gear
from
GLOBE ELECTRONICS
and
THE HALLICRAFTER COMPANY

WRL WORLD RADIO LABORATORIES
3415 W. BROADWAY • PHONE 32 8-1851
COUNCIL BLUFFS, IOWA

Send Late Reconditioned Eqpt. Lists and Complete Information on the:
 CB-100 2-Way Radio S-38E

NAME: _____
ADDRESS: _____
CITY & STATE: _____

PE6

115

POPULAR ELECTRONICS

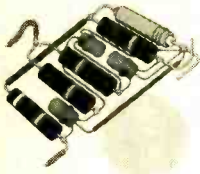

Send
POPULAR ELECTRONICS

Every
Month

name _____

address _____

city _____ zone _____ state _____

3 years for \$10

Check one: 2 years for \$7

1 year for \$4

Payment Enclosed

Bill Me

In the U. S., its possessions and Canada. Foreign rates: Pan American Union countries, add .50 per year; all other foreign countries, add \$1 per year.

Mail to: **POPULAR ELECTRONICS**

Dept. PE-660, 434 S. Wabash Ave., Chicago 5, Ill.

TV PICTURE TUBES AT LOWEST PRICES

10BP4 \$ 7.95	16WP4 \$12.00	17TP4 \$17.00	21EP4 \$13.50
12LP4 8.50	16PT4 9.95	19AP4 16.00	21FP4 14.50
14B/CP4 9.95	17AVP4 12.50	20CP4 13.50	21WP4 14.00
16DP4 12.00	17BP4 9.95	20HP4 14.50	21YP4 14.50
16EP4 12.75	17CP4 17.00	21AP4 22.10	21ZP4 13.50
16GP4 14.50	17GP4 17.60	21ALP4 15.75	24CP4 23.50
16KP4 9.95	17HP4 12.50	21AMP4 15.75	24DP4 24.50
16LP4 10.95	17LP4 11.50	21ATP4 15.75	27EP4 39.95
16RP4 9.95	17QP4 9.95	21AUP4 15.75	27RP4 39.95

1 YEAR WARRANTY

Aluminized tubes \$3.00 for 21"; \$5.00 for 24" and 27" additional. Prices include the return of an acceptable similar tube under vacuum. These tubes are manufactured from reprocessed used glass bulbs. All materials including the electron gun are brand new.

ALL PRICES FOR CHICAGO, ILLINOIS. Deposit required. When old tube is not returned, refundable at time of return. 25% deposit required on COD shipments. Old tubes must be returned prepaid. Tubes shipped Rail Express. We ship to the Continental U. S. and Canada, only.

WRITE FOR COMPLETE LIST

—PICTURE TUBE OUTLET—

2922 MILWAUKEE AVE., CHICAGO 18, ILLINOIS
Dickens 2-2048

FREE 5" PLASTIC EXTENDER
• Push Button Assembly • Pin-Point Application • Won't Cause Shorts

"No-Noise" VOLUME CONTROL and CONTACT RESTORER
2 oz. bil. • Cleans • 6 oz. can \$1.
• Lubricates \$2.25
• Protects

"No-Noise" TUNER-TONIC
With Perma-Film
"A little does a lot!"
6 oz. aerosol can \$3.25

Insist On Genuine "No-Noise" Products
ELECTRONIC CHEMICAL CORP. At Your Dist. Only
813 Communipaw Ave. Jersey City 4, N. J.

Inside the Tape Recorder

(Continued from page 48)

tion. The most common equalizer uses a feedback loop from the output of the second triode to the cathode of the first. A combination of resistors and capacitors in the feedback loop achieves the equalization.

Commercial tapes will provide a flat response if equalized with an NAB equalizer, the curve of which is given in Fig. 4. This curve was originally worked out for 15-ips tapes, but Ampex has modified it by adding more treble boost in the recording curve to make it effective at 7½ ips. All commercial 7½-ips tapes are recorded to produce a flat response to 10,000 cycles or more when played back with NAB equalization.

Although there is no official standard for 3¾-ips tapes, Ampex has developed an equalization which is similar to the NAB curve except that the turnover is 2 octaves lower—at around 800 cycles. The recording curve requires a boost of about 14 db at 7500 cps and a low-end boost similar to that of the 7½-ips standard. At the moment, the Ampex curve appears to be the one most widely used for 3¾-ips tapes.

Recording Amplifiers. Recorders must have preamplifiers to amplify the weak input of a microphone and amplifiers to drive the recording head. The preamps generally follow usual hi-fi circuitry, although one or two professional types use the cascode arrangement for the input stage of the microphone preamp in order to assure the best signal-to-noise ratio. To attain a noise figure of 55 db or better, noise and hum must be minimized; therefore, in the highest-quality recorders, d.c. heater supplies and low-noise resistors are employed.

While the simpler home-type recorders often make one amplifier do double duty in playback and in record, the more elaborate recorders have separate record and playback amplifiers. By using the playback amplifier in conjunction with a separate playback head, it is possible to monitor the tape as it is recorded.

Naturally, the more elaborate and costly the unit, the better it will be able to approximate ideal performance. Home-type recorders, although they are modestly priced in comparison to professional machines, generally are good values. They are far superior to their ancestors and deliver very acceptable performance.

—30—

Short - Wave Report

(Continued from page 76)

as well as for other hams. The ARRL Bureau then forwards the SWL cards to those who have provided a self-addressed, stamped envelope, or they send them to a local SWL club, such as the Newark News Radio Club. Most SWL clubs also forward QSL's, but only to their members. When they receive cards for SWL's who are not members, they classify them as "undeliverable" after a reasonable attempt to locate the addressees.

One of the large SWL clubs reports that many QSL cards are being received from hams addressed only to WPE call signs. Naturally, the SWL club must, in turn, contact POP'tronics to obtain the addresses before the cards can be forwarded. Should the recipient not be a member of the club, the club is under no obligation to forward the cards to him.

Of course, you have a much better chance of receiving the QSL if you include your name and address as well as your WPE call when you request a card. (There is no reason why you should not do so since QRM on postcards is quite low.) If you wish, you can also include return postage, and the ham can send your QSL direct to you. Check with your postmaster for information on International Reply Coupons so you will not have to enclose currency.

For the time being, your Short-Wave Editor is willing to assume the duties of a QSL Bureau for "undeliverable" SWL's, but only for clubs and not for individuals. Clubs wishing to use this service should send me



The listening post of Donald House, WPE3KA, Lancaster, Pa. His equipment includes a Zenith Trans-Oceanic portable, a Hallicrafters S-38E, and a broadcast-band receiver. Don has collected 70 cards from amateurs, with six countries confirmed.

June, 1960

To build the
projects in
this
issue
of

POPULAR
ELECTRONICS

Use these
STANCOR
TRANSFORMERS

"Black Box Magic"

T1—Output Transformer
use Stancor TA-29
List Price \$6.20

They are available from any Stancor Distributor . . . and have been verified for their application in the construction projects listed.

LOOK FOR this helpful listing every month. It appears regularly in Popular Electronics.

CHICAGO STANDARD
TRANSFORMER CORPORATION
3501 W. Addison St. Chicago, Illinois

BUILD THE
PROJECTS
DESCRIBED
IN THIS
ISSUE OF

WITH THESE



PRODUCTS

POPULAR
ELECTRONICS

Low-Cost Transistor Tester

Use BUD CU-278 (Steel) \$1.22

or

BUD AU-1028 (Aluminum) \$1.29

Build An RF Power Meter

Use BUD CU-2105 (Steel) \$1.25

or

BUD CU-3005 (Aluminum) \$0.94

All Bud products are available for immediate delivery from your Authorized Bud Distributor. They are the best for applications described in these projects.

WATCH FOR THESE LISTINGS EVERY MONTH
IN POPULAR ELECTRONICS

BUD RADIO, INC.
2118 East 55th Street Cleveland 3, Ohio
Dept. P.E.

a list of club members and their WPE calls. Operators of SWL club QSL Bureaus may then send undeliverable cards (only those bearing a WPE call sign) directly to me, and I'll do my best to forward them. Individuals are specifically requested not to ask for addresses of call-sign holders.

At a later date we hope it may be possible to organize a full-scale WPE QSL Bureau. However, it takes a lot of hard work to get such a bureau organized, and continuous effort to maintain it in good order. It is pretty much of a thankless job. On the other hand, it might be an interesting project for those who handle it. Only time will tell. In any case, you can rest assured that the SWL QSL Bureau is coming—now that the SWL is being recognized more and more, and now that we have our own call signs.

Current Station Reports

The following is a compilation of current reports. All times shown are Eastern Standard and the 24-hour system is used. At time of compilation all reports are as correct as possible; stations often change schedule and/or frequency with little or no advance notice. Please send all reports to P. O. Box 254, Had-

donfield, N. J., in time to reach Your Editor by the eighth of each month.

Afghanistan—Kabul is noted on 9703 kc., dual to (but not heard on) 4750 kc., with an Eng. xmsn from 1030 to 1059 and from 1415 to 1430 s/off with pop and classical recordings. (WPE3NF, WPE8GF)

Algeria—Algeria Renaissance (Voice of Free Algeria) is heard on 8220A kc. with Arabic chanting at 0045-0100 followed by talks in French; Arabic music resumed at 0111. (WPE3AGZ)

Brazil—ZYR96, Sao Paulo, 17,710 kc., has been heard well at 1940-2100 with music and Portuguese anmts. (WPE4BC)

Bulgaria—Sofia is heard well on 9700 kc. with Eng. to N.A. at 2000-2030 and 2300-2330. A mailbag program is given on Thursdays and Sundays and a DX program on the first Friday of each month. Other Eng. xmsns are noted at 1430-1500 and 1635-1705 (the latter is dual to 7670 and 7255 kc.) to the United Kingdom. A daily concert is scheduled at 1835-1900 on 9700 kc. to N.A. and England. A new outlet on 11,850 kc. is heard at 1900 in Spanish and at 1930-2000 in Bulgarian. (WPE2ACO, WPE2BAT, WPE3AJC, WPE4ASH, WPE4DZ, WPE5CN, WPE8BEU, WPE9KM, WPE9DN, WPE9NY, WPEOABI, VE3PE5S, HJE, JK, JR)

Chile—CE1515, R. Corporacion de Santiago, Santiago, is noted with a strong signal on 15,150 kc. from 2130 with programs of American and L.A. music. (WPE3HP)

HI-FI RECORDING TAPE

FREQ. RESPONSE 30-15 KC.
10 DAY MONEY BACK GUARANTEE

	3	10	25
1200' Acetate, each	\$1.29	\$1.17	\$.99
1800' Acetate, each	1.79	1.59	1.45
1800' Mylar, each	2.09	1.99	1.85
2400' Mylar, each	3.29	2.99	2.75

Any assortment permitted for quantity discount. Add postage 15¢ per spool—25 or over 10¢.

In Stock—Hi-Fi under mfgs. franchise—A. R. Bell, Bogen, Dynaco, E. V. Elec, ESL, Fisher, Garrard, Har-Kar, Norcent, Pilot, Rek-O-Kut, Shure, Thorens, United Dual, Univ. Wharfedale, Wallensack & many many other components & Tape Recorders.

Send for low, low return mail quotation. "We Guarantee to Save You Money." Wholesale catalog free.

Hi Fidelity

CENTER

1799P 1st Ave.

New York 28, N. Y.

engineering degree in 27 months

Grasp your chance for a better life. Rapid advancement. Better income. BACHELOR OF SCIENCE DEGREE IN 27 MONTHS in Elect. (Electronics or Power major), Mech., Civil, Aero., Chem., Engineering. IN 36 MONTHS in Business Administration (General Business, Acctg., Motor Transport Mgt. majors). Small classes. More professional class hours. Well-equipped labs. Campus. Dorms. Modest costs. Year-round operation. Founded 1884. Enter Sept., Jan., May, July. Write J. D. McCarthy, Director of Admissions, for Catalog and "Your Career in Engineering and Commerce" Book.

TRI-STATE COLLEGE

3660 College Avenue
Angola, Indiana

NOW—AVIATION WEATHER REPORTS, IN YOUR CAR

Be a weather expert! TC-1 Weather Radio receives 24 hour aircraft weather reports (200-400 K.C.) on your car radio. Minutes to install, no electrical connections, won't interfere with AM reception. Nationwide reception. 3 year guarantee. Send check or money order. \$35.50, postpaid.

Boulevard Electronics, 1229 W. Washington, Chicago Ill. Dept PE-6



Send for free illustrated brochure

For the true hi-fi enthusiast who wants a "custom" accessory for his high fidelity system . . .

Decor designed by Mosley electronic specialists . . . neat, convenient and efficient!

See the complete line of American Made Mosley speaker switches, attenuator plates and speaker wall outlets.

Literature is yours for the asking . . . write today!

Mosley Electronics, Inc.

BRIDGETON, MISSOURI

PE-6



England—The European Service of the BBC has German at 2345-0015 on 3952.5 kc. and English-by-radio at 0000-0015 on 3975 kc. Both channels carry a program in Czechoslovakian at 0015. (WPE2ACO)

Finland—OIX4, Pori, 15,190 kc., is heard very well at 0630-0800 with programming in Finnish, pop and classical music. A DX program is aired on Saturdays at 0630-0700. A xmsn in Swedish/Finnish to Europe is noted at 1100-1330, dual to 17,800 and 6120 kc. At 1100-1120 on alternate Fridays, there is an Eng. DX session. A new Eng. program is planned for 15,190 and 17,800 kc. at 1730-1800 on Mondays only. (WPE1BM, WPE2ACO, WPE2BMO, WPE8HF)

Gabon Republic—R. Gabon, Libreville, has moved from 5025 to 4774 kc. and is quite

New Stations

The *Voice of America* will shortly begin construction on two mammoth transmitting sites and a receiving station around an 18-mile triangle near East Greenville, N. C. With a total power of nearly 5 megawatts, there will be six 500-kw. units, six 250-kw. transmitters, and 10 lesser-powered stations. The antennas involved will include nearly 100 curtain, rhombic, and log periodic types with 400 towers ranging from 50' to 375' high. Several presently scattered VOA installations will be concentrated at this new site. (WPE8-AD, DG)

A new short-wave station is to be constructed at Forney, Texas, and will operate somewhere between 15,100 and 15,450 kc. with a power of 50,000 watts. The owners, Global Broadcasting Co., plan broadcasts in Spanish and English beamed to Peru, Ecuador, Colombia, Venezuela, British Guiana, Surinam, and parts of Brazil and Bolivia. No call letters have yet been assigned. (WPE5AC)

From Monaco you can expect to pick up the signals of *Trans World Radio*, a new 100,000-watt transmitter of the *Voice of Tangier*. Complete information on this station, regarding frequencies and schedules, is unavailable at the moment and it is possible that this is only a medium-wave station. (AS)

Mr. I. C. Griggs, Chief Engineer of the *Sierra Leone Broadcasting Service*, writes that they are hoping to increase the power of their short-wave outlet to 10,000 watts and may, in addition, operate on a different frequency during daylight hours. The new outlet is not expected to be in operation until after 1960. (WPE8MS)

strong until 1600 s/off (Saturdays to 1700). (WPE3NF)

Germany (East Zone)—R. Berlin International, 11,765 kc., has an Eng. test program at 1130-1200 to the Middle East and another Eng. xmsn at 1230-1300. The new Arabic Service is heard at 2305-2335. (WPE8MS, WPE9AWO, WPE9KM)

Ghana—Accra, 3366 and 4915 kc., has Home June, 1960

OVER
60 PAGES
OF
COLOR
PHOTOGRAPHS
YOURS IN—

COLOR
PHOTOGRAPHY

1960



NOW ON SALE

AT NEWSSTANDS AND CAMERA STORES
OR ORDER BY COUPON TODAY.

The world's only publication devoted exclusively to color photography! It features the most exciting and comprehensive treasury of color shots ever published—compiled by the editors of POPULAR PHOTOGRAPHY.

YOU'LL ENJOY FEATURES LIKE:

- BERT STERN'S LITTLE GIRLS
- HALSMAN'S WOMEN
- HAUNTED VIEW OF NEW YORK
- SAUL LEITER'S DREAM WORLD
- THE NUDE—IN COLOR OR NOT?
- THE NATURE OF COLOR PHOTOGRAPHY

BE SURE TO GET YOUR COPY OF THIS
HANDSOME ANNUAL TODAY!

Only \$1.25

Ziff-Davis Publishing Company
Department PE 66
434 S. Wabash Avenue, Chicago 5, Illinois

Please send me a copy of COLOR PHOTOGRAPHY 1960. I enclose \$1.25, the cost of COLOR PHOTOGRAPHY, plus 10¢ to cover mailing and handling charges.

NAME _____

ADDRESS _____

CITY _____ ZONE _____ STATE _____

GIANT CITIZENS BAND CLEARANCE SALE!!!

Nationally Advertised Transceiver Kits

110 volt kits..... **\$29.95** 6 or 12 volt kits..... **\$31.95**

Philmore TC-11—115 volt Transceiver Kits..... **\$39.95**

Philmore TC-612—6 & 12 volt Transceiver Kits..... **\$44.49**

Special Offer: \$9 Mobile CB Antenna Free with above Kits!!!

Antenna Specialists Top Quality Ground Plane Antenna..... **\$15.95**

Antenna Specialists 102" Mobile CB Antenna—heavy duty—swivel base and heavy spring-chromed stainless steel whip..... **\$11.97**

Famous make 100" CB Antenna—stainless steel whip—chrome plated swivel base and spring—reg. \$14.95..... **\$9.95**

Antenna Specialists Heavy Duty Bumper Mount..... **\$5.25**

Antenna Specialists Double Chain Bumper Mount—Professional..... **\$7.95**

Famous Make Citizens Band Crystals—Specify frequency..... **\$1.89**

No C.O.D.—include postage—order early—send for our latest flyer!!!!

TV ELECTRONIC SUPPLY CO.

4645 S. COTTAGE GROVE

CHICAGO 53, ILLINOIS

MOBILE-FIXED CONVERTER

POLICE • FIRE • CITIZENS' BAND



#315A is a practical converter for emergency use. Easily installed. Tuning range approximately 12 MC in the 26-50 MC band—30 MC in the 108-174 MC band. Designed for mobile or home use. **\$13.95**

Available crystal controlled up to 54 MC. **\$19.95**

Also available crystal controlled up to 165 MC. **\$22.95**



#316A VARIABLE CONVERTER. Front panel tuning permits rapid change between separated signals over 10 MC range in 26-54 or 108-174 MC bands. **\$19.95**

#331B Crystal controlled converter for use with 12 V. Transistor type car radios. 26-50 MC. Can be installed in seconds. **\$24.95**

Other models for 108-162 MC available.



#311A CITIZENS BAND TUNEABLE CONVERTER. This universal converter covers the entire Citizens Band and is designed for use with home, car or communications sets—AC-DC or standard models. Also available: 200-400 Kf Aircraft, 2-3 MC Marine, 4.5 MC-CAP or Amateur 2-30 MC. **\$24.95**

Full line of converters and receivers for every application. **ORDER TODAY or WRITE for LITERATURE**

KUHN ELECTRONICS
20 GLENWOOD CINCINNATI 17, OHIO

news at 0100, "Radio Newsreel" (from the BBC) at 0115, Eng. language lessons to 0130, and recorded music to 0200. The IS is African drumbeats. (WPE1AAC, WPE1KW, WPE2TA, WPE3HP, WPE4JP, WPE8MS)

Gilbert & Ellice Islands—R. Tarawa, VSZ10, 6050 kc., has been tuned at 0230-0300 with music and talks in native language, and an Eng. ID. (WPE8BGF)

Guatemala—R. Nacional de Quetzaltenango, 6118 kc., is noted from 0039 to 0102 s/off with news and ID in Spanish. Sunday is the best day. (WPE3DS)

India—Eng. broadcasts from Delhi are as follows: 2330-2340 to E. Africa on 21,620 and 17,810 kc.; 1045-1100 to E. Africa on 17,840 and 15,225 kc.; 1930-1950 to Burma on 11,895 and 15,280 kc.; 2130-2145 to S.E. Asia on 17,830 kc.; 0830-0930 to S.E. Asia on 21,605 and 17,705 kc.; 0500-0600 to Australia and New Zealand on 17,795 and 21,690 kc.; 0500-0600 to N.E. Asia on 21,615, 17,705, and 15,205 kc.; 1445-1545 to Europe and England on 11,710 and 9675 kc.; and 1445-1545 to W. Africa on 17,790 and 15,105 kc. (WPEICE, WPE8MS)

Iraq—The Eng. xmsn from Baghdad was recently rescheduled to 1600-1630 on 6030 kc. (WPE1AGM, WPE1BY)

Israel—The Voice of Zion, Jerusalem, 9009 kc., is beamed to W. Africa at 1615-1645 in Eng., and to 1715 in French. Other xmsns are broadcast at 1530-1600 in Eng. and at 1430-1500 in French, both beamed West. A dual outlet on 9727 kc. is not announced but carries Eng. at 1545-1600. (WPE1AGM, WPE1ANK, WPE4KB, WPE8MS, WPE9AGB, WPE9KM)

Japan—Tokyo has replaced 9525 kc. with 17,825 kc. to N.A. and Hawaii. (WPE6EZ)

Liberia—ELWA, Monrovia, is good on 21,515 kc. at 2015-2152 on Tuesdays only in Eng., and on 11,980 kc. at 0030 to past 0115 with Eng. until 0100. A new outlet on 11,825 kc. has been noted at 0030 beamed to West and Central Africa; French from 0100. (WPE9KM, WPEQEW, WPEOVU)

Monrovia's 4770-kc. outlet is heard very well during their late afternoon xmsn with the signal peaking around 1630; Eng. religious programing. (WPE2FT)

Luxembourg—R. Luxembourg carries German religious services at 0000-0030 on 6090 kc. (WPE5AG)

Malaya—The BBC Far Eastern Station, Singapore, 11,955 kc., is tuned at 0433-0445 with pop music followed by the General Overseas Service sports results, and at 1125-1141 with classical music and commentary. (VETPEIR, RB)

Netherlands New Guinea—RONG (Radio Omroep New Guinea) Bosnek, Biak, 6072 kc., is fair on this new outlet at 0724 with choral music and anmts in Dutch. (WPE3NF)

New Guinea—VLT6, Port Moresby, 6130 kc., is noted with dance music at 0315 and ID at 0330. This station has only 2000 watts power. (WPEQVB)

Nigeria—Lagos is noted on 4990 kc. with Eng. news at 1600. After a native language period, English at 1634 with recordings. (WPE1AGM)

The Kaduna outlet on 3326 kc. has Eng.

ELECTRONIC KITS 1960 DIRECTORY



500 ELECTRONIC KITS

WHAT THEY ARE!
WHAT THEY COST!
WHAT THEY DO!

Yours in the brand new 1960

ELECTRONIC KITS 1960 DIRECTORY

Here it is—the only complete, comprehensive directory covering the exciting world of electronic kits! It's yours in the 1960 ELECTRONIC

KITS DIRECTORY—over 160 pages—listing over 500 kits of all kinds. Each listing gives you manufacturers, specifications, prices, everything you need to know about kits!

You'll find such informative features as:

- **GIANT KIT BUILDERS GUIDE**

Gives you the latest improvements, and innovations in kits...helps you select the right kit...identifies parts for you, too!

- **COMPLETE SURVEY AND DIRECTORY OF:**

Kits for HI-FI—make your own amplifiers, preamps, speakers, turntables, stereo control units, and tone arms.

Kits for COMMUNICATIONS—Rundowns on kits for oscilloscopes, tube testers, power supplies, transmitters, receivers, transceivers. Kits

for EDUCATION—Coverage of radio kits and many other special projects.

NOW ON SALE AT YOUR FAVORITE
NEWSSTAND OR ELECTRONIC PARTS
STORE **ONLY \$1.00**

Don't miss 1960 ELECTRONIC KITS DIRECTORY. Now on sale at newsstands, electronic parts stores and hi-fi salons! Buy your copy today, or order by using the handy coupon at right. Only \$1.00.

Ziff-Davis Publishing Company
Department PE 66
434 S. Wabash Ave., Chicago 5, Illinois
Please send me a copy of the 1960
ELECTRONIC KITS DIRECTORY. I enclose
\$1.00 plus 10¢ to cover mailing and handling
charges. (Canada and Foreign \$1.25 plus 10¢
postage).

Name _____

Address _____

City _____ Zone _____ State _____

news at 0030 with a BBC news relay at 0100. (WPE8MS)

Portugal—Lisbon is noted in Eng. on 17-895 kc. at 1215-1300 (news at 1245) to S. Africa and at 0845-0930 on 21,495 and 17,880 kc. to India, Pakistan, and the Persian Gulf area. Their usually excellent musical programs and all-Portuguese anmts can be heard at 1300-

SHORT-WAVE CONTRIBUTORS

Stanley Schwartz (WPE1AAC), Bridgeport, Conn.
 James Silk (WPE1AGM), Madison, Conn.
 Dave Swedock (WPE1ANK), Meriden, Conn.
 Anson Boice (WPE1BD), New Britain, Conn.
 Jerry Berg (WPE1BM), West Hartford, Conn.
 Alan Roth (WPE1BY), Bridgeport, Conn.
 David Gerns (WPE1CE), Concord, Mass.
 Johnny Chane (WPE1KW), Winchester, Mass.
 Paul Buer (WPE2ACO), Harrison, N. Y.
 Thomas Jaworski (WPE2BAT), Brooklyn, N. Y.
 Jim Teeling (WPE2BAJO), Orange, N. J.
 Peter Collins (WPE2BXD), Elmira, N. Y.
 Edward Cooperman (WPE2CD), Wantagh, N. Y.
 Your Short-Wave Editor (WPE2FT)
 Charles Schwartzbard (WPE2TA), Passaic, N. J.
 C. Vernon Hyson (WPE3AGZ), Kensington, Md.
 Ed MacDonald (WPE3AJC), Malvern, Pa.
 Dan Metro (WPE3DS), McKeesport, Pa.
 Richard Morcroft (WPE3HP), Bellevue, Pa.
 George Cox (WPE3NF), New Castle, Del.
 L/Cpl. W. J. Hogg (WPE4ASH), Camp Lejeune, N. C.
 Grady Ferguson (WPE4BC), Charlotte, N. C.
 Roger Nash (WPE4DZ), Memphis, Tenn.
 Bill Bruner (WPE4JP), Key West, Fla.
 Glenn Cuthrell (WPE4KB), Maxton, N. C.
 Daniel Garrison (WPE5ABD), Houston, Texas
 Jim Cumbie (WPE5AC), Dallas, Texas
 William Bing (WPE5AN), New Orleans, La.
 Arno Feltnor (WPE5CN), New Braunfels, Texas
 Jack Stephenson (WPE5XX), Oklahoma City, Okla.
 J. Art Russell (WPE6EZ), San Diego, Calif.
 Rob Wintersteen (WPE7CB), Sunnyside, Wash.
 Dick Araway (WPE7UQ), Ferndale, Wash.
 Layoyd Kuncy (WPE8AD), Detroit, Mich.
 James Painter (WPE8BEU), Charleston, W. Va.
 Charles Sutton (WPE8BGF), Toledo, Ohio
 Dan Wilt (WPE8HF), Akron, Ohio
 Mike Kander (WPE8MS), Dayton, Ohio
 Earl Kinmonth (WPE9AGB), Joliet, Ill.
 Mike Young (WPE9AWO), Cahokia, Ill.
 J. P. Arendt (WPE9DN), Aurora, Ill.
 A. R. Niblack (WPE9KM), Vincennes, Ind.
 Mike Nielsen (WPE9NY), Park Ridge, Ill.
 Paul King (WPE9QAB), Minneapolis, Minn.
 John Beaver, Sr. (WPE9AE), Pueblo, Colo.
 James Howard (WPE9EW), Kansas City, Mo.
 George Buchanan (WPE9VB), Webster Groves, Ill.
 Wendel Craighead (WPE9VU), Kansas City, Kansas
 David Digweed (VE3PE5S), St. Catharines, Ont.
 David Bennett (VE7PE1R), Richmond, B. C.
 Bernard Brown (BB), Derby, England
 Ross Brownell (RB), Vancouver, B. C.
 Henry & Julia Edwards (HJE), Goldsboro, N. C.
 Del Green (DG), Salt Lake City, Utah
 Shaler Hanisch (SH), Pasadena, Calif.
 John Kennedy (JK), Shelby, Ohio
 John Rushton (JR), S. Providence, R. I.
 Alan Spencer (AS), Castle Creek, N. Y.
 Bruce Skogen (BS), APO, New York, N. Y.
 Ron Young (RY), Chelmsford, England

1600 on 17,895 kc. to S. Africa; at 0930-1215 on 21,700 kc., 1630-2045 on 17,895 kc., and 1645-2100 on 15,125 kc. to Brazil; at 1900-2145 on 15,125 kc. to N. A. and Canada; at 2100-2300 to Pacific Coast areas on 11,840 kc.; and at 1630-1930 on 15,100 kc. to the Portuguese fishing fleet off Eastern Canada. (WPE2TA, WPE7CB, WPE7UQ, RY)

Rhodesia & Nyasaland—Here is the latest schedule from Lusaka. African "A" Service:

2300-0100 (weekdays) on 4826 and 7285 kc.; 0500-1030 (Sundays from 0600) on 11,882 and 7285 kc.; 1030-1300 on 7285 and 3955 kc.; and 1300-1400 on 7285, 4826, and 3955 kc. African "B" Service: 0900-1300 on 4826 kc. English and Commercial Service: 2300-0000 (daily), 0900-1900 (Saturdays), 0000-1805 (Monday through Friday) and 1000-1500 (Sundays) on 4911 and 6018 kc.; 0000-0230 on 6018 and 7220 kc., and 0230-0700 (Sundays from 0100) on 6018 and 9505 kc. Reports go to Federal Broadcasting Service of Rhodesia & Nyasaland, Engineering Division, P. O. Box R. W. 15, Ridge-way, Lusaka, Northern Rhodesia. (WPE2BXD).

Senegal—R. Senegal, Dakar, 4893 kc., has Eng. news (relay from Brazzaville) at 1730 and returns with French at 1739. (WPE3NF)

Sierra Leone—Freetown has local news in Eng. at 0145 on 3316 kc., local language news

SHORT-WAVE ABBREVIATIONS

A—Approximately	kc.—Kilocycles
anmt—Announcement	kw.—Kilowatts
BBC—British B/C Corp.	L.A.—Latin American
Eng.—English	N. A.—North American
ID—Identification	R.—Radio
IS—Interval signal	s/off—Sign-off
xmsn—Transmission	

at 0150, and a BBC relay of news at 0200. (WPE1AAC, WPE8MS)

Tahiti—R. Tahiti, Papeete, 6135 kc., has French news at 0100 and is noted with a good signal until 0230/close. Programing consists largely of French recordings and anmts. (WPE1AAC, WPE9VB)

Tanganyika—Dar-es-Salaam has been noted on a new frequency, 4785 kc., from 1300 to 1415 s/off with the "Second Program." (RY)

Thailand—HSK, Bangkok, 15,385 kc., has Eng. at 2315-0015. (WPE1BY)

Tunisia—R. Tunis has been found on 6105 kc., from 1530 with Arabic chants, talks, and news; s/off at 1902. ID is Huna Tunis. (WPE3NF)

Another outlet on 9630 kc. has been heard fairly well in Arabic at 1300-1400 and also around 0000. (WPE1BY)

United Arab Republic—Cairo is scheduled as follows: 0130-0200 on 7050 and 11,670 kc. with dictation news; 1200-1400 on 17,690 kc. to W. Africa with Eng. news at 1300; 1015-1215 and 1245-1330 to E. Africa on 17,915 kc.; 1400-1730 on 11,990 kc. with French news at 1402, German news at 1515, Italian news at 1602, and Eng. news at 1645 (European beam); 0000-1830 on 9585 kc. in the Home Service. Dual to 9585 kc. is 15,390 kc. at 0000-0200, 0400-0600 (Fridays), 0930-1200 (except Fridays), 0945-1200 (Fridays), and 1200-1830. (R. Cairo Engineering Staff, WPE1BD, WPE1BY, WPE2CD, WPE5ABD, WPE9DN, WPE9AE, SH, BS)

(Editor's Note: Despite a personal letter from R. Cairo, several of our Monitors have positively found Cairo on 12,030 kc. rather than 11,990 kc. during the scheduled English period.)

Windward Islands—Grenada has been relaying cricket games to the United Kingdom on 21,680 kc. from 1130 onwards and has been noted as late as 1545. (WPE2ACO, WPE5XX, WPE7CB, BB)

**POPULAR
ELECTRONICS**

BARGAIN BASEMENT

SAVE ON THESE SPECIAL BUYS OF THE MONTH

ALL BAND TRAP ANTENNA!



Reduces Interference and Noise on All Makes Short Wave Receivers. Makes World Wide Reception Stronger. Clearer on All Bands!

For ALL Amateur Transmitters. Guaranteed for 300 Watts Power for Pi-Net or Link Direct Feed. Light, Neat, Weatherproof

Complete as shown total length 102 ft. with 87 ft. of 72 ohm balanced feedline. Hi-imped matched insulators and sealed automatic frequency changing resonant trimmer (Wt. 3 oz. 1 1/4" long). You just tune to desired band for best like results. Excellent for ALL world wide short wave receivers and amateur transmitters. For NOVICE AND ALL CLASS AMATEURS! NO EXTRA TUNERS OR GADGETS NEEDED! Eliminates 3 separate antennas with better performance guaranteed. NO HAYWIRE HOUSE APPEARANCE! EASY INSTALLATION!
 40-20-15-10 meter bands. Complete. \$12.95
 40-20-15-10 meter bands. 34 ft. antenna (best for worldwide sw's) \$11.95
 20-15-10 meter bands. Dual Trap. 24 ft. Antenna. \$18.95
SEND ONLY \$3.00 (cash, ck, mo) and pay postman balance COD plus postage on approval or send full price for postpaid delivery. Available only from:
WESTERN RADIO • Dept. AEL-6 • Kearney, Nebraska

NEW SILICON 500MA RECTIFIERS

GENERAL PURPOSE SPECIAL 2 FOR \$1 400 PIV AT 250 MA 25 FOR \$10

rms / p/iv 35 / 50 30c	rms / p/iv 70 / 100 45c	rms / p/iv 140 / 200 50c	rms / p/iv 210 / 300 65c
rms / p/iv 280 / 400 78c	rms / p/iv 350 / 500 \$1.00	rms / p/iv 420 / 600 \$1.26	rms / p/iv 490 / 700 \$1.50
rms / p/iv 560 / 800 \$1.59	rms / p/iv 630 / 900 \$1.89	rms / p/iv 700 / 1000 \$2.58	rms / p/iv 770 / 1100 \$3.12

Use in F.W. Bridge or F.W.C.T. up to 750ma DC or 4mg 2" sq Pins for 1.5Amp. (Orders \$5 or more we pay postage 48 states.) Send 25c for Catalogue

"TAB" 111PJ Liberty St. N. Y. 6, N. Y.

ONE CENT SALE Buy One At Our Regular Low Price And Get The Second For Only 1c More

CITIZENS BAND TRANSMITTER (27 MC) 5 watt chassis, complete with crystal \$14.99 each, two for \$15.00
CITIZENS BAND RECEIVER chassis tunable through all 22 channels. Complete with audio amplifier \$9.99 ea., two for \$10.00
AMATEUR BAND TRANSCEIVER (144-148 MC) chassis with dual VHF triodes for walkie-talkie radiophone, \$9.99 ea., two for \$10.00
SIGNAL BOOSTER for 27 MC. High gain (20DB) double tuned RF pentode amplifier. Improves performance of any Citizen Band Receiver. Complete with tube \$11.99 each, 2 for \$12.00.
KIT OF PARTS for AM-FM-VHF radio receiver. Tunable from 80-200 mc. which includes U.S. satellite frequencies. \$6.99 ea., two for \$7.90.
CONVERTER (Control) for 27 MC (Citizens Band). Adapts any standard broadcast radio to 27 MC band. Tunes all 22 channels. Complete with tubes and crystal. \$14.99 each, 2 for \$15.00.
LIMITED QUANTITY—NO LITERATURE OR CATALOG
 Remit in full. Include sufficient postage. No C.O.D.'s.

VANGUARD ELECTRONIC LABS. Box 12-E-6 Hollis 23, N. Y.

POLICE, CITIZENS BAND, AIRCRAFT

may be monitored from any car radio using the model 104 fully transistorized converter. Any one frequency from 25 to 175 Mcs. Fully miniaturized (4x2 1/4 x 2 1/4"), it can be installed in seconds. No power is required from auto radio. Internal mercury battery approaches shelf life. Provides double conversion reception. Order now or send for free information. State Frequency.
 Model 104.....\$16.95 TR233R Battery.....\$2.00
Robin Radio Co. 13229 Red Fern Lane Dallas 30, Tex.

Experimenters • Amateurs • Hobbyists

Extraordinary values await you in government surplus electronic components. Don't buy anything until you have our "Bargain Bulletin"; new material for mere dimes on the dollar. Remember, everything is brand new; here are typical values:

- Stancor P-4004 power transformer, \$21 list 9 lbs. \$4.44
- Cornell-Dubilier T11-15100, 10 mfd/1500 v oil 4 lbs. 2.19
- BC-610 tuning units, specify TU number 4 lbs. 3.45
- 6V6GT vacuum tubes, a dozen for 3 lbs. 6.95
- 5 vet fil xfrms, 15 W in 220-240 60 ph 19 lbs. 6.45
- Auto xfrm, 110 60 to 220 60, 90 watts 7 lbs. 2.29
- Sealed 115 v 60 cyc relay, DPDT rated 5 amps, 10 oz. 1.95
- Astatic 400-D tone arm with dual sapphires, cor. 1 lb. 7.45
- 455 KC IFA, National or equal 10 oz. 7.9
- Electrolytic, 3 x 20/400 volts—8 oz. 59c 10 for 4.95

WRITE TODAY FOR FREE GOVERNMENT SURPLUS BARGAIN BULLETIN

JOE PALMER P.O. Box 6188 CCC, Sacramento, California

WALKIE TALKIE RADIO SENDING SET



YOUR OWN POCKET SIZE RADIO STATION
 Talk to any house or car radio without wires or hookups of any kind! Wt. only 1 1/2 lb. Size 1 1/2" x 2 1/2" x 4 1/2". Built-in antenna. "Break-in" on regular radio broadcasts with "Dial Setter" and "Push-to-Talk" switch. Self-contained flashlight batteries—Power transistor. Talk to radios in the same building and to cars or between cars up to one block or more away—(depending on local conditions. No license or permit needed! Practical and real fun in a million ways. Guaranteed to work—1 year service guaranteed.
SEND ONLY \$3.00—(cash, ck, mo) and pay postman only \$3.95 plus COD postage or send \$12.00 for postpaid delivery. Shipped complete ready to operate with instructions for all kinds of operation. New 1961 Model Radio Talkie is now Super-powered! Order yours now—Today! Available only from:
WESTERN RADIO, Dept. TEL-6, Kearney, Nebr.

RADIO PARTS STORES & HI-FI SALONS!

Hundreds of dealers across the nation profit by selling POPULAR ELECTRONICS each month to their customers. Are you one of them? POPULAR ELECTRONICS helps build store traffic . . . keeps customers coming back month after month for the merchandise you sell—and, best of all, you can earn a neat profit on each copy sold—No RISK INVOLVED.

So get all the details on selling POPULAR ELECTRONICS, the world's largest selling electronics hobbyist magazine. Or, order your copies now. Just use the handy coupon.

Direct Sales Department
 Popular Electronics
 One Park Avenue, New York 16, New York

Att: Jerry Schneider

- Send me _____ copies of POPULAR ELECTRONICS for resale in my store each month. No risk involved on my part.
- Send me details on selling POPULAR ELECTRONICS in my store.

STORE NAME _____
 ADDRESS _____
 CITY _____ ZONE _____ STATE _____
 SIGNATURE _____

PE-660

INDEX

TO VOLUME 12

Jan.-June, 1960

AMATEUR RADIO AND SWL

Across the Ham Bands (Brier)	89 Jan.
Ham Transmitters	79 Feb.
Linear Amplifier Story	95 Mar.
Noise in R.F. Amplifier Tubes	97 Apr.
Handling Messages by Ham Radio	91 May
Why Buy Used Ham Equipment?	71 June
How to Prevent Trouble with the FCC	50 Jan.
Antenna, Easy-to-Build Beam (Fahnestock)	98 Jan.
Bandspread—DX'ing Delicacies (Kneitel)	65 Jan.
Converter, Six-Meter (Heath Kit)	53 May
Converter, Transistorized DC-to-AC (Maynard)	54 June
DX'ing on TV (Schafer)	89 May
Grid-Dip Meter, Modulate Your (Winklepleck)	89 Mar.
Ham Lingo, Understanding (Walker)	69 May
Harmonic, Case of Elusive (Schauers)	92 May
Harmonics, Suppress Those (Brier)	120 Jan.
Modulator, Hi-Fi Amplifier as (Brier)	59 Mar.
Phone Patch, Acoustic (Fischesser)	52 June
R. F. Power Meter, Build an (Tartas)	121 Feb.
Screen-Modulate the DX-20 (Brier)	129 Mar.
Short-Wave Monitor Registration	71 Jan.
Short-Wave Report (Bennett)	88 Feb., 66 Mar., 100 Apr., 84 May, 76 June
Traffic Nets	88 Feb.
Inaccurate Reports	100 Apr.
QSL Bureaus	76 June
Signal Booster (Brier)	97 Mar.
Test Signals—WWV, Free Government (Winter)	47 Jan.
Transceiver (Viking Messenger)	85 Feb.
Transmitter, 6 and 2-Meter (Globe Kit)	52 May
Tuner, Single-Sideband (Brier)	99 Apr.
Wave Trap, Broadcast-Band (Garner)	78 Mar.

CITIZENS BAND RADIO

FCC Report (Tall)	12 May
Rule Changes	10 June
Applications	116 Jan., 125 Feb., 134 Mar., 130 Apr., 78 May, 88 June
On the Citizens Band (Kneitel)	85 Feb.
Transceiver (Viking Messenger)	88 May
Transceiver, Four-Channel (Poly-Comm II)	100 Mar.
Transceivers, Roundup of	43 Feb.
Transmitter, 11-Meter R/C (Hall)	

CONSTRUCTION PROJECTS

Amplifier, Portable Utility (Vicens)	83 Mar.
Amplifier, Unusual (Romellanger)	47 Apr.
Antenna, Easy-to-Build Beam (Fahnestock)	50 Jan.
Bench Supply, Half-Amp Variable Transistor (Richardson)	45 Mar.
Black Box Magic (Richardson)	57 June
Construction Tips for the Beginner (Garner)	79 Mar.
Convert a Car Radio for Home Use (Louis)	51 Feb.
Converter, Transistorized DC-to-AC (Maynard)	53 May
Diode-Transistor Radio, Sensitive (Trauffer)	73 Jan.
Driver Alarm, Transistorized (Gordon)	98 Mar.
Dry Cell Tester and Rejuvenator (Murphy)	61 Jan.
Fence Controller, Transistorized (Winklepleck)	50 Apr.
Flasher, Auto Safety (Garner)	64 May
Frequency Meter, Direct-Reading (D'Entremont)	85 Jan.
Grip-Dip Meter, Modulate Your (Winklepleck)	89 May
Harmonics, Suppress Those (Brier)	92 May
House-Sitter, Electronic (Garner)	73 Feb.
Intercom, Battery-Powered (Garner)	62 May

Metronome, Wireless (Patrick)	87 Jan.
Modulator, Hi-Fi Amplifier as (Brier)	120 Jan.
Music Box, Electronic (Louis)	63 Mar.
One-Tube Laboratory (Burgess)	41 Jan.
Phone Patch, Acoustic (Fischesser)	59 Mar.
Potentiometers, Unusual Uses of (Richardson)	92 Mar.
Power Megaphone (Garner)	60 May
Power Megaphone, Super Simple (Tort)	74 Jan.
Projects, Six One-Evening (Garner)	67 Mar.
1: First-Project Receiver	68 Mar.
2: D. C. Control Unit	70 Mar.
3: Combination Checker	72 Mar.
4: Hi-Fi Speaker Crossover	74 Mar.
5: Fuse Saver	76 Mar.
6: Broadcast-Band Wave Trap	78 Mar.
R/C Transmitter, 11-Meter (Hall)	43 Feb.
R. F. Power Meter (Tartas)	52 June
Receiver, Transistorized Pocket (Garner)	67 May
Rectifier Tube Socket, Universal (Moreno)	66 Jan.
Screen-Modulate the DX-20 (Brier)	121 Feb.
Signal Booster (Brier)	97 Mar.
Signal Injector, Transistorized (Gordon)	81 Feb.
Speaker System, 3-Way	77 Feb.
Tesla's Trickery (Richardson)	72 May
"Tiny Mile" (Frantz)	73 June
Transistor Tester, Dual-Meter (Shaughnessy)	59 Feb.
Transistor Tester, Low-Cost (Patrick)	68 June
Tuner, How to Convert Radio to AM (Gordon)	95 Apr.
Tuner, Single-Sideband (Brier)	99 Apr.
Tuning Meter, Add to FM Receiver (Gordon)	53 Mar.
Wattmeter, Build Your Own (Frantz)	87 Apr.

DEPARTMENTS

Across the Ham Bands (Brier)	89 Jan., 79 Feb., 95 Mar., 97 Apr., 91 May, 71 June
Carl and Jerry (Frye)	104 Jan., 98 Feb., 106 Mar., 106 Apr., 100 May, 89 June
FCC Report (Tall)	12 May, 10 June
Letters from Our Readers	10 Jan., 10 Feb., 12 Mar., 10 Apr., 16 May, 14 June
New Products	30 Jan., 32 Feb., 30 Mar., 30 Apr., 32 May, 34 June
Notes from the Editor (Read)	8 Jan., 8 Feb., 8 Mar., 8 Apr., 8 May, 8 June
On the Citizens Band (Kneitel)	116 Jan., 125 Feb., 134 Mar., 130 Apr., 78 May, 88 June
POP'tronics Bookshelf	16 Jan., 16 Feb., 18 Mar., 16 Apr., 20 May, 22 June
Short-Wave Report (Bennett)	71 Jan., 88 Feb., 66 Mar., 100 Apr., 84 May, 76 June
Tips and Techniques	24 Jan., 22 Feb., 24 Mar., 22 Apr., 26 May, 28 June
Transistor Topics (Garner)	75 Jan., 63 Feb., 93 Mar., 57 Apr., 79 May, 77 June

FEATURE ARTICLES

Angling, Electronics Adds Angle to (Hammond)	50 June
Bandspread—DX'ing Delicacies (Kneitel)	98 Jan.
Bulb, Find Brightest (Balin)	56 Apr.
Capacitor, The (Gilmore)	67 Apr.
Carl and Jerry (Frye)	104 Jan., 98 Feb., 106 Mar., 106 Apr., 100 May, 89 June
Car Radio, Take Noise Out of (Part 2) (Darr)	79 Jan.
Communications Satellites—Key to World-Wide TV (Gilmore)	41 Mar.
Computers—Yesterday and Today (Yates)	69 Feb.
Constructions Tips for the Beginner (Garner)	79 Mar.
Crystals (After Class) (Kyle)	83 Apr.
Eavesdropping on Outer Space (Gilmore)	41 June
FCC, Showdown for (Gilmore)	45 May
Familiar Farces (Kohler)	82 Jan.
Fiddler, Frustrated (Fantel)	55 Feb.
Generator, Experimental Wind-Power	62 Mar.
Ham Lingo, Understanding (Walker)	89 Mar.
Harmonic, Case of Elusive (Schauers)	69 May
Maser, Amazing (Dillard)	41 Apr.
Molecular Electronics (Locke)	89 Apr.
News, Electronics in	72 Jan., 105 Mar., 62 Apr., 77 and 94 May
Nuclear Kilowatts (Janvier)	49 Mar.
Pay TV's First Battle (Lenk)	79 June
Phones of the Future	46 Jan.
Photograph Electronic Equipment (Trauffer)	67 Jan.
R/C Cloud (Kohler)	86 Feb.
Record Changer, Inside Hi-Fi (Marshall)	55 Mar.

Short-Circuited Enthusiast (Kohler & Williams)	90 Mar.
Spraying Techniques, Professional (Vicens)	66 Feb.
Stabistor Diode (After Class) (Shaughnessy)	69 Jan.
Stereo Record, Compatible (Angus)	65 June
Stereo Speakers, How to Place (Milder)	82 June
Tape Recorder, Inside Hi-Fi (Marshall)	63 Apr.
Tape Transport Mechanisms	56 May
Bias, Erase, and Equalization Circuits	46 June
Tesla's Trickery (Richardson)	72 May
Test Instruments	
Audio Generator (Parts 1-3) (Klein)	
Wien Bridge Circuit	54 Jan.
Sulzer Bridge-T Circuit	83 Feb.
Clippers, Cathode Followers, Metering	86 Mar.
Signal Generator (Parts 1-3) (Harrison)	
What It Is and How It Works	92 Apr.
Aligning AM Receivers	81 May
Trouble-Shooting and Other Uses	62 June
Test Signals—WWV, Free Government (Winter)	47 Jan.
Thermoplastic Recording, Dr. Glenn's Magic Wrinkles (Remington)	53 Apr.
300-ohm Line, How to Splice (Comstock)	53 Jan.
300-ohm Line, What Is a (Geiger)	52 Jan.
Tone Arm, Inside Hi-Fi (Marshall)	47 Feb.
Transceivers, Roundup of Citizens Band	100 Mar.
Tubes for Hi-Fi (Milder)	49 May
Turntable, Inside the Hi-Fi (Marshall)	57 Jan.
TV's Trick Techniques (Zuckerman)	41 May
Vectors, Language of (After Class) (Harris)	
Part 1	85 May
Part 2	85 June

HI-FI AND AUDIO

Amplifier, Integrated Stereo (Paco Kit)	46 Apr.
Amplifier, Portable Utility (Vicens)	83 Mar.
Amplifier, Unusual (Romelfanger)	47 Apr.
Audio Aids	64 Jan.
Intercom, Battery-Powered (Garner)	62 May
Fiddler, Frustrated (Fantel)	55 Feb.
Music Box, Electronic (Louis)	63 Mar.
Power Megaphone, Super Simple (Tort)	74 Jan.
Record Changer, Inside Hi-Fi (Marshall)	55 Mar.
Record Changer, Stereo-Mono (Dual 1006)	60 Apr.
Speaker Crossover, Hi-Fi (Garner)	74 Mar.
Speaker System, How to Build a 3-Way	77 Feb.
Stereo Record, Compatible (Angus)	65 June
Stereo Speakers, How to Place (Milder)	82 June
Tape Recorder, Inside Hi-Fi (Marshall)	63 Apr.
Tape Transport Mechanisms	56 May
Bias, Erase, and Equalization Circuits	46 June
Tape Recorder, Unusual (Universal)	48 Mar.
Tone Arm, Inside Hi-Fi (Marshall)	47 Feb.
Tone Arm, Stereo (Empire 98)	76 Feb.
Tubes for Hi-Fi (Milder)	49 May
Tuner, Convert Radio to AM (Gordon)	95 Apr.
Tuning Meter, Add to FM Receiver (Gordon)	53 Mar.
Turntable, Inside Hi-Fi (Marshall)	57 Jan.
Turntable Tips	84 Jan.

PRODUCT REPORTS

A. C. Supply, Variable (Olson Kit)	86 Apr.
Amplifier, Integrated Stereo (Paco Kit)	46 Apr.
Checker, Handy Filament Continuity (EICO Kit)	78 Jan.
Converter, Six-Meter (Heath Kit)	65 Jan.
Record Changer, Stereo-Mono (United Audio)	60 Apr.
Tape Recorder (Uher)	48 Mar.
Tone Arm, Stereo (Audio Empire)	76 Feb.
Transceiver (Johnson)	85 Feb.
Transceiver, Four-Channel Citizens Band (Polytronics)	88 May
Transmitter, 6- and 2-Meter (Globe Kit)	52 May
Volt/Ammeter (Knight Kit)	49 June
VOM, Pocket-Size (Knight Kit)	88 Jan.
VIVM, Audio (Arkay Kit)	89 Feb.

TELEVISION

Baby-Sitter, Electronic (Miller)	65 Mar.
Communications Satellites—Key to World-Wide TV (Gilmore)	41 Mar.

DX'ing on TV (Schafer)	54 June
Pay TV's First Battle (Lenk)	79 June
300-ohm Line, How to Splice (Comstock)	53 Jan.
300-ohm Line, What Is a (Geiger)	52 Jan.
TV's Trick Techniques (Zuckerman)	41 May

TEST EQUIPMENT

Bench Supply, Half-Amp Variable Transistor (Richardson)	45 Mar.
Checker, Combination (Garner)	72 Mar.
Dry Cell Tester and Rejuvenator (Murphy)	61 Jan.
Frequency Meter, Direct-Reading (D'Entremont)	85 Jan.
Grid-Dip Meter, Modulate Your (Winklepleck)	89 May
One-Tube Laboratory (Burgess)	41 Jan.
R. F. Power Meter, Build an (Tartas)	52 June
Signal Injector, Transistorized (Gordon)	81 Feb.
Test Instruments	
Audio Generator (Parts 1-3) (Klein)	
Wien Bridge Circuit	54 Jan.
Sulzer Bridge-T Circuit	83 Feb.
Clippers, Cathode Followers, Metering	86 Mar.
Signal Generator (Parts 1-3) (Harrison)	
What It Is and How It Works	92 Apr.
Aligning AM Receivers	81 May
Trouble-Shooting and Other Uses	62 June
Transistor Tester, Dual-Meter (Shaughnessy)	59 Feb.
Transistor Tester, Low-Cost (Patrick)	68 June
Wattmeter, Build Your Own (Frantz)	87 Apr.

THEORY

Capacitor, The (Gilmore)	67 Apr.
Crystals (After Class) (Kyle)	83 Apr.
Record Changer, Inside Hi-Fi (Marshall)	55 Mar.
Stabistor Diode (After Class) (Shaughnessy)	69 Jan.
Tape Recorder, Inside Hi-Fi (Marshall)	63 Apr.
Tape Transport Mechanisms	56 May
Bias, Erase, and Equalization Circuits	46 June
Test Instruments	
Audio Generator (Parts 1-3) (Klein)	
Wien Bridge Circuit	54 Jan.
Sulzer Bridge-T Circuit	83 Feb.
Clippers, Cathode Followers, Metering	86 Mar.
Signal Generator (Parts 1-3) (Harrison)	
What It Is and How It Works	92 Apr.
Aligning AM Receivers	81 May
Trouble-Shooting and Other Uses	62 June
Tone Arm, Inside Hi-Fi (Marshall)	47 Feb.
300-ohm Line, What Is a (Geiger)	52 Jan.
Turntable, Inside Hi-Fi (Marshall)	57 Jan.
Vectors, Language of (After Class) (Harris)	
Part 1	85 May
Part 2	85 June

TRANSISTORS

Amplifier, Portable Utility (Vicens)	83 Mar.
Bench Supply, Half-Amp Variable Transistor (Richardson)	45 Mar.
Black Box Magic (Richardson)	57 June
Converter, DC-to-AC (Maynard)	53 May
Diode-Transistor Radio, Sensitive (Trauffer)	73 Jan.
Driver Alarm (Gordon)	98 Mar.
Fence Controller (Winklepleck)	50 Apr.
Flasher, Auto Safety (Garner)	64 May
Megaphone, Power (Garner)	60 May
Intercom, Battery-Powered (Garner)	62 May
Metronome, Wireless (Patrick)	87 Jan.
Power Megaphone, Super Simple (Tort)	74 Jan.
Receiver, Pocket (Garner)	67 May
Signal Injector (Gordon)	81 Feb.
"Tiny Mile," Let's Build the (Frantz)	73 June
Transistor Tester, Dual-Meter (Shaughnessy)	59 Feb.
Transistor Tester, Low-Cost (Patrick)	68 June
Transistor Topics (Garner)	
75 Jan., 63 Feb., 93 Mar., 57 Apr., 79 May,	77 June
Transmitter, 11-Meter R/C (Hall)	43 Feb.

POPULAR ELECTRONICS

Advertisers' Index

JUNE 1960

ADVERTISER	PAGE NO.
Airex Radio Corporation	106
Allied Radio	31
Amperex Electronic Corp.	20
Atlas Sound Corp.	114
Audio Devices Inc.	17
B & K Manufacturing Co.	101
Bell Telephone Laboratories	2nd Cover
Boulevard Electronics	118
Bud Radio, Inc.	117
Burgess Battery Company	24
Capitol Radio Engineering Institute	23
Central Technical Institute	108
Chicago Standard Transformer Corporation	117
Cleveland Institute of Electronics	25
Coyne Electrical School	11
DeVry Technical Institute	7
Dynaco, Inc.	14
E-Z Hook Test Products	108
EICO	38, 40
Electronic Chemical Corp.	116
G C Electronics Co.	111
Grantham School of Electronics	9
Greenlee Tool Co.	36
Hallcrafters	28
Heath Company	94, 95, 96, 97
Hi Fidelity Centre	118
Indiana Technical College	111
International Crystal Mfg. Co., Inc.	35
Johnson Co., E. F.	106, 109
Key Electronics Co.	111
Kuhn Electronics	120
Lafayette Radio	33
Lektron	99
Micro Electron Tube Co.	32
Miller, Teleplex Company, R. G.	114
Milwaukee School of Electronics	103
Mosley Electronics, Inc.	111, 118
Moss Electronic Inc.	3rd, 4th Cover, 130
National Radio Co., Inc.	100
National Radio Institute	3
National Technical Schools	13
Olson Radio Corporation	104
Paco Electronics Company, Inc.	22
Palmer, Joe	123
Picture Tube Outlet	116
Popular Electronics Book Division	18, 19, 113, 129
Progressive "Edu-Kits" Inc.	29
RCA Institutes, Inc.	15
Rad-Tel Tube Co.	39
Radio Publications, Inc.	110
Radio Shack Corp.	108
Reeves Soundcraft Corp.	5
Rider Publisher Inc., John F.	26
Rinehart & Co., Inc.	105
Robin Radio Co.	123
Sherwood Electronic Laboratories, Inc.	107
Shure Brothers, Inc.	12
Sonotone Corp.	36
Sprayberry Academy of Radio-Television	21
Springfield Enterprises	100
Sylvania Semiconductor Division	10
"TAB"	123
Telectronic Corporation	34
Teltron Electric Co.	30
Terado Company	104
Texas Crystals	112
Tri-State College	118
Trinidad State Junior College	114
Tru-Vac Electric Company	16
TV Electronic Supply Co.	120
Vanguard Electronic Labs.	123
Valparaiso Technical Institute	110
Western Radio	123
World Radio Laboratories	115
Xcelite, Inc.	112

Pay TV's First Battle

(Continued from page 81)

Telemeter is aiming for a goal of 40,000 subscribers in the Toronto area. The break-even point is said to be 10,000, a figure that the company hopes to have in the fold before the year is over.

Next Target: the USA. The Canadian installation is only the beginning, according to Telemeter. Since FCC approval is not required for a wire system, the company promises that four or five communities in this country—probably on the East Coast—will be wired for toll TV this year. The densely populated upper-middle-income sections in the suburbs of New York City are the most likely spots.

Negotiations are already being made for programs to supplement motion-picture fare. And in the eventuality that the FCC should okay the use of the airwaves for pay TV, Telemeter has a system ready to go.

No Cheating Possible. One word to the technically minded: you can't beat the system. The Telemeter engineers have stayed awake nights to prevent it. The signal cable is terminated inside the attachment and inside a wall receptacle, both of which are sealed. When the collector picks up your payments, he carefully checks both seals for evidence of tampering.

If you put in a coin and then try to pull it out, the mechanism stops. If you try to switch over to a more expensive program after paying for a cheaper one, you lose both programs. And if you do finally get into the attachment and try to shake out the coins, it will automatically lock from the inside. So if you are entertaining plans for acquiring some pay-TV programs for free, forget them. It's like trying to break into Fort Knox.

Perhaps the most important facet of the Canadian toll-TV installation is that pay TV is here, ready and willing to compete with movies and sponsored TV. Neither the government nor the networks can stop it. Now, it's up to the public—you and me—to decide its fate.

-50-

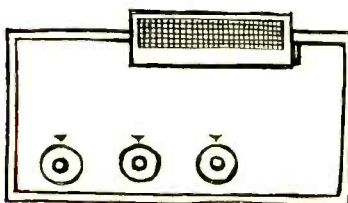



ELECTRONICS MARKET PLACE

RATE: 50c per word. Minimum 10 words prebid. August issue closes June 8th. Send order and remittance to Martin Lincoln, POPULAR ELECTRONICS, 1 Park Ave., New York 16, N. Y.

FOR SALE

CITIZENS Band Handy—Talkie. Plans 95c. Electronics. 16103 Biltmore, Detroit 35, Michigan.

15 DISTANCE One-tube plans—25c. with Transistor experiments. Catalog. Laboratories, 1131-L Valota, Redwood City, California.

HAMS, Experimenters: printed circuit boards made to order. Details, Ramsay Engineering, P.O. Box 271 Norwalk, Calif.

SOMETHING for sale? Place a classified ad in this section. Low-cost, fast results. It's easy.

TELEVISION Sets \$9.95 plus Shipping—Jones T V., Sanatoga, Pa.

DIAGRAMS for repairing radios \$1.00, Television \$2.00. Give make, model. Diagram Service, Box 672-PE, Hartford 1, Conn.

GOVERNMENT Surplus Receivers, Transmitters, Snooperscopes, Parabolic Reflectors, Picture Catalog 10c. Meshna, Malden 48, Mass.

AUTO Radio Distributor Selling, Servicing, Becker Blaupunkt, FM-AM, other European, American Sets. Save 30% + Square Electronics, 150-60 Northern Blvd., Flushing, New York.

GOVERNMENT Sells! Surplus Electronics; Test equipment; Oscilloscopes; Transceivers; Jeeps; Boats; Aircrafts; Misc.—Send for U. S. Depot Directory & Procedure \$1.00—"Government Surplus Sales," Box 425 PE, Nanuet, N. Y.

FM Tuners, 88-108 megacycles, 4 tubes complete, \$12.95. Grutman, 1 E. 167 st., N. Y. 52, N. Y.

WPE-SWL-CB-QSL Cards—Samples 10c—"Brownie" W3CJI, 3110A Lehigh, Allentown, Penna.

RADIO & TV Tubes at Manufacturer's prices! 100% Guaranteed! Brand New! No re-brands or pulls! United Radio, Box 1000-E, Newark, N. J.

BUY Government Surplus direct. Depot List and Procedure \$1.00. "Surplus" Box 543 Royal Oak, Mich.

CITIZENS Band! Add a Hushpuppy noise Suppressor to your Heathkit Transceiver! Squelch Action! Completely Wired. Guaranteed. \$4.98. Western Mass. Electronics, Great Barrington, Mass.

SURPLUS Walkie Talkies, Command Sets, VHF-UHF, Tech Manuals, Over 5000 items, Catalog 10c, Bill Slep Company, Box 178, PE Ellenton, Florida.

MAGAZINES (back issue)—radio, tv, electronic. Landa, Clayton 2-1, Ga.

RECHARGEABLE Batteries, complete. Replaces Burgess 2 U 6 and Eveready 216. Only \$4.77. P. O. Box 282, Brigham City, Utah.

WANTED

CASH for used short-wave Ham Receivers, Transmitters and Accessories. Treger, W9IVJ. 2023 N. Harlem Ave., Chicago 35B, TUXedo 9-6429.

WANT to buy good equipment and accessories? Place a low-cost classified ad in this space.

CYLINDER and old disc phonographs. Edison Conqueror. Idelia, and Oratorio models. Berliner Gramophones and Zono-o-phones, Columbia cylinder Graphophones, and Coin-operated cylinder Phonos. Want old catalogues and literature on early phonos prior to 1919. Will pay cash or trade late hi-fi components. Popular Electronics, Box 50, 1 Park Ave., New York 16, N. Y.

June, 1960

HIGH-FIDELITY



PRICES? The Best! Factory-sealed Hi-Fi Components? Yes! Send for free catalog. Audion, 25P Oxford Road., Massapequa, N. Y.

DISGUSTED with "Hi" Hi-Fi Prices? Unusual discounts on your High Fidelity Requirements. Write Key Electronics, 120 Liberty St., New York 6, N. Y. Cloverdale 8-4288.

PRECISION Receiver alignment: FM—\$5; AM/FM—\$9. Kit Construction Problems solved. Telephone: Ed-4-4490. I. Pollack, Westbury, L. I., N. Y.

KITS, Tapes, Components, Recorders. Special Quotes. Bayla Co., 1470-P Elmer Road, Wantagh, N. Y.

TAPE & RECORDERS

TAPE Recorders, Hi-Fi components. Sleep Learning Equipment, tapes. Unusual Values. Free Catalog. Dressner, 69-02F, 174 St. Flushing 65, N. Y.

AMPEX, Concertone, Magnecord, Presto, Bogen, Tandberg, Pentron, Sherwood, Rek-O-Kut, Scott, Shure, Dynakit, others, Trades. Boynton Studio, Dept. PE, 10 Pennsylvania Ave., Tuckahoe, N. Y.

RENT Stereo Tapes—over 1,000 different—all major labels—free catalog, Stereo-Parti, 811-P Centinela Ave., Inglewood 3, California.

RECORDERS, Components Free wholesale catalogue. Carston, 125-P East 88, N. Y. C. 28.

FOUR Stereo component systems to fit every need. Sealed Cartons, Huge Savings. Hi-Fi, Box 183, Paoli, Pa.

UNUSUAL Values. Hi-Fi components, tapes, tape recorders. Catalogue; package quotations. Budget Hi-Fi; 83-06E Victor Ave., Elmhurst, N. Y.

MUSIC

SONGPOEMS And Lyrics Wanted! Mail to: Tin Pan Alley, Inc., 1650 Broadway, New York 19, N. Y.

SONGS into Dollars! Share \$33 million dollars yearly for New Songwriters, songpoets. Any subject, songs composed, Published, promoted by largest firm. Information, appraisal Free. Send Nordyke Music Publishers, 6000 Sunset, Hollywood 283, California.

POEMS Wanted for musical setting and recording. Send poems. Free examination. Crown Music, 49-TM West 32, New York 1.

PATENTS

INVENTORS—Apply for a U. S. Patent to protect your invention. New Patent Kit now makes it easy. Free "Registration Form." Miss Clare Ardun, 806 Wm. Penn Annex, Philadelphia 5, Penna.

INVENTIONS WANTED

INVENTIONS wanted. Patented: unpatented. Global Marketing Service, 2420-P 77th, Oakland 5, Calif.

PLASTICS

NEW Liquid Casting Plastic, clear colors. Embed real flowers, minerals, biological specimens, delicate instruments, electronic parts. Also cold-setting resin and fiberglass for laminating, casting, molding, coating. Manual 25¢. Castolite, Dept. G-108, Woodstock, Illinois.

BUSINESS OPPORTUNITIES

RADIO Parts Stores & Hi-Fi Salons: Someone "borrowing" your personal copy of Popular Electronics each month? You ought to be taking advantage of Popular Electronics' convenient re-sale plan. Sell copies in your store . . . perform a good service for your customers . . . with no risk involved. For details, write: Direct Sales Department, Popular Electronics, One Park Avenue, New York 16, New York.

INSTRUCTION

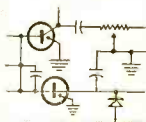

DETECTIVE Profession. Home Study. Badge, Certificate, Future. Box 41197-AG, Los Angeles 41, California.

TRANSISTORIZE your automobile ignition system. Complete plans and instructions: \$2.50. Technical Services Institute, 5699-24th Terrace North, St. Petersburg 10, Florida.

COMPLETE your high school at home in spare time with 63-year-old school. Texts furnished. No classes. Diploma. Information booklet free. American School, Dept. XA63—Drexel at 58th, Chicago 37, Illinois.

EXPERIMENT with nature's electronics! Instructions—Stillwater, Box 337-W, Morris Plains, New Jersey.

LEARN Code. Qualify for Amateur or Commercial License. Free Book. Candler, Dept. PE-6, Box 9226, Denver 20, Colo.

MATHEMATICS Inexpensive paperbacks, magazines, recreations. Worldwide Lists, 50¢ Math-Books, 4960 Maplewood, Montreal Canada.

ADD AFC to heathkit FM-3 tuner. Tested circuit installed quickly with soldering iron. Utilizes precision semiconductor. Complete kit with instructions \$5.95. Vortex Associates, P.O. Box 502, Inglewood, California.

ALGEBRA or Calculus, Easy Lessons, First Four \$1. Mathco, 4256-8 Minmor, Cincinnati 17, Ohio.

HIGHLY Effective home study review for FCC commercial phone exams. Free literature. Write Wallace Cook, "Chief Instructor", Cook's School of Electronics, Dept. "C", Box 10634, Jackson 9, Miss.

PASS the 1st, the first time with the help of this brand new study examination. Based on Element 4 of the latest FCC publication, over 280 multiple choice questions are logically arranged for subject study. Formulas, Diagrams and Math the easy way. Send \$3.00 to Hilger Enterprises, Box 2798, Dept. A, Long Beach, California.

MAKE Money anywhere in the world! Be a memory Bank! Details free. Research Center. Box D—7192, El Paso 3, Texas.

DIAGRAMS and parts list for, transistorized, broadcast, transmitter; used as transmitter, P. A. system, receiver; No C.O.D. Send \$1.25 to—Schematic Service, 145-47 7 Ave., Whitestone 57, N. Y.

128

WRITE Martin Lincoln, Popular Electronics, 1 Park Avenue, New York 16, N. Y. for information on how to place a classified ad in this section.

REPAIR Instructions, Schematics, Radios, T.V.'s, HiFi's, 99¢. Model? "Coop" Box 5938 Kansas City 11, Missouri.

MISCELLANEOUS

MYSTIC Antenna reveals secrets of nature's electronics! Locate hidden springs, water, gas, sewer lines, buried treasure! Works indoors; outdoors. Saves work, money! Easy to use. Fun for experiments! Details free. Stillwater, Box W-337, Morris Plains, New Jersey.

CALLING All Citizens Banders—The 5-Watt Wizards (see our write-up in 1960 CB Call Book) have gone National. Join the club that can help you get the most from CB! Write 5WW's, 137-27A 68th Drive, Kew Gardens Hills 67, N. Y.

WHATEVER your needs, Popular Electronics classified can solve them. Simply place an ad in these columns and watch your results pour in.

SHOPPING GUIDE Classified

A HANDY REFERENCE TO PRODUCTS AND SERVICES NOT NECESSARILY ELECTRONIC, BUT OF WIDE GENERAL INTEREST.

BUSINESS OPPORTUNITIES

VENDING Machines—No Selling. Operate a route of coin machines and earn amazing profits. 32-page catalog free. Parkway Machine Corporation, Dept. 12, 715 Ensor St., Baltimore 2, Md.

BUY direct from factories—Appliances, Cameras, Watches! Free details! Cam Company, 6810 PE—20th Ave., Brooklyn 4, N. Y.

EARN extra money selling advertising book matches. Free samples furnished. Matchcorp., Dept. MD-60, Chicago 32, Illinois.

GROW Mushrooms. Cellar, shed and outdoors. Spare, full time, year round. We pay \$4.50 lb. dried. We have 29,000 customers. Free Book. Mushrooms, Dept. 334, 2954 Admiral Way. Seattle, Wash.

AUTOMOTIVE

AUTOMOBILES. How to buy a Used Car—data tells all. Get Best Car for Least Money. Save Hundreds! Satisfaction Guaranteed. \$2.00. Carfacts, 1855 Almond, Anaheim, California.

PHOTOGRAPHY—FILM EQUIPMENT, SERVICES

OPTICAL Science Math Bargains Request Free Giant Catalog "CJ" — 128 pages — Astronomical Telescopes, Microscopes, Lenses, Binoculars, Kits, Parts. Amazing war surplus bargains. Edmund Scientific Co., Barrington, New Jersey.

Always say you saw it in—POPULAR ELECTRONICS

FREE every month—Blackhawk's newspaper-size catalog 8mm. 16mm. movies, 2"x2" color slides. Biggest selection in USA. Bargains in used 16mm. sound films, projectors. Blackhawk Films, Davenport 24, Iowa.

16MM. SOUND Films Features and shorts, free catalogue. William Franz, 202 Hazelwood Ave., Pittsburgh, Pa. (Zone 7.)

EMPLOYMENT INFORMATION

JOBS: High pay. Foreign countries, USA. All trades. Write Dept. 55G. National Employment Information, 1020 Broad, Newark, N. J.

OVERSEAS Employment. American firms and United States Government. Comprehensive job information \$2.00. Foreign Opportunities, Box 172, Columbus 16, Ohio.

LEATHERCRAFT

FREE "Do-it-Yourself" Leathercraft Catalog. Tandy Leather Company, Box 791—M-34. Fort Worth, Texas.

STAMPS & COINS

200 DIFFERENT U. S. Stamps \$1.00. Approvals included. Shelton, Box 907-J New York 8, N. Y.

OVER 320,000 buyers and sellers will read your ad when placed in this space. It costs only 50¢ per word; minimum of 10 words including your name and address.

FREE One half pound of United States Mixture with Approvals. Send 20¢ for postage. Wm. Rice, 87 Washington Ave., Kingston 43, N. Y.

MISCELLANEOUS

KEY chains, personalized ashtrays, smoke sets—hundreds of useful novelties for home, office and gifts. Inexpensive items. Write for free catalog. House of Brand, Dept. PE-2, 3458 Fish Avenue, New York 69, New York.

"WINEMAKING: Beer, Ale Brewing." Illustrated. \$2.20. Eaton Books, Box 1242-C, Santa Rosa, California.

17 **PROVEN** ways to make money typing at home. Detailed instructions \$1 (refundable). Ryco Service, 210-M Fifth Ave., Suite 1102, New York 10.

FREE! New 1960 catalog of all photographic books available for your copy. Send postcard with name and address to Catalog, Popular Photography Book Service, One Park Ave., New York 16, N. Y.

COMMANDO defense holds! Quick knock-out blows! Illustrated. \$1.98. Wilford Publications, 7400 Benjamin Franklin Station, Washington 4, D. C.

HOMEBREWED Wines, Beers. Complete instructions—\$1.00. Dean's, Box 40-EL, Elberton, Georgia.

How You Can "GET ON THE AIR" --Without An EXAM!

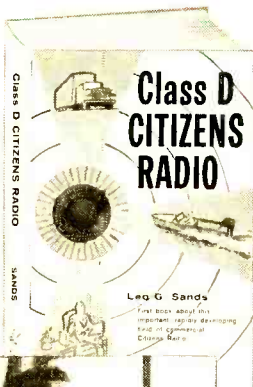

NEW Class "D" Citizens Radio Handbook Answers ALL Your Questions About: How to use two-way radios for business and pleasure—to talk from car to car, ship to shore, office to mobile unit, between farm buildings, on hunting trips, and dozens of other useful applications.

HERE'S how to get the most out of your Class D Citizens Band Radio Set—how to buy and use equipment for the ultimate in fun and practicality! This new, fully illustrated, easy-to-read book tells you, in layman's language, EVERYTHING the Citizens Banders needs to know. Contents include what to buy and how much it will cost...which set will suit your needs best...how to apply for your free license (no FCC examination required). Discusses

transmitters, receivers, antennas, power requirements, and gives you full instructions for installation and maintenance. Tells you how and where you can use your set and includes complete FCC rules and regulations. Contains 180 clear simply-written pages and 72 informative illustrations; only \$4.95 plus few cents for shipping. FREE 7 Day Trial—Send no money! Mail coupon at once.

Mail Coupon TODAY for 7 DAY FREE TRIAL Examination!



ELECTRONICS BOOK SERVICE

A Division of the Ziff-Davis Publishing Co. CRE660
431 South Wabash Avenue, Chicago 5, Ill.

Please send me copies of CLASS D CITIZENS RADIO and bill me only \$4.95 per copy plus a few cents postage. If I am not pleased with the book, I may return it within 7 days and I will owe you nothing.

CHECK HERE AND SAVE MONEY. I enclose payment for book(s) herewith, and you will pay the postage. (Same 7-day return privilege.)

PRINT NAME.....

ADDRESS.....

CITY.....ZONE.....STATE.....

N. Y. C. Residents, Please add 3% Sales Tax.

EXAMINE ANY OF THESE TESTERS **BEFORE** YOU BUY!!

Yes, we offer to ship at our risk one or more of the testers described on these pages.

Superior's New Model 76

ALL PURPOSE BRIDGE

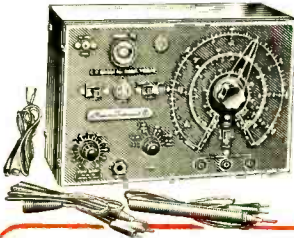

Model 76 ALL PURPOSE BRIDGE
Total Price \$26.95
Terms: \$6.95 after 10 day trial, then \$5.00 per month for 4 months if satisfactory. Otherwise return, no explanation necessary.

IT'S A CONDENSER BRIDGE
IT'S A RESISTANCE BRIDGE

IT'S A SIGNAL TRACER
IT'S A TV ANTENNA TESTER

✓ **CAPACITY BRIDGE SECTION**
4 Ranges: .00001 Microfarad to .005 Microfarad; .001 Microfarad to .5 Microfarad; .1 Microfarad to 50 Microfarads; 20 Microfarads to 1000 Microfarads. Will also measure the power factor of all condensers from .1 to 1000 Microfarads.
✓ **RESISTANCE BRIDGE SECTION**
2 Ranges: 100 ohms to 50,000 ohms; 10,000 ohms to 5 megohms.
✓ **SIGNAL TRACER SECTION**
With the use of the R.F. and A.F. Probes included with the Model 76, you can

make stage gain measurements, locate signal loss in R.F. and Audio stages, localize faulty stages, locate distortion and hum, etc.
✓ **TV ANTENNA TESTER SECTION**
Loss of sync., snow and instability are only a few of the faults which may be due to a break in the antenna, so why not check the TV antenna first? Locates a break in any TV antenna and measures the location of the break in feet from the set terminals.
Complete with R.F. and A.F. probes and test leads **\$26.95 Net**

Superior's New Model TV-50A GENOMETER

7 Signal Generators in One!

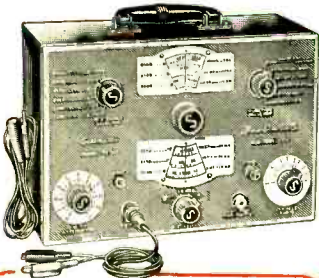

Model TV-50A GENOMETER . . .
Total Price \$47.50
Terms: \$11.50 after 10 day trial, then \$6.00 monthly for 6 months if satisfactory. Otherwise return, no explanation necessary.

- ✓ R.F. Signal Generator for A.M. ✓ Bar Generator ✓ Marker Generator
- ✓ R.F. Signal Generator for F.M. ✓ Cross Hatch Generator
- ✓ Audio Frequency Generator ✓ Color Dot Pattern Generator

This versatile All-Inclusive GENERATOR Provides ALL the Outputs for Servicing:
A.M. Radio • F.M. Radio • Amplifiers • Black and White TV • Color TV

R. F. SIGNAL GENERATOR: The Model TV-50A Genometer provides complete coverage for A.M. and F.M. alignment. Generates Radio Frequencies from 100 Kilocycles to 60 Megacycles on fundamentals and from 60 Megacycles to 180 Megacycles on powerful harmonics.

BAR GENERATOR: The Model TV-50A projects an actual Bar Pattern on any TV Receiver Screen. Patterns will consist of 4 to 16 horizontal bars or 7 to 20 vertical bars.

VARIABLE AUDIO FREQUENCY GENERATOR: In addition to a fixed 400 cycle sine-wave audio, the Model TV-50A Genometer provides a variable 300 cycle to 20,000 cycle peaked wave audio signal.

DOT PATTERN GENERATOR (FOR COLOR TV): Although you will be able to use most of your regular standard equipment for servicing Color TV, the one addition which is a "must" is a Dot Pattern Generator. The Dot Pattern projected on any color TV Receiver tube by the Model TV-50A will enable you to adjust for proper color convergence.

CROSS HATCH GENERATOR: The Model TV-50A Genometer will project a cross-hatch pattern on any TV picture tube. The pattern will consist of non-shifting, horizontal and vertical lines interlaced to provide a stable cross-hatch effect.

MARKER GENERATOR: The Model TV-50A includes all the most frequently needed marker points. The following markers are provided: 189 Kc., 262.5 Kc., 456 Kc., 600 Kc., 1000 Kc., 1400 Kc., 1600 Kc., 2000 Kc., 2500 Kc., 3579 Kc., 4.5 Mc., 5 Mc., 10.7 Mc. (3579 Kc. is the color burst frequency).

The Model TV-50A comes absolutely complete with shielded leads and operating instructions. Only **\$47.50**

DID YOU EVER?

Order merchandise by mail, including deposit or payment in full, then wait and write . . . wait and write?

Purchase anything on time and sign a lengthy complex contract written in small difficult-to-read type?

Purchase an item by mail or in a retail store then experience frustrating delay and red tape when you applied for a refund?

Obviously prompt shipment and attention to orders is an essential requirement in our business . . . We ship at our risk!

PRINTED IN U.S.A.

Always say you saw it in—POPULAR ELECTRONICS

NO

CONTRACT TO SIGN CO-MAKERS EMPLOYER NOTIFICATION

The simple, direct authorization included in this offer is all you sign. We ask only that you promise to pay for or return the goods we ship in good faith.

EXAMINE ANY ITEM YOU SELECT IN THE PRIVACY OF YOUR OWN HOME

Then if completely satisfied pay on the interest-free terms plainly specified. When we say interest-free we mean not one penny added for "interest" for "finance" for "credit-checking" or for "carrying charges." The net price of each tester is plainly marked in our ads—that is all you pay except for parcel post or other transportation charges we may prepay.

Superior's New
Model 82A

A truly do-it-yourself type TUBE TESTER

TEST ANY TUBE IN 10 SECONDS FLAT!



- 1 Turn the filament selector switch to position specified.
- 2 Insert it into a numbered socket as designated on our chart (over 600 types included).
- 3 Press down the quality button—

THAT'S ALL! Read emission quality direct on bad-good meter scale.

FEATURES:

- Tests over 600 tube types.
- Tests OZ4 and other gas-filled tubes.
- Employs new 4" meter with sealed air-damping chamber resulting in accurate vibrationless readings.
- Use of 22 sockets permits testing all popular tube types and prevents possible obsolescence.
- Dual Scale meter permits testing of low current tubes.
- 7 and 9 pin straighteners mounted on panel.
- All sections of multi-element tubes tested simultaneously.
- Ultra-sensitive leakage test circuit will indicate leakage up to 5 megohms.

Production of this Model was delayed a full year pending careful study by Superior's engineering staff of this new method of testing tubes. Don't let the low price mislead you! We claim Model 82A will outperform similar looking units which sell for much more—and as proof, we offer to ship it on our examine before you buy policy.

Model 82A comes housed in handsome, portable, Saddle-Stitched Texon case. Only....

\$36⁵⁰
Net

Model 82A—Tube Tester

Total Price **\$36.50**

Terms: \$6.50 after 10 day trial, then \$6.00 monthly for 5 months if satisfactory. Otherwise return, no explanation necessary.

SUPERIOR'S
NEW
MODEL 83

C.R.T. TESTER

Tests and Rejuvenates ALL PICTURE TUBES

ALL BLACK AND WHITE TUBES ALL COLOR TUBES

From 50 degree to 110 degree types
—from 8" to 30" types.

- Model 83 is not simply a rehashed black and white C.R.T. Tester with a color adapter added. Model 83 employs a new improved circuit designed specifically to test the older type black and white tubes and the newer type black and white tubes and all color picture tubes.
- Model 83 provides separate filament operating voltages for the older 6.3 types and the newer 8.4 types.
- Model 83 employs a 4" air-damped meter with quality and calibrated scales.
- Model 83 properly tests the red, green and blue sections of color tubes individually—for each section of a color tube contains its own filament, plate, grid and cathode.
- Model 83 will detect tubes which are apparently good but require rejuvenation. Such tubes will provide a picture seemingly good

Test ALL picture tubes—in the carton—out of the carton—in the set!

but lacking in proper definition, contrast and focus. To test for such malfunction, you simply press the rej. switch of Model 83. If the tube is weakening, the meter reading will indicate the condition.

• Rejuvenation of picture tubes is not simply a matter of applying a high voltage to the filament. Such voltages improperly applied can strip the cathode of the oxide coating essential for proper emission. The Model 83 applies a selective low voltage uniformly to assure increased life with no danger of cathode damage.

Housed in handsome portable Saddle Stitches Texon case—complete with sockets for all black and white tubes and all color tubes. Only

\$38⁵⁰

Model 83—C.R.T. Tube Tester

Total Price **\$38.50**

Terms: \$8.50 after 10 day trial, then \$6.00 monthly for 5 months if satisfactory. Otherwise return, no explanation necessary.

We invite you to try before you buy any of the models described on this page, the preceding page and the following pages. If after a 10 day trial you are completely satisfied and decide to keep the Tester, you need send us only the down payment and agree to pay the balance due at the monthly indicated rate.

NO INTEREST OR FINANCE CHARGES ADDED!

If not completely satisfied, you are privileged to return the Tester to us, cancelling any further obligation.

SEE OTHER SIDE

CUT OUT AND MAIL TODAY! ▶

MOSS ELECTRONIC, INC.

Dept. D-749 3849 Tenth Ave., New York 34, N. Y.

Please send me the units checked on approval. If completely satisfied I will pay on the terms specified with no interest or finance charges added. Otherwise, I will return after a 10 day trial positively cancelling all further obligation.

Model 76 . . . Total Price \$26.95
\$6.95 within 10 days. Balance
\$5.00 monthly for 4 months.

Model 83 . . . Total Price \$38.50
\$8.50 within 10 days. Balance
\$6.00 monthly for 5 months.

Model TV-50A . . . Total Price \$47.50
\$11.50 within 10 days. Balance
\$6.00 monthly for 6 months.

Model 70 . . . Total Price \$15.85
\$3.85 within 10 days. Balance
\$4.00 monthly for 3 months.

Model 82A . . . Total Price \$36.50
\$6.50 within 10 days. Balance
\$6.00 monthly for 5 months.

Model 80 . . . Total Price \$42.50
\$12.50 within 10 days. Balance
\$6.00 monthly for 5 months.

Name

Address

City Zone State

All prices net, F.O.B., N. Y. C.

SHIPPED ON APPROVAL NO MONEY WITH ORDER - NO C.O.D.

Superior's New Model 70 UTILITY TESTER®

FOR REPAIRING ALL ELECTRICAL APPLIANCES and AUTOMOBILE CIRCUITS



As an electrical trouble shooter the Model 70:

- Will test Toasters, Irons, Broilers, Heating Pads, Clocks, Fans, Vacuum Cleaners, Refrigerators, Lamps, Fluorescents, Switches, Thermostats, etc.
- Measures A.C. and D.C. Voltages, A.C. and D.C. Current, Resistances, Leakages, etc.
- Will measure current consumption while the appliance under test is in operation.
- Incorporates a sensitive direct-reading resistance range which will measure all resistances commonly used in electrical appliances, motors, etc.
- Leakage detecting circuit will indicate continuity from zero ohms to 5 megohms (5,000,000 ohms).

As an Automotive Tester the Model 70 will test:

- Both 6 Volt and 12 Volt Storage Batteries • Generators • Starters • Distributors • Ignition Coils • Regulators • Relays • Circuit Breakers • Cigarette Lighters • Stop Lights • Condensers • Directional Signal Systems • All Lamps and Bulbs • Fuses • Heating Systems • Horns • Also will locate poor grounds, breaks in wiring, poor connections, etc.

INCLUDED FREE This 64-page book—practically a condensed course in electricity. Learn by doing.

Just read the following partial list of contents: What is electricity? • Simplified version of Ohms Law • What is wattage? • Simplified wattage charts • How to measure voltage, current, resistance and leakage • How to test all electrical appliances and motors using a simplified trouble-shooting technique. • How to trace trouble in the electrical circuits and parts in automobiles and trucks.

Model 70 comes complete with 64 page book and test leads

\$15⁸⁵
Only

Model 70—UTILITY TESTER
Total Price...\$15.85—

Terms: \$3.85 after 10 day trial, then \$4.00 monthly for 3 months, if satisfactory. Otherwise return, no explanation necessary.

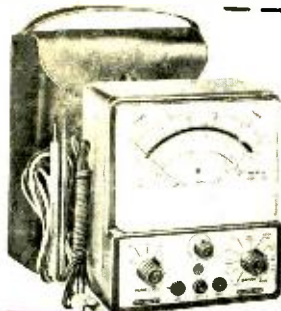

Model 80 ALLMETER

Total Price \$42.50

Terms: \$12.50 after 10 day trial, then \$6.00 monthly for 5 months if satisfactory. Otherwise return, no explanation necessary.

NOTE: The line cord is used only for capacity measurements. Resistance ranges operate on self-contained batteries.

SUPERIOR'S NEW MODEL 80

20,000 OHMS PER VOLT ALLMETER

THE ONLY 20,000 OHMS PER VOLT V.O.M. SELLING FOR LESS THAN \$50 WHICH PROVIDES ALL THE FOLLOWING FEATURES:

- ✓ 6 INCH FULL-VIEW METER provides large easy-to-read calibrations. No squinting or guessing when you use Model 80.
- ✓ MIRRORED SCALE permits fine accurate measurements where fractional readings are important.
- ✓ CAPACITY RANGES permit you to accurately measure all condensers from .00025 MFD to 30 MFD in addition to the standard volt, current, resistance and decibel ranges.
- ✓ HANDSOME SADDLE-STITCHED CARRYING CASE included with Model 80 Allmeter at no extra charge enables you to use this fine instrument on outside calls as well as on the bench in your shop.

- SPECIFICATIONS:
- 7 D.C. VOLTAGE RANGES (At a sensitivity of 20,000 Ohms per Volt) 0 to 15/75/150/300/750/1500 Volts.
 - 6 A.C. VOLTAGE RANGES: (At a sensitivity of 5,000 Ohms per Volt) 0 to 15/75/150/300/750/1500 Volts.
 - 3 RESISTANCE RANGES: 0 to 2,000/200,000 Ohms. 0-20 Megohms.
 - 2 CAPACITY RANGES: 0.0025 Mfd. to 3 Mfd., .05 Mfd. to 30 Mfd.
 - 5 D.C. CURRENT RANGES 0-75 Microamperes, 0 to 7.5/75/750 Milliamperes, 0 to 15 Amperes.
 - 3 DECIBEL RANGES: -- 6 db to + 18 db, + 14 db to + 38 db + 34 db to + 58 db

Model 80 Allmeter comes complete with operating instructions, test leads and portable carrying case. Only **\$42⁵⁰**

TRY FOR 10 DAYS BEFORE you buy! THEN if satisfactory

pay in easy, interest free, monthly payments. See coupon inside.

We invite you to try before you buy any of the models described on this and the preceding pages. If after a 10 day trial you are completely satisfied and decide to keep the Tester, you need send us only the down payment and agree to pay the balance due at the monthly indicated rate. (See other side for time payment schedule details.)

NO INTEREST OR FINANCE CHARGES ADDED!

If not completely satisfied, you are privileged to return the Tester to us, cancelling any further obligation.

SEE OTHER SIDE

CUT OUT AND MAIL TODAY!

FIRST CLASS

Permit No. 61430

New York, N. Y.

VIA AIR MAIL

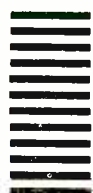

BUSINESS REPLY CARD

No Postage Stamp Necessary if Mailed in the U. S.

POSTAGE WILL BE PAID BY —

MOSS ELECTRONIC, INC.

3849 TENTH AVENUE

NEW YORK 34, N. Y.