

SPECIAL: Build a One-Tube Laboratory

POPULAR ELECTRONICS

JANUARY
1960

35
CENTS

HI-FI • HAM RADIO • SWL • TEST GEAR

How to Build a:

- Dry Cell Rejuvenator
- Wireless Metronome
- Beam Antenna
- Frequency Meter

All About:

- Free Test Signals
- Hi-Fi Turntables

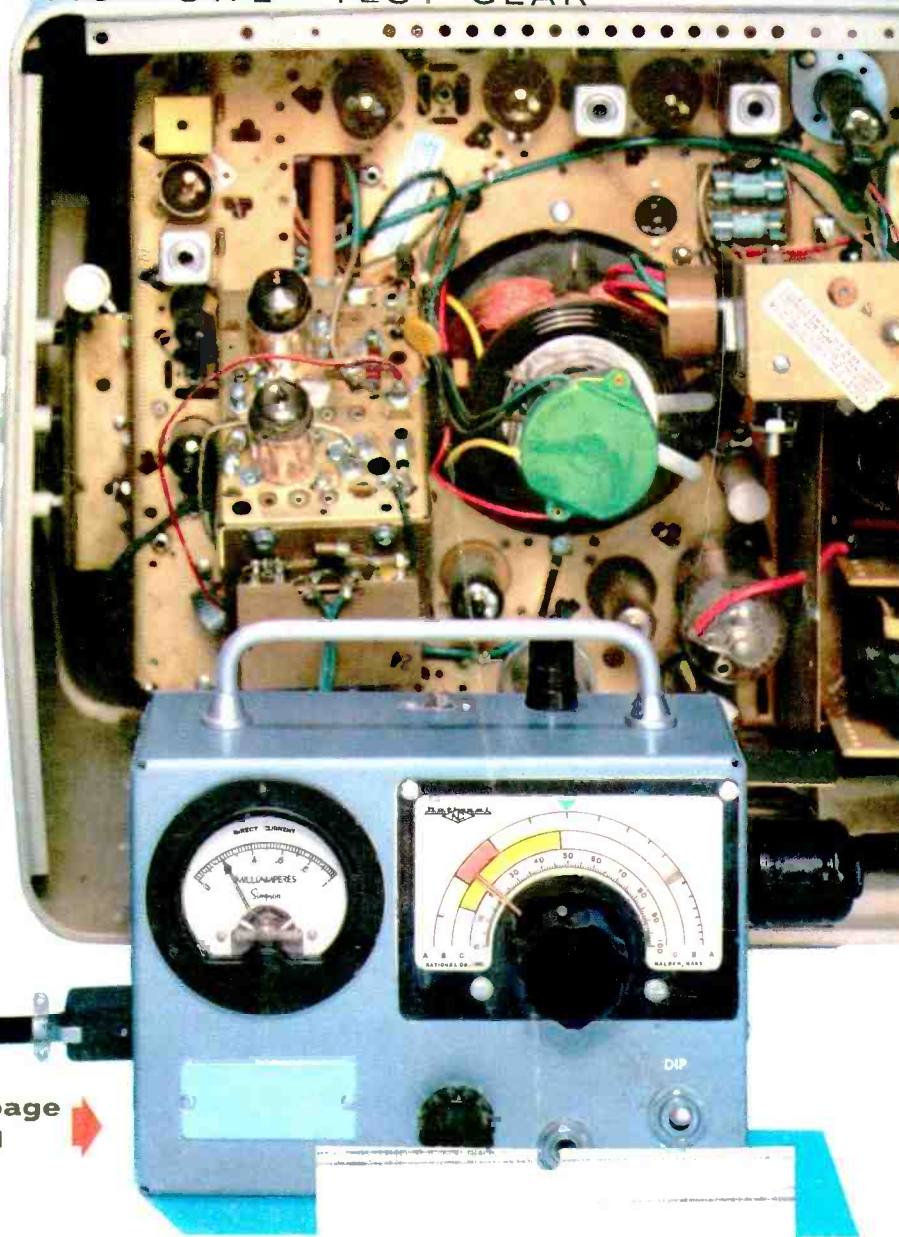

see page 41 

STABISTORS: What They

E20S106811
 LOUIS HOFFART
 18108 WINDWARD
 CLEVELAND 19 OHIO

SHIPPED ON APPROVAL

NEW

CRT TESTER-REACTIVATOR Model CRT-2

NOW . . . a TESTER-REACTIVATOR really designed to test, repair and reactivate EVERY PICTURE TUBE MADE — whether black and white or color . . . with exclusive features never before found in picture tube testers.

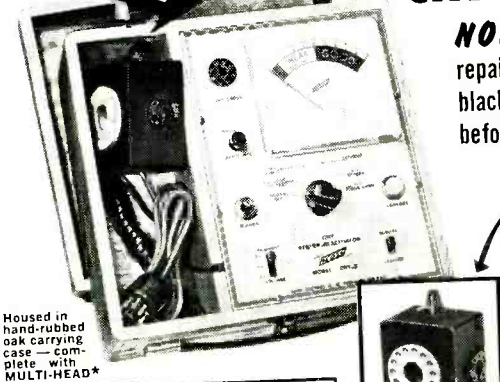

Housed in hand-rubbed oak carrying case — complete with MULTI-HEAD*

Model CRT-2
\$57.50
Net

TERMS: \$13.50 within 10 days. Balance \$11 monthly for 4 months.

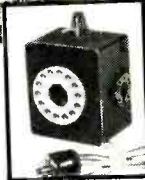

The CRT-2 steps in and solves the limitations and shortcomings of present day CRT Testers. Unlike ordinary CRT testers that keep entering the field with a limited range of operation, the CRT-2 employs a new brilliantly engineered circuit designed to test, repair and reactivate every black and white or color picture tube made. The CRT-2 eliminates the guesswork and risk that until now, has always been present when a picture tube is reactivated. It accomplishes this by providing perfect control of either the "Boost" or "Shot" method of reactivation.

THE CRT-2 DOES ALL THIS RIGHT IN THE CARTON, OUT OF THE CARTON OR IN THE SET

TEST

- ✓ for quality of every black and white and color picture tube
- ✓ for all inter-element shorts and leakage up to one megohm
- ✓ for life expectancy

REPAIR

- ✓ Will clear inter-element shorts and leakage
- ✓ Will weld opens between any two elements in the tube gun

REACTIVATE

- ✓ The unique controlled "SHOT" (high voltage pulse) method of reactivation provided by the CRT-2 will restore picture tubes to new life in instances where it was not possible before. Furthermore the high voltage is applied without danger of stripping the cathode as you always have perfect control of the high voltage pulse.
- ✓ The "BOOST" method of reactivation also provided by the CRT-2 is used effectively on tubes with a superficially good picture but with poor emission and short life expectancy. It will improve definition, contrast and focus greatly and add longer life to the picture tube.

1. **THE MULTI-HEAD** (patent pending) . . . A SINGLE PLUG IN CABLE AND UNIQUE TEST HEAD — A tremendous advance over the maze of cable and adapters generally found with other testers. Enables you to test, repair and reactivate every type of picture tube with greater convenience than ever before . . . 50 degree to 110 degree types from 8" to 30", whether 12 pin base, 8 pin base, 14 pin base . . . even the very latest 7 pin base. A special color switch on the MULTI-HEAD enables you to test, repair and reactivate each of the red, green and blue color guns separately.
2. **WATCH IT REACTIVATE THE PICTURE TUBE** — You actually see and control the reactivation directly on the meter as it takes place, allowing you for the first time to properly control the reactivation voltage. This eliminates the danger of stripping the cathode and whether the build-up is lasting. You will see if the cathode contamination is too great and if the picture tube is too far gone to be reactivated.
3. **CONTROLLED "SHOT" WITH HIGHER VOLTAGE FOR BETTER REACTIVATION** — Stronger than any found in other testers . . . high enough to really do the job — yet controlled to avoid damage to the picture tube.
4. **UNIQUE HIGH VOLTAGE PULSE CIRCUIT** — Will burn out inter-element shorts and weld open circuits with complete safety to the picture tube.
5. **VISUAL LIFE TEST** — Enables both you and your customer to see the life expectancy of any picture tube right on the meter. The fact that your customer can see the results of your tests as you make them virtually eliminates resistance to picture tube replacement when necessary.
6. **TESTS, REPAIRS AND REACTIVATES SPECIAL LOW SCREEN VOLTAGE TUBES** — Many new type picture tubes use special low voltage of approximately 50 volts. The CRT-2 will test, repair and reactivate these types with the same thoroughness as the regular types with complete safety.
7. **SEPARATE FILAMENT VOLTAGES** — Including the very latest 2.35 volt and 8.4 volt types as well as the older 6.3 volt types.
8. **TESTS, REPAIRS AND REACTIVATES 'SF' PICTURE TUBES** — found in the newest Sylvania and Philco TV sets. These picture tubes have different base pin connections than standard picture tubes and there is always an element of risk that the tube may be burned out when tested with ordinary picture tube testers. The CRT-2 is designed to accommodate this new base pin arrangement and will test the tube with no danger of damage.

ADDITIONAL FEATURES

- Employs the time proven dynamic cathode emission test principle • Large 4 1/2" meter with heavily damped movement for smooth action, accuracy and long life
- Provides separate shorts test for each element in the picture tube • Filament continuity is shown on a separate glow indicator • An easy to read instruction manual contains all the latest testing information on old and new type picture tubes • Housed in handsome hand-rubbed oak carrying case with special compartment for MULTI-HEAD and line cord. * patent pending

IN-CIRCUIT CONDENSER TESTER Model CT-1

Here is an IN-CIRCUIT CONDENSER that DOES THE WHOLE JOB! The CT-1 actually steps in and takes over where all other in-circuit condenser fail. The ingenious application of a dual bridge principle gives the CT-1 a tremendous range of operation . . . and makes it an absolute "must" for every serviceman.

in-circuit checks:

- ✓ Quality of condensers even with circuit short resistance . . . (This includes leakage, shorts, opens, intermittents)
- ✓ Value of all condensers from 200 mmfd. to .5 mfd.
- ✓ Quality of all electrolytic condensers (the ability to hold a charge)
- ✓ Transformer, socket and wiring leakage capacity

out-of-circuit checks:

- ✓ Quality of condensers . . . (This includes leakage, shorts, opens and intermittents)
- ✓ Value of all condensers from 50 mmfd. to .5 mfd.
- ✓ Quality of all electrolytic condensers (the ability to hold a charge)
- ✓ High resistance leakage up to 300 megohms
- ✓ New or unknown condensers . . . transformer, socket, component and wiring leakage capacity

OUTSTANDING FEATURES

- Ultra-sensitive 2 tube drift-free circuitry
- Multi-color direct scale readings for both quality and value . . . in-circuit or out-of-circuit
- Simultaneous readings of circuit capacity and circuit resistance
- Built-in hi-leakage indicator sensitive to over 300 megohms
- Cannot damage circuit components
- Electronic eye balance indicator for every greater accuracy
- Isolated power line
- Housed in sturdy hammertone finish steel case . . . comes complete with test leads

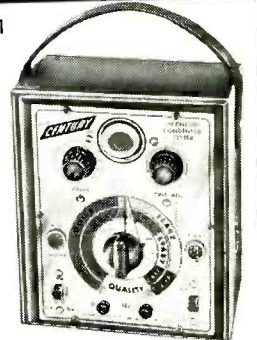

Model CT-1
\$34.50
Net

TERMS: \$9.50 within 10 days. Balance \$5 monthly for 5 months.

EASY TO BUY IF SATISFIED — see order form on facing page ➔

FOR 10 DAY FREE TRIAL

Convince yourself at no risk that CENTURY instruments are indispensable in your every day work. Send for instruments of your choice without obligation... try them for 10 days before you buy... only then, when satisfied, pay in easy-to-buy monthly installments — without any financing or carrying charges added.

NOW a Battery Operated Peak-to-Peak VACUUM TUBE VOLT METER Model VT-1

WITH LARGE EASY-TO-READ 6" METER —

featuring the sensational new MULTI-PROBE * Patent Pending

No extra probes to buy! The versatile MULTI-PROBE does the work of 4 probes

- ① DC Probe ② AC-Ohms Probe ③ Lo-Cap Probe ④ RF Probe

The VT-1 is a tremendous achievement in test equipment. With its unique MULTI-PROBE it will do all the jobs a V.T.V.M. should do without the expense of buying additional probes. No longer do you have to cart around a maze of entangled cables, lose time alternating cables or hunting for a misplaced probe. With just a twist of the MULTI-PROBE tip you can set it to do any one of many time-saving jobs. A special holder on side of case keeps MULTI-PROBE firmly in place ready for use.

FUNCTIONS

DC VOLTMETER ... Will measure DC, down to 1.5 volts full scale with minimum circuit loading, and give accurate readings of scale divisions as low as .025 volts ... Will measure low AGC and oscillator bias voltages from 1 volt or less up to 1800 volts with consistent laboratory accuracy on all ranges ... Zero center provided for all balancing measurements such as discriminator, ratio detector alignment and hi-fi amplifier balancing.

AC VOLTMETER ... True Peak-to-Peak measurements as low as 3 volts of any wave form including TV sync, deflection voltages, video pulses, distortion in hi-fi amplifiers, AGC and color TV gating pulses ... Scale divisions are easily read down to 1 volts ... Measures RMS at 1/20th the circuit loading of V.O.M. ... Unlike most other V.T.V.M.'s there is no loss in accuracy on the lowest AC range.

ELECTRONIC OHMMETER ... Measures from 0 to 1000 megohms ... Scale divisions are easily read down to .2 ohms ... Will measure resistance values from .2 ohms to one billion ohms ... Will detect high resistance leakage in electrolytic and by-pass condensers.

RF and LO-CAP MEASUREMENTS ... With these extra VT-1 functions you can measure voltages in extremely high-impedance circuits such as sync and AGC pulses, driving saw tooth voltages, color TV gating pulses, mixer output levels, i.f. stage-by-stage gain and detector inputs.

OUTSTANDING FEATURES

- Completely portable — self powered with long life batteries — permits use everywhere
- New advanced pentode amplifier circuit assures amazingly low battery drain
- Large 6" 100-microampere meter, many times more sensitive than meters used in most V.T.V.M.'s
- Laboratory accuracy performance — 2% of full scale on DC, 5% of full scale on AC
- Simplified multi-color easy-to-read 4-scale meter
- No heat operation assures rigid stability and accuracy
- Immune to power line fluctuations
- Amplifier rectifier circuit with frequency compensated attenuator — a feature found only in costly laboratory instruments
- Meter completely isolated — practically burn-out proof
- Hand-crafted circuitry eliminates the service headaches of printed circuitry
- 1% resistors used for permanent accuracy
- Separate RF ground return for low-loss RF measurement
- Micro-phonie type coaxial connector
- Matching cover protects instrument face — snaps on and off instantly.

SPECIFICATIONS

- DC Volts — 0 to 1.5/6/30/150/300/600/1500 volts
- AC Volts (RMS and Peak-to-Peak) — 0 to 3/12/60/300/1200 volts
- Ohms — 0 to a billion ohms, 10 ohms center scale — Rx1/10/100/1K/10K/100K/1M
- RF — Peak reading demodulator supplied for use on all DC ranges
- Zero Center — available on all DC volt ranges with zero at mid-scale
- Decibels — from -10 Db to +10/22/36/50/62 based on the Dbm unit: 0Db-1mW in 600 ohms
- Impedance — 11 megohms DC, 1 megohm AC, 10 megohms Lo-Cap
- Input Capacity — 130 mmfd. RMS, 250 mmfd. Peak-to-Peak, 25 mmfd. Lo-Cap



Housed in hammertone steel-case — complete with MULTI-PROBE

Model VT-1
\$58.50
Net

TERMS: \$14.50 within 10 days. Balance \$11 monthly for 4 months.



FAST-CHECK TUBE TESTER Model FC-2

Simply set two controls ... insert tube ... and press quality button to test any of over 700 tube types completely, accurately ... IN JUST SECONDS!

Over 20,000 servicemen are now using the FAST-CHECK in their every day work and are cutting servicing time way down, eliminating unprofitable call-backs and increasing their dollar earnings by selling more tubes with very little effort. See for yourself at no risk why so many servicemen chose the FAST-CHECK above all other tube testers.

PICTURE TUBE TEST ADAPTER INCLUDED WITH FAST-CHECK
Enables you to check all picture tubes including the new short-neck (10 degree type) for cathode emission, shorts and life expectancy ... also to rejuvenate weak picture tubes.

RANGE OF OPERATION

- ✓ Checks quality of over 700 tube types, employing the time proven dynamic cathode emission test. This covers more than 99% of all tubes in use today, including the newest series-string TV tubes, auto 12 plate-volt tubes, O24s, magic eye tubes, gas regulators, special purpose hi-fi tubes and even foreign tubes.
- ✓ Checks for inter-element shorts and leakage.
- ✓ Checks for gas content.
- ✓ Checks for life-expectancy.

SPECIFICATIONS

- No time consuming multiple switching ... only two settings are required instead of banks of switches located inside cover. No annoying roll chart checking ... tube chart listing over 700 tube types is located inside cover. New listings are added without costly roll chart replacement
- Checks each section of multi-section tubes and if only one section is defective the tube will read "Bad" on the meter scale mounted on panel
- Large 4 1/2" D'Arsonval type meter is the most sensitive available, yet rugged — fully protected against accidental burn-out
- Special scale on meter for low current tubes
- Compensation for no shock hazards
- Long lasting etched aluminum panel
- Separate gas and short jewel indicators
- Line isolated — NOTE: The Fast-Check positively cannot become obsolete ... circuitry is engineered to accommodate all future tube types as they come out. New tube listings are furnished periodically at no cost.

Housed in hand-rubbed oak carrying case complete with CRT adapter

Model FC-2
\$69.50
Net

TERMS: \$14.50 within 10 days. Balance \$11 monthly for 5 months.

CONVENIENT TIME PAYMENT PLAN — NO FINANCING CHARGES

CENTURY ELECTRONICS CO., INC.

ALL CENTURY INSTRUMENTS ARE GUARANTEED FOR ONE FULL YEAR

The extremely low prices are made possible because you are buying direct from the manufacturer.

- CHECK INSTRUMENTS DESIRED
- Model CRT-2 CRT TESTER REACTIVATOR \$57.50 \$13.50 within 10 days. Balance \$11 monthly for 4 months.
 - Model CT-1 In-Circuit Condenser Tester \$34.50 \$9.50 within 10 days. Balance \$5 monthly for 5 months.
 - Model VT-1 Battery Vacuum Tube Volt Meter \$58.50 \$14.50 within 10 days. Balance \$11 monthly for 4 months.
 - Model FC-2 Fast-Check Tube Tester \$69.50 \$14.50 within 10 days. Balance \$11 monthly for 5 months.
- Prices Net F.O.B. Mineola, N. Y.

111 Roosevelt Avenue, Dept. 301, Mineola, New York

Please rush the instruments checked for a 10 day free trial. If satisfied I agree to pay the down payment within 10 days and the monthly installments as shown. If not completely satisfied I will return the instruments within 10 days and there is no further obligation. It is understood there will be NO INTEREST or FINANCING charges added.

Name _____ Please print clearly

Address _____

City _____ State _____

POPULAR ELECTRONICS is published monthly by Ziff-Davis Publishing Company, William B. Ziff, Chairman of the Board (1946-1952), at 434 S. Wabash Ave., Chicago 5, Ill. Second-class postage paid at Chicago, Illinois. Authorized by Post Office Department, Ottawa, Canada, as second-class matter. SUBSCRIPTION RATES: One year U.S. and possessions, and Canada \$4.00; Pan-American Union countries \$1.50; all other foreign countries, \$5.00.

POPULAR ELECTRONICS

JANUARY

1960

VOLUME 12

NUMBER 1



Special Construction Feature

One-Tube Laboratory.....Howard Burgess 41

Electronic Construction Projects

Dry Cell Tester and Rejuvenator.....James E. Murphy 61
Universal Rectifier Tube Socket.....Manuel A. Moreno 66
Sensitive Diode-Transistor Radio.....Art Trauffer 73
Direct Reading Frequency Meter.....Robert J. D'Entremont 85
Wireless Metronome.....Martin H. Patrick 87

Audio and High Fidelity

Test Instruments—The Audio Generator (Part 1).....Larry Klein 54
Inside the Hi-Fi Turntable.....Joseph Marshall 57
Audio Aids.....64
Super Simple Power Megaphone.....Jay Tort 74
Turntable Tips.....84

Amateur and SWL

Free Government Test Signals—WWV.....Perry Winter, K2VLR 47
Easy-to-Build Beam Antenna.....Jim Fahnestock, W2RQA 50
Six-Meter Converter.....65
Bandspread.....Tom Kneitel 98
Short-Wave Monitor Registration.....113

Electronic Features and New Developments

Phones of the Future.....46
What Is a 300-Ohm Line?.....D. L. Geiger 52
How to Splice 300-Ohm Line.....John A. Comstock 53
How to Photograph Electronic Equipment.....Art Trauffer 67
The Stabistor Diode (an After Class Feature).....R. J. Shaughnessy 69
Electronics in the News.....72
Handy Filament Continuity Checker.....78
Take the Noise Out of Your Car Radio (Part 2).....Jack Darr 79
Familiar Farces.....Carl Kohler 82
Pocket-Size VOM Kit.....88

Departments

Notes from the Editor.....Oliver Read, W1ETI 8
Letters from Our Readers.....10
POP'tronics Bookshelf.....16
Tips and Techniques.....24
New Products.....30
Short-Wave Report.....Hank Bennett, W2PNA 71
Transistor Topics.....Lou Garner 75
Across the Ham Bands.....Herb S. Brier, W9EGQ 89
Carl and Jerry.....John T. Frye, W9EGV 104
On the Citizens Band.....Tom Kneitel, 2W1965 116

HEAR

BASS NOTES DOWN TO 35 CPS... BUILD THE ELECTRO-VOICE ARISTOCRAT

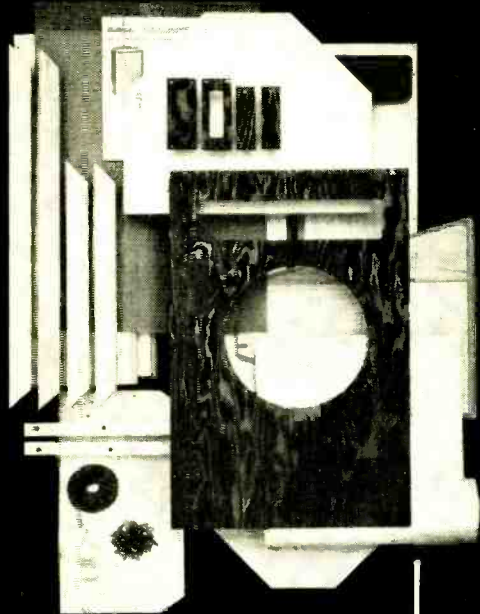

DRAMATIC PERFORMANCE has made the Electro-Voice Aristocrat the world's most popular enclosure for 12" loudspeakers. The Aristocrat will make an exciting difference in the performance of your loudspeaker—hear deep, extended bass response without annoying boom; sharp, well-defined low frequency transients, and all with greatly increased power handling capacity.

ASSEMBLE THE ARISTOCRAT YOURSELF AND SAVE 50%. When completed, the KD6 Aristocrat Kit interior construction is identical to E-V's factory-assembled Aristocrat enclosure, but with this difference: you save 50% and have an evening's fun.

AS EASY AS ONE . . . TWO . . . THREE. The KD6 Aristocrat Kit can be assembled in only one evening with E-V's exclusive sub-assembled parts and exploded view, step-by-step instructions. All you need is a screw driver; the rest is in the box. And E-V's accurately milled, furniture grade woods and veneers plus a choice of six finishing kits create an enclosure that will match your finest furniture.

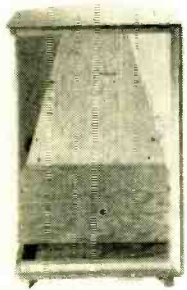

2

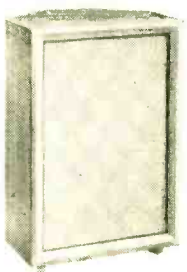

3

Model KD6 Aristocrat Kit

Audiophile Net. \$39.00

Model FK Finishing Kits, each

Audiophile Net. 5.00

Factory Finished Aristocrat Enclosure, Mahogany

Audiophile Net. 72.00

Limed Oak or Walnut

Audiophile Net. 79.00

Mail this coupon for free illustrated literature . . . see why more E-V Enclosure Kits have been built than all others combined.



Electro-Voice® , INC.

BUCHANAN, MICHIGAN

Superb New Products Through Research:

- Microphones—Phono Cartridges—
- High Fidelity Loudspeakers and Enclosures—
- Public Address Speakers—
- Marine Instruments—Communication Equipment—
- Electronic Test Instruments and
- Material for Defense.

Electro-Voice, Inc.
Buchanan, Michigan

Dept. 10-P

Gentlemen: Please send me free illustrated literature on E-V kits, enclosures and speakers.

NAME _____

ADDRESS _____

CITY _____ ZONE _____ STATE _____

Editor & Publisher

OLIVER READ, WIET

Managing Editor

JULIAN M. SIENKIEWICZ, WA2CQL

Technical Editor

LARRY KLEIN

Feature Editor

FURMAN HEBB

Art Editor

ALFONS J. REICH

Associate Editors

**MARGARET MAGNA
PERRY WINTER, K2VLR**

Editorial Assistant

DOLORES GIMBEL

Contributing Editors

**H. BENNETT, W2PNA
H. S. BRIER, W9EGQ
J. T. FRYE, W9EGV
L. E. GARNER, JR.
T. KNEITEL, 2W1965
D. I. STONER, W6TNS**

Art and Drafting Dept.

**K. W. PAUL, JR.
J. A. ROTH
W. K. VAHLSING, WV2GYL**

Advertising Director

JOHN A. RONAN, Jr.

Advertising Manager

WILLIAM G. McROY

ZIFF-DAVIS PUBLISHING COMPANY,
One Park Ave., New York 16, N. Y.
William B. Ziff, Chairman of the Board
(1946-1953); William Ziff, President;
W. Bradford Briggs, Executive Vice
President; Michael Michaelson, Vice
President and Circulation Director; Hershel
B. Sorbin, Vice President; J. Leonard
O'Donnell, Treasurer.



BRANCH OFFICES: Midwestern Office,
434 S. Wabash Ave., Chicago 5, Ill.,
Jim Weakley, advertising manager;
Western Office, 215 W. 7th St., Los
Angeles 17, Calif., Don Cena, Western
Manager.

Foreign Advertising Representatives:
D. A. Goodall Ltd., London; Albert Mil-
hoda & Co., Antwerp and Dusseldorf.

SUBSCRIPTION SERVICE: Forms 3579 and all subscription correspondence should be addressed to Circulation Department, 434 South Wabash Avenue, Chicago 5, Illinois. Please allow at least four weeks for change of address. Include your old address as well as new—enclosing if possible an address label from a recent issue.

CONTRIBUTORS: Contributors are advised to retain a copy of their manuscripts and illustrations. Contributions should be mailed to the New York Editorial Office and must be accompanied by return postage. Contributions will be handled with reasonable care, but this magazine assumes no responsibility for their safety. Any copy accepted is subject to whatever adaptations and revisions are necessary to meet the requirements of this publication. Payment covers all author's, contributor's and contestant's rights, titles, and interest in and to the material accepted and will be made at our current rates upon acceptance. All photos and drawings will be considered as part of material purchased.

POPULAR ELECTRONICS

Average Net Paid Circulation 266,479

This month's cover photo by Bruce Pendleton

COMING NEXT MONTH



(ON SALE JANUARY 26)

Featured on the cover of our February issue is a transistorized 27.255-megacycle low-power R/C transmitter. Small enough to fit in the palm of your hand, it is suitable for radio-controlled operations of all kinds—from opening garage doors to steering model planes. Complete plans are provided, including numerous pictorials. This should be one of P.E.'s most popular and easy-to-build projects.

You will also find complete plans on how to:

- Convert a Car Radio for Home Use
- Build a Dual-Meter Transistor Tester
- Make a Safe AM Tuner from an AC-DC Radio
- Build an Electronic Baby Sitter

plus many more interesting and informative articles.

POPULAR ELECTRONICS

**LET DeVRY TECH PREPARE YOU IN
SPARE TIME AT HOME AS AN**

ELECTRONICS TECHNICIAN



**NO PREVIOUS TECHNICAL EXPERIENCE
OR ADVANCED EDUCATION NEEDED!**

Laborers and bookkeepers, store clerks, shop men, farmers, salesmen — men of nearly every calling — have taken the DeVry Tech program and today have good jobs or service shops of their own in Electronics. You don't have to quit your present job. If you are 17 to 55, see how you may get yourself ready for a future in the fast-growing Electronics field.

Whether you prepare at home or in our well-equipped Chicago or Toronto Laboratories, you get sound, basic training in both principles and practice. At home, you use educational movies. You build actual circuits and test equipment. You read simple directions, follow clear illustrations. When you finish, you are prepared to step into a good job in an excitingly different field. You may even start a service shop of your own. Mail coupon for free facts today.

Live-Wire Employment Service



Puts you in touch with job opportunities — or helps you toward a better position in the plant where you are now employed.

Draft Age?

We have valuable information for every man of draft age; so if you are subject to military service, be sure to check the coupon.

SAMPLE BOOKLET

We'll give you a free copy of an interesting booklet, "Electronics and YOU." See for yourself how you may take advantage of the opportunities in this fast-growing field.

FREE!



Electronics in
SPACE TRAVEL

**A GUIDE
to a
BETTER JOB,
A BRIGHTER
FUTURE**

Electronics

Radar

Guided
Missiles

Television

Micro-Waves

Communications

Radio

Industrial
Electronics

Computers

Automation
Electronics

Remote Control
Systems

Broadcasting

Your Own
Service Shop

MAIL TODAY FOR FREE FACTS

"One of North America's Foremost Electronics Training Centers"



Accredited Member
of National
Home Study Council

DeVRY TECHNICAL INSTITUTE

CHICAGO 41, ILLINOIS

DeVry Technical Institute

4141 Belmont Ave., Chicago 41, Ill., Dept. PE-1-Q

Please give me your FREE booklet, "Electronics and YOU," and tell me how I may prepare to enter one or more branches of Electronics as listed above.

NAME _____ AGE _____

STREET _____ Please Print _____ APT. _____

CITY _____ ZONE _____ STATE _____

Check here if subject to military training.

1090 DeVry Tech's Canadian Training Center is located at
626 Roselawn Avenue, Toronto 12, Ontario

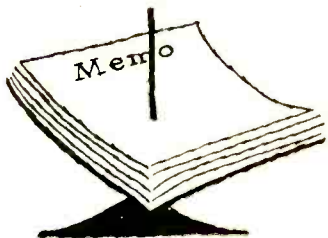

Notes from the Editor

WE DO OUR BEST—but every now and then a letter crosses our desk from a reader which says: "I built the two-transistor whatzit, but it won't work as well as I expected. Don't you test out transistor circuits before you print them?"

These occasional letters are always a concern to the editors—especially the editor who, as part of his job, devoted a great deal of painstaking effort to check the circuit and its performance.

We are always most careful to screen out any construction items which, for one reason or another, may have "built-in" bugs. First of all, we try to determine if there is sufficient interest in the gadget described to make a worthwhile article. If we agree that it's a good item, then we ask ourselves, "Can it be constructed with parts and equipment available to the average builder?"

Then we consider costs. Is it really worth what it will cost to build? After all, what's the sense of building a simple little transistor pocket radio that requires \$50 worth of parts. Again, along the lines of economy, we ask ourselves, "Is there a kit on the market that does the same thing at the same (or a lower) price?"

Finally, if at all possible, we test out the item in our lab. Every construction project found in POPULAR ELECTRONICS goes through the above screening process.

In most cases where a P. E. reader runs into trouble with a transistor project, we find that he's erred in some way. It may be a matter of poor soldering technique or reversed battery leads. He may have used transistors with high leakage—or he may have used cheap transistors with low gain.

The majority of failures involving transistorized equipment would not occur if the transistors were first checked on an inexpensive checker. It is a worthwhile investment to spend a few dollars for (or to build) a transistor tester that indicates both gain and leakage.

If you're interested in building your own tester, you'll find the construction details for an inexpensive unit—under \$15—in our February issue. It will check both audio and power transistors, and has two meters for monitoring base and collector currents under varying bias settings. Such testers are the best possible insurance for successful transistor projects.

Oliver Read

These men are getting practical training in **NEW Shop-Labs of**

ELECTRICITY

COYNE

ELECTRONICS ON REAL

Motors—Generators
—Switchboards—
Controls—Modern
Appliances—
Automatic
Electronic
Control Units

in Chicago—prepare for today's TOP OPPORTUNITY FIELD. Train on real full-size equipment at COYNE where thousands of successful men have trained for over 60 years—largest, oldest, best equipped school of its kind. Professional and experienced instructors show you how, then do practical jobs yourself. No previous experience or advanced education needed. Employment Service to Graduates.

START NOW—PAY LATER—Liberal Finance and Payment Plans. Part-time employment help for students. **GET FREE BOOK**—"Guide to Careers" which describes all training offered in **ELECTRICITY** and **TELEVISION-RADIO ELECTRONICS**—no obligation; **NO SALESMAN WILL CALL.**

TELEVISION

RADIO ELECTRONICS ON REAL

TV Receivers—
Black and White
and Color
AM-FM and
Auto Radios
Transistors
Printed Circuits
Test Equipment

Coyne Electrical School, 1501 W. Congress Parkway
Chartered Not For Profit • Chicago 7, Dept. 10-2C

MAIL COUPON OR WRITE TO ADDRESS BELOW

COYNE ELECTRICAL SCHOOL
Dept. 10-2C—New Coyne Building
1501 W. Congress Pkwy., Chicago 7, Ill.

Send **BIG FREE** book and details of all the training you offer. However, I am especially interested in:

Electricity Television Both Fields

Name _____

Address _____

City _____ State _____



**COYNE offers
LOW COST**

TELEVISION RADIO - COLOR TV

**Training in
Spare Time AT HOME**

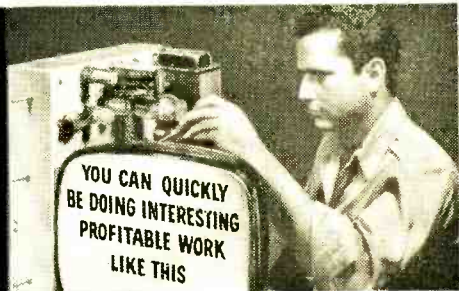

The future is **YOURS** in **TELEVISION!**

A fabulous field—good pay—fascinating work—a prosperous future in a good job, or independence in your own business!

*Send Coupon or write to address below
for Free Book*

and full details,
including easy
Payment Plan.

**No obligation, no
salesman will call.**



Coyne brings you **MODERN-QUALITY** Television Home Training; training designed to meet Coyne standards at truly lowest cost—you pay for training only—**no costly "put together kits."** Not an old Radio Course with Television "tacked on." Here is **MODERN TELEVISION TRAINING** including **Radio, UHF and Color TV.** No Radio background or previous experience needed. Personal guidance by Coyne Staff. **Practical Job Guides** to show you how to do actual servicing jobs—**make money early in course.** Free Lifetime Employment Service to Graduates.

COYNE Television

Home Training Division
Dept. 10-HZ, New Coyne Building
1501 W. Congress Pkwy., Chicago 7, Ill.

Send **Free Book** and details on how I can get Coyne Quality Television Home Training at *low cost and easy terms.*

Name _____

Address _____

City _____ State _____

COYNE ELECTRICAL SCHOOL

**CHARTERED AS AN EDUCATIONAL INSTITUTION
NOT FOR PROFIT**

1501 W. Congress Parkway • Chicago 7, Dept. 10-HZ



B.W. COOKE, Jr., President
Coyne—the Institution behind this training... the largest, oldest, best equipped residential school of its kind. Founded 1899.

NOW WITH NEW TICONAL[®] VIII

MAGNETS
(30% MORE POWERFUL THAN ALNICO)

Norelco[®]

T-7 LOUSPEAKERS

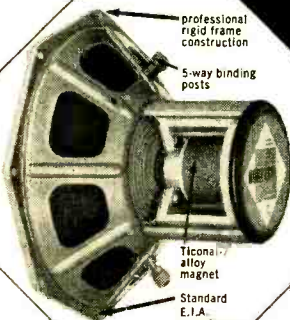

... AND A NEW LINE OF ACOUSTICALLY MATCHED ENCLOSURES

The world's greatest buys on the basis of listening quality, the new T-7 series of 5" to 12" loudspeakers incorporates magnets of Ticonal-7 steel, the most powerful of magnet alloys, for maximum efficiency and damping... dual cones for wide frequency response... constant impedance resulting in an extremely straight response curve... longer effective air-gaps and extra high flux density to provide exceptional transient response and to eliminate ringing and overshoot. For descriptive literature write to North American Philips Co., Inc., High Fidelity Products Division, Dept. 3F1, 230 Duffy Avenue, Hicksville, Long Island, New York.

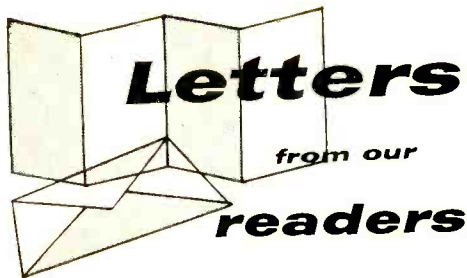

Police Special Conversion

■ A couple of other fellows and myself built three "Police Special" receivers, as described in the July issue. While they all work fine, we wonder if we could convert them to cover 152-162 mc. instead of 30-50 mc.

GLOVER J. SWEENEY
Camden, N. J.

We have had a number of requests for information on how to convert the Police Special to frequencies other than those for which it was designed. It is possible to increase the upper limits of this receiver by reducing the number of turns on L1 and L2; however, this technique may only extend the frequency coverage to about 100 mc.

Satisfied Customer

■ I finally got around to building the "Duo-Flex" speaker system described in your February issue, and I thought you might be interested in my experiences with it.

For an extra buck I had plywood cut to size; this undoubtedly saved me a lot of time and money because everything went together quickly and accurately. I departed from the plans in only two instances: (1) I added a jack in order to facilitate using the system in several different lo-

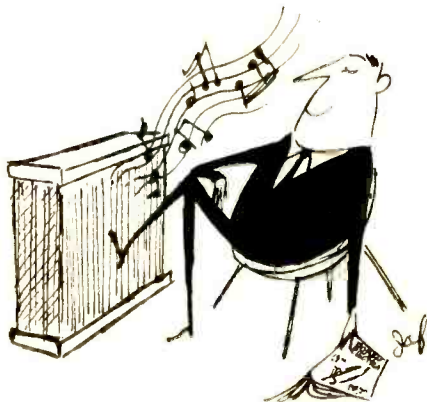

cations, and (2) I put a decorative molding around the edges. Then, after applying several coats of flat black enamel, I gave it two coats of flat varnish and a good waxing. All in all, it turned out to be a very presentable piece of furniture.

As for performance, I have no testing equipment other than my ear, which may be more discerning and demanding than the standard measuring equipment used. I find the unit uniformly good and superior to many speakers which cost much

Always say you saw it in—POPULAR ELECTRONICS

Learn Electronics

PREPARE FOR YOUR F. C. C. LICENSE—YOUR TICKET TO A BETTER JOB AND HIGHER PAY!



F. C. C. LICENSE—THE KEY TO BETTER JOBS

An F. C. C. *commercial* (not amateur) license is your ticket to higher pay and more interesting employment. This license is Federal Government evidence of your qualifications in electronics. Employers are eager to hire *licensed* technicians.

WHICH LICENSE FOR WHICH JOB?

The **THIRD CLASS** radiotelephone license is of value primarily in that it qualifies you to take the second class examination. The scope of authority covered by a third class license is extremely limited.

The **SECOND CLASS** radiotelephone license qualifies you to install, maintain and operate most all radiotelephone equipment except commercial broadcast station equipment.

The **FIRST CLASS** radiotelephone license qualifies you to install, maintain and operate every type of radiotelephone equipment (except amateur) including all radio and television stations in the United States, its territories and possessions. This is the highest class of radiotelephone license available.

GRANTHAM TRAINING PREPARES YOU

The Grantham Communications Electronics Course prepares you for a **FIRST CLASS** F. C. C. license, and it does this by **TEACHING** you electronics. Each point is covered simply and in detail, with **emphasis** on making the subject easy to understand. The organization of the subject matter is such that you progress, step-by-step, to your specific objective—a first class F. C. C. license.

CORRESPONDENCE OR RESIDENCE CLASSES

Grantham training is available by correspondence or in resident classes. Either way (residence or correspondence), we train you quickly and well—no previous training required. Even a beginner may qualify for his first class license in a relatively short time.

FOUR COMPLETE SCHOOLS: *To better serve our many students throughout the entire country, Grantham School of Electronics maintains four complete Divisions—located in Hollywood, Calif., Seattle, Wash., Kansas City, Mo., and Washington, D.C. All Divisions of Grantham School of Electronics offer the same rapid courses in F. C. C. license preparation, either by home study or in resident classes.*

Get your First Class Commercial F. C. C. License Quickly

This booklet
FREE!



This free booklet gives details of our training and explains what an F. C. C. license can do for your future.

Upgrade Your Income with a First Class F. C. C. LICENSE

In resident classes or by home study, Grantham training is the easy way to learn more quickly and to prepare more thoroughly for F. C. C. examinations. And your first class F. C. C. license is the quick, easy way to prove to your employer that you are worth more money.

If you already have practical experience in radio-electronics, the Grantham course can add a knowledge of theory and an F. C. C. license to that practical experience. This is most important in qualifying you for higher pay and greater job security.

Our free booklet gives details of how you can prepare quickly for a better job in the rapidly expanding electronics industry. Clip the coupon below and mail it to the Grantham School nearest you.

GRANTHAM SCHOOL OF ELECTRONICS

HOLLYWOOD CALIF.

1505 N. Western Ave. (HO 7-7727)
Hollywood, Calif.

SEATTLE WASH.

408 Marion Street (MA 2-7227)
Seattle, Wash.

KANSAS CITY MO.

3123 Gillham Road (JE 1-6320)
Kansas City, Mo.

WASHINGTON D. C.

821 - 19th Street, N. W. (ST 3-3614)
Washington, D. C.

MAIL COUPON TO SCHOOL NEAREST YOU

(Mail in envelope or paste on postal card)

To: **GRANTHAM SCHOOL OF ELECTRONICS**

1505 N. Western • 408 Marion • 3123 Gillham Rd. • 821-19th, NW
Hollywood • Seattle • Kansas City • Washington



Gentlemen:

Please send me your free booklet telling how I can get my commercial F. C. C. license quickly. I understand there is no obligation and no salesman will call.

Name _____ Age _____

Address _____

City _____ State _____

I am interested in: Home Study, Resident Classes 03-A

MORE PICTURE POWER

new
BLONDER-TONGUE

B-24 POW-R BOOSTER



\$24⁹⁵
list

*it's a powerful booster
... or an amplified coupler!*

**provides sharp, clear TV pictures on
1, 2 or more TV sets with only 1 antenna**

'straight-thru' circuit provides up to 10 db gain as a powerful one-set booster

'couple-two' circuit provides up to 5 db gain (per set) as an amplified two-set coupler

'straight-thru' circuit and B-T 4-set coupler provide no-loss 4-set distribution system

Employs new frame-grid tube 6DJ8, new circuitry to achieve highest signal gain and "lower-than-cascode" noise factor. Provides full broadband amplification covering low and high VHF channels. Features "NO-STRIP" 300 ohm terminals for positive, electrical connections in seconds. Has "on/off" switch.

Improve TV reception today on 1, 2 or more TV sets with a single antenna.



Available at parts distributors. For details write:
BLONDER-TONGUE LABORATORIES, INC.

9 Ailing Street, Dept. PE-1, Newark 2, N. J.

In Canada: Teleequipment Mfg. Co., Ltd., London, Ont. Export: Morhan Export Corp., N. Y. 13, N. Y. • hi-fi components • UHF converters • master TV systems • industrial TV cameras • FM-AM radios

Letters

(Continued from page 10)

more. The treble is clear and crisp all the way up and the bass is round and mellow. What more can you ask for the price?

I am going to build an exact duplicate and use the pair for stereo. Incidentally, I found the article most interesting and the plans and explanations clear and accurate.

HAROLD GOLDMAN
Studio City, Calif.

"Meggers"

■ Please allow me to point out to Mr. Robert Franke (who took Mr. Saunder Harris to task in the October *Letters From Our Readers* for recommending the use of a megohmmeter in making ground readings) that "meggers" have been used by utility companies for measuring ground resistance for many years. The one that we have has three scales: 0-3, 30, 300 *ohms*. Some of our ground systems must be kept below two *ohms*. Incidentally, this instrument bears an initial patent date of 1899.

J. A. CAREY
Minneapolis, Minn.

Pro-Hi-Fi Reader

■ I would like to disagree with Mr. Lanny Marcus' view that you should cut down on your hi-fi articles (see *Letters From Our Readers*, October, '59). This seems like rather selfish thinking on his part. What does he think millions of people



listen to each day? Ringing telephone bells? Just because he's a ham, does he think the whole magazine should be devoted to "hamming?"

Personally, I would like to see a few more features on the application of electronic gear and a few more on the subject of records. And, while I'm at it, aren't there any pre-recorded monophonic tapes for those of us who don't have a stereo recorder?

As a beginner in this field, I wish you would print some articles on "how to read those blasted schematics." I would also like to have plans for a d.c.-to-a.c. converter.

MICHAEL HILL
Waterloo, Nebr.

In answer to Reader Hill's comments: (1) we hope that we will be able to keep both him and Reader Marcus happy by providing a suitable balance between all types of electronics coverage; (2) pre-recorded mono tapes unfortunately seem to have gone the way of the single-sided 78-rpm record; (3) we think one of the best ways to learn how to read schematic diagrams is to compare the schematics that appear in POPULAR ELEC-



Accredited by the National Home Study Council

good training
doesn't cost . . .
it pays!

How To Get an



FCC License (Commercial)

Get Your FCC License
Quickly

Your FCC License or Your Money Back

Get all 3 FREE
We guarantee
to train you until you receive
Your FCC License
—or your money back

The Master Course in Electronics will provide you with the mental tools of the electronics technician and prepare you for a First Class FCC License (Commercial) with a radar endorsement. When you successfully complete the Master Course, if you fail to pass the FCC examination, you will receive a full refund of all tuition payments.

Cleveland Institute training results in job offers like these:

Radio Operators

TWA has opportunities for radio operators with a 2nd class license or better. Must be able to type at least 35 wpm. Free transportation for self and family. Vacation and many other benefits.

Electronic Technicians

Goodyear Aircraft Corp. has openings for electronic technicians, to work as assistants to engineers on developmental electronics projects such as missile systems, radar, antennas and analog computers.

And our trainees get good jobs

"Investment in training really pays off"
"I am now employed by the Western Electric Company as an electronic tester. My status as a student of Cleveland Institute was an important factor in my being employed. Knowledge gained through the course has proved amazingly helpful and affords me a feeling of complete confidence."
T. E. Spence, Greensboro, N. C.

Cleveland Institute of Electronics

4900 Euclid Ave. Desk PE-60 Cleveland 3, Ohio

January, 1960

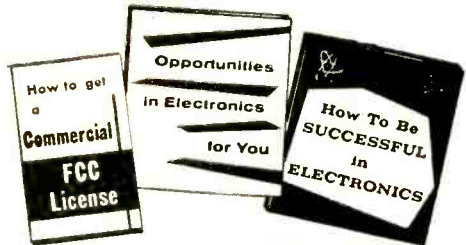

Cleveland Institute of Electronics

Desk PE-60, 4900 Euclid Ave., Cleveland 3, Ohio

Please send Free Booklets prepared to help me get ahead in Electronics. I have had training or experience in Electronics as indicated below:

- | | |
|---|---|
| <input type="checkbox"/> Military | <input type="checkbox"/> Broadcasting |
| <input type="checkbox"/> Radio-TV Servicing | <input type="checkbox"/> Home Experimenting |
| <input type="checkbox"/> Manufacturing | <input type="checkbox"/> Telephone Company |
| <input type="checkbox"/> Amateur Radio | <input type="checkbox"/> Other _____ |

In what kind of work are you now engaged ?

In what branch of Electronics are you interested ?

Name _____ Age _____

Address _____

City _____ Zone _____ State _____

PE-60

Letters

(Continued from page 12)

TRONICS with their pictorial diagrams—and, an excellent book on "How To Read Schematic Diagrams" is available from John F. Rider Publisher, 116 West 14th St., New York 11, N.Y.; and (4) we have in the works a d.c.-a.c. converter which will probably appear in the near future.

Modifying the Fish Lure

■ The "Electronic Fish Lure" by James G. Busse in the September issue is certainly a good idea. It can be simplified, however, by taking out the high-voltage section altogether, thus reducing the parts required and eliminating the expensive high-voltage battery.

The article suggested that a resistance be added

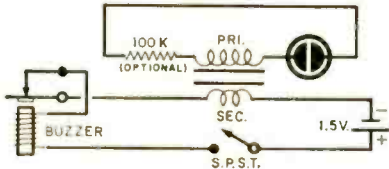

in series with the buzzer to keep its volume down, but this might be considered inefficient as the power dissipated in the resistor would be wasted. A more efficient circuit (see diagram) would replace this dropping resistor with the secondary of a small high-ratio output transformer. The resistance would be sufficient to lower the buzzer output and enough a.c. would be induced

into the transformer primary to light the neon lamp brightly.

GEORGE HARRISON
Ontario, Canada

Souped-Up Super-Satelliter

■ I built the Super-Satelliter antenna described in the November '58 issue and have been very pleased with its performance. I modified the elements to pick up the 19-meter band and have received *Radio Moscow*, *Radio Peking*, and others.

I enjoy the Short-Wave Report very much and would like more articles on receiving equipment.

ALEX VLASOV, WPE6AY
San Francisco, Calif.

Signal Generator as Dip Meter

■ The article in your October issue on employing an r.f. signal generator as a grid dip meter suggests the use of $\frac{3}{4}$ "-diameter plug-in coil forms (Amphenol 24-6H). According to my catalogs, this coil form is $1\frac{1}{16}$ " x $\frac{1}{4}$ ". What gives?

Also, is it necessary to use RG-59/U coaxial cable or can the type usually furnished with the signal generator be used?

HILMAR GRIESS
Waukegan, Ill.

The $\frac{3}{4}$ "-coil diameter is correct. However, the Amphenol coil form number should be 24-511 and the socket number should be 7855S. Most generators are supplied with 52-ohm cable, but cables with slightly higher impedances are usually satisfactory.

-30-

The last
preamp-
amplifier
you'll ever
have
to buy!



a 40-watt stereo
preamp-amplifier
in kit form
for only
\$79.95
by

PACO
also available
factory wired
SA-40W, \$129.95

PACO is the kit division of **PRECISION** Apparatus Co., Inc., world famous manufacturers of laboratory electronic instruments for over a quarter century.

The new PACO Model SA-40 offers you greater reserve power capacity than any other preamp-amplifier in its category. Its exceptional circuit design assures highly stable performance with extremely low distortion. And...the SA-40 provides maximum flexibility in any stereophonic high fidelity system present or contemplated.

outstanding specifications:

POWER OUTPUT: 20 watts per channel, 40 watts total

RESPONSE: 30 cps to 90 Kc \pm 1 db

DISTORTION:

Harmonic — less than .2% at 20 watts per channel

less than .1% at 10 watts per channel

Intermodulation — less than 1% at full rated output

FRONT PANEL CONTROLS: 14 controls including

separate bass and treble controls

POWER SUPPLY: Silicon diode, low impedance for minimum distortion

EXTERNAL DESIGN: gold and satin black hooded case with panel illumination and satin gold panel

COMING SOON!



Model ST-45
AM/FM Stereo Tuner Kit
matching companion
for the SA-40

At leading electronic parts distributors and wherever good sound is sold.

For complete information, write to:

PACO ELECTRONICS COMPANY, INC.
70-31 84th Street, Glendale 27, Long Island, New York
Export: Morhan Exporting Corp., 458 B'way, N.Y. 13, N.Y.
Canada: Atlas Radio Corp., 50 Wingold Ave., Toronto 19, Ont.

**ALL TUBES
INDIVIDUALLY BOXED
UNCONDITIONALLY GUARANTEED
FOR ONE YEAR**

Send for Free Complete Tube List & Order Blank. Your Inquiry Will Put You on Our Mailing List

TELTRON SMASHES PRICES on TUBES for '60!

GIFT OFFER

ONE 6BG6G tube will be shipped FREE with any \$10.00 or more order accompanying this ad.

FREE

\$7.50 list value. Bonus box includes 3 6SN7 tubes & 25 assorted resistors & condensers with receiving tubes & special parts.

FREE EICO TUBE TESTER



By popular demand we are repeating this fabulous offer.

You get this EICO tube tester kit worth \$25.00 absolutely FREE when you purchase \$19.00 worth of receiving tubes from TELTRON within 60 days.

Tube tester may be purchased outright for \$34.95 PREPAID. Send for FREE list on EICO test eqmt. & Hi-Fi Compnts.

SAVE ON ALL TUBES PARTIAL LIST OF MOST OFTEN USED TUBES

024	45	6AL5	43	6DE6	43	12BE6	46
183GT	62	6AN8	59	6DG6GT	50	12BH7	61
1RS	51	6AQ5	48	6DQ6	89	12BQ6	63
1SS	51	6AU6	52	6EJ5	47	12BY7	51
1T4	51	6AU4GT	60	6E6	61	12CR6	43
1U5	51	6AV6	43	6G6GT	41	12DB5	63
1X2	62	6AW8	50	6SA7	45	12DQ6	63
2AF4	1.02	6BA7	37	6S4	41	12K5	44
3AU6	55	6BA8	56	6SL7GT	45	12K7	45
3BC5	58	6BC4	48	6SN7GT	60	12SN7GT	56
3BN6	90	6BC5	48	6SQ7	38	12V6GT	43
3CB6	45	6BE6	59	6T8	38	12V6GT	43
3D7G	51	6BF5	48	6T8	38	12V6GT	43
3V4	51	6BG6G	1.18	6U8	76	12V6GT	43
48C8	48	6BH6	51	6V6GT	48	17DQ6	68
48Q7	75	6BK5	75	6W6GT	53	19A4	68
4C6G	59	6BK7	78	6X4	37	19BG6G	60
5AN8	51	6BL7GT	78	6X4	37	25BQ6GT	48
5AN8	54	6BN4	44	6X4	37	25C6G	41
5AV8	54	6BQ6GT	90	6X8	54	25C6G	41
5BK7	68	6BQ7A	85	6X8	54	25C6G	41
5B7	68	6BQ7B	85	6X8	54	25C6G	41
5U4C	49	6BQ7C	85	6X8	54	25C6G	41
5U4G	49	6BQ7D	85	6X8	54	25C6G	41
5U4G	49	6BQ7E	85	6X8	54	25C6G	41
5U4G	49	6BQ7F	85	6X8	54	25C6G	41
5U4G	49	6BQ7G	85	6X8	54	25C6G	41
5U4G	49	6BQ7H	85	6X8	54	25C6G	41
5U4G	49	6BQ7I	85	6X8	54	25C6G	41
5U4G	49	6BQ7J	85	6X8	54	25C6G	41
5U4G	49	6BQ7K	85	6X8	54	25C6G	41
5U4G	49	6BQ7L	85	6X8	54	25C6G	41
5U4G	49	6BQ7M	85	6X8	54	25C6G	41
5U4G	49	6BQ7N	85	6X8	54	25C6G	41
5U4G	49	6BQ7O	85	6X8	54	25C6G	41
5U4G	49	6BQ7P	85	6X8	54	25C6G	41
5U4G	49	6BQ7Q	85	6X8	54	25C6G	41
5U4G	49	6BQ7R	85	6X8	54	25C6G	41
5U4G	49	6BQ7S	85	6X8	54	25C6G	41
5U4G	49	6BQ7T	85	6X8	54	25C6G	41
5U4G	49	6BQ7U	85	6X8	54	25C6G	41
5U4G	49	6BQ7V	85	6X8	54	25C6G	41
5U4G	49	6BQ7W	85	6X8	54	25C6G	41
5U4G	49	6BQ7X	85	6X8	54	25C6G	41
5U4G	49	6BQ7Y	85	6X8	54	25C6G	41
5U4G	49	6BQ7Z	85	6X8	54	25C6G	41
5U4G	49	6BQ80	85	6X8	54	25C6G	41
5U4G	49	6BQ81	85	6X8	54	25C6G	41
5U4G	49	6BQ82	85	6X8	54	25C6G	41
5U4G	49	6BQ83	85	6X8	54	25C6G	41
5U4G	49	6BQ84	85	6X8	54	25C6G	41
5U4G	49	6BQ85	85	6X8	54	25C6G	41
5U4G	49	6BQ86	85	6X8	54	25C6G	41
5U4G	49	6BQ87	85	6X8	54	25C6G	41
5U4G	49	6BQ88	85	6X8	54	25C6G	41
5U4G	49	6BQ89	85	6X8	54	25C6G	41
5U4G	49	6BQ90	85	6X8	54	25C6G	41
5U4G	49	6BQ91	85	6X8	54	25C6G	41
5U4G	49	6BQ92	85	6X8	54	25C6G	41
5U4G	49	6BQ93	85	6X8	54	25C6G	41
5U4G	49	6BQ94	85	6X8	54	25C6G	41
5U4G	49	6BQ95	85	6X8	54	25C6G	41
5U4G	49	6BQ96	85	6X8	54	25C6G	41
5U4G	49	6BQ97	85	6X8	54	25C6G	41
5U4G	49	6BQ98	85	6X8	54	25C6G	41
5U4G	49	6BQ99	85	6X8	54	25C6G	41
5U4G	49	6BQ100	85	6X8	54	25C6G	41

New and hard to get types.

Prompt delivery.

10N5	90
10G37	70
2CY5	50
3AF4	1.02
4DE6	55
4DT6	59
5C0B	59
6B8B	64
6B05	59
6C0B	74
6C8X	64
6D55	75
8AW8	75
8C8X	90
11CV7	74
12KE6	59
17AX4GT	50
17D4	50
50EH5	59

These and many other "NEW & HARD TO GET" types in stock now. SEND APPROX. MARKET COST FOR ANY TYPE. EXCESS WILL BE REFUNDED.

A small portion of obsolete and seldom used tubes.

Immediate shipment!

1A6	93	7A7	42
1C5GT	57	7A8	44
1C7G	39	7A9	44
1F5G	39	7B8	47
1H4G	39	7C5	44
1L4G	66	7F8	77
1L8A	69	7H7	51
1LH4	66	7N7	52
1LNS	66	7V7	62
3L4	66	7Y4	35
5T4	59	7Z4	40
6A6	1.00	12A8GT	45
6A7	50	12K7GT	48
6L8	40	12Q7GT	48
6B7	60	12SR7	57
6B7	60	14A7	43
6AQ7GT	60	14B6	36
6A57G	1.50	14Q7	52
6D5	59	7	45
6E6	44	35A5	48
6F5GT	42	35A4	35
6F6	42	35A4	35
657G	89	37	39
65B7	50	39	44
65R7	43	45	55
6U5	54	50A5	48
6U7G	40	56	48
7A4	47	7A	65
7A6	47	75	44
7A8	46	80	40

FREE Postage on all tube Specials

Receiving Tube Specials

65N7GT A & B	Lots of 50	\$24.50
	Lots of 100	\$44.50
6W4GT	Lots of 50	\$18.95
	Lots of 100	\$34.95
12AU7 & A	Lots of 50	\$24.95
	Lots of 100	\$47.95
6AU6 & A	Lots of 50	\$18.95
	Lots of 100	\$34.95
6CB6 & A	Lots of 50	\$22.95
	Lots of 100	\$41.95

PARALLEL PICTURE TUBE BRIGHTENER

Series type. \$1.39

AUTO VIBRATORS

6v 4 Pr. Universal	\$1.59
12v 3 Pr. Standard	1.79
22v 4 Pr. Standard	1.99

Tubes listed may be factory seconds or used tubes and are clearly marked.

New Price Schedule of TELEVISION PICTURE TUBES

PICTURE GUARANTEED FOR ONE (1) YEAR

8DP4	17AVP4	15.75	21AUP4	19.25
10BP4	17EP4	13.25	21AVP4	19.25
10BP4	17CP4	17.25	21AWP4	18.75
12LP4	17HP4	16.49	21FP4	19.25
14RP4	17AP4	17.45	21RP4	19.25
14CP4	17JP4	16.49	21WP4	17.25
14QP4	17LP4	13.25	21XP4	18.75
14RP4	17OP4	16.49	21YP4	17.25
16AP4	17TP4	16.49	21ZP4	19.25
16CP4	17UP4	18.25	24ADP4	*
16DP4	19AP4	15.75	24AP4	27.25
16EP4	20CP4	15.75	24BP4	28.75
16FP4	21AP4	21.95	24DP4	*
16GP4	21LP4	18.75	24EP4	*
16HP4	21MP4	18.75	24FP4	*
16IP4	21NP4	21.25	24GP4	*
16JP4	21OP4	19.25	27RP4	*

* Price upon request. Aluminized on any tube, \$4.00 extra. All picture tubes require a deposit on your dud. Please add an additional \$5.00 on tube sizes to 17". Add \$7.00 on sizes 19", 20", 21" and 24". Your cash deposit will be refunded immediately upon receipt of your dud prepaid.

The Picture tubes are shipped promptly from our warehouse (the US. Continent and Canada only) P.O.B. Harrison, New Jersey.

Complete Outdoor All Channel Conical Antenna. Local or fringe. Incl: 8' elmt antenna w/serib; 3ft. mast; aluminum, int. or 7-ft. wall brkt (state need) 8 standoffs; 50' 300-ohm wire (list \$15.57.99); lots of 3, \$7.49; FOB Harrison, N. J. Im. divy.

Switch-Type Indoor Antenna. Shipped Postage Paid. New 9 position switch for use on UHF, VHF and color sets. Net Pkg. \$2.99 Lots of 6 \$2.49

FIBER FUSE CLIPS

12 for \$1.65 PPD.

RCA CHEATER CORDS

6 for \$1.95 PPD.

Heavy Duty Solder Gun Kit

135w gun with dual switch. Incl. wire soldering brush, make light wire twists and re-open old solder joints. Lg. pkg. solder prep. \$4.95; 3 for \$14.29

NEW LIBERAL TERMS. No minimum order. Free postage on all tube & parts orders over \$5.00 in U.S.A. APOs & Territories. 25% deposit required on CODs. Please send approximate postage on Canadian and foreign shipments. Excess will be refunded. All picture tubes and outdoor antennas shipped FOB Harrison, New Jersey.

TELTRON ELECTRIC CO.

428 Harrison Ave. Harrison, N. J. Phone HUmboldt 4-9848

DEPT. PE-1

COMPLETE SERVICE TRAINING

... written so you can understand it!



Only \$13
for the complete
2-volume course

3 MONTHS TO PAY

Fix any TV or Radio Ever Made

EASIER-BETTER-FASTER!

No complicated theory or mathematics! These famous Chirardi books get right down to brass tacks in showing you how to handle all types of AM, FM, and TV service work by approved professional methods. Almost 1500 pages and over 800 clear illustrations show how to handle every phase of troubleshooting and servicing. Each book is co-authored by A. A. Chirardi whose manuals have helped train more servicemen than any other books or courses of their kind!

1—Radio and Television Receiver TROUBLESHOOTING AND REPAIR

A complete guide to profitable professional methods. For the beginner, it is a comprehensive training course. For the experienced serviceman, it is a quick way to "brush up" on specific jobs, to develop improved techniques or to find fast answers to puzzling service problems. Includes invaluable "step-by-step" troubleshooting charts that show what to look for and where. 820 pages, 417 illustrations, price \$7.50 separately.

2—Radio and Television Receiver CIRCUITRY AND OPERATION

This 669-page volume is the ideal guide for servicemen who realize it pays to know what really makes modern radio-TV receivers "tick" and why. Gives a complete understanding of basic circuits and circuit variations; how to recognize them at a glance; how to eliminate guesswork and useless testing in servicing them. 417 illus. Price separately \$6.75.

Special low price . . . you save \$1.25

If broken into lessons and sent to you as a "course," you'd regard these two great books as a bargain at \$75 or more!

Under this new offer, you buy both books for only \$13.00 . . . you save \$1.25—and have the privilege of paying in easy installments while you use them! No lessons to wait for. You learn fast—and right!

STUDY 10 DAYS FREE!

Dept. PE-10, RINEHART & CO., Inc.
232 Madison Ave., New York 16, N. Y.

Send books below for 10-day FREE EXAMINATION. In 10 days I will either remit price indicated (plus postage) or return books postpaid and owe you nothing.

Radio & TV Receiver **TROUBLESHOOTING & REPAIR** (Price \$7.50 separately)

Radio & TV **CIRCUITRY & OPERATION** (Price \$6.75)

Check here for **MONEY-SAVING COMBINATION OFFER**
Save \$1.25. Send both of above big books at special price of only \$13.00 for the two. (Regular price \$14.25 . . . you save \$1.25.) Payable at rate of \$4 plus postage after 10 days if you decide to keep books and \$3 a month for 3 months until the total of \$13.00 has been paid.

Name

Address

City, Zone, State

Outside U.S.A.—\$8.00 for **TROUBLESHOOTING & REPAIR**; \$7.25 for **CIRCUITRY & OPERATION**; \$14.00 for both. Cash only, but money refunded if you return books in 10 days.

POP'tronics Bookshelf

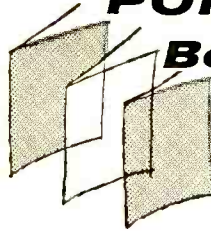

"PRINTED CIRCUITS" published by Gernsback Library, Inc., 154 West 14th St., New York 11, N. Y. 224 pages. Paper cover. \$2.90.

A virtual encyclopedia on printed circuits, this book traces their history, tells how they are manufactured commercially and how the reader can make his own. It discusses the rapidly expanding role of printed-circuit boards in modern electronic equipment and explains how different types of components are used with them. Applications and maintenance techniques are examined in detail.



"R-F AMPLIFIERS" edited by Dr. A. Schure. Published by John F. Rider Publisher, 116 West 14th St., New York 11, N. Y. 104 pages. Soft cover. \$2.40.

Clearly written and complete, this book is an ideal reference work on r.f. amplifiers. It covers the design and theory of a wide variety of r.f. voltage and power amplifiers, with special emphasis on the properties of resonant circuits as applied to amplifiers of this kind. All classes of vacuum-tube and transistorized amplifiers are discussed thoroughly.



"101 WAYS TO USE YOUR SIGNAL GENERATOR" by Robert G. Middleton. Published by Howard W. Sams and Co., Inc., 2201 East 46th St., Indianapolis 5, Ind. 123 pages. Soft cover. \$2.00.

This is the fourth in Mr. Middleton's "101 Ways" series on test equipment. Like the others, it is chock full of useful information, with every conceivable application for the signal generator being explained and diagrammed. As Mr. Middleton implies in his introduction, this book is perhaps one of the few substitutes for actual experience. As such it is highly recommended.

(Continued on page 20)

**GREATEST
ADVANCE IN
SHOP-METHOD
HOME TRAINING**

EARN MORE MONEY...GET INTO TELEVISION ELECTRONICS-RADIO

Learn ALL 8 PHASES in ONE MODERN HOME-STUDY COURSE
At Home -- In Spare Time

YOU GET ALL THIS NEWEST PRACTICAL EQUIPMENT

- Parts to build a modern TV set, including all tubes plus a large screen Picture Tube
- Parts to build a powerful Superhet Receiver, standard broadcast and short wave
- Parts to conduct many experiments and build Continuity Checker, RF Oscillator, TV Circuits, Audio Oscillator, TRF Receiver, Signal Generator
- A Valuable Professional Multitester

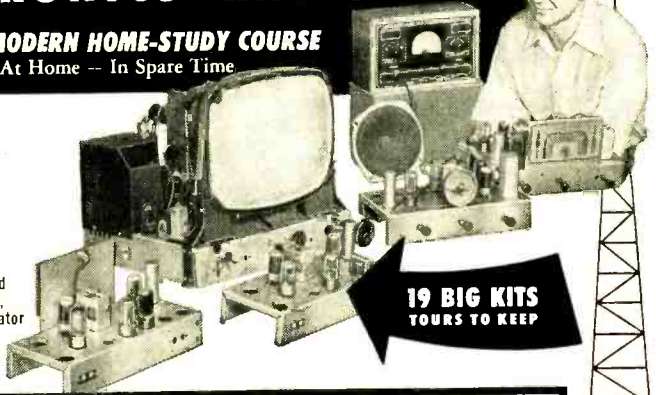

**19 BIG KITS
TOURS TO KEEP**

YOUR NATIONAL SCHOOLS TELERAMA COURSE COVERS ALL 8 PHASES

- | | |
|------------------------------------|--------------------------------|
| 1. TELEVISION, INCLUDING COLOR TV | 5. PREPARATION FOR FCC LICENSE |
| 2. RADIO, FM AND AM | 6. AUTOMATION |
| 3. INDUSTRIAL ELECTRONICS | 7. RADAR AND MICRO WAVES |
| 4. SOUND RECORDING AND HI FIDELITY | 8. COMMUNICATIONS |

YOU ARE NEEDED IN THE TELEVISION-ELECTRONICS-RADIO INDUSTRY!
You can build a secure future for yourself if you get into Electronics NOW! Today's shortage of trained technicians creates tremendous opportunities. National Schools Shop-Method trained technicians are in constant and growing demand for high-pay jobs in Broadcasting and Communications, Electronic Research, Servicing and Repair, and many other branches.

Let National Schools, a Resident Technical School for over 50 years train you for today's unlimited opportunities in electronics! Our Shop Method trains you to be a MASTER-TECHNICIAN. Completely up to date, developed by experienced instructors and engineers, your Telerama Course will teach you all phases of the industry quickly, clearly and correctly. You can master the most modern projects, such as Color TV, printed circuits — even prepare for FCC License without taking a special

course. You can handle sales, servicing, manufacturing, or make good money in your own business. SEND FOR FACTS TODAY!

EARN AS YOU LEARN. Many of our students earn their entire tuition and more in Spare Time jobs we show them how to do while learning.

YOU GET EVERYTHING YOU NEED — Clear, profusely illustrated lessons, shop-tested manuals, modern circuit diagrams, practical job projects — all the valuable equipment shown above

— many other materials and services — consultation privilege with our qualified staff, and Graduate Employment Service. **EVERYTHING YOU NEED** for outstanding success in Electronics.

RESIDENT TRAINING AT LOS ANGELES

If you wish to take your training in our Resident School at Los Angeles, the world's TV capital, start NOW in our big, modern Shops, Labs and Radio-TV Studios. Here you work with latest Electronic equipment—professionally installed—finest, most complete facilities offered by any school. Expert, friendly instructors. Personal attention. Graduate Employment Service. Help in finding home near school—and part time job while you learn. Check box in coupon for full information.



FREE!

Fully illustrated "Career" Book in TV-Radio-Electronics. PLUS actual sample lesson—yours at no cost, no obligation. CLIP COUPON NOW... MAIL IT TODAY!



MEMBER



APPROVED FOR G. I. TRAINING NATIONAL SCHOOLS

4000 S. FIGUEROA ST., LOS ANGELES 37, CALIF.

NATIONAL SCHOOLS

TECHNICAL TRADE TRAINING SINCE 1905
LOS ANGELES 37, CALIFORNIA

GET FAST SERVICE—MAIL NOW TO

NATIONAL SCHOOLS, DEPT. R2G-10
4000 S. FIGUEROA ST.
LOS ANGELES 37, CALIF.
Rush free TV-Radio "Opportunity" Book and sample lesson. No salesman will call.

NAME _____ AGE _____
ADDRESS _____
CITY _____ ZONE _____ STATE _____

Check if interested ONLY in Resident School training at Los Angeles. VETERANS. Give date of Discharge

knight-kits[®] make the **Big News...**

A PRODUCT OF ALLIED RADIO



FREE
send
for it

see them in **ALLIED'S 1960 catalog**
THE WORLD'S LEADING ELECTRONIC SUPPLY GUIDE

See these and scores of other great **knight-kits**



Y-731 Deluxe FM-AM Stereo Hi-Fi Tuner (Multiplex add-in) **\$87.50**
only \$5 down



Y-712 Custom Superhet Citizen's Band Transceiver **\$79.95**
only \$5 down



Y-608 Lab AC VTVM with Automatic Range Selection **\$99.50**
only \$5 down

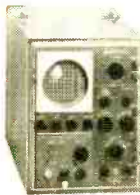

Y-611 Lab DC Scope with Triggered Sweep and Plug-in Vertical Preamps (Less Preamps) **\$285.00**
only \$10 down

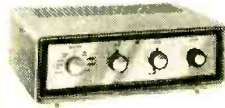

Y-773 Super-Value 20-Watt Stereo Hi-Fi Amplifier **\$44.50**
only \$2 down

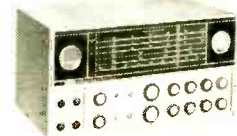

T-400 400-Watt Transmitter (AM and SSB add-ins available) **\$395.00**
only \$10 down



Y-708 1000 Ohm/Volt Pocket Volt-Ohm-Milliammeter **\$9.95**

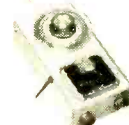

G-30 Amateur Grid Dip Meter (1.5-300 mc) **\$22.95**
only \$2 down



Y-711 Ammeter-Voltmeter for Cars and Boats **\$10.75**



NEW LOWEST TERMS

Only \$5 down (or less) on orders up to \$200; up to 24 months to pay. Fast handling—no red tape.

there's a money-saving **knight-kit** for every need

SEE PAGE AFTER PAGE OF FASCINATING KITS, INCLUDING:

HI-FI KITS

Stereo Deluxe Preamp
60-Watt Stereo Amplifier
Stereo Control
25-Watt Amplifier
18-Watt Amplifier
12-Watt Amplifier
FM-AM Tuner
FM Tuner
Speaker Systems
and others

HOBBYIST KITS

"Span-Master" Receiver
"Space-Spanner" Receiver
"Ranger" Radios
"Ocean Hopper" Radio
Clock-Radio
Radio-Intercom
5-Transistor Portable
2-Transistor Pocket Set
2-Way Intercom
Electronic Lab Kits
Photoelectric System,
and many others

INSTRUMENT KITS

DC VTVM
Volt-Ohm-Milliammeters
5" Oscilloscopes
Tube Checkers
RF Signal Generator
Signal Tracer
Audio Generator
Sweep Generator
Battery Eliminator
Capacity Checker
Transistor Checker
R/C Tester, plus many others

sold exclusively by

ALLIED RADIO

the **Best News** in electronic kits for 1960

world's easiest-to-build kits
SAVE UP TO 50%

BUILD THE BEST



Y-774 Deluxe 40-Watt Stereo Amplifier (with Center Channel) **\$79.50**
only \$5 down



R-100 Amateur Communications Receiver (Hi-gain, with built-in Q-Multiplier) **\$104.50**
only \$5 down



Y-713 Citizen's Band Transceiver **\$39.95**
only \$2 down

BEST... by Design



with the exclusive *knight-kit*

MONEY-BACK GUARANTEE

KNIGHT-KITS are an exclusive product of Allied Radio. Every KNIGHT-KIT meets or exceeds published specifications, or we refund your money in full.

**BUY ANY KNIGHT-KIT! BUILD IT!
IT MUST PERFORM EXACTLY AS CLAIMED
- OR WE REFUND YOUR MONEY!**

only *knight-kits* have
"CONVENIENCE ENGINEERING"
for easiest building...no previous
electronic experience needed

Exclusive in Knights-Kits, "convenience engineering" means special attention to every detail: resistors are carded and numbered for easy selection...all parts and hardware are packaged in clear plastic bags for easy identification...wire is precut, stripped, tinned and color-coded to save time... special printed circuitry is used to eliminate complex wiring...all parts are top premium quality...you get everything—even the solder! Finally, Knight-Kit instructions are clear as crystal; step-by-step procedure and wall-sized picture diagrams make assembly a marvel of simplicity. Your final reward is proud enjoyment of the superior performance designed into your Knight-Kit.



SEE THEM HERE →

AMATEUR KITS

50-Watt Transmitter
Self-Powered VFO
100 kc Crystal Calibrator
RF "Z" Bridge
Code Practice Oscillator

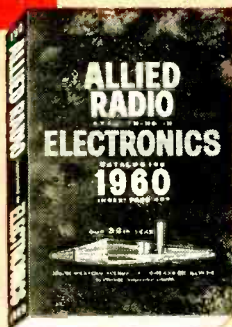

FREE send for the value-packed
1960 ALLIED CATALOG

Write for the 1960 ALLIED Catalog featuring the complete KNIGHT-KIT line—see the big news in electronic kits—get this leading Buying Guide for everything in Electronics. Send for your FREE copy.

ALLIED RADIO CORP., Dept. 163-AO
100 N. Western Ave., Chicago 80, Ill.

Send FREE 1960 ALLIED Catalog

Name _____

Address _____

City _____ Zone _____ State _____

Pioneers in the development of the world's finest electronic kits



our 39th year

THE WORLD'S LARGEST ELECTRONIC SUPPLY HOUSE

One thing has always bothered us, though. How does he come up with exactly 101 ways every time? It's uncanny.



"ALL ABOUT MISSILES AND SATELLITES" by David Mark. Published by Cowan Publishing Corp., 300 West 43rd St., New York 36, N. Y. 96 pages. Soft cover. \$1.50.

As one might suspect, this book serves as an introduction to missiles and satellites, and it is an excellent one. Although the amount of space devoted to each subject is limited (the section on missiles covers only 35 pages plus 22 pages which describe the various American missiles), the author has done a good job and has produced a book which is very successful within its space limitations.



"BASIC AUDIO" by Norman Crowhurst. Published by John F. Rider Publisher, Inc., 116 West 14th St., New York 11, N. Y. Three-volume set with soft covers, \$2.90 per volume. Three-volume set bound in one cloth binding, \$9.95. 368 pages.

This set of books is effectively a complete course in basic audio theory. As the material is presented one idea at a time (and usually one idea to a page), the reader can readily follow increasingly complex hi-fi circuits. The author presupposes that the reader has a knowledge of basic electronics. Many large pictorial drawings make for easy comprehension of the material covered, and at the end of each section there are questions and problems which allow the reader to judge how well he is assimilating the material. Highly recommended to anyone interested in the "how-it-works" aspect of high fidelity.

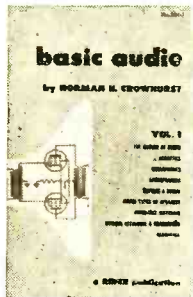

"HOW TO INSTALL AND SERVICE AUTO RADIOS" by Jack Darr. Second Edition. Published by John F. Rider Pub-

lisher, Inc., 116 West 14th St., New York 11, N. Y. 160 pages. Soft cover. \$3.25.

The first edition of this book was a valuable asset to the service technician active in auto radio servicing.

Now, Jack Darr has expanded it and brought it completely up to date in this second edition. Included are techniques for servicing signal-seeking tuners, hybrid and transistor models, printed-circuit wiring, 12-volt series string tube systems for converting from 6-volt to 12-volt operation, and many time-saving ideas.

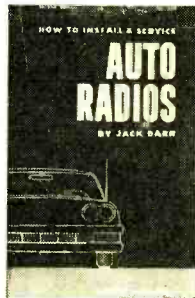

"THE PRACTICAL HI-FI HANDBOOK" by Gordon J. King. Published by the Macmillan Co., 60 Fifth Ave., New York 11, N. Y. 224 pages. \$5.00.

By now, it is known that our British brothers are every bit as wacky about hi-fi as we are here in the States. It is to their credit, however, that they conduct themselves with a bit more decorum than is common in hi-fi matters over here. Their equipment is conservatively rated, and their advertising claims modest. The same "well-bred" approach is evident in British high-fidelity writing. A good case in point is this very straightforward treatment of audio—from pickup cartridges to loudspeakers—written by Mr. King. The main subjects dealt with are preamplifiers and power amplifiers; loudspeakers, enclosures, pickups, turntables and tone arms, microphones and mixers; disc and tape recording. The American audiophile will find this book a worth-while guide in choosing, operating, and servicing high-fidelity equipment.



"TUBE REPLACEMENT GUIDE" by H. G. Cisin. Published by H. G. Cisin, Amagansett, N. Y. 49 pages. Soft cover. \$1.00.

The 1960 expanded edition of this little book lists over 2700 substitutes for more than 1500 radio and television receiving tubes, television picture tubes, specialized hi-fi tubes, and foreign tubes now being im-

**WE'RE MAKING IT EASIER THAN EVER TO BECOME A WELL PAID
RADIO-TELEVISION SERVICE TECHNICIAN**

**NOW - Just \$6 Starts You Training in
RADIO-TELEVISION**

the SPRAYBERRY "Learn-by-Doing" Way . . .

**25 BIG, COMPLETE KITS
of PARTS & EQUIPMENT**

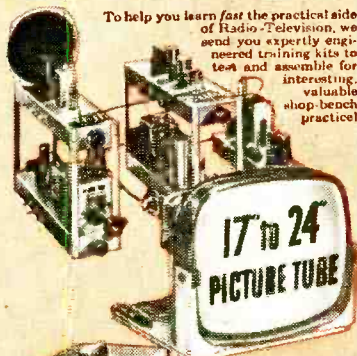

To help you learn fast the practical side of Radio-Television, we send you expertly engineered training kits to test and assemble for interesting, valuable shop-bench practice!



- The new Sprayberry Training Television Receiver, built and tested in 5 sections.
- Now offered . . . this fine modern oscilloscope.
- You build this powerful two-band superheterodyne radio receiver.



**Big New
CATALOG
AND
Sample Lesson
FREE!**

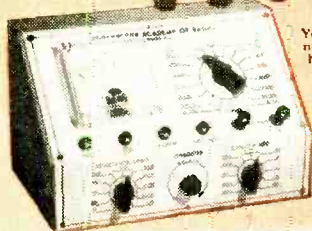

You build the new Sprayberry tester—a complete 15-range Volt-Ohm-Milli ammeter test meter.



HOW TO MAKE MONEY IN
Radio-Television
TRAINING PLAN
GETTING YOUR
START IN RADIO
TELEVISION

★ ★ ★ ★ This great industry is begging for trained men . . . to step into good paying jobs or a profitable business of their own! Our new plan opens the doors of Radio-Television wide to every ambitious man who is ready to act at once!

Men by the thousands . . . trained Radio-Television Service Technicians . . . are needed at once! Perhaps you've thought about entering this interesting, top paying field, but lack of ready money held you back. Now—just \$6 enrolls you for America's finest, most up to date home study training in Radio-Television! Unbelievable? No, the explanation is simple! We believe Radio-Television *must* have the additional men it needs as quickly as possible. We are willing to do our part by making Sprayberry Training available for less money down and on easier terms than ever before. This is your big opportunity to get the training you need . . . to step into a fine job or your own Radio-Television Service Business.

Complete Facts Free—Act Now; Offer Limited

Only a limited number of students may be accepted on this liberal and unusual basis. We urge you to act at once . . . mail the coupon below and get complete details plus our big new catalog and an actual sample lesson—all free. No obligation . . . no salesman will bother you.

HOME STUDY TRAINING IN SPARE TIME

Under world-famous 27-year old Sprayberry Plan, you learn entirely at home in spare time. You keep on with your present job and income. You train as fast or as slowly as you wish. You get valuable kits of parts and equipment for priceless shop-bench practice. And everything you receive, lessons and equipment alike, is all yours to keep.

LET US PROVE HOW EASILY YOU CAN LEARN!

Radio-Television needs YOU! And Sprayberry is ready to train you on better, easier terms, than any ambitious man can afford. *Just \$6 starts you!* Mail coupon today . . . let the facts speak for themselves. You have everything to gain. Let us prove the kind of opportunity in store for you!

SPRAYBERRY Academy of Radio-Television

1512 W. Jarvis Avenue, Dept. 105-F, Chicago 26, Illinois

Mail This Coupon Now—No Salesman Will Call

Sprayberry Academy of Radio-Television
Dept. 105-F, 1512 W. Jarvis Ave., Chicago 26, Ill.

Please rush all information on your ALL-NEW Radio-Television Training Plan. I understand this does not obligate me and that no salesman will call upon me. Include New Catalog and Sample Lesson FREE.

NAME..... Age.....

ADDRESS.....

CITY..... ZONE..... STATE.....

Bookshelf (Continued from page 20)

ported. Highly recommended for amateurs and professionals in the electronics field, it is a "must" for anyone who is active in experimenting or in service work.



"**SILICON ZENER DIODE HANDBOOK**" published by Motorola, Inc., Semiconductor Products Division, 5005 East McDowell Rd., Phoenix, Arizona. 130 pages. Soft cover. \$1.00.

Zener diodes are voltage-limiting diodes that have characteristics similar to voltage-regulating tubes but wider application. Since they are so new to the field of electronics, few people are familiar with them; consequently, this excellent first book on the subject is very welcome.

The use of Zener diodes in regulated power supplies is fully covered, as in their use in protecting against load current surges, supply voltage surges, decreasing supply voltage, arcing, and over-voltage in transistor circuits and circuits incorporating meters. How these diodes can be employed

as coupling devices and biasing elements is also discussed.

Incidentally, a slide rule calculator for designing circuits which use Zener diodes is available from Motorola for \$1.00.

Free Literature Roundup

Two useful bulletins on transistors, both written by Bud Tomer, are available from CBS Electronics, Information Service, 100 Endicott St., Danvers, Mass. "Servicing Transistor Equipment" (Bulletin PA-217) recommends tools and equipment for repairing transistor units, describes current and voltage measurements, includes a section on balancing output transistors, and covers transistor signal tracing. "How to Test Transistors" (Bulletin PA-219) describes simple resistance checks, tests for gain, and how to make distortion measurements using a calibrated oscilloscope.

"Tips on Ultrasonic Cleaning," a 12-page booklet which discusses various aspects of cleaning with ultrasonic frequencies, can be obtained from Circo Ultrasonic Corp., 51 Terminal Ave., Clark, N. J.

MICRO

ELECTRON TUBE

INTRODUCES FOR THE FIRST TIME
ANYWHERE A SELECT STOCK OF USED
TUBES AT A FABULOUS LOW PRICE

37

¢ ea.

\$35

PER
HUNDRED
ASSTD.

FOR any TUBE LISTED

Jan Surplus Tubes!

ALL TUBES SENT POSTAGE PAID
Please send 25¢ handling for orders under \$5. Send 25% deposit on C.O.D. orders. Send approximate postage on Canadian and foreign orders.

MICRO

ELECTRON TUBE CO. P.O. BOX 55 Park Station, Paterson 3, N. J.

- Each and every tube is tested in our own laboratory for mutual conductance and life test.
- We guarantee FREE replacement for one year of any tube purchased from us which fails to function efficiently under any or all operating conditions. Prompt refunds are made on any defective merchandise.
- The advertised tubes are not necessarily new, but may be electrically perfect factory seconds or used tubes—each is clearly so marked.

0A2	5X8	6BH6	6SF5	7Z4	19BG6G
0A4	5Y3GT	6EJ5	6SF7	12A8	19J6
1A7GT	5Y4G	6BK5	6S7	12A8S	19T6
1B3GT	6A7	6BK7	6S7	12AT6	24A
1H4G	6AB	6BL7GT	6SK7	12AT7	25AV5
1N9GT	6AB4	6BN6	6SL7GT	12AU5	25B06
1L4	6AC7	6BQ6GT	6SN7GT	12B6	25D06
1L4	6AF4	6B7	6S0T	12AU7	25W4GT
1N9GT	6AG5	6BY5C	6S5T	12AV6	25Z5
1Q5GT	6A0T	6BZ6	6T8	12AV7	25L6GT
1R5	6A4GT	6BZ7	6U8	12AX4GT	25W4GT
1S8	6AH6	6C5	6V6	12AX7	25Z5
174	6AK5	6C6	6W4GT	12A27	25Z6
1U4	6AL5	6C8	6W6GT	12B4	26
1UB	6AL7	6C8B	6W6GT	12BA6	35A5
1V2	6AM8	6C8C	6X4	12BA7	35B5
1X2	6AN8	6C8G	6X8	12BE6	35C5
2A3	6AO5	6C8Q	6Y6	12BF6	35L6GT
2AF6	6AQ5	6CF6	6Z4/XXL	12BF6	35W4
3BC8	6A08	6C7	7A8	12B06	35Y4
3BZ6	6AQ7GT	6CL8	6V6	12B7	35Z5GT
3CB6	6AR3	6CM6	7A8	12B7	37
3CF6	6AS8	6CN7	7A8	12B7	39/44
3CS0	6AT8	6CN7	7A8	12B7	42
3L4	6A8T	6CS6	7A7	12B7	43
3L4	6A8T	6C7	7A8	12B7	43
3V4	6A8T	6DE6	7B4	12J5	44
4B07A	6A8T	6DQ6	7B5	12K7	45
4BZ7	6A8T	6E6	7B6	12L6	50A5
5A5B	6A8T	6H6	7B7	12M7	50B5
5A7B	6AV5GT	6J4	7B8	12S7	50C5
5A8	6AV8	6J5	7C4	12S7	50L6GT
5A8	6AW8	6J7	7C5	12S7	50S6GT
5A8	6AX5GT	6K6GT	7C6	12SK7	56
5AW4	6B8	6K7	7C7	12SN7GT	57
5B7	6B8	6K8	7E6	12S0T	58
5I6	6B8	6K8	7E7	12V6GT	71A
5I6	6B8	6L7	7E7	12W6GT	75
5U4G	6B8	6N7	7F7	12X4	78
5U8	6BE8	6Q7	7F8	12X4	78
5V4G	6BF5	6S4	7H7	12Z3	77
5V6GT	6BF6	6S4T	7H7	14A7/12B7	80
	6BG6	6S7	7J7	14B6	80
		6S7	7X7/XXFM	14Q7	84/624
			7Y4	19A4GT	11723
				19	11726

WRITE DEPT. PE1, FOR OUR FREE COMPLETE LIST OF TUBES & SPECIAL PURPOSE TUBES

"I'm 32 and an electronics technician. I have a wife and two children to support. I've got a good job, but it's getting tougher every day because I'm supposed to know all the answers to complex assignments.

"To hold my present job, and be ready for promotion, I need a college-level education in electronic engineering technology, but I can't quit work to go to school.

I'M IN A BOX."



SOUND FAMILIAR?

It's a box CREI helps men out of.

Since 1927 we have directed the technical education of students—as individuals and in groups—in advanced electronic engineering technology. CREI students (more than 20,400 are currently enrolled) keep pace with the needs of the ever-advancing electronics industry and are eagerly sought by employers who offer solid opportunities for rapid promotion.

Among the many CREI home study advantages: You need not quit your present position. You meet family responsibilities while gaining essential college-level knowledge of electronic engineering technology. Your education is accomplished on your own time, during hours chosen by you. No time is wasted in travel. You have plenty of time to do your best. Your work is under a regular staff instructor who guides your progress step by step. Courses are prepared by experts, presented in easy-to-understand form, kept up to date by constant revision.

Design, construction, and maintenance of complex electronics equipment—missiles, radar, servomechanisms, astronomical devices, satellites—

demand men with advanced theoretical and practical knowledge. CREI home study courses can make you eligible to meet such demands. Your CREI diploma is a door-opener to better positions, added responsibilities, and salary increases.

QUALIFICATIONS FOR CREI. If you have had basic electronic education, practical experience in electronics, and a high school education, you can probably qualify. To find out, use coupon below to get free 54-page book. Tuition is reasonable; it may be paid monthly. Available to veterans under G.I. Bill.

RESIDENCE SCHOOL for those who can attend classes in Washington, D. C. Day and evening classes start at regular intervals. Qualified graduates earn AAS degree in 27 months. Electronics experience not required for admission.

CAPITOL RADIO ENGINEERING INSTITUTE

Dept. 1201-G1 3224 16th St., N.W.
Washington 10, D. C.



MAIL THIS COUPON FOR FREE 54-PAGE BOOK

CAPITOL RADIO ENGINEERING INSTITUTE

ECPD Accredited Technical Institute Curricula • Founded 1927
Dept. 1201-G1 3224 16th St., N.W., Washington 10, D. C.

Please send me your course outline and FREE illustrated 54-page book "Insurance for Your Future in the New World of Electronics" . . . describing opportunities and CREI home study courses in Electronic Engineering Technology.

CHECK FIELD OF GREATEST INTEREST

Radar, Servo and Computer Engineering Technology

Electronic Engineering Technology

Communications Engineering Technology

Television Engineering Technology

Aeronautical Electronic Engineering Technology

Automation & Industrial Electronic Engineering Technology

AA

Name Age

Street

City Zone State

CHECK: Home Study Residence School Korean Veteran

To obtain fast, immediate service and to avoid delay, it is necessary that the following information be filled in:

EMPLOYED BY

TYPE OF PRESENT WORK

EDUCATION: YEARS HIGH SCHOOL

OTHER

ELECTRONICS EXPERIENCE

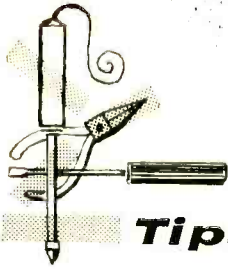

Tips and Techniques

HACKSAW BLADE TAPE CUTTER

If you want to be able to cut off pieces of electrician's tape easily, take a short length of old hacksaw blade and bend it around the roll as shown. If the blade is of high-quality steel, you might heat it first

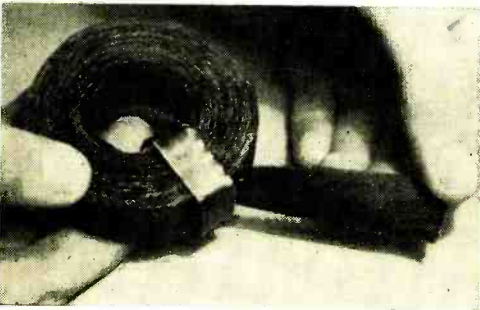

over a gas flame to remove the temper and bend it carefully to avoid breaking it. You'll find this cutter a real convenience.—*John A. Constock, Wellsboro, Pa.*

SOLDER GUN MOUNT

Avoid smashing your soldering gun case by accidentally knocking it from the workbench. Hang it on a wire loop either over

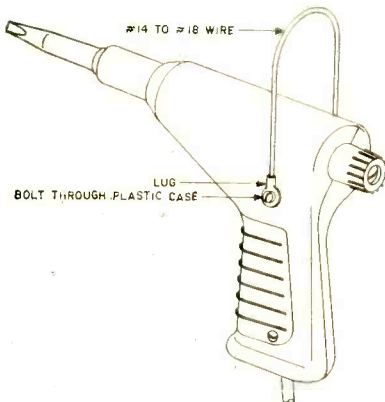

or under the workbench, out of the way, but still within reach. You can make a suitable wire loop from #14 to #18 wire, as shown, and attach it to the long bolt that holds the

gun case together. Both ends of the wire loop are terminated in large lugs which are fastened at either end of the bolt.—*Russell T. Bluckard, Murfreesboro, Tenn.*

BULK COIL CUTTING

How many times have you sawed the plastic strips on bulk Miniductor-type coils and wished someone would come up with an easy way of cutting off the turns? The problem can be solved by bolting a soldering lug to the tip of an electric solder gun. When you press the trigger, the lug heats

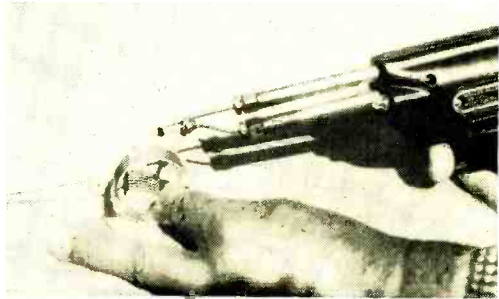

up and slices through the plastic like a hot knife cutting butter. Install the bolt close to the "business end" of the tip and don't leave the gun on too long.—*E. H. Mariner, W6BLZ, La Jolla, Calif.*

LOWER SOLDER'S MELTING POINT

When working with printed circuits, transistors, etc., you may want solder with a lower than usual melting temperature. Ordinary solder can be made to melt at a low temperature by rubbing it first with a little mercury or quick-silver. The more mercury the solder is allowed to absorb, the lower its melting temperature. For most applications, use very little mercury.—*Bob Culter, Oswego, Ore.*

"THIRD HAND" WHILE SOLDERING

To overcome the problem of having only one hand for the soldering iron, one hand for the solder and nothing to hold the com-

ponents with, try building a "third hand" by embedding two alligator clips in cement as shown. First, mix cement and water and pour about one inch of the mixture into the bottom of a quart-size waxed-paper milk carton. Let it harden for a few hours. Next, take two test clips or alligator clips

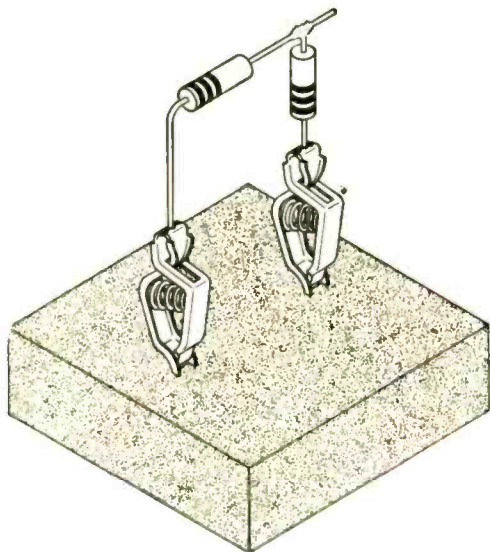

and insert them into the wet cement up to the hinge of the jaws. Allow to dry overnight, then cut off waxed carton. The cement makes a good fireproof soldering iron rest or platform.—*John T. Fehlandt, San Francisco, Calif.*

TUBE PULLER FROM GARDEN HOSE

A short length of $\frac{1}{2}$ " or $\frac{5}{8}$ " plastic garden hose can be made into a nifty miniature tube puller. Heat one end of the hose in hot water, then force it over the glass bulb of an old miniature tube. When the hose cools, remove it. You can then use the hose for removing hot or hard-to-reach miniature tubes.—*Jerome Cunningham, Chicago, Ill.*

WORKBENCH MAT

An excellent top for an electronics workbench can be made from a rubber or plastic drain mat similar to those used in kitchens. The soft, resilient surface prevents scratches on front panels and painted chassis, while the molded grooves keep batteries, tubes, screws, and tools from rolling off the bench. In addition, the "grip" afforded by the mat's surface minimizes any tendency for small chassis or circuit boards to slip while parts are installed or removed. Final-

ly, the mat's insulating qualities help prevent accidental shorts when you are working on a "hot" circuit. Try your local hardware store, and choose a *flat*—rather than a

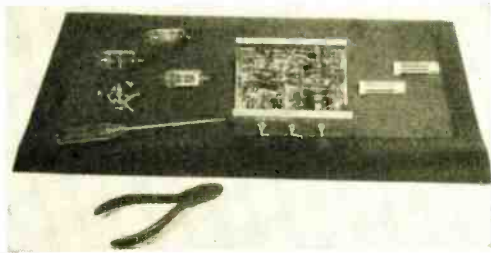

shaped—mat, preferably one having relatively small grooves.—*Louis E. Garner, Jr., Silver Spring, Md.*

BAYONET SOCKET CONVERSION

Many times a screw-type socket is needed for a small screw-base light bulb. If one is not available, a bayonet socket can be easily adapted for this purpose. By taking a pair of long-nose pliers and bending the edge of one L-slot of a bayonet socket slightly inward, a screw-base bulb will easily screw into the adapted socket.—*Jacob Jacobs, W6GCU, Oakland, Calif.*

TAPE STORAGE BOX

The next time you buy a box of tape, don't throw away that carton. You can make a handy storage container simply by cutting the box as shown in the photo. If you wish, you can spray it with a pressurized can of touch-up paint available at your local radio store. Typewritten labels glued to the edge of the box and/or reel containers will minimize the possibility of misplacing tapes.—*Don Stoner, Ontario, Calif.*



AUTO IGNITION POINT TEST

It is possible to use your test equipment to determine the condition of the ignition points in an automobile. Turn on the ignition with the engine stopped in such a position that the points are closed. Then switch your multimeter to the lowest d.c. voltage range and connect it between ground and

RESIDENT SCHCOLL COURSES



Industry needs Electronic Technicians!

Let RCA train you in Advanced Electronics

This is the college-level training you need to work with professional engineers on research, development or production projects in such fields as automation, guided missiles, radar, television, computers and other advanced electronic applications.

RCA Institutes Resident School in New York City offers this comprehensive course that prepares you for any field of electronics you may choose. Other courses in TV & General Electronics, Radio & TV Servicing, and Radio Teletype Operating.

Classes start four times each year. Admissions now being accepted. Approved for veterans.



RCA INSTITUTES, INC.
SCHOOLS OF TELEVISION AND
ELECTRONIC TECHNOLOGY

A Service of Radio Corporation of America
Another Way RCA Serves Education Through Electronics

RCA INSTITUTES, DEPT. PER-10
350 W. Fourth St., N. Y. 14, N. Y.

Please send me your FREE catalog of
Resident School courses in New York.

NAME.....
please print

ADDRESS.....

CITY.....ZONE.....STATE.....

FOR HOME STUDY COURSES SEE AD ON OPPOSITE PAGE

Tips (Continued from preceding page)

the distributor primary wire or terminal. The meter reads the voltage drop across the contacts. If this drop is more than a few tenths of a volt, the points are dirty and need cleaning or replacing. However,

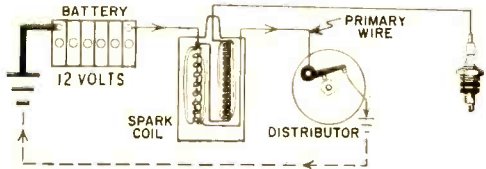

if the drop is less, the points are okay regardless of how they may look or how many miles they may have run.—*Charles Erwin Cohn, Chicago, Ill.*

GET RID OF ANTENNA NOISE

When I discovered that the noise my receiver was reproducing was originating somewhere along the antenna and not within the set, I simply soldered a 68-ohm resistor from the antenna terminal on the receiver to a ground lug on the chassis. The value of the resistor is not critical by any means but it should be a small value. In my case, the level of the incoming signal was reduced slightly, but the noise cleared up completely.—*Arthur Fregeau, WPE1QV, Bristol, Conn.*

TINY TIP FOR SOLDERING GUN

When the ordinary tip of a soldering gun is used on printed-circuit boards and similar delicate work, too much heat from the

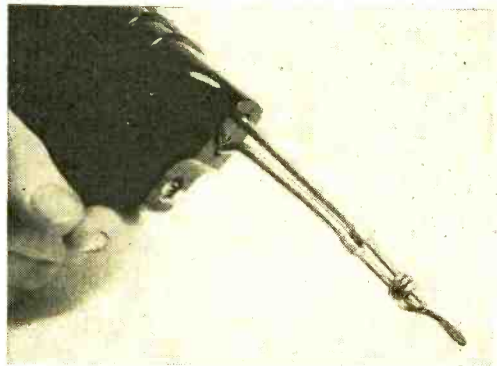

tip usually proves disastrous. Coil some heavy-gauge solid copper wire around the tip as shown to avoid ruining circuit components. You'll also be able to reach into tight spots easily with the new tip.—*Joseph Carroll, Brooklyn, N. Y.*



LET RCA TRAIN YOU IN ELECTRONICS

RCA Institutes, one of the world's leading electronic technical schools, offers a Home Study Course in . . .

ELECTRONICS FOR AUTOMATION

. . . Now you have *four* comprehensive courses for your electronic training . . . from basic electronic theory to the more advanced principles of color TV and Automation.

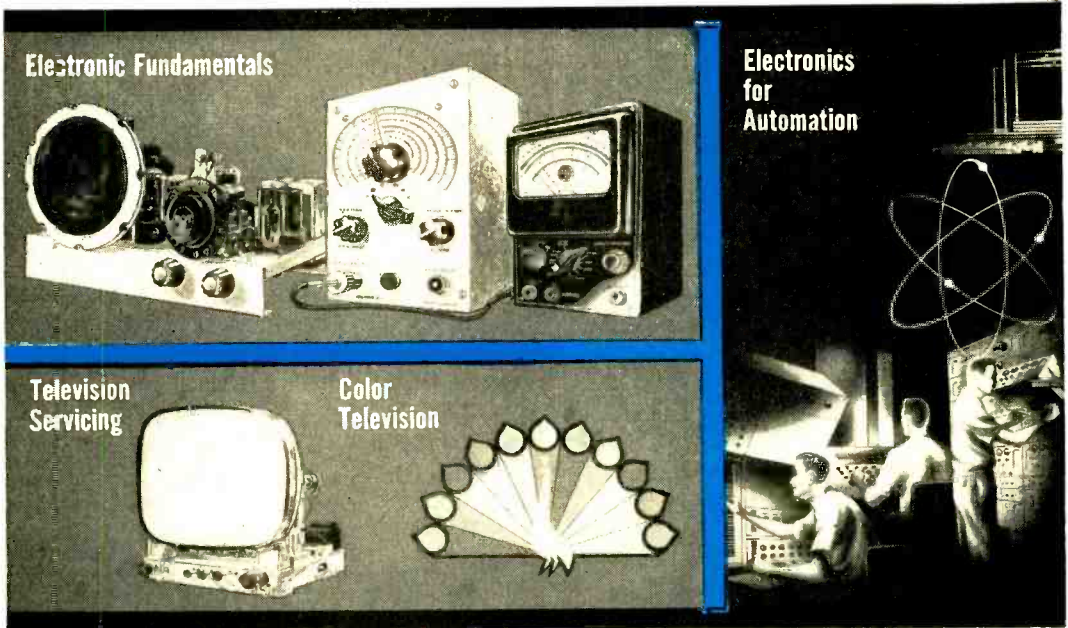

Send for our
64 page Home
Study Catalog

FREE!

**FOR
RESIDENT SCHOOL
COURSES**

See Ad on opposite page

ANOTHER WAY RCA SERVES EDU-
CATION THROUGH ELECTRONICS

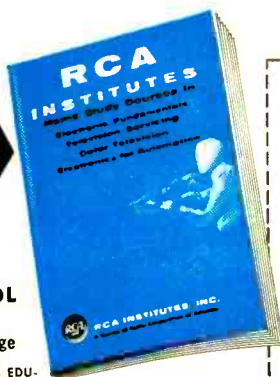

Practical work with the very first lesson. Pay-as-you-learn. You need pay for only one study group at a time.

RCA INSTITUTES, Inc. Home Study School, Dept. ZPE-10

A Service of Radio Corporation of America
350 West Fourth Street, New York 14, N. Y.

Without obligation, send me the FREE catalog of Home Study Courses. No salesman will call.

Name Age

Please print

Address

City Zone State

Veterans: Enter discharge date

CANADIANS — Take advantage of these same RCA courses at no additional cost. No postage, no customs, no delay. Send coupon to: RCA Victor Company, Ltd., 5001 Cote de Liesse Rd., Montreal 9, Quebec
To save time, paste coupon on postcard

Lafayette Superior Quality Hi-Fi Kits

The *FINEST* . . . through research . . . engineered by *LAFAYETTE!*

KT-250 IN KIT FORM
64.50

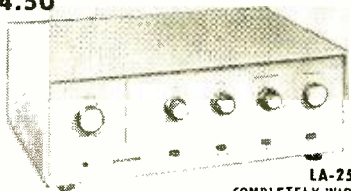

LA-250
COMPLETELY WIRED
89.50

50 WATT INTEGRATED STEREO AMPLIFIER

- RESPONSE 17-21,000 CPS \pm 1 DB (at normal listening level)
- UNIQUE "BLEND" CONTROL ● PREMIUM EL86 OUTPUT TUBES
- 50 WATTS MONAURAL—25 WATTS EACH STEREO CHANNEL ● CLUTCH-OPERATED VOLUME CONTROL ● SEPARATE BASS & TREBLE CONTROLS

A completely new stereo high fidelity amplifier with a high quality of reproduction, remarkable versatility and new distinctive styling. Full range of controls include a unique "blend" control for continuously variable channel separation—from full monaural to full stereo, 4-position Selector, Mode, Loudness and Phasing switches plus outputs for 4, 8 or 16 ohm speakers. Harmonic distortion less than 0.25%, IM distortion less than 1%. Hum and Noise 74 db below full output. Assembly is simple—no special skills or tools required. Complete with deluxe cabinet and legs, all parts, tubes and detailed instruction manual. Shpg. wt., 26 lbs.

KT-250 WX Stereo Amplifier Kit 5.00 Down Net 64.50
LA-250 WX Stereo Amplifier, wired & tested 5.00 Down Net 89.50

KT-600 IN KIT FORM
79.50

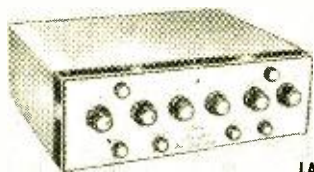

LA-600
COMPLETELY WIRED
134.50

PROFESSIONAL STEREO CONTROL CENTER

- RESPONSE 5-40,000 CPS \pm 1 DB ● UNIQUE STEREO & MONAURAL CONTROL FEATURES ● PRECISE "NULL" BALANCING SYSTEM ● CONCENTRIC INPUT LEVEL CONTROLS

A truly professional stereo preamplifier and master audio control center—solves every stereo/monaural control problem. Features unique Bridge Control for variable cross-channel feed for elimination of exaggerated channel separation effects—plus controlled 3rd channel output. Has all-concentric controls—including clutch-operated Volume Balance control. Provides complete and advanced facilities for accepting, controlling and providing undistorted gain for any and all program sources. Sensitivity 2.2 mv for 1 volt out (low level inputs). Dual low impedance "plate follower" outputs 1500 ohms. Response 5-40,000 cps \pm 1 db. Less than .03% IM distortion. Less than .1% harmonic distortion. Hum and noise 80 db below 2 volts (high level inputs). Uses 7 new 7025 low-noise dual triodes. Size: 14" x 4 1/2" x 10 3/8". Shpg. wt., 16 lbs. Complete with all parts, tubes, deluxe cabinet and detailed instruction manual.

KT-600 WX Stereo Preamplifier Kit 5.00 Down Net 79.50
LA-600 WX Stereo Preamplifier, wired and tested 5.00 Down Net 134.50

KT-310 IN KIT FORM
47.50



LA-310
COMPLETELY WIRED
72.50

STEREO/MONAURAL POWER AMPLIFIER KIT

- 36 WATT STEREO AMPLIFIER—18 WATTS EACH CHANNEL ● EMPLOYS 4 PREMIUM-TYPE 7189 TUBES ● 2 PRINTED CIRCUIT BOARDS FOR SIMPLIFIED WIRING ● RESPONSE BETTER THAN 35-30,000 CPS \pm 1/2 DB AT 18 WATTS ● LESS THAN 1% HARMONIC OR IM DISTORTION

A superb basic stereo amplifier in easy-to-build kit form. Unit may be used with a stereo preamplifier to provide two 18 watt stereo channels or, at the flick of a switch, as a fine 36 watt monaural amplifier. Controls include 2 input volume controls, Channel Reverse switch and Monaural-Stereo switch. Dual outputs for 4, 8, 16 or 32 ohm speakers. Input sensitivity .45 volts per channel for full output. Tubes are 2-6ANB, 4-7189, GZ-34 rectifier. Sizes 10-9/16" d x 5 1/4" h x 13 1/2" w. Complete kit with cage, all parts, tubes and detailed instruction manual. wt., 22 lbs.

KT-310 WX Stereo Power Amplifier Kit 2.00 Down Net 47.50
LA-310 WX Stereo Power Amplifier, wired and tested 5.00 Down Net 72.50

KT-500 IN KIT FORM
74.50



LT-50
COMPLETELY WIRED
124.50

FM-AM STEREO TUNER KIT

- 11 Tubes (4 dual-purpose) + Tuning Eye + Selenium rectifier provide 17 tube performance ● Multiplex Output for new Stereo FM ● Armstrong Circuit with Dual Limiters and Foster-Seeley Discriminator ● Extreme Sensitivity and Wide Frequency Response.

A precision engineered, highly stable tuner—perfect for lifelike stereo FM-AM broadcast reception, FM reception and/or AM reception. Features separate tuning and volume controls for AM and FM. Magic eye on AM and FM, plus automatic frequency control on FM for accurate tuning—stations are "lacked" in. Other deluxe features include cathode follower outputs and 5-position Function Selector. Efficient, broadband circuitry on AM with built-in antenna. FM section features include 2 microvolts sensitivity for 30 db quieting, frequency response 20-20,000 cps \pm 1/2 db and full 200 KC bandwidth. Two printed circuit boards make wiring simple—even for such a complex unit. Complete kit includes all parts, deluxe cabinet and detailed instruction manual. Size is 13 3/4" W x 10 3/8" D x 4 1/2" H. wt., 22 lbs.

KT-500 WX FM-AM Stereo Tuner Kit 5.00 Down Net 74.50
LT-50 WX Same as above, wired & tested 5.00 Down Net 124.50

KT-236
IN KIT FORM



52.50

36-WATT INTEGRATED STEREO AMPLIFIER KIT

- 36-WATTS MONAURALLY—18 WATTS PER CHANNEL ● FREQUENCY RESPONSE 15-30,000 CPS \pm 1 DB ● UNIQUE "BLEND" CONTROL ● CONCENTRIC CLUTCH-OPERATED VOLUME CONTROL ● DUAL CONCENTRIC BASS AND TREBLE CONTROLS ● 4-EL84 TUBES IN PUSH PULL

This exciting new amplifier kit combines dual preamplifiers and dual 18 watt power amplifiers on one compact chassis. Instant selection from monophonic to stereophonic is provided by the turn of a switch. An amazing new "Blend" control gives continuously variable channel separation from full monophonic to full stereo. The concentric clutch-operated volume control offers independent or simultaneous level adjustments of both channels. Dual concentric bass and treble controls furnish 4 independent tonal adjustments. Harmonic distortion less than 0.15% at normal listening level. 1.M distortion is less than .3%. Hum and noise 70 db below rated output. Complete with cage, legs and detailed instructions. Shpg. wt., 24 lbs.

KT-236 WX Stereo Amplifier Kit 5.00 Down Net 52.50

Lafayette Radio

165-08 Liberty Ave. JAMAICA, N. Y.
AXtel 1-7000

NEW YORK, N. Y.
100 6th Ave.
Worth 6-3300

BOSTON, MASS.
110 Federal St.
Hubbard 2-7850

BRONX, N. Y.
542 E. Fordham Rd.
Fordham 7-8813

NEWARK, N. J.
24 Central Ave.
Market 2-1661

PLAINFIELD, N. J.
139 W. 2nd St.
Plainfield 6-4718

NEW! Lafayette 50 Watt Complete Stereo Phono System



LAFAYETTE LA-250



WOOD BASE

GARRARD RC121/11

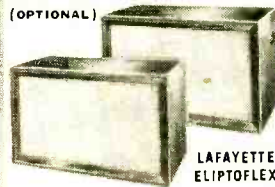

(OPTIONAL)

LAFAYETTE ELIPTOFLEX



NEW GE VR-22

LAFAYETTE SK-58

COMPONENTS

LAFAYETTE LA-250 50-WATT AMPLIFIER	89.50
NEW GE VR-22 (.7 MIL) DIAMOND STEREO CARTRIDGE	24.45
GARRARD RC 121/11 STEREO CHANGER	41.65
LAFAYETTE WOOD CHANGER BASE	3.95
2- LAFAYETTE SK-58 FAMOUS FREE EDGE	
12" COAXIAL SPEAKERS @ 29.50	59.00
REGULAR CATALOG PRICE 218.95	

COMPLETE STEREO SYSTEM

174.50 You Save **44.05**
YOUR GUARANTEED BEST STEREO SYSTEM BUY!

This superb system will add a new dimension in living to your home with all the excitement and realism of a live concert! The new Lafayette LA-250, 50-watt stereo amplifier (25 watts each channel) forms the heart of this outstanding stereo hi-fi phonograph music system—the features, versatility and advanced circuitry of this unit are second to none. Also included is the famous Garrard RC121/11 intermix 4-speed automatic record changer with full manual or automatic operation supplied with your choice of stereo cartridges—the new GE VR-22 (.7 Mil) diamond stereo cartridge, Pickering 371-7D (.7 Mil) diamond stereo cartridge, Shure M7D (.7 Mil) diamond stereo cartridge. Supplied with the Lafayette wood base cut for the RC121 in your choice of finishes. These outstanding components are coupled with the 2 famous free edge Lafayette SK-58 12" Coaxial speakers with built-in crossover network and brilliance level control. System supplied with plugs, cables and simple instructions. Shpg. wt., 67 lbs.

- HF-681WX HI-FI STEREO PHONO SYSTEM with choice of cartridge and mahogany, walnut or blond changer base (please specify) 5.00 Down Net 174.50
- HF-683WX Same as HF-681, but with 2 Laf Eliptoflex Series Bookshelf Enclosures (please specify finish). Shpg. wt., 143 lbs. 10.00 Down Net 229.95
- HF-682WX Stereo AM-FM-Phono System. Same as HF-681 but including the Lafayette LT-50 stereo tuner. Shpg. wt., 85 lbs. 10.00 Down Net 287.50

Our
39th
Year



Leaders in Hi-Fi

The most complete selection and largest stocks of hi-fi components and systems—available for immediate delivery at the lowest possible prices. Save even more on Lafayette endorsed "best-buy" complete systems.

FREE! 1960 CATALOG

308 GIANT SIZED PAGES!

The Complete Catalog Featuring
"The Best Buys In The Business"

- FOR THE NEWEST AND FINEST IN STEREOGRAPHIC HI-FI EQUIPMENT AND SYSTEMS
- TAPE RECORDERS ● PUBLIC ADDRESS SYSTEMS
 - AMATEUR EQUIPMENT ● INDUSTRIAL SUPPLIES
 - MINIATURE COMPONENTS ● RADIO & TV TUBES AND PARTS
 - EXCLUSIVE LAFAYETTE TRANSISTOR & HI-FI KITS

Send for Lafayette's FREE Catalog—the most complete, up-to-the-minute electronic supply catalog crammed full of everything in electronics at our customary down-to-earth money-saving prices.

A "must" for the economy-minded hi-fi enthusiast, experimenter, hobbyist, engineer, technician, student, serviceman and dealer.

Lafayette
Radio
"Everything in Electronics"

FREE

LAFAYETTE RADIO, Dept. 1A-6
P.O. Box 222, Jamaica 31, N. Y.
308 GIANT SIZED PAGES — FREE



Name
Address
City State

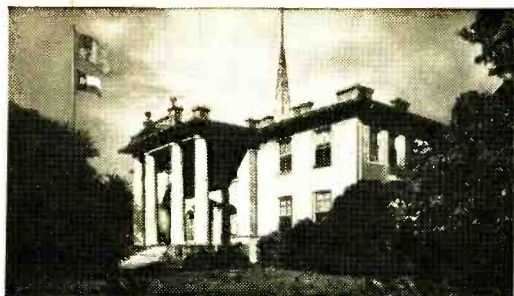

PORT ARTHUR COLLEGE

ELECTRONICS • COMMUNICATIONS
RESIDENT • CO-EDUCATIONAL
AM-FM RADIO • TV STATIONS
MARINE RADIO

TRAINING Is the finest. Well equipped college classrooms and laboratories with AM, FM transmitters, radar and marine equipment, color fundamentals, transistors, television, camera chain, experimental laboratory test equipment, etc. used as standard part of curriculum.

PRACTICAL On-the-job-training program. College operates Radio Station KPAC, co-owner of KPAC-TV. You learn the interesting way. You learn by doing.

G.I. APPROVED

CO-EDUCATIONAL You enjoy the personal growth and cultural advantages that only the American co-educational college system can provide.

LOW COST Being a non-profit vocational institution explains our low tuition rates . . . \$36 per month. Room and board at campus dormitory only \$52 per month. Monthly payments accepted.

FREE PLACEMENT SERVICE Our graduates are in demand at good salaries. We have trained men from all 49 states and abroad.

INVESTIGATE Write for illustrated booklet P-48 for further details. Classes now forming. Non high school graduates must pass entrance examination. Persons 21 years or older may be accepted on individual approval.

PORT ARTHUR COLLEGE

PORT ARTHUR, P-981, TEXAS
 Founded in 1909

NEW products

BATTERY CHARGER

The Model C-300 battery charger has recently been announced by *Gyro Electronics*

Co., 36 Walker St., New York, N. Y. It is designed for charging wet cells, nickel cadmium cells, and silver cells according to the battery manufacturer's specifications. The charging cur-

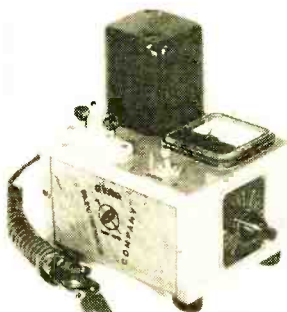

rent can be precisely controlled by varying the charge-rate control while noting the reading on the built-in meter. Price, \$13.95.

VTVM KIT

Features of the Grommes "Little Genie" VTVM kit include a 4½" meter, 11-megohm

input impedance, 1% resistors in multiplier circuit, separate calibration controls for a.c., d.c. and ohms, and a 15-volt full-scale range for low-voltage measurements. A polarity reverse switch eliminates test lead switching. The kit is easy to

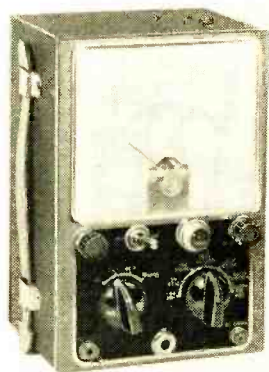

wire due to open-type construction employing point-to-point connections. It comes complete with hardware, test leads. \$27.95. (*Precision Electronics, Inc.*, 9101 King Ave., Franklin Park, Ill.)

CAR WINDOW SPEAKER SUPPORT

An easy-to-install bracket for supporting p.a. speakers on car windows is available from *Atlas Sound Corp.*, 1449 39th St.,

**DEALERS SERVICEMEN
TUBE TESTER ROUTE OPERATORS
EXPERIMENTERS
HAMS**



**BRAND NEW
INDIVIDUALLY BOXED**
In Famous Green & Black Carton

**GUARANTEED
FOR ONE YEAR**

We will replace all defective tubes within 12 months from date of purchase, excepting only burned out or broken tubes. Standard Customer Warranty 90 Days.

SEND IN A TRIAL ORDER TODAY! You'll be delighted with our speedy service — and in due time you will join our host of customer friends who rank ZALYTRON as a First Class Source of Supply for Tubes. Your Trial Order will be shipped on our **FULL MONEY BACK GUARANTEE!** Try ZALYTRON Tubes at **OUR Risk, and JUDGE FOR YOURSELF!**

TYPE	EACH	TYPE	EACH	TYPE	EACH	TYPE	EACH	TYPE	EACH	TYPE	EACH
0Z4	\$ 85	5CQ8	1.30	6BF5	1.35	6DQ6	1.10	12AV6	.60	12AV7	.85
1AX2	.70	5J6	.75	6BF6	.55	6DT6	.60	12AX4	.95	12AX7	.65
1B3	.95	5TR	.86	6BG6	2.25	6J5	.70	12B4	.70	12BA6	.60
1S5	.60	5U4G GB	.75	6BH6	.70	6J6	.60	12B6	.60	12BE6	.60
1T4	.55	5U8	.75	6BH8	.90	6K6	.80	12BH7	.80	12BQ6	1.10
1U4	.45	5V6	.55	6BJ6	.65	6L6	1.15	12B77	.80	12C5	.60
1U5	.55	5Y3GT	.55	6BK5	1.40	654	.60	12C6	1.10	12C6	1.10
1X2A/B	.95	6AB4	.55	6BK7A B	.90	65A7	.80	12D6	1.10	12D6	1.10
2AF4	1.00	6AC7M	.90	6BL7	1.55	65C7	.80	12F8	.65	12K5	.70
3AF4	1.05	6AF4	1.05	6BN6	.75	65K7	.75	12L6	.65	12S7	.85
3AL5	4.65	6AG5	.65	6B05	.70	65L7	.90	12S7	.85	12S7	.85
3AU6	.55	6AG7M	1.25	6B06	1.10	65N7	.85	12S7	.85	12S7	.85
3AV6	.45	6AH4	1.30	6B07A	1.10	65O7	.85	12S7	.85	12S7	.85
3BN6	.75	6AH6	1.35	6BR8	.95	6T4	1.00	12S7	.85	12S7	.85
3BU8	.75	6AK5	.85	6B8U	.70	6T8	.95	12S7	.85	12S7	.85
3BY6	.60							12S7	.85	12S7	.85
3BZ6	.60							12S7	.85	12S7	.85
3CB6	.60							12S7	.85	12S7	.85
3CF6	.65							12S7	.85	12S7	.85
3C56	.60							12S7	.85	12S7	.85
3D76	.55							12S7	.85	12S7	.85
3Q4	.65	6AL5	.55	6BY7	1.65	6U8	.85	12S7	.85	12S7	.85
3S4	.65	6AM8	.85	6BY6	.60	6V6	.80	12S7	.85	12S7	.85
3V4	.70	6AN8	.95	6BZ6	.65	6W4	.80	12S7	.85	12S7	.85
4BC8	1.00	6AQ5	.55	6BZ7	1.10	6W6	.95	12S7	.85	12S7	.85
4BN6	.75	6A55	.90	6C4	.50	6X4	.45	12S7	.85	12S7	.85
4B07A	1.10	6AT6	.55	6C86	.70	6X5	.65	12S7	.85	12S7	.85
4BS8	1.00	6ATR	.85	6CD6	1.70	6XR	.85	12S7	.85	12S7	.85
4BZ7	1.10	6AU4	1.00	6CF6	.70	6Y6	.95	12S7	.85	12S7	.85
4CB6	.60	6AUS	1.75	6CG7	.65	8AU8	.90	12S7	.85	12S7	.85
4DT6	1.00	6AU6	.65	6CG8	.80	8AW8	.95	12S7	.85	12S7	.85
5AM8	.80	6AUR	.90	6CL6	1.35	RCG7	.65	12S7	.85	12S7	.85
5AN8	.85	6AV5	1.60	6CM7	.70	10DE7	1.15	12S7	.85	12S7	.85
5AQ5	.55	6AV6	.55	6CN7	.70	11CY7	.75	12S7	.85	12S7	.85
5AT8	.85	6AW8	.90	6CQ8	1.35	12AD6	.55	12S7	.85	12S7	.85
5AU4	.95	6AX4	.95	6CS6	.70	12AF6	.60	12S7	.85	12S7	.85
5BK7	.90	6BA6	.65	6CS7	1.15	12AQ5	.36	12S7	.85	12S7	.85
5BQ7	.98	6BC5	.60	6C05	1.00	12AT6	.40	12S7	.85	12S7	.85
5CG8	.85	6BR8	1.10	6C06	1.10	12AT7	.76	12S7	.85	12S7	.85
5CL8	.80	6BD6	.65	6C17	.75	12AU6	.70	12S7	.85	12S7	.85
		6BE6	.55	6DE6	.70	12AU7A	.60	12S7	.85	12S7	.85

WE PAY ALL SHIPPING CHARGES
on all orders accompanied by remittance in full.

Above is only a partial listing of our huge tube stocks. Send today for **FREE** Complete up-to-date Tube Price List and Catalog. We Ship all Orders **COMPLETE** Same Day Received! C.O.D. **ORDERS:** 25% Deposit with order, balance C.O.D. plus all shipping charges. **MINIMUM ORDER (Special for This Ad) \$5.00.**

ZALYTRON TUBE CORPORATION
220 West 42nd Street New York 36, N. Y.
Telephone: BRyant 9-2542 **DEPT. PE-1**

FREE!

Giant New Wholesale Catalog of Radio & TV Receiving Tubes, Electronic Components. Free on Request.



with **ZALYTRON** QUALITY BRAND
RADIO & TELEVISION RECEIVING TUBES

You "play ball" with "MAJOR LEAGUERS" when you buy ZALYTRON Tubes! "Tubes" are OUR MIDDLE NAME! We have been supplying tubes for many years to service dealers and Tube Tester Route Operators . . . and the ZALYTRON Brand name has achieved a reputation for quality and performance, second to none!

Yes, you "play it SAFE" with Zalytron because you get BRAND NEW Tubes:

• **NOT USED** • **NOT PULLED** from equipment • **NOT REJECTS**

but Zalytron's First Quality! And, important too: by selling **DIRECT** to the electronics trade, we pass the middleman's profit on to our customers . . . helping them to meet and beat competition in their areas.

THIS MONTH'S SPECIAL

GET THIS DELUXE SHELL 102
**TEST-O-MATIC
SELF-SERVICE
TUBE TESTER**

(Nationally Advertised by the
Factory at a Net Cost of \$199.95)

PLUS ZALYTRON "PACKAGE DEAL" OF
150 RADIO & TV TUBES

COMPLETE \$24500 F.O.B. NYC.
FOR ONLY \$4500

When you buy our "Package Deal" you are, in effect, getting with it a Stock of Tubes worth \$450 retail, FOR ONLY \$45.00 — which is actually 90% discount!

Quan.	Type	Quan.	Type	Quan.	Type	Quan.	Type
1	0Z4	5	6AQ5	5	6CB6	2	12A77
3	1B3	1	6A55	1	6CD6	5	12AU7A
1	1R5	1	6AT6	1	6CG7	1	12AV6
1	1S5	1	6A78	1	6CM7	1	12AX7
1	1T4	5	6AU6	2	6C06	1	12B4
1	1U4	1	6AU8	1	6DQ6	3	12B6
1	1U5	1	6AV6	5	6J6	1	12BE6
3	1X2A/B	1	6AW8	1	6K6	2	12BH7
1	1Y4	3	6A8A	1	654	1	12BQ6
1	1Z4	3	6BA6	1	65A7	1	12B77
1	1S4	1	6B8C	1	65K7	1	12C6
1	1S4G	1	6B8R	5	65N7	1	12SA7
1	1S8	2	6BE6	1	65O7	1	12S7
2	1Y3	1	6BG6	1	6T8	1	12S7
1	1S8	1	6BH6	5	6U8	1	12S7
2	1Y3	1	6BJ6	2	6V6	1	12S7
1	6AC7M	1	6BK7A	2	6W4	1	12S7
3	6AG5	1	6BN6	1	6W6	1	12S7
1	6AH6	2	6BQ6	1	6X4	2	12S7
1	6AK5	2	6BQ7A	1	6X5	1	12S7
5	6AL5	1	6BZ6	2	6XR	2	12S7
1	6AM8	2	6BZ7	1	6Y6	1	12S7
1	6AN8	1	6C4	1	8AU8	1	12S7

To ZALYTRON Tube Corp., **DEPT. PE-1**
220 West 42nd Street, New York 36, N. Y.

Send FREE 1960 Catalog.

NAME _____
ADDRESS _____
CITY _____ ZONE _____ STATE _____

products

(Continued from page 30)

Brooklyn 18, N. Y. The WM-1 bracket features a rubberized cork-lined channel that slips over the top of the window, in addition

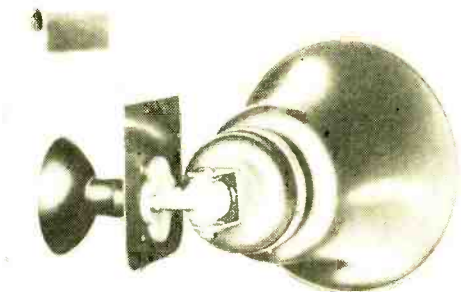

to a rubber suction cup. Raising the window locks in the bracket securely. Price, \$5.00.

FM RECEIVERS

Two receivers for monitoring police, fire, forestry, taxi, civil defense, and marine communications are available from *Monitoradio Division, I.D.E.A., Inc.*, 7900 Pendleton Pike, Indianapolis 26, Ind. Both units

are a.c.-d.c. operated and each features 10-microvolt sensitivity. A temperature-

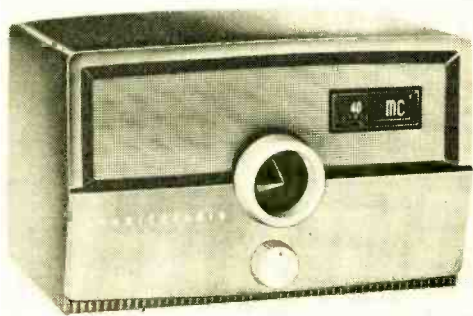

compensated superheterodyne circuit minimizes drift. Model PR-35 tunes the 30-50 mc. band and Model PR-155 tunes 152-174 mc. Price, \$49.95 each.

STEREO TAPE RECORDER

A four-track stereo record and playback tape recorder has been announced by *North American Philips Co., Inc.*, Hicksville, L.I., N.Y. The Norelco Continental "400" provides complete four-track facilities for both mono and stereo operation. Two-track pre-recorded stereo tapes are also accommo-

NOW YOU CAN SECURE A HIGH SALARIED • TOP PRESTIGE CAREER IN ELECTRONICS IN ONLY ONE YEAR!

ELECTRONICS is the fastest growing industry in America today, creating unlimited opportunities for high salaries, with rapid advancement in **INDUSTRY AND THE ARMED FORCES** for Bailey Trained electronic engineering technicians.

LARGE CORPORATIONS from coast to coast, and **BRANCHES OF THE ARMED FORCES** send recruiters to visit each graduating class at Bailey Tech, offering unusually high starting salaries.

BAILEY GRADUATES ARE BEING HIRED for such fascinating and interesting work as technical salesmen, research and development of guided missiles, electronic business machines and automatically controlled manufacturing plants, etc., also good **RATINGS IN THE ARMED FORCES**.

UP TO SEVEN TECHNICIANS are needed for every engineer... this, plus superior training is why Bailey Graduates are being paid more to start, and are advancing more rapidly than many men who have spent four years in training.

Resident training is easier and costs less than you may think! We provide housing and part-time jobs while in school, plus free nationwide employment service for graduates. If you want to quickly enter America's fastest growing and most exciting industry, write for free booklet... no obligation.

VETERAN APPROVED
BAILEY TECHNICAL SCHOOLS
1625 S. Grand • St. Louis 4, Mo.



This Minneapolis-Honeywell system controls hundreds of automatic manufacturing operations. Experience on live equipment is emphasized at Bailey and is another reason for the tremendous backlog of high pay positions waiting **BAILEY GRADUATES**.

MAIL TODAY

Please mail immediately this free booklet without obligation

Name _____

Address _____

City _____ State _____



Your best buy . . .

TRU-VAC®

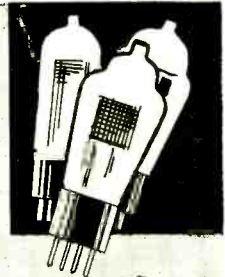

REMARKABLE TUBE VALUES AT 1950 PRICES

ALL TUBES INDIVIDUALLY BOXED, CODE DATED
AND BRANDED "TRU-VAC®"
Typical TRU-VAC® Bargains!

THIS IS A PARTIAL LIST 6SN7GT ----- ALWAYS 30c
Thousands More Always In Stock 6W4GT ----- ALWAYS 30c

OY4	3AU6	6A6	6B8	6CH8	657	784	12A16	12SA7	36
OZ4	38C5	6AB4	6BA6	6CL6	69GT	785	12A17	12S17	38
1A7GT	38N5	6AC7	6BC5	6CM6	6SA7	786	12AU6	12SK7	39/44
1B3GT	3B76	6AF4	6BC8	6CM7	6SD7GT	787	12AU7	12S17GT	41
1C6	3CB6	6AG5	6BD6	6CN7	6SF5	788	12AV6	12S207	42
1C7	3Q4	6AH4GT	6BE6	6CO8	6F7	7C4	12AV7	12V6GT	43
1F4	3S4	6AH6	6BF5	6CR6	6G7	7C5	12AX4GT	12W6GT	45
1F5	3V4	6AK5	6BG6G	6CS6	6H7	7C6	12AX7	12X4	50A5
1G4	4BQ7A	6AL5	6BH6	6CU5	6J17	7C7	12AZ7	14A7/12B7	50B5
1H5GT	4B58	6AM8	6BJ6	6CU6	6K7	7E5	12B4	14B6	50C5
1I4	4B27	6AN8	6BK5	6D6	6L17	7E6	12BA6	14O7	50L6
1I6	4CB6	6AO5	6BK7	6DE6	6S07	7E7	12BA7	19	56
1N5GT	5AM8	6AC6	6BL7GT	6DG6GT	6SR7	7E7	12D06	19AU4GT	57
1R5	5AN8	6AO7	6BN6	6D06	6I4	7F8	12BE6	19BG6G	58
1S5	5AT8	6AR5	6BO6GT	6F5	6U8	7G7	12BF6	19J6	71A
1T4	5AV8	6A55	6B07	6F6	6V6GT	7H7	12BH7	1918	75
1U4	5AZ4	6A16	6BR8	6H6	6W6GT	7N7	12BO6	24A	76
1U5	5BR8	6AU4GT	6B58	6J4	6X4	7O7	12BR7	2526GT	77
1V2	5J6	6AUSGT	6BY5G	6J5	6XS5GT	757	12BY7	26	78
1X2	5R4	6AU6	6B26	6J6	6X8	7X6	12CA5	27	80
2AF4	5U4	6AU8	6B27	6J7	6Y6G	7X7	12CN5	35	84/624
2BN4	5UB	6AV5GT	6C4	6K6GT	7A4/XXL	7Y4	12D6	35A5	117Z3
2CY5	5V4G	6AV6	6C86	6K7	7A5	7Z4	12F5	35B5	
3A4	5V6GT	6AW8	6CD6G	6N7	7A6	12A8	12K7	35C5	
3A5	5X8	6AX4GT	6CF6	6Q7	7A7	12A85	12L6	35W4	
3AL5	5Y3	6AX5GT	6CG7	6S4	7A8	12AQ5	12Q7	35Z5	

35¢

\$ 33 PER HUNDRED

For any used or factory second tube!

1 YEAR GUARANTEED PICTURE TUBES

Brand New* Allied A-1 Tubes Brand New
Below listed prices do not include dud. Add Additional \$5.00 Deposit
on tube sizes to 20"; on 21" and 24" tubes - \$7.50. Deposit refunded
immediately when dud is returned prepaid. Aluminized tubes - \$4.00
extra.

Picture tubes shipped only to continental USA and Canada - All tubes
F.O.B. Harrison, N. J.

10BP4	799	1AMP4	1219	17CP4	164	10AP4	1839	21ATP4	1879	21FP4	1839	21YP4	1839
12IP4	1049	16KP4	1199	17CP4	1789	20CP4	1589	21AMP4	1799	21KP4	1839	21ZP4	1749
14B/CP4	1199	16IP4	1219	17MP4	1659	20DP4	1589	21AUP4	1879	21MP4	2339	24AP4	2949
16AD4	1699	18BP4	1199	17FP4	1699	20HP4	1789	21AVP4	1879	21VP4	1839	24CP4	2729
16DP4	1219	17AP4	1549	17OP4	1289	21AP4	2159	21AWP4	1749	21WP4	1749	24DP4	2929
16GP4	1609	17BP4	1349	17TP4	1699	21ALP4	1879	21EP4	1729	21XP4	1749		

ATTENTION!
Get More For Your Money
Get Quality And
Bigger Selection
Get Truly Remarkable
Tube Values When You
Buy At
TRU-VAC

FREE FUSE CLIP!
Sent With Any
Order Of \$5
Or More

GUARANTEE
Only TRU-VAC guarantees
to replace free any tube
which becomes defective in
use within one year of
date of purchase.

USED TV CONSOLES
GUARANTEED To Work
When You Receive Them

10" & 12"	\$29
14" & 16"	\$37
17"	\$45
19"	\$59
20" & 21"	\$70

All sets shipped in two cartons to avoid
breakage. Sets shipped express to conti-
nental U.S.A. and Canada only. F.O.B.
Harrison, New Jersey.

FREE BONUS-RABBIT EARS
\$.75 Value
FREE with each set purchased

ATTENTION QUANTITY USERS!
Big Discounts Are Yours . . . Call or Write For Our 1000 Tube "Private
Label" Special! Attention Branding Dept. MGR.
MONEY CHEERFULLY REFUNDED WITHIN FIVE (5) DAYS,
IF NOT COMPLETELY SATISFIED!

TRU-VAC® PAYS YOUR POSTAGE
On orders of \$5 or more in U.S.A. and Territories. Send approximate
postage on Canadian and foreign orders. Any order less than \$5
requires 25c handling charge. Send 25% on C.O.D.'s. All orders subject
to prior sale.

Complying with Federal regulations, the following statement appears
in all Tru-Vac advertising: Tubes appearing in this ad may be FAC-
TORY SECONDS or USED tubes and are clearly marked.

TRU-VAC®

Harrison Avenue Box 107 Harrison, New Jersey
Humboldt 4-9770

Write Dept. L For FREE LIST of Other Tube
Types and Products Sold by TRU-VAC®
Electric Company
Visit Our Huge Testing Dept. In The Heart
Of Harrison, N. J.'s Electronics Industry.

FREE ALLIED'S MONEY-SAVING 1960 ELECTRONIC SUPPLY CATALOG

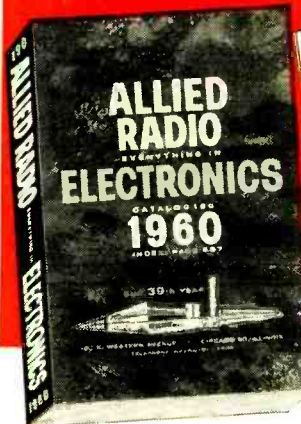

value-packed
SEND FOR IT!

SAVE
ON EVERYTHING
IN ELECTRONICS

EASIEST TERMS
only \$2 down on
orders up to \$50

WORLD'S LARGEST STOCKS

Send for the most widely used buying guide to everything in Electronics for Experimenters, Builders, Amateurs, Servicemen, Engineers and Hi-Fi enthusiasts. Save on:

- KNIGHT-KITS® — Best in Build-Your-Own
- Everything in STEREO Hi-Fi
- Hi-Fi Music Systems and Components
- Tape Recorders & Phono Equipment
- Public Address & Paging Systems
- TV Tubes, Antennas, Accessories
- Amateur Station Equipment
- Latest Test & Lab Instruments
- Parts, Tubes, Transistors
- Everything in Tools & Technical Books

SAVE on everything in Electronics at ALLIED — get fastest service, expert personal help, guaranteed satisfaction. Send today for your FREE 1960 ALLIED Catalog.

Everything in Electronics
from One Reliable Source

our 39th year



ALLIED RADIO

• ALLIED RADIO CORP., Dept. 79-A
• 100 N. Western Ave., Chicago 80, Ill.

Rush FREE 1960 ALLIED Catalog.

Name _____

Address _____

City _____

Zone _____ State _____

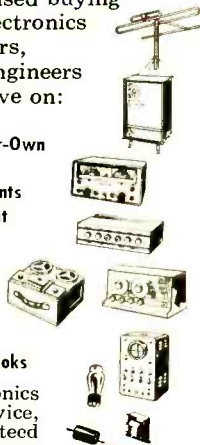

SEND FOR
FREE
CATALOG



products

(Continued from page 32)

dated. Other advantages are "piano-key" operation, three speeds (7½, 3¾, and 1⅞ ips), built-in stereo amplifiers, and one playback speaker. Only one external speak-



er is required for stereo playback. Frequency response at 7½ ips is 50-18,000 cps; at 3¾ ips, 50-14,000 cps; and at 1⅞ ips, 50-7000 cps. Price (including a stereo microphone), \$399.50.

TRANSISTOR CHECKER

Introduced by the *Seco Manufacturing Co.*, 5015 Penn Ave. South, Minneapolis, Minn., the Model 100 transistor checker tests transistors under actual operating conditions. In addition to checking for "opens," shorts, and gain, it automatically identifies and checks *p-n-p* and *n-p-n* types. Powered by a single 1.5-volt battery, the unit utilizes a NE-51 glow lamp indicator as a visual signal to indicate test results. Price, complete with battery, \$19.95.

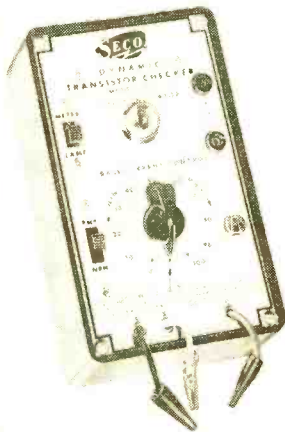

FORTY-WATT AMPLIFIER

Available either wired or in kit form, the Dynakit "Mark IV" amplifier delivers 40 watts of power at less than 1% distortion from 20 cps to 20 kc. Frequency response is

Always say you saw it in—POPULAR ELECTRONICS

coming in:

build an 11-meter transistorized remote- control TRANSMITTER!



Here are complete plans for building your own 27.255 megacycle low-power transmitter for radio-controlled operations of all kinds! Using four transistors and one low cost battery, this handy device will operate model airplanes... toy boats... garage doors... and many other objects by remote control.

Don't miss this special construction feature coming your way in February POPULAR ELECTRONICS—complete with easy-to-follow illustrations and diagrams.

You'll also enjoy such interesting, informative February POPULAR ELECTRONICS articles as:

● **COMPUTERS—YESTERDAY AND TODAY**

From Abacus to Giant Brain—the story of the computer has been unwinding for over 300 years! Here's the complete, exciting story of its development.

● **HOW TO CONVERT YOUR CAR RADIO TO HOME USE**

If you've been wanting to convert an old car radio to home use, here are complete instructions on how to alter the power supply to receive 117 Volts AC.

● **PLUS MANY OTHER EXCITING, HELPFUL ARTICLES**

All these features are coming your way in February POPULAR ELECTRONICS—typical of the coverage you'll enjoy month after month in the world's leading electronic hobbyist magazine. Take advantage of the present low subscription rates to bring POPULAR ELECTRONICS to your door every month. Subscribe today!

SUBSCRIPTION RATES

One year \$4

Two years \$7

Three years \$10

POPULAR ELECTRONICS, 434 South Wabash Avenue, Chicago 5, Illinois

Globe Chief Deluxe

BANDSWITCHING — 90 WATTS



ONLY
10%
DOWN

Kit: \$59.95

Only \$6.00 down

\$5.00
per mo.

Wired: \$79.95

Only \$8.00 down

\$5.00
per mo.

A powerful, compact, handsome transmitter with power supply built in, either wired or in kit form. Numerous modern features include choice of cathode or grid block keying, easy plug-in receptacles for later addition of modulators and VFO's, NEW WIDE RANGE Pi-network, and others. Multi-colored kit construction diagrams.

Globe Scout Deluxe

90 WATTS CW; 85 WATTS FONE



Wired Only

\$149.95

\$15.00 down

\$8.70
per mo.

Smartly styled, compact, versatile transmitter with built-in power supply. Outstanding features include straight through operation of final amplifier, high level plate modulation, NEW WIDE RANGE pi-net on 10-80 meters — link coupled on 6 with front panel loading adjustment and many others.

TOP
TRADES
ALWAYS

and the Complete
IN STOCK line
of all Globe Products.



WORLD'S MOST PERSONALIZED ELECTRONIC SUPPLY HOUSE

World Radio
LABORATORIES
PH. 2-0277

200 Pages
FREE
1960
Catalog
Send Today

3415 W. BROADWAY COUNCIL BLUFFS, IOWA

Rush Free Catalog Info on Scout & Chief

NAME: _____

ADDRESS: _____

CITY & STATE: _____

products

(Continued from page 34)

±1 db from 10 cps to 40 kc. Prewired printed circuitry, detailed step-by-step in-



structions, and pictorial diagrams make the kit easy to construct. (Dynaco Inc., 617 North 41 St., Philadelphia 4, Pa.)

SPEAKER SAVER

ProSound Corp., 175 Fifth Ave., New York 10, N. Y., has produced a fuse box arrangement that

will protect speakers from voice coil burn out caused by overloads from amplifiers, faulty wiring, switching transients and amplifier failure. The Gramercy

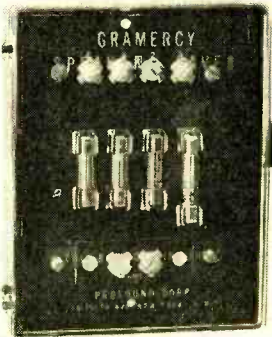

"Speaker - Saver" is wired to accommodate speakers whose voice coil impedance is 4 ohms, 8 ohms, or 16 ohms. Complete with fuses and instructions, \$4.98.

PROFESSIONAL TONE ARM

Lafayette Radio, 165-08 Liberty Ave., Jamaica 33, N. Y., is offering new 12" and 16" professional tone arms. Four hardened-steel



knife-edge pivots and bearings allow frictionless freedom of motion. Installation is facilitated by the bubble level at the top of the support column, plus three adjustments on the base for perfect leveling;

DON'T

throw
your
money

Get Rad-Tel's First Quality

Brand New TUBES

BETTER
THAN
70%
OFF!

GUARANTEED ONE FULL YEAR

down the drain . . .
ON USED AND "PULL OUT" TUBES!

**EACH TUBE INDIVIDUALLY AND ATTRACTIVELY BOXED!
YOU CAN RELY ON RAD-TEL'S SPEEDY ONE DAY SERVICE!**

Qty.	Type	Price	Qty.	Type	Price	Qty.	Type	Price	Qty.	Type	Price	Qty.	Type	Price	Qty.	Type	Price
.79	4A4U	.54	.47	6A5L	.47	.39	6X4	.39	.43	12A16	.43	.69	12D85	.69	1.06	17DQ6	1.06
.62	4BA6	.51	.78	6AM8	.78	.43	6X5GT	.53	.76	12A17	.76	.75	12D88	.75	.58	17L6	.58
.79	4BC5	.56	.95	6AN4	.95	.54	6X8	.77	.60	12A18	.60	.85	12DL8	.85	.70	17W6	.70
.55	4BC8	.96	.85	6AN8	.85	1.42	7A17	.61	.60	12A19	.60	.67	12DM7	.67	.83	19AU4	.83
.73	4BE6	.54	.50	6A05	.50	.64	7A8	.68	.97	12A20	.97	1.04	12DQ6	1.04	1.39	19BG6	1.39
.73	4BN6	.75	.55	6A05	.55	.60	7B6	.69	.41	12A21	.41	.79	12D57	.79	.80	19T8	.80
.73	4B07	.96	.60	6A55	.60	.77	7Y4	.69	.75	12A22	.75	.56	12D26	.56	1.49	21EX6	1.49
1.05	4BS8	.98	.43	6A76	.43	.66	8A08	.83	.67	12A23	.67	.50	12EL6	.50	.87	25AU4	.87
.69	4BU8	.71	.79	6A78	.79	.65	8A8	.93	.63	12A24	.63	.54	12EG6	.54	1.11	25BQ6	1.11
.79	4BZ6	.58	.82	6A04	.82	.51	8B05	.60	.86	12A25	.86	.56	12EK6	.56	.53	25C5	.53
.59	4BZ7	.96	.50	6A06	.50	.57	8C67	.62	.63	12B4	.63	.53	12E26	.53	.59	25CA5	.59
.62	4CB6	.59	.61	6A07	.61	.58	8C07	.68	.50	12BA6	.50	.66	12F5	.66	1.44	25CD6	1.44
.51	4CS6	.61	.87	6A08	.87	1.08	8C07	.97	.50	12B6	.50	.66	12F8	.66	1.11	25CU6	1.11
.58	4DE6	.62	.40	6AV6	.40	.70	8CX8	.93	.53	12BE6	.53	.45	12FM6	.45	1.42	25DN6	1.42
.57	4DK6	.60	.89	6AW8	.89	.71	8EB8	.94	.44	12BF6	.44	.65	12K5	.65	.55	25EH5	.55
.50	4DT6	.55	.65	6AX4	.65	.68	10DA7	.71	.73	12BH7	.73	.86	12SA7M	.86	.57	25L6	.57
.82	5AM8	.79	.64	6AX7	.64	.69	11CY7	.75	.56	12BK5	.56	.71	12SK7GT	.71	.68	25W4	.68
.96	5AN8	.86	.49	6BA6	.49	.58	12A4	.60	.70	12BL6	.70	.67	12SN7	.67	.66	25Z6	.66
.60	5A05	.52	.54	6BC5	.54	.59	12AB5	.55	1.06	12BQ6	1.06	.73	12SQ7M	.73	.51	35C5	.51
.71	5AT8	.80	.94	6BC7	.94	1.10	12AC6	.49	.74	12BY7	.74	.62	12U7	.62	.57	35L6	.57
.42	5BK7A	.82	.97	6BC8	.97	.76	12AD6	.57	.75	12BZ7	.75	.53	12V6GT	.53	.52	35W4	.52
.51	5B07	.97	.68	6BD6	.68	.53	12AE6	.43	.56	12C5	.56	.69	12W6	.69	.60	35Z5GT	.60
.41	5BR8	.79	.55	6BE6	.55	.79	12AF3	.73	.59	12CA5	.59	.38	12X4	.38	.60	50B5	.60
.51	5C68	.76	.44	6BF6	.44	.79	12AF6	.49	.56	12CN5	.56	.67	17AX4	.67	.53	50C5	.53
.54	5CL8	.76	1.66	6BG6	1.66	.94	12AJ6	.46	.54	12CR6	.54	1.09	17BQ6	1.09	.37	50DC4	.37
.52	5EA8	.80	.65	6BH6	.65	.58	12AL5	.45	.58	12CU5	.58	.58	17C5	.58	.55	50EH5	.55
.63	5EU8	.80	.87	6BH8	.87	.51	12AL8	.95	1.06	12CU6	1.06	.62	17CA5	.62	.61	50L6	.61
.76	5J6	.68	.62	6BJ6	.62	.67	12AQ5	.52	.54	12CX6	.54	.69	17D4	.69	.61	117Z3	.61
.78	5T8	.81	.80	6BK5	.80	.58	6K6	.58									
.55	5U4	.60	.85	6BK7	.85	.54	6S4	.48									
.55	5U8	.81	1.00	6BL7	1.00	.76	6SA7GT	.76									
.54	5V6	.56	.57	6BN4	.57	.74	6SK7GT	.74									
.60	5X8	.78	.74	6BN6	.74	.80	6SL7	.80									
.52	5Y3	.46	.65	6B05	.65	.65	6SN7	.65									
.71	6AB4	.46	1.05	6B06GT	1.05	.73	6SQ7	.73									
.62	6AC7	.96	.95	6B07	.95	.64	6T4	.99									
.60	6AF3	.73	.78	6BR8	.78	.80	6T8	.80									
.50	6AF4	.97	.90	6BS8	.90	.68	6U8	.78									
.80	6AG5	.65	.54	6BU8	.54	.70	6V6GT	.70									
.61	6AH6	.99	.54	6BY6	.54	.57	6W4	.57									
.58	6AK5	.95	.54	6BZ6	.54	.69	6W6	.69									

NOT AFFILIATED WITH ANY
OTHER MAIL ORDER TUBE CO.

**Brand New JAN 3BP1
Cathode Ray Tube \$145 each**
6.3V Deflect. Sensit.
Five X 5BP1—Electrostatic
Focus & Deflection

USE THIS AS YOUR ORDER BLANK
Rad-Tel Tube Co. 55 Chambers St. Newark, N. J.

NAME _____
ADDRESS _____

TERMS: 25% deposit must accompany
all orders—balance C.O.D. ORDER
UNDER \$5, \$1 HANDLING CHARGE.
Subject to prior sale. All shipments
F.O.B. Newark warehouse. No
C.O.D.'s outside continental U.S.A.

RAD-TEL TUBE CO.

55 CHAMBERS ST. Mitchell 2-3147 NEWARK 5, N. J.

products

(Continued from page 36)

plug-in heads accommodating all stereo and monaural cartridges are provided. The 12" arm (PK-270) is \$17.50; the 16" arm (PK-280), \$19.50.

TUBE TESTER

A new B&K dynamic mutual conductance tube tester, Model 550, tests each section of a tube under normal operating conditions. In addition to measuring dynamic mutual conductance, it tests for shorts, grid emission, gas content, and leakage. Most commonly used tube types, with the correct settings, are listed directly on the front panel for easy reference. A more complete tube chart is included in the cover of the

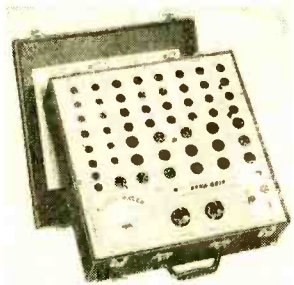

case. Net price, \$119.95. (B&K Manufacturing Co., 3726 North Southport Ave., Chicago 13, Ill.)

PORTABLE OSCILLOSCOPE

Available either in kit form or factory-wired and calibrated, the RCA WO-33A oscilloscope is designed for portability — it weighs only 14 pounds and incorporates a 3" CRT. For narrow-band operation, the sensitivity is 3 millivolts per inch with a bandwidth of 20 cps to 150 kc.; for wide-band operation, the sensitivity is 100 millivolts per inch with a bandwidth of 5.5 cps to 5.5 mc. Construction of the kit model is facilitated by the use of modules. (RCA Electron Tube Division, Harrison, N. J.)

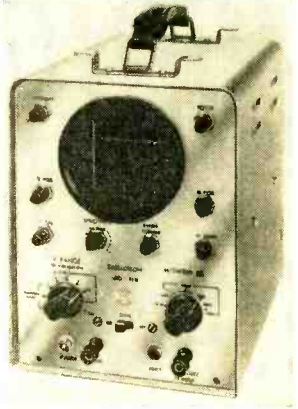

-30-

Build the Best Portable... EICO®



6-TRANSISTOR RADIO RA-6

Kit \$29.95

Wired \$49.95

INCLUDES F. E. T., LESS 9V BATTERY

Easy creative fun to build... a lifetime of big-set entertainment wherever you go... designed so that even the novice can build it & obtain a handsome professional assembly & outstanding performance. American-made modern super-heterodyne all-transistor circuitry, plus finest quality parts throughout, assure you of highest durability & stability.

- high sensitivity & selectivity • big-set volume & tone quality with 4" x 6" PM speaker & 250 mw push-pull audio output stage • built-in Ferrite rod antenna for good reception in any location • pre-aligned RF & IF transformers
- planetary vernier tuning (7:1 reduction) for easy station selection & tuning • high-impedance earphone jack for private listening; eliminates drain of output stage when using earphone • attractive tan leatherette case, retractable handle
- compact: 8 1/2" w, 4 1/2" h, 2 1/2" d. Only 3 lbs.

Build the BEST BUYS in "HAM" gear...



*U. S.
Pat. No.
D-184,776



90-WATT CW TRANSMITTER #720
Kit \$79.95 Wired \$119.95
"Ideal for veteran or novice" — ELECTRONIC KITS GUIDE. "Top quality" — POPULAR ELECTRONICS. "Well designed" — ELECTRONICS WORLD. 80 thru 10 meters with one-knob band-switching. Full "clean" 90W input, 65W external plate mod. Matches loads 50 to 1000 ohms. May be used as basic exciter unit. TVI shielded. Tubes: 6146, 6CL6, 2-6AQ5, G234. Attractive "living room" low-silhouette design. 15" w, 5" h, 9" d.



UNIVERSAL MODULATOR-DRIVER #730
Kit \$49.95 Wired \$79.95
Cover E-5 \$4.50

Delivers 50W undistorted audio. Modulates transmitters having r.f. inputs up to 100W. Unique over-modulation indicator. Output transformer matches 500-10,000 ohms. Low-level speech clipping & filtering. Inputs for xtal or dynamic mikes, phone patch, etc. 7 tubes. 6" h, 14" w, 8" d.



GRID DIP METER #710
Kit \$29.95 Wired \$49.95
Includes complete set of coils for full band coverage. 400 kc-230 mc in 8 overlapping ranges. 500 ua meter. Plug-in coils are pre-wound, pre-calibrated to 0.5% accuracy. Transformer-operated power supply 2 1/4" h, 2 1/4" w, 6 7/8" l.

Compare — judge for yourself — at your neighborhood EICO distributor. For free catalog on 65 models of EICO test instruments, hi-fi & "ham" gear, fill out coupon on Page 40. Add 5% in the West

ELECTRONIC INSTRUMENT CO., Inc., 33-00 N. Blvd., L. I. C. 1, N. Y.

JUST OFF THE PRESS!

Here is an opportunity for you to examine free, two of the most valuable electronics books ever published: **COMPUTERS AND HOW THEY WORK**, and **THE ELECTRONIC EXPERIMENTER'S MANUAL**. If you have a stake in electronics, these books belong in your library. Fill in and mail the certificate below and you'll be among the first to receive copies of the limited first editions of these important volumes.

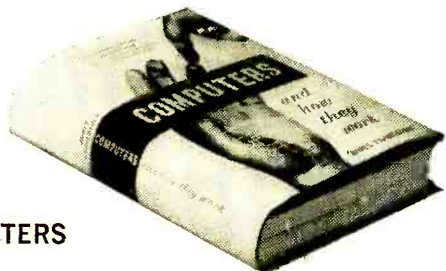

COMPUTERS AND HOW THEY WORK

Here is a complete guidebook to the wonder world of electronic computers. In it, James Fahnestock takes you step by step through the workings of every type of computer ever used. *No knowledge of electronics is necessary.* It traces the history of computers from the introduction of the abacus up to the most complex computing units in operation today.

Non-technical comparisons, used to illustrate the basic principles of computers, make this book an easy-to-understand adventure into one of man's greatest fields. If you understand how a see-saw operates, you will be able to understand computer memories, flip flops and the binary counting systems. If you have ever filled out an income tax form, you are well on your way to understanding how a computer programmer tells his machine what to do.

COMPUTERS AND HOW THEY WORK tells you how computers read, write and remember. You'll learn the two digit mathematical language of computers, where $1+1=10$. Using this language you can add, subtract, multiply and divide by simple addition.

Other chapters show you how computers use vacuum tubes and transistors to make logical decisions in thousands of a second—how they figure payrolls for giant companies so fast that the high-speed checking machines can't keep up.

Here is a fact-filled, exciting guidebook with more than 120 illustrations and tables in 10 big chapters. For the student interested in a career in this growing field or for the man in electronics who wants to know all about computers, this book is a must.



THE ELECTRONIC EXPERIMENTER'S MANUAL

With a few dollars worth of basic tools, and this book to guide you, you can explore the magic of electronics experimentation more thoroughly than ever before. In a few short hours, you'll have enough basic know-how to start your first project.

This book was written by David A. Findlay, Editor of 6 Ziff-Davis Electronics Division Publications, and a noted authority on electronics experimentation. It is designed expressly for all experimenters—those who wish to "follow the simple directions" with more authority, as well as those keenly interested in knowing the "why" of everything in a project.

You'll learn about every component used in experimentation, every tool, its purpose, how it differs from similar components or methods, what its function is, and why it is used. This book is a perfect stepping-off point to project designs of your own.

There are ten big sections, each covering specific phases of electronic construction such as Techniques For The Experimenter, Wiring The Circuit, Making Printed Circuits, etc. There is a giant section of projects you can build, test equipment you'll assemble and use in your other work, special tools you can construct—even plans for a complete compact workshop that will adapt to any working area, no matter how limited.

THE ELECTRONIC EXPERIMENTER'S MANUAL is a big, handsome volume, containing hundreds of specially prepared diagrams and construction drawings. This book will give you professional know-how you must have no matter what phase of electronics is your specialty.

7 DAY FREE EXAMINATION

When your book arrives, read it and enjoy its diversity of contents, and the thoroughness of its coverage. Then, after 7 days examination, if you decide that it is not everything you want, send it back and you will receive a complete refund of the purchase price.

USE THIS CERTIFICATE FOR 7 DAY FREE EXAMINATION

ELECTRONICS BOOK SERVICE,
A Division of the Ziff-Davis Publishing Co.
434 S. Wabash Ave., Chicago 5, Illinois

Gentlemen:

Send me _____ copies of **THE ELECTRONIC EXPERIMENTER'S MANUAL**, and bill me at only \$4.95 a copy plus a few cents postage.

Send me _____ copies of **COMPUTERS AND HOW THEY WORK**, and bill me at only \$4.95 a copy plus a few cents postage.

If I don't agree that this is one of the best electronics investments I've ever made, I may return the book(s) within 7 days and get a full refund.

\$_____ enclosed. (SAVE MONEY! Enclose payment with this coupon and we'll pay the postage.)

Name _____

Address _____

City _____ Zone _____ State _____

ZE-160

the experts say
your BEST BUY
 is **EICO**...

EICO, 33-00 Northern Blvd., L. I. C. 1, N. Y. PE-1
 Show me HOW TO SAVE 50% on 65 models of top-quality:
 HI-FI TEST INSTRUMENTS "HAM" GEAR
 Send FREE catalog & name of neighborhood EICO dealer. Send free STEREO Hi-Fi Guide.

NAME.....
 ADDRESS.....
 CITY..... ZONE..... STATE.....

ADD 5% IN THE WEST

...in
STEREO and MONO HI-FI



STEREO Dual Amplifier-Preamplifier HF81
 Kit \$69.95.
 Wired \$109.95.
 "Excellent" — SATURDAY REVIEW; HI-FI MUSIC AT HOME.



Mono Preamplifier HF65A:
 Kit \$29.95.
 Wired \$44.95.
 With Power Supply HF65:
 Kit \$33.95. Wired \$49.95.

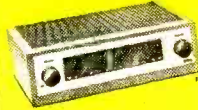

*Less Cover, F.E.T. incl.

FM Tuner HFT90
 Kit \$39.95*.
 Wired \$65.95*.
 Cover \$3.95.
 "One of the best buys" — AUDIOCRAFT
 AM Tuner HFT94
 Kit \$39.95. Wired \$65.95.
 incl. Cover & F.E.T.
 FM/AM Tuner HFT92
 Kit \$59.95. Wired \$94.95.
 incl. Cover & F.E.T.



STEREO Dual Preamplifier HF85
 Kit \$39.95.
 Wired \$64.95.
 "Extreme flexibility" — HI-FI REVIEW
 a bargain!



Mono Power Amplifiers (60, 50, 35, 30, 22, 14-Watt; use 2 for Stereo)
 from Kit \$23.50.
 Wired \$41.50.



2-Way Bookshelf Speaker System HFS1 complete with factory-built cabinet: \$39.95.



STEREO Dual Power Amplifier HF86
 Kit \$43.95.
 Wired \$74.95.



Mono Integrated Amplifiers: (50, 30, 20, 12-Watt; use 2 for Stereo)
 from Kit \$34.95.
 Wired \$57.95.



NEW! COMPLETE STEREO DUAL AMPLIFIER AF-4
 Kit \$38.95
 Wired \$64.95
 TRUE HI-FI quality to drive hi efficiency speakers to concert volume.

TWO STEREO Dual Power Amplifier HF87 Kit \$114.95 Wired \$114.95

...and in
TEST INSTRUMENTS



New Power & Bias Supply for Transistorized Eqpt. #1020*
 Kit \$19.95.
 Wired \$27.95.
 *Patent pending



Miniaturized Multi-Signal Tracer #145A
 Kit \$19.95.
 Wired \$28.95.



Vacuum Tube Voltmeter #221
 Kit \$25.95.
 Wired \$39.95.



Peak-to-Peak VTVM #232 & Uni-Probe (pat. pend.)
 Kit \$29.95.
 Wired \$49.95.



New TUBE & CRT FIL. Tester #612
 Kit \$3.95.
 Wired \$5.95.
 Fast-checks radio/TV tubes, pilot lamps, etc.



1000 Ohms/Volt V-O-M #536
 Kit \$12.90.
 Wired \$14.90.



5" Push-Pull Scope #425
 Kit \$44.95.
 Wired \$79.95.



Tube Tester #625
 Kit \$34.95.
 Wired \$49.95.



RF Signal Generator #324
 Kit \$26.95.
 Wired \$39.95.



Series/Parallel R-C Combination Box #1140
 Kit \$13.95. Wired \$19.95
 1350 Combinations!



6V & 12V Battery Eliminator & Charger #1050
 Kit \$29.95. Wired \$38.95.
 Extra-filtered for transistor eqpt. #1060
 Kit \$38.95. Wired \$47.95



R-C Bridge & R-C-L Comparator #950B
 Kit \$19.95.
 Wired \$29.95.

IN STOCK! Compare, take them home — right "off the shelf" — from 2000 neighborhood dealers. Over 1 MILLION EICO instruments in use throughout the world.

© 1960, ELECTRONIC INSTRUMENT CO., INC., 33-00 N. BLVD., L.I.C. 1, N.Y.

See Page 38 for EICO'S BEST BUYS in "HAM" GEAR and TRANSISTOR RADIOS

ONE-TUBE Laboratory

*Easily constructed test unit operates
as an all-band receiver,
grid dipper, modulation indicator,
and many other instruments*

HOW WOULD YOU LIKE to have a grid dip meter, modulation monitor, and a multi-band regenerative receiver all rolled up into one neat test-bench instrument? A few evenings' work and an assortment of inexpensive components will give you an instrument capable of all those functions—and a lot more, depending upon your ingenuity.

This one-tube laboratory began with the discovery that a simple regen receiver circuit (even without modification) could in itself function as a useful piece of test equipment. (See the section on the operation of the All-Band Receiver.) And then

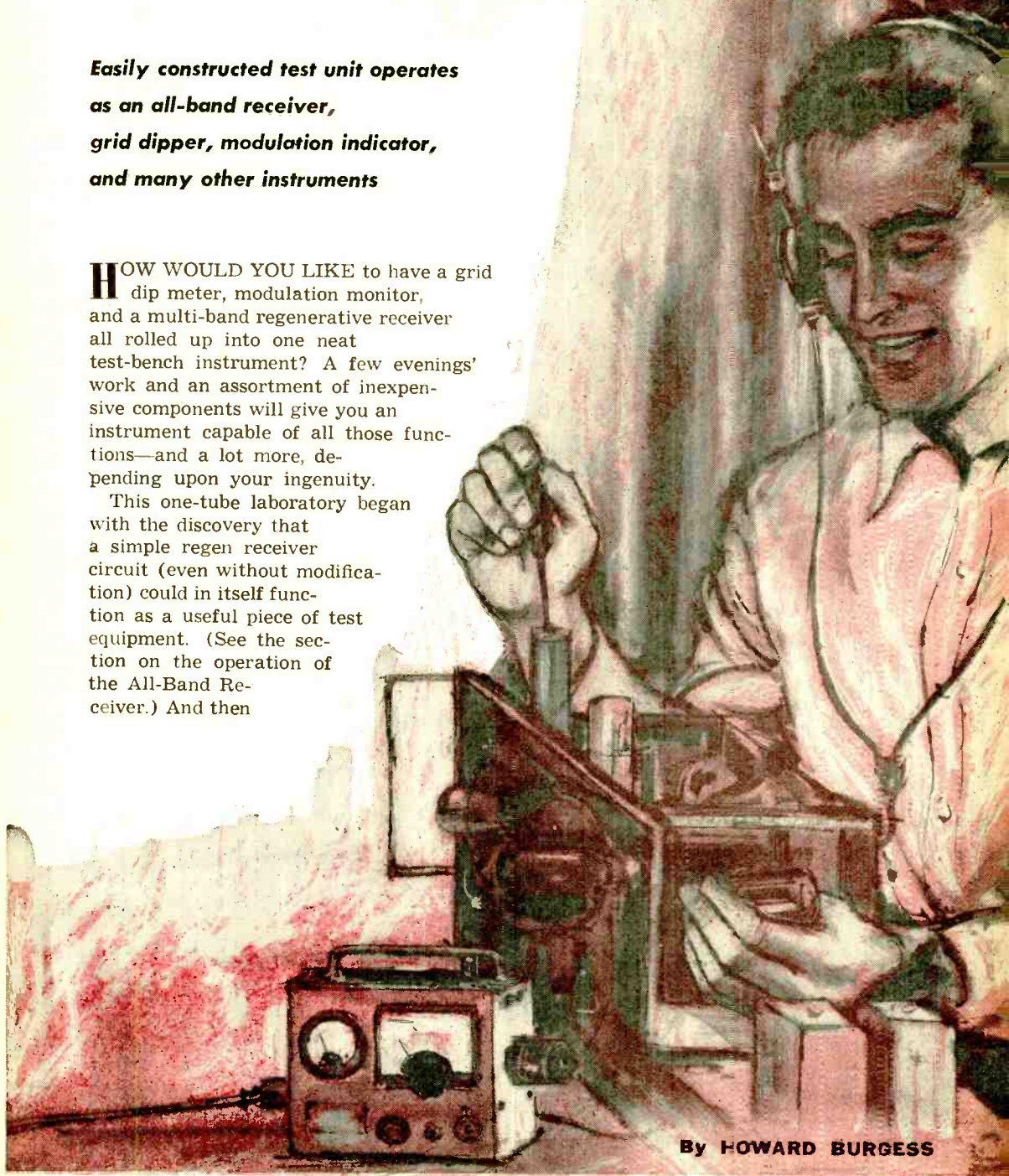

By HOWARD BURGESS

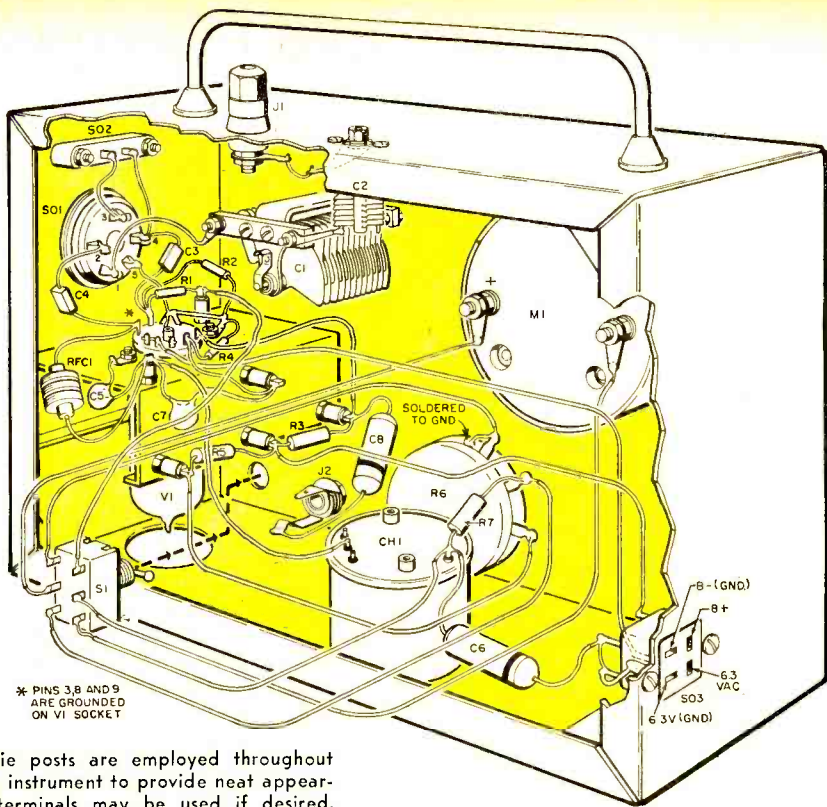

Standoff-type tie posts are employed throughout the multi-purpose instrument to provide neat appearance. Standard terminals may be used if desired.

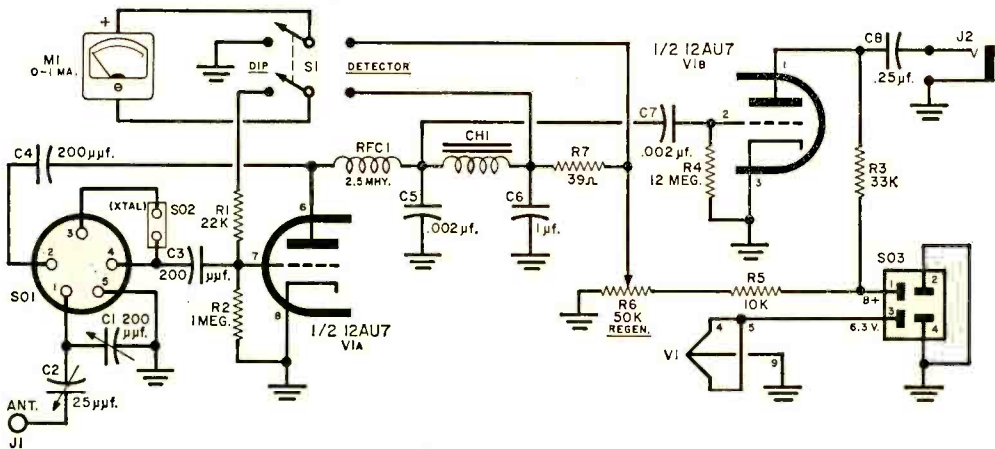

ONE-TUBE LAB PARTS LIST

- | | | |
|---|--|----------------------------|
| C1—200- μ f. tuning capacitor | R2—1 megohm | All resistors |
| C2—25- μ f. air padder capacitor | R3—33,000 ohms, 1 watt | $\frac{1}{2}$ -watt unless |
| C3, C4—200- μ f. mica capacitor | R4—12 megohms | otherwise indicated |
| C5, C7—.002- μ f. ceramic capacitor | R5—10,000 ohms, 1 watt | |
| C6—1- μ f., 200-volt paper capacitor | R6—50,000-ohm, 2-watt wire-wound potentiometer | |
| C8—25- μ f., 400-volt capacitor | R7—39 ohms | |
| C9—33- μ f. mica capacitor (see Crystal Adapter) | RFC1—2.5-millihenry r.f. choke | |
| CH1—Small low-current audio choke of 10 henrys or more, or plate winding of small audio transformer | S1—D.p.d.t. toggle switch | |
| J1—Insulated binding post | SO1—Five-prong socket | |
| J2—Phone jack | SO2—Crystal socket | |
| L1, L2, L3, L4—See Coil Data | SO3—Four-prong Jones socket | |
| M1—0.1 milliammeter | V1—12AU7A tube | |
| R1—22,000 ohms | 1—3" x 5" x 7" chassis box | |
| | 1—Nine-prong tube socket | |
| | Misc. coil forms, handle, adapter plug | |

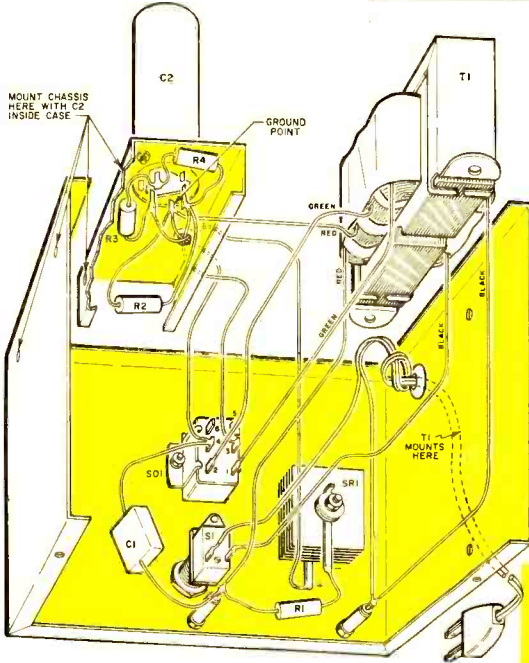
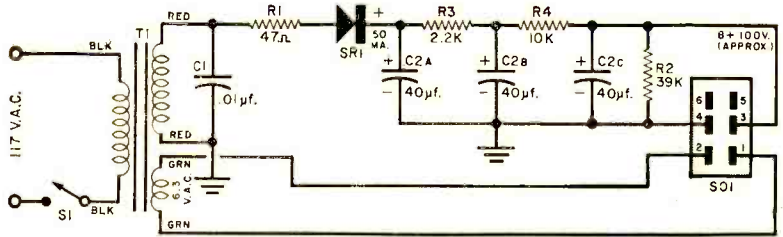

Output socket (SO1) in power supply can be six-prong type (two unused) or four-prong type. Power cable plug should match.

Triple-section filter capacitor can (C2) in the power supply is grounded through its metal mounting ring as shown in diagram.

POWER SUPPLY PARTS LIST

- C1—0.01- μ f., 600-volt paper or mica capacitor
 - C2—40/40/40 μ f., 150-volt twist-prong electrolytic capacitor
 - R1—47 ohms
 - R2—39,000 ohms
 - R3—2200 ohms
 - R4—10,000 ohms
 - S1—S.p.s.t. toggle or slide switch
 - SO1—Four- or six-prong Jones power take-off socket to match plug at end of cable
 - SR1—170-volt, 50-ma. selenium rectifier
 - T1—Power transformer; secondaries, 117-125 volts @ 50 ma., 6.3 volts @ 2 amp. (Merit P-3045 or Allied Radio 61G411)
- 1—3" x 4" x 5" cabinet (approx.)
 1—Four-conductor power cable with plugs to match sockets on one-tube lab and power supply
- All resistors
2-watt
composition

the thought occurred that since many of the well-known circuits are very much alike except for one or two connections, it would be an easy matter to construct a "basic" unit that could be changed to any one of a number of different testers by merely changing the plug-in coil or inserting an adapter.

Construction. A 5" x 7" x 3" chassis houses the complete unit. The 12AU7A tube and the small parts are mounted on an aluminum shelf attached to the case just below the coil socket as shown in the pictorial diagram. Layout is not important if leads are kept short. As the front-to-back depth of the chassis is small, a National dial is used but without the vernier drive.

Since a full milliamperere of current is drawn for some functions, a 1-ma. movement was chosen for M1. A more sensitive

meter would probably be an advantage when the unit is operated as a grid dip meter but the extra cost might not be justified for general use of the instrument. Power can be furnished from the small power supply shown or from batteries. The tube filament requires 6.3 volts at .3 ampere and the plate will need 60 to 100 volts of d.c. at several milliamperes.

All-Band Receiver. To operate the instrument as a regenerative receiver, the proper coil is plugged into SO1, a long-wire

Three coils used with the one-tube laboratory are shown at right, together with the crystal adapter and plug, and four-conductor power cable. Information on the wiring and winding of the coils appears on the next page.

antenna is connected to antenna post *J1* and switch *S1* is placed in the *Detector* position. The *Regen* control (*R6*) is advanced to a point just below oscillation (squealing) when a signal is tuned in. Capacitor *C2* should be set to the maximum value that will still allow oscillation.

The Coil Data table (on page 45) gives the suggested values for several frequencies. The number of turns on coil *L1* determines the frequency range, but a variation in coil size or a change in layout may vary the turns required. Coils *L1* and *L2* must be wound in the same direction for proper regeneration. If *L2* has too few turns or is reversed, the set will not regen-

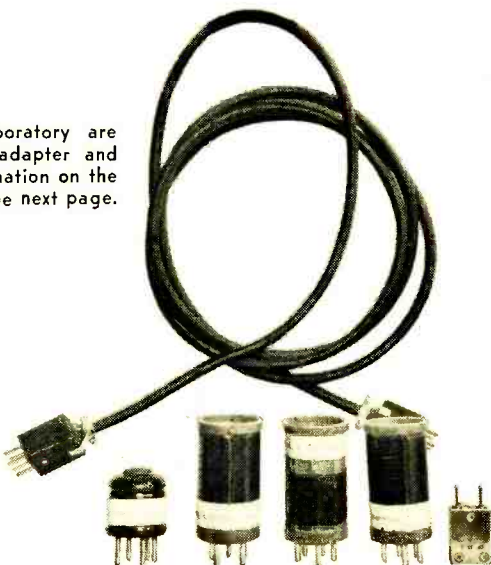

erate; with too many turns, regeneration will be difficult to control.

A receiver such as this, when it is operated just below the point of oscillation, is useful in checking a transmitter for spurious frequencies as it will not have the images and "birdies" so familiar in the superhet.

Signal Generator. A crystal-controlled signal generator has many uses, and, by means of inexpensive surplus crystals, almost any frequency can be covered. Accurate alignment of TV sets, receivers, and i.f. systems is possible. Or the generator can be used just to put "markers" across the dial of an all-band receiver.

The *Crystal Adapter* is placed in the coil socket and a crystal plugged into crystal socket *SO2*. Almost any fundamental-cut crystal will oscillate in the circuit. If a 1-mc. or 5-mc. crystal is used, it can be zero-adjusted to WWV with capacitor *C1*. In most cases, *C1* should be kept at minimum capacity.

Markers will be found at multiples of the crystal frequency. When the unit is employed as a signal generator, *S1* is placed in the *Dip* position and the output can be controlled to very low levels with the *Regen* control (*R6*). The meter will indicate only when the crystal is oscillating and will give a relative indication of the activity of a crystal. If you want to use an overtone crystal, the *Crystal Oscillator Coil* is plugged into the coil socket. The coil is

HOW IT WORKS

The "One-Tube Laboratory" is based on the fact that an ordinary triode vacuum tube can function as an oscillator, detector or rectifier, depending on the hookup of the plate, grid, and cathode. In the one-tube lab. leads to these three elements of one triode of a 12AU7 tube (*V1*) are brought out to a five-prong socket (*SO1*), enabling the various circuits to be set up merely by changing the plug-in coil or adapter. Tuning capacitor *C1*, for example, must be in the plate circuit for some applications; in others it is required in the grid circuit. A meter is provided to read either plate or grid current, as the circuit requires. The second triode of the 12AU7 functions as an audio amplifier to add sensitivity to the unit.

A **grid dip meter** is basically an oscillator with a low-value grid resistor and a meter to read the current through this resistor. The same circuit makes a good detector if the grid resistor is increased to a high value. This is done with the same switch that places the meter in the plate circuit. Oscillation can be controlled by varying the plate voltage with a variable resistor.

A **crystal oscillator circuit** is formed when the jumpers in the coil form base are arranged to place a coil and the tuning capacitor in the plate circuit and to connect the crystal socket from grid to ground. This results in a plate-tuned crystal oscillator. For an untuned crystal oscillator, the jumpers are arranged to form a Pierce circuit.

A **field strength meter** or modulation monitor can be set up by putting a coil and a capacitor in the grid circuit and turning off the plate voltage. The circuit is now a diode rectifier and the rectified current can be read on the meter. With the same plug-in coil, the meter can be switched to the plate circuit and the plate voltage increased until about 1-ma. plate current flows, and the instrument now becomes a grid leak detector which is much more sensitive. Many well-known circuits can be set up by varying the coil and jumper combinations.

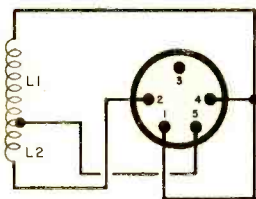

RECEIVER AND GRID DIP COIL

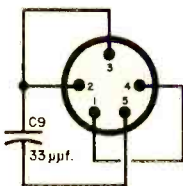

CRYSTAL ADAPTER

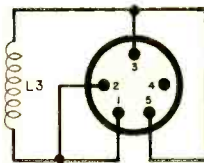

CRYSTAL OSCILLATOR COIL

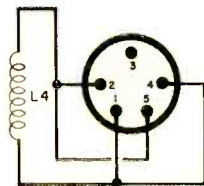

MODULATION MONITOR COIL

wound to resonate at the frequency of the crystal when it is tuned with *C1*. (If the crystal's fundamental frequency is below 10 mc., use the *Crystal Adapter*.)

Calibrator. For accurate calibration of a standard r.f. signal generator, the instrument should be operated as a crystal-controlled signal generator (as described above) but with a pair of headphones plugged into *J2*. Output from the generator to be calibrated is connected to the antenna post (*J1*). A beat note will be heard in the phones as the generator being calibrated is tuned through any multiple or submultiple of the crystal used in the one-tube lab. In this manner, the full range of a standard r.f. oscillator can be calibrated with a single crystal.

Grid Dip Meter. If you want to operate the unit as a grid dip meter, plug in the *Receiver and Grid Dip Coil* covering the desired range, flip *S1* to the *Dip* position and turn *Regen* control *R6* full up. The grid current indicated on the meter will be low because only a 1-ma. meter is used. However, more sensitivity can be had by listening on the headphones for the "plop" that indicates resonance. To calibrate the grid dip meter, just listen on the phones as signals of a known frequency are tuned through zero beat.

The unit will also serve as a tunable signal generator for many kinds of work. Output can be controlled by reducing the *Regen* control setting but there will be some shift in the frequency calibration.

Modulation Monitor. To operate the tester as a modulation monitor on amplitude-modulated transmitters, use the *Modulation Monitor Coil*. Turn the *Regen* control fully counterclockwise and place *S1* in *Dip* position. The tester is coupled to the transmitter by bringing a short length of wire connected to *J1* near the transmitter's antenna lead. Increase the coupling to the transmitter until meter *M1* reads half scale.

COIL DATA

Tuning Range	L1	L2	Wire Size
3.5-8 mc.	18 turns	7 turns	#26
8-16 mc.	8 turns	4 turns	#26
15-36 mc.	4 turns	2½ turns	#26

All coils are 1¼" in diameter, with a space the diameter of the wire separating turns. L1 and L2 must be wound in the same direction. Frequency range may vary with the degree of antenna coupling. Refer to the *ARRL Handbook* for coil specifications for particular frequencies.

Coils wound with the base connections as shown in the *Crystal Oscillator Coil* (L3) will give a plate-tuned crystal oscillator, and coils with the base connections as shown in the *Modulation Monitor Coil* (L4) will form a diode rectifier circuit using the grid of the tube as the diode plate. Both L3 and L4 can be specially wound to cover the desired frequency, but the number of turns specified for L1 above will be very close to the values required.

The meter now functions as a carrier shift indicator; if the meter needle fluctuates when the transmitter is modulated, excessive modulation is being used. With this arrangement, *M1* can also be used as an indicator for tuning the transmitter to maximum output on a desired frequency.

Another form of field strength indicator or wavemeter can be had by using the *Modulation Monitor Coil* plug-in arrangement. With switch *S1* in the *Detector* position, the *Regen* control is advanced to give a full-scale meter reading. Audio from the transmitter can then be heard in the phones. As is customary with grid detection, the detector and meter reading is nonlinear. A short whip antenna connected to *J1* may be necessary for adequate pickup.

Only a few of the many uses for this instrument have been covered here. A little study of the circuit, and the possibilities inherent in the one-tube lab will become obvious.

Phones of the Future



The experimental push-button-operated telephone at left is under development by Bell Telephone Laboratories. To make a call, you simply depress the numbered buttons in the desired sequence instead of dialing. This push-button system can be operated in about half the time needed for dialing a standard phone. Every physical feature of the new phone was extensively user-tested before the prototype model was constructed. Although present switching systems cannot accommodate the push-button phone, work presently being done may enable conventional systems of switching to become "bi-lingual" and service both types of telephones.

A radical departure from the time-honored two-piece design, the "Ericofon" combines mouthpiece, earpiece, and dialing mechanism in a single unit. (Two such units are shown at right.) Manufactured by L. M. Ericsson, the Swedish telephone maker, the Ericofon stands vertically on a base less than half the diameter of a conventional phone. The dialing mechanism of the 15-ounce unit is on the underside of the base. You hold the phone in one hand and dial with the other. Placing the set on a table automatically "hangs it up." Being both functional and attractive, the Ericofon was included in an exhibit held at New York's Museum of Modern Art as an example of good modern design.





Free Government Test Signals



Calibrate your audio and r.f. equipment against accurate WWV transmissions

By **PERRY WINTER**
Associate Editor

YOU CAN USE the super-accurate WWV transmissions broadcast by the National Bureau of Standards for a great number of useful tests in your shack or home laboratory. If you have a short-wave receiver which can tune to 2.5, 5, 10, 15, 20, or 25 mc., you have a valuable test instrument.

As you may know, the WWV transmitters in Maryland operate 24 hours a day. They broadcast on their assigned frequencies with an accuracy of 1 part in 100 million—if we were to aim a missile at the place where the Russian rocket hit the moon and land within 13 feet of it, we would be achieving the same accuracy. For parts of each hour the carrier frequencies are modulated with highly accurate 440- or 600-cps tones. You get a free, precision “tick” for 59 seconds each minute, and there is a special “silent” period of four minutes each hour when all WWV transmitters go off the air.

In addition, our 50th state, Hawaii, has similar transmitters operating on 5, 10, and 15 mc.—using the call WWVH. Between them, these two stations have world-wide coverage. The various transmissions are explained in Figs. 1 and 2.

All this is well and good, you may say, January, 1960

but my receiver is not a signal generator. It does receive WWV—but what good is that? Well, there are two ways in which WWV transmissions can be used: one is by direct comparison and the other by harmonic comparison. Let’s see exactly how the two techniques are employed in a couple of practical examples.

For direct comparison, simply tune your receiver to a WWV transmission, say 2.5 mc., and couple the signal generator you want to calibrate to the receiver antenna as shown in Fig. 3. Set the signal generator to the band that includes 2.5 mc. Then tune

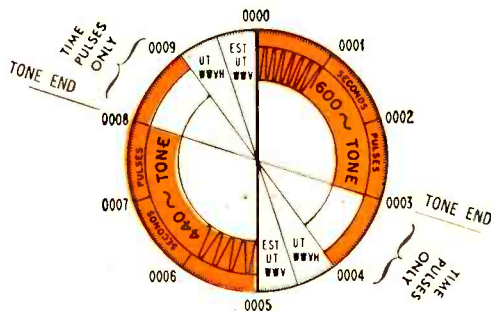
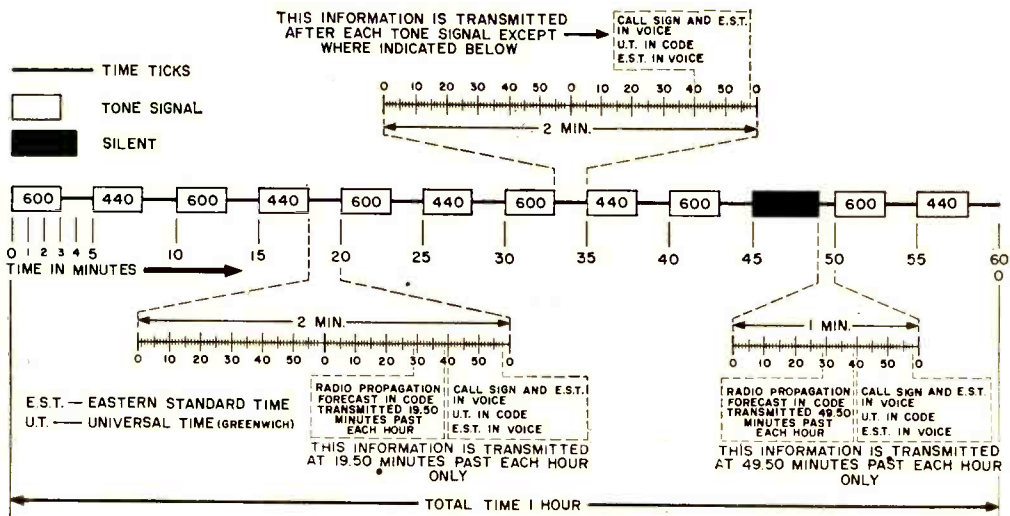

Fig. 1. All WWV and WWVH transmissions go through this ten-minute cycle. Note that the 440- and 600-cps tones are each sent for three minutes.



STATION WWV TRANSMITS 24 HOURS DAILY ON THE FOLLOWING FREQUENCIES —

2.5 Mcs. 15 Mcs.
5 Mcs. 20 Mcs.
10 Mcs. 25 Mcs.

RADIO PROPAGATION		
DISTURBED GRADES (W)	UNSETTLED GRADE (U)	NORMAL GRADES (N)
1 — USELESS	5 — FAIR	6 — FAIR-TO-GOOD
2 — VERY POOR		7 — GOOD
3 — POOR	9 — EXCELLENT	8 — VERY GOOD
4 — POOR-TO-FAIR		

Fig. 2. This convenient chart shows what happens every hour on any of the six WWV frequencies. Radio propagation reports can be used by SWL's and hams to determine best DX-ing times.

the generator until you hear a "whistle" on the receiver. The pitch of the whistle corresponds to the difference frequency between the WWV frequency and the signal generator frequency. When you hear the whistle, you know that you're within a few thousand cycles of the WWV transmission.

Now you listen for a "toneless" WWV transmission, and carefully tune the signal generator for "zero-beat" with the WWV carrier. You achieve zero-beat by adjusting the signal generator until the "whistle" in the receiver loudspeaker goes down in frequency, similar to the sound of a falling bomb, to the point where the "whistle" disappears. (The "whistle" does not *actually* disappear; it becomes a sub-audible note in the range between 0 and 20 cps.) Adjust for the lowest possible beat. If your signal generator has been operating for some time and is stabilized, you can mark the dial with "2.5" mc. You're on the nose.

Another way to get zero-beat is to switch on the receiver BFO with the generator off. You listen to a toneless WWV transmission and adjust the BFO pitch control for a pleasing note, say 1500 cps. Now switch on the generator and tune it for zero-beat

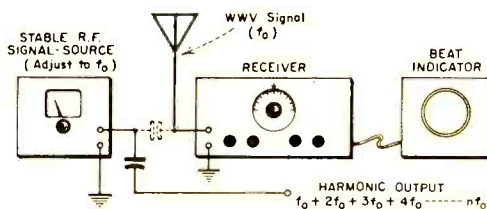

Fig. 3. After you calibrate your r.f. generator against WWV transmissions, you can use the generator's harmonic output for accurate frequency "fixes." Receiver loudspeaker or oscilloscope serves as beat indicator. Use "gimmick" capacitor to couple generator to receiver by twisting insulated wire around the antenna and generator output leads.

with WWV. In this case zero-beat will be heard as a very slow, gentle rise and fall in volume of the 1500-cps BFO tone.

Harmonic comparison of unknown signal sources is made in a similar manner but you zero-beat the harmonic of the unknown signal instead of the signal itself. Let's calibrate another of the signal generator's frequencies below the 5-mc. WWV transmission using harmonic comparison.

First, switch the band setting on the signal generator to include 1 mc. Then care-

fully tune the generator to 1 mc. (or where you'd expect 1 mc. to be), and listen for the zero-beat of the generator's fifth harmonic with the 5.0-mc. WWV transmission.

Harmonic comparison takes advantage of the fact that r.f. oscillators and signal generators usually have a rich harmonic output. When you set your generator to 1 mc., you will probably be able to listen for each whole-numbered harmonic at 2, 3, 4, and 5 mc., etc., and perhaps beyond 125 mc., if your receiver tunes that high.

But what if you accidentally tune your generator to .5 mc.? Wouldn't you get the tenth harmonic at 5 mc. instead of the fifth harmonic of 1 mc.? Absolutely. This is one point you must watch carefully; there are many harmonics that may give zero-beats with WWV. One way to get the approximate frequency of a fundamental is to zero-beat it against a known frequency, for example, a broadcast-band station. Then you can be sure of which harmonic you are beating against WWV.

Crystal-controlled frequency standards can also be calibrated against WWV transmissions. Figure 4 shows two circuits for a 100-kc. crystal-controlled frequency standard. (The transistorized version is described fully in the June '57 issue of POPULAR ELECTRONICS.) You can make minor changes in the frequency of either one by adjusting the variable capacitor.

To calibrate the 100-kc. standard, zero-beat the 100th harmonic of the standard against the 10-mc. WWV transmission. If you get a beat rate of 1 cps, your crystal oscillator will still be within 1/100th cps of 100 kc. But the error multiplies as you go up in frequency. Using the 200th harmonic of your newly calibrated frequency standard, you would be off 2 cps at 20 mc. And you would be off 3 cps at 30 mc. with the 300th harmonic—which is accurate enough for all practical purposes.

Calibrated standards can be used to align that receiver you messed up one day while trying to improve it or they can be used to calibrate the dial settings of a home-made receiver. Just switch on your 100-kc. frequency standard and power up the signal generator which you set to 1 mc. Both the 100-kc. standard and the generator should be calibrated against WWV.

Starting with the first short-wave band above the broadcast band, you can locate 2 mc. with the second harmonic of your

(Continued on page 118)

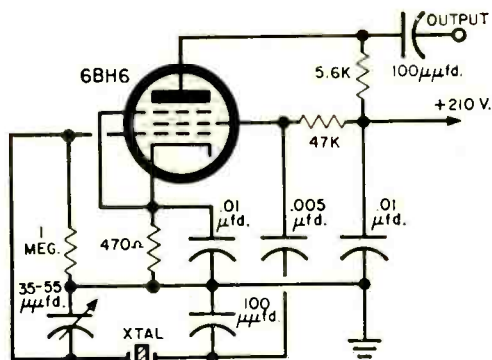

Fig. 4. Each of these crystal-controlled frequency standards (above and below) has a variable capacitor for making very small changes in frequency of oscillation for calibration against WWV. In the transistorized version, RFC1 is a 5-35 mhy. variable choke.

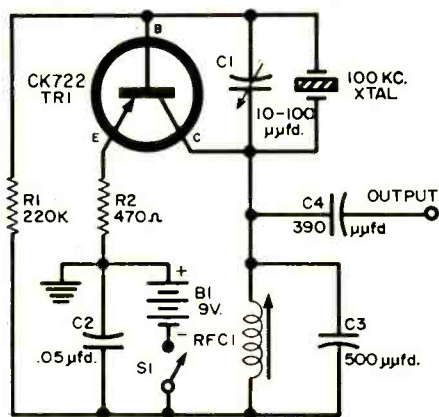
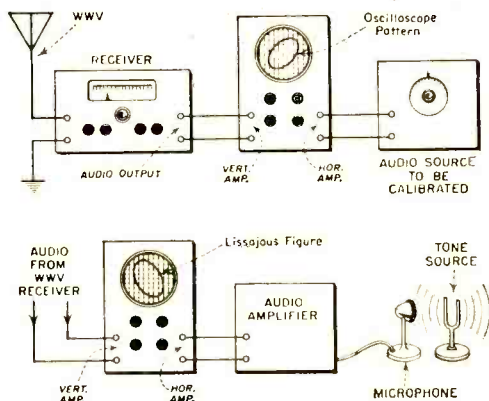

Fig. 5. Audio frequency comparison of WWV's 440- and 600-cps modulation is made by using a cathode-ray oscilloscope and observing Lissajous patterns.



By JIM FAHNESTOCK, W2RQA

**Pull in the DX and cut down
noise and interference with this**

Easy-to-Build Beam Antenna

BEAM ANTENNAS are becoming increasingly popular among users of frequencies above 14 megacycles. While once considered a luxury in amateur radio circles, the beam is rapidly joining the list of necessities as the spectrum becomes more crowded and competition more severe.

Thanks to "do-it-yourself" aluminum, which can be found in almost any hardware store, a ham or short-wave listener can start on a beam for a small investment of tubing and brackets. To squeeze out every possible ounce of performance, let's sacrifice multi-band operation and pick 15 meters, meeting place for veterans and Novices alike.

The dimensions shown in Fig. 1 were chosen for approximately the middle of the c.w. portion of the 15-meter band (21.2 mc.). These dimensions are not extremely critical. For other frequencies, the proper lengths can be calculated using the simple formulas:

$$\begin{aligned} \text{Driven element (in feet)} &= \frac{475}{\text{freq. (mc.)}} \\ \text{Director (in feet)} &= \frac{455}{\text{freq. (mc.)}} \end{aligned}$$

The *gamma* matching bar is a proportionate length.

Construction. The boom is a 6' length of 1 1/4" tubing. (See Fig. 2.) The two center element sections are 8' lengths of 1" tubing and the four end element sections

are 8' lengths of 3/4" tubing telescoped into the center elements. A 1 1/4" x 6' length of tubing serves as a mast. You can substitute a length of 2"x3" lumber for the mast in the initial installation if you wish.

To create a snug fit at the telescope joints, the following procedure is recommended. Take a 6" length of 1" tubing and, with a hacksaw, cut a 3/8" slice along the length of the tube. Then, squeezing the slotted section in a vise, reform the tube by closing the slot. This will create a new piece whose outside diameter corresponds roughly to the inside diameter of the 1" tubing, and whose inside diameter approximates the 3/4" tubing's outside diameter.

After you prepare four such shims, and

Fig. 1. Shield of 52-ohm line is connected to driven element and inner conductor to gamma element via the variable capacitor. To eliminate the box, use a weatherproofed fixed capacitor of optimum value.

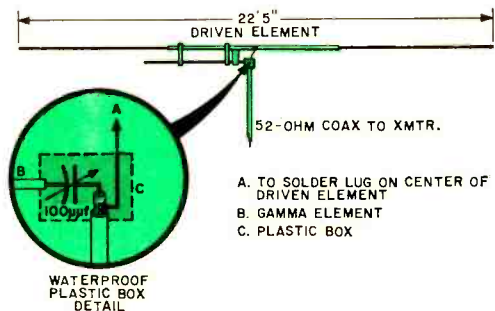

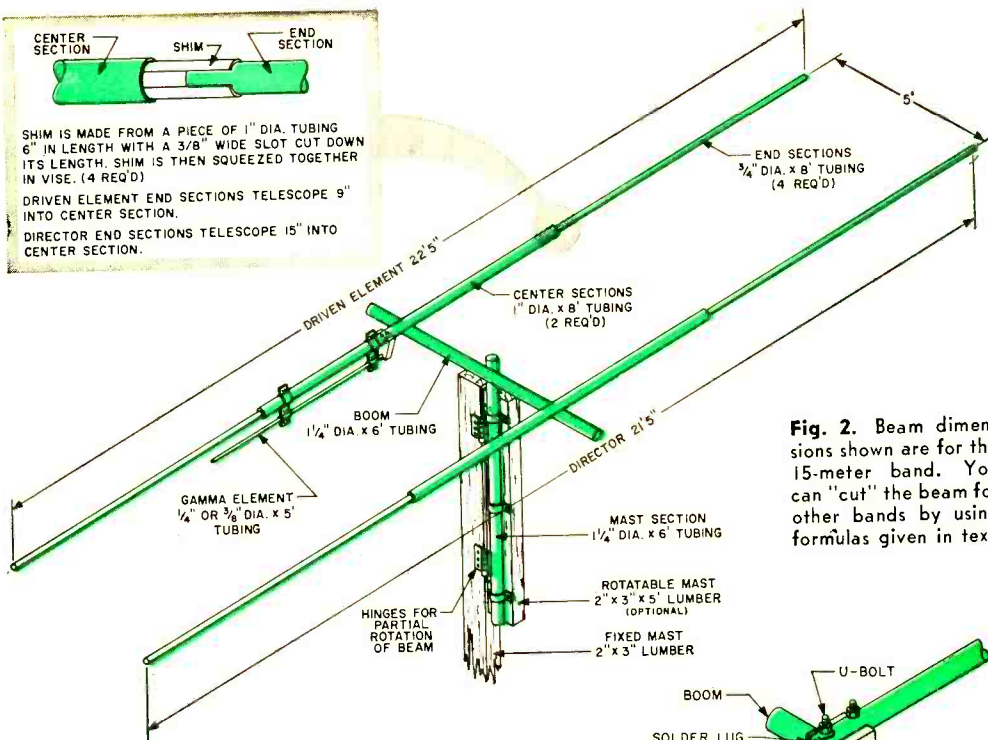
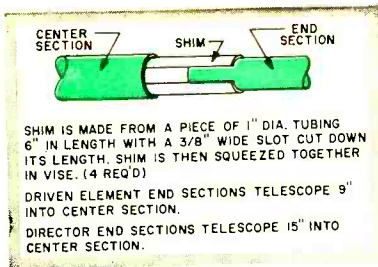
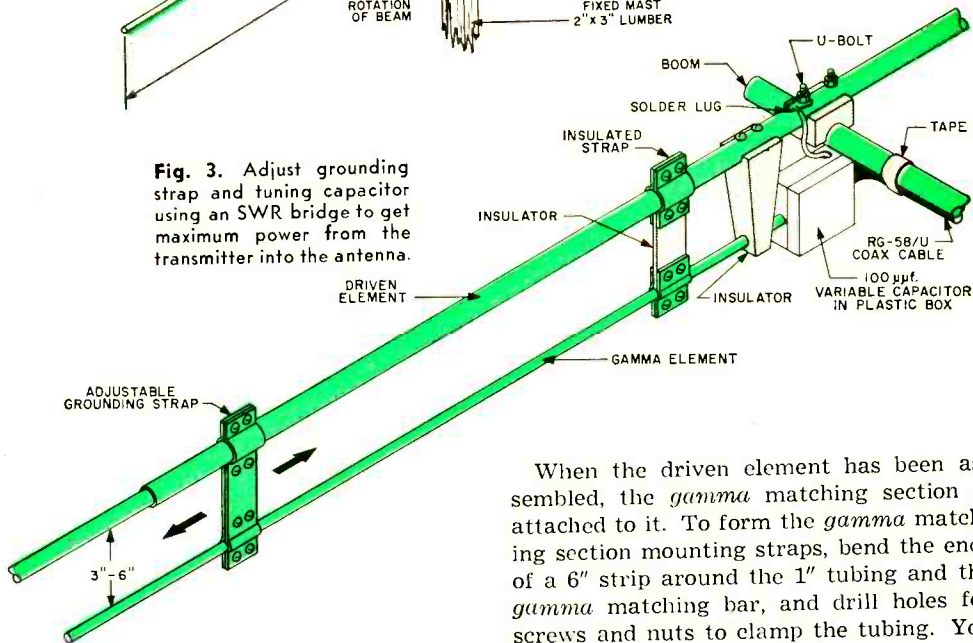

Fig. 2. Beam dimensions shown are for the 15-meter band. You can "cut" the beam for other bands by using formulas given in text.

Fig. 3. Adjust grounding strap and tuning capacitor using an SWR bridge to get maximum power from the transmitter into the antenna.



insert them into the ends of the 8' sections of 1" tubing, then insert the 8' sections of 3/4" tubing into the shims. For the radiator, or driven element, the overlap will be 9", and for the shorter director, the overlap will be 15". The 3/4" end sections can be held firmly in place by several sheet metal screws which are long enough to pass through both pieces of tubing and the shim as well.

When the driven element has been assembled, the *gamma* matching section is attached to it. To form the *gamma* matching section mounting straps, bend the ends of a 6" strip around the 1" tubing and the *gamma* matching bar, and drill holes for screws and nuts to clamp the tubing. You can make the *gamma* matching bar from five feet of 1/4" or 3/8" tubing. The strap on the inner end must be insulated from the driven element, and the insulation must be strong enough to withstand anticipated strain due to wind—its electrical properties are not too critical.

The insulated waterproof box housing the receiving-type 100-μf. variable capacitor can be attached to the boom or the

(Continued on page 122)

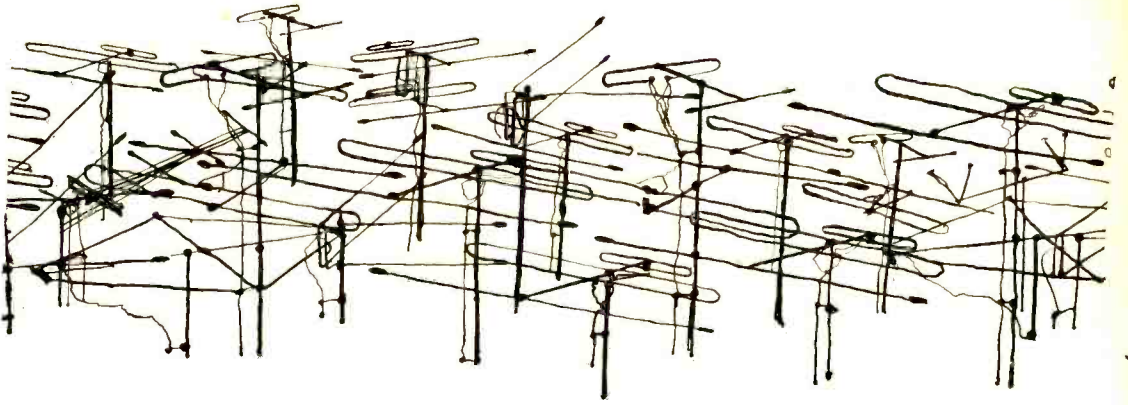

What is a 300-Ohm Line?

WE HEAR a great deal these days about characteristic impedance, which is also sometimes called iterative impedance or surge impedance. What is meant by characteristic impedance? When we speak of 300-ohm twin-lead for TV antennas, just what does the "300-ohm" refer to?

The characteristic impedance of a transmission line is the impedance measured at the input of an infinitely long section of the line. Thus, if we measure the input impedance at some r.f. frequency of a 300-ohm twin-lead several miles long, it will



be found to be approximately 300 ohms. If a short length of transmission line is terminated in an impedance equal to the characteristic impedance of the line, the input impedance to the line will be equal to the characteristic impedance. The above statement is true regardless of frequency. For example, if we connect a 300-ohm resistor across the far end of a 300-ohm twin-



lead 50 feet long, and then measure the impedance at the input, it will be found to be 300 ohms. This is true regardless of the

frequency at which the impedance measurement was made.

However, if the transmission line is terminated in some value other than its characteristic impedance, the input impedance may be widely different from the characteristic impedance, and its value depends greatly upon the length of the transmission line. If the transmission line is one-quarter wavelength long, the results are most striking. In this case, the lower the terminating impedance, the higher the input impedance, and conversely, the higher the terminating impedance, the lower the input impedance. As an extreme case, if the far end of a quarter wavelength line is short-circuited, the input impedance will be extremely high, infinitely high if the line itself was without loss. Or, if the far



end of the quarter wavelength line was left an open circuit, the input impedance would be very low, zero ohms if the line itself was without loss. A line which is any odd mul-



multiple of a quarter wavelength (such as three-fourths wavelength) acts the same as

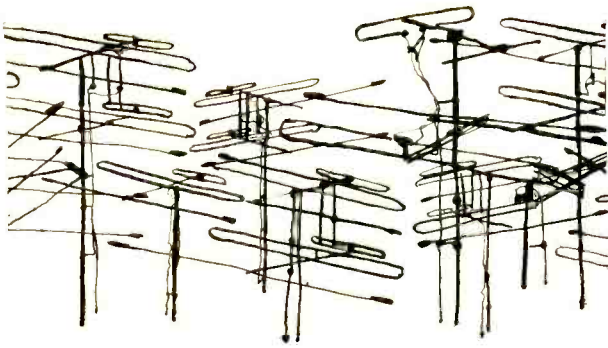

a standard one-quarter wavelength line. When a transmission line is one-half wavelength long (or a multiple of one-half wavelength), the measured input impedance will always be equal to the ter-



minating impedance. When the length of line is between one-quarter wavelength and one-half wavelength, its characteristics will be between those for a quarter wavelength and those for a half wavelength.

Since the input impedance of a line terminated in its characteristic impedance is the same regardless of the length of the line, such a line is called an *untuned* transmission line. When a line is terminated in other than its characteristic impedance, the input impedance depends upon the length of the line, and is therefore called a *tuned* transmission line.

In order to transfer the most energy from a source through a transmission line to a load, each end of the line should be terminated in a load which matches the line impedance. For example, to obtain a maximum signal into a TV set through a 300-ohm twin-lead-in, the line should be connected at one end to an *antenna* with 300 ohms impedance, and at the other end to a *set* with an input impedance of 300 ohms. As each end of the line is terminated in its characteristic impedance, we have an untuned line that can be any length.

—D. L. Geiger
Cleveland Institute
of Radio Electronics

How to Splice 300-Ohm Line

The 300-ohm twin-lead line interconnecting your TV set and antenna is an important link in the circuit. Many times in relocating the set in the house, you will need to splice two lengths of 300-ohm line. Special care must be taken in splicing lead-in outside the house, exposed to the weather. Uninsulated and carelessly made splices might generate noise and introduce line losses, especially in rainy weather. For this reason, it is essential that you know how to make a good splice. If you follow the photos below, your spliced line will be mechanically strong and durable, and as good as new electrically.

—John A. Comstock

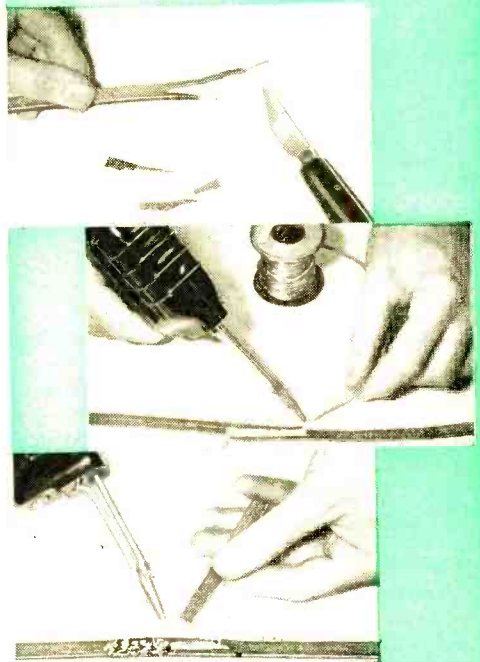

First, cut one end of the 300-ohm line with one conductor about 1" longer than the other. Bare both conductors for about 1/2". Do the same to the other end to be spliced. Next, twist the bare leads together, the short lead of one end and the long lead of the other. Solder the splice with good resin core solder. Finally, insulate the splice using melted plastic from a scrap piece of tape, covering the splice as well as the spaces between it on both sides of the tape.

**Test
Instruments**



the **Audio Generator**

By **LARRY KLEIN**
Technical Editor

Part 1 Wien Bridge Circuit

THE INSTRUMENTS we've discussed so far in this series could all be called "signal measurers." The VOM, VTVM, and oscilloscope, each in its respective fashion, tell you something about the amplitude, shape or frequency of the signal you're checking. But where do these test signals come from?

Some of the signals we know are generated by the instrument under examination. A transmitter is a good example of a device that supplies its own signal to be tested. A TV receiver is another device that supplies a large number of its own internal "test" signals. But you'll find that most electronic devices cannot be accurately adjusted, aligned, calibrated or tested without the aid of some special signal applied from outside. Such a device, logically enough, is called a *signal generator*.

Signal generators can be separated into two major groupings—r.f. types and audio types. Of course, in each group you'll find design variations among the instruments depending upon the particular job to be done. In our discussion of audio generators, which we will take up first, we will mostly confine ourselves to the typical audio test

bench equipment used by the engineer, hobbyist, and service technician for their every-day jobs.

An Inside View. Once you've removed the cabinet of an audio generator (or audio oscillator—the terms are used interchangeably), you may be surprised by the number and variety of tubes the instrument uses. Two popular audio generators and their tube line-ups are shown on pages 55 and 109. Although both of these instruments were designed to do the same job—provide an undistorted sine wave over the audio range and beyond—they take different design paths toward the same objective.

Let's discuss the general theory of operation of the instruments and later go into the details of the specific special features—how they work and what they will do for you on your test bench. The basic questions are: how does a generator produce an audio signal, and what determines its frequency?

First of all, the generator contains an oscillator circuit. Almost all vacuum-tube oscillator circuits have one thing in common: a portion of the output signal is connected back into the input circuit. That

sounds like a definition of feedback, doesn't it? It is feedback, but not the distortion-reducing *negative* feedback that we are familiar with from hi-fi. This kind of feedback is of the *positive* variety.

For comparison purposes, Figs. 1 and 2 show circuits using the two kinds of feedback. Figure 1 is a negative feedback hookup, such as is found in hi-fi amplifiers, and Fig. 2 is the type of positive feedback circuit used in a number of commercial audio oscillators.

Note that the sine waves shown at the various circuit elements in Fig. 2 represent the phase relationships of the signal traveling through the circuit *at any one instant*. If the input signal is a 1000-cps sine wave, for example, at any one moment the wave may be at its peak *positive* voltage and 1/2000 of a second later at its peak *negative* voltage. It is important to remember here that the phase relationships throughout the circuit stay the same as long as the circuit values are unchanged.

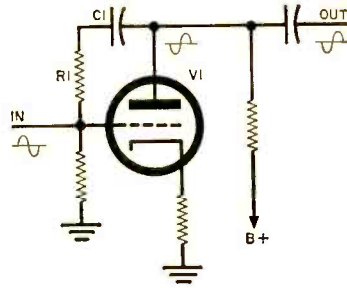

Fig. 1. R_1 and C_1 comprise a negative feedback circuit such as is commonly found in hi-fi amplifiers.

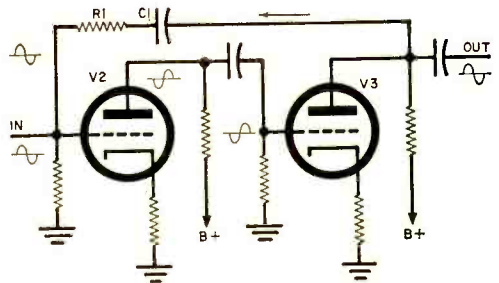
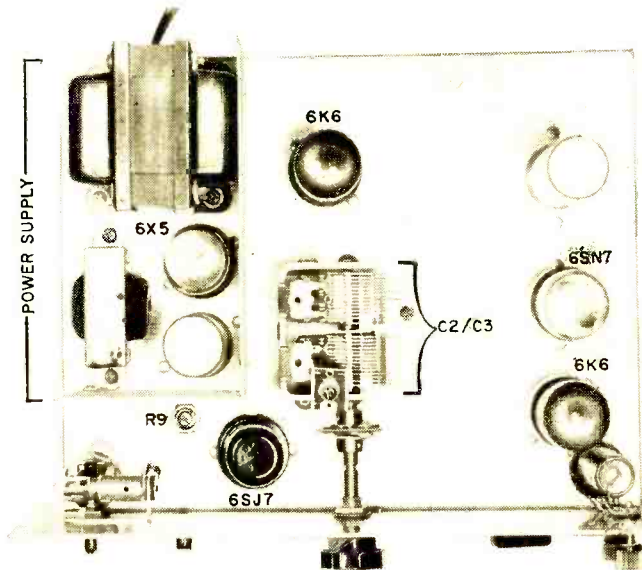

Fig. 2. Positive feedback is applied through C_1 and R_1 . Note phase similarity at V_3 output and V_2 input.



Tube line-up and chassis arrangement of the EICO 377 audio generator. Power supply is shielded from the remainder of the components.

Note that it is the phase relationship between the point in the circuit where the feedback voltage is tapped off and the point where it's reapplied that determines whether the effect of the feedback is positive or negative.

Feedback Phasing. Referring again to Fig. 1, we see that through the normal action of triode V_1 the phase of the input

signal has been flipped from positive-going at the input grid to negative-going at the plate. Resistor R_1 feeds a percentage of the plate signal back to the grid; the exact amount is determined by the ratio of R_1 to the input grid resistor.

Capacitor C_1 has a dual role to play: (1) it blocks the high positive plate voltage from being fed back along with the signal

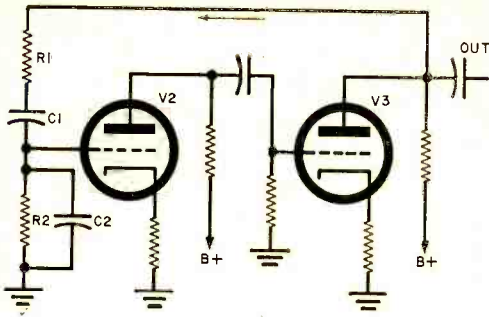

Fig. 3. Positive feedback path with a frequency discriminating network consisting of R1-C1 and R2-C2.

voltage; and (2) it may serve as part of a feedback frequency-determining network. But more on that later. In any case, since the output signal being fed back is opposite in polarity to the signal at the point where it's reapplied, we call the feedback "negative."

Now let's take a look at the positive feedback circuit of Fig. 2. Note that there are *two* amplifying stages; this isn't because more gain is required, but rather because we need the extra tube to "flip" the signal another 180 degrees to bring it back *in phase* at the input. The small sine-wave signals drawn on the schematic, as in Fig. 1, indicate the phase changes that take place from grid to plate. In-phase feedback is called "positive" and, like "negative" feedback, has nothing to do with the polarity of the signal itself (which is going from positive to negative and back again many cycles per second).

We know that negative feedback, along with its advantages in minimizing distortion, improving linearity, etc., reduces the over-all gain of an amplifier stage. Now, let's see what positive feedback does.

Fig. 4. General shape of the response curve resulting from the effect of the series and shunt attenuation action of R1-C1 and R2-C2 when set for 1 kc.

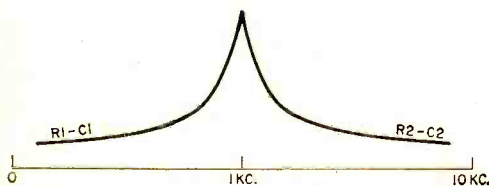

Whereas negative feedback stabilizes a stage, positive feedback tends to introduce instability. You can see that a small signal applied to the grid of V2 (Fig. 2) is going to be amplified and appear as a much larger signal at the plate of V3. When a portion of this beefed-up signal is sent back to the input grid of V2, it adds itself onto the original input signal, is sent through the tubes again, is fed back to V2 again at an even higher amplitude and . . . you can guess where all this leads. The original input signal gets "swamped out" while the amplifier oscillates a signal round and round from input to output and back again.

An Acoustic Example. Let's wander slightly off the subject for a moment in order to provide an illustration of what takes place. The sort of positive feedback loop we've been discussing is perhaps more familiar to you in a different context. Think back to the last time you were at a concert or public event.

The odds are that at one time or another during the program, the p.a. system spontaneously made its own contribution to the proceedings in the form of a small "moan." Or perhaps it tacked on a "ringing" quality to the guest of honor's already rounded tones. And, if the man in charge of the installation didn't reach the amplifier's gain control in time, the p.a. system really took off and howled at the technician who didn't have enough sense to keep the loudspeakers from feeding back into the microphones.

If your memory is good, you'll recall that the frequency of this howl had no relationship to the noise or voice that touched it off. Once the original stimulus was applied, the system oscillated at a frequency of its own choosing. Now the question arises: what determines the frequency of oscillation?

In the case of the p.a. system, the basic frequency of the howl is determined by the acoustics of the hall, and the frequency responses of the microphone, amplifier and loudspeaker. Since p.a. equipment is designed to operate most efficiently in the middle audio frequency band, the howl is usually around 1000 cycles.

Occasionally you'll come across a case of acoustic feedback in a high-fidelity system—usually from the loudspeaker to the pickup arm. Invariably the feedback howl is of a fairly low frequency—in fact, it sounds more like a growl than a howl. It

(Continued on page 108)

By
JOSEPH MARSHALL

INSIDE *the* **Hi-Fi**

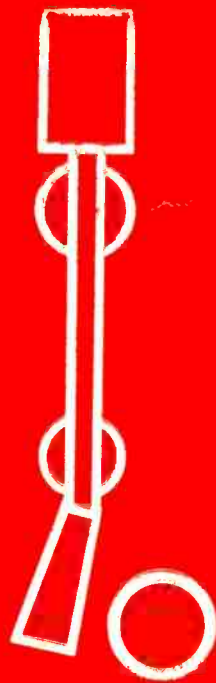

TURNTABLE

AT FIRST GLANCE, it would seem that the design of a good turntable would be a simple enough job. A closer look at the problems involved, however, reveals a number of factors which combine to make the design and production of a really fine turntable one of the toughest of all engineering and manufacturing jobs in the high-fidelity field.

Take the matter of making the turntable

go around. Not only must it turn, but it must turn at a constant and uniform speed. Any variation in rotational speed will cause the pitch of the sound recorded in the grooves to vary. A speed deviation is not serious if it is constant—for instance, if A is played back at 450 or 430 cps instead of 440 cps, most listeners would not know the difference. However, if the speed varies intermittently or cyclically, some very un-

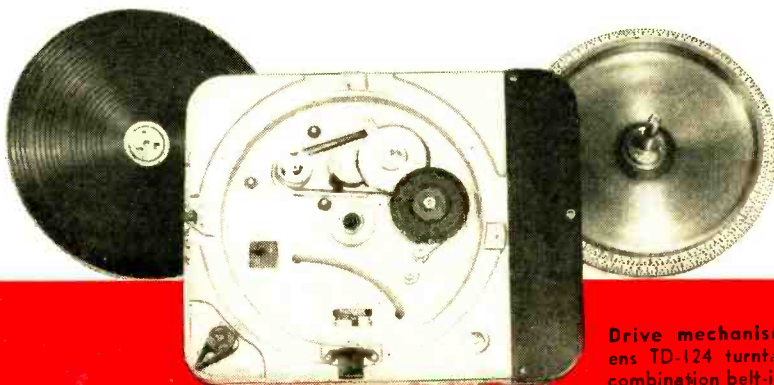

Drive mechanism of Thorens TD-124 turntable uses a combination belt-idler system.

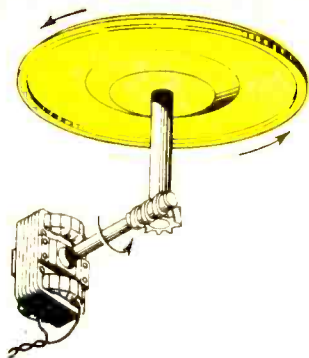

Fig. 1. Direct drive by gear reduction is used in recording turntables which have heavy-duty drive requirements.

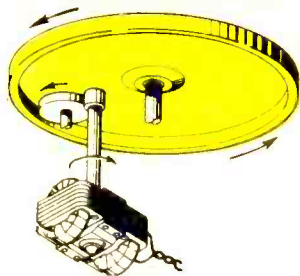

Fig. 2. Inner rim drive by a pulley and idler arrangement is the most popular system among the inexpensive four-speed record players.

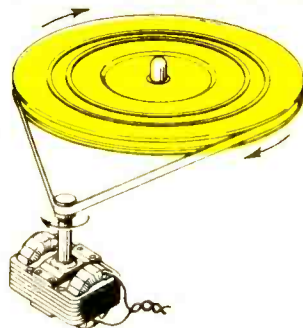

Fig. 3. Direct belt drive is used with several single-speed machines. Belt helps filter out motor vibration transmission.

pleasant effects called *flutter* and *wow* are produced.

Motor Problems. Speed variations can be caused by several things, but the primary difficulty stems from problems inherent in certain types of electrical motors.

The simplest type of motor suitable for driving a turntable is the two-pole induction motor, consisting of an armature placed between two electromagnets. The armature is kicked, or pushed, twice during each revolution—once on the positive half-cycle and once on the negative half-cycle of the 60-cycle alternating current that drives it. In between kicks, it tends to slow down, causing the speed to vary slightly during each revolution. Two-pole motors also have a very high hum field. For these reasons, such motors are used only in inexpensive record players.

The most popular type of motor for high-fidelity turntables is the four-pole motor. Just as a four-cylinder engine is smoother than a 2-cylinder engine, a four-pole motor provides smoother "output" than does a two-pole motor, because the armature receives four pushes every revolution instead of two. Some inconsistencies of speed still exist, however, and it is up to other elements of the turntable to smooth them out.

Variations in speed can be smoothed out to some extent by employing a heavy turntable which acts as a flywheel. When a flywheel is put into motion, it tends to maintain a uniform speed. The mass of the flywheel provides inertia which tends to prevent it from accelerating when it is kicked by the motor or slowing down between kicks. Almost all fine record players use

relatively heavy turntables to make the most of the flywheel effect.

Even better than the four-pole motor is the hysteresis synchronous motor which has the equivalent of a large number of poles and is therefore capable of very smooth performance. This motor has another important advantage over the four-pole motor: *speed accuracy*.

Although the speed of both the hysteresis and the four-pole motor is determined by the frequency of the input voltage, the more uniform a motor's magnetic field, the less likely it is to "skip" when the line voltage decreases. The winding of a hysteresis synchronous motor is so constructed that the rotating magnetic field is extremely even, causing the motor to stay in "synch" with the alternations of the input voltage even though the voltage itself varies appreciably. And since the power companies maintain the frequency of their current with great accuracy, the synchronous motor will run at the same speed even though the line voltage varies considerably. In comparison, the four-pole motor will fall out of "synch" with the input voltage and consequently tend to slow down.

In addition, the hysteresis synchronous motor has an insignificant hum field and, because of its customary better workmanship, its mechanical vibration is quite small. Since this type of motor has so many obvious virtues, it is easy to see why it is used in most of the better turntables. Its only disadvantage is an economic one: it is rather expensive.

Drive Systems. Several interesting problems arise in coupling the motor to the

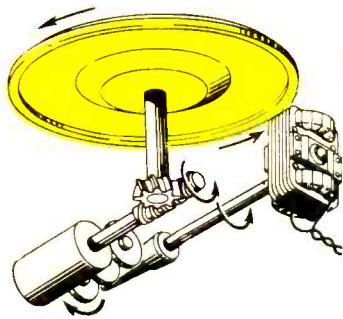

Fig. 4. Combination of gear and idler drive is used by Scott for optimum isolation of the platter from mechanical operating noise.

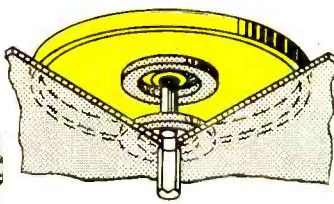

Fig. 5. New design by Pickering incorporates two magnetic rings which serve to float the turntable platter in its bearing well.

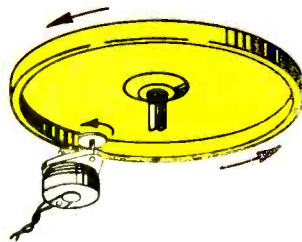

Fig. 6. Direct drive by live-rubber pulley fitted on the shaft of a clock-type motor is a feature of the Weathers turntable.

turntable. Since the armatures of most turntable motors revolve at a speed of about 1800 rpm, some kind of speed-reducing device between the motor and the turntable must be provided to make the turntable revolve at 78, 45, 33 $\frac{1}{4}$, or 16 rpm.

One way to do this is to use a system of gears similar to those in an automobile transmission system. See Fig. 1. This method is used with recording lathes and some broadcast studio record players but is seldom found in home-type turntables because the precision-cut gears required are quite expensive. For a time, though, all Thorens record players used gear drive exclusively.

A far simpler approach to the problem of designing a drive system is to employ an *idler* wheel as the link between the motor and the turntable. The motor shaft turns the idler and the idler in turn drives the turntable. See Fig. 2. By choosing the proper diameters of motor shaft, idler, and turntable, it is easy to make the turntable revolve at any desired speed; and by putting a stepped pulley on the motor shaft, different speeds can be achieved by switching the idler to the "step" with the appropriate diameter.

Rumble. A phono pickup translates minute mechanical vibrations into an electric current. If any motor vibration is transmitted to the stylus, the pickup will generate an output signal in accordance with the vibration of the motor—usually in the frequency range of 25-35 cps. This unwanted signal, called *rumble*, is amplified and reproduced through the loudspeaker. Not only is rumble annoying in itself, but

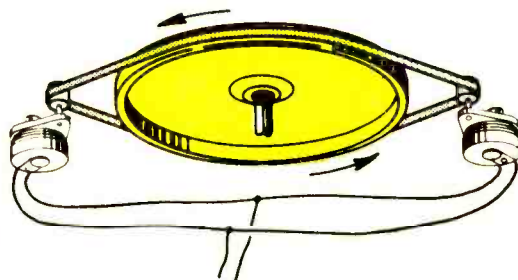

Fig. 7. Dual light-weight motors and a belt drive are part of the novel design of the new Stromberg-Carlson PR-500.

it also can distort the higher frequencies through the process of intermodulation.

Paradoxically, rumble presents less of a problem with cheap reproducing systems since a 30-cps signal can't be reproduced efficiently. In the better systems, however, rumble is difficult to eliminate once it is generated in the system. Rumble filters, to have any effect at 30 cycles, have to start cutting off frequencies two or three octaves higher; most of them start rolling off the bass response at around 100 cycles.

Obviously, the use of a rumble filter entails the loss of a substantial part of the system's bass response. It is clear that if we want to hear real bass without the intrusion of rumble, we have to deal with it at its source—by eliminating motor vibration, or at least preventing it from getting to the pickup.

Isolating Vibration. The first step in keeping rumble out of a system is to use a motor with little vibration; a four-pole

motor has less vibration than a two-pole motor and a hysteresis synchronous motor has less than a four-pole motor. The next step is to get rid of any remaining vibration before it reaches the pickup. This can be done by damping it out mechanically. Rubber, for example, offers high resistance to the passage of vibration. Thus, a rubber-tired idler wheel not only serves as a transmission link but also as a vibration-absorbing element.

The use of belt drive is another means of isolating motor vibrations. As the motor of a belt-driven unit is usually mounted at a distance from the turntable, less vibration is likely to be transmitted through the turntable base than in the idler-wheel drive system. Also, the belt is an exceedingly good vibration damper. Practically all motor vibration is dissipated in the belt and thus is not transmitted to the turntable. See Fig. 3. Users of belt drive include Gray, Components, and Rek-O-Kut (in single-speed models).

Motor vibration is communicated not only through the drive system but also through any solid materials which are common to the motor and the turntable. Consequently, the motor and the turntable must be isolated as much as possible. One way of doing this is to mount the motor and/or the turntable on springs or on rubber damping elements.

Perhaps the most elaborate system of damping is featured by the Scott turntable. Here, the motor and the turntable are mounted on separate platforms supported by vibration-absorbing springs and damping pads. The drive system is also designed to prevent the transmission of vibration; the idler wheels are made of vibration-absorbing synthetic rubber and the shaft between the turntable and the idlers incorporates two damping elements. See Fig. 4.

A unique and interesting anti-rumble design is used in the Pickering "Gyropoise" turntable. The engineers at Pickering figured that they would eliminate rumble by literally floating the turntable in air. This they did by installing a powerful ring magnet on the underside of the turntable and an opposing ring magnet on the mounting plate. The two magnets push against each other with such force that the turntable shaft never touches the bottom of the shaft bearing; as a matter of fact, all the turntable shaft does is center the turntable. No vertical vibration is transmitted to the

turntable because it is absorbed in the magnetic suspension system. See Fig. 5.

Such heroic methods are needed because stereo pickups are far more sensitive to rumble than are monophonic pickups. Since mono cartridges respond only slightly to vertical vibration, vertical rumble is not a problem with mono pickups. But stereo pickups are sensitive to both vertical and lateral vibration.

The rumble problem is aggravated by the exceptionally good low-frequency responses of the newer speaker systems. Whereas a few years ago few speakers could reproduce 30 cycles, today many systems go down this low. Consequently, to get the most enjoyment out of these speakers, rumble must be reduced to a minimum.

Rules and Exceptions. Generally speaking, a four-pole motor produces less rumble than a two-pole motor, and a hysteresis synchronous motor less than a four-pole motor. And, as a rule, belt drive results in less rumble than idler drive, and a turntable with a heavy table will have a more constant speed than one with a lighter table. But in actual fact, none of these elements is in itself determining.

The Scott turntable, for example, uses a four-pole motor instead of a hysteresis synchronous one and a combination of idler and gear drive; yet it achieves a noise figure as good as some turntables which use a hysteresis synchronous motor and belt drive. Another example of hybrid design is the highly successful Thorens TD-124. This unit, shown partly disassembled in the photo on page 57, uses a combination of idler wheel and belt drive. The manufacturer claims that the TD-124 embodies the best characteristics of both types of drive. Here, as in everything else, there are many roads to perfection; different engineers may use different design approaches to achieve similar results.

For instance, Paul Weathers broke all the rules when he designed his turntable. We have noted that the flywheel effect is a useful device for maintaining constant speed, and therefore most designers use heavy turntables to obtain a good flywheel effect. A heavy turntable requires a bigger motor which in turn produces more vibration, thus complicating the rumble problem. Weathers, however, uses an extremely light turntable—a stamping of thin aluminum. He drives it with a tiny clock-type

(Continued on page 111)

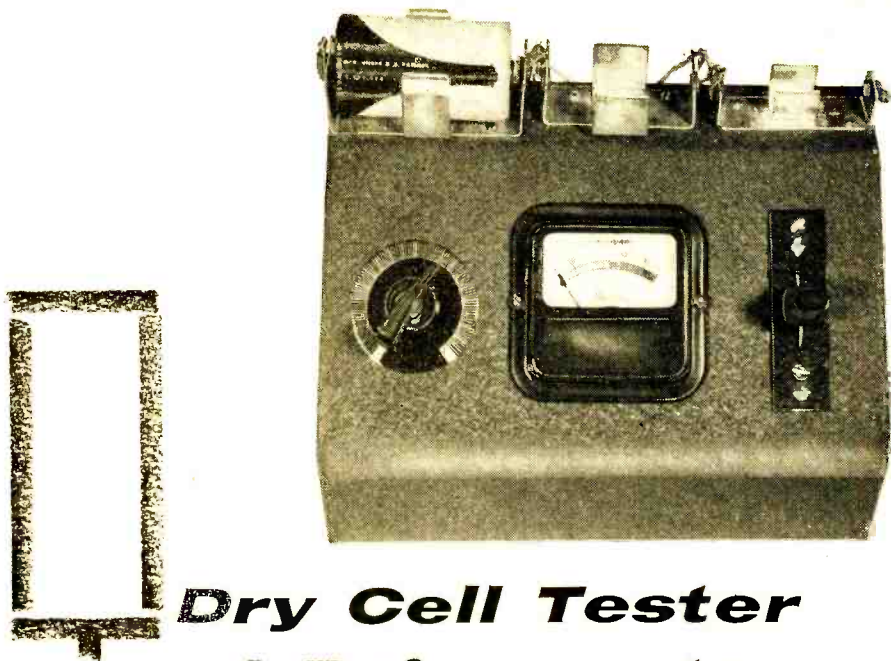

Dry Cell Tester and Rejuvenator

Simple circuit functions as
Fountain of Youth for run-down 1½-volt dry cells

By JAMES E. MURPHY



SMALL 1½-volt dry cells, originally developed for flashlight service, are finding increasing use in children's toys, transistor radios, and all sorts of electronic gadgets. Since the life of these units is limited, a simple recharging or rejuvenating method can result in real savings.

Rejuvenation circuits of the simpler variety include a small transformer, a rectifier, and a fixed resistor. More complicated circuits have a means of varying the charging rate, and a meter to read the charging current. In some cases, a small amount of unrectified a.c. is passed through the cell, since this appears to improve performance, probably by providing a sort of mixing or stirring action within the cell during charging. The unit described here includes all of these features.

One problem immediately presents itself to anyone who tries to rejuvenate dry cells: there is no way to determine how weak a cell may be, other than by trying it out in a flashlight or other apparatus.

During the rejuvenation period, the same problem arises: there is no simple method for determining just when the cell has been brought back to its original condition.

With this rejuvenator, a flick of the switch indicates on the meter the exact condition of the cell. If the cell is below par, but not too far gone, the switch can be flicked to another position, and the rejuvenation process started. The charging rate, which is adjustable, is read from the same meter. The condition of the cell during the rejuvenation can be checked at any time by merely moving the switch to the test position. If more charging is needed, the switch is moved back to the charge position. All this can be done without removing the cell from the holder.

Construction is quite simple. Almost any type of cabinet, even a cigar box, can be used. Holes for the meter (*M1*) and function switch (*S1*) are drilled and all parts mounted except *S1* and the calibrating control (*R2*). Switch *S1* is wired before

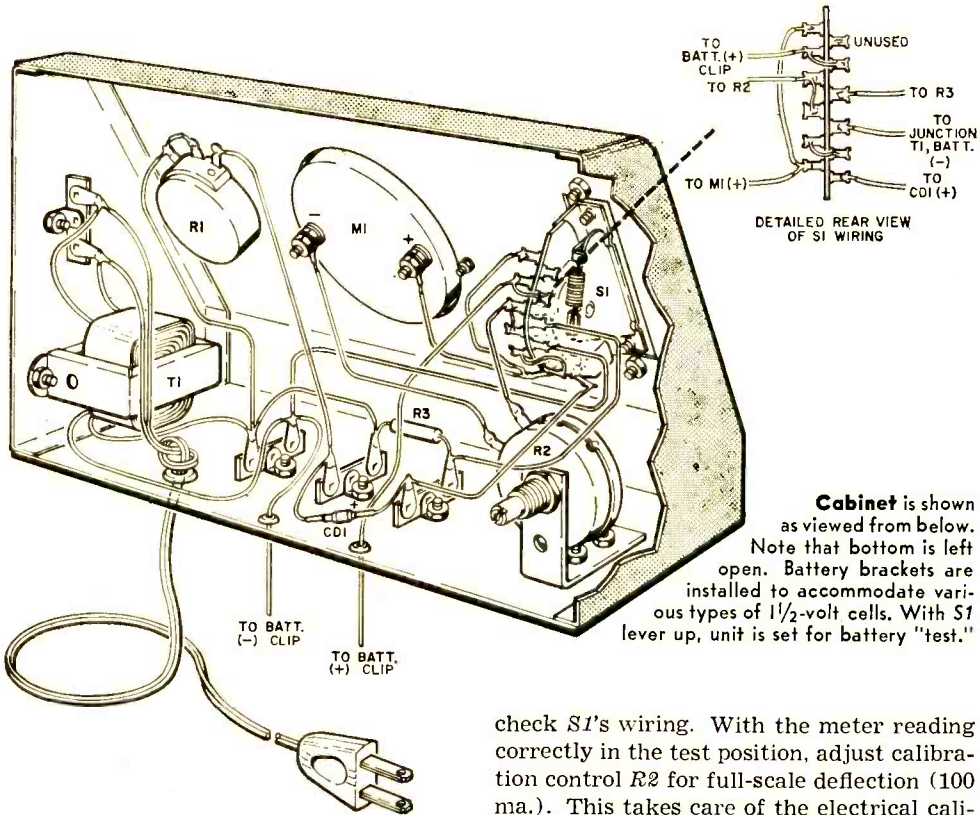

Cabinet is shown as viewed from below. Note that bottom is left open. Battery brackets are installed to accommodate various types of 1½-volt cells. With *S1* lever up, unit is set for battery "test."

mounting, leaving long leads where necessary to connect to other parts; *R2* is left till the last to allow room for mounting *S1*.

Wiring should present no difficulties, but be sure to observe the correct polarity of the meter and the diode (*CD1*). The three cell holders are wired in parallel with the wires brought through holes in the back of the case.

Testing and calibration of the completed unit must be done with a fresh size D cell in the appropriate holder. Plug in the line cord, and set *S1* to the charge position. The meter should read upscale. If it reads downscale, reverse the diode. Set the charging rate for about 20 ma., as read on the meter, and then reverse the cell in the holder. The meter will now read either higher or lower.

The position which gives the *lowest* reading is the correct position. Mark the terminal contacted by the positive pole of the cell with red fingernail polish and use the same polarity with all cells for both charging and testing.

Move *S1* to the test position. The meter should read upscale. If it reads downscale,

check *S1*'s wiring. With the meter reading correctly in the test position, adjust calibration control *R2* for full-scale deflection (100 ma.). This takes care of the electrical calibration, but the calibration of the meter scale to read *Good-Weak-Reject* requires a bit of calculation.

Since the current, as read on the meter, is 100 ma. (0.1 ampere), and the cell voltage is 1.5 volts, Ohm's law indicates that the combined resistance of the meter and *R2* is 15 ohms. (The internal resistance of a fresh cell is too small to take into consideration.) From this information, it is possible to calculate the power furnished by the fresh cell to the 15-ohm load using $P=I^2R$. The answer (*P*) is found to be 0.15 watt.

Let's say that a cell which can deliver 75% or better of full power to a 15-ohm load is okay; one which delivers 50% to 75% is weak; and one which delivers less than 50% is no longer usable. With a little algebra, the formula for watts can be converted into a form which allows the watts to be converted into milliamperes.

% Power	Watts	Ma.
100	0.150	100
75	0.113	87
50	0.075	71

If we now carefully remove the cover from the meter, and color the region be-

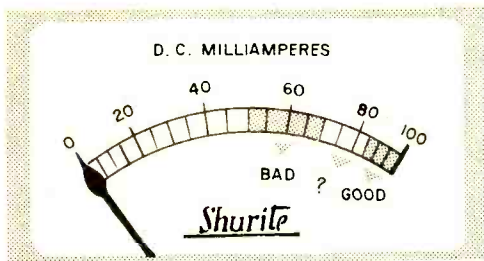

Meter movement face should be color-coded for direct reading of battery's condition. Charging current is read on 100-ma. scale.

tween 87 and 100 on the scale with green ink, the region from 71 to 87 with yellow ink, and from 50 to 71 with red ink, the relation of these colored regions to the *Good-Weak-Reject* condition of a cell under test becomes obvious.

Operation of the instrument is simple. Just place a cell in the proper holder, observing the correct polarity. If the meter reads full scale with the selector switch in the test position, the cell is okay. If the reading is less than full scale, but in the *Good* or *Weak* region, move *S1* to the charge position; this will automatically start the

HOW IT WORKS

In the charge position, the a.c. which has been rectified by diode *CD1* to d.c. is passed through the cell (via sections *a* and *b* of *S1*, and meter *M1*) in a direction opposite to the cell's normal current flow. This current causes a reversal of some of the chemical reactions which are responsible for the normal activity of the cell, and thus serves to extend the life of the cell.

In the test position, *CD1* is disconnected from the cell and the meter, and the cell is reconnected to the meter so that the normal current from the cell flows through the meter and calibrating control *R2*. Since the direction of this current is opposite to the direction of the charging current, sections *c* and *d* of *S1* reverse the meter connections.

Control *R2* is used to calibrate *M1* for full-scale deflection with a fresh cell. Potentiometer *R1* adjusts the charging current through the cell.

Function switch *S1* is shown in the charge position. Any small 6.3-volt filament transformer will be suitable for use as *T1*.

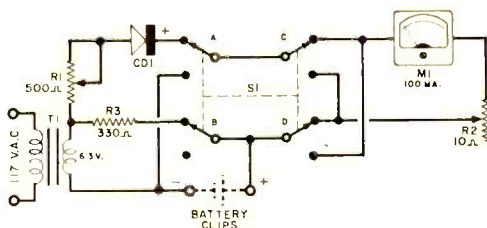

PARTS LIST

- CD1*—1N56 or 1N34A crystal diode (see text)
- M1*—100-ma. meter (Shurite Model 950)
- R1*—500-ohm, 2-watt wire-wound potentiometer (Mallory Type R500L or equivalent)
- R2*—10-ohm, 2-watt wire-wound calibrating control (Mallory Type M10RK or equivalent)
- R3*—330-ohm, 1/2-watt resistor
- S1*—4-p.d.t. lever switch (Centralab #1458 or equivalent)
- T1*—6.3-volt filament transformer
- 1—4" x 4 1/2" x 7" sloping front cabinet (Bud C1609)
- Misc. dry cell holders, terminal strips, pointer knob, hardware

charging cycle, and the charging rate can be adjusted by *R1* and read from the original 0-100 meter scale.

The charging rate is a matter of considerable controversy, but is limited in this case to 50 ma. by the maximum rating of *CD1*. Within reason, the charging rate is limited by the amount of heating of the cell being charged, and a high rate can be used as long as the cell does not get too warm. A charging rate of 100 ma. can be obtained by installing two diodes in parallel. Some writers, however, recommend only 10 to 20 ma. There is a considerable range here for individual experimentation. In any case, do not expect quick results; a charging time of several hours will be required for most cells.

Substitution of parts other than those indicated may be made. For example, almost any of the low-voltage germanium or silicon diodes can be used. The 100-ma. meter specified represents about the best load for testing size D cells, but any meter with a full-scale reading of 50 to 200 ma. will be satisfactory. Some of the low-priced meters may have too high an internal resistance to give full-scale deflection with 1.5 volts; such a meter can be employed but the maximum power point will have to be calculated from the maximum deflection obtained with a fresh cell. The more expensive moving-coil meters have very low resistance, and calibrating control *R2* will have to be increased to 20 to 25 ohms if a meter of this type is used.

Charging several cells at once, in series or parallel, is practical if the cells are similar in age and condition, and are all the same size. The circuit given here is suitable for parallel charging, but remember that the current read on the meter will divide among the cells in parallel, so that charging two cells in parallel at 50 ma. is the same as charging one at 25 ma. —30—

AUDIO AIDS

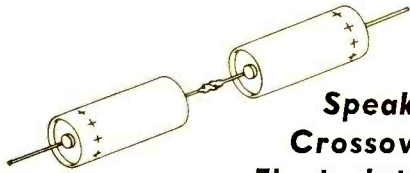



Speaker Crossover Electrolytics

The use of standard electrolytics in speaker crossover networks as a method of obtaining high capacitance at low cost has a drawback. Unlike non-polarized paper or oil capacitors, electrolytics require a high percentage of their operating voltage to charge themselves to their rated capacity. The new miniature, low-voltage electrolytics are the answer. Two 10-15 volt, 20- μ f. capacitors, mounted back to back to provide 10 μ f. in a crossover, perform within 3 db of a 10- μ f. oil capacitor.

—B. E. Wrigley

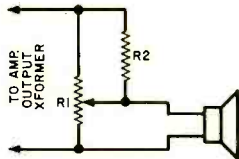
"P"-Pad Speaker Control



The "P" pad is a single-potentiometer loudspeaker volume control. Like its more expensive dual-pot counterparts, it retains a fairly constant impedance to the amplifier even though the speaker may be completely shunted out of the circuit. Potentiometer R_1 and R_2 should have approximately double the resistance of the speaker, and at least a four-watt rating. Note that it's always preferable to control speaker volume at the amplifier rather than with a remote pad.

—Glenn A. Towill

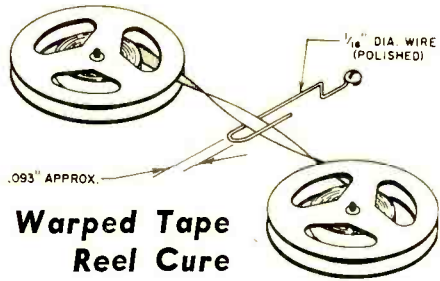

Warped Tape Reel Cure

Warped tape recorder reels can generate considerable noise due to the tape dragging over the outer reel edge. By threading the tape through a looped wire with about a $\frac{1}{16}$ " gap, you can put a quarter-twist in the tape and keep it clear of the reel edge. Do not use an iron or steel wire because of the possibility of magnetization.

—Charles W. Bittner

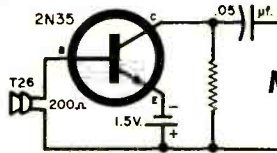

Carbon Microphone Input

A transformerless matching hookup for a carbon microphone can be obtained with the circuit shown above. A 2N35 $n-p-n$ transistor is used but the equivalent $p-n-p$ job will serve if the battery polarity is reversed. The mike is an Army surplus T-26 carbon-button type of about 200 ohms but others will work as well. Depending upon the gain of the transistor, this circuit arrangement will give about the same output as a crystal microphone. Experiment with the value of the collector resistor, selecting the resistance that provides the best results in terms of distortion and gain.

—Robert B. Hoy

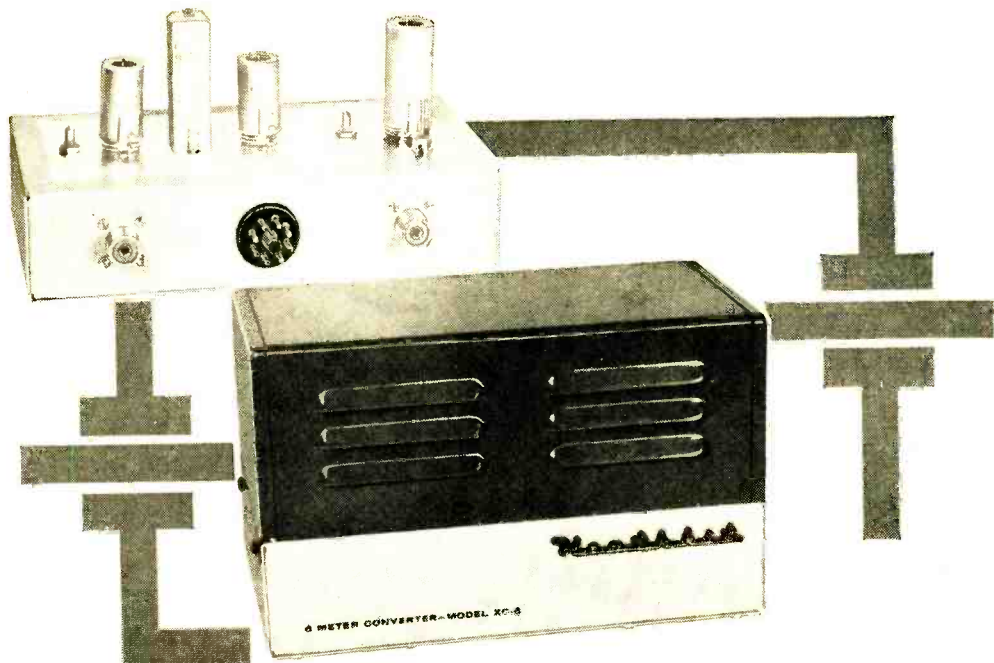

Expand your ham coverage with this Heathkit Model XC-6

Six-Meter Converter

EVERY NIGHT on six meters hams all over the country are enjoying rag-chews, making new friends, and swapping information on how to increase their DX. With band openings extending beyond the line-of-sight capabilities of six meters to hundreds and even thousands of miles, more and more hams are getting their 50-mc. WAS (Worked All States).

You can join the gang "on six" with the neat little Model XC-6 crystal-controlled six-meter converter kit which is available from the Heath Company (Benton Harbor, Mich.) for \$32.75. Although designed primarily for use with the Heath "Mohawk" receiver, this 9" x 5 $\frac{1}{4}$ " x 4 $\frac{3}{4}$ " unit can be operated with any receiver tuning 22 to 26 mc. A signal-to-noise ratio of 8 db is possible with only 1 microvolt from the antenna.

Circuit Highlights. Two high-gain pentode stages are followed by a dual-section triode mixer-oscillator. Tube noise, usually more important than background QRN in v.h.f. converters, barely makes itself heard on six meters, so that slightly noisier pentode r.f. stages can be used instead of the

quieter, less stable cascode stages which are a must on two meters.

Standard coaxial input and output jacks on the rear panel terminate the 52-ohm input and output impedance. If your receiver has an input impedance in the 300-ohm region, the mismatch between receiver and converter should not result in very much loss. The converter's input impedance will match most commercial antennas.

A shielded r.f. transformer between the first and second r.f. stage eliminates feed-through of signals in the i.f. bandpass as well as v.h.f. images. The first r.f. stage and r.f. transformer are shown in the schematic diagram on the following page. An external r.f. gain control consisting of a single potentiometer may be used with this stage. Or you can ground the cathode resistor (*R1*) for maximum r.f. gain. The remaining circuitry is standard and the kit is supplied with tubes and a 28-mc. third overtone crystal for operation in the 22 to 26 mc. i.f. range.

Power requirements are so low—6.3 volts a.c. at .65 ampere and 210 volts d.c. at 35 ma.—that almost any receiver could be

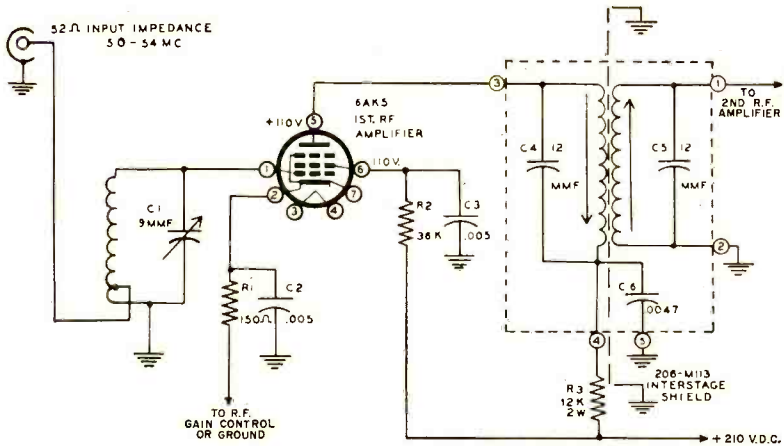

First r.f. stage of converter features a shielded r.f. transformer which reduces i.f. feedthrough and v.h.f. images.

tapped for B+ and heater current without ill effects. The rear panel of the converter mounts an octal power plug, and material for a handy power cable is supplied so you can plug right into the accessory jack of your receiver. Heath also provides a one-yard length of coax and a couple of male coax connectors to couple the receiver to the converter. If your receiver doesn't already have a coaxial female antenna jack, it would be well worth your while to install one.

Assembly. The layout under the chassis leaves enough room for a fellow with a big pair of "mitts" to move around. Pre-cut coil stock and slug-tuned inductors simplify wiring.

A sheet metal wall divides the underside of the chassis, separating the first r.f. stage from the rest of the circuitry. Tiny sheet metal walls are also supplied for each r.f. stage; they are mounted across the

tube socket base and serve to shield the input and output circuits.

Midget ceramic variable capacitors and ceramic tube sockets are used throughout. The 28-mc. crystal uses no socket and is simply wired in by its leads. With the bottom plate secured and the good-looking blue-gray cover on, the Model XC-6 looks better than many factory-built jobs and certainly performs as well.

If you've never heard a converter in action, the results obtained with this Heath unit will amaze you. Some of us are lucky enough to have a six-meter band on our receivers but most older single-conversion sets don't work well on six meters. Using the converter with one of these older receivers gives the image rejection characteristic of double conversion receivers.

Remember, if you can hear 'em, you can work 'em; and with this XC-6 converter, you can.

-30-

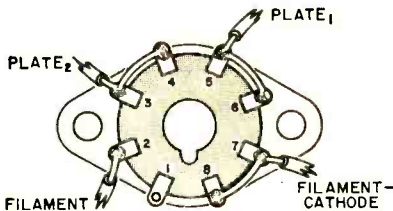

Universal Rectifier Tube Socket

Here is a useful modification for the rectifier tube socket in your power supply. If jumpers are wired on the socket of the octal rectifier tube as shown, you will find that a number of different rectifier tube types will operate in the socket. This is handy if you've blown a tube and don't have the exact replacement.

Connect three jumpers between each of the following pairs of pins, leaving all other wiring intact: pins 3 and 4; 5 and 6; 7 and 8. For the 5-volt rectifier in your set you will be able to use any of the following tubes: 5R4, 5T4, 5U4, 5V4, 5W4, 5Y3, 5Z4, 5AX4, 5AZ4, and 5931.

—Manuel A. Moreno

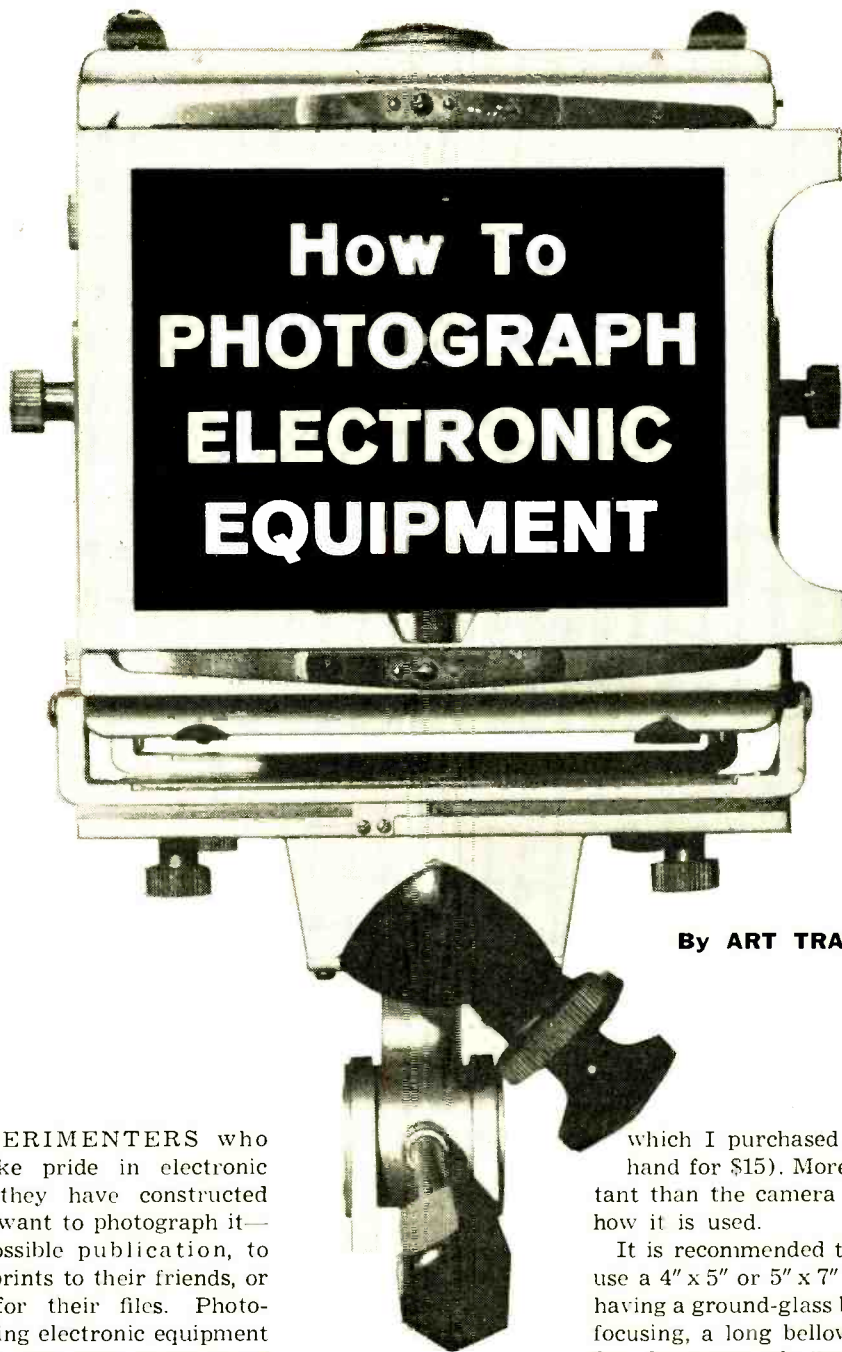

By ART TRAUFFER

EXPERIMENTERS who take pride in electronic gear they have constructed often want to photograph it—for possible publication, to send prints to their friends, or just for their files. Photographing electronic equipment is not easy, but there are a number of factors involved which, once understood, greatly increase the chances of obtaining good results.

Basic Equipment. The primary requirement is a suitable camera and lens. These need not be expensive (for years, I have made all my photos with an old 5" x 7" view camera with an anastigmatic lens,

which I purchased second-hand for \$15). More important than the camera itself is how it is used.

It is recommended that you use a 4" x 5" or 5" x 7" camera having a ground-glass back for focusing, a long bellows draw for close-up work, and a tilting-and-swinging back and lensboard adjustments for perspective control. This is a super setup that almost guarantees optimum results. However, twin-lens 2¼" x 2¼" reflex cameras equipped with parallax correcting close-up lenses will do a terrific job if used properly. The inexpensive models available from Lafayette Radio,

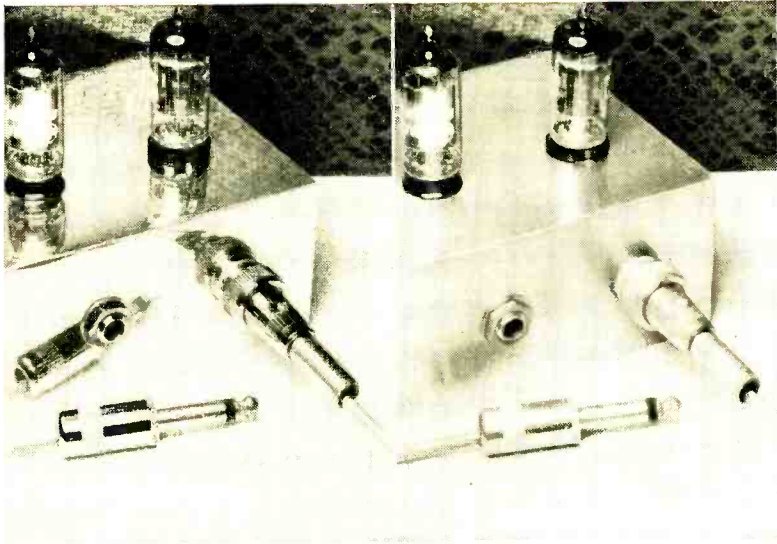

1 Photo of polished aluminum chassis and connectors made in the usual manner. Reflections on chassis and plugs confuse detail.

2 Same equipment as in Photo 1, with lighting unchanged but with shine taken off parts. Note reduction in reflections and better detail.

Radio Shack and others are suitable for equipment photography. A 35-mm. camera is less suitable because the necessary enlargements are frequently grainy.

An anastigmatic lens is recommended, but many of the older and cheaper "rapid rectilinear" lenses will produce sparkling photos with surprisingly good definition. Fast lenses and shutters are not required because the lens is generally closed down to minimum aperture in order to achieve maximum depth of field.

Films and Paper. Panchromatic films are recommended because they do a good job of color rendition; that is, they reproduce colors in their proper shades of gray. My favorite films are Eastman Kodak Portrait Panchromatic, Super Panchro-Press, and Royal Pan, the speeds of which range from medium-fast to very-fast. For $2\frac{1}{4} \times 2\frac{1}{4}$ " cameras, Kodak Verichrome Pan or Panatomic-X will work well, depending on the film speed desired.

Photos intended for publication should be printed on glossy paper and should be at least 5×7 " in size, but 4×5 " prints are sometimes usable if they are sharp.

Prints and enlargements should be a little on the "contrasty" side because they soften up a little in being processed for publication. However, soft prints show more detail in highlights and shadows. If

in doubt, include a soft print and a contrasty print from the same negative and let the editors decide between them.

For film developing, I use Eastman DK-50 full-strength, and I develop my films in a tray by the time-and-temperature method. For paper developing, I use Eastman Dektol, one part stock to two parts water.

Controlling Reflections. One thing that makes electronics gear difficult to photograph is the predominance of bright metal parts such as plated or polished steel or aluminum chassis, screw-heads and nuts, chrome-plated plugs and connectors, etc. When you are building a piece of electronics gear which will be photographed for publication, it's a good idea to avoid shiny metal parts. When such parts must be used, they can be "toned down" by various methods to reduce reflections.

Photo 1 shows a polished aluminum chassis and a pair of chrome-plated connectors. Note the annoying highlights and reflections which spoil the detail.

Photo 2 shows the same equipment with lighting unchanged, but here the polish was taken off the aluminum chassis by rubbing it with a damp cloth and kitchen scouring powder (Ajax). The chrome-plated connectors were patted lightly and evenly with ordinary glazier's putty to put a dull film

(Continued on page 114)

SINCE the introduction of the transistor, the semiconductor industry has produced a miscellany of fascinating devices from double-anode Zener diodes to multiple-layer solid thyratrons. While the technician, serviceman or experimenter is interested in such new developments, he seldom finds them adaptable to his personal needs. In a great many of the cases where they do apply, their cost is prohibitive. But the "Stabistor," still another addition to the growing semiconductor list, is an inexpensive device with application possibilities that are endless.

The Stabistor is a diode designed to "break over" and conduct at a certain voltage. This is the normal forward conduction of a diode also characteristic of Zener diodes which *avalanche* into conduction when a breakdown (backward) voltage is exceeded. Figure 1 (on next page) shows the characteristics of three

the "break over" potential and then it is practically a "short."

How can we use this feature? Well, why not put the Stabistor *across* a sensitive meter and let it work as an overload protection device. You'll remember that fuses are put in *series* with the loads they protect. But in the case of the Stabistor, the infinite resistance characteristic below the "break over" voltage will not affect the meter reading when the Stabistor is *across* the meter. When the voltage applied to the meter becomes high enough to damage it, the Stabistor will start conducting and "bypass" the excessive current, thus protecting the meter.

You can use a pair of Stabistors connected in parallel and back-to-back across the meter movement as shown in Fig. 2 to build a burn-out-proof voltmeter. This arrangement of Stabistors has the added advantage of protecting

The Stabistor Diode

By
R. J. SHAUGHNESSY

**One of the newest members of
the semiconductor family, the Stabistor
has many interesting and practical applications**

Stabistors presently available from the manufacturer (Transitron Electronic Corp., 168 Albion St., Wakefield, Mass.).

You can see that each curve strikes the voltage axis at a small positive voltage, approximately 0.2, 0.4, 0.6 volt, depending on the Stabistor. Below these voltages the Stabistors do not conduct, as shown by the zero voltage line crossing the zero current line. This means that a Stabistor's junction is an open circuit until the voltage across it reaches

the movement against any damage that might result from an accidental reversal of the test leads.

Or you can build an interesting temperature-sensitive bridge using a Stabistor as the sensing element, as shown in Fig. 3. Voltages E1 and E2 are within a few millivolts of each other and a temperature change in the sensing Stabistor causes a linear voltage change across the output terminals. Possible uses for such a bridge include probing

Fig. 1. Stabistor characteristic curves for three Transitron types. Never exceed the maximum continuous current ratings. Intermittent peak current ratings are about four times higher.

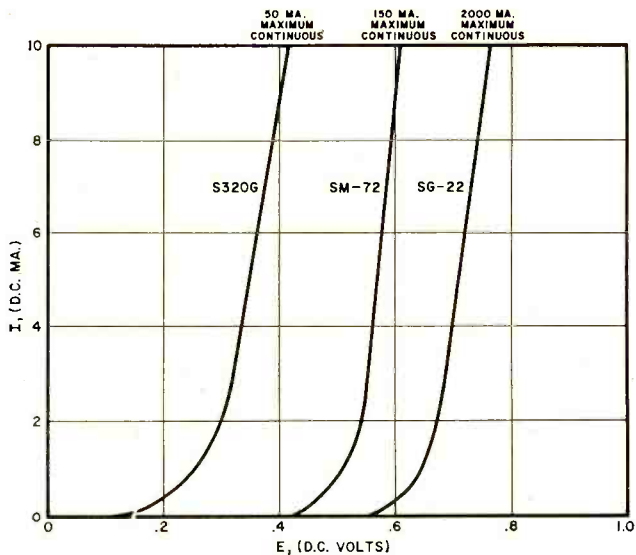
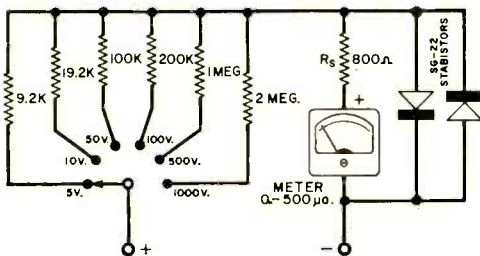

Fig. 2. Stabistor-protected multirange d.c. voltmeter uses 1% resistors for accuracy. Two Stabistors are employed to protect against reversal of probes as well as overloads.



the throats of multi-carburetor or sports car engines for intake temperature matching, checking equipment cabinets for hot spots, and indoor-outdoor thermometers.

The Stabistor volume compressor circuit shown in Fig. 4 has an output that increases only .1 volt for a 20 db increase at the input. In this way, a wide dynamic range of input signals can be applied to a preamplifier without fear of overload.

If you need a squelch in your receiver, try the Stabistor limiter circuit shown in Fig. 5. Weak background noise and static at the input below .3 volt will be attenuated more than 40 db at the output. Desired signals over .5 volt will "pass through" easily with a dynamic loss of only 6 db.

Figure 6 illustrates still another application for Stabistors—a regulated voltage divider. With this setup, you can get a positive and negative output from your transistor power source using only three Stabistors; regulation of the 3-volt output will be maintained within 1% for input voltage changes of 15%. -30-

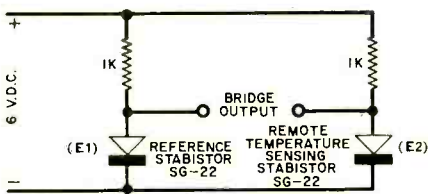

Fig. 3. Temperature-sensitive Stabistor bridge has linear voltage output with respect to change in temperature. The bridge supply voltage may vary as much as 20% and still maintain constant output.

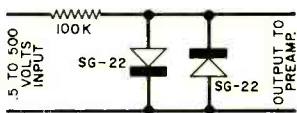

Fig. 4.

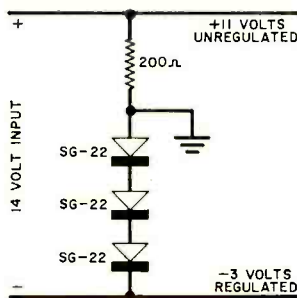

Fig. 6.

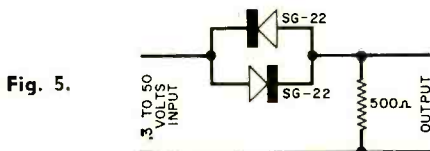
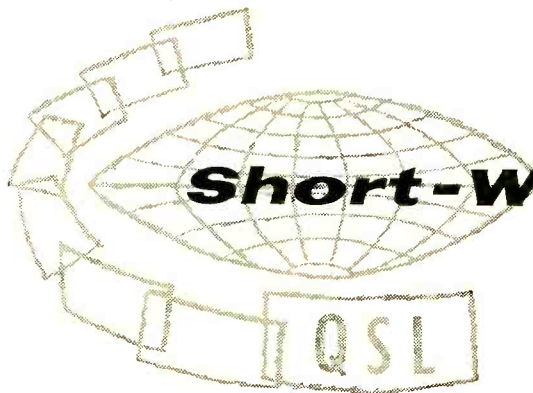

Fig. 5.



Short-Wave Report

By **HANK BENNETT**

W2PNA/WPE2FT

ONE of the old-timers from the "crystal-set" era, J. Art Russell, POP'tronics Monitor WPE6EZ, began DX'ing with one of these sets back in 1923. His best DX was a station located 400 miles away—not far by today's standards but still good for a crystal set. Art is 50 years old, married, and operates at 3128B Jarvis St., San Diego 6, Calif.

Incidentally, your Short-Wave Editor also started out with a crystal set—a Westinghouse—and our best DX was WLW's 500,000-watt outlet on 700 kc. By comparison, one of our southern monitors only recently built a crystal set capable of tuning the short waves, and his reports indicate that he has been having exceptional results with it.

The current line-up of equipment in Art Russell's monitoring station is a Hammarlund HQ-100 and a Hallicrafters S-40B, an RME DB-23 pre-selector, and a Bud frequency standard. His antenna is a "V" dipole cut to the 31-meter band.

In recent years, Art has not been sending out reports purely for the sake of collecting more QSL's but has been devoting much time to a certain few stations. He has been monitoring for the BBC—at their request—on several frequencies, sending them weekly reports; and he listens to *Deutsche Welle* (Germany) and *Radio Japan* on a more irregular basis. However, he has also managed to log 103 countries, his best catches being Port

Moresby (New Guinea), Perth (Australia), Colombo (Ceylon), and Lourenco Marques (Mozambique). In addition, he has logged planes in flight off the coast of Brazil and near the Marshall Islands.

Take a close look at that globe (in the inset photo) which sits atop the S-40B in Art's station. Inserted in the globe are map pins in white (for fixed land stations), yellow (for aircraft) and blue (for ships). Only stations with positive identifications are represented. A plane, for instance, only warrants a pin after it has given its location in longitude and latitude and has been veri-

(Continued on page 123)

Old-timer J. Art Russell, San Diego, Calif., uses a Hammarlund HQ-100 and a Hallicrafters S-40B. Note his world globe and the WPE6EZ certificate.



53-Ton Horn

Made of precast reinforced concrete, the 53-ton horn at right is being anchored in place during the construction of an acoustical test chamber at Goodyear Aircraft Corporation's plant in Litchfield Park, Arizona. The chamber will incorporate the latest devices for studying sound pressure waves and their effect on the electronic components used in supersonic aircraft and missiles. The horn, part of a 100-ton assembly, is designed to direct sound to plane-wave and reverberant-type chambers.

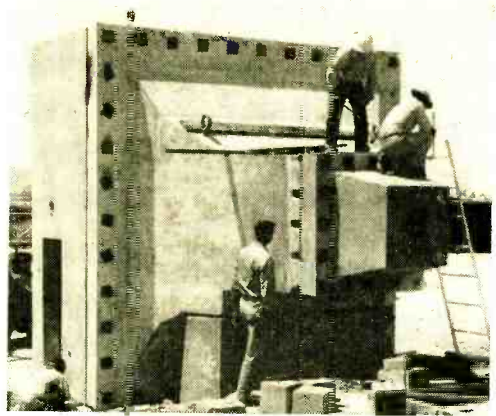

Sun-Powered Generator

This thermoelectric generator can convert the energy of sunlight into 2.5 watts of power—enough to operate a radio transmitter far out in space. Developed jointly by Westinghouse and Boeing engineers, it may have application in long-mission satellites and manned space vehicles of the future. The concave, highly polished reflector, which resembles a "fun house" mirror, collects the sun's energy and concentrates it on a portion of the cylinder-shaped generator in front of the reflector.

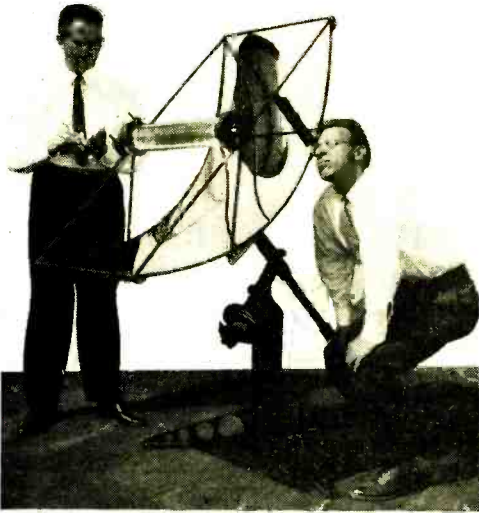

TV Monitors Airport

At the FAA's Annual Fly-In, held recently in Atlantic City, N. J., aircraft operations were observed on a Scanoscope wide-screen monitor in the main control tower of the airfield. A development of Grimson Color Inc., Scanoscope's "Cinemascope-like" 7 x 3 aspect ratio picture can present almost twice the runway and taxiway information as standard 4 x 3 aspect ratio screens. Two Scanoscope wide-screen TV cameras atop the tower, remotely controlled through the control panel under the monitor, provided a 70° wide angle view of the airport area or close-up telephoto shots for landing and take-off identification.



Sensitive Diode-Transistor Radio...

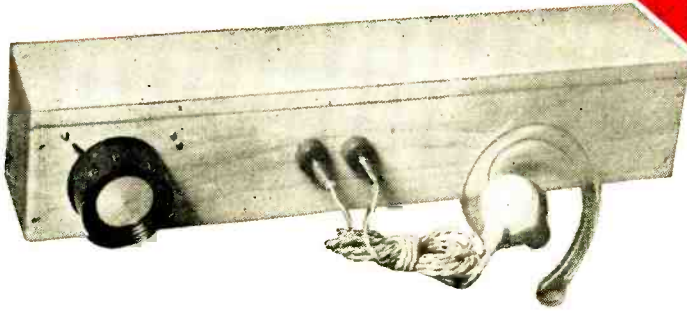

By
ART TRAUFFER

... uses homemade antenna coil to pep up reception

YOU WILL LIKE this little radio because you can carry it around anywhere in the house. It needs no outside antenna or ground; you simply aim it at your favorite local station (broadside toward the station). Due to radio-frequency pickup from between-the-wall house wiring and pipes, you can even use this radio as a "metal locator"; just slide it along the wall or ceiling until a local station comes in the loudest—then you will be close to house wiring or pipes.

The high efficiency of this little radio is due to the use of a specially made ferrite

core antenna and a 1N54A high-back resistance diode detector. One stage of audio is provided by the 2N217 transistor which is coupled to the headphones.

The complete set is built into a thin wooden box at least 7 $\frac{3}{4}$ " long to accommodate the ferrite core antenna. Make the antenna from a 7 $\frac{1}{2}$ " x .33" ferrite antenna rod (Lafayette MS-332) using 100 turns of 7/41 litz wire (Belden #8817). Mount the completed antenna coil and 365- μ f. variable capacitor with Duco cement, keeping the capacitor near the "ground" end of the coil. All the other parts are compactly

Mark the location of your favorite stations by pushing small round-head brass pins into the wood around the tuning capacitor.

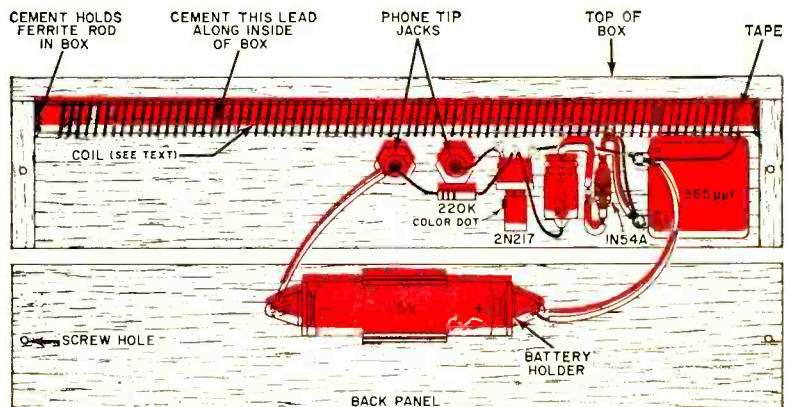

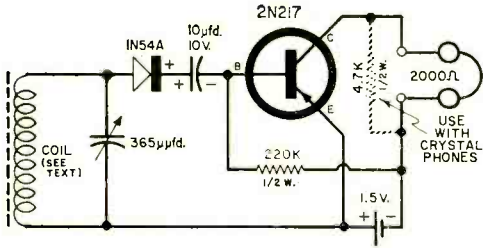
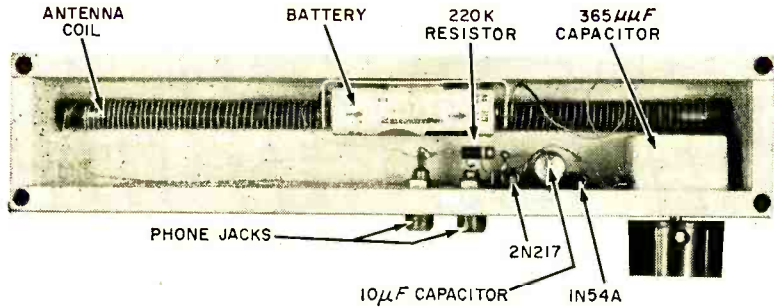

Mount tuning capacitor near ground end of the antenna coil which is connected to the positive terminal of the battery.

grouped close to the "ground" end of the coil to keep metal away from its sensitive end.

Mount the crystal diode with its leads uncut to prevent damage by heat from the

soldering iron. The transistor socket is supported by its leads. Be sure to observe polarity when connecting the diode, transistor, battery and fixed capacitor. Actually, you can save money and get almost as good results by using a paper .02- μ f. capacitor in place of the 10- μ f. electrolytic unit. Note that no battery switch is needed because the battery is effectively disconnected when you pull one of the phone tips from its jack.

For best results, use a sensitive pair of high-impedance magnetic earphones of at least 2000-ohm impedance, preferably higher, or a sensitive high-impedance earpiece. If you use a crystal earphone, connect a 4700-ohm, 1/2-watt fixed resistor across the phone jacks—but disconnect it if you switch to magnetic phones. —30—

Super Simple Power Megaphone

There's no need to strain your lungs at those public functions, dances, rallies, etc. Either of these two circuits will turn a conversational tone into a shout and only cost you about \$5.

Build the circuit shown in (A) if you can get along with 1/5-watt output. The transistor drains from .25 to .5 ampere so that four size "D" flashlight cells in series-parallel will have a reasonably long life. Use a press-to-talk switch, either push-button or lever type.

If you need more power, the circuit in (B) will provide up to 1/3-watt output. As about .5 to .75 ampere is drained, a heavier battery is required.

The type of speaker and mounting used is optional. A p.a.-type horn or efficient 12" loudspeaker of 3-4 ohms impedance in a baffle will serve adequately. But be careful to isolate the microphone to prevent annoying oscillation due to acoustic feedback.

—Jay Tort

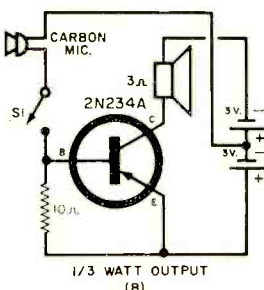
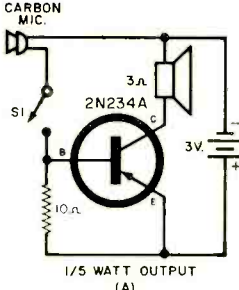

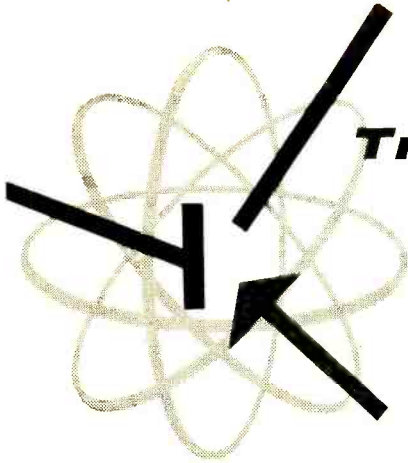

Transistor Topics

By LOU GARNER

EACH YEAR at this time yours truly is faced with an interesting and challenging task—that of predicting the coming developments in semiconductor technology. But before we look to the future, let's check our score on last year's predictions.

In 1959 we suggested that you watch for: transistorized short-wave receivers selling for under \$100.00—*check*—several outlets have offered such sets, although lagging public demand has kept national advertising to a minimum . . . a continued drop in the price of transistors—*check*—TI recently announced a series of commercial quality transistors selling for less than 50¢ each in production quantities, and all transistor prices have dropped . . . a moderate-priced r.f. power transistor—*partial check*, depending on your definition of “moderate,” for r.f. power transistors are still in the “over \$20” price class.

We anticipated the appearance of: high-current power transistors—*double-check*—Motorola scooped the industry a few months back by introducing 25-ampere power transistors . . . high-efficiency sun batteries—*check*—units with 10% and higher efficiencies are now available from International Rectifier . . . a sun-powered receiver for under \$50.00—*check*—such an item has been offered by at least one importer . . . moderate power v.h.f. transistors—*check*—some of the new “Mesa” types can handle input levels on the order of a watt in

the “over 100 mc.” range, with outputs up to several hundred milliwatts.

We also hoped to see: transistorized table model receivers—*check*—they are available from both local and mail order outlets . . . moderate-cost transistorized test equipment—*check*—a variety of such instruments are now on the market . . . a portable transistorized color-TV system—*check*—such a

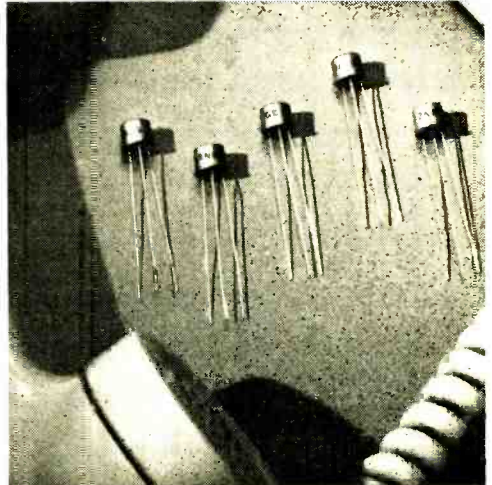

Silicon switching transistors (above) and controlled rectifiers (below), recently announced by General Electric, feature high-frequency, high-temperature and high-power operation. See page 110 for details.

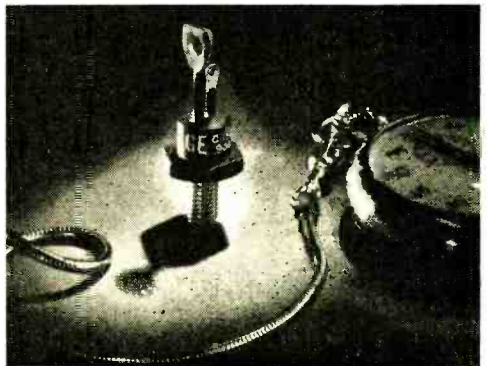

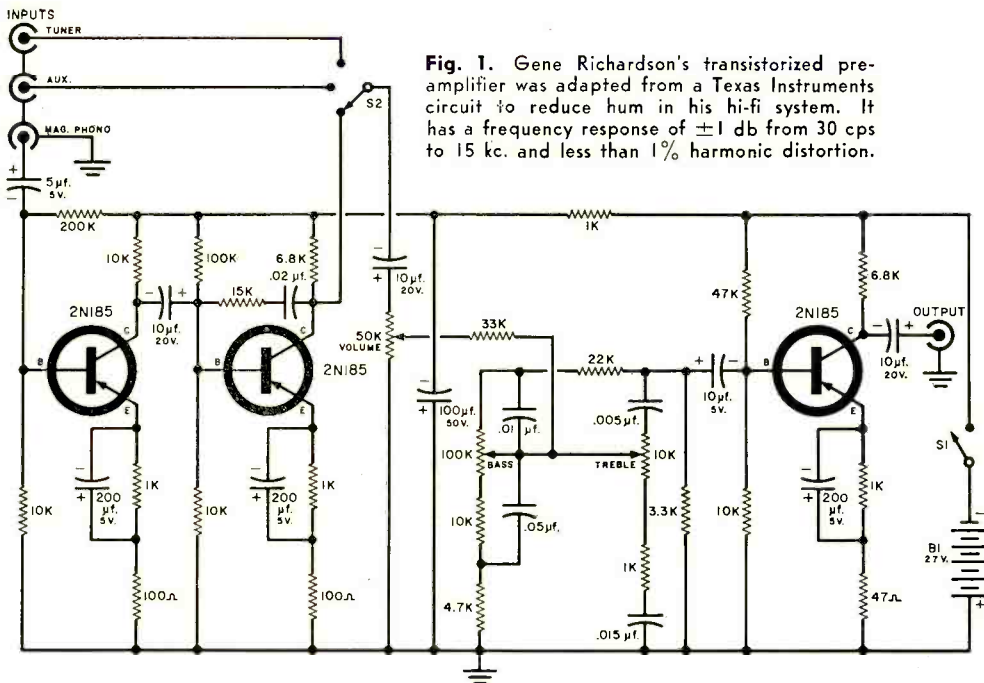

Fig. 1. Gene Richardson's transistorized pre-amplifier was adapted from a Texas Instruments circuit to reduce hum in his hi-fi system. It has a frequency response of ± 1 db from 30 cps to 15 kc. and less than 1% harmonic distortion.

system was demonstrated at several military shows.

A number of earlier predictions have finally come true also. Transistorized TV receivers are available today (Philco's "Safari," for one). Power transistors are available at *under one dollar* (check Olson or Lafayette Radio catalogs). Low-priced *fully transistorized* receivers have flooded the market in the past few months, with prices ranging from under \$20 for a 4- or 5-transistor set to under \$10 for 2- and 3-transistor carphone receivers (we predicted an "under \$10" price last year). Literally dozens of *special-purpose* semiconductor devices have been introduced, including "Dynistors," "Trigistors," controlled rectifiers, and bistable diodes.

Things to Come. In 1960, watch for: an American satellite circling the moon and carrying a transistorized *instrument package* . . . transistorized *two-way radios* for foot patrolmen to help combat crime . . . transistorized FM receivers or "hybrid" sets for *automobiles* . . . transistorized *ignition systems* as standard in many 1961 model autos, and available as an optional accessory with almost all cars . . . the long-awaited "*two-bit*" transistor . . . a semiconductor "*picture tube*" for possible future use in transistorized TV sets.

The new year should also bring: a

semiconductor "vacuum tube" in which a *semiconductor element* replaces the usual filament and cathode . . . special low-priced "experimenter's" *v.h.f.* transistors . . . an r.f. moderate power transistor at *under \$10.00* . . . "hybrid" or fully transistorized Citizens Band *radiotelephone* equipment . . . and transistorized *control devices* for the home.

Reader's Circuit. A hi-fi fan and amplifier experimenter from way back, reader Gene Richardson (Alexandria, Va.) recently decided that the best way to reduce *hum* in a high-quality music system was to use a fully transistorized, battery-powered pre-amplifier. Accordingly, he adapted a circuit developed originally by Texas Instruments and assembled his own unit.

Designed to match a G.E. magnetic cartridge, this preamplifier has a frequency response of ± 1 db from 30 cps to 15 kc. and less than 1% harmonic distortion. See Fig. 1. It can deliver a peak output of 1 volt into a 2000-ohm load and has standard RIAA equalization. The design includes an input selector, both phono and tuner inputs, and the usual volume, treble and bass controls.

Type 2N185 *p-n-p* transistors are used in a three-stage resistance-coupled preamplifier, with the common-emitter arrangement employed in all stages. The first two stages

serve as a preamp for the phono cartridge, with the output stage handling either the phono signal or the audio signal obtained from a tuner or other unit, depending on the setting of input selector switch *S*₂. Large-value electrolytic capacitors are used for interstage coupling to insure good low frequency response. Stabilized base bias is applied to all stages to insure consistent performance with changes in ambient temperature conditions.

You can assemble a similar preamplifier using standard components. All resistors are half-watt units, and, for best results, should have 5% tolerance ratings. Standard electrolytic capacitors can be used, but smaller capacitors (those with an under 1.0- μ f. rating) should be paper or ceramic units. Working voltage should be at least 50 volts except where noted otherwise.

Either conventional chassis-type or etched-circuit-board construction techniques can be used; and while layout and lead dress are not overly critical, good wiring practice should be followed. Keep all signal leads short and direct, and make sure there is ample separation between input and output circuits. The transistors can be wired permanently in place or installed using small sockets; if they are soldered in position, be sure to use a heat sink to avoid damage.

Power switch *S*₁ can be a separate s.p.s.t. switch or can be ganged to one of the tone controls (many builders gang the power switch to the treble control). The 27-volt battery, *B*₁, is made up by connecting three standard 9-volt transistor batteries in series; use Burgess Types 2N6, P6, or RCA

Type VS300A. For minimum external hum pickup, assemble the completed preamplifier in a small metal cabinet or box.

Double-check all connections *before* installing the batteries or connecting the preamplifier to your hi-fi system. Pay special attention to electrolytic capacitor polarities. The preamplifier's output can be connected to any standard power amplifier requiring approximately a 1-volt signal for full output. The radio tuner (if used) should have a low impedance output and should deliver a peak signal of from 0.5 to 1.5 volts. Standard shielded cables should be used for all inter-equipment connections.

Special-Purpose Semiconductors.

More and more special-purpose semiconductor devices are being introduced by component manufacturers. Many of these have unique characteristics which permit them to handle special jobs much more efficiently than can standard combinations of transistors and diodes. "Switching" devices of various types are in great demand for military gear, industrial control equipment, and electronic computers and data-processing instruments. One of the newest devices in this class is the "Trigistor," a bistable semiconductor component with characteristics which approximate the circuit function of a bistable (or flip-flop) multivibrator.

Introduced by Solid State Products, Inc. (One Pingree Street, Salem, Mass.), the Trigistor is a *p-n-p-n* device having a triggered turn-off as well as a triggered turn-on control at its base. It will conduct with the application of a small positive-going

(Continued on page 110)

Fig. 2. Comparison of flip-flop circuits which utilize the "Trigistor" (A), a new special-purpose semiconductor, and (B) standard transistors. Note simplicity of Trigistor circuit.

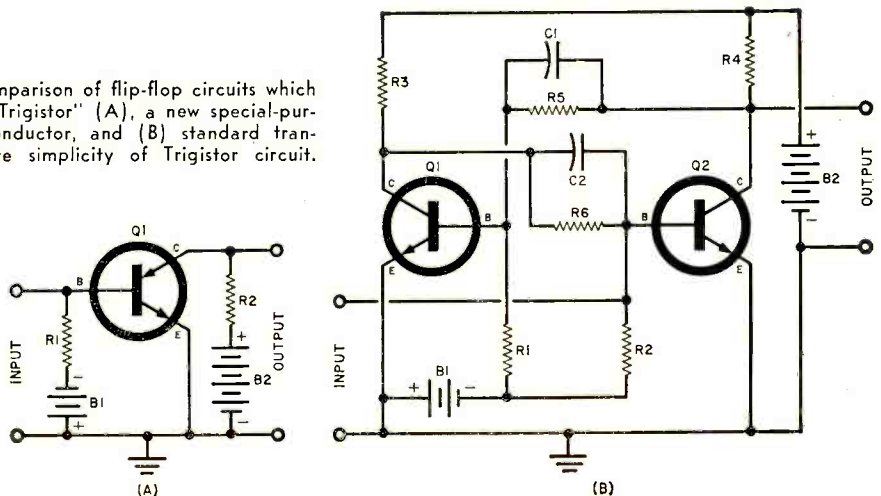



Handy Filament Continuity Checker

Quickly assembled EICO Model 612 speeds up series-filament tube checking

A TIME-CONSUMING job in servicing series-string TV and radio receivers is finding tubes which are defective due to an open filament. A full-facility tube tester is not ideally suited for checking filaments because too much time is wasted making settings for each tube. The EICO Model 612 Filament Continuity Tester (Electronic Instrument Co., Inc., 33-00 Northern Blvd., L. I. C. 1, N. Y.) is designed to operate without controls or switches.

Features. The Model 612 is both safe and convenient to use since it is powered by internal batteries. Filaments are tested merely by removing the tube from the set and plugging it into the appropriate socket of the tester while observing the indicator lamp. Test sockets are provided for 9-pin, octal, loctal, and 7-pin tubes; 7-pin and 9-pin miniature tube pin straighteners are also on the panel as a convenience.

Receiving tubes other than series-string types can also be filament-tested in the EICO unit. In addition, an adapter cord is provided for testing television picture tubes, as well as other facilities for checking bayonet or screw-type pilot lamps and cartridge-type fuses.

Assembly. All the parts are mounted and wired onto the faceplate which serves as the chassis. Only standard wiring tools and a pencil soldering iron are needed for assembly. The chassis fits neatly into a light plastic case, and the finished unit is rugged enough to drop into the bottom of your tool kit without fear of breakage.

About 50% of set failures are due to burnt-out tube filaments. In series-wired sets, the Model 612 provides a means for checking each tube rapidly without substituting known good tubes.

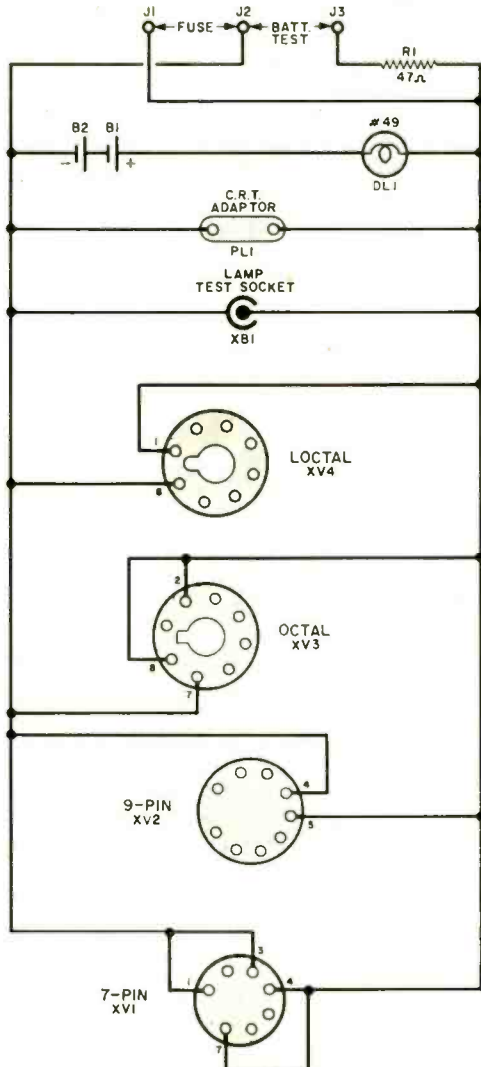



Take the

Out of Your Car Radio

Part 2

By JACK DARR

Some final tests and checkpoints that will help you localize and eliminate some of the more obscure noise sources

HELICAL COIL SPRING



Wheel noise due to an intermittent ground and subsequent static electricity discharge can be eliminated by the installation of helical coil springs under inner hub cap.

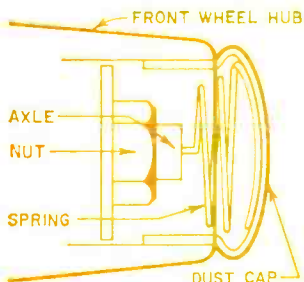

LAST MONTH the three types of interference that plague auto radios were broken down into the categories of *pulse*, *hash*, and *intermittent noise*. Several possible causes of noise were investigated, pin-pointed, and remedies suggested. Now we'll finish up by providing some trouble-shooting suggestions on how to localize and quiet down other major sources of noise trouble: the wheels, body and antenna.

Wheel and Body Noises. Once in a while you'll find noises that do not originate in the electrical system. Front wheels are the most frequent offenders. As a wheel turns, it intermittently becomes temporarily "insulated" from the car by the grease in the bearings. The tires will build up a charge of static electricity from friction with the road surface and when the wheel makes contact again, there is a discharge to the car chassis, resulting in a loud pop or scratching noise in the radio.

This kind of noise is usual when driving on dry pavements; you seldom find it on dirt roads, and never on wet days. It's easy to check. Drive at medium speed

on a smooth road, until the noise shows up. As soon as you hear it, apply your brakes lightly. The brake shoes will ground the wheel, stopping the noise.

Another way of checking this kind of noise is to cut off the engine, leaving the radio turned on, and let the car coast to a stop. If the noise slows down and stops just as the car stops, then it's quite likely to be front-wheel noise.

There is a possibility of confusion here, between wheel noise and fuel-gauge noise. Check by driving over an unpaved road, or in the rain. Fuel-gauge noise will be worse on the rough road, and will still be present in rainy weather. Probably the best way would be to check and eliminate the fuel-gauge noise before checking for wheel static.

To remove wheel noise, it's necessary to insure perfect contact at all times between the wheel and the front spindle (which is grounded firmly to the car body). A special spiral spring can be obtained at garages and radio parts houses for this purpose. Such springs are installed in the inner hub-caps, the small "grease-caps." Place the big

part of the spring inside the cap, and set the point on the other end in the tiny depression in the end of the front spindle. Replace the cap, being sure that the point of the spring stays in the cup. Figure 5 shows a detailed view of the relationship between the spring and the cup.

If you drive an "old-timer" whose body, to put it delicately, is a wee bit loose here and there, you may have other popping noises, especially on bumpy roads. These noises can be caused by loose parts of the body which are not firmly grounded. The cure is easy. Simply tighten all bolts firmly, and replace those missing. If this doesn't get all the noise out, try "bonding" the parts together with heavy woven-metal straps, like those used for battery ground cables.

The hood is a frequent offender in this department. Try grounding it, with engine and radio both running, by jamming a large screwdriver, or the end of a large flat file, between hood and body. If this reduces the noise, install bonding straps made of $\frac{1}{2}$ " or $\frac{3}{4}$ " metal braid between the underside of the hood and the firewall, one on each side at the back. And see that the hood latch is tight.

Always be sure that the hood is closed and latched when you are testing for noise. If it is open, noise will "feed out" from the ignition system, etc., and may be picked up by the antenna itself, nullifying the test results.

Elimination Circuits. Electrical noise is kept out of the radio circuits by special construction techniques in the sets, and by the use of filtering in the leads coming out of the chassis.

Figure 6 shows the noise shielding in a typical auto radio. The "solid" metal box (solid to radio-frequency noises, that is, even though it will have ventilation holes) acts as a shield to prevent the noise from entering. All wiring coming out of the box is provided with filters, in the form of "spark-plates" and r.f. chokes. Spark-plates are small metal plates, fastened to the sides of the case and insulated with "fish-paper," which act as small capacitors. The box itself is always well grounded by the bolts which hold it in place in the car.

The antenna lead-in of the average car is probably the most sensitive point in the whole circuit.

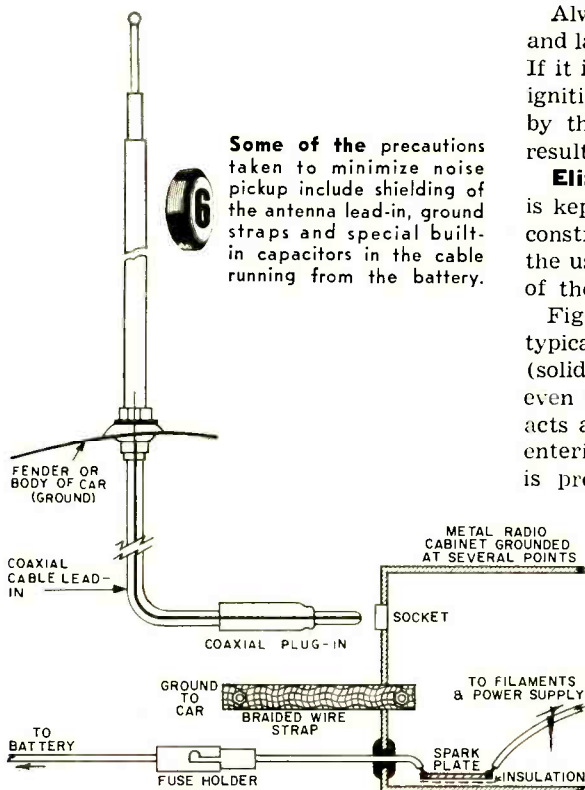

Since it feeds the radio's input, any noise picked up will be amplified by the full gain of the set. Therefore, the lead-in cable is always a coaxial, with the outer shield braid well grounded at the set and at the antenna base, where the lead-in goes outside the car through the fender or cowl and joins the antenna proper.

Noise Pickup Checks. Auto radios suffer from two kinds of noise pickup: antenna pickup—where the noise is entering through the antenna or lead-in; and chassis pickup—where the noise is coming in through the power supply lead, etc. There's a quick check to tell which is which.

With the engine running, and while the noise is heard, pull the antenna lead-in out of its socket. If the noise stops, then it was the antenna pickup. If it doesn't, then you've got chassis pickup troubles. Fortunately, due to the increased efficiency of chassis filtering, chassis pickup is very seldom encountered in modern sets.

The first step, in all cases, should be to make sure that there is a "minimum noise-suppression kit," which consists of a suppressor in the distributor lead and a bypass capacitor across the generator armature. With these in place, start the engine, tune the radio off-station at fairly high volume, and check for noise. If you can hear only faint noises, with the volume full up, try a distant station. If the signal drowns out the noise completely, the job is done and your worries are over.

Antenna Troubles. The antenna lead-in must be well grounded at *both* ends to limit noise pickup. If one end is not perfectly grounded, due to corrosion, a loose plug, etc., you'll get a condition such as that shown in Fig. 7. The noise pulses will cause the formation of "standing waves" on the shield, which will be transferred to the "hot" center conductor and fed into the set. With both ends of the shield properly grounded, standing waves cannot be set up, and the noise energy never reaches the center conductor.

So, if noise appears suddenly, check both ends of the antenna lead-in for grounding with an ohmmeter. The shield should read a dead short, to the body of the car, with the antenna plug pulled out of the set. If there is even a small resistance, 10 ohms or less, disassemble the antenna base and clean it up. After you scrape or sand off all rust or corrosion, reassemble the base, tightening it well.

You can make a fast check by plugging another antenna into the radio. Hold it only by a part which would normally be grounded, the bottom of the base, and ground this against an exposed part of the car body. If the noise stops, then check your original antenna carefully.

Incidentally, moisture leakage inside the antenna base can cause an electrical leakage across it, not only cutting down your signal strength, but even introducing noise into the radio. While you've got the plug out of the set, measure from the center pin to the shield; this should read absolutely open, even on the highest range of your ohmmeter. A damp antenna will usually give you a reading of about 5000 to 10,000 ohms. Most of the time, the only practical cure for this trouble is replacement with a better grade of antenna!

In summary, we might say that removing the noise from any auto radio *can* be a tiresome, dirty job! However, the increased listening pleasure that results makes it worthwhile. You don't have to be a Sherlock Holmes; know-how, elbow grease, the proper parts and a little common sense will go a long way toward licking the most elusive case of auto radio noise pickup that chances to come your way.

-30-

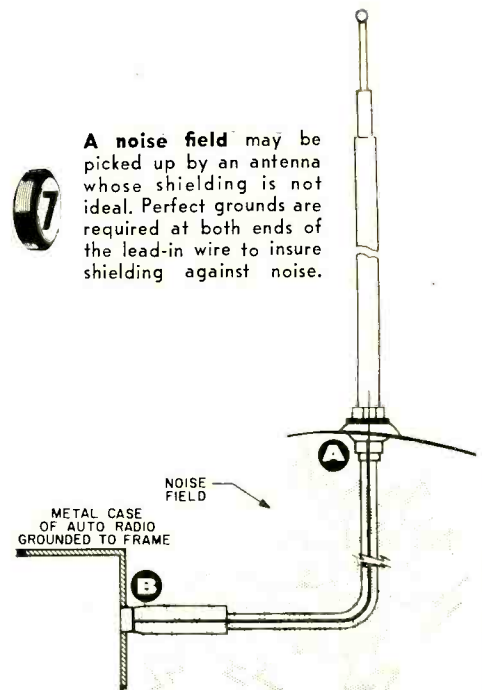

Familiar Farces

The world is full of characters whose main joy is derived from "bugging" their fellow beings, and the electronics enthusiast seems to meet more than his share of these types. Cartoonist Kohler presents a brief casebook of the exceptionally outrageous varieties still roaming around loose . . .

Somehow, this joker has gotten the idea that you will be only too delighted to spend your precious project time repairing his assorted beat-up electrical appliances (gratis, of course) when you would rather be having a ball with your own favorite projects.



"When you get a spare moment . . ."

The basic trouble with this guy is that he doesn't know an astigmatism control from an L-pad, but he never allows mere ignorance to deter him from giving you advice.

Since none of his theories are likely to lead to anything more exciting than a short-circuit, you better lock the work-shack door if you are fortunate enough to see him coming.



"Golly, I hardly touched it and . . ."

Apologetic destruction on two feet, this clown could be armed with a powder puff, released near any major electronics installation, and make the place a shambles within minutes—to his great astonishment and shame, naturally.

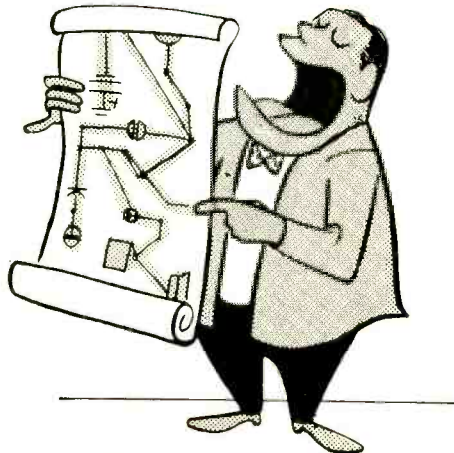

"Now my theory is . . ."

POPULAR ELECTRONICS



"If you think that's a problem . . ."

No matter *what* kind of fascinating difficulties you may be having with a project, this boy can top them with colorful problems *he's* having that make your little items sound childish by comparison. He hasn't actually built anything since 1927, but he *has* mastered the techniques of "One-Upmanship."

Har de har, har. *When* and *if* you ever see his happy face again, he'll con you out of still more components—which he finds cheaper to "borrow" from you than purchase at his local parts store. You might get him off your back by lending him some burned-out tubes. Dirty pool, perhaps—but effective.



"I'll return these parts in a few days . . ."



"And then I says to him . . ."

This wretch is a chronic talker. He will only descend upon the peace and quiet of your workbench when you are having a mental tussle with an especially complicated piece of trouble-shooting or when you are trying to solder a particularly tricky connection. Then he will drop by and drive you out of your mind with his rapid-fire stock of banalities.

TURNTABLE TIPS

Automatic Tape Recorder Shutoff

Here's a trouble-saving idea for those who do a lot of transferring from discs to tape. If your record changer has an automatic shutoff, simply wire an a.c. receptacle in parallel with the record player motor. When your tape recorder is plugged into it, your setup can be left unattended during the transfer time. For when your record changer switches off, so will your tape recorder.

—Charles W. Bittner

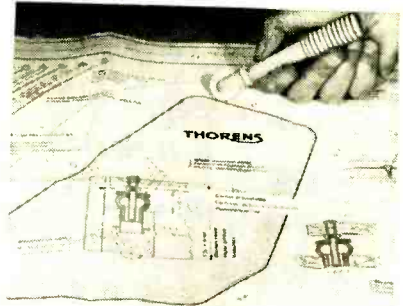
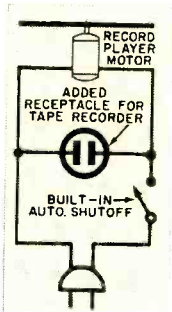

Mounting Templates

Those who prefer to mount their own high-fidelity equipment in the cabinet of their choice find that one of the most tedious jobs in mounting a professional hi-fi turntable is cutting out the mounting board. Of course, if you use the manufacturer's base, this problem is avoided; but for those who want to mount a turntable in a console cabinet, the manufacturer of the turntable provides a template for cutting out the required size and shape hole. There is an excellent and easily available hand tool for transferring the pattern of the template to the board to be cut out—it's sold in 5 and 10 cent stores as a tracing wheel for dress patterns, under the Dritz brand name among others. To use the wheel, simply staple or tape the paper template to the turntable board to be cut out. Then run the tracing wheel over the outline. The impression of the wheel's teeth comes through clearly without excessive pressure.

—Dave Gordon

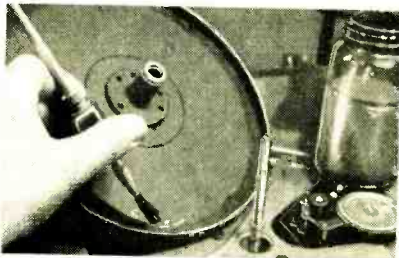

Drive Slippage

The record changer that won't go into (or can't complete) its change cycle frequently has a problem of idler slippage. This slippage is sometimes so bad that the turntable won't even start. In such cases, there is a very simple remedy. Remove the turntable and apply a coating of rubber cement to the inner surface of the rim. The cement, available at any stationary store, will remain "tacky" and effectively put an end to idler slippage.

—Glen F. Stillwell

Direct Reading Frequency Meter

**This handy gadget
measures frequencies from
20 to 5000 cps**

HERE IS a direct-reading frequency meter that requires no tubes or batteries. A handy gadget for the workbench, it will measure frequencies between 20 and 5000 cps at any voltage between 15 and 200 volts, and will indicate the frequency directly on a meter scale which, once calibrated, needs no further adjustment.

You can build the unit in a 6"x5"x4" aluminum utility case and arrange the components to your own liking. Calibration potentiometers *R3* and *R4* should be recessed behind the panel to prevent them from being turned after the instrument has been calibrated.

Calibration. An audio generator having an accurate range of at least 20 to 5000 cps and an output of 15 volts or more will be needed for the initial calibration of the frequency meter.

First, turn potentiometer *R1* fully counterclockwise and set selector switch *S1* to the "X1" position. Now connect the audio generator output to the frequency meter input. The generator should be set for 15 or more volts output at 500 cps. Adjust *R1* until meter *M1* reads half-scale, or 25 microamperes. (As frequencies or voltages are shifted, *M1* may go off its center scale reading. If it does, use *R1* to reset *M1* to a center scale reading.)

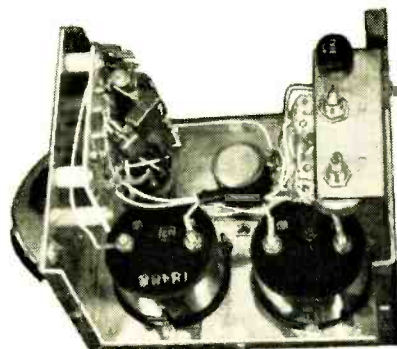
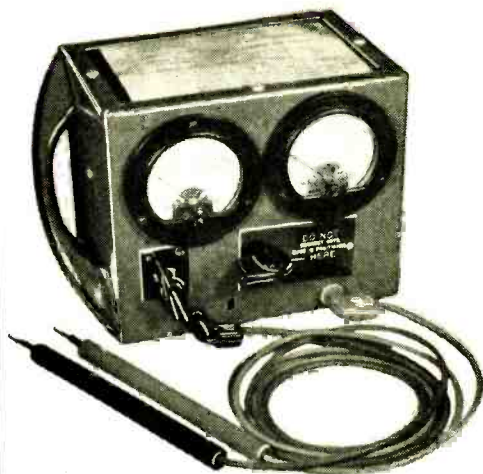

By ROBERT J. D'ENTREMONT

Next, adjust *R4* until meter *M2* reads full scale (1 ma.). Progressively decrease the frequency as follows: 500, 400, 350, 300, 250, 200, 170, 150, and in steps of 10 cps down to 20 cps. Keep a record of *M2*'s reading at each frequency.

Repeat the above procedure with *S1* in the "X10" position. Set the generator to 5000 cps and set *R3* for a full-scale (1-ma.) reading of *M2*. Decrease the frequency as follows: 5000, 4000, 3500, etc., as was done for the lower scale. Keep *M1* at center scale at all times.

Now the scales should line up for all frequencies in the ratio of 1 to 10; for example, 400 cps and 4000 cps should be at the same point on the meter scale. If they do not line up, it means that *C1* does not

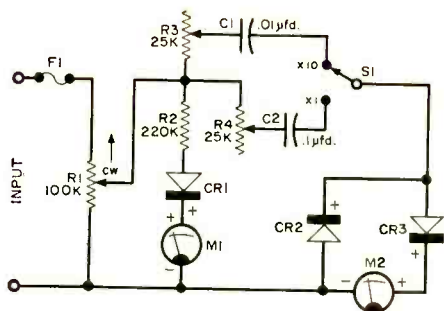

PARTS LIST

- C1—0.1- μ f., 400-volt capacitor
- C2—1- μ f., 400-volt capacitor
- CR1, CR2, CR3—1N34A diode
- F1— $\frac{1}{8}$ -amp. 3AG fuse, and holder
- M1—0.50 μ amp. d.c. meter (Lafayette TM-70 or equivalent)
- M2—0.1 ma. d.c. meter (Lafayette TM-60 or equivalent)
- R1—100,000-ohm, 2-watt wire-wound potentiometer
- R2—220,000-ohm, $\frac{1}{2}$ -watt resistor
- R3, R4—25,000-ohm potentiometer
- S1—S.p.d.t. rotary switch
- 1—6" x 5" x 4" aluminum utility case
- Misc. test lead wire, tip jacks, knobs, hardware

HOW IT WORKS

Input level indicator meter *M1*, in conjunction with *R1*, *R2* and *CR1*, serves to set a standard reference level. The actual reading of *M1* is not critical provided the same setting is used for the initial calibration and all subsequent readings.

When an alternating voltage of constant amplitude and waveform is impressed upon capacitor *C1* or *C2* (depending upon the scale being used), the current through the capacitor is directly proportional to the input frequency. If the frequency is increased, the current through the capacitor to diodes *CR2* and *CR3* increases proportionately. The d.c. output of the diodes is read by meter *M2*, which indicates the frequency.

Polarity of the meters and diodes must be observed. For reasons of economy, a 1-ma. meter could be used for *M1*, instead of the 0.50 μ amp. meter specified in the parts list, and a 11,000-ohm resistor for *R2*. In this case, *R1* would have to be adjusted for an input level reading of .5 ma. on *M1* for all measurements.

have exactly one-tenth the capacity of *C2*. To correct this situation, either add or remove capacitance to change *C1* slightly until the scales agree.

After recording the relationship of ma. to frequency, a new meter scale can be lettered, or a record of current vs. frequency may be pasted on the instrument case. Letter the scale from "0" to "500" and mark switch *S1* showing the "X1" and "X10" positions. If you wish, you can also attach operating instructions to the case.

Operation. Set switch *S1* to "X10." Be sure to rotate potentiometer *R1* fully counterclockwise. Connect the leads from the input terminals to the unknown voltage and frequency source, and rotate *R1* slowly clockwise until *M1* reads 25 microamperes. If the meter needle of *M2* is above 50 on the scale, that reading multiplied by 10 equals the frequency in cps.

If the meter reads below 50, the frequency under test is less than 500 cps and you can use the "X1" scale. In this case, set *S1* to "X1," readjust *M1* to 25 μ amp., and then read the frequency directly on meter *M2*.

—50—

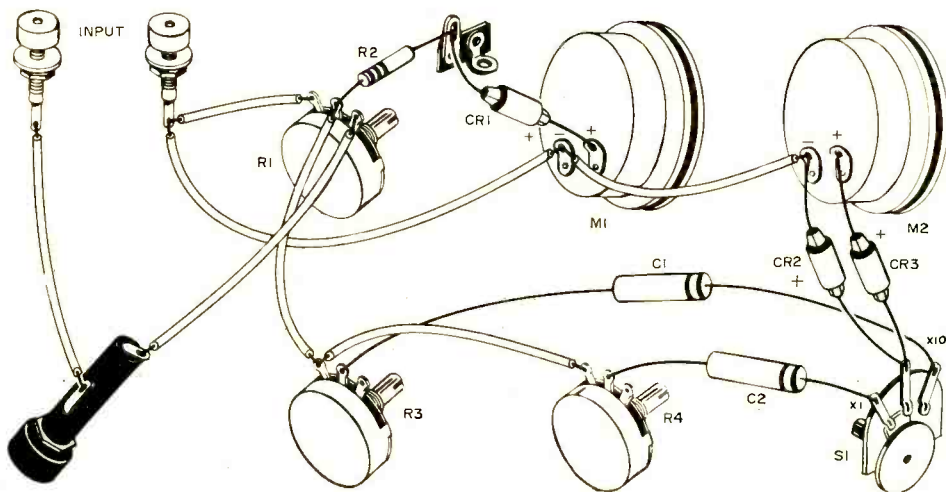

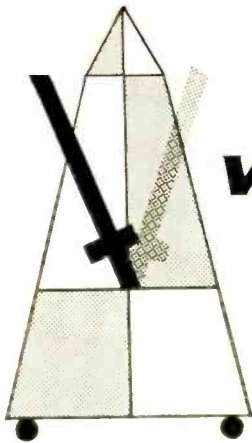

Wireless Metronome

By MARTIN H. PATRICK

Single-transistor unit transmits beat to broadcast radio

MUSIC LOVERS, both classical and rock 'n' roll, can get on the beat with this simple self-powered metronome that "sounds" through a radio without need for wired connections. And for just "puttering" around, you'll find that the damped-wave "putt-putts" from this unit can be fun at parties and the like.

Assembled in a small plastic box, the entire unit is powered by three 1½-volt cells (Eveready #912 or the equivalent). A 2N35 *n-p-n* audio transistor (*Q1*) is connected as a Hartley oscillator, and a 25- μ f., 12-volt electrolytic capacitor (*C1*) provides the audio feedback. (If you want to use a *p-n-p* transistor, *C1* and the battery should be reversed.) Shunted across *C1* is a 6800-ohm resistor

(*R2*) in series with a one-megohm potentiometer (*R1*), as the timing control.

Coil *L1* is made by scramble-winding about 700 turns of #25 enamel-covered wire on a ¼" iron bolt, about 1½" long. At the five-hundredth turn, twist the wire to a pigtail for the tap and continue adding the remaining two hundred turns. You'll find it easier to wind *L1* if you place two plastic end stops on the bolt. Coil *L1* is tuned by capacitor *C2*, a .01- μ f. unit.

Set the metronome on top of a radio, select a dead spot on the dial, and adjust *R1* for timing. Turning the metronome in one direction or another will give different results.

The power radiation of this circuit is extremely small, so the

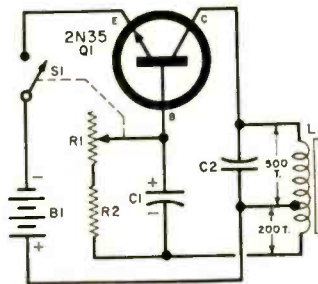

A *p-n-p* transistor with a similar power rating can be used instead of the *n-p-n* unit shown but connections to battery and capacitor *C1* must be reversed.

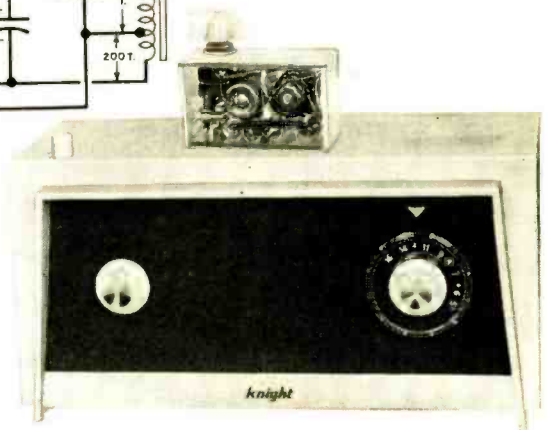

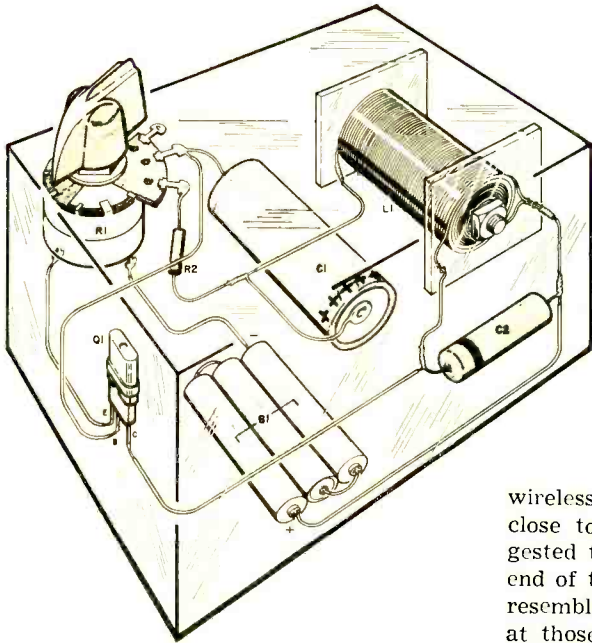

To vary the range of the metronome's oscillation, try connecting capacitor C2 across the entire coil (L1) or its two-hundred turn winding.

wireless metronome should be placed as close to the radio as possible. It is suggested that the radio be tuned to the low end of the broadcast band since the clicks resemble those of a mechanical metronome at those frequencies.

-30-

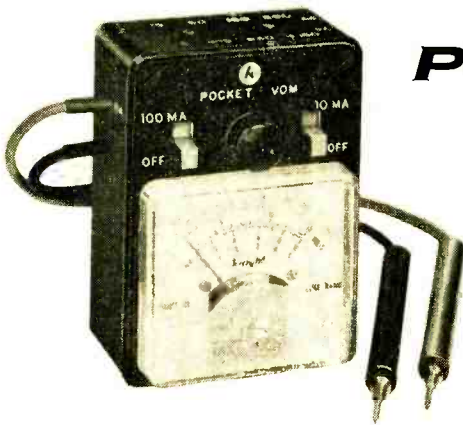

Pocket-Size VOM Kit

THOSE old-timers who can remember back to the days when service instruments were identical to lab equipment—and cost as much—will appreciate the design of the new Knight-Kit VOM (No. 83 Y 708, Allied Radio, 100 N. Western Ave., Chicago, Ill.). It's a fine example of just how simple a combination volt-ohm-milliammeter can be.

Hardly larger than a pack of cigarettes, this new pocket instrument features five a.c. and six d.c. voltage ranges with 1000 ohms/volt sensitivity. Top voltage range on both functions is 500 volts. The one-ohmmeter scale indicates up to 30,000 ohms with a 1200-ohm mid-scale position, and three d.c. current ranges are provided which cover 0 to 100 ma.

The circuit of the instrument is practically self-explanatory. Series-wired resistors R-1 to R-5 comprise the d.c. voltage ranges, and range selection is made by inserting the test lead plug in the appropriate jack. Resistors R-9 to R-12 serve similarly for the a.c. ranges.

-30-

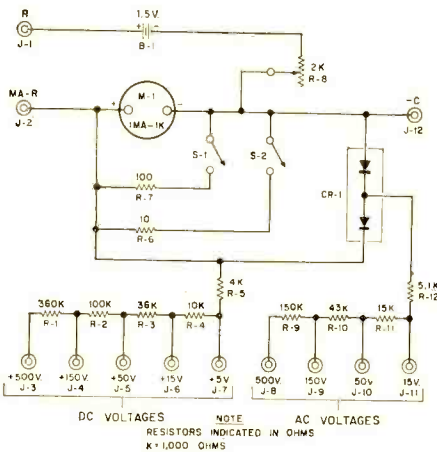

Across the Ham Bands

By
HERB S. BRIER
W9EGQ

HAM TRANSMITTERS

SCARCELY a day goes by at W9EGQ that someone does not ask about buying some piece of transmitting equipment. But I really hit the "jackpot" this week. A couple of beginning local hams passed their Novice exams; six Novices received their General Class licenses; and two Technicians came by looking for information on 50- and 145-mc. equipment! Here is the result of much catalog-thumbing and many discussions of the whole problem of selecting ham transmitting equipment with beginners and old-timers alike.

Novice Transmitters. If you are a Novice, it is very easy for me to advise you what kind of a transmitter to obtain for your first one, assuming that your main idea is to get a General Class license as soon as possible. By sticking to any of the commercially available, 50- to 75-watt,

crystal-controlled c.w. transmitters covering the ham bands between 80 and 10 meters, you can hardly go wrong.

With such a transmitter, you can get on the 80-, 40- and 15-meter Novice bands with a minimum of expense and with the assurance that there will not be enough difference between your signal and the signal from any other transmitter operated from your location in accordance with the FCC Novice regulations for even an expert to detect. After you have built your code speed up to 12 wpm and have obtained your General Class license, you can splurge on more elaborate equipment.

General Class. Of course, with a General Class license in your hot little hand, you can operate on all ham frequencies. But a General Class transmitter is usually thought of as being one that covers the

Ham of the Month

In 1948, Beth Taylor, W7NJS, Manzanita, Oregon, began a four-year teaching stint at an isolated, one-room school ten miles from Ritter, Oregon. This is probably the longest period on record that a virtually sightless person has taught an entire school of pupils with normal vision. Early in 1949, Beth earned her Conditional license, writing the code test on the school blackboard. Later she passed the Advanced Class examination.

W7NJS can be proud of her record in providing emergency communications. For example, operating at Ritter, where the nearest outside telephone line was 35 miles away, Beth managed to get a bloodhound from Walla Walla to find a five-year-old boy lost in the woods. She has also handled important Western Union messages in emergencies when all wires were down.

Beth's first husband Frank, W7HJI, died suddenly in 1953. A few years ago, she married Bill Taylor, W7PPG, whom she had worked often on the air and met at a ham convention. Beth and Bill each have a 150-watt station; the two stations are set up side-by-side in the living room of their home. They both work 75-meter phone, but not at the same time.

An active member of several clubs, Beth was president of the YLRL in 1958. Bill reads her mail to her, but she answers it herself on the typewriter, which she taught herself to use. Beth hopes that other visually handicapped people will want to learn all about ham radio and the many things it can offer them.





Steve Fogt, K8IQA, Sidney, Ohio

3.5 to 29.7 mc. bands, contains a variable-frequency oscillator, and will operate on both phone or c.w. It may have a power rating up to 1000 watts, although the average is much less than this. In fact, transmitter power is something like horsepower in an automobile. A car with a 375-horsepower motor is fine, if you can afford it, but the Fords and Volkswagens usually get there, too.

In the long run, when you get your General Class license, your best bet is probably to obtain the best transmitter in wired or kit form with the above features that you can afford. But this does not mean that you cannot add a variable frequency oscillator and a modulator to a crystal-controlled c.w. transmitter successfully. You certainly can, and learn a lot about how ham transmitters work in the process.

VFO's. Without exception, every experienced ham I asked about it said that the most valuable device around his station was his variable frequency oscillator. With a VFO, you can range over the entire band

Roger Simpson, WV6DCF, Downey, Calif.

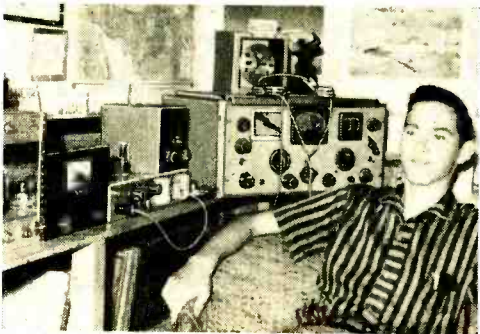

you are operating to make contacts, instead of being chained to a few crystal frequencies. Also, you can shift frequency just enough to slide into a hole in the interference when you call CQ or are working another station—which is a big help with low power.

Before selecting a VFO, check your transmitter instruction manual to determine whether you need one with its own power supply or whether your transmitter has provisions for furnishing power to an external VFO. Some do, and some do not. In any event, a VFO with its own power supply will isolate it from the voltage variations of the main power supply caused by changes in loading, keying, modulation, etc. This results in a steadier signal from the transmitter and keeps you from sounding like a sparrow chirping when you key.

Going on Phone. Eliminating single sideband for the moment, there are three practical methods for converting a c.w. transmitter to phone operation: screen modulation, cathode modulation or plate modulation of final amplifier. The least expensive method is *screen* modulation, with kits selling for about \$12, but this requires the most work in hooking up to a transmitter. It also reduces the output of the transmitter on phone to approximately one-quarter of its rated c.w. output.

Cathode modulation, on the other hand, requires slightly more circuitry than screen modulation but gives a higher percentage of modulation and is simply plugged into the transmitter key-jack. Like screen modulation, cathode modulation requires only a heater current supply. (See the April '59 issue for a schematic of a simple cathode modulator suitable for rigs with final inputs up to 100 watts.)

With *plate* modulation, which can give you 100% modulation, the output remains almost the same as with c.w. operation. But the modulator must deliver an audio power output equal to half the d.c. input to the transmitter and may cost more than the entire transmitter did originally. In our construction section this month, you'll see how K9OLL/8 uses a hi-fi amplifier as a plate modulator.

It's no secret that it is harder to make contacts on phone than on c.w. with low power, but just how much harder is very difficult to predict accurately. However, you can give yourself an approximate idea

(Continued on page 119)

BUILD 16 RADIO

CIRCUITS AT HOME ONLY \$22.95

with the New
PROGRESSIVE RADIO "EDU-KIT"®

A Practical Home Radio Course

Now Includes

- ★ 12 RECEIVERS
- ★ TRANSMITTER
- ★ SIGNAL TRACER
- ★ SIGNAL INJECTOR
- ★ CODE OSCILLATOR

- ★ No Knowledge of Radio Necessary
- ★ No Additional Parts or Tools Needed
- ★ EXCELLENT BACKGROUND FOR TV
- ★ School Inquiries Invited
- ★ Sold in 79 Countries



FREE EXTRAS

• SET OF TOOLS

- SOLDERING IRON
- ELECTRONICS TESTER
- PLIERS-CUTTERS
- ALIGNMENT TOOL
- WRENCH SET
- VALUABLE DISCOUNT CARD
- CERTIFICATE OF MERIT
- TESTER INSTRUCTION MANUAL
- HIGH FIDELITY GUIDE + QUIZZES
- TELEVISION BOOK + RADIO TROUBLE-SHOOTING BOOK
- MEMBERSHIP IN RADIO-TV CLUB: CONSULTATION SERVICE + FCC AMATEUR LICENSE TRAINING
- PRINTED CIRCUITRY

YOU DON'T HAVE TO SPEND HUNDREDS OF DOLLARS FOR A RADIO COURSE

The "Edu-Kit" offers you an outstanding PRACTICAL HOME RADIO COURSE at a rock-bottom price. Our Kit is designed to train Radio & Electronics Technicians, making use of the most modern methods of home training. You will learn radio theory, construction practice and servicing. THIS IS A COMPLETE RADIO COURSE IN EVERY DETAIL. You will learn how to build radios, using regular schematics; how to wire and solder in a professional manner; how to service radios. You will work with the standard type of punched metal chassis as well as the latest development of Printed Circuit chassis. You will learn the basic principles of radio. You will construct, study and work with RF and AF amplifiers and oscillators, detectors, rectifiers, test equipment. You will learn and practice code, using the Progressive Code Oscillator. You will learn and practice trouble-shooting, using the Progressive Signal Tracer, Progressive Signal Injector, Progressive Dynamic Radio & Electronics Tester and the accompanying instructional material. You will receive training for the Novice, Technician and General Classes of F.C.C. Radio Amateur Licenses. You will build 16 Receiver, Transmitter, Code Oscillator, Signal Tracer and Signal Injector circuits, and learn how to operate them. You will receive an excellent background for television, Hi-Fi and Electronics.

Absolutely no previous knowledge of radio or science is required. The "Edu-Kit" is the product of many years of teaching and engineering experience. The "Edu-Kit" will provide you with a basic education in Electronics and Radio, worth many times the complete price of \$22.95. The Signal Tracer alone is worth more than the price of the entire Kit.

THE KIT FOR EVERYONE

You do not need the slightest background in radio or science. Whether you are interested in Radio & Electronics because you want an interesting hobby, a well paying business or a job with a future, you will find the "Edu-Kit," a worth-while investment. Many thousands of individuals of all

ages and backgrounds have successfully used the "Edu-Kit" in more than 79 countries of the world. The "Edu-Kit" has been carefully designed, step by step, so that you cannot make a mistake. The "Edu-Kit" allows you to teach yourself at your own rate. No instructor is necessary.

PROGRESSIVE TEACHING METHOD

The Progressive Radio "Edu-Kit" is the foremost educational radio kit in the world, and is universally accepted as the standard in the field of electronics training. The "Edu-Kit" uses the modern educational principle of "Learn by Doing." Therefore you construct, learn schematics, study theory, practice trouble-shooting—all in a closely integrated program designed to provide an easily-learned, thorough and interesting background in radio.

You begin by examining the various radio parts of the "Edu-Kit." You then learn the function, theory and wiring of these parts. Then you build a simple radio. With this first set you will enjoy listening to regular broadcast stations, learn theory, practice testing and trouble-shooting. Then you build a more advanced radio, learn more advanced theory and techniques. Gradually, in a progressive manner, and at your own rate, you will find yourself constructing more advanced multi-tube radio circuits, and doing work like a professional Radio Technician.

Included in the "Edu-Kit" course are sixteen Receiver, Transmitter, Code Oscillator, Signal Tracer, and Signal Injector circuits. These are not unprofessional "breadboard" experiments, but genuine radio circuits, constructed by means of professional wiring and soldering on metal chassis, plus the new method of radio construction known as "Printed Circuitry." These circuits operate on your regular AC or DC house current.

THE "EDU-KIT" IS COMPLETE

You will receive all parts and instructions necessary to build 16 different radio and electronics circuits, each guaranteed to operate. Our Kits contain tubes, tube sockets, variable, electrolytic, mica, ceramic and paper dielectric condensers, resistors, tie strips, coils, hardware, tubing, punched metal chassis, Instruction Manuals, hook-up wire, solder, etc.

In addition, you receive Printed Circuit materials, including Printed Circuit chassis, special tube sockets, hardware and instructions. You also receive a useful set of tools, a professional electric soldering iron, and a self-powered Dynamic Radio and Electronics Tester. The "Edu-Kit" also includes Code Instructions and the Progressive Code Oscillator, in addition to F.C.C.-type Questions and Answers for Radio Amateur License training. You will also receive lessons for servicing with the Progressive Signal Tracer and the Progressive Signal Injector, a right to a Quiz Book. You receive Membership in Radio-TV Club, Free Consultation Service, Certificate of Merit and Discount Privileges. You receive all parts, tools, instructions, etc. Everything is yours to keep.

PRINTED CIRCUITRY

At no increase in price, the "Edu-Kit" now includes Printed Circuitry. You build a Printed Circuit Signal Injector, a unique servicing instrument that can detect many Radio and TV troubles. This revolutionary new technique of radio construction is now becoming popular in commercial radio and TV sets.

A Printed Circuit is a special insulated chassis on which has been deposited a conducting material which takes the place of wiring. The various parts are merely plugged in and soldered to terminals.

Printed Circuitry is the basis of modern Automation Electronics. A knowledge of this subject is a necessity today for anyone interested in Electronics.

SERVICING LESSONS

You will learn trouble-shooting and servicing in a progressive manner. You will practice repairs on the sets that you construct. You will learn symptoms and causes of trouble in home, portable and car radios. You will learn how to use the professional Signal Tracer, the unique Signal Injector and the dynamic Radio & Electronics Tester. While you are learning in this practical way, you will be able to do many a repair job for your friends and neighbors, and charge fees which will far exceed the price of the "Edu-Kit." Our Consultation Service will help you with any technical problems you may have.

J. Statitis, of 25 Poplar Pl., Waterbury Conn., writes: "I have repaired several sets for my friends, and made money. The "Edu-Kit" paid for itself, I was ready to spend \$240 for a course, but I found your ad and sent for your Kit."

FROM OUR MAIL BAG

Ben Valerio, P. O. Box 21, Magna, Utah: "The Edu-Kits are wonderful. Here I am sending you the questions and also the answers for them. I have been in Radio for the last seven years, but like to work with Radio Kits, and like to build Radio Testing Equipment. I enjoyed every minute I worked with the different kits; the Signal Tracer works fine. Also like to let you know that I feel proud of becoming a member of your Radio-TV Club."

Robert L. Shuff, 1534 Monroe Ave., Huntington, W. Va.: "Thought I would drop you a few lines to say that I received my Edu-Kit, and was really amazed that such a bargain can be had at such a low price. I have already started repairing radios and phonographs. My friends were really surprised to see me get into the swing of it so quickly. The Troubleshooting Tester that comes with the Kit is really swell, and finds the trouble, if there is any to be found."

UNCONDITIONAL MONEY-BACK GUARANTEE

ORDER DIRECT FROM AD—RECEIVE FREE BONUS RESISTOR AND CONDENSER KITS WORTH \$7

- Send "Edu-Kit" postpaid. I enclose full payment of \$22.95.
- Send "Edu-Kit" C.O.D. I will pay \$22.95 plus postage.
- Rush me FREE descriptive literature concerning "Edu-Kit."

Name

Address

PROGRESSIVE "EDU-KITS" INC.

1186 Broadway, Dept. 564D, Hewlett, N. Y.



Transistor Clock Radio Kit

New

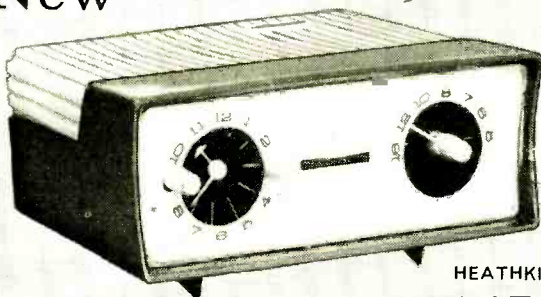

HEATHKIT TCR-1
\$45⁹⁵



LEATHER CARRYING CASE
HEATHKIT No. 93-3
Shpg. Wt. 2 lbs.
\$4⁹⁵

Everything A Clock Radio Can Offer And Portable Too!

- Completely portable, all transistor circuit
- Runs up to 500 hours on standard batteries
- Deluxe features at half the cost
- Easy to assemble—even by beginners

"YOUR CUE" TRANSISTOR CLOCK RADIO KIT (TCR-1)

Take all the deluxe features found in the most expensive clock-radios, add the convenience of complete portability, plus a modern 6-transistor battery operated circuitry . . . then slash the price at least in half, and you have the new HEATHKIT "Your Cue", Transistor Portable Clock Radio.

Packing every modern clock-radio feature into a compact, beautifully styled turquoise and ivory plastic cabinet, "Your Cue" lulls you to sleep, wakes you up, gives you the correct time and provides top quality radio entertainment any time, any place. It can also be

used with the Heathkit Transistor Intercom system, below, to provide music or a "selective alarm" system.

An "alarm-set" hand, hour hand, minute hand and sweep second hand grace the easy-to-read clock dial. The "lull-to-sleep" control sets the radio for up to an hour's playing time, automatically shutting off the receiver when you are deep in slumber. Other controls set "Your Cue" to wake you to soft music or conventional "buzzer" alarm. A special earphone jack is provided for private listening or connection to your intercom or music system.

Six easily obtainable penlight-size mercury batteries power the radio receiver up to 500 hours, while the clock operates up to 5 months from a single battery of the same type. Ordinary penlight cells may also be used, with reduced battery life. The handsome two-tone cabinet, measuring only 3½" H. x 8" W. x 7½" D. fits neatly into the optional carrying case for beach use, boating, sporting events, hunting, hiking or camping. Shpg. Wt. 5 lbs.

Transistor Intercom Kit

Master unit can call any one, any combination, or all five remote stations. Remote stations can turn system "on" and call another. Each remote unit equipped with "privacy" switch. Master unit can be connected to new transistor clock-radio shown above (or any radio not AC-DC operated) to supply music or alarm to system; separate listen and talk volume controls; handsome case of two-tone ivory and turquoise high-impact plastic. Remotes are "look-alike" miniatures of master. Eight flashlight batteries power system up to 300 hours. Master and remotes sold separately; order up to five remote stations for each master station ordered.

INTERCOM AC POWER SUPPLY (XP-1): Adapts Intercom for permanent operation from household AC current. Fits in space normally occupied by battery supply. Shpg. Wt. 2 lbs. Heathkit XP-1 \$9.95

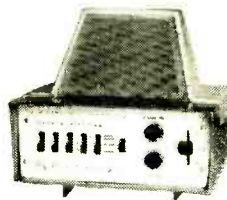

BATTERIES NOT INCLUDED
HEATHKIT XI-1 Master. **\$27⁹⁵**
Shpg. Wt. 6 lbs.
HEATHKIT XIR-1 Remote. **\$6⁹⁵**
Shpg. Wt. 4 lbs.

HEATH COMPANY / Benton Harbor, Michigan

 a subsidiary of Daystrom, Inc.

New Stereo Amplifiers

14/14-WATT STEREO AMPLIFIER KIT (SA-2)

A complete dual channel amplifier/preamplifier combination the new Heathkit SA-2, in one compact, handsomely styled unit provides all the modern features required for superb stereo reproduction... yet is priced well within your budget.

The SA-2 delivers 14 watts per stereo channel, and 28 watts total monophonic. Maximum flexibility is provided by the 6-position function switch which gives you instant selection of "Amp. A" or "Amp. B" for single channel monophonic; "Mono. A" or Mono. B" for dual channel monophonic using either preamp with both amplifiers; and "stereo" or "stereo reverse". A four position input selector switch provides choice of magnetic, phono, crystal phono, tuner, and an extra high level auxiliary input for use with tape recorder, TV, etc. The magnetic input is RIAA equalized and features 3 mv sensitivity—adequate for the lowest output cartridges available today.

The dual-concentric volume control is equipped with a friction clutch which can be set to lock the two controls together once the balancing of the two amplifiers has been accomplished.

Ganged dual tone controls adjust bass and treble response of both channels simultaneously. Proper speaker phasing may be conveniently accomplished with the speaker phase reversal switch located on the rear chassis apron. A hum balance control is provided for each channel. Two AC outlets, one controlled by the power switch, provide convenient accommodation for accessory equipment. As beautiful as it is functional, the SA-2 features the latest Heathkit styling in vinyl-clad steel with leather-like texture in black with inlaid gold design. Shpg. Wt. 23 lbs.

SPECIFICATIONS—Power output: 14 watts per channel, "hi-fi"; 12 watts per channel, "professional"; 16 watts per channel, "utility". **Power response:** ± 1 db from 20 cps to 20 kc at 14 watts output. **Total harmonic distortion:** less than 2%, 30 cps to 15 kc at 14 watts output. **Intermodulation distortion:** less than 1% at 16 watts output using 60 cps and 6 kc mixed 4:1. **Hum and noise:** mag. phono input, 47 db below 14 watts; tuner and crystal phono, 63 db below 14 watts. **Controls:** dual clutched volume, ganged bass, ganged treble; 4-position selector, speaker phasing switch. **AC receptacle:** 1 switched; 1 normal. **Inputs:** 4 stereo or 8 monophonic. **Outputs:** 4, 8 and 16 ohms. **Dimensions:** 4 $\frac{1}{2}$ " H. x 15" W. x 8" D. **Power requirements:** 117 volts, 50/60 cycle, AC, 150 watts (fused).

best stereo buy ever!



HEATHKIT SA-2
\$52⁹⁵

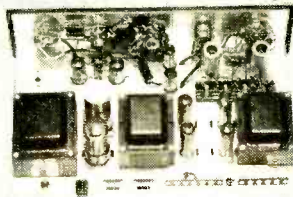

ECONOMY STEREO AMPLIFIER KIT (SA-3)

This amazing performer delivers more than enough power for pure undistorted room-filling stereophonic sound at the lowest possible cost. Featuring 3 watts per stereo channel and 6 watts as a monophonic amplifier, the SA-3 has been proven by exhaustive tests to be more than adequate in volume for every listening taste. You will find its ease of assembly another plus feature. Heathkit construction manuals, world famous for their clarity and thoroughness, lead you a simple step at a time to successful completion of the kit. Tastefully styled in black with gold trimmed control knobs and gold screened front and rear panel. A tremendous buy at this low Heathkit price. Shpg. Wt. 13 lbs.

SPECIFICATIONS—Power output: 3 watts per channel. **Power response:** ± 1 db from 50 cps, 20 kc at 3 watts out. **Total harmonic distortion:** less than 3%; 60 cps, 20 kc. **Intermodulation distortion:** less than 2% @ 3 watts output using 60 cycle & 6 kc signal mixed 4:1. **Hum and noise:** 65 db below full output. **Controls:** dual clutched volume, ganged treble, ganged bass; 7-position selector; speaker phasing switch; on-off switch. **Inputs (each channel):** tuner, crystal or ceramic phono. **Outputs (each channel):** 4, 8, 16 ohms. **Finish:** black with gold trim. **Dimensions:** 12 $\frac{1}{2}$ " W. x 6 $\frac{1}{2}$ " D. x 3 $\frac{1}{4}$ " H.

Go stereo for just \$29.95



HEATHKIT SA-3
\$29⁹⁵

New



Amplifiers



HEATHKIT EA-3
\$29⁹⁵



HEATHKIT FM-4
\$34⁹⁵



HEATHKIT UA-2
\$22⁹⁵



HEATHKIT W-7A
\$54⁹⁵



'BOOKSHELF' 14-WATT HI-FI AMPLIFIER KIT (EA-3)

Without doubt one of the finest investments you can make in a top quality amplifier and preamplifier combination. Features three switch-selected inputs, separate bass and treble tone controls, RIAA equalization and a special hum balance control. Tastefully styled in black simulated-leather with brushed gold trim. Shpg. Wt. 15 lbs.

NOTE THESE OUTSTANDING SPECIFICATIONS—Power output: Hi-Fi rating 14 watts; Professional rating 12 watts. Power response: ± 1 db 20 cps to 20 kc at 14 watts output. Total harmonic distortion: less than 2%, 30 cps to 15 kc at 14 watts output. Intermodulation distortion: less than 1% at 16 watts output using 60 cps and 6 kc signal mixed 4:1. Hum and noise: mag. phono input 47 db below 14 watts; tuner and crystal phono, 63 db below 14 watts. Output impedances: 4, 8 and 16 ohms.

HIGH FIDELITY FM TUNER KIT (FM-4)

This handsomely styled FM tuner features better than 2.5 microvolt sensitivity, automatic frequency control (AFC) with on-off switch, flywheel tuning and prewired, prealigned and pretested tuning unit. Clean chassis layout, prealigned IF transformers and assembled tuning unit makes construction simple and guarantees top performance. Flywheel tuning and new soft, evenly lit dial scale provide smooth, effortless operation. Housed in attractive vinyl-clad steel case with gold design and trim. A multiplex adapter output is also provided. Your best buy in an FM tuner. Shpg. Wt. 8 lbs.

UNIVERSAL 14-WATT HI-FI AMPLIFIER KIT (UA-2)

Living up to its title "universal" the UA-2 performs with equal brilliance in countless Hi-Fi and PA applications. Easily meets 14 watt hi-fi and 12 watt professional standards. Power response is ± 1 db from 20 cps to 20 kc at 17 watts output. Harmonic distortion is less than 2% and IM distortion is less than 1% at 14 watts output. Output taps are provided for 4, 8 and 16 ohm speakers. High quality, remarkable economy and ease of assembly make it one of the finest values in high fidelity equipment. Shpg. Wt. 13 lbs.

55-WATT HI-FI AMPLIFIER KIT (W7-A)

Best buy in its power class! Combines modern components, unique output transformer, power supply and circuit design to bring you a superb high fidelity amplifier at less than a dollar a watt. Power response is ± 1 db from 20 cps to 20 kc at full 55 watt output. Total distortion is less than 2% at full output. Output taps are 4, 8 and 16 ohms plus 70 volt line for use in wired music systems. On-off switch, gain control, and max, or unity damping switch are located on the front panel. Clean, open circuit layout are precut, cabled wiring harness for easy assembly. Shpg. Wt. 28 lbs.

STEREO-MONO PREAMP KIT (SP-2A, SP-1A)

Available in two outstanding versions! SP-2A (stereo) and SP-1A (monophonic). SP-1A convertible to stereo with conversion kit C-SP-1A. Use as the control center of your entire high fidelity system. Six inputs in each channel accommodate most any program source. Switch selection of NARTB or RIAA, LP and 78 rpm record compensation.

- HEATHKIT SP-2A (two-channel stereo). Shpg. Wt. 15 lbs. **\$56.95**
- HEATHKIT SP-1A (single-channel monophonic). Shpg. Wt. 13 lbs. **\$37.95**
- HEATHKIT C-SP-1A (converts SP-1A to SP-2A). Shpg. Wt. 4 lbs. **\$21.95**

New Tape Recorders



Have fun making your own recordings with one of these outstanding tape recorder kits

STEREO MONO TAPE RECORDER KITS

Our most versatile tape recorder kit, you can buy the new two-track (TR-1AH) or four-track (TR-1AQ) versions which record and playback both Stereo and Monophonic programming or the two-track Monophonic record-playback version (TR-1A). Precision bearings and close machining tolerances hold flutter and wow to less than 0.35%. NARTB equalization, separate record and playback gain controls and a safety interlock. Provision for mike or line inputs with 6E5 "magic eye" tube as sound level indicator.

MODEL TR-1A: Monophonic two-track record/playback with fast forward and rewind functions. Includes one TE-1 Tape Electronics Kit. Shpg. Wt. 24 lbs. \$10.00 DN., \$9.00 MO. **\$99⁹⁵**

MODEL TR-1AH: Two-track monophonic and stereo record/playback with fast forward and rewind functions. Two TE-1 Tape Electronics Kits. Shpg. Wt. 26 lbs. \$15.00 DN., \$13.00 MO. **\$149⁹⁵**

MODEL TR-1AQ: Four-track monophonic and stereo record/playback with fast forward and rewind functions. Two TE-1 Tape Electronics Kits. Shpg. Wt. 36 lbs. \$15.00 DN., \$13.00 MO. **\$149⁹⁵**

PROFESSIONAL QUALITY TAPE RECORDER KITS

Precision tape mechanism complete and tested, build only the amplifier. Two circuit boards for easy assembly, and high stability. Separate record and playback heads and amplifiers for monitoring while recording. Includes sound level meter, counter, pause control, record interlock, 2 (switch-selected) speeds 3 $\frac{3}{4}$ and 7 $\frac{1}{2}$ IPS. Response: ± 2.5 db 30 to 12,000 cps at 7 $\frac{1}{2}$ IPS. NARTB equalization. Compares to \$350 to \$400 units. Shpg. Wt. 30 lbs.

MODEL TR-1E: 4-track stereo playback, monophonic record & play. **\$169⁹⁵**

MODEL TR-1D: 2-track stereo playback, monophonic record & play. **\$169⁹⁵**

MODEL TR-1C: monophonic record playback. **\$159⁹⁵**

MODEL C-TR-1D: converts TR-1D to TR-1E, 2 lbs. **\$14.95**

MODEL C-TR-1C: converts TR-1C to TR-1D, 2 lbs. **\$19.95**

MODEL C-TR-1CQ: converts TR-1C to TR-1E, 2 lbs. **\$19.95**

New Acoustic Suspension Hi-Fi Speaker System Kit

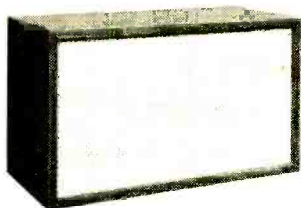

HEATHKIT AS-2M
(mahogany)
\$79⁹⁵

HEATHKIT AS-2U
(unfinished)
\$69⁹⁵

HEATHKIT AS-2B
(birch)
\$79⁹⁵

The Acoustic Research speaker is accepted as most praiseworthy in the world of hi-fi sound reproduction. Heathkit, sole kit licensee from AR Inc., now offers a kit version of this remarkable speaker system in money saving, easy to build form. The 10" acoustic suspension woofer delivers clean, clear extended range bass response and a specially designed "cross-fired" two-speaker tweeter assembly provides outstanding high frequency distribution. Response at 10 watts input ± 5 db from 42 to 14,000 cps. Impedance 8 ohms. Cabinets are preassembled and available unfinished in birch or mahogany and unfinished in furniture-grade birch only. Shpg. Wt. 32 lbs.

HEATH COMPANY / Benton Harbor, Michigan

 a subsidiary of Daystrom, Inc.

New



Ham Radio Gear

Maximum power
at minimum cost



HEATHKIT KL-1
\$415⁰⁰

Top power,
plus economy and safety

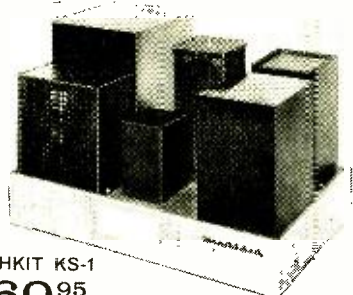

HEATHKIT KS-1
\$169⁹⁵



HEATHKIT XC-2
\$36⁹⁵



HEATHKIT UT-1
\$28⁹⁵

"CHIPPEWA" KILOWATT LINEAR AMPLIFIER KIT (KL-1)

Operates at maximum legal amateur power inputs in SSB, CW or AM service using any of the popular CW, SSB and AM exciters as a driver. Premium tubes (4-400's) push the "Chippewa" to top performance levels while a centrifugal blower provides maximum cooling. Shpg. Wt. 70 lbs.

SPECIFICATIONS—RF section: Driving power required (10 meters): Class AB1 (tuned grid) 10 watts peak; Class C (tuned grid) 40 watts; Class AB1 (swamped grid) 60 watts peak. **Power input:** Class AB1 (SSB-voice modulation) 2000 watts PEP; Class AB1 (SSB-two tone test) 1300 watts; Class AB1 (AM linear) 1000 watts; Class C (CW) 1000 watts. **Power output (20 meters):** Class AB1 (SSB-voice modulation) 900 watt PEP; Class AB1 (SSB-two tone test) 550 watts; Class AB1 (AM linear) 300 watts; Class C (CW) 750 watts. **Output impedance:** 50 to 72 ohms (unbalanced). **Band coverage:** 80, 40, 20, 15 and 10 meters. **Panel metering:** 0 to 50 ma, grid current; 0 to 100 ma screen current; 0 to 5000 plate voltage, 0 to 1000 ma plate current. **Tube complement:** Final tubes, (2) 4-400A; clamp tube (1) 6DQ6; voltage regulators, (4) OD3, (2) OC3. **Power requirements:** AC (power supply primary circuit), 250 watts, 115 volt, 50/60 cycles; DC, 3000 to 4000 volts, 450 ma. **Cabinet size:** 19½" W. x 11½" H. x 16" D.

KILOWATT POWER SUPPLY KIT (KS-1)

Ideal companion for the "Chippewa" Linear Amplifier . . . and supplies plate power to most other RF amplifiers in medium to high power class. Features oil-filled, hermetically sealed plate transformer and 60 second time delay relay. Shpg. Wt. 105 lbs.

SPECIFICATIONS—Maximum DC power output: 1500 watts. **Nominal DC voltage output:** 3000 or 1500 volts. **Maximum DC current output:** Average 500 ma, peak 1000 ma. **Regulation:** 180 to 600 ma (typical linear amplifier), 8%; 0 to 300 ma (typical class C amplifier), 10%; 0 to 500 ma, 15%. **Ripple:** Less than 1%. **Tube complement:** (2) 866A mercury vapor rectifier. **Recommended ambient temperature:** 50 to 100 degrees F. **Circuit:** Two half-wave mercury vapor rectifiers in a full wave, single-phase configuration with swinging choke input filtering. **Line power requirements:** 115 V, 50/60 cycles, 20 amperes; 230 V, 50/60 cycles, 10 amperes. **Chassis size:** 17½" W. x 12" H. x 13" D.

2 METER CONVERTER KIT (XC-2)

Extends coverage of the Heathkit "Mohawk" Receiver to the 2 meter band. Use also with receivers tuning a 4 mc segment between 22 and 35 mc with appropriate crystal. Shpg. Wt. 7 lbs.

"BEST BUY" UTILITY POWER SUPPLY KIT (UT-1)

Converts "Cheyenne" and "Comanche" mobile transmitter and receiver to fixed station operation. May also be used to provide filament and plate voltage for wide variety of ham gear. Shpg. Wt. 15 lbs.

FM TEST OSCILLATOR KIT (FMO-1)

Complete FM test facilities in one compact, easy to use instrument. First of its kind on the market.

SPECIFICATIONS—Output frequencies: for RF alignment, 90 mc (FM band low end), 100 mc (FM band middle range), 107 mc (FM band high end). **Modulation:** 400-cycle incidental FM. **IF and detector alignment:** 10.7 mc sweep. **Sweep width markers:** 200 kc to over 1 mc, variable, 10.7 mc (crystal), 100 kc sub-markers. **Modulation:** 400-cycle AM. **For other applications:** 10.0 mc (crystal) and harmonic; 100 kc, 400-cycle audio. **Controls:** main frequency selector, modulation switch/concentric level control, marker oscillator switch/concentric level control, sweep width—power switch, output control, AF-RF (source impedance) switch. **Power supply:** transformer, selenium rectifier. **Power requirements:** 105-125 V, 50/60 cycles, 12 watts. **Cabinet size:** 7¾" H. x 4¾" W. x 4¾" D.

RF SIGNAL GENERATOR KIT (RF-1)

High precision performance . . . for troubleshooting and aligning RF and IF circuits of all kinds. Preassembled and aligned bandswitch/coil assembly. Shpg. Wt. 7 lbs.

SPECIFICATIONS—Frequency range: Band A, 100 kc to 320 kc; Band B, 310 kc to 1.1 mc; Band C, 1 mc to 3.2 mc; Band D, 3.1 mc to 11 mc; Band E, 10 mc to 32 mc; Band F, 32 mc to 110 mc. **Calibrated harmonics:** 110 mc to 220 mc. **Accuracy:** 2%. **Output:** Impedance, 50 ohms; voltage, in excess of 100,000 uv on all bands. **Modulation:** internal, 400 cycles approx. 30% depth; external, approx. 3 V across 50 k ohm for 30%. **400 cycles audio output:** approx. 10 V open circuit. **Tube complement:** V1 12AT7 RF oscillator, V2 6AN8 modulator and output. **Power requirements:** 105-125 V, 50/60 cycles AC, 15 watts. **Aluminum cabinet dimensions:** 6½" W. x 9½" H. x 5" D.

New Test Equipment

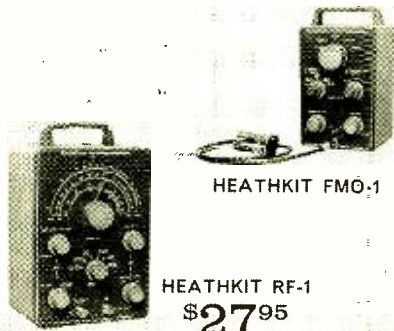

HEATHKIT RF-1
\$27⁹⁵

HEATHKIT FMO-1

New Citizen's Band Transceiver

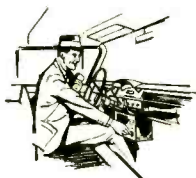

**WIRED OR
KIT FORM!**



Kit Model, Heathkit CB-1 \$42.95
Wired Model, Heathkit W-CB-1 \$60.95 (\$6.10 dwn. \$6.00 mo.)
Both Models Include Transceiver, crystal, microphone and
Two Special Power Cords.

ANTENNAS

- CBU-1 "UTILITY" ANTENNA** \$9.95
Good coverage, portable antenna for temporary mobile or
fixed installations. Shpg. Wt. 3 lbs.
- CBM-1 "MOBILE" ANTENNA** \$19.95
Best coverage mobile antenna. 9' whip.
Bumper mount. Shpg. Wt. 7 lbs.
- CBF-1 "FIXED LOCATION" ANTENNA** \$19.95
Excellent coverage, 1/2 wave, 9' elements. 50' connecting cable
and mounting bracket. Shpg. Wt. 7 lbs.

WIRED AND KIT FORM POWER SUPPLIES FOR MOBILE USE OF CB-1

- 6-VOLT VIBRATOR POWER SUPPLY**
- KIT: model VP-1-6, Shpg. Wt. 4 lbs. \$7.95
- WIRED: model W-VP-1-6, Shpg. Wt. 4 lbs. \$11.95
- 12-VOLT VIBRATOR POWER SUPPLY**
- KIT: model VP-1-12, Shpg. Wt. 4 lbs. \$7.95
- WIRED: model W-VP-1-12, Shpg. Wt. 4 lbs. \$11.95

CITIZEN'S BAND TRANSCEIVER KIT (CB-1)

Have your own wireless communications system! Make necessary personal contacts with family, friends, or associates from your car, home, boat or office. Light, compact, easy to use, the Transceiver reliably covers distances from one to ten miles depending on location, antenna and type of installation. Transmitter frequency is crystal controlled. Receiver tunes any of the 23 channels assigned to the 11 meter "Citizen's Band". Operates from 117 volt AC line using internal power supply, or from 6 or 12 V. batteries using separate vibrator power supply. Can be transferred in minutes from fixed to mobile operation. All pertinent FCC regulations, and station license application forms are furnished. Comes complete with microphone, two power cords, station identification card, set of stick-on call letters and crystal for one channel. Smartly styled in rich mocha and beige. Shpg. Wt. 10 lbs.

FREE Send now for latest Heathkit Catalog describing in detail over 100 easy-to-assemble kits for the Hi-Fi fan, radio ham, boat owner and technician.



*pioneer in
do-it-yourself
electronics*

HEATH COMPANY / BENTON HARBOR 10, MICH.

Da subsidiary of Daystrom, Inc.

Send latest Free Heathkit Catalog.

All prices and specifications subject to change without notice. Please include postage on orders to be shipped parcel post. 20% deposit is required on all C.O.D. orders. All prices are NET F.O.B. Benton Harbor, Mich., and apply to Continental U.S. and Possessions only.

NAME _____

ADDRESS _____

CITY _____ ZONE _____ STATE _____

QUAN.	MODEL NO.	KIT NAME	PRICE

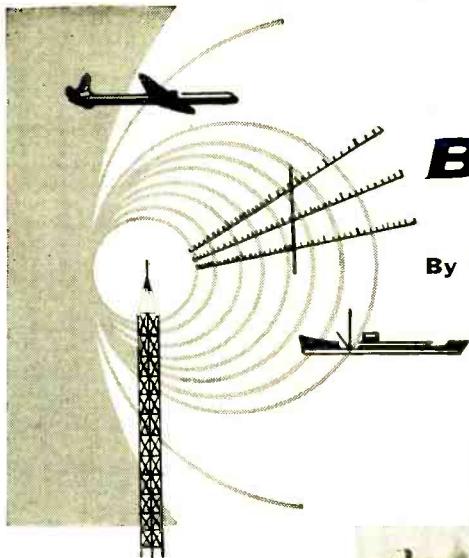

Bandspread

By TOM KNEITEL, WPE2AB

**Time signals from
England and other
DX'ing delicacies**

FAR FROM the hustle and bustle of the bulging short-wave broadcast bands, peeking out every now and then under QRM is Station MSF, located in Rugby, England. MSF is the British answer to our own WWV.

Operated by The National Physical Laboratory, MSF sends out signals accurate to one-part-in-one-million on 60, 2500, 5000, and 10,000 kc. Their signal consists of the familiar time pulses alternated with a 1000-cps tone. There is also a voice transmission during the last minute of each quarter hour period.

Station MSF operates 24 hours per day on the short-wave channels, and one hour on 60 kc. The latter transmission is at 1959 GMT (1459 EST) and they run 10 kw. on this broadcast. The transmitters on the other frequencies are 500-watt jobs.

It doesn't take a wheelbarrow of imagination to realize that MSF is going to be a



Station MSF is the British counterpart of our Station WWV. Short-wave listeners can pick up MSF's ultra-accurate signals during WWV's toneless periods. Top photo shows a station operator checking the equipment. (Photos courtesy of British Information Services)

tough baby to coax out from under WWV's steamroller signal. Your best bet is to go for the 1-minute voice ID under the last half of WWV's toneless periods (13, 28, 43, and 58 minutes past the hour). Try between 2100 and 0400 GMT (1600-2300 EST).

This station's message to DX'ers is: "The MSF service of transmissions is still experimental and reports concerning reception will be welcomed. They should be addressed

(Continued on page 102)

Learn Radio-TV Electronics

*by Practicing
at Home in
Spare Time*

Without Extra Charge

You Get special NRI kits developed to give actual experience with Radio-TV equipment. You build, test, experiment with receiver or broadcasting circuits. Keep all equipment.



Have High Pay, Prestige, Good Future as a Skilled Radio-TV Electronic Technician

People *look up to* and depend on the Technician, more than ever before. His opportunities are great and are increasing. Become a Radio-TV Electronic Technician. At home, and in your spare time, *you* can learn to do this interesting, satisfying work—qualify for important pay.

A steady stream of new Electronic products is increasing the job and promoting opportunities for Radio-Television Electronic Technicians. Right now, a solid, proven field of opportunity for good pay is servicing the tens of millions of Television and Radio sets now in use. The hundreds of Radio and TV Stations on the air offer interesting jobs for Operators and Technicians.

More Money Soon—Make \$10 to \$15 a Week Extra Fixing Sets in Spare Time

NRI students find it easy and profitable to start fixing sets for friends a few months after enrolling, pick up \$10, \$15 and more a week extra spending money. Many who start in spare time soon build full time Radio-Television businesses.

Act Now—See What NRI Can Do for You NRI has devoted 40 years to developing simplified practical training

methods. You train at home, learn by doing.

NATIONAL RADIO INSTITUTE
Wash. 16, D. C.



NRI Has Trained Thousands for Successful Careers in Radio-TV



Studio Engr., Station KATV
"I am now Studio Engineer at Television Station KATV. Before enrolling, I was held back by limitation of a sixth grade education." **HILLY SANCHEZ**, Pine Bluff, Ark.

Has All the Work He Can Do
"I have repaired more than 2,000 TV and Radio sets a year. NRI training certainly proved to be a good foundation." **H. R. GORDON**, Milledgeville, Georgia

Has Good Part Time Business
"Early in my training I started servicing sets. Now have completely equipped shop. NRI is the backbone of my progress." **E. A. BREZA**, Tacoma, Washington

▶ ▶ ▶ ▶ **SEE OTHER SIDE** ▶ ▶ ▶ ▶

Cut Out and Mail This Card—No Stamp Needed

Sample Lesson and Catalog Both Sent FREE

OLDEST & LARGEST HOME STUDY RADIO-TV SCHOOL
National Radio Institute
Dept. 6, Washington 16, D.C.

Please send me sample lesson of your Radio-Television Training and Catalog FREE. (No salesman will call.)

Name.....Age.....

Address.....

City.....Zone.....State.....

ACCREDITED MEMBER NATIONAL HOME STUDY COUNCIL

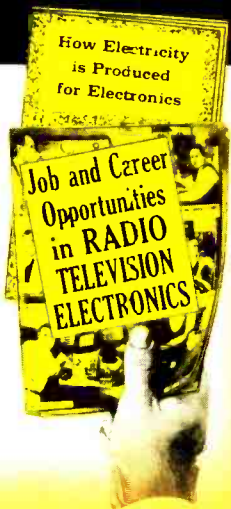

NRI SUPPLIES LEARN-BY-DOING KITS WITHOUT EXTRA CHARGE
Technical Know-How Pays Off in Interesting, Important Work



YOU BUILD AC-DC Superhet Receiver

NRI Servicing Course includes all needed parts. By introducing defects you get actual servicing experience practicing with this modern receiver. Learn-by-doing.



YOU BUILD This 17 Inch Television Receiver

As part of your NRI course you can get all components, tubes, including 17" picture tube to build this latest style Television receiver, get actual practice on TV circuits

YOU BUILD Broadcasting Transmitter

As part of NRI Communications Course you build this low power Transmitter, learn commercial broadcasting operators' methods, procedures. Train for your FCC Commercial Operator's License.

YOU BUILD Vacuum Tube Voltmeter

Use it to earn extra cash fixing neighbors' sets, bring to life theory you learn from NRI's easy-to-understand texts.



For Higher Pay, Better Jobs
Be a Radio-TV Electronic Technician



Servicing Needs More Trained Men

Portable TV, Hi-Fi, Transistors, Color TV are making new demands for trained Technicians. Good opportunities for spare time earnings or a business of your own. Enjoy prestige.



Train at Home the NRI Way Famous for Over 40 Years

J. E. Smith, Founder

NRI is America's oldest and largest home study Radio-Television school. The more than 40 years' experience training men, the outstanding reputation and record of this school—benefits you many ways. Successful graduates are everywhere, in small towns, big cities. You train in your own home, keep your present job while learning. Let us send you an actual lesson, judge for yourself how easy it is to learn.

Broadcasting Offers Satisfying Careers

4000 TV and Radio stations offer interesting positions. Govt. Radio, Police, Two-Way Communications are growing fields. Trained TV-Radio Operators have a bright future.



No Experience Necessary - NRI Sends Many Kits for Practical Experience

You don't have to know anything about electricity or Radio to understand and succeed with NRI Course. Clearly written, illustrated NRI lessons teach Radio-TV-Electronic principles. You get NRI kits for practical experience. All equipment is yours to keep. Mailing the postage-free card may be one of the most important acts of your life. Do it now. Reasonable tuition, low monthly payments available. National Radio Institute, Wash. 16, D.C.

FIRST CLASS
 Permit No. 20-R
 (Sec. 34.9, P. L. & R.)
 Washington, D.C.

NRI Graduates Do Important Work



NRI Course Easy to Understand
 "Opened my own shop before receiving diploma. I am independent in my own business." D. P. CRESSEY, Stockton, California.

Works on Color TV
 "NRI changed my whole life. If I had not taken the course, probably would still be a fireman, struggling along." J. F. MELINE, New York.

BUSINESS REPLY CARD
 No Postage Stamp Necessary if Mailed in the United States

POSTAGE WILL BE PAID BY
NATIONAL RADIO INSTITUTE
3939 Wisconsin Avenue
Washington 16, D.C.

See Other Side

SAMPLE LESSON
64-page CATALOG
both FREE

NEW FOR 1960! INTRODUCTORY OFFER!

FREE! CHOOSE 2 ANY PAKETTES

WITH EVERY 12 PAKETTE ORDER

6 PAKETTE ORDERS—CHOOSE ANY 1 PAKETTE FREE

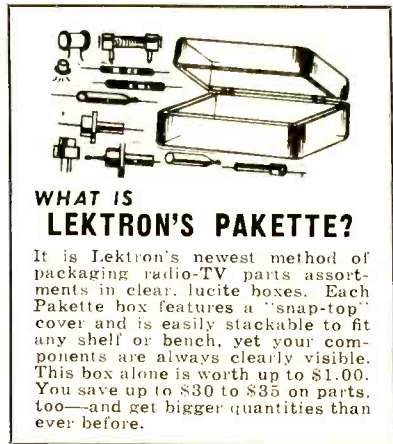

WHAT IS LEKTRON'S PAKETTE?

It is Lektron's newest method of packaging radio-TV parts assortments in clear, lucite boxes. Each Pakette box features a "snap-top" cover and is easily stackable to fit any shelf or bench, yet your components are always clearly visible. This box alone is worth up to \$1.00. You save up to \$30 to \$35 on parts, too—and get bigger quantities than ever before.

LISTED BELOW

Pick your FREE PAKETTES from this listing!

MINIMUM \$2.00 ORDERS
CLIP 'N MAIL USE AS ORD-GRAM



- | | | | |
|--|--|---|--|
| <p>30 "SEALED" CIRCUITS
Built-in resistor coupling networks. Reg. \$20. \$1</p> <p>40 MOLDED CONDENSERS
0.0001 to 1 to 1000VDC. Oils, porcelain, black beauties. Reg. \$30. \$1</p> <p>65 RESISTOR SPECIAL
W.W., & carbon, precision, power, variable, mini. types too. 1/2W to 50W. Reg. \$17. \$1</p> <p>40 POWER RESISTORS
5 to 50W to 10,000 ohms. Reg. \$15. \$1</p> <p>50 TRANSISTOR COND.
Mini condensers: 0.00025 to 0.1 mf. In 100's of trans. sets. Reg. \$7. \$1</p> <p>100 HALF WATTERS
Resistors: carbon, 10 ohms to 2 meg. 10% tol. Pop'r makers. Reg. \$10. \$1</p> <p>15 "GRAIN-O-WHEAT"
Lamps: by G-E, 1.5 VDC. For mini. work. Worth 25¢ ea. \$1</p> <p>70 MICA CONDENSERS
0.00025 to .01 to 1000VDC. "Silvers" too. 20 val-ues. Reg. \$13. \$1</p> <p>35 TWO WATTERS
10 ohms to 500K, 5% too. 100 ohms to 500K, 5% too. Reg. \$8. \$1</p> <p>15 ROTARY SWITCHES
1, 2, 3 rang. long shafts. Pop'r types. Reg. \$15. \$1</p> <p>15 VOLUME CONTROLS
Long & single shafts. Up to 1 meg. Sizable, duals. 5 switch types. Reg. \$20. \$1</p> <p>2 SOLAR BATTERIES
Generates power from Sun & "dark" light. 100's of projects. Reg. \$4. \$1</p> <p>20 TWIST DRILLS
1/16 thru 1/4" with cali-brated case. For electric drills. Reg. \$2.50. \$1</p> <p>24 ARTISTS BRUSHES
1 to 6 sizes. 100% pure camel hair bristles. \$1</p> <p>40 HI Q CONDENSERS
SPO's, standoff types too. 20 values. Finest, prec. quality. Reg. \$9. \$1</p> <p>60 TERMINAL STRIPS
Solder lug type; 0.1 to 10 lugs. Used in every elec. proj. \$1</p> | <p>\$25 SURPRISE PAKETTE
Wide variety of radio n popular electronic parts. \$1</p> <p>70 TUBULAR CONDENSERS
20 values, 0.0001 to 1 mfd to 1000 VDC. Reg. \$10. \$1</p> <p>30 "SILVER" MICAS
1 & 5%. Asst. values. \$1</p> <p>70 INSULATED RESIST'S
Carbon, 1 & 5% tol. 10 ohms to 10 meg. 30 values. 1/2, 1, 2W. Reg. \$15. \$1</p> <p>10 RCA PLUG 'N JACK SETS
Matched pairs. For tun-ers, amps, recorders. \$1</p> <p>300-FT. HOOK-UP WIRE
16 thru 24 Plastic glass, insulated. Asst. colors. \$1</p> <p>60 RADIO-TV KNOBS
Asst. colors, set screw type too! Plastic 1/4" to 4" dia. Some \$1 ea. \$1</p> <p>50 ONE PERCENT-ERS
Precision carbon-film resis-tors. Nifty lab case. 15 val-ues. 100 ohms to 1 meg. \$1</p> <p>60 CONDENSER SPECIAL
Incl. molded, porcelain, oils, electrolytic, mica, disc. \$1</p> <p>5 ROLLS MICRO-WIRE
#24 to #32. Asst. colors; insulation. Tinned. \$1</p> <p>1500 PCS HARDWARE
Nuts, bolts, screws, brack-ets, etc. Handy shop \$1 pakette.</p> <p>3 HOBBY TRANSISTORS
For experimental & shop use. Specs unknown. \$1 Worth \$3 ea.</p> <p>WORLD'S SMALLEST RADIO
Kit. Germanium powered. Lasts for life. Incl. all parts, instructions. \$1</p> <p>12 GERMANIUM DIODES
For radio & TV detectors. Limiters, rectifiers. Glass sealed, lead leads. \$1</p> <p>125 RESISTORS
Non-insulated. 30 popular values: 1/2, 1, 2W, 5% too. 10 ohms to 10 megs. Reg. \$15. \$1</p> <p>10-IN-1 PAKETTE
Incl. diodes, resistors, electros, sockets, lites, wire, knobs, v-controls, strips, condensors. \$1</p> <p>TRANSISTOR RADIO BASIC
Incl. transistor & socket, diode, loonstick. In \$1 handy pakette.</p> | <p>2 POWER TRANSISTORS
Handles 10 watts. For audio circuits in cars, etc. \$1 Worth \$10 ea.</p> <p>2 SILICON RECTIFIERS
500 mill. Axial leads. Size of 1W resistor. Reg. \$3. \$1 ea.</p> <p>8-PC. NUTDRIVER SET
Molded, lucite handle. Nickel socket wrenches. 3/16, 7/32, 1/4, 5/16, 11/32, 7/16". In carry case. \$1</p> <p>10 PANEL SWITCHES
115 VAC. micro, glide, etc. Some worth \$1.00 ea. \$1</p> <p>4 OUTPUT XFMR'S
50LB, 6V6, 6K6, etc. Open frame types. Some worth \$2.50 ea. \$1</p> <p>2 FLEA POWER MOTORS
1 1/2 VDC. Powerful. 100's of control uses. \$1</p> <p>40 TUBE SOCKETS
4, 5, 6, 7, 8, 9 pins. Octal, mini types. Some shield. mica, ceramic. Reg. \$10. \$1</p> <p>30 PILOT LITES
Mini bay, & screw types. "Grain o' wheat" too. 1.5 to 6V. \$1</p> <p>40 DISC CONDENSERS
Incl. world's tiniest; only 1/4" x 10mmf to 1000 VDC. \$1</p> <p>15 "POLY PAKETTES"
Incl. poly boxes, vials, asst sizes. For radio, TV sub-mini parts. \$1</p> | <p>15 ELECTROLYTICS
PP & tubular paper & can types. Single, duals & triple values. 10 to 500 mf to 450 VDC. Reg. \$20. \$1</p> <p>100 CERAMIC SPECIAL
Incl. discs, SPO's, molded, tubular, dog bones, 25 \$1 values.</p> <p>75 ONE WATTERS
Resistors incl 1 & 5% car-bons, 20 popular values. \$1 Reg. \$18.</p> <p>2 POSTAGE STAMP MIKE
Crystal. By Brush. 1" sq. Nifty, "hide-away" unit. 100 to 7000 cps response. \$1</p> <p>7 SILICON DIODES
Used in prov'l & "space" work. 1N21; 1N22, etc. \$1 Worth \$10 ea.</p> <p>70 COILS & CHOKES
IP, ant. osc., slug-tuned, & IP styles. 15 types. \$1 Reg. \$22.</p> <p>60 PLUGS & REC'T'LS
Power, battery, audio, 15 types. \$1</p> <p>15 POLY VIALS
For stocking submini & trans-istor parts. E-Z to see, to read, to "stick". Asst. \$1 sizes.</p> <p>CRYSTAL PHONE
Use as mike too! W cord & plug set. Hearing aid type. 100 to 6000 cps resp. \$1</p> |
|--|--|---|--|

Due to the larger physical size a few assortments, poly paks are used!

CIVIL DEFENSE! BUSINESS! DOCTORS! HOSPITALS! HOMES! FARMS! BOATS! TAXIS! CONTRACTORS!



PHILMORE CITIZENS' BAND 2-WAY TRANSCEIVER

- NO FCC LICENSE REQUIRED!
 - NO TESTS OR CODE TO LEARN!
 - ANYONE CAN GET LICENSE!
- \$39⁹⁵ KIT**

Easy-to-build, step-by-step pictorials designed by world's finest engineers. Crystal controlled, up to 10 miles distance, 5-watt output, 22-channels for xmitr & revr. Includes all parts, mike, crystal, cabinet, 12 lbs. TC11 for 115VAC, \$39.95 (TC612 for 6 & 12VDC, \$44.49). TC15 whip antenna, \$4.50.

FREE! GIANT BARGAIN CATALOG YEAR'S SUBSCRIPTION

Include check or M.O. with sufficient postage; excess returned. C.O.D. orders, 25% down; rated, net 30 days.

INCLUDE POSTAL ZONE in address. (Canada postage, 48c 1st lb.; 28c ea. add'l lb.)

My FREE PAKETTES are:

- Check each item wanted
- Return ad with order
- Avg. wt. 1 lb. per Pakette
- Each Pakette guaranteed

1. _____

2. _____

LEKTRON 135 EVERETT AVE. CHELSEA 50, MASS.

January, 1960

to The Director, National Physical Laboratory, Teddington, Middlesex, England." So, go to it, gang! A QSL from MSF will make you the fastest overnight sensation since King Kong broke loose in Times Square.

U. S. Navy. Are there any of you who aren't "Gung Ho!" enough to know that the whopping c.w. signal just a hair's breath outside of the high end of the 75-meter ham band is Station NSS of the U. S. Navy in Washington?

Oddball Signal. Ben Jackson, WPE-6KJ/W6JF, of Dana Point, Calif., reports hearing a very strong unmodulated carrier on about 30 mc. On most of the day, the carrier is interrupted every half hour and the call letters WWI are sent in c.w. (dit-

Request a verification, but don't expect to hear from them for a long time. The speed with which reports are processed makes Rip Van Winkle look like a 100-yard dash star. About six months after you send the report you'll receive a verification card and a booklet describing the satellite you heard.

The QSL's themselves are the standard red, white, and blue VOA cards with "EXPLORER," "PIONEER," or "VANGUARD" printed across the face in red block letters. They'll be a prized addition to the wall of your shack.

"Utility" Lists. Of late, a big chunk of the mail we receive is from fellows interested in knowing where they can latch onto

You can get an "Explorer" QSL card—as well as other satellite veries for your "off-beat" collection—from Voice of America.



dahdah-ditdahdah-ditdit). Then, after a minute and three quarters of golden silence, it's back for another half-hour stint. Ben's cubical quad antenna says that WWI is towards the east, which makes us suspect that this is a station of the National Bureau of Standards in Havana, Ill., which has been heard testing on about 5052 kc.

We used to hear a station signing WWI in the 2-mc. region—in fact, it sent the same type of unmodulated carrier as the 30-mc. station. It was generally believed that the 2-mc. station was run by the NBS in Sterling, Va.; however, this signal hasn't been heard since the days when Yul Brynner had hair.

QSL'ing U. S. Satellites. We were quite surprised to learn that many of the gang did not know that they could grab off verifications from our satellites. If you should meet up with signals from one of these gizmos, dash out a detailed report and send it to the Voice of America, Washington 25, D. C.

lists of the various "utility" stations. International press and telephone station lists, as well as lists of aero stations, beacons, ship, fixed maritime, and special service stations, are published by The Secretary General, International Telecommunications Union, Palais Wilson, Geneva, Switzerland. You can write direct for a catalog and prices. By the way, these Swiss lists cost a pretty penny, so be prepared.

Excellent lists of world-wide weather and beacon stations are made up and sold by the Hydrographic Office of the U. S. Navy. Write to them in Washington, D. C., and ask for data on publications "H.O. 205" and "H.O. 206." They're our "Bibles" here.

Police, fire, taxi, forestry, power utility, radio paging, emergency and other two-way stations heard in the 30 to 50 and 150 to 170 mc. bands are included in lists sold by The Communications Engineering Book Company, Radio Hill, Monterey, Mass. Tell 'em we sent you.

Latest word on new stations, frequency

changes and schedules can be obtained from the "Utilities" section of a good "DX Club" monthly bulletin. From experience, we have found the "Utility" section in the Newark News Radio Club's paper to be as handy as a third ear in a DX contest. This section is officiated by Charles McCormick, one of the best "utility" experts in these parts. You can get a sample bulletin and membership information from club HQ at 215 Market Street, Newark, N. J.

Bringing Home the Beacon. Interesting DX can be rolled up on the medium-frequency aero beacon band, which runs from the high end of the standard broadcast band at 1605 kc. and goes to 1750 kc. Most of these beacons are located in the Caribbean and South American areas, and even with low power they are often received on one-lung receivers as far away as northern Canada.

Some recently reported beacons are listed in the accompanying table. Their c.w. identification is sent at snail's pace, so you can probably copy them with little or no difficulty even if your c.w. knowledge is nil. Try after 2200 GMT (1700 EST); pickup will be best after midnight, when the strong local broadcast stations are off the air. You'll find that most of the medium-wave beacon stations will QSL.

Well, back to the headphones for a while; hope we'll meet again soon. Let us hear about some of the utility stations you've captured.

-30-

Frequency (kc.)	Identification	Location
1610	CTG	Cartagena, Columbia
1612	CHA	Charana, Bolivia
1613	RAB	Rabinal, Guatemala
1618	LMM	Los Mochis, Mexico
1625	MZT	Mazatlan, Mexico
	TIKX	El Coco, Costa Rica
	TIKY	Coco Solo, Costa Rica
1648	TDE	La Libertad, Guatemala
1649	ASC	Ascencion, Bolivia
1668	HMU	Hermosillo, Mexico
1680	NAU	Nautla, Mexico
1688	CTM	Chetumal, Mexico
	PPE	Puerto Penasco, Mex.
1690	MDE	Medellin, Columbia
1705	LPZ	La Paz, Bolivia
1710	IQQ	Iquique, Chile
1719	MZL	Manzanillo, Mexico
1720	VER	Vera Cruz, Mexico
1730	NOR	Guatemala City, Guatemala

Some of the active medium-wave beacon stations which can be easily heard throughout North America.

January, 1960

"best
35¢
I ever
spent"

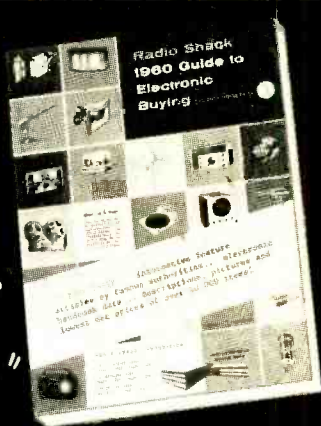

From every corner of the electronics world comes this unanimous report: Radio Shack's new "king size" 312-page Guide to Electronic Buying is the most comprehensive, most exciting catalog bargain ever! Send for yours today!

"Outstanding in the industry . . .", comments a Pennsylvania hi-fi enthusiast. "Tops! . . .", says a Michigan radio amateur. A hi-fi manufacturer writes, ". . . congratulations . . . excels all others I have ever seen".

81,000 copies already sold in the few short months since its publication! Hundreds of unsolicited "testimonials" tell us that we've published not merely another "free catalog", but literally an electronics education worth many dollars.

Over 10,000 products listed in its 312 rotogravure 8½ x 11 pages — test equipment, laboratory supplies, stereo and high fidelity components and accessories, products for industry, public address, ham gear, optical goods, electronic textbooks, records, tape, tools — with lowest net prices, clearly written specifications, fine quality halftone illustrations.

Stimulating articles and helpful engineering data, too. On pages 8-9, for example, is an article entitled "Selecting Your Stereo System". On pages 41-42 the internationally known authority G. A. Briggs explains "Room Acoustics". And beginning on page 301 you'll see Radio Shack's quick-reference "Handbook" of electronic specifications, symbols, schematic diagrams and formulas for students and engineers.

Fill out this coupon now.

Radio Shack Corporation, Dept. 1B
730 Commonwealth Avenue, Boston 17, Mass.

Please send POSTPAID the new 1960 Radio Shack Guide to Electronic Buying. I enclose 35¢. Cash Check M.O.

Name _____

Address _____

City _____ Zone _____ State _____

New Guide also on sale in our 3 stores:
167 Washington St., Boston 8, Mass.
730 Commonwealth Avenue, Boston 17, Mass.
230 Crown St., New Haven 10, Conn.

By
JOHN T. FRYE
W9EGV



Carl and Jerry

Whirling Wheel Magic

CARL CAME through the outside door of the basement laboratory stamping the wet snow from his boots. Jerry, busy at the bench, waved a greeting without looking up. A semicircle of wire arched up from the top of the bench in front of him. At the center of the semicircle was fastened a powerful alnico magnet salvaged from a PM speaker. In Jerry's hand was a two-inch square of cardboard with a thread fastened to its center. A small iron nut was attached to the end of the thread, and the attraction of the nut to the magnet kept the thread taut as Jerry slowly moved the piece of cardboard in a tangential position around the edge of the semicircle.

"What's the significance of the two nuts on the thread?" Carl asked as he wiped the steam from his glasses.

"You'd better get those eye crutches changed," Jerry advised sarcastically. "There's only one nut on that thread."

"I see one on both ends of it!" Carl chortled as he thumped his pal lustily between the shoulder blades.

Jerry decided to ignore this display of so-called humour. "Before you ask," he said, "I'm trying to understand SPIRE, or Space Inertial Reference Equipment. Last fall I saw a *Conquest* program on TV about it that has been haunting me ever since. Dr. Charles S. Draper, Director of the Instrumentation Laboratory of the Department of Aeronautics and Astronautics of M. I. T. and the inventor of SPIRE, together with Eric Severeid as commentator, gave a demonstration to curl your hair. They made a trip in a B29 from the East Coast to Los Angeles, some 2250 nautical miles, in which the pilot never touched the controls after take-off until the plane arrived directly over Los Angeles, its pre-set destination, some twelve hours later.

SPIRE controlled the plane during the entire trip and kept them informed as to their exact location every minute of the time."

"Dr. Draper gave a simplified description of the apparatus in which he said it basically consisted of a gyroscope, a pendulum, and a clock," Jerry continued as he walked to the other end of the bench and flipped a switch. An electric motor, about the size and shape of one used on a large electric fan, began to hum; and as the seconds ticked away, this hum kept climbing in pitch as the motor increased its speed.

"This is a gyroscope out of a surplus bomb sight that's supposed to operate on 28 volts d.c.," Jerry explained. "I'm running it off this storage battery substitute that will only put out 20 volts maximum; so the motor won't come up to full speed; but it's going fast enough to acquire strong gyroscopic characteristics. Take hold of the top of it and try to twist it around."

Carl grasped the top of the whining motor with his large strong hand and tried to twist it in a clockwise direction. Instead of moving in that direction, the motor very, very slowly began to tip backward. When he tried to turn it counterclockwise, it slowly straightened up.

"THE IMPORTANT THING about a gyroscope," Jerry said as he went back and picked up his piece of cardboard, "is that it tends to keep its spin axis fixed in one position with regard to space. You can move it about all you wish without resistance until you try to twist that spin axis out of position; then you meet with a lot of stubborn resistance.

"Now suppose we have a platform, represented by this little piece of cardboard, with three gyroscopes mounted on it, each with

its spin axis at right angles to the other two; and suppose the platform is gimbal-mounted so that the twisting and turning of the device on which the platform is carried will not be imparted to the platform. Do you see that the combined action of the gyroscopes will keep this platform in exactly the same position with regard to space that it had when the gyroscopes were started?

"Suppose," Jerry continued, "that we pointed this front edge exactly at Los Angeles and leveled the platform perfectly at our East Coast starting point. Let's say the top of this semicircle of wire, representing the curved surface of the earth, is

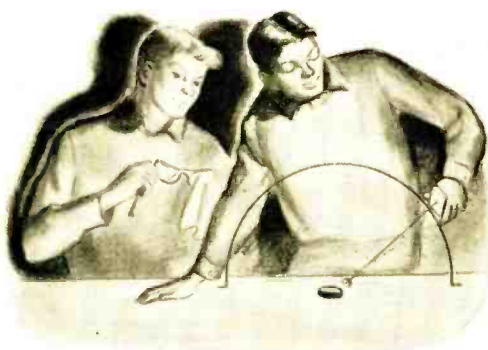

that point. Note that our pendulum, which gravity, represented by the magnet, always pulls toward the center of the earth, is hanging straight down and so is perpendicular to the plane of the platform."

"Gotcha, Professor!" Carl encouraged.

"Okay. Now note that as our plane flies along the great-circle path to Los Angeles, our gyro-stabilized platform keeps its exact position in space so that it *seems* to be revolving slowly on an axis through the plane's wings, and our center-of-the-earth-pointing pendulum makes a decreasing angle with the 'back' of the platform. Quarter-way around the earth the angle between the pendulum and the back of the platform would be zero; half-way around, the pendulum would again be perpendicular to the platform on the opposite side."

"I think I get the idea!" Carl interrupted. "To find where you are on the earth's surface at a given moment, all you have to do is measure the angle the pendulum makes with the platform!"

"Almost right!" Jerry applauded; "but keep in mind that the earth is turning all the time you're flying. That's where the

clock comes in. It keeps track of the turning globe beneath the plane. Information from both the clock and the platform-pendulum combination is fed into a computer that keeps track of the plane's position on the face of the globe. Moreover, if the plane veers to the right or left of the proper great-circle path, the pendulum shows this and a correcting command is given to the plane.

"Of course, the pendulum is not a simple thing like this nut hanging on a thread, or it would be thrown off proper indication by the plane's acceleration. A 'Schuler tuned' pendulum is used that simulates a pendulum with an 84-minute period of oscillation. Such a pendulum *will* indicate properly on board a plane. The gyros, too, are a far cry from that crude affair on the other end of the bench. The least unbalance in the rotor of a gyro or the smallest amount of friction on the gimbal bearings will cause a gyro to 'drift.' Dr. Draper's gyros run in helium, and their cases are floated in a liquid to take the weight off the jeweled gimbal bearings. Their drift rates have been cut to a fantastically small figure."

"THIS HAS BEEN so interesting I almost forgot why I came over," Carl remarked as he took an apparently heavy package from beneath his coat and set it on the bench. "Here's a very expensive alternator which was made in that big factory on the south side of town. Someone has been stealing these things from the shipping room of the factory at the rate of one a day for several weeks. Police Chief Morton sent the manager, a Mr. Deck, to us to see if we could help him find who's doing



the grabbing. You were out of town yesterday; so Mr. Deck talked to me and took me to the factory to see the layout."

"How come the police don't handle it?"

"A good question, and one that I asked. Factory management doesn't want to upset the employees with any kind of shake-down or general search because a touchy new contract is being negotiated with the union. They want to find the thief with a minimum of publicity and without putting spies in the factory or doing anything else that might make honest employees feel they were distrusted."

"Hm-m-m-m, no wonder the chief sicked Mr. Deck on us. What did you find out at the factory?"

"Well, it's not going to be easy. Almost anyone in the plant could be the thief. Most of the fellows carry their lunch and eat in the shipping room. At that time the thief apparently slips one of these packaged alternators into his roomy lunch box, in which it fits perfectly. Then at night he simply walks out the gate with the loot."

"Tell me: don't the employees come out that gate on Brown Street and then turn right to go to the factory parking lot?"

"Yeah, but what's that got to do with the price of hay in China?"

"You'll soon see—I hope. Hop on your bike and get us five of those compact six-volt lantern batteries at the store while I hunt up that little alarm clock we made into a timer. Go, man, go!"

BRIGHT AND EARLY the next morning Carl and Jerry were in Mr. Deck's office.

"All you have to do," Jerry was explaining, "is to arrange for this boxed alternator to be very easy to steal. Place it where it



will be easier than any other to pick up without being noticed. Can you do that?"

"Sure," Mr. Deck replied; "but how's that going to help?"

"Suppose you trust us for right now. I

can tell you, though, that we've made some changes in the contents of this particular package. You had better give us a check for the contents, so if the thief takes this package out of the factory he will really be stealing from you. Here's the bill."

"That's shrewd thinking," Mr. Deck observed as he reached for his checkbook. "What else must I do?"

"Just have Chief Morton parked across the street from the gate tonight when the factory closes. We'll be there, too; and if the thief takes our bait, we'll be able to pick him out without any doubt."

"Okay, boys; I hope you know what you're doing," Mr. Deck said with a sigh. "The chief said I could rely on you, and I guess that's what I'll have to do."

At five that evening Carl, Jerry, Chief Morton, and Mr. Deck were all seated in Chief Morton's personal car parked across from the factory gate. At about five minutes after the hour, the laughing, jostling crowd of men began pouring out the gate and turning to the right as they headed for their parked cars.

"Keep your eyes on the lunch boxes," Jerry breathed.

Several minutes later almost all of the men had passed through the gate, and the boys were beginning to think the thief had foiled them. Then a short, heavy-set man sauntered through. As he turned, his right arm carrying his lunch box twisted at a strange angle, and he looked down in amazement at the lunch pail that seemed to be suddenly possessed of a demon. In spite of the effort of his straining muscles, the box was slowly tilting away from the horizontal. With a cry of fear the man let go of the handle, and the box fell to the pavement. There it stood on one corner, defying the law of gravity, and waltzed solemnly around in a circle.

Police Chief Morton snapped handcuffs on the unresisting man as he continued to stare in horror and amazement at the strangely behaving lunch box. When the chief told him why he was being arrested, the man readily admitted his guilt and said the other alternators would be found in his garage. Carl and Jerry picked up the "live" lunch box and accompanied Mr. Deck back into his office.

IT'S REALLY quite simple," Jerry explained as he lifted the package out of the lunch box and opened it. "As you can

see, we just substituted a gyroscope for the alternator. It runs off these five batteries wired in series. When the gyro starts, it draws about two or three amperes; but as the speed winds up, this comes down to less than half an amp; so these small batteries can take care of that easily for a short while. We put in this timer clock to turn on the gyro at three minutes after five. We



wanted the thief to get the lunch box out of his locker and be headed for the gate before the gyro motor started. It runs so smoothly that he wouldn't notice the vibration, and it takes a few minutes for it to come up to speed; so we figured he wouldn't notice anything funny until he made that right-angle turn after passing through the gate. It worked beautifully. I'll never forget how the poor guy looked when he discovered his lunch box had developed a mind of its own."

"I can imagine how he felt," Mr. Deck said as he tried in vain to jerk the still-coasting gyro motor about. "According to our agreement, I've got to sell this thing back to you two; but will you do me a favor? Can I keep it until tomorrow? When I was a boy I always wanted a gyroscope top and never got one. This is my chance to play with a really king-size top. How about it? Please!"

"Sure, Mr. Deck," Carl spoke up with genuine sympathy in his voice. "Every man ought to have a chance to play with a gyroscope!"

-30-

Can you think faster than this Machine?

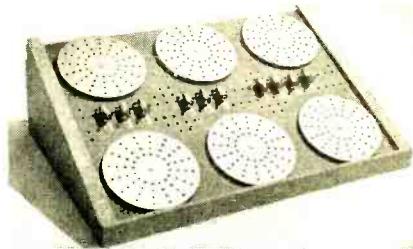

GENIAC® set up to do a problem in check valve research

Be careful before you answer. GENIAC the first electrical brain construction kit is equipped to play tic-tac-toe, cipher and encipher codes, convert from binary to decimal, reason in syllogisms, as well as add, subtract, multiply and divide. Specific problems in a variety of fields—actuarial, policy claim settlement, physics, etc.—can be set up and solved with the components. Connections are solderless and are completely explained with templates in the manual. This covers 125 circuits and shows how new ones can be designed. You will find building and using GENIACs a wonderful experience; one kit user wrote us: "this kit has opened up a new world of thinking to me." You actually see how computing, problem solving, and game play (Tic-tac-toe, him, etc.) can be analyzed with Boolean Algebra and the algebraic solutions, transformed directly into circuit diagrams. You create from over 400 specially designed and manufactured components a machine that solves problems faster than you can express them.

—MAIL THIS COUPON—

SCIENCE KITS, Dept. PE-10, Oliver Co., Inc.
108 E. 16 St., N. Y. 3, N. Y.

Please send me:

1 GENIAC Electrical Brain Construction Kit and Manual.

\$19.95 (East of Mississippi)

\$20.95 (Elsewhere in United States)

\$21.95 (Outside the United States)

Returnable in seven days for full refund if not satisfied.

I enclose \$..... in full payment.
My name and address are attached.

FREE!

H. H. Scott Helps You
PLAN FOR STEREO
With New Hi Fi Guide
and Catalog

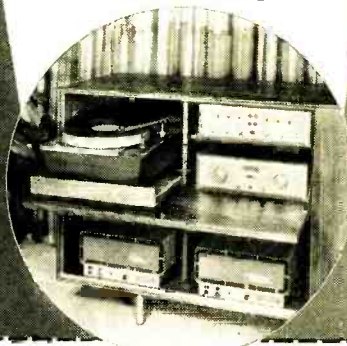

H. H. Scott Inc., 111 Powdermill Road, Dept. PE-12, Maynard, Mass.

Rush me your **FREE** Hi Fi Guide and catalog to help me plan my stereo system.

Name

Address

City State

Test Instruments

(Continued from page 56)

seems that the low resonance of the pickup arm prevents it from resonating to the higher frequencies put out by the loudspeaker, but it does respond to the lower frequencies which (1) have more energy and (2) are probably transmitted by the

in Fig. 3. Resistors R_1 and R_2 are always equal in value as are C_1 and C_2 . These four components together form a frequency-determining network which delivers the chosen frequency to the grid of V_2 .

Since R_1-C_1 attenuates the feedback *below* a certain frequency (1 kc. for example), and C_2-R_2 attenuates the feedback *above* the same frequency, the resultant

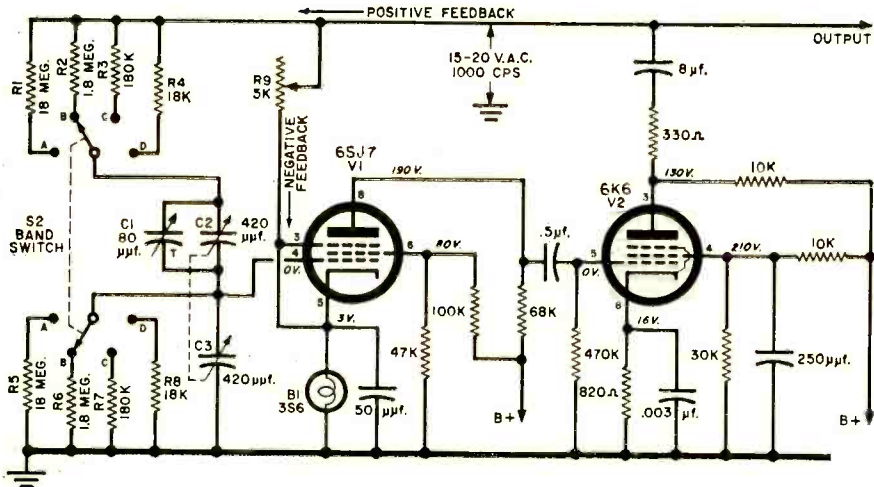

Fig. 5. Wien bridge section of the EICO audio generator.

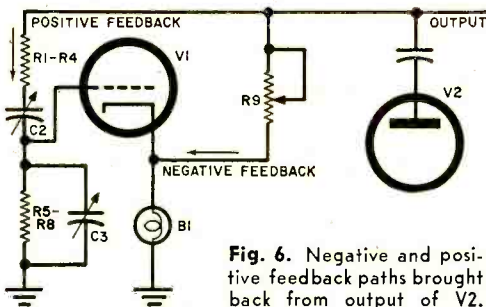

Fig. 6. Negative and positive feedback paths brought back from output of V_2 .

cabinet also. In effect, we have a situation where the feedback operates at the lower frequencies only.

Let's return to the generator now. You can see that while positive feedback will produce oscillation, other factors determine the frequency of oscillation. From the examples of acoustic feedback given above, it would seem that we need some means to tune the feedback to the one desired frequency.

Finding the Frequency. A tuning technique which has found wide acceptance in audio generator design uses a Wien bridge feedback loop. Part of the circuit is shown

response curve for the positive feedback loop resembles Fig. 4. As you might expect, this positive feedback peak at 1 kc. determines the oscillator frequency.

Now let's depart from the theoretical and look into the circuit of a practical audio generator using the Wien bridge circuit—the EICO Model 377.

The Wien bridge portion of the Model 377 is shown in Fig. 5. Probably the first thing that will strike you is how much more complicated this schematic appears than the circuit of Fig. 3. There are several reasons for this complexity aside from the fact that pentodes are used instead of the triodes shown in our theoretical circuits.

The eight resistors and three variable capacitors grouped around bandswitch S_2 (at the left of the schematic) are all part of the frequency-determining network. Resistors R_1 to R_4 in Fig. 5 correspond to R_1 in Fig. 3, and variable capacitor C_2 in Fig. 5 corresponds to C_1 in Fig. 3. By the same token, R_5 to R_8 corresponds to R_2 , and

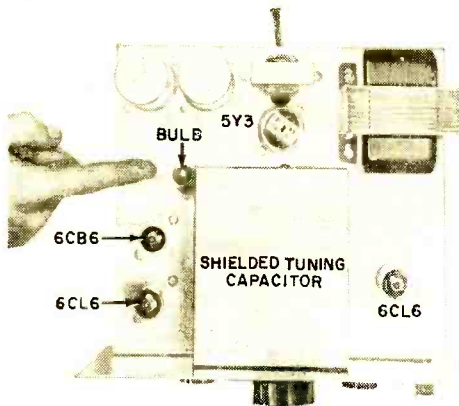

Three-watt voltage regulating bulb *B1* is mounted on top of the chassis in this Knight-Kit unit.

Fig. 7. Circuit components of Fig. 6 rearranged schematically to show the bridge configuration.

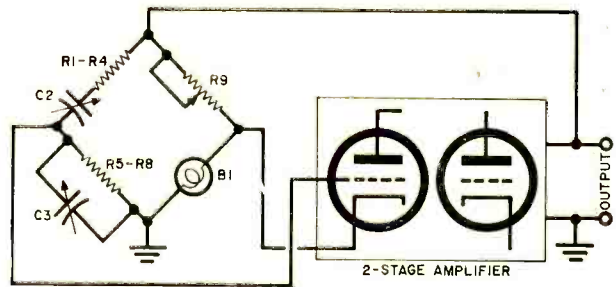

C3 corresponds to *C2*. Trimmer capacitor *C1* in Fig. 5 has the job of adjusting for any differences in capacity that may exist between the sections of the two-gang capacitor *C2/C3*.

By a judicious selection of component values, this instrument's designer managed to get a frequency spread of from 20 cycles to 200,000 cycles in only four ranges. The resistors (corresponding to *R1* and *R2* of Fig. 3), which are selected in pairs by switch *S1*, set the particular band of frequencies to be covered (20-200 cycles, 200 cycles—2 kc., 2-20 kc., 20-200 kc.); and ganged capacitor *C2/C3* serves as a "fine tuner" and selects the specific frequency within the band.

Negative Feedback and AGC. Two other components in Fig. 5 deserve special mention. Potentiometer *R9*, which is connected from the feedback line to the suppressor grid and cathode, puts a certain amount of negative feedback into the act. See Fig. 6.

As was explained before, a feedback loop can be negative or positive depending upon the phase relationship between the two points it connects—or its effect on the circuit. Although *R9* introduces a positive-

going signal at the cathode (which already has a positively phased signal on it), the effect is to throw the grid negative. This puts an out-of-phase signal (out of phase, that is, with the positive feedback signal) on the grid—and negative feedback results. Adjustment of *R9* sets the gain of the two stages and, in conjunction with *B1* stabilizes and linearizes the output.

The 3-watt bulb (*B1*) in the cathode circuit puzzles people who see it for the first time. Its presence is not at all mysterious, however. Notice that the lamp is actually part of a voltage divider, since it

is effectively in series with *R9*. Although a standard hardware store item, the lamp has what is known formally as a "positive temperature coefficient." This means that as more current flows through *V1* (and hence the lamp) the lamp's filament resistance goes up.

As the resistance of the filament increases, the ratio of negative feedback voltage across *R9* and *B1* changes, with more voltage appearing across *B1*. As soon as the negative feedback level at the cathode of *V1* starts to climb, *V1*'s gain drops. Ergo, we have automatic gain control action—which gives us a stabilized circuit with a linear output level right across the audio frequency bands.

If you're wondering why the Wien circuit is referred to as a bridge, Fig. 7 (a redrawn version of Fig. 6) should answer the question.

Now that we've crossed over the Wien bridge, next month we are going to discuss a circuit which many experts feel to be a basic improvement on the Wien arrangement. It was designed by our own U. S. Bureau of Standards and is finding application in several of the newer instruments currently available.

Send
**POPULAR
 ELECTRONICS**
 Every
 Month

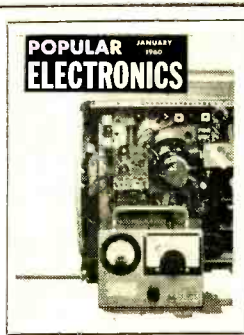

name _____

address _____

city _____ zone _____ state _____

3 years for \$10

Check one: 2 years for \$7

1 year for \$4

Payment Enclosed Bill Me

In the U. S., its possessions and Canada. **Foreign rates:** Pan American Union countries, add .50 per year; all other foreign countries, add \$1 per year.

Mail to: POPULAR ELECTRONICS

Dept. PE-109, 434 South Wabash Ave., Chicago 5, Ill.

YOUR OWN 2-WAY RADIO!



Messenger
 FROM
\$12975

Anyone can operate—
 license issued by the FCC on request!

The very finest Citizens' Transceiver available! Excellent selectivity and sensitivity for maximum range. Maximum legal power. Dozens of features!

WRITE TODAY FOR FULLY ILLUSTRATED BROCHURE



E. F. JOHNSON COMPANY
 124 SECOND AVE. S. W. • WASECA, MINNESOTA

EASY TO LEARN CODE

Learn to increase speed with an InstructoGraph—the Radio-Telegraph Code Teacher that takes the place of an operator-instructor and enables anyone to master code without further assistance. Available tapes from beginners alphabet to typical messages on all subjects. Speed range 5 to 40 WPM. Always ready—no QRM. Thousands have "acquired the code" with the InstructoGraph System. Write today for convenient rental or purchase plans.



INSTRUCTOGRAPH COMPANY
 4713 SHERIDAN ROAD, CHICAGO 40, ILLINOIS
 357 West Manchester Ave., Los Angeles 3, California

Transistor Topics

(Continued from page 77)

trigger pulse to its base, and then will remain in its "on" (conducting) condition without sustaining base bias. A negative-going pulse on the base will turn the unit "off," and it will remain in this condition until it is retriggered by a positive pulse.

The use of a Trigistor and standard transistors in basic flip-flop circuits is illustrated in Fig. 2. Note the much simpler circuit required for the Trigistor. In both circuits, the application of a positive pulse followed by a negative pulse will develop a single output pulse signal.

Product News. General Electric's Semiconductor Products Department (Liverpool, N. Y.) has announced a new series of high-frequency silicon transistors capable of dissipating 500 milliwatts at 25°C without an external heat sink, and an expanded line of silicon controlled rectifiers designed for d.c. to a.c. conversion, d.c. static switching, pulse width modulation, power equipment conversion, and current-limiting circuit breaker use. The silicon transistors (Type 2N332A to 2N336A) are made using fixed-bed construction to insure high mechanical reliability, and have a minimum collector-to-emitter breakdown voltage rating of 45 volts, with alpha cutoff frequencies ranging from 10 to 15 mc. The new controlled rectifiers are available with peak inverse voltage ratings of 100, 150, 200, 250 and 300 volts, and are designed to handle average forward currents of up to 16 amperes continuously and frequencies up to 20 kc. The prices of these units are a little high at the moment but you can expect them to come down.

Lafayette Radio (165-08 Liberty Ave., Jamaica 33, N. Y.) is now offering a fully transistorized power megaphone. Powered by a standard 9-volt transistor battery, the unit weighs less than 3½ pounds and measures only 12½" over-all; the horn mouth is 7½" in diameter. It is equipped with a built-in detachable microphone and has an effective range of over 300 yards. Carrying stock No. PA-56, it nets for \$29.50, plus postage.

From the International Rectifier Corporation (1521 E. Grand Ave., El Segundo, Calif.) comes word of a new series of low-cost silicon power rectifiers. Relatively small, these units have current ratings of 25 to 35 amperes and PIV ratings of from

Always say you saw it in—POPULAR ELECTRONICS

WANTED!

Equipment, components or parts!

The 320,000 purchasers of POPULAR ELECTRONICS are always in the market for good used equipment or components. So, if you have something to sell, let PE readers know about it in our classified columns.

It costs very little: just 50¢ per word including name and address. Minimum message: 10 words. For further information write:

Martin Lincoln
POPULAR
ELECTRONICS
One Park Avenue
New York 16, New York

LEARN

RADAR MICROWAVES COMPUTERS TRANSMITTERS CODE • TV • RADIO

Phila. Wireless Technical Institute
1533 Pine St. Philadelphia 2, Penna.

A Non-Profit Corp. Founded in 1908

Write for free Catalog to Dept. P-160

ENGINEERING DEGREES



E.E. Option Electronics or Power
Degree Courses in Liberal Arts
& Bus. Admin.

Also through **HOME STUDY**
Pacific International College of
Arts & Sciences

Primarily a correspondence School
Resident classes also available
5719-W Santa Monica Blvd.
Hollywood 38, California

down is rarely objectionable, even with very good speaker systems. Many turntables reach the latter figure—in various price ranges and in assembled as well as kit form.

Incidentally, advertised rumble figures are not an absolutely safe basis of comparison. Unfortunately, there is no universally accepted standard of rating rumble, and different manufacturers use different reference levels. Thus, Fairchild uses the broadcast standard—which is far stricter than that used by others—and a turntable rated by Fairchild as 45 db down may well have a lower rumble content than some rated as more than 50 db down.

Choosing a Turntable. The turntable should be chosen to complement the speakers. If the speakers go down to 30 cycles, the best turntable is necessary. A turntable with a lot of rumble will make such speakers impossible to listen to. If the speakers cut off at a higher point—40 or 50 cycles—a turntable with a higher rumble level can be used.

Turntables are available in single-speed and multiple-speed types. Multiple-speed turntables with low rumble are expensive because the speed-changing mechanism complicates the problem of maintaining good mechanical damping from motor to turntable. For stereo, a 33 $\frac{1}{3}$ -rpm turntable is actually all that is necessary; you just won't find very many 78-rpm stereo discs around.

Next month we will take a look at the device that holds the cartridge and see what design features are considered important for the production of a high-quality tone arm.

-30-



on c.w. on the three low-frequency Novice bands, Technicians can use them on 50 mc., and Generals can use them on all frequencies within their range. Similarly, the 50- and 144-mc. transmitters may be used by a Novice on the 145-147 mc. segment and then on both bands when he gets his Technician or General Class license.

HI-FI AMPLIFIER AS MODULATOR

The picture and the diagram below show how Jeff Binckes, K9OLL/8, Collins Hall, Miami U., Oxford, Ohio, uses a small

screen voltages to the final. In this manner, the low-impedance output of the amplifier is stepped up to match the higher impedance load of the modulated amplifier.

Jeff used a junk-box transformer, but a "universal" speaker output transformer, such as the Stancor A3849 10-watt transformer designed to match a 1500-to-10,000 ohm plate resistance to a voice coil, should work well at this point. Experiment with its taps to obtain best modulation.

If your amplifier has a microphone or a magnetic phono input, no other changes are

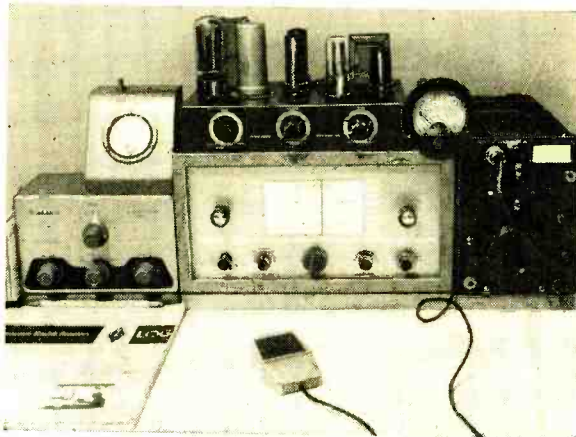

A hi-fi amplifier can be used as a modulator by connecting a replacement output transformer back-to-back with the amplifier output transformer as shown in the diagram. Jeff Binckes, K9OLL/8, uses a Heathkit amplifier (left) to modulate his AR-3 receiver, as described in the text.

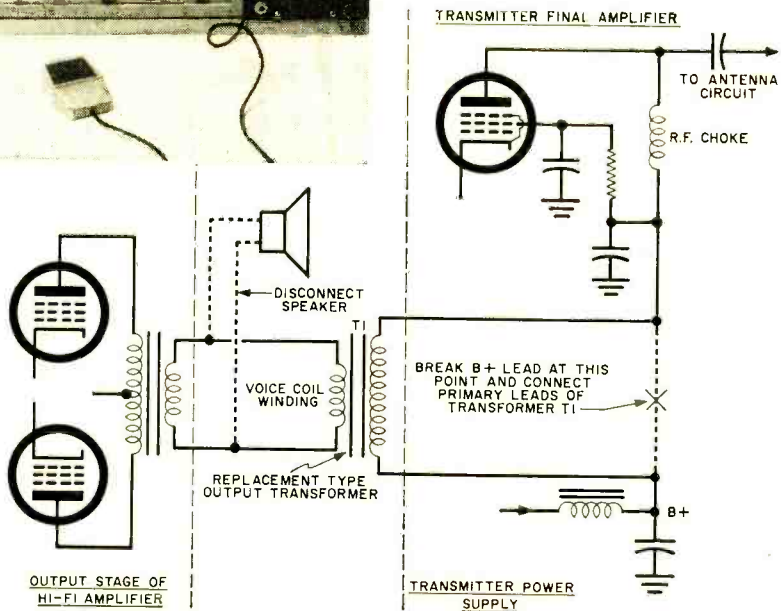

Heathkit hi-fi amplifier as a modulator for his transmitter on 40-meter phone. He connected the speaker output terminals of the amplifier to the voice coil terminals of a standard replacement type output transformer. He then connected the primary winding of this transformer in series with the lead from the B+ terminal of the transmitter power supply carrying the plate and

required to use it as a modulator; you can plug in the mike directly. If your amplifier doesn't have a microphone input, use any standard microphone preamplifier as described in ham texts; this preamp may be built on the hi-fi amplifier chassis.

Although Jeff's amplifier is rated at only six watts, it does an excellent job of modulating 400 volts at 60 ma. on speech.

Across the Ham Bands

(Continued from page 88)

of how well you will do on phone by referring to your c.w. results.

A phone signal must be three "S" units (18 db) above the noise level to be intelligible.* Assuming a noise level of S3 at the receiver, this means that any time your log-book shows that you received a report of S6 or better on c.w., you could have gotten through on plate-modulated phone with the same power. On the same basis, your c.w. report would have had to be S7 for screen modulation, with its 4-to-1 reduction in power output, to get through.

The accuracy of this method of predicting your results on phone depends upon the assumption that your c.w. reports are accurate and that the noise level at the receiver is not over S3. But, from checks made at W9EGQ, the predicted results are reasonably close to actual results when interference is not too bad in the phone bands.

Technician Transmitters. Technician Class hams may operate on phone or c.w. in the 50-to-54 mc. band, and in the 145-to-147 mc. segment of the 144-to-148 mc. band, as well as all the higher-frequency ham bands. Until the recent opening of the 145-to-147 mc. band to Technicians, practically all Technicians operated on the 50-to-54 mc. band, but many are now using the new band, too.

High power is not required on either band. Most transmitters for them run about 50 watts when plate-modulated and up to 100 watts or so when screen-modulated. In fact, some of the most popular units for these bands are transmitter/receiver units by Gonset and Hallicrafters that deliver less than 10 watts to the antenna on "transmit." When they are connected to good antennas, they cover distances comparable to those covered by the more powerful units.

No presently available commercial transmitters cover all ham bands from 3.5 to 148 mc., but the Globe Electronics Co. "Globe Chief 680A" and the E. F. Johnson "Challenger" do cover the six bands between 3.5 and 54 mc., and might be considered "triple-threat" Novice, Technician, and General Class transmitters. Novices can use them

* See "Minimum Noise Levels Obtained in Short-Wave Receiving Systems," K. G. Jansky, *Proc. I.R.E.*, Vol. 25, page 1517, December, 1937.

January, 1960

FOR 11 METER OPERATION THE CITIZEN BAND ANTENNAS

Model 113-G

\$36⁹⁵

the Citizens Beam

Three element citizens band beam provides 8.5 DB forward gain (multiplies power 7 times; makes 5 watt citizens transceiver equivalent to 35 watts). For long range point-to-point communications. Commercial duty construction of light weight $\frac{1}{8}$ " to $\frac{3}{16}$ " O.D. aluminum elements and $1\frac{1}{2}$ " O.D. galvanized steel boom. Completely factory pre-adjusted and gamma matched for perfect 52 ohm match. Boom length 8', longest element approximately 16.5' weighs only 18 pounds. Positive grip "U" bolt attaches to any mast up to 1.5" in diameter. Makes possible long distance communications up to 50 miles and more. Rotate with any TV rotor. Model CC-50 Coax Kit for Beam \$8.95

Other **4-gain** Citizen Band Antennas

Citizens Whip, Model CW	\$ 6.95
Citizens Dipole, Model CD	12.95
Citizens Mobile, Model CM	11.95
Heavy Duty Ground Plane, Model GP-1	32.50
Citizens Ground Plane, Model CGP	18.95

SEE YOUR NEAREST DISTRIBUTOR
OR WRITE FOR FREE BROCHURE

4-gain

antenna
products

1135 NO. 22ND • LINCOLN NEBRASKA

EASIEST TO BUILD

LAYER BUILT
COLOR GUIDE

Grommes

DE LUXE HI-FIDELITY

KITS

101GTK
FM TUNER



Finest tuner kit offered! "Standard Coil" tuning unit is pre-wired, pre-aligned and can be tuned-in as soon as completed, without professional adjustments. Better reception than tuners costing 2 or 3 times as much. Latest circuits, matched crystal diode detector, Foster Seeley Discriminator, AFC, Electronic Tuning Eye. Quiet, drift-free. Simply and successfully assembled by anyone with screwdriver, pliers and soldering iron. Step-by-step instructions. Model 101GTK, only \$59.50

20 WATT STEREO AMP.



De Luxe stereo at half the cost! Two 10 watt channels with 2 pre-amps. 40 watts peak. Fre. Res. ± 0.5 DB. 20-20,000 CPS. Complete controls. 20LJK \$59.50

10 WATT AMPLIFIER



With built-in pre-amp. 20 watts peak. Fre. Res. ± 1 DB. 20-20,000 CPS. 4 inputs Output: 4, 8, 16 ohms. Automatic Loudness Control. 1J6K \$24.95

Many other kits available—
At dealers or sent prepaid with check or M.O.

FREE!

GROMMES Div. of Precision Electronics, Inc.
9101-F King Ave., Franklin Park, Ill.
Please rush details on Grommes Kit Line.

Name

Address

City State

detail because it absorbs almost all of the light. The red knob in the center strikes a happy medium and shows good detail. Avoid pure-white and coal-black wires and parts unless you want to use them for contrasting purposes.

The sketch below shows a simple way to set up an unbroken background having no horizon-line. Simply curve a large sheet of drawing paper, blotter, or window shade material as shown. A few thumbtacks hold the background material to the card table and box. Photos are usually improved by having the background ma-

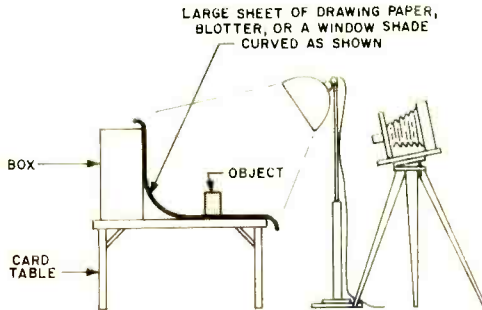

Simple way to make an unbroken background having no horizon-line. Shadows can be nearly eliminated by moving the floodlamp around during a time exposure.

terial contrast with the object being photographed. For example, the outlines of an aluminum chassis will show up well against a dark background and the outlines of a dark object will show up nicely on a light background.

Special Effects. Sometimes you can make eye-catching "exploded views" of electronics gear by taking the device apart and arranging the parts in an attractive manner. One example is shown in Photo 5. The diaphragm and cap of a magnetic earphone were suspended in the air by means of stiff wire supports hidden behind the parts. The shadows add to the realism by proving that the parts are actually in the air. In this shot, the background shown in the sketch was used, with a single photolamp in a fixed position providing the illumination.

And don't overlook the human interest factor. Whenever possible and practical, pose a person or a person's hands with the device being photographed. This will provide size comparison as well. —30—

prepare for your career in ELECTRONICS ELECTRICAL ENGINEERING RADIO-TV COMPUTERS

At MSOE, you can equip yourself for a career in many exciting, growing fields:
MISSILES • RADAR • AVIONICS
AUTOMATION • RESEARCH
DEVELOPMENT • ELECTRICAL
POWER • ROCKETRY

When you graduate from the Milwaukee School of Engineering, you are prepared for a dynamic career as an Electrical Engineer or Engineering Technician. Under a faculty of specialists, you gain a sound technical education in modern, completely equipped laboratories and classrooms. As a result, MSOE graduates are in great demand and highly accepted by industries nationally.

At MSOE, you will meet men from all walks of life and all parts of the country — some fresh out of high school or prep school, others in their twenties — veterans and non-veterans.

You can start school in any one of four quarters and begin specializing immediately. Engineering technicians graduate in 2 years with an Associate in Applied Science degree. For a Bachelor of Science degree in Engineering, you attend 4 years. A 3-month preparatory course also is available.



FREE CAREER BOOKLET!

If you're interested in any phase of electronics, radio or television, be sure to look into the programs of study offered by the Milwaukee School of Engineering. Just mail the coupon.

MILWAUKEE SCHOOL OF ENGINEERING

Dept. PE-160, 1025 N. Milwaukee St.
Milwaukee, Wisconsin

Please send FREE Career Booklet. I'm interested in
 Electronics Electrical Power Radio-TV
 Mechanical Engineering Computers Electrical Engineering Industrial Electronics Preparatory

PLEASE PRINT

Name..... Age.....

Address.....

City..... Zone..... State.....

I'm eligible for veterans education benefits

ONE CENT SALE

BUY ONE AT OUR REGULAR LOW PRICE
AND GET THE SECOND FOR ONLY 1¢ MORE

CITIZENS BAND TRANSMITTER (27 MC) chassis complete with crystal. \$12.49 each, two for \$12.50.

TRANSMITTER similar to above but with 5 watt RF stage instead of 1 watt. \$14.99 each, two for \$15.00.

CITIZENS BAND RECEIVER chassis tunable through all 22 channels. Complete with audio amplifier. \$9.99 each, two for \$10.00.

AMATEUR BAND TRANSCEIVER (144-148 MC) chassis with dual VHF triodes for walkie-talkie radiophone. \$9.99 each, two for \$10.00.

TRANSCEIVER TRANSFORMER: Mike to grid input and plate to low impedance headphone output. Good for telephones handsets. \$1.99 pair, two for \$2.00.

TELEPHONE HANDSETS with push-to-talk switch. \$5.99 each, two for \$6.00.

MICROPHONE High output 200 ohm carbon with terminal lugs. \$1.49 each, two for \$1.50.

COILED CORD 4 conductor 11' telephone cord. Extends to over 4 ft. .99 each, two for \$1.00.

KIT OF PARTS for AM-FM VHF radio receiver. Tunable from 80-200 mc. which includes U. S. satellite frequencies. \$6.99 each, two for \$7.00.

TRANSISTOR AUDIO AMPLIFIER gives 50X voltage gain on low level signals. Operates on 1½ volts. \$3.99 each, two for \$4.00.

CONVERTER (Crystal controlled) for 27 MC Citizens Band. Adapts any standard broadcast radio to 27 MC band. Tunes all 22 channels. Complete with tubes and crystal. \$14.99 each, 2 for \$15.00.

TRANSMITTER CRYSTALS in holders. Assorted frequencies for experimenters. Bag of 10 only \$1.49—two bags for \$1.50.

ALL MERCHANDISE GUARANTEED

Limited Quantity—No Literature or Catalog
Remit in full. Include sufficient postage. No C.O.D.'s.

VANGUARD ELECTRONIC LABS.

Box 12-E-1

Hollis 23, N. Y.

On the Citizens Band



By TOM KNEITEL, 2W1965

AS YOU SKIP DOWN the pathways of a life, you will no doubt come across certain shady characters who seem willing to do almost anything to separate you from a buck. We CB'ers now have the dubious honor of having fallen prey to some sharpies who seek to take advantage of the average CB'er's lack of technical knowledge and eagerness to pick up a bargain whenever possible.

A case in point is an ad which I received the other day stating: "Complete Radio Station for \$10 Covers All CB Channels!" The unsuspecting victim sees the low price and promptly sends his check, only to receive a reconditioned World War II surplus tank transceiver which runs 30 watts with frequency modulation, just about useless for the Citizens Band. True, it covers the CB channels, but extensive modification by a skilled technician is required before it can be used for CB work.

The surplus rigs which seem to be offered most are BC's 603, 604, 620, 683, 684, and 1335. Also offered are second-hand Motorola, RCA, G.E., Bendix, Link, and other commercially built police and taxicab units, which cost more but are equally useless to CB'ers.

The Boy Scouts have latched onto CB, realizing its potential for their specialized needs. Channel 20 has been suggested as the "Scouting" frequency, and it is proposed that the various Troops and Patrols maintain and monitor the channel. If this materializes, the Scouts should have the makings of a whopping good cross-country network of radio stations ready for use in any emergency.

Vocaline's "Commaire ED-27" is a welcome addition to the 27-mc. scene, and from the way things look, it's going to be one of the more popular units.

Remember when we mentioned the "fine-tuning" factor and how important it was going to be when the band loaded up? Many CB'ers are already grumbling about

engineering degree in 27 months

Grab your chance for a better life. Rapid advancement. Better income. **BACHELOR OF SCIENCE DEGREE IN 27 MONTHS** in Elec., Electronics or Power majors. Mech., Civil, Aero., Chem., Engineering. **IN 36 MONTHS** in Business Administration (General Business, Acctg., Motor Transport Mgt. majors). Small classes. More professional class hours. Well-equipped labs. Campus. Dorms. Modest costs. Year-round operation. Founded 1884. Enter Mar., June, Sept., Jan. Write J. D. McCarthy, Director of Admissions, for Catalog and "Your Career in Engineering and Commerce" Book.

TRI-STATE COLLEGE 3610 College Avenue
Angola, Indiana

MOVING

Make sure you notify our subscription department about any change of address. Be sure to include your postal zone number as well as both old and new addresses. Please allow four weeks' time for processing.

POPULAR ELECTRONICS
434 South Wabash Avenue
Chicago 5, Illinois

**ENGINEERING
DEGREE IN
27 MONTHS**

INDIANA TECHNICAL COLLEGE

B.S. degree (27 mo.): Aero., Chem., Civil, Elec., Mech. & Electronics. B.E. (36 mo.): Aero., Chem., Civil, Elec., Mech., Metallurgical. B.S. (36 mo.): Math., Chem., Physics. Preparatory courses. Demand for graduates. Campus. 20 hqgs., dorms. Gym. Low rate. Earn board. G.I. app. Enter March, June, Sept., Dec. Catalog 2310 E. Washington Blvd., Fort Wayne 2, Ind. Keeping pace with progress

Interference from nearby stations operating on adjacent channels, and the problem will probably cause quite a few headaches in days to come. The Commaire was designed with this in mind, and it really ignores the unwanted signals.

We're running some on-the-air tests with the Commaire and we'll keep you posted on the results.

Even though you can't "ham", it's inevitable that you get to know some of the local gang on your "party-line" channel, possibly by relaying messages for them, or helping them raise a wayward mobile unit. We've made several nice CB friendships in this manner, and have even gotten together off-the-air with some of the other boys.

A perplexing question for many CB'ers is whether or not a station can be operated outside the geographical area where it was licensed. Part 19 states that you may operate your station anywhere in the United States; so if you live in Florida (7W prefix) and want to use your set in New York (2W prefix), you don't have to worry. However, if you change your address permanently, regardless of the geographical area, you must apply to the FCC for a modified station license.

CB radio clubs seem to be of interest to many CB'ers according to our mail. Many of the boys in the New York area have received questionnaires about CB radio clubs from the FCC. Apparently the FCC is very much interested in seeing local Class D Citizens Band clubs get started, and wants to help them along as much as possible by sending engineers to speak at meetings. There is also the possibility of the FCC using these clubs to set up a self-policing system on 27 mc., which we would certainly like to see come to pass.

After giving the matter considerable thought, it is our personal feeling that some sort of CB club in each area would be beneficial to all of its members. Exchange of news, views and general information about CB could take place at the meetings, and maybe there could be a grievance committee to settle differences arising from two stations which might be interfering with each other.

If you belong to a CB radio club, please tell us about it. If you would like to join such a club, drop us a card and we'll try to put you in touch with other stations in your area with similar interests.

-30-

PURCHASING A HI-FI SYSTEM?

Send Us
Your List of
Components
For A
Package
Quotation

WE WON'T BE
UNDERSOLD

All merchandise is brand new,
factory fresh and guaranteed.

Free Hi-Fi Catalog

AIREX RADIO

CORPORATION

64-PE Cortlandt St., N. Y. 7

CO 7-2137

PARTIAL LIST OF BRANDS

Altec Lansing
Electrovoice
Jensen • Hartley
University • Stephens
Acoustic Research
Janszen
Wharfedale
Karlon Cabinets
Viking
Concertone
Bell • G. E.
Weathers
Harman-Kardon
Eico • Pilot
Sherwood
Acrosound
Fisher • Ferrograph
Bogen • Leak
Dynakit • Tandberg
H. H. Scott
Dual Changer
Ampex • DeWald
Revere • Challenger
Wollensak • Pentron
Garrard
Miracord
Glaser-Steers
Components
Rek-O-Kut
Norelco
Fairchild
Pickering • Gray
Audio Tape • Conrac
Welicor Cabinets



* FREE

*
Fill in coupon for a FREE One Year Subscription to
OLSON RADIO'S Fantastic Bargain Packed Catalog
— Unheard of LOW, LOW, WHOLESale PRICES
on Brand Name Speakers, Changers, Tubes, Tools, Hi-
Fi's, Stereo Amps, Tuners and other Bargains.

NAME _____

ADDRESS _____

CITY _____ ZONE _____ STATE _____

If you have a friend interested in electronics send his
name and address for a FREE subscription also.

**OLSON RADIO
CORPORATION**

803 S. Forge St. Akron 8, Ohio



Let me show you

HOW TO SPEAK AND WRITE LIKE A COLLEGE GRADUATE

I have helped thousands of men and women who have not had college training in English to become effective speakers, writers, and conversationalists. With my new C. I. METHOD, you can stop making mistakes, build up your vocabulary, speed up your reading, develop writing skill, learn the "secrets" of conversation. You don't have to go back to school. Takes only 15 minutes a day at home. Costs little. 32-page booklet mailed FREE upon request. Send me a card or letter TODAY!

Don Bolander, Career Institute

Dept. E-1041, 30 E. Adams Street, Chicago 3, Illinois

Please mail me your FREE 32-page booklet on English.

Name _____

Address _____

City _____ Zone _____ State _____

The Battery That's Used in Guided Missiles Now Released as Government Surplus

For Photography, Aircraft, Models, Search-lights, Radios, Boat Running Light, etc. **\$1.95** ea. Postpaid



Sintered-plate Nickel Cadmium alkaline storage batteries designed for "NIKE" Missile and now surplus due to design change. A lifetime battery with no known limit of service (over 5000 recharges on test without loss of capacity). Other features: Virtually indestructible, compact & lightweight, withstands heavy shock and vibration. Flat voltage curve during discharge retains charge year or more, high discharge rate up to 50 amps. for this cell, no corrosive fumes to harm clothing or equipment, spill-proof construction, discharge in any position, indefinite storage without deterioration, operates in temperatures -60° F to +200° F. Each cell is approx. 6 ampere hour capacity. Nominal voltage per cell is 1.8 volts. (A 6 V. battery requires 5 cells. Cell size 6" H. x 2" W. x 1/2" T. Wt. 6 oz. ea. Uses Potassium-Hydroxide (30%) electrolyte. Negligible loss during lifetime service. Add only distilled water once a year. A fraction of Government cost.

Used Test Cells \$1.85 ea. Postpaid
Brand New Cells 2.95 ea. Postpaid
24 V. Battery (20 cells) in metal case used \$40.00 New \$60.00. Plastic battery cases may have slight cracks—repaired easily with household cement or you may add 25c to price of each to insure uncracked cases.

All cells guaranteed to your satisfaction or money refunded (less postage). Dept. J

ESSE RADIO COMPANY

42 W. South Street
Indianapolis 25, Indiana



Print Your Own

Cards, Stationery, Advertising, Circulars, labels, photo and movie titles, church work, tags, etc. Save money. Sold direct from factory only. Raised printing like engraving, too.

Own a Printing Business

Print for Others Good Profit. Have home shop. Junior press \$16; Senior \$29 up. We supply everything. Easy rules. Pays for self in short time. Write for free catalog of outfits and all details. **KELSEY PRESSES, C-10 Meriden, Conn.**

GET INTO ELECTRONICS

V.T.I. training leads to success as technicians, field engineers, specialists in communications, guided missiles, computers, radar, automation. Basic & advanced courses in theory & laboratory. Assoc. degree in 29 mos. B. S. obtainable. ECPD accredited. G.I. approved. Graduates with major companies. Start Feb., Sept. Dorms, campus. H. S. graduates or equivalent. Catalog.

VALPARAISO TECHNICAL INSTITUTE
Dept. PE VALPARAISO, INDIANA



LOOK

NO FURTHER . . . IF YOU'RE UNHAPPY WITH "HI" HI-FI PRICES. WRITE FOR OUR UNUSUAL AUDIO CATALOG. **KEY ELECTRONICS CO.**
120-B Liberty St., N. Y. 6

WWV Test Signals

(Continued from page 49)

generator, which corresponds to the 20th harmonic of the 100-kc. standard. Then for each 100 kc. thereafter, you can mark 2.1, 2.2, 2.3 mc., etc., on your receiver using the harmonics from the 100-kc. standard. You can calibrate each mc. and 100-kc. point all the way up to the highest frequency on your receiver.

For convenience and to double-check, calibrate the fundamental outputs of your signal generator against WWV transmissions at 5 mc. and 10 mc. You'll be able to use the harmonics from these points to help determine which harmonic of your 100-kc. standard you are listening to.

The 440- and 600-cps tones on any WWV transmission can be used to calibrate your audio generator or to determine an unknown audio frequency as shown in Fig. 5. To use the tones, connect the receiver output to the vertical input of your oscilloscope. The horizontal input is connected to the audio source to be calibrated.

Begin by adjusting the receiver for best reception of WWV during a modulation period. Then adjust the audio source to produce a stationary circle or ellipse on the CRT screen. Your audio source is then at the same frequency as the WWV modulation. Remember that the 440- and 600-cps tones alternate in five-minute cycles on all WWV transmissions.

As in the r.f. harmonic comparison method, whole-number multiples or even-sub-multiples of WWV tones can be determined using the Lissajous patterns produced on the CRT screen. See the March '57 issue of POPULAR ELECTRONICS, p. 63, or any standard ham text for an explanation of how to use Lissajous patterns.

Any unknown audio tones may also be calibrated in the same way by picking up the sound with a microphone. Maybe your piano needs tuning. The 440-cps tone from WWV is "A" above middle "C". The note from the piano is picked up by the microphone, amplified, and fed into the horizontal amplifier of the oscilloscope, and the WWV tone is applied to the vertical amplifier. Look for the circle, ellipse or other Lissajous pattern.

To sum up, you'll find that the WWV transmissions are downright handy in calibrating any r.f. or a.f. signal source in your shack. And they don't cost a cent. -50-

News and Views

A week ago, **Jim Manning, K9RUH, 2477 Waverly Drive, Gary, Ind.**, put his new Heathkit "Apache" transmitter on the air. Although his own TV receiver was completely free of TVI, he clobbered a neighbor's set, both picture and sound, especially on 40-meter phone. The neighbor announced that no one was going to put a high-pass filter on his TV receiver. Instead, he was going to have Jim thrown off the air. Three days later, the neighbor told Jim that what he heard Jim saying over his TV receiver was a lot more interesting than the TV programs. "How can I get a Ham license?" he wanted to know. In rapid succession, Jim told the man what to do, gave him a License Manual, sold him his old DX-20 transmitter, and offered to help him and his brother learn the code. Then Jim drove his new friend to his TV dealer to pick up a high-pass filter.

Len Kruczynski, KN1KSE, 40 Windham St., Worcester 10, Mass., uses a Heathkit DX-20 feeding a 40-meter dipole antenna, and a Hallicrafters SX-99 receiver. Len operates 40 meters and has worked 18 states. His best DX is Oregon, but he still has not worked Vermont, New Hampshire, or Rhode Island, each within 100 miles of him! Len passed his General exam last week and plans to get a VFO as soon as the ticket comes. Read this, Len: **Gary Davis, KN1LEM, RD #2, Burlington, Vermont**, offers to sked anyone needing Vermont for WAS. Or maybe you would prefer to work his mother, who is **KN1LNF**. Gary uses a Heathkit DX-40 transmitter and a Hallicrafters S-38E receiver; in three months he has worked 15 states.

Neil, KN7IPP, Route 1, Box 23hp, Gig Harbor, Wash., has worked 32 states, including Hawaii and Alaska, with 23 confirmed, in three months on 40 meters. His tools are a Globe Chief 90A feeding a dipole antenna and a Hallicrafters S-38D helped along with a Heath QF-1 Q-Multiplier. . . . **Bob Kircher, WV6FDB, 2766 W. Stonybrook Dr., Anaheim, Calif.**, has made 120 contacts in nine states on 40 meters with a home-built, 50-watt transmitter and a regenerative receiver.

John Frazier, K4ARB, 841 Wooden Blvd., Orlando, Fla., has been chasing DX mostly on 15-meter c.w. since getting his General license, but he offers to sked anyone needing Florida on 40, 20, 15, or 10 meters. He's waiting for his 20-wpm code-proficiency certificate from ARRL. . . . **Steve Fogt, K81QA, 315 Brookburn Ave., Sidney, Ohio**, has worked 350 stations in 22 states on six meters. He uses an LW-51 transmitter feeding an 8-element Hy-Gain beam, 35' high. He receives with a Hallicrafters S-76 and an LW-61 converter and LW-80 preamp. Steve is going for his General license soon and offers to help prospective hams get their tickets.

The opening paragraph of the November, 1959, *Across The Ham Bands* may have given the impression that **Howy, W2QHH**, was a beginner in collecting QSL cards. Actually, Howy is famous for his collection of rare QSL cards and DX certificates. I hope to have more to report on Howy next month.

Herb, W9EGQ



"Forget that lousy ruby, Ed. Let's pry this Jensen cartridge loose."

TODAY'S BEST QUALITY BUY

AWARD WINNING

arkay

HI-FI STEREO

KITS
and
WIRED

ARKAY CS-28
STEREO AMP/PRE-AMP
COMPLETE CONTROL CENTER

Full 28 watts stereo or monaural, 60 watts peak • 14 watts each channel • reverse stereo • balance control • two-channel gain control • full range bass and treble controls • 1M distortion, 4 to 1 • harmonic distortion, 1% 30-20,000 cps • dual pre-amp 2V output jacks • speaker outputs, 4, 8, 16, 32 ohms • response, 20-20,000 cps • push-pull EL84 Williamson circuit.

Wired and tested \$99.95 Easy-to-build Kit **\$64.95**

ARKAY ST-11
AM-FM
STEREO TUNER

Separate AM and FM tuning with drift-free stability • variable FM-AFC • 4 uV for 20 db quieting in FM channel • wide band AM IF's • whistle filter • cathode follower outputs • level controls

Wired and tested \$74.50 Easy-to-build Kit **\$49.95**

ARKAY SPA-55 55 watt — STEREO AMP

Wired and tested \$79.95 Easy-to-build Kit **\$64.95**

ARKAY CS-12
STEREO PRE-AMP
AND AMP

12 watts of clean power. Operates from ceramic or crystal cartridge, tape, tuners, auxiliary equipment.

Easy-to-build Kit **\$36.95**

See and hear completely wired ARKAY Kits at your dealer. Write for detailed specifications & catalog. Dept. PE

All prices 5% higher west of Mississippi

88-06 Van Wyck Expressway
Richmond Hill 18, N.Y.

HAVE MORE FUN WITH YOUR HOME TAPE RECORDER

with

"HOME RECORDER TRICKS"

the fascinating new guide to
trick taping by

DICK JURGENS
big-name bandleader

The only one of its kind, this amazing booklet gives easy-to-understand, step-by-step instructions for making tapes of:

- animals talking and singing with you
- duets and trios of your own voice
- duets between you and a popular vocalist
- echoes, garbled sounds, demonstration tapes and many other unique sounds

Amaze your friends on the tape recorder. Send for your copy of "Home Recorder Tricks" today! Only \$1.98 postpaid.

DICK JURGENS RECORDING ASSOCIATES
1405 SOUTH 8TH ST., COLORADO SPRINGS, COLO.

TV PICTURE TUBES AT LOWEST PRICES

10BP4	\$ 7.95	16WP4	\$12.00	17TP4	\$17.00	21EP4	\$13.50
12LP4	8.50	16PT4	9.95	19AP4	16.00	21FP4	14.50
14B/CP4	9.95	17AVP4	12.50	20CP4	13.50	21WP4	14.00
16DP4	12.00	17BP4	9.95	20HP4	14.50	21YP4	14.50
16EP4	12.75	17CP4	17.00	21AP4	22.10	21ZP4	13.50
16GP4	14.50	17GP4	17.60	21ALP4	15.75	24CP4	23.50
16KP4	9.95	17HP4	12.50	21AMP4	15.75	24DP4	24.50
16LP4	10.95	17LP4	11.50	21ATP4	15.75	27EP4	39.95
16RP4	9.95	17QP4	9.95	21AUP4	15.75	27RP4	39.95

1 YEAR WARRANTY

Aluminized Tubes \$5.00 more than above prices. Prices include the return of an acceptable similar tube under vacuum. These tubes are manufactured from reprocessed used glass bulbs. All materials including the electron gun are brand new.

ALL PRICES FOB CHICAGO, ILLINOIS. Deposit required when old tube is not returned, refundable at time of return. 25% deposit required on COT shipments. Old tubes must be returned prepaid. Tubes shipped Rail Express.

WRITE FOR COMPLETE LIST

—PICTURE TUBE OUTLET—

3032 MILWAUKEE AVE., CHICAGO 18, ILLINOIS
Dickens 2-2048

LEARN WHILE YOU SLEEP!



Hypnotize self, others while asleep with amazing hypnotic phonograph records, tapes. Free catalog lists 200 unusual records, tapes & equipment for sleep-learning & hypnosis experimenters. Sleep-Learning Research Ass'n., Box 24V Olympia, Washington.

Easy-to-Build Beam Antenna

(Continued from page 51)

driven element. Note that the outer conductor of the coax must be connected to the center of the driven element so that the exact location of the box depends on its size. A fixed capacitor could be used instead, and its value determined by experiment; this would eliminate need for the box.

Assemble the antenna by laying the two completed elements on the ground and attaching the boom using standard hardware intended for holding TV antennas to their masts. Separation of the driven element and the director is not too critical—with the full 6' length as the boom, the elements can be placed 4" to 6" from either end. Movement of the elements after installation affords a degree of adjustment to improve front-to-back ratio using a remote signal strength indicator.

Connect the center of the boom, by means of another TV clamp, to a mast of 1 1/4" tubing. In lieu of a mast, a vertical 2" x 3" may be used with a 1 1/4" pipe strap to hold the boom. By connecting this "mast" to another 2"x3" with heavy hinges, the array can be rotated almost 180° at minimum cost. The beam and its aluminum mast are so light that they can be supported in a fixed position using a small vise to hold the mast to some permanent part of the house or other structure.

Adjustment. The *gamma* matching section presents the correct impedance for standard five-cent-per-foot 52-ohm coaxial cable (RG-58/U). In adjusting the dimensions of the *gamma* matching section, there is no substitute for a standing-wave-ratio bridge or reflected power indicator. Both the matching section and the value of the capacitor should be adjusted to minimize SWR.

You'll find that the gain of the antenna will theoretically be only unity, but signals arriving at the ends will definitely be weaker than those arriving broadside. Later, if you wish, you can add a third element—a reflector—for increased gain.

Aside from adding to the signal strength of a station, a beam adds to the morale and courage of its user. The rare ones become more common. Disappointments in multiple layer pile-ups are rare, and 100% QSO's are the rule rather than the exception.

—50—

Short-Wave Report

(Continued from page 71)

fied by a land station reading the information back to the plane.

For easy listening, Art prefers Berne, Tokyo, Lima, Melbourne, and the BBC. His equipment is usually tuned to the 31-meter band.

Art remembers the days when all U. S. broadcast stations would close down at certain times, and the DX'ers would nurse their one- or two-tube receivers in an attempt to hear European stations. He also recalls the first day his Dad brought a new tube home, wrapped in several feet of soft packing inside a heavy corrugated box; the children could watch the process of unpacking but they *could not touch!*

How many of you old-timers can recall the "Lord" sailing ship? Art remembers hearing it as it passed down the East Coast and, later, when it was in the Pacific shortly before its round-the-world cruise had to be abandoned. Can anyone supply us with the first name of Mr. Lord?

WPE6EZ is a member of the Newark News Radio Club. His other hobbies include photography and oil painting. Art told us that he would like to see, possibly as a regular part of this column, a listing of the interval signals of the lesser known stations. Would you?

Current Station Reports

The following is a resume of the current reports. All times shown are Eastern Standard and the 24-hour system is used. At time of compilation all listings are correct. Stations often change schedule and/or frequency with little or no advance notice.

Andorra—Andorradio, 6305 kc., can be noted at times with fair strength in French and Spanish. The schedule is 0300-1800 weekdays (from 0600 on Sundays). The power is 5 kw. Listeners in Eastern states might also try for the 100-kw. outlet on 818 kc. (VE3PE3W)

Ascension Island—A station in the non-broadcast service is ZBI235, 23,583 kc., noted from 0900 in 'phone contact with New York. A marker gives the ID followed by the call in c.w. (WPE1BM)

Austria—OEI23, Wien, has moved from 9665 to 9670 kc., at 0200-1600. (WPE1BY)

Bolivia—R. La Cruz del Sur, La Paz, beams programs to Argentina, mostly in Spanish, at 0600-1215 and 1630-2130 (Sundays at 0615-1930) over CP38, 9444 kc. (WPE1BY)

Cameroun—Cameroun III, Garoua, 5010 kc., has been noted from 1625 in French news or talks. The final ID for "Ici Garoua" was given at 1629 and followed by the same closing number used by Yaounde. (WPE3NF)

China—At time of compilation, Peking's

January, 1960

2-WAY RADIO KITS

NO CODE - NO TESTS

ONLY
\$37.50
each
In Pairs

or \$39.95 each

Complete with All Parts, Tubes, Instructions



- ★ Easy to Assemble
- ★ Simple to Operate
- ★ Only Finest Parts No Surplus

**GET ON
THE AIR**

FCC Form 505 for Station License Included
Business, Sports, Vacations - Hundreds of Uses

Please Rush

FREE
1960

Catalog ...
and
Complete
Info on
The
Citizens
Band
2-Way
Radio Kit. City & State:



Name: _____
Address: _____
City & State: _____

NOW!

Step ahead faster as an INDUSTRIAL ELECTRONICS TECHNICIAN

Turn your experience into a
big, new better-paying career!

Day by day industrial plants are adding more electronic devices—for sorting, counting, checking almost any control job you can name. Cash in on industry's great need for men who can keep these devices in top working order. Make more money, feel more secure, doing work that is second nature to you. With what you already know about electronics you have a long head start in a field just beginning to boom. GET INTO IT RIGHT NOW with the help of



PRACTICAL INDUSTRIAL ELECTRONICS LIBRARY

No long sessions on math or theory! These 4 practical volumes show you how to keep the plant's electronic equipment working . . . how to locate and correct tube and circuit troubles . . . how to install, service, and maintain even brand new equipment without being stumped by new circuits.

**EASY TERMS
FREE TRIAL—**

4 volumes (1369 pp., \$102 illus.);
Chuce's Electronics
in Industry
Miller's Maintenance Manual of Electronic Control.
Markus & Zeluff's Handbook of Industrial Electronics Circuits.
Henny & Fahnestock's Electron Tubes in Industry

McGraw-Hill Book Co.,
327 W. 41st St., NYC 36, Dept. PEL-1
Send me the Practical Industrial Electronics Library for 10 days' examination on approval. In 10 days I will send \$3.50, then \$5.00 a month until \$23.50 is paid. (A saving of \$5.00 under the regular price of \$28.50.) Otherwise I will return books postpaid.
(Print) Name: _____
Address: _____
City: _____ Zone: _____ State: _____
Company: _____
Position: _____ PEL-1
This offer applies in U.S. only.

To build the projects in this issue of

POPULAR ELECTRONICS

Use these STANCOR TRANSFORMERS

"One Tube Laboratory"

T1—Power Transformer use Stancor PA-8421, List Price \$6.40

CH1—Audio Choke use Stancor C-1003, List Price \$3.61

"Dry Cell Tester and Rejuvenator"

T1—Filament Transformer use Stancor P-6134, List Price \$3.50

They are available from any Stancor Distributor . . . and have been verified for their application in the construction projects listed.

LOOK FOR this helpful listing every month. It appears regularly in Popular Electronics.

CHICAGO STANDARD TRANSFORMER CORPORATION
350 1. W. Addison St. Chicago, Illinois

NEVER FAIL—ZONE YOUR MAIL

The Post Office has divided 106 cities into postal delivery zones to speed mail delivery. Be sure to include zone number when writing to these cities; be sure to include your zone number in your return address—after the city, before the state.

MOBILE-FIXED CONVERTER
POLICE • FIRE • CITIZENS' BAND



#315A Is a practical converter for emergency use. Easily installed. Tuning range approximately 12 MC in the 26-50 MC band—30 MC in the 108-174 MC band. Designed for mobile or home use. **\$13.95**
Available crystal controlled up to 54 MC. **\$18.95**

Also available crystal controlled up to 165 MC. **\$19.95**

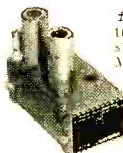

#316A VARIABLE CONVERTER. Front panel tuning permits rapid change between separated signals over 10 MC range in 26-54 or 108-174 MC bands. **\$19.95**

#331B Crystal controlled converter for use with 12 V. Transistor type car radios, 20-50 MC. Can be installed in seconds. **\$24.50**

Other models for 108-162 MC available.

Full line of converters and receivers for every application.

ORDER TODAY or WRITE for LITERATURE

KUHN ELECTRONICS
20 GLENWOOD CINCINNATI 17, OHIO

English schedule read: to S.E. Africa at 1200-1300 on 15,060 and 17,675 kc.; to West Africa at 1630-1730 on 9510 and 11,945 kc.; to Great Britain and Western Europe at 1400-1500 and 1530-1630 on 9457 and 15,060 kc.; to Eastern N.A. at 2000-2100 and 2130-2230 on 15,095 and 17,720 kc.; to Western N.A. at 2230-2330 on

CERTIFICATES RETURNED

If your name appears on the list below, it means that we have sent you a Short-Wave Monitor Certificate which was returned due to an insufficient or incorrect address. If you will drop us a post card, giving us your correct and complete address, we will be glad to mail the certificate out again. Send the card to: Monitor Registration, POPULAR ELECTRONICS, One Park Avenue, New York 16, N. Y.

- John Anthony, Seattle, Wash.
- Donald Dee Aultman, Trivoli, Ill.
- Nigel Bell, Ottawa, Ont., Canada
- Fay D. Bruning, Orlando, Fla.
- Richard L. Burk, Forest Park, Ill.
- Robert G. Byrd, Chicago, Ill.
- Kevan Corder, Daytona Beach, Fla.
- David C. Dees, Glenview, Ill.
- Robert W. Denman, Manesquan, N. J.
- Michel Desormiers, Montreal, Que., Canada
- Gene S. Edgcomb, Santa Monica, Calif.
- Walton E. Finley, Greenville, S. C.
- Courtney V. Franklin, Jr., Philadelphia, Pa.
- Carl Fredrickson, Watertown, Mass.
- Donn Fryant, Mountlake Terrace, Utah
- John T. Grantham, Elkridge, Md.
- Lewis P. Graves, Miami, Fla.
- Bob Hill, Grand Canyon, Arizona
- Mike Hollingsworth, Oneida, N.S., Canada
- Raymond La Pointe, Tewksbury, Mass.
- Lee Lannoye, Green City, Wis.
- Ronnie McCardle, West Chester, Pa.
- Michael J. McRae, Washington, D. C.
- Robert Matson, Coudesport, Pa.
- James D. Moore, Port Campbells, Wis.
- James P. O'Neill, Miami, Fla.
- Mort Orchin, Cincinnati, Ohio
- Joe Otto, Canal Winchester, Ohio
- Larry Patten, Ide City, Iowa
- Mike Reaves, Dallas, Texas
- James Reynolds, Chicago, Ill.
- Norman P. Schmid, Philadelphia, Pa.
- George Symons, Evergreen, Colo.
- James H. Taylor, Miami, Fla.
- Glenn E. Terry, Orlando, Fla.
- Gerald E. Texley, Clarksville, Tenn.
- B. G. Thompson, Port Angeles, Wash.
- Allan Tobias, Jackson Heights, N. Y.
- Glenn D. Vaughan, Ashland, Ky.
- Mike Weidemann, Pensacola, Fla.
- Tom Yancey, Charlottesville, Va.

15,115 and 17,745 kc.; to Australia and New Zealand at 0330-0425 and 0430-0525 on 15,060 and 17,835 kc.; to S.E. Asia at 0700-0800 on 11,820 and 15,095 kc.; and to India, Pakistan, and Ceylon at 1000-1100 on 15,060 and 17,675 kc. The following changes may have been instituted by the time you read this: programs are to be beamed to S.E. Africa on the 31- and 25-meter bands, to W. Africa on the 31- and 49-meter bands, to Eastern N.A. on the 31- and 25-meter bands, to Western N.A. on the 16-, 19-, and 25-meter bands, to Great Britain and Western Europe on the 31- and 41-meter bands, and to India, Pakistan, and Ceylon on the 25- and 31-meter bands. (WPE1BM, WPE1CU, WPE2ACO, WPE3YM, WPE7CB, WPE9BR, TW)

Costa Rica—TIFC, Faro del Caribe, San Jose, has moved from 6037 to 6043 kc. and is

Always say you saw it in—POPULAR ELECTRONICS

SHORT-WAVE ABBREVIATIONS

anmt—Announcement	kw.—Kilowatts
BBC—British Broadcasting Corp.	N.A.—North America
c.w.—Continuous wave	R.—Radio
Eng.—English	s/on—Sign-on
ID—Identification	s/off—Sign-off
IS—Interval signal	xmsn—Transmission
kc.—Kilocycles	xmtr—Transmitter

heard in Spanish at 2000 and in Eng. at 2345 with a good signal. (WPE3NF, WPE7MY, DXRA)

A station is reportedly testing from San Jose on 9500 kc. No times given. (DF)

Cuba—The Cuban weekly "Carteles" recently carried this item: "Senor Enrique Oltuski, Cuban Minister of Communications, announced before his departure for the Geneva telecommunications meeting that a national radio station will be set up in the near future, using high-powered transmitters in all principal short-wave bands." No further details are known. (WPE3HP)

Egypt—Cairo has moved from 12,060 to 12,030 kc., broadcasting in Eng. to Europe at 1630-1730; all music except for news at 1645-1700. Other xmsns noted include Arabic at 1330-1400 and 1600-1630, French at 1400-1500, and German at 1500-1600. (WPE2ACO, WPE2TA, WPE9DN, WPEOAE)

Germany—R. Democratic Germany, Leipzig, was noted at 2130-2145 on 9730 kc. with editorials and talks on Germany. (WM)

Guatemala—The Radio Voice of the Central American Mission, Guatemala City, operates on 9668 kc. (TGNB) and 5952.5 kc. (TGNA), with Eng. scheduled at 2200-2230 on Mondays, Wednesdays, and Fridays (to 2245 Tuesdays and Thursdays). Reports go to: Apartado 601, Guatemala City. (WPE1KW, WPE7CB, WM)

A station on 6243 kc. heard around 2100 with marimba music and thought to be R.

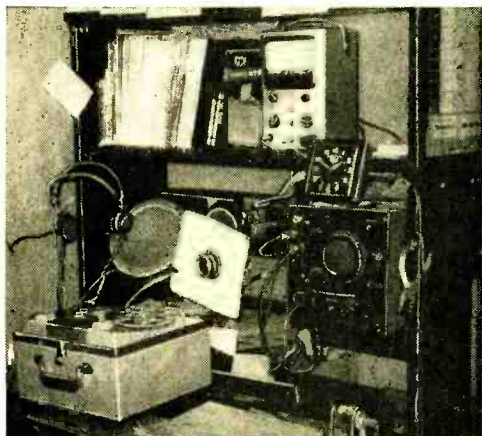

The equipment of Nathan Reiss, New York City, includes a Stromberg-Carlson seven-tube receiver, a Heath QF-1 Q-Multiplier, a Telectro tape recorder, and an oscilloscope for signal monitoring.

January, 1960

CITIZENS BAND ^{\$39⁹⁵} TRANSCEIVER KITS!!!

RUSH YOUR ORDER TODAY!!!

for
HOME • CAR
OFFICE
BOAT



- HANDSOME TWO-TONE CABINETS
- DRIFT-FREE RECEIVER
- FULL 5 WATTS OUTPUT
- AUTOMATIC LIMITING AT 100% MODULATION
- HI-Q CERAMIC COILS
- CRYSTAL MICROPHONE
- COMPLETE WITH ALL PARTS—TUBES—CRYSTAL
- 3 MODELS—6 VOLT—12 VOLT—110 VOLT
- FCC FORM 505 INCLUDED

4-SECTION MOBILE ANTENNA
FENDER OR TRUNK MOUNTING
SHOCK ABSORBING MOUNT
TENITE STATIC BALL
3 1/2" COLLAPSED—100"
EXTENDED

\$4⁹⁵

Available at distributors or order direct

GROVE ELECTRONIC MFG. CO.

4103 W. BELMONT

CHICAGO, ILL.

 **YOU NEED THIS**

FREE GIANT 1960 B-A CATALOG

A Complete Buying Guide for Everything in

**RADIO 1960
TV
ELECTRONICS**

ANNUAL CATALOG
601

BA
SINCE 1937

Guarantee

**204
KING-SIZED
PAGES**

**EVERYTHING
IN RADIO
TV AND
ELECTRONICS**

**100'S OF
NEW ITEMS
LISTED HERE
FOR 1ST TIME**

**21 PAGES
OF BARGAINS
NOT IN ANY
OTHER CATALOG**

BURSTEIN-APPLEBEE CO.

Dept. PE, 1012 McGee St., Kansas City 6, Mo.

Send Free 1960 B-A Catalog No. 601.

Name.....

Address.....

City..... State.....

SEND
FOR IT
TODAY

YOUR COPIES OF POPULAR ELECTRONICS ARE VALUABLE



**KEEP THEM
NEAT . . . CLEAN
. . . READY FOR
INSTANT
REFERENCE!**



Now you can keep a year's copies of POPULAR ELECTRONICS in a rich-looking leatherette file that makes it easy to locate any issue for ready reference. Specially designed for POPULAR ELECTRONICS, this handy file—with its distinctive, washable Kivar cover and 16-carat gold leaf lettering—not only looks good but keeps every issue neat, clean and orderly. So don't risk tearing and soiling your copies of POPULAR ELECTRONICS—always a ready source of valuable information. Order several of these POPULAR ELECTRONICS volume files today. They are \$2.50 each, postpaid—3 for \$7.00, or 6 for \$13.00. Satisfaction guaranteed or your money back. Order direct from:

JESSE JONES BOX CORP.

Dept. PE

(Established 1843)

Box 5120

Philadelphia 41, Pa.

AMAZING MINIATURE BROADCAST TRANSMITTER



FOOL YOUR FRIENDS with this transmitter . . . by broadcasting on any radio or car radio and watch their startled faces when they hear YOUR voice on their radio. Can be used as FTN MAKER, P.A. SYSTEM, WALKIE TALKIE, CALL TO CAR COMMUNICATIONS and MANY OTHER USES described with instructions. Use on HUNTING and FISHING TRIPS.

Completely portable (5 1/2" x 4 1/2" x 1 1/2") with self contained battery and control with TELESCOPING ANTENNA. ABSOLUTELY WIRELESS . . . NO WIRES to run to your radio . . . NO GROUND WIRES or HOOKUPS in back on transmitter. Works up to ONE BLOCK OR MORE . . . NO LICENSE REQUIRED. THE "SPACECASTER" transmits THROUGH WALLS! SIMPLY push the button and talk!

The "SPACECASTER" has a built-in station selector so you can tune in on any station you desire!
Three models: M27—\$9.95, higher powered M37—\$10.95, super power de luxe M47—\$12.95 (not incl. Or send just 1.00 & pay postman balance. Batteries 2.50 extra. Kits now available, all models. Two dollars less than above prices.

Available only from **HALCO ELECTRONICS, DEPT. B.**
9211 Venice Blvd., Los Angeles 34, California

Quetzal, has been tentatively identified as TGR.T. R. Pical. (WPE9KM)

Haiti—4VEH, Cap Haitien, 6000 and 9770 kc., schedules Eng. as follows: 0445-0600 (Sundays at 0515-0630), 0800-1000 (Sundays at 0730-0900), 1500-1715 (Sundays only), 2000-2200 (Sundays, Mondays, and Saturdays), and 2200-2300 (Sundays and Mondays). On the last noted xmsn, 15,360 kc. is used in place of 9770 kc. (WPE1CU, WPE5FS, GM)

Iran—The latest schedule of the Foreign Service from R. Tehran reads: 0700 in Urdu on EQO75, 3780 kc., and EQO31, 9660 kc.; 1230-1330 in Kurdish and 1330-1430 in Arabic on EQC49, 6040 kc.; 1500-1515 in Turkish, 1515-1530 in French, and 1530-1600 in Eng. on EPB19, 15,123 kc. The 9680-kc. outlet has definitely moved to 9660 kc. and carries Persian at 2100-2130. (WPE2ACO, WPE9KM)

Italy—The National Service of Radio Roma can be heard with anmts in various languages including Eng. at 1835-0035 on 9515 kc. English news is carried every hour. The xmtr location is Caltanissetta, Sicily. Other Eng. xmsns include: 1930-1950 on 11,900 and 15,400 kc. and 2205-2225 on 11,900 and 9570 kc. to

SHORT-WAVE CONTRIBUTORS

James Silk (WPE1AGM), Madison, Conn.
Jerry Berg (WPE1BM), W. Hartford, Conn.
Alan Roth (WPE1BY), W. Haven, Conn.
Paul Johnson (WPE1CU), Arlington, Mass.
Gary Lunney (WPE1IO), W. Haven, Conn.
Johnny Chané (WPE1KW), Winchester, Mass.
James Dionne (WPE1LB), Westwood, Mass.
Paul Buer (WPE2ACO), Harrison, N. Y.
Riley Sundstrum (WPE2AJ), Stockton, N. J.
Thomas Owens (WPE2AJZ), Utica, N. Y.
Charles Schwartzbard (WPE2TA), Passaic, N. J.
Richard Morcroft (WPE3HP), Pittsburgh, Pa.
George Cox (WPE3NF), New Castle, Del.
Richard David (WPE3QJ), Newark, Del.
Howard Bachman, Jr. (WPE3YM), Wilmington, Del.
William Bing (WPE5AG), New Orleans, La.
Richard Harris (WPE5FS), El Dorado, Ark.
J. Art Russell (WPE6EZ), San Diego, Calif.
Rob Wintersteen (WPE7CB), Sunnyside, Wash.
Earnest Hopsker (WPE7MV), Corvallis, Mont.
Ken Boord (WPE8GB), Morgantown, W. Va.
Larry Dillinger (WPE8LG), Cincinnati, Ohio
Mike Kander (WPE8MS), Dayton, Ohio
Mike Rossman (WPE9BR), Joliet, Ill.
J. P. Arendt (WPE9DN), Aurora, Ill.
A. R. Niblack (WPE9KM), Vincennes, Ind.
John Beaver (WPE0AE), Pueblo, Colo.
Maurice Ashby (WPE0HM), Wichita, Kansas
Bob Prinsky (VE2PE1U), Westmount, Quebec
James Bannister (VE3PE3W), Brampton, Ontario
Danny Ferguson (DF), Columbia, S. C.
Grady Ferguson (GF), Charlotte, N. C.
Allen Inversin (AI), Ardsley, N. Y.
Gerhardt Martens (GM), Frazee, Minn.
W. Reed McCartney (WM), Alliquippa, Pa.
Thomas Wright (TW), Topeka, Kansas
DXplorers Radio Association (DXRA)

N.A.; 1035-1055 on 21,560 and 17,770 kc. to S. Africa; 0400-0440 on 21,560, 17,810, and 15,320 kc. to the Pacific area. (WPE1BY, WPE1CU)

Ivory Coast—R. Abidjan, 4940 kc., has been noted at 1700-1730 with French news and music. This is a 10-kw. station. (AI)

Kenya—ZHW2, Nairobi, 4934 kc., s/on at 2228 with a musical number, then a three-note chime at 2230 with ID in native language. A program of religious music follows. VQ7LO, Nairobi, 4885 kc., was noted on a Saturday

with an extended schedule to 1600/closing. (WPE3NF)

Liberia—The Voice of America will build a ten million dollar relay station in Monrovia to replace the Tangier outlets. This will be the most powerful relay station in Africa. Full details are not expected until the summer of 1960. (WPE1BY, WPE6EZ, WPE9DN)

Libya—Benghazi has moved from 9930 to 9895 kc. and is noted weakly at 1615 s/off with a musical number and Arabic ID. (WPE3NF)

Martinique—Fort-de-France, 5994 kc., s/on at 1730 after a six-note IS. Classical music noted at 1745 and 1810; popular U.S. and European music at 1830-1900; other varied musical shows to 2057 s/off. (WPE1BM, WPE1BY, WPE2ACO, WPE3NF, WPE5AG, WPE8MS, WPE9DN, VEPE1U)

Mexico—R. Mante. XECMT, Ciudad Mante, operates daily on 6090 kc. and closes at 2100. Reports go to: R. Mante, Apartado Postal 97, Ciudad Mante, Mexico. They send a nice pennant for correct reports. (WPE1AGM)

Monaco—R. Monte Carlo carries Eng. on Tuesdays and Thursdays at 1805-1835 (to 1905 on Tuesdays) on 3AM3, 6035 kc., and 3AM4, 7140 kc. "Musique de Nuit" is scheduled Mondays at 1805-0020. (WPE8MS)

Mongolia—A letter from R. Ulan Bator confirms that this station operates on 6342 kc. at 0710 with Oriental music and anmts. Reports go to: ZUNDUI, Dir. of the Information and Broadcasting Board, Ulan Bator, The Mongolian Peoples Republic. (WPEOHH)

New Zealand—The newest schedule from Wellington reads: to Pacific Islands at 1200-1345 on 11,780 kc., at 1400-0045 on 15,280 kc., and at 0100-0345 on 6080 and 9540 kc.; to

WPE REPORTING ADDRESS

We would like to remind you that all reports should be sent to the following address in time for them to arrive by the tenth of each month:

Hank Bennett, Short-Wave Editor
POPULAR ELECTRONICS
P. O. Box 254
Haddonfield, N. J.

If you have your POPULAR ELECTRONICS call letters, please use them, so that our listings may be as complete as possible. But please do not send applications for Short-Wave Monitor Certificates to this address as that will only delay your receipt of the PE call letters. If you have not sent for your certificate yet, you will find an application blank on page 113.

Australia at 0400-0645 on 6080 and 9540 kc., and at 1500-0045 on 15,280 kc.; and to Antarctica (Sundays only) at 0315-0345 on 11,780 kc. Call-signs: 11,780 kc., ZL3; 15,280 kc., ZL4; 9540 kc., ZL2; and 6080 kc., ZL7. (WPE1BM, WPE1CU, WPE2AJ, WPE8LG, WPE8MS, WPE9BR, WPEOAE, GF)

Rhodesia and Nyasaland—The Federal Broadcasting Service is scheduled as follows: Commercial Service at 2300-0000 (often noted, according to reports received by Your Editor), at 1500-1600 (to 1700 on Saturdays) on 3396 and 4911 kc., at 0000-0100 on 6018 and 7220 kc., and at 0100-0500 on 6018 and 9505 kc.; African Service "A" at 2300-0100 on 3955 and 4826 kc., at 0500-1030 on 7285 and 9580 kc., at 1030-1300 on 3955 and 7295 kc., and at 1300-

POPULAR
ELECTRONICS

BARGAIN BASEMENT

SAVE ON THESE SPECIAL BUYS OF THE MONTH

ONE CENT SALE Buy One At Our Regular Low Price And Get The Second For Only 1c More

CITIZENS BAND TRANSMITTER (27 MC) chassis complete with crystal, \$12.49 each, two for \$12.50.
TRANSMITTER similar to above but with 5 watt RF stage instead of 1 watt, \$14.99 ea., two for \$15.00.
CITIZENS BAND RECEIVER chassis tunable through all 22 channels. Complete with audio amplifier, \$9.99 ea., two for \$10.00.
AMATEUR BAND TRANSMITTER (144-148 MF) chassis with dual VHF triodes for walkie talkie radiophone, \$9.99 ea., two for \$10.00.
COILED CORD 4 conductor 1/4" telephone cord. Extends to over 4 ft., .99 ea., two for \$1.00.
KIT OF PARTS for AM-FM-VHF radio receiver. Tunable from 80-200 mc. which includes U.S. satellite frequencies, \$6.99 ea., two for \$7.00.
CONVERTER (Crystal Controlled) for 27 MC Citizens Band. Adapts any standard broadcast radio to 27 MC band. Tunes all 22 channels. Complete with tubes and crystal, \$14.99 each, 2 for \$15.00.

All merchandise guaranteed.
LIMITED QUANTITY—NO LITERATURE OR CATALOG
Remit in full. Include postage. No C.O.D.'s.
VANGUARD ELECTRONIC LABS. Box 12-E-1
Hollis 23, N. Y.

Experimenters • Amateurs • Hobbyists

Extraordinary values await you in government surplus electronic components. Don't buy anything until you have our "Bargain Bulletin"; new material for mere dimes on the dollar. Remember, everything is brand new; here are typical values:

Scope xfmr 115 v pri, 2500 3, 2.5 1.75 5 = 51.95
Dynamotor, 6 v in, 600 v 150 mils out, Eicar 10 = 56.95
455 KC IF xfmr; your choice National/Wilcox 10 oz. = 7.9c
Pwr xfmr, 115-230 v pri, 600 ct/350, 12.6 ct/11 18 = 54.2J
Pwr supply, basic components kit, S25 value 16 = 55.55
Meter, 0-50 microamps, Burlington Mod 921 114 = 54.95
Fil xfmr, 115 v pri, 6.3 v, 27 amp 9 = 53.79
Filter cond, 10 mfd/1000 doww, ceramic terms 3 = 51.73
BC-1141-C amplifier is still available 12 = 55.95
10 & 15 tube assortments still available at 51.95 = 52.95

WRITE TODAY FOR FREE GOVERNMENT SURPLUS BARGAIN BULLETIN

JOE PALMER P.O. Box 6188 CCC,
Sacramento, California

NEW SILICON 500MA RECTIFIERS

rms/piv 35/50 30c	rms/piv 70/100 45c	rms/piv 140/200 50c	rms/piv 210/300 65c
rms/piv 280/400 78c	rms/piv 350/500 \$1.00	rms/piv 420/600 \$1.26	rms/piv 490/700 \$1.50
rms/piv 560/800 \$1.59	rms/piv 630/900 \$1.89	rms/piv 700/1000 \$2.58	rms/piv 770/1100 \$3.12

Use in F.W. Bridge or F.W.C.T. up to 750ma DC or mtg 2" sq Fins for 1.5Amp. Orders \$5 or more we pay postage 48 states

"TAB" 111PA LIBERTY ST. N. Y. 6, N. Y.

SAY YOU
SAW IT IN

POPULAR ELECTRONICS

POPULAR ELECTRONICS

Advertiser's Index

JANUARY 1960

ADVERTISER	PAGE NO.
Airex Radio Corporation	117
Allied Radio Corp.	19, 18, 34
Arkay	121
Bailey Technical Schools	32
Blonder-Tongue Laboratories, Inc.	12
Burstein-Applebee Company	125
Capitol Radio Engineering Institute	23
Career Institute, Don Blonder	118
Century Electronics Co., Inc.	2nd Cover, 3
Chicago Standard Transformer Corp.	124
Cisin, H. G.	111
Cleveland Institute of Electronics	13
Coyne Electrical School	9, 103
DeVry Technical Institute	7
EICO	38, 40
Electro-Voice, Inc.	5
Esse Radio Company	118
Garfield Co., Inc., Oliver	107
Grantham School of Electronics	11
Grommes—Div. of Precision Electronics, Inc.	119
Grove Electrical Mfg. Co.	125
Halco Electronics	126
Hallcrafters	111
Heath Company	92, 93, 94, 95, 96, 97
Hy-Gain Antenna Products	119
Indiana Technical College	116
Instructograph Company	110
Jensen Industries, Inc.	121
Jesse Jones	126
Johnson Company, E. F.	110
Jurgens Recording Associates, Dick	122
Kelsey Presses	118
Key Electronics Co.	118
Kuhn Electronics	124
Lafayette Radio	28, 29
Lektron	101
McGraw-Hill Book Co.	123
Micro Electron Tube Co.	22
Milwaukee School of Engineering	115
Moss Electronics, Inc.	3rd, 4th Cover, 132
National Radio Institutes	99, 100
National Schools	17
Norelco	10
Olson Radio Corporation	117
Pacific International College	112
Paco Electronics Co., Inc.	14
Palmer, Joe	127
Phila. Wireless Technical Institute	112
Picture Tube Outlet	122
Popular Electronics Book Division	39
Popular Electronics Classified Ad	112
Popular Electronics Dealer Ad	131
Popular Electronics Subscriptions	110
Popular Electronics Upcoming Contents	35
Port Arthur College	30
Progressive "Edu-Kits" Inc.	91
RCA Institutes, Inc.	26, 27
Radio Shack Corporation	103
Rad-Tel Tube Co.	37
Rinehart & Co., Inc.	16
Scott, Inc., H. H.	107
Sleep-Learning Research Ass'n	122
Sprayberry Academy of Radio-Television	21
"TAB"	127
Teltron Electric	15
Tri-State College	116
Tru-Vac Electric Company	33
Valpairaiso Technical Institute	118
Vanguard Electronic Labs	116, 127
World Radio Laboratories	36, 123
Zalytron Tube Co.	31

1400 on 3955, 4826, and 7285 kc.; African Service "B" at 1000-1300 on 4826 kc. There is a special Eng. session at 1400-1500 on 3396 and 4911 kc. Reports are welcomed and should be sent to: Engineering Division, P.O. Box R.W. 15, Ridgeway, Lusaka, Northern Rhodesia. (WPE1BM, DXRA)

Somaliand Protectorate—A long-awaited verification from *R. Somali* confirms that Eng. news is scheduled at 1005 on 9667 kc. (WPEQHM)

South Africa—The South African Parliament has been discussing changes in the Africa Service of the South African Broadcasting Co.'s Domestic Service. It is now thought that the Africa Service should be used for various language broadcasts to Central Africa and other parts of Africa to counteract propaganda coming from *Radio*

Supplies Available

Once again we would like to remind our readers that we have the following items available: reporting cards and sheets (for reporting to this column); "high-voltage" decals; an amateur radio reference leaflet; a 12-page DX log; and a leaflet outlining suggestions for sending reports to short-wave stations. Any or all of these items may be had on request. Please enclose stamp to help defray postage. See page 127 for address to use.

Cairo and Radio Moscow, both having powerful stations beamed to Africa. (*Arne Skoog in R. Sweden's DX Bulletin via WPE8GB*)

Tahiti—Papeete is scheduled at 1645-1800 (from 1500 Sundays) on 11,825 kc., and at 2230-0230 (from 2200 Tuesdays and Wednesdays, to 0245 Fridays and Saturdays) on 6135 kc. The station now belongs to the Radio-diffusion Television Française network. (WPE9DN)

Turkey—Ankara is definitely using 9745 kc. rather than 9465 kc. with Eng. closing at 1645. The dual 7285-kc. channel is heard at 1600-1645 beamed to Western Europe. (WPE1LB, WPE9KM)

USSR—According to a recent verification from *Radio Kiev*, they broadcast nightly to N.A. in Ukrainian on 11,740 and 11,890 kc. They confirmed by registered letter. Reports go to: Radio Centre, Kiev, Ukrainian SSR. (WPE1BM)

Venezuela—YVKD, *R. Cultura*, Caracas, 5050 kc., has an Eng. feature titled "Night Beat" on Wednesdays at 2045-2100. (WPE9KM)

Windward Islands—Grenada continues to come in strong on 15,086 kc. at 1600-2115, with BBC news at 2100. Their dual channel, 3365 kc., should be fairly easy to hear in Eastern areas. (WPE110, WPE2AJZ, WPE3QJ)

Clandestine—*The Voice of Free Russia*, location unknown, was noted on 10,500 kc. from 1700 to 1713 s/off but has not been heard since. The xmsn consisted of anti-Communist talks in English. Has anyone else heard this station? (WPEQAE)

-50-



ELECTRONICS MARKET PLACE

RATE: 50¢ per word. Minimum 10 words prepaid. March issue closes January 7th. Send order and remittance to POPULAR ELECTRONICS, 1 Park Ave., New York 16, N. Y.

FOR SALE

20-WATT 80-40 CW transmitters with power supply, \$16.95 to \$25.95. Free information. Jackson Electronics, 1605, South Raleigh, Denver 19, Colorado.

20 ASSORTED one and two tube circuit diagrams. Radio Receivers, Transmitters, Amplifiers, Power Supplies, etc. 50 cents with free catalogue.—Electronic Services, 16 Bayside Ave., Hamilton, Ontario, Canada.

15 TESTED One-tube circuits—25¢ with Transistor experiments. catalog. Laboratories, 1131-L Valota, Redwood City, California.

CARDS—SWLs—QSLs—Comics—Personal. \$1-1.00 Samples. 10. Riesland, Del Mar, Calif.

CITIZENS Band Vertical Antenna, \$12.95; Ham 6-80 Meter Vertical Antenna, \$16.95; 11,000 sold; DX on low power: guaranteed; send check or money order, shipment immediately express collect. Valuable antenna catalog, free. Gotham, 1805 Purdy, Dept. PE, Miami Beach, Fla.

RADIO & TV Tubes at Manufacturers' Prices! 100% Guaranteed! Brand New! No re-bands or pulls! United Radio, Box 1000, Newark, N. J.

DIAGRAMS for repairing radios \$1.00, Television \$2.00. Give make, model. Diagram Service, Box 672-PE, Hartford 1, Conn.

TELEVISION & Radio Tubes, Parts and Supplies. Guaranteed. Hi-Quality Tube Co., Inc., 284 Lafayette St., Rahway, New Jersey.

GOVERNMENT Surplus Receivers, Transmitters, Sniperscopes, Parabolic Reflectors, Picture Catalog 10¢. Meshna. Maiden 48, Mass.

TUBES—TV, Radio, Transmitting and Industrial Types at Sensibly Low Prices. New. Guaranteed 1st Quality Top Name Brands Only. Write for Free Catalog or Call WALKER 5-7000. Barry Electronics Corp., 512 Broadway, New York 12N, N. Y.

TRADE-IN Television Sets \$9.95 Plus Shipping. Jones TV, Sanatoga, Pa.

FM TUNERS, 88-108 megacycles. 4 tubes complete, \$14.95. Grutman, 1 E. 167 St., New York 52, New York.

AUTO Radio Distributor Selling, Servicing, Becker Blaupunkt, FM-AM, other European, American Sets. Save 30% + Square Electronics, 150-60 Northern Blvd., Flushing, New York.

6-METER Miniature Transmitter. 18 Watts, Phone.—Blueprints—\$2.00. K8NQH, 238 Knower, Toledo, Ohio.

WPE-SWL-QSL Cards—Samples 10¢—"Brownie" W3CJ1, 3110A Lenigh, Allentown, Penna.

ORGAN Builders: Special transformers, coils, diagrams now available. R. E. Paveika Company, Box 5985, Cleveland 1, Ohio.

DIAL inter-com telephone system. Build it yourself for few dollars from our plans. Only \$3.00. Gerry Miller Electronics, Maquoketa, Iowa.

SHORT Wave Antenna Plans, 25¢. Hartman, Lincoln College, Lincoln, Illinois.

POLICE Calls from Car Radio. Transistorized converter enables you to hear 25-54 Megacycle police, citizens, amateur signals on any car radio. Simple installation requires no internal connections. \$16.95. Write for Free Information. Robin Radio, 13229 Red Fern Lane, Dallas 30, Texas.

TRANSISTOR Tester, use with your VTVM. Professional accuracy, sensitivity, yet inexpensive. Complete plans, instructions—25¢. CPS, 4061 Hillwood Dr., Sacramento 21, California.

TRANSISTOR and FM Radios. Lowest Prices. Free Catalog. Myers Imports, 623 Gay, Knoxville, Tenn.

GOVERNMENT Sells: Surplus Electronics; Test Equipment; Oscilloscopes; Transceivers; Jeeps; Boats; Aircrafts; Misc.—Send For U.S. Depot Directory & Procedure \$1.00—"Government Surplus Sales," Box 425-PE, Nanuet, N. Y.

January, 1960

AUTOMATIC Door Operators new famous make. Only \$59.95. Buy direct. Save! Free literature. Demasco, Inc., Sebring 4, Ohio.

WANTED

CASH Paid! Sell your surplus electronic tubes. Want unused, clean transmitting, special purpose, receiving, TV types, magnetrons, klystrons, broadcast, etc. Also want military & commercial lab test and communications gear. We swap too, for tubes or choice equipment. Send specific details in first letter. For a fair deal write, wire or telephone: Barry, 512 Broadway, New York 12, N. Y. WALKER 5-7000.

CASH for used short-wave Ham Receivers, Transmitters and Accessories. Treger, W9IVJ, 2023 N. Harlem Ave., Chicago 35, TUXEDO 9-6429.

CYLINDER and old disc phonographs. Edison Conqueror, Idelia, and Oratorio models. Berliner Gramophones and Zono-o-phones, Columbia cylinder Graphophones, and Coin-operated cylinder Phonos. Want old catalogues and literature on early phonos prior to 1919. Will pay cash or trade late hi-fi components. Popular Electronics, Box 50, 1 Park Ave., New York 16, N. Y.

HIGH-FIDELITY



RECORDERS, Hi Fi. Free Wholesale Catalogue. Carston, 125-P East 88, N.Y.C. 28.

DISGUSTED with "HI" Hi-Fi Prices? Unusual discounts on your High Fidelity Requirements. Write Key Electronics, 120 Liberty St., New York 6, N. Y. CLOVERDALE 8-4288.

BUSINESS OPPORTUNITIES

RADIO Parts Stores & Hi Fi Salons: Someone "borrowing" your personal copy of Popular Electronics each month? You ought to be taking advantage of Popular Electronics' convenient re-sale plan. Sell copies in your store . . . perform a good service for your customers . . . with no risk involved. For details, write: Direct Sales Department, Popular Electronics, One Park Avenue, New York 16, N. Y.

TAPE & RECORDERS

TAPE Recorders, Hi-Fi Components, Sleep Learning Equipment, Tapes. Unusual Values. Free Catalog. Dressner, 69-02F, 174 St., Flushing 65, N. Y.

HIGHEST Trade-In Allowances Toward Ampex, Concertone, Crown, Ferrograph, Presto, Pentron, Components, Accessories. Catalog. Boynton Studio, 10-PE Pennsylvania, Tuckahoe, N. Y.

RECORDS From Your Tapes, LP's—78's—45's 12 inch LP—\$6.00; 3/\$15.00. I. M. P., Box B, 1266 Oak Bluffs, Mass.

RECORDERS, Stereo Tapes, Hi-Fi Components, Tremendous values. Catalog, Efsco, 270-P Concord, West Hempstead, N. Y.

RENT Stereo Tapes—over 900 different—all major labels—free catalog. Stereo-Parti, 1608-P Centinela Ave., Inglewood 3, California.

UNUSUAL Budget Values. Tape recorders, tapes and Hi-Fi Components. Send for package quotations and free catalogue, Budget Hi-Fi Distributors, 83-06 Vietor Ave., Elmhurst, N. Y.

NEW Book Mobile Hi-Fi Stereo Taperecorders F-M etc. \$5.00. Ekeradio, 650 North Fair Oaks, Pasadena, California.

PLASTICS

NEW Liquid Casting Plastic, clear colors. Embed real flowers, minerals, biological specimens, delicate instruments, electronic parts. Also cold-setting resin and fiberglass for laminating, casting, molding, coating. Manual 25¢. Castolite, Dept. A-108, Woodstock, Illinois.

INVENTIONS WANTED

INVENTIONS wanted. Patented: unpatented. Global Marketing Service, 2420-P 77th, Oakland 5, Calif.

PATENTS

INVENTORS—Protect your invention. Apply for your Patent. New "Patent Kit" now makes it easy. Free "Registration Certificate." Miss Clare Arduin, 806 Wm. Penn Annex, Philadelphia 5, Penna.



SHOPPING GUIDE

Classified

A HANDY REFERENCE TO PRODUCTS AND SERVICES NOT NECESSARILY ELECTRONIC, BUT OF WIDE GENERAL INTEREST.

FOR SALE

FREE Fluorescent Bargain Catalog—Fixture kits, Fixtures, Circles, Parts. Shoplite, 650 E. Franklin, Nutley 10, New Jersey.

PHONOGRAPH Records cheap, postpaid. Catalogue. Paramount, Box 2026-E, Pine Castle, Fla.

STAMPS & COINS

200 ALL Different Stamps only 25¢ with approvals. Wm. Rice, 87 Washington Ave., Kingston 19, N. Y.

100 Different U. S. Commemoratives 50¢, Approvals included. Shelron, Box 907-J New York 8, N. Y.

130

INSTRUCTION

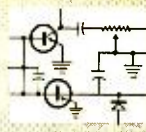

COMPUTER logic kit \$9.95, Math course \$9.95. Other courses computers, physics, transistors. Courses, Box 125, Grand Prairie, Texas.

LEARN Code—Instructions, 33 RPM record \$1.00. Olsen's School of Science, Iona, Idaho.

ALGEBRA or Calculus, Powerful Modern Mathematics, Easy Practical Lessons, First Four \$1, Mathco, 4256-8 Minmor, Cincinnati 17, Ohio.

HAVE siren burglar alarm in your car! Instructions—diagrams \$1.00. Ryco, 15402 Corkhill, Maple Heights 37, Ohio.

DETECTIVE Profession. Home Study. Badge, Certificate, Future. Box 41197-AG, Los Angeles 41, California.

COMPLETE Correspondence Course in Radio, TV, & Electronics. Only 12 sections. Includes 1st Class License Prep. Very low rates. Ascot School of Electronics, Box 29092, Los Angeles 29, Calif.

LEARN While Asleep, Hypnotize with your recorder, phonograph or amazing new Electronic Educator endless tape recorder. Catalog, details free. Sleep-learning Association, Box 24-ZD, Olympia, Washington.

MISCELLANEOUS

YOUR classified advertisement in this space will be seen by 320,000 readers. Why not send your ad to Martin Lincoln, Popular Electronics Classified Advertising, One Park Avenue, New York 16, N. Y.

TERRIFIC Stamp Bargain. Israel-Iceland-Vatican Assortment plus exotic triangle set—also fabulous British Colonial Accumulation—Plus large stamp book—All four offers free—Send 10¢ to cover postage. Empire Stamp Corp., Dept. Z2, Toronto, Canada.

THREE Brilliant uncirculated Mexican Silver Dollars, \$1.00. Universal Services, Box 675, San Antonio 6-U1, Texas.

BUSINESS OPPORTUNITIES

BUY direct from factories—Appliances, Cameras, Watches! Free details! Cam Company, 6810 PE—20th Ave., Brooklyn 4, N. Y.

FREE Picture Folder, "How to Make \$3,000 Yearly Sparetime, Backyard, Raising Earthworms! Oakhaven-103, Cedar Hill, Texas.

VENDING Machines—No Selling. Operate a route of coin machines and earn amazing profits. 32-page catalog free. Parkway Machine Corporation, Dept. 12, 715 Ensor St., Baltimore 2, Md.

Always say you saw it in—POPULAR ELECTRONICS

GROW Mushrooms. Cellar, shed and outdoors. Spare, full time, year round. We pay \$4.50 lb. dried. We have 29,000 customers. Free Book. Mushrooms, Dept. 334, 2954 Admiral Way, Seattle, Wash.

EARN extra money selling advertising book matches. Free samples furnished. Matchcorp, Dept. MD-10, Chicago 32, Illinois.

MAKE \$25-\$50 Week, clipping newspaper items for publishers. Some clippings worth \$5.00 each. Particulars free. National, 81-DG, Knickerbocker Station, New York City.

PHOTOGRAPHY—FILM EQUIPMENT, SERVICES

COLORFUL Autumn—New York State. Eight Colorslides \$1.00. Edgings. Roberts Avenue, Corning, N. Y.

FREE! Blackhawk's big sale catalog 8mm, 16mm. movies, 2"x2" color slides. Biggest selection anywhere! Projectors, cameras, supplies—big discounts! Get free, every three weeks, 12-page newspaper size bargain list! Blackhawk Films, Davenport 24, Iowa.

LEATHERCRAFT

FREE "Do-it-Yourself" Leathercraft Catalog. Tandy Leather Company, Box 791—D31, Fort Worth, Texas.

EMPLOYMENT INFORMATION

FOREIGN Employment Information—\$1. Parks, Box 1665A, Lake City, Seattle 55, Wash.

OVERSEAS Employment. American Firms and United States Government. Comprehensive Job Information \$2.00. Foreign Opportunities. Box 172, Columbus 16, Ohio.

EMPLOYMENT Agency names, 30 cities, \$1. Box 234, Old Saybrook, Conn.

MISCELLANEOUS

MONSTER Mails 15¢ Gigantic Mails 25¢. William Greener—B, Burley, Idaho.

BECOME Tax Consultant. Graduates earn \$1,000-\$3,000 every tax season preparing returns evenings. State approved. Union Institute, Lakewood 3G, N. J.

BAKE New Greaseless Doughnuts in kitchen. Sell stores. Free recipes. Niagara, 3605 South 15th, Minneapolis 7, Minnesota.

SONGPOEMS And Lyrics Wanted! Mail to: Tin Pan Alley, Inc., 1650 Broadway, New York 19, N. Y.

"WINEMAKING: Beer, Ale Brewing." Illustrated. \$2.00. Eaton Books, Box 1242-C, Santa Rosa, California.

OPTICAL Bargains—Request Free Giant Catalog "CJ". 144 pages—Astronomical Telescopes, Microscopes, Lenses, Binoculars, Kits, Parts. Amazing war surplus bargains. Edmund Scientific Co., Barrington, New Jersey.

**SAY YOU SAW IT
IN POPULAR
ELECTRONICS**

RADIO PARTS STORES & HI-FI SALONS!

Hundreds of dealers across the nation profit by selling POPULAR ELECTRONICS each month to their customers. Are you one of them? POPULAR ELECTRONICS helps build store traffic . . . keeps customers coming back month after month for the merchandise you sell—and, best of all, you earn a neat profit on each copy sold—**NO RISK INVOLVED.**

So get all the details on selling POPULAR ELECTRONICS, the world's largest selling electronics hobbyist magazine. Or, order your copies now. Just use the handy coupon below.

Direct Sales Department
Popular Electronics
One Park Avenue
New York 16, New York

Att: Jerry Schneider

- Send me _____ copies of POPULAR ELECTRONICS for resale in my store each month. No risk involved on my part.
- Send me details on selling POPULAR ELECTRONICS in my store.

STORE NAME _____

ADDRESS _____

CITY _____ ZONE _____ STATE _____

SIGNATURE _____

PE-10

SHIPPED ON APPROVAL NO MONEY WITH ORDER — NO C. O. D.

SUPERIOR'S
NEW
MODEL 83

C.R.T. TESTER

Tests and Rejuvenates **ALL** PICTURE TUBES

ALL BLACK AND WHITE TUBES **ALL COLOR TUBES**

From 50 degree to 110 degree types
—from 8" to 30" types.

● Model 83 is not simply a rehashed black and white C.R.T. Tester with a color adapter added. Model 83 employs a new improved circuit designed specifically to test the older type black and white tubes, the newer type black and white tubes and all color picture tubes. ● Model 83 provides separate filament operating voltages for the older 8.3 types and the newer 8.4 types. ● Model 83 employs a 4" air-damped meter with quality and calibrated scales. ● Model 83 properly tests the red, green and blue sections of color tubes individually— for each section of a color tube contains its own filament, plate, grid and cathode. ● Model 83 will detect tubes which are apparently good but require rejuvenation. Such tubes will provide a picture seemingly good

Test ALL picture tubes—in the carton— out of the carton—in the set!

but lacking in proper definition, contrast and focus. To test for such malfunction, you simply press the rej. switch of Model 83. If the tube is weakening, the meter reading will indicate the condition. ● Rejuvenation of picture tubes is not simply a matter of applying a high voltage to the filament. Such voltages improperly applied can strip the cathode of the oxide coating essential for proper emission. The Model 83 applies a selective low voltage uniformly to assure increased life with no danger of cathode damage.

Housed in handsome portable Saddle Stitched Texon case— complete with sockets for all black and white tubes and all color tubes. Only **\$38⁵⁰**

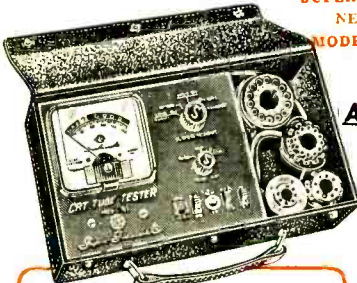

Model 83—C.R.T. Tube Tester
Total Price **\$38.50**
Terms: \$8.50 after 10 day trial, then \$6.00 monthly for 5 months if satisfactory. Otherwise return, no explanation necessary.

RCA RADIATION COUNTER

MADE TO SELL FOR \$160 — OFFERED FOR ONLY **\$47⁵⁰**
(Much less than cost of Manufacture.)

INDICATES
RADIOACTIVITY
IN 3 WAYS!

- 1—BY NEON
- 2—BY PHONE
- 3—BY METER



RCA Radiation Counter
Total Price **\$47.50**
Terms: \$11.50 after 10 day trial, then \$6.00 monthly for 6 months if satisfactory. Otherwise return, no explanation necessary.

Endless experiments and discoveries in the new exciting field of nuclear energy are made possible when you acquire this finely built and engineered device. In the past, a rugged counter which was suitable for the prospecting of radioactive ores such as uranium, thorium and radium, was unsuitable for laboratory work due to the inability of combining accuracy with ruggedness. Conversely, a laboratory counter, while being extremely sensitive, could not withstand use in the field where it would be subjected to abuse and abnormally hard knocks. The Model WF-10AWB combines the laboratory and field counter in one rugged instrument. The use of phones and a visible lamp permits the operator greater freedom of operation as he no longer has to keep his eyes on a relatively small indicator.

In the laboratory where determinations of intensity (counts) of a reading are necessary, the WF-10AWB provides sensitivity far surpassing many laboratory counters.

- Employs the extra sensitive 1B85 Bis-muth Type Geiger Counter tube. Sensitivity is .05 Roentgens per hour (1 MR/HR=2000 counts per minute).
- Three counting ranges: 0-100/1,000/10,000 counts per minute.
- Handy reset button.
- Ideal for survey work as the complete unit weighs only 5½ lbs.
- Sight and sound indications by neon

flashes and headphone. Then when an indication is obtained you switch to meter reading for exact measurements.

- Decontamination easy with damp cloth applied to the weatherproofed aluminum case.
- A radioactive specimen is included for instrument checking and experiments.
- Included at no extra charge—U.S. Atomic Energy Commission booklet titled "Prospecting with a Counter."

SPECIFICATIONS

Three counting ranges are available
0-100 counts per minute—used in cosmic ray and extremely low activity determinations.
0-1,000 counts per minute—used for average activity and normal work.
0-10,000 counts per minute—used for tracer and high activity determinations. High accuracy is assured by the handy reset button, located on the front panel, which permits compensation for variations of battery voltages and background count.

A rugged weather-proof aluminum case houses this light economical unit. The batteries will provide over 200 hours of intermittent operation from the two 67½ volt batteries and 50 hours from the three flash light batteries.

Comes with complete set of batteries, carrying strap, head, phone, radio-active specimen and A.E.C. booklet Only **\$47⁵⁰**

USE APPROVAL FORM ON NEXT PAGE

We invite you to try before you buy any of the models described on this and the following pages. If after a 10 day trial you are completely satisfied and decide to keep the Tester, you need send us only the down payment and agree to pay the balance due at the monthly indicated rate.

MOSS ELECTRONIC, INC.

**NO INTEREST OR FINANCE CHARGES
ADDED!**

If not completely satisfied, you are privileged to return the Tester to us, cancelling any further obligation.

Dept. D-695 3849 Tenth Avenue, New York 34, N. Y.

PRINTED IN U.S.A.

TRY FOR 10 DAYS

before you buy!

then if satisfactory pay in easy, interest free, monthly payments. See coupon below.



Model 82A—Tube Tester
 Total Price \$36.50
 Terms: \$6.50 after 10 day trial, then \$6.00 monthly for 5 months if satisfactory. Otherwise return, no explanation necessary.



Model TW-11—Tube Tester
 Total Price \$47.50
 Terms: \$11.50 after 10 day trial, then \$6.00 monthly for 6 months if satisfactory. Otherwise return, no explanation necessary.

Superior's New
 Model 82A

A truly do-it-yourself type **TUBE TESTER**

TEST ANY TUBE IN 10 SECONDS FLAT!

- ① Turn the filament selector switch to position specified.
- ② Insert it into a numbered socket as designated on our chart (over 600 types included).
- ③ Press down the quality button—

THAT'S ALL! Read emission quality direct on bad-good meter scale.

FEATURES:

- Tests over 600 tube types. • Tests OZ4 and other gas-filled tubes. • Employs new 4" meter with sealed air-damping chamber resulting in accurate vibrationless readings. • Use of 22 sockets permits testing all popular tube types and prevents possible obsolescence. • Dual Scale meter permits testing of low current tubes. • 7 and 9 pin straighteners mounted on panel. • All sections of multi-element tubes tested simultaneously. • Ultra-sensitive leakage test circuit will indicate leakage up to 5 megohms.

Production of this Model was delayed a full year pending careful study by Superior's engineering staff of this new method of testing tubes. Don't let the low price mislead you! We claim Model 82A will outperform similar looking units which sell for much more—and as proof, we offer to ship it on our examine before you buy policy.

Model 82A comes housed in handsome, portable, Saddle-Stitched Texon case. Only... **\$36.50** Net

Superior's
 New Model

STANDARD PROFESSIONAL

TW-11 **TUBE TESTER**

- Tests all tubes, including 4, 5, 6, 7, Octal, Lockin, Hearing Aid, Thyatron, Miniatures, Sub-miniatures, Novals, Subminars, Proximity Fuse Types, etc.

- Uses the new self-cleaning Lever Action Switches for individual element testing. All elements are numbered according to pin-number in the RMA base numbering system. Model TW-11 does not use combination type sockets. Instead individual sockets are used for each type of tube. Thus it is impossible to damage a tube by inserting it in the wrong socket.

- Free-moving built-in roll chart provides complete data for all tubes. Printed in large easy-to-read type.

NOISE TEST: Phono-jack on front panel for plugging in either phones or external amplifier detects microphonic tubes or noise due to faulty elements and loose internal connections.

EXTRAORDINARY FEATURE
SEPARATE SCALE FOR LOW-CURRENT TUBES Previously, on emission-type tube testers, it has been standard practice to use one scale for all tubes. As a result, the calibration for low-current types has been restricted to a small portion of the scale. The extra scale used here greatly simplifies testing of low-current types.
 Housed in handsome, Saddle-Stitched Texon case. Only **\$47.50** Net

We invite you to try before you buy any of the models described on this page, the preceding page and the following pages. If after a 10 day trial you are completely satisfied and decide to keep the Tester, you need send us only the down payment and agree to pay the balance due at the monthly indicated rate.

NO INTEREST
OR FINANCE
CHARGES ADDED!

If not completely satisfied, you are privileged to return the Tester to us, cancelling any further obligation.

**SEE OTHER
 SIDE**

CUT OUT AND MAIL TODAY!

MOSS ELECTRONIC, INC.
 Dept. D-695 3849 Tenth Ave., New York 34, N. Y.

Please send me the units checked on approval. If completely satisfied I will pay on the terms specified with no interest or finance charges added. Otherwise, I will return after a 10 day trial positively cancelling all further obligation.

- | | |
|---|---|
| <input type="checkbox"/> Model 83 . . . Total Price \$38.50
\$8.50 within 10 days. Balance \$6.00 monthly for 5 months. | <input type="checkbox"/> Model 82A . . . Total Price \$36.50
\$6.50 within 10 days. Balance \$6.00 monthly for 5 months. |
| <input type="checkbox"/> RCA RADIATION COUNTER
Total Price \$47.50
\$11.50 within 10 days. Balance \$6.00 monthly for 6 months. | <input type="checkbox"/> Model 80 . . . Total Price \$42.50
\$12.50 within 10 days. Balance \$6.00 monthly for 5 months. |
| <input type="checkbox"/> Model TW-11 . . . Total Price \$47.50
\$11.50 within 10 days. Balance \$6.00 monthly for 6 months. | <input type="checkbox"/> Model 79 . . . Total Price \$38.50
\$8.50 within 10 days. Balance \$6.00 monthly for 5 months. |

Name
 Address
 City Zone State

All prices net, F.O.B., N. Y. C.

SHIPPED ON APPROVAL NO MONEY WITH ORDER — NO C. O. D.



Model 79—Super Meter
Total Price \$38.50
Terms: \$8.50 after 10 day trial, then \$6.00 monthly for 5 months if satisfactory. Otherwise return, no explanation necessary.



Model 80 ALLMETER
Total Price \$42.50
Terms: \$12.50 after 10 day trial, then \$6.00 monthly for 5 months if satisfactory. Otherwise return, no explanation necessary.

NOTE: The line cord is used only for capacity measurements. Resistance ranges operate on self-contained batteries.

SUPERIOR'S NEW MODEL 79 **SUPER-METER** WITH NEW 6" FULL-VIEW METER

A Combination VOLT-OHM MILLIAMMETER
Plus CAPACITY, REACTANCE, INDUCTANCE & DECIBEL MEASUREMENTS
Also Tests SELENIUM & SILICON RECTIFIERS, SILICON & GERMANIUM DIODES

The model 79 represents 20 years of continuous experience in the design and production of SUPER-METERS, an exclusive SICO development. It includes not only every circuit improvement perfected in 20 years of specialization but, in addition includes those services which are "musts" for properly servicing the ever-increasing number of new components used in all phases of today's electronic pro-

duction. For example with the Model 79 SUPER-METER you can measure the quality of selenium and silicon rectifiers and all types of diodes — components which have come into common use only within the past five years, and because this latest SUPER-METER necessarily required extra meter scale. SICO used its new full-view 6-inch meter.

SPECIFICATIONS:

• D.C. VOLTS: 0 to 7.5 15 75 150 750 1500. • A.C. VOLTS: 0 to 15 30 150/300 1500 3000. • D.C. CURRENT: 0 to 1.5 15 150 Ma. 0 to 1.5 15 Amperes. • RESISTANCE: 0 to 1,000/100,000 Ohms, 0 to 10 Megohms. • CAPACITY: .001 to 1 Mfd., 1 to 50 Mfd. • REACTANCE: 50 to 2,500 Ohms, 2,500 Ohms to 2.5 Megohms. • INDUCTANCE: 15 to 7 Henrys, 7 to 7,000 Henrys. • DECIBELS: —6 to +18, +14 to +38, +34 to +58. The following components are all tested for QUALITY at appropriate test po-

tentials. Two separate BAD-GOOD scales on the meter are used for direct readings. All Electrolytic Condensers from 1 MFD to 1000 MFD. All Germanium Diodes. All Selenium Rectifiers. All Silicon Diodes. All Silicon Rectifiers.

Model 79 comes complete with operating instructions, test leads, and streamlined carrying case. Use it on the bench—use it on calls. Only **\$38.50**

SUPERIOR'S NEW MODEL 80

20,000 OHMS PER VOLT ALLMETER

THE ONLY 20,000 OHMS PER VOLT V.O.M. SELLING FOR LESS THAN \$50 WHICH PROVIDES ALL THE FOLLOWING FEATURES:

- ✓ 6 INCH FULL-VIEW METER provides large easy-to-read calibrations. No squinting or guessing when you use Model 80.
- ✓ MIRRORED SCALE permits fine accurate measurements where fractional degrees are important.
- ✓ CAPACITY RANGES permit you to accurately measure all condensers from .00025 MFD to 30 MFD in addition to the standard volt, current, resistance and decibel ranges.
- ✓ HANDSOME SADDLE-STITCHED CARRYING CASE included with Model 80 Allmeter at no extra charge enables you to use this fine instrument on outside calls as well as on the bench in your shop.

- SPECIFICATIONS:
- 7 D.C. VOLTAGE RANGES (At a sensitivity of 20,000 Ohms per Volt) 0 to 15 75/150/300/750/1500/7500 Volts.
 - 6 A.C. VOLTAGE RANGES: (At a sensitivity of 5,000 Ohms per Volt) 0 to 15 75/150/300/750/1500 Volts.
 - 3 RESISTANCE RANGES: 0 to 2,000/200,000 Ohms. 0-20 Megohms.
 - 2 CAPACITY RANGES: .00025 Mfd. to 3 Mfd., .05 Mfd. to 30 Mfd.
 - 5 D.C. CURRENT RANGES 0-75 Microamperes, 0 to 7.5/75/750 Milliampers, 0 to 15 Amperes.
 - 3 DECIBEL RANGES: —6 db to +18 db, +14 db to +38 db, +34 db to +58 db.

Model 80 Allmeter comes complete with operating instructions, test leads and portable carrying case. Only **\$42.50**

TRY FOR 10 DAYS BEFORE you buy! THEN if satisfactory

pay in easy, interest free, monthly payments. See coupon inside.

We invite you to try before you buy any of the models described on this and the preceding pages. If after a 10 day trial you are completely satisfied and decide to keep the Tester, you need send us only the down payment and agree to pay the balance due at the monthly indicated rate. (See other side for time payment schedule details.)

NO INTEREST OR FINANCE CHARGES ADDED!

If not completely satisfied, you are privileged to return the Tester to us, cancelling any further obligation.

SEE OTHER SIDE

CUT OUT AND MAIL TODAY!

FIRST CLASS

Permit No. 61430

New York, N. Y.

VIA AIR MAIL

BUSINESS REPLY CARD

No Postage Stamp Necessary if Mailed in the U. S.

POSTAGE WILL BE PAID BY —

MOSS ELECTRONIC, INC.

3849 TENTH AVENUE

NEW YORK 34, N. Y.