

TRANSISTOR CIRCUITS MADE EASY

POPULAR AUGUST 1959 ELECTRONICS

35 CENTS

HI-FI · SWL · TEST GEAR · HAM RADIO

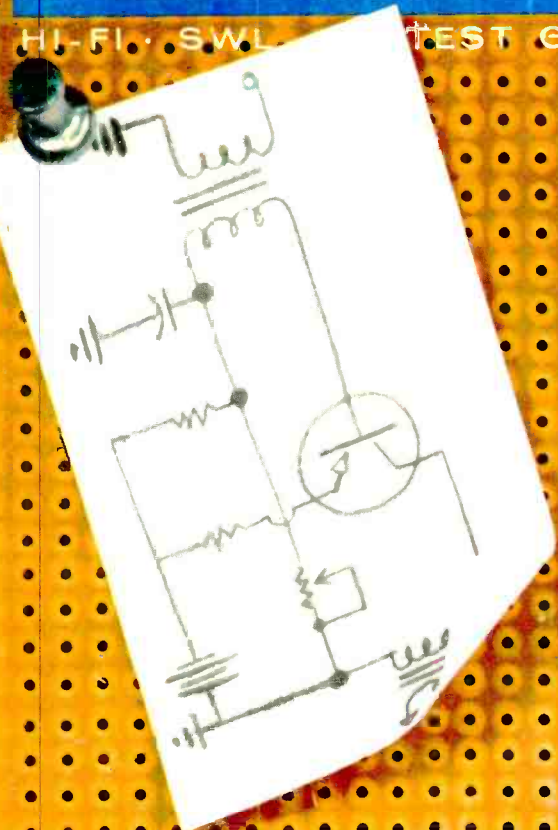

Transistorized
6 and 10 Meter Receiver

15 Circuits
Requested by Readers

SPECIAL! IGNITION SYSTEM
TUNE-UP SIMPLE

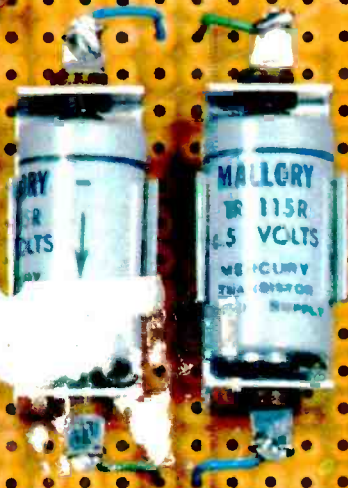
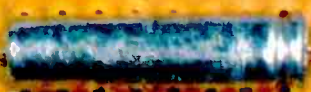

"PACKAGING" MICROWAVES FOR MOUNTAIN TOPS



"TJ" radio-relay station at Black Mesa, Arizona

In Arizona, the telephone company faced a problem. How could it supply more telephone service between Phoenix and Flagstaff—through 135 miles of difficult mountain territory?

Radio offered the economical answer: a new microwave radio-relay system recently created at Bell Telephone Laboratories. Operating at 11,000 megacycles, it was just right for the distance, and the number of conversations that had to be carried.

But first other problems had to be solved: how to house the complex electronic equipment; how to assemble and test it at hard-to-reach relay stations way up in the mountains; and how to do it economically.

On-the-spot telephone company engineers had some ideas. They worked them out with engineers at the American Telephone and Telegraph Company and at Bell Telephone Laboratories. The result: a packaged unit.

The electronic equipment was assembled in trailer-like containers at convenient locations and thoroughly checked out. The complete units were then trucked up the mountains and lifted into position.

The system, now operating, keeps a watch on itself. When equipment falters, a relay station switches in stand-by equipment, then calls for help over its own beam.

The new Phoenix-Flagstaff link illustrates again how Bell System engineers work together to improve telephone service. Back of their efforts is the constant development of new communications systems at Bell Laboratories.



BELL TELEPHONE LABORATORIES

World center of communications research and development



How to make Stereo Recordings off-the-air with the Bell Tape Transport: Model shown here in portable carrying case has Record Pre-Amps already installed, is all set to record stereo broadcast from Bell Stereo Tuner.

With these components you can keep your favorite performances permanently on tape, then playback through the matching Bell Stereo Amplifier. Smart lookin'... and a smart way to save money, too.

Record your own 4-track stereo tapes with a new Bell Stereo Tape Transport

Add it to your hi-fi system. Record Stereo broadcasts. Copy your own stereo tapes and records.

New models play 4-track stereo tapes; give you twice as much playing time.

Makes a complete stereo system with Bell Stereo Amplifier and new matching Bell Stereo Tuner.

With the many new releases of 4-track stereo tapes at 7½ ips, here's the economical way to build your own stereo tape library.

Add a Bell Stereo Tape Transport to your hi-fi system. New models now available play and record 4-track stereo tapes. Give you more playing time on tape for less money!

Already have your own Bell Stereo Tape Transport? You can install your own 4-track head conversion kit for as little as \$25.00.

For playback of your favorite stereo recordings, all you need is the Bell Model 3030, a 2-channel stereo amplifier with built-in pre-amps... now available with its own matching Bell Stereo Tuner at a combined savings to you.

See your Bell Dealer today, and find out about this amazing introductory offer. Or, write us.

Bell Sound Division • THOMPSON RAMO WOOLDRIDGE Inc.
 555 Marion Road • Columbus 7, Ohio
 In Canada: THOMPSON PRODUCTS, Ltd., Toronto

POPULAR ELECTRONICS is published monthly by Ziff-Davis Publishing Company, William B. Ziff, Chairman of the Board (1946-1953), at 131 S. Wabash Ave., Chicago 5, Ill. Second-class postage paid at Chicago, Illinois. Authorized by Post Office Department, Ottawa, Canada, as second-class matter. **SUBSCRIPTION RATES:** one year U.S. and possessions, and Canada \$4.00; Pan-American Union countries \$4.50, all other foreign countries, \$5.00.

POPULAR ELECTRONICS

AUGUST

1959



VOLUME 11

NUMBER 2

"Bonus" Feature

- Understanding Transistor Circuits.....*James Butterfield* 67
A novice and an expert discuss circuit design in this special 16-page section and prove that understanding transistor circuitry can be a cinch.

Electronic Construction Projects

- Mark-A-Spot Frequency Standard.....*Don Lewis* 61
Pocket Regen Receiver..... 84
R.F. Preamplifier..... 84
Sensitive Photo Relay..... 86
Wireless Microphone..... 86
Magnetize Your Tools.....*John Shields* 98
Tubeless Transistorless Code Practice Oscillator.....*Leon A. Wortman* 99

Audio and High Fidelity

- Inside the Power Amplifier (Part 2).....*Joseph Marshall* 57
Eight-Watt Audio Amplifier..... 83
High-Frequency Xtal Oscillator..... 84
Dynamic Microphone Preamp..... 85
Stereo Phono Oscillator.....*Joseph Elkhorne* 94

Electronic Features and New Developments

- Electronics Against Cancer.....*R. E. Atkinson* 41
Shocking But True.....*Forrest H. Frantz, Sr.* 49
Radar Eyes for TV Weather Forecasts.....*Art Zuckerman* 52
Tips for Citizens Band Applicants..... 53
The World Within the Atom.....*Saunders Harris, W1NXL* 63
Radio Triggers Street Lights.....*Walter F. Valaika* 87
Chinese Language Teleprinter; Magnetic Plastic..... 88
Tune Up Your Car's Ignition System.....*Joseph Tartas, W2YKT* 89
Customize Your Kits.....*Donald L. Stoner, W6TNS* 96
Unpopular Electronics..... 114

Amateur and SWL

- The Trans-Six Receiver.....*John J. Sury, K8NIC* 45
Build a Solar-Powered 40-Meter Transmitter.....*Donald L. Stoner, W6TNS* 55
Code Practice Oscillator..... 83
Code Keyer..... 85
Build a 4-Band Regen Receiver..... 95
Short-Wave Monitor Registration..... 139

Departments

- Notes from the Editor.....*Oliver Read, W1ETI* 8
Letters from Our Readers..... 10
POP'tronics Bookshelf..... 18
Tips and Techniques..... 24
New Products..... 34
Transistor Topics.....*Lou Garner* 100
After Class.....*Saunders Harris, W1NXL* 103
Short-Wave Report.....*Hank Bennett, W2PNA* 105
Carl and Jerry.....*John T. Frye, W9EGV* 118
On the Citizens Band.....*Tom Kneitel, 2AØ3Ø5* 130

Copyright © 1959 by ZIFF-DAVIS PUBLISHING COMPANY. All rights reserved.

POPULAR ELECTRONICS

Discover for yourself why Sherwood is the most honored line of high fidelity components in the field. Sherwood Tuners (the first ever to achieve sensitivity under 0.95 microvolts) feature: Inter-Channel Hush, a noise muting system which makes FM tuning easier than ever • FM Multiplex Output • "Feather-Ray" Tuning Eye • Automatic Frequency Control • Flywheel Tuning. Combine these tuners with either of Sherwood's "mated" stereo amplifier choices; 20 + 20 watts or 36 + 36 watts. And only Sherwood offers all these features: Single Dual Bass & Treble Controls • Mid-Range Presence Rise • Stereo-Mono Function Indicator Lights • Phase-Reverse Switch • Damping Factor selection. Sherwood also offers either 36 or 60 watt monaural amplifiers, FM Multiplex Adapters and a complete decorator-styled line of cabinetry and 3-way speaker systems —The Finest in High Fidelity. Sherwood Electronic Laboratories, Inc., 4300 N. California Avenue. Chicago 18, Illinois.

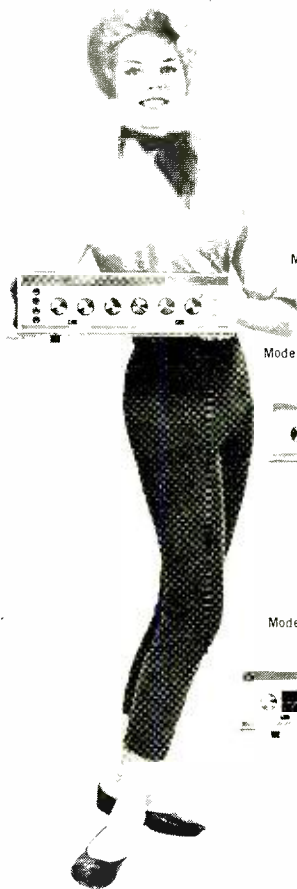

Model S-4400. Stereo Preamp. + 36W Amp —\$159 50

Model S-5000 20 + 20W Stereo Dual Amplifier —\$189.50



Model S-3000 II. FM Tuner —\$105 50

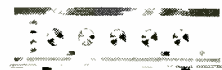

Model S-1000 II. 36W Monaural Amplifier —\$109 50



Model S-2000 II FM-AM Tuner —\$145 50

only for those who want the ultimate

SHERWOOD-HIGH FIDELITY

For complete technical details write Dept. PE-8

August, 1959

POPULAR ELECTRONICS

World's largest-selling Electronics Magazine

Editor & Publisher

OLIVER READ, W1ETI

Assistant Editor

JULIAN M. SIENKIEWICZ, WV2CQL

Technical Editor

LARRY KLEIN

Art Editor

ALFONS J. REICH

Associate Editors

**FURMAN HEBB
MARGARET MAGNA
PERRY WINTER**

Editorial Assistant

DOLORES GIMBEL

Contributing Editors

**H. BENNETT, W2PNA
H. S. BRIER, W9EGQ
J. T. FRYE, W9EGV
L. E. GARNER, Jr.
T. KNEITEL
H. POLLACK
D. L. STONER, W6TNS**

Art and Drafting Dept.

**K. W. PAUL, JR.
J. A. ROTH
W. K. VAHLSING**

Advertising Director

JOHN A. RONAN, Jr.

Advertising Manager

WILLIAM G. McROY

This month's cover photo by Bob Loeb

COMING NEXT MONTH

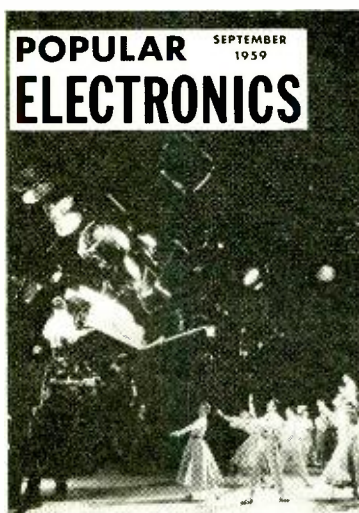

(ON SALE AUGUST 20)

ZIFF-DAVIS PUBLISHING COMPANY,
One Park Ave., New York 16, N. Y.
William B. Ziff, Chairman of the Board
(1946-1953); William Ziff, President;
W. Bradford Briggs, Executive Vice
President; Michael Michaelson, Vice
President and Circulation Director; Hersh-
el B. Sorbin, Vice President; Howard
Stoughton, Jr., Treasurer; Albert Gruen,
Art Director.



BRANCH OFFICES: Midwestern Office,
434 S. Wabash Ave., Chicago 5, Ill.,
Jim Weakley, advertising manager;
Western Office, Room 412, 215 W. 7th
St., Los Angeles 17, Calif., James R.
Pierce, advertising manager.

Foreign Advertising Representatives:
D. A. Goodall Ltd., London; Albert Mil-
hado & Co., Antwerp and Dusseldorf.

Keep your eyes open for the September cover—it will show a picture of a color TV show under way. This ties in with a no-holds-barred evaluation of color TV to date. See page 39 for details.

A whole batch of novel construction projects will appear in next month's POPULAR ELECTRONICS. Here is just a partial list: an electronic fish lure that really works; a completely transistorized stereo tape preamplifier to provide the best possible results from stereo tapes; and a pocket-sized three-transistor portable radio with a built-in loudspeaker.

Also coming are interesting and informative feature articles and, of course, all our regular features for experimenters, hams, SWL's and hi-fi'ers.

SUBSCRIPTION SERVICE: Forms 3579 and all subscription correspondence should be addressed to Circulation Department, 434 South Wabash Avenue, Chicago 5, Illinois. Please allow at least four weeks for change of address. Include your old address as well as new—enclosing if possible an address label from a recent issue.

CONTRIBUTORS: Contributors are advised to retain a copy of their manuscripts and illustrations. Contributions should be mailed to the New York Editorial Office and must be accompanied by return postage. Contributions will be handled with reasonable care, but this magazine assumes no responsibility for their safety. Any copy accepted is subject to whatever adaptations and revisions are necessary to meet the requirements of this publication. Payment covers all author's, contributor's and contestant's rights, titles, and interest in and to the material accepted and will be made at our current rates upon acceptance. All photos and drawings will be considered as part of material purchased.

**LET DeVRY TECH PREPARE YOU IN
SPARE TIME AT HOME AS AN**

ELECTRONICS TECHNICIAN



**NO PREVIOUS TECHNICAL EXPERIENCE
OR ADVANCED EDUCATION NEEDED!**

Laborers and bookkeepers, store clerks, shop men, farmers, salesmen — men of nearly every calling — have taken the DeVry Tech program and today have good jobs or service shops of their own in Electronics. You don't have to quit your present job. If you are 17 to 55, see how you may get yourself ready for a future in the fast-growing Electronics field.

Whether you prepare at home or in our well-equipped Chicago or Toronto Laboratories, you get sound, basic training in both principles and practice. At home, you use educational movies. You build actual circuits and test equipment. You read simple directions, follow clear illustrations. When you finish, you are prepared to step into a good job in an excitingly different field. You may even start a service shop of your own. Mail coupon for free facts today.

Live-Wire Employment Service



Puts you in touch with job opportunities—or helps you toward a better position in the plant where you are now employed.

Draft Age?

We have valuable information for every man of draft age: so if you are subject to military service, be sure to check the coupon.

SAMPLE BOOKLET FREE!

We'll give you a free copy of an interesting booklet, "Electronics and YOU." See for yourself how you may take advantage of the opportunities in this fast-growing field.

FREE!



MAIL TODAY FOR FREE FACTS



Accredited Member
of National
Home Study Council

DEVRY TECHNICAL INSTITUTE

CHICAGO 41, ILLINOIS

FORMERLY

DEFOREST'S TRAINING, INC.



AN INDEX to a BETTER JOB, A BRIGHTER FUTURE

Electronics

Radar

Guided
Missiles

Television

Micro-Waves

Communications

Radio

Industrial
Electronics

Computers

Automation
Electronics

Remote Control
Systems

Broadcasting

Your Own
Service Shop

DeVry Technical Institute

4141 Belmont Ave., Chicago 41, Ill., Dept. PE-8-P

Please give me your FREE booklet, "Electronics and YOU," and tell me how I may prepare to enter one or more branches of Electronics as listed above.

NAME _____ AGE _____
STREET _____ Please Print _____ APT. _____
CITY _____ ZONE _____ STATE _____

Check here if subject to military training

DeVry Tech's Canadian Training Center is located at
625 Roselawn Avenue, Toronto 12, Ontario

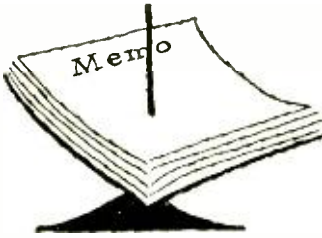

Notes from the Editor

TRANSISTORS. Some months back, included in our morning mail along with the usual bills, press releases, and notes from our readers, was a Yukon-postmarked manuscript typed on a code-copying typewriter. After wading through the mass of capital letters, we discovered that we had in our hands an explanation, in dialogue form, of how transistor circuits work, and how to design them by using Ohm's law and common sense.

This unusual manuscript so impressed us that we immediately got off a letter to the frozen north, asking the author, Jim Butterfield, to expand the article to the point where we could make a special feature out of it. After a series of conferences via trans-Canadian mail, Jim came up with "Understanding Transistor Circuits," which begins on page 67 of this issue. We think it's a pretty fine exposition of the transistor.

Unless you know your transistors cold, don't expect to absorb the whole story in one sitting. Take the three sections slow and easy, one at a time, and think over what you've read before going on to the next section. If you've been bogged down in textbook-style math or so "brainwashed" by vacuum-tube theory that the new transistor current amplification concepts have trouble getting through, you'll enjoy and appreciate "Understanding Transistor Circuits."

NEW COLUMN. Citizens Band radio has really gone over with a bang. Most manufacturers of Citizens Band equipment are in the frustrating but nevertheless happy situation of being unable to produce enough gear to satisfy the demand. Since our mailbag indicates a tremendous interest in this new service, we have arranged with Tom Kneitel, one of our contributing editors, to write a monthly column on the latest news and happenings on the Citizens Band. Tom's first column starts this month, on page 130.

CIRCUITS AND PROJECTS. Through the years, our reader mail has always indicated that a number of circuits were special favorites. In this issue we have assembled some of the most popular ones. Starting on page 83 is a four-page section which presents nine old stand-bys in "capsule" form.

Also in this issue are six other build-it-yourself projects which were requested by readers. If there are other projects you would like to see in the future, drop us a line. When we get enough requests for any particular item, we will publish complete plans.

POPULAR ELECTRONICS

**GREATEST
ADVANCE IN
SHOP-METHOD
HOME TRAINING**

EARN MORE MONEY...GET INTO TELEVISION ELECTRONICS-RADIO

Learn ALL 8 PHASES in ONE MODERN HOME-STUDY COURSE
At Home - In Spare Time

YOU GET ALL THIS NEWEST PRACTICAL EQUIPMENT

- Parts to build a modern TV set, including all tubes plus a large screen Picture Tube
- Parts to build a powerful Superhet Receiver, standard broadcast and short wave
- Parts to conduct many experiments and build Continuity Checker, RF Oscillator, TV Circuits, Audio Oscillator, TRF Receiver, Signal Generator
- A Valuable Professional Multitester

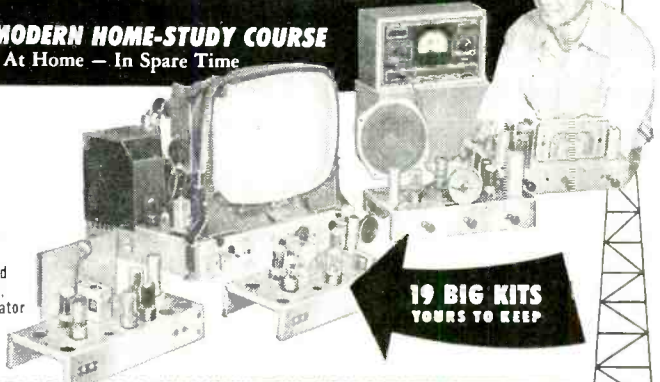

**19 BIG KITS
YOURS TO KEEP**

YOUR NATIONAL SCHOOLS TELERAMA COURSE COVERS ALL 8 PHASES

- | | |
|------------------------------------|--------------------------------|
| 1. TELEVISION, INCLUDING COLOR TV | 5. PREPARATION FOR FCC LICENSE |
| 2. RADIO, FM AND AM | 6. AUTOMATION |
| 3. INDUSTRIAL ELECTRONICS | 7. RADAR AND MICRO WAVES |
| 4. SOUND RECORDING AND HI FIDELITY | 8. COMMUNICATIONS |

YOU ARE NEEDED IN THE TELEVISION-ELECTRONICS-RADIO INDUSTRY!
You can build a secure future for yourself if you get into Electronics NOW! Today's shortage of trained technicians creates tremendous opportunities. National Schools Shop-Method trained technicians are in constant and growing demand for high-pay jobs in Broadcasting and Communications, Electronic Research, Servicing and Repair, and many other branches.

Let National Schools, a Resident Technical School for over 50 years train you for today's unlimited opportunities in electronics! Our Shop Method trains you to be a MASTER-TECHNICIAN. Completely up to date, developed by experienced instructors and engineers, your Telerama Course will teach you all phases of the industry quickly, clearly and correctly. You can master the most modern projects, such as Color TV, printed circuits - even prepare for FCC license without taking a special

course. You can handle sales, servicing, manufacturing, or make good money in your own business. SEND FOR FACTS TODAY!

EARN AS YOU LEARN. Many of our students earn their entire tuition and more in Spare Time jobs we show them how to do while learning.

YOU GET EVERYTHING YOU NEED - Clear, profusely illustrated lessons, shop-tested manuals, modern circuit diagrams, practical job projects - all the valuable equipment shown above

- many other materials and services - consultation privilege with our qualified staff, and Graduate Employment Service. EVERYTHING YOU NEED for outstanding success in Electronics.

RESIDENT TRAINING AT LOS ANGELES

If you wish to take your training in our Resident School at Los Angeles, the world's TV capital, start NOW in our big, modern Shops, Labs and Radio-TV Studios. Here you work with latest Electronic equipment - professionally installed - finest, most complete facilities offered by any school. Expert, friendly instructors. Personal attention. Graduate Employment Service. Help in finding home near school - and part time job while you learn. Check box in coupon for full information.



FREE! Fully illustrated "Career" Book in TV-Radio-Electronics. PLUS actual sample lesson - yours at no cost, no obligation. **CLIP COUPON NOW... MAIL IT TODAY!**



MEMBER



NATIONAL SCHOOLS

4000 S. FIGUEROA ST., LOS ANGELES 37, CALIF.

NATIONAL SCHOOLS

TECHNICAL TRADE TRAINING SINCE 1905
LOS ANGELES 37, CALIFORNIA

GET FAST SERVICE - MAIL NOW TO

NATIONAL SCHOOLS, DEPT. R2G-89
4000 S. FIGUEROA ST.
LOS ANGELES 37, CALIF.

Rush free TV-Radio "Opportunity" Book and sample lesson. No salesman will call.

NAME _____ AGE _____
ADDRESS _____
CITY _____ PHONE _____ STATE _____

Check if interested ONLY in Resident School training at Los Angeles
VETERANS: Give date of Discharge _____

SPECIAL OFFER!

SAVE \$36.39

Campers, boaters, hams away-from-home . . . Here's a great cash savings on National Radio's famed NC-66, portable shortwave/ham receiver. Features 5 bands, including marine and aircraft direction finding beacons, standard AM, 160-5 meter amateur, and world-wide short wave bands. AC/DC or battery pack.

THIS IS WHAT YOU GET:

NC-66 portable receiver, reg. price.....	\$129.95*
RDF-66 direction finder, reg. price.....	39.95*
Eveready "Magnet Torch-lite" incl. cells.....	2.49
Marine Electronic Handbook.....	3.95
(Published by Howard W. Sams)	
Total value	\$176.34

NATIONAL'S SPECIAL PACKAGE PRICE..... 139.95
YOU SAVE..... \$ 36.39

This is a limited time offer . . . so see your National Radio distributor now, or write for full catalog and dealer's name nearest you.

*Sugg. list, slightly higher west of Rockies and outside U. S. A.

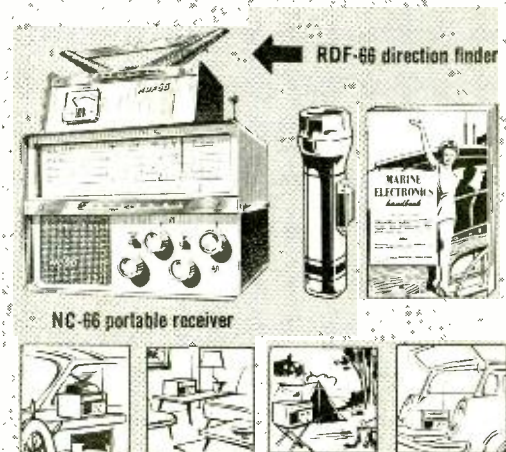

MELROSE 76, MASS.

A wholly owned subsidiary of National Co., Inc.

THIS SPECIAL OFFER IS SUBJECT TO WITHDRAWAL AT ANY TIME, WITHOUT NOTICE

Letters

from our readers

Perplexing Stereoplex

■ I want to build the "Stereoplex" amplifier which appears in your April issue, but am unable to find the output transformers. Could you please tell me where I can purchase these transformers?

S/SGT. BUDDIE BAILEY
 APO 332, New York, N. Y.

The Stancor A-3872 can be ordered from any of the larger mail-order supply houses for \$4.66 plus shipping charges. Incidentally, please note that capacitor C8 in the Stereoplex is shown on the schematic with its positive end connected to ground—the negative end of C8 should go to ground.

Ham Band Romance

■ My name appeared in Herb Brier's column in the November 1956 edition of POPULAR ELECTRONICS. At that time I offered my assistance to anyone who might need help in getting an amateur radio operator's license. One of the letters I received was from a girl in Lambertville, N. J. She and I soon found that we had a great many things



in common. One thing led to another; and to make a long story short, we will be married on September 25th. If it weren't for your magazine, we would never have met. Please accept thanks from both of us for the role that POPULAR ELECTRONICS played in bringing us together.

NATHAN J. SCHULMAN, K4OYG
 Eau Gallie, Fla.

We're overwhelmed. We never thought we'd be playing Cupid. Anyway—congratulations and best wishes for a long and happy marriage.

Replace the Buffer, Too

■ Having serviced auto radios for several years, I enjoyed reading "How to Repair Auto Radios" in

**Want To
Double
Your Pay**
Get into Radio—
TV-Electronics

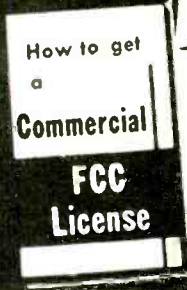

Get all 3 FREE

FIND OUT what the FCC license means

Your FCC license is recognized by employers as proof of your technical ability.

FIND OUT how the FCC license helps you get a better job or increase your pay on your present job

"License and \$25 raise due to Cleveland Institute training." "I sat for and passed the FCC exam for my second class license. This meant a promotion to Senior Radio Technician with the Wyoming State Highway Department, a \$25 a month raise and a District of my own for all maintenance on the State's two-way communication system.

"I wish to sincerely thank you and the school for the wonderful radio knowledge you have passed on to me. I highly recommend the school to all acquaintances who might possibly be interested in radio. I am truly convinced I could never have passed the FCC exam without your wonderful help and consideration for anyone wishing to help themselves." Charles C. Roberson Cheyenne, Wyoming

FIND OUT how we guarantee your FCC license

The Master Course in Electronics will provide you with the mental tools of the electronics technician and prepare you for a First Class FCC License (Commercial) with a radar endorsement. When you successfully complete the Master Course, if you fail to pass the FCC examination, you will receive a full refund of all tuition payments.

FIND OUT how employers make job offers like this to our graduates every month

RADIO OPERATORS: TWA has opportunities for radio operators with a 2nd class license or better. Must be able to type at least 35 wpm. Free transportation for self and family. Vacation and many other benefits.

CLEVELAND INSTITUTE OF RADIO ELECTRONICS
Desk PE-54 4900 Euclid Avenue Cleveland 3, Ohio



good training doesn't cost . . . it pays!



Accredited by the National Home Study Council

Cleveland Institute of Radio Electronics

Desk PE-54 4900 Euclid Avenue Cleveland 3, Ohio

Please send Free Booklets prepared to help me get ahead in Electronics. I have had training or experience in Electronics as indicated below:

- Military
- Radio TV Servicing
- Manufacturing
- Amateur Radio
- Broadcasting
- Home Experimenting
- Telephone Company
- Other

In what kind of work are you now engaged? In what branch of Electronics are you interested?

Name Age

Address

City Zone State

Desk PE-54

for
CITIZENS BAND
marine
radio

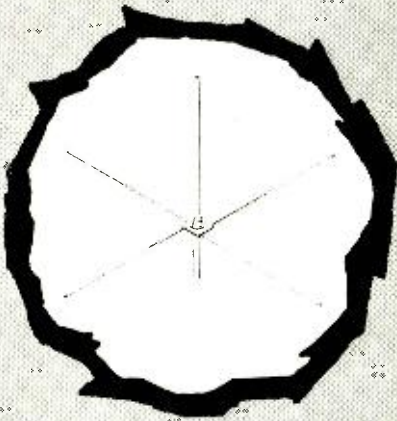

MOSLEY V-27-GP

100% RUST PROOF Vertical Antenna for the 11 meter Citizens Band. 360° radiation pattern for effective communication at any heading when antenna is mounted clear of interacting objects.

Radiator and radials are of heavy gauge 61ST6 aluminum. Fittings and hardware are brass, copper and stainless steel. Vertical and radials are each 9' long. Heavy duty base mount with coax connector fits 1¼" ID pipe mast. Supplied with Mosley Antenna Coat for protection against salt corrosion. Model V-27-GP, less mast & RG-8/U coax. Net Price, \$34.95

Available from most electronic equipment distributors—coast-to-coast.

Mosley
Electronics, Inc.
 ST. LOUIS 14, MISSOURI

Letters

(Continued from page 10)

your May issue. However, the article failed to mention the buffer capacitor and the spark plate.

Many times the buffer capacitor shorts out as well as the vibrator. If a faulty vibrator is replaced with a new one and the buffer capacitor is shorted, the new vibrator can be damaged. In fact, many manufacturers guarantee their vibrators only if the buffer capacitor is replaced along with the vibrator.

BILL CARLISLE, USAF
 Keesler AFB, Miss.

Although good service practice dictates replacing the buffer capacitor along with the vibrator, the primary aim of this article was to show how to get an inoperative auto receiver working again without removing it from the car. If the set is taken out of the car—or can be without too much difficulty—always replace the buffer capacitor.

Better Convert to Monophonic

■ Can you tell me if there is a device for shutting out sounds such as stereophonic music which can be placed over the ears (not inside the ears), and where I can secure this? Such a device could be

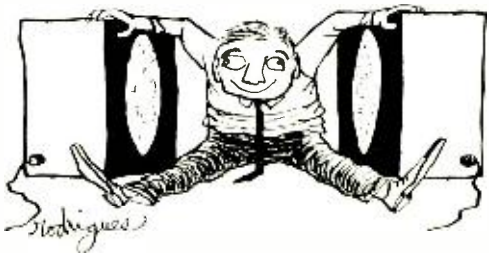

worn by one person who does not like stereophonic music without taking away that particular enjoyment from others who do.

MRS. ORRIS McCARTNEY
 Napa, Calif.

Have you tried the car muff and ear plug manufacturers?

Correction on "Dice"

■ Just a note to let you know that I have heard from Ira Glickstein on his "Eight-Sided Dice" article, and that he was able to straighten out the trouble I was having. The dice work swell now and are great fun. The one thing you might correct for your readers is the listing of the push-button switch for this unit. It should be a Switchcraft 1009 and not a 9001 as shown in the parts list.

STAN FARMER
 Grand Junction, Colo.

More on Contra-Polar Energy

■ Referring to Lawrence Jenkins' letter in the April issue concerning contra-polar energy, I would like to point out that although such matter—with positive electrons and negative protons—would be incompatible with our conventional matter, the particles which would make it up definitely do exist. A full report on the present status of the particles and anti-particles is contained in the

"HOW A 'CRAZY RUMOR' GOT ME PROMOTED!"



What I overheard one morning shook me right out of a rut!

"Company's getting ready to cut back . . . bound to be layoffs," I heard them say. "Just another crazy rumor," I told myself.

Just the same, I took quick stock of myself that night. Came up with four good reasons why the company would keep me on:

- Three years' experience*
- Getting along with foreman*
- Turning out acceptable work*
- Prompt and dependable*

And four just-as-good reasons why they might let me go:

- Making no real headway*
- Others better qualified*
- Still rated "semi-skilled"*
- Needs special training*

I wasn't in trouble. But I sure wasn't "in solid" like I should be. That's when I made up my mind to enroll for training with I.C.S.

I picked I.C.S. because it's the oldest and largest with 259 courses. The training is quick and thorough. It's recognized by my company and accredited by the National Home Study Council. You study in your spare time and get personalized, practical instruction—know-how you can apply next day on the job.

That was a year ago. There have been two layoffs since then. While some of the others were just hanging on or being released, I was moving up. My I.C.S. training started something. Not only did it get me promoted (with a fat pay hike), but it put me in line for real advancement.

Don't wait for a "crazy rumor" to set you straight. Take out your "job insurance" right now. Mail the coupon and get full, free details on how I.C.S. has helped thousands, how it can help you. No obligation—and you get three valuable books *free!* (1) How to Succeed; (2) Catalog of opportunities in the field of your choice; (3) Sample lesson (math).

For Real Job Security—Get an I. C. S. Diploma! I. C. S., Scranton 15, Penna. Accredited Member, National Home Study Council

INTERNATIONAL CORRESPONDENCE SCHOOLS



BOX 73622G, SCRANTON 15, PENNA.

(Partial list of 258 courses)

Without cost or obligation, send me "HOW TO SUCCEED" and the opportunity booklet about the field BEFORE which I have marked X (plus sample lesson):

- | | | | | |
|---|--|--|---|--|
| <p>ARCHITECTURE and BUILDING CONSTRUCTION</p> <ul style="list-style-type: none"> <input type="checkbox"/> Air Conditioning <input type="checkbox"/> Architecture <input type="checkbox"/> Arch. Drawing and Designing <input type="checkbox"/> Building Contractor <input type="checkbox"/> Building Estimator <input type="checkbox"/> Carpenter Builder <input type="checkbox"/> Carpentry and Millwork <input type="checkbox"/> Carpenter Foreman <input type="checkbox"/> Heating <input type="checkbox"/> Painting Contractor <input type="checkbox"/> Plumbing <input type="checkbox"/> Reading Arch. Blueprints <p>ART</p> <ul style="list-style-type: none"> <input type="checkbox"/> Commercial Art <input type="checkbox"/> Magazine Illus <input type="checkbox"/> Show Card and Sign Lettering <input type="checkbox"/> Sketching and Painting <p>AUTOMOTIVE</p> <ul style="list-style-type: none"> <input type="checkbox"/> Automobile <input type="checkbox"/> Auto Body Rebuilding and Refinishing <input type="checkbox"/> Auto Engine Tuneup <input type="checkbox"/> Auto Technician | <p>AVIATION</p> <ul style="list-style-type: none"> <input type="checkbox"/> Aero-Engineering Technology <input type="checkbox"/> Aircraft & Engine Mechanic <p>BUSINESS</p> <ul style="list-style-type: none"> <input type="checkbox"/> Accounting <input type="checkbox"/> Advertising <input type="checkbox"/> Business Administration <input type="checkbox"/> Business Management <input type="checkbox"/> Cost Accounting <input type="checkbox"/> Creative Salesmanship <input type="checkbox"/> Managing a Small Business <input type="checkbox"/> Professional Secretary <input type="checkbox"/> Public Accounting <input type="checkbox"/> Purchasing Agent <input type="checkbox"/> Salesmanship <input type="checkbox"/> Salesmanship and Management <input type="checkbox"/> Traffic Management <p>CHEMICAL</p> <ul style="list-style-type: none"> <input type="checkbox"/> Analytical Chemistry <input type="checkbox"/> Chemical Engineering <input type="checkbox"/> Chem. Lab. Technician <input type="checkbox"/> Elements of Nuclear Energy <input type="checkbox"/> General Chemistry <input type="checkbox"/> Natural Gas Prod. and Trans. <input type="checkbox"/> Petroleum Prod. and Engr. <input type="checkbox"/> Professional Engineer (Chem) <input type="checkbox"/> Pulp and Paper Making | <p>CIVIL ENGINEERING</p> <ul style="list-style-type: none"> <input type="checkbox"/> Civil Engineering <input type="checkbox"/> Construction Engineering <input type="checkbox"/> Highway Engineering <input type="checkbox"/> Professional Engineer (Civil) <input type="checkbox"/> Reading Struc. Blueprints <input type="checkbox"/> Sanitary Engineer <input type="checkbox"/> Structural Engineering <input type="checkbox"/> Surveying and Mapping <p>DRAFTING</p> <ul style="list-style-type: none"> <input type="checkbox"/> Aircraft Drafting <input type="checkbox"/> Architectural Drafting <input type="checkbox"/> Drafting & Machine Design <input type="checkbox"/> Electrical Drafting <input type="checkbox"/> Mechanical Drafting <input type="checkbox"/> Sheet Metal Drafting <input type="checkbox"/> Structural Drafting <p>ELECTRICAL</p> <ul style="list-style-type: none"> <input type="checkbox"/> Electrical Engineering <input type="checkbox"/> Elec. Engr. Technician <input type="checkbox"/> Elec. Light and Power <input type="checkbox"/> Practical Electrician <input type="checkbox"/> Practical Lineman <input type="checkbox"/> Professional Engineer (Elec) <p>HIGH SCHOOL</p> <ul style="list-style-type: none"> <input type="checkbox"/> High School Diploma | <ul style="list-style-type: none"> <input type="checkbox"/> Good English <input type="checkbox"/> High School Mathematics <input type="checkbox"/> High School Science <input type="checkbox"/> Short Story Writing <p>LEADERSHIP</p> <ul style="list-style-type: none"> <input type="checkbox"/> Industrial Foremanship <input type="checkbox"/> Industrial Supervision <input type="checkbox"/> Personnel-Labor Relations <input type="checkbox"/> Supervision <p>MECHANICAL and SHOP</p> <ul style="list-style-type: none"> <input type="checkbox"/> Diesel Engines <input type="checkbox"/> Gas-Elec. Welding <input type="checkbox"/> Industrial Engineering <input type="checkbox"/> Industrial Instrumentation <input type="checkbox"/> Industrial Metallurgy <input type="checkbox"/> Industrial Safety <input type="checkbox"/> Machine Shop Practice <input type="checkbox"/> Mechanical Engineering <input type="checkbox"/> Professional Engineer (Mech) <input type="checkbox"/> Quality Control <input type="checkbox"/> Reading Shop Blueprints <input type="checkbox"/> Refrigeration and Air Conditioning <input type="checkbox"/> Tool Design <input type="checkbox"/> Tool Making <p>RADIO, TELEVISION and GENERAL ELECTRONICS TECH</p> <ul style="list-style-type: none"> <input type="checkbox"/> Industrial Electronics <input type="checkbox"/> Practical Radio-TV Eng'g <input type="checkbox"/> Practical Telephony <input type="checkbox"/> Radio-TV Servicing | <p>RAILROAD</p> <ul style="list-style-type: none"> <input type="checkbox"/> Car Inspector and Air Brake <input type="checkbox"/> Diesel Electrician <input type="checkbox"/> Diesel Engr. and Fireman <input type="checkbox"/> Stationary Locomotive <p>STEAM and DIESEL POWER</p> <ul style="list-style-type: none"> <input type="checkbox"/> Combustion Engineering <input type="checkbox"/> Power Plant Engineer <input type="checkbox"/> Stationary Diesel Engr. <input type="checkbox"/> Stationary Fireman <p>TEXTILE</p> <ul style="list-style-type: none"> <input type="checkbox"/> Carding and Spinning <input type="checkbox"/> Cotton Manufacture <input type="checkbox"/> Cotton Warming and Weaving <input type="checkbox"/> Loom Fixing Technician <input type="checkbox"/> Textile Designing <input type="checkbox"/> Textile Finishing & Dyeing <input type="checkbox"/> Throwing <input type="checkbox"/> Warp and Weaving <input type="checkbox"/> Worsted Manufacturing |
|---|--|--|---|--|

Name _____ Age _____ Home Address _____
 City _____ Zone _____ State _____ Working Hours _____ A.M. to P.M.
 Occupation _____

Canadian residents send coupon to International Correspondence Schools, Canadian, Ltd., Montreal, Canada . . . Special low monthly tuition rates to members of the U. S. Armed Forces.

Letters

(Continued from page 12)

March issue of "Scientific America." Further information on anti-particles can be found in Van Nostrand's *Scientific Encyclopedia*. Considering the dilemma faced by present-day physicists, it may just be that there is such a thing as a negative frequency!

BRUCE L. WARD, JR.
U.S.S. Essex (CVA-9)

See "The World Within the Atom" on page 63 for more information on anti-particles.

■ In performing some basic research on the subject of contra-polar energy, I have uncovered some facts which may be of interest to your readers.

Everyone with a basic knowledge of electronics is familiar with the formula for finding the resonant frequency of an inductive-capacitive circuit:

$$f = \frac{1}{2\pi\sqrt{LC}}$$

As the square root of a number can be either positive or negative, it follows that the square root of LC may be either positive or negative, which, in turn, would make f , the resonant frequency of the circuit, either positive or negative. Since the amount of current drawn by a circuit is equal to the voltage divided by the reactance, a negative reactance would make the circuit draw a negative amount of current.

Since contra-polar energy is itself negative, it changes electrons to positively charged particles

or positrons, the anti-particles of electrons. As a result, positron flow is from positive to negative, and in this way power is produced.

When electrons pass through the filament of a light bulb, they collide with other particles and photons are emitted. However, when positrons flow through the filament, anti-photon are emitted. These anti-photon are the anti-matter particles of photons and, in effect, produce negative light. In daylight, anti-photon hit protons produced by the sun and the two types of particles neutralize each other, thus producing darkness.

When electrons flow through a resistance, heat is produced by the collision of electrons with positively charged protons. However, when contra-polar energy is applied and the electrons change their charge to positive, the movement of particles is stopped, thereby producing cold. Therefore, if a wire or resistance element is run through a tray of water and contra-polar energy is applied to it, the water will freeze.

Experimentation with devices using contra-polar energy has shown the following formula to be very helpful:

$$\frac{D^0 n(T)}{\beta_e (1/\epsilon) E_e e} \sqrt{\frac{eV^e(R)Y}{r(h')(N_g)} UC}$$

VLADIMIR NEMEC
Brookfield, Ill.

Room for Improvement

■ Your magazine is one of the best we have ever read in this complex field of amateur radio and electronics. We have collected all but a few of the

MICRO

ELECTRON TUBE

INTRODUCES FOR THE FIRST TIME
ANYWHERE A SELECT STOCK OF USED
TUBES AT A FABULOUS LOW PRICE

37¢

ed.

\$35 PER HUNDRED ASSTD.

FOR *any* TUBE LISTED

Jan Surplus Tubes!

ALL TUBES SENT POSTAGE PAID
Please send 25c handling for orders under \$5. Send 25% deposit on C.O.D. orders. Send approximate postage on Canadian and foreign orders.

MICRO

ELECTRON TUBE CO.

P.O. BOX 55 Park Station, Paterson 3, N. J.

- Each and every tube is tested in our own laboratory
- for mutual conduction and life test.
- We guarantee FREE replacement for one year of any tube purchased from us which fails to function efficiently under any or all operating conditions. Prompt refunds are made on any defective merchandise.
- The advertised tubes are not necessarily new, but may be electrically perfect factory seconds or used tubes—each is clearly so marked.

02Z	6X8	6H6	6SF5	724	19BG6G
02B	6Y3GT	6DJ6	6SF7	12A8	19J6
1A7GT	6Y4G	6BK5	6S17	12AQ5	19T8
1B3GT	6A8	6BK7	6SN7	12AT7	2A4
1H4GT	6AB4	6BL7GT	6SL7GT	12AU6	25A4V5
1L4	6AF4	6BN6	6SN7GT	6SQ7	25B06
1L8	6AC7	6BQ6GT	6SB7	6SS7	25D06
1N3GT	6AG5	6B7	6BY5C	6T4	25D06
1Q3GT	6A07	6B7Z	6B7Z	6T8	25L6GT
1R3	6A07	6B7Z	6C4	6U6	25W4GT
1S5	6A4GT	6C27	6C5	6V6	25Z5
1T4	6A5	6C4	6C5	6V6	25Z5
1U4	6A5	6C4	6C5	6V6	25Z5
1V2	6A5	6C4	6C5	6V6	25Z5
1X2	6A5	6C4	6C5	6V6	25Z5
2A3	6A8	6C8B	6C8B	6V6	25Z5
2AF4	6A8	6C8B	6C8B	6V6	25Z5
3B1C5	6A8	6C8B	6C8B	6V6	25Z5
3B26	6A8	6C8B	6C8B	6V6	25Z5
3C86	6A8	6C8B	6C8B	6V6	25Z5
3C76	6A8	6C8B	6C8B	6V6	25Z5
3C50	6A8	6C8B	6C8B	6V6	25Z5
3LF4	6A8	6C8B	6C8B	6V6	25Z5
3J4	6A8	6C8B	6C8B	6V6	25Z5
3K4	6A8	6C8B	6C8B	6V6	25Z5
4007A	6A8	6C8B	6C8B	6V6	25Z5
4B27	6A8	6C8B	6C8B	6V6	25Z5
5A58	6A8	6C8B	6C8B	6V6	25Z5
5AT8	6A8	6C8B	6C8B	6V6	25Z5
5AV8	6A8	6C8B	6C8B	6V6	25Z5
5AW4	6A8	6C8B	6C8B	6V6	25Z5
5B7	6A8	6C8B	6C8B	6V6	25Z5
5J6	6A8	6C8B	6C8B	6V6	25Z5
6T8	6A8	6C8B	6C8B	6V6	25Z5
6U4	6A8	6C8B	6C8B	6V6	25Z5
5U8	6A8	6C8B	6C8B	6V6	25Z5
5V4G	6A8	6C8B	6C8B	6V6	25Z5
5V6GT	6A8	6C8B	6C8B	6V6	25Z5

SEND FOR OUR FREE COMPLETE LIST OF TUBES & SPECIAL PURPOSE TUBES

These men are getting practical training in **ELECTRONICS**

ELECTRICITY

ELECTRONICS

ON REAL

- Motors—Generators
- Switchboards—
- Controls—Modern
- Appliances—
- Automatic
- Electronic
- Control Units

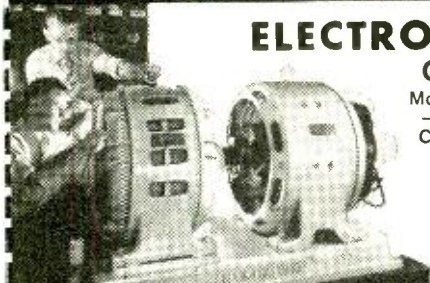

TELEVISION

RADIO ELECTRONICS

ON REAL

- TV Receivers—
- Black and White
- and Color
- AM-FM and
- Auto Radios
- Transistors
- Printed Circuits
- Test Equipment



Train in NEW Shop-Labs of COYNE

in Chicago—prepare for today's TOP OPPORTUNITY FIELD. Train on real full-size equipment at COYNE where thousands of successful men have trained for over 60 years—largest, oldest, best equipped school of its kind. Professional and experienced instructors show you how, then do practical jobs yourself. No previous experience or advanced education needed. Employment Service to Graduates.

START NOW—PAY LATER—Liberal Finance and Payment Plans. Part-time employment help for students. **GET FREE BOOK**—"Guide to Careers" which describes your training in **ELECTRICITY-ELECTRONICS** and **TELEVISION-RADIO ELECTRONICS**—no obligation; **NO SALESMAN WILL CALL.**

Coyne Electrical School, 1501 W. Congress Parkway
Chartered Not For Profit • Chicago 7, Dept. C9-2A

MAIL COUPON OR WRITE TO ADDRESS BELOW

COYNE ELECTRICAL SCHOOL
Dept. C9 2A —New Coyne Building
1501 W. Congress Pkwy., Chicago 7, Ill.

Send **BIG FREE** book and details of all the training you offer.

Name _____
Address _____
City _____ State _____



COYNE offers
LOW COST

TELEVISION

RADIO - COLOR TV

Training in
Spare Time **AT HOME**



The future is **YOURS** in **TELEVISION!**

A fabulous field—good pay—fascinating work—a prosperous future in a good job, or independence in your own business!

Coyne brings you **MODERN-QUALITY** Television Home Training; training designed to meet Coyne standards at truly lowest cost—you pay for training only—**no costly "put together kits."** Not an old Radio Course with Television "tacked on." Here is **MODERN TELEVISION TRAINING** including **Radio, UHF and Color TV.** No Radio background or previous experience needed. Personal guidance by Coyne Staff. **Practical Job Guides** to show you how to do actual servicing jobs—**make money early in course.** Free Lifetime Employment Service to Graduates.

COYNE
ELECTRICAL SCHOOL

CHARTERED AS AN EDUCATIONAL INSTITUTION
NOT FOR PROFIT

1501 W. Congress Parkway • Chicago 7, Dept. C9-H2



B. W. COOKE, Jr., President
Coyne—the institution behind this training... the largest, oldest, best equipped residential school of its kind. Founded 1899.

Send Coupon or write to address below
for Free Book

and full details,
including easy
Payment Plan.

**No obligation, no
salesman will call.**



COYNE Television
Home Training Division
Dept. C9-H2, New Coyne Building
1501 W. Congress Pkwy., Chicago 7, Ill.

Send Free Book and details on how I can get Coyne Quality Television Home Training at low cost and easy terms.

Name _____
Address _____
City _____ State _____

New Low-Cost Transistors

...from Sylvania

Eight diversified types to help you build or rebuild a wider range of transistorized equipment economically

Now you can transistorize more circuits at lower cost with these eight quality transistors from Sylvania:

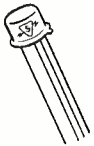

For high-gain RF-IF amplifier applications, a new PNP drift type, 2N1264—now available at \$1.30.



For AF and RF circuits, PNP types, 2N1265 and 2N1266 and equivalent NPN types, 2N229 and 2N233—now available at 65 cents.



For power requirement, 3 PNP Power types, 2N255, 2N307* and 2N554 with 15 v, 35 v and 30 v max. collector-base voltage respectively—each now available at \$1.35.

*Shown in use on the front cover of this issue of POPULAR ELECTRONICS.

Contact your nearby authorized Sylvania distributor or write the Semiconductor Division directly for applications literature on these new Sylvania transistors.

Sylvania Electric Products Inc.
Semiconductor Division
100 Sylvan Rd., Woburn, Mass.

SYLVANIA

Subsidiary of
GENERAL TELEPHONE & ELECTRONICS



Letters

(Continued from page 14)

back issues and plan on completing our collection in the near future. The past few issues have been much better than those of the first few years, but we would like to see more construction projects. How about a few construction projects on v.h.f.



converters? Actually, anything that is connected with the v.h.f. frequencies will help, as this is one of the most neglected parts of the ham program.

PHILIP W. KELLEN, K9POS
THOMAS D. MURPHY, K9POY
Chicago, Ill.

Help, Please!

■ I have searched through all kinds of radio books but cannot find instructions for winding base loading coils for a 10- to 80-meter vertical 21' antenna. The vertical tubing is $\frac{1}{2}$ " in diameter.

C. K. ESER
2304 Jefferson St.
Baltimore 5, Md.

Citizens Band Stations

■ I have been reading your articles on Citizens Band Class D radio and have enjoyed them very much. However, I wonder why you don't mention the fact that anyone who maintains such a station must have a first- or second-class commercial radiotelephone operator's license.

When I first heard of the new Class D band, I wrote the FCC asking about it. The answer I received said: "Installation tuning and maintenance work on Class D citizens radio transmitters may be performed only by the holder of a first- or second-class operator's license. If you do not intend to employ such an operator and desire to obtain your own license to do the maintenance work, you will be required to pass the necessary examination." In view of this reply from the FCC office in Chicago, I wonder if you might be misleading some hopefuls who believe they can do all the work themselves.

HORACE N. SMITH, W0PPD
Hagerstown, Ind.

If you do not hold a radiotelephone license, you may build a Citizens Band radio provided that all adjustments are made with a resistive dummy load connected to the antenna. The transmitter circuit must be the type approved by the FCC (as was the POPULAR ELECTRONICS unit in the June 1950 issue) and the output frequency tolerance must be at least .005%.

-30-

F.C.C. COMMERCIAL OPERATOR F.C.C. LICENSE

Training... for Jobs in Electronics

F.C.C. LICENSE—THE KEY TO BETTER JOBS

An F.C.C. commercial (not amateur) license is your ticket to higher pay and more interesting employment. This license is Federal Government evidence of your qualifications in electronics. Employers are eager to hire licensed technicians.

WHICH LICENSE FOR WHICH JOB?

The THIRD CLASS radiotelephone license is of value primarily in that it qualifies you to take the second class examination. The scope of authority covered by a third class license is extremely limited.

The SECOND CLASS radiotelephone license qualifies you to install, maintain and operate most all radiotelephone equipment except commercial broadcast station equipment.

The FIRST CLASS radiotelephone license qualifies you to install, maintain and operate every type of radiotelephone equipment (except amateur) including all radio and television stations in the United States, its territories and possessions. This is the highest class of radiotelephone license available.

GRANTHAM TRAINING PREPARES YOU

The Grantham Communications Electronics Course prepares you for a FIRST CLASS F.C.C. license, and it does this by TEACHING you electronics. Each point is covered simply and in detail, with emphasis on making the subject easy to understand. The organization of the subject matter is such that you progress, step-by-step, to your specific objective—a first class F.C.C. license.

CORRESPONDENCE OR RESIDENCE CLASSES

Grantham training is available by correspondence or in resident classes. Either way, you are trained quickly and well. Write, or mail the coupon below, to any division of Grantham School of Electronics. Our free booklet will be sent to you immediately.

HERE'S PROOF...

that Grantham students prepare for F.C.C. examinations in a minimum of time. Here is a list of a few of our recent graduates, the class of license they got, and how long it took them:

	License	Weeks
Ron Taylor, 29 S. Franklin St., Chambersburg, Pa.	1st	12
Beri Moore, P.O. Box 169, Opp, Alabama	1st	15
Donald R. Titus, 270 Park Terrace, Hartford 6, Conn.	1st	12
Robert G. Okamoto, P.O. Box 373, Honolulu, Hawaii	1st	12
Billy R. Kirby, Route 2, Smithfield, N. C.	1st	12
J. H. Reeves, 10621 Bunkleton, Los Angeles 47, Calif.	1st	12
Donald H. Ford, 15 Avonnet Rd., Cape Cod, Barnstable, Mass.	1st	12
James D. Hough, 409 S. Church St., East Troy, Wis.	1st	12

FOUR COMPLETE SCHOOLS: To better serve our many students throughout the entire country, Grantham School of Electronics maintains four complete Divisions—located in Hollywood, Calif., Seattle, Wash., Kansas City, Mo., and Washington, D.C. All Divisions of Grantham School of Electronics offer the same rapid courses in F.C.C. license preparation, either by home study or in resident classes.

Get your First Class Commercial F.C.C. License in 12 weeks by training at

Grantham School OF ELECTRONICS

for FREE Booklet CLIP COUPON and mail
in envelope or paste on postal card.



1505 N. Western Ave.
Hollywood 27, Calif.
(Phone: HO 7-7727)

408 Marion Street
Seattle 4, Wash.
(Phone: MA 2-7227)

3123 Gillham Road
Kansas City 9, Mo.
(Phone: JE 1-6320)

821-19th Street, N. W.
Washington 6, D. C.
(Phone: ST 3-3614)

MAIL COUPON NOW

To: GRANTHAM SCHOOL OF ELECTRONICS
 1505 N. Western • 408 Marion • 3123 Gillham Rd. • 821 19th, N.W.
 Hollywood • Seattle • Kansas City • Washington

Please send me your free booklet telling how I can get my commercial F. C. C. license quickly. I understand there is no obligation and no salesman will call.

Name _____ Age _____
 Address _____
 City _____ State _____

I am interested in: Home Study, Resident Classes 93 M

**"TOPS
in the class"**



BURGESS
Leakproof
FLASHLIGHT BATTERIES

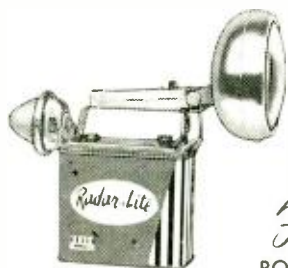

AMERICA'S
Favorite
PORTABLE LIGHTS

BURGESS BATTERY COMPANY

FREEPORT, ILL.

DIVISION OF SERVEL INC.

NIAGARA FALLS, CANADA

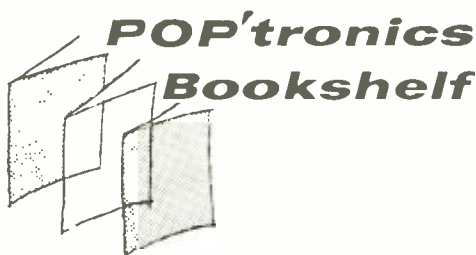

"ELECTRON TUBES AND SEMICONDUCTORS" by Joseph J. De France. Published by Prentice-Hall, Inc., 70 Fifth Ave., New York 11, N. Y. 288 pages. Hard cover. \$8.00.

Here is a basic text written in a conversational style which presents theory discussions with a minimum of mathematics. Frequent use of illustrations, logical sequence of sub-topics, and illustrative problems all combine to make this book easy to follow and understand. A basic knowledge of high school algebra, trigonometry, and a.c. and d.c. fundamentals is required.



"DICTIONARY OF GUIDED MISSILES AND SPACE FLIGHT" edited by Grayson Merrill. Published by D. Van Nostrand Co., Inc., 257 Fourth Ave., New York 10, N. Y. 688 pages. \$17.50.

As its name implies, this is a dictionary of terms used in the guided missile and space flight fields. Terms defined cover current and historical guided missiles and spacecraft, systems used in guidance and control, propulsion, armament, and launching, and all related terms from aerodynamics, astrodynamics, electronics, astronomy, and physics. This book is recommended for those working in the field and those who have a serious interest in guided missiles and space vehicles.



"MOBILE RADIO TELEPHONES" by H. N. Gant. Published by The Macmillan Company, 60 Fifth Ave., New York, N. Y. 125 pages. Hard cover. \$4.50.

Now that new techniques have opened up the higher frequency bands (allowing greater space for channels of communication), and have succeeded in greatly reducing the size of the necessary equipment, mobile radio has become a natural aid to business and administration. Previous

**WE'RE MAKING IT EASIER THAN EVER TO BECOME A WELL PAID
RADIO-TELEVISION SERVICE TECHNICIAN**

**NOW - Just \$6 Starts You Training in
RADIO-TELEVISION
the SPRAYBERRY "Learn-by-Doing" Way...**

**25 BIG, COMPLETE KITS
of PARTS & EQUIPMENT**

To help you learn just the practical side of Radio-Television, we send you expertly engineered training kits to test and assemble for interesting, valuable shop-bench practice!

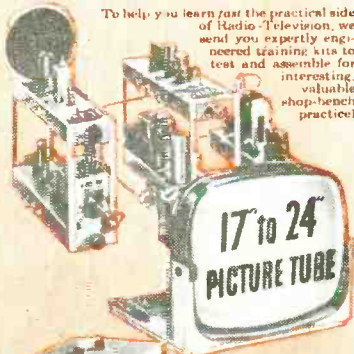

• The new Sprayberry Training Television Receiver, built and tested in 5 sections.

• Now offered, this fine modern oscilloscope.

• You build this powerful two-band superheterodyne radio receiver.

**Big New
CATALOG
AND
Sample Lesson
FREE!**



You build the new Sprayberry tester—a complete 18-range Volt-Ohm-Mill ammeter test meter.



*** This great industry is begging for trained men... to step into good paying jobs or a profitable business of their own! Our new plan opens the doors of Radio-Television wide to every ambitious man who is ready to act at once!

Men by the thousands... trained Radio-Television Service Technicians... are needed at once! Perhaps you've thought about entering this interesting, top paying field, but lack of ready money held you back. Now—just \$6 enrolls you for America's finest, most up to date home study training in Radio-Television! Unbelievable? No, the explanation is simple! We believe Radio-Television *must* have the additional men it needs as quickly as possible. We are willing to do our part by making Sprayberry Training available for less money down and on easier terms than ever before. This is your big opportunity to get the training you need... to step into a fine job or your own Radio-Television Service Business.

Complete Facts Free—Act Now; Offer Limited

Only a limited number of students may be accepted on this liberal and unusual basis. We urge you to act at once... mail the coupon below and get complete details plus our big new catalog and an actual sample lesson—all free. No obligation... no salesman will bother you.

HOME STUDY TRAINING IN SPARE TIME

Under world-famous 27-year old Sprayberry Plan, you learn entirely at home in spare time. You keep on with your present job and income. You train as fast or as slowly as you wish. You get valuable kits of parts and equipment for price-less shop-bench practice. And everything you receive, lessons and equipment alike, is all yours to keep.

LET US PROVE HOW EASILY YOU CAN LEARN!

Radio-Television needs YOU! And Sprayberry is ready to train you on better, easier terms, than any ambitious man can afford. Just \$6 starts you! Mail coupon today... let the facts speak for themselves. You have everything to gain. Let us prove the kind of opportunity in store for you!

SPRAYBERRY Academy of Radio-Television

1512 W. Jarvis Avenue, Dept. 105-A, Chicago 26, Illinois

Mail This Coupon Now—No Salesman Will Call

Sprayberry Academy of Radio-Television

Dept. 105-A, 1512 W. Jarvis Ave., Chicago 26, Ill.

Please rush all information on your ALL-NEW Radio-Television Training Plan. I understand this does not obligate me and that no salesman will call upon me. Include New Catalog and Sample Lesson FREE.

NAME..... Age.....

ADDRESS.....

CITY..... ZONE..... STATE.....

Build your own Electronic Devices around the RCA-2N307



**New RCA Booklet
featuring 2N307
circuits**



**NOW AVAILABLE AT YOUR LOCAL
RCA SEMICONDUCTOR DISTRIBUTOR**

RCA's high-performance, low-cost 2N307 power transistor is a "natural" for hams, experimenters, hobbyists and others who enjoy building electronic devices for education and fun. The new 16-page RCA booklet shown above provides complete, easy-to-build circuits and parts lists for the following devices using RCA-2N307 transistors.

- 12-watt "Hi-Fi" Amplifier • Sinusoidal Power Oscillator • Regulated Power Supply
- Regulated Power Supply With Amplified Correction Signal • Push-Pull DC-to-DC Converter • Intercommunication System
- Light Flasher • Electronic Photoflash Power Supply • DC-to-AC Inverter

Now, for a limited time only, this brand new Practical Transistor Circuit Booklet will be available through your local Authorized RCA Semiconductor Distributor. See him today for your copy.



**RADIO CORPORATION
OF AMERICA**

**Semiconductor Products—Distributor Sales
Harrison, N. J.**

Bookshelf (Continued from page 18)

books on this subject have been written for the technicians—design, installation and maintenance engineers—but Mr. Gant, realizing that mobile radio is now so much the executive's responsibility, has written this book especially for those people who deal with and organize transportation. While it will present little new information to the qualified design engineer, it should provide common understanding for the layman user and the skilled technician responsible for the installation and maintenance of mobile equipment.



"FUNDAMENTALS OF DIGITAL COMPUTERS" by Matthew Mandl. Published by Prentice-Hall, Inc., 70 Fifth Ave., New York 11, N. Y. 297 pages. \$9.00.

At a time when digital computers are fast becoming an integral part of modern life, this book offers clear and accurate explanations of their design, operation, and maintenance. Topics include basic circuits, computer arithmetic applications, special circuits, calculation circuits, storage systems, commercial computers, maintenance factors, etc. If you're interested in the intricacies of digital computers, this book is a good choice.



"RECORD CHANGER MANUAL: VOLUME II" compiled and published by Howard W. Sams and Co., Inc., Indianapolis 6, Ind. \$2.95.

This book provides a comprehensive coverage of 11 basic units used in 40 models of automatic record changers produced in 1957 and 1958. Exploded views, operational data, and detailed service instructions are included. The information presented here should be of great value to the service technician who is called upon to adjust and repair automatic record changers.



"FUNDAMENTALS OF HIGH FIDELITY" by Herman Burstein. Published by John F. Rider, Inc., 116 West 14th St., New York 11, N. Y. 144 pages. Soft cover. \$2.95.

As its title suggests, this is another basic book on high fidelity; it differs from a num-

Compare your job, your age
your pay, with that of

men who enroll at CREI

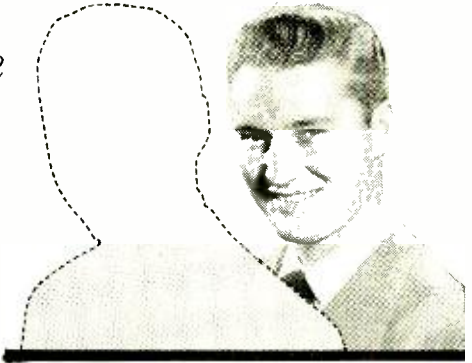

... then consider how handicapped you'll be without the knowledge of advanced electronics engineering technology which CREI teaches via home study

Men can stand still—or lose their jobs—even in a growing industry. They're doing it now in the fast-growing electronics industry. Companies actively seeking men with advanced technological knowledge are simultaneously firing mediocre men.

CREI students (more than 17,000 are currently enrolled) keep pace with electronics progress—and are eagerly sought by employers who offer solid opportunities for rapid advancement.

We analyzed the backgrounds of men who enrolled for CREI advanced electronics home study in a recent month. Compare yourself:

- 62% were civilians. 38% were in the Armed Services.
- Of the 62% who were civilians, 35% were electronic technicians, lab technicians, engineering aides, research assistants, electronic specialists, and similar high-rated electronics engineering men.
- Average pay: \$435 per month (range: \$300 to \$900). Average age: 28. Median age: 26. Previous formal electronic training varied from six months to more than a year.
- 9.4% of the civilians were technical representatives—field engineers who were school- or factory-trained to help install, maintain, service and teach the use and operation of electronic equipment. Average pay: \$525 per month. Median age: 28.
- 6.5% of the civilians held college degrees, most in a field more or less related to electronics (engineering,

physics, chemistry, etc.). These men were not in basic electronic work. Reason most often given for enrollment: to supplement job-know-how with better understanding of electronics.

• The remainder of the civilians were small groups of small percentages.

Even if you compare favorably with new CREI enrollees now, how do you think your salary will compare with theirs a year from now? Five years from now?

Qualify for positions which require advanced electronics education—while retaining your present job—via CREI home study. Meet your family responsibilities while gaining knowledge of electronic engineering technology so essential for career advancement. College degree is not essential. If you have had basic electronic education, practical experience in electronics, and a high school education, you can probably qualify. Use coupon below to find out, or write CREI, Dept. 128 F1, 3224 16th St., N.W., Wash. 10, D. C.

CREI RESIDENCE SCHOOL IN WASHINGTON, D. C.

For those who can attend classes, CREI operates full time residence school. Day and evening classes start at regular intervals. Qualified graduates earn AAS degree. Electronics experience not required for admission.



Get This New Fact-Packed Booklet—It's Free!

CAPITOL RADIO ENGINEERING INSTITUTE

ECPD Accredited Technical Institute Curricula • Founded 1927
Dept. 128 F1, 3224 Sixteenth St., N.W., Washington 10, D. C.
Please send me your course outline and FREE illustrated Booklet "Insurance for Your Future in the New World of Electronics" . . . describing opportunities and CREI home study courses in Practical Electronic Engineering Technology.

CHECK
FIELD OF
GREATEST
INTEREST

- Radar, Servo & Computer Engineering Technology
- Electronic Engineering Technology 5
- Broadcast (AM, FM, TV) Engineering Technology
- Television Engineering Technology
- Aeronautical Electronic Engineering Technology

Automation and Industrial Electronics Engineering Technology

Name _____ Age _____

Street _____

City _____ Zone _____ State _____

Check: Home Study Residence School Korean Veteran

To obtain fast, immediate service and to avoid delay, it is necessary that the following information be filled in:

Employed By _____

Type of Present Work _____

Education:

Yrs. High School _____

Other _____

Electronics Experience _____

AT LAST!

RADIO-TV and ELECTRONICS TRAINING

... AT A PRICE YOU CAN AFFORD!



*21 INCH Receiver Kit included

Yes, this great course costs far less than any training of its kind given by other major schools! Radio-Television Training School will train you for a good job in Television or Industrial Electronics — AT HOME in YOUR SPARE TIME.

Think of it—a complete training program including over 120 lessons, Fourteen Big Radio-Television Kits, Complete Color-TV Instruction, Unlimited Consultation Service ... ALL at a really big saving to you. How can we do this? Write to us today ... and find out!

And what's more — you can (if you wish) **OPEN YOUR OWN RTS-APPROVED AND FINANCED RADIO-TV SERVICE SHOP**

We Want Many More Shops This Year

This 37 year old training organization — called RTS, that's Radio-Television Training School — wants to establish a string of Radio-TV Repair Shops in principal cities throughout the U. S. So far, a great many such shops are NOW IN BUSINESS AND PROSPERING. We are helping and training ambitious men to become future owners and operators of these shops in all areas.

FOR UNSKILLED INEXPERIENCED MEN ONLY — WE TRAIN YOU OUR WAY!

We must insist that the men we sign up be trained in Radio-TV Repair, Merchandising and Sales by our training methods—because WE KNOW the requirements of the industry. Therefore, we will TRAIN YOU ... we will show you how to earn EXTRA CASH, during the first month or two of your training period. YOU KEEP YOUR PRESENT JOB. TRAINING TAKES PLACE IN YOUR OWN HOME, IN YOUR SPARE TIME!

COMPLETE COLOR INSTRUCTION INCLUDED

you build these and other units

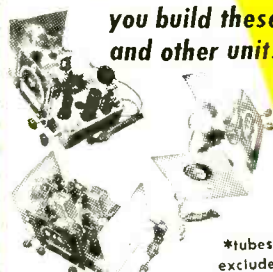

*tubes excluded

RADIO-TELEVISION TRAINING SCHOOL

5100 S. VERMONT AVENUE
LOS ANGELES 37, CALIFORNIA

Est. 1922



ACT NOW!

Get your free book on the **FAMOUS RTS BUSINESS PLAN** find out how you can open **A REPAIR SHOP OF YOUR OWN**

We supply and finance your equipment

When you are ready and qualified to operate one of our RTS-Approved TV Repair Shops **WE WILL SUPPLY AND FINANCE EVERY BIT OF EQUIPMENT YOU NEED TO GET STARTED** plus an inventory of parts and supplies. In other words we will stake you ... **AN OFFER NEVER MADE BEFORE BY ANY TRAINING ORGANIZATION.** Under the RTS Business Plan you receive:

1. An electric sign for the shop front.
2. Radio and TV test Equipment.
3. Letterheads, calling cards, repair tickets, etc.
4. Basic inventory of tubes, parts, supplies.
5. Advertising and promotional material.
6. Plans for shop arrangement.
7. Instructions on how to go into business.
8. Continuous consultation and help.
9. The right to use RTS Seal of Approval and the RTS Crest.
10. The right to use the Famous Trade Mark.



RTS' Membership in The Association of Home Study Schools is your assurance of Reliability, Integrity, and Quality of Training.

ALL THESE FREE!

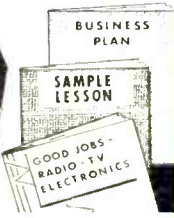

CUT OUT AND MAIL — TODAY!

RADIO-TELEVISION TRAINING SCHOOL
5100 S. Vermont Avenue, Dept. PE-89,
Los Angeles 37, California

SEND ME FREE — all of these big opportunity books — "Good Jobs in TV-Electronics," "A Repair Shop of Your Own" and "Sample Lesson." I am interested in:

- Radio-Television Industrial Electronics (Automation)

Name _____ Age _____
Please Print
Address _____
City & State _____
300

IMPROVE

your
Amplifier
in
5 ways

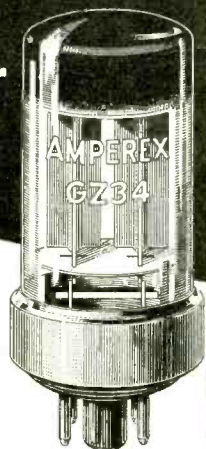

with the

Amperex® GZ34 / 5AR4 RECTIFIER

A LOW-IMPEDANCE, INDIRECTLY HEATED, FULL-WAVE RECTIFIER WITH 250 MA OUTPUT CAPACITY

The unique AMPEREX GZ34 replaces, without circuit changes, in the majority of amplifier circuits, an entire line of popular, heavy-duty 5-volt rectifiers—5U4G, 5V4G, 5T4, etc.—with the following benefits:

- Better voltage regulation due to lowered power supply impedance;
- Higher power supply output voltage for more power;
- Added filter condenser protection due to reduced surge;
- Cooler operation due to low voltage drop;
- Protection of costly power output tubes through delayed warm-up.

OTHER **Amperex TUBES** FOR HIGH-FIDELITY AUDIO APPLICATIONS:

EL84/6BQ5	9-pin power pentode; 17 W PP
6CA7/EL34	High-power pentode; 100 W PP
EF86/6267	Low-noise high- μ pentode
ECC81/12A7	Low-noise medium- μ dual triode
ECC82/12AU7	Low-noise low- μ dual triode
ECC83/12AX7	Low-noise high- μ dual triode
ECC85/6AQ8	High- μ dual triode for FM tuners
EZ80/6V4	9-pin rectifier; cathode; 90 ma.
EZ81/6CA4	9-pin rectifier; cathode; 150 ma.

At All Leading Electronic Parts Distributors



**Amperex
ELECTRONIC CORP.**
230 Duffy Ave., Hicksville, Long Island, N.Y.

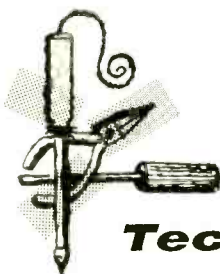

Tips and Techniques

ROTATING SHELF FOR SCOPE

Unlike other test instruments, the oscilloscope does not fit very well on the usual shallow shelf. Here's a good way to mount your scope on your workbench. Cut a piece of plywood the same size as the scope base and fasten it to the shelf with a bolt, using two nuts with a lock washer between them for safety. When the scope is placed on the plywood base, it can be turned to face in

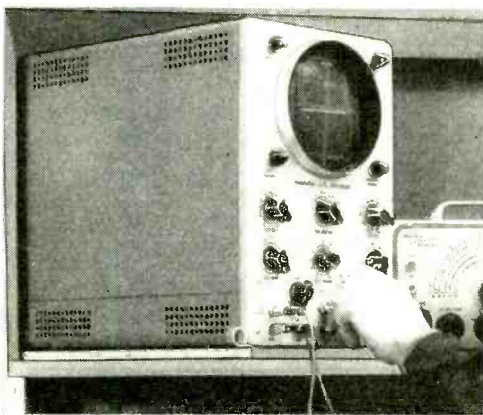

the most convenient direction. Make sure the base is fastened well enough to withstand being twisted and turned.—*Myron Bookwalter, Spokane, Wash.*

SUPPRESSING TV RADIATION

Most TV viewers have encountered some form of TVI at one time or another. Interference of this type results when the TV set picks up unwanted signals such as automobile ignition "noise." However, on occasions a TV set itself may radiate and interfere with radio reception. This condition might be dubbed "TVR."

Radiations emanating from a TV set can be suppressed by stapling ordinary household aluminum foil to the inside surfaces of the TV cabinet and grounding the foil to the TV chassis. If more shielding is necessary, staple metal window screening to the inside of the back panel and ground

Can you think faster than this Machine?

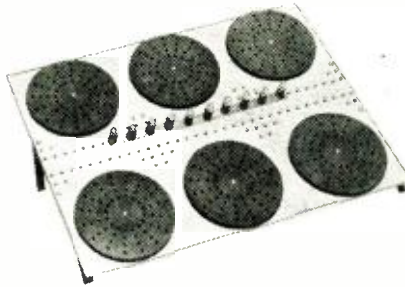

Control Panel of GENIAC set up to do a problem in space ship engineering

Be careful before you answer. GENIAC® the first electrical brain construction kit is equipped to play tic-tac-toe, cipher and encipher codes, convert from binary to decimal, reason in syllogisms, as well as add, subtract, multiply and divide. Specific problems in a variety of fields—actuarial, policy claim settlement, physics, etc., can be set up and solved with the components. Connections are solderless and are completely explained with templates in the manual. This covers 125 circuits and shows how new ones can be designed.

You will find building and using GENIACS® a wonderful experience; one kit user wrote us: "this kit has opened up a new world of thinking to me." You actually see how computing, problem solving, and game play (Tic-tac-toe, nim, etc.) can be analyzed with Boolean Algebra and the algebraic solutions transformed directly into circuit dia-

grams. You create from over 400 specially designed and manufactured components a machine that solves problems faster than you can express them.

Schools and colleges, teachers of science or math, engineering, philosophy or psychology will find these excellent demonstrators of circuitry solutions in symbolic logic, theory of numbers, cybernetics, and automation.

NOTE: Teachers take advantage of our 10% discount to educational institutions and for group purchases.

Send for your GENIAC® kit now. Only \$19.95 with over four hundred components and parts, fully illustrated manual and wiring diagrams. We guarantee that if you do not want to keep GENIAC after two weeks you can return it for full refund.

A MACHINE THAT PLAYS NIM

Yes every GENIAC® comes complete with the materials and circuits for wiring up a machine that plays NIM. No extra charge. See article in January Popular Electronics.

NEW—A MACHINE THAT COMPOSES MUSIC

Our amazing machine that composes music was designed by one of the people (a sixteen year old boy) who bought the GENIAC® to learn how to design computers. Use it to make up your own tunes automatically with the GENIAC® computer kit, 1959 Model.

Some Firms and Institutions that have ordered GENIAC:

Allis-Chalmers
Remington-Rand
International
Business
Machines
Wheeldey Mfg. Co.
Manuel Missionary
College
Los Angeles
Public Schools
Kansas State
University
Duke University
Coral Gables
Bell Telephone
Laboratories

Walter V. Clarke
Associates
Barnard College
Westinghouse
Electric
Phillips
Laboratories
General Insurance
Co. of America
Lafayette Radio
Rohr Aircraft Co.
Albert Einstein
Medical College
Naval Research
Laboratories

Other machines you can build with your 1959 Model GENIAC® Computer Kit.

Machine for a Space Ship's Airlock—Special Combination Lock—Adding-subtracting multiplying and dividing machines—Comparing and reasoning machines—Intelligence testing machines—Uranium Shipment and the Space Pirates—Machine to play Tic-Tac-Toe—Translator from binary to decimal and dozens of others.

What Comes With Your 1959 Model GENIAC?

Back, shown in picture; parts tray; guaranteed long lasting American Manufacture bulbs; porcelain sockets; special wipers and contacts; tools, battery; uniquely designed holder plus seven booklets and publications including: 64 Page GENIAC® manual; GENIAC® Wiring Diagrams; Beginners Manual for the person who has little or no knowledge of circuits; GENIAC® Study Guide, the equivalent of a full course in computer fundamentals, lists additional reading; and exclusively in 1959 Model GENIAC® Symbolic Logic and Circuits Design by Claude Shannon.

SEND for your GENIAC® now. At only \$19.95 a bargain! Comes complete with over 400 parts and components, 7 books and manuals. We guarantee that if you do not want to keep GENIAC® after two weeks you can return it for full refund.

K1—Only
\$19.95
(Add \$1.00 W. of Miss.
\$2.00 Outside U. S.)

OLIVER GARFIELD CO., INC.

DEPT. PE-89

108 E. 16th STREET

NEW YORK 3, N. Y.

August, 1959

25

RESIDENT SCHOOL COURSES

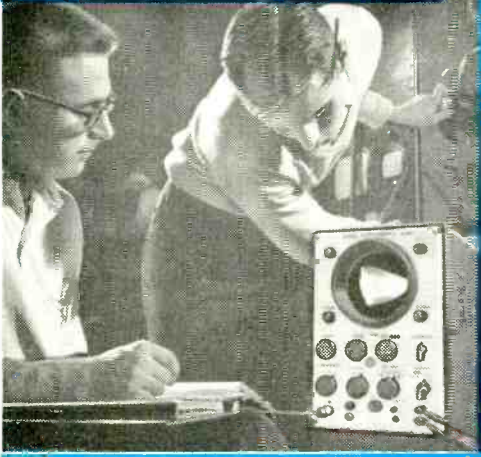

Industry needs Electronic Technicians!

Let RCA train you in Advanced Electronics

This is the college-level training you need to work with professional engineers on research, development or production projects in such fields as: automation, guided missiles, radar, television, computers and other advanced electronic applications.

RCA Institutes Resident School in New York City offers this comprehensive course that prepares you for any field of electronics you may choose. Other courses in TV & General Electronics, Radio & TV Servicing, and Radio Telegraph Operating.

Classes start four times each year. Applications now being accepted for men and women. Approved for Veterans.



RCA INSTITUTES, INC.
SCHOOL OF TELEVISION
AND ELECTRONIC TECHNOLOGY
A Service of Radio Corporation of America



RCA INSTITUTES, DEPT. PER-89
350 W. Fourth St., N. Y. 14, N. Y.

Please send me your FREE catalog of Resident School courses in New York.

NAME.....
please print

ADDRESS.....

CITY.....ZONE.....STATE.....

For Home Study Courses see ad on opposite page

Tips

(Continued from page 24)

it to the chassis.—*Wm. B. Rasmussen, Prosser, Wash.*

BATTERY PACK SAFEGUARD

It's a wise safeguard to wrap battery packs in plastic food bags before installing them in portable radios or other portable electronics gear. Should a battery



pack develop a leak, the plastic bag will keep the corrosive acid from damaging parts mounted nearby.—*Jerome A. Cunningham, Chicago, Ill.*

FAHNESTOCK CLIP CONNECTORS

In experimental "haywire" hookups where the leads of resistors, fixed capacitors, coils, crystal diodes, etc., are continually being connected and disconnected, you can save time, and wear and tear on the leads, by using small Fahnestock clips as connectors. The clips need not be fastened

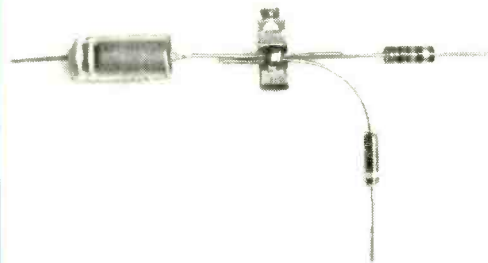

to the board, but can simply be used as clamps, where needed, to hold leads together.—*Art Trauffer, Council Bluffs, Iowa.*

DOT YOUR COLLECTORS

Many new transistors do not have in-line leads and it is not immediately apparent which lead is which. A person who is a bad guesser can kill many a 2N'er! A simple and efficient way to stop this needless slaughter is to paint a red dot on the col-

Always say you saw it in—POPULAR ELECTRONICS



LET RCA TRAIN YOU IN ELECTRONICS

RCA Institutes celebrates Fifty Years of Electronic Training by introducing its newest Home Study Course . . .

ELECTRONICS FOR AUTOMATION

. . . Now you have *four* comprehensive courses for your electronic training . . . from basic electronic theory to the more advanced principles of color TV and Automation.

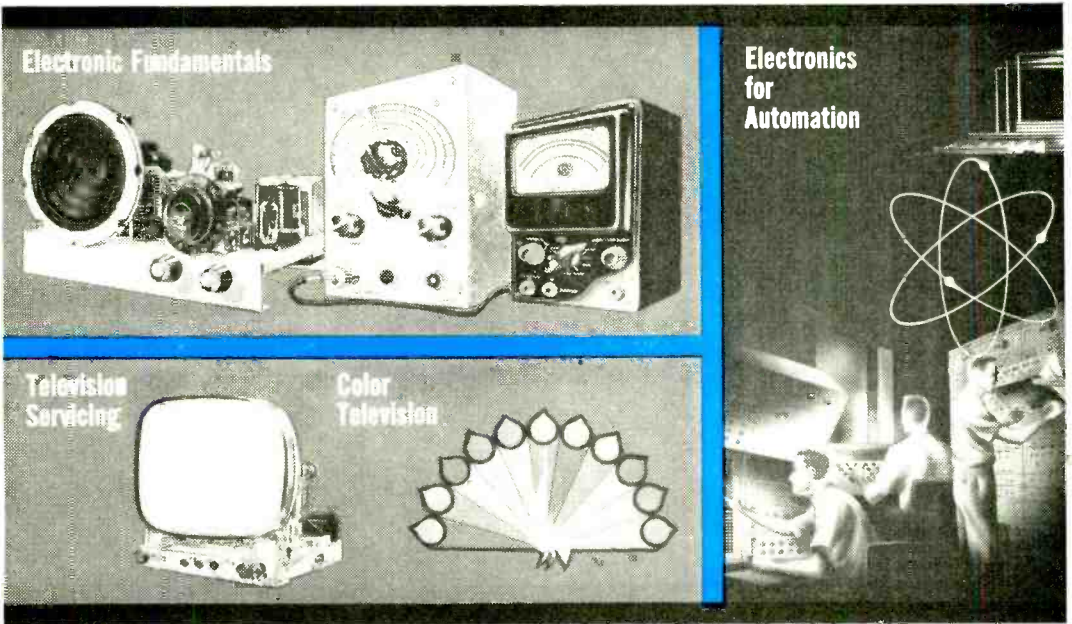

Send for our
64 page Home
Study Catalog

FREE!

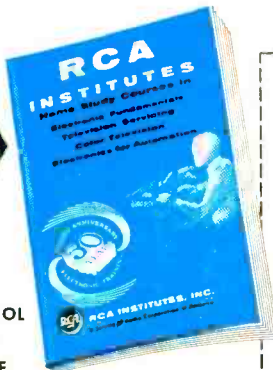

FOR RESIDENT SCHOOL
COURSES SEE AD
ON OPPOSITE PAGE.

August, 1959

Practical work with the very first lesson. Pay-as-you-learn. You need pay for only one study group at a time.

RCA INSTITUTES, Inc. Home Study School, Dept. PE-89

A Service of Radio Corporation of America
350 West Fourth Street, New York 14, N. Y.

Without obligation, send me the FREE catalog of Home Study Courses. No salesman will call.

Name Please print

Address

City Zone State

Korean Vets! Enter Discharge Date

CANADIANS — Take advantage of these same RCA courses at no additional cost. No postage, no customs, no delay. Send coupon to: RCA Victor Company, Ltd., 5001 Cote de Liesse Rd., Montreal 9, Quebec
To save time, paste coupon on postcard.

Save Half
ASSEMBLING
 ONE OF THESE TWO
Schober
**ELECTRONIC
 ORGANS** in KIT form

"CONCERT" "CONSOLETTA"



NO SPECIAL SKILLS
 PAY KIT-BY-KIT

CONSOLETTA MODEL
 Occupies only 2' x 3'2"
 Floor Space

- HANDSOME ASSEMBLED CONSOLES
 - DOUBLE KEYBOARDS — 122 KEYS
 - ABOVE-KEYBOARD TABS
 - CONCERT MODEL CONFORMS TO A G O SPECIFICATIONS. Occupies 3'5" x 4'7" Floor Space
 - BUILT-IN SPEAKERS OPTIONAL (For Consolette Model only)
 - COMPLETE DETAILED INSTRUCTIONS
 - FREE—NEW 1959 EDITION of 16-page BOOKLET DESCRIBING BOTH MODELS
 - 10" LP RECORD DEMONSTRATING BOTH MODELS available for \$2, refundable on receipt of order
- Write today—see what fine instruments you can have at such great savings.

The **SCHOBER ORGAN CORP.**
 2248-X Broadway, New York 24, New York

**SAY YOU SAW IT
 IN
 POPULAR ELECTRONICS**

**TV PICTURE TUBES
 AT LOWEST PRICES**

10BP4 \$ 7.95	16WP4 \$12.00	17TP4 \$17.00	21EP4 \$13.50
12LP4 8.50	16PT4 9.95	19AP4 16.00	21FP4 14.50
14B/CP4 9.95	17AVP4 12.50	20CP4 13.50	21WP4 14.00
16DP4 12.00	17BP4 9.95	20HP4 14.50	21YP4 14.50
16EP4 12.75	17CP4 17.00	21AP4 22.10	21ZP4 13.50
16GP4 14.50	17GP4 17.60	21ALP4 15.75	24CP4 23.50
16KP4 9.95	17HP4 12.50	21AMP4 15.75	24DP4 24.50
16LP4 10.95	17LP4 11.50	21ATP4 15.75	27P4 39.95
16RP4 9.95	17QP4 9.95	21AUP4 15.75	27RP4 39.95

1 YEAR WARRANTY

Aluminized Tubes \$7.00 more than above prices. Prices include the return of an acceptable similar tube under vacuum. These tubes are manufactured from reprocessed used glass bulbs. All materials including the electron gun are brand new.

ALL PRICES FOB CHICAGO, ILLINOIS. Deposit required, when old tube is not returned, refundable at time of return. 25% deposit required on COD shipments. Old tubes must be returned prepaid. Tubes shipped Rail Express.

WRITE FOR COMPLETE LIST

—PICTURE TUBE OUTLET—
 3032 MILWAUKEE AVE., CHICAGO 18, ILLINOIS
 Dickens 2-2048

Tips

(Continued from page 26)

lector corners of all your transistors and all your transistor sockets. This method assures positive identification because the base is always in the middle and the emitter is the only unidentified lead.—Stanley Tenen, Brooklyn, N. Y.

INSPECTION MIRROR FUSE CLIP

Don't just toss your inspection mirror around the bench with other tools—they are liable to break it and you'll be destined to receive "seven years of bad luck." In-



stead, attach a fuse holder to your tool panel or bench and snap the mirror in place. You'll find it makes a perfect fit.—Charles A. Lang, San Francisco, Calif.

STYLUS INSPECTION

A home movie projector can be used for inspecting phono needles with amazing results. Just position the tip of the stylus near the light source where the film goes through the projector. A magnified image of the tip will be projected onto the screen and can be used to determine its condition.—Gary A. Rork, Pueblo, Colo.

DOUBLE SUN BATTERY VOLTAGE

It is possible to double, triple, or even quadruple the output voltage from sun batteries by divid-

ing your present cells into several pieces and wiring them in series. Many sun batteries can be cut with a fine jeweler's saw or a very fine coping saw. After the surgery, the edges should be smoothed with a fine file and coated with a thin layer of clear household cement. Care should be taken not to chip the photosensi-

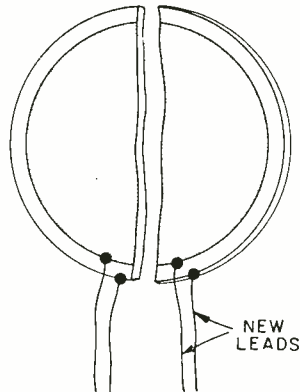

NOT USED, NOT PULLED OUT OF OLD SETS

Brand New TUBES

**BETTER
THAN
70%
OFF!**



**and RAD-TEL'S FIRST QUALITY!
REMEMBER... ALL RAD-TEL TUBES
GUARANTEED ONE FULL YEAR**

Rad-Tel — Suppliers In Mail Order For Over 10 Years!

Type	Price	Type	Price	Type	Price	Type	Price	Type	Price	Type	Price	Type	Price	Type	Price
1AX2	.62	5AM8	.79	6AMB	.78	6BQ5	.65	6DT6	.53	12AQ5	.52	12L6	.58	19T8	.80
1B3GT	.79	5AN8	.86	6AN8	.85	6BQ6GT	.51	6J5GT	.51	12AT6	.43	12S47M	.86	25BQ6GT	
1S5	.51	5AQ5	.52	6AQ5	.50		1.05	6J6	.67	12AT7	.76	12SK7GT			1.11
1U4	.57	5AT8	.80	6AT6	.43	6BQ7	.95	6K6GT	.58	12AU6	.50		.74	25C5	.53
1U5	.50	5BK7A	.82	6AT8	.79	6BR8	.78	6L6	.84	12AU7	.60	125N7GT		25CD6	1.44
1X2B	.82	5B7	.97	6AU4GT	.82	6BY6	.54	654	.48	12AV6	.41		.64	25CU6	1.11
2AF4	.96	5CG8	.76	6AU6	.50	6BZ6	.54	6X4	.39	12AV7	.75	12V6GT	.53	25L6	.57
2BN4	.60	5CL8	.76	6AU8	.87	6BZ7	.97	6X8	.77	12AX7	.63	12W6	.69	35C5	.51
3AL5	.42	5J6	.68	6AV6	.40	6C4	.43	6Y6G	.65	12AZ7	.86	17AX4	.67	35Z5GT	.60
3AU6	.51	5T8	.81	6BA6	.49	6CB6	.54	8AU8	.83	12B4	.63	17BQ6	1.09	50B5	.60
3AV6	.41	5U4GB	.60	6BC5	.54	6CD6	1.42	8AW8	.93	12BD6	.50	19AU4	.83	50C5	.53
3BZ6	.55	5U8	.81	6BD6	.51	6CF6	.64	11CY7	.75	12BE6	.53	19EG6	1.39	50L6GT	.61
3BY6	.55	5V6	.56	6BE6	.55	6CG7	.60	12A4	.60	12BH7	.73				
3CB6	.64	5X8	.78	6BF6	.44	6CG8	.77	12AD6	.57	12AF6	.49	128Q6GT			
3CF6	.50	5Y3GT	.46	6BG6G	1.66	6CM7	.66	12AF6	.49				1.06		
3DT6	.50	6AB4	.46	6BH8	.87	6CN7	.65	6SK7GT	.74	12B7Y	.74				
3V4	.58	6A7M	.96	6BK7	.85	6CS6	.57	65N7GT	.65	12C5	.56	SEND FOR NEW FREE BROCHURE OF TUBES AND PARTS			
4BN6	.75	6AF4	.97	6BN4	.57	6CU6	1.08	6T4	.99	12CUS	.58				
4BQ7	.96	6AG5	.65	6BN6	.74	6CY7	.71	6T8	.80	12CU6	1.06	USE THIS AD AS YOUR ORDER BLANK			
4DT6	.55	6AH6	.99	6BQ/		6DE6	.58	6U8	.78	12DQ6	1.04				
4BZ7	.96	6AK5	.95	CU6	1.25	6DG6GT	.59	6V6GT	.54	12F8	.66				
4CB6	.59	6AL5	.47			6DQ6	1.10	6W4GT	.57	12K5	.65				
								6W6GT	.69						

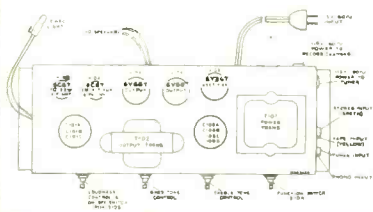

RCA RS-151B HI-FI AMPLIFIER

BELOW DIST. COST

Convert Your Present System To Stereo!

- For Stereo System • 3 Stages of Audio Amplification; Push-Pull Output • 4 Inputs — tuner, phono, tape, left or right channel of stereo system • Front Panel Control • Separate Bass, Treble and Loudness Control • Negative Feedback
- 10 Watts with less than 1/2% distortion.
15W maximum. Frequency response 45 to 20,000 cycles.
2-6CG7; 2-6V6; 1-5Y3

COMPLETE,
\$2295 ea.
Lots of **\$2095** ea.
3

RAD-TEL TUBE CO.

Est. 1945 **55 Chambers Street
Newark 5, N. J.
Mitchell 2-3147**

Not Affiliated With Any Other Mail Order Tube Co.

TERMS: 25% dep. must accompany all orders — bal. C.O.D. All shipments F.O.B. Newark warehouse. NO HANDLING CHARGE WITH THIS AD. Subject to prior sale. No C.O.D.'s outside continental U.S.A.

Tips

(Continued from page 28)

tive surface while filing it. Leads can be soldered to the cell after the enamel protective coating is scraped off. Insulate your connections with household cement, connect your cells in series, and you have twice the voltage. If you decide you want the original voltage and current capacity back, just connect the cells in parallel.—*Stanley Tenen, Brooklyn, N. Y.*

TEST PROD SAFETY DEVICE

When you are measuring voltages around crowded tube sockets and the like, cut about a half inch of $\frac{1}{8}$ " "spaghetti" and slip it over the end of the test prod. This will reduce the possibility of touching nearby exposed leads. The spaghetti can be slipped off for less cluttered circuits.—*Arthur Fregeau, Bristol, Conn.*

INDOOR SHORT-WAVE ANTENNA

Gummed aluminum tape (used in store and bank windows for protection against burglars) makes an efficient, quickly installed indoor short-wave radio antenna.

Simply run the tape around the ceiling of the room. It is so good-looking that you may even be able to convince your wife that you are decorating the room. If the tape is put up over wall paper, it should be fastened (with tacks or cellophane tape) at the corners of the room.—*Ira Glickstein, Brooklyn, N. Y.*

BIT AND TAP HOLDER

You will find it convenient to drill a block of wood to hold the tap, tap drill and body drill for the most-often-used sizes of machine screws. A good assortment of sizes includes: 5-40, 6-32, 8-32, 10-32 and $\frac{1}{4}$ -20.—*Charles V. Bittner, Erlton, N. J.*

REMOVING ENAMEL FROM FINE WIRE

The enamel insulation on the hair-fine wire used in r.f. coils is very difficult to remove without breaking the wire. To remove the insulation from this tiny litz wire without breaking the strands, dip the wire in nail-polish remover. After the solvent has had time to soak in (this requires about five minutes), you can gently pull the enamel off with your fingernail. When you solder these

NOW YOU CAN SECURE A HIGH SALARIED • TOP PRESTIGE CAREER IN ELECTRONICS IN ONLY ONE YEAR!

ELECTRONICS is the fastest growing industry in America today, creating unlimited opportunities for high salaries, with rapid advancement in **INDUSTRY AND THE ARMED FORCES** for Bailey Trained electronic engineering technicians.

LARGE CORPORATIONS from coast to coast, and **BRANCHES OF THE ARMED FORCES** send recruiters to visit each graduating class at Bailey Tech, offering unusually high starting salaries.

BAILEY GRADUATES ARE BEING HIRED for such fascinating and interesting work as technical salesmen, research and development of guided missiles, electronic business machines and automatically controlled manufacturing plants, etc., also good **RATINGS IN THE ARMED FORCES**.

UP TO SEVEN TECHNICIANS are needed for every engineer... this, plus superior training is why Bailey Graduates are being paid more to start, and are advancing more rapidly than many men who have spent four years in training.

Resident training is easier and costs less than you may think! We provide housing and part-time jobs while in school, plus free nationwide employment service for graduates. If you want to quickly enter America's fastest growing and most exciting industry, write for free booklet... no obligation.

VETERAN APPROVED

BAILEY TECHNICAL SCHOOLS

1625 S. Grand • St. Louis 4, Mo.



This Minneapolis-Honeywell system controls hundreds of automatic manufacturing operations. Experience on live equipment is emphasized at Bailey and is another reason for the tremendous backlog of high pay positions waiting **BAILEY GRADUATES**.

MAIL TODAY

Please mail immediately this free booklet without obligation

Name _____

Address _____

City _____ State _____



build this great new **knight-kit**

A PRODUCT OF ALLIED RADIO

stereo hi-fi amplifier...save up to 50%

COMPARABLE IN EVERY WAY TO WIRED AMPLIFIERS COSTING TWICE AS MUCH



tremendous value at only

\$44⁵⁰

only \$4.45 down

*never before such performance...
such styling...such quality
at so low a price...*

knight-kit 20-watt stereo hi-fi amplifier

Newest complete Stereo high-fidelity amplifier at an amazing low \$44.50. Incomparable value: Includes two built-in preamps for magnetic cartridges. Single switch selects phono, tuner or auxiliary stereo inputs, plus stereo reverse on each; also switches monophonic input to both amplifier channels. Bass and treble controls boost and attenuate. Special clutch-type concentric volume control permits individual channel balancing, plus overall volume control. Total output is 20 watts (10 watts per channel at less than 1½% distortion). Response, 20-20,000 cps, ± 1.5 db. Hum and noise better than 85 db below full output. Has four pairs of stereo inputs: magnetic cartridge, ceramic cartridge, tuner, auxiliary. RIAA equalized for stereo discs. Expertly designed push-pull output circuitry. Beautiful custom-styled case, 4¼ x 13¼ x 9". With case, tubes, all parts, wire, solder and instructions. Shpg. wt., 27 lbs.

Model Y-773. Knight-Kit Stereo Amplifier, F.O.B. Chicago... \$44⁵⁰

**EXCLUSIVE knight-kit
MONEY-BACK GUARANTEE**
Every KNIGHT-KIT meets or exceeds published specifications, or we refund your money.

**ONLY knight-kits ARE
CONVENIENCE ENGINEERED**
for easiest building—no previous electronic experience needed...

see over 50 other fine **knight-kits**... write for catalog

HI-FI KITS

Stereo Amplifiers
Stereo Preamp
Stereo Control
Hi-Fi Tuners
Hi-Fi Amplifiers
Speaker Systems,
and others

HOBBY KITS

Short-Wave Radios
AC-DC Table Radios
Clock-Radio
Radio-Intercom
Transistor Radios
Electronic Lab Kits
and many others

INSTRUMENT KITS

VTVM Cap. Checker
VOM's R/C Tester, etc.
Tube Checkers
Oscilloscopes
Signal Tracer
Audio Generator
Sweep Generator

HAM KITS

Receiver
Transmitter
VFO, etc.

EASY TERMS ON ORDERS AS LOW AS \$20

**1959 ALLIED
CATALOG FREE**

Send for this value-packed catalog featuring the complete KNIGHT-KIT line, as well as the world's largest stocks of everything in Electronics.

WRITE FOR YOUR COPY TODAY

ALLIED RADIO Dept. 19-H9

100 N. Western Ave., Chicago 80, Ill.

- Ship Model Y-773 Knight-Kit Stereo Amplifier. \$_____encl.
 Send FREE ALLIED 1959 Catalog

Name _____

Address _____

City _____ Zone _____ State _____

PACO

quality electronic equipment in KIT FORM

PACO is the only line of test instrument kits engineered and produced under the auspices of a leading test equipment and meter manufacturer.

and, you pay nothing extra for the convenience of buying PACO kits directly from your own local parts distributor.

COMPARE PACO against any other kits for performance, appearance, ruggedness, ease of operation and simplicity of assembly and wiring.

COMPARE PACO'S superbly detailed, step-by-step instruction manuals and giant size wiring diagrams, against any you have ever seen.

MODEL B-10
BATTERY ELIMINATOR KIT
KIT NET PRICE: \$41.95
FACTORY WIRED: 49.50

MODEL C-20
RES-CAP-RATIO BRIDGE KIT
KIT NET PRICE: \$20.95
FACTORY WIRED: 31.50

MODEL G-30
RF SIGNAL GENERATOR KIT
KIT NET PRICE: \$28.50
FACTORY WIRED: 39.95

MODEL M-40
HIGH SENSITIVITY V-O-M KIT
KIT NET PRICE: \$31.50
FACTORY WIRED: 37.50

MODEL S-50
5" OSCILLOSCOPE KIT
KIT NET PRICE: \$49.50
FACTORY WIRED: 84.50

MODEL S-55
WIDEBAND 5" OSCILLOSCOPE
KIT NET PRICE: \$87.50
FACTORY WIRED: 139.50

MODEL T-60
TUBE CHECKER KIT
KIT NET PRICE: \$38.75
FACTORY WIRED: 54.50

MODEL T-65
TRANSISTOR AND CRYSTAL
DIODE TESTER KIT
KIT NET PRICE: \$39.95
FACTORY WIRED: 59.50

MODEL V-70
VACUUM TUBE VOLTMETER KIT
KIT NET PRICE: \$31.50
FACTORY WIRED: 47.50

MODEL Z-80
RF-AF SIGNAL TRACER KIT
KIT NET PRICE: \$29.50
FACTORY WIRED: 42.50

MODEL SA-40
40-WATT STEREO
PREAMP-AMPLIFIER KIT
KIT NET PRICE: \$ 79.95
FACTORY WIRED: 129.95

COMING SOON! MODEL ST-45
AM/FM STEREO TUNER KIT

▶ Write for latest, complete catalog.
▶ Available at leading electronic parts distributors.

PACO ELECTRONICS CO., INC.
70-31 84th Street, Glendale 27, L. I., N. Y.

Export: 458 B'way., N. Y. 13 • Canada: Atlas Radio Corp., Toronto 19
A DIVISION OF **PRECISION Apparatus Company, Inc.**



B-10



C-20



G-30



M-40



S-50



S-55



T-60



T-65



V-70



Z-80



SA-40

Tips

(Continued from page 30)

small wires, use flux and heat sparingly—excess heat will weaken the wires.—James A. Clifford, Detroit, Mich.

FELT PADS QUIET TV NOISE

Noise which is transmitted from a vibrating TV antenna can be eliminated by wrapping narrow strips of felt around the standpipe or other support. Metal bands are placed over the felt strips and then drawn tight in the same way an automatic radiator hose is clamped.—Gale Foster, Hingham, Mass.



USING BARRIER TERMINAL STRIPS

The electronic experimenter usually finds that he wastes a lot of time in soldering and unsoldering components. Also, after the same components have been employed several times, their leads frequently become broken. Both of these troubles can be eliminated by using inexpensive barrier terminal strips for hooking up experiment-

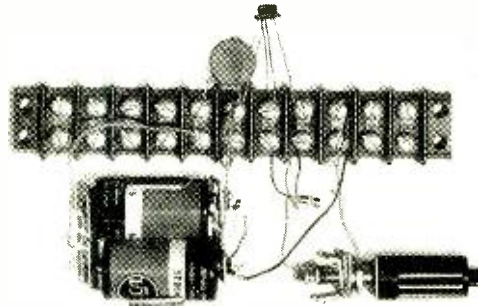

al circuits. As many as six components can be connected to one set of terminals on the strip. Circuits can be assembled very rapidly, and if it is necessary to change components, a twist of a screwdriver does it.—George Sollman, Cobleskill, N. Y. —30—

CITIZEN BANDER for *KIT FANS!*

ADD TO WHAT YOU HAVE OR BUILD ONE
ALL YOUR OWN WITH THESE
SUB-ASSEMBLIES!

**MAKE
YOUR
OWN!**

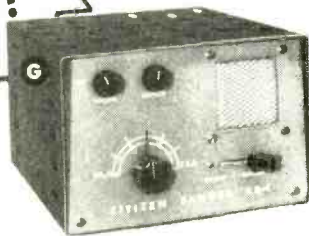

G Cabinet (all metal) includes hardware, switches, speakers, panel, case, etc. Complete instructions. Shipping weight 10 lbs. \$20.00.

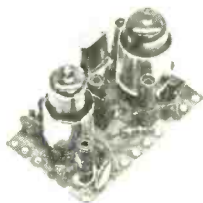
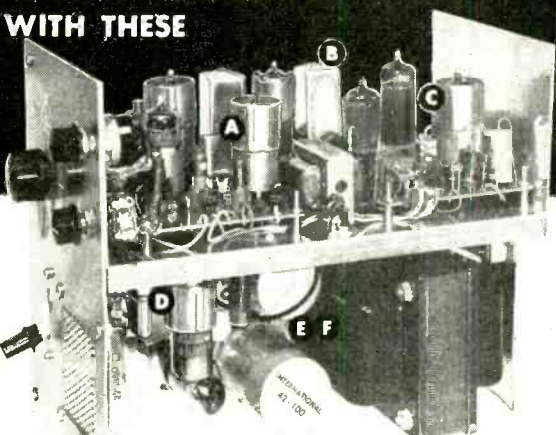

A RF Converter (printed circuit prewired), two-tubes, crystal controlled. Use with IF unit B. Shipping weight 2 lbs. \$14.00.

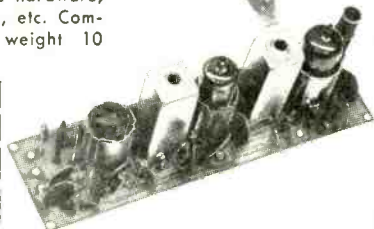

B IF Unit (printed circuit prewired) consists of mixer and tunable local oscillator feeding 262 KC IF stage. Includes noise-limiter and squelch circuits. Designed to work with units A and C. Makes dual conversion receiver. Shipping weight, 2 lbs. \$16.00.

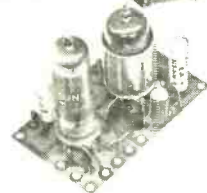

C Audio Unit (printed circuit prewired), speech amplifier for crystal or carbon microphone, first audio for receiver and power amplifier/modulator stage. Designed to follow unit B. Includes output transformer but not speaker. Shipping weight 2 lbs. \$13.50.



E Power Supply 115 VAC (not prewired). All parts necessary to construct power supply to operate Units A, B, C and D. Shipping weight 10 lbs. \$12.00.

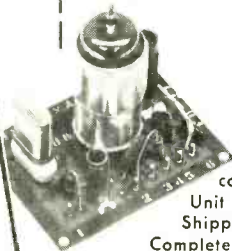

D Transmitter Unit (prewired and tuned) Oscillator and amplifier. Crystal controlled. Requires Unit C for modulation. Shipping weight 2 lbs.

Complete with crystal and tube certified .005% tolerance. \$14.50.

F Power Supply 3-way 6 VDC, 12 VDC or 115 VAC (not prewired). Shipping weight 10 lbs. \$20.00.

CRYSTALS
For amateur or commercial uses. Send for free catalog. Write: Crystal Dept.

SEE YOUR DEALER* OR
ORDER DIRECT...

*Prices slightly higher

Terms F.O.B. Oklahoma City. Other shipments C.O.D. On C.O.D. orders of \$25.00 or more, 1/3 down payment with order is required.

INTERNATIONAL CRYSTAL MFG. CO., INC.
18 N. LEE • OKLAHOMA CITY, OKLA.

NOW

Science proves you can learn while you sleep

$$H^2 = A^2 + B^2$$



ladies & gentlemen...

NOW YOU CAN LEARN AWAKE AND ASLEEP

Just think what it can mean to you in dollars and cents, confidence, success, fun to learn a language, speech, statistics, facts, figures, music, *anything*—OVERNIGHT . . . and learn it FASTER—RETAIN IT BETTER.

That's what *really* happens when scientifically proved Dormiphone "works" to train your memory for you awake and asleep . . . and what's more the Dormiphone not only puts your sleeping time to use, but helps you sleep more soundly as well. In addition, this amazing versatile instrument "plays" for you, too, provides fine entertainment with high quality reproduction of sound—both voice and music for your greater enjoyment.

Get the scientific evidence TODAY. Write, call for FREE Book, FREE Demonstration.

MODERNOPHONE, INC. Circle 7-0830
292-089 Radio City, N. Y. 20, N. Y.

Gentlemen: Please send me your FREE Book. I am interested in learning more about the DORMIPHONE and what it can do for me. No obligation—no salesman will call.

NAME

ADDRESS

CITY ZONE..... STATE.....

My main interest in Dormiphonics is for:

- | | |
|--|---|
| <input type="checkbox"/> Language Learning | <input type="checkbox"/> Speech Improvement |
| <input type="checkbox"/> Memorization | <input type="checkbox"/> Sleep Inducement |
| <input type="checkbox"/> Habit Correction | <input type="checkbox"/> School or College Work |

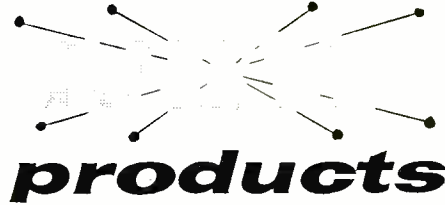

AM-FM TUNER

The FM sensitivity of Scott's Model 320 AM-FM tuner is 3 microvolts for 20-db quieting on 300-ohm antenna terminals. Circuit features include a 2-mc. wide-band FM detector to assure high selectivity, high-capture ratio and drift-free FM reception. The r.f. stage assures high sensitivity on

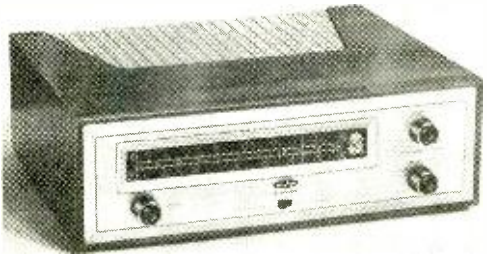

both AM and FM sections. Tape recorder and multiplex outputs are included. Write to the manufacturer for further specifications. \$139.95. (H. H. Scott, Inc., 111 Powdermill Rd., Maynard, Mass.)

VACUUM-TUBE VOLTMETER

All of the following measurements can be made with the new EMC Model 107A VTVM: peak-to-peak voltages from .2 volt to 2800 volts; a.c. r.m.s. voltages from .1 volt to 1000 volts; capacitance from 50 μ f.

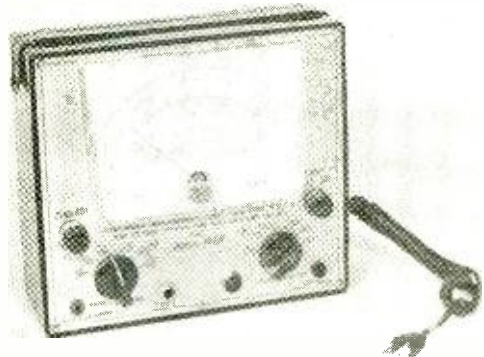

to 5000 μ f.; and resistance from .2 ohm to 100 megohms. The 107A is also capable of measuring inductance from 1.4 to 140,000 henries. Wired, \$51.40; and in kit form,



"The only thing that will draw him out, Dearie, is a Jensen needle."

BECOME A RADIO TECHNICIAN For Only \$22.95

BUILD 16 RADIO

Reg. U. S. Pat. Off.

CIRCUITS AT HOME
All Guaranteed to Work!

PRACTICAL only
HOME RADIO
COURSE **\$22.95**

Progressive Radio "Edu-Kit"®

NOW INCLUDES

- ★ 12 RECEIVERS
- ★ TRANSMITTER
- ★ SIGNAL TRACER
- ★ SIGNAL INJECTOR
- ★ CODE OSCILLATOR
- ★ No Knowledge of Radio Necessary
- ★ No Additional Parts or Tools Needed

Unconditional Money-Back Guarantee

It is understood and agreed that should the Progressive Radio "Edu-Kit" be returned to Progressive "Edu-Kits" Inc. for any reason whatever, the purchase price will be refunded in full, without quibble or question, and without delay.

The high recognition which Progressive "Edu-Kits" Inc. has earned through its many years of service to the public is due to its unconditional insistence upon the maintenance of perfect engineering, the highest instructional standards, and 100% adherence to its Unconditional Money-Back Guarantee. As a result, we do not have a single dissatisfied customer throughout the entire world.



FREE EXTRAS

• SET OF TOOLS

- SOLDERING IRON
- ELECTRONICS TESTER
- PLIERS-CUTTERS
- ALIGNMENT TOOL
- WRENCH SET
- VALUABLE DISCOUNT CARD
- CERTIFICATE OF MERIT
- TESTER INSTRUCTION MANUAL
- HIGH FIDELITY GUIDE
- TELEVISION BOOK
- TROUBLE-SHOOTING BOOK
- MEMBERSHIP IN RADIO-TV CLUB
- CONSULTATION SERVICE
- FCC AMATEUR LICENSE TRAINING
- PRINTED CIRCUITRY

SERVICING LESSONS

You will learn trouble-shooting and servicing in a progressive manner. You will practice repairs on the sets that you construct. You will learn symptoms and causes of trouble in home, portable and car radios. You will learn how to use the professional Signal Tracer, the unique Signal Injector and the dynamic Radio & Electronics Tester. While you are learning in this practical way, you will be able to do many a repair job for your friends and neighbors, and charge fees which will far exceed the price of the "Edu-Kit". Our Consultation Service will help you with any technical problems you may have.

J. Stataitis, of 25 Poplar Pl., Waterbury, Conn. writes: "I have repaired several sets for my friends, and made money. The "Edu-Kit" paid for itself. I was ready to spend \$240 for a Course, but I found your ad and sent for your Kit."

FROM OUR MAIL BAG

Ben Valerio, P. O. Box 21, Magna, Utah: "The Edu-Kits are wonderful. Here I am sending you the questions and also the answers for them. I have been in Radio for the last seven years, but like to work with Radio Kits, and like to build Radio Testing Equipment. I enjoyed every minute I worked with the different kits; the Signal Tracer works fine. Also like to let you know that I feel proud of becoming a member of your Radio-TV Club."

Robert L. Shuff, 1534 Monroe Ave., Huntington, W. Va.: "Thought I would drop you a few lines to say that I received my Edu-Kit, and was really amazed that such a bargain can be had at such a low price. I have already started repairing radios and phonographs. My friends were really surprised to see me get into the swing of it so quickly. The Troubleshooting Tester that comes with the Kit is really swell, and finds the trouble, if there is any to be found."

YOU DON'T HAVE TO SPEND HUNDREDS OF DOLLARS FOR A RADIO COURSE

The "Edu-Kit" offers you an outstanding PRACTICAL HOME RADIO COURSE at a rock-bottom price. Our Kit is designed to train Radio & Electronics Technicians, making use of the most modern methods of home training. You will learn radio theory, construction practice and servicing. THIS IS A COMPLETE RADIO COURSE IN EVERY DETAIL.

You will learn how to build radios, using regular schematic, how to wire and solder in a professional manner; how to service radios. You will work with the standard type of punched metal chassis as well as the latest development of Printed Circuit chassis.

You will learn the basic principles of radio. You will construct, study and work with RF and AF amplifiers and oscillators, detectors, rectifiers, test equipment. You will learn and practice code, using the Progressive Code Oscillator. You will learn and practice trouble-shooting, using the Progressive Signal Tracer, Progressive Signal Injector, Progressive Dynamic Radio & Electronics Tester, and the accompanying instructional material.

You will receive training for the Novice, Technician and General Classes of F.C.C. Radio Amateur Licenses. You will build 16 Receiver, Transmitter, Code Oscillator, Signal Tracer and Signal Injector. You will learn how to operate them. You will receive an excellent background for television, Hi-Fi and Electronics.

Absolutely no previous knowledge of radio or science is required. The "Edu-Kit" is the product of many years of teaching and engineering experience. The "Edu-Kit" will provide you with a basic education in Electronics and Radio, worth many times the complete price of \$22.95. The Signal Tracer alone is worth more than the price of the entire Kit.

THE KIT FOR EVERYONE

You do not need the slightest background in radio or science. Whether you are interested in Radio & Electronics because you want an interesting hobby, a well paying business or a job with a future, you will find the "Edu-Kit" a worthwhile investment.

Many thousands of individuals of all

ages and backgrounds have successfully used the "Edu-Kit" in more than 79 countries of the world. The "Edu-Kit" has been carefully designed, step by step, so that you cannot make a mistake. The "Edu-Kit" allows you to teach yourself at your own rate. No instructor necessary.

PROGRESSIVE TEACHING METHOD

The Progressive Radio "Edu-Kit" is the foremost educational radio kit in the world, and is universally accepted as the standard in the field of electronics training. The "Edu-Kit" uses the modern educational principle of "Learn by Doing." Therefore you construct, learn schematics, study theory, practice trouble-shooting—all in a closely integrated program designed to produce a worthwhile investment.

You begin by examining the various radio parts of the "Edu-Kit." You then learn the function, theory and wiring of these parts. Then you build a simple radio. With this first set you will enjoy listening to regular broadcast stations, learn theory, practice testing and trouble-shooting. Then you build a more advanced radio, learn more advanced theory and techniques. Gradually, in a progressive manner, and at your own rate, you will find yourself constructing more advanced multi-tube radio circuits, and doing work like a professional Radio Technician.

Included in the "Edu-Kit" course are sixteen Receiver, Transmitter, Code Oscillator, Signal Tracer, and Signal Injector circuits. These are not unprofessional "breadboard" experiments, but genuine radio circuits, constructed by means of professional wiring and soldering on metal chassis, plus the new method of radio construction known as "Printed Circuitry." These circuits operate on your regular AC or DC house current.

THE "EDU-KIT" IS COMPLETE

You will receive all parts and instructions necessary to build 16 different radio and electronics circuits, each guaranteed to operate. Our Kits contain tubes, tube sockets, variable, electrolytic, mica, ceramic and paper dielectric condensers, resistors, tie strips, coils, hardware, tubing, punched metal chassis, Instruction Manuals, hook-up wire, solder, etc. In addition to F.C.C.-type Questions and Answers for Radio Amateur License training. You also receive a useful set of tools, a professional electric soldering iron, and a self-powered Dynamic Radio and Electronics Tester. The "Edu-Kit" also includes Code Instructions and the Progressive Code Oscillator. In addition to F.C.C.-type Questions and Answers for Radio Amateur License training. You will also receive lessons for servicing with the Progressive Signal Tracer and the Progressive Signal Injector, a High Fidelity Guide and a Quiz Book. You receive Membership in Radio-TV Club. Free Consultation Service, Certificate of Merit and Discount Privileges. You receive all parts, tools, instructions, etc. Everything is yours to keep.

PRINTED CIRCUITRY

At no increase in price, the "Edu-Kit" now includes Printed Circuitry. You build a Printed Circuit Signal Injector, a unique servicing instrument that can detect many Radio and TV troubles. This revolutionary new technique of radio construction is now becoming popular in commercial radio and TV sets.

A Printed Circuit is a special insulated chassis on which has been deposited a conducting material which takes the place of wiring. The various parts are merely plugged in and soldered to terminals.

Printed Circuitry is the basis of modern Automation Electronics. A knowledge of this subject is a necessity today for anyone interested in Electronics.

ORDER DIRECT FROM AD—RECEIVE FREE BONUS RESISTOR AND CONDENSER KITS WORTH \$7

- Send "Edu-Kit" postpaid. I enclose full payment of \$22.95.
- Send "Edu-Kit" C.O.D. I will pay \$22.95 plus postage.
- Rush me FREE descriptive literature concerning "Edu-Kit."

Name

Address

PROGRESSIVE "EDU-KITS" INC.

Progressive Building, Dept. 559D, 1184-86 Broadway, Hewlett, N. Y.

ASSEMBLE YOUR OWN
**WALKIE-TALKIE
RADIOPHONES**



**New Model for 27 mc
Citizens Band**

Electronic Chassis ONLY **\$18⁹⁸** post-paid

- Meets FCC requirements for new class "D" citizens band radio-telephone.
- License easily obtained on application by any U. S. citizen 16 years or over. No tests to take.
- Transmits and receives one to several miles depending on obstructions and elevation.
- Assembled unit is completely portable and requires no external connections. Operates from self contained batteries obtainable at your local radio store.
- Electronic chassis is wired, tested, guaranteed and includes crystal controlled oscillator, R.F. power amplifier, audio modulator, receiver with R.F. stage, and a new transistorized audio booster stage for extra loud reception plus a complete set of tubes and transistor.
- Radio receiver is tunable to any of the 22 channels by a single control knob. Features ultra-high amplification, automatic volume control and noise clipping.
- Instructions and photographs are supplied with each chassis for completing the walkie-talkie as illustrated. Accessories are not included but are available at low cost.

FREE R.F. power indicator kit with each order.

SEND YOUR ORDER TODAY. INCLUDE POSTAL MONEY ORDER FOR FAST DELIVERY. C.O.D.'s REQUIRE \$5.00 DEPOSIT. N. Y. City residents add sales tax.

SPRINGFIELD ENTERPRISES

Box 54-E-8

Springfield Gardens 13, N. Y.

products

(Continued from page 34)

\$36.50. For more information, write to *Electronic Measurements Corporation*, 625 Broadway, New York 12, N. Y.

STEREO CHANGER

A new Collaro stereo changer has been announced by the *Rockbar Corp.*, 650 Halsted Ave., Mamaroneck, N. Y. The Model TC-99 Constellation features a non-magnetic 6½-lb. turntable which provides a 10-db reduction in magnetic hum pickup



as compared with steel turntables. Its heavy-duty precision-balanced four-pole motor is screened with triple interleaved shields to provide an additional 25-db reduction in magnetic hum pickup. The two-piece stereo transcription type tone arm comes equipped with a detachable five-terminal plug-in shell. Price, \$59.50; slightly higher in the West.

SIX-METER CONVERTER

Greater sensitivity with better signal-to-noise ratio is provided in the new, improved version of the *Globe 6-meter converter*. The Model 6 PMC has a cascode r.f. stage and bandpass coupling, and is available in a range of output frequencies. It may be used with all types of communications receivers as well as 6- or 12-volt auto radios. Wired, \$29.95; in kit form, \$21.95;

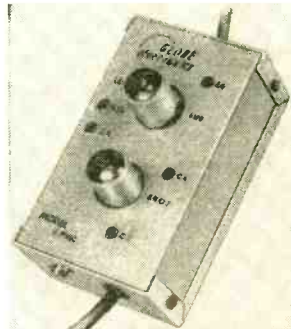

Choose **XCELITE**
Hand Tools... the Professionals do!

You need the BEST TOOLS
to do the BEST JOB...



Your Radio, TV and
Electronic Parts Distributor has them!

Select from the Complete XCELITE Line of
Quality Tools and Handy Kits...

XCELITE, INCORPORATED
ORCHARD PARK, NEW YORK
Canada: Charles W. Pointon, Ltd., Toronto

XCELITE
Quality Hand Tools
PREFERRED BY THE EXPERTS

New!
YEARS AHEAD!

Lafayette STEREO TUNER KIT

THE MOST FLEXIBLE TUNER EVER DESIGNED

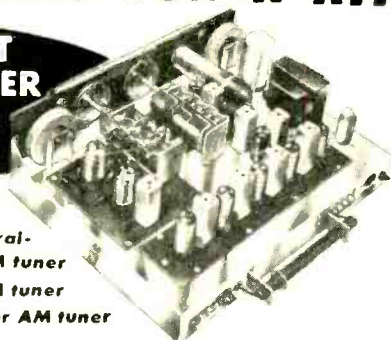

Use it as a Binaural-Stereophonic FM-AM tuner

Use it as a Dual-Monaural FM-AM tuner

Use it as a straight Monaural FM or AM tuner

- Multiplex Output for New Stereo FM
- 11 Tubes (including 4 dual-purpose) + Tuning Eye + Selenium rectifier Provide 17 Tube Performance
- 10KC Whistle Filter • Pre-aligned IF's
- Tuned Cascade FM • 12 Tuned Circuits
- Dual Cathode Follower Output
- Separately Tuned FM and AM Sections
- Armstrong Circuit with FM/AFC and AFC Defeat
- Dual Double-Tuned Transformer Coupled Limiters.

More than a year of research, planning and engineering went into the making of the Lafayette Stereo Tuner. Its unique flexibility permits the reception of binaural broadcasting (simultaneous transmission on both FM and AM), the independent operation of both the FM and AM sections at the same time, and the ordinary reception of either FM or AM. The AM and FM sections are separately tuned, each with a separate 3-gang tuning condenser, separate flywheel tuning and separate volume control for proper balancing when used for binaural programs. Simplified accurate knife-edge tuning is provided by magic eye which operates independently on FM and AM. Automatic frequency control "locks in" FM signal permanently. Aside from its unique flexibility, this is, above all else, a quality high-fidelity tuner incorporating features found exclusively in the highest priced tuners.

The 5 controls of the KT-500 are FM Volume, AM Volume, FM Tuning, AM Tuning and 5-position Function Selector Switch. Tastefully styled with gold-brass escutcheon having dark maroon background plus matching maroon knobs with gold inserts. The Lafayette Stereo Tuner was designed with the builder in mind. Two separate printed circuit boards make construction and wiring simple, even for such a complex unit. Complete kit includes all parts and metal cover, a step-by-step instruction manual, schematic and pictorial diagrams. Size is 13 3/4" W x 10 3/8" D x 4 1/2" H. Shpg. wt., 22 lbs.

The new Lafayette Model KT-500 Stereo FM-AM Tuner is a companion piece to the Models KT-600 Audio Control Center Kit and KT-310 Stereo Power Amplifier Kit.

KT-500 IN KIT FORM
74.50 7.45 Down 7.00 Monthly
LT-50 COMPLETELY WIRED 124.50
12.45 Down—10.00 Monthly

KT-500..... Net **74.50**
LT-50 Same as above, completely factory wired and tested..... Net **124.50**

NEW! LAFAYETTE PROFESSIONAL STEREO MASTER AUDIO CONTROL CENTER

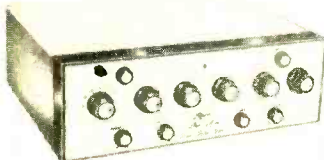

KT-600 79.50
IN KIT FORM
ONLY 7.95 DOWN
LA-600 COMPLETELY WIRED AND TESTED 134.50

Solves Every Stereo/Monaural Control Problem!

- UNIQUE STEREO & MONAURAL CONTROL FEATURES
- AMAZING NEW BRIDGE CIRCUITRY FOR VARIABLE 3d CHANNEL OUTPUT & CROSS-CHANNEL FEED
- PRECISE "NULL" BALANCING SYSTEM

A REVOLUTIONARY DEVELOPMENT IN STEREO HIGH FIDELITY. Provides such unusual features as a Bridge Control, for variable cross-channel signal feed for elimination of "ping-pong" (exaggerated separation) effects and for 3d channel output volume control for 3-speaker stereo systems; 3d channel output also serves for mixing stereo to produce excellent monaural recordings. Also has full input mixing of monaural program sources, special "null" stereo balancing and calibrating system (better than meters), 24 equalization positions, all-concentric controls, rumble and scratch filters, loudness switch. Clutch type volume controls for balancing or as 1 Master Volume Control. Has channel reverse, electronic phasing, input level controls. Sensitivity 2.2 millivolts for 1 volt out. Dual low-impedance outputs (plate followers), 1300 ohms. Response 5:40,000 cps \pm 1 db. Less than 0.3% IM distortion. Uses 7 new 7025 low-noise dual triodes. Size 14" x 4 1/2" x 10 1/4". Shpg. wt., 16 lbs. Complete with printed circuit board, cage, profusely illustrated instructions, all necessary parts.

LAFAYETTE KT-600 — Stereo Pre-amplifier kit Net 79.50
Lafayette LA-600— Stereo Pre-amplifier, Wired..... Net 134.50

NEW! LAFAYETTE STEREO/MONAURAL 36-WATT BASIC AMPLIFIER



KT-310 47.50
IN KIT FORM ONLY 4.75 DOWN

- 36-WATT STEREO AMPLIFIER
- 4 PREMIUM-TYPE 7189 OUTPUT TUBES
- RESPONSE 35-30,000 CPS \pm 1/2 DB • 18 WATTS PER STEREO CHANNEL OR 36 WATTS MONAURALLY
- 2 PRINTED CIRCUIT BOARDS FOR NEAT, EASY WIRING

A superbly-performing basic stereo amplifier, in easy-to-build kit form to save you lots of money and let you get into stereo now at minimum expense! Dual inputs, each provided with individual volume control. The unit may be used with a stereo preamplifier for 2 18-watt stereo channels, or at the flick of a switch, as a top-quality 36-watt monaural amplifier; or, if desired, it may be used as 2 separate monaural 18-watt amplifiers! **CONTROLS** include 2 input volume controls, channel reverse switch (AB-BA), monaural-stereo switch. **DUAL OUTPUT IMPEDANCES** are: 4, 8, 16 and 32 ohms (permitting paralleled monaural operation of 2 speaker systems of up to 16 ohms). **INPUT SENSITIVITY** is 0.45 volts per channel for full output. **TUBES** are 2-6AN8, 4-7189; GZ34 rectifier. **SIZE** is 9-3/16" d (10-9/16" with controls) x 5 1/4" h x 13 1/4" w. Supplied complete with perforated metal cage, all necessary parts and detailed instructions. Shpg. wt., 22 lbs.

KT-310 Stereo Power Amplifier Kit Net **47.50**

Lafayette Radio

P. O. Box 511 JAMAICA 31, N. Y.
DEPT. IH-9

CUT OUT AND PASTE ON POST CARD

Send FREE LAFAYETTE Catalog 590
Name.....
Address.....
City..... Zone..... State.....

165-08 Liberty Ave. JAMAICA, N. Y. AXtel 1-7000

NEW YORK BOSTON BRONX NEWARK PLAINFIELD
100 Sixth Avenue 110 Federal St. 342 E. Fordham Rd. 74 Central Ave. 139 W. Second St.

products

(Continued from page 36)

printed-circuit construction. (Globe Electronics, Inc., 3417 W. Broadway, Council Bluffs, Iowa)

TRANSISTOR POWER SUPPLY

Available as a kit or wired, the Eico Model 1020 serves as a power supply as well as a variable bias supply to bias transistors or vacuum tubes in circuit development or study. For service work it can be used to offset a.v.c. and a.g.c. voltages in the alignment of TV and radio receivers. It provides continuous variable output voltage monitored by a dual range voltmeter (0-6, 0-30 volts d.c.). Two



type 2N256 power transistors are incorporated in the transformer-operated circuit. Up to 30 volts output is available. Kit, \$19.95; wired, \$27.95. (Electronic Instrument Co., Inc., 33-00 Northern Blvd., Long Island City, N. Y.)

RADIO CODE COURSE

The "Sound-N-Sight" radio code course published by John F. Rider Publisher, Inc., 116 W. 14th St., New York 11, N. Y., utilizes long-playing records of code signals and the instructor's voice, as well as flash identification cards and an instruction book. The student advances in steps of one-word-per-minute per-day. Novice Course, (0 to 8 wpm), #REC-08, \$9.50; Advanced Course, (9 to 20 wpm), #REC-920, \$8.95; Complete Course, covering all licenses up to commercial (0 to 20 wpm), #REC-020, \$15.95.

"Y" AUDIO ADAPTERS

Connection of audio equipment can be simplified by the use of three new "Y" adapters introduced by Switchcraft, Inc., 5555 N. Elston Ave., Chicago 30, Ill. Two phono jack connectors or two male microphone connectors in parallel with a stand-

(Continued on page 132)



Build the Best Portable... **EICO**

6-TRANSISTOR RADIO RA-6

Kit \$29.95

Wired \$49.95

INCLUDES F. E. T., LESS 9V BATTERY

Easy creative fun to build... a lifetime of big-set entertainment wherever you go... designed so that even the novice can build it & obtain a handsome professional assembly & outstanding performance. American-made modern super-heterodyne all-transistor circuitry, plus finest quality parts throughout, assure you of highest durability & stability.

- high sensitivity & selectivity • big-set volume & tone quality with 4" x 6" PM speaker & 250 mw push-pull audio output stage • built-in Ferrite rod antenna for good reception in any location • pre-aligned RF & IF transformers
- planetary vernier tuning (7:1 reduction) for easy station selection & tuning • high-impedance earphone jack for private listening; eliminates drain of output stage when using earphone • attractive tan leatherette case, retractable handle
- compact: 8 1/2" w. 4 1/2" h. 1 1/2" d. Only 3 lbs.

Build the BEST BUYS in "HAM" gear...

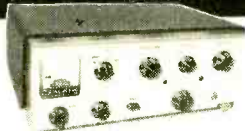

90-WATT CW TRANSMITTER #720

Kit \$79.95 Wired \$119.95

"Ideal for veteran or novice" - ELECTRONIC KITS GUIDE. "Top quality" - POPULAR ELECTRONICS. "Well designed" - ELECTRONICS WORLD. 80 thru 10 meters with one-knob band-switching. Full "clean" 90W input, 65W external plate mod. Matches loads 50 to 1000 ohms. May be used as basic exciter unit, 1V1 shielded. Tubes: 6146, 6CL6, 2-6AQ5, 6Z34. Attractive "living room" low-silhouette design. 15" w. 5" h. 9" d.



UNIVERSAL MODULATOR-DRIVER #730

Kit \$49.95 Wired \$79.95

Cover E-5 \$4.50

Delivers 50W undistorted audio. Modulates transmitters having r.f. inputs up to 100W. Output transformer matches 500-10,000 ohms. Low-level speech clipping & filtering. Inputs for xtal or dynamic mikes, phone patch, etc. 7 tubes. 6" h. 14" w. 8" d.



GRID DIP METER #710

Kit \$29.95 Wired \$49.95

Includes complete set of coils for full band coverage. 400 kc-230 mc in 8 overlapping ranges. 500 ua meter. Plug-in coils are pre-wound, pre-calibrated to 0.5% accuracy. Transformer-operated power supply 2 1/4" h. 2 1/4" w. 6 7/8" l.

Compare - judge for yourself - at your neighborhood EICO distributor. For free catalog on 65 models of EICO test instruments, hi-fi & "ham" gear, fill out coupon on Page 40. Add 5% in the West.

ELECTRONIC INSTRUMENT CO., Inc., 33-00 N. Blvd., L. I. C. 1, N. Y.



NEXT MONTH IN POPULAR ELECTRONICS:

Should you buy color TV now?

How good is color television? You'll find out in September POPULAR ELECTRONICS, which features an up-to-the-minute report on the status of color TV today.

In this important, revealing article, service technicians and set owners across the nation have been interviewed on every facet of color television.

You'll find a complete, frank rundown on color television today—its quality, reliability, ease of operation, service problems, antenna requirements, and programming.

You'll also enjoy these informative features next month:

- WHICH TAPE SHOULD BE USED?
- INSIDE THE HI-FI TUNER
- THE OSCILLOSCOPE—HOW IT FUNCTIONS
- THE MAGIC OF CROSS-COUNTRY COMMUNICATIONS

Plus such practical construction projects as:

- 3-TRANSISTOR POCKET RECEIVER WITH BUILT-IN SPEAKER
- VOLTAGE REGULATED POWER SUPPLY FOR CONVERTERS
- TRANSISTOR PULSE GENERATOR

● *And many more complete, do-it-yourself projects*

September POPULAR ELECTRONICS is typical of the good reading and practical construction projects you'll find month after month in the world's most widely read electronic hobbyist magazine. Look for POPULAR ELECTRONICS on your newsstand—or better still, take advantage of one of POPULAR ELECTRONICS' money-saving subscription rates. You'll get every issue delivered right to your door. Subscribe today!

REGULAR SUBSCRIPTION RATES

One year \$4

Two years \$7

Three years \$10

POPULAR ELECTRONICS • 434 South Wabash Avenue • Chicago 5, Illinois

the experts say
your BEST BUY
 is **EICO**...

EICO, 33-00 Northern Blvd., L. I. C. 1, N. Y. PE-8
 Show me HOW TO SAVE 50% on 65 models of top-quality:

HI-FI TEST INSTRUMENTS "HAM" GEAR
 Send FREE catalog & name of neighborhood EICO dealer.

NAME
 ADDRESS
 CITY ZONE STATE

ADD 5% IN THE WEST

...in
STEREO and MONO HI-FI

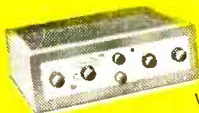

STEREO Dual Amplifier-Preamplifier HF81
 Kit \$69.95.
 Wired \$109.95.
 "Excellent!" — SATURDAY REVIEW; HI-FI MUSIC AT HOME.

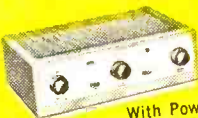

Mono Preamplifier HF65A:
 Kit \$29.95.
 Wired \$44.95.
 With Power Supply HF65:
 Kit \$33.95. Wired \$49.95.



FM Tuner HFT90
 Kit \$39.95*.
 Wired \$65.95*.
 Cover \$3.95.
 "One of the best buys you can get in high fidelity kits" — AUDIOCRAFT Kit Report.
 AM Tuner HFT94
 Kit \$39.95. Wired \$65.95.
 incl. Cover & F.E.T.



STEREO Dual Preamplifier HF85
 Kit \$39.95.
 Wired \$64.95.
 "Extreme flexibility... a bargain!" — HI-FI REVIEW



Mono Power Amplifiers (60, 50, 35, 30, 22, 14-Watt; use 2 for Stereo) from Kit \$23.50.
 Wired \$41.50.



2-Way Bookshelf Speaker System HFS1 complete with factory-built cabinet: \$39.95.



STEREO Dual Power Amplifier HF86
 Kit \$43.95.
 Wired \$74.95.

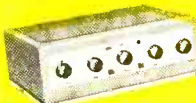

Mono Integrated Amplifiers: (50, 30, 20, 12-Watt; use 2 for Stereo) from Kit \$34.95.
 Wired \$57.95.



Omnidirectional Speaker System HFS2 completely factory-built, \$139.95.
 36" H, 15 1/4" W, 11 1/2" D.
 "Eminently musical" HIGH FIDELITY.
 "Fine for Stereo" — MODERN HI-FI.

...and in
TEST INSTRUMENTS



New Power & Bias Supply for Transistorized Eqp., = 1020
 Kit \$19.95.
 Wired \$27.95.



Miniaturized Multi-Signal Tracer = 145A
 Kit \$19.95.
 Wired \$28.95.



Vacuum Tube Voltmeter = 221
 Kit \$25.95.
 Wired \$39.95.



Peak-to-Peak VTVM = 232 & Uni-Probe (pat. pend.)
 Kit \$29.95.
 Wired \$49.95.



New TUBE & CRT FIL. Tester = 612
 Kit \$3.95.
 Wired \$5.95.
 Fast-checks radio/TV tubes, pilot lamps, etc.



1000 Ohms/Volt V-O-M = 536
 Kit \$12.90.
 Wired \$14.90.



5" Push-Pull Scope = 425
 Kit \$44.95.
 Wired \$79.95.



Tube Tester = 625
 Kit \$34.95.
 Wired \$49.95.



RF Signal Generator = 324
 Kit \$26.95.
 Wired \$39.95.



Series/Parallel R-C Combination Box = 1140
 Kit \$13.95. Wired \$19.95.
 1350 Combinations!



6V & 12V Battery Eliminator & Charger = 1050
 Kit \$29.95. Wired \$38.95.
 Extra-filtered for transistor equip., #1060
 Kit \$38.95. Wired \$47.95.



R-C Bridge & R-C-L Comparator = 950B
 Kit \$19.95.
 Wired \$29.95.

IN STOCK! Compare, take them home — right "off the shelf" — from 2000 neighborhood dealers. Over 1 MILLION EICO instruments in use throughout the world.

© 1959, ELECTRONIC INSTRUMENT CO., INC., 33-00 N. BLVD., L. I. C. 1, N. Y.

See Page 38 for EICO'S BEST BUYS in "HAM" GEAR.

Electronics Against Cancer



X-ray machine made by G.E. provides two million volts of cancer-destroying power.

By R. E. ATKINSON

***Electronics faces its greatest challenge
in the fight against cancer***

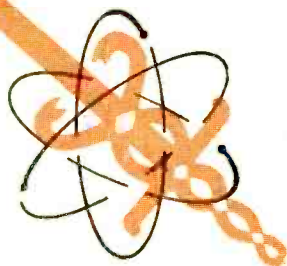

ONCE the word "cancer" was whispered. Now we say it firmly, as a challenge. People are learning to spot the signs of early cancer, and are seeing their doctors regularly; alert physicians are also detecting cancer in time to remove malignant growths before they can spread. The situation is far from hopeless. Statistics show that more and more people are being saved from cancer each year.

Dramatic examples of electronics being used to help mankind are found in the battle against cancer. Electronic de-

vices are invaluable in the diagnosis and treatment of cancer, and more important, they promise to provide the key which will open the door to an understanding of what causes normal cells to start multiplying wildly and grow into malignant masses.

In the field of cancer diagnosis, radioactive chemicals injected into the blood stream act as invisible bloodhounds which track down malignant tissue. In the treatment of cancer, atoms and electrons are used to destroy cancerous areas, even those deep within the body. Ultrasound, too, has been used to shatter malignant cells under the skin. Electric shock has been employed in a few cases to relieve pain, and cancer

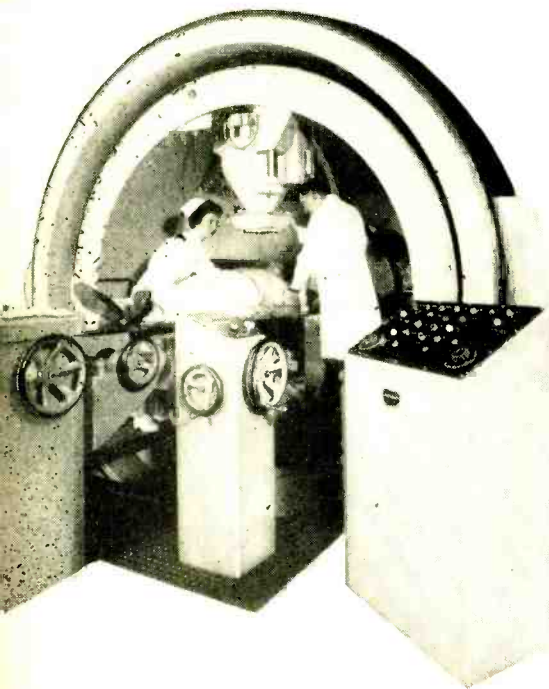

research leans heavily on electronic instruments such as the electron microscope.

Cancer Therapy. A big gun in our anti-cancer arsenal was unveiled this March at the Brookhaven National Laboratory, Long Island, N. Y. A uranium-powered 1000-kilo-watt atomic reactor has been completed for use in medical research and treatment. The first reactor specially designed with medical uses in mind, the Brookhaven installation is integrated with a research center and hospital. Cancer is its chief target.

One of the experimental techniques that scientists at Brookhaven are working on is

a treatment called "neutron capture." Boron, a chemical which "captures" a large number of neutrons, is carefully injected into the patient's blood stream. After the boron is carried by the blood to an area known to be cancerous, neutron particles from the atomic reactor are beamed directly at the tumor area. When neutrons strike the boron, the resulting radiation kills the tumorous tissue with little damage to surrounding healthy tissue. Treatment is promising, scientists report, but is still in the research stage.

Most powerful of all the weapons against cancer is a kind of X-ray machine called a "synchrotron." While X-ray machines used in cancer therapy in the past generated 250,000 volts, the University of California synchrotron generates an X-ray beam amounting to 70 million volts. The synchrotron's high power is equivalent to penetration power and is of value when a tumor is located deep within the body. Of course, brute force is not enough. The problem in treating cancer with X-rays

Radioactive cobalt machines such as the one shown at left can produce radiations equal to those from a 3,000,000-volt X-ray. These radiations destroy malignant tissues.

is to destroy the cancer tissue and leave the adjacent healthy tissue undamaged. Consequently, although the synchrotron produces enormous power, its accuracy in focusing beams of cancer-killing X-rays is a marvel of engineering.

Cancer Can Be Cured. In the therapy of cancer with X-rays and other methods, the primary interest is in curing the patient outright. The Cured Cancer Congress, which met recently in Washington, D. C., is living testimony that cancer can be cured. To qualify as a member of the Cured Cancer Congress, a cancer victim must have had no sign of the disease for five or more years after treatment. This year 40 delegates represented almost one million Americans cured of cancer.

Many of these people would not be alive today if it weren't for medical electronics. For example, Mrs. Richard A. Flacco of Bellflower, Calif., received surgical treatment of an abdominal cancer after X-rays revealed it in time for early care; follow-up

radiation treatment finished the job. Mrs. Flacco leads a normal life today and two of her three children have been born since the surgery was performed.

Just as early and accurate diagnosis was so important to Mrs. Flacco, it is vital to the well-being of hundreds of thousands of people. One of the most promising electronic diagnostic devices is the "cytoanalyzer." Cancer cells have a peculiar center, or nucleus, by which they may be identified, and the cytoanalyzer looks at slides of cells and measures their degree of density from nucleus to outer edges. Thus, it is capable of determining which cells are cancerous.

The cytoanalyzer is many times faster

Examination of cells suspected of being cancerous is speeded by the use of the cytoanalyzer. This device can tell if cells are normal (upper circle) or cancerous (lower circle).

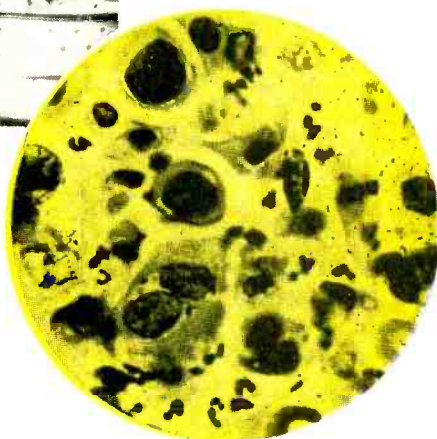
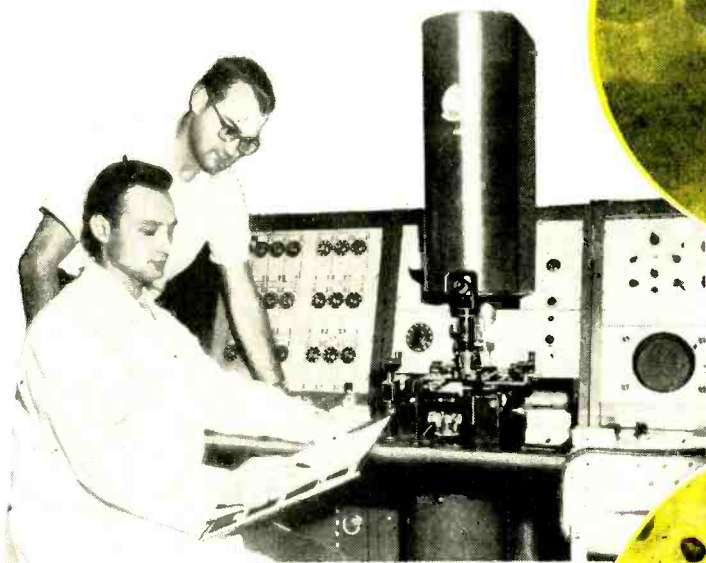

than a human lab technician, scanning each slide in less than one fifth of a millisecond. In a test recently reported by the National Cancer Institute, the cytoanalyzer was fed over 1000 slides to analyze. Technicians had already determined that 20 of these slides contained specimens of cancer cells. The cytoanalyzer detected every one of these slides, and also labeled a few others as "suspicious."

The radioactive isotope—another diagnostic aid—has been called a hitch-hiker with a walkie-talkie. If it finds cancer, it reports back to an isotope counter. Here's how it works. After scientists find chemi-

Photographs courtesy of American Cancer Society and National Cancer Institute

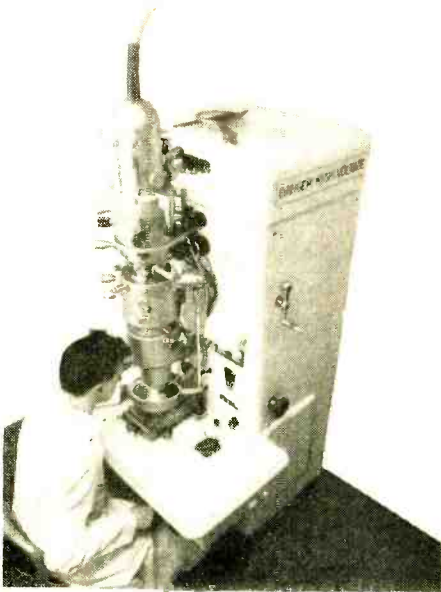

Electron microscopes enable researchers to see cell processes which are invisible to ordinary microscopes.

Research is also aided by the use of the mass spectrometer. It measures the relative weights of molecules by electronic means.

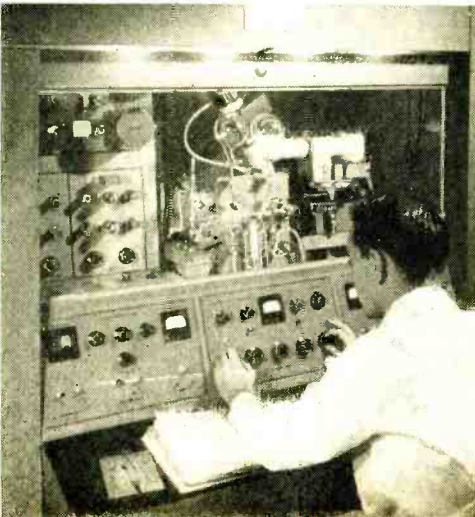

cals that are especially attracted to cancer tissues in certain parts of the body, they "tag" them with a small dose of radioactivity.

For example, thyroid tissue has a special thirst for iodine. If offshoots of thyroid cancer travel to any part of the body, they, too, attract more iodine than do other tissues. A patient thought to have thyroid cancer is injected with radioactive iodine and is then placed under a scanner—an isotope counter. As the patient is moved under the scanner, impulses from the radioactive iodine indicate the areas in which bits of thyroid cancer have begun to grow. Often, with early detection, it is possible to remove these stray growths.

Cancer Research. Why does a cell go berserk and start multiplying wildly? Do germs upset the cell's own control centers? Does some chemical imbalance cause the cellular havoc we call cancer? In seeking the answers to these questions, the re-

POSSIBLE SIGNS OF EARLY CANCER

1. A lump or thickening in the breast or elsewhere.
2. Unusual bleeding or discharge from body opening.
3. Persistent indigestion or difficulty in swallowing.
4. Unexplained changes in bowel or bladder habits.
5. Persistent hoarseness or cough.
6. Changes in color or size of a mole or a wart.
7. Any sore that does not heal promptly.

Don't wait for symptoms to become painful; pain is not an early cancer sign. Have a complete physical examination at least once a year.

searcher would be almost helpless without electronic instruments to extend the limits of his perception. In addition to the many devices which are useful in detecting and treating cancer, electron microscopes and other electronically controlled instruments are now enabling us to study the structure of the cell itself. Such devices may turn up the clue which will lead to an understanding of the behavior of cancer cells.

Progress in cancer-therapy techniques has already raised the life-saving rate from one in four to one in three. But it is possible even today, says the American Cancer Society, to save *half* of all the people stricken by cancer by early diagnosis and treatment. Eventually, we will find out exactly what cancer is, why it starts, and how to cure it. Until that time, medical electronics will continue to face its sternest challenge, the conquest of cancer. —30—

The Trans-Six Receiver

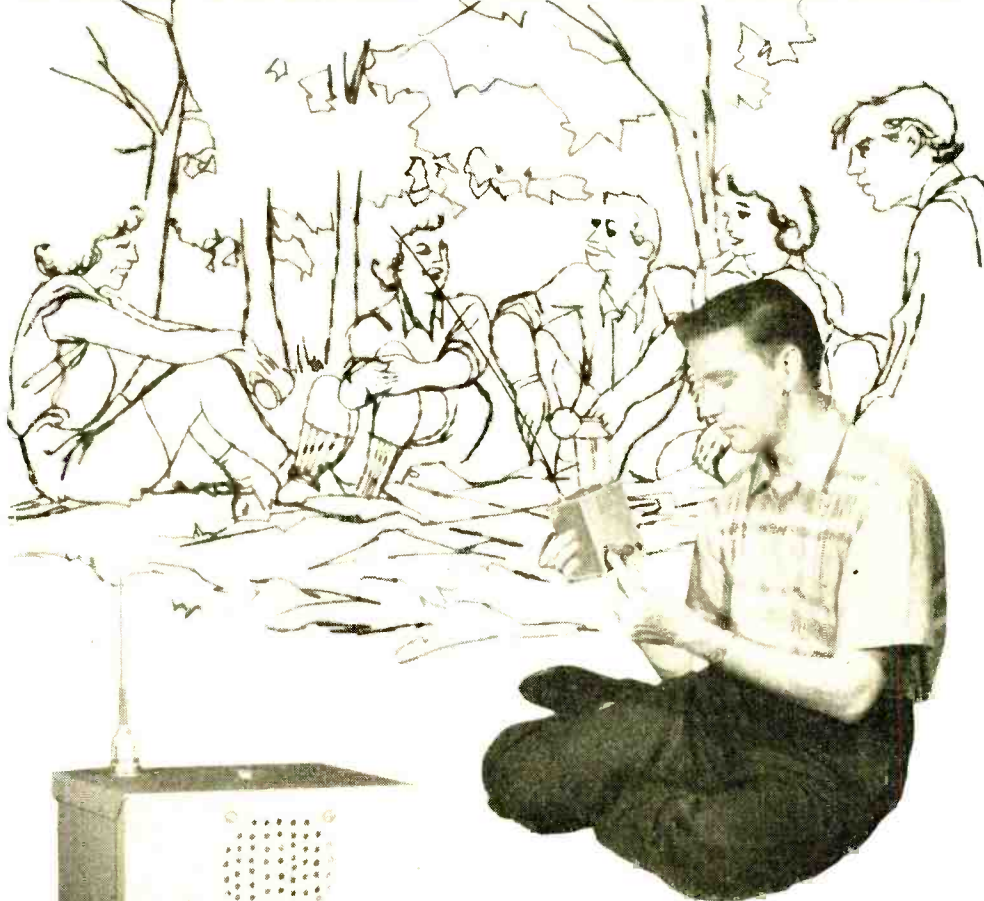

By JOHN J. SURY, K8NIC

**Transistorized superregenerator
tunes 6- and 10-meter ham bands**

HERE is a "hot" little superregenerative receiver designed for the ham or ardent DX'er. It includes an audio section with a push-pull output feeding a miniature speaker.

The tank circuit coil may be rewound for the 10- and 20-meter bands, and amazing pickup can be had with only a short whip antenna. The superregen pot does a fine job in separating stations in conjunction with the tank circuit.

Total cost of the project should be \$16.00 or under, made possible by the introduction of the Philco 2N588 MADT transistor at less than \$3.00.

Chassis and Cabinet. The subchassis is made from a piece of $\frac{3}{32}$ " fiberboard. A triangular file can be used to make the rectangular transistor socket holes. L-brackets of scrap aluminum mount the sub-

HOW IT WORKS

A Micro-Alloy Diffused-Base (MADT) Philips transistor (Q2) is employed in a superregen circuit. When Q1 oscillates, a negative voltage change (C) and the transistor blocks. As C1 discharges, conduction resumes. The periodic blocking results in background hiss. Choke R/CC1 in the emitter lead blocks the signal.

Diode CDI rectifies the signal and feeds back energy so that the superregenerator also amplifies at audio frequency. The signal is then fed into the base of Q2 which is coupled to driver transformer T1.

The push-pull stage consists of two *p-n-p* transistors (Q3 and Q4) connected in Class B using the grounded-emitter arrangement. Two separate battery supplies are employed in this circuit for stability, as the supply voltage will not shift too greatly during heavy audio drive. Power output is between 50 and 100 milliwatts.

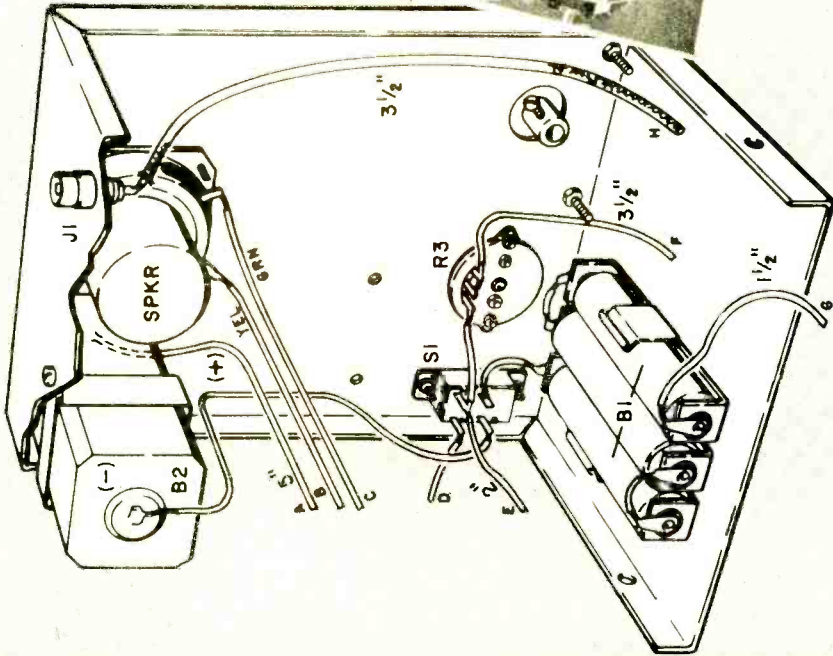

PARTS LIST

- B1—4.5-volt battery (3 penlight cells in series)
 B2—6-volt battery (Eveready 724)
 C1—15- μ f. variable capacitor (Johnson 15M11)
 C2—10- μ f. disc ceramic capacitor
 C3, C4—001- μ f. disc ceramic capacitor
 CD1—1N34A diode (or equivalent)
 J1—RCA-type phone jack
 L1—6 turns of #14 enameled wire, $\frac{3}{8}$ " diameter
 Q1—2N588 transistor (Philco)
 Q2—2N233 transistor
 Q3, Q4—2N107 transistor
 R1—18,000 ohms
 R2, R6—2700 ohms
 R3—5000-ohm miniature or standard potentiometer
 R4—270 ohms
 R5—150 ohms
 (All resistors $\frac{1}{2}$ watt)
 RFC1—32 turns of #28 wire close-wound on $\frac{1}{8}$ " form
 S1—D.p.s.t. slide switch
 T1—Driver transformer; primary 10,000 ohms, secondary 2000 ohms (Olson T-230 or equivalent)
 T2—Output transformer; primary 500 ohms, secondary to match speaker voice coil impedance.
 1— $1\frac{1}{2}$ " - 3" speaker
 1—5" x 4" x 3" Minibox
 1— $3\frac{1}{2}$ " x $2\frac{1}{2}$ " x $3\frac{3}{32}$ " thick fiberboard subchassis
 1—Vernier dial (Calrad VD.36 or equivalent)
 4—3-pin transistor sockets
 1—Coil socket (Amphenol 78-S55)

The letter-coded leads from the subchassis are connected to the equivalently coded leads shown in the pictorial diagram of the cabinet (above). Lead lengths are specified in the cabinet pictorial. X-ray view of the subchassis shows both top and bottom chassis wiring.

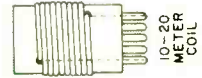
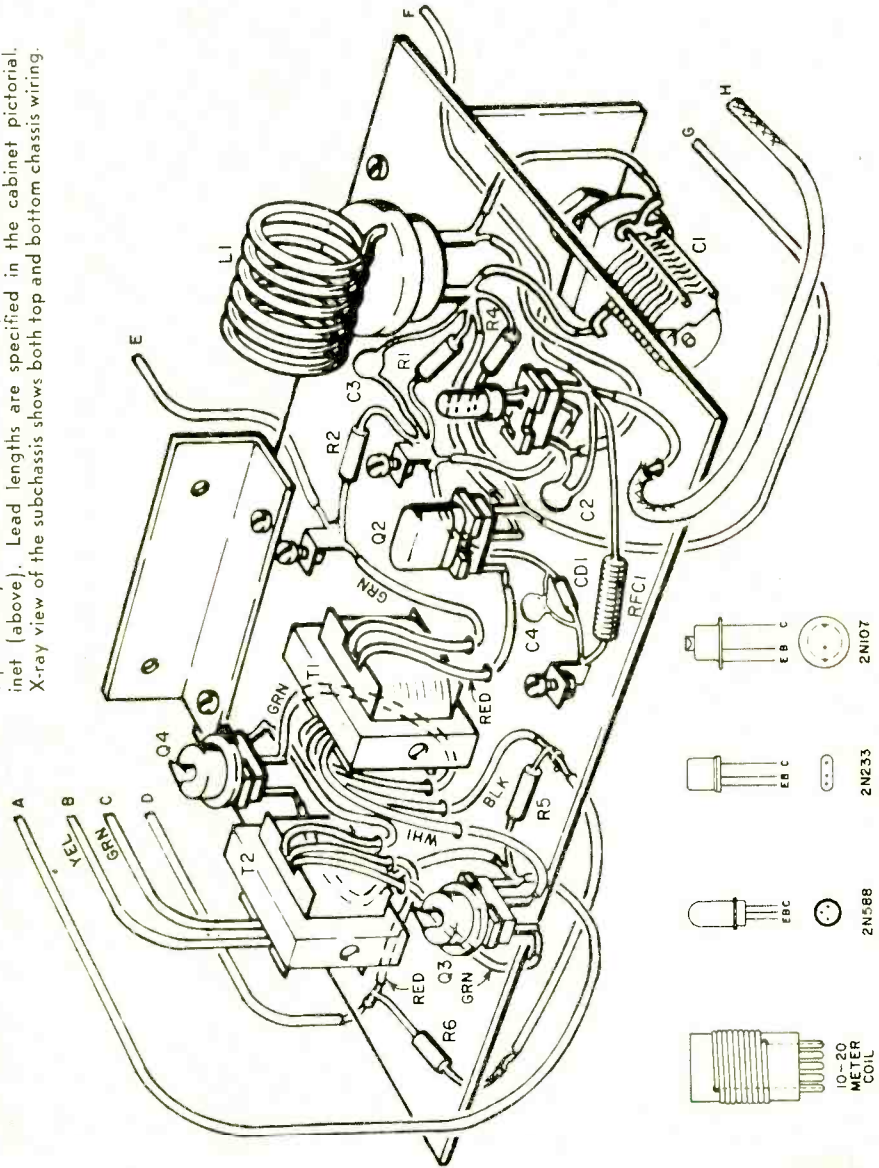



the cabinet. A $\frac{1}{4}$ "-o.d. and $\frac{3}{16}$ "-i.d. sleeve will be needed to couple the dial to the shaft of *C1*. Once the vernier dial is properly aligned with *C1*, drill the holes and mount.

Install the 6-volt battery that powers the amplifier with a small bracket. Then wire the battery into the amplifier circuit, carefully observing polarity.

For the antenna connection, use a piece of RG-58 A/U shielded cable and connect it from the emitter pin of *Q1* to the antenna connector *J1*. Do *not* ground the shield at either end.

Coil *L1* consists of six turns of $\frac{3}{4}$ "-diameter #14 enameled wire, closely spaced. Tin the ends of the coil for better contact in the socket.

After you insert all transistors and *L1*

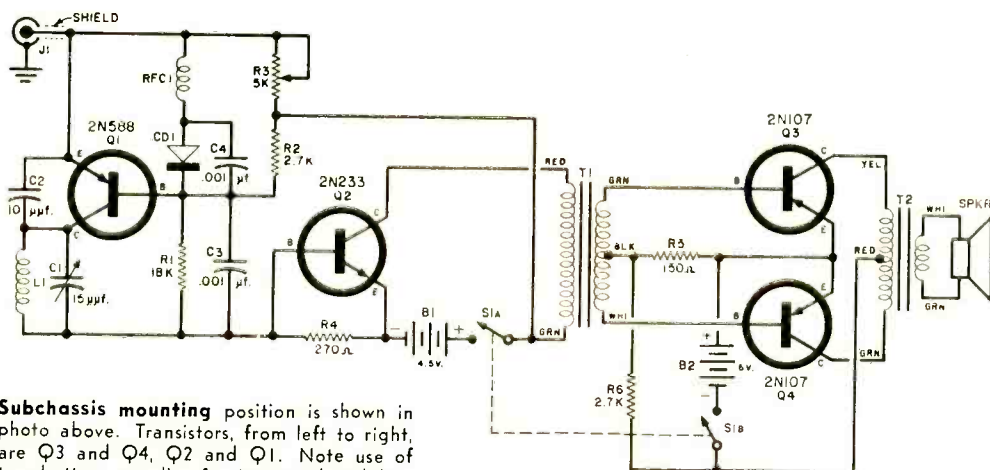

Subchassis mounting position is shown in photo above. Transistors, from left to right, are *Q3* and *Q4*, *Q2* and *Q1*. Note use of two battery supplies for increased stability.

chassis to the inside of the cabinet and *C1* to the subchassis.

Prepare the cabinet by drilling all holes except the ones that are to be used for mounting the vernier dial. To insure good alignment, don't drill holes for the vernier dial until the receiver is assembled.

Wiring and Mounting. Keep all wires in the superregen circuit as short as possible, using ground lugs as tie points. After subchassis wiring is completed, mount the chassis to the inside of the cabinet using an L-bracket and 4-40 hardware. Install the penlight battery holders in the cabinet beneath the chassis and wire to the superregen circuit.

Install the vernier dial on the front of

in their proper locations, you will be ready to use the receiver.

Tuning and Operation. This is a very easy superregenerative receiver to tune. Hook a fairly good six-meter antenna to it, then turn the receiver on and adjust *R3* until a loud hiss is heard. Tune the vernier dial and adjust *R3* until you get the best reception.

The author had no problem in receiving hams on six meters. Also on the higher end of the band is TV Channel 2.

Additional coils may be made up for the lower ham bands, but use only a single wire antenna. With this little rig, the author has heard stations all over the United States and South America.

SHOCKING

But True

Ignorance of electrical safety rules could cost you your life

By FORREST H. FRANTZ, Sr.

MOST OF US have been "bit" at one time or another. If the shock was a mild one, we said "ouch" or "d-n" and that was that. We gave it no further thought. However, we *should* think about it. An appliance that in one situation may produce a slight tickle, in another may jolt us right into a hospital bed or worse. Each year electrical shock takes approximately 800 lives in this country, and these 800 executions are usually accomplished with less power than it takes to press a shirt!

Shocks are caused by a combination of two factors: voltage and current. The relationship between voltage and current can be compared to that of a gun with a bullet in its firing chamber, with *voltage* being the gun itself, and with *current*—the actual death-dealer—being the bullet. The current, or bullet, is harmless until it is "fired" by the voltage. Thus neither voltage nor current is dangerous until they exist in the proper relationship. This explains why a 50-volt jolt occasionally will cause death, while an automobile's ignition system—with its several *thousand* volts of shocking power—is rarely a killer.

Watch That Current! The amount of current that flows depends on the amplitude and source of the voltage, the physical size of the individual who is shocked, the portion of his body through which the current flows, and the condition of the skin at the points of contact.

The amount of shock current can be calculated by ($I = E/R$). Assuming a voltage of 80 volts and an *internal* body resistance

of 400 ohms, a fatal current of 200 milliamperes would flow. Fortunately, in addition to the internal body resistance, there is contact resistance between the voltage source and the skin. Dry skin contact resistance is between 100,000 and 600,000 ohms, but this figure decreases rapidly as the contact area increases and the skin becomes damper. A small amount of perspiration can lower skin contact resistance to 50,000 ohms or less, while complete wetting of the skin and increased contact area can reduce the contact resistance to between 500 and 1000 ohms.

Wet-body contact might involve a total resistance of about 1000 ohms from the right to the left side of the body. With a voltage source of only 50 volts, the current would be 50 ma., a deadly level.

After initial contact has been made, contact resistance decreases. If the decrease in contact resistance lowers the total resistance to 500 ohms, the current will rise to 100 ma.—enough to cause ventricular fibrillation, a heart condition that results in death.

Current-Limiting Factors. But what about the cases where several hundred volts from a Geiger counter battery or thousands of volts from an automobile spark coil or a laboratory high-voltage machine do not cause death? In calculating the effect of a 50-volt shock, it was assumed that no internal resistance existed within the voltage source and that current was limited only by body resistance. This is not always the case. Any electric battery or

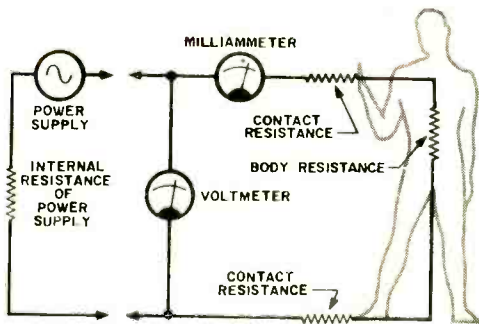

The amount of current in a "shock" circuit is determined by the applied voltage in relation to the sum of the internal resistance of the power supply, the resistance of the body, and contact resistance at the points where the circuit is completed.

electric generator has an internal resistance. If this internal resistance is low in comparison to body resistance, total body resistance will determine the amount of current flow.

On the other hand, if the internal resistance of a battery or generator is almost as great or greater than body resistance, current flow is partially limited. If the internal resistance of the voltage source is many times the body and contact resistance, current flow is limited to an almost constant value. Thus, in a 1000-volt generator with an internal resistance of 100,000 ohms, the current could never exceed 10 ma.

Electrostatic generators such as Wimshurst machines or small van de Graaff generators can develop hundreds of thousands of volts. But, although these machines produce high voltages, their power output (volts x amperes) is small. When contact is made with a "hot" van de Graaff generator, the current flow is limited to a low value, as it is with automobile ignition systems. However, live experiments should be avoided because there are exceptions!

Effects of A.C. Shocks. Special physiological effects of electrical shocks are determined by the frequency of the voltage. While both d.c. and a.c. can cause burns, low-frequency alternating current—and this includes the standard 60-cycle house current—affects the nervous system.

At current values between 8 and 15 ma., a.c. shocks are painful, but most individuals retain enough control of their muscles to withdraw from contact. Currents between 15 and 20 ma. cause pain and loss of muscular control. The victim cannot voluntarily withdraw from contact. Unless the

current is interrupted, the victim becomes exhausted and lapses into unconsciousness. When a.c. shock currents reach values between 20 and 50 ma., pain is very intense and paralysis of the breathing muscles will cause suffocation.

When a 60-cps alternating current of between 100 and 200 ma. is applied to the body, the frequency superimposed over the heart's normal beat can disrupt its timing. Since the heart is being told to pump at a rate of 72 times a minute by the nervous system, and, at the same time, it receives external stimuli from the house power supply at the rate of 60 per second, it becomes confused and begins to flutter aimlessly. This is ventricular fibrillation.

Currents greater than 200 ma. stop the heart's movements completely, rather than causing ventricular fibrillation. If exposure to the shock is not prolonged more than three or four minutes, however, the heart will sometimes resume its action.

Shocking Situations. The knowledge that it takes two contacts to cause a shock



Don't adjust your radio while taking a bath. This is an easy way to start a one-way trip to Paradise.

tempts some people to take foolish chances. Don't work on your house wiring until the power switch is turned off. Although you may have one of the wires completely taped up, if you happen to be working with the "hot" wire and then you back into a cold water pipe, zowie! If you're standing on damp ground or on a concrete floor, you can get a shock right through your shoes.

A number of people have been killed each year because they touched light fixtures, switches, or radios while standing in a bathtub. If you're taking a bath and you want

to change the radio station, *don't*—it's such an undignified way to leave this world. Switches are normally insulated from the a.c. line; but a defect in wiring, or an insulation breakdown, can cause a fatal accident. If these things seem unlikely, keep in mind the 800 Americans who die each year from "unlikely" shocks.

Portable electric tools are a "sneak-path" threat. To minimize the chances of sneak-path electrocution, most portable tool manufacturers provide a grounding wire con-



Always ground the third wire from a 3-wire portable electric tool. If the motor shorts out to the frame, the grounded wire will protect you from shock.

nected to the frame of the tool. If the insulation breaks down or a short from the motor to the frame occurs, current will return to ground through the grounding wire (if it's grounded, of course) instead of through the user. The short will usually necessitate the replacement of a blown fuse. This is small trouble, however, compared to what might happen otherwise.

The a.c./d.c. radio and other a.c./d.c.-operated electrical devices are additional sources of danger. In the earlier a.c./d.c. devices, one side of the line was connected directly to the chassis. If the line cord for one of these units is inserted so that the chassis is connected to the hot side of the line, body contact from chassis to ground (even though the equipment is not turned on) can result in electrocution.

At present, most a.c./d.c. equipment is manufactured with the chassis connected to one side of the line through a capacitor. But even this measure does not completely eliminate the shock hazard. At 60 cycles, a 0.5- μ f. capacitor has a reactance of 5300 ohms, and a 0.1- μ f. capacitor has a react-

ance of about 26,500 ohms. If the body is placed in series with a 0.5- μ f. capacitor across the line, electrocution can occur. Although electrocution is unlikely from body contact to the a.c. line through a 0.1- μ f. capacitor, a shock will occur. The experimenter should proceed with caution when working with a.c./d.c. equipment. If possible, isolate the equipment from the line with an isolation transformer.

Emergency Procedures. In any shock emergency, the circuit should be broken as quickly as possible, preferably with a switch. If you can't get to a switch, remove the victim from the circuit. *But take precautions to avoid becoming a second victim.* Remember, the victim is "hot," and if you simultaneously touch him and a good ground, you won't be in a position to help anyone.

If the victim is not able to breathe after he is removed from the circuit, don't waste

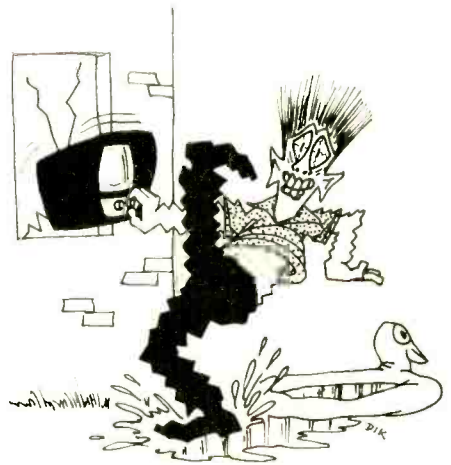

Never touch electrical equipment while you are standing on a damp surface. If you do, you have a good chance of getting 117 volts through your body.

time calling a doctor. Apply artificial respiration immediately and keep it up until someone else brings a doctor.

With the observation of basic safety rules, electronics is *not* a dangerous hobby. But a complete knowledge of the "enemy" and his "tactics" is your best insurance against painful and possibly serious accidents. Don't take chances with house wiring, don't touch any electrical fixture when your hands or feet are wet, and don't work with a.c./d.c. equipment unless you are aware of its shock hazard.

RADAR EYES for TV Weather Forecasts

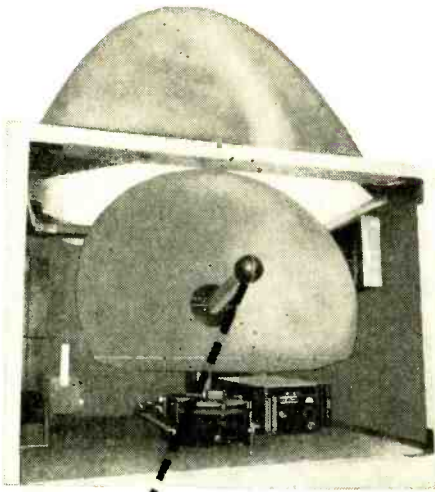

AS you're watching your favorite "weather girl" on television, she starts talking about a storm that's headed your way. While she is describing the storm, the image of a radarscope is suddenly superimposed over her weather map. You

actually see the storm as it looks on radar. You watch its progress as it seems to crawl toward your city.

This type of "See It Now" weather reporting will probably become a reality in the near future, thanks to the development of a special ground weather radar system by Radio Corporation of America. Designed with the special needs of television stations in mind, the compact, easy-to-install unit can pick up approaching storms from as far away as 150 miles. It also provides "close-ups" of weather conditions within a 20-mile radius and a detailed view of the weather within 50 miles.

With this unit, television stations can do their own on-the-spot weather forecasting and fill in the blank spots of more general forecasts by giving their particular localities a detailed analysis of the weather that's in store for them. A little practice will even enable a telecaster to forecast the amount of rainfall by studying the presentation on the radar screen.

A disc-shaped antenna housed in a Plexiglas dome is the heart of the radar device. It can be mounted on top of the television station's transmitter antenna tower or on the roof of a tall building. The antenna rotates constantly, sending out pulses and receiving echoes from weather targets.

The pulses are fed to a simple control console equipped with a small radarscope. Here the broadcasters see the radar image. To show it to the viewing audience, they merely move up a studio vidicon camera of the type used to show motion pictures on TV and focus it on the radarscope. The radar presentation can be shown by itself or mixed with an image supplied by another camera.

-30-

By ART ZUCKERMAN

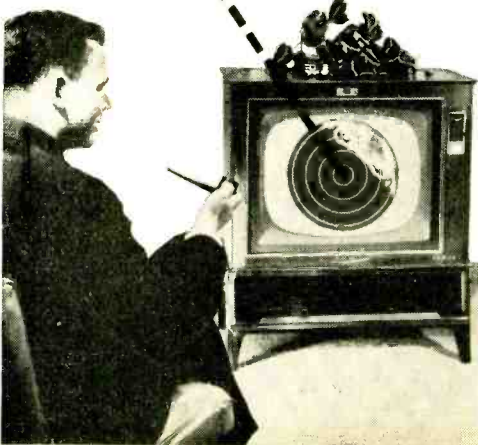

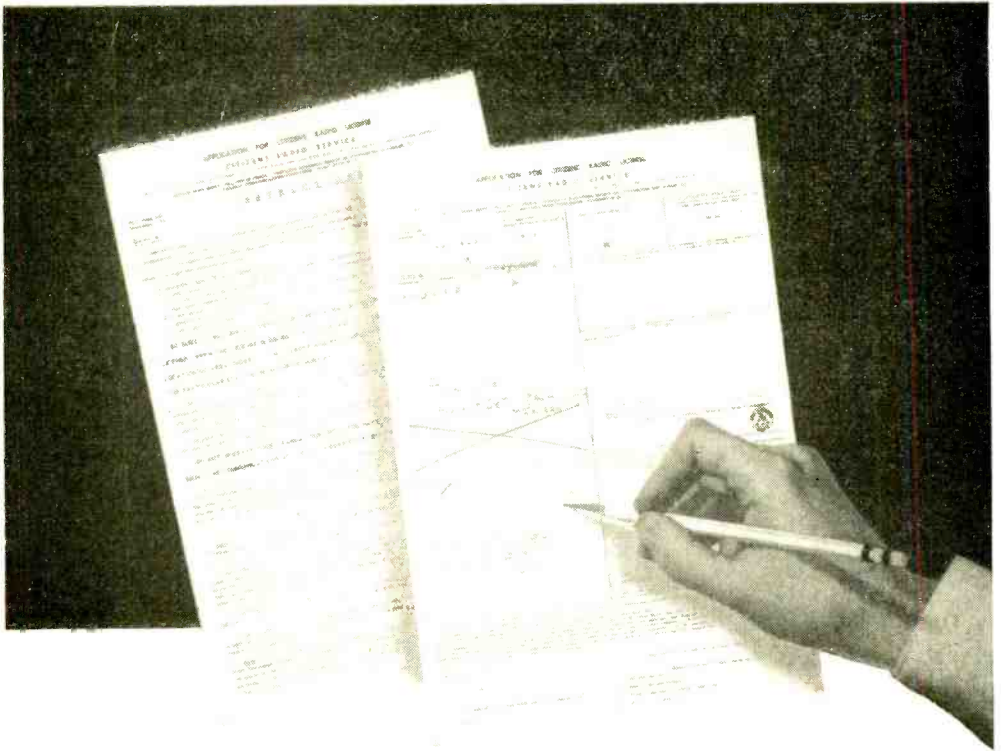

Tips for Citizens Band Applicants

THE new 27-mc. Citizens Band has created considerable interest on the part of private individuals and businessmen. It is now possible for any U. S. citizen (over 18 years old) to obtain a license to operate a low-power radio station for voice communications purposes. The rules also permit youngsters who are at least 12 years old to operate transmitters for controlling model airplanes or for other radio control purposes. There are no stiff examinations or code tests. You just fill out a form, with four carbon copies, and mail it to Washington, D. C. It's as simple as that!

The form (FCC Form 505, September 1958) is used as an application for several classes of license, and the references to the rules and regulations may confuse some applicants. The simple 27-mc. voice communications license is called "Class D," and you are probably interested in this one.

***If you plan to use the
Citizens Band, save this guide
for filling out FCC Form 505***

Radio control transmitters operating on 27-mc. frequencies are called "Class C." Be sure you understand the various classes.

Your Application. When you purchase a Citizens Band radio unit, you will probably find a license application packed in the

box. If you purchase two or more units, each package will have an application form, but you need only fill out one. A separate Form 505 is required for each group of Class C or Class D stations (use a separate form for each class) which is to operate in a separate geographical area.

If you do not receive an "Application For Citizens Radio License" with your radio, copies may be obtained by writing your local FCC office.

Before you attempt to fill out the application, send an airmail letter to the Superintendent of Documents, U. S. Government Printing Office, Washington 25, D. C. (include 10 cents in coin) and request Part 19, Rules Governing Citizens Radio Service. You *must* have a copy of Part 19; when you fill out the application, you have to swear under oath that you have read and understood these rules.

If you should ever be cited for operating your station improperly, you cannot plead ignorance of the rules!

Use a Work Sheet. After you have "digested" the rules, you are ready to "attack" the application form. You will note that the papers include a work sheet. This should be filled out in pencil. After you have filled it out, you can show this sheet to someone who has already applied, if you like, and make any changes that might be necessary. In this way, you can avoid messing up the sheets that you mail to Washington. The following is a guide to filling out the work sheet.

Item 1. Under the heading *Frequencies*, write "Class D." Under the heading *Emission*, also write "Class D." Write the number of transmitters you plan on using under the heading *Mobile*. For Class C or Class D do not write anything in the *Base* or *Fixed* columns (for an explanation of this, carefully read Item 1 in the Instructions). If you are filing for a 27-mc. radio control license, write "Class C" under *Frequencies* and *Emission*, and specify the number of transmitters you will use (usually one) in the *Mobile* column.

Item 2. Fill out your name, address, city, county, and state.

Item 3. Since your transmitters are listed as mobile units, this question need not be answered.

Item 4. Check the box marked *Class D*, unless you are filing for radio control on 27 mc., in which case you should check the box marked *Class C*.

Item 5. Write "In the vicinity of the city of _____" (or names of counties or states in which you plan to operate). If you plan to operate outside of your registered area for longer than two weeks, you *must* notify the Commission Engineers in charge of the district you are leaving and the district you plan to operate in. Notification must be provided even if you will still be in the same district.

Item 6. Since *Item 3* was not answered, no answer is required in this space.

Item 7. Check the box marked *Individual* (or whatever other term applies).

Item 8. Check Box 8A if you own the equipment yourself. If not, check Box 8B. Ignore 8C.

Item 9. State briefly how Citizens Radio is to be used in connection with your business or personal activities. As an example: "For personal communication between husband and wife (no business application)." On a Class C application, you might say: "For controlling model aircraft." Use your own words, however.

Item 10. This space is used only for modifying your original license (change of address, new units, etc.).

Item 11. Check the box marked *Yes* if your transmitter is crystal-controlled.

Item 12. Since your antenna can be no higher than 20 feet above existing structures (see rules), no answer is required here.

Item 13. There are no fixed stations in Class C or Class D service, so no answer is required.

Item 14. If the commercial transmitter you purchase is crystal-controlled, no answer is required.

Although you are not required to answer several of the questions, it is always a good idea to "dash in" the appropriate space so it will be obvious that you did not overlook a particular question.

Mailing Procedure. When you have your work sheet completed to your satisfaction, type it up (do not use pencil or pen) along with the four copies. Read the small print above the signature space, and the conditions and warnings on the reverse side of the application. Take the application to a notary public and sign it exactly as you have typed your name in Item 2. Check the box marked *Individual Applicant*, and have it notarized.

Mail your application to the Federal
(Continued on page 140)

Build a SOLAR-Powered 40-Meter Transmitter

RADIO AMATEURS with privileges in the 40-meter band (7.0-7.3 mc.) can build this solar-powered transmitter to make local contacts. When connected to a 66' length of wire and a good ground, it is capable of transmitting several thousand feet. A test between WV6BGD and WV6BMI (about 1000 feet apart) produced an RST report of 569 in a heavily populated band. During the early morning hours, when 40-meter activity is low, the unit can be heard for even greater distances.

Simplicity is the keynote of this circuit. A single-transistor crystal-controlled oscillator is powered by two inexpensive silicon solar cells. The cost of all the parts will be less than \$20.00. You can use the solar cells in other projects, too.

Construction. The unit is built on a 2 $\frac{1}{4}$ " x 4 $\frac{1}{4}$ " x 2 $\frac{1}{2}$ " chassis box. The r.f. components (transistor, crystal, coil, and antenna terminal) are located at one end of the chassis, while the key jack and the solar cells are at the opposite end. Two $\frac{3}{8}$ " holes are drilled below the cells for the red and black leads. A $\frac{3}{8}$ " grommet is installed near the center of the chassis and the transistor is shoved tightly inside; this mounting is rugged and free from shock and vibration. The transistor leads are soldered directly to the components. A fourth transistor lead (exactly in the center of the case) is a shield connection and should be grounded along with the emitter lead. All components are self-supporting and no terminal strips are used.

Wire the solar cells by connecting a red lead from one cell to the black lead of the other cell, and tape the connection. The remaining black wire is connected to the lug of *L1* nearest the chassis. The remaining red wire is connected to the ungrounded terminal of the key jack. When you mount the key jack, it is automatically grounded to the chassis through the frame. The collector of *Q1* should

By
DONALD L. STONER
W6TNS

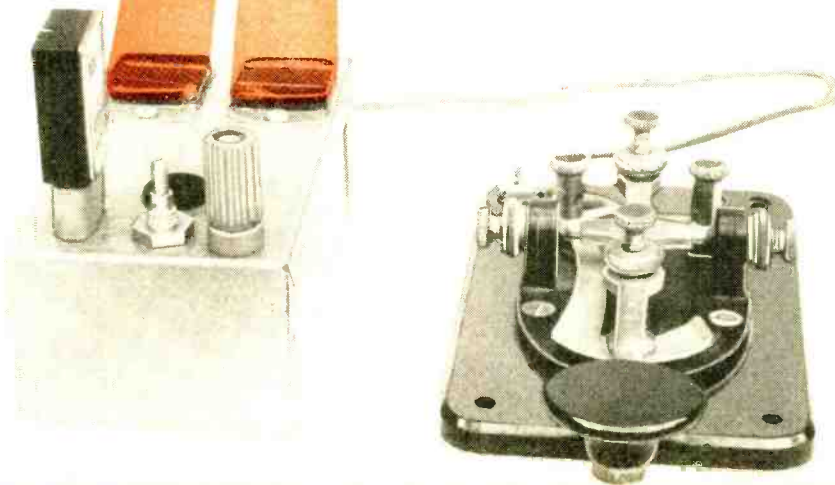

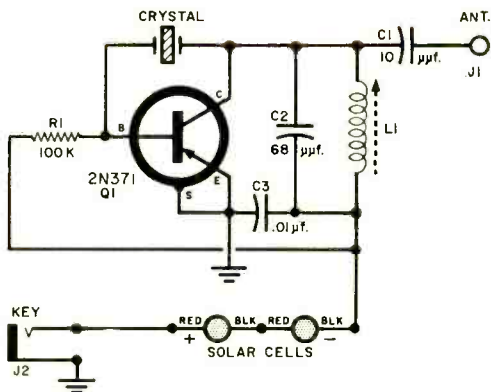

Carefully check the solar cell connections with the diagram after wiring the transmitter.

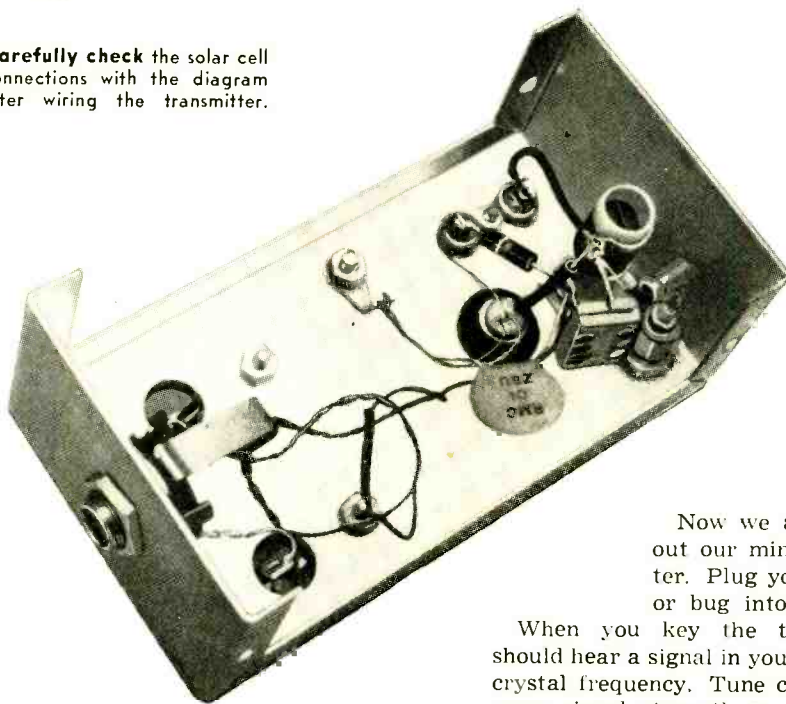

PARTS LIST

- C1—10- μ f. ceramic disc capacitor
- C2—68- μ f. ceramic disc capacitor
- C3—.01- μ f. ceramic disc capacitor
- J1—Nylon pin tip jack
- J2—Phone jack
- L1—25 turns of #26 enameled wire, close-wound on $\frac{3}{8}$ " slug-tuned form
- Q1—2N371 transistor
- R1—100,000-ohm, $\frac{1}{2}$ -watt resistor
- Solar Cells—Two 0.4-volt solar cells (Type SD-1020B, available from International Rectifier Corp., 1521 E. Grand Ave., El Segundo, Calif.)
- 1—Crystal, 7.0-7.2 mc. fundamental
- 1—4 $\frac{1}{4}$ " x 2 $\frac{1}{4}$ " x 2 $\frac{1}{2}$ " chassis (LMB #777)
- Misc. #6 solder lug, 6-32 nut and bolt, 4-40 nuts (4), bolts and washers

be connected to the lug of *L1* farthest from the chassis.

Adjustment and Operation. The transmitter should be connected to a good antenna-ground system. Insert a 40-meter crystal and hold a lamp bulb near the solar cells. *Caution*—do not put the bulb any closer than two or three inches from the solar cells, as excessive heat will damage the cells. Feel the cells occasionally to make sure they are not too hot. They work much better at lower temperatures.

Now we are ready to try out our miniature transmitter. Plug your standard key or bug into phone jack *J2*.

When you key the transmitter, you should hear a signal in your receiver on the crystal frequency. Tune coil *L1* for maximum signal strength as indicated by an S-meter or with the help of a local ham. The adjustment is very broad and not very critical. The c.w. note should be "pure d.c.," with no sign of "chirp." After coil adjustment, the unit should operate with bright sunlight illuminating the cells.

Power can be greatly increased by replacing the solar cells with two series-connected 1.5-volt penlight cells (don't use more than two). Connect the positive terminal to *J2* and the negative terminal to *L1*.

Keep in mind that although this is a "micro-power" transmitter, you still need an amateur license to put it on the air. It does not qualify for the so-called "phono oscillator rules."

INSIDE the

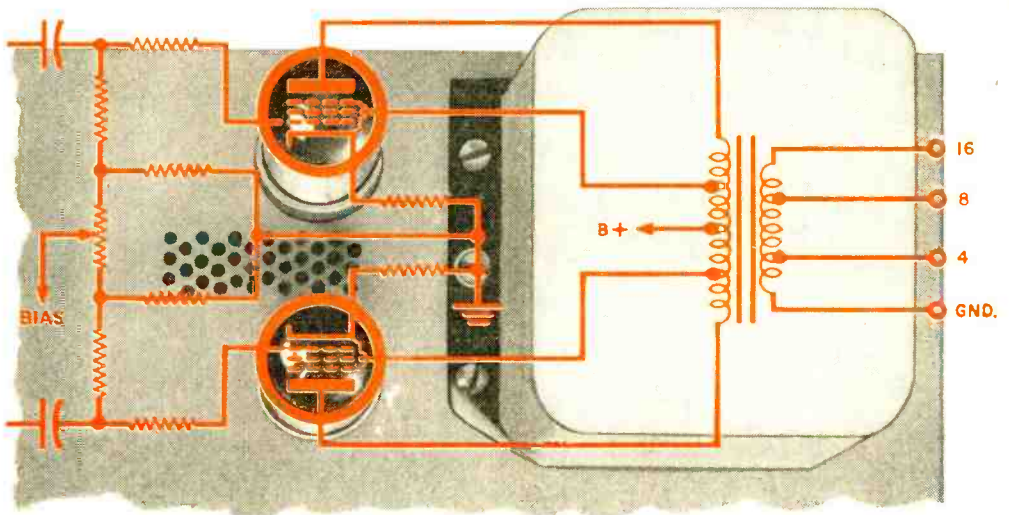

POWER AMPLIFIER

Part 2

The Power Output Stage

By JOSEPH MARSHALL

THE power amplifier's sole function is to produce the power to drive a loud-speaker. This seems simple enough, but as we have noted previously, it takes a lot of doing to get the job done right.

Power amplifier tubes differ from voltage amplifier tubes principally in the amount of current drawn. A voltage amplifier tube may pull 2 or 3 ma. of plate current; a power amplifier may draw well over 100 mils. For voltage amplification, we design tubes so that a given variation in the input signal will produce the largest possible voltage swing in the load. In a power amplifier, on the other hand, we need tubes that will produce the largest possible current variation for a given change in input signal.

Clearly, voltage amplifier tubes are not suited for application in power output cir-

cuits. Consequently, an entirely different breed of tubes capable of handling high currents has been developed.

Probably more than 80% of the power amplifiers now being manufactured utilize EL84's (for power outputs under 20 watts) and EL34's or KT88's (for higher outputs). The other 20% are accounted for, in the most part, by the KT66, 5881, 6L6, 6V6, and the new 6973 and 7027.

Push-Pull Circuits. Power output stages in hi-fi amplifiers almost always operate in "push-pull." As one output tube grid is driven more positive, and thus draws more current, the other tube is driven more negative and it draws less current. Thus the current swing in the load is twice as great as that produced by one tube working alone.

Two conditions must be met for the push-pull output stage to operate properly. First,

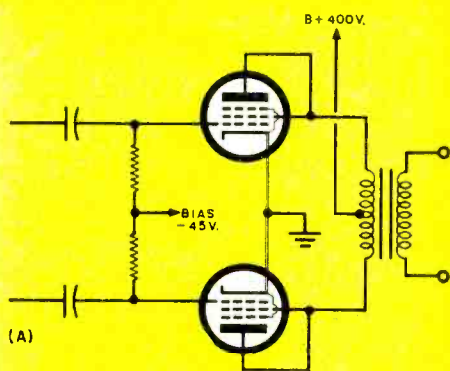

(A)

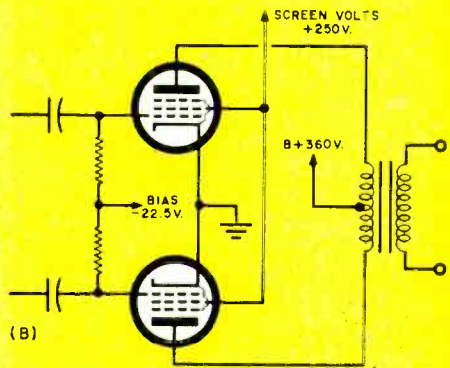

(B)

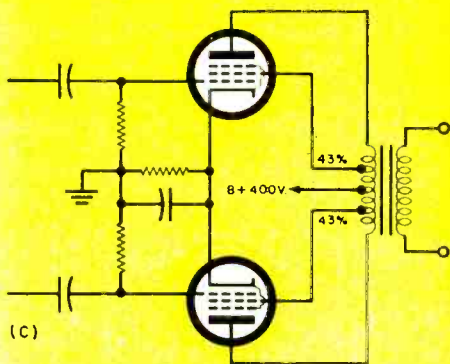

(C)

Fig. 1. The four most common power output arrangements: (A) push-pull triodes, (B) push-pull pentodes, (C) Ultra-Linear, or "screen-tapped" circuit, and (D) McIntosh's "Unity-Coupled" circuit.

the two tubes must be fed by identical but exactly out-of-phase signals. Secondly, the tubes must be balanced very closely so that one half of the output swings up as far as the other swings down. If the push-pull circuit is perfectly balanced, the even-order harmonic distortion cancels in the output transformer.

Because of this distortion-cancelling feature of the push-pull circuit, we can drive tubes in push-pull much harder than we could in a single-ended circuit. The distortion-cancelling feature enables far more usable power at low distortion from a push-pull pair than could be obtained from a pair of the same tubes in parallel.

Where one pair of tubes in push-pull does not deliver all the power required, we can use two more tubes in parallel with the first pair to double the power output. This operation is called "push-pull parallel."

Power Output Circuits. There is a great variety of circuits for push-pull operation, but practically all commercial amplifiers use one of the four circuits diagrammed in Fig. 1.

In Fig. 1(A) we have a push-pull triode pair. The tubes can be true triodes, though more often they are tetrodes or pentodes used as triodes by connecting the screen grids to the plates. Although power triodes were very popular at one time because of their low distortion characteristics, they have some serious disadvantages.

Triodes need about twice as much drive voltage as pentodes to produce the same power output; it is not easy to deliver these high signal voltages at low distortion and still keep the circuit simple enough to allow large amounts of feedback. Another dis-

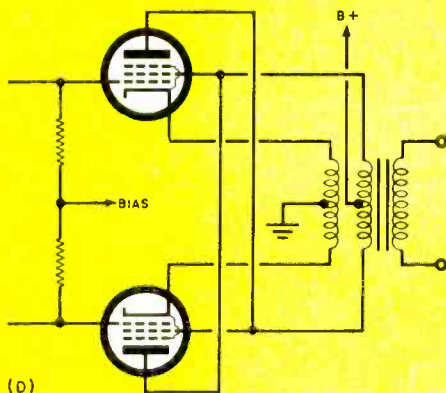

(D)

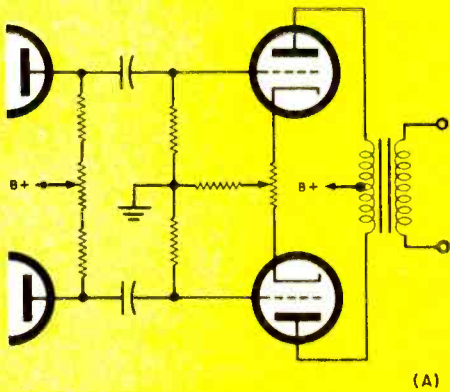

(A)

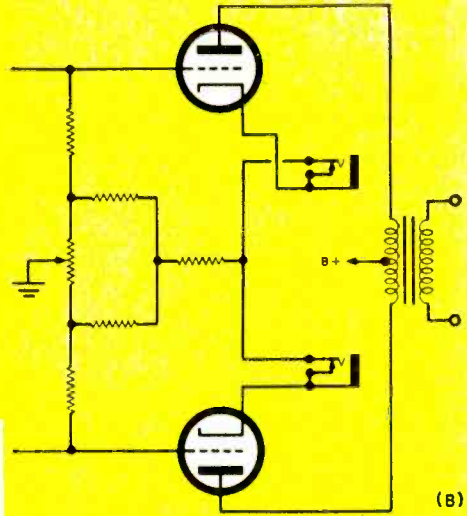

(B)

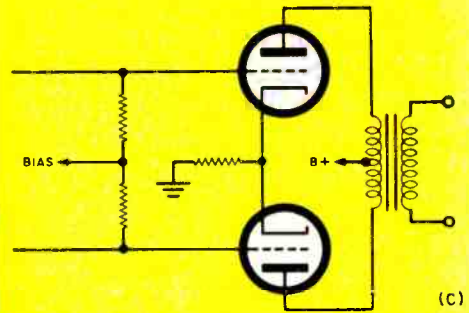

(C)

advantage of triodes is their high plate-to-grid and output capacitances which together result in losses at high frequencies; these losses make it difficult to maintain a flat response, and thus present real problems in obtaining high amounts of feedback with adequate stability.

The pentode configuration of Fig. 1(B) is highly sensitive and efficient. Furthermore, the capacitances of pentodes are very low and therefore losses at high frequencies are low and high feedback factors are easy to obtain. Pentode output stages are finding wide usage, particularly in the 10- to 20-watt class of amplifiers utilizing EL84 output tubes.

Today's most popular circuit is the "screen-tapped" or Ultra-Linear arrangement in Fig. 1(C). This circuit is built around an output transformer with special primary taps which are connected to the screen grids of the output tubes. The result is a sort of hybrid operation somewhere between that of triodes and pentodes, combining the best features of each. Among other things, given good output transformers, it permits the use of very high feedback factors.

The fourth major output configuration—the "Unity-Coupled" circuit shown in Fig. 1(D)—is found only in the McIntosh amplifiers. This circuit is basically a "split-load" type, with part of the load in the plate circuit and part in the cathode circuit. The two loads are "unity-coupled" by winding the primaries side by side in bifilar form. Also, the plates are cross-coupled in relation to the cathodes and screens.

The efficiency of the "Unity-Coupled" cir-

Fig. 2. Balancing arrangement shown in (A) uses a pot in the cathode circuit of the output tubes to provide d.c. balance. A pot in the driver plate circuits provides a.c. balance. The well-known Williamson balancing circuit is shown in (B), and (C) is the semi-automatic balancing circuit used for bias correction in the Dyna amplifiers.

cuit is very high since the large amounts of negative feedback within the stage permit the tubes to be operated in Class B without incurring the penalty of high distortion.

Balancing Circuits. We have noted that when a push-pull stage is perfectly balanced, even-order distortion is cancelled. It is obviously advantageous to provide a means for balancing the output stage, and many amplifiers incorporate this feature.

One approach is to use a wire-wound pot (from 10 to 50 ohms) in the cathode circuit, as shown in Fig. 2(A). This pot permits adjusting the bias on the two output tubes

until the tubes draw equal current. Balance is usually indicated by connecting a voltmeter from one cathode to the other and is achieved when the voltage difference between cathodes is zero.

One of the most popular balancing systems was first used in the Williamson amplifier and is still employed by many amplifiers. See Fig. 2(B). Here we have a pot in the common grid and cathode return which is adjusted until the tubes draw equal current. This adjustment not only provides static, or d.c. balance, but also provides a slight adjustment of the input signal delivered to each tube, thereby allowing a degree of dynamic balance as well.

There is an increasing trend toward the use of more-or-less-automatic balancing arrangements. A typical circuit used in the Dyna amplifiers is shown in Fig. 2(C). Here a small (10- to 15-ohm) resistor is inserted



between the two cathodes and ground. This resistor provides bias correction on each tube and, in addition, acts as a feedback device.

The above-mentioned balancing methods are primarily for achieving *static* or d.c. balance. However, the output stage is not truly balanced unless the signal delivered to both grids is equal. Some amplifiers, notably the Marantz and the Acro, provide a means of balancing the input signal as shown in Fig. 2(A). Here, a potentiometer is inserted between the plate load resistors of the driver stage. This pot can be used to vary the plate loads until the two tubes put out equal signals. For lowest distortion, this type of dynamic balancing control is best adjusted while checking the amplifier with an intermodulation analyzer.

Several amplifiers have meters and switching arrangements to permit metered

static and dynamic balancing. In these, an external voltmeter is usually connected from cathode to cathode of the output tubes. Small resistors are provided to permit measurements and are usually switched out of the circuit when the amplifier is in normal use.

Output Transformers. The last—and most important—element in a power amplifier is the output transformer. The transformer in your radio or TV set probably weighs a few ounces, cost a dollar—or less—and has a flat frequency response from 200 to 5000 cps. Hi-fi output transformers may weigh as much as 25 pounds and cost up to \$50.00.

Transformer response at the extreme low end of the frequency range is limited by the size of the core and its magnetic properties. A flat response to 20 cps at 10 watts or more takes a lot of core, special expensive core materials, and complicated core structures.

There is a lot of wire in a transformer and obviously the windings produce not only inductance and resistance, but also capacitances. These capacitances limit frequency response at the high end by providing bypass paths for the high frequencies. Various clever and costly methods of winding transformers have been developed to minimize unwanted capacitances. Although the end product is expensive, output transformers with frequency responses to 100,000 cps or better are now available.

You may well ask, if transformers pose such problems and cost so much, why use them at all? And it is a good question. One of these days, when transistors are refined, possibly we will not need output transformers. But as long as we have to use vacuum tubes to develop high power outputs, we must use output transformers.

Optimum loads for power tubes run from a minimum of 500 ohms all the way to 10,000 ohms, with an average of around 5000 ohms. Loudspeakers have impedances of between 4 and 15 ohms. Since no power generator can deliver power efficiently unless it is matched to its load, the output transformer is required as an impedance-matching device.

In effect, the output transformer “steps up” the low impedance of the speaker until it seems to the tubes that they are working into their proper load. By proper design, we can obtain matching ratios as high as 2500

(Continued on page 128)

Build the Mark-A-Spot Frequency Standard

Printed-circuit board simplifies assembly

By DON LEWIS

ARE you having trouble determining the frequency of that new short-wave station accurately? Or, if you are a ham, do you park your VFO near the center of the band because you are not sure where the edge is? If the answer is yes, in either case, you need a frequency standard to calibrate your equipment.

The "Mark-A-Spot" frequency standard will generate a signal every 100 kc. ($\frac{1}{40}$ th mc.) up to 30 mc. You can put it to work on 40 meters, for example, and the unit will generate a carrier on both 7.2 and 7.3 mc. to mark the edges of the phone band.

SWL's will discover that the 100-kc. markers are handy for checking the frequency of short-wave broadcasts. The frequency of a station between the 100-kc. markers can be estimated with great accuracy.

Construction. The Mark-A-Spot is built on a $5\frac{1}{4}$ " x 3 " x $1\frac{1}{4}$ " aluminum chassis box with a small rectangle cut out for printed-circuit oscillator board mounting.

The rectifier used in the author's model snap-mounts into a $\frac{3}{16}$ " hole but any small rectifier with any terminal arrangement may be used.

Wiring the unit should take about an hour. The printed-circuit board is wired according to the manufacturer's instructions.

Testing. Before applying power to the unit, check for 100,000 ohms resistance or more across *C1*. If your ohmmeter indicates less, try reversing the leads.

Connect a d.c. voltmeter across *C1* (negative lead to chassis) and set on the 200-volt (or higher) scale. Insert the 6BA6 tube and crystal and apply power. The meter should read about 150 volts instantly.

Connect the output wire to the antenna jack of your receiver. With the BFO on, you should be able to detect the oscillator signals each 100 kc.

Adjusting the Beat. A variable capacitor is provided to trim the crystal frequency and put it "on the nose." This adjust-

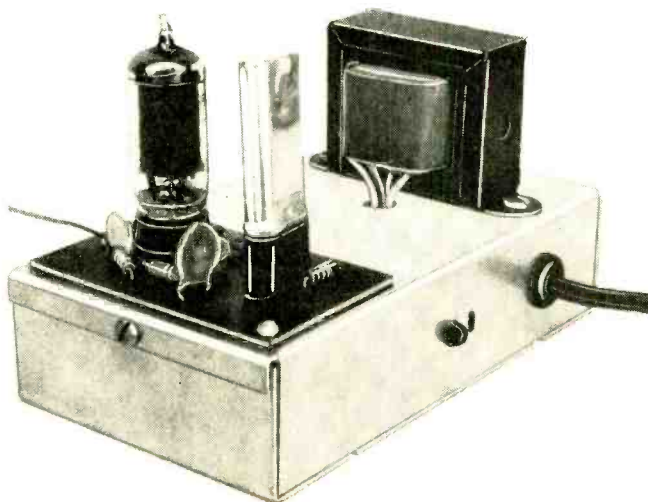

Chassis layout shown need not be followed exactly. Critical wiring is part of printed-circuit board.

August, 1959

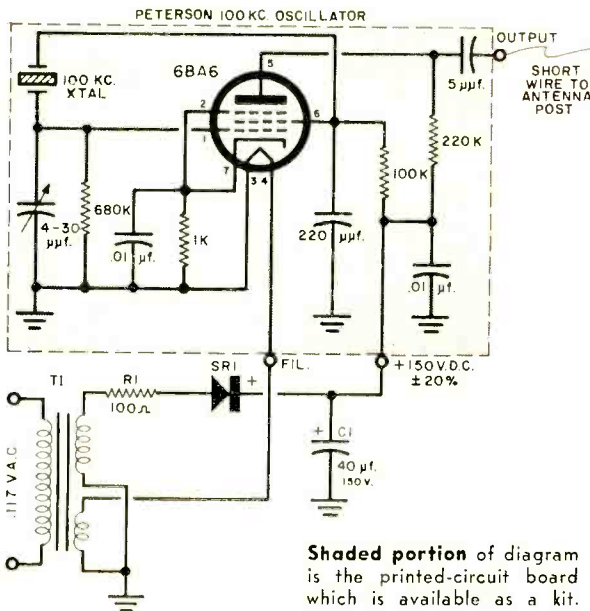
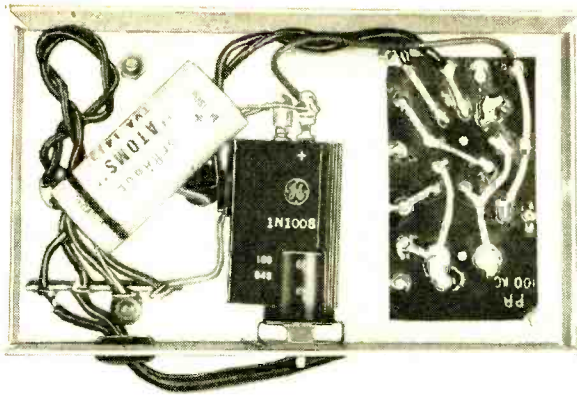

Shaded portion of diagram is the printed-circuit board which is available as a kit.

PARTS LIST

- C1—40- μ f., 150-volt electrolytic capacitor
- R1—100-ohm, $\frac{1}{2}$ -watt resistor
- SRI—20-ma. (or higher) selenium rectifier
- T1—Power transformer; secondary 117-130 volts a.c., 15 ma., 6.3 volts a.c., 0.6 amperes (Triad R54-X or equivalent)
- 1—6BA6 tube
- 1—100-kc. printed-circuit oscillator (Peterson Radio Co., 2800 Broadway, Council Bluffs, Iowa)
- 1— $5\frac{1}{4}$ " x 3 " x $1\frac{1}{4}$ " aluminum chassis (LMB #136)

HOW IT WORKS

When power is applied, the crystal is stressed and it begins to oscillate. These oscillations are fed to the control grid of the 6BA6 tube and are amplified. A few of the electrons, representing the amplified signal, strike the screen grid and are fed back to the crystal. The feedback energy from the screen grid circuit will "twang" the crystal each cycle, thereby continuing the oscillation. The remainder of the electrons continue on to the plate circuit and are coupled to your receiver. The output circuit is coupled to the oscillator circuit only by means of the electron stream (hence the name "electron-coupled") which isolates the plate circuit connections from the oscillator.

ment is set in the following manner.

Warm up your receiver and the Mark-A-Spot for about an hour. Tune in WWV on 5, 10, 15 or 20 mc. and couple the frequency standard to the antenna terminal. During the WWV "silent period" just before the voice announcement, adjust the trimmer capacitor until you hear a whistle or "beat note" which is a harmonic of the 100-kc. fundamental. As you adjust the trimmer, the note will drop in pitch, go into the inaudible region, then rise to a high pitch.

The trimmer should be set so that the beat note is in the center of this region and is inaudible. If your receiver has an S-meter, you will note that in this inaudible region the meter needle pumps up and down very rapidly. You can obtain a much more accurate adjustment if you set the trimmer so that the needle moves at a very low frequency or not at all. This is known as "zero beat."

When the harmonic of the calibrator is "dead on" with our primary frequency standard, WWV, all other 100-kc. beat notes will have the same accuracy as the standard.

Operation. No power switch is included in the Mark-A-Spot for two reasons. The power consumed is negligible—less than the average "night light," and the oscillator will be more stable if left running. The components must be at the temperature they were when the unit was aligned to duplicate the frequency.

If you do not want to leave the unit on continuously, you can insert a toggle switch in one side of the line cord. It is also possible to connect the line cord across the primary transformer leads in your receiver. Then the frequency standard will come alive when you switch on the set.

THE WORLD WITHIN THE ATOM

... an atomic detective story

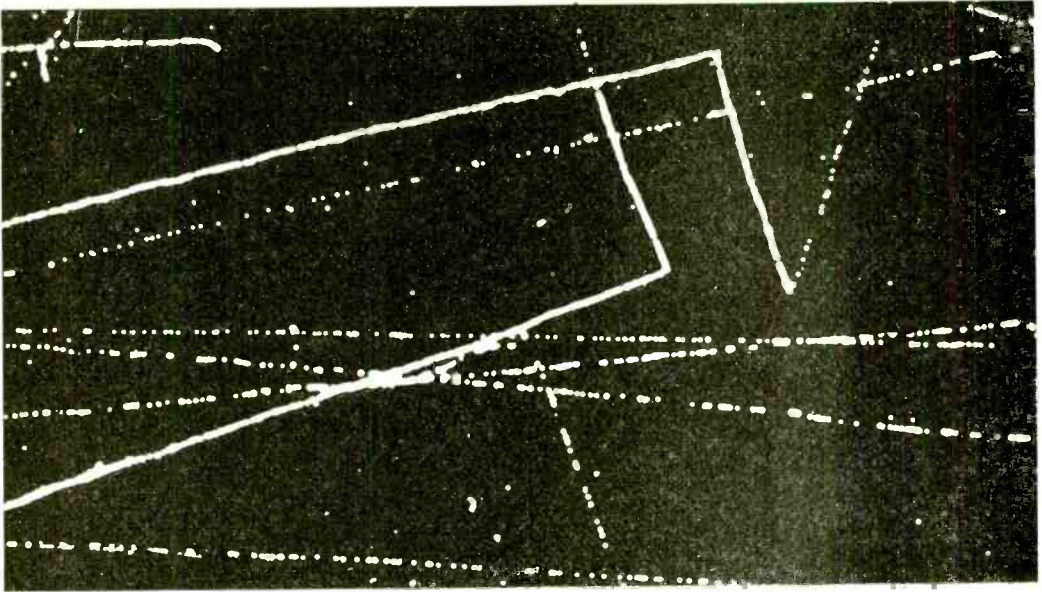

Atomic cloud chamber "footprints" have shed new light on the inner world of the atom.

By SAUNDER HARRIS, WINXL

BELIEVE IT or not, our Atomic Age is over 2500 years old. It all started back with the ancient Greek philosophers. One in particular, named Democritus, suggested that a particle existed which was basic to all matter. This particle, he said, was invisible and could not be divided. The Greeks had a name for it . . . they called it the *atom*.

Early Atomics. This idea of a basic particle or substance was more hunch than scientific theory, and it took thousands of years before it could be put to test. Our present concept of the atom began with the work of John Dalton, an English chemist, who first described the laws of chemical compounds and elements in 1802. He separated matter down to its basic building blocks, the elements.

To visualize Dalton's discoveries, im-

agine that we have a basket of mixed citrus fruit. The complete basket with all the various fruits would be comparable to a chemical *compound*. If we took out the fruits and separated them into groups of lemons, oranges, grapefruit and so on, we would be breaking the compound down into its *elements*. Then, if we set apart one orange, for example, we would be isolating a single *atom*. The next step would be to peel the orange and take a bite of the fruit within. In the case of the atom, this first bite was taken by the English physicist, Sir Joseph J. Thomson, in 1897.

Discovering the Electron. During the middle years of the 19th century, scientists had discovered that if an electric current were passed between two electrodes placed at the ends of a partially evacuated glass tube, a visible beam of unknown nature

would travel from negative to positive electrode. Experiments indicated that this beam was negative in its electrical charge.

Sir J. J. Thomson, using the apparatus shown in Fig. 1, was able to compute the ratio of the charge of a single particle in the beam to its mass. In so doing he proved that the beam was composed of individual, negatively charged particles. This was the discovery of the *electron*.

In other experiments, Thomson tried using various gases in the tube, but in each case his results were the same. The particle was independent of the material from which it came. Thomson therefore concluded that the electron was a basic constituent of all atoms.

You can see that Thomson's apparatus

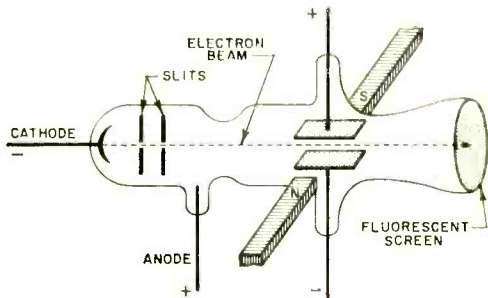

Fig. 1. Thomson was able to calculate the ratio of the electron's charge to its mass by bending the electron beam with known electrostatic and magnetic fields.

was similar to our cathode-ray tube. In fact, the picture tube in your TV set is a direct descendant of the one Thomson used. If you take a strong magnet and place it against the face of the tube while the set is on, you will see a distortion caused by the magnetic field bending the tube's negative electron beam. This is essentially the same effect that led Thomson to identify the electron.

The Proton. The discovery of the electron was only the first step in the exploration of the inner world of the atom. Since the atom was known to be electrically neutral, the physicist now began to search for the positive particles which would balance out the negative charge of the electron.

In 1914, another English physicist, Sir Ernest Rutherford, found such a positive particle and called it the *proton*. The elec-

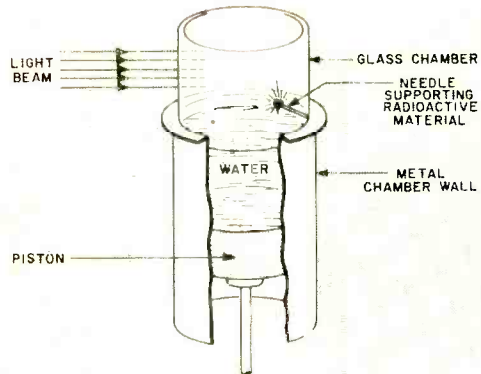
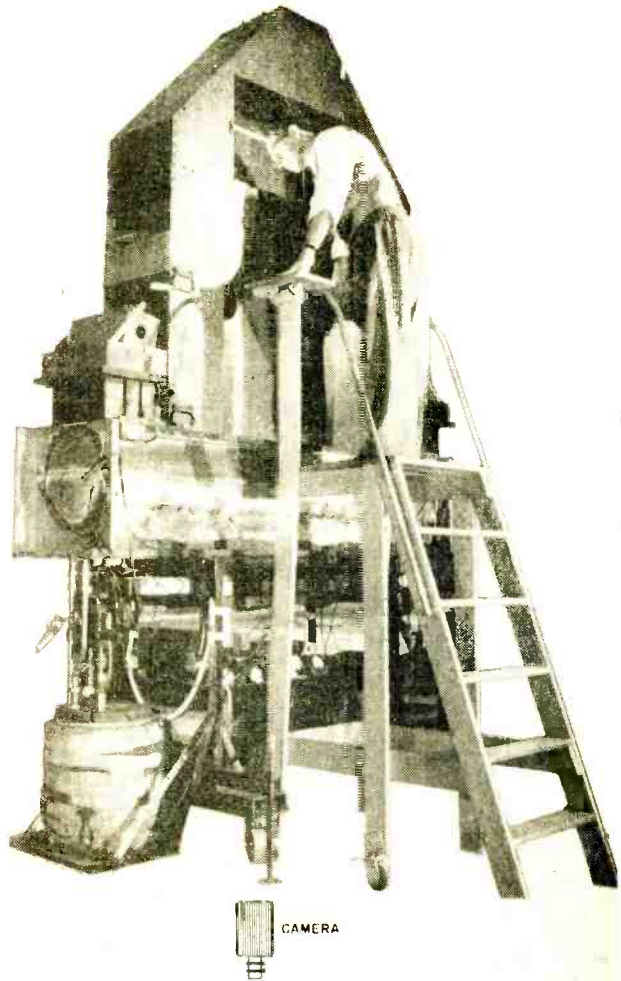

Fig. 2. Cloud chambers such as the one above at the Brookhaven National Laboratory provide clues for atomic detectives. The device bombards atomic nuclei with billion-volt nuclear particles. Atomic fragments leave a path in the moist, gas-filled air which can be photographed and interpreted. Diagram shows basic construction of cloud chamber.



Tracks left by high-speed protons on a sheet of photographic film are shown at left. The dotted horizontal lines were made by protons. The "star" was made when an atom disintegrated in the photographic emulsion. (Brookhaven Lab photo)

tron's charge was assigned a value of -1 and the proton's charge a value of $+1$. Besides the difference in charge, it was also discovered that the proton was much greater in *mass* than the electron. It was, in fact, 1836 times the mass of its smaller opposite.

Obviously, a proton is too small to be seen directly, and you may wonder how it was detected. Consider a trail left in the sky by a jet plane traveling at high speed. By looking at such a trail you can follow the flight of the jet without actually seeing the plane. On a smaller scale, this is how atomic particles are observed. Figure 2 shows a cloud chamber, a major tool in the detection of atomic particles.

As high-speed particles pass through the cloud chamber, they produce ions in the chamber's gas-filled atmosphere. When the piston in the bottom of the cloud chamber is suddenly lowered, this gas, which is saturated with water vapor, expands and drops in temperature. Water vapor condenses on the ions and outlines the path of atomic particles through the gas. Photographs can be made of the ion tracks, and by studying photos of the trails, physicists are able to identify the mass and charge of the various particles.

Bohr's Atomic Model. In physics, when a theory is proposed, the known facts are often organized by fitting them into a model. Based on this model, observations are explained and predictions are made. Our present understanding of the atom has come about in such a manner.

The first proposed model of the atom suggested that it was spherical, like a golf ball, and that its mass consisted of protons with rings of electrons between them. This

SUB-ATOMIC PARTICLES			
Particle	Charge	Mass	Life in Seconds
Electron	-	1	stable
Positron	+	1	stable
Photon	0	0	stable
Nutrino	0	0	stable
Graviton	0	0	stable
Proton	+	1836	stable
Neutron	0	1838.5	750
Positive Mu Meson	+	210	2.1×10^{-6}
Negative Mu Meson	-	210	2.1×10^{-6}
Neutral Pi Meson	0	265	10^{-15}
Positive Pi Meson	+	276	2.6×10^{-8}
Negative Pi Meson	-	276	2.6×10^{-8}
Lambda	0	2182	2.7×10^{-10}
Xi	-	2585	10^{-10}
Tau Meson	\pm	975	10^{-8}
Kappa Meson	\pm	1100	?
Positive Chi Meson	+	1400	10^{-9}
Negative Chi Meson	-	1400	10^{-9}

ANTI-MATTER		
Particle	Mass	Charge
Anti-nutrino	0	0
Anti-electron	1	+
Anti-proton	1836	-
Anti-neutron	1837	0

model, however, did not explain certain phenomena such as atoms giving off light when excited electrically or by heat. It remained for a Danish physicist, Niels Bohr, to offer a model which would explain these phenomena.

Bohr's conception of the simplest atom, the hydrogen atom, consisted of a positively charged nucleus with a "planetary" electron in orbit around it. To move around the nucleus, the electron had to be influenced by some force. This force, Bohr

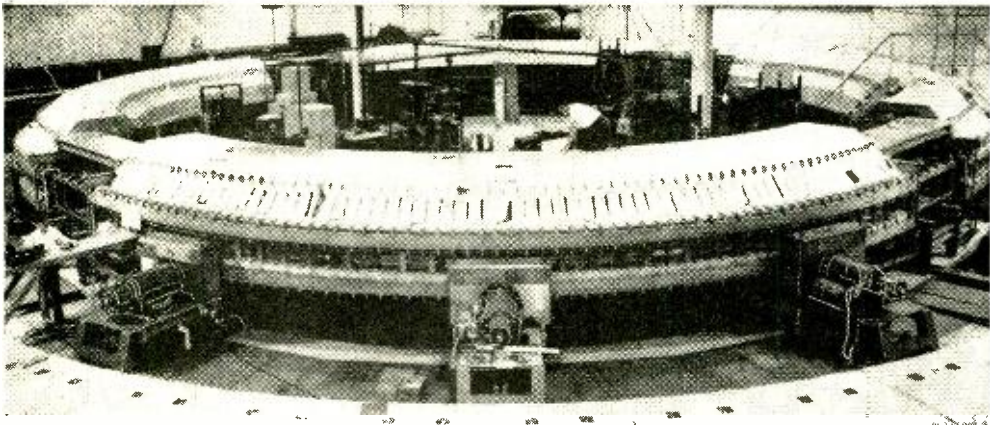

Cosmotron at the Brookhaven National Laboratory accelerates particles to energies of two or three billion volts. Inside diameter of the Cosmotron is over 60 feet.

said, was the electrostatic attraction of the positive proton nucleus for the outer electron. Figure 3 shows a model of the Bohr atom. Bohr was able to explain with mathematics many of the experimental results which were obtained through the use of his model.

Isotopes. In 1932 a new particle was unexpectedly discovered. While experimenting with radioactive polonium, German scientists detected a strong, penetrating radiation. In France, the Curies noticed that the placing of a substance containing hydrogen in the path of this radiation caused the release of high energy protons. These results were analyzed in the laboratory of James Chadwick, an English physicist, and it was determined that the radiation was a new type of particle which had no charge. This third particle was called the *neutron*.

The fact that various atoms of the same element had been found to have different weights could now be explained by the difference in the number of neutrons in their nuclei. For example, there are three types of hydrogen. H^1 has a nucleus which contains one proton. H^2 has a proton and a neutron in the nucleus. The heaviest, H^3 , so rare that only three pounds of it are thought to exist on earth, has one proton and two neutrons in the nucleus. Atoms

with an "excess" of neutrons are called *isotopes*.

Isotopes can appear in all elements. The important thing to remember is that planetary electrons in the outer orbits balance the number of protons in the nucleus.

Energy and Radioactivity. With our three particles, the electron, the proton, and the neutron, we could set up a mechanical model of the atom such as Bohr's. This model would account for most of the things physicists have observed. What it would *not* do is explain how mass could be converted into energy (and energy into mass) without loss. In other words, the
(Continued on page 137)

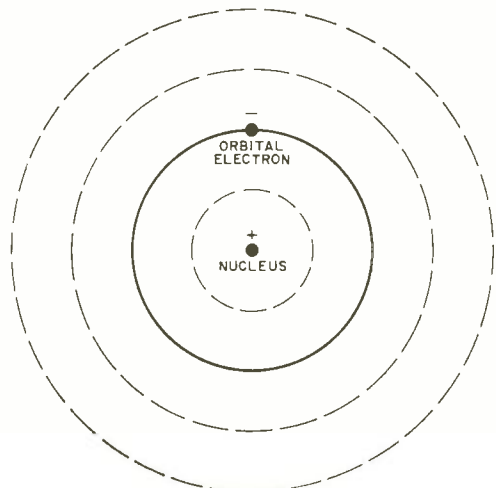
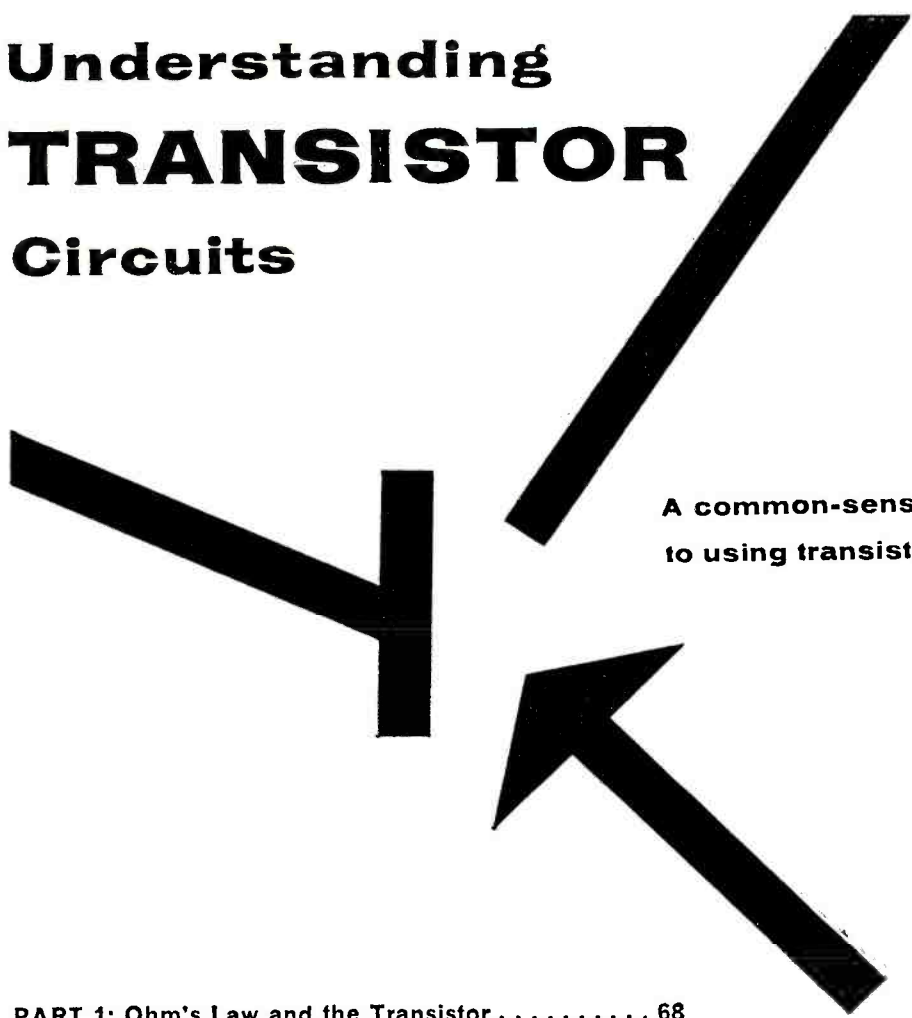

Fig. 3. Bohr's model of the hydrogen atom. Solid line indicates normal orbit of the planetary electron. When electron moves to inner orbit, energy in the form of light is given off. When energy in the form of heat is applied, the electron will move to the outer orbits.

Understanding **TRANSISTOR** Circuits



**A common-sense guide
to using transistors**

PART 1: Ohm's Law and the Transistor 68

Pete introduces Johnny to the grounded emitter circuit. Its "why's" and "how's" are investigated and the not-too-mysterious matters of base and collector bias are discussed. The rule is, as Pete explains it, "Let Ohm's law be your guide."

PART 2: Design "Do's" and "Don'ts". 73

Trying to design a one-transistor amplifier, Johnny gets tangled up with input and output impedance problems. Pete straightens him out with some important "do's" and "don'ts" in getting a signal in and out of a transistor.

PART 3: Controlling, Coupling, and Testing 78

The transistorized approach to filters and tone and volume controls is detailed by Pete with some practical suggestions on the testing of transistor characteristics. Coupling problems are discussed, and Pete draws up a chart that matches the coupling capacitor to the collector resistor.

By James Butterfield
Canadian National Telegraphs

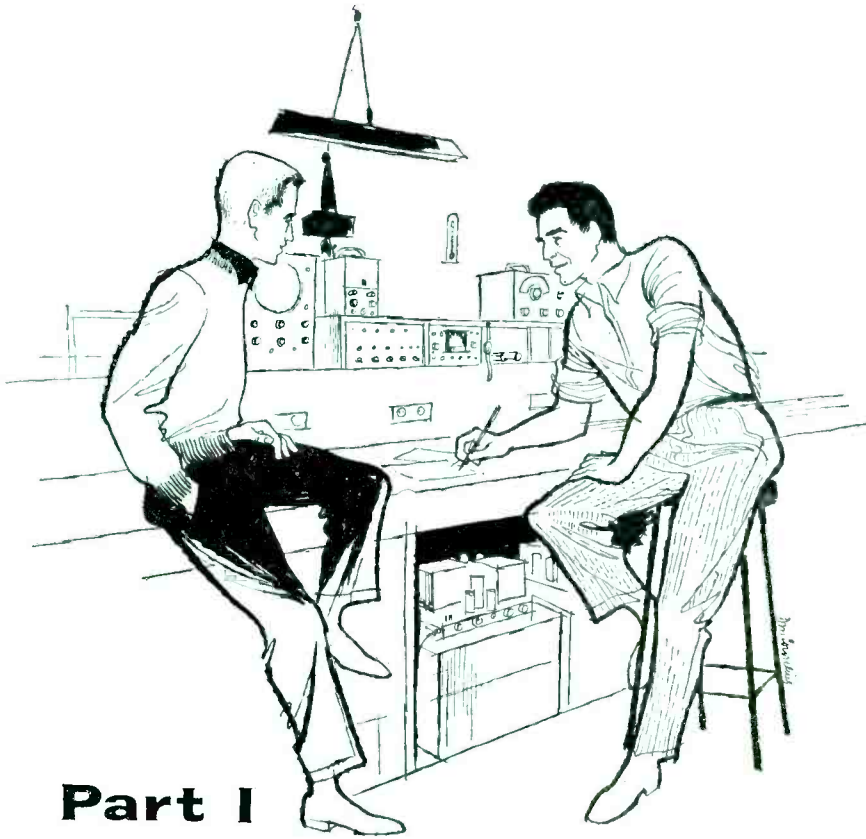

Part I

Ohm's Law and the Transistor

"This should do it," grunted Pete, as he soldered a final connection. "Now, let's try out the amplifier."

"That's an amplifier?" snorted Johnny. "You must have dreamed up that circuit during a fit of indigestion! Anybody knows even the simplest transistor amplifiers are bristling with resistors and oversize coupling capacitors. And where's the output transformer for the speaker?"

"Don't need any." Pete clipped on the ground lead from the audio generator and inserted a .1- μ f. capacitor in series with the other lead. "Trouble with most of you experimenters is that you just copy diagrams—maybe change 'em a little here and there to see what happens—but you never bother to find out what really makes things tick." He touched the other end of the capacitor to his input lead, and the speaker sang with a clear tone.

"Pete, I've got six books on transistors, and I still don't know what I'm doing," complained Johnny. "They are either so simplified that they don't say anything—or they're crammed with equations from stem to stern."

"Nothing wrong with equations." Pete was busy tidying up his workbench. "But you don't always need 'em. I threw this amplifier together without fancy calculations—just horse sense. Let's go into the kitchen for coffee, and I'll try to fill you in on the *practical* side of transistors."

Diodes Back to Back

"First off," said Pete settling in a chair, "You know that a transistor is sort of like a pair of diodes, back to back, like this." He sketched rapidly on a napkin.

"The way I've shown it here, the transistor is a *p-n-p* unit. To get an *n-p-n* job, you flip both diodes end-for-end. We'll dig deeper into this later—but for now, just remember when positive voltage is on the *p* section and negative voltage on the *n* section, the transistor conducts."

"I suppose the lead in the middle is the base," said Johnny. "But which is the collector and which is the emitter? Your diagram doesn't show any difference."

"Here's something that will probably surprise you, Johnny. The collector and the emitter could be changed around and the transistor would still work! But since the manufacturer normally builds the collector bigger and stronger than the emitter—take his advice and use the collector lead as the collector.

"The real difference between the collector and emitter is in the way we treat them. The emitter is biased to allow *maximum* current flow (forward bias) and the collector, on the other hand, is back-biased for *minimum* current."

"Hey," Johnny cut in. "Wouldn't a heavy current flow from the base through the emitter mean that there would be darn little voltage drop between the emitter and base?"

"Right, Johnny, there's seldom more than a quarter of a volt difference between emitter and base,

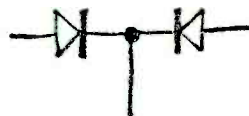

which makes it easy to figure emitter current. Take this circuit for example:

"The collector isn't important just for the moment, so I won't show any wiring to it. Since the emitter is at ground, you can figure that the base is almost exactly at ground, too. This means . . ."

"I get it," cried Johnny. "The battery puts exactly three volts across the 1500-ohm resistor, so Ohm's law says that the current must be . . . ah . . . two milliamps!"

"Bravo!" chuckled Pete. "And since this part of the transistor is conducting in the forward direction, the current will not be affected by the collector. By the way, what type of transistor did I show in the diagram?"

"Negative voltage on the base, and positive on the emitter . . . so the transistor must be a *p-n-p*!" exclaimed Johnny triumphantly.

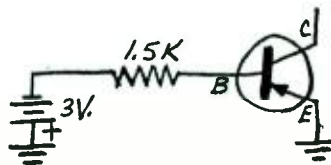

A Current Problem

"Now, here's point number two. The collector must be biased in the *non*-conducting direction. How would you do that?"

"Put negative voltage on it, I suppose," said Johnny thoughtfully. "But, wouldn't that mean that no current would ever flow?"

"That would be true if the collector and base *only* were connected," replied Pete. "But when the emitter is in the circuit with positive bias, an interaction allows current to flow through the collector."

"Now you're getting complicated," complained Johnny. "You sound like a textbook."

"Okay, let's put it this way. Whatever current flows through the base will produce an amplified current through the collector. You know how to find the base current—we just did it by Ohm's law. So you take the base current (I_b), multiply it by your amplification factor (H_{fe})—and there's I_c , your collector current."

"Just a minute," argued Johnny. "Suppose I put a higher voltage on the collector. Wouldn't that make more current flow?"

"Not at all! Ignoring the fine points, I_c will always equal $I_b \times H_{fe}$. The latest G.E. transistor

$$I_c = I_b \times H_{fe}$$

manual, by the way, lists H_{fe} for over four hundred transistors of all makes.

"The experimenters' transistors, such as the 2N107 and the CK722, have gains of about 20. Commercial grade transistors can run gains as high as 100 or more.

"Let's take a look at another circuit," Pete continued, sketching rapidly. "See what you make of this."

"Let me see," murmured Johnny. "With the emitter grounded, the base has to be at almost zero volts—which will cause the battery's three volts to drop across the 33,000-ohm resistor. That would give about 0.1 ma. flowing through the base. If the amplification of the transistor is 20, that means the collector will take almost two milliamps. But, doesn't the size of resistor R make any difference to the collector current at all?"

"Nope," said Pete cheerfully, "with one exception. What would happen if that resistor were, say, 2000 ohms?"

"Well . . . Ohm's law says that two milliamps times 2000 ohms makes a drop of four volts. Oh, I see what you're getting at. If your collector resistor is too big, it won't pass any voltage . . ."

"And once you lose the voltage, you lose your transistor action," finished Pete. "A resistance of about 800 ohms would be dandy for this circuit."

"That would give a collector voltage of—let's see—three volts minus a 1.6-volt drop across the resistor leaves a little under a volt and a half for the collector. Isn't that too low? You'd never be

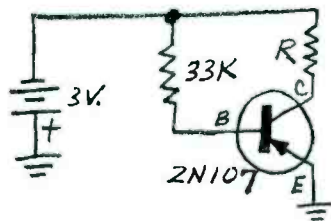

able to put out a decent signal voltage with a supply like that.”

“Depends on what you’re using the amplifier for. Usually, you don’t need voltage—all you want is current.”

Beating the Heat

“Another thing, Pete, what about heat effects? Are transistors as heat-sensitive as some of my books say? Does the gain change, or what?”

“No, the gain of a transistor usually stays fairly steady; but when the thermometer is high, a little leakage current sneaks through. Don’t worry about it, though. You’ll seldom have trouble if you stay well within the maximum ratings of the transistor.”

“These ‘max’ ratings—anything complicated about them?”

“Gosh, no! Maximum collector-to-base voltage, maximum collector current, and maximum collector dissipation—that’s all you’ll have to worry about. They mean just what they say. Don’t put too much voltage across a transistor; don’t put too much current through it; and don’t heat it up too much with a combination of the two.

“Now—you’ve made a start on logical transistor design. The fine points will come later. Whomp yourself up a few circuits. You’ll find that theory and practice go hand in hand. Then when you think you’ve got the basic idea under your hat, we’ll dig into this thing a little deeper.”



Part II

Design "Do's" and "Don'ts"

"Pete, I've been playing around with transistors like you told me, and I've got problems."

Pete carefully set down his soldering gun and turned toward his visitor. "What seems to be the trouble, Johnny?"

"Well . . . I wanted to boost the output of the radio I'm using as a tuner. I laid out a circuit the way you showed me, but it doesn't seem to work right. The volume is just as low as before—and what's worse, the tone is mushy and distorted. I tried a new transistor with no better results. Pete, tell me, where did I goof?"

Pete grinned. "I think I know what the trouble is, Johnny. Your circuit is probably good for a vacuum tube. You'll have to learn to think in different terms for transistor amplifiers."

"First of all," said Pete, reaching for a pencil and scratch pad, "do you remember how I told you that a transistor was really a pair of diodes back to back?"

"Yes. I got that part okay."

"Fine. Now let's go back to fundamentals again and attack the problem from a different position."

"Remember that the base-emitter 'diode' must be hooked up to conduct in the forward direction. Let's look at the circuit of an ordinary transistor amplifier."

"As I told you last time, in a *p-n-p* transistor negative voltage is applied to the base and positive voltage to the emitter, and conduction takes place in the diode formed by the base and emitter. I'll sketch this part of the circuit in detail for you."

"When a diode conducts, it's just as if a switch has been closed. Now, when this base-to-emitter diode is conducting, all your a.c. signal goes directly through the diode to ground. For most purposes, the input impedance is so low that you can consider it zero."

"Just a minute," interrupted Johnny. "If the input is a short circuit, how can you get any ampli-

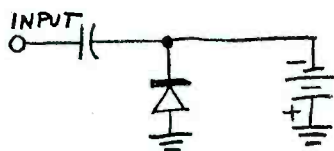
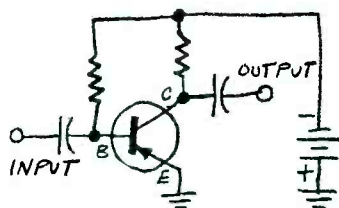

fication? There won't be any voltage left at the input if you short it all out."

"Forget about voltages. Here's the important thing. Since the transistor has a 'short-circuit' input, it may not have much voltage at the input, but *current* flows *into* the transistor. Current is what a transistor amplifies.

"Suppose we have a transistor with a *beta*—that's current gain—of 20. Then if I put one milliamperere of signal into the base, I'll get 20 ma. at the collector. Write this in your notebook in capital letters an inch high—A TRANSISTOR AMPLIFIES CURRENT."

"Pete, I notice you always put your signal into the base and take your amplified output from the other collector. It seems to me I've heard of other ways of connecting a transistor."

"Forget them, Johnny. There are very few jobs that can't be handled by the grounded emitter. We'll talk about the other circuits when an occasion arises that requires their use."

Cascaded Amplifiers

"Pete, how do I go about using an output that's rated in milliamps instead of volts? The current goes through the collector resistor, so it can't be used as it stands."

"That's not exactly true, Johnny. It depends on how you hook into the transistor output.

"Suppose we put the output directly into another transistor stage," continued Pete. "Since the input of this stage is a short circuit, all your signal will be 'shorted' directly to this stage through the coupling capacitor. In other words, all your output goes to the next stage.

"If both these transistors have a current amplification of 40, we can do some fairly accurate figuring. An input of 0.5 ma. will produce 20-ma. output. All of this goes to the second stage to be amplified, giving you a final output of 800 ma.—almost a full ampere."

"Wow!" Johnny exclaimed. "That's a lot of current!"

"A little too much current for comfort. To pass that amount of current, even in a power transistor, you'd have to be careful of heat effects.

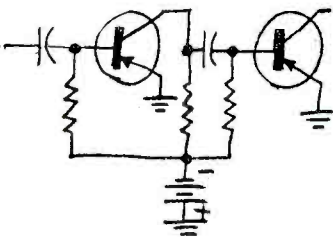

This doesn't just mean mounting your transistors to dissipate heat—it means using special circuits to compensate for heat effects.

“For the time being, with the simple circuit we're using, it would be wise to keep your output signal to a quarter of an ampere or less. At this level, you can bring your d.c. bias down to about a third of an amp collector current, which is well within safety limits for a low collector voltage. If you use more than a couple of volts on the collector, keep an eye on your power ratings. And use a heat sink, of course.”

“Pete, I still don't see how we're going to use that final output current. Do you connect a coupling capacitor to the speaker or what?”

“You could do that, but you'd waste a lot of power. The easiest way to do it is to put the speaker directly in series with the collector, like this. But if the collector load is too *small*, there won't be enough voltage drop across it for appreciable power to be transferred to the speaker. Ohm's law, $W=I^2R$, (where W is the wattage delivered to the speaker, I is the collector current, and R is the speaker impedance) explains the problem.

“Get a transformer whose primary matches the collector load requirements and whose secondary fits the speaker, and you're in business.”

Voltage Out

“Let's get back to your original question on figuring your output. If you're using a transistor as a preamplifier for a vacuum tube, you'll have to know your voltage out. This is really very easy when you think about it, because the input of the vacuum tube is usually high enough to ignore.

“In this diagram, the total transistor load is the 5000-ohm collector resistor shunted by a ½-megohm volume control. For all practical purposes, our output load is 5000 ohms. If our design shows we have a signal current of one milliampere on the collector, we use Ohm's law . . .”

“Don't tell me!” exclaimed Johnny. “That will be . . . ah . . . five volts!”

“You're sharp this morning. May I point out that if you want to use a transistor in this way—

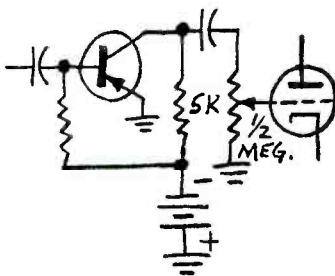
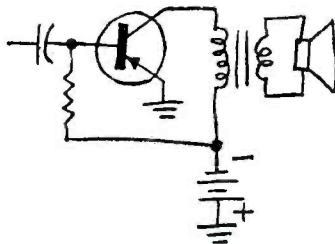
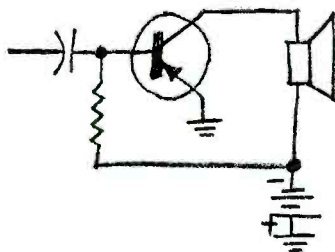

and handle these levels—it would be common sense to put at least seven volts or so on the collector?”

“I see what you mean, Pete. And I suppose it would also be a good idea to have at least one milliamperere of d.c. current through the collector?”

“Right. Remember, of course, that a milliamp of a.c. will draw almost 1.5-ma. peak current, so you should allow a little extra. And that’s just for pure sine waves—when you’re figuring in terms of average music levels, leave lots of room for swing.

“Generally, it’s best to choose your d.c. bias currents keeping in mind the a.c. signal voltages you want to handle,” Pete went on. “And usually it’s best to have at least 1 ma. of collector current, even at low levels. The reason for this is complex, having to do with impedances and distortion. We’ll save this topic for another time.”

N-P-N or P-N-P

“You’ve probably noticed that all the transistors I’ve shown have been *p-n-p* types. As far as signal amplification goes, *n-p-n* transistors are exactly the same. Your signal goes into the base and comes out from the collector. Your connections for bias

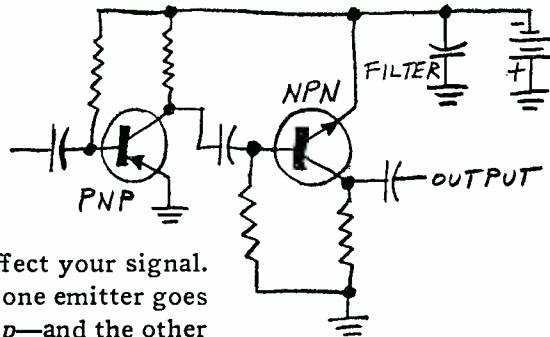

will be different, but that won’t affect your signal.

“If you use both types together, one emitter goes to positive ground—that’s the *p-n-p*—and the other emitter will go to your negative voltage supply. This is quite okay, since they are connected together signal-wise through the filter capacitor, making both emitters ‘grounded.’

“Your bias currents are easy to set up on any of these stages. I’ve left the base and collector resistors unmarked, for two reasons. First, the size of these resistors depends on the battery voltage you are using. And, second, it will do you good to work out the values yourself using the techniques I showed you before.”

Getting the Signal In

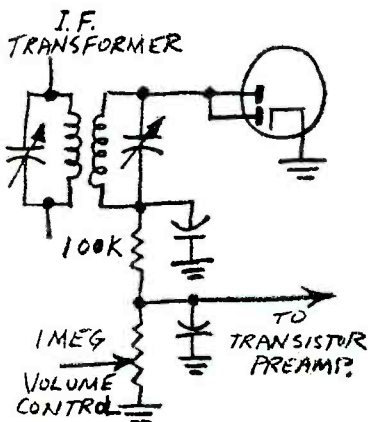

"Let's discuss the booster you tried your hand on, now. Where did you connect the transistor?"

"Across the volume control. I wanted to be able to turn the volume on the radio down and still feed my hi-fi."

"Well, let's sketch out a typical receiver circuit. Notice that the detector is designed to work into a very high resistance . . ."

"I see!" exclaimed Johnny. "The transistor booster would short out the volume control, and put a heavy load on the detector circuit. Well . . . how can I get the input impedance high enough so that it won't affect the circuit?"

"That's a story in itself, Johnny. The best way is usually to put a resistance in series with your input. But even though your radio isn't an a.c./d.c. job, you'll probably have hum problems if you try using a common ground. For the moment I'll say this: the best way will probably be to use an input transformer that matches from 500K down to about 100 ohms.

"In the meantime, dust off some of those old transistors and see if you can put them to work. A lot of design 'failures' result from the experimenter forgetting to take into account the very low impedance of transistors.

"Look me up when you've digested this session and I'll show you how to check out some of the transistor design parameters, and incidentally how to test the little gadgets."





Part III

Controlling, Coupling and Testing

It was a week later that Johnny once again sauntered down the stairs into Pete's basement workshop. Pete looked up from a small amplifier he was wiring. "How's tricks, Johnny?"

"I'm just a little confused, Pete. All this dope you've been giving me on transistors is hard to digest so fast. For example, you said that the input is a short circuit. Well, the *Radio Amateur's Handbook* has a table of specs for quite a few transistors, and for the 2N107 they say . . ."

"They told you the input impedance was around 600 ohms, I bet. Well, in a sense we're both correct. Here, Johnny, look at it this way—you've done a fair amount of wiring. How much resistance would you say there is in hookup wire?"

"I never thought about it. Oh . . . maybe a half an ohm a foot . . . but it doesn't make much difference to the circuit."

"Why not?" demanded Pete.

"Because even if the resistance were as high as an ohm or two, it's usually so much smaller than any other resistance in the circuit that you don't count it. Who cares about half an ohm or so when you're dealing with resistors of several thousand ohms?"

"Right you are, Johnny. And the same thing goes for your question about a transistor input impedance. Even at six hundred ohms, it's so much smaller than any other resistance in the circuit that you can count it as a short."

Short and Simple

"It's very simple to figure out a circuit this way, too. Using the short-circuit input approach, you eliminate most of the calculating."

"But wouldn't that make your calculations inaccurate? You couldn't get the exact values of gain. You'd have to be a few per cent off."

"Look at it this way, Johnny. To begin with, transistors are never rated exactly. A transistor with a rated gain of 20 might have an actual gain as low as 10 or as high as 40. So, fancy calculations usually aren't worth the trouble."

Johnny nodded. "True. But let me draw you a circuit. Now, if the voltage supply were very low—such as a single dry cell—then the collector resistor R would have to be small enough so that it didn't drop all the battery voltage. Wouldn't that mean...?"

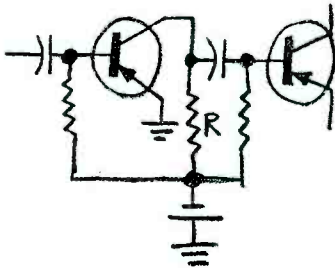

Pete chuckled. "Johnny, you're too sharp for me today. Yes, that would mean your small collector resistor would prevent some of the signal from getting to the next stage. Not only would amplification be poor, but the low resistance would call for some mighty hefty coupling capacitors. And to put another fly in the ointment, as soon as your signal began to get lost in the resistor, distortion would increase sharply. But don't worry—unusually low voltages are almost the only cause of such a situation."

"Pete, you lost me. I guess I still don't dig this whole low impedance input idea."

"You've been brainwashed by vacuum-tube theory, Johnny—you've got to learn to rethink the problems. Let's look at some volume controls."

Volume Control

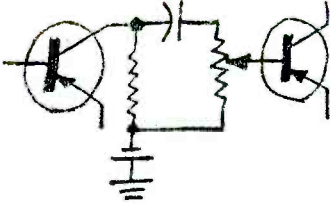

“A vacuum-tube circuit volume control transferred to a transistor circuit would look like this. Whereas a tube draws almost no grid current, the base input of the transistor does—and right through the control. You can see how moving the “pot” arm up and down is not only going to tap off a part of the signal current, which is what we want it to do, but unfortunately it’s also going to change the value of the base bias resistor. A volume control with no problems looks like this.

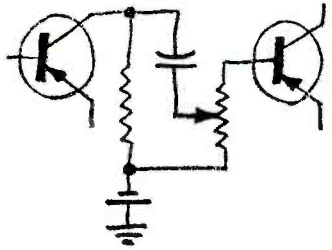

“If you run into volume control problems such as distortion at low volume, abrupt changes in volume as you move the control, or just excessive noise from the control, check to make sure that you’re not goofing up the bias in some way and that there isn’t too much current flowing through the control.”

Capacitors – Filtering and Coupling

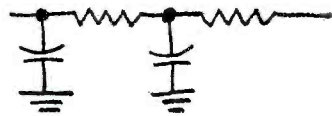
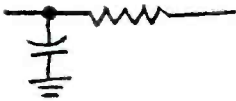
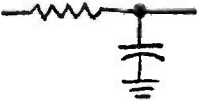

“You’ll find that transistor filter circuits, too, have to be approached differently,” Pete continued. “Here’s a typical tube low-pass filter. A transistor input following the filter would short out the capacitor, making it useless.

“We’ll redraw the circuit for transistor use like this. It could function as a scratch filter or a simple equalizer for a magnetic phonograph cartridge. The values, of course, depend on the use.”

“Could I put two filter sections together, like this?” asked Johnny.

“You sure could. That will give you a sharper frequency cutoff.”

“Looks like all you have to do to adapt a vacuum-tube circuit for transistors is turn it end for end.”

“That’s partly right, Johnny. But it applies only to coupling circuits between transistors, and it won’t always work. Remember to make the resistances smaller and the capacitances larger than with tubes. And check out your circuit *practically* after you work up the design.”

“Speaking of capacitors, Pete, I’ve been meaning to ask you: how do you figure the size of your blocking capacitor?”

“Match it to your collector resistor, usually. You know the formula—it goes, ‘C equals 1 over . . .’ ”

“Ouch! Spare me those formulas!”

“Tarnation!” grumbled Pete. “If you ever want to get anywhere in electronics, you’ll have to start using formulas. Things are getting too complicated for anyone to get along with a wet finger and a screwdriver.

“This time I’ll give you a break. Here’s a table for you. I’ve rounded off the values for a frequency response down to about 20 cycles.”

COLLECTOR RESISTOR	BLOCKING CAPACITOR
2K	4 MFD.
4K	2
8K	1
10K	0.8
20K	0.4

Test Techniques

Johnny looked at his watch. “Pete, I’ll have to run soon. But first, you told me last time that you’d give me the low-down on how to test transistors.”

“Well, it’s fairly easy. A nice thing about transistors is that they usually *don’t* gradually deteriorate—they burn out. And you can spot almost all faults real quick by two simple tests: leakage and gain.

“This makes the transistor easy to check—no fancy testers needed. Just select *n-p-n* or *p-n-p*, check for leakage and current gain . . . and that’s it!”

“Just how do you make these tests, Pete?”

“Easy. Let’s take leakage. If I leave the base of a transistor disconnected, current can’t flow through the other two leads. The transistor is just two diodes, back to back; so one of them will block the current flow.

“Practically, this isn’t quite true. A small leakage current will flow—usually less than a tenth of a milliamperere for most low and medium power transistors. A reading over 1 ma. means your transistor has ‘had it’.

“So, to test for leakage, just place about six volts across the emitter and collector, using the normal polarity for the transistor type. A milliammeter with a range of anywhere from 1 - 10 ma. will do the trick. And for the protection of the meter, it’s a good idea to add a 2000-ohm series resistor. This won’t affect the accuracy of the test.

“Testing for gain is just as simple. Think back to our first talk. Whatever current is put into the base of a transistor appears multiplied by the am-

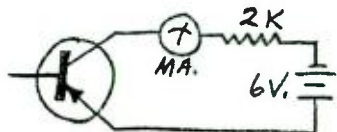

plification factor (*beta*) in the collector circuit.”

“Of course,” exclaimed Johnny. “All you have to do is put a milliammeter in the base circuit, another in the collector circuit—and you can see your amplification!”

“You can do it even easier than that,” replied Pete. “With an exact known current in the base, you need only one meter in the collector, which you can calibrate to read directly in gain, if you wish. The ratio of the collector current to the base bias current gives you your gain figure. An open element, of course, gives you a zero-gain reading, as does a base-to-emitter short.

“If a transistor’s *beta* reads low, don’t throw it out. Remember, you’re *not* working with vacuum tubes where low gain usually means that the tube is wearing out.

“Power transistors are checked in the same way—but you’ll find much more leakage, sometimes as high as 10 ma. Because of this, it’s easiest to check this type at much higher current levels.

“Transistor testers are quite inexpensive. Kit models are available, and it’s a lot easier to build yourself a finished tester than it is to rig up a circuit every time you want to check a transistor.

“And another thing. You’d better learn how to use a little math! Those formulas are there to help you. Dust off an old textbook, and . . .”

“Yes, sir! Just as you say, sir! I’m on my way right now!” Johnny seized the pile of circuit sketches and ran up the stairs. He waved back. “Thanks, Pete. See you later!”

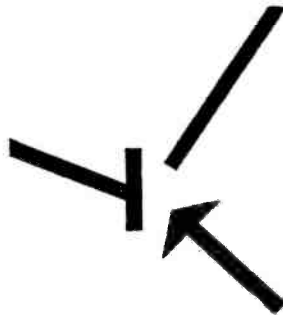
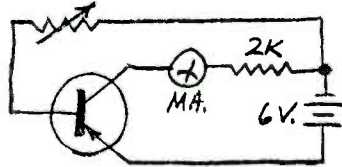

8-Watt Audio Amplifier

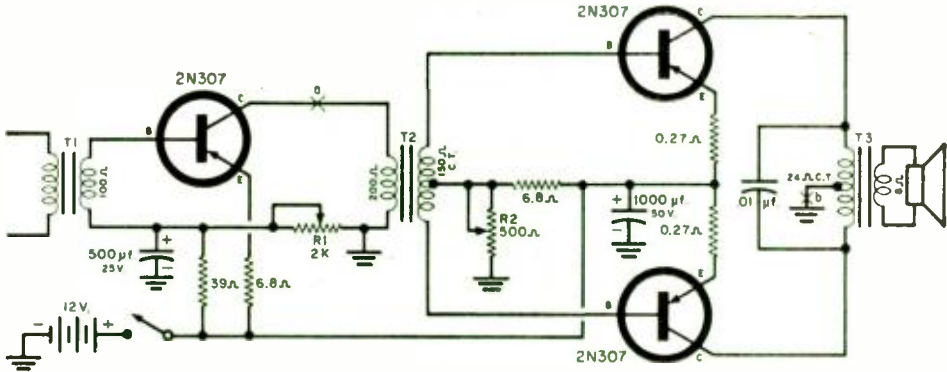

Driver stage of the above amplifier is mocked up on this month's cover

This class B audio amplifier will deliver 8 watts output with less than .5 watt of audio drive. $T1$'s impedance primary is chosen to load the previous stage properly. Collector current in the first stage is set at 70 ma. at *a* with $R1$. Pot $R2$ is adjusted for 100 ma. at *b*. Both output transistors require the use of large heat sinks for proper operation.

Code Practice Oscillator

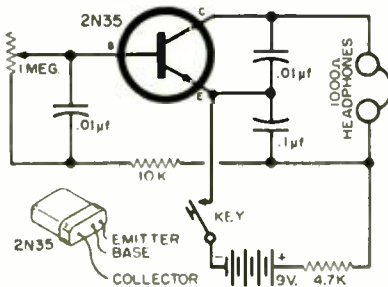

A transistor version of the Colpitts oscillator is used here as a code practice oscillator. The 1-megohm tone control may be adjusted for the most pleasing tone. Ordinary magnetic headphones are used and serve as an inductance in the oscillator circuit.

Pocket Regen Receiver

Regenerative detectors are easily adapted to transistor radio use. In this circuit, coil $L1$ is a standard transistor antenna coil and the feedback winding ($L2$) consists of 10-15 turns of wire wound around the center of $L1$. The 1-megohm potentiometer is the regeneration control and should be set just below the point where whistles or "motorboating" are heard in the headphones. If no regeneration is heard, reverse the connections to tickler feedback coil $L2$.

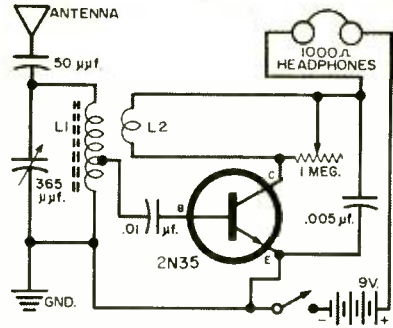

R.F. Preamplifier

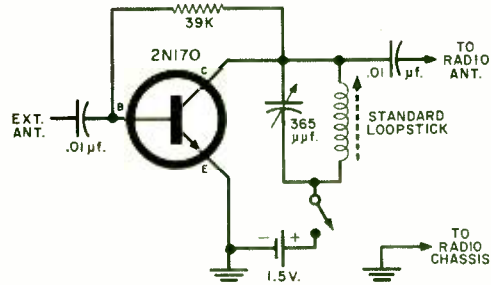

Some of the better broadcast-band receivers include an r.f. stage for increased sensitivity. Extra r.f. amplification can be added to almost any receiver without any complicated rewiring by means of a simple r.f. preamp such as the one shown here.

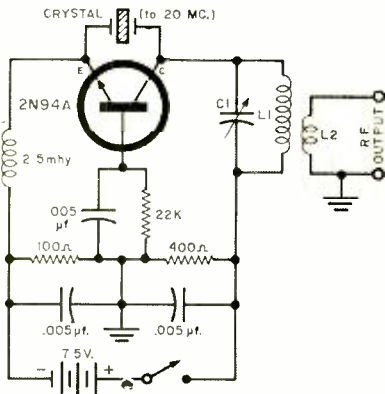

High-Frequency

Xtal Oscillator

Shown above is a general-purpose crystal oscillator for use at frequencies up to 20 mc. designed around a 2N94A transistor. Approximately 10 milliwatts of r.f. output are developed at the crystal frequency. The low-impedance pickup coil ($L2$) consists of two or three turns wound close to the lower end of $L1$. Coil $L1$ and $C1$ are chosen to resonate at the crystal frequency.

Code Keyer

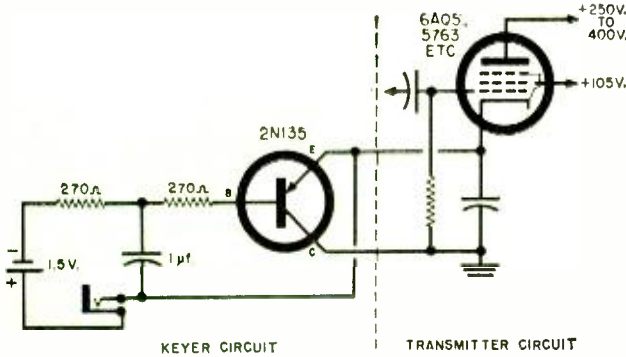

Here is a code keyer unit designed to eliminate the key clicks and thumps that may be cluttering up your transmissions. With the key up, the transistor is cut off, as is the tube being keyed. With the key down, current drop across the collector-emitter circuit is about 0.1 volt, and you're on the air.

Before adding the keyer unit to your transmitter, make these checks. 1. Connect a 20,000-ohm voltmeter across your transmitter key jack. If the voltage is greater than 25 volts, it may be necessary to reduce the screen voltage on the keyed tube to 150 volts or less. Use a voltage-regulated supply or voltage-divider network rather than a simple series resistor.

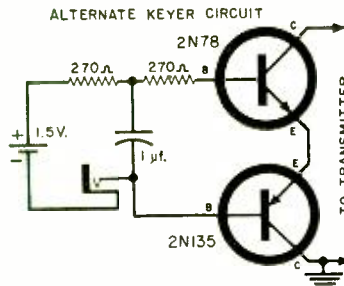

2. Measure the current to be keyed by placing a milliammeter across the key. This current should not be much greater than 50 ma. 3. If it was necessary to lower the screen voltage, check the r.f. output. If the output is too low, return the screen voltage to normal and use two complementary transistors in series back-to-back, as shown in the alternate circuit diagram. Note that the keyer should never be left in the key-down condition.

Dynamic Microphone Preamp

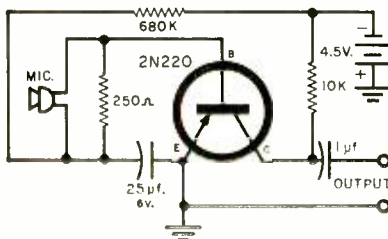

Some high-grade dynamic microphones have too low an output to be used with tape recorders or p.a. systems. A simple self-contained preamp can be designed using one transistor which will boost the output of these low-level microphones sufficiently for almost any type of application.

Wireless Microphone

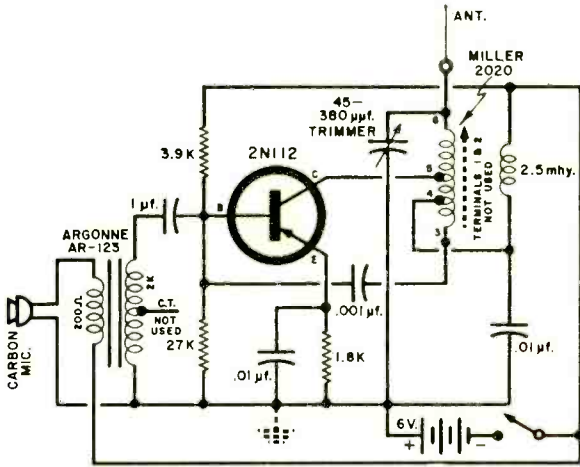

A miniature hand-held wireless microphone can be constructed using an r.f. transistor in a Hartley-type oscillator. Good short-range results can be obtained on the broadcast band with a 2' whip antenna.

Follow the manufacturer's coil terminal numbering shown or oscillation will not occur. Adjust the coil and trimmer for best reception on a clear spot in the broadcast band.

Sensitive Photo Relay

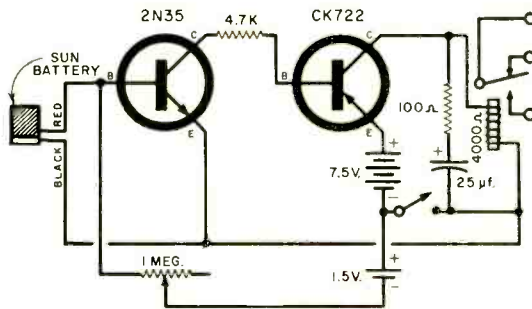

This two-stage direct-coupled circuit offers high sensitivity in photocell applications. A 1-megohm pot is included for sensitivity adjustment over a wide range. The relay is a sensitive Advance Type SO/1C/4000D or equivalent.

By
**WALTER F.
VALAIKA**



Radio Triggers Street Lights

EVERY DAY at dusk in Chicago, millions of lumens of light burst into action, illuminating the State Street shopping district. The State Street system utilizes radio control for the automatic switching of street lights.

Similar radio techniques are now being used to control traffic lights in several major U. S. cities, but Chicago is the first to employ them to turn street lights on and off at desired times.

The radio control equipment handles the simultaneous switching of all the lights and eliminates the necessity for costly tearing up of pavement to install new ducts and conduits for wired control circuits.

Designed by General Electric, the system consists of a master controller base station (transmitter), centrally located in a department store building, and receiving units located in the bases of 28 light poles. The control system turns all lights on at dusk, turns some lights off at midnight, turns the balance of the lights off at dawn, and turns special decorative festoon-lighting circuits on and off at any chosen time.

In the base station, there is a 30-watt transmitter and an astronomically calibrated timer and control panel which automatically advances or retards the lights accordingly. A code sender panel selects a particular switching operation, keys the transmitter, and produces an audio-frequency pulsed-tone code which modulates the transmitter carrier.

The receivers in the bases of the light poles, and the circuit breakers and heavy-duty contactors (which perform the actual switching operations), have heaters to protect them from freezing weather and moisture. Special weather-proof adapters were made to mount whip antennas to the pole tops.

-30-

Language Teleprinter

Chinese

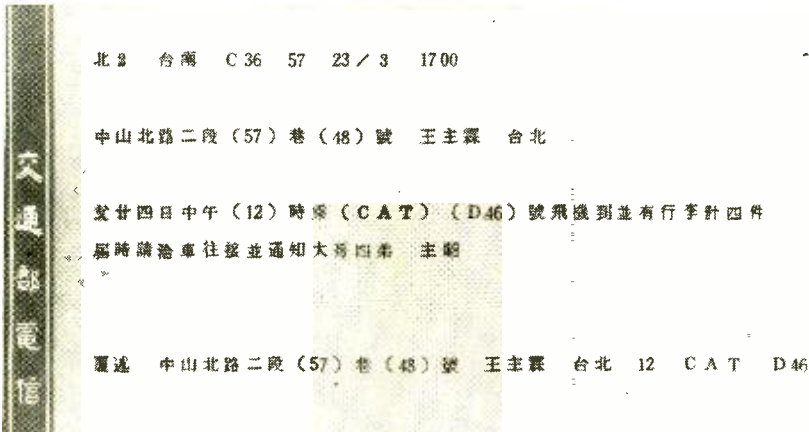

The development of a Chinese Teleprinter marks a new era in the history of Chinese telegraphic communications, allowing the Chinese language to enjoy the same technical advantages as Western languages in the telecommunications field. Containing 4300 selected Chinese characters in addition to the English alphabet, numerals, and punctuation, the teleprinter utilizes International Standard five-unit code teletype impulses.

Since the inauguration of Chinese telegraphic communications in 1882, the Chinese characters, a selection of approximately 8000 of them, have been transmitted over the line by means of four-digit figure representation. For instance, the Chinese character for "home" is transmitted by the four-digit number "1367"; the receiving end then decodes the figure into its corresponding Chinese character, according to a code book published by the Ministry of Communications. This code book has been recognized by the International Telecommunication Convention as a means of telecommunication in the Chinese language.

The new teletype transmitter has the same keyboard that an English language machine has. Only numerical keys are used for Chinese language telecommunication.

Magnetic Plastic

This flexible magnet developed by B. F. Goodrich for refrigerator door seals proves its drawing power by holding king-size paper clips. The new lightweight magnetic material has twice the permanency of many conventional rigid magnets. It should find thousands of uses in many products—from toys and novelties to home appliances.



POPULAR ELECTRONICS

UNDER the hood of your car is a high-voltage pulse generator consisting of only a few simple parts. During high motor speeds, as many as 48,000 pulses are generated every minute with a peak amplitude as high as 30,000 volts. This is the ignition system of your car's engine. If it is properly adjusted, the engine will operate at peak efficiency, start easily, and run economically. Improperly adjusted, as much as 20% of your gas will be wasted, and generally poor performance will result. Or even worse, your car will not start at all.

It is surprising that some people will go to great lengths to keep their appliances, TV sets, hi-fi's, etc., working as efficiently as possible, yet will balk at the equally simple task of adjusting their car's igni-

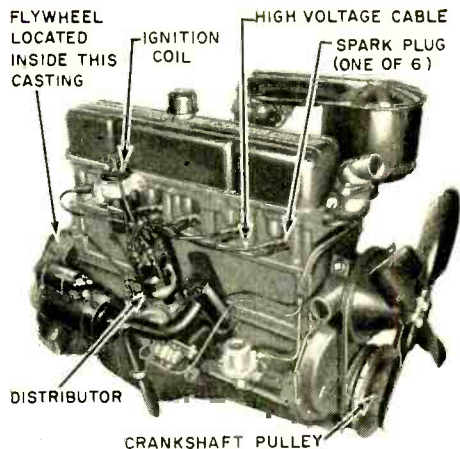

Fig. 1. 1959 Chevrolet six-cylinder engine.

TUNE UP Your Car's IGNITION SYSTEM

tion system. The parts required can be purchased in kits from local auto parts stores or mail order houses like Sears-Roebuck. Replaceable parts of a distributor, for example, cost three dollars or less, depending upon the make of the car. When compared with the price charged by garages for an ignition tune-up, it is easily seen that a do-it-yourself tune-up can save a handy hunk of cash.

The complete ignition system tune-up consists of replacement of the contacts, condenser, rotor, and cap, and the gapping and timing of the points in the distributor. This should be done, of course, only after the spark plugs have been replaced or cleaned and gapped.

Parts and Functions. Before you can begin your ignition tune-up, you must be able to recognize the various parts and their location on the engine. Figures 1 and 2 point out the ignition system parts on typical 6-cylinder and 8-cylinder engines. Figure 3 shows a top view of a distributor with the cap and rotor removed, and also a cross-section view of a complete distributor. The distributor shown is for a 6-cylinder engine since the cam (5 of Fig. 3) has six sides. The cam for an 8-cylinder engine has eight sides.

The ignition system has two functions:

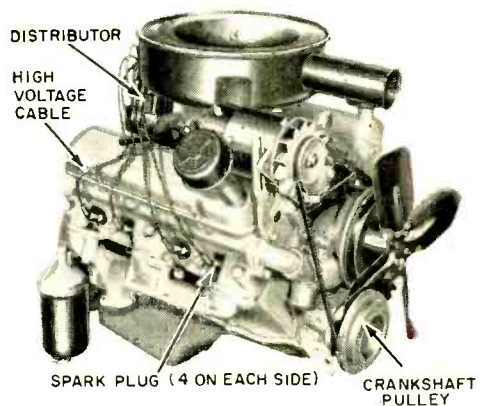

Fig. 2. 1958 Pontiac eight-cylinder engine.

You can bring your gasoline bill down by following these simple instructions

By **JOSEPH TARTAS, W2YKT**

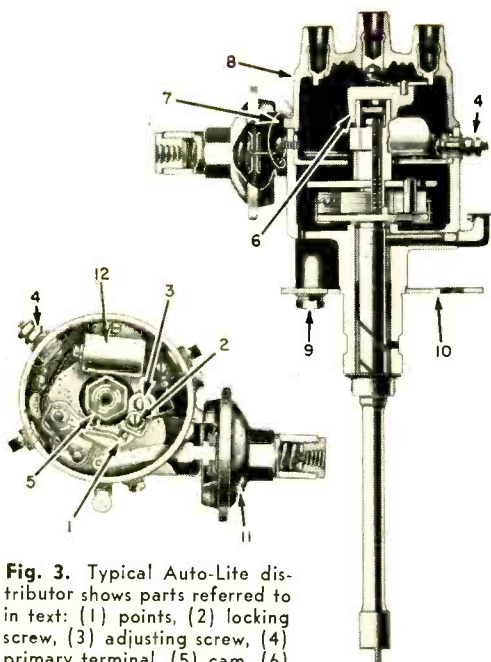

Fig. 3. Typical Auto-Lite distributor shows parts referred to in text: (1) points, (2) locking screw, (3) adjusting screw, (4) primary terminal, (5) cam, (6) rotor, (7) cap retaining spring, (8) cap, (9) plate adjusting screw, (10) adjusting plate, (11) vacuum advance mechanism, and (12) condenser.

it converts the low d.c. of the battery to high-voltage pulses and it delivers these pulses to the spark plugs at the proper instant in the engine cycle. The gas-air mixture in the cylinders is then ignited in proper sequence for best engine performance.

When the points close, as in Fig. 4(A), the battery is connected to the primary winding of the ignition coil and a magnetic field builds up. When the points open, as in Fig. 4(B), the magnetic field collapses, and the high voltage induced in the secondary winding jumps the gap in the spark plug. The minimum voltage required to jump the gap is about 4000 volts. However, the ignition system usually produces around 25,000 volts to insure a good spark.

The condenser across the points (Fig. 5) provides a path for the current while the points are opening, thus quenching the spark due to the coil inductance to prevent excessive burning and pitting of the points.

The action of the distributor (Fig. 6) is the same for each spark plug. The internal rotor supplies the high voltage to one spark plug at a time, in the proper sequence. This is done by connecting the distributor

shaft on which the rotor is attached to the engine via a gear drive. The rotor advances to each contact in the distributor cap in the engine firing order. Cables connect these contacts to the spark plugs.

Removing the Distributor. Since few manufacturers place the distributor where it can be worked on easily, it's advisable to remove it from the car and take it to your workbench.

The first step in removing the distributor is to unsnap the two clips holding the distributor cap. Push the cap out of the way, being careful not to pull out any high-voltage cables. Using a small wrench, back out the nut that connects the copper tubing to the vacuum advance mechanism on the side of the distributor. (See Fig. 3.) Pull out the flared end of the tubing, being careful not to bend it excessively.

Now remove the wire connected to the primary terminal of the distributor (Fig. 3). Loosen the adjusting plate that fastens the body of the distributor to the engine block. Note the position of the rotor and make a scratch on the distributor case opposite the end of the rotor. (This step is very important for the re-installation of the distributor.) Then remove the distributor by pulling it away from the block, twisting it back and forth slightly at the same time. The replacement of the points may now be done at the workbench.

Replacing the Points. Pull off the rotor and discard it. Loosen the screw or nut connecting the condenser lead. Remove the condenser lead and wire from the primary terminal (Fig. 3). Remove all the screws holding the condenser and points in place. Then, take out the condenser and points

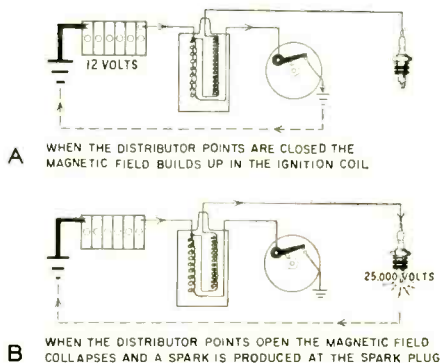

Fig. 4. The distributor points function as a switch in the ignition coil circuit to generate high-voltage pulses.

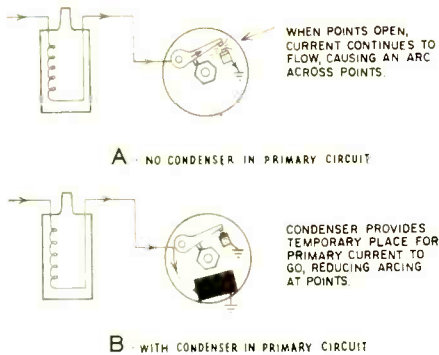

Fig. 5. Distributor condenser reduces arcing and thus increases useful service life of points.

and discard both. You are now ready for the new points and condenser.

Points are installed in reverse order to the removal procedure. Insert the locking screw to hold the points in place. Tighten the screw until it is snug, but not tight. Put a drop of oil on the shaft over which the points fit. Make sure the contacts align properly, as shown in Fig. 7, bending only the stationary contact support (if necessary) to make this adjustment.

The old condenser usually held down by a single screw should now be replaced. Be sure the new condenser is correctly positioned by seating guides. Attach the condenser lead and wire from the primary terminal to the same screw as the spring of the moving point and tighten. Smear a small amount of *high-melting-point* grease on the cam where the insulating block rides. (See Fig. 8.) This reduces block wear and increases contact life. The reassembly of the points and condenser is now complete.

Adjusting the Gap. Turn the shaft until the insulating block is on one of the high points of the cam, and the gap between the points is at its widest mark. By turning the eccentric adjusting screw (Fig. 8), you can now vary the gap. With a wire gauge between the points, turn the adjusting screw until the gauge drags slightly as it is moved back and forth in the gap. The size of the gauge will be determined by the make and year of your car (see chart on page 92). Now, gradually tighten the locking screw. If the gauge binds, readjust until it drags when the locking screw is tight.

If the stationary contact on the points

is a screw, the same procedure may be used to set the gap, except that the adjustment is made by turning the screw, then tightening the lock nut. For dual points, set and lock each point individually. Run a strip of clean cloth between the contacts to remove any grease or oil that might cause burning of the new contacts.

Put *one drop* of oil on the felt in the end of the shaft. Install the new rotor by placing it over the distributor shaft in the proper position and pressing it into place. Note that the rotor is keyed to fit in only one way.

Replacing the Distributor. Align the rotor with the scratch mark on the distributor which was made when the old rotor was removed. Using a back-and-forth motion, push the distributor back into place. If there is a gasket between the distributor and the engine block, check it for alignment and condition. Make sure the wire connecting to the primary terminal is not touching metal.

Now use your starter to turn the motor

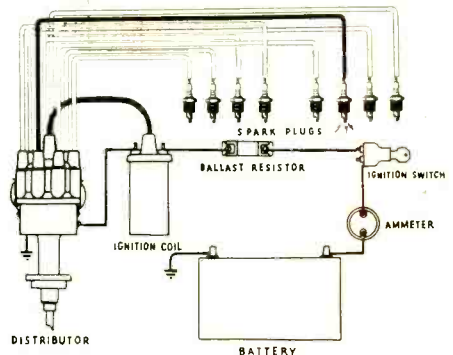

Fig. 6. This ignition system is for a standard eight-cylinder car.

over. Timing marks will be seen on the crank shaft pulley as it turns, or in some cars a small ball will appear in a window near the flywheel at the rear of the engine. Often, this window or hole is near the starter motor. The crank shaft pulley is located directly below the cooling fan.

A fixed pointer is mounted over the crank shaft pulley to indicate the timing mark position—when the markings are on the crank shaft pulley. These marks indicate the number of degrees before or after top dead center. When the proper mark is near the pointer, a quick flick of the starter will cause a slight advance. If necessary,

PLUG GAP AND POINT GAP CHART

Make	Plug Gap	Point Gap	Make	Plug Gap	Point Gap	Make	Plug Gap	Point Gap	Make	Plug Gap	Point Gap
BUICK			1956-57 All	.035	.017	MERCURY			1957 All (exc. V-8 Fury)		
1946-52 All	.025	.015	1938 All	.035	.016	1939-48 All	.025	.015	1958 All	.035	.020
1953-54 Ser	.025	.015	1959 All	.035	.017	1949-54 All	.030	.015	1959 6 Cyl. V-8	.035	.020
1953-55 V-8	.032	.015	DODGE			1955-56 All	.034	.015	PONTIAC		
1956 All	.032	.015	1946-55 All 6 Cyl. (Reg.)	.030	.020	1957 All	.034	.015	1934-49 6 Cyl.	.025	.020
1957-59 All	.032	*	(Resistor)			1958-59 All	.032	.015	1934-37 8 Cyl.	.025	.018
CADILLAC			1953-55 V-8 (Reg.)	.030	.017	NASH			1938-49 8 Cyl.	.025	.015
1946-48 All	.030	.015	(Resistor)			1941-49 All	.025	.020	1950-53 6 Cyl. 8 Cyl.	.025	.022
1949-52 All	.035	.015	1956 All 6 Cyl. (Reg.)	.030	.017	1950-54 All (exc. Metropolitan)	.030	.020	1954 All	.025	.016
1953-55 All	.035	.016	(Resistor)			1954-56 Metropolitan	.025	.020	1955-56 All	.025	.016
1956-59 All	.035	*	All V-8	.035	.020	1955 Statesman	.030	.022	1957-59 All	.035	.016
CHEVROLET			1957 All	.035	.017	1955 Ambassador, 6 Cyl. V-8	.030	.022	RAMBLER		
1941-48 All	.040	.018	1958 6 Cyl.	.035	.017	1956 Ambassador, Packard V-8	.035	.017	1953-55 All	.030	.020
1949-52 All	.035	.018	Coronet and Royal	.035	.017	Nash V-8	.030	.016	1956 6 Cyl. V-8	.030	.016
1953-55 All (exc. Corvette)	.035	.016	Sta. Wag.—Cust. Royal	.035	.020	1956 Statesman	.030	.016	1957-59 All	.030	.016
1953-54 Corvette	.035	.015	1959 6 Cyl. V-8	.035	.017	1957 All	.030	.016	STUDEBAKER		
1955 Corvette	.035	.018	EDSEL			1937-50 6 Cyl.	.040	.020	1942-50 All	.025	.020
1956 All	.035	.016	1958-59 All	.035	.015	1937-54 8 Cyl.	.030	.015	1951-54 6 Cyl.	.025	.020
1957-59 6 Cyl. V-8	.035	*	FORD			1955 All	.030	.016	1951-55 V-8	.035	.015
CHRYSLER			1938-48 All	.025	.015	1956-59 All	.030	*	1955-59 6 Cyl.	.030	.020
1946-53 6 Cyl. (Reg.)	.030	.020	1949-51 All 6 Cyl.	.030	.025	PACKARD			1956 Golden Hawk	.035	.016
8 Cyl. (Reg.)	.030	.018	1952-54 All V-8	.030	.015	1937-49 All 6 Cyl.	.028	.020	1956 All Other V-8	.035	.015
All (Resistor)	.035	.017	1954-56 All V-8	.035	.015	1937-50 (Early) All 8 Cyl. (110 mm.)	.028	.020	1957 All V-8	.035	.015
1954 All 6 Cyl. (Reg.)	.030	.020	All V-8	.035	.025	1950 (late) All (114 mm.)	.025	.015	1958-59 V-8	.035	.016
(Resistor)	.035	.020	1955-57 All 6 Cyl.	.034	.015	1951-54 All	.025	.015	WILLYS		
All V-8 (Reg.)	.030	.017	1957-59 All	.034	.015	1955-56 All	.025	.016	1941-45 Military Jeeps	.030	.020
(Resistor)	.035	.017	HUDSON			1957-58 All	.035	.015	1942-59 All	.030	.020
1955 All (Reg.)	.030	.017	1938-56 All 6 Cyl.	.032	.020	PLYMOUTH					
(Resistor)	.035	.017	1938-52 All 8 Cyl.	.032	.017	1946-56 All 6 Cyl. (Reg.)	.030	.020			
1956-59 All	.035	.017	1955-57 All	.035	.016	(Resistor)	.035	.020			
DE SOTO			LINCOLN			1955 V-8 (Reg.)	.030	.017			
1946-55 All 6 Cyl. (Reg.)	.030	.020	1940-48 All	.025	.015	(Resistor)	.035	.020			
(Resistor)	.035	.020	1949-52 All	.030	.015	1956 All V-8	.032	.017			
1952-54 All V-8 (Reg.)	.030	.017	1953-57 All	.035	.015	(Resistor)	.035	.017			
(Resistor)	.035	.017	1958-59 All	.035	.015	1956 All V-8	.035	.017			
1955 Fire dome V-8, Fireflite	.035	.017									

*For "External Adjustment," insert hex wrench through window, turn screw clockwise until engine misfires, then turn counterclockwise 180°.

EDITOR'S NOTE: Space prevents listing of all years and all models. Check with your dealer for point gap and plug gap settings if your car is not listed.

turn the motor over several times until it is within two degrees of the recommended setting.

Connect a timing indicator to the primary terminal of the distributor and the primary lead which normally connects to the terminal. Turn the ignition switch on. The timing indicator will now light up. Next turn the distributor case until the indicator light goes out, showing that points have just opened.

The distributor should now be tightened to the engine by its mounting clamp or plate. Make certain the setting does not change as this is done. Then turn the ig-



niton switch off. This completes the timing itself—now all you have to do are the “finishing operations.”

First, reconnect the tubing to the advance mechanism and tighten the nut. Then disconnect the timing light and reconnect the wire to the primary terminal. After installing the new distributor in the car, make sure that all cables are firmly inserted into the corresponding holes of the cap being replaced. This is very important. If done incorrectly, the motor will run very roughly if it starts at all.

New Type of Distributor. Beginning in 1957, GM adopted a new type of distributor for its V-8's which uses a pre-assembled point assembly with the spring

tension, point alignment, and gap factory-adjusted. A trap door (Fig. 9) in the side of the cap allows a “hex” wrench to be inserted to adjust the timing with the motor running, and eliminates the need for timing marks and indicators.

To remove the cap, insert a screwdriver in the slot head of the latch, press down, and turn one-quarter turn either way. The

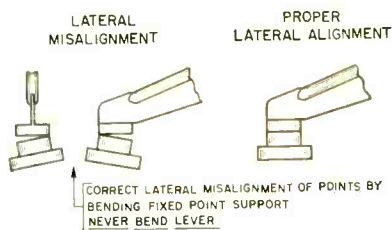
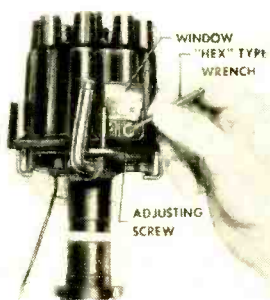

Fig. 7. Improper point alignment will result in excessive burning, pitting, and uneven point wear.

Fig. 8. Points are adjusted for proper gap width with a screwdriver and a wire gauge. See text for details.

Fig. 9. Adjustment of late-model GM distributor (below) is easy. It is partially factory-adjusted.



point adjustment may be made with the indicator lamp at the workbench or in the car. Turn the screw in until the lamp goes out, or until the motor begins to miss (if it is done with the motor running), and then back it out one-half turn. This completes the gap and timing adjustment simultaneously. Replacement of the point assembly and condenser is the same as in

(Continued on page 135)

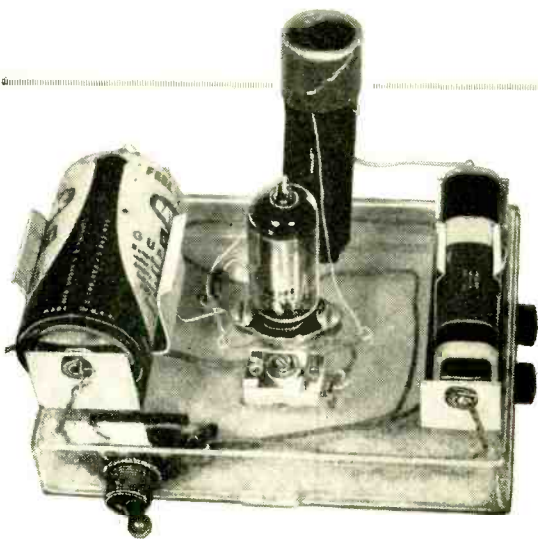

Stereo Phono Oscillator

YOU haven't had an opportunity to get your feet wet in the stereo swim? Here's an easy way to do it at a total cost of only \$12.00 or so, which includes an inexpensive ceramic or crystal stereo cartridge.

The trick is to use a phono oscillator for broadcasting the second stereo channel to a nearby AM radio. All you have to do is replace your present cartridge with a stereo model and run the extra stereo signal leads to the oscillator unit.

Find a dead spot on your radio dial and tune the oscillator to it. Place the radio for the best stereo effect. Quality of reproduction is of course limited by the radio used.

The oscillator unit is built on a small plastic case, with the battery holders, tube socket, capacitor and coil form all mounted on the hinged lid. Wiring is straightforward, with all leads as short as possible. The coil is hand-wound on a $\frac{5}{8}$ " plastic or fiber form, using #30 enameled wire.

Output of the oscillator is through a short length of wire. When it is brought into the vicinity of an AM radio, signal pickup will take place over a frequency spread of about 1100 to 1500 kc.

-30-

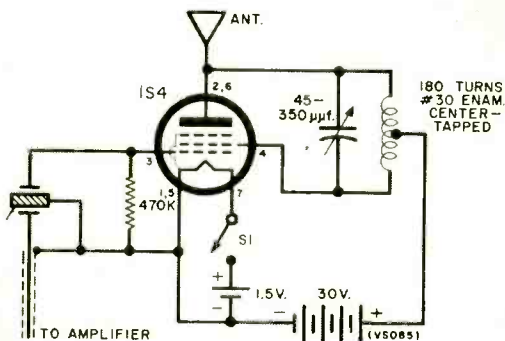

By JOSEPH ELKHORNE

POPULAR ELECTRONICS

Builds a

4-Band Regen Receiver

*Easy to assemble,
the Knight-Kit Span Master
tunes in a new world
of listening adventure*

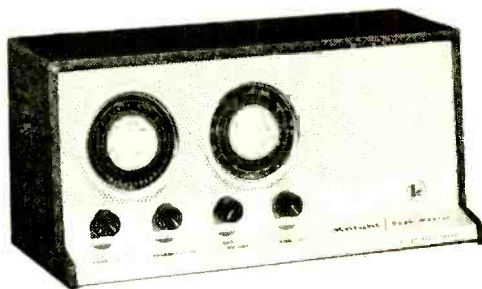

THE Knight-Kit "Span Master" four-band kit (Allied Radio, 100 N. Western Ave., Chicago 80, Ill.) is an ideal receiver for the SWL'er who gets a kick out of DX'ing stations with a two-tuber.

The received signal is detected and amplified in the 6BZ6 tube. A portion of the signal is taken off the screen of the 6BZ6

large pictorial diagrams direct your every move. All parts, including precut wire and solder, are included in the kit.

Operation of the receiver is slightly different from that of a superhet. After the bandswitch is set to the frequency range desired, slowly turn the regeneration control clockwise until a whistle is heard, then

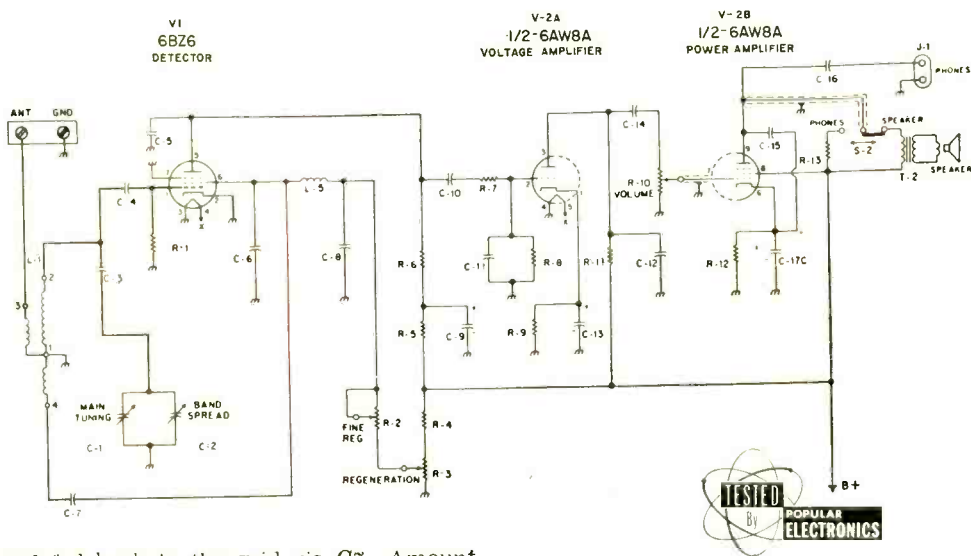

and fed back to the grid via C7. Amount of feedback or regeneration is controlled by REGEN and FINE REGEN potentiometers which raise or lower the screen voltage. A 6AW8A combines the functions of audio amplifier and power output tube.

Assembly procedure is a marvel of simplicity. Step-by-step instructions and extra

stop. Turn the main tuning dial until a very low pitch sound is heard. Then turn the regeneration control counterclockwise until the hissing stops and the station comes in loud and clear. The fine regen control is for critical settings.



Customize Your Kits

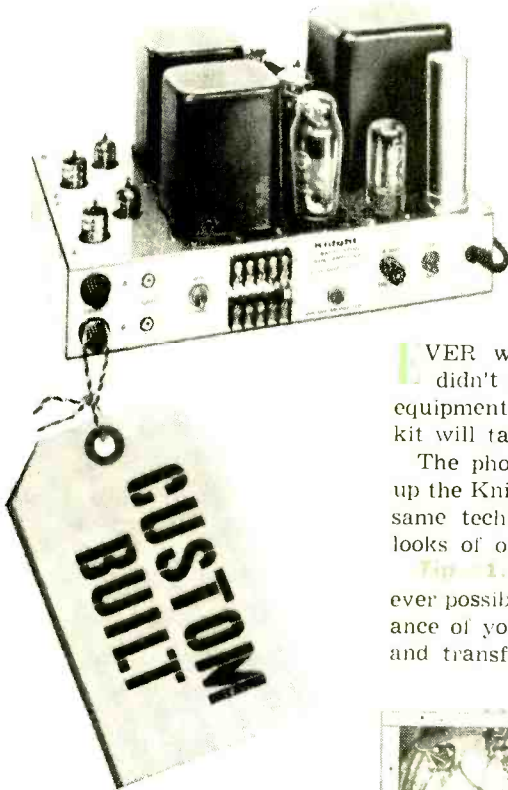

EVER wonder why your latest kit project didn't look as neat as a piece of commercial equipment? Follow these tips and your next kit will take on that factory-built appearance.

The photos show what can be done to jazz up the Knight-Kit 60-watt stereo amplifier. The same techniques can be used to improve the looks of other units.

Tip #1. Cable groups of wires together whenever possible. Nothing will improve the appearance of your kit more than neatly laced wires and transformer leads.

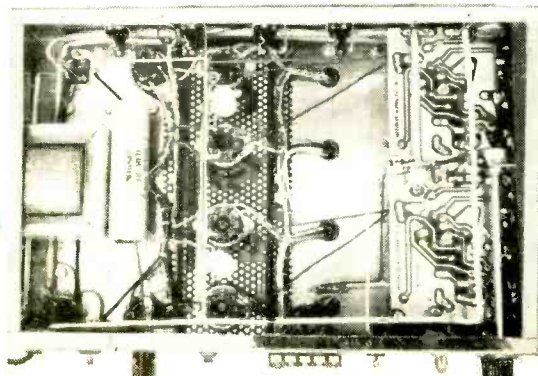
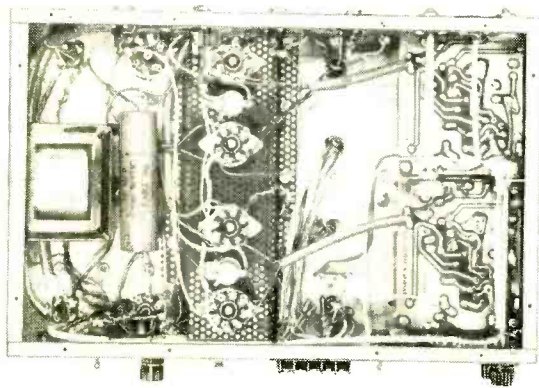

Cabling helps to minimize the tangle of wires under the chassis. Compare chassis which has been wired conventionally (at right, above) with chassis wired using cabling techniques (below). "Square-corner" wiring also improves the under-chassis appearance.

Here are some tips that will help give your next kit

that finished professional look

By **DONALD L. STONER**, W6TNS

Tip #2. When you are working with printed circuits, mount all components before soldering. Then, after bending the leads sharply to keep them in place, cut them just above the eyelets. The solder will cover the joint and give the board the appearance of having been dip-soldered.

Tip #3. After a printed-circuit board has been completed, use a stiff toothbrush and solvent to remove the soldering flux. This will cause the conductive sections of the printed circuit to stand out.

Tip #4. Remove varnish and wax from small parts such as chokes, etc. Then shine 'em up with steel wool and apply a protective coat of clear plastic lacquer to prevent rusting.

Tip #5. Position resistors so tolerance bands all point in the same direction. Mount capacitors so that their values may be easily read.

Tip #6. If the chassis of your kit isn't chrome-plated, don't forget that a chrome job does wonders for a chassis. —30—

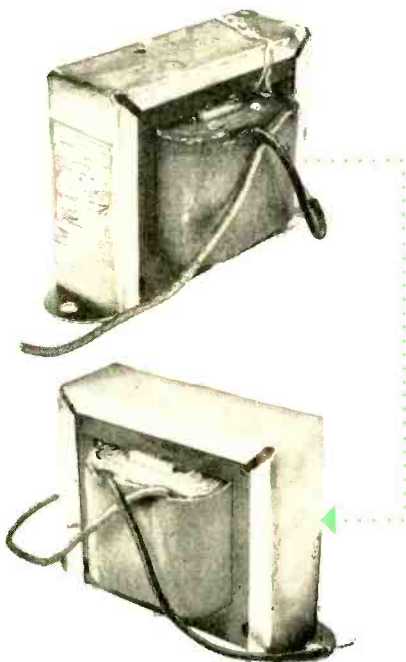

It's the little things that count! Top photo above shows choke as it was received from the manufacturer; below it is the same choke after varnish has been removed and case has been polished with steel wool.

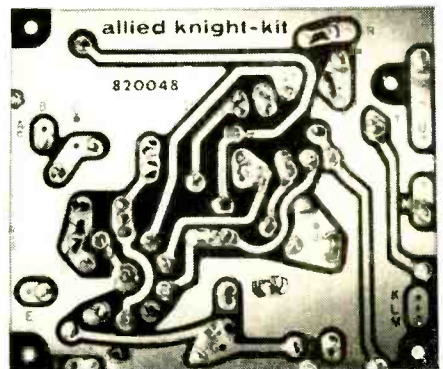

Printed-circuit boards look better if solder completely covers the joints and excess flux is removed with a toothbrush and solvent.

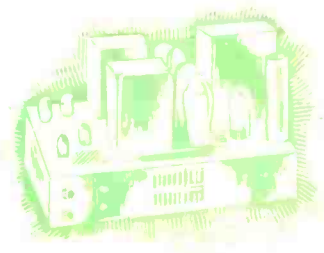

Magnetize Your Tools

...with this easy-to-build unit

By JOHN SHIELDS

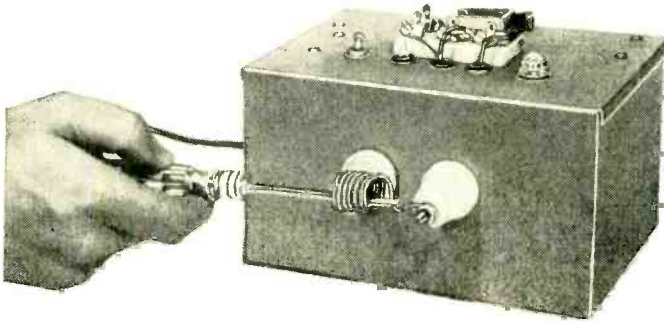

THERE are many times when the experimenter has need of a simple, effective magnetizer for screwdrivers, nut drivers, PM speaker magnets, various small parts, etc. The unit described here works on the same principle as the large commercial magnetizers, and will completely saturate a small block or slug of Alnico 5. It is quite simple in construction and, even if all new parts are used, the cost is under \$15.00.

The principle of operation involves the gradual charge of one or more large capacitors from a d.c. source through a comparatively large resistor, then the discharge of the capacitors through a low resistance coil

in which the work to be magnetized is placed. When the capacitors are discharged, a tremendous surge current (several hundred or more amperes) will pulse through the coil, generating a brief but intense magnetic field.

Construction Tips. The magnetizer is simple enough to be "breadboarded" but the author's model was built into a small aluminum cabinet. While the unit will perform just as well if powered directly from 117-volt lines, the use of an isolation transformer is preferred to eliminate shock hazard. A silicon rectifier was used because it hap-

pened to be on hand, although a 100-ma. selenium rectifier would be just as satisfactory.

There is one item in the magnetizer that cannot be skipped on. This is the d.p.d.t. knife switch which *must not* be replaced by a toggle switch as the contacts of a smaller switch would probably weld together the first time it was used, due to the extremely heavy surge

currents involved. As many capacitors as desired can be paralleled: the greater the capacitance, the greater the charging current. The capacitors need not be of the same capacitance value as long as they are rated at a minimum of 150 working volts d.c. or higher.

The magnetizing coil should be wound with at least #10 and preferably heavier wire. Four to seven turns of wire should be shaped roughly to the form of the work to be magnetized.

Heavy Current. The king-size feed-through insulators are not really necessary; (Continued on page 136)

PARTS LIST

- C1-C6—150- μ l., 150-volt electrolytic capacitor (connected in parallel)
- F1—1-amp. fuse and holder
- NL1—NE-2 neon bulb
- PL1—#47 pilot light assembly
- R1—100,000-ohm, $\frac{1}{2}$ -watt resistor
- R2—150,000-ohm, $\frac{1}{2}$ -watt resistor
- R3—100,000-ohm, 10-watt wire-wound resistor (adjustable)
- S1—S.p.s.t. toggle switch
- S2—D.p.d.t. knife switch
- SR1—100-ma. selenium rectifier
- T1—Power transformer; secondary 117 volts, 50 ma., 6.3 volts, 2 amperes (Merit P 3045 or equivalent)

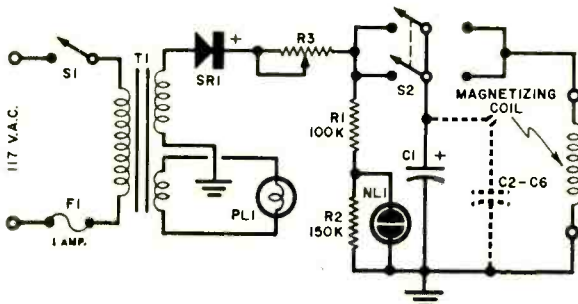

POPULAR ELECTRONICS

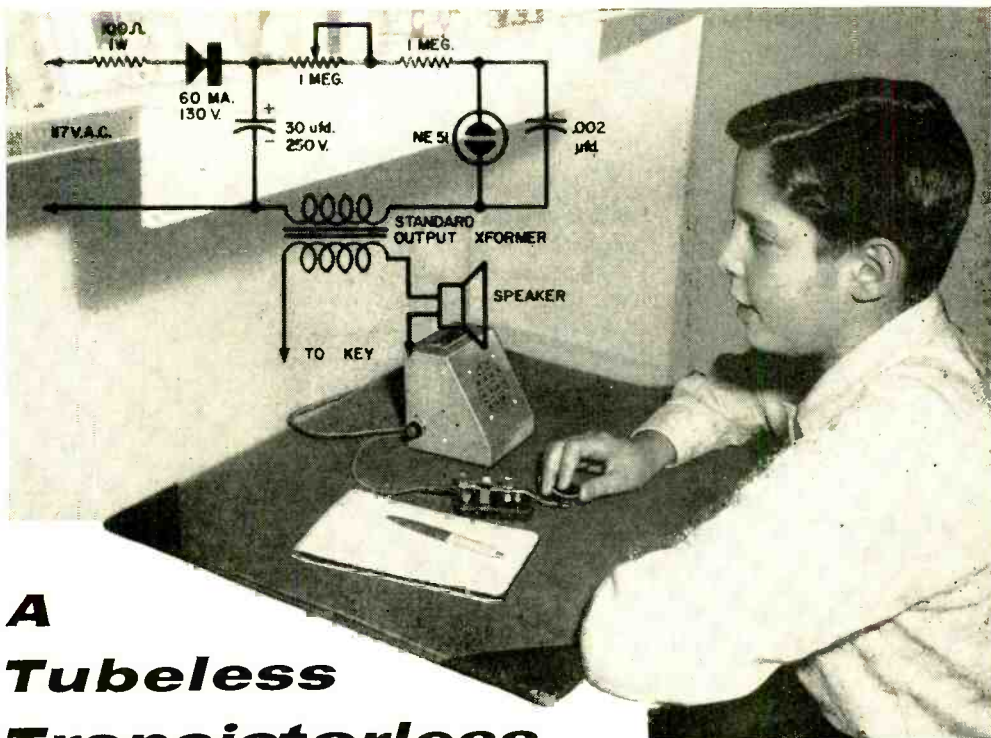

A Tubeless Transistorless Code Practice Oscillator

HERE'S a simple CPO that uses a neon tube relaxation oscillator. It operates without tubes or transistors and has enough output to drive a built-in loud-speaker. And if extra power is needed to serve a code class of a dozen or more people, output to an amplifier can be tapped off across the speaker voice coil leads.

A case intended for use with a 3" meter movement serves as a housing for the unit. Such cases are obtainable with the meter holes already cut out, thus saving you considerable time and labor. A small square of perforated metal or metal window-screening can be placed behind the cutout to serve as a loudspeaker grille.

It is convenient to use one of the so-called "Postlite" neon indicators (manufactured by the Drake Company) for the neon lamp oscillator; this is a plastic unit, threaded for panel mounting, with the neon lamp molded in. Or, you may prefer to use a standard NE-51 along with a socket assembly.

Keying is accomplished by putting a key in series with the secondary winding of

the output transformer. The circuit shown works nicely on 105 to 125 volts a.c. If it is used with d.c. power lines, or with a 90-volt battery, the selenium rectifier and the 30- μ f. capacitor should be eliminated. For power line operation, make sure that no part of the circuit is connected to the cabinet.

No warm-up time is necessary—just plug in the line cord and press the key.

The potentiometer varies the pitch of the generated tone. Parts values given provide a variable-pitch control from about 500 to 900 cps. If you want to experiment with a wider tone range, try other values for the .002- μ f. capacitor and the pot. —30—



By **LEON A. WORTMAN**

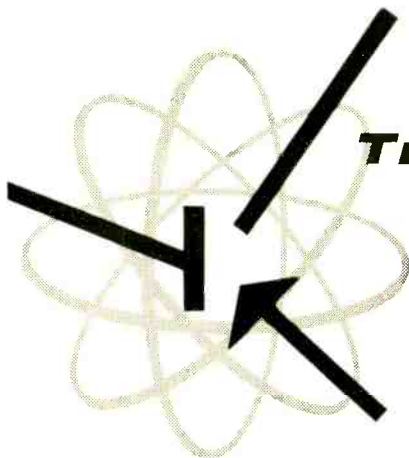

Transistor Topics

By LOU GARNER

RESearch scientists have long sought some electronic or electromechanical method for duplicating the basic functions of animal nervous systems. This goal has been brought a step closer to reality by engineers of the Bell Telephone Laboratories, who have developed a transistorized circuit which simulates the functions of the biological *neuron*. As you may recall, the transistor itself was invented a little over a decade ago at these same laboratories.

In case biology isn't one of your strong points, the neuron is the basic "building block" cell of a human or animal nerve system, including the brain. This cell receives electrical signals developed by receptor cells sensitive to light, heat, or other stimuli and, in turn, delivers an electrical control pulse of fixed amplitude and duration to other cells in the body.

The schematic wiring diagram of a single artificial neuron, designed by Bell scientist R. M. Wolfe, is given in Fig. 1. Using four *p-n-p* transistors, this circuit delivers output pulses of standard amplitude and duration; if driven by a constant excitation signal or "stimulus," it develops a train of pulses, with the pulse frequency or repetition rate directly proportional to the intensity of the input signal.

As in a biological neuron, the input excitation must exceed a minimum threshold value; however, the circuit will integrate two or more input pulses, each of which is below the threshold value, and will "fire" on the combined signal. Provision is also made for applying an "inhibitory" signal which prevents the circuit from responding to other inputs. This permits a group of cells to be connected together in such a way that a very strong signal applied to one cell prevents the other cells from responding.

The circuit simulates a biological neuron in still another way; immediately after responding to a signal pulse, its threshold level rises almost to infinity, so that it will not fire on additional input pulses for a few milliseconds.

Fig. 1. Transistorized "nerve" cell circuit developed at Bell Telephone Laboratories.

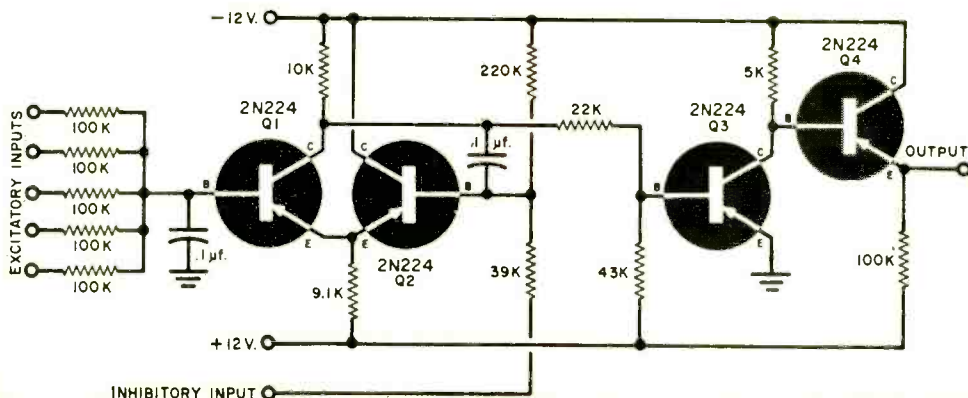

Physically, the electronic neuron circuit is assembled on a 3" x 4" printed-circuit card designed for plug-in mounting. This simplifies the assembly of groups of cells into networks roughly analogous to nerve systems in animal and human organs.

For example, several cells may be combined with photosensitive semiconductors to simulate simple functions in the eye's retina. Here, the photocells take the place of the light-sensitive rods and cones found in the eye and serve as receptors for the

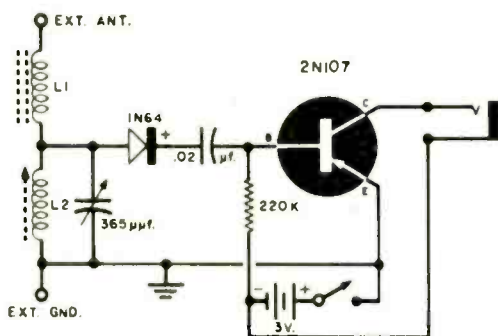

circuits may be designed which can duplicate the functions of every basic cell found in an animal's body.

If these "cells" are manufactured using the microminiaturization techniques discussed in an earlier column, it may become possible to assemble an electronic computer which duplicates the sensing and thinking processes of a human being.

Readers' Circuits. This month we are featuring another pair of those ever-popular single-transistor receiver circuits. Designed for reception of the AM broadcast band (550-1600 kc.), the circuit shown in Fig. 2 was submitted by readers Jay Evilsizer (2257 Fairway) and George Aspbury (2344 Fairway), Birmingham, Mich. Easily

Fig. 2. Single-transistor receiver circuit for the 550-1600 kc. broadcast band submitted by Jay Evilsizer and George Aspbury.

neuron circuits. As in the eye, some receptors, known as "on" receptors, trigger the neuron only when the light intensity they receive is increasing; "off" receptors fire only when the light is decreasing; and, finally, "during" receptors fire only when they are receiving a steady light.

Some cell combinations have permitted flicker-fusion phenomena to be duplicated. Known as "persistence of vision" in the human eye, this causes a sequence or train of flashes to be seen as continuous illumination. It is this characteristic of vision, of course, that makes motion pictures and television possible.

Eye nerve system operation is not the only bodily function that has been duplicated electronically using transistorized "nerve" cells. Other experiments are being conducted with nerve system models simulating the operation of the ear.

The immediate goal of these experiments is to learn more about the functioning of visual and auditory nerve systems and, more specifically, how the signals developed by these systems are interpreted by the brain. The knowledge derived from this research may lead to better and more economical communication systems. On a long-term basis, it is conceivable that other

Fig. 3. Reader Peter James, WV6CVT, contributed this short-wave receiver circuit.

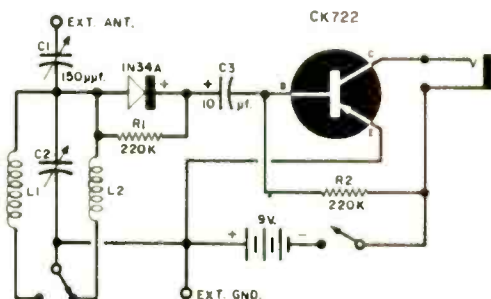

assembled in a single evening from standard components, this receiver, according to Jay and George, has better selectivity and sensitivity than is usually found in single-transistor sets. They report picking up broadcast stations up to 15 miles away with "ear-splitting" volume, and without using an external antenna or ground connection.

Referring to the schematic diagram, L1 is a ferrite antenna coil (Lafayette No. MS-330) and L2 is a variable loopstick (Lafayette No. MS-299). The on-off switch can be omitted entirely if you prefer, since current drain is very low when the earphones are unplugged. The receiver can be used with any moderate or high impedance magnetic earphones. Neither layout nor

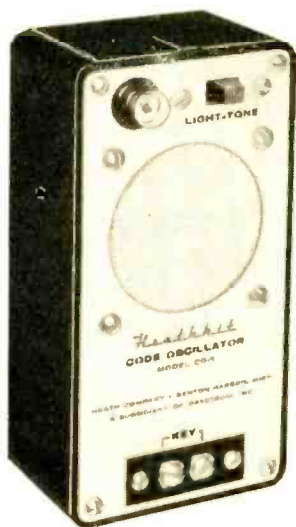

Transistorized code practice oscillator for the beginning amateur introduced by Heath in kit form.

lead dress should be critical, and you can assemble a duplicate receiver on a metal chassis, on an etched-circuit board, or in a small plastic case.

In response to your many requests for simple short-wave receiver circuits, another such circuit is given in Fig. 3. Submitted by reader Peter James, WV6CVT, (4801 Thor Way, Carmichael, Calif.), this set is designed for use with a moderately long outside antenna and a good ground. According to WV6CVT, he's had good luck in picking up other amateur stations in Arizona and Nevada with standard 1000-ohm magnetic earphones.

Capacitor *C1* may be either a fixed mica or ceramic instead of the variable unit shown; a variable capacitor is preferred, however, as this permits "trimming" the antenna circuit for maximum sensitivity

and selectivity. *C2* is a standard 100- μf . tuning capacitor, but a 365- μf . unit could be used. *C3* is a 12- or 15-volt electrolytic, and *B1* is a 9-volt transistor battery.

Coils *L1* and *L2* are hand-wound to cover the frequency range desired. WV6CVT indicates that he used standard 1 1/4"-diameter coil forms for each, with *L1* consisting of 20 turns of No. 28 enamel-covered wire close-wound in a single layer, and *L2* made up of 14 turns of the same wire. Using a 100- μf . tuning capacitor (*C2*), he found that *L1* provided coverage from 2.8 to 4.1 mc. and *L2* from 4.1 to 7.8 mc. If you wish to cover other bands, use more turns for lower frequency coverage, fewer turns for the higher frequency bands.

In operation, either *L1* or *L2* is connected across *C2*, depending on the coverage desired. Signals picked up by the antenna-ground system are selected by the tuned circuit and detected by the 1N34A. The resulting audio signal is coupled through *C3* to a common-emitter audio amplifier which, in turn, drives a pair of standard magnetic earphones. Depending on the exact characteristics of the transistor used, you may find that some experimentation with *R2*'s value will prove profitable; try values from 100,000 ohms to 1 megohm here, installing the one which gives maximum gain.

Pin-Point Your Troubles. Coyne Electrical School (1501 West Congress Parkway, Chicago 7, Ill.) is now publishing the latest in their series of "Pin-Point" books. Entitled *Pin-Point Transistor Troubles in 12 Minutes*, this volume covers practical servicing techniques, and includes dozens of easy-to-use trouble-shooting charts. Although the book's major emphasis is on techniques of value to the serviceman and technician, experimenters and gadgeteers will find the methods described valuable in "debugging" their experimental projects.

Items of particular interest are a tran-
(Continued on page 134)



Personal-sized six-transistor receiver now available from Argonne features push-pull output to its built-in PM loudspeaker.

After Class

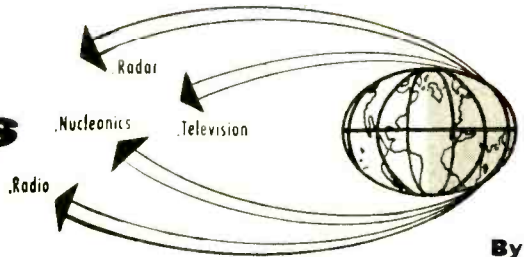

By
SAUNDER HARRIS
WINXL

GROUND, GROUNDS, AND GROUNDED

WHY is a good ground so important? Why are some circuits grounded and others not grounded? What is the physical and electrical meaning of the ground symbol when it appears in a diagram?

Grounding actually means making an electrical connection between a piece of equipment or circuit and the earth, thus bringing the connected point to the earth's neutral potential. There are many ways of accomplishing this. The most common way is by connecting the equipment to a cold water pipe by means of a wire and a metal grounding clamp.

Why specifically a *cold* water pipe? Well, a cold water pipe goes directly to the outside water line which is buried in the earth. A hot water pipe is connected to a furnace or hot water heater and is not a direct ground connection.

Another way of making a ground connection is by connecting the equipment to a metal rod which has been driven deep into the earth. The metal rod is called a ground rod and, to be effective, should go at least eight feet into the ground. A properly installed ground rod is shown in Fig. 1.

If you check your TV antenna, you may find that a ground rod is part of the installation, as is a lightning arrestor. Should lightning strike the antenna, it would find an easier path through the lightning arrestor to the ground rod, and thus into the earth, than through your house.

A Good Ground. Whether or not a ground is "good" is determined by the amount of ohmic resistance between the ground rod, or other means of grounding used, and the earth. The less this "earth resistance," the better the ground. The actual resistance measurement is made with an instrument called a megohmmeter which applies a high voltage to a resistance and then measures the current flow.

There are many factors that determine the earth resistance. Some of the more important are:

1. Moisture content of the soil surrounding the grounding element.
2. Composition of the soil. For example: clay is a good contact, rock a poor one.
3. Temperature of the soil.
4. Size, shape, and number of the grounding elements buried in the earth. The more element area in contact with the soil, the better the ground.

Circuit Grounds. The ground in an electrical circuit is the circuit's electrical reference point. Normally when something is "above" ground, it is positive, since the negative side of the circuit is usually grounded. There are times, however, when

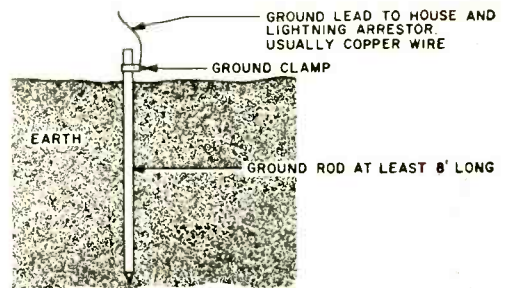

Fig. 1. Ground rod system of grounding is good if the rod is driven well into some moist earth.

the positive side is grounded, as in some of the new 12-volt automobile electrical systems. In such cases, the potentials would be considered negative or below ground. Before installing mobile equipment in a car, it is important to determine whether the positive or the negative terminals of the battery are grounded.

When a circuit is grounded and the cir-

cuit diagram shows various parts to be at ground potential by the ground symbol, it means, in effect, that these parts are electrically connected. This is generally done by using the chassis as a common grounding point and then connecting the chassis to an external ground.

Equipment is grounded as a safety measure as well as for proper operation of the circuit. If a ground connection is made to the chassis, possibility of shock through contact with the chassis is eliminated since

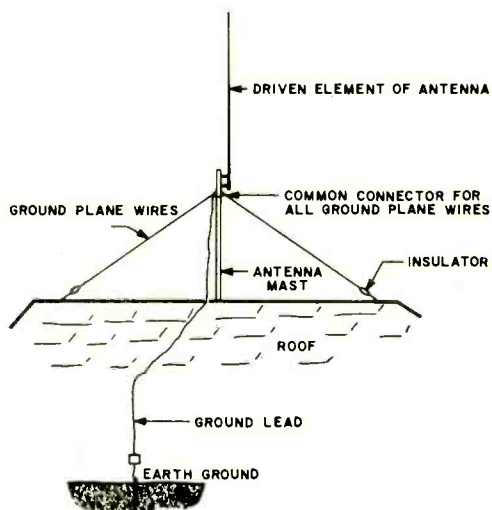

Fig. 2. Ground plane system is useful when an antenna must be installed at a distance from an external ground.

both you and the chassis are at "ground potential."

There are some circuits, in which the chassis is "hot," that should never be grounded. A common example of equipment which should not be grounded is the typical a.c.-d.c. table radio. The instructions which come with these sets generally state, "Caution: Do not connect a ground wire to this set." Since you may have either ground potential or 117 volts a.c. on the chassis (depending on which way you insert the a.c. plug into the power line), these inoffensive-appearing little sets should be handled with due respect, and never be operated outside of their insulated cabinets without taking proper precautions.

Grounds and Antennas. An antenna is nothing more than a conductor whose specific job is to radiate or receive electromagnetic energy. Very often in ham radio

the same antenna serves for both transmitting and receiving through the use of a switching arrangement. In this discussion we shall limit ourselves to the role that the earth, or ground, plays in the functioning of the antenna system.

Although antennas are sometimes discussed without taking the earth into consideration, we cannot ignore the earth. When the antenna radiates electromagnetic energy, the earth acts as a reflector for energy which is directed in a downward direction. These waves are reflected back by the earth and combine with the waves which have been radiated directly from the antenna.

If the reflected wave and the direct wave are in phase, that is, if their maximums and minimums coincide, they tend to strengthen each other. If they are out of phase, or do not coincide, the reflected wave weakens the direct wave to the point where, if the two waves are 180° out of phase, cancellation occurs. The way the two waves combine depends to a large extent on the relationship of the antenna to the ground beneath it. Is the ground a good conductor or a poor conductor? Is it rocky? Is it wet or dry? Is the antenna high above the earth? All of these factors are important.

Currents are induced in the earth by that portion of the radiated wave which travels along the ground and is known as the ground wave. Valuable energy is dissipated into the earth by the ground wave and every attempt is made to keep ground-wave losses to a minimum. Fewest losses occur when the wave travels over ground which is a good conductor. This is the reason many commercial stations place their antenna systems near water or marsh lands, the water or wet earth being a much better conductor than dry earth.

Where this physical placement is not possible, in order to make the ground around the antenna as conductive as possible, metal rods or mesh screens are buried near the surface of the earth. They extend about one-half wavelength to either side or radially around the antenna. The actual height of the antenna then becomes its height above this ground screen.

Many times it is practical to mount a vertical antenna on the roof of a building at an inconvenient distance from a good grounding point. A ground system is still

(Continued on page 141)



Short-Wave Report

By **HANK BENNETT**
W2PNA/WPE2FT

FOR the DX'er who can resist the temptation of a shady hammock and a mint julep, a dial-spinning session on the higher frequency bands may provide good hunting during August. The summer months are usually the slack season on the lower frequencies, from the broadcast band upwards to around the 49-meter band (540 to 6300 kc.). Thunderstorm activity causes frequent static, which cuts long-distance logging in those ranges. The static is much less on the higher frequencies.

There are those brave souls, however, who will ignore the heat and static, and continue to tune the various bands and faithfully send in monthly reports. But regardless of whether you are a hammock-swinger or a dial-spinner, the late summer is about the best time for you to overhaul your installation. With a new DX season in the immediate offing, you should have every piece of equipment and all accessories in top operating condition.

Check Your Equipment. The receiver and other vacuum-tube equipment should have a complete tube check. This includes preselectors, crystal calibrators, Conelrad monitors and any test or maintenance equipment, as well as your transmitter, if you are a licensed operator. All tubes found to be low in operating efficiency should be discarded. If your receiver is operating much below normal operating efficiency, it might be a good idea to have it thoroughly overhauled and aligned. You might consider returning the receiver to the manufacturer for this work; be sure to write for shipping instructions first, however.

The next step is to check all the wiring. Have all electric plugs in good condition; replace those that are faulty. Extension cords and other wiring should be kept off

the floor where possible. Don't permit any wiring to be placed under rugs where it could become a fire hazard.

Check your antenna and ground connections to the receiver. Make sure that the wire is bright and clean where the insulation has been removed. If it is dirty, it can be cleaned by gently scraping it with a pocket knife or a piece of emery cloth.

Check the lead-in connection to the antenna itself. Be sure each splice is soldered. And make certain that the ground wire connection to the grounding pipe is clean and tight.

By all means protect your equipment with a lightning arrester. Another safety



Royston Lawson, WPE4EB, of Murfreesboro, Tenn., DX's on a Hallicrafters SX-99 and has 89 countries logged. His antenna is a 50' long wire running north-south.

feature would be to install—or have installed—a master switch which, when switched to “Off,” would immediately cut the power from all equipment.

Short-Wave Stationery. Check your supply of report cards and sheets (available from your Short-Wave Editor at no charge) and other necessary items such as logbooks, station listings and reference books, and note paper of course, so that you'll be ready to begin a new season of

digging out the rare ones. The details are now being worked out. Every SWL who registered for a Short-Wave Monitor Certificate will be eligible. If you have not yet sent for yours, don't delay.

Broadcast Station Books. The Foreign Broadcast Information Service has a set of four books available for the DX'er that is an excellent source of station listings. These four books may be purchased in whole or in part. They are known as



The listening post of Don Beebe, Seattle, Wash., features a Halli-crafters SX-99 and an RME DB-23. WPE7AT's antenna is 60' long and 50' high; he also uses a 15' vertical.

DX'ing. Your Editor also has available high-voltage decals, an amateur radio reference sheet, a DX log, and a leaflet explaining preferred methods of sending reports to stations. There is no charge for any of these items.

If you are running low on correspondence stationery, such as report forms, letterheads, envelopes, or QSL's, make sure you have your Short-Wave Monitor call letters printed on them when you reorder. If you have not yet received your own call letters and Short-Wave Monitor Certificate, you'll find the registration form and instructions on page 139. Your own call letters on your correspondence will help identify you and your station.

Incidentally, the Short-Wave Monitor Registration Program being run by POPULAR ELECTRONICS is fast becoming a project of major importance to SWL's. With over ten thousand SWL's already registered, the project is giving the short-wave fraternity the distinction it has long deserved, and promises many worthwhile advantages.

An Achievement Award program is being planned to give outstanding DX'ers formal recognition of their skill and experience in

“Broadcasting Stations Of The World” and the Catalog number is Pr 34.659:957/pt 1 (to pt 4).

All known radio stations in broadcasting service are listed as follows: in Part 1 according to country and city (316 pages), \$1.50; in Part 2 according to frequency (245 pages), \$1.50; and in Part 3 according to station name or slogan (110 pages), \$1.25. Part 4 lists FM and TV stations (124 pages), \$0.75. All stations outside of the Continental United States are included.

Orders for these books should be addressed *only* to the U. S. Government Printing Office, Division of Public Documents, Washington 25, D. C.

Current Reports. The following is a resume of the current station reports. At time of compilation all reports are accurate. Stations often change frequencies and/or schedules with little or no advance notice. Please send all reports to Hank Bennett, W2PNA, Short-Wave Editor, P.O. Box 254, Haddonfield, N. J., in time for them to arrive by the tenth of each month. All times shown here are Eastern Standard and the 24-hour system is used.

(Continued on page 142)

READY FOR A FLYING START



AS A U.S. AIR FORCE PILOT

The Air Force pilot is a man of many talents. He is, first of all, a master of the air—and no finer exists. In addition, he has a background in navigation, airborne electronics and engineering. Then, too, he must show outstanding qualities of leadership, initiative and self-reliance. In short, he is a man eminently prepared for an important technological future in the new Age of Space.

Find out if you can qualify for training as an Air Force pilot. Paste the coupon below on a postal card and mail it now.

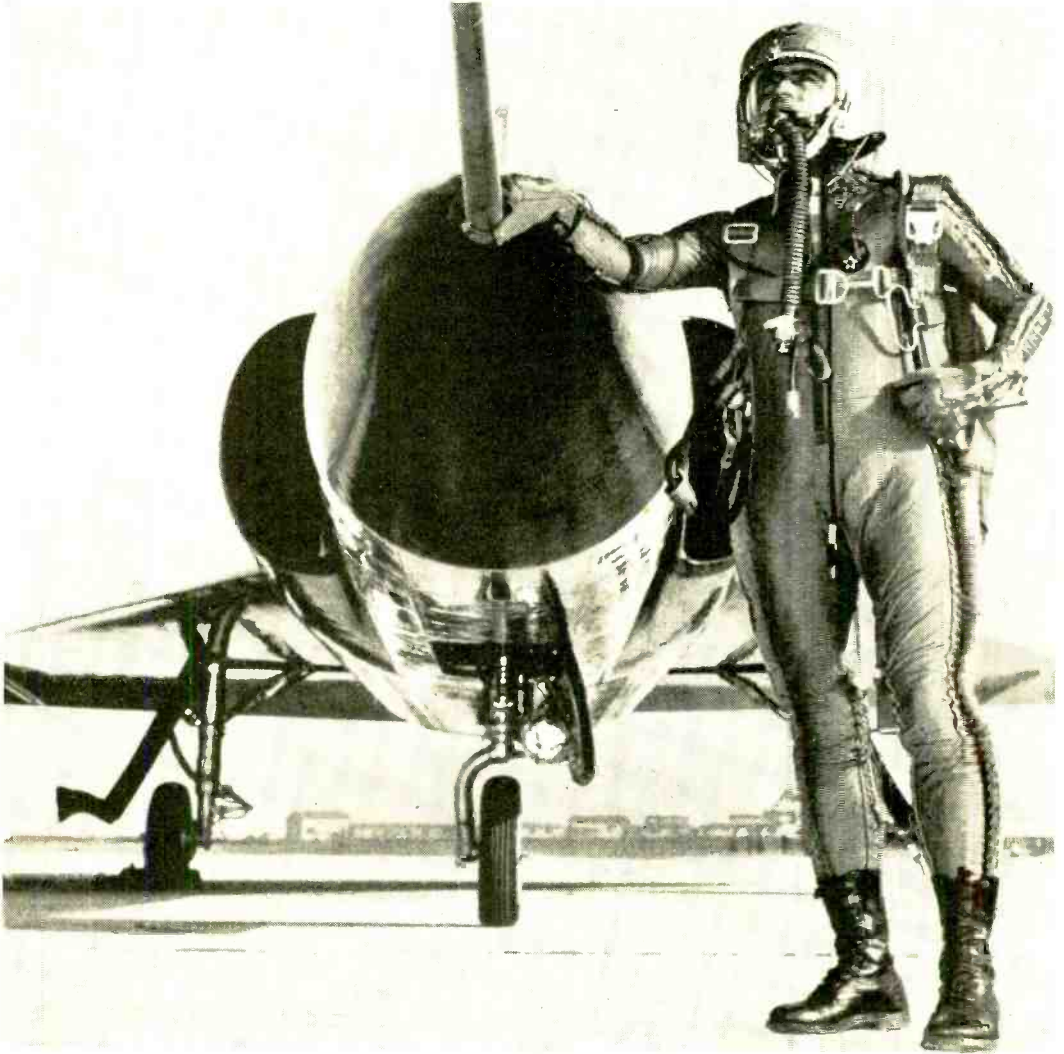

GRADUATE THEN FLY

U. S. AIR FORCE
AVIATION CADET PROGRAM

August, 1959

MAIL THIS COUPON TODAY

Aviation Cadet Information, Dept. MP-98
Box 7608, Washington 4, D. C.

Please send me details on my opportunities as an Aviation Cadet in the U. S. Air Force. I am a U. S. citizen, between the ages of 19 and 26½ and a resident of the U. S. or possessions.

Name _____ College _____

Street _____

City _____ Zone _____ State _____



do-it-yourself kits put top quality within easy reach

With absolutely no previous experience or knowledge of electronics you can assemble your own HEATHKIT hi-fi system, Ham station, test equipment or marine gear. Easy to understand step-by-step instructions, along with large pictorial diagrams, guarantee your success — and you save 1/2 or more on the highest quality equipment available today at any price!

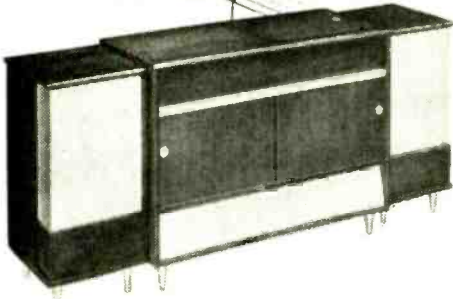
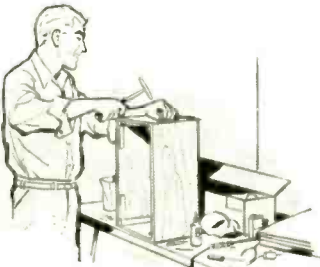

STEREO EQUIPMENT CABINET KIT

A thing of beauty as well as utility, this stereo equipment cabinet ensemble houses your complete stereo hi-fi system. It consists of a stereo equipment center flanked by two stereo speaker enclosures. The kit is supplied with mounting panels pre-cut to accommodate Heathkits and interchangeable blank panels are also furnished. The pre-cut panels accommodate the Heathkit AM-FM Tuner (PT-1), Stereo Preamplifier (SP-2), and Stereo Record Changer (RP-3-S). The changer slides out smoothly for easy record loading. Convenient record and tape storage space is provided. Ample room is provided in the rear of the center cabinet for a pair of matching Heathkit amplifiers from 12 to 70 watts. The stereo wing speaker enclosures are open-backed, cloth-grilled cabinets designed to hold the Heathkit SS-3 or similar speaker enclosures. The cabinets are available in beautifully grained 3/4" solid core Phillipine mahogany or select birch plywood suitable for the finish of your choice. Entire top features a shaped edge. Hardware and trim are of brushed brass and gold finish.

\$149⁹⁵

STEREO EQUIPMENT CABINET KIT

Model SE-1B (birch)
Model SE-1M (mahogany)

each
shpg. wt. 162 lbs.)

\$39⁹⁵

STEREO WING SPEAKER ENCLOSURE KIT

Model SC-1BR (birch—right end)
Model SC-1BL (birch—left end)
Model SC-1MR (mahogany—right end)
Model SC-1ML (mahogany—left end)

each
shpg. wt. 42 lbs.)

MODEL MF-1

\$26⁹⁵



DIAMOND STYLUS HI-FI PICKUP CARTRIDGE

Get the most from your LP microgroove records. Designed to Heath specifications by Fairchild Recording Equipment Corporation, the MF-1 is one of the finest pickup cartridges on the market today. Shpg. Wt. 1 lb.

ENJOY A HOME HI-FI SYSTEM NOW! PAY LATER . . .



Heath's convenient Time Payment Plan allows you to buy all of your hi-fi components right away . . . and pay for them in easy installments. Only 10% down on purchases of \$55 or more. Send coupon today for FREE Heathkit catalog with full time-pay details.



TRADITIONAL

Model CE-2T (mahogany)

CONTEMPORARY (not shown)

Model CE-2B (birch)

Model CE-2M (mahogany)

\$43⁹⁵
each

CHAIRSIDE ENCLOSURE KIT

Put your entire hi-fi system right at your fingertips with this handsome enclosure. Available in either traditional or contemporary models and constructed of beautiful veneer-surfaced plywood suitable for the finish of your choice. It is designed to house the Heathkit AM and FM Tuners (BC-1A and FM-3A), the WA-P2 Preamplifier, the RP-3 Record Changer, and adequate space is provided for any Heathkit amplifier designed to operate with the WA-P2. All parts pre-cut and pre-drilled for easy assembly. Shpg. Wt. 46 lbs.



NEW

HEATHKIT EA-3
\$29⁹⁵

NEW! 14-WATT HI-FI ECONOMY AMPLIFIER (EA-3)

From HEATHKIT audio labs comes an exciting new kit . . . New Styling. New Features, Brilliant Performance! Designed to function as the "heart" of your hi-fi system, the EA-3 combines the preamplifier and amplifier into one compact package. Providing a full 14 watts of high fidelity power, more than adequate for operating the average system, the EA-3 provides all the controls necessary for precise blending of musical reproduction to your individual taste.



*Build it in
one Evening*

HEATHKIT SS-2
\$39⁹⁵

"BASIC RANGE" HI-FI SPEAKER SYSTEM KIT

With performance comparable to speakers costing many times more, the SS-2 employs a Jensen 8" woofer and compression-type tweeter to provide total frequency response of 50 to 12,000 CPS. Shpg. Wt. 26 lbs.

ATTRACTIVE BRASS TIP ACCESSORY LEGS: convert the SS-2 into handsome consolette. Shpg. Wt. 3 lbs. No. 91-26. **\$4.95.**

BASIC FIR MODEL: same as SS-2 except constructed of non-premium plywood without trim or grille cloth. Shpg. Wt. 26 lbs. Model SS-3. **\$34.95.**



HEATHKIT FM-3A **\$26⁹⁵**

HIGH FIDELITY FM TUNER KIT

The thrills of FM entertainment are yours at budget cost with this handsomely styled tuner. Featuring broad-banded circuits for full fidelity and better than 10 microvolt sensitivity for 20 db of quieting, the FM-3A pulls in stations with clarity and full volume. Shpg. Wt. 8 lbs.



HEATHKIT W-7M **\$54⁹⁵**

"EXTRA PERFORMANCE" HI-FI 55 WATT AMPLIFIER KIT

Offering full fidelity at less than a dollar per watt, the power output of this remarkable amplifier is conservatively rated at 55 watts from 20 CPS to 20 kc with less than 2% total harmonic distortion throughout this entire range. Shpg. Wt. 28 lbs.



HEATHKIT PT-1
\$89⁹⁵

MONAURAL-STEREO AM-FM TUNER KIT

This professional quality 16-tube tuner offers you outstanding AM, FM or stereo AM/FM performance at minimum expense. Features include individual flywheel tuning and automatic frequency control. A multiplex jack is also provided. Shpg. Wt. 24 lbs.



HEATHKIT SP-2
\$56⁹⁵

MONAURAL-STEREO (two channel mixer) PREAMPLIFIER KIT

Control your entire stereo system with this 2-channel preamplifier. A remote balance control with 20' of cable allows balancing the stereo system from listening position. Shpg. Wt. 15 lbs.



HEATHKIT TR-1A **\$99⁹⁵**

Includes tape deck, tape recorder electronics, microphones and roll of blank tape.

HIGH FIDELITY TAPE RECORDER KIT

Whether making your own recordings or playing pre-recorded tapes you'll enjoy the many fine features of this tape recorder kit. Included are fast forward and rewind functions and choice of 7½ or 3¼ IPS tape speeds. Printed circuit boards simplify assembly. Shpg. Wt. 24 lbs.

HEATHKIT RP-3
\$64⁹⁵

(stereo model RP-3S \$74.95)



AUTOMATIC HI-FI RECORD CHANGER KIT

Combining the convenience of an automatic record changer with true turntable quality the RP-3 obtains full fidelity from your hi-fi and stereo records while treating them with the care they demand. A "turntable pause" feature prevents records from dropping on moving turntable or disk. Plays at 33½, 45, 78 and 16 RPM. Shpg. Wt. 19 lbs.

HEATH COMPANY
Benton Harbor, Mich.

A Subsidiary of Daystrom, Inc.



HEATHKIT TX-1
\$234⁹⁵

"APACHE" HAM TRANSMITTER KIT

Features 150 watt phone input and 180 watt CW input. Provision for single-sideband transmission using the SB-10 External Adapter. Shpg. Wt. 110 lbs.



HEATHKIT RX-1
\$274⁹⁵

"MOHAWK" HAM RECEIVER KIT

Covers from 160 through 10 meters on 7 bands with an extra band calibrated to cover 6 and 2 meters using a converter. Outstanding SSB reception. Shpg. Wt. 66 lbs.



HEATHKIT SB-10
\$89⁹⁵

SINGLE SIDEBAND ADAPTER KIT

A compatible plug-in adapter unit for the "Apache" Transmitter, the SB-10 covers 80, 40, 20, 15 and 10 meter bands. Produces USB, LSB or DSB signals, with or without carrier insertion. Shpg. Wt. 12 lbs.



HEATHKIT DX-40
\$64⁹⁵

PHONE AND CW TRANSMITTER KIT

Providing phone and CW operation on 80, 40, 20, 15, and 10 meters, the DX-40 features built-in modulator and power supplies. Shpg. Wt. 25 lbs.



HEATHKIT MP-1
\$44⁹⁵

MOBILE POWER SUPPLY KIT

Furnishes all power required to operate both MT-1 Transmitter and MR-1 Receiver from 12-14 volt battery. Delivers full 120 watts continuously or 150 watts intermittently. Kit includes 12' battery cable, tap-in studs for battery posts, power plug and 15' connecting cable. Shpg. Wt. 8 lbs.

**Mobile Fun! With all New
Heathkit Mobile Ham Gear**



HEATHKIT MR-1
\$119⁹⁵

"COMANCHE" MOBILE HAM RECEIVER KIT

Handsome styling, rugged construction, top quality components and economy are all wrapped up in the "Comanche". It is an 8-tube superheterodyne receiver operating AM, CW and SSB on the 80, 40, 20, 15 and 10 meter amateur bands. Operates from 12 volt car battery through the MP-1 Mobile Power Supply. Can be converted in minutes to a fixed station unit by using an AC power supply. Shpg. Wt. 19 lbs.

MOBILE ACCESSORIES

Quality 5" PM speaker in rugged steel case with mounting brackets. Heathkit AK-7. \$5.95. Shpg. Wt. 4 lbs.

Mobile base mount holds both transmitter and receiver. Universal floor mounting bracket. Heathkit AK-6. \$4.95. Shpg. Wt. 5 lbs.

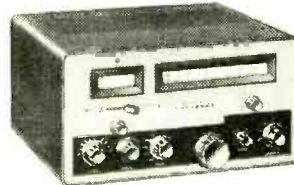
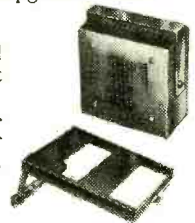

HEATHKIT MT-1
\$99⁹⁵

"CHEYENNE" MOBILE HAM TRANSMITTER KIT

The fun and convenience of mobile operation are yours with the compact and efficient "Cheyenne" Transmitter. Featuring high power with minimum battery drain, the unit provides up to 90 watts phone input and covers 80, 40, 20, 15 and 10 meters. Featured are a built-in VFO, modulator, 4 RF stages with a 6146 final amplifier pi network (coaxial) output coupling. The "Cheyenne" is designed as a companion to the "Comanche" receiver and is powered by the MP-1 Power Supply. Shpg. Wt. 19 lbs.



HEATHKIT VHF-1
\$159⁹⁵

"SENECA" VHF HAM TRANSMITTER KIT

General, technician or novice class hams wishing to extend transmission into the VHF region will find the "Seneca" ideal. A completely self-contained 6 and 2 meter transmitter, the VHF-1 features up to 120 watts input on phone and 140 watts input on CW in the 6 meter band. Included are controlled carrier phone operation, built-in VFO for both 6 and 2 meters, and four switch-selected crystal positions. Shpg. Wt. 56 lbs.



HEATHKIT V7-A
\$25⁹⁵

**ETCHED CIRCUIT
VTVM KIT**

World's largest selling VTVM, the V7-A measures AC voltage (RMS), AC voltage (Peak-to-peak), DC voltage and resistance. Features 7 AC (RMS) and DC voltage ranges of 0-1.5, 5, 15, 50, 150, 500 and 1500. In addition there are 7 peak-to-peak AC ranges of 0-4, 14, 40, 140, 400, 1400 and 4000. Seven ohmmeter ranges are provided. Battery and test leads are included with kit. Shpg. Wt. 7 lbs.

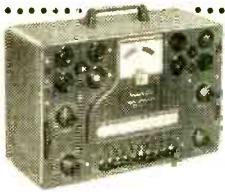

HEATHKIT TC-3
\$39⁹⁵

TUBE CHECKER KIT

An invaluable aid to servicemen, the TC-3 tests for open, short, leakage, heater continuity and quality of all tube types commonly encountered in radio and TV servicing. Checks 4, 5, 6 and 7-pin large, 7 and 9-pin miniature, 7-pin sub-miniature, octal and loctal tubes and pilot lamps. A blank socket provides for future tube types. Shpg. Wt. 12 lbs.



Model 355.

TV PICTURE TUBE TEST ADAPTER
For use with TC-3 or earlier model TC-2. Includes 12-pin TV tube socket, 4' cable. Octal connector and data. No. 355. Shpg. Wt. 1 lb. \$4.50.

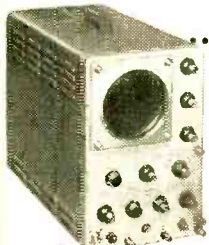

HEATHKIT OP-1
\$179⁹⁵

"PROFESSIONAL" 5" DC OSCILLOSCOPE KIT

Offering complete versatility, the OP-1 features DC coupled amplifiers and also DC coupled CR tube unblanking. Triggered sweep circuit operates on internal or external signals and may be either AC or DC coupled. Transformer operated power supply has silicon diode rectifiers. Shpg. Wt. 34 lbs.



HEATHKIT GM-3
\$39⁹⁵

"GENERAL PURPOSE" 5" OSCILLOSCOPE

Ideal in servicing as well as routine laboratory work, the OM-3 features wide vertical amplifier frequency response, extended sweep generator operation and improved stability. Vertical response is within ± 3 db from 4 CPS to 1.2 mc. Sweep range covers 20 CPS to over 150 kc. Shpg. Wt. 22 lbs.



HEATHKIT T-4
\$19⁹⁵

VISUAL-AURAL SIGNAL TRACER KIT

Doubling as a utility amplifier, test speaker, or substitution transformer, the T-4 represents an outstanding buy. Traces RF, IF and audio signals in AM, FM and transistor-type radios. Shpg. Wt. 5 lbs.



HEATHKIT SG-8
\$19⁵⁰

RF SIGNAL GENERATOR KIT

Aligns RF, IF and tuned circuits of all kinds. Provides extended frequency coverage in five bands from 160 kc to 110 mc on fundamentals and up to 220 mc on calibrated harmonics of the fundamental frequencies. Shpg. Wt. 8 lbs.



HEATHKIT CT-1
\$7⁹⁵

IN-CIRCUIT CAPACI-TESTER KIT

Check capacitors for "open" or "short" right in the circuit. Detects open capacitors from 50 mmf up and checks shorted capacitors up to 20 mfd. Checks all bypass, blocking and coupling capacitors of the paper, mica and ceramic types. Shpg. Wt. 5 lbs.



HEATHKIT TO-1
\$16⁹⁵

TEST OSCILLATOR KIT

Provides fast and accurate selection of test frequencies most used by servicemen in repairing and aligning modern broadcast receivers. Five fixed-tuned frequencies are quickly selected for trouble-shooting. Shpg. Wt. 4 lbs.

HEATH COMPANY
Benton Harbor, Mich.

A Subsidiary of **Daystrom, Inc.**



add that "extra" speaker

HEATHKIT US-1
\$750

12" UTILITY SPEAKER

This high quality auxiliary speaker offers many possibilities in audio, radio and TV work and will handle up to 12 watts with a frequency response from 50 to 9,000 CPS ± 5 db. Speaker impedance is 8 ohms and employs a 6.8 ounce magnet. Shpg. Wt. 7 lbs.



HEATHKIT BR-2
\$18⁹⁵
(less cabinet)

BROADCAST BAND RADIO KIT

Fun to build, and a fine receiver for your home. Covers complete broadcast band from 550 to 1600 kc. Built-in 5 1/2" PM speaker and rod-type antenna. Transformer operated power supply. Excellent sensitivity and selectivity. Shpg. Wt. 10 lbs.

Cabinet optional extra: No. 91-9A. Shpg. Wt. 5 lbs. \$4.95.

HEATHKIT AK-1
\$9⁹⁵



MICROPHONE ACCESSORY KIT

Useful in countless applications, this kit consists of a rugged high fidelity crystal mike and three holders; a mike stand adapter, a lavalier neck-band and desk stand. An 8' cable with phone plug is included. Shpg. Wt. 1 lb.



check engine RPM

HEATHKIT TI-1 \$25⁹⁵

ELECTRONIC TACHOMETER KIT

Easy-to-build and simple to install. Operates directly from the spark impulse of any 2 or 4 cycle engine with any number of cylinders. Operates on 6, 8, 12, 24 or 32 volt DC systems and is completely transistorized. The easy-to-read indicator shows RPM from 500 to 6,000. A calibration control is also provided. Shpg. Wt. 4 lbs.



Fun for the whole family

HEATHKIT XR-1P
\$29⁹⁵

6 TRANSISTOR PORTABLE RADIO KIT

This easy-to-build portable radio offers fun and enjoyment for the whole family. Features 6 transistors, large 4" x 6" PM speaker for "big-set" tone quality, and built-in rod-type antenna. Uses standard size "D" flashlight cells for extremely long battery life (between 500 and 1,000 hours). The modern molded plastic case with pull-out carrying handle is two-tone blue with gold inlay and measures 9" L. x 7" H. x 3 3/4" D. Shpg. Wt. 6 lbs.

Complete Engine "Tune-Up" Facilities!

NEW



ELECTRONIC IGNITION ANALYZER KIT (IA-1A)

Just clip the two test leads to operating engine (400 to 5,000 RPM) and check condition of coil, condenser, points, plugs and wiring. Shows either primary or secondary circuit patterns, parade or superimposed secondary patterns. Shpg. Wt. 20 lbs.

MODIFICATION KIT for IA-1 Models: Provides switch selection of primary and secondary circuit patterns, or, choice of parade and superimposed secondary patterns. Shpg. Wt. 2 lbs.
Heathkit MK-6.....\$4.95

HEATHKIT IA-1A \$59⁹⁵

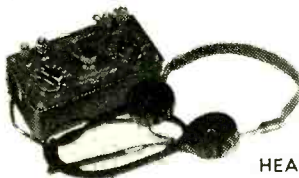

Let your boy learn radio

HEATHKIT CR-1 \$7⁹⁵

CRYSTAL RADIO KIT

Any youngster interested in radio or electronics will enjoy building and using this fine little crystal receiver. Frequency coverage is from 540 to 1600 kc. A sealed germanium diode is used for detection —no critical "cats whisker" adjustment. Headphones included. Measures 6" L. x 3" W. x 2 1/8" D. Shpg. Wt. 3 lbs.

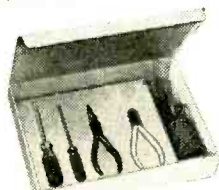

COMPLETE TOOL SET

This handy tool kit provides all the basic tools required for building any Heathkit. Includes pliers, diagonal sidecutters, screwdrivers, and soldering iron with holder. Pliers and sidecutters are equipped with insulated rubber handles that provide protection from electrical shock. All of the tools are of top quality case hardened steel for rugged duty and long life. Shpg. Wt. 3 lbs.

HEATHKIT TK-1
\$9⁹⁵



HEATHKIT DF-2
\$69⁹⁵

2-BAND TRANSISTOR RADIO DIRECTION FINDER KIT

Economically powered by 6 standard flashlight cells, the DF-2 provides you with a completely portable 6-transistor standard and beacon band receiver of unusual quality and performance. Covers the beacon band from 200 to 400 kc and broadcast band from 540 to 1620 kc. A tuning dial light is provided for night operation. Large 4" x 6" speaker provides superb tone reproduction. Shpg. Wt. 9 lbs.

HEATHKIT PC-1
\$24⁹⁵

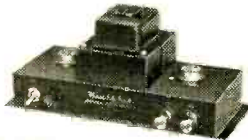

12 VOLT POWER CONVERTER KIT

Household electricity right on your boat or in your automobile is yours with this 12-volt power converter kit. Operate your radio, electric razor, lights, etc., directly from your 12-volt boat or car battery. Power rating is 125 watts continuously and 175 to 200 watts intermittently. Note: not recommended for record players, tape decks, power tools or radio transmitters. Shpg. Wt. 8 lbs.

Free Send now for latest Heathkit Catalog describing in detail over 100 easy-to-assemble kits for the Hi-Fi fan, radio ham, boat owner and technician.



HEATH

pioneer in do-it-yourself electronics

COMPANY BENTON HARBOR 10, MICH.

D a subsidiary of Daystrom, Inc.

Send latest Free Heathkit Catalog.

NAME _____

ADDRESS _____

CITY _____ ZONE _____ STATE _____

QUANTITY	KIT NAME	MODEL NO.	PRICE

All prices and specifications subject to change without notice. Please include postage on orders to be shipped parcel post. 20% deposit is required on all C. O. D. orders. All prices are NET F. O. B. Benton Harbor, Mich., and apply to Continental U.S. and Possessions only.

MARINE CONVERTER KIT



HEATHKIT MC-1
\$39⁹⁵

Charge your 6 or 12 volt batteries at dockside even while your boat's electrical system is in use. Provides up to 20 amperes continuously for charging 6-volt batteries or 10 amperes continuously for charging 12-volt batteries, regardless of type. Charging current is continuously monitored by a 25 ampere meter. Shpg. Wt. 16 lbs.

MARINE BATTERY CHARGE INDICATOR KIT

See at a glance the exact percentage of charge in your boat batteries. Checks from 1 to 8 storage batteries instantly. Operates on 6, 8, 12 or 32 volt systems. Note: for mounting on non-ferrous metals or wood only. Shpg. Wt. 3 lbs.



HEATHKIT CI-1
\$16⁹⁵



HEATHKIT FD-1-6
(6 volt)
FD-1-12
(12 volt)
\$35⁹⁵ each

FUEL VAPOR DETECTOR KIT

Protecting against fire and explosion on your boat, the FD-1 indicates the presence of explosive fumes and shows immediately if it is safe to start the engine. The kit is complete including spare detector unit. Shpg. Wt. 4 lbs.



Cornelius Cathode, electronics misfit,
 Saved up his dough and bought him a kit,
 Did away with instructions; "For beginners," said he,
 "I know what I'm doing, just watch me and see."
 He finished in jig time, plugged the thing in.
 Smoke, fire and sparks burned off his smug grin.

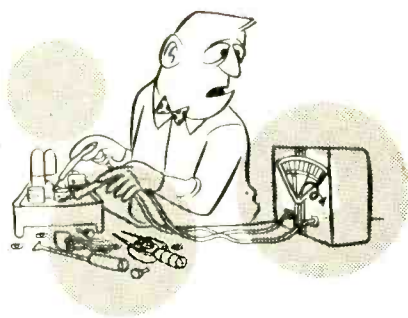

Percival Prod paid no heed,
 To where he placed the meter lead,
 To where he set the meter switch,
 Red or black, no matter which.
 Now pity poor Perc who repents his sin,
 With the meter needle wrapped 'round the pin.

Poems by
**Saunders
 Harris**

UNPOPULAR ELECTRONICS

Cartoons by
**Carl
 Kohler**



Timothy Twerp was most astounded,
 When what he thought was—WASN'T grounded.
 In fact, one could say, he was really transfixed
 With his thumb on pin 3 of a live 6L6.

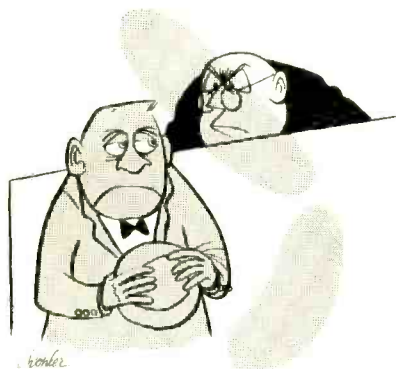

A wizard at wireless named Wallace McGee,
 Never thought he'd be caught by the old FCC;
 But to his surprise, they received him quite well.
 Unlicensed, his choice was a fine or a cell.

Learn Radio-TV Electronics

*by Practicing
at Home in
Spare Time*

Without Extra Charge

You Get special NRI kits developed to give actual experience with Radio-TV equipment. You build, test, experiment with receiver or broadcasting circuits. Keep all equipment.



Have High Pay, Prestige, Good Future as a Skilled Radio-TV Electronic Technician

People *look up to* and depend on the Technician, more than ever before. His opportunities are great and are increasing. Become a Radio-TV Electronic Technician. At home, and in your spare time, you can learn to do this interesting, satisfying work—qualify for important pay.

A steady stream of new Electronic products is increasing the job and promotion opportunities for Radio-Television Electronic Technicians. Right now, a solid, proven field of opportunity for good pay is servicing the tens of millions of Television and Radio sets now in use. The hundreds of Radio and TV Stations on the air offer interesting jobs for Operators and Technicians.

More Money Soon—Make \$10 to \$15 a Week Extra Fixing Sets in Spare Time

NRI students find it easy and profitable to start fixing sets for friends a few months after enrolling, pick up \$10, \$15 and more a week extra spending money. Many who start in spare time soon build full time Radio-Television businesses.

Act Now—See What NRI Can Do for You

NRI has devoted 40 years to developing simplified practical training methods. You train at home, learn by doing.

NATIONAL
RADIO
INSTITUTE
Wash. 16, D. C.

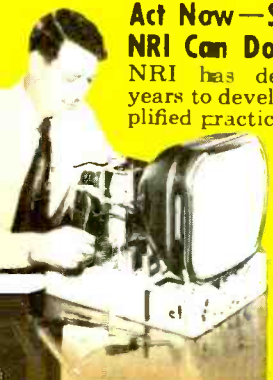

NRI Has Trained Thousands for Successful Careers in Radio-TV



Studio Engr., Station KATV
"I am now Studio Engineer at Television Station KATV. Before enrolling, I was held back by limitation of a sixth grade education." **HILLY SANCHEZ**, Pine Bluff, Ark.



Has All the Work He Can Do
"I have repaired more than 2,000 TV and Radio sets a year NRI training certainly proved to be a good foundation." **H. R. GORDON**, Milledgeville, Georgia.



Has Good Part Time Business
"Early in my training I started servicing sets. Now have completely equipped shop. NRI is the backbone of my progress." **E. A. HENNA**, Tacoma, Washington.

SEE OTHER SIDE

Cut Out and Mail This Card—No Stamp Needed

Sample Lesson and Catalog Both Sent FREE

OLDEST & LARGEST HOME STUDY RADIO-TV SCHOOL
National Radio Institute
Dept. 6, Washington 16, D.C.

Please send me sample lesson of your Radio-Television Training and Catalog FREE. (No salesman will call.)

Name..... Age.....

Address.....

City..... Zone..... State.....

ACCREDITED MEMBER NATIONAL HOME STUDY COUNCIL



NRI SUPPLIES LEARN-BY-DOING KITS WITHOUT EXTRA CHARGE
Technical Know-How Pays Off in Interesting, Important Work



YOU BUILD AC-DC Superhet Receiver

NRI Servicing Course includes all needed parts. By introducing defects you get actual servicing experience practicing with this modern receiver. Learn-by-doing.



YOU BUILD This 17 Inch Television Receiver

As part of your NRI course you can get all components, tubes including 17" picture tube, to build this latest style Television receiver; get actual practice on TV circuits



YOU BUILD Vacuum Tube Voltmeter

Use it to earn extra cash fixing neighbors' sets; bring to life theory you learn from NRI's easy-to-understand texts.

YOU BUILD Broadcasting Transmitter

As part of NRI Communications Course you build this low power Transmitter, learn commercial broadcasting operators' methods, procedures. Train for your FCC Commercial Operator's License.



For Higher Pay, Better Jobs
Be a Radio-TV Electronic Technician



Servicing Needs More Trained Men

Portable TV, Hi-Fi, Transistors, Color TV are making new demands for trained Technicians. Good opportunities for spare time earnings or a business of your own. Enjoy prestige.



Train at Home the NRI Way Famous for Over 40 Years

J. E. Smith, Founder

NRI is America's oldest and largest home study Radio-Television school. The more than 40 years' experience training men, the outstanding reputation and record of this school benefits you many ways. Successful graduates are everywhere, in small towns, big cities. You train in your own home, keep your present job while learning. Let us send you an actual lesson, judge for yourself how easy it is to learn.

Broadcasting Offers Satisfying Careers

4000 TV and Radio stations offer interesting positions. Govt. Radio, Police, Two-Way Communications are growing fields. Trained TV-Radio Operators have a bright future.



No Experience Necessary - NRI Sends Many Kits for Practical Experience

You don't have to know anything about electricity or Radio to understand and succeed with NRI Course. Clearly written, illustrated NRI lessons teach Radio-TV-Electronic principles. You get NRI kits for practical experience. All equipment is yours to keep. Mailing the postage-free card may be one of the most important acts of your life. Do it now. Reasonable tuition, low monthly payments available. National Radio Institute, Wash. 16, D.C.

FIRST CLASS
 Permit No. 20-R
 (Sec. 34.9, P. L. & R.)
 Washington, D.C.

NRI Graduates Do Important Work



NRI Course Easy to Understand
 "Opened my own shop before receiving diploma. I am independent in my own business." D. P. CRESSEY, Stockton, California.

Works on Color TV
 "NRI" changed my whole life. If I had not taken the course, probably would still be a fireman, struggling along." J. F. MELINE, New York.

BUSINESS REPLY CARD
 No Postage Stamp Necessary if Mailed in the United States

POSTAGE WILL BE PAID BY
NATIONAL RADIO INSTITUTE
3939 Wisconsin Avenue
Washington 16, D.C.

See Other Side

SAMPLE LESSON
64-page CATALOG
both FREE

2

POLY PAKS FOR

1

During Lektron's 4-Week 1,000,000 Radio-TV Parts Free-For-All Sale!

- DISC CONDENSERS
- GERMANIUM DIODES
- TRANSISTOR SOCKETS
- ★ \$15 GEIGER COUNTER TUBE
- ★ POLY BOXES
- TRANSISTOR PRINTED CIRCUITS
- MICA CONDENSERS
- PLUG 'n RECEPTACLES

- | | |
|------------|---------|
| 1st Pak | 2nd Pak |
| 30 for 88¢ | FREE |
| 6 for 88¢ | FREE |
| 6 for 88¢ | FREE |
| 1 for 88¢ | FREE |
| 10 for 88¢ | FREE |
| 15 for 88¢ | FREE |
| 50 for 88¢ | FREE |
| 50 for 88¢ | FREE |

8
OF OUR
MOST
POPULAR
POLY-PAKS

★ STARRED ITEMS ON A WHILE-THEY-LAST BASIS AT THIS "2-for-1" PRICE, SUPPLY LIMITED!

FREE!

POLY-PAK OF YOUR CHOICE

WITH EVERY \$8 ORDER—above "2 for 1" Paks can apply

2 TRANSISTOR VARIABLES
Miniature, transistor. Covers Dual 365 mmf. Wt. 1 lb. Reg. 88¢ \$3.00.

4 OSCILLATOR COILS
Miniature, 1000 kc. Reg. \$4.00. 88¢

3 TRANSISTOR XFMRs
Miniature size. 100's of projects; audio, interstage, etc. Reg. 88¢ \$10.

100 RESISTORS
Carbon and precision; 1/2, 1, 2W; 1W and 5/2, 50 ohms to 2 megs. 3 lbs. Reg. 88¢ \$25.00.

POWER TRANSISTOR P-N-P
10W rating; for audio, auto. 88¢ other uses too. Reg. \$10.00.

35 TWO-WATTERS
Carbon resistors; incl. 1/2, 1, 2W. Reg. \$12. 88¢

000-999 COUNTER
Vander-Roos. Automatic reset. Motors, coils, etc. Reg. 88¢ \$3.

12-HR. "SPACE" CLOCK
Powered by pebble battery, 6 oz. Hobbyists. note! 88¢ Reg. \$8.

SUN BATTERY
Similar to famed B2M. 1" long. Reg. \$2.50. 88¢

HEARING AID PHONE
Crystal, w/ record set & plug. Reg. \$5. 88¢

4 OUTPUT XFMRs
50/0, etc. 3 lbs. Reg. 88¢ \$8.

POSTAGE STAMP MIKE
Crystal, 100 to 8,000 cps. 1 lb. Reg. \$7. 88¢

40 TUBE SOCKETS
4 to 6-pin, ceramic mica, shield-angled incl. 2 lbs. 88¢ Reg. \$10.

2 TRANSISTOR IF'S
Double-tuned. Only 1/2" square. 450 kc. 88¢

70 TBLR COND'S'RS
Paper, molded, oil, paper, to 5mf to 10mfV. 2 lbs. 88¢ Reg. \$14.

WIRE STRIPPER
Strips, cuts, 1/2 thru 22 hookup wire. Wt. 1 lb. 88¢

10 ELECTROLYTICS
Radio, TV, 10-50 mf to 450VDC. 3 lbs. Reg. \$12. 88¢

60 RADIO-TV KNOBS
Ass'd. colors, insulation. Some worth \$1 ea. 2 lbs. Reg. 88¢ \$17.

16-END WRENCH SET
For home & auto. box & open; 15-64 thru 7-16". 16 88¢ sizes. Reg. \$2.50.

70 ONE-WATTERS
Ass'd. value carbon resistors. 5/2, too! 88¢

2 NPN TRANSISTORS
Used in Pub. make rds. 88¢ other uses too.

35 POWER RESISTORS
W.W. 5 to 50W, to 10,000 ohms. Vitreous, too! 3 lbs. 88¢ Reg. \$15.

40 HI-Q CONDENSERS
FINEST porcelain, NPO's, too! 1 lb. Reg. \$15. 88¢

5 ROLLS MICRO-WIRE
24 thru 32; for transistor, sub-mini circuits. 1 lb. 88¢

2 VARI-LOOPSTICKS
Adj. 500-1500 kc. Transistor radios, etc. 1 lb. 88¢

MINI-RADIO KIT
World's smallest! 2 x 1 x 1", loopstick, jacks, diode, etc. w/ instructions. 1 lb. Reg. \$4. 88¢

100 RADIO PARTS
Wide variety resistors, potentiometers, pots, forms. 3 lbs. 88¢

4 POWER WOOD BITS
Hi-Q steel, 4x, 1/2, 3/4, 1", 5" long. Reg. \$3. 88¢

FREE!
SURPRISE GIFT
FREE WITH
EVERY ORDER!

10 TUBULAR ELECTROS
Ass'd. paper types, AC, DC, Hobby. 3 lbs. Reg. \$15. 88¢

20 ARTISTS BRUSHES
100% pure bristle; sizes 1-0. Reg. \$2.50. 88¢

8 RCA PLUG-N-JACK
Sets, matched. Most pop. ampb. tuners, phono. 88¢

60 TERMINAL STRIPS
Solder-lut & binding. 10 types. 2 lbs. 88¢

60 COILS, CHOKES
IF, RF, anti-slag-tuned, too. 3 lbs. Reg. \$15. 88¢

88¢ EA.

HOBBY BENCH VISE
Clamp type. Fits tables, too. Steel; 1 lb. 88¢

300-FT. HOOKUP WIRE
Tinned, ass'd. sizes, colors. 2 lbs. Reg. \$5. 88¢

100 HALF-WATTERS
Ass'd. value carbon resistors; incl. 5/2. Reg. \$12. 88¢

30 MOLDED COND'S'RS
Ass'd. Finest made! Wt. 2 lbs. 88¢

10 ROTARY SWITCHES
Ass'd. ranges. 3 lbs. Reg. \$12. 88¢

40 PRECISION RESISTORS
Carbon, W.W. wide variety; 1/2, 1/2, 1, 2 w. 1 lb. 88¢ Reg. \$15.

5-IN-1 DRILL BIT
Beams, saws, cones, slimpes, drills; hand or power drills. 88¢

40 SUBMINI RESIST'RS
1/2, 1/2, Ass'd. values; 1/5W to 10 megs. Reg. \$6. 88¢

5" HOBBY SPEAKER
For radios, code use, intercom. 2 lbs. Reg. \$5. 88¢

TEN 3-SECOND TIMER
Mechanisms; precision geared. 2 lbs. Reg. \$30. 88¢

6 SILICON DIODES
Silvania 1N22, 1N23. Reg. 88¢ \$36.

\$25 SURPRISE PACK!
Large, varied assortment Radio, TV parts. 3 lbs. 88¢

7-SCREWDRIVER SET
7 ass'd. drivers w/ wall-hack. Plastic handles. 1 lb. list 88¢ \$3.50.

40 SUBMINI COND'S'RS
For transistor, printed circuit work. 1 lb. Reg. \$7. 88¢

70 HI-Q RESISTORS
Insulated, carbon; 1/2, too! 1/2 & 1W, 10 ohms to 10 megs. 2 lbs. Reg. \$15. 88¢

FREE!

FULL YEAR'S
SUBSCRIPTION
TO LEKTRON'S
"FAMILY SHOPPER"

ELECTRONICS • TOOLS
JEWELRY • NOVELTIES
HI-FI • HOUSEWARES

Write Today!

1500 PCS. HARDWARE
Nuts, screws, washers, etc. 88¢ 1 1/2 lbs. Reg. \$6.

60 CONDENSER SPLCI
Molded, paper, ceramic, oil, mica; discs; variable. 2 lbs. 88¢

75 RESISTOR SPECIAL!
W.W. precision, carbon, variable, mini types. 3 lbs. Worth 88¢ \$15.

15-PC. DRILL SET
1-14" diam. 1/2, 3/8, 1/2, 5/8, 3/4, 1" w/ adjustable case. Reg. \$4. 88¢

10 VOLUME CONTROLS
Some w/ switches. 2 lbs. 88¢ Reg. \$9.

HOW TO ORDER:

ORDER BY BLACK-TYPE HEADLINES, i.e.,
30 DISK CONDENSERS 88¢

State price with each item. Send check or M.O. including sufficient postage; excess returned. C.O.D. orders, 25% down; rated net 30 days. INCLUDE POSTAL ZONE in address. (Canada Postage, 48¢ 1st lb.; 28¢ ea. add'l lb.)

LEKTRON

131-133 EVERETT AVE.
CHELSEA 50, MASS.

By
JOHN T. FRYE
W9EGV



Carl and Jerry

Away From It All

JULY was melting into August; and Carl and Jerry, sitting on the latter's front steps watching the advent of another hot summer day, were becalmed in the Dog Day Doldrums.

"You know, Jer," Carl remarked, as he brushed the palm of his hand pleurably back and forth across the close-cropped, dew-wet grass beside the steps, "lately I get the feeling we're hitting the electronic kick a little too hard. It's reached the point where we aren't interested in anything unless it's somehow mixed up with wires, tubes, transistors, batteries, and so on. Electronics is the most fascinating thing in the world, but I don't want to become a nut about it—or about anything else, for that matter."

"Me, neither," Jerry promptly agreed; "and I think, too, that we're getting a little far out on the subject of electronics. The other day I caught myself walking along the street reading the signs and mentally tapping them out in Morse code."

"Brother, you're sicker than I thought! You're just about ready to be fitted for a white jacket with the wrap-around sleeves. We better act fast. Let's pack up our gear,

grab our bicycles, and go for an overnight camping trip up along the river; and let's not take a single thing electronic, or even electrical, with us."

"Not even a flashlight?" Jerry queried.

"Not even a flashlight," Carl said firmly. "We'll use candles. And the first one who mentions electronics has to pitch the shelter and do all the cooking. Let's make like electricity hasn't even been discovered yet."

"It's a deal," Jerry said as he grasped Carl's wet hand. "Get your part of the camping stuff and let's get going."

THE BOYS had done this sort of thing often enough in the past so that a minimum of preparation was necessary. An hour later they were pedaling past the city limits sign with all the needed gear contained in two neat bundles fastened to the luggage carriers of the bikes.

They soon turned off on the quiet tree-lined river road and cycled leisurely along the shaded tunnel formed by the arching limbs. Now and then they stopped to watch huge leather-back turtles sunning themselves on the rocks or to drink from a cool spring that bubbled up through the limestone. Even so, when the sun was directly overhead they were several miles from home and were beginning to look for a camping site.

After they had pedaled briskly up a steep incline, Carl braked sharply.

"How's this?" he asked as he looked down at the river twisting and turning below. "We'll get any breeze that's blowing up here, and the mosquitoes won't be as bad as they are down close to the water. We can pitch our shelter over there in the grove of trees where we can't be seen from



the road and where we can look right down on the river. This bluff must be the highest place for miles. What a spot for a six-meter rig!"

As soon as the words left his lips, Carl realized what he had done; and he glanced quickly at Jerry in the hope that his chum had not noticed the slip. No such luck! Jerry's round face was wreathed in a bland smile as he leisurely got off his bicycle, sat down on the ground, and leaned lazily back against the trunk of a big tree.

"Well, you brought up the forbidden subject," he drawled; "so get with it. I think I'll take a nap while you pitch the shelter. When that's done, you can get some dinner. I'd like three or four eggs, well basted, and several slices of crisp bacon. Open a can of pork and beans, too. When it's all ready, wake me; but do it gently. I startle easily."

"Do you suppose a dash of cold water right in your smirking face would startle you?" Carl growled as he began unrolling the light, waterproof shelter. Jerry relented, though, and cut and sharpened tent stakes while Carl was laying out the tent. Then he gathered firewood and had a good fire going by the time the shelter was up.

After dinner the boys made everything shipshape in their camp and then rested an hour before going for a swim. The river below the bluff on which their tent was pitched was quiet, crystal-clear, and just about shoulder-deep, with a sandy bottom free of holes and step-offs; it was a good safe place to swim. Carl and Jerry spent the whole afternoon playing in the river and exploring the shallow caves worn into the base of the cliff by the water.

When the trees on the bank began throwing long shadows far out across the mirror surface of the river, the boys changed out of their swimming trunks and made their way back to camp. The exercise had given them wolfish appetites, but they took time to prepare a good nourishing supper that was no less appetizing for being smoked, slightly scorched, and seasoned with wood ashes.

By the time the tin pans had been thoroughly scoured and put away, the sun had gone down—after setting fire to a few small clouds drifting in the western sky. Darkness closed in rapidly. The boys kept their little fire going by alternately feeding it with pieces of broken branches. It was strange how the camp site that looked so friendly and inviting in daylight sud-

GET MORE WORK OUT OF YOUR OSCILLOSCOPE

Learn to service
ANY radio or TV
faster . . . with the
handiest instrument of all!



The book
that tells you
what you need to know
about 'scopes!

Here, in a big 2nd edition, is THE book that really shows you how to use oscilloscopes!

Clearly as A-B-C, MODERN OSCILLOSCOPES AND THEIR USES tells you exactly when, where and how. You learn to locate either AM or FM radio or television troubles in a jiffy. Tough realignment jobs are made easy. No involved mathematics! Every detail is clearly explained—from making connections to adjusting circuit components and setting oscilloscope controls. And you learn to analyze patterns fast and RIGHT!

Includes latest data on use of 'scopes in industrial electronics, teaching, atomic energy work—plus details on quantitative measurements—the slickest method of diagnosing many color TV troubles and aligning sets properly. Over 400 pages and over 400 clear pictures. Dozens of pattern photos make things doubly clear. Price only \$6.50. Use coupon for 10-day free trial.

DON'T THROW OLD RADIOS AWAY!

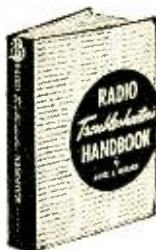

This giant book shows
exactly how to fix them
. . . without a lot of
previous experience!

Just look up the how-to-do-it data on that old radio you want to fix!

Four times out of 5 this giant, 3½-pound, 744-page Ghirardi RADIO TROUBLESHOOTER'S HANDBOOK gives exactly the information you need. Tells what is likely to be causing the trouble . . . shows how to fix it. Covers practically every radio receiver model made by 202 manufacturers between 1925 and 1942. Using it, even beginners can easily fix old sets which might otherwise be thrown away because service information is lacking. With a few simple repairs, most of these old sets can be made to operate perfectly for years to come. Included are common trouble symptoms and their remedies for over 4,800 models of old home, auto radios and record changers: Airline, Apex, Arvin, Atwater Kent, Belmont, Bosch, Brunswick, Clarion, Crosley, Emerson, Fada, G-E, Kolster, Majestic, Motorola, Philco, Pilot, RCA, Silvertone, Sparton, Stromberg and dozens more. Includes hundreds of pages of invaluable old time tube and component data, service short cuts, etc. Price \$6.95—10-day free trial.

PRACTICE 10 DAYS FREE!

Dept. PE-89, RINEHART & CO., INC.,
232 Madison Ave., New York 16, N. Y.

Send books checked below for free examination. In 10 days, I will either send price shown (plus postage) or return books postpaid and owe nothing.

MODERN OSCILLOSCOPES AND THEIR USES, \$6.50 RADIO TROUBLESHOOTER'S HANDBOOK, \$6.95

SAVE! Send cash with order and we pay postage. Same 10-day return privilege.

Name

Address

City, Zone, State

OUTSIDE U.S.A.—Add 50¢ to each book, cash with order only. Same 10-day return privilege with money refunded.

SHIPPED ON APPROVAL

IN-CIRCUIT CONDENSER TESTER

Model CT-1

AN ABSOLUTE 'MUST' FOR EVERY SERVICEMAN!

Here is an in-circuit condenser tester that does the whole job. The CT-1 actually steps in and takes over where all other in-circuit condenser testers fail. The ingenious application of a dual bridge principle gives the CT-1 a tremendous range of operation. . . .

in-circuit checks:

- ✓ Quality of over 80% of all condensers even with circuit shunt resistance present. . . (leakage, shorts, opens, intermittents)
- ✓ Value of all condensers from 200 mmfd. to .5 mfd.
- ✓ Quality of all electrolytic condensers (the ability to hold a charge)
- ✓ Transformer, socket and wiring leakage capacity

out-of-circuit checks:

- ✓ Quality of 100% of all condensers . . . (leakage, shorts, opens and intermittents)
- ✓ Value of all condensers from 50 mmfd. to .5 mfd.
- ✓ Quality of all electrolytic condensers (the ability to hold a charge)
- ✓ High resistance leakage up to 300 megohms
- ✓ New or unknown condensers . . . transformer, socket, component and wiring leakage capacity

SPECIFICATIONS

- Ultra-sensitive 2 tube drift-free circuitry
- Multi-color direct scale precision readings for both quality and value . . . (in-circuit or out of circuit)
- Simultaneous readings of circuit capacity and circuit resistance
- Built-in hi-leakage indicator sensitive to over 300 megohms
- Cannot damage circuit components
- Electronic eye megohms
- Isolated power line balance indicator for even greater accuracy
- Multi-color direct scale precision readings for both quality and value . . . (in-circuit or out of circuit)
- Simultaneous readings of circuit capacity and circuit resistance
- Built-in hi-leakage indicator sensitive to over 300 megohms
- Cannot damage circuit components
- Electronic eye megohms
- Isolated power line balance indicator for even greater accuracy

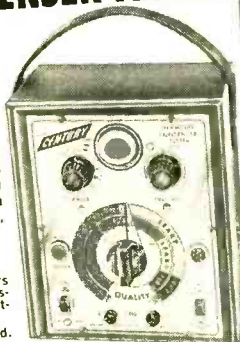

Model CT-1 — housed in sturdy hammer-tone finish steel case complete with test leads
\$34.50 Net
 SIZE: W-6" H-7" D-3 1/4"

MINI-CHECK TUBE TESTER

Model MC-1

A Real ECONOMY MULTIPLE SOCKET TUBE TESTER without sacrifice in ACCURACY, SPEED or VERSATILITY

Here is a multiple socket tube tester designed to meet limited budgets. Although low in price it boasts a unique circuitry that enables you to check over 600 tube types — and has a range of operation that far exceeds others in its price class.

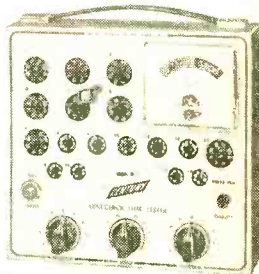

Model MC-1 — housed in sturdy wrinkle finish steel case
\$39.50 Net
 SIZE: W-9" H-8 1/2" D-2 3/4"

SPECIFICATIONS

- Checks emission, inter-element shorts and leakage of over 600 tube types. This covers 0244, series-string TV tubes, gas regulators, auto 12 plate volt, hi-fi and foreign tubes • 3 settings enable a test of any tube in less than 10 seconds • Employs dynamic cathode emission test principles • 3 1/2" D'Arsonval type meter — most accurate type available . . . its greater sensitivity means more accuracy . . . its jewel bearing means longer life • 17 long lasting phosphor bronze tube sockets • Combination gas and short jewel indicator • 9 filament positions • Handy tube chart contained in special back compartment • New tube listings furnished periodically at no cost • Detachable line cord

plus these BONUS FEATURES . . . found in no other low price tube tester

- ✓ Checks for cathode to heater shorts
- ✓ Checks for gas content
- ✓ Checks all sections of multiple purpose tubes . . . will pickup tubes with one "Bad" section
- ✓ Line isolated — no shock hazard
- ✓ Variable load control enables you to get accurate results on all tubes
- ✓ Positively cannot become obsolete as new tubes are introduced.

IN-CIRCUIT RECTIFIER TESTER

Model SRT-1

Checks all power rectifiers in-circuit whether SELENIUM, GERMANIUM, SILICON, etc.



Model SRT-1—housed in sturdy hammer-tone finish steel case complete with test leads
\$29.50 Net
 SIZE: W-6" H-7" D-3 1/4"

With the growing trend towards compactness, portability and low price, TV manufacturers are resorting more and more to producing series-string TV sets employing selenium, germanium or silicon power rectifiers. Now the need for an in-circuit rectifier tester is greater than ever.

THE SRT-1 CHECKS ALL POWER RECTIFIERS IN-CIRCUIT AND OUT-OF-CIRCUIT WITH 100% EFFECTIVENESS FOR:

- ✓ Quality
- ✓ Fading
- ✓ Shorts
- ✓ Opens
- ✓ Arcing
- ✓ Life Expectancy

SPECIFICATIONS

- Checks all types of power rectifiers rated from 10 ma. to 500 ma. (selenium, germanium, silicon, etc.) both in-circuit or out-of-circuit.
- Will not blow fuses even when connected to a dead short.
- Large 3" highly accurate multi-color meter . . . sensitive yet rugged.
- Separate meter scales for in-circuit and out-of-circuit tests.
- Cannot damage or over heat rectifier being tested.

SIMPLE TO OPERATE

Just clip SRT-1 test leads across rectifier under test right in the circuit without disconnecting rectifier from circuit. Press test switch and get an instant indication on the easy-to-read three-color meter scales. . . .

TRANSISTOR TESTER

Model TT-2

AN INEXPENSIVE QUALITY INSTRUMENT DESIGNED FOR ACCURATE AND DEPENDABLE TESTS OF ALL TRANSISTORS AND DIODES QUICKLY AND ACCURATELY

Every day more and more manufacturers are using transistors in home portable and car radios, in hearing aids, intercoms, amplifiers, industrial devices, etc. Since transistors can develop excessive leakage, poor gain, shorts or opens, the need for TRANSISTOR TESTER is great.



Model TT-2—housed in sturdy hammer-tone finish steel case complete with test leads
\$24.50 Net
 SIZE: W-6" H-7" D-3 1/4"

SPECIFICATIONS

- Checks all transistors, including car radio, power output, triode, tetra-ode and unijunction types for current gain, leakage, opens, shorts, cut-off current
- Checks all diodes for forward to reverse current gain
- All tests can be made even if manufacturers' rated gain is not available
- Less than half a minute required for tests of either transistors or diodes
- Large 3" meter is extremely sensitive
- Power is supplied by an easy to replace 9-volt battery — current drain due to accidental shorting of test leads
- Cannot burn-out its own meter or clips enable tests without entirely removing transistor from circuit
- Test terminal is assured
- Comes complete with replaceable transistor set-up chart that fits into a special rear compartment.

IMPORTANT FEATURE: The TT-2 cannot become obsolete as you to check all new type transistors as they are introduced. New listings will be furnished periodically at no cost.

EASY TO BUY IF SATISFIED
 see order form on facing page

FOR 10 DAY FREE TRIAL

Convince yourself at no risk that CENTURY instruments are indispensable in your every day work. Send for instruments of your choice without obligation... try them for 10 days before your buy... only then, when satisfied, pay in easy-to-buy monthly installments — without any financing or carrying charges added.

NEW Battery Operated Peak-to-Peak VACUUM TUBE VOLT METER Model VT-1

WITH LARGE EASY-TO-READ 6" METER — featuring the sensational new MULTI-PROBE Patent Pending

- No extra probes to buy! The versatile MULTI-PROBE does the work of 4 probes
1 DC Probe 2 AC-Ohms Probe 3 Lo-Cap Probe 4 RF Probe

The VT-1 is a tremendous achievement in test equipment. With its unique MULTI-PROBE it will do all the jobs a V.T.V.M. should do without the expense of buying additional probes. No longer do you have to cart around a maize of entangled cables, lose time alternating cables or hunting for a misplaced probe. With just a twist of the MULTI-PROBE tip you can set it to do any one of many time-saving jobs. A special holder on side of case keeps MULTI-PROBE firmly in place ready for use.



SIZE: W-7 3/4" H-9" D-4 3/4"

FUNCTIONS

DC VOLTMETER... Will measure D.C. down to 1.5 volts full scale with minimum circuit loading... and give accurate readings of scale divisions as low as .025 volts... Will measure low AC and oscillator bias voltages from .1 volts or less up to 1500 volts... Zero center provided for all balancing measurements such as discriminator, ratio detector alignment and hi-fi amplifier balancing.

AC VOLTMETER... True Peak-to-Peak measurements of any wave form including TV sync, deflection and color TV gating pulses... Scale divisions are easily read down to .1 volts... Measures RMS at 1/20th the circuit loading of a V.O.M... Unlike most other V.T.V.M.'s there is no loss in accuracy on the lowest AC range.

ELECTRONIC OHMMETER... Measures from 0 to 1000 megohms... Scale divisions are easily read down to .2 ohms... Will measure resistance values from .2 ohms to one billion ohms... Will detect high resistance leakage in electrolytic and by-pass condensers.

RF and LO-CAP MEASUREMENTS... With these extra VT-1 functions you can measure voltages in extremely high-impedance circuits such as sync and AGC pulses, diving saw tooth voltages, color TV gating pulses, mixer output levels, I.F. stage-by-stage gain and detector inputs.

OUTSTANDING FEATURES

- Completely portable — self powered with long life batteries — permits use everywhere
- New advanced pentode amplifier circuit assures amazingly low battery drain
- Large 6" 100-microampere meter, many times more sensitive than meters used in most V.T.V.M.'s
- Laboratory accuracy performance — 2% of full scale on DC, 5% of full scale on AC
- Simplified multicolor rigid stability and accuracy
- No heat operation assures fluctuations
- Amplifier rectifier circuit with frequency compensating attenuator — a feature found only in costly laboratory instruments
- Meter completely isolated — practically burn-out proof
- Hand-crafted circuitry eliminates the service headaches of printed circuitry
- 1% resistors used for permanent accuracy
- Separate phone type co-axial connector
- Matching cover protects instrument face — snaps on and off instantly.

SPECIFICATIONS

- DC Volts — 0 to 1.5/6/30/150/300/600/1500 volts
- AC Volts (RMS and Peak-to-Peak) — 0 to 3/12/60/300/1200 volts
- Ohms — 0 to a billion ohms, 10 ohms center scale — Rx1/10/100/1K/10K/100K/1M
- RF — Peak reading demodulator supplied for use on all DC ranges
- Zero Center — available on all DC volt ranges with zero at mid-scale
- Decibels — from —10 Db to +10/22/36/50/62 based on the Dbm unit: 0Db-1mW in 600 ohms
- Impedance — 11 megohms DC, 1 megohm AC, 10 megohms Lo-Cap
- Input Capacity — 130 mmfd. RMS, 250 mmfd. Peak-to-Peak, 25 mmfd. Lo-Cap

Model VT-1 — fully wired and calibrated, housed in hand-some hamster-tone finish steel case complete with MULTI-PROBE and thorough instruction manual covering all the applications in detail. **\$58.50** Net



Model FC-2 — housed in hand-ubbed carrying case complete with CRT adapter. **\$69.50** Net

FAST-CHECK TUBE TESTER Model FC-2

Simply set two controls... insert tube... and press quality button to test any of over 700 tube types completely, accurately... IN JUST SECONDS!

Over 20,000 servicemen are now using the FAST-CHECK in their every day work and are cutting by selling more tubes with very little effort. See for yourself at no risk why so many servicemen chose the FAST-CHECK above all other tube testers.

PICTURE TUBE TEST ADAPTER INCLUDED WITH FAST-CHECK

Enables you to check all picture tubes (including the new short-neck 110 degree type) for cathode emission, shorts and life expectancy... also to rejuvenate weak picture tubes.

RANGE OF OPERATION

- Checks quality of over 700 tube types, employing the time proven dynamic cathode emission test. This covers more than 99% of all tubes in use today, including the newest series-string TV tubes, auto 12 plate-volt tubes, OZs, magic eye tubes, gas regulators, special purpose hi-fi tubes and even foreign tubes.
- Checks for inter-element shorts and leakage.
- Checks for gas content.
- Checks for life-expectancy.

SPECIFICATIONS

- No time consuming multiple switching... only two settings are required instead of banks of switches on conventional testers
- No annoying roll chart checking... tube chart listing over 700 tube types is located inside cover
- Without costly roll chart replacement
- Checks each section of multi-section tubes and if only one section is defective the tube will read "Bad" if the meter scale is mounted on panel
- Large 4 1/2" Dial-arc type meter is the most sensitive available, yet rugged — fully protected against accidental burn-out
- Special scale on meter for low current tubes
- Line voltage variation — 12 filament positions
- Separate gas and short voltage indicators
- Line isolated — no shock hazards
- Long lasting etched aluminum panel
- The Fast-Check possibly cannot become obsolete... circuitry is engineered to accommodate all future tube types as they come out. New tube listings are furnished periodically at no cost.

CONVENIENT TIME PAYMENT PLAN — NO FINANCING CHARGES

ALL CENTURY INSTRUMENTS ARE GUARANTEED FOR ONE FULL YEAR
 The extremely low prices are made possible because you are buying direct from the manufacturer.

CHECK INSTRUMENTS DESIRED

- Model CT-1 In-Circuit Condenser Tester \$34.50 \$9.50 within 10 days. Balance \$5 monthly for 5 months.
 - Model MC-1 Mini-Check Tube Tester \$39.50 \$9.50 within 10 days. Balance \$5 monthly for 5 months.
 - Model SRT-1 In-Circuit Rectifier Tester \$29.50 \$4.50 within 10 days. Balance \$5 monthly for 5 months.
 - Model TT-2 Transistor Tester \$24.50 \$4.50 within 10 days. Balance \$5 monthly for 4 months.
 - Model VT-1 Battery Vacuum Tube Volt Meter \$58.50 \$14.50 within 10 days. Balance \$11 monthly for 4 months.
 - Model FC-2 Fast-Check Tube Tester \$69.50 \$14.50 within 10 days. Balance \$11 monthly for 5 months.
- Prices Net F.O.B. Mineola, N. Y.

111 Roosevelt Avenue, Dept. 308, Mineola, New York

Please rush the instruments checked for a 10 day free trial. If satisfied I agree to pay the down payment within 10 days and the monthly installments as shown. If not completely satisfied I will return the instruments within 10 days and there is no further obligation. It is understood there will be NO INTEREST or FINANCING charges added.

Name _____ Please print clearly
 Address _____
 City _____ State _____

TARZIAN Offers 48-Hour, Direct Factory Service on Tuner Repairs

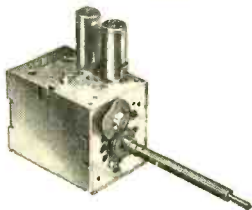

only
\$7.50

That's right. Net, \$7.50 per unit and \$15 for UV combinations, including ALL replacement parts. 90-day warranty against defective workmanship and parts failure. Tuners repaired on approved, open accounts. Replacements offered at these prices* on tuners not repairable:

VHF 12 position tuner.....	\$22.00
VHF 13 or 16 position tuner.....	23.00
VHF/UHF combination.....	25.00
UHF only.....	15.50

* Subject to change



Tarzian-made tuners are easily identified by this stamping on the unit. When inquiring about replacements for other than Tarzian-made tuners, always give tube complement . . . shaft length . . . filament voltage . . . series or shunt heater . . . IF frequency and chassis identification. Use this address for fast, 48-hour service:

SARKES TARZIAN, Inc.

Att.: Service Dept. A, Tuner Division
East Hillside Drive Bloomington, Indiana

PORT ARTHUR COLLEGE ELECTRONICS COMMUNICATIONS

AM FM Television Broadcast Engineering
Marine Radio Radar

CHECK THESE FEATURES: Tuition \$34 per mo., room & board \$50 per mo. in dorm on campus. College operates 5 KW broadcast station. Students get on-the-job training at studios on campus. FCC license training with all courses. Well equipped classrooms & lab., am fm transmitters, radar & marine eqmt., television camera chain, experiment lab test eqmt. & other training aids. Our graduates in demand at good salaries. Free placement service. Have trained men from all 49 states. Approved for GI. Write to Dept. PE-8 for details.

PORT ARTHUR COLLEGE Port Arthur
Established in 1909 Texas



MOBILE-FIXED CONVERTER POLICE • FIRE • CITIZENS' BAND

#315A is a practical converter for emergency use. Easily installed. Tuning range approximately 12 MC in the 26-50 MC band - 15 MC in the 152-162 MC band. Designed for mobile or home use. **\$13.95**

Available crystal controlled up to 54 MC. **\$18.95**

Also available crystal controlled up to 165 MC. **\$22.50**

ORDER TODAY or WRITE for LITERATURE

KUHN ELECTRONICS
20 GLENWOOD CINCINNATI 17, OHIO

denly changed into a place filled with mystery and menace in the dark.

AS the little campfire flickered bravely, grotesque shadows leaped and fell amid the surrounding bushes. The tall trees seemed to lean in and tower threateningly over the two boys. The deathly stillness was broken only by strange chirps and cries and the rustling of the fallen leaves.

"Kinda spooky, ain't it?" Carl said, as he hugged his knees and threw back his head to peer through the openings in the leaves at the stars twinkling overhead.

"Yeah," Jerry agreed. "I suppose those are squirrels and field mice we hear out there—"

He was interrupted by the thud of a heavy body striking the earth somewhere out beyond the ring of light cast by their fire, and this was followed by what sounded like a muffled human curse.

"Field mice are pretty b-b-b-big around here, aren't they?" Carl stammered in a hoarse whisper.

Jerry didn't answer. Attracted by some sound from the river below, he walked over to the edge of the cliff and looked down. Carl was right behind him, and as he looked over his chum's shoulder a sound of surprise escaped him. A circle of bright white light was moving slowly along the surface of the water.

"What do you know!" Carl exclaimed in a whisper; "underwater flying saucers!"

Before Jerry could answer he was frozen

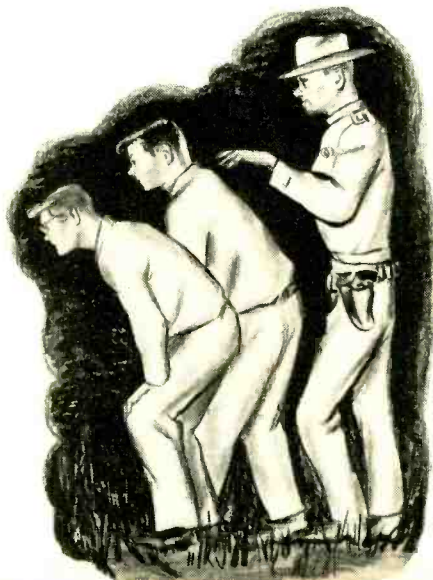

announcing

TRU-VAC®

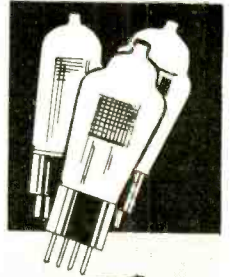

REMARKABLE TUBE VALUES AT 1950 PRICES

ALL TUBES INDIVIDUALLY BOXED, CODE DATED AND BRANDED "TRU-VAC®"

Typical TRU-VAC® Bargains!

THIS IS A PARTIAL LIST
Thousands More Always In Stock

6SN7GT	6W4GT	ALWAYS 30c	ALWAYS 30c						
OY4	3AU6	6A5	688	6CH8	657	784	12A16	12SA7	36
OZ4	3BC5	6A84	68A6	6C16	658GT	785	12A17	12S17	38
1A7GT	38N6	6AC7	68C5	6CM6	65A7	786	12AU6	12SK7	39/44
181GT	38Z6	6AF4	68C8	6CM7	65D7GT	787	12AU7	12SN7GT	41
1C6	3CB6	6AG5	68D6	6CN7	65F5	788	12AV6	12SQ7	42
1C7	3Q4	6AH4GT	68E6	6C08	65F7	7C4	12AV7	12V6GT	43
1F4	354	6AH6	68F5	6CR6	65G7	7C5	12AX4GT	12W6GT	45
1F5	3V4	6AK5	68G6G	6C56	65H7	7C6	12AX7	12X4	50A5
1G4	48Q7A	6AL5	68H6	6C05	65J7	7C7	12AZ7	14A7/12B7	50B5
1H5GT	48S8	6AM8	68J6	6C06	65K7	7E5	12B4	14B6	50C5
1L4	4B27	6AN8	68K5	6D6	65L7	7E6	12BA6	14Q7	50L6
1L6	4C86	6A05	68K7	6D16	65Q7	7E7	12B47	19	56
1NSGT	5AM8	6A06	68L7GT	6DG6GT	65R7	7F7	12B06	19AU4GT	57
1R5	5AN8	6A07	68N6	6D06	614	7F8	12R6	19B6G6	58
1S5	5AT8	6AR5	68Q6GT	6F5	6U8	7G7	12R6	19L6	71A
1T4	5AV8	6AS5	68Q7	6F6	6V6GT	7H7	12B7	19R8	75
1U4	5AZ8	6AT6	68R8	6H6	6W6GT	7H7	12R06	24A	76
1U5	5BR8	6AU4GT	68S8	6J4	6X4	7O7	12H87	25Z6G1	77
1V2	516	6AUSGT	68Y5G	6J5	6X5GT	757	12B7	26	78
1X2	5R4	6AU6	68Z6	6J6	6X8	7R6	12CA5	27	80
2AF4	5U4	6A08	6B27	6J7	6Y6G	7K7	12CN5	35	84/624
28N4	5U8	6AV5GT	6C4	6K6GT	7A4/XXL	7Y4	12D4	35A5	117Z3
2CY5	5V4G	6AV6	6CB6	6K7	7A5	7Z4	12F5	35B5	
3A4	5V6GT	6AW8	6CD6G	6N7	7A6	12A8	12K7	35C5	
3A5	5X8	6AX4GT	6CF6	6O7	7A7	12A85	12L6	35W4	
3AL5	5Y3	6AX5GT	6CG7	654	7A8	12A05	12Q7	35Z5	

35¢

\$33 PER HUNDRED

For any used or factory second tube!

1 YEAR GUARANTEED PICTURE TUBES

Brand New* Allied A-1 Tubes Brand New
Below Listed prices do not include dud. Add Additional \$5.00 Deposit on tube sizes to 20"; on 21" and 24" tubes - \$7.50. Deposit refunded immediately when dud is returned prepaid. Aluminized tubes - \$4.00 extra.

Picture tubes shipped only to continental USA and Canada — All tubes F.O.B. Harrison, N. J.

10PA 7.99	10MPA 12.19	12CP4 16.99	15AP4 18.29	21AP4 18.79	21FP4 18.29	21YP4 18.29
12PA 10.49	12MPA 11.99	12CP4 17.99	20CP4 15.89	21AMP4 17.99	21BP4 18.29	21ZP4 17.49
14B/CP4 11.99	16PA 12.19	17MP4 16.99	20DP4 15.89	21AU4 18.79	21MP4 22.29	24AP4 19.49
16AD4 16.09	16PA 11.99	17FP4 16.99	20MP4 12.89	21AVP4 18.79	21FP4 18.29	24CP4 27.79
16DP4 12.19	17AP4 12.49	17DP4 13.89	21AP4 21.49	21AWP4 17.49	21MP4 17.29	24DP4 29.79
16GP4 16.09	17BP4 12.49	17FP4 16.99	21ALP4 18.79	21BP4 17.29	21CP4 17.49	

SENSATIONAL \$100,000 GIVE-AWAY
We want 100,000 new customers by Sept. 1st. For every new order of \$25 or more received by that date, we will send you a crisp, new dollar bill.

FREE FUSE CLIP!
Sent With Any Order Of \$5 Or More

GUARANTEE
Only TRU-VAC guarantees to replace free any tube which becomes defective in use within one year of date of purchase.

ATTENTION QUANTITY USERS!
Big Discounts Are Yours... Call or Write For Our 1000 Tube "Private Label" Special! Attention Branding Dept. MGR.

MONEY CHEERFULLY REFUNDED WITHIN FIVE (5) DAYS, IF NOT COMPLETELY SATISFIED!

TRU-VAC® PAYS YOUR POSTAGE
On orders of \$5 or more in U.S.A. and Territories. Send approximate postage on Canadian and foreign orders. Any order less than \$5 requires 25¢ handling charge. Send 25¢ on C.O.D.'s. All orders subject to prior sale.

Complying with Federal regulations, the following statement appears in all Tru-Vac advertising: Tubes appearing in this ad may be FACTORY SECONDS or USED tubes and are clearly marked.

TRU-VAC®

Harrison Avenue Box 107 Harrison, New Jersey
Humboldt 4-9770

Write Dept. L For FREE LIST OF Other Tube Types and Products Sold By TRU-VAC® Electric Company

Visit Our Huge Testing Dept. In The Heart Of Harrison, N. J.'s Electronics Industry

USED TV CONSOLES GUARANTEED To Work When You Receive Them

10" & 12"	\$29
14" & 16"	\$37
17"	\$45
19"	\$59
20" & 21"	\$70

All sets shipped in two cartons to avoid breakage. Sets shipped express to continental U.S.A. and Canada only. F.O.B. Harrison, New Jersey.

FREE BONUS—RABBIT EARS
\$7.95 Value
FREE with each set purchased

BIG MONEY IN THE 4 CORNERS OF THE WORLD!

in TELEVISION, RADIO,
ELECTRONICS, RADAR, SONAR

**ONLY CHRISTY OFFERS
COMPLETE TRAINING!**

Investigate the Christy Complete Course. Why be satisfied with less? CTS Shop Method, Home Training makes learning easy. You learn by working with actual equipment. You receive Comprehensive training from the start. Can **EARN AS YOU LEARN**. You become qualified to open your own Electronics Repair business or to gain high pay as a TV, Radio, Electronics, etc., Technician.

17 TRAINING KITS INCLUDED! You receive a Multi-Tester, Oscillator, Signal Tracer, Oscilloscope, Signal Generator, Electronic Timer, Regenerative Radio, 24" TV set (optional) and other valuable testing equipment. **FREE BOOK** and **TWO FREE LESSONS** yours for the asking! No obligation.

CHRISTY TRADES SCHOOL

3214 W. Lawrence Ave.
Dept. T-186 Chicago 25, Ill.



**SEND for 3
FREE BOOKS**



CHRISTY TRADES SCHOOL, Dept. T-186
3214 W. Lawrence Ave., Chicago 25, Ill.

Please send me the 3 FREE BOOKS and Special Form for
PAYING LATER from EARNINGS MADE WHILE LEARNING.

NAME AGE.....

ADDRESS

CITYZONE.....STATE.....

HEAR MARITIME, COAST GUARD, POLICE BROADCASTS IN YOUR CAR—

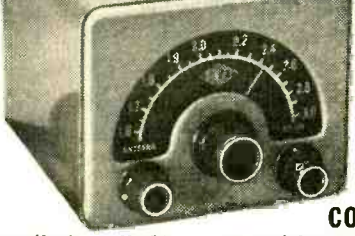

**GONSET
CONVERTER**

easily installed/operates with your car radio
Now you can extend the reception of your car radio to include the widely used frequency range of 1600 to 3000 Kc. The Gonset Converter lets you switch instantly from standard broadcast to police broadcasts, ship-to-shore and ship-to-ship communications, special weather and time broadcasts, and amateur frequencies of 1.8 to 2 Mc. Full-vision dial is precisely calibrated. Simple plug-in installation requires no soldering or technical knowledge.* Only 3½" x 4" x 4". Aluminum case, hammertone gray. Model 3163... Only \$29.50.

Write for free literature and name of dealer in your area.



GONSET Division/Young Spring and Wire Corp.,
Burbank, California. *USABLE ONLY ON 12-VOLT BATTERY SYSTEMS

by the clutch of a huge hand on his shoulder.

"Be quiet!" a man's voice whispered gruffly. "I'm the game warden, and the light you see is on the boat of a couple of guys who are illegally spearing fish. I saw your fire and thought you boys might be connected with them until I sneaked up and heard you talking. I tripped over a root out there in the darkness and darned near broke my neck. Did you hear me?"

"Did we!" Jerry quavered. "Mister, don't ever sneak up and grab me like that again. If you hadn't got a good hold on me, I'd have jumped right off that cliff."

"I'm sorry," the warden said, "but I was afraid you'd call out or something and scare the giggers away. Now I'm going back to my car and radio for help. We'll catch those two red-handed."

"We're going along," Jerry announced. "You've spooked us until we're afraid to stay here alone."

THE CAR parked along the road at the foot of the hill was easy to spot because its courtesy light was shining out the open door.

"Oh, oh!" the warden exclaimed; "someone's been here. I never left that door open."

Someone *had* been there; and that someone had ripped out the speaker from beneath the dash, had broken off the little whip antenna protruding from the roof, and had stolen the distributor rotor from the engine.

"The spearkers did this," the warden said bitterly. "Those two are always armed and know I can't take them by myself. They wrecked my radio and crippled my car to make sure I don't get help. The transmitter and receiver are locked up in the trunk out of reach, but their making off with the speaker and breaking the antenna puts both units out of commission anyway. Now they're out there slaughtering all kinds of fish just for the fun of it—they only keep about one fish in ten they kill with the gig—and they're laughing at me, knowing I can't do a thing about it."

"I'm not so sure," Jerry said as he used the warden's flashlight to peer beneath the raised hood. "You got any tools?"

The warden unlocked the trunk and brought out a small tool box.

"Here, Carl, use these pliers to cut a strand of wire from that old fence," Jerry

Brand New!



Special to
our readers
for only...

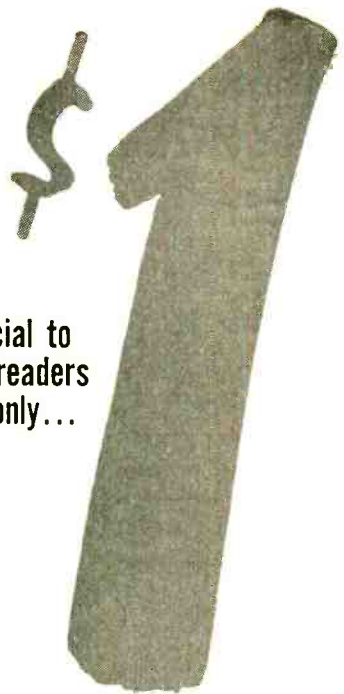

As a man who is seriously interested in hi-fi, you will certainly want to be among the first to take advantage of this new and important test record. It will enable you to know your system inside-out. As a result, your listening enjoyment will be even greater than ever before.

Here are some of the questions this record will answer for you!

- ✓ How good is my stylus? Is it worn? Will it damage my records?
- ✓ What about my stereo cartridge? Does it have enough vertical compliance so that it won't ruin my expensive stereo records?
- ✓ Is my turntable running at the right speed? Is it free of rumble, wow, and flutter?
- ✓ What sort of standing waves do I get in my listening room?
- ✓ Are my speakers hooked up correctly? Are they phased properly, and is the correct speaker connected to the right stereo channel?
- ✓ How perfectly is my system equalized?
- ✓ What about separation? Is it adequate?

You'll get on-the-spot answers to these and many other questions when you use this Stereo-Monophonic Test Record. It's the most complete test record of its kind—contains the widest range of essential check-points ever incorporated into one test disc! And, best of all, you need no expensive test equipment when you use this record! Just listen and get the thorough results you want—all checks can be made by ear!

As a man who is seriously interested in hi-fi, you can immediately see the ex-

traordinary 2-way value you get from this special test record. First, it guides you in evaluating the quality of reproduction your equipment now produces. Second, it specifies the adjustments necessary to get the best recorded sound you have ever heard! Add up the advantages! Check the special low price! This is easily the best value of the year for everyone who owns a hi-fi system—either monophonic or stereo!

Supply limited—Order your Test Record for just \$1 now!

This stereo-monophonic test record will only be sold to you by mail, at the special reader-price of just \$1. You can be sure that it comes as close to perfection as is humanly possible, because the editors of *Electronics World*—leading technical magazine in the field of electronics—have poured their accu-

mulated know-how into this project for a period of many, many months. But the supply is limited, so it will have to be *first-come, first-served!* Avoid disappointment—place your order right now. Fill in and mail the coupon, together with your check (\$1 per record) today!

Special Features of ELECTRONICS WORLD
7" Stereo-Monophonic Test Record

- Four bands for stereo checks only—plus three bands for checking stereo or monophonic equipment!
- Made of top-quality virgin vinyl for long wear!
- Specially-reinforced center resists wear!
- Delivered in special polyethylene envelope—dust and dirt are sealed out!
- Fully guaranteed!

POPULAR ELECTRONICS • P.O. Box 8, New York 8, N. Y.

Please send me _____ test records at \$1 each. My check (or money order) for \$_____ is enclosed. I understand that you will pay the postage and that each record is fully guaranteed.

Name _____ Please print

Address _____

City _____ Zone _____ State _____

SORRY—no charges or C.O.D. orders!

E8

Send
**POPULAR
ELECTRONICS**
Every
Month

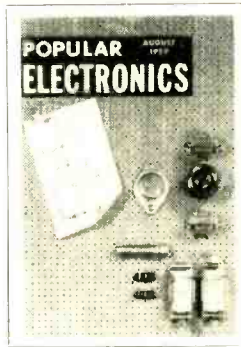

name _____

address _____

city _____ zone _____ state _____

- Check one: 3 years for \$10
 2 years for \$7
 1 year for \$4

In the U. S., its possessions and Canada. **Foreign rates:** Pan American Union countries, add .50 per year; all other foreign countries, add \$1 per year.

Mail to: POPULAR ELECTRONICS
 Dept. PE-89, 434 South Wabash Ave., Chicago 5, Ill.

ordered as he traced some figures in the sand with his finger. "Let's see: this rig works somewhere around 154 megacycles. A quarter-wave antenna in inches equals 2770 divided by the frequency in megacycles, or about eighteen inches. Cut a piece of wire that long according to the steel tape and tape it to the stub of the antenna on the roof."

"You going to transmit blind? You won't be able to hear without a speaker," Carl pointed out.

"I'm going to try to use one of the car horns for a speaker," Jerry's muffled voice came from where he was upended across the car fender as he unbolted a horn mounted behind the grille.

IN A FEW MINUTES the makeshift antenna was in place and the auto horn was lying on the front seat and was connected to the broken speaker leads. Jerry handed the mike to the warden. "Let's try it," he said.

The warden pushed the button on the mike, and the dynamotor could be heard whirring in the trunk. He gave a short call for the sheriff's office and released the transmit button. Instantly an answering voice, far away and tiny but perfectly intelligible, came from the horn.

"It's not exactly hi-fi, but it works!" Jerry gloated.

Quickly the warden explained the situation. Arrangements were made for the sheriff to come out and help capture the poachers. A game warden and sheriff from an adjoining county were to approach on the other side of the river to cut off possible escape that way. "And bring me another rotor for my distributor," the warden said as he signed off.

While waiting for the sheriff to arrive, the warden and the two boys scouted up and down the river bank until they located the boat trailer well hidden in some bushes. That told them where the fish-giggers would land, so when the sheriff arrived an ambush was quickly organized. They were none too soon, for almost immediately the bright circle of light that the boys had seen once before now appeared around the edge of the bluff and came directly toward them.

As the light approached, the boys could see that two gasoline lanterns were mounted on a platform fastened to the front of the flat-bottomed boat right at

YOURS FREE-
**THIS BIG WALSCO
 ELECTRONICS PRODUCTS
 CATALOG!**

Send postcard today for your free copy of Walsco's 64-page Catalog 59... or ask for one at your distributor.

WALSCO ELECTRONICS MFG. CO.
 Division of Textron Inc.
 Western Plant: Los Angeles 18, California
 Main Plant: **ROCKFORD, ILLINOIS, U. S. A.**
 In Canada: Atlas Radio Corporation

**CODE! - DIFFICULT?
 NOT WITH YOUR TAPE RECORDER**

TAPEDCODE

**THE FINEST
 MOST COMPLETE
 COURSE AVAILABLE**

NOVICE—Basic learning & Practice to 8 WPM \$6.50
 ADVANCED—Practice material 9 to 18 WPM \$5.50
 Practice material is both plain language and code groups.
 COMPLETE COURSE—(Both above 2 hour tapes) \$11.00 Postpaid
 in U. S. & Can.—Pa. Res. include 3 1/2% tax. 7" Reels, 1200'
 (Acetate) Dual track recordings @ 33 1/3 IPS. From your local
 Ham Distributor. If he doesn't have them, order direct. Dealer
 Inquiries Solicited.

TAPEDCODE BOX 31B LANGHORNE, PA.

the water level. A curved hood of sheet aluminum kept the light from the eyes of the spearwielder standing on the front of the boat. The man at the rear of the boat poled it silently toward the shore.

The sheriff and warden waited until both men were on the bank, one carrying the spear and the other a big string of fish, when they turned a spotlight on them and

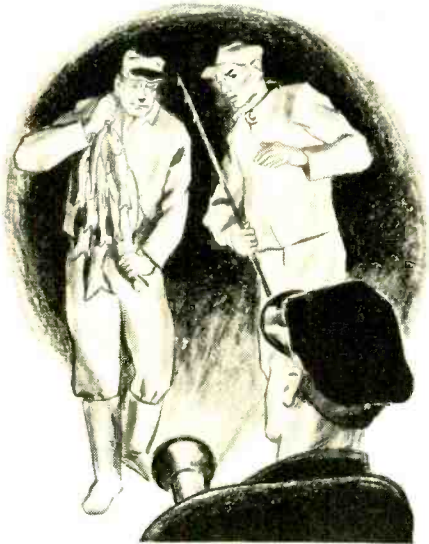

ordered them to surrender. The man with the gig tried to hurl it back into the river, but the warden was too quick for him and grabbed it. In a matter of minutes the men were handcuffed and ordered into the sheriff's car.

"If you boys are afraid to stay out here, you can ride back to town with me," the warden offered. "We certainly owe you a lot more than that for the help you gave us tonight."

"Aw, we're not scared now," Carl said. "I'm just shaking because this night air is turning chilly. But could we borrow your flashlight to find our way back to our tent?"

SOON the two boys were snuggled beneath their blankets watching the dying embers of the camp fire through the open flap of their tent.

"Well, Carl," Jerry said as he smothered a huge yawn, "we got away from electronics for a little while, anyway."

"That we did," Carl answered drowsily; "but electronics found us, even away out here."



**YOU
SAVE MORE!
YOU
SERVICE BETTER
with...**

EMC TEST EQUIPMENT

PRECISION MADE to assure highest quality...
LOWEST POSSIBLE PRICES with the most advanced engineering techniques guaranteed.

Model 206—Mutual Conductance Tube Tester

Checks mutual conductance on a calibrated microhmo and "reject-good" scale. Checks tube for gas content. Complete switching flexibility. Tests tubes for noise. Model 206P, with hand rubbed oak carrying case, \$83.50. Model 206C, sloping counter case, \$79.50. Model CTA, cathode ray tube adaptor, \$6.50.

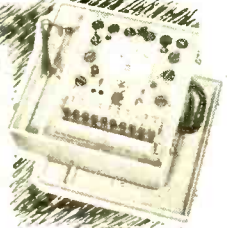

Model 104—Voltmeter

Features a 4 1/2", 50 microampere meter, with 3 AC current ranges and 3 resistance ranges to 20 megohms. Specifications... DC Voltage: 5 ranges (20,000 ohms per volt): 0 to 6-60-300-600-3000 volts. AC Voltage: 5 ranges (1,000 ohms per volt): 0 to 6-60-300-600-3000 volts. DC Current—3 Ranges: 0 to 6-60-600 ma. AC Current—3 ranges: 0 to 30-300 ma; 0 to 3 amps. 3 Resistance Ranges: 0 to 20K, 0 to 200K, 0 to 20 megs. 5DB Ranges: -4 to +67 DB.

Model 104, with carrying strap: Wt. 2 lbs. 5 oz. Size: 5 1/4" x 6 3/4" x 2 7/8", \$26.95; Kit, \$19.95. Model HVT, 30,000 volt probe for \$7.95.

Model 204—Tube-Battery- Ohm Capacity Tester

Emission tube tester. Completely flexible switching arrangement. Checks batteries under rated load on "reject-good" scale. Checks condenser leakage to 1 meg. Checks resistance up to 4 megs. Checks capacity from .01 to 1 mfd. Model 204P, illustrated, \$55.90. Model CRA, Cathode ray tube adaptor, \$4.50.

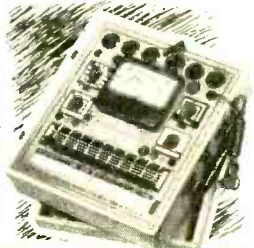

Yes, tell me more, send me **FREE**—a detailed catalog of the complete EMC line. **PE-89**

NAME _____

ADDRESS _____

CITY _____

STATE _____

EMC Electronic Measurements Corp.
625 B'way, New York 12, N. Y.
Ex. Dept., 432 Greenwich St., New York 13, N. Y.

Inside the Power Amplifier

(Continued from page 60)

to 1 — to match for example, a 4-ohm speaker to 10,000-ohm power tubes.

Feedback Loops. Despite every effort to keep distortion out of the amplifier, it always creeps in. The feedback loop is added to bring the distortion down to an acceptable level. The loop usually starts at

ways necessary to "trim" the feedback loop to obtain adequate stability.

The problem is to keep the feedback in the negative feedback loop from turning positive at extreme frequencies and causing a peak in the response curve, usually at some supersonic frequency between 20 kc. and 200 kc. If a peak is present, the amplifier will "ring" or may even go into outright oscillation at the peak frequency.

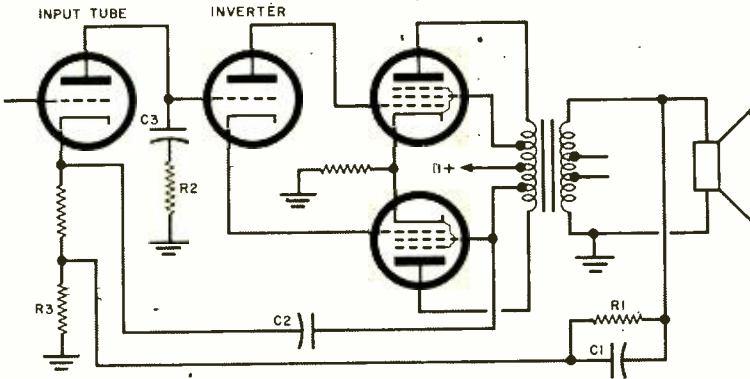
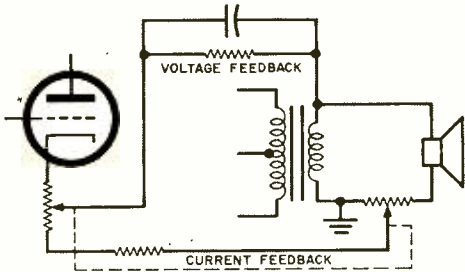

Fig. 3. Simplified diagram of feedback amplifier. Parallel circuit of R_1 and C_1 is primary feedback path. Additional "trimming" is provided by C_2 and bypass network of R_2 and C_3 . Note that components not essential to feedback operation are omitted for the sake of clarity.

Fig. 4. Ganged potentiometers allow varying the damping factor of the amplifier without affecting the amount of feedback.



the secondary of the output transformer and goes to the cathode of the input tube as indicated in Fig. 3. The amount of feedback is a function of the ratio of R_1 to R_3 and also of the gain inside the loop. In the highest quality amplifiers, designers aim for about 20 db of feedback; but even the most modest hi-fi amplifiers have 14 db.

Feedback is usually taken from a single tap on the secondary of the output transformer. At least one manufacturer, however, goes a little further. In Marantz amplifiers there is a separate loop for each tap to guarantee equal stability with speakers of various impedances.

Phase Correction. Feedback is worse than useless unless the amplifier is stable under operating conditions. It is almost al-

A 10- or 20-kc. square wave, as observed on a scope, gives a good indication of stability. In a perfectly stable amplifier the top of the trace should be flat. An unstable amplifier produces traces with jagged tops which indicate ringing.

An easy way to trim a feedback loop is shown in Fig. 3. By inserting a small capacitor (C_1) in parallel with the feedback resistor (R_1), the feedback remains truly negative over a wide frequency range. The value of C_1 is usually selected by observing a 10-kc. square wave on an oscilloscope and then trying various values until the best possible square wave is produced by the amplifier.

Sometimes additional trimming is needed. The Dyna amplifier obtains extra

trimming by putting an "inner" feedback loop inside the over-all loop, from the screen of one of the output tubes to the input cathode. This loop consists of capacitor C2, which rolls off the gain at the frequencies that are causing trouble.

Another way to obtain this roll-off is by inserting a bypass or "step" network inside the feedback loop to bypass the troublesome frequencies to ground. This is the function of R2 and C3 in Fig. 3.

Damping Factor. The greater the feedback factor, the more the amplifier damps a loudspeaker. A certain amount of damping is highly desirable to remove peaks in the speaker response and to improve the transient response. But too much damping may reduce the bass efficiency of some speakers and result in a "dead" tone.

Actually, while every speaker has a critical or optimum damping factor, there is a great deal of controversy as to the objective necessity for adjusting an amplifier to it. In any case, an amplifier's damping factor can be adjusted by using a second feedback loop to provide *current* feedback which, while it also decreases distortion, has the effect of decreasing damping instead of increasing it. By varying both the voltage and current feedback loops with a ganged pot, as in Fig. 4, simultaneously but in opposite directions, it is possible to keep the over-all feedback factor constant but provide a wide variation in damping factor. Many amplifiers provide such a damping control.

Five or ten years ago, the true hi-fi fan looked with scorn on any power amplifier that wasn't built on two chassis, had fewer than eight tubes, and weighed less than 30 pounds per chassis. Nowadays amplifiers have been greatly reduced in size and complexity, and due to the availability of new tubes and output transformers, they outperform their predecessors handily.

Price has also been brought down considerably, and one well-known amplifier kit offers hi-fi output at a cost of less than a dollar a watt. We don't know what the future holds in store for us, but if improvements in amplifier design continue at the pace of the last ten years, the amplifiers of the future should approach perfection.

Be sure and join us next month for a discussion of hi-fi tuners. If you own a tuner, or are planning to buy one, you should find "Inside the Hi-Fi Tuner" of considerable interest.

Make More Money Soon Fixing Electric Appliances

Train at Home in Spare Time



Better Pay—More Opportunities

Get into a field where there is important work and opportunity for the trained man. Millions of electric appliances are sold every year. Every wired home now has an average of 8. Many of them need service and repair. Owners pay well to have them fixed quickly, properly. This is your opportunity for a better job, your own part time or full time business. NRI can give you the training you need, at home, in your spare time.

Spare Time Earnings Start Soon

Soon after starting you will be able to earn extra cash fixing toasters, clocks, fans, vacuum cleaners, etc., for neighbors and friends. Keep your job while learning and earning. Put spare time to work for you. Work in your basement, garage, spare room. You'll be amazed how easily, quickly you, too, can start earning many extra dollars. NRI shows you how. Even before you finish training your spare time earnings may pay for the course and equipment.

NRI Sends Tester to Learn and Earn

You need proper equipment to service today's automatic appliances. With this course you get parts to build professional type, multi-use Appliance Tester. You learn to use it. Takes guess work out of servicing. Mail coupon for FREE book and Sample Lesson. See how easy it is to learn. Find out about NRI—a school that for more than 40 years has been training men, through home study, for success, good pay jobs. Our reputation, record, experience back up this course. Write now to: NATIONAL RADIO INSTITUTE, Dept. D4119, Washington, D. C.



**FREE Lesson and Book
Mail this NOW!**

NATIONAL RADIO INSTITUTE

Dept. D4H9, Washington 16, D. C.

Send me Lesson and Book Free. No Salesman will call.

Name Age

Address

City Zone State

Accredited Member National Home Study Council

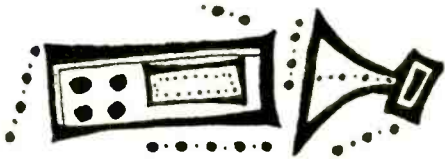

WANTED!

*Equipment,
components or parts!*

The 235,000 purchasers of POPULAR ELECTRONICS are always in the market for good used equipment or components. So, if you have something to sell, let PE readers know about it in our classified columns.

It costs very little: just 50¢ per word including name and address. Minimum message: 10 words. For further information, write:

Martin Lincoln
POPULAR ELECTRONICS
One Park Ave., New York 16, N. Y.

ENGINEERING DEGREES



E.E. Option Electronics or Power Degree Courses in Liberal Arts & Bus. Admin.

Also Earned through Home Study
Pacific International College of Arts & Sciences

Primarily a correspondence School
Resident classes also available
5719-W Santa Monica Blvd.
Hollywood 38, California

GET INTO ELECTRONICS

V.T.I. training leads to success as technicians, field engineers, specialists in communications, guided missiles, computers, radar, automation. Basic & advanced courses in theory & laboratory. Assoc. degree in 29 mos. B. S. obtainable. ECPD accredited. G.I. approved. Graduates with major companies. Start Sept., Feb. Dorms, campus. H. S. graduates or equivalent. Catalog.

VALPARAISO TECHNICAL INSTITUTE
Dept. PE VALPARAISO, INDIANA

On the Citizens Band



By TOM KNEITEL, 2A0305

IN RECENT months there has been a heap of interest in the new 27-mc. (11-meter) Citizens Band. Along with the interest, there has been a big cloud of dust kicked up by manufacturers eager to get their CB equipment on the market, with new rigs appearing faster than you can say "transceiver."

The prospective CB'er therefore has many sets to choose from before deciding which rig is the one for him. If you are going to contact only your Uncle Elmer's set, you need not worry about having a tunable receiver. If you intend to work various stations which may or may not be operating on your own frequency, you will want a tunable job.

Transceivers made by International Crystal are available in either version. Others, like Gonset and RCA models, send and receive on one channel. Globe, Polytronics, and Multi-Elmac sets send and receive on 3-, 4-, and 5-crystal controlled channels (respectively). The soldering gun crowd will be pleased to see a number of kits on the market, with many of the major circuits pre-wired.

Of the kits available, we just recently tried out the one made up by Essco. This kit is based generally on the Stoner unit shown in the March RADIO & TV NEWS, plus several improvements.

Using a ground plane antenna on top of a 15-story building, we grabbed off an S-5 report from a station over 20 miles distant. We worked a solid S-8 contact with a station 15 miles away in a valley, and also snagged numerous local boys who reported that we were making them jealous with our ferocious signal. We then tried just a mobile whip on the window sill on the first story and had reliable contacts over five miles away. This set is a peewee in size, but it's packed with power.

One of the big things in CB is going to be antennas. With everyone running five watts, the deciding factor in signal

strength will be what happens to the signal when it leaves the transmitter's antenna posts.

From our preliminary experiments with antennas, we found that height is a big factor in tossing the signal into the ether. Not that without the height you should throw in the towel, but a little altitude will give you that extra zing. Of course this relates mainly to "ground wave" contacts. When "skip" conditions are right, you'll be able to knock off stations hundreds of miles away even if you operate from the bottom of a well.

Station activities in New York are progressing nicely. Most of the stations are active on the lower CB channels (Channel 1 through 7), with just about everyone raising a squawk about the periodic diathermy noise which wipes out a handful of channels at a clip. There is also a c.w. station somewhere which sort of murders the CB Channel 4 (27.005 mc.) with some regularity when the band is "open."

The most convenient way to calibrate your receiver if you live in New York is to line it up with what is lovingly known as "Boop-Beep." This is an R/C signal with a real loud carrier on 27.255 mc.

In the area of New York City, the biggest CB signal is 2W1352, operated by Fred Turner in Brooklyn. Fred keeps his transmitter tuned to the teeth, with nary an ounce of signal lost en route to his antenna, which happens to be a ground plane on the roof of Fred's house.

The local "ground-wave" distance record for a two-way contact is held by, of course, 2W1352, who worked Bob, 2W1409, in Franklin Lakes, N. J., about 25 miles as the carrier flies.

The best signal from out of town has been 19W1552, ably run by Joe Baznik in Cleveland, Ohio. Joe has been heard in New York several times during the past few weeks with an S-7 signal.

A word to the wise should remind CB'ers that they are *not* allowed to work Canadian hams, who are still quite active on 11 meters. CB stations are allowed to QSO only other CB stations, and this doesn't include VE's, no matter how tempting they are.

If you are now on the air, or if you just listen on 11 meters, we would like to hear from you. Tell us about your station, your antenna, your contacts (or stations heard), and the general 11-meter activity in your area.

prepare for your career in

ELECTRONICS ELECTRICAL ENGINEERING RADIO-TV COMPUTERS



At MSOE, you can equip yourself for a career in many exciting, growing fields:
**MISSILES • RADAR • AVIONICS
AUTOMATION • RESEARCH
DEVELOPMENT • ELECTRICAL
POWER • ROCKETRY**

When you graduate from the Milwaukee School of Engineering, you are prepared for a dynamic career as an Electrical Engineer or Engineering Technician. Under a faculty of specialists, you gain a sound technical education in modern, completely equipped laboratories and classrooms. As a result, MSOE graduates are in great demand and highly accepted by industries nationally.

At MSOE, you will meet men from all walks of life and all parts of the country — some fresh out of high school or prep school, others in their twenties — veterans and non-veterans.

You can start school in any one of four quarters and begin specializing immediately. Engineering technicians graduate in 2 years with an Associate in Applied Science degree. For a Bachelor of Science degree in Engineering, you attend 4 years. A 3-month preparatory course also is available.



FREE CAREER BOOKLET!

If you're interested in any phase of electronics, radio or television, be sure to look into the programs of study offered by the Milwaukee School of Engineering. Just mail the coupon.

MILWAUKEE SCHOOL OF ENGINEERING

Dept. PE 859 1025 N. Milwaukee St.
Milwaukee, Wisconsin

Please send FREE Career Booklet. I'm interested in
 Electronics Electrical Power Television
 Mechanical Engineering Radio Computers
 Electrical Engineering Industrial Electronics

PLEASE PRINT

Name _____ Age _____

Address _____

City _____ Zone _____ State _____

I'm eligible for veterans education benefits

MS-12S



HOW DO YOU LIKE MY VIKING "NAVIGATOR" WITH TIMED SEQUENCE KEYING? **BOY! IT'S REALLY SWEET! 40 WATTS INPUT-- BUILT-IN VFO--T.V.I. SUPPRESSED--IT'S EASY TO OPERATE AND PUTS OUT A SOLID SIGNAL!**

WELL, NOW THAT YOU'VE OPERATED BOTH THE VIKING "ADVENTURER" AND "NAVIGATOR" TRANSMITTERS AT THE CLUB STATION--WHICH DO YOU LIKE BEST? **I'D RECOMMEND EITHER UNIT. THEY'RE BOTH AVAILABLE IN EASY-TO-BUILD KITS --BOTH PRODUCE A CLEAN CW NOTE-- AND THEY'RE PRICED RIGHT, TOO!**

OUR COMMUNITY WANTS TO THANK YOU AND YOUR FELLOW AMATEUR OPERATORS FOR A JOB WELL DONE.

CIVIL DEFENSE

THANK YOU FOR THE PUBLIC SERVICE AWARD--BUT WE CAN'T TAKE ALL THE CREDIT. OUR VIKING TRANSMITTERS REALLY STOOD UP UNDER SEVERE CONDITIONS, PROVIDING US WITH CONTINUOUS AND RELIABLE COMMUNICATIONS!

E. F. JOHNSON COMPANY
2713 Second Ave., S. W., Waseca, Minnesota

Name _____
Address _____
City _____ State _____

MAIL TODAY FOR YOUR FREE CATALOG

SAY YOU SAW IT IN POPULAR ELECTRONICS

NEW MAGIC RADIO WALKIE TALKIE

YOUR OWN POCKET SIZE RADIO STATION!
BROADCASTS TO ANY HOME OR CAR RADIO WITHOUT WIRES OR HOOKUPS! Wt. only 5 oz. Size only 1 1/2" x 2 1/2" x 4 1/2". Built-in telescoping antenna. Powerful Transistor-sensitive microphone, frequency setter, break-in switch! Runs for weeks on self-contained flashlight batteries. Durable plastic case. With this Radio Talkie you CAN TALK TO YOUR FRIENDS nearby or--TALK between two or more automobiles--INSTANT OPERATION--Just push button to talk! No license needed. Uses inductive field magnetic radiation. Useful and real fun in a million ways! GUARANTEED TO WORK. 1 YEAR SERVICE GUARANTEE.

SEND ONLY \$3.00 (cash, ck. mo) and pay postman \$9.98 COD postage or send \$12.99 for prepaid delivery. COMPLETE READY TO OPERATE with instructions and hundreds of ways and tricks for broadcasts thru any radio you desire. Get your NEW POWERFUL RADI-VOX RADIO TALKIE NOW.

Available only from: WESTERN RADIO, Dept. REL-8, Kearney, Nebr.

INVENTORS

Send for **PATENT INFORMATION Book and INVENTOR'S RECORD** without obligation

GUSTAVE MILLER
89-PE WARNER BUILDING WASHINGTON 4, D. C.

REGISTERED PATENT ATTORNEY
ASSOCIATE EXAMINER
U.S. PAT. OFF. 1922-1929

Patent Attorney & Advisor
U. S. NAVY DEPT. 1930-1947
PATENT LAWYER

products

(Continued from page 38)

ard 2-conductor phone plug, \$1.90. Two phono jack connectors in parallel with a



standard phono plug, \$1.75. All adapters are completely shielded.

9-VOLT TRANSISTOR BATTERIES

Two new 9-volt transistor batteries are being made available by *Olson Radio Warehouse*, 260 South Forge St., Akron, Ohio. Model BA-48 is 1" in diameter and 2" long including terminals. Model BA-50 is 1 1/16" x 1" x 5/8". Both have snap-type polarized connectors. These batteries are designed for use in all types of miniaturized transistor equipment.

BULK ERASER FOR MAGNETIC TAPE

Lafayette is offering a professional-type bulk eraser for all magnetic recording tapes. This heavy-duty degausser will handle any reel up to 10 1/2" in diameter. The field generated is strong enough to erase any tape without rewinding or turning the reel over.



In operation, the reel is placed on the degausser, rotated until each segment of the reel passes over the field area several times, then lifted off slowly to a distance of six or more feet. The demagnetizer is then switched off and the tape is ready for re-recording. List price, \$21.50. (*Lafayette Radio*, 165-08 Liberty Ave., Jamaica 33, N. Y.)

PLUG-IN INVERTERS

A line of d.c.-to-a.c. inverters ideally suited for use in automobiles is being offered by *American Television and Radio Co.*, 300 East 4th St., St. Paul, Minn. These inverters are for operation with 6- or 12-volt d.c.

inputs and provide enough power output to operate tape recorders, record players, and other small electrical devices from the cigarette lighter receptacle found in most au-



tomobiles. There is a plug-in attachment for easy connection to the lighter receptacle. List prices are from \$19.95 up, depending on the power-handling capacity required.

FIVE-PIECE PLIER SET

Kraeuter & Co., Inc., 583 18th Ave., Newark 3, N. J., is marketing a 5-piece set of pliers consisting of an electrician's side cutter, heavy-duty diagonal, all-around diagonal, chain nose with cutter, and chain nose hobby plier. A metal bracket which

fits home workshop peg-boards is supplied with the kit. Price, \$16.40.

"MAGNERAMIC" STEREO CARTRIDGE

A newly designed ceramic stereo cartridge has recently been announced by *Electro-Voice, Inc.*, Buchanan, Mich. The "Magneramic 31" features a built-in printed circuit which converts the output to a velocity curve. This enables direct plug-in to magnetic phono inputs. Frequency response is from 20 to 20,000 ± 2 db, channel separation is 28 db at 1000 cps, and vertical

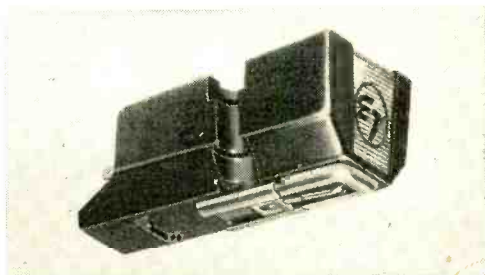

and lateral compliance is 3.5×10^{-6} cm/dyne. Recommended tracking weight is 2-4 grams. Available with 0.5-mil or 0.7-mil diamond styli. Net, \$24.00.

-30-

2-WAY CITIZENS RADIO TELEPHONE

(27 MC. CLASS D)



PRICE
\$124.⁵⁰

No exam for FCC license . . . !

for

- BOATING
- HOME
- FARMING
- CAMPING

- MOBILE
- BUSINESS
- SPORTS
- INDUSTRY

5 CRYSTAL CONTROLLED CHANNELS
SQUELCH CIRCUIT • NOISE LIMITER
5 WATTS OF POWER • 7 TUBES IN RECEIVER

Two Models: MODEL CD-5/6 6 VOLT DC AND 110 VOLT AC
MODEL CD-5/12 12 VOLT DC AND 110 VOLT AC

See your dealer, now!

Citi-fone®

*Price includes: MICROPHONE, 1 SET OF CRYSTALS,
1 AC CORD, 1 DC CORD WITH CIGAR LIGHTER PLUG

by
MULTI-ELMAC

MULTI-PRODUCTS COMPANY
21470 COOLIDGE HWY. OAK PARK, MICHIGAN

AMAZING MINIATURE BROADCAST TRANSMITTER



FOOL YOUR FRIENDS with this transmitter... by broadcasting on 10 any radio or car radio and watch their startled faces when they hear YOUR voice on their radio. Can be used as FUN MAKER, P.A. SYSTEM, WALKIE TALKIE, CAR TO CAR COMMUNICATIONS and MANY OTHER USES described with instructions. Use on HUNTING and FISHING TRIPS.

Completely portable (5 3/8" x 3 1/2") with self contained batteries. **ABSOLUTELY WIRELESS**... no wires to run to your radio... No GROUND WIRES or HOLES TO make on transmitter... Works up to ONE BLOCK OR MORE... NO LICENSE REQUIRED. The "HALICASTER" transmits THROUGH WALLS! SIMPLY push the button and talk!

The "HALICASTER" has a built-in station selector so you can tune in on any station you desire! SEND ONLY \$1.00 CASH, CHECK OR MONEY ORDER and PAY POSTMAN THE BALANCE OF \$8.95 FOR TESTED READY TO USE "HALICASTER" OR SEND JUST \$9.95 FULL PRICE AND WE PAY POSTAGE.

(Batteries \$2.50 extra)

Kit now available for **\$7.95 full price**
Available only from **HALCO ELECTRONICS, DEPT. A,**
9211 Venice Blvd., Los Angeles 34, California

ALL BAND TRAP ANTENNA!

Reduces interference and noise on All Makes Short Wave Receivers. Makes World Wide Reception Stronger. Clearer on All Bands!



For ALL Amateur Transmitters. Guaranteed for 300 Watts. Power for Packet or Link Direct Feed, Light, Neon, Weatherproof

Complete as shown total length 102 ft. with 87 ft. of 72 ohm balanced feedline. Hi-impact molded insulators and sealed automatic frequency changing resonant traps (Wt. 3 oz. 1" x 5" long). You just tune to desired band for best results. Excellent for ALL world wide short wave receivers and amateur transmitters. For NOVICE AND ALL CLASSES AMATEURS! NO EXTRA TUNING OR GADGETS NEEDED! Eliminates 5 separate antennas with better performance guaranteed. NO HAYWIRE HOUSE APPEARANCE! EASY INSTALLATION!
80-60-20-15-10 meter bands. Complete assembled... \$12.95
40-20-15-10 meter bands. 54 ft. antenna, assembled... \$11.95
80-15-10 Dual Trap. 24 ft. Antenna, assembled... \$18.95
SEND ONLY \$1.00 (cash, ck., mo) and pay postman balance COD plus postage on arrival or send full price for postpaid delivery. Available only from:
WESTERN RADIO • Dept. AEL 8 • Kearney, Nebraska

earn as TAX EXPERT

\$15
HOURLY

Our students earn as much as \$3,000 in 3 short months preparing income tax returns in spare time. Also operate lucrative year-round Business Tax Service. Dignified home-office business. Experience unnecessary. We train you; help you start. State approved home training program. Write today for free prospectus.

UNION INSTITUTE Lakewood 30-B, New Jersey

ENGINEERING
DEGREE IN
27 MONTHS

INDIANA TECHNICAL COLLEGE

B.S. degree (27 mo.): Aero., Chem., Civil, Elec., Mech. & Electronics.
B.E. (36 mo.): Aero., Chem., Civil, Elec., Mech., Metallurgical, B.S. (36 mo.): Math., Chem., Physics.
Preparatory courses. Demand for graduates. Campus. 20 bldgs.; dorms; gym. Low rate. Earn board. G.I. app. Enter Sept., Dec., March, June. Catalog.
2389 E. Washington Blvd.
Fort Wayne 2, Ind.
Keeping pace with progress



LOOK

NO FURTHER... IF YOU'RE UNHAPPY WITH "HI" HI-FI PRICES. WRITE FOR OUR UNUSUAL AUDIO CATALOG.
KEY ELECTRONICS CO.
120-B Liberty St., N. Y. 6

EASY TO LEARN CODE

Learn to increase speed with an Instructograph—the Radio-Telegraph Code Teacher that takes the place of an operator-instructor and enables anyone to master code without further assistance. Available tapes from beginners alphabet to typical messages on all subjects. Speed to 40 WPM. Always ready-to GO! Thousands have "acquired the code" with the Instructograph System. Write today for convenient rental or purchase plans.

INSTRUCTOGRAPH COMPANY
4713 SHERIDAN ROAD, CHICAGO 40, ILLINOIS
357 West Manchester Ave., Los Angeles 3, California



Transistor Topics

(Continued from page 102)

sistor interchangeability chart, and many complete schematics of commercially built transistorized gear—ranging from single-transistor preamps to multi-band short-wave receivers. Included, too, are numerous schematics of special-purpose transistorized equipment, such as a short-wave converter, phono oscillator, transistorized photoflash, lamp flasher, and test instruments. For price and delivery information, contact your local parts distributor or write directly to Coyne.

F.A.T. Transistors. In the past, transistor manufacture has been largely a hand operation, in contrast to the fully automatic methods used in the production of vacuum tubes. This, in part, accounts for the relatively higher price of transistors versus tubes. However, the Lansdale Tube Company (division of Philco Corporation) has recently installed semi-automatic production equipment which greatly speeds up the manufacture of high-frequency transistors.

Using this equipment, nine operators can turn out 450 transistors per hour—or, with two shifts working, up to 1,000,000 transistors per year. The components are moved from one processing station to another using rapid automatic transfer techniques, with the result that the system has been dubbed a "F.A.T." line (for Fast Automatic Transfer).

Product News. The Heath Company (Benton Harbor, Mich.) has introduced a transistorized code practice oscillator kit. Designed specifically for Boy Scout groups and beginning radio amateurs, it uses a single transistor and is powered by two size "C" cells. A panel switch allows selection of either the built-in loudspeaker for tone operation or a blinker light indicator for silent practice.

The "in-circuit" transistor tester recently developed by Philco Corporation is now being produced by a Philco subsidiary, Sierra Electronic Corporation (Menlo Park, Calif.). This instrument permits a check of transistor *beta* to an accuracy of 5%, accomplished in almost all cases without removing the transistors from their circuits.

Argonne Electronics Manufacturing Corporation (165-11 South Road, Jamaica 33, N. Y.) has a new six-transistor personal-

sized receiver. Available through the nearly 700 Argonne distributors across the nation, the AR-800 is supplied complete with battery, a personal magnetic earphone, and a leather carrying case. Covering the standard broadcast band, it features push-pull output to its built-in PM loudspeaker.

From CBS-Hytron comes news of a series of *n-p-n* power transistors to complement their well-known *p-n-p* line. This will permit the design of power amplifiers using complementary-symmetry configurations and the construction of high-gain direct-coupled complementary control and instrument amplifiers. For technical data and price information, write directly to CBS-Hytron at Lowell, Mass.

Burgess Battery Company (Freeport, Ill.) and the Sonotone Corp. (Elmsford, N. Y.) have both announced a complete line of hermetically sealed nickel-cadmium batteries. These are *rechargeable* units especially suited to the design of transistorized receivers, amplifiers, and other equipment. Included are units which are the same size as popular mercury cells and penlight and flashlight batteries as well as higher voltage assemblies.

That does it for now, fellows. See you next month. . . .

Lou

Ignition System Tune-Up

(Continued from page 93)

standard types of distributors used in other cars.

The cam faces are lubricated by a wick. Never add any lubricant to it, but replace the wick whenever the contacts are replaced. Adjust it until the wick's end just touches the cam lobes.

Timing Indicator. A simple timing indicator will allow the timing to be set properly in accordance with the car manufacturer's recommendations. It shows that the points open at the proper time.

If the primary lead is disconnected from the distributor, a panel lamp of the same voltage as the car battery, with clip-leads attached, may be connected with one clip on the primary terminal and the other on the primary lead from the coil. This places the contacts in series with the bulb and acts as a switch to turn the light on or off as the contacts open or close.

The bulb may be mounted in a pilot-

FOR THE FIRST TIME

**A COMMUNICATIONS
RECEIVER KIT YOU WANT
AND CAN AFFORD**

PHILMORE MODEL CR5AC



**EASY PAYMENT PLAN \$4.00 DOWN
FEATURE PACKED**

- COVERS ALL FREQ. 550 KC TO 30 MC IN 4 BANDS
- BUILT-IN CALIBRATED S-METER
- 11" SLIDE RULE DIAL WITH FLY WHEEL ACTION
- FULL ELECTRICAL BANDSPREAD ON EACH BAND
- TRANSFORMER-OPERATED POWER SUPPLY

Positively surpasses all other all-band receiver kits on the market at anywhere near this low price.

Professionally engineered by Philmore, one of the oldest names in radio kits, to meet the exacting requirements of the present day amateur, novice, ham and short-wave listener.

The Model CR5AC features—A highly sensitive five-tube including rectifier superheterodyne circuit with individual adjustable coils for each band. Built-in calibrated S-meter employing its own driver tube. Transformer operated power supply for safe shockproof operation. Four-band operation covering all frequencies up to 30 megacycles including amateur bands from 10 to 160 meters. A built-in BFO with fully adjustable tone control for optimum CW reception. Built-in speaker with heavy magnet fully protected and top-mounted so that receiver can be placed between additional gear. Input jack for external Q multiplier when desired. Front panel controls include: a full range RF Gain Control, incorporating an AVC on-off switch; function selector for phone or CW reception, with standby position for use while transmitting; large no-slip bandswitch knob; bandspread calibrated from 0-100; volume control with AC switch; front mounted phone jack for external speaker or earphone. Tube complement 6X4, 6BE6, 6AZ8, 6AV6 and 6AQ5. Size 15-3/16" w. x 6-9/16" h. x 10" d.

Complete Kit with tubes and instruction book less cabinet. Shpg. wt. 12 lbs. **\$39.95**

No. 37A37. Model CR5AC. Net. **\$39.95**
Beautiful Grey Wrinkle All Steel Cabinet for above. **\$7.95**

No. 37A38. Shpg. wt. 5 lbs. Net. **\$7.95**
Model CR5AC Communication Receiver as above wired and tested in Cabinet. Shpg. wt. 17 lbs. **\$79.95**

No. 37A40. Net. **\$79.95**

BURSTEIN-APPLEBEE CO.

1012-14 McGee ENCLOSE \$2.00 FOR
Kansas City 6, Mo. POSTAGE AND HANDLING.

Please Rush Me _____ Receiver Kit
 At \$39.95 each or \$79.95 wired

NAME _____

ADDRESS _____

CITY _____ STATE _____

CLASS "D" CITIZEN BAND CRYSTALS



3rd Overtone; Hermetically Sealed
.005% tolerance—Meet F C C require-
ments, 1/2" pin spacing—.050 pin diam-
eters. (.093 pins avail-
able, add 15¢ per crys-
tal.)

\$2.95
EACH

22 CHANNELS

(add 5¢ per crystal for postage and handling)

The following Class "D" Citizen Band frequencies in stock (frequencies listed in megacycles): 26.965, 26.975, 26.985, 27.005, 27.015, 27.025, 27.035, 27.055, 27.065, 27.075, 27.085, 27.105, 27.115, 27.125, 27.135, 27.155, 27.165, 27.175, 27.185, 27.205, 27.215, 27.225.

RADIO CONTROL CRYSTALS in HC6/U HOLDERS—SIX FREQUENCIES

In stock for immediate delivery (frequencies listed in mega-
cycles); tolerance .005%, 1/2" pin spacing, .050 pin diameter,
(.093 pins available, add 15¢ per crystal.) Specify frequency
desired.

26.995, 27.045, 27.095, 27.145, **\$2.95**
27.195, 27.255 EACH

(add 5¢ per crystal for postage and handling)

Send for FREE CRYSTAL CATALOG
WITH OSCILLATOR CIRCUITS

ASK YOUR PARTS DEALER FOR TEXAS CRYSTALS

See big red display if he doesn't stock them, send us
his name and order direct from nearest factory.

ORDER FROM NEAREST PLANT

TEXAS CRYSTALS

All Phones: Gladstone 3-3555 (River Grove, Illinois)

Texas Crystals, Dept. P-89 Texas Crystals, Dept. P-89

8538 West Grand Avenue OR Crystal Drive

River Grove, Illinois Ft. Myers, Florida

ALL ORDERS SHIPPED 1st CLASS MAIL

TODAY'S BEST QUALITY BUY

AWARD WINNING

arkay KITS
and WIRED

HI-FI STEREO



ARKAY CS-28
STEREO AMP/PRE-AMP
COMPLETE CONTROL CENTER

Full 28 watts stereo or monaural,
60 watts peak • 14 watts each

channel • reverse stereo • balance control • two-channel gain
control • full range bass and treble controls • 1M distortion, 4
to 1 • harmonic distortion, 1% 30-20,000 cps • dual pre-amp 2V
output jacks • speaker outputs, 4, 8, 16, 32 ohms • response,
20-20,000 cps • push-pull EL84 Williamson circuit.

Wired and tested \$99.95 Easy-to-build Kit **\$64.95**



ARKAY ST-11
AM-FM
STEREO TUNER

Separate AM and FM tuning with drift-free sta-
bility • variable FM-AFC • 4 uV for 20 db quieting
in FM channel • wide band AM IF's • whistle filter
• cathode follower outputs • level controls.

Wired and tested \$74.50 Easy-to-build Kit **\$49.95**



ARKAY CS-12
STEREO PRE-AMP
AND AMP

12 watts of clean power.
Operates from ceramic
or crystal cartridge,
tape, tuners, auxiliary
equipment.

Easy-to-build Kit **\$36.95**

ARKAY SPA-55 55 watt—STEREO AMP
Wired and tested \$79.95 Easy-to-build Kit **\$64.95**

See and hear completely wired ARKAY Kits at your dealer.
Write for detailed specifications & catalog, Dept. PE

All prices 5% higher west of Mississippi

arkay 88-06 Van Wyck Expressway
Richmond Hill 18, N.Y.

PACE

light socket or the leads may be soldered directly to the bulb terminals. Test the bulb assembly by clipping it across the battery terminals. If it lights, it is ready to use.

Periodical Tune-Up. All cars, old or new, require a periodical tune-up if they are to function properly. A complete replacement of points need only be made about once a year, or about every 10,000 miles. Points should be cleaned, dressed smooth, squared off with a point file, properly gapped, and new gaskets installed at this time. To get best performance when most needed, replace plugs and points before a long vacation trip.

Trying to stretch the life of plugs and points is false economy, and you will find that proper maintenance of your ignition system will pay dividends by improving performance, economy, and your own driving disposition.

—30—



Magnetize Your Tools

(Continued from page 98)

they were handy, too. Possibly, it might be better to use a heavy-duty barrier strip such as the Jones Type 2-150. Whatever you use, don't forget that you are dealing with very heavy currents in the discharge circuit. It would be a good idea to use wire in the discharge circuit as heavy as that in the magnetizing coil.

A neon lamp indicates when the capacitors are fully charged. Since the NE-2 will fire at around 75 volts d.c., it is tapped down a voltage divider composed of R_1 and R_2 so that it will not light until the voltage at the top of the divider reaches approximately 140 volts.

Adjustment. With the slider of the variable charging resistor, R_3 , set at maximum resistance, plug the magnetizer into a source of 117 volts a.c. Turn the unit on and place the knife switch in the *charge* position.

When the neon lamp indicates that the capacitors are charged, throw the knife switch to the *discharge* position. With a loud snap, the capacitors will discharge through the low-resistance coil, magnetizing the work.

The slider of R_3 should now be adjusted for an approximately ten-second charging time. The setting of R_3 will depend upon the number of capacitors used.

—30—

The World Within the Atom

(Continued from page 66)

fly in the atomic ointment would be Einstein's famous equation $E = MC^2$ (energy = mass times speed of light squared).

According to Einstein, it is possible to change these two, mass and energy, into each other without a loss. The three-particle model of the atom could not mathematically explain how this is possible. Physicists were thus forced to the realization that there was more to the atom than the electron, the proton, and the neutron.

The first inkling that there was energy in the atom came about through the studies of Curie and Becquerel in the field of radioactivity. Three different types of radiation were found to be given off by naturally radioactive radium and uranium: *alpha*, *beta* and *gamma* rays. The *alpha* and *beta* rays were high-speed particles while the *gamma* rays were found to be powerful streams of energy with 100 times the penetrating power of *beta* particles.

Investigating these radiations in the light of Einstein's equation, physicists found that the energy given off did not balance with the loss of mass. In order for everything to balance, the Italian physicist, Enrico Fermi, suggested still another particle. This he called the *neutrino* or "little neutral one." Fermi theorized that the neutrino would have to be almost pure energy to make the scales balance. It would also be very difficult to detect because of its high speed and lack of charge and mass. It was finally found in 1956 through delicate atomic detective work, a major scientific triumph.

Atom Smashers. When the big "atom smashers" were built, scientists were given the necessary tools for probing the inner atom. There are many types of atom smashers, or particle accelerators, their scientific name. Among them are the cyclotron, the betatron, and the cosmotron.

Without going into detail on their operation, it is enough to understand that the atom smashers whirl ions of gas around in circular paths by electrical and magnetic means. These ions increase in velocity until they approach the speed of light. They are then deflected magnetically into an opening where they bombard the nuclei of substances under study. If you have ever whirled a stone on a string and had the

RADIO SHACK EXCLUSIVE! 8-TRANSISTOR Portable Radio



\$29⁹⁵

\$5 Down, \$5 Monthly

8 transistors, 2 crystal diodes and a thermistor set new standards for comparison in portables! Amazing selectivity, sensitivity and tone plus phono input for use as an amplifier-speaker, and earphone outlet. Only 6½" long, heavy leather case. Runs for weeks on single 59c battery (included).

FREE! **350 PAGES OF BARGAINS**

24 to 36 pages month after month . . . and each crammed with unbelievable savings on hi-fi, stereo, LP-records, pre-recorded tape, ham radio, cameras, sporting goods, tools, appliances, test equipment, electronic parts! Radio Shack gets first offerings from manufacturers needing cash, closeouts, brand new items!

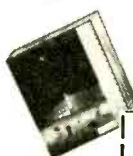

ELECTROSTAT-3
World Famous Tweeter Now in
Stock for Immediate Delivery

\$27.50



35c

**READY IN
SEPTEMBER**
Radio Shack's
Big, Better
New 1960
**GUIDE FOR
ELECTRONIC
BUYING**

RADIO SHACK CORPORATION, Dept. 8B
730 Commonwealth Ave., Boston 17, Mass

- Send 8-TRANSISTOR Radio at \$29.95
 Send Electrostat-3 at \$27.50
 Send FREE Bargain Bulletins
 Send FREE LP Record Bulletins
 Send 35c Electronic Buying Guide
 Check Money Order C.O.D.

Name _____
 Address _____
 City _____ Zone _____ State _____

NEW 2-WAY CITIZEN'S BAND RADIO-TELEPHONE KIT

11-METER
TRANSCIVER

\$39.95

Complete Kit

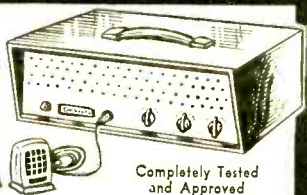

Completely Tested
and Approved

CHECK THESE "EXCLUSIVE" FEATURES

- ✓ Complete as Shown with All Tubes and Parts
- ✓ Sockets and Small Parts Riveted to Chassis
- ✓ Transmitting Crystal
- ✓ Punched Chassis
- ✓ Hi-Gain Crystal Mike
- ✓ Modulation Indicator
- ✓ Coaxial Connector Mounted on Chassis
- ✓ 25-ft. of RG58U Included for Your Antenna
- ✓ Tunable Receiver
- ✓ Full 5-Watt Input
- ✓ Operates 110V-AC
- ✓ Silver Slug Shielded Coils

Complete Diagram Furnished

GROUND PLANE ANTENNA KIT \$19.95

DON'T WAIT! ORDER YOURS NOW!

**HERSHEL
RADIO CO.**

5249 GRAND RIVER Detroit 8, Michigan

Phone TYler 8-9400

Special Cash
Price Offer
on 25% down
balance C.O.D.
All orders
P.O. preferred

NOW AVAILABLE

BUILD-IT-YOURSELF KITS for the NEW 27 mc
CITIZEN'S BAND "WALKIE TALKIE" TRANSCIVER

See JUNE POPULAR ELECTRONICS pg 48 for details

DELUXE KIT of all parts, tubes, chassis, microphone, etc. \$39.95
With Wired superior quality RF assembly, Esco model T200 54.95
TRANSCIVER custom wired and air checked 69.95

All units include guaranteed .005% tol. XTAL, antenna, tubes,
F1 microphone and dynamic type earphone unit-Full Instructions.
Special power pack operating from self contained rechargeable heavy
duty 2 volt storage cell. With built-in or external 110V. AC and 2-12 volt
DC charger. Eliminates expensive dry type A/B batteries. Delivers "clean"
filtered & regulated voltages. 34.95

DELUXE HIPOWER (5 watts) transceiver for operation from
110 V. AC and 6-12 V. DC. See March Radio & TV News, pg 49 for details.
Use as base station to "work" field stations, etc. only. 39.95

CITIZEN BAND .005% tolerance crystals, all channels. 3.95

ESSCO-NEW YORK TOP QUALITY MATERIALS ONLY
58 Walker St. NYC 13, N.Y. Money back guarantee.

CITIZENS LOW COST 2 WAY RADIO!

NOW! TWO WAY RADIO FOR EVERYONE

No license or permit needed on new Low Power 100mW 27mc. Citizens
Band. No age limit—no restrictions of any
kind. Talk and listen to ANYONE—ANY-
TIME. Complete ready to operate—weights
only 4 lbs. Size: 6 1/2" W. x 4 1/4" H. x 9 1/2" deep.
Includes microphone and speakerphone. Talk-
listen switch, 5 ft. top of cabinet antenna,
carrying handle, steel cabinet. Range de-
pends on location but can be from 1/2 to 2
miles. Operation everywhere on 110 volt plug-in.
Absolutely nothing else to buy—Just touch switch
to talk or listen—meets all Gov't FCC requirements.
Two or more units can be used together, as desired.



SEND ONLY \$5.00 (bill, ek. mo.) deposit
for each 2-way radio
desired and we will send COD for balance of \$4.95 plus postage and COD charges
or send \$29.95 plus \$2.00 (postage and insurance) for each radio wanted. Guarant-
teed to work or money back. Order now for early delivery before price goes up.
Available only from:

WESTERN RADIO Dept. HPL-8 **KEARNEY, NEBR.**

string break, you will understand the principle of an atom smasher.

With the aid of these giant scientific instruments, some of them filling huge buildings, more new particles were discovered. Many of these had been mathematically predicted—and now they were revealed. A particle was found which was the same as the electron, but opposite in charge: it was called a *positron* or positive electron. Then in the 1950's an important announcement . . . the discovery of *anti-matter*.

Anti-Matter. The French physicist, Dirac, mathematically concluded that each of the basic particles should have an opposite, or *anti*-particle. Four such anti-particles were found.

Anti-matter proved very difficult to detect because of its short life; the anti-matter particles combine with their opposites and annihilate each other almost instantly. *Gamma* rays equal to their former mass are given off. It is thought that anti-matter differs from its opposite only in that its magnetic poles are reversed, with each particle being considered a small magnet.

Mesons and Hyperons. Next, two other particles were found: the *meson*, whose existence was predicted by the Japanese physicist, Yukawa, and the *hyperon*, the most massive of all atomic particles. These are each actually families of particles, rather than single units. Mesons and hyperons are believed to act as a "glue" which binds the particles of the nucleus together.

Where do we go from here? Our 2500-year search for an understanding of matter is far from being finished. There is still no final model of the atom. Man has yet to find the complete answer to nature's atomic puzzle.

-30-



"Mother! Mother! Gwen is on her way to the moon!"

Always say you saw it in—POPULAR ELECTRONICS

Short-Wave Monitor Registration

Thousands upon thousands of POPULAR ELECTRONICS' Short-Wave Monitor certificates have been mailed to date and the end is not in sight. An SWL fraternity of over 10,000 has come into being in less than six months. Why not get on the bandwagon and register *your* listening station. Just fill out the form below and mail to: Monitor Registration, POPULAR ELECTRONICS, One Park Ave., New York 16, N. Y. Please include ten cents to help cover cost of mailing and processing your certificate.

(Please Print)

Name _____

Address _____ City _____ State _____

Receiver	Make _____	Model _____
	Make _____	Model _____

Principal SW Bands Monitored _____ Number of QSL Cards Received _____

Type of Antenna Used _____

Signature _____ Date _____

GET ON THE AIR TRANSMIT AND RECEIVE NO EXAMINATION
for Business or Fun ONLY \$37⁵⁰ KIT No Tests Required*

With this New CITIZENS BAND Transceiver Kit!

AS DESCRIBED IN THE MARCH, 1959 ISSUE OF RADIO & TELEVISION NEWS

- ✓ COMPLETE WITH ALL PARTS, CRYSTALS, TUBES, PUNCHED CHASSIS, ETC.
- ✓ SOCKETS AND SMALL PARTS RIVETED TO CHASSIS FOR QUICK-E-Z CONSTRUCTION
- ✓ ONLY FINEST PARTS — NO SURPLUS.
- ✓ COMPLETE REPRINT INSTRUCTIONS FROM RADIO & TV NEWS.
- ✓ ALL YOU NEED IS SOLDERING IRON, SCREWDRIVER AND PLIERS.
- ✓ INSTRUCTIONS FOR MAKING YOUR OWN ANTENNA.

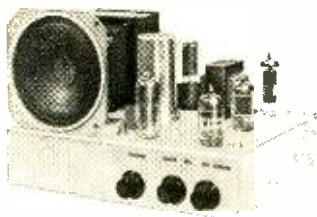

- ✓ RADIO & TV NEWS SAYS: "Even with 5 watts, it is perfectly capable of transmitting and receiving over distances of 3000 miles or more when Old Mother Nature has the ionosphere in good working order."
- ✓ SIMPLE TO OPERATE: VOLUME, TUNING AND TRANSMITTER/RECEIVER SWITCHES.

Only \$39⁹⁵
 2 OR MORE — \$37.50 EACH
 IF YOU WISH, PAY JUST **\$5⁰⁰** DOWN,
\$5⁰⁰ PER MO.

*You must be U.S. Citizen over 18 years of age. Simply fill out FCC form 505. (Form included.)

WORLD'S MOST PERSONALIZED ELECTRONIC SUPPLY HOUSE

World Radio

LABORATORIES
PH. 2-0277

1415 W BROADWAY COUNCIL BLUFFS IOWA

Please rush your FREE Catalog ... Enclosed is my check or money order for one, two Transceiver Kit(s).

NAME: _____

ADDRESS: _____

CITY & STATE: _____

PE-8

ATTENTION

electronics schools!

Is your School registered with Popular Electronics? As you probably know, Popular Electronics is eager to keep you advised whenever a special opportunity arises that would interest and benefit your School.

If you are not already on PE's School Announcements list — please send your name, address and the name of your School Secretary to: Popular Electronics, School Department, One Park Avenue, New York 16, N. Y.

Citizens Band Applicants

(Continued from page 54)

Communications Commission, Citizens Radio License Section, Washington 25, D. C. Do not mail it to your local FCC office. Processing time will be 60 - 90 days.

If, for any reason, you "goof up" your application, it will be returned to you. If you correct it and return it to the FCC in 30 days, it will be put in its original place in the processing line; otherwise it will be treated as a new application. When you make any changes on the returned form, it *must* be re-notarized. If the application is so badly "fouled up" that you have to make out a new one, be sure to include the original with the new application.

Follow These Rules. Here are a few important rules to which you should pay particular attention:

1. Profane, indecent, or obscene language is prohibited by law, and severe penalties are provided for violators.

2. You may *not* engage in either broadcasting (music, radio programs, etc.) or in communications for hire.

3. When you change your address, you *must* obtain a new license showing the new address.

4. The tip (or top) of your antenna may *not* exceed 20 feet above the ground, natural formation, or existing structure (building, water tower, etc.).

5. You are responsible for the manner in which your station is operated, regardless of who is actually operating it.

6. Your license can be revoked for failure to comply with the law and the FCC rules. Keep informed of changes in regulations.

7. Your radio equipment can *not* be used for any purpose contrary to federal, state, or local law.

8. Transmitter adjustments which might affect the proper operation of the station must be made by or under the supervision and responsibility of a licensed commercial operator holding a first- or second-class license.

9. Finally, remember that the Citizens Radio Service was set up to fill a need for a short-range personal or business communications service for the average citizen. It will work only if each user shows due regard for the rights of the other fellow. It is *not* a "no examination" ham service and it is *not* meant to be used by "rag-chewer" clubs or would-be DX artists. —30—

LEARN

RADAR MICROWAVES COMPUTERS TRANSMITTERS

CODE ● TV ● RADIO

Phila. Wireless Technical Institute

1533 Pine St.

Philadelphia 2, Penna.

A Non-Profit Corp. Founded in 1908

Write for free Catalog to Dept. P-859

TINY RADIO PLAYS FOR 10 YEARS!



**NO TUBES—TRANSISTORS—
BATTERIES OR "PLUG-INS" NEEDED**
Smaller than a pack of cigarettes, 1960 model never runs down or burns out. Guaranteed to receive local radio stations most anytime, anywhere—without EXTRA ANTENNA WIRES. Easy thumb station tuner — Perma wave detector. Chrome black plastic case. BUILT IN SPEAKERPHONE — NO SEPARATE DANGLING EARPHONE. American made and service guaranteed for 10 years.

SEND ONLY \$2.00

(cash, ch. mo) and pay postman \$4.99 COD on arrival or send \$6.99 for postpaid delivery. Sent complete—Ready to listen with 10 year guarantee. No extras to buy. Free 1000 mile antenna enclosed if you order at once.

MIDWAY COMPANY Dept. TPL-8 KEARNEY, NEBR.

After Class

(Continued from page 104)

necessary for the antenna to operate properly and may be accomplished by simulating a ground condition at the base of the antenna through the use of a ground plane system (see Fig. 2).

In the ground plane system, copper wires cut to quarter wavelengths of the frequencies to which the antenna is tuned are attached radially, with wires of the same length opposite each other, to the base of the antenna mounting. They are insulated from the antenna's driven element and the roof but connected to a good earth ground and the transmission line shield.

In effect, the ground plane system provides a ground cut to specified wavelengths and then suspended in mid-air at the point where it is needed. In practice, ground plane radials generally act as supports for the vertical antenna mast as well as being part of the electrical installation.

Safety and Efficiency. A sound knowledge of basic ground theory and procedures is necessary for each person who works or experiments with electronic devices. Good grounding techniques assure the operation of electronic equipment at maximum efficiency and with minimum electrical shock hazard.

-30-

FCC AMATEUR RULE CHANGE

Novice, Technician and Conditional Class amateurs can now be required to take an FCC-supervised examination whenever quiet hours are imposed on their stations. In the past only Conditional Class "mail order" licensees were subject to re-examination. The exact text of the new rule change is given below.

12.45 Additional Examination for holders of Novice, Technician, or Conditional Class operator licenses.

(a) The Commission may require a licensee holding a Novice, Technician, or Conditional Class of operator license to appear for a Commission-supervised license examination at a location designated by the Commission. If the licensee fails to appear for this examination when directed to do so, or fails to pass such an examination, the Novice, Technician, or Conditional Class operator license previously issued shall be subject to cancellation, and upon cancellation, a new license will not be issued for the same class operator license as that cancelled.

(b) Whenever the holder of a Novice, Technician, or Conditional Class amateur operator license is required by the Commission to restrict the operation of his amateur station, in accordance with the provisions of 12.152, 12.153, or 12.154, the necessity for such restriction shall be considered sufficient grounds to require the holder of the Novice, Technician, or Conditional Class license to appear for a Commission-supervised examination.

only 15c for this authoritative guide to building an inexpensive record library!



reprinted from
HiFi REVIEW

Now—you can build a record library of hi-fi classics from the steadily growing catalogue of \$1.98 releases! More than half a dozen big record companies are re-issuing great performances on the new \$1.98 labels. You can have a guide to the best of these for 15¢—by ordering this reprint of a recent article in HiFi REVIEW. Complete with catalogue number, artist, orchestra and conductor information—it's a fabulous guide to building up a high fidelity library of basic classics!

In addition, HiFi REVIEW's Music Editor, David Hall, gives you the background of the \$1.98 market . . . evaluates the discs being offered at this price . . . pinpoints the future of high-quality, low-price records.

If you've been thinking of starting a record collection or adding to the one you have—this reprint is your best guide! Order your copy today—simply mail 15¢ in coin or stamps with the coupon below. But the supply is limited, so order now!

HiFi REVIEW

PE 89

Box 1778R

Church Street Station

New York 8, N. Y.

Please rush my copy of the HiFi REVIEW
reprint on building a library of \$1.98 records.

I enclose 15¢ to cover postage and handling.

Name _____

Address _____

City _____ Zone _____ State _____

Short-Wave Report

(Continued from page 106)

Argentina—*R. Nacional*, LRA, Buenos Aires, operates as follows: to Central Europe on 15,345 kc. at 1400 in Spanish, 1500 in German, 1600 in Italian, 1700 in French, 1800 in English, and 1900 in Portuguese; to Eastern N.A. on 9690 kc. at 2100 in Spanish, 2200 in English; to Western N.A. on 9690 kc. at 2302 in Spanish, 0002 in English. Reports go to: *Radio Nacional*, Sarmiento 151, Buenos Aires, Argentina. They usually answer reports by registered mail. (WPE3EK, BT)

Ascension Island—This rare country can be heard at times between 0900 and 1100 when Cable & Wireless, Ltd. beams a single-sideband transmission to New York over ZBI235, 23,583 kc. This 5-kw. telephone station reportedly will QSL. (TF)

Belgium—Brussels may be noted daily except Wednesdays on 11,850 and 9655 kc. at 1930-2000. The 9655-kc. channel is the Leopoldville (Belgian Congo) relay station. Reports go to: The International Goodwill Station, P. O. Box 26, Brussels, Belgium. (WPE9LF, WPE2RV, WPE3EK)

Burma—Rangoon has been noted on 6035 kc. with ID at 0915, Eng. news from 1000 to 1015 s/off with fading. The 9640-kc. channel has not been heard lately. (URDXC)

The Rangoon outlet on 15,365 kc. also has news at 1000; it faded rapidly. The dual 11,765-kc. channel was not heard. (MO)

China—The latest schedule from Peking reads: to N.A. East Coast at 2030-2130 on 15,095 and 17,720 kc.; to N.A. West Coast at 2230-2330 on 15,115 and 17,745 kc.; to Asia at 0400-0430 and 0730-0800 on 11,820 and 15,095 kc., and at 1030-1100 on 15,060 and 17,675 kc.; to Oceania at 0400-0457 on 15,060 and 17,835 kc.; and to Europe at 1400-1500 and 1600-1700 on 9457 and 11,650 kc. They have a "Letter-box" on Sundays and also on Mondays. (WPE0FA, WPE3EK, MR)

Czechoslovakia—A late schedule from Prague reads: 1930-2000 on 9550, 11,745, 15,230, 15,285, and 17,895 kc.; 2200-2300 on 9550, 11,725, 11,745, 15,230, and 15,285 kc.; and 0333-0430 on 11,725, 17,795, and 21,450 kc. Answers to listeners are given on Saturdays at 2200, Sundays at 0330 and 1930, and Mondays at 0000. Notes for hams and SWL's are given on the first and third Friday of the month at 1930 and 0000 and on the first and third Thursday of the month at the same times. (WPE5HO and WPE1JM)

Denmark—Copenhagen currently radiates the following xmsns: on 9520 kc. at 2030-2130 and 2200-2300 to N.A. and at 1800-1900 (Mondays, Wednesdays, Fridays only) to So. America; on 15,165 kc. at 0400-0500 (Tuesdays, Thursdays, Saturdays only) to the Far East, Australia, and New Zealand; at 0900-1000 (Tuesdays, Thursdays, Saturdays only) to South Asia; at 1140-1240 (Tuesdays, Fridays only) and at 1240-1615 (daily) to Africa and the Mid-East. The latter xmsn is a Home Service program. A DX program is broadcast on Tuesdays from 2113 to 2138. (WPE3EJ, WF, JM, RQ)

Ecuador—New stations are as follows: HCMVI, *R. San Miguel de Ibarra*, Ibarra, 6215 kc., 250 watts; HCFK5, *R. Cuenca*, Cuenca, 6135 kc., 250 watts; HCXO1, *R. Otavalo*, Otavalo, 6115 kc., 250 watts; HCRQ2, *La Voz del Tropico*, Quevedo, 6030 kc., 200 watts; HCNF5, *R. Difusora del Ecuador*, Cuenca, 6020 kc., 250 watts; HCMH6, *Organizacion Radiofonica de Cotapaxi*, Latacunga, 5970 kc., 300 watts; HCR11, *R. Centro Radiofonica Imbabura*, Ibarra, 5170 kc.; HCMV5, *R. Popular Independiente*, Cuenca, 5060 kc., 250 watts; HCPS5, *Ondas Canaris*, Azogues, 5030 kc., 250 watts; HCOB5, *Ondas Azules*, Cuenca, 5028 kc., 250 watts; HCGH1, *R. Tarqui*, Quito, 4970 kc., 300 watts; HCSJ1, *R. Javier*, Quito, 4950 kc.; HCUN2, *R. Unidad Nacional*, Guayaquil, 4025 kc., 200 watts; HCSM6, *R. Sira*, Ambato, 3975 kc., 200 watts; HCPZ1, *R. Rumichaca*, Tulcan, 3950 kc., 200 watts. (WRH)

El Salvador—A station with the ID *La Voz de Comercia* was found on 9544 kc. at 1930-

SHORT-WAVE CONTRIBUTORS

Bill Fredericks (WPE1AP), Everett, Mass.
R. W. Robillard (WPE1JM), Holyoke, Mass.
William O'Brien (WPE2RV), Syracuse, N. Y.
Paul Buer (WPE2UP), Harrison, N. Y.
Richard Woodyatt (WPE3EJ), Scranton, Pa.
Richard Freeman (WPE3EK), Philadelphia, Pa.
George Cox (WPE3NF), New Castle, Del.
Royston Lawson (WPE4EB), Murfreesboro, Tenn.
Jerry Chouinard (WPE5HO), Dallas, Texas
William Flynn (WPE6AF), Pittsburg, Calif.
Rex Lundquist (WPE6BO), Los Angeles, Calif.
August Balbi (WPE6CW), Los Angeles, Calif.
J. Art Russell (WPE6EZ), San Diego, Calif.
George Crabb (WPE6CQ), St. Clair Shores, Mich.
Ray Bohnenstuhl (WPE9LF), Collinsville, Ill.
John Beaver (WPE0AE), Pueblo, Colo.
Bob Cronberg (WPE0BO), Minneapolis, Minn.
James Brown (WPE0EM), St. Marys, Kansas
Curtis Schild (WPE0FA), St. Louis, Mo.
George Henley (G2PE3Y), Watford, England
Abie Cox (AC), Asheville, N. C.
Michael Chabak (MC), Astoria, N. Y.
Tom Farmerie (TF), Pittsburgh, Pa.
Werner Funkenhauser (WF), Kingsville, Ont.
Pierre Gagne (PG), Hull, Quebec
Charles Hailer (CH), Washington, D. C.
H. Kato (HK), Okayama, Japan
Charles Majko (CM), Newark, N. J.
Jim Murphy (JM), Northville, Mich.
Vince McGarry (VM), Clayton, N. J.
Al Neller (AN), Lansing, Mich.
Jim Monahan (MO), East Haven, Conn.
Larry Price (LP), Rome, Italy
Richard Quam (RQ), Syracuse, N. Y.
Donald Reed (DR), APO 119, New York, N. Y.
Michael Rossman (MR), Joliet, Ill.
Eugene Simpson (ES), Arlington, Mass.
Robert Schwartz (RS), Brooklyn, N. Y.
Butch Thornthwaite (BT), Huntsville, Ala.
World Radio Handbook (WRH)
Universal Radio DX Club (URDXC)

1945 with music. This may possibly be the listed YSS on 9552 kc. (VM)

England—The current schedule from the British Broadcasting Corp. reads: to Canada, U.S. and Mexico at 1600-1845 on 17,715 kc., 1600-2115 on 15,310 kc., at 1800-2200 on 11,780 kc., and at 2100-2200 on 9825 kc.; to the West Indies, Central and South America (North of the Amazon) at 1500-1815 and 1845-1945 on 21,550 kc., at 1600-1815 and 1845-2200 on 17,810 kc., at 1800-1815 and 1845-2200 on 15,070 kc.,

and at 1945-2200 on 11,750 kc.; to South America (south of the Amazon) at 1500-1945 on 17,870 kc., at 1600-2200 on 15,360 kc., and at 1800-2200 on 12,040 kc.; to South Georgia at 1700-1945 on 12,095 kc. Call signs are: GST (21,550 kc.); GRP (17,870 kc.); GSV (17,810 kc.); GRA (17,715 kc.); GSP (15,360 and 15,310 kc.); GWC (15,070 kc.); GRF (12,095

SHORT-WAVE ABBREVIATIONS

BBC—British Broadcasting Corp.
 Eng.—English
 ID—Identification
 kc.—Kilocycles
 kw.—Kilowatts
 N.A.—North America(n)
 QSL—Verification
 R—Radio
 s/off—Sign-off
 s/on—Sign-on
 xmsn—Transmission from station
 xmtr—Transmitter used by station

kc.); GRV (12,040 kc.); GVV (11,780 kc.); GSD (11,750 kc.); and GRH (9825 kc.). (WPEOAE)

Luxembourg—R. Luxembourg, 6090 kc., is scheduled in Eng. at 1300-1900 (to 1930 on Saturdays) with request records at 1300-1500 Monday to Saturday. (WPE2UP, G2PE3Y, MO, LP, DR)

Netherlands—The latest schedule from Hilversum reads: to Australia, N.Z. and Pacific Areas at 0400-0440 on 25,610, 21,480, and 17,810 kc.; to South Asia and Africa at 1045-1125 on 21,480, 17,810, and 15,455 kc. (and also on 6025 kc. to Europe); to Europe and N.A. at 1615-1655 on 17,810, 15,455, and 11,950 kc. (and also on 6025 kc. to Europe; and to N.A. at 2130-2210 on 11,950, 9745, and 6025 kc. A hobby session is aired on the third Friday of each month. (WPE5CQ, WPE0BO, WPE0EM, WPE2RV, AC, CH, ES, RS)

Norway—The 100-watt LLA, 25,900 kc., is noted with a good signal at 0600 s/on dual to LLN, 17,825 kc., LLP, 21,670 kc., and 15,175 and 11,735 kc. (URDXC)

Panama—HOLA, R. Atlantico, Colon, is noted on 9505 kc. with Eng. at 2100-2200 with news, pop music, and commercials. This program is not on the air Sundays. (CM)

Portuguese Guinea—A station believed to be CQM, Bissau, has been heard broadcasting on 3975 kc. from 1743 to 1756 with music and Portuguese announcements. Further checks are being made. (WPE0AE)

Rhodesia and Nyasaland—The Federal B/C Corp. is noted on 4911 kc. at a new time of 2300 with varied musical numbers, Eng. announcements, and frequent time checks. So far it has been noted on Sundays only. (WPE3NF)

Sierra Leone—The outlet on 3316 kc. has been operating on reduced power of 1250 watts, rather than the listed 5000 watts, with a single-wire dipole antenna. This information came from I. C. Griggs, Chief Engineer of the station. (WPE6AF)

South Korea—HLK29, Seoul, 17,745 kc., and HLK28, 15,410 kc., operate to Western N.A. at

SPECIAL PURCHASE!

Hi Power TRANSISTORS



Most Universal and Rugged
Power Transistors Made!

Originally sold
as high as \$16

Now Only

\$1.50
each

\$15.00 Dozen

While they last!

Perfect for
Experimentors
Hobbyists
Radio Service
Men
Students, etc.

Can be used for

1. Heavy Duty Rectifier
2. Solar Battery (By removing cap)
3. Sensitive Light Meter Cell
4. Audio Power in Transistor Radios (with less battery drain)

Will replace any

**AUTOMOBILE
RADIO
POWER
TRANSISTOR**
(with slight
modifications)

Schematic enclosed with each order
Each one tested and fully guaranteed

ORDER NOW! OFFER LIMITED!

Please send check or money order with each order.
25% deposit on C.O.D. orders.

LONGTON BROS. ELECTRONICS

1627 Euroka Avenue

Wyandotte, Michigan

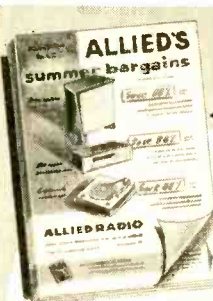

save on
everything in
electronics

SEND FOR **ALLIED'S
BARGAIN SUPPLEMENT**

free

BIGGEST VALUES EVER! Save most on Stereo hi-fi systems and components. See top buys in build-your-own KNIGHT-KITS. Hundreds of values in recorders, amateur gear, P. A. systems, test instruments, TV accessories, electronic parts, tubes and tools. Send for your FREE Allied Supplement packed with bargains and new products. Save as never before!

ALLIED RADIO

ALLIED RADIO CORP., Dept. 79-H9
100 N. Western Ave., Chicago 80, Ill.

Send FREE Allied Supplement No. 185

Name _____

Address _____

City _____

Zone _____

State _____

FREE
SUPPLEMENT

ADVERTISER'S INDEX

ADVERTISER	PAGE NO.
Allied Radio	31, 143
Apparatus Development Co.	145
Arkay	136
Bailey Technical Schools	30
Bell Sound Division	3
Bell Telephone Laboratories	2nd Cover
Burgess Battery Company	18
Burstein-Applebee Co.	135
Capitol Radio Engineering Institute	21
Century Electronics Co., Inc.	120, 121
Christy Trades School	124
Cleveland Institute of Radio Electronics	11
Coyne Electrical School	15
DeVry Technical Institute	7
EICO	38, 40
Electronic Measurements Corp.	127
Electronics Schools	140
Esco	138
Garfield Co., Inc., Oliver	25
General Cement Mfg. Co.	126
Gonset	124
Grantham School of Electronics	17
Grove Electronic Supply Company	145
Halco Electronics	134
Heath Company	108, 109, 110, 111, 112, 113
Hershel Radio Co.	138
Indiana Technical College	134
Instructograph Company	134
International Correspondence Schools	13
International Crystal Mfg. Co., Inc.	33
Jensen Industries, Inc.	34
Jesse Jones Box Corp.	145
Johnson & Co.	32
Key Electronics Co.	134
Kuhn Electronics	122
Lafayette Radio	37
Lektron	117
Longton Brothers Electronics	143
Micro Electron Tube Co.	14
Midway Company	140
Miller, Gustave	132
Milwaukee School of Engineering	131
Modernaphone, Inc.	34
Mosley Electronics, Inc.	12
Moss Electronics, Inc.	148
Multi-Products Company	133
National Radio Co., Inc.	10
National Radio Institute	115, 116, 129
National Schools	9
North American Philips Co., Inc.	24
Pacific International College	130
Paco Electronics Co., Inc.	32
Palmer, Joe	145
Phila. Wireless Technical Institute	140
Picture Tube Outlet	28
Popular Electronics Beginner's Luck	141
Popular Electronics Classified	130
Popular Electronics Subscription	126
Popular Electronics Upcoming Contents	39
Port Arthur College	122
Progressive "Edu-Kits" Inc.	35
RCA Institutes, Inc.	26, 27
RCA (Semiconductor)	20
Rad-Tel Tube Co.	29
Radio-Television Training School	23
Radio Shack Corp.	137
Rinehart & Co., Inc.	119
Sarkes Tarzian	122
Schober Organ Corp., The	28
Sherwood Electronic Laboratories	5
Sprayberry Academy of Radio-Television	19
Springfield Enterprises	36
Stereo Disc	125
Sylvania Electric Products Inc.	16
Tapedcode	126
Texas Crystals	136
Tru-Vac Electric Company	123
U. S. Air Force	107
Union Institute	134
Valparaiso Technical Institute	130
Vanguard Electronic Labs.	145
Video Electric Company	22
Western Radio	132, 134, 138
World Radio Laboratories	139
Xcelite Inc.	36

0030-0130, replacing 11,925 kc. Eng. is carried to 0100. (WPE6CW, WPE6EZ, URDXC)

Spain—Madrid can be well heard to N. A. on 9363 kc. at 2215-2300, 2315-0000, and 0015-0100. The dual channel is 6130 kc. (WPE6BO, WPE2RV, CH)

United Arab Republic—Cairo. 11,990 kc., carries Eng. to Europe at 1630-1730 with music, news, and concerts. (WPE3EJ, WPE1AP, WPE2RV, PG, AN)

Cairo's 17,920-kc. channel is heard well in Japan in Eng. at 0830-0928 with news from 0845. (HK)

Damascus is heard in Eng. on 15,165 kc. with news at 1615, and in German on 9555 kc. from 0045 to 0125 s/off. (WPE2RV, WPE3EK)

United States—The National Bureau of Standards, WWV, Boulder, Colo., has been conducting an extensive survey to determine the advisability of locating one xmtr in the central part of the U.S.A. This would be a unit of increased power that would enable the station to be heard throughout the service area at all times. (WPE6EZ)

USSR—Two stations noted recently are Khabarovsk, 9565 kc., weak at 1430 s/on, dual to 9376, but blocked by jamming from 1500 (also noted at 0600), and Magadan, 7270 and 9500 kc. at 0625 in Russian. (WPE3NF)

Vatican City—Radio Vaticana has Eng. daily at 1000 and 1315 and on Mondays and Wednesdays at 0530 and 1100 on 9660 and 11,740 kc. (WPE3EK)

Clandestine—The *Greek Voice of Truth*, is noted on 8067 and 9932 kc. at 0015-0030 in Greek; do not confuse this with *R. Espana Independiente*. A Caucasian Anti-Communist Alliance Station is heard on 8726 kc. with s/on at 2115 and the ID *Govorit Kavkaz*; beware of spurious 31-meter signals in this area. Another station is *Viva La Republica Dominicana Liberacion*, noted on 14,352 kc. from 1930 in Spanish. (WPE3NF, WPE4EB)

Utility Stations—For three difficult countries to log, try the following: **Bermuda**—through the Coast Guard Station NOC on 2182 kc. at

CLUB NEWS

The Teen Shortwave Club (TSWC) is a year-old club with dues of \$1.50 per year. Bulletins are currently being issued at one-month intervals. Report forms and various short-wave certificates are also available for members. Further details may be obtained from: David Schade, 2801 Pyramid Ave., Pittsburgh 27, Pa.

2230-0000 (the ID is *Coast Guard Radio*, and if you want a verification, send a stamped reply card); **Libya**—try for Wheelus Air Force Base on 11,228 kc. around 1800-2000 (mail reports to 1950th AACS Squadron, APO 231, New York, and enclose a stamp); **Hawaiian Islands**—try for Hickam Field on 13,215 kc. at 0000-0300 (ID is merely *Hickam*, and reports go to Officer in Charge, USAF Aero Station, APO 953, San Francisco, Calif. with stamp enclosed). (MC)

-30-

**POPULAR
ELECTRONICS**

BARGAIN BASEMENT

SAVE ON THESE SPECIAL BUYS OF THE MONTH

ONE CENT SALE Buy One At Our Regular Low Price And Get The Second For Only 1c More

CITIZENS BAND TRANSMITTER (27 MC) chassis complete with crystal. \$9.99 ea. two for \$10.00.

TRANSMITTER similar to above but with 5 watt RF stage instead of 1 watt. \$12.49 ea. two for \$12.50.

CITIZENS BAND RECEIVER chassis tunable through all 22 channels. Complete with audio amplifier. \$8.99 ea. two for \$10.00.

AMATEUR BAND TRANSCEIVER (144-148 MC) chassis with dual VHP triodes for wideband in radiohome. \$16.99 ea. two for \$30.00.

COILED CORD 4 conductor 11' telephone cord. Extends to over 4 ft. .99 ea. two for \$1.00.

KIT OF PARTS for AM-FM VHP radio receiver. Tunable from 80-200 mc. which includes 11.5 watt transistors. \$6.99 ea. two for \$7.00.

SUPER SPECIAL: 25 watt, 30 to 40 mc. crystal controlled FM radiohome mobile transmitter with 8 tubes and dynamotor power supply. Orig. coat over \$300.00. Can be converted to Citizens band. Used good condition \$24.99 ea. two for \$25.00 F.O.B. Hollis N.Y.

LIMITED QUANTITY—NO LITERATURE OR CATALOG

Remit in full. Include sufficient postage. No C.O.D.s.

VANGUARD ELECTRONIC LABS. Box 12-E8
Hollis, 23, N.Y.

DOUBLE-VALUE TRANSISTOR SALE!!

2N234	2 for \$2.89	2N255	2 for \$2.99
2N464	2 for 2.99	2N256	2 for 2.99
2N107	2 for 1.35	CK721	2 for 1.35
CK722	2 for 1.35	5B100 S. Barrier	2 for 1.89
AO1 5 Barrier	2 for 2.49	2N180	2 for 1.49
2N109	2 for 1.49	2N170	2 for 1.49
2N35	2 for 1.49	2N554	2 for 2.49
GT761	2 for 2.79	CK760	2 for 2.79
2N136	2 for 2.99	2N138	2 for 2.99

Kit of 25 Assorted Tubular Bypass Condensers Only 5.29

Kit of 10 Assorted 25-50-100 Watt Resistors Only 5.99

Varicap High Q Voltage Variable Capacitor Only 5.39

3 to 30mmf—1 to 500 Megacycles—Peak 200 Volts—Herm. Sealed

6 Transistor Portable Radio Kits with Cabinet Only \$21.95

4 Transistor Portable Radio Kits with Cabinet Only \$14.95

GROVE ELECTRONIC SUPPLY COMPANY
4103 W. BELMONT AVE. CHICAGO 41, ILLINOIS
Include postage with money order—Send for bargain flyer.

EXPERIMENTERS AMATEURS HOBBYISTS

We are again reducing a large inventory of brand new vacuum tubes and this "get-acquainted" offer is limited to the stock on hand. All tubes in each assortment are different, and every tube is brand-spanking new.

- 10 electron tubes including 3" cathode ray tube only. . . \$1.95
- 15 including 5" CRT. . . \$2.95
- 20 including 7" CRT. . . \$3.95

All three of the above assortments for just. . . \$7.95

Order early and we will include in your assortment a special high voltage rectifier and famous WE-717-A tubes. Your order will be sent in insured parcel post; just pay postman postage plus small COD charge. We have many unbelievable values in government electronic surplus, much of it for sale at prices representing mere pennies on the dollar of cost.

WRITE FOR FREE GOVERNMENT SURPLUS BARGAIN BULLETIN

JOE PALMER

P. O. Box 6188 CCC Sacramento, California

DIAGNYZER \$9.95 COMPLETE

ELECTRONIC TESTER

for DO-IT-YOURSELF SERVICING
COMPLETE TRAINING COURSE AND SERVICE MANUAL INCLUDED FREE WITH EACH INSTRUMENT
INDISPENSIBLE—FOR TV, RADIO, Hi-Fi
Appliances, Auto, Electrical Tools. Used in Home, Shop and Farm, Checks Radio and TV Tubes, Components, Voltages and Circuits, etc.
INEXPENSIVE TO OWN, EASY TO USE
Anyone can do servicing with this wonderful instrument, pays for itself the first time you use it. Best value for money, nothing else like it. Write Today.

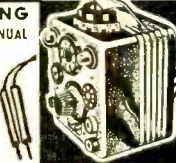

APPARATUS DEVELOPMENT CO.
Dept. K11 Wethersfield, Conn.

YOUR COPIES OF POPULAR ELECTRONICS ARE VALUABLE

KEEP THEM
NEAT . . . CLEAN
. . . READY FOR
INSTANT REFERENCE!

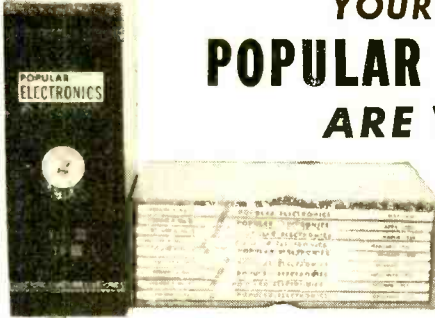

Now you can keep a year's copies of POPULAR ELECTRONICS in a rich-looking leatherette file that makes it easy to locate any issue for ready reference.

Specially designed for POPULAR ELECTRONICS, this handy file—with its distinctive, washable Kivar cover and 16-carat gold leaf lettering—not only looks good but keeps every issue neat, clean and orderly.

So don't risk tearing and soiling your copies of POPULAR ELECTRONICS—always a ready source of valuable information. Order several of these POPULAR ELECTRONICS volume files today. They are \$2.50 each, post-paid—3 for \$7.00, or 6 for \$13.00. Satisfaction guaranteed, or your money back. Order direct from:

JESSE JONES BOX CORP., Dept. PE

(Established 1843)

Box 5120

Philadelphia 41, Pa.



ELECTRONICS MARKET PLACE

RATE: 50¢ per word. Minimum 10 words prepaid. October issue closes August 5th. Send order and remittance to POPULAR ELECTRONICS, 1 Park Ave., New York 16, N. Y.

FOR SALE

FREE Fluorescent Lighting Bargain Catalog—Easily assembled kits; repair parts; fixtures. Shoprite, 650 E. Franklin, Nutley 10, New Jersey.

SEALED Cartons: Fisher 55A \$119; 80-T \$140; Dynavox Stereo Phono \$30; ReKO-kut K-33 \$30; Bell T206 \$175; BJ Arm \$13; E-V Aristocrat \$50. Free Catalog HiFi, Roslyn, Pa.

PORTABLE Physics laboratory complete with all apparatus and manual of 107 experiments, \$49.00. Model Atom Smasher, \$9.95 up, 3-in-1 Electromagnet, \$14.95, Raymaster Cloud Chamber, \$16.00 up, Spinharscope, \$2.00. Send 25¢ for literature about these and many other fascinating new scientific products. Atomic Laboratories, 3086 Claremont Ave., Berkeley, Calif.

SAFCORDE Electrical Outlet Model W-1, 120 Volts, 10 Amperes, 1200 Watts, Six Outlets, Switch, Pilot Light. Both lines fused \$9.95. P. W. Carpenter, Box 52, Barre, Vermont.

GOVERNMENT Surplus Receivers, Transmitters, Snooperscopes, Parabolic Reflectors, Picture Catalog 10¢. Meshna, Malden 48, Mass.

TRADE-IN Television Sets \$9.95 Plus Shipping. Jones TV, Sanatoga, Pa.

TELEVISION & Radio Tubes, Parts and Supplies. Guaranteed. Hi-Quality Tube Co., Inc., 284 Lafayette St., Rahway, New Jersey.

TUBES—TV, Radio, Transmitting and Industrial Types at Sensibly Low Prices. New, Guaranteed 1st Quality Top Name Brands Only. Write for Free Catalog or Call WALKER 5-7000. Barry Electronics Corp., 512 Broadway, New York 12N, N. Y.

DIAGRAMS for repairing radios \$1.00, Television \$2.00. Give make, model. Diagram Service, Box 672-PE, Hartford 1, Conn.

GOVERNMENT Sells—Surplus Electronics; Walkie-Talkies; Test Equipment! Oscilloscopes; Radar; Sonar; Surplus Aircrafts; Boats; Jeeps; Misc.—You buy direct now from U. S. Government Depots at fractions of Army & Navy costs—Send for bulletin "Depot List & Procedure," \$1.00. Box 8-PE, Sunnyside 4, New York.

RADIO & TV Tubes at Manufacturers Prices! 100% Guaranteed! Brand New! No re-bands or pulls! United Radio, Box 1000, Newark, N. J.

BARGAINS—on Resistors, Capacitors, Transformer, and other Electronic parts. Write for catalogue, just send 20¢. JJJ Electronics & Co., Box 226, Yerington, Nev.

SERVICE, popular brand electronic kits wired, tested and calibrated by First Class Technician. Inquiries invited, no obligation. Fincher Electronics, Lennox, South Dakota.

SEXIAC. World's only electronic digital computer kit. Can be expanded to include internal programming. Not a toy. 14 triodes, printed circuits and 2 lesson course. \$27.50 complete. Willis G. McCormick Co., 15733 Septo St., Sepulveda, Calif.

15 TESTED One-Tube circuits with transistor "Radiobuilder"—25¢. Laboratories, 1131-L Valota, Redwood City, California.

INSTRUCTION

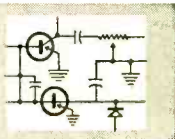

ELECTRONIC And Aeronautical Engineering Technology. Two Year Courses. Bachelor of Science Degree in three years. Northrop Institute in Southern California prepares you for highly paid positions in Aviation and Electronic industries. Employment assistance during school and after graduation. Approved for Veterans. Write for free catalog. Northrop Institute of Technology, 1183 Arbor Vitae, Inglewood 1, California.

BOOKS 10¢—all subjects—catalog 10¢. Cosmic, Clayton 2-3, Ga.

CALCULUS or Algebra, Easy Practical Lessons. First Four \$1. Mathco, 4256 Mimor, Cincinnati 17, Ohio.

COMPLETE Correspondence Course in Radio, TV, & Electronics. Only 12 sections. Includes 1st Class License Prep. Very Low rates. Ascot School of Electronics, Box 29092, Los Angeles 29, Calif.

CAMERA Repairmen greatly needed! You can learn manufacturer's service methods at home, in your spare time! Free, big illustrated book tells how! Write today, National Camera Repair School, Dept. (ZE) (3) Englewood, Colorado.

CODE learned forever in 24 minutes with amazing memory aid. \$1. McKenzie Enterprises, Box 245, Palo Alto, California.

SPECIAL offer, complete correspondence course in Radio, Electronics and Television. All new material. Only \$49.50. Formerly sold for over \$300.00. 44 books, over 2000 pages. Limited supply. For details write Box 601, % Popular Electronics, One Park Avenue, New York 16, N. Y.

CITIZENS and ham band. Complete plans and assembly instructions crystal controlled receiver, transmitter and cabinet. Send \$1.50 to L. Fletcher WØEXC, 1017 Goodrich, St. Paul 5, Minnesota.

LEARN Transistors—\$2.00 per lesson—learn by doing—test transistors quick test—Alpha, Beta factors, NPN, PNP—build receiver—repair radios—10 lessons complete course. Crystal Instruction Co., Box 827, Boston 3, Mass.

CITIZENS Band Transceiver printed circuit board, use your own parts, eliminates most wiring, full instructions, parts list. \$12.75. No. C.O.D. Electronic Service, 318 Dorwil Drive, Akron 19, Ohio.

TELEPHONE Extension in your car. Answer your home telephone by radio from your car. Complete diagrams and instructions \$1.25. C. Carrier Co., 5880 Hollywood Blvd., Hollywood 28, Calif.

EAVERDROP with a pack of cigarettes. Miniature transistorized radio transmitter. Complete diagrams and instructions \$1.25. C. Carrier Co., 5880 Hollywood Blvd., Hollywood 28, Calif.

POLICE Radar Detector. Stop before those radar speed traps. Fool proof, legal system. Complete diagrams and instructions \$2.75. C. Carrier Co., 5880 Hollywood Blvd., Hollywood 28, Calif.

BE a Spy! Correspondence course in wire tapping, bugging, recording techniques, microphotography, invisible and remote photography, telescopic and aerial photography. Lessons in surveillance, tailing and use of equipment. Complete course \$22.50. C. Carrier Co., 5880 Hollywood Blvd., Hollywood 28, Calif.

TV Tape Recorder. Correspondence course and home construction details. Build your own Video Recorder. Complete course and construction details \$18.75. C. Carrier Co., 5880 Hollywood Blvd., Hollywood 28, Calif.

MATHEMATICS. Home study. Consult catalog in public library. UCSM, Philadelphia 26.

HIGH-FIDELITY

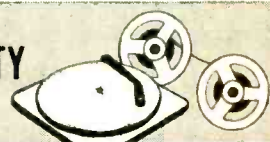

RECORDERS, Hi Fi. Free Wholesale Catalogue. Carston, 215-East 88, N.Y.C. 28.

DISGUSTED with "HI" Hi-Fi Prices? Unusual discounts on your High Fidelity Requirements. Write Key Electronics, 120 Liberty St., New York 6, N. Y. Evergreen 4-6071.

UNUSUAL Values. HiFi Components, tapes and tape recorders. Send for package quotations. Stereo Center, 18 W. 37 St., N. Y. C.

INVENTIONS WANTED

INVENTIONS wanted. Patented: unpatented. Global Marketing Service, 2420 77th, Oakland 5, Calif.

WANTED

CYLINDER and old disc phonographs. Edison Conqueror, Idelia, and Oratorio models. Berliner Gramophones and Zono-o-phones, Columbia cylinder Graphophones, and Coin-operated cylinder Phonos. Want old catalogues and literature on early phonos prior to 1919. Will pay cash or trade late hi-fi components. Popular Electronics, Box 50, 1 Park Ave., New York 16, N. Y.

MERCURY, Platinum, Silver, Precious Metals. Ores Assayed. Mercury Refiners, Norwood, Massachusetts.

CASH Paid! Sell your surplus electronic tubes. Want unused, clean transmitting, special purpose, receiving, TV types, magnetrons, klystrons, broadcast, etc. Also want military & commercial lab test and communications gear. We swap too, for tubes or choice equipment. Send specific details in first letter. For a fair deal write, wire or telephone: Barry, 512 Broadway, New York 12, N. Y. Walker 5-7000.

TAPE & RECORDERS

HIGHEST Trade-In Allowances Toward Ampex, Concertone, Crown, Ferrograph, Presto, Pentron, Components. Accessories. Catalog. Boynton Studio, 10-PE Pennsylvania, Tuckahoe, N. Y.

TAPE Recorders, Hi-Fi Components, Sleep Learning Equipment, Tapes. Unusual Values. Free Catalog. Dressner, 69-02F, 174 St., Flushing 65, N. Y.

12 IN. LP's from your tape \$6.00, 3/\$15.00. Impco, Box 1266, Oak Bluffs, Mass.

PATENTS

SAVE High Fees. Apply for your patent yourself. New Kit now makes it easy. Free "Registration Form." Miss Clare Ardu, 806 Wm. Penn Annex, Philadelphia 5, Pa.

MISCELLANEOUS

KITS wired and tested. Naczas Kit Service, 273 Belmont Street, Manchester, N. H.

SHOPPING GUIDE *Classified*

A HANDY REFERENCE TO PRODUCTS AND SERVICES NOT NECESSARILY ELECTRONIC, BUT OF WIDE GENERAL INTEREST.

BUSINESS OPPORTUNITIES

MAKE \$25-\$50 Week, clipping newspaper items for publishers, Some worth \$5.00 each. Particulars free. National, 81-DG, Knickerbocker Station, New York City.

WE Pay \$4.50 lb. dried. Grow Mushrooms. Cellar, shed and outdoors. Spare, full time, year round. We pay \$4.50 lb. Free Book. Mushrooms, Dept. 334, 2954 Admiral Way, Seattle, Wash.

EARN extra money selling advertising book matches. Free samples furnished. Matchcorp, Dept. MD-49, Chicago 32, Illinois.

VENDING Machines—No Selling. Operate a route of coin machines and earn amazing profit. 32-page catalog free. Parkway Machine Corporation, Dept. 12, 715 Ensor St., Baltimore 2, Md.

FIND Money In your mailbox. Start your own Mail Order business. Experience unnecessary. Experts show you how. Write Richton Company, 157K, Maplewood, New Jersey.

OPERATE Profitable mail order business!! Write: Bond, 1637-X, West Vernon, Phoenix, Arizona.

RUN a spare-time Greeting Card and Gift Shop at home. Show friends samples of our new 1959 Christmas and All Occasion Greeting Cards and Gifts. Take their orders and earn to 100% profit. No experience necessary. Costs nothing to try. Write today for samples on approval. Regal Greetings, Dept. 148, Ferndale, Michigan.

DETECTIVES—Work home—travel. Experience unnecessary. Detective Particulars free. Write, Wagoner, 125-X West 86th, N. Y.

PLASTICS

NEW Liquid Casting Plastic, clear colors. Embed real flowers, minerals, biological specimens, delicate instruments, electronic parts. Also cold-setting resin and fiberglass for laminating, casting, molding, coating. Manual 25¢. Castolite, Dept. J-108, Woodstock, Illinois.

EMPLOYMENT INFORMATION

JOBS Overseas! Janecek Development Co., 109 Hub Station, New York 55, N. Y.

AMERICAN Overseas Jobs. High Pay. Men, Women, Transportation Paid. Free Information. Write: Transworld, Dept. NR, 200 West 34th St., New York 1.

STAMPS & COINS

REVISED Coin Bargain Catalog, 25¢! Dollar Collections: (7 Indian Cents); (6 Liberty Nickels)—both, \$1.89! "Prices Paid" listing, \$1.00! Sullivan, 128-FH East Fourth, St. Paul 1, Minn.

105 DIFFERENT U.S. stamps 25¢. Approvals included. Shelron, Box 907-E, New York 8, N. Y.

LEATHERCRAFT

FREE "Do-It-Yourself" Leathercraft Catalog. Thandy Leather Company, Box 791—D31, Fort Worth, Texas.

MISCELLANEOUS

ELECTRIC Pencil: Engraves all Metals \$2.00. Beyer Mfg., 10511 2D Springfield, Chicago 43.

ADVERTISE: 24 words, 100 Canadian Newspapers, \$5.50. Lists Free. Advertising Bureau, 10511-PA Springfield, Chicago 43.

"WINEMAKING: Beer, Ale Brewing." Illustrated. \$2.00. Eaton Books, Box 1242-C, Santa Rosa, California.

BIZARRE Fashions! Illustrated Catalogue, \$1.00. Renee, Box 2804-P, Hollywood 28, Calif.

SONGPOEMS And Lyrics Wanted! Mail to: Tin Pan Alley, Inc., 1650 Broadway, New York 19, N. Y.

NEW 1959 Automobiles—to 25% off retail. Delivered anywhere. Meder, 550-PE, Fifth Avenue, New York 36.

SHIPPED ON APPROVAL NO MONEY WITH ORDER—NO C. O. D.

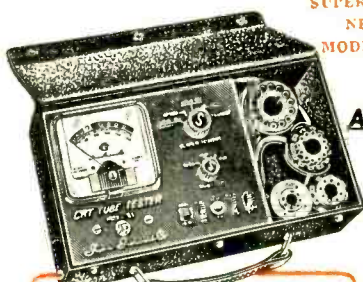

SUPERIOR'S
NEW
MODEL 83

C.R.T. TESTER

Tests and Rejuvenates ALL PICTURE TUBES

ALL BLACK AND WHITE TUBES

From 50 degree to 110 degree types
—from 8" to 30" types.

● Model 83 is not simply a refashed black and white C.R.T. Tester with a color adapter added. Model 83 employs a new improved circuit designed specifically to test the older type black and white tubes, the newer type black and white tubes and all color picture tubes. ● Model 83 provides separate filament operating voltages for the older 6.3 types and the newer 8.4 types. ● Model 83 employs a 4" air-damped meter with quality and calibrated scales. ● Model 83 properly tests the red, green and blue sections of color tubes individually—for each section of a color tube contains its own filament, plate, grid and cathode. ● Model 83 will detect tubes which are apparently good but require rejuvenation. Such tubes will provide a picture seemingly good

ALL COLOR TUBES

Test ALL picture tubes—in the carton—out of the carton—in the set!

but lacking in proper definition, contrast and focus. To test for such malfunction, you simply press the rej. switch of Model 83. If the tube is weakening, the meter reading will indicate the condition. ● Rejuvenation of picture tubes is not simply a matter of applying a high voltage to the filament. Such voltages improperly applied can strip the cathode of the oxide coating essential for proper emission. The Model 83 applies a selective low voltage uniformly to assure increased life with no danger of cathode damage.

Housed in handsome portable Saddle Stitched Texon case—complete with sockets for all black and white tubes and all color tubes. Only

\$38⁵⁰

Model 83—C.R.T. Tube Tester

Total Price \$38.50

Terms: \$8.50 after 10 day trial, then \$6.00 monthly for 5 months if satisfactory. Otherwise return, no explanation necessary.

Superior's New Model TV-50A GENOMETER

7 Signal Generators in One!

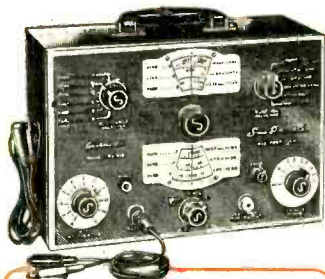

- ✓ R.F. Signal Generator for A.M.
- ✓ R.F. Signal Generator for F.M.
- ✓ Audio Frequency Generator
- ✓ Bar Generator
- ✓ Cross Hatch Generator
- ✓ Color Dot Pattern Generator
- ✓ Marker Generator

This versatile All-Inclusive GENERATOR Provides ALL the Outputs for Servicing:

A.M. Radio • F.M. Radio • Amplifiers • Black and White TV • Color TV

Model TV-50A GENOMETER

Total Price \$47.50

Terms: \$11.50 after 10 day trial, then \$6.00 monthly for 6 months if satisfactory. Otherwise return, no explanation necessary.

R. F. SIGNAL GENERATOR: The Model TV-50A Genometer provides complete coverage for A.M. and F.M. alignment. Generates Radio Frequencies from 100 Kilocycles to 60 Megacycles on fundamentals and from 60 Megacycles to 180 Megacycles on powerful harmonics.

VARIABLE AUDIO FREQUENCY GENERATOR: In addition to a fixed 400 cycle sine-wave audio, the Model TV-50A Genometer provides a variable 300 cycle to 20,000 cycle peaked wave audio signal.

BAR GENERATOR: The Model TV-50A projects an actual Bar Pattern on any TV Receiver Screen. Patterns will consist of 4 to 16 horizontal bars or 7 to 20 vertical bars.

CROSS HATCH GENERATOR: The Model TV-50A Genometer will project a cross-hatch pattern on any TV picture tube. The pattern will consist of non-shifting, horizontal and vertical lines interlaced to provide a stable cross-hatch effect.

DOT PATTERN GENERATOR (FOR COLOR TV) Although you will be able to use most of your regular standard equipment for servicing Color TV, the one addition which is a "must" is a Dot Pattern Generator. The Dot Pattern projected on any color TV Receiver tube by the Model TV-50A will enable you to adjust for proper color convergence.

MARKER GENERATOR: The Model TV-50A includes all the most frequently needed marker points. The following markers are provided: 189 Kc., 262.5 Kc., 456 Kc., 600 Kc., 1000 Kc., 1400 Kc., 1600 Kc., 2000 Kc., 2500 Kc., 3579 Kc., 4.5 Mc., 5 Mc., 10.7 Mc., (3579 Kc. is the color burst frequency).

The Model TV-50A comes absolutely complete with shielded leads and operating instructions. Only

\$47⁵⁰

USE APPROVAL FORM ON NEXT PAGE ▶

We invite you to try before you buy any of the models described on this and the following pages. If after a 10 day trial you are completely satisfied and decide to keep the Tester, you need send us only the down payment and agree to pay the balance due at the monthly indicated rate.

NO INTEREST OR FINANCE CHARGES ADDED!

If not completely satisfied, you are privileged to return the Tester to us, cancelling any further obligation.

MOSS ELECTRONIC, INC.

Dept. D-619 3849 Tenth Avenue, New York 34, N. Y.

TRY FOR 10 DAYS

before you buy!

then if satisfactory pay in easy, interest free, monthly payments. See coupon below.



Model 82A—Tube Tester
Total Price \$36.50
 Terms: \$6.50 after 10 day trial, then \$6.00 monthly for 5 months if satisfactory. Otherwise return, no explanation necessary.

Superior's New Model 82A **A truly do-it-yourself type**
TUBE TESTER

TEST ANY TUBE IN 10 SECONDS FLAT!

- 1 Turn the filament selector switch to position specified.
- 2 Insert it into a numbered socket as designated on our chart (cover 600 types included).
- 3 Press down the quality button—

THAT'S ALL! Read emission quality direct on bad-good meter scale.

FEATURES:

- Tests over 600 tube types. • Tests OZ4 and other gas-filled tubes. • Employs new 4" meter with sealed air-damping chamber resulting in accurate vibrationless readings. • Use of 22 sockets permits testing all popular tube types and prevents possible obsolescence. • Dual Scale meter permits testing of low current tubes. • 7 and 9 pin straighteners mounted on panel. • All sections of multi-element tubes tested simultaneously. • Ultra-sensitive leakage test circuit will indicate leakage up to 5 megohms.

Production of this Model was delayed a full year pending careful study by Superior's engineering staff of this new method of testing tubes. Don't let the low price mislead you! We claim Model 82A will outperform similar looking units which sell for much more—and as proof, we offer to ship it on our examine before you buy policy.

Model 82A comes housed in handsome, portable, Saddle-Stitched Texon case. Only... **\$36.50 Net**



Model TW-11—Tube Tester
Total Price \$47.50
 Terms: \$11.50 after 10 day trial, then \$6.00 monthly for 6 months if satisfactory. Otherwise return, no explanation necessary.

Superior's **STANDARD PROFESSIONAL**
 New Model **TUBE TESTER**
 TW-11

- Tests all tubes, including 4, 5, 6, 7, Octal, Lockin, Hearing Aid, Thyatron, Miniatures, Sub-miniatures, Novals, Subminors, Proximity Fuse Types, etc.

- Uses the new self-cleaning Lever Action Switches for individual element testing. All elements are numbered according to pin-number in the RMA base numbering system. Model TW-11 does not use combination type sockets. Instead individual sockets are used for each type of tube. Thus it is impossible to damage a tube by inserting it in the wrong socket.

- Free-moving built-in roll chart provides complete data for all tubes. Printed in large easy-to-read type.

NOISE TEST: Phono-jack on front panel for plugging in either phones or external amplifier detects microphonic tubes or noise due to faulty elements and loose internal connections.

EXTRAORDINARY FEATURE SEPARATE SCALE FOR LOW-CURRENT TUBES Previously, an emission-type tube testers, it has been standard practice to use one scale for all tubes. As a result, the calibration for low-current types has been restricted to a small portion of the scale. The extra scale used here greatly simplifies testing of low-current types.

Housed in hand-rubbed oak cabinet **\$47.50 Net**

We invite you to try before you buy any of the models described on this page, the preceding page and the following pages. If after a 10 day trial you are completely satisfied and decide to keep the Tester, you need send us only the down payment and agree to pay the balance due at the monthly indicated rate.

NO INTEREST OR FINANCE CHARGES ADDED!

If not completely satisfied, you are privileged to return the Tester to us, cancelling any further obligation.

SEE OTHER SIDE

CUT OUT AND MAIL TODAY!

MOSS ELECTRONIC, INC.
 Dept. D-619 3849 Tenth Ave., New York 34, N. Y.

Please send me the units checked on approval. If completely satisfied I will pay on the terms specified with no interest or finance charges added. Otherwise, I will return after a 10 day trial positively cancelling all further obligation.

- | | |
|---|---|
| <input type="checkbox"/> Model 83 Total Price \$38.50
\$8.50 within 10 days. Balance \$6.00 monthly for 5 months. | <input type="checkbox"/> Model 82A Total Price \$36.50
\$6.50 within 10 days. Balance \$6.00 monthly for 5 months. |
| <input type="checkbox"/> Model TV-50A Total Price \$47.50
\$11.50 within 10 days. Balance \$6.00 monthly for 6 months. | <input type="checkbox"/> Model 77 Total Price \$42.50
\$12.50 within 10 days. Balance \$6.00 monthly for 5 months. |
| <input type="checkbox"/> Model TW-11 Total Price \$47.50
\$11.50 within 10 days. Balance \$6.00 monthly for 6 months. | <input type="checkbox"/> Model 79 Total Price \$38.50
\$8.50 within 10 days. Balance \$6.00 monthly for 5 months. |

Name

Address

City Zone State

All prices net. F.O.B., N. Y. C.

SHIPPED ON APPROVAL NO MONEY WITH ORDER — NO C. O. D.

Superior's New Model 77 **VACUUM TUBE VOLTMETER** WITH NEW 6" FULL-VIEW METER

Compare it to any peak-to-peak V. T. V. M. made by any other manufacturer at any price!



Model 77—VACUUM TUBE VOLTMETER. Total Price . . . \$42.50
Terms: \$12.50 after 10 day trial, then \$6.00 monthly for 5 months if satisfactory. Otherwise return, no explanation necessary.

- Extra large meter scale enables us to print all calibrations in large easy-to-read type.
- Employs a 12AU7 as D. C. amplifier and two 9006's as peak-to-peak voltage rectifiers to assure maximum stability. • Meter is virtually burn-out proof. The sensitive 400

AS A DC VOLTMETER: The Model 77 is indispensable in Hi-Fi Amplifier servicing and a must for Black and White and color TV Receiver servicing where circuit loading cannot be tolerated.

AS AN ELECTRONIC OHMMETER: Because of its wide range of measurement leaky capacitors show up glaringly. Because of its sensitivity and low loading, Intermittents are easily found, isolated and repaired.

AS AN AC VOLTMETER: Measures RMS values if sine wave, and peak-to-peak value if complex wave. Pedestal voltages that determine the "black" level in TV receivers are easily read.

micro-ampere meter is isolated from the measuring circuit by a balanced push-pull amplifier. • Uses selected 1% zero temperature coefficient resistors as multipliers. This assures unchanging accurate readings on all ranges.

SPECIFICATIONS

- DC VOLTS—0 to 3/15/75/150/300/750/1,500 volts at 11 megohms input resistance.
- AC VOLTS (RMS)—0 to 3/15/75/150/300/750/1,500 volts. • AC VOLTS (Peak to Peak)—0 to 8/40/200/400/800/2,000 volts.
- ELECTRONIC OHMMETER—0 to 1,000 ohms/10,000 ohms/100,000 ohms/1 megohm/10 megohms/100 megohms/1,000 megohms.
- DECIBELS: -10 db to +18 db, +10 db to +38 db, +30 db to +58 db. All based on 0 db = 006 watts (6 mw) into a 500 ohm line (1.73v).
- ZERO CENTER METER—For discriminator alignment with full scale range of 0 to 1.5/7.5/37.5/75/150/375/750 volts at 11 megohms input resistance.

Comes complete with operating instructions, probe leads, and streamlined carrying case. Operates on 110-120 volt 60 cycle. Only . . . **\$42.50**

SUPERIOR'S NEW MODEL 79 **SUPER-METER** WITH NEW 6" FULL-VIEW METER

A Combination VOLT-OHM MILLIAMMETER

Plus CAPACITY, REACTANCE, INDUCTANCE & DECIBEL MEASUREMENTS
Also Tests SELENIUM & SILICON RECTIFIERS, SILICON & GERMANIUM DIODES

The model 79 represents 20 years of continuous experience in the design and production of SUPER-METERS, an exclusive SICO development. It includes not only every circuit improvement perfected in 20 years of specialization but, in addition includes those services which are "musts" for properly servicing the ever-increasing number of new components used in all phases of today's electronic production.

For example with the Model 79 SUPER-METER you can measure the quality of selenium and silicon rectifiers and all types of diodes — components which have come into common use only within the past five years, and because this latest SUPER-METER necessarily required extra meter scale. SICO used its new full-view 6-inch meter.

SPECIFICATIONS:

- D.C. VOLTS: 0 to 7.5 15 75 150 750 1,500. • A.C. VOLTS: 0 to 15 30 150 300 1,500 3,000. • D.C. CURRENT: 0 to 1.5 15 150 Ma. 0 to 1.5 15 Amperes. • RESISTANCE: 0 to 1,000 100,000 Ohms, 0 to 10 Megohms. • CAPACITY: .001 to 1 Mfd., 1 to 50 Mfd. • REACTANCE: 50 to 2,500 Ohms, 2,500 Ohms to 2.5 Megohms. • INDUCTANCE: .15 to 7 Henries, 7 to 7,000 Henries. • DECIBELS: -6 to +18, +14 to +38, +34 to +58. The following components are all tested for QUALITY at appropriate test potentials.

Two separate BAD-GOOD scales on the meter are used for direct readings. All Electrolytic Condensers from 1 MFD to 1000 MFD. All Germanium Diodes. All Selenium Rectifiers. All Silicon Diodes. All Silicon Rectifiers.

Model 79 comes complete with operating instructions, test leads, and streamlined carrying case. Use it on the bench—use it on calls. Only **\$38.50**



Model 79—Super Meter
Total Price . . . \$38.50
Terms: \$8.50 after 10 day trial, then \$6.00 monthly for 5 months if satisfactory. Otherwise return, no explanation necessary.

TRY FOR 10 DAYS BEFORE you buy THEN if satisfact

pay in easy, interest free, monthly payments. See coupon inside.

We invite you to try before you buy any of the models described on this and the preceding pages. If after a 10 day trial you are completely satisfied and decide to keep the Tester, you need send us only the down payment and agree to pay the balance due at the monthly indicated rate. (See other side for time payment schedule details.)

NO INTEREST OR FINANCE CHARGES ADDED!

If not completely satisfied, you are privileged to return the Tester to us, cancelling any further obligation.

SEE OTHER SIDE

CUT OUT AND MAIL TODAY!

FIRST CLASS

Permit No. 61430

New York, N. Y.

VIA AIR MAIL

BUSINESS REPLY CARD

No Postage Stamp Necessary if Mailed in the U. S.

POSTAGE WILL BE PAID BY —

MOSS ELECTRONIC, INC.

3849 TENTH AVENUE

NEW YORK 34, N. Y.