

Home-Built Police Band Receiver

# POPULAR ELECTRONICS

JULY  
1959

35  
CENTS

HI-FI · HAM RADIO · SWL · TEST GEAR



**Radio Airwatch Spots  
Traffic Jams** (see page 41)

**32** PAGE

*Special  
Section on*

**MARINE  
ELECTRONICS**



# Can you think faster than this Machine?

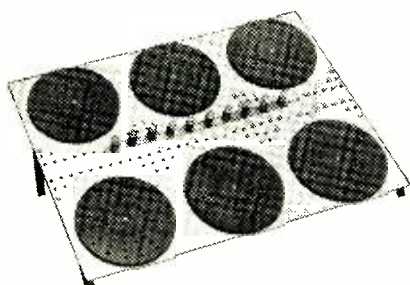

Control Panel of GENIAC set up to do a problem in space ship engineering

Be careful before you answer. GENIAC® the first electrical brain construction kit is equipped to play tic-tac-toe, cipher and encipher codes, convert from binary to decimal, reason in syllogisms, as well as add, subtract, multiply and divide. Specific problems in a variety of fields—actuarial, policy claim settlement, physics, etc., can be set up and solved with the components. Connections are solderless and are completely explained with templates in the manual. This covers 125 circuits and shows how new ones can be designed.

You will find building and using GENIACS® a wonderful experience; one kit user wrote us: "this kit has opened up a new world of thinking to me." You actually see how computing, problem solving, and game play (Tic-tac-toe, nim, etc.) can be analyzed with Boolean Algebra and the algebraic solutions transformed directly into circuit dia-

grams. You create from over 400 specially designed and manufactured components a machine that solves problems faster than you can express them.

Schools and colleges, teachers of science or math, engineering, philosophy or psychology will find these excellent demonstrators of circuitry solutions in symbolic logic, theory of numbers, cybernetics, and automation.

NOTE: Teachers take advantage of our 10% discount to educational institutions and for group purchases.

Send for your GENIAC® kit now. Only \$19.95 with over four hundred components and parts, fully illustrated manual and wiring diagrams. We guarantee that if you do not want to keep GENIAC after two weeks you can return it for full refund.

## A MACHINE THAT PLAYS NIM

Yes every GENIAC® comes complete with the materials and circuits for wiring up a machine that plays NIM. No extra charge. See article in January Popular Electronics.

## NEW—A MACHINE THAT COMPOSES MUSIC

Our amazing machine that composes music was designed by one of the people (a sixteen year old boy) who bought the GENIAC® to learn how to design computers. Use it to make up your own tunes automatically with the GENIAC® computer kit. 1959 Model.

### Some Firms and Institutions that have ordered GENIAC:

Allis-Chalmers Remington-Rand International Business Machines Wheeldex Mfg. Co. Manuel Missionary College Los Angeles Public Schools Kansas State University Duke University Coral Gables Bell Telephone Laboratories	Walter V. Clarke Associates Barnard College Westinghouse Electric Phillips Laboratories General Insurance Co. of America Lafayette Radio Rohr Aircraft Co. Albert Einstein Medical College Naval Research Laboratories
--	--

### Other machines you can build with your 1959 Model GENIAC® Computer Kit.

Machine for a Space Ship's Airlock—Special Combination Lock—Adding-subtracting-multiplying and dividing machines—Comparing and reasoning machines—intelligence testing machines—Uranium Shipment and the Space Pirates—Machine to play Tic-Tac-Toe—Translator from binary to decimal and dozens of others.

### What Comes With Your 1959 Model GENIAC?

Rack, shown in picture; parts tray; guaranteed long lasting American Manufacture bulbs; porcelain sockets; special wipers and contacts; tools, battery; uniquely designed holder plus seven booklets and publications including: 64 Page GENIAC® manual; GENIAC® Wiring Diagrams; Beginners Manual for the person who has little or no knowledge of circuits; GENIAC® Study Guide—the equivalent of a full course in computer fundamentals, lists additional reading; and exclusively in 1959 Model GENIAC® Symbolic Logic and Circuits Design by Claude Shannon.

SEND for your GENIAC® now. At only \$19.95 a bargain. Comes complete with over 400 parts and components, 7 Books and manuals. We guarantee that if you do not want to keep GENIAC after two weeks you can return it for full refund.

K1—Only  
**\$19.95**  
(Add \$1.00 W. of Miss.  
\$2.00 Outside U. S.)

## OLIVER GARFIELD CO., INC.

DEPT. PE-79

108 E. 16th STREET

NEW YORK 3, N. Y.

# Learn Radio-Television

## Servicing or Communications

### by Practicing at Home

### in Spare Time

N. R. I. SENDS kits with which you practice building circuits common to Radio and TV sets. You LEARN-BY-DOING to locate Radio-TV troubles. As part of N. R. I. Servicing Course, you build Vacuum Tube Voltmeter and AC-DC receiver. Use VTVM to conduct experiments, earn extra money fixing sets in spare time.

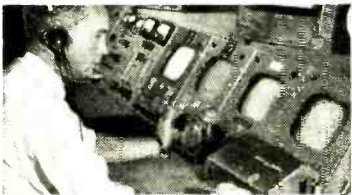
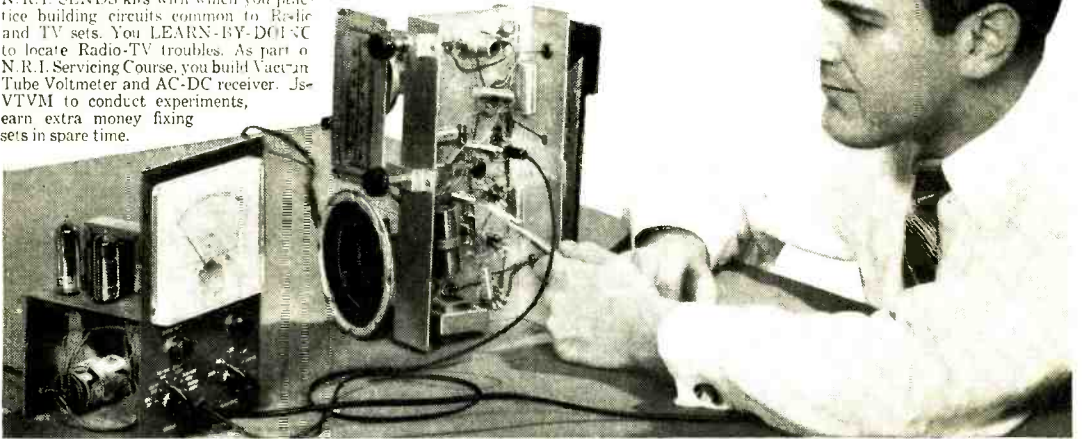

**RADIO-TV BROADCASTING** (see above) offers important positions as Operators and Technicians. **RADIO-TV SERVICING** Technicians (see below) needed in every community. Their services are respected, their skill appreciated.



## Fast Growing Field Offers You Good Pay, Success, Bright Future



**J. E. SMITH**  
Founder

Bigger than ever and still growing fast. That's why Radio-TV has special appeal to ambitious men not satisfied with their job and earnings. More than 4,000 Radio and TV stations. More than 150 million home and auto Radios, 40 million TV sets. Color TV promises added opportunities. For the trained man, there are good jobs, bright futures in Radio-TV Servicing or Broadcasting. Training PLUS opportunity is the ideal combination for success. So plan now to get into Radio-TV. The technical man is looked up to. He does important work, gets good pay for it. Radio-Television offers that kind of work. NRI can supply training quickly, without expense of going away to school. Keep your job while training. You learn at home in your spare time. NRI is the OLDEST and LARGEST home study Radio-TV school. Its methods have proved successful for more than 40 years.

### Added Income Soon - \$10, \$15 a Week in Spare Time

Soon after enrolling, many NRI students start to earn \$10, \$15 a week in spare time fixing sets. Some pay for their training and enjoy extra luxuries this way. Some make enough to start their own Radio-TV shops. NRI training is *practical*—gets quick results. Easy to understand, well illustrated lessons teach you basic principles. And you LEARN-BY-DOING by practicing with kits of equipment which "bring to life" things you study.

### Find Out What NRI Offers

NRI has trained thousands for successful careers in Radio-TV. Study fast or slow—as you like. Diploma when you graduate. Mail coupon now. Paste it on a postcard or mail in envelope. **ACTUAL LESSON FREE.** Also 64 page catalog that shows opportunities, shows equipment you get. Cost of NRI courses low. Easy terms. **NATIONAL RADIO INSTITUTE, Dept. 9GD4, Washington 16, D. C.**

## N. R. I. TRAINED THESE MEN FOR SUCCESS



"I was repairing Radios by 10th lesson. Now have good TV job." **M. R. LINDEMUTH,** Fort Wayne, Ind.



"Doing spare time repairs on Radio and TV. Soon servicing full time." **CLYDE HIGGINS,** Waltham, Mass.

"I had a successful Radio repair shop. Now I'm Engineer for WHPE." **V. V. WORKMAN,** High Point, N. C.



"There are a number of NRI graduates here. I can thank NRI for this job." **JACK WAGNER,** Lexington, N. C.



## VETERANS Approved Under G. I. Bills

## SEND FOR BOTH FREE

### National Radio Institute

Dept. 9GD4, Washington 16, D. C.

Mail me Sample Lesson and 64-Page Catalog FREE. (No salesman will call. Please write plainly.)

Name \_\_\_\_\_ Age \_\_\_\_\_

Address \_\_\_\_\_

City \_\_\_\_\_ Zone \_\_\_\_\_ State \_\_\_\_\_

Accredited Member National Home Study Council

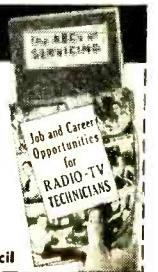

**POPULAR ELECTRONICS** is published monthly by Ziff-Davis Publishing Company, William B. Ziff, Chairman of the Board (1936-1953), at 434 S. Wabash Ave., Chicago 5, Ill. Second-class postage paid at Chicago, Illinois. Authorized by Post Office Department, Ottawa, Canada, as second-class matter. **SUBSCRIPTION RATES:** One year U.S. and possessions, and Canada \$4.00; Pan-American Union countries \$4.50; all other foreign countries, \$5.00.

# POPULAR ELECTRONICS

JULY

1959

VOLUME 11

NUMBER 1



## Marine Electronics for the Small Boat

Electronics Afloat (an editorial).....	68
Radiotelephones for Small Boats.....	B. H. Ballard, Jr. 69
Automatic Pilots.....	Oliver Read, W1ETI 72
Small Boat Antenna Systems.....	Elbert Robberson 75
Transistors or Tubes in Marine Gear?.....	Louis E. Garner, Jr. 79
The Radio Direction Finder.....	Ralph Rosenfeld 81
Shipboard-TV Keeps the Kids Happy.....	84
Citizens Band Radio for Small Boats.....	Donald L. Stoner, W6TNS 85
Radar and Loran.....	Clark E. Jackson 87
Depth Sounders and Fish Finders.....	Leo G. Sands 90
Electrolysis and Corrosion.....	Elbert Robberson 93
Manufacturers of Marine Electronic Equipment.....	97

## Electronic Construction Projects

Police Special Receiver.....	George J. Whalen, K2BIE 50
Build a Field Strength Meter.....	Donald L. Stoner, W6TNS 61
Inexpensive Lock Switch.....	D. Derek Verner 62
Experimenter's Variable Power Supply.....	Charles H. Welch 99
Wide-Range Electronic Timer.....	R. L. Winklepleck 113
Simple AF-RF Signal Tracer.....	Art Trauffer 116

## Audio and High Fidelity

Maze of Mikes.....	Elliot Gordon 47
Inside the Power Amplifier (Part 1).....	Joseph Marshall 57
Raymond Scott: Electronics Enthusiast.....	Alan D. Haas 102
Build the Reflex 12.....	Dave Gordon 104
Build a Stereo Control Unit.....	125

## Electronic Features and New Developments

Operation Radio Airwatch.....	Morris Moses 41
Recent Developments in Battery Design.....	Saunders Harris, W1NXL 44
Electronic Sticklers.....	64
Test Instruments (Part 6).....	Larry Klein 109
Electronic Drone Scouts the Enemy.....	112
Electronics in the News.....	132

## Amateur and SWL

The DX-O-GRAPH.....	C. F. Rockey, W9SCH 54
Hamming in Braille.....	Howard Sheperd 63
Build a Six-Meter Transmitter.....	65
10,000 Short-Wave Monitors Registered.....	127

## Departments

Notes from the Editor.....	Oliver Read, W1ETI 8
Letters from Our Readers.....	10
POP'tronics Bookshelf.....	16
Tips and Techniques.....	24
New Products.....	32
Among the Novice Hams.....	Herb S. Brier, W9EGQ 117
After Class.....	Harvey Pollack 119
Transistor Topics.....	Lou Garner 122
Short-Wave Report.....	Hank Bennett, W2PNA 126
Carl and Jerry.....	John T. Frye, W9EGV 128

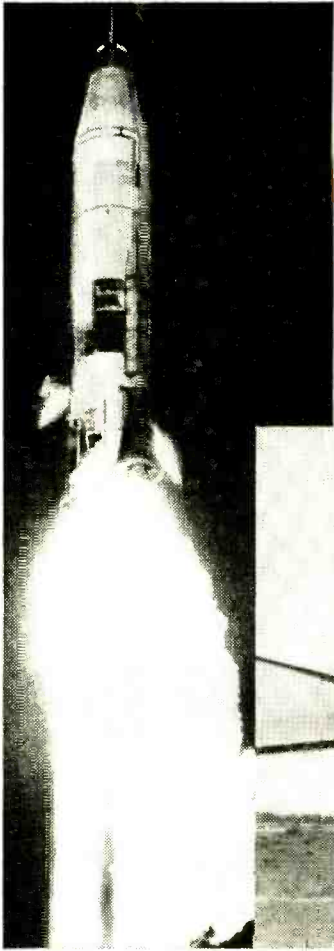

# FORMER SERVICEMEN: TAKE A FRONT ROW SEAT IN THE NEW AGE OF SPACE

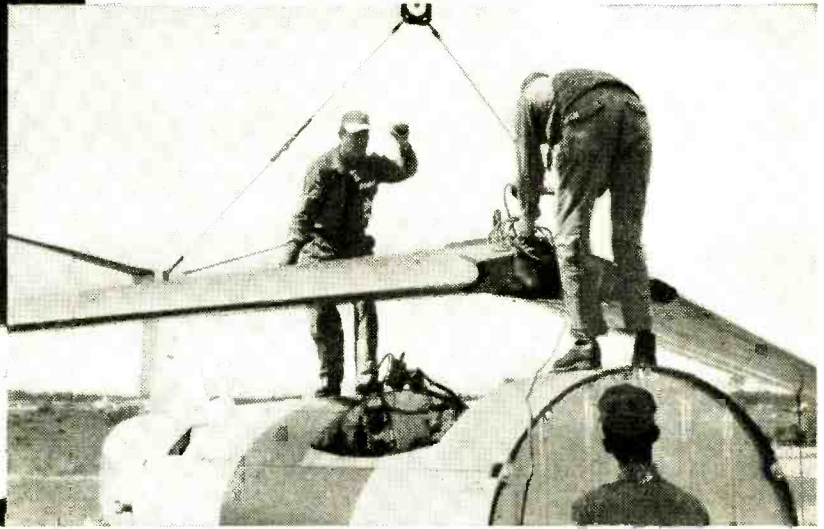

## AS A SPECIALIST IN THE U. S. AIR FORCE



If you have a technical skill, make the most of it, where the Age of Space is *now*—in the U. S. Air Force. You'll work with the latest equipment, learn the latest advances of your specialty. What's more, you'll hold down an *important*, responsible job, and you can look forward to a future that's guaranteed. But the time to act is now, while your skill is at peak value. See your local Air Force Recruiter, or mail the coupon.

**PASTE ON POSTAL CARD AND MAIL TO:**

Prior Service Information, Dept. MP-97  
Box 7608, Washington 4. D. C.

Please send me more information on the Air Force Prior Service Program.

Name \_\_\_\_\_

Address \_\_\_\_\_ Age \_\_\_\_\_

City \_\_\_\_\_ Zone \_\_\_\_\_ State \_\_\_\_\_

**Editor & Publisher**  
**OLIVER READ, W1ET1**

**Assistant Editor**  
**JULIAN M. SIENKIEWICZ, WV2CQL**

**Technical Editor**  
**LARRY KLEIN**

**Art Editor**  
**ALFONS J. REICH**

**Associate Editors**  
**SIMON DRESNER**  
**FURMAN HIBB**  
**MARGARET MAGNA**

**Editorial Assistant**  
**DOLORES GIMBEL**

**Contributing Editors**  
**H. BENNETT, W2PN**  
**H. S. BRIER, W9EGQ**  
**J. T. FRYE, W9EGV**  
**L. E. GARNER, Jr.**  
**T. KNEITEL**  
**H. POLLACK**  
**D. L. STONER, W6TMS**

**Art and Drafting Dept.**  
**K. W. PAUL, JR.**  
**J. A. ROTH**  
**W. K. VAHLSING**

**Advertising Director**  
**JOHN A. RONAN, Jr.**

**Advertising Manager**  
**WILLIAM G. McROY**

ZIFF-DAVIS PUBLISHING COMPANY,  
One Park Ave., New York 16, N. Y.  
William B. Ziff, Chairman of the Board  
(1946-1953); William Ziff, President;  
W. Bradford Briggs, Executive Vice  
President; Michael Michaelson, Vice  
President and Circulation Director; Hersh-  
el B. Sarbin, Secretary; Howard Stough-  
ton, Jr., Treasurer; Albert Gruen, Art  
Director.



**BRANCH OFFICES:** Midwestern Office,  
434 S. Wabash Ave., Chicago 5, Ill.,  
Jim Weakley, advertising manager;  
Western Office, Room 412, 215 W. 7th  
St., Los Angeles 17, Calif., James R.  
Pierce, advertising manager.

**Foreign Advertising Representatives:**  
D. A. Goodall Ltd., London; Albert Mil-  
hodo & Co., Antwerp and Dusseldorf.

**SUBSCRIPTION SERVICE:** Forms 3579 and all subscription correspondence should be addressed to Circulation Department, 434 South Wabash Avenue, Chicago 5, Illinois. Please allow at least four weeks for change of address. Include Your old address as well as new—enclosing if possible an address label from a recent issue.

**CONTRIBUTORS:** Contributors are advised to retain a copy of their manuscripts and illustrations. Contributions should be mailed to the New York Editorial Office and must be accompanied by return postage. Contributions will be handled with reasonable care, but this magazine assumes no responsibility for their safety. Any copy accepted is subject to whatever adaptations and revisions are necessary to meet the requirements of this publication. Payment covers all author's, contributor's and contestant's rights, titles, and interest in and to the material accepted and will be made at our current rates upon acceptance. All photos and drawings will be considered as part of material purchased.

# POPULAR ELECTRONICS

World's largest-selling Electronics Magazine

This month's cover by Fred Swartz

COMING NEXT MONTH

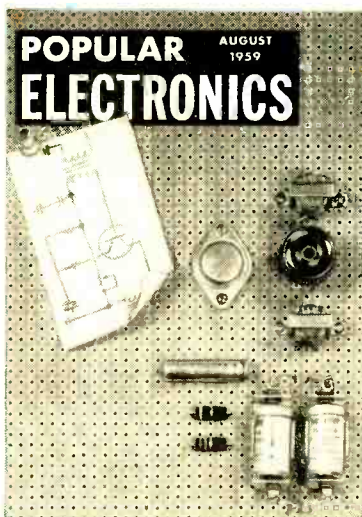

(ON SALE JULY 23)

Our August cover will feature a life-size two-watt transistor audio amplifier on a mock-up board. This will be a reminder that inside the issue you will find a 16-page special section on transistor circuit design. See page 25 for details.

Planning to get your Citizens Band license? If so, don't miss "Tips for Citizens Band Applicants." It will give you complete "battle plans" for tackling Form 505. Many applications are being returned because they are incorrectly or incompletely filled out. We think this article will be a big help in filling out the form.

Also in the August issue will be construction features on a solar-powered 40-meter transmitter . . . a radio-frequency standard . . . and a stereo phono oscillator.

SOMETHING **NEW**\* HAS BEEN ADDED TO THE  
**DEVRY TECH TRAINING PROGRAM**

Prepare in Spare Time At Home for a

# JOB THAT PAYS REAL MONEY

in **TELEVISION-RADIO-ELECTRONICS**

Many DeVry-trained men who now hold good jobs paying real money were once looking for opportunity, yet wondering if they needed advanced schooling, special experience, or higher math. They clipped a DeVry Tech coupon, mailed it in—and were pleasantly SURPRISED! Now they work in one of today's fastest-growing fields—TELEVISION-RADIO-ELECTRONICS. Many have their own profitable service shops. DeVry Tech's "Learn-by-Seeing," "Learn-by-Reading," "Learn-by-Doing" training made the difference! You, too, may train at home the DeVry Tech way with wonderful, helpful movies, clear texts and valuable home laboratory equipment—or in our well-equipped Chicago or Toronto Training Centers.

Now something NEW\* has been added to help you learn more by "doing." You can choose to build and keep your own top quality 6-speaker STEREOPHONIC SOUND SYSTEM that will provide thrilling enjoyment for years to come. Plans are furnished so that you can also build your own speaker cabinets—or we can tell you where to buy them. DeVry Tech's specially designed Stereo System includes:

- Turntable with Stereo cartridge
- Stereo Amplifier
- Stereo Pre-Amplifier
- 2 Cross-Over Networks
- Six Speakers: two 12-in., two 8-in., two 3-in.

When you build your own equipment, you learn about the working parts. You can repair, adjust, maintain. You learn by doing—the DeVry Tech way. You put basic principles into "on-the-job" practice.



VACUUM TUBE  
 VOLT METER

5 INCH  
 WIDE BAND  
 OSCILLOSCOPE

**\* NEW!**  
**Build Your Own  
 6-Speaker  
 HIGH FIDELITY  
 STEREOPHONIC  
 SOUND SYSTEM**

... another wonderful DeVry advantage

Special SHORT COURSE in High Fidelity Sound Reproduction including Stereophonic Systems also available. Ideal for hobbyists, music lovers and those wanting to ADD to their incomes.

### MANY OPTIONS!

NOW . . . DeVry Tech men can take their choice of any or all of the quality equipment shown above: The Stereo System . . . the Scope and Meter . . . a 21-inch TV Set (not pictured) . . . or ALL THREE. But no matter which way you do it, you get practical home training at its best . . . the kind you need to get started in the fast-moving Electronics field. Send coupon for details.

"One of North America's  
 Foremost Electronics  
 Training Centers"



Accredited Member of  
 National Home Study Council

**DEVRY TECHNICAL INSTITUTE**

4141 BELMONT • CHICAGO 41, ILL. • Formerly DeFOREST'S TRAINING, Inc.

**GET  
 2  
 FREE  
 BOOKLETS!**

Clip the coupon now for two booklets that answer many questions about your chances for success in this field. "Electronics and YOU" and the remarkable "Pocket Guide to Real Earnings" (just off the press) are yours without obligation.

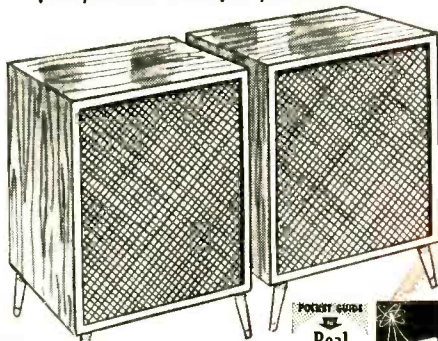

### EMPLOYMENT SERVICE

DeVry Tech offers real, down-to-earth employment service to help you toward a good job after graduation — even provides help in starting your own servicing business.



### MAIL TODAY FOR FREE FACTS

DeVry Technical Institute  
 4141 Belmont Ave., Chicago 41, Ill., Dept. PE-7-P  
 Please give me your two FREE booklets, "Pocket Guide to Real Earnings" and "Electronics and You," and tell me how to prepare to enter one or more branches of Electronics.

NAME \_\_\_\_\_ AGE \_\_\_\_\_  
 STREET \_\_\_\_\_ APT. \_\_\_\_\_  
 CITY \_\_\_\_\_ ZONE \_\_\_\_\_ STATE \_\_\_\_\_

Check here if subject to military training.  
 DeVry Tech's Canadian Training Center is located at  
 2053 626 Roselawn Avenue, Toronto 12, Ontario

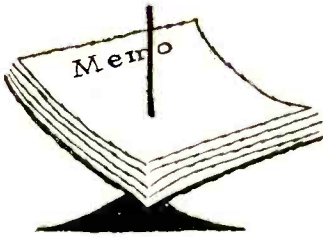

## Notes from the Editor

**MARINE SECTION.** You don't have to be a boat owner, nor do you have to have much interest in things nautical to benefit from the special section on marine electronics beginning on page 67 of this issue. The operation of marine electronic gear is a timely and important subject for the student, the experimenter, and the technician.

If you do own a boat, you'll have a better understanding and appreciation of marine equipment if you become more familiar with basic "how-it-works" principles and circuitry. Knowing how to use electronic devices properly can only come from practice. An informed skipper is far safer afloat than the novice with a host of equipment who has not mastered its operation.

If you are a technician or a radio amateur, you may want to consider opportunities for business ventures in the fast-growing field of marine electronics. If you obtain a FCC radiotelephone license, second class, you will be able to install and service marine electronic devices.

Too little knowledge can be dangerous to life, limb and property. The marine radiotelephone, in far too many cases, is grossly misused and operated as a plaything. Unnecessary transmissions have already interfered with distress communications and lives have been lost as a result. Only a week ago, a youngster asked me why I had not responded when he called me via radiotelephone moments before. The "shocker" was that his boat was tied up to the same dock as mine, only about 200 feet away. Such disrespect for this life-saving device could be disastrous.

Citizens Band radio equipment has found new applications in the boating field. These relatively simple devices for short line-of-sight communications between boats, etc., if properly used, can supplement more advanced communications equipment such as the radiotelephone. There are limitations, however, as to range and utility, and these should be understood by the layman.

Whatever your interest in electronics, we hope you will read and enjoy our special section on marine electronics.

**TRANSISTOR ISSUE.** Next month we have another "plum" to offer. With all the interest today in transistors and transistorized circuits, we've been wanting to do something special for our many readers who would like to have detailed practical information on transistors. In addition to other articles on transistors, our August issue will contain a 16-page "bonus" feature which covers transistors from alpha (cutoff) to omega. This section concentrates on transistors from the experimenter's viewpoint, and tells how to design transistor circuits by using basic electronic theory, by understanding how transistors operate, and by the application of common sense. Don't miss it because you'll want to keep it handy in your reference library.

*Oliver Read*



These men are getting practical training in **ELECTRONICS**

# ELECTRICITY

## ELECTRONICS

### ON REAL

Motors—Generators  
—Switchboards—  
Controls—Modern  
Appliances—  
Automatic  
Electronic  
Control Units

# TELEVISION

## RADIO ELECTRONICS

### ON REAL

TV Receivers—  
Black and White  
and Color  
AM-FM and  
Auto Radios  
Transistors  
Printed Circuits  
Test Equipment

# Train in NEW Shop-Labs of COYNE

in Chicago—prepare for today's TOP OPPORTUNITY FIELD. Train on real full-size equipment at COYNE where thousands of successful men have trained for over 60 years—largest, oldest, best equipped school of its kind. Professional and experienced instructors show you how, then do practical jobs yourself. No previous experience or advanced education needed. Employment Service to Graduates.

**START NOW—PAY LATER**—Liberal Finance and Payment Plans. Part-time employment help for students. **GET FREE BOOK**—"Guide to Careers" which describes your training in **ELECTRICITY-ELECTRONICS** and **TELEVISION-RADIO ELECTRONICS**—no obligation; **NO SALESMAN WILL CALL.**

Coyne Electrical School, 1501 W. Congress Parkway  
Chartered Not For Profit • Chicago 7, Dept. B9-2A

## MAIL COUPON OR WRITE TO ADDRESS BELOW

**COYNE ELECTRICAL SCHOOL**  
Dept. B9-2A —New Coyne Building  
1501 W. Congress Pkwy., Chicago 7, Ill.  
Send **BIG FREE** book and details of all the training you offer.

Name \_\_\_\_\_  
Address \_\_\_\_\_  
City \_\_\_\_\_ State \_\_\_\_\_



**COYNE offers  
LOW COST**

# TELEVISION RADIO - COLOR TV

Training in  
Spare Time **AT HOME**

The future is **YOURS** in **TELEVISION!**

A fabulous field—good pay—fascinating work—a prosperous future in a good job, or independence in your own business!

Coyne brings you **MODERN-QUALITY** Television Home Training; training designed to meet Coyne standards at truly lowest cost—you pay for training only—**no costly "put together kits."** Not an old Radio Course with Television "tacked on." Here is **MODERN TELEVISION TRAINING** including **Radio, UHF and Color TV.** No Radio background or previous experience needed. Personal guidance by Coyne Staff. **Practical Job Guides** to show you how to do actual servicing jobs—**make money early in course.** Free Life-time Employment Service to Graduates.

**COYNE  
ELECTRICAL SCHOOL**

CHARTERED AS AN EDUCATIONAL INSTITUTION  
NOT FOR PROFIT

1501 W. Congress Parkway • Chicago 7, Dept. B9-H2



B. W. COOKE, Jr., President

*Coyne—the institution behind this training... the largest, oldest, best equipped residential school of its kind. Founded 1899.*

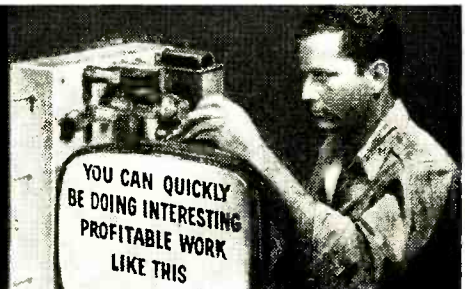

Send Coupon or write to address below  
for Free Book

and full details,  
including easy  
Payment Plan.  
**No obligation, no  
salesman will call.**



**COYNE Television  
Home Training Division**  
Dept. B9-H2, New Coyne Building  
1501 W. Congress Pkwy., Chicago 7, Ill.

Send Free Book and details on how I can get  
Coyne Quality Television Home Training at  
low cost and easy terms.

Name \_\_\_\_\_  
Address \_\_\_\_\_  
City \_\_\_\_\_ State \_\_\_\_\_

# New Low-Cost Transistors

## ...from Sylvania

Eight diversified types to help you build or rebuild a wider range of transistorized equipment economically

Now you can transistorize more circuits at lower cost with these eight quality transistors from Sylvania:



For high-gain RF-IF amplifier applications, a new PNP drift type, 2N1264—now available at \$1.30.



For AF and RF circuits, PNP types, 2N1265 and 2N1266 and equivalent NPN types, 2N229 and 2N233—now available at 65 cents.



For power requirement, 3 PNP Power types, 2N255, 2N307 and 2N554 with 15 v, 35 v and 30 v max. collector-base voltage respectively—each now available at \$1.35.

Contact your nearby authorized Sylvania distributor or write the Semiconductor Division directly for applications literature on these new Sylvania transistors.

Sylvania Electric Products Inc.  
Semiconductor Division  
100 Sylvan Rd., Woburn, Mass.

# SYLVANIA

Subsidiary of  
GENERAL TELEPHONE & ELECTRONICS

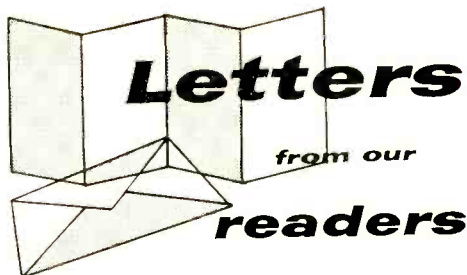

### Have Receiver, Will Listen

■ I enjoy your special features such as "DX'ing the Airlines" and "QSL'ing the Coast Guard" with the frequencies given. I DX both of these types of stations a good deal.

In my short-wave listening, I use the following receivers: Racal RA-17C and RA-37C Low Frequency Converter; Hallicrafters SX-62; Zenith Trans-Oceanic T600, R623W, and Transistor Royal 500; RCA Victor 6-BX-63 and 5-C-502; Ampro Radio Tuner No. 149; Regency Transistor



TR-1; Silvertone Console; Japanese Germanium Diode; Philco 8-Tube Car Radio; and Motorola 21" TV 21-C-8.

I monitor all frequencies from 12½ kc. through 108 mc. in addition to TV DX'ing, and use a long-wire 100' E-W antenna.

LEONARD L. LOCKWOOD  
Olympia, Wash.

*Most SWL fans get along on one or two good receivers. Perhaps Len wants extra insurance against tube failure.*

### Fluorescent Lamps and Radar

■ "The Electronics of Fluorescent Lamps" by Edgar D. Morgan (April '50) brought to mind a question which I have never seen satisfactorily answered. Working primarily with x-band radar, I have noticed that a radar beam will cause a fluorescent bulb to glow. I believe this to be due to the radar energy ionizing the gas and causing the phosphors to emit light. However, if a fluorescent bulb is "on," a radar beam will turn it "off," or at least will cause dark spots in the tube.

Perhaps this can be explained as follows: The frequency of radiation from the gas (electrons

# Do you WISH you were EMPLOYED in ELECTRONICS?

## F.C.C. LICENSE—THE KEY TO BETTER JOBS

An F.C.C. *commercial* (not amateur) license is your ticket to higher pay and more interesting employment. This license is Federal Government evidence of your qualifications in electronics. Employers are eager to hire *licensed* technicians.

### WHICH LICENSE FOR WHICH JOB?

The **THIRD CLASS** radiotelephone license is of value primarily in that it qualifies you to take the second class examination. The scope of authority covered by a third class license is extremely limited.

The **SECOND CLASS** radiotelephone license qualifies you to install, maintain and operate most all radiotelephone equipment except commercial broadcast station equipment.

The **FIRST CLASS** radio telephone license qualifies you to install, maintain and operate every type of radiotelephone equipment (except amateur) including all radio and television stations in the United States, its territories and possessions. This is the highest class of radiotelephone license available.

### GRANTHAM TRAINING PREPARES YOU

The Grantham course covers the required subject matter completely. Even though it is planned primarily to lead directly to a first class FCC license, it does this by **TEACHING** you electronics. Some of the subjects covered in detail are: Basic Electricity for Beginners, Basic Mathematics, Ohm's and Kirchhoff's Laws, Alternating Current, Frequency and Wavelength, Inductance, Capacitance, Impedance, Resonance, Vacuum Tubes, Transistors, Basic Principles of Amplification, Classes of Amplifiers, Oscillators, Power Supplies, AM Transmitters and Receivers, FM Transmitters and Receivers, Antennas and Transmission Lines, Measuring Instruments, FCC Rules and Regulations, and extensive theory and mathematical calculations associated with all the above subjects explained simply and in detail.

### OUR GUARANTEE

If you should fail the F.C.C. exam after finishing our course, we guarantee to give additional training at **NO ADDITIONAL COST**. Read details in our free booklet.

# Get Your First Class Commercial F.C.C. LICENSE QUICKLY!

## CORRESPONDENCE OR RESIDENCE CLASSES

Grantham School of Electronics *specializes* in F.C.C. license preparation. Correspondence training is conducted from Hollywood, Seattle, Kansas City and Washington; also, resident **DAY** and **EVENING** classes are held in all four cities. Either way, by correspondence or in resident classes, we train you quickly and well.

**This booklet FREE!**

This free booklet gives details of our training and explains what an F.C.C. license can do for your future.



### HERE'S PROOF...

that Grantham students prepare for F.C.C. examinations in a minimum of time. Here is a list of a few of our recent graduates, the class of license they got, and how long it took them:

	License	Weeks
Robert J. Conley, 129 W. 46th St., New York 36, N. Y.	1st	14
W. R. Smith, 1335 E. 8th St., Long Beach, Calif.	1st	12
Howard E. Martz, 301 S. Penn. St., Fairmount, Ind.	1st	24
John W. Dempsey, Box 55, Rising Sun, Md.	1st	12
Donald H. Ford, Hyannis Rd., Barnstable, Mass.	1st	12
Richard J. Falk, 2303 Holman St., Bremerton, Wash.	1st	22
Denson D. McNully, 1117 N. Houston St., Amarillo, Texas	1st	9
James D. Hough, 400 S. Church St., East Troy, Wis.	1st	12
Odie B. Perry, Jr., Rt. #3, Zebulon, N. C.	1st	12
Milton C. Gee, Rt. #1, Washington, N. J.	1st	11

# Grantham School of Electronics

### Hollywood Division

1505 N. Western Ave.  
Hollywood 27, Calif.  
(Phone: HO 7-7727)

### Seattle Division

408 Marion Street  
Seattle 4, Wash.  
(Phone: MA 2-7227)

### Kansas City Division

3123 Gillham Road  
Kansas City 9, Mo.  
(Phone: JE 1-6320)

### Washington Division

821-19th Street, N. W.  
Washington 6, D. C.  
(Phone: ST 3-3614)

## MAIL COUPON TO SCHOOL NEAREST YOU

(Mail in envelope or paste on postal card)



**TO: GRANTHAM SCHOOL OF ELECTRONICS**

1505 N. Western • 408 Marion • 3123 Gillham Rd. • 821-19th, NW  
Hollywood • Seattle • Kansas City • Washington

Gentlemen:

Please send me your free booklet telling how I can get my commercial F.C.C. license quickly. I understand there is no obligation and no salesman will call.

Name \_\_\_\_\_ Age \_\_\_\_\_

Address \_\_\_\_\_

City \_\_\_\_\_ State \_\_\_\_\_

I am interested in:  Home Study,  Resident Classes 93-K

NOW WITH NEW  
**TICONAL<sup>®</sup> VIII**  
 MAGNETS  
 (30% MORE POWERFUL THAN ALNICO)

**Norelco<sup>®</sup>**

**T-7 LOUDSPEAKERS**

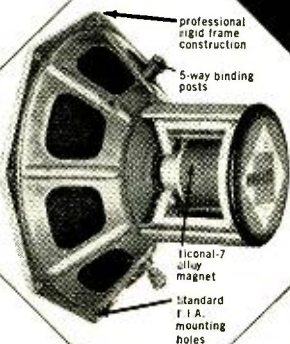

AD-3800M

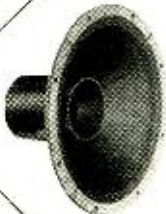

AD-5277M



**... AND A NEW LINE OF  
 ACOUSTICALLY MATCHED ENCLOSURES**

The world's greatest buys on the basis of listening quality, the new T-7 series of 5" to 12" loudspeakers incorporates magnets of Ticonal-7 steel, the most powerful of magnet alloys, for maximum efficiency and damping... dual cones for wide frequency response... constant impedance resulting in an extremely straight response curve... longer effective air-gaps and extra high flux density to provide exceptional transient

response and to eliminate ringing and overshoot. For descriptive literature write to North American Philips Co., Inc., High Fidelity Products Division, Dept. 3F7, 230 Duffy Avenue, Hicksville, Long Island, New York.



**Letters**

(Continued from page 10)

returning to a lower energy level) determines whether visible or invisible light will be obtained. When an operating bulb is hit by radar energy, the frequency of radiation of the gas may be increased to a point where the phosphors emit primarily invisible light.

PAUL W. PETERSON, JR.  
 San Rafael, Calif.

*It's more probable that standing waves are set up in the tube which cause the phenomenon to which you refer.*

**Correction from Knight-Kit**

■ In your April issue you reported that the distortion on the Knight-Kit 60-watt stereo basic amplifier was 0.8% at full output. Actually the distortion is only 0.08% at full output.

We can't blame POPULAR ELECTRONICS because this is the way we submitted the specification as a result of a typist's error. However, this is an important specification, and I believe your readers would want to have the correct information.

J. W. RUBIN  
 Allied Radio Corp.  
 Chicago, Ill.

**Better Game Computer**

■ Enclosed is a picture of a game computer we built to enter in the Buhl Planetarium Pittsburgh Science Fair. We modified the circuit in the September 1957 issue of POP'tronics in the following way. We installed a push-button power switch so

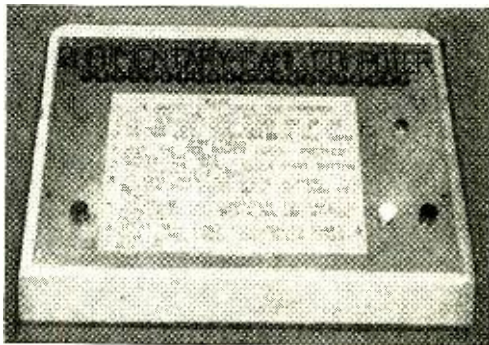

that it could not be left on. We wired a pilot light across the capacitor to discharge the power supply when not in use. And we mounted it in a wooden cabinet with a recessed, sloping, metal panel.

Please publish some more articles on building computers.

ROBERT BLAIR  
 FRANCIS RAHL  
 Greensburg, Pa.

**Radio Ghost**

■ Recently I was "fooling around" with a small table-model radio, hooking it up to a spare amplifier. I was surprised to hear the radio coming in faintly even though the speaker was disconnected from both the radio and the amplifier. The program appeared to come from some spot in the chassis. I wonder if you could explain what was

# FOR REAL JOB SECURITY —GET AN I.C.S. DIPLOMA

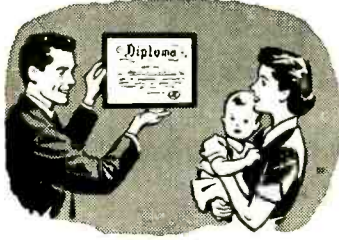

"You can stop worrying, Jane. My job's secure now! And here's the insurance policy to prove it—my I.C.S. diploma!"

This feeling of security is probably typical of every I.C.S. graduate. Because—as the job situation gets tighter, the man with I.C.S. training has the advantage.

Why? Your I.C.S. diploma tells your present employer three important things: (1) You want to make the most of your present job.

(2) You have the training you need for advancement. (3) You look for better ways of doing things on your own.

What you do about your future is up to you. Do nothing and stay at your present job at the same old pay. Or earn an I.C.S. diploma in your spare time for security, promotions, more pay! Your first step is to mark the course that interests you in the coupon below, and mail it to us.

### Three Free Books

We'll send you three interesting books. The first, "How to Succeed," is a gold mine of helpful tips. Points out many small things in your personality and behavior that can make the difference between success and failure. The second tells about the opportunities in the field of your choice. The third is a sample lesson (Math).

### Costs pennies a day

Many an I.C.S. student has made up the cost of his course in one month with the salary increase his I.C.S. training earned for him. By studying at home in your spare time, you pay yourself many times an hour more than you're now making. (One student reports—"My I.C.S. course was worth \$95 an hour to me.")

The security of your present job—or success in finding the new job you've always wanted—is in your hands. Move ahead with I. C. S. training while others stay behind on the routine, small-pay jobs.

Remember, your first step to security is to mail this coupon. Take a few minutes and do it now. If you put it off, it can cost you your future.

For Real Job Security—Get an I. C. S. Diploma! I. C. S., Scranton 15, Penna.

Accredited Member,  
National Home Study Council

## INTERNATIONAL CORRESPONDENCE SCHOOLS



BOX 81622F, SCRANTON 15, PENNA.

(Partial list of 258 courses)

Without cost or obligation, send me "HOW TO SUCCEED" and the opportunity booklet about the field BEFORE which I have marked X (plus sample lesson):

- |  |  |  |   |   |
|--|--|--|---|---|
| <p><b>ARCHITECTURE and BUILDING CONSTRUCTION</b></p> <ul style="list-style-type: none"> <li><input type="checkbox"/> Air Conditioning</li> <li><input type="checkbox"/> Architecture</li> <li><input type="checkbox"/> Arch. Drawing and Designing</li> <li><input type="checkbox"/> Building Contractor</li> <li><input type="checkbox"/> Building Estimator</li> <li><input type="checkbox"/> Carpenter Builder</li> <li><input type="checkbox"/> Carpentry and Millwork</li> <li><input type="checkbox"/> Carpenter Foreman</li> <li><input type="checkbox"/> Heating</li> <li><input type="checkbox"/> Painting Contractor</li> <li><input type="checkbox"/> Plumbing</li> <li><input type="checkbox"/> Reading Arch. Blueprints</li> </ul> <p><b>ART</b></p> <ul style="list-style-type: none"> <li><input type="checkbox"/> Commercial Art</li> <li><input type="checkbox"/> Magazine Illus.</li> <li><input type="checkbox"/> Show Card and Sign Lettering</li> <li><input type="checkbox"/> Sketching and Painting</li> </ul> <p><b>AUTOMOTIVE</b></p> <ul style="list-style-type: none"> <li><input type="checkbox"/> Automobile</li> <li><input type="checkbox"/> Auto Body Rebuilding and Refinishing</li> <li><input type="checkbox"/> Auto Engine Tuneup</li> <li><input type="checkbox"/> Auto Technician</li> </ul> | <p><b>AVIATION</b></p> <ul style="list-style-type: none"> <li><input type="checkbox"/> Aero-Engineering Technology</li> <li><input type="checkbox"/> Aircraft &amp; Engine Mechanic</li> </ul> <p><b>BUSINESS</b></p> <ul style="list-style-type: none"> <li><input type="checkbox"/> Accounting</li> <li><input type="checkbox"/> Advertising</li> <li><input type="checkbox"/> Business Administration</li> <li><input type="checkbox"/> Business Management I</li> <li><input type="checkbox"/> Cost Accounting</li> <li><input type="checkbox"/> Creative Salesmanship</li> <li><input type="checkbox"/> Managing a Small Business</li> <li><input type="checkbox"/> Professional Secretary</li> <li><input type="checkbox"/> Public Accounting</li> <li><input type="checkbox"/> Purchasing Agent</li> <li><input type="checkbox"/> Salesmanship</li> <li><input type="checkbox"/> Salesmanship and Management</li> <li><input type="checkbox"/> Traffic Management</li> </ul> <p><b>CHEMICAL</b></p> <ul style="list-style-type: none"> <li><input type="checkbox"/> Analytical Chemistry</li> <li><input type="checkbox"/> Chemical Engineering</li> <li><input type="checkbox"/> Chem. Lab. Technician</li> <li><input type="checkbox"/> Elements of Nuclear Energy</li> <li><input type="checkbox"/> General Chemistry</li> <li><input type="checkbox"/> Natural Gas Prod. and Trans.</li> <li><input type="checkbox"/> Petroleum Prod. and Engr.</li> <li><input type="checkbox"/> Professional Engineer (Chem)</li> <li><input type="checkbox"/> Pulp and Paper Making</li> </ul> | <p><b>CIVIL ENGINEERING</b></p> <ul style="list-style-type: none"> <li><input type="checkbox"/> Civil Engineering</li> <li><input type="checkbox"/> Construction Engineering</li> <li><input type="checkbox"/> Highway Engineering</li> <li><input type="checkbox"/> Professional Engineer (Civil)</li> <li><input type="checkbox"/> Reading Struc. Blueprints</li> <li><input type="checkbox"/> Sanitary Engineer</li> <li><input type="checkbox"/> Structural Engineering</li> <li><input type="checkbox"/> Surveying and Mapping</li> </ul> <p><b>DRAFTING</b></p> <ul style="list-style-type: none"> <li><input type="checkbox"/> Aircraft Drafting</li> <li><input type="checkbox"/> Architectural Drafting</li> <li><input type="checkbox"/> Drafting &amp; Machine Design</li> <li><input type="checkbox"/> Electrical Drafting</li> <li><input type="checkbox"/> Mechanical Drafting</li> <li><input type="checkbox"/> Sheet Metal Drafting</li> <li><input type="checkbox"/> Structural Drafting</li> </ul> <p><b>ELECTRICAL</b></p> <ul style="list-style-type: none"> <li><input type="checkbox"/> Electrical Engineering</li> <li><input type="checkbox"/> Elec. Engr. Technician</li> <li><input type="checkbox"/> Elec. Light and Power</li> <li><input type="checkbox"/> Practical Electrician</li> <li><input type="checkbox"/> Practical Lineman</li> <li><input type="checkbox"/> Professional Engineer (Elec)</li> </ul> <p><b>HIGH SCHOOL</b></p> <ul style="list-style-type: none"> <li><input type="checkbox"/> High School Diploma</li> </ul> | <ul style="list-style-type: none"> <li><input type="checkbox"/> Good English</li> <li><input type="checkbox"/> High School Mathematics</li> <li><input type="checkbox"/> High School Science</li> <li><input type="checkbox"/> Short Story Writing</li> </ul> <p><b>LEADERSHIP</b></p> <ul style="list-style-type: none"> <li><input type="checkbox"/> Industrial Foremanship</li> <li><input type="checkbox"/> Industrial Supervision</li> <li><input type="checkbox"/> Personnel-Labor Relations</li> <li><input type="checkbox"/> Supervision</li> </ul> <p><b>MECHANICAL and SHOP</b></p> <ul style="list-style-type: none"> <li><input type="checkbox"/> Diesel Engines</li> <li><input type="checkbox"/> Gas-Elec. Welding</li> <li><input type="checkbox"/> Industrial Engineering</li> <li><input type="checkbox"/> Industrial Instrumentation</li> <li><input type="checkbox"/> Industrial Metallurgy</li> <li><input type="checkbox"/> Industrial Safety</li> <li><input type="checkbox"/> Machine Shop Practice</li> <li><input type="checkbox"/> Mechanical Engineering</li> <li><input type="checkbox"/> Professional Engineer (Mech)</li> <li><input type="checkbox"/> Quality Control</li> <li><input type="checkbox"/> Reading Shop Blueprints</li> <li><input type="checkbox"/> Refrigeration and Air Conditioning</li> <li><input type="checkbox"/> Tool Design</li> <li><input type="checkbox"/> Tool Making</li> </ul> <p><b>RADIO, TELEVISION</b></p> <ul style="list-style-type: none"> <li><input type="checkbox"/> General Electronics Tech.</li> </ul> | <ul style="list-style-type: none"> <li><input type="checkbox"/> Industrial Electronics</li> <li><input type="checkbox"/> Practical Radio-TV Eng'g</li> <li><input type="checkbox"/> Practical Telephony</li> <li><input type="checkbox"/> Radio-TV Servicing</li> </ul> <p><b>RAILROAD</b></p> <ul style="list-style-type: none"> <li><input type="checkbox"/> Car Inspector and Air Brake</li> <li><input type="checkbox"/> Diesel Electrician</li> <li><input type="checkbox"/> Diesel Engr. and Fireman</li> <li><input type="checkbox"/> Diesel Locomotive</li> </ul> <p><b>STEAM and DIESEL POWER</b></p> <ul style="list-style-type: none"> <li><input type="checkbox"/> Combustion Engineering</li> <li><input type="checkbox"/> Power Plant Engineer</li> <li><input type="checkbox"/> Stationary Diesel Engr.</li> <li><input type="checkbox"/> Stationary Fireman</li> </ul> <p><b>TEXTILE</b></p> <ul style="list-style-type: none"> <li><input type="checkbox"/> Carding and Spinning</li> <li><input type="checkbox"/> Cotton Manufacture</li> <li><input type="checkbox"/> Cotton Warming and Weaving</li> <li><input type="checkbox"/> Loom Fixing Technician</li> <li><input type="checkbox"/> Textile Designing</li> <li><input type="checkbox"/> Textile Finishing &amp; Dyeing</li> <li><input type="checkbox"/> Throwing</li> <li><input type="checkbox"/> Warping and Weaving</li> <li><input type="checkbox"/> Worsted Manufacturing</li> </ul> |
|--|--|--|---|---|

Name \_\_\_\_\_ Age \_\_\_\_\_ Home Address \_\_\_\_\_

City \_\_\_\_\_ Zone \_\_\_\_\_ State \_\_\_\_\_ Working Hours \_\_\_\_\_ A.M. to P.M.

Occupation \_\_\_\_\_

Canadian residents send coupon to International Correspondence Schools, Canadian, Ltd., Montreal, Canada. . . . Special low monthly tuition rates to members of the U. S. Armed Forces.

**IF YOU HAVE  
2 EARS AND A  
SMALL POCKETBOOK**

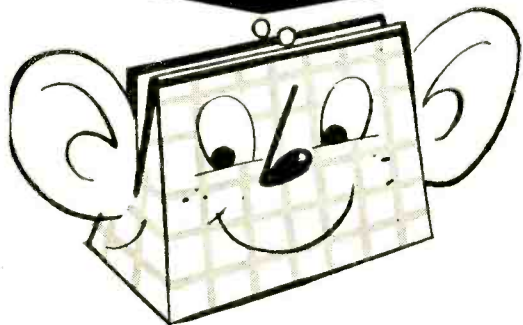

**STEREO  
IS FOR YOU**



**New  
Single-Element  
Stereophonic  
Cartridge by ERIE**

- Fits any standard tone arm
- Simply plug it in . . . adapter is included
- Dual styli . . . diamond-sapphire or sapphire-sapphire
- Frequency response: 20 to 16,000 cycles
- Tracking force: 5-6 grams
- 20 DB channel separation
- 0.5v. output, each channel
- **LOW IN PRICE . . . HIGHEST FIDELITY**

*For literature and name of your local ERIE Distributor,  
write to:*

**ERIE Electronics Distributor Division**  
ERIE RESISTOR CORPORATION  
Erie, Pennsylvania

## Letters

(Continued from page 12)

acting as the transducer in this case, and how it is possible to get sound from a speakerless radio!

DAVE WINEGAR  
San Francisco, Calif.

*Loose laminations in an output transformer will sometimes cause it to "sing" in tune with the audio signal even though no speaker is connected to it. Don't make a practice of listening this way, though, as the output tubes and transformer may be damaged.*

### Flea-Power Transmitter Needed

■ There are four of us, all licensed hams who live within a three-mile radius, who are interested in getting a schematic of an xtal-controlled phone



rig (low power) using series filament tubes of the miniature type with either a 35W4 or selenium rectifier. We would like to use an xtal mike, preamp and 35B5 modulator with a 12-volt filament oscillator and a 35B5 final. Maybe one of your readers has built such a transmitter.

We are on quite often, running higher power and QSO'ing locally, when we could just as well be on low (flea power) and perhaps lessen the QRM for others.

H. E. PARMETER, W0CGM  
Cogswell, N. D.

*If any of our readers have plans for such a transmitter and have built and tested the unit, send us a photo and schematic. We would like to see them.*

### He Builds Them

■ I just finished the Simplex Stereo Amplifier (April, 1959) and am very pleased with the results. I found, however, that it was physically impossible to build it on a 5" x 7" x 3" chassis. I think the author built his on a chassis that was 10" long and gave you the wrong dimensions. The pictures seem to indicate that the dimensions given are wrong.

I also built one of the Duo-Flex Speaker Systems (February, 1959) and am now building another for stereo.

JOHN L. SIKES  
Charleston, S. C.

*There was a typographical error in the chassis size given in the stereo amplifier article. It should be 5" x 9 1/2" x 3". The smaller chassis could be used but very neat and exacting chassis punching would be required.*

-30-



# LET RCA TRAIN YOU IN ELECTRONICS

RCA Institutes celebrates Fifty Years of Electronic Training by introducing its newest Home Study Course . . .

## ELECTRONICS FOR AUTOMATION

. . . Now you have four comprehensive courses for your electronic training . . . from basic electronic theory to the more advanced principles of color TV and Automation.

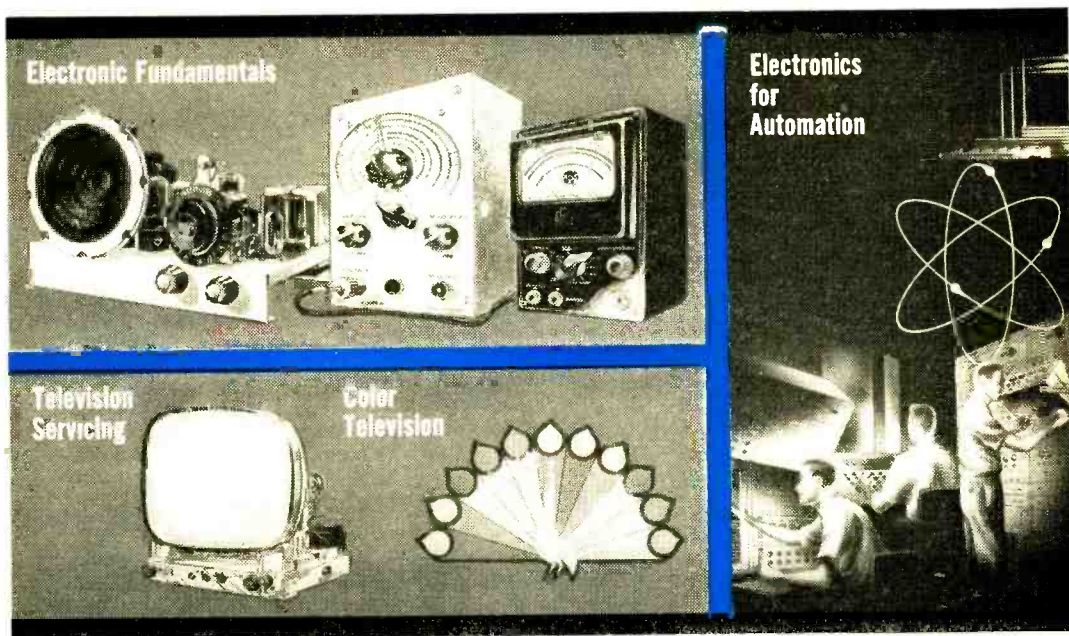

Send for our  
64 page Home  
Study Catalog

**FREE!**

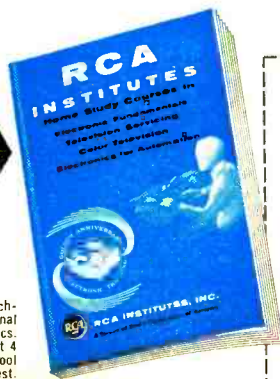

RESIDENT SCHOOL offers Technical Institute and Vocational School Courses in Electronics. Day and Evening classes start 4 times each year. Resident School Catalog sent free on request.

Practical work with the very first lesson. Pay-as-you-learn. You need pay for only one study group at a time.

**RCA INSTITUTES, Inc.** Home Study School, Dept. PE-79

A Service of Radio Corporation of America

350 West Fourth Street, New York 14, N. Y.

Without obligation, send me the FREE catalog of Home Study Courses. No salesman will call.

Name  Please print

Address

City  Zone  State

Korean Vets! Enter Discharge Date

**CANADIANS** — Take advantage of these same RCA courses at no additional cost. No postage, no customs, no delay. Send coupon to: RCA Victor Company, Ltd., 5001 Cote de Liesse Rd., Montreal 9, Quebec  
To save time, paste coupon on postcard.

for  
CITIZENS BAND

# marine radio

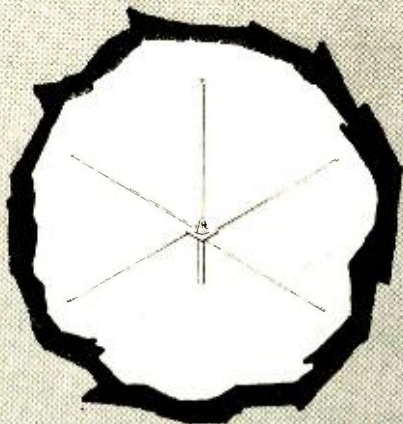

**MOSLEY V-27-GP**

100% RUST PROOF Vertical Antenna for the 11 meter Citizens Band. 360° radiation pattern for effective communication at any heading when antenna is mounted clear of interacting objects.

Radiator and radials are of heavy gauge 61ST6 aluminum. Fittings and hardware are brass, copper and stainless steel. Vertical and radials are each 9' long. Heavy duty base mount with coax connector fits 1¼" ID pipe mast. Supplied with Mosley Antenna Coat for protection against salt corrosion. Model V-27-GP, less mast & RG-8/U coax.

**Net Price, \$34.95**

Available from most electronic equipment distributors—coast-to-coast.

**Mosley**  
*Electronics, Inc.*  
ST. LOUIS 14, MISSOURI

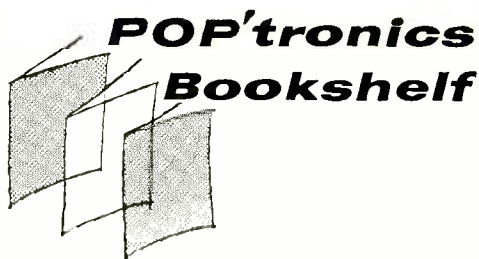

"TRANSISTOR PHYSICS AND CIRCUITS" by Robert L. Riddle and Marlin P. Ristenbatt. Published by Prentice-Hall, Inc., 70 Fifth Ave., New York 11, N. Y. 428 pages. Hard cover. \$10.00.

Requiring only a background knowledge of high-school trigonometry and algebra, this book is a clear, mostly non-mathematical treatment of the operation and design of transistor circuits—from the viewpoint of familiar physical and electrical laws. As such, the book is especially useful for those who have had little or no previous transistor instruction. It should serve nicely as a transistor circuit theory source for electronic technicians, designers, and radio amateurs, and as a thorough introduction to the subject for electrical engineers.



"MARINE ELECTRONICS HANDBOOK" by Leo G. Sands. Published by Howard W. Sams and Co., 2201 East 46th St., Indianapolis 6, Ind. 264 pages. Soft cover. \$3.95.

Complete service maintenance information is given here on electronic equipment in use on both large and small marine craft. The equipment covered ranges from Citizens Band transceivers and radiotelephones to sonar and radar gear. Included are many schematics and service tips. Boat owners and service technicians who do marine electronic repair will find this book most useful.



"FUNDAMENTALS OF RADIO TELEMETRY" by Marvin Tepper. Published by John F. Rider, Inc., 116 West 14th St., New York 11, N. Y. 136 pages. Soft cover. \$2.95.

The importance of telemetry in the research and development of guided missiles and supersonic speed aircraft cannot be





Accredited by the National Home Study Council

good training  
doesn't cost . . .  
it pays!

# How To Get an

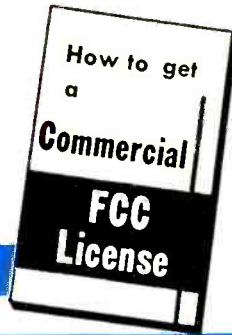

# FCC License (Commercial)

Get Your FCC License  
Quickly

**We Guarantee** to train you **until you receive** **Your FCC License**

## Get all 3 FREE

**We guarantee**  
to train you until you receive  
**Your FCC License**

—or your money back

The Master Course in Electronics will provide you with the mental tools of the electronics technician and prepare you for a First Class FCC License (Commercial) with a radar endorsement. When you successfully complete the Master Course, if you fail to pass the FCC examination, you will receive a full refund of all tuition payments.

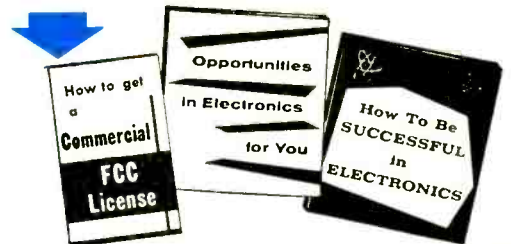

**Cleveland Institute of Radio Electronics**

Desk PE-53, 4900 Euclid Ave., Cleveland 3, Ohio

Cleveland Institute training results in job offers like these:

### Radio Operator

Capital Airlines (Ohio) is looking for a radio operator. A touch typing speed of 40 wpm is necessary. Must have at least a restricted operators' permit, but a radio-telephone 2nd or 1st class license is desirable.

### Service Technician

Man needed in Cleveland, Ohio, to service and maintain electronic medical instruments and equipment. Must have a solid knowledge of electronic fundamentals. A car is required. Company benefits include retirement plan.

**And our trainees get good jobs**

### "Investment in training really pays off"

"Thought you would like to know that in almost two years since I completed your course and obtained my first phone license, my pay has increased \$5 per week every six months. I don't believe any other investment could pay off as well as this one did."

Harold E. Phipps, North Augusta, S. C.

**Cleveland Institute of Radio Electronics**

4900 Euclid Ave.

Desk PE-53

Cleveland 3, Ohio

July, 1959

Please send Free Booklets prepared to help me get ahead in Electronics. I have had training or experience in Electronics as indicated below:

- |   |   |
|---|---|
| <input type="checkbox"/> Military           | <input type="checkbox"/> Broadcasting       |
| <input type="checkbox"/> Radio-TV Servicing | <input type="checkbox"/> Home Experimenting |
| <input type="checkbox"/> Manufacturing      | <input type="checkbox"/> Telephone Company  |
| <input type="checkbox"/> Amateur Radio      | <input type="checkbox"/> Other _____        |

In what kind of work are you now engaged?

In what branch of Electronics are you interested?

Name \_\_\_\_\_ Age \_\_\_\_\_

Address \_\_\_\_\_

City \_\_\_\_\_ Zone \_\_\_\_\_ State \_\_\_\_\_

PE-53

# BIG NEWS

# CITIZEN BANDER for KIT FANS!

Yes! Your own design and your own construction of 2-way Citizens Radio is now possible with dependable International components. Everything is pretuned and prewired for you. Just order the parts you need and combine them with components you already have . . . or order a complete package made up of the sub-assemblies illustrated and easy-to-follow instructions. Get in on the fun and many practical uses of Citizens Radio! Order what you need today!

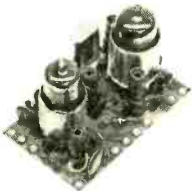
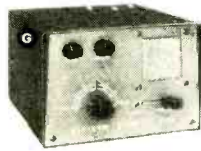
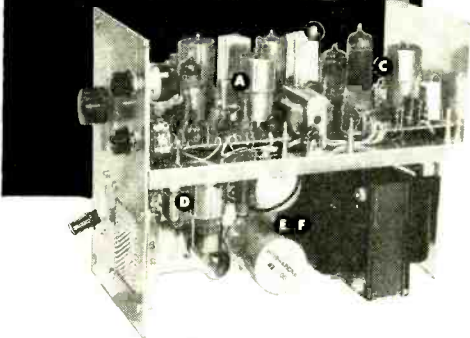

**A** RF Converter Unit (Printed circuit prewired) Two-tube crystal controlled converter. Converts Citizens frequencies to range of tunable IF. Can be used with IF unit (B) or any communication receiver. 6BA6 RF and 12AT7 mixer-oscillator. Shipping weight 2 lbs. \$14.00

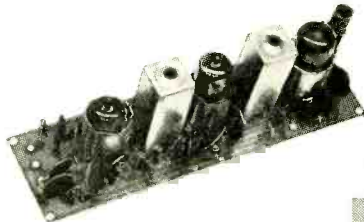

**B** IF Unit (Printed circuit prewired) Consists of mixer and tunable local oscillator feeding 262 KC IF stage. Includes noise-limiter and squelch circuits. 6AN8 mixer-oscillator, 6BA6 IF amplifier, diode detector, 6AL5 noise-limiter/squelch. Designed to work with units A and C. Makes dual conversion receiver. Shipping weight 2 lbs. \$16.00

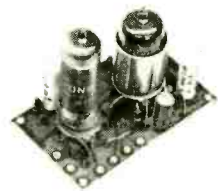

**C** Audio Unit (Printed circuit prewired) Consists of speech amplifier for crystal microphone, first audio for receiver and power amplifier/modulator stage. Designed to follow unit B. 6AN8 speech amplifier/audio, 6AQ5 power amplifier modulator. Includes output transformer but not speaker. Shipping weight 2 lbs. \$13.50

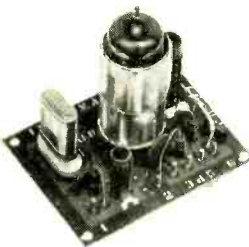

**D** Transmitter Unit (Printed circuit prewired) Oscillator and amplifier. Crystal controlled .005% tolerance to meet FCC regulations. Requires Unit C for modulation. 6AU8 tube. Shipping weight 2 lbs. Complete with crystal and tube. \$14.50

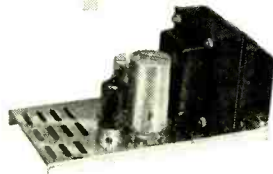

**E** Power Supply 115 VAC only (not prewired). Consists of all parts necessary to construct a power supply to operate Units A, B, C and D. Shipping weight 10 lbs. \$12.00

**F** Power Supply 3-way 6 VDC, 12 VDC or 115 VAC (not prewired). Same as E but will operate from any of three different power sources. Shipping weight 10 lbs. \$20.00

**INTERNATIONAL CRYSTAL MFG. CO., INC.**  
18 N. LEE • OKLAHOMA CITY, OKLA.

**G** Cabinet (all metal) Includes all necessary hardware, switches, speakers, panel, case, etc., to combine Units A, B, C, D and E or F into a complete receiver-transmitter assembly. Complete with instructions. Shipping weight 10 lbs. \$20.00

# DESIGN YOUR OWN CITIZENS RADIO with International Components

... AND THESE ACCESSORIES



**WHIP ANTENNA**  
Bumper mount  
whip antenna for  
mobile use.  
\$15.80

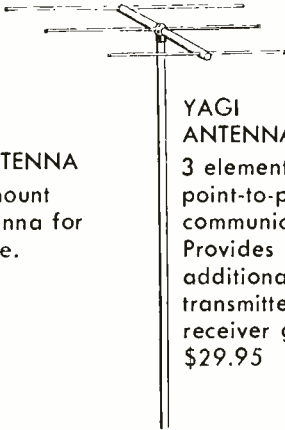

**YAGI ANTENNA**  
3 element, for  
point-to-point  
communications.  
Provides  
additional  
transmitter and  
receiver gain.  
\$29.95

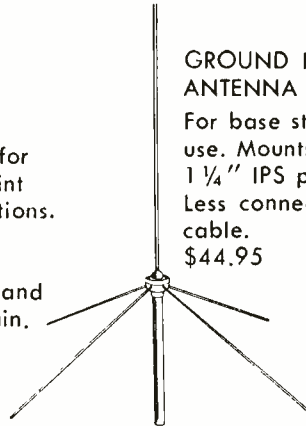

**GROUND PLANE ANTENNA**  
For base station  
use. Mounts on  
1 1/4" IPS pipe.  
Less connecting  
cable.  
\$44.95

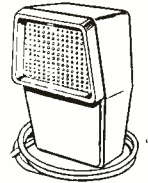

**CRYSTAL MICROPHONE**  
\$3.95

**YOU'LL FIND  
MANY USES  
FOR YOUR  
2-WAY  
RADIO**

**FOR BUSINESS**—Ideal communication between office and service trucks operating in a restricted area. Also practical for office and factory liaison.  
**FOR THE FARM**—The solution to fast communication from the farm home to the field. Wonderful in an emergency.  
**FOR SPORTS**—From ship to shore or from base camp to the scene of the hunt, an enjoyable accessory in the field of sports.  
**FOR THE HOME**—From the kitchen to the den or workshop or from the sick room to the living room 2-way communication will save many steps.

Dept. PE  
International Crystal Mfg. Co., Inc., 18 N. Lee, Oklahoma City, Oklahoma  
Gentlemen: Please place my order for the following:

ITEM	NO. OF UNITS	PRICE EACH*	TOTAL
Unit A—RF Converter		\$14.00	
Unit B—IF Unit		16.00	
Unit C—Audio Unit		13.50	
Unit D—Transmitter Unit		14.50	
Unit E—Power Supply, 115 VAC		12.00	
Unit F—Power Supply, 3-way		20.00	
Unit G—Cabinet		20.00	
Whip Antenna for mobile use		15.80	
Yagi Antenna		29.95	
Ground Plane Antenna		44.95	
Crystal Microphone		3.95	

Check  Money Order Amount \$ \_\_\_\_\_  Information on time payment plan

\* Available at your local dealer at slightly higher prices.

**HOW TO ORDER:**

Order direct from International Crystal, address below. Terms F.O.B. Oklahoma City. Other shipments C.O.D. On C.O.D. orders of \$25.00 or more, 1/3 down payment with order is required.

NAME \_\_\_\_\_

ADDRESS \_\_\_\_\_

CITY \_\_\_\_\_ STATE \_\_\_\_\_

Please include in check or money order sufficient postage and insurance for your Parcel Post Zone. Shipments exceeding 20 lbs. will be made via express, C.O.D.

**Bookshelf** (Continued from page 16)

overemphasized. We are not going to get very many volunteers to take a ride in our "one-way" missiles and radio back observations. Besides, with the amount of data that it is necessary to recover from each flight, it would take several hundred men to transmit simultaneously all the information gathered.

This new Rider publication is devoted to the problems and techniques of missile and satellite telemetry and hardware, data recording and processing. Specially prepared and carefully selected illustrations will make important telemetry fundamentals crystal clear to the engineer or layman new to the subject.



"ELECTRICAL SAFETY" by H. W. Swann. Published by the Philosophical Library, 15 East 40th St., New York, N. Y. 292 pages. \$15.00.

The author of this book was for some years a Senior Electrical Inspector in the British Home Office. He tells of his experi-

ences in the call of duty, why accidents occurred, and how they could have been prevented. A great deal of space is devoted to the explanation of British electrical safety regulations.

Although there is much useful information here, it is quite obvious that this book is not aimed at an American audience. The reader may at times find himself thrown off by some of the British phrasing such as "an earthed metal pipe" and a "rubber tyred petrol tanker." Considering its high price and its British focus, this book is recommended only to those who are particularly interested in the subject.



"METALLIC RECTIFIERS & CRYSTAL DIODES" by Theodore Conti. Published by John F. Rider, Inc., 116 West 14th St., New York 11, N. Y. 164 pages. Soft cover. \$2.95.

Civilian, military and all kinds of industrial electronic equipment designs are tending more and more toward the use of metallic rectifiers and crystal diodes in place of vacuum tubes. In this book, the principles and practices of metallic rectifiers and

# MICRO

**ELECTRON TUBE**

INTRODUCES FOR THE FIRST TIME ANYWHERE A SELECT STOCK OF USED TUBES AT A FABULOUS LOW PRICE

37

¢ ea.

**\$35** PER HUNDRED ASSTD.

Jan Surplus Tubes!

FOR any TUBE LISTED

ALL TUBES SENT POSTAGE PAID  
Please send 25¢ handling for orders under \$5. Send 25% deposit on C.O.D. orders. Send approximate postage on Canadian and foreign orders.

# MICRO

**ELECTRON TUBE CO.** P.O. BOX 55 Park Station, Paterson 3, N. J.

- Each and every tube is tested in our own laboratory for mutual conductance and life test.
- We guarantee FREE replacement for one year of any tube purchased from us which fails to function efficiently under any or all operating conditions. Prompt refunds are made on any defective merchandise.
- The advertised tubes are not necessarily new, but may be electrically perfect factory seconds or used tubes—each is clearly so marked.

0A2	6X8	6BH6	6SF5	7Z4	19BG6C
0Z4	6Y3GT	6B16	6SF7	12A8	19J6
1A7GT	6Y4Q	6BK5	6S17	12AQ5	19T8
1B3GT	6A7	6BK7	6SK7	12AT6	24A
1M9GT	6A8	6BL7GT	6SL7GT	12A7	25AV5
1L6	6A84	6BN6	6SN7GT	12A77	25B06
1L8	6A7	6B0GT	6S07	12A76	25DN6
1N8GT	6AF6	6B07	6SS7	12AV6	25L6GT
1Q5GT	6AG3	6B25	6T4	12AV7	25W4GT
1R5	6AH4GT	6B27	6TB	12AX4GT	25Z5
1S5	6AHC	6C4	6VB	12AX7	25Z6
1T4	6AK3	6C5	6V8	12AZ7	26
1U4	6AL5	6C6	6W4GT	12B4	35A5
1U8	6AL7	6C6	6W6GT	12B4	35B5
1V2	6AM8	6C6	6X4	12B6	35C5
1X2	6AN8	6C6	6X3	12B7	35L6GT
2A3	6AQ	6C6	6X4	12B7	35W4
2AF4	6AQ6	6C7	6X6	12B8	35Y4
3BC8	6AQ7GT	6C7	6YC	12B7	35Z5GT
3B86	6AS	6CM7	7A5	12B8	37
3C86	6AT8	6CMT	7A6	12B8	39/44
3CF6	6AT8	6CS6	7A7	12B7	42
3CS6	6AT8	6CUG	7A8	12CA5	43
3LF4	6AU4GT	6DE6	7B4	12C8	45
3Q4	6AU5GT	6DE6	7B5	12K7	45
3S4	6AUS	6FE	7B6	12L6	45
3V4	6AUS	6FE	7B7	12Q7	50A5
4B07A	6AV5GT	6HG	7B8	12S47	50B5
4B27	6AV6	6H	7C4	12S07	50C5
5A38	6AW8	6J5	7C5	12S17	50L6GT
5A78	6AX4GT	6J7	7C5	12S17	50X6
5AV8	6AX5GT	6K6GT	7C7	12S7GT	56
5AW4	6B8	6K7	7E6	12S07	57
5B7	6BA6	6K8	7E7	12V6GT	58
5J6	6BC5	6L7	7E7	12W6GT	71A
5T6	6BC8	6N7	7E7	12X4	75
5U4G	6BD6	6N7	7E8	12Z3	78
5U8	6BE6	6Q7	7H7	14A7/12B7	78
5V4G	6BF6	6S4	7H7	14B6	80
5V6GT	6BF6	6S4GT	7Q7	14X7	84/6Z4
	6BGC	6SA7	7X7/XXFM	1466	117Z3
		6SCT	7Y4	19	117Z6
				19AU4GT	

SEND FOR OUR FREE COMPLETE LIST OF TUBES & SPECIAL PURPOSE TUBES

**WE'RE MAKING IT EASIER THAN EVER TO BECOME A WELL PAID  
RADIO-TELEVISION SERVICE TECHNICIAN**

**NOW - Just \$6 Starts You Training in  
RADIO-TELEVISION**

**the SPRAYBERRY "Learn-by-Doing" Way...**

**25 BIG, COMPLETE KITS  
of PARTS & EQUIPMENT**

To help you learn *fast* the practical side of Radio-Television, we send you expertly engineered training kits to test and assemble for interesting, valuable shop-bench practice!

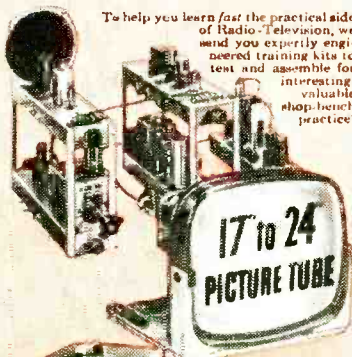

• The new Sprayberry Training Television Receiver, built and tested in 5 sections.

• Now offered... this fine modern oscilloscope.

• You build this powerful two-band superheterodyne radio receiver.

**Big New  
CATALOG  
AND  
Sample Lesson  
FREE!**



You build the new Sprayberry tester—a complete 18-range Volt-Ohm-Milli-ammeter test meter.



\*\*\* This great industry is begging for trained men... to step into good paying jobs or a profitable business of their own! Our new plan opens the doors of Radio-Television wide to every ambitious man who is ready to act at once!

Men by the thousands... trained Radio-Television Service Technicians... are needed at once! Perhaps you've thought about entering this interesting, top paying field, but lack of ready money held you back. Now—*just \$6 enrolls you* for America's finest, most up to date home study training in Radio-Television! Unbelievable? No, the explanation is simple! We believe Radio-Television *must* have the additional men it needs as quickly as possible. We are willing to do our part by making Sprayberry Training available for less money down and on easier terms than ever before. This is your big opportunity to get the training you need... to step into a fine job or your own Radio-Television Service Business.

**Complete Facts Free—Act Now; Offer Limited**

Only a limited number of students may be accepted on this liberal and unusual basis. We urge you to act at once... mail the coupon below and get complete details plus our big new catalog and an actual sample lesson—all free. No obligation... no salesman will bother you.

**HOME STUDY TRAINING IN SPARE TIME**

Under world-famous 27-year old Sprayberry Plan, you learn entirely at home in spare time. You keep on with your present job and income. You train as fast or as slowly as you wish. You get valuable kits of parts and equipment for priceless shop-bench practice. And everything you receive, lessons and equipment alike, is all yours to keep.

**LET US PROVE HOW EASILY YOU CAN LEARN!**

Radio-Television needs YOU! And Sprayberry is ready to train you on better, easier terms, than any ambitious man can afford. *Just \$6 starts you!* Mail coupon today... let the facts speak for themselves. You have everything to gain. Let us prove the kind of opportunity in store for you!

**SPRAYBERRY Academy of Radio-Television**

1512 W. Jarvis Avenue, Dept. 105-X, Chicago 26, Illinois

**Mail This Coupon Now—No Salesman Will Call**

**Sprayberry Academy of Radio-Television**  
Dept. 105-X, 1512 W. Jarvis Ave., Chicago 26, Ill.

Please rush all information on your ALL-NEW Radio-Television Training Plan. Understand this does not obligate me and that no salesman will call upon me. Include New Catalog and Sample Lesson FREE.

NAME..... Age.....

ADDRESS.....

CITY..... ZONE..... STATE.....



# SPECIAL OFFER!

## SAVE \$36.39

**Campers, boaters, hams away-from-home . . .** Here's a great cash savings on National Radio's famed NC-66, portable shortwave/ham receiver. Features 5 bands, including marine and aircraft direction finding beacons, standard AM, 160-5 meter amateur, and worldwide short wave bands. AC/DC or battery pack.

### THIS IS WHAT YOU GET:

NC-66 portable receiver, reg. price.....	\$129.95*
RDF-66 direction finder, reg. price.....	39.95*
Eveready "Magnet Torch-lite" incl. cells.....	2.49
Marine Electronic Handbook.....	3.95

(Published by Howard W. Sams)

Total value \$176.34

NATIONAL'S SPECIAL PACKAGE PRICE..... 139.95

YOU SAVE..... \$ 36.39

This is a limited time offer . . . so see your National Radio distributor now, or write for full catalog and dealer's name nearest you.

\*Sugg. list, slightly higher west of Rockies and outside U. S. A.

**← RDF-66 direction finder**

**NC-66 portable receiver**

**MARINE ELECTRONICS handbook**

**NATIONAL RADIO CO., INC.**  
**MELROSE 76, MASS.**  
 A wholly owned subsidiary of National Co., Inc.  
**THIS SPECIAL OFFER IS SUBJECT TO WITHDRAWAL AT ANY TIME, WITHOUT NOTICE**

## Bookshelf (Continued from page 20)

crystal diodes are covered in a very comprehensive manner. While the emphasis is not on design problems, the details given enable the reader to gain a great insight into the "where" as well as the "how" of these devices in a broad variety of applications.

Well illustrated and readable, this book will add materially to the technical background and capabilities of engineers, laboratory technicians, students of electronics, television and radio repair personnel, and radio amateurs, as well as the experimenters who are keeping up with the modern ideas of electronic technology.



**"THE RADIO AMATEUR'S HANDBOOK"** (Thirty-Sixth Edition—1959) by the Headquarters Staff of the American Radio Relay League. Published by American Radio Relay League, Inc., West Hartford 7, Conn. 746 pages. \$3.50.

An invaluable reference work for radio amateurs, experimenters, students, and engineers, this book has sold over three million copies in the last 30 years. In this latest edition, it has been brought up to date and completely revised. Theory and actual construction projects are fully outlined, and there are over 1300 illustrations—including some 500 tube-base diagrams. This is highly recommended as a reference book for everyone interested in electronics.

### Free Literature Roundup

A folder illustrating tape splicing techniques is being offered by the manufacturers of "Scotch" tapes. It tells how to cut the tape, how to butt the edges together, and what will happen if the wrong angle is used. Write Minnesota Mining and Manufacturing Co., Dept. M8-340, St. Paul, Minn., for your copy.

"Photocells and How to Use Them" is the title of a new bulletin published by CBS Electronics which explains photo-emission and spectrum response. It also describes the phenomenon of gas amplification and the photocell rating system. Typical circuits are included. Write to CBS Electronics Advertising Service, Parker St., Newburyport, Mass.

-30-

# Learn from men who are pioneering electronics!

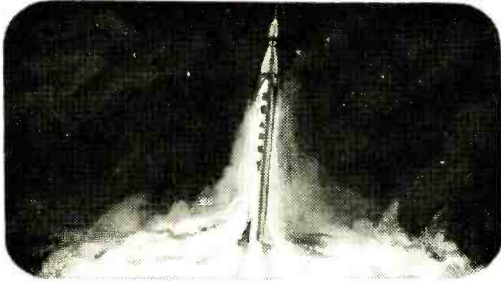

**PIONEERED BY TODAY'S ARMY.** Development of guided missiles and electronics for defense was *pioneered* by today's Army. That's why Army electronics and missile training rank with the *world's finest*. And that's why you're now able to get a technical education worth thousands of dollars—at no cost to you!

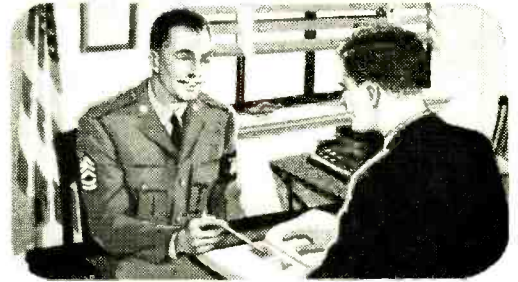

**CHOOSE BEFORE ENLISTMENT.** Train in a field you pick yourself! Choose from Electronics; Radar & TV Repair; Atomics; Guided Missiles; many more. If you qualify for *either* the Graduate Specialist Program or the "Choose-it-Yourself" Vocational Training System—your choice is guaranteed *before* enlistment!

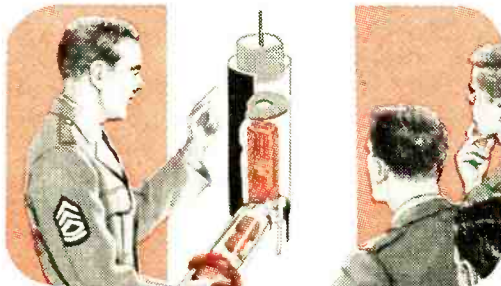

**GRADUATE SPECIALIST PROGRAM.** The Army's exclusive Graduate Specialist Program allows qualified high school graduates to choose from 107 classroom technical courses. Successful candidates have their chosen course guaranteed *before* enlistment. (High school seniors can apply *before* graduation and enlist *after*.)



**"CHOOSE-IT-YOURSELF" VOCATIONAL TRAINING SYSTEM.** For the capable man who may lack a high school diploma, the new Army "Choose-it-Yourself" Vocational Training System lets you *choose* your vocational training *before* you enlist. To qualify, you must pass selective aptitude and physical examinations.

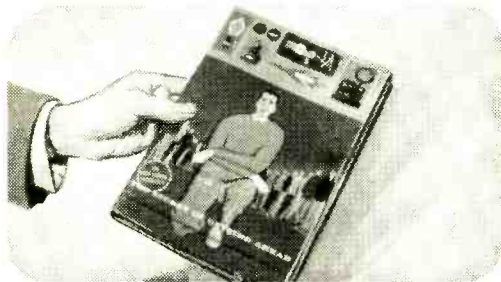

**SEND FOR THIS NEW BOOKLET... IT'S FREE.** Find out all about these two Army educational opportunities in a new 48-page booklet entitled *The Secret of Getting Ahead*. Learn how to apply, how to qualify, how to choose your electronics training *before* enlistment. Order your free copy by mailing coupon *today*.

Without obligation, please rush me a free copy of

**THE SECRET OF GETTING AHEAD PE-7-59**

PRINT NAME \_\_\_\_\_

ADDRESS \_\_\_\_\_

CITY \_\_\_\_\_ ZONE \_\_\_\_\_

STATE \_\_\_\_\_

**TODAY, CLIP THIS COUPON AND MAIL TO:**

**THE ADJUTANT GENERAL**  
 Dept. of the Army  
 Washington 25, D.C., ATTN: AGSN

AT BETTER ELECTRONIC PARTS JOBBERS



**Electro  
Kit**

**KPS-2**  
Best of all—  
and costs less

**\$43.50**

(wired \$49.95)

## NEW DC POWER SUPPLY operates 6/12 v. auto sets, transistor portables, experimental transistor circuits

Will charge batteries, operate model railroads, relays. Ideal for laboratory work, electroplating and many other low voltage applications.

2 output ranges: 0-16 V. 5 amps. 0.5% maximum ripple: 0-20 V. 75 MA. 0.15% ripple • Separate meters for each output • Patented conduction cooling • Easy-to-follow instructions.

Send for **FREE** literature, name of your jobber!

Electro Products Laboratories  
4501-P Ravenswood, Chicago 40, Ill.

Name \_\_\_\_\_

Address \_\_\_\_\_

City \_\_\_\_\_ Zone \_\_\_\_\_ State \_\_\_\_\_

## HEAR MARITIME, COAST GUARD, POLICE BROADCASTS IN YOUR CAR—



### GONSET CONVERTER

*easily installed/operates with your car radio*

Now you can extend the reception of your car radio to include the widely used frequency range of 1600 to 3000 Kc. The Gonset Converter lets you switch instantly from standard broadcast to police broadcasts, ship-to-shore and ship-to-ship communications, special weather and time broadcasts, and amateur frequencies of 1.8 to 2 Mc. Full-vision dial is precisely calibrated. Simple plug-in installation requires no soldering or technical knowledge.\* Only 3½" x 4" x 4". Aluminum case, hammertone gray. Model 3163... **Only \$29.50.**

Write for free literature and name of dealer in your area.

**GONSET** Division/Young Spring and Wire Corp., Burbank, California. \*USABLE ONLY ON 12-VOLT BATTERY SYSTEMS

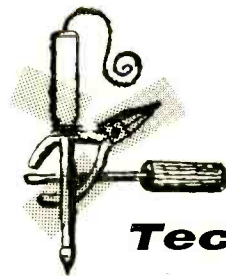

## Tips and Techniques

### ADD A LIGHT TO YOUR MIRROR

If you've ever tried using an unilluminated inspection mirror in the dark corner of a chassis, you've probably wished that you had one with a built-in light. Just attach a one-cell penlight to the shaft of your inspection mirror with rubber bands or

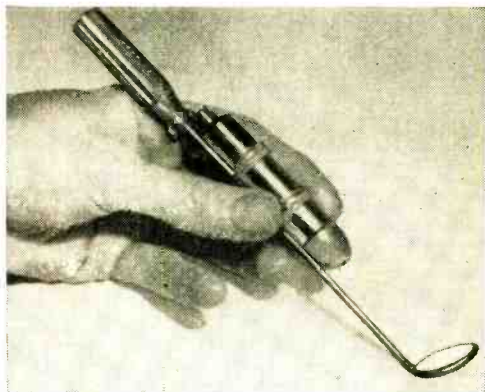

with a strip of tape. Don't strain your eyes needlessly.—*John A. Comstock, Wellsboro, Pa.*

### CAMBRIC FOR COILS

Need some cambric between-the-windings insulation for a coil or transformer you are winding or repairing? Thin sheet

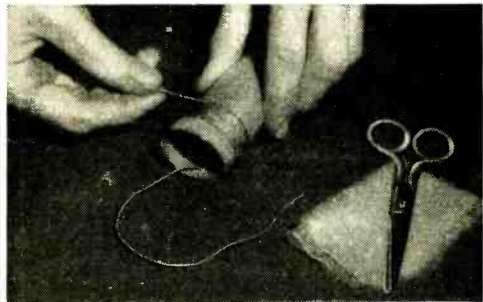

plastic like the kind available at hardware stores or the kind used for packaging dry cleaning and foods is perfect for this purpose. It's tough, thin and moisture-proof—



**NEXT MONTH:**

# TRANSISTORS!

A special 16 page bonus feature in August POPULAR ELECTRONICS tells you how to understand and use transistors. What's more, there are schematics for more than a dozen practical transistorized devices.

As a man interested in electronics, you'll certainly want to know everything you can about the practical transistor—how to design and utilize transistor circuits. And you'll enjoy putting together exciting transistorized projects, such as:

● RF PREAMPLIFIER

● VOLTMETER

● CODE KEYS UNIT

● 10 METER RECEIVER

● LOW-NOISE MIKE  
PREAMP

● CODE OSCILLATOR

● PHOTOCCELL RELAY

● AUDIO AMPLIFIER

● WIRELESS MIKE

● REGEN RECEIVER

...plus other useful build-it-yourself projects.

August POPULAR ELECTRONICS will contain all regular features as well, including:

● **ELECTRONICS AGAINST CANCER**

Learn how Electronic Instruments help detect and cure Cancer.

● **RADAR EYES FOR TV WEATHER FORECASTS**

New RCA System aids TV weather predictions.

● **SOLAR POWER 40-METER TRANSMITTER**

Complete, easy-to-follow plans for a Ham daytime portable unit.

● **FREQUENCY STANDARD**

Helps you align your short-wave receiver.

● **MAGNETIZER UNIT**

Make your own magnets from any steel bar.

● **STEREO-OSCILLATOR**

Use your AM Receiver as your second Stereo Channel.

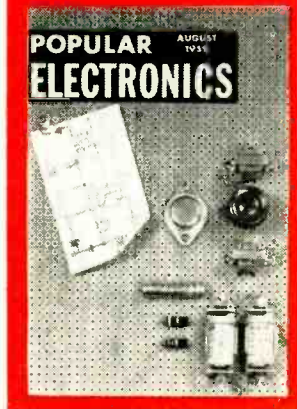

In short, next month's issue is typical of the good reading and practical construction projects you'll find month after month in POPULAR ELECTRONICS. Look for big, exciting POPULAR ELECTRONICS on your newsstand, or better still, take advantage of one of POPULAR ELECTRONICS' money-saving subscription rates. You'll get every issue delivered right to your door. Subscribe today!

### REGULAR SUBSCRIPTION RATES

**One year \$4**

**Two years \$7**

**Three years \$10**

POPULAR ELECTRONICS, 434 South Wabash Avenue, Chicago 5, Illinois

## Tips

(Continued from page 24)

ideal insulation for low-wattage coils or transformers.—*Charles Lang, San Francisco, Calif.*

### SAVE MINIATURE PLUGS

Because of the small size and delicateness of miniature plugs, wires sometimes pull loose from them. This can be avoided by filling the plug's shell with Duco or a similar household cement. The leads should also be cemented to each other for a distance of about a quarter inch from the shell. After the cement has set, it will be practically impossible for the leads to pull out.—*Stanley Tenen, Brooklyn, N. Y.*

### S-METER COVER STATIC

Users of communications receivers which have an S-meter enclosed in a plastic cover may find that a static electric charge is built up on the plastic surface after a severe electrical disturbance. This results in a discrepancy in the reading which can vary from a few decibels to a temporary "pinning" of the indicator. To remedy, merely clean the meter face with a light de-

tergent. The static condition will be eliminated and you'll have a clear easy-to-read meter to boot.—*Dave Johnson, Levittown, Pa.*

### STARTING "STUCK" VIBRATORS

Oxidation of vibrator contacts is often the cause of automobile radio troubles. To start

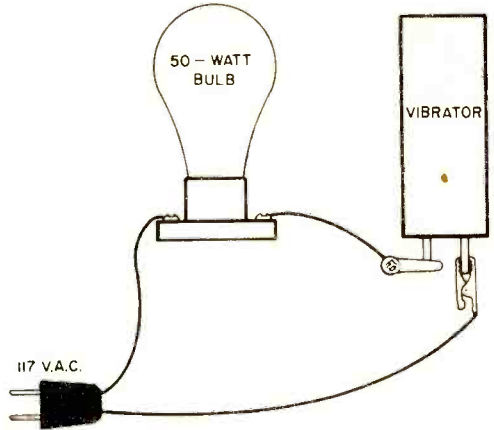

a vibrator that seems to have a sticking reed, connect it to 117 volts a.c. in series with an ordinary 50-watt bulb. By operat-

## NOW YOU CAN SECURE A HIGH SALARIED • TOP PRESTIGE CAREER IN ELECTRONICS IN ONLY ONE YEAR!

ELECTRONICS is the fastest growing industry in America today, creating unlimited opportunities for high salaries, with rapid advancement in **INDUSTRY AND THE ARMED FORCES** for Bailey Trained electronic engineering technicians.

**LARGE CORPORATIONS** from coast to coast, and **BRANCHES OF THE ARMED FORCES** send recruiters to visit each graduating class at Bailey Tech, offering unusually high starting salaries.

**BAILEY GRADUATES ARE BEING HIRED** for such fascinating and interesting work as technical salesmen, research and development of guided missiles, electronic business machines and automatically controlled manufacturing plants, etc., also good **RATINGS IN THE ARMED FORCES.**

**UP TO SEVEN TECHNICIANS** are needed for every engineer... this, plus superior training is why Bailey Graduates are being paid more to start, and are advancing more rapidly than many men who have spent four years in training.

Resident training is easier and costs less than you may think! We provide housing and part-time jobs while in school, plus free nationwide employment service for graduates. If you want to quickly enter America's fastest growing and most exciting industry, write for free booklet... no obligation.

**VETERAN APPROVED**  
**BAILEY TECHNICAL SCHOOLS**  
1625 S. Grand • St. Louis 4, Mo.



This Minneapolis-Honeywell system controls hundreds of automatic manufacturing operations. Experience on live equipment is emphasized at Bailey and is another reason for the tremendous backlog of high pay positions waiting **BAILEY GRADUATES.**

### MAIL TODAY

Please mail immediately this free booklet without obligation

Name \_\_\_\_\_

Address \_\_\_\_\_

City \_\_\_\_\_ State \_\_\_\_\_



# NOW FREE!

350 JUMBO PAGES  
OF RADIO SHACK  
BARGAIN BULLETINS  
FOR NEXT  
12 MONTHS!

If you write today!

GUARANTEED! The CREAM BARGAINS  
... picked from over 250,000  
authentic Radio Shack "best buys"!

THE ONLY WAY TO INFORM YOURSELF OF THE  
WORLD'S BIGGEST BARGAINS WHEN THEY HAPPEN!

- ★ HI-FI, STEREO!
- ★ AMATEUR RADIO!
- ★ TAPES! LP RECORDS!
- ★ POWER TOOLS!
- ★ ELECTRONIC TUBES, PARTS!
- ★ CAMERAS! OPTICAL GOODS!
- ★ APPLIANCES! GIFTS!
- ★ SPORTING EQUIPMENT!

Month after month you get the latest offerings on makers' closeouts, inventory clearances, volume purchases for cash. It's written by experts in hi-fi, amateur radio, all fields... printed VIVIDLY in glowing rotogravure on fine glossy paper! DON'T MISS this exclusive opportunity to INFORM yourself while INTRODUCING yourself to fabulous new activities!

LIMITED TIME OFFER ORDER BY MAIL TODAY!

**ORDER NOW!** 1960 GUIDE TO ELECTRONIC BUYING  
Articles by top authorities on hi-fi, amateur radio, electronics! Most complete directory of HI-FI, HAM GEAR, TOOLS, INDUSTRIAL ELECTRONICS etc.

**RADIO SHACK CORPORATION**

167 Washington St., Boston 8, Mass.  
730 Commonwealth Ave., Boston 17, Mass.  
230-240 Crown St., New Haven 10, Conn.

FILL IN - CLIP - MAIL TODAY!

RADIO SHACK CORP. Dept. 7B  
730 Commonwealth Avenue, Boston 17, Mass.

Please send me:

- FREE Bargain Bulletins for full year
- 1960 Guide To Electronic Buying @ 35c
- Transceiver Kit Order No. 45DX136 @ \$39.95
- Check  Money  C.O.D.

Name \_\_\_\_\_

Address \_\_\_\_\_

City \_\_\_\_\_ Zone \_\_\_\_\_ State \_\_\_\_\_

NOW! BUILD and OPERATE YOUR OWN SHORTWAVE  
2-WAY RADIO STATION WITHOUT FCC EXAMS!

NEW CLASS D

## CITIZENS BAND TRANSCEIVER KIT



FCC APPROVED!

\$ 39<sup>95</sup>

with Antenna and Microphone

\$5 down, \$5 monthly  
Order No. 45DX136 Sh. Wt. 11 lbs.



IMMEDIATE DELIVERY!

- FIXED or MOBILE OPERATION!
- You get CALL LETTERS, just like licensed operators!
- Pre-punched chassis!
- Brand new jobber parts! No surplus! No seconds!

FCC BARRIERS ARE DOWN! For the first time you can send and receive on the 11-meter band on equipment you assemble yourself... without an amateur radio license! Radio Shack engineers worked around the clock with the world famous STANCOR Factory to bring you this easy-to-build professional quality transceiver that lets you "talk" or "listen" with just the twist of a knob!

EASY TO BUILD! Kit includes detailed instructions and photos, 5 tubes, transmitter, receiver, aluminum chassis, speaker, power supply, etc.

**ASSEMBLE YOUR OWN**

# WALKIE-TALKIE RADIOPHONES



**New Model for 27 mc  
Citizens Band**

**Electronic Chassis ONLY \$18<sup>98</sup> post-paid**

- Meets FCC requirements for new class "D" citizens band radio-telephone.
- License easily obtained on application by any U. S. citizen 18 years or over. No tests to take.
- Transmits and receives one to several miles depending on obstructions and elevation.
- Assembled unit is completely portable and requires no external connections. Operates from self contained batteries obtainable at your local radio store.
- Electronic chassis is wired, tested, guaranteed and includes crystal controlled oscillator, R.F. power amplifier, audio modulator, receiver with R.F. stage, and a new transistorized audio booster stage for extra loud reception plus a complete set of tubes and transistor.
- Radio receiver is tunable to any of the 22 channels by a single control knob. Features ultra-high amplification, automatic volume control and noise clipping.
- Instructions and photographs are supplied with each chassis for completing the walkie-talkie as illustrated. Accessories are not included but are available at low cost.

FREE R.F. power indicator kit with each order.

**SEND YOUR ORDER TODAY. INCLUDE POSTAL MONEY ORDER FOR FAST DELIVERY. C.O.D.'s REQUIRE \$5.00 DEPOSIT. N. Y. City residents add sales tax.**

**SPRINGFIELD ENTERPRISES**

Box 54-E-7 Springfield Gardens 13, N. Y.

## CLASS "D" CITIZEN BAND CRYSTALS



3rd Overtone; Hermetically Sealed  
.005% tolerance—Meet F C C requirements.

1/2" pin spacing—.050  
pin diameter (for .093  
pin diameter, add 15c).

**\$2<sup>95</sup> EACH**

**22 CHANNELS**  
(add 5c per crystal for postage and handling)

The following Class "D" Citizen Band frequencies in stock (frequencies listed in megacycles): 26.965, 26.975, 26.985, 27.005, 27.015, 27.025, 27.035, 27.055, 27.065, 27.075, 27.085, 27.105, 27.115, 27.125, 27.135, 27.155, 27.165, 27.175, 27.185, 27.205, 27.215, 27.225.

### RADIO CONTROL CRYSTALS in HCG/U HOLDERS—SIX FREQUENCIES

In stock for immediate delivery (frequencies listed in megacycles): tolerance .005%, 1/2" pin spacing, .050 pin diameter. Specify frequency desired (for .093 pin spacing add 15c).

**26.995, 27.045, 27.095, 27.145, 27.195, \$2<sup>95</sup> EACH**  
27.255

Ceramic socket for HCG u crystals—20c ea.  
(add 5c per crystal for postage and handling)

**Send for FREE CRYSTAL CATALOG  
WITH OSCILLATOR CIRCUITS**

**ASK YOUR PARTS DEALER FOR TEXAS CRYSTALS**  
See big red display . . . if he doesn't stock them, send us his name and order direct from nearest factory.

**ORDER FROM NEAREST PLANT**

## TEXAS CRYSTALS

All Phones: Gladstone 3-3555 (River Grove, Illinois)  
Texas Crystals, Dept. P-79 Texas Crystals, Dept. P-79  
8538 West Grand Avenue OR Crystal Drive  
River Grove, Illinois Ft. Myers, Florida

**ALL ORDERS SHIPPED 1st CLASS MAIL**

## Tips (Continued from page 26)

ing the unit on ordinary a.c. for about five minutes, the trouble will usually clear up without your having to take the vibrator apart.—*Joseph Carroll, Brooklyn, N. Y.*

### "SPAGHETTI" IN A CAN

If you have a can of insulating tool dip on your bench, keeping a stock of "spaghetti" is no problem at all.



When you want to insulate a length of bare wire, just dip it in the tool dip and hang it up to dry. By dipping the wire three or more times, you can build up the insulation to withstand voltages as high as 220 volts. Use a small brush to paint the insulation on wire splices that can't be dipped. A can of tool dip can be obtained at any radio parts store.—*James A. Clifford, Detroit, Mich.*

### EASILY MADE POLARIZED PLUG

For safety's sake, all the a.c. plugs in your workshop and hi-fi system should be polarized. If you look closely at an ordinary a.c. outlet, you will notice that one slot is slightly longer than the other, indicating

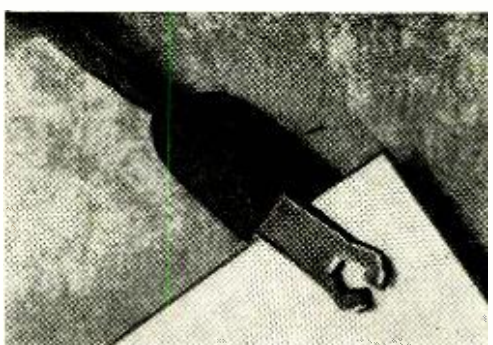

that it is the grounded side. A regular plug may be polarized by splitting and widening the tip of one of its prongs. This widened tip will only fit into the longer—or grounded—side of the a.c. outlet.—*Ira Glickstein, Brooklyn, N. Y.*

**AT  
LAST!**

# RADIO-TV and ELECTRONICS TRAINING

**... AT A PRICE  
YOU CAN AFFORD!**



**\*21 INCH**  
Receiver Kit included

Yes, this great course costs far less than any training of its kind given by other major schools! Radio-Television Training School will train you for a good job in Television or Industrial Electronics — **AT HOME IN YOUR SPARE TIME.**

Think of it—a complete training program including over 120 lessons, Fourteen Big Radio-Television Kits, Complete Color-TV Instruction, Unlimited Consultation Service . . . **ALL at a really big saving to you.** How can we do this? Write to us today . . . and find out!

And what's more — you can (if you wish)  
**OPEN YOUR OWN RTS-APPROVED AND  
FINANCED RADIO-TV SERVICE SHOP**

**We Want Many More Shops This Year**

This 37 year old training organization — called RTS, that's Radio-Television Training School — wants to establish a string of Radio-TV Repair Shops in principal cities throughout the U. S. So far, a great many such shops are **NOW IN BUSINESS AND PROSPERING.** We are helping and training ambitious men to become future owners and operators of these shops in all areas.

**FOR UNSKILLED  
INEXPERIENCED MEN ONLY —  
WE TRAIN YOU OUR WAY!**

We must insist that the men we sign up be trained in Radio-TV Repair, Merchandising and Sales by our training methods—because **WE KNOW** the requirements of the industry. Therefore, we will **TRAIN YOU . . .** we will show you how to earn **EXTRA CASH**, during the first month or two of your training period. **YOU KEEP YOUR PRESENT JOB. TRAINING TAKES PLACE IN YOUR OWN HOME, IN YOUR SPARE TIME!**

**COMPLETE  
COLOR  
INSTRUCTION  
INCLUDED**

*you build these  
and other units*

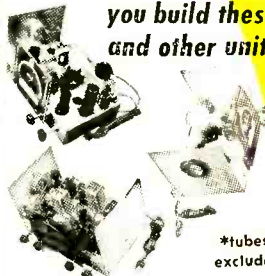

\*tubes  
excluded

## RADIO-TELEVISION TRAINING SCHOOL

5100 S. VERMONT AVENUE  
LOS ANGELES 37, CALIFORNIA

Est. 1922



**ACT  
NOW!**

**RTS  
APPROVED  
SERVICE  
SHOP**

Get your free book on the  
**FAMOUS RTS BUSINESS PLAN**  
find out how you can open  
**A REPAIR SHOP OF YOUR OWN**

*We supply and finance your equipment*

When you are ready and qualified to operate one of our RTS-Approved TV Repair Shops **WE WILL SUPPLY AND FINANCE EVERY BIT OF EQUIPMENT YOU NEED TO GET STARTED** plus an inventory of parts and supplies. In other words we will stake you . . . **AN OFFER NEVER MADE BEFORE BY ANY TRAINING ORGANIZATION.** Under the RTS Business Plan you receive:

1. An electric sign for the shop front.
2. Radio and TV test Equipment.
3. Letterheads, calling cards, repair tickets, etc.
4. Basic inventory of tubes, parts, supplies.
5. Advertising and promotional material.
6. Plans for shop arrangement.
7. Instructions on how to go into business.
8. Continuous consultation and help.
9. The right to use RTS Seal of Approval, and the RTS Credo.
10. The right to use the Famous Trade Mark.



RTS' Membership in The Association of Home Study Schools is your assurance of Reliability, Integrity, and Quality of Training.

**ALL  
THESE  
FREE!**



**CUT OUT AND MAIL — TODAY!**

### RADIO-TELEVISION TRAINING SCHOOL

5100 S. Vermont Avenue, Dept. PE-79,  
Los Angeles 37, California

SEND ME FREE — all of these big opportunity books — "Good Jobs in TV-Electronics," "A Repair Shop of Your Own" and "Sample Lesson." I am interested in:

- Radio-Television       Industrial Electronics (Automation)

Name \_\_\_\_\_ Age \_\_\_\_\_

Please Print

Address \_\_\_\_\_

City & State \_\_\_\_\_

300

# SHIPPED ON APPROVAL

## IN-CIRCUIT CONDENSER TESTER

Model CT-1

### AN ABSOLUTE 'MUST' FOR EVERY SERVICEMAN!

Here is an in-circuit condenser tester that does the whole job. The CT-1 actually steps in and takes over where all other in-circuit condenser testers fail. The ingenious application of a dual bridge principle gives the CT-1 a tremendous range of operation. . . .

#### in-circuit checks:

- ✓ Quality of over 80% of all condensers even with circuit shunt resistance present . . . (leakage, shorts, opens, intermittents)
- ✓ Value of all condensers from 200 mmfd. to 5 mfd.
- ✓ Quality of all electrolytic condensers (the ability to hold a charge)
- ✓ Transformer, socket and wiring leakage capacity

#### out-of-circuit checks:

- ✓ Quality of 100% of all condensers . . . (leakage, shorts, opens and intermittents)
- ✓ Value of all condensers from 50 mmfd. to 5 mfd.
- ✓ Quality of all electrolytic condensers (the ability to hold a charge)
- ✓ High resistance leakage up to 300 megohms
- ✓ New or unknown condensers . . . transformer, socket, component and wiring leakage capacity

#### SPECIFICATIONS

- Ultra-sensitive 2 tube drift-free circuitry • Multi-color direct scale precision readings for both quality and value . . . (in-circuit or out of circuit) • Simultaneous readings of circuit capacity and circuit resistance • Built-in hi-leakage indicator sensitive to over 300 circuit resistance • Cannot damage circuit components • Electronic eye megohms • Cannot damage circuit components • Electronic eye megohms • Cannot damage circuit components • Isolated power line balance indicator for even greater accuracy

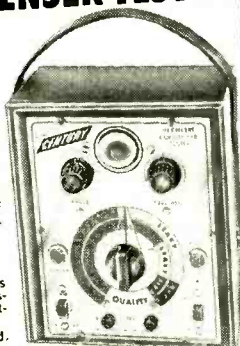

Model CT-1 — housed in sturdy hammerstone finish steel case complete with test leads  
**\$34.50** Net  
 SIZE: W-6" H-7" D-3 1/4"

## MINI-CHECK TUBE TESTER

Model MC-1

### A Real ECONOMY MULTIPLE SOCKET TUBE TESTER without sacrifice in ACCURACY, SPEED or VERSATILITY

Here is a multiple socket tube tester designed to meet limited budgets. Although low in price it boasts a unique circuitry that enables you to check over 600 tube types — and has a range of operation that far exceeds others in its price class.

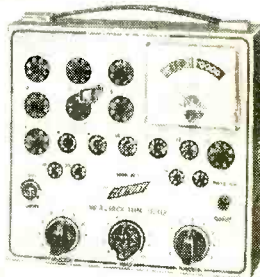

Model MC-1 — housed in sturdy wrinkle finish steel case  
**\$39.50** Net  
 SIZE: W-9" H-8 1/2" D-2 1/4"

#### SPECIFICATIONS

- Checks emission, inter-element shorts and leakage of over 600 tube types. This covers 024s, series-string TV tubes, gas regulators, auto 12 plate volt. hi-fi and foreign tubes • 3 settings enable a test of any tube in less than 10 seconds • Employs dynamic cathode emission test principles • 3 1/2" D'Arsonval type meter — most accurate type available . . . its greater sensitivity means more accuracy • 17 long lasting phosphor bronze tube sockets • Combination gas and short jewel indicator • 9 filament positions • Handy tube chart contained in special back compartment • New tube listings furnished periodically at no cost • Detachable line cord

plus these BONUS FEATURES . . . found in no other low price tube tester

- ✓ Checks for cathode to heater shorts ✓ Checks for gas content
- ✓ Checks all sections of multiple purpose tubes . . . will pickup tubes with one "Bad" section ✓ Line isolated — no shock hazard ✓ Variable load control enables you to get accurate results on all tubes
- ✓ Positively cannot become obsolete as new tubes are introduced.

## IN-CIRCUIT RECTIFIER TESTER

Model SRT-1

### Checks all power rectifiers in-circuit whether SELENIUM, GERMANIUM, SILICON, etc.

With the growing trend towards compactness, portability and low price, TV manufacturers are resorting more and more to producing series-string TV sets employing selenium, germanium or silicon power rectifiers. Now the need for an in-circuit rectifier tester is greater than ever.

#### THE SRT-1 CHECKS ALL POWER RECTIFIERS IN-CIRCUIT AND OUT-OF-CIRCUIT WITH 100% EFFECTIVENESS FOR:

- ✓ Quality ✓ Fading ✓ Shorts ✓ Opens
- ✓ Arcing ✓ Life Expectancy

SIZE: W-6" H-7" D-3 1/4"

#### SPECIFICATIONS

- Checks all types of power rectifiers rated from 10 ma. to 500 ma. (selenium, germanium, silicon, etc.) both in-circuit or out-of-circuit.
- Will not blow fuses even when connected to a dead short.
- Large 3" highly accurate multi-color meter . . . sensitive yet rugged.
- Separate meter scales for in-circuit and out-of-circuit tests.
- Cannot damage or over heat rectifier being tested.

#### SIMPLE TO OPERATE

Just clip SRT-1 test leads across rectifier under test right in the circuit without disconnecting rectifier from circuit. Press test switch and get an instant indication on the easy-to-read three-color meter scales. . . .



Model SRT-1—housed in sturdy hammerstone finish steel case complete with test leads  
**\$29.50** Net

## TRANSISTOR TESTER

Model TT-2

### AN INEXPENSIVE QUALITY INSTRUMENT DESIGNED FOR ACCURATE AND DEPENDABLE TESTS OF ALL TRANSISTORS AND DIODES QUICKLY AND ACCURATELY

Every day more and more manufacturers are using transistors in home portable and car radios. . . . in hearing aids, intercoms, amplifiers, industrial devices, etc. Since transistors gain, shorts or opens, the need for TRANSISTOR TESTER is great.

#### SPECIFICATIONS

- Checks all transistors, including car radio, power output, triode, letter code and junction types for current gain, leakage, opens, shorts, cut-forward to reverse current gain • All tests can be made even if manufacturers' rated gain is not available. Less than half a minute required for yet rugged . . . with multi-color scales designed for quick easy readings so small, service life almost equal to shelf life. Battery cannot be drained due to accidental shorting of test leads • Cannot burn-out its own meter or clips enable test is not available. Less than half a minute required for tests of either transistors or diodes • Large 3" meter is extremely sensitive • Power is supplied by an easy to replace 6-volt battery — current drain damage transistor or diode under test • Long test leads and insulated test leads are identified by E.I.A. color code so that connection to the correct terminal is assured • Comes complete with replaceable transistor set-up chart that fits into a special rear compartment.

**IMPORTANT FEATURE:** The TT-2 cannot become obsolete as you to check all new type transistors as they are introduced. New listings will be furnished periodically at no cost.



Model TT-2 — housed in sturdy hammerstone finish steel case complete with test leads  
**\$24.50** Net  
 SIZE: W-6" H-7" D-3 1/4"

**EASY TO BUY IF SATISFIED**  
 see order form on facing page

**FOR 10 DAY FREE TRIAL** Convince yourself at no risk that CENTURY instruments are indispensable in your every day work. Send for instruments of your choice without obligation... try them for 10 days before your buy... only then, when satisfied, pay in easy-to-buy monthly installments — without any financing or carrying charges added.

**NEW** Battery Operated **VACUUM TUBE VOLT METER** Model VT-1  
**Peak-to-Peak**  
**WITH LARGE EASY-TO-READ 6" METER** —

featuring the sensational new **MULTI-PROBE** Patent Pending  
 No extra probes to buy! The versatile MULTI-PROBE does the work of 4 probes

- 1 DC Probe 2 AC-Ohms Probe 3 Lo-Cap Probe 4 RF Probe

The VT-1 is a tremendous achievement in test equipment. With its unique MULTI-PROBE it will do all the jobs a V.T.V.M. should do without the expense of buying additional probes. No longer do you have to cart around a maze of entangled cables, lose time alternating cables or hunting for a misplaced probe. With just a twist of the MULTI-PROBE tip you can set it to do any one of many time-saving jobs. A special holder on side of case keeps MULTI-PROBE firmly in place ready for use.

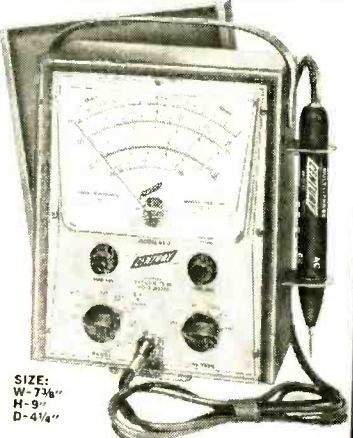

SIZE: W-7 3/4" H-9" D-4 1/4"

**FUNCTIONS**

**DC VOLTMETER**... Will measure D.C. down to 1.5 volts full scale with minimum circuit loading, and give accurate readings of scale divisions as low as .025 volts... Will measure low AGC and oscillator bias voltages from .1 volts or less up to 1500 volts with consistent laboratory accuracy on all ranges... Zero center provided for all balancing measurements such as discriminator, ratio detector alignment and hi-fi amplifier balancing.

**AC VOLTMETER**... True Peak-to-Peak measurements of any wave form including TV sync, deflection voltages, video pulses, audio in hi-fi amplifiers, AGC easily read down to .1 volts... Scale divisions are 1/20th the circuit loading of a V.O.M.... Unlike most other V.T.V.M.'s, there is no loss in accuracy on the lowest AC range.

**OUTSTANDING FEATURES**

- Completely portable — self powered with long life battery — permits use everywhere
- New advanced pentode amplifier circuit assures amazingly low battery drain
- Large 6" 100-microampere meter, many times more sensitive than meters used in most V.T.V.M.'s
- Laboratory accuracy performance — 2% of full scale on DC, 5% of full scale on AC
- Simplified multi-color easy-to-read 4-scale meter
- No heat operation assures rigid stability and accuracy
- Immune to power line fluctuations
- Amplifier rectifier circuit with frequency compensated attenuator — a feature found only in costly laboratory instruments
- Hand-crafted circuitry practically burn-out proof
- Meter completely isolated — eliminates the service headaches of printed circuitry
- 1% resistors used for permanent accuracy
- Separate RF ground return for low-loss RF measurement
- Microphone type coaxial connector
- Matching cover protects instrument face — snaps on and off instantly.

**SPECIFICATIONS**

- DC Volts — 0 to 1.5/6/30/150/300/600/1500 volts
- AC Volts (RMS and Peak-to-Peak) — 0 to 3/12/60/300/1200 volts
- Ohms — 0 to a billion ohms, 10 ohms center scale — Rx1/10/100/1K/10K/100K/M
- RF — Peak reading demodulator supplied for use on all DC ranges
- Zero Center — available on all DC volt ranges with zero at mid-scale
- Decibels — from -10 db to +10/22/36/50/62 based on the Dbm unit: 0db: 1mW in 600 ohms
- Impedance — 11 megohms DC, 1.2 megohms AC, 10 megohms Lo-Cap
- Input Capacity — 130 mmfd. RMS, 250 mmfd. Peak-to-Peak, 25 mmfd. Lo-Cap

Model VT-1 — fully wired and calibrated, housed in standard case complete with MULTI-PROBE and thorough instruction manual covering all the applications in detail.

**\$58.50** Net

**ELECTRONIC OHMMETER**... Measures from 0 to 1000 megohms... Scale divisions are easily read down to 2 ohms... Will measure resistance values as high as 1000 megohms... Will detect high resistance leakage in electrolytic and by-pass condensers.

**RF and LO-CAP MEASUREMENTS**

With these extra VT-1 functions... voltages in extremely high-impedance circuits such as color TV gating pulses, mixer output levels, I.F. stage-by-stage gain and detector inputs.

**FAST-CHECK TUBE TESTER** Model FC-2

Simply set two controls... insert tube... and press quality button to test any of over 700 tube types completely, accurately... IN JUST SECONDS!

Over 20,000 servicemen are now using the FAST-CHECK in their every day work and are cutting servicing time way down, eliminating unprofitable call-backs and increasing their dollar earnings by selling more tubes with very little effort. See for yourself at no risk why so many servicemen chose the FAST-CHECK above all other tube testers.

**PICTURE TUBE TEST ADAPTER INCLUDED WITH FAST-CHECK**

Enables you to check all picture tubes (including the new short-neck 110 degree type) for cathode emission, shorts and life expectancy... also to rejuvenate weak picture tubes.

**RANGE OF OPERATION**

- Checks quality of over 700 tube types, employing the time proven dynamic cathode emission test. This covers more than 99% of all tubes in use today, including the newest series-string TV tubes, auto 12 plate-volt tubes, 024s, magic eye tubes, gas regulators, special purpose hi-fi tubes and even foreign tubes.
- Checks for inter-element shorts and leakage.
- Checks for gas content.
- Checks for life-expectancy.

**SPECIFICATIONS**

No time consuming multiple switching... only two settings are required instead of banks of switches located inside cover. No annoying roll chart checking... tube chart listing over 700 tube types is mounted on panel. Large 4 1/2" D'Arsonval type meter is the most sensitive available, yet rugged — fully protected against accidental burn-out. Special scale on meter for low current tubes. Compensation for line voltage variation. 12 filament positions. Separate gas and short jewel indicators. Line isolated — all future tube types as they come out. New tube listings are furnished periodically at no cost.

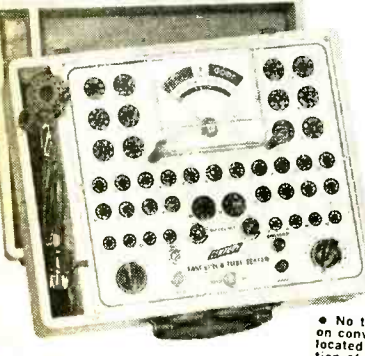

SIZE: W-14 1/2" H-11 1/4" D-4 3/4"

Model FC-2 — housed in hand-lidded oak carrying case complete with CRT adapter

**\$69.50** Net

**CONVENIENT TIME PAYMENT PLAN — NO FINANCING CHARGES**

ALL CENTURY INSTRUMENTS ARE GUARANTEED FOR ONE FULL YEAR

The extremely low prices are made possible because you are buying direct from the manufacturer.

**CENTURY ELECTRONICS CO., INC.**

**CHECK INSTRUMENTS DESIRED**

<input type="checkbox"/> Model CT-1 In-Circuit Condenser Tester	\$34.50
<input type="checkbox"/> \$9.50 within 10 days. Balance \$5 monthly for 5 months.	
<input type="checkbox"/> Model MC-1 Mini-Check Tube Tester	\$39.50
<input type="checkbox"/> \$9.50 within 10 days. Balance \$6 monthly for 5 months.	
<input type="checkbox"/> Model SR-1 In-Circuit Resistor Tester	\$29.50
<input type="checkbox"/> \$4.50 within 10 days. Balance \$5 monthly for 5 months.	
<input type="checkbox"/> Model TT-2 Transistor Tester	\$24.50
<input type="checkbox"/> \$4.50 within 10 days. Balance \$5 monthly for 4 months.	
<input type="checkbox"/> Model VT-1 Battery Vacuum Tube Volt Meter	\$58.50
<input type="checkbox"/> \$14.50 within 10 days. Balance \$11 monthly for 4 months.	
<input type="checkbox"/> Model FC-2 Fast-Check Tube Tester	\$69.50
<input type="checkbox"/> \$14.50 within 10 days. Balance \$11 monthly for 5 months.	

Prices Net F.O.B. Mineola, N. Y.

111 Roosevelt Avenue, Dept. 307 Mineola, New York

Please rush the instruments checked for a 10 day free trial. If satisfied I agree to pay the down payment within 10 days and the monthly installments as shown. If not completely satisfied I will return the instruments within 10 days and there is no further obligation. It is understood there will be NO INTEREST or FINANCING charges added.

Name \_\_\_\_\_

Address \_\_\_\_\_

City \_\_\_\_\_ State \_\_\_\_\_

Please print clearly

# CUT HOLES IN 1-1/2 MINUTES

(OR LESS)

with Greenlee  
Chassis Punches

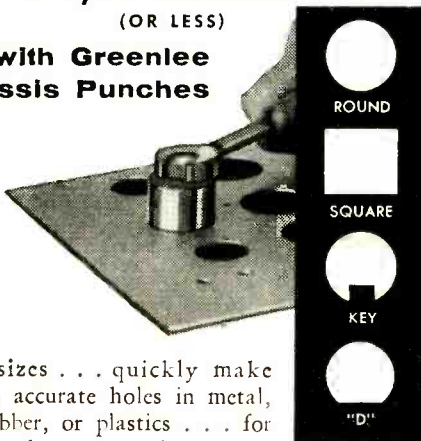

Many sizes . . . quickly make smooth, accurate holes in metal, hard rubber, or plastics . . . for sockets, plugs, controls, meters, panel lights, etc. Easy to use, simply turn with a wrench. Write today for free literature.



**GREENLEE TOOL CO.**  
1783 Columbia Avenue, Rockford, Ill.



## LET RUSS DO IT! SAVE ON QUALITY DEVELOPING and PRINTING

### KODACHROME EKTACHROME ANSCOCHROME PROCESSING



620, 120, unmounted . . . . .	1.15
35MM, (20 exp.) and 828 mounted . . . . .	1.15
35MM, 36 exp., including mounting . . . . .	2.00
STEREO: 35MM, 15 stereo pairs	
including mounting . . . . .	1.75
28 stereo pairs, including mounting . . . . .	2.75
<b>KODACHROME ONLY</b>	
8MM 25 ft. roll . . . . .	1.15
8MM 25 ft. magazine . . . . .	.90
16MM 50 ft. magazine . . . . .	1.20
16MM 100 ft. roll . . . . .	2.75

### KODACOLOR PRINTS and PROCESSING

<b>35MM</b> 20 exp. roll dev. & ptd. 2 1/2x3 1/2 . . . . .	<b>\$3.50</b>
12 exp. roll dev. & ptd. 3 1/2x3 1/2 . . . . .	\$3.50
8 exp. roll dev. & ptd. 3 1/2x5 . . . . .	2.50
Kodacolor prints 3 1/2x5 . . . . .	4 for \$1.00

sorry no  
C.O.D.'s  
Send for  
FREE  
Mailers and  
Complete  
Price List

## RUSS PHOTO SERVICE

P. O. BOX 823-E Cooper Sta., N. Y. 3, N. Y.

# NEW products

## "FOLD-OVER" ANTENNA TOWER

Rohn Manufacturing Company, 116 Limestone, Bellevue, Peoria, Ill., has announced a new "fold-over" antenna tower suitable for amateur radio, experimentation and general purposes. The "fold-over" feature allows on-the-ground servicing of antenna or rotator. This tower is available in a height up to 70 feet and is designed to handle practically all sizes and types of antennas. Sections are 10 feet in length for easy installation. Write to the manufacturer for further details.

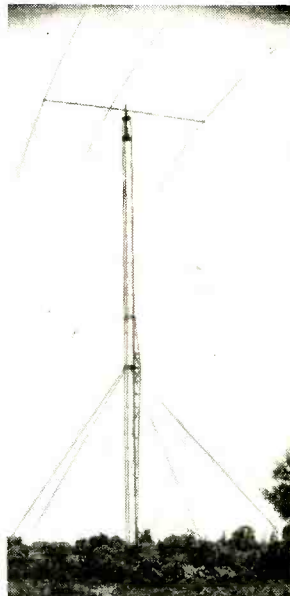

## STEREO SWITCH

The HS 234 four-position stereo switch can be installed between tuners and preamps, stereo cartridges and preamps, stereo

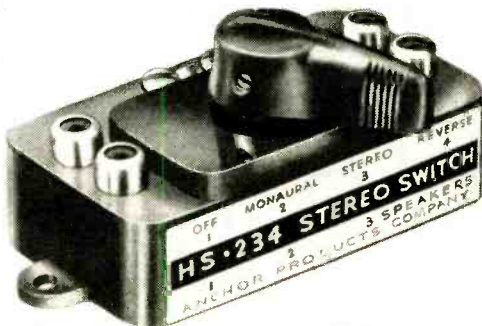

preamps and amplifiers, tape heads and preamps. It will also serve as a multiple speaker control switch. Positions are



**GREATEST  
ADVANCE IN  
SHOP-METHOD  
HOME TRAINING**

# EARN MORE MONEY...GET INTO TELEVISION ELECTRONICS - RADIO

**Learn ALL 8 PHASES in ONE MODERN HOME-STUDY COURSE**  
At Home - In Spare Time

## YOU GET ALL THIS NEWEST PRACTICAL EQUIPMENT

- Parts to build a modern TV set, including all tubes plus a large screen Picture Tube
- Parts to build a powerful Superhet Receiver, standard broadcast and short wave
- Parts to conduct many experiments and build Continuity Checker, RF Oscillator, TV Circuits, Audio Oscillator, TRF Receiver, Signal Generator
- A Valuable Professional Multitester

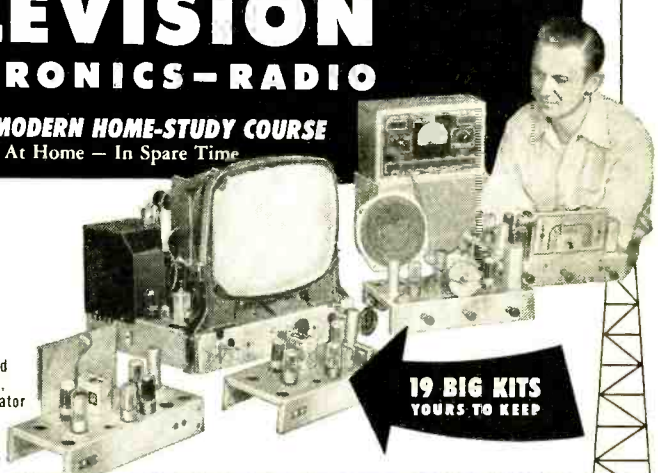

**19 BIG KITS  
YOURS TO KEEP**

## YOUR NATIONAL SCHOOLS TELERAMA COURSE COVERS ALL 8 PHASES

- |                                    |                                |
|------------------------------------|--------------------------------|
| 1. TELEVISION, INCLUDING COLOR TV  | 5. PREPARATION FOR FCC LICENSE |
| 2. RADIO, FM AND AM                | 6. AUTOMATION                  |
| 3. INDUSTRIAL ELECTRONICS          | 7. RADAR AND MICRO WAVES       |
| 4. SOUND RECORDING AND HI FIDELITY | 8. COMMUNICATIONS              |

## YOU ARE NEEDED IN THE TELEVISION-ELECTRONICS-RADIO INDUSTRY!

You can build a secure future for yourself if you get into Electronics NOW! Today's shortage of trained technicians creates tremendous opportunities. National Schools Shop-Method trained technicians are in constant and growing demand for high-pay jobs in Broadcasting and Communications, Electronic Research, Servicing and Repair, and many other branches.

— many other materials and services  
— consultation privilege with our qualified staff, and Graduate Employment Service. EVERYTHING YOU NEED for outstanding success in Electronics.

Let National Schools, a Resident Technical School for over 50 years train you for today's unlimited opportunities in electronics! Our Shop-Method trains you to be a MASTER-TECHNICIAN. Completely up to date, developed by experienced instructors and engineers, your Telerama Course will teach you all phases of the industry quickly, clearly and correctly. You can master the most modern projects, such as Color TV, printed circuits — even prepare for FCC License without taking a special

course. You can handle sales, servicing, manufacturing, or make good money in your own business. SEND FOR FACTS TODAY!

**EARN AS YOU LEARN.** Many of our students earn their entire tuition and more in Spare Time jobs we show them how to do while learning.

**YOU GET EVERYTHING YOU NEED** — Clear, profusely illustrated lessons, shop-tested manuals, modern circuit diagrams, practical job projects — all the valuable equipment shown above

## RESIDENT TRAINING AT LOS ANGELES

If you wish to take your training in our Resident School at Los Angeles, the world's TV capital, start NOW in our big, modern Shops, Labs and Radio-TV Studios. Here you work with latest Electronic equipment—professionally installed—finest, most complete facilities offered by any school. Expert, friendly instructors. Personal attention. Graduate Employment Service. Help in finding home near school—and part time jobs while you learn. Check box in coupon for full information.



**FREE!**

Fully illustrated "Career" Book in TV-Radio-Electronics. PLUS actual sample lesson—yours at no cost, no obligation. CLIP COUPON NOW... MAIL IT TODAY!

APPROVED FOR G. I. TRAINING

# NATIONAL SCHOOLS

4000 S. FIGUEROA ST., LOS ANGELES 37, CALIF.

## NATIONAL SCHOOLS

TECHNICAL TRADE TRAINING SINCE 1905  
LOS ANGELES 37, CALIFORNIA

GET FAST SERVICE—MAIL NOW TO

NATIONAL SCHOOLS, DEPT. R2G-79  
4000 S. FIGUEROA ST.  
LOS ANGELES 37, CALIF.

Hush free TV-Radio "Opportunity" Book and sample lesson. No salesman will call.

NAME \_\_\_\_\_ AGE \_\_\_\_\_

ADDRESS \_\_\_\_\_

CITY \_\_\_\_\_ ZONE \_\_\_\_\_ STATE \_\_\_\_\_

Check if interested ONLY in Resident School training at Los Angeles.  
VETERANS Give date of Discharge \_\_\_\_\_

# DYNAKITS

the finest high fidelity equipment  
in dollar-saving kit form

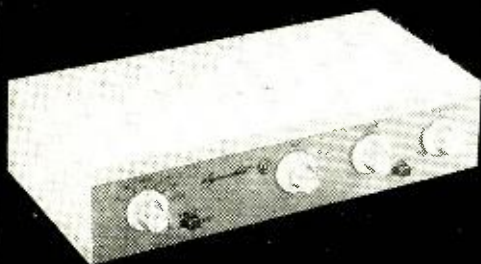

Unequalled simplicity of construction makes it practical for anybody to build Dynakits. The use of premium quality components and advanced engineering techniques provide superior quality of performance and resultant listening pleasure.

**IT'S FUN TO BUILD THE BEST.**

See them at your Hi Fi dealer or  
write for complete literature.

DYNACO, INC., 617 N. 41st St., Phila. 4, Pa.



*Artisan*  
**ELECTRONIC ORGAN**  
for your HOME!  
**BUILD-IT  
YOURSELF  
SAVE!**

Now you can own a professional electronic organ and save up to 50% on an easy pay-as-you-build plan... The world famous ARTISAN ORGAN — in 14 models from the popular 2-manual Home entertainment style to the majestic 4-manual Theatre and Church style is now available in kit form. Simple step-by-step instructions, pictorial diagrams and schematics make this an ideal spare-time project for anyone.



**SEND FOR THIS  
FREE LITERATURE TODAY!**

Get ALL the facts on the magnificent 20th Century Successor To The Pipe Organ — The ARTISAN! Gives you information you should know before you purchase ANY organ-kit or commercial model.

**ELECTRONIC  
ORGAN ARTS, INC.**

4949 York Blvd., Dept. PE-7  
Los Angeles 42, California

## products

(Continued from page 32)

"Stereo" for two-channel sound, "Monaural" for combining both channels, and "Channel Reverse" for compatible listening. List price, \$6.50. (Anchor Products Co., 2712 W. Montrose Ave., Chicago 18, Illinois.)

### CITIZENS BAND TRANSCEIVER

Model CB-100, a three-channel Citizens Band transceiver, has been announced by Globe Electronics, Inc., 3417 W. Broadway,



Council Bluffs, Iowa. Operation is simple since there are only three controls: Channel, Squelch and On-Off/Volume. The CB-100 operates on either 117 volts a.c. or 12 volts d.c. Power input is 5 watts. Complete with push-to-talk microphone and crystals for one channel. \$129.95.

### HEX DRIVER KIT

Vaco Products Co., 317 E. Ontario St., Chicago 11, Ill., is offering an "Allen" hex driver kit in a sectioned plastic tool roll for compactness and easy access. The kit contains an amberyl handle with clutch and six hex bits. Long hex blades permit you to reach hard-to-get-at places. Further particulars can be obtained from the manufacturer.

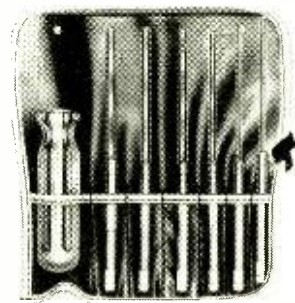

### AUTOMATIC VOLTAGE STABILIZER

Designed for TV receivers, amplifiers, hi-fi sets and other electronic equipment, the Acme voltage stabilizer maintains 118 volts output though the input may vary from 95 to 130 volts. A built-in relay automatically disconnects the primary circuit

# build this great new **knight-kit** A PRODUCT OF ALLIED RADIO

## stereo hi-fi amplifier... save up to 50%

COMPARABLE IN EVERY WAY TO WIRED AMPLIFIERS COSTING TWICE AS MUCH



tremendous value at only

**\$44.50** only \$4.45 down

never before such performance...  
such styling... such quality  
at so low a price...

### **knight-kit 20-watt stereo hi-fi amplifier**

Newest complete Stereo high-fidelity amplifier at an amazing low \$44.50. Incomparable value: Includes two built-in preamps for magnetic cartridges. Single switch selects phono, tuner or auxiliary stereo inputs, plus stereo reverse on each; also switches monophonic input to both amplifier channels. Bass and treble controls boost and attenuate. Special clutch-type concentric volume control permits individual channel balancing, plus overall volume control. Total output is 20 watts (10 watts per channel at less than 1½% distortion). Response, 20-20,000 cps, ± 1.5 db. Hum and noise better than 85 db below full output. Has four pairs of stereo inputs: magnetic cartridge, ceramic cartridge, tuner, auxiliary. RIAA equalized for stereo discs. Expertly designed push-pull output circuitry. Beautiful custom-styled case, 4¼ x 13¼ x 9". With case, tubes, all parts, wire, solder and instructions. Shpg. wt., 27 lbs.

Model Y-773. Knight-Kit Stereo Amplifier, F.O.B. Chicago... **\$44.50**

#### EXCLUSIVE **knight-kit** **MONEY-BACK GUARANTEE**

Every KNIGHT-KIT meets or exceeds published specifications, or we refund your money.

ONLY **knight-kits** ARE  
**CONVENIENCE ENGINEERED**  
for easiest building—no previous electronic experience needed...

#### see over 50 other fine **knight-kits**... write for catalog

##### HI-FI KITS

Stereo Amplifiers  
Stereo Preamp  
Stereo Control  
Hi-Fi Tuners  
Hi-Fi Amplifiers  
Speaker Systems,  
and others

##### HOBBY KITS

Short-Wave Radios  
AC-DC Table Radios  
Clock-Radio  
Radio-Intercom  
Transistor Radios  
Electronic Lab Kits  
and many others

##### INSTRUMENT KITS

VTVM  
VOM's  
Tube Checkers  
Oscilloscopes  
Signal Tracer  
Audio Generator  
Sweep Generator  
Cap. Checker  
R/C Tester, etc.  
**HAM KITS**  
Receiver  
Transmitter  
VFO, etc.

EASY TERMS ON ORDERS AS LOW AS \$20

### 1959 ALLIED **FREE** CATALOG

Send for this value-packed catalog featuring the complete KNIGHT-KIT line, as well as the world's largest stocks of everything in Electronics.

WRITE FOR YOUR COPY TODAY



## ALLIED RADIO Dept. 19-G9

100 N. Western Ave., Chicago 80, Ill.

- Ship Model Y-773 Knight-Kit Stereo Amplifier. \$\_\_\_\_\_encl.  
 Send FREE ALLIED 1959 Catalog

Name \_\_\_\_\_  
Address \_\_\_\_\_  
City \_\_\_\_\_ Zone \_\_\_\_\_ State \_\_\_\_\_

$H^2 = A^2 + B^2$

**NOW Science**  
**shows you how to**  
**Learn by "EAR"**  
*ladies & gentlemen...*

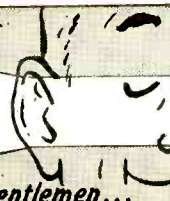

**NOW YOU CAN LEARN AWAKE AND ASLEEP**

Just think what it can mean to you in dollars and cents, confidence, success, fun to learn a language, speech, statistics, facts, figures, music, *anything—OVERNIGHT* . . . and learn it **FASTER—RETAIN IT BETTER.**

That's what *really* happens when scientifically proved Dormiphone "works" to train your memory for you awake and asleep . . . and what's more the Dormiphone not only puts your sleeping time to use, but helps you sleep more soundly as well. In addition, this amazing versatile instrument "plays" for you, too, provides fine entertainment with high quality reproduction of sound—both voice and music for your greater enjoyment.

Get the scientific evidence **TODAY.** Write, call for **FREE Book, FREE Demonstration.**

**MODERNOPHONE, INC.** Circle 7-0830  
**292-079 Radio City, N. Y. 20, N. Y.**

Gentlemen: Please send me your **FREE Book.** I am interested in learning more about the **DORMIPHONE** and what it can do for me. No obligation—no salesman will call.

NAME .....

ADDRESS .....

CITY ..... ZONE ..... STATE .....

My main interest in Dormiphonics is for:

<input type="checkbox"/> Language Learning	<input type="checkbox"/> Speech Improvement
<input type="checkbox"/> Memorization	<input type="checkbox"/> Sleep Inducement
<input type="checkbox"/> Habit Correction	<input type="checkbox"/> School or College Work



"... and the first one who finds it gets to keep it . . . the needle—The *Jensen* needle, that is."

**products**

*(Continued from page 34)*

when TV set is turned off. The unit adequately accommodates power requirements of television receivers with up to 24"

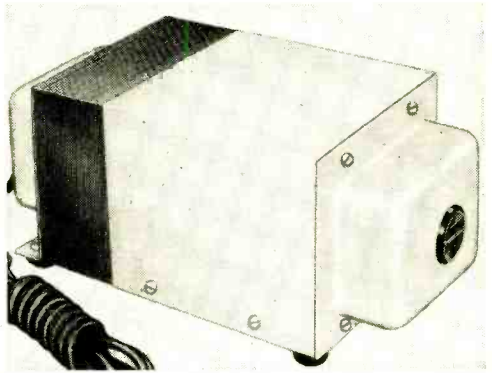

screens. \$45.85. (Acme Electric Corp., 391 Water St., Cuba, N. Y.)

**ELECTROSTATIC TWEETER**

A three-element electrostatic tweeter is being offered by *Lafayette Radio*, 165-08 Liberty Ave., Jamaica 33, N. Y. The tweeter provides smooth high frequency response from 5000 cycles to beyond 25,000 cycles. It has a built-in crossover network and a built-in power supply to provide the necessary high voltage for electro-

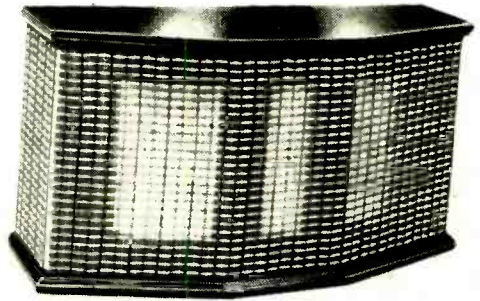

static speaker operation. Available in mahogany (SK-150), walnut (SK-151) and blonde (SK-152). \$27.50.

**STEREO RECORD CHANGER**

*United Audio*, 202 E. 19th St., New York 3, N. Y., has placed a professional four-speed record changer on the market. Unusual features of the Dual-1006 include a 5 1/4-lb. turntable and a built-in direct-reading pressure gauge. The one-piece tone arm employs a lock-key snap-in cartridge holder and double set of direct-acting

**New!**  
**YEARS AHEAD!**

# Lafayette STEREO TUNER KIT

**THE MOST  
FLEXIBLE TUNER  
EVER  
DESIGNED**

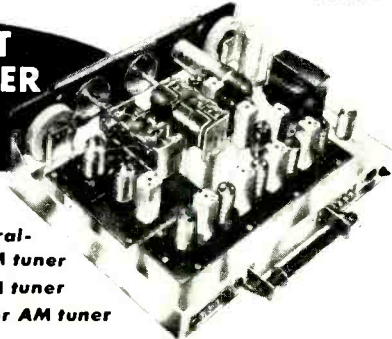

Use It as a Binaural-  
Stereophonic FM-AM tuner

Use It as a Dual-Monaural FM-AM tuner

Use It as a straight Monaural FM or AM tuner

- Multiplex Output for New Stereo FM
- 11 Tubes (including 4 dual-purpose) + Tuning Eye + Selenium rectifier Provide 17 Tube Performance
- 10KC Whistle Filter • Pre-aligned IF's
- Tuned Cascade FM • 12 Tuned Circuits
- Dual Cathode Follower Output
- Separately Tuned FM and AM Sections
- Armstrong Circuit with FM/AFC and AFC Defeat
- Dual Double-Tuned Transformer Coupled Limiters.

More than a year of research, planning and engineering went into the making of the Lafayette Stereo Tuner. Its unique flexibility permits the reception of binaural broadcasting (simultaneous transmission on both FM and AM), the independent operation of both the FM and AM sections at the same time, and the ordinary reception of either FM or AM. The AM and FM sections are separately tuned, each with a separate 3-gang tuning condenser, separate fly-wheel tuning and separate volume control for proper balancing when used for binaural programs. Simplified accurate knife-edge tuning is provided by magic eye which operates independently on FM and AM. Automatic frequency control "locks in" FM signal permanently. Aside from its unique flexibility, this is, above all else, a quality high-fidelity tuner incorporating features found exclusively in the highest priced tuners.

The 5 controls of the KT-500 are FM Volume, AM Volume, FM Tuning, AM Tuning and 5-position Function Selector Switch. Tastefully styled with gold-brass escutcheon having dark maroon background plus matching maroon knobs with gold inserts. The Lafayette Stereo Tuner was designed with the builder in mind. Two separate printed circuit boards make construction and wiring simple, even for such a complex unit. Complete kit includes all parts and metal cover, a step-by-step instruction manual, schematic and pictorial diagrams. Size is 13 3/4" W x 10 3/8" D x 4 1/2" H. Shpg. wt., 22 lbs.

The new Lafayette Model KT-500 Stereo FM-AM Tuner is a companion piece to the Models KT-600 Audio Control Center Kit and KT-310 Stereo Power Amplifier Kit.

**KT-500**.....Net **74.50**  
**LT-50** Same as above, completely factory wired and tested .....Net **124.50**

**KT-500 IN KIT FORM**  
**74.50** 7.45 7.00  
Down Monthly  
**LT-50 COMPLETELY WIRED 124.50**  
12.45 Down—10.00 Monthly

## NEW! LAFAYETTE PROFESSIONAL STEREO MASTER AUDIO CONTROL CENTER

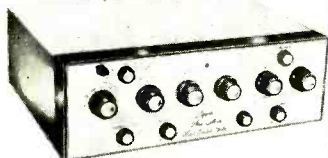

**KT-600 79.50**  
IN KIT FORM  
ONLY 7.95 DOWN  
-----  
**LA-600**  
COMPLETELY WIRED AND TESTED  
**134.50**

- Solves Every Stereo/Monaural Control Problem!**
- UNIQUE STEREO & MONAURAL CONTROL FEATURES
  - AMAZING NEW BRIDGE CIRCUITRY FOR VARIABLE 3d CHANNEL OUTPUT & CROSS-CHANNEL FEED
  - PRECISE "NULL" BALANCING SYSTEM

**A REVOLUTIONARY DEVELOPMENT IN STEREO HIGH FIDELITY.** Provides such unusual features as a Bridge Control, for variable cross-channel signal feed for elimination of "ping-pong" (exaggerated separation) effects and for 3d channel output volume control for 3-speaker stereo systems; 3d channel output also serves for mixing stereo to produce excellent monaural recordings. Also has full input mixing of monaural program sources, special "null" stereo balancing and calibrating system (better than meters), 24 equalization positions, all-concentric controls, rumble and scratch filters, loudness switch. Clutch type volume controls for balancing or as 1 Master Volume Control. Has channel reverse, electronic phasing, input level controls. Sensitivity 2.2 millivolts for 1 volt out. Dual low-impedance outputs (plate followers), 1300 ohms. Response 5-40,000 cps  $\pm$  1 db. less than .03% IM distortion. Uses 7 new 7025 low-noise dual triodes. Size 14" x 4 1/2" x 10 3/4". Shpg. wt., 16 lbs. Complete with printed circuit board, cage, profusely illustrated instructions, all necessary parts.

**LAFAYETTE KT-600** — Stereo Preamplifier kit ..... Net **79.50**  
**Lafayette LA-600** — Stereo Preamplifier, Wired..... Net **134.50**

## NEW! LAFAYETTE STEREO/MONAURAL 36-WATT BASIC AMPLIFIER



**KT-310**  
**47.50**  
IN KIT FORM  
ONLY  
**8.75 DOWN**

- 36-WATT STEREO AMPLIFIER
- 4 PREMIUM-TYPE 7189 OUTPUT TUBES
- RESPONSE 35-30,000 CPS  $\pm$  1/2 DB
- 18 WATTS PER STEREO CHANNEL OR 36 WATTS MONAURALLY
- 2 PRINTED CIRCUIT BOARDS FOR NEAT, EASY WIRING

A superbly-performing basic stereo amplifier, in easy-to-build kit form to save you lots of money and let you get into stereo now at minimum expensel Dual inputs, each provided with individual volume control. The unit may be used with a stereo preamplifier for 2 18-watt stereo channels, or at the flick of a switch, as a top-quality 36-watt monaural amplifier; or, if desired, it may be used as 2 separate monaural 18-watt amplifiers! **CONTROLS** include 2 input volume controls, channel reverse switch (AB-BA), monaural-stereo switch, **DUAL OUTPUT IMPEDANCES** are: 4, 8, 16 and 32 ohms (permitting paralleled monaural operation of 2 speaker systems of up to 16 ohms). **INPUT SENSITIVITY** is 0.45 volts per channel for full output. **TUBES** are 2-6AN8, 4-7189, GZ34 rectifier. **SIZE** is 9-3/16" d (10-9/16" with controls) x 5 1/2" h x 13 1/2" w. Supplied complete with perforated metal cage, all necessary parts and detailed instructions. Shpg. wt., 22 lbs.

**KT-310 Stereo Power Amplifier Kit** ..... Net **47.50**

*Lafayette Radio*

P. O. Box 511 JAMAICA 31, N. Y.  
DEPT. IG-9

CUT OUT  
AND PASTE  
ON POST  
CARD

Send FREE LAFAYETTE Catalog 590  
Name.....  
Address.....  
City..... Zone..... State.....

65-08 Liberty Ave. JAMAICA, N. Y. AXtel 1-7000

NEW YORK BOSTON BRONX NEWARK PLAINFIELD  
100 South Avenue 110 Federal St 542 E. Fordham Rd 24 Central Ave 139 W. Second St

The specs are the proof... now your  
BEST BUY in  
ham gear is

**EICO**®

New

**90-WATT CW TRANSMITTER . . #720**  
KIT \$79.95 WIRE \$119.95

Conservative, highly efficient design plus stability, safety, and excellent parts quality. 80 thru 40, 20, 15, 11, 10 meters (popular operating bands) with one knob band-switching. 6146 final amplifier for full "clean" 90 W input, protected by clamper tube. 6CL6 Colpitts oscillator, 6AQ5 clamper, 6AQ5 buffer-multiplier, GZ34 rectifier. "Novice limit" calibration on meter keeps novice inside FCC-required 75W limit. No shock hazard at key. Wide range, hi-efficiency pi-network matches antennas 50-1000 ohms, minimizes harmonics. EXT plate mod. terminals for AM phone modulation with 65W input. Excellent as basic exciter to drive a power amplifier stage to max. allowable input of 1KW. Very effective TVI suppression. Ingenious new "low silhouette" design for complete shielding and "living room" attractiveness. Conservatively rated parts, copper-plated chassis, ceramic switch insulation. 5" H, 15" W, 9 1/2" D.

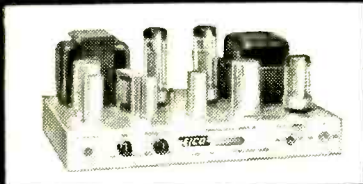

**NEW UNIVERSAL MODULATOR-DRIVER #730**  
KIT \$49.95 WIRE \$79.95 Cover E-5 \$4.50

Superb, truly versatile modulator at low cost. Can deliver 50 W of undistorted audio signal for phone operation, more than sufficient to modulate 100% EICO #720 CW transmitter or any xmitter whose RF amplifier has plate input power of up to 100W. Multi-match output xmttr matches most loads between 500-10,000 ohms. Unique over-modulation indicator permits easy monitoring, no need for plate meter. Lo-level speech clipping & filtering with peak speech freq. range circuitry. Low distortion feedback circuit, premium quality audio power pentodes, indirectly heated rectifier filament. Balance & bias adj. controls. Inputs for xtal or dynamic mikes, phone patch, etc. Excellent deluxe driver for high-power class B modulation; EC83/12AX7 speech ampl., 6AL5 speech clipper, 6AN8 ampl. driver, 2E134/6CA7 power output, EMBa over-mod. indicator, GZ34 rect. Finest quality, conservatively rated parts, copper-plated chassis. 6" H, 14" W, 8" D.

**NEW GRID DIP METER . . . . . #710**  
KIT \$29.95 WIRE \$49.95 including complete set of coils for full band coverage.

Exceptionally versatile. Basically a VFO with micro-ammeter in grid, determines freq. of other osc. or tuned circuits, sens. control & phone jack facilitate "zero beat" listening. Excellent absorption wave meter. Ham uses: pre-tuning & neutralizing xmitters, power indication, locating parasitic osc., antenna adj., correcting TVI, de-bugging with xmitter power off, determining C.T.Q. Servicing uses alignment of filters, IF's; as sig. or marker gen. Easy to hold & thumb-tune with 1 hand. Continuous 400 kc-250 mc coverage in 7 ranges, pre-wound 0.5% accurate coils. 500 uA meter movement, 6AF4(A) or 614 Colpitts osc. Xmttr-operated set, rect. 2 1/4" H, 2 1/2" W, 6 1/4" L. Satin deep-etched aluminum panel, grey wrinkle steel case.

**NOW IN STOCK!**

Compare & take them home—right off the shelf—from 1900 neighborhood EICO dealers. For free catalog mail coupon in EICO ad 2 pages forward. In the West, add 5%. Over 1 MILLION EICO instruments in use throughout the world.

33-00 Northern Blvd., Copr. © 1958.  
Long Island City 1, N.Y. Electronic Instr. Co., Inc.

**EICO**®

See EICO's other ad on page 40.

**products**

(Continued from page 36)

ball-bearings for both vertical and lateral axes, and will track records with as little as two grams stylus pressure. The changer

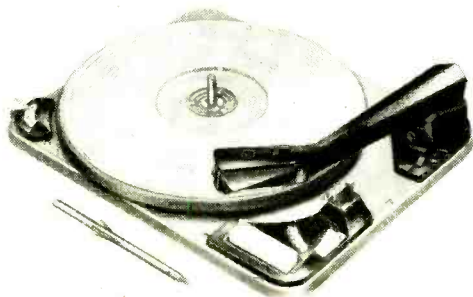

mechanism operates with any diameter record from 5" to 12" and intermixes ten records in any sequence. \$69.95.

**PHOTOELECTRIC UNIT**

A unique transistor-type photoelectric unit for all types of control functions has been developed by the Bartlett Co., 231 W. Superior St., Chicago, Ill. The 2" x 4" unit has a two-circuit relay and comes complete with relay, resistors, and capacitor chassis. For protection against air and

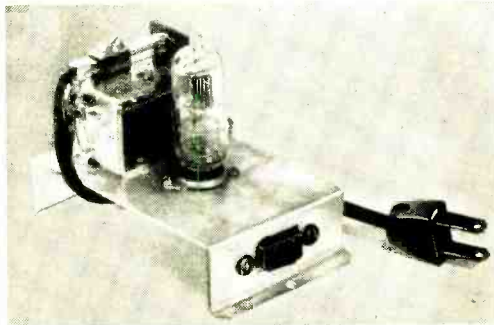

moisture, the photoelectric cell is hermetically sealed in a vacuum tube. Power-handling capacity, 1000 watts. \$9.95.

**MAGNETIC PICK-UP TOOL**

A handy magnetic gadget that can pick up loose screws, nuts, bolts, and the like is offered by Amertest Products Corp., 1280B Sheridan Ave., New York 56, N. Y. This magnetic pick-up tool is basically an Alnico magnet mounted at the end of a flexible 13" shaft. It's just the thing for retrieving loose parts from the innards of a crowded chassis. Price, \$1.00.

-30-

# BUILD 16 RADIO

## CIRCUITS AT HOME

with the New 1959  
PROGRESSIVE RADIO "EDU-KIT"®

ONLY  
\$22.95

### A Practical Home Radio Course

Now Includes

- ★ 12 RECEIVERS
- ★ TRANSMITTER
- ★ SIGNAL TRACER
- ★ SIGNAL INJECTOR
- ★ CODE OSCILLATOR

- ★ No Knowledge of Radio Necessary
- ★ No Additional Parts or Tools Needed
- ★ EXCELLENT BACKGROUND FOR TV
- ★ School Inquiries Invited
- ★ Sold in 79 Countries



Reg. U. S.  
Pat. Off.

### YOU DON'T HAVE TO SPEND

HUNDREDS OF DOLLARS FOR A RADIO COURSE

The "Edu-Kit" offers you an outstanding PRACTICAL HOME RADIO COURSE at a rock-bottom price. Our Kit is designed to train Radio & Electronics Technicians, making use of the most modern methods of home training. You will learn radio theory, construction practice and servicing. THIS IS A COMPLETE RADIO COURSE IN EVERY DETAIL.

You will learn how to build radios, using regular schematics; how to wire and solder in a professional manner; how to service radios. You will work with the standard type of punched metal chassis as well as the latest development of Printed Circuit chassis.

You will learn the basic principles of radio. You will construct, study and work with RF and AF amplifiers and oscillators, detectors, rectifiers, test equipment. You will learn and practice code, using the Progressive Code Oscillator. You will learn and practice trouble-shooting, using the Progressive Signal Tracer, Progressive Signal Injector, Progressive Dynamic Radio & Electronics Tester and the accompanying instructional material. You will receive training for the Novice, Technician and General Classes of F.C.C. Radio Amateur Licenses. You will build 16 Receiver, Transmitter, Code Oscillator, Signal Tracer and Signal Injector circuits, and learn how to operate them. You will receive an excellent background for television, Hi-Fi and Electronics.

Absolutely no previous knowledge of radio science is required. The "Edu-Kit" is the product of many years of teaching and engineering experience. The "Edu-Kit" will provide you with a basic education in Electronics and Radio, worth many times the complete price of \$22.95. The Signal Tracer alone is worth more than the price of the entire Kit.

### THE KIT FOR EVERYONE

You do not need the slightest background in radio or science. Whether you are interested in Radio & Electronics because you want an interesting hobby, a well paying business or a job with a future, you will find the "Edu-Kit" a worth-while investment. Many thousands of individuals of all

ages and backgrounds have successfully used the "Edu-Kit" in more than 79 countries of the world. The "Edu-Kit" has been carefully designed, step by step, so that you cannot make a mistake. The "Edu-Kit" allows you to teach yourself at your own rate. No instructor is necessary.

### PROGRESSIVE TEACHING METHOD

The Progressive Radio "Edu-Kit" is the foremost educational radio kit in the world, and is universally accepted as the standard in the field of electronics training. The "Edu-Kit" uses the modern educational principle of "Learn by Doing." Therefore you construct, learn schematics, study theory, practice trouble-shooting—all in a closely integrated program designed to provide an easily-learned, thorough and interesting background in radio.

You begin by examining the various radio parts of the "Edu-Kit." You then learn the function, theory and wiring of these parts. Then you build a simple radio. With this first set you will enjoy listening to regular broadcast stations, learn theory, practice testing and trouble-shooting. Then you build a more advanced radio, learn more advanced theory and techniques. Gradually, in a progressive manner, and at your own rate, you will find yourself constructing more advanced multi-tube radio circuits, and doing work like a professional Radio Technician.

Included in the "Edu-Kit" course are sixteen Receiver, Transmitter, Code Oscillator, Signal Tracer, and Signal Injector circuits. These are not unprofessional "breadboard" experiments, but genuine radio circuits, constructed by means of professional wiring and soldering on metal chassis, plus the new method of radio construction known as "Printed Circuitry." These circuits operate on your regular AC or DC house current.

### THE "EDU-KIT" IS COMPLETE

You will receive all parts and instructions necessary to build 16 different radio and electronics circuits, each guaranteed to operate. Our Kits contain tubes, tube sockets, variable electrolytic, mica, ceramic and paper dielectric condensers, resistors, tie strips, coils, hardware, tubing, punched metal chassis, Instruction Manuals, hook-up wire, solder, etc. in addition to F.C.C.-type Questions and Answers for Radio Amateur License training. You special tube sockets, hardware and instructions. You also receive a useful set of tools, a professional electric soldering iron, and a self-powered Dynamic Radio and Electronics Tester. The "Edu-Kit" also includes Code Instructions and the Progressive Code Oscillator. In addition to F.C.C.-type Questions and Answers for Radio Amateur License training. You will also receive lessons for servicing with the Progressive Signal Tracer and the Progressive Signal Injector, a High Fidelity Guide and a Quiz Book. You receive Membership in Radio-TV Club, Free Consulting Service, Certificate of Merit and Discount Privileges. You receive all parts, tools, instructions, etc. Everything is yours to keep.

### PRINTED CIRCUITRY

At no increase in price, the "Edu-Kit" now includes Printed Circuitry. You build a Printed Circuit Signal Injector, a unique servicing instrument that can detect many Radio and TV troubles. This revolutionary new technique of radio construction is now becoming popular in commercial radio and TV sets.

A Printed Circuit is a special insulated chassis on which has been deposited a conducting material which takes the place of wiring. The various parts are merely plugged in and soldered to terminals.

Printed Circuitry is the basis of modern Automation Electronics. A knowledge of this subject is a necessity today for anyone interested in Electronics.

### FREE EXTRAS

#### • SET OF TOOLS

- SOLDERING IRON
- ELECTRONICS TESTER
- PLIERS-CUTTERS
- ALIGNMENT TOOL
- WRENCH SET
- VALUABLE DISCOUNT CARD
- CERTIFICATE OF MERIT
- TESTER INSTRUCTION MANUAL
- HIGH FIDELITY GUIDE • QUIZZES
- TELEVISION BOOK • RADIO TROUBLESHOOTING
- MEMBERSHIP IN RADIO-TV CLUB: CONSULTATION SERVICE • FCC AMATEUR LICENSE TRAINING
- PRINTED CIRCUITRY

### SERVICING LESSONS

You will learn trouble-shooting and servicing in a progressive manner. You will practice repairs on the sets that you construct. You will learn symptoms and causes of trouble in home, portable and car radios. You will learn how to use the professional Signal Tracer, the unique Signal Injector and the dynamic Radio & Electronics Tester. While you are learning in this practical way, you will be able to do many a repair job for your friends and neighbors, and charge fees which will far exceed the price of the "Edu-Kit." Our Consultation Service will help you with any technical problems you may have.

J. Stataitis, of 25 Poplar Pl., Waterbury, Conn., writes: "I have repaired several sets for my friends, and made money. The "Edu-Kit" paid for itself. I was ready to spend \$240 for a Course, but I found your ad and sent for your Kit."

### FROM OUR MAIL BAG

Ben Valerio, P. O. Box 21, Magna, Utah: "The Edu-Kits are wonderful. Here I am sending you the questions and also the answers for them. I have been in Radio for the last seven years, but like to work with Radio Kits, and like to build Radio Testing Equipment. I enjoyed every minute I worked with the different Kits; the Signal Tracer works fine. Also like to let you know that I feel proud of becoming a member of your Radio-TV Club."

Robert L. Shuff, 1534 Monroe Ave., Huntington, W. Va.: "Thought I would drop you a few lines to say that I received my Edu-Kit, and was really amazed that such a bargain can be had at such a low price. I have already started repairing radios and phonographs. My friends were really surprised to see me get into the swing of it so quickly. The Troubleshooting Tester that comes with the Kit is really swell, and finds the trouble, if there is any to be found."

### UNCONDITIONAL MONEY-BACK GUARANTEE

#### ORDER DIRECT FROM AD—RECEIVE FREE BONUS

#### RESISTOR AND CONDENSER KITS WORTH \$7

- Send "Edu-Kit" postpaid. I enclose full payment of \$22.95.
- Send "Edu-Kit" C.O.D. I will pay \$22.95 plus postage.
- Rush me FREE descriptive literature concerning "Edu-Kit."

Name .....

Address .....

### PROGRESSIVE "EDU-KITS" INC.

1186 Broadway, Dept. 558D, Hewlett, N. Y.

the experts say  
**your BEST BUY**  
 is **EICO**...

EICO, 33-00 Northern Blvd., L. I. C. 1, N. Y. PE-7  
 Show me HOW TO SAVE 50% on 65 models of top-quality:

HI-FI  TEST INSTRUMENTS  "HAM" GEAR  
 Send FREE catalog & name of neighborhood EICO dealer.

NAME.....  
 ADDRESS.....  
 CITY..... ZONE..... STATE.....

ADD 5% IN THE WEST

...in  
**STEREO and MONO HI-FI**



**STEREO Dual Amplifier-Preamplifier HF81**  
 Kit \$68.95.  
 Wired \$109.95.  
 "Excellent!" —

**SATURDAY REVIEW: HI-FI MUSIC AT HOME.**



**STEREO Dual Preamplifier HF85**  
 Kit \$39.95.  
 Wired \$54.95.  
 "Extreme flexibility... a bargain!" — HI-FI REVIEW



**STEREO Dual Power Amplifier HF86**  
 Kit \$43.95.  
 Wired \$74.95.



**Mono Preamplifier HF65A:**  
 Kit \$29.95.  
 Wired \$44.95.  
 With Power Supply HF65:  
 Kit \$33.95. Wired \$49.95.



**Mono Power Amplifiers (60, 50, 35, 30, 22, 14-Watt; use 2 for Stereo) from Kit \$23.50. Wired \$41.50.**



**Mono Integrated Amplifiers: (50, 30, 20, 12-Watt; use 2 for Stereo) from Kit \$34.95. Wired \$57.95.**



**FM Tuner HFT90**  
 Kit \$39.95\*.  
 Wired \$65.95\*.  
 Cover \$3.95.  
 "One of the best buys you can get in high fidelity kits" — AUDIOCRAFT Kit Report.  
**AM Tuner HFT94**  
 Kit \$39.95. Wired \$65.95, incl. Cover & F.E.T.

\*Less Cover, F.E.T. incl.



**2-Way Bookshelf Speaker System HFS1** complete with factory-built cabinet: \$39.95.



**Omni-directional Speaker System HFS2** completely factory-built, \$139.95. 36" H, 15 1/4" W, 11 1/2" D. "Eminently musical" — HIGH FIDELITY. "Fine for Stereo" — MODERN HI-FI.

...and in  
**TEST INSTRUMENTS**



**New Power & Bias Supply for Transistorized Eqp., = 1020**  
 Kit \$19.95.  
 Wired \$27.95.



**New TUBE & CRT FIL. Tester = 612**  
 Kit \$3.95  
 Wired \$5.95  
 Fast-checks radio/TV tubes, pilot lamps, etc.



**RF Signal Generator = 324**  
 Kit \$26.95.  
 Wired \$39.95.



**Miniaturized Multi-Signal Tracer # 145A**  
 Kit \$19.95.  
 Wired \$28.95.



**1000 Ohms/Volt V-O-M = 536**  
 Kit \$12.90.  
 Wired \$14.90.



**Series/Parallel R-C Combination Box # 1140**  
 Kit \$13.95. Wired \$19.95  
 1350 Combinations!



**Vacuum Tube Voltmeter = 221**  
 Kit \$25.95.  
 Wired \$39.95.



**5" Push-Pull Scope = 425**  
 Kit \$44.95  
 Wired \$79.95.



**6V & 12V Battery Eliminator & Charger # 1050**  
 Kit \$29.95. Wired \$38.95.  
 Extra-filtered for transistor equip. # 1060  
 Kit \$38.95. Wired \$47.95



**Peak-to-Peak VTVM # 232 & Uni-Probe (pat. pend.)**  
 Kit \$29.95.  
 Wired \$49.95.



**Tube Tester # 625**  
 Kit \$34.95.  
 Wired \$49.95.



**R-C Bridge & R-C-L Comparator # 950B**  
 Kit \$19.95.  
 Wired \$29.95.

IN STOCK! Compare, take them home — right "off the shelf" — from 2000 neighborhood dealers. Over 1 MILLION EICO instruments in use throughout the world.

© 1969, ELECTRONIC INSTRUMENT CO., INC., 33-00 N. BLVD., L. I. C. 1, N. Y.

See Page 38 for EICO's BEST BUYS in "HAM" GEAR.



An aerial night photograph of a multi-lane freeway in Los Angeles, California. The freeway is illuminated by streetlights, and a helicopter is flying above it. The helicopter has "KABC" written on its side. The background shows the city lights of Los Angeles.

**OPERATION**

**RADIO AIRWATCH**

By  
**MORRIS MOSES**

**Radio-equipped helicopter spots  
Los Angeles Freeway traffic snarls**

**C**HOCK-FULL of electronic and radio communication equipment, a colorful helicopter prowls above the traffic-congested freeway system in Los Angeles, California. The roving whirlybird seems to be everywhere at once, knows in an instant when safety is threatened below, and shares this knowledge with some three million harassed drivers faster than you can say, "turn off at the nearest intersection."

On call six days a week, 24 hours a day if need be, the trim \$50,000 Bell 47-H flies pilot Max Schumacher and newscaster Donn Reed 500 to 2500 feet above the jammed freeway system. Hovering at a standstill, or cruising at 80 miles per hour the "Operation Airwatch" team transmits reports on traffic conditions to Radio

The cockpit of the radio-equipped helicopter is shown at left. Control box can be seen mounted between two portable receivers. The standby "Handie-Talkie" is kept on the seat. At right is photo of pilot Max Schumacher and announcer Donn Reed on the job.



Station KABC which re-transmits these messages on its regular assigned frequency, 790 kc. The driving public keeps its auto radios tuned to KABC for the latest traffic information.

Once Max and Donn spotted a little girl innocently playing with a ball right in the middle of whizzing traffic on the Los Angeles Harbor Freeway. Donn got on the air in about two seconds, and blurted out a warning to the Harbor Freeway traffic. Minutes later, police arrived and bundled the little girl off to their lost-and-found department.

**Ingenious Equipment.** Engineers and technicians at KABC wanted a minimum of controls and switches on the 'copter. Simplicity, economy, and reliability were the technical watchwords. Even though most of the equipment is of commercial origin,

there is a feeling of radio ham ingenuity and even "homemade" simplicity about the installation.

The link between the 'copter and Station KABC is a commercial General Electric 15-watt FM transmitter and receiver. Units are identical at both the fixed and mobile stations, with the exception of power supplies. The base station is a.c.-powered and the equipment on the 'copter is powered from its 24-volt d.c. supply. The receiver is a G.E. superheterodyne using a triple-conversion circuit, with each converter employing a separate crystal-controlled oscillator.

**Air Rescues.** Police radio calls are monitored with the aid of a converted RCA transistorized broadcast receiver. In between routine traffic guidance, the busy whirlybird has followed the police calls to



some very unusual air-rescue adventures.

When three teen-age boys and a rubber life raft were mixing it up with the Los Angeles River, pilot Max swooped down on the youths and helped push them ashore with a blast from the whirlybird's rotors. Meanwhile announcer Donn gave the radio audience below a spray-by-spray description of the rescue.

Other aircraft and landing field towers are contacted with a Lear 108-128 mc. transceiver mounted on the instrument panel. Pilot Max keeps an "ear" on this (as well as on the police call channel), leaving newscaster Donn free to study developments on the complex highway panorama stretching below. Chats with passing aircraft often help the Airwatch crew learn about urgent traffic situations not immediately within their vision.

**DX'ing Missouri.** Just in case the main equipment should fail, a battery-operated, crystal-controlled Motorola transceiver is always kept ready to go. This set puts out about 3 watts at 26.19 mc. and can hold out for about 40 hours of normal operation. The Motorola was the original set used by the Airwatch, and by some freak of transmission is often picked up by Radio Station KFRU in Columbia, Missouri. "We have a regular ritual here . . . of listening to the Los Angeles Freeway helicopter reports" . . . wrote KFRU.

Once the G.E. equipment "konked out." On went "Mickey-Mouse" (pilot Max's

name for the Motorola transceiver), and just in time; a serious freeway collision had occurred involving an immense truck-trailer and four cars. Traffic started backing up for miles. Newscaster Donn recalls: "Five minutes after I radioed alternate routes, the freeway was so clear of traffic you could have fired a cannon ball down it and not hit a car."

Cruising at about 80 mph one afternoon on a routine freeway report "mission," the radio 'copter saw the first few wisps of suspicious-looking smoke. Where there's that kind of smoke at that hour in Los Angeles, there's probably a fire. There was; at a codeine factory. Airwatch reported to the KABC base at 3:50 P.M. The station called the Fire Department. The fire was snuffed out at 4:15.

**Following the Cars.** On weekends the radio watchbird follows seashore-bound motorists to California's jammed beaches. Motorists are given weather reports, visibility estimates, water and air temperatures, and advice on parking problems. At baseball games the 'copter is always welcome, since traffic is particularly heavy.

How does the average driver feel about Operation Airwatch? Well, when Max and Donn asked the drivers to turn on their lights one evening, the bumper-to-bumper caravan responded wholeheartedly. Result: the whole freeway system was lit up like a fantastic Christmas tree. And that's a lot of watts.



## **Recent Developments**

### **in BATTERY DESIGN**

**T**WO SOLDIERS at a front-line observation post crouch behind a strange-looking device that looks like a spotlight. As they wait in the darkness, instead of straining their eyes to discern enemy movements, their attention is riveted to the spotlight-like device. Capable of spotting a single enemy soldier a half-mile away in total darkness, this is the Army's new "Silent Sentry" mobile radar set.

Under battle conditions quiet operation of the Silent Sentry could be a matter of life or death; therefore, a noiseless source of power for the unit is essential. Obvious-

ly, here is a job tailor-made for batteries. But which type should be used? Of a whole parade of new batteries, the Army has chosen one of the newest—the little-known fuel cell—to power the Silent Sentry.

The fuel cell is only one of the new battery types which are today proving their worth. Already on the commercial market are the tiny, power-packed mercury cell and the rechargeable nickel-cadmium battery. Before long, the fuel cell, too, will be available to private citizens. And the most fascinating development in batteries—the amazing promethium cell which is powered

**Atomic batteries, fuel cells, and other new battery types hold great promise for the future**

By SAUNDER HARRIS, WINXL

by energy from the atom itself—is now being tested and refined in research laboratories in this country.

Let's examine these "wonder" batteries. First, since it's one of the newest, we'll take a look at the fuel cell, the power source of the Silent Sentry.

**Fuel Cell.** The most interesting characteristic of the fuel cell is that, unlike conventional batteries, it never becomes exhausted. Since it produces electrical current from the electrochemical reaction which takes place when oxygen and hydrogen are combined, the fuel cell itself remains usable as long as the "fuel"—oxygen and hydrogen—is supplied.

Operation of the fuel cell is diagrammed in Fig. 1. Oxygen and hydrogen enter the cell through two hollow carbon electrodes. Since these electrodes are porous, the gases rapidly diffuse to the outer surface of the electrodes where they come into contact with the electrolyte, a solution of potassium hydroxide. The chemical reaction which takes place releases electrons from the hydrogen electrode which flow through the external circuit and are returned at the oxygen electrode. It is this flow of electrons which provides the electric

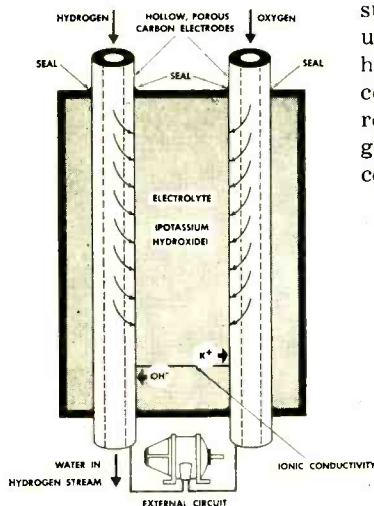

**Fig. 1.** Operation of the fuel cell. Electron flow from hydrogen electrode to oxygen electrode provides electric current.

**The scientist** who did much of the research on the fuel cell, Dr. Karl Kordesch, examines an electrode used in the cell.



**Nickel-cadmium** and mercury batteries such as these are already on the market.

current. Water, a by-product of the reaction, is passed from the cell in the hydrogen stream.

One fuel cell can produce only about one volt. Any required voltage may be attained, however, by simply connecting the cells together in series. As with ordinary dry cells, the amount of current which can be drawn from a fuel cell is a function of its physical size. Thus, by varying the number and size of the cells, many variations of voltage and current can be obtained. Fuel cells have been operating eight hours a day, five days a week, for over a year with no sign of deterioration.

It is very possible that the fuel cell will be the practical means of putting both nuclear energy and solar energy to use. At present, one of the big difficulties involved in using the energy of the sun is in storing its power for future use. Now, during the sunlight hours, the sun's energy could be used to decompose water, producing both hydrogen and oxygen for later use in fuel cells. In the same manner, where nuclear reactors are used as heat sources in steam generating plants, the nuclear energy decomposes water. Instead of this being a



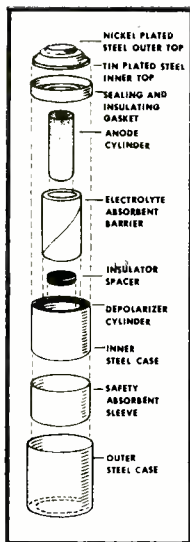

**Fig. 2.** Exploded view of mercury battery (courtesy National Carbon Company)

**Fig. 3.** Comparison of discharge curves of mercury cell and carbon-zinc cell. It is readily seen that the mercury cell enjoys a much longer useful service life.

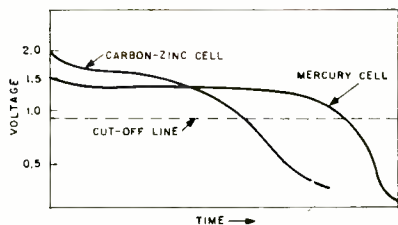

disadvantage, as it has been, this process can now be the means of producing the necessary hydrogen and oxygen for fuel cell operation.

**Mercury Batteries.** Wherever long life and lots of punch must be jammed into a small package, the mercury battery has come into wide use. This battery was developed primarily for hearing aids and other ultra-miniature equipment.

An exploded view of a typical mercury battery is shown in Fig. 2. The materials used in its construction are high-purity zinc powder for the anode, mercuric oxide and carbon for the cathode, and potassium hydroxide as the electrolyte. The mercury cell develops an open-circuit voltage of approximately 1.35 volts.

Figure 3 illustrates the difference in performance between the mercury cell and the standard carbon-zinc cell. It can be readily seen that the voltage of the mercury cell remains constant over a longer period of time than does the carbon-zinc cell.

For general use, the mercury battery is very expensive. The size "D" mercury battery (flashlight size) costs about \$2.50 as compared with a price of 20 cents for an

ordinary carbon-zinc "D" cell. This high cost is due to the expensive materials used in construction. Mercury batteries became financially practical only when devices such as hearing aids were designed to use them.

**Nickel-Cadmium Battery.** Along with other dry cells, the mercury battery suffers from one big disadvantage. It cannot be recharged. However, rechargeable nickel-cadmium batteries are just coming into popular use today in rechargeable flashlights, radios and electric razors. Tomorrow they may be used to power TV sets, portable electric drills, and perhaps even your car.

After conventional dry cells have been used awhile, the action of the cell is gradually choked off by a gas which is developed in the cell. In the nickel-cadmium battery, the recharging process converts this gas back into a liquid, thus reactivating the cell. Recharging is accomplished by plugging the battery unit into the house power line. Figure 4 shows a typical half-wave rectifying circuit used for this purpose. In

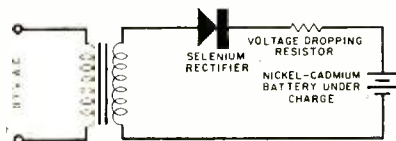

**Fig. 4.** Typical simple rectifier circuit employed to reactivate rechargeable batteries.

**Fig. 5.** Promethium cell composed of center layer of promethium and phosphor with outer layers made up of photocells.



most cases, the rectifier is built into the same unit as the battery.

Nickel-cadmium cells can't give you something for nothing, however. Rechargeable cells cost more, and give less energy per charge than an ordinary carbon-zinc cell. For example, a nickel-cadmium flashlight cell costs about \$2.75 as against 20 cents for a comparable carbon-zinc cell. But it can be charged over and over.

*(Continued on page 144)*

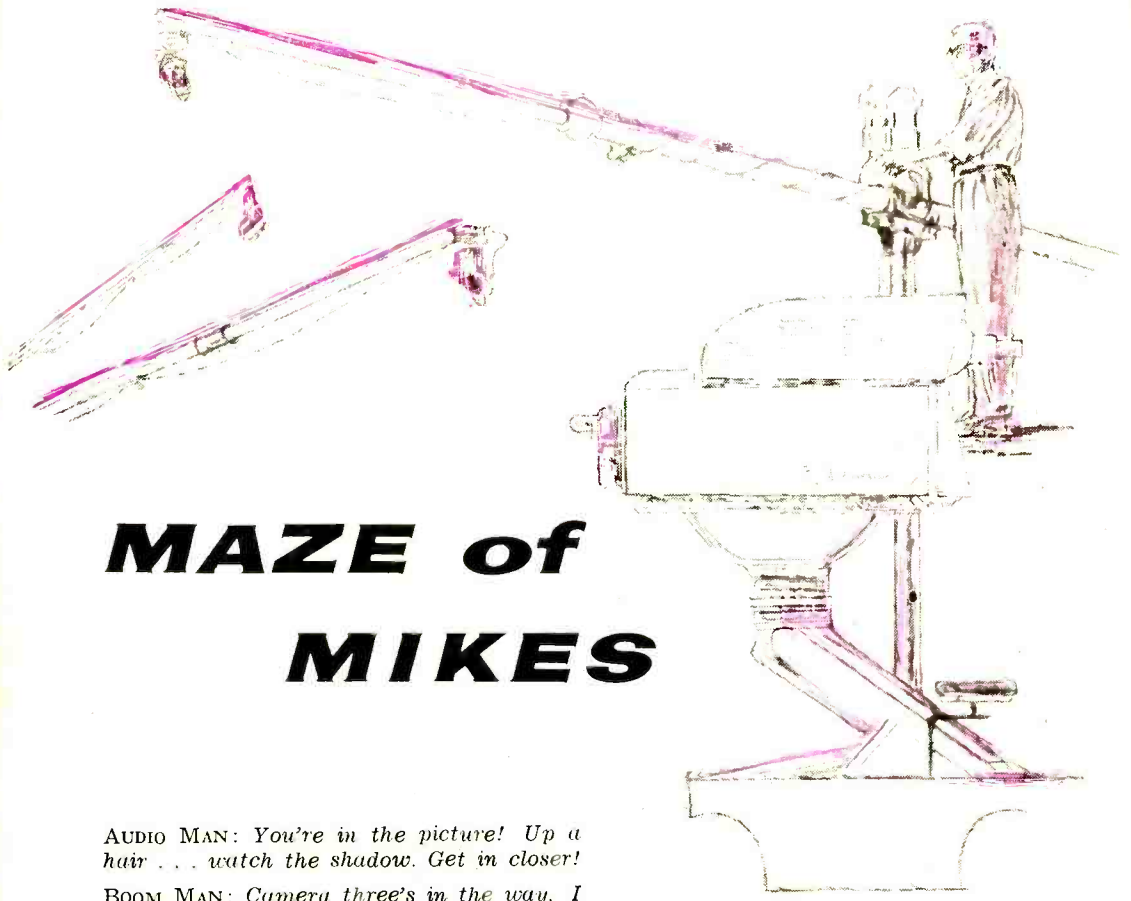

# MAZE of MIKES

AUDIO MAN: *You're in the picture! Up a hair . . . watch the shadow. Get in closer!*

BOOM MAN: *Camera three's in the way. I can't reach the performer!*

AUDIO MAN: *She has a thin voice. You've gotta get closer . . .*

*The low-down on  
television audio techniques*

**“OFF-STAGE”** DIALOGUE never goes out over the air, yet without it the audio portion of a TV show could not be up to network standards. For a behind-the-scenes picture of the audio aspects of television, let's take a look at the setup used by a typical show, "The Verdict Is Yours."

**Setting Them Up.** Although it is seen in the afternoon, "The Verdict Is Yours" is a video-taped show, and the week's programs start going on tape bright and early Monday morning.

After a hurried cup of coffee, the chief audio man calls together his aides. They head for the equipment locker where they select the audio paraphernalia, including no less than 15 microphones, several thousand feet of two-conductor shielded mike cable, and assorted head sets and intercom

**By ELLIOT GORDON**

devices. About an hour later, during which a continuous wave of shouting is heard—"Where do you want the judge?" . . . "How's the height of the witness?" . . . "I need a.c. for the monitor"—the setup is complete.

Since the producer has conceived the show as a simulated remote pickup, the audio man is called upon to duplicate the "off-mike" audio quality which is characteristic of an out-of-the-studio show. There is a paradox here. You might think that if an off-mike quality is called for, one mike in the center of all the activity would fill the bill. Not so. The number of microphones

used varies between 10 and 13, depending on the format of the show.

Boom microphones are employed only on the live commercial portions. Of the 13 mikes used for the show itself, four are RCA 77D's which are suspended from the ceiling. Others are on desks and floor stands

audio man's point of view, shows are planned for the most part without sufficient concern for the audio portion of the show; but he philosophically accepts his role as the orphan of the TV operation.

**Manning the Console.** The hub of all audio activity is the audio engineer's con-

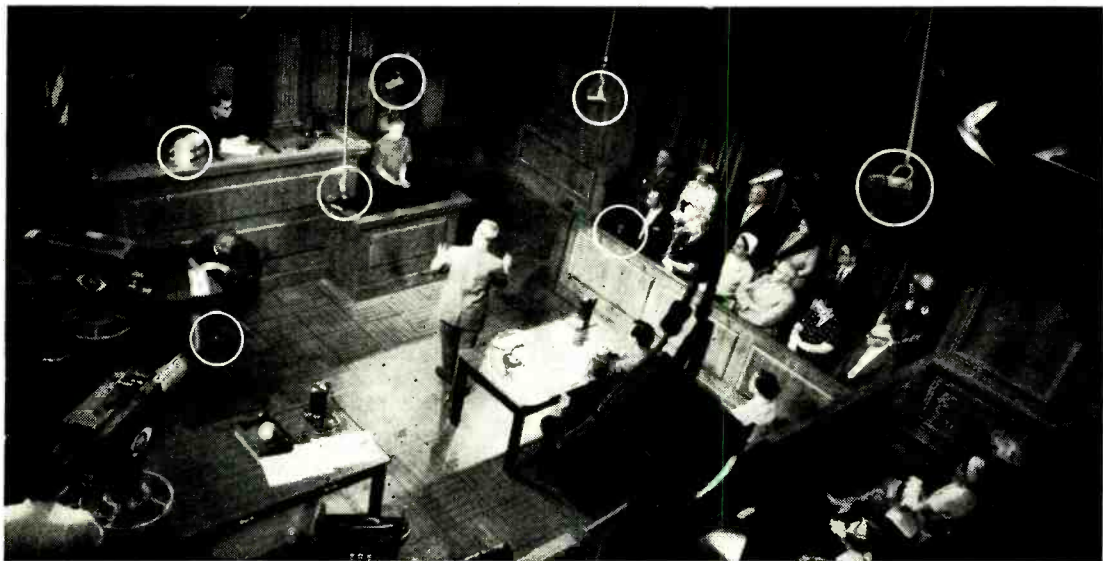

**Microphone setup** for "The Verdict Is Yours." Additional mikes are employed for commercials and for picking up audience reaction. (CBS photo)

or taped to the legs of desks. Where an omni-directional pickup is required, the Electro-Voice 655 is used. Happily, voice reproduction problems are less "sticky" than for a pickup of an orchestra.

All the overhead mikes must be adjusted every time the studio is reset (which happens every week to make way for other TV programs). The lighting director generally wages a running battle with the video man about levels of video in relation to the amount of needed light, while the audio man defends the honor of the boom man and his need to get the mike in close. Low-flying booms are a major cause of moving shadows while fixed mikes can cause fixed shadows; both of these effects are strenuously avoided.

Glancing at the photograph above, we can see that the mikes are placed to provide best possible coverage of the set. From the

sole. This sloping desk-type unit with the VU meter perched in its center is loaded with "pots," plugs, and a patchboard. Dangling out of the patchboard is what usually looks like a hopeless tangle of cables.

Basically, the audio console is a souped-up mixer which has eight volume controls and a master gain control. At any time, the audio man can ride gain on up to 12 or 14 mikes. If the show has an audience, additional mikes for picking up audience reaction are scattered throughout the studio. These mikes are also controlled by the audio console.

Just to add to the confusion at the console, sometimes a public address system is installed. Often the p.a. is controlled by the audio man, while at other times a separate console is operated by a p.a. man. And to compound the hubbub further, when you hear an actor or singer whose voice seems to have a haunting echo-like quality, you may be assured that the audio man is mixing in reverberation.

A major problem of all multi-miked shows is how to achieve optimum pickup





**First job** of the TV audio man is to organize his equipment. At left Charles "Doc" Dickson chooses the required lengths of mike cable.

**Good audio men** know their microphones backward and forward. Below "Doc" Dickson selects (left) and installs (right) typical microphone for upcoming TV show.

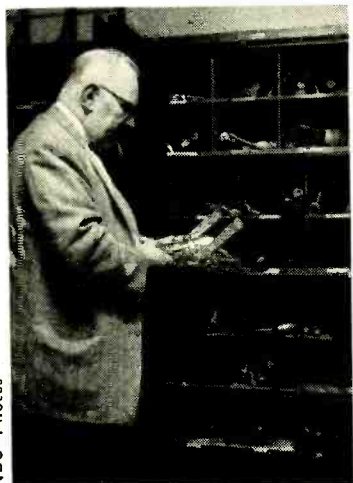
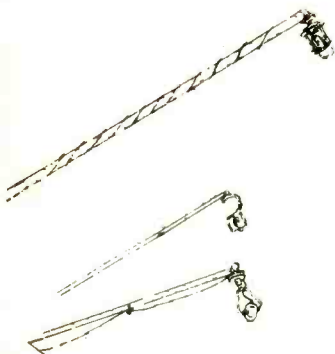

NBC Photos

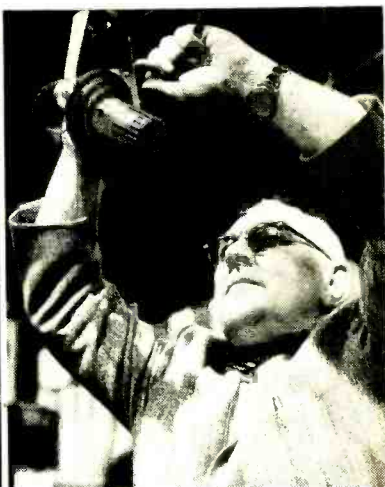

and a good signal-to-noise ratio. Since nothing is more irritating than an "open" mike picking up coughs, wheezes, and room noise, as few mikes as possible are left open. The noise problem is further compounded in "The Verdict Is Yours" by the great distances between the mikes and the performers.

Next time you're tuned to the show, watch the lawyer wandering from one side of the courtroom to the other preparing the witness for "the kill" and then, while still talking, make a mad rush forward. Unless you're in the control room, you won't see the audio man jumping from "pot" to "pot" on the audio console. But you'll be able to hear the results. If the audio levels stay reasonably even from performer to performer, you'll know the audio man is winning his frantic battle with actors and decibels.

-30-



**Audio console** is "brain" of the TV audio operation. As well as mixing and controlling the many mikes, it can also be used to add reverberation and other special effects to audio portion of show.

# Police Special

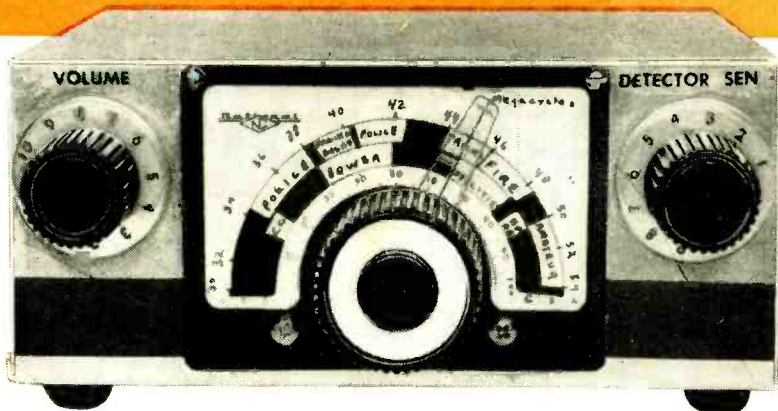

SOME of the most thrilling radio listening to be found today is in the 30-50 mc. v.h.f. Public Service Band. You can join police and fire department emergency crews at the scene of a crime or disaster, ride with the driver of a truck carrying high explosives, or speed through the streets with an ambulance driver as he races against time and death. These vital emergency broadcasts and the communications of other services spaced throughout these frequencies generate high-voltage excitement and a feeling of participation on the part of the listener that no other band can match.

Unfortunately, commercially manufactured receivers for this band are very costly, and are generally priced out of the reach of most experimenters. However, the "Police Special" offers the constructor a simple, low-cost means of hearing these vital services in action. The entire project should cost no more than \$15 to \$20, and an adequately stocked junk box will bring the cost down even further.

**Superior Performance.** Amazing as it may seem, the two-tube Police Special will give many a factory-made superhet a run for its money in the sensitivity, stability, versatility and frequency-coverage departments. The high gain of the receiver is produced by mating two well-known and respected circuits—the cascode r.f. amplifier and the superregenerative detector. Together, they develop as much gain as

**Compact 30-50 mc. tuner**

**picks up public service bands**

the "front-end" and i.f. strip of many conventional 30-50 mc. superhet receivers.

As a measure of the sensitivity of these stages, a 1-microvolt signal at the grid of the r.f. amplifier will produce a 30-db quieting in the normal "rush" of the superregenerator. In order to test its stability, the model was tuned to the local police communications channel, and left in operation for 18 hours; at the end of this time, the total measured frequency drift of the oscillating detector was *less* than 1500 cycles.

These features, coupled with the inherent automatic volume control and impulse noise-suppression characteristics, plus the detector's versatility in demodulating either FM or AM signals, make the Police Special suitable for dependable monitoring work by the SWL, experimenter and amateur.

**Construction.** Over-all construction of the receiver is straightforward. Some slight modification of the National vernier dial is necessary to allow proper mounting on the front wall of the LMB chassis box. However, this only amounts to trimming  $\frac{1}{16}$ " from the bottom of the drive-assembly, and does not affect the smooth operation of the dial at all.

# Receiver

By GEORGE J. WHALEN, K2B1E

Using the pictorials and photographs as a guide, lay out the mounting holes for the *Main-Tuning* dial, *Volume*, and *Sensitivity* controls on the front wall of the chassis box, and the antenna terminal strip (*TB1*), audio output connector (*J1*), and headphone jack (*J2*) on the rear wall.

Next, mount all power supply components in the bottom section of the chassis box. Power transformer *TL*, filter choke *CH1*, and selenium rectifier *SR1* are all mounted at the left rear of the box. Filter capacitor *C12* is located at the right front, next to the receiver subchassis. Use  $\frac{1}{2}$ " stand-offs and a metal mounting plate so as to ground the can properly. The power supply should then be wired as shown.

Length of leads in this section of the receiver is not critical, but they should be dressed carefully to prevent r.f. pickup. B-plus and filament power supply leads are brought out to a terminal strip near choke

*CH1*, for easy connection to the subchassis.

**Subchassis.** The major circuitry of the receiver is contained on a  $2\frac{1}{2}$ " x  $4\frac{3}{4}$ " subchassis, cut from thin sheet aluminum. It is prewired, then mounted vertically in-

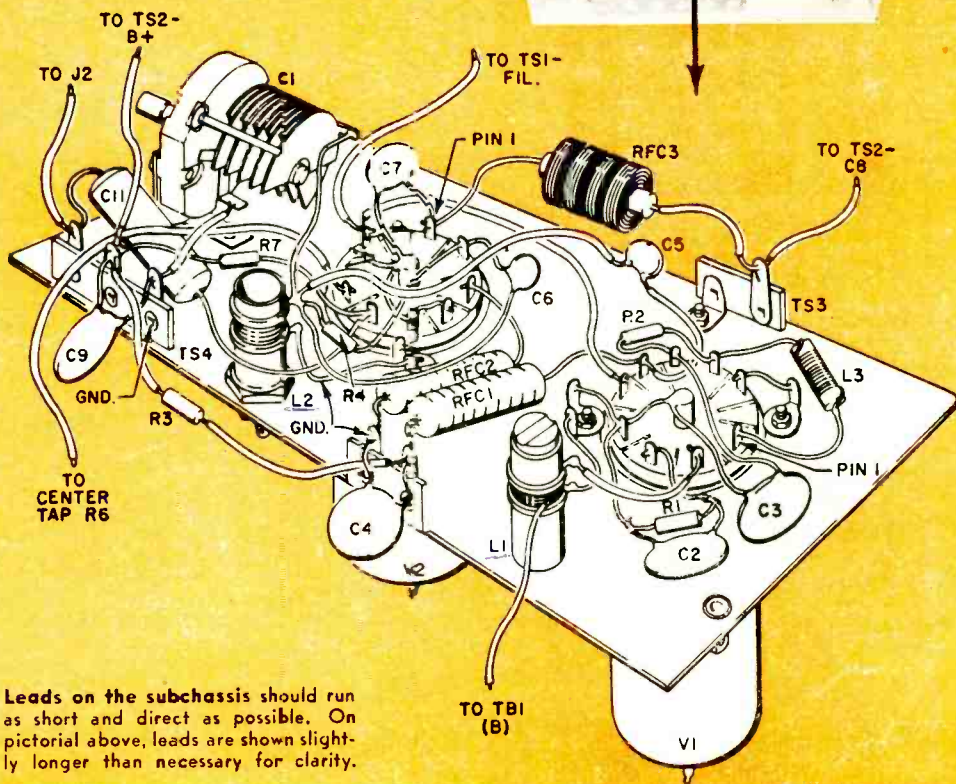
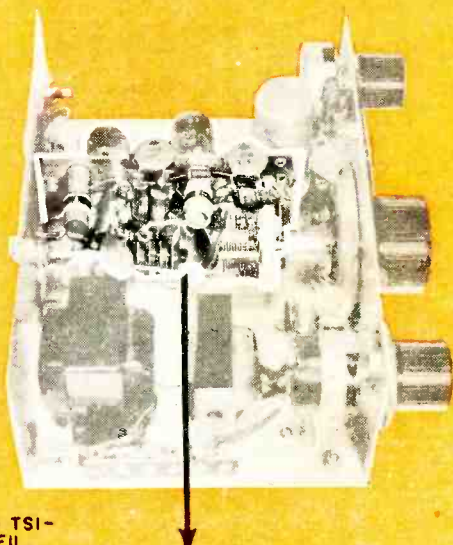

Leads on the subchassis should run as short and direct as possible. On pictorial above, leads are shown slightly longer than necessary for clarity.

side the box by three small right-angle brackets. This type of construction was chosen to give the receiver a "streamlined" modern appearance, so popular in the design of hi-fi equipment. Whether it is used by itself or as a tuner alongside your living-room hi-fi gear, the unit will not look out of place.

### PARTS LIST

- C1—3.3-17  $\mu$ fd. variable capacitor (Hammarlund HF-15 or E. F. Johnson 15J12)
- C2, C3, C4, C9—.005- $\mu$ fd. disc capacitor
- C7, C8—.001- $\mu$ fd. disc capacitor
- C5—3.3- $\mu$ fd. ceramic capacitor
- C6—22- $\mu$ fd. silver mica capacitor
- C10—.05- $\mu$ fd., 200-volt paper capacitor
- C11—.02- $\mu$ fd., 200-volt paper capacitor
- C12a/C12b—20/20- $\mu$ fd., 150-volt dual electrolytic can capacitor
- CH1—8-henry, 40-ma. choke
- J1—Panel-mounting microphone connector (Amphenol 75-PC1M)
- J2—Open-circuit phone jack
- L1, L2, L3—See text and coil winding diagram
- R1—30-ohm,  $\frac{1}{2}$ -watt resistor
- R2—470,000-ohm;  $\frac{1}{2}$ -watt resistor
- R3—220-ohm,  $\frac{1}{2}$ -watt resistor
- R4—2-megohm,  $\frac{1}{2}$ -watt resistor
- R5—50,000-ohm potentiometer (Sensitivity)
- R6—500,000-ohm potentiometer (with s.p.s.t. switch S1) (Volume)
- R7—5600-ohm,  $\frac{1}{2}$ -watt resistor
- R8—18,000-ohm, 1-watt resistor
- RFC1, RFC2—R.F. choke (Ohmite Z-50)
- RFC3—2.5-mh. choke (National R-50)
- S1—S.p.s.t. switch (on R6)
- SRI—65-ma. selenium rectifier
- T1—Power transformer; secondary 120 volts, 20-ma., 6.3 volts, .6 amp. (Thordarson 26R32 or Stancor PS-8415)
- TBI—Two-screw terminal tie strip
- TS1-4—Tie strips (see pictorials)
- V1—6BZ7 tube
- V2—12AT7 tube
- 1—7" x 5" x 3" chassis box (LMB 145)
- 1—Vernier dial (National MCN)
- 2—Knobs (National HRS-3)
- 1—2 $\frac{5}{8}$ " x 4 $\frac{3}{4}$ " aluminum plate for subchassis

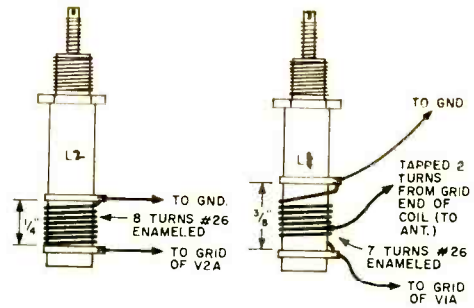

The coil forms used for L1 and L2 are Cambridge Thermionic  $\frac{3}{8}$ " ceramic slug-tuned units (Type LS-3).

Sockets for the 6BZ7 (V1) and 12AT7 (V2) tubes are mounted on the same center, spaced about  $1\frac{1}{2}$ " apart. The sockets should be positioned as shown so that short leads may be used for all connections.

Coils L1 and L2 are wound as shown on the coil diagram above. Coat the windings with Duco cement or a good-quality coil dope, and allow them to dry thoroughly before mounting. The  $\frac{1}{4}$ " mounting holes for the coils are positioned adjacent to the sockets for V1 and V2.

Next, attach C1 to the mounting bracket sold with it, and mark the position it will occupy on the subchassis with a grease

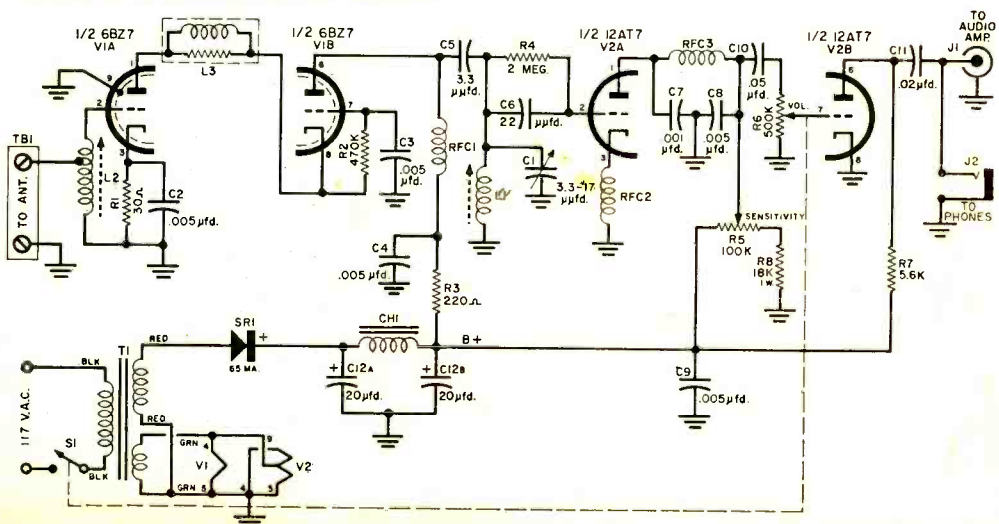

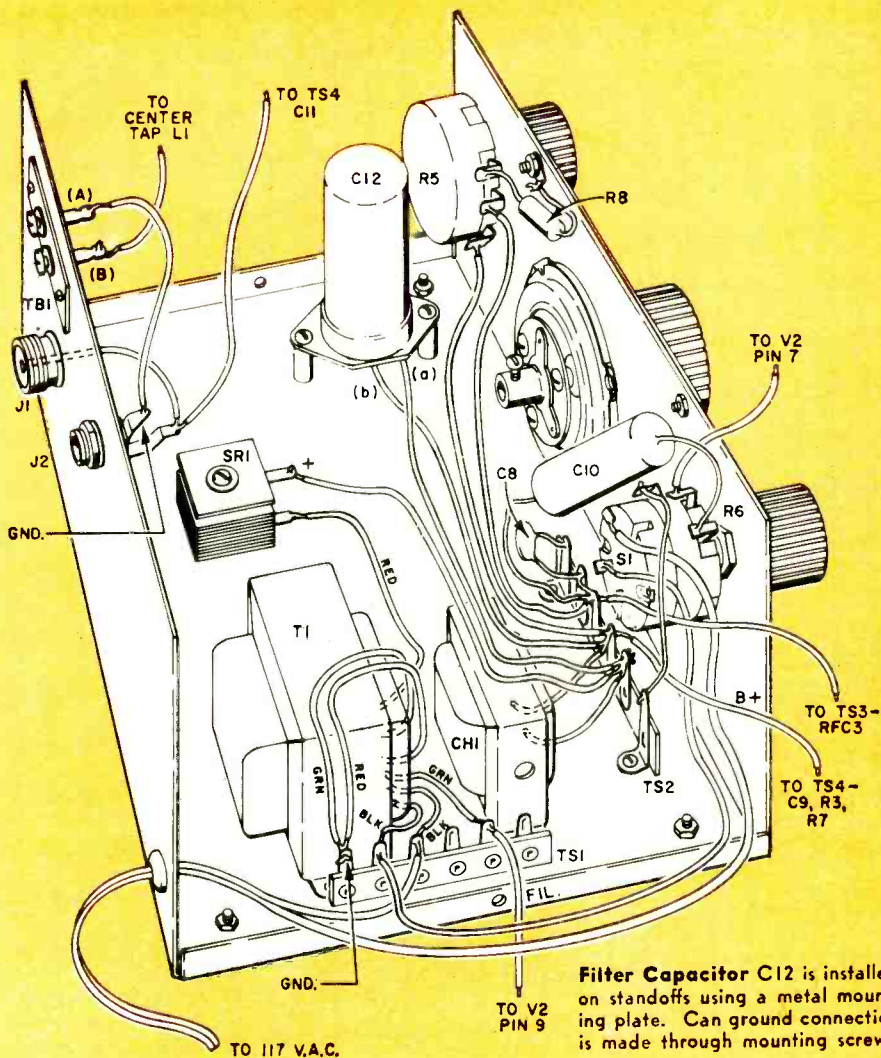

pencil or scribing tool. Do not mount *C1* until the other wiring has been completed.

To prevent interaction between the r.f. amplifier and detector, a separate ground point should be established for each stage. Ground the center post of each tube socket, and return all leads to be grounded within that stage to the center post. This results in shorter leads, and prevents r.f. "ground-loops," which could cause annoying squeals and heterodynes on the received signal.

When all wiring has been completed, mount and connect *C1*. Then slip the sub-chassis into place within the box and

mount it by the three right-angle brackets mentioned previously. Connect the sub-chassis to the B-plus and filament tie points, sensitivity and volume controls, output jacks, and antenna terminal strip.

**Checkout and Operation.** The final construction step in this (or any other) project, should be a careful step-by-step check of the wiring for errors and shorts. Remember that one solder-blob short could turn your Police Special into a collection of junk box spare parts.

If all wiring checks, plug a pair of high-  
(Continued on page 141)

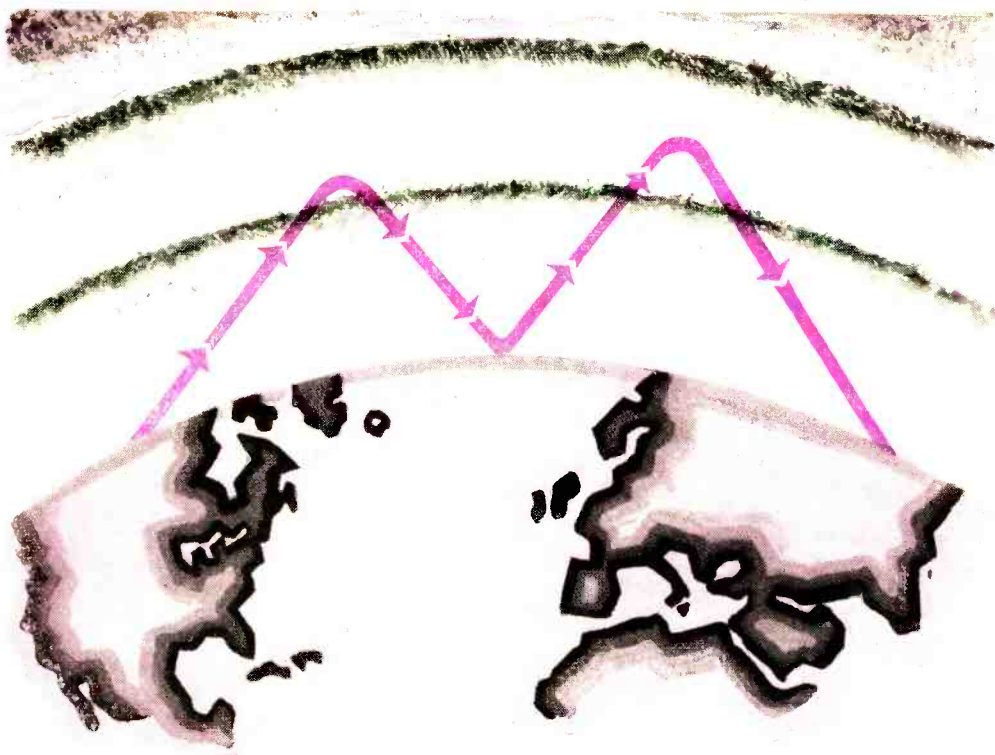

# The DX-O-GRAPH

*An easy-to-use signal strength estimator*

By C. F. ROCKEY, W9SCH

**O**F ALL the topics discussed when the hams get together, few command more interest than feats of long distance (DX) contact. As the fisherman extols the length of the "muskie" landed with light tackle, so the radio amateur brags of the "miles-per-watt" achievement of his station. However, the serious amateur experimenter longs for an objective yardstick with which to measure his success. The "DX-O-GRAPH" may provide him with such a measure.

The serious ham, too, likes to have some idea of how much a proposed increase in transmitter power will boost his signal strength in Europe or in some other distant spot. The DX-O-GRAPH is a practical aid for such estimates.

No claim is made that the DX-O-GRAPH supersedes the professional propagation

data now available at the higher scientific level. But when the amateur tries to use these elegant aids, the usual consequence is creeping frustration. Although the DX-O-GRAPH may cause dismay in the electronic elite, it will give useful answers to anyone with a small amount of patience.

The results predicted by the DX-O-GRAPH compare favorably with actual operating experience. Try it and see. All you need is a ruler and pencil.

**Using the Chart.** The DX-O-GRAPH is based upon the assumption that half-wave dipoles, or equivalent\* antennas, are used at both ends of the path, and that the transmitter plate power input and great-

\* Antennas with the same order of gain and directivity as the half-wave dipole, such as "ground plane" antennas, trap verticals, and "long wires" which are less than two wavelengths long.

circle distance between transmitter and receiver are known.

Here's how to use it:

1. Place the left end of a ruler on *Scale No. 1* on the mark corresponding to your final amplifier plate power input. If your input is slightly different from one of the marked values, split the difference as closely as you can.

2. Using the left end of the ruler (placed as above) as a pivot point, line up the ruler with the great-circle distance to the point of interest. This distance is marked off in thousands of miles on *Scale No. 2*.

3. Now, note where the ruler crosses the *Intermediate Scale* and, with a pencil, mark this point on the *Intermediate Scale*. Call this point of intersection *Point P*.

4. Next, remove the ruler from this position, and place its left end on *Point P*. Using *Point P* as a pivot point, place the ruler so that it passes through the point on *Scale No. 4* which represents the frequency you are working and the conditions influencing transmission.

If you are interested in checking up on a fellow ham's boast as to signal strength, give him the benefit of doubt and use the *Ideal Conditions* point (appropriate to the band used) on this scale. Thus, you can soon learn the magnitude of his imagination. The *Normal Conditions* points represent the best estimate for those who want to evaluate signal strength most typical of the usual "good DX conditions" on the band. *Poor Conditions* points represent

**Success of long-distance ham radio communications is predicted by the "DX-O-GRAPH."**

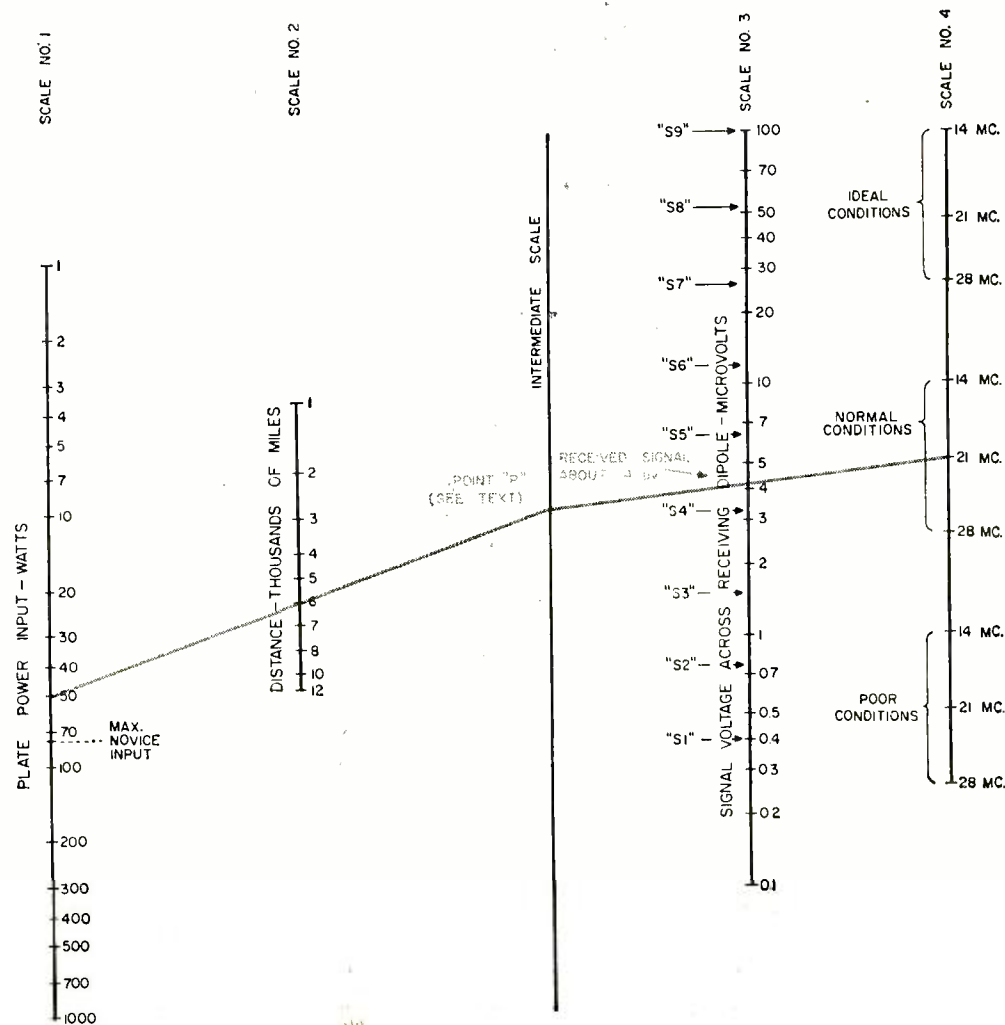

about the worst conditions under which amateur signals will get through at all, and are extremely conservative.

5. Finally, mark the point where the ruler intersects *Scale No. 3*. This point represents the received signal strength to be expected under the conditions assumed.

The received signal strength is expressed in terms of the voltage developed by the incident wave across the terminals of a half-wave dipole, or similar antenna, having an impedance of 50 ohms. This value is, in the writer's opinion, the best compromise between many common values. Of course, there will be some loss in the transmission line between the antenna and the receiver, but such losses may be neglected in a proper installation.

For antennas having a higher impedance, the received voltage will be slightly greater, but hardly enough to influence the results practically. When directive "beam" antennas are used on either end, greater signal voltage may also be observed. The chart can be considered valid for either vertical or horizontal antennas.

In addition to the amount of *signal voltage*, an "S-unit" scale is also provided on *Scale No. 3*. This is set up in accordance with the specifications of a well-known amateur receiver manufacturer. It is purposely conservative, but represents the writer's sincere opinion on this matter.

**Typical Example.** Consider an amateur radiotelegraph transmitter operating in the

21-mc. "15-meter" band and tuning 50 watts input. Let us assume that we are interested in the signal strength to be expected in Europe, which is about 6000 miles from an amateur located in the midwest.

We draw a line from the 50-watt point on *Scale No. 1* to the 6000-mile point on *Scale No. 2* and extend it to the *Intermediate Scale*, intersecting it at *Point P*. Moving our ruler now to bridge *Point P* with the point on *Scale No. 4* which represents operation under normal conditions on the 21-mc. band, we find that the signal strength to be expected across a receiving dipole in Europe will be about four microvolts.

This corresponds to a signal strength report of S4 to S5; and experience on the 21-mc. band near Chicago confirms this "forecast." The DX-O-GRAPH also tells us that signal strength reports of S6 to S7 may be expected under ideal conditions.

Incidentally, in compiling this chart, we assumed that only about 33% of the transmitter's power input appears as actual radiation. This figure is conservative and it is to be expected that a truly effective station will do better. It is, however, a realistic estimate of the efficiency of the typical amateur station.

**Distances and Watts.** Some interesting conclusions may be drawn from the study of this chart. One which should give heart to the younger, economically limited fellows is that high power is not essential to long-distance amateur communication.

A one-watt transmitter is readily audible, under good conditions, at a distance of 12,000 miles. Of course, the signal will be weak, but it will be there, and a skillful operator can receive it. On the other hand, with a thousand watts (all the U. S. law allows), you will receive about an S6 report at the same distance when simple antennas are used. Beam antennas will boost the signal strength, of course.

The DX-O-GRAPH will not be reliable for distances less than one thousand miles, or for frequency bands other than 14, 21, or 28 mc. And don't forget that no prediction system can account for noise at the receiving station, for interference, or for the attitude of the receiving operator.

If you get consistently better signal reports than this chart would indicate you should, don't blame the writer for being inaccurate; rather, slap yourself on the back. Your station is just more effective than average, you lucky guy!

-30-

#### Assumptions Made in Preparing the DX-O-GRAPH

1. The radio wave suffers no absorption except when passing through the ionosphere.

2. Antennas employed are omnidirectional, at least in the horizontal plane, and have the transmission and reception gains of the half-wave dipole.

3. Polarization effects do not enter into the calculations.

4. Terminal impedance of the receiving antenna is 50 ohms and is purely resistive. (Actual antennas commonly used have impedances of from about 30 to 300 ohms and are made resistive by their resonant condition.) It is assumed to be connected to a 50-ohm resistive load.

5. The ratio of the power actually radiated by the antenna divided by the d.c. plate power input to the stage feeding the antenna is assumed equal to 0.33, a value justified by the author's experience.

6. Power intercepted by a half-wave receiving dipole is inversely proportional to the square of the frequency. Of the power intercepted, half is re-radiated and half is available to a matched receiver or transmission line.

7. Ionosphere losses are as follows: ideal conditions, 0 db; average conditions for good communication, 10 db; poor conditions, 20 db. These are again based upon the author's observations.

8. Both transmitting and receiving antennas are "in the clear" and favorably situated for effective transmission and reception over the desired path.



# INSIDE the

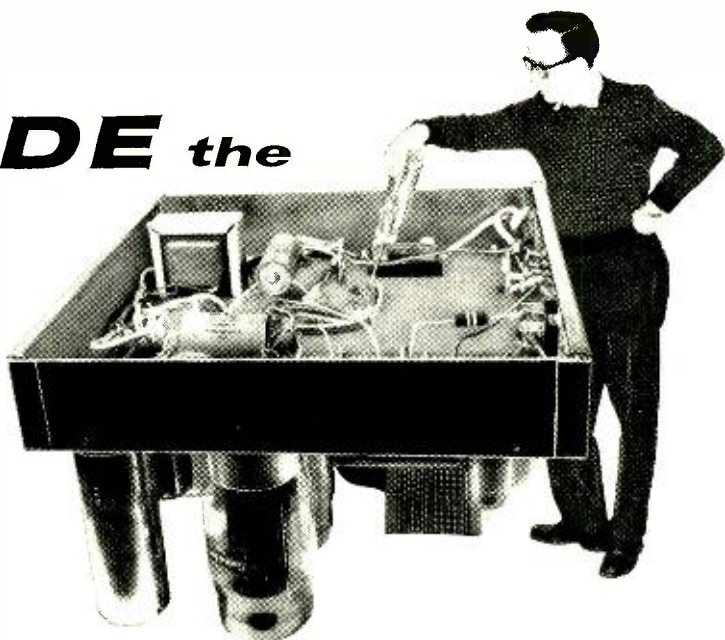

## POWER AMPLIFIER

### Part 1

By JOSEPH MARSHALL

**I**N PREVIOUS ARTICLES in this series we have discussed the functions performed by a hi-fi preamplifier. But when the preamp's job is done, what have we? Only a puny little signal that is rarely more than two volts, and more commonly in the neighborhood of one volt, and—most important of all—with no power behind it. If you feed this voltage to a speaker system, nothing will happen—no sound, no nothing. Clearly, we need another link in our hi-fi chain, a power amplifier.

The purpose of the power amplifier is to take the weak signal from the preamp and amplify it until it is powerful enough to drive a loudspeaker system to the loudness level of a symphony orchestra. And it must do this without changing the signal. The first part of this task is not too tough; it is the second part that enables audio engineers to make a comfortable living.

**Disappearing Watts.** The sound level of a symphony orchestra can be reproduced in the average living room with a power of about 0.5 acoustic watt. Unfortunately, however, loudspeakers are inefficient devices. It may take anywhere from 5 to 50 watts of audio power to drive some speakers to 0.5 acoustic watt, and as much as 100 audio watts to drive other speakers to

the level liked by some audio fans. At one time, 10-watt amplifiers were thought to be the "ultimate" in power, but with the introduction of several speakers with unusually low efficiencies, amplifiers of higher power have become quite popular.

Although the maximum output of an amplifier is usually rated at a frequency of 400 or 1000 cps, a hi-fi amplifier may have to deal with signals from 20 to 20,000 cps. Therefore, it should be able to deliver full output over the entire audio range. But it is a lot harder to deliver full output at 20 and 20,000 cps than it is at 400 or 1000 cycles. To get a flat response over the full range at 10 watts, we may need an amplifier rated at 15 or more watts.

Figure 1 shows the response curves of a typical low-priced amplifier at various power levels. Curve A is the response at a level of 1 watt, Curve B at 10 watts; and Curve C at the rated output of 15 watts. Note that the amplifier delivers 15 watts between about 60 and 10,000 cps, but it

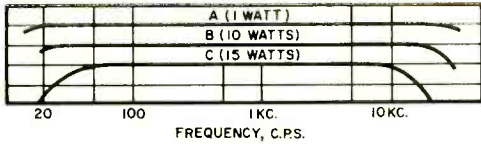
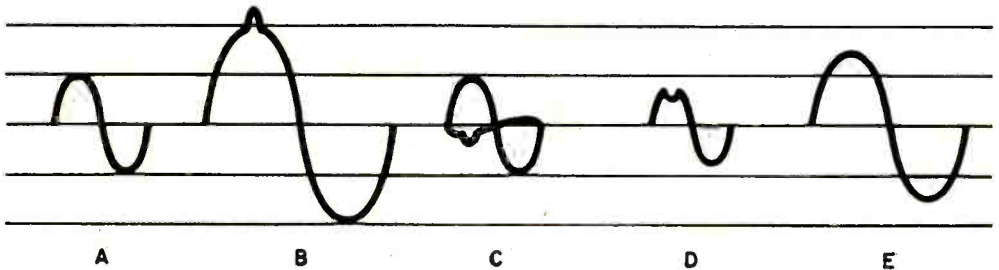

**Fig. 1.** Frequency response curves of typical low-priced amplifier show that response at high and low frequencies suffers at high power output levels.

delivers less than 15 watts at 20 and 20,000 cps. Therefore, although this amplifier can be honestly rated by the manufacturer as a 15-watt job (at 1000 cps), it does not function as a 15-watt amplifier at the extremes of the audio range.

**Negative Feedback.** Although the maximum output of hi-fi amplifiers is usually rated at the point where the distortion reaches 2%, it is generally agreed that amplifier distortion should not exceed 0.5% at any point in the audio range. Negative feedback is the major distortion-reduction tool of the audio designer.

The principle of negative feedback is



**Fig. 2.** Negative feedback reduces distortion. In (A) original signal is undistorted, but after passing through amplifier, it appears as (B), with a "pip" on top. Portion of output is fed back to input of amplifier out of phase with original signal (C), and resultant input signal is shown in (D). "Pre-distorting" the input signal allows resultant output (E) to follow original input signal accurately. Typical feedback circuit is shown below; feedback path is from plate of second tube to cathode of first tube.

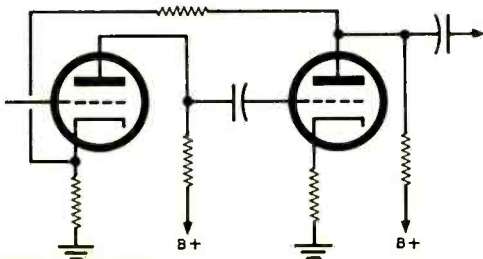

shown in Fig. 2. In Fig. 2(A) we have the original signal, pure and undistorted; but when it comes out of the amplifier as shown in Fig. 2(B), it has a peak or "pip" on it.

Now suppose we take a portion of the output signal and apply it to the input tube of the amplifier in parallel with the input signal, but exactly out of phase with it. See Fig. 2(C). Because the signal we feed back is in reverse phase, it will subtract from the input signal and reduce its amplitude. Clearly, it will reduce the amplitude more at the point where the peak in the feedback signal appears, and, in fact, will put a dip at the exact point where the amplifier puts a peak. The resultant signal at the grid of the input tube is shown in Fig. 2(D). When this signal goes through the amplifier, the peaking effect of the amplifier fills in the dip we have created, and the resulting output, shown in Fig. 2(E), although of lower amplitude than that of Fig. 2(B), is almost as pure as the input signal.

Thus, by "pre-distorting" the signal at the input, feedback compensates for the

distortion of the amplifier. Although it's never possible to eliminate distortion entirely, if we use enough feedback we can come very close to it. For example, we can take an amplifier that delivers 15 watts with 2.5% distortion and, by adding 20 db of feedback, we can theoretically reduce the distortion to 0.25%.

**Design Considerations.** Negative feedback is not miraculous. Like anything else, it has its limitations. The problem can be visualized by referring to Fig. 3.

At Curve A we have the response of an amplifier without feedback. Note the slopes at the two ends of the curve. One of the hard facts of hi-fi life is that where there is a slope there is also a phase shift. As we apply feedback to the ranges repre-

sented by the two slopes, the phase of the feedback is no longer exactly  $180^\circ$  out of phase, but is either slightly greater or less than  $180^\circ$ .

If we go far enough, or if the slope is steep enough, we come to a point where the feedback signal, rather than being out of phase, is actually *in* phase. When in-phase signals are fed back, we get a pair of peaks at the opposite ends of the audio spectrum, as indicated in Curve B. When such peaks are present, the amplifier is usually unstable and may be thrown into momentary

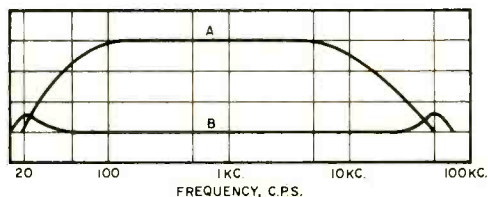

Fig. 3. Curve A above shows response curve of amplifier with no negative feedback. If feedback is used in an amplifier which has an inadequate frequency response, amplifier may become unstable, as indicated by Curve B.

or continuous oscillation at the frequencies where the peaks occur. We can avoid this by controlling the amount of feedback used in the circuit.

Obviously, the flatter the response of the amplifier before feedback is applied, the more stable the amplifier will be when we apply feedback. Therefore, the audio designer starts by designing the best possible circuit without feedback. In fact, almost any genuine hi-fi amplifier is flat at least over the audio range even without the feedback loop.

Now we undertake the problem of keeping the amplifier's response flat over a wide bandwidth. At the low end, a sloping response is the result of time constants in the circuit produced principally by the coupling capacitors between stages. The fewer the coupling capacitors, the fewer the time constants, and the less the slope. There are two ways to reduce the number of coupling capacitors: (1) by reducing the number of stages that have to be coupled; and (2) by direct coupling (no capacitors) between stages. Almost all modern power amplifiers employ a combination of these two methods.

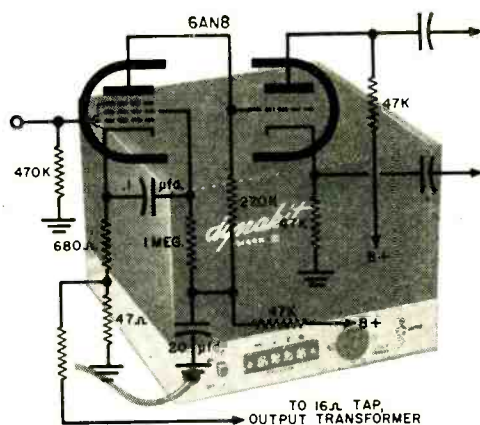

Fig. 4. Dyna "Mark III" power amplifier features a pentode voltage amplifier direct-coupled to a triode split-load inverter. Both functions are handled by one tube, a 6AN8.

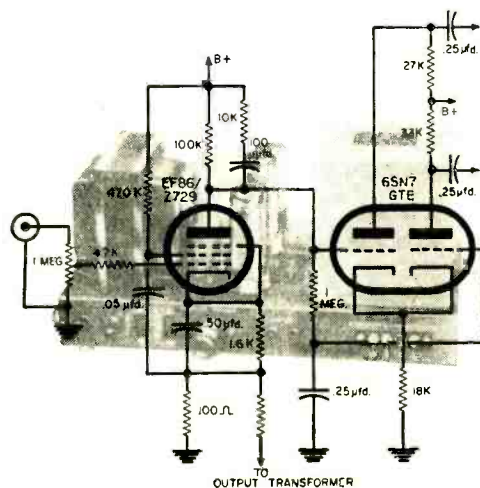
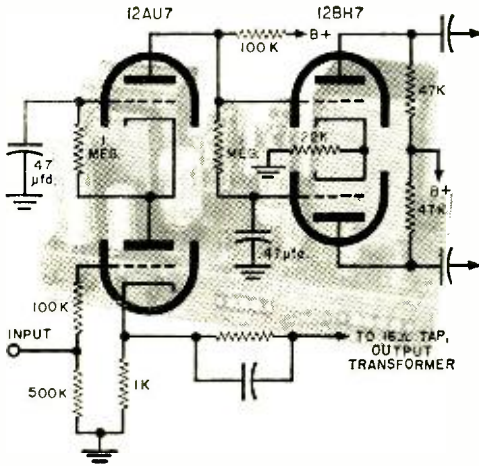

Fig. 5. Mullard circuit as employed in the Eico HF-60 uses a pentode voltage amplifier direct-coupled to a cathode-coupled inverter.

Excluding the output stage, the power amplifier usually has at least two stages: a phase inverter to convert the single-ended audio signal to push-pull (to feed the push-pull output stage); and a voltage amplifier stage. Most modern amplifiers employ a voltage amplifier directly coupled to the inverter (or vice versa) which is capacitor-coupled to the output stage. Thus, we have only one time constant to affect low frequency performance.

Two major causes of a sloping high end



**Fig. 6.** Grommes 250K utilizes a 12AU7 as cascode voltage amplifier followed by a 12BH7 cathode-coupled phase inverter.

**Fig. 7.** Acro "Ultra-Linear II" has a cathode-coupled inverter direct-coupled to push-pull triodes. This feature results in an "all push-pull" amplifier.

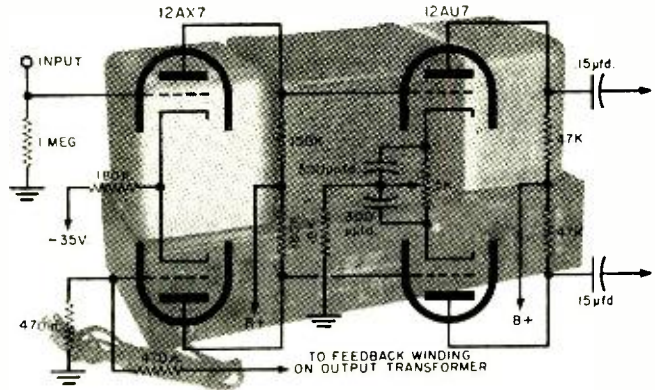

response in the front end of the power amplifier are: (1) the grid-to-plate capacitance of the tubes which acts as a bypass around the tube at high frequencies; and (2) capacitance from tube elements and wiring to ground. Obviously, the fewer the stages, the fewer the bypass points; hence, reducing the number of stages to a minimum helps the high end as well as the bottom end.

Problems of tube capacitances are minimized by using special miniature tubes designed for less capacitance than larger tubes and by using pentodes rather than triodes. Pentodes have very low capacitance and can provide response well above the audio range. As a result, a high proportion of modern amplifiers employ pentodes as voltage amplifiers.

**Phase Inverters.** Almost all commercial amplifiers today use either the split-load or the cathode-coupled inverter.

In the split-load inverter, the load is di-

vided evenly between plate and cathode. The output at the cathode is always 180° opposite in phase and equal to that at the plate; therefore, we have the necessary push-pull signal needed to drive a push-pull stage. This inverter is simple and inexpensive, it has low distortion, and with carefully matched plate and cathode resistors, it is capable of well-balanced output. The split-load inverter, however, provides no signal gain.

In the cathode-coupled inverter, a high-mu twin-triode is usually employed. The signal is fed to one triode which operates as a regular amplifier with a large cathode resistor. The other tube operates as a

grounded-grid amplifier, obtaining its input from the cathode of the first tube. Outputs from the plates of the two triodes are 180° out of phase, and thus, again, we have the needed push-pull signal to drive the output stage. This inverter can be designed for considerable gain.

**Typical Circuits.** A very successful circuit first used in the Dyna amplifiers is diagrammed in Fig. 4. Here we have a pentode as the input tube/voltage amplifier direct-coupled to a triode split-load inverter. Both the triode and the pentode are part of a single 6AN8 tube. The bandwidth of this circuit is very wide and has very small losses at both low and high frequencies. Given a good output transformer, it is no trick to obtain 20 or 30 db feedback with it. This circuit supplies the 30-55 volts of signal to drive the larger output tubes, such as the EL34, KT88, 6550, etc.

In lower powered amplifiers, a triode is  
(Continued on page 140)

# Build a Field Strength Meter for the Citizens Radio Service

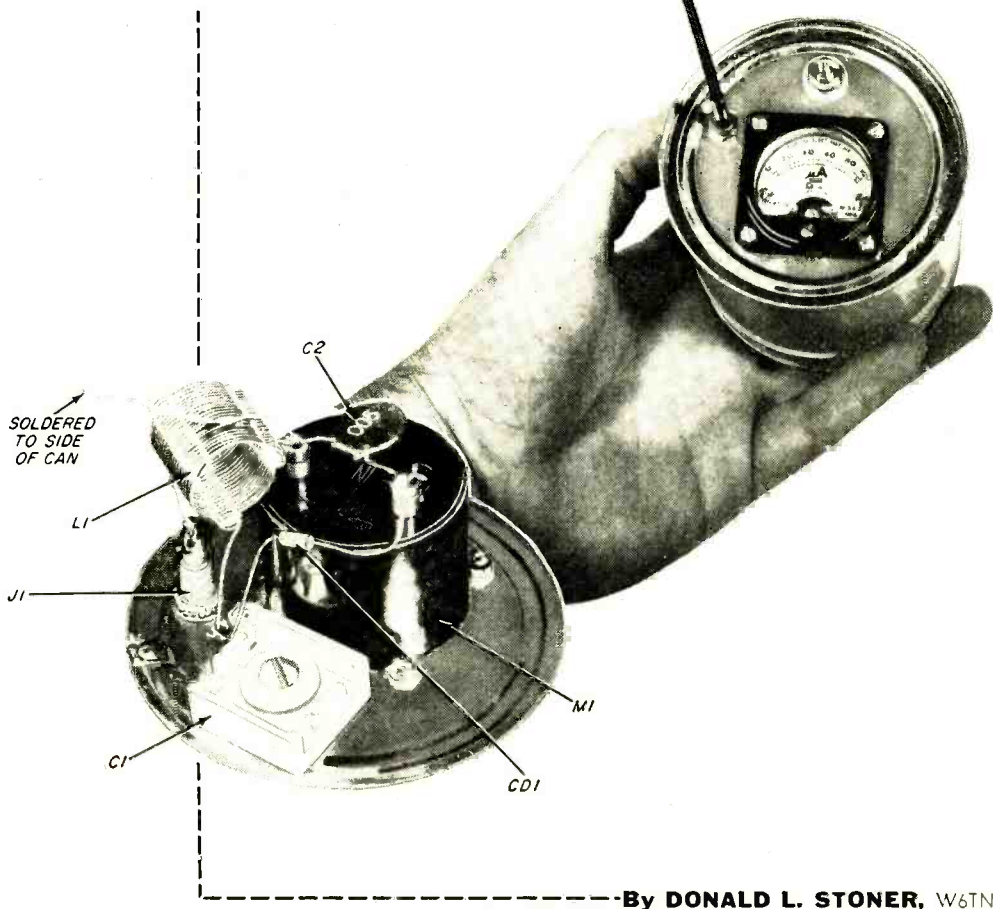

By DONALD L. STONER, W6TNS

**Y**OU can squeeze the last drop of power from your transmitter and antenna system with the help of this Citizens Band Class C and D field strength meter. By "peaking-up" the transmitter adjustments for the highest field strength meter reading, you can be sure that your Citizens Band station is working at top efficiency. The antenna length of the transceiver, which is usually critical, can be "trimmed" for the strongest signal.

The author's model was constructed in a discarded peanut can, but any suitable metal cabinet will serve. You can cut holes in the metal with a sharp jack knife, or drill them in the normal manner.

**Construction.** The meter (*M1*), sensitivity control (*C1*), and the antenna jack

(*J1*) are mounted on top on the "front panel" and are positioned to avoid ridges in the can. The relative positions of these components are not critical.

Coil *L1* is formed by counting off 20 turns and cutting off the remainder of the coil, making sure to leave about 1" of lead on each end. Prepare the coil for tapping by counting up 7½ turns from one end. Depress the turns on each side of the tap to prevent shorting the turns. Tin the tap point for connection later.

Ground one terminal of *C1* to the can. Connect one end of *L1* (closest to the tap) to the *ungrounded* terminal of *C1*. The other end of *L1* (furthest from the tap) is connected to *J1*. Connect the *unbanded* end of diode *CD1* to the *ungrounded* terminal of

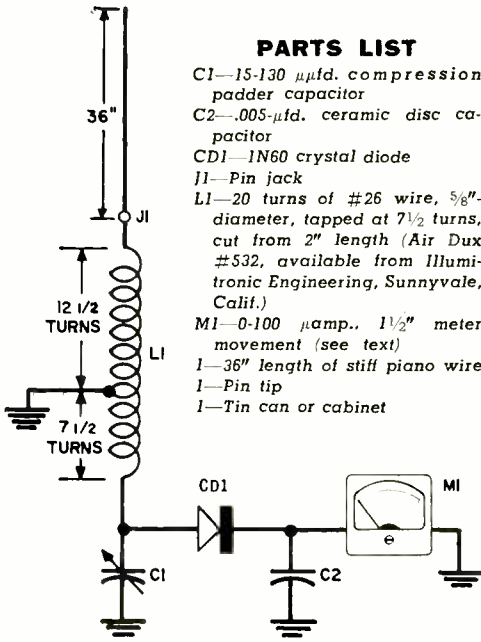

### PARTS LIST

- C1—15-130  $\mu$ fd. compression padder capacitor  
 C2—.005- $\mu$ fd. ceramic disc capacitor  
 CD1—1N60 crystal diode  
 J1—Pin jack  
 L1—20 turns of #26 wire, 5/8" diameter, tapped at 7 1/2 turns, cut from 2" length (Air Dux #532, available from Illuminonic Engineering, Sunnyvale, Calif.)  
 M1—0-100  $\mu$ amp., 1 1/2" meter movement (see text)  
 I—36" length of stiff piano wire  
 I—Pin tip  
 I—Tin can or cabinet

### HOW IT WORKS

The unit consists of a "loaded" whip antenna tuned to 27 mc. which feeds coil L1 and capacitor C1, tuned to the same frequency. R.f. energy from your Citizens Band transmitter appears across the tuned circuit and is rectified by crystal diode CD1. The rectified signal is filtered and used to actuate meter M1.

Note that when the instrument is hand-held, body capacity is added to the antenna system. To obtain accurate measurement, calibration and adjustment must always be made in the same way, i. e., if you operate the instrument hand-held at one time, it must be hand-held the next time. Or if it is calibrated on an insulated workbench, it should be operated on the bench.

The antenna consists of a 36" length of stiff piano wire (available at model shops) soldered to an earphone tip plug to fit J1.

**Sensitivity.** The sensitivity control will allow you to obtain a meter reading up close. By proper adjustment, you can obtain a meter indication as much as 100 feet away from the transceiver. If this sensitivity is not required, use a less sensitive (and expensive) meter than the 0-100  $\mu$ amp. unit specified. A 0-1 ma. meter will reduce the range to about 10 feet. Any odd-value meter movement can be employed whose sensitivity is within ranges specified as scale markings are not used. Tune for maximum swing of the meter needle. —30—

C1. Connect the banded end of CD1 to the plus terminal of M1. Then connect the .005- $\mu$ fd. capacitor (C2) across the meter terminals, and wire the remainder of the connections.

## Inexpensive Lock Switch



IT IS often necessary to add a lock switch to an electrical device to prevent its unauthorized use, but sometimes it is difficult to obtain such a switch. An inexpensive substitute can be made from a discarded five-pin tumbler lock of the type used on doors. These locks are of a much better quality than those in most com-

mercial lock switches and have the added advantage that as many keys as desired can be made by the local locksmith.

The switch itself may be almost any type of rotary switch, single or multiple position, snap action or spring return. Be certain that its capacity is large enough to carry the current being controlled.

Cut a slot in the shaft of the switch large enough to fit the small metal bar that protrudes from the rear of the lock. The lock should be mounted in such a manner as to make it difficult to get at the back and place a jumper across the switch. Cut a hole for the lock with a chassis punch, fly-cutter or brace and bit depending on the material. Mount the switch on a small metal bracket and position it so its shaft lines up with the metal bar.

—D. Derek Verner

By  
**HOWARD SHEPHERD**



**H**OUSED in a building nestled on a hill in East Los Angeles is the Radio Amateur Civil Emergency Service net control station at the Command and Information Center of Los Angeles County. The R.A.C.E.S. station has an air of quiet efficiency with row after row of transmitters and receivers. An adjacent room houses the Los Angeles County Sheriff's Department main transmitter and microwave control circuits.

Visitors to the station are usually impressed by the orderly and complete setup. However, the man whose name appears most often on its logs has never seen it. Twenty-nine-year-old Jerry Kunz, with ham license W6BVG, has been blind since birth.

Upon graduation from a technical high school in Los Angeles, Jerry enrolled in a radio amateur's class at the Braille Institute. Extensive study and hard work resulted in Jerry's obtaining the General radio operator's license that now hangs over one of the many transmitters which he operates.

Under the direction of Peter J. Pitchess, Sheriff of Los Angeles County, R.A.C.E.S. coordinates relays and originates broadcast information on a state-wide basis, as well as augmenting police and fire communications when needed. Among the hundreds of volunteers, Jerry Kunz is the only permanent operator.

Most visitors are astonished to see Jerry in action. As a message begins to come in, one hears the unmistakable clacking of Jerry's Braille typewriter, a gift donated by his friends. About the only interruption in Jerry's typing is his occasional pause to adjust the controls for better reception. He spends eight to ten hours a day, five days a week, at his desk, sending and receiving messages, taking them down in Braille, and then transcribing them on a regulation typewriter so his operations are not a mystery to the other personnel.

For all the service that Jerry performs, not only in a Civil Defense capacity, but for the Sheriff's Department as well, there is no compensation. This is because the position he holds is strictly on a voluntary basis. Jerry lives with his parents in Montebello, and they see that he gets to and from work. His subsistence is augmented by gifts from a few interested citizens.

"There are undoubtedly many other 'Jerrys' in ham radio," says Sheriff Pitchess, "but we are proud to have W6BVG with us at K6CPT."

-30-

## HAMMING in BRAILLE

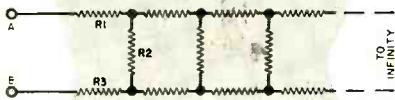

**1** Here is a tricky network consisting of one-ohm resistors with the ladder continuing out to infinity. Joe Homm computed the network's resistance at points A and B in five minutes. Can you?

—William Plummer

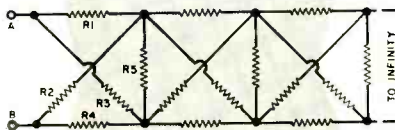

**2** Without stopping to rest, Joe went to work on *this* network of one-ohm resistors, and came up with the wrong answer. Can you do better?

—John Sankey

## Electronic Sticklers

(Answers on page 146)

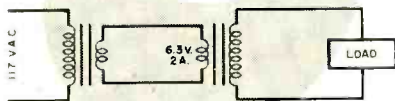

**3** Sam Aveapenny did not want to buy an isolation transformer, so he decided to hook up two filament transformers as shown above. He planned to use the transformers with a 200-watt load so he employed the formula:  $P = IE$ . Figuring that the voltage was about 120 volts, he arrived at:  $120x = 200$ ,  $x = 1.66$ . Since the transformers were rated at 2 amperes each, he went ahead with the job. To his surprise, the transformers burned out. Why?

—Stephen Lewis

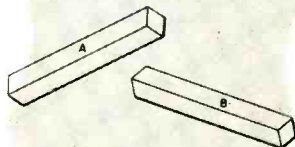

**4** Ted Ingot was locked in a magnetically shielded room with two small bars, A and B. One bar, he was told, was a magnet, the other made of soft iron. Using only the two bars, Ted had to find out which one was the magnet. Ted had no problem. Would you?

—Jim Banzhaf



**Builds a**

## **6-Meter Transmitter**

**Easy-to-wire LW Electronic Laboratory kit  
provides 50 watts input to final stage**

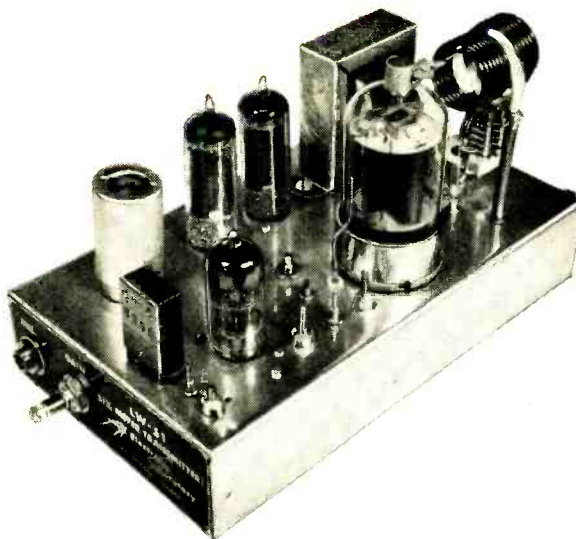

**T**HE RADIO WORLD above 50 megacycles is coming alive with ham talk on the six-meter band. For years many radio amateurs shied away from six-meter broadcasting because they believed that only line-of-sight transmission was possible. Old timers would drop the simple equation " $d$  (in miles) =  $1.33\sqrt{h}$  (feet)" into a discussion and state:

"If you get your antenna 100 feet ( $h$ ) in the air looking over a flat terrain, the maximum distance ( $d$ ) on the ground will be 13.3 miles. Heck, I could holler that far! Why should I build a six-meter rig?"

But these old-timers were in for some surprises. A few adventurers started working on six meters, and soon 700- to 1300-mile DX reports were pouring in. They were a bit slow at the start, but gradually grew to near avalanche proportions as more rigs went on the air.

To help hams get on the six-meter bandwagon, the LW Electronic Laboratory, Route 2, Jackson, Mich., offers a 50-watt 6-meter transmitter kit, Model LW-51. The chassis comes with all major components premounted, which cuts down assembly time to about four hours. Chassis lacing cord is provided for under-

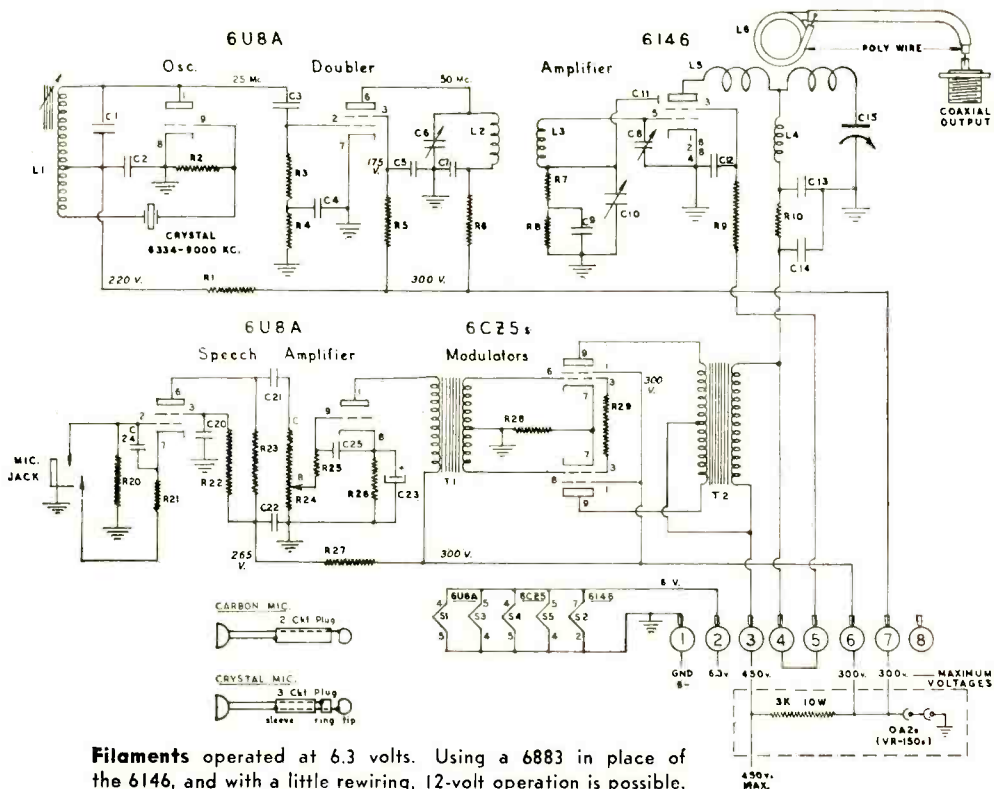

chassis cable lacing, resulting in an exceptionally neat layout.

**Features.** One half section of a 6U8A is used as a crystal oscillator with a tuned-frequency LC tripler circuit. The amplified tripler frequency output is supplied by the second half of the 6U8A, which is a frequency doubler. An LC circuit in the plate coupling is tuned to the fifth harmonic of the crystal fundamental. The doubler's output is coupled to the 6146 final r.f. amplifier stage, and the output of the 6146 is inductively coupled to the antenna coaxial output jack via a tuned-coupling circuit.

Either a crystal or carbon mike can be fed to the 6U8A speech amplifier, whose output drives two 6CZ5 modulators coupled to the plate circuit of the 6146.

An external power supply is required for the 450-volt plate voltage and 300-volt regulated screen voltage needed. Lower voltages could be used if desired. A 6.3-volt transformer rated at 3.5 amperes will take care of the filament requirements.

**Comment.** After completing the assembly, a careful half hour was spent aligning the transmitter. Results were good with local hams. So far, the best DX is 300 miles and we're optimistic.

The LW-51's small size and rated input make it just right for mobile installation. Why not get into the six-meter swim? The air waves are fine.

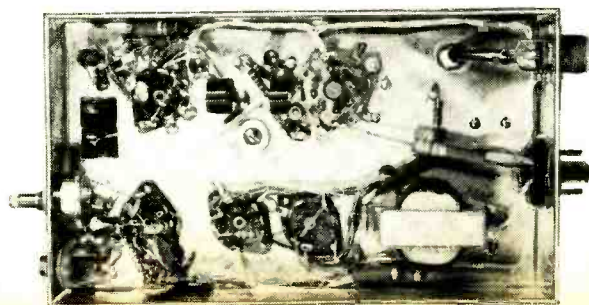

Well placed components and laced cables result in a neat underchassis layout. Check wiring for accuracy before lacing cables.

# MARINE ELECTRONICS for the Small Boat

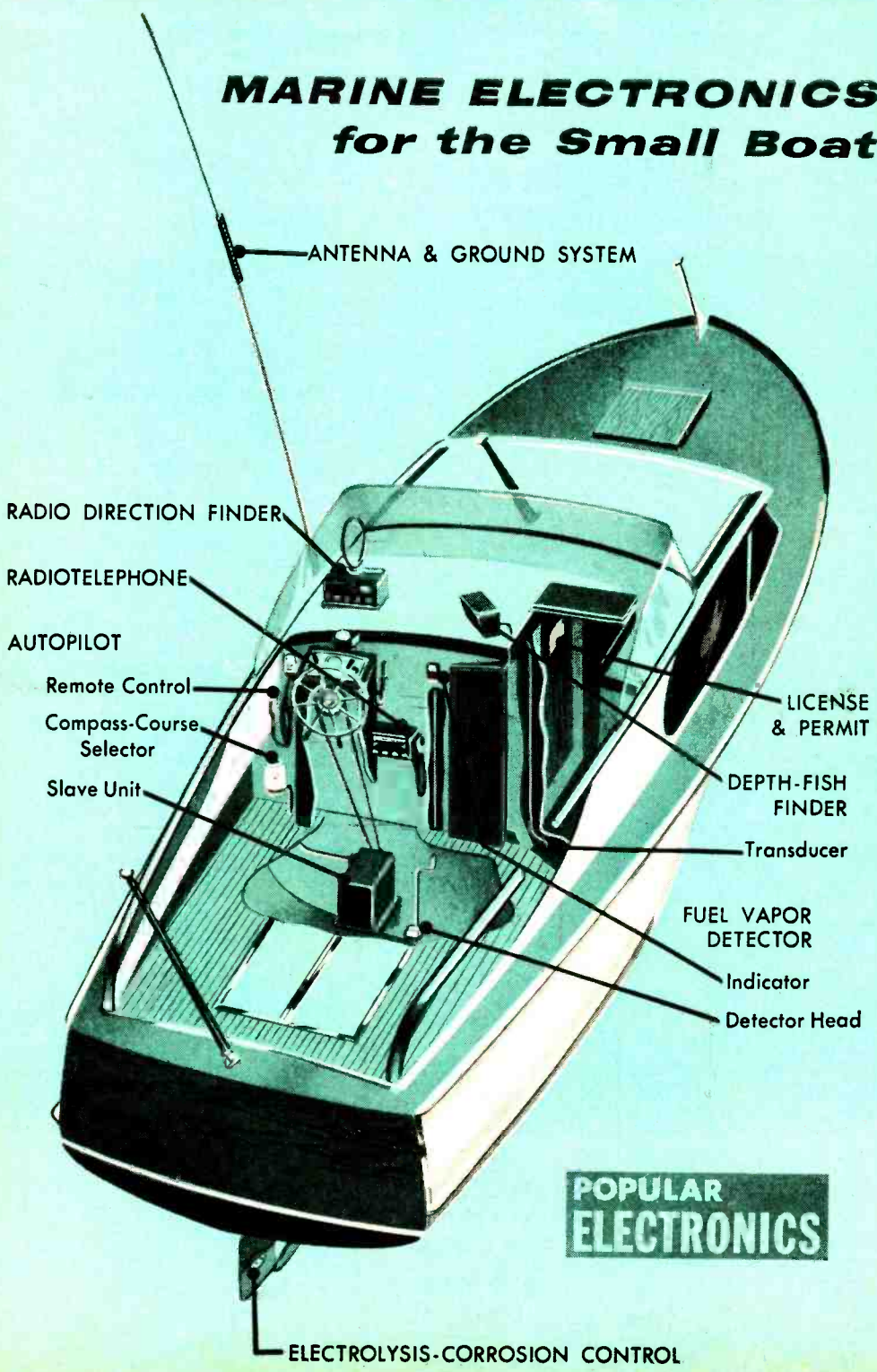

**POPULAR  
ELECTRONICS**



**Topics** for this special marine section being discussed by Wm. McKeown, Editor of POPULAR BOATING, and Oliver Read, Editor of POPULAR ELECTRONICS.

## **Electronics Afloat**

**O**UR modern electronic age is taking to the water. Today's boatman can multiply the pleasures of his sport with new products now available. Safety, comfort, and ease of operation are benefits electronic accessories can bring.

Every boat is suitable—no craft is now too small. The 6- and 12-volt automotive batteries used to start outboard motors can power a radiotelephone and depth sounder as well. Newest large outboards now include generators to keep your battery at full power. The boating family that ties up at dockside berths serviced with electric lines may use heavy-duty cooking and refrigeration conveniences, while offshore a converter can change battery current to voltage needed for even a TV set and similar luxuries.

Safety, however, should come first for the boatman, and it is here that electronics is now making a major contribution. The best method of handling trouble at sea is to avoid it, and the skipper who can always determine exactly where he is may then plot his course to avoid shoals and rocks under the water, strong currents on the surface, and storm squalls which are predicted overhead. The portable radio that gives weather reports, the refined model that can pick up long-wave aircraft forecast data every half hour, and the short-wave set that monitors reports from the Coast Guard and other boatmen—each of these adds to security afloat. The radio direction finder can be used to determine position, plot a course, or "home" on shore stations. Your depth finder will not only indicate sufficient water under your keel but, when used with a government chart, will show you where you are during times of bad visibility. And should you still get into trouble, your radiotelephone is invaluable for calling for help.

Electronics also makes the operation of your boat much easier today. The outboard boatman may now move about his boat, steering it with a remote control, while the inboard cruiser skipper can install an automatic pilot to hold a predetermined course as well. Even small radar sets designed specifically for the yachtsman are now available.

And since pleasure boating is for fun, comfort is important for the family afloat. In addition to the peace of mind which electronic aids to navigation can bring, they also offer radio entertainment, predictions of where the best weather will be, power megaphones to communicate with friends, and even indications as to when fishing will be best—by helping the boatman to locate his favorite fishing hole and then detect whether or not fish are present.

To provide a better understanding of marine electronic devices, and to show how they work, the Editors of POPULAR ELECTRONICS and POPULAR BOATING have selected the following feature articles which we hope will serve to educate the layman and to widen the knowledge of the experienced boatman.

# Radiotelephones for Small Boats

By  
B. H. BALLARD, JR.

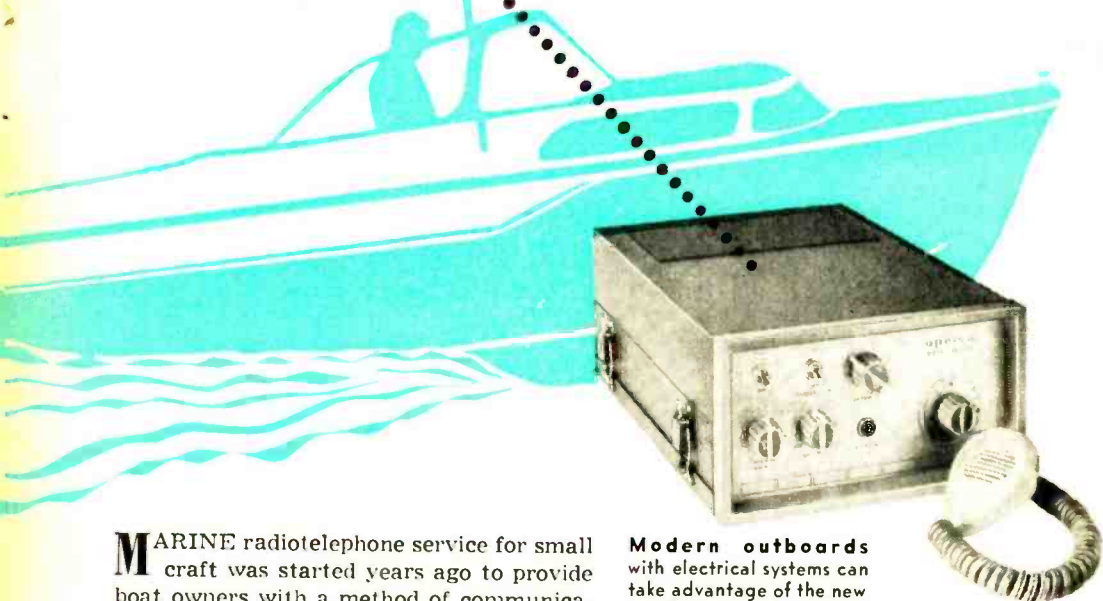

**M**ARINE radiotelephone service for small craft was started years ago to provide boat owners with a method of communication other than hand waving, horn signals, flags or lights. Now, radiotelephones are used by thousands of boating enthusiasts everywhere.

All outboard motor manufacturers offer versions of their larger engines with starter batteries and generators, and this makes it possible to use a variety of 12-volt operated "extras." Two-way radio is one of them.

**Coast Guard Contact.** Safety is the most important reason for putting a two-way radio on your boat, regardless of size. After all, small boats are more easily affected by foul weather than larger boats.

A radio-equipped outboard can call the U. S. Coast Guard for help, if necessary, on the international "Calling and Distress" frequency of 2182 kilocycles. Distress calls have top priority and the law states that all boats must clear the 2182-kc. channel immediately if a distress signal is heard. Just

**Modern outboards** with electrical systems can take advantage of the new small radiotelephones, like the Apelco unit above, which are simple to install and operate.

knowing you can call the Coast Guard for help if you need it will add a lot to your boating pleasure.

**Boat-to-Boat Contact.** Two channels have been set aside by the Federal Communications Commission for talking from one boat to another. You can use these frequencies for keeping track of boat locations during a group cruise, relaying information about an intended stop, checking weather ahead or, for that matter, calling to another boat to find out where the fish are biting! Outboarders on the inland rivers can also use their two-way radios for contacting lock operators about lock operation schedules.

Because the number of channels set aside

for boat-to-boat contact is limited, the FCC requires that conversations on these frequencies be confined to the business of the boat. In other words, the channels should not be used for general "gossiping."

**Marine Operator Calls.** Several telephone companies, including the Bell System, maintain radio stations at many locations on the coast line, Great Lakes and larger rivers. Through the Marine Operator at each of these stations, it is possible to call any land telephone from your boat.

To use the service, all you have to do is open an account with the shore station in your area just as you did for the telephone in your home. However, there is no monthly service charge since calls are billed to you on an individual basis. Average cost is about \$1.25 per call plus the regular toll charges from the shore station to the telephone being called.

**Marine Frequencies.** A good idea of what frequencies are available for marine communications and their relation to the regular broadcast and short-wave bands can be had by referring to the drawing on page 71. Ship radiotelephone systems operate at radio frequencies below the standard AM broadcast band as well as at medium frequencies above it.

Several frequencies in the 2 - 3 megacycle (medium-frequency) band between 1600 and 2850 kc. are available to small commercial vessels and pleasure craft for radiotelephone operation. This is the band which is most used by small-boat owners. Specific frequencies (channels) in this band are assigned for ship-to-ship radiotelephone communications. Communications is permitted between all ships licensed and equipped for operation in this band.

In making a distress call on 2182 kc., you should repeat the international distress signal, "MAYDAY," three times, following which you should state the name of your boat, location and nature of your trouble. Keep calling at short intervals until you get an answer.

**Choosing a Radiotelephone.** The simplest types of marine two-way radiotelephones for outboards and small craft cost about \$250 for a 20-watt, 3-channel model, and \$300 for a 30-watt, 5-channel unit. Usually the price includes antenna, antenna mounts and crystals for at least two channels. More elaborate or higher power units are proportionately more expensive.

Quality, features and performance should be carefully considered, as well as the price. Use these pointers as a guide:

- Up-to-date lower powered units are partially transistorized to reduce battery drain. However, don't look for an "all-transistor" radiotelephone of high power. Good radiotelephone performance is had from a combination of transistors and vacuum tubes.

- Even though you may not be very technically-minded, you can still recognize quality construction when you see it. For example, check the material used in the outside case of the radio. If it is metal, you are assured of maximum shielding. Nonferrous covers (like Fiberglas), may seem to be adequate, but they will give you no electrical shielding from motor ignition noise.

- The well-designed two-way set will have an automatic noise limiter and antenna trimmer control. Both are necessary for efficient operation of the equipment under all conditions.

- Does the radio have tube clamps? It should if it's going to stand up under the pounding it will get in the average outboard. Ask your dealer to show you the inside of the set as well as the outside!

- Some radiotelephones use self-contained batteries. It may be true that you can listen to the radio "on the beach" if it has a dry battery in it; but will it give you the necessary volume when your boat is underway? Your best bet is to skip the dry batteries and choose a set that receives its power from the boat's 12-volt starter battery.

- Look at the antenna. The higher the antenna loading coil is above water, the better the signal strength will be.

**Communication Range.** The range of ship-to-shore or ship-to-ship communications depends upon a number of factors. The most important ones are: transmitter power, operating frequency, location, atmospheric conditions, time of day and year, and the efficiency of the antenna system (see the article entitled "Small Boat Antenna Systems" on page 75).

In the 2-3 mc. band, communications range can be figured by a rule-of-thumb as approximately one mile per watt of transmitter power input. Thus, a 30-watt transmitter gives a 30-mile range and a 100-watt transmitter a 100-mile range. Above 100 watts, doubling the input power adds only

25 to 30% to the range over sea water. Increasing the power ten times increases the range only three times.

Man-made noise and natural static have a severe effect on range by lowering the intelligibility of speech. In such cases, higher transmitter power can sometimes push through the noise.

**Noise and Interference.** Noise can be natural atmospheric static, such as thunderstorms, or it can be caused by the ignition system of the vessel or other sources of man-made interference. Noise exists most of the time, but varies widely in intensity.

A strong radio signal completely eliminates noise in a set equipped with a.v.c. (automatic volume control). The a.v.c. reduces the sensitivity of a receiver when a strong signal appears, and increases it as the signal weakens or disappears. In effect, a strong signal overrides the noise.

Many receivers have squelch circuits which cut out background noise when no signal is being received. Some have noise limiter circuits which reduce or eliminate noise pulses.

**You Need a License.** Boats equipped with two-way radios must obtain a station license from the FCC, which also shows the boat's "call letters." Besides this, the radiotelephone operator must have a "Restricted Radiotelephone Operator Permit."

But don't let these requirements worry you! There are no examinations to take and the procedure is more like a registration than anything else. Let your dealer help you with the FCC forms and marine telephone service applications.

One other thing: after a two-way radio has been installed in a boat, federal law requires that an individual holding at least a 2nd Class FCC License must first put the station on the air and certify that the equipment meets prescribed frequency and modulation requirements. Here again, the dealer selling you the radio can take care of this for you—be sure he makes the entry in your logbook.

Keep in mind that the radiotelephone is primarily a safety device, and should be used only to further the safety or efficiency of your boat. Idle talk unnecessarily ties up channel space which others may urgently need, besides being against the FCC regulations. Enjoy your radiotelephone—but use it well.

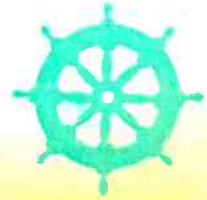
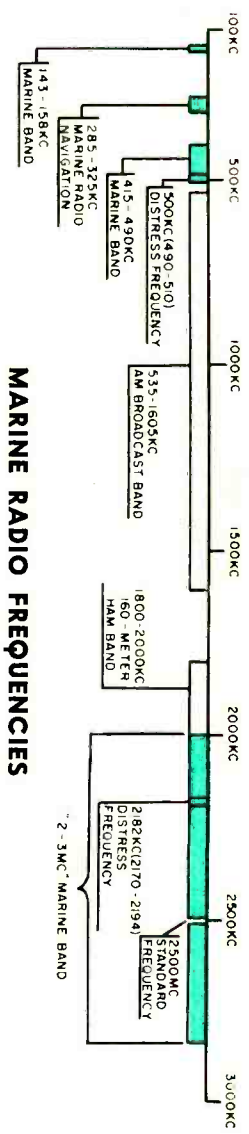
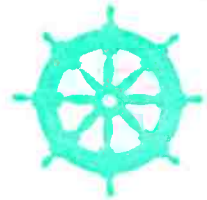

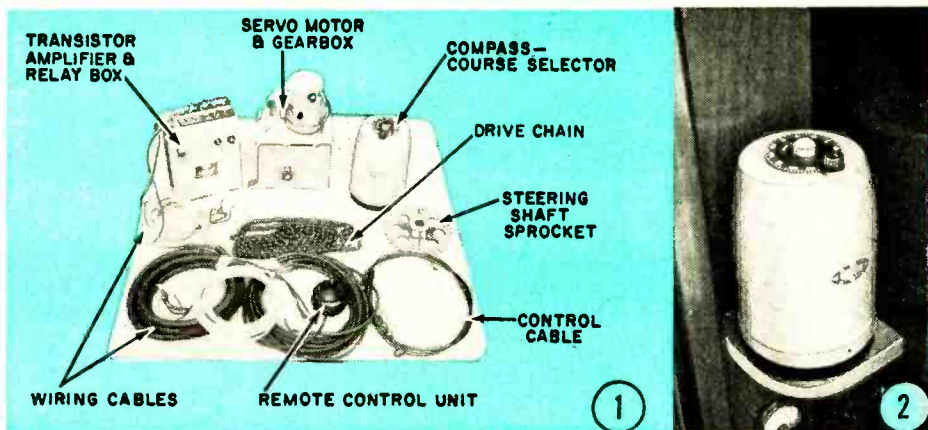

Sperry

# Automatic Pilots for Small Boats

By **OLIVER READ**  
 Editor & Publisher  
 POPULAR ELECTRONICS

**They save fuel, eliminate**

**fatigue, reduce running time, and give added safety**

**A**UTOMATIC STEERING has long been used on ocean liners for purposes of safety and economy. Today, the smaller boat, too, can have a compact autopilot installed, and at a relatively low price. An automatic pilot is, in effect, like having another hand on board. This means that the limited crew of smaller boats has a chance for relaxation and thus can avoid making the navigational errors to which overtired skippers are prone.

In times of bad weather, an autopilot allows the helmsman to leave the wheel at any time to secure loose gear, lay new courses, or handle any emergency that may arise.

A properly adjusted autopilot steers a much straighter course than can any helmsman. More accurate courses mean real savings in fuel consumption and running time. Where time and fuel costs are high, an autopilot is an excellent investment.

**Principle of Operation.** The principle of the autopilot is not complicated. The unit which senses the heading of the boat is basically a gimballed magnetic compass. As the compass rotates, a beam (or beams) of light passes through slits in the compass card and falls on one or two photocells. When the boat deviates from its course, the compass card turns, allowing more or less light to fall on the photocells.

Since the photocell is sensitive to light variations, it creates a corresponding change in electrical current. This small change of current is then amplified by





1 The major components of an automatic pilot are shown arranged on a hatch cover before installation on the author's Trojan cruiser. This unit, by Wilfrid O. White & Sons, Inc., Boston, includes a hand-size remote steering control with a 25-foot cable.

2 Compass-course selector unit is shown mounted near the wheel on a specially built bracket. It should be located at least 30 inches away from the ship's compass and other magnetic materials. Small knob at top selects desired heading for vessel.

3 Motor and gear unit is also mounted on special bracket, with sprocket parallel to wheelshaft sprocket. Bracket on top of unit is for clutch control shaft to engage or disengage autopilot.

4 Split sprocket fits over wheelshaft, should be in same plane as gear-box sprocket. Size of wheel sprocket is determined by steering ratio of wheel to rudder and by desired cruising speed.

5 Chain is draped over both sprockets, then cut to size and riveted closed. The box at the bottom of the wheel housing holds a 45-volt "B" battery which powers the amplifier and relays. The ship's regular battery powers the steering motor.

6 Completed installation shows chain closed and taut between both sprockets. Chain is kept tight by adjusting the mounting of the motor gear-box unit. Any backlash will result in erratic steering.

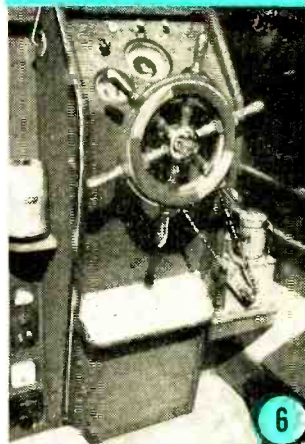

transistors or tubes to the point where it can actuate a relay which controls the electric motor in the steering unit. Then the steering unit gives right or left rudder to bring the vessel back on its proper course.

**Remote Control.** An automatic pilot with control available only at the helm position would leave much to be desired, since the operator would have to stay near the helm a good part of the time if he wanted to dodge floating objects or make temporary course changes. However, most autopilots include a hand-held remote con-

trol unit connected to the automatic steering unit by a long cable.

The skipper can take the remote control unit with him up forward or to the stern and know that if any emergency should arise, such as dodging a buoy, he can override the autopilot and change course by the flick of a switch. By flicking the switch back, he can return control to the autopilot and bring the boat back to its original heading.

**Installing an Autopilot.** Since the compass and binnacle unit is basically a magnetic compass, it is affected by nearby

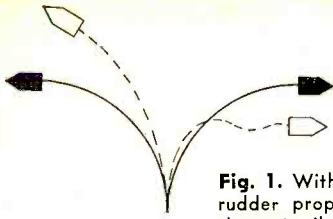

**Fig. 1.** With left and right rudder properly equalized, the autopilot should move the boat in identical turns to the left or to the right. Dotted lines show the effect of unequal rudder control.

metals and magnetic materials. This means that it will affect the regular ship's compass, and vice versa, so that new deviation tables will have to be made, both for the autopilot compass and for the ship's compass.

Considerable magnetic fields are also generated by the motor and gear-box as well as by the relay box and the magnets inside the relays. This means that the compass-binnacle unit should be at least thirty inches away from any other compass, although convenient to the steering wheel, and far enough away from magnetic and mechanical devices such as wind-

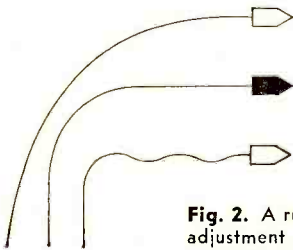

**Fig. 2.** A rudder amplitude adjustment determines how much the rudder will react to a change in course. Top wake shows too small a rudder angle, turn is too slow. Bottom wake shows too great a rudder angle, resulting in over-steering and a fishtail effect. Middle wake shows correct adjustment.

shield wipers, remote control devices, etc. Careless installation can cause the compass card to move sluggishly on some courses, and too rapidly on others, resulting in erratic steering.

The amplifier-relay unit should be mounted in a dry, cool, and ventilated place so as to minimize the effects of moisture on the delicate relays and components. It should be at least three feet from the com-

pass unit as the relays are magnetic and create a disturbing field.

The gear-box should always be kept filled with oil. In securing the chain between the wheelshaft sprocket and the gear-box sprocket, make sure that the two sprockets are parallel (in the same plane) and that the chain is taut. Any backlash in the chain will result in loose steering and poor functioning of the autopilot. To avoid this, the motor gear-box unit should be mounted with adjustable bolts which can be tightened or loosened as required.

Limit switches are connected to the gear-box shaft and preset at the factory to shut off the motor after a certain number of turns, usually representing about 60° (total) rudder travel.

**Adjustment.** Since every boat handles and steers differently, two simple types of adjustment are usually necessary to make the autopilot function properly: left and right rudder equalization; and rudder amplitude adjustment. Left and right rudder equalization means merely that the autopilot will move the rudder the same number of degrees to the left as to the right for a given change in course to the left or right. (See Fig. 1.)

Most important is the rudder amplitude control, which determines how great the rudder angle to either side will be when course is changed. Too great a rudder angle will give a fishtailing effect to the boat because the autopilot will oversteer for small changes in course. Too small a rudder angle will give a slow and sluggish response to rapid course changes and leave the boat to the mercy of wind, wave, and tide. (See Fig. 2.)

Of course, the correct rudder amplitude (or the amount of steering) depends on the speed of the boat, and the rudder amplitude control should be adjusted for normal cruising speed. Once set, it will usually function efficiently six or seven knots faster or slower than cruising speed. At very low speeds or at planing speeds, however, the autopilot should not be used, or it should be readjusted accordingly (if this can be done).

Keep in mind that an automatic pilot should not be used in harbors or congested areas—it's strictly an open-water cruising device. Chances are that once you've used an autopilot for extended cruising or fishing, you won't understand how you ever managed without one.



# **Small Boat Antenna Systems**

***You can double your signal strength with  
an efficient antenna system***

**T**HERE ARE two ways of pushing a signal out beyond the horizon. One is to have plenty of power—but boat-transmitter power is limited by the capacity of the boat's battery and the owner's pocket lining. The other way is to have the best possible antenna system. This does not necessarily cost a lot of money, but it does require careful planning, workmanship, and materials.

**Power Leaks and Efficiency.** Maximum efficiency in radio transmission is achieved when all the transmitter output power is radiated, i.e., turned into radio waves. Two conditions are necessary for maximum efficiency: the transmitter output impedance must match the antenna impedance, and the antenna impedance should consist only of the radiation resistance, which makes radio signals.

The first requirement is easy to meet—properly tuned marine radiotelephone out-

**By  
ELBERT ROBBERTSON**

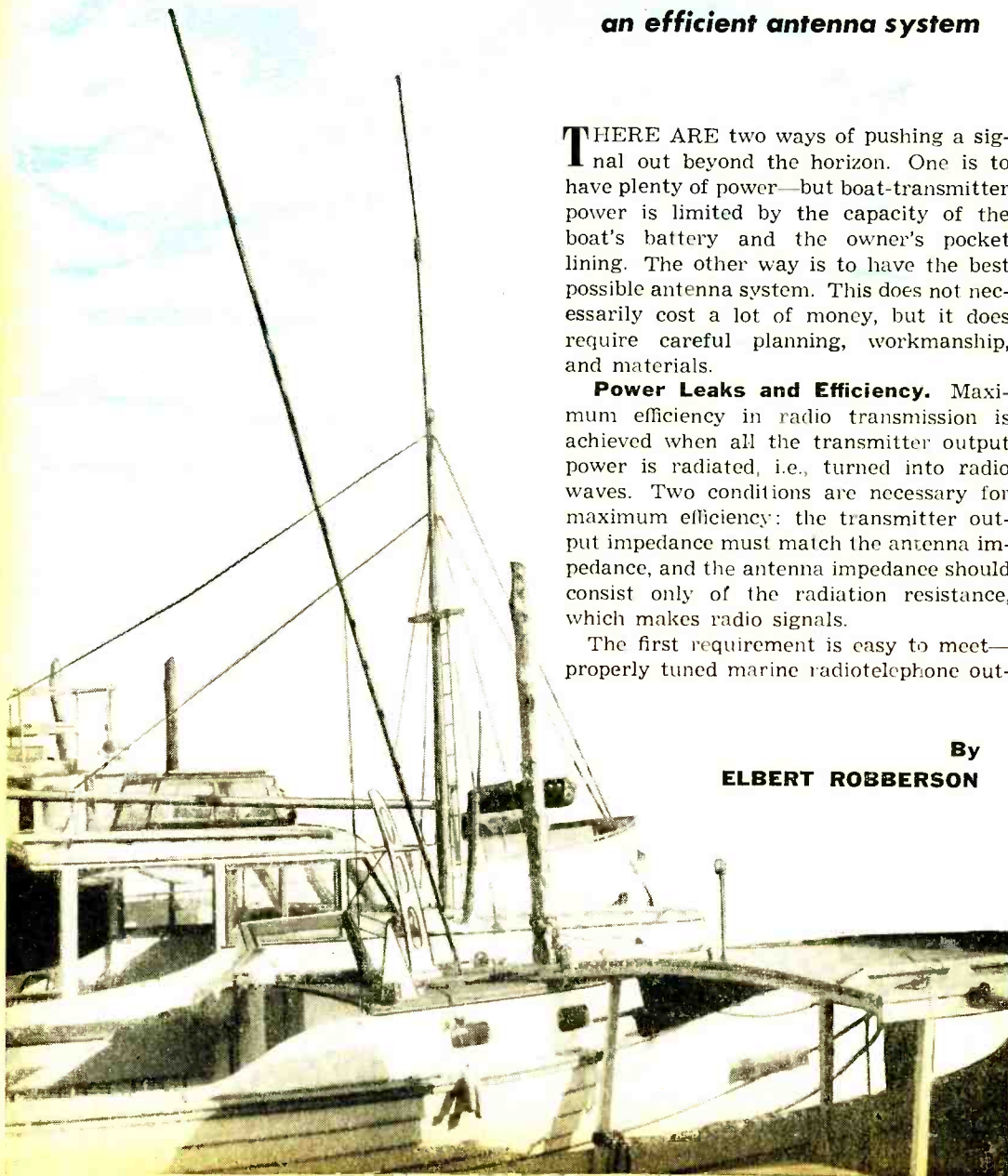

**Fig. 1.** Radiation resistance of Marconi antennas having heights that vary from 10 to 26 feet.

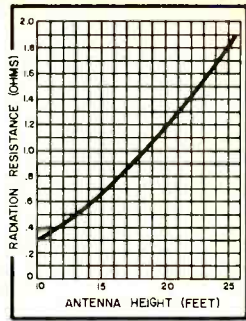

put circuits are designed to match any normal antenna impedance found on a small boat. But here is the egg in the fan: the small boat antenna system harbors many resistances other than radiation resistance.

Starting with the output terminals on the transmitter, precious watts are dissipated right and left. For example, there is dielectric loss due to leaky insulation (very common, once insulation is hit with salt water or spray), absorption in nearby metals and conductive materials, antenna

**Fig. 2.** Technique for running antenna lead-in wires through deck or bulkheads. All connections should have large surface areas. No. 10 copper wire or larger should be used, or 1/4" copper tubing.

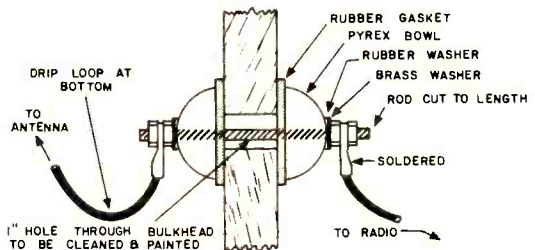

“loading-coil” resistance, the ohmic and skin effect resistance of antenna system wire, and—most important—resistance of the ground connection.

Antenna height (the length of the radiating portion, not the height above ground) determines how much loss resistance you can afford. Figure 1 shows how antenna height determines radiation resistance, that is, the resistance of the antenna which actually radiates power. The ratio of the radiation resistance to the loss resistance determines the proportion of transmitter power which is actually converted into radio signals.

Consequently, a major consideration in choosing an antenna is to select the tallest one that is practical for your boat to carry.

**Antenna and Loading Coil.** Marine antennas are different from other types of

antennas for good reason. Need for mechanical strength, corrosion resistance, adequate mountings, and special electrical characteristics has resulted in a highly specialized breed, developed through many years of experience in boat installations. The basic design is a rod or tube of light-weight weatherproof material, such as heavily protected aluminum, or a plastic tube with a molded-in conductor, from 12 feet in length on up to the maximum size practical for a small boat.

Somewhere in the antenna, near the top, center, or bottom, there is a loading coil to increase the electrical length and to help in resonating the system. Loss resistance in the loading coil is easy to come by. In early antennas, consisting of a wooden pole wrapped with wire, coil resistances of dry antennas have been measured from 5 to 15 ohms—but, after one dash of rain water, this could jump to 25 to 50 or more ohms.

A good way to judge antennas is to mosey around the boatyards, examining the ones that have seen service. You can assume

that like-sized products of experienced manufacturers start about even in effectiveness. But a little exposure to the elements will soon cut into the efficiency of those antennas which are less resistant to flexing, vibration, sun, and spray. When water gets into coils, when connections corrode, plastic begins to crack, and insulators become weather-beaten—your antenna is shot, no matter how effective it was at first. Try to get one which retains its desirable properties the longest.

**Lead-In and Wiring.** It was popular at one time to use automobile ignition cable for the antenna lead-in because of its superior insulation. But some ignition wire has stainless-steel conductors, and since stainless steel has a high resistance (in comparison with copper), the use of such wire can make 40 watts sound like 10 watts

on the air. Even if the conductor is copper, however, the gauge is too small for best efficiency.

The old Navy-style lead-in, 1/4" copper tubing mounted on stand-off insulators, is efficient if there is room for it. Or, instead of copper tubing, insulated No. 10 wire can be used. Never paint over lead-in wires—

**Fig. 3.** A well installed ground plate gives better antenna loading and a stronger signal.

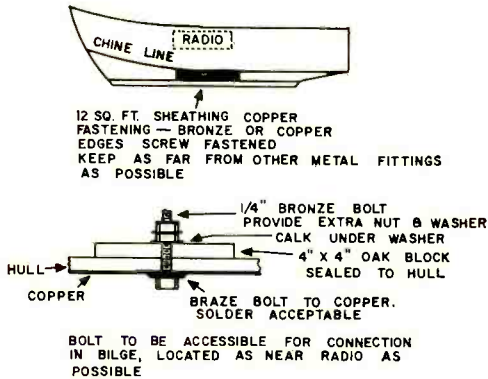

metallic pigment in the paint causes losses.

Good lead-in wires have been made of the inner conductor and insulation of RG-8/U cable *with the outer sheath and braid skinned off*. Don't attempt to use coaxial cable in the conventional manner, because the shunt capacitance between the inner conductors and other braid will route some of your power to ground, constituting another loss. Coax cable was not designed for use with marine antennas.

Where it is necessary to go through decks or bulkheads, high-grade feedthrough in-

ulators should be used. (See Fig. 2.) Glass, polystyrene or highly glazed porcelain or steatite insulation is good, but in ceramic insulators watch out for unglazed spots through which moisture might seep. Husky transmitters have gone off the air because of a little salt in the insulators.

**The Ground System.** Marine radiotelephones are built to work into a Marconi antenna system, in which a good ground connection is essential. A good ground is one that is close to the radiotelephone, and which has the lowest possible resistance.

If your boat is metal, you have no problems. Connect the radiotelephone ground terminal to the nearest solid member of the boat and you have the best ground that can be realized. Use heavy wire—a good rule is to make the ground lead the same size as the battery-power leads—and install a bolt and nut in the boat member for the ground terminal.

A ground plate of large surface area is next best. For passenger-carrying boats, the FCC calls for bare plate or strips (or a combination of both) of corrosion-resistant metal having at least 12 square feet in aggregate area, affixed to the hull below waterline. (See Fig. 3). You can figure that if this recommendation is good for commercial vessels, it is also good for pleasure craft; try to meet this standard if the construction of the boat permits.

A good ground plate can be made of

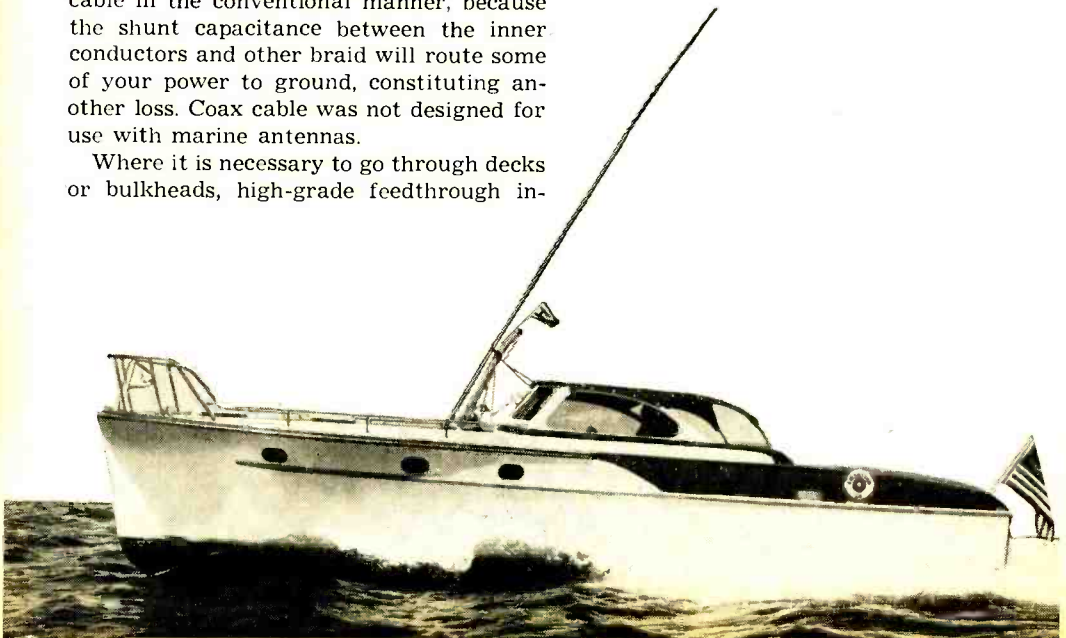

flashing-copper sheet, available from hardware and plumbing supply stores. Fasten the sheet to the bottom, or alongside keel or deadwood, with bronze or monel screws spaced 1" around the edge and about 6" apart across the center area. Do not use common brass—it will soon corrode.

For connection, install a 1/4" bronze bolt through plate and hull, as close to the telephone as possible, backing it on the inside of the hull with bedding compound as shown in Fig. 3. You can solder the head of the bolt to the copper with a torch or a very heavy soldering iron.

On many boats an external ground plate is out of the question. Your best bet, then, is to install the copper sheet or strips inside the hull below the waterline, connecting them together and soldering or bolting your ground wire to a point close to the telephone. Copper screen might be used here—solder a bead along the edges so all wires are tied into the circuit; however, this cannot be expected to last as long as heavier material.

The last and poorest expedient for a ground is just to connect to the engine. This should be a temporary measure at the most. There is no use spending hundreds of dollars for transmitter watts and then throwing most of them away for the lack of a good ground.

In any event, always bond the motor to the radio-ground connection with wire of at least No. 10 gauge. In the case of outboard motors, connect the motor covers to the motor frame as well. Also bond metal tanks or other large metal objects or pipes—every bit of extra metal adds capacitance and helps improve ground efficiency. *Always* use heavy wire for the ground connection, and route it in as straight and as short a line as possible.

**Solid Mounting.** Objects on a boat often are severely tossed and pounded, and anything which is mechanically insecure may not stick around very long. Poorly installed antennas get badly bent or broken, or wrenched completely off the boat, sometimes taking part of the superstructure along.

Side-mounting insulators should be spaced as far apart as possible, and used only on boat structures which will withstand many pounds of pull. If there is no such member on the boat, it may be advisable to install a stub mast from the keel up through the deck on the boat's center-

line, to hold the antenna. This makes a very shipshape job.

There are several antennas which are light enough to be installed on deck or cabin top on an insulated base mounting. These are very neat, as well as being easy to install. If the deck is thin or flexible, back it up underneath with an oak or mahogany block, preferably cambered to the deck line and secured to adjacent beams or carlings (fore-and-aft beams under deck or cabin top).

**Measuring Antenna Efficiency.** At a laboratory, the job of measuring antenna efficiency would involve a van load of black boxes and a corps of specialists. However, simple measurements can be made which show whether a boat antenna system is poor (10% efficiency or less), fair (20% efficiency), or excellent (30% or better). The system is based on the familiar formula: power = (current)<sup>2</sup> × resistance. This is juggled around to read: resistance = power/(current)<sup>2</sup>. If you know your transmitter output power and the antenna current, the latter formula will give you the total antenna-circuit resistance.

Transmitter output can be measured with a dummy antenna of known resistance, at standard input voltage and plate current to the r.f. amplifier. Or, for comparative purposes, you may assume that output is 50% of the plate input. When the transmitter is tuned, measure the r.f. antenna current at the transmitter, and apply the formula.

As an example, suppose your transmitter output is ten watts and the antenna current is 0.7 ampere. Your total antenna-circuit resistance is 20 ohms. Now, if the antenna height is such that the radiation resistance is 2 ohms, it follows that there is an 18-ohm loss resistance and 10% of the transmitter output is being radiated.

Your object: cut that loss resistance. Make sure of wire size, insulation, cleanliness, dryness, and connections. By hook or crook, make the equivalent ground area as great as possible.

Follow these common-sense procedures and you will have the most effective antenna your boat will carry. You may be amazed at how far a few watts will go. ⚙

*EDITOR'S NOTE: Excellent grounding has been achieved in our Trojan 22' inboard cruiser using new Dynaplates designed to substitute for conventional ground systems.*

By  
LOUIS E. GARNER, JR.

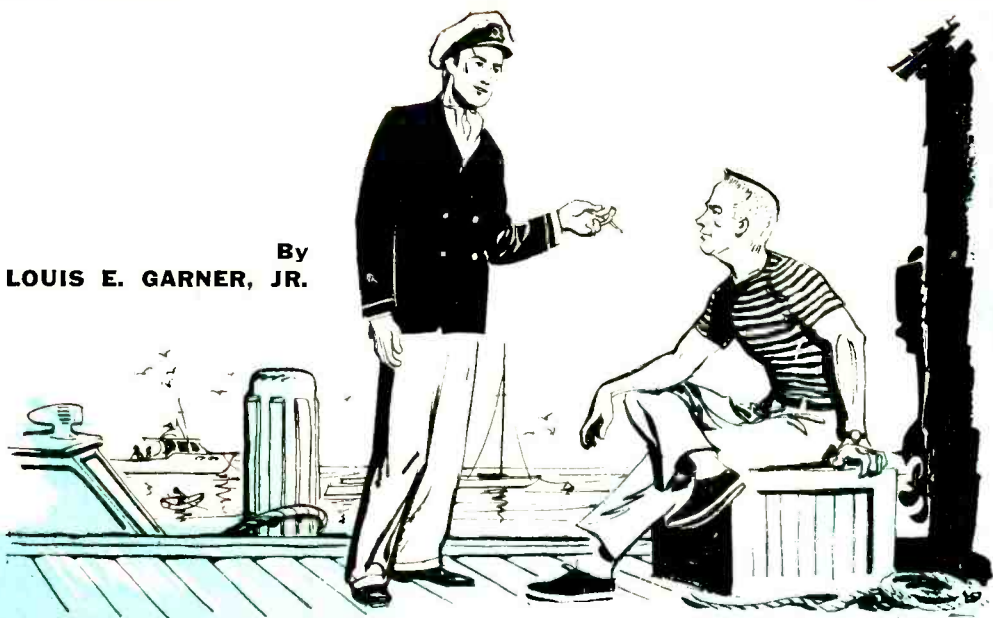

## Transistors or Tubes in Marine Gear?

A boating enthusiast asks . . .

**"Should I wait for transistorized gear?"**

*Some—but not all—electronic gear for boats is transistorized. Since transistors have been widely publicized, many prospective users wonder if they should delay adding such equipment to their boats until fully transistorized units are available. Here, an imaginary interview between Bill, a boating enthusiast, and Ed, an electronics expert, serves to answer some of the questions about transistorized gear which have been puzzling boat owners.*

**Bill:** Some of the fellows down at the Marina have been batting around this question of tubes versus transistors. We'd all like to get more electronic gear for our boats. And from what we've heard, we'd like to buy transistorized gear. But much of the equipment now available uses vacuum tubes. As a result, we don't know whether

to buy now or to wait until fully transistorized equipment comes out. Wonder if you could help us reach a decision?

**Ed:** I'll try. What do you want to know?

**Bill:** First off, transistors are better than tubes, aren't they?

**Ed:** That's a loaded question if I ever heard one. Transistors and vacuum tubes are different types of devices. Each has its advantages and disadvantages. Transistors are better than vacuum tubes for some applications. But the reverse is also true.

**Bill:** Well, I can understand that. A 40-horsepower outboard motor is better than a 15-hp. job for a small cruiser, but not for a two-man dinghy. But let's get down to cases. What are the transistor's advantages compared to the vacuum tube.

**Ed:** Generally speaking, transistors are much smaller than vacuum tubes, weigh

a fraction as much, and have a much longer service life. They are more rugged mechanically, and some types can stand shocks as great as those encountered by being fired from guns. In most applications, transistors are much more efficient than vacuum tubes, requiring but a fraction of the power to do a given job. Finally, and this is most important when mobile or portable applications are considered, they can operate efficiently on low voltages—such as the 6- and 12-volt power sources available on small boats.

**Bill:** I guess that explains why most portable radio receivers are transistorized. But I've noticed that most transistorized receivers are more costly than vacuum-tube receivers. Why is that?

**Ed:** You've hit on one of the transistor's disadvantages, although it's probably a temporary one. At the present time, transistors are still more costly than vacuum tubes, and because common types provide less gain than vacuum tubes, you may need a five- or six-transistor receiver to duplicate the performance of, say, a four-tube radio set. These two factors tend to raise the cost of transistor equipment. But transistor prices are coming down. In fact, they've been dropping steadily since the first transistor was manufactured for commercial sale. At the same time, transistors are constantly being improved.

**Bill:** But I suppose there are applications where the transistor's high cost is offset by its advantages. That's true, isn't it?

**Ed:** Right! Where equipment weight, ruggedness, size, and power considerations are more important than cost, the transistor holds a decided edge on the vacuum tube. Thus, transistors are ideal for shipboard radio receivers, radio direction finders, compact depth indicators, and fish locators. In addition, there are a number of applications where the transistor may actually be less costly than the vacuum tube.

**Bill:** But the transistor's chief disadvantage is cost, isn't it?

**Ed:** In a general way, yes. For example, while no manufacturer is now producing *high-power* radio-frequency transistors, there are moderate-power units available—transistors capable of delivering several watts at frequencies up to ten or twelve megacycles, well above the 2- to 3-mc. band used for ship-to-shore radiotelephone. But, if a ship-to-shore radiotelephone were designed to use such transistors, its retail

price might be as much as five to ten times higher than currently available partially transistorized equipment.

**Bill:** I guess this means transistors can't be used in power applications—right?

**Ed:** On the contrary. There are many power transistor types available, and some of these are capable of handling quite high power, but at low frequencies. Most low-cost automobile radio receivers, for example, are "hybrid" sets using both tubes *and* transistors. Interestingly enough, the transistors in these sets are used in the audio *power output* stage.

**Bill:** A friend of mine has a ship-to-shore radio transmitter. The unit requires 500 volts d.c. for its plate supply. At the moment, this voltage is supplied by a vibrator power pack. But my friend has had a lot of trouble with the vibrators; he has to replace them quite frequently. Can transistors be used in a d.c.-to-d.c. power supply?

**Ed:** A cinch. It's only a matter of circuit design. Transistor power supplies are more efficient and less noisy than either vibrator power packs or dynamotors, and, most important, generally require far less maintenance.

**Bill:** How about summing it up for me?

**Ed:** Okay, I will. First, low-power gear can be *fully* transistorized. Transistors can be used effectively in power converters—incidentally, d.c.-to-a.c. supplies are sometimes called *inverters*. And ship-to-shore radiotelephone equipment can be partially transistorized without becoming too costly. Finally, transistorized marine gear offers smaller size, lighter weight, improved ruggedness, less maintenance, and more efficient operation, with a resulting saving of your boat's power supply.

**Bill:** Then how would you answer the question, "Should I wait for transistorized gear?"

**Ed:** Let's put it this way. You can't enjoy any equipment while it's sitting on your dealer's shelves. Equipment which may not be available for a year—or two—or three—can't provide much safety or convenience this season! Even though transistors theoretically are ideally suited for marine electronic equipment, if you can't buy the piece of gear you want, theoretical advantages don't do you much good. A wide range of tube-operated and transistorized equipment is available today. So, like the man says, "You pays your money and you takes your choice." 



# The Radio Direction Finder

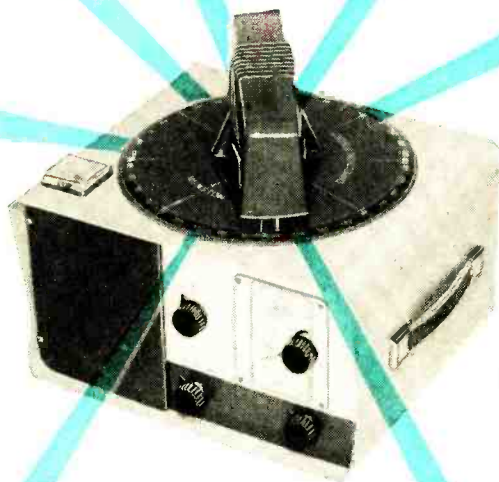

By  
**RALPH ROSENFELD**

**I**N TIMES of bad weather and low visibility, a radio direction finder can be an invaluable navigational aid, especially for small boats in coastal areas. And it is simple to operate.

Commonly called an RDF, the radio direction finder can take very accurate bearings on marine radio beacon stations, regular broadcast stations, and any radio station which the receiver can tune in and whose position is known. Bearings on other ships' transmitters can also be taken.

If you can't afford a gyrocompass, a dead-reckoning indicator, or radar equipment, an RDF is your best insurance in foul-weather navigation. Portable transistorized equipment can be installed on the smallest of boats without any difficulties about current requirements, weight, or expense. Even if you do have radar, the RDF can't be beat as a quick navigational check.

**How It Operates.** All radio direction finding equipment is based on a simple

principle—the fact that a loop antenna is very directive, that is, it tends to pick up radio signals coming from one direction more strongly than from another. If the loop antenna is connected to a radio tuned in on a specific station, the station signal will be strong or weak depending on how the loop is turned. If the loop is turned for the minimum signal, and the location of the radio station is known, it is possible to determine the directional angle with respect to a magnetic compass reading, and the result can then be plotted on a chart.

Of the three components making up an RDF—a highly sensitive receiver, a directional rotatable loop antenna, and a signal null indicator—the most important is the loop antenna. The better the directivity, or “sharpness” of an antenna, the more accurate the bearing.

**Loop Antennas.** Available in many shapes and forms, a loop antenna may be wound or pressed into an insulating mate-

rial; or it may be in the form of a doughnut winding encased in plastic or metal tubing, as in the Munston "Bay Shore" shown on the preceding page, or the doughnut may be formed into a square or rectangle.

Although some loops may be as large as a foot in diameter, compact and very efficient loops have recently been designed around a solid core of special magnetic material known as ferrite. Loops wound on ferrite cores (as used with the Munston "Bay Shore"), may be only 7 inches long and 2 inches high, but can be just as sensitive and directional as a large air-core loop.

The directional characteristics of rotatable loop antennas are shown in diagram at right. The point of minimum signal pickup for an air-core loop is in the direction of "A" and is extremely sharp. The point of maximum signal pickup is in the direction of "B." This is the point at which the plane of the loop is parallel to the direction of the incoming wave. However, the maximum response is rather broad and cannot be used to give a sharp indication. The minimum is called the "null" point and is normally used in taking a bearing. That is why the pointer attached to the loop is always at right angles to the plane of the air-core loop, i.e., in the direction of minimum sensitivity.

The behavior of a ferrite-core loop is the same, but in this case the loop windings are at right angles to the axis of the ferrite rod on which the windings are placed. Hence, minimum signal (null) occurs when the rod points to the station. Under these conditions, the actual loop windings are at right angles to the direction of the incoming signal, just as was the case with the air-core loop.

**Frequencies Used.** RDF receivers may cover only marine radio beacon frequencies, or they may also cover broadcast and short-wave frequencies. In general, bearing accuracies improve as the frequency in use is lowered and deteriorate as the frequency is increased. The loop normally operates on vertically polarized signals traveling horizontally (ground waves); but when confronted by combinations of ground and downward (sky) waves such as are found at the higher frequencies, the induced voltages can result in a serious bearing error. The more accurate frequencies for direction finding are in the 190 to 400 kc. band. This band contains both Coast Guard radio beacons and airway beacons.

Marine radio beacons are transmitting stations located on lightships and at light-houses. Most beacons transmit a series of identifying code letters during a specified time period. Their frequencies and position are shown on charts published by the U. S. Coast & Geodetic Survey.

Coastal broadcast stations in the 540 to 1600 kc. region may also be used for direction finding. And, during daylight, frequencies above 1600 kc. can be used for moderately accurate bearings, if the transmitter location is within 20 miles. Errors due to refraction and combinations of ground and sky waves are more likely to increase at night.

**Error Sources.** All metallic objects aboard the boat (such as metal masts, guy wires, etc.) tend to distort the directional

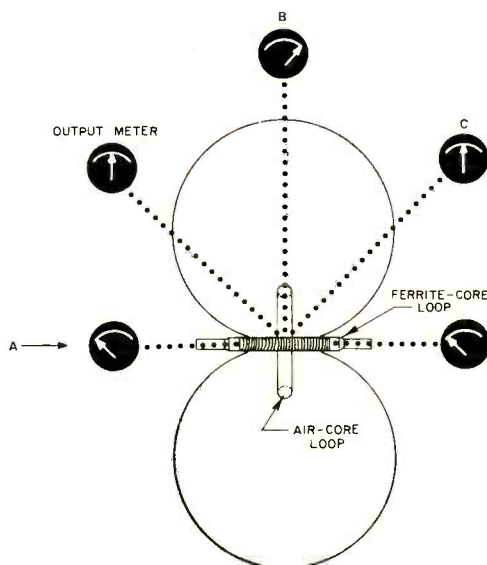

**Directional radio reception pattern of a loop antenna.** The meters show signal strength in various directions from the plane of the loop.

pattern of the loop. Such errors are accounted for by constructing a card similar to the deviation card used with the magnetic compass. These errors vary with the radio bearing relative to the ship's heading (and not the ship's heading alone, as do the deviation errors in a magnetic compass).

The instrument error in taking a radio bearing may be  $\pm 2\%$ . The probable error due to calibration problems will be at least one degree. Consequently, the over-all error might be  $\pm 3\%$ .

It is quite essential to practice using the

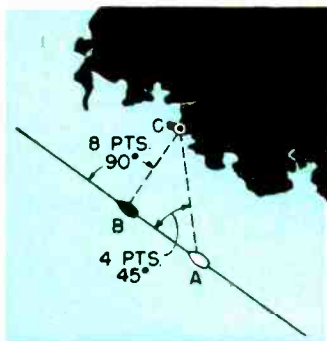

#### Four-Point Radio Bearing

Observation A on radiobeacon C is taken over bow at 4 points or 45°. The log is read or time noted. Another observation, B, is taken on C at beam or 90° and log read or time noted. The distance run from A to B will equal distance from vessel at B to C.

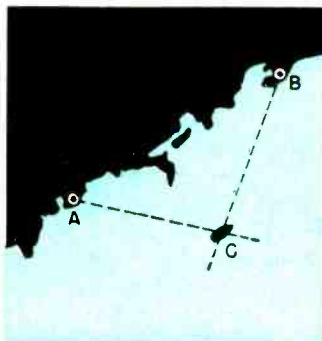

#### Cross Bearing

A bearing is taken on radiobeacon A and at the same time another bearing is taken on radiobeacon B for the same position, and these bearing lines are drawn on the chart. The position of boat will be at or near the intersection of the two bearing lines, point C.

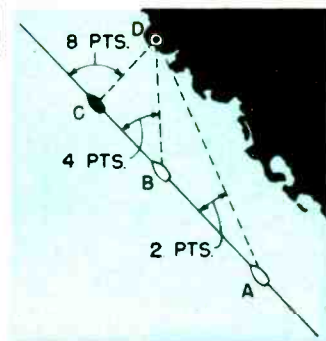

#### Doubling the Angle

Bearing on radiobeacon D is taken at 4 points or 45° from B on the same course and again at 8 points or 90° from C. The distance between points of observation is noted from the log. Thus, according to a simple geometric identity, AB equals BD and BC equals CD.

equipment. Don't wait until you are lost in a fog.

**Using the RDF.** Bearings taken on the RDF should be used in the same manner as visual bearings. Accuracy improves as the boat gets closer to the transmitter. A note of caution, however: if you take a radio bearing "over the bow" and steer for it "dead ahead," beware of piling up on the rocks in front of the beacon station, or running down another vessel while navigating in a heavy fog.

Some beacon stations send out a radio signal simultaneously with a foghorn signal. The radio signal arrives at your boat almost instantaneously but the sound from the foghorn travels only at the speed of sound, about 1100 feet per second. If you hear the foghorn 33 seconds after you hear the radio beacon signal, you know you are about six miles from the beacon. This information, along with a directional bearing from the RDF, can give you your approximate position. Accuracy of distance measurement is about 10%.

Many a skipper has come to rely on his RDF as a prime means of navigation. In view of its low cost, ease of operation, and invaluable assistance in poor weather, it seems quite possible that an RDF will soon be carried by every small boat as standard equipment.

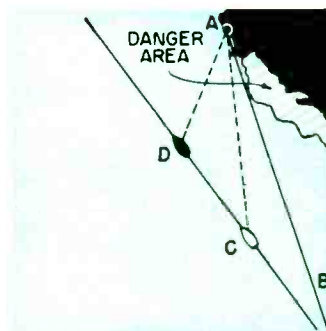

#### Danger Bearing

Draw through A the line AB clear of all danger and note direction by compass rose. If bearings on A from C and D show AC and AD to be to the right of AB, you can be sure that your ship is on the left or safe side of the danger line.

Diagrams above courtesy of Raytheon Mfg. Co.

## **Shipboard-TV Keeps the Kids Happy**



**F**AMILY LIFE aboard a boat has its problems, and one of them is keeping the small fry occupied during the long hours at dockside. A solution is to keep a portable TV set aboard and plug it into the dock's 117-volt a.c. power outlet when the boat is tied up. When the boat is under way, 117-volt power can be provided by transistor power converter such as the Heath PC-1.

Since space is at a premium on small cruisers, one of the new shallow wide-angle tube sets should be used, like the General Electric "Gramercy" 17" set shown here. It's a good idea to use a set that has a full power transformer to minimize shock hazard. The case should be of plastic or metal, with a fully enclosed back. ⚙

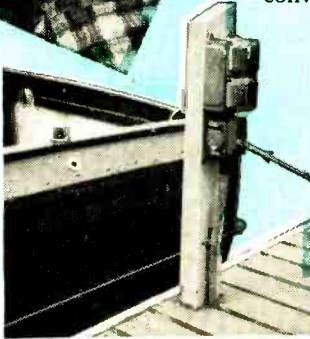

## **Fuel Vapor Detector**

### **Prevents Explosions**

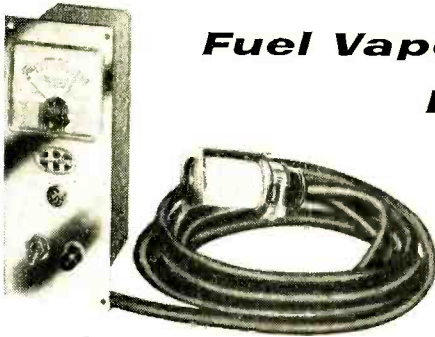

**E**VERY BOATMAN knows that fire or explosion at sea is a deadly hazard. Vaporized fuel can explode and cause the destruction of a valuable boat, plus personal injury or even death. A half-cup of gasoline spilled in the bilge can increase the vapor content to the point where a single spark could cause an explosion violent enough to destroy the boat and its occupants.

Instruments to detect gasoline or fuel vapor are commercially available but rather expensive. However, a fuel vapor detector in kit form can be had for \$35.95. The Heathkit FD-1-6 (above) consists of a detector which is placed in the engine compartment and a control head which is mounted on the bridge or in the cockpit.

The detector used in the FD-1-6 is a screened housing made of Monel metal which shelters two filaments. One filament is sealed within glass and the other is in an open glass enclosure; the sealed filament is the "standard," the other samples the air in the engine compartment. When the molecular weight of the surrounding atmosphere changes due to the presence of explosive gases, the resistance of the unsealed filament changes and unbalances an electrical bridge circuit, registering "safe," "dangerous," or "explosive" on a meter.

This simple safety device is energized by the boat's battery, or by an auxiliary six-volt battery. A pilot light on the control head glows when the device is turned on. If the detector unit is burned out, the lamp will glow dimly. If one of the detector filaments is burned out, the meter will indicate a dangerous condition. For safety's sake, a spare detector unit should be kept aboard the boat. ⚙

**Low-cost reliable  
ship-to-shore communications**

**By  
DONALD L. STONER  
W6TNS**



## **Citizens Band Radio for Small Boats**

**A**LTHOUGH there are more than seven million pleasure boats splashing about on our country's waterways, the latest report from the Federal Communications Commission reveals that only 65,000 vessels are equipped for two-way radio communications. Even if you assume that all of the 65,000 radio-equipped boats are pleasure craft, this figure still represents far less than 1% of the total pleasure craft in use.

One reason for the lack of more radio-equipped boats in the past has been the high cost of equipment and the additional costs of professional installation. A typical radiotelephone on a commercial fishing vessel is priced in the neighborhood of \$1000. After the equipment is purchased, it must be installed and serviced by licensed technicians.

But this picture is rapidly changing. One recent development now makes it possible to purchase not one, but two radios, for less than \$250. One can be installed in your boat, and the other located anywhere you

like. If it's too rough for boating one weekend, you can take the two units to the mountains and use them for communications there.

**Citizens Band.** The new Citizens Band allocation makes this possible. The Federal Communications Commission has set aside a small segment of our crowded short-wave bands for wireless communications by "Mister Average Joe." This band consists of 22 individual channels grouped near 27 mc. (just below the 10-meter "ham" band). Any citizen of the United States over 18 years old can obtain a license simply by applying for it. There are no stiff examinations or code tests.

Citizens Band equipment can be used anywhere, not just between your boat and house. You can use it between your boat and auto or between your home and car. Applications are limited only by your imagination. Small, portable transmitter-receivers are available which work either on 117-volt household current or on 6-12

volts d.c. from your car or boat. Some units will work on either power source simply by the flip of a switch.

On land the useful range of Citizens Band equipment is usually reduced because of buildings, trees, etc., but out on the "briny deep" you can expect optimum performance because there are no obstructions and reception is always "line-of-sight." With the antenna mounted 20 feet above the deck, good reception at up to five miles should be attainable, with ten miles being the outer limit for reliable radio communications.

**Obtaining Your License.** When you purchase a transmitter-receiver (sometimes called a transceiver), you will find a license application packed with the unit. If such is not the case, it can be obtained by requesting a Citizens Radio License Application (Form 505, dated Sept. 1958) from your local FCC office.

Before you fill out this form, you should obtain a copy of the Citizens Band Regulations, Part 19. You swear that you have read (and understood) the regulations when you sign the application form. This document is available from the Superintendent of Documents, U. S. Government Printing Office, Washington 25, D. C., for ten cents in coin.

The form includes a "work sheet" which you keep as a copy of the application. You can do this part in pencil so it may be changed if necessary. When you are sure all is correct, type up the application (and its four copies), and have it notarized. If you have any trouble "battling" with the form, ask whoever sells you the equipment to help you out.

Airmail the application directly to the Federal Communications Commission, Citizens Radio License Division, Washington 25, D. C. Do *not* send it to your local FCC office.

Don't expect any action for at least 90 days because the Commission is currently flooded with applications. If you are in a hurry to use your radio station, your license will be forwarded to you by air if you enclose a seven-cent airmail stamp along with your application. This will not shorten the handling time, but may cut the overall delay by a number of days. If you urgently need to get your station into operation, you can request that you be notified by collect telegram when your application has been processed. This will permit you to put your

station on the air while your license is in the mail.

**Installation.** The best part of Citizens Band operation for small boat owners is that no professional aid is required for the installation of the equipment. And your completed installation need not be inspected by the FCC.

If your boat has an electrical system, connect the radio as indicated in the instruction manual. If your boat does not have an electrical system, an automobile battery will provide power for a full day's communication. Make a wooden box for transporting the battery or purchase one of the new plastic units now available. In some convenient spot in the boat you can build another box that the battery carrier will slip into. The radio unit can be strapped to a seat or bulkhead. Connect the mike, battery, antenna, and you are ready to go on the air.

You can either build a Citizens Band antenna yourself or buy one ready-made. In either case, the tip of the antenna may extend no higher than 20 feet above the deck of your boat, in compliance with Federal Communications Commission rules.

The engine, whether inboard or outboard, *may* cause electrical interference. The cure is similar to suppressing auto interference, and amateur radio handbooks can be consulted for the various means to correct this. Your boating supplier could also be of assistance with this problem.

Performance and range can sometimes be improved by grounding the radio equipment to a metal keel or a copper strip running the full length of the hull under water. Twelve square feet of copper is recommended. (See article entitled "Small Boat Antenna Systems" beginning on page 75.)

To protect the radio equipment from salt spray, make a plastic bag to cover the equipment when it is not in use. Also make sure that the transceiver doesn't get a dose of salt spray while you're flying over the whitecaps. Salt water can play havoc with the parts and wires used in radio gear, necessitating expensive repairs. ⚙

EDITOR'S NOTE: Citizens radio is not a substitute for the marine radiotelephone. Using the Citizens Band, you cannot place a land telephone call nor can you summon the U. S. Coast Guard directly, but you will find it a useful communications aid.

Photo courtesy of  
Raytheon Mfg. Co.



# **Radar and Loran**

**Vital electronic aids to navigation**

By **CLARK E. JACKSON**

**F**OR MORE than a decade, the navigator has had electronic eyes which penetrate fog and darkness, seek out hidden dangers, and chart the surroundings for him. Radar (Radio Detection and Ranging) was a secret word during the early part of World War II and has been credited by many as having been most instrumental in bringing victory to the Allies in Europe and the Pacific. Loran (Long Range Navigation) was also developed during World War II as a rapid and simple way of getting accurate navigational fixes. Today more and more standard navigational charts have

loran lines, making it possible to transform a loran receiver reading directly into a graphic navigational fix.

## **RADAR**

A crude form of "radar" was in use before electronic radar came into being. From the beginning of time, navigators have used audio signals to determine their distance off steep shores hidden in fog, by sounding a short blast with a whistle or horn and then listening for the echo. Knowing the speed of sound to be approximately 1100 feet per second, if it took five seconds for

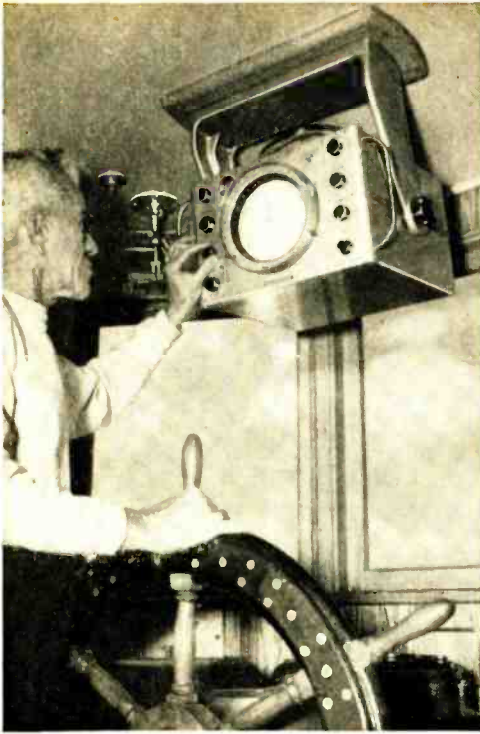

**Ceiling radar installation** saves space and allows shorter lead-in cables to antenna atop wheelhouse. (RCA photo)

an echo to return, the shore or cliff was known to be about a mile away.

A radar unit transmits short bursts of microwave radio energy (between 1000 and 30,000 megacycles) which are reflected by solid objects. Distance is determined by the length of time it takes a radar pulse to hit a target and return. Since radio waves travel at the speed of light—186,000 miles per second—the time from the instant a radar pulse is transmitted to the instant the echo returns is measured in microseconds (millionths of a second).

In a typical radar unit, more than a thousand pulses per second are transmitted in rapid succession as if fired from a machine gun. The pulses are spaced far enough apart in time to allow an echo to return before the next pulse is transmitted. The time required for a pulse to travel to a target and return as an echo is measured on a cathode-ray tube, similar in many respects to a TV picture tube. The echoes appear on the round screen as glowing "blips."

**Antenna Requirements.** Radar pulses should travel in a narrow beam in order to

allow the detection of small objects and the determination of direction as well as distance. A modified form of parabolic reflector, the so-called "dish" antenna, is used to focus microwave signals into a narrow beam. The antenna is rotated 360° horizontally so it can scan in all directions, and the antenna rotator motor is synchronized with another motor at the radar screen.

As the antenna rotates, the trace line on the radar screen sweeps around with it. This is done by rotating the magnetic sweep coils around the neck of the cathode-ray tube. The sweep starts at the center of the round tube face and rotates in step with the antenna. It looks something like a windshield wiper. Blips appear along the trace whenever a radar echo is received.

A long-persistence picture tube is used, so that the echoes remain on the screen until the sweep has rotated a full revolution and sometimes longer. As the radar beam rotates, a map of the surrounding area is "painted" on the screen. Large areas, such as the shoreline and islands, appear as large lighted masses. Boats and other small objects appear as small blips. Lighter hash or clutter may appear near the center of "home" point on the screen due to "sea return," a mass of echoes from the surface of the water.

Although marine radar equipment sometimes has a range up to 40 miles, maximum range is limited by the height of the antenna above water. Radar is a line-of-sight device, and as the antenna height is decreased, the effective range is reduced. While it might be interesting to see objects 20 miles away, objects within a range of eight miles are generally of more concern to the navigator.

**Typical Installation.** A marine radar installation consists of a transmitter, receiver, antenna, monitor, and power supply. One antenna serves both transmitter and receiver since the transmitter is turned on for only a microsecond or so and then pauses to allow the receiver to intercept the echo. The antenna is automatically switched from the transmitter to the receiver electronically.

Use of radar on pleasure craft is limited by space, the capacity of the electric power source, and the owner's pocketbook. Prices for radar units start at about \$1500. Power requirements are heavy, running from 300 watts to more than 1500 watts, which





**Lightweight,** low-cost radar equipment can be installed on a 28-footer without placing too much of a burden on the ship's battery. (Bendix-Pacific photo)

means that small boats equipped with 12-volt batteries may not have enough reserve electrical power for radar equipment. An auxiliary generator driven by a small engine can be used if a boat does not have 32- or 115-volt batteries.

An FCC radio station license is required and the radar equipment must qualify for FCC type acceptance. It must be installed and serviced under the supervision of a person holding a suitable FCC operator's license endorsed for radar. The master of a vessel, however, may use a licensed radar set without being required to have an operator's license. No one else may use the radar except under his personal supervision.

## LORAN

Conventional navigational devices such as radio direction finders are being supplemented on military and commercial vessels by loran, with its longer range than a conventional radio direction finder, no loop to rotate, and greater accuracy. Like radar, loran employs pulses, but operates at much lower frequencies (1750-1950 kc.) Loran, however, does not require a transmitter on board ship.

Sometimes called an "electronic stop watch," loran measures the difference in the time required for radio signals to arrive from different synchronized radio stations. Since radio waves travel at constant

velocity, the traveling time of a signal is proportional to the distance between transmitter and receiver.

**Chain of Operation.** A loran chain consists of two or three radio stations, a "master" and one or two "slaves." These transmitters are located from 200 and 400 miles apart and transmit short pulses simultaneously or offset by a precise time interval. The pulses are repeated between 25 and 35 times per second.

The difference in arrival time of signals from a group of loran stations is measured by a loran unit aboard ship. To get a "fix," it is necessary to take readings on two pairs of loran stations or a single three-station loran chain. The ship is located at the point where the hyperbolic curves or distance lines on the loran chart intersect.

Daytime range of loran is around 700

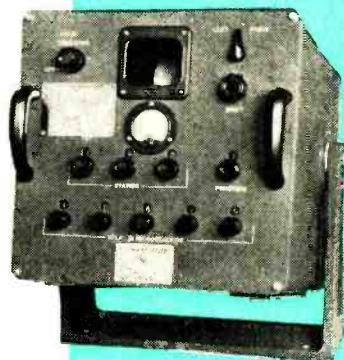

**Loran equipment is excellent for long-range navigation.** (Edo Corp. photo)

miles over water and about 450 miles at night, using the direct ground wave from the loran stations. At night, the reflected sky wave permits use at distances up to 1400 miles, but the results are less accurate. Error in line position of up to  $\pm 3$  nautical miles and in fixing of up to  $\pm 10$  nautical miles is apt to occur in using night sky waves at extreme distances.

Power requirements for loran are more modest than for radar (as little as 135 watts), but the cost of the equipment is about the same, starting at around \$1500. For reliable fixes in all kinds of weather, loran is of great importance to the boatman who ventures offshore beyond the range of radar or direction finders.

# Depth Sounders and Fish Finders

By LEO G. SANDS

**T**O MANY boatmen, the depth sounder is the most valuable piece of electronic gear one can have on a small boat. They find that it can be used as a navigational aid, a fish finder and a safety device.

It is easy to navigate with the aid of a depth sounder by comparing depth readings with the water depth markings on navigational charts. As a safety device, the instrument continuously monitors water depth and indicates the location of shallow areas and submerged objects. Fishermen no longer have to try fishing various spots, hoping to make a catch; instead, with a depth sounder, they can find the fish electronically.

**Echoes Measure Depth.** Also called a fathometer, a depth sounder transmits sound pulses through water and measures distance by noting the time it requires for a pulse to travel to an underwater target and for the echo to return. It is a form of sonar, which is used by the military for locating submarines as well as vessels.

A sonic pulse, as produced by a depth sounder, travels at a speed of about 4800 feet per minute through water. Although it is called a sound or sonic pulse, it is really an ultrasonic pulse, since it is too high in pitch to be heard by the human ear.

Pulses are generated by an electronic oscillator whose output frequency is somewhere in the range between 30,000 and

200,000 cycles (30-200 kc.). Actually, the oscillator produces a continuous frequency which is turned on and off to form pulses. One pulse is transmitted for each sounding.

The pulses are fed to a device called a transducer, which converts the electrical energy into sound waves (like a loudspeaker) directing them toward the bottom. The short burst of sound waves travels downward as a cone of sound. When the sound waves strike a solid object, such as the bottom, a submerged log or a school of fish, they are reflected back to the transducer (see Fig. 1). These reflected sounds are called echoes.

Distance is determined by measuring the time it requires for a sonic pulse to travel to the bottom or other target and return as an echo. If the water is 100 feet deep, for instance, it will take about 42 milliseconds (0.042 seconds) for the round trip. Depth sounders, however, can pick up more than one echo, so that it is possible to determine not only how deep the water is but also how far below the boat and how far above the bottom a passing school of fish might be.

**Neon, Scope or Tape.** All depth sounders for use on small boats operate on the same basic principle, but vary in the manner in which depth information is displayed. Most use a rotating flashing neon lamp whose position along a calibrated circular scale indicates depth in feet or fathoms or

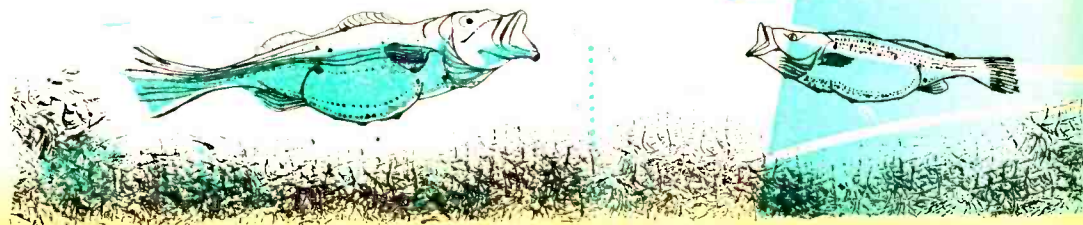

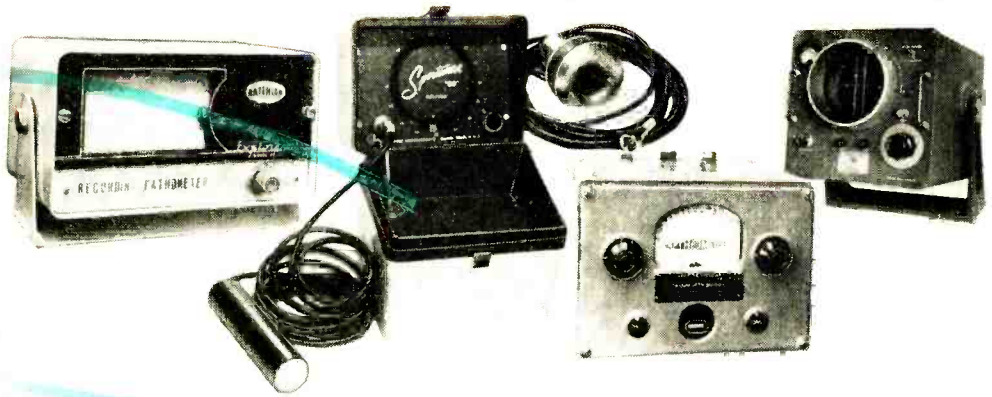

both. Others use an oscilloscope or a direct-reading meter. Depth recorders use a paper tape on which the distance to submerged objects and an outline of the contour of the bottom are recorded.

Most depth sounders employ from three to seven tubes and operate from a 6- or 12-volt battery, using a vibrator power supply to convert the d.c. to a.c. for operation of a small motor, whose function will be described later, and to provide a.c. for the plate voltage rectifier. The tube-type depth sounders require from 2 to 8 amperes when operated from a 6-volt battery and from 1 to 4 amperes when operated from a 12-volt battery, depending upon the make, type and complexity of the instrument.

Transistor-type depth sounders have been introduced recently, such as that made by Ross Laboratories, Inc., which operate from self-contained dry batteries. One of these uses a 7½-volt battery; current drain is only one-tenth of an ampere, and battery life is rated at 300-500 hours of operation.

**Flashing Light Indicator.** The electronic circuitry consists of an ultrasonic transmitter and a receiver plus means for actuating the indicator. In the types that use a flasher indicator, the neon bulb is attached to a disc or arm which is rotated by a small electric motor at a constant speed somewhere between 200 and 3600 rpm, depending upon depth wanted and the make

**Four basic types** of depth finders are, from left to right, the recording fathometer (Raytheon), rotating flashing neon lamp type (Ross), meter indicator type (Bludworth Marine), scope type (Edo).

and type of instrument. The disc is behind a translucent circular (or semicircular) scale calibrated in feet, fathoms or both.

The neon bulb always flashes when it passes the scale zero position, at which time a pair of switch contacts turns on (triggers) the oscillator. It is at this moment that a pulse is transmitted. The switch contacts open and, as the disc rotates, the receiver waits for the return of an echo. When an echo is received, and amplified, the neon bulb flashes again. The position at which it flashes behind the scale indicates the depth.

When more than one echo is received, more than one flash will occur at different points along the scale. The brightest flash, however, is generally the one caused by the echo from the bottom. When only a depth reading is desired, the extra flashes can usually be eliminated by adjustment of the sensitivity control.

A pulse is transmitted only at the time the neon bulb passes the triggered zero position. In some depth sounders, the neon lamp disc rotates two turns between pulses to extend the time allowed for receipt of

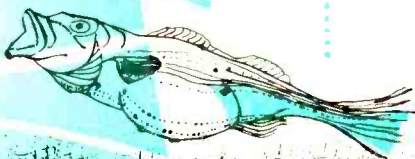

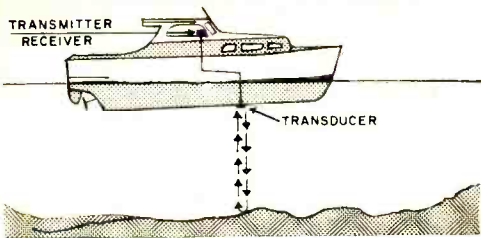

**Fig. 1.** Depth sounders operate on the principle of sound reflection from the sea bottom. A transducer mounted below the waterline alternately sends out a sound pulse and listens for the echo, with the elapsed time shown on some type of indicator.

echoes, and thereby double the range.

In more elaborate depth sounders, a cathode-ray tube is used as the indicator. The echoes may be seen along a calibrated trace. This type of indicator is obviously more expensive than the flashing bulb type but provides greater sensitivity.

In a depth recorder, the depth indications are recorded on a paper tape, as in Fig. 2, that is drawn slowly and continuously past a stylus which changes its position in response to intercepted echoes. A permanent graphic recording is made of the contour of the bottom as well as the locations of submerged objects with respect to the bottom. Soundings are automatically made several times a second, resulting in a jagged, continuous trace on the paper which can be viewed as soundings are made or referred to later.

**Crystal Transducer.** The transducer, which transmits pulses and receives echoes, is something like an intercom loudspeaker since it functions both as a loudspeaker and a microphone. It converts alternating electrical current into mechanical energy which results in transmission of sound waves through the water in a beam about  $10^\circ$  or more in width. As soon as the pulse has been transmitted, the transducer acts as a

microphone, waiting for returning echoes. These echoes cause mechanical stresses in the transducer which are converted into alternating current. This current is amplified and used to trigger the indicating system.

Most transducers use a barium titanate or ceramic crystal encased in plastic to prevent entry of water. Generally, the transducer is mounted under the boat, so that the transducer housing makes actual contact with the water. Sometimes it is mounted inside the bilge.

A transducer can be used on a temporary basis. By attaching it to a hollow pipe through which the interconnecting cable is run, the transducer can be dunked in the water by holding the pipe over the side.

Most depth sounders use only one transducer which functions both as transmitter and receiver. Some, however, use two of them, one for transmitting, the other for receiving.

**Finding Fish.** No FCC license is required for a depth sounder since it does not transmit airborne radio waves. It is simple to operate and can be used at cruising speeds when measuring water depth.

To find fish, however, the boat should move slowly, since the echoes from fish can be very feeble and easily missed. It has been said that the echoes are produced only by the bladders of the fish, and that there might not be any echoes from small numbers of tiny fish. Large fish or heavy concentrations of fish produce strong echoes.

Depth sounders are available from around \$125 and up. Most depend upon the availability of a storage battery with which most power boats are equipped. The new portable transistor types, however, can be used on sailboats and even rowboats, from self-contained battery cells.

For the man who takes his fishing seriously, a depth sounder is a must. And, for the man who just likes to sail, the depth sounder is a valuable navigational aid as well as an important safety device. ⚓

**Fig. 2.** This fathometer recording clearly shows the various sound reflecting layers between the surface and sea bottom. The same information is also shown on a rotating flasher type of indicator.

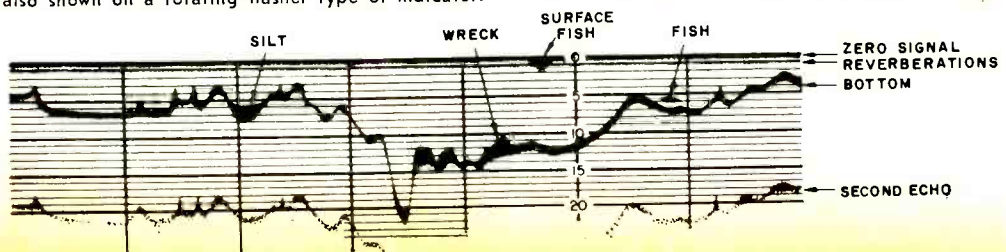

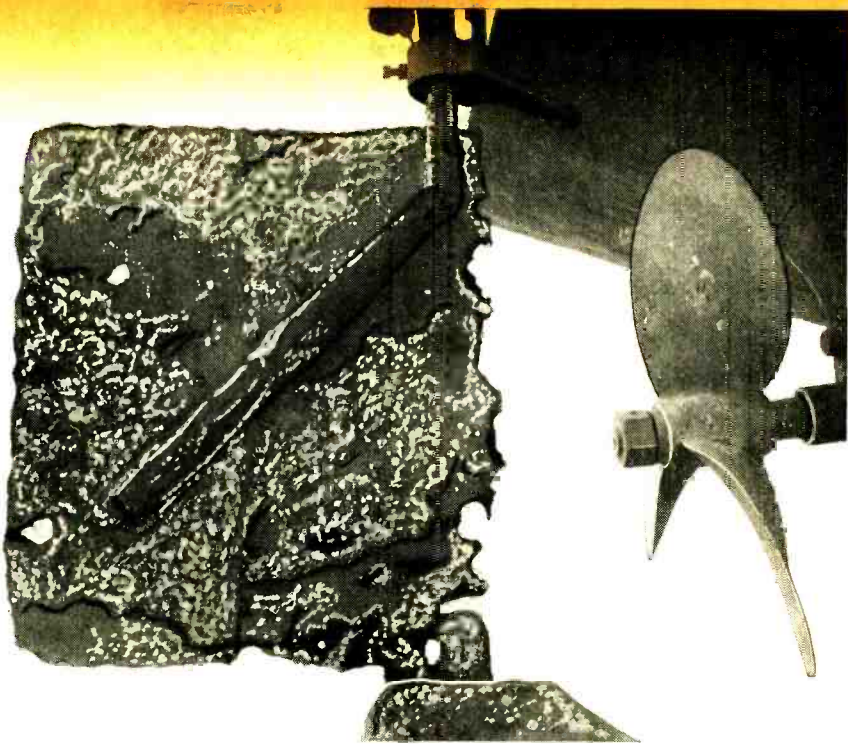

Severe galvanic corrosion in a steel rudder connected to copper-bottom sheathing, bronze shaft and propeller. The boat almost became a casualty.

**T**O A JET PILOT, it's a flameout. To a parkway pilot, it's a flat tire in the Holland Tunnel. For the owner of a boat, it's electrolysis—a boating problem ever since metal parts have found their way aboard.

Talk to old-time boatmen, dealers, or shipyard mechanics, and you'll probably hear plenty about this sea-water scourge . . . stories of boat and engine parts falling off, propellers turned to lace, boats sinking. It's true that these things can happen because of electrolysis, but no conscientious boatman need suffer—because electrolysis is easily prevented. First, however, let's find out exactly what it is.

**What Is Electrolysis?** The term "electrolysis" has come to be very loosely applied in the small-boat field. What many boatmen call "electrolysis" is often really some kind of corrosion.

Depending upon your dictionary, you will get all kinds of definitions from the simple "The decomposition of a chemical by an electric current," to a fat paragraph in Webster's New International Dictionary dealing with electrolytes, ions, and Faraday's laws.

In the strict sense of the term, electrolysis concerns chemical changes in the *solution* (in this case, the salt water) due to the passage of current. Since we need a

## ***Electrolysis and Corrosion***

***How to save your boat  
from the ravages  
of electrical corrosion***

By  
**ELBERT ROBBERSON**



term to work with, however, let's call the corrosion of metal parts involved in electrolysis "electrolysis corrosion."

**When Does It Occur?** Electrolysis corrosion occurs when direct current, as from a battery or generator, passes through the water from one conductor to another. You can get a good example of this activity very quickly and easily.

Dunk a pair of copper strips in a cup of salt water (table salt will do), and connect them to a 6-volt battery. Bubbles boil from the negative electrode and nothing much happens at the positive one—except that you may observe a green cloud creeping out from it into the water. What is happening is that the metal of the positive strip is going into the solution. In a short while, the weight loss of this electrode can be measured with a sensitive scale. Carry on your experiment long enough and there won't be any positive-end copper left.

This is what boatmen commonly call electrolysis—loss of metal due to battery current between underwater parts. Run battery current between a boat's underwater metal parts, and the positive part corrodes rapidly away. Stop the current flow, and the process halts.

Since no one would reasonably connect a battery between underwater metals on his boat, how can this possibly happen? Very easily, due to the fact that one side of the battery circuit for motors and many electrical boat accessories and lights, etc., is connected to the frame, shell, or "ground."

If you cross-ground one gadget by using opposite ground polarity from that used on any other fixture, you've set up your boat for possible electrolysis corrosion. The damaging current flow can take place through bilge water as well as through the water under the boat; and it has also been known to take place through wet wood. So, when installing fixtures, taking batteries ashore for charging, or doing anything with the electrical system of the boat—keep the polarity of the ground connections the same. Lately, manufacturers have begun to standardize to a large degree on negative grounding; but don't count on it—investigate and be sure.

Another way to invite electrolysis corrosion is to use insufficient heavy wire to supply power to heavy-drain items, such as a radiotelephone, which have ground connections to the water. Voltage drop occurring in the ground leg of the power

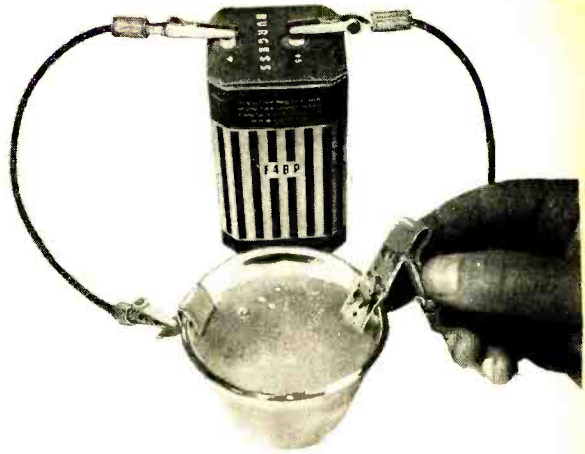

supply circuit is just the same as with battery voltage: if there is a difference of potential between points A and B underwater, no matter if the voltage is from a generator, battery, or a voltage drop in a wire, trouble can result. Use large wire for power leads to keep voltage drop close to zero. In addition, it is a good idea to connect grounded objects together inside the boat with a "bonding" wire of at least No. 10 gauge, and also bond in the engine frame and radio ground plate, if any.

**Galvanic Corrosion.** Most underwater corrosion has no connection whatever with electrolysis, contrary to popular thought. This trouble is simply "galvanic corrosion." It takes place when three conditions are satisfied: the metals are in contact with salt water; they are different in composition; and they are in electrical contact through a metallic path. This forms a galvanic cell—like a primary battery cell. Current is generated, flows through the water, and the metal supplying the current corrodes.

This automatically happens when ordinary hardware-store brass is used for underwater fittings or fastenings on a boat. Ordinary brass is an alloy composed of about 30% zinc and 70% copper. The table on page 96 shows the galvanic activity of boat metals. Note that zinc is at one end of the scale and copper near the other. Result: the zinc is corroded, leaving a spongy copper mass in place of the brass. This has no strength, so holes appear and fastenings disappear.

Many alloys are so cannibalistic that

◀ **Electrolysis corrosion** can be studied by immersing copper strips in brine, and connecting a battery. In a short time, the current flow will cause the positive electrode to corrode—eventually be entirely eaten.

**"Self-devouring"** propeller at right suffered from faulty alloy, so zinc block, mounted on wood, above, gave no protection.

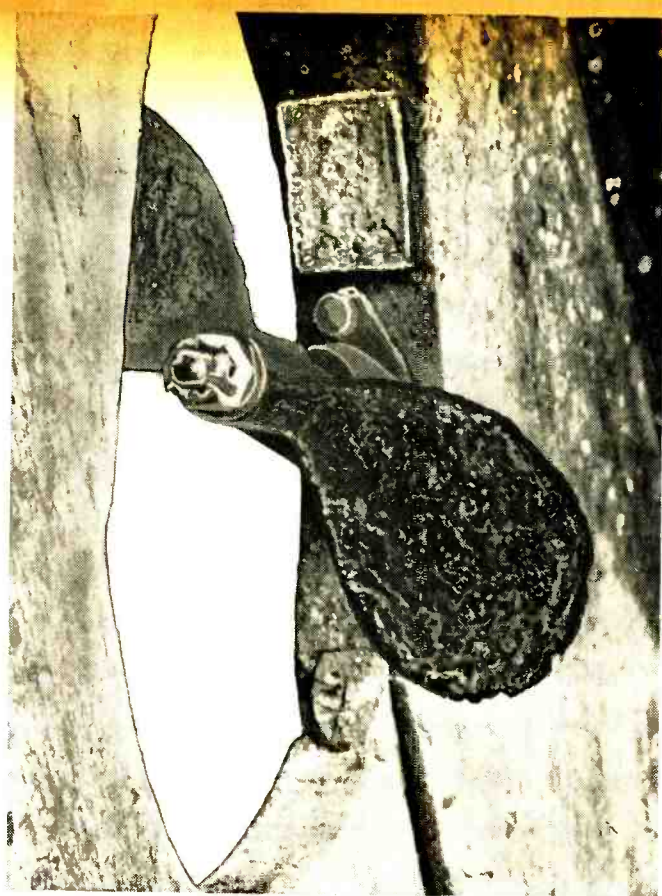

they will feed on themselves in this fashion. So, the first rule which must be followed to avoid galvanic corrosion is to use only fittings and fastenings which are made of seaworthy metal: bronze, Everdur, Monel, stainless steel, and—if you are loaded—titanium, gold and platinum. All are extremely resistant to corrosion.

Next, make sure that all of the different underwater metals are of the same family. Avoid galvanized iron or steel if there is copper or any of the other more noble metals around. Always try to use fastenings which are more noble than the metal of the object they are holding in place. This way, if there is the least bit of corrosion, it will affect the comparatively bulky piece of hardware (which can afford to lose a few grams weight) instead of the smaller fastening which may weaken to the point of failure after the loss of just a little metal.

An outboard motor is, unfortunately, mostly active metal, and likely to corrode quite rapidly if given the right conditions. To be on the safe side, when your motor is not actually in use, keep it up out of the water . . . especially if it has a bronze propeller.

The importance of avoiding unlike combinations of metal underwater cannot be stressed too much. And never install an object made of a metal about which you are unsure.

The builders of a beautiful yacht, the "Sea Call," learned this the hard way. Monel is practically proof against corrosion, so they built the underwater shell of pure Monel. But the frames, stem and rudder were steel; and while most of the rivets were Monel, a few steel rivets were accidentally mixed in. Shortly after the vessel was placed in the water, one of these steel rivets disappeared, and people began to get suspicious. Upon dry-docking the yacht, it was found that all of the steel near the Monel metal was rapidly corroding, while the Monel, of course, remained unaffected. The yacht was built in 1915 and scrapped in 1916!

**Cures for Corrosion.** Prevention is the best cure for corrosion, of course, but many times it is not possible to have conditions as perfect as would be desired. Good underwater metals may pick up dirt or oxide which changes their galvanic activity; small impurities in a metal can create galvanic hot spots; and it is conceivable that somewhat different metals must, of necessity, sometimes be used. On large ships, you will often find combinations of aluminum and steel or bronze.

If it is necessary to use different metals,

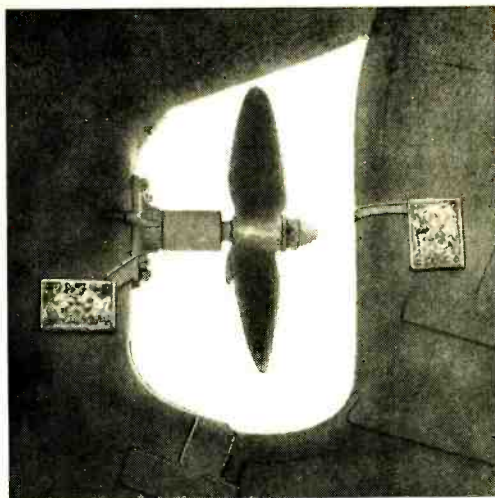

**Zinc blocks** must be connected to metal that they are to protect. This propeller nut has a zinc overcoat. Blocks on deadwood and rudder are connected by copper straps to rudder post and stern bearing.

they must be electrically insulated from each other. Plastic gaskets, Micarta separators and sleeves, rubber or other water-proof insulating material can be used. As long as there is "no circuit," corrosion will stay away.

You can also obtain protection with unbroken coverings of plastic paint, neoprene compound, or other insulating coverings.

But the most popular method of protecting metals which unavoidably suffer from galvanic corrosion was cooked up by Sir Humphrey Davy in 1824. The copper sheathing on warships was corroding. "Attach blocks of zinc to the copper," said Sir Humphrey. The idea was that, being more

active than any surrounding metal, the zinc would supply metal for all of the galvanic action, and the other metal would remain unscathed. This idea was so good that even today U. S. Navy vessels which must be as light and maneuverable as possible have tons of zinc *anodes* attached to their hull plating.

Special zinc anodes are made for small boats, in the form of plates, propeller-nut caps, and shaft sleeves, and are available from marine hardware stores. The zinc must be as pure as possible (less than .0014% iron content), and it must be attached or electrically connected to the metal which it is supposed to protect. It must not be painted, however, and when it has corroded badly (it will corrode, if it is providing any protection), the zinc anodes must be replaced.

A more modern method of protection is to supply a reverse current from a platinum anode fitted to the hull, powered by a battery-operated regulated supply. Although this is highly effective, it is somewhat more expensive.

**The Scapegoat.** Underwater metal comes apart for many more reasons than electrolysis and corrosion. Among these are abrasion from mud and sand, and cavitation.

At the time when comparatively little was known about the installation of electrical and electronic equipment on small boats, it was fashionable, and very easy, to blame every bit of underwater trouble on electrolysis. Radio had a bad name. Sober-faced "experts" actually claimed that the instant you installed a radiotelephone on a boat, the underwater hardware would start to fall off.

But since ghosts have gone out of vogue, don't tremble at the awful specter of electrolysis. Keep track of your electrical circuits so that current does not flow through the water; use sea-going metals and be sure they are properly mated; and use zinc anodes, if necessary. Take these basic protective measures, and you should have no trouble.

#### GALVANIC ACTIVITY OF BOAT METALS

When different electrically connected metals (listed below) are immersed in salt water, the metals closest to the base end corrode, and the ones closest to the noble end of the scale do not corrode.

BASE END

Magnesium  
Zinc  
Galvanized Steel or Iron  
Aluminum (Pure)  
Steel and Iron  
Lead  
Brasses  
Copper  
Bronzes, Everdur  
Monel  
Stainless Steel

NOBLE END



# MANUFACTURERS OF MARINE ELECTRONIC EQUIPMENT

## RADIOTELEPHONES

**Aerosonic Marine, Inc.**, Hercules & Range Rd., Clearwater, Fla.  
**Applied Electronics Co., Inc.**, 213 E. Grand Ave., S. San Francisco, Calif.  
**Bendix-Pacific**, 8211 Lankershim Blvd., N. Hollywood, Calif.  
**Bludworth Marine**, 1500 Main Ave., Clifton, N. J.  
**Central Electronics Corp.**, 6013 Ackley Rd., Cleveland 29, Ohio  
**Gray Radio Co., Inc.**, 501 Forest Hill Blvd., W. Palm Beach, Fla.  
**Hudson American**, 29-01 Borden Ave., Long Island City, New York  
**Ray Jefferson, Inc.**, 40 E. Merrick Rd., Freeport, N. Y.  
**Kaar Engrg. Corp.**, 2995 Middlefield Rd., Palo Alto, Calif.  
**Micro-Lab Industries, Inc.**, 10 Clair St., Anderson, Ind.  
**Multi-Products Co.**, 21470 Coolidge Highway, Oak Park, Mich.  
**Munston Mfg. & Service, Inc.**, Beech St., Islip, N. Y.  
**George O'Day**, 9 Newbury St., Boston 16, Mass.  
**Pearce Simpson, Inc.**, 2295 N.W. 14th St., Miami, Fla.  
**Radio Corp. of America**, Building 15-1, Camden, N. J.  
**Raytheon Marine Products**, 100 River St., Waltham, Mass.  
**Rowe Industries**, 1702 Wayne St., Toledo 9, Ohio  
**Schuttig-Atlantic**, Box 1451, Annapolis, Md.  
**Sonar Radio Corp.**, 3050 W. 21st St., Brooklyn, N. Y.



## RADIO DIRECTION FINDERS

**Allen & Bradford**, 3181 N. Elston Ave., Chicago, Ill.  
**Applied Electronics Co., Inc.**, 213 E. Grand Ave., S. San Francisco, Calif.  
**Bendix-Pacific**, 8211 Lankershim Blvd., N. Hollywood, Calif.  
**Bludworth Marine**, 1500 Main Ave., Clifton, N. J.  
**Cas Mfg. Co.**, 413 E. Hub, Mineral Wells, Texas  
**Guest Products Corp.**, 35-04 30th St., Long Island City, New York  
**Heath Company**, Benton Harbor, Mich.  
**Ray Jefferson, Inc.**, 40 E. Merrick Rd., Freeport, N. Y.  
**Kaar Engrg. Corp.**, 2995 Middlefield Rd., Palo Alto, Calif.  
**Munston Mfg. & Service, Inc.**, Beech St., Islip, N. Y.  
**National Co., Inc.**, 61 Sherman St., Malden 48, Mass.  
**George O'Day**, 9 Newbury St., Boston, Mass.  
**Radio Corp. of America**, Building 15-1, Camden, N. J.  
**Raytheon Marine Products**, 100 River St., Waltham, Mass.  
**Robinson & Co.**, Box 213, Gardena, Calif.  
**Sonar Radio Corp.**, 3050 W. 21st St., Brooklyn 24, N. Y.  
**Sperry Piedmont Co.**, Route 29, Charlottesville, Va.



## DEPTH SOUNDERS

**Applied Electronics Co., Inc.**, 213 E. Grand Ave., S. San Francisco, Calif.  
**Bendix-Pacific**, 8211 Lankershim Blvd., N. Hollywood, Calif.

July, 1959

**Bludworth Marine**, 1500 Main Ave., Clifton, N. J.  
**Edo Corp.**, 13-10 111th St., College Pt., N. Y.  
**Jackson Electrical Instrument Co.**, 18 S. Patterson Blvd., Dayton, Ohio  
**Pearce Simpson, Inc.**, 2295 N.W. 14th St., Miami, Fla.  
**Radio Corp. of America**, Building 15-1, Camden, N. J.  
**Raytheon Marine Products**, 100 River St., Waltham, Mass.  
**Ross Laboratories, Inc.**, 124 Lakeside Ave., Seattle 22, Wash.  
**Sonar Radio Corp.**, 3050 W. 21st St., Brooklyn 24, N. Y.  
**Wilfrid O. White & Sons, Inc.**, 178 Atlantic Ave., Boston 10, Mass.



## AUTOMATIC PILOTS

**Applied Electronics Co., Inc.**, 213 E. Grand Ave., S. San Francisco, Calif.  
**Belock Instrument Co.**, Marine Div., 11203 14th Ave., College Pt., N. Y.  
**Bendix-Pacific**, 8211 Lankershim Blvd., N. Hollywood, Calif.  
**Cowelca**, 1634 W. 14th St., Long Beach 13, Calif.  
**Hill-Cunningham**, Los Angeles, Calif.  
**La Marche Sales Co.**, 49 Woodruff Ave., Wakefield, R. I.  
**Metal Marine Pilot, Inc.**, 342 Golden Gate Ave., Tacoma, Wash.  
**Richardson Controls Corp.**, 2563 Post Rd., Warwick, R. I.  
**Silva, Inc.**, 702 Ridgeway St., La Porte, Ind.  
**Sperry Piedmont Co.**, Route 29, Charlottesville, Va.  
**Ware Marine Products, Inc.**, 6763 S.W. 81st St., Miami 43, Fla.  
**Wilfrid O. White & Sons, Inc.**, 178 Atlantic Ave., Boston 10, Mass.



## RADAR EQUIPMENT

**Bendix-Pacific**, 8211 Lankershim Blvd., N. Hollywood, Calif.  
**Bludworth Marine**, 1500 Main Ave., Clifton, N. J.  
**Chemalloy Electronics Corp.**, Gillespie Airport, Santee, Calif.  
**Decca Radar**, 386 4th Ave., New York 16, N. Y.  
**Edo Corp.**, 13-10 111th St., College Pt., N. Y.  
**Lavoie Laboratories Corp., Inc.**, Matawan Freehold Rd., Morgansville, N. J.  
**Radio Corp. of America**, Building 15-1, Camden, N. J.  
**Raytheon Marine Products**, 100 River St., Waltham, Mass.  
**Sperry Piedmont Co.**, Route 29, Charlottesville, Va.



## RADIO RECEIVING SETS

(Short-Wave and Marine Bands)

**Applied Electronics Co., Inc.**, 213 E. Grand Ave., S. San Francisco, Calif.  
**Bendix-Pacific**, 8211 Lankershim Blvd., N. Hollywood, Calif.

# MANUFACTURERS OF MARINE ELECTRONIC EQUIPMENT

(Continued from the preceding page)

**Burlington Electric Corp.**, Keim Blvd., Burlington, N. J.  
**Cas Mfg. Co.**, 413 E. Hub, Mineral Wells, Texas  
**Channelmaster, Inc.**, Ellenville, N. Y.  
**Kaar Engng. Corp.**, 2995 Middlefield Rd., Palo Alto, Calif.  
**Machine & Supply Co.**, Drawer 391, Morehead City, N. C.  
**Micro-Lab Industries**, 10 Clear St., Anderson, Ind.  
**National Co., Inc.**, 61 Sherman St., Malden 48, Mass.  
**Pearce Simpson, Inc.**, 2295 N.W. 14th St., Miami, Calif.  
**Radio Corp. of America**, Building 15-1, Camden, N. J.  
**Robinson & Co.**, 731 W. 129th St., Gardena, Calif.  
**Rowe Industries**, 1702 Wayne St., Toledo 9, Ohio  
**James S. Spivey, Inc.**, 4908 Hampden Lane, Bethesda, Maryland.  
**Sturman Instrument Co.**, 2023 Ashland Ave., Baltimore, Maryland.  
**Vocaline Co. of America**, Old Saybrook, Conn.  
**Zenith Radio Corp.**, 6001 W. Dickens Ave., Chicago, Ill.



## RADIO ANTENNAS

**Admiral Corp.**, 3800 Cortland St., Chicago, Ill.  
**Applied Electronics Co., Inc.**, 213 E. Grand Ave., S. San Francisco, Calif.  
**Bendix-Pacific**, 8211 Lankershim Blvd., N. Hollywood, Calif.  
**Garelick Mfg. Co.**, 644 Second St., St. Paul Park, Minn.  
**Hudson American**, 29-01 Borden Ave., Long Island City, New York  
**Instrument Associates**, 351 Great Neck Rd., Great Neck, New York  
**Ray Jefferson, Inc.**, 40 E. Merrick Rd., Freeport, N. Y.  
**Kaar Engng. Corp.**, 2995 Middlefield Rd., Palo Alto, Calif.  
**Master Mobile Mounts, Inc.**, 1306 Bond St., Los Angeles 15, Calif.  
**Morad Electronics Corp.**, 2434 1st Ave., S., Seattle 4, Wash.  
**Munston Mfg. & Service, Inc.**, Beech St., Islip, N. Y.  
**Pearce Simpson, Inc.**, 2295 N.W. 14th St., Miami, Calif.  
**Premax Products**, College & Highland Aves., Niagara Falls, N. Y.  
**Radio Corp. of America**, Building 15-1, Camden, N. J.  
**Raytheon Marine Products**, 100 River St., Waltham, Mass.  
**Rowe Industries**, 1702 Wayne St., Toledo 9, Ohio  
**South West Electronics Co.**, 12629 W. Washington Blvd., Culver City, Calif.  
**James S. Spivey, Inc.**, 4908 Hampden Lane, Bethesda, Maryland  
**Sturman Instrument Co.**, 2023 Ashland Ave., Baltimore, Maryland  
**Vocaline Co. of America**, Old Saybrook, Conn.  
**Washington Aluminum Co., Inc.**, Knecht Ave. & Pennsylvania R.R., Baltimore 29, Md.  
**Webster Mfg. Co., Inc.**, 242 Shoreline Highway, Mill Valley, Calif.



## POWER MEGAPHONES

**Antrex Corp.**, 856 N. Rockwell, Chicago 22, Ill.  
**Audio Equipment Co.**, 75 Harbor Rd., Port Washington, New York  
**Bell Products**, St. Louis, Mo.  
**Guest Products Corp.**, 35-04 30th St., Long Island City, New York  
**Kaar Engng. Corp.**, 2995 Middlefield Rd., Palo Alto, Calif.  
**Keenzales Enterprises, Inc.**, 6112 S. Grand Ave., Buena Park, Calif.  
**Merriman Brothers, Inc.**, Armory St., Boston 30, Mass.  
**Pye Corp. of America**, 1149 Raritan Ave., Highland Park, New Jersey  
**Radio Corp. of America**, Building 15-1, Camden, N. J.  
**Sound Craft Systems**, 661 Rochester Rd., Pittsburgh, Pa.  
**South West Electronics, Inc.**, 12629 W. Washington Blvd., Culver City, Calif.  
**Sturup, Inc.**, 50 Silver St., Middletown, Conn.



## PORTABLE RADIO RECEIVERS

**Admiral Corp.**, 3800 Cortland St., Chicago, Ill.  
**Andrea Radio Corp.**, 27-01 Ridge Plaza N., Long Island, New York  
**Antrex Corp.**, 856 N. Rockwell, Chicago 22, Ill.  
**Cas Mfg. Co.**, 413 E. Hub, Mineral Wells, Texas  
**Central Electronics Corp.**, 20168 Bonniebank Blvd., Rocky River, Ohio  
**Channelmaster, Inc.**, Ellenville, N. Y.  
**Heath Co.**, Benton Harbor, Mich.  
**Magnavox Co.**, Fort Wayne, Ind.  
**Motorola, Inc.**, 4545 W. Augusta Blvd., Chicago 51, Ill.  
**National Co., Inc.**, Sherman St., Malden 48, Mass.  
**Radio Corp. of America**, Building 15-1, Camden, N. J.  
**Robinson & Co.**, 731 W. 129th St., Gardena, Calif.  
**South West Electronics, Inc.**, 12629 W. Washington Blvd., Culver City, Calif.  
**James S. Spivey, Inc.**, 4908 Hampden Lane, Bethesda, Maryland  
**Taylor Co., Inc., N. A.**, Gloversville 15, N. Y.  
**Zenith Radio Corp.**, 6001 Dickens Ave., Detroit 14, Mich.



## RADIO INTERFERENCE

(Shielding Systems, Grounds, etc.)

**Aquadynamics Co.**, 6930 Farmdale Ave., N. Hollywood, Calif.  
**Chas. Engelhard, Inc.**, 850 Passaic, E. Newark, N. J.  
**Hallet Mfg. Co.**, 5910 Bowcraft St., Los Angeles 16, Calif.  
**Morad Electronics Corp.**, 2434 1st Ave., S., Seattle 4, Wash.  
**Pearce Simpson, Inc.**, 2295 N.W. 14th St., Miami, Calif.

# Experimenter's Variable Power Supply



**Special circuit  
provides 0-500 volts  
of filtered,  
regulated d. c.**

**I**F YOU "breadboard" much electronic equipment, you know that it is sometimes a tedious chore. When you start "stealing" B-plus and filament voltages from other instruments, the usual result is a string of voltage-dropping resistors crawling over your workbench. And, not infrequently, the aroma of charred resistors hangs heavily in the air. If you want to eliminate these headaches once and for all, try investing a little time and cash in this variable power supply.

Utilizing a standard series-type regulation circuit, the POP'tronics VR supply will provide from zero to 500 volts d.c. at currents ranging up to 100 milliamperes. And the regulation is so good that at a no-load output of 300 volts, the sudden application of 3000 ohms (representing a 100-ma. load) to the output terminals will not even produce a visible twitch of the voltage meter. The filtering, too, is excellent, with the a.c. ripple content held to a small fraction of 1%.

The power supply is built on a 7" x 7" x 2"

**By  
CHARLES H. WELCH**

aluminum chassis with front panels and sides made of sheet aluminum and top and bottom covers of perforated aluminum. All the sheet metal parts can be fabricated in the home shop without any special tools, or chassis boxes may be used. The bottom cover is simply a square of this material which is held in place by the screws which mount the rubber feet.

**Heat Dissipation.** Since parts layout is not critical, the photographs provide sufficient information for duplication of the author's unit. The same physical layout need not be followed if the very important considerations of heat dissipation and ventilation are kept in mind.

Heat is a special problem since the series-regulator tubes, which act as a sort of variable resistor, grow quite hot when low-

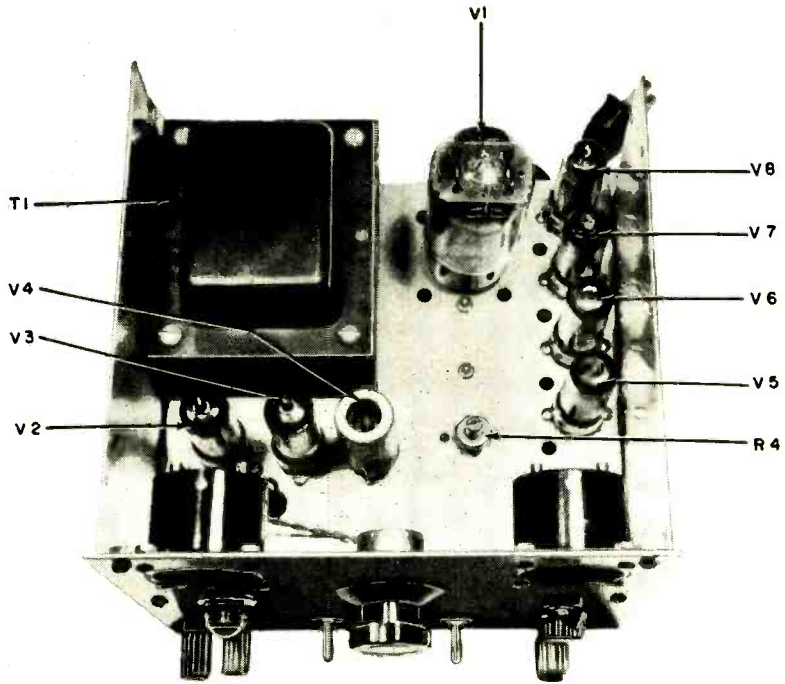

**Parts arrangement** shown in the top and bottom chassis layouts is recommended for best heat dissipation of the variable power supply.

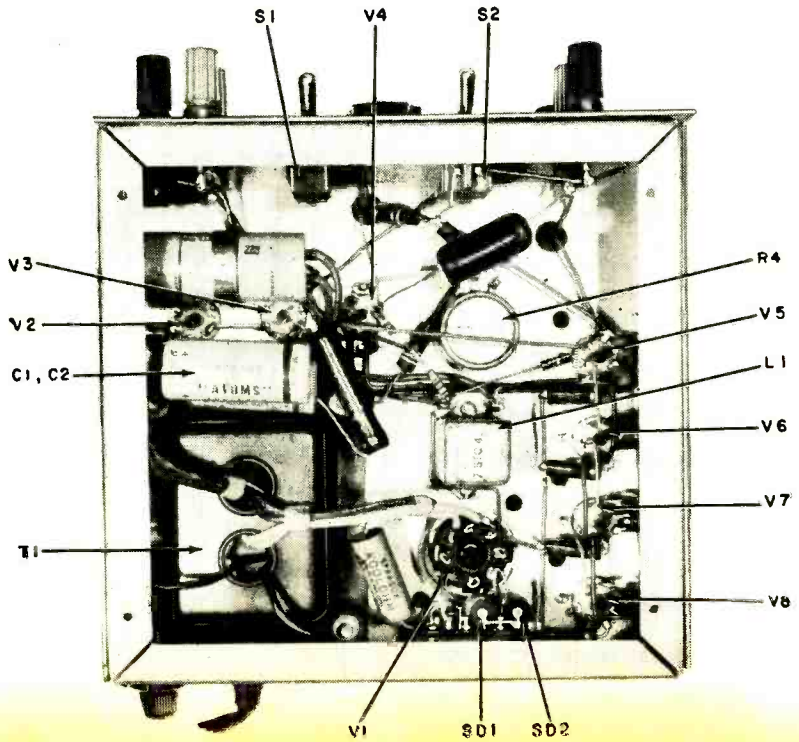

## PARTS LIST

C1, C2—12- $\mu$ d., 450-volt electrolytic capacitor  
 C3—8- $\mu$ d., 600-volt dual unit or separate electrolytic capacitors  
 C4—0.1- $\mu$ d., 600-volt capacitor  
 F1—3AG fuse holder with 2-amp. fuse  
 L1—10-henry, 25-ma. choke  
 PL1—6.3-volt pilot light assembly  
 R1—600-ohm, 5-watt wire-wound resistor  
 R2—10,000-ohm, 10-watt wire-wound resistor  
 R3—12,000-ohm, 1-watt carbon resistor  
 R4—5000-ohm, 2-watt wire-wound potentiometer (slotted shaft)  
 R5—39,000-ohm, 1-watt resistor  
 R6—560,000-ohm,  $\frac{1}{2}$ -watt resistor  
 R7—1-megohm,  $\frac{1}{2}$ -watt carbon resistor

voltage, high-current output requirements are met. For this reason the series-regulator tubes and the rectifier tube have been located near the back of the chassis and adequate holes provided for convection air circulation. In addition, the electrolytic capacitors and the silicon bias rectifiers have been located below the chassis since they are quite sensitive to heat.

**Optional Meters.** The metering circuits, which measure the output voltage and current of the power supply, are strictly op-

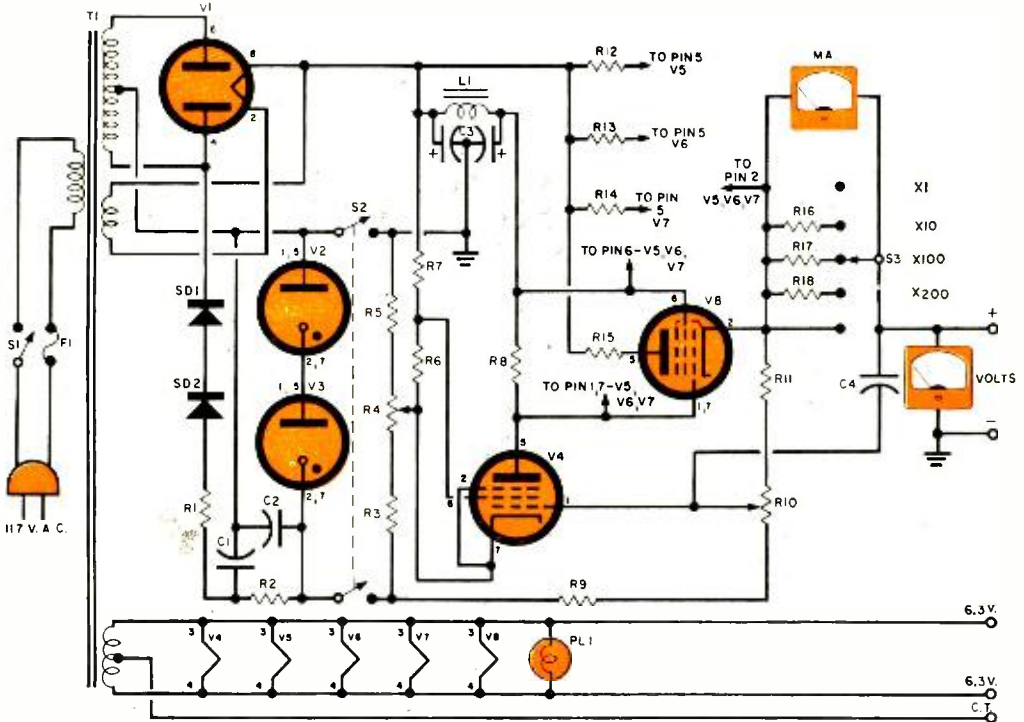

R8—10.0 megohm,  $\frac{1}{2}$ -watt carbon resistor  
 R9—220,000-ohm, 1-watt resistor  
 R10—500,000-ohm potentiometer (linear taper)  
 R11—2.2-megohm, 1-watt resistor  
 R12, R13, R14, R15—22-ohm, 1-watt carbon resistor  
 R16—22.5-ohm meter shunt (x 10)—see text  
 R17—2.25-ohm meter shunt (x 100)—see text  
 R18—1.1-ohm meter shunt (x 200)—see text  
 S1—S.p.s.t. toggle switch  
 S2—D.p.s.t. toggle switch  
 S3—1-pole, 5-pos. rotary switch (shorting type)  
 SD1, SD2—Silicon rectifier (Sarkes-Tarzian K200)  
 T1—Power transformer, secondary 750 volts center-tapped @ 150 ma.; 5 volts @ 3 amp.; 6.3 volts @ 5 amp.  
 V1—5U4G tube (rectifier)  
 V2, V3—0A2 tube (gas regulator)  
 V4—6AU6 tube (control amplifier)  
 V5, V6, V7, V8—6AQ5 tube (series regulator)  
 1—0-1 ma. d.c. meter (1 $\frac{1}{2}$ " )  
 1—0-500 volt d.c. voltmeter (1 $\frac{1}{2}$ " )  
 5—Five-way binding posts, three red, two black  
 1—7" x 7" x 2" aluminum chassis

**Regulator tubes V5, V6, and V7** have been omitted from schematic for clarity.

tional and may be omitted entirely in the interests of simplicity or economy if the builder prefers.

If you use the meters, wire the voltmeter permanently across the output terminals of the power supply. The current meter, which is basically a 0-1 milliammeter, is provided with shunts which may be switched in for full-scale readings of 10, 100, and 200 ma., plus an *Off* position in which the meter is shorted out of the circuit entirely.

The shunt resistors can be selected from  
 (Continued on page 148)

# Raymond Scott: Electronics Enthusiast *Par Excellence*

By ALAN D. HAAS

The house where Raymond Scott and Dorothy Collins and their two children live is not a home—in any ordinary sense; it is a 32-room electronic labyrinth. A completely self-taught engineer, Raymond has filled many of the rooms with special electronic devices used in his composing and recording chores that have confounded experts in the field. The exact worth of all the electronic installations is a mystery, even to Raymond, but he estimates that he has a "couple of hundred thousand dollars" invested in the equipment . . .



Dorothy Collins records a new tune while hubby Raymond Scott works the dials. This room contains equipment which would do credit to any commercial recording studio. Both Dorothy and Raymond make test recordings in Raymond's studio before doing an actual recording.

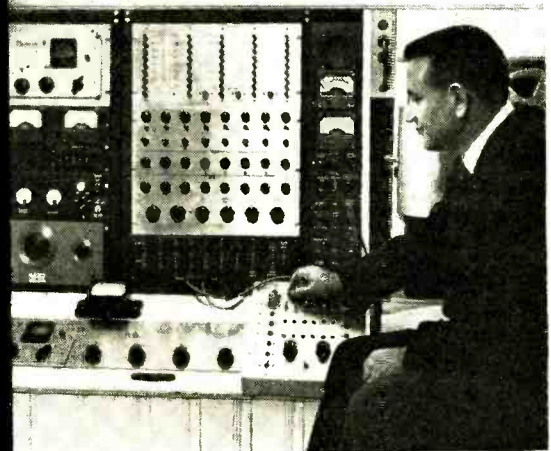

Raymond listens to the playback. Several tape recorders and complex control equipment allow him to make any type of stereo or monophonic recording.

In his basement workshop (at right) Raymond has all the machinery necessary for building his sound equipment. Most of the units in his recording studio were designed and built in this workshop.

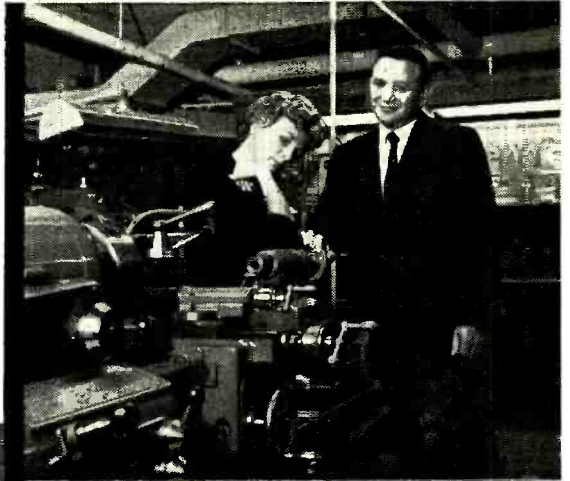

The "videola" (above) is one of Raymond's own inventions. He uses it to write musical scores for motion pictures. As the film is projected on the screen, he plays the accompanying music. The piano is recorded by the tape recorder shown at the left of the "videola."



**What a junk box!** One complete room in the basement is filled with nothing but cabinets full of spare parts. Raymond employs a full-time assistant to build and maintain his complex equipment.



**All this and a ham, too!** Raymond Scott spends many of his leisure hours communicating with his friends on the ham bands.



## **Build the Reflex 12**

**Friction-loaded enclosure provides excellent performance with low-resonance speakers**

**By  
DAVE GORDON**

A well-designed bass reflex speaker system is constructed in such a way that the Helmholtz resonance of the air within the cabinet cancels out the electro-acoustic resonance of the loudspeaker. However, resonance caused by panel vibration is another question altogether. A great deal of the "muddy" bass response characteristic of the lower priced or homemade speaker systems which is usually blamed on the speaker is actually due to the panel resonance of the cabinet.

There are various techniques of minimizing panel vibration. One authority advocates solid brick enclosures or, if that proves unfeasible, sand-filled panels. Others suggest the use of 1 1/4" plywood construction—liberally screwed, glued, and cleated. All these ideas work well but their sheer weight eliminates them from the living rooms of most households.

Luckily for those of us with thin "modern" floors in our homes, very good vibration reduction can be achieved by the use of well-arranged internal bracing—at a considerable  
*(Text continued on page 107)*



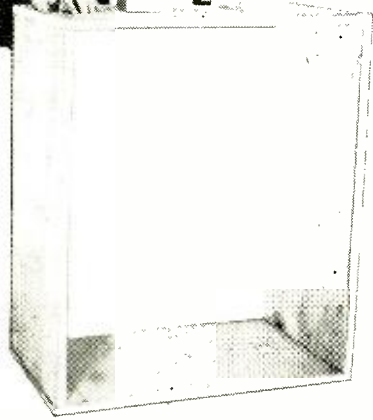

**1** Sides, top and bottom of enclosure are assembled using a good wood glue and 8d (penny) finishing nails. All joints are butted with five or six nails per joint. Design of cabinet makes use of cleats unnecessary.

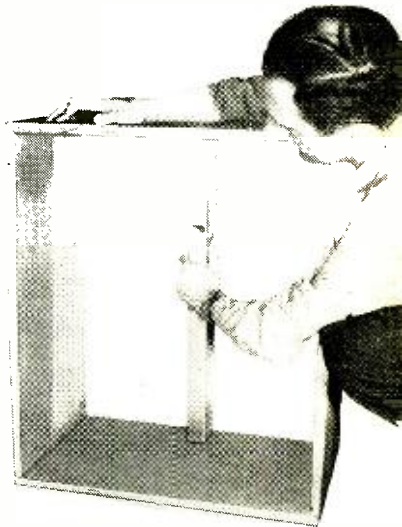

**2** Rear 2" x 4" brace is placed with narrow side flush with rear edge of top and bottom panels. Two #8 flat-head wood screws and glue should be used at each end to hold 2" x 4" brace in position.

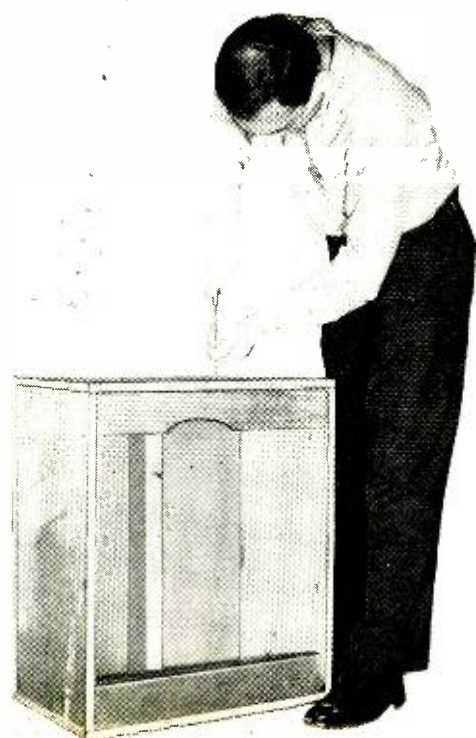

**3** After back panel is glued and nailed in place, 2" x 4" cross-braces are installed. Wood screws and glue are used to tighten rear panel to the 2" x 4" rear brace and to secure cross-braces. Cracks should be calked with wood putty to prevent air leaks.



**4** Cabinet divider is fitted next. Exact angle is unimportant, but it should not be mounted parallel with top panel. Glue and two wood screws at each end hold it in place. Slight arc cut out of the top brace enables speaker to mount properly. Front edge of shelf should be flush with front edges of enclosure.



**5** Finishing panel, although not necessary, may be added for the sake of appearance. Four wood screws through cabinet hold 30" x 16" panel in place. Interior of top compartment should be loosely lined with Fiberglass, rock wool, or other acoustical damping material. Cabinet may be used upright as lowboy, finished or unfinished, as desired.

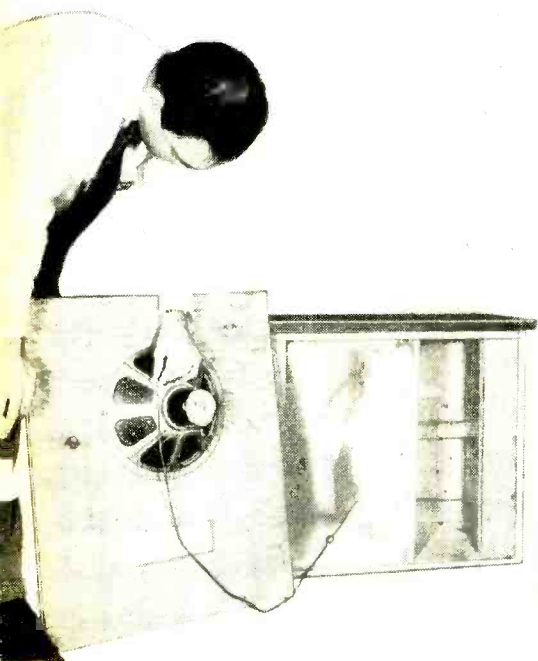

**6** Speaker is mounted on front panel with four  $1\frac{1}{2}$ " bolts and nuts. Speaker cable is attached to the binding posts on the speaker frame and comes out through a small hole drilled in the back panel of the enclosure.

7 One layer of ordinary burlap is stapled tightly over the port to provide "friction loading" of the speaker. See graph for effect of adding burlap. If more "resonant" bass is desired, omit the burlap strip.

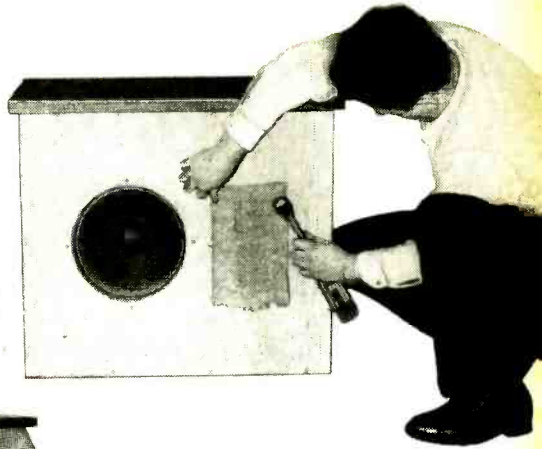
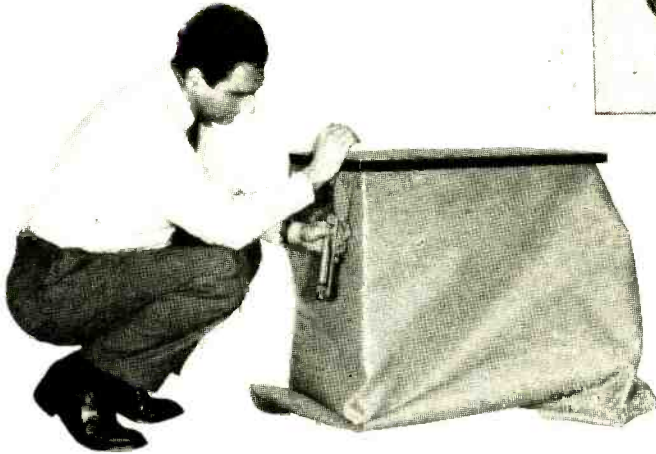

8 Plastic hi-fi grille cloth made by Mellotone is wrapped around cabinet and stapled into place. This material is recommended for speaker enclosures because it is strong, good-looking, and acoustically transparent. After the grille cloth is stapled, legs or a base can also be installed.

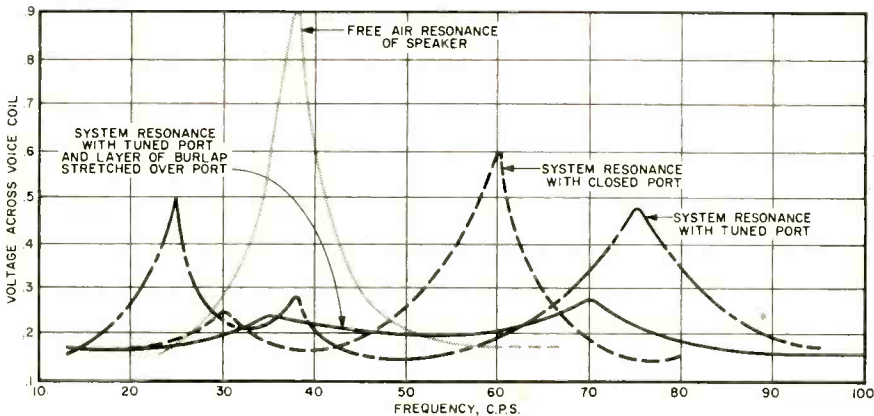

**Impedance curves** indicate performance. Free-air resonance of Norelco 4277 is 38 cycles (gray line). Installation of speaker in sealed cabinet causes the resonant peak to move up in frequency but down in amplitude (dashed line). Cutting a  $2\frac{1}{2}$ " x 8" port tunes the cabinet properly, as shown by the two peaks of approximately equal amplitude (dot-dash line). The smaller peak at 37 cycles is apparently caused by a "subharmonic" of the 74-cycle peak. The final curve (solid line) is the result of stapling a layer of burlap over the port. Completed system has a very smooth bass response down to about 35 cycles. The treble end extends to 18,000 cps and is relatively uninfluenced by cabinet design.

saving in weight. In addition, if the bracing is part of the internal design, two acoustic birds can be killed with one stone.

**Practical Design.** In response to requests from readers for the construction details of an enclosure which would accommodate a 12" speaker, a "rattle-proof" tuned enclosure for a typical 12" speaker—the Norelco 4277—has been designed.

The enclosure is basically a bass-reflex design employing a friction-loaded port tuned to the electro-acoustic resonance of the speaker. Any 12" speaker with a fundamental resonance about the same as the

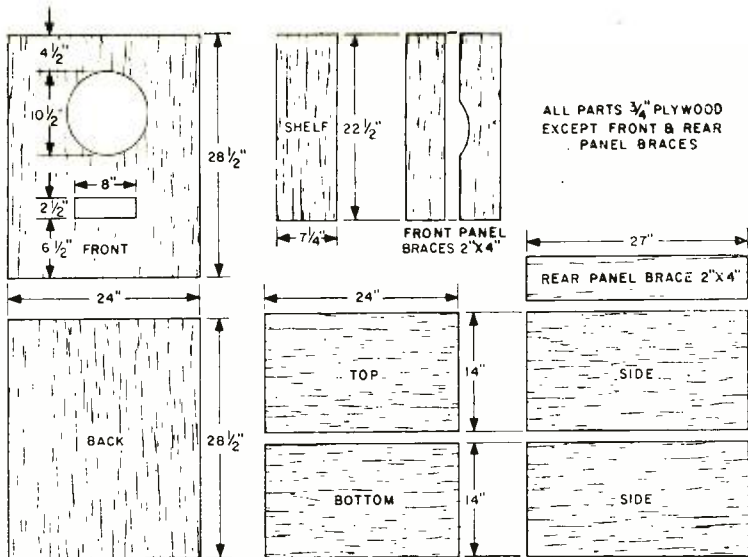

**Construction** of the Reflex 12 is simple since all joints are butted. At left, wooden parts are shown cut to required dimensions. Below is an exploded view of the enclosure's construction.

Norelco can be used successfully in this enclosure. The 4277 resonates at 38 cps, and speakers with resonances from 35 to 40 cps should be quite satisfactory.

It's a good idea to play new loudspeakers at a fairly loud volume for a day or so before attempting to tune a cabinet to them. A number of speakers, including the Norelco, require a workout period before their fundamental resonance settles down. However, if the cabinet design shown here is followed, no "pre-playing" is necessary and the Norelco will slide into tune with the enclosure after a short period of use, generally within an hour or two.

**Simple Construction.** Woodworking is simplified by the use of butt joints throughout. Plenty of glue and 8d finishing nails insure tight joints. Screws are used to fix the panels to the 2" x 4" braces and for mounting the removable front panel. The cabinet divider serves in both an acoustic role and as a brace for the side and front panels, all three of which should be screwed securely to it. Construction is simple, but the reader should follow the plans closely to avoid mistuning.

The performance of the system with the

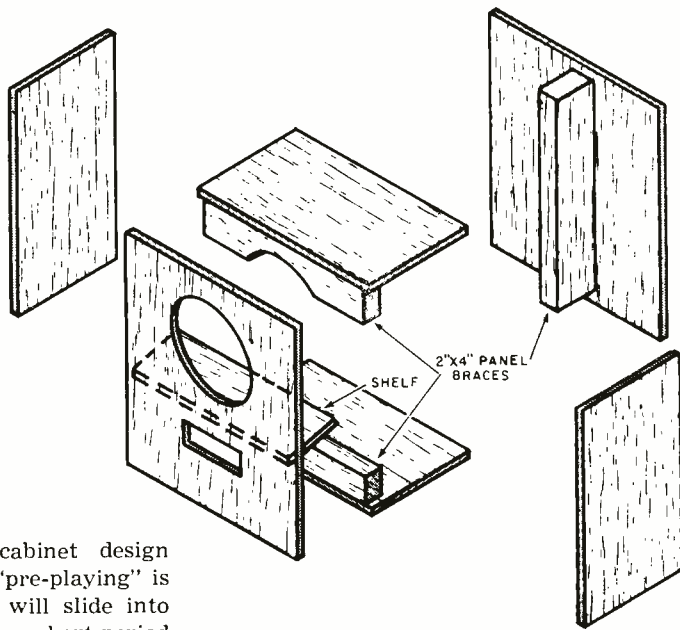

Norelco 4277 was extremely gratifying. In fact, when it was compared with one of the most acclaimed "book-shelf" type systems, the general opinion of the listeners favored this home-built job. The roughest test of all—the reproduction of the male voice with natural bass but no boom—was passed with flying colors. Since the response of the 4277 extends to about 18,000 cps, the response of the entire system covers the range smoothly from 35 to 18,000 cps without the use of a separate tweeter for the high frequencies.

# Test Instruments

Part 6

## THE VACUUM-TUBE VOLTMETER

### Signal Tracing in a Hi-Fi Amplifier

By  
**LARRY KLEIN**  
Technical Editor

**I**N CHECKING OUT the vacuum-tube voltmeter in the last two installments of *Test Instruments*, we discovered that one of the most important reasons for using a VTVM was "sensitivity." In practical terms, the sensitivity of a measuring instrument determines how it affects the circuit under test. Using a low ohms/volt meter in a high impedance circuit is like trying to gauge a person's strength with a 10-ton weight. What you're trying to measure crumbles under the load.

One area where the VTVM comes into its own is in signal voltage measurement in hi-fi amplifiers. For not only can the VTVM measure the a.c. signal voltage without knocking it to its knees, but it will perform the measurement in the presence of d.c. at any frequency in the amplifier's range. If there's a large enough signal at a tube pin—your VTVM will read it.

What's so important about signal voltage? Well, signal voltage is what your magnetic phono cartridge (or tape head or tuner) supplies to your amplifier to be passed on to your speaker. Your amplifier is not just a passive element, but is more like an electronic Charles Atlas that builds up the weakling input signals into the sort of powerful currents that can move, if not mountains, at least speaker cones. If we take a look at the signal voltage at each

stage of its development, we can get a good idea of exactly what contribution is made by each tube in the circuit.

**The Guinea Pig.** Let's take a standard hi-fi amplifier as our guinea pig and put it through its paces using an audio generator to supply the signal voltage and a VTVM to measure it.

The amplifier we will work with—the Eico HF-12—is not only well designed but, in addition, has the advantage for us that it shares a number of its circuit configurations with amplifiers of similar and higher

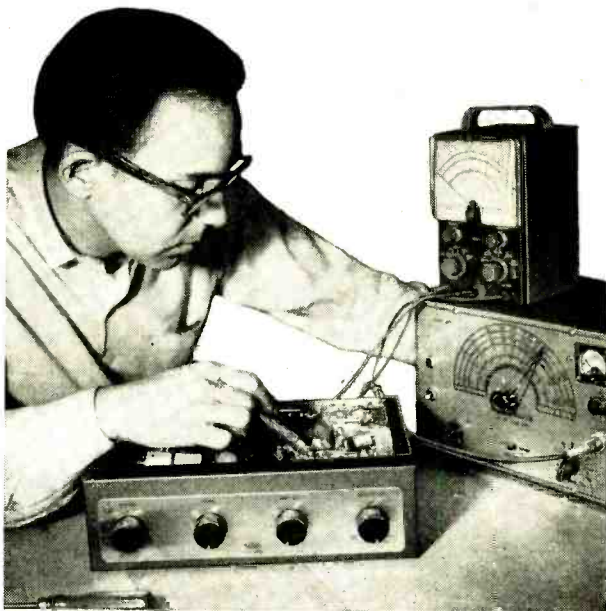

**Fig. 11.** Interconnections between test instruments and amplifier when making gain and wattage checks.

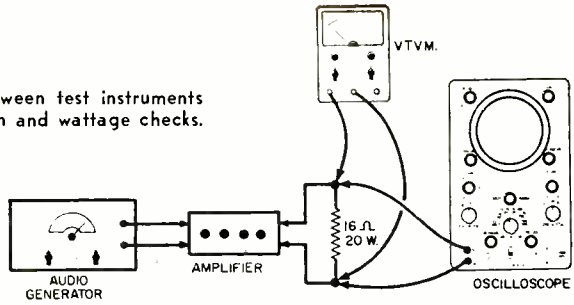

**Fig. 12.** Slight (A) and extreme (B) clipping which occurs when output stage of amplifier is overdriven.

the selector switch to *Aux*. Do *not* plug the amplifier in yet.

**Watts** =  $E^2/R$ . Switch on the audio generator and set it up for 1 kc. with the output control at minimum, and the output lead plugged into the amplifier's *Aux*. input.

Set your VTVM to the 15-volt, a.c., or higher range, and connect the test leads across the 16-ohm load resistor. *Now* plug in the amplifier, let it warm up, and *slowly* turn up the output level of the audio generator.

Watch the VTVM meter needle climb up scale—when it reaches about 14 volts, we know the amplifier is putting out a healthy 12 watts. How do we know? Ohm's law tells us so—using the formula:  $W = E^2/R$ :

wattage. The same tests and techniques we use to check out the Eico unit can therefore also be applied to other mono and stereo amplifiers.

Let's take a quick look at the HF-12's schematic in Fig. 14. The preamp stage uses a 12AX7 tube (*V1*) with plate-to-grid feedback equalization. The two triodes of a 12AU7 tube (*V2*) comprise the Baxandall negative feedback tone control circuit which in turn feeds a modified Williamson-type power amplifier comprising a dual-triode driver/inverter (*V3*) and a pair of push-pull pentode outputs (*V4* and *V5*).

For the tests we have in mind, we'll need a VTVM and an audio oscillator. Any of the small fixed-frequency transistorized sine-wave generators will do for gain tests, but for tone control check-out a variable frequency audio generator such as the Heath, Eico, or Knight-Kit units is required.

First, the test instrument setup. A vital item in our check-out procedure is a 16-ohm "load" resistor connected across the amplifier's 16-ohm output terminals. Since the Eico at full output will throw a good 12 watts into the load resistor, we better use one with at least a 20-watt rating—and expect it to get pretty hot. Several series/parallel resistors will do as well as a single wire-wound job as long as the resistance and wattage demands are met.

Set up the amplifier with the tone controls at *flat*, volume control on *full*, and

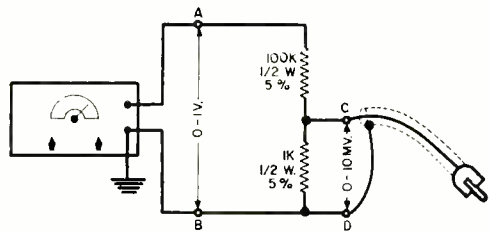

**Fig. 13.** Voltage divider set-up which can be used to supply a signal in the millivolt range to amplifier under test.

where  $E$  is the voltage developed across the 16-ohm ( $R$ ) load resistor and  $W$ , of course, is watts output.

If available, an oscilloscope can be used to monitor the output waveform of the amplifier by connecting it across the load resistor. At about the 5-watt level, a good-looking sine wave will be seen on the scope. Pushing the amplifier to the 12-watt level (by boosting the input signal voltage), the scope will begin to show "clipping" as in

Fig. 12(A). Boost the input voltage even more, and a waveform resembling Fig. 12(B) results.

At any rate, just barely visible clipping, all other factors being equal, usually corresponds to about 1% harmonic distortion. This test is used by a number of manufacturers to rate the power output of their amplifiers.

Now that we've determined how to get the twelve watts *out* of the amplifier, let's use our VTVM to trace the signal from the input through the jungle of resistors and capacitors which make up an amp's "works."

**Stage By Stage.** If we want to start our tracing at the high gain input of the amplifier, we will have to feed in a signal in the 5-10 millivolt range. If your audio generator lacks an attenuator switch, the circuit shown in Fig. 13 will take a one-volt signal and knock it down to approximately 10 millivolts. Use your VTVM to set the A-B voltage and trust to the attenuator for the correct C-D output voltage.

Set up the amplifier's controls as before, but set the selector switch at the "mag. phono" position and plug the lead from the attenuator setup into the *mag. phono* jack. Turn up the audio generator's output, using your VTVM to monitor the output wattage across the 16-ohm load resistor.

When the VTVM hits 14 volts (about 12.5 watts), transfer the VTVM leads across A-B on the attenuator. On the Eico, if everything is going well, the VTVM

(Continued on page 140)

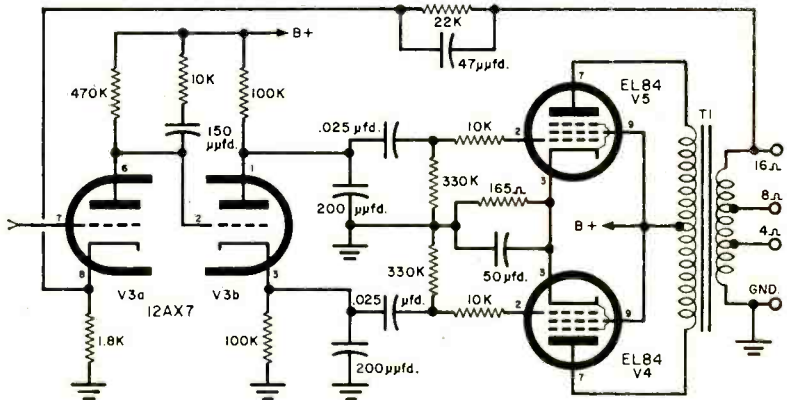
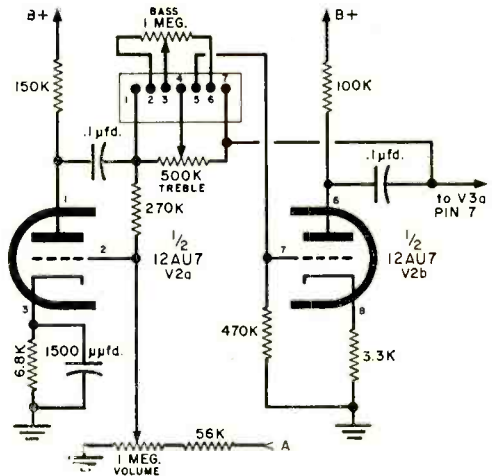
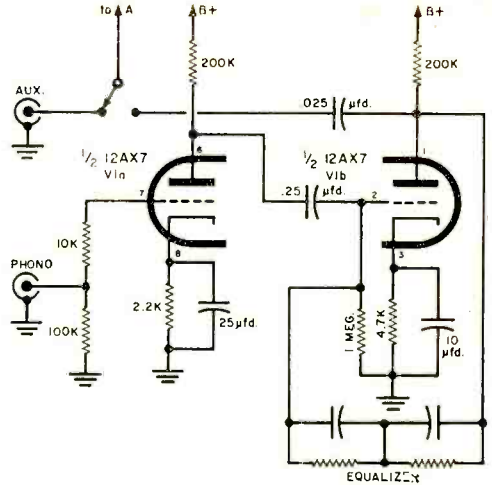
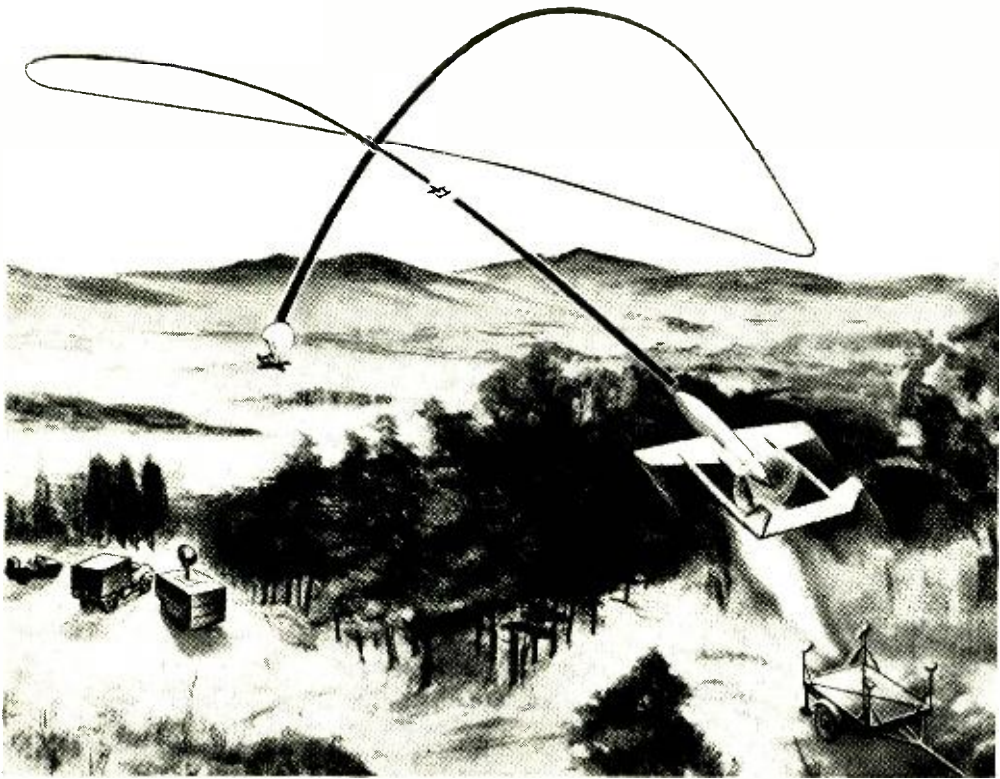

Fig. 14. Eico HF-12 amplifier circuit broken down into its separate sections for the purpose of discussion in the text. Reading from top to bottom, sections are: preamplifier, tone control and power amplifier.



## **ELECTRONIC DRONE**

### **Scouts the Enemy**

**A** MINIATURE flying "snooper" has been developed by the U. S. Army that can scout behind enemy lines and bring back military information. Called a surveillance drone, it is 15' long and has an 11' wing spread—a big-brother version of a radio-controlled model plane. It can swoop over the battlefield and gather information before being "ordered" back to the launching site.

The drone is started on its mission by being fired directly into the air by rockets from a special mobile trailer launcher. Once airborne, the rockets are separated from the drone and a 140-horsepower reciprocating engine takes over.

In the air, the drone will use advanced electronic sensory devices for guidance control and observation of enemy troop movements, fortifications, and battlefield installations. Interchangeable nose units enable rapid switches from one surveillance technique, such as photography, infrared, radar or television, to a different type, depending on mission requirements.

Missions can be programmed in advance for automatic flights or they can be controlled from ground monitoring stations. Radar checks on the drone's position and radio controls its flight. Landing is accomplished by an automatic parachute device which floats the drone back to earth. Special inflatable rubber mats, contained within the drone, cushion the fall.

The surveillance drone can operate in all kinds of weather and at very low altitudes, where its tiny size will aid in dodging enemy radar and guns.

-30-



# Wide-Range ELECTRONIC TIMER



**W**HEN IT COMES to timing short intervals, electronic devices have it all over their mechanical brothers. Micro-second accuracy is an everyday achievement of *RC* circuits which measure intervals by the length of time it takes a charged capacitor to discharge through a resistor. However, stray current leakage paths in electronic timers can (and do) limit the timing intervals to 60 seconds or less.

Use of a 1B3 high-voltage, high-vacuum rectifier tube in the electronic timer presented here virtually removes the upper limits of the timing interval. The 1B3's high leakage resistance, which makes this circuit possible, results from its high vacuum and the fact that the anode is supported solely by its lead sealed into the dome of the glass envelope.

With such a high resistance from anode to cathode, an extremely high resistance can be used in the discharge circuit, enabling time delays approaching five hun-

***New circuit permits  
timing intervals from a few  
seconds to several hours***

**By  
R. L. WINKLEPLECK**

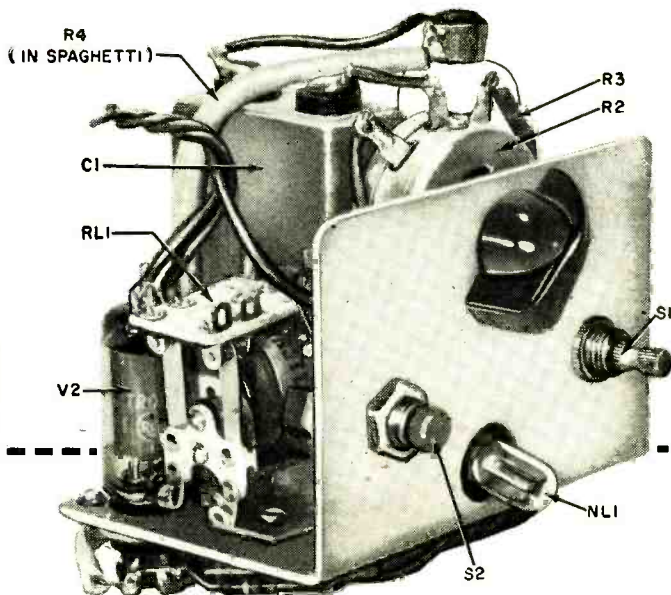

**Construction** of the timer is facilitated by the use of an L-shaped chassis. Unit fits into a 4" x 5" Minibox.

dred seconds per microfarad of storage capacitance.

**Many different types** of operation can be handled with this timer. For short intervals, the values of timing capacitor  $C1$  and  $R4$  can be reduced until it's possible to set potentiometer  $R2$  for just a few seconds and still have a much higher maximum range than could be had with a conventional circuit. By making  $C1$  larger and increasing  $R4$  to 200 megohms, it is possible to achieve delays of several hours.

Capacitor  $C1$  must be a high-quality unit with low leakage. This requirement eliminates the use of electrolytics, unless accuracy is unimportant.  $R4$  can be increased until it is no longer possible to bias the thyatron beyond cutoff.

If you connect the ABC set of relay contacts in place of the similarly labeled terminals of  $S2$ , the timer will repeat the timing cycle automatically. In this case, the relay coil would have to be shunted by an electrolytic capacitor in series with a 680-ohm resistor to hold the relay contacts closed long enough to charge  $C1$ . Eight microfarads, for instance, permits the accumulation of about 75% charge. Such an arrangement might be used for a flashing light, life-test cycling or interval photography.

As a matter of fact, this unit can be adapted to any situation which requires that something be turned on or off at an

- PARTS LIST**
- $C1$ —1- $\mu$ fd. capacitor (see text)
  - $C2$ —.01- $\mu$ fd., 400-volt capacitor
  - NL1—NE51 neon pilot lamp
  - $R1$ —47,000-ohm,  $\frac{1}{2}$ -watt resistor
  - $R2$ —50,000-ohm wire-wound potentiometer
  - $R3$ —6800-ohm,  $\frac{1}{2}$ -watt resistor
  - $R4$ —100-megohm resistor (see text)
  - $R5$ —22-ohm, 1-watt resistor
  - $R6$ —10-megohm,  $\frac{1}{2}$ -watt resistor
  - RL1—D.p.d.t. 117-volt a.c. relay (Advance midget antenna Type AM/2C/115va or equivalent)
  - S1—S.p.s.t switch
  - S2 S.p.d.t. spring-return switch
  - S01, S02—Panel mounting a.c. receptacle
  - T1—6.3-volt filament transformer
  - V1—1B3 rectifier tube
  - V2—2D21 thyatron tube

interval varying from seconds to hours, automatic or manual. Applications are limited only by the ingenuity of the builder.

**The circuit shown** on page 115 has a  $C1$ - $R4$  combination which permits delays from five seconds to seven minutes.  $R3$  is used only to extend the timing periods over the entire rotation of  $R2$ . Otherwise, a portion of the lower end of  $R2$  would produce an applied voltage which would not drop the grid of  $V2$  below cutoff, and calibrations would be crowded to the upper end of rotation.

If  $R4$  is made larger,  $R3$  can also be increased, and vice versa. For instance, if 22 megohms were used at  $R4$ ,  $R3$  could be 1500 ohms, and delays would range from a couple of seconds to nearly two minutes—an ideal range for photographic enlarging.

Parts placement and wiring of the unit is completely non-critical.

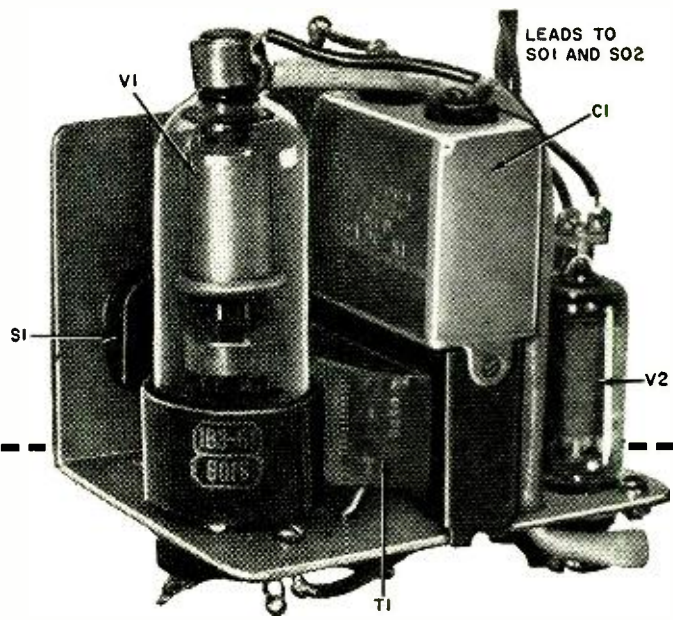

Values of C1 and R4 shown in schematic permit timing periods from five seconds to seven minutes. Capacitor and resistor in parallel with relay coil allows automatic recycling; typical values are 8  $\mu$ fd. and 680 ohms.

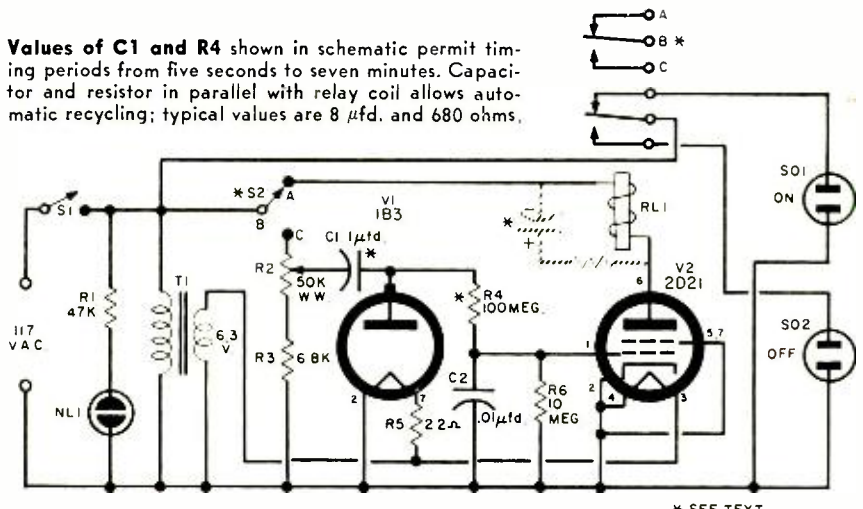

\* SEE TEXT

Incidentally,  $R_4$  can consist of two or more resistors whose total resistance equals the desired value.

The relay contacts are connected so one of the receptacles receives power only during the timing interval and the other is "hot" only after the interval is completed.

If you want to assemble a unit in a 3" x 4" x 5" Minibox as illustrated, consider the placement of the parts carefully. Wiring will be simplified if you assemble the unit on an L-shaped chassis. Both parts placement and wiring are completely noncritical. Be sure to use a high-quality (possibly oil-filled) capacitor at  $C_1$ , and watch those stray leakage paths.

-30-

### HOW IT WORKS

With spring-return switch S2 depressed (at C),  $C_1$  is charged through the 1B3 ( $V_1$ ) to a voltage dependent on the setting of  $R_2$ . This voltage is divided across  $R_2$ ,  $R_3$ ,  $R_4$  and  $R_6$  which form the discharge resistance path. The voltage at the grid of the 2D21 ( $V_2$ ) biases it below cutoff.

With S2 in position A, the charging source is removed and the plate-cathode circuit of  $V_2$  is completed.  $C_1$  will discharge through  $R_2$ ,  $R_3$ ,  $R_4$  and  $R_6$ . Assuming that  $R_4$  is much larger than the others, although this is not mandatory, the discharge time will be approximately  $R_4 \times C_1$ . This is the standard  $T$  (seconds) =  $R$  (megohms)  $\times C$  ( $\mu$ fd.) formula which determines the time required for the voltage across a capacitor to drop to 63% of the applied voltage.

Note, however, that the applied voltage can be varied with  $R_2$  and that the voltage the grid of  $V_2$  "sees" is  $R_6/R_4$  of this applied voltage. After a time, the grid voltage rises above cutoff, and  $V_2$  fires and closes the relay.

# Simple AF-RF Signal Tracer

By ART TRAUFFER



Completed unit is installed in an inexpensive plastic container.

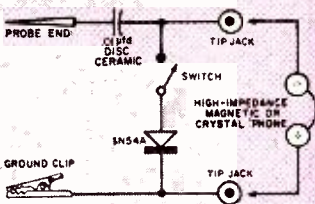

Follow assembly details shown below if you use "E-Z Stitcher" case. Otherwise, schematic above will serve as wiring guide.

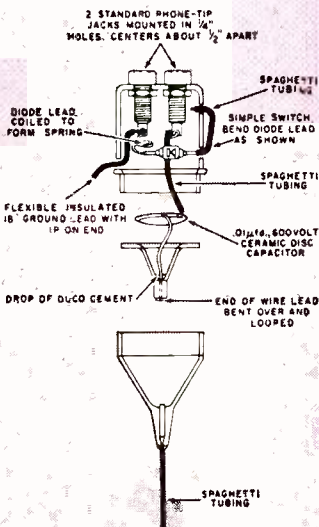

**T**HIS simple signal tracer works like a crystal detector radio. It needs no power supply and can be used for trouble-shooting in r.f., oscillator, i.f., detector, and audio stages in radio receivers, and in audio amplifier systems.

A 1N54A high-conductance diode is the rectifying element. When the signal tracer is employed with a sensitive pair of high-impedance magnetic or crystal earphones, no audio amplification is needed. An extremely simple "switch" connects the diode for r.f. tracing and disconnects it for a.f. tracing.

The plastic case used by the writer looks just as if it were designed for a signal tracer, but it's actually an "E-Z Stitcher" which sells for 39 cents in some dime and department stores. Any plastic container or pill box will do.

**Using the Tracer.** Plug a pair of sensitive high-impedance magnetic or crystal phones into the tracer, and clip the ground lead to the chassis of the radio under test. Tune the radio to the frequency of a powerful local broadcast station, or feed a modulated signal from an r.f. generator into the radio. Starting at the antenna, touch the tracer's probe to the input and output of each stage, one stage at a time, until the signal is lost. The bad component will show up between the last good stage and the adjacent stage where no signal is heard.

When you want to trace r.f. stages, press the "switch" to put the germanium diode into the circuit. When tracing through audio stages, release the switch to disconnect the diode and make sure the set's volume control is down low to avoid overload of either the earphones or your ears. If the audio signal is too weak, you can always turn the volume control up to suit yourself. Never touch the probe to the rectifier tube's terminal—the rectified pulsating voltages might damage the diode, or the resulting signal would be deafening.

**Caution.** In signal tracing a.c.-d.c. radios, keep away from wet floors, or grounded objects, as the radio's chassis may be "hot"; and use an isolation transformer or an additional .01- $\mu$ fd. blocking capacitor in the ground lead of the tracer.

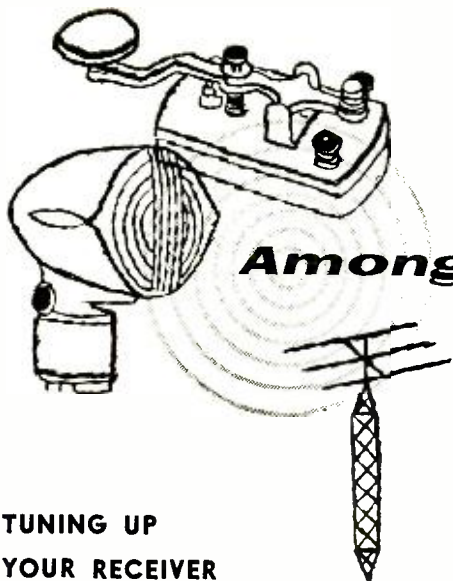

## Among the Novice Hams

### TUNING UP YOUR RECEIVER

**G**ETTING the "feel" of receiver controls is easiest if you work with steady signals. So let's start practicing on the broadcast band and later transfer operations to one of the amateur bands.

Begin with the controls in the following positions: sensitivity control (sometimes called "r.f. gain" or "i.f. gain") full *on*; automatic volume control (a.v.c.) *off*; beat frequency oscillator (BFO or the equivalent) switch *off* or at *phone*; standby-receive switch at *receive*; selectivity control at minimum ("broad" or highest number); Q-Multiplier, notch filter, etc., *off*; bandspread dial indicator at 100 on its logging scale; noise limiter (ANL) *off*; antenna trimmer to mid scale; and audio gain (volume) control one-quarter turn clockwise.\*

Tune in a signal with the main tuning dial by adjusting it for maximum deflection of the receiver signal strength (S) meter or for the clearest voice or music accompanied by the least amount of background noise. Adjust the antenna trimmer for maximum signal strength, and set volume with the audio gain knob.

\* Should your receiver not have a control mentioned here, skip the discussion referring to it. But make sure the control isn't actually present under a slightly different name than is used here.

Tune across the band, noting that although signal strengths vary greatly, as indicated by the S-meter or the amount of noise accompanying the signals, the a.v.c. holds the loudspeaker volume relatively constant.

Now experiment with the bandspread dial. A broadcast signal that occupies about a division on the main dial will occupy many divisions on the bandspread dial. This bandspread feature is invaluable on the short-wave bands, where a division on the main dial represents 50 to 200 kc. or more. In fact, for amateur band operation, the main dial is normally set to a calibrated point for each band, and all tuning



**Chuck, K9OVC,** uses photo of his station as DX QSL card.

is done on the receiver's bandspread dial.

Next, reduce the r.f. (and i.f.) gain control(s) to minimum, set the a.v.c. control at *off*, advance the audio gain control almost to maximum (clockwise), and use the r.f. gain control to control loudspeaker volume. The receiver will tune sharper than before, because its amplification will not automatically increase as the receiver

is tuned away from a signal. Controlling receiver sensitivity manually in this manner often permits copying a weak amateur signal which is covered up by a strong adjacent signal with the r.f. gain up and the a.v.c. on.

**Code Reception.** Tune in a signal with the a.v.c. off and the r.f. gain retarded (counterclockwise). Then snap on the BFO



**Bill, KNØSYI,** knocked off 32 states and Canada in two weeks.

**Johnny, KN4BYM,** (right), and his "all-band" Novice station.

Now tune the bandsread dial and compare the strength of the two beat notes.

Repeat these adjustments, but set the pitch control to the second position giving the same beat note, and compare the strength of the two beat notes as you turn the bandsread dial. Select the adjustments that result in the greatest difference, and always tune the bandsread dial for the louder beat note.

**Selectivity.** Inexpensive amateur receivers can usually separate signals about 10 kc. apart, while more expensive ones have several degrees of selectivity. For voice work, selectivity up to 3 kc. can be used without affecting voice quality too much. Two-kc. selectivity degrades voice quality greatly, but the signal remains intelligible. But higher degrees of selectivity reduce intelligibility rapidly. For code reception, selectivity up to 100 cycles can be used if available and if the receiver is good



switch and adjust the BFO pitch control until a clear whistle is heard from the speaker. Tuning the bandsread dial will then reveal a second setting of this dial very close to the first one that will produce a similar beat note. However, the second one should be weaker than the first, because the receiver is actually detuned a bit from its maximum output position to produce it.

The difference in strength between the two beat notes will depend upon the selectivity of the receiver. But you can accentuate the difference in the following manner.

Carefully tune in a steady signal with the BFO off and the a.v.c. on. Then turn the bandsread dial until the S-meter indication just begins to decrease. Next, turn the a.v.c. off and the BFO on, and adjust the pitch control for a pleasing beat note.

enough to handle the resulting razor-sharp tuning.

Probably the best way to become adept in using high selectivity is to operate your receiver with its selectivity control well advanced even when interference is not heavy. In this way, you obtain experience in using it at times when you do not have to concentrate your entire attention on copying a signal through heavy interference. Doing so also prevents the frustrating experience of losing the desired signal as you increase selectivity to combat interference.

The better communications receivers also incorporate a "phasing control," "notch tuning," Q-Multiplier, etc., to "null out" an interfering signal a kilocycle or so away from the desired signal, thereby eliminating the resulting heterodyne. Only by prac-

*(Continued on page 149)*

# After Class

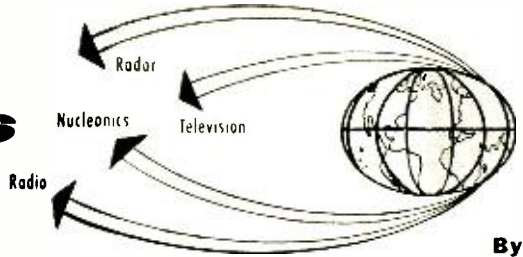

By  
**HARVEY POLLACK**

## THYRATRONS IN SERVO CONTROL CIRCUITS

VACUUM-TUBE servo amplifiers are limited to circuits with moderately light current demands; the normal high plate resistance of a vacuum tube results in excessive voltage drop within the tube itself when it is used with high current servo devices. A thyatron is an entirely different breed. The arrangement of its electrodes (Fig. 1) and the intentional insertion of argon or hydrogen give it unique properties.

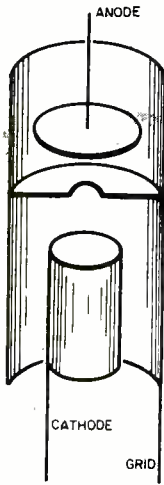

Fig. 1.

As one changes the control grid voltage in a vacuum triode, the plate current varies in a more or less linear fashion within a limited range, as in Fig. 2(A). In this sense, a vacuum tube performs like a smooth variable resistor. A thyatron, however, exhibits *switch-like* characteristics, as shown in Fig. 2 (B).

When the anode voltage is high, a relatively large negative grid potential is required to prevent the tube from firing. However, a smaller negative grid voltage can be used if the plate voltage is also diminished.

Consider what happens when the anode supply voltage is a.c. The thyatron can conduct only when its anode voltage is swinging positive, and then only if the grid is above its critical potential. Since critical potential is, as we saw, a function of anode voltage, it varies from a small negative

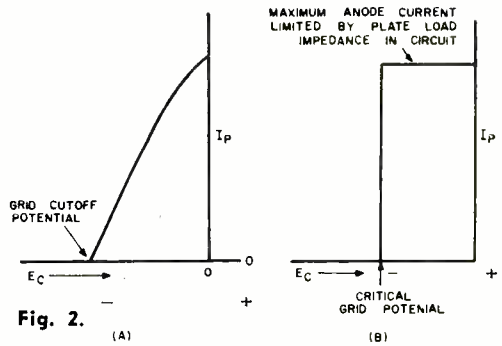

Fig. 2.

When the control grid of the thyatron is more negative than the *critical potential*, the tube does not conduct at all. This is the "off" state similar to an open switch. As the grid voltage is raised in a positive direction, nothing occurs until the critical potential is reached. Then, the gas suddenly ionizes and *maximum* anode current instantly flows. This is the "on" state. Once the thyatron fires, the grid can no longer influence the anode current. Thus, the thyatron behaves like a closed switch. The only way to open the thyatron switch is by removing the plate potential.

**Critical Potential.** A thyatron's critical potential is determined by the voltage

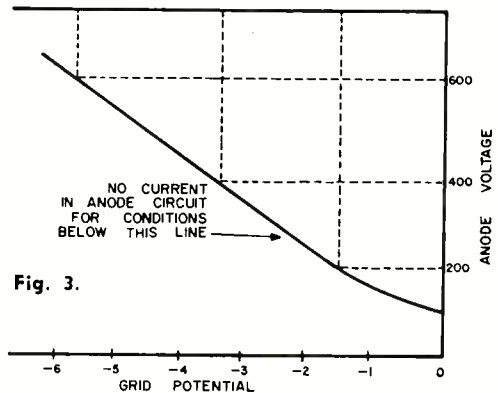

Fig. 3.

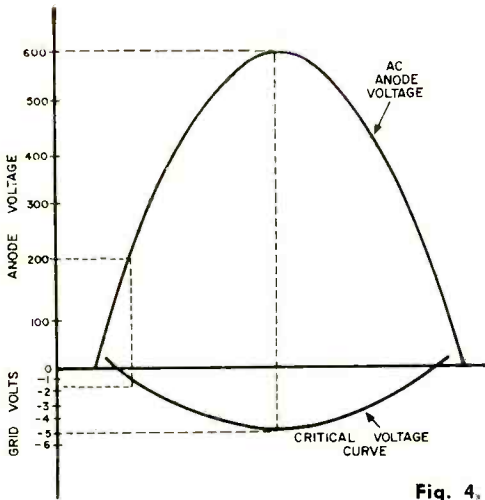

Fig. 4.

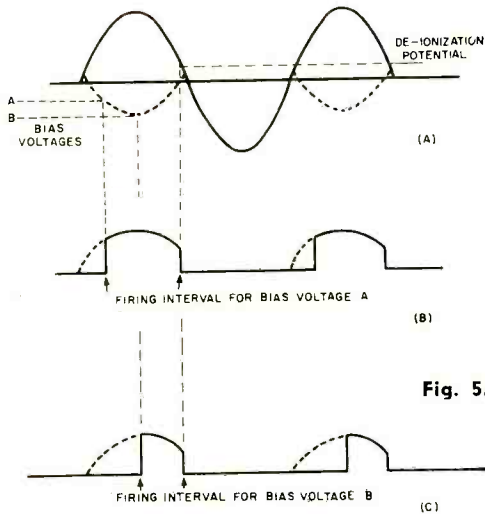

Fig. 5.

value at the beginning and end of the positive anode voltage half-cycle to a larger value at the peak of the anode swing (Fig. 4). By selecting a bias voltage of the proper magnitude, the thyatron firing can be delayed until a part of the thyatron anode voltage half-cycle is completed. Thus, the *average* anode current will be less than if the thyatron conducted throughout the entire positive half-cycle.

By varying the bias voltage, the load current of the thyatron may be varied over a small range. The usefulness of this control system is limited, however, by the fact that the firing point can never be delayed more than one quarter of a cycle ( $90^\circ$ ). If the bias voltage is made more negative than the critical anode potential, the thyatron will not fire at all (Fig. 5).

For example, when an incandescent lamp is connected in series with the thyatron anode as a load, and the grid voltage is gradually made more negative, the lamp will be seen to dim smoothly until a point is reached where it suddenly goes out. In short, the load current of a thyatron can never be controlled smoothly from maximum down to zero merely by changing the grid bias voltage. However, this characteristic can be overcome by using a new circuit.

**Phase-Shift Control.** Using an alternating grid voltage of constant amplitude which can be *shifted in phase*, the thyatron average current can be varied from maximum to zero. Figure 6 shows how a phase-shift grid control voltage affects plate current during a cycle.

In Fig. 6(A), the grid voltage is in phase with the plate voltage so that the tube fires for a full  $180^\circ$  (one-half cycle). When the grid signal is  $90^\circ$  out of phase with the anode voltage, the thyatron firing period is approximately  $90^\circ$  long (one-quarter cycle) as in (B). Figure 6(C) shows a  $20^\circ$  conduction interval when the grid voltage is  $160^\circ$  out of phase with the anode supply voltage.

Thus, phase-shift grid control permits a smooth variation of load current from maximum right down to zero. For this reason, the phase-shift method is used almost ex-

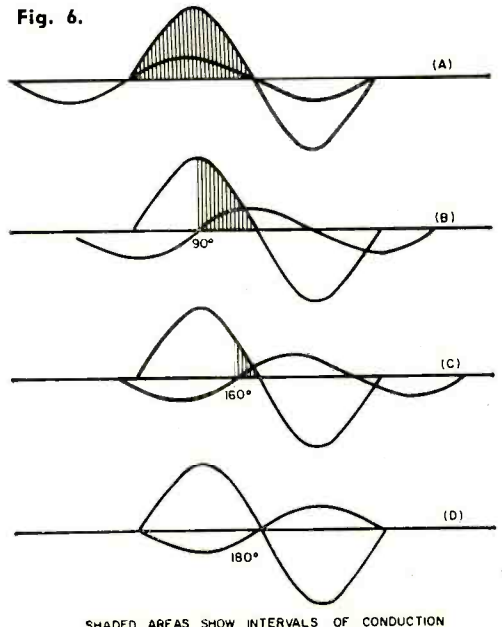



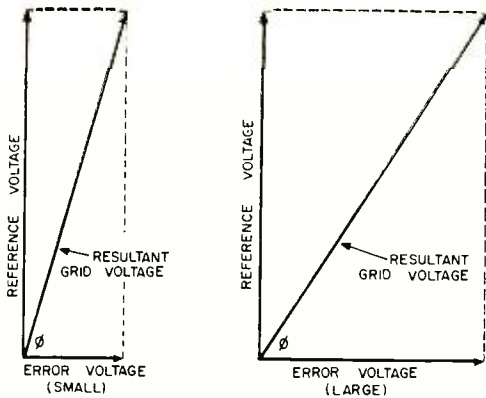

Fig. 7.

clusively in servomechanism control equipment.

**Amplification.** To see how phase-shift control is applied to a servo control system, let us go back to the a.c. error signal explained previously. The objective now is to cause the error signal to shift the phase of the voltage applied to the grid of one or more thyratrons to obtain a corresponding variation in anode current. A d.c. motor which is sensitive to current strength and current direction can then be used in place of a vacuum-tube amplifier.

It has been stated that the a.c. error signal from the balanced potentiometer detector grows larger as the deviation from the preset action increases. Thus, a system is needed in which an a.c. error voltage is made to shift in phase by an amount proportional to the *magnitude* of the error signal. The easiest way to accomplish this is to superimpose the error signal on another fixed a.c. voltage of the same frequency but different in phase from the error signal.

By using a simple vector diagram (Fig. 7), the complex waveform analysis necessary to determine exactly what takes place can be shown. The two voltages—one the fixed reference voltage and the other the error signal—add together to yield a result-

ant whose phase depends upon the size of the error signal.

A basic uni-directional thyatron servo control is shown in Fig. 8. Assume that the transformer turns ratios and polarities are such that, with no error signal introduced, the resultant voltage applied to the thyatron grid is at least equal to the critical voltage and out of phase with the anode potential, as in Fig. 6(D), so that no conduction occurs at all. For this condition, the motor will be supplied with zero power and will not turn.

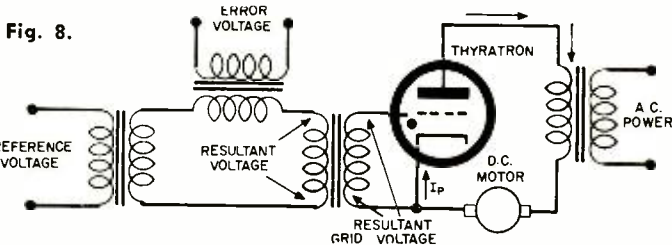

Fig. 8.

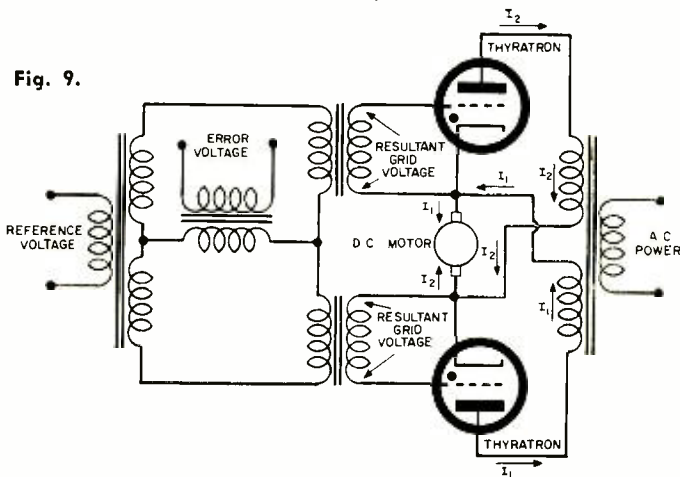
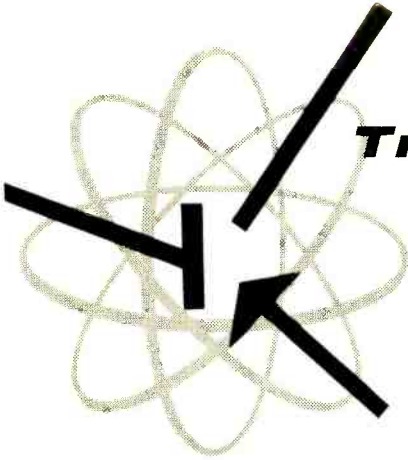

Fig. 9.

As soon as the error signal appears, the resultant grid voltage undergoes a shift of phase, possibly to the condition given in Fig. 6(C), so that a small current now flows through the motor. This current will drive the motor in the direction which reduces the error signal. If the error signal is larger, the phase shift is correspondingly greater, the conduction interval increases, and the motor turns farther and faster to correct the larger error.

**Bi-Directional Circuit.** The system may be converted to a bi-directional one by add-

(Continued on page 149)



# Transistor Topics

By LOU GARNER

SOME TIME AGO a popular science-fiction novelist wrote a fantastic story about an "incredible shrinking man." Today, just about anyone could write a story almost as fantastic about the "incredible shrinking circuit." But the latter story *would be true*, for recent technical advances have "shrunk" electronic circuits to unbelievably small dimensions.

A trend towards more compact circuitry started over two decades ago with the development of special vacuum tubes for hearing aid amplifiers and the introduction of the "small" GT and metal tube types as substitutes for the bulbous "G" types. This trend received a shot in the arm during World War II as the military demanded—and got—subminiature vacuum tubes and components for their now-famous Proximity Fuzes. After the war, circuits continued to shrink as more and more manufacturers started to use printed and etched circuits for wiring and miniature glass tubes in place of the larger (and older) GT types.

Things were progressing rather nicely on the miniaturization "front"—you could buy a hearing aid, for example, not *much* larger than a package of king-sized cigarettes—when the invention of the transistor threw a technical bombshell in the works. Overnight, electronic circuits shrank to "impossible" sizes. Now a multistage amplifier could be built in the space formerly required by a single subminiature tube.

Shortly after the introduction of the transistor, the trend toward circuit miniaturization hit a small snag. Component designers were lagging behind the semiconductor manufacturers and, often, the resistors, capacitors, and other parts required in a complete circuit were *several times larger* than the transistors with which they were used.

This temporary roadblock was overcome when component manufacturers found that they could "print" resistors, capacitors and other circuit elements on ultra-small ceramic boards. Since circuit wiring could be "printed" at the same time, it became possible to make up complete circuit *modules* which, compared to conventional "miniature" circuits, were "really" small. Centralab, one of the pioneer manufacturers of printed-circuit components, now produces a complete four-stage transistorized ampli-

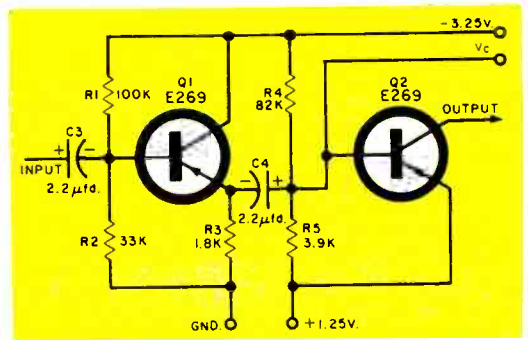
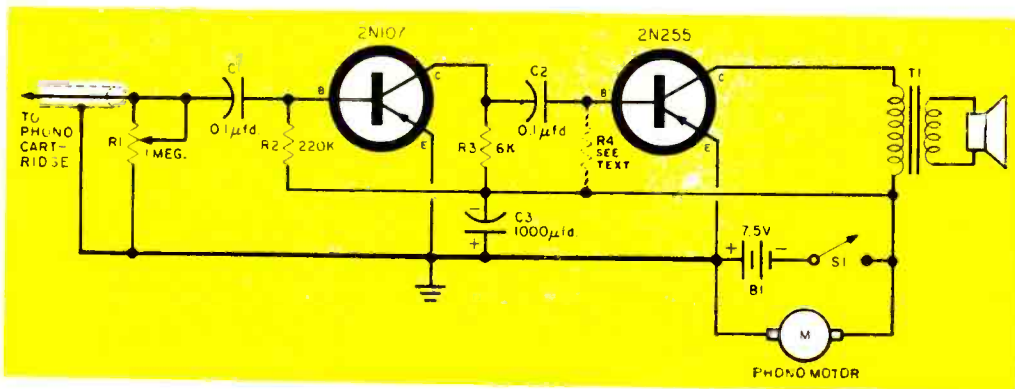

Fig. 1. Schematic of a micro-module audio amplifier. About 1/5" long by 1/3" square, the assembled unit weighs less than a tenth of an ounce, yet provides 32 db gain and 1 mw. power output.

fier on a ceramic board measuring a little over an inch long by about two thirds of an inch wide; the unit is about a quarter-inch thick.

The old terms "miniature" and "subminiature" were becoming passé, and it was necessary to invent a new word to describe



**Fig. 2.** The simplified phono-amplifier circuit which was submitted by reader Richard Mauro.

circuits which were several times smaller than "subminiature" vacuum tubes. The word: *microminiature!*

Recently, RCA announced the pilot production of an extensive line of *micro-modules*: complete circuits in packages measuring but a fraction of an inch on each side and weighing less than a tenth of an ounce. The schematic diagram of a micro-module audio amplifier is given in Fig. 1. With these units, it is possible to assemble a *complete receiver in half a cubic inch*. Parts "density" is on the order of 600,000 parts per cubic foot!

To many, this may sound like the "ultimate" in microminiaturization—but it isn't! Texas Instruments has announced a new circuit construction technique in which transistors, resistors, diodes, capacitors, and other components become an *integral* part of single microscopic-sized pieces of semiconductor material. Still in the developmental stage, this technique permits a component density of up to 34,000,000 parts per cubic foot.

If these trends continue, the day is not far off when every technician will need a high-powered magnifying glass . . . not to repair circuits . . . but simply to find them! Tom Thumb: move over.

**Readers' Circuits.** Last month, we featured a phonograph amplifier circuit submitted by reader Warren Boehling of Lake Hiawatha, N. J. Some readers may have found the design a little more complex than they cared to tackle. As you may recall, Warren's circuit employed a push-pull power output stage, with transformer-coupling between the power amplifier and the two-stage resistance-coupled "preamp." The project required four transistors, two transformers, and a good double-handful of smaller components.

Submitted by reader Richard A. Mauro (2326 Powell Ave., Bronx 62, N. Y.), the phonograph circuit in Fig. 2 requires only

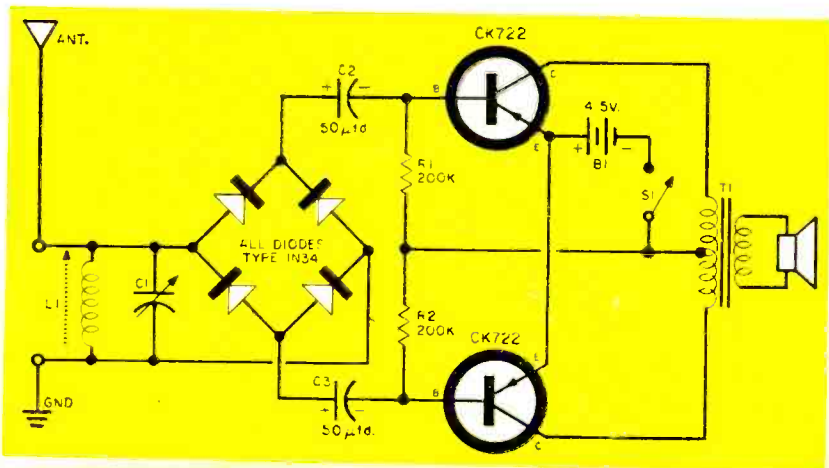

**Fig. 3.** Nurhan Seyhan's receiver circuit features push-pull detection and a push-pull amplifier.

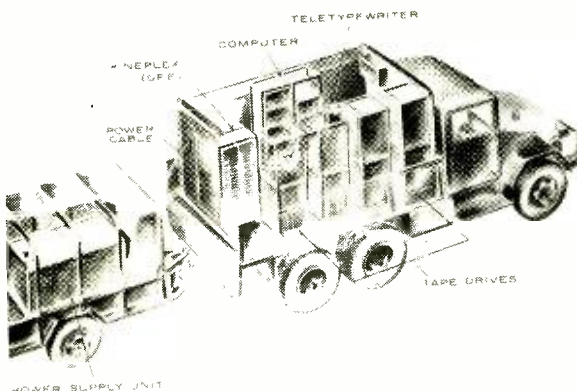

Artist's sketch of mobile transistorized computer designed by Philco Corp. for military field operations.

two transistors, one transformer, and a mere half-dozen resistors and capacitors. All parts are standard and readily available. Unless you work at a snail's pace, you should find it no trick at all to assemble this amplifier . . . or even the complete phonograph . . . in a single evening. Both layout and lead dress are non-critical.

Referring to Fig. 2,  $R1$  is a standard volume control and  $R2$  and  $R3$  are half-watt resistors.  $C1$  and  $C2$  are low-voltage (15 to 50 volt, d.c.) paper, ceramic, or electrolytic capacitors.  $C3$ , a 12-volt electrolytic, was not specified in Richard's original circuit, but a large bypass across the power supply is needed in most battery-operated phonographs to eliminate motor noise.  $T1$  is a standard transistor output transformer (such as an Argonne Type AR-172).  $S1$

may be ganged to the Volume control ( $R1$ ) or can be a separate s.p.s.t. toggle or slide switch.  $B1$  is made up of five standard flashlight cells connected in series to supply 7.5 volts. Any standard battery-operated turntable ( $M$ ) is okay. Use a 4" to 8" PM loudspeaker.

The pickup arm and cartridge are not critical, and you can follow your own inclinations here. However, best results are obtained with a high-output crystal or ceramic cartridge mounted in an arm requiring minimum tracking pressure.

Output bias resistor  $R4$  (shown dotted in Fig. 2) was not used in Richard's amplifier. He found that the 2N255's normal cutoff current provided adequate bias for his purposes. However, the cutoff current will vary considerably from one individual transistor to another, and you have to add a small resistor here to obtain satisfactory performance. Use a half-watt unit, determining its value by experiment. It will probably be somewhere between 4700 and 16,000 ohms.

Double-check your work *before* installing the batteries. Watch for accidental shorts, and pay particular attention to  $C3$ 's polarity. Don't expect to "rattle the windows" when you turn up the volume; while this amplifier should provide a usable output level, it is *not* a high-power device.

The receiver circuit in Fig. 3, submitted by reader Nurhan Seyhan of Istanbul, Turkey, represents one of the "neatest" approaches to simplified receiver design that we have  
(Continued on page 141)



Solar energy demonstration kit developed by Hoffman Electronics Corp. can be used with standard lamp bulb.

# Build a STEREO CONTROL UNIT

FOR THOSE trying to go stereo the easy way, by using two monophonic amplifiers, the Knight-Kit Stereo Control is a boon indeed. Designed for connection between two standard amplifiers and two speakers, this unit adds the conveniences of a master volume control, channel balancing, mode selection and phase reversal (of one speaker), all from your easy chair.

The Knight-Kit unit (Allied Radio Corp., 100 N. Western Ave., Chicago 80, Ill.) is capable of controlling the output of two 20-watt amplifiers with output impedances of 8 or 16 ohms. The two switches and two controls are on the front panel.

The *Master Volume* control permits simultaneous volume adjustment of both channels. When the *Balance* control is moved from the center setting, it increases the output of one channel while decreasing the output of the other channel. The *Phase Rev.* switch changes the phase of the A channel speaker with respect to the B channel speaker.

The *Channel Selector* switch has six positions. Two positions permit stereo listening (either normal stereo or reversed stereo), while two others permit monophonic

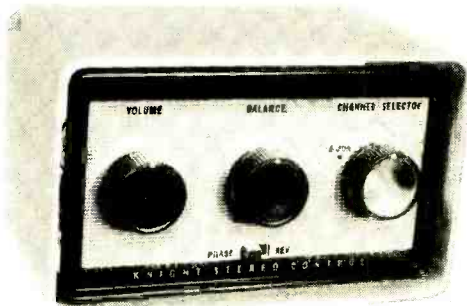

**The Knight-Kit 83 Y 778 provides full centralized stereo control**

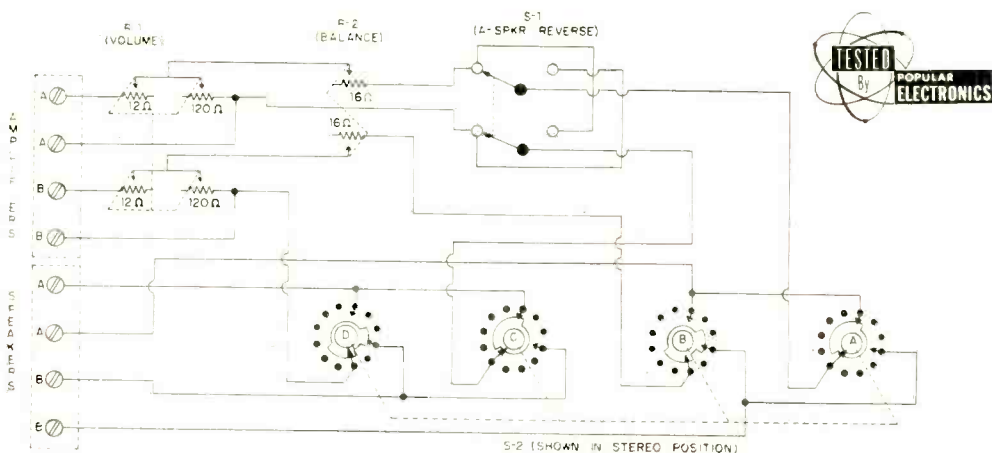

listening to either of the amplifiers on both speakers. The remaining positions provide switching on either channel A only or channel B only for balancing the stereo system.

Since the Knight-Kit circuit consists of just two multi-section potentiometers and two rotary switches, mounting and wiring was completed in about one hour. Here is a convenient and inexpensive route to centralized stereo control.

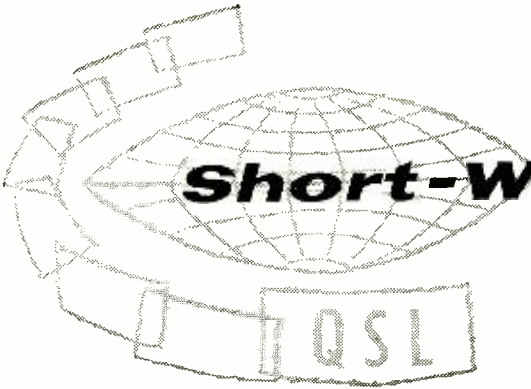

# Short-Wave Report

By **HANK BENNETT**  
W2PNA/WPE2FT

**O**UR FEATURED DX'er this month is William S. Murphy of 1914 Highland Ave., Troy, N. Y. Bill is 39 years old, a bachelor, and a plant and produce grower by trade. He began DX'ing some 25 years ago and has been fairly active since then with the exception of the summer season which is, understandably, the busy season in his work.

Although Bill did not specifically say so, he left your Editor with the impression that he listens to the short-wave bands more for the pleasure of hearing good musical programs than trying to log all the stations on the air. In this, he has a goodly number of friends.

The receiver in the Murphy Listening Post is a 1934 RCA Model 240, an eight-tube receiver that covers the frequencies from 540 to 18,000 kc. The antenna is a 50' wire 10' high; Bill recently added an-

other 28' segment running in a different direction.

Through the years Bill has logged some 83 countries, of which 46 are verified. His prized veries are from: *Radio Australia*; CT1AA, Lisbon, Portugal; and Budapest, Hungary (back in 1936). His best-heard station is HCJB, Ecuador, while the most difficult station verified—from the standpoint of reception—is Damascus, Syria. Two stations from which he has never received veries are PZC, Paramaribo, Surinam, and CXA60, Montevideo, Uruguay.

Bill prefers to work the 19-meter band because it has produced the greatest number of new stations for his log, and also because it holds up so well in the evenings. His favorite stations are Berne (Switzerland), Wellington (New Zealand), and Hilversum (Netherlands) for their excellent music programing, and HCJB, Quito

(Ecuador) for religious broadcasts. The best DX catches in the Murphy log include *Radio Pakistan*, *The Voice of America* station in the Philippines, and *Radio Ceylon* in Colombo.

In addition to DX'ing Bill's hobbies include photography and tape recording. He has made a recording of over 30 stations announcing in English.

(Continued on page 154)

**Bill Murphy**, veteran DX'er, shown with some of his prized veries. Bill does his listening with a 1934 RCA receiver.

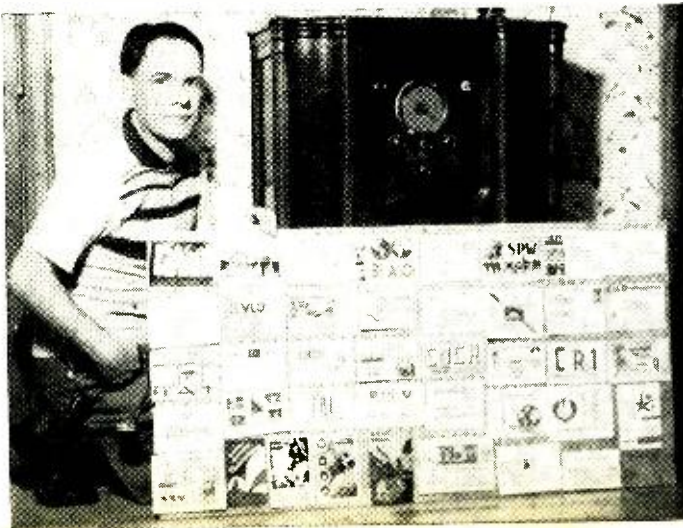

## 10,000 Short-Wave Monitors

**O**VER 10,000 short-wave monitors from every continent have already received their short-wave certificates and station letters. The certificates are awarded by POPULAR ELECTRONICS to qualified short-wave monitors. The attractively printed 8½" x 11" certificate has each monitor's individual station letters prominently displayed. All registration certificates and the assigned station letters are kept on permanent file. Station letters are assigned according to equivalent amateur radio call areas (WPE1AA, WPE4AA, WPE7MR, WPE9MS, etc.)



The success of the POPULAR ELECTRONICS registration program and the benefits to the SWL fraternity depend on you. Every SWL who registers helps toward the recognition of this important hobby.

Among the many projects in the planning stage which will be of value to SWL's is an Achievement Award program. The purpose of this program will be to give due recognition to outstanding SWL's who have shown proficiency and skill in monitoring the short-wave and broadcast bands. The details of this award program are being worked out. Obtain your certificate now so as to be eligible for future awards.

Fill out the form below and mail to: Monitor Registration, POPULAR ELECTRONICS, One Park Ave., New York 16, N. Y. Please include ten cents to help cover cost of mailing and processing your certificate.

SHORT-WAVE MONITOR REGISTRATION

(Please Print)

Name		
.....		
Address	City	State
.....	.....	.....
Receiver	Make	Model
.....	.....	.....
	Make	Model
.....	.....	.....
Principal SW Bands Monitored	Number of QSL Cards Received	
.....	.....	
Type of Antenna Used		
.....		
Signature	Date	
.....	.....	

By  
**JOHN T. FRYE**  
W9EGV



## **Carl and Jerry**

### **The Blubber Banisher**

“**S**AY, what's the matter with you? You got ants or something?” Carl demanded of his chum Jerry. “Every few minutes you glance at your watch and then get up and pace around the lab. This can't be old hate-to-make-an-unnecessary-move Jerry. Am I keeping you from something?”

“Oh, no!” Jerry said quickly. “I'm not going anywhere. I'm just restless.”

He sat down gingerly on the worn leather couch in the boys' basement laboratory, and there was a moment of deep silence.

“Hey, what's that ticking sound?” Carl suddenly demanded. “Sounds like it's coming from you.”

“Okay, okay! It is coming from me,” Jerry shouted in exasperation. “If you must know, it's my new Blubber Banisher.”

Carl's look of complete bafflement was answered by Jerry's pulling up a pants leg to reveal a small glass tube with a bead of mercury in it strapped to his pudgy leg above the knee. Two wires from the device vanished up his thigh.

“I've decided I'm a trifle overweight and should take off a few pounds,” he explained. “There're just two ways to do this: eat less or burn up more energy. Dieting isn't my dish; but I've noticed that nervous people who tap their fingers, shuffle their feet, and are constantly hopping up and down seldom become fat. So-o-o-o, I cooked up this little device to see to it that I move around nervously.”

“I don't get it,” Carl said flatly.

“This thing is the guts of an automobile clock,” he said, taking a gadget out of his hip pocket. “Such a clock has a short mainspring that is rewound every few minutes by the closing of a set of contacts that actuate a solenoid. In this case the solenoid is operated from five penlight cells con-

nected in series. I have the clock arranged so the contacts are closed by the unwinding spring every ten minutes.

“Now this little glass tube taped to my leg is a mercury switch. As you can see, when I stand up, like so, the glob of mercury rolls against the contacts in the end of the tube and shorts them out; but if I sit or lie down, the mercury rolls to the other end of the tube and leaves the contacts open. The primary winding of this model airplane ignition coil is connected across the mercury switch contacts. The coil's 'hot' lead is taped against my skin.

“The batteries, the solenoid, the mercury switch, and the rewinding contact points of the clock are all connected in series. If I'm standing when the contact points close, the

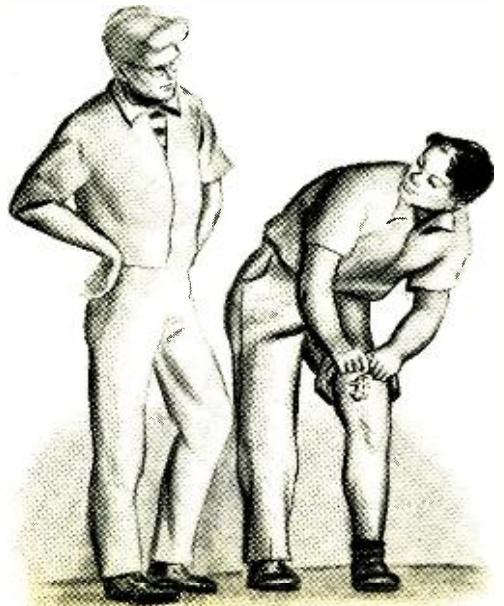



solenoid simply rewinds the spring. No current flows through the primary of the ignition coil that's shorted out by the mercury switch. But if I happen to be caught sitting or lying down when these contact points close, the current to the solenoid flows through the ignition coil primary and produces a high voltage in the secondary. I get a sharp shock when the contacts close and another when they open. After you're stung with that a couple of times, you make very sure you're on your feet well before the time the contacts should close. As soon as I've checked the thing out, I'll patent it and get filthy rich taking pounds off women."

"That will be the day!" Carl jeered to conceal his envy of Jerry's Rube Goldberg ingenuity. "I'd like to see you get a woman to wear that thing."

"I see you don't know much about women," Jerry said loftily. "They will undergo any torture or suffer any indignity if they're convinced it will make them more attractive eventually."

"Okay, Mr. Know-All-About-Women! Let's see you prove it. I noticed Norma taking a sunbath out in her backyard when I came down here. Let's see you get her to wear your contraption."

Jerry hesitated a moment. "That's hardly fair. You know as well as I that Norma doesn't have an ounce that isn't right where it belongs; but I'm game to try. Let's go."

**S**URE ENOUGH, their young neighbor, Norma, looking very trim and lovely, was stretched out in her swim suit on a blanket in the back yard. She glanced up lazily through her dark glasses as the boys came through the hedge and waved a languid welcome to them.

"Don't move!" Jerry said in hushed tones as he stopped short. "Just let me stand here and drink in your loveliness. I want to remember you always just as you are at this moment!"

Norma rolled over, sat up, and whipped off her sun glasses as she looked suspiciously at her two youthful neighbors. "I don't like this," she muttered dubiously. "You sound like you've been smooching with the Blarney Stone."

"I never kiss anything that can't kiss back," Jerry retorted with what was intended to be a leer but which came out more like an engaging grin. "Say, Pal, Carl and I are going up to the lake with

the folks Sunday. How'd you like to come along and have us teach you to water-ski as we promised you we would last winter?"

"You mean it?" Norma said excitedly. "You've got yourself a date! I'm just dying to learn to ski. On top of that, I need the exercise. While I'm afraid to get on the scales, I just know I put on three or four nasty old pounds last winter."

Carl and Jerry exchanged glances. "Well! Isn't that a coincidence," Jerry exclaimed. "You're a very lucky girl. You shall be the very first one to benefit from our B—B—our Secret Slenderizer!"

"Oh, oh! Me and my big mouth!" Norma



groaned as she sloshed suntan lotion on her arms. "What have you two Marconi moppets dreamed up now?"

Jerry pulled up his pants leg and gave a simplified explanation of the workings of the Blubber Banisher.

"You mean you think I'm going to cart around that pint-sized Big Ben?" Norma asked. "I'll become a big fat slob first!"

"We just want you to wear it tomorrow and give us your reaction," Jerry wheedled. "You said yourself you wanted to lose weight, and I'm sure this will do it."

"Sounds more like it would give me a nervous breakdown," Norma retorted.

"Okay; it's your life," Jerry said with a shrug; "but Carl and I have always been so proud of your appearance. When and if we take you skiing, we'll really be sad to see our former streamlined neighbor looking so pudgy and—"

"Okay, you brute; I know when I'm being blackmailed," Norma said through clenched teeth. "I'll try out your gadget."

**T**HE NEXT NIGHT Carl and Jerry were already seated in the moonlight on Norma's front step when they heard her high heels clicking smartly along the sidewalk;

she greeted them cordially and sat down between them.

"Well," Jerry asked anxiously, "does it work?"

"Does it ever!" Norma said with an irrepressible giggle. "It's the best wolf-repellent I've found yet."

"Did you say *wolf-repellant*?" Carl asked.

"Check; but let me take it from the top. This was a very busy day at the office; so I had no trouble at all keeping your little monster from shocking me; but if I get the reputation of being a clock-watcher, it's all your fault. And it's amazing how much of my work I find I can do standing up. Anyway, I wanted to see a show at the State Theater; so I dropped in there about seven. No sooner had I got settled, though, when a specimen of *lupus cinemacus* sat down in the seat next to me."

"*Lupus Cinemacus*?" Carl repeated.

"That's right. It's a type of wolf that inhabits dark movie theaters and tries to pick up lone women. A girl with good sense has no trouble handling them. First, you move. If he moves, too, you call the ushers. They will take care of him *may pronto*.

"This greasy character used the standard approach. First he tried to get me to talk about the picture. Very casually he allowed his arm to rest on the back of my seat. I was just getting ready to pack up my popcorn and move when, during a quiet part of the picture, he said something that gave me an idea: 'For a little thing, that watch of yours sure has a loud tick,' he said.

"With a start I realized your little time bomb was still ticking and time was running out. Very abruptly I jumped up and placed my popcorn on my seat. 'Watch this for me,' I told White Fang.

"As I reached the aisle, I felt the little doojiggy wind the clock spring. That had been close. I knew I had to disarm the

gadget if I were to enjoy the show; so I repaired to the powder room and pulled the little wire loose from where it was taped against my skin. Then I carefully worked it through the cloth of my skirt so that a couple of inches of bare wire was protruding from the right side. Finally I waited until it was only a couple of minutes until the next clock-winding was due, and then I went back to my seat.

"White Fang was waiting for me eagerly. I had scarcely got seated when that arm was across the back of the seat and his fingers were casually touching my shoulder. That was what I wanted. I carefully moved my knee so that I was certain the bare end of the wire was pressing against his leg, and then I braced myself for the shock I knew would be coming.

"All at once he let out a howl and jumped to his feet. 'Help,' he bellowed, 'I'm being electrocuted.' I didn't blame him for thinking so. Even though I was expecting it, that jolt that went through both of us shook me up.

"The usher came running with his flashlight, but Mr. Wolf almost ran over him in his haste to get away from me. 'There's a short circuit or something in that row of seats,' he called back over his shoulder as he limped up the aisle rubbing his leg.

"Is anything wrong here?" the usher asked me and the others in the row of seats.

"'Not now,' I said. The usher gave me a long look and then a knowing grin spread over his face as he flicked off his light and returned to his station. I guess everyone likes to see one of those low-lifers get what's coming to him."

**F**OR SEVERAL MINUTES the three of them talked and laughed about the event.

"Well," Norma finally said, "I'm hungry. After all, I'm sure that all the exercise I got today, thanks to your Secret Slenderizer, plus the emotional wear and tear of playing Little Red Ridinghood to that wolf, plus the exercise I'll get water-skiing tomorrow with you two entitles me to a little indulgence. I know where there are three wedges of chocolate cake with icing all gooey and fattening and *this* thick as well as some Cokes to go along. Would my favorite inventors care to join me?"

"Would we!" Carl and Jerry chorused as each grabbed an arm and hoisted Norma up. "Lead the way, Little Red!"



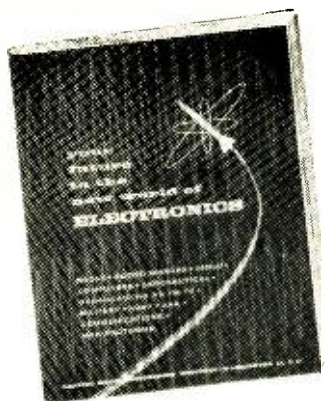

# The data that Launched Thousands of Careers is yours **FREE**

## Tells how you can be successful in **ELECTRONICS**

Send for your *Free Copy* today!

This is a brand new edition of the book which has launched thousands of men on good-paying careers in electronics.

It brings you completely up to date—answers important questions on newest career developments in electronics, including AUTOMATION, INSTRUMENTATION, INDUSTRIAL ELECTRONICS, AERONAUTICAL ELECTRONICS, GUIDED MISSILES, RADAR, SERVO-MECHANISMS, COMPUTERS, ASTRONAUTICS, TELEMETERING, COMMUNICATIONS, MANUFACTURING.

Since its founding in 1927, CREI has provided thousands of professional electronics men with technical education. During World War II, CREI trained thousands for the Armed Services. Leading firms recommend CREI training for their own personnel. Among them: All American Cables and Radio, Inc.; Canadian Broadcasting Corporation; Columbia Broadcasting System; Gates Radio Company; Federal Electric Corp.; The Martin Company; Douglas Aircraft Co.; U. S. Information Agency (Voice of America); Canadair Limited; Trans-Canada Air Lines; United Air Lines. Their choice of training for their own personnel is a good cue for your choice of a school.

You don't have to be a college graduate. You do have to be willing to study—at home. You can do it while holding down a full-time job.

Thousands have. Since 1927 CREI has provided alert young men with the technical knowledge that leads to more responsibility, more job security, more money. And CREI has constantly kept pace with the rapid expansion and progress in electronic achievement. Remember this: CREI starts with fundamentals and takes you along at your own speed. You are not held back by a class, not pushed to keep up with others. You set your own pace. CREI instructors guide you through the lesson material and grade your written work personally. You master the fundamentals, then get into more advanced phases of electronics engineering principles and practice.

**Brand-New Course Added: Automation and Industrial Electronics Engineering Technology:** Complete course, covers all phases of electronic automation. Special emphasis on theory, functioning and applications of servo-mechanisms and computers. Also noteworthy: Lessons on machine control, instrumentation, data processing and telemetry.

CREI ALSO OFFERS residence training in Washington, D. C. . . . at the same high technical level. Day and evening classes start at regular intervals. Qualified residence school graduates earn degree as "Associate in Applied Science." You can qualify for CREI home study education if you have had electronic training, or experience in electronics—and realize the need of a high level technical knowledge to make good in the better electronic jobs. (Electronics experience is not required for admission to CREI Residence School.)

What's the next step? Certainly to get more information than we can cram into one page. Fill out and mail coupon today, or write Capitol Radio Engineering Institute, Dept. 127-F, 3224 - 16th St., N.W., Wash., 10, D. C.

### MAIL THIS COUPON—TODAY!

#### CAPITOL RADIO ENGINEERING INSTITUTE

ECPD Accredited Technical Institute Curricula—Founded 1927  
Dept. 127-F 3224 Sixteenth St., N.W., Washington 10, D. C.

Please send me your course outline and FREE illustrated Booklet "Your Future in the New World of Electronics" . . . describing opportunities and CREI Home Study courses in Practical Electronic Engineering Technology.

- CHECK FIELD OF GREATEST INTEREST
- Radar, Servo and Computer Engineering Technology
  - Electronic Engineering Technology
  - Broadcast (AM, FM, TV) Engineering Technology
  - Television Engineering Technology
  - Aeronautical Electronic Engineering Technology
  - Automation and Industrial Electronics Engineering Technology

B<sup>3</sup>

Name ..... Age .....

Street .....

City ..... Zone ..... State .....

CHECK:  Home Study  Residence School  Korean Veteran

To obtain fast, immediate service, and to avoid delay it is necessary that the following information be filled in:

Employed By .....

Type of Present Work .....

Education: Years High School .....

Other .....

Electronics Experience .....

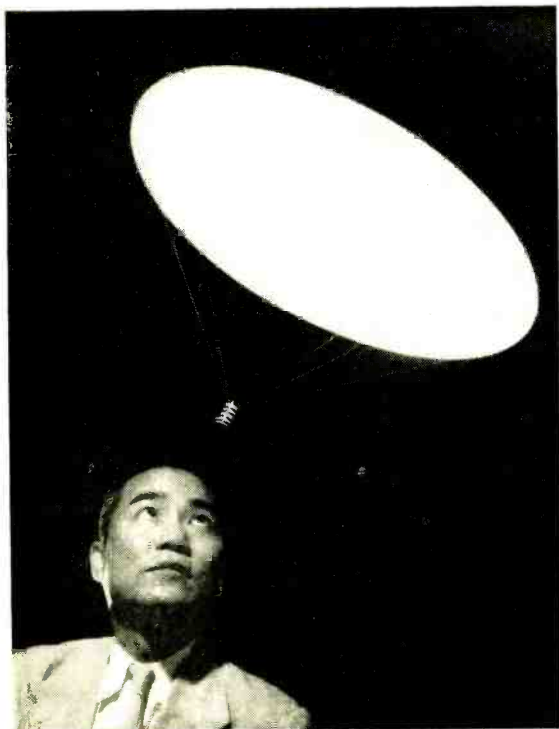

## **Solar Space Sail**

A lightweight aluminum foil or plastic sail one ten-thousandth of an inch thick may propel future spacecraft. Shot into orbit by a conventional rocket, the solar sail would use the pressure of the sun's radiation to accelerate beyond the earth's escape velocity. Westinghouse scientists believe that a spaceship could navigate in space by turning the sail in different directions.



## **Flying Isotopes**

Radioactive isotopes are now being transported from Britain's Harwell atomic pile in special compartments built in the wing-tips of a plane. The distance from the cabin protects the passenger from radiation. Upon arrival, the isotopes are removed and loaded into lead boxes with long-handled rods. Formerly heavy lead covering had to be used when isotopes were stored in baggage compartments.

announcing

# TRU-VAC®



REMARKABLE TUBE VALUES AT 1950 PRICES

ALL TUBES INDIVIDUALLY BOXED, CODE DATED AND BRANDED "TRU-VAC"

Typical TRU-VAC® Bargains!

**THIS IS A PARTIAL LIST** 6SN7GT ALWAYS 30c  
Thousands More Always In Stock 6W4GT ALWAYS 30c

OY4	3AU6	6A6	6B8	6CH8	657	784	12A76	12S47	36
OZ4	3BC5	6AB4	6BA4	6CL6	658GT	785	12A77	12S77	38
1A7GT	3B6	6AC7	6BC5	6CM6	65A7	786	12A78	12S78	39/44
1B3GT	3B76	6AF4	6BC8	6CM7	65D7GT	787	12A79	12S79GT	41
1C6	3CB6	6AG5	6BD6	6CN7	65F5	788	12A80	12S80	42
1C7	3C4	6AH4GT	6BE6	6C08	65F7	7C4	12A81	12V6GT	43
1F4	3S4	6AM6	6B75	6CR6	65G7	7C5	12A82GT	12W6GT	45
1F5	3V4	6AK5	6BG6G	6C56	65H7	7C6	12A83	12X7	50A5
1G4	4RQ7A	6AL5	6BH6	6CUS	65J7	7C7	12A84	14A7/12B7	50B5
1H5GT	4B58	6AM8	6BJ6	6CUS	65K7	7E5	12B8	14B6	50C5
1I4	4B77	6AN8	6BK5	6DA	65L7	7E6	12B8A	14C7	50L6
1I6	4CB6	6AQ5	6BK7	6DEA	65O7	7E7	12B87	19	56
1NSGT	5AM8	6A06	6BL7GT	6DG6GT	65R7	7F7	12B8A	19A4GT	57
1R5	5AN8	6A07	6RN6	6DQ6	614	7F8	12B8A	19B6G	58
1S5	5A18	6AR5	6RO6GT	6F5	6U8	7G7	12B8A	19J6	71A
1T4	5AV8	6A55	6S07	6H6	6V6GT	7H7	12B87	19I8	75
1U4	5A24	6AT6	6S83	6H6	6V6GT	7H7	12B87	24A	76
1U5	5BR8	6AU4GT	6S85	6J4	6X4	7Q7	12B87	25Z6GT	77
1V2	5J6	6AUSGT	6R5Y5G	6J5	6X5GT	7S7	12B17	26	78
1X2	5R4	6AU6	6BZ6	6J6	6X8	7X6	12C45	27	80
2AF4	5U4	6AUB	6BZ7	6J7	6Y6G	7X7	12C55	35	81/624
2B8A	5U8	6AV5GT	6C4	6K6GT	7A4/XXL	7Y4	12D4	35A5	117Z3
2CY5	5V4G	6AV6	6CB6	6K7	7A5	7Z4	12F5	35B5	
3A4	5V6GT	6AW8	6CD6G	6N7	7A6	12A8	12K7	35C5	
3A5	5X8	6AX4GT	6CF6	6O7	7A7	12A85	12L6	35W4	
3AL5	5Y3	6AX5GT	6CG7	6S4	7A8	12A85	12O7	35Z5	

# 35¢ ea.

**\$33 PER HUNDRED**

For any used or factory second tube!

**1 YEAR GUARANTEED PICTURE TUBES**  
Brand New\* Allied A-1 Tubes Brand New  
Below listed prices do not include dud. Add Additional \$5.00 Deposit on tube sizes to 20"; on 21" and 24" tubes - \$7.50. Deposit refunded immediately when dud is returned prepaid. Aluminized tubes - \$4.00 extra.  
Picture tubes shipped only to continental USA and Canada - All tubes F.O.B. Harrison, N. J.

10BP4	7 99	16HP4	12 19	17CP4	16 99	19AP4	15 19	21AP4	18 79	21FP4	18 39	21VP4	18 39
12FP4	10 49	16FP4	11 99	17CP4	17 89	20CP4	15 89	21AMP4	17 99	21KP4	18 39	21ZP4	17 49
14B/CP4	11 99	16IP4	12 19	17HP4	16 99	20DP4	15 89	21B14	18 79	21MP4	22 39	24AP4	30 49
16AD4	16 09	16PP4	11 99	17IP4	16 99	20HP4	17 89	21AVP4	18 79	21YP4	18 39	24CP4	27 79
16DP4	12 19	17AVP4	15 49	17CP4	13 89	21AP4	21 49	21WP4	17 59	21XP4	17 49	24DP4	29 79
16OP4	16 09	17BP4	13 49	17IP4	16 99	21AP4	18 79	21EP4	17 29	21XP4	17 49		

**SENSATIONAL \$100,000 GIVE-AWAY**  
We want 100,000 new customers by Sept. 1st. For every new order of \$25 or more received by that date we will send you a crisp, new dollar bill.

**FREE FUSE CLIP!**  
Sent With Any Order Of \$5 Or More

**GUARANTEE**  
Only TRU-VAC guarantees to replace free any tube which becomes defective in use within one year of date of purchase.

**ATTENTION QUANTITY USERS!**  
Big Discounts Are Yours . . . Call or Write For Our 1000 Tube "Private Label" Special! Attention Branding Dept. MGR.

**MONEY CHEERFULLY REFUNDED WITHIN FIVE (5) DAYS, IF NOT COMPLETELY SATISFIED!**

**TRU-VAC® PAYS YOUR POSTAGE**  
On orders of \$5 or more in U.S.A. and Territories. Send approximate postage on Canadian and foreign orders. Any order less than \$5 requires 25¢ handling charge. Send 25% on C.O.D.'s. All orders subject to prior sale.

Complying with Federal regulations, the following statement appears in all Tru-Vac advertising: Tubes appearing in this ad may be FACTORY SECONDS or USED tubes and are clearly marked.

# TRU-VAC®

Harrison Avenue Box 107 Harrison, New Jersey  
HUMboldt 4-9770

Write Dept. L For FREE LIST Of Other Tube Types and Products Sold By TRU-VAC®  
**Electric Company**

**USED TV CONSOLES GUARANTEED To Work When You Receive Them**

10" & 12"	\$29
14" & 16"	\$37
17"	\$45
19"	\$59
20" & 21"	\$70

All sets shipped in two cartons to avoid breakage. Sets shipped express to continental USA and Canada only. F.O.B. Harrison New Jersey.

**FREE BONUS—RABBIT EARS**  
\$7.95 Value  
FREE with each set purchased



## do-it-yourself kits put top quality within easy reach

*With absolutely no previous experience or knowledge of electronics you can assemble your own HEATHKIT hi-fi system, Ham station, test equipment or marine gear. Easy to understand step-by-step instructions, along with large pictorial diagrams, guarantee your success—and you save 1/2 or more on the highest quality equipment available today at any price!*

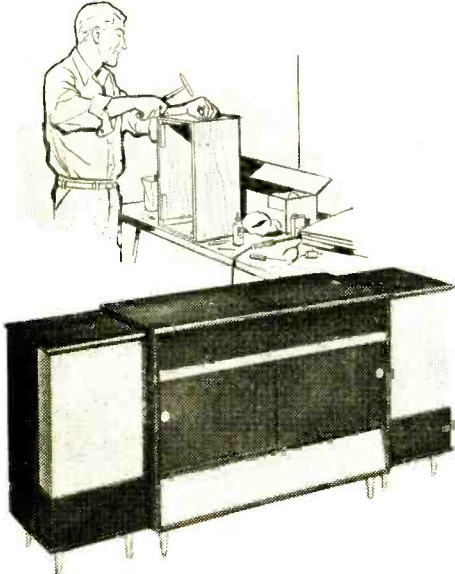

**\$149<sup>95</sup>**

each  
(shpg. wt. 162 lbs.)

**STEREO EQUIPMENT CABINET KIT**  
Model SE-1B (birch)  
Model SE-1M (mahogany)

**\$39<sup>95</sup>**

each  
(shpg. wt. 42 lbs.)

**STEREO WING SPEAKER ENCLOSURE KIT**  
Model SC-1BR (birch—right end)  
Model SC-1BL (birch—left end)  
Model SC-1MR (mahogany—right end)  
Model SC-1ML (mahogany—left end)

### STEREO EQUIPMENT CABINET KIT

A thing of beauty as well as utility, this stereo equipment cabinet ensemble houses your complete stereo hi-fi system. It consists of a stereo equipment center flanked by two stereo speaker enclosures. The kit is supplied with mounting panels pre-cut to accommodate Heathkits and interchangeable blank panels are also furnished. The pre-cut panels accommodate the Heathkit AM-FM Tuner (PT-1), Stereo Preamplifier (SP-2), and Stereo Record Changer (RP-3-S). The changer slides out smoothly for easy record loading. Convenient record and tape storage space is provided. Ample room is provided in the rear of the center cabinet for a pair of matching Heathkit amplifiers from 12 to 70 watts. The stereo wing speaker enclosures are open-backed, cloth-grilled cabinets designed to hold the Heathkit SS-3 or similar speaker enclosures. The cabinets are available in beautifully grained 3/4" solid core Phillipine mahogany or select birch plywood suitable for the finish of your choice. Entire top features a shaped edge. Hardware and trim are of brushed brass and gold finish.

MODEL MF-1

**\$26<sup>95</sup>**



### DIAMOND STYLUS HI-FI PICKUP CARTRIDGE

Get the most from your LP microgroove records. Designed to Heath specifications by Fairchild Recording Equipment Corporation, the MF-1 is one of the finest pickup cartridges on the market today. Shpg. Wt. 1 lb.

**ENJOY A HOME HI-FI SYSTEM NOW! PAY LATER...**



*Heath's convenient Time Payment Plan allows you to buy all of your hi-fi components right away... and pay for them in easy installments. Only 10% down on purchases of \$55 or more. Send coupon today for FREE Heathkit catalog with full time-pay details.*

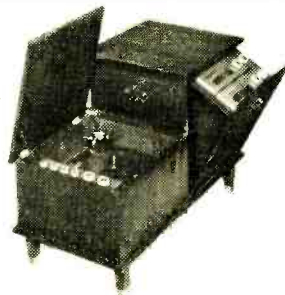

**TRADITIONAL**  
Model CE-2T (mahogany)

**CONTEMPORARY** (not shown)  
Model CE-2B (birch)  
Model CE-2M (mahogany)

**\$43<sup>95</sup>**  
each

### CHAIRSIDE ENCLOSURE KIT

Put your entire hi-fi system right at your fingertips with this handsome enclosure. Available in either traditional or contemporary models and constructed of beautiful veneer-surfaced plywood suitable for the finish of your choice. It is designed to house the Heathkit AM and FM Tuners (BC-1A and FM-3A), the WA-P2 Preamplifier, the RP-3 Record Changer, and adequate space is provided for any Heathkit amplifier designed to operate with the WA-P2. All parts pre-cut and predrilled for easy assembly. Shpg. Wt. 46 lbs.



**NEW**

HEATHKIT EA-3  
**\$29<sup>95</sup>**

**NEW! 14-WATT HI-FI ECONOMY AMPLIFIER (EA-3)**

From HEATHKIT audio labs comes an exciting new kit . . . New Styling. New Features. Brilliant Performance! Designed to function as the "heart" of your hi-fi system, the EA-3 combines the preamplifier and amplifier into one compact package. Providing a full 14 watts of high fidelity power, more than adequate for operating the average system, the EA-3 provides all the controls necessary for precise blending of musical reproduction to your individual taste.



*Build it in  
one Evening*

HEATHKIT SS-2  
**\$39<sup>95</sup>**

**"BASIC RANGE" HI-FI SPEAKER SYSTEM KIT**

With performance comparable to speakers costing many times more, the SS-2 employs a Jensen 8" woofer and compression-type tweeter to provide total frequency response of 50 to 12,000 CPS. Shpg. Wt. 26 lbs.

**ATTRACTIVE BRASS TIP ACCESSORY LEGS:** convert the SS-2 into handsome consolette. Shpg. Wt. 3 lbs. No. 91-26. \$4.95.

**BASIC FIR MODEL:** same as SS-2 except constructed of non-premium plywood without trim or grille cloth. Shpg. Wt. 26 lbs. Model SS-3. \$34.95.



HEATHKIT FM-3A  
**\$26<sup>95</sup>**

**HIGH FIDELITY FM TUNER KIT**

The thrills of FM entertainment are yours at budget cost with this handsomely styled tuner. Featuring broad-banded circuits for full fidelity and better than 10 microvolt sensitivity for 20 db of quieting, the FM-3A pulls in stations with clarity and full volume. Shpg. Wt. 8 lbs.

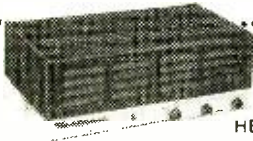

HEATHKIT W-7M  
**\$54<sup>95</sup>**

**"EXTRA PERFORMANCE" HI-FI 55 WATT AMPLIFIER KIT**

Offering full fidelity at less than a dollar per watt, the power output of this remarkable amplifier is conservatively rated at 55 watts from 20 CPS to 20 kc with less than 2% total harmonic distortion throughout this entire range. Shpg. Wt. 28 lbs.



HEATHKIT PT-1  
**\$89<sup>95</sup>**

**MONAURAL-STEREO  
AM-FM TUNER KIT**

This professional quality 16-tube tuner offers you outstanding AM, FM or stereo AM/FM performance at minimum expense. Features include individual flywheel tuning and automatic frequency control. A multiplex jack is also provided. Shpg. Wt. 24 lbs.



HEATHKIT SP-2  
**\$56<sup>95</sup>**

**MONAURAL-STEREO (two channel mixer)  
PREAMPLIFIER KIT**

Control your entire stereo system with this 2-channel preamplifier. A remote balance control with 20' of cable allows balancing the stereo system from listening position. Shpg. Wt. 15 lbs.



HEATHKIT TR-1A  
**\$99<sup>95</sup>**

Includes tape deck, tape recorder electronics, microphone and roll of blank tape.



**HIGH FIDELITY  
TAPE RECORDER KIT**

Whether making your own recordings or playing pre-recorded tapes you'll enjoy the many fine features of this tape recorder kit. Included are fast forward and rewind functions and choice of 7 1/2 or 3 3/4 IPS tape speeds. Printed circuit boards simplify assembly. Shpg. Wt. 24 lbs.

HEATHKIT RP-3  
**\$64<sup>95</sup>**

(stereo model RP-3S \$74.95)

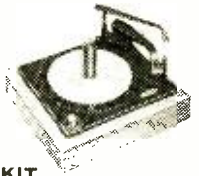

**AUTOMATIC HI-FI  
RECORD CHANGER KIT**

Combining the convenience of an automatic record changer with true turntable quality the RP-3 obtains full fidelity from your hi-fi and stereo records while treating them with the care they demand. A "turntable pause" feature prevents records from dropping on moving turntable or disk. Plays at 33 1/3, 45, 78 and 16 RPM. Shpg. Wt. 19 lbs.

**HEATH COMPANY**  
Benton Harbor, Mich.

A Subsidiary of Daystrom, Inc.



HEATHKIT TX-1  
\$234<sup>95</sup>

**"APACHE" HAM TRANSMITTER KIT**

Features 150 watt phone input and 180 watt CW input. Provision for single-sideband transmission using the SB-10 External Adapter. Shpg. Wt. 110 lbs.



HEATHKIT RX-1  
\$274<sup>95</sup>

**"MOHAWK" HAM RECEIVER KIT**

Covers from 160 through 10 meters on 7 bands with an extra band calibrated to cover 6 and 2 meters using a converter. Outstanding SSB reception. Shpg. Wt. 66 lbs.



HEATHKIT SB-10  
\$89<sup>95</sup>

**SINGLE SIDEBAND ADAPTER KIT**

A compatible plug-in adapter unit for the "Apache" Transmitter, the SB-10 covers 80, 40, 20, 15 and 10 meter bands. Produces USB, LSB or DSB signals, with or without carrier insertion. Shpg. Wt. 12 lbs.



HEATHKIT DX-40  
\$64<sup>95</sup>

**PHONE AND CW TRANSMITTER KIT**

Providing phone and CW operation on 80, 40, 20, 15, and 10 meters, the DX-40 features built-in modulator and power supplies. Shpg. Wt. 25 lbs.



HEATHKIT MP-1  
\$44<sup>95</sup>

**MOBILE POWER SUPPLY KIT**

Furnishes all power required to operate both MT-1 Transmitter and MR-1 Receiver from 12-14 volt battery. Delivers full 120 watts continuously or 150 watts intermittently. Kit includes 12' battery cable, tap-in studs for battery posts, power plug and 15' connecting cable. Shpg. Wt. 8 lbs.

**Mobile Fun! With all New Heathkit Mobile Ham Gear**



HEATHKIT MR-1  
\$119<sup>95</sup>

**"COMANCHE" MOBILE HAM RECEIVER KIT**

Handsome styling, rugged construction, top quality components and economy are all wrapped up in the "Comanche". It is an 8-tube superheterodyne receiver operating AM, CW and SSB on the 80, 40, 20, 15 and 10 meter amateur bands. Operates from 12 volt car battery through the MP-1 Mobile Power Supply. Can be converted in minutes to a fixed station unit by using an AC power supply. Shpg. Wt. 19 lbs.

**MOBILE ACCESSORIES**

Quality 5" PM speaker in rugged steel case with mounting brackets. Heathkit AK-7. \$5.95. Shpg. Wt. 4 lbs.

Mobile base mount holds both transmitter and receiver. Universal floor mounting bracket. Heathkit AK-6. \$4.95. Shpg. Wt. 5 lbs.

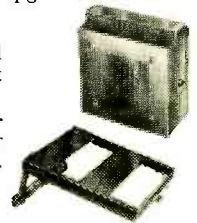

HEATHKIT MT-1  
\$99<sup>95</sup>

**"CHEYENNE" MOBILE HAM TRANSMITTER KIT**

The fun and convenience of mobile operation are yours with the compact and efficient "Cheyenne" Transmitter. Featuring high power with minimum battery drain, the unit provides up to 90 watts phone input and covers 80, 40, 20, 15 and 10 meters. Featured are a built-in VFO, modulator, 4 RF stages with a 6146 final amplifier pi network (coaxial) output coupling. The "Cheyenne" is designed as a companion to the "Comanche" receiver and is powered by the MP-1 Power Supply. Shpg. Wt. 19 lbs.



HEATHKIT VHF-1  
\$159<sup>95</sup>

**"SENECA" VHF HAM TRANSMITTER KIT**

General, technician or novice class hams wishing to extend transmission into the VHF region will find the "Seneca" ideal. A completely self-contained 6 and 2 meter transmitter, the VHF-1 features up to 120 watts input on phone and 140 watts input on CW in the 6 meter band. Included are controlled carrier phone operation, built-in VFO for both 6 and 2 meters, and four switch-selected crystal positions. Shpg. Wt. 56 lbs.





HEATHKIT V7-A  
\$25<sup>95</sup>

**ETCHED CIRCUIT  
VTVM KIT**

World's largest selling VTVM, the V7-A measures AC voltage (RMS), AC voltage (Peak-to-peak), DC voltage and resistance. Features 7 AC (RMS) and DC voltage ranges of 0-1.5, 5, 15, 50, 150, 500 and 1500. In addition there are 7 peak-to-peak AC ranges of 0-4, 14, 40, 140, 400, 1400 and 4000. Seven ohmmeter ranges are provided. Battery and test leads are included with kit. Shpg. Wt. 7 lbs.



HEATHKIT TC-3  
\$39<sup>95</sup>

**TUBE CHECKER KIT**

An invaluable aid to servicemen, the TC-3 tests for open, short, leakage, heater continuity and quality of all tube types commonly encountered in radio and TV servicing. Checks 4, 5, 6 and 7-pin large, 7 and 9-pin miniature, 7-pin sub-miniature, octal and local tubes and pilot lamps. A blank socket provides for future tube types. Shpg. Wt. 12 lbs.



Model 355.

**TV PICTURE TUBE TEST ADAPTER**

For use with TC-3 or earlier model TC-2. Includes 12-pin TV tube socket, 4' cable. Octal connector and data. No. 355. Shpg. Wt. 1 lb. \$4.50.

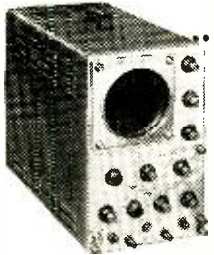

HEATHKIT OP-1  
\$179<sup>95</sup>

**"PROFESSIONAL" 5"  
DC OSCILLOSCOPE KIT**

Offering complete versatility, the OP-1 features DC coupled amplifiers and also DC coupled CR tube unblanking. Triggered sweep circuit operates on internal or external signals and may be either AC or DC coupled. Transformer operated power supply has silicon diode rectifiers. Shpg. Wt. 34 lbs.



HEATHKIT OM-3  
\$39<sup>95</sup>

**"GENERAL PURPOSE"  
5" OSCILLOSCOPE**

Ideal in servicing as well as routine laboratory work, the OM-3 features wide vertical amplifier frequency response, extended sweep generator operation and improved stability. Vertical response is within  $\pm 3$  db from 4 CPS to 1.2 mc. Sweep range covers 20 CPS to over 150 kc. Shpg. Wt. 22 lbs.



HEATHKIT T-4  
\$19<sup>95</sup>

**VISUAL-AURAL SIGNAL TRACER KIT**

Doubling as a utility amplifier, test speaker, or substitution transformer, the T-4 represents an outstanding buy. Traces RF, IF and audio signals in AM, FM and transistor-type radios. Shpg. Wt. 5 lbs.



HEATHKIT SG-8  
\$19<sup>50</sup>

**RF SIGNAL GENERATOR KIT**

Aligns RF, IF and tuned circuits of all kinds. Provides extended frequency coverage in five bands from 160 kc to 110 mc on fundamentals and up to 220 mc on calibrated harmonics of the fundamental frequencies. Shpg. Wt. 8 lbs.



HEATHKIT CT-1  
\$7<sup>95</sup>

**IN-CIRCUIT CAPACI-TESTER KIT**

Check capacitors for "open" or "short" right in the circuit. Detects open capacitors from 50 mmf up and checks shorted capacitors up to 20 mfd. Checks all bypass, blocking and coupling capacitors of the paper, mica and ceramic types. Shpg. Wt. 5 lbs.



HEATHKIT TO-1  
\$16<sup>95</sup>

**TEST OSCILLATOR KIT**

Provides fast and accurate selection of test frequencies most used by servicemen in repairing and aligning modern broadcast receivers. Five fixed-tuned frequencies are quickly selected for trouble-shooting. Shpg. Wt. 4 lbs.

**HEATH COMPANY**  
Benton Harbor, Mich.

A Subsidiary of Daystrom, Inc.



add that "extra" speaker

HEATHKIT US-1  
\$750

### 12" UTILITY SPEAKER

This high quality auxiliary speaker offers many possibilities in audio, radio and TV work and will handle up to 12 watts with a frequency response from 50 to 9,000 CPS  $\pm 5$  db. Speaker impedance is 8 ohms and employs a 6.8 ounce magnet. Shpg. Wt. 7 lbs.

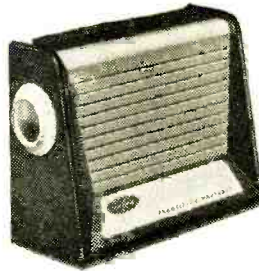

HEATHKIT XR-1P  
\$29<sup>95</sup>

### 6 TRANSISTOR PORTABLE RADIO KIT

This easy-to-build portable radio offers fun and enjoyment for the whole family. Features 6 transistors, large 4" x 6" PM speaker for "big-set" tone quality, and built-in rod-type antenna. Uses standard size "D" flashlight cells for extremely long battery life (between 500 and 1,000 hours). The modern molded plastic case with pull-out carrying handle is two-tone blue with gold inlay and measures 9" L. x 7" H. x 3 3/4" D. Shpg. Wt. 6 lbs.

Fun for the whole family



HEATHKIT BR-2  
\$18<sup>95</sup>  
(less cabinet)

### BROADCAST BAND RADIO KIT

Fun to build, and a fine receiver for your home. Covers complete broadcast band from 550 to 1600 kc. Built-in 5 1/2" PM speaker and rod-type antenna. Transformer operated power supply. Excellent sensitivity and selectivity. Shpg. Wt. 10 lbs.

Cabinet optional extra: No. 91-9A. Shpg. Wt. 5 lbs. \$4.95.

Complete Engine "Tune-Up" Facilities!

### ELECTRONIC IGNITION ANALYZER KIT (IA-1A)

NEW



Just clip the two test leads to operating engine (400 to 3,000 RPM) and check condition of coil, condenser, points, plugs and wiring. Shows either primary or secondary circuit patterns, parade or superimposed secondary patterns. Shpg. Wt. 20 lbs.

**MODIFICATION KIT for IA-1 Models:** Provides switch selection of primary and secondary circuit patterns, or, choice of parade and superimposed secondary patterns. Shpg. Wt. 2 lbs.  
Heathkit MK-6. . . . . \$4.95

HEATHKIT IA-1A \$59<sup>95</sup>

HEATHKIT AK-1  
\$9<sup>95</sup>



### MICROPHONE ACCESSORY KIT

Useful in countless applications, this kit consists of a rugged high fidelity crystal mike and three holders; a mike stand adapter, a lavalier neck-band and desk stand. An 8' cable with phone plug is included. Shpg. Wt. 1 lb.



### CRYSTAL RADIO KIT

Any youngster interested in radio or electronics will enjoy building and using this fine little crystal receiver. Frequency coverage is from 540 to 1600 kc. A sealed germanium diode is used for detection—no critical "cats whisker" adjustment. Headphones included. Measures 6" L. x 3" W. x 2 1/8" D. Shpg. Wt. 3 lbs.

Let your boy learn radio

HEATHKIT CR-1 \$7<sup>95</sup>



HEATHKIT TI-1 \$25<sup>95</sup>

check engine RPM

### ELECTRONIC TACHOMETER KIT

Easy-to-build and simple to install. Operates directly from the spark impulse of any 2 or 4 cycle engine with any number of cylinders. Operates on 6, 8, 12, 24 or 32 volt DC systems and is completely transistorized. The easy-to-read indicator shows RPM from 500 to 6,000. A calibration control is also provided. Shpg. Wt. 4 lbs.



HEATHKIT TK-1  
\$9<sup>95</sup>

### COMPLETE TOOL SET

This handy tool kit provides all the basic tools required for building any Heathkit. Includes pliers, diagonal sidecutters, screwdrivers, and soldering iron with holder. Pliers and sidecutters are equipped with insulated rubber handles that provide protection from electrical shock. All of the tools are of top quality case hardened steel for rugged duty and long life. Shpg. Wt. 3 lbs.



HEATHKIT DF-2  
\$69<sup>95</sup>

**2-BAND TRANSISTOR RADIO DIRECTION FINDER KIT**

Economically powered by 6 standard flashlight cells, the DF-2 provides you with a completely portable 6-transistor standard and beacon band receiver of unusual quality and performance. Covers the beacon band from 200 to 400 kc and broadcast band from 540 to 1620 kc. A tuning dial light is provided for night operation. Large 4" x 6" speaker provides superb tone reproduction. Shpg. Wt. 9 lbs.

HEATHKIT PC-1  
\$24<sup>95</sup>



**12 VOLT POWER CONVERTER KIT**

Household electricity right on your boat or in your automobile is yours with this 12-volt power converter kit. Operate your radio, electric razor, lights, etc., directly from your 12-volt boat or car battery. Power rating is 125 watts continuously and 175 to 200 watts intermittently. Note: not recommended for record players, tape decks, power tools or radio transmitters. Shpg. Wt. 8 lbs.

**Free** Send now for latest Heathkit Catalog describing in detail over 100 easy-to-assemble kits for the Hi-Fi fan, radio ham, boat owner and technician.



**MARINE CONVERTER KIT**



HEATHKIT MC-1  
\$39<sup>95</sup>

Charge your 6 or 12 volt batteries at dockside even while your boat's electrical system is in use. Provides up to 20 amperes continuously for charging 6-volt batteries or 10 amperes continuously for charging 12-volt batteries, regardless of type. Charging current is continuously monitored by a 25 ampere meter. Shpg. Wt. 16 lbs.

**MARINE BATTERY CHARGE INDICATOR KIT**

See at a glance the exact percentage of charge in your boat batteries. Checks from 1 to 8 storage batteries instantly. Operates on 6, 8, 12 or 32 volt systems. Note: for mounting on non-ferrous metals or wood only. Shpg. Wt. 3 lbs.



HEATHKIT CI-1  
\$16<sup>95</sup>



HEATHKIT FD-1-6 (6 volt)  
FD-1-12 (12 volt)  
\$35<sup>95</sup> each

**FUEL VAPOR DETECTOR KIT**

Protecting against fire and explosion on your boat, the FD-1 indicates the presence of explosive fumes and shows immediately if it is safe to start the engine. The kit is complete including spare detector unit. Shpg. Wt. 4 lbs.

**HEATH**  
*pioneer in do-it-yourself electronics*

**COMPANY** BENTON HARBOR 10, MICH.

 a subsidiary of Daystrom, Inc.

Send latest Free Heathkit Catalog.

NAME \_\_\_\_\_

ADDRESS \_\_\_\_\_

CITY \_\_\_\_\_ ZONE \_\_\_\_\_ STATE \_\_\_\_\_

QUANTITY	KIT NAME	MODEL NO.	PRICE

## Inside the Power Amplifier

sometimes substituted for the pentode because the tubes (usually the EL84) used in these amplifiers need fewer volts of drive. A twin-triode is generally used; one half for the amplifier and the other half as the inverter.

Another popular circuit is the so-called "Mullard" configuration shown in Fig. 5. Again we have a pentode voltage amplifier, direct-coupled to a twin-triode cathode-coupled (or long-tailed pair) inverter which is capacitor-coupled to the output stage. This circuit has more gain than the Dyna circuit, but losses at very high frequencies are slightly greater. Here, again, a triode is sometimes substituted for the pentode in lower powered amplifiers.

The preceding circuits are used in probably 90% of the power amplifiers on the market, but there are a number of interesting variations. In Fig. 6 we have a circuit used by Grommes which employs a twin-triode as a cascode voltage amplifier. The cascode has most of the virtues of the pentode and, in addition, is perhaps a little more stable. The cascode voltage amplifier feeds a cathode-coupled inverter.

In Fig. 7, in a circuit used by Acro, we have a cathode-coupled inverter at the input which is direct-coupled to a push-pull pair of triode amplifiers. This results in an amplifier that is push-pull from beginning to end. Feedback from a special winding on the output transformer is applied to the inverter grid, which is normally at a.c.-ground potential.

Though each of these circuits has its own advantages and disadvantages, all are capable of producing superb performance. But over-all design, not the design of any single circuit, determines the end quality of an amplifier. Next month we will consider the design of power output stages and the part it plays in the over-all circuitry of an amplifier. —30—



### Test Instruments

(Continued from page 111)

should indicate anywhere from 0.4 volts to slightly less than 1 volt. An exact reading can't be quoted because there are just too many variables for on-the-nose results to be expected.

What have we achieved with the preceding test? Well, with one quick measurement, we've ascertained that the complete amplifier's sensitivity and power output are both up to snuff.

If you want to make individual stage gain measurements, use a slight variation in technique. Keeping the same input signal at *mag. phono*, as used for the over-all wattage check, take a measurement at the grid of  $V2A$ . With your *VTVM* set for the lowest a.c. scale, expect about 0.5 volt. Remember, we applied about .005 volt (5 mv.) to the *mag. phono* input; now, at the output of  $V1$ , it's paying off to the tune of 0.5 volt. A little calculation will reveal that we've achieved a gain of 100 on our investment.

Stage gain measurements in the remainder of the circuit are as simple—but don't expect the tube manual to be a reliable guide to the gains to be expected. Remember, negative feedback is used throughout the better hi-fi amplifiers and cuts down gain-per-stage considerably. For example, in the tone control stage, with 0.5 volt from the preamp applied to the input grid of  $V2A$ , less than 1.5 volts of signal will be found at the plate of  $V2B$ —a gain of somewhat less than 3 for both triodes.

At  $V3$ , we come to the direct-coupled voltage amplifier/phase inverter stage. About 1.4 signal volts applied at pin 7 of  $V3$  will get you 8 signal volts at its plate—a gain of less than 6.

**A Balanced Diet.** When the 8 volts of signal are fed to the grid of the split-load phase inverter ( $V3B$ ), signal voltages are developed across *both* the plate and cathode resistors. The voltages (about 7.75) should be exactly equal and opposite ( $180^\circ$  out of phase).

The push-pull signal developed here feeds the output tubes their balanced diet. Unequal signals at the plate and cathode (which will cause "upset" in the output stage in the form of distortion) are usually due to mismatch in the plate and cathode load resistors. Optimally, they should measure within 1% of each other.

This has been a fast guided tour following a signal through a typical amplifier. Of course, there are many more specialized measurements the *VTVM* can make in amplifiers as well as other equipment. Anywhere that sensitivity and wide frequency response are important, you'll find the *VTVM* ready and able to do its part. —30—

## Transistor Topics

(Continued from page 124)

seen in some time. Nurhan has modified a conventional detector-amplifier circuit by using a *bridge-type* detector, providing a push-pull output signal which, in turn, is used to drive a standard push-pull power amplifier circuit.

*L1* is a standard broadcast-band loopstick antenna coil, *C1* is a 365- $\mu$ fd. tuning capacitor and *C2* and *C3* are 6- or 12-volt electrolytics. The power pack, *B1*, is made up of three penlight (or flashlight) cells in series to supply 4.5 volts. Output transformer *T1* may be an Argonne Type AR-170. Use a s.p.s.t. toggle, slide or rotary switch for *S1*. Any size PM loudspeaker will do; in general, the larger the speaker, the better the performance.

Layout shouldn't be critical. You can assemble a duplicate circuit on a small Bakelite or plastic board, or you can employ "conventional" metal chassis construction. In most locations, best results will be obtained if the receiver is used with an external antenna-ground system.

**Help Wanted.** Transistor experimenters are always looking for special circuits to meet their particular needs. If you have—or know of—circuit data which will help the following readers, please write them.

H. G. Weber, 2927 W. 97th St., Evergreen Park 42, Ill., would like to find a circuit for a *transistorized sonar set* suitable for locating schools of fish.

L. W. Russell, 120 Park St., Bangor, Maine, wants construction data for a fully transistorized *short-wave receiver*.

Fred Bartlett, 6110 West 26th St., Cicero 60, Ill., needs information on a transistorized, pocket-sized *multiplex receiver for the FM broadcast band*. This is a tough one, Fred, but perhaps someone can help!

**Mobile Computer.** Electronic computers and data processors often are immense complexes filling a floor or two in a fair-sized office building. Where transistorized circuitry is used, however, a tremendous reduction in size, weight, and power requirements is possible.

The Philco Corporation is now developing a mobile electronic data processor for the U. S. Army. Designed to meet military field requirements under combat conditions, these units will be installed in self-contained all-weather shelters which can be carried easily by medium-sized trucks. The

computers will be used for such jobs as artillery survey calculations, meteorological computations, and drone aircraft control.

**Solar Energy Kit.** Designed for experimental use in schools and industrial laboratories, a device demonstrating the direct conversion of light into electricity has been developed by Hoffman Electronics Corporation (3761 S. Hill St., Los Angeles 7, Calif.) It consists of four silicon solar cells wired in series and connected to a small electric motor; the motor, in turn, is fitted with a four-blade propeller. The entire assembly is mounted on a 3" x 5" plastic base.

The solar cells in this device are similar to those which are used to power one of the Vanguard satellite radio transmitters. They furnish sufficient power to spin the motor at a good clip when exposed to sunlight—or even to the light of a 150-watt incandescent bulb. The kit is available at cost (\$14.00) to teachers, scientists, engineers, and other qualified individuals.

**New Transistors.** RCA (Semiconductor Div., Harrison, N. J.) has introduced a whole new line of *n-p-n* silicon transistors manufactured using the diffused-junction mesa technique. Five types are being offered: the 2N1092 medium-power unit, intermediate-power types 2N1067 and 2N1068, and high-power types 2N1069 and 2N1070. Current and power ratings range from 0.5 amp. and 1 watt for the 2N1092 to 4.0 amp. and 25 watts for the 2N1070.

From Motorola (Phoenix, Arizona) comes news of a power transistor with a maximum current rating of 25 amperes. The MN-86 is a germanium *p-n-p* unit for high current switching and audio applications. Two basic versions are available, one with maximum collector-emitter voltage of 35 volts, the other rated at 60 volts. Collector dissipation at 30° C is 50 watts maximum.

That's the transistor story for now. See you next month . . .

Lou

## Police Special Receiver

(Continued from page 53)

impedance phones into *J2*, and apply power. As the receiver warms up, you should hear a loud hissing noise or "rush" in the headphones. This is known as "thermal-agitation noise," and is the product of the remarkable gain of the detector stage. Attach a 30" length of ordinary hookup

wire to the "hot" terminal of *TB1*, and slowly tune *C1* across the band.

As you encounter a signal, the hissing noise in the phones will drop to a level dependent on the strength of the received carrier. A fairly strong signal will cause the hiss to drop out completely. As you tune past the signal, or if it leaves the air, the hiss will return. The sensitivity control

shown on the front panel is not critical in its setting; it can be adjusted once for best response and then forgotten.

**Alignment and Calibration.** If either a signal generator or grid-dip meter is handy, alignment and calibration of the receiver is quite simple. If you cannot beg, borrow, or otherwise appropriate one of these, you can do a surprisingly good job of alignment in the following manner.

If there is a television station operating in your area on Channel 2, the upper tuning limit of the receiver can be set by using the station's video carrier as a marker. With the receiver in operation, tune *C1* to its minimum (full open) capacity position. Next, adjust the slug in detector coil *L1* with an insulated, non-metallic alignment tool, until the video carrier (a loud 60-cycle buzz) is heard in the headphones.

The upper frequency limit of the receiver is now 54 mc. If specifications were followed in winding coil *L1*, the receiver will automatically fall into alignment at the low end of the band. The alignment of *L2* is not critical, and its slug may be peaked on any signal in the middle of the band (approximately 42 mc.).

### HOW IT WORKS

The "Police Special" is made up of two well-known circuits: the cascade r.f. amplifier and superregenerative detector. A 6BZ7(V1) serves to amplify all incoming signals while isolating the detector from the antenna. The amplified signal is coupled loosely to the detector grid-coil (*L1*) by capacitor *C5*.

One-half of a 12AT7 dual-triode (V2) acts as a superregenerative detector, and is connected as a modified Hartley grounded-plate oscillator. The oscillator is brought in and out of oscillation at a low frequency rate determined by *R4*, *C6*, and *C8*. This "quench-frequency" allows tremendous gain by the detector, without instability due to excessive feedback.

Audio recovered from the AM or FM carrier is coupled to the other half of the 12AT7, which serves as a conventional audio amplifier, delivering output to headphones or an external amplifier. The receiver power supply is transformer-operated to prevent any shock hazard. Choke filtering of the B-plus supply is used to provide a pure d.c. output and higher voltage under load.

# 2-WAY CITIZENS RADIO TELEPHONE

(27 MC. CLASS D)

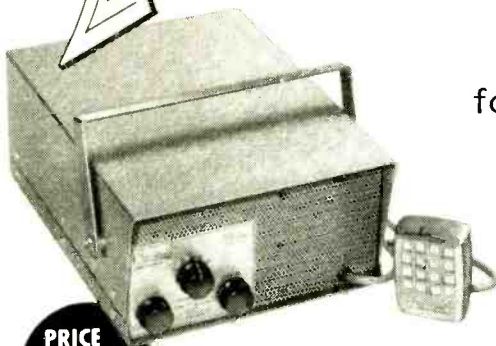

PRICE  
\$124.<sup>50</sup>

No exam for FCC license...!

- for
- BOATING
  - HOME
  - FARMING
  - CAMPING
- MOBILE
  - BUSINESS
  - SPORTS
  - INDUSTRY

5 CRYSTAL CONTROLLED CHANNELS  
SQUELCH CIRCUIT • NOISE LIMITER  
5 WATTS OF POWER • 7 TUBES IN RECEIVER

Two Models: MODEL CD-5/6 6 VOLT DC AND 110 VOLT AC  
MODEL CD-5/12 12 VOLT DC AND 110 VOLT AC

\*Price includes: MICROPHONE, 1 SET OF CRYSTALS,  
1 AC CORD, 1 DC CORD WITH CIGAR LIGHTER PLUG

See your dealer, now!  
**Citi-fone**®

by  
**MULTI-ELMAC**

**MULTI-PRODUCTS COMPANY**  
21470 COOLIDGE HWY. OAK PARK, MICHIGAN

### SERVICE ALLOCATIONS CHART\*

Service	Frequencies (mc.)
Automotive Emergency	35.7 - 36
Highway Trucks	35.78 - 35.94
Power Companies	37.5 - 37.86
Police (local)	38 - 41
Motor Carrier	44.1 - 44.42
Fire Department	47.2 - 47.9
Public Utility	47.7 - 48.5
Highway Patrol (State Police)	48 - 49.5
Radio Amateur	50 - 54 (six meters)

\* A more complete listing of services operating in the 30-50 mc. band may be found in the "Registry of Police Radio Systems" or "Registry of Industrial Radio Services," both published by the Communications Engineering Book Company, Monterey, Mass.

The dial can then be calibrated by listening for the various services and determining their frequencies from the allocations chart.

If you wish, the Police Special can be connected to an outdoor TV antenna. However, the receiver may be overloaded by the excessive signal input, and the 30" lead will provide more than enough signal pickup in any but the most remote locations. Suffice it to say that radio amateur signals from California have been heard "5 by 7" in New York City on the six-meter section of the receiver, with nothing more than the 30" "long-wire" antenna. -30-

### STATE REGULATIONS

Many states, such as those noted below, have ordinances pertaining to the installation and operation of short-wave receiving equipment on the 30-50 mc. band. If you have any question as to your state's requirements, check with the local Police Department.

**California.** Los Angeles has a city ordinance prohibiting the installation in a motor vehicle of receiving equipment which can tune to municipal (fire and police) frequencies.

**Florida.** The law prohibits the use in a motor vehicle of equipment capable of receiving on police frequencies; however, amateurs are specifically exempted.

**Indiana.** Use in motor vehicles of equipment capable of receiving on police frequencies is prohibited.

**New Jersey.** Use in motor vehicles of equipment capable of receiving on police frequencies is prohibited, unless user has a permit from the local chief of police.

**New York.** Same as New Jersey.

**North Dakota.** Installation and use of mobile short-wave receivers without a permit is prohibited.

**South Dakota.** Same as North Dakota.



**Trusted symbol of quality for a quarter-century**

**... now on 11 meter Citizens' Band**

Unqualified superior performance is the promise behind Hallicrafters' famous "Circle-H" symbol, now introducing the dependable new CB-1 transmitter/receiver. Here's the stability and crispness you want in your own personal two-way radio system... a super heterodyne receiver with tremendous sensitivity and selectivity... transmitter with 100% modulation... specially engineered to meet all FCC specifications, including maximum suppression of spurious radiation. Put the CB-1 to work for you now in business, recreation, home, farm or factory.

**CB-1 by hallicrafters** 

citizens' band transmitter/receiver

Chicago, Illinois

... where the best ideas in communications are born.

Export Sales: Internat'l Div. • Raytheon Mfg. Co. • Waltham, Mass.

## 27 months for engineering degree

Realize your dream of a career: higher income, a better life. BACII. SC. DEGREE in 27 months in Elec. (electronics or Power major), Mech., Civil, Chem., Aero. Engineering. In 36 months in Business Administration (Gen. Bus., Acctg., Motor Transport Mgt.). For earnest, capable students. Small classes. Enrollment limited. More professional class hours. Well-equipped labs. Modest costs. Veteran approved. Year-round operation. Beautiful campus. Enter Sept., Jan., Mar., June. Write J. D. McCarthy, Director Admissions, for Catalog and "Your Career" Book.

**TRI-STATE COLLEGE** 3679 College Avenue  
Angola, Indiana

**PEE WEE BATTERYLESS TUBELESS "LIFETIME" RADIO**

(AMERICAN MADE) **GUARANTEED FOR YOUR LIFE**

AS LONG AS YOU OWN IT! NO TUBES, BATTERIES, TRANSISTORS OR ELECTRICAL PLUG-INS NEEDED! Will never run down or burn out! SMALLER THAN A PACK OF CIGARETTES! RECEIVES LOCAL RADIO STATIONS MOST ANYTIME - ANYWHERE! VAC. COIL Easy thumb tuner. NO DANGLING EARPHONES! HAS BUILT-IN SPEAKER PHONE! Black gold plastic casing, semi-conductor wave detector. NOT IMPORTED! MADE AND GUARANTEED BY AMERICANS! You can always get service. Bill ok. mol. and

**SEND ONLY \$2.00** (plus Postman \$4.99)

COD postage on arrival or send \$6.00 for postpaid delivery. RENT COMPLETE READY TO LISTEN WITH LIFE GUARANTEED - NOTHING EXTRA TO BUY EVER! FREE LONG DISTANCE ANTENNA if you order now. Available only from:

**MIDWAY COMPANY Dept. WPL-7 KEARNEY, NEBR.**

**ENGINEERING DEGREE IN 27 MONTHS**

**INDIANA TECHNICAL COLLEGE**

B.S. degree (27 mo.): Aero., Chem., Civil, Elec., Mech. & Electronics.  
B.E. (36 mo.): Aero., Chem., Civil, Elec., Mech. Metallurgical. B.S. (36 mo.): Math., Chem., Physics.  
Preparatory courses. Demand for graduates. Campus. 20 bldgs.; dorms, gym. Low rate. Earn board. G.I. app. Enter Sept., Dec., March, June. Catalog. 2379 Washington Blvd. Fort Wayne 2, Ind. Keeping pace with progress

Send  
**POPULAR  
 ELECTRONICS**  
 Every  
 Month

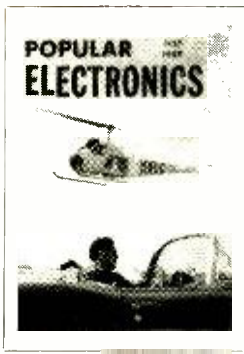

name \_\_\_\_\_

address \_\_\_\_\_

city \_\_\_\_\_ zone \_\_\_\_\_ state \_\_\_\_\_

- 3 years for \$10  
 Check one:  2 years for \$7  
 1 year for \$4

In the U. S., its possessions and Canada. **Foreign rates:** Pan American Union countries, add .50 per year; all other foreign countries, add \$1 per year.

**Mail to: POPULAR ELECTRONICS**

Dept. E-7-9, 434 South Wabash Ave., Chicago 5, Ill.

**PORT ARTHUR COLLEGE  
 ELECTRONICS COMMUNICATIONS**

**AM FM Television Broadcast Engineering  
 Marine Radio Radar**

CHECK THESE FEATURES: Tuition \$34 per mo., room & board \$50 per mo. in dorm on campus. College operates 5 KW broadcast station. Students get on-the-job training at studios on campus. FCC license training with all courses. Well equipped classrooms & lab., am fm transmitters, radar & marine eqmt., television camera chain, experiment lab test eqmt. & other training aids. Our graduates in demand at good salaries. Free placement service. Have trained men from all 48 states. Approved for GI. Write to Dept. PE-7 for details.

**PORT ARTHUR COLLEGE** Port Arthur  
 Texas  
 Established in 1909

**CODE! - DIFFICULT?  
 NOT WITH YOUR TAPE RECORDER**



THE FINEST  
 MOST COMPLETE  
 COURSE AVAILABLE

NOVICE—Basic learning & Practice to 8 WPM.....\$6.50  
 ADVANCED—Practice material 9 to 18 WPM.....\$5.50  
 Practice material is both plain language and code groups.  
 COMPLETE COURSE—(Both above 2 hour tapes) \$11.00 Postpaid  
 in U. S. & Can.—Pa. Res. include 3 1/2% tax. 7" Reels, 1200"  
 (Acetate) Dual track recordings @ 3 3/4 IPS. From your local  
 Ham Distributor. If he doesn't have them, order direct. Dealer  
 Inquiries Solicited.

**TAPEDCODE BOX 31B LANGHORNE, PA.**

**Developments in Battery Design**

(Continued from page 46)

Even more expensive than the nickel-cadmium battery is its highly refined "cousin," the *silver-cadmium battery*. This battery enjoys all the advantages of the nickel-cadmium design, and, in addition, offers higher output at one-half to one-third its size and weight. Since the silver-cadmium battery is quite costly, its greatest application so far has been in rockets, missiles, and satellites.

**Atomic Batteries.** Much misleading publicity has surrounded the atomic battery. In spite of newspaper reports which would lead you to believe that an atomic-powered radio is just around the corner, this is not the case. As one battery engineer put it, "there are a great many problems to be solved before atomic batteries are brought out of the laboratories and put into your home."

One objection to the atomic battery is its potential danger. How would you like to have a little package of radioactivity around the house where it might be broken into by youngsters with a yen for experiments? Another objection is cost; at this time, the material which goes into such batteries is extremely expensive. The batteries we have working for us now do a good job at reasonable cost and the idea of replacing them with atomic batteries might be novel but cannot be considered practical at present.

However, laboratory research continues on the atomic battery. Radioactive promethium—promethium is a by-product of uranium fission—is the power source. It is valuable because it emits large amounts of *beta rays* (actually electrons) over its 2 1/2-year half-life. These *beta rays* can be tapped as a source of power. *Alpha* and *gamma rays* are emitted only in small quantities.

The actual size of the promethium cell and its shielding is about that of a penny. Figure 5 shows a typical promethium cell in cross section. The center layer is a mixture of promethium and phosphor. Small photocells compose the outer layers. When the promethium gives off *beta rays*, they strike the phosphor with great force. The phosphor then lights up in much the same manner as your TV screen does when the electron stream of the cathode-ray tube hits it. This light is then converted to elec-





SANTA HELPED US BUY 1,000,000 RADIO & TV PARTS TO BRING LEKTRON SHOPPERS THIS "CHRISTMAS in JULY"

# DOUBLE-BONUS OFFER!

**BOTH FREE WITH EVERY \$8 ORDER!**

**BONUS #1:**  
**FREE! PICK ANY POLY-PAK® FREE WITH \$8 ORDER!**

**BONUS #2:**  
**FREE! \$15 WORTH OF RADIO-TV PARTS (OUR PRE-PACKAGED ASSORTMENT) FREE WITH EACH \$8 ORDER!**

**FREE!**  
**FULL YEAR'S SUBSCRIPTION to Lektron's "Family Shopper" ELECTRONICS • TOOLS • JEWELRY • NOVELTIES • HI-FI • HOUSEWARES**  
Write Today!

**★ NOT ONE, BUT BOTH BONUSES YOURS FREE WITH EVERY \$8 ORDER!** TWO DOUBLE-BONUSES FREE WITH \$16 ORDER... THREE WITH \$24 ORDER, etc.

**SAVINGS OF \$3 TO \$35... OVER 700,000 POLY-PAKS® SOLD!**

**HEARING AID PHONE**  
Crystal, w/gcord set and plug. Reg. \$3 **88¢**

**4 OUTPUT XFMRS.**  
501.6, etc. 3 lbs. Reg. \$8 **88¢**

**POSTAGE STAMP MIKE**  
Crystal, 100 to 8,000 cps. 1 lb. Reg. \$7 **88¢**

**MINI GEIGER COUNTER TUBE**  
Dozens of radiation, detection uses! 2" long 1/2" dia. **88¢**

**75-FT. TV TWINLEAD**  
300 ohm. Banded, tinned. 3 1/2 lbs. Reg. \$3.50 **88¢**

**10 ELECTROLYTICS**  
Radio, TV, 10-500mf to 450 VDC. 2 lbs. Reg. \$12 **88¢**

**60 RADIO-TV KNOBS**  
Ass'd. colors, insulation. Some worth \$1 each. 2 lbs. Reg. \$8 **88¢**

**4 POWER WOOD BITS**  
Hi-Q steel. 3/8, 1/2, 3/4, 1". 5" long. Reg. \$1 **88¢**

**10 TUBULAR ELECTROS**  
Ass'd. paper types, AC, DC. Hobby, 3 lbs. Reg. \$15 **88¢**

**20 ARTISTS' BRUSHES**  
100% pure bristle. sizes 1-6. Reg. \$2.50 **88¢**

**75 MICA CONDENSERS**  
.00425 to .01 to 1200V! silver, too. 25 values. Reg. \$28 **88¢**

**15-PC DRILL SET**  
1/16" thru 1/4" x 64ths. w/calibrated case. Reg. \$3 **88¢**

**75 RESISTOR SPCL!**  
WW, precision, carbon, variable, mini types. 3 lbs **88¢**

**60 CONDENSER SPCL!**  
Molded, paper, ceramic, oil, mica discs. 2 lbs. **88¢**

**1500 PCS. HARDWARE**  
Nuts, screws, washers, etc. 1 1/2 lbs. Reg. \$6 **88¢**

**8 GERMANIUM DIODES**  
Glass-sealed, w/long leads. For all hobby projects. **88¢**

**30 DISC CONDENSERS**  
Water-thin; up to 3,000VDC. Reg. \$5 **88¢**

**60 PLUGS/RECPT'LES**  
Audio, power, line, battery, spkr. 3 lbs. Reg. \$7 **88¢**

**40 SUB-MINI COND'SRS**  
For transistor, printed circuit work. 1 lb. Reg. \$7 **88¢**

**8 SUB-MINI SOCKETS**  
Mica-filled. For transistors. Too! **88¢**

**40-RECORD CADDY**  
Wrought iron, holds 40 records & albums. 2 lbs. Reg. \$8 **88¢**

**60 HI-Q RESISTORS**  
Insulated, carbon; 1/2 watt 1/2 & 1 W, 10 ohms to 10 meg. 2 lbs. Reg. \$13 **88¢**

**HOBBY BENCH VISE**  
Clamp type. Fits tables, too. Steel. 1 lb. **88¢**

**100 RADIO PARTS**  
Wide variety resistors, condensers, pots, forms. 3 lbs. **88¢**

**5 ROLLS MICRO-WIRE**  
#24 thru #32; for transistor, sub-mini circuits. 1 lb. **88¢**

**30 PILOT LITES**  
Pop. flashlight size; mini bay, type. Reg. \$9. 1 lb. **88¢**

**16-END WRENCH SET**  
For home and auto! 16 sizes, box and open; 15/64 thru 7/16". Reg. \$2.50 **88¢**

**100 CERAMIC COND'SRS**  
Hi-Q discs, tubular; to .01 mfd. 2 lbs. Reg. \$12 **88¢**

**40 TUBE SOCKETS**  
4 to 9-pin; ceramic, mica, shield-based incl. 2 lbs. **88¢**

**10 POLY BOXES**  
Clear plastic, hinged w/zipper locks. Ass'd. sizes. 1 lb. **88¢**

**40 PRECISION RESISTORS**  
1/2, 1/2 to 1W, carbon & WW; to 10 megs. Reg. \$17 **88¢**

**\$25 SURPRISE PACK!**  
Large, varied assortment radio, TV parts. 3 lbs. **88¢**

**6 SILICON DIODES**  
Pop. Silicon type. Reg. \$36 **88¢**

**8-PC. NUTDRIVER SET**  
\$8 value! Plastic handle; 3 to 7/16" socket wrenches. 1 lb. **88¢**

**10 VOLUME CONTROLS**  
Some w/switches. 2 lbs. Reg. \$9 **88¢**

**70 ONE-WATERS**  
Ass'd. values, carbon resistors. 5% incl. **88¢**

**100 HALF-WATERS**  
Ass'd. value carbon resistors, incl. 5%. Reg. \$12 **88¢**

**35 POWER RESISTORS**  
WW, 5 to 50W, to 10,000 ohms. Vitreous, too! 3 lbs. Reg. \$15 **88¢**

**40 HI-Q CONDENSERS**  
Finest porcelain, NPO's too! 1 lb. Reg. \$6 **88¢**

**MINI-RADIO KIT**  
World's smallest! 2 x 1 x 1". Loopstick, jacks, diode, etc w/instructions. 1 lb. Reg. \$3 **88¢**

**60 TERMINAL STRIPS**  
Solder-lug & binding; to 20 terms. 2 lbs. **88¢**

**60 COILS, CHOKES**  
IF, RF, ant., slug-tuned, too. 3 lbs. Reg. \$15 **88¢**

**300-FT. HOOKUP WIRE**  
Tinned, ass'd. sizes, colors. 2 lbs. Reg. \$5 **88¢**

**30 MOLDED COND'SRS**  
Ass'd. Finest made! Wt. 2 lbs. **88¢**

**15 ROTARY SWITCHES**  
Ass'd. gangs. 3 lbs. Reg. \$12 **88¢**

**5-IN-1 DRILL BIT**  
Reams, saws, copes, shapes, drills. Hand or power drill. **88¢**

**\$15 MOBILE RELAY**  
For GVDG projects. 31ST contacts, silver, Herm. sealed. 1 lb. **88¢**

**8 RCA PLUG-N-JACK SETS.**  
Matched. Most pop. amps, tuners, phones. **88¢**

**2 VARI-LOOPSTICKS**  
Adj. 540-1500 kcs. Transistors radios, etc. 1 lb. **88¢**

**WIRE STRIPPER**  
Strips, cuts = 16, thru = 22 hook-up wire. Wt. 1 lb. **88¢**

**0-60 MINUTE TIMER**  
For desk, kitchen, lab, sleep, kitchen. Loud alarm. 2 lbs. **88¢**

**65 T/BLR COND'SRS**  
Paper, molded, oil, porc.; to .5mf to 1000V. 2 lbs. Reg. \$14 **88¢**

**2 N-P-N TRANSISTORS**  
Used in many pop. make radios. Worth \$5! **88¢**

**2 TRANSISTOR IF'S**  
Double-tuned. Only 1/2" square. 4.5k kcs. **88¢**

**TEN 3-SECOND TIMER MECHANISM.**  
Precision geared. 2 lbs. Reg. \$30 **88¢**

**5" HOBBY SPEAKER**  
For radios, code osc., inter-com. 2 lbs. Reg. \$5 **88¢**

**40 SUB-MINI RESIST'RS**  
1/2" long. 20 values; 1/5W to 10 lbs. Reg. \$6 **88¢**

**15 INSTRMT. KNOBS**  
Carbon resistors, incl. 1 1/2" Reg. \$12 **88¢**

**3S TWO-WATERS**  
Knurled black bakelite, w/painter; brass inserts, set-screws. Reg. \$5 **88¢**

**000-999 COUNTER**  
Veeder-Root, automatic reset. Motors, coils, etc. Reg. \$8 **88¢**

**12-HR. "SPACE" CLOCK**  
Powered by pen-lite battery. 4 oz. Hobbyists, note! Reg. \$8 **88¢**

**SUN BATTERY**  
Similar to famed B2M. 1 1/2 hour. Reg. \$2.50 **88¢**

**2 TRANSISTOR VAR'IBLES**  
1 1/2" x 1 1/2" x 2" shaft, dual 365mmf. Wt. 1 lb. Reg. \$8 **88¢**

**4 OSCILLATOR COILS**  
Miniature, transistor; cover. 540 to 1600 kcs. Reg. \$2 **88¢**

**3 TRANSISTOR XFMRS.**  
Submini size; for hundreds transistor projects! Reg. \$8 **88¢**

**100 RESISTORS**  
Carbon & precision. 1/2, 1, 2W; 1 and 5% 56 ohms to 2 meg. 3 lbs. Reg. \$25 **88¢**

**HOW TO ORDER:**

**ORDER BY BLACK-TYPE HEADLINES, i.e. 35 TWO-WATERS, 88¢**

**LEKTRON** 131-133 EVERETT AVE. CHELSEA 50, MASS.

State price with each item. Send check or M.O. including sufficient postage; excess returned. C.O.D. orders, 25% down; rated, net 30 days. INCLUDE POSTAL ZONE in address. (Canada postage, 48¢ 1st lb.; 28¢ ea. add'l. lb.)

July, 1959

# ATTENTION

## electronics schools!

Is your School registered with Popular Electronics?

As you probably know, Popular Electronics is eager to keep you advised whenever a special opportunity arises that would interest and benefit your School.

If you are not already on PE's School Announcements list—please send your name, address and the name of your School Secretary to: Popular Electronics, School Department, One Park Avenue, New York 16, N. Y.

### "The Capri Dual"

#### STEREO AMPLIFIER & PREAMP



**ONLY**  
**\$37.50**

(postpaid)  
(Calif. residents  
add 4% tax)

At last! A FULL, HIGH FIDELITY, STEREO Power Amplifier and Pre-amplifier, with performance seldom found at this low price. Provides rich, full range sound from 20 to 20,000 cycles with full 10 watts output power. Variable frequency response on both channels allows compensation for all records. Ultra modern styling.

**CAPRI ELECTRONICS**  
Division of J & J Machine Co.  
823 E. Jefferson Blvd.

• Order from  
this ad.  
Los Angeles 11, Calif.

## GET INTO ELECTRONICS

V.T.I. training leads to success as technicians, field engineers, specialists in communications, guided missiles, computers, radar, automation. Basic & advanced courses in theory & laboratory. Assoc. degree in 29 mos. B.S. obtainable. ECPA accredited, G.I. approved. Graduates with major assignments: Dept. of Defense, Fed. Dorns, campus. H.S. graduates or equivalent. Catalog.

**VALPARAISO TECHNICAL INSTITUTE**  
Dept. PE VALPARAISO, INDIANA

trical energy by the two outer layers of photocells.

Output of the promethium cell is small—actually less than one-millionth of the electrical power used by a 40-watt bulb. It does give off power, though, and the power comes from atomic radiation. Considering its early stage of development, the promethium cell shows great promise.

Any discussion of batteries must necessarily lead us back to the fact that the carbon-zinc cell is still battery king of the present. And in the distant future, when you send one of the kids down to the Lunar Hardware on the Moon to pick up a battery for your flashlight, chances are you will end up with our old friend, the carbon-zinc cell.

-30-

### Answers to Electronic Sticklers

on page 64

1. Joe's answer was 2.73 ohms. As a check, compute the resistance of one section only, then two, three and four sections. Note that with the addition of each section the computed resistance value drops. The resistance of added sections in parallel with R2 will drop toward zero but will never get there—as calculation will show.
2. Joe did not realize that the junctions of R1 and R2, and R3 and R4 are equipotential. Resistor R5 will have no current passing through it. Hence, Joe could replace it with a wire (short circuit). All resistors to the right of R5 have no effect on the resistance measured at points A and B. A quick check of the remaining circuit will show a resistance of one ohm.
3. Sammy used the formula on the wrong leads. He forgot that only 6.3 volts were going through the secondary leads of the transformers. He should have used transformers that had a rating of 33.5 amperes or better ( $6.3 \times 200$ ).
4. Place one end of bar A at the center of bar B. Slide the end of bar A to either end of bar B. If the magnetic pull between the bars increases, bar B is the magnet. If the pull remains constant, bar A is the magnet.

If you know of a tricky Electronic Stickler, send it in with the solution to the editors of POPULAR ELECTRONICS. If it is accepted, we will send you a \$5 check. Write each Stickler you would like to submit on the back of a postcard. Submit as many postcards as you like but, please, just one Stickler per postcard. Send to: POPULAR ELECTRONICS STICKLERS, One Park Ave., New York 16, N. Y. Sorry, but we will not be able to return unused Sticklers.

**VIDEO ELECTRIC COMPANY says: DOWN WITH RISING COSTS OF ELECTRON TUBES OVER ONE MILLION USED TUBES TO SELECT FROM at only**

Each and every tube is tested by our supplier under actual operating conditions in Radio, FM, Hi-Fi, Industrial equipment and Television Chassis or Intricate Testing Equipment for Mutual Conductance and Life Test.

BELOW IS A PARTIAL LIST OF OVER THREE HUNDRED POPULAR TYPES! WRITE FOR FREE COMPLETE LIST AND ORDER BLANK!

- |       |        |        |          |           |        |
|-------|--------|--------|----------|-----------|--------|
| 0A2   | 5X8    | 6BH6   | 6SF5     | 7Z4       | 19BG6  |
| 0Z4   | 5Y3CT  | 6BJ6   | 6SF7     | 12AR      | 19J6   |
| 1A7GT | 5Y4G   | 6BK5   | 6SK7     | 12AQ5     | 24A    |
| 1B3GT | 6A7    | 6BL7GT | 6SL7GT   | 12AT7     | 25AV5  |
| 1H4G  | 6A8    | 6BN6   | 6SN7GT   | 12AU6     | 25BQ6  |
| 1H5GT | 6AB4   | 6BQ6GT | 6SQ7     | 12AV6     | 25DQ6  |
| 1L4   | 6AC7   | 6BQ7   | 6S97     | 12AV7     | 25L6GT |
| 1L6   | 6AF4   | 6BZ6   | 6T4      | 12AX4GT   | 25W4GT |
| 1N5GT | 6AG5   | 6BZ7   | 6T8      | 12A7      | 25Z5   |
| 1Q5GT | 6AG7   | 6C4    | 6UM      | 12B4      | 25Z6   |
| 1R5   | 6AH-GT | 6C5    | 6V6      | 12BA6     | 26     |
| 1S5   | 6AH6   | 6C6    | 6W6GT    | 12BA7     | 35A5   |
| 1T4   | 6AK5   | 6C6    | 6W6GT    | 12B8A     | 35B5   |
| 1U4   | 6AL5   | 6C6    | 6X5      | 12B8E     | 35C5   |
| 1U5   | 6AL7   | 6C6G   | 6X5      | 12BF6     | 35L6GT |
| 1V2   | 6AM8   | 6C6G   | 6X8      | 12BH7     | 35W4   |
| 1X2   | 6AN8   | 6C6G   | 6Y6G     | 12BQ6     | 35Z5GT |
| 2A3   | 6AQ5   | 6C6G   | 7A4/XXL  | 12BR7     | 37     |
| 2A3   | 6AQ6   | 6C6G   | 7A5      | 12BY7     | 39/44  |
| 2AF4  | 6AQ7GT | 6C6G   | 7A6      | 12CA5     | 42     |
| 3BC5  | 6AR5   | 6C6G   | 7A7      | 12C5      | 43     |
| 3BN6  | 6AS5   | 6C6G   | 7B7      | 12D6      | 45     |
| 3BZ6  | 6AT6   | 6C6G   | 7B8      | 12E7      | 50A5   |
| 3CB6  | 6AT8   | 6C6G   | 7B8      | 12F6      | 50B5   |
| 3CF6  | 6AU4GT | 6C6G   | 7B8      | 12G7      | 50C5   |
| 3CS6  | 6AU5GT | 6C6G   | 7C4      | 12H7      | 50L6GT |
| 3LF4  | 6AU6   | 6C6G   | 7C5      | 12J6      | 50X6   |
| 3Q4   | 6AU8   | 6C6G   | 7C6      | 12SK7     | 56     |
| 3S4   | 6AV5GT | 6C6G   | 7C7      | 12SN7GT   | 57     |
| 3V4   | 6AV6   | 6C6G   | 7E6      | 12SQ7     | 58     |
| 4BQ7A | 6AW8   | 6C6G   | 7E7      | 12V6GT    | 71A    |
| 4BZ7  | 6AX4GT | 6C6G   | 7E7      | 12W6GT    | 75     |
| 5AS8  | 6AX5GT | 6C6G   | 7F7      | 12X4      | 76     |
| 5AT8  | 6B8    | 6C6G   | 7F8      | 12X3      | 77     |
| 5AV8  | 6BA6   | 6C6G   | 7H7      | 12Z3      | 78     |
| 5AW4  | 6BC5   | 6C6G   | 7N7      | 14A7/12B7 | 80     |
| 5BK7  | 6BC8   | 6C6G   | 7Q7      | 14B6      | 84/6Z4 |
| 5J6   | 6BD6   | 6C6G   | 7X7/XXFM | 14Q7      | 117Z3  |
| 5T8   | 6BE6   | 6C6G   | 7Y4      | 19A4GT    | 117Z6  |
| 5U4G  | 6BF5   |        |          |           |        |
| 5U8   | 6BF6   |        |          |           |        |
| 5V4G  | 6BG6   |        |          |           |        |
| 5V6GT | 6BG6   |        |          |           |        |



**GUARANTEE: WE GUARANTEE TO REPLACE FREE FOR ONE (1) YEAR ANY TUBE PURCHASED FROM US WHICH FAILS TO FUNCTION EFFICIENTLY UNDER ACTUAL OPERATING CONDITIONS. REFUNDS WILL BE MADE PROMPTLY FOR ANY DEFECTIVE MERCHANDISE. THE TUBES ADVERTISED HEREIN ARE NOT NECESSARILY NEW TUBES BUT MAY BE ELECTRICALLY PERFECT FACTORY SECONDS OR USED TUBES AND ARE SO MARKED.**

**WE HAVE OVER 1000 USED TV SETS**  
 At All Times In Our Huge Warehouse. Buy one or more of the WORKING TV's to sell or use as your own second set! All sets in GOOD WORKING condition! Your Choice—Console or Table Model.  
 10" ... \$23.00 19" ... \$58.00  
 12" ... \$28.00 20" ... \$64.00  
 14" ... \$33.00 21" ... \$72.00  
 16" ... \$40.00 24" ... \$99.00  
 17" ... \$46.00  
 When ordering TV's, state whether table model or console is desired. Also, preference on make of set. All TV's sent railway express F.O.B. Newark. On any quantity, WIRE or CALL today!

**FREE**  
 RCA "Cheater"  
 Cord Given with Any Tube Order of \$7.00 or More!!

**FREE**  
 Bonus Antenna Given with Any TV Set Order!!

SEND for our **FREE** complete **TUBE & PARTS LIST** and order blank.

**VIDEO**

**FREE POSTAGE**  
 in U.S.A. and Territories on orders over \$5.00. 25c handling charge on orders under \$5.00. 25% deposit required on C.O.D.'s. Please send approximate postage or freight on Canadian and foreign orders. Subject to prior sale.

Phone **HUMboldt 4-9848**

**ELECTRIC COMPANY**  
 9-15 6TH ST., HARRISON, N. J.

# WANTED!

## Equipment, components or parts!

The 267,000 purchasers of POPULAR ELECTRONICS are always in the market for good used equipment or components. So, if you have something to sell, let PE readers know about it in our classified columns.

It costs very little: just 50¢ per word including name and address. Minimum message: 10 words. For further information write:

Martin Lincoln

## POPULAR ELECTRONICS

One Park Avenue, New York 16, New York

## CITIZENS LOW COST 2 WAY RADIO!

### NOW! TWO WAY RADIO FOR EVERYONE!

No license or permit needed on new Low Power 100Mw 27mc. Citizens Band. No size limit—no restrictions of any kind. Talk and listen to ANYONE—ANYTIME. Complete ready to operate—weighs only 4 lbs. Size: 6 1/2" W. x 4 1/4" H. x 6 3/4" deep. Includes microphone and speakerphone. Talk-listen switch, 5 ft. top of cabinet antenna, carrying handle, steel cabinet. Range depends on location but can be from 1/2 to 5 miles. Operation everywhere on 110 volt plug-in. Absolutely nothing else to buy—just touch switch to talk or listen—meets all Gov't FCC requirements. Two or more units can be used together, as desired.

**SEND ONLY \$5.00** (bill, ck., mo.) deposit for each 2-way Radio desired and we will send COD for balance of \$24.95 plus postage and COD charge or send \$29.95 plus \$2.00 (postage and insurance) for each radio wanted. Guaranteed to work or money back. Order now for early delivery before price goes up. Available only from:

WESTERN RADIO Dept. HPL-7 KEARNEY, NEBR.

## ENGINEERING DEGREES

E.E. Option Electronics or Power Degree Courses in Liberal Arts & Bus. Admin.

Also Earned through Home Study Pacific International College of Arts & Sciences

Primarily a correspondence School Residence classes also available 5719-W Santa Monica Blvd. Hollywood 38, California

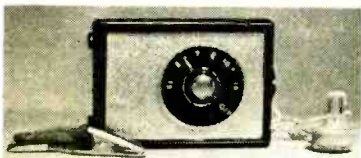

## Have More Fun with This New MIDGET TRANSISTOR RADIO

BUY DIRECT FROM MAKER AND SAVE! This new transistor radio covers entire broadcast band. Includes transistor, germanium diode, ferrite tuning core, and extension antenna to help pull in distant signals; plus individual earplug for private listening. Operates over 1,000 hrs. on single 10c battery. Made by American transistor mfr. Arrives completely assembled, ready to operate. 10-DAY MONEY-BACK GUARANTEE. Sold nationally at \$7.98 ea. Order now! At our special low price we expect a sell-out!

Semiconductors Inc. \$4.95 or 195-02 JAMAICA AVE. ea. 2 for \$8.95 JAMAICA 23, NEW YORK Save COD fee, send full amount

## Variable Power Supply

(Continued from page 101)

stock carbon resistors if an accurate means of resistance measurement is available, or they could be wound of resistance wire. Since the exact ohms-per-foot value of resistance wire is always specified, very accurate resistances can be determined by careful measurement of the length of the wire.

**Output Filtering.** The circuit may appear to be lacking in proper output filtering when you are used to thinking in terms of the brute force filtering usually employed in power supplies. Actually, it is adequate for any normal use, and is based on the fact that series regulator tubes are able to respond quickly enough to variations in output voltage to regulate ripple right out of the output.

**Zero Adjustment.** Slotted-shaft potentiometer  $R_4$  is the zero adjustment control. To set this control, turn the power supply on with switch  $S_1$  and allow the filaments to warm up thoroughly. Then switch *high-voltage* switch  $S_2$  on and turn the output control ( $R_{10}$ ) to the full counterclockwise position.

Check the voltage at the power supply output terminals with a test meter. It will probably be a few volts positive or negative, and  $R_4$  should be adjusted carefully until the output is exactly zero as read on a low-voltage scale of the test meter.

Lock  $R_4$  in that position. The full travel of  $R_{10}$  should then swing the output voltage from zero to approximately 500 volts with no load.

## HOW IT WORKS

The secret of the circuit's ability to control the output voltage of the power supply lies in the bank of series-regulator tubes:  $V_5$ ,  $V_6$ ,  $V_7$  and  $V_8$ . These tubes are connected in series with the load and act like variable resistors since the amount of current which may flow through them is controlled by the bias voltage applied to the control grids.

Grid bias for the series-regulator tubes is developed by the  $IR$  drop across the plate load resistor ( $R_8$ ) of the control amplifier tube ( $V_4$ ), and will vary according to the current flow through  $V_4$ . Since the bias voltage on the control grid of  $V_4$  is taken from the slider of output potentiometer  $R_{10}$ , the position of that slider will decide the current flow through the control tube, the bias on the series regulators and, finally, the output voltage of the power supply.

Since  $R_{10}$  is part of a voltage divider, the upper end of which is connected to the output voltage, any variation in output voltage because of load changes will be reflected in a proportional voltage shift at the control grid of  $V_4$ , causing an instantaneous corrective action in the series-regulator tubes.

## After Class

(Continued from page 121)

ing a second thyatron and modifying the transformers to conform with the new circuit, as shown in Fig. 9. The operation in this case is identical with that just described except that the motor will reverse its rotation when the error signal reverses polarity.

When the error signal has one polarity (or phase), the upper thyatron may conduct heavily while the lower one conducts very little or not at all. Should the phasing of the error signal now become inverted, there will be an interchange of conduction and non-conduction between the thyatrons, thereby supplying the d.c. motor with a pulsating current in the opposite direction.

Thyatron servo controls can be used in servomechanisms where the current demands run up to 50 amperes or more. Due to the fact that phase-shift control makes use of *time* of current flow rather than increasing or decreasing resistance to govern current magnitude, the power losses within the tubes are at a minimum. This, of course, makes for high efficiency of operation and long life for the tubes. —30—

## Among the Novice Hams

(Continued from page 118)

tice will you become adept at removing the heterodyne without also eliminating the desired signal.

**Sideband Signals.** Broadcast stations and most amateur phone stations transmit conventional amplitude-modulated signals, which consist of a carrier and two intelligence-carrying sidebands. Single-sideband stations, however, transmit only one sideband and suppress the carrier. When properly generated and received, sideband signals have greater communication efficiency than conventional phone signals. But they are unintelligible gibberish when tuned in like conventional signals.

To receive them, it is necessary to replace the suppressed carrier at the receiver by adjusting the receiver as for code reception, so that the BFO will supply the missing carrier, and tune very carefully. Only one of two possible correct settings of the BFO pitch control will normally be correct for receiving a given sideband signal,

# Handle any Radio-TV Service Job

**EASIER - BETTER - FASTER!**

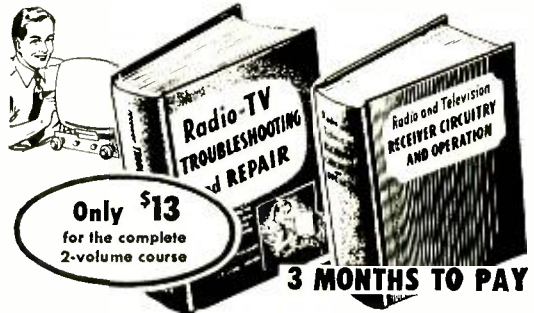

## COMPLETE SERVICE TRAINING ... written so you can understand it!

No complicated theory or mathematics! These famous Ghirardi books get right down to brass tacks in showing you how to handle all types of AM, FM, and TV service work by approved professional methods. Almost 1500 pages and over 800 clear illustrations show how to handle every phase of troubleshooting and servicing. Each book is co-authored by A. A. Ghirardi whose manuals have helped train more servicemen than any other books or courses of their kind!

### 1—Radio and Television Receiver TROUBLESHOOTING AND REPAIR

A complete guide to profitable professional methods. For the beginner, it is a comprehensive training course. For the experienced serviceman, it is a quick way to "brush up" on specific jobs, to develop improved techniques or to find fast answers to puzzling service problems. Includes invaluable "step-by-step" troubleshooting charts that show what to look for and where. 820 pages, 417 illustrations, price \$7.50 separately.

### 2—Radio and Television Receiver CIRCUITRY AND OPERATION

This 669-page volume is the ideal guide for servicemen who realize it pays to know what really makes modern radio-TV receivers "tick" and why. Gives a complete understanding of basic circuits and circuit variations; how to recognize them at a glance; how to eliminate guesswork and useless testing in servicing them. 417 illus. Price separately \$6.75.

## Special low price . . . you save \$1.25

If broken into lessons and sent to you as a "course," you'd regard these two great books as a bargain at \$7.50 or more! Under this new offer, you save \$1.25 on the two books—and have the privilege of paying in easy installments while you use them! No lessons to wait for. You learn fast—and right!

### STUDY 10 DAYS FREE!

Dept. PE-79, RINEHART & CO., Inc.  
232 Madison Ave., New York 16, N. Y.

Send books below for 10-day FREE EXAMINATION. In 10 days I will either remit price indicated (plus postage) or return books postpaid and owe you nothing.

Radio & TV Receiver **TROUBLESHOOTING & REPAIR** (Price \$7.50 separately)

Radio & TV **CIRCUITRY & OPERATION** (Price \$6.75)

Check here for **MONEY-SAVING COMBINATION OFFER**. Send both of above big books at special price of only \$13.00 for the two. (Regular price \$14.25 . . . You save \$1.25.) Payable at rate of \$1 plus postage after 10 days if you decide to keep books and \$3 a month for 3 months until the total of \$13.00 has been paid.

Name .....

Address .....

City, Zone, State .....

Outside U.S.A.—\$8.00 for **TROUBLESHOOTING & REPAIR**; \$7.25 for **CIRCUITRY & OPERATION**; \$14.00 for both. Cash only, but money refunded if you return books in 10 days.

# HELP US OBTAIN OUR HAM LICENSES

## K1/W1 CALL AREA

Charles J. Burke, Jr., P. O. Box 332, No. Oxford, Mass. (Code, theory, regulations and selection of equipment)

Bill French, 6 Benton Ave., Claremont, N. H. Phone: 1913. (Code, theory, regulations and selection of equipment)

Paul Hunt (13), 10 Bloomfield St., Lexington, Mass. Phone: VO 2-9546. (Code and regulations)

R. Braga, 50 Davis St., Taunton, Mass. (Code, theory, regulations and selection of equipment)

Tony Parker (15), 112 Leary Dr., Holyoke, Mass. (Code and theory)

Phil Brady, 60 Park Ave., Needham Heights 94, Mass. (Code, theory and selection of equipment)

Don Sinclair (15), 105 Tolman St., Westbrook, Maine. Phone: UL 4-8560. (General Class code, theory and selection of equipment)

## K2/W2 CALL AREA

Matthew Liebman, 517 Beach 136 St., Belle Harbor 94, N. Y. Phone: GR 4-3353. (Code and theory)

Charles Kroll, 2103 Howell St., Camden, N. J. Phone: EM 5-0018. (Code, theory and regulations)

Chester Kozna, 745 Lee St., Perth Amboy, N. J. (Code, theory and regulations)

Bruce Hedandal, 228 Jefferson Ave., Paramus, N. J. (Code, theory, regulations and selection of equipment)

Thomas Vasko, 214 Ridgewood Dr., Snyder 26, N. Y. (Code)

Joseph Sweeney, 70-03 252 St., Bellrose 26, N. Y. Phone: FI 3-5129. (Code, theory and regulations)

Lester Chadwich, Youngstown-Lockport Rd., Ransomville, N. Y. Phone: SY 1-3319. (Code, theory and regulations)

Bob Zinsmeister, 481 Onondaga St., Lewiston, N. Y. Phone: PL 4-4198. (Code, theory and regulations)

Erwin Cohen, 3962 Wolkow Ave., Seaford, L. I., N. Y. Phone: SU 5-9231. (Code)

Robert Heimmel, 618 Bailey Ave., Elizabeth, N. J. Phone: EL 2-2190. (Code)

Ronald Faith, 521 Belview Ave., Clayton, N. J. (Code)

## K3/W3 CALL AREA

Raymond E. Kibler, 3803 St. Margaret St., Baltimore 25, Md. (Code and theory)

Richard A. Fisher, 315 Audrey Lane, Washington 21, D. C. (Code)

Ray Pisaneschi, Jr., 123 Simpson St., Swoyerville, Pa. Phone: BU 7-4404. (Code and theory)

Douglas J. Adams, 4108 Coleman Ave., Baltimore 13, Md. (Code and theory)

Paul Ait, 315 Harding St., Dupont, Pa. Phone: OL 4-6349. (Code and selection of equipment)

## K4/W4 CALL AREA

Hank Pettigrew (15), 56 Pine Valley, Moultrie, Ga. (Code and theory)

Bill Tyler, 3619 Napier Ave., Macon, Ga. (Code and theory)

Fred H. Schipman (46), 311 Franklin Dr., Florence, S. C. (Code and theory)

Bill Perry III (15), 8711 Whipps Mill Rd., Lyndon, Ky. Phone: TW 3-5293. (Code and selection of equipment)

David Wakefield, 4156 Outer Dr., Nashville 4, Tenn. (Code and theory)

Kraig A. Lenius, 336 Blue Heron Dr., Winter Park, Fla. Phone: MI 4-8873. (Code and theory)

## K5/W5 CALL AREA

Carl E. Bradley, P. O. Box 525, Mena, Ark. (Code and theory)

Gary Koppelman, 3616 S. E. 26th, Pel City, Okla. (Code, theory, regulations, and selection of equipment)

Ed Venable, 1711 Post Office, Galveston, Tex. Phone: SO 2-4450. (Code)

Joe S. Barnes, 2612 Florence St., Kilgore, Tex. (Code, theory and regulations)

Larry Parham, 2605 Avenue Q, Wichita Falls, Tex. (Code and theory)

## K6/W6 CALL AREA

Lester Sade, 652 Second, San Bruno, Calif. (Code, theory and regulations)

Alexander de Timofeev, 674 34 Ave., San Francisco 21, Calif. Phone: EV 6-3167. (Code, theory and regulations)

Mac Ammons, 248 N. 4th St., San Jose, Calif. (Code, theory and regulations)

## K7/W7 CALL AREA

Jerry S. Savoy, 901 Sahara Way, Las Vegas, Nev. Phone: DU 4-0017. (Code, theory and regulations)

## K8/W8 CALL AREA

Bill Jacobs (14), 5990 Glenwood Ave., Boardman, Ohio. Phone: SK 8-5949. (General Class code)

Larry Raterman, 4422 Carnation Ave., Cincinnati 38, Ohio. Phone: GR 1-1454. (Code, theory and selection of equipment)

Alvar Lauttamus, R. D. 3, Box 23, Wellsburg, W. Va. (Theory and regulations)

Bill Maurer, 1303 E. Maple Rd., Flint, Mich. (Code and theory)

Dee German, 100 W. Fifth St., Man, W. Va. (Code and theory)

Michael Bodin (15), 1861 Meadow Ridge, Walled Lake, Mich. (Code, theory and regulations)

Larry A. Demario (14), 1218 Vineyard Dr., Monroe, Mich. Phone: CH 1-7072. (Code and theory)

James D. Sutton (29), S. Hopkins Rd., Mentor, Ohio. Phone: BL 5-2775. (Theory)

## K9/W9 CALL AREA

Rodger Rhodus, 1209 S. Main St., Bloomington, Ill. (Code and theory)

Bill Kennedy, 1507 N. Mayfield, Chicago 51, Ill. (Code and theory)

## K0/W0 CALL AREA

Robert Urich (15), Garner, Iowa. Phone: 32R3. (Code, theory and regulations)

Jim and Dave Richardson, 1827 Broadway, Mitchell, Nebr. (Code, theory, regulations and selection of equipment)

Frank Timmers, Jr., Victor, Minn. (Code, theory, regulations and selection of equipment)

Nelda Jo Byrd, General Delivery, Ozark, Mo. (Code and theory)

Charles McDonough, 310 Rolla St., Fort Leonard Wood, Mo. (Code, theory, regulations and selection of equipment)

John Spirk, 405 Crocker St., Fort Leonard Wood, Mo. (Code, theory, regulations and selection of equipment)

Dennis Madokoro, 209 10th Ave., N. Fort Leonard Wood, Mo. (Code, theory and selection of equipment)

## VE AND OTHERS

Norman Brossard, 11235 St. Gertrude, Montreal North, Que., Canada. (Code, theory and selection of equipment)

Joseph Evanson, Ramgoolies Ave., Curepe, Port-of-Spain, Trinidad, T. W. I. (Code and theory)

Wolfgang Schmidt, Wunstorfer Strasse 26, Hanover, Germany.

Robert Pelley (14), P. O. Box 725, Gander, Newfoundland. (Code and theory)

depending upon which sideband is being transmitted.

Usually, the lower sideband is transmitted on the 80- and 40-meter bands, and the upper one is transmitted on the higher frequency bands. Therefore, after determining by experiment the correct pitch control setting for a given band, you can reset the control to the same position for later sideband reception on that band. Some receivers have a special switch for changing sidebands, which may also be used on conventional phone signals.

It must be admitted that it is virtually impossible to read sideband signals on inexpensive amateur a.c.-d.c. receivers, and it is quite a trick to do it on some of the older models of more expensive ones. However, it can be done on the great majority of amateur receivers with careful tuning. At any rate, when you can tune in sideband signals easily, you are a "pro" at tuning your receiver.

Oh, yes! Turn on the noise limiter when noise is bad.

#### News and Views

**Quincy Clements, KN5LL**, (15), 1821 Bever Blvd., Arlington, Texas, gets 35 watts "output" from his Harvey-Wells TBS-50A transmitter on 15 and 40 meters. His antenna is a combination 15- and 40-meter doublet, and he receives with a Hallicrafters SX-71. This equipment and seven months on the air have resulted in contacts with 25 states, 15 of which are confirmed. Quincy will help anyone get his Novice license. See him for a Texas QSL card, too. . . . **Bob Staib, KN4DFT**, 1434 Haskin Ave., Louisville, Ky., divides his attention between the 80- and 15-meter Novice bands. He has separate folded-dipole antennas for each band. His transmitter is a DX-40, and his receiver is an AR-3, both Heathkits. In three months, he has worked 37 states; 33 are confirmed, and he hopes the other cards are in the mail. Bob is particularly proud of his four California contacts on 80 meters.

. . . . **Hal Bergeson, KN7GOG**, R.F.D. #1, Lewiston, Utah, has made 214 confirmed contacts in 34 states in four months on the air. He has also worked some DX. Hal uses a National SW-54 receiver, a WRL Globe Chief 90 transmitter, and a 65' end-fed antenna. He will be glad to help others get their Novice licenses and is open for skeds, if you need a Utah contact—and who doesn't?

**Robert A. Durdle, K8HJI**, (15), 2457 West River Drive, Grand Rapids 4, Mich., has been a ham for a year and a half and has worked 42 states, an Englishman, and many Canadians. His favorite band is 40 meters, where he operates both phone and c.w.; he prefers c.w. because it is easier to get out with it, and interference is less. . . . **Ken Quin, KN5TSQ**, 1020 So. 13th St., Edinburg, Texas, must have

## FREE CAREER BOOKLET



To guide you to a successful future in

## ELECTRONICS RADIO-TV COMPUTERS ELECTRICAL ENGINEERING

This interesting pictorial booklet tells you how you can prepare for a dynamic career as an Electrical Engineer or Engineering Technician in many exciting, growing fields:

**MISSILES • AVIONICS • AUTOMATION  
SALES • DEVELOPMENT  
ELECTRICAL POWER • ROCKETRY  
RADAR • RESEARCH**

Get all the facts about job opportunities, length of study, courses offered, degrees you can earn, scholarships, part-time work — as well as pictures of the Milwaukee School of Engineering's educational and recreational facilities. No obligation — it's yours free.

### MILWAUKEE SCHOOL OF ENGINEERING

#### MAIL COUPON TODAY!

**Milwaukee School of Engineering**  
Dept. PE-759, 1025 N. Milwaukee St., Milwaukee, Wis.  
Please send FREE "Your Career" booklet  
I'm interested in

Electronics  Radio-TV  Computers  
 Electrical Engineering  Mechanical Engineering

Name ..... Age .....

PLEASE PRINT

Address .....

City ..... Zone ..... State .....

I'm eligible for veterans education benefits.  
Discharge date .....

MS-117

# TV PICTURE TUBES

## AT LOWEST PRICES

10BP4	\$ 7.95	16WP4	\$15.20	17TP4	\$19.30	21EP4	\$14.95
12LP4	8.95	16TP4	10.95	20AP4	19.30	21FP4	15.95
14B/CP4	9.95	17AVP4	15.20	20CP4	13.90	21WP4	17.30
16DP4	14.95	17BP4	10.95	20HP4	17.95	21YP4	15.95
16EP4	15.90	17CP4	17.00	21AP4	22.10	21ZP4	14.95
16GP4	15.90	17GP4	17.60	21ALP4	20.95	24CP4	23.95
16KP4	10.95	17HP4	13.60	21AMP4	19.95	24DP4	26.95
16LP4	10.95	17LP4	13.60	21ATP4	20.95	27EP4	39.95
16RP4	10.95	17QP4	11.95	21AUP4	20.95	27RP4	39.95

### 1 YEAR WARRANTY

Aluminized Tubes \$5.00 more than above prices. Prices include the return of an acceptable similar tube under vacuum. These tubes are manufactured from reprocessed used glass bulbs. All materials including the electron gun are brand new.

**ALL PRICES FOB CHICAGO, ILLINOIS.** Deposit required when old tube is not returned, refundable at time of return. 25% deposit required on COD shipments. Old tubes must be returned prepaid. Tubes shipped Rail Express.

WRITE FOR COMPLETE LIST

## —PICTURE TUBE OUTLET—

3032 MILWAUKEE AVE., CHICAGO 18, ILLINOIS  
Dickens 2-2048

### LEARN

## RADAR MICROWAVES

## COMPUTERS

## TRANSMITTERS

## CODE • TV • RADIO

Phila. Wireless Technical Institute

1533 Pine St. Philadelphia 2, Penna.

A Non-Profit Corp. Founded in 1908

Write for free Catalog to Dept. P-759

## The Battery That's Used in Guided Missiles Now Released as Government Surplus

For Photography, Aircraft, Models, Search-**\$1.95** ea.  
lights, Radios, Boat Running Lights, etc. Postpaid



Sintered-plate Nickel-Cadmium alkaline storage batteries designed for "NIKE" Missile and now surplus due to design change. A lifetime battery with no known limit of service (over 5000 recharges on test without loss of capacity). Other features: Virtually indestructible, compact & lightweight, withstands heavy shock and vibration. Flat voltage curve during discharge retains charge year or more, high discharge rate up to 50 amps. for this metal, spill-proof construction, discharge in any position, indefinite storage without deterioration, operates in temperatures  $-60^{\circ}\text{F}$  to  $+200^{\circ}\text{F}$ . Each cell is approx. 10 ampere hour capacity. Nominal voltage per cell is 1.2 volts. (A 6 V. battery requires 5 cells.) Cell size 6" H. x 2" W. x 1/2" T. We. 6 oz. ea. Uses Potassium-Hydroxide (30%) electrolyte. Negligible loss during lifetime service. Add only distilled water once a year. A fraction of Government cost.

Used Test Cells ..... \$1.95 ea. Postpaid

Brand New Cells ..... 2.95 ea. Postpaid

All cells guaranteed to your satisfaction or money returned (less postage).

**ESSE RADIO COMPANY** Indianapolis 25, Indiana

## EASY TO LEARN CODE

Learn to increase speed with an Instructograph—the Radio-Telegraph Code Teacher that takes the place of an operator-instructor and enables anyone to master code without further assistance. Available tapes from beginners alphabet to typical messages on all subjects. Speed range 5 to 40 WPM. Always ready—no waiting. Thousands have "acquired the code" with the Instructograph System. Write today for convenient rental or purchase plans.

**INSTRUCTOGRAPH COMPANY**  
4713 SHERIDAN ROAD, CHICAGO 40, ILLINOIS  
357 West Manchester Ave., Los Angeles 3, California



been sitting at his key when his license came. In four weeks, he has made 218 contacts in 35 states and Puerto Rico. Twenty-six states are confirmed. Ken's equipment includes a DX-20 transmitter, a Knight "De Luxe" receiver, and a doublet antenna. Ken also offers to help prospective Novices. . . . **James De Feo, K2TIM**, 60 Washington Ave., Roosevelt, N. Y., (Tel.: MA 3-5098), has been a ham for three years, but school activities limit most of his ham activities to the summer months. He offers to help anyone who can come to his home during the summer to obtain either a Novice, Technician, or General license. He is studying for an Extra Class ticket for himself. Jim operates all bands, 80 through 10 meters, and has worked all states and 45 countries on c.w., using a DX-40 transmitter and a National NC-125 receiver. On two meters, he uses a converted BC-522 transmitter and a 20-element beam; he has worked 11 states on that band.

Back in September, 1957, **Bob A. Copella**, Box 25, Byrnedale, Pa., had his name listed in the "Help" section. Since then, he has gotten his General license, **K3CMC**. His dad, **K3DDH**, is a Technician, and now his mother, Sylvia, is **KN3AIO**. Dad and Mom are studying for the General. . . . **Steve Victor, WV2DTW**, 4034 E. Tremont Ave., Bronx 65, N. Y., runs 20 watts to a BC-522 transmitter feeding an indoor dipole on two meters, and has been having a barrel of fun working locals on phone. But he is also getting his low-frequency code equipment ready to go. . . . **John Francis, KN9QJF**, 1174 Benton St., Gary, Ind., reports excellent results with the Q-Multiplier described in the February column on his Hallcrafters S-85 receiver. John, who came from England, applied for his Novice license the same day he received his U.S. citizenship papers. In about eight weeks on the air, he has made around 300 contacts in 14 states, using a converted "surplus" BC-458 transmitter and a random-length antenna about 60' long.

**Peter James, WV6CVT**, (13), 4801 Thor Way, Carmichael, Calif., has worked 28 states, Hawaii, and Canada feeding a 33' end-fed antenna about 16' high with his DX-20 on 40 meters. He receives with an Allied Space Spanner. . . . Helped by having his name in our "Help" section, **Alexander "Al" Nicholson**, Box 340, Sturgis, Sask., Canada, is now **VE5NQ**. In six weeks on the air, Al's Heathkit DX-20 and Hallicrafters C-40A have accounted for about 50 contacts in four Canadian provinces and six states. Studying for exams cut down on his air time. Check with Al for a VE5 contact. He works all the low-frequency ham bands, except 20 meters. . . . **Bill Boulay, KN0SYI**, 7703 E. Highway 40, Kansas City, Mo., just happened to be on vacation when his ticket came. In two weeks on the air, he has knocked off 32 states and Canada, with 22 states already confirmed. He operates the three low-frequency Novice bands with a WRL Globe Chief transmitter, a Hallicrafters S-85 receiver, and separate doublet antennas for each band.

That does it for another month. Keep those reports, pictures and technical hints coming. 73,

Herb, W9EGQ



# Brand New!

Get top performance  
from your hi-fi system  
with this complete  
**STEREO-MONOPHONIC  
TEST RECORD**  
produced by the editors of  
**ELECTRONICS WORLD**  
(another ZIFF-DAVIS publication)



Special to  
our readers  
for only...

As a man who is seriously interested in hi-fi, you will certainly want to be among the first to take advantage of this new and important test record. It will enable you to know your system inside-out. As a result, your listening enjoyment will be even greater than ever before.

Here are some of the questions this record will answer for you!

- ✓ How good is my stylus? Is it worn? Will it damage my records?
- ✓ What about my stereo cartridge? Does it have enough vertical compliance so that it won't ruin my expensive stereo records?
- ✓ Is my turntable running at the right speed? Is it free of rumble, wow, and flutter?
- ✓ What sort of standing waves do I get in my listening room?
- ✓ Are my speakers hooked up correctly? Are they phased properly, and is the correct speaker connected to the right stereo channel?
- ✓ How perfectly is my system equalized?
- ✓ What about separation? Is it adequate?

You'll get on-the-spot-answers to these and many other questions when you use this Stereo-Monophonic Test Record. It's the most complete test record of its kind—contains the widest range of essential check-points ever incorporated into one test disc! And, best of all, you need no expensive test equipment when you use this record! Just listen and get the thorough results you want—all checks can be made by ear!

As a man who is seriously interested in hi-fi, you can immediately see the ex-

traordinary 2-way value you get from this special test record. First, it guides you in evaluating the quality of reproduction your equipment now produces. Second, it specifies the adjustments necessary to get the best recorded sound you have ever heard! Add up the advantages! Check the special low price! This is easily the best value of the year for everyone who owns a hi-fi system—either monophonic or stereo!

**Supply limited—Order your Test Record for just \$1 now!**

This stereo monophonic test record will only be sold to you by mail, at the special reader-price of just \$1. You can be sure that it comes as close to perfection as is humanly possible, because the editors of *Electronics World*—leading technical magazine in the field of electronics—have poured their accu-

mulated know-how into this project for a period of many many months. But the supply is limited, so it will have to be *first-come, first-served!* Avoid disappointment—place your order right now. Fill in and mail the coupon, together with your check (\$1 per record) *today!*

Special Features of ELECTRONICS WORLD  
7" Stereo-Monophonic Test Record

- Four bands for stereo checks only—plus three bands for checking stereo or monophonic equipment!
- Made of top-quality virgin vinyl for long wear!
- Specially-reinforced center resists wear!
- Delivered in special polyethylene envelope—dust and dirt are sealed out!
- Fully guaranteed!

**POPULAR ELECTRONICS • P.O. Box 211, New York 46, N. Y.**

Please send me \_\_\_\_\_ test records at \$1 each. My check (or money order) for \$\_\_\_\_\_ is enclosed. I understand that you will pay the postage and that each record is fully guaranteed.

Name \_\_\_\_\_ Please print

Address \_\_\_\_\_

City \_\_\_\_\_ Zone \_\_\_\_\_ State \_\_\_\_\_

50KRT—no charges w/ C.O.D. orders!

E7

# NOW AVAILABLE

**BUILD-IT-YOURSELF KITS for the NEW 27 mc  
CITIZEN'S BAND "WALKIE TALKIE" TRANSCEIVER**

See JUNE POPULAR ELECTRONICS pg 48 for details

- DELUXE KIT** of all parts, tubes, chassis, microphone, etc. .... \$39.95
  - With Wired superior quality RF assembly, Esco model T200 ..... \$4.95
  - TRANSCEIVER** custom wired and air checked ..... \$9.95
- All units include guaranteed .005% tol. XTAL, antenna, tubes, F1 microphone and dynamic type earphone unit-Full Instructions. Special power pack operating from self contained rechargeable heavy duty 2 volt storage cell. With built-in or external 110V. AC and 2-12 volt DC charger. Eliminates expensive dry type A/B batteries. Delivers "clean" filtered & regulated voltages ..... 34.95
- DELUXE HIPOWER** (5 watts) transceiver for operation from 110V. AC and 6-12V. DC. See March Radio & TV News, pg 49 for details. Use as base station to "work" field stations, etc. only ..... 39.95
  - CITIZEN BAND** .005% tolerance crystals, all channels ..... 3.95

**ESCO-NEW YORK TOP QUALITY MATERIALS ONLY**  
58 Walker St. NYC 13, N.Y. Money back guarantee.

## EMERGENCY PORTABLE POWER PLANTS

Push Button Start — 115 V AC (and 12 V DC). Always available. Only unit at these low factory prices fully shielded and filtered for radio, and individually checked by scope. Brand new 4 cycle easy starting engines, fiber glass insulated generators, and control boxes with voltmeter. Conservatively rated. Just the generator for CD, Field Day, Camping and Boats.

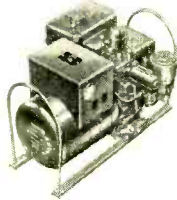

- 700 watt (A712) Shpg. wt. 77 lbs. .... \$143.50
- 1000 watt (A1012) Shpg. wt. 90 lbs. .... 195.50
- 2500 watt (A2512) Shpg. wt. 225 lbs. .... 325.50

Sizes to 35K W F.O.B. factory

Dual voltage models, automatic controls, etc., available.

**GENERAL ELECTRONIC SERVICE CO.**  
376 Wilmot Ave., Burlington, Wisconsin

# TELEPHONES



**YOUR OWN • MODERN DIAL**  
FOR PRIVATE CIRCUITS and extensions, easy to install, invaluable for residence—farm—estates or industrial purposes. Surplus phones—slightly used—fully standard, complete with dial, bell, cords, etc. With male 4-prong plug—add \$1.75. Instructions and diagram included.

GOV'T COST: \$32.50 each

**NOW**

**10.50**

each C.O.D.'s

**FENNER SALES**  
Dept. PE-2  
Hysham, Mont.

**100% Satisfaction Guaranteed**

Send Check or Money Order **10.50** We pay postage anywhere in U.S.A.



# LOOK

NO FURTHER . . . IF YOU'RE UNHAPPY WITH "HI" HI-FI PRICES. WRITE FOR OUR UNUSUAL AUDIO CATALOG. **KEY ELECTRONICS CO.**  
120-B Liberty St., N. Y. 6

# INVENTORS

Send for **PATENT INFORMATION** Book and **INVENTOR'S RECORD** without obligation

**GUSTAVE MILLER**  
79-PE WARNER BUILDING  
WASHINGTON 4, D. C.

**REGISTERED PATENT ATTORNEY**  
ASSOCIATE EXAMINER  
U.S. PAT. OFF. 1922-1929

Patent Attorney & Advisor  
U. S. NAVY DEPT. 1930-1947  
**PATENT LAWYER**

## Short-Wave Report

(Continued from page 126)

The following is a resume of the current reports. At time of compilation all reports are correct. Stations often change frequency and/or schedule with little or no advance notice. All times shown are Eastern Standard, and the 24-hour system is used.

**Argentina**—LRA, *R. Nacional*, Buenos Aires, 15,345 kc., broadcasts to Europe Mondays through Fridays at 1400-1500 in Spanish, 1500-1600 in German, 1600-1700 in Italian, 1700-1800 in French, 1800-1900 in English, and 1900-2000 in Portuguese. They are asking for reports. (WPE3NF, WPE8DB, WPE1PD, VE2PEIU, GF)

Another Eng. xmsn is noted over the 9690-kc. outlet at 2200-2300 beamed to N.A. (OO)

**Australia**—The new schedule for English language programs from *Radio Australia* reads as follows: to East Asia and North Pacific areas at 1550-1700 on VLA15, 15,240 kc., at 0244-0700 on VLB11, 11,810 kc., and at 0459-0900 on VLG15, 15,200 kc.; to S., S.E., and S.W. Asia at 1714-1830 on VLG15, 15,210 kc., at 1714-0445 on VLD21, 21,540 kc., at 1815-0230 on VLB17, 17,840 kc., at 1915-1930 on VLC15, 15,160 kc., 0129-0430 and 0800-0815 on VLA15, 15,160 kc., at 0459-1230 on VLD9, 9580 kc., at 0800-0830 and 0930-1230 on VLC7, 7220 kc., at 0829-1230 on VLA11, 11,710 kc., and at 0930-1000 on VLB11, 11,810 kc.; to the South Pacific Islands at 0100-0415 on VLC11, 11,710 kc., and at 1500-1700 on VLB11, 11,710 kc.; to the Mid-Pacific Islands at 0129-0445 on VLG11, 11,760 kc., and at 1500-1700 on VLC15, 15,315 kc.; to the British Isles and Europe at 0100-0230 on VLC11, 11,710 kc.; to Africa at 2329-0045 on VLC21, 21,680 kc.; to Eastern N.A. at 0714-0815 on VLB11, 11,810 kc.; to Western N.A. at 1014-1115 on VLB11, 11,810 kc. Transmitter power: VLA and VLB are 100 kw., VLC and VLD are 50 kw., and VLG is 10 kw. The popular DX program is broadcast on Saturdays at 1700-1710 to E. Asia on 15,240 kc., on Sundays at 0030-0040 to Africa on 21,680 kc., on Sundays at 0215-0225 to Europe and S. Pacific Islands on 11,710 kc., Sundays at 0800-0810 to Eastern N.A. on 11,810 kc., and on Sundays at 1100-1110 to Western N.A. on 11,810 kc. and on 11,710, 9580, and 7220 kc. to S. Asia. (WPE1BM, WPE2TK, WPE9DN, WPEOAE, WPE8HF, DG)

**Belgium**—The Eng. "Belgian Magazine" is carried on Sundays, Tuesdays, Thursdays, and Fridays at 1730-1800 on 15,335, 11,850, and 11,720 kc., on the same days at 1930-2000 on 11,850 and 9665 kc., on Tuesdays at 0730-0800 on 11,850 and 9665 kc., and on Saturdays at 1815-1900 on 11,850 and 9665 kc. The 9665-kc. channel is the Belgian Congo outlet in Leopoldville. All programs are beamed to North and South America. (WPE9DN, WPE4ET)

**British Honduras**—According to the schedule, the Belize station operates at 0730-0900, 1300-1400, and 1800-2315 on 3300 kc. A newscast is given at 2030. (WPE5CN, WPE9DS, WPE7EZ, WPE4IQ, WPE0EW, WPE0CL, WPE7EL, WR)

**Canada**—*Radio Canada*, Montreal, has added

two new English/French programs: "Alouette" on Saturdays at 0730-0800 on 21,600 and 17,820 kc., and "Canadian Concert" on Saturdays and Sundays at 1030-1100 on 17,820 and 15,320 kc. (WPE1FG, WPE4BR, WPE9CP)

**Ecuador**—Radio Mundial, Riobamba, has moved from 6255 kc. to 6287 kc. (WPE4FI)

**Egypt**—The United Arab Republic B/C Service, Cairo, now airs its Eng. program for

4465, 4475, 4565, 5125, 5195, 5740, 5790, 5845, 5890, 6970, 6995, 7440, 7825, 9090, 9145, 9170, 9250, 10,190, 10,210, 10,315, 10,760, 11,675, 13,690, 15,885, 16,240, 20,060, 20,505, 20,545, 20,650, and 20,935 kc. The Voice of America also operates some relays from Ismaning, Germany, and assigned channels are 3636, 5275, 5435, 5450, 6873.5, 7332.5, 7605, 7622.5, 7725, 9855, 10,522.5, 12,223.5, 13,702.5, 13,999, and 15,520 kilocycles. (WPE5AC)

**Ghana**—R. Ghana, Accra, has been noted in Eng. at 1715 s/off on 4915 kc. and at 0200 on 3366 kc. with home news and London-relayed news and sports. (WPE2DM, WPE0EX, KM)

**Gilbert Islands**—Being reported to this column for the first time, R. Tarawa, 6050 kc., was noted at 0245-0259 with pop music, at 0300-0305 with news. Heard until after 0400, it was barely readable from 0305. You can expect a lot of interference if you go after this one! (WPE0AE)

**Greece**—R. Athens carries French at 1715-1730 and Eng. at 1730-1745 on 17,775 kc. to N.W. Europe. An Eng. and French xmsn at 1215-1245 has not been heard in midwestern areas due to interference and jamming on 21,485 and 15,345 kc. (WPE9DN, MK)

**Honduras**—HRN, Tegucigalpa, has moved from 5873 kc. to 5850 kc. (WPE4FI)

**India**—All India Radio, Delhi, has been noted at the following times: on 15,130 kc. at 1215-1230 and 15,105 kc. at 1245-1300 with music; on 15,105 kc. at 1935-2015 with native music; Eng. only at s/off; in the General Service on 15,140 kc. at 1815-1915; at 1445-1545 in Eng.

### NEW REPORTING ADDRESS

From now on, for convenience in handling, please send all reports to:

Hank Bennett, Short-Wave Editor  
POPULAR ELECTRONICS  
P. O. Box 254  
Haddonfield, N. J.

Make sure you use your WPE call letters. If you haven't yet obtained your certificate and call letters, just fill out the application form on page 127.

Europe at 1630-1730 (formerly 1600-1700) on 11,990 kc. News is presented at 1645. (WPE2UP)

**Ethiopia**—R. Addis Ababa, 15,345 kc., has a daily program of light and classical music at 1430-1600 with anmts in Eng. and native language. Reception is fairly good in western states. (DXRA)

**Germany**—The occasionally reported Radio Free Europe relay xmts are located in Holzkirchen, Germany. The assigned frequencies:

**GET ON THE AIR**  
for Business or Fun

TRANSMIT AND RECEIVE

ONLY \$37.50  
KIT

**NO EXAMINATION**  
No Tests Required\*

### With this New CITIZENS BAND Transceiver Kit!

AS DESCRIBED IN THE MARCH, 1959 ISSUE OF RADIO & TELEVISION NEWS

✓ COMPLETE WITH ALL PARTS, CRYSTALS, TUBES, PUNCHED CHASSIS, ETC.

✓ SOCKETS AND SMALL PARTS RIVETED TO CHASSIS FOR QUICK-E-Z CONSTRUCTION

✓ ONLY FINEST PARTS — NO SURPLUS.

✓ COMPLETE REPRINT INSTRUCTIONS FROM RADIO & TV NEWS.

✓ ALL YOU NEED IS SOLDERING IRON, SCREWDRIVER AND PLIERS.

✓ INSTRUCTIONS FOR MAKING YOUR OWN ANTENNA.

\*You must be U.S. Citizen over 18 years of age. Simply fill out FCC form 505. (Form included.)



✓ RADIO & TV NEWS SAYS: "Even with 5 watts, it is perfectly capable of transmitting and receiving over distances of 3000 miles or more when Old Mother Nature has the ionosphere in good working order."

✓ SIMPLE TO OPERATE: VOLUME, TUNING AND TRANSMITTER/RECEIVER SWITCHES.

Only \$39.95

2 OR MORE — \$37.50 EACH

IF YOU WISH, PAY JUST \$5.00 DOWN, \$5.00 PER MO.

WORLD'S MOST PERSONALIZED ELECTRONIC SUPPLY HOUSE

**World Radio**

ELECTRONIC LABORATORIES  
PH. 2-0277

3415 W. BROADWAY COUNCIL BLUFFS IOWA

Please rush your  FREE Catalog . . . Enclosed is my check or money order for  one,  two Transceiver Kit(s).

NAME: \_\_\_\_\_

ADDRESS: \_\_\_\_\_

CITY & STATE: \_\_\_\_\_ PE-7

# BEFORE YOU BUY... GET THIS CATALOG FREE!

Send postcard today for your free G-C Catalog 158... 80 pages of valuable service aids available at your distributor.



**GENERAL CEMENT MFG. CO.**  
division of Textron Inc. Western Plant: Los Angeles 18, California  
Main Plant: ROCKFORD, ILLINOIS, U.S.A.

## AMAZING MINIATURE BROADCAST TRANSMITTER

FOOL YOUR FRIENDS with this transmitter... broadcast as on any radio or car radio and which their startled faces when they hear YOUR voice on their rad... Can be used as FUN MAKER, P.A. SYSTEM, WALKIE TALKIE, CAR TO CAR COMMUNICATIONS and MANY OTHER USES described with three instructions. Use on HUNTING and FISHING TRIPS.



Completely portable (5 3/4 x 1 3/4 x 1 1/4) with self-contained batteries and equipped with TELESCOPING ANTENNA. ABSOLUTELY WIRELESS. No ground wires or HOOKUPS to make on transmitter. Works up to ONE BLOCK OR MORE. NO LICENSE REQUIRED. The "HALICASTER" transmits THROUGH WALLS! SIMPLY push the button and talk!

The "HALICASTER" has a built-in station selector so you can tune in on any station you desire. SEND ONLY \$1.00 CASH, CHECK OR MONEY ORDER AND PAY POSTMAN THE BALANCE OF \$ 8.99 FOR INSTANT READY TO USE "HALICASTER" OR SEND JUST \$9.95 FULL PRICE AND WE PAY POSTAGE.

(Batteries \$2.50 extra)

Kit now available for \$7.95 full price

Available only from **HALCO ELECTRONICS, DEPT. A,**  
9211 Venice Blvd., Los Angeles 34, California

## NEW MAGIC RADIO WALKIE TALKIE!

**YOUR OWN POCKET SIZE RADIO STATION!**  
BROADCASTS TO ANY HOME OR CAR RADIO WITHOUT WIRES OR HOOKUPS! Wt. only 5 oz. Size only 1 1/2" x 2 1/2" x 4 1/8". Built-in telescoping antenna. Powerful Transmitter-sensitive microphone, frequency setter, break-in switch! Runs for weeks on self-contained flashlight batteries. Durable plastic case.



With this Radio Talkie you CAN TALK TO YOUR FRIENDS nearby or—Talk between two or more automobiles.—INSTANT OPERATION. Just push button to talk! No license needed. Uses inductive field magnetic radiation. Useful and real fun in a million ways! GUARANTEED TO WORK. 1 YEAR SERVICE GUARANTEE.

SEND ONLY \$3.00 (cash, ck. mo) and pay postman \$9.98 COD postage or send \$12.95 for prepaid delivery. COMPLETE READY TO OPERATE with instructions and hundreds of ways and tricks for broadcasts thru any radio you desire. Get your NEW POWERFUL RADIO WALKIE NOW!

Available only from: **WESTERN RADIO, Dept. REL-7, Kearney, Nebr.**

## MOBILE-FIXED CONVERTER POLICE • FIRE • CITIZENS' BAND

#315A is a practical converter for emergency use. Easily installed. Tuning range approximately 12 MC in the 26-50 MC band—15 MC in the 152-162 MC band. Designed for mobile or home use.



Available crystal controlled up to 54 MC. \$13.95  
\$18.95  
Also available crystal controlled up to 165 MC. \$22.50

ORDER TODAY or WRITE for LITERATURE

**KUHN ELECTRONICS**  
20 GLENWOOD CINCINNATI 17, OHIO

to Europe on 11,710 and 9670 kc. and to West Africa on 15,170 and 11,800 kc.; and at 1930-1940 in Eng. to Asia. The new channel, 21,695 kc., is heard well in Tamil at 1915-2015, dual to 17,720 kc. (WPE1KJ, WPE2UP, WPE4FI, WPE9DN, VE3PEIS, JB)

**Indonesia**—Voice of Indonesia, Djakarta, has Eng. at 1400-1500 on 11,785 kc. dual to 9868 kc. with news at 1415. (WPE2UP, WPE3NF, WPE0AE)

**Japan**—Tokyo now operates in Eng. to Eastern N.A. at 1930-2030 on 17,855 and 21,620 kc. (WPE1KJ, WPE4FI, WPE5AG, WPE6AA, WPE6EZ, WPE8DB, WPE1PD, WPE2MM, RB, GF, DG, DP)

**Macao**—According to the World Radio Handbook bulletin, R. Vila Verde has dropped all short-wave broadcasts. (WPE1BY)

**New Guinea**—VLT6, Port Moresby, 6130 kc., is noted at 0325-0415, all-English. Weather is given at 0350; news at 0400. (WPE0AE)

**New Zealand**—ZL19, Wellington, 11,830 kc., is heard well at 0130-0340 with Eng. to Pacific Islands. News is read at 0230. (WPE8BX, WPE8CV)

**Niger Republic**—R. Niger, Niamey, 5020 kc., operates weekdays at 0030-0130 and 1230-1600 (from 1100 on Sundays). (WPE1BM, WPE4FI)

**Norway**—R. Norway, Oslo, now operates to North and Central America at 2000-2115 and to N.A. at 2300-0015 on 15,175, 11,735, 9610, and 6130 kc. (WPE1BM, WPE2UP, WPE6FA, WPE8HF)

**Pakistan**—Karachi is noted well to S.E. Asia at 1930-2015 with Eng. news at 2000-2005 on

### SHORT-WAVE ABBREVIATIONS

anmt—Announcement	N.A.—North America(n)
B/C—Broadcasting	R.—Radio
Eng.—English	s/off—Sign-off
ID—Identification	s/on—Sign-on
kc.—Kilocycles	xmsn—Transmission
kw.—Kilowatts	xmtr—Transmitter

15,335 and 11,885 kc. Another Eng. newscast is heard at 2130-2145 on 11,885 kc. (WPE2UP, WPE4IQ, VM)

**Panama**—HOLA, R. Atlantico, Colon, 9505 kc., has Eng. at 2100-2200 with a request-type program. (WPE9DN)

**Senegal**—Radiodiffusion de L'AOF, Dakar, has been heard with Eng. at 1730-1750 on 4950 kc. Noted on Tuesdays, Thursdays, and Saturdays, this may possibly be a daily xmsn. (WPE2UP)

**Sierra Leone**—Freetown can be heard at times on 3316 kc. at 0145-0210 with an Eng. newscast at 0200. (WPE0AE, WK)

**Solomon Islands**—VQO2, Honiara, 5960 kc., is noted at 0310-0430 with various musical shows; an Eng. news period is at 0415-0430. (WPE0AE)

**South Korea**—The latest schedule from Seoul reads: to N.A. and Hawaii at 0030-0100 (Eng.) on 15,410 and 11,925 kc., and at 0100-0130 (Korean) on the same channels; at 0230-0300 (Eng.) and 0300-0330 (Korean) on 11,925 kc.; in the General Overseas Service at 0530-0600 (Eng.) on 9640 and 7935 kc.; to Japan at 0800-0830 (Japanese) on 9640 and 7935 kc.; to S.E. Asia at 0900-0930 (Eng.) and 0930-1000

# SPECIAL OFFER

FOR READERS OF POPULAR ELECTRONICS  
WHO ARE ALSO INTERESTED IN BOATING

**18 ISSUES OF**  
**POPULAR BOATING FOR ONLY \$3<sup>85</sup>!**

A 12-month subscription costs \$4. But this offer gives you 18 issues for less than the price of 12! That means you enjoy...

**6 ISSUES FREE!**

If your hobby interests include boating, sign up right now for a special 18-month test cruise with POPULAR BOATING! You'll get practical ideas and expert guidance on building, repairing and maintaining everything from prams to blue-water cruisers...tips on patching hulls...new aids for water-ski fun...plus many "how-to" articles that will really capture your interest and increase your skills! Up-to-the-minute news on new boats, boating personalities — scores of photos and x-ray drawings, too! And remember — this great special offer gives you 6 issues FREE! So act now! Fill in, detach and mail the coupon today!

**FILL IN, DETACH  
AND MAIL  
THIS ORDER FORM  
TODAY!**

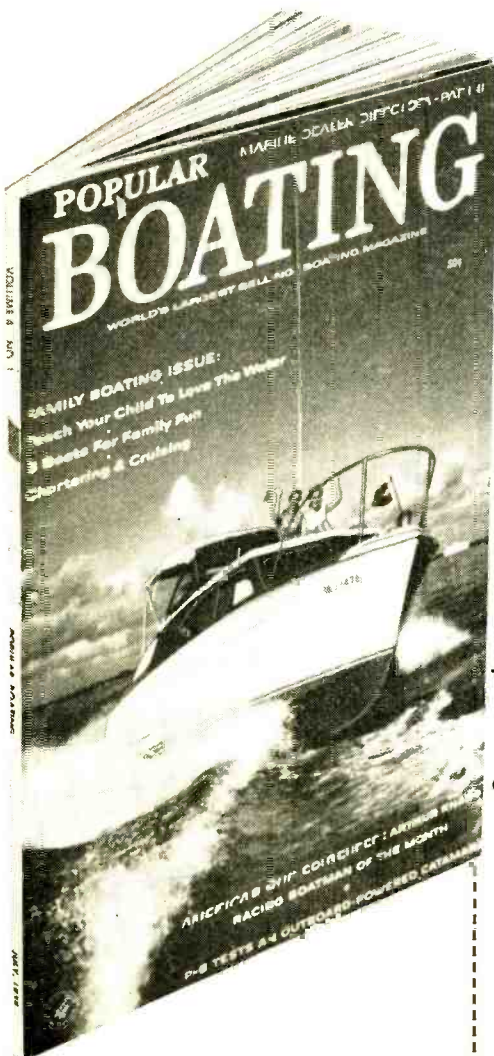

Popular Boating • 434 So. Wabash Ave., Chicago 5, Ill.

**Yes!** Enter my subscription to **Popular Boating** at the special rate of 18 months for \$3.85.

- Payment enclosed. (Save us billing costs and we'll add 1 extra issue FREE!)  Please bill me.

Name \_\_\_\_\_  
please print

Address \_\_\_\_\_

City \_\_\_\_\_ Zone \_\_\_\_\_ State \_\_\_\_\_

PE79

# ADVERTISER'S INDEX

ADVERTISER	PAGE NO.
Allied Radio	35
Apparatus Development Co.	161
Bailey Technical Schools	26
Capitol Radio Engineering Institute	131
Capri Electronics	146
Century Electronics Co., Inc.	30, 31
Cleveland Institute of Radio Electronics	17
Coyne Electrical School	9
DeVry Technical Institute	7
Dynaco, Inc.	34
EICO	38, 40
Electronic Organ Arts, Inc.	34
Electro Products Laboratories	24
Electronics Schools	146
Electronics World Stereo Disc	153
Erie Resistor Corporation	14
Esse Radio Company	152
Esco	154
Fenner Sales	154
Garfield Co., Inc., Oliver	2nd Cover
General Cement Mfg. Co.	156
General Electronic Service Co.	154
Gonsel	24
Grantham School of Electronics	11
Greenlee Tool Co.	32
Grove Electronic Supply Company	161
Halco Electronics	156
Hallicrafters	143
Heath Company	134, 135, 136, 137, 138, 139
Indiana Technical College	143
Instructograph Company	152
International Correspondence Schools	13
International Crystal Mfg. Co., Inc.	18, 19
Jensen Industries, Inc.	36
Jesse Jones Box Corp.	161
Key Electronics Co.	154
Kuhn Electronics	156
Lafayette Radio	37
Lektron	145
Micro Electron Tube Co.	20
Midway Company	143
Miller, Gustave	154
Milwaukee School of Engineering	151
Modernophone, Inc.	36
Mosley Electronics, Inc.	16
Moss Electronic, Inc.	162, 3rd & 4th Covers
Multi-Products Company	142
National Radio Co., Inc.	22
National Radio Institute	3
National Schools	33
North American Philips Co., Inc.	12
Pacific International College	148
Palmer, Joe	161
Phila. Wireless Technical Institute	152
Picture Tube Outlet	152
Popular Boating Subscription	157
Popular Electronics Classified	148
Popular Electronics Subscriptions	144
Popular Electronics Upcoming Contents	25
Port Arthur College	144
Progressive "Edu-Kits" Inc.	39
RCA Institutes, Inc.	15
Radio-Television Training School	29
Radio Shack Corp.	27
Rinehart & Co., Inc.	149
Russ Photo Service	32
Semiconductors Inc.	148
Sprayberry Academy of Radio-Television	21
Springfield Enterprises	28
Sylvania Electric Products Inc.	10
Tapedcode	144
Texas Crystals	28
Tru-Vac Electric Company	133
Tri-State College	143
U. S. Air Force	5
U. S. Army	23
Valparaiso Technical Institute	146
Vanguard Electronic Labs.	161
Video Electric Company	147
Western Radio	148, 156
World Radio Laboratories	155

(French) on 15,410 and 9640 kc. (WPE9DN, WPE7EZ, WPE41Q. MK)

**Spanish Guinea**—Bata has moved from 7846 to 7794 kc. and is noted from 1613 with popular dance music. ID is *Aqua Radio Ecuatorial en Bata, La Voz de Espana en Guinea*. The xmtr is a Hallicrafters BC610. (WPE3NF)

**Surinam**—AVROS, Paramaribo, has moved from 4848 kc. to 3395 kc. Covered by YVOJ, Venezuela, most evenings, it is well heard on Sundays at 1900-2130. (WPE4FI)

**Switzerland**—The Swiss DX program is now being carried every Friday at 2100 on 11,865 and 9535 kc. (WPE9BR, WPE9KM, WPE3AK)

**Tanganyika**—If you need this country for your log, try for Dar-es-Salaam on 5050 kc. at

## SHORT-WAVE CONTRIBUTORS

Jerry Berg (WPE1BM), West Hartford, Conn.  
 Alan Roth (WPE1BY), Bridgeport, Conn.  
 Wayne Foster (WPE1FG), Montpelier, Vt.  
 Bradley Graham (WPE1KJ), Fayerweather Island, Conn.  
 Anson Boice (WPE1PD), New Britain, Conn.  
 Richard McCurdy (WPE2DM), Harrison, N. Y.  
 Bob Schwartz (WPE2AM), Brooklyn, N. Y.  
 Robert Salamack (WPE2TK), Amsterdam, N. Y.  
 Paul Bauer (WPE2UP), Harrison, N. Y.  
 Ed Kowalski (WPE3AK), Philadelphia, Pa.  
 George Cox (WPE3NF), New Castle, Del.  
 Algic Adams (WPE4BR), Roanoke, Va.  
 Eddie Bailey (WPE4ET), Auburn, Ala.  
 Roger Legge (WPE4FI), McLean, Va.  
 Sidney Fleming (WPE5IO), Miami, Fla.  
 Jim Cumbie (WPE5JA), Sherman, Texas  
 William Bing (WPE5AG), New Orleans, La.  
 Arno Feltner (WPE5CA), New Braunfels, Tex.  
 Stewart MacKenzie (WPE6AA), Long Beach, Calif.  
 J. Art Russell (WPE6EZ), San Diego, Calif.  
 Werner Howard (WPE6FA), Los Angeles, Calif.  
 Richard Quam (WPE7EL), Longview, Wash.  
 Dave Borino (WPE7EZ), Cheyenne, Wyo.  
 M. J. Van Gorder (WPE8BY), Detroit, Mich.  
 H. R. Odell (WPE8CV), Barboursville, W. Va.  
 Robert Sabin (WPE8DB), Wilmington, Ohio  
 Dan Wilt (WPE8HF), Barberton, Ohio  
 Michael Rossmann (WPE9BR), Joliet, Ill.  
 Kevin Jessup (WPE9CP), Westville, Ill.  
 J. P. Arendt (WPE9DN), Aurora, Ill.  
 Jim Hall (WPE9DS), Loves Park, Ill.  
 A. R. Niblack (WPE9KM), Vincennes, Ind.  
 John Beaver (WPE0AE), Canon City, Colo.  
 John McGurk (WPE0CL), Waynesville, Mo.  
 James Howard (WPE0EW), Kansas City, Mo.  
 W. D. Rogers (WPE0EX), St. Louis, Mo.  
 Robert Prinsky (VE2PE1U), Westmount, Que.  
 Cyril Gilmour (VE3PE1S), St. Catharines, Ont.  
 Middle Eastern Correspondent (ZC4PE1A)  
 Joel Bowers (JB), Brooklyn, N. Y.  
 J. Ross Brownell (RB), Vancouver, B. C.  
 Grady Ferguson (GF), Charlotte, N. C.  
 David Gerns (DG), Fairfax, Va.  
 Algis Kaupas (AK), Garden City, Mich.  
 Mike Kander (MK), Dayton, Ohio  
 William Kelley (WK), Kennett, Mo.  
 Kent Mueller (KM), Youngstown, Ohio  
 Vince McGarry (VM), Clayton, N. J.  
 Orval Oppertshauer (OO), Toronto, Ont.  
 Dick Powers (DP), Detroit, Mich.  
 Woody Railey (WR), Lamar, Colo.  
 DXplorers Radio Association (DXRA)

2315-0000 or on 7167 kc. at 0400-0615. Both xmsns are in English. (AK)

**Trinidad**—R. Trinidad, VP4RD, 6085 and 3275 kc., is no longer operating on the short waves. The Home Service continues on 730 kc. only at 0500-2200. (WPE0AE)

**Zanzibar**—A weak carrier, believed to be that of *Sauti ya Unguja*, Zanzibar, 4797 kc., with its 3.5-kw. xmtr, was noted at 1600 but was unreadable. They have also been conducting tests on 6005 kc. (WPE3NF, ZC4PE1A) —50—

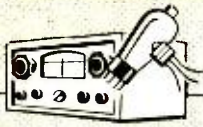

# ELECTRONICS MARKET PLACE

RATE: 50c per word. Minimum 10 words prepaid. September issue closes July 3rd. Send order and remittance to POPULAR ELECTRONICS, 1 Park Ave., New York 16, N. Y.

## FOR SALE

**PORTABLE** Physics laboratory complete with all apparatus and manual of 107 experiments, \$49.00. Model Atom Smasher, \$9.95 up, 3-in-1 Electromagnet, \$14.95, Raymaster Cloud Chamber, \$16.00 up, Spinthariscopes, \$2.00. Send 25c for literature about these and many other fascinating new scientific products. Atomic Laboratories, 3086 Claremont Ave., Berkeley, Calif.

**SAFCORDE** Electrical Outlet Model W-1, 120 Volts, 10 Amperes. 1200 Watts, Six Outlets, Switch, Pilot Light. Both lines fused \$9.95. P. W. Carpenter, Box 52, Barre, Vermont.

**GOVERNMENT** Surplus Receivers, Transmitters, Snooperscopes, Parabolic Reflectors, Picture Catalog 10c. Meshna, Malden 48, Mass.

**TRADE-IN** Television Sets \$9.95 Plus Shipping. Jones TV, Sanatoga, Pa.

**TELEVISION & Radio Tubes, Parts and Supplies.** Guaranteed. Hi-Quality Tube Co., Inc., 284 Lafayette St., Rahway, New Jersey.

**TUBES**—TV, Radio, Transmitting and Industrial Types at Sensibly Low Prices. New, Guaranteed 1st Quality Top Name Brands Only. Write for Free Catalog or Call WALKER 5-7000. Barry Electronics Corp., 512 Broadway, New York 12N, N. Y.

**DIAGRAMS** for repairing radios \$1.00, Television \$2.00. Give make, model. Diagram Service, Box 672-PE, Hartford 1, Conn.

**GOVERNMENT** Sells—Surplus Electronics; Walkie-Talkies; Test Equipment! Oscilloscopes; Radar; Sonar; Surplus Aircrafts; Boats; Jeeps; Misc.—You buy direct now from U. S. Government Depots at fractions of Army & Navy costs—Send for bulletin "Depot List & Procedure," \$1.00. Box 8-PE, Sunnyside 4, New York.

**TELEVISION** Fix-it Manual Only .50 (coin). Chas. Casey, Cartersville, Georgia.

**TELEPHONE** Extension in your car. Answer your home telephone by radio from your car. Complete diagrams and instructions \$1.25. C. Carrier Co., 5880 Hollywood Blvd., Hollywood 28, Calif.

**EAVESDROP** with a pack of cigarettes. Miniature transistorized radio transmitter. Complete diagrams and instruction \$1.25. C. Carrier Co., 5880 Hollywood Blvd., Hollywood 28, Calif.

**POLICE** Radar Detector. Stop before those radar speed traps. Fool proof, legal system. Complete diagrams and instructions \$2.75. C. Carrier Co., 5880 Hollywood Blvd., Hollywood 28, Calif.

**BRAIN** Wave Machine—Experimenters—6 Channels—41 tubes—high gain amplifiers—6 Electronic pen Oscilloscopes—14 rolls writer paper—silver electrodes and headband—originally \$3000—\$275. F.O.B.—Stein—175 State Street—Springfield, Mass.

**TELEVISION** and Radio Tubes. 59c, year guarantee. Evergreen Electronics 2006 Hewitt, Everett, Washington.

**15 TESTED** One tube Circuits with Transistor "Radiobuilder"—25c. Laboratories, 1131-L Valota, Redwood City, California.

**CITIZENS** band radio transceivers! Provide radio communications for all kinds of business, home, pleasure applications. Anyone may operate without operators license! Equipment for 27 MC and 465 MC citizens bands, Free Literature: House Electronics, Pukwana, S. Dak.

**WALKIE-TALKIES.** Hand sized two-way radios. Any citizen may operate. Several miles range. \$49.95. Kit \$34.95. Free information. Dixon Electronics, 13444 West McNichols, Detroit 35, Michigan.

**FOR Sale:** Service, Popular Brand Electronics Kits wired, tested, and calibrated by first class technicians. Inquiries invited, no obligation. Fincher Electronics, Lennox, S. Dak.

**MAGNETIC** Amplifiers—fastest growing field in electronics! A treatment anyone can understand and a "must" for the informed man. \$1.00 ppd. Minnetonka Engineering Co., R. 4, Excelsior, Minn.

**8-TEST** Equipment circuits from old radios—\$1.00. Whitener—Box 4384, Austin 51, Texas.

**RADIO & TV Tubes** at Manufacturers Prices! 100% Guaranteed! Brand New! No re-bands or pulls! United Radio, Box 1000, Newark, N. J.

**BUY** surplus electronic items, receivers, transmitters, walkie-talkies, aircraft, jeeps, boats, etc. direct from government. List, procedure—\$1.00 Included Free: "Non-government surplus", "Second-hand bargains" reports. Christopher Publications, Holtzville 27, N. Y.

## WANTED

**MERCURY,** Platinum, Silver, Precious Metals. Ores Assayed. Mercury Refiners, Norwood, Massachusetts.

**CASH** Paid! Sell your surplus electronic tubes. Want unused, clean transmitting, special purpose, receiving, TV types, magnetrons, klystrons, broadcast, etc. Also want military & commercial lab test and communications gear. We swap too, for tubes or choice equipment. Send specific details in first letter. For a fair deal write, wire or telephone: Barry, 512 Broadway, New York 12. N. Y. WALKER 5-7000.

**CYLINDER** and old disc phonographs. Edison Conqueror, Idelia, and Oratorio models. Berliner Gramophones and Zono-o-phones, Columbia cylinder Graphophones, and Coin-operated cylinder Phonos. Want old catalogues and literature on early phonos prior to 1919. Will pay cash or trade late hi-fi components. Popular Electronics, Box 50, 1 Park Ave., New York 16, N. Y.

## HIGH-FIDELITY

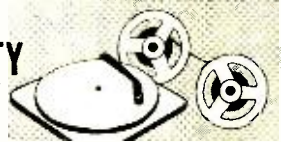

**RECORDERS,** Hi Fi. Free Wholesale Catalogue. Carston, 215-P East 88, N.Y.C. 28.

**DISGUSTED** with "Hi-Fi" Hi-Fi Prices? Unusual discounts on your High Fidelity Requirements. Write Key Electronics, 120 Liberty St., New York 6, N. Y. Evergreen 4-6071.

**UNUSUAL** Values. HiFi Components, tapes and tape recorders. Send for package quotations. Stereo Center, 18 W. 37 St., N. Y. C.

## PATENTS

**SAVE** High Fees. Apply for your patent yourself. New Kit now makes it easy. Free "Registration Form." Miss Clare Arden, 806 Wm. Penn Annex, Philadelphia 5, Penna.

## TAPE & RECORDERS

**TAPE** Recorders, Hi-Fi Components, Sleep Learning Equipment Tapes. Unusual Values. Free Catalog. Dressner, 69-02F, 174 St., Flushing 65, N. Y.

**HIGHEST** Trade-In Allowances Toward Ampex, Concertone, Crown, Ferrograph, Presto, Pentron, Components, Accessories. Catalog. Boynton Studio, 10-PE Pennsylvania, Tuckahoe, N. Y.

**12 IN. LP's** from your tape \$6.00, 3 \$15.00. Impco, Box 1266, Oak Bluffs, Mass.

**WE will not be undersold!** We meet any competition! Send us any competitor's advertising, showing a lower price for a tape recorder and we will not only meet this lower price, but will include with your purchase, a 1200 foot tape of your choice, Free! (73 models in stock.) Commissioned Electronics, 1776 Columbia Road, Washington, D. C.

## LEATHERCRAFT

**FREE "Do-It-Yourself" Leathercraft Catalog.** Thandy Leather Company, Box 791—D31, Fort Worth, Texas.

## INVENTIONS WANTED

**INVENTIONS** wanted. Patented: unpatented. Global Marketing Service, 2420 77th, Oakland 5, Calif.

## MISCELLANEOUS

**SONGPOEMS** And Lyrics Wanted! Mail to: Tin Pan Alley, Inc., 1650 Broadway, New York 19, N. Y.

**QSL'S** 300 for \$5.00. Stamp for Samples. Harold Morse, 4025 25th Avenue, Moline, Illinois.

**KIT** and custom building of any equipment. Kwikit, P.O.B. 111, Brooklyn 19, N. Y.

## INSTRUCTION

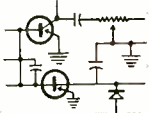

**COMPLETE** Correspondence Course in Radio, TV, & Electronics. Only 12 sections. Includes 1st Class License Prep. Very Low rates. Ascot School of Electronics, Box 29092, Los Angeles 29, Calif.

**CODE** learned forever in minutes with amazing memory aid. \$1. McKenzie Enterprises, Box 245, Palo Alto, California.

**CALCULUS** or Algebra. Easy Practical Lessons, First Four \$1. Mathco, 4256 Minmor, Cincinnati 17, Ohio.

**1959 INDUSTRY** Training. Home-Study Drafting, Design, Electronics. Aero Tech, 2162-ZD Sunset Blvd., Los Angeles 26, Calif.

**CODE** courses to enable passing Radio Amateur examinations. Designed and tape recorded by former U.S.N. Radio Operator and R.R. Telegrapher. Both sides 7"1200' reels. Learning to Six W.P.M. or Six to Sixteen W.P.M. Response enables reduction to \$3.98 each. Postpaid in U.S.A. Elham Inc., P.O. Box 98, Hawthorne, California.

**SPECIAL** offer, complete correspondence course in Radio, Electronics and Television. All new material. Only \$49.50. Formerly sold for over \$300.00. 44 books, over 2000 pages. Limited supply. For details write Box 601, Popular Electronics, One Park Avenue, New York 16, N. Y.

**BE a Spy!** Correspondence course in wire tapping, bugging, recording techniques, microphotography, invisible and remote photography, telescopic and aerial photography. Lessons in surveillance, tailing, and use of equipment. Complete course \$22.50. C. Carrier Co., 5880 Hollywood Blvd., Hollywood 28, Calif.

**TV Tape Recorder.** Correspondence course and home construction details. Build your own video recorder. Complete course and construction details \$18.75. C. Carrier Co., 5880 Hollywood Blvd., Hollywood 28, Calif.

**BOOKS** 10¢—all subjects—catalog 10¢. Cosmic, Clayton 2-3, Ga.

**TRANSISTORIZE** your automobile ignition system for better performance. Complete plans and instructions—\$2.50. Technical Services Institute, 5234P Fourth Street N. E., Washington 11, D. C.

**CAMERA** Repairmen greatly needed! You can learn manufacturer's service methods at home, in your spare time! Free, big illustrated book tells how! Write today. National Camera Repair School, Dept. (ZE) (2) Englewood, Colorado.

# SHOPPING GUIDE

## Classified

A HANDY REFERENCE TO PRODUCTS AND SERVICES NOT NECESSARILY ELECTRONIC, BUT OF WIDE GENERAL INTEREST.

## BUSINESS OPPORTUNITIES

**FIND** Money in your mailbox. Start your own Mail Order business. Experience unnecessary. Experts show you how. Write Richton Company, 157K, Maplewood, New Jersey.

**VENDING** Machines—No selling. Operate a route of coin machines and earn amazing profit. 32-page catalog free. Parkway Machine Corporation, Dept. 12, 715 Ensor St., Baltimore 2, Md.

**MAKE** \$25-\$50 Week, clipping newspaper items for publishers. Some worth \$5.00 each. Particulars free. National, 81-DG, Knickerbocker Station, New York City.

**WE** Pay \$4.50 lb. dried. Grow Mushrooms. Cellar, shed and outdoors. Spare, full time, year round. We pay \$4.50 lb. Free Book. Mushrooms, Dept. 334, 2954 Admiral Way, Seattle, Wash.

**OPERATE** Profitable mail order business!! Write: Bond, 1637-X, West Vernon, Phoenix, Arizona.

**EARN** extra money selling advertising book matches. Free samples furnished. Matchcorp, Dept. MD-49, Chicago 32, Illinois.

## STAMPS & COINS

**105 DIFFERENT** U.S. stamps 25¢. Approvals included. Shelron, Box 907-E, New York 8, N. Y.

**25 STAMPS** from 25 different countries free with approvals. Send 10¢ to cover mailing. W. Nasek, 1351 Water St., Fitchburg, Mass.

## PHOTOGRAPHY—FILM EQUIPMENT, SERVICES

**SAVE \$\$\$** Fresh 8mm. 16mm B & W; and color film. Home Processing Equipment. Free Catalog. Superior Bulk Film Co., 442-458 N. Wells, Chicago 10.

**OPTICAL** Bargains—Request Free Giant Catalog "CJ." 96 pages—Astronomical Telescopes, Microscopes, Lenses, Binoculars, Kits, Parts. Amazing war surplus bargains. Edmund Scientific Co., Barrington, New Jersey.

## EMPLOYMENT INFORMATION

**JOBS** on Ships and Yachts Traveling Foreign Countries. Davenport's, 1354-N, GPO, N. Y. 1, N. Y.

Always say you saw it in—**POPULAR ELECTRONICS**



**POPULAR  
ELECTRONICS**

# BARGAIN BASEMENT

SAVE ON THESE SPECIAL BUYS OF THE MONTH

## 11-METER CITIZENS BAND TRANSCEIVER KITS!!!

NO AMATEUR LICENSE NEEDED—NO TEST TO TAKE!!!  
22 CHANNELS TO CHOOSE FROM—26.965 MC. TO 27.225 MC.  
COMPLETE KIT OF PARTS, TUBES, TRANSFORMERS, CHASSIS,  
CRYSTAL, PRE-WOUND COILS, ETC. **ONLY \$29.88**

CRYSTAL MICROPHONE FOR ABOVE KIT . . . . . ONLY \$1.99  
12-VOLT DYNAMOTOR FOR ABOVE KIT . . . . . ONLY \$3.99  
27 MEGACYCLE CRYSTALS .005% TOLERANCE . . . . . ONLY \$2.50

ALL COMPONENTS FOR TRANSCEIVER KITS AVAILABLE AT  
LOW PRICES!! WRITE FOR LATEST CATALOG AND COMPLETE  
INFORMATION!!!!!!

**GROVE ELECTRONIC SUPPLY COMPANY**  
4103 W. BELMONT AVENUE CHICAGO 41, ILLINOIS  
INCLUDE POSTAGE W/ORDER WEIGHT OF KIT 9 LBS.

## DIAGNYZER \$9.95 ELECTRONIC TESTER COMPLETE

for DO-IT-YOURSELF SERVICING  
COMPLETE TRAINING COURSE AND SERVICE MANUAL

INCLUDED FREE WITH EACH INSTRUMENT  
INDISPENSIBLE—FOR TV, RADIO, Hi-Fi  
Appliances, Autos, Electrical Tools. Used in Home,  
Shop and Farm. Checks Radio and TV Tubes, Com-  
ponents, Voltages and Circuits, etc.  
INEXPENSIVE TO OWN. EASY TO USE  
Anyone can do servicing with this wonderful instru-  
ment, pays for itself the first time you use it. Best  
value for money, nothing else like it. Write Today.

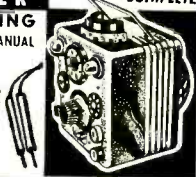

**APPARATUS DEVELOPMENT CO.**  
Dept. K11 Wethersfield, Conn.

**JOBS**—High Pay; USA, So. America, The Islands. All trades.  
Many companies pay fare. Write Dept. 71N, National Employ-  
ment Information, 1020 Broad, Newark, N. J.

**JOBS** Overseas! Janecek Development Co., 109 Hub Station, New  
York 55, N. Y.

## MISCELLANEOUS

**ELECTRIC** Pencil: Engraves all Metals, \$2.00. Beyer Mfg.,  
10511-ZD Springfield, Chicago 43.

**BIZARRE** Fashions! Illustrated Catalogue, \$1.00. Renee. Box  
2804-P, Hollywood 28, Calif.

"WINEMAKING: Beer, Ale Brewing." Illustrated. \$2.00. Eaton  
Books, Box 1242-C, Santa Rosa, California.

**SOLAR** System Map. Includes map of the moon. 50 x 38 inches.  
\$1.00 ppd. Boston Enterprises, Box 75895, Los Angeles 5,  
California.

**FREE!!** 5000 Books available free! Largest directory of free  
publications ever compiled. Each title individually listed. \$1—  
National Publishers, Box 950-E, Washington 10, D. C.

**HYPNOTIZE** . . . One Word . . . One fingersnap on stage. Satis-  
faction — or refund. \$2. Hypnomaster, 846-S8 Sunnyside,  
Chicago 40.

**REFINISH** Dark Cabinet into Modern Blond without removing  
old finish. Free Literature. Flamholtz Products Co., Box 461,  
No. Grafton, Mass.

**500 NEW** Mother Names, \$3.00, Krapf, Box 247, Butler, Pa.

**CALL** Letters—5" high \$4.00 postpaid. Porcelain enamel sign  
letters all colors, sizes, prices, install yourself anywhere. Triad,  
350 Haymaker, Monroeville, Pa.

July, 1959

## ONE CENT SALE Buy One At Our Regular Low Price And Get The Second For Only 1c More

**CITIZENS BAND TRANSMITTER** (27 MC) chassis complete with crystal,  
\$9.99 ea. two for \$10.00.

**TRANSMITTER** similar to above but with 5 watt RF stage instead of 1 watt.  
\$12.49 ea. two for \$12.50.

**CITIZENS BAND RECEIVER** chassis tunable through all 22 channels. Complete  
with audio amplifier. \$9.99 ea. two for \$10.00.

**AMATEUR BAND TRANSCEIVER** (144-148 MC) chassis with dual VHF triodes  
for walkie-talkie radiophone. \$9.99 ea. two for \$10.00.

**COILED CORD** 4 conductor 11' telephone cord. Extends to over 4 ft. .99 ea. two for  
\$1.00.

**KIT OF PARTS** for AM-FM VHF radio receiver. Tunable from 80-200 mc. which  
includes U.S. satellite frequencies. \$6.99 ea. two for \$7.00.

**SUPER SPECIAL** 25 watt, 30 to 40 mc. crystal controlled FM radiophone mobile  
transmitter with 8 tubes and dynamotor power supply. Orig. cost over \$300.00.

Can be converted to Citizens Band. Used good condition \$24.99 ea. two for \$25.00  
F.O.B. Hollis N.Y.

**LIMITED QUANTITY—NO LITERATURE OR CATALOG**  
Remit in full. Include sufficient postage. No C.O.D.'s.

**VANGUARD ELECTRONIC LABS.** Box 12-E7  
Hollis, 23, N. Y.

## EXPERIMENTERS AMATEURS HOBBYISTS

We are again reducing a large inventory of brand new vacuum  
tubes and this "well-acquainted" offer is limited to the stock on  
hand. All tubes in each assortment are different, and every tube  
is brand-spanking new.

10 electron tubes including 3" cathode ray tube only . . . \$1.95

15 including 5" CRT . . . \$2.95 20 including 7" CRT . . . \$3.95

All three of the above assortments for just . . . \$7.95

Order early and we will include in your assortment a special high  
voltage rectifier and famous VE-717-A tubes. Your order will be  
sent via insured parcel post; just pay instant postage plus  
small COD charge. We have many unbelievable values in govern-  
ment electronic surplus, much of it for sale at prices representing  
mere pennies on the dollar of cost.

**WRITE FOR FREE GOVERNMENT SURPLUS BARGAIN BULLETIN**

**JOE PALMER**

P. O. Box 6188 CCC

Sacramento, California

## YOUR COPIES OF POPULAR ELECTRONICS ARE VALUABLE

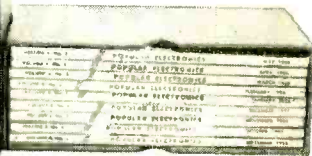

## KEEP THEM NEAT . . . CLEAN . . . READY FOR INSTANT REFERENCE!

Now you can keep a year's copies of **POPULAR  
ELECTRONICS** in a rich-looking leatherette file  
that makes it easy to locate any issue for ready  
reference.

Specially designed for **POPULAR ELECTRONICS**,  
this handy file—with its distinctive, washable  
Kivar cover and 16-carat gold leaf lettering—  
not only looks good but keeps every issue neat,  
clean and orderly.

So don't risk tearing and soiling your copies of  
**POPULAR ELECTRONICS**—always a ready source  
of valuable information. Order several of these  
**POPULAR ELECTRONICS** volume files today. They  
are \$2.50 each, postpaid—3 for \$7.00, or 6  
for \$13.00. Satisfaction guaranteed, or your  
money back. Order direct from:

**JESSE JONES BOX CORP.** Dept. PE  
(Established 1843)  
Box 5120 Philadelphia 41, Pa.

# SHIPPED ON APPROVAL NO MONEY WITH ORDER - NO C. O. D.

Superior's New Model 76

## ALL PURPOSE BRIDGE

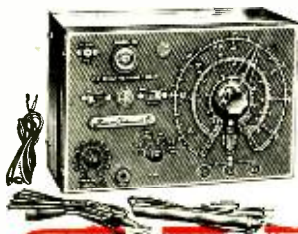

**Model 76 ALL PURPOSE BRIDGE**  
Total Price . . . . . **\$26.95**  
Terms: \$6.95 after 10 day trial, then \$5.00 per month for 4 months if satisfactory. Otherwise return, no explanation necessary.

IT'S A **CONDENSER BRIDGE**

IT'S A **RESISTANCE BRIDGE**

✓ **CAPACITY BRIDGE SECTION**

4 Ranges: .00001 Microfarad to .005 Microfarad; .001 Microfarad to .5 Microfarad; .1 Microfarad to 50 Microfarads; 20 Microfarads to 1000 Microfarads. Will also measure the power factor of all condensers from .1 to 1000 Microfarads.

✓ **RESISTANCE BRIDGE SECTION**

2 Ranges: 100 ohms to 50,000 ohms; 10,000 ohms to 5 megohms.

✓ **SIGNAL TRACER SECTION**

With the use of the R.F. and A.F. Probes included with the Model 76, you can

IT'S A **SIGNAL TRACER**

IT'S A **TV ANTENNA TESTER**

make stage gain measurements, locate signal loss in R.F. and Audio stages, localize faulty stages, locate distortion and hum, etc.

✓ **TV ANTENNA TESTER SECTION**

Loss of sync., snow and instability are only a few of the faults which may be due to a break in the antenna, so why not check the TV antenna first? Locates a break in any TV antenna and measures the location of the break in feet from the set terminals.

Complete with R.F. and A.F. probes and test leads

**\$26.95** Net

## Superior's New Model TV-50A GENOMETER

### 7 Signal Generators in One!



**Model TV-50A GENOMETER . . .**  
Total Price . . . . . **\$47.50**  
Terms: \$11.50 after 10 day trial, then \$6.00 monthly for 6 months if satisfactory. Otherwise return, no explanation necessary.

- ✓ R.F. Signal Generator for A.M.
- ✓ R.F. Signal Generator for F.M.
- ✓ Audio Frequency Generator
- ✓ Bar Generator
- ✓ Cross Hatch Generator
- ✓ Color Dot Pattern Generator
- ✓ Marker Generator

This versatile All-Inclusive GENERATOR Provides ALL the Outputs for Servicing:

A.M. Radio • F.M. Radio • Amplifiers • Black and White TV • Color TV

**R. F. SIGNAL GENERATOR:** The Model TV-50A Genometer provides complete coverage for A.M. and F.M. alignment. Generates Radio Frequencies from 100 Kilocycles to 60 Megacycles on fundamentals and from 60 Megacycles to 180 Megacycles on powerful harmonics.

**VARIABLE AUDIO FREQUENCY GENERATOR:** In addition to a fixed 400 cycle sine-wave audio, the Model TV-50A Genometer provides a variable 300 cycle to 20,000 cycle peaked wave audio signal.

**BAR GENERATOR:** The Model TV-50A projects an actual Bar Pattern on any TV Receiver Screen. Patterns will consist of 4 to 16 horizontal bars or 7 to 20 vertical bars.

**CROSS HATCH GENERATOR:** The Model TV-50A Genometer will project a cross-hatch pattern on any TV picture tube. The pattern will consist of non-shifting, horizontal and vertical lines interlaced to provide a stable cross-hatch effect.

**DOT PATTERN GENERATOR (FOR COLOR TV)**  
Although you will be able to use most of your regular standard equipment for servicing Color TV, the one addition which is a "must" is a Dot Pattern Generator. The Dot Pattern projected on any color TV Receiver tube by the Model TV-50A will enable you to adjust for proper color convergence.

**MARKER GENERATOR:** The Model TV-50A includes all the most frequently needed marker points. The following markers are provided: 189 Kc., 262.5 Kc., 456 Kc., 600 Kc., 1000 Kc., 1400 Kc., 1600 Kc., 2000 Kc., 2500 Kc., 3579 Kc., 4.5 Mc., 5 Mc., 10.7 Mc., (3579 Kc. is the color burst frequency).

The Model TV-50A comes absolutely complete with shielded leads and operating instructions. Only

**\$47.50**

# USE APPROVAL FORM ON NEXT PAGE ▶

We invite you to try before you buy any of the models described on this and the following pages. If after a 10 day trial you are completely satisfied and decide to keep the Tester, you need send us only the down payment and agree to pay the balance due at the monthly indicated rate.

**NO INTEREST OR FINANCE CHARGES ADDED!**

If not completely satisfied, you are privileged to return the Tester to us, cancelling any further obligation.

MOSS ELECTRONIC, INC.

Dept. D-612 3849 Tenth Avenue, New York 34, N. Y.

# TRY FOR 10 DAYS

before you buy! then if satisfactory pay in easy, interest free, monthly payments. See coupon below.

**SUPERIOR'S NEW MODEL TW-11**

**STANDARD PROFESSIONAL**

# TUBE TESTER



★ Tests all tubes, including 4, 5, 6, 7, Octal, Lock-in, Hearing Aid, Thyatron, Miniatures, Sub-miniatures, Novals, Sub-minars, Proximity fuse types, etc.

★ Uses the new self-cleaning Lever Action Switches for individual element testing. Because all elements are numbered according to pin-number in the RMA base numbering system, the user can instantly identify which element is under test. Tubes having tapped filaments and tubes with filaments terminating in more than one pin are truly tested with the Model TW-11 as any of the pins may be placed in the neutral position when necessary.

★ The Model TW-11 does not use any combination type sockets. Instead individual sockets are used for each type of tube. Thus it is impossible to damage a tube by inserting it in the wrong socket.

★ Free-moving built-in roll chart provides complete data for all tubes. All tube listings printed in large easy-to-read type.

★ NOISE TEST: Phono-jack on front panel for plugging in either phones or external amplifier will detect microphonic tubes or noise due to faulty elements and loose internal connections.

## EXTRAORDINARY FEATURE

SEPARATE SCALE FOR LOW-CURRENT TUBES. Previously, on emission-type tube testers, it has been standard practice to use one scale for all tubes. As a result, the calibration for low-current types has been restricted to a small portion of the scale. The extra scale used here greatly simplifies testing of low-current types.

The Model TW-11 operates on 105-130 Volt 60 Cycles A.C. Comes housed in a beautiful hand-rubbed oak cabinet complete with portable cover. **\$47<sup>50</sup>**

**Model TW-11—TUBE TESTER . . . Total Price \$47.50—Terms: \$11.50 after 10 day trial, then \$6.00 per month for 6 months if satisfactory. Otherwise return, no explanation necessary!**

We invite you to try before you buy any of the models described on this page, the preceding page and the following pages. If after a 10 day trial you are completely satisfied and decide to keep the Tester, you need send us only the down payment and agree to pay the balance due at the monthly indicated rate.

## NO INTEREST OR FINANCE CHARGES ADDED!

If not completely satisfied, you are privileged to return the Tester to us, cancelling any further obligation.

**SEE OTHER SIDE**

**CUT OUT AND MAIL TODAY!**

**MOSS ELECTRONIC, INC.**  
Dept. D-612 3849 Tenth Ave., New York 34, N. Y.

Please send me the units checked on approval. If completely satisfied I will pay on the terms specified with no interest or finance charges added. Otherwise, I will return after a 10 day trial positively cancelling all further obligation.

- |  |   |
|--|---|
| <input type="checkbox"/> Model 76 . . . . . Total Price \$26.95<br>\$6.95 within 10 days. Balance \$5.00<br>monthly for 4 months.      | <input type="checkbox"/> Model TW-11 . . . . . Total Price \$47.50<br>\$11.50 within 10 days. Balance \$6.00<br>monthly for 6 months. |
| <input type="checkbox"/> Model TV-50A . . . . . Total Price \$47.50<br>\$11.50 within 10 days. Balance \$6.00<br>monthly for 6 months. | <input type="checkbox"/> Model 80 . . . . . Total Price \$42.50<br>\$12.50 within 10 days. Balance \$6.00<br>monthly for 5 months.    |
| <input type="checkbox"/> Model 77 . . . . . Total Price \$42.50<br>\$12.50 within 10 days. Balance \$6.00<br>monthly for 5 months.     |   |

Name .....

Address .....

City ..... Zone ..... State .....

All prices net, F.O.B., N. Y. C.

# SHIPPED ON APPROVAL NO MONEY WITH ORDER - NO C. O. D.



## Superior's New Model 77 **VACUUM TUBE VOLTMETER** WITH NEW 6" FULL-VIEW METER

Compare it to any peak-to-peak V. T. V. M. made by any other manufacturer at any price!

• Extra large meter scale enables us to print all calibrations in large easy-to-read type.  
• Employs a 12AU7 as D. C. amplifier and two 9006's as peak-to-peak voltage rectifiers to assure maximum stability. • Meter is virtually burn-out proof. The sensitive 400

micro-ampere meter is isolated from the measuring circuit by a balanced push-pull amplifier. • Uses selected 1% zero temperature coefficient resistors as multipliers. This assures unchanging accurate readings on all ranges.

### SPECIFICATIONS

• DC VOLTS—0 to 3/15/75/150/300/750/1,500 volts at 11 megohms input resistance.  
• AC VOLTS (RMS)—0 to 3/15/75/150/300/750/1,500 volts. • AC VOLTS (Peak to Peak)—0 to 8/40/200/400/800/2,000 volts.  
• ELECTRONIC OHMMETER—0 to 1,000 ohms/10,000 ohms/100,000 ohms/1 megohm/10 megohms/100 megohms/1,000 megohms. • DECIBELS—-10 db to +18 db, +10 db to +38 db, +30 db to +58 db. All based on 0 db = .006 watts (6 mw) into a 500 ohm line (1.73v). • ZERO CENTER METER—For discriminator alignment with full scale range of 0 to 1.5/7.5/37.5/75/150/375/750 volts at 11 megohms input resistance.

AS A DC VOLTMETER: The Model 77 is indispensable in Hi-Fi Amplifier servicing and a must for Black and White and color TV Receiver servicing where circuit loading cannot be tolerated.

AS AN ELECTRONIC OHMMETER: Because of its wide range of measurement leaky capacitors show up glaringly. Because of its sensitivity and low loading, Intermittents are easily found, isolated and repaired.

AS AN AC VOLTMETER: Measures RMS values if sine wave, and peak-to-peak value if complex wave. Pedestal voltages that determine the "black" level in TV receivers are easily read.

Comes complete with operating instructions, probe leads, and streamlined carrying case. Operates on 110-120 volt 60 cycle. Only **\$42.50**

**Model 77—VACUUM TUBE VOLTMETER.** Total Price . . . **\$42.50**  
Terms: \$12.50 after 10 day trial, then \$6.00 monthly for 5 months if satisfactory. Otherwise return, no explanation necessary.

### SUPERIOR'S NEW MODEL 80

# 20,000 OHMS PER VOLT **ALLMETER**

THE **ONLY** 20,000 OHMS PER VOLT V.O.M. SELLING FOR LESS THAN \$50 WHICH PROVIDES **ALL** THE FOLLOWING FEATURES:

- ✓ 6 INCH FULL-VIEW METER provides large easy-to-read calibrations. No squinting or guessing when you use Model 80.
- ✓ MIRRORED SCALE permits fine accurate measurements where fractional readings are important.
- ✓ CAPACITY RANGES permit you to accurately measure all condensers from .0025 MFD to 10 MFD in addition to the standard volt, current, resistance and decibel ranges.
- ✓ HANDSOME SADDLE-STITCHED CARRYING CASE included with Model 80 Allmeter at no extra charge enables you to use this fine instrument on outside calls as well as in the bench in your shop.

- SPECIFICATIONS:**
- 7 D.C. VOLTAGE RANGES  
(At a sensitivity of 20,000 Ohms per Volt)  
0 to 15/75/150/300/750/1500/7500 Volts.
  - 6 A.C. VOLTAGE RANGES:  
(At a sensitivity of 5,000 Ohms per Volt)  
0 to 15/75/150/300/750/1500 Volts.
  - 3 RESISTANCE RANGES:  
0 to 2,000/200,000 Ohms. 0-20 Megohms.
  - 2 CAPACITY RANGES:  
.00025 Mfd. to .3 Mfd., .05 Mfd. to 30 Mfd.
  - 5 D.C. CURRENT RANGES  
0-75 Microamperes, 0 to 7.5/75/750 Milliampere, 0 to 15 Amperes.
  - 3 DECIBEL RANGES: -6 db to +18 db, +14 db to +38 db +34 db to +58 db

Model 80 Allmeter comes complete with operating instructions, test leads and portable carrying case. Only **\$42.50**

**Model 80 ALLMETER.** Total Price **\$42.50**  
Terms: \$12.50 after 10 day trial, then \$6.00 monthly for 5 months if satisfactory. Otherwise return, no explanation necessary

NOTE: The line cord is used only for capacity measurements. Resistance ranges operate on self-contained batteries.

## TRY FOR 10 DAYS BEFORE you buy! THEN if satisfactory

pay in easy, interest free, monthly payments. See coupon inside.

We invite you to try before you buy any of the models described on this and the preceding pages. If after a 10 day trial you are completely satisfied and decide to keep the Tester, you need send us only the down payment and agree to pay the balance due at the monthly indicated rate. (See other side for time payment schedule details.)

**NO INTEREST OR FINANCE CHARGES ADDED!**

If not completely satisfied, you are privileged to return the Tester to us, cancelling any further obligation.

**SEE OTHER SIDE**

CUT OUT AND MAIL TODAY!

FIRST CLASS

Permit No. 61430

New York, N. Y.

BUSINESS REPLY CARD

No Postage Stamp Necessary if Mailed in the U. S.

VIA AIR MAIL

POSTAGE WILL BE PAID BY —

MOSS ELECTRONIC, INC.

3849 TENTH AVENUE

NEW YORK 34, N. Y.