

Build a Transistor Inverter for Car or Boat

POPULAR ELECTRONICS

JULY
1958

35
CENTS

Relive Your Vacation
with Snapshots in Sound



- Simple
- Hi-Fi fo
- Convers

L-29-147762-10
LOUIS HAFORD
18108 WINDWARD
CLEVELAND 19 OHIO

BUILD 16 RADIO

CIRCUITS AT HOME

with the New Deluxe 1958

PROGRESSIVE RADIO "EDU-KIT"

A Practical Home Radio Course

Now Includes

- ★ TRANSMITTER
- ★ SIGNAL TRACER
- ★ SIGNAL INJECTOR
- ★ CODE OSCILLATOR

- ★ No Knowledge of Radio Necessary
- ★ No Additional Parts or Tools Needed
- ★ EXCELLENT BACKGROUND FOR TV
- ★ School Inquiries Invited
- ★ Sold in 79 Countries

ONLY
\$22.95



**YOU DON'T HAVE TO SPEND
HUNDREDS OF DOLLARS FOR A RADIO COURSE**

The "Edu-Kit" offers you an outstanding PRACTICAL HOME RADIO COURSE at a rock-bottom price. Our Kit is designed to train Radio & Electronics Technicians, making use of the most modern methods of home training. You will learn radio theory, construction practice and servicing. THIS IS A COMPLETE RADIO COURSE IN EVERY DETAIL. You will learn how to build radios, using regular schematics, how to wire and solder in a professional manner; how to service radios. You will work with the standard type of punched metal chassis as well as the latest development of Printed Circuit chassis.

You will learn the basic principles of radio. You will construct, study and work with RF and AF amplifiers and oscillators, detectors, rectifiers, test equipment. You will learn and practice code, using the Progressive Code Oscillator. You will learn and practice trouble-shooting, using the Progressive Signal Tracer, Progressive Code Oscillator, Progressive Dynamic Radio & Electronics Tester and the accompanying instructional material.

You will receive training for the Novice, Technician and General Classes of F.C.C. Radio Amateur License, build 16 Receiver-Transmitter, Code Oscillator, Signal Tracer and Signal Injector circuits, and learn how to operate them. You will receive an excellent background for Television, Hi-Fi and Electronics.

Absolutely no previous knowledge of radio or experience is required. The "Edu-Kit" is the product of many years of teaching and engineering experience. The "Edu-Kit" will provide you with a basic education in Electronics and Radio, worth many times the complete price of \$22.95. The Signal Tracer alone is worth more than the price of the entire Kit.

THE KIT FOR EVERYONE

You do not need the slightest background in radio or science. Whether you are interested in Radio & Electronics because you want an interesting hobby, a well paying business or a job with a future, you will find the "Edu-Kit" a worthwhile investment. Many thousands of individuals of all

ages and backgrounds have successfully used the "Edu-Kit" in more than 79 countries of the world. The "Edu-Kit" has been carefully designed, step by step, so that you cannot make a mistake. The "Edu-Kit" allows you to teach yourself at your own rate. No instructor is necessary.

PROGRESSIVE TEACHING METHOD

The Progressive Radio "Edu-Kit" is the foremost educational radio kit in the world, and is universally accepted as the standard in the field of electronics training. The "Edu-Kit" uses the modern educational principle of "Learn by Doing." Therefore you construct, learn schematics, study theory, practice, trouble-shooting all in a closely integrated program designed to provide an easily-learned, thorough and interesting background in radio.

You begin by examining the various radio parts of the "Edu-Kit." You then learn the function, theory and wiring of these parts. Then you build a simple radio. With this first set you will enjoy listening to regular broadcast stations, learn theory, practice testing and trouble-shooting. Then you build a more advanced radio, learn more advanced theory and techniques to proceed in a progressive manner, and at your own rate, you will find yourself constructing more advanced multi-tube radio circuits, and doing work like a professional Radio Technician.

Included in the "Edu-Kit" course are sixteen Receiver, Transmitter, Code Oscillator, Signal Tracer, and Signal Injector circuits. These are not unprofessional "breadboard" experiments, but genuine radio circuits, constructed by means of professional wiring and soldering on metal chassis, plus a new method of radio construction known as "Printed Circuitry." These circuits operate on your regular AC or DC house current.

THE "EDU-KIT" IS COMPLETE

You will receive all parts and instructions necessary to build 16 different radio and electronics circuits, each guaranteed to operate. Our Kits contain tubes, tube sockets, variable, electrolytic, mica, ceramic and paper dielectric condensers, resistors, tie strips, coils, hardware, tubing, punched metal chassis, Instruction Manuals, hook-up wire, solder, etc.

In addition you receive Printed Circuit materials, including Printed Circuit chassis, special tube sockets, hardware and instructions. You also receive a useful set of tools, a professional electric soldering iron, and a self-powered Dynamic Radio and Electronics Tester. The "Edu-Kit" also includes Code Instructions and the Progressive Code Oscillator, in addition to F.C.C.-type Questions and Answers for Radio Amateur License training. You will also receive lessons for servicing with the Progressive Signal Tracer and the Progressive Signal Injector, High Fidelity Guide and a Quiz Book. You receive Membership in Radio-TV Club, Free Consultation Service, Certificate of Merit and Discount Privileges. You receive all parts, tools, instructions, etc. Everything is yours to keep.

PRINTED CIRCUITRY

At no increase in price, the "Edu-Kit" now includes Printed Circuitry. You build a Printed Circuit Signal Injector, a unique servicing instrument that can detect many Radio and TV troubles. This revolutionary new technique of radio construction is now becoming popular in commercial radio and TV sets.

A Printed Circuit is a special insulated chassis on which has been deposited a conducting material which takes the place of wiring. The various parts are merely plugged in and soldered to terminals.

Printed Circuitry is the basis of modern Automatic Electronics. A knowledge of this subject is a necessity today for anyone interested in Electronics.

FREE EXTRAS

- SET OF TOOLS
- SOLDERING IRON
- ELECTRONICS TESTER
- PLIERS-CUTTERS
- ALIGNMENT TOOL
- WRENCH SET
- VALUABLE DISCOUNT CARD
- CERTIFICATE OF MERIT
- TESTER INSTRUCTION MANUAL
- HIGH FIDELITY GUIDE & QUIZZES
- TELEVISION BOOK RADIO
- TROUBLE-SHOOTING BOOK
- MEMBERSHIP IN RADIO-TV CLUB
- CONSULTATION SERVICE, FCC AMATEUR LICENSE TRAINING
- PRINTED CIRCUITRY

SERVICING LESSONS

You will learn trouble-shooting and servicing in a progressive manner. You will practice repairs on the sets that you construct. You will learn symptoms and causes of troubles in home, portable and car radios. You will learn how to use the professional Signal Tracer, the unique Signal Injector and the dynamic Radio & Electronics Tester. While you are learning on this practical way, you will be able to do many a repair job for your friends and neighbors, and charge fees which will far exceed the price of the "Edu-Kit." Our Consultation Service will help you with any technical problems you may have.

J. Stataitis, of 25 Poplar Pl., Waterbury, Conn., writes: "I have repaired several sets for my friends, and made money. The "Edu-Kit" paid for itself. I was ready to spend \$240 for a Course, but I found your ad and sent for your Kit."

FROM OUR MAIL BAG

Ben Valerio, P. O. Box 21, Magna, Utah: "The Edu-Kits are wonderful. Here I am sending you the questions and also the answers for them. I have been in Radio for the last several years, but like to work with Radio Kits, and like to build Radio Testing Equipment. I employed every minute I worked with the different kits; the Signal Tracer works fine. Also like to let you know that I feel proud of becoming a member of your Radio-TV Club."

Robert L. Shuff, 1534 Monroe Ave., Huntington, W. Va.: "Thought I would drop you a few lines to say that I received my Edu-Kit, and was really amazed that such a bargain can be had at such a low price. I have already started repairing radios and phonographs. My friends were really surprised to see me get into the swing of it so quickly. The Troubleshooting Tester that comes with the Kit is really swell, and finds the trouble, if there is any to be found."

UNCONDITIONAL MONEY-BACK GUARANTEE

ORDER DIRECT FROM AD—RECEIVE FREE BONUS
RESISTOR AND CONDENSER KITS WORTH \$7

- Send "Edu-Kit" postpaid. I enclose full payment of \$22.95.
- Send "Edu-Kit" C.O.D. I will pay \$22.95 plus postage.
- Send me FREE additional information describing "Edu-Kit."

Name
Address

PROGRESSIVE "EDU-KITS" INC.

Progressive Building, Dept. 546 D 1186 Broadway, Hewlett, N. Y.

Just 2 settings on the NEW Model FC-2 FAST-CHECK TUBE TESTER



tests over 600 tube types completely, accurately ... AND IN SECONDS!

- NO MULTIPLE SWITCHING
- NO ROLL CHART CHECKING
- CANNOT BECOME OBSOLETE

Engineered to accommodate all future tube types . . . new tube listings furnished periodically.

The FAST-CHECK enables you to save valuable time and eliminate unprofitable call backs. You earn extra money and win confidence by showing your customer the actual condition and life expectancy of the tube on the large meter scale of the FC-2. The extra tubes you will sell each day will pay for the FAST-CHECK in a very short time.

SIZE:
H: 11 1/2"
W: 14 3/4"
D: 4 3/8"

NEW Special compartment to accommodate line cord and CRT Test Adapter cable

TRY THE FC-2 BEFORE YOU BUY IT!

Shipped on approval for **FREE 10 day trial** . . . No obligation to buy

EASY TO BUY IF YOU'RE SATISFIED!

Pay in small monthly payments at net cash prices . . . no financing charges

MODEL FC-2—housed in rugged oak carrying case complete with CRT adapter, tube listings . . . only

\$69.50 GUARANTEED FOR ONE FULL YEAR Net

This extremely low price is made possible only because YOU ARE BUYING DIRECT FROM THE MANUFACTURER

"You've really made tube testing a snap" . . . "I've almost got the cost of the Fast-Check paid off with the extra money I've made, and it's only 2 weeks" . . . "It's easier to use than you said" . . . "I wouldn't ever want to be without it" . . . "I use it in the shop and take it along on every call." *Names on request

WHAT SERVICEMEN* are SAYING ABOUT THE FC-2.

WIDE RANGE OF OPERATION

- Checks quality of over 600 tube types . . . more than 99% of all TV and radio tubes, including the newest series-string TV tubes, auto 12 plate-volt tubes, OZ4s, magic eye tubes and gas regulators.
- Checks inter-element shorts and leakage.
- Checks for gas content.
- Checks for life expectancy.

IMPORTANT FEATURES

- ✓ Checks each section of multi-section tubes and even if only one section is defective the tube will read "Bad"
- ✓ 41 long lasting phosphor-bronze tube sockets accommodate all present and future tube types—cannot become obsolete
- ✓ Less than 10 seconds required to test any tube
- ✓ Large D'Arsanval type meter is extremely sensitive yet rugged—is fully protected against accidental burn-out
- ✓ Line isolated
- ✓ 7-pin and 9-pin straighteners conveniently mounted on panel
- ✓ Quick reference tube chart lists over 600 tube types
- ✓ Line voltage compensation

NEW A specially designed PICTURE TUBE ADAPTER cable is now part of the FC-2 . . . making it a highly efficient CRT Tester-Rejuvenator. This feature eliminates the need of carrying extra instruments and makes the FC-2 truly an all-around tube tester. The adapter enables you to check all picture tubes (including the new short-neck 110 degree picture tubes) for cathode emission, shorts and life expectancy . . . also to rejuvenate and restore cathode emission of weak picture tubes.

MAIL COUPON NOW—NO MONEY REQUIRED WITH ORDER . . . ABSOLUTELY NO RISK ON YOUR PART

CENTURY ELECTRONICS CO., INC. 111 Roosevelt Avenue Dept. 307, Mineola, N. Y.

Please rush the new Model FC-2 FAST-CHECK TUBE TESTER for a 10 day trial period. If I am not completely satisfied I will return the instrument within 10 days without further obligation. If fully satisfied I agree to pay the down payment within 10 days and the monthly installments as shown. No financing charges are to be added. Should I fail to make payment when due, the unpaid balance shall become due and payable at once.

- BUDGET TERMS:** Pay \$14.50 within 10 days after receipt of instrument. Balance \$11.00 monthly for 5 months, plus shipping charges.
- PREPAID TERMS:** Enclose \$69.50 with coupon as payment in full and Century will pay all shipping costs. 10 day money-back guarantee

Name.....
Address.....
City..... State.....

POPULAR ELECTRONICS

VOLUME 9

NUMBER 1

CONTENTS

FEATURE Articles and Electronic Developments

3D Color-TV Is Here!.....	Louis E. Garner, Jr.	31
Talent Hunt Unearths Junior Scientists.....		34
Tape for Pictures.....		38
Amateurs Help the Tuna Fleet.....	E. H. Marriner, W6BLZ	45
Operation Blub.....	Carl Kohler	50
Radiation and Radio Lick Floods.....	Don Walker	55
TV in a Car; at Railroad Crossing.....		56
What the Sputniks Said.....	A. J. Steiger	57
How a Vacuum-Tube Voltmeter Works.....	Ed Bukstein	60
Electronics Today.....		64
For Your Test Bench.....		66

ELECTRONIC Build-It-Yourself Projects

Transistors Replace Wall Outlet.....	Robert B. Tomer	35
Compute—with Pots.....	Forrest H. Frantz, Sr.	39
Antennas for Satellite Reception.....	William I. Orr, W6SAI	51
Converter for Daytime DX.....	Joseph W. Doherty, K2SOO	61
Tuner + Audio = Radio.....	Leon A. Wortman	67

AUDIO and Hi-Fi Features

Snapshots in Sound.....	Mike Bienstock	42
Go Mobile with the "Auto-Fi".....	B. van Sutphin	47
Record Grooves Wiggle Magnet.....		69
Which Mike Should I Use?.....	E. Eugene Garnes	73
Hi-Fi Highlights.....		82

Experimenter's Workshop

Color-Code Your Circuits.....	E. D. Morgan	78
How to Reduce Receiver Gain.....	Wm. B. Rasmussen	78
Lock-In Relay Systems.....	Alan Cariffe, K6DDN	84
Repairing Wire-Wound Pots.....	Frank H. Tooker	84

(Also see page 6 for DEPARTMENTS)

Cover photo by Joe Petrovec
Outdoor furniture courtesy of Mollia Inc.
Tape recorder courtesy of North American Philips Co., Inc.

Copyright © 1958 by Ziff-Davis Publishing Company.
All rights reserved.

Average Net Paid Circulation 267,256

JULY

1958

Publisher & Editor
OLIVER READ, W1ETI

Managing Editor
VIN ZELUFF, W2HSU

Technical Editor
LARRY KLEIN

Associate Editors
MIKE BIENSTOCK
MARGARET MAGNA

Contributing Editors
H. BENNETT L. E. GARNER, Jr.
H. S. BRIER H. POLLACK
J. T. FRYE R. P. TURNER

West Coast Editor
EDWARD A. ALTSHULER

Art Editor
ALFONS J. REICH

Art and Drafting Dept.
J. A. ROTH
W. K. VAHLISG
M. WHELPLEY

Advertising Director
JOHN A. RONAN, Jr.

Advertising Manager
WILLIAM G. McROY

William B. Ziff
Chairman of the Board
1946-1953



ZIFF-DAVIS PUBLISHING CO., One Park Ave., New York 16, N. Y. William Ziff, President; H. J. Morganroth, Vice President; W. Bradford Briggs, Vice President; Michael Michaelson, Vice President and Circulation Director; Victor C. Stabile, Treasurer; Albert Gruen, Art Director.



Member
Audit Bureau
of Circulations



BRANCH OFFICES: Midwestern Office, 434 S. Wabash Ave., Chicago 5, Ill., Jim Weakley, advertising manager; Western Office, Room 412, 215 W. 7th St., Los Angeles 17, Calif., John E. Payne, manager.

SUBSCRIPTION SERVICE
All communications concerning subscriptions should be addressed to Circulation Dept., 434 S. Wabash Ave., Chicago 5, Ill. Include your old address as well as new—enclosing if possible an address label from a recent issue of this magazine. Allow at least 4 weeks for change of address.

CONTRIBUTORS:
Contributors are advised to retain a copy of their manuscripts and illustrations. Contributions should be mailed to the New York Editorial Office and must be accompanied by return postage. Contributions will be handled with reasonable care, but this magazine assumes no responsibility for their safety. Any copy accepted is subject to whatever adaptations and revisions are necessary to meet the requirements of this publication. Payment covers all author's, contributor's and contestant's rights, titles, and interest in and to the material accepted and will be made at our current rates upon acceptance. All photos and drawings will be considered as part of material purchased.

POPULAR ELECTRONICS

TRAIN FOR OPPORTUNITY FIELD OF

ELECTRONICS

ON REAL EQUIPMENT
IN THE GREAT SHOPS
OF **COYNE**

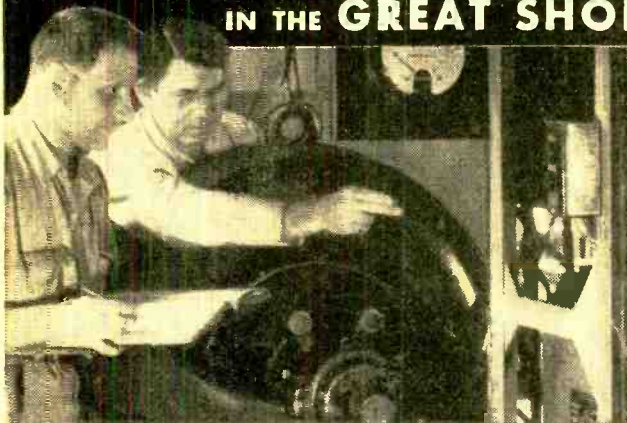

**LARGEST, OLDEST AND BEST EQUIPPED
SCHOOL OF ITS KIND IN U.S.**

This five story Chicago building is occupied entirely by Coyne. Five big floors of Classrooms and over a quarter of a million dollars worth of Equipment. Thousands of successful men have trained at Coyne. There is no substitute for Coyne's wealth of experience.



OPPORTUNITIES IN ELECTRICITY-ELECTRONICS

Train the Coyne way for a better job in *Electricity-Electronics*—a field that offers a world of opportunities now and in the years ahead. In industry—in the home—Electricity and Electronics are playing a vastly greater role than ever before. New developments and rapid growth are creating increasing job opportunities. Automation Electronics—one of the more recent applications of Industrial Electronics to manufacturing processes—promises to create additional demands for trained Electrical-Electronics men such as we have never seen. Electrical-Electronics Training can be taken separately or combined with Television-Radio training. Send coupon for more information.

Training in Refrigeration and Electric Appliances can be included.

YOU TRAIN IN CHICAGO—Learn the easier practical way in shops of Coyne in Chicago. Shop work plus technical training. No advanced education or previous experience needed. Lifetime Employment Service to Coyne Graduates.

START NOW—PAY LATER

New liberalized credit terms and Finance Plans. Part-time employment service to students. Help in making housing arrangements.

VETERANS OR NON-VETERANS

Coyne training is offered to Veterans and Non-Veterans alike. We'll send Bulletin giving full information. Send coupon for details.



TELEVISION — RADIO ELECTRONICS

Great opportunity for a good job or your own business in one of America's fastest growing branches of Electronics! New stations by the hundreds . . . new sets by the millions . . . and now Color TV . . . all means greater opportunities in Sales and Service. Separate courses in Radio-Television or in combination with Electricity-Electronics available. Coupon brings details.

Mail coupon for big free book!

48 Page Illustrated Book, "Guide to Careers" gives you all the facts. Whether you prefer Electricity-Television-Radio or Combined Electronics Training this book describes all training offered.

Information comes by mail. No obligation and no salesman will call.



Coyne Electrical School, Dept. B8-2A
500 S. Paulina St., Chicago 12, Ill.

Send FREE BOOK, "Guide to Careers," and details of all training you offer.

Name _____

Address _____

City _____ State _____

(I understand no Salesman will call.)



1. You are told the how and why of each job.



2. You're shown how to do it by trained instructors.



3. You do the jobs yourself on finest equipment.

B. W. COOME JR., President

COYNE
ELECTRICAL SCHOOL

FOUNDED 1899

A Technical Trade Institute Operated Not For Profit

500 S. Paulina Street, Chicago, Dept. B8-2A

ELECTRICITY • RADIO • TELEVISION • REFRIGERATION • ELECTRONICS

July, 1958

QUALITY CUT QUARTZ FOR EVERY SERVICE



All crystals made from Grade "A" imported quartz—ground and etched to exact frequencies. Unconditionally guaranteed! Supplied in:

- FT-243 holders** in HC/6U metal sealed holders
pin spacing $\frac{3}{4}$ " pin diameter .093
- DC-34 holders** in metal sealed holders
pin spacing $\frac{3}{4}$ " pin diameter .156
- MC-7 holders** in metal sealed holders
pin spacing $\frac{3}{4}$ " pin diameter .125
- HC/6U metal sealed holders**
pin spacing .486" pin diameter .050 or .093
- FT-171 holders**
pin spacing $\frac{3}{4}$ " banana pins

MADE TO ORDER CRYSTALS

- 1001 KC to 2500 KC:
.01% Tolerance... \$1.75 .005% Tolerance... \$2.50
 - 2501 KC to 9000 KC:
.01% Tolerance... \$1.50 .005% Tolerance... \$2.50
- Specify holder wanted.
3500 KC hermetically sealed frequency marker crystal .005% tolerance fits octal tube socket. Special \$1.00

ANY AMATEUR BAND CRYSTALS .05% Tolerance NOVICE BAND CRYSTALS

- 80 meters 3701—3749 KC
 - 40 meters 7152—7198 KC
 - 15 meters 7034—7082 KC
- 99c ea.**

6 METER TECHNICIAN BAND CRYSTALS

8335KC-8550KC within 1 KC.....each **99c**
Exact Frequency .01% \$1.50 ea.

ASK YOUR LOCAL PARTS DISTRIBUTOR FOR TEXAS CRYSTALS . . . LOOK FOR THE YELLOW AND RED DISPLAY BOARD

SEALED OVERTONE CRYSTALS supplied in metal HC/6U holders—pin spacing .486. diameter .050.
10 to 30 MC .005 tolerance \$3.85 ea.
30 to 54 MC .005 tolerance \$4.10 ea.
55 to 75 MC .005 tolerance \$4.25 ea.

FUNDAMENTAL FREQ. SEALED CRYSTALS in HC/6U holders from 1400KC-10,000KC any frequency .005 tolerance \$3.50 ea.

TEXAS CRYSTALS, TRANSISTORIZED 100 KC MARKER OSCILLATOR

Compact, portable, in attractive metal carrying case with handle. Size: 4"H x 3"W x 6"D. Connects to any receiver to get 100 KC markers from 100 KC to 50 MC. Factory wired with two transistors, one 100 KC crystal, self-contained battery. Shipping weight, 10 oz. Add 50c for prepaid parcel post. Net **\$17.95**

MARINE FREQUENCY CRYSTALS—All marine frequencies from 2000-3200 KC .005 tolerance. \$2.50 (Supplied in either FT-243, MC-7, or FT-171 holders.)

RADIO CONTROL CRYSTAL • 27.255 MC sealed crystals ($\frac{3}{4}$ " pin spacing . . . specify pin diameter093 or .050) \$2.50 ea.

Stock crystals in FT-243 holders from 5675 KC to 8650 KC in 25 KC steps..... **50c**

FT-241 lattice crystals in all frequencies from 370 KC to 540 KC (all except 455 KC and 500 KC) Matched pairs = 15 cycles \$2.50 per pair. **50c**

200 KC Crystals, \$2.00; 455 KC Crystals, \$1.00; 500 KC Crystals, \$1.00; 100 KC Frequency Standard Crystals, \$4.50; 1000 KC Frequency Standard Crystals, \$3.50; Dual Socket for FT 243 Crystals, 15c; Ceramic socket 11C/6U Crystals, 15c.

(Add 5c per crystal for postage and handling.)

WRITE FOR CATALOG AND QUANTITY PRICES

Texas Crystals

The Biggest Buy in the U.S.

8538 W. GRAND AVENUE • RIVER GROVE, ILL.
ALL PHONES — GLADSTONE 3-3555

Terms: All items subject to prior sale and change of price without notice. All crystal orders MUST be accompanied by check, cash or M.O. WITH PAYMENT IN FULL. NO C.O.D.s. Postpaid shipments made in U.S. and possessions only. Add 5c per crystal for postage and handling charge.

DEPARTMENTS

Carl & Jerry	John T. Frye	8
Letters from Our Readers		20
Out of Tune		24
POP'tronics Bookshelf		26
Kit Builder's Korner		70
Among the Novice Hams	Herb S. Brier	79
After Class		85
Transistor Topics	Lou Garner	88
Short-Wave Report	Hank Bennett	90
Tips and Techniques		98
Tools and Gadgets		104

COMING NEXT MONTH (AUGUST)

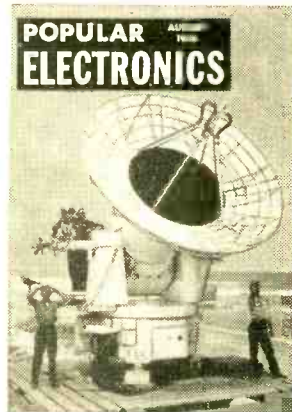

(ON SALE JULY 22)

Our cover photo next month shows RCA's FPS-16 tracking radar in use at the missile testing center at Cape Canaveral. Its range is classified but is said to be over 2500 miles. Just how this radar works, together with its companion at Grand Bahamas 150 miles away, should make fascinating reading, especially since the Range Safety Officer uses data from these radars in pushing (or not pushing) the "destruct" button.

Do-it-yourself articles will include: how to make a power supply that will substitute for the A and B batteries of almost any battery-operated portable receiver . . . an electronic foghorn for your boat . . . the "Quizzomat" with built-in "cheat catcher" and "suspense" circuits . . . and how to interconnect your hi-fi components.

IN THIS MONTH'S RADIO & TV NEWS (JULY)

- Speakers for Stereo
- Electronic Ignition Analyzer
- Simple Transistor Mixer
- Transistorized Automatic Key
- Two-Band V.H.F. Converter
- Designing a Telephone Amplifier



The ONLY Integrated High-Fidelity
Speaker System and Enclosure
for use
Inside or Out!

ONLY \$48⁰⁰ AUDIOPHILE NET

NEW *Electro-Voice*[®] MUSICASTER

You'll enjoy your high-fidelity listening all the more when you can relax and hear it outdoors in the gentle breeze of summer. Enliven a Saturday afternoon with an outdoor dance party . . . or broil steaks, lounge on the patio, to high-fidelity background music. Wherever you use your Musicaster, you'll appreciate your high-fidelity system just that much more! *Musicaster* is weather-proof for outdoors, handsome for indoors, portable and sturdy for a quick, easy change to any listening locale.

VERSATILE MUSICASTER SPEAKER/ENCLOSURE SYSTEM
DESIGNED FOR BOTH INDOOR AND OUTDOOR USE.

- TRUE HIGH-FIDELITY SOUND . . . in the Electro-Voice tradition.

- WEATHERPROOF . . . a true outdoors-the-year-around system.
- EASY TO INSTALL . . . simply place it where you want it.
- PORTABLE . . . wonderfully light and easy to carry.
- RUGGED DIE-CAST CONSTRUCTION . . . ideal for patio or rumpus-room activities.
- STEREPHONIC SOUND . . . use two easily-portable Musicasters!
- PUBLIC ADDRESS SYSTEM . . . use it as a family paging unit.

Frequency Response	60 to 16,000 cps
Impedance	8 ohms
Power Handling Capacity	30 watts continuous duty
Height	21 1/2"
Width	21 1/2"
Depth	8 1/2"
Finish	Baked enamel

The *MUSICASTER* is an exclusive product of

Electro-Voice[®] | ELECTRO-VOICE, INC.
BUCHANAN, MICHIGAN

IN CANADA: E-V of Canada, Ltd., 73 Crockford Blvd., Scarborough, Ontario

OUTDOORS OR IN—ALWAYS RELY ON E-V FOR HIGHEST-FIDELITY SYSTEMS!

FULL-TIME classroom and
laboratory training for a

CAREER WITH A FUTURE

IN ALL PHASES OF

ELECTRONICS



Rapid strides in the development of TV, Radio, Radar, and Guided Missiles have made electronics the fastest growing technical career open to young men today . . . a career that offers high pay, security and rapid advancement.

The Radio Engineering Institute offers you an opportunity to be fully trained to take your place in this exciting, interesting field. REI is a full-fledged, recognized school where you can get proper training in classrooms, labs, and shops under the guidance of skilled, experienced teachers. Resident training is easier — more complete — and costs less than you may think.

If you are interested in a career with a future — higher pay — and have completed high school or its equivalent, send today for the new REI booklet. It contains complete information on courses offered at REI, facilities, equipment, fees, housing and lifetime job placement service. There's no obligation and no salesman will call on you.

FOR
INFORMATION
ON A CAREER
WITH A
FUTURE
SEND COUPON
TODAY!

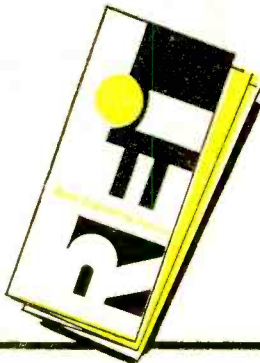

RADIO ENGINEERING INSTITUTE, Dept. JU-58
2610 Leavenworth Street, Omaha, Nebr.

Name.....
(please print)

Address.....

City..... Zone..... State.....
(just paste on post card and mail)

HIGH PAYING POSITIONS WITH SOME OF THE NATION'S
LEADING MANUFACTURERS AWAIT REI GRADUATES

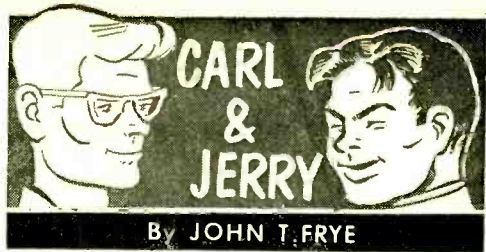

By JOHN T. FRYE

Parfum Elektronique

NORMA was taking a Sunday afternoon siesta in a hammock stretched beneath the trees of her backyard. In her crisp blouse, tailored shorts, and dark glasses, she made a very pretty, relaxed picture lying there in the hammock. Suddenly, though, she wrinkled her nose in distaste, sat up, and looked all around.

Chortling with glee, Carl and Jerry rose from where they had been hiding behind the hedge and came over to the hammock. Jerry was carrying a rather strange object—strange, at least, for a boy to be carrying. It was a large woman's purse made of basket-woven metallic ribbon so that it looked more like a miniature silver clothes-hamper than anything else.

"I might have known!" Norma said, as she smiled down at the two boys who had sprawled on the grass. "How did you jokers produce that horrible smell?"

"You, lucky girl, are the very first person to experience our new invention, *Parfum Elektronique*," Jerry announced grandly.

"Only the belle of Buzzard's Roost would be caught dead wearing that perfume," Norma said with conviction.

"That putrid smell was just one of our six basic odors," Jerry explained. "What does this smell like?" he asked, as he fumbled with something on the bottom of the purse. Instantly a sweet, flowery odor seemed to come from everywhere.

"Magnolia," Norma replied.

"And this?"

"Gingerbread . . . pine trees . . . fruit stand . . . burning rags," Norma ticked off the odors that wafted up from the purse.

"Right on the nose!" Carl exclaimed, as he and Jerry swapped pleased glances. "You identified correctly every one of our six basic odors: spicy, fruity, flowery, scorched, resinous, and foul."

"How does the-the-the little stinker work?" Norma wanted to know.

"This purse has a false bottom. In the

BUILD 125 COMPUTERS AT HOME WITH GENIAC®

ONLY \$19⁹⁵

With the 1958 model GENIAC®, the original electric brain construction kit including seven books and pamphlets, over 400 parts and component rack, and parts tray, and all materials for experimental computer lab plus DESIGN-O-Mat®.

A COMPLETE COURSE IN COMPUTER FUNDAMENTALS

The GENIAC Kit by itself is the equivalent of a complete course in computer fundamentals, in use by thousands of colleges, schools and industrial training labs and private individuals. Includes everything necessary for building an astonishing variety of computers that reason, calculate, solve codes and puzzles, forecast the weather, compose music, etc. Included in every set are seven books described below, which introduce you step-by-step to the wonder and variety of computer fundamentals and the special problems involved in designing and building your own experimental computers—the way so many of our customers have.

ANYONE CAN BUILD IT!

You can build any one of these 125 exciting electric brain machines in just a few hours by following the clear cut step by step directions given in these thrilling books. No soldering required . . . no wiring beyond your skill. But GENIAC is a genuine electric brain machine—not a toy. The only logic and reasoning machine kit in the world that not only adds and subtracts but presents the basic ideas of cybernetics, boolean algebra, symbolic logic automation etc. So simple to construct that a twelve year old can build what will fascinate a PhD. In use by thousands of schools, colleges etc. and with the special low circuitry you can build machines that compose music, forecast the weather, which have just recently been added.

TEXT PREPARED BY MIT SPECIALIST

Dr. Claude Shannon, known to the readers of Popular Electronics for his invention of the electronic mouse, that runs a maze, learning as it goes, formerly a research mathematician for Bell Telephone Laboratories is now a research associate at MIT. His books include publications on Communication theory and the recent volume "Automat Studies" on the theory of robot construction. He has prepared a paper entitled "A Symbolic Analysis of Relay and Switching Circuits" which is available to purchasers of the GENIAC. Covering the basic theory necessary for advanced circuit design it vastly extends the range of our kit.

The complete design of the kit and the manual as well as the special book DESIGN-O-Mat® was created by Oliver Garfield, author of "Minds and Machines," editor of the "Gifted Child Magazine" and the "Review of Technical Publications."

KIT IS COMPLETE

The 1958 GENIAC comes complete with the following books and manuals and over 400 components.

- 1) A sixty-four page book "Simple Electric Brains and How to Make Them."
- 2) Beginners Manual—which outlines for people with no previous experience how to create electric circuits.
- 3) "A Symbolic Analysis of Relay and Switching Circuits" By Dr. Claude Shannon provides the basis for new and exciting experimental work by the kit owner who has finished book No. 1.
- 4) DESIGN-O-Mat® introduces the user to over 50 new circuits that he can build with GENIAC and outlines the practical principle of circuit design.
- 5) GENIAC STUDY GUIDE equivalent to a complete course in computer fundamentals, this guides the user to more advanced literature.
- 6) A Machine to Compose Music shows in an actual circuit what other GENIAC owners have been able to do on their own in designing new devices.
- 7) A Machine to Forecast the Weather—again a new adventure in scientific thinking created by one of our users who was trained on his GENIAC kit.

Plus all the components necessary for the building of over 125 machines and as many others as you can design yourself.

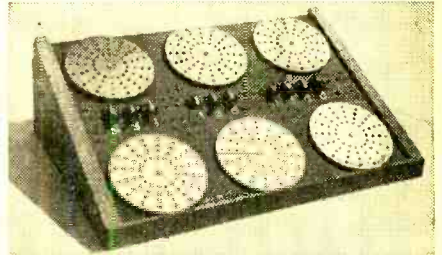

OVER 20,000 SOLD

We are proud to announce that over 20,000 GENIACS are in use by satisfied customers—schools, colleges, industrial firms and private individuals—a tribute to the skill and design work which makes it America's leading scientific kit. People like yourself with a desire to inform themselves about the computer field know that GENIAC is the only method for learning that includes both materials and texts and is devoted exclusively to the problems faced in computer study.

You are safe in joining this group because you are fully protected by our guarantee, and have a complete question and answer service available at no cost beyond that of the kit itself. You share in the experience of 20,000 kit users which contributes to the success of the 1958 GENIAC—with DESIGN-O-Mat® the exclusive product of Oliver Garfield Co., Inc., a Geniac is truly the most complete and unique kit of its kind in the world.

COMMENTS BY CUSTOMERS

We know the best recommendation for GENIAC is what it has done for the people who bought it. The comments from our customers we like best are the ones that come in daily attached to new circuits that have been created by the owners of GENIACS. Recently one man wrote: "GENIAC has opened a new world of thinking to me." Another who designed the "Machine that Forecasts the Weather" commented:

"Several months ago I purchased your GENIAC Kit and found it an excellent piece of equipment. I learned a lot about computers from the enclosed books and pamphlets and I am now designing a small relay computer which will include arithmetic and logical units . . . another of my pet projects in cybernetics is a weather forecaster. I find that your GENIAC Kit may be used in their construction. I enclose the circuits and their explanation." Eugene Dowling, Malden.

Oliver Garfield Co., Inc.

Dept. PE-78

108 East 16th St., N. Y. 3, N. Y.

Please send me at once the GENIAC Electric Brain Construction Kit, 1958 model. I understand that it is guaranteed by you and may be returned in seven days for a full refund if I am not satisfied.

I have enclosed \$19.95 (plus 80¢ shipping in U. S., \$1.50 west of Miss., \$2.00 foreign), 3% New York City Sales Tax for N. Y. City Residents.

Send GENIAC C.O.D. I will pay postman the extra C.O.D. charge.

Name

Address

Leo Says: here's the



LEO I. MEYERSON
W6CFQ

Perfect Pair

for
LOW COST • HIGH POWER
from

"World's Largest Distributor of Amateur Radio Eqp't."

WRL's Model UM-1 Universal Plate Modulator Kit



(less tubes)
\$3250 Cash
or Wired, \$49.95
\$5.00 down
\$5.00 per mo.

Supplies 10-45 watts audio output, depending on tube types and class of operation. May be used as Class A or B modulator to modulate RF inputs 8-100w, or as drive for higher power modulator, or as PA amplifier. Output matching impedance, 500-20,000 ohms. Carbon or crystal mike may be used; provisions for external meter for monitoring modulator cathode currents; for remote control of modulator. 6F6, 6K6, 6V6, 6L6, 5881 or similar tubes may be used as modulators. Complete instructions included. Size, with cover (\$3.00 extra), 6x7x11".

Ideal Companion for Globe Chief 90A



\$74.50 Cash
\$7.45 Down
\$615 per mo.
KIT: Only \$59.95

A handsome, compact, self-contained 90W transmitter. Completely bandswitching, 160-10M. Combination Pi-Net with provisions for antenna change-over relay, speech modulator input, VFO input and operation. Built-in, well-filtered power supply. Modified Grid-Block keying. Kit contains prepinched chassis, all parts and detailed assembly instructions.

FREE 1958 CATALOG!

New 200 page catalog with hundreds of illustrations of over 15,000 quality items from the nation's leading manufacturers. Everything for the ham, hi-fi enthusiast, experimenter and serviceman. Send for your copy today!



Free Catalog! Info on Chief UM-1 PE-7

NAME:

ADDRESS:

CITY & STATE:

WORLD'S MOST PERSONALIZED RADIO SUPPLY HOUSE

World Radio
LABORATORIES

ELECTRONIC HEADQUARTERS

WORLD RADIO LABORATORIES

3415-W BROADWAY, CO. BLUFFS, IA. Phone 2-0277

Carl & Jerry (Continued from page 8)

compartment beneath are six coils of resistance wire wound on an asbestos form. Each coil can be connected through a separate rheostat to a battery, and each is coated with a substance that gives off a different distinctive odor when it is heated by current flowing through the resistance wire. The more current, the stronger the odor. By proper selection and mixing of these basic odors, we expect to be able to reproduce all recognizable smells—some fifty or more in number."

"Where did you get the stuff to put on the coils?"

"Pastes made of ground-up incense cakes took care of the spicy, resinous, and flowery smells. Stuff scraped off a selenium rectifier gives a dandy putrid odor. Scrapings from a wool sweater mixed into a paste gives that scorched smell, and the druggist fixed us up with some oils to produce the fruity odor."

"Excruciatingly interesting," Norma said languidly as she smothered a yawn and lay back in the hammock.

"It's a lot more than interesting," Carl urged. "Think of being able to have exactly the right scent with you for every occasion and of being able to change the nature and intensity of the fragrance at will."

"I'll think of it," Norma promised drowsily.

"We want you to do something about it," Jerry broke in. "We want you to try our invention out on your date tonight."

"Now just a little minute!" Norma said,



"... Right on the nose!" Carl exclaimed. "You identified correctly every one of our basic odors: spicy, fruity, flowery, scorched, resinous, foul" . . .

Always say you saw it in—POPULAR ELECTRONICS

LET DeVRY TECH PREPARE YOU IN
SPARE TIME AT HOME AS AN

ELECTRONICS TECHNICIAN



**NO PREVIOUS TECHNICAL EXPERIENCE
OR ADVANCED EDUCATION NEEDED!**

Labcrers and bckkeepers, store clerks, shop men, farm-
e's, salesmen — men of nearly every calling — have taken the
DeVry Tech program and today have good jobs or service
shops of their own in Electronics. You don't have to quit your
present job. If you are 17 to 55, see how you may get your-
self ready for a future in the fast-growing Electronics field.

Whether you prepare at home or in our well-equipped
Chicago or Toronto Laboratories, you get sound, basic training
in both principles and practice. At home, you use educational
movies. You build actual circuits and test equipment. You read
simple directions, fo low clear illustrations. When you finish,
you are prepared to step into a good job in an excitingly
dfferent field. You may even start a service shop of your own.
Mail coupon for free facts today.

Live-Wire Employment Service



Puts you in touch with job
opportunities—or helps you
to ward c better position in
the plant where you are
ncw employed.

Draft Age?

We have valuable information
for every man of draft age; so
if you are subject to military
service, be sure to
check the coupon.

SAMPLE BOOKLET **FREE!**

We'll give you a free copy of an interesting booklet,
"Electronics and YOU." See for yourself how you
may take advantage of the opportunities in this fast-
growing field.



- AN INDEX**
to a
**BETTER JOB,
A BRIGHTER
FUTURE**
- Electronics
 - Radar
 - Guided Missiles
 - Television
 - Micro-Waves
 - Communications
 - Radio
 - Industrial Electronics
 - Computers
 - Automation Electronics
 - Remote Control Systems
 - Broadcasting
 - Your Own Service Shop

MAIL TODAY FOR FREE FACTS

"One of North America's Foremost Electronics Training Centers"



Accredited Member
of National
Home Study Council

DEVRY TECHNICAL INSTITUTE
CHICAGO 41, ILLINOIS
FORMERLY
DEFOREST'S TRAINING, INC.



DeVry Technical Institute
4141 Belmont Ave., Chicago 41, Ill., Dept. PE-7-0

Please give me your FREE booklet, "Electronics and YOU," and tell me
how I may prepare to enter one or more branches of Electronics as
listed above.

NAME _____ AGE _____
STREET _____ Please Print _____ APT. _____
CITY _____ ZONE _____ STATE _____

Check here if subject to military training.
1090 DeVry Tech's Canadian Training Center is located at
626 Roselawn Avenue Toronto 12, Ontario

Carl & Jerry (Continued from page 10)

whipping off her sun glasses and opening her dark eyes wide. "This date of mine tonight is a brand-new one, and I'm taking no chances of flubbing things up. In the past, you know, some of our electronic experiments with my love life have not turned out too well; so this time I appreciate the honor, but I'm not having any."

"I think the girl needs a little gentle persuasion," Jerry said quietly to Carl as they both rose to their feet.

"Right!" Carl exclaimed as he grabbed both sides of the hammock and brought them together over the top of Norma. He held them in place in spite of Norma's shrieks, struggles, and threats, until Jerry fastened them together with two huge horse-blanket pins that had been clipped around the hammock ropes. Then the boys stood at each end of the hammock and tugged alternately at the ropes to bounce and toss the pinned-in girl wildly about.

"Stop! Stop!" she finally gasped. "I'll do it! And if you've messed up my permanent, I'm going to kill you both."

"Ah, Norma," Carl said, unfastening the

pins and grinning down at the tousled but very pretty girl; "from now on you will always be our favorite pin-up!"

"What chance has a poor girl got against such a bullying, flattering pair?" Norma asked, smiling in spite of herself, as she smoothed her hair. "Clue me in on how to work *Parfum Elektronique*."

"Just remember that when the lid-snap of the purse is toward you the little knobs on the bottom, reading from left to right, control spicy, fruity, flowery, scorched, resinous, and foul odors in that order. The farther you turn a knob clockwise, the stronger will be the smell," Jerry explained. "Turning a knob entirely counterclockwise cuts off that odor. Until we've had time to do more experimenting, I'd stick to one basic odor at a time. You can't be sure what kind of results you might get if you try to mix them."

"Gotcha!" Norma said, picking up the purse and starting for the house. "If you two are still up when I get home, I'll give you a report."

CARL AND JERRY certainly intended to be up. Eleven-thirty found them sitting

ASSEMBLE YOUR OWN WALKIE-TALKIE RADIOPHONES

GENERAL Specifications applying to all models:

Highest quality workmanship and materials, silver plated coils, ceramic capacitors and advanced design assures maximum performance with the longest battery life. Sensitive receivers can detect signals as small as one microvolt and feature automatic volume control and noise clipping. Transmitters use high level amplitude modulation, have a power input of one watt to the R.F. stage and will radiate a signal for 1 to 5 miles (depending on obstructions using antennas supplied. Up to 40 miles have been reported by some of our customers when communicating with stations having directional beam antennas. Radiophones can be used singularly to communicate with fixed stations or two or more to communicate with each other providing they are for the same frequency band. Fully portable, no external connections needed. Uses standard radio and flashlight batteries available at your local store. Total weight of completed unit including all accessories is less than 5½ lbs.

Model TC-144. Meets FCC requirements for general class amateur license. No minimum age requirement. Variable frequency transceiver circuit. Tunes from 144 to 148 mc. Wired, tested and guaranteed electronic chassis complete with two high frequency triodes (3A5) **\$7.98**

Model TR-144. Similar to above but with independently tuned receiver and transmitter circuits, using 4 high frequency triods (2-3A5's). Permits receiving frequency to be changed without affecting transmitting frequency. **\$11.98**

Model TRX-50. Crystal controlled transmitter and variable frequency receiver with R.F. stage. Tunable from 50 to 54 mc. Meets FCC requirements for general and technician class amateur licenses as well as for civil defense and other special services. Wired, tested and guaranteed electronic chassis complete with six high frequency triode. (3-3A5's) **\$16.98**

Model TRX-50-A. Similar to above but with transistorized audio booster stage for extra loud reception. **\$18.98**

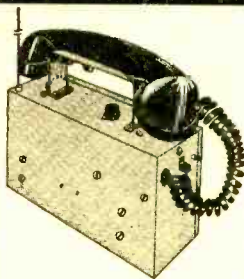

for as little as

\$7.98

plus accessories

The following accessories are required to complete the walkie-talkie as illustrated.

Strong 16 gauge 8" x 5" x 3" aluminum case satin etched and anodized with all holes punched for quick assembly. Heavy duty battery holders with phosphor-bronze contacts, battery switch, telephone handset cradle, retractable coiled cord, adjustable shoulder strap, 18" or 24" antenna with loading coil (depending on frequency) and necessary hardware.

All for only.....**\$9.98**

Western Electric telephone handset with push-to-talk switch...**\$6.98**

Handset similar to above but used surplus.....**\$3.98**

Input and output impedance matching transformers for either of the above handsets. Both for.....**\$1.98**

Very active quartz transmitting crystal for models TRX-50 and TRX-50-A ground to .01% of your desired frequency and hermetically sealed.....**\$3.98**

HOW TO ORDER: If your dealer cannot supply you with products you may order direct from our factory by checking each item desired and ADD 5% of total for postage and insurance. Orders not paid in full will be sent COD for the balance due. COD orders must include \$3.00 deposit. All orders immediately acknowledged.

Dealer inquiries invited.

FREE power output indicator kit with each order over \$20.00.

Manufacturing division

Box 54-E7, Springfield Gardens 13, N.Y.

SPRINGFIELD ENTERPRISES

"HOW A 'CRAZY RUMOR' GOT ME PROMOTED!"



What I overheard one morning shook me right out of a rut!

"Company's getting ready to cut back . . . bound to be layoffs," I heard them say. "Just another crazy rumor," I told myself.

Just the same, I took quick stock of myself that night. Came up with four good reasons why the company would keep me on:

- Three years' experience*
- Getting along with foreman*
- Turning out acceptable work*
- Prompt and dependable*

And four just-as-good reasons why they might let me go:

- Making no real headway*
- Others better qualified*
- Still rated "semi-skilled"*
- Needs special training*

I wasn't in trouble. But I sure wasn't "in solid" like I should be. That's when I made up my mind to enroll for training with I.C.S.

I picked I.C.S. because it's the oldest and largest with 257 courses. The training is quick and thorough. It's recognized by my company and accredited by the National Home Study Council. You study in your spare time and get personalized, practical instruction—know-how you can apply next day on the job.

That was a year ago. There have been two layoffs since then. While some of the others were just hanging on or being released, I was moving up. My I.C.S. training started something. Not only did it get me promoted (with a fat pay hike), but it put me in line for real advancement.

Don't wait for a "crazy rumor" to set you straight. Take out your "job insurance" right now. Mail the coupon and get full, free details on how I.C.S. has helped thousands, how it can help you. No obligation—and you get three valuable books *free!* (1) How to Succeed; (2) Catalog of opportunities in the field of your choice; (3) Sample lesson (math).

For Real Job Security—Get an I. C. S. Diploma! I. C. S., Scranton 15, Penna. Accredited Member, National Home Study Council

INTERNATIONAL CORRESPONDENCE SCHOOLS



BOX 73295F, SCRANTON 15, PENNA.

(Partial list of 257 courses)

Without cost or obligation, send me "HOW TO SUCCEED" and the opportunity booklet about the field EEFORE which I have marked X (plus sample lesson):

ARCHITECTURE and BUILDING CONSTRUCTION

- Air Conditioning
- Architecture
- Arch. Drawing and Designing
- Building Contractor
- Building Estimator
- Carpentry and Millwork
- Carpenter Foreman
- Heating
- Interior Decoration
- Painting Contractor
- Plumbing
- Reading Arch. Blueprints

ART

- Commercial Art
- Magazine & Book Illus.
- Show Card and Sign Lettering
- Sketching and Painting

AUTOMOTIVE

- Automobiles
- Auto Eddy Rebuilding and Refinishing
- Auto Engine Tuneup
- Auto Technician

AVIATION

- Aero-Engineering Technology
- Aircraft & Engine Mechanic

BUSINESS

- Accounting
- Advertising
- Business Administration
- Business Management
- Cost Accounting
- Creative Salesmanship
- Managing a Small Business
- Professional Secretary
- Public Accounting
- Purchasing Agent
- Salesmanship
- Salesmanship and Management
- Traffic Management

CHEMICAL

- Analytical Chemistry
- Chemical Engineering
- Chem. Lab. Technician
- Elements of Nuclear Energy
- General Chemistry
- Natural Gas Prod. and Trans.
- Petroleum Prod. and Engr.
- Professional Engineer (Chem)
- Pulp and Paper Making

CIVIL ENGINEERING

- Civil Engineering
- Construction Engineering
- Highway Engineering
- Professional Engineer (Civil)
- Reading Struc. Blueprints
- Structural Engineering
- Surveying and Mapping

DRAFTING

- Aircraft Drafting
- Architectural Drafting
- Drafting Machine Design
- Electrical Drafting
- Mechanical Drafting
- Sheet Metal Drafting
- Structural Drafting

ELECTRICAL

- Electrical Engineering
- Elec. Engr. Technician
- Elec. Light and Power
- Practical Electrician
- Practical Lineman
- Professional Engineer (Elec)

HIGH SCHOOL

- High School Diploma

- Good English
- High School Mathematics
- Short Story Writing

LEADERSHIP

- Industrial Foremanship
- Industrial Supervision
- Personnel-Labor Relations
- Supervision

MECHANICAL and SHOP

- Diesel Engines
- Gas-Elec. Welding
- Industrial Engineering
- Industrial Instrumentation
- Industrial Metallurgy
- Industrial Safety
- Machine Design
- Machine Shop Practice
- Mechanical Engineering
- Professional Engineer (Mech)
- Quality Control
- Reading Shop Blueprints
- Refrigeration and Air Conditioning
- Tool Design
- Tool Making
- General Electronics Tech.

INDUSTRIAL ELECTRONICS

- Industrial Electronics
- Practical Radio-TV Eng'g
- Practical Telephony
- Radio-TV Servicing

RAILROAD

- Car Inspector and Air Brake
- Diesel Electrician
- Diesel Engr. and Fireman
- Diesel Locomotive

STEAM and DIESEL POWER

- Combustion Engineering
- Power Plant Engineer
- Stationary Diesel Engr.
- Stationary Fireman

TEXTILE

- Carding and Spinning
- Cotton Manufacture
- Cotton Warping and Weaving
- Loom Fixing Technician
- Textile Designing
- Textile Finishing & Dyeing
- Throwing
- Warping and Weaving
- Worsted Manufacture

Name _____ Age _____ Home Address _____

City _____ Zone _____ State _____ Working Hours _____ A.M. to P.M. _____

Occupation _____ Canadian residents send coupon to International Correspondence Schools, Canadian, Ltd., Montreal, Canada. . . . Special tuition rates to members of the U. S. Armed Forces.

NORELCO®

presents
the world's

second finest*

pickup
cartridge

a
new
MAGNETO-DYNAMIC
design
by Philips of the Netherlands



*to
find
out
which
pickup
cartridge

is the **finest**
and why the **NORELCO** is the

second finest

... write
to



NORTH AMERICAN PHILIPS CO., INC.
High Fidelity Products Division, Dept. 2F-7
230 Duffy Avenue, Hicksville, L. I., N. Y.

Carl & Jerry (Continued from page 12)

on the moonlit front steps of Jerry's house.

"Say, Jer," Carl drawled, "I've been thinking."

"So."

"If those resistance coils of the *Parfum Elektronique* were resonated with capacitors to different supersonic frequencies, or were fed from external circuits resonated at these frequencies, the coils could be heated with the high-frequency circulating currents instead of a battery. If these supersonic frequencies were used to modulate a radio or TV carrier, and our gadget was attached to the receiver so that these recovered supersonic signals activated it, the broadcaster could produce any fragrance wanted in any amount desired by regulating the frequency and strength of the supersonic modulation."

"So now you're inventing Smell-O-Vision," Jerry said with a chuckle. "Others have thought of that, too. There's one big catch in trying to work out a complete system for reproducing odors faithfully at a distance. No one has been able to come up with an 'electronic nose' that will translate odors into electrical currents having distinctive characteristics determined by each particular odor. Incidentally, a plain old nose is a pretty doggoned sensitive detector. It can easily detect 1/460,000,000 of a milligram of mercaptan diffused in the air—"

He broke off as a car pulled up in front of Norma's house. A tall young man helped her out of the car and escorted her to the door, but he did not dally. In fact, he seemed in unseemly haste to get back to his car.

As the car went around the corner, Norma came out and sat down in the porch swing. Carl and Jerry plopped down on both sides of her. "How did it work?" Carl asked anxiously.

"Well," Norma said, "at first, everything worked fine. We went to a show at the 'State,' and about halfway through the fea-



... And then the boys tugged alternately at the ropes to bounce the pinned-in girl wildly about ...

Always say you saw it in—POPULAR ELECTRONICS

See The Best Before You Build!

SEE THE AMAZING
ALLIED knight-kits
IN THIS EXCITING ELECTRONICS CATALOG



FREE! send for it now

EASY
TERMS
AVAILABLE



THERE'S A **knight-kit** FOR EVERY NEED

- LOWEST COST • EASIEST TO BUILD
- LATEST DESIGN • FINEST QUALITY

Do-It-Yourself: SAVE UP TO 50%

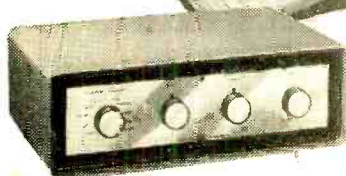

knight-kits:
**BEST BUY
HI-FI
KITS**

- 18-Watt Amplifier
- 30-Watt Amplifier
- 25-Watt Amplifier
- 20-Watt Amplifier
- 10-Watt Amplifier
- FM-AM Tuner
- FM Tuner
- Preamplifier
- 2-Way Speaker System
- 3-Way Speaker System

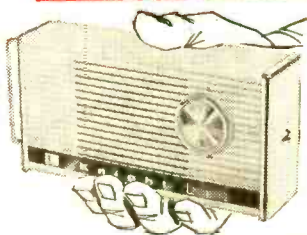

knight-kits:
**BEST BUY
HOBBY
KITS**

- "Space-Spanner" Radio
- "Ocean-Hopper" Radio
- "Ranger" Superhet Radio
- 2-Way Intercom
- Electronic Lab Kits
- Crystal Set
- Wireless Broadcaster
- 5-Transistor Portable
- 2-Transistor Pocket Radio
- Transistor Lab Kit
- 1-Transistor Radio
- Photoelectric System
- Electronic Photoflash
- Phono Oscillator



knight-kits:
**BEST BUY
INSTRUMENT
KITS**

- 5" Oscilloscopes
- Vacuum Tube Voltmeter
- Tube Tester
- VOM's
- RF Signal Generator
- Signal Tracer
- Audio Generator
- Sweep Generator
- R/C Substitution Boxes
- Voltage Calibrator
- Capacitor Checker
- R/C Tester
- Transistor Checker
- Flyback Checker
- Battery Eliminator

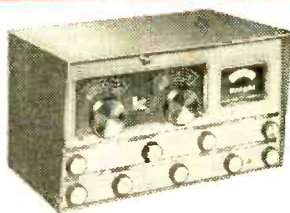

knight-kits:
**BEST BUY
AMATEUR
KITS**

- All-Band Ham Receiver
- Self-Powered VFO
- 100 kc Crystal Calibrator
- 50-Watt Transmitter
- RF "Z" Bridge
- Code Practice Oscillator

404-PAGE ALLIED CATALOG

FREE!

Send for this value-packed catalog featuring the complete ALLIED KNIGHT-KIT line, as well as the world's largest stocks of everything in Electronics. You'll want this valuable, money-saving Buying Guide.

WRITE FOR YOUR FREE COPY TODAY



ALLIED RADIO CORP., Dept. 120-G8
100 N. Western Ave., Chicago 80, Ill.

Send FREE 1958 ALLIED 404-Page Catalog

Name _____

Address _____

City _____ Zone _____ State _____

The TRUTH About Radio-TV-Electronics

Electronics is the *fastest-growing* major U. S. industry. 4,200 companies employ a work force of 1,500,000, with sales of \$11.5 billion annually. And Radio-TV servicing and broadcasting continues strong . . . better than ever before. Latest count: 120 million radios plus over 40 million TV sets. Here is real opportunity for men who are willing to prepare for the future.



APPROVED FOR VETERANS

I would like to send you my FREE book shown above. It will tell you all about the Electronics-Radio-Television field . . . show you the many high-pay careers open to trained men . . . and explain how you can qualify yourself in a minimum of time, at a minimum of cost. Demand for Central graduates greatly exceeds the supply. Just check the positions held by these recent Central graduates picked at random from our files: Vince Kytes, LABORATORY ENGINEER, Thompson Products; Harold J. Baert, STUDIO ENGINEER, Station WCCO-TV; Paul Stewart, INSTRUMENT TECHNICIAN, Atomic Energy Commission; Herbert Ganuce, PRODUCTION WRITER, Collins Radio Co. Over 50,000 successful graduates since 1951.

P. L. Foster
C. L. Foster, President

Clip and Mail TODAY—No Obligation!

ELECTRONICS DIVISION—Central Technical Institute
Dept. A-78, 1644 Wyandotte St., Kansas City 8, Mo.

(Offering engineering technician curricula accredited by Engineers Council for Professional Development.)

Please tell me more about how your training can qualify ME for a high-pay Electronics career. (Check specific field(s) of interest below, if you wish.)

- | | | |
|--------------------------------------|---|---|
| <input type="checkbox"/> Radio | <input type="checkbox"/> Guided Missile | <input type="checkbox"/> Technical Drafting |
| <input type="checkbox"/> Television | <input type="checkbox"/> Atomic Energy | <input type="checkbox"/> Armed Forces |
| <input type="checkbox"/> Color TV | <input type="checkbox"/> Radar | <input type="checkbox"/> Civil Service |
| <input type="checkbox"/> Electronics | <input type="checkbox"/> Aviation | <input type="checkbox"/> Your Own Business |
| <input type="checkbox"/> Other | | |

I am interested in Home Study Resident Training



MEMBER
National Home Study Council
National Council of Technicians

Name _____
Address _____
City _____
State _____ County _____
Age _____ Education _____
Korean Vets, give discharge date _____

Carl & Jerry (Continued from page 14)

ture picture there was a romantic scene with the hero talking to the heroine beneath a big pine tree. I cautiously reached down and gave that 'resinous' knob about half a turn, and the most wonderful odor of pine needles came out of the purse. Everyone around us began to sniff and whisper to one another, 'Do I imagine I can *smell* that pine tree?'

"A little later there was another scene in which a car upset a fruit vendor's cart; and when I turned on the 'fruity' odor, the people around us almost created a disturbance with their unabashed sniffing. They thought it was something the theater management was pulling."

"AFTER THE SHOW," Norma continued, I was hungry as a bear, but George, my date, said nothing about eating. When we were waiting at a stoplight, I gave the 'spicy' knob a little nudge, and all at once the car took on the appetizing smell of a bakery. 'Say,' George says to me, 'how about getting something to eat? All at once I'm starved.'

"My faith in your gadget was mounting by the minute, and soon I was to have further proof of its power. We went for a drive after we ate, and George suggested we park and 'enjoy the beauty of the night.' However, when he pulled off on that little blind road just across Davis Street Bridge, I decided that was *too* secluded; so I held my breath and turned that far-right knob, the 'putrid' one, full on. The result was instantaneous. George gasped, 'Something must be dead around here'; and he started the car and took off in a shower of gravel.

"A little later he pulled off the road on that high bluff at Cedar Rapids, and we sat there looking down at the moonlight glimmering on the Wabash below and shining on the white trunks of the sycamores. I soon found out I had been alarmed unnecessarily before about George. There he was in a beautiful setting on an ideal June night with a not-too-revolting girl beside him—and all he wanted to talk about was his precious car: how fast it would go, how easy it was to start on cold mornings, how many miles-to-the-gallon he got, and so on.

"After about a half hour of this I decided something had to be done; so I quietly turned up the 'flowery' knob. The most beautiful fragrance of dew-washed magno-

YOUR
SKILL



SOUND
TRAINING

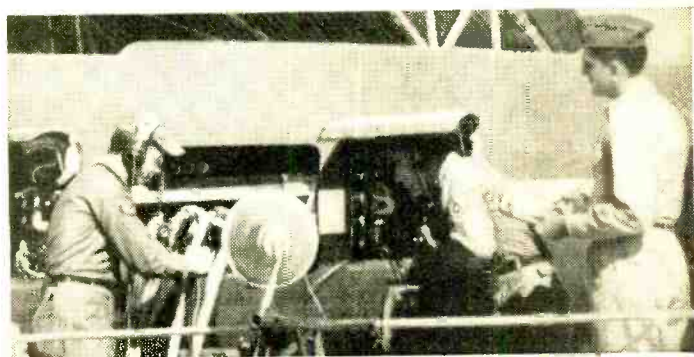

means a real future in the new

AGE OF SPACE

go places faster in the

**U.S.
AIR
FORCE**

If you "like to get under the hood," you have a great future in the new Age of Space. This is the age of the technician—the man who knows rocketry, jet propulsion, electronics or another of the allied fields. As an Airman in the U. S. Air Force, you get the most complete training available in these Space Age specialties. Remember: *the future belongs to the Airman.* Talk to your Air Force Recruiter, today, or mail the attached coupon.

PASTE COUPON ON POSTCARD AND MAIL TO:

Airman Information, Dept. PE-232
Box 7608, Washington 4, D. C.

Please send me information on my opportunities in the U. S. Air Force. I am between the ages of 17-34 and reside in U.S.A. or possessions.

NAME _____
ADDRESS _____
CITY _____ ZONE _____ STATE _____

SENSITIVITY SELECTIVITY STABILITY AND SSB



**MAKE NATIONAL'S NC-109
YOUR BEST BUY
IN ITS PRICE CLASS!**

Sensitivity, selectivity and stability best measure receiver performance. How does the NC-109 stack up? You be the judge.
SENSITIVITY: 1-2 microvolts with 10 db signal/noise ratio.
SELECTIVITY: Only the NC-109 has National's exclusive new "Microtome" filter . . . provides 5 degrees of razor-sharp selectivity plus normal bandwidth for voice.

	NORMAL	SHARP
6 db	5.2 kc	200 cycles
60 db	29.5 kc	10 kc

PLUS FOUR ADDITIONAL INTERMEDIATE DEGREES OF SHARPNESS STABILITY: Separate high frequency oscillator with temperature compensated ceramic coil forms reduce drift to .01% or less. Best news of all . . . the NC-109 is America's lowest priced Single Sideband receiver!

Only \$19.95 down . . . up to 20 months to pay at most stores. Suggested list only \$199.95 (slightly higher west of Rockies and outside U. S. A.)

Need to know more? See your National Distributor or write for specifications.

National

Since 1914



MALDEN 48, MASS.

Carl & Jerry (Continued from page 16)

lia arose about us. As if by magic George quit talking about his car, and when he spoke again it was to describe the kind of home he wanted some day: a little cottage with honeysuckle climbing over it and magnolia growing by the window and a pretty wife to greet him at the end of the day. You know—corny but sweet!

"This was such a change in the right direction that I decided to help it along by turning the 'flowery' knob a little higher, but that's where I made a mistake. Suddenly George stopped in mid-sentence, leaped from the car, ran around to my side, opened the door and pulled me out. I thought he had flipped for sure; but just as I was getting ready to belt him with your *Parfum Elektronique*, he yanked the front seat out of the car and began sniffing around under the dash like a bloodhound. Then I realized what was wrong. In reaching for the 'flowery' knob I had accidentally got hold of the 'scorched' one next to it. When George got a whiff of burning rags, he thought his precious car was on fire.

"Of course I turned the knob off, but the damage was done. He put the seat back in the car and we started home, but he was too busy sniffing for smoke to hear anything I said. I'll bet the poor fellow doesn't sleep a wink tonight."

"Would you say our invention was a success?" Jerry asked.

"Yes, I'd say it was," Norma replied thoughtfully; "but like any powerful perfume, it must be used sparingly and cautiously with a full realization of its power. It's definitely not for amateurs!"

-30-

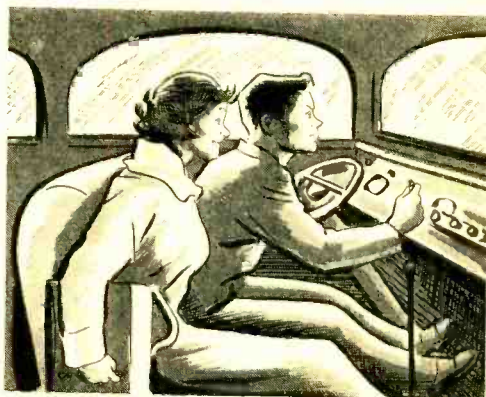

. . . "I decided that was too secluded; so I held my breath and turned that far-right knob, the 'putrid' one, full on. The result was instantaneous." . . .

Always say you saw it in—POPULAR ELECTRONICS

WE'RE MAKING IT EASIER THAN EVER TO BECOME A WELL PAID
RADIO-TELEVISION SERVICE TECHNICIAN

NOW - Just \$6 Starts You Training in
RADIO-TELEVISION
 the **SPRAYBERRY "Learn-by-Doing" Way . . .**

25 BIG, COMPLETE KITS
of PARTS & EQUIPMENT

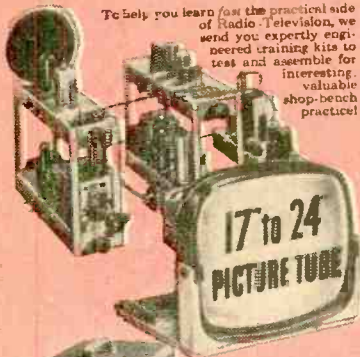

To help you learn (as the practical side of Radio-Television, we send you expertly engineered training kits to test and assemble for interesting, valuable shop-bench practice!



- The new Sprayberry Training Television Receiver, built and tested in 6 sections
- Now offered... this fine modern oscilloscope.
- You build this powerful two-band superheterodyne radio receiver.

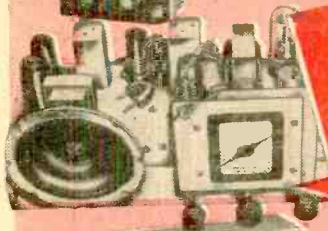

Big New CATALOG
 AND
Sample Lesson FREE!

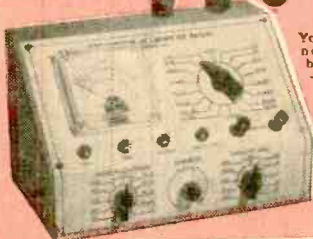

You build the new Sprayberry tester—a complete 18-range Volt-Ohm-Milli-ammeter test meter.



*** This great industry is begging for trained men . . . to step into good paying jobs or a profitable business of their own! Our new plan opens the doors of Radio-Television wide to every ambitious man who is ready to act at once!

Men by the thousands . . . trained Radio-Television Service Technicians . . . are needed at once! Perhaps you've thought about entering this interesting, top paying field, but lack of ready money held you back. Now—just \$6 enrolls you for America's finest, most up to date home study training in Radio-Television! Unbelievable? No, the explanation is simple! We believe Radio-Television must have the additional men it needs as quickly as possible. We are willing to do our part by making Sprayberry Training available for less money down and on easier terms than ever before. This is your big opportunity to get the training you need . . . to step into a fine job or your own Radio-Television Service Business.

Complete Facts Free—Act Now; Offer Limited

Only a limited number of students may be accepted on this liberal and unusual basis. We urge you to act at once . . . mail the coupon below and get complete details plus our big new catalog and an actual sample lesson—all free. No obligation . . . no salesman will bother you.

HOME STUDY TRAINING IN SPARE TIME

Under world-famous 27-year old Sprayberry Plan, you learn entirely at home in spare time. You keep on with your present job and income. You train as fast or as slowly as you wish. You get valuable kits of parts and equipment for priceless shop-bench practice. And everything you receive, lessons and equipment alike, is all yours to keep.

LET US PROVE HOW EASILY YOU CAN LEARN!

Radio-Television needs YOU! And Sprayberry is ready to train you on better, easier terms, that any ambitious man can afford. Just \$6 starts you! Mail coupon today . . . let the facts speak for themselves. You have everything to gain. Let us prove the kind of opportunity in store for you!

SPRAYBERRY Academy of Radio-Television
 1512 Jarvis Avenue, Dept. 105-J, Chicago 26, Illinois

Mail This Coupon Now—No Salesman Will Call.

Sprayberry Academy of Radio-Television
 Dept. 105-J, 1512 W. Jarvis Ave., Chicago 26, Ill.
 Please rush all information on your ALL-NEW Radio-Television Training Plan. I understand this does not obligate me and that no salesman will call upon me. Include New Catalog and Sample Lesson FREE.

NAME..... Age.....

ADDRESS.....

CITY..... ZONE..... STATE.....

LETTERS

FROM OUR READERS

Hints for FM in Car

■ In the May issue *After Class*, I read about the automobile FM tuner installation and problems encountered by Mr. Welch. I have had a German Becker AM-FM receiver in my car for the past year, and the following experiences and observations may prove helpful.

By far the worst source of interference was my own car and, on the suggestion of the dealer from whom the radio was purchased, I installed Autolite resistor spark plugs. This one change should result in a 100% improvement.

Since FM generally has short-range, line-of-sight reception, several peculiarities may be noticed—one of which is momentary interruption of the signal due to dead spots. I drove my car through one of the areas where this condition was experienced and stopped in one of these dead spots. Moving the car only 2 or 3 feet made the difference between very poor and excellent reception.

This condition is usually prevalent when the car is in a low area and shielded from the transmitter by high ground. Because of this, reception is often only fair a short distance from the transmitter and yet will be much better three or four

times farther away if the car is on high ground. Mobile installations also present the problem of trying to install an efficient antenna, which is again more of a problem with FM than with AM. Improved reception *might* result from the installation of a booster, although a manufacturer to whom I wrote did not believe it would be worth the expense.

H. A. RADER
Philadelphia 44, Pa.

Helpful Feedback from Readers

■ I just wanted to say that I like the idea of using *After Class* occasionally for answering readers' questions. I think this service is beneficial to all since such a general field is covered.

JAMES HOWARD
Los Angeles, Calif.

■ Bravo for "How to Make Parts Substitutions," April, 1958, page 55. This article gives more down-to-ground information than several textbooks I have.

IRVING T. WORTHLEY
Paia, Maui, T. H.

Selective Antenna Needed

■ If Walter Ray of Shreveport, who wrote in the April '58 issue about a turntable belt, will discard the round belt, he can make a splendid flat belt out of two layers of Scotch cellophane tape stuck face to face.

My belt is about .003" thick and stands up

better reception on 1, 2 or 3 tv sets...
with one antenna

NEW **B-T** LABS B-23

TWO-SET BOOSTER only \$23.95

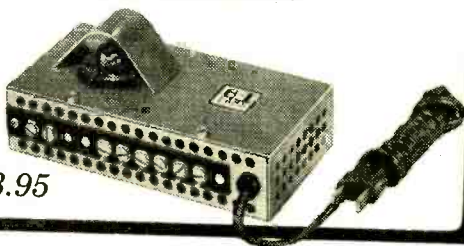

From B-T comes the most important advance in better TV reception for 1958 — a broadband TV amplifier that boosts signal strength on all VHF channels and operates 1, 2 or 3 TV sets with one antenna — no tuning required.

Combines two functions in one —

- BOOSTS signal strength on 1 or 2 TV sets — up to 6 db gain operating two TV sets from one antenna.
- COUPLES 2 or 3 TV sets — using the present antenna. Outperforms non-powered couplers in any reception area by more than 2 to 1.

Check these B-23 features:

- Ideal for color — add a color TV set and keep present black-and-white set, use the same antenna — the result, sharper, clearer pictures on both sets.
- Low noise figure — works with new VHF sets.
- Reduces interference.
- Easily installed at antenna terminals of set. Mounts out of sight at rear of set.
- Automatically amplifies channels 2-13.
- Ideal small TV system.

For operating 3 to 8 TV sets, use the DA8-B — more than 10 db gain on all VHF channels

The DA8-B Distribution Amplifier is a broadband, all-channel unit that requires no tuning, impedance matching devices, pre-amps or other special fittings. Ideal for all small TV systems (garden apartments, motels, TV showrooms). For color. Only \$94.50.

The B-23, the DA8-B, and other B-T quality engineered products, are available at parts distributors.

For further information, use coupon.

BLONDER-TONGUE LABS., INC. PE-7
9 Alling Street, Newark 2, New Jersey
Please send me literature covering:

B-T B-23 B-T TV Accessories

Name _____
Address _____
City _____ Zone _____ State _____

Always say you saw it in—POPULAR ELECTRONICS



RCA INSTITUTES



OFFERS YOU THE FINEST OF HOME STUDY TRAINING

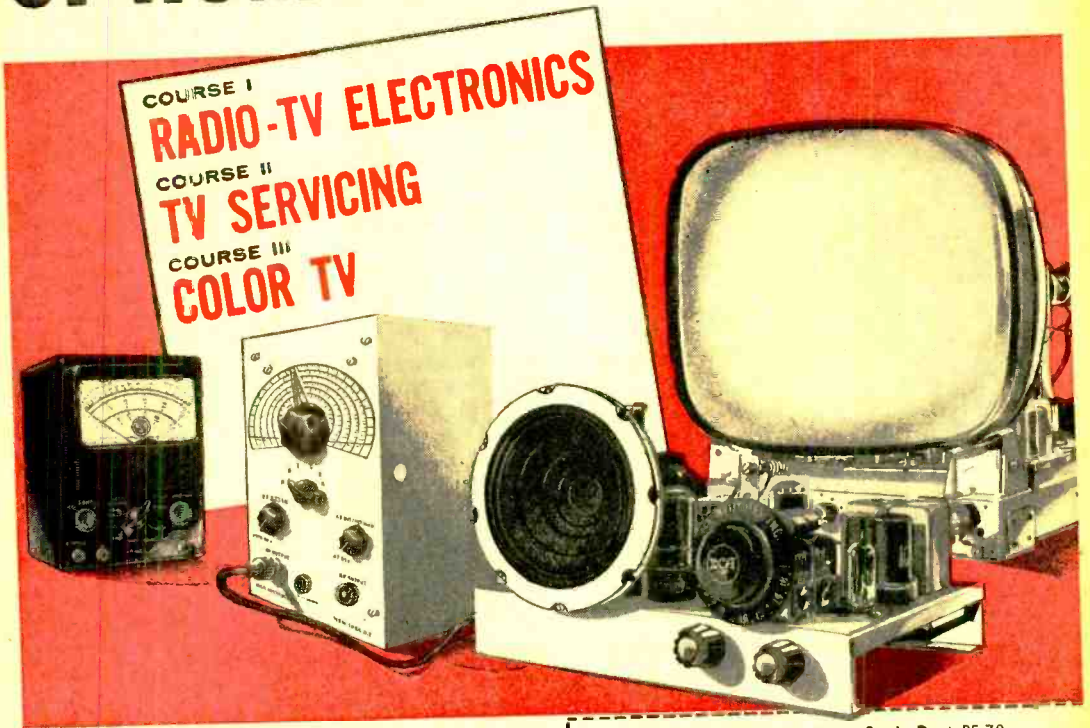

The equipment illustrated and text material you get with each course is yours to keep. Practical work with very first lesson. Courses for the beginner and the advanced student. Pay-as-you-learn. You need pay for only one study group at a time.

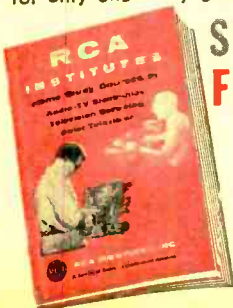

SEND FOR THIS FREE BOOK NOW

Resident School courses in New York City offer comprehensive training in Television and Electronics. Day and evening classes start four times each year. Detailed information on request.

RCA Institutes, Inc. Home Study Dept. PE-78
A Service of Radio Corporation of America
350 West Fourth Street, New York 14, N. Y.

Without obligation, send me FREE 52 page CATALOG on Home Study Courses in Radio, Television and Color TV. No Salesman will call.

Name..... Please print

Address.....

City..... Zone..... State.....

Korean Vets! Enter discharge date.....

CANADIANS—Take advantage of these same RCA courses at no additional cost. No postage, no customs, no delay. Send coupon to:

RCA VICTOR COMPANY, LTD.
5001 Cote de Liesse Rd., Montreal 9, Que.

To save time, paste coupon on postcard

DYNAKITS

Acclaimed as the finest available—
by laboratory test or critical listen-
ing—in money-saving kit form!

- Easiest assembly due to use of printed circuit boards with all parts factory mounted. The use of printed circuitry insures accurate reproducibility of the characteristics of Dynakit high fidelity kits.
- Outstanding quality of components and circuitry insures the finest listening quality.

Dynakits have been selected for display at the Brussels World's Fair as representative of the highest quality American high fidelity equipment!



Mark III Power Amplifier 79.⁹⁵ net

A full 60 watts of low distortion power with peak capabilities of 140 watts. This patented circuit uses new KT-88 tubes and Dynaco Super-Fidelity output transformers for superb transient response and excellent stability of operation.



Low Noise Pre-Amplifier 34.⁹⁵ net

A new all feed-back design which includes dc heater supply, gives complete flexibility for all program sources including tape head.

NEW! Dynakit Stereo Control Kit!

Adds complete stereo control functions to two preamplifiers for only 12.⁹⁵

Descriptive literature including complete performance data available on request.

DYNACO INC.

617 N. 41st St., Philadelphia 4, Pa.
Export Division: 25 Warren St., New York 7, N. Y.

Letters

(Continued from page 20)

well going around a .240" pulley at 1700 rpm. Mr. Scully, who makes recording lathes, says the thinnest possible belt gives the lower wow and flutter, and you can't go much under this except by using half-mil Mylar.

Cut the ends at a 3/1 angle and have the inner and outer joints opposite one another 180° apart. Don't let any adhesive-to-adhesive contact take place unless you're sure everything is just as you're going to want it permanently. The adhesive-to-adhesive joint is very strong and very difficult to separate.

Maybe someone can help me. I need an antenna that is directional or tunable and pulls in plenty of signal. I built a Miller-type tubeless tuner, a diode bandpass job, from the circuit in the Sylvania diode book, and I can't get WQXR—which is 25-30 miles to the south—because of WNLK (1350 kc.) being only about one mile east.

This tuner is designed for 30'-50' of antenna for proper reactance and flat-top curves, and more than this just spreads WNLK all over the top of the dial. The installation is to be permanent in the "short-wave" corner of a house with cinder-block ground floor and a partially finished attic above.

H. H. SMITH
So. Norwalk, Conn.

A large loop antenna tuned and oriented to WQXR frequency might help.

We Would Like To

■ Your magazine roused my interest so much that it inspired me to take a course in electronics. I would like to correspond with anyone who has any information about the building of an electronic organ; parts or in kit form. And how about publishing a series on this subject?

NORMAN GUDERIAN
Thornhill, Manitoba, Canada

WWV Signals

■ Your article in February called "Can You Spare the Time?" was very interesting. I have listened to the signals of WWV many times in endless curiosity.

There are hundreds of other noisy signals on the air. Could you print an article on these unearthly sounding transmissions?

You certainly have very attractive covers.

HOWARD THARP
Alexandria, Ohio

We'll cover other services in future issues. See the article on "Thunderbolts and Whistlers" which appeared in our December 1956 issue.

Historical Research with Locator

■ I have just completed the electronic detector section of the metal locator published in your June 1955 issue. The results were very satisfactory with a test loop. (I haven't finished the final loop yet.) It is very sensitive when tuned to the lowest beat note and works exactly as you indicated in your article.

I do a great deal of historical research during the summer as a hobby, and I am sure this locator will add excitement and pleasure to my trips

Always say you saw it in—POPULAR ELECTRONICS

**"50% to 70% OF MISSILES
ARE ELECTRONIC PARTS"**

The Future is Wide Open in Guided Missile **ELECTRONICS**

when you acquire high-level training in
ELECTRONIC ENGINEERING TECHNOLOGY

**CREI prepares you
quickly for success in**

Guided Missiles Radar
Instrumentation Automation
Servomechanisms Telemetry
Computers Electronics Manufacturing
Aeronautical Electronics
Communications Astronautics

SEND NOW FOR CREI'S NEW FREE BOOKLET

Crammed with facts and data—containing a time-proved plan to make you ready for the big jobs and high-salaried, secure, life-time careers now being offered in America's fastest growing industry.

Tells what employers demand of YOU in technical knowledge.

Tells about opportunities — what they pay — the security and other benefits when you qualify.

Tells how you can qualify for top-pay jobs in Radar, Guided Missiles, Servos, Computers, Aeronautical

Electronics, Electronic Manufacturing, Communications.

CREI also offers residence training in Washington, D. C. at the same high technical level. Day and evening classes start at regular intervals. Qualified residence school graduates earn degree as "Associate in Applied Science." Check coupon if you prefer residence or home study information or write, Capitol Radio Engineering Institute, Dept. 127E, 3224 - 16th Street, N.W., Wash. 10, D. C.

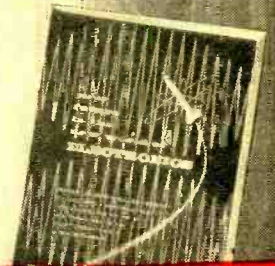

MAIL TODAY FOR YOUR FREE BOOKLET

CAPITOL RADIO ENGINEERING INSTITUTE

ECPD Accredited Technical Institute Curricula — Founded 1927
Dept. 127-E 3224 16th St., N. W., Washington 10, D. C.

Please send me your course outline and FREE illustrated Booklet, "Your Future in the New World of Electronics" . . . describing opportunities and CREI home study courses in Practical Electronic Engineering Technology.

- CHECK FIELD OF GREATEST INTEREST
- Radar, Servo and Computer Engineering Technology
 - Electronic Engineering Technology
 - Broadcast (AM, FM, TV) Engineering Technology **M**
 - Television Engineering Technology
 - Aeronautical Electronic Engineering Technology

Name Age

Street

City Zone State

Check: Home Study Residence School Korean Veteran

If you have had a high school education, and experience in electronics—and realize the need of a high-level technical knowledge to make good in the better electronics jobs—you can qualify for CREI home study training. (Electronics experience not required for admission to CREI Residence School.) Please fill in the following information:

EMPLOYED BY

TYPE OF PRESENT WORK

EDUCATION: YEARS HIGH SCHOOL

YEARS COLLEGE

ELECTRONICS EXPERIENCE

When Converting Your Phono to Stereo Use ...

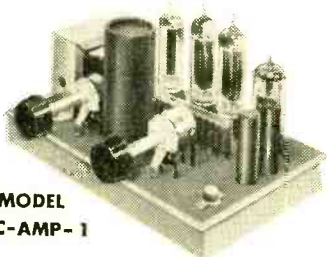

MODEL
PAC-AMP-1

The ERIE AUDIO-AMPLIFIER KIT

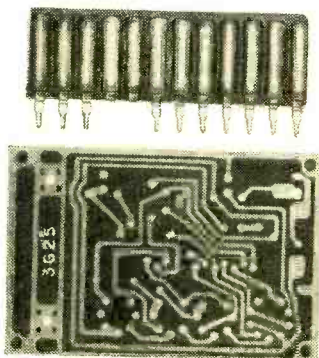

featuring "PAC" and an ERIE Printed Wiring Board

With these Plug-in Components:

- ERIE "PAC" (Pre-Assembled Components)
- ERIE PRINTED BOARD
- OUTPUT TRANSFORMER
- FILTER CAPACITOR
- VOLUME CONTROL and SWITCH
- TUBE SOCKETS
- CAPACITORS
- TONE CONTROL
- TUBES

SPECIFICATIONS FOR ERIE STANDARD AUDIO-AMPLIFIER

- Frequency Response: 30 cycles to 12,000 cycles ± 0 , -3.5 db.
- Sensitivity: 0.56 volt RMS (input at 1 KC) for 2 watt output.
- Power Output: 2 watts • Input Impedance: 2 megohms.
- Output Impedance: 4 ohms • AC Power Consumption: 17 watts.
- Overall Dimensions: $6\frac{3}{4}$ " L x $4\frac{3}{16}$ " W x $3\frac{3}{4}$ " H.
- Shipping Weight: 2 lbs.

See and hear it at your local distributor
or write for nearest source.



Letters

(Continued from page 22)

around old farms, fort sites, etc. May I ask if others have built the locator and how successful they have been with it?

GERALD T. LANDRY
Dectham, Mass.

Perhaps some readers will report on their results.

-30-

Out of Tune

Build a "Half-Pack" (May, 1958, page 49): Soldering points 25 and 26 were omitted from printed-circuit board PC1. The correct positions of these points are shown here. If the board has already been etched,

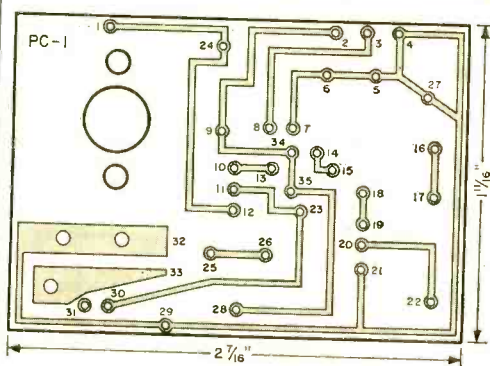

you can add 25 and 26 by drilling two $\frac{1}{16}$ " holes in the proper positions and installing a short length of wire between them.

In the schematic diagram on page 48, RFC1 (L3 in the Parts List) can be any small r.f. choke or section or winding from an r.f. coil. It's not critical.

Transistorized Photoflash (June, 1958, page 61): The wiring represented by the dotted

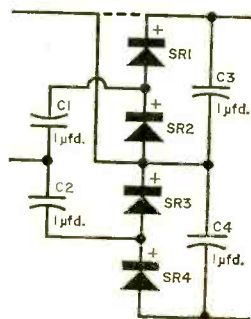

line in the portion of the schematic shown here should be omitted.

-30-

Always say you saw it in—POPULAR ELECTRONICS

**GREATEST
ADVANCE IN
SHOP-METHOD
HOME TRAINING**

EARN MORE MONEY...GET INTO

TELEVISION ELECTRONICS-RADIO

Learn ALL 8 PHASES in ONE MODERN HOME-STUDY COURSE
At Home - In Spare Time

**YOU GET ALL THIS NEWEST
PRACTICAL EQUIPMENT**

- Parts to build a modern TV set, including all tubes plus a large screen Picture Tube
- Parts to build a powerful Superhet Receiver, standard broadcast and short wave
- Parts to conduct many experiments and build Continuity Checker, RF Oscillator, TV Circuits, Audio Oscillator, TRF Receiver, Signal Generator
- A Valuable Professional Multitester



**19 BIG KITS
YOURS TO KEEP**

YOUR NATIONAL SCHOOLS TELERAMA COURSE COVERS ALL 8 PHASES

- | | |
|------------------------------------|--------------------------------|
| 1. TELEVISION, INCLUDING COLOR TV | 5. PREPARATION FOR FCC LICENSE |
| 2. RADIO, FM AND AM | 6. AUTOMATION |
| 3. INDUSTRIAL ELECTRONICS | 7. RADAR AND MICRO WAVES |
| 4. SOUND RECORDING AND HI FIDELITY | 8. COMMUNICATIONS |

YOU ARE NEEDED IN THE TELEVISION-ELECTRONICS-RADIO INDUSTRY!
You can build a secure future for yourself if you get into Electronics NOW! Today's shortage of trained technicians creates tremendous opportunities. National Schools Shop-Method trained technicians are in constant and growing demand for high-pay jobs in Broadcasting and Communications, Electronic Research, Servicing and Repair, and many other branches.

— many other materials and services
— consultation privilege with our qualified staff, and Graduate Employment Service. **EVERYTHING YOU NEED** for outstanding success in Electronics.

Let National Schools, a Resident Technical School for over 50 years train you for today's unlimited opportunities in electronics! Our Shop Method trains you to be a **MASTER-TECHNICIAN**. Completely up to date, developed by experienced instructors and engineers, your Telerama Course will teach you all phases of the industry quickly, clearly and correctly. You can master the most modern projects, such as Color TV, printed circuits — even prepare for FCC License without taking a special

course. You can handle sales, servicing, manufacturing, or make good money in your own business. **SEND FOR FACTS TODAY!**

EARN AS YOU LEARN. Many of our students earn their entire tuition and more in Spare Time jobs we show them how to do while learning.

YOU GET EVERYTHING YOU NEED — Clear, profusely illustrated lessons, shop-tested manuals, modern circuit diagrams, practical job projects — all the valuable equipment shown above

RESIDENT TRAINING AT LOS ANGELES

If you wish to take your training in our Resident School at Los Angeles, "the world's TV capital", start NOW in our big, modern Shops, Labs and Radio-TV Studios. Here you work with latest electronic equipment — professionally installed, finest, most complete facilities offered by any school. Expert, friendly instructors. Personal attention. Graduate Employment Service. Help in finding home near school — and part time job while you learn. Check box on coupon for full information.



FREE!

Fully illustrated "Career" Book in TV-Radio-Electronics. **PLUS** actual sample lesson — yours at no cost, no obligation. **CLIP COUPON NOW... MAIL IT TODAY!**



MEMBER



APPROVED FOR G. I. TRAINING
NATIONAL SCHOOLS

4000 S. FIGUEROA ST., LOS ANGELES 37, CALIF.

NATIONAL SCHOOLS

TECHNICAL TRADE TRAINING SINCE 1905
LOS ANGELES 37, CALIFORNIA

GET FAST SERVICE — MAIL NOW TO

NATIONAL SCHOOLS, DEPT. R2G-78

4000 S. FIGUEROA ST.

LOS ANGELES 37, CALIF.

Rush Free TV-Radio "Opportunity" Book and sample lesson. No salesman will call

NAME _____ AGE _____

ADDRESS _____

CITY _____ ZONE _____ STATE _____

Check it interesting ONLY in Resident School training at Los Angeles

VETERAN: Give date of Discharge _____

POP'tronics

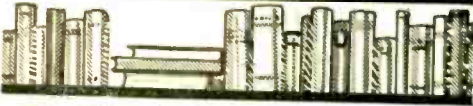

BOOKSHELF

"THE BOYS' SECOND BOOK OF RADIO AND ELECTRONICS" by Alfred Morgan. Published by Charles Scribner's Sons, 597 Fifth Ave., New York 17, N. Y. 276 pages. Hard cover. \$3.00.

Readers of the first volume in this series will welcome this new book, which contains detailed directions and working drawings for easily made electronic projects such as receivers, amplifiers, oscillators, photo-electric "eyes," capacity-operated relays, and the like. It is up-to-date, written by an electrical engineer with a background of seven other books on science for youth, and extremely readable. Best of all, it is not "written down" to a child's level.

Recommended: to beginners in elec-

tronics, young or otherwise, who wish to construct working models while they learn the subject.

"TAPE RECORDER MANUAL (VOL. I)" compiled and published by Howard W. Sams & Co., Inc., Indianapolis, Ind. 148 pages. Soft cover. \$2.95.

As a result of the growing tape recorder market, Sams is now putting out a series of volumes devoted exclusively to tape recorders. This first publication in the new series covers 14 tape players and recorders and incorporates an index to all the tape, disc and wire recorders that have appeared in previous Sams Record Changer and Tape Recorder service manuals.

Both home-recording units and the more expensive professional models are covered in the usual comprehensive Sams manner. Photos, schematics and special exploded views contribute toward a complete understanding of a machine's electrical and mechanical operation. In addition, you'll find complete information on possible

Abraham Marcus, co-author of famous best-seller, "Elements of Radio" makes amazing offer!



TRY MY TV and RADIO REPAIR COURSE FREE FOR 1 MONTH

"If you haven't earned at least \$100 in spare time during that period you pay not a cent."

Here it is! The most amazing guarantee ever offered on any radio-TV course anywhere! We'll send you Abraham Marcus' course to use FREE for one full month! If in that time you haven't actually made \$100 fixing radios and TV sets, just return the books to us and pay not a penny!

Why do we make this sensational offer? First, because these books are so easy to use. They are written in the same clear, easy-to-understand language that made the author's "Elements of Radio" a 1,000,000-copy best-seller. Second, because these books get right to the point—tell you what to do in 1-2-3 fashion. For example, once you master the first few chapters of the TV book you are ready for business—ready to do service jobs in the field—jobs that account for over 80% of all service calls.

DON'T WAIT! You risk nothing when you send the coupon at right. You don't have to keep the books and pay for them unless you actually make extra money fixing radios and TV sets. Even when you decide to keep them, you pay on easy terms. Mail the coupon now.

WHAT YOU GET IN THESE 3 GIANT VOLUMES

ELEMENTS OF TELEVISION SERVICING. Analyzes and illustrates more TV defects than any other book, and provides complete, step-by-step procedure for correcting each. You can actually SEE what to do by looking at the pictures. Reveals for the first time all details, theory and servicing procedures for the RCA 28-tube color television receiver, the CBS-Columbia Model 205 color set, and the Motorola 18-inch color receiver.

RADIO PROJECTS. Build your own receivers! Gives you 10 easy-to-follow projects, including crystal detector receiver—diode detector receiver—regenerative receiver—audio-frequency amplifier—tuned-radio-frequency tuner—AC-DC superheterodyne receiver—etc.

RADIO SERVICING Theory and Practice. Here is everything you need to know about radio repair, replacement, and readjustment. Easy-to-understand, step-by-step self-training handbook shows you how to locate and remedy defects quickly. Covers TRF receivers; superheterodyne receivers; short-wave, portable, automobile receivers, etc. Explains how to use testing instruments such as meter, vacuum-tube voltmeters, tube checkers, etc., etc.



MAIL THIS COUPON

Prentice-Hall, Inc., Dept. 5702-J3
Englewood Cliffs, New Jersey

Please send me Abraham Marcus' TV & RADIO REPAIR COURSE (3 volumes) for 10 days FREE examination. Within 10 days I will either return it and owe nothing, or send my first payment of \$3.60 plus a few cents postage. Then, after I have used the course for a FULL MONTH, if I am not satisfied I may return it and you will refund my first payment. Or I will keep the course and send you two more payments of \$3.60 a month for two months.

Name

Address

City

Zone State

FREE LAFAYETTE CATALOG

FEATURING THE BEST BUYS IN THE BUSINESS



The newest and largest assortment of Electronic, Radio and TV parts, Hi-Fi and Public Address Components and systems, Test Equipment, tubes, Transistor Kits and miniaturized components for transistor circuitry, Ham Equipment, Builders Kits, Tools, Books, Microscopes, Binoculars, Telescopes, Cameras, and Drafting Equipment.—ALL AT LOWEST PRICES—Catering to the economy minded dealer, serviceman, engineer, technician, experimenter and hobbyist. **CRAMMED FULL OF MONEY SAVING BUYS. SEND FOR YOUR FREE COPY TODAY.**

NEW! 6 TRANSISTOR SUPERHET RECEIVER with LATEST NPN-PNP TRANSISTORS



- GE 2N188A AUDIO OUTPUT TRANSISTORS • 100% SUBMINIATURE PARTS—NO COMPROMISES!
- CLASS B PUSH-PULL AMPLIFICATION—PLENTY OF POWER. • FOR GROUP AND PRIVATE LISTENING
- LABORATORY DESIGNED—SENSITIVE, SELECTIVE, STABLE!

Superb Performance! Incomparable Value!

Transistor-wise Lafayette proudly presents its newly revised 6 Transistor Superhet Receiver Kit KT-119A. This improved model uses the latest GE NPN-PNP Transistors in an ingeniously engineered, laboratory tested-circuit providing superb performance and an amazing superior commercial quality. The circuit features a specially matched set of 3 IF transformers, Oscillator Coil, High-Q Loop, Class B Push-Pull Audio Amplification and optimum Transformer Coupling in audio and output stages. Has efficient 2 3/4" speaker for exemplary reproduction and earphone jack for private listening. Complete with all parts, transistors, pre-punched chassis, but less battery and leather case. New 28 page easy-to-follow step-by-step instruction book. Size 6 x 3 1/2 x 1 1/2. Shpg. wt., 3 lbs.

- KT-119A — Complete Kit—Less Case and Battery.....Net 29.95
- BATTERY 9V BURGESS 2N6.....Net 1.30
- MS-339A — Sturdy attractive brown leather case with carrying strap for KT-119A. 6 x 3 1/2 x 1 1/2". Shpg. wt., 1 lb.....Net 2.95
- MS-366 — Sensitive matching earphone.....Net 1.29

R/C ELECTRIC SIRVO MECHANISM

DESIGNED AND PRICED FOR HOBBYISTS

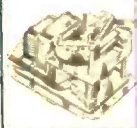

New, powerful, motor driven R/C actuator. Delivers positive, instantaneous action. Provides selective steering and electric, automatic return to neutral. Extremely efficient when used with model boats and land vehicles. Only 2 1/2" x 2" x 3/4". Includes instructions and linkage. F-327 Net 4.95

LITTLE "JEWEL" R/C RELAY

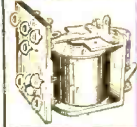

The Mighty Mite of the R/C field. Weighs less than 1/2 oz. Only 3/4" H x 17/32" W x 1-1/16" L. Highly sensitive—extremely rugged. Pulls at 1.4 Ma—drops out 1.2 Ma D.C. S.P.D.T. 5000 ohm coil. F-250 Net 2.75

Lafayette's Radio-Control Specialties

LAFAYETTE SPECIAL R/C TRANSMITTER

New crystal controlled 27.255 MC R/C transmitter, completely assembled, tested and guaranteed. Includes tube, crystal and 6 section telescoping antenna. Approx. 1 mile range. Size 8 1/2 x 2 3/4 x 1 1/4". Shpg. wt., 2 1/2 lbs. Less batteries. F-249 R/C TRANSMITTER (Less Batteries) Net 14.95

LAFAYETTE SPECIAL R/C RECEIVER

New factory wired and tested RC receiver. Completely enclosed — for use around water — case may be removed. Ready to operate on exam-free 27.255 MC band. Has fine tuning control, antenna lead, and connector plug. Requires one 1.5V and one 45V battery. Complete with 354 tube, less one 45V battery. Size 3 x 2 3/4 x 1 1/2". Ideal companion for F-249 Transmitter. Shpg. wt., 8 oz. F-208 R/C RECEIVER (Less Batteries) Net 8.95

SPECIAL COMBINATION OFFER

Consists of R/C Transmitter (F-249) and R/C Receiver (F-208) F-259 Combination Net 22.90



3 TRANSISTOR SUPERHET POCKET RADIO KIT

TRUE POCKET SUPERHET RECEIVER—NO EXTERNAL ANTENNA! • NO EXTERNAL GROUND!



A remarkable sensitive, super-selective pocket superhet receiver with astonishing performance over the complete broadcast band. Uses 2 high-frequency and one audio transistor plus efficient diode detector and features 2 specially matched IF transformers for maximum power transfer. The components are housed in a professional looking beige plastic case.

The receiver's appearance enhanced by attractive maroon and silver station dial. Sensitive built-in ferrite antenna eliminates need for external antenna. A designer's dream in a true pocket superhet receiver! Complete with all parts, transistors battery, case, dial and easy to follow step-by-step instructions. 4 1/4" x 2 1/2" x 1-1/16". Shpg. wt., 1 lb.

- KT-116—Complete Kit, less earphone.....Net 16.95
- MS-260—Super Power Dynamic Earphone.....Net 3.95

LAFAYETTE SIGNAL GENERATOR

COMPLETELY WIRED AND TESTED! ACCURACY AND QUALITY GUARANTEED!

22.50

- FREQUENCY 120KC to 260MC
- 120KC to 120MC ON FUNDAMENTALS!
- 30 DAY TRIAL PERIOD! FULL REFUND IF YOU ARE NOT SATISFIED FOR ANY REASON



Completely wired and tested instrument. Do not confuse with kits sold in the same price range. Has the quality and accuracy of instruments selling for 3 to 4 times as much. Six overlapping ranges — 120KC to 320KC, 320KC to 1000KC, 1MC to 3.2MC, 3.2MC to 11MC, 11MC to 38MC, 37MC to 130MC — all on fundamentals — calibrated harmonics from 120MC to 260MC. Switch between internal modulation at 400 cps or any external source at other frequencies. 400 cps signal can be used separately. Outputs are unmodulated RF, modulated RF and 400 cps audio. RF output is in excess of 100,000 micro volts. Jacks are provided for high or low RF output.

Highly stable special circuit design. Fine adjust RF control. AF output 2-3 volts, input 4 volts, across 1 megohm. 5 inch etched dial plate — protected by clear plastic bezel. Common AF terminals for EXT-MOD input and INT-AF output eliminates need for special connectors. Gray metal case — carrying handle — complete with leads, line cord and plug. For 105-126V, 60-60 cycle A.C. Shpg. wt., 8 lbs.

LSG-10 — Signal Generator 22.50

NEW! HIGH SENSITIVITY POCKET MULTITESTER

20,000 OHMS PER VOLT DC — 10,000 OHMS PER VOLT AC



A terrific buy in a convenient accurate, completely wired instrument. Has a 3" 36 microamp meter, 1% precision resistors and efficient single selector switch. Scales: Volts DC and AC; 0-10-50-250-500-1000 Ohms; 0-50K-500K-5 Meg; DC current; 0-50 microamp-1MA-25MA-500MA. Decibels; —20 to +22, —20 to 36. Attractive plastic front in rugged shielding metal case. Imparted to save you money. Size: 3-5/8 x 5 1/4 x 1-5/8". Complete with batteries and test leads. Shpg. wt., 3 1/2 lbs. RW-50 Imported.....Net 14.50

Lafayette Radio 165-08 Liberty Ave. DEPT 1-G JAMAICA 33; N. Y. 100 SIXTH AVE. NEW YORK, N. Y. PLAINFIELD, N. J., 339 W. Second St. BOSTON 10, MASS., 110 Federal St. BRONX 50, N. Y., 542 E. Fordham Rd. NEWARK 2, N. J., 74 Central Ave. Include postage with order.

Bookshelf (Continued from page 26)

troubles and their remedies, and a complete mechanical and electrical list of replacement components available from the manufacturers or distributors.

Recommended: to technicians and audio fans who want to make adjustments on their own tape systems.



"VACUUM TUBE RECTIFIERS" by A. Schure, Ph.D. Published by John F. Rider, Inc., 116 W. 14th St., New York, N. Y. 69 pages. Soft cover. \$1.50.

Most of us are aware of the differences between the various types of rectifiers. However, when we are asked about filter circuits, voltage regulation, power supply impedance and other matters directly involved with power supply design, we're apt to be a little vague and unsure of our answers. This book provides those answers. There's a minimum of mathematical explanation, but the treatment of each topic is comprehensive enough for interested students, technicians or engineers to de-

velop a rounded approach to rectifier theory.

Recommended: for a fast brush-up on rectifier theory or as a basic study guide for the novice.

Free Literature Roundup

Engineering data on the Norelco EM-75B electron microscope is available in a 6-page folder from the Instruments Division of Philips Electronics, Inc., 750 S. Fulton Ave., Mount Vernon, N. Y. The text explains the electron optical system, lens system and view screen, and instrument operation. Four micrographs show the results obtained on typical problems.

Mechanical and electrical characteristics and typical operating conditions for over 300 television picture tubes are contained in a new Raytheon booklet. Data is included on aluminized, black-and-white and color picture tubes, and there is a full page of basing diagrams in large easy-to-read type. Write to Raytheon Manufacturing Co., 55 Chapel St., Newton 58, Mass., for your copy.

**NOW YOU CAN SECURE A
HIGH SALARIED • TOP PRESTIGE
CAREER IN ELECTRONICS
IN ONLY ONE YEAR!**

ELECTRONICS is the fastest growing industry in America today, creating unlimited opportunities for high salaries, with rapid advancement in **INDUSTRY AND THE ARMED FORCES** for Bailey Trained electronic engineering technicians.

LARGE CORPORATIONS from coast to coast, and **BRANCHES OF THE ARMED FORCES** send recruiters to visit each graduating class at Bailey Tech, offering unusually high starting salaries.

BAILEY GRADUATES ARE BEING HIRED for such fascinating and interesting work as technical salesmen, research and development of guided missiles, electronic business machines and automatically controlled manufacturing plants, etc., also good **RATINGS IN THE ARMED FORCES**.

UP TO SEVEN TECHNICIANS are needed for every engineer... this, plus superior training is why Bailey Graduates are being paid more to start, and are advancing more rapidly than many men who have spent four years in training.

Resident training is easier and costs less than you may think! We provide housing and part-time jobs while in school, plus free nationwide employment service for graduates. If you want to quickly enter America's fastest growing and most exciting industry, write for free booklet... no obligation.

**VETERAN APPROVED
BAILEY TECHNICAL SCHOOLS
1625 S. Grand • St. Louis 4, Mo.**



This Minneapolis-Honeywell system controls hundreds of automatic manufacturing operations. Experience on live equipment is emphasized at Bailey and is another reason for the tremendous backlog of high pay positions waiting **BAILEY GRADUATES**.

MAIL TODAY

Please mail immediately this free booklet without obligation

Name _____

Address _____

City _____ State _____



**AT
LAST!**

RADIO-TV and ELECTRONICS TRAINING

... **AT A PRICE
YOU CAN AFFORD!**



***21 INCH**
Receiver Kit included

Yes, this great course costs far less than any training of its kind given by other major schools! Radio-Television Training School will train you for a good job in Television or Industrial Electronics — **AT HOME IN YOUR SPARE TIME.**

Think of it—a complete training program including over 120 lessons, Fourteen Big Radio-Television Kits, Complete Color-TV Instruction, Unlimited Consultation Service . . . **ALL at a really big saving to you.** How can we do this? Write to us today . . . and find out!

And what's more — you can (if you wish)
**OPEN YOUR OWN RTS-APPROVED AND
FINANCED RADIO-TV SERVICE SHOP**

We Want 100 More Shops This Year

This 35 year old training organization — called RTS, that's Radio-Television Training School — wants to establish a string of Radio-TV Repair Shops in principal cities throughout the U. S. So far, 36 such shops are **NOW IN BUSINESS AND PROSPERING.** We are signing contracts with ambitious men to become future owners and operators of these shops in all areas.

**FOR UNSKILLED
INEXPERIENCED MEN ONLY —
WE TRAIN YOU OUR WAY!**

We must insist that the men we sign up be trained in Radio-TV Repair, Merchandising and Sales by our training methods—because **WE KNOW** the requirements of the industry. Therefore, we will **TRAIN YOU . . .** we will show you how to earn **EXTRA CASH**, during the first month or two of your training period. **YOU KEEP YOUR PRESENT JOB. TRAINING TAKES PLACE IN YOUR OWN HOME, IN YOUR SPARE TIME!**

**COMPLETE
COLOR
INSTRUCTION
INCLUDED**

*you build
all these units*



*tubes
excluded

RADIO-TELEVISION TRAINING SCHOOL

5100 S. VERMONT AVENUE
LOS ANGELES 37, CALIFORNIA

Est. 1922

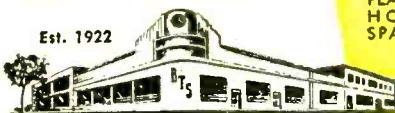

**ACT
NOW!**

Get your free book on the
FAMOUS RTS BUSINESS PLAN
find out how you can open
A REPAIR SHOP OF YOUR OWN

We supply and finance your equipment*

When you are ready and qualified to operate one of our RTS-Approved TV Repair Shops **WE WILL SUPPLY AND FINANCE EVERY BIT OF EQUIPMENT YOU NEED TO GET STARTED** plus an inventory of parts and supplies. In other words we will stake you **AN OFFER NEVER MADE BEFORE BY ANY TRAINING ORGANIZATION.** Under the RTS Business Plan you receive:

1. An electric sign for the shop front.
2. Complete laboratory of test equipment.
3. Letterheads, calling cards, repair tickets, etc.
4. Basic inventory of tubes, parts, supplies.
5. Complete advertising and promotional material.
6. Plans for shop arrangement.
7. Instructions on how to go into business.
8. Continuous consultation and help.
9. The right to use RTS Seal of Approval, and the RTS Credo.
10. The right to use the Famous Trade Mark.



RTS' Membership in The Association of Home Study Schools is your assurance of Reliability, Integrity, and Quality of Training.

**ALL
THESE
FREE!**



CUT OUT AND MAIL — TODAY!

RADIO-TELEVISION TRAINING SCHOOL

5100 S. Vermont Avenue, Dept. PE 78,
Los Angeles 37, California

SEND ME FREE — all of these big opportunity books — "Good Jobs in TV-Electronics," "A Repair Shop of Your Own" and "Sample Lesson." I am interested in:

- Radio-Television Industrial Electronics (Automation)

Name _____ Age _____

Address _____

City & State _____

300

Just off the press
NEW 16 pg. CATALOG
FREE!

EICO saves you 50% on test
 instruments & hi-fi. 55 models to
 choose from. MAIL COUPON NOW



Home, car,
 TV appliance
 repairs:
READI-TESTER
 =540
 KIT \$12.95
 WIRED \$15.95



**VACUUM TUBE
 VOLTMETER**
 =221
 KIT \$25.95
 WIRED \$39.95



**PEAK-TO-PEAK
 VTVM =232
 & UNI-PROBE**
 (pat. pend.)
 KIT \$29.95
 WIRED \$49.95



**1000 Ohms/Volt
 V-O-M**
 =536
 KIT \$12.90
 WIRED \$14.90

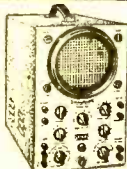

**5" PUSH-PULL
 SCOPE =425**
 KIT \$44.95
 WIRED \$79.95
 Lowest-priced
 professional Scope



TUBE TESTER =625
 KIT \$34.95 WIRED \$49.95



**RF-AF SIGNAL
 GENERATOR =324**
 (150 kc to 435 mc!)
 KIT \$26.95 WIRED \$39.95

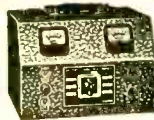

**6V & 12V
 BATTERY
 ELIMINATOR
 & CHARGER
 1050**
 KIT \$29.95 WIRED \$38.95
 Extra-filtered for transistor
 eqipt. =1060
 1 KIT \$38.95 WIRED \$47.95



**R-C BRIDGE & R-C-L
 COMPARATOR =950B**
 KIT \$19.95 WIRED \$29.95

**you build
 EICO KITS
 in one
 evening—
 but they last
 a LIFETIME!
 OVER 1
 MILLION
 in use
 today!**

**HIGHEST
 QUALITY
 HI-FI
 at lowest
 prices...
 only from**



NEW! FM TUNER HFT90
 KIT, less cover: \$39.95*
 WIRED, less cover: \$65.95*
 Cover: \$3.95
 *excise tax incl.



**MASTER CONTROL
 PREAMPLIFIER HF61**
 KIT \$24.95 WIRED \$37.95
 with Power Supply:
 KIT \$29.95 WIRED \$44.95



**12-WATT Williamson-type
 INTEGRATED AMPLIFIER HF12**
 KIT \$34.95 WIRED \$57.95

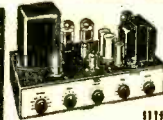

**20-WATT
 Ultra-Linear
 Williamson-type INTEGRATED
 AMPLIFIER HF20**
 KIT \$49.95 WIRED \$79.95



**60-WATT
 Ultra
 Linear
 POWER
 AMPLIFIER**
**HF60 with ACRO
 TO-330 OUTPUT XFMR**
 KIT \$72.95 WIRED \$99.95

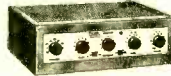

**NEW!
 30-WATT INTEGRATED
 AMPLIFIER HF32**
 KIT \$57.95 WIRED \$89.95



**NEW
 Standard
 Speaker
 System
 HFS2**
 \$139.95

Vitally
 different
 & better!

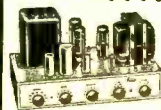

**50-WATT
 Ultra-Linear INTEGRATED
 AMPLIFIER HF52**
 KIT \$69.95 WIRED \$109.95

**COMPLETE
 with
 FACTORY-
 BUILT
 CABINET:
 2-WAY
 SPEAKER
 SYSTEM**
HFS1 \$39.95

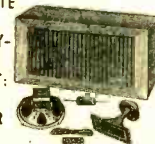

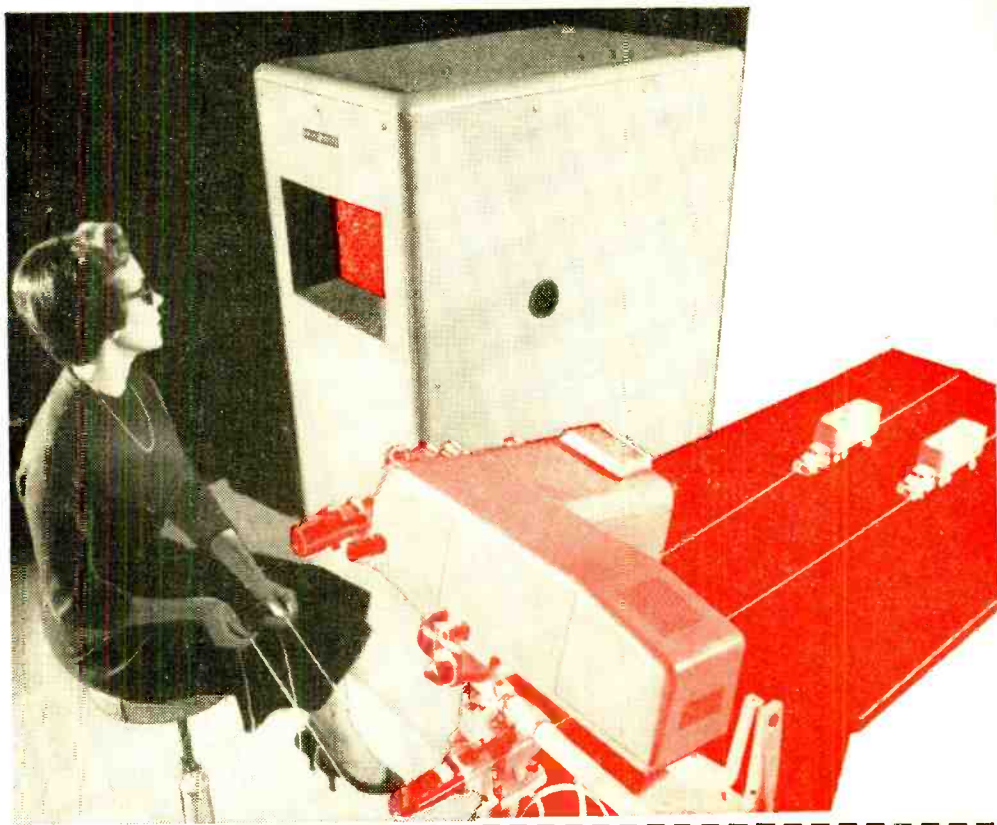

3D Color-TV is Here!

THREE-DIMENSIONAL color-TV is now providing realistic viewing of adjustments inside a nuclear reactor. Use of stereo allows the precise depth perception necessary for correct positioning of controls, and use of color-TV permits quick identification by the control operator of reactor equipment in the dangerous area where no human is safe.

The camera is installed inside the "hot" area, and cables carry the 3D color picture signal to a viewing console located safely outside the dangerous area behind thick shielding walls. The viewer watches the picture on the TV screen while operating remote manipulators which position and shift reactor components in the radioactive area.

This equipment was designed for use by General Electric's Aircraft Nuclear

Remote operator of nuclear

reactor can now view

in depth and color

By LOUIS E. GARNER, JR.

Closed-circuit three-dimensional color-TV system being adjusted by a project engineer at G.E. laboratory.

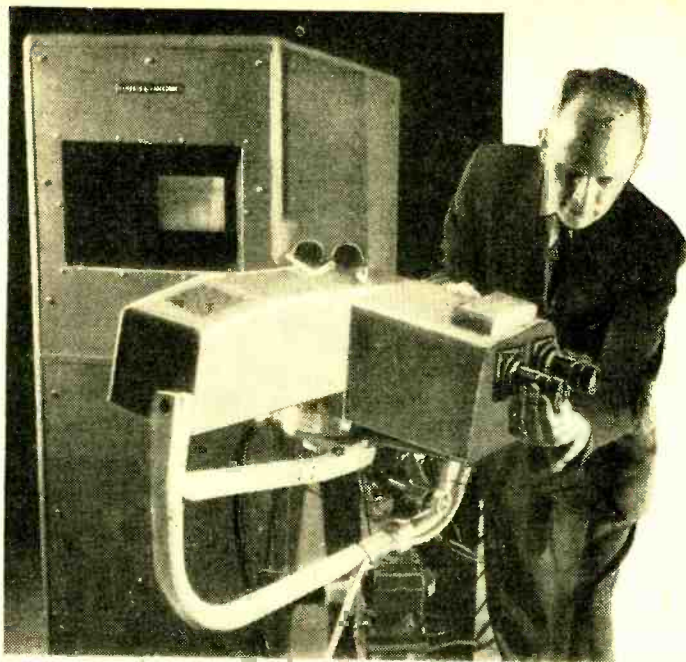

Propulsion Department at the Atomic Energy Commission's test site at Idaho Falls, Idaho.

How It Was Developed. To give the illusion of depth to a picture reproduced on a flat surface, two images are necessary. One is a view of the reproduced scene as it would be seen with the left eye, while the other is the view as seen with the right eye. Each eye must be able to see *only* the image that is intended for it.

There are several ways of accomplishing this. In the old-fashioned stereoscope and in hand-viewers, two complete pictures are used, with separate optical paths for each eye.

Theoretically, such a system could be used for 3D television. Two complete TV channels would be required, with each channel having its own camera, transmitter and receiver, and the viewer would have to use a special optical device for viewing the separate screens. But this type of system would be cumbersome and generally impractical.

A somewhat different system was developed and used in prewar motion pictures. A red image (for one eye) and a blue image (for the other eye) were projected *simultaneously* onto a single motion picture screen. The observer was supplied

with a special viewer which had red and blue filters; it was held in front of the eyes like a pair of spectacles and permitted one eye to see only the blue image and the other to see only the red image.

In postwar motion pictures, this early system was modified to permit the showing of full-color 3D films. The picture was reproduced using *polarized* light and the observer was supplied with a special pair of spectacles having properly oriented polarizing filters.

If the vibration of light is restricted to a single plane—such as the vertical—the light is said to be *polarized*. Such polarization may be achieved by means of simple optical filters. The color of light depends upon its frequency of vibration and not upon its plane of polarization. Thus, polarized light does not lose its color characteristics.

Once polarized, the light can pass through another polarizing filter *only* if the second filter is oriented to transmit light of the same polarization. In other words, if light is polarized in the vertical plane, it will not pass through a polarizing filter oriented to transmit light polarized in the horizontal plane, and vice-versa.

In practice, the image intended for one eye is vertically polarized and the image intended for the other eye is horizontally

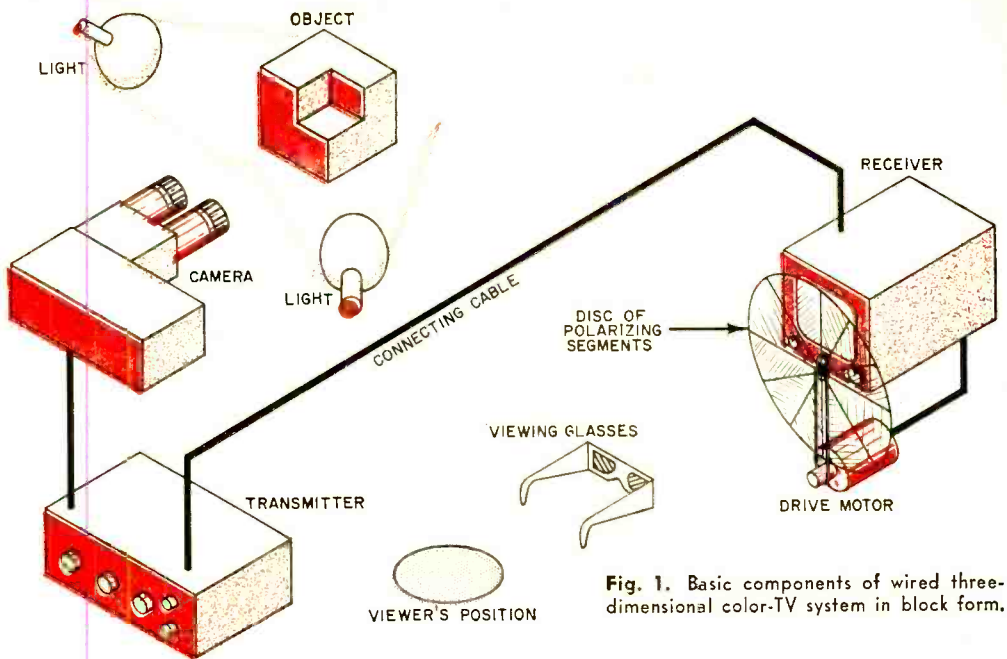

Fig. 1. Basic components of wired three-dimensional color-TV system in block form.

polarized. The special viewer used by the observer is equipped with one filter for each eye, which sees only the image meant for it, with each image retaining the full color of the original scene. It is this system, used in 3D motion pictures, that has been adapted to 3D color television.

How It Operates. A functional diagram of the basic system is shown in Fig. 1. The three components—camera, transmitter and receiver—are connected by multi-conductor cables. The camera is equipped with a dual optical system having a perspective similar to that of two eyes, and the scene viewed through the two lenses is transmitted through a rotating shutter to a special color-TV camera tube.

Instead of presenting the image to two

sensitive surfaces, as in the human eye, the 3D TV system presents the two images to a single sensitive surface (the camera tube) on a time-sharing basis, depending on the speed of the rotating shutter. The frequency of the time-sharing is at the picture rate of the television system—in the G. E. equipment, the rate is 90 pictures per second. Half of these pictures (or frames) are meant for each eye alternately. Thus, the frame-rate for an individual eye is 45 pictures per second.

Except for the frame rate and the use of a rotating shutter and dual optical system, the circuitry of the 3D color camera is quite similar to that of a conventional color-TV camera. It incorporates video

(Continued on page 117)

Fig. 2. Rotating drum of polarizing filters separates right and left images instead of disc in Fig. 1. See text on page 117.

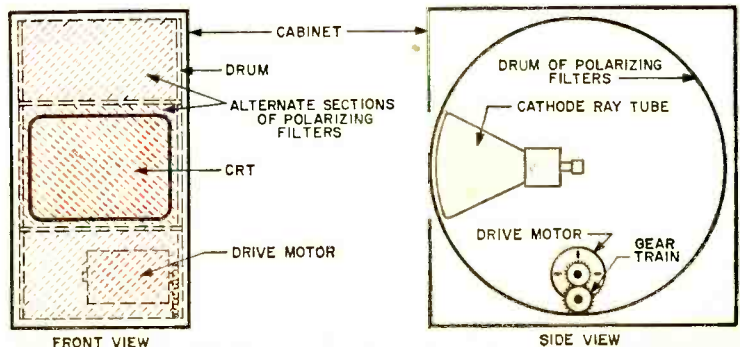

TALENT HUNT UNEARTH'S JUNIOR SCIENTISTS

IT HAS BECOME increasingly popular these days to weigh the youth of America on the scale of achievement and find it wanting. In many cases, the balance has been upset by glaring headlines and lurid newspaper tales of "juvenile delinquency." But there are other ways to measure the teen-ager in the United States.

Shown at left is a cyclotron and its young builder,

Reinier Beeuwkes III, who took the top award in the annual Westinghouse Science Talent Search held for the 17th time this year. He designed and built this cyclotron for accelerating electrons to high speeds. It cost less than \$150, and is only as complex "as a radio," he says, but it netted the 17-year-old Newton, Mass., lad a \$7500 science scholarship.

Reinier's scholarship was one of five such scholarships; the others ranged from \$6000 to \$3000. In addition, there were 35 cash awards. In all, a total of almost \$35,000 was presented to eight girls and 32 boys who were the winners—chosen from a field of 25,039 entries.

Begun in 1942, the science talent search was launched in the belief that the ability of America to maintain its scientific leadership depended upon the discovery and development of scientific ability among high-school youth. It is conducted by the Science Clubs of America through Science Service. The Westinghouse Educational Foundation, supported by Westinghouse Electric Corp., provides the financial backing.

The search is open to any high-school senior, who must face a science aptitude exam, submit a 1000-word report on his project, and allow his school to furnish a transcript of his scholarship record. This takes place in December of each year. All data are sifted and the field is reduced to about 600, then 300, and finally to about 40. This group is invited to Washington, D. C., where the boys and girls face a three-man board of judges which makes the final selections.

—30—





Transistors Replace Wall Outlet

**For boat or car,
transistorized oscillator
changes 12 volts from
battery to power line-
operated FM/AM receiver
or other equipment**

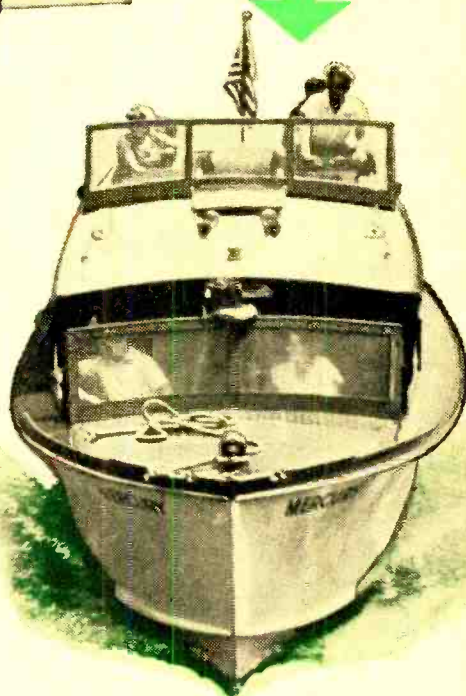

AN INVERTER is a device for changing direct current to alternating current. One type of inverter is used where the only commercial power available is d.c., to make it possible for people to operate a.c. appliances such as radios, TV sets and hi-fi systems. This is the heavy-duty rotary type, which is a motor and an alternator in one housing on the same shaft.

Inverters are also used in cars and boats to convert the 6 or 12 volts d.c. of the batteries to 117 volts a.c., to permit the operation of dictating machines, tape recorders and even television sets. These are the vibrator type, like those found in automobile radios before the advent of transistors. Both types are bulky and draw relatively large currents from the battery.

For Shipboard Use. The author owns a low-current three-way portable radio, designed to cover the broadcast band, the FM band, and the low-frequency beacon band,

July, 1958

By
ROBERT B. TOMER

and wanted to use this radio on board a small cruiser which had a 12-volt d.c. electrical system. It *could* be operated from its internal dry batteries, but since it contains quite a number of tubes, battery life would be relatively short. Intended for use as a "standby" unit, the radio might be expected to operate for hours at a time on a cruise.

The most desirable situation would be to be able to draw power for the set from the 12-volt system while under way, or while at anchor. If the 12-volt supply should become exhausted, as a result of running other shipboard electronic gear, the radio's internal batteries would always be available for emergencies.

An inverter was needed which would convert the 12 volts d.c. to 117 volts a.c. at the lowest possible drain. Several small vibrator supplies were investigated, but after considerable time and effort spent in unsuccessful attempts to filter the "hash" out of the radio (radio interference caused by vibrators), they were abandoned. Their power drain would have been excessive even if the filtering had been successful.

The answer was found to be the transistor inverter shown in Fig. 1. The finished unit could have been smaller, but it was convenient to build it on an available 6" x 4" x 4" aluminum chassis. It weighs less than a pound and draws less than an ampere from the 12-volt system when operating the radio. It has no moving parts and is completely silent. No filtering other than a 0.1- μ fd. capacitor is needed.

Construction. The original model of transistor inverter was built around a home-made transformer. There is now available a transformer which will exactly fit this job. It is Type 6L6000, made by Thermador Electrical Mfg. Co., 2000 S. Camfield Ave., Los Angeles 22, Calif.

Transformer *T1* is mounted on a small aluminum chassis, made by cutting the top off a 6" x 4" x 4" chassis. Cut it one inch deep so that you have a 6" x 4" x 1" chassis. A second chassis, having the original dimensions, is used as a cover for the unit when it is finished.

Mount the two power transistors, *TR1* and *TR2*, being sure to use mica insulators under them to prevent their shells from contacting the chassis directly. Use fiber insulating washers under their mounting screws. The transistor case is connected internally to the collector, and this must

not be allowed to ground. You can check to be sure *TR1* and *TR2* are not grounded by using an ohmmeter and measuring between case and chassis. If only a few ohms are read, locate and eliminate the short.

After mounting the transistors, mount the on-off switch, a pilot light socket and the a.c. outlet socket. Terminals will be needed for the 12-volt input connections and a fuse block is added for safety.

The wiring consists merely of connecting the appropriate leads from *T1* to *TR1* and *TR2* and to the output. Connect the pilot light, *C1*, and the unit is ready for test.

Trying It Out. In testing the unit, a scope is most valuable, but an a.c. voltmeter will do. A variable d.c. source is

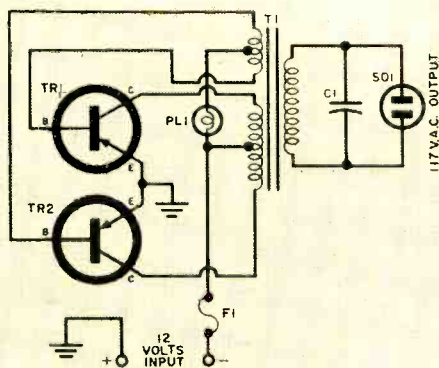

PARTS LIST

- C1*—0.1- μ fd., 600-volt capacitor
- F1*—4-amp., 32-volt fuse (Littelfuse Type SFE)
- PL1*—Pilot light (G. E. #1815)
- SO1*—Power socket
- T1*—Special transformer (Thermador 6L6000)
- TR1, TR2*—2N256 p-n-p power transistor
- 2—6" x 4" x 4" aluminum chassis

HOW IT WORKS

The inverter works as a free-running oscillator. One transistor starts it by drawing somewhat more collector current than its mate, due to the inevitable differences that exist between transistors.

As its collector current flows through transformer *T1*, it induces a current in the base winding. This winding has been so connected that the current is in the right direction to bias its base more negatively, and more collector current flows.

At the same time, because it is a transformer, the other end of this base winding is going positive, and this is being fed to the other transistor. The positive flowing current keeps this transistor "turned off."

The conducting transistor keeps on conducting as long as the rising collector current is matched by a rising base current. Eventually, the transformer core material saturates and its field commences to collapse.

When this happens, the current in the base winding suddenly reverses, the conducting transistor is switched "off," and the one that was not conducting is switched "on." This results in a square-wave voltage being induced in the secondary. It is this voltage stepped up which is used to operate the radio.

Output frequency is close to 60 cycles.

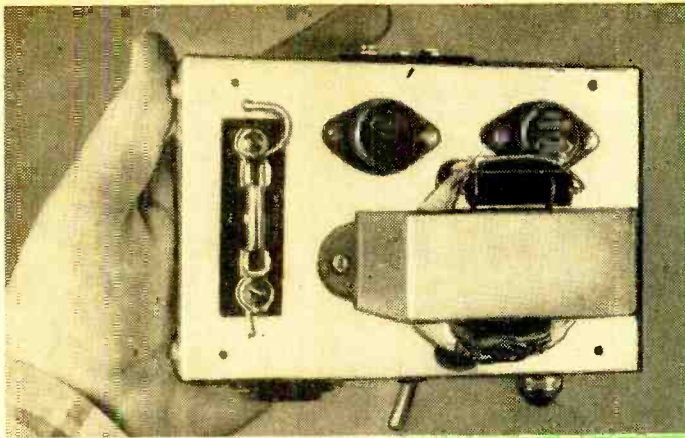
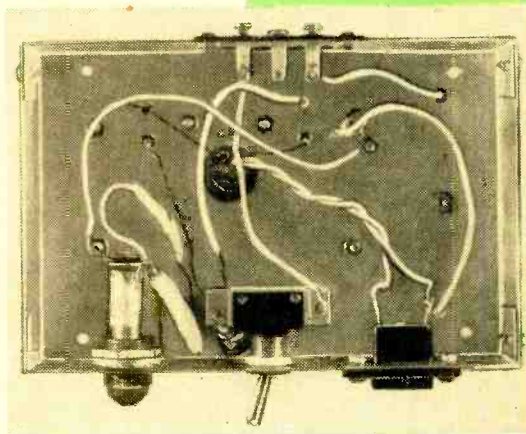

Fig. 1. Power transistors in oscillator circuit (on page 36) operate from 12-volt battery.

Chassis of inverter makes a convenient handful (above). Be sure to insulate the transistors from the chassis.

All parts and wiring are placed in the shallow chassis (left); the other one is used only as a cover.



also desirable. Connect the inverter to the d.c. supply with the input reduced to one or two volts. Be sure the battery's positive terminal is grounded to the chassis.

Observe the a.c. voltmeter connected across the output receptacle and note the voltage at the reduced d.c. input. If it shows nothing, reverse the two leads which go to the base connections of the transistors. The meter will now show voltage.

Increasing the input to 12 volts should cause the meter to read around 150 volts a.c., without a load connected. Pilot light *PL1* should light dimly. Plug a small, three-way portable radio into the outlet socket. A 10-watt, 117-volt bulb may be substituted if desired.

No load drawing more than 10-15 watts should be plugged into this inverter. When a load is applied, *PL1* should brighten to full brilliance. The inverter is functioning normally if the input current, when loaded to about 10 watts, is around 1.0 ampere.

This will indicate an efficiency of around 80 to 90%. The unloaded input current should be about half that amount.

What the Pilot Light Does. The base of each transistor returns to the negative side of the battery through the base winding center tap and then through the pilot light. When the system is turned "on" and the oscillations have not as yet started, *PL1* is cold and its resistance is quite low.

The battery voltage divides across the input resistance of the base diodes and *PL1*'s cold resistance. This places a high forward bias on both *TR1* and *TR2*, insuring their starting, even under full load.

When oscillations start, this heavy base current is unnecessary and would not be economical; so it is desirable to cut it down. This is done automatically by *PL1*'s rise in temperature as the increased base current flows through it. The hot resistance is several times the cold resistance,

(Continued on page 106)



Tape for Pictures

ONE of the most ticklish aspects of the whole video tape operation is the manufacture of the tape itself. In these photos taken at the new ORRadio plant in Opelika, Ala., we can see some of the inspection steps used to insure perfect tape—which will “play back” a signal just about indistinguishable from a live telecast.

At the top, a technician checks a sample roll used to record the opening-day ceremonies at ORRadio on a new Ampex VR-1000 Videotape Recorder. Each inch of tape must carry about 20,000 bits of information.

Above, right, a machinist gauges the adjustment between the cutter blades used to shear a master roll of 1'-wide tape into smaller widths. To insure accuracy, the tape is not sliced. Rather, the blades scissor it into strips.

At right, the tape is being inspected for imperfections which might cause “drop out.” This phenomenon, which shows up as pips on a TV screen, may be caused by some flaw in the deposit of iron oxide on the magnetic tape. —30—

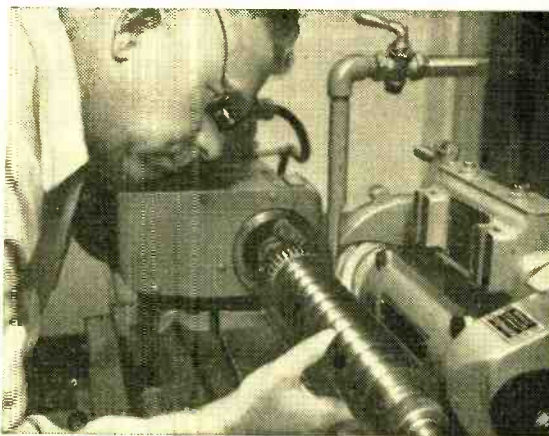

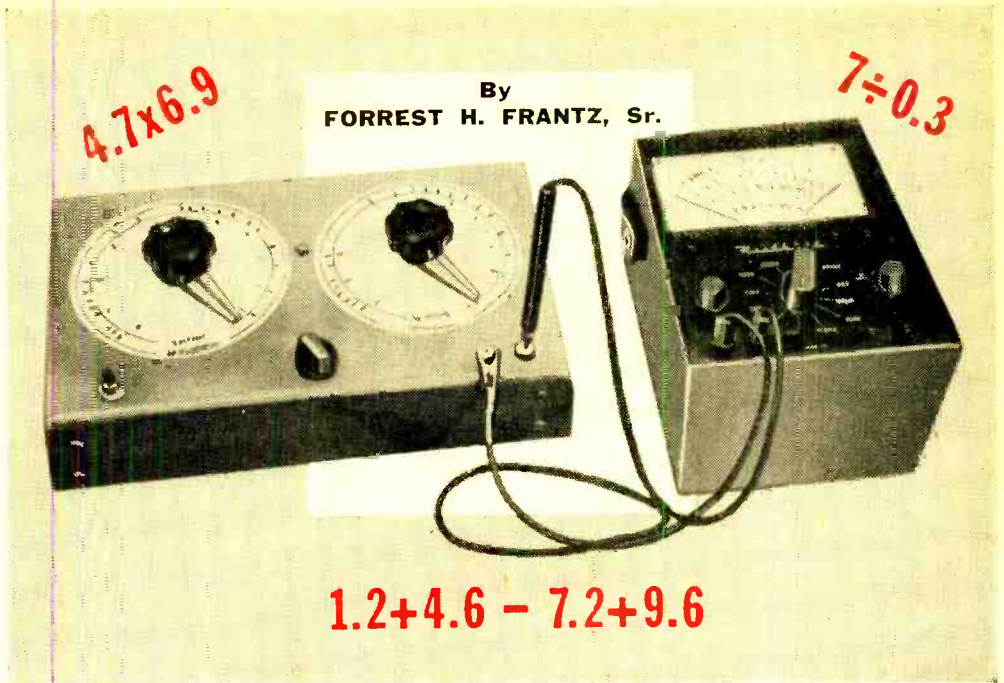

Compute—With Pots

How to
MULTIPLY
DIVIDE
ADD
and SUBTRACT
with simple potentiometer circuits

WHEN we think about *arithmetic*, we think about addition, subtraction, multiplication and division. *Algebra* extends the usefulness of arithmetic by employing symbols for quantities. *Trigonometry* brings into play the relationship between sides and angles of triangles. Using one or more of these three mathematical approaches, most of the design problems encountered in electronic equipment can be solved. And since these branches of mathematics are required so frequently, long-hand "figuring" is becoming antique and impractical.

New techniques of calculating include the principle of *analogy*. Some physical quantity is used to represent the unit one. For example 1 inch may equal the unit 1 or 1 pound may equal the unit 1. Thus 5 would

be represented by 5 inches or 5 pounds. These quantities are then physically added or subtracted, and the remaining quantity is actually measured or weighed to determine the answer. Since mechanical analogies are bulky and sometimes expensive, electrical quantities are more convenient in most cases.

You can multiply a voltage by amplifying it. However, an amplifier usually has constant gain, and in order to create a *variable* multiplier, a gain control (potentiometer) must be included. The potentiometer can then be calibrated in terms of multiplying units.

If a large enough voltage is used and the read-out (indicating) voltmeter is sensitive enough, no amplifier is necessary. A poten-

tiometer calibrated from zero to 10, or zero to 100 can be used to simulate multiplication, although it actually performs division.

Figure 1. If an input of 10 volts is applied across the end terminals of a linear potentiometer, 1 volt will exist across terminals 1 and 2 when the shaft is rotated one-tenth of the way from terminal 1 toward terminal 3. When the shaft is rotated an additional one-tenth (or a total of two-tenths) of the way toward terminal 3, 2 volts can be read. This relationship holds all the way up to the number 10 (at full rotation) where the voltage will be 10 volts.

Thus, a simple pot can be used to generate the numbers from one to ten. If intermediate points are calibrated, numbers like 2.3, or 5.8 are easily generated. If a second pot is connected with its end terminals across the terminals 1 and 2 of the first pot, the second one will "multiply" the number generated by the first. (See *After Class* in May 1958 POPULAR ELECTRONICS, pages 76

Top and under-panel views of multiplier show the simplicity of the wiring. Use direct, point-to-point connections. One or both terminals should be insulated from the metal chassis.

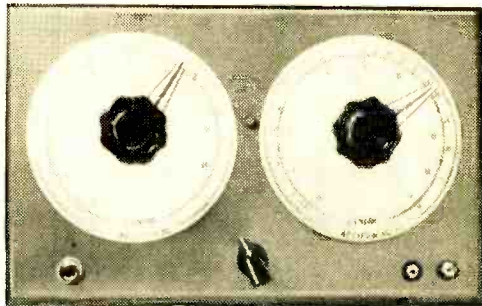

and 118, for alternate circuit and additional explanation.)

Figure 2. In this simple two-number multiplier, voltage is furnished by a flashlight battery when the momentary contact switch *S1* is pushed. *Rcal* is the calibration control, potentiometers *A* and *B* are operational multiplier elements, and a voltmeter is connected across the output terminals.

Use one flashlight cell if the lowest scale on your voltmeter is 1.5 volts or less; use two cells for 2.5 volts. If the lowest scale is greater than 2.5 volts, but less than 4.5 volts, use six cells in series-parallel to furnish 4.5 volts. (Pots with asterisks in Figs. 2 and 3 are Clarostat Type 58C1.)

The circuit in Fig. 2 will yield most accurate results with VTVM's and voltmeters having sensitivities of 5000 ohms per volt or greater. For voltmeters with sensitivities between 5000 and 10,000 ohms per volt, *Rcal* should be connected as a series rheostat by breaking the connection at the point marked *X*. A fixed series resistance may have to be inserted in the lead at point *Y* which can be determined experimentally.

To calibrate: (1) connect your voltmeter to the output jacks and set it to the lowest d.c. volts scale; (2) set *A* and *B* full clockwise beyond 10 on the scale marked *Linear*; (3) push switch *S1* and adjust calibration pot for a full-scale deflection of the voltmeter if you have a scale on your meter that is a multiple of one (i.e., 1, 10, or 100 volts)*; (4) adjust the dial knobs on potentiometer *A* and *B* shafts so that zero meter deflection is not experienced until the hairlines cross the zero mark; (5) check accuracy by moving pot *A* to the whole number markings from zero to 10 with pot *B* on 10. Record meter readings. Repeat with pot *B*

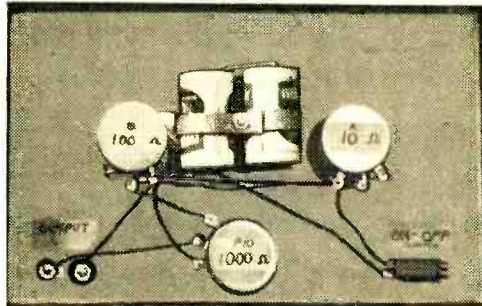

being moved and pot *A* set to 10. If the results are not accurate, you may be able to improve them by resetting one of the pointer knobs on the shaft.

Suppose you want to multiply 4.7 x 6.9. Perform calibration adjustment (3). Set 4.7 on one pot and 6.9 on the other, and read the result, 32.4, on the voltmeter. Note that the proper scale factor must be used in reading your answer. Thus, if you had wanted to multiply 47 x 69, you would have assumed the potentiometers to be cali-

* Otherwise, set *Rcal* for deflection to one on the scale which will use the greatest portion of the scale. For example, if your voltmeter has d.c. scales that are multiples of 1.5 and 5, set *Rcal* for deflection to one on the 1.5-volt scale; if your scales are multiples of 2.5 and 10, use the 2.5-volt range, but adjust for full-scale deflection and read results on the 0-10 scale.

brated from 0-100 instead of 0-10, and the answer would have been read as 3240.

As with analog devices in general, the answer is not exact. It is, however, sufficiently correct for most engineering purposes. Practice may be required for correct scale interpretation.

The dial knob pointers can be made from thin plastic. Scratch the line with a pointed tool, using a ruler as a guide. Then allow a small quantity of India ink to flow into the scratch to produce the hairline. The plastic pointer is cemented to the knob.

On the dial scale layout (below) for the operational potentiometers, the scale

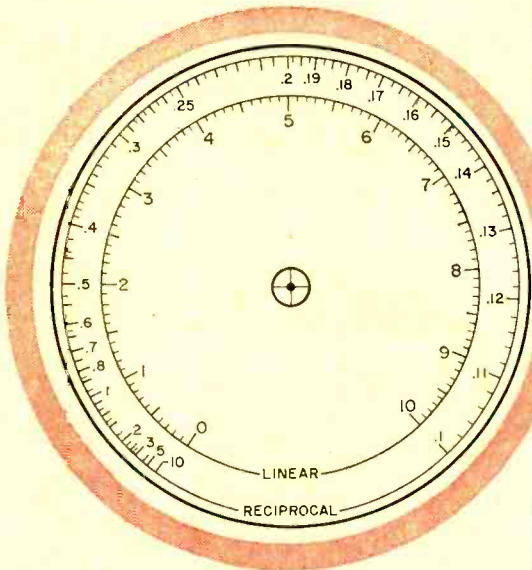

Dial scale layout above is identical for each pct. See text for details.

marked *Linear* (which isn't exactly linear since the loading of the following potentiometers is accounted for) is used to represent a number appearing as a multiplier. The scale marked *Reciprocal* is used to represent a number appearing as a divisor.

Thus, to divide 7 by 0.3, set pot *A* to 7 on the linear scale, and set pot *B* to 0.3 on the voltmeter. This is quite close to the more exact answer, 23.3, and sufficiently accurate for engineering purposes. If your knowledge of math is sufficient, it's possible to add cosine, sine, tangent, or log, square root, and square scales.

Figure 3. This advanced four-number multiplier circuit utilizes an a.c. voltage
(Continued on page 123)

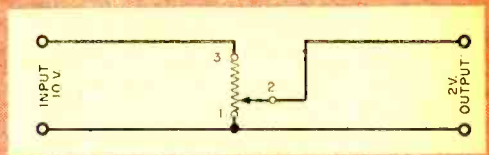

Fig. 1. Basic unit showing mode of operation.

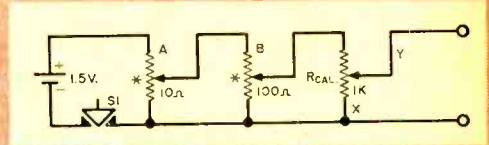

Fig. 2. Two-number d.c.-operated multiplier.

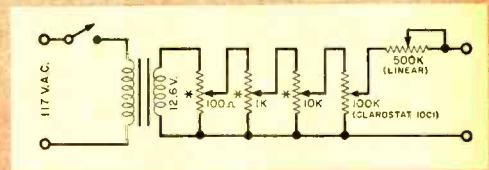

Fig. 3. Four-number a.c.-operated multiplier.

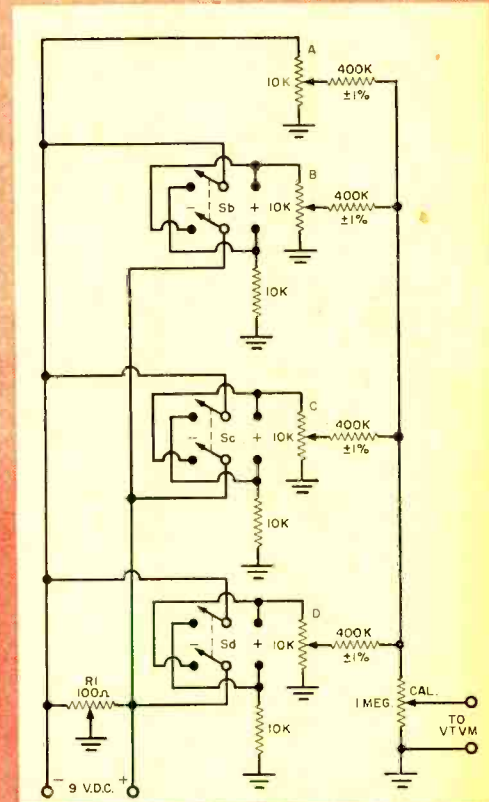

Fig. 4. Four-number adder-subtractor unit.

Snapshots in Sound

**Relive your summer vacation
with a record on tape**

YOU'RE ALL PACKED and ready for that summer vacation you've planned for a whole year. You make a last-minute check. Got the bathing suits? Travelers checks? Suntan oil, guide book, maps, camera, film . . . ?

Didn't you forget something? You took a camera, maybe even a movie camera, too, to make a permanent record of fun in the sun. But did you ever think of making a *sound* record of your vacation?

The results, if you do it properly, may be every bit as enjoyable as the reels of color film you'll run during the long winter evenings . . . perhaps more so, if you can supplement some careful planning with a little bit of luck.

Recordings of just little, simple things can evoke wonderful memories of surf at the beach, the gang singing in the moonlight, talk around the campfire at that dude ranch, the thunder of the falls at Niagara, the hoot of a ferryboat passing the Statue of Liberty, or the roar of traffic at Times Square.

Narration or your description of the scenes can be put on the tape right away and intermingled with vacation sounds. If you don't have the time to do this in detail while on vacation, it can be done later at home and spliced in at the proper point.

Another facet of your vacation recording would be to capture the scene on tape *as you film it!* For instance, you might take a black-and-white or color movie at the same time you record the sound effects and your thoughts.

What Kind of Recorder? In effect, you are limited only by your imagination this



Folkways Records photo
of Serbian musicians

summer, but you should keep the following tips in mind.

For convenience, the best machine would be one of two types: the recorder whose amplifier and motor are powered by batteries, or the one whose amplifier is battery-powered but whose motor is driven by winding a spring. Be sure you take along enough batteries, or check to make certain replacements are available wherever you go.

Prices for models which have a frequency response of 50 to 6000 or 7500 cps (best for music recording) range from

Telectro recorder

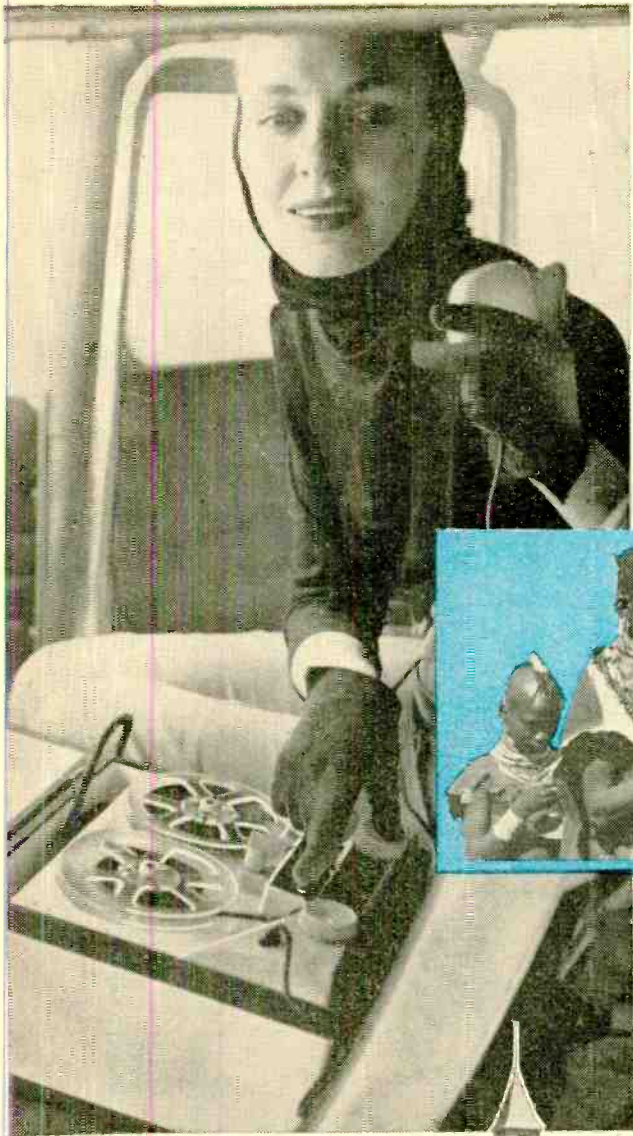

By **MIKE BIENSTOCK**
Associate Editor

Photo of Uganda natives courtesy
Uganda Information Department



about \$250 to \$500. You can get these in speeds of 3% and 7½ ips, and here you'll have to decide which is best. For higher fidelity, pick the higher speed, but you'll have to sacrifice playing time. For most purposes, the slower speed will do, and you'll get a lot more recording.

If you take the standard 60-cps recorder, you will have little trouble in

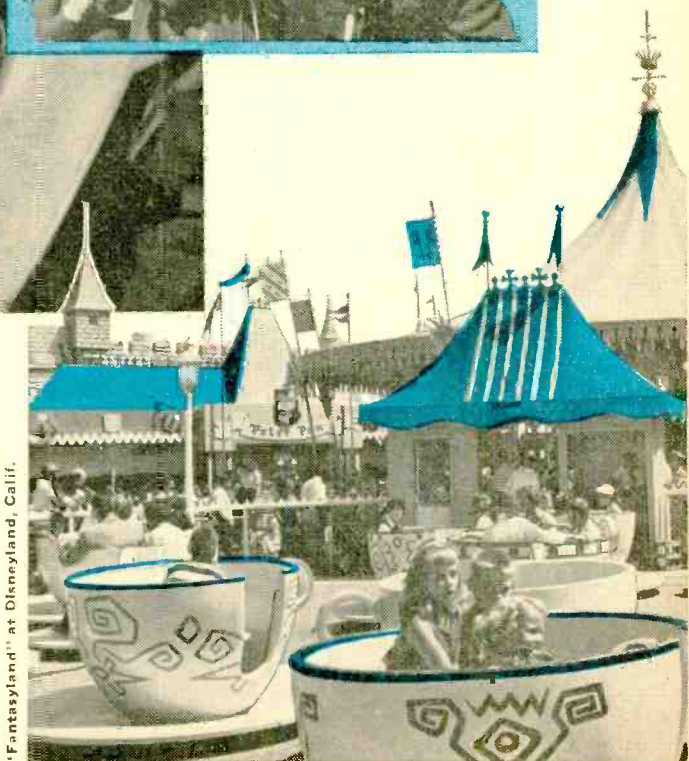

"Fantasyland" at Disneyland, Calif.



this country since most United States lines are 117 volts a.c., 60 cps. Small areas in a few cities may have 25 cps. Check with the utility company when you arrive.

You can send to the Superintendent of Documents, U. S. Government Printing Office, Washington, D. C., for a copy of "Electric Current Abroad," available for 25 cents. It will give you data for every area in the world that has a generator.

Most foreign countries use 50-cycle current, with voltages varying all over the lot from 100 volts in Japan to 13,000 in Harbel, Liberia (a rubber plantation). Mostly, however, you can bank on about 220 to 240 volts.

As a general rule, power-line voltages in Canada and the West Indies seem to run about the same as the United States, although there are exceptions. Countries in Europe favor 50 cycles at 220 volts, but



One of the newest recorders on the market is the Italian Geloso shown (above, left) in use in a car. Its light weight—only 7½ pounds—makes it ideal for vacations. Some recorders have batteries to power the amplifier and a spring to run the motor, such as the Swiss Nagra II C1 (above), which weighs just under 12 pounds. Probably the easiest recorder to use is the kind which employs batteries to power both amplifier and motor, such as the Stancil-Hoffman Minitape (left) which weighs in at 13 pounds and is available at all speeds.



An inverter is necessary for outdoor operation of the 117-volt recorder, to change battery power to a.c. Shown above is an ATR, which supplies 117 volts at 60 cycles. If you convert your machine to 220-volt, 50-cycle operation for Europe, and you want to use it outdoors, get a European inverter.

there are many variations even within one country.

Converting Your Machine. To record at 50 cps and have the playback at the correct speed when you get home, you'll have to get the recorder converted. This is usually a rather simple affair, necessitating only the change of a bushing or drive wheel. Conversion kits are available for many machines at a nominal sum—the bushing will cost perhaps \$4 or \$5, and the labor \$3 or \$4.

A step-down transformer (if the voltage is higher than your machine operates on) or a step-up transformer (if the reverse is

(Continued on page 108)

127' long, holds 340 tons of tuna, crew of 15.

National Steel & Shipbuilding diesel clipper.



AMATEURS HELP THE TUNA FLEET

They relay messages and news of the fishermen to families waiting at home **By E. H. MARRINER**

AFTER A FEW MONTHS at sea off South America, the crew members of tuna clippers out of San Diego, Calif., become lonesome for home and news of their loved ones. Their families, on the other hand, are concerned for their men at sea.

One radio amateur, Don Campbell, W6SK, has won the gratitude of many of the crew members and their families by setting up a local clearing point to relay messages and phone patches. Campbell has had some exciting contacts with the fleet, relaying news of it to

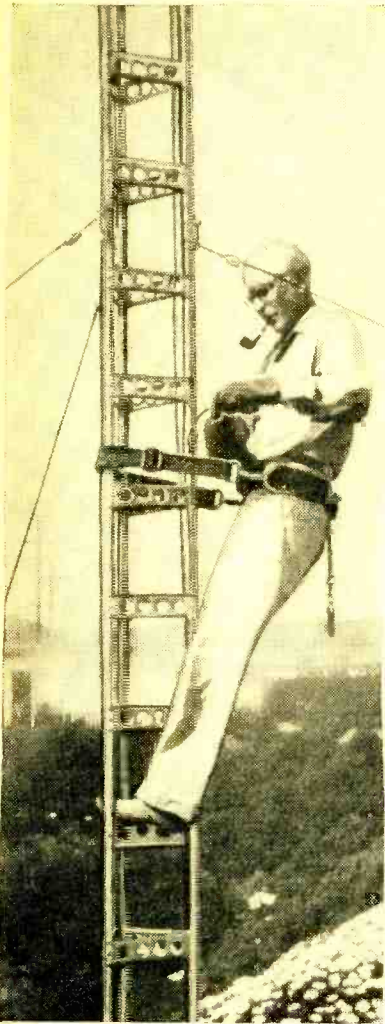

W6SK, San Diego, repairs an antenna (above) before schedules with amateur stations aboard the tuna ships. At right is his operating position.

local authorities concerning deaths, sickness, groundings and other emergencies.

One emergency where amateur operators helped was in handling traffic from the "Sun Pacific" clipper which sank in a squall in the Gulf of Tehuantepec. Emil Piraino, K6BOM/MM, from his station aboard another tuna vessel, relayed emergency traffic via station W6SK after the SOS had been cleared.

Almost any night amateurs can hear W6SK talking to the tuna clippers beating their way back up the Central American coast toward home. The tuna boat operators may be describing their view of volcanoes spewing smoke off Guatemala, or listeners may hear the sounds of a heavy storm tearing off a cabin door and flooding the engine room. There might even be a blow-by-blow description of fishing gear going over the side.

The tuna men must continually adjust themselves to meet the ever-changing mood of the sea which one day is calm, beautiful, friendly, and the next day angry and turbulent, forcing them to struggle for their lives against it.

Aboard the clipper "Conte Bianco," for example, radio operator W6YXK/MM, Larry Herman, was basking in the tropical sun 80 miles off the coast of Peru on the 14,000-fathom bank. As he was about to go in and fire up his transmitter to contact the States, the crew below called for help. They had been pulling in the bait boat when one man slipped, hitting his head. W6YXK/MM sent out an emergen-

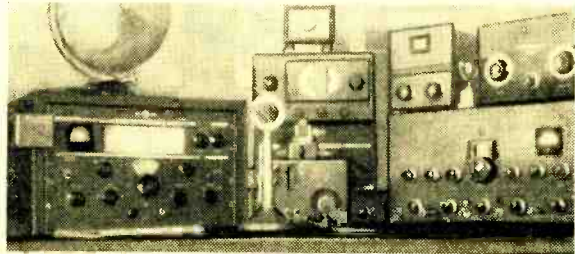

cy call on the 21-mc. band and contacted K4KQY in Jacksonville, Florida, who in turn contacted the doctor at the U. S. Naval Air Station. But it was too late, and the crewman died. That evening Herman sent the message of grief to San Diego via W6SK.

If you eavesdrop, you can soon appreciate what a boon amateur radio has been, even though these fishermen-amateurs are only allowed to operate on the 28-mc. and 21-mc. amateur band. The fishermen aboard the boats know that there are some amateur operators back home who care. —30—

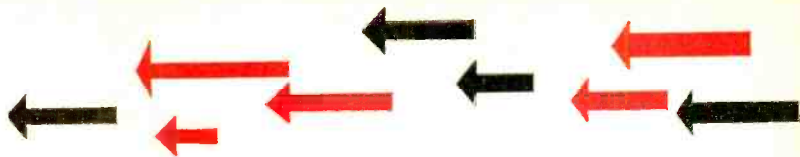

Go Mobile with the "Auto-Fi"



MANY HI-FI FANS have attempted to improve their listening pleasure in the family automobile by adding a rear-seat speaker. The "Auto-Fi" will give you better response than mounting a speaker in the trunk cavity of your car.

The enclosure must be compact. And it must use a relatively small single opening, since it would be difficult to cut additional holes in the rear shelf.

The speaker used in the model is a 6"x9" coaxial oval speaker, Lafayette SK-75. Crossover is obtained automatically without a separate network. Experiments showed that a parallelogram speaker opening would be satisfactory with the use of an oval speaker, which simplified construction.

Angling the Speaker. Parts for the enclosure are shown in Fig. 2. They are cut from $\frac{3}{8}$ " plywood. Blocks are pine.

The speaker mounts on a separate mounting board $8\frac{1}{2}$ "x $9\frac{1}{4}$ " which is set back from the front panel by two $\frac{3}{8}$ "x $\frac{3}{8}$ "x $8\frac{1}{2}$ " spacing blocks, like a sandwich, allowing for air space (see Fig. 1). Both the speaker on the mounting board and the parallelogram opening in the front panel

**Improve auto radio listening
with novel enclosure**

By B. VAN SUTPHIN

are angled with respect to the long dimension of the enclosure. This gives better sound dispersal.

Glue $\frac{3}{4}$ "x $\frac{3}{4}$ "x $9\frac{3}{8}$ " bracing blocks to the long edges of each end piece. Use wood clamps to hold the glue joints securely. When dry, drill pilot holes and install $\frac{3}{4}$ " wood screws previously dipped into the wood glue. Use enough screws to hold solidly.

Temporarily clamp the sides in place and drill pilot holes for installing $\frac{3}{4}$ " wood screws to hold the side pieces to the bracing blocks. Be sure to fit the side pieces flush to the back. They will overlap $\frac{3}{8}$ " to allow

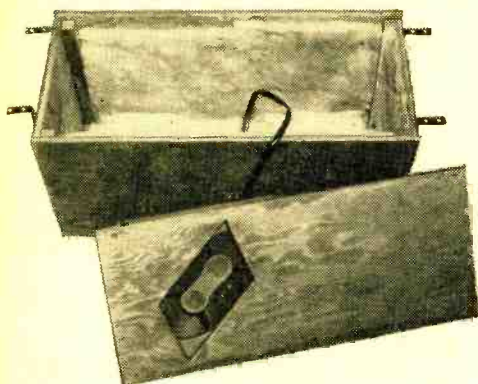
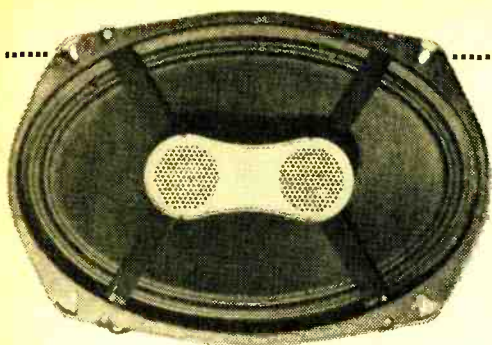

for mounting the front panel. (See Fig. 1.)

Place the back on the enclosure. Pilot holes should be drilled at the four corners at the bracing blocks. Use $\frac{3}{4}$ " wood screws dipped in wood glue.

Prepare the front panel for the enclosure by following Fig. 2. Draw the parallelogram and cut it out with a keyhole or jig saw. The edges can be smoothed with a wood rasp.

Now cut out the angled ellipse in the center of the speaker mounting board. A template is convenient for marking the cutting line. If you do not have one, place a sheet of paper over the front of the speaker and trace lightly around the *inside* edge of the speaker rim. Paste the sheet to a piece of medium-weight cardboard and cut out the ellipse.

Mounting the Speaker. First, mount the sound insulating material. No insula-

Unusual Lafayette oval twin-tweeter speaker shown at top of page is ideal for the car enclosure seen opened up directly above. The speaker can be seen through the parallelogram opening. While it's not evident above, the speaker is actually mounted on a board separated from the front panel by two spacing blocks made of pine.

Fig. 1. Note the exact construction details (at right). You can see the sandwich effect of the speaker mounting board separated from the front by spacers.

Fig. 2. Parts for the enclosure (on page 49). Cut elliptical opening for speaker in mounting board and parallelogram in front panel as shown in diagram.

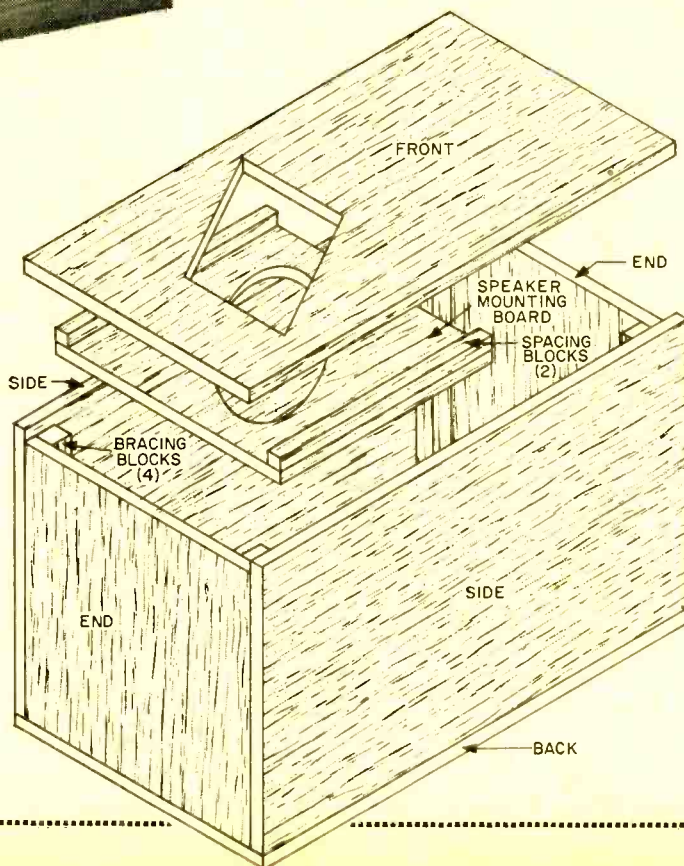

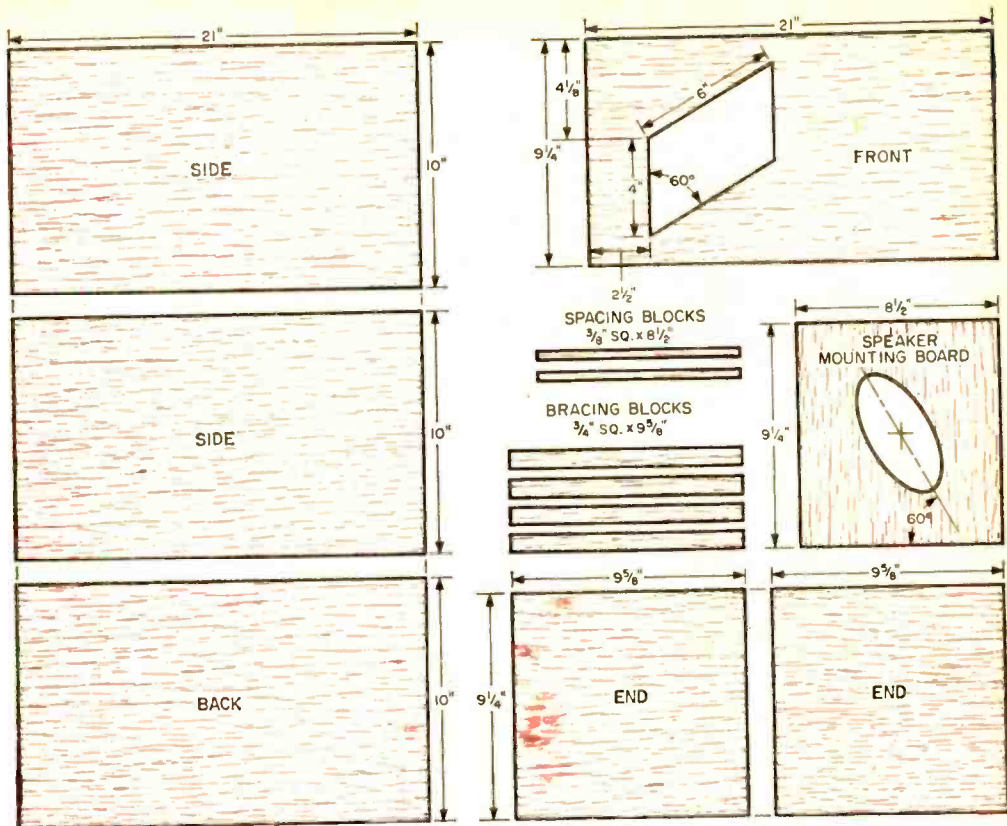

tion is used on the front panel or the end nearest the speaker. Insulation is required on both sides, the back, and the end farthest from the speaker.

For best results, spread a thin layer of glue where the insulation is to be placed and cut the insulating material to size. Staples at various points—most desk-style staplers can be opened for tacking—will hold the material while the glue dries.

Mount the spacing blocks on the front panel. The ends of these blocks must be $1\frac{1}{8}$ " from the end of the front panel. Use glue and wood screws for secure mounting.

Mount the speaker on its board and mount the board on the spacing blocks. Drill a hole in one of the enclosure sides for the speaker leads to pass through, then connect the speaker leads. (The Lafayette SK-75 speaker has two terminals connected to the woofer voice coil. One of these terminals is also connected to the tweeter assembly. Connecting the other terminal to the speaker frame puts the two tweeters in parallel with the woofer for proper operation.)

After passing the leads through the hole, place the front panel in position and drill pilot holes for the mounting screws. The screws must go through the panel and into the ends of the bracing blocks at the four corners. Do not use glue—1" wood screws will hold the panel securely while allowing easy removal.

Putting It In. Mount the enclosure beneath the rear shelf, under a hole slightly to the right of the car center. To hold the unit in place, use stove bolts passing through angle brackets screwed to the ends of the enclosure.

It may be necessary to drill holes in the shelf to obtain proper positioning. Use two nuts on each bolt for positive locking action.

The enclosure must be tight against the shelf to prevent vibration, and also to prevent air leakage into the trunk. Glue insulating strips around the underside of the shelf hole to seal.

Grille cloth backed with wire screening or perforated aluminum can be used to cover the opening.

OPERATION BLUB



By Carl Kohler

SHE WAS SLENDER. She was shapely. She was, beyond any doubt, a gorgeous little thing. And, best of all, she was *mine*. Crooning soft melodies of love, I fondly stroked her gleaming, trim form.

Suddenly, the workshop door flew open.

"My good gosh!" hissed my wife, "Are you still playing around with *her*?"

"Jealous, dear?" I smiled in spite of myself.

"You're darn right, I'm jealous! What

those kind that go inside a bottle when you told me you intended starting a boat project," complained the wife. "Instead, you come up with *this* amazon! Five feet of boat, yet!"

"Honeypot," I said quietly, "when one builds an R/C boat, one does not put it in a bottle. One puts it in the water and that's exactly where I'm going to launch 'The Mermaid.' In the water."

The wife touched the brass fittings on the model cruiser with a tentative finger.

"Golly, she sure looks like the real thing! Only smaller, of course. You've sure put a lot of work and time into building her. It certainly will be a pity."

"Pity? What will be a pity?"

"Oh, *you* know . . ." she trailed off, meaningfully.

"No," I said in a voice harder than congealed suspicion, "I do not know. You tell me. Exactly *what* will be a pity?"

"Oh—heh, heh, heh—you know what *always* happens!"

I drew myself up to my full height. This never proves anything or impresses her, but it somehow always makes me feel a heck of a lot more authoritative and dignified.

"You are, I presume, referring to several . . . ah . . . unfortunate and certainly . . . ah . . . accidental mishaps concerning other, previous R/C projects?"

"You dig me, dad!" she giggled.

"Well, sister, dig *this*!" I snarled. "I distinctly remember one occasion when all the failure involved was a direct result of a certain wife with butterfingers who stupidly dropped the transmitter-unit, thereby practically insuring nothing but—"

(Continued on page 113)

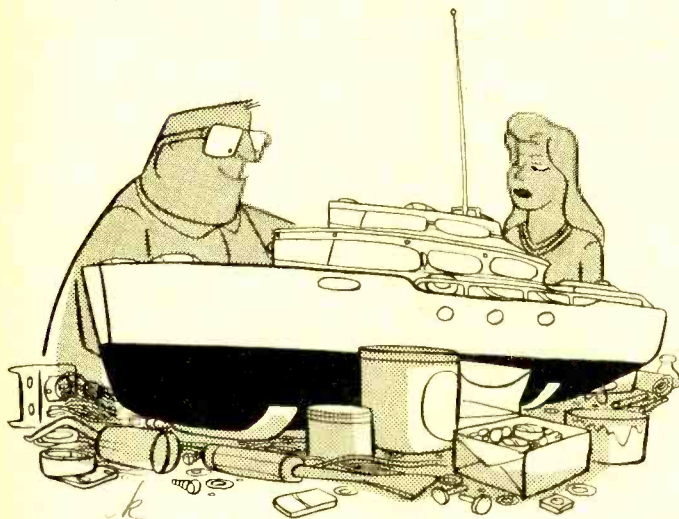

. . . "I thought you were going to build one of those kind that go inside a bottle . . ."

hard-working, faithful, loyal wife wouldn't be jealous? You've spent every evening for the past three weeks in here with *her*!"

I wiped my hands on a piece of wastecloth and put a comforting arm about the wife.

"Well, now, I'll tell you how it—" I began.

"Look at her!" stormed the wife. "Sitting there—all five feet of her a brazen hussy with no compunction about stealing other girls' husbands!"

"Yeh, she's a real—"

"I thought you were going to build one of

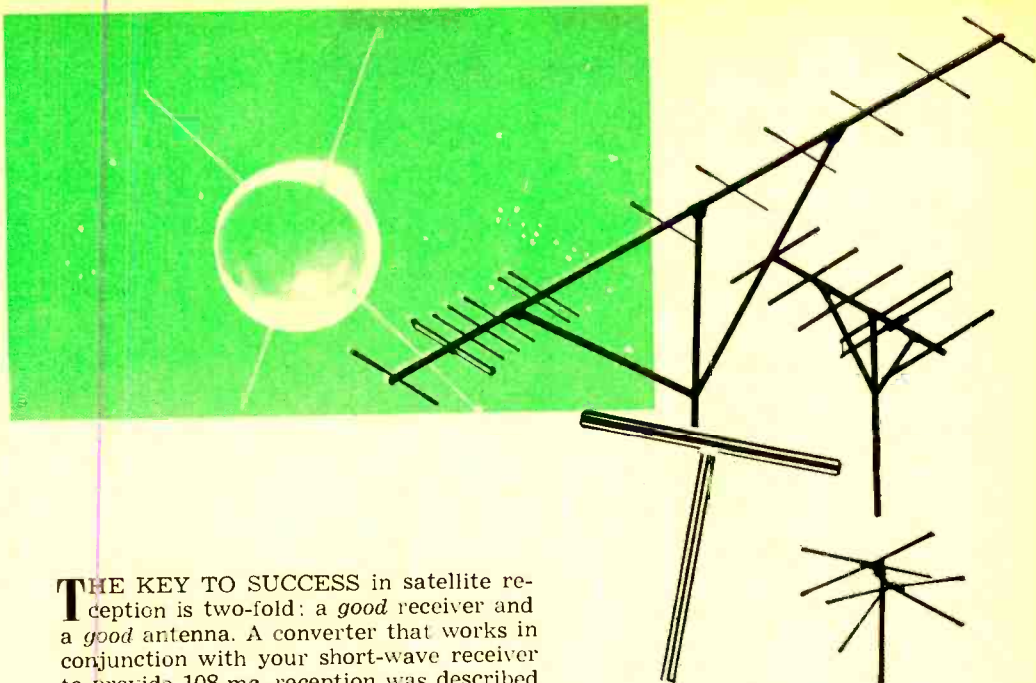

THE KEY TO SUCCESS in satellite reception is two-fold: a *good* receiver and a *good* antenna. A converter that works in conjunction with your short-wave receiver to provide 108-mc. reception was described in detail in the April issue of **POPULAR ELECTRONICS**. To complete the picture, here are some inexpensive, efficient antennas you can build that will work with that converter, or with any other 108-mc. converter or receiver.

Simple Dipole Antenna. If you live in the southern part of the United States, the satellites launched from the Florida site will pass almost over your head. Signals from the miniature radio transmitters aboard these pioneer space vehicles should be loud and strong. If you are further north, the signals will be weaker, as the satellites are at a greater distance from you and lower on your optical horizon. For those listeners living under the sweep of a satellite, a simple folded-dipole antenna might suffice to pick up a strong signal.

A suitable folded dipole can be made from a short length of 300-ohm, TV "ribbon" lead-in, as shown in Fig. 1. The antenna element is a piece of ribbon cut to resonate at 108 mc. Twist the two copper wires of the ribbon together at each end and solder as shown. One of the two parallel wires should be cut at the exact center of the antenna, and each "leg" soldered to one wire of a random length of ribbon line that serves as the lead-in.

This dipole can be tacked to a light piece of wood which is mounted in a horizontal position atop a short mast. Make the installation high enough so that it is in the clear and free of nearby metallic objects, such as tin roofs, drain pipes, etc. The horizontal portion of the antenna should run east and

Antennas for Satellite Reception

Four different types

allow you to choose the best

for your location.

By WILLIAM I. ORR, W6SAI

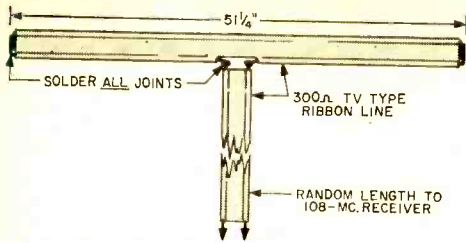
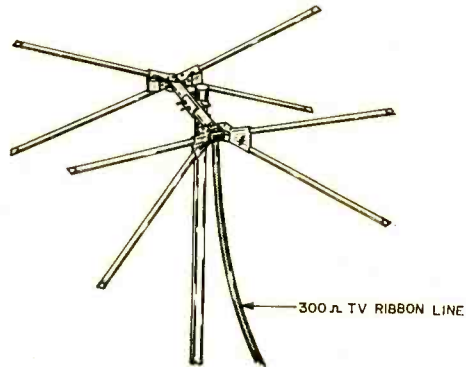

Fig. 1. Simple folded dipole is mounted horizontally and in the clear. Solder and tape all joints.

Fig. 2. This TV conical antenna can be used for satellite reception without alteration. It is available with roof-mounting or chimney-mounting accessories.



west for maximum signal pickup from satellites launched in an east-west direction.

Bring the ribbon lead-in into your house, just as you would the usual TV-type lead-in. A simple matching device (to be described later) should be used to couple the lead-in to your satellite receiver or converter.

Adapting a TV Antenna. Listeners in the central part of the U. S. should arm themselves with a more efficient antenna than a folded dipole. As the signals will be weaker, a boost in signal pickup will be of much help in hearing the flying radio stations.

Readily available through most television parts distributors is the well-known and popular all-channel conical TV antenna shown in Fig. 2. It provides a substantial signal gain over the simple dipole and may be used for 108-mc. reception without alteration. A single-bay conical antenna can "double in brass" for TV reception.

The conical antenna should be installed in the manner described for the dipole, and pointed southward for preliminary reception tests. After the satellite signal is found, it can be oriented for optimum reception. A simple matching system is also required at the receiver or converter for best performance.

TV Yagi Antennas. The best results in marginal reception areas can be obtained from a Yagi parasitic antenna array. It is composed of a single pickup element placed in line with a number of parasitic elements which provide a high degree of signal gain, covering a relatively small area in front of the antenna.

Because of the high directivity, you have to aim the Yagi beam antenna at the path of the onrushing satellite (Fig. 3). As the width of the pattern of optimum reception is roughly inversely proportional to the signal gain of the antenna, the larger arrays require careful positioning.

An inexpensive antenna can be made from a cut-down channel-6 Yagi television array. Either a 5-element or a 10-element Yagi can be used, the larger assembly providing the greater signal gain.

Trim the lengths of the elements to move

their resonant frequency from channel 6 (about 83.25 mc.) to the satellite channel. A few minutes work with tin snips or hacksaw can complete the job. Trim equal lengths off the tips of each element to change the operating frequency. The new over-all dimensions (tip-to-tip) for a 5-element array are shown in Fig. 3.

Each element should be trimmed so that both sides are of equal length. The folded dipole may be cut at each end and the extra U-section at the tips discarded. Flatten the ends of the tubes with a hammer and drill for 6-32 bolts. Place short lengths of heavy copper wire between the bolts to complete connection at the element tips.

This Yagi antenna is fed with 300-ohm ribbon line in conjunction with the balancing unit to be described. For initial reception, the antenna should be pointed to the south and oriented for best reception of the satellite as it passes the vicinity of your receiver.

A cut-down 10-element channel-6 Yagi will provide more signal pickup than the 5-element beam. The price that must be paid for the higher gain is the disadvantage of a sharper pickup pattern which is about 25° wide on either side of the axis of the boom. This Yagi must be "aimed" at the satellite with a fair degree of accuracy. It probably will be necessary to vary its position for best pickup.

No element dimensions can be provided for a Yagi array of this length as optimum

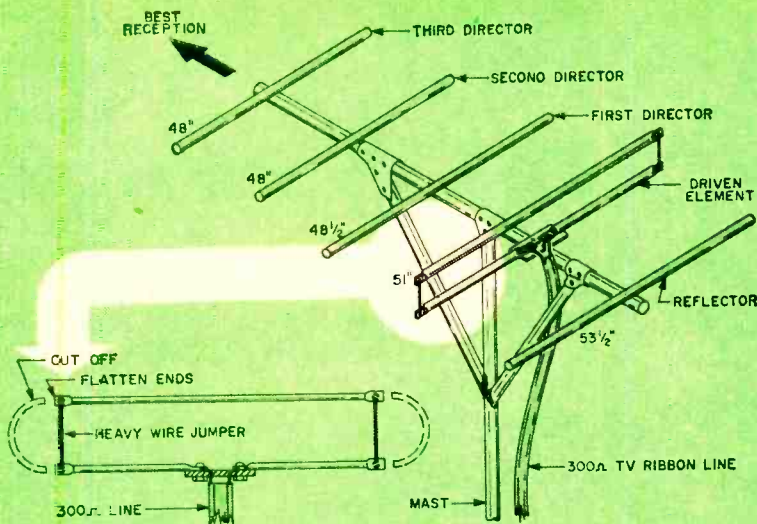

Fig. 3. Channel-6 TV Yagi antenna cut down for 108 mc. will provide more gain than a conical antenna or a folded dipole. Elements are cut to the new over-all lengths shown.

performance is dependent upon a combination of factors, such as interelement spacing, element lengths and diameters. Since these dimensions vary from one make of Yagi to another, a general procedure applicable to all antennas of this type must be employed.

A satisfactory process is to apply a reduction ratio to the original dimensions. The spacing and diameter of the elements can remain unchanged but the over-all element lengths must be shortened by the ratio of the contemplated frequency to the original frequency of antenna operation.

As the design frequency is 83.25 mc. in this case, and the satellite frequency is 108 mc., each element must be shortened in length by a factor of $83.25/108$. For example, if the driven element of the Yagi is $63\frac{1}{2}$ " long, it must be trimmed to $63\frac{1}{2} \times 83.25/108$ or 49".

The folded dipole can be cut and trimmed as described for the 5-element Yagi. A 300-ohm lead-in and the balancing unit should also be used.

The Long Long Yagi. In areas of marginal reception, or where the strongest possible signal is desired, an extended Yagi antenna should be employed, such as the 13-element unit shown in Fig. 4. This home-built *long long* Yagi is designed for highest possible gain at 108 mc.

Element lengths, interelement spacing, and element diameters are chosen to provide a power gain figure greater than 16 db at operating frequency. This is equivalent to an increase in power of the satellite transmitter by a factor of 40! As the effective beam pattern of maximum signal gain is only about 15° on either side of the axis of the boom, care must be taken in

orienting the antenna for maximum signal strength.

Eleven parasitic directors of uniform length are resonated for maximum signal pickup over a frequency span covering 107-108.5 mc. This range encompasses any auxiliary telemetering channels that may be adjacent to the 108-mc. center frequency of satellite transmission. All dimensions in Fig. 4 should be copied closely as this Yagi is critically tuned.

The structure is a metal supporting frame (or boom) through which the various elements are affixed. Make the boom out of two pieces of $1\frac{1}{2}$ " aluminum tubing having a 0.062"-thick wall. This tubing is rigid enough to prevent the array from flexing in a heavy wind. Brace boom to mast with two lighter sections of tubing.

Cut 11 directors and one reflector from lengths of $\frac{3}{16}$ "-diameter rod or tubing. Smooth and buff the ends of these elements to the correct length, then pass each element through an oversize $\frac{3}{16}$ " hole drilled horizontally through the body of the boom.

The element is centered in the hole as shown, and a simple clamp made from a sheet metal screw and a scrap of aluminum holds it securely to the boom.

Care should be taken when the boom is drilled to make sure that all the element mounting holes lie in the same plane, or the completed array will have an unkempt air about it. It is best to drill all element holes at one time. Use a drill press and a bench

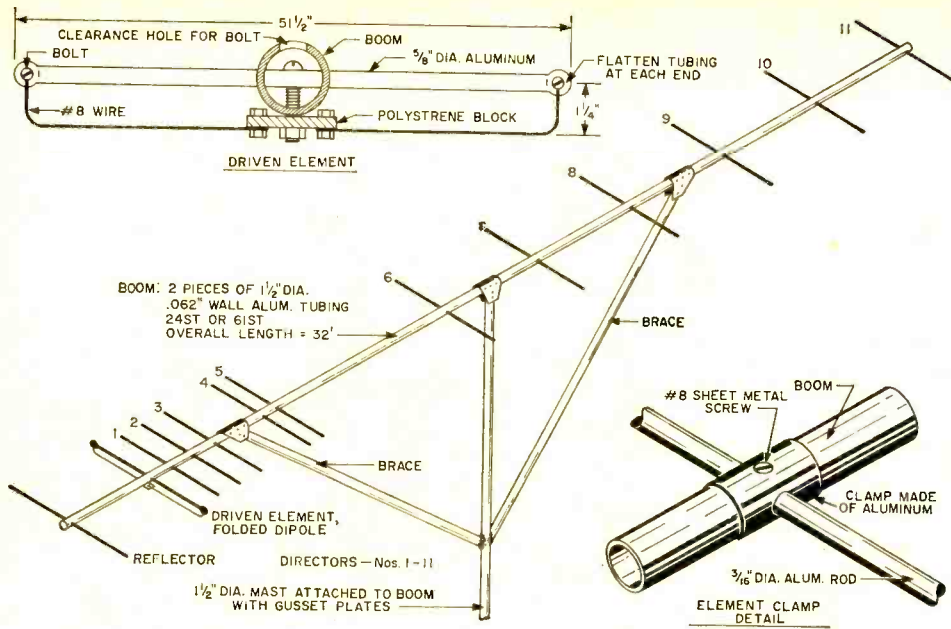

Fig. 4. A long long Yagi, with 13 elements on a 32' boom, has 16 db forward gain.

ELEMENT	ELEMENT LENGTHS	SPACING FROM DIPOLE
Reflector	54 $\frac{3}{4}$ "	25 $\frac{1}{4}$ "
Driven Element	51 $\frac{1}{2}$ "
Directors	All directors are 48 $\frac{3}{4}$ " long	#1 9 $\frac{1}{4}$ " #2 19 $\frac{1}{4}$ " #3 29 $\frac{1}{4}$ " #4 50 $\frac{1}{2}$ " #5 93 $\frac{1}{4}$ " #6 136" #7 178 $\frac{1}{2}$ " #8 221" #9 264" #10 307" #11 349"

wise if you can, and it will be a simple job.

Make the driven element of the long long Yagi out of a length of $\frac{5}{8}$ "-diameter aluminum tubing passed through clearance holes drilled in the boom. Use a plated 6-32 nut and bolt to clamp the element to the boom. After the element is passed through the boom, carefully flatten the ends and drill for 6-32 plated bolts. Be sure to use plated or galvanized hardware at all points as untreated hardware will rust in damp air.

The remaining portion of the driven element is made of two lengths of #8 enamel copper wire. Clean one end of each length of the enamel and wrap it around the bolt placed at the tip of the element. A nut and lock washer will hold the wire firmly in place. Bend the two sections of wire back along the aluminum tubing, maintaining a spacing of $1\frac{1}{4}$ " from the tubing.

Clean the ends of the wires and wrap them around the two 6-32 mounting bolts that are passed through a small piece of polystyrene, Lucite, or similar insulating material held in position by the nut and bolt that lock the driven element to the boom. Attach the "ribbon" feedline to the driven element at these two bolts.

Upon completion, attach the antenna to the top of a TV-type mast or other support with the aid of two gusset plates cut from aluminum. Bolt the plates to the top of the

mast, and affix the boom of the Yagi to the plates as shown.

Balancing Transformer. Two-wire, balanced 300-ohm transmission line commonly used for TV reception is recommended for connecting a satellite antenna to your 108-mc. converter or receiver. It is lower in price than coaxial line and has appreciably less signal loss. As most satellite receivers are designed for unbalanced, 52- or 72-ohm coaxial transmission lines, you will have to construct a balancing transformer to convert the balanced 300-ohm termination of the antenna and transmission line to a low-impedance source. This conversion can be accomplished with a simple balun, as shown in Fig. 5.

The balun is a linear transformer made
(Continued on page 112)

Radiation and Radio Lick Floods

By DON WALKER

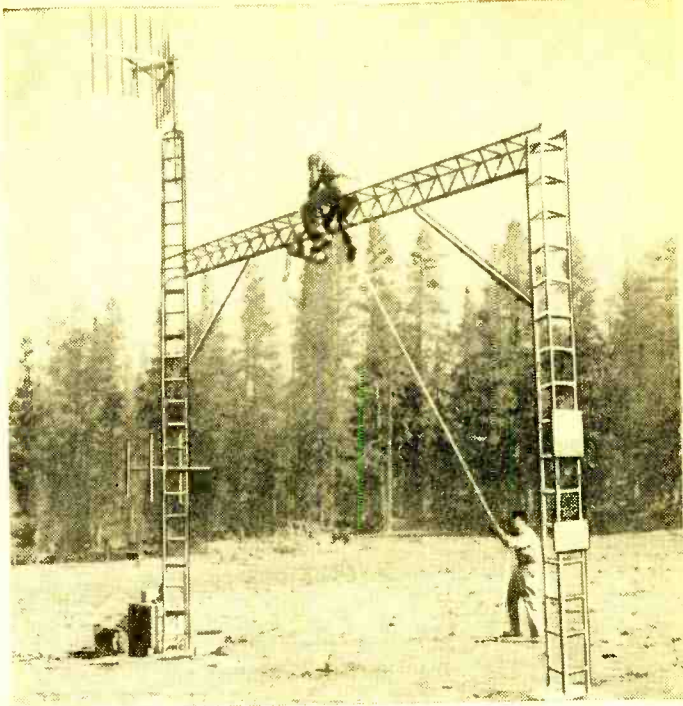

ELECTRONICS and radioactive cobalt 60 have joined in the fight to cut flood loss. They are teamed up in radioisotope snow gauges to give weathermen density measurements of the snow pack in remote areas—information used in forecasting spring run-offs.

The gauges are being erected by Army Engineers in California and Idaho to improve reliability of winter snow records and give weathermen a head start in warning of flood damage potential.

To speed the process of gathering snow information, measurements will be sent by radio transmitters built into the gauges to a relay station in the Idaho project, then to a receiving center at the Corps of Engineers office about 100 miles away where the data will be interpreted.

At each gauge station, a cobalt 60 radiating capsule will be placed in a tube in the ground. Each capsule will radiate up through the snow to a scintillation or Geiger counter mounted on a tower above the snow, which will measure the rate of radiation. The radiation will be proportional to the depth of the snow.

The radioisotope gauges are capable of measuring up to about 15 feet of snow or the equivalent of about four feet of water over the isotope capsule. Each installation will be protected by a heavy fence, marked to indicate the danger of approaching too closely to the equipment.

It is expected that these gauges will go a long way toward cutting down on loss of life and property due to ravaging spring floods.

-30-

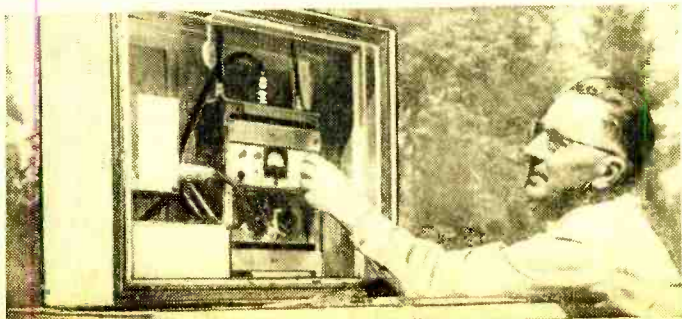

Data is picked up by Geiger counter (being installed in snow gauge in top photo) through the snow from a tube of cobalt 60 directly below it. At left is receiver and transmitter at base of gauge. The radiation data is automatically transmitted to a Corps of Engineers' receiving station.

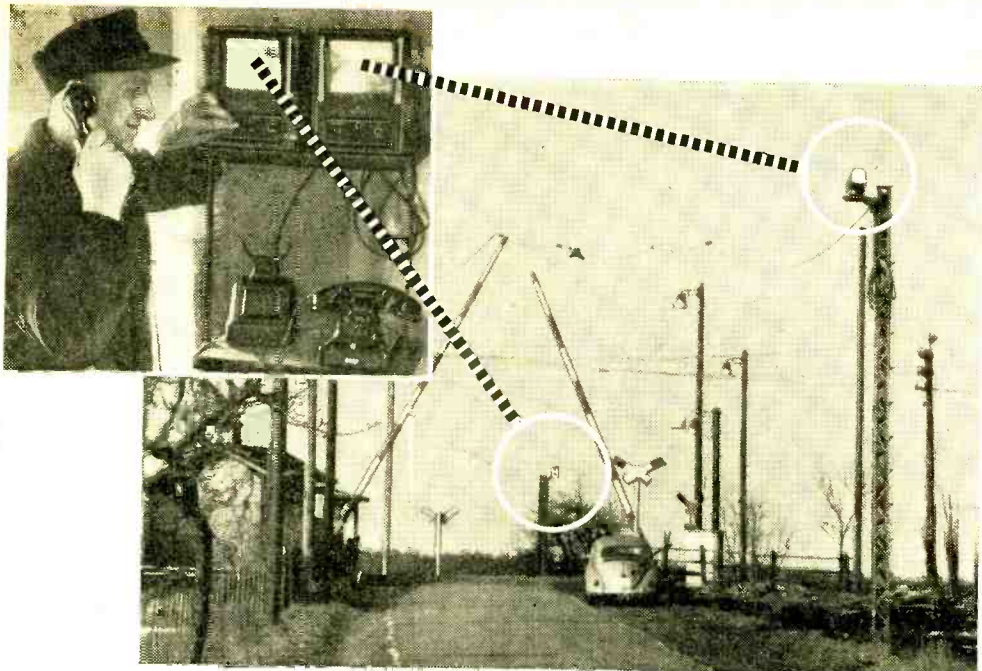

TV AT RAILROAD CROSSING

Television controls for highway traffic at railway crossings are getting a tryout by West Germany's railroads. The first installation, at Dieburg, is shown above. Two cameras, one at each side of the crossing and aimed at the intersection, are tied by closed circuit to a central control station. The view of the highway on the screens lets the controller raise and lower the gates when needed with a remote switch.



TV IN A CAR

The kids looking so raptly at the TV screen at left are seated in the back of a moving automobile. This was a demonstration of an experimental auto television set developed by General Motors' Delco Radio Division for Oldsmobile. It is dual-purpose, operating in a car and removable for use on line current. Having eight-inch screens, such sets were first shown by Oldsmobile this year at the Chicago and Detroit automobile shows.

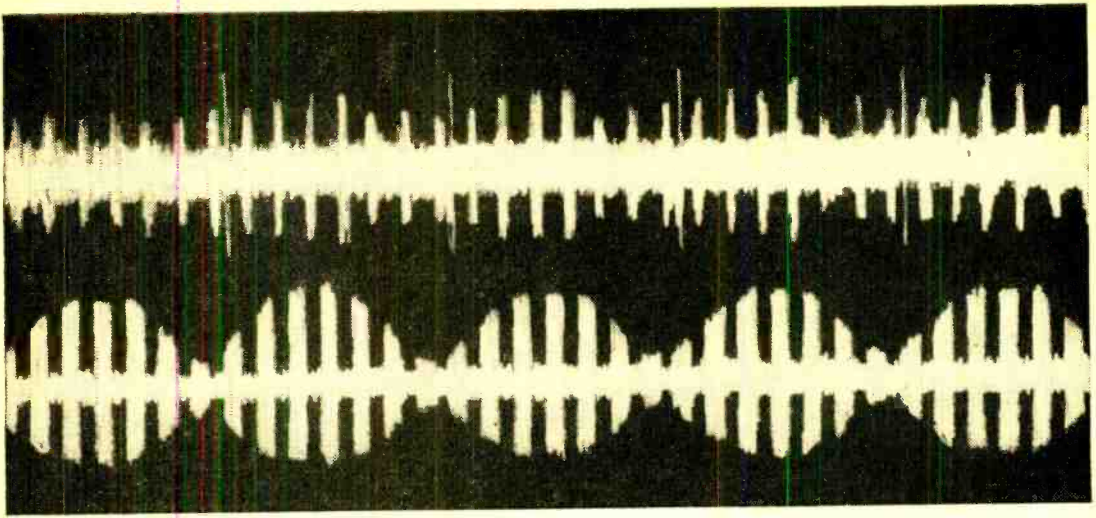

What the Sputniks Said

Russian scientists disclose how radio waves travel from their satellites to earth

By A. J. STEIGER

RADIO LISTENERS who tracked the earth-circling travels of Sputnik I have reported new discoveries in short-wave propagation, including a round-the-world echo, according to preliminary findings published in a recent issue of *Radio*, a Russian popular electronics journal.

What the Sputniks discovered about prospects for using solar power to operate space vehicle instruments is also discussed in the Moscow journal. These reports on Russia's pioneer space vehicles' discoveries, the first to be published, are translated here.

Propagation Conditions. "Preliminary results of reception of Sputnik I radio signals," writes Prof. A. Kazantsev, Doctor of Technical Sciences, in *Radio*, "show that in the 15-meter wave band these signals were received at very great distances, far surpassing the distance of direct visibility and in a number of cases reaching 10,000 kilometers. Very valuable material on

possible ways of short-wave propagation can be derived from study of the data on long-distance reception of these signals.

"It will be recalled that the satellite orbit's perigee (its lowest point) was in the northern hemisphere and its apogee (highest point) was in the southern hemisphere. The apogee's altitude reached about 1000 kilometers above the earth's surface. In the southern hemisphere, therefore, the satellite traveled above the principal layer of the ionosphere, layer *F2*, which conditions short-wave reflection.

"Concerning the northern hemisphere, especially interesting short-wave propagating conditions were created. At certain intervals Sputnik I was above the *F2* layer of maximum ionization, at others below it, and at certain times close to the maximum.

"When Sputnik I was above layer *F2*, then passing from above through the mass

Fig. 1. With Sputnik I above the ionosphere, two types of signals received by the Russians were: direct, and reflected.

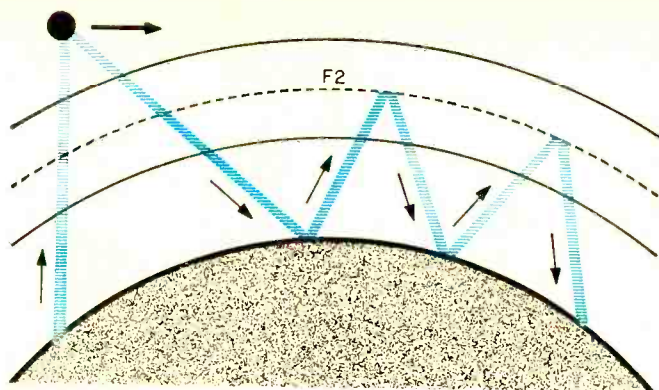
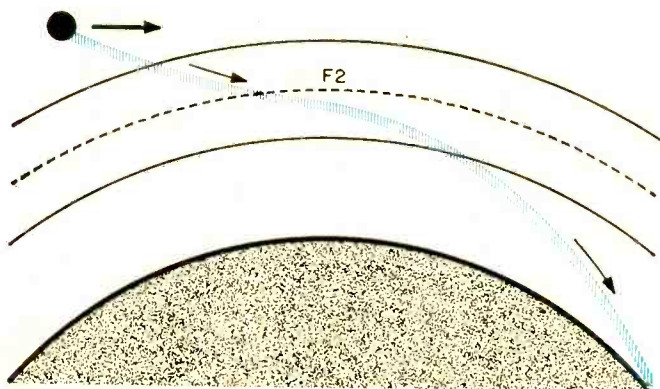

Fig. 2. Another type of reception picked up by the Russians with the Sputnik above the ionosphere was: refracted (slanted).



of the ionosphere, the radio waves were reflected from the earth's surface and propagated further by single or multiple reflection from layer F_2 in those areas where its critical frequency had sufficiently high values (Fig. 1).

"It is also possible that radio waves coming into the ionosphere from above at a sloping angle are considerably refracted and therefore penetrate into an area outside the bounds of direct geometric visibility (Fig. 2).

"When Sputnik I was below layer F_2 (Fig. 3), and approached an observation point from a global area lighted by the sun, the radio signals on the 15-meter wave band could come from the satellite to a point of reception, after going through consecutive reflections from layer F_2 and the earth's surface, and then through direct visibility."

Limited Reception. "If the satellite, after passing over the observation point, moved away into an unlighted area of the globe, signal reception ceased in a

relatively short distance, depending on limits of visibility.

"Non-symmetrical reception conditions were also observed. When the satellite was close to layer F_2 of maximum ionization, then especially favorable conditions might develop for the formation of radio-wave conducting channels able to propagate radio waves over very long distances (Fig. 4).

"There is evidence, in fact, that along with satellite signals which reached the observation point by the shortest route, signals were sometimes received that had traveled around the globe (round-the-world radio echo). One of the USSR's most skillful radio amateurs, Yu. N. Prozorskiy of Moscow, on October 8 at 0007-0008 hours recorded the reception of such a round-the-world radio echo in the 15-meter wave band.

"Concerning signals in the 7.5-meter wave band, as far as can be judged at present, they were as a rule received in the limits of direct visibility, although

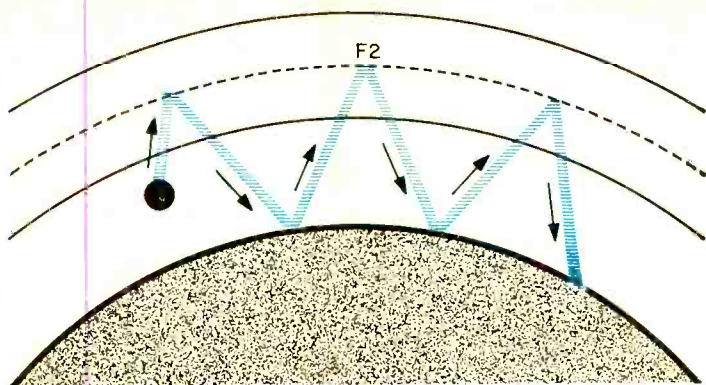

Fig. 3. When the satellite was below the ionosphere, Russian listeners heard reflected signals at times.

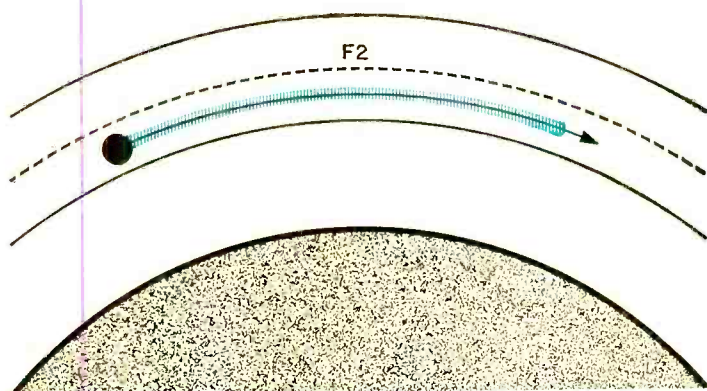

Fig. 4. At other times, the scientists picked up the peculiar round-the-world echo when the Sputnik was near the F2 layer.

in certain cases owing to high values of daytime critical frequencies of the F2 layer, this wave could be propagated also outside direct visibility.

"A conclusion can be drawn as to precisely what way radio-wave propagation occurred after correlation has been established between the altitudes of Sputnik I and the real altitudes of the F2 layer at one and the same moment, and analysis of the propagation conditions."

Sun's Radiation. Discussing preliminary findings of Sputnik II with respect to solar radiation in outer space, Russian Academician A. I. Berg, leading Russian authority
(Continued on page 118)

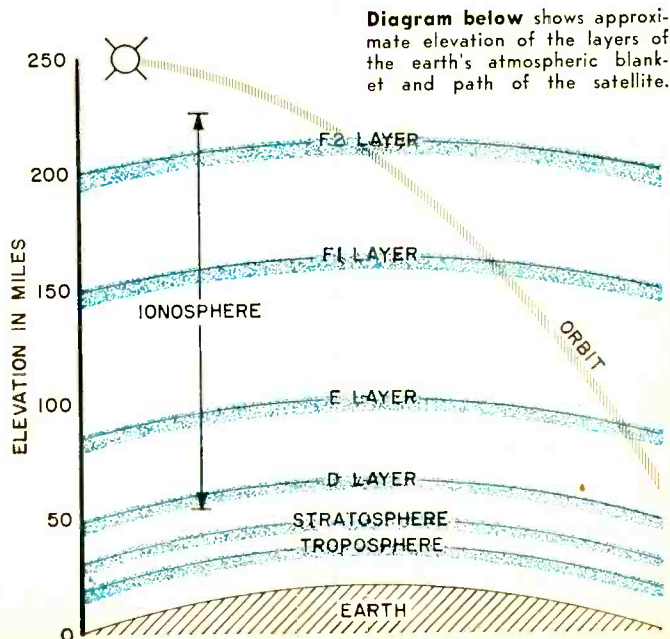

Diagram below shows approximate elevation of the layers of the earth's atmospheric blanket and path of the satellite.



THE ACCURACY of any voltmeter reading depends upon the extent to which it affects the circuit under measurement. After the voltmeter is connected, the voltage no longer has the same value it had before the instrument was attached.

With two equal-value resistors connected across a 100-volt source, the voltage across each resistor should be 50 volts. However, a voltmeter connected across either resistor will read less than 50 volts. The reason for this inaccuracy is that the internal resistance of the voltmeter forms a parallel circuit with the resistor across which it is connected.

For example, if the meter in Fig. 1 has an internal resistance of 100,000 ohms, the total resistance between points *B* and *C* is 50,000 ohms. Since this is only half as great as the resistance between points *A* and *B*,

How a Vacuum-Tube Voltmeter Works

By ED BUKSTEIN

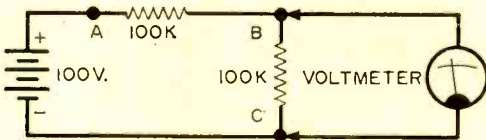

Fig. 1. Before measurement is taken, the voltage drop across the two 100,000-ohm resistors is equal. Shunting effect of meter causes an unequal voltage division and the meter reads less than half the voltage applied across *A* and *C*.

only half as much voltage will appear between points *B* and *C* as appears between points *A* and *B*.

This means that of the total of 100 volts, 66⅔ volts will appear from *A* to *B*, and 33⅓ volts will appear from *B* to *C*. The voltmeter therefore reads 33⅓ volts when connected from *B* to *C*, even though the voltage between these points was 50 volts before the measurement was attempted.

The higher the internal resistance of a voltmeter, the less current it will drain from the circuit under measurement and the more accurate its reading will be. This is the advantage of the vacuum-tube voltmeter (VTVM). Because of its high input impedance, the VTVM provides a reading practically identical to the voltage existing before the test leads were connected.

A basic circuit of a VTVM with 11-megohms input impedance is shown in Fig. 2. The voltage to be measured is applied to the grid of tube *V1*. This causes the cathode voltage of *V1* to change, and this change is indicated on the meter.

If a positive voltage is applied to the grid of *V1*, this tube will draw more plate current and its cathode will become more positive. The increased plate current of *V1* produces a larger bias across resistor *Rk* and causes the plate current of *V2* to decrease.

(Continued on page 111)

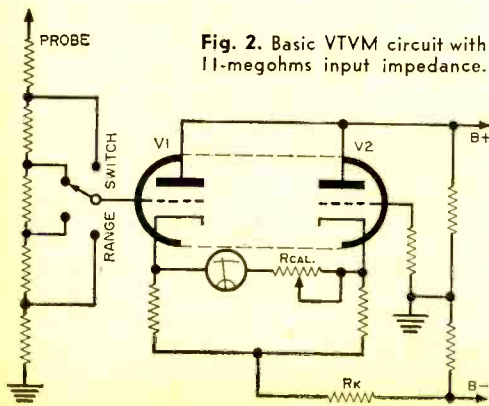
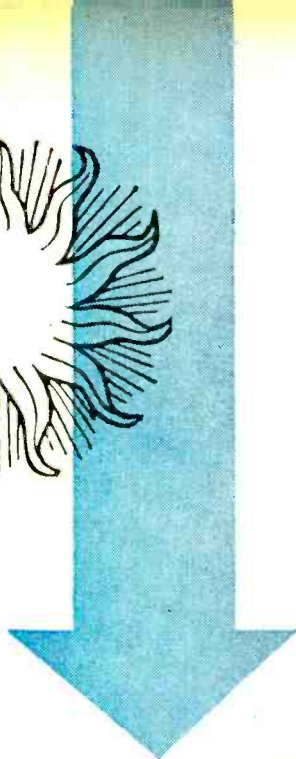
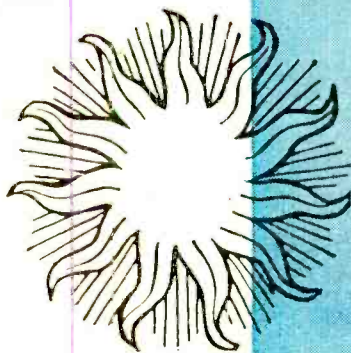
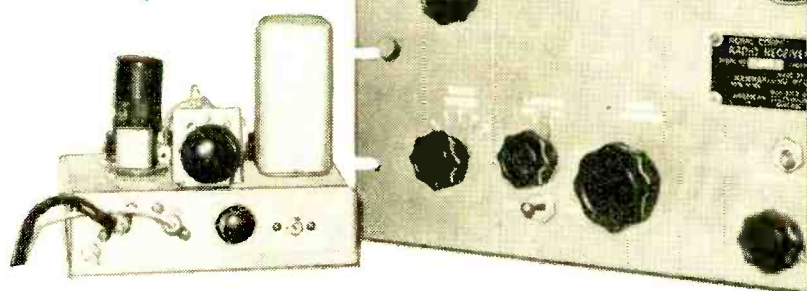

Fig. 2. Basic VTVM circuit with 11-megohms input impedance.



By
JOSEPH W. DOHERTY
K2500



CONVERTER FOR DAYTIME DX

***How to extend the range of receivers that
don't cover frequencies higher than 20 mc.***

MANY A NOVICE making his start in ham radio develops a yen for something more in the way of DX than is available on the 80- and 40-meter Novice bands, especially during daytime hours when DX is scarce. For the SWL or ham whose receiver lacks coverage of 15 meters, here is an inexpensive, easy-to-build converter which will introduce the owner to the many stations near this wavelength and which will add zest to the hobby.

This converter functions as a front end

to a broadcast-band receiver that serves as a tunable i.f. amplifier. There are two sections to the converter: the oscillator-mixer stage incorporating the 6SA7 tube; and the beat-frequency oscillator (BFO) using a 6J5 tube.

The BFO enables you to hear continuous-wave (c.w.) or unmodulated signals by providing a beat-note for their reception. Its frequency is nearly the same as the intermediate frequency in the broadcast receiver, and it is variable so that the pitch

of the audible beat-note produced by it can be varied. Because the i.f. of most broadcast receivers is 450-455 kc., the BFO must be designed to operate in the same region.

You can also use the converter with a communications receiver. If your receiver already has a BFO, this part of the converter unit can be eliminated.

Many older receivers do not include the 15-meter amateur band. We tried the converter with a National NC 101XA receiver, and used a 19.700-mc. crystal. When mixed with 21-mc. signals, this produced a difference frequency range which fell into the unused 160-meter band on the receiver with excellent results.

Construction. Input coil *L1* consists of a B & W Miniductor #3011 or the equivalent ($\frac{3}{4}$ " diameter, 16 turns per inch) using a total of 21 turns. Ground one end of the coil to the chassis and connect the other end to the signal grid of the 6SA7 tube and capacitor *C1*.

Connect the antenna wire (about 9' long) directly to the coil at a point three to four turns up from the ground end of the coil. This point provides the best average impedance match for the antenna, consistent with good tuning characteristics for the antenna trimmer capacitor *C1*, and good sensitivity over the entire 15-meter band.

Output coil *L2* is a Vari-Loopstick and should be tuned to approximately 1200 kc., as will be explained later. The oscillator plate tank consists of *C8* and *L4*.

BFO coil *L3* is commercially available at most radio supply houses. *S1* is the BFO "on-off" switch. The BFO output is coupled via *C7* to the filament lead at the terminal strip to simplify coupling to the receiver i.f. amplifier circuit. In so doing, it has been assumed that power for the converter will be taken from the receiver power supply. If this is not the case, the BFO output can be introduced to the receiver via a separate lead loosely coupled to the i.f. amplifier or second-detector circuits.

In constructing the converter, one pre-

The converter is designed for use with a transformer-powered broadcast receiver.

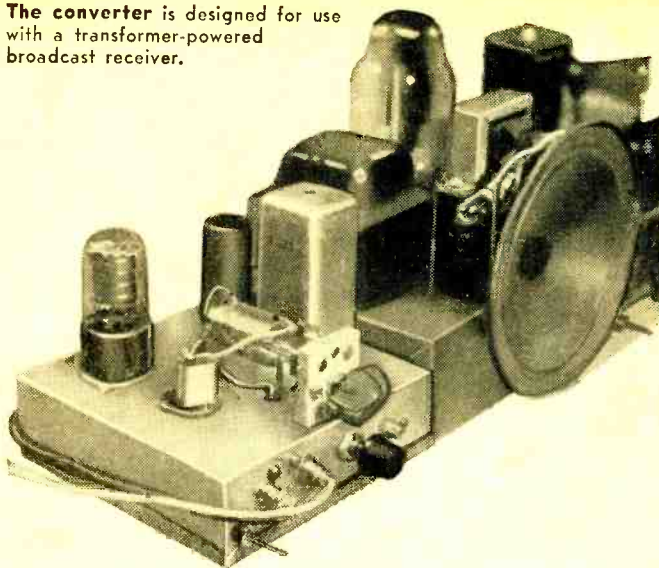

caution should be taken. Locate the input circuit (*L1* and *C1*) away from the oscillator tank circuit (*L4*, *C8*), and away from the output coil (*L2*). Note that the input coil and capacitor are mounted on top of the chassis and the two other coils are underneath and spaced from one another.

The crystal required might not be available locally. However, it can be ordered by mail from any of several crystal manufacturing companies. The one in the model cost \$3. Order the crystal before you begin construction so that you will have it when you need it.

Operation. When connecting the converter to the receiver, it will be necessary to disconnect the antenna lead from the receiver and connect it to the converter input. Connect the converter output to the antenna post on the receiver, using a short shielded wire to prevent stray broadcast pickup.

Power for the converter can be taken from the receiver or a separate power supply. The unit takes 6 volts for filament, 150-250 volts d.c. for plate supply. Because of shock hazard, connection to an a.c./d.c. receiver is not recommended unless an isolation transformer is used between the receiver and power line.

Turn on the receiver and, after it has warmed up, adjust *C1* for maximum signal. Then adjust *L2* for maximum signal strength with the receiver tuning dial set

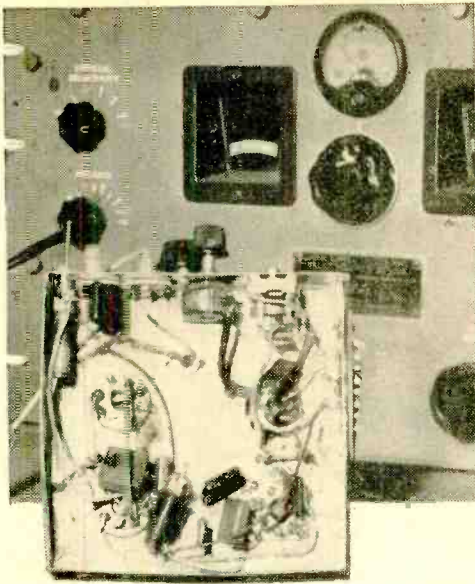

When the unit is connected to extend the frequency range of a communications receiver, the 6J5 BFO tube should be omitted.

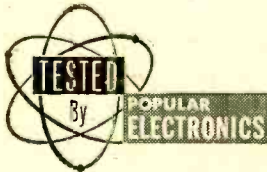

at approximately 1200 kc., the mid-point of the desired frequency band.

Tune across the receiver dial. You should hear lots of activity at dial settings from 1000 kc. through 1400 kc. If you do not, first check antenna trimmer *C1* for maximum signal strength, then check the oscillator circuit.

If removing the crystal has no effect on what you hear, the oscillator is not functioning. Replace the crystal and check *L4*, the slug-tuned oscillator plate coil. This must be adjusted to provide the proper impedance for the oscillator plate circuit. Misadjustment of the slug will cause the

(Continued on page 106)

HOW IT WORKS

Incoming signals are introduced through *L1*, *C1* to the signal grid of the 6SA7 mixer tube. *L1* and *C1* are tuned to the frequency of the desired signal in the 21-mc. region. The input circuit functions best with a single-wire antenna about 8' or 9' long. The antenna connects to a point four turns up from the grounded end of *L1*. This point provides adequate sensitivity without greatly sacrificing selectivity.

Output of the crystal oscillator is combined with the signal frequency in the mixer tube and the difference between the two is the signal at the intermediate frequency which appears in the plate circuit of the 6SA7.

If the converter is to operate ahead of a broadcast receiver, the i.f. output must fall within the broadcast band. The signal frequency for the 15-meter band is from 21,000 through 21,450 mc. Operating the crystal oscillator at 20 mc. provides a difference i.f. of 1000 kc. with an input signal frequency of 21 mc.

With an input signal of 21,450 mc., the difference frequency is 1450 kc. Therefore, the broadcast receiver dial is tuned from 1000 kc. (the center of the broadcast band) for 21 mc. and to 1450 kc. for 21,450 mc.

PARTS LIST

- C1*, *C4*—25- μ fd. variable air padder capacitor
- C2*, *C10*—0.001- μ fd. mica capacitor
- C3*, *C5*, *C7*, *C9*—100- μ fd. mica capacitor

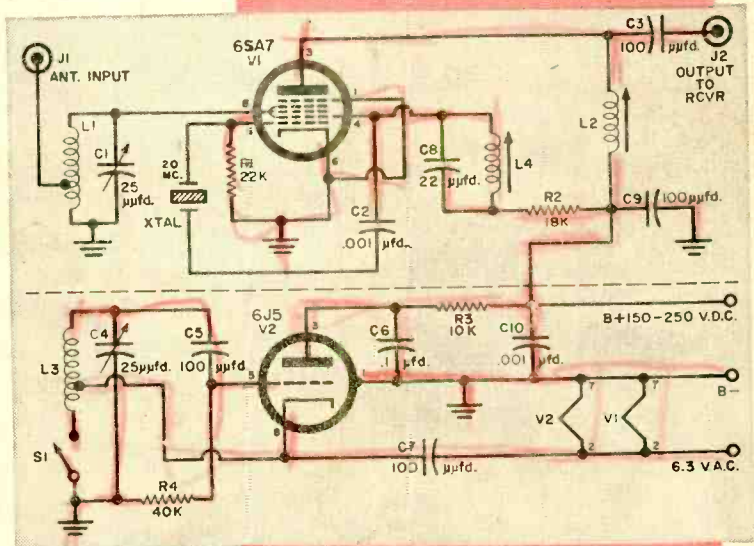

- C6*—0.1 μ fd., 600-volt paper capacitor
- C8*—22- μ fd. mica capacitor
- J1*, *J2*—Miniature phono jack with ceramic center insulator (General Cement #H-667-F)
- L1*—B & W Mini-ductor coil #3011 (see text)
- L2*—Superec Vari-Loopstick
- V3*—BFO transformer (Meissner #17-6753 or equivalent)
- L4*—18 turns close-wound #18 enameled wire on $\frac{3}{8}$ " slug tuned coil form
- R1*—22,000-ohm $\frac{1}{2}$ -watt resistor
- R2*—18,000-ohm $\frac{1}{2}$ -watt resistor
- R3*—10,000-ohm $\frac{1}{2}$ -watt resistor
- R4*—40,000-ohm $\frac{1}{2}$ -watt resistor
- S1*—BFO "on-off" switch
- V1*—6SA7 tube
- V2*—6J5 tube
- Xtal*—20-mc., third overtone crystal (International Crystal or equivalent)
- 1*—Octal ceramic socket for crystal



Photos by Hamilton Wright

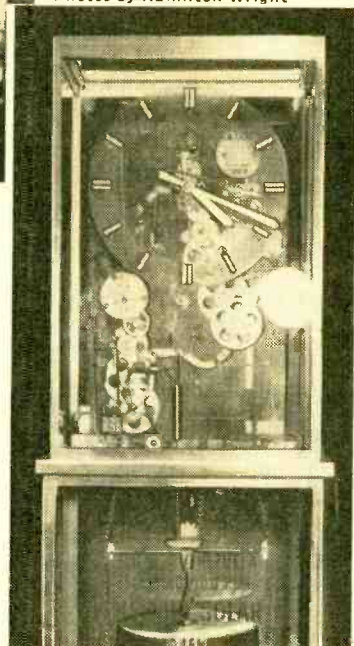

Electronics Today

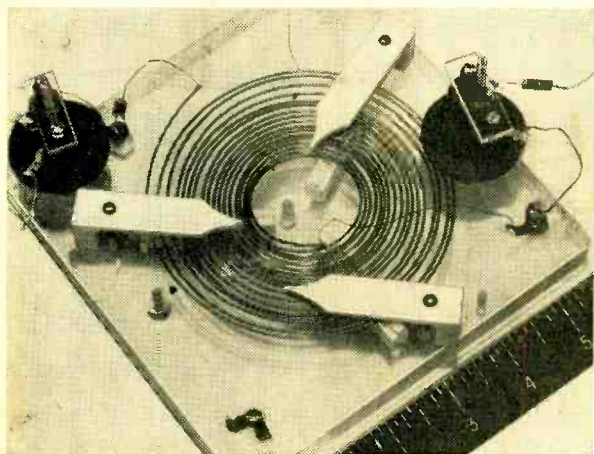

The "watchspring" above is actually a torsional delay line, a device used in such applications as computer work, trigger-delay circuits and radar range measurement. Developed at Bell Telephone Labs, it is made of Vibralloy, a ferromagnetic alloy. The spiral permits clear resolution of 10-microsecond pulses spaced 20 microseconds apart.

Strange-looking plastic ball (upper left) contains series of solar cells which are used to power a large clock (above). Built in Caracas, Venezuela, the system can store enough solar energy to run the clock mechanism for 100 days. Actually, the clock is driven by a 52-pound balance weight which is hoisted into position by an electric motor powered by the eight silicon cells in the plastic ball. The bells of the clock are powered by another balance weighing 10 pounds. The clock's inventor, Curt Kickbusch, expects to build only a half dozen more in his lifetime. This one is located at University City in Caracas. He plans to build an extra-large one at a cost of about \$100,000 for the center arch of a bridge spanning Lake Maracaibo.



A camera writes its own captions! The illustration above shows how position, altitude and other pertinent data necessary to Air Force reconnaissance can be recorded automatically on photos. Developed by Federal Telecommunication Labs, the Digital Data Recording Device records all data in coded dot form (lower right on photo). During development, a ground-based reader decodes and prints data under picture.

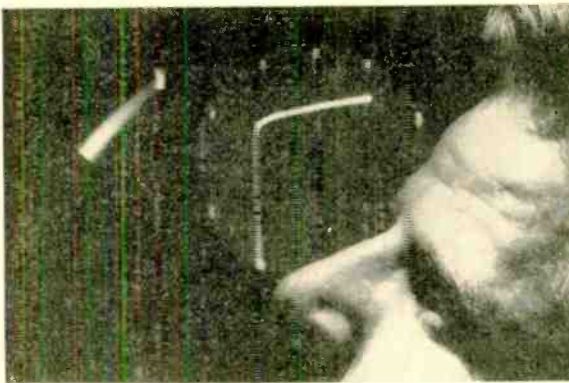

Tiny silicon carbide rectifier being heated red-hot by a torch (above) continues to change alternating to direct current in spite of the heat, as shown by oscilloscope trace in background. Developed by Westinghouse, the rectifier is the result of a new method of preparing ultra-pure silicon carbide. It will be used in rockets and missiles.

July, 1958

The Tennessee Highway Patrol and Civil Defense bus below is ready for any emergency. Stock towers made by Tele-Vue lie flat across the top of the bus until needed, then swiftly crank up to their maximum vertical position of 45 feet. In addition, the bus carries six transmitters and receivers which can be operated simultaneously, and a generator which can be rigged to supply a hospital or other such center with emergency power. The bus, built at a cost of about \$14,000, will be used in such disasters as flood, tornado or forest fire by the patrol.

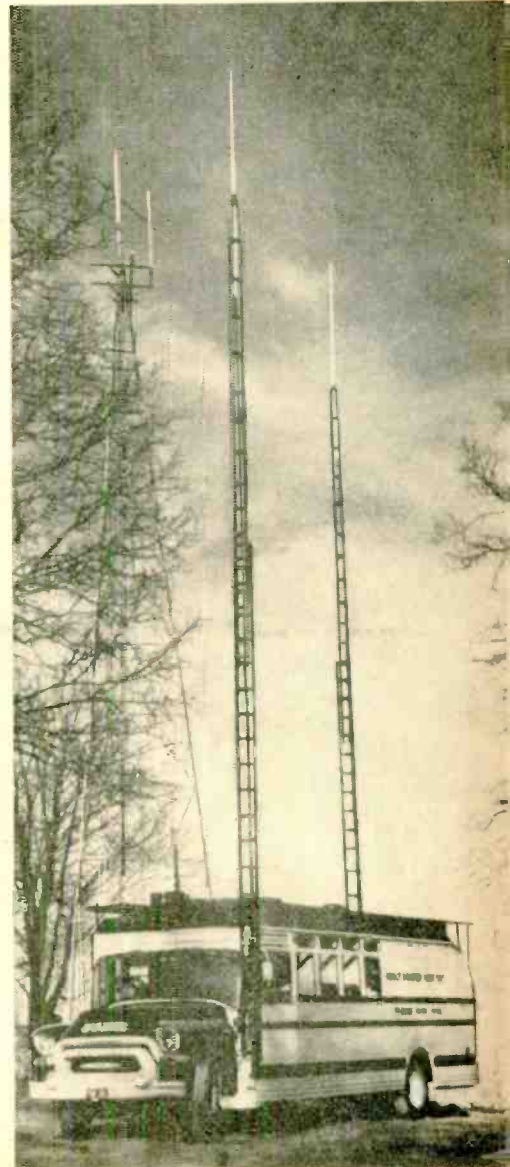

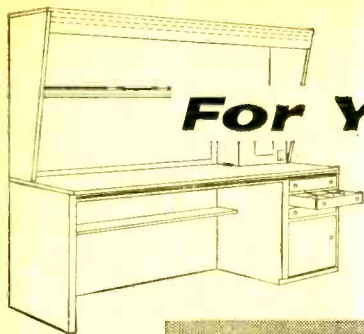

For Your Test Bench

MANUFACTURERS are going all out to produce useful and interesting items for your test bench and tool kit.

The fountain-pen multimeter at left reads volts and ohms on a miniature $\frac{3}{4}$ " meter built into the top of the probe. A.c. and d.c. volts ranges are 0-12, 300 and 600 at 1000 ohms/volt sensitivity. The ohm-meter scale is 0-50,000 ohms using a self-contained battery. A twist of the probe end changes voltage ranges, and it switches from a.c. to d.c. volts by reversal of a plug at the side of the tester. This multimeter comes with a flexible 24" negative lead with needle tip test prod from Olson Radio Warehouse.

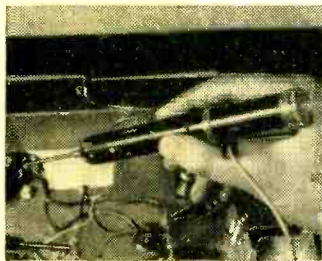

A power supply kit designed to power transistor circuits and qualified for laboratory or utility use has been made available by TAB. Model TPSK2 has two separate filtered outputs, each supplying 12 volts at one ampere with less than 0.5% ripple. When connected in series (plus to minus), 24 volts at one ampere is available. When connected in parallel (plus to plus, minus to minus), output is 12 volts at two amperes. A transformer with 117-volts/60-to-400-cps input, and two secondaries, feeds two full-wave bridge rectifiers.

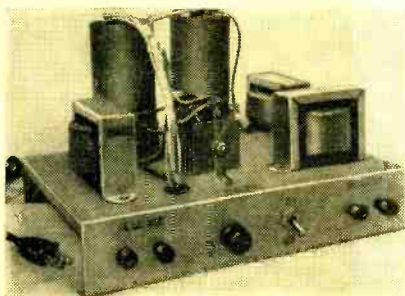

The a.c./d.c. neon-tube voltmeter at left has the added advantage of clips as an integral part of the test probes. Telematic's Mini-Tester has a wide variety of uses, which include polarity checking, determining the ground side of a supply line, and spotting open circuits. Voltage range is from 65 to 800 volts, a.c. and d.c.

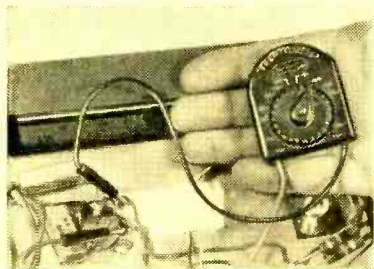

Of interest to beginners and teachers who want to save meters from burn out is the overload protection feature of a new multimeter. If the range is set incorrectly for a low-voltage reading and the test leads put on a high-voltage circuit, a red reset button snaps up, disconnecting the instrument from the circuit being measured. All ranges are either self-protected in this manner or fused. Sensitivity is 20,000 ohms/volt, and voltage ranges up to 1200. Resistance can be measured up to 100 megohms with Hickok's Model 455. -30-

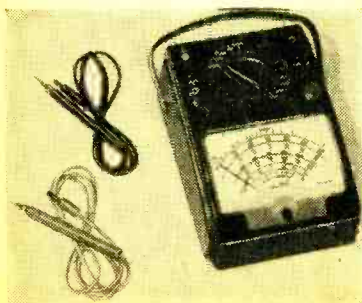

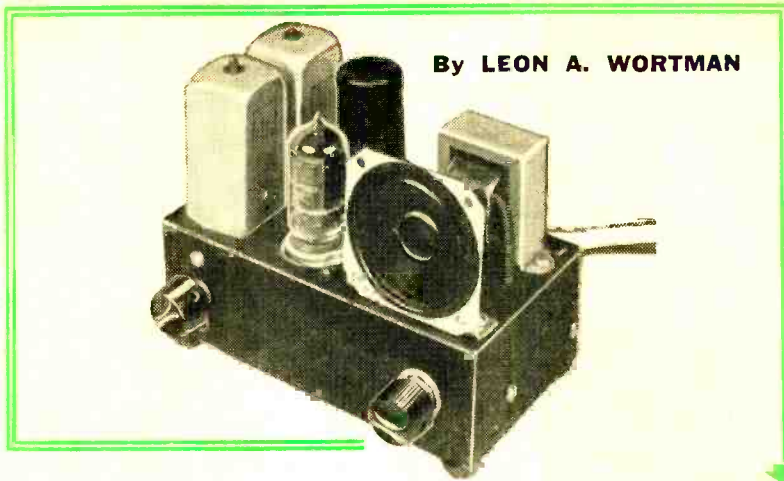

Tuner + Audio = Radio

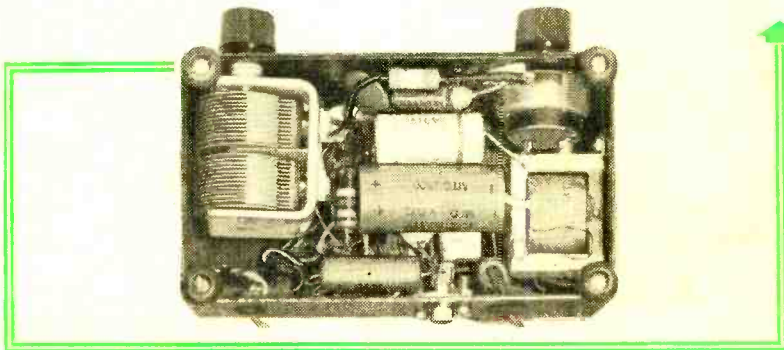

With one tube, a speaker, and a few parts, you can monitor programs before heating up your hi-fi system

IF YOU HAVE already constructed the "One-Tube Hi-Fi AM Tuner" described in P.E. (June '58), this will show you how to convert it to a complete *radio* by adding one more tube, a few components, and a small loudspeaker. Or you can start from scratch by following the text, photos and schematic diagram.

The chassis for the entire *tuner-radio* measures only 5¼"x3"x1½". Of course, other chassis sizes will do, provided you have room for the parts. You can reduce the chassis size by making use of the miniature coils and capacitors now available.

To convert the tuner to a radio, all you have to do is add an amplifier and speaker on the same chassis. In the original tuner, the filter capacitor, C6a/C6b, is

an upright can type. If you remove it and substitute a dual tubular-type electrolytic which can be mounted under the chassis, you will have space for a 12AU7 tube (V2) and its 9-pin socket.

One triode section of V2 serves as a voltage amplifier for the output of the diode detector and the second triode section is the output amplifier. The output transformer (T1) is installed under the chassis, just back of the volume control.

Some reorientation of parts may be necessary if you are converting from the original tuner construction. Little difficulty should be experienced, however, because there are no critical stages in the design.

A phono jack is mounted at the rear of the chassis which permits the unit to

PARTS LIST

C1—0.005- μ d., 600-volt capacitor
C2a/C2b—365-365 μ d., 2-gang, TRF-type tuning capacitor
C3—0.01- μ d., 400-volt capacitor
C4—250- μ d. mica or ceramic capacitor
C5—0.01- μ d., 200-volt capacitor
C6a/C6b—20-20 μ d., 150-volt dual electrolytic tubular capacitor
C7—0.05- μ d., 400-volt capacitor
C8—0.01- μ d., 400-volt capacitor
C9—50- μ d., 25-volt electrolytic capacitor
C10—0.005- μ d., 400-volt capacitor
CR1—1N34A or CK705 germanium diode
J1—Phono jack
R1—330-ohm, 1/2-watt resistor
R2—500,000-ohm potentiometer
R3—1000-ohm, 1-watt resistor

R4—100-ohm, 1/2-watt resistor
R5—3.3-megohm, 1/2-watt resistor
R6—100,000-ohm, 1/2-watt resistor
R7—470,000-ohm, 1/2-watt resistor
R8—470-ohm, 1/2-watt resistor
S1—S.p.s.t. on-off switch (on R2)
Spkr.—2 1/2" loudspeaker
SR1—20-ma., 130-volt selenium rectifier
T1—Antenna coil (Miller A-320-A)
T2—Detector coil (Miller A-320-RF)
T3—Power transformer, 117-volt primary, 125 volts @ 15-ma. secondary, and 6.3-volt, 0.6-amp. filament winding (Stancor PS8415)
T4—Output transformer, 8000-10,000 ohm plate to voice coil (Stancor A3328)
V1—6SK7 tube
V2—12AU7 tube

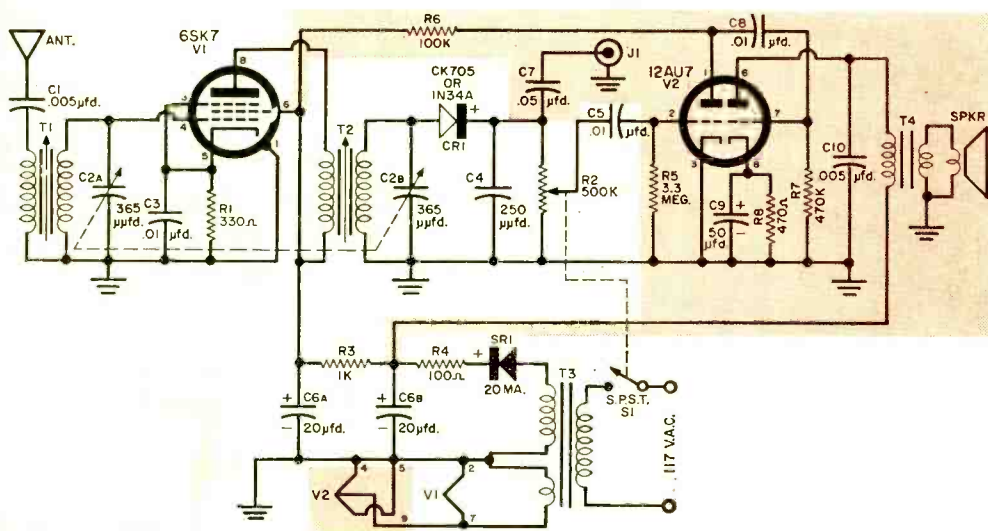

Portions of the schematic and the new parts shown in color above indicate the areas in which changes or additions are made to convert the tuner to a radio. A shielded or unshielded socket may be used for the 12AU7 wiring shown in the pictorial at left.

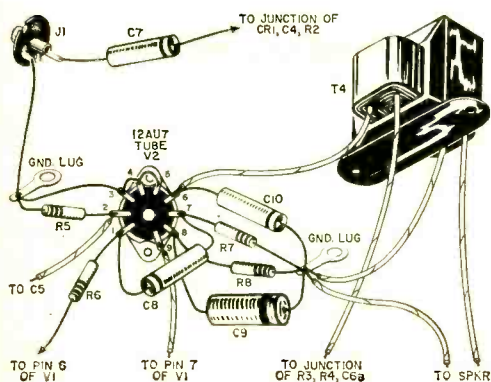

be used as either a self-contained radio or as a tuner for your hi-fi system. Capacitor **C7** is connected from the "high" side of volume control **R2** to this jack. Since the audio output signal of the tuner is not affected by **R2**, this permits the exclusive use of the volume control on your hi-fi amplifier for controlling the tuner.

The shielded cable between the output of the tuner and the input of your hi-fi amplifier should be kept to less than 4' in length.

Adding loudspeaker operation to your tuner has several advantages. The miniature speaker will act as a "monitor" and allow you to tune in a station with your hi-fi system volume turned down, and save yourself the headache-provoking output of interstation noise that would normally come rushing through your big amplifier.

When the unit serves as a radio, the audio output is limited in tone quality by the small loudspeaker. A baffle consisting of a small piece of Celotex with a circular opening cut in it will do wonders for some of the lower frequencies.

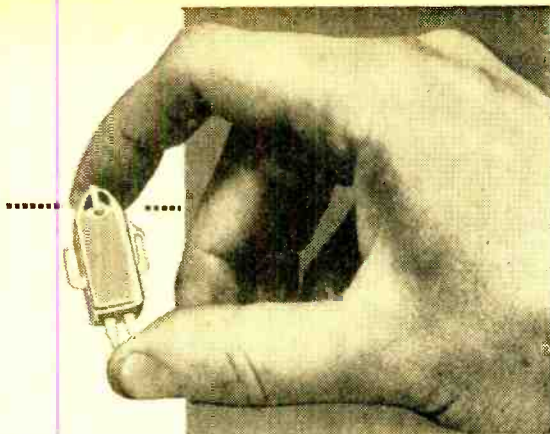

Record Grooves Wiggle Magnet

MAGNETIC PHONO PICKUPS have incorporated either a moving coil (dynamic type) or a moving iron armature (variable-reluctance) driven mechanically by the pickup needle. Both types contain a permanent magnet, fixed in position. Another method is to have the needle move the magnet, as is done in the magnetodynamic type developed by Philips Laboratories.

The movable magnet is made of Ferroxdure, a ferrite material, and is formed into a rod $\frac{1}{32}$ " in diameter and $\frac{1}{2}$ " long (see *M* at right). The rod is magnetized, not in the usual manner with north and south poles at opposite ends, but with the poles at opposite sides of the rod along its length.

Movements of stylus *N* are translated by cantilever stylus bar *L* into motion of the magnetic Ferroxdure rod mounted in neoprene bearings. Audio voltage is developed in coils *S* by the varying magnetic flux.

The specs of the Philips Norelco pickup show a frequency response from 10 to 20,000 cps, ± 2 db. Output voltage is 35 mv.

Translated into listening quality, a frequency response which extends above and below the normal hearing range coupled with high stylus compliance should pay off in undistorted reproduction of musical transients. Violin pizzicato, triangles, trapdrums, etc., come through clean, free from buzz or extraneous vibration. The ± 2 db

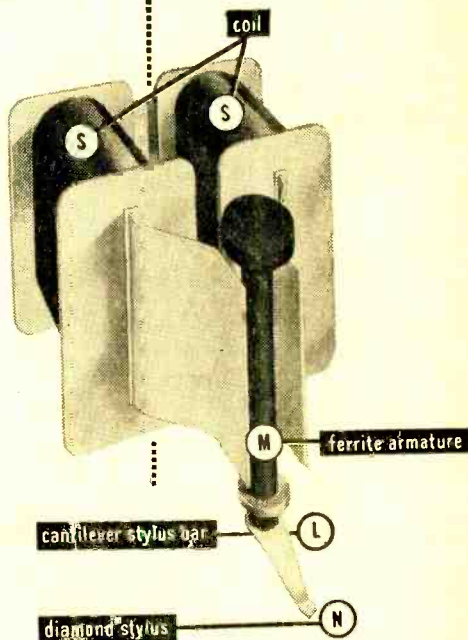

maximum frequency variation indicates that no "holes" or peaks in response will be present. "Holes" generally result in a loss of "body," and peaks contribute to emphasis of record noise and listening fatigue.

The cartridge is equipped with an LP diamond stylus. Tone arm mounting is simplified by the slotted mounting design; the cartridge can be shifted forward or back in the slots to achieve the exact overhang specified by the tone arm manufacturer. (See "Give Your Pickup A Chance," in the March 1958 issue of POPULAR ELECTRONICS.)

-30-

TECHNICAL DISCUSSIONS between hi-fi fans often include mention of the circuitry of the various amplifiers and preamplifiers available and the specifications of each. One of the amplifier systems often mentioned is that of the Dynakit preamp and Mark II amplifier, a 50-watt job. Re-

Putting It Together. That the instructions have been carefully assembled is evident from the first one, covering the mounting of the input sockets, to the last one. The first directs the reader to scrape the paint on the chassis until the metal around the input socket is bright, to insure

DYNAKIT Preamplifier



cently the 60-watt Mark III amplifier was added to the Dynakit line by Dynaco, Inc., 617 N. 41st St., Philadelphia 4, Pa. This presents us with an opportunity of reviewing the new kit as well as the preamplifier kit.

The Dynakit preamplifier is designed to be a complete control unit of a hi-fi system. Although it is powered by the amplifier with which it is used, it switches the a.c. line to the auxiliary equipment. Thus, the associated basic amplifier can easily be tucked away at a remote spot if desired. All switching of the audio circuit and setting of controls is done at the preamp.

This preamplifier can be supplied with power from most of the usual amplifiers that have or can be provided with an octal power socket feeding 6.3 volts a.c. and 200 to 400 volts d.c. A voltage-doubler rectifier in the Dynakit preamp changes the a.c. supplied to it to 11 volts d.c. for the heaters of the two 12AX7 tubes.

Printed-circuit board of tube circuits is clearly shown in rear view of preamp, below. The 6AN8 circuits of the amplifier on the facing page are on similar board.

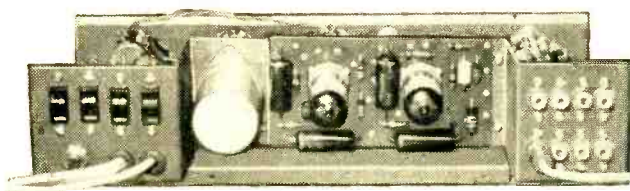

a perfect ground. However, not much scraping is needed, because a disc of adhesive tape was placed on the metal around the hole before the chassis was sprayed with paint. Its removal leaves the bare metal.

Wiring proceeds rapidly and no unusual problems should be encountered. All critical parts of the Dynakit preamplifier circuit are assembled and connected on a printed-circuit board at the factory. Sixteen connections are made to numbered eyelets on the board. Each eyelet is filled with solder at the factory, so it is only necessary to

touch the iron or gun to the eyelet until the solder melts, then slip the tinned wire in and let the joint cool. Avoid using a large iron here, or use it very carefully, because too much heat can ruin the board.

One of the six input sockets can be used for almost anything. Directions are given

of the rat's nest of wires. Poking an iron and long-nose pliers into such places often results in melting or burning the insulation of adjacent wires or parts. No such problems were encountered with the Dynakit's. All of the spots that are close to the chassis or in corners get their leads early in the



DYNAKIT Mark III Amplifier

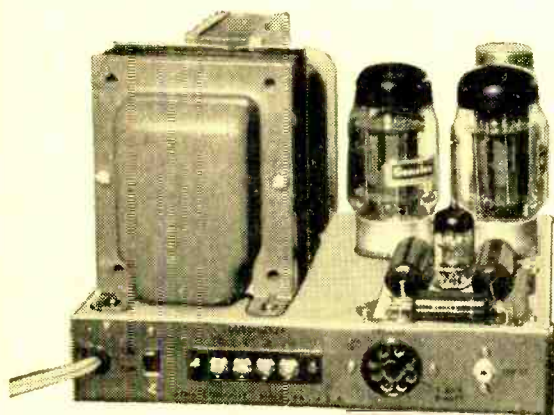

for connecting it as extra RIAA phono input, or as a microphone or a tape head input. It can be connected to be fed directly from a tape head without a preamplifier. Being a tape fan, this reviewer chose the tape head input for this socket. Wiring of the input selector switch then follows with changes according to the choice.

One of the disconcerting problems in building some kits is that the early wiring piles up in certain corners or otherwise crowded places. Later, a few wires have to be soldered to terminals at the bottom

game; none are left for squeezing in later.

It was found to be helpful to check once in a while against the pictorial diagrams. Although the reviewer is an old hand at wiring from schematics and is somewhat impatient with pictorials, he made a mistake. After connecting a certain wire to one lug, he somewhat skeptically checked all previous connections against the pictorial. To his dismay, he found that the connection he had just made should have had another wire from a previous step. Frantically tracing leads, he found that the other wire had been soldered to the wrong lug.

After that mistake he was more careful. One of the final instructions warns to check that all connections are soldered. Having learned his lesson, he did, and found one terminal with several leads that he had forgotten to solder. That one would be enough to make the whole system fade, cut in and out, or cause noisy operation . . . and probably not right away, but months later, after the terminal and wires had oxidized or loosened.

Be careful with the spring "nut" that holds the plastic pilot light indicator in place. Hold it tightly with pliers while

putting it over the indicator. Loosen your grip, and it flies about 20 feet away from you.

Special Features. The low-level input of the preamplifier is used for magnetic phono pickups, such as the G.E. and Fairchild, which have less than 15 millivolts output. The high-level input is for pickups like the Miratwin and Pickering, whose output is more than 15 millivolts.

A switch on the control panel provides correction for low settings of the volume control because the ear is not as sensitive to high and low frequencies at low volume level as it is at high volume. When the switch is on, boost is provided for frequencies below 400 cps and above 3000 cps. When the switch is off, there is no frequency discrimination. For the statistically minded, the intermodulation distortion is said to be less than 0.1% and the response is ± 0.5 db from 6 cps to 60 kc. when the tone controls are zeroed. Square waves are passed without deformation or ringing from 20 cps to 20 kc. at any volume setting.

The Amplifier. Wiring of the Dynakit Mark III amplifier takes less time than the preamplifier. It can be done in one evening. The major portion is already done—it's on

the bias voltage. This can be done with any voltmeter whose sensitivity is 1000 ohms per volt or higher. Correct setting of the bias voltage provides a total cathode current of the KT88 tubes of 140 ma. When this current flows through the built-in precision 11.2-ohm resistor, it produces a voltage drop of exactly 1.56 volts d.c. This voltage can be checked at one terminal of the preamplifier power take-off socket. The same voltage is furnished by a "D" type flashlight dry cell, so one of these can be used as an accurate reference standard for bias setting. You don't need to depend on your voltmeter scale; it's probably off a little anyway. Just buy a fresh "D" cell—its voltage is 1.56 when new. Whatever it reads on the voltmeter scale, that's the point for 1.56 volts. Full instructions for this test are in the Dynakit booklet.

The Dynakit Mark III can be used with any conventional preamplifier. One with a built-in power supply can be used by connecting its audio cable to the input socket. Units which require power from the ampli-

The Mark III amplifier (right) and the preamplifier ready for use. All switching of the audio circuit and setting of controls is done at the preamp.

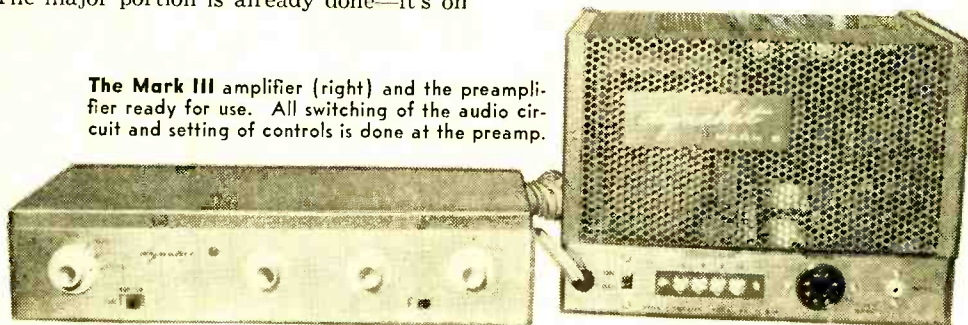

a printed-circuit board. The few wiring operations that remain consist mostly of the power supply leads and output transformer leads.

In the Dynakit Mark III amplifier, the pentode portion of a 6AN8 is used as a voltage amplifier and is directly coupled to a "cathodyne" phase inverter. High-frequency compensation is employed in a capacitive feedback loop, to correct the inherent unbalance of this type of phase inverter. The inverter drives the KT88 output tubes which are operated with fixed bias.

The Dynakit amplifier includes a novel circuit which greatly simplifies setting of

fier can be used if the power socket on the front panel of the Mark III is properly wired.

Comment. The Mark III amplifier puts out 60 watts with 1.6-volts input. The preamplifier, of course, brings up the output of any low-level signal source such as a pickup or tape head to about the 1.6-volt level.

Operation of the two units with different audio inputs showed that the performance and specifications are certainly worthy of discussion by hi-fi fans. Shortcomings in your reviewer's auxiliary equipment, never noticed before, showed up at once. Where is that speaker catalog?

Which Mike Should I Use?

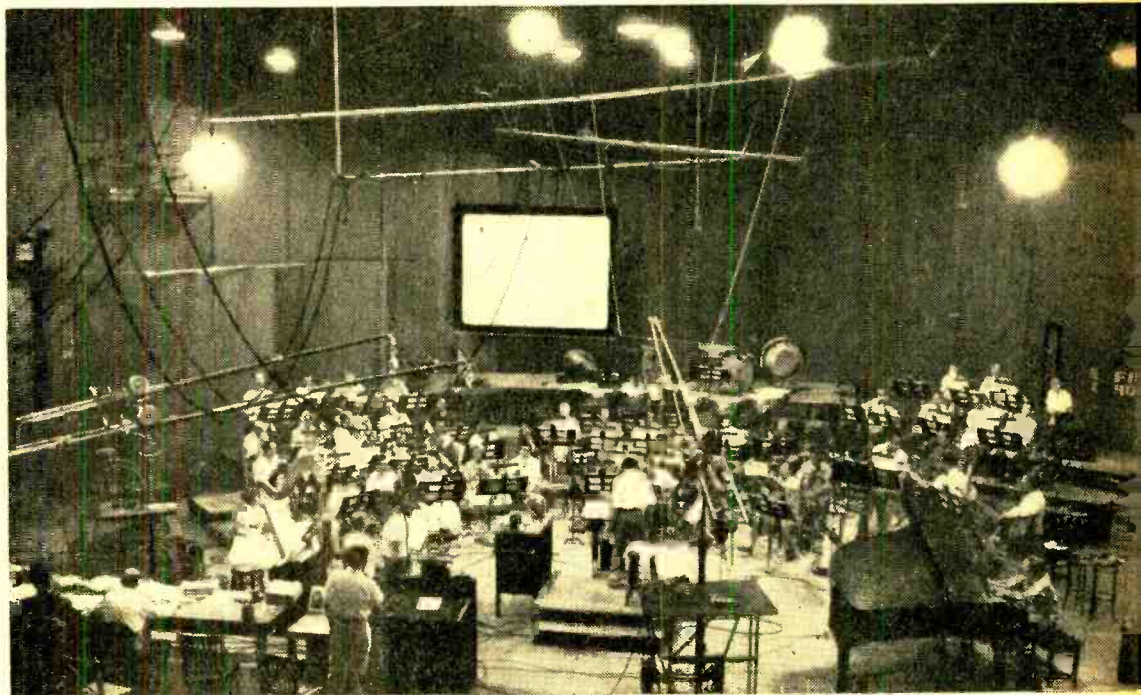

*Which one to choose is up to you—
here are the characteristics of each type*

By E. EUGENE GARNES

BE IT TAPE or disc recording, the quality of the finished product can be no better than the microphone. It is here that fidelity begins . . . or ends! The serious recordist cannot be too economy-conscious when selecting a microphone. In many instances, certain units serve special purposes, giving superior results over other types.

TYPES OF MICROPHONES

The following opinions are those of the author, gained from 15 years of recording

July, 1958

experience with the various types of microphones.

Carbon. Although generally restricted to communications work at the present time, the carbon mike once had its heyday when it was widely used by broadcasting stations. Now it is the telephone "transmitter" in your home.

The principle of operation of a carbon mike is simple. A diaphragm compresses carbon granules in a small container. This causes the granules to act as a varying resistance which changes the electrical



crystal element and produces the audio signal. Depending upon price, frequency response is usually somewhere between 50 and 9000 cps.

Dynamic. The majority of the dynamic (pressure) microphones available today are omnidirectional, although there are a few with directional characteristics. Very often, economical versions are supplied with home tape recorders.

In the mechanical layout of the dynamic microphone, the metallic diaphragm has fastened to it a coil form on which is

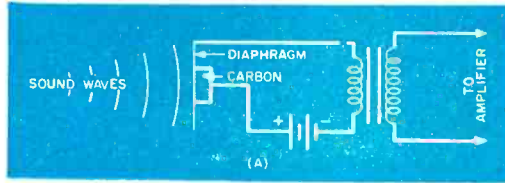

Carbon mikes such as the Elgin National, above, left, are generally used in communications work (and in the telephone "transmitter" at home). Circuit is shown above.

current provided by a battery. A transformer is used to feed the input circuit of a following amplifier.

Disadvantages of a carbon mike are the need for a d.c. excitation voltage and limited frequency range.

Crystal. This type of microphone has gained wide popularity in amateur recording and public address work primarily because of its low cost and good voice quality.

Crystal units have a high output impedance which is convenient for feeding the amplifier grid directly. This charac-

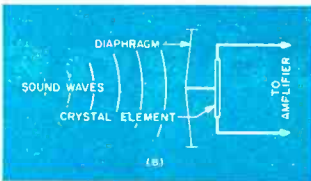

The crystal mike has the advantages of low cost and good voice quality, which makes it popular for amateur recording and public address work. Above, left, is an Electro-Voice model. Typical circuit is at far left.

teristic, however, has a definite disadvantage in that the mike must be located near the amplifier. Severe high-frequency attenuation and possible hum pickup results when you use long mike cables. Generally, the manufacturer supplies the maximum length of cable that can be used without obvious impairment of performance.

These mikes are also susceptible to high temperature and humidity conditions. They are usually omnidirectional. In operation, the diaphragm movement stresses the

wound a copper or aluminum wire. The coil is suspended in a strong magnetic field. Sound pressure striking the diaphragm causes the coil assembly to vibrate. This induces an electrical signal in the coil whose frequency and intensity are proportional to the original sound.

Impedance of the coil is quite low, usually on the order of 10 to 30 ohms. A transformer is used to raise this to 150,

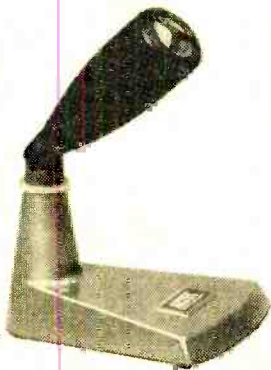
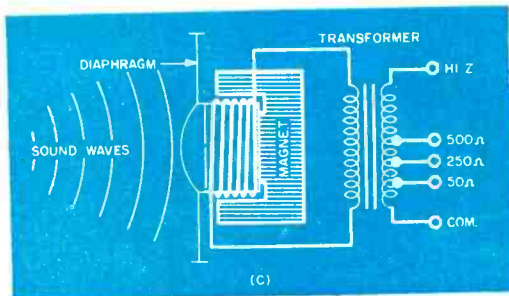
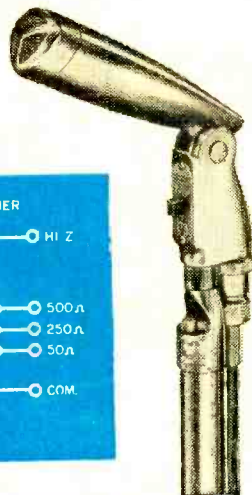

Most dynamic mikes tend to be omnidirectional. Models surrounding the circuit diagram are: Altec (left), Turner (above, left), and Electro-Voice (above, right).

250, 500 ohms, or even higher, to match the amplifier input. Such transformers are generally tapped to allow selection of any popular impedance. In one instance, that of the Altec 633A, the voice coil (30 ohms) is used directly to feed a 50-ohm amplifier input.

Dynamic mikes are quite rugged, unaffected by temperature or humidity, making them desirable for field use. With a microphone of 500-ohm or less impedance, almost unlimited cable lengths can be employed, as the cable capacitance has little effect at these impedances.

Price determines the final performance of the unit. Better instruments boast a range of 40 to 15,000 cps with ± 2.5 db variation. These are considered professional mikes and worthy of hi-fi classification.

Velocity. Widely used in the broadcasting field for years, the ribbon or velocity microphone has proved reliable and versatile.

A single, very thin strip of corrugated

aluminum is suspended in a magnetic field. This corrugated ribbon acts as diaphragm and "voice coil" all in one. Its output impedance is extremely low, a fraction of an ohm, and in all cases a matching transformer is necessary to raise the impedance.

The term "velocity" comes from the nature of the mike's operation. The aluminum ribbon is extremely flexible, actually capable of moving $\frac{1}{8}$ " front to back without damage. It is caused to vibrate *with* the air surrounding it, not under pressure as in the case of other mikes.

Sound waves that hit the ribbon broadside will cause it to vibrate. Sound approaching from the side will have little effect, since the ribbon is so thin that the air loading in this direction is negligible. This means that the mike is sound-sensitive at the front and rear but "dead" on the sides—hence giving a bidirectional result.

A velocity mike will accentuate low frequencies at close range. For "flat" response, the sound source should be at least two feet away from the mike. A word of caution: the ribbon is susceptible to high velocities of air and should never be used where there is wind out-of-doors lest the diaphragm be stretched beyond its normal range.

Velocity mikes generally have a frequency range of from 30 to 15,000 cps,

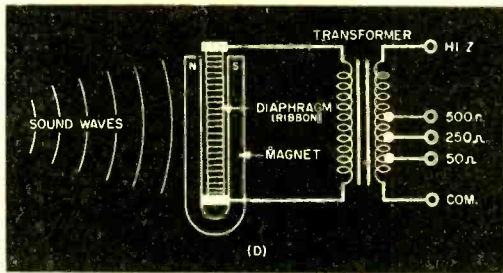

The diaphragm back-plate assembly is a high-precision device and should be treated as such. This fact should not frighten one away, however. One of the largest radio and television networks has been using such mikes constantly for several years and has yet to encounter a mechanical failure.

A capacitive mike unit has an extremely high output impedance which makes it

Velocity (ribbon) mikes are widely used in broadcasting. The unit above is a Shure Bros. model. Diagram above, right, shows typical circuit.



and are in the medium-to-high price bracket.

Condenser. Early models of the condenser microphone suffered from resonant peaks within the sound spectrum and were not stable, being affected by humidity and insulation breakdown. With the development of modern materials, however, it has been possible to create models that represent the "Rolls Royce" of the microphone market in performance and cost.

In operation, the diaphragm and back plate act as a capacitor, varying the charge as they come closer or get farther apart. Since the electrical signal is derived solely from the proximity of the diaphragm to the rigid back plate, the diaphragm doesn't have much action. It has no coil to move and no crystal to flex. This permits the use of extremely thin, light, flexible materials that respond readily to sound vibrations.

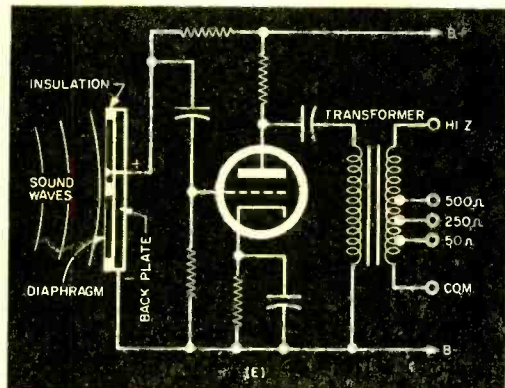

The condenser mike, while perhaps the best of all, requires a power unit with multiconductor cable connection. Typical is the Telefunken mike and amplifier combination (above, center). Circuit is directly above.

Proper placement of microphones is as important as the proper choice of mike. Diagrams at right and below show two basic examples of good placement and can be used as guides to many other installations.

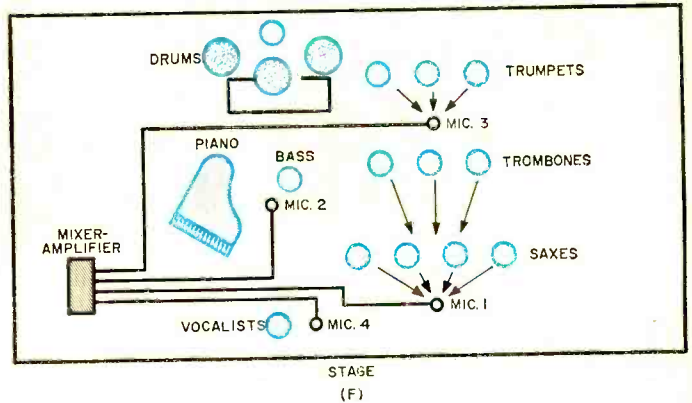
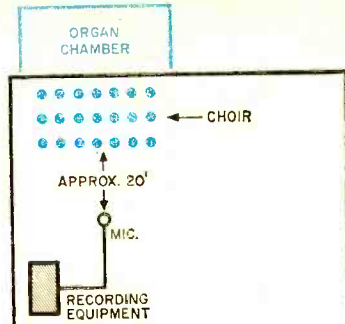

necessary to place an amplifier or cathode-follower stage in the same housing with the pickup unit. This vacuum-tube circuit can then be arranged to provide any desirable low impedance for high-fidelity work, generally by means of a high-quality transformer.

One disadvantage of the condenser mike is that a power supply must provide the necessary polarizing and operating voltages for the capacitor assembly and vacuum tube. The power unit is always a separate device requiring a multiconductor cable from it to the mike proper.

Condenser microphones have the widest range of all—20 to 18,000 cps, ± 2 -db variation, being quite common. Initial cost is rather high, but if you are the type who needs a microphone with that "something extra," choose a condenser unit. They are available in combination omnidirectional and unidirectional models.

APPLICATIONS

It is impossible to manufacture one microphone which possesses all qualities necessary to handle all recording tasks. Therefore, we have a variety of units available for use singly or in combination.

An Elementary Project. Suppose you want to record the local church choir

with organ. Although the sound (organ and possibly 20 voices) comes from a relatively large area and the massive tones demand much from the recording equipment, one well-placed mike should do the job faithfully. Such a sound source is more or less "self-balancing" if the organist doesn't have a heavy foot.

After experimenting, you will probably find that the mike should be located about 20 feet in front of the choir. If it is any closer, you may begin to pick up individual voices. Place it too far away and, although you will retain proper balance, "presence" will be lost; also, depending on the prevailing acoustics, you may get excessive reverberation or echo. Assuming that the organ loft is located near the choir, you can disregard it, since the organist is responsible for balance with regard to the choir.

The pickup pattern of the mike in this instance is not critical. If the congregation is present, it will be worthwhile to employ a unidirectional type to minimize pickup of coughing and other random noise originating behind it.

This one-mike technique is also satisfactory for recording symphony orchestras, small combos, solo instruments, and

(Continued on page 110)

HOW TO REDUCE RECEIVER GAIN

Those of us who live in metropolitan areas or near powerful broadcasting stations sometimes suffer from overload of our AM receiver circuits on strong local stations. This results in distortion and general deterioration of sound quality.

With radio receivers having loop antennas, gain can be reduced without making internal circuit alterations. The remedy

is simply to short out the effective number of turns in the loop, which is best determined experimentally.

Connect a test probe lead to one terminal of the loop. Tune the receiver to the offending station and turn the volume control all the way down. The probe is used to make contact with the individual turns by piercing the insulation on the antenna wire. Then, by working in turn by turn, the antenna loop is progressively "shortened" until the volume is reduced to an acceptable level.

Pick loose a section of the indicated turn from the loop and solder a wire to it, as shown in the photo. This tap on the loop is connected to the antenna terminal through a single-pole switch mounted at a convenient location on the radio. For local station reception, the switch is closed.

—Wm. B. Rasmussen

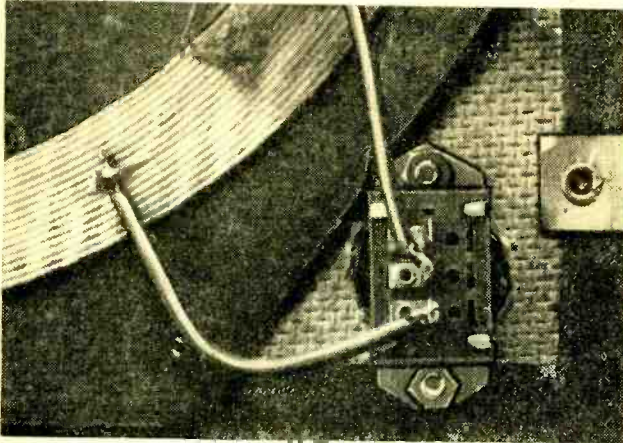

COLOR-CODE YOUR CIRCUITS

The accepted way to identify resistors and capacitors is through the use of the EIA (RETMA) standard color code. There is another color code, less generally known, which can also be of value to hobbyists and experimenters in electronics. This is the EIA wiring code.

While it may be a little more bother to select the proper colored wire to conform to this standard, it can pay off in the long run. After wiring is completed, it is easier to check it against the schematic because every section of the wiring identifies its function by its color. If you have to run tests or troubleshoot a circuit, a glance at the wiring colors will tell you what voltages or resistances to expect at each point in the chassis.

This color code is given in the table at right. The average circuit doesn't require all of the colors; it is generally sufficient to use brown for the filaments, red for B+, black for ground or common connections, and green for signal and grid leads. These four colors are usually enough to enable easy identification of the different circuits.

Practically the entire electronics industry uses this code. By learning and using it yourself, you will find it easier to identify the wiring in many pieces of commercial and military equipment. And even without a schematic, you will be able to trace out the type of circuit you're investigating.

—E. D. Morgan

EIA CHASSIS WIRING COLOR CODE	
Color	Circuit
Black	Grounds, grounded elements, and returns
Brown	Heaters or filaments, off ground
Red	Power Supply B-plus
Orange	Screen grids
Yellow	Cathodes
Green	Control grids
Blue	Plates
Violet	Not used
Gray	A.C. power lines
White	Above or below ground returns, a.v.c., etc.



Among the Novice Hams

By HERB S. BRIER, W9EGQ



IN the May issue, we learned that a tuned circuit consisting of an inductance and a capacitance in series will pass a signal at its resonant frequency, but will oppose the passage of signals of other frequencies. Conversely, an inductance and a capacitance connected in parallel will oppose the passage of signals at their resonant frequency but will pass other signals readily.

Selectivity. The ability of resonant circuits to pass or reject signals of different frequencies is called *selectivity*. We use selective circuits in our receivers to tune in those of the thousands of signals always on the air that we wish to listen to.

Consider the circuit of Fig. 1. If we plot its selectivity with different values of series resistance (R), we will obtain a set of curves similar to those in Fig. 2. From these curves, we see that the lower the value of the series resistance, the more selective the circuit.

For example, with a selectivity curve like *A*, resulting from a low value of series resistance, a signal that was not tuned in right "on the nose" would be much attenuated going through the circuit. However, with a curve like *C*, resulting from a high value of series resistance, a signal quite different in frequency than the resonant frequency of the circuit would not be attenuated greatly.

While plotting our curves, we would also discover that the higher the value of the series resistance, the greater the power that is drawn from the signal generator, in order to supply the power consumed by the resistance.

Tuned Circuit Q . From these curves, we can see that varying the resistance in series with the inductor and capacitor changes the sharpness of the selectivity curve of the circuit. More accurately, it is the *ratio* of the resistance to the reactance of either the inductance or the capacitance of the circuit (at resonance,

the reactances are equal) that determines the selectivity.

This ratio is the measure of the Q of the circuit. In this circuit, $Q = X/R$; where X is the reactance of either the capacitor (condenser) or the inductor (coil) at the resonant frequency of the circuit in ohms, and R is the resistance in ohms.

For the purpose of passing amateur examinations, the important things to re-

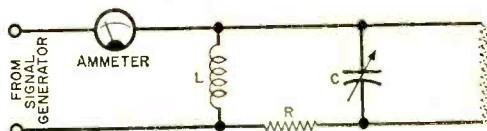
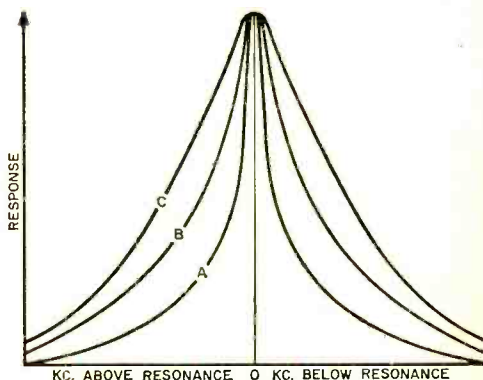

Fig. 1. Theoretical circuit used to illustrate discussion of selectivity and Q .

Fig. 2. How response (selectivity) of resonant circuit (Fig. 1) varies with Q .



member about Q are the above formula and the fact that a high- Q circuit has high selectivity. The resonant circuits in our transmitters normally should have an effective Q of at least 10 for sufficient selectivity to suppress harmonics and other undesired frequencies unavoidably gener-

HELP US OBTAIN OUR HAM LICENSES

Prospective amateurs requesting help and encouragement in obtaining their licenses are listed here. To have your name listed, write to Herb S. Brier, W9EGQ, c/o POPULAR ELECTRONICS, One Park Avenue, New York 16, N. Y. Please print your name and address clearly. Names are grouped geographically by amateur call areas.

K1/W1 CALL AREA

Michael Bresloff, 873 Shippan Ave., Stamford, Conn. (Theory)

Bill McGurk, 86 W. Glenn St., Holyoke, Mass. (Code)

Joseph Clough (13), 177 St. John St., Portland, Me. Phone: SP 3-0165. (Code, theory and regulations)

Tom Donegan, 30 Cowles St., Devon, Conn. Phone: TR 4-0983. (Code and theory)

Ronald Toscano, 39 Storow St., Lawrence, Mass. Phone: MU 2-7180. (Code)

Neil Bartlett, Lincoln St., Melville, Mass. Phone: TU 3-6877. (Code and theory)

K2/W2 CALL AREA

Bill Young, R. F. D. #1, Monmouth Junction, N. J. (Code and theory)

Dick Steinfeldt, 325 Roslyn St., Rochester 19, N. Y. (General code and theory)

Anthony Vitole, 169-14 21st Ave., Beechhurst 57, N. Y. (Code and theory)

Santiago Benitez, 34 Carroll St., Paterson 1, N. J. Phone: MU 4-1793. (Code and theory)

Emanuel Meyer, 490 West End Ave., New York 24, N. Y. (Code, theory, regulations and selection of equipment)

Skip Porteous (14), Hillsdale, N. Y. (Code and theory)

Kenneth E. Anderson, Hq. A.M.F.E.A., A.P.O. 633, New York, N. Y. (Code and theory)

Tony Cirillo (17), 1520-64th St., Brooklyn 19, N. Y. Phone: BE 2-4496. (Code, theory and regulations)

Leo Stein, 456 Bedford Ave., Mt. Vernon, N. Y. Phone: MO 8-2085.

K3/W3 CALL AREA

Frank J. Ayd, 6231 York Rd., Baltimore 12, Md. Phone: ID 5-7113. (Code and theory)

Charles Staudé, 2102 Moredale St., Pittsburgh 10, Pa. Phone: TU 208579. (Code and theory)

Jeremiah M. Lane, 2014 Gilpin Ave., Wilmington, Del. (Code and regulations)

Edwin Markel, Jr., Plymouth & Johnson Rds., Norristown, RD 4, Pa. (General code and theory)

Michael Kohn (14), 1103 Curtis Dr., Wyncote, Pa. Phone: TU 7-2692. (General code and theory)

John Repice (13), 110 Sharon Ave., Collingdale, Pa. (Code and theory)

J. Michael Cox, 121 Third St., Elizabeth, Pa. (Code and theory)

Sy Post, 3901 E. Roosevelt Blvd., Philadelphia 24, Pa. Phone: JE: 5-0456. (Code and theory)

K4/W4 CALL AREA

Jack Bradley, 206 E. Harvey St., Maryville, Tenn. (Code, theory and selection of equipment)

A/2c Richard D. Dunlap, 2044th A.A.C.S. Sq., Box 332, Ft. Myer, Arlington 8, Va. (Code and theory)

Bert Headden (15), Route #1, Trimble, Tenn. Phone: 66R. (Code, theory, regulations and selection of equipment)

Jim Roberts, 500 W. Vance St., Wilson, N. C. Phone: 7-1714. (General Class code and theory)

George Pully, Jr. (13), Middle Rd., Winchester, Va. (Code, theory and regulations)

Lanny Langford (13), 4519 Orange Dr., Louisville 13, Ky. Phone: EM 6-3310. (Code and theory)

Gary Jacobs, Box 35, Collegedale, Tenn. (Code and theory)

Capt. D. B. Sanderson, HMR-461, MCAF, Jacksonville, N. C. (Code and theory)

Terrill Dixon, 905 W. "X" St., Pensacola, Fla. (Code and theory)

Carlos Ward, 3004 W. DeSoto St., Pensacola, Fla. (Code and theory)

Dennis Ritchie, 13120 S. W. 82 Ave., Miami Beach, Fla.

K5/W5 CALL AREA

William J. Gentry, 500 West 1st St., Fort Worth 3, Tex. Phone: ED 5-0538.

Wade Anderson (10), 109 Page, Poteau, Okla. (Code, theory, regulations and selection of equipment)

Tommy Edmondson, 3210 Anzio Dr., Dallas, Texas. (Code, theory and regulations)

Marshall Wilson (15), 3023 Aster St., Dallas 11, Texas. Phone: FE 1-8991. (Code, theory, regulations and selection of equipment)

Carl D'Aquila, Jr., Woodville, Miss. Phone: 5801. (Code, theory and regulations)

Daniel Galvin, Box J, Whiteface, Texas. (Code and theory)

K6/W6 CALL AREA

Frank Edtl, 2821 Glenside Dr., Concord, Calif. Phone: MU 2-4891. (Code, theory and selection of equipment)

Bob Lauder milk, 1534 South Fifth, Fresno, Calif. (Code, theory and regulations)

Mike Barnett (12), 4148 Shady Glade Ave., Studio City, Calif. Phone: ST 7-3693. (Theory and selection of equipment)

Marcus W. Nichols (12), P. O. Box 32, Julian, Calif. (Code and theory)

Eric Vasco, 6153 Lakewood Blvd., Lakewood, Calif. (Code and selection of equipment)

Bob Labagh (15), 51 Laurel Ave., San Anselmo, Calif. (Code and theory)

Dan and Carole Lay, 2511 N. Buena Vista, Burbank, Calif. (Code, theory and selection of equipment)

Ernest O. Barney (15), 4118 W. Adams Blvd., Los Angeles 18, Calif. (Code and theory)

Doug Kennedy (16), 782 Dolores Ave., San Leandro, Calif. Phone: LO 2-3363. (Code and theory)

Dick Burroughs (13), 599 Raymond St., Up-land, Calif. Phone: YU 2-6328. (Code, theory and regulations)

Jim Howard (16), 921 E. Angeleno Ave., Burbank, Calif. Phone: TH 8-6763. (Code, theory, regulations and selection of equipment)

Marcus Parthow, 1721 Lake St., Huntington Beach, Calif. (Code, theory and selection of equipment)

Ed Kelley, 712 N. 4th St., San Jose, Calif. (Code and theory)

Jack Skokan, 25110 Muir St., Hayward, Calif. Phone: LU 2-2573. (Code, theory, regulations and selection of equipment)

Craig Stimmel, Treadway Division, Devereux Schools, Goletia, Calif. Phone: WO 7-2345. (Code and theory)

K7/W7 CALL AREA

Larry Nutting (12), 3123 W. Garland, Spokane, Wash. (Code, theory and selection of equipment)

Joe Naccarato, Box 476, Kellogg, Idaho. (Code and theory)

Robert Hamilton II (22), 1107 Hillside Place, Las Vegas, Nev. (Code and theory)

Richard Imes, 315 Lark, Casper, Wyo. Phone: 3-5285. (Code, theory and selection of equipment)

Mickey Souders (15), 306 Market St., Pine Bluffs, Wyo. Phone: CH 5-3581. (Code, theory and selection of equipment)

K8/W8 CALL AREA

Fred Lins, Jr., 911 Hampshire Rd., Dayton 19, Ohio. Phone: AX 3-7980. (Code and theory)

Skipper Brewer, 244 So. Market St., Marine City, Mich. Phone: RO 2-0661. (Code and theory)

William J. English (15), 1279 Hathaway Ave., Lakewood 7, Ohio. Phone: LA 1-1874. (Code, theory and selection of equipment)

Robert Arcy, 24406 Fairmount, Dearborn, Mich. Phone: LO 5-4831. (Code, theory and regulations)

Ed Whitaker (13), 4319 Lander Rd., Chagrin Falls, Ohio. Phone: TE 1-9825. (General Class code and theory)

Dave Hinkins (16), 5322 Bewick, Detroit 13, Mich. Phone: WA 4-3631. (Code and theory)

Mike Arthur (15), 20515 Lake Rd., Rocky River 16, Ohio. Phone: ED 1-9180. (Code, theory and selection of equipment)

David Prueter (15), 3710 Heatherdowns, Toledo 14, Ohio. Phone: WA 3062. (Code and theory)

Pat Morris, 2920 5th Ave., Huntington 2, W. Va. Phone: JA 2-5539. (Code, theory and selection of equipment)

Louis Kaufman, 1212 6th St., Moundsville, W. Va. (Code and theory)

Dwayne E. Foltz, 1721 Grand Ave., Dayton 7, Ohio. (Code)

Charles H. Small, 14 E. Dixon, Dayton, Ohio. (Code and theory)

Bcb Rowan, 1342 W. 64th St., Cleveland 2, Ohio. (Code and theory)

Tim Telzrow, 4222 E. 116th St., Cleveland 5, Ohio. (Code, theory and selection of equipment)

Elwood Weston (11), 547 E. 110 St., Cleveland 8, Ohio. Phone: UL 1-2542. (Code and theory)

Richard Richards, 10471 Maple Ave., Davison 3, Mich. (Code, theory and selection of equipment)

K9/W9 CALL AREA

Richard Kostelc (16), 1001 Highland Ave., Joliet, Ill. Phone: 3-2569. (Code, theory and regulations)

Bob Shaw, 1425 Maple, Glenview, Ill. (Code and theory)

Martin Bess, 236 North Oakland St., Green Bay, Wis. Phone: HE 7-4501. (Code, theory and regulations)

Howard Unger, Jr., R. F. D. 2, Peru, Ind. (Code and theory)

Matthew Loeffler, 2169 So. 64 St., West Allis 19, Wis. Phone: LI 1-6676. (Code and theory)

Duane Meyer, 2550 S. 65th St., Milwaukee 19, Wis. Phone: LI 1-3216. (Code and theory)

Richard A. Simonis (15), 1035 S. 19th St., LaCrosse, Wis. Phone: 2-3292. (Code, theory and selection of equipment)

Thomas F. Dornback, 2711 So. Karlov Ave., Chicago 23, Ill. Phone: LA 1-7668. (Code and theory)

KØ/WØ CALL AREA

Richard Prokop (13), 1157 Hubbard Ave., St. Paul, Minn. Phone: MI 5-5349. (Code and theory)

Darold Schroeder (16), R. R. 3, Sweet Springs, Mo. (Code and theory)

Gary Thiel (15), 107 N. 4th St., Stillwater, Minn. Phone: HE 9-2108. (Code and theory)

Gary Hanson (14), Heron Lake, Minn. (Code and selection of equipment)

Ross Thenhaus, 11330 W. Center Ave., Denver 15, Colo. Phone: BE 3-4911. (General Class code, theory and regulations)

VE AND OTHERS

Frank Buchanan, Box 110, 40 Queen St., Sussex, N. B., Canada. (Code and theory)

Barry Brace, 1103 4th Ave. N. W., Moose Jaw, Saskatchewan, Canada. (Code and theory)

Lloyd G. Gimbel, Box 811, Lacombe, Alberta, Canada. (Code and theory)

Paul Costello, 378 Brock St., Winnipeg 9, Manitoba, Canada. (Code and theory)

Bob Carter (17), 177 Antrim St. Peterborough, Ontario, Canada. Phone: RI 5-8242. (Code, theory, regulations and selection of equipment)

Robert Chew (18), 41 Scotts Road, Singapore 9, Malaya. (Code, theory and regulations)

ated in transmitters, so that they will not be radiated.

If, instead of connecting a resistance in series with the tuned circuit, we connect it across the circuit, as shown in dashed lines in Fig. 1, we can duplicate the curves of Fig. 2. However, the resistance required to produce a given curve will be much higher than with the series connection. For the parallel connection, $Q = R/X$.

The resistances shown in the theoretical circuit represent the effective resistance of the antenna or other load coupled to the tuned circuit in an actual application. Therefore, only in special applications will you normally find an actual resistor connected in a tuned circuit.

When the effective value of the load resistance is low, it is usually connected



Joe, W7DWE, puts the rare state of Idaho on the air from Rexburg. See News and Views item on page 122.

in series with the tuned circuit; and when it is high, it is connected in parallel with the tuned circuit. Sometimes, however, a low-resistance load may be tapped across only part of the tuned circuit.

Answering Questions. There are several questions in the General Class section of the "License Manual," as well as in the actual examinations, that require drawing the schematic diagrams of simple resonant circuits to answer. Let us review some of them.

Draw a schematic diagram of a filter for reducing amateur interference to broadcast reception consisting of (A) a series-tuned circuit connected in shunt with the broadcast receiver input to bypass the

(Continued on page 120)

Hi-Fi Highlights

MANY READERS have been writing in to inquire about new and novel developments in high-fidelity equipment that they have heard about. To help supply such information quickly, POPULAR ELECTRONICS presents a roundup of the most interesting high-fidelity accessories crossing our desks in recent weeks. Each brief description is numbered and a box appears on page 107 along with additional items. Just circle the numbers in the box pertaining to the items that interest you and send the box in to the address given. You'll receive complete information on those items.

-30-



1

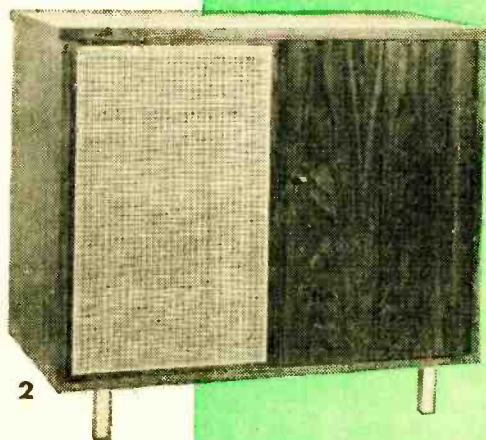

2



3

1 Speaker system on baffleboard built in Denmark, designed for most enclosures, uses 12" woofer, 5" mid-range, 2" tweeter, LC crossover at 800 and 4000 cps. Power rating of system is 15 watts. Olson AS-321 Shieldcrest.

2 Enclosure within enclosure. Inner one is acoustically isolated from major cabinet, preventing acoustic feedback due to possible interaction between light-weight tone arm and vibration resulting from bass reproduction. Grommes and Phillips GPC-600.

3 Stereo amplifier includes noise filters, reverse switch, output combining switch to parallel two 10's to give full 20-watt monophonic output. It replaces earlier model. Bell Pacemaker 2221.



4

4 Tone arm kit wired for stereo phono cartridges is available in 12" and 16" models. Only phono arm kit on the market. Assembly time is short, only about 15 minutes. Audax.



5

5 Central switching and volume control unit for stereo. Amplifiers plug in and unit's master volume control takes over function of changing volume. It reverses channels, allows paralleling of amplifiers for use with monophonic source. Scott Stereo-Dapter.

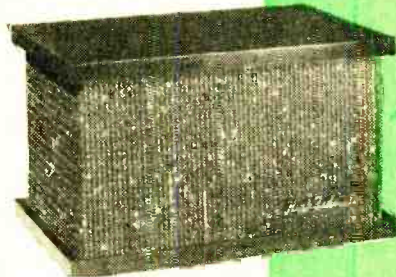

6

6 Bookshelf type speaker system uses dynamic air coupling to make entire air chamber a phase-matching transformer said to give optimum results at high and low end. Recommended for stereo, enclosure is 9" x 9" x 16" in four finishes. Telematic "Minstrel".¹¹



7

7 Stereo preamplifier designed to work with two basic amplifiers. Ganged selector, turnover, roll-off, volume bass and treble controls. It can use one channel to drive two amplifiers monophonically. Self-powered, with d.c. on filaments. Grommes Model 208.

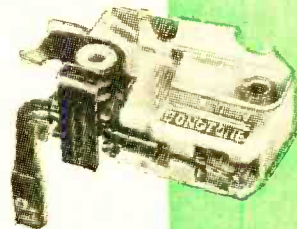

8

8 Ceramic cartridge said to offer nearly twice the compliance and smoother frequency response of earlier models in the price range. Sonotone Series 7.

More hi-fi items on page 107

LOCK-IN RELAY SYSTEMS

Frequently a relay is needed which, when closed by a momentary surge or pulse of current, will remain closed until a momentary break releases it. Expensive two-coil relays are available which operate by having one armature hinged between the two coils. The armature, which can be pulled in either direction, will close contacts and keep them closed until the coil opposite is energized. However, a standard inexpensive momentary relay can be wired to convert its operation so as to function similarly in most applications.

Essentially, the circuit consists of the proper power source for the d.p.d.t. relay you are using, and for the two control switches which are s.p.d.t. push buttons. As the diagram shows, *S1* is the controlling switch. When it is closed momentarily, either manually or by another relay, current from the relay power source flows through *S2* and relay *RL1*, causing two of the top relay contacts to close. This action

effectively replaces *S1* in the circuit. At this point, *RL1* is energized, and locked, until *S2* is used to break the current flow momentarily, thus opening *RL1*. This auto-

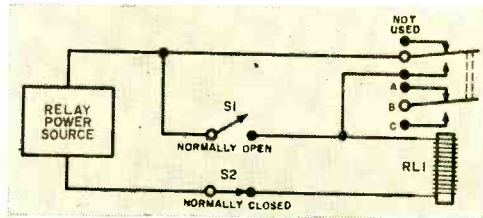

matically stops all voltage from reaching the coil until *S1* is closed again.

Many applications will suggest themselves to the hobbyist and ham, such as voice-controlled break-in, photography timers, telephone answering devices, and dozens of remote control systems.

—Alan Cariffe, K6DDN

REPAIRING WIRE-WOUND POTS

Wire-wound potentiometers are usually quite rugged, but if even a single strand of the resistance wire is broken, the pot becomes useless. A potentiometer or rheostat winding is very difficult, if not impossible, to solder. However, in cases where

ohmmeter. Rotate the pot contact arm slowly and carefully until it rests at a point where a reading is just obtained, which is the location of the break. Mark this point on the pot housing. Then move the arm to either extreme of its rotation.

Take a short length of No. 20 bare or tinned copper wire and flatten one end to a fine point with a hammer to form a thin, flat wedge. At the break, press the wedge down between the winding and the strip of insulation that separates it from the pot housing.

Press the wedge in firmly and securely to about half the depth of the potentiometer housing. Then wiggle the copper wire gently back and forth until it breaks off. The break should occur at the top of the insulation. Make sure that it does not occur at a point where the projecting end of the wedge will interfere with rotation of the contact arm. Reconnect the pot to an ohmmeter and rotate the contact arm back and forth to confirm by meter reading that the wedge is properly bridging the break in the potentiometer resistance wire.

—Frank H. Tooker

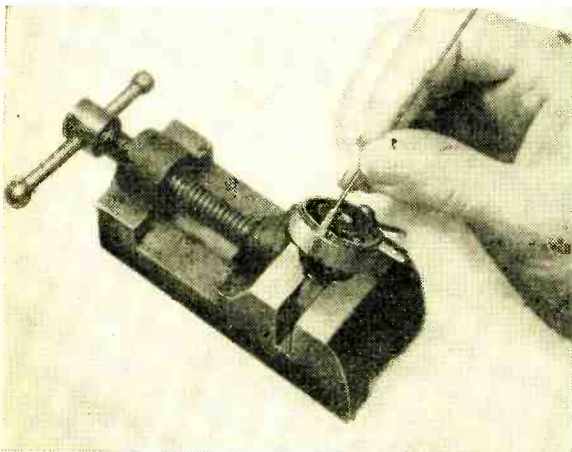

the resistance element is fitted into a cup-like metal housing, a satisfactory repair can often be made.

First, locate the break in the winding by connecting the center terminal and either side terminal of the potentiometer to an

AFTER CLASS



Special Information on Radio, TV,

Radar and Nucleonics

FOUR UNIQUE DEMONSTRATIONS

ARE YOU looking for a project to build for your science or physics class—or just for the fun of it? The demonstration units described in these pages are easy to assemble from scrap or surplus parts. Two of the four ideas are brand-new in execution, and the other two are modifications of standard demonstrations which heretofore required expensive commercial components.

Direct Proof of Lenz' Law. A small brass weight of about 200 grams is hung

ordinary white shellac. The laminated weight spins freely whether between the poles of the magnet or not.

Explanation. Lenz' law states that when a conductor cuts magnetic lines of force a current is induced in the conductor in such a direction that the magnetic field thus produced opposes the original motion of the system. The solid brass weight spinning between the magnet's poles is cutting through the lines of force; hence, an induced current flows in it and gives rise to a new magnetic field that did not previously exist.

According to Lenz' law, this field must oppose the original motion, that is, the back-spin. Thus, the rotation of the weight is slowed down substantially.

If the weight is laminated as described, and if the laminations are insulated from each other by a layer of cement, the induced current cannot flow through the weight as a whole because of the cement insulation. It is therefore forced to take smaller paths in each individual slice; as the opposing

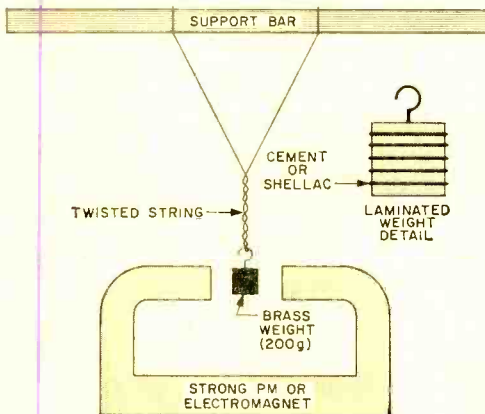

Fig. 1. Direct proof of Lenz' law.

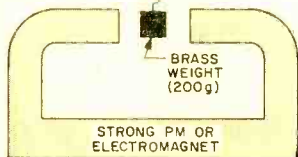

Fig. 2. Electronic electroscop.

from a double string so that it is centered between the poles of a strong magnet. (See Fig. 1.) The string is then twisted by spinning the weight between the fingers. When the weight is released, the string begins to untwist due to the torque of the distorted fiber. The spin of the brass weight is very slow, however, as compared to its rate when hanging free of the magnet.

This demonstration is repeated using a special weight of identical size that has been sliced in at least eight pieces by a hacksaw or jeweler's saw. The sawed discs are re-assembled with the help of Duco cement or

fields from such small loops are much weaker, there is little resisting force applied.

Electronic Electroscop. A high-transconductance pentode tube (6J7), a socket, a 6.3-volt filament transformer, and a 2-watt neon tube are all you need for an electronic electroscop (Fig. 2). A metal plate about 4" in diameter is soldered to the grid cap to improve the sensitivity of response.

In the standby condition, one semicircular disc of the neon tube glows softly. When a negatively charged object such as a vulcan-

ite rod rubbed with fur is brought near the plate, the neon tube is extinguished. Upon the approach of a positively charged object, the neon lamp glows with greater intensity but goes out for a short time when the positive body is removed.

The sensitivity of this electroscope to small static charges is so great that the neon lamp will flicker when a well-charged hard-rubber comb is waved back and forth at a distance of 10 feet. It may also be used

charge at the grid is neutralized by ions always present in the air.

The "Actinoscope." One of the simplest detectors of electromagnetic radiation we have ever seen is the "Actinoscope" (Fig. 3). Two NE-2, NE-51, or NE-16 glow lamps are connected in parallel across a 1- μ f.d. capacitor that is in series with a 1-megohm potentiometer and a 90-volt source.

One of the neon lamps is at the end of a 6' extension cable and serves as a probe;



Radio course students at WNYE, the educational FM station operated by the Board of Education, City of New York, have the opportunity of using professional audio equipment—transmitters, amplifiers, audio consoles, etc. The students learn techniques from Station WNYE's engineering staff.

to prove that the fur used to make the rod negative by friction in itself becomes positive.

Explanation. With the grid of the 6J7 floating, the plate resistance of the tube is quite high, but not too high to prevent ionization potential from appearing across the neon tube. Due to plate-circuit rectification, only one section of the neon lamp glows. When a negative body approaches the sensing plate, the grid becomes more negative until the potential reaches a value that causes extinction of the glow.

A positive body causes the grid to become more positive; hence, the plate current increases and the glow lamp brightens. While the grid is positive, however, it attracts electrons, so that the system as a whole gains negative charges.

After withdrawing the positive charge, these excess electrons accumulate at the grid and plate current decreases until the glow lamp is extinguished. The neon tube will light again when the excess negative

the other lamp is mounted in the little case that houses the capacitor, potentiometer and battery.

In operation, the "local" glow lamp flickers on and off at a rate determined by the *RC* time constant of the capacitor and resistance of the section of the potentiometer in use. When the probe tube is brought near any kind of electromagnetic radiation—and this includes a 60-cycle a.c. field, a source of bright light, or an r.f. field—the local lamp goes out and the probe lamp begins to flicker. Upon removal of the probe from the electromagnetic radiation, the original condition is restored.

In setting up this apparatus during test, it was possible to get a positive response from the feeble radiations from a radium-dial wrist-watch. Bringing the probe lamp in contact with the outer insulation of a wire connected to an a.c. receptacle also caused a positive switchover from the local to the probe lamp.

Explanation. The effects obtained are due

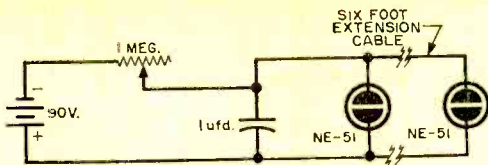

Fig. 3. The "Actinoscope." This is a simple detector of electromagnetic radiation utilizing two neon lamps which are connected in parallel.

to the small differences in ionization potentials that exist even between apparently identical neon tubes. Two tubes are selected having firing voltages very nearly alike, and the one with the higher firing voltage is mounted in the case as the local indicator.

The battery, resistor, and capacitor make up a simple relaxation oscillator which periodically fires the lamp having the lower ionization potential. During the glow interval, the lamp discharges the capacitor and extinguishes itself.

Any ionizing source, such as a strong field or radioactive particles or rays, encourages the probe tube to fire first by triggering the ionization of the neon gas in this lamp. Effectively, the ionization potential of the probe tube is kept in its diminished state as long as the field is in action, so that switchover continues until the probe tube is removed from the field.

Blowout Magnetizer. Almost any steel bar ranging in size from a knitting needle to a half-pound screwdriver blade can be magnetized to full saturation by the simple device shown in Fig. 4. The nicest part of this demonstration is that a source of d.c.—usually an inflexible prerequisite for any magnetizer—is not required!

With the equipment connected as shown, a horseshoe magnet that has lost its magnetism (or a pair of bar magnets having weak fields) is inserted in the coils. When the switch is closed, there is a violent flash from the series fuse wire; this opens the circuit. The formerly weak magnets will now be found to be strong (although their

fields may be reversed as compared with their initial magnetic condition).

In magnetizing single rods, the effect will be appreciably improved if two similar straight pieces are placed in the coils and their tops connected by a piece of soft iron. In short, better magnetic effects are obtained by magnetizing pairs of bar magnets, knitting needles, screwdriver blades, and compass needles.

Explanation. The fuse wire selected for use with the magnetizer should be about 30% lower in rating than the building fuse. For example, if the house wiring contains a 10-ampere fuse, use 6-ampere fuse wire; if the building fuse is 15 amperes, use 10-ampere fuse wire, and so on.

When the switch is closed, you catch the a.c. on its way toward a negative or a positive peak—there is no way to predict or control this. A heavy current begins to flow through the magnetizing coils almost instantly, building up in intensity as the a.c. voltage peak is approached. The fuse blows just before the current reaches dangerous proportions. The circuit is opened, therefore, prior to the reversal of the a.c.; hence the magnetizing current is unidirectional and very large in magnitude.

Note the emphasis on the word "almost." This is a fortunate circumstance, because if the action were instantaneous instead of "almost" instantaneous, the switch that closes the circuit initially would not last long. Luckily, the *RL* time constant of the circuit prevents the first surge of current

(Continued on page 124)

Fig. 4. Simple blowout magnetizer described in text. Coils are wound on 6" lengths of cardboard tubing, each tube having about 3/4" inside diameter. Number 18 wire is suggested, but other sizes may be used. At least 9 layers of turns are applied to each coil, with tape between each layer. Wind all turns on given coil in same direction, then cross to other coil and wind in opposite direction. You will need close to 1000 feet of #18 wire, double cotton-covered. Total d.c. resistance of finished coils should be about 6 ohms.

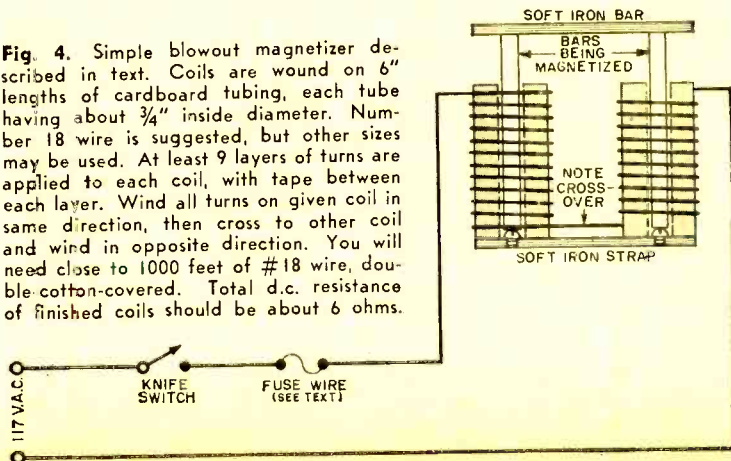



Transistor Topics

By LOU GARNER

MORE AND MORE TRANSISTORS are being used in communication and industrial applications for which vacuum tubes are not suited because of their size or power requirements.

For example, a city-wide paging service has been undergoing tests in the Allentown-Bethlehem (Pa.) area for some time now. The central operator signals the individual subscriber by sending out a modulated r.f. signal at approximately 35 mc. This signal is picked up by the subscriber's transistorized pocket receiver, demodulated, amplified, and used to energize highly selective vibrating reeds. These reeds respond only when energized in the proper sequence and, in turn, trigger a blocking oscillator which sounds a tone in a midget loudspeaker. When the subscriber hears the tone, he knows that there is a message waiting for him; he then calls the service operator as soon as he can reach a telephone.

In Chicago, a traffic control system developed by Motorola employs transistors and plated circuits to provide centrally controlled and synchronized traffic lights through the use of radio signals. A central "programer," controlled by a clock and punched cards (or tapes), supplies the basic control signal. These signals are translated into tone codes and transmitted to FM receivers at each intersection. Here, a decoder interprets the tones and operates the local controller accordingly.

Reader's Circuit. While just about every home experimenter enjoys trying new circuits he finds in magazines and books, there are many who obtain much greater thrills in developing new circuits "on their own" or in modifying published circuits to meet special needs. Lee S. Baker, of 40 Schley, New Rochelle, N. Y., specializes in transistor circuit design and experimentation. One of his circuits, a five-transistor audio amplifier, is given in Fig. 1.

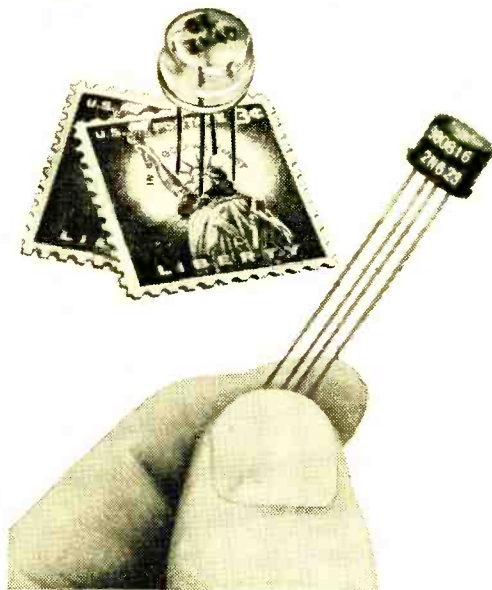

New Developments. Glass-cased transistors are now being produced by several manufacturers on an experimental basis. The unit shown at top, compared in size with a postage stamp, is a General Electric transistor package which meets the JETEC-recommended T0-9 outline. A switchover from metal to glass cases could result in a substantial reduction in transistor prices. Also shown above is a newly available high-frequency p-n-p diffused-base transistor—Texas Instruments Type 2N623. See pages 116, 117 for further details.

Perhaps the most interesting feature of Lee's amplifier is that it requires *no audio transformers*, yet provides good gain and can deliver usable loudspeaker volume. According to Lee, this amplifier can be driven satisfactorily with the signal obtained from a high-level crystal phonograph cartridge, or with the output signal obtained from a crystal or transistor receiver capable of delivering normal headphone volume.

In operation, the input signal is applied across gain control *R1*. A portion of this

POPULAR ELECTRONICS

signal, depending on the setting of R_1 , is applied through coupling capacitor C_1 to the base of the first stage, a $p-n-p$ transistor used as a split-load phase-inverter. The amplified signals appearing across collector load resistor R_3 and emitter load R_4 are coupled through capacitors C_2 and C_3 , respectively, to a push-pull driver amplifier using a pair of $n-p-n$ transistors.

Base bias current for the first stage is supplied through R_2 , with base currents for the push-pull driver furnished through R_5 and R_6 . A single penlight cell, B_1 , supplies operating current for the first stage as well as for the driver amplifier. The push-pull driver is direct-coupled to a push-pull power output stage, which employs a pair of $p-n-p$ transistors as common-collector amplifiers.

An amplified output signal appears across emitter load resistors R_7 and R_8

paper units. Layout and lead dress are not too critical.

For best results, Lee suggests that each pair of push-pull transistors (driver and output) be matched as closely as possible as far as β (gain) and I_{co} (leakage) are concerned.

Three resistor values are fairly critical and may have to be chosen experimentally for optimum performance. R_2 should be adjusted for maximum gain with minimum distortion. R_5 and R_6 should be adjusted for a *balanced* output current (through R_7 and R_8) of from 25 to 35 ma. The values in Fig. 1 are satisfactory as "starting" values, and *may* work without modification in your particular amplifier.

"Powerless" Receivers. Have you ever thought of building a transistorized radio receiver that requires *no external source of power* . . . neither dry cells, stor-

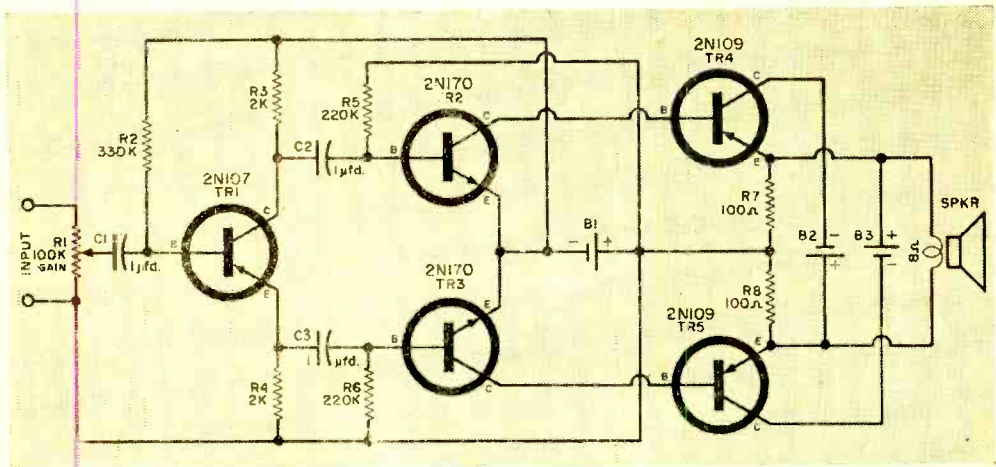

Fig. 1. Reader Lee Baker's five-transistor audio amplifier requires no audio transformers, yet provides good gain.

and is directly coupled to the 8-ohm voice coil winding of a standard PM loudspeaker. Operating power for the output stage is supplied by a pair of 1.5-volt flashlight batteries (size D cells), B_2 and B_3 .

You can assemble a similar amplifier on a conventional metal chassis or one of the perforated Bakelite "chassis" so popular with transistor experimenters. R_1 is a standard volume control, while all other resistors are half-watt units. Capacitors C_1 , C_2 , and C_3 may be 1.0- μ fd. electrolytics (3 volt d.c., or more), ceramic, or tubular

age batteries, nor solar cells? L. R. Crump, of Silver Spring, Md., an employee of the government's Diamond Ordnance Fuze Laboratory, has developed, and patented, a receiver circuit that is powered exclusively by the radiated energy picked up from radio and television stations. Some versions of his receiver furnish sufficient output to drive a PM loudspeaker.

Telepower, of 12108 Atherton Drive, Silver Spring, Md., offers a schematic and layout diagram for assembling a receiver

(Continued on page 116)

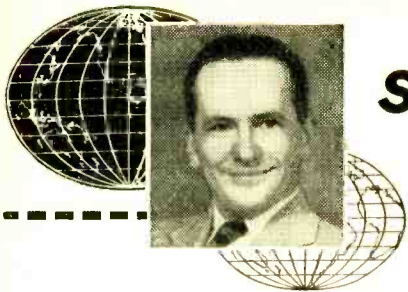

Short-Wave Report

By HANK BENNETT

BBROADCASTING ACTIVITIES in Finland were started in the early 1920's by a group of radio amateurs. The most prominent of the organizations they founded was the Radio Society of Finland, which has evolved into the Finnish Broadcasting Company. The official name of the station is *Oy Yleisradio Ab*.

In Finland the land is sparsely settled, the climate is cold, the winters long and dark. Communications difficulties have been largely overcome by radio. At the end of 1956, one out of every four persons possessed a receiving license.

During 1955 the total number of broadcasting hours was 5690. The short-wave outlets accounted for another 1148 hours. Musical programs make up the largest portion of the broadcasts, plus talks, news, religious programs, plays, literary programs, and light entertainment.

The four short-wave outlets are all lo-

cated in Pori. The largest is a 100-kw. unit opened in 1948 and the remainder are 10-15 kw. units. Transmissions include selections from the general Swedish and Finnish programs, news reports in English and French. On Sundays special programs in Finnish and Swedish are beamed to crews of ships at sea. One of the stations (Pori, OIX7, 6120 kc.) broadcasts the regular Finnish programs.

Short-wave broadcasts are as follows: to Europe and South America on 15,190 and 17,800 kc. at 1700-1800 (March 21 to September 22) and 0550-0650 (remainder of year); and to North America on 15,190, 17,800, and 9550 kc. at 2200-0000 (March 21 to September 22) and 0700-0900 (remainder of year).

The larger medium and long-wave stations for the veteran DX'er are: Kuopio (755 kc., 20 kw.), Oulu (433 kc., 10 kw.),

(Continued on page 124)

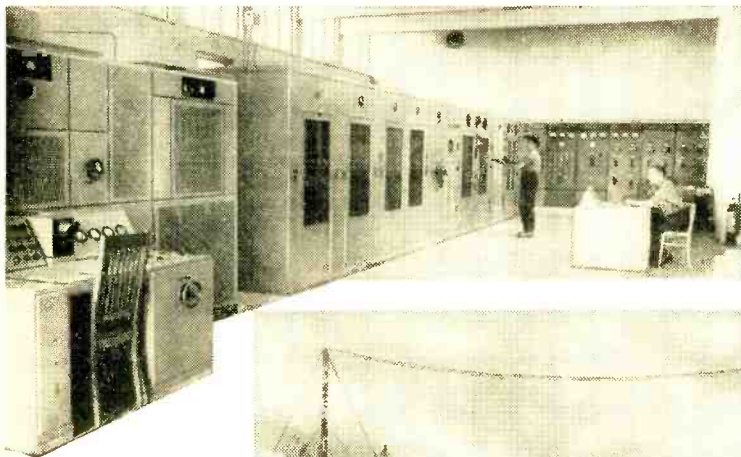

Radio Finland's transmitter building in Pori. Outside view below also shows the antennas.

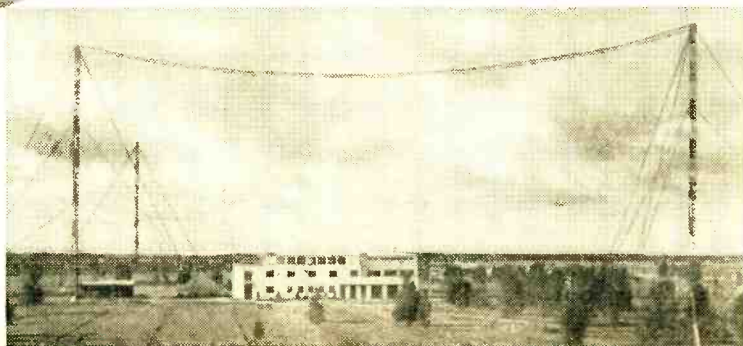

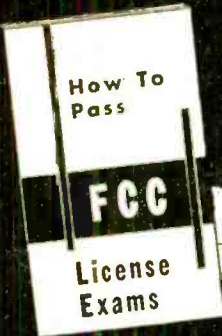

Want To Double Your Pay

Get into Radio-TV-Electronics

Get both FREE

FIND OUT what the FCC license means

Your FCC license is recognized by employers as proof of your technical ability.

FIND OUT how the FCC license helps you get a better job or increase your pay on your present job

"License and \$25 raise due to Cleveland Institute training."
"I sat for and passed the FCC exam for my second class license. This meant a promotion to Senior Radio Technician with the Wyoming State Highway Department, a \$25 a month raise and a District of my own for all maintenance on the State's two-way communication system."

"I wish to sincerely thank you and the school for the wonderful radio knowledge you have passed on to me. I highly recommend the school to all acquaintances who might possibly be interested in radio. I am truly convinced I could never have passed the FCC exam without your wonderful help and consideration for anyone wishing to help themselves."
Charles C. Roberson
Cheyenne, Wyoming

Accredited by the National Home Study Council

MAIL COUPON TODAY
You'll Be Glad You Did

good training doesn't cost . . . it pays!



FIND OUT how we guarantee your FCC license

The Master Course in Electronics will provide you with the mental tools of the electronics technician and prepare you for a First Class FCC License (Commercial) with a radar endorsement. When you successfully complete the Master Course, if you fail to pass the FCC examination, you will receive a full refund of all tuition payments.

FIND OUT how employers make job offers like this to our graduates every month

RADIO OPERATOR: Capital Airlines (Ohio) is looking for a radio operator. A touch typing speed of 40 wpm is necessary. Must have at least a restricted operator's permit, but a radio-telephone 2nd or 1st class license is desirable.

CLEVELAND INSTITUTE OF RADIO ELECTRONICS
Desk PE-43 4900 Euclid Avenue Cleveland 3, Ohio

Cleveland Institute of Radio Electronics

Desk PE-40 4900 Euclid Avenue Cleveland 3, Ohio

Please send Free Booklets prepared to help me get ahead in Electronics. I have had training or experience in Electronics as indicated below:

- | | |
|---|---|
| <input type="checkbox"/> Military | <input type="checkbox"/> Broadcasting |
| <input type="checkbox"/> Radio TV Servicing | <input type="checkbox"/> Home Experimenting |
| <input type="checkbox"/> Manufacturing | <input type="checkbox"/> Telephone Company |
| <input type="checkbox"/> Amateur Radio | <input type="checkbox"/> Other_____ |

In what kind of work are you now engaged? _____
In what branch of Electronics are you interested? _____

Name _____ Age _____
Address _____
City _____ Zone _____ State _____

Desk PE-40

build your own  for fun!



Don't let a lack of experience keep you from enjoying the fun and savings of "Do-it-yourself" kit construction. The easy-to-follow diagrams that come with every Heathkit insure your success. Let our experience be your teacher—and you'll save one-half or more over the price of "built-up" equipment of equal quality.

HEATH COMPANY A subsidiary of Daystrom, Inc. BENTON HARBOR 10, MICH.



"BASIC" SPEAKER SYSTEM

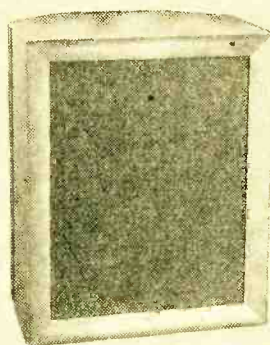

RANGE EXTENDER

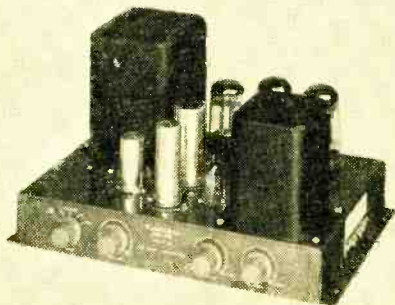

A-9C 20-WATT AMPLIFIER

**HEATHKIT "BASIC RANGE"
HIGH FIDELITY SPEAKER SYSTEM KIT**

This amazing speaker system can fulfill your present needs and still provide for future expansion. Fine hi-fi performance the result of using high quality speakers in an enclosure especially designed for them. Features two Jensen speakers to cover 50 to 12,000 CPS within ± 5 db. Power rating is 25 watts, and impedance is 16 ohms. Enclosure constructed of veneer-surfaced plywood, $\frac{1}{2}$ " thick, and measures $11\frac{1}{2}$ " H x 23" W x $11\frac{1}{4}$ " D. Precut and predrilled for quick assembly.

Shpg. Wt. 30 Lbs.

Model SS-1
\$39⁹⁵

**HEATHKIT RANGE EXTENDING
HIGH FIDELITY SPEAKER SYSTEM KIT**

Designed especially for use with SS-1 "Basic" system. Contains 15" woofer and compression-type super tweeter. Extends basic unit to 35-16,000 CPS, ± 5 db. Impedance 16 ohms. Measures 29" H x 23" W x $17\frac{1}{2}$ " D, and is constructed of $\frac{3}{4}$ " veneer-surfaced plywood.

Shpg. Wt. 80 lbs.

Model SS-1B
\$99⁹⁵

**HEATHKIT A-9C HIGH FIDELITY
AMPLIFIER KIT**

This model incorporates its own power supply and preamplifier. Plenty of power with full 20 watt rating. Four separate inputs, selected by panel-mounted switch, and separate bass and treble controls. Ideal for home or PA applications. Output transformer tapped at 4, 8, 16 or 500 ohms. Response within ± 1 db from 20 to 20,000 CPS.

Shpg. Wt. 23 lbs.

Model A-9C
\$35⁵⁰

HEATHKIT HIGH FIDELITY FM TUNER KIT

Now you can have full-fidelity FM performance from 88 to 108 mc at reasonable cost. Features temperature-compensated oscillator—built in power supply, and beautiful cabinet. Components prealigned at factory!

Shpg. Wt. 8 lbs.

Model FM-3A
\$25⁹⁵

(with cabinet)

HEATHKIT BROADBAND AM TUNER KIT

Tunes standard AM band from 550 to 1600 kc with fine sensitivity and broadband characteristics. Features include built-in power supply and low-distortion detector. All RF circuits prealigned for simplified construction.

Shpg. Wt. 8 lbs.

Model BC-1A
\$25⁹⁵

(with cabinet)

**HEATHKIT "MASTER CONTROL"
HI-FI PREAMPLIFIER KIT**

Provides extra amplification, selection of inputs, volume and tone controls, and turnover and rolloff controls, for Williamson-type amplifiers. Beautiful satin-gold enamel cabinet. Derives operating power from amplifier.

Shpg. Wt. 7 lbs.

Model WA-P2
\$19⁷⁵

(with cabinet)

**HEATHKIT 25-WATT HIGH FIDELITY
AMPLIFIER KIT**

Outstanding 25-watt Williamson-type amplifier employs KT66 tubes and Peerless output transformer, tapped at 4, 8, and 16 ohms. A fine amplifier for the "deluxe" system. WA-P2 preamplifier required for operation. Express only.

Shpg. Wt. 31 lbs.

Model W-5M
\$59⁷⁵



FM TUNER

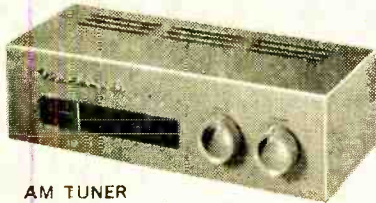

AM TUNER



PREAMPLIFIER

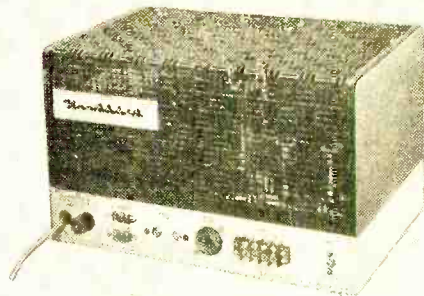

W-5M 25-WATT AMPLIFIER



World's finest
electronic equipment
in kit form...



Choose your own "Do-it-yourself" project
from the world's largest kit manufacturer

HEATH COMPANY

A subsidiary of Daystrom, Inc.

BENTON HARBOR 10, MICHIGAN

Now you can have radio
wherever you go —
with the portable
that plays anywhere!



TRANSISTOR
PORTABLE RADIO

HEATHKIT TRANSISTOR PORTABLE RADIO KIT

A new concept in radio reception! Now you can forget about external electrical connections and have fine radio performance anywhere! Low-drain circuit using regular flashlight cells makes battery operation cheaper than power-line operation of table model sets. Tunes 550 to 1600 kc and features a 4" x 6" speaker for "big-set" tone, six Texas Instrument transistors for fine sensitivity and selectivity, built-in rod-type antenna, and unbreakable molded plastic cabinet in "Holiday" gray. Measures 9" L x 8" H x 3 1/4" D. Appearance and performance are unmatched at this price level. Easy to build! Shpg. **\$34⁹⁵** Wt. 4 lbs.

Model XR-1

(with cabinet less batteries)

HEATHKIT BROADCAST BAND RADIO KIT

Covers 550 to 1600 kc with good sensitivity and selectivity. Has 5 1/2" PM speaker for good tone quality. Features transformer power supply and built-in antenna. Signal generator recommended for alignment. Cabinet, as shown, available separately. Shpg. Wt. 10 lbs.

Model BR-2

\$18⁹⁵

(less cabinet)

HEATHKIT CRYSTAL RADIO KIT

Features a sealed germanium diode to eliminate critical "cats whisker" adjustment. Employs two tuning condensers for good selectivity, and covers the broadcast band from 540 to 1600 kc. Requires no external power. Kit price includes headphones. Shpg. Wt. 3 lbs.

Model CR-1

\$7⁹⁵

HEATHKIT ENLARGER TIMER KIT

The dial of this handy timer covers 0 to one minute calibrated in five-second gradations, so that the timing cycle of a photographic enlarger can be electronically controlled. Built-in relay handles up to 350 watts, and enlarger merely plugs into receptacle of front panel. Also provision for plugging in safe-light. An easy-to-build device that makes a fine addition to any dark room. Shpg. Wt. 3 lbs.

Model ET-1

\$11⁵⁰

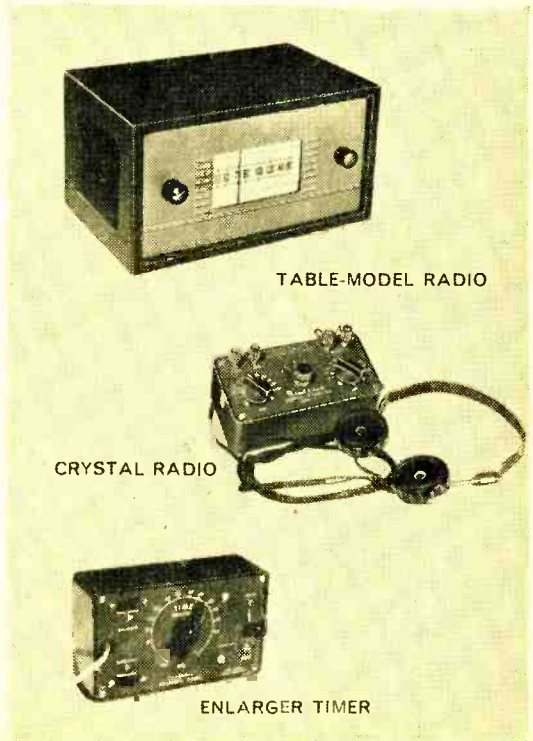

TABLE-MODEL RADIO

CRYSTAL RADIO

ENLARGER TIMER

HEATHKIT FUEL VAPOR DETECTOR KIT

The FD-1 is a safety device to detect fuel vapor in the engine compartment or other sections of your boat. The detector unit mounts in the area to be checked, and the indicating meter and controls mount on the control panel. Will operate intermittently or continuously, and indicates dangers of fire or explosion to protect your boat and its passengers. Models FD-1-6 (6 volts DC) and FD-1-12 (12 volts DC) operate from boat batteries. Kit even includes spare detector unit. Shpg. Wt. 4 lbs.

6-volt FD-1-6,
12-vt. FD-1-12
\$35⁹⁵
each

HEATHKIT RF POWER METER KIT

This handy device measures the RF field in the vicinity of a transmitter, whether it be marine, mobile, fixed, etc. Requires no electricity, nor direct connection to the transmitter. Provides a continuing indication of transmitter operation. Merely place it in proximity to the transmitter antenna and it will produce a reading on its 200 ua panel meter when the transmitter is in use. Operates with any transmitter between 100 kc and 250 mc. Includes a sensitivity control for meter. Shpg. Wt. 2 lbs.

Model PM-1
\$14⁹⁵

HEATHKIT TRANSISTOR RADIO DIRECTION-FINDER KIT

The Heathkit Transistor Radio Direction-Finder model DF-1 is a self-contained, self-powered, 6-transistor super heterodyne broadcast radio receiver incorporating a directional loop antenna, indicating meter, and integral speaker. It is designed to serve primarily as an aid to navigation when out of sight of familiar landmarks. It can be used not only aboard yachts, fishing craft, tugs, and other vessels which navigate either out of sight of land or at night, but also for the hunter, hiker, camper, fisherman, aviator, etc. It is powered by a 9-volt battery. (A spare battery is also included with the kit.) The frequency range covers the broadcast band from 540 to 1600 kc and will double as a portable radio. A directional high-Q ferrite antenna is incorporated which is rotated from the front panel to obtain a fix on a station and a 1 ma meter serves as the null and tuning indicator. The controls consist of: tuning, volume and power (on-off), sensitivity, heading indicator (compass rose) and bearing indicator (antenna index). Overall dimensions are 7½" W x 5¾" H x 5¾" D. Supplied with slip-in-place mounting brackets, which allow easy removal from ship bulkheads or other similar places. Shpg. Wt. 4 lbs.

Model DF-1
\$54⁹⁵

NEW! Heathkits for the boating enthusiast

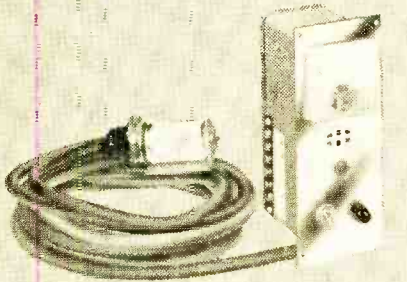

FUEL VAPOR DETECTOR

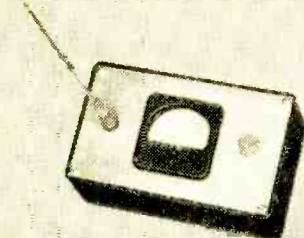

POWER METER



RADIO DIRECTION-FINDER

HEATHKIT



DX-20 TRANSMITTER



RF SIGNAL GENERATOR



GRID DIP METER



HANDITESTER

HEATHKIT DX-20 CW TRANSMITTER KIT

This Heathkit straight-CW transmitter is one of the most efficient rigs available today. It is ideal for the novice, and even for the advanced-class CW operator. It employs a 6DQ6A tube in the 50-watt final amplifier circuit, a 6CL6 oscillator and a 5U4GB rectifier. Single-knob band switching covers 80, 40, 20, 15, 11, and 10 meters. The DX-20 is designed for crystal excitation, but may be excited by an external VFO. Pi network output circuit is employed to match antenna impedances between 50 and 1000 ohms.

Model DX-20
\$35⁹⁵

Shpg. Wt. 18 lbs.

HEATHKIT GRID DIP METER KIT

An instrument of many uses for the ham, experimenter, or service technician. Useful in locating parasitics, neutralizing, determining resonant frequencies, etc. Covers 2 mc to 250 mc with prewound coils. Use to beat against unknown frequencies, or as absorption-type wave meter.

Model GD-18
\$19⁹⁵

Shpg. Wt. 4 lbs.

HEATHKIT RF SIGNAL GENERATOR KIT

Produces rf signals from 160 kc to 110 mc on fundamentals on five bands, and covers 110 mc to 220 mc on calibrated harmonics. Output may be pure rf, rf modulated at 400 CPS, or audio at 400 CPS. Prewound coils eliminate the need for calibration after completion.

Model SG-8
\$19⁵⁰

Shpg. Wt. 8 lbs.

HEATHKIT HANDITESTER KIT

Measures AC or DC voltage at 0-10, 30, 300, 1000 and 5000 volts. Direct current ranges are 0-10 ma and 0-100 ma. Ohmmeter ranges are 0-3000 and 0-300,000 ohms. Sensitivity is 1000 ohms/volt. Features small size and rugged construction in sleek black bakelite case.

Model M-1
\$14⁵⁰

Shpg. Wt. 3 lbs.

HEATHKIT ETCHED-CIRCUIT VTVM KIT

Sensitivity and reliability are combined in the V-7A. It features 1% precision resistors, large 4 1/2" panel meter, and etched circuit board. AC (RMS) and DC voltage ranges are 0-1.5, 5, 15, 50, 150, 500, and 1500. Peak-to-peak AC ranges are 0-4, 14, 40, 140, 400, 1400 and 4000 volts. X1, X10, X100, X10k, X100k, and X1 megohm.

Model V-7A

Shpg. Wt. 7 lbs. **\$24⁵⁰**

HEATHKIT ALL-BAND RADIO KIT

This receiver covers 550 kc to 30 mc in four bands, and is ideal for the short wave listener or beginning amateur. It provides good sensitivity and selectivity, combined with good image projection. Amateur bands clearly marked on the illuminated dial scale. Employs transformer-type power supply—electrical band spread—antenna trimmer—separate rf and af gain controls—noise limiter and headphone jack. Built-in BFO for CW reception. Cabinet, as shown, available separately.

Model AR-3

Shpg. Wt. 12 lbs. **\$29⁹⁵**

(less cabinet)

HEATHKIT "GENERAL PURPOSE" 5" OSCILLOSCOPE KIT

This oscilloscope sells for less than the previous model, yet incorporates features for improved performance. The OM-2 provides wider vertical frequency response, extended sweep generator coverage, and increased stability. Vertical channel is essentially flat to over 1 mc. Sweep generator functions from 20 CPS to over 150 kc. Amplifiers are push-pull, and modern etched circuits are employed in critical parts of the design. A 5BP1 cathode ray tube is used. The scope features external or internal sweep and sync, 1-volt peak-to-peak reference voltage, three-position step attenuated input, and many other "extras."

Model OM-2

Shpg. Wt. 21 lbs. **\$42⁵⁰**

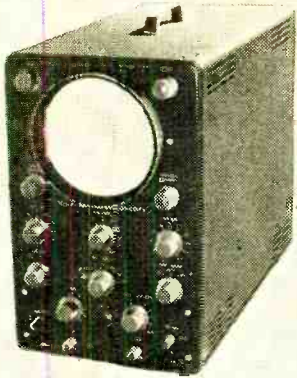

"GENERAL-PURPOSE" SCOPE

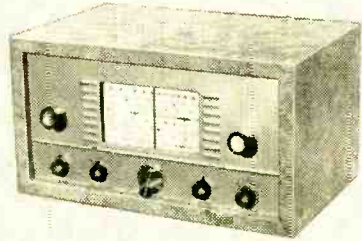

ALL-BAND RADIO



VACUUM TUBE VOLTMETER



FREE 1958 CATALOG

Write today for this FREE CATALOG listing more than 100 "do-it-yourself" kits.

HEATHKIT'S

World's finest electronic equipment in kit form...

HOW TO ORDER...

Just identify the kit you desire by its model number and send check or money order to address below. Don't hesitate to ask about HEATH TIME PAYMENT PLAN.

Pioneer in "do-it-yourself" electronics

ORDER BLANK

HEATH

COMPANY

A subsidiary of Daystrom, Inc.
Benton Harbor 15, Mich.

Name _____
Address _____
City _____ Zone _____ State _____

SHIP VIA
 Parcel Post
 Express
 Freight
 Best Way

Quantity	Item	Model No.	Price

SEND FREE Heathkit Catalog

Enclosed find check money order for \$ _____. Please ship C.O.D. postage enclosed for _____ lbs. On express orders do not include transportation charges—they will be collected by the ex-

press agency at time of delivery. On parcel post orders include postage for weight shown. Orders from APO's must include full remittance. NOTE: All prices are subject to change without notice and are F.O.B. Benton Harbor, Mich.

POSTAGE

TOTAL

TIPS and TECHNIQUES

INEXPENSIVE DUMMY LOAD

Here's an inexpensive dummy load for your ham station which utilizes an auto-radio type antenna connector and an ordinary household incandescent bulb equal to the power rating of your transmitter. Solder a wire to the end contact of the lamp and run it down through the center of the connector. Spread the four metal

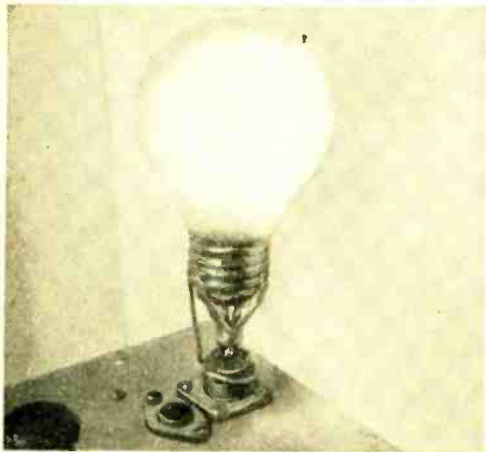

strips comprising the shell of the connector apart and solder them to the lamp base as shown. Then solder a piece of #12 copper wire to the lamp base and extend it to form a circle around the connector pin. It should fit snugly around the barrel of the transmitter's coax connector. —R. K.

NICHROME REPAIRS

Make a quick and lasting repair on a broken Nichrome wire or ribbon element by bringing the broken ends together. Sprinkle the ends with a little borax, turn on the juice, and the resulting spark will weld the ends together. —S. C.

NOVEL IRON HOLDER

This handy soldering iron holder is made by securing a large spring clip to the base

of a discarded fan. It is as useful as a third-hand when soldering loose parts. The iron can be angled to nearly any position

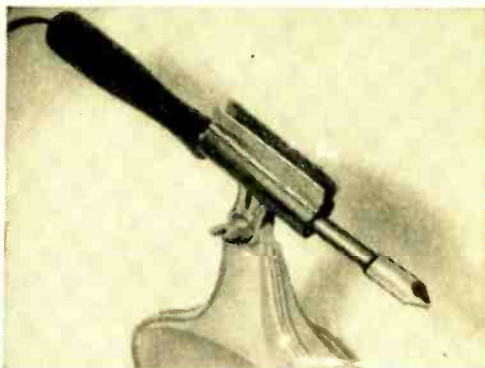

and the heavy metal base anchors it fast. Secure the clip to the base with a machine screw and wing nut through the clip's handle. Bend the jaws, if necessary, to receive the iron's barrel. —J. A. C.

ECONOMICAL DIAL CABLE

Radio experimenters who use a lot of dial cable will find that #6 fishing line serves the purpose quite well. It doesn't last as long as expensive linen dial cable, but it comes in handy in a pinch and costs very

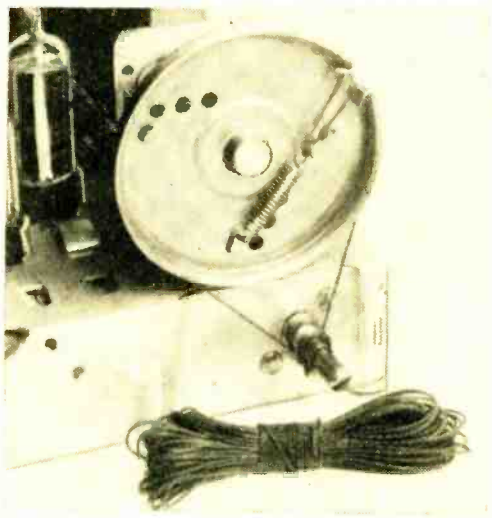

little. The photo shows a 6-cent hank of Western Auto #6 cotton fish line, with some of it being used on a radio. —A. T.

PILL VIAL HOLDS FLUX

If you only have an occasional use for soldering paste, there's little sense carrying a large can of it around in your tool kit;

Learn TELEVISION-RADIO

Servicing or Communications
by Practicing at Home
in Spare Time

WITHOUT EXTRA CHARGE you get special NRI kits developed to give actual practice with TV-Radio equipment. You build, test, experiment with receiver or broadcasting circuits. All equipment yours to keep.



NRI Has Trained Thousands for Successful Careers in TV-Radio



Have the High Pay, Prestige, Good Future of a Skilled TV-Radio Technician

People look up to and depend on the Technician, more than ever before. His opportunities are great and are increasing. Become a TV-Radio Technician. At home, and in your spare time, you can learn to do this interesting, satisfying work—quality for important pay.

A steady stream of new Electronic products is increasing the job and promotion opportunities for Television-Radio Technicians. Right now, a solid, proven field of opportunity for good pay is servicing the tens of millions of Television and Radio sets now in use. The hundreds of TV and Radio stations on the air offer interesting jobs for Operators and Technicians.

Studio Engineer KATV
 "Now Studio Engineer at KATV. Before enrolling, I was held back by sixth grade education." **BILLY SANCHEZ**, Pine Bluff, Arkansas.

All the Work He Can Do
 "Since finishing NRI Course I have repaired 2,000 TV and Radio sets a year. NRI proved a good foundation." **H. B. GORDON**, Milledgeville, Georgia.

Has Good Part Time Business
 "Quite early in my training I started servicing sets. Now have completely equipped shop. All equipment is paid for." **E. A. BREDA**, Tacoma, West.

The Tested Way To Better Pay **See Other Side**

CUT CUT AND MAIL CARD NOW

More Money Soon—Make \$10 to \$15 a Week Extra Fixing Sets in Spare Time

NRI students find it easy to start fixing sets for friends a few months after enrolling, pick up \$10, \$15 and more a week extra spending money. Many who start in spare time soon build full time TV-Radio businesses.

Act Now—See What NRI Can Do for You

NRI has devoted 40 years to developing simplified practical training methods. You train at home, learning by doing. **NATIONAL RADIO INSTITUTE**, Washington 16, D.C.



SAMPLE LESSON AND CATALOG BOTH FREE

NO STAMP NEEDED! WE PAY POSTAGE

This card entitles you to Actual Lesson on Servicing, shows how you learn Television-Radio at home. You'll also receive 64-Page Catalog.

NATIONAL RADIO INSTITUTE, Dept. 8GD4 Washington 16, D. C.

Please mail me the FREE sample lesson and 64-Page Catalog. (No Salesman will call.)

Name.....Age.....

Address.....

City.....Zone.....State.....

ACCREDITED MEMBER, NATIONAL HOME STUDY COUNCIL



**Technical "KNOW-HOW" Can Give You Interesting, Important Work
LEARN-BY-DOING with Kits NRI Sends at No Extra Charge**



YOU BUILD AC-DC Superhet Receiver

NRI Servicing Course includes all needed parts. By introducing defects you get actual servicing experience practicing with this modern receiver. Learn-by-doing.

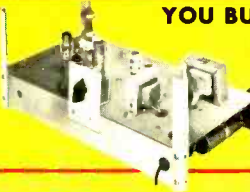
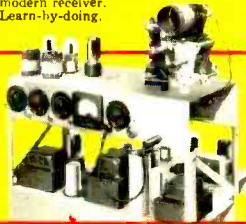

YOU BUILD Signal Generator

You build this Signal Generator. Learn how to compensate high frequency amplifiers, practice aligning typical I.F. amplifiers in receiver circuits. Make tests, conduct experiments.

YOU BUILD Broadcasting Transmitter

As part of NRI Communications Course you build this low power Transmitter, learn commercial broadcasting operators' methods, procedures. Train for your FCC Commercial Operator's License.

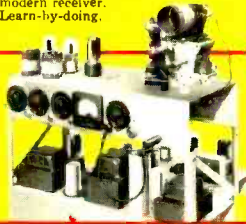

YOU BUILD Vacuum Tube Voltmeter

Use it to earn extra cash fixing neighbors' sets; bring to life theory you learn from NRI's easy-to-understand texts.



**For Higher Pay, Better Jobs
Be a Television-Radio Technician**



Servicing Needs More Trained Men

Portable TV, Hi-Fi, Transistors, Color TV are making new demands for trained Technicians. Good opportunities for spare time earnings or a business of your own. Enjoy prestige.



J. E. Smith, Founder

**Train at Home the NRI Way
Famous for Over 40 Years**

NRI is America's oldest and largest home study Television-Radio school. The more than 40 years' experience training men, the outstanding reputation and record of this school—benefits you many ways. Successful graduates are everywhere, in small towns, big cities. You train in your own home, keep your present job while learning. Let us send you an actual lesson, judge for yourself how easy it is to learn.

Broadcasting Offers Satisfying Careers

4000 TV and Radio stations offer interesting positions. Govt. Radio, Police, Two - Way Communications are growing fields. Trained TV-Radio Operators have a bright future.



No Experience Necessary — NRI Sends Many Kits for Practical Experience

You don't have to know anything about electricity or Radio to understand and succeed with NRI Courses. Clearly written, illustrated NRI lessons teach Radio-TV-Electronic principles. You get NRI kits for practical experience. All equipment is yours to keep. Mailing the postage-free card may be one of the most important acts of your life. Do it now. Reasonable tuition, low monthly payments available. National Radio Institute, Wash. 16, D.C.

NRI Graduates Do Important Work



NRI Course Easy to Understand

"Opened my own shop before receiving diploma. I am independent in my own business." D. P. CRESSEY, Stockton, California.

Works on Color TV

"NRI changed my whole life. If I had not taken the course, probably would still be a fireman, struggling along." J. F. MELINE, New York.

See Other Side for More Information to Better Pay

FIRST CLASS

Permit No. 20-R
(Sec. 34.9, P. L. & R.)
Washington, D.C.

BUSINESS REPLY CARD

No Postage Stamp Necessary if Mailed in the United States

POSTAGE WILL BE PAID BY

NATIONAL RADIO INSTITUTE

Washington 16, D. C.

**SAMPLE LESSON
64-page CATALOG
both FREE**

MONTH-LONG JULY SELL-A-BRATION!

A MILLION PARTS BOUGHT FOR THIS

GIANT PENNY SALE

OF OUR SIX MOST POPULAR
POLY-PAK ASSORTMENTS!



FREE!
YOUR CHOICE OF ANY
ONE DOLLAR
POLY-PAK
FREE WITH
EVERY \$10 ORDER!

NAMED BRAND TUBES

70 TO 90% OFF!
1-YR. GUARANTEE!

TYPE	SALE	TYPE	SALE
024	\$0.49	6C86	.59
1A3	.59	6C86G	1.42
1B3	.79	6C87	.63
1L4	.69	6CL6	.91
1R5	.59	6C97	.69
1S4	.79	6C56	.59
1S5	.59	6DUG	1.19
1T4	.59	6D85	.69
1U5	.59	6D86	.59
1X2	.79	6DT6	.59
3A4	.69	6J5	.49
3A5	.49	6K6	.59
3CB6	.59	6S4	.55
3DT6	.59	6N7	.99
3Q4	.69	6N7	.69
3S4	.69	6S07	.75
3V4	.59	6S17	.75
4B27	.99	6SK7	.69
5AQ5	.59	6S17	.79
5AT5	.89	6S07	.68
5T4	1.39	6S07	.65
5U4	.59	6T4	.99
5U8	.79	6T8	.85
5V4	.79	6U6	.89
5Y3	.49	6U6	.59
5AR4	.59	6W4	.61
5AC7	.59	6W6	.71
5AF4	.99	6X4	.49
5AG5	.49	6X5	.59
5AG7	.59	6X8	.79
5AH4	.85	6X8	.49
5AH6	.49	7N7	.79
5AK5	.59	12AT6	.66
5AL5	.53	12AT7	.79
5AM8	.83	12AV7	.79
5AN4	1.20	12AX4	.69
5AN8	.89	12AY7	.69
5AQ5	.49	12AY7	.69
5AT5	.59	12AZ7	.69
5AU5	.95	12B4	.69
5AU6	.59	12B4	.69
5AU8	.92	12BE6	.54
5AV5	.99	12BE6	.55
5AVE	.45	12BH7	.79
5AW8	.95	12S47	.69
5AX4	.75	12S47	.69
5BA6	.57	12S47	.69
5BC5	.59	12SQ7	.69
5BE5	.59	12SQ7	.69
5BF5	.75	12SQ7	.69
5BEG	1.59	19AG6	1.83
5BK5	.81	25AV5	1.10
5BK6	.89	25BQ6	1.19
5BK7	.89	25L6	.59
5BN6	.95	35A5	.99
5BN6	.79	35C5	.54
5BQ6	1.16	35L6	.61
5BQ7A	.99	35W4	.45
5BK7	.95	35Z5	.49
5BY5	1.14	35Y4	.59
5BZ6	.59	50A5	.79
5BZ7	.59	50B5	.69
6C4	.44	50C5	.59

- ★ CERAMIC CONDENSERS 75 for 88¢ 150 for 89¢
- ★ PRECISION RESISTORS 30 for 88¢ 60 for 89¢
- ★ DISC CONDENSERS 30 for 88¢ 60 for 89¢
- ★ GERMANIUM DIODES 6 for 88¢ 12 for 89¢
- ★ CARBON RESISTORS 75 for 88¢ 150 for 89¢
- ★ TRANSISTOR SOCKETS 6 for 88¢ 12 for 89¢

IDEAL FOR BEACH & BOAT!

FAMOUS Regency

VEST POCKET
TRANSISTOR



RADIO
READY TO
PLAY!

INCLUDING BATTERIES \$14.95
AND SENSITIVE PHONE

Lektron scoops the field with the "hottest" pocket transistor radio since the advent of the transistor! Designed and built by Regency, one of America's great names in radio. Uses an exclusive circuit with RF, DET. and AMP stages. SMALLER THAN A PACK OF CIGARETTES!—only 3 1/2 x 2 1/2". NO EXTERNAL ANTENNA OR GROUND—no hanging wires! Amazing sensitivity, volume and selectivity. Attractively designed two-tone styrene case. Variable tuning covers 340 to 1500 kc. READY TO PLAY when you receive it! 1000-hour batteries and ultra-sensitive phone included in this fabulously low price! Gift packed. Wt. 1 oz.

POWER SUPPLY COMBINE

Power Transf.: 115VAC, 60 cycles to 375-0-375 VCT @ 200 ma; 5 VCT @ 3A; 6.3 VCT @ 5A. Choke: 6H @ 200 mhs. Bush oil enclosed with color-coded leads. Ship. wt. 13 lbs. \$5.88

12" COAX SPEAKER

40 to 15,000 cps. range. 12" woofer, built-in extended range tweeter & crossover, 6-8 ohm V.C. Ilv. Alnico magnet. Wt. 5 lbs. Reg. \$19.95. \$8.88

POCKET MULTI-TESTER



3 1/2 x 2 x 1 1/2", bakelite case. 100 ohms/volt Zero adj. 0.15/150/1000 AC & DC V, 0-150 ma; 0/100,000 ohms. W test leads & battery. In orig. pack. \$13 value! \$6.99

3-TUBE AC-DC AMPLIFIER

Fully wired, ready for use. Reg. \$5. Sep. vol.-tone controls. Lowest price ever! \$2.99

□ TUBES, \$1.91 EXTRA

SAVE \$3 TO \$30 ON
EACH OF THESE
WORLD-FAMOUS

POLY-PAKS

\$1 EACH

- SUN BATTERY, HUNDREDS USES
- 5 HORSESHOE MAGNETS
- 3 VARI-LOOPSTICKS 540-1600 kcs.
- 2 VARIABLES 1 1/2" sq. 10-365 mf.
- TV STEEL MIRROR, 12 x 10"
- 4 G-E 1N69 herm. seal DIODES
- 10 3-SECOND TIMERS
- 60 HI-Q RESISTORS 1 lb.
- 50-FT. "ZIP" CORD 2 lbs.
- 5 25' ROLLS "micro" WIRE
- 250-FT. HOOKUP WIRE 2 lbs.
- 115/1/60 FAN MOTOR 1 lb.
- SIGMA 10,000 ohm MINI RELAY
- 40 MOLDED CONDENSERS
- 20 PRINTED CIRCUITS 1 lb.
- 5 "RED" DIAL LITES 1 lb.
- VEEDER-ROOT COUNTER 0-9999
- 40 TUBE SOCKETS 2 lbs.
- 1" SQ. CRYSTAL MIKE
- "MICRO" MOTOR 1 1/2 VDC
- 20 INSTRUMENT KNOBS 1 lb.
- 2000 PCS. HARDWARE 2 lbs.
- 6 SILICON DIODES 1 lb.
- 10 POWER SWITCHES 115 VAC
- 40 PRINTED CIRCUIT PARTS
- 60 COILS & CHOKES 2 lbs.
- 15 VOLUME CONTROLS 2 lbs.
- 50 PUGS, RECEPTACLES
- 6 FERRITE CORES, to 7" 2 lbs
- 40 POWER RESISTORS 3 lbs.
- 70 TUBULAR CONDENSERS
- 10 HI-Q CONDENSERS 2 lbs.
- 1 MINI-METER 0-6A, AC 1 lb.
- 40 HI-Q CONDENSERS 2 lbs.
- 8-pc NUTDRIVER SET 1 lb.
- 50 RADIO, TV KNOBS 2 lbs.
- 10 "POLY" BOXES 1 lb.
- 100 RADIO PARTS 2 lbs.
- 75-pc RESISTOR ASST. 2 lbs.
- 75-pc CONDENSER ASST. 2 lbs.
- 2 PNP TRANSISTORS \$5 value
- 70 MICA CONDENSERS 2 lbs.
- 15-pc TWIST DRILL SET 1 lb.
- 40 SUBMINI RESISTORS 1 lb.
- 10 ELECTROLYTICS 3 lbs.

SATISFACTION GUARANTEED

BIG BUYS in 'MINI' TYPE

- MICROSCOPE, 100-200-300 power \$3.99
- TELEGRAPH KEY, bakelite base chrome \$1.19
- PIC TUBE BRITENER, parallel, series .88
- 3-SPEED ARM, w/cart. & sapphire needles 2.99
- TELEPHONE PICKUP-COIL, rec. msgs 1.99
- 1 1/2" SUBMINI PM SPEAKER, 3 ohm 1.99
- PILLOW SPEAKER, crystal, cord, plug 2.69
- CRYSTAL HEARING AID PHONE, cord, plug 1.19
- 5,000-ohm MINI PHONE, cord, plug 1.69
- BAROMETER, 5" round, chrome 3.88
- COPE, SAW, DRILL, REAM BIT, for all drills 1.19
- SCOOP; 4 HAMMERS, 10" wood handles 1.19
- TRANSISTOR TRANSFORMER, 20K to 1K; 10K to 2KCT; 500CT to 3.2 ohms each 1.39
- 0 to 1 ma METER, 1 1/2" square 3.99
- 0 to 50 microA METER, 1 1/2" square 5.99
- TURNER MIKE, crystal-Hd., desk, stand, 100-8000 cps, 2 cable 2.98
- 0-60 MINUTE TIMER with alarm each 1.00
- 12-HOUR SPACE CLOCK, operates on 1 1/2VDC penlite battery 1.98
- LEAK SOLDERING GUN, 115VAC, for fine work. Easy-grip, incl. tip 4.99

AUTO SPEAKER KIT

Bear deck 5 1/2" PM speaker. Switch, grille, wire, hardware \$3.98

6x9" SPEAKER KIT, only \$4.44

WORLD'S SMALLEST RADIO KIT 21x8x1 1/4" w/ permeability tuner, diode, all parts, directions. Reg. \$3.50. \$1.19

HI-FI TWEETER

Metal-cased cone; 20W to 16,000 cps. Max rating: 30W, 27x2 1/2" w/ flat surface diff. backed, 1 to 4 ohms; 8 ohm or 16 ohm impedance. Each \$3.99

HI-FI 12" SPEAKER

40 to 10,000 cycles. Famous make. 6-8 ohm V.C. Ilv. Alnico magnet. Wt. 3 lbs. \$3.99

HOW TO ORDER:

ORDER BY "BLACK TYPE" HEADLINES, i.e., ONE POWER SUPPLY COMBINE, \$5.88

State price with each item. Send check or M.O. including sufficient postage; excess returned. C.O.D. orders, \$5.00 down; rest 30 days (Canada postage, 45c 1st lb., 28c ea. addl. lb.) EXPORT ORDERS INVITED

LEKTRON 131-133 EVERETT AVE.
CHELSEA 30, MASS.

International's

NEW 1958

Catalog!

NOW AVAILABLE
Precision
CRYSTALS
and
Electronic
EQUIPMENT



Send for your **FREE** copy . . . Today!

FOR AMATEUR, EXPERIMENTAL and COMMERCIAL USE: Crystals, 100 KC to 100 MC; FO-1 and FO-11 Printed Circuit Oscillators; FO-6 Oscillator Assembly; C-12 Alignment Oscillator; FCV-1 Crystal Controlled Converter; RC-100 Transmitter . . . and other popular units.

International Crystal Mfg. Co. Inc.

18 N. LEE PHONE RE 6-3741 OKLAHOMA CITY, OKLAHOMA



"RADIO INTERCOM ADAPTOR"



Apply this **NEW-COMPACT-INTERCOM ADAPTOR** to your ac/dc Radio (am or fm)—Provides a complete professional P.A. system for your Home, Office, Motel, Restaurant, Farm AT **LOW COST**

- 4 position switch supplies: Normal radio use, remote music, talk/listen through your radio
- Operates up to 6 remote speaker stations
- Ideal baby sitter and monitor
- Guaranteed performance, ready to operate with 1 free 4" PM speaker (extra 4" speaker stations @ \$1.50)
- Completely assembled, easy to install with instructions

\$14.95 send check or M. O.

RA-TECH LABS

7613 Wisconsin Ave., Bethesda, Md.

**When Answering
Advertisements**

**Please Be Sure To Mention
POPULAR ELECTRONICS**

instead, fill a small medicine bottle or vial with the flux. You can pick up several small plastic vials at a drugstore for a few

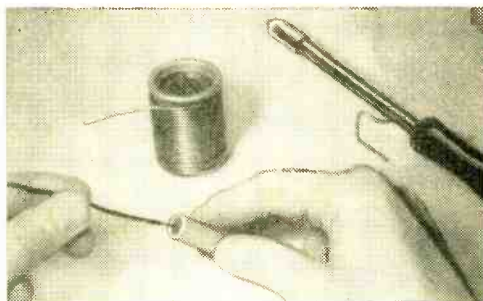

cents. It's a clean, convenient way of dispensing flux . . . easy to carry, too.—*J.A.C.*

PAPER CLIPS AS CONNECTORS

Ordinary wire paper clips are useful for making temporary low-voltage electrical connections, when experimenting with breadboard-type electronic circuits, for ex-

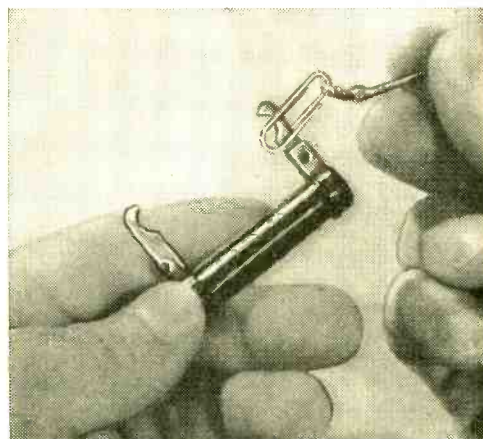

ample. One of these clips will connect the ends of several wires together instantly and is easily attached to the posts of resistors, capacitors, etc. A tug on a wire serves to disconnect it, so no time is wasted.—*K.M.*

LOW-COST CONTACT CLEANER

Here's an easy way to make a good grade of contact cleaner at low cost. Mix about four parts of carbon tetrachloride to one part of a good grade of oil, and shake thoroughly. Apply to volume control, relay and switch contacts, using one of the injectors available at most radio parts suppliers. Keep the mix stored in a tight bottle to prevent evaporation. Caution: avoid prolonged breathing of the carbon tet vapor as it can be harmful.—*J. E. P.*

**VIDEO ELECTRIC COMPANY says: DOWN WITH RISING COSTS OF ELECTRON TUBES
OVER ONE MILLION USED TUBES TO SELECT FROM at only**

Each and every tube is tested by our supplier under actual operating conditions in Radio, FM, Hi-Fi, Industrial Equipment and Television Chassis or Intricate Testing Equipment for Mutual Conductance and Life Test.

BELOW IS A PARTIAL LIST OF OVER THREE HUNDRED POPULAR TYPES! WRITE FOR FREE COMPLETE LIST AND ORDER BLANK!

- | | | | | | |
|-------|--------|--------|----------|-----------|--------|
| 0A2 | 5X6 | 6BH6 | 6SF5 | 7Z4 | 198GG |
| 0Z3 | 5Y3GT | 6BB6 | 6SF7 | 12A8 | 19J6 |
| 1B3GT | 5Y4G | 6BK5 | 6SJ7 | 12A05 | 19T8 |
| 144G | 6A7 | 6BK7 | 6SK7 | 12AT6 | 24A |
| 145GT | 6AB4 | 6BL7GT | 6SL7GT | 12A7 | 25AV5 |
| 1L4 | 6AC7 | 6BN6 | 6SN7GT | 12A06 | 25BQ6 |
| 1L6 | 6AF4 | 6BQ6GT | 6SQ7 | 12A07 | 25DNG |
| 1N5GT | 6AG5 | 6B7 | 6S57 | 12A07 | 25L6GT |
| 1Q5GT | 6AG7 | 6B7 | 6T4 | 12AV7 | 25W4GT |
| 1R5 | 6AH4GT | 6B7 | 6T8 | 12AX7 | 25Z5 |
| 1T4 | 6AH6 | 6B7 | 6U8 | 12AX7 | 25Z6 |
| 1U4 | 6AL5 | 6B7 | 6V6 | 12AX7 | 26 |
| 1U5 | 6AL7 | 6B7 | 6W4GT | 12BA6 | 35A5 |
| 1V2 | 6AM8 | 6B7 | 6W6GT | 12BA7 | 35B5 |
| 2A3 | 6AM8 | 6B7 | 6X4 | 12BE6 | 35C5 |
| 2AF4 | 6AQ5 | 6B7 | 6X5 | 12BF6 | 35L6GT |
| 3BC5 | 6AQ6 | 6B7 | 6X8 | 12BH7 | 35W4 |
| 3BN6 | 6AQ7GT | 6B7 | 6Y6G | 12BQ6 | 35Y4 |
| 3CB6 | 6AR5 | 6B7 | 7A4/XXL | 12BR7 | 35Z5GT |
| 3CB6 | 6AS5 | 6B7 | 7A5 | 12BY7 | 37 |
| 3CF6 | 6AT6 | 6B7 | 7A5 | 12CA5 | 39/44 |
| 3CS6 | 6AT8 | 6B7 | 7A6 | 12J5 | 42 |
| 3LF4 | 6AU4GT | 6B7 | 7A7 | 12K7 | 43 |
| 3Q4 | 6AUSGT | 6B7 | 7A8 | 12L6 | 45 |
| 354 | 6AU6 | 6B7 | 7B4 | 12Q7 | 50A5 |
| 3V4 | 6AUB | 6B7 | 7B5 | 12SA7 | 50B5 |
| 4B27A | 6AV5GT | 6B7 | 7B6 | 12SG7 | 50C5 |
| 4B28 | 6AV6 | 6B7 | 7B7 | 12S7 | 50L6GT |
| 5A7B | 6AW8 | 6B7 | 7B8 | 12SK7 | 50X6 |
| 5AV8 | 6AX4GT | 6B7 | 7C4 | 12SN7GT | 56 |
| 5AW4 | 6AX5GT | 6B7 | 7C5 | 12SQ7 | 57 |
| 5BK7 | 6BB | 6B7 | 7C6 | 12V6GT | 58 |
| 5J6 | 6BA6 | 6B7 | 7C7 | 12W6GT | 71A |
| 5T8 | 6BC5 | 6B7 | 7E6 | 12X4 | 75 |
| 5U4G | 6BC8 | 6B7 | 7E7 | 12Z3 | 76 |
| 5U8 | 6BD6 | 6B7 | 7F7 | 14A7/12B7 | 77 |
| 5V4G | 6BE6 | 6B7 | 7F8 | 14B6 | 78 |
| 5V6GT | 6BF6 | 6B7 | 7N7 | 14Q7 | 80 |
| | 6BGG6 | 6B7 | 7Q7 | 19A | 84/6Z4 |
| | | 6B7 | 7X7/XXFM | 19A4GT | 117Z3 |
| | | 6B7 | 7Y4 | | 117Z6 |

400 ¢



GUARANTEE: WE GUARANTEE TO REPLACE FREE FOR ONE (1) YEAR ANY TUBE PURCHASED FROM US WHICH FAILS TO FUNCTION EFFICIENTLY UNDER ACTUAL OPERATING CONDITIONS. REFUNDS WILL BE MADE PROMPTLY FOR ANY DEFECTIVE MERCHANDISE.

WE HAVE OVER 1000 USED TV SETS

At All Times In Our Huge Warehouse. Buy one or more of these WORKING TVs to sell or use as your own second set! All sets in GOOD WORKING condition! Your Choice—Console or Table Model.

10" ...	\$23.00	19" ...	\$58.00
12" ...	\$28.00	20" ...	\$64.00
14" ...	\$33.00	21" ...	\$72.00
16" ...	\$40.00	24" ...	\$99.00
17" ...	\$46.00		

When ordering TVs, state whether table model or console is desired. Also, preference on make of set. All TVs sent railway express F.O.B. Newark. On any quantity, WIRE or CALL today!

SEND for our **FREE** complete **TUBE & PARTS LIST** and order blank.

FREE RCA "Cheater" Cord Gives with Any Tube Order of \$7.00 or More!!	FREE Bonus Antenna Given with Any TV Set Order!!
---	--

FREE POSTAGE in U.S.A. and Territories on orders over \$5.00. 25¢ handling charge on orders under \$5.00. 25% deposit required on C.O.D.'s. Please send approximate postage or freight on Canadian and foreign orders. Subject to prior sale.

Phone **Humboldt 4-9846**

VIDEO

ELECTRIC COMPANY
79 CLINTON PL. NEWARK, N. J.

TOOLS and GADGETS



P. A. CONTROL UNIT

Designed for converting any public address system to an intercom and paging system, the new Allied Radio intercom and paging control unit requires no a.c. power and includes a volume control, talk-listen-program switch, and an all-call switch. A



built-in speaker also serves as a microphone, or an external microphone may be used. Simple connections to the input of the amplifier and to the speaker circuits are necessary to convert an existing p.a. system to a 20-station paging and intercom system. Stock No. 93 SX 056, \$77.50. (Allied Radio Corp., 100 N. Western Ave., Chicago 80, Ill.)

COPPER ALLOY SOLDER

"SAVBIT" alloy solder is said to extend the life of copper soldering tips up to ten times. The incorporation of copper in its construction prevents absorption of copper from the tip into the alloy. It is available in Ersin Multicore 5-core solder in 1-pound cartons and 7-pound reels. SAVBIT is slightly stronger than the standard tin/lead alloys, with no appreciable differ-



ence so far as melting point, electrical conductivity, tensile and shear strength are concerned. (Multicore Sales Corp., Department K37, Port Washington, N. Y.)

VOM KIT

Extended ranges are featured in the Model M-40 VOM kit: up to 20,000 ohms/volt d.c., and 10,000 ohms/volt a.c. Other features include: a rugged $4\frac{5}{8}$ " 50- μ a., 2% accurate meter mounted in a clear acrylic case; double-jeweled D'Arsonval meter movement; deposited-film and wire-wound resistors of 1% accuracy; all o h m m e t e r

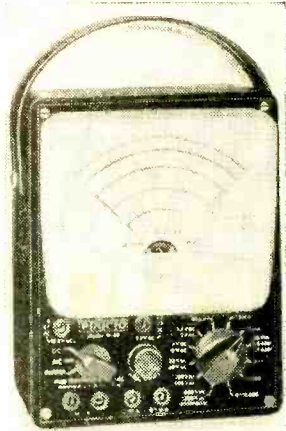

ranges, powered by standard flashlight and penlight cells. The completed instrument is housed in a $5\frac{1}{4}$ " x $6\frac{7}{8}$ " x $2\frac{3}{8}$ " molded phenolic case. Detailed instructions on assembly and operation come with the kit. Net price, \$31.50. (PACO Electronics Co., Inc., 70-31 84th St., Glendale 27, L.I., N. Y.)

"TYPELESS" TUBE TESTER

Model FC-2 is a new "Fast-Check" tube tester with circuitry engineered to accom-

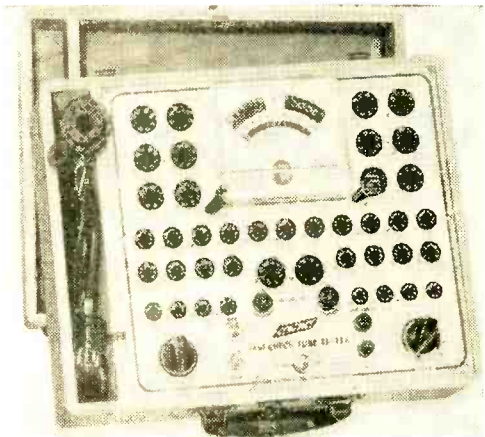

modate new tube types without modification. Each section of a multisection tube is checked separately. The meter is protected against accidental burn out, and 7-pin

and 9-pin straighteners are conveniently mounted on the panel. Guaranteed for one year, Model FC-2 comes housed in an oak carrying case complete with picture tube adapter cable and tube chart listing over 600 tube types. New listings are issued periodically. Price, \$69.50. (Century Electronics Co., Inc., 111 Roosevelt Ave., Mincola, N. Y.)

RADIO/TV SELENIUM RECTIFIERS

Reduced in size, six new types of all-purpose, high-density selenium rectifiers can replace any half-wave rectifier now in use in radio and TV sets. Five of them are rated at 130 volts, a.c., and cover all current ratings up to 650 ma. The sixth is a 650-ma., 195-volt unit intended for color-



TV replacement. Shown in the photo is a 500-ma. unit with 1.6"-square cells. (Radio Receptor Co., Inc., 240 Wythe Ave., Brooklyn 11, N. Y.)

COMPACT TUBE-SAVER

Low-cost surge protection for TV, radio and hi-f sets is provided by the Wuerth Model 125 "Tube-Saver." It limits in-rush



current until tube heaters are warmed sufficiently to accept full voltage without

July, 1958

Learn at Home

in your spare time

to Fix Electric Appliances



Better Pay—More Opportunities

Get into a field where there is important work and opportunity for the trained man. Millions of electric appliances are sold every year. Every wired home now has an average of 8. Many of them need service and repair. Owners pay well to have them fixed quickly. This is your opportunity for a better job, your own part time or full time business. NRI can give you the training you need, at home, in your spare time.

Spare Time Earnings Start Soon

Soon after starting you will be able to earn extra cash fixing toasters, clocks, fans, vacuum cleaners, etc., for neighbors and friends. Keep your job while learning and earning. Put spare time to work for you. Work in your basement, garage, spare room. You'll be amazed how easily, quickly you, too, can start earning many extra dollars. NRI shows you how. Even before you finish training your spare time earnings may pay for the course and equipment.

NRI Sends Tester to Learn and Earn

You need proper equipment to service today's automatic appliances. With this course you get parts to build professional type, multi-use Appliance Tester. You learn to use it. Takes guess work out of servicing. Mail coupon for FREE book and Sample Lesson. See how easy it is to learn. Find out about NRI—a school that for more than 40 years has been training men, through home study, for success, good pay jobs. Our reputation, record, experience back up this course. Write now to: National Radio Institute, Dept. D4G8, Washington 16, D. C.

FREE Lesson and Book
Mail this NOW!



NATIONAL RADIO INSTITUTE

Dept. D4G8, Washington 16, D. C.

Send me Lesson and Book Free. No Salesman will call.

Name _____ Age _____

Address _____

City _____ Zone _____ State _____

ACCREDITED MEMBER NATIONAL HOME STUDY COUNCIL

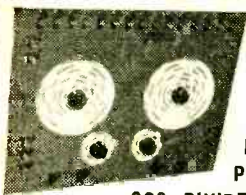

**TO ADD,
SUBTRACT,
FIND ROOTS,
POWERS, SIN,
COS, DIVIDE, MULTIPLY,
SOLVE TRIG AND ALGEBRA.**

THE ALLSOLVER

Now TRANSISTORIZED, with special dials to add several numbers at once, multiply as many as ten numbers at once by adding a few more parts! _____ Based on the principle of Analog computers

Courses:

- C14 Computer Master, 50 lessons plus projects. Diploma issued. \$22.50 down, then \$12.40 for six months.
- C15 Electronics, radio, television, computers, telemetering and radar. \$22.50 down and then \$10.00 for five months. Ask for our new catalog.

EBE Inc., 1015 Atkin Ave., Salt Lake City 6, Utah

Send the ALLSOLVER encl. \$38.50 ppd.

Send course

encl. \$22.50 down Send free catalog
attach name and address

PORT ARTHUR COLLEGE ELECTRONICS COMMUNICATIONS

AM FM Television Broadcast Engineering
Marine Radio Radar

CHECK THESE FEATURES: Tuition \$36 per mo., room & board \$52 per mo. in dorm on campus. College operates 5 KW broadcast station. Students get on-the-job training at studios on campus. FCC license training with all courses. Well equipped classrooms & lab., am fm transmitters, radar & marine eqmt., television camera chain, experiment lab test eqmt. & other training aids. Our graduates in demand at good salaries. Free placement service. Have trained men from all 48 states. Approved for GI. Write to Dept. PE-7 for details.

PORT ARTHUR COLLEGE

Port Arthur
Texas

Established in 1909

HI-FI ACCESSORIES

by **Vidaire**

SPEAKER SWITCHES, FADERS L-PADS, T-PADS ON PANEL OR WALL PLATES, CROSSOVER NETWORKS, EQUALIZERS, VOLUME EXPANDERS.

AT YOUR NEAREST SUPPLIER OR WRITE
VIDAIRE ELEC. MFG. CORP., Baldwin, New York

EASY TO LEARN CODE

Learn or increase speed with an Instructograph—the Radio-Telegraph Code Teacher that takes the place of an operator-instructor and enables anyone to master code without further assistance. Available tapes from beginners alphabet to typical messages on all subjects. Speed range 5 to 40 WPM. Always ready—no QRM. Thousands have "acquired the code" with the Instructograph System. Write today for convenient rental and purchase plans.



INSTRUCTOGRAPH COMPANY

4713-F Sheridan Road Chicago 40, Illinois

damage. In addition, B+ voltages are temporarily held down to prevent "cathode stripping." (*General Manufacturing Company, Rockford, Ill.*)

SUBMINIATURE SOCKET WRENCHES

Those of you who use standard jeweler's screwdrivers of the replaceable blade type will be interested in Desco subminiature socket wrenches which fit right into a handle. Intended for quick, easy assembly or repair of miniature and model parts, they come in seven sizes— $\frac{5}{64}$ ", $\frac{3}{32}$ ", $\frac{7}{64}$ ", $\frac{1}{8}$ ", $\frac{5}{32}$ ", $\frac{3}{16}$ " and $\frac{1}{4}$ ". They are available in kits of five and seven, or can be purchased separately. (*Desco Manufacturing Co., Glendale 2, Calif.*)

-30-

Converter for Daytime DX

(Continued from page 63)

oscillator to cease functioning, and the converter will not operate.

The adjustment is not critical, however, and once properly made need not be done again. It should be turned about halfway in for stable operation.

Yours for the Listening. So there you have it—or rather you will have it if you get busy with your wire strippers and soldering iron. The 15-meter band will provide plenty of fun.

This is the real DX band available to the Novice and the reward involved will be well worth the effort. Once the DX bug bites you, you'll be glad it did.

-30-

Transistors Replace Outlet

(Continued from page 37)

and this automatically reduces the base current to the desired level.

One of the nice things about transistor power supplies and transistor inverters is that in the event they are overloaded, they "fail safe" and stop oscillating. When they do, their current drain drops to a very low value dependent upon the fixed bias on the transistors. Thus, you cannot burn up a transistor power supply if the load short-circuits. But on a boat, no amount of caution is too much, and in case some part of the primary circuit shorts to ground, the fuse will help prevent a fire from occurring.

-30-

Hi-Fi Highlights
(Continued from page 83)



9

FM tuner incorporates many features usually found only in more expensive units, including a.f.c., tuning indicator, grounded-grid r.f. amplifier, limiter, Foster-Seeley discriminator. Sensitivity is 3 μ v. for 20-db quieting. Miller 560.



10

Thirty-watt amplifier features three-way speaker selector switch; rumble and scratch filter, loudness control and 12 equalization positions. Knight KN-530 (Allied Radio).

POPULAR ELECTRONICS

P. O. Box 1873

July

CHURCH STREET STATION

New York 8, N. Y.

Please send me additional information concerning the products whose code numbers I have circled.

1 2 3 4 5
6 7 8 9 10

TOTAL NUMBER OF REQUESTS

NAME

ADDRESS

CITY ZONE STATE

Get

**Your First Class Commercial
F. C. C. LICENSE**
in
12 Weeks!

F.C.C. License—the Key to Better Jobs

An FCC commercial (not amateur) license is your ticket to higher pay and more interesting employment. This license is Federal Government evidence of your qualifications in electronics. Employers are eager to hire licensed technicians.

Grantham Training Prepares You

Grantham School of Electronics specializes in preparing students to pass F.C.C. examinations. Correspondence training is conducted from Washington and Hollywood; resident DAY and EVENING classes are held in both cities. Either way, we train you quickly and well—NO previous training required. A beginner may qualify for his first class F.C.C. license in as little as 12 weeks.

Here's Proof!

Recent graduates, the license they got, and how long it took them:

	License	Weeks
Edward Dahl, 7800 Old Chester Rd., Bethesda, Md.	1st	11
Griffin Kane, 3125 Wabash Ave., Los Angeles, Calif.	2nd	9
Beamon Meares, 1536-17th St., NW, Washington, D.C.	1st	11
Larry Pacifico, 65 Main St., Roseto, Pa.	1st	12
Tooru Iwahashi, Honolulu, Hawaii	2nd	8
Basil D'Imperio, 2223 H St., NW, Washington, D.C.	1st	12
John Ward, 407 E. Cowden Ave., Midland, Texas	1st	10
Herbert Halbig, 315 Park St., Tupper Lake, N. Y.	1st	11
Vregh Godoshian, 312 E. Wilson St., Pontiac, Mich.	1st	11
Antone Mello, 68 Union St., Nantucket, Mass.	1st	10
James Farish, 926 Cardone Ave., Reno, Nev.	1st	12
Charles Page, General Delivery, Yuma, Ariz.	1st	16
E. H. Siddall, 13351 Magnolia Ave., Van Nuys, Cal.	2nd	8
James Craig, 4004-19th St., S., Arlington, Va.	1st	11

OUR GUARANTEE

If you should fail the FCC exam after finishing our course, we guarantee to give you additional training at NO ADDITIONAL COST. Read details in our free booklet.

FCC-TYPE EXAMS

FCC-type tests are used throughout the Grantham course. Constant practice with these FCC-type tests helps you prepare for the actual FCC examination.

Our free booklet, "Opportunities in Electronics," gives details of how you can get your license quickly and make more money in the electronics industry. Send for your free copy today.

MAIL TO SCHOOL NEAREST YOU

(mail in envelope or paste on postal card)

Grantham Schools, Desk 83-K

1505 N. Western Ave. OR 821—19th Street, N.W.
Hollywood 27, Calif. Washington 6, D. C.

Please send me your free booklet, telling how I can get my commercial FCC license quickly. I understand there is no obligation and no salesman will call.

Name Age

Address

City State

I am interested in: Home Study, Resident Classes

A Theatre Organ for YOUR HOME!

The Artisan simplified step-by-step assembly system with all mechanical and wood parts fully assembled lets you build a magnificent 2-manual and full pedal organ at a saving of up to 50%! No special skill needed!

the *Artisan*
ELECTRONIC ORGAN

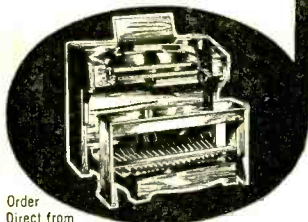

Order
Direct from

ELECTRONIC ORGAN ARTS, INC.
4878 EAGLE ROCK BLVD. DEPT B-27 LOS ANGELES 41, CALIF.



New
12"
LP
ALBUM

Only \$2.98

Hear the thrilling tones of the Artisan as played by prominent artists of the Theatre Organ. With explanatory notes.

PORTFOLIO of ORGAN FACTS jam-packed with vital information about organs. Only \$1.00

(LP Album and Portfolio—both for only \$3.49)

LEARN RADAR MICROWAVES COMPUTERS TRANSMITTERS CODE • TV • RADIO

Phila. Wireless Technical Institute

1533 Pine St.

Philadelphia 2, Penna.

A Non-Profit Corp. Founded in 1908

Write for free Catalog "P"

2 WAY PORTABLE RADIO SET

SENDS—RECEIVES UP TO 10 MILES AS SHOWN

With built-in antenna or hundreds of miles with outside antenna! Works on 80 and 40 meter (Novice) amateur radio bands—also Aircraft and emergency frequencies (3 to 8 mc). PORTABLE SELF-CONTAINED POWERED WITH STANDARD PORTABLE RADIO BATTERIES. NO AC PLUG-INS NEEDED! Take it with you everywhere you go—on trips, vacations, camping—Keep in contact with home, friends. Has 5 watt crystal controlled transmitter—Sensitive Regenerative Receiver. Send-Receive switch. Wt. only 3 lbs. Size only 6"x4"x4". TESTED—PROVEN—SIMPLIFIED—PRACTICAL—Full information given on quick easy to get license.



WESTERN RADIO

SEND ONLY \$3.00 (bill, ck. mo) and pay postman \$12.95 C.O.D. postpaid on arrival or send \$15.95 for postpaid delivery. Complete kit includes all parts, tubes, coils, plastoid cabinet, easy instructions. (Set of batteries \$3.49; crystal \$1.49). COMPLETELY WIRED AND TESTED POSTPAID \$19.95. A regular \$49.95 value—Order now before price goes up. GUARANTEED—AVAILABLE ONLY FROM: DEPT. BNE-7 KEARNEY, NEBR.

GET INTO ELECTRONICS

V.T.I. training leads to success as technicians, field engineers, specialists in communications, guided missiles, computers, radio-automation. Basic & advanced courses in theory & laboratory. Assoc. degree in 20 mos. B.S. obtainable. ECPD accredited, G.I. approved. Graduates with major companies. Start Sept., Feb. Dorms, campus. H. S. graduates or equivalent. Catalog.

VALPARAISO TECHNICAL INSTITUTE
Dept. PE VALPARAISO, INDIANA

Snapshots in Sound

(Continued from page 44)

true) is equally inexpensive. This is a plug-in affair, and doesn't need installation. (Some machines, particularly imported ones, have an internal switch to change the operating voltage requirement.) You can get one for as little as \$5.75 or so at "TAB," 111 Liberty St., New York, N. Y.

Incidentally, you'll have to reconvert the recorder when you get back home. That is a simple matter.

There is another thing you should consider. If your vacation is to be an auto tour, either in this country or abroad, and you want to record outdoors, you'll have to provide yourself with an inverter, to change your 6- or 12-volt auto battery output to 117 volts a.c. These are fairly expensive, and should be matched to the power requirements of your recorder. Some recorders draw as little as 70 watts, and would therefore need an inverter costing about \$28 to \$30 minimum. There are some 124-watt-or-more recorders, requiring units priced at \$50 or more.

It would be wise to stock up on tape before you leave. Chances are you won't be able to get the tape you want (or *any* tape, for that matter) in many areas of the world as cheaply as at your local dealer's. It's hard to say just how much tape you'll need. It depends entirely on just how much recording you want to do. Certainly, on a two-week trip, 6 to 12 of the largest size reels you can use would not be too much. You can always take care of any extra footage at home. You might want to use the new double-time or time-and-a-half thin tape.

Recording Suggestions. What kind of recordings are you going to make? That, too, depends on you. You may just want to record the sounds in a Jamaica jungle at dawn, or the conversation around an Alpine fireplace at dusk. Or you may want to make an on-the-spot running commentary about all the places you're visiting or passing.

Some of the things you might want to capture on tape are listed on page 109. Before you go on your trip, you should contact the State tourist bureau or the consul of the country you're visiting for additional information.

There are hundreds of folk music possibilities, which you can find easily by

UNITED STATES		EUROPE	
Mid-Atlantic Appalachian regions	Mountain music	Austrian Alps	Zither, hachbrett and schuhplattler music
Midwestern barn dances	Country music	Finland	Kantels (dulcimer-like instrument)
New Orleans French Quarter bands	"Gut-bucket" jazz	France	Mountain shepherd music in the Auvergne
Ozark areas of Arkansas and Missouri	Mountain music	Italy (especially south of Naples)	Tarantellas
Revival meetings in almost any Southern state	Religious music	Norway	Hardange (fiddle)
Western rodeos	Cowboy ballads	Poland	Accordion polkas
WEST INDIES		Romania	Gypsy music
Cuba and Puerto Rico	Afro-Spanish music	Scotland	Bagpipe
Haiti	Afro-French-Spanish ritual music	Spain	Flamenco
Trinidad, Jamaica	Steel bands and wash-board bands, calypso	Sweden	Massed fiddlers
		Switzerland	Yodeling
		Wales	Harp singing

checking the folk music section of any record catalog. In addition, you will discover others on your trip. You will have to keep your eyes open, ears tuned and—most important—stay in the background. There is nothing so disquieting to a native singer or instrumentalist as to have a microphone

poked at him, especially by a foreigner.

Try to make arrangements in advance—it may take a few cents in American money to the person in charge—but it will be worth it when you get back home and spin those reels. It will be just as if you were on that vacation again. —30—

Get This Valuable Book

FREE



Yes you get our big Diagrams book. FREE! It's like a road-map that shows you the way to easier Radio-TV repair. Needed by every serviceman. Complete 11x22" Schematic Diagrams on many radio and TV sets help cut servicing time. Includes simple instructions on how to use diagrams and picture patterns. This book is yours FREE for asking to see Coyne's great new 7-book set "Applied Practical Radio-Television!"

AT LAST! MONEY-MAKING "KNOW-HOW" ON TRANSISTORS, COLOR TV AND SERVICING

Coyne's new 7-volume set gives you all the answers to servicing problems—quickly! For basic "know-how," you'll find everything you want in Volumes 1 to 5 on over 5000 practical facts and data. Every step is completely explained from fundamentals to installing, servicing and trouble-shooting all types of radio and TV sets. So up-to-date it covers COLOR TV, UHF and latest on TRANSISTORS.

EXTRA! NEW TV CYCLOPEDIA For speedy on-the-job use, you get Vol. 6—the six large TV CYCLOPEDIA. Answers problems on servicing, alignment, installation, etc. in ABC order. All this plus Volume 7—NEW Coyne TECHNICAL DICTIONARY with over 1000 definitions of the latest terms, symbols and abbreviations. Use all 7 books FREE for 7 days; get the Servicing Book FREE!

Just For Examining COYNE'S New Set

"Applied Practical Radio-Television"

on 7 DAY FREE TRIAL!



NOW!
7 BIG BOOKS
IN ONE GREAT SET!

SEND NO MONEY!

Just mail coupon for 7-volume set on 7 days free trial. We'll include book of 150 TV-Radio Patterns and Diagrams. If you keep the set, pay \$3 in 7 days and \$3 per month until \$24.50 plus postage is paid. (Cash price, only \$22.95.) Or you can return the library at our expense in 7 days and owe nothing. YOU BE THE JUDGE. Either way, book of TV-Radio Patterns is yours FREE to keep! Offer limited. ACT NOW!

FREE BOOK—FREE TRIAL COUPON!

Educational Book Publishing Division
COYNE ELECTRICAL SCHOOL, Dept. 78-PE
500 S. Paulina St., Chicago 12, Ill.

YES! Send 7-Volume "Applied Practical Radio-Television" for 7 days FREE TRIAL per your offer. Include TV-Radio Patterns & Diagram Book FREE.

Name Age

Address

City Zone State

Where Employed

Check here if you want library sent C.O.D. You pay postman \$22.95 plus C.O.D. postage on delivery. 7-day money-back guarantee.

Educational Book Publishing Division

COYNE ELECTRICAL SCHOOL

500 S. Paulina St., Dept. 78-PE Chicago 12, Ill.

MAKE TINY GENIUS COMPUTERS WITH

BRAINIAC

a new and better ELECTRIC BRAIN CONSTRUCTION KIT

Makes 106 computing, reasoning, arithmetical, logical, puzzle-solving and game-playing machines . . . all 33 GENIACS (1955), 13 TYNIACS (1956), and 60 All New BRAINIACS® (1957)

- Scientific • Fun • Instructive • Safe
- Reusable solderless Parts • Full Plans

THIS IS BRAINIAC! With our Brainiac Kit (K 15), you can build over 100 small electric brain machines and toys which "think," compute, reason and display intelligent behavior. Each one works on a single flashlight battery . . . is FUN to make, FUN to use and play with, and TEACHES you something new about electrical computing and reasoning circuits. Originated and produced exclusively by Berkeley Enterprises, Brainiac is the result of 7 years' development work with miniature mechanical brains, including Geniac, Tyniac, Tit-Tat-Toe Machine pictured in LIFE Magazine, Simon (baby automatic computer), Squee (electronic robot squirrel), etc.

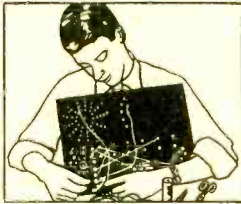

WHAT CAN YOU MAKE WITH BRAINIAC KIT K 15? 106 small machines including—LOGIC MACHINES: Logical Truth Calculator, Syllogism Prover, Intelligence Test, Boolean Algebra Circuits, etc. GAME-PLAYING MACHINES: Tit-Tat-Toe, Nim, Black Match, Wheeled Bandit, etc. COMPUTERS: To add, subtract, multiply or divide, using decimal or binary numbers; Forty-Year calendar, etc. CRYPTOGRAPHIC MACHINES: Coders, Decoders, Combination Lock with 15,000,000 combinations, etc. PUZZLE-SOLVING MACHINES: The Missionaries and the Cannibals, Age Guessing Machine, Submarine Rescue Chamber, Daisy Petal Machine, Fox-Hen-Corn & Hired Man, and dozens of others. QUIZ MACHINES: History, geography, trigonometry, etc.

WHAT COMES WITH YOUR BRAINIAC? Complete plans and instructions. • Manual by E. C. Berkeley on small electric brain machines. • Over 120 circuit diagrams including 46 exact wiring templates. • Introduction to Boolean Algebra for designing circuits. • Every part needed to build Geniacs, Brainiacs—over 400 pieces including control panel, switch discs, jumpers, improved wipers, bulbs, sockets, washers, wire, battery, special tools . . . Price: \$17.95 (For shipment west of Mississippi, add 80¢—Outside U. S., add \$1.80)

7-DAY FULL REFUND GUARANTEE IF NOT SATISFACTORY

MAIL THIS COUPON

BERKELEY ENTERPRISES, Inc.
815 Washington St., R-132, Newtonville 60, Mass.
Please send me Brainiac Kit K 15. (Returnable in 7 days for full refund if not satisfactory—if in good condition, I enclose \$ in full payment.
My name and address are attached.

Which Mike Should I Use?

(Continued from page 77)

vocal groups . . . in fact, any sound source that is capable of balancing itself as far as the human ear is concerned.

Solving the Band Problem. Let us consider a more involved assignment. Say you want to record the local dance band as it performs in a ballroom. The orchestra is set up as shown in the diagram on page 77.

I'm sure you will agree that a dance band is not in the self-balancing class. When the brass is blaring, try to hear the piano and base. Impossible! Then, too, would you expect to hear the vocalist without a p.a. system? This type of recording poses a problem, but one which can be solved by correct selection of microphones. Their placement in this example can be used as a guide in all cases of a similar nature.

You will need a mike in front of the saxophones . . . preferably unidirectional to minimize random sound pickup. This mike should serve trumpets and trombones as well, except for muted trumpet solos. Then, use another unidirectional mike in front of the trumpets to be turned on only for solos. If you speak to the soloist ahead of time, he can co-operate by aiming his instrument directly at the microphone. He will be glad to do so as it will be to his own advantage.

This leaves but one section of the band to pick up—a very important one—rhythm. You can ignore the drums; they are sufficiently intense to be picked up on the other mikes. One bidirectional mike between bass and piano should do the job. Although any kind of mike will suffice, the velocity type offers rich bass as well as good piano pickup. You may have to test to find the exact spot between the two for a good balance. Be sure to have

NOW!
ENJOY MUSIC
OUT-OF-DOORS

FOR PATIOS, PORCHES
TERRACES, LAWNS

with the new **MODEL UNIVERSITY MLC**

A complete high fidelity coaxial speaker system with separate low and high frequency drivers. Operates off your present phonograph, TV, radio, or high fidelity system. Weatherproof . . . compact . . . easy-to-install. Exceptional uniformity of response; clean, highly efficient bass, natural highs. At an unusually low cost! \$32.70 user net.

See your high fidelity dealer today! Or for full information, write Desk A-5, University Loudspeakers, Inc., 80 South Kensico Ave., White Plains, N.Y.

LISTEN *University sounds better*

WANT TO SEE THE WORLD'S FAIR?

Rek-O-Kut and Sabena Belgian World Airlines have teamed up for their annual "Window of the World" contest. Until the end of July, Rek-O-Kut, turntable and turntable arm manufacturer, is sponsoring a dealer and consumer high-fidelity contest. Grand prize is two tickets to the Brussel's World's Fair, via Sabena Airlines. Runner-up prizes consist of 100 pieces of equipment.

Just drop in at your local hi-fi dealer, listen to a Rek-O-Kut hi-fi demonstration, and fill out an entry blank with your name and address and the name of the dealer. There is nothing to buy, no coupons to clip, and no jingles to finish. The winners are selected by an independent contest organization.

one dead side of the mike toward the drums or your recording may turn out to be a beautiful percussion solo.

A unidirectional mike will serve the vocalist nicely. Ideally, the dead side of the mike should favor the brass section to minimize "spill-over" when opening the mike for the vocal. This will not be possible if you are dealing with a public performance, and the vocalist must face the audience. It is suggested, in such a case, that you have the singer work close to the mike but sing across rather than directly into it. That will help to eliminate "poofing" of "P's."

Provision for Monitoring. With a multiple mike setup, you must use a mixer amplifier with some provision for monitoring, either a speaker—if you are located remotely in a side room—or earphones if you are on stage. Don't expect too much on your first try. Operating a mixer board requires a certain amount of skill and this can be developed only with experience.

When recording either voice or solo instruments in the average living room, a little secret that will professionalize your work is to place the talent as close to the mike as possible. This will reduce the "living room" sound resulting so often from short reverberation time in the average home.

In the above discussion, we have only stipulated the desired directional characteristics. It goes without saying that the better the mike, the better the sound in all cases.

-30-



How a VTVM Works

(Continued from page 60)

The cathode of V_2 therefore becomes less positive.

Since the two cathodes are no longer at the same potential (cathode V_1 has become more positive and cathode V_2 less positive), a voltage drop appears across the meter and the pointer is deflected accordingly.

The variable resistor (*Rcal*) in series with the meter serves as a calibration control. A known voltage is applied to the probe, and the calibration control is adjusted to make the meter read correctly. The voltage divider and tap switch in the grid circuit of V_1 provide the meter with several different full-scale voltage ranges.

For each position of the tap switch, a different amount of voltage must be applied to the probe to produce a full-scale deflection of the pointer. The resistor in the probe helps to increase the input impedance of the instrument.

-30-

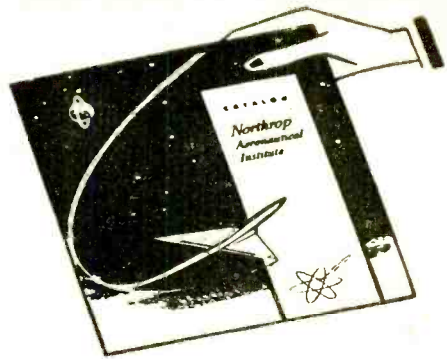

You can have this

ILLUSTRATED
FREE BOOK
32 page



Shows You — Tells You
about the wonderful career opportunities
in the world's fastest growing
interdependent industries:

• AERONAUTICS • ELECTRONICS

Tells how you can take your place in a surprisingly short time, at Big Pay and with a Future Unlimited, alongside the hundreds of successful Northrop graduates. They are employed by many of the country's leading companies on such projects as:

Electronic Computer Planning,
Missile Flight Test Engineering,
Design of Servomechanisms,
Design of Rocket Powerplants,
Celestial Guidance Systems,
and many more.

It will cost you nothing but a postage stamp to find out about the wonderful future open to you, and about the great demand for Northrop Institute graduates.

APPROVED FOR VETERANS



Northrop

Aeronautical Institute

An Accredited Technical Institute

1187 W. Arbor Vitae Street
Inglewood 1, California

NORTHROP AERONAUTICAL INSTITUTE

1187 W. Arbor Vitae Street, Inglewood 1, Calif.

Please send me immediately the Northrop catalog, employment data, and schedule of class starting dates. I am interested in:

- Electronic Engineering Technology
- Aeronautical Engineering Technology
- Aircraft Maintenance Engineering Technology
- Master Aircraft and Engine Mechanic
- Jet Engine Overhaul and Maintenance

Name Age

Address

City Zone State

Veterans: Check here for Special Veteran Training Information.

ORDER by MAIL and SAVE!

TV PICTURE TUBES

10BP4	\$ 7.95	16WP4	\$15.20	17TP4	\$19.30	21EP4	\$14.95
12LP4	8.95	16TP4	10.95	19AP4	19.30	21FP4	15.95
14B/CP4	9.95	17AVP4	15.20	20CP4	13.90	21WP4	17.30
16DP4	14.95	17BP4	10.95	20HP4	17.95	21YP4	15.95
16EP4	15.90	17CP4	17.00	21AP4	22.10	21ZP4	14.95
16GP4	15.90	17GP4	17.60	21ALP4	20.95	24CP4	23.95
16KP4	10.95	17HP4	13.60	21AMP4	19.95	24DP4	26.95
16LP4	10.95	17LP4	13.60	21ATP4	20.95	27EP4	39.95
16RP4	10.95	17QP4	11.95	21AUP4	20.95	27RP4	39.95

27"-8 month guarantee—all others 1 year. Aluminized Tubes \$5.00 more than above prices. These prices are determined to include the return of an acceptable similar tube under vacuum.

ALL PRICES FOB CHICAGO, ILLINOIS. Deposit required when old tube is not returned, refundable at time of return. 25% deposit required on COD shipments. Old tubes must be returned prepaid. We ship anywhere.

WRITE FOR COMPLETE LIST

—PICTURE TUBE OUTLET—
3032 MILWAUKEE AVE., CHICAGO 18, ILLINOIS
Dickens 2-2048

NEW MAGIC RADIO WALKIE TALKIE



YOUR OWN POCKET SIZE RADIO STATION!
 BROADCASTS TO ANY HOME DR CAR RADIO WITH-
 OUT WIRES OR HOOKUPS! Wt. only 5 oz. Size (1 1/2 x 2 1/2 x
 1 1/4"). Built-in telescoping antenna. Powerful Transistor—
 sensitive microphone. Frequency setter, break-in switch!
 Runs for weeks on self-contained flashlight batteries. Du-
 rable plastic case. With this Radio Talkie you CAN TALK
 TO YOUR FRIENDS UP TO A BLOCK OR MORE
 AWAY! Talk up to 1 mile or more between two auto-
 mobile INSTANT OPERATION! Just push button to
 talk! No license needed. Uses inductive field magnetic
 radiation. Useful and real fun in a million ways.
**GUARANTEED TO WORK. 1 YEAR SERVICE
 GUARANTEE.**
 SEND ONLY \$3.00. (cash, ck, mo) and pay post-
 man \$9.99 COD postage or send \$12.99 for prepaid
 delivery. COMPLETE READY TO OPERATE with
 instructions and hundreds of ways and tricks for broad-
 casts thru any radio you desire. Price may go up soon so
 get your NEW POWERFUL RADIO WALKIE TALKIE
 NOW. Available only from:
WESTERN RADIO Dept. REL-7, KEARNEY, NEBR.

Flush Mount SPEAKER WALL PLATES

USE FOR YOUR HI-FI INSTALLATIONS—CAR AND STATION
 WAGON REAR SEAT SPEAKERS, INTERCOMS AND OTHER USES
 TOO NUMEROUS TO MENTION.
 Fabricated of heavy gauge steel and perforated metal for rigid speaker
 support.

WP-5 FOR 5 INCH SPEAKERS 1.35
 WP-8 FOR 8 INCH SPEAKERS 1.80
 Satin White, Satin Black, Gray Hammerstone or Prime Coat.
 SEND CASH CHECK OR M. O. WE PAY POSTAGE.



JOHNSON & CO. DEPT. E7 - 249 OAKHURST, N. J.

Say You Saw It in POPULAR ELECTRONICS



**QUAL-KITS
ARE
EASIEST!**

And they have the finest features and specs. Fully illustrated step-
 by-step 28-page manual makes assembly a snap! WRITE FOR FREE
 CATALOG! * 10% for new Federal Tax.

QUALITY ELECTRONICS Dept. P-7 New York 13, N. Y.
 319 Church Street

Antennas for Satellites

(Continued from page 54)

from a half-wave length of coaxial line placed across the terminals of the 300-ohm ribbon at the point where it is attached to the input terminals of the receiver. It is cut to a length of 35 1/2", resonating it to 108 mc. When placed in shunt with the 300-ohm line, it provides an unbalanced termination of 75 ohms, suitable for most converters. Once trimmed to length, the balancing transformer is inserted in the antenna circuit and forgotten.

Installing Your Antenna. Mount your satellite antenna in the clear, above nearby metallic objects and adjacent antennas. Television-type masts and hardware may be used to place the array in position. Suitable hardware for roof and chimney mounts can be purchased from almost any TV dealer or radio distributor.

Regardless of the type of mount, the antenna assembly must be protected from inclement weather and corrosive moisture in the atmosphere. If it is installed near the sea coast, the salt-laden air will soon play havoc with its aluminum portions. To retard corrosion, the boom of the array can be given a coat of aluminum paint or other protective covering.

The elements of the array must be treated with caution, particularly in the case of the long long Yagi. A coating of paint or other thick insulating substance will detune the elements to such a degree

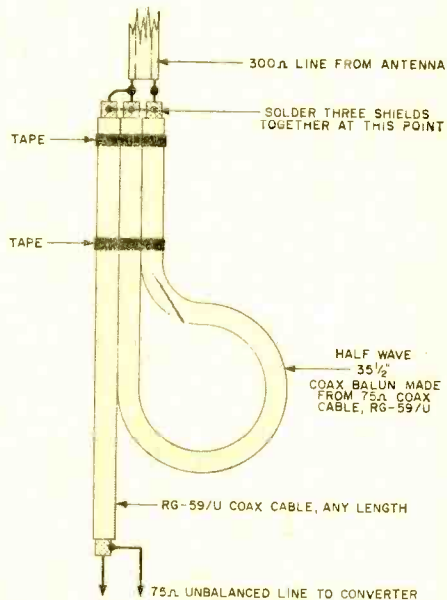

Fig. 5. Balun transformer at receiver provides an impedance change of 4:1 and is used to connect a balanced termination to an unbalanced one.

that effectiveness is largely lost. The new Krylon plastic spray may be used on the elements to provide a clear, tough coat of waterproof acrylic compound. Sprayed on under pressure, it will prevent rusting and pitting and will make them salt-spray-resistant. The whole antenna and supporting boom could be sprayed.

If you want to track the satellite, the antenna can be supported and rotated by a TV-style rotator. This will come in handy for making tape recordings of the signal or for studying the Doppler shift. Of several suitable rotators, the Cornell-Dubilier TR-16 has been used for this type of work with good results as it has a remote direction indicator and an instant-locking mechanical brake.

-50-

Operation Blub!

(Continued from page 50)

"Oh?" her eyebrows scampered toward her hairline. "And what about those times your old radio-controlled gismos went berserk—but amok—for no other reason than pure mechanical flubbing. Certainly, you're not going to pin *your* inability to construct reliable controls on poor *me*?"

Something told me to be charitable . . . the same something which always lets me know I'm right on the verge of losing still another discussion.

"Let's not argue about past failures," I said soothingly, bending a smile of truce in her direction. "There simply is no danger of 'The Mermaid' meeting with untoward mechanical tragedy because all the components are brand-new, all guaranteed, and I made a painstakingly careful check of each part as it was installed. From the Forster .99 motor to the servo-mechanisms through the R/C-operated transmission and back again. And I've carefully checked the transmitter-unit. Only tide, storm or an act of Providence is likely to create difficulty for this craft!"

"Wanna bet?"

"Sure—but you understand this is *one time* when you don't get to put your grubby little digits on the transmitter-unit or the boat, don't you?"

"I'll *still* give you odds!"

"Go raid your mad-money, sucker!" I chortled happily. "Who am I to turn down a sure thing!"

SEVERAL AFTERNOONS LATER found us standing on a deserted section of waterfront near the Long Beach Marine Stadium. I'd chosen a weekday afternoon since water traffic was less in evidence.

Launching "The Mermaid," we sprinkled

Interesting, Pictorial FREE BOOKLET

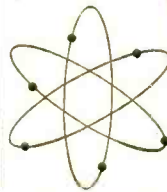

to help you decide on YOUR CAREER IN ENGINEERING

Here is a graphic story about dynamic careers as engineers and engineering technicians. Booklet covers such subjects as:

- Wide variety of job opportunities.
- The courses offered, degrees you can earn, and what you are qualified to do.
- Pictures of the Milwaukee School of Engineering, its facilities, plus Milwaukee scenes.
- Recreation, student organizations, fraternities.
- Scholarships, part-time work, admission requirements.

— and many other important and interesting facts to help you understand and decide on your career in engineering. Send for your *free copy today* — no obligation whatsoever.

MS-73

Milwaukee School of Engineering
— dedicated to serving young men and industry

SEND COUPON

Milwaukee School of Engineering
Dept. PE-758, 1025 N. Milwaukee St., Milwaukee, Wis.

Please send me free the new booklet
"Prepare for Your Career in Engineering"

I'm interested in:

Electrical Engineering Mechanical Engineering

Name _____ Age _____

Address _____

City _____ Zone _____ State _____

I'm eligible for veteran's education benefits.

Yes No Discharge date _____

WANTED!

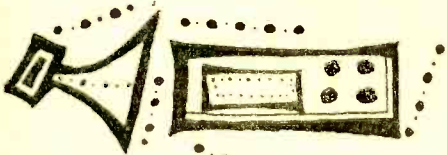

Equipment, components or parts!

The 265,000 purchasers of POPULAR ELECTRONICS are always in the market for good used equipment or components. So, if you have something to sell, let PE readers know about it in our classified columns.

It costs very little: just 50¢ per word including name and address. Minimum message: 10 words. For further information, write:

Martin Lincoln
POPULAR ELECTRONICS
One Park Avenue
New York 16, New York

ELECTRIC WELD · BRAZE & CUT

REPAIR MOST EVERYTHING MADE OF METAL

Home Appliances, Auto parts, Farm-wooden equipment, toys. Make and repair playground equipment, lawn chairs, tables, ornamental iron work gates, wagons, etc. Solder, heat, bend, and straighten, with terrific heat from arc torch. Cut and weld up to ½" steel plate. A million uses for home, auto, farm, inventors, factories, etc. Works from any house 110 volt plug-in. Complete with dark welders mask, arc torch, supply of carbon welding and brazing rods. Solder, flux, and complete Welding Instruction Book. Attractive—portable—efficient—durable—1 year guarantee. Wt. only 8 lbs.

SEND ONLY \$3.00 (cash, c.k., m.o.) and pay postman \$6.95 plus C.O.D. postage on arrival or send \$9.95 plus \$1.50 postage and we will send Postpaid. Ideal gift for mechanically minded home owners, relatives, friends. Order now for early delivery. Available only from:
MIDWAY WELDER Dept. DPL-7 Kearney, Nebraska



Your OWN — Modern DIAL

TELEPHONES

GOV'T COST: **\$8.50**

\$32.50 each

Working order guaranteed 100%

For private circuits or extensions to main line: easy to rig up. Invaluable for residential, farm, industrial, estate uses. Surplus phones, slightly used, fully standard, base complete with dial, bell, cord, etc. Instructions and diagram included.

Send check—we pay postage; or C.O.D. plus postage.

BOHNSACK EQUIPMENT COMPANY

Box 11

Germentown, N. Y.

WANT A BETTER JOB: BECOME AN ELECTRONIC ENGINEER

ONLY 32 MONTHS TO EARN A BACHELOR OF SCIENCE DEGREE IN ELECTRONICS ENGINEERING. Class enrollment limited to allow for individual instructions. Chartered by state of California. Nonprofit-non-sectarian, co-educational—established 26 years.

APPROVED FOR VETS—ENROLL NOW!

SEND FOR FREE CATALOG

PACIFIC STATES UNIVERSITY

1516 S. WESTERN AVE. Dept. M LOS ANGELES, CALIF.

a few drops of champagne over her bow and I started her engine. She vibrated slightly in *neutral*, drifting gracefully upon the water.

"Let's get her under way," I said enthusiastically, and snapped on the transmitter-unit—punching the button which would send the signal responsible for activating the R/C servo system consisting of *Forward, Reverse, Due Port, Due Starboard*. Simultaneously, I punched the button which would feed a signal to the waiting R/C-controlled transmission comprising the three motor-speeds up to a maximum of the seven knots for which the throttle had been set.

She glided off across the water smoothly, her bow cutting the surface beautifully. Like a dream she went, leaving a realistic wake behind her. We watched, entranced by the sight.

"Pay your bet, sucker!" I gloated, holding out my hand.

"The voyage isn't over yet!"

"Welcher!" I muttered.

"Well, it's not!"

For the next ten minutes I sent 'The Mermaid' through a breath-grabbing series of complicated maneuvers, and she responded to each signal immediately, flawlessly. I began to understand a little how admirals, commodores and captains felt: *powerful!*

"Well," sighed Friend Wife, "I guess you win." She reached for her purse.

SUDDENLY, the toothsome "Mermaid"—now about two hundred feet from shore and making a wide, sweeping turn—leaped erratically forward, rolled heavily to starboard and began obviously settling aft into the water.

"I told you!" shrieked Friend Wife, hastily snapping her purse shut. "Look at that!"

"It's *not* the control system!" I raged, punching various buttons and watching my beloved "Mermaid" sluggishly respond to each change of direction as she mused along through the unfriendly water which was slowly, steadily claiming her trim hull. "See? See how she still responds? Maybe she struck a rock or something. I've got to get her back to shore before she sinks! I've got to!"

Without warning, the boat lurched sharply to starboard again, sinking even lower into the water. For several agonizing seconds she bravely—nay, gallantly—struggled on her course shoreward. Then . . . *blub*: "The Mermaid" sank in a froth of churning water and bubbles.

"I told you," said ex-friend Wife, looking as pleased as a barracuda with a deed to the Pacific Ocean. "And after all those hours you spent fooling with her. Tsk, tsk, tsk!"

"Shut up, you psychic, unfeeling, hard-hearted—"

I wheeled about and headed for the car, knowing now why sea captains insisted upon going down with *their* ships. I had taken about ten stumbling steps when I heard somebody shout: "Hey, Mac! Is this 'whatchamacallit' yours?"

A character, wearing a skin diver's neoprene suit and underwater breathing apparatus, waded out of the water holding "The Mermaid" in his arms. I stared, miserably, at the two steel spear-shafts that pierced her hull.

"I'm awfully sorry, Mac," he burred, handing me a dripping, ruined "Mermaid." "I was just exploring around, looking for the leopard shark that's been reported to be bothering folks in this area, and when I spotted *this* baby scooting along—why I naturally—"

"Yeh, I know," I said bitterly, "you just naturally thought it looked fishy. Well, I suppose I can't really blame you for taking a shot at it."

Tenderly lugging "The Mermaid," I rushed blindly for the car. The way I was feeling, I might break into racking sobs any moment. Ruefully, I investigated "The Mermaid's" damaged innards. She was a mess. What the spears hadn't smashed, the salt water had finished. It would require a week of Sundays just to clean the intricate components before they started rusting.

ON THE WAY HOME silence filled the car with a sad atmosphere until the wife, sliding a sympathetic arm around my shoulder, murmured: "You win the bet, anyway. That should offer some consolation. You can use the money to start the next project."

I nodded.

"What do you think it'll be?" she asked, more to offer solace than anything else.

"We got any bottles around the house?"

"What kind of bottles?" she inquired.

"The kind people build boat models in," I said.

-30-

ELECTRONIC TECHNICIANS WANTED

An examination for Electronic Technician has been announced by the U. S. Civil Service. Technicians are needed to install and maintain electronic equipment such as computers, detectors, testing and communications equipment, and to assist in the research and development of such equipment.

Positions to be filled are in the various Federal agencies in the Washington, D. C., area, and will pay from \$3175 to \$7570 a year. Further information and application forms may be obtained from most post offices throughout the country or from the U. S. Civil Service Commission, Washington 25, D. C.

NOW—faster, easier ball-bearing drive for GREENLEE chassis punches



New GREENLEE Ball-Bearing Drive Nuts and Drive Screws reduce friction and make it easier than ever to cut smooth, accurate holes with GREENLEE No. 730 round Radio Chassis Punches. The new faster drives are available for all round-type GREENLEE Punches sizes 11/16" through 2-25/32". Operate with ordinary wrench for quick socket openings etc. in metal, bakelite, or hard rubber.



GREENLEE TOOL CO.

2387 Columbia Avenue
Rockford, Illinois

COYNE
TRAINS YOU
IN SPARETIME
AT HOME

COYNE
QUALITY
TRAINING
AT LOWEST
COST

TELEVISION

RADIO-COLOR TV

Only from famous COYNE do you get this modern up-to-the-minute TV Home Training, Easy to follow, Step-by-Step instructions—fully illustrated with 2150 photos and diagrams. Not an old Radio Course with Television tacked on. Personal guidance by Coyne Staff. So practical you can quickly EARN MONEY IN A TV-RADIO SALES AND SERVICE BUSINESS—part time or full time. Not only FINEST TRAINING but COSTS MUCH LESS—pay only for training—no costly "put together kits."

SEND COUPON FOR FREE BOOK
SEND COUPON for Free Book and full details including EASY PAYMENT PLAN. NO COST OR OBLIGATION—NO SALESMAN WILL CALL.



B. W. COOKE, JR.

President

COYNE
ELECTRICAL SCHOOLS

FOUNDED 1899

A TECHNICAL TRADE INSTITUTE OPERATED NOT FOR PROFIT
500 S. Pauline Dept. B8-H2 Chicago 12, Illinois

B. W. COOKE, Jr., President
COYNE ELECTRICAL SCHOOLS
500 So. Paulina St., Chicago 12, Ill., Dept. B8-H12

Send FREE Book and details of your Television Home Training offer.

Name
Address
City State

In 106 cities—NO ADDRESS IS COMPLETE without a Postal Zone Number

The Post Office has divided 106 cities into postal delivery zones to speed mail delivery. Be sure to include zone number when writing to these cities; be sure to include your zone number in your return address—after the city, before the state.

Transistor Topics

(Continued from page 89)

based on Mr. Crump's design for only seventy-five cents (75¢), postpaid. This firm also offers a complete kit for assembling a "Telepower" receiver for only \$6.50, postpaid.

News from Overseas. Arie Lieberman, president of Talk-A-Phone Co. (1512 Pulaske St., Chicago, Ill.), has announced that transistorized home-intercom systems will be exhibited in both the design and function categories at the World's Fair.

A radio receiver that can be worn *entirely in the ear* has been developed by two German engineers. It is only slightly larger than a flashlight bulb and employs sub-miniature transistors. Don't rush to your corner store to buy one, however . . . it's not yet in production!

A Hague firm, N. V. Electrologica, has developed a new transistorized computer. Intended for the medium-sized business firm, it has a ferrite-core memory and uses punched paper tape, or cards, for programming.

In Japan, the Fugi Electrical Manufacturing Co. has signed agreements with both Western Electric and RCA to make transistors and other semiconductor components. The Sony Corp., a radio-TV manufacturer, has signed an agreement with International G.E. covering the manufacture of transistors and diodes. And Nippon Electric has signed with RCA to produce transistors.

Glass Cases. The metal cases in which most transistors are housed cost the manufacturer close to a dime each. A glass case of about the same dimensions would cost about a nickel less. When these costs are translated into terms of final selling prices, a switchover from metal to glass cases could result in a substantial reduction in transistor prices.

Several manufacturers are producing glass-cased transistors on an experimental basis. General Electric, however, is the first to produce a transistor package meeting the JETEC-recommended TO-9 outline. In case the expression "JETEC" is new to you, this stands for the Joint Electron Tube Engineering Council, a committee composed of representatives of both the Electronic Industries Association and the National Electrical Manufacturers Association.

NEW - MIDGET SHORT WAVE RADIO



GETS STATIONS 12,000 MILES AWAY!

Tunes ALL foreign short wave bands. London, Paris, Moscow, Australia. ALL Amateur bands 160 to 10 meters! ALL long distance Air Force and Air Line aircraft. Ships at Sea, A.F. overseas broadcasts. State-County Police, Industrial Bands —U.S. Radio Broadcasts. Tunes 500 KC to 40 mc.—600 to 7 meters! NOTHING LIKE IT ON MARKET ANYWHERE AT ANY PRICE. Super-regenerative Receiver. Short antenna included—look up in 1 second! PORTABLE SELF-CONTAINED — POWERED WITH RADIO BATTERIES SOLD EVERYWHERE. NO AC PLUG-INS! Size only 4 1/2" x 4" x 4". Wt. complete—3 lbs. Calibrated hi-ratio easy tuning dial. Wonderful for Boy Scouts. Tourists, vacations, amateurs, short wave listeners. EVERYONE CAN NOW HEAR THE WHOLE WORLD TALKING!

SEND ONLY \$4.00 (bill, ok, mol and pay postman \$12.95 COD) postage on arrival or send \$16.95 for postpaid delivery. Complete easy to wire kit includes all parts, tubes, broadcast coil, plastic cabinet, instructions—(Set of long life batteries \$2.99 extra). **COMPLETELY WIRED AND TESTED** —**POSTPAID IN USA \$22.95.** Easily a \$49.95 value. Order now before price goes up—**GUARANTEED—AVAILABLE ONLY FROM WESTERN RADIO Dept. BRE-7 KEARNEY, NEBRASKA**

INVENTORS

Send for **PATENT INFORMATION** Book and **INVENTOR'S RECORD** without obligation

GUSTAVE MILLER
78-PE WARNER BUILDING
WASHINGTON 4, D. C.

REGISTERED PATENT ATTORNEY

ASSOCIATE EXAMINER
U.S. PAT. OFF. 1922-1929

Patent Attorney & Advisor
U. S. NAVY DEPT. 1930-1947
PATENT LAWYER

ENGINEERING DEGREES



E.E. Option Electronics or Power
Earned Through HOME STUDY
or Residence Work

5719-W Santa Monica Blvd.
HOLLYWOOD 38, CALIFORNIA

Operating as College of Engineering only at present.

Because of their low cost, the first glass-cased transistors probably will be entertainment types, designed for use in portable and car radios and phonographs, with industrial and military types scheduled for production at a later date.

New Transistors. Texas Instruments (Dallas, Texas) has announced the production and commercial availability of a new high-frequency *p-n-p* diffused-base transistor. Type 2N623 features a 200-mc. maximum frequency of oscillation and a 90-mc. *alpha* cutoff frequency. It will deliver 50-db gain at 1 mc. and 13-db gain at 50 mc.

A new drift transistor, designed for r.f. amplifier service in entertainment-type battery-operated receivers, has been introduced by the Semiconductor Division of RCA (Somerville, N. J.). A *p-n-p* germanium alloy type, the 2N544 features a low value of collector-to-base capacitance. This unit can provide a power gain of 30.4 db at 1500 kc. in circuits utilizing a neutralizing network.

Raytheon Manufacturing Co. (55 Chapel St., Newton 58, Mass.) has developed a diffused-base power transistor capable of delivering 5 watts, Class A, at 100° C and with only 10% distortion. Still in the development stage, this transistor may not be in production for several months.

That's all for now, fellows. Have fun . . .

Lou



3D Color-TV Is Here!

(Continued from page 33)

amplifiers, synchronizing circuits, clippers, and related electronic circuitry. A single composite picture signal is obtained from the transmitter.

At the receiver, a full-color image is formed on the screen of a single-color cathode-ray tube. Polarizing filters are passed in front of the receiving tube's screen, with alternate segments having their axes of polarization at right angles to each other.

These polarizing filters may be rotated in front of the screen by means of a disc, as in early color-TV experiments, or by means of a drum of alternate filter segments, as shown in Fig. 2. The motor driving the disc (or drum) is synchronized with the television frame rate so that alternate picture frames are polarized vertically and horizontally.

The viewer wears polarizing spectacles

July, 1958

Leading Editors Say:

"NEWCOMER, OR OLD 'PRO' YOU CAN LEARN ALL ABOUT TELEVISION WITH . . . BASIC TELEVISION

Editors of leading electronic magazines, service technician publications and industrial magazines—the experts—unanimously acclaim Basic Television, new five volume "picture-book" training course as the easiest possible way of learning all about black and white television.

Electronic Technician, April 1958

"One picture is worth 10,000 words," so you can imagine the information contained in the more than 700 figures included here. Each of these drawings is illustrated in the manner which makes the most difficult concept readily understandable. Text is very clear. . . . If you are a relative newcomer to TV, this work will be a most valuable "Bible"; if you are an old pro, you will be surprised at how much you can learn."

Radio Television News, May 1958

"For those who have thought about studying television but have been intimidated by the complexity of the average engineering text, this easy-to-take introduction to the subject should be encouraging. . . . There is no reason why the student with an elementary radio and electronics background couldn't use this 'course' as a springboard to a career as a service technician in the television field."

Telephony, April 1958

"This is undoubtedly the most understandable presentation of the basic theory, operation and circuitry of black and white television ever published. Everything from the transmitter to the picture on the screen is explained with utmost clarity in words as well as illustrations that 'visualize' each concept discussed."

Signal, April 1958

"Only a knowledge of basic electronics and radio is presupposed. The coverage, ranging from the creation of the TV image in the studio to its appearance on the receiver screen, contains many topics absent in the more traditional text."

Navy News, April 1958

"Here is an excellent encyclopedia on television from A to Z . . . this is, indeed, the most complete work of its kind . . . suitable for the beginner as well as the advanced technician, and anyone interested in TV."

If you want to learn all about black and white television, quickly, easily and economically, this 5 volume "picture-book" course BASIC TELEVISION is the answer. Now available at your local bookstore or electronic parts distributor. If your dealer does not have this book, order direct.

10 day unconditional money-back guarantee.



John F. Rider, Publisher, Inc.
116 West 14th Street
New York 11, N. Y.

PE-7

I have enclosed \$ _____ Please send me:
 | — 5 vol. Basic Television set (soft cover) \$10.00
 | per set
 | — Deluxe cloth bound edition, all 5 vols. in single
 | binding, \$11.50

I understand I may return the books in 10 days for complete refund of full purchase price if I am not satisfied.

NAME _____
 Address _____
 City _____ Zone _____ State _____

Now
You
Can

TEST CONDENSERS

In
Your
Set

And Selenium Rectifiers UNDER WORKING CONDITIONS
Quickly, Accurately Checks:



- Paper, Mica Co-
lamic Capacitors
- Electrolytics
- Continuity
- Selenium
Rectifiers
- Flashbulbs
- AC/DC Voltages
- NOT A KIT

\$9.95 postpaid, net. Complete, ready to operate.
10-DAY MONEY BACK GUARANTEE!

FREE Set of leads with each CAPACITEST for Limited Time!

CAPACITEST 2 With thousands already in use, is an improved, compact tester. It does a giant job to avoid call-backs and save you time and money. Tests Selenium Rectifiers! Checks condensers at 150 V., the approx. working voltage since applied voltage is 10% or less. Accurately, quickly shows open, shorted or intermittent capacitors and leaky electrolytics. Compact: 4" x 4" x 2". Lightweight, for bench or tool kit. Order direct from "The BARJAY Co." \$3 deposit with C.O.D.'s. Save PP & COD fees. Send \$9.95 & we'll pay postage.

The BARJAY Co.
145 W. 40 St., New York 18, N. Y.

"TI-NEE" BATTERYLESS TUBELESS LIFETIME RADIO

"TI-NEE" RADIO IS GUARANTEED TO WORK FOR YOUR LIFETIME! USES NO TUBES, BATTERIES OR ELECTRICAL PLUGS-IN. Never runs down! SMALLER THAN A PACK OF CIGARETTES! RECEIVES LOCAL RADIO STATIONS MOST ANYTIME ANYWHERE WITHOUT EXTRA ANTENNA. Uses semiconductor crystal diode—Hi-Q Tuner. Beautiful black gold plastic cabinet. Built-in Speakerphone.
SEND ONLY \$2.00 (bill, ok, mo) and pay postman \$4.99 COD on arrival or send \$6.99 for postpaid delivery. **SENT COMPLETE, READY TO LISTEN—NOTHING EXTRA TO BUY EVER!** (Extra long distance Aerial kit included free for stations up to 1000 miles away.) Available only from **AMERICAN MADE MIDWAY COMPANY, Dept. GPL-7, Kearney, Nebraska**



GERMAN 6-SHOT AUTOMATIC REPEATER—22 CAL.

- Blank Cartridges
 - No Permit Required
 - Latest Models
 - Fully Automatic
- Self ejecting clip. Firing spring adjustable. Precision made by the Finest West German Gunsmiths—Wonderful for sporting events, theatrical performances, to scare would-be attackers, etc. 4" long, perfectly balanced. Sold on a money back guarantee (not available to residents of Calif. or N. Y.)—Send \$6.95 Cash, check, or Money order to: **BEST VALUES COMPANY, Dept. G-103, 403 Market St., Newark, N. J.**



6.95

(Post Paid)

HAMS! SWL's! WORK THE WORLD

ALL-BAND VERTICAL ANTENNA FOR 80, 40, 20, 15, 10, 6 METERS. NEEDS LITTLE SPACE, ALL ALUMINUM; 5,000 IN USE. **\$16.95** EXP. COLL.

GOTHAM 1805-A PURDY AVE. MIAMI BEACH, FLA.

ENGINEERING DEGREE IN 27 MONTHS

B.S. Degree. Aero., Chem., Civil, Elec., Mech. & Electronic Eng. (inc. Radio, TV). 36 month B.S. degree in Math., Chem., Physics. Prep courses. Demand for grads. Spacious campus, 20 bldgs., dorms, auditorium, gym. Low rate. Earn board. G.I. approved. Enter Sept., Dec., March, June. Catalog. 2378 E. Washington Boulevard Fort Wayne 2, Indiana

Keeping pace with progress

INDIANA TECHNICAL COLLEGE

BE A SPY

Correspondence course on wire tapping, bugging, telescopic sound pickup, recording techniques, microphotography, invisible and remote photography, telescopic and aerial photography. **WORLD'S ONLY CORRESPONDENCE COURSE IN WIRE TAPPING AND BUGGING.** Complete course just \$22.50.

C. CARRIER CO.

5880 Hollywood Blvd. Hollywood 28, California

and sees only the left-hand picture images with his left eye and the right-hand pictures with his right eye as alternate pictures are flashed on the screen and as alternate filter sections move before the cathode-ray tube. The two images, combined by the brain, give the illusion of depth to the reproduced composite picture.

How It Will Be Used. Although not yet feasible for the living room, this closed-circuit 3D color-TV system may have many industrial and scientific applications.

For example, such a system might well be used to observe nuclear power plant operation in the giant nuclear-powered rockets of the future. The crew of such a rocket will have to be located behind adequate shielding outside the reactor's area, yet will need to see the control rods and other control components.

Other applications may include the observation of submarine life at great ocean depths, the exploration of the interior of active volcanoes or of the depths of deep mines and caverns, and the study of natural phenomena in remote or dangerous locations.

-30-

What the Sputniks Said

(Continued from page 59)

on space-flight electronics, wrote in *Radio*:

"Of special interest for radio specialists was the data picked up by the second Soviet satellite on solar radiation in the short-wave band which has a direct effect on conditions in the upper layers of the atmosphere.

"During the course of more than a hundred years, scientists have been exploring the intensity and spectral composition of the radiant energy which falls on the earth from the sun, and have on this basis indirectly been attempting to determine what these magnitudes are for conditions outside the earth's atmosphere.

"The most reliable data at present permit assuming that the density of the stream of the sun's radiant energy, beyond the limits of the atmosphere, is equal to 1.4 kilowatt per square meter. In actinometry and meteorology, this magnitude is called the 'solar constant.' About 9% of this stream falls on the ultraviolet part of the solar spectrum, about 40% on the visible part, and 51% on the far red and infrared parts of the sun's spectrum.

"At the earth's surface, with the sun standing at an altitude of 30° above the horizon, the density of the stream of solar energy is considerably less owing to the dispersion and absorption of solar energy by the atmosphere. It amounts to not more than 30 to 35% of the stream density beyond atmospheric limits and is differently distributed. Only 2 to 3% of it falls in the spectrum's ultraviolet part, 44% in the visible spectrum, and 54% in spectral heat rays.

"Making these data more precise, particularly the direct measurement of stream density of the sun's radiant energy, i.e., the solar constant beyond atmospheric limits, will make it possible to determine accurately the sun's effective temperature and density of the radiant energy stream emitted by a unit of solar surface. Precise measurement here is of interest to astrophysics first of all, but it is of more than [theoretical] importance."

Battery Requirements. "If a transistor solar battery of 1 square meter in area be constructed and faced toward the sun even with the accuracy of a 30° angle, then as might be expected this surface will be exposed to solar power of the order of 1 kilowatt. With 10% battery efficiency in conversion of solar energy to electricity, the output of such a solar battery surface might be expected to reach 100 watts of electric power.

"But if it be assumed that a satellite flying at a great height is exposed to the sun's rays approximately two-thirds of its orbit circuit time around the earth, then the solar battery can be expected to produce 100 watt-hours of energy. However, to secure such conditions, the spectral characteristics of the transistor battery must be close to the above-indicated frequency distribution of solar energy, especially in the visible and infrared parts of the spectrum, and, moreover, such a battery must operate on an optimum load.

"Unfortunately, the materials presently known that will permit creating batteries that possess high internal resistance are complex and cumbersome. A much lower magnitude of electric energy should therefore be expected. But even this would nevertheless have great importance as a possible alternate way of powering space vehicle measuring instruments—a solar battery, for example, used in combination with an ordinary or storage battery." —30—



Now offers you excellent

POLICE-MARINE

reception from your car.

Converter tunes 1.6-3.0 mc range, covers.....

Municipal, County and State Police...

Inter-ship and ship-to-shore telephone.....



- Marine weather....
- Coast Guard....
- Time signals....
- Amateur (1.8-2.0 mcs)
- Size: 3 1/2" H, 4" W, 4" D

Model #3163

2950

Available at Your Marine or Electronics Distributor.

*(Usable only on cars with 12 volt battery systems.)

This new S-W CONVERTER operates with existing auto radio* without need for alterations to the auto set. Merely plug-in with cable supplied, attach clip to accessory post under dash. Installation is simple, rapid.



NOW Science shows you how to Learn by "EAR"
ladies & gentlemen...

$$H^2 = A^2 + B^2$$



NOW YOU CAN LEARN AWAKE AND ASLEEP

Now, at last, science gives you an easy shortcut to learning. With this amazing new tool, you "start" to learn while awake—then the university-tested Dormiphone takes over, continues the learning process for you while you go off to sleep.

Do you want to learn a language—Memorize a speech or an array of important facts, figures, formulae—Correct your speech—Break bad habits? The Dormiphone SAVES YOUR TIME—EFFORT. So simple to use, children benefit—so helpful and practical it is used by scientists, educators, psychologists, people of all ages, occupations.

Find out how the Dormiphone works FOR YOU. Write for FREE Book or call for FREE DEMONSTRATION—Get the Scientific Evidence Today.

MODERNOPHONE, INC. Circle 7-0830
292-078 Radio City, N. Y. 20, N. Y.

Gentlemen: Please send me your FREE Book. I am interested in learning more about the DORMIPHONE and what it can do for me. No obligation—no salesman will call.

NAME

ADDRESS

CITY..... ZONE..... STATE.....

My main interest in Dormiphones is for:

() Language Learning () Speech Improvement
 () Memorization () Sleep Inducement
 () Habit Correction () School or College Work

Among the Novice Hams

(Continued from page 81)

interfering signal and (B) a parallel-tuned trap circuit in series with the receiver input to reject the interfering signal.

In Fig. 3(A), C and L in series are resonant to the frequency of the undesired signal. Consequently, it flows harmlessly through the circuit to ground, instead of into the receiver. However, the impedance of the series-tuned circuit is so high at other frequencies that the desired signals pass into the receiver without attenuation. In Fig. 3(B), the undesired signal can-

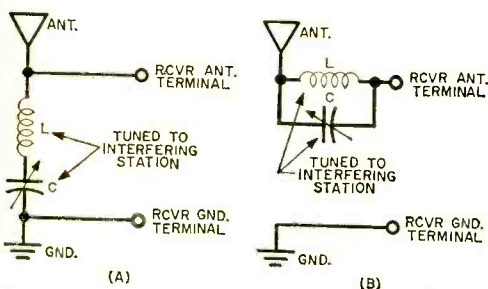

Fig. 3. Series-tuned (A) and parallel-tuned (B) trap circuits to reduce amateur interference to broadcast reception.

not force its way through the trap which is parallel-resonant at its frequency, but the desired signals pass through it easily.

The article entitled "Trap Those Unwanted Stations," by Louis E. Garner, Jr., page 51, *POPULAR ELECTRONICS*, February, 1958, contains much practical information on using such trap circuits in conjunction with various types of receivers, including broadcast receivers without external antennas, FM and TV receivers.

Draw a schematic diagram of a wavemeter with an indicating device.

See Fig. 4. In operation, the wavemeter coil is brought close to the coil of a circuit containing radio-frequency energy,

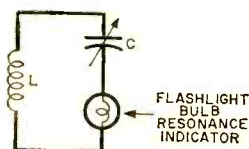

Fig. 4. Wavemeter with a resonance indicator.

and the wavemeter capacitor is resonated to that frequency, as indicated by maximum glow of the bulb. Then, by consulting the wavemeter calibration, the frequency is determined.

Power to light the bulb is obtained from the circuit being tested by *inductive coupling*. As we know, any coil (inductance) containing alternating current has an alternating field around it. And when another inductance is placed in the field, a replica of the original circuit is induced in it. Maximum current flows when the wavemeter is tuned to the exciting frequency, because then the inductive and capacitive reactance cancel each other, and only the resistance of the bulb limits the flow of circulating current.

Wavemeters insure that the resonant circuits of transmitters are actually tuned to the desired frequency, rather than to a harmonic or subharmonic of it, which often puts the emitted signal outside the amateur bands. This can be embarrassing.

Draw a schematic diagram of a low-pass filter with a constant- k , pi-section, unbalanced type.

While a complete explanation of filter operation and design can become quite involved, a general understanding of its operation is not difficult. A low-pass filter is usually connected between the output terminals of a transmitter and the antenna system, as in Fig. 5.

At low frequencies, the reactance of the inductance L is low and that of the capacitors C is high; therefore, signals pass

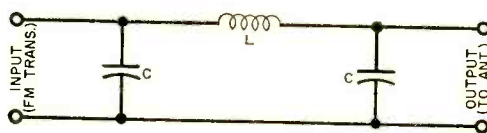

Fig. 5. Schematic diagram of low-pass filter.

through the filter with little opposition. At frequencies above the *cutoff* (resonant) frequency of the filter, however, the reactance of the capacitors becomes increasingly low. Consequently, these frequencies are diverted to ground, instead of going through the filter.

Thus, the low-pass filter permits the desired signal to reach the antenna, but it traps out harmonics and spurious components above the cutoff frequency (usu-

ally around 40 mc.), so that they cannot cause interference to nearby television receivers.

Draw a schematic diagram of a high-pass filter with a constant-k, pi-section, balanced type.

A high-pass filter is normally connected between the antenna system and the an-

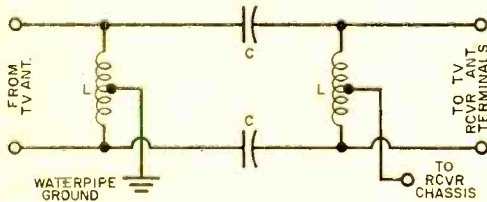

Fig. 6. Schematic diagram of high-pass filter.

tenna terminals of a TV receiver, as in Fig. 6. Television signal frequencies above 54 mc., which are above the filter cutoff frequency, pass through it easily. Frequencies below the cutoff frequency have an increasingly difficult time getting through the capacitors but flow easily to ground via the center-tapped coils, thus protecting the TV receiver from strong low-frequency signals picked up by its antenna.

Putting equal values of capacitance in each side of the filter, instead of all in one side, and grounding the centers of the inductances, instead of the bottom ends, makes a balanced filter.

News and Views

Gene, K1BHM, has just received his Technician license. As soon as he promotes a 6-meter receiver or a converter for his BC-348 receiver, he will fire up his WRL Globe Scout 680A transmitter on "6." In six months of operation on the 80- and 40-meter Novice bands, Gene has worked 34 states and three countries. He QSL's (confirms with cards) 95% of his contacts and gets about a 60% return. Gene has a 15-wpm code certificate, and his brother is ready to take his Novice examination. . . . **Bill, KN9LUH**, hopes to work the 48 states as a Novice. And he is going at it in the right way, having made 58 contacts in 23 states, all on 40 meters, in eight days on the air. Quite a record when you consider that TVI (television interference) forces him to do most of his operating in the early morning hours. Bill's equipment consists of a Heathkit DX-40 transmitter, a National NC-109 receiver, and a 40-meter doublet antenna.

Jerry, W4OHK, advises new Novices not to get discouraged because their equipment is not the best. He used a 12-watt, home-built transmitter feeding a 40-meter doublet with three bends in it and 12' high on one end and 20'

INFRARED SNIPERSCOPE TELESCOPE and PARTS

See in the dark—without being observed. War surplus Sniperscope M-2 contains the famous IP25A Image Tube. Gov't cost about \$1200. Used for industrial plant security; research lab experiments; infrared photography; spectroscopy, etc. Instrument complete, ready to use. Includes Power Pack, infrared light source. Will operate from 6 Volt auto battery. Battery or transformer available.



Stock No. 85,053-DZ \$150.00

Shipping weight approx. 12 lbs., f.o.b. Barrington, N. J.
Order by stock No.—Send check or M.O.—money-back guarantee!

Save still more money! Build your own Sniperscope! We will furnish instructions—parts, including: Power Packs, 1P25A image tubes, light units, filters, etc. For details—request FREE Catalog "DZ."

SPECIAL! INFRARED 1P25A IMAGE TUBE

Stock No. 70,127-DZ \$9.95 postpaid
Order by stock No.—Send check or M.O.—money-back guarantee!

COLOR TV TUBESCOPE

Save time, effort in alignment of color dot pattern.
Stock No. 50,139-DZ \$24.50 postpaid
Order by stock No.—Send check or M.O.—money-back guarantee!

WRITE FOR FREE CATALOG "DZ"!

Complete line of Astronomical Telescope Parts and Assembled Telescopes. Satellites. Also huge selections of lenses, prisms, war surplus optical instruments, parts, and accessories. Telescopes, microscopes, binoculars, etc. Request Catalog "DZ"!

ORDER BY STOCK NUMBER, SEND CHECK OR MONEY ORDER. SATISFACTION GUARANTEED!
EDMUND SCIENTIFIC CO., BARRINGTON, N. J.

Grommes-Phillips

CUSTOM HI-FI CABINETS



MODEL
GPC
1000

FEATURING
"FREE-FLOATING
SOUND"

MODEL
GPC
600



Sensibly priced Cabinets and Enclosures of all types. Models illustrated feature "FREE-FLOATING" enclosures. Compact, one-unit beauty with multi-unit isolation. Novel applications of finest hardwoods and durable laminates. See your local Distributor—or

SEND COUPON FOR FREE LITERATURE

GROMMES-PHILLIPS

5857 W. Lawrence Ave.,
Chicago 30, Ill.

NAME
ADDRESS
CITY STATE

Shrinks Hemorrhoids New Way Without Surgery

Science Finds Healing Substance That
Relieves Pain—Shrinks Hemorrhoids

For the first time science has found a new healing substance with the astonishing ability to shrink hemorrhoids and to relieve pain—without surgery.

In case after case, while gently relieving pain, actual reduction (shrinkage) took place.

Most amazing of all—results were so thorough that sufferers made astonishing statements like "Piles have ceased to be a problem!"

The secret is a new healing substance. (Bio-Dyne*)—discovery of a world-famous research institute.

This substance is now available in *suppository or ointment form* under the name *Preparation H.** Ask for it at all drug counters—money-back guarantee. *Reg. U. S. Pat. Office

INFRA-RED

**SNOOPERSCOPIES
OPTICS • LAMPS
TUBES • PARTS**



U.S. ARMY M-2
SNOOPERSCOPE

Former "Top-Secret" Infra-Red Viewers For Seeing In Total Darkness... Undetected. Now Available for Civilian Applications!!

Army Model M-2 Snooperscopes made by BELL & HOWELL. Use RCA 1P25-A Image Tube. Priced from \$50.00 to \$85.00. Write for Descriptive Bulletins listing prices & applications, also detailed descriptions of all the Infra-red Parts we stock.

INFRA-RED LIGHT SOURCE—Lamp for M-2 Snooperscope. Input 6-volts. 5 amperes. 5/8" Glass Filter. Projects a powerful beam of invisible infra-red radiation up to 400 feet. For I-R Viewing, communication, photography. **BRAND NEW \$5.95 Ppd.** Viewing, communication, photography. **BRAND NEW \$5.95 Ppd.** H.V. **POWER SUPPLY**—M-2 Image Tube supply. For 1P25-A or CV-147 tubes. Input 6-v.d.c. 0.33 ampere. Output 4,250-v.d.c. 4 1/2"x3"x8". Gov't cost \$92.00. Complete w/diagram. **\$7.95 Ppd.**

TERMS: Cash With Order. No COD's. Merchandise Guaranteed.

McNEAL ELECTRIC & EQUIPMENT CO.
4736 Olive Street Dept. P-7 St. Louis 8, Mo.



ROAD TO RICHES

You can be the next uranium millionaire! Government guarantees huge bonus! PRI instruments from \$29.95. See your local dealer today! **FREE CATALOG!**

Write PRI, 4223 PT W. Jefferson
Los Angeles 16, California

DEALERS WANTED



LEARN WHILE YOU SLEEP!



100 page fact-filled illustrated instruction book tells all. How to do it... what it costs... results obtained... plus hundreds of time-saving hints. Price \$2.00. Satisfaction guaranteed. Sleep-Learning Research Ass'n, P.O. Box 24F, Olympia, Washington.

Unlimited opportunity in ENGINEERING OR COMMERCE

BACH. SC. DEGREE IN 27 MONTHS in Mech., Civil, Elect., Chem., Aero., Radio (TV-Electronics) Engineering. IN 36 MONTHS in Bus. Adm. (Gen. Bus., Acctg., Motor Transport Mgt.). Capable students faster. Visit campus, see well-equipped labs. More professional class hours. Placement service. Prep courses. Approved for Vets. Enter Sept., Jan., March, June. Low Cost. Write *Dean McArthur, Dir. Adm.*, for catalog and book "Your Career in Engineering and Commerce."

at **TRI-STATE COLLEGE** 3678 College Ave.
Angola, Indiana

high on the other end. Yet, in a few months of operation, he worked 18 states in six call areas. His receiver was, and still is, a Hallcrafters S-38C, although he hopes to have an SX-99 soon. Jerry is now using a pair of converted ARC-5 "surplus" transmitters on 80 and 40 meters. He offers to sked anyone who wants a Georgia contact. . . . It sometimes seems hard to believe that hams in the "rare" states have trouble trying to work all states, but it's true. **Joe, W7DWE**, is still looking for seven more states to complete his WAS from Idaho. W7DWE transmits with a Heathkit DX-100 feeding an "all-band" trap doublet, and receives on an SX-99. He operates on all bands between 80 and 10 meters.

Walter Luhr reports that an ordinary broadcast receiver with a loop antenna makes a fair code-practice receiver. Wind about a 6' length of insulated wire into a coil approximately an inch in diameter and connect its ends across the receiver loop antenna terminals (not the ones marked "external antenna"). Pull the plug from the power socket before sticking your hands inside the receiver. . . .

Orv, KN8IUF, thinks his record is as good as KN9HOB's, mentioned in the April column. Orv's WRL Globe Chief-90 transmitter and National 183D receiver with a Q-Multiplier have helped him make 102 contacts in 22 states in 15 days on the air. He operates on 80, 40, and 15 meters and has 20 crystals. His "antenna farm" consists of separate dipoles for 80, 40, and 15 meters, plus a 3-element, 15-meter beam about 45' high. Oh, yes. Orv also has a 6-meter folded dipole, which he uses when he works a nearby Technician amateur "cross band." Rounding out his equipment are

FCC News

Confirming our news about call signs in the December 1957 issue, the Federal Communications Commission has now made an official announcement. Whenever the supply of amateur call signs beginning with a single K or W and a number are exhausted in a call area, new permanent class call signs in that area will start with the prefix WA. Novice call signs will begin with WV, with the V being changed to A when a permanent class license is obtained.

Effective May 10, 1958, the FCC withdrew the 1875-1900 and 1900-1925 kc. segments of the 160-meter band from amateur use to make room for a new Loran "radio navigation" station. However, amateurs may still operate in the 1800-1825 and 1975-2000 kc. segments of this shared band.

a Heathkit reflected power meter and an antenna tuner.

Doc, K4MIH, worked 40 states, the Panama Canal Zone (KZ5), four Puerto Ricans (WP4), and a couple of Canadians in eight months on the air as a Novice. In compiling this record, he made over 700 contacts—mostly on 40 meters, a few on 15 meters—using a Johnson Adventurer to feed a 40-meter doublet antenna. He receives with a Hallicrafters S-40B receiver with a Heathkit Q-Multiplier added.

If you need a Georgia contact—QSL card sure—contact K4MIH. . . . Tom, KN8GCV, learned the code from W8HYJ, who saw Tom's request for help in the "Help Wanted" column. In eight months on the air, he has demonstrated how well he learned it to Novices on 40 meters in 43 states. A Globe Chief-90 transmitter exciting a 66' "long wire" about 20' high and a SX-99 receiver helped the demonstration.

Contributors to *News and Views*: Eugene H. Carapetyan, K1BHM, Candlewood, Isle, Conn.; Bill Kent, KN9LUH, 304 Division St., Galesburg, Ill.; Jerry Barton, K4ØHK, 1230 Troupe St., Augusta, Ga.; Joseph F. Rytting, W7DWE, 229 West Main, Rexburg, Idaho; Walter Luehr, Box 36, Elmwood Place, Ohio; Orville Otis, KN8IUF, R.R. 3, Box 40, Coldwater, Mich.; Doc Shellhorse, K4MIH, 113 East Carter St., Cartersville, Ga.; Tom Koerber, KN8GCV, (15), 725 Charles St., Middletown, Ohio.

Let us hear how you are doing on the air, and send in that picture of yourself and your station. And, if you have any little trick that makes operating your ham station more enjoyable or more efficient, tell us about it. 73, Herb, W9EGQ



Compute—With Pots

(Continued from page 41)

input as an energy source and an audio VTVM for the read-out device. The audio VTVM must be used since output voltage becomes small for most calculations.

It is possible to multiply four numbers like $(27.2 \times 11.3 \times 7.57 \times 928)$ in one operation. A calculator utilizing this circuit has been built whose error was less than 2% total, or ½% per number entering the calculation. Dial scales are the same as those for the two-number multiplier.

Figure 4. With this four-number add-subtractor circuit, you can solve problems like $(1.2 + 4.6 - 7.2 + 9.6)$ in one setup. Balance control $R1$ is adjusted for equal positive and negative voltages from ground to potentiometer $R1$ end terminals. The "add-subtract" switches Sb , Sc , and Sd allow the polarity of the voltage to the respective pots to be changed so that the numbers represented may be made positive or negative. Currents through the 400,000-ohm resistors are proportional to the potentials at the potentiometer arms. The currents flow through the 1-meg. calibration pot where they are summed.

To calibrate: (1) balance the \pm balance control ($R1$) with pots A , B , C , and D set to 10, switch Sb set to (+), and Sc , Sd set to (-); with the output connected to the VTVM, $R1$ is adjusted for zero deflection of the VTVM on the lowest d.c. voltage scale; (2) switch Sc and Sd to the + position without changing any other control settings, and set the 1-meg. calibration control for a deflection of the VTVM of 4 volts. —30—

Here's the
EASIEST
way
to learn
code!

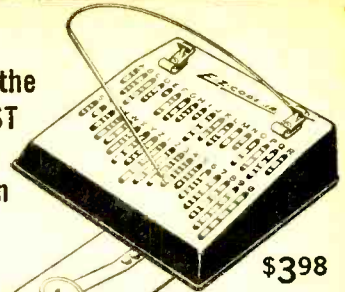

THE
AEROVOX

E-Z-CODE JR.

Learning the code is easier than ever now with the E-Z CODE JR. This clever new device enables anyone to "send" code 10 minutes after you open the box. Simply draw unique electric pencil down lettered printed-wiring slots and buzzer automatically sounds off dots and dashes. Hide-away telegraph key lets you practice and feel key sending just like the professionals do it. Operates on a single flashlight battery.

Write today for free code booklet and name of dealer in your neighborhood that sells the E-Z CODE JR.

AEROVOX

CORPORATION • DISTRIBUTOR DIVISION
740 BELLEVILLE AVENUE • NEW BEDFORD, MASS.

A BOX IS NOT A MUSICAL INSTRUMENT!

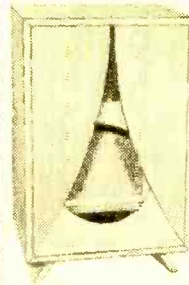

No skilled musical instrument maker, including even those in aboriginal tribes, has ever found a rectangular box satisfactory. IN SPITE OF THIS, today many Hi-Fi speaker systems proclaim the ultimate in high fidelity, yet they employ nothing more than the most elementary boxes to perform the most complicated function of transforming the vibrations of the loudspeaker into sound.

In the KARLSON PATENTED* ENCLOSURES, specially curved internal and external structures are used to provide you with the highest performance capabilities available in the industry today. Actually the Karlson Enclosure is one of the most fabulous musical instruments ever created and is capable of reproducing every sound from a baby's breath to the mighty roar of thunder. After long and rigorous tests, we know definitely that

the Karlson Enclosure can outperform all other units now available on the market at any price.

Despite their fantastic performance characteristics these units are available to you in 20 different models in KIT, UNFINISHED AND FINISHED FORMS, at prices you can afford, ranging from \$18.60 to \$174.00.

SEND FOR OUR COMPLETE CATALOG TODAY AND LEARN HOW THE KARLSON ENCLOSURE CAN BE FITTED TO YOUR SPECIFIC NEEDS. *PAT. #2,816,619.

KARLSON ASSOCIATES, INC.
433 Hempstead Avenue
West Hempstead, New York

Please send catalog.

Name
Address
City State



60

NEW PROJECTS FOR "DO-IT YOURSELVERS"

In the NEW EDITION of the

ELECTRONIC EXPERIMENTER'S HANDBOOK

IMPORTANT NEWS! The new 1958 Edition of the *Electronic Experimenter's Handbook* is now on sale. If you like to build useful, profitable electronic devices, pick up a copy of the new *Handbook* now.

60 Devices . . . Nearly 200 pages . . . a Practical "File" of Electronics Ideas and Information

FOR YOUR HI-FI. Presence control. Hi-fi crossover. Filter. Electrostatic speaker system. Mixer equalizer. Spare amplifier. \$5 coax. Oval-Flex speaker enclosure. Junior hi-fi. Hardware store crossover.

RECEIVERS. Shirt pocket transistor superhet. Superegen unit. Miniature VHF car. Junkbox BC receiver. Etched circuit two-tuber.

FOR YOUR HOME. Invisible light door opener. Picnic power amp. DC supply for AC/DC motors. Light-operated relay. Transistorized intercom. Radio intercom. Installing a back seat speaker.

FOR YOUR DARKROOM. Audio photometer. Transistor slave flash unit. Photographer's electric pencil. Light distributor. Dark-room timer. Enlarger exposure meter.

FOR YOUR HAM SHACK. Simple shortwave receiver. VHF explorer's receiver. 70-watt transmitter. Double your Heathkit AT-1 output. Code practice set. Antenna tuner. Transistor 10-meter receiver.

FOR YOUR WORKSHOP. Economy signal generator. Simple oscilloscope calibrator. Rejuvenator for dry cells. \$14 signal tracer. Transistor checker. Capacitance meter. Low-cost multimeter. Transistorized signal tracer. Buzzer-type power supply.

FOR THE KIDS. IQ tester. Electronic worm digger. Model spaceship. Game computer. Transistorized phonograph amplifier. Coin-operated oscillator.

SPECIAL PROJECTS. Solar battery experiments. Electronic anemometer. Varistrobe. Detectorscope. Simplified etched circuits. Car rattle locator. Simple burning tool.

NOW ON SALE

Only \$1

Pick up your copy today at your newsstand or radio parts store

ZIFF-DAVIS PUBLISHING CO.,

434 S. Wabash Ave., Chicago 5, Ill.



After Class

(Continued from page 87)

from reaching very large values during the contact-making period so that the arcing is not severe. It is still advisable to use an open knife switch in this position. The fuse wire (available at electrical supply houses) can be mounted between two alligator clips.

Our thanks to the teachers at the New Paltz meeting of the American Physical Society for setting up and demonstrating the above equipment. In particular, we should like to mention: F. Henderson, Oakwood School, Poughkeepsie, N. Y., for the Actinoscope; Chester F. Bass, Colonie Central School, N. Y., for the electronic electroscope; and Marvin J. Pryor, New Paltz Teachers College, N. Y., for the Lenz law demonstration.

-50-

Short-Wave Report

(Continued from page 90)

Ylivieska (836 kc., 10 kw.), and Lahti (254 kc., 100 kw.). Your best chance to log these Home Service stations would be during the first transmission at 2330-0110 (from 0045 on Sundays) or possibly during the second period at 0350-0710, although the latter may be quite difficult to log because of the approaching daylight hours. There is no English on the Home Service outlets.

Current Reports

The following is a resume of current reports. All times shown are EST and the 24-hour system is used.

Algeria—R. Algeria has moved up to 11,840 kc. and is being tuned with a musical program, followed by news in French, and closing at 1645. (420)

A new 50-kw. xmtr has been found on 9685 kc. at 1300-1800 in Arabic. (100)

Angola—CR6RH, Sierra da Bandeira, 5024 kc., was noted closing at 1602 with final ID in Portuguese. Weak level and a rough one to log. (166)

Australia—The current winter schedule from R. Australia reads: to Eastern N.A. at 0714-0845 on 11,810 kc.; to Western N.A. at 1014-1115 on 11,810 kc.; to British Isles and Europe at 0100-0230 on 11,710 kc. and 0100-0130 on 15,200 kc.; to Africa at 2329-0045 on 15,200 kc.; to N. E. Asia and North Pacific Islands at 0244-0700 on 11,810 kc., 0459-0900 on 15,200 kc., and 1559-1930 on 15,240 kc.; to Mid-Pacific Islands at 0330-0445 on 11,760 kc. and 1500-1700 on 17,840 kc.; to New Zealand and South Pacific Islands at 0100-0130 on 15,200 kc., 0100-0415 on 11,710 kc., and 1500-1700 on 15,315 kc.; and to South, S. E. and S. W. Asia at 1714-1815 on 11,840 kc., 1714-1729 on 15,210 kc., 1714-1729, 1830-1930, 2329-0130, and 0230-

0500 on 15,160 kc., 1714-1729 and 1830-0045 on 17,840 kc., 1829-0130 and 0230-0445 on 21,540 kc., 0429-0500 and 0815-1230 on 7220 kc., 0459-1230 on 9580 kc., 0829-1230 on 11,710 kc., and 0859-1000 on 11,810 kc. (61, 363, 378)

Burma—Rangoon, 11,764 and 7117.5 kc., is noted in the East Coast xmsn at 0915-1015 with news in English at 1000. Another outlet is reportedly operating in dual on 9615 kc. but this has not been tuned as yet. (166, 400)

Cameroons—R. Douala, 9270 kc., is noted at times from 1530 to 1728 s/off with pop music and jazz. Apparently this channel has been reactivated. QRM from WSY, CAA station at Barneget, N. J. (MM)

Cancry Islands (?)—A station with ID of *Radio Atlantico* has been noted with salon music from 2130 to 2200 s/off, on 9370 kc. It signed off with the same theme as R. Spain on 9360 kc. but programs differed. (304)

Costa Rica—TIQ, R. Casino, Puerto Limon, is again active on 5960 kc. and can be noted to 0005 s/off. Frequency may vary. (281, 420)

Cuba—*Reloj de Cuba*, 11,750 kc., is noted at various times throughout day and night with ID and time check every minute. (378)

Finland—The 1700-1800 and 2200-0000 xmsns from R. Finland on 15,190 and 17,798 kc. are now in effect with Eng. news at 1700-1707 and 2200-2207. (100)

Formosa—BED7, Taipei, has moved from 7130 kc. to 7226 kc. and is heard well at 0700 in an English period. (166)

French Equatorial Africa—Radio AEF, Brazzaville, is on 15,440 kc. and not on 15,400 kc.

Satellite Tracking

Although this column normally carries no listings for amateur stations, the following information received from John Sanders, Danbury, Conn., may be of interest to you. A new prefix, XQ, has been assigned to U. S. satellite-tracking stations in Chile. Reports should be addressed to: Amateur Radio Station XQ—, U. S. Vanguard Tracking Station, % U. S. Consulate, Antofagasta, Chile.

This channel is heard well at 0015-0030 with Eng. news, dual to 9730 and 5970 kc. (GS, 100)

The 11,970-kc. outlet has been noted of late giving location as "French Central Africa." The broadcast for the Far East and Pacific Coast areas at 2145-2200 is easily tuned in the Eastern states as well. (MR, 385)

Guatemala—Two of the 49-meter stations currently being noted are TGQA, 6118 kc., around 2155 with marimba music, and TGAZ, 6150 kc., around 2330 with L.A. music. Both are in Guatemala City. (420)

Honduras—A new outlet in this country is HRCM, R. Tegucigalpa, 6030 kc., heard from 1900 to 0100 s/off, ID every half-hour. (281)

Iceland—TFJ, R. Iceland, Reykjavik, 12,175 kc., transmits a daily xmsn in the Icelandic language to Denmark and Europe at 1600-1700 but is seldom heard after 1630. An Icelandic xmsn on Sundays only at 0815-0915, to Europe, has not yet been tuned. No English. (61)

India—The current schedule from *All-India*

Name your own

7 WONDERS OF THE WORLD

and visit them all FREE VIA TWA

TRANS WORLD AIRLINES
U.S.A. · EUROPE · AFRICA · ASIA

Just list any 7 places, people, or events in the world that you would most like to visit and photograph, and you can win this fabulous contest!

TWA-TRANS WORLD AIRLINES will fly you to the 7 world wonders of your choice in luxurious comfort aboard a JETSTREAM* airliner!

AMERICAN EXPRESS will make all arrangements for first class accommodations through its worldwide Travel Service! Your expenses will be covered by safe, convenient, AMERICAN EXPRESS Travelers Cheques, spendable everywhere!



POPULAR PHOTOGRAPHY magazine reveals how you can get aboard this exotic magic carpet . . . with full details of the most unique contest ever—in the current issue.

Read complete details in POPULAR PHOTOGRAPHY : : : on sale now

*Jetstream is a service mark owned exclusively by TWA.

SHORT-WAVE ABBREVIATIONS

anmt—Announcement
BBC—British Broadcasting Corp.
Eng.—English
ID—Identity, identification
kc.—Kilocycles
kw.—Kilowatts
L.A.—Latin America(n)
N.A.—North America(n)
QRM—Station interference
R.—Radio station
s/off—Sign-off
s/on—Sign-on
xmsn—Transmission from station
xmtr—Transmitter used by station

Radio is: 0500-0600 on 15,105, 17,705, 17,760 and 21,690 kc. to Australia and N. Z. (English); 0615-0730 on 17,705 and 21,570 kc. to Burma and Indonesia; 0700-0815 on 15,125 and 17,760 kc. to China; 0830-0930 on 17,760 and 21,650 kc. to S. E. Asia (Eng.); 1000-1030 and 1045-1130 on 15,105 and 17,830 kc. to Africa; 1115-1215 on 15,170 and 17,835 kc. to Mid-East; 1130-1215 on 17,830 kc. and 1130-1300 on 21,585 kc. to Africa; 1230-1330 on 15,105 and 17,720 kc. to Near East (Arabic); 1345-1430 on 15,105 and 17,835 kc. to W. Asia (French); 1400-1430 on 15,170 and 17,820 kc. to Portugal (Portuguese); 1445-1545 on 11,710, 15,105, 15,170, and 17,725 kc. to Europe and W. Africa (Eng.); 1745-1800 on 11,895 and 15,105 kc. to Indonesia; 1815-1915 on 11,945 and 15,370 kc. and 1915-2015 on 15,105 and 17,820 kc. to S. E. Asia; 1830-1845 on 15,105 and 17,720 kc. to S. E. Asia (French); 1930-1950 on 15,160

SHORT-WAVE CONTRIBUTORS

John Carnaghie (JC), St. Petersburg, Fla.
George Fenerty (GF), Halifax, N. S.
William Kahn (WK), Houghton, Mich.
Mark Murphy (MM), McDonald, Pa.
Jack Rouse (JR), Wallingford, Conn.
Mike Reagan (MR), Cincinnati, Ohio
Gary Slattery (GS), Florida, N. Y.
Roger Vlaminck (RV), Gent, Belgium
Gary Williamson (GW), Seattle, Wash.
Stanley Zagaski (SZ), Norwich, Conn.
William Flynn (7), Pittsburg, Calif.
Chuck Maxant (11), Baldwin, N. Y.
Peter Kisse (23), Atlanta, Ga.
J. Ross Brownell (39), Vancouver, B. C.
Anson Boice (44), New Britain, Conn.
Grady Ferguson (59), Charlotte, N. C.
John Beaver (61), Canon City, Colo.
Roger Legge (100), McLean, Va.
Ed Kowalski (104), Philadelphia, Pa.
Bob Schwartz (156), Brooklyn, N. Y.
George Cox (166), New Castle, Del.
Stewart MacKenzie, Jr. (225), Long Beach, Calif.
William Bing, (226), New Orleans, La.
Don Davenport (279), Monroe, Wis.
Ronald Kenyon (281), Ashland, Ky.
Robert Kapsch (282), Roselle Park, N. J.
Maurice Ashby (286), Wichita, Kansas
Hank Reixach (303), Washington, D. C.
Stan Sosnowski (304), Detroit, Mich.
Ronnie Ballard (332), Bakersfield, Calif.
Larry Kramer (353), Brighton, Colo.
John Cobb, Jr. (358), Cartersville, Ga.
William McEachern (363), Fort William, Ont.
William Davis (369), Chicago, Ill.
Lee Easley, Jr. (370), Indianapolis, Ind.
J. P. Arendt (378), Aurora, Ill.
Patricio McGrath (379), Half-Way-Tree, Jamaica
Max Ovodock, Jr. (385), Philadelphia, Pa.
Paul Damai (388), Calumet City, Ill.
Bob Palmer (396), Spokane, Wash.
August Balbi (400), Los Angeles, Calif.
A. R. Niblack (420), Vincennes, Ind.

and 17,885 kc. to Burma (Eng., 1930-1940); 2230-2300 on 15,105 and 17,795 kc. to Africa; 2245-2300 on 17,830 and 21,700 kc. to Mid-East; 2315-2330 on 17,795 and 21,650 kc. to Africa; 2330-0030 on 15,105 and 17,795 kc. to Africa (Eng., 2330-2340); and 0000-0030 on 15,160 and 17,830 kc. to Mid-East. (JR, 100, 303, 420)

Iran—Teheran has been testing a new 100-kw. xmtr on 11,730 kc. at 1500 with an English period. Signals have been only fair. (166)

Mexico—The new XECMT, Ciudad El Mante, 6090 kc., is very good to 2100 s/off with frequent ID. Does anyone have address? (281)

Netherlands New Guinea—R. Sorong, 3395 kc., is noted at 0430-0508 with light music and Dutch announcements. Very careful tuning is needed for this one. (61)

New Zealand—The current winter schedule from Wellington is as follows: to the Pacific Islands at 1200-1530 on 11,780 kc., 1545-0140 on 15,280 kc., and 0155 to close on 6080 kc.; to Australia at 1500-0140 on 15,280 kc. and 0155-close on 9540 kc. Closing times are 0545 weekdays, 0620 Saturdays, 0500 Sundays. Calls: 11,780 kc.—ZL3; 15,280 kc.—ZL4; 9540 kc.—ZL2; and 6080 kc.—ZL7. (SZ, 61)

Nicaragua—YNWA, R. Mundial, 6141 kc., is heard with music at 2000. Hard to pick out but they ID clearly. YNLU, R. Managua, 5975 kc. (moved from 6040 kc.), is noted at 2300-0000 with music at good strength. Location for both is Managua. (281)

Peru—R. La Cronica, OAX4J, Lima, has moved higher and is now on 9495 kc. Noted at 2130 and 0145-0200 in Spanish. They may operate all night. (396, 420)

OAX8K, R. Atlantida, Iquitos, is a new station on 9623 kc., tuned from 2030 (when Brazzaville goes off) to 0000 s/off. (100)

OAX4V, R. America, Lima, 5995 kc., seems to have a clear channel with ID at 1945. HRP1, Honduras, currently not being heard. (7)

Portugal—R. Lisbon has been found on a new channel of 15,080 kc. at 1600-2100 to the Central Atlantic, N. W. Africa, and Brazil with much good music and Portuguese anmts. It is dual to 17,895 and 11,964 kc. (61)

The Lisbon-to-Holzkirchen relay stations of Radio Free Europe were noted on 22,970 and 23,070 kc. around 1015 with poor signals. (23)

Sarawak—R. Sarawak, Kuching, has opened a new outlet on 9565 kc. and is heard at 0600-0830 with Eng. at 0600-0630 and 0800-0830. (100, 166)

The 5052-kc. outlet continues to be well heard in the western areas at 0330-0400 with native music and talks in Malayan, and at 0400-0430 with light opera music. (61)

Sierra Leone—Another rare country to hear is this one! Try 3366 kc. for programs from Freetown at 0200-0300 with news, weather, talks, music, and ID on the hour and half-hour. This is an English xmsn. (61)

Spanish Guinea—Bata has moved up to 7846 kc. and has been heard as late as 1708 with operatic music. The ID at 1710 was "Ariba Espana," followed by an anthem. (166)

R. Calatrava, 6682 kc., is audible at times at 1430-1600 with some Eng. at 1430-1445; prior to close at 1600 they present the "Ave Maria Hour." (RV, 11, 166)

Switzerland—The schedule in effect until

TUBES TESTED GUARANTEED

New, Surplus & Used Our 12th Year in Business

0A2	.80	9LP7	1.00	6BQ6	2.00	7Q7	.79
0B2	.72	45	4/51	6RQ7	.99	12AT6	.59
0B3	.82	71Q3	2/51	6C4	2.81	12AT7	.79
0C3	.84	434A	1.98	6B6	2.81	12AU7	.69
0D3	.80	1N34A	2/51	6C86	.69	12AV6	.59
0Z4	.50	58P4	.52	6C06	1.49	12A6	.59
1AX2	.98	58P4	.52	6E4	2.51	12AX4	.79
1B3	.78	5V4	.89	6J6	2.51	12AX7	.79
1L4	.82	5Y3	.59	6K6	2/51	12BH7	.89
1R4	.88	6AB4	.59	6K7	.79	12BY7	.89
1R5	.78	6AC7	.79	6L6	1.19	12SA7	.69
1S4	.78	6AG7	.97	6S4	.59	12SK7	.69
1S5	.69	6AH4	.89	6SA7	.79	12SN7	.69
1T4	.69	6AH6	.95	6SH7	.69	12SQ7	.69
1U5	.59	6AK5	.69	6SJ7	.69	12T7	.69
1X2	.66	6AL5	.59	6SK7	.69	198G6	1.69
155	.69	6AQ5	.66	6SL7	.69	25BQ6	1.29
388A	2/51	6AS7	.75	6SW7	2/51	25Z6	.79
2V3	2/51	6AT6	.49	6SQ7	.59	35C5	.59
3A5	.69	6AU4	.89	6T4	1.19	35L6	.59
954	10/51	6AU6	.59	6TR	.89	35W4	.59
955	4/51	6AX4	.79	6U8	.89	35Z5	.55
957	3/51	6BA6	.59	6V6	.59	50A5	.69
1619	4/51	6BC5	.59	6W6	.79	50R5	.79
1625	4/51	6BA6	.59	6X4	.39	50C5	.69
1626	5/51	6BF5	.79	7A8	.79	50A6	.69
1629	4/51	6BG6	1.49	7C7	.79	75	1.00
807	1/51	6B7	.89	7F7	.79	75	5/51
808	.89	6BL7	.99	7FB	.79	75	5/51
5BP1	3.98	6BN6	.89	7N7	.79	10Y	3/51

Registered Guaranteed Replacement Needles—All Cartridges Single Diamond \$7; Dual Dia \$14; Dia-Sapphire \$8 @ Send Cartridge Name & Number • Postpaid 48 States

"TAB" FINEST HI-FI RECORDING TAPE
 7" Reel—1200 Ft. Per Reel Lots
 Sold on Money Back Guarantee \$1.45 @ 6
 Highest quality Hi-Fi Precision Coated & Silt.
 "ERIN" MFR & PROCESS. quality controlled, constant output
 Noise FREE, Splice FREE Plastic Tape. Free. 1/2 IPS. 40-15KC
 Oxide-Wnd-III. "TAB" @ \$1.50 ea. New 1st quality "MYLAR" 2400 Ft. 7" Reel.
 "ERIN" GLOSS & PROGRESS RECORDING TAPE \$4.49 @ 3/512

"IBM" COMPUTER MEMORY CORES. NEW!
 Miniature Plugs—into 9-pin socket. Mfr. cost \$9. Special 2/51

NEW! INTERNATIONAL RECTIFIER CORP.
FULL WAVE BRIDGE RECTIFIER
 120VAC factory rated 350MA 100VDC. Gtd. output up to One-Half AMP. 20 Plates 4-5-1; Newly mfrd. for Gov. Cost \$8.10.
 "TAB" SPECIAL \$1.25 @; 5 for \$5 • Postpaid 48 States

TPSK2—KIT FOR DC POWER FOR TRANSISTORS!!
 See Article This Month's P.E.
 Transistor! Filtered Power Supply Kit used to power transistor circuits, amplifiers, etc. Delivers 12VDC at 2AMPS filtered less than 0.5% ripple or 28VDC at 1A TPSK2 Kit \$18. TPS2K assembled & wired \$24.

115VAC Inpt Transformer & Full Wave Bridge Rectified or 12VDC @ 2AMPS. RECTRAN KIT RTK1. \$4.50
 RT2K Kit 12 or 18VDC up to 6 AMPS. \$9.00

NEW GTD RADIO & T.V. RECTIFIERS
 35MA 40c @ 6 for \$2; 65MA 45c @ 5 for \$2; 75MA 49c @ 5 for \$2; 100MA 59c @ 4 for \$3; 150MA 70c @ 4 for \$5; 250MA 79c @ 6 for \$4; 300MA 88c @ 5 for \$4; 350MA \$1.00 @ 8 for \$7; 400MA \$1.10 @ 5 for \$5; 500MA \$1.35 @ 4 for \$5; 650MA 260V 5/110 5 for \$5; PACARTE, CONTAIN BRIDGE RECTIFIER & 18 to 24V 6 AMP TRANS. 115 VAC INPUT, 9/10; 100MA 156V 95c @ 300MA 156V \$1.75 3/45.
 NEW SILICON 500MA 100V C 140V Rectifier Hmt Sealed with clip \$1.55; less clip 4 for \$5; 25 for \$27.
 Order \$10, Postpaid 48 States!

BATTERY CHARGER KIT 2 to 4 Amps. CHARGES 2-4-6 & 12 VOLT BATTERIES. Kit BCK-1 SPECIAL. \$9.95

NEW "TABTRON" SELENIUM RECTIFIERS
 FULL WAVE BRIDGE
 Dated—One Year Guarantee
 18VAC 14VDC—1 Amp \$1.40; 2A \$2.00; 3A \$2.90;
 4A \$3.50; 6A \$3.95; 10A \$5.85; 12A \$7.20; 4 for \$5;
 36VAC 28VDC—1 Amp \$2.80; 2A \$3.40; 3A \$4.10;
 4A \$6.40; 6A \$7.70; 10A \$11.35; 12A \$14.25.
 18 VOLT @ 8 AMP DC PARTS, PACKAGED, CONTAIN BRIDGE RECTIFIER & 18 to 24V 6 AMP TRANS. 115 VAC INPUT, \$20 Value. Delivers 14 to 20 VDC. Ideal R.R. SPECIAL \$11

KITS! Each "TAB" Kit Contains The Finest Selection

Kit 35 Precision Resistors	Kit 40 Insulators
Kit 10 Switches	Kit 35 Power Resistors
Kit 75 Resistors 1/2/1/2W	Kit 75 Mica Condensers
Kit 150 Carbon Resistors	Kit 5 Crystal Diodes
Kit 45 Panel Lamps	Kit 250 Ft. Hook Up Wire, Asst'd
Kit 12 Electrolytic Cond's	Kit 100 Fuses, asst'd all types
Kit 15 Volume Controls	Kit 100 Ceramic Condensers
Kit 36 Tube Sockets	Kit 150 Coil Forms
Kit 65 Tubular Condensers	Kit 5 Crystals & Holders
Kit 500 Lugs & Eyelets	Kit 65 Inductors & Coils
Kit 10 Bathtub Oil Cond's	Kit 5 Microswitches
Kit 5 lbs. Surprise Package	Kit 10 Wheat Lamps
Kit 10 Transmit Mica Cond's	Kit 3 Transistor Xfms

Order Ten Kits **ONE EACH ABOVE**
 We Ship Eleven!!! **KIT ONLY 99c**

"TAB" TERMS: Money Back Gtd. \$2 min. order F.O.B. N.Y.C. Add shipping charges or for C.O.D. 25% Dep. Prices shown are subject to change.
 111K Liberty St., N.Y. 6, N.Y. Rector 2-6245

Oct. 31 reads as follows (new frequencies are in *Italics*): 0215-0430 on 11,865, 15,305, 21,520 kc. to Australia, N. Z. and Far East; 0745-0930 on 15,305, 17,784, and 21,520 kc. to S. E. Asia and Japan; 0945-1130 on 11,865 and 21,605 kc. to India and Pakistan; 1145-1330 on 17,784 and 21,605 kc. to Middle East; 1345-1530 on 7210 and 9665 kc. to United Kingdom and Ireland; 1545-1730 on 9665 and 11,865 kc. to Spain and Portugal; 1800-1945 on 9535, 11,865, and 15,315 kc. (HEU6) to L.A.; 2030-2215 on 6165, 9535, and 11,865 kc. to Eastern N.A.; 2230-2300 on 9535 and 11,865 kc. to L.A.; 2315-0000 on 9535, 11,865, and 15,305 kc. to Western N.A.; 0015-0200, 0500-0730, and 1445-1740 on 21,520 kc. to Africa; and 0015-0200, 0500-0800, 1000-1740 (Sundays, 0115-1740) on 6165 and 9535 kc. to Europe. Use of 9655, 17,720, and 25,640 kc. was dropped. (GF, GW, 39, 100, 156, 282)

Tunisia—Radio Tunis is reportedly constructing a new 50-kw. Telefunken xmtr that will

Converter Booklet
 Radio Nederland has a booklet describing converters for use in the 11-, 13-, and 16-meter short-wave bands. For your free copy, write to *Radio Nederland*, International Service, P. O. Box 137, Hilversum, Netherlands. (JC)

be in use by the end of the year. Frequencies are not known. (11)

Union of South Africa—The S. African B/C Corp., Johannesburg, 25,800 kc., can be heard at 1200-1300 with news ending at 1210, followed by musical programs. (353, 370)

Another outlet on 9680 kc. is noted with the commercial service with Eng. news at 2330 followed by request records, commercials. (WK)

Uruguay—You have a very good chance to hear this country on Mondays only at 2000-2100 over CXA60, R. Sarandi, Montevideo, 15,385 kc. They feature L.A. music and talks on the country. The signals are usually good during this Eng. period. (286, 332)

USSR—R. Tashkent, 11,690 kc., is still widely reported at 0730-0800 in Eng. to L.A. and at 1800-1830 with a relay of the morning program. Other xmsns noted are at 1000-1015 in language and 1130-1200 in Eng., the latter to India and Pakistan. (7, 59, 379, 396)

Vatican City—The Vatican radio broadcasts to L. A. in Portuguese at 1800-1815 on 11,685 and 17,840 kc. and in Spanish at 1830-1845 on 17,738 and 21,740 kc., 1900-1915 on 11,685 and 15,120 kc., and 1930-1945 on 9645 and 11,685 kc. They have no programs beamed to the U.S.A. at present. (MM, 100, 279, 400)

Windward Islands—The Windward Islands B/C System, Grenada, seems to be using 17,910 kc. for the entire Home Service xmsn at 1600-2115. This channel was used for an experiment for several weeks. Caribbean area news at 1700, BBC news at 1800 and 2100. (RV, 7, 23, 44, 59, 104, 225, 226, 304, 369, 379, 388, 400)

Clandestine—Radio Free and Fighting Algeria, 6630 kc., has been heard at 1700 in Arabic; also noted on 6980 and 6780 kc. (166)
 A Cuban clandestine station was found one evening on 14,240 kc. with excited speech from 2240 s/on to 2310 s/off. (358)

**POPULAR
ELECTRONICS**

BARGAIN BASEMENT
SAVE ON THESE SPECIAL BUYS OF-THE MONTH

GOVERNMENT SURPLUS KITS

Electronic and Electro-Mechanical Parts

Tremendous assortment of Army-Navy surplus, either stripped from equipment or still packaged in brand new condition. EXPECT TO BE DELIGHTED! Selectronics includes items usually unheard of in bargain kits. While all kits are different, they include such items as:

- | | | |
|--------------|-----------|----------|
| Resistors | Tubes | Timers |
| Condensers | Sockets | Counters |
| Transformers | Bulbs | Relays |
| Chokes | Switches | Meters |
| Rectifiers | Solenoids | Selsyns |

... Plus many, many other kinds of electronic parts & equipment.

KIT "A"

35-40 lbs. \$4.95

KIT "B"

100 lbs. \$9.95

FOB Philadelphia, Pa. Purchase price refunded if not completely satisfied.

SELECTRONICS 1206-18 South Napa Philadelphia 46, Pa.

METAL LOCATOR ENTHUSIASTS

This is for you... BC-1141-C amplifier, the electronic heart of the famous SCR-625 mine detector. This unit is brand new with 2-1N5 and 1-1Q6 vacuum tubes. In steel carrying case with handle; net weight with batteries is only 10 pounds. It operates from internal batteries (not included) and is complete with schematic diagram of the whole SCR-625 detector set. Case measures 14" by 6" by 5" including hinged cover. Operating panel hinges out for easy access to interior shock mounted chassis. This is a 1000 cycle fixed frequency amplifier, brand spanking new, and a once-in-a-lifetime bargain at \$5.95. Set of 3 spare vacuum tubes \$1.00. Shipping weight 12 pounds.

Write for free government surplus bargain bulletin
JOE PALMER, P. O. Box 6188 CCC, Sacramento, California

TRANSISTOR EXPERIMENTER'S LABORATORY KIT I I I I

PACKED IN A HANDSOME TRANSISTOR RADIO CABINET—THIS KIT CONSISTS OF THE FOLLOWING TRANSISTOR COMPONENTS:

- | | |
|---|--|
| CATALOG | 1—FERRITE ANTENNA LEOPSTICK |
| 3—P-N-P TRANSISTORS | 5—SUBMINIATURE ELECTROLYTIC CONDENSERS |
| 3—N-P-N TRANSISTORS | 5—POPULAR SIZE VOLUME CONTROLS |
| 18—TRANSISTOR DIODE CLIPS | 1—INPUT TRANSFORMER—PRI.: 20,000 SEC.; 1,000 |
| 1—2-INCH PH SPEAKERS | 1—DRIVER TRANSFORMER—PRI.: 10,000 SEC.; 2,000 C.T. |
| 1—MATCHING OUTPUT TRANSFORMER FOR SPEAKER | 50—ASSORTED 1/2-1 WATT RESISTORS |
| 1—MINIATURE 365 MMF VARIABLE CONDENSER | |
| 2—TRANSISTOR I.F. TRANSFORMERS | |
| 1—TRANSISTOR OSCILLATOR COIL | |

GROVE ELECTRONIC SUPPLY COMPANY
4103 W. BELMONT AVE. CHICAGO 41, ILLINOIS
INCL. POSTAGE W/ORDER OR 50% DEPOSIT—
SEND FOR LATEST ARGONNE CATALOG

RADIO CONTROL Headquarters

- For Models F R E E Send for FCC Form 505 & Catalog
R/C RECEIVER 27 1/4 Mc. Compl. w. Relay Tube, Access., 8.61
Wired 11.95
R/C XMITTER Hi-Power HAND-HELD, compl., \$17.95; Kit 11.95
R/C TRANSMITTER & RECEIVER KIT: 27 1/4 mc. 5 watt 2-Tube Simple Transm. & 2-Tube Rec. incl. Drilled Base, 9.95
Wound Co. I. Res., Cond., SIGMA Relay, Instruc. 2.95
HANDIE-TALKIE Transmitter & Receiver Chassis, New, Wired, with tube—2 Triodes 6.65
SIGMA 4F RELAY: 8,000 ohm. \$4.25... 6 Reed Relay 14.95
2-6V Battery Charger Kit, \$4.95... Wired 6.95
R/C BOOKS: Model Control \$1; Radio Control \$1; Handbook 2.95
CRYSTALS: 27,255 Mc. \$2.85... HOLDER .15
2" METERS 0-1 Ma. \$3.65... 500 MicroA \$3.95; 3 Ma. 2.95
RELAY CONTROL UNIT Incl. Sensitive 10,000 ohm Sigma Relay (1 1/2 Ma) Thermal Bi-metal Strip, Heating Element, Hi Z Audio Choke, Mini Alnico V Magnet, Neon Lamp, Resistors, Capacitors, only 99c
TUBES: XFG1, RK61, 3A4, 3A5, 1A4, 6X4, Transistor
RELAYS: 10K ohm, 2 Ma DC or 110V AC SPDT, 95c; SPST 325-P CANAL ST. 85c
GYRO ELECTRONICS NEW YORK 13, N. Y.

ADVERTISER'S INDEX

ADVERTISER	PAGE NO.	ADVERTISER	PAGE NO.
Aerovox Corporation	123	Milwaukee School of Engineering	113
Allied Radio Corp.	15	Modernophone, Inc.	119
Bailey Technical Schools	28	Moss Electronic Distributing Co., Inc.	132, 3rd & 4th Covers
Barjay Co., The	118	National	18
Berkeley Enterprises, Inc.	110	National Radio Institute	99, 100, 105
Best Values Company	118	National Schools	25
Blonder-Tongue Labs., Inc.	20	North American Philips Co., Inc.	14
Bohnsack Equipment Company	114	Northrop Aeronautical Institute	111
Capitol Radio Engineering Institute	23	Olson Radio Warehouse	127
Carrier Co., C.	118	Pacific International University	116
Central Technical Institute	16	Pacific States University	114
Century Electronics Co., Inc.	3	Palmer, Joe	129
Cleveland Institute of Radio Electronics	91	Phila. Wireless Technical Institute	108
Coyne Electrical School	5, 109, 115	Photography Directory	131
DeVry Technical Institute	11	Picture Tube Outlet	11
Dynaco Inc.	22	Popular Electronics Classified	114
Ebe Inc.	106	Popular Photography Contest	125
Edmund Scientific Co.	121	Port Arthur College	106
EICO	30	Precision Radiation Instruments, Inc.	122
Electronic Experimenter's Handbook	124	Prentice-Hall, Inc.	26
Electronic Organ Arts, Inc.	108	Progressive "Edu.Kits" Inc.	Second Cover
Electro-Voice, Inc.	7	Quality Electronics	112
Eric Resistor Corporation	24	RCA Institutes, Inc.	21
Garfield Co., Inc., Oliver	9	Ra-Tech Labs	102
Gonset	119	Radio-Engineering Institute	8
Gotham	118	Radio-Television Training School	29
Grantham Schools	107	Rider Publishing, Inc., John F.	117
Greenlee Tool Co.	115	Selectronics	129
Grommes-Phillips	121	Sleep-Learning Research Ass'n.	122
Grove Electronic Supply Company	129	Sprayberry Academy of Radio-Television	19
Gyro Electronics	129	Springfield Enterprises	12
Heath Company	92, 93, 94, 95, 96, 97	"TAB"	128
Indiana Technical College	118	Texas Crystals	6
Instructograph Company	106	Tri-State College	122
International Correspondence Schools	13	U. S. Air Force	17
International Crystal Mfg. Co., Inc.	102	University Loudspeakers, Inc.	110
Johnson & Co.	112	Valparaiso Technical Institute	108
Karlson Associates, Inc.	123	Valdrie Elec. Mfg. Corp.	106
Lafayette Radio	27	Video Electric Company	103
Lektron	101	Western Radio	108, 112, 116
McNeal Electric & Equipment Co.	122	Whitehall Pharmaceutical Co.	122
Midway Company	118	World Radio Laboratories	10
Midway Welder	114		
Miller, Gustave	116		

Classified

RATE: 50c per word. Minimum 10 words prepaid. September issue closes July 3rd. Send order and remittance to: POPULAR ELECTRONICS, 1 Park Ave., New York 16, N. Y.

FOR SALE

TUBES-TV, Radio, Transmitting And Industrial Types At Sensibly Low Prices. New, Guaranteed 1st Quality Top Name Brands Only. Write For Free Catalog or Call Walker 5-7000. Barry Electronics Corp., 512 Broadway, New York 12N, N. Y.

NEW! Pocket radio transmitter uses transistor. Plans 25¢. Free literature on all our products available at factory prices. Springfield Enterprises, Box 54-E7, Springfield Gardens 13, N. Y.

WALKIE-TALKIE chassis \$6.98. See our display ad in this issue. Springfield Enterprises.

WALKIE-TALKIE. Build wireless portable radiophone for less than \$10.00. Plans for variable frequency and crystal control types, only 50¢ for both, including assembly photographs. Springfield Enterprises, Box 54-E7, Springfield Gardens 13, N. Y.

CITIZEN'S band radio plans for building your own receiver and information on transmitter design, FCC requirements, etc. plus special discount on type approved transceivers. All for \$1.00. Springfield Enterprises, Box 54-E7, Springfield Gardens 13, N. Y.

DIAGRAMS for repairing radios \$1.00. Television \$2.00. Give make, model. Diagram Service, Box 672-PE, Hartford 1, Conn.

GOVERNMENT Surplus Receivers, Transmitters, Sniperscopes, Parabolic Reflectors, Picture Catalog 10¢. Meshna, Malden 48, Mass.

GOVERNMENT Sells—Surplus Electronics; Walkie-Talkies; Test Equipment; Oscilloscopes; Radar; Sonar; Surplus Aircrafts; Boats; Jeeps; Misc.—You buy direct now from U. S. Government Depots at fractions of Army & Navy costs—Send for bulletin "Depot List & Procedure" \$1.00. Box 8-PE, Sunnyside 4, N. Y.

TELEVISION Sets \$11.95 Plus Shipping. Jones, 147 High Street, Pottstown, Pa.

MAKE, repair, Fluorescent Fixtures. Kits, parts, fixtures catalog—10¢. Shoplite, 650E Franklin, Nutley 10, New Jersey.

DIAGRAMS! Repair Information! Radios—amplifiers—recorders \$1.00. Televisions \$1.50. Give make, model, chassis. TV Miltie, Box 101RA, Hicksville, New York.

TELEVISION & Radio Tubes. Parts and Supplies at low prices. One Year Guarantee. Write Hi-Quality Tube Co., Inc., 284 Lafayette St., Rahway, New Jersey for Free price list. Distributorship openings.

CODE-PRACTICE oscillator. Operates up to one year on 2 flashlight batteries. Audio feedback principle. Shipped postpaid—\$7.95. Edward M. Golde Enterprises, P.O. Box 548, Oakland 4, Calif.

"15 TESTED One-Tube Circuits" with catalog—25¢. Laboratories, 1131-L Valota, Redwood City, California.

RADIO, Television, Recorder repair diagrams \$1.00. Give make and model. Air service. Mac's Service, 11557 Evanston, Seattle, Wash.

1" MINIATURE Meters; Stock ranges Available, Details; Alco Electronics, Lawrence, Mass.

WORLD'S Largest Electronic Parts Catalog. Over 150,000 standard items sold through parts distributors at your fingertips. Complete product descriptions, specifications, prices: 11,500 illustrations. 1584 pages. Used by hams, hobbyists, experimenters everywhere. Only \$3.50 from local radio-TV parts distributors, or send check/money order direct. Radio-Electronic Master, 58 Madison Avenue, Hempstead, N. Y. Free Panel Flashlight Lamp Chart with Direct Order.

INVENTIONS WANTED

INVENTIONS wanted. Patented; unpatented. Global Marketing Service, 2420—77th, Oakland 5, Calif.

INVENTIONS FOR SALE

TAPE position indicator attachment for tape recorders. You may name the price. Buford Hall, Stuttgart, Arkansas.

BUSINESS OPPORTUNITIES

BUY Wholesale! 25,000 Nationally Advertised Products. Get Amazing Dealer Catalogs. Complete Details Free. American Wholesalers, 1841-DA Levee, Dallas 7, Texas.

MAKE \$25-\$50 Week, clipping newspaper items for publishers. Some worth \$5.00 each. Particulars free. National, 81-PE, Knickerbocker Station, New York City.

START a fast growing, money making business. Operate a self-service tube tester route spare or full time. No selling. Stores make money for you every open hour. Send for Free booklet describing this proven business. Century Electronics, 111-R Roosevelt Avenue, Mineola, N. Y.

EMPLOYMENT INFORMATION

HIGH Paying Jobs, Opportunities, foreign, U.S.A. All trades. Companies pay fare. For information write Dept. 57N, National Employment Information, 1020 Broad, Newark, New Jersey.

TAPE & TAPE RECORDERS

TAPE Recorders, hi-fi components, tapes. Unusual Values. Free Catalog. Dressner, 69-02F, 174 St., Flushing 65, N. Y.

RECORDERS, Hi-Fi, Tapes. Free wholesale catalogue. Carston, 215-P, East 88 St., N.Y.C. 28.

HIGHEST Trade-In Allowances Toward Ampex, Concertone, Crown, Ferrograph, Presto, Pentron, Components. Accessories. Catalog, Boynton Studio, 10-PE Pennsylvania, Tuckahoe, N. Y.

DISCOUNTS to 50%, recorders, tapes, hi-fi components, consoles, photograph equipment. Request specific prices only. Long Island Audio & Camera Exchange, 3 Bay 26th Street, Brooklyn 14-L, N. Y.

HIGH FIDELITY

DISGUSTED with "Hi" Hi-Fi Prices? Unusual Discounts on your High Fidelity Requirements. Write Key Electronics, 120 Liberty St., New York 6, N. Y. Evergreen 4-6071.

ENCLOSURES you can build for better listening. Also stereophonic. Free list. Loco Plans, 6705 Murray Ave., Cincinnati 27, Ohio.

DISCOVER our "Six Unique Services" on Hi-Fi! Stereo. Exceptional values. Write The Silver Trumpet, 406P Walnut, Alexandria, Indiana.

RECORDS

PHONOGRAPH Records cheap, postpaid. Catalogue. Paramount, Box 242-R, Williamsport, Pennsylvania.

INSTRUCTION

USED Correspondence Courses, Educational Books, Bought, Sold, Free Catalog, Vernon, Summerville, Ga.

ENGINEERING Degrees, EE Option Electronics earned through home study. Residence classes also available. Pacific International University (Operating as a College of Engineering only at present), 5719-J Santa Monica Boulevard, Hollywood 38, Calif.

"TRANSISTORS For Beginners." At last a treatment of transistors you can easily understand. Clearly describes in simple language transistor action, amplification, biasing, NPN and PNP transistors, etc. Completely diagrammed. A must for beginners. \$1.00. P. Polton, 3702 E. Oakwood, South Milwaukee, Wisconsin.

LEARN Code Easily! Use Kord-All's elementary course. 12" microgroove record, \$3.50 postpaid. Kord-All, Box 444, Warren, Ohio.

CORRESPONDENCE COURSES

COMPLETE Correspondence Course in Radio, TV, & Electronics. Includes FCC 1st Class License Prep. Special Summer Rates. Enroll Now. Ascot—School of Electronics, Box 29092, Los Angeles 29, California.

SPECIAL SERVICES

BOOK Manuscripts Considered for national distribution. All subjects welcomed. New authors encouraged. Atten. Mr. Blythe, Greenwich Book Publishers, 489 Fifth Avenue, New York, N. Y.

ELECTRICAL EQUIPMENT & SUPPLIES

TWO-WAY Communications Supplies. Free Catalog. RCE, 520 S. Virginia, Reno, Nevada.

PRINTED Circuits made to order, in small quantities at reasonable prices. For full information write Electronic Production Company, 22905—56th, West Montlake-Terrace, Washington.

TV and Radio Servicemen—Amazing electronic machine instantly reprocesses tubes. Portable. Guaranteed. National Tube Repair, Box 924, Maywood, N. J.

FREE information on Printed Circuits. Circuit Laboratories, Box 52, Norwalk, Connecticut.

MINERAL & PROSPECTING

ROCKHOUNDS—Prospectors—Treasure Hunters—Gem Cutters . . . make big money in your spare time. Free Booklet now available with information on sources, materials, know-how . . . from the biggest suppliers to the jewelry trade. Free—Free . . . Grieger's, 1633 E. Walnut, Pasadena 95, Calif.

LEATHERCRAFT

FREE "Do-It-Yourself" Leathercraft Catalog. Tandy Leather Company, Box 791—J27, Fort Worth, Texas.

WANTED

CASH Paid! Sell your surplus electronic tubes. Want unused, clean transmitting, special purpose, receiving. TV types, magnetrons, klystrons, broadcast, etc. Also want military & commercial lab test and communications gear. We swap, too, for tubes or choice equipment. Send specific details in first letter. For a fair deal write, wire or telephone: Barry, 512 Broadway, New York 12, N. Y. Walker 5-7000.

CYLINDER and old disc phonographs. Edison, Conqueror, Idelia, and Oratorio models. Berliner Gramophones and Zono-o-phones, Columbia cylinder Graphophones, and Coin-operated cylinder Phonos. Want old catalogues and literature on early phones prior to 1919. Will pay cash or trade late hi-fi components. Popular Electronics, Box 50, 1 Park Ave., New York 16, N. Y.

MERCURY, Platinum, Silver, Precious Metals. Ores Assayed. Mercury Refiners, Norwood, Massachusetts.

July, 1958

MISCELLANEOUS

SONGPOEMS And Lyrics Wanted! Mail to: Tin Pan Alley, Inc., 1650 Broadway, New York 19, N. Y.

"WINEMAKING; Beer, Ale Brewing" Illustrated. \$2.00. Eaton Books, Box 1242-C Santa Rosa, California.

PROTECT By Laminating your Valuable Wallet Size Photos, Social Security Card, Ham License, etc. Send \$1.00. Quotes on any larger items. J. Schneider, 2662 Hewlett Lane, Bellmore, L. I., N. Y.

SIGHT Without Glasses 153pp. clothbound book explains exercises for regaining 20-20 vision. \$2.00 postpaid. Clarence Vranish, Box 315, Roundup, Montana.

Attention Photographers THE SECRET OF "BUYING SMART" costs you only a Dollar!

You've noticed how some people seem to have a knack for buying photo equipment. Before they go into a store they know the kind of equipment they want, the manufacturer, model, features, and the price. They've compared beforehand . . . and saved themselves time, effort and money.

What's the secret? For many it's the *Photography Directory & Buying Guide* . . . a handsome catalog of all photographic equipment on the market compiled by the editors of *Popular Photography*. It tells you everything you want to know about more than 5,000 products, from cameras and lenses to film and filters—for black and white or color, for movie or still photography. The cost? Only \$1.00.



Now On
Sale
Everywhere!

The new *Photography Directory* is now on sale. This 1958 Edition, priced at only \$1.00, will sell fast! So to insure yourself of a copy, pick one up at your newsstand or photo dealer's now.

ZIFF-DAVIS PUBLISHING COMPANY
434 S. Wabash Ave., Chicago 5, Illinois

131

SUPERIOR'S NEW MODEL 82

RAPID TESTER

The Very Best Value In Multi-Socket Tube Testers!

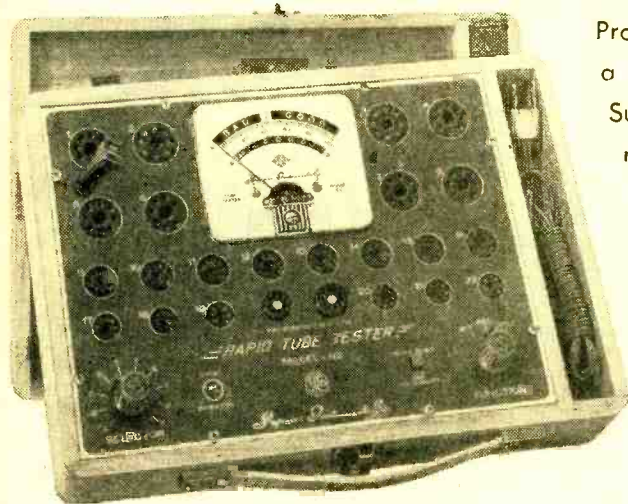

YES — COMPLETELY WIRED,
READY TO USE — Only \$36.50

Primarily, the difference between the conventional tube tester and the multi-socket type is that in the latter, the use of an added number of specific sockets (for example, in Model 82 the noval is duplicated eight times) permits elimination of element switches thus reducing testing time and possibility of incorrect switch readings.

To test any tube, you simply insert it into a numbered socket as designated, turn the filament switch and press down the quality switch — THAT'S ALL! Read quality on meter. Inter-element leakage, if any indicates automatically.

Production of this Model was delayed a full year pending careful study by Superior's engineering staff of this new method of testing tubes. We don't expect it to replace conventional testers but if you want to try this new type of tester, you can do no better than mail the coupon below. Don't let the low price mislead you! We claim Model 82 will outperform similar looking units which sell for much more — and as proof, we offer to ship it on our examine before you buy policy.

FEATURES:

- ★ Dual Scale meter permits testing of low current tubes.
- ★ 7 and 9 pin straighteners mounted on panel.
- ★ All sections of multi-element tubes tested simultaneously.
- ★ Use of 22 sockets permits testing all popular tube types and prevents possible obsolescence.
- ★ Ultra-sensitive leakage test circuit will indicate leakage up to 5 megohms.

\$36⁵⁰

SHIPPED ON APPROVAL
NO MONEY WITH ORDER — NO C. O. D.

SEE FOLLOWING PAGE FOR COMPLETE DETAILS

MOSS ELECTRONIC DISTRIBUTING CO., INC. DEPT. D-477 3849 TENTH AVENUE, NEW YORK 34, N. Y.

TRY FOR 10 DAYS

before you buy! **then** if satisfactory pay in easy, interest free, monthly payments. See coupon below.

Superior's

New Model
TW-11

STANDARD PROFESSIONAL

TUBE TESTER

• Tests all tubes, including 4, 5, 6, 7, Octal, Lockin, Hearing Aid, Thyratron, Miniatures, Sub-miniatures, Novals, Subminars, Proximity Fuse Types, etc.

• Uses the new self-cleaning Lever Action Switches for individual element testing. All elements are numbered according to pin-number in the RMA base numbering system. Model TW-11 does not use combination type sockets. Instead individual sockets are used for each type of tube. Thus it is impossible to damage a tube by inserting it in the wrong socket.

• Free-moving built-in roll chart provides complete data for all tubes. Printed in large easy-to-read type.

NOISE TEST: Phono-jack on front panel for plugging in either phanes or external amplifier detects microphonic tubes or noise due to faulty elements and loose internal connections.

EXTRAORDINARY FEATURE
SEPARATE SCALE FOR LOW-CURRENT TUBES Previously, an emission-type tube testers, it has been standard practice to use one scale for all tubes. As a result, the calibration for low-current types has been restricted to a small portion of the scale. The extra scale used here greatly simplifies testing of low-current types.

Housed in hand-rubbed oak cabinet **\$47⁵⁰ Net**



Model TW-11 — Tube Tester
Total Price \$47.50
Terms: \$11.50 after 10 day trial, then \$6.00 per month for 6 months.

Superior's

New Model
TV-12

TRANS-CONDUCTANCE TUBE TESTER

★ Employs improved TRANS-CONDUCTANCE circuit. An in-phase signal is impressed on the input section of a tube and the resultant plate current change is measured. This provides the most suitable method of simulating the manner in which tubes actually operate in Radio & TV receivers, amplifiers and other circuits. Amolification factor, plate resistance and cathode emission are all correlated in one meter reading.

★ NEW LINE VOLTAGE ADJUSTING SYSTEM. A tapped transformer makes it possible to compensate for line voltage variations to a tolerance of better than 2%.

★ SAFETY BUTTON — protects both the tube under test and the instrument meter against damage due to overload or other form of improper switching.

EXTRA FEATURE:

Model TV-12 Also Tests Transistors!

A transistor can be safely and adequately tested only under dynamic conditions. The Model TV-12 will test all transistors in that approved manner, and quality is read directly on a special "transistor only" meter scale.

Housed in hand-rubbed oak cabinet **\$72⁵⁰ Net**



Model TV-12—Transconductance Tube Tester—Total Price \$72.50
Terms: \$22.50 after 10 day trial, then \$10.00 per month for 5 months.

We invite you to try before you buy any of the models described on this page, the preceding page and the following pages. If after a 10 day trial you are completely satisfied and decide to keep the Tester, you need send us only the down payment and agree to pay the balance due at the monthly indicated rate.

NO INTEREST OR FINANCE CHARGES ADDED!

If not completely satisfied, you are privileged to return the Tester to us, cancelling any further obligation.

SEE OTHER SIDE

CUT OUT AND MAIL TODAY! ▶

MOSS ELECTRONIC DISTRIBUTING CO., INC.

Dept. D-477 3849 Tenth Ave., New York 34, N. Y.

Please send me the units checked on approval. If completely satisfied I will pay on the terms specified with no interest or finance charges added. Otherwise, I will return after a 10 day trial positively cancelling all further obligation.

- | | | | |
|--------------------------------------|--|--------------------------------------|---|
| <input type="checkbox"/> Model 82 | Total Price \$36.50
\$6.50 within 10 days. Balance \$6.00
monthly for 5 months. | <input type="checkbox"/> Model TV-12 | Total Price \$72.50
\$22.50 within 10 days. Balance \$10.00
monthly for 5 months. |
| <input type="checkbox"/> Model TW-11 | Total Price \$47.50
\$11.50 within 10 days. Balance \$6.00
monthly for 6 months. | <input type="checkbox"/> Model 76 | Total Price \$26.95
\$6.95 within 10 days. Balance \$5.00
monthly for 4 months. |
| <input type="checkbox"/> Model 77 | Total Price \$42.50
\$12.50 within 10 days. Balance \$6.00
monthly for 5 months. | | |

Name

Address

City Zone State

All prices net, F.O.B., N. Y. C.

SHIPPED ON APPROVAL NO MONEY WITH ORDER NO C.O.D.

Superior's New Model 76

ALL PURPOSE BRIDGE

IT'S A CONDENSER BRIDGE
IT'S A RESISTANCE BRIDGE

IT'S A SIGNAL TRACER
IT'S A TV ANTENNA TESTER

✓ CAPACITY BRIDGE SECTION

4 Ranges: .00001 Microfarad to .005 Microfarad; .001 Microfarad to .5 Microfarad; .1 Microfarad to 50 Microfarads; 20 Microfarads to 1000 Microfarads. Will also measure the power factor of all condensers from .1 to 1000 Microfarads.

✓ RESISTANCE BRIDGE SECTION

2 Ranges: 100 ohms to 50,000 ohms; 10,000 ohms to 5 megohms.

✓ SIGNAL TRACER SECTION

With the use of the R.F. and A.F. Probes included with the Model 76, you can

make stage gain measurements, locate signal loss in R.F. and Audio stages, localize faulty stages, locate distortion and hum, etc.

✓ TV ANTENNA TESTER SECTION

Loss of sync., snow and instability are only a few of the faults which may be due to a break in the antenna, so why not check the TV antenna first? Locates a break in any TV antenna and measures the location of the break in feet from the set terminals.

Complete with R.F. and A.F. probes and test leads

\$26.95
Net



Model 76 - All Purpose Bridge
Total Price \$26.95

Terms: \$6.95 after 10 day trial then \$5.00 per month for 4 months.



Model 77 - Vacuum Tube Voltmeter - Total Price \$42.50

Terms: \$12.50 after 10 day trial, then \$6.00 per month for 5 months.

Superior's
New
Model 77

VACUUM TUBE VOLTMETER

WITH NEW 6" FULL-VIEW METER

Compare it to any peak-to-peak V. T. V. M. made by any other manufacturer at any price!

• Model 77 completely wired and calibrated with accessories (including probe, test leads and portable carrying case) sells for only \$42.50. • Model 77 employs a sensitive six inch meter. Extra large meter scale enables us to print all calibrations in large easy-to-read type. • Model 77 uses new improved SICO printed circuitry. • Model 77 employs a 12AU7 as D.C. amplifier and two 9006's as peak-to-peak voltage rectifiers to assure maximum stability. • Model 77 uses a selenium-rectified power supply resulting in less heat and thus reducing possibility of damage or value changes of delicate components. • Model 77 meter is virtually burn-out proof. The sensitive 400 microampere meter is isolated from the measuring circuit by a balanced push-pull amplifier. • Model 77 uses selected 1% zero temperature coefficient resistors as multipliers. This assures unchanging accurate readings on all ranges.

SPECIFICATIONS

AS A DC VOLTMETER: The Model 77 is indispensable in Hi-Fi Amplifier servicing and a must for Black and White and color TV Receiver servicing where circuit loading cannot be tolerated.

AS AN AC VOLTMETER: Measures RMS values of sine wave, and peak-to-peak value of complex wave. Pedestal voltages that determine the "black" level in TV receivers are easily read.

AS AN ELECTRONIC OHMMETER: Because of its wide range of measurement leaky capacitors show up glaringly. Because of its sensitivity and low loading, intermittents are easily found, isolated and repaired.

Model 77 comes complete with operating instructions, probe and test leads. Use it on the bench - use it on calls. A streamlined carrying case, included at no extra charge, accommodates the tester, instruction book, probe and leads. Operates on 110-120 volt 60 cycle. Only

• DC VOLTS - 0 to 3/15/75/150/300/750/1,500 volts at 11 megohms input resistance. • AC VOLTS (RMS) - 0 to 3/15/75/150/300/750/1,500 volts. • AC VOLTS (Peak to Peak) - 0 to 8/40/200/400/800/2,000 volts. • ELECTRONIC OHMMETER - 0 to 1,000 ohms/10,000 ohms/100,000 ohms/1 megohm/10 megohms/100 megohms/1,000 megohms. • DECIBELS - 10 db to +18 db, -10 db to +38 db, +30 db to +58 db. All based on 0 db = .006 watts (6 mw) into a 500 ohm line (1.73). • ZERO CENTER METER - For discriminator alignment with full scale range of 0 to 1.5/7.5/37.5/75/150/375/750 volts at 11 megohms input resistance.

\$42.50
Net

TRY FOR 10 DAYS BEFORE you buy! THEN if satisfactory

pay in easy, interest free, monthly payments. See coupon inside.

We invite you to try before you buy any of the models described on this and the preceding pages. If after a 10 day trial you are completely satisfied and decide to keep the Tester, you need send us only the down payment and agree to pay the balance due at the monthly indicated rate. (See other side for time payment schedule details.)

**NO INTEREST
OR FINANCE
CHARGES ADDED!**

If not completely satisfied, you are privileged to return the Tester to us, cancelling any further obligation.

**SEE OTHER
SIDE**

CUT OUT AND MAIL TODAY!

FIRST CLASS

Permit No. 61430

New York, N. Y.

VIA AIR MAIL

BUSINESS REPLY CARD

No Postage Stamp Necessary if Mailed in the U. S.

POSTAGE WILL BE PAID BY -

MOSS ELECTRONIC DIST. CO., INC.

3849 TENTH AVENUE

NEW YORK 34, N. Y.