

# POPULAR ELECTRONICS

NOVEMBER  
1955

25  
CENTS

In U. S. and Canada

HI-FI • AMATEUR RADIO • R/C • SWL • GADGETS

## Introducing "Puzzle-tronics"



Using Solar Batteries  
\$2 Speaker Baffle  
Tech-Band Converter  
Micro-Miniature Tubes

# CABINART '56

- MODEL 10
- MODEL 11
- MODEL 21
- MODEL 22
- MODEL 27
- MODEL 28
- MODEL 27U
- MODEL 28U
- MODEL 65
- MODEL 70
- MODEL 7112
- MODEL 7115
- MODEL 90
- MODEL 91
- MODEL 90U
- MODEL 91U
- MODEL 800
- MODEL 800U
- MODEL KR-3
- MODEL KR-3U
- MODEL KR-4-12
- MODEL KR-4-15
- MODEL KR-5
- MODEL KR-5-U
- MODEL KR-5-P
- MODEL ST-1
- MODEL ST-2
- MODEL ST-3
- MODEL ST-4
- MODEL ST-5
- MODEL ST-6
- MODEL ST-7
- MODEL ST-8
- MODEL ST-9

## MODEL 65



storage  
for tape recorder, turntable,  
record changer, tuner, amplifier  
and speaker, if desired.

• 16 NEW EQUIPMENT CABINETS

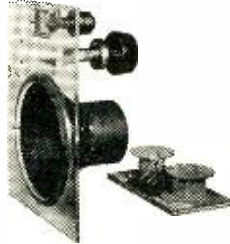

THE THE THE

*Rebel 3* *Rebel 4* *Rebel 5*  
SPEAKERS SPEAKERS SPEAKERS

CABINART SPEAKER SYSTEMS

- KIT 27K
- KIT 28K
- KIT 80
- KIT 8112
- KIT 8115
- KIT K-3
- KIT K-4-12
- KIT K-4-15
- KIT KST-1
- KIT KST-2
- KIT KST-3
- KIT KST-4
- KIT KST-5
- KIT KST-6
- KIT KST-7
- KIT KST-8
- KIT KST-9

## MODEL 27K MODEL 28K

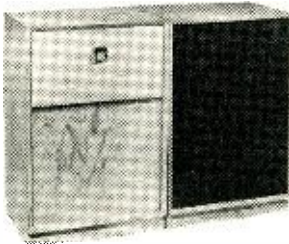

• TWELVE NEW HI-FI KITS

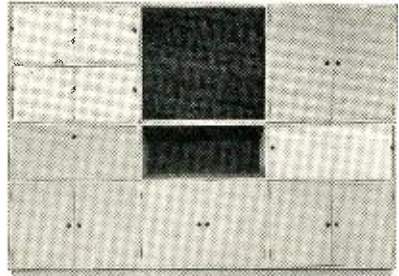

EVEN HI-FI WALL STORAGE CABINETS

- ACC-1
- ACC-2
- ACC-2U
- ACC-3
- ACC-4
- ACC-5
- ACC-6
- ACC-7
- ACC-7A



TURNTABLE BASE  
WITH LEVEL  
AND LEVELING  
DEVICES



RECORD  
CABINETS  
... 3 SIZES

and NINE HI-FI ACCESSORIES FOR THE SOUND ENTHUSIASTS.



Factory and Offices: B'klyn., N. Y.

Each CABINART design is an engineer's answer to an individual hi-fi equipment storage problem. Each cabinet, properly used, is a designer's expression of the elements of good furniture design.

If your hi-fi dealer does not stock Cabinart, write for the name of our nearest Cabinart dealer or mail order house.

**WRITE**

CABINART '56 CATALOGS:

1. EQUIPMENT STORAGE
2. EQUIPMENT/ENCLOSURE KITS
3. REBEL HORNS & SPEAKERS
4. THE CABINART STORAGEWALL
5. HI FI ACCESSORIES



The pioneers in high fidelity radio furniture

Cabinart is a division of G & H Wood Products Co., Inc. • 99 N. 11th St. • Brooklyn 11, N. Y.

# Learn to Service TV Sets—any make or model—Quickly

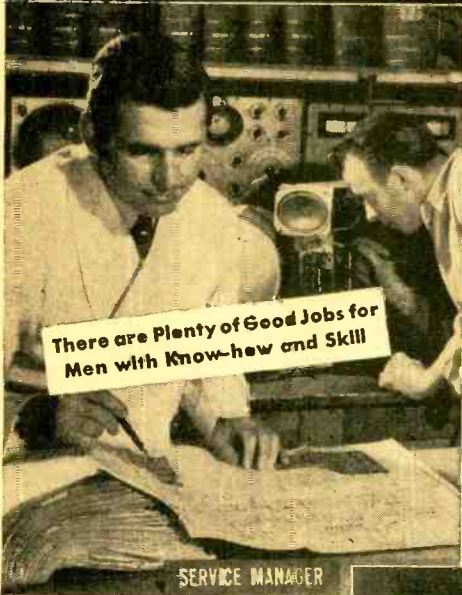

There are Plenty of Good Jobs for Men with Know-how and Skill

SERVICE MANAGER

17" Picture Tube, Components for a TV Receiver, Scope, Signal Generator, HF Probe—all included in introductory price under \$200—Easy Terms

If you want to go places in TV servicing, you will act quickly to find out what you get, what you practice, what you learn and how NRI's new course in Professional Television Servicing will help you advance through better technical knowledge and training. See pictures of equipment supplied, read what you practice in book offered FREE to ambitious men with some knowledge of Radio or TV fundamentals. Find out about this ALL PRACTICE Professional TV Servicing Course now.



**COUPON BRINGS IMPORTANT BOOK FREE**

Get this book and judge for yourself how this course will further your ambition to reach the top in TV Servicing or help to build a more secure business of your own in TV. Many of tomorrow's top TV Servicemen... men who can service any make, any model, UHF, VHF or Color TV, will be graduates of this training. Mail the coupon now. There is no obligation.

## New ALL PRACTICE Method trains you at home to become a Professional TV Serviceman

### You learn the time saving techniques, methods used by top TV Servicemen

This is 100% learn-by-doing, practical training. NRI supplies all necessary equipment, all tubes, including a 17-inch picture tube; and comprehensive manuals covering a thoroughly planned program of practice. You learn how experts diagnose TV receiver defects quickly. You easily learn the causes of defects—audio and video—and how to fix them accurately.

You get actual experience aligning TV receivers, isolating complaints from scope patterns, eliminating interference, using germanium crystals to rectify the TV picture signal, adjusting the ion trap and hundreds of other valuable Professional techniques.

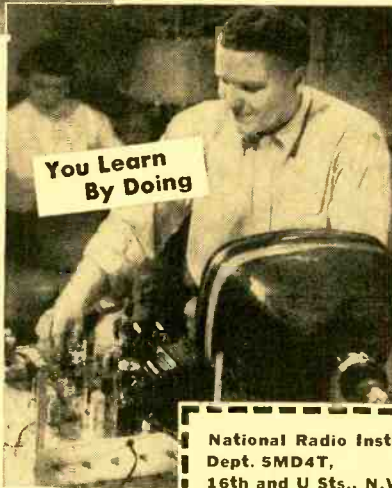

You Learn By Doing

## UHF and COLOR Create Growing Opportunities

To cash in on the present UHF and the coming COLOR TV boom you'll need the kind of knowledge and experience NRI's Course gives. You'll get practice installing front-end channel selector strips in modern UHF-VHF receivers. You learn UHF servicing problems and their solution. Mail the coupon now. Discover how NRI's new course in PROFESSIONAL TELEVISION SERVICING meets the needs of the man who wants to get ahead in TV Servicing.

### Not for Beginners

If you have some knowledge of Radio-TV fundamentals, or have had some Radio Shop experience or some Radio school training, this course IS FOR YOU. Mail coupon today. Address: National Radio Institute, Dept. SMD4T, 16th & U. Sts., N.W., Washington 9, D.C.

**MAIL NOW**

National Radio Institute,  
Dept. SMD4T,

16th and U Sts., N.W., Washington 9, D.C.

Please send my FREE copy of "How to Reach the Top in TV Servicing." I understand no salesman will call.

Name..... Age.....

Address.....

City..... Zone... State.....

APPROVED MEMBER NATIONAL HOME STUDY COUNCIL

POPULAR ELECTRONICS is published monthly by Ziff-Davis Publishing Company, William B. Ziff, Chairman of the Board (1946-1950), at 64 E. Lake St., Chicago 1, Ill. Entered as second class matter August 27, 1954 at the Post Office, Chicago, Illinois. SUBSCRIPTION RATES: One year U.S. and possessions, and Canada \$3.00; Pan-American Union Countries \$3.50; all other foreign countries \$4.00.

# POPULAR ELECTRONICS

Registered U. S. Patent Office

## CONTENTS

CIC—Navy's Electronic Clearinghouse . . . . .	E. D. Morgan	29
Training for Electronics by Home Study . . . . .	Norman Eisenberg	33
Micro-Miniature Tubes . . . . .		41
Reflex Receiver . . . . .	Serge L. Krauss	43
"Tech-Band" Converter . . . . .	J. T. Goode	48
Introduction to "Puzzle-tronics" . . . . .	Harvey Pollack	52
B-C Flash Gun . . . . .	Clinton E. Clark	58
Experiments with Simple Solar Batteries . . . . .	Rufus P. Turner	66
The Permanent Electric Clock . . . . .	Frank H. Tooker	70
Easily Built Chassis Rack . . . . .	Louis E. Garner, Jr.	72
The Versatile "Electro-Kit" . . . . .		100
Ultrasonic Drill . . . . .		101

## POPULAR ELECTRONICS Audio and Hi-Fi Section

Disc and Tape Review . . . . .	Bert Whyte	77
\$2 Speaker Baffle . . . . .	David B. Weems	79
Basic Tape Recorder Maintenance . . . . .	Eugene F. Coriell, Major, USAF	82
The Meaning of Frequency Response (Part 3) . . . . .	Norman H. Crowhurst	84
Making an Etched Preamp . . . . .	H. J. Carter	87
Tape Playback and Erasure . . . . .	Leon Wortman	90

## DEPARTMENTS

Letters from Our Readers . . . . .		8
What's the PE Answer . . . . .		22
Transistor Topics . . . . .		56
Tuning the Short-Wave Bands . . . . .	Hank Bennett	60
The Transmitting Tower . . . . .	Herb S. Brier	62
Carl & Jerry . . . . .	John T. Frye	64
R/C Notes . . . . .		76
POP'tronics Bookshelf . . . . .		104
After Class . . . . .		106
Tools & Gadgets . . . . .		113
Ama-Touring . . . . .	Roger Legge	116
Tips and Techniques . . . . .		120
Glossary of Electronic Terms . . . . .		136

(Also see page 6)

Cover Painting by Ed Valigursky

NOVEMBER 1955

VOL. 3—NUMBER 5

EDITOR  
OLIVER READ, W1ET1

MANAGING EDITOR  
O. P. Ferrell

TECHNICAL EDITOR  
H. S. Renne

FEATURE EDITOR  
Norman Eisenberg

ASSOCIATE EDITORS  
M. C. Magna  
Charles Tepfer

ART EDITOR  
A. J. Reich

CONTRIBUTING EDITORS  
H. Bennett R. Legge  
H. S. Brier H. Pollack  
J. T. Frye R. P. Turner  
L. E. Garner, Jr.

ART DEPARTMENT  
Frank Sayles (Director)  
J. A. Galanek M. Whelpley  
W. K. Vahlsing

ADVERTISING DEPARTMENT  
NEW YORK (MU 7-8080)  
L. L. Osten—Adv. Dir.  
Wm. G. McRoy—Adv. Mgr.  
T. Suito

CHICAGO (AN 3-5200)  
James Weakley  
LOS ANGELES (Mich. 9856)  
John E. Payne



Copyright 1955  
(All Rights Reserved)

Member  
Audit Bureau of  
Circulations

## ZIFF-DAVIS PUBLISHING COMPANY

W. B. ZIFF (1898-1953) FOUNDER

Also Publishers of  
RADIO & TELEVISION NEWS  
Editorial and Executive Offices  
366 Madison Ave., New York 17, N. Y.

PRESIDENT  
B. G. DAVIS

VICE-PRESIDENTS  
H. J. MORGANROTH M. FROELICH

SECRETARY-TREASURER  
G. E. CARNEY

CIRCULATION MANAGER  
M. MICHAELSON

BRANCH OFFICES  
Chicago (1), 64 E. Lake St.  
Los Angeles (14), Stalter Center,  
900 Wilshire Blvd.

SUBSCRIPTION SERVICE:  
All communications concerning subscriptions should be addressed to Circulation Dept., 64 E. Lake St., Chicago 1, Ill. Include your old address as well as new—enclosing if possible an address label from a recent issue of this magazine. Allow at least 4 weeks for change of address.

CONTRIBUTORS:  
Contributors are advised to retain a copy of their manuscripts and illustrations. Contributions should be mailed to the New York Editorial Office and must be accompanied by return postage. Contributions will be handled with reasonable care, but this magazine assumes no responsibility for their safety. Any copy accepted is subject to whatever adaptations and revisions are necessary to meet the requirements of this publication. Payment covers all author's, contributor's and contestant's rights, title, and interest in and to the material accepted and will be made at our current rates upon acceptance. All photos and drawings will be considered as part of material purchased.

POPULAR ELECTRONICS



Train for Better  
Jobs in

# ELECTRICITY OR TELEVISION-RADIO

in Great  
Shops of COYNE

## GREAT OPPORTUNITY FIELDS

Conditions are changing. Many "one operation" jobs that have paid well will not last. *Don't be satisfied with a "no future" job.* Whether 17 or up to 45 years of age, train the Coyne way for a better job and a real future in **ELECTRICITY** or **TELEVISION-RADIO**, *fields that offer a world of opportunities.*

## YOU can TRAIN in great CHICAGO SHOPS

Train on real, full-size equipment at COYNE where thousands of successful men have trained for over 56 years — **largest, oldest, best equipped school of its kind**—established in 1899. No advanced education or previous experience needed. **TRAINING APPROVED FOR VETERANS.**

E. W. COOKE, President

# COYNE

**ELECTRICAL SCHOOL**

FOUNDED 1899

A TECHNICAL TRADE INSTITUTE OPERATED NOT FOR PROFIT  
506 S. PAULINA STREET, CHICAGO, Dept. 85-71H

**ELECTRICITY ★ RADIO ★ TELEVISION ★ REFRIGERATION ★ ELECTRONICS**

**START NOW—PAY LATER**—Finance Plan and Easy Monthly Payment Plan. Also part-time employment help for students.

### Get FREE Book

Send coupon for 48 page illustrated book "Guide to Careers in Electricity and Television-Radio." No cost; no obligation; no salesman will call. Get vital facts now!



B. W. COOKE, President  
**COYNE ELECTRICAL SCHOOL**  
500 S. Paulina St., Chicago 12, Ill., Dept. 85-71H

Send **BIG FREE** book and details of your training offer. This does not obligate me and no salesman will call. I am interested in:

Electricity  Television-Radio

Name \_\_\_\_\_

Address \_\_\_\_\_

City \_\_\_\_\_ State \_\_\_\_\_

COYNE offers  
LOW COST

# TELEVISION RADIO-ELECTRONICS

Training in  
Spare Time **AT HOME**

The future is **YOURS** in TV-RADIO!

A fabulous field—good pay—fascinating work—a prosperous future! Good jobs, or independence in your own business!

Coyne brings you the first *truly lower cost*, MODERN—QUALITY Television Home Training; training designed to meet Coyne standards. Not an old Radio Course with Television "tacked on". Here is MODERN TELEVISION TRAINING including working knowledge of Radio. Includes UHF and **COLOR TV**. No Radio background or previous experience needed. Personal guidance by Coyne Staff. **Practical Job Guides** to show you how to do actual servicing jobs—*make money early in course*. With Coyne Television Home Training you pay only for your training, *no costly "put together kits"*.

B. W. COOKE, President



Coyne—the Institution behind this training... the largest, oldest, best equipped residential school of its kind. Established 1899.

# COYNE

**ELECTRICAL SCHOOL**

500 S. Paulina St., Dept. 85-HT7

A TECHNICAL TRADE INSTITUTE OPERATED NOT FOR PROFIT



## SEND COUPON FOR FREE BOOK

and full details, including easy Payment Plan. **No obligation, no salesman will call.**



**COYNE ELECTRICAL SCHOOL**  
Television Home Training Div.  
500 S. Paulina St., Chicago 12, Ill.,  
Dept. 85-HT7

Send Free Book and details on Television Home Training. This does not obligate me and no salesman will call.

Name \_\_\_\_\_

Address \_\_\_\_\_

City \_\_\_\_\_ State \_\_\_\_\_

# RAYTHEON CK722 TRANSISTORS

**NOW \$1.25**

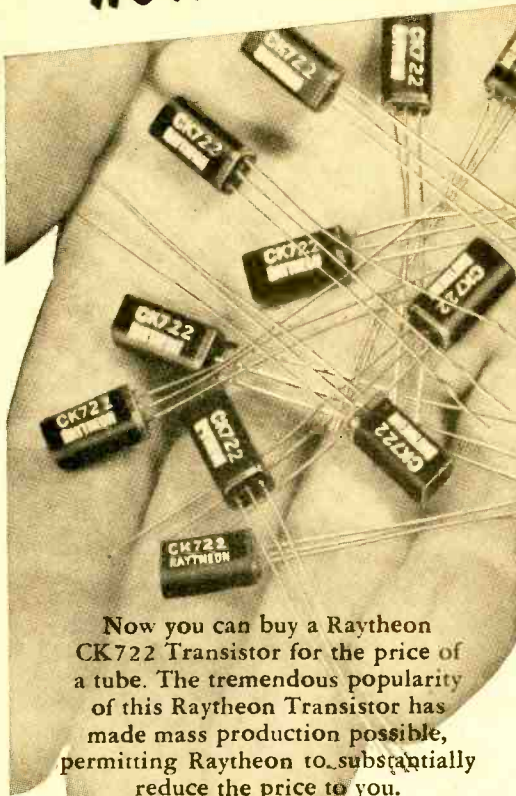

Now you can buy a Raytheon CK722 Transistor for the price of a tube. The tremendous popularity of this Raytheon Transistor has made mass production possible, permitting Raytheon to substantially reduce the price to you.

### Get This RAYTHEON TRANSISTOR APPLICATION BOOK!

116 pages — over 50 practical circuits including timers, receivers, oscillators, etc. all using low cost Raytheon Transistors. For your copy send 50¢ to Department P7.



## RAYTHEON MFG. CO.

Receiving and Cathode Ray Tube Operations  
Newton 58, Massachusetts

RELIABLE SUBMINIATURE AND MINIATURE TUBES  
SEMICONDUCTOR DIODES AND TRANSISTORS  
NUCLEONIC TUBES

RECEIVING AND PICTURE TUBES • MICROWAVE TUBES

## ITEMS OF INTEREST

Fire Box Telephone Alarm .....	38
G.E. Ham Award Nominations Open until Jan. 3, 1956 .....	38
The Antenna Was There—But The Receiver Was Not .....	38
U.H.F. Tetrode Transistor Works at 1000 Mc. ....	38
Germany Tests "Ionophon" .....	39
New Zenith Radio Permits Use of Headphones. ....	39
U. S. Navy Tests Radio-Controlled Helicopter. ....	39
"Snooper" Finds Line Breaks .....	40
Counter Battles Smog .....	55
Solar Battery in Operation .....	69
"Frequency Meter" at No Cost .....	102

## NEW PRODUCTS

Antenna Housed Inside Globe .....	40
Miniaturized Hearing Aid .....	40
Kit Builds Wrist Radio .....	55
One-Tube Radio Kit .....	55
Tape Recorders for Hi-Fi, Schools, Industry. ....	81
Economy 8" Enclosure in Kit Form .....	86
Low-Cost Cabinets House Hi-Fi Equipment. ....	94
Professional Features in New Preamplifier Control Unit .....	94
Tester Revives Picture Tubes .....	109

## COMING NEXT MONTH

### POPULAR ELECTRONICS

#### Electronic Toys for Xmas '55

Preparation and construction of four different toys are discussed, for young people in various age groups. Included are: "Winking Clown," "Gadget Box," "Electronic Piano," and "Electronic Maze."

#### Unusual Sounds from Your Tape Recorder

Many suggestions are offered as to how the home recordist can best use a recorder to provide delayed echoes and other unusual sounds.

#### Slave Photoflash Trigger

When coupled to a second photoflash bulb and reflector, this self-contained unit will fire that bulb the instant the primary flash goes off.

#### An Amateur's Audio Oscillator

This unit will help readers who are interested in learning International Morse Code to pass their amateur exams. It can be used for code practice by simply plugging a key into a jack on the front panel.

High-Fidelity Audio ■ Kits ■ Radio Control  
■ Short-Wave Listening ■ What's New ■  
How It Works ■ How to Make It ■ How to  
Use It ■ Carl & Jerry ■ Tips & Techniques

## IN THIS MONTH'S

### RADIO & TELEVISION NEWS

(November—Special Audio Feature Issue)

Buying a Hi-Fi Amplifier?

Stereophonic Sound for the Home

A Musician Looks at Hi-Fi

Evolution of the Phonograph

A 100-Watt Power Amplifier

# THEY SAID HE COULDN'T LEARN TV AT HOME



L. C. Lane, B.S., M.A.  
President, Radio-Television  
Training Association  
Executive Director, Pierce  
School of Radio & Television.

... but now he  
repairs their sets

Read this letter from  
one of my students —  
It can help YOU!



I CAN DO FOR YOU WHAT  
I DID FOR THIS MAN!

YOU can get top pay in the fast-growing Television-Radio-Electronics field just as this man did. My easily understood lessons — especially prepared for home study — can bring you the same success they brought hundreds of men, many of them with no more than grammar school training.

"Dear Mr. Lane:  
"How to begin this letter, I don't really know. I can never begin to tell you how happy I am with the outcome of your Radio and Television course. I'll never regret clipping your ad out and sending it to you. Believe me, it has changed my whole outlook on life. I believe this is the beginning of a bright new future for me, thanks to RTTA.  
"Already I have established a small reputation in our city and I am looking to the very near future when I go into the radio and TV repair business full time. The last few months I've come very close to doubling my weekly income with very little time spent at it.  
"Now it is my turn to laugh at the people who said I was wasting my time, that I couldn't learn vision sets for some of these people and they admit that they were wrong.  
"I look back now just a short year and remember how I stayed up many a night until after midnight studying and experimenting. At the same time I was wondering whether something would really come of it. Now I can proudly say it did. Because I reached out and grasped the opportunity RTTA gave me. For that I'll be forever grateful."  
A. F. Duschl, Lancaster, Pa. 1.24.55

## LEARN BY DOING



You work with actual parts and equipment I send you as part of your course. You get enough equipment to set up your own home laboratory and prepare for a top-pay TV job. You build and keep an Electromagnetic TV RECEIVER designed and engineered to take any size picture tube up to

21-inch. (10-inch tube furnished. Slight extra cost for larger sizes)... Also a Super-Het Radio Receiver, AF-RF Signal Generator, Combination Voltmeter-Ammeter-Ohmmeter, C-W Telephone Transmitter, Public Address System, AC-DC Power Supply. Everything supplied, including all tubes.

### FCC COACHING COURSE

Important for BETTER-PAY JOBS requiring FCC license. You get this training AT NO EXTRA COST! Top jobs go to FCC-licensed technicians.

CHOOSE FROM THREE COMPLETE COURSES  
covering all phases of Radio, FM and TV

RADIO-FM-TELEVISION TECHNICIAN COURSE — no previous experience necessary.

FM-TV TECHNICIAN COURSE — previous training or experience in radio required.

TV CAMERAMAN AND STUDIO TECHNICIAN COURSE — advanced training for men with Radio or TV training or experience.

EXTRA TRAINING IN NEW YORK CITY AT NO EXTRA COST!

After you complete either the Radio-FM-TV Technician or the FM-TV Technician course you get two weeks of Lab work on modern electronic equipment at our associate resident school in New York City, Pierce School of Radio & Television. Available if you want it — AT NO EXTRA COST WHATSOEVER!

## Radio Television Training Association

52 EAST 19th STREET • NEW YORK 3, N. Y.

Licensed by the State of New York • Approved for Veteran Training

### FREE



I'll send you my new 40-page book, "How to Make Money in Television, Radio, Electronics," a Free sample lesson, and other literature showing how and where you can get a top-pay job in Television.

## VETERANS

My school fully approved to train Veterans under new Korean G.I. Bill. Don't lose your school benefits by waiting too long. Write discharge date on coupon.

### MAIL THIS COUPON TODAY!

Mr. Leonard C. Lane, President  
RADIO-TELEVISION TRAINING ASSOCIATION  
Dept. E-11C, 52 East 19th Street, New York 3, N. Y.

Dear Mr. Lane: Mail me your NEW FREE BOOK, FREE SAMPLE LESSON, and FREE aids that will show me how I can make BIG MONEY IN TELEVISION. I understand I am under no obligation and no salesman will call.

(PLEASE PRINT PLAINLY)

Name \_\_\_\_\_ Age \_\_\_\_\_

Address \_\_\_\_\_

City \_\_\_\_\_ Zone \_\_\_\_\_ State \_\_\_\_\_

I AM INTERESTED IN:

- Radio-FM-TV Technician Course
- FM-TV Technician Course
- TV Cameraman & Studio Technician Course

### VETERANS!

Write discharge date

## NO SALESMAN WILL CALL!

# WHAT'S NEW

## in Magnetic Recording?

**BIGGEST ADVANCE** in magnetic recording in years! That's what experts are calling new Extra Play Magnetic Tape 190, the revolutionary recording tape developed by "SCOTCH" Brand. Thinner, but made with strength to spare, new Extra Play Tape gives you 50% more recording time. That means you can now record longer broadcasts, concerts, dramatic performances without annoying interruptions for reel change.



**TWO REELS** of new "SCOTCH" Brand Extra Play Tape offer as much recording time as 3 reels of conventional tape . . . plus a generous 3 db. boost in the high frequency range. So, it's easy to understand why Extra Play Tape is already the favorite with high-fidelity fans across the country.

**YOU'LL NOTICE** a crisper tone, more brilliant sound on new Extra Play Tape. It's the result of "SCOTCH" Brand's exclusive oxide dispersion process. By laying fine-grain oxide in a neat, orderly pattern, "SCOTCH" Brand is able to pack in thousands of *additional particles* — to produce a super-sensitive magnetic recording surface. Yet, it's actually 50% thinner than conventional coatings used by other long play tapes. That's important to remember when buying. Because leading engineers are aware that a thinner, more potent oxide coating is essential for improved results with long play tapes.

**SEE THE DIFFERENCE** yourself! Here's an artist's conception of two oxide coatings seen by an electron photo microscope. At left, old-fashioned coating still used by most long play tapes. Compare this jumbled surface with neat pattern at right. "SCOTCH" Brand's unique dispersion method packs in thousands of additional particles to give it sound superiority.

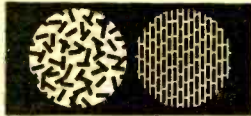

### FREE BOOKLET!

Mail this coupon for the fascinating new booklet, "A Glossary of Tape Recording Terms".

MAGNETIC TAPE DIVISION, DEPT. IJ-115  
Minnesota Mining and Mfg. Co., St. Paul 6, Minn.

NAME \_\_\_\_\_

STREET \_\_\_\_\_

CITY \_\_\_\_\_ ZONE \_\_\_\_\_ STATE \_\_\_\_\_

THE TERM "SCOTCH" AND THE PLAID DESIGN ARE REGISTERED TRADEMARKS FOR MAGNETIC TAPE MADE IN U.S.A. BY MINNESOTA MINING AND MFG. CO., ST. PAUL 6, MINN. EXPORT SALES OFFICE: 99 PARK AVENUE, NEW YORK 16, N.Y.

# LETTERS

## FROM OUR READERS

### Painting Coil in Metal Locator

■ I have completed building the portable metal locator described by Harvey Pollack in your June issue, and would now like to know if I can paint the search coil. I would like to have the unit all the same color. Would a coat of paint affect the operation of the metal locator?

MERYLE HANSEN  
Ruthton, Minn.

*Painting the search coil of the metal locator will not affect its operation to any great extent. We suggest using the best possible grade of enamel paint.*

### Enclosure for Small Speaker

■ I am a hi-fi enthusiast and am trying to obtain a folded-horn or bass-reflex enclosure for a 6" speaker. Have you any information on this?

ALLEN SMITH  
Stony Creek, Conn.

*We have seen few good plans of an enclosure for use with a single 6" speaker in a hi-fi system. The smallest speaker diameter acknowledged to be capable of hi-fi reproduction is the 8" speaker. Using several 6" or 5" speakers within one enclosure is, of course, another matter. Plans for an enclosure using an 8" single speaker are published in this issue on page 79.*

*Remember that Briggs has pointed out in his books on loudspeakers not to expect an enclosure to compensate for inherent deficiencies of the speaker—and unless your 6" unit is quite remarkable, it must have considerable deficiencies when measured by hi-fi standards.*

### Plans for Intercom

■ I am hoping to find plans and some info on an intercom. Since my radio room is soundproof, anyone paging me may go unheard, thus making it necessary to climb a flight of stairs.

AL HAUCK  
Guelph, Ontario

*Plans for a simple intercom will be published in an early issue.*

### Use for Surplus Tuning Unit

■ Regarding a letter in your August issue from Jack Williams of Misenheimer, N. C.—if he's a ham and interested in tinkering, that BC-746 tuning unit makes a fair "flea-power" c.w. rig.

I utilized one, plus the schematic from the one-tube transmitter you published in February, plus some of my own ideas, and fired her up on 40 meters. Worked five states on Memorial Day, power running about 7 watts to a haywire antenna!

BRIAN S. WARD  
Gary, Indiana

POPULAR ELECTRONICS



A dramatic demonstration of a new idea to help you understand music better and enjoy it more...

# MUSIC-APPRECIATION RECORDS

NOTE: Because of the length of the symphony, the Tchaikovsky recording is on two records—a 12" disc with the performance on both sides, and a 10" disc with the analysis on both sides.



Will you accept  
**WITHOUT CHARGE**

A COMPLETE PERFORMANCE—WITH AN ILLUMINATING  
ANALYSIS ON A SEPARATE RECORD—OF

## Tchaikovsky's

FIFTH SYMPHONY

MAX RUDOLF, conducting

THE STADIUM CONCERTS SYMPHONY ORCHESTRA



ON ONE SIDE there is a full performance of a great musical work, featuring artists and orchestras of recognized distinction. You listen to this performance, and then...

SPONSORED BY THE BOOK-OF-THE-MONTH CLUB, this new idea is designed for those who enjoy good music but who are aware, too often, that they do not listen to it with complete understanding. There is no doubt about the reason: most of us are not primed about *what to listen for*. MUSIC-APPRECIATION RECORDS meet this need—for a fuller understanding of music—better than any means ever devised.

*obligated to take any specified number of records.*

TWO TYPES OF RECORDS . . . These are high-fidelity long-playing records of the highest quality—33½ R.P.M. on Vinylite. They are *twelve-inch* discs priced at \$3.60. An Analysis-Only Record—a *ten-inch* disc—is also provided for those who may want it alone, and is priced at \$2.40. (A small charge is added to cover postage and handling.)



ON THE OTHER SIDE is an analysis of the music, with the main features played separately and explained, so that you can learn *what to listen for*.

YOU TAKE ONLY RECORDS YOU WANT . . . A new MUSIC-APPRECIATION RECORD is issued every month preceded by an announcement written by Deems Taylor. After reading this descriptive essay you may take the record or not, as you decide. *You are not*

TRY IT ONE MONTH—NO OBLIGATION TO CONTINUE . . . The *Tchaikovsky* recording will be sent to you at once—at *no charge*. You may end the subscription immediately after hearing this recording or any time thereafter.



YOU WILL RECEIVE  
SEPARATELY  
A GLOSSARY OF  
MUSICAL TERMS

PLEASE RETURN ONLY IF YOU HAVE A 33½ R.P.M. RECORD PLAYER

MUSIC-APPRECIATION RECORDS R68-11  
c/o Book-of-the-Month Club, Inc., 345 Hudson Street, New York 14, N. Y.

Please send me at once the Music-Appreciation recording of *Tchaikovsky's Fifth Symphony*, without charge, and enroll me as a Trial Subscriber to MUSIC-APPRECIATION RECORDS, with the privilege of canceling at any time. I understand that, as a subscriber, I am not obligated to buy any specified number of records, but may take only those I want. Also, I may cancel my subscription after hearing the first recording, or any time thereafter at my pleasure, but the gift offer is free in any case.

Mr. }  
Mrs. } ..... (PLEASE PRINT)  
Miss }

ADDRESS.....

CITY..... Postal Zone No. STATE..... MAR 40  
(if any)

**Build the instruments  
the professionals specify...  
BUILD EICO KITS—SAVE 50%**



**Vacuum Tube  
Voltmeter  
KIT \$25.95  
Wired \$39.95**

**EICO VTVMs  
in use in labs  
of Stromberg-  
Carlson,  
Rochester, N. Y.**

EICO test instrument kits are complete and professional from circuitry to front panel—are utilized by TV leaders like Stromberg-Carlson, CBS-Columbia, Emerson, etc., leading electronic schools and universities, and over 60,000 radio-electronic servicemen coast to coast.

Exclusive "Beginner - Tested" step-by-step instructions make it easy, educational and enjoyable to build EICO Kits. Only basic tools, no electronics knowledge required. *You build 'em in one evening—they last a lifetime.* Exclusive 5-way Guarantee on instructions, components, performance, lifetime service and calibration. No wonder there are over 1/2-million in use the world over!

42 models to choose from. There is an EICO Distributor in your neighborhood. Write for his address & FREE CATALOG PE-11.

Prices 5% higher  
on West Coast © 55

**EICO**®

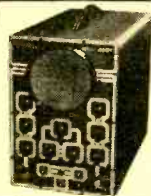

**5" Push Pull  
Oscilloscope  
Kit \$44.95  
Wired \$79.95**



**6V & 12V Battery  
Eliminator & Charger  
KIT \$29.95  
Wired \$38.95**



**1000 Ohms/Volt  
Multimeter  
KIT \$12.90  
Wired \$14.90**

84 Withers Street  
Brooklyn 11, N. Y.

## Using the Decibel

■ I read with interest your article on "Using the Decibel" (March, 1955). It cleared up many points for me. In connection with this, how do you convert decibels to gain, as you did in the last sentence in the last paragraph of your article? Here you mention 25 db and 36 db in reference to 316.2 and 4000 gain.

"INTERESTED"  
New York, N. Y.

*The decibel figures (25 and 36) are mathematical shorthand for expressing power ratios of the two amplifiers in question. Twenty-five db corresponds to a power ratio of 316.2 (amplifier output over input), while 36 db corresponds to a ratio of 4000 (approximately). Since the db figures are logarithmic, they are added—although the larger numbers which they represent would have to be multiplied to provide the required answer. Changing the actual gain figures (316.2 and 4000) to db figures (or vice versa) is readily done by using the table or the formula given in the article.*

## Correction re Diamond Styli

■ I think you gave "short-shrift" to the manufacturers of sapphire styli in your article on page 91 of the October issue.

The statement with the drawing is fine—if you carefully examine the drawing at the same time as you read the caption. But, reading the caption alone makes it appear as though all sapphire or osmium styli will ruin LP recordings—regardless of how new they are.

A. COLLIER  
Brookline, Mass.

*Reader Collier is correct and this misstatement was caught during the printing of the October issue. A few issues were released with the badly phrased caption, but later issues bore a caption to the illustration on page 91 which conveyed what the author had in mind, i.e., eventually you should replace any styli—diamond, sapphire, or osmium.*

## Annual Index PLEASE!

■ Many of your readers are saving every issue and I would suggest that a contents index be published every December.

EDWARD FRAZIER  
Toledo, Ohio

■ The instructors here (De La Salle High School) would like to index your articles—has anything been published to save us some time?

BROTHER AMBROSE, FSC  
Minneapolis, Minn.

*Provisions are being made to issue an index of POP'tronics articles within the near future.*

## Nuclear Battery

■ Could the nuclear battery described in the September issue be used in a Geiger counter?

R. L. BIERSHWALE  
San Antonio, Texas

*Good idea, but not practical because the weight is more than that of a common battery, the current drain is too much, and—last but not least—the radioactivity would probably foul up the Geiger counter.*

Now.. In Your Own Home **LEARN**

# TELEVISION RADIO-ELECTRONICS

THE AMAZINGLY EFFECTIVE  
**D.T.I. WAY**

**NO PREVIOUS TECHNICAL  
EXPERIENCE NEEDED**

**NOW... get  
EVERYTHING  
YOU NEED**

for real Laboratory-  
type training  
**AT HOME**

-with the aid of BOTH  
**HOME LAB EQUIPMENT  
and HOME MOVIES**

What will mailing the coupon below do for YOU? Just this! You'll find out about one of today's most remarkable... practical ways to prepare to get into America's amazing billion dollar opportunity field of TELEVISION-RADIO-ELECTRONICS. You'll see how to get into highly interesting work that pays well... that offers one of America's most promising futures... that enables you to start your own business almost "on a shoe string," if you prefer this to a job opportunity.

And above all, you'll get some GOOD NEWS especially welcomed by men anxious to earn REAL MONEY in this growing field. For you'll see that NOW you can get the kind of practical, laboratory-type training so desirable for making real progress in Television-Radio-Electronics AND WITHOUT LEAVING HOME.

You'll see that DeVRY Technical Institute sends everything needed to set up your own HOME LABORATORY. You get and keep the same type of basic electronic equipment used in our modern Chicago Training Laboratories. You get home training that includes the knowledge and experience gained from training thousands of students first hand in Chicago. And to top it all, you use DTI's amazingly effective and exclusive home training aid—INSTRUCTIVE MOVIES. But why not get the complete story? Mail coupon today for complete facts.

1. Build over 300 fascinating experiments from 16 BIG SHIPMENTS of Electronic-Radio parts which you KEEP.
2. Build valuable commercial-type test equipment—as shown to the left—which you KEEP. This includes a quality 5 INCH oscilloscope and jewel bearing Multi-Meter—both highly useful, for Television work.
3. Build and keep a big 21 INCH TV Set.
3. (D.T.I. offers another home training in Television-Radio-Electronics, but without the TV set.)
4. Use a 16 mm. movie projector and... new series of highly instructive movies—a wonderful aid to help you grasp important fundamentals faster... easier... better.
5. Enjoy well-illustrated, easy-to-read lessons with handy FOLD-OUT diagrams.
6. Get an honest-to-goodness EMPLOYMENT SERVICE to help you get a good job after graduating—or assistance in starting your OWN SALES AND SERVICE BUSINESS. Mail coupon today for the complete details.

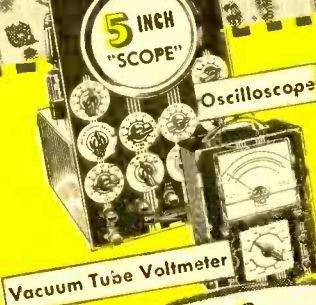

**21 INCH**

Build and keep this BIG DTI Engineered TV set—easily converted to U.H.F. (DTI offers another home training, but without the TV set.)

Above:  
Work over  
300  
interesting  
experiments  
with this  
equipment

"ONE OF AMERICA'S FOREMOST  
TELEVISION TRAINING CENTERS"

Home Movies

Get this  
information-  
packed  
publication  
**FREE!**

**89 WAYS  
TO  
EARN  
MONEY  
IN TELEVISION  
RADIO  
ELECTRONICS**

MODERN  
LABORATORIES

If you prefer, get all your preparation in our new Chicago Training Laboratories—one of the finest of its kind. Ample instructors, modern equipment. Write for details!

MILITARY SERVICE!

If you're subject to military service, the information we have for you should prove very helpful. Mail coupon today.

Member of National Home Study Council

**DeVRY TECHNICAL INSTITUTE**

4141 BELMONT AVE., CHICAGO 41, ILL. Dept. PE-11-L

I would like your valuable information-packed publication showing how I can get started toward a good job or my own business in Television-Radio-Electronics.

Name \_\_\_\_\_ Age \_\_\_\_\_  
Please Print  
Street \_\_\_\_\_ Apt. \_\_\_\_\_  
City \_\_\_\_\_ Zone \_\_\_\_\_ State \_\_\_\_\_  
D.T.I.'s Training is available in Canada

**DeVRY TECHNICAL INSTITUTE**  
FORMERLY  
**DeFOREST'S TRAINING, INC.**  
CHICAGO 41, ILLINOIS



I'LL SHOW YOU HOW TO

# FIX ANY TYPE RECORD CHANGER

as easily as an expert



—for big service profits or cash-saving home repairs

**EVEN** if you never changed a needle before, you can quickly learn to repair your own or other people's record changers. Brand-new instruction manual gives trouble-shooting and repair methods for all models.

Book is so clear, you can handle half the usual changer troubles in 3 or 4 days—advance quickly to difficult repairs. Step-by-step directions, fully illustrated, on everything from simple troubles to complex mechanical breakdowns.

**JUST OUT**



Makes every adjustment, replacement, or repair clear. Includes portables, high-fidelity units, tape-recorders. Helps you save money by keeping your own units in trouble-free service. Or start a profitable changer service business. Tells what you need, how to set up, how to make calls, etc. Rush coupon now!

**NO ELECTRONIC SKILL NEEDED**  
Simple mechanical work—easy to learn.

**—GOOD MONEY**  
when you do your own full or part time record changer repairs—book shows every step.

**INCLUDES HI-FI UNITS**  
Saves you money and avoids out-of-service delays. Shows easy-to-follow repair methods.



**McGraw-Hill Book Co., Inc., Dept. PEL-11**  
327 West 41st St., New York 18, N. Y.  
Send Ecklund's "Repairing Record Changers" for 10-DAY FREE EXAMINATION. If not satisfied, I will return it—pay nothing. Otherwise, I will keep it—send only \$5.95 plus delivery cost.

Name.....  
Address.....  
City..... State.....  
Company..... Position.....  
 **SAVE POSTAGE.** Check here if enclosing \$5.95 WITH coupon. Then WE pay delivery. Money back if you return book. PEL-11

**Covers:**

- Needles
- Records
- Pickups
- Motors
- Drives
- Tripping mechanisms
- Record dropping action
- Shut-offs
- Cycling pick-up arm
- 45-rpm changers and spindles
- etc.

for faultless playback of pre-recorded tape!

PROVIDING FULL FIDELITY PERFORMANCE—40-14,000 CPS at 7.5"

**\$59.95**

USER NET

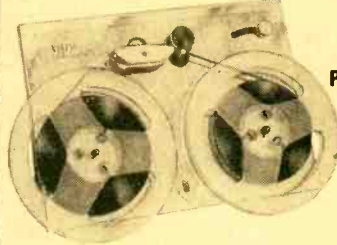

## VIKING Full Fidelity 75 TAPE DECK

• Check Viking's coordinated line of NARTB standard pre-amps, erase bias oscillators, record/playback amplifiers.

Sold thru dealers; write for information



**VIKING OF MINNEAPOLIS** Dept. PE11

3520 E. 43rd St., Minneapolis, Minn.

# SAVE UP TO 90% OFF LIST PRICES ON PARTS & TUBES

For every dollar you spend for parts or tubes you'll receive a coupon redeemable for FREE gifts! These gifts include Electrical Appliances, etc! Use them over the counter! Send for FREE PREMIUM CATALOGUE... But better yet place your order NOW. Start collecting these valuable coupons!

- All tubes individually boxed
- All tubes RTMA guaranteed for one full year
- Same day service

Several or one of these brands will be supplied on your order: Hallcrafters, Admiral, Stewart-Warner, Zenith, Emerson, Philco, Stanton, Crosley, Motorola, Sona, American, Muntz.

TYPE	PRICE	TYPE	PRICE	TYPE	PRICE	TYPE	PRICE
OZ4	.45	6AL7GT	.70	6SA7GT	.50	12SA7	.52
1B3GT	.79	6AS5	.50	6SC7	.50	12SH7	.47
1L4	.56	6AS6	2.00	6S07	.43	12SJ7GT	.50
1L6	.60	6AS7G	2.25	6S7	.45	12SK7	.50
1L4A	.66	6AT6	.40	6S7GT	.45	12SL7GT	.69
1L4B	.66	6AU5GT	.70	6SK7	.50	12SWGT	.60
1L6C	.66	6AV6	.46	6SL7GT	.70	12SQ7GT	.44
1L5	.66	6AV5GT	.85	6SN7GT	.60	14A5	.59
1L3	.66	6AX5GT	.59	6SQ7GT	.44	14A7	.45
1L5B	.66	6B4G	.90	6V6GT	.48	14B6	.40
1L4H	.66	6B8A	.49	6V4GT	.40	14Q7	.52
1L5	.49	6BC5	.55	6W6	.60	19B6GT	1.18
1N5GT	.55	6BE6	.50	6W6GT	.56	19L6	.66
1R4	.66	6B6GT	1.18	6X4	.35	19T8	.70
1R5	.67	6B8E	.61	6X5	.39	25A7GT	1.50
1S4	.65	6B8J	.49	6X5GT	.35	25AV5GT	.80
1S5	.65	6BK5	.70	6X8	.75	25B6GT	.90
1T4	.65	6BK7A	.78	6Y6G	.63	25Y5	.45
1U5	.50	6B8E	.59	7A4-XXL	.47	25Z5	.38
1V	.57	6B7GT	.77	7A5	.55	25Z6GT	.42
1X2A	.79	6B06GT	.88	7A6	.47	35A5	.48
2D21	1.00	6BQ7A	.80	7A7	.45	35B5	.52
2V3G	.80	6BZ7	.90	7A8	.46	35C5	.51
2X2A	1.00	6BY5G	.60	7B5	.45	35Z3	.41
3D6	.45	6C4	.39	7B7	.43	35W4	.39
3F4	.60	6C5	.36	7B8	.47	35Y4	.40
3Q4	.62	6C6	.50	7C4	.40	40A5	.45
3Q5GT	.63	6C6B5	.55	7C5	.44	35Z5GT	.39
3V4	.65	6C6DG	1.18	7C6	.45	50B5	.52
5T4	.70	6D6	.50	7F8	.70	50B5	.51
5U4G	.45	6E5	.55	7Y4	.33	50L6GT	.48
5V4G	.71	6F6	.40	12A76	.46	75	.44
5Y3GT	.39	6H6GT	.40	12A77	.68	77	.39
5Y4G	.43	6I4	2.30	12AUG	.46	78	.39
6A8	.59	6J5GT	.40	12AUI	.60	80	.35
6A8B	.48	6K6GT	.39	12AV6	.46	83V	.60
6AF4	.80	6L7	.44	12AX7	.70	117L7GT	.70
6AG5	.56	6N7	.61	12AY7	.90	117N7GT	.70
6AH6	.80	6Q7	.45	12BA6	.48	117P7GT	.70
6AK5	.80	6S4	.48	12B4	.70	117Z3	2.00
6AL5	.44	6S7G	.47	12BE6	.50	117Z6GT	.65
				12B7	.70		
				12BY7	.68		

**PARTS SPECIALS TILL DEC. 1ST**

**AC-DC PHONO-AMPLIFIER**  
Attention: Here's a unit that features tone control and volume control. Has 2-watt output. Comes complete with line cord and diagram. Completely wired and ready for use. Uses 50B5, 35W4, 12AT6, 1 diode. Usually boxed. Less tubes. Stock SE-158  
Lots of 6 Ea. **2.39**  
Each **2.49**  
Lots of 3, **2.59**  
Each **2.59**

**25 Paper BY-PASS CONDENSERS**  
25 assorted by-pass condensers. Most popular sizes and voltages. Stock No. SE-163.  
Kit of 25. **99c**  
Lots of 5 Kits **89c** ea.  
**89c** Kit

**MICA CONDENSER KITS**  
All popular sizes. For FM and T.V. use. Reg. list price **\$1.50**.  
Kit of 50. **1.75**  
Lots of 5, **1.75**  
No. SE-164

**RESISTOR KIT**  
100 ass't. resistors in most wanted ohms. RMA coded in 1/2, 1, 2 watt. List **\$12.50**.  
Each **99c**  
Kit **99c**  
Stock price **\$10**  
No. SE-123.

**CERAMICON**  
Assortment of 50 ceramic discs, bi-plates, tubular condensers. Popular sizes. List price **\$1.99** each.  
Lots of 5, ea. **1.89**  
Lots of 10, ea. **1.89**  
No. SE-162.

**UNIVERSAL**  
4-Prong Vibrator Stock No. SE-116  
Perfect Replacement for Malloy 294, 859, 901M. Also Radiart 5300, 5301, Vokar N.P.-42-V and many others. Can size 1 1/2 x 2 7/8". List price **\$4.90**. Individually boxed. **\$1.49** each.  
Lots of 10 \$1.29 each  
Stock price **\$1.50**  
Lots of 25 \$1.19 each  
Lots of 50, ea. **99c**

**FREE** order! 5-Pc. Sylvania Repair Kit. Value \$4.95. Includes: flashlight head, Phillips screwdriver, flat head screwdriver, alignment tool and polystyrene case.

Special Purpose Transmitting and Cathode Ray TUBES  
Send for parts and tube listing.

**TERMS:** 25% deposit required on all orders; balance COD. Save COD charges, send full remittance plus postage with order. All unused money refunded with order. NO MINIMUM ORDER.

OPEN ACCOUNT TO RATED FIRMS

Dept. PE-11

GRegory 1-2498

# Stanley ELECTRONICS CORP.

935 MAIN AVENUE - PASSAIC, N. J.

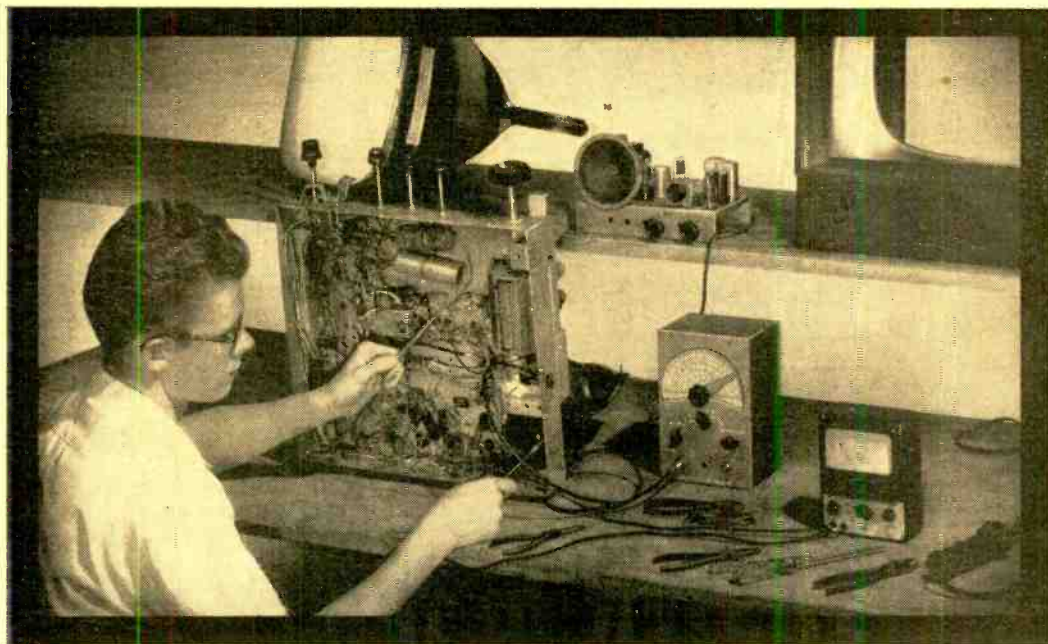

# NOW...RCA trains you at home to be an expert technician in RADIO TV ELECTRONICS • TV SERVICING • COLOR TV SERVICING

## NOW THREE HOME STUDY COURSES

... prepared by instructors of RCA Institutes in cooperation with technicians, engineers, and training specialists of RCA. Clearly written... easy to understand... the same high caliber instruction as given in resident classrooms of RCA INSTITUTES.

● **COURSE I—RADIO-TELEVISION ELECTRONICS**—starts you from the ground up to a solid working knowledge of electronics. Without any previous experience, you get a thorough training in radio theory and servicing techniques for AM, FM, home and car radios... plus an introduction to the fundamental theory and practices of television.

● **COURSE II—TELEVISION SERVICING**—prepares you to advance from radio into the expanding field of television servicing as a well-trained service technician. If you have completed Course I or are now working in the field of radio or TV, Course II will show you the many special techniques of trouble-shooting, aligning, checking, and repairing modern black and white TV sets.

## NEW TV KIT AVAILABLE WITH

**COURSE II**—there is no better way to learn than by *doing* and RCA Institutes has developed a large-screen TV KIT available to home study students to build while taking Course II. It has the most modern up-to-date circuitry, actually enabling you to apply at home all the latest servicing techniques.

● **COURSE III—COLOR TELEVISION SERVICING**—covers all phases of color servicing techniques. It is a practical, down-to-earth course in color theory as well as how-to-do-it servicing procedure. A natural move "up" from Course II or for those now employed in TV.

**SINCE 1909, RCA INSTITUTES** has trained thousands for successful careers in electronics. Many gradu-

ates have established their own paying business. Now this opportunity is available to you at home.

**"PAY-AS-YOU-LEARN" PLAN**... you pay for one study group at a time, as you progress through the course. Tuition costs are amazingly low. For full details, mail coupon.

**A SERVICE OF RADIO CORPORATION OF AMERICA—RCA INSTITUTES** is licensed by the N. Y. State Education Department... recommended by radio and television service organizations.

**SEND FOR  
FREE  
CATALOG  
NOW**



RCA Institutes, Inc., Home Study, PE-115  
350 West Fourth Street, N. Y. 14, N. Y.  
Without obligation, send me FREE CATALOG on Home Study Courses in Radio, Television and Color TV. No salesman will call.

Name \_\_\_\_\_  
Please Print  
Address \_\_\_\_\_  
City \_\_\_\_\_ Zone \_\_\_\_\_ State \_\_\_\_\_



**RCA INSTITUTES, INC.**  
A SERVICE OF RADIO CORPORATION of AMERICA  
350 WEST FOURTH STREET, NEW YORK 14, N. Y.



got a

# MECHANICAL SKILL?

*You'll go places*  
**FASTER in the**

# U.S. AIR FORCE!

**HERE'S WHY:** Men with mechanical skills find that they can get ahead in the U. S. Air Force. As an Airman, you'll have the chance to develop your technical ability and learn a skill that will pay well – and win you extra stripes. Such interesting

career fields as Aircraft and Engine Maintenance, Rocket Propulsion and Intricate Equipment Maintenance are open to you, if you qualify.

Don't delay—visit your local Air Force Recruiter, or mail the coupon.

**SEND FOR YOUR FREE BOOKLET**



M-28-PE

AIRMAN INFORMATION BRANCH  
Box 2202, Wright-Patterson AFB, Ohio

Please send me more information on my opportunities as an Airman in the U. S. Air Force.

Name \_\_\_\_\_

Address \_\_\_\_\_

City \_\_\_\_\_ Zone \_\_\_\_\_ State \_\_\_\_\_

# U. S. AIR FORCE

# HOW TO MAKE YOUR TIME WORTH \$95 AN HOUR!

Here's part of a letter we got from an I. C. S. student—

"Every spare-time hour I spent earning my I. C. S. diploma has been worth \$95 to me! My position, my \$7000 a year income, my home, my family's happiness—I owe to I. C. S."

Hardly a day goes by without a letter like this coming in from an I. C. S. student . . . from men and women of all ages who, in their spare time, at home, pulled themselves out of the small-pay rut and put themselves on the road to success.

Take the case of I. C. S. student Frank B. "I was making \$152 a month when I signed up with I. C. S.," he writes. "My present income is \$395.25 a month."

I. C. S. is the oldest and largest correspondence school. 277 courses. Business, industrial, engineering, academic, high school. One for you. Direct, job-related. Bedrock facts and theory plus practical application. Complete lesson and answer service. No skimping. Diploma to graduates.



**3 FREE BOOKS**—a 36-page pocket-size guide to advancement, a gold mine of tips on "How to Succeed." Also a big catalog outlining opportunities in your field of interest and a sample I. C. S. lesson text.

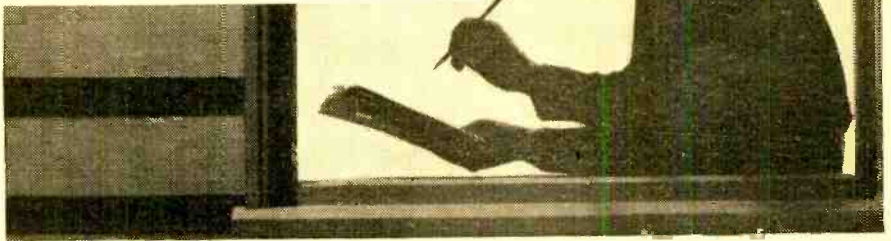

For Real Job Security—Get an I. C. S. Diploma! I. C. S., Scranton 9, Penna. Member, National Home Study Council

## INTERNATIONAL CORRESPONDENCE SCHOOLS



BOX 94295K, SCRANTON 9, PENNA.

(Partial list of 277 courses)

Without cost or obligation, send me "HOW TO SUCCEED" and the opportunity booklet about the field BEFORE which I have marked X (plus sample lesson):

- |  |   |  |   |   |
|--|---|--|---|---|
| <p><b>ARCHITECTURE and BUILDING CONSTRUCTION</b></p> <ul style="list-style-type: none"> <li><input type="checkbox"/> Air Conditioning—Refrig.</li> <li><input type="checkbox"/> Architecture</li> <li><input type="checkbox"/> Architectural Interior</li> <li><input type="checkbox"/> Building Contractor</li> <li><input type="checkbox"/> Building Maintenance</li> <li><input type="checkbox"/> Carpenter and Mill Work</li> <li><input type="checkbox"/> Estimating</li> <li><input type="checkbox"/> Heating</li> <li><input type="checkbox"/> Painting Contractor</li> <li><input type="checkbox"/> Plumbing</li> <li><input type="checkbox"/> Reading Arch. Blueprints</li> </ul> <p><b>ART</b></p> <ul style="list-style-type: none"> <li><input type="checkbox"/> Cartooning</li> <li><input type="checkbox"/> Commercial Art</li> <li><input type="checkbox"/> Fashion Illustrating</li> <li><input type="checkbox"/> Magazine Illustrating</li> <li><input type="checkbox"/> Show Card and Sign Lettering</li> <li><input type="checkbox"/> Sketching and Painting</li> </ul> <p><b>AUTOMOTIVE</b></p> <ul style="list-style-type: none"> <li><input type="checkbox"/> Auto Body Rebuilding</li> <li><input type="checkbox"/> Auto Elec. Technician</li> <li><input type="checkbox"/> Auto-Engine Tune Up</li> <li><input type="checkbox"/> Automobile</li> </ul> | <p><b>AVIATION</b></p> <ul style="list-style-type: none"> <li><input type="checkbox"/> Aeronautical Engineering Jr.</li> <li><input type="checkbox"/> Aircraft &amp; Engine Mechanic</li> </ul> <p><b>BUSINESS</b></p> <ul style="list-style-type: none"> <li><input type="checkbox"/> Advertising</li> <li><input type="checkbox"/> Bookkeeping and Accounting</li> <li><input type="checkbox"/> Business Administration</li> <li><input type="checkbox"/> Business Correspondence</li> <li><input type="checkbox"/> Public Accounting</li> <li><input type="checkbox"/> Creative Salesmanship</li> <li><input type="checkbox"/> Federal Tax</li> <li><input type="checkbox"/> Letter-writing Improvement</li> <li><input type="checkbox"/> Office Management</li> <li><input type="checkbox"/> Professional Secretary</li> <li><input type="checkbox"/> Retail Business Management</li> <li><input type="checkbox"/> Sales Management</li> <li><input type="checkbox"/> Stenographic-Secretarial</li> <li><input type="checkbox"/> Traffic Management</li> </ul> <p><b>CHEMISTRY</b></p> <ul style="list-style-type: none"> <li><input type="checkbox"/> Analytical Chemistry</li> <li><input type="checkbox"/> Chemical Engineering</li> <li><input type="checkbox"/> Chem. Lab. Technician</li> <li><input type="checkbox"/> General Chemistry</li> <li><input type="checkbox"/> Natural Gas Prod. &amp; Trans.</li> <li><input type="checkbox"/> Petroleum Engineering</li> <li><input type="checkbox"/> Plastics</li> <li><input type="checkbox"/> Pulp and Paper Making</li> </ul> | <p><b>CIVIL, STRUCTURAL ENGINEERING</b></p> <ul style="list-style-type: none"> <li><input type="checkbox"/> Civil Engineering</li> <li><input type="checkbox"/> Construction Engineering</li> <li><input type="checkbox"/> Highway Engineering</li> <li><input type="checkbox"/> Reading Struct. Blueprints</li> <li><input type="checkbox"/> Sanitary Engineering</li> <li><input type="checkbox"/> Structural Engineering</li> <li><input type="checkbox"/> Surveying and Mapping</li> </ul> <p><b>DRAFTING</b></p> <ul style="list-style-type: none"> <li><input type="checkbox"/> Aircraft Drafting</li> <li><input type="checkbox"/> Architectural Drafting</li> <li><input type="checkbox"/> Electrical Drafting</li> <li><input type="checkbox"/> Mechanical Drafting</li> <li><input type="checkbox"/> Mine Surveying and Mapping</li> <li><input type="checkbox"/> Plumbing Drawing and Estimating</li> <li><input type="checkbox"/> Structural Drafting</li> </ul> <p><b>ELECTRICAL</b></p> <ul style="list-style-type: none"> <li><input type="checkbox"/> Electrical Engineering</li> <li><input type="checkbox"/> Electrical Maintenance</li> <li><input type="checkbox"/> Electrician <input type="checkbox"/> Contracting</li> <li><input type="checkbox"/> Lineman</li> </ul> <p><b>HIGH SCHOOL</b></p> <ul style="list-style-type: none"> <li><input type="checkbox"/> Commercial <input type="checkbox"/> Good English</li> <li><input type="checkbox"/> High School Subjects</li> <li><input type="checkbox"/> Mathematics</li> </ul> | <p><b>LEADERSHIP</b></p> <ul style="list-style-type: none"> <li><input type="checkbox"/> Foremanship</li> <li><input type="checkbox"/> Industrial Supervision</li> <li><input type="checkbox"/> Leadership and Organization</li> <li><input type="checkbox"/> Personnel-Labor Relations</li> </ul> <p><b>MECHANICAL AND SHOP</b></p> <ul style="list-style-type: none"> <li><input type="checkbox"/> Gas—Electric Welding</li> <li><input type="checkbox"/> Heat Treatment <input type="checkbox"/> Metallurgy</li> <li><input type="checkbox"/> Industrial Engineering</li> <li><input type="checkbox"/> Industrial Instrumentation</li> <li><input type="checkbox"/> Industrial Supervision</li> <li><input type="checkbox"/> Internal Combustion Engines</li> <li><input type="checkbox"/> Machine Design-Drafting</li> <li><input type="checkbox"/> Machine Shop Inspection</li> <li><input type="checkbox"/> Machine Shop Practice</li> <li><input type="checkbox"/> Mechanical Engineering</li> <li><input type="checkbox"/> Quality Control</li> <li><input type="checkbox"/> Reading Shop Blueprints</li> <li><input type="checkbox"/> Refrigeration</li> <li><input type="checkbox"/> Sheet Metal Worker</li> <li><input type="checkbox"/> Tool Design <input type="checkbox"/> Toolmaking</li> </ul> <p><b>RADIO, TELEVISION</b></p> <ul style="list-style-type: none"> <li><input type="checkbox"/> Industrial Electronics</li> <li><input type="checkbox"/> Practical Radio TV Eng'ng</li> <li><input type="checkbox"/> Radio and TV Servicing</li> <li><input type="checkbox"/> Radio Operating</li> </ul> | <ul style="list-style-type: none"> <li><input type="checkbox"/> Television Technician</li> </ul> <p><b>RAILROAD</b></p> <ul style="list-style-type: none"> <li><input type="checkbox"/> Air Brakes <input type="checkbox"/> Car Inspector</li> <li><input type="checkbox"/> Diesel Locomotive</li> <li><input type="checkbox"/> Locomotive Engineer</li> <li><input type="checkbox"/> Section foreman</li> </ul> <p><b>STEAM AND DIESEL POWER</b></p> <ul style="list-style-type: none"> <li><input type="checkbox"/> Combustion Engineering</li> <li><input type="checkbox"/> Diesel—Elec. <input type="checkbox"/> Diesel Eng's</li> <li><input type="checkbox"/> Electric Light and Power</li> <li><input type="checkbox"/> Stationary Fireman</li> <li><input type="checkbox"/> Stationary Steam Engineering</li> </ul> <p><b>TEXTILE</b></p> <ul style="list-style-type: none"> <li><input type="checkbox"/> Carding and Spinning</li> <li><input type="checkbox"/> Cotton, Rayon, Woolen Mfg.</li> <li><input type="checkbox"/> Finishing and Dyeing</li> <li><input type="checkbox"/> Loom Fix'g <input type="checkbox"/> Textile Des'ng</li> <li><input type="checkbox"/> Textile Eng'g <input type="checkbox"/> Throwing</li> <li><input type="checkbox"/> Warping and Weaving</li> </ul> <p><b>MISCELLANEOUS</b></p> <ul style="list-style-type: none"> <li><input type="checkbox"/> Domestic Refrigeration</li> <li><input type="checkbox"/> Marine Engineering</li> <li><input type="checkbox"/> Ocean Navigation</li> <li><input type="checkbox"/> Professional Engineering</li> <li><input type="checkbox"/> Short Story Writing</li> <li><input type="checkbox"/> Telephony</li> </ul> |
|--|---|--|---|---|

Name \_\_\_\_\_ Age \_\_\_\_\_ Home Address \_\_\_\_\_

City \_\_\_\_\_ Zone \_\_\_\_\_ State \_\_\_\_\_ Working Hours \_\_\_\_\_ A.M. to P.M. \_\_\_\_\_

Occupation \_\_\_\_\_

Canadian residents send coupon to International Correspondence Schools, Canadian, Ltd., Montreal, Canada. . . . Special tuition rates to members of the U. S. Armed Forces.

# KNOW YOUR P'S AND Q'S ABOUT GOOD TEST EQUIPMENT

only EMC  
instruments  
give you ...

**Precision**  
components  
and assembly  
techniques  
insuring  
unexcelled

**Performance**  
and accuracy  
never before  
at such a low

**Price**  
with the  
famous EMC  
standards of

**Quality**  
all of which means  
you get a greater

**Quantity**  
of modern equipment  
for better,  
faster servicing.



## NEW RF Signal Generator

EMC Model 501  
with leads  
\$37.90 (Wired &  
Tested)  
\$24.90 (Kit Form)



NEW  
Resistance-Capacity  
Substitution Box  
EMC Model 900  
\$19.90 (Wired &  
Tested)  
\$10.25 (Kit Form)

Free

Yes, tell me more, send me — FREE — a  
detailed catalog of the complete EMC line.

Name .....  
Street .....  
City ..... State .....

PE-11

# EMC

ELECTRONIC MEASUREMENTS CORP.  
280 LAFAYETTE STREET  
NEW YORK 12, NEW YORK

EXPORT DEPT. - 370 BROADWAY, N. Y. 13, N. Y.

## Inca! Inca! Who's Got an Inca?

■ Suggest that reader Miller (September issue, page 10) try the *Stancor A-3833*.

F. O. SMITH  
Shreveport, La.

■ Substitute it with the *Stancor A-3833* or *Thor-darson T20A03*.

KEN KELLERMANN, K2AOE  
Great Neck, L. I., N. Y.

■ *Stancor A-3833* will do fine. I built the unit Mr. Miller mentions and worked six miles on first try.

BOB PODEWILES, W9RNI  
Milwaukee, Wis.

*Guess that settles it.*

## Hi-Fi: Keep It Coming!

■ Greatly appreciated your article in the September issue on "What You Should Know About Record Players," as I have been having quite a time selecting one. The article was informative.

ROBERT W. E. PETERSON  
Livingston, N. J.

■ I surely appreciate your study on hi-fi by sections as per your stories on phono pickups, distortion, etc. Keep up the good work!

JAMES H. VAN NEELAND  
FPO, New York, N. Y.

■ You can perform a terrific service if you will review equipment and chart characteristics of the various models on the market (tape recorders, amplifiers, etc.).

RAPHAEL HOFFMAN  
Greenbelt, Md.

## Electronic Fire Alarm

■ Although my primary interest is high fidelity and its related subjects, I was wondering if we could see plans on an electronic fire alarm system. Undoubtedly, many readers with young children would welcome this.

L. CLYDE HENDEE  
Chattanooga, Tenn.

*Excellent suggestion, Clyde, and we are pleased to report that progress is being made on just such a gadget to be published in POPtronics.*

## Single-Wire Antenna

■ We were having a discussion on a receiving antenna. Some books seem to say that if your antenna (single-wire) points north to south you receive from the east and west. Other books say the opposite. Which is right?

GERRY HOHN and RICHARD COBUTA  
Winnipeg, Manitoba

*In all probability, both radio books were correct. But wait a minute—don't blow your tops. The factor which has not been considered in your letter is the length of the single-wire antenna.*

*If the antenna is very long, it will receive best from areas slightly off of the ends. If it is short (and in some cases, resonant), it will receive best from directions at right angles to the plane of the antenna.*

*Thus, a single-wire antenna of fixed length will receive best from different directions at different frequencies.*





CARL E. SMITH, E. E.  
President

I can train you to pass your FCC License Exams in a minimum of time if you've had any practical experience — amateur, military, radio servicing, etc. We can put you on the road to success.



An  
Approved  
Member

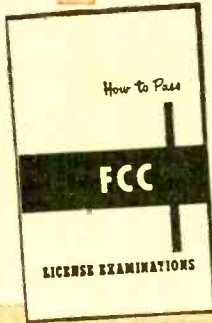

**FREE**

Tells where to apply and take FCC examinations, location of examining office, scope of knowledge required, approved way to prepare for FCC examinations, positive method of checking your knowledge before taking the examination.

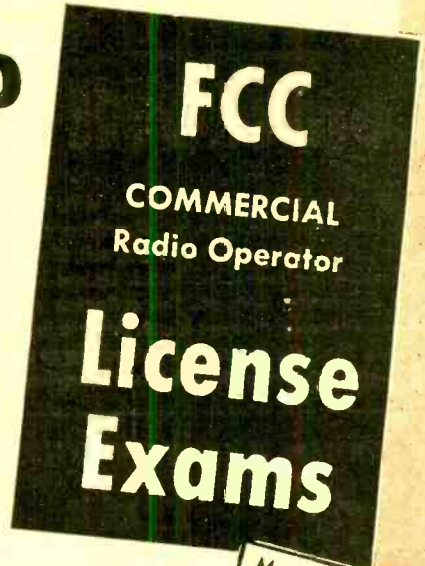

GET YOUR FCC TICKET IN A MINIMUM OF TIME

## Get This Valuable Booklet **FREE**

**TELLS HOW**

# WE GUARANTEE

To Train and Coach You at Home  
In Spare Time Until You Get

# YOUR FCC LICENSE

If You Have Had Any Practical Experience—Amateur, Military, Radio Repair, Experimenting, Etc.

**TELLS HOW**

**Our Effective  
JOB FINDING Service Helps CIRE  
Trainees Get Better Jobs—**

**INDUSTRIAL ELECTRONICS**—"Upon my discharge from the Navy I used your Job-Finding Service and as a result I was employed by North American Aviation in electronic assembly (final checkout)." Glen A. Furlong, Fresno, Calif.

**TELLS HOW**

**Employers Make  
JOB OFFERS Like These to Our  
Graduates Every Month . . .**

**WEST COAST MANUFACTURER**—"We are currently in need of men with electronics training or experience in radar maintenance, and we would appreciate if you will refer interested persons to us."

**CLEVELAND INSTITUTE OF RADIO ELECTRONICS**  
4900 Euclid Bldg. Desk PE-6 Cleveland 3, Ohio

Here's Proof FCC Licenses Are Often Obtained in a Few Hours of Study with Our Coaching at Home in Spare Time

	License	Time
A/IC Ronald H. Person, St. Louis 20, Mo.	1st	25 weeks
Carl Verboomen, Wrightstown, Wis.	1st	18 weeks
Marvin F. Kimball, Lafayette, Ind.	2nd	21 weeks
L. M. Bonino, Harlington AFB, Tex.	2nd	16 weeks

**MAIL THIS COUPON TODAY  
GET ALL 3 FREE!**



**CLEVELAND INSTITUTE OF  
RADIO ELECTRONICS**  
Desk PE-6, 4900 Euclid Bldg.,  
Cleveland 3, Ohio

I want to know how I can get my FCC ticket in a minimum of time. Send me your FREE booklet, "How to Pass FCC License Examination" (does not cover exam for Amateur License), as well as a Sample FCC-type lesson and the amazing new booklet "Money-Making FCC License Information." Be sure to tell me about your Television Engineering Course.

**PLEASE PRINT CLEARLY**

NAME .....

ADDRESS .....

CITY .....

STATE .....

**FOR PROMPT RESULTS SEND AIR MAIL**  
Special tuition rates to members of the U. S. Armed Forces  
Electronic Training Available To Canadian Residents

# It Won't Come Off!



All recording tape is coated with magnetic oxide. This coating rubs off ordinary tapes in use, and forms a harmful deposit of abrasive dust on the recording head. Unless the head is constantly cleaned, the collector of abrasive eventually wears it out. After a few playings, the tape loses enough coating to alter its original frequency response characteristic.

WITH TAPE MADE BY THE EXCLUSIVE



**irish**

BRAND

**FERRO-SHEEN  
PROCESS**

**The Oxide Will  
NOT Rub Off!**

The irish FERRO-SHEEN process of tape manufacture anchors the oxide coating to the base inseparably and much more smoothly. The entire vicious cycle of shedding and abrasion of recording head and tape is eliminated, resulting in longer life for both tape and head and improved frequency response.

**FERRO-SHEEN**  
is now available in  
these four quality  
**irish**  
BRAND  
TAPES



**SHAMROCK #300:** The ultimate in premium, professional tape for broadcast and studio use. 1200'...\$3.80 Hi-Fi net  
**LONG-PLAYING #600:** Extends playing time 50% over conventional tapes on some size reel. New Dupont 1-mil Mylar base. 1800'...\$5.50 Hi-Fi net  
**SOUND PLATE #220:** The super-tough tape pioneered by ORRadio, now on 1.5-mil Mylar, for masters and permanent program storage. 1200'...\$5.50 Hi-Fi net  
**DOUBLE-PLAY #7-2400:** Now, 2400' on standard 7" reel, doubling playing time at all speeds. 2400'...\$7.50 Hi-Fi net

If not available at your local dealer's, write direct to:  
**ORRADIO INDUSTRIES, INC., Opelika 1, Ala.**  
Export Division: Morhan Exporting Corp., N. Y. C.  
In Canada: Atlas Radio Corp., Ltd., Toronto

## Receiver Plans

■ I think you could have given a better answer to a request for a "simple FM radio" in this department, July issue. While it is true that a fairly complex receiver is required to take full advantages of FM transmissions, I'm sure your readers would appreciate a clever version of a 2- or 3-tube superregenerative receiver using the slope of the detection curve for demodulating FM signals. Such sets are capable of amazing sensitivity with simple antennas. The lack of high fidelity in such a set would not discourage a set-building enthusiast.

In an earlier issue, which I cannot locate right now (it may have been RADIO & TELEVISION NEWS), you gave a very discouraging answer to a request for a long-wave receiver. I believe many readers would like to have such a set. Using modern tubes with their high efficiency, easy-to-get inductances like chokes or r.f. pies could be utilized. Anyone going for a commercial ticket would do well to stand an 8 to 12 p.m. evening watch on 500 kc. now and then. The easy and clean rhythm of old professional lists on the low frequencies is something that all c.w. students should appreciate.

I really like your friendly edited magazines, but please do not turn down requests for receiver plans. There should be some sort of radio receiver in every issue, in my humble opinion.

EDWARD G. SLUKA  
Riverside, Ill.

*We hesitate to believe that a superregenerative receiver using slope detection could afford reasonably good FM reception. Such circuits will work, but they leave much to be desired when the constructor specifically wants to use a loudspeaker.*

*It cannot be denied that many readers would like to have long-wave receivers, but—unfortunately—there are few models commercially available at reasonable prices.*

*We will continue to look for plans for a simple FM tuner. As a matter of fact, a fairly good design was published in RADIO & TELEVISION NEWS about two years ago. We hope to be able to modify that set for use in POPULAR ELECTRONICS.*

## Building Tape Recorders

■ Please put in POP'tronics plans which will enable me to build my own tape recorder.

CHARES DEE COE  
Silverton, Ore.

*This is not an easy or simple task. In fact, we would be inclined to believe that it is too difficult. Tape transports are available, but the reader would be much better off to buy the oscillator bias supply at the same time. Building a tape transport is impossible at present.*

## Inventor of Bath Signal

■ I think a few words of appreciation are due Mr. Morris G. Moses, W8UVC, who invented the bath signaling gadget mentioned on page 41 of your September issue.

M. BLAÑ  
New York, N. Y.

And there they are.

—30—

The New Streamlined Model TC-55

# TUBE TESTER

TESTS TUBES IN LESS TIME THAN IS REQUIRED TO SET-UP AND ADJUST OLDER, COMPLICATED MODELS!

The first realistic approach towards solving the problems of quickly testing the ever increasing number of tube types used in Radio, Hi-Fi, Monochrome and Color TV.



Speedy, yet efficient operation is accomplished by:

1. Simplification of all switching and controls.
2. Elimination of old style sockets used for testing obsolete tubes (26, 27, 57, 59, etc.) and providing sockets and circuits for efficiently testing the new Noval and Sub-Minar types.

The Model TC-55 will of course also test the Octal, Loctal and 7 pin Miniature types. Although the TC-55 is a comparatively low-priced tester, it will we feel sure, be used more frequently than your higher-priced tube tester if you have one; for this new, streamlined model will often test a tube in a shorter time than would be required to set up and adjust some of the older, complicated tube testers.

## FEATURES

### ✓ YOU CAN'T INSERT A TUBE IN THE WRONG SOCKET.

It is impossible to insert the tube in the wrong socket when using the new Model TC-55. Separate sockets are used, one for each type of tube base. If the tube fits in the socket it can be tested.

### ✓ "FREE-POINT" ELEMENT SWITCHING SYSTEM.

The Model TC-55 incorporates a newly designed element selector switch system which reduces the possibility of obsolescence to an absolute minimum. Any pin may be used as a filament pin and the voltage applied between that pin and any other pin, or even the "top-cap." Please note this is not a variation of the commonly used "floating-filament" arrangement but instead represents a real advance in design, inasmuch as it provides a true "free-point" system. Tubes having tapped filaments and tubes with filaments terminating in more than 1 pin are truly tested with the Model TC-55 as any of the pins may be placed in neutral position when necessary.

### ✓ EACH SECTION IN MULTI-PURPOSE TUBES IS TESTED SEPARATELY.

The new free-point system described above permits the Model TC-55 to overcome the difficulties encountered with other emission type tube testers when checking Diode, Triode and Pentode sections of multi-purpose tubes, because sections can be tested individually. The special isolating circuit allows each section to be tested as if it were in a separate envelope.

The Model TC-55 comes complete with operating instructions and charts. Housed in rugged steel cabinet. Use it on the bench — use it for field calls. A streamlined carrying case, included at no extra charge, accommodates the tester and book of instructions.

**\$26<sup>95</sup>**

# SHIPPED ON APPROVAL NO MONEY WITH ORDER — NO C. O. D.

Try it for 10 days before you buy. If completely satisfied then send \$6.95 and pay balance at rate of \$5.00 per month for 4 months — No Interest or Finance Charges Added! If not completely satisfied, return to us, no explanation necessary.

MOSS ELECTRONIC DIST. CO., INC.  
Dept. D-177 3849 Tenth Ave., New York 34, N. Y.

Please rush 1 Model TC-55. I agree to pay \$6.95 within 10 days after receipt and \$5.00 per month thereafter.

Name \_\_\_\_\_

Address \_\_\_\_\_

City \_\_\_\_\_ Zone \_\_\_\_\_ State \_\_\_\_\_

# LIFETIME GUARANTEED TUBES

## BRAND NEW PICTURE TUBES

• RCA Licensed.  
• One Year Unconditional Guarantee.

Type	Price	Type	Price
10BP4	\$11.90	17BP4	\$20.63
12LP4	14.38	19AP4	24.81
14BP4	16.85	21AP4	28.79
16RP4	19.38	21EP4	28.79
16LP4	19.38	24AP4	42.50

Picture Tubes shipped F.O.B. Harrison, N.J.

## NEW INDOOR ANTENNA

Both UHF and VHF. Brings better reception than most outdoor antennas. Use on top of TV.

List Price \$9.95. \$3.99 each  
**YOUR PRICE \$3.29** each Lots of 3

## FREE BONUS BOX With Every \$25 Order

- 1 RCA Cheater Cord
- 10 Assorted resistors
- 10 Assorted 2 Color "blank" tube cartons
- 1 8B26GT tube
- 1 6AU6 tube
- 1 6CB6 tube

## FREE CLOCK RADIO

With Every \$125 Purchase Within 30 Days Wakemaster clock radio with famous Sessions clock movement wakes you up to music or alarm. May be purchased outright from MAJOR BRAND for \$17.95. In ivory or rust.

## FREE GIFT CERTIFICATE\*

Worth \$5 toward the purchase of any of our merchandise on future orders will be sent with any order of \$50 or more. \*Free Gift Certificate cannot be used to obtain another certificate unless order is \$55 or more.

WE PAY ALL POSTAGE on orders shipped in USA, Territories and APO's. Send only purchase price of merchandise. Please include approximate postage on foreign shipments. All orders subject to prior sale. Add 25¢ handling on orders under \$5.00. Quantity users write for special discount.

Write For FREE Tube List—Order Blank—and FREE Sample Tube Carton. We want Y-O-U On Our Mailing List!

• We guarantee to replace tubes labeled MAJOR BRAND forever. Each Tube Individually Boxed And Guaranteed For Life. • Over A Half Million Tubes Always In Stock • Immediate Shipment • Free Postage On All Orders With Full Remittance.

## HERE'S HOW LIFETIME GUARANTEED TUBES

### SAVE YOU MONEY

• There are fewer "call backs" • There are no "out of date" tubes. • "Peak Performance" testing in our fully equipped Testing Department before shipment guarantees quality.

02A .43	38N6 .70	6AX4GT .60	6K8 .65	7C6 .43	14B6 .38
1A4P .33	3CB6 .52	6AX5GT .57	6L6 .68	7C7 .45	14Q7 .50
187GT .43	3Q4 .46	6B4Q .52	6L7 .42	7E3 .45	19B6G 1.15
183GT .65	3Q5GT .57	6B8 .69	6N7 .60	7E6 .55	19T8 .65
1C5GT .41	354 .47	6BA6 .47	6Q7 .40	7E7 .70	24A .39
1D5GT .43	3V4 .47	6B8A .58	6S4 .40	7F7 .59	25AV5GT .78
1E7GT .41	58Q7 .89	6B8T .47	6S7 .45	7F8 .70	25BQ5GT .76
1G6GT .41	4BZ7 .95	6B7 .50	6S7 .48	7G7 .75	25L6GT .47
1W4C .43	5AW4 .75	6B6 .45	6S7 .41	7M7 .50	25W4GT .43
1H5GT .47	5J6 .63	6B5 .40	6SH7 .43	7J7 .75	25Z5 .37
116GT .47	5T4 .69	6B6 .50	6S17 .43	7K7 .75	25Z6 .37
1L4 .48	5U4G .43	6B06G 1.15	6SK7 .45	7L7 .75	27 .25
1L6 .58	5U8 .74	6B8 .50	6SL7GT .55	7N7 .50	35A5 .46
1L4A .57	5V4Q .59	6B16 .47	6SN7GT .85	12AT6 .37	35B5 .50
1L8A .47	5Y3 .31	6BK5 .68	6SQ7 .39	12AT7 .68	35C5 .50
1L84 .57	5Y4Q .36	6BK7 .76	6SR7 .42	12AZ7 .63	35L6GT .47
1LCS .49	5Z3 .41	6BL7GT .75	6S7 .41	12AUG .41	35W4 .34
1LC6 .47	6A7 .57	6BN6 .58	6T4 .95	12AU7 .53	38V4 .34
1LD5 .57	6A8 .45	6BQ6GT .78	6T8 .68	12AV6 .35	35Z3 .39
1LNS .57	6A4A .43	6BQ7 .78	6VB .75	12AV7 .35	35Z5GT .34
1LG5 .57	6AC7 .67	6BYSG .58	6V3 .80	12AX4GT .65	37 .29
1LM4 .64	6AF4 .79	6BZ7 .88	6V6GT .46	12AX7 .58	50A5 .46
1LNS5 .47	6AG5 .50	6C4 .37	6W4GT .39	12B4 .68	50B5 .50
1NS5GT .50	6AM6 .69	6CB6 .49	6X4 .34	12BD6 .48	50L6GT .43
1R5 .50	6AJ5 .70	6CD6G 1.15	6X5 .34	12BE6 .46	75 .42
155 .42	6AK5 .54	6C6 .48	6X8 .75	12B7 .60	76 .42
174 .50	6AL5 .39	6E5 .44	6Y6 .55	12B77 .65	77 .38
1U4 .47	6AQ5 .46	6F5 .37	7A4 .45	12BZ7 .61	78 .38
1U5 .42	6ARS .46	6F6 .38	7A5 .53	12CUG .95	80 .34
1V2 .65	6AS5 .48	6G8 .40	7A6A .45	12M7 .60	86 24 .44
1X2 .61	6AS6 1.70	6H6 .38	7A7 .43	12S7 .45	117L7GT .45
2A3 .55	6A57Q 2.19	6J4 1.78	7A8 .45	12SK7 .45	117N7GT 1.09
2A5 .57	6AT6 .39	6J8 .39	7B5 .45	12SN7GT .56	117P7GT 1.09
2A7 .55	6AU4GT .65	6J6 .47	7B6 .42	12SQ7 .37	117R7GT 1.09
3A4 .51	6AUSGT .59	6J7 .43	7B7 .41	12SR7 .45	117T7GT 1.09
3A5 .45	6AUE .42	6J8 .48	7B8 .45	12TGT .45	117Z3 .35
3A6 .46	6AV5GT .65	6K6GT .37	7C4 .39	12X4 .37	117Z6GT .63
3BC5 .84	6AV6 .39	6K7 .39	7C5 .42	14A7 .42	

### This Ad Is Worth M-O-N-E-Y

Clip out this ad and attach it to your order. Three 6SN7GT's will be shipped FREE with any order of \$10 or more.

Write Dept. 11 PE

# MAJOR BRAND TUBE CO.

Romano Bldg. ESsex 4-1106 Harrison, N. J.



# HIGH-PAY CAREERS

IN ELECTRONICS — TELEVISION — RADIO

## Await Men with COMPLETE Training!

Nationally-recognized, accredited Central training is designed to get you into high-paying career positions in the shortest possible time. In addition, Central's "Progressive Plan" is so arranged that each phase of training you complete qualifies you for a more important, better-pay position. In just a few short weeks you are qualified for certain basic jobs. Then, with every additional training phase that you complete, you qualify "up the ladder" for more advanced types of positions. Central offers complete Electronics-TV-Radio training leading to an Associate of Science degree, and qualifying you as an *Electronics Engineering Technician!*

Thousands of Central graduates have been placed at almost every technical level in the electronics industry. Free nation-wide placement service.

Don't limit yourself! Get the facts on Centrals complete training that can take you just as far as you want to go in the electronics technician field. Send coupon today for FREE brochure on your opportunities in Electronics.

**VETERANS!** Central offers courses approved under G.I. Bill

## CENTRAL TECHNICAL INSTITUTE

Dept. A-115, 1644 Wyandotte St., Kansas City 8, Mo.

Tell me more about how you can qualify me for a high-pay Electronics career.

Name \_\_\_\_\_ Age \_\_\_\_\_

Address \_\_\_\_\_

City \_\_\_\_\_ State \_\_\_\_\_

If Korean veteran, give approximate discharge date \_\_\_\_\_

## 3 PROVEN TRAINING PLANS

(Choose the one that fits your requirements)

- 1. HOME STUDY COURSE** (with 9 kits of equipment)—Qualifies you for diploma, FCC license, and a variety of electronics jobs (or transfer into advanced resident training).
- 2. HOME STUDY-RESIDENT COURSE** (with 9 kits of equipment)—Home study, followed by short period of resident training. Qualifies you for diploma, FCC license, and a wide variety of Electronics-TV-Radio positions (or continue with advanced resident training). An accredited technical institute curriculum.
- 3. FULL RESIDENT COURSE**—Qualifies you for Associate of Science (A.S.) degree and top-pay employment opportunities as Electronics Engineering Technician. Part-time employment opportunities available for students while training. An accredited technical institute curriculum.

# ★ Surplus Bargains ★

LEEDS & NORTHRUP

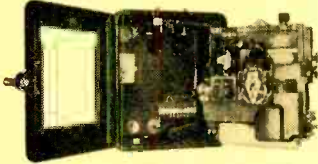

## MICROMAX RECORDERS

Strip type recorders used for controlling and recording a wide variety of processes. Used originally for temp. range of 350-550 degrees C. May be changed for other applications. Operates on Wheatstone bridge principle using AC galvanometer movement. Original cost several times our price. Units were removed from demilitarized equipment which in many cases was new, but all instruments sold as used and guaranteed. Money back \$179.50 if not satisfied. PRICE ea.

**\$179.50**

## RL-42-B Antenna Reel/Motor

**—\$2.50**

Used originally for remote controlling of automatic trailing wire antenna. Motor is 3/8 HP, 24 V. DC with oil-less sleeve bearings. The gear train, breaking and disconnect mechanism, reversible and variable speed motor makes this an ideal unit for conversion to coil winders, etc. Ship. wgt. approx. 5 lbs.

PRICE. Used...\$2.50 New... **\$3.95**

## TU-7, TU-26, and TU-10-B Tuning Units—\$1.95 ea.

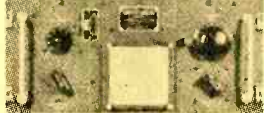

Used in the BC-375 transmitter, but the most favorable and acceptable piece of surplus gear for obtaining good cheap useable parts. The TU-10-B contains three double spaced transmitting type variable condensers of 16, 27, and 7 plate varieties, 3 mica transmitting type micas, 2 isolantite shaft couplings, antenna coupling switch, two precision vernier dials, chokes, inductances and other useful parts. Better order plenty before supply is exhausted again. TU-7 and TU-26 also in stock, same price. Ship. wt. 13 lbs. Size 4 1/2" x 16 1/2" x 7 1/2". PRICE.

Used, ea. ...\$1.95 New, ea. ... **\$2.50**



**Rectifier Special!**  
For Model Trains—  
**\$1.50 ea.**

24 V. DC 3 Amp. Selenium rectifiers—\$1.50 ea. Just what you have been waiting for—a selenium rectifier to give you the DC source for operation of the many surplus items. Make up your power supply to deliver from 12 to 28 V. DC with these rectifiers and your AC source of from 18 to 36 volts. Parallel several for greater amperage cad. Measures 5 1/2" x 1 3/4" x 1 1/4". Brand new, ea. **\$1.50**

Only

**\$4.95**

## BC-455-B Receiver



Ideal receiver for mobile or fixed operation with excellent sensitivity and frequency stability. New surplus release order—new supply will not last long at this price. For 6-9.1 Mc. operation. Complete with tubes and guaranteed. Less dynamotor. PRICE.

Used, ea. ...\$4.95 New, ea. ... **\$6.95**

## R-1/ARR-1 RECEIVER—\$2.95



Described in "Radio TV News" Jan. 1949 for use as 220 Mc. converter. Essentially a two stage RF acorn tube superhet converter as it now stands. Also can be used for a preselector. Small enough for mobile only 3 1/2" W x 3" H x 10" D. Rugged Aluminum construction. Has four 954 acorn tubes. Filaments now operate on 12 or 24 volts by merely throwing switch in unit or can be easily modified for 6 V. operation. Dial is calibrated in range of 234-258 Mc. Operation can be changed for use from 50 to possibly 300 Mc. Wgt. of unit 4 lbs. Cover not shown but included. Complete with conversion as written in above mag. Brand new demilitarized units.

PRICE. Brand new... **\$2.95**

ARR-1 Antennas for above receiver and frequencies. New, ea. **\$1.25**

Co-axial antenna relay for use with above or other transmitter-receiver combinations. New, ea. **\$1.25**

## MALLORY AC CAP. SELECTOR—\$1.95

Brand New Mallory MSS-100 capacity selector for determining correct capacity for making replacements or starting some of the surplus 3 phase motors on single phase current. Only a fraction of original cost. Ship. wgt. 2 lbs.

PRICE. New... **\$1.95**

## CRYSTALS—50 for \$4.95

Quartz crystals in various holders. As received from Signal Corp Surplus. Not picked over but chosen at random, from supply of over 1/2 million. All guaranteed.

PRICE. 50 for... **\$4.95**

100 for... **\$7.95**

## Miniature Storage Batteries (For Pocket Radio & Radio Control)



BB-51, 6 V. Miniature consisting of 3 lead acid cells delivering 6 V. for 2.75 hours through a 30 ohm resistance. Pin type terminals. Size overall 4-3/16" x 1 1/4" x 15/16", wgt. approx. 5 ozs. New, dry-charged, ea. **\$1.75**

BB-52, 36 V. Miniature consisting of 18 lead acid cells delivering 36 volts for 3 hrs. through a 1200 ohm resistance. Pin type terminals. Size overall 4 1/2" x 1-7/16" x 15/16". Wgt. approx. 5 ozs. New, dry-charged, ea. **\$1.95**

## BC-AS-230 TRANSMITTER—\$3.95



Brand new transmitters made to operate on 12 V. DC. Ideal for mobile use in new cars with 12 V. system. Contains four tubes with power output of approx. 25 watts. 0-1.5 amp. RF ammeter alone worth the price. Freq. range 195-13,975 kc. with full set of plug-in coils; only one coil included in content when checked at random. Wgt. approx. 13 lbs. Shock mt. included.

PRICE. BRAND NEW... **\$3.95**

## T-39/APQ-9 RADAR XMTR



Described in Feb. '50 "CQ" for conversion for the 420-450 Mc. amateur band and citizens band. Also contains many parts for the CEF experimenter such as 2-8012 tubes, fan and motor, switches, pots, gears, counter, etc. Equipment removed from aircraft. Our Close Out, quantity limited. Ship. wgt. 43 lbs.

PRICE, ea. **\$4.95**

## Torque Amplifier, New, \$9.75 ea.

Ideal unit for your application for power steering, antenna rotation, or power control of any rotating device. Small amount of power applied to input shaft is reproduced in any direction with greatly multiplied torque on the output shaft. Speed varies directly in any direction according to input. 110 V. AC 1/40 hp. motor supplies added torque through gear and mechanical hookups. Motor requires capacitor of 85-120 mfd. for single phase starting. Mallory cap. selector listed in this ad ideally suited. These were used on gun control device by the Government and cost hundreds of dollars to mfg. Get one or more now for future applications as these surely won't last long and will be hard to locate later. Unit fully enclosed in aluminum case size overall 12" h x 5 3/4" w x 7 1/2" d. Wgt. 23 lbs. Packed approx. 30 lbs.

BRAND NEW. orig. pack, ea. **\$9.75**



Complete Pack BB-208. Includes three of the BB-52 and one of the BB-51 storage batteries above, all packed in vacuum sealed can. Price, new, dry-charged, ea. **\$6.00**

BB-54-A, 2 V. 34AH. Plastic case size 4" x 3" x 5 3/4" h. Dry-charged, fill with 1.265 spec. g. sulphuric acid. **\$1.95**

Wgt. 3 1/2 lbs., ea.

Remit shipping charge and instructions with all orders, otherwise order will be shipped express collect. All items guaranteed to your satisfaction or money refunded if returned within 10 days of receipt. Minimum order \$5.00.

# ESSE

RADIO CO. • 42 WEST SOUTH STREET • INDIANAPOLIS 25, INDIANA

November, 1955

21

free!

# 1956 ALLIED

## ELECTRONIC SUPPLY CATALOG

324  
value-packed  
pages

Save on Everything  
in TV and Radio  
Parts & Equipment



Everything for Experimenters,  
Builders, Amateurs, Servicemen,  
Engineers & Hi-Fi Specialists

Send for ALLIED's big 324-page value-packed guide to *everything* in TV, Radio and Electronics! Select from the world's largest stocks of High Fidelity systems and components; recorders and phono equipment; TV tubes, antennas and accessories; Amateur station equipment and supplies; P.A. systems; test instruments; latest build-your-own kits; industrial electronic supplies—plus *everything* in electronic parts, tubes, transistors, tools and books. Save on everything in Electronics—send today for your FREE 1956 ALLIED Catalog.

Everything in Electronics  
From One Reliable Source

send for it

FREE  
CATALOG

## ALLIED RADIO

ALLIED RADIO CORP., Dept. 79-L-5  
100 N. Western Ave., Chicago 80, Ill.

Rush FREE 1956 ALLIED 324-Page Catalog

Name \_\_\_\_\_

Address \_\_\_\_\_

City \_\_\_\_\_ Zone \_\_\_\_\_ State \_\_\_\_\_

# WHAT'S THE PE ANSWER?

## Speed of Radio Waves

I would like to know the relationship between the speed of sound (720 mph) and the speed of r.f. and light (186,230 mps). I understand that sound merges into r.f. and r.f. into light as the frequency grows higher in cps.

WOODY GIBSON  
West Hartford, Conn.

There is no definite relationship between the speed of sound waves and the speed of radio waves. Two entirely different methods of propagation are involved. Sound waves, which travel about 1100 feet per second (720 miles per hour) in air at sea level, may be generated at frequencies up to several million cycles. When the highest frequency audible to the human ear (about 18,000 cycles) is exceeded, the term "ultrasonic waves" is applied, but such waves do not take on the characteristics of radio frequency waves.

Conversely, although radio frequency waves as low as 10,000 cycles (or lower) may be generated, these waves are not audible and are still propagated at the speed of light (about 186,000 miles per second).

## Licensing and the FCC

I would like to know what licenses, if any, are necessary for a set of Army surplus "hand-talkies" and how to obtain them.

ROGER LEE MCKENZIE  
Williamsburg, Ohio

Would you please tell me if it is necessary to obtain a license from the FCC in order to operate a walkie-talkie?

LEON KAUFMAN  
Philadelphia, Pa.

What are the possibilities of seeing in your magazine an article on the construction of a portable transceiver operating on the Citizens band?

RICHARD ULIN  
Burbank, Calif.

Is it possible for an amateur to get a license or permit to operate a transmitter and receiver set in an automobile. If so, how can the permit be obtained?

CLARENCE VANCE, JR.  
Jackson, Mich.

It is evident from the large number of requests similar to the above that many of our readers would like more information on the subject of licensing. As a result, full details on radio amateur licenses are being published in our monthly column entitled "The Transmitting Tower." This column started in the August issue. With certain limitations, properly licensed amateurs are permitted to operate

Get This Valuable Book

Just for Examining COYNE'S New 6-Volume Set

**FREE**



*"Applied Practical Radio-Television"*

**ON 7 DAY  
FREE  
TRIAL!**



Yes, you get this big, brand new book, "150 Radio-Television Picture Patterns and Diagrams Explained", absolutely FREE! Just off the press! Gives complete wiring circuits and diagrams on the latest Radio and Television Sets. Easy-to-read, large 8 1/2 x 11" pages, with full instructions on how to read and use the diagrams. A "must" in every Radio and Television service-man's repair kit. You get this valuable book as a FREE Gift for asking to see Coyne's great new 6-book set, "Applied Practical Radio-Television"!

**Here's "Know-How" That Makes You Worth More!** Coyne's great new 6-volume set gives you all the answers to servicing problems—quickly! For basic "know-how" that is easy to understand, you'll find everything you want, in volumes 1 to 5 which contain over 5000 practical facts and data. They cover every step from principles to installing, servicing, trouble-shooting and aligning all types of radio and TV sets. So up-to-date it includes COLOR TV and UHF, adapters and converters. Also covers very latest information on **TRANSISTORS**.

**900-Page Television Cyclopeda Included** And then, for speedy on-the-job use, you get volume 6—the famous Coyne **TELEVISION CYCLOPEDIA**. It answers today's television problems on servicing, alignment, installation and others. In easy-to-find ABC order, cross indexed. Use this 6 volume **TV-RADIO LIBRARY** free for 7 days; get the valuable Servicing Book **ABSOLUTELY FREE!**

Educational Book Publishing Division

**COYNE**

**ELECTRICAL SCHOOL**

500 S. Paulina St., Dept. B5-PE Chicago 12, Ill.

**SEND NO MONEY!** Just mail coupon for 6-volume set on 7 days free trial. We'll include book of 150 TV-Radio Patterns & Diagrams. If you keep the set, pay \$2 in 7 days and \$2 per month until \$22.50 plus postage is paid. (Cash price \$20.95). Or you can return the library at our expense in 7 days and owe nothing. **YOU BE THE JUDGE. Either way, the book of TV-Radio Patterns is yours FREE to keep!** Offer is limited. Act NOW!

**FREE BOOK—FREE TRIAL COUPON!**

- Coyne Electrical School, Educational Book Publ. Div., Dept. B5-PE, 500 S. Paulina St., Chicago 12, Ill.
- YES! Send 6-volume "Applied Practical Radio-Television" for 7 days FREE TRIAL per your offer. Include TV-Radio Patterns & Diagram Book FREE.

Name..... Age.....

Address.....

City..... Zone..... State.....

Where Employed.....

( ) Check here if you want library sent COD. You pay postman \$20.95 plus COD postage on delivery. 7-day money-back guarantee.



*Because You Asked for It!*

**NEW! DIFFERENT!**

**HOLLYWOOD  
CRT DYNAMIC RESTORER**

ONLY **\$49<sup>95</sup>** AT YOUR DISTRIBUTORS  
STANDARD RETMA WARRANTY

**NO MORE NEON LAMPS!**

READS ALL CONDITIONS ON A HIGHLY SENSITIVE, ILLUMINATED METER

**READS DIRECTLY ON METER**

- FILAMENT CONTINUITY
- LEAKAGE
- INTERMITTENT CONDITIONS OF SHORTS OR OPENS
- SHORTED ELEMENTS
- GAS CONTENT
- QUALITY ON A "BAD-GOOD" SCALE
- OPEN ELEMENTS (CHECKS ACTUAL RESISTANCE OF WELD INDICATING QUALITY OF WELD)

For further information write

- ELIMINATES OXIDATION
- RESTORES EMISSION
- WELDS OPEN ELEMENTS
- REMOVES SHORTS AND LEAKAGE —DISPERSES GAS

SPECIALLY DESIGNED TRANSFORMER PRODUCES MOST SUCCESSFUL CATHODE WELD

**ANOTHER HOLLYWOOD FIRST!**

New KILOVOLTER measures to 30 KV. Instrument complete with HV PROBE **\$9<sup>95</sup>**

**HOLLYWOOD INSTRUMENT CO.**

206 S. MAIN ST.,  
ROYAL OAK, MICHIGAN

ORIGINAL DESIGNERS OF CRT RESTORING INSTRUMENTS. MFRS. OF MIDWEST CATHODE BEAMER

Of this  
you can be sure...

*there is no finer*

Record Changer than  
the

**Collaro**  
**RC-54**

*Automatic Intermix*

- + Supplied with pre-cut Mounting Board, Power Cord and Audio Cable.
- + Automatically Intermixes All Size Records without Presetting.
- + Rapid, 7-second Change-over Cycles  
... and other outstanding features



You can SEE it at your Sound Dealer.

You can READ about it in our Folder.

Mail This Coupon Today

**ROCKBAR CORPORATION, Dept. YL-18**  
215 East 37th St., New York 16, N. Y.

Please send Literature describing the  
Collaro RC-54 Record Changer.

NAME \_\_\_\_\_

ADDRESS \_\_\_\_\_

CITY \_\_\_\_\_ ZONE \_\_\_\_\_ STATE \_\_\_\_\_

transmitting and receiving equipment in their personal automobiles.

In general, all transmitting devices used for communications purposes must be licensed by the Federal Communications Commission, regardless of the range and intended use. Equipment for the 460-470 mc. Citizens band must meet certain performance standards and must be approved by the FCC. This requirement prevents the use of home-constructed equipment for the band.

Complete details on equipment and licensing requirements for radio control appeared in the R/C Notes column for July, page 59, so they will not be repeated here. Similar details on Canadian requirements were published in the R/C Notes column for August, page 73.

If there is any question in your mind regarding the necessity of obtaining a license, it is best to contact the FCC, Washington 25, D. C. For the price of a three-cent stamp, future trouble may be avoided!

### Resonant Frequency of Ferrite Coils

Is there a formula for computing inductance and resonant frequency of ferrite slug-tuned coils? If so, would you please print it?

**BILL RAGSDALE**  
Paso Robles, Calif.

To the best of our knowledge, there is no set formula for making such computations. There are so many variables involved that it appears unlikely that a usable formula can be developed for this purpose.

### FM Commercial Eliminator

In Miami Beach, WLRD-FM broadcasts a note between 16,000 and 20,000 cycles with its commercials. That note cannot be heard by the human ear and is not noticed, but it can be used to eliminate commercials in the following manner.

The output of the ratio detector is attached to a tuned circuit which isolates the note by use of a TV horizontal ringing coil, normally tuned to 15,750 cps but now detuned to the frequency of the note from the station, in parallel with a 3900- $\mu$ fd. capacitor. This note is rectified out negatively and used to bias or cut off the audio amplifier of the radio for the duration of the commercial.

As you can see, the system is fully automatic; but not all FM stations have this system, and the circuit is quite difficult to adjust and build in the first place.

**STUART RAPEE**  
Miami Beach, Fla.

We are passing the above information along, as quite a number of FM stations use a similar system.

### Underground Water Supplies

Do you know of any gadget on the market for detecting whether there is water on property so that one could drill?

**MAUD E. HOWARD**  
New York, N. Y.

There is no "sure fire" electronic device for detecting underground water, although geophysical surveys may be employed to detect the possibility that water exists.

-30-





Get more money!  
More security! More out of life!



# Learn TELEVISION • RADIO • ELECTRONICS

Get the best!

## Get National Schools' SHOP-METHOD HOME TRAINING!

Start now! Why wait around for that raise or promotion that may never come? Get started *now* in high-paying TV-Radio-Electronics! National Schools' SHOP METHOD Home Training prepares you for success in a top-salary job or in your own business. You learn *all three*... Television, Radio, Electronics... in one complete course. Our Shop-Tested lessons and manuals help you master all phases in shortest possible time! Send coupon. find out today!

### WHY NATIONAL SCHOOLS LEADS THE FIELD

Located in the "Television Center" of the world, our staff is in close touch with latest developments and opportunities. We give you personalized job placement assistance. We also give you confidential help with both technical and personal problems relating to your training. We show you how to make Part Time Earnings as you progress. Whether you live 30 miles away, or 3,000, you will always be pleased with our prompt, friendly service!

**DRAFT AGE?** Our home training helps you achieve specialized ratings and higher pay grades if you go in service.

We send you this precision-tested Multitester! Plus parts to build Oscillators, Receivers, Signal Generator, Continuity Checker, Combination Short Wave and Standard

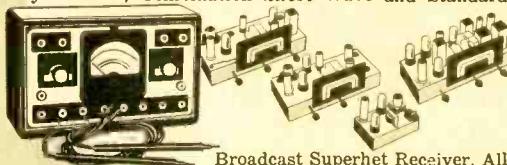

Broadcast Superhet Receiver. All this equipment is part of your National Schools course. **NO EXTRA CHARGES!** Send coupon for free books!

**NATIONAL SCHOOLS**, world-famous technical trade school. Now entering our 50th year!



## NATIONAL SCHOOLS

TECHNICAL TRADE TRAINING SINCE 1905

LOS ANGELES 37, CALIFORNIA

In Canada: 811 W. Hastings St., Vancouver, B. C.

• APPROVED FOR G. I. TRAINING

• BOTH HOME STUDY AND RESIDENT COURSES OFFERED

### 30 MILLION TV SETS

need regular repair! Color TV means more sets than ever before. NOW is the golden opportunity to cash in on this multi-billion-dollar industry. Or "write your own ticket" in broadcasting, manufacturing, and other specialized phases!

**YOUR AGE  
IS NO  
OBSTACLE!**



Send for  
**FREE LESSON!**  
FREE BOOK & SAMPLE LESSON  
will convince you!  
SEND COUPON TODAY!

### MAIL NOW TO OFFICE NEAREST YOU!

(mail in envelope or paste on a postal card)

**NATIONAL SCHOOLS, DEPT. R2G-115**

4000 SOUTH FIGUEROA STREET  
LOS ANGELES 37, CALIFORNIA

OR 323 WEST POLK STREET  
CHICAGO 7, ILLINOIS

Please rush **FREE BOOK**, "My Future in Radio-Television-Electronics," and **FREE LESSON** at once. I understand there is no obligation, and no salesman will call.

NAME \_\_\_\_\_ BIRTHDAY \_\_\_\_\_ 19 \_\_\_\_\_

ADDRESS \_\_\_\_\_

CITY \_\_\_\_\_ ZONE \_\_\_\_\_ STATE \_\_\_\_\_

Check if interested **ONLY** in Resident Training at Los Angeles.

**VETERANS:** Give date of discharge \_\_\_\_\_

# HERSHEL SPECIALS

## All New MYSTERY PACKAGE of ELECTRONIC PARTS



Worth \$40.00

Our Price  
**\$395**

Ship. Wt. 20 lbs.

It's the surprise of your life! 20 pounds of brand new usable Govt surplus. The ideal gift for hams, etc.

We now ship parcel post to save you more money!

## KIT SPECIALS

**KIT 1, HARDWARE**  
Over 1,000 pcs. Assorted.  
For Radio & TV  
**99c**

**KIT 2, CERAMICS**  
100 Assorted  
75 mmdfd. to 6,000 mmdfd.  
**\$250**

**KIT 4, Rotary Switches**  
25 Assorted  
Terrific Buy!  
**\$250**

**KIT 5, RESISTORS**  
100 Assorted  
1 ohm to 15 meg. 1/2 to 5 watts  
**\$175**

## HI GAIN DYNAMIC MIKE KIT

Uses UTC Transformer and Western Electric Mike. Ideal for Hams, PA, CAP, Recording, Mobile Equip. -50 DB/80. 7500 CPS. Diagram Furnished  
**\$195**

## PHOTO ELECTRIC CELL

**95¢** CE Vacuum Cell used in AMPRO Sound Projector. Also useful for opening garage doors and Alarm Systems.

## BUTTERFLY CONDENSERS



**TYPE A** 1/4" Dia.  
TYPE A-106-320 MC-Antenna Type



**TYPE B** 3/8" Dia.  
TYPE B-300-1000 MC-Use 308AS tube



**TYPE C** 2 1/2" Dia.



**TYPE D** 2 1/2" Dia.

TYPE C-300 1000 MC Clip for Dial Det

TYPE D-135 485 MC

**YOUR CHOICE**

**\$495**

These units make the finest tuners for Ultra-high frequency transmitters, receivers, frequency meters, and oscillators.

## RCA OUTPUT TRANSFORMER



P.P.616'S  
25 watt

**\$195**

PRI 5000 Ohms output, Sec. #1 500 Ohms, Sec. #2 600 Ohms, Sidetone 15 to 15,000 cy. Rat.

## VARIABLE CONDENSERS



**YOUR CHOICE**

**95c**



100 MMFD - Double Spaced size 2 1/2" x 1 1/2" M. Hammerlund Mfg.

300 MMFD - Shiloh Can 1/4" shaft

## Ceramic Type PHONOGRAPH CRYSTAL

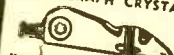

Made by Sonotone Mfg. 1 1/4 Volt Out. Needle .20 to .24 500 cycle. Frq. 10000 Hz. Pl. Special

Only **\$225**

## ARC-5 COMMAND TRANSMITTER



**YOUR CHOICE**

**\$695**

2,1 to 3 MC. 7 to 9.1 MC. Brand New. in Cartons with tubes.

HOTTEST BUY IN THE COUNTRY

## GUN CAMERA MOTOR



**95c**

Brand New Used in Gun Camera 24 VDC. Will run on 110 VAC.

**HERSHEL RADIO CO.**

5249 GRAND RIVER  
Detroit 8, Michigan  
Phone TYler 8-9400

TERMS: Cash with order or 25% DOWN—BALANCE C.O.D.  
ALL PRICES NET F.O.B. DETROIT  
MINIMUM ORDER \$2.00



# IRVING KOLODIN

Comments on  
Diamond  
Phonograph  
Needles

*Irving Kolodin*

"Only one material really suffices—(as a phonograph needle) the diamond. Nothing else matches it . . . anything else may categorically be denied consideration as . . . high fidelity."

Music Editor, Saturday Review

Insist on a BRAND NAME DIAMOND



PLAY SAFE  
PLAY DIAMOND

**TETRAD**

WORLD'S LARGEST  
MANUFACTURER  
OF DIAMOND STILLS

For further information write to: Dept. PE, 62 St. Mary St., Yonkers, N. Y.

## Perma-Power Radio Controlled Garage Door Opener

Now, the newest, finest Radio-Control Garage Door Opener styled in a modern spun-aluminum fixture that beautifies garage interiors.

Convenience and safety features galore — New automatic shut-off, positive locking of door, FCC authorized radio frequency . . . and many more plus qualities!

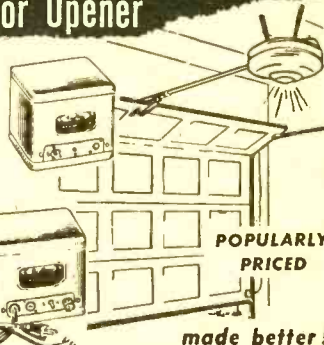

POPULARLY PRICED

Write today for descriptive literature.

made better!

Everyone can afford this modern convenience!

- \* It's really simple to install . . . one man can do it easily!
- \* Takes just an afternoon with common hand tools; no soldering.
- \* Complete instructions assure professional-type installation.

MAIL THIS COUPON FOR COMPLETE FACTS!

Perma-Power COMPANY 4727 N. DAMEN AVE. CHICAGO 25, ILL.

- Please send FREE descriptive literature on your GARAGE DOOR OPENER
- Please advise name of your nearest electronic parts distributor carrying your GARAGE DOOR OPENER

NAME \_\_\_\_\_  
ADDRESS \_\_\_\_\_  
CITY \_\_\_\_\_ STATE \_\_\_\_\_

**DELEHANTY starts PRACTICAL SHOP WORK with your FIRST LESSON!**

**Only DELEHANTY gives YOU a MONEY-BACK GUARANTEE! No Risk! No Obligation!**

**NO PREVIOUS TRAINING OR EXPERIENCE NEEDED!**

**YOU GET FULL-SIZE  
21" TV SET & TUBE  
at No Extra Charge!**

**First Kit of Tools and Parts sent Immediately with First Training Unit!**

**Learn At HOME TELEVISION RADIO & ELECTRONICS**

**...We Furnish ALL Your EQUIPMENT at No Extra Cost!**

**The DELEHANTY INSTITUTE**

For nearly 50 years, there has been no finer name than DELEHANTY in the entire field of Vocational Training! More than Half a Million students have benefited by our Practical Home Study and Resident Courses. We have developed a SHOP-TRAINING-AT-HOME METHOD that is SO PRACTICAL and EFFECTIVE that it is unhesitatingly offered with an UNCONDITIONAL MONEY BACK GUARANTEE!

**FRESH, NEW, UP-TO-THE-MINUTE TRAINING THAT INCLUDES NEARLY 400 PRACTICAL SHOP PROJECTS!**

Perfect by a large staff of electronic experts, engineers, technicians and teachers with extensive practical field experience. Entirely new and up-to-date. Includes Ultra High Frequency, Color TV, Printed Circuits, Transistors, Geiger Counters, High Fidelity, and other last-minute electronic developments. You enjoy over 400 interesting and practical experiments in applied electronics during your training with 15 Big Kits of Tools, Tubes, Parts and Equipment that we furnish at NO EXTRA COST!

**EARN EXTRA MONEY SOONER!**

Because you get right down to business with practical work from the very beginning you are able to earn money quickly in spare time. By repairing radios and electrical appliances for friends and neighbors you can actually earn the money to pay for this unique Delehanty training!

In a Matter of Months You Can Be Ready for **GOOD FULL-TIME JOBS** or a **PROFITABLE BUSINESS OF YOUR OWN!**

**STUDY AT YOUR OWN PACE... PAY AS YOU GO, AVOID DEBT!**

DELEHANTY TRAINING is taken at your leisure ... Order each training unit only when you want it... ALL UNITS AT ONE LOW PRICE... no time payments to worry about... YOU PAY AS YOU GO and YOU'RE NEVER IN DEBT... when training is completed you owe nothing and will own and

**KEEP AS YOUR OWN PROPERTY**

- 21" TV SET WITH 21" PICTURE TUBE • TOOLS
- SUPERHETERODYNE RADIO WITH ALL TUBES
- MULTITESTER-AMMETER-OHMMETER-VOLTMETER
- RADIO TELEPHONE TRANSMITTER • AUDIO AMPLIFIER • OSCILLATORS • MODULATORS • RF AMPLIFIERS • OTHER ELECTRONIC DEVICES
- REFERENCE LIBRARY IN HANDSOME LOOSE-LEAF BINDERS



**MAIL COUPON TODAY FOR FREE ILLUSTRATED BOOKLET**

NO OBLIGATION • NO SALESMAN WILL CALL

DELEHANTY INSTITUTE OF TELEVISION PE 11-5  
115 East 15th Street, New York 3, N. Y.

Please send me by return mail your Free Booklet "How to Achieve Success in Television, Radio and Electronics." This does not obligate me in any way.

NAME \_\_\_\_\_ AGE \_\_\_\_\_

ADDRESS \_\_\_\_\_

CITY \_\_\_\_\_ ZONE \_\_\_\_\_ STATE \_\_\_\_\_

(PLEASE PRINT - Paste on Post Card or Mail in Envelope)

**DELEHANTY INSTITUTE OF TELEVISION**

APPROVED BY STATE OF NEW YORK  
115 EAST 15 ST., NEW YORK 3, N. Y.

# LAFAYETTE POPULAR ELECTRONICS KITS!

HEADQUARTERS FOR  
HARD TO GET PARTS FOR KITS -  
WE HAVE THEM!

## TWO TRANSISTOR RADIO RECEIVER KIT



This regenerative two Transistor Radio has given more than ample earphone volume on broadcast stations located several hundred miles away. When used with 60 ft. outside antenna well beyond 1000 miles have been repeatedly heard. Kit comes complete with two transistors, Argonne transistor audio transformers, condensers, resistors, masonite board, etc.; schematic diagram plus 115 page book, showing more than 50 practical transistor circuits and "How-to-do-it-Instructions".

KT-70 Complete Kit with Batteries ..... Net ..... 10.95

## 3 TRANSISTOR PUSH-PULL AUDIO AMPLIFIER FOR SPEAKER OPERATION



NOTE: Input impedance 1000 ohms. For high impedance inputs matching transformer is needed (AR-100) for magnetic input use per amp (KT-71)

With the New Lafayette KT-89 Kit you can now build a self-powered, push-pull Class "B" transistor audio amplifier for speaker operation, having a frequency response of 100-8000 cps. The Argonne Transistor transformers were especially designed for transistor circuits. Kit comes complete with 3 transistors, push-pull input and output transformers chassis 3"x4"x1", condensers, resistors, battery holders, etc., schematic diagram.

KT-89 Complete with batteries... Net 17.95

## TWO TRANSISTOR PREAMP KIT

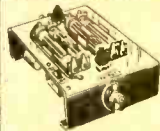

With the Lafayette KT-71 you can now build a simple Transistor preamp in a matter of hours. The overall result will be noiseless, humless and virtually distortionless amplifier. The complete unit is mounted on an aluminum chassis size 2"x4"x1". The Kit comes complete with two transistors, condensers, resistors, battery holders, batteries, etc., and schematic diagram.

KT-71 Complete Kit ..... Net 8.95

## LAFAYETTE GEIGER COUNTER KIT WITH HIGH SENSITIVITY VICTOREEN TUBE 1B85

Lafayette Geiger Counter Kit with High Sensitivity Victoreen 1B85 tube, makes this one of the most outstanding kit buys in the country. This tube is used only in the most expensive equipment. Easy to build, at only a fraction of the price of commercial instruments of this type. Just turn it on, flip the high voltage switch and listen to the clicks. Kit includes all parts, tube, carrying case, 2 1/2" and 1 1/2" Volt Batteries. Complete instructions for quick assembly. Shpg. wt., 1 1/2 lbs.

KT-75 ..... Net 14.95



A new light weight Dynamic Ear Phone.



Fits right into the ear. Excellent sensitivity of 65 db. Ideal for use with miniature sets, hearing aids, transistor pocket radios, etc.

MS-72 ..... Net 1.95  
MS-100 Impedance 8 ohm for Silent Radio or TV viewing.  
Net ..... 1.95

## MINIATURE CRYSTAL MICROPHONE



Here's a typical Lafayette special for the experimenter, student or dealer. An extremely sensitive and small crystal microphone used in hearing aids and other small apparatus. Can be used as lapel mike—miniature transmitter mike for concealed locations, etc. Its size and performance gives it joint versatility. Brand new. Size only 1 3/8" Diam. x 5/16" deep. Imported to save you money.

MS-108 ..... Net 1.95

## TRANSISTOR POCKET RADIO RECEIVER KIT

Utilizing One Transistor and Crystal Diode Detector with New Miniature 365 mmf Variable Condenser.

Here is an ideal low cost transistor pocket radio kit for students, hobbyists and the experimenter, who desire to obtain a practical knowledge of transistorized circuits. The circuit utilizes a Ferris-Loopstick and a specially designed miniaturized 365 Variable Condenser permitting the entire receiver to be built in a plastic case size 3"x2"x1". The 1N64 Crystal Diode is used as a detector, the transistor is connected as a grounded emitter amplifier. This receiver with a 50 foot antenna and good ground will bring in good reception over a 50 mile radius. The kit comes complete with transistor, crystal diode, battery holders, batteries, condensers, resistors, plastic case, etc., plus a 115 page book, showing more than 50 practical transistor circuits and How-To-Do-It-Instructions.



KT-80 Complete Kit (less earphones) ..... 4.95  
1 Miniature Crystal Ear Receiver MS-111 ..... 1.49

## TRANSISTOR TELEPHONE PICK-UP AMPLIFIER KIT TWO CAN LISTEN ON SAME PHONE CONVERSATION

With this ingenious Kit you can build a tiny transistorized telephone pick-up amplifier, with which two people can listen in on telephone conversations without the need of an extension phone. Also serves as a high gain amplifier to feed into a tape recorder, for recording telephone conversations. Can also be used as a portable amplifier with crystal microphone and matching transformer when desired. The circuit utilizes a transformer coupled audio for high gain and two R.C. coupled stages. Kit comes complete with 3 Transistors, Transistor Audio Transformer, Condensers, Resistors, etc., and Plastic Case. Size: 2 1/2" x 1 1/2" x 3/8".



KT-76 Complete Kit ..... Net 9.95  
MS-16 Telephone Pick-Up ..... Net 2.95  
MS-72 Miniature Dynamic Ear Phone ..... Net 1.95

## 2 TRANSISTOR POCKET RADIO KIT

Packed into a 2 1/2" x 3 1/2" x 1 1/4" plastic case. This Two Transistor plus crystal diode radio kit offers many surprises, utilizing a regenerative detector circuit with transformer coupled audio stage, gives you high gain and excellent selectivity. Pulls in distant stations with ease with more than ample earphone volume. Kit comes complete with two transistors, crystal diode, loopstick, Argonne transistor audio transformer resistors, condensers, plastic case, etc., including schematic and instructions.



KT-68 Complete kit with Miniature Dynamic Earphones ..... Net 13.75  
Less Earphones or Audio ..... Net 11.80

## CRYSTAL MICROPHONE

COMPARE IT WITH ANY MIKE AT 2 TO 3 TIMES THE PRICE

A quality crystal Microphone for PA systems, house recorders, etc. Frequency response 30 to 10,000 cycles. Output level -52 db. Provides ample output for use with low gain amplifiers. Complete with 5 ft. of shielded cable. Shpg. wt., 3 1/2" lbs.

PA-24—in lots of 3, each 3.95 singly, each ..... 4.25



## TRANSISTOR 455 KC I.F.

Specially designed for transistor circuits, only 1 1/2" square by 3/4" high. MS-126—138  
In lots of 10, each 79¢  
Single, Each ..... 89¢

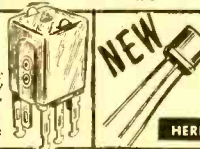

TRANSISTOR TYPE 2N222 P-N-P 99c HERMETICALLY SEALED

## NEW POCKET AC-DC VOM MULTITESTER



1,000 ohms per Volt  
AC-DC MULTITESTER. An ideal portable unit that meets the need for a compact, yet rugged test instrument. Uses full 3" rectangular meter with large easy to read scale. Uses 1 1/2% precision resistors, levelled D'Arsonval microamp meter movements. Ranges: AC-DC output volt. 0-5, 0-25, 0-250, 0-1000V. DC current, 0-1, 0-10, 0-100, MA; Resistance 0-10K and 0-100K ohms. Size: 2 1/2" x 3 1/2" x 1 1/2". Supplied complete with test leads and batteries. Shpg. Wt. 2 1/2 lbs.  
MODEL RW-27C Complete—Singly, ea. 7.95

## TRANSISTOR TYPE 2N107

P-N-P \$1.25

## TIMER-SWITCH SALE 3.95

Automatically turns on radio, television sets, toasters, coffee makers, etc.—at any pre-set time within 12 hour period; also tells time. Requires 3 1/2" diameter round hole. Depth behind dial face 2 1/4". Shpg. wt. 1 1/2 lbs. MS-62, for 110V/60 Cy AC



send for FREE CATALOG

Lafayette Radio DEPT. 1-K  
100 SIXTH AVE. NEW YORK, N.Y.  
BOSTON, MASS. 110 Federal St.  
BRONX, N.Y. 542 E. Fordham Rd.  
NEWARK, N.J. 24 Central Ave.  
139 West 2nd St.  
Include postage with order.



Data gathered by radar operators, picket ships, radio contacts, etc., are displayed on vertical plotting board which reveals an up-to-date picture of air activity.

## CIC—NAVY'S ELECTRONIC CLEARINGHOUSE

**W**HILE MUCH has been said and written about the capabilities of modern electronic military equipment, little has been published on how the information that this equipment gathers is coordinated, uniting the fleet into a potent striking force. Intelligence gathered by detection equipment must be assembled and displayed so that intelligent decisions can be based upon it.

The location where this takes place on a Naval vessel is known as the CIC—"Combat Information Center." It is here that the information is made available to responsible officers so that tactical operations can be successfully directed.

Many of the details of this complex "brain" of men and machines are highly classified. Some phases of the operations can be disclosed, however, indicating how this maze of electronics enables the Navy to assemble an efficient striking power.

### Use of Radar

One of the keys to modern military warfare is radar. This "silent watchman" guards the country's security, and through its "eyes" the entire course of events is planned. But one man peering into a radar-

By E. D. MORGAN

*How information is coordinated at Combat Information Center on Naval vessels, uniting fleet into a potent striking force*

scope is not enough to set huge naval forces into action. This is accomplished through the coordinated efforts of many highly skilled men, and is based on data provided by the CIC.

The information gathered by the radar operator is displayed to others trained in tactical warfare through a vertical plotting board. Each radar operator relays by telephone the range and bearing of targets indicated on his scope while others plot the locations on a large plastic screen. From the complexity of X's and O's on the board, the movements of all aircraft in the area can be followed.

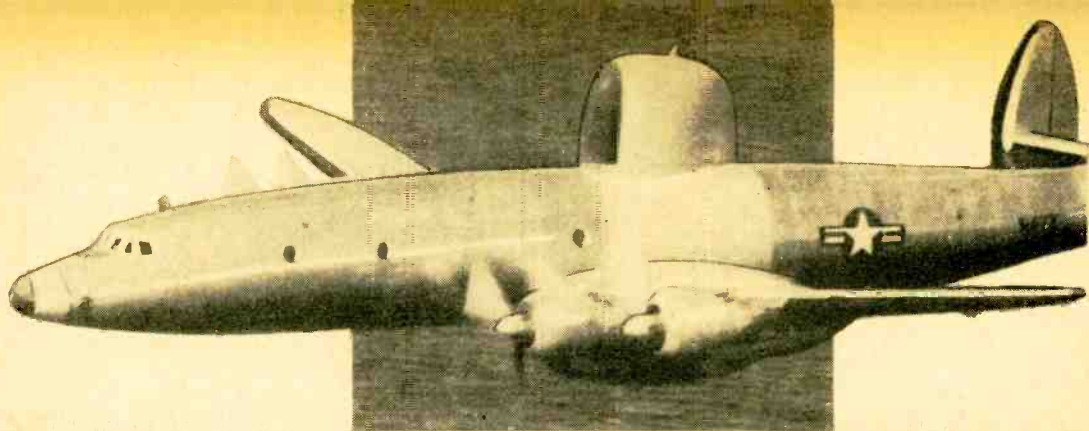

Some of the information plotted arrives from other sources. Radar picket destroyers operate far out in advance of the fleet and relay their findings by radio. AEW (Airborne Early Warning) planes, patrol and fighter planes, also report over radio links. Here, then, is where the pulse of any battle can be felt. Here is where the entire network of radar, radio, and other electronic equipment pools its knowledge so that the course of action can be directed.

### How CIC Operates

Some highly specialized tasks are performed in CIC. If a group of enemy planes is to be intercepted by carrier fighters, an operator using a special radar display and radio transmission goes into action. By maneuvering the fighters into an advantageous position, an attack may be started before Naval pilots have even sighted and fully ascertained the strength of the enemy.

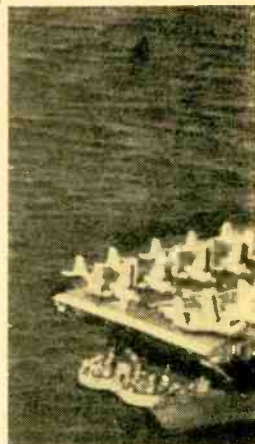

Horizontal plotting boards like this one are used to display a surface picture of the area. Location of vessels enables maneuvering tactics to be decided. Navigation and heavy bombardment problems are also directed from the displayed plot.



Especially equipped AEW planes extend radar coverage far beyond the horizon. The plane at left, a modified Lockheed Constellation, has a large radome hump top and bottom for carrying the powerful radar equipment. Radar fixes on known landmarks enable CIC personnel to direct heavy bombardment attacks on particular targets even with poor visibility and in treacherous waters. Photograph at bottom of page shows a Naval destroyer, outfitted with long-range radar, which can operate ahead of a task force to warn of impending attacks.

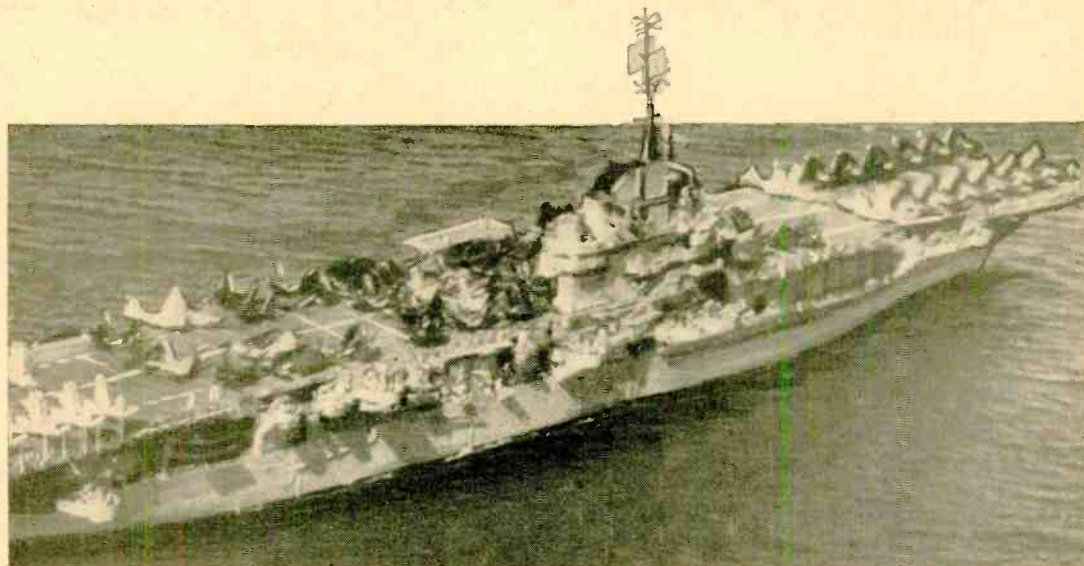

If enemy planes escape the fighter attacks, CIC personnel, kept informed by their radar pictures, prepare anti-aircraft defenses for action. Many of these gun batteries are controlled by very accurate, short-range radar transmitters of their own. It is the job of CIC to direct this fire-control radar onto the proper target. If there are simultaneous attacks, the targets are shared among the different gun batteries or even different ships to insure that none are unopposed.

While all of this is taking place, additional data continues to flow into





This photograph of the main battery plotting room was taken on the USS Missouri in Korean waters. Carrier-based fighters depend on CIC information to intercept enemy planes before they can reach and damage the fleet. Accurate gunfire is directed from here on targets kept under surveillance by radar and CIC plots.

CIC. The plots are kept up to date and forces are deployed in the most efficient manner. Surface search radars continually provide data on the location of both Navy and enemy vessels. This information is also kept on plotting boards, usually horizontal, so that surface maneuvers can be coordinated. If a heavy bombardment attack is being made, it is the CIC which must determine the target's range and bearing by radar when it is not visible from the bridge. Through these accurate plots, fire-power can be concentrated on specific targets and kept there, even while Navy or enemy ships may be rapidly maneuvering.

Sonar information feeds in by phone from the sonar operators, and enemy submarine searches and attacks are plotted here. Maneuvering in enemy coastal waters is often directed from CIC using radar and sonar fixes on known landmarks, thus insuring the exact location of the fleet. In this way, shore bombardment can be concentrated on a certain location and treacherous waters can be navigated without running aground.

Thus, CIC provides the link between the electronic wizardry of the nation and the powerful combination of men, ships and planes that fight battles.

-30-



Seated at a console, the radar operator relays target data by telephone so that the rest of the fleet may be kept informed. The small square scope at top of console is called an A Scope, and the large round cathode-ray tube he is peering into is a PPI—Plan Position Indicator.



Third article in series describes correspondence schools and their programs of very useful training

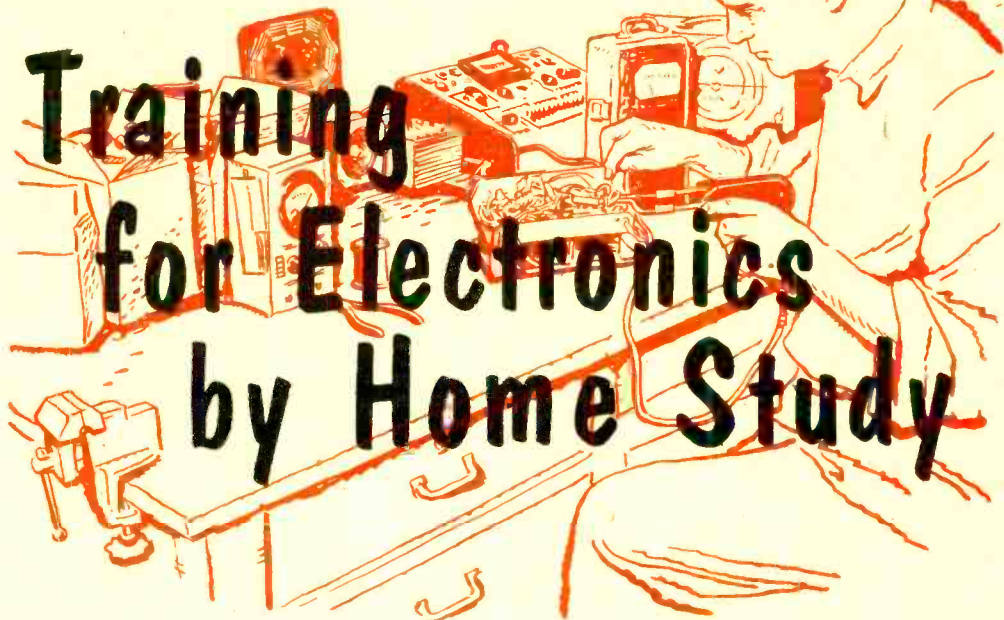

# Training for Electronics by Home Study

**T**RAINING acquired by spare-time study in the privacy and quiet of one's home has proven a boon for thousands who have wanted to advance themselves but who couldn't, for any of a number of reasons, attend school. With the steadily increasing demand for trained personnel in electronics, the type of training known as "home study" or "correspondence course" has taken on new importance. For the men or women already employed—either in electronics or some other field—who can devote a few hours weekly to study at home, this type of training affords vast opportunities to get ahead.

Few people realize the extent of home-study education. According to recent figures, approximately two million persons throughout the world are studying by the correspondence method. This type of education has a long and venerable tradition, dating back to the days of the Roman Empire and the middle ages. There is little new in the *idea* of home study. What is new, and quite remarkable, is the superb manner in which the profession has organized itself to teach successfully to large numbers of people the complexities of a field as intricate and varied as electronics.

Modern home study, as practiced by leading technical schools, involves carefully

By **NORMAN EISENBERG**  
Feature Editor

prepared texts, specially designed kits, conscientious grading of students' work, continuous contact between the institute and the trainee, and excellent guidance and placement facilities. The home-study method today can train a man at home in d.c. fundamentals as well as in the construction of a color television receiver. With their remarkable facilities, skilled full-time staffs, special instructional aids that—in some cases—even include movies sent to the trainee, the correspondence schools of today can boast a proud record of achievement in realistically appraising the needs of industry and then setting about to help fill those requirements.

## Advantages of Home Study

Home study is the logical answer for thousands who either want to get started on a new career, or who need a "little extra study" to advance themselves within their chosen field. One of the best things about it is that, in effect, the school comes to the student. Everything needed is sent. Often this involves expanding an already existing workshop or home-hobby facilities. Or it may imply embarking on a new home

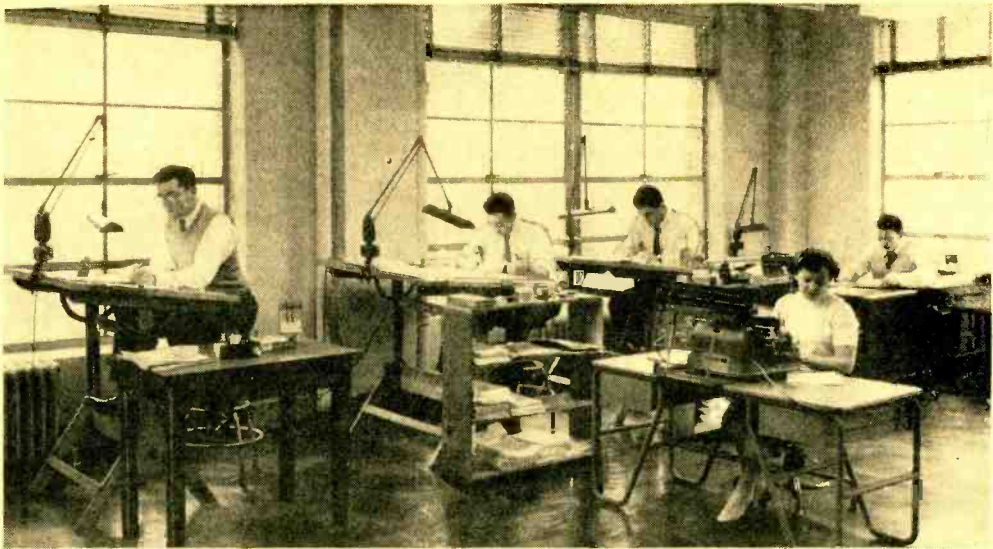

Correspondence schools maintain permanent staffs to prepare material used by home-study trainees. Other staff members grade students' papers and answer all queries by mail.

activity, with untold discoveries and the joy of accomplishment yet to be realized.

Beyond this personal aspect of home study is its potential dollar-and-cents value in terms of the trainee's eventual value on the job market. No person who has successfully completed a home-study course need feel any qualms about listing this training as part of his qualifications for a job. Correspondence school courses are recognized and accepted by industry as sufficient evidence of required training.

There are other advantages, unique to home study, that might well be considered by the prospective student. One of these is the obvious factor of time convenience. A student can begin his course of study whenever he is ready, without reference to formal semester schedules. Often this factor ties in nicely with his present job needs and budgeting. Then, too, "class" can start whenever convenient for the student—in the evening, or on weekends, etc. Completely on his own in this respect, the trainee may spend as little or as much time as he wants to on a particular phase of the work, connecting and reconnecting a given circuit until he knows it by heart. He can, effectively, lengthen or shorten any lesson to suit his own needs. Also, such events as bad weather or illness, etc., need not keep a correspondence course trainee from his studies.

Inherent in the home-study method is the development of good work habits on the part of the trainee. He cannot "coast along," anonymously, and hope to pass. He must "prove" himself—in writing—in order

to qualify for the next lesson and ultimately earn his certificate or diploma. He must master each principle before going on to the next. This element, plus the written record he accumulates of his work and the instructor's written comments on it, will go a long way in building habits and procedures that should prove valuable in any future line of work.

And, as Mr. G. O. Allen, vice-president of the *Cleveland Institute of Radio Electronics*, points out: ". . . the home training method . . . does not disrupt the economic and social life of the trainee or the employer. . . . A man can continue to work on a regular basis and study in off hours. Earning capacity is unaffected and production time is not lost. . . . Your school is as close as your mail box."

Among the more tangible items that a student receives are tools and components ranging from a soldering iron to a signal generator, from a table model radio to a color television receiver. Naturally, the cost varies with the material supplied. Where hand tools are furnished, the student can expect the cost of the course to be proportionately higher than a course in which such tools are not supplied. In any case, costs are fair and not exorbitant. Moreover, the components and tools are *bona fide* equipment representing the best standard commercial practice. Kits are complete, with no "tie-ins" or "sales hooks" that require the student to spend additional money in order to complete a given unit of work. As a matter of fact, schools are enjoined—by law and other influences—

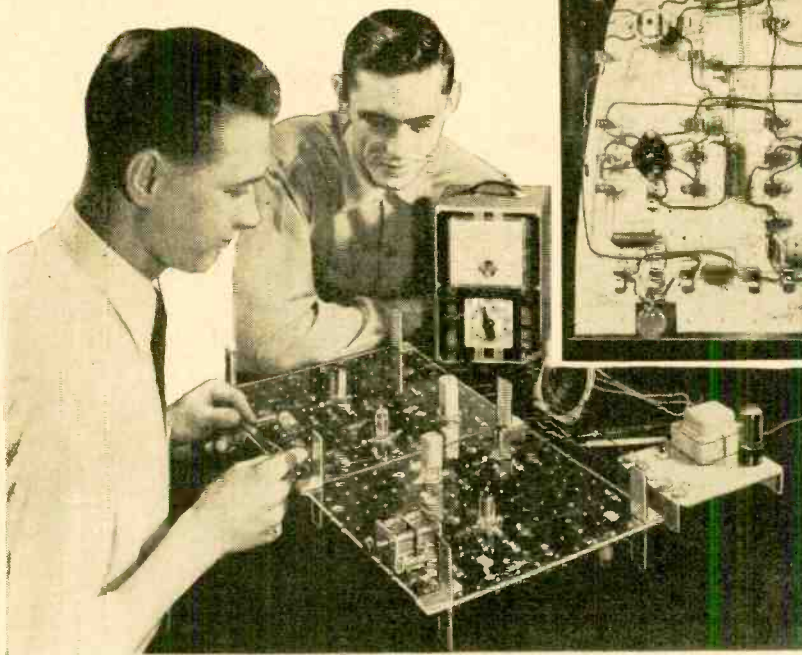

to maintain the utmost honesty and integrity in living up to their claims and agreements made with students.

### Behind the Scenes

Many trainees and prospective students have wondered: what goes on at the other end of the postal route? Is the home-study school more than just another post-office box number?

Kits sent by schools often incorporate the most advanced circuit-building techniques. In the one shown above, special diagrams and connectors enable the novice to wire more than 300 different construction jobs.

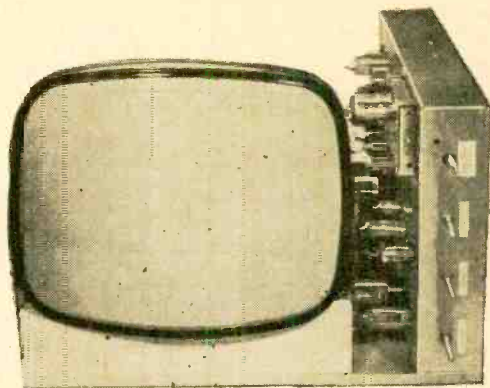

From basic kit to complete television receiver, the range of electronic construction that may be accomplished at home is almost limitless. Step-by-step instructions and diagrams accompany each project.

The extent to which modern home study has advanced is suggested by the use of such aids as a movie projector, shipped to the student's home for use at his convenience.

School sends parts and instructions; trainee builds and tests TV receiver. The printed lessons help coordinate theory and bench work.

Young Sharon Pakinas, of Bothell, Wash., became a licensed ham after passing FCC exam. She studied lessons sent to her father.

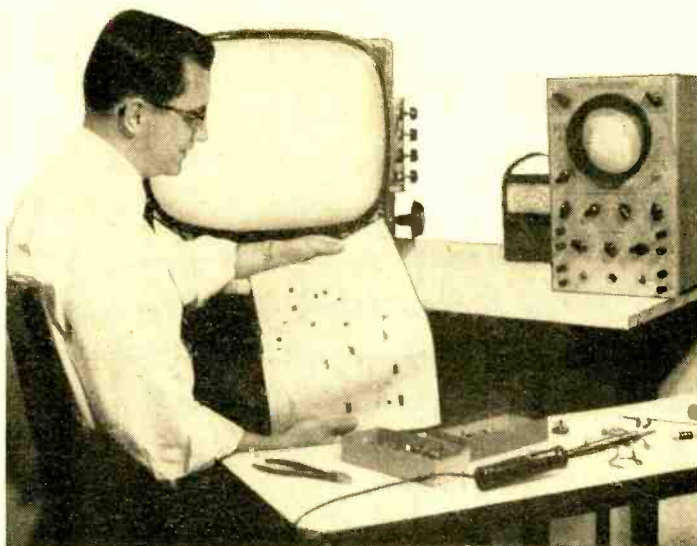

packing and mailing is, in itself, a major operation requiring a special work area, equipment, and a trained staff.

But all this is only one aspect of what goes on behind the scenes at a correspondence school headquarters. Continuous contact with students is maintained by a special instructional staff which teaches, in effect, by remote control. All written work submitted by students is thoroughly checked by specialists, usually assigned to given portions of the course. Mistakes are corrected; weaknesses in the student's concepts or their presentation are pointed out; and the over-all submission is graded by standard educational methods. All material is then returned to the student to keep as part of his permanent record and information file. If he has passed that particular phase of the work, he is so advised and may advance to the next subject. If he has failed, he has the opportunity to go over his mistakes and try again.

The answer is an emphatic "Yes!" For example, the Home Study Department of *RCA Institutes, Inc.*, maintains a full-time staff of technical and clerical personnel in a modern office building. The setup here is representative of the excellent practices in most schools. One group of writers and editors prepares lessons, while a staff of draftsmen works on diagrams and schematics to be included. An artist lays out the pages which are varityped or printed. Pages are then reproduced, collated and packaged for mailing.

In the meantime, the equipment to be built and studied has been designed and prepared in kit form. All parts have been received, inspected, and allocated. Final

At any point along the way, the student may—by mail—request additional help, ask questions, raise points for clarification, etc. To do this, of course, requires that the trainee put his problem in writing, often accompanied by his own drawing of a particular schematic diagram. This enforced method of asking a question has a pedagogical value all of its own, for it necessitates that the student analyze the problem well enough to be able to phrase an intelligent question about it. It has often been shown that the ability to ask a question intelligently is half the battle of learning the answer. All such requests are handled speedily by the school's staff, with the correct answer on its way back to the student in the next mail.

## Directory of Home-Study Schools

Advance Training  
5944 N. Newark Ave.  
Chicago 31, Ill.

American School  
Drexel at 58th  
Chicago 37, Ill.

Canadian Institute of Science & Technology,  
Ltd.  
263 Adelaide St. W.  
Ontario 1, Canada  
or  
590 Century Bldg., 412 5th St., N. W.  
Washington, D. C.

Capitol Radio Engineering Institute  
3224 16th St., N. W.  
Washington 10, D. C.

Central Technical Institute  
17th & Wyandotte St.  
Kansas City 8, Mo.

Cleveland Institute of Radio Electronics  
4900 Euclid Ave.  
Cleveland 3, Ohio

Commercial Trades Institute  
1400 Greenleaf Ave.  
Chicago 36, Ill.

Delehanty School of Television  
111-117 East 11th St.  
New York 3, N. Y.

DeVry Technical Institute  
4141 Belmont Ave.  
Chicago 41, Ill.

Grantham School of Electronics  
6064 Hollywood Blvd.  
Hollywood 28, Calif.

International Correspondence Schools  
Box 2951  
Scranton 9, Pa.

National Radio Institute  
16th and U Streets, N. W.  
Washington 9, D. C.

National Schools  
4000 S. Figueroa St.  
Los Angeles 37, Calif.  
or  
323 West Polk St.  
Chicago 7, Ill.

Progressive Electronics Institute  
Box 543  
Akron 9, Ohio

RCA Institutes, Inc.  
Home Study Department  
350 West 4th St.  
New York 14, N. Y.

Radio Television Training Association  
52 East 19th St.  
New York 3, N. Y.

Sprayberry Academy of Radio  
111 N. Canal St.  
Chicago 6, Ill.

United Television Laboratories  
3947 Park Drive  
Louisville 16, Ky.

Video Specialties  
4570 E. Firestone Blvd.  
South Gate, Calif.

The schools listed above offer home-study courses in electronics and allied fields. For specific information, write directly to the school concerned.

### High Standards Maintained

Prospective students are carefully screened before course assignments are made. It must be determined whether the student is to take a beginner's course or an advanced course; whether his interest is in television servicing or industrial electronics; whether he needs groundwork in mathematics or in circuit fundamentals; if he wants to prepare for an FCC license exam; and what he hopes to get out of his studies.

Standards of acceptance and instruction are high, in keeping with the schools' two-fold responsibility to the student as well as to industry. The courses taught are well standardized—both in content and methodology—as a result of official and quasi-official supervision from government bureaus, industrial contacts, and an association of the schools themselves. In many

areas, the activities of home-study schools are regulated by the Department of Education of various state governments.

Then, there is the *National Home Study Council*. This is an association of various correspondence schools, organized to promote business ethics and educational standards in the field. The *Council* has established standards for the contents of courses, sales and advertising practices, and personnel and equipment used by the schools. Of special interest to the prospective student is the fact that most of the provisions of the "Trade Practice Rules for Private Home Study Schools," approved by the U.S. Federal Trade Commission, are written into the code of standards of the NHSC. These rules forbid schools to make false or misleading statements; they assure that certificates and diplomas issued to students

(Continued on page 105)



## Fire Box Telephone Alarm

OMAHA, NEBRASKA has begun to replace the old familiar red fire alarm box with a direct telephone connection to fire alarm headquarters. Field-tested by the *Bell Telephone Laboratories*, this system will also soon be used in Indianapolis, Ind., Miami, Fla., Syracuse, N. Y., and Sioux Falls, S. D. Fire box telephones will enable firemen and policemen to talk directly to a person at the scene of the alarm.

In a typical installation, the telephone is mounted in a brightly painted cast-aluminum housing. Lifting the telephone from the hook will flash an alarm signal to the operator at alarm headquarters. Each signal will automatically register the location of the box in case the person spreading the alarm is too excited to speak. Whenever necessary, the operator at alarm headquarters can switch the call directly to police headquarters. —30—

## G.E. Ham Award Nominations Open until Jan. 3, 1956

THE FOURTH ANNUAL SEARCH for the "Ham of the Year" is under way. This award is sponsored by the *General Electric Company* and is popularly referred to as the Edison Award.

The purpose of the award is to impress upon the general public the notable work performed by radio hams during 1955. Previous awards have been given to a ham who maintained communications during a tornado, another who relayed messages and traffic from isolated Arctic outposts, and last year to a school teacher whose spare hours were devoted to Civil Defense.

Judges of the award recipient this year include several national figures. Nominations are made by mail and must be post-marked not later than January 3, 1956. Official rules are available from the Edison Award Committee, Tube Department, *General Electric Co.*, Schenectady 5, N. Y. —30—

## U.H.F. Tetrode Transistor Works at 1000 Mc.

AN IMPORTANT PROBLEM in the operation of transistors at radio frequencies appears solved with the introduction of the "junction tetrode" transistor by the *Bell Telephone Laboratories*.



Previous transistors have been of the "triode" or three-element nature. Addition of a fourth element enables operation up to the 1000-mc. band.

The size of the new transistor can be seen in the photograph. The wires supporting the germanium bar are

made of gold and are less than half as thick as a human hair. This uncased transistor is for experimental work. —30—

## The Antenna Was There—But The Receiver Was Not

THE *Snyder Manufacturing Co.* has announced that not all homes with television antennas on the roof have a TV set in the living room. Likewise, not all automobiles with radio antennas have auto radios.

A year-long survey has been completed by *Snyder's* distributors and field men. It was discovered that out of every 100 homes with TV antennas visible on top of the roof, 7.3 have no working TV set. Of 100 automobiles inspected by *Snyder*, approximately 12.1 do not have radio receivers.

Non-working TV antennas were attributed to home owners who put up cheap an-

tennas to give the impression that they owned TV sets. Some families (about two out of every 100) owned TV sets that went bad and had not been repaired. One family out of every 500 explained that they were anticipating color TV and had not installed a black-and-white receiver to go with their antenna.

As for the 12.1 cars with "phony" car radio antennas, the *Snyder* survey indicated that virtually all such motorists were putting up a false front. To meet this demand (?), the *Snyder Co.* will soon market a "Tenna-Phony." —30—

## Germany Tests "Ionophon"

THE *Telefunken Company*, Hanover, Germany, has acquired the rights to develop the M. S. Klein "Ionophon" loudspeaker. In this loudspeaker, the air cushion usually surrounding the speaker cone is instead ionized by a high-voltage coil. The ionized air is then modulated into audible sounds. Reproduction is claimed to be more natural and more precise with an absence of speaker resonance.

"Ionophon" speakers manufactured by *Telefunken* will be designed for high-quality audio installations and movie theaters. One of the first speakers is pictured above. The close-up view shows the high-voltage Tesla coil used to ionize the air in the small fixture at the top right. The other view shows the horn flare that spreads the sound over a wide angle.

-30-

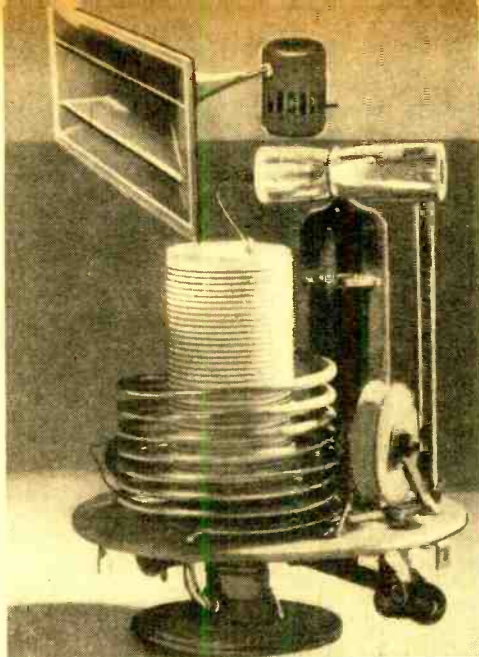

## U. S. Navy Tests Radio-Controlled Helicopter



A REMOTE CONTROL HELICOPTER, the world's first successful model of this type, has been developed by the *Kaman Aircraft Corporation*. Designed for the U. S. Navy, the modified *Kaman* HTK-1 has been flying for more than a year and has over one hundred hours of R/C operation.

Command signals are transmitted by radio from a ground operator whose controls resemble those in the plane. Systems for flying fixed-wing airplanes have been in use for some time, but this is the first time the peculiar problems of helicopter operation have been overcome.

So far, all flights have been limited to the visual range of the ground operator, as seen in the photo.

-30-

## New Zenith Radio Permits Use of Headphones

*ZENITH Radio Corp.* is now making available to the general public an adaptor package which will permit headphones to be connected to table and clock model radios. The adaptor is being sold with wiring instructions. Attachment to a clock radio can be made by the average individual in a matter of minutes.

Accessories available at slight extra cost include a set of double phones, a single headphone unit, or an 8-foot twisted cord that is designed to plug into the earpiece.

It will be recalled that *Zenith* previously developed a similar "private listening" accessory for television receivers. The radio adaptor will enable those with a hearing deficiency to enjoy radio programs without fear of disturbing the remainder of the family. Hearing-aid earphones can be directly connected to the adaptor. Suggested retail price is said to be about \$2.50.

-30-

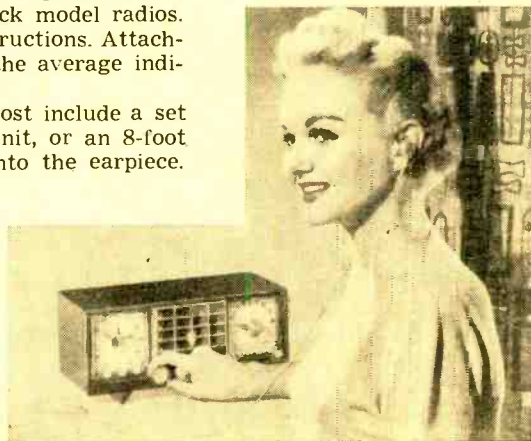

## "Snooper" Finds Line Breaks

TELEPHONE LINE TROUBLES are detected automatically by the "Snooper," an electronic device invented by two California engineers employed by the *Pacific Telephone and Telegraph Company*.

This device is connected to a central network from which it sends electronic impulses along the lines. A potential break or weak spot in any line causes a break in the impulse. This, in turn, activates a machine which punches out the approximate location of the "trouble spot." Telephone repair crews then know where to find the trouble, and can repair it before an actual breakdown occurs.

The "Snooper" is so sensitive that it will ferret out tiny holes in telephone cables nibbled by the so-called "cable bug," a tiny insect which chews up lead sheathing around underground cables. It will also discover and report bullet holes in overhead wires, caused by hunters who aim at birds sitting on telephone wires—and miss. During the winter, the machine is par-



ticularly useful in spotting "wet weather" trouble, where water has seeped into the wire or cable through its protective heavy fiber and plastic sheathing.

Inventors of the ingenious "Snooper" are Roger Plyer of Mountain View, Calif., and William Jensen of Santa Clara, Calif. —30—

## Antenna Housed Inside Globe

FINE PERFORMANCE and unique design are incorporated in the "Globe-Tenna"—an indoor antenna built inside a handsome 12" globe. Rotating the globe by hand finds the best position of the antenna for optimum reception.

The antenna is a triple loop or modified halo type. Recommended for u.h.f. and v.h.f. television, as well as for FM radio reception, it is claimed by the manufacturer to outperform any other indoor-style antenna. The antenna lead-in has a three-way clamp for easy connection to any set. The globe itself is an authentic, full color map of the world, mounted on a polished brass base which will not mar any furniture surface.

Available at parts distributors and dealers, the "Globe-Tenna" (Cat. No. A-9265) nets for \$19.95. Additional information may be obtained from the manufacturer, *Telco Electronics Mfg. Co.*, division of *General Cement Mfg. Co.*, 919 Taylor Ave., Rockford, Ill. —30—



## Miniaturized Hearing Aid

A COMPLETE ONE-UNIT three-transistor hearing aid which can be worn entirely in the ear has been announced by *The Dahlberg Co.*, Golden Valley, Minneapolis, Minn. Known as the "Miracle-Ear," the tiny instrument weighs less than half an ounce and is about the size of a lady's earring. It eliminates the need for a separate cord and receiver, and enables the user to hear at normal ear level.

Telephoning, too, is simplified. Using the new aid, a person can hold the telephone receiver right at his ear, as in normal hearing. In addition, the aid can be put on or taken off like a pair of glasses and carried easily in pocket or purse.

The three microscopic transistors are used in conjunction with a power cell no bigger than a button. In the photograph, the new hearing aid and its component parts are shown beneath two current models that employ cords and separate receivers. For additional information on price and availability, write directly to the manufacturer mentioned above. —30—

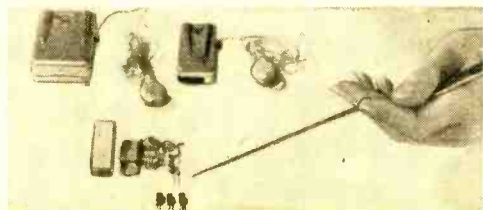



•  
•  
•  
•  
•

General Electric  
opens new vistas  
in TV tube design

•  
•  
•  
•  
•  
•



## Micro-Miniature Tubes

•  
•  
•  
•  
•

**A** RADICAL new concept in radio receiving tube design has been announced by the *General Electric Company*. It is the "micro-miniature" ceramic radio tube.

This tube has been primarily designed for u.h.f. TV receivers. It will enable amplification of microwave signals to strengths heretofore impossible with vacuum tubes of metal and glass construction. Transistors are not capable of operating efficiently at these frequencies.

To be known as the 6BY4, this tiny micro-miniature tube will soon be made available to the general public and to manufacturers of television receivers. The latter are being urged to adapt it to their present receivers and thus permit many people in u.h.f. TV areas to obtain as good TV reception as is possible in metropolitan v.h.f. TV zones.

The 6BY4 tube is classified as a triode. Preliminary ratings indicate that production models will open new horizons in terms of

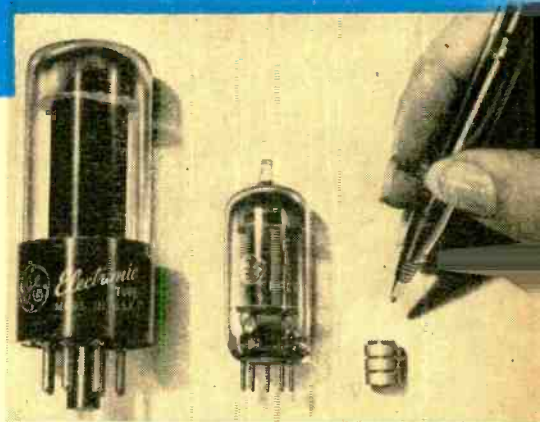

At top of page, James E. Beggs of the General Electric Research Laboratory holds a miniature ceramic vacuum tube designed by him and a group of his associates following extensive research. The photograph below shows various milestones in radio and television receiving tube development: at left is a conventional glass type with a plastic base, in the center is a miniature-type tube, and at right is the ceramic micro-miniature tube.

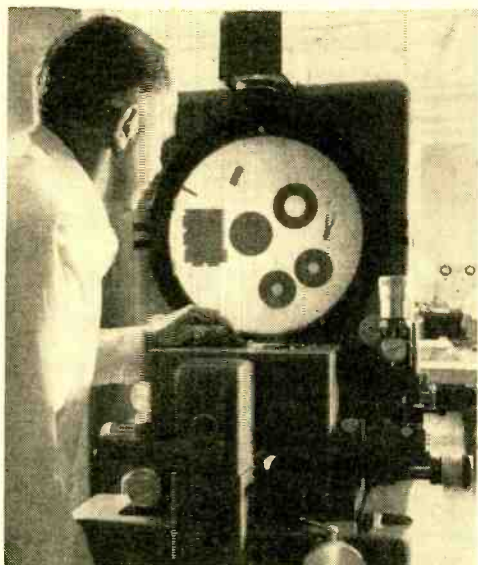

noise figure, extreme operating temperatures, miniaturization, and ruggedization. Physically, the tube is three-eighths of an inch long and five-sixteenths of an inch in diameter. It is made of white ceramic and titanium rings sealed together instead of the usual glass bulb which encloses the elements of common vacuum tubes.

Although this first version of the micro-miniature tube is designed for television, there are indications that the amazing heat-resistance of the ceramic jacket will be important for other uses. Such a tube will operate while glowing red hot at a temperature near 1000° Fahrenheit. This is far beyond the point where glass melts. It approaches the temperatures found in jet engines, guided missiles, and perhaps even man-made satellites.

Mechanical design of the 6BY4 will be more compatible with the automatic manufacture of vacuum tubes than conventional glass or metal receiving tubes. The extreme small size has necessitated great precision. At the same time, the "in-line" construction permits ready adaptation to automation principles.

Use of the micro-miniature ceramic 6BY4 will give a noise figure of less than 9 db and a power gain of 15 db at 900 mc. The transconductance has been measured at 6000 micromhos with an amplification factor of 100. Required plate voltage is about 200 and the heater operates at 6.3 volts and 0.4 amp. The 6BY4 is best suited to grounded-grid service because of the parallel-plane construction with micro-spacing between elements.

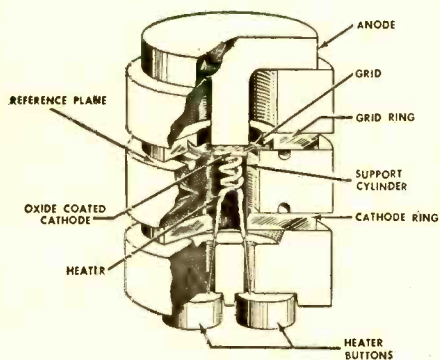

G-E MICRO-MINIATURE CERAMIC TUBE, TYPE 6BY4

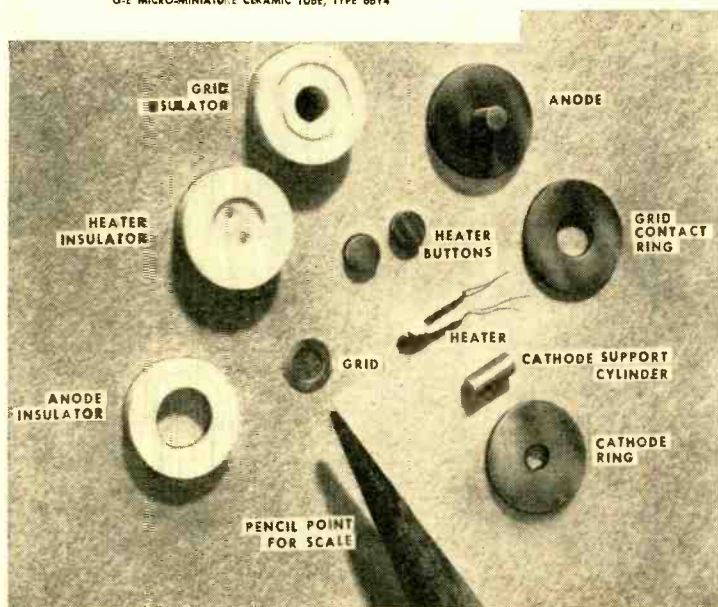

At the upper left, a G.E. technician examines the parts of the 6BY4 micro-miniature tube through the use of a shadowgraph. This optical comparator brings the parts up to a size reasonable to the naked eye. The diagram at the center is a cross-section view of the 6BY4. Individual pieces of a ceramic 6BY4 are shown in the bottom view. The extreme simplicity in constructing such tubes is obvious from this latter view.



**E**CONOMY of operation is featured in this little radio receiver. As it consumes about the same amount of power as an electric clock, continuous operation is practical. Maintenance cost should be negligible, for it has only one tube to wear out and the balance of the parts are operated at such a small fraction of their ratings that they should never require replacement.

This receiver is capable of providing ample sound level to fill a living room, but its power is limited so that it cannot be used to annoy one's neighbors. A measure of its performance is daylight loudspeaker reception of the major Chicago stations, 100 miles distant, using 12 inches of antenna wire.

Low power consumption allows the unit to be built into the wall or a piece of furniture without providing ventilation. Built into the headboard of a bed, it makes an excellent slumber-time radio, for it needn't be turned off. Inclusion of a phone jack allows private listening with headphones. The addition of a phono jack and switch will permit moderate reproduction from an inexpensive record player.

#### Circuit

The circuit diagram is shown in Fig. 1. A stage of radio frequency amplification, a germanium diode detector, and a stage of audio frequency amplification are em-

# REFLEX

# RECEIVER

By **SERGE L. KRAUSS**

*Loudspeaker operation with but one tube is obtained by using the tube for both radio and audio frequency amplification*

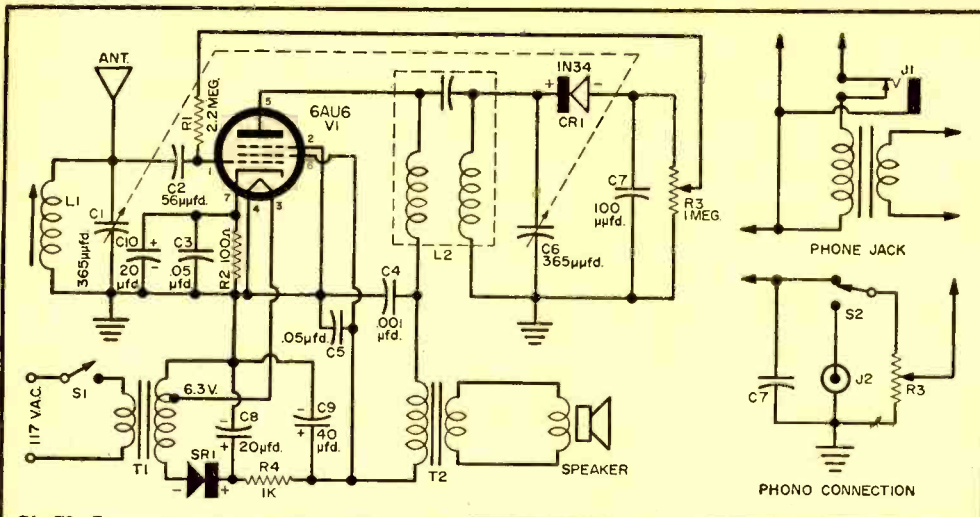

C1, C6—Two-gang tuning capacitor, 365  $\mu$ fd. per gang (approx.)

C2—56- $\mu$ fd. mica capacitor

C3, C5—0.05- $\mu$ fd., 200-volt tubular capacitor

C4—0.001- $\mu$ fd., 400-volt tubular capacitor

C7—100- $\mu$ fd. mica capacitor

C8, C9, C10—20-40-20  $\mu$ fd., 150-150-25 volt electrolytic capacitor

CR1—Type 1N34 crystal diode

J1—Closed-circuit phone jack

J2—Phono jack

L1—Ferrite core antenna coil (General Cement 8866)

L2—Shielded r.f. coil (Meissner 14-2437)

R1—2.2-megohm,  $\frac{1}{2}$ -watt resistor

R2—100-ohm,  $\frac{1}{2}$ -watt resistor

R3—1-megohm volume control with switch S1

R4—1000-ohm, 1-watt resistor

S1—S.p.s.t. switch (on R3)

S2—S.p.d.t. switch

Speaker—6" permanent magnet speaker (any convenient size is satisfactory)

SR1—65-ma. selenium rectifier

T1—Power transformer, 125 v. @ 15 ma., 6.3 v. @ 0.6 amp. (Stancor PS-8415)

T2—Output transformer, 25,000 ohms to voice coil (Merit A-2937)

V1—Type 6AU6 tube

1—7-prong miniature socket

1—Chassis,  $1\frac{1}{4}$ " x  $6\frac{1}{8}$ " x 3"

1—Line cord and plug

1—Single-lug tie point

Misc. screws, solder, metal shields, etc.

Catalog price of parts, approx. \$15.00

Fig. 1. Schematic and parts list. Head-phone and phono connections shown at right.

picked up by the antenna, it is fed through capacitor C2 to the grid of the 6AU6, where it is amplified and applied to the primary winding of the r.f. coil L2. Detection of the r.f. signal induced into the secondary of L2 takes place in CR1, a crystal diode, with the resulting audio signal appearing across volume control R3. This audio signal is impressed on the grid of the 6AU6 through resistor R1, amplified, passed through the primary of the r.f. coil L2, and impressed on the primary of the loudspeaker output transformer T2. The signal induced in the secondary is applied to the voice coil.

Amplification of both radio and audio frequency signals by a single tube is made possible by the discriminating action of coupling capacitor C2, r.f. coil L2, and bypass capacitor C4. Capacitor C2 passes r.f. signals readily but does not appreciably shunt the audio signal impressed through resistor R1. The r.f. coil L2 is relatively immune to the audio frequency signal that is conducted through it to the speaker output transformer. Capacitor C4 bypasses the r.f. signal. This type of circuit is generally called a *reflex* circuit, a very popular type in the early twenties when tubes were both expensive and inefficient.

### Components

The ferrite core antenna coil—sometimes called a "loopstick"—has a high *Q*, and with a foot or two of antenna lead is very effective in picking up signals. This type of antenna circuit is almost non-directional, especially if the antenna wire is mounted in a vertical direction. Such an arrangement is excellent for a built-in installation where the antenna wire may be simply dropped down the wall between the studs. For a table or portable receiver, one of the tele-

played. The same tube, a 6AU6, is used for amplifying the signal at both radio and audio frequency. Sensitivity of the receiver is directly related to the transconductance of this one tube, which might bring to mind the use of such "hot" tubes as the 6AC7, 6AH6, etc. Unfortunately, the much higher grid-to-plate capacity of these tubes results in regenerative instability that can only be controlled by cathode degeneration which lowers the effective transconductance.

The receiver circuit functions in the following manner. After the r.f. signal is

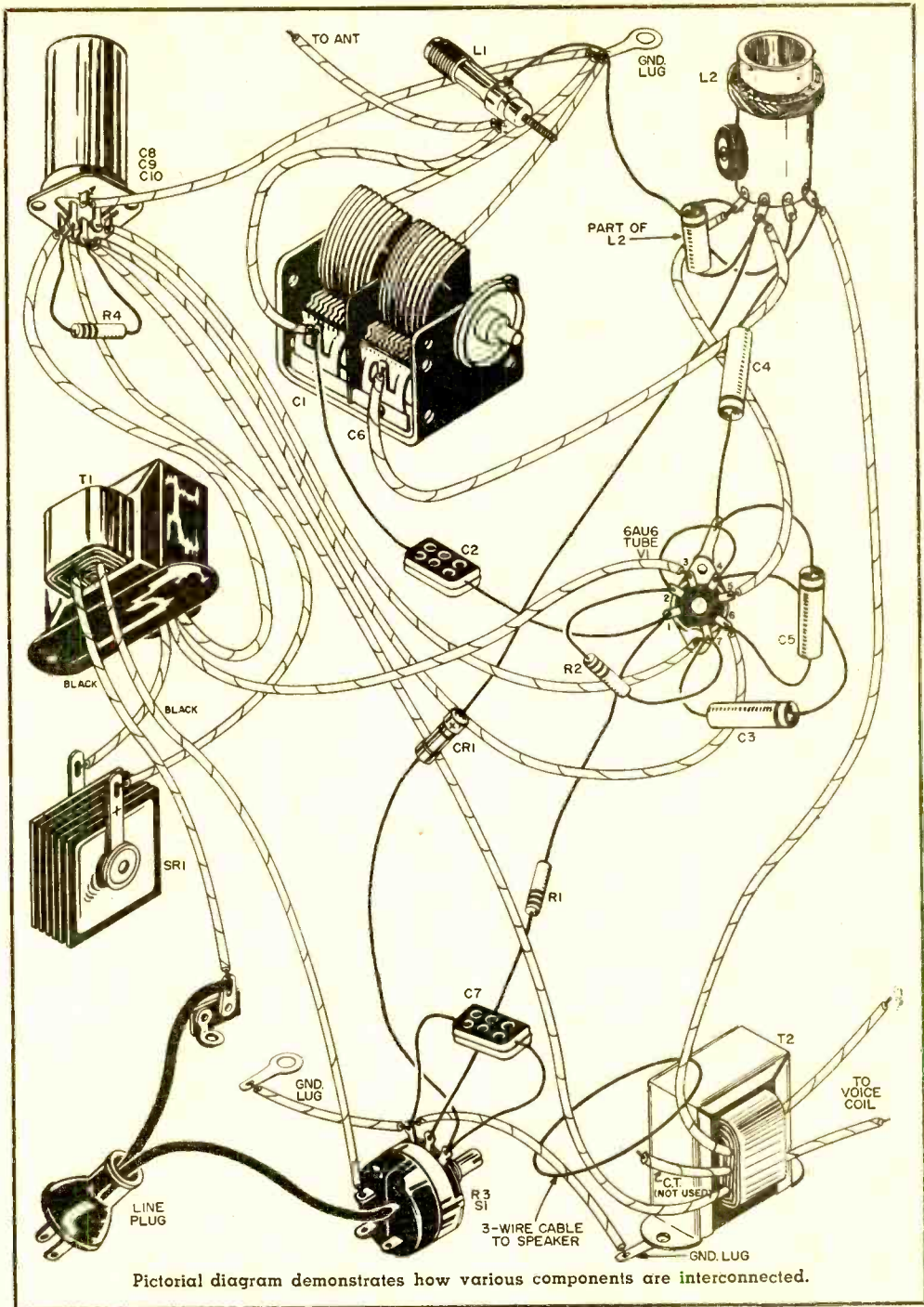

scoping sections of a "rabbit ear" TV antenna makes an excellent collapsible antenna and allows the receiver to be enclosed in a metal case if desired.

Sensitivity of a speaker is related to the magnet, cone, and voice coil size. Generally,

the larger the magnet and cone, and the smaller the voice coil, the more sensitive will be the speaker. A standard 6" speaker with a 1½-ounce magnet (*Utah SP6C*) was used on the model. The output transformer should reflect a plate load of 25,000 to

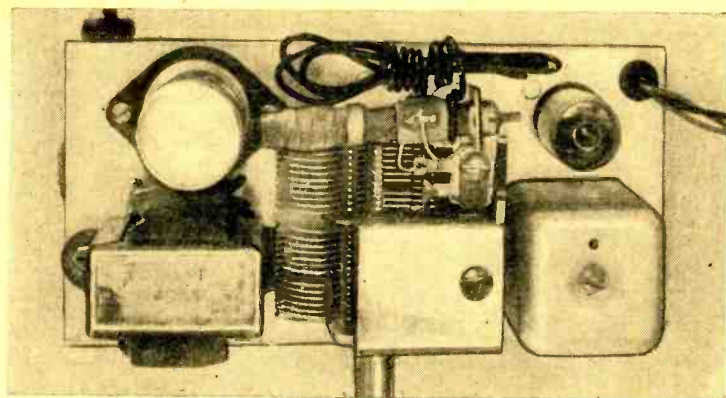

Fig. 2. Above-chassis view shows location of the major components. Note shield over one section of the tuning capacitor, and the three-wire cable to the speaker (right).

50,000 ohms. Being a pentode, the 6AU6 acts in a manner similar to a constant current generator, so power output is very nearly proportional to the reflected load, and doubling the load practically doubles the power obtained from the same signal. The model shown uses a standard 25,000 ohm-to-voice-coil transformer, *Merit* A2937.

The power transformer is of the type commonly used in TV boosters and converters. These transformers are available new in standard brands, but one might be salvaged from a second-hand TV booster. If the transformer being used has a separate filament winding, connect both the top end of the high-voltage winding and the ungrounded filament lead to socket terminal 3.

### Chassis Layout

Chassis layout for the receiver is quite simple. Figure 2 shows the placement of the major parts. Good parts arrangement gives dual results, for it assures stability of operation and cuts down on the amount of wiring. In this simple receiver, wiring is reduced to a minimum.

The model was built on a 1¼" high by 6½" long by 3" wide chassis, available as *ICA* 29080 if the builder prefers to purchase it ready to drill. The two-gang variable tuning capacitor will probably require mounting hardware. Either spade bolts, as used on the model, or simple brackets made from tin plate (metal from a food can) will be adequate.

The method of mounting will have to be determined before the chassis drilling can be laid out. All parts can be mounted with round holes except the r.f. coil. A 1¼"-square opening should be drilled or filed out, leaving two ears or tabs for the coil shield mounting spade bolts. A wire from the variable tuning capacitor rotor wiper or center shield to the r.f. coil is needed to avoid regeneration, and should be attached before mounting the tuning capacitor.

If the tuning capacitor center shield does not project well beyond the frame, a divider strip made from tin plate should be soldered in place before mounting it. This strip should extend the center shield to the chassis to cut off any coupling between the two stator connection terminals. The small metal shield cover over the top of the front tuning capacitor section and trimmer is conveniently installed at this time. A hole in the shield gives access to the trimmer screw. Spot-solder the rotor wiper to the shield at one point.

The seven-contact miniature tube socket should have a tubular shield eyelet in the center. Either a molded or wafer-type socket may be employed, but a wafer-type socket with a grounding strap between the eyelet and one of the mounting holes—as used in the model—eliminates a wire.

Use a Bakelite insulating disc for mounting the filter capacitor. The tin-plate shield under the chassis separating the tube socket from the r.f. coil should be fitted before wiring but not installed until after wiring. Rubber grommets or smooth eyelets are recommended for the power transformer wire holes in the chassis. The output transformer should be mounted on the speaker. Primary wires will have to be extended. Include an extra wire for grounding the speaker frame to the receiver chassis.

### Wiring

Wiring is probably best started with the line cord, switch, and power transformer, then the heater wiring to the tube socket, the rectifier, filter capacitor, resistor, and wires to the tube socket. Wires from the tuning capacitor to the r.f. coil should be short and dressed near the chassis, as should the capacitor *C2*. Speaker leads are installed next, followed by the resistors and capacitors.

The germanium diode is susceptible to damage from soldering heat. Leave the

Under-chassis view shows placement of components not indicated in Fig. 2. The strip of tin at left center is the "losser" shield discussed in text. Speaker cable is at left.

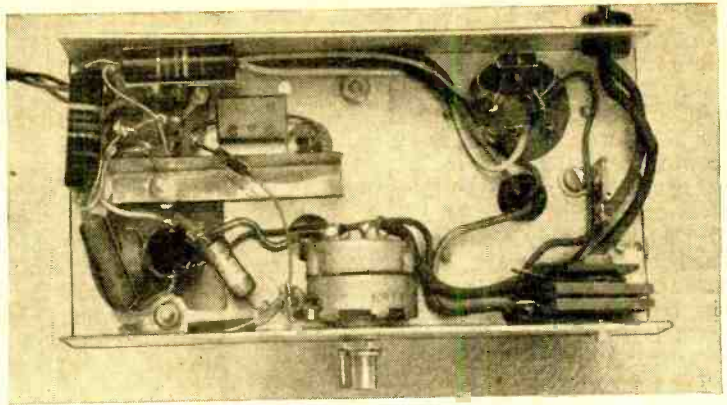

leads full length but coil them, corkscrew fashion, so that the diode just spans the distance between the coil and volume control terminals. Tin the ends gingerly, let them cool, then solder in place with a quick touch of the iron. Be sure the cathode or + end is attached to the coil terminal.

Mount the antenna coil to the tuning capacitor with the bracket accompanying it. Remove the short piece of antenna wire attached to one terminal of the coil, and replace it with two feet of hookup wire, hitched around the bare coil form near the bracket. Connect this same terminal to the tuning capacitor stator terminal. Connect the other coil terminal to the mounting bracket.

### Using the Receiver

When the receiver is completely wired, adjust the core on the antenna coil so that it is about flush with the end of the coil form. Loosen the rear trimmer on the tuning capacitor until the spring does not touch the mica separator. Separate the antenna and speaker wires, and turn on the switch. It should now be possible to tune in local stations.

Select a station near the minimum capacity setting of the tuning capacitor. Adjust the front trimmer for maximum volume while rocking the tuning capacitor back and forth across the station. Next, select a station near the maximum capacity setting of the tuning capacitor. Adjust the antenna coil core for maximum volume while rocking the tuning capacitor across the station. Repeat the trimmer and coil adjustments until no further improvement can be noted. The receiver now should be properly aligned.

At this stage, the receiver may have a tendency to oscillate at the high-frequency end of the band. This condition is readily controlled by a "losser," a small piece of tin plate bent into a U-shape and clipped over the antenna coil form near the ter-

минаl end of the winding as shown in the photos. The size of the "losser" should, of course, be only large enough to prevent oscillation. Otherwise, the sensitivity and selectivity will be impaired.

This tendency to oscillate is caused by feedback through the small but finite grid-to-plate capacity of the tube. Such action should not be confused with the continuous oscillation which will result if the shields specified are omitted, or if one of the bypass capacitors is defective. The addition of a "losser" will require touching up the alignment slightly.

In case the receiver fails to function at all, the voltages on the 6AU6 tube should be checked. The plate and screen potentials (terminals 5 and 6) should be between 120 and 140 volts. The bias or cathode potential (terminal 7) should be between .8 and 1.5 volts. This receiver has such a low hum level that it can barely be perceived with one's ear in the speaker, so any audible hum may be considered a malfunction. A baffle is essential for the speaker to operate efficiently. To avoid misjudging the performance, at least install the speaker in a cardboard carton for preliminary tests.

No enclosure or dial has been detailed, for it is felt that each constructor will have a particular application for the receiver. If the receiver is to be built into the wall, a complete metal enclosure and fuse is recommended as generally required by building codes for fire protection. A simple dial can be a large bar knob in front of a paper disc for logging stations. Covering the paper with a transparent plastic will protect it from soil.

If good parts are used and the instructions followed, the performance attainable from this one-tuber is little less than amazing. It is really a thrill to tune across the band and pick up station after station over a loudspeaker with a receiver using but one tube, practically no electricity, and only a foot or two of antenna wire.

WITH the new FCC regulations allowing Technician class licensees to operate on the 6-meter band, a comparatively unused amateur band has come to life. This band offers many of the good features of the 2-meter band as well as an opportunity to work some DX.

Anyone with a limited amount of technical ability and a receiver that will tune to 4000 kc. is only eight hours away from receiving signals on six meters. While the tuner to be described is simple, it is by no means a toy. The approximate cost of parts is \$15.00, less the amount of any parts found in the junk box.

The 6-meter band does not present some of the construction problems of the higher frequencies. Chassis layout and lead length are important but not critical. Most of the miniature tubes still operate satisfactorily on this band. Obtaining gain is not difficult. It's a band where the average technician can build his own equipment, expect

output transformer, *C7* the oscillator grid capacitor, and *R4* the grid leak. *L4* is a tapped oscillator coil. Negative coefficient trimmer capacitor *C6* compensates for drift. *C5* is the main tuning capacitor. Coupling capacitor *C4* feeds injection voltage from the oscillator into the grid of the mixer.

Chokes *RFC1* and *RFC2* are heater chokes and *C11* and *C12* are heater bypass capacitors. Standard-type coil *L3* requires no modification. *L1*, *L2* and *L4* were made by modifying *J. W. Miller* Type 1474 coils. It is not necessary to use these coils but they do have high-frequency cores and lugs on the coil forms which make winding coils a simple process. The only actual requirement is to wind coils that will tune to the proper frequency without too much reduction in *Q*.

The modification of these coils is as follows. Remove wire from a *Miller* Type 1474 coil form. Wind 14 turns of No. 24 enameled wire, close-wound on the top end of the

## Tech-Band Converter

Two-tube converter for the 50-mc. band requires few parts for sensitive and efficient operation

good results, and conduct vital experiments. No short cuts were taken to reduce the cost of this tuner at the expense of quality. It's simplicity dictated low parts cost. The tuner consists of six resistors, twelve capacitors, six coils and two tubes. All parts are commercially available. The coils require modification which is not difficult.

### Operation

Operation of the tuner is as follows. *L1* is the antenna coil. The only capacity across this coil is the input capacity of the tube. Cathode resistor *R1* is shunted by capacitor *C1*. *C2* is the screen bypass capacitor which serves as the B+ capacitor for *L2* as well. Decoupling resistor *R2* is also used to reduce the plate voltage to 100 volts.

Capacitor *C3* couples the plate of *V1* to the grid of *V2A*. *R3* is a grid resistor, and *C10* is the plate capacitor for *L3*. *C9* is a B+ bypass capacitor, while *R6* serves as a decoupling resistor as well as the plate voltage dropping resistor to reduce the voltage to 100 volts. *C8* is a bypass capacitor for the screen and the plate of the oscillator. *R5* is a decoupling resistor, *L3* the i.f.

coil form. Attach wires to the top and bottom lugs on the coil form. Then, place a layer of Scotch tape over the winding. Wind three more turns over the ground end of the coil. Attach the ends of the coil to the coil form lugs, and paint the windings with polystyrene cement.

Wind coil *L2* the same way as *L1*, using nine turns, but omit Scotch tape and second winding. Apply cement to winding.

Coil *L4* is slightly different since a tap is used. Start winding the coil from the bottom of the coil form. At three turns, attach the wire to one of the lugs; bring the wire back up the coil form and complete the next five turns. Apply cement to the winding.

Chokes *RFC1* and *RFC2* are made by close-winding 20 turns of No. 24 enameled wire around a 1/8" rod. After removing winding from the rod, dip coils in polystyrene cement and let dry. These coils are light and are wired point to point.

### Construction Notes

First wire *V1* socket. Attach a ground lug close to this socket. Use No. 22 solid tinned wire and connect pin 3, pin 7, center



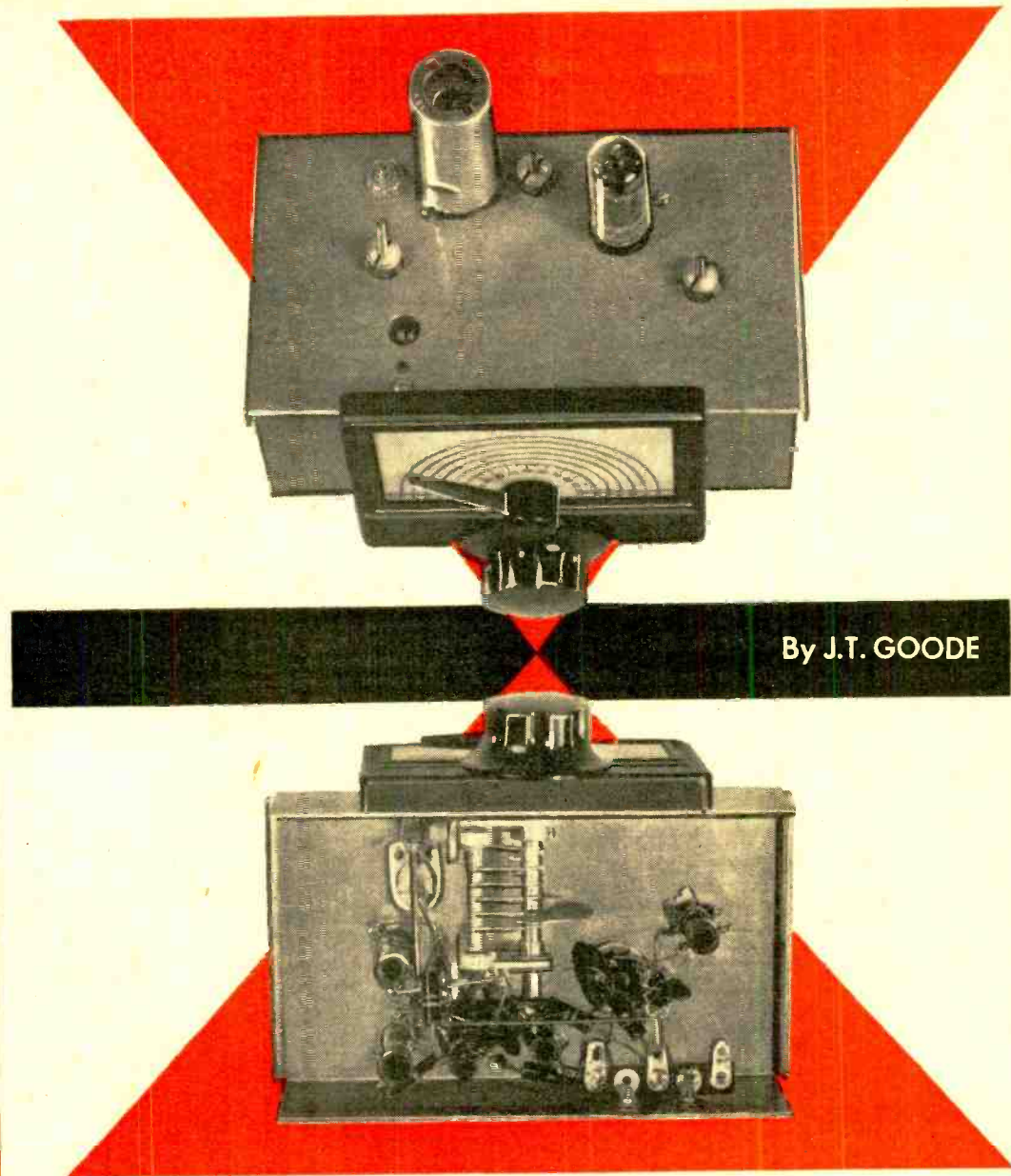

By J.T. GOODE

post of tube socket, and the ground end of  $L1$  to the ground lead. Keep these leads as short as possible. Connect  $R1$  and  $C1$  from pin 2 to ground lug.  $C2$  is wired from pin 6 to ground lug. Keep this lead short.  $R2$  goes from pin 6 to insulated tie point mounted at rear of chassis. Pin 5 connects to the top lug of  $L2$  and the bottom lug connects to pin 6. Pin 1 is wired to the top lug of  $L1$ .  $RCF1$  connects from pin 4 to the tie point, and  $C11$  goes from pin 4 to pin 3. This completes the wiring of the r.f. stage.

Wire the mixer stage circuit next. Locate a ground lug between the mixer socket and

variable capacitor. With No. 22 solid tinned wire, connect pin 5, pin 7 and center post of socket to ground lug.  $C12$  connects to pin 4 and pin 5.  $RFC2$  is wired from pin 4 to heater tie point.

$C8$  connects from ground lug to pins 1 and 3.  $R5$  extends from pin 1 to B+ tie point.  $C3$  connects from top lug of  $L2$  to pin number 2, and  $R3$  goes from pin 2 to ground lug.  $C4$  connects from pin 2 to top lug of  $L4$ .

$C10$  is wired from pin 6 to ground lug. Pin 6 also connects to  $L3$ . Note that this connection should be to the end of the

coil winding which is away from the pick-up winding. The end of the coil nearest the pickup coil is always connected to B+, thus reducing capacity coupling in this coil.

Capacitor C9 connects from the B+ end of L3 to the ground lug. R6 goes from this same point to the insulated tie point located on the variable capacitor. From this tie point, a piece of heavy busbar No. 16 is used to make connection to the tie point at the rear of the chassis. This additional tie point was added since the lead length of R6 was not sufficiently long to reach from L3 to the B+ tie point.

Wiring of the oscillator section comes next. Ground the ground lug on the end of the variable capacitor to the common ground lug with busbar. The bottom end of L4 and the ground side of C6 connect to the ground lug. C6 is a ceramic trimmer and the ground contact is the lug connected to the movable part of the capacitor. The stators of both C5 and C6 extend to the top of L4. C7 connects from the top of L4 to pin 9, and pin 8 is wired to the tap on L4. C4 goes from the top of L4 to pin 2.

### Connecting the Antenna

The antenna lead should be coaxial cable. A proper match is made when the coil is tuned by adjusting the iron core of L1 to the desired frequency. The cable should be wired directly to lugs on the coil form.

Output connections should be made with coaxial cable connecting directly to the lugs on the coil form of L3. This will reduce stray pickup in the output leads.

Power connections are made at the tie point located at the rear of the chassis.

Power requirements: 6.3 volts, a.c. or d.c., 0.5 amperes. B+ voltage is 150 volts at 20 ma.

A grid dip oscillator is required to make the initial adjustments. The adjustments will only take about five minutes. Those builders who do not own such a piece of equipment should be able to borrow one for the short time required.

Rotate the main tuning capacitor C5 for maximum capacity. Rotate trimmer C6 for minimum capacity. Tune L1 to 52 megacycles. Tune L2 to 50 mc., L4 to 45

- C1, C2, C8, C11, C12—.001- $\mu$ fd. ceramic capacitor  
 C3—470- $\mu$ fd. ceramic capacitor  
 C4—0.68- $\mu$ fd. ceramic capacitor  
 C5—Three-plate variable capacitor made from a BUD Type MC-900 by removing all but one of the rotor plates  
 C6—2.6- $\mu$ fd. trimmer similar to Centralab 820-A  
 C7—20- $\mu$ fd. zero coefficient ceramic capacitor  
 C9—.01- $\mu$ fd. capacitor  
 C10—30- $\mu$ fd. capacitor  
 L1—9/32 outside-diameter coil form with 14 turns of No. 24 enamel wire on secondary and 3 turns No. 24 enamel on primary  
 L2—9/32 outside-diameter coil form with 9 turns of No. 24 enamel wire on primary  
 L3—Similar to J. W. Miller B-5495-A  
 L4—9/32 outside-diameter coil form with 8 turns of No. 24 enamel tapped at 3 turns (both L1, L2 and L4 were made from Miller 1474 coils)  
 R1—220-ohm, 1/2-watt resistor  
 R2, R5, R6—10,000-ohm, 1-watt resistor  
 R3—470,000-ohm, 1/2-watt resistor  
 R4—43,000-ohm, 1/2-watt resistor  
 RFC1, RFC2—20 turns close-wound of No. 24 enamel wire on 1/8" inside-diameter form  
 V1—6BJ6 tube  
 V2—6U8 tube  
 Chassis—2" x 3 1/2" x 6"

Wiring schematic and parts list.

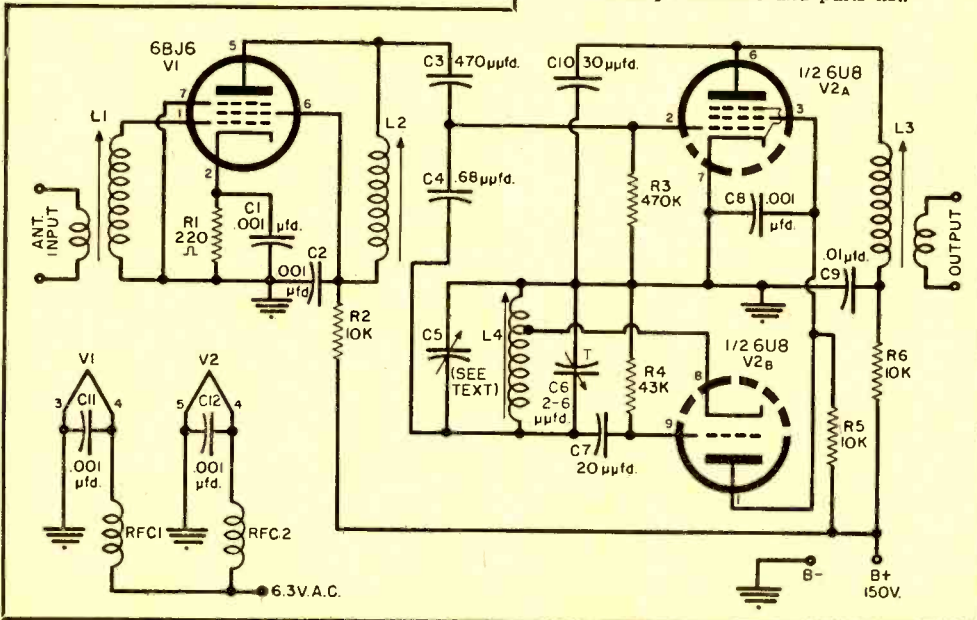

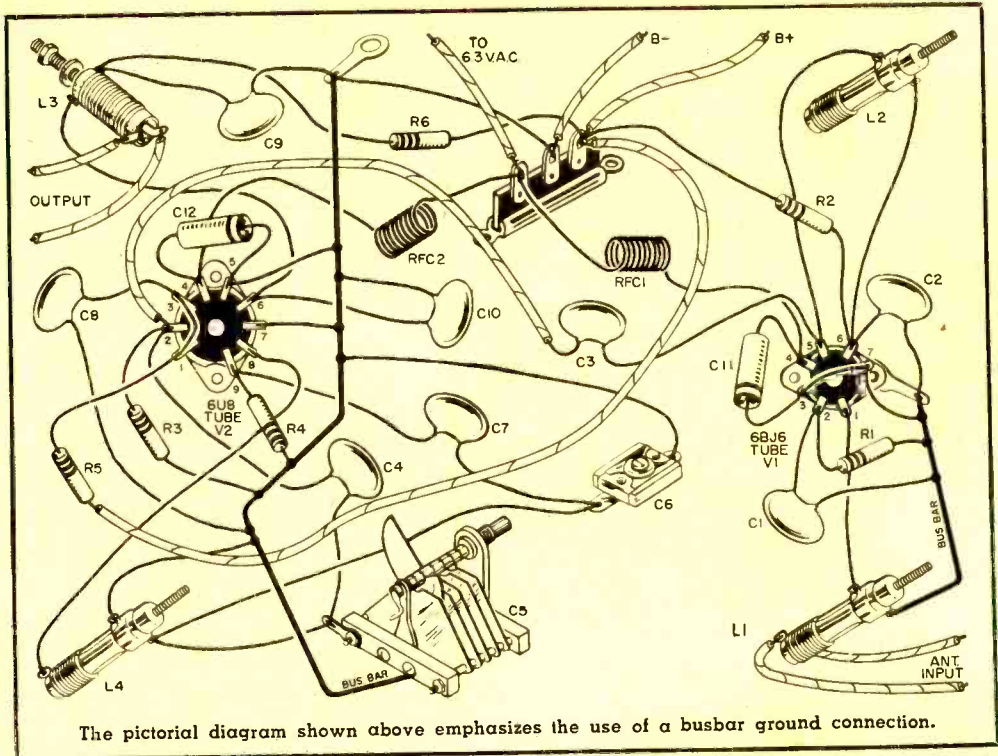

The pictorial diagram shown above emphasizes the use of a busbar ground connection.

mc., and  $L_3$  to 4000 kc. Apply voltage to the tuner and check with the grid dip oscillator to see that the oscillator circuit is oscillating at 45 mc. Final tuning can be completed on received signals.

Connect the output winding of  $L_3$  by means of coaxial cable to the antenna and ground terminals of a receiver that will tune to 4000 kc. Filament and B+ voltage can be supplied from the receiver. The current drain of the tuner is low, so that the power supply should not be overloaded in the receiver.

### Minimum Frequency Drift

Reducing frequency drift to a satisfactory amount is an adjustment that requires no test equipment. If the drift is noticeable, increase the capacity of trimmer  $C_6$  slightly and adjust the iron core of  $L_4$  to return the dial calibration to normal. A majority of the drift will take place in the first 20 minutes. It may be necessary to make this adjustment several times. Final calibration should not be made until the drift adjustment is finalized. The center of the dial calibration should be 52 mc. To set the calibration, adjust the iron core of oscillator coil  $L_4$ .

With a received signal, adjust iron core of  $L_1$  for maximum gain. This adjustment should take place when the received signal is near the center of the band. The adjust-

ment of  $L_2$  is the same but there will be calibration change when  $L_2$  is adjusted. It will be necessary to retune the dial for maximum signal while adjusting  $L_2$ . When maximum gain is obtained, readjust  $L_4$  for correct dial calibration.

This pulling effect between the oscillator circuit and the mixer circuit tends to cause tracking over the band. The tuner is essentially a fixed-tuned, broadband 4-mc. bandpass converter.

With the iron core adjustment, the Miller B-5495-A coil used for  $L_3$  will tune from 4 to 6 mc. If it is desirable to use 6000 kc. as an intermediate frequency, simply adjust the iron core of  $L_3$  to this frequency. The oscillator should then tune from 48 to 44 mc.  $L_4$ 's iron core will allow this much adjustment.

The tuner can be operated from batteries. In this case, reduce the value of  $R_2$ ,  $R_5$  and  $R_6$  to 1000 ohms,  $\frac{1}{2}$  watt, and use a 90-volt battery. If small B batteries are used, it is not necessary to make any connections other than an antenna connection to a car receiver. The filament voltage can be supplied by the car battery.

-30-

Editor's Note: As specified in the parts list, the tuning capacitor,  $C_5$ , is constructed from a BUD Type MC-900 variable capacitor. The number of rotor plates is reduced until only one is left in place anywhere on the rotor.

# INTRODUCTION TO PUZZLE-TRONICS

By HARVEY POLLACK

*Entertain your friends with these intriguing puzzles, which can be assembled in one evening from a few inexpensive parts*

ONCE UPON A TIME a farmer approached a stream on his way to market. With him were a hen, a bushel of corn, and a pet wildcat. On the shore was a boat which could carry the farmer—the only one who could row, of course—and one of his possessions at a time. The hen's consuming desire was to eat the corn while—at the same time—the wildcat had exactly the same ideas about the hen. On the other hand, the wildcat, being strictly carnivorous, looked with disdain upon the corn. Only the presence of the farmer prevented the massacre of his possessions, so he had to be careful which of them he left alone with the others. After some meditation, he discovered a way to transport all of them across the river without having any of them consumed. How did he do it?

Solving puzzles like this is fun in itself, but planning and constructing electrical puzzle circuits (or "pircuits" as they are sometimes called) is even more exciting. Then, after they are built, they can provide many evenings of entertainment for friends and visitors.

Essentially, a puzzle circuit is an electrical arrangement of switches, battery, and buzzer which maintains complete silence as long as the human player executes each move without error, but which buzzes raucously when the wrong move is made. The player gets the sensation of

being inexorably monitored by a machine of deadly accuracy, and he quickly learns that every action must be thought out carefully if he is to avoid being caught by the electronic "brain."

## "Farmer" Circuit

For those who would like to try their hands at this amusing electrical work, it is suggested that they start with a relatively simple setup like that of the farmer and his stock, building up the circuit (Fig. 1) on a cigar box or similar enclosure.

When the farmer problem is considered for a while, it becomes apparent that only the wildcat and the bushel of corn can be left unguarded. Thus, the farmer first carries the hen across the stream, leaves her there alone, and returns to pick up the bushel of corn. He takes the corn to the other side but brings the hen back with him on the return trip. Depositing the hen on the shore, he then rows the wildcat across and leaves the wildcat with the bushel of corn while he goes back once more for the hen. When the switches are moved in this sequence, the circuit to the buzzer is never completed, so it remains silent; but should the switches that simulate the hen and the corn, or the hen and the wildcat ever make contact while the farmer switch is in the opposite position, the machine instantly sounds off.

The prospective builder should trace out

the schematic diagram of this circuit for each possibility so that he may see the logic behind the switching arrangement. Readers should note that this puzzle can be constructed using three single-pole, double-throw switches and one double-pole, double-throw switch instead of the arrangement shown. A schematic diagram of this simpler version is also given here (Fig. 2).

### "Three Jealous Husbands"

The more adult puzzle illustrated in Figs. 3, 4 and 5 goes something like this. Three insanely jealous husbands—the proverbial threesome: Tom, Dick, and Harry—and their beautiful brides must cross a stream on their way to a honeymoon resort. All six people are accomplished rowers. The only available boat can carry a maximum of two people. None of the husbands will permit his bride to be on the same side of the stream with another man unless he, the rightful husband, is also there. For example, if Tom has crossed to the north shore leaving Tina on the south shore with either Dick or Harry or both, the situation is intolerable even though Dora or Helen may still be with their own husbands. One, two, or all three wives may be on the side opposite their husbands only if no other men are with them.

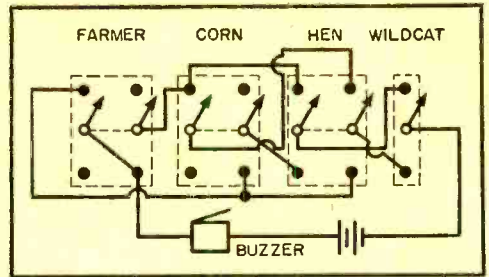

Fig. 1. Original "farmer" puzzle schematic.

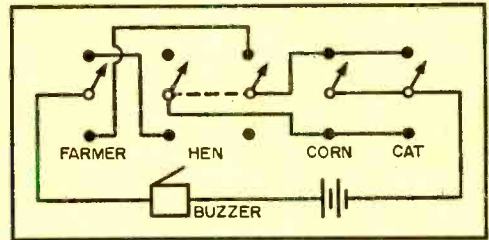

Fig. 2. Revised circuit for "farmer" puzzle.

Starting from either of the two shores, switches may be moved singly or in pairs to conform with these conditions until the crossing is accomplished peacefully. If the buzzer sounds—indicating an illegal com-

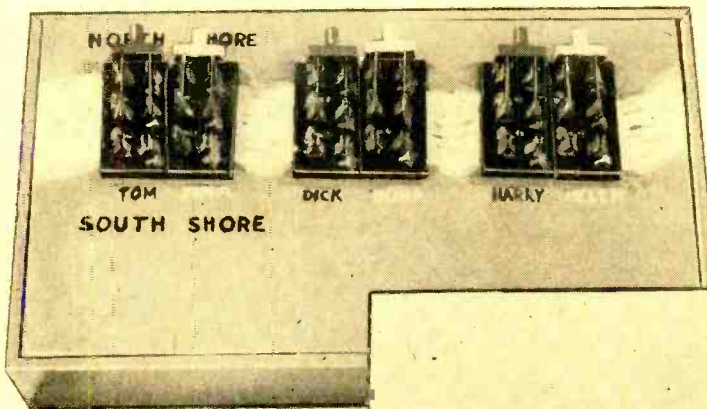
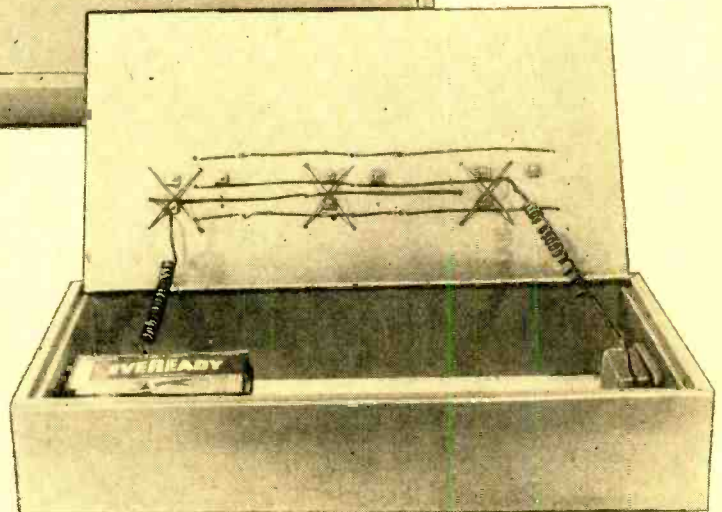
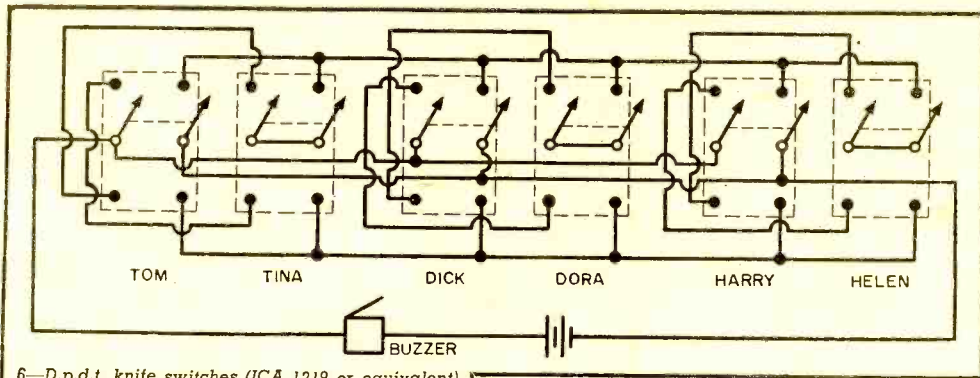

Fig. 3. Top view of the author's version of the "jealous husbands" puzzle. A specially made wooden box was employed, but any suitable enclosure of metal or wood may be used.

Fig. 4. Interior view of "jealous husbands" puzzle, showing a portion of the wiring. Some of the wiring is hidden underneath the switches (see text).





- 6—D.p.d.t. knife switches (ICA 1219 or equivalent)
  - 1—Doorbell buzzer
  - 1—4½-volt battery (Eveready No. 736, Burgess No. F3, RCA Type VS 067)
  - 1—Enclosure, metal or wood (Figs. 3 and 4)
  - Misc. wire, solder, etc.
- Catalog price of parts, approx. \$7.50

Fig. 5. Schematic diagram and parts list for the "jealous husbands" puzzle.

combination on either shore—the player must start from the beginning again. It is helpful to emphasize that the boat must go back and forth with passengers at all times since it has no volition of its own.

Switches representing the husbands are painted red (jealousy is the red-eyed monster) and those which simulate the brides are bright yellow (the color of sun-kissed

blonde hair). The wiring is quite symmetrical and requires no more than a few hours of work after the parts are mounted on the panel. In this model, the jumpers which join the movable knives on each of the "wife" switches were wired in under the respective switches before mounting them on the panel, so that they are not visible in the underside view. The battery, which provides 4½ volts for the buzzer, is held to the side of the case by means of two aluminum "U" brackets bent from thin sheet stock. Wires leading from the panel to the battery and buzzer are wound around a pencil and then slipped off, to provide a bit of spring action that prevents flopping leads yet permits the panel to be lifted without stretching the wires taut.

The solution to the husband-and-wife problem can be shown mathematically to require a minimum of 11 moves. To get some idea of the difficulty of the problem, use six squares of paper correctly labeled and simulate the river crossings with these, being careful not to permit forbidden combinations to occur. If it works out—fine! If not, follow the 11 boat trips shown in Fig. 6, noting each time how the required conditions are met.

It's worlds of fun designing new "pircuits" around problems involving sequential moves based upon a set of rigid rules. Also, many refinements and trimmings can be added to make the puzzles more interesting. Relays may be used to show the position of the boat after each crossing, "location" lights being employed for the purpose. A thermal time-delay relay of perhaps three or four seconds may be included to keep the player in suspense after each move. To provide light as well as aural signals of errors, a trouble lamp can be used in conjunction with the buzzer. An electronic time-delay circuit of 15 to 25 seconds may also be utilized to force the plays to be made quickly.

In any case, whether simple or complicated, puzzle circuits can be exciting and amusing. Try one and see!

Fig. 6. Solution to the puzzle of Fig. 5.

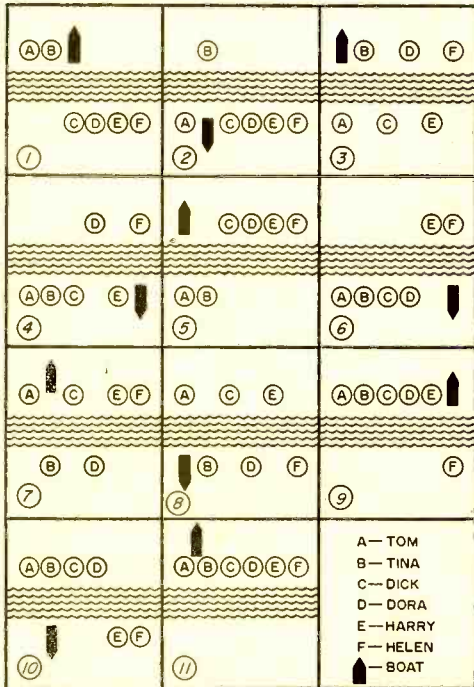

## Counter Battles Smog

IN LOS ANGELES, Calif., there is a saying: "If you don't breathe, you aren't interested; but if you do, smog is your problem too." Scientists, scholars, politicians, oil men and John Doe burning trash in his back yard have all advanced theories about the cause of and solution to the problem of "smog." But to date this dilemma, which harasses 4½ million people daily, has no apparent cause; the "villain" in the drama cannot be identified.

Scientists have shown real concern since reports from other cities prove that smog can kill on specific occasions. Their latest

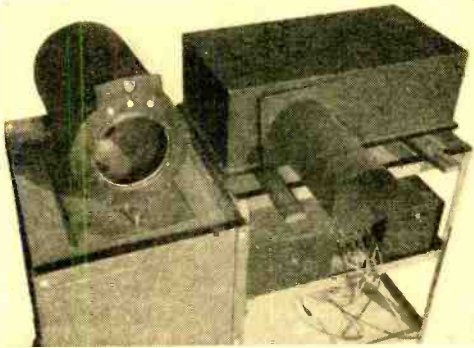

Outside view of the electronic counter. Transmitter is at left; receiver, right.

weapon is a photoelectric ozone counter. Dr. Roger S. Estey, vice president of *Borhman Engineering Co.*, developed the machine and supervises its operation.

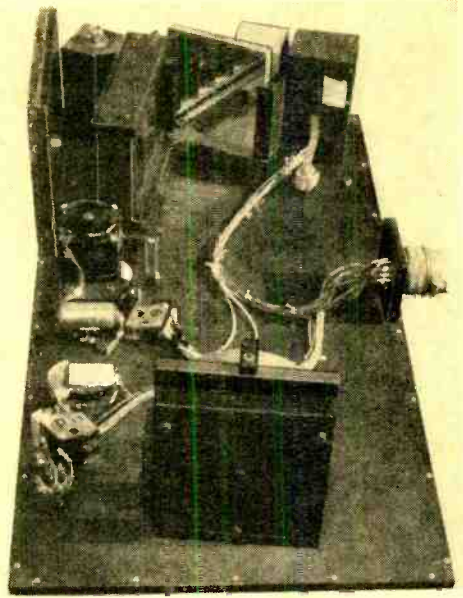

Inside view of receiver. Amplifiers and converter are mounted directly beneath.

A high-pressure mercury lamp projects a light beam to a prism spectrometer mounted 300 feet away. The spectrometer measures successive wavelengths via a synchronous clock motor so that measurements are repeated every 15 minutes daily. Radiation is picked up on a photomultiplier tube. The signal is amplified by a narrow bandpass amplifier, and then converted to d.c. and recorded on a 24-hour chart. —30—

## Kit Builds Wrist Radio

"LITTLE MITE," a newly designed wrist radio, is now available from *Huckert Electronics*, 4406 74th Ave., Hyattsville, Md. The set features a high-gain regenerative circuit and a transistorized audio amplifier.

It is reported that this receiver, using its own antenna, will pull in stations up to 400 miles away with good selectivity. Detailed "build-your-own" plans (\$1.98), a basic parts kit (\$2.98), a complete kit (\$17.95), and a wired, ready-to-play set (\$39.95) are available. Write to the manufacturer for details. —30—

## One-Tube Radio Kit

RECOMMENDED FOR THE NOVICE constructor is the one-tube radio kit manufactured by *The Gaertner Co.* of Los Angeles. Available in either battery or a.c. models, the kit may be assembled readily by one with no previous knowledge of electronics.

Maximum sensitivity is assured through

the use of a loopstick antenna and a tickler coil. The standard broadcast band is covered, as well as police call frequencies. Containing all parts, the kit includes chassis and illustrated instructions.

The battery version sells for \$6.95; the a.c. kit for \$8.95. For further information, write to the *A & M Company*, Dept. A., 616 S. Serrano Ave., Los Angeles 5, Calif. —30—

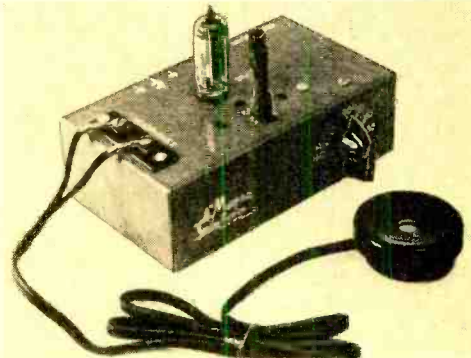

# Transistor Topics

## Sylvania Announces Kit

Especially designed for experimenters is a new kit recently announced by *Sylvania Electric Products Inc.* It consists of two 2N35 transistors, one general-purpose 1N34A diode, and a copy of the *Sylvania* booklet. The latter, if you have not already obtained it, may



be purchased separately for 25 cents. It has 28 different circuit designs for transistorized receivers, amplifiers, and gadgets.

## G.E. Urges Use of 2N107

*General Electric Company* is now distributing a free booklet outlining six possible circuits for their 2N107 transistor. This booklet is available from radio parts jobbers and distributors selling the 2N107. *G.E.* continues to popularize this transistor, which is now selling for well under \$2. It is a *p-n-p* type with a maximum frequency cutoff at 2.5 mc. and a power gain of 38 db.

The booklet contains schematics for a simple audio amplifier, a simple broadcast receiver (where the 2N107 is the audio amplifier), a code practice oscillator, two transistor receivers, TV antenna orientation meter, and last but not least, a loudspeaker audio amplifier using three 2N107's. Experimenters will do well to have this booklet in their files, if only for the ideas it contains.

## Hydro-Aire Booklet Available

Although supposedly directed toward radio hams, the Electronics Division of *Hydro-Aire*, 3000 Winona Ave., Burbank, Calif., has made available to the general public a valuable free booklet on the use of its CQ-1 transistor. Readers will want to see the three-stage regenerative receiver featured in this publication. Write directly to *Hydro-Aire* at the address above for your copy. (Say that you saw it in *POPULAR ELECTRONICS*.)

In addition to the receiver circuit mentioned above, this booklet also contains information on a dynamic microphone preamp, an electronic timer, relay control circuit, audio oscillator, etc.

At this writing, the CQ-1 is priced at about \$2.50, with some indications that the price will soon drop. It is a *p-n-p* type with a frequency cutoff at 500 kc. Maximum power gain (common emitter) is about 30 db.

## Regenerative Receiver

Mr. R. Zarr, of Brooklyn, N. Y., brings to our attention a very simple broadcast band circuit using a CK722. A particular feature of this circuit is the regenerative arrangement consisting of two capacitors between emitter and collector.

The coil, *L1*, may be either a Vari-Loopstick or *Walsco* loop. The tuning capacitor, *C3*, is a small dual unit commonly found in cheaper superhet BC radios with the two units con-

A few months ago, "Carl and Jerry" commented on the size and sensitivity of a transistorized pocket BC receiver. Although the story did not specifically mention it by name, the boys were talking about the *Regency* receiver that markets for \$49.95. Absence of the manufacturer's name brought forth a veritable flood of inquiries which, if nothing else, has convinced us that transistors are here to stay and that the readers of *POP'tronics* want to see more editorial space devoted to this subject.

After discussing the problem of how this was to be accomplished, the Editors foresaw two possibilities and have decided to take advantage of both. One is to publish feature material on construction projects using transistors. The second one is to devote a monthly or bi-monthly department to news and views on transistors, the latter also to contain suggested experimental circuits developed by the editorial staff or sent in by readers.

The new department is being introduced herewith. How frequently it will appear will depend upon you, the reader. If you want to see it every month, be sure to write in and say so. If you have a pet circuit using transistors, send it in; and if we can use it in this department, we will immediately pay for it at our current editorial rate.

THE EDITORS



nected in parallel, giving a maximum capacity of 500-600  $\mu\text{f}$ d. An antenna must be used with this circuit. For best results, the designer employed a wire about 30' long and grounded the chassis to a radiator. Note that the regenerative capacitors and the coil/capacitor  $L1/C3$  will not permit tuning across the entire broadcast band. Approximately 400 kc. can be

### Ultra Simple BC Receiver

For a circuit using a minimum of parts, Mr. Joseph Chernof, of Sunland, Calif., has suggested the design shown below. He claims that the receiver operates perfectly without the coupling capacitor and resistor usually seen between the crystal diode and transistor. In fact, on strong local stations the transistor

The transistor regenerative receiver can be built in a small metal case.

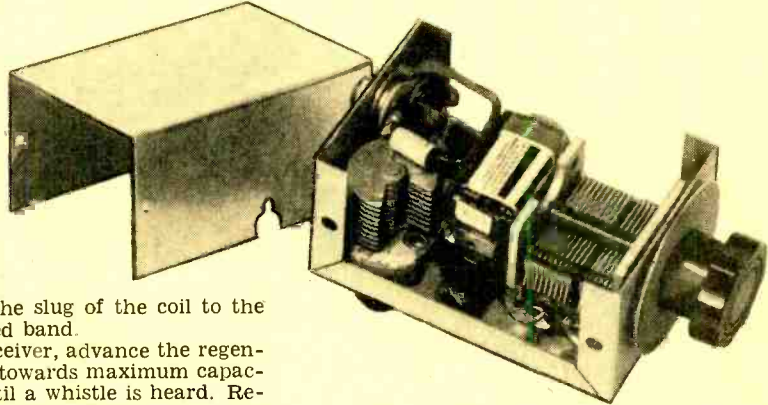

covered by setting the slug of the coil to the middle of the desired band.

To operate the receiver, advance the regeneration control,  $C2$ , towards maximum capacity, and tune  $C3$  until a whistle is heard. Retard the regeneration control to stop the whistle. Signals should be heard best at the spot just before the set goes into oscillation. With the 30' antenna, the strength of signals should equal the best obtainable from an older-style crystal set. The great difference will be in selectivity. Because of the regeneration used in this circuit, it is possible to separate stations with comparative ease. Mr. Zarr reports that crystal sets using 1N34 diodes will pick up two stations in the New York City area clear across the dial.

The photograph shows how the receiver can be mounted in a small aluminum box. The tuning capacitor is at one end, the regeneration control is on the side, and the phone jack is on the other end.

Experimenters may find it useful to try a CK760 in this circuit. The latter transistor should be easier to "get going" and will probably work up to 4 or 5 mc. with the proper tuning coil-capacitor combination.

will drive a 5" loudspeaker if coupled through a suitable output transformer to the headphone jack.

Power to operate the receiver was obtained from two 1½-volt penlite cells connected in series. A fixed capacitor was added in parallel

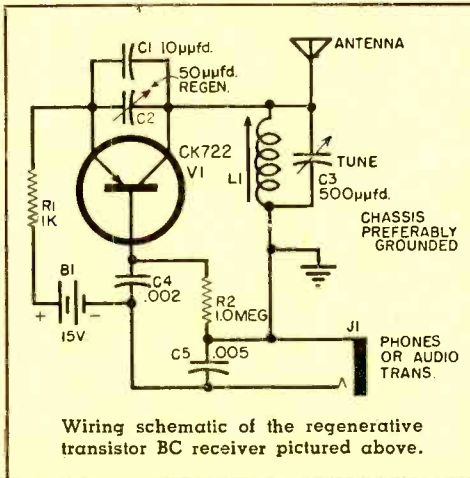
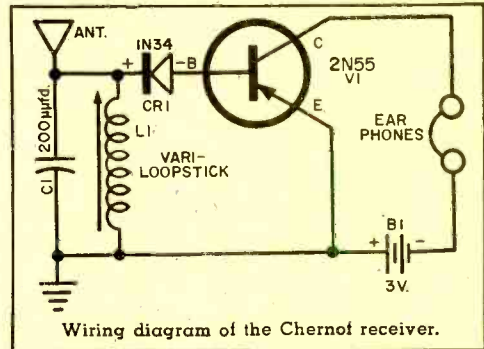

with the Vari-Loopstick. This will not completely cover the broadcast band and some experimenters may want to add a trimmer across both the coil and capacitor.

Any headphones in the range of 2000 to 5000 ohms will work with the output of the Westinghouse 2N55. Higher impedance phones will sometimes give a little boost in volume. It should be noted that several other commercially available *p-n-p* transistors can be used in this circuit.

As shown in the photograph, the entire receiver fits into a small plastic box. The core adjustment of the Vari-Loopstick sticks through one end of the box for tuning adjustments. Mr. Chernof lives in a valley some 20 miles from his nearest broadcast station. He found a fair-sized antenna to be necessary as well as a good ground. Possibly in metropolitan areas the ground would not be required and the antenna could be smaller.

# B-C Flash Gun

*Inexpensive unit features simple circuit and quick connect/disconnect receptacles to bulb and camera*

**T**HIS SIMPLE B-C flash gun is designed for flexibility beyond the limits of most commercially available models. Because of the method of connecting it to the camera, several different picture-taking techniques may be used. The reflector may be held in the hand, attached by a clamp to furniture, or affixed to the camera itself. Many other ideas will undoubtedly come to mind after the unit has been constructed.

The B-C flash principle is quite simple. Instead of directly "firing" the flash bulb from the battery, a circuit is devised which permits the battery to charge a capacitor, and the surge from this capacitor ignites the bulb. This system is sure to work, and after its use has been mastered, the hobbyist will produce fewer weak or overexposed flash pictures.

Build the B-C flash unit in an aluminum box similar to the ICA "Flexi-Mount" Type

29439. Mount the components on a piece of Masonite cut to fit into the aluminum box. Holes are drilled through the Masonite and the side of the box for bolts to secure the mounting board in place. A  $\frac{3}{8}$ " hole is drilled through the side of the box under the Masonite to permit wires to be connected to the TV lead-in connecting socket (similar to Mosley Type 311). This socket is mounted on the aluminum box with a small strip of scrap metal. The photographs serve to illustrate how this is accomplished.

On page 59 is the wiring schematic of the unit. The 100- $\mu$ fd. capacitor (*Sprague* TVA-1207) is charged by the 22 $\frac{1}{2}$ -volt hearing-aid battery through the resistor and flash bulb. The circuit is arranged to fire the bulb by shorting the capacitor across the line between the battery, resistor, and flash lamp. This quick surge of power is far in

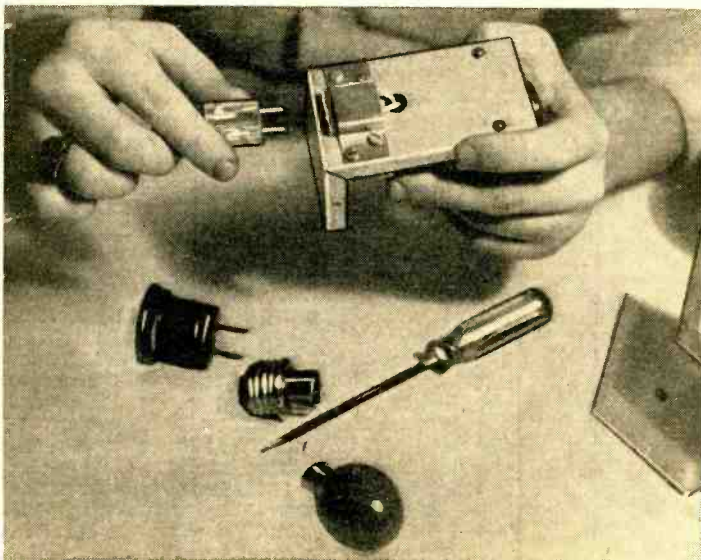

A feature of the B-C gun is the use of connectors originally designed for coupling 300-ohm TV lead-in cables. The socket is secured to the small case with a metal strap. A plug (held in the author's hand) allows quick connection to any style of camera.



By  
**CLINTON E. CLARK**

Bulb and reflector with this simple B-C flash gun are plugged into a plate-mounted receptacle at the end of the chassis box. A quick connect/disconnect cable is coupled to the camera.



excess of the amount given by common flashlight batteries. Concern over battery deterioration can be eliminated since the life of the battery will be equal to its shelf-life with normal usage.

Connecting the camera will depend upon the type of camera used by the constructor. Connection to the B-C unit is through a *Mosley* Type 301 plug. The reflector used

by the author consisted of a 6" satin-finish metal mixing bowl. A hole was cut in the bottom for a snug fit to the screw base of one of the large-size flash bulbs. This then provided a seat for the adapter plug shown in the photographs and diagram. A bracket for attaching the B-C unit to the camera was salvaged from a short length of aluminum bar stock.

-30-

Very simple circuit at left may be mounted on a piece of Masonite as shown at right.

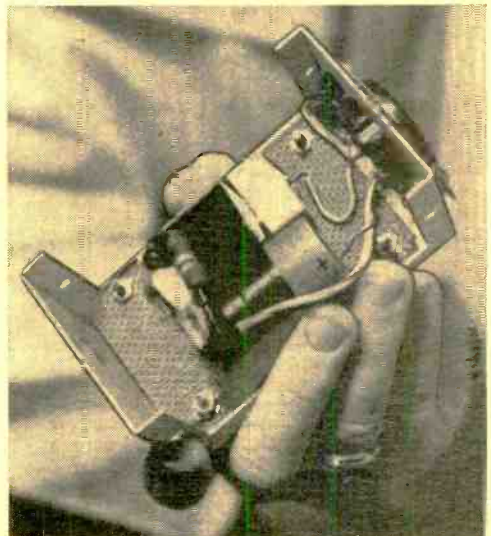
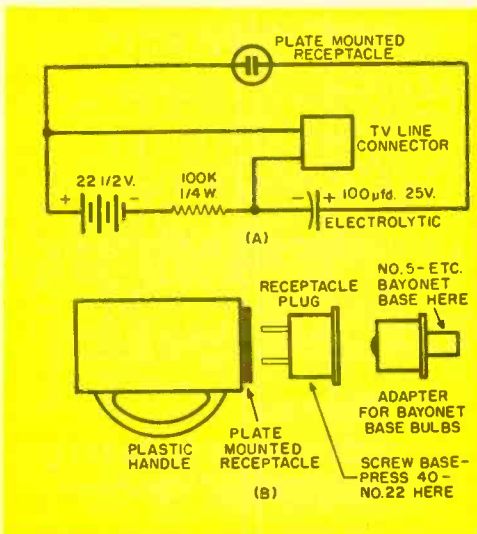

# Tuning the Short-Wave Bands



—with Hank Bennett—

WE HAVE received quite a number of letters requesting that we write an item dealing with reception reports and verifications. Before starting, however, we'll ask you to bear in mind the fact that no two persons have the same thoughts as to what should be included in a reception report. This column, therefore, will give the basic essentials that should be included in a report. Any additions or deviations can be made by the individual.

## Reception Reports

It is not necessary to have printed cards with which to send reports to s.w. stations, although a goodly percentage of SWL's do have their own cards. In fact, a letter containing the essential data is often of more value to a station engineer than a printed card with its many blanks filled in. And needless to say, the more comprehensive the technical data, the more welcome it will be to the recipient.

Included in your report should be the date and exact time. If possible, show the time in the local time of the area in which the station is located. If you use EST (or your own local time), be sure to specify that fact. Pro-

gram details are very important; they enable the engineer to check in his log and make sure that you heard his station. When listing program details, be sure that you include names of musical selections (if known), the general text of the announcements, and any other information that you are able to get. Give the time that you heard each detail. Show a signal report.

QSA1 to QSA5 indicates readability of the signal, 1 being almost completely unreadable and 5 being completely readable with ease. S1 to S9 indicates the strength of the signal, 1 being nearly too weak to hear and 9 being indicative of a loud and clear signal—the kind that would shake your radio table if you turned the gain way up. For those of you who have no "S" meter, an approximation will suffice. Many of the larger stations are often received around S7 to S9+. The weaker ones usually run around S4 to S6. The ones "way down in the mud" are often S2 or S3.

You might also include the type of receiver you are using, the number of tubes in the set, and the antenna (type, how long, how high, and in what direction it is pointed).

Some fellows include the current weather conditions. Others list location in relation to large cities, and altitude above sea level.

In any event, when your report is completed, address it to the station. If you know the exact address, it will speed delivery on the other end. The *World Radio Handbook* lists nearly all the addresses of the s.w. stations and even the person to whom reports should be sent.

And always—ALWAYS—include return postage. An International Reply Coupon, available at all post offices, is preferable. If you want a fast reply, ask them in your letter to reply by airmail but include two or even three IRC's for this purpose. We feel that although stations are usually glad to receive reports they are under no obligation to reply. In sending you a verification card or letter they are actually doing you a favor. Always thank them in advance by including enough return postage.



In the shack of Lida and Jack Livingston, 86 Martine Ave., North, Fanwood, N. J., there is a Hallicrafter SX-71 receiver with a DB23 preselector, modified for the s.w. bands. A BC453 Q5'er and a BC221AK complete the equipment layout. Antennas used include a 20-meter ribbon folded dipole and an "L" shaped doublet 80' long.

WE TRY TO DISCUSS subjects that are requested by our readers. Should you like to see a discussion on some certain phase of our SWL'ing hobby, please write and let me know. Sooner or later we'll cover your subject. And our thanks again to the many who have already written. Your continued cooperation will help the column to grow.

Now for this month's reports. All times are EST, 24-hour system.

**Belgian Congo**—According to a Belgian Newspaper, *Radio Congo Belge* has inaugurated a second regional station for its African xmsns. At this moment, two stations operate on s.w.: (1) Elisabethville on 6030 kc. (3000 w.) directed to Katanga; (2) Stanleyville on 6085 kc. (3000 w.) directed to the East Province, Kivu, and Ruanda Urundi.

**Brazil**—*Radio Brazil Central* now has two xmtrs in operation on 31 and 25 meters with power of 5 kw., plus one of 1-kw. power on 4995 kc. *Radio Nacional* is planning two new 50-kw. s.w. xmtrs. *Radio Clube Paranaense* is planning to increase power of 11,935-kc. outlet to 25 kw. The call signs for *Radio Emissora Paranaense*, Curitiba, are ZYS30 (9545 kc.) and ZYZ9 (broadcast band). The address is Rua Senador Alencar Guimaraes 97, 5, Caixa Postal 471, Curitiba, Paranaense, Brazil. Call signs for *Fundacao Radio Maua* are ZYX24 (9705 kc.) and ZYX25 (11,885 kc.). Probable call for *Radio Clube Paranaense* on 11,935 kc. is ZYR35. A new station is *Fundacao Casper Libero*, Sao Paulo, operating on 5955 kc. (ZYR76, 7½ kw.), 9685 kc. (50 kw.), and 15,325 kc. (20 kw.). *Service Radio Difusao Educativa*, Rio de Janeiro, is on 5990 kc. (10 kw.), 9770 kc. (PRL4, 10 kw.), and 11,950 kc. (PRL5, 7500 w.). According to various reports, this station is also conducting tests on 17,875 around 2300, carrying programs from other channels. Reports wanted!

More new stations include: *Radio Difusora do Amazonas*, Parintins, 2360 kc., 250 w., and Itacoatiara, 2340 kc., 250 w.; *Radio Caraja de Anapolis*, Anapolis, 2420 kc., 500 w.; *Radio Clube de Pouso Alegre*, Pouso Alegre, 2440 kc., 500 w.; *Radio Cultura de Aracatuba*, Aracatuba, 2450 kc., 500 w.; *Soc. Radiodifusao Cacique de Sorocaba*, Sorocaba, 2460 kc., 1000 w.; *Radio Ribeirao Preto*, Ribeirao Preto, 3265 kc., 1000 w.; *Radio Aparecida*, Aparecida, ZYR44, 3285 kc., 1000 w. (also operating the reported outlet on 9620 kc., ZYR83, 7½ kw.); *Radio Esperanca*, Sao Jose do Rio Preto, 3305 kc., 1000 w.; *Radio Difusora Parana*, Londrina, 3365 kc., 500 w.; *Radio Difusora Roraima*, Boa Vista, 4835 kc., 1000 w.; *Radio Difusora Acreana*, Rio Branca, 4885 kc., 1000 w.; *Governo do Territorio Federal do Amapa*, Macapa, 4915 kc., 2000 w.; *Radio Cultura de Campos*, Campos, 4955 kc., 2000 w.; and *Radio Mapinguaru*, Sao Goncalo, ZYP20, 4965 kc., 1000 w.

**Canada**—CKLX, 15,090 kc., is being well heard to Europe and the Canadian Forces Overseas at 0815-0930. CKNC, 17,820 kc., and CKCX, 15,190 kc., are heard variously from 1905 to 2000 in several European languages. All are located in Sackville, N. B.

**Colombia**—HJCX, *La Voz de Bogota*, 6018 kc., is good many evenings from 1900 on. HJEF, *Radiodifusora de Occidente*, Cali, 4768 kc., is heard well most any time in the evening when 60-meter reception is good. This one verifies with an English letter and an attractive pennant. Another pennant-sending station is HJFW, *Emissoras Caldas*, Manizales.

**Ecuador**—Delete the following stations (no longer on the air): HC2ET (4835 kc.); HC2AN (7350 kc.); HC2MX (4770 kc.); HC1JT (5970

kc.); and HC5ED (6140 kc.). New stations include: *Radio Catolica*, Quito, HC1RP, 5015 kc., 250 w.; *Radio La Voz del Norte*, Ibarra, HC1DF, 6000 kc., 200 w.; *Radio Ondas Azules*, Otavalo, HC1GB, 3325 kc., 250 w.; *Radio Tulcan*, Tulcan, HC1JM, 5970 kc., 200 w.; *Radio La Voz del Campesino*, Naranjal, HC2NL, 3510

**TOLEDO 12, OHIO ~ U.S.A.**  
Charles E. Sutton, Operator  
405 Duaneville Ave.

W8-SWL

---

**CAMDEN, NEW JERSEY.**  
312 Erie Street.

Radio W2PNA Date 5-3-52 Time 2:05 S.T.  
Ur/Exp Mc. Sigs RST 5-7 Conditions GRM

SWL-2

---

**SHORT WAVE MONITORING STATION  
NEW BRUNSWICK, NEW JERSEY**  
70 SENIOR ST.

EX-W2BJZ

Radio W2PNA Ur..... sigs heard on..... mtr. band on 4/1w 1952.  
at..... E.S.T. Ur sigs ORR..... OSA..... "S" Meter.....  
Remarks.....  
PSE QSL to confirm this report. 73 JOHN J. OSKAY, EX-W2BJZ 1930-30

United States of America

The SWL reporting cards above are examples of those in current use by several of the well-known s.w. listeners throughout the USA. Made from special stock, such cards are available from QSL card printers.

kc., 200 w.; *Radio Cenit*, Portoviejo, HC4MX, 4770 kc., 200 w.; *Radio Nueva-Austral*, Cuenca, HC5AL, 5025 kc., 250 w.; *Radio La Voz de Asoguez*, Asoguez, HC5CB, 5015 kc., 200 w.; and *Radio Roxi*, Riobamba, HC5ET, 5045 kc., 200 w.

HC2RL, *Radio Quainta Piedad*, 6635 kc., Guayaquil, is being noted at 2200-2306 with uninterrupted classical music and opera, except for identity. This stn is on only one day per week from 2100-2300A, and announces that it is interested strictly in presenting non-commercial classical music. HCINE, 4660 kc., *Radio Nacional Espejo*, Quito, has moved here from 4470 kc., and is very good at 2245-2330 with musical pgms.

**Falkland Islands**—F. I. Broadcasting Service, on 6125 kc., should have its English service to South America by now. This one has been heard in the USA.

**French Equatorial Africa**—*Radio Brazzaville* is using a new frequency of 5970 kc. with 3 kw. *Radio AEF* has a new station on 3232 kc.

**Gilbert & Ellice Islands**—According to the New Zealand DX Times, VTW, Tarawa, is on 844 kc. (broadcast band) each Saturday at

(Continued on page 131)

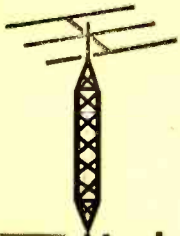

# THE TRANSMITTING TOWER

Herb S. Brier, W9EGQ

**T**HE SPRINGBOARD from which the signal generated by a transmitter jumps off into space is the transmitting antenna, and the doorway through which an incoming signal, weakened from its long journey, reaches the receiver is the receiving antenna. Obviously, antennas play an important part in determining the results obtained from an amateur radio station.

Generally speaking, anything that makes for an efficient transmitting antenna also makes for an efficient receiving antenna, and vice versa. For this reason, most amateurs use the same antenna for receiving and transmitting, and employ an antenna changeover switch or relay to transfer the antenna from receiver to transmitter.

## Antenna Theory

For a better understanding of how an antenna works, let's review some fundamental theory. We know that around any conductor carrying an electrical current there is a magnetic field. The strength of the magnetic field is proportional to the amount of current flowing through the conductor. As the current increases, more energy is stored in the field; and as the current decreases, the energy in the field is reconverted into electrical energy that tries to prevent the decrease in the current.

If the current is alternating, there is a constant interchange of power between the conductor and the fields around it. When the a.c. frequency is low, there is time between cycles for the power in the collapsing fields to get back on the conductor before the next cycle starts to build up. However, as the frequency is increased, there is less and less time between cycles; and soon succeeding fields build up faster than the preceding ones can collapse. As a result, each expanding field drives the one ahead of it away from the conductor, off into space.

Thus, the conductor is radiating part of the energy fed into it. It is acting as a transmitting antenna.

Every time the fields that are driven into space sweep past another conductor, they induce a minute current in it. Should this conductor be a receiving antenna, it will deliver a replica of the original a.c. signal to the receiver. A communications circuit has been established.

How well a conductor performs as an antenna depends upon the exciting frequency and the length of the conductor in reference to the frequency. Radio frequencies as low as

12,000 cycles per second (12 kc.) are used for communications but require an antenna several miles long. On the other hand, antennas for the various amateur frequencies vary in length from about 250 feet down to a couple of feet.

The best antenna length is based upon the *wavelength* of the signal to be transmitted or received. To define wavelength, we refer to Fig. 1 which depicts an alternating current of any frequency.

Starting at zero, the current builds up to its maximum amplitude in one-quarter cycle. Then it decreases, again becoming zero at the end of one-half cycle. From this point, it increases in the other direction, reaching its maximum value at the end of a three-quarter cycle. At the end of one complete cycle, the current is again zero, and the entire cycle starts to repeat itself.

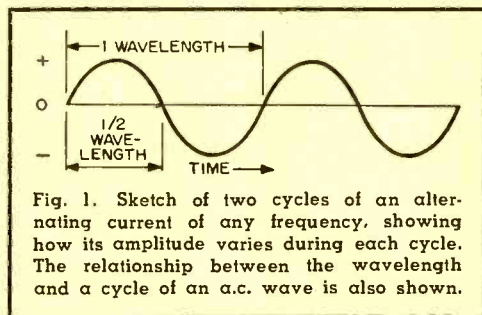

Fig. 1. Sketch of two cycles of an alternating current of any frequency, showing how its amplitude varies during each cycle. The relationship between the wavelength and a cycle of an a.c. wave is also shown.

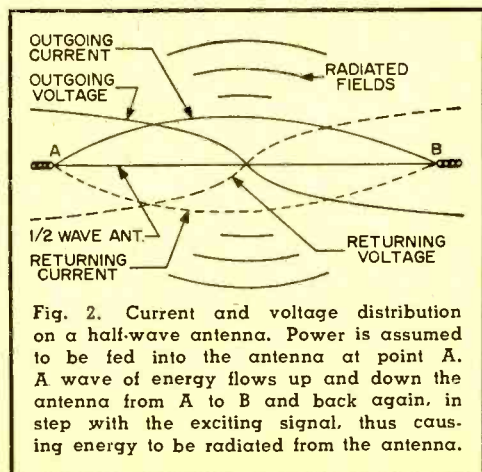

Fig. 2. Current and voltage distribution on a half-wave antenna. Power is assumed to be fed into the antenna at point A. A wave of energy flows up and down the antenna from A to B and back again, in step with the exciting signal, thus causing energy to be radiated from the antenna.



Bill, K6IYJ, (Calif.), has worked 24 states with Johnson "Adventurer" transmitter at 50 watts and Hallicrafters SX-71 receiver.

Because electricity travels at the speed of light (300,000,000 meters per second), an a.c. wave travels an appreciable distance in one cycle. The distance traveled during one cycle is the wavelength of the signal. For example, a 4000-kc. wave will travel a distance of 75 meters in one cycle, calculated by dividing the speed by the frequency:  $300,000,000/4,000,000 = 75$ . Conversely, dividing 300,000,000 by the wavelength of a signal gives its frequency.

#### How an Antenna Works

Now let's cut a wire a half-wave long at some radio frequency and hang it in the air between two insulators (Fig. 2). Assume that power of this frequency is being fed into one end of the wire (point A). An alternating current will flow down the wire until it runs out of wire (point B). There, the current will do the only thing that it can do: it will come to a dead stop. Immediately, the magnetic field around the wire will collapse, and the energy in the field will be converted into a high-voltage (electrostatic) charge.

This voltage will then start a current flowing back down the wire towards point A. As this current approaches the center of the wire, more and more of the energy in the voltage field will be converted back into current until, at the center—one-quarter wave from either end—the current will be maximum and the voltage minimum. Then, as the current continues to flow towards A, it begins to decrease again and the voltage to increase. At point A, the current is zero and the voltage is maximum. Here, the direction of current flow again reverses, and the cycle repeats itself.

Each time these energy waves charge up and down the antenna, a field of power is radiated from it, as indicated in Fig. 2. But the energy so lost is replaced by the transmitter exciting the antenna.

Those of you who are familiar with the way currents and voltages swap back and forth between the inductance and the capacitor in an ordinary tuned circuit will note the sim-

ilarity with a half-wave antenna. The reason for the similarity is that both contain inductance and capacity. The difference is that in the coil-capacitor combination the quantities are *lumped* together, while in the antenna they are *distributed* throughout its length. In either case, *resonance* is achieved when the *capacitive reactance* in the circuit exactly balances the *inductive reactance*. At the frequency where this occurs, each "looks like" a pure resistance and will accept power most readily.

A significant difference between lumped coil-capacitor circuits and simple antennas is that the former has one resonant frequency for a given set of values, while the latter



With his 10-watt, one-tube transmitter, KNØBEJ (Kansas) has worked eight states. His receiver, not shown here, is an S-38.

will resonate at *harmonics* of the fundamental frequency.

At these harmonic frequencies, the antenna is long enough to accommodate several half-waves of current at once. Each half-wave segment acts as described above. This is the basis upon which "all-band" antennas work.

#### Varying Resonant Frequency

Resonant frequency of a "lumped" circuit can be changed by varying either the inductance or the capacity. The only way to change the true self-resonant frequency of an antenna is to change its physical dimensions. However, its effective resonant frequency can be varied by connecting a capacity or an inductance in series with it. A capacitor reduces its effective length, and an inductance increases it.

The disadvantage of varying effective antenna length in this manner is that losses in the loading coil or capacitor decrease the actual power reaching the antenna to be radiated. These losses become extremely large when a short antenna is resonated to a low frequency with a large loading coil. For example, an 8' to 10' whip antenna loaded to the

(Continued on page 133)

# CARL & JERRY

By

JOHN T. FRYE

## Lie Detector Tells All

JERRY, stretched out on the worn old-leather-covered couch in his basement laboratory, was jerked out of his pleasant reverie by the banging of the cellar door against the wall as his chum and neighbor, Carl Anderson, came striding in.

"Hey, Jer, how do you give artificial respiration to a night crawler?" Carl asked excitedly as he dangled a very limp worm, a full ten inches long, directly in front of Jerry's crossing eyes.

"Get that young snake out of my face," Jerry commanded as he struggled to a sitting position; "and what kind of a stupid question is that?"

"It's *not* stupid," Carl denied heatedly. "If we can just bring Old Droopy here and his buddies back to life, we're on our way to being millionaires!"

"Again?" Jerry said languidly as he smothered a yawn. "Let's hear your latest lid-flipper."

"On their drive last Sunday, my folks gathered up a couple of bushels of walnuts along the road," Carl explained. "I have to lid them by driving them through a knothole in a board. As you know, this is a messy business; so to avoid getting any more of the sticky, staining walnut hull juice on me than necessary, I decided to run water over the crate of nuts before starting. The water filtered down through them and spread over the ground. In nothing flat, worms started wriggling up out of the wet earth. Apparently that walnut hull juice gave them a real hot-foot, for they were in such a hurry to get away from it that they popped to the surface and practically stood on their tails.

"I grabbed them faster than a woman snatching up the contents of her spilled purse, but in just a few minutes they stopped wriggling. I washed them off in clear water and even tried brushing Droopy here with some of Mom's super-gentle soap powder, but he refuses to come around. I figure artificial respiration is the last hope; if you will just point out where his ribs are so I'll know where to put my thumbs, we'll get started. If we can revive him, we're in business. We can grind up the walnut hulls and sell a small vial of the powder for a dollar. The purchaser need only mix a few gallons of water with this powder and pour the solution on the ground. After a few minutes, he can pick up a couple of cans of fish worms and be on his way. Think of it: no strain, no pain, and no spading!"

"Well," Jerry commented, as he gingerly

prodded with his forefinger the worm Carl had placed on the couch beside him, "all I can suggest is that you include a bottle of embalming fluid with every vial of that walnut hull powder. That's the only thing that will 'save' Droopy now. How come you're all at once money mad, anyway?"

"I've decided we need an oscilloscope for our laboratory," Carl announced importantly. "After boning up on this instrument, I'm convinced there are any number of interesting experiments and important tests that can be made with it. What's more, it would come in mighty handy for checking my transmitter, especially now that I'm starting to build a single-sideband suppressed-carrier job. We can buy a scope kit that will fill our needs nicely for around fifty dollars, but first we've got to latch on to the fifty."

"I commend your ambition, but I decry your methods," Jerry announced pompously. "You must learn to think electronically. If we need new electronic equipment, let's make the electronic equipment and know-how we already have pay for it."

"Such as how?" Carl demanded.

"It's all arranged," Jerry said, with elaborate casualness. "The Acme TV Service Shop is opening this weekend and holding open house on both Friday and Saturday. I



Carl dangled a very limp worm directly in front of Jerry's crossing eyes . . .

talked the guy who owns it into a big deal of letting me set up a lie detector there in the store and give free lie-detector tests to anyone who wants to try it. He figures this will be just the unusual type of gimmick to draw a crowd; he'll pay me 25 bucks for giving tests Friday night and all day Saturday."



"Oh fine! Now all you gotta do is buy a lie detector!"

"No such thing. Back in May, 1955, POPULAR ELECTRONICS published an article on how to make a gadget to use with your v.t.v.m. to serve as a lie detector. This is a simple little gadget; and all the parts for it, except the tube and B battery, came out of our junk box. I 'borrowed' these other two items from Dad's portable radio that he won't be using—I hope—until next spring. Come on over to the bench, and I'll show you how it works.

Just then, however, Mr. and Mrs. Bishop, Jerry's parents, came in through the inside door leading to the basement storage room. Mrs. Bishop had a bushel basket, and Mr. Bishop carried a spading fork, and had the unhappy look of a man reluctantly being prodded into digging up flower bulbs for winter storage.

"Well, well, what are our young inventors up to now?" he questioned, with the hysterical joviality of a man snatching at straws to put off the start of an unpleasant job.

"I was just going to show Carl how my new lie detector works," Jerry explained.

"Show me!" Mr. Bishop insisted. "I always did want to see if those things really could tell when an iron-nerved man like myself chose to toy with the truth."

"Well, all right," Jerry agreed. "Just slip these two metal thimbles with the wires attached over the middle fingers on each hand. They are the connecting electrodes that enable the instrument to measure any change in the resistance path between them. When you are emotionally disturbed, as you will be if you try to avoid the truth, the change in your body resistance will be indicated by the swing of this meter pointer on the vacuum-tube voltmeter."

With an amused smile, Mr. Bishop slipped the electrodes on his finger tips and watched his son balance the bridge circuit so that the meter pointer rested in the left-hand portion of the scale.

"What is your name?" Jerry asked.

"Milton Bishop."

"Where do you live?"

"1810 Spear Street."

"What do you work at?"

"I'm an architect."

Mrs. Bishop, who had been impatiently watching the quiet needle of the v.t.v.m., broke in with: "Let my try. You told me you couldn't come home for dinner last night because you had to work late at the office. Is that true?"

"Certainly," was Mr. Bishop's prompt reply as he turned to smile fondly at his wife. For a split second nothing happened, and then the meter started to climb. As it reached full-scale, Mr. Bishop turned harriedly from the accusing meter to the still more accusing eyes of his wife.

"I *did* work late, a whole half hour," he insisted; "then a bunch of us fellows went over to Vic Cline's to see his new twenty-five horsepower outboard motor. A little game started somehow . . . and the time sort of got away from us . . ."

As his voice trailed off in this weak explanation, he jerked off the thimbles as though

they were red-hot and flung them down on the bench.

"Well, come on, Iron Nerves; let's make with the spading fork," Mrs. Bishop suggested with a mocking, victorious smile.

"Oh, no, you don't!" her husband exclaimed. "Let's see *you* try the lie detector, Mabel."

In spite of her protests, Mr. Bishop slipped the thimbles on her fingers and watched impatiently while Jerry rebalanced the bridge circuit.

"Your name, Madam?" Mr. Bishop snapped.



For a split second nothing happened, then the meter started to climb . . .

"Mabel Bishop."

"Your age?"

"Thirty-seven—no, I mean thirty-eight,"

Mrs. Bishop hurriedly amended, as the meter pointer began a threatening upward movement.

"Just a few minutes ago I noticed a long scratch on the right rear fender of the car. Would you know anything about that?"

"I was intending to mention that to you," Mrs. Bishop began calmly. "It must have happened in the supermarket parking lot. I didn't notice it until I came home . . . or at least I don't remember noticing it . . . or if I did I forgot about it . . . or maybe I do remember hearing a little noise as I was backing out of the garage . . ."

She kept talking more and more frantically in her effort to stop the relentless march of the meter pointer up-scale, but it was no use. In spite of Jerry's repeated rebalancing of the bridge, the pointer kept crawling up.

"I thought so!" Mr. Bishop gloated. "For your information, that scratch is just level with the hasp on the door frame."

"Maybe we had better go and dig those bulbs now," Mrs. Bishop remarked quietly, as she removed the thimbles and placed them gently on the bench. Obediently, but with a smirk still on his face, Mr. Bishop followed her outside.

"Boy, that thing really works!" Carl said enthusiastically, as Jerry's parents closed the door behind them.

"Yes," Jerry agreed, as he slipped on the

(Continued on page 125)

By RUFUS P. TURNER

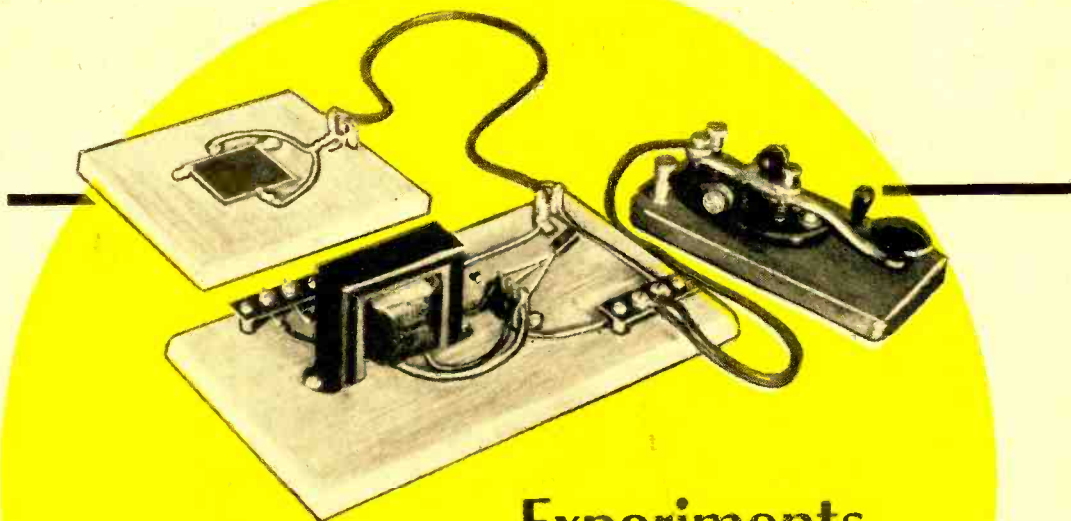

## Experiments with Simple **SOLAR BATTERIES**

Interesting wiring arrangements demonstrate several practical applications of readily available selenium-type photocells

**P**UT THE SUN TO WORK as a generator of electricity with a regular self-generating photocell. While the amount of current obtained in this way will not be large, it can be used to perform some interesting experiments.

When the self-generating cell is illuminated, it produces a d.c. voltage. The stronger the light, the higher the voltage. The photocell with light shining on it acts as a small battery and will force a small current through a circuit.

Several self-generating photocells of the selenium type are on the market. A few may be found in war surplus. The one shown in the experiments in this article is the *International Rectifier Corp.* Type B15. This particular cell has a high output (with bright sunlight, nearly 5 milliamperes in a 25-ohm circuit). However, other types can be used with somewhat lower current out-

put. For example, the same manufacturer produces the inexpensive Type B2M cell, which it calls a "sun battery," and this type will generate 2 milliamperes d.c. in a 10-ohm circuit. It also will deflect a vacuum-tube voltmeter to 5 volts under the influence of bright sunlight.

The B15 photocell is a thin, flat plate,  $1\frac{1}{16}$ " square. Its smooth (front) face is the side that is sensitive to light. When illuminated, the front face becomes negative, and the rough back face positive.

It is not advisable to solder connections to the B15 photocell, since the heat might damage the device. Figure 1 shows one way of mounting the cell and making connections to it. In this scheme, the cell is held to a wooden base by means of solder lugs screwed to the base. Two lugs, *A* and *B* in Fig. 1, are held by the same screw, lug *B* making contact with the back face

Pictured at the left is a tone-type c.w. oscillator utilizing a B15 selenium photocell. A CK722 transistor and a small transformer comprise the remaining components used in this tone or audio generator.

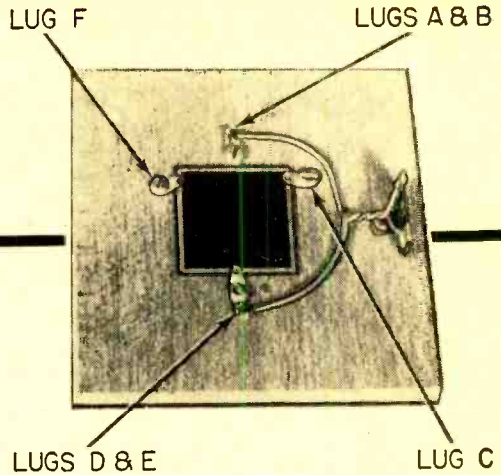

Fig. 1. Mounting of the B15 photocell on a small wooden board. Do not solder directly to the photocell. Use the scheme shown above to contact the surfaces of the cell with small soldering lugs. See text for more details.

of the cell. Similarly, two lugs, *D* and *E*, are held by another single screw, lug *D* making contact with the silvery rim of the front face of the cell.

The accompanying illustrations show several simple experiments and devices using the self-generating photocell as a solar battery.

**Experiment 1—Meter Deflection:** The simplest way to demonstrate that the cell produces a current when exposed to light is to connect a 0-1 d.c. milliammeter to the cell terminals, as shown in Fig. 2. The stronger the light, the higher the meter reading. A solid, opaque object passing



Fig. 2. Meter deflection.

between the sun and the cell will cause the meter reading to decrease or to fall to zero. The simple cell and meter circuit is the basis of light meters similar to the well-known photographic meter.

**Experiment 2—Compass Deflection:** It is possible to use a magnetic compass in place of a milliammeter to demonstrate the flow of current from a photocell, as shown in Fig. 3.

Wind three turns of insulated hookup wire around the compass in a direction perpendicular to the north-south resting position of the magnetic needle, and connect

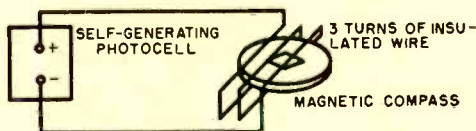

Fig. 3. Compass deflection.

the ends of this coil to the cell terminals. When light falls on the cell, current flowing through the coil will set up a magnet field, which then will draw the needle around in an east-west position in line with the turns of the coil. When the cell is darkened, the

needle will swing back to its north-south position.

Sometimes, when the sunlight is very strong, only one loop of wire will be enough of a coil to do the job.

**Experiment 3—Charging a Capacitor:** The d.c. output of the photocell can be used to charge a capacitor which will hold the charge for some time afterward. It is interesting, after a long interval, to detect the charge that the sunlight left!

The setup for this experiment is shown in Fig. 4. The meter is a d.c. vacuum-

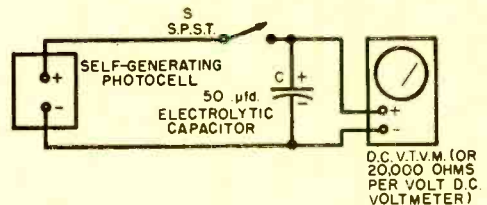

Fig. 4. Charging a capacitor.

tube voltmeter or a 20,000 ohms-per-volt d.c. voltmeter set to its low range. A 50-microfarad electrolytic capacitor, *C*, is connected in parallel with this meter, and a single-pole, single-throw switch, *S*, in series with the photocell.

With the cell exposed to sunlight, close the switch and the meter will read, showing that the cell is generating a voltage. Now, open the switch, disconnecting the cell. The meter continues to read, indicating that the capacitor, *C*, was charged by the sun-generated current. The meter reading will decrease very slowly, showing that the capacitor is discharging through

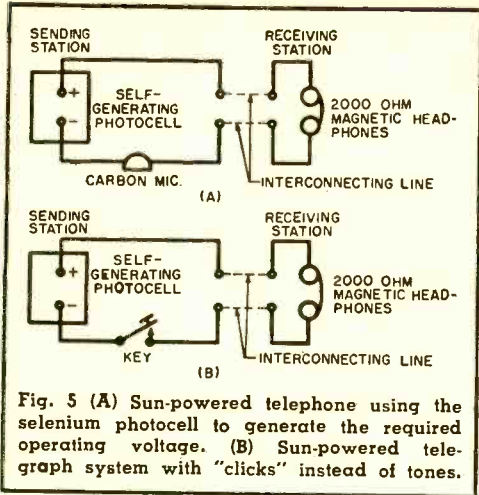

Fig. 5 (A) Sun-powered telephone using the selenium photocell to generate the required operating voltage. (B) Sun-powered telegraph system with "clicks" instead of tones.

the meter. To illustrate how slowly this discharge takes place: when a 10-megohm v.t.v.m. is used with a good grade 50- $\mu$ fd. capacitor, several hours may elapse before the meter reading finally falls completely to zero.

**Experiment 4—Sun-Powered Telephone:**

Fig. 5(A) shows a simple circuit in which the output of the sun-lighted photocell furnishes current for a telephone. A carbon microphone is used at the transmitting end and magnetic-type headphones at the receiving end. The headphones should have a resistance of 2000 ohms or better. Crystal headphones cannot be used since they will block the flow of direct current.

This circuit has been tested with 200 feet separating the transmitting and receiving stations. Ordinary rubber-covered, 2-conductor cord was used as the interconnecting line. The circuit should work over longer distances. Headphone volume is not tremendous, but the voice is easily recognized and understood at the receiving end.

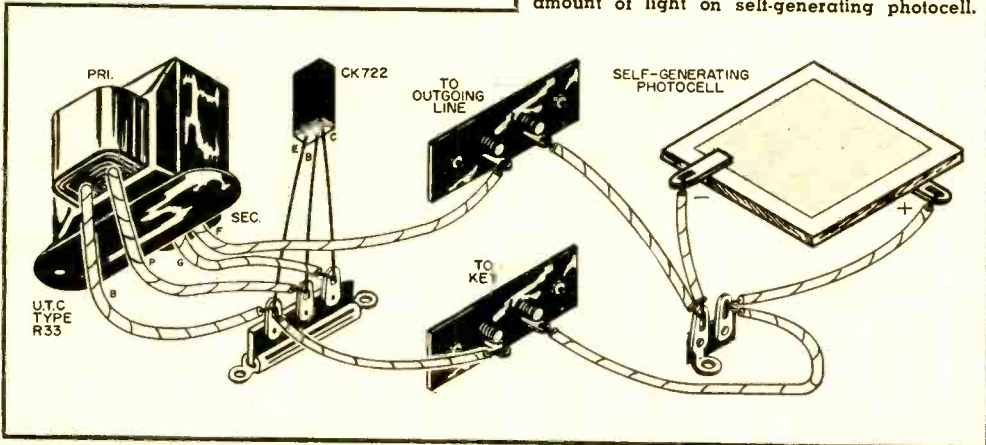

**Experiment 5—Sun-Powered Click-Type Telegraph:**

Figure 5(B) shows a telegraph operated from the direct current delivered by a sun-lighted photocell.

A click is heard in the headphones each time the key is depressed and each time it is released. These clicks can be used to exchange messages. The regular radio code is not nearly as useful with the clicks as is the American Morse code which is used extensively with the clicking telegraph sounders.

The click-type telegraph is quite simple. Nevertheless, it can be used over long lengths of wire. Clearly audible clicks can be heard even when the photocell is not in *direct* sunlight.

**Experiment 6—Tone-Type Telegraph:**

Figure 6 shows the circuit of a tone-type telegraph. With this setup, an audible tone is heard in the headphones as long as the key is held down. The tone stops as soon as the key is released.

Here, the d.c. output of the sun-lighted photocell furnishes the power necessary to operate a transistor audio oscillator. No

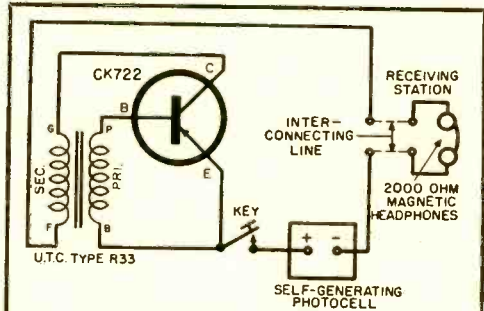

Fig. 6. Transistors enable solar batteries to be used where the voltage demands are very small. This circuit is that of the audio tone generator which is pictured on page 66. Experimenters can also use it as a code practice oscillator. Frequency of tone from the oscillator will vary according to the amount of light on self-generating photocell.

other power supply is needed. With the type of transformer shown and a B15 photocell, the tone frequency is about 2000 cycles in moderate sunlight. The frequency decreases as the lighting increases, and vice versa.

This circuit will also operate in a lighted room. Only a small amount of light is needed for the transistor oscillator to generate a tone. Aside from its use as a telegraph, the circuit also can be used as a code-practice oscillator requiring no batteries or power-line connection. While there is light, there is code!

Transformer, photocell, and transistor must be connected exactly as shown in the circuit schematic, Fig. 6. Observe the polarities carefully. Reverse either of the connections, and the oscillator will not work.

The transistor is mounted by soldering its three pigtail leads to the contacts of a 3-lug, insulated terminal strip. When soldering, hold the pigtail with long-nose pliers to conduct the heat away from the transistor.

Parts are mounted on an 8½" x 5" wood-en breadboard. A metal chassis or box can be used if the board-type construction is not desired.

**Experiment 7—Sun-Operated Relays:** Figures 7 and 8 show simple light-sensitive relay circuits for operation in sunlight. These circuits can be used to turn lights on and off in response to changing daylight conditions. They can also be used as daytime burglar alarms. The circuit in Fig. 7 will operate on moderate daylight, as well as direct sunlight.

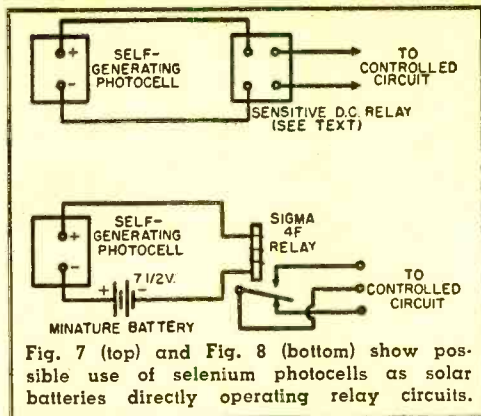

Fig. 7 (top) and Fig. 8 (bottom) show possible use of selenium photocells as solar batteries directly operating relay circuits.

Figure 7 uses a sensitive d.c. relay. Such relays as the *Weston* "Sensitrol" and *Barber-Colman* "Micropositioner" can be obtained to close on currents of a few microamperes. They will operate easily from the photocell, even with small amounts of light.

When an expensive d.c. relay of this type cannot be afforded, however, the circuit of Fig. 8 may be used. The relay in this hookup is a *Sigma* Type 4F. This relay can still be found in the war surplus market or a new unit may be purchased. Its sensitivity can be increased by turning the pivot screw clockwise a small amount to loosen the spring. The battery maintains a small direct current flowing through the relay coil, but this current is insufficient to operate the relay. Additional current from the sun-lighted photocell raises the coil current to the necessary value. —30—

## Solar Battery in Operation

THE SOLAR BATTERY developed by *Bell Telephone Laboratories*, New York City, received its first practical test as part of the telephone system this past summer. An experimental unit—similar to the model shown—was installed in Americus, Ga., to supply power to terminal equipment on rural telephone lines.

Heart of the solar battery is a specially prepared silicon disc which converts sunlight into electricity. This model contains 432 such discs, arranged in 48 units of nine discs each.

During daylight hours, the solar battery will power terminal equipment directly and, at the same time, will charge a storage battery to provide power for nighttime operation and periods of lowered sun intensity. Flexible features of the mounting allow the face of the solar battery to be

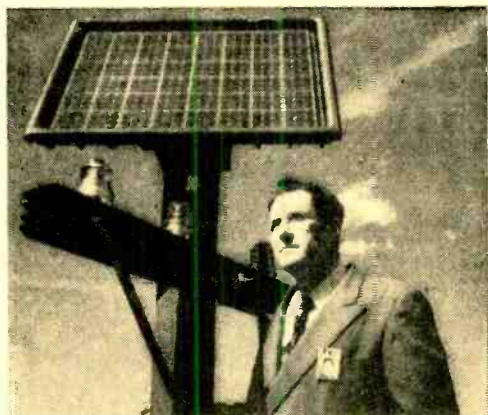

tilted to the most favorable angle for maximum sun exposure in any latitude.

The *Bell* solar battery is the first successful device to convert sunlight directly and efficiently into useful amounts of electricity. —30—

There are no "time breaks" with this 6-volt automobile clock

powered by a.c. or batteries

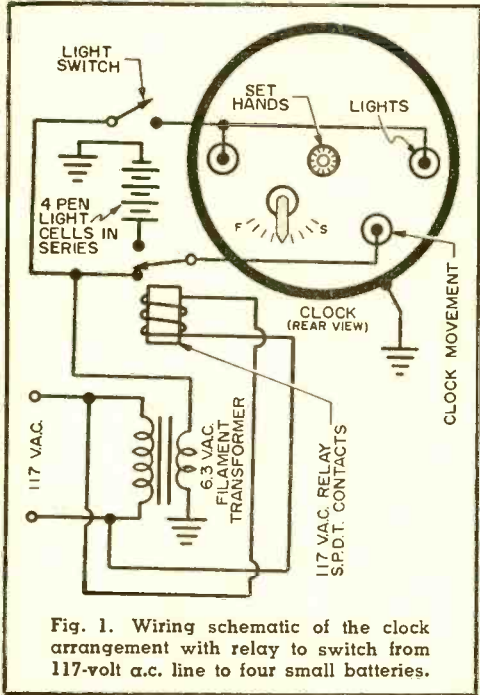

Fig. 1. Wiring schematic of the clock arrangement with relay to switch from 117-volt a.c. line to four small batteries.

AN ELECTRIC CLOCK that operates whether it's supplied with house current (117 volts, a.c.) or not is a handy device to have around, especially in an area where a power line failure occurs now and then during a thunderstorm. Living or vacationing in a house trailer and moving around a lot will also prove its handiness. With the addition of another simple circuit, this device will make a beautiful indirectly illuminated television clock.

The heart of the "permanent clock" is an automobile dashboard clock. These, or similar units, are available from time to time as surplus items and can be purchased for small amounts. The one in these photos cost the author only \$2.50. It is mounted in a 6" x 6" x 3½" case made by cutting down a standard 6" x 6" x 6" aluminum box. The handle on the top of the case is an ordinary screen door handle.

While automobile clocks are made to operate on direct current, most if not all of them will operate just as well on alternating current. All the constructor will

## the permanent

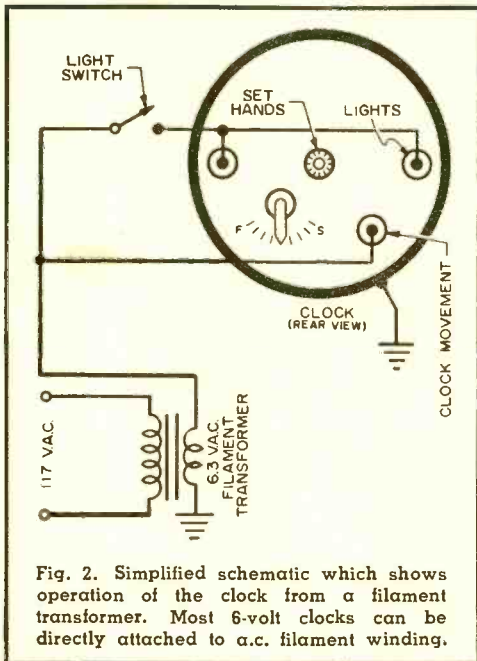

Fig. 2. Simplified schematic which shows operation of the clock from a filament transformer. Most 6-volt clocks can be directly attached to a.c. filament winding.

need is an ordinary 6.3-volt step-down or filament transformer. To give the clock the "permanent" feature, simply add a 117-volt a.c. relay with s.p.d.t. contacts, and four small penlight cells connected in series.

As shown in the wiring diagram, Fig. 1, the relay normally connects the clock to the 6.3-volt a.c. source. In the event of a power failure, the relay flips over and connects the clock to the four penlight cells. Since the clock movement draws only a few milliamperes, the life of the dry cells is just about equal to their shelf life—even when the clock is connected to them for extended periods of time. When a.c. power is restored, the relay automatically disconnects the clock from the batteries and returns it to a.c. operation, scarcely missing a tick!

Almost every automobile clock has a beautiful indirectly lighted dial and hands. Mounted in a case with or without the relay and batteries, it makes an especially nice television or bedside clock. The simplified circuit for such use is shown in Fig. 2.

The author purchased this clock as a surplus item in an automotive supply store. It was then mounted in a cut-down metal case with an ordinary screen door handle on top. Clock face is indirectly lighted by two lamps built into unit.

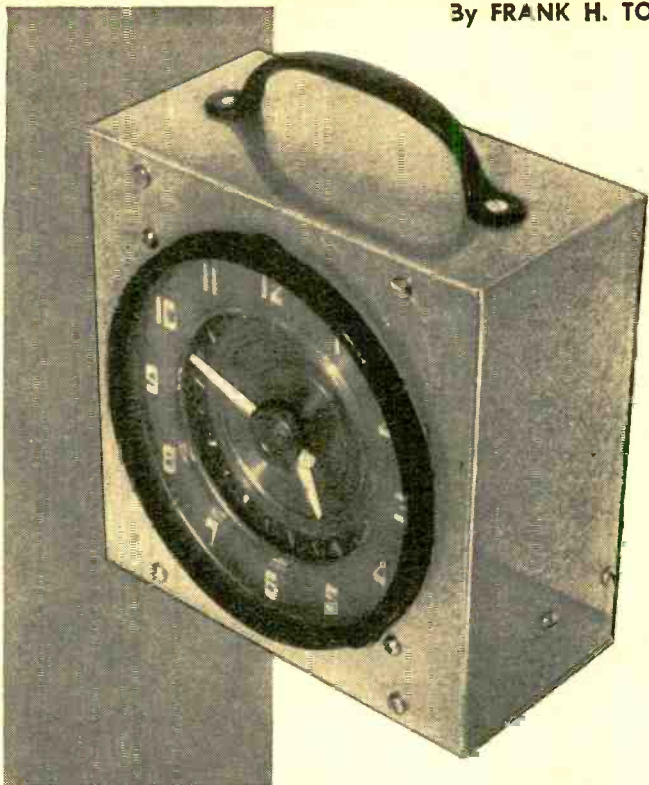

## electric clock

Relay, filament transformer, and four small batteries are mounted behind panel on rear of clock case. The two projections on back of clock are 6-volt lamps that illuminate the face. Such a clock can be taken on trips to isolated areas where a.c. power lines might fail.

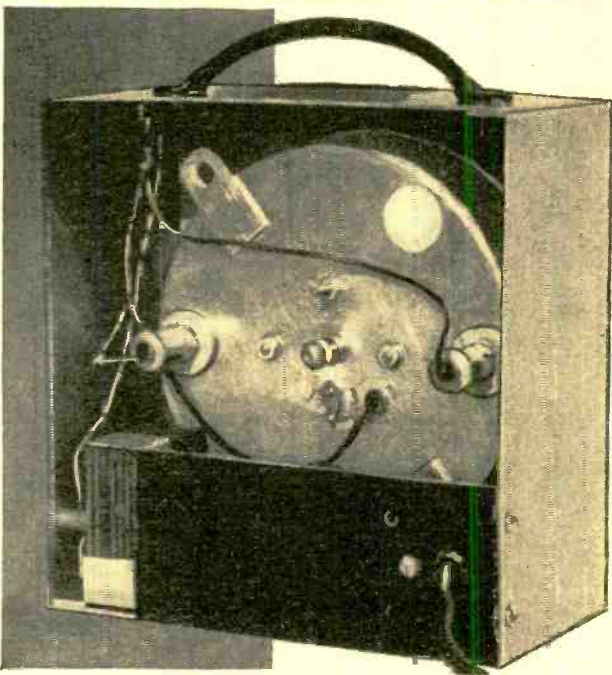

# easily built chassis rack

**U**NDER-CHASSIS wiring and repair work would not be difficult if the electronic or radio chassis would rest on its top as evenly and securely as it does on its base. But, unfortunately, such is not the case. On the usual chassis, transformers, filter capacitors, shielded coils and other components protrude from the top in an uneven jumble, and it is sheer luck if two or more of the parts happen to line up to form even support points.

But with a properly designed rack to hold the chassis, confusion and frustration ends. The chassis can be mounted in just the right position for easy wiring, and below chassis work becomes enjoyable instead of

a chore. And, in addition, if the rack is designed to hold the chassis at an angle and height to allow ready access from both sides, permitting tubes to be changed and alignment adjustments to be made without shifting the equipment's position, below chassis work becomes a real pleasure.

The relatively few inexpensive parts required to build a chassis rack are readily available. Expensive machine tools or special skills are not necessary for the job. With a small drill and the usual assortment of hand tools, a chassis rack can be assembled in two or three evenings or on a week end. It is an ideal "rainy day" project.

Parts needed are specified in the bill of

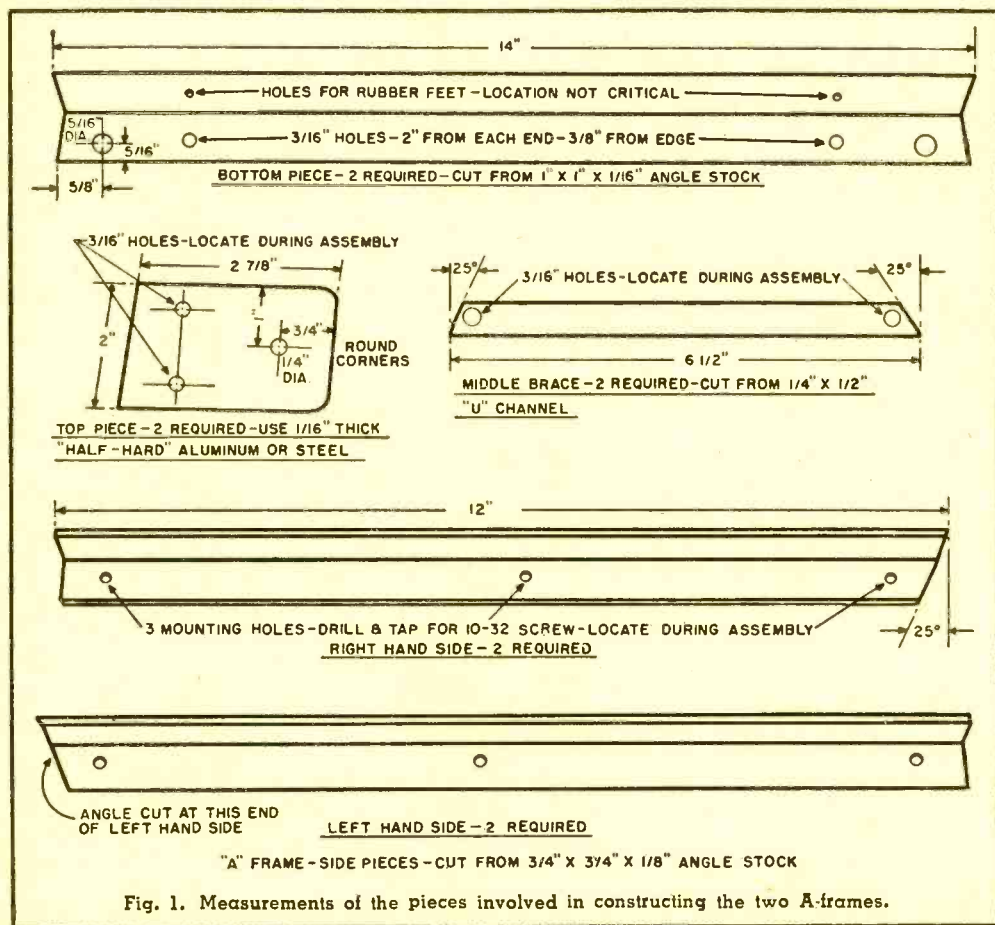
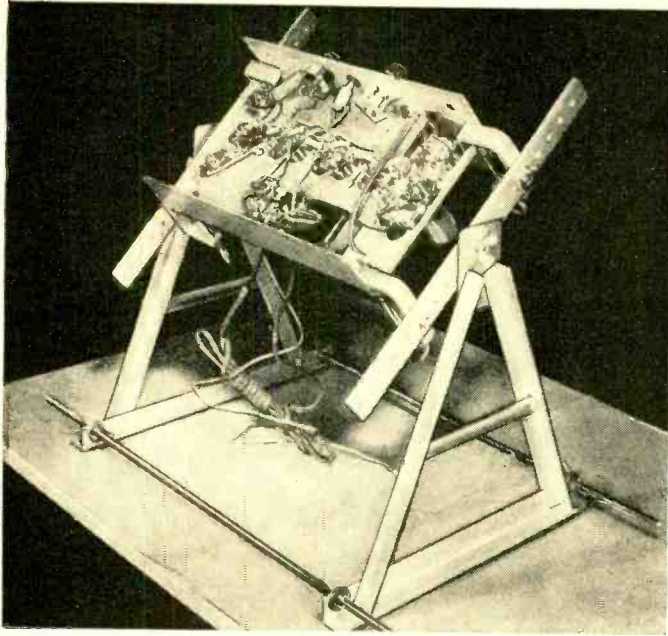

Fig. 1. Measurements of the pieces involved in constructing the two A-frames.





By LOUIS E. GARNER, Jr.

*Why break glass tubes or bend components out of shape when a rugged chassis rack can be assembled in a few hours*

materials. With the exception of the rubber feet, most of the material should be available at the local hardware store. The new Reynolds "Do-It-Yourself" aluminum is used extensively in the rack design. This is a special soft alloy that may be worked with ordinary woodworking tools—no need for special "high-speed" drill bits or saw blades.

#### Building the Chassis Rack

The chassis rack consists of three relatively independent subassemblies, the "A" end frames, the "rocker arms," and the base. These may be fabricated individually, then assembled together to make the complete rack.

**"A" End Frames:** Two A-frames are needed. The parts required for assembling a single unit are shown in Fig. 1, while the completed A-frame is shown in Fig. 2. Cut and shape each part out of stock material, then drill all holes at the points indicated. *Note that exact hole locations are not shown in some cases.* To locate these holes, assemble the cut-out pieces of stock material on the top of the workbench, then mark hole locations with a center punch. With the A-frame loosely assembled in this fashion, perfect alignment of all parts before final assembly can be made. The mounting holes in the side pieces are tapped for a 10-32 machine screw. When the drilling and tapping is completed, assemble each A-frame, using  $\frac{3}{8}$ " long 10-32 binding head machine screws—use Fig. 2 as a guide during assembly.

**"Rocker Arms":** The rocker arms act to support the chassis proper, and each consists of two Stanley "Handy Clamps" assembled on a heavy bar cut from  $\frac{1}{4}$ " x 1" aluminum stock. Two are required. Parts needed and the basic layout used is shown in Fig. 3, while an assembled rocker arm is shown in Fig. 4. Prepare the "Handy Clamps" for mounting by drilling and tapping a hole for a  $\frac{3}{16}$ " x 24 stove bolt, centered on the back strap of the clamp. Insert  $\frac{3}{4}$ "-long  $\frac{3}{16}$ " bolts from the inside, as shown in Fig. 3. Drill and tap a hole for a  $\frac{1}{4}$ " x 20 stove bolt in the center of the

Fig. 2. Assembled A-frame using the pieces shown on the facing page. Two are required.

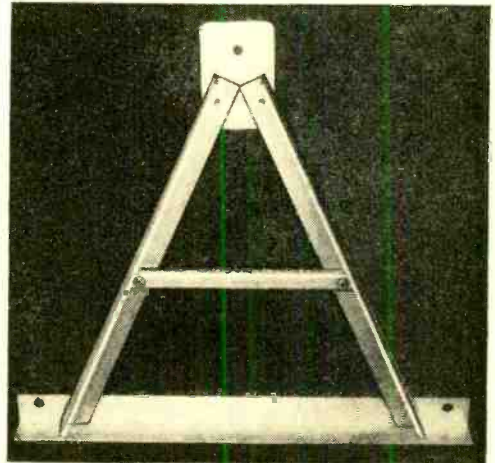

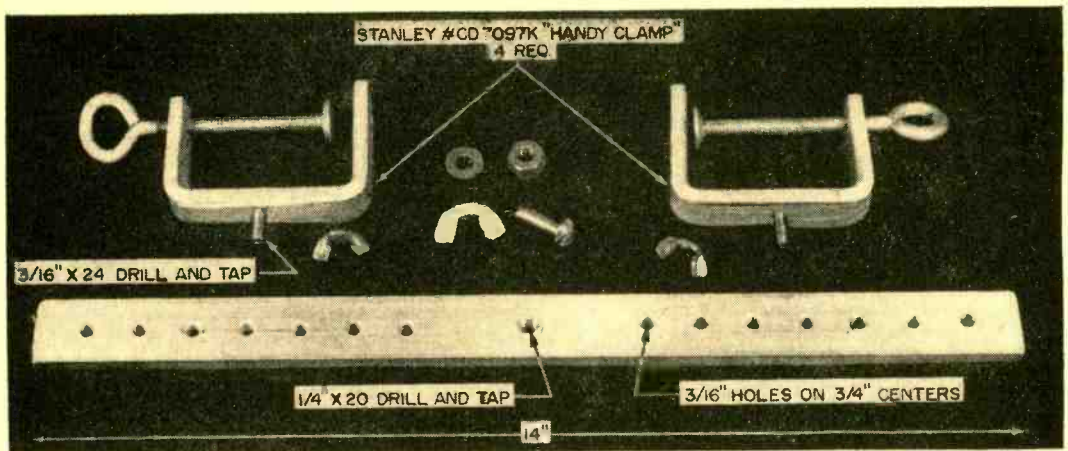

Fig. 3. Basic layout for making a single rocker arm including all necessary parts.

#### BILL OF MATERIALS

- 2—14" lengths of 1" x 1" x 1/16" aluminum angle stock\*
  - 4—12" lengths of 3/4" x 3/4" x 1/8" aluminum angle stock\*
  - 2—14" lengths of 1/4" x 1" aluminum bar stock\*
  - 2—6 1/2" lengths of 1/4" x 1/2" aluminum "U" channel stock\*
  - 1—2" x 6" piece of "half-hard aluminum"
  - 2—24" lengths of 5/16" Redi-Bolt stock
  - 8—5/16" wing nuts to fit above Redi-Bolt stock
  - 8—Flat washers with 5/16" hole
  - 4—Stanley "Handy Clamps" (#CD 7097K)
  - 4—3/16" x 24 x 3/4" long stove bolts
  - 4—3/16" x 24 wing nuts
  - 2—1/4" x 20 x 3/4" stove bolts
  - 2—1/4" x 20 hex nuts
  - 2—1/4" x 20 wing nuts
  - 2—Flat washers with 1/4" hole
  - 12—10-32 x 3/8" machine screws with binding heads
  - 4—Rubber feet
  - 4—#6 x 3/8" sheet metal screws
- \* Marketed by the Reynolds Aluminum Company as "Do-It-Yourself" aluminum

rocker arm bar and insert a 3/4"-long 1/4" bolt. A 1/4" x 20 hex nut is placed over this central bolt and acts to hold the rocker arm away from the A-frame during final assembly.

**Base:** The base consists simply of two 24" lengths of 5/16" Redi-Bolt, each equipped with a pair of wing nuts and flat washers at each end. See Fig. 5 for details.

**Final Assembly:** A-frames are assembled to the Redi-Bolt base pieces, using wing nuts and flat washers, as shown in Fig. 6. Note that a flat washer is placed on each side of the bottom angle piece of the A-frame; this serves to increase the clamping area of the wing nuts and to insure a stronger connection. The flat washers also act to reduce scratches in the soft aluminum alloy as the wing nuts are tightened and released.

(Continued on page 130)

Fig. 4. Completely assembled rocker arm, two of which are required to hold chassis.

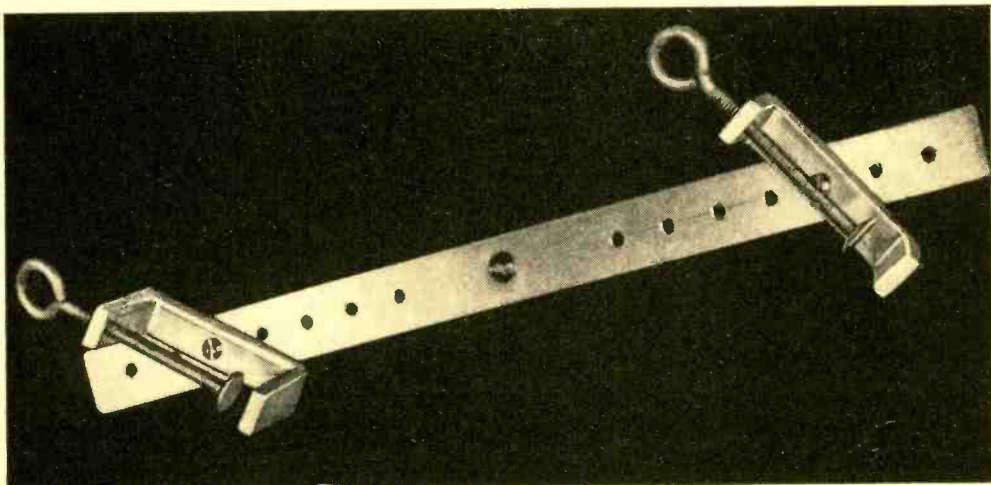

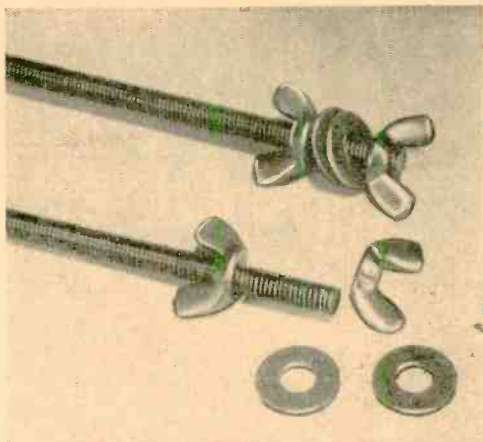
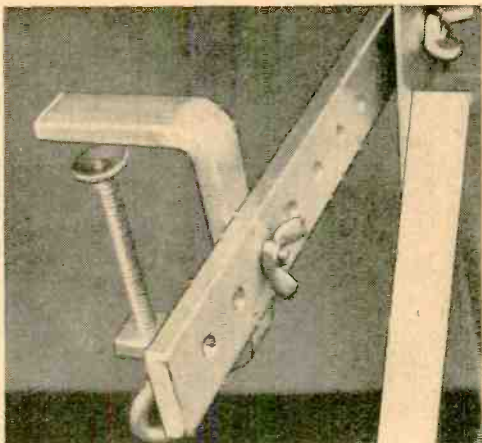

Detail view (above) of the mounting for one of the "Handy Clamps," which are manufactured by Stanley and are available from most hardware stores. To compensate for varying chassis weights, the clamps may be moved along the rocker bar to new pre-drilled positions.

Fig. 5. The base consists of two 24" lengths of 5/16" Redi-Bolt (upper right), equipped with wing nuts and flat washers at each end. This photograph serves to point out the necessity of using washers under each wing nut.

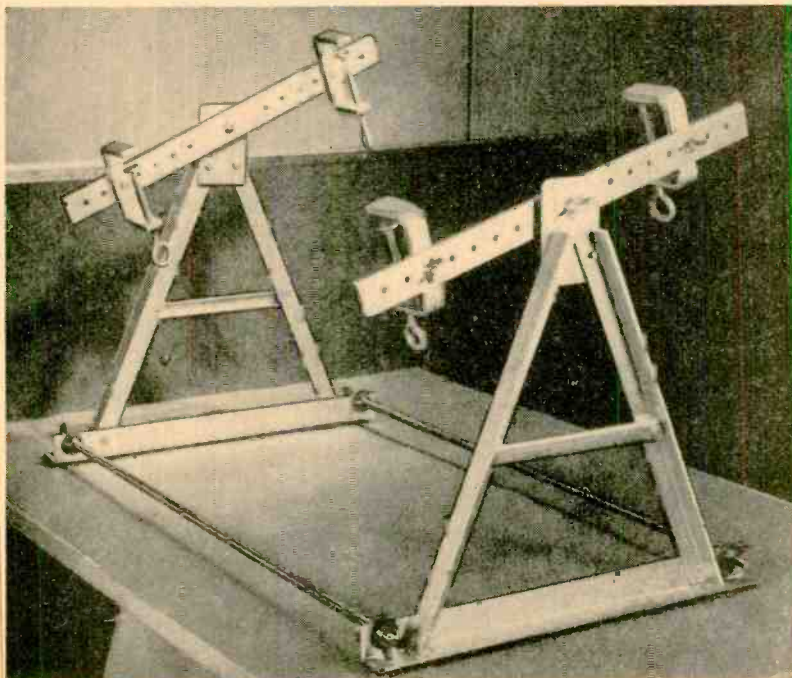
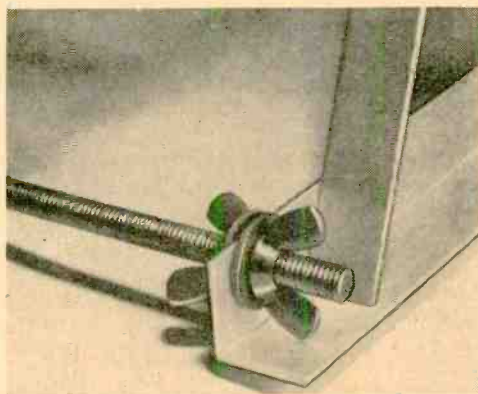
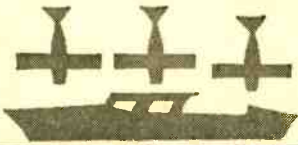

Fig. 6. A-frame and base assembly (above). Note that A-frame may be moved by loosening the wing nuts and setting them in a new position determined by the width or length of chassis held in the cradle. The use of washers under the wing nuts will prevent excessive scoring of A-frame.

Fig. 7. Fully assembled chassis rack (left). "Handy Clamps" on the rocker arms hold the chassis, which may be swung around to permit working on either the top or the bottom. Vary the position of the A-frame on Redi-Bolts to fit different lengths and/or widths.

# R/C NOTES



WE'RE NOT ALARMISTS, but a situation is developing on the 27.255-mc. Citizens band which, if allowed to continue, may force many R/C'ers off the band. It seems that for the past year and a half the FCC has been awarding licenses on the 27.255-mc. band to trucking companies, police, and similar groups for communications purposes. These users do not confine themselves to the puny 5-watt output of the R/C'er, but use hundreds of watts. For example, the proposed radio-controlled traffic light system for Chicago, Ill., uses a transmitter with an output of 250 watts. You don't have to be a mathematical genius to figure out what havoc a 250-watt transmitter on 27.255 mc. can cause. This applies to R/C garage door openers and other home applications as well as it does to model airplanes and boats.

It has been suggested that one way to combat the possible monopolization of this band by industrial users is to gather evidence of interference for presentation to the FCC at some future formal protest. It seems a pretty good idea to us and we would like to encourage all readers who are active R/C'ers on the 27.255-mc. band to log all interference on this band and to track it down if possible. Remember, you must have conclusive evidence that the interference is caused by another licensed user of the band.

DUANE LOEWEN, one of our readers in Toronto, Canada, has done some interesting and useful research on small batteries used in R/C equipment, and has come up with an excellent recommendation. Using a No. 915 1½-volt penlite cell as the "A" supply in a two-tube subminiature circuit with a current drain of about 20 milliamperes, he found that the useful life of the battery during continuous duty was only about four to five hours. Needless to say, this short life span does not make for reliability. Of course, when used for intermittent service, for which it was designed, the No. 915 will give up to nine hours use with a 20-milliamperere drain.

This all leads to the discovery by Duane of the No. 1015 battery, which has the same physical dimensions as the No. 915. The 1015 was originally designed for con-

tinuous duty as the "A" supply for hearing aids, and will give approximately 25 to 30 hours of continuous use with a 20-milliamperere drain. This is an increase in useful life of about six times over the 915. The 1015 is available at almost all electronic supply houses for about the same price as the 915.

WE'VE JUST RECEIVED copies of Paul F. Runge's "R/C Bibliography" and recommend it without reservation to all R/C'ers who construct their own gear. It is a complete index to all R/C theory, practice, and construction articles that have appeared in the nine major model and technical radio magazines which publish R/C material. The period covered is from June, 1948, through July, 1955.

The booklet is supplied in loose-leaf form and there is plenty of space for additions to keep it up to date as new articles appear. We are particularly happy to note that POPULAR ELECTRONICS and our sister publication, RADIO & TELEVISION NEWS, are well represented in Paul's authoritative bibliography. Copies of the booklet are for sale, and additional information may be obtained by writing to *Ace Radio Control*, Box 301, Higginsville, Mo.

THE NEWEST ITEM for the R/C boat fan to catch our eye is the new *Babcock* electric motor speed control and sequence reversing switch shown here. This 1½-ounce,

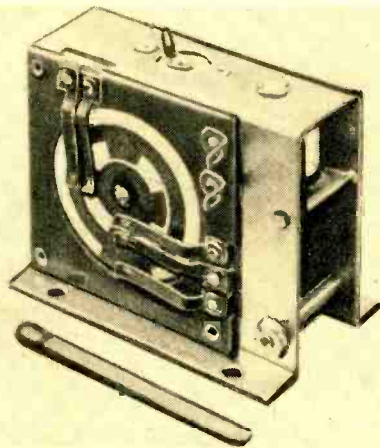

1½" x 1¾" x 1½" unit will enable you to obtain two speeds forward, stop, reverse, and start. It can handle 10 amperes at 6 volts through its rhodium-plated commutator.

No rubber bands or external motors are required for this switch; it looks like the real thing for R/C boats. Built by one of the largest R/C equipment manufacturers in the country, it is obtainable through your local hobby dealer for \$12.95. -30-

# POPULAR ELECTRONICS

## Audio and Hi-Fi Section

77	Disc and Tape Review . . . . .	<i>Bert Whyte</i>
79	\$2 Speaker Baffle . . . . .	<i>David B. Weems</i>
82	Basic Tape Recorder Maintenance . . . . .	<i>Eugene F. Coriell, Major, USAF</i>
84	The Meaning of Frequency Response (Part 3) . . . . .	<i>Norman H. Crowhurst</i>
87	Making an Etched Preamp . . . . .	<i>H. J. Carter</i>
90	Tape Playback and Erasure . . . . .	<i>Leon Wortman</i>

## Disc and Tape Review

I STATED last month that after our little venture into some "musical spice" we would return to our survey of recordings in the standard repertoire. This we will do, but instead of the material I had in mind, I will bow to the wishes of a number of readers who have requested certain specific works of music. However, before we get on with the job, I want to report to you on a most significant development in the field of stereophonic music.

By **BERT WHYTE**

### Stereophonic Playback Unit

During the first part of August, I had the pleasure of attending a press review given by the *AmpeX Corp.* at which a new tape machine was unveiled that I feel will furnish the needed impetus to "put over" stereophonic sound as the "medium of choice" for the reproduction of music. This machine, which the *AmpeX* people call a "tape phonograph," is basically their Model 600 tape recorder with considerable modification. For one thing, this unit is for *playback only* . . . in other words, it has no erase head, nor record head, nor record amplifier. It employs matched stereophonic playback heads in the "stacked" (one head directly on top of the other) arrangement. When playing a stereophonic tape, the output of the heads is fed to a pair of matched preamplifiers (which are self-contained within the unit), and the signal is then fed to a pair of power amplifiers and thence to two speakers. Combining all of the excellent tape transport features of the Model 600, such as hysteresis synchronous motor, easy slot tape threading, etc., this stereo Model 612 is surely going to cause a re-evaluation of the prerecorded tape market by record companies. It is a versatile unit as

it also permits the playback of either full-track or half-track monaural recordings.

Well, this all sounds very nice . . . but what's the price tag? And *that* is the best part of the whole deal. For many years now, this writer has maintained that a major tape machine company could turn out a first-class tape playback machine, with provisions for stereo and with sync motor, etc., for less than \$400.00. Well, the tag on the Model 612 is not too far down from that figure, the units without cabinets for custom installation nicking you for \$379.50. Now I'll be the first to admit that 379 bucks isn't exactly "beer money," but it is a far cry from the eight or nine hundred dollar minimum which heretofore had to be laid out for a stereo tape machine.

Just to make the package complete, *AmpeX* has the Model 612 available in nicely styled furniture cabinets (to make your selling job with the "Missus" a little easier), and has also turned out the 620 amplifier-speaker in furniture cabinets. Thus, a complete stereo-tape playback system, all in matching cabinets, is available for those people who do not want to bother with individual component amplifiers, speakers, etc. This package is tagged at \$699.00.

How did the setup sound? Superb! With some of the new *Victor* stereo-tapes and also with some by *Livingston* and others, that incredible realism which is the special province of stereo-tape was perfectly realized. It is true that there are still some factors about initial mike placement in making the stereo-recordings that have not been resolved into so-called "standards," and the same holds true for speaker placement in the home. But, by and large, most of the stereo heard was recorded within reasonable limits of mike placement, and orchestral balance was generally quite good.

To those who argue that they want a unit which is a stereo-recorder as well as a playback unit, let me say this . . . unless you are a professional, this is a mighty expensive operation to undertake as a hobby. The problem is one of source . . . a lay person owning a stereo-recorder will soon get tired of recording the

church choir or the high school band. And where do you go from there? Even if you were reasonably near a "name" band or a symphony orchestra, and even if you obtained permission from the band leader or conductor to record, you would most likely be stopped by the local musicians' union. Believe me, friends, I *know!* I learned the hard way!

This is about as much as I can tell you about the Model 612 at the moment. I expect to have a unit for use before too long, and if I can pry *Victor* loose from some of the stereo-tapes, I will give you a first-hand report on my experiences.

Now back to the still far-from-mundane world of the phonograph record.

### Franck Symphony

It seems that quite a number of people must be contemplating the acquisition of the *Franck D Minor Symphony*, judging from the number of requests I have received asking for a breakdown on this work. A quick glance at the LP catalog reveals no less than 16 versions, so it is small wonder that some folks are a bit confused as to which is the version of choice! To complicate matters still further, we are faced with a most unusual situation in that 10 of the 16 versions can be considered recordings of hi-fi quality! Unfortunately, space does not permit an evaluation of all of these recordings, so I will discuss the two or three outstanding versions and then list the rest in order of descending quality of sound.

Running practically neck and neck for first-place honors is the Paul Paray-Detroit Symphony reading on *Mercury* 50023 and the Wilhelm Furtwangler-Vienna Philharmonic effort on *London* LL-967. A choice between these two is a matter of degree and personal preferences. Paray is closer to the letter of the score than Furtwangler, although it must be said that for the most part Furtwangler does not indulge very much in his usual mannerisms. Paray makes of the work a most robust document, a strong-lined vigorous interpretation that almost might be called "earthy." Furtwangler treats the score more

(Continued on page 126)

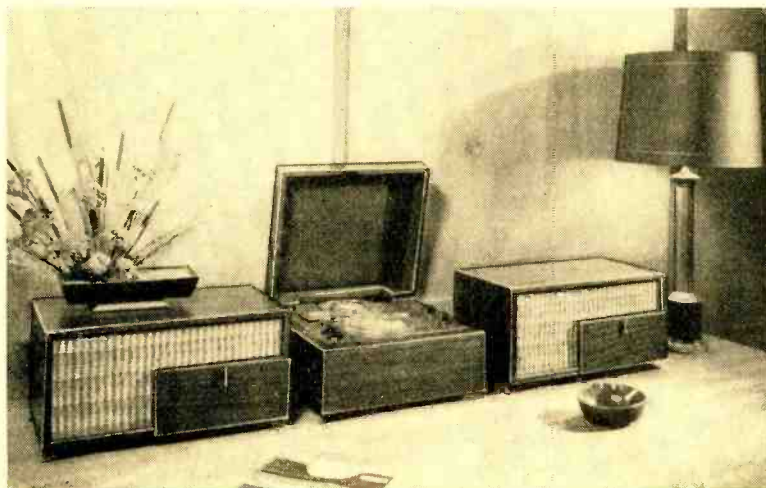

The Ampex Model 612 consists of three separate units. At far right and left are Model 620F amplifiers and speakers. The center unit is tape playback for full-track, half-track or two-track stereophonic tapes. In a living room, the two speakers are spaced farther apart to get stereophonic effect.

# \$ 2 Speaker Baffle

*This labyrinth speaker corner baffle can be made with a saw and hammer and a single sheet of cheap Celotex*

Unpainted baffle sits in corner of author's living room. Baffle must be flush with walls to prevent escape of sound directly behind speaker.

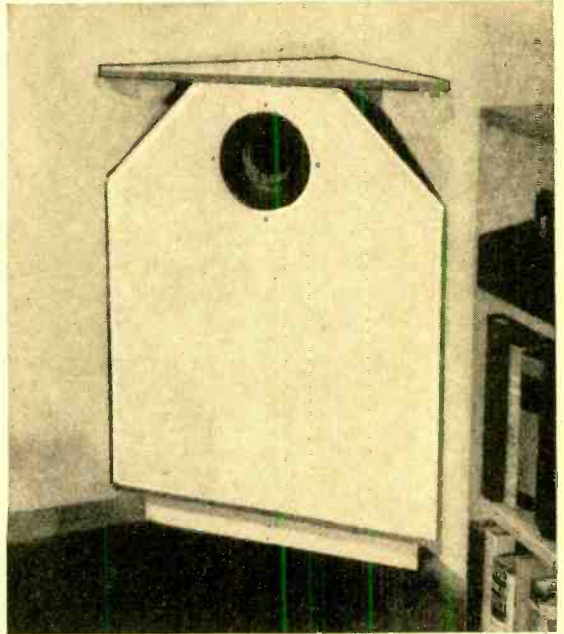

**T**HIS SPEAKER BAFFLE (it can hardly be called a cabinet) is admirably suited as a temporary or extra installation because of its low cost and ease of construction. The six functional parts can be cut and fitted together in about an hour. It doesn't require a finished cabinet maker either, the design is not critical, and the material allows for some tolerances in measurements. In fact, anyone who can recognize a saw and a hammer should have no trouble with the carpentry.

The design was evolved after several types of baffles were considered. Horn-type cabinets were immediately rejected. The small Helmholtz resonator designs quickly followed the way of the horns as being too complex. Next studied was the bass reflex, but it is susceptible to booming unless the box is carefully tuned. Furthermore, the above-mentioned types require expensive lumber, as does the infinite baffle, which would necessarily be the largest and perhaps the most expensive of all.

Only the labyrinth remained as the baffle which was least critical and, because of less internal sound pressure, also adaptable to cheap building material. This one sits unobtrusively back in a corner, a position which fortuitously improves the bass response.

Celotex was chosen for the job because it is non-resonant and needs little or no internal padding. It is normally sold in 4' x 8' sheets, but most lumber yards will gladly cut a sheet in half. The cost is about eight cents per square foot or a little more than \$1.25 for a half sheet. It is advisable to mark out every part before sawing, in order to obtain all of the parts from a single half sheet.

After the sections have been sawed to the measurements shown on page 80, nail the side pieces (*C* and *D*) to the back insert (*E*). Next, nail the front to the side pieces. Both the side pieces and the front should be oriented so that the rough surfaces are inward, toward the speaker. When the top

(B) and bottom (F) are in place, the cabinet is finished. "Feet" (G and H) may be added if desired or when necessary to clear a wall molding. The size of the nails should be about "six-penny," although smaller ones may be used, especially if glue is applied to the joints. After completion, the entire external surface may be painted to match the walls of the room.

The baffle should work very well with any good-quality 8" speaker. The choice for this particular installation was a *Permoflux* 8T8-1, which proved to be very satisfactory.

Amount of padding needed in any loud-speaker enclosure may be determined by the room acoustics, the speaker, and other factors, especially that most unpredictable element of personal taste. In an average room, this baffle should need little or no padding since the Celotex provides its own acoustical treatment. Also, the back of the speaker compartment is formed by the room walls at the corner, which places the walls at a 45° angle with the front and discourages standing waves.

The writer has in the past spent much time constructing cabinets that were de-

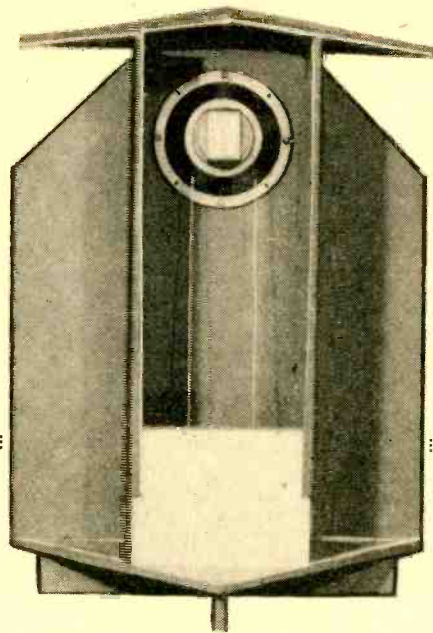

Placement of speaker is obvious from this rear view of the labyrinth baffle.

All the parts of this baffle may be cut from a single half sheet of Celotex.

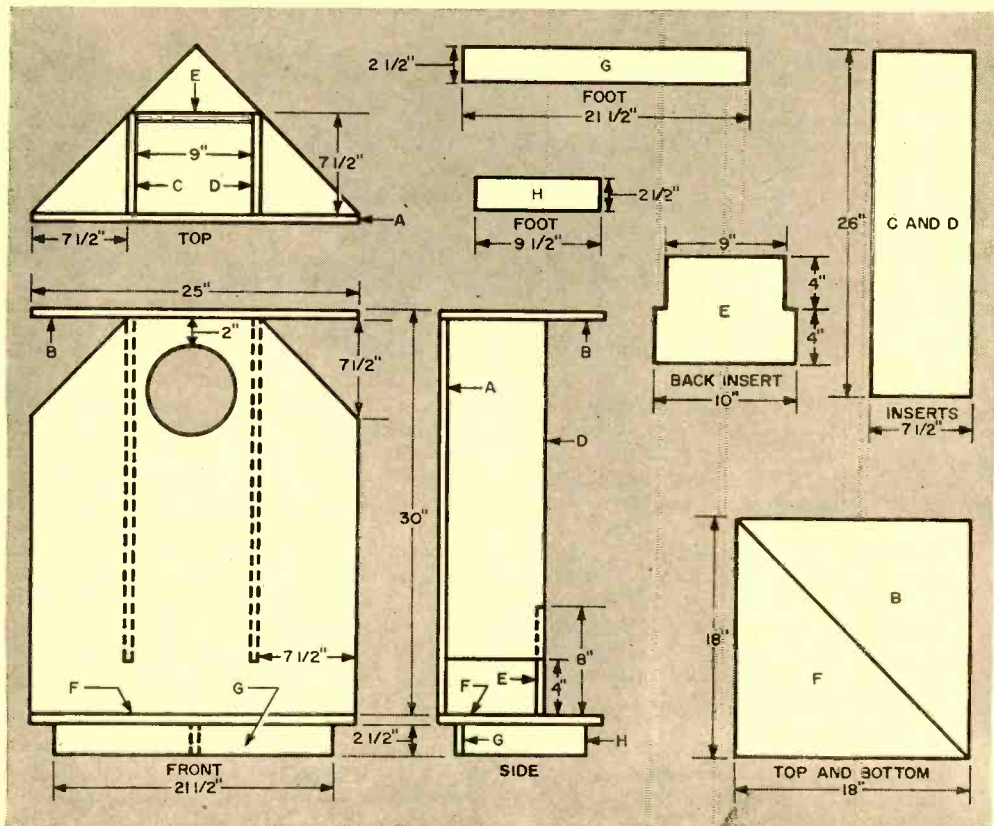



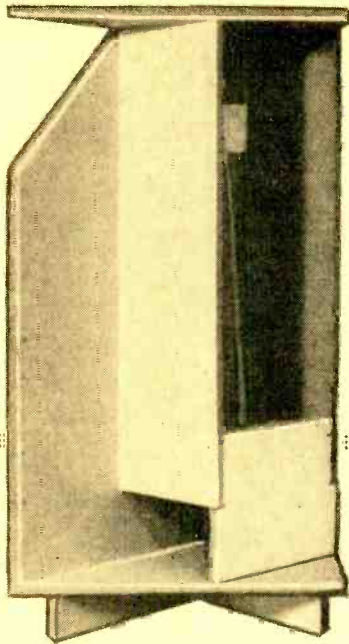

Rear view of enclosure shows placement of the various Celotex sections.

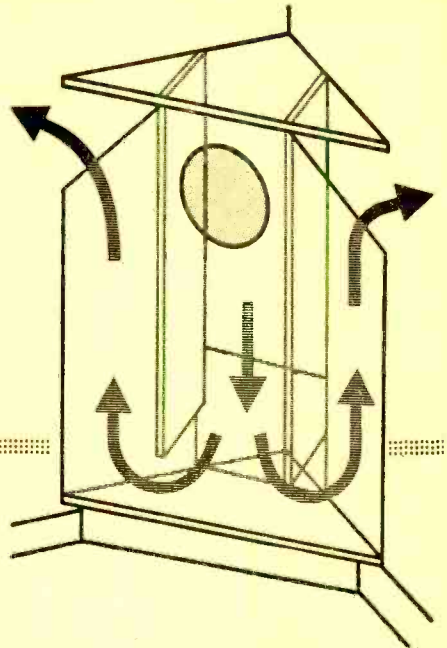

Phantom view of the enclosure shows sound paths from rear of the speaker.

scribed in glowing terms only to find on completion that he did not like the sound they imparted to a good speaker. This baffle does not color the sound of the speaker. The sound appears to be quite free, to come out into the room without the boxi-

ness or booming of most small installations. A big advantage of using this baffle is that money can then be put into other actual components. Its performance is so satisfactory that one may be tempted to use it indefinitely.



## Tape Recorders for Hi-Fi, Schools, Industry

RECENT ADDITION to the well-known line of "Magneorder" tape recorders is the M30 series, designed specifically for home hi-fi use as well as for schools and industry. Model M30 may be removed from its carrying case for rack-mounting or custom installation as part of a hi-fi system. Model M33 includes a built-in power output stage and its own loudspeaker. Model M34 is similar, with the added features of a 10-watt power amplifier, twin 6" speakers, and separate tone controls in a single detachable case; the amplifier and speaker combination may be used separately for public address work.

Reported specifications of the new line are: frequency response,  $\pm 2$  db from 50 to 10,000 cycles at  $7\frac{1}{2}$  i.p.s.;  $\pm 2$  db from 50 to over 5000 cycles at  $3\frac{3}{4}$  i.p.s.; flutter and wow, less than 0.3%; signal-to-noise ratio, 50 db.

Inputs include high-impedance microphone, high-impedance phono, or tuner. Outputs are provided for connection to external amplifier and speaker as well as

to earphones for monitoring, and to an external vu meter.

Net prices are: Model M30, \$299.00; Model M33, \$329.00; Model M34, \$429.00. A "de luxe" version of the M30, mounted in a fine wooden cabinet, is available at \$339.00. For further details, write to *Magneorder, Inc.*, 1101 S. Kilbourn Ave., Chicago 24, Illinois.



# BASIC

# TAPE RECORDER

## MAINTENANCE

*These simple checks may help avoid tape recorder failure at crucial moment*

**T**HE HOME TAPE RECORDER is a little more complicated than a record player, but it can be just as dependable if care is lavished upon it. While there are variations in detail, all tape recorders are similar in basic components and operating principles.

### Electrical Checks

Start with the microphone cable and its plug. The cable consists of a thin insulated conductor surrounded by a woven metal braid which is both the second conductor and also the shield for the first conductor. Make sure the plug is firmly attached and soldered to the cable.

While there are several types of plugs used on home tape recorder microphones, they all consist of a central pin—the “hot” leg of the circuit—surrounded by an insulated shell or skirt which is the “ground” or return leg. As shown in Fig. 1, the central conductor of the cable is connected to the center pin of the plug and the shield braid is soldered to the plug shell or skirt. Loose connections here may cause noise, hum, intermittent operation or complete loss of signal. For the same reason, avoid kinking the microphone cable.

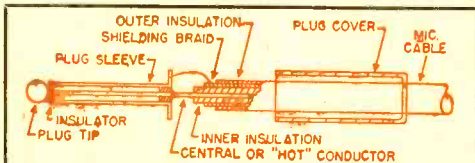
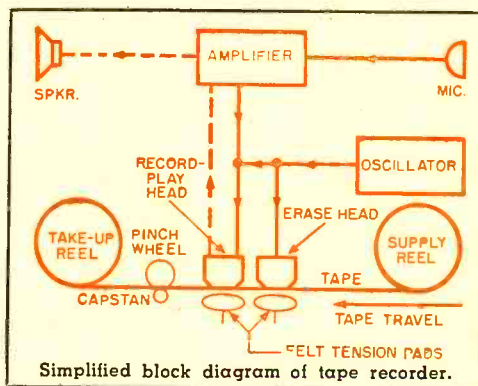

Fig. 1. Sectional view of microphone plug and cable with cover slipped back. Note the cable shield is also ground return conductor. Breakage of cable at this point is often a cause of recorder failure. Hum and noise can be generated by a bad connection. Some microphones use regular phono plug which is inherently smaller and weaker.

By **EUGENE F. CORIELL**, Major, USAF

Check the tubes from time to time. In general, substitution of known good tubes, coupled with before-and-after listening tests, is more satisfactory than using a tube checker. Make sure all tubes are fully seated. With the volume control well advanced and the machine set for playback, tap all tubes lightly with a pencil and replace any which produce a loud ringing or



crackling noise. If the volume and tone controls are noisy, allow a few drops of control-cleaning fluid to run down their shafts, which are exposed after the control knobs are removed.

### Mechanical Checks

While the recorder is open for tube checks, clean off all tubes, transformers, motors and other components so that a layer of dust will not permit dangerous temperatures to build up and thereby shorten the life of these elements. Check the cooling fan on the motor shaft; make sure the fan is tight on the shaft, and if the blades are bent, carefully bend them back into line.

Some machines use a drive belt; if it is frayed or nicked, replace it. A new belt is also indicated if the original has stretched to the point of insufficient tension, since a loose belt will cause uneven speed and consequent “wows.”

Like most mechanisms, tape recorders have lubrication requirements. However, in some makes, these requirements have already been met by the manufacturer through the use of oil-less bearings. It is, therefore, a good idea to check the instruction book before going to work with an oil can. Too much oil is as bad as too little, particularly if it gets on the capstan, or on the belt or under-the-deck driving wheel surfaces. This may cause slippage and deterioration of rubber elements. If necessary, remove oil from these parts with alcohol.

Cleaning of the record-playback and erase heads, shown in the close-up of Fig. 2, is most important. The heads accumulate dirt and minute particles of oxide from the tape. This causes loss of output and poor reproduction of the higher musical tones since it prevents the tape from making good contact with the head. Dirty erase heads may cause poor erasure for the same reason. Clean the heads with a soft cloth wrapped around a matchstick and moistened with carbon tetrachloride or alcohol.

The tape is held firmly against the heads by small felt pressure pads. If the pads are loose on their mountings, they should be reglued; badly worn pads should be replaced. Also, clean the capstan and pressure idler or "pinch wheel" with a soft cloth. If these members are coated with oxide, moisten the cloth with alcohol and

then dry the parts thoroughly. Do not use carbon tetrachloride on rubber elements such as the pinch wheel.

Case and panel deserve some care since these directly affect the appearance of the recorder, and hence pride of ownership. A coat of wax will impart a lustrous sheen to the fabric covering of the case; the panel and control knobs will likewise gleam after waxing. Any scratches in the fabric can be covered up by a child's grease crayon, and it is worth remembering that rubbing in a little soldering paste will generally hide scars which may appear in brown and mahogany-colored fabrics.

A few final words of caution: Never use magnetized tools around a recorder as they may magnetize the record-playback head, resulting in noisy recording. Such tools may also put noise directly on the tape. Should the head become magnetized, it can be neutralized by a commercial "demagnetizer."

#### Further Maintenance

Readers interested in the maintenance of a machine beyond the simple procedures described in this article should write the manufacturer for a maintenance manual which is usually more detailed than the instruction book received with the unit. For some tape recorders, a detailed maintenance guide called a "Photo-Fact Folder," published by the *Howard W. Sams Company*, is available from radio supply houses. -30-

Fig. 2. Close-up view of recorder panel with dust cover over heads and tape drive removed. While various makes of units may differ in style and layout, the Pentron Model 225 illustrated here is a good example of the mechanical arrangement. The tape is pulled past the heads by the friction resulting from the pinch wheel forcing the tape against the motor-driven capstan. The pressure pads, shown here disengaged, press the tape firmly against the heads.

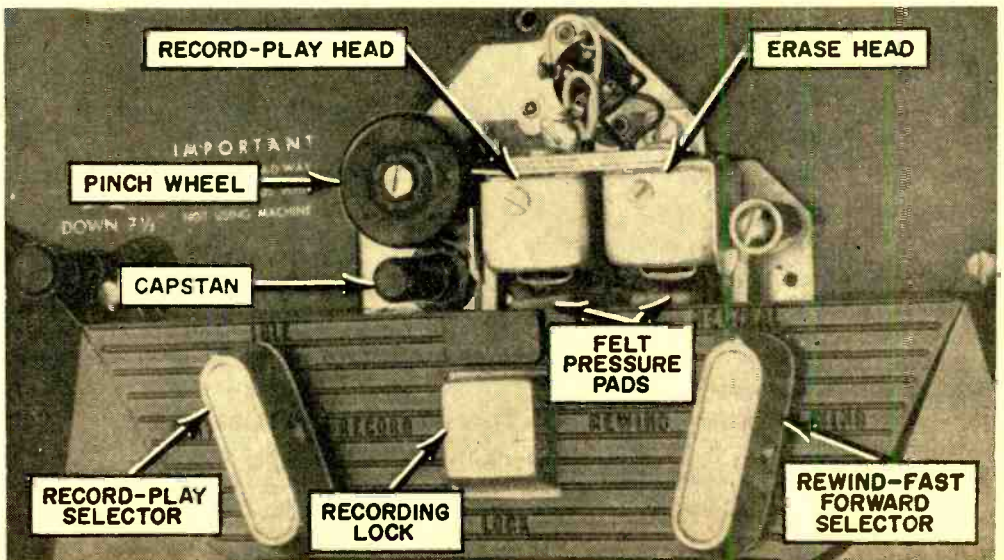

# THE MEANING OF

# FREQUENCY RESPONSE

(PART 3)

BY NORMAN H. CROWHURST

*Final installment in this series outlines effects of capacitance and resistance in hi-fi response curves*

**I**N THE preceding parts of this series (September, page 77, and October, page 92), the contribution of the basic reactances which determine frequency response was introduced. This was done to show how each of them can give rise to low- or high-frequency losses and serious phase shifts.

So far, only the most elementary ways in which these reactances can contribute to frequency response have been mentioned. The present article will discuss the possible combinations that may occur in an amplifier circuit to cause different variations in the combined response which these basic elements can produce.

## "Shelf" Circuits

The simplest variant from the basic "roll-offs"—as the simple circuits are called because they roll the frequency response off

at some low or high frequency, never to come up again—is the "shelf" or "step" circuit. To see how such a circuit is derived from a roll-off circuit, first consider the way in which capacitance causes a high-frequency roll-off, as shown in Fig. 1. Adding to the basic stray capacitance that causes high-frequency roll-off by deliberately putting in a capacitor from grid to ground will result in the roll-off occurring at a definitely lower frequency.

Now if, in series with this capacitor, another resistor is added, the ultimate roll-off produced by the capacitor is limited. Without this resistor, as frequency goes on up, less and less of the voltage appears across the capacitor, until all of it appears across the circuit resistance. But by adding another element of resistance in series with the capacitor, as the frequency gets higher, some of the voltage in the circuit appears across this series resistor. Although the capacitor arrives at a point where it develops no voltage at all, there will still be a residual voltage across the resistor in series with it. This results in a flattening off of the characteristic again (curve "C").

Using a much larger value of capacitor will permit the high-frequency roll-off to occur at a frequency down near (or even

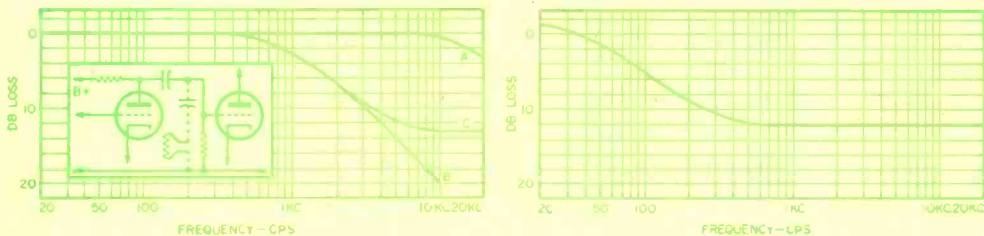

Fig. 1. (Left) The response curves in this drawing show steps in developing low-frequency boost by creating a high-frequency roll-off. Curve "A" indicates normal response without capacitor addition shown by dotted lines. Curve "B" has capacitor added to circuit, but no series resistor. Curve "C" shows response with capacitor and series resistor connected in circuit. Fig. 2 (right) illustrates response curve when capacitor is of fairly large value. The effect is to make the over-all response into a low-frequency boost.

below) the bottom end of the audio range, and the flattening off will still be at quite a low frequency. This produces the response curve shown in Fig. 2. What the capacitor is now doing to the frequency response could be more accurately considered as a low-frequency boost (after turning up the gain) rather than as a high-frequency loss, because the level part of the characteristic—in the middle and higher audio range—is at the bottom end of the slope caused by the capacitor.

Now look at Fig. 3, which is a simple basic coupling circuit. The effect here would be to produce a gradual low-frequency roll-off. If a resistor is put in parallel with the series capacitor, a limit to the amount of voltage that can be dropped across the series capacitor is applied. Without the parallel resistor, continued reduction in frequency reaches a point where all of the voltage applied at the input is stopped by the series capacitor, and none of it reaches the output resistor. But placing a resistor in parallel with the capacitor provides an alternative path for current to reach the output resistor, and so the response levels off again.

If the value of this capacitor is reduced so as to make the whole response move up in frequency, the result is a high-frequency boost circuit, as shown in Fig. 4. This can be applied to a practical circuit by the arrangement shown in Fig. 5. Here the capacitor  $C1$  is the regular blocking capacitor needed to prevent the high plate voltage of the preceding stage from getting on to the grid of the following tube. This will be a relatively large capacitor giving its usual low frequency roll-off contribution (Fig. 3). The second capacitance  $C2$  is the one whose value is reduced so as to produce the rising response toward the high-frequency end, shown in Fig. 4.

### Resonance

So far, this discussion has been concerned with what single reactances can do

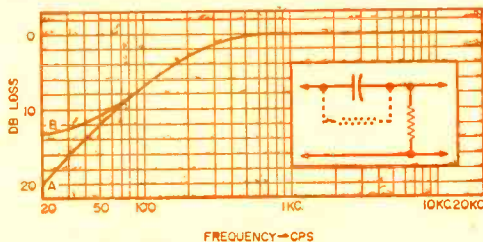

Fig. 3. A high-frequency boost can be produced from a low-frequency roll-off. Shown by curve "A" is the response when a series capacitor is inserted in a circuit without the shunt resistor. Curve "B" illustrates the response when the capacitor is shunted by a medium value resistor.

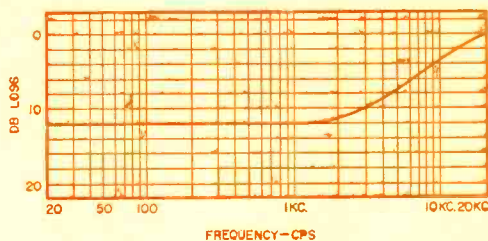

Fig. 4. Using a smaller value of capacitor in circuit of Fig. 3 will shift curve "B" and produce a good high-frequency boost.

by themselves—mostly the effect of capacitors. The final group of practical arrangements will concern cases where inductance and capacitance both appear in the same circuit to contribute to frequency response. This gets a little bit more complicated. Here, the hi-fi enthusiast must contend with an effect called *resonance*.

Going back to introductory radio theory, remember that a capacitor has the property of storing a voltage or charge while an inductor can be considered as storing a current. To cause the voltage across a capacitor to fluctuate requires passage of a current in and out of the capacitor. Similarly,

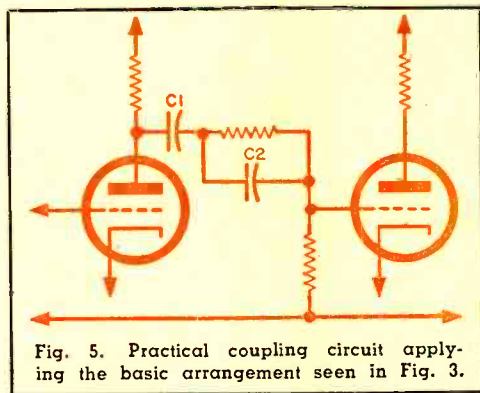
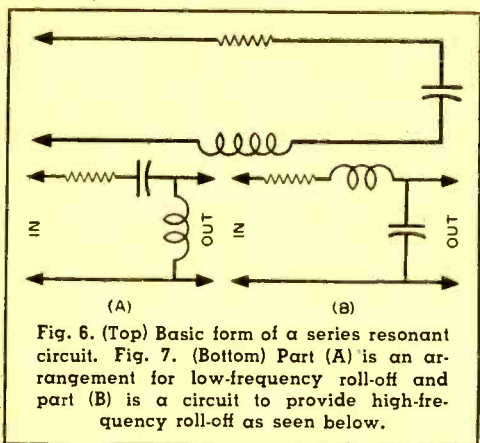

Fig. 5. Practical coupling circuit applying the basic arrangement seen in Fig. 3.

to cause the current in the inductor to fluctuate, a varying voltage has to be applied across it.

Now suppose the values of inductance and capacitance combined in the same circuit are such that, at the frequency of fluctuation which is being used, the relationship between voltage and current fluctuation for both elements happens to be the same. Then the voltage fluctuation generated by the change of current in the inductance, applied to the capacitor, will make the capacitor draw the right current variations through the inductance to continue producing the voltage fluctuations. A kind of vicious circle is set up in which each of the two quantities builds up the other quantity.



When this happens, the only limitation to the voltage and currents developed in the circuit is the resistance that may be in the circuit. Thus, considering the circuit of Fig. 6, at what is termed *resonance frequency*, the current through the resistance will be the same for the applied voltage as if the inductance and capacitance were not there. And the voltage across the inductance and capacitance will each be equal, but in the opposite phase or direction, and determined by the value of reactance of each component at this frequency.

In Fig. 7(A), the arrangement is such that either the capacitance by itself or the inductance by itself would produce a low-

frequency roll-off. But due to the fact that a resonance occurs, the inductance and capacitance can interact to produce a high-voltage peak on the output side. How high it is will depend upon the residue resistance in the circuit. If the resistance is high enough, there will be no peak but just a simple combined roll-off due to the effect of the two reactances acting together. At extremely low frequencies, all the voltage applied at the input will be dropped across the resistance and capacitance in series, and there will be no voltage developed across the inductance. Response shapes produced by this arrangement are shown in Fig. 8.

The arrangement of Fig. 7(B), consisting of a resistance feeding through a leakage inductance to a stray winding capacitance, will ultimately produce a high-frequency roll-off, due to the cumulative effect of leakage inductance and stray capacitance. But at some frequency the leakage inductance and stray capacitance will produce a resonance, and if the resistance in the circuit is low enough, this will produce a peak. Figure 9 shows a variety of response characteristics for different values of resistance in the circuit of Fig. 7(B).

This completes the discussion of the possible combinations of inductance and capacitance which contribute to frequency response. In a practical amplifier, of course, many capacitors and stray capacitances and a few inductances will contribute to the final over-all frequency response. -30-

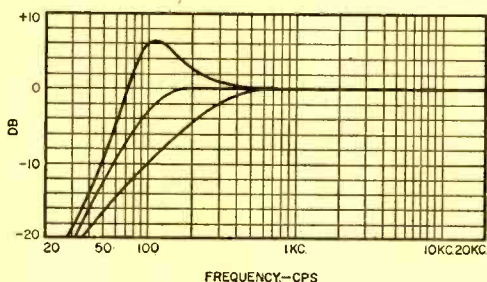

Fig. 8. This variety of responses may be obtained through the use of different component values in circuit shown in Fig. 7(A).

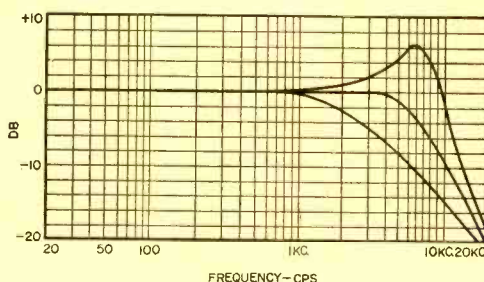
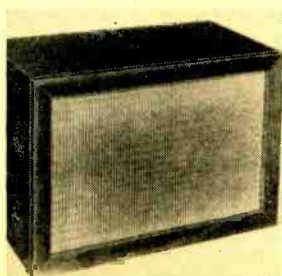

Fig. 9. High-frequency roll-off response curves resulting from different values used in the circuit diagrammed in Fig. 7(B).



## Economy 8" Enclosure in Kit Form

A SMALLER AND LOWER-PRICED version of the well-known *Karlson* speaker enclosure has been announced by *Karlson Associates, Inc.*, 1610 Neck Road, Brooklyn 29, N. Y. Known as the "Karlson 8," it is designed for 8" hi-fi speakers and may be placed on a bookshelf. This speaker enclosure is available in various forms, including an "assemble-it-yourself" kit at \$17.90 net, and a completely finished unit at \$49.50 net. Additional information, including a free booklet on the *Karlson* line, may be obtained from the manufacturer. -30-

Printed circuit techniques as utilized in this unit result in a preamp which is light in weight and very easy to build



**A**DDING a preamplifier to a hi-fi or radio amplifier is often complicated by lack of mounting space for the preamp. A neat way out of this difficulty is to use an etched circuit board mounted under the amplifier chassis.

An etched preamp can be made for the same cost as a standard chassis type and mounted practically anywhere. The circuit shown here is that of the well-known *G-E* preamp, which may be modified for any pickup or microphone by changing the value of the input shunt resistor *R1*.

Of course, a handmade board will not look as "pretty" as a commercial product since no photographic process is used, but it is just as functional. Once the steps to be described here have been completed, any other circuit can be laid out and etched with ease.

The circuit is etched onto a piece of phenolic laminated with .0028" copper foil on one side. There are a number of brands of laminate available, such as those manufactured by the *Synthane Corporation* and the *Continental-Diamond Fibre Company*.

# MAKING AN ETCHED PREAMP

Etching is done in a small glass or plastic dish which should be placed in a sink. Flush all excess etching solution down the drain with plenty of water when the etching process has been completed.

By H. J. CARTER

Consult the "plastics" section of the classified telephone directory for local distributors.

Order the laminate cut to the required size,  $4\frac{3}{4}'' \times 2\frac{1}{2}'' \times \frac{1}{16}''$ , and . . . if possible . . . have the supplier cut the  $\frac{3}{8}''$  socket hole shown on the guide line diagram. If preferable, the socket hole can be cut by clamping the board to a smooth piece of wood for backing and using a hole saw or flycutter; a hole punch would crack the phenolic. Be sure to start cutting from the copper foil side. All other holes are drilled after etching the board.

## Etching

The first step in making the etched board is to wash the copper surface to eliminate grease films. Use a kitchen cleanser and rinse in warm water. After the board is dry, cover the entire copper surface with strips of "Scotch" brand flat-back tape No. 255. Overlap the strips about  $\frac{1}{8}''$ , and rub with a spoon bowl to insure good adhesion and removal of air bubbles.

Next, trace the guide line diagram onto translucent paper. Cut a piece of carbon paper the same size as the board, and lay

the tracing over the carbon paper with the carbon surface next to the tape. Use some cellophane tape to hold the tracing and carbon paper in place.

Now go over the tracing with a sharp pencil to transfer the guide lines onto the tape. Remove the tracing and carbon paper and ink in the lines with India ink, using a "Speedball" pen No. B-3. The pen will make

heavy lines of correct width but the lines should be widened at each of the small circles, as shown in Fig. 2.

Next, cut the tape on the sides of the inked lines with a sharp knife such as an "X-acto" No. 16. Bear down to be sure of cutting through the tape. Remove the tape between ink lines, leaving the tape on those portions where the copper is to remain after etching. Trim and press down the edges of the tape remaining on the card. Before etching, check the card against Fig. 2 to be sure the pattern is correct.

The etching is done with ferric chloride, obtainable at any drug store. Three ounces dissolved in six ounces of water will be sufficient if a small glass or plastic dish deep enough to cover the board is used. *Caution:* do the etching in a sink. Handle the solution with the same precautions that would be taken with photographic chemicals or household ammonia.

Immerse the board tape-side-up in the etching solution. Wait a few minutes after bubbles cease to appear, and then slowly flood the dish with tap water to wash the solution away. When the wash water is clear, pick up the board and remove the tape resist. Rinse under running water and dry.

### Construction

Place the board on a hard surface and put a *small* center punch mark at each wide section of conductor, following the pattern in the guide line diagram. Drill a No. 54 drill hole at each punch mark, and drill the four corner mounting holes with a No. 25 drill. Compare with Fig. 2 before mounting the parts.

Prepare the parts for mounting by grasping them next to the body with small-nose pliers and bending their leads at right angles, keeping them in the same plane. Remove the mounting flange from the socket, insert the socket into the  $\frac{3}{4}$ " hole and bend the lugs until they are close to the conductors, as shown in the pictorial

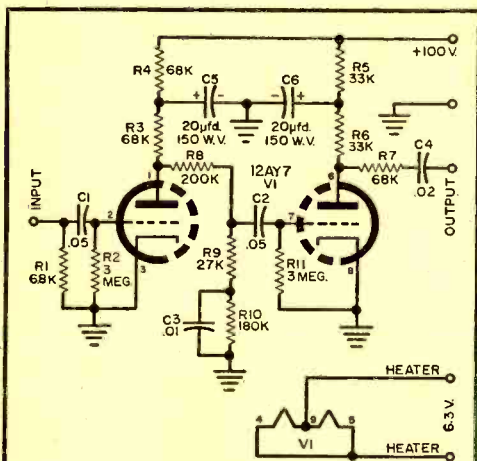

- C1, C2—0.05  $\mu$ d., 200 v. tubular capacitor
- C3—0.01  $\mu$ d., 200 v. tubular capacitor
- C4—0.02  $\mu$ d., 200 v. tubular capacitor
- C5, C6—20  $\mu$ d., 150 v. elec. capacitor
- R1—6800 ohm,  $\frac{1}{2}$  w. resistor (see text)
- R2, R11—3 megohm,  $\frac{1}{2}$  w. resistor
- R3, R4, R7—68,000 ohm,  $\frac{1}{2}$  w. resistor
- R5, R6—33,000 ohm,  $\frac{1}{2}$  w. resistor
- R8—200,000 ohm,  $\frac{1}{2}$  w. resistor
- R9—27,000 ohm,  $\frac{1}{2}$  w. resistor
- R10—180,000 ohm,  $\frac{1}{2}$  w. resistor
- V1—12AY7 tube
- 1— $4\frac{3}{4}$ " x  $2\frac{1}{2}$ " x  $1\frac{1}{16}$ " piece of copper-clad laminate
- 3 oz.—Ferric chloride crystals or powder
- 1—9-pin socket (Cinch-Jones, 9EB)
- 1—Roll Scotch tape (No. 255) 1" wide

Catalog price of parts, approx. \$8.00

Fig. 1. Schematic diagram and parts list

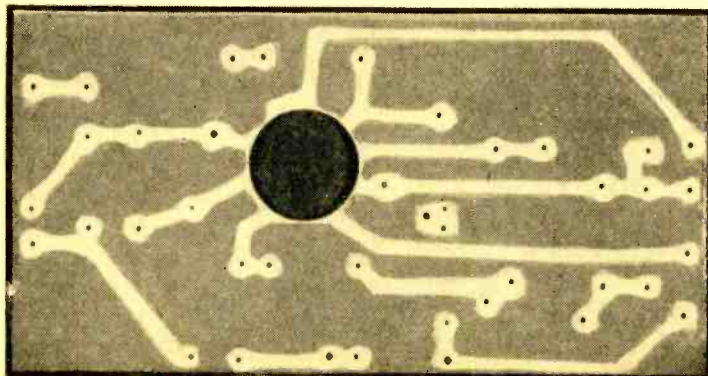

Fig. 2. The etched board, drilled and cleaned, and ready for mounting socket and component parts. Mounting holes for the electrolytic capacitors may have to be enlarged somewhat.



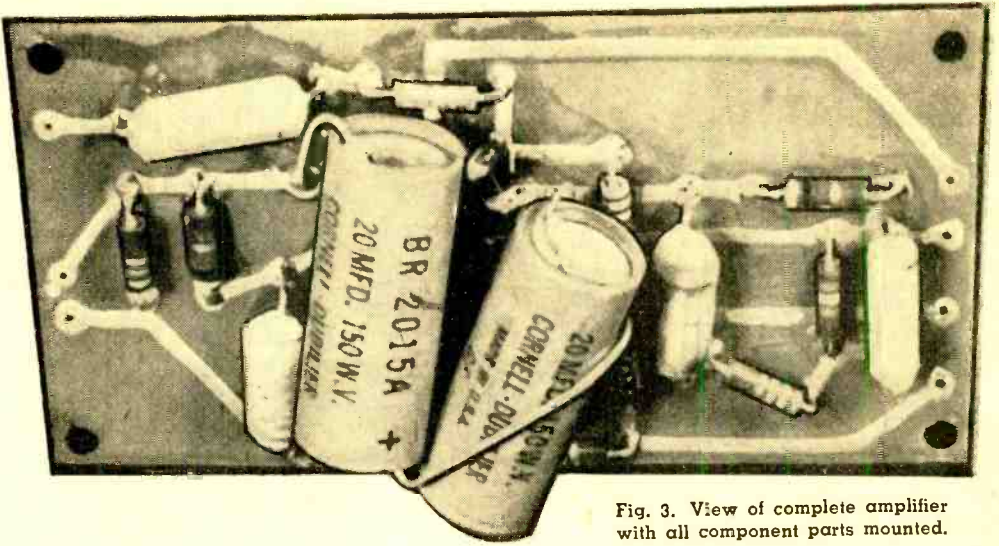

Fig. 3. View of complete amplifier with all component parts mounted.

drawing. Rotate the socket to the correct position and solder into place. Solder a small bare wire strap across the socket to connect pins 3 and 8 if both external ground terminals are not grounded at the same place on the chassis.

Install all the resistors and capacitors except *C5* and *C6*, bending their leads behind the board to hold them in place. After soldering the leads to the conductors with rosin-core solder and a small pencil iron, clip the protruding leads flush with the card back. Finish the assembly by soldering *C5* and *C6* into place.

Resistor *R1* is shown as 6800 ohms, the correct value for the *G.E.* pickup. This re-

sistor can be easily changed to the value recommended for any other pickup. Power requirements for the preamp are very modest. The *B+* voltage should be in the neighborhood of 100 volts, and the current drain is less than 1 ma. For the 12AY7 heater, 6.3 volts at 0.3 amp. or 12.6 volts at 0.15 amp. is necessary. Socket is shown wired for a 6.3-volt supply. Power can usually be obtained from the main amplifier without danger of overload.

Mount the board on insulating standoffs with 6-32 screws, and connect the power terminals to the amplifier power supply. The pickup shield should be grounded at the input ground conductor terminal. -30-

Fig. 4. This pictorial diagram shows the exact size of the mounting board, and may be used as a guide line diagram. Components are not drawn to scale.

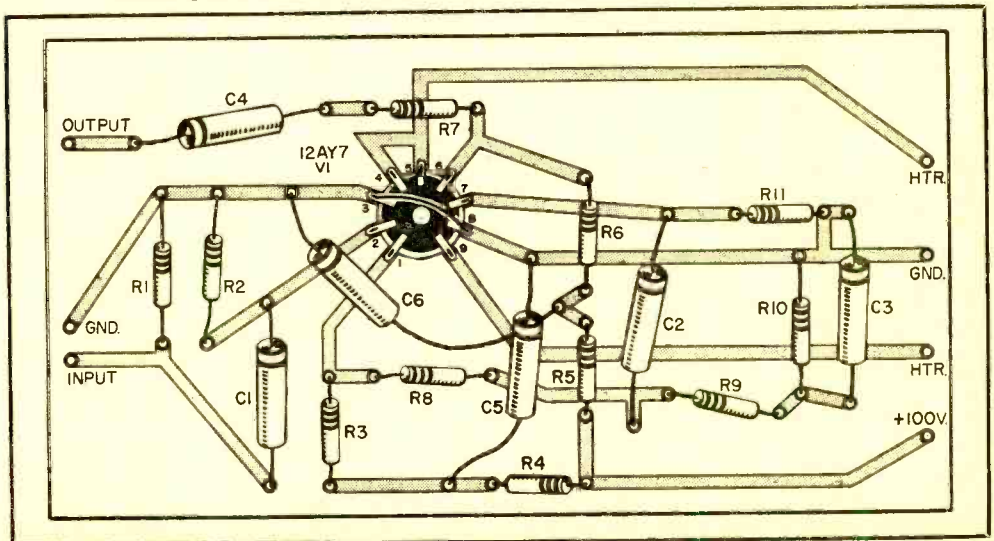

# T A P E

## PLAYBACK and ERASURE

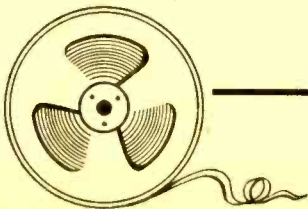

**T**HE previous article in this series (October issue) discussed the recording of sound on magnetic tape. How tape is played back and how recordings are erased, so that tape can be reused, are explained in this article.

A typical setup for playing back magnetic tape recordings is shown in the block diagram of Fig. 1. At the far left is the *playback head*. In many home-type recorders, as well as a few professional machines, this is usually the same unit as the *record head*, simply reconnected and electronically frequency-compensated. The switching of circuits that changes the magnetic head from "record" to "playback" is performed when the playback switch is operated by the user.

### How Playback Is Accomplished

During playback, the magnetic field that was previously recorded on the tape is moved past the gap in the head. This action induces a fluctuating current through the coil surrounding the head. The current will vary in frequency and intensity in direct proportion to the variations present in the recorded material on the tape's surface. Connected to a load of suitable resistance, this current develops a voltage that varies in accordance with the taped sound.

Electrical impulses which come from the playback head are extremely weak, and must be greatly amplified before they can be used to produce audible sounds. The electronic section following the playback head is a high-gain preamplifier. Depending on the original design of the playback head, the preamplifier section may contain one or more stages of amplification; two usually suffice.

After preamplification, the signals are put through a frequency equalizer circuit. The equalizer is fixed in its values and non-variable in its effects, which were carefully selected and determined for the particular equipment in which it is installed.

The purpose of the equalizer is to complement the frequency amplitude relationship inserted during the recording process. Also, the equalizer is usually provided with some constants to compensate for the frequency response characteristics and sensitivity of the head itself. The object of all this equalizing and compensating is to get as close to an over-all "flat response,"

## For the tape hobbyist: a simplified—but complete—explanation of two very important functions performed by the tape recorder

consistent with minimum distortion, as is technically and practically possible. Since the magnetic tape goes through two distinctly separate steps—record and playback—and since most magnetic tapes are played back on the same machine on which they are recorded, the goal is to have the played-back tape respond exactly like the sound originally fed to the machine while it was recording. In other words, flat-response input should result in flat-response output, a requirement for high fidelity.

In accomplishing its important effects, the equalizer-compensator circuitry causes considerable loss in signal voltages. Therefore, immediately following this circuitry there is an additional stage of amplification. Because the word "preamplifier" is only applied to the amplifier stage at the very beginning of a setup, this next amplifying section is often referred to as an "intermediate amplifier." Its purpose is to step up the small voltages which come from the equalizer-compensator to a value large enough to drive the final amplifying stage, the "power amplifier." This final stage actuates the loudspeaker.

### Single-Chassis Switching

It may be seen that the electronic stages of tape playback duplicate some that are used during the recording process. Because of this duplication, many recorders do not have distinctly different circuits for record and playback. They combine record and playback on the same chassis, with the same circuits doubling in brass for more than one function. The more expensive tape recording equipment utilizes separate record and playback heads and circuits, enabling manufacturers to design each unit for one specific job and for optimum performance without compromise.

In recorders which combine record and

playback functions in one circuit, ingenious switching arrangements handle the necessary changes in circuitry and parts values. The block diagram of Fig. 2 shows how record and playback may be combined on the same chassis, and how the basic switching is accomplished.

During the recording process, signals from the microphone are fed to the preamplifier, into the record equalizer-compensator, then to the intermediate amplifier, and finally to the record head. At the same time, the "bias-erase oscillator" supplies its a.c. bias voltage to the record head. Simultaneously, an erase voltage is supplied to the *erase head*. The tape being recorded passes in front of the erase head before it is permitted to pass by the record head. This assures that a completely "clean" surface is available for recording.

During playback (switches in Fig. 2 are shown in this position), signals from the playback head are fed to the preamplifier, the playback equalizer-compensator, the intermediate amplifier, the power amplifier, and the loudspeaker. The bias-erase oscillator does not function during playback.

The basic method of erasing is to "flood" the tape with a strong magnetic field, magnetizing the tape to saturation and completely disarranging the magnetic field of the iron particles on the tape's surface. Some recorders use permanent magnets to produce the saturating magnetic field. This is called "d.c. erase." The magnetic tape to be erased is transported in actual physical contact with the magnet material, "wiping" across it so to speak, obtaining maximum effective use of the magnetic field.

### "A.C. Erase" Method

Somewhat more complex is "a.c. erase." In this method, the tape is passed across the gap in the erase head. This unit, while

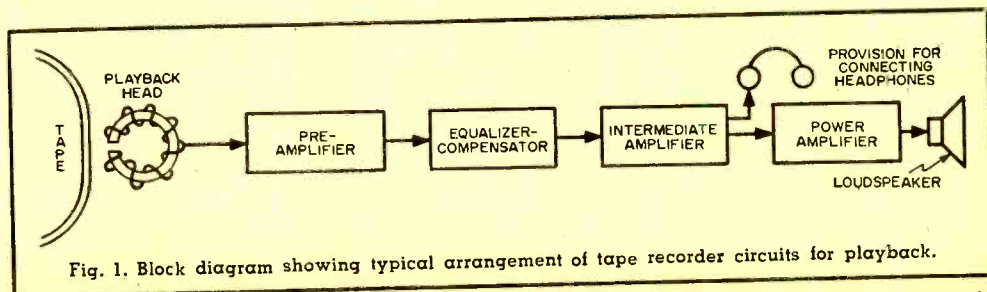

Fig. 1. Block diagram showing typical arrangement of tape recorder circuits for playback.

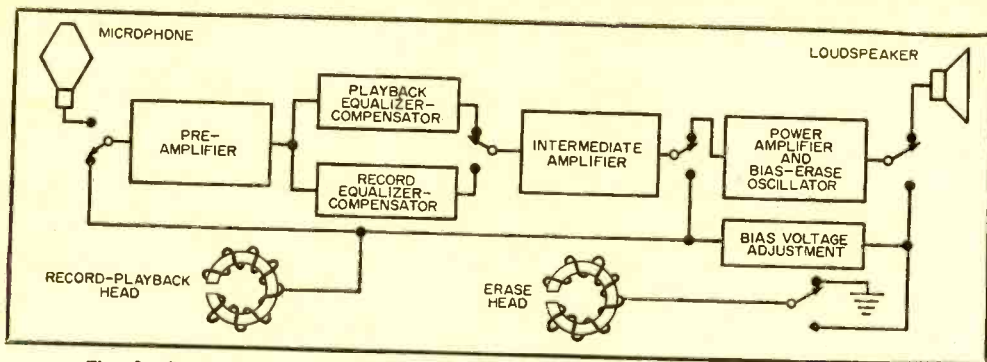

Fig. 2. Single-chassis switching is illustrated in this block diagram of a complete tape recorder. All switches are shown in playback position. Many recorders use separate circuits for power amplifier and bias-erase oscillator. For simplicity of explanation, however, the unit shown here combines these two functions in one stage.



Complete erasure in a matter of minutes is provided by commercial "bulk erasers" such as those shown here. See text for details.



closely resembling the appearance of the other heads, handles considerably stronger currents and generates heavier fields. Therefore, its gap is considerably wider, and its winding is made of much heavier wire. Power is supplied to the erase head by the bias-erase oscillator. This circuit supplies a.c. at an ultrasonic frequency.

The majority of home-type recorders employ "a.c. erase." All high-fidelity units use it, too. Some small-size, portable, professional tape-recording equipment employs d.c. erase with permanent magnets mechanically rotated into contact with the tape for erase action. This is done to reduce weight and cost of parts. Broadly speaking, "a.c. erase" is the preferred method, especially where quality of sound during the recording process is important.

Sometimes a heavily over-recorded tape will not erase completely after being run through the erase action. Usually, running the tape through the erase action once again, or even a third time, will result in a clean erase. Incidentally, it is the practice to design magnetic tape recorders so that the erase section is turned on automatically when the record switch is actuated, because the erase power generator also supplies the bias for the record head.

There is another technique for erasing heavily over-recorded magnetic tapes which utilizes a *bulk eraser*. This is a large magnet connected to the a.c. power line. It is quite convenient to use and requires no "threading." In one type, the entire reel of magnetic tape is simply laid flat on the bulk eraser and slowly turned round and round. Then the tape is slowly lifted off and away. Another type of bulk eraser is shaped much like the lid of a pot, with a handle and a hollow underside. In operation, it is placed over the reel of tape and rotated while the reel remains stationary.

(Continued on page 129)

# This book is a Gold Mine Send for it Immediately!

**FREE**

**REVEALS HOW YOU CAN GAIN QUICKER SUCCESS  
OR TURN YOUR HOBBY INTO A WELL-PAID CAREER  
IN RADIO . . . TELEVISION . . . ELECTRONICS**

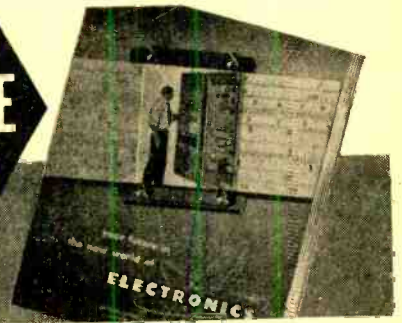

Whether you're an amateur . . . a hobbyist . . . or already in electronics, let us show you how to have a bright career in

## RADIO! TELEVISION! ELECTRONICS!

### TURN YOUR HOBBY INTO A HIGH-PAY CAREER!

Today thousands of electronics hobbyists have an opportunity to turn their hobby into profits. It's the "Age of Electronics!" Trained men are in crucial demand! You may be "outside" the electronics industries now, working on a job you enjoy far less than experimenting, building, transmitting, receiving; working for less money than is being paid to electronics engineering technicians. But your "true love" is electronics. Why not awaken to your opportunities—now?

### ELECTRONICS IS SCREAMING FOR MEN LIKE YOU!

Here are just three of the high-level opportunities available from coast to coast:

"Openings will occur in the GS-10 grade, starting salary \$5500 per year, for men who can qualify for the servicing of 35mm motion picture sound and projection equipment. Although some previous experience in this field is desirable, it is not essential if the individual has sufficient training in radio . . ."—Departments of the Army and Air Force.

"Just about four months have passed since I made my first recruiting trip to CREI. As a result of that visit Messrs. Kohs, Plante and Wenger are now members of the Laboratories and Mr. Kresge soon will be . . . we have some openings now and will have others . . ."—Bell Telephone Laboratories, Murray Hill, N. J.

"Two openings in our Field Service . . . aircraft electronics . . . starting salary is \$330 and up . . ."—North American Aviation, Inc., Columbus, O.

### ACQUIRE NECESSARY TRAINING AT HOME

Use spare-time hobby hours for CREI Home Study as thousands of successful technicians have since 1927. Get concentrated training in minimum time, then step into a good job and enjoy good pay in the mushrooming electronics industry.

### COUNTLESS POSITIONS MUST BE FILLED

And only trained men can fill them. You can get your share, if you take time now to gain that indispensable knowledge.

### ALL YOU NEED IS ADVANCED TECHNICAL TRAINING

Sure you have some experience. But the fellows with only partial technical knowledge move slowly, or stand still, while you—the man with advanced technical training—plunge ahead in the golden world of electronics opportunities.

### SEND FOR FREE BOOKLET, IT TELLS YOU HOW

How to gain career success in the tremendous electronics industries. It pinpoints opportunities which exist. By 1960, the electronics industries will do no less than \$10 billion worth of business per year, not counting military orders. Take TV for example: There are about 34,000,000 TV sets and 411 TV stations on the air. Color TV is pushing ahead furiously. There is but one field of maximum opportunity in this electronic age.

### CREI TRAINS YOU IN MINIMUM TIME AT HOME

Thousands of men before you have benefited quickly from CREI Home Study training. Thousands of CREI graduates are now employed in industry here and abroad. Here is what they say:

"In this time of less than two years, I have almost doubled my salary and have gone from wireman, to engineering assistant and now to junior engineer. I have CREI to thank."—Frank A. Eckert, 22 Clover Lane, Levittown, Pa.

### Famous for 28 YEARS

CREI is known and respected throughout the Electronic world. Since 1927, we have trained thousands in the military, industry and government.  
**"ASK ANY ENGINEER."**

**VETERAN?** If discharged after June 27, 1950, let new Korean GI Bill of Rights help you get resident instruction. Check coupon for full data.

### LIKE TO STUDY IN WASHINGTON?

CREI also offers resident instruction at same high level day or night. Classes start often. Check coupon for Residence School catalog. Qualified residence graduates earn degree: "Associate in Applied Science."

## MAIL THIS COUPON . . . TODAY!

To help us answer your request intelligently, please give the following information:

EMPLOYED BY . . . . .

TYPE OF PRESENT WORK . . . . .

SCHOOL BACKGROUND . . . . .

ELECTRONICS EXPERIENCE . . . . .

IN WHAT BRANCH OF ELECTRONICS ARE YOU MOST INTERESTED? . . . . .

**CAPITOL RADIO ENGINEERING INSTITUTE**  
Accredited Technical Institute Curricula—Founded in 1927  
3224 16th St., N. W., Dept. 1211B, Washington 10, D. C.  
Send booklet "Your Future in the New World of Electronics" and course outline.

CHECK FIELD OF GREATEST INTEREST

- Practical Television Engineering
- Broadcast Radio Engineering (AM, FM, TV)
- Practical Electronic, Radio Engineering
- Aeronautical Electronic Engineering

Name . . . . .

Street . . . . .

City . . . . . Zone . . . . . State . . . . .

Check:  Home Study  Residence School  Korean War Veteran



## Professional Features in New Preamplifier Control Unit

FEATURES NORMALLY FOUND in professional studio consoles have been built into the Fisher 80-C "Master Audio Control," a complete "front end" for home hi-fi systems.

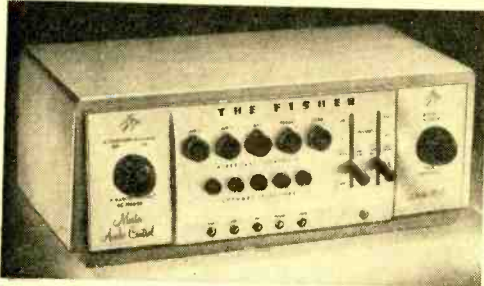

Besides serving as a preamplifier-equalizer for any type of input signal, the 80-C provides mixing and fading facilities for two to five channels, tape recorder input to operate directly from the tape playback head, 16 combinations of phonograph equalization, push-button channel selectors which—in addition to selecting the audio input signals—also operate the a.c. power to auxiliary equipment, and individual channel indicator pilot lights.

Separate equalization and amplification directly from the tape playback head is featured in what appears to be an innovation in preamps intended for home use. Seven input receptacles are provided, and a high-gain microphone preamplifier is wired into the circuit. A switch is provided that changes the conventional volume control to an accurately calibrated loudness control, conforming to the Fletcher-Munson curves. Independent bass and treble controls of the variable-crossover feedback type are included. Two cathode-follower outputs enable the 80-C to be remotely located with respect to the power amplifier, and the rest of the h-fi installation.

Completely self-powered, the 80-C contains two separate selenium rectifier circuits; one furnishes B+, the other provides d.c. for tube heaters. Hum, intermodulation and harmonic distortion have been reported as unmeasurable, while a uniform response of 10 to 100,000 cycles is claimed by the manufacturer. Net price is \$99.50. For additional information, write to *Fisher Radio Corp.*, 21-21 44th Drive, Dept. P, Long Island City 1, N. Y. —30—

## Low-Cost Cabinets House Hi-Fi Equipment

A NEW LINE of "Cabinart" custom accessories for the hi-fi enthusiast has been introduced by *G & H Wood Products Co., Inc.*, 99 North 11th St., Brooklyn 11, N. Y. Included are cabinets and speaker enclosures of various types, the Klipsh-designed "Rebel" series of horn-type enclosures, and a ten-unit hi-fi storage wall for equipment and accessories.

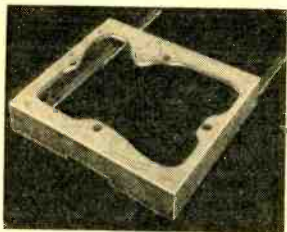

The units are designed to suit the re-

quirements of any type of home installation, using any combination of components. Design and variety of available units are calculated to provide the home listener with the utmost in flexibility and versatility in laying out a hi-fi system, as well as in providing for future expansion. Items may be purchased in various stages of assembly, from "do-it-yourself" kits to factory-finished furniture.

Among the newest items is a box for mounting a record changer. Pre-cut and assembled, this box features a set of slide drawers for quick installation. Another unit offers suitable mounting facilities for a professional turntable and tone arm. Record storage units, table bases, and equipment cabinets are also available.

The 10' storage wall is designed as a complete home entertainment center, with adequate housing for tuner, amplifiers, phono and tape equipment, full-sized speaker enclosure, and ample storage area for records, tapes, books, and accessories. The wall may be purchased complete, or in the form of separate units to be arranged as the user requires.

Additional information on these items may be obtained by writing to the manufacturer. —30—

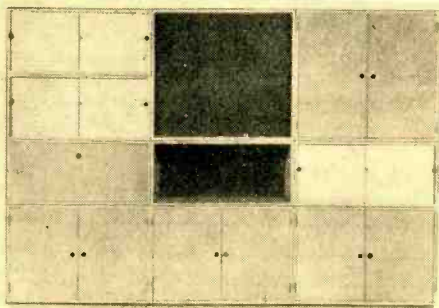

Here is the  
tape  
recorder  
that  
"couldn't be  
made"...

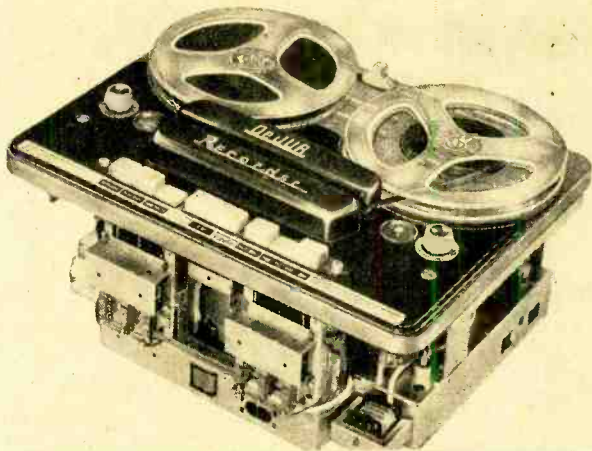

What a serious high fidelity enthusiast wants in a tape recorder has never been a mystery. He wants a recorder which, at  $7\frac{1}{2}$  ips will equal or exceed professional performance at 15 ips — and at a price comparable to the price of the usual garden variety of "home recorder". In other words, he wants flat response over the entire audio range, undetectable noise, hum, wow and flutter and professional NARTB equalization—at  $7\frac{1}{2}$  ips (to give up to 90 minutes of playing time on a 7" reel at a cost lower than one good LP record) — and all for less than \$300.

Now, DeJUR, a great name in high-quality precision cameras, answers the demands of the HiFi enthusiast in every particular. For the first time in America, he can have a tape recorder meeting his most exacting performance requirements for a fraction of the price he would normally expect to pay. Compare it in an A-B test with the most expensive professional recorder your high-fidelity outlet carries. We're that sure you won't be able to tell the difference!

Now, let's get down to specifications. They have been checked by an independent engineering firm and confirmed by the testing laboratories of America's largest high fidelity distributors.

**FREQUENCY RESPONSE** At  $7\frac{1}{2}$  ips, the frequency response is 40 cps to 16,000 cps  $\pm 2$  db (the closest comparable machine is 1,000 cps less and \$100 more!) Even at  $3\frac{3}{4}$  ips, the DeJUR Dual Professional is flat from 50 cps to 10,000 cps  $\pm 2$  db.

**SIGNAL-TO-NOISE RATIO** Noise is down 55 db (that equals or exceeds the figure for recorders priced at \$600 and up!)

**FLUTTER AND WOW** The DeJUR Dual Professional uses a heavy-duty genuine hysteresis dual-speed, synchronous motor, the same type of motor used in \$1,000 studio recorders (even the better "home recorders" use only 4-pole motors!) A hysteresis motor is independent of line voltage fluctuations, thus eliminating a major source of wow and flutter. Both are held to 0.1% at  $7\frac{1}{2}$  ips, 0.2% at  $3\frac{3}{4}$  ips (the competitive recorder closest in performance has 0.25% at  $7\frac{1}{2}$  ips and costs \$100 more!)

**EQUALIZATION** Professional NARTB equalization is used throughout the DeJUR Dual Professional. This means that, not only can you make and play back tapes of perfect fidelity, but you can also play commercial pre-recorded tapes the way they were meant to be played.

**INSTANT TRACK SWITCHING** Four separate heads are employed in the Dual Professional—an erase head and a record-playback head for each track. When you reach the end of a reel on the first track, you simply press a button and the tape reverses its motion recording or playing back the second track! Anyone who has fussed and fumed as he tried to

change reels in the middle of a symphony will greet this feature with cheers!

**ELECTROMAGNETIC DYNAMIC BRAKING** In the DeJUR Dual Professional, there are no mechanical clutches, belts and pulleys to get out of order. The dual speed hysteresis motor is reversible and electromagnetic dynamic braking is employed for instantaneous stops and starts without tape strain or stress.

**ILLUMINATED TAPE COUNTER** An illuminated, clock-like dial indicates elapsed footage so accurately that the tape can be indexed to a single note!

**AUTOMATIC STOP** Inexpensive DeJUR aluminum foil leaders are available which automatically stop tape motion in either direction! There's no need to re-thread — no flopping tape ends.

**PUSH-BUTTON KEYBOARD** A piano key switchboard controls all recording and playback functions through relays. Even your wife can operate the DeJUR Dual Professional without an instruction manual!

**OTHER EXCEPTIONAL FEATURES** Instantaneous stopping in record or playback, less than  $\frac{1}{4}$ " in fast wind; 2 high impedance and 1 low impedance inputs controlled by selector switch, rewind time of 90 seconds for 1200-foot reel in either direction, foam rubber pressure rollers, relay operated and triple-fused for protection against improper operation, 105-220 volt, 60 cycle AC operation.

And the price? That's the biggest surprise of all! The DeJUR Dual Professional Tapedeck, is only \$299.50 audiophile net.

Also available in a handsome, scuff-proof carrying case complete with built-in 6-watt power amplifier, 2 electrostatic speakers, 3 PM speakers and wide-range cardioid dynamic microphone for only \$379.50 audiophile net.

**AVAILABLE ACCESSORIES** Remote control foot switch \$19.50. DeJUR wide-range cardioid microphone \$29.50.

WRITE FOR COMPLETE SPECIFICATIONS...

DeJUR-AMSCO CORPORATION

Dept. PE-1, Long Island City 11, N. Y.

NOTHING COMPARES WITH A

**DeJUR**   
*Dual Professional*  
TAPE RECORDER

# Build YOUR OWN HEATHKITS

INTERESTING—EDUCATIONAL



work has already been done for you. No cutting, drilling, or painting required. All parts furnished including tubes. Knowledge of electronics, circuits, etc., not required to successfully build Heathkits.

Heathkits are fun to build with the simplified easy-to-follow Construction Manual furnished with every kit. Only basic tools are required, such as soldering iron, long-nosed pliers, diagonal cutting pliers, and screwdriver. All sheet metal

New charcoal gray baked enamel panel with highly readable white lettering.

## New PRINTED CIRCUIT VACUUM TUBE VOLTMETER KIT

The VTVM is the standard basic voltage measuring instrument for radio and TV servicemen, engineers, laboratory technicians, experimenters, and hobbyists. Because of its extremely high input resistance (11 megohms) the loading effect on the circuit being measured, is virtually negligible. The entire instrument is easy to build from a complete kit, with a detailed step-by-step Construction Manual. Featured in this instrument is an easy-to-wire fool-proof printed circuit board which cuts assembly time in half.

**CIRCUIT AND RANGES:** Full wave AC input rectifier permits 7 peak-to-peak voltage ranges with upper limits of 4000 volts peak-to-peak. Just the ticket for you TV servicemen. Seven voltage ranges, 1.5, 5, 15, 50, 150, 500 and 1500 volts DC and AC RMS. Peak-to-peak ranges 4, 14, 40, 140, 400, 1400, and 4000 volts. Ohmmeter ranges X1, X10, X100, X1000, X10K, X100K, X1 meg. Additional features are a db scale, center scale zero position, and a polarity reversal switch.

**IMPORTANT DESIGN FEATURES:** Transformer operated—1% precision resistors—6AL5 and 12AU7 tubes—selenium power rectifier—individual AC and DC calibrations smoother improved zero adjust control action—new panel styling and color—new placement of pilot light—new positive contact battery mounting—new knobs—test leads included. Easily the best buy in kit instruments.

New peak-to-peak meter scale—new color calibration—new control knobs.

New printed circuit board for faster, easier construction—exact duplication of Laboratory development model.

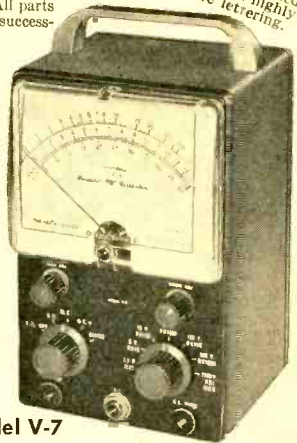

Model V-7

**\$24.50**

Shpg. Wt. 7 lbs.

New easy-to-read open panel layout. Off-on switch incorporated in selector switch.

## Heathkit HANDITESTER KIT



MODEL M-1  
**\$14.50**

Shpg. Wt. 3 lbs.

The Heathkit Model M-1 Handitester readily fulfills all requirements for a compact, portable volt-ohm-milliammeter. Its small size permits the instrument to be tucked into your coat pocket, tool box or glove compartment of your car. Always the "handitester" for those simple repair jobs. Packed with every desirable feature required in an instrument of this type. AC or DC voltage ranges, full scale 10, 30, 300, 1000 and 5000 volts. Ohmmeter ranges 0-3000 ohms and 0-300,000 ohms. DC milliammeter ranges 0-10 milliamperes and 0-100 milliamperes. Uses 400 microampere meter—1% precision resistors—hearing aid type ohms adjust control—high quality Bradley rectifier. Test leads are included.

## Heathkit MULTIMETER KIT



MODEL MM-1

**\$29.50** Shpg. Wt. 6 lbs.

Here is an instrument packed with every desirable service feature and all of the measurement ranges you need or want. High sensitivity 20,000 ohms per volt DC, 5000 ohms per volt AC. Has the advantage of complete portability through freedom from AC line—provides service ranges of direct current measurements from 150 microamperes up to 15 amperes—can be safely operated in RF fields without impairing accuracy of measurement.

Full scale AC and DC voltage ranges of 1.5, 5, 50, 150, 500, 1500, and 5000 volts. Direct current ranges are 150 microamperes, 15, 150, and 500 milliamperes and 15 amperes. Resistances are measured from .2 ohms to 20 megohms in three ranges and db range from -10 to +65 db. Ohmmeter batteries and necessary test leads are furnished with the kit.

# HEATH COMPANY

A SUBSIDIARY OF DAYSTROM, INC.  
BENTON HARBOR 10, MICHIGAN



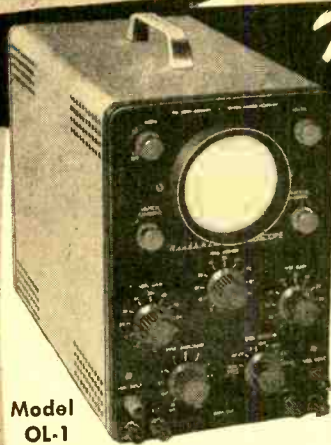

**New** *Heathkit*  
PRINTED  
CIRCUIT  
**3" OSCILLOSCOPE KIT**

Ideal for individual home work, ham shack, or as extra instrument for outside servicing.

Compact size, light weight, portable — perfect for service work or held operation.

New, modern styling, gray lettering, light gray knobs and case — contrasting red and black terminal posts.

New printed circuit for constant performance, rugged component mounting — assembly time cut in half!

**USE:** This brand new Utility Scope was designed especially for servicemen and radio amateurs, and is adaptable for use in all general Scope applications. Perfect for modulation monitoring, etc. Use it to tackle alignment or adjustment problems. Equally valuable in breadboard work. A must for ham shack or for outside servicing.

**DESCRIPTION:** Front panel controls of the Model OL-1 are "bench tested" for ease of operation and convenience. Sharp focusing 3" CRT. Printed circuit for ease of assembly and constant performance. Assembly time cut in half! High quality electronic components used. Sensitive hor. and vert. amplifiers with broad freq. response; cathode follower for isolation. Push-pull hor. and vert. output to deflection plates. Int. 60 cycle, or ext. sync. Sweep freq. range 10-100,000 cycles. Direct connection to deflection plates. Provision for Z axis input. Uses 3G11 CRT, 4-12A7 hor. and vert. amplifiers, 1-12AX7 sweep gen., 1-6X4 LV rect., and 1-1V2 HV rect. The Heathkit Model OL-1 is a real standout value at only \$29.50, and is another example of the famous Heathkit combination: quality plus economy.

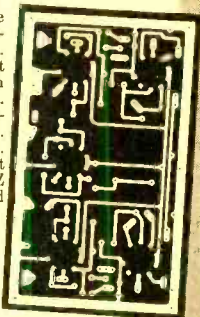

Model  
OL-1

**\$29.50**

Shpg. Wt.  
15 lbs.

Measures only 11 3/4" x 6 3/4" x 19 1/2" and weighs only 11 pounds.

*Heathkit*  
**SIGNAL GENERATOR KIT**

**USE:** This instrument is "serviceman engineered" to fill the requirement for a reliable basic service instrument at moderate cost. Frequency coverage extends in five bands from 160 Kc to 110 Mc on fundamentals, and dial is calibrated to 220 Mc for harmonics. Pre-wound and pre-aligned coils make calibration unnecessary for service applications.

**DESCRIPTION:** The Heathkit Model SG-8 Signal Generator provides a stable modulated or unmodulated RF output of at least 100,000 microvolts which can be controlled by both a continuously variable and a fixed step attenuator. Internal modulation is at 400 cycles, or can be externally modulated. AF output of 2-3 volts is also available for audio testing. Uses dual purpose 12AU7 as Colpitts RF oscillator and cathode follower for stable, isolated, low impedance output, and type 6C4 tube for 400 cycle oscillator. Operation of the SG-8 is well within the frequency limits normally required for service work. Modern styling features high definition white letters on charcoal gray panel with re-designed control knobs. Modern professional appearance and Heathkit engineering know-how combine to place this instrument in the "best buy" category. Only \$19.50 complete.

New, modern panel and knob styling — professional appearance and professional performance.

Broad frequency coverage — fundamentals from 160 KC to 110 MC in 5 bands — up to 220 MC on calibrated harmonics.

Cathode follower output for good isolation — fixed step and continuously variable attenuation.



Output selection — internal modulation, pure r.f., or audio output.

MODEL SG-8 **\$19.50**

Shpg. Wt.  
8 lbs.

*Heathkit*  
**ANTENNA IMPEDANCE METER KIT**



MODEL  
AM-1

**\$14.50** Shpg. Wt.  
2 lbs.

The Model AM-1 Antenna Impedance Meter makes an ideal companion unit for the GD-1B Grid Dip Meter or a valuable instrument in its own right. Perfect for checking antenna and receiver impedance and match for optimum system operation. Use on transmission lines, halfwave, folded dipole, or beam antennas. Will double as monitor or relative field strength meter. Covers freq. range of 0-150 Mc and impedance range of 0-600 ohms. Uses 100 microampere meter and special calibrated potentiometer. A real buy at only \$14.50 complete.

*Heathkit*  
**GRID DIP METER KIT**



MODEL  
GD-1B

**\$19.50** Shpg. Wt.  
4 lbs.

Amateurs and servicemen have proven the value of this grid dip meter many times over. Indispensable for locating parasitics, neutralizing, and aligning filters and traps in TV or Radio and for interference problems. The Model GD-1B covers from 2 Mc to 250 Mc with 5 pre-wound coils. Featuring a sensitive 500 microampere meter and phone jack, the GD-1B uses a 6AF4 or 6T4 tube. An essential tool for the ham or serviceman.

**ACCESSORIES:** Low freq. coverage to 355 KC with two extra coils and calibration curve, Set No. 341A for GD-1B and set No. 341 for GD-1A. Shipping weight 1 lb. Only \$3.00.

**HEATH COMPANY**  
A SUBSIDIARY OF DAYSTROM, INC.  
**BENTON HARBOR 10, MICHIGAN**

# New Heathkit VFO KIT



**MODEL VF-1**  
**\$19.50**

Ship. Wt. 7 lbs.

- Smooth acting illuminated and precalibrated dial.
- 6AU6 electron coupled Clapp oscillator and OA2 voltage regulator.
- 7 Band coverage, 160 through 10 meters—10 Volt RF output.
- Copper plated chassis—aluminum cabinet—easy to build—direct keying.

Here is the new Heathkit VFO you have been waiting for. The perfect companion to the Heathkit Model AT-1 Transmitter. It has sufficient output to drive any multi-stage transmitter of modern design. A terrific combination of outstanding features at a low kit price. Good mechanical

and electrical design insures operating stability. Coils are wound on heavy duty ceramic forms, using Litz or double cellulose wire coated with polystyrene cement. Variable capacitor is of differential type construction, especially designed for maximum bandspread and features ceramic insulation and double bearings.

This kit is furnished with a carefully precalibrated dial which provides well over two feet of calibrated dial scale. Smooth acting vernier reduction drive insures easy tuning and zero beating. Power requirements 6.3 volts AC at .45 amperes and 250 volts DC at 15 mills. Just plug it into the power receptacle provided on the rear of the AT-1 Transmitter Kit. The VFO coaxial output cable terminates in plastic plug to fit standard 1/4" crystal holder. Construction is simple and wiring is easy.

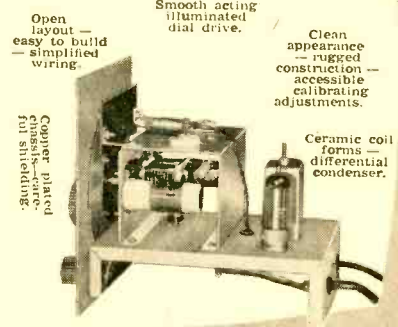

Open layout — easy to build — simplified wiring.

Smooth acting illuminated dial drive.

Clean appearance — rugged construction — accessible calibrating adjustments.

Copper plated chassis for shielding.

Ceramic coil forms — metered differential condenser.

# Heathkit AMATEUR TRANSMITTER KIT



**MODEL AT-1**  
**\$29.50**

Ship. Wt. 16 lbs.

- SPECIFICATIONS:**
- Range 80, 40, 20, 15, 11, 10 meters.
  - 6AG7 ..... Oscillator-multiplier.
  - 6L6 ..... Amplifier-doubler.
6U4G ..... Rectifier.
  - 105-125 Volt A.C. 50-60 cycles 100 watts. Size: 8 1/4 inch high x 13 1/4 inch wide x 7 inch deep.

Crystal or VFO excitation.

Here is a major Heathkit addition to the Ham radio field, the AT-1 Transmitter Kit, incorporating many desirable design features at the lowest possible dollar-per-watts price. Panel mounted crystal socket, stand-by switch, key click filter, A. C. line filtering, good shielding, etc. VFO or crystal excitation—up to 35 watts input. Built-in power supply provides 425 volts at 100 MA. Amazingly low kit price includes all circuit components, tubes, cabinet, punched chassis, and detailed construction manual.

Rugged, clean construction.

Prewound coils — metered operation.

Single knob band switching.

52 ohm coaxial output.

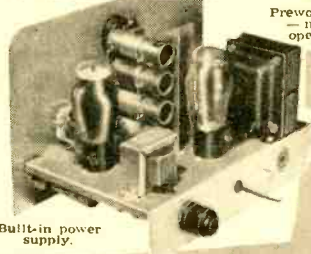

Built-in power supply.

# Heathkit COMMUNICATIONS RECEIVER KIT

RF gain control with AVC or MVC.

Electrical bandspread and scale.

Stable BFO oscillator circuit.

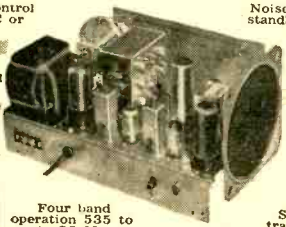

Four band operation 535 to 35 Mc.

Noise limiter—standby switch.

1/2 inch PM Speaker-Headphone Jack.

Six tube transformer operation.

- SPECIFICATIONS:**
- Range.....535 Kc to 35 Mc
  - 12BE6 ..... Mixer-oscillator
  - 12BA6 ..... I. F. Amplifier
  - 12AV6 Detector—AVC—audio
  - 12BA6 ..... B. F. O. oscillator
  - 12AB6 ..... Beam power output
  - 6Y3GT ..... Rectifier
  - 105-125 volts A.C. 50-60 cycles, 45 watts.

A new Heathkit AR-2 communications receiver. The ideal companion piece for the AT-1 Transmitter. Electrical bandspread scale for tuning and logging convenience. High gain miniature tubes and IF transformers for high sensitivity and good signal to noise ratio.

Construct your own Communications Receiver at a very substantial saving. Supplied with all tubes, punched and formed sheet metal parts, speaker, circuit components, and detailed step-by-step construction manual.

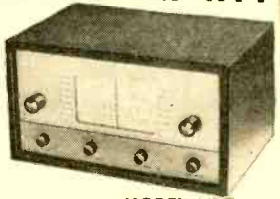

**MODEL AR-2**  
**\$25.00**

Ship. Wt. 12 lbs.

**CABINET:**

Proxylon impregnated fabric covered plywood cabinet. Shipp. weight 5 lbs. Number 91-10, \$4.50.

**HEATH COMPANY**  
 A SUBSIDIARY OF DAYSTROM, INC.  
 BENTON HARBOR 10, MICHIGAN



# The Versatile "Electro-Kit"

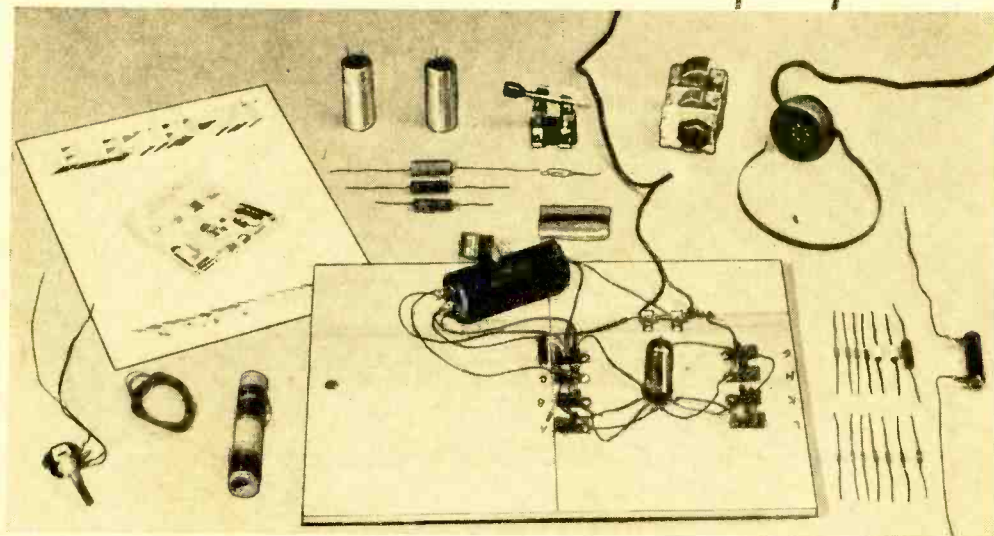

**I**F YOU have a well-developed bump of curiosity and enjoy using your imagination, the new "Electro-Kit" is just your meat. It offers numerous possibilities for experimentation, over and above the 36 formal experiments that are diagrammed and described in the booklet which accompanies the kit.

All of the electrical and mechanical components needed to perform all of the experiments listed in the manual are included. The only additional items which the user will have to supply are a mounting board (any type will do as long as it is at least  $\frac{1}{2}$ " thick), a pair of pliers, a screwdriver, and a soldering iron. The manufacturer lists the soldering iron as "optional" but it is our experience that repeated connection or disconnection of the wire will eventually cause the solder lugs on the various parts to break or bend excessively over a period of time.

Some of the experiments outlined call for the use of a good, long-wire antenna (from 100' to 125' long) mounted in the clear on insulators, plus an earth ground. Prospective builders should make their plans accordingly and arrange for such an antenna and ground system. The antenna wire, insulators, and ground rod are not supplied with the kit.

Every experiment makes use of 117-volt a.c. or d.c. house current, so that batteries and separate power supplies are not required.

Parts supplied with the kit are all good-quality, standard components. There are a few slight variations in the parts, as supplied, and as specified in the listing of components accompanying the kit. These variations are, however, unimportant and will not affect the experiments as outlined in the manual.

The 26 diagrams in the manual cover not only the experiments to be performed but such details as winding the antenna coil, setting up the long-wire antenna, and laying out the clipboard.

All-in-all, we found the kit fun to assemble and the experiments varied enough to keep up our interest. The manual contains enough explanatory material regarding each experiment so that the builder, without quite being aware of the fact, learns a lot of important basic electronic theory and practice.

The "Electro-Kit" #E-1002 is available from *Electro-Kit*, P.O. Box 3468, Maplewood 17, Missouri.

-30-

Impact grinder in action. Close-up below shows a formed tool with the machined impression that it made in a plate of tungsten carbide. The tool was made of brass, yet was worn very little by its contact with the carbide as it cut its way through.

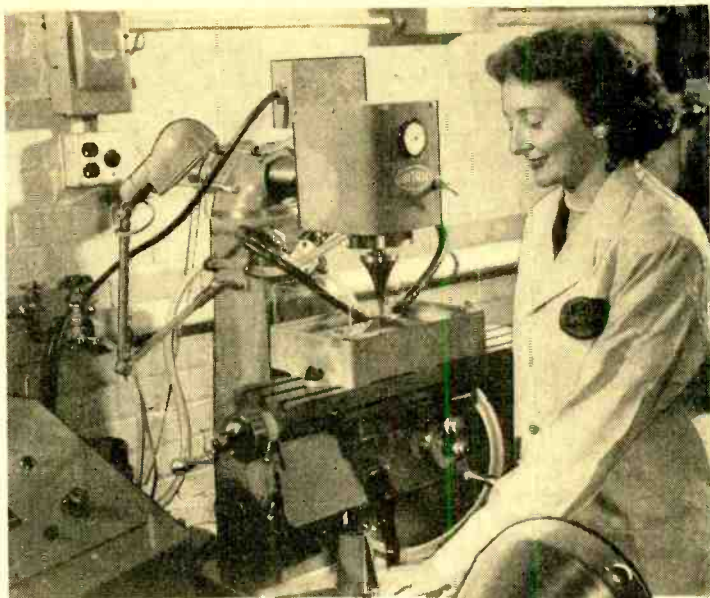

# Ultrasonic Drill

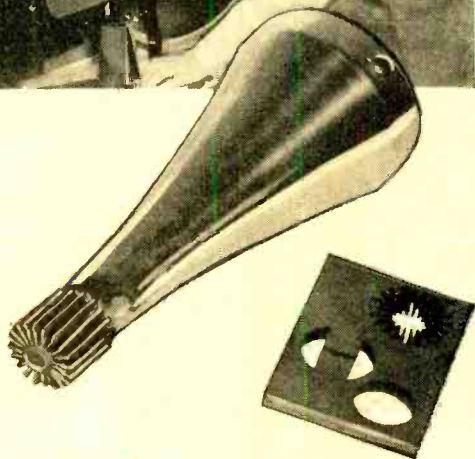

*Electronic tool machines hardest materials without contact*

**T**HE HARDEST MATERIALS in the world—diamond, glass, ceramics, and tungsten carbide—are now carved, drilled, and machined by an electronic tool that never touches the work! Known as an “ultrasonic machine tool,” the “Impact Grinder” was developed by the *Raytheon Manufacturing Company*, Waltham, Mass., for work in such materials as hardened steel, stone, carbides, and in gemstones, all of which are extremely difficult or impossible to machine by ordinary methods.

Strangely enough, the impact grinder uses a soft brass or mild steel cutting tool. Its control circuits change ordinary alternating current to high frequency vibrations at 25,000 cps. This vibratory motion is amplified mechanically and transferred to the tool tip. The tool, which moves a small fraction of an inch up and down at the “ultrasonic” rate, is lowered until it is nearly—but not quite—in contact with the work. Then

an abrasive liquid is run over the work. The tiny abrasive particles between the tool and the work are accelerated enormously, so that they strike the work surface with impact forces up to 150,000 times their normal weight. This “impact grinding” action chips away the surface, and while each particle removes only a minute bit of material, the great number of particles and the tremendous speed of repetition enable the tool to make rapid progress.

*Raytheon* engineers state that this tool is capable of holding very close tolerances, and have tested it in such jobs as machining fancy shapes in fine cut glassware; forming raised or depressed lettering in stone; making intricate dies in tungsten carbide; drilling holes through gemstones; and many other difficult projects. For some problems, this type of device is said to be the only practical equipment which is capable of doing the work.

—30—

# LEARN TV

the practical way--

17", 21"  
and  
27"

## BUILD *the New* TRANSVISION TV KIT

Designed so that  
COLOR can be added

\*THIS MODEST INVESTMENT gets you started on a most fascinating project — assembling the new "E" type Transvision TV Kit in easy stages. For \$15 you get PACKAGE #1 (standard first package for all new "E" kits). This package gives you the BASIC CHASSIS and required first-stage TV COMPONENTS, with complete instructions. When ready, you order the next stage (pkg. #2), etc.

**\$15<sup>00</sup>**  
ONLY gets you started\*

- 1 Learn TV
- 2 Save up to 50%
- 3 Prepare for COLOR TV

Shows 8 Great TV Kits:

EXCLUSIVE: Only Transvision TV Kits are adaptable to UHF. Ideal for FRINGE AREAS. No Previous Technical Knowledge required. Write now!

**FREE  
CATALOG**

**TRANSVISION**  
NEW ROCHELLE, N. Y.

MAIL THIS COUPON TODAY  
TRANSVISION, INC., NEW ROCHELLE, N. Y. Dept. E-11

I'm enclosing \$ \_\_\_\_\_ deposit. Send standard kit PACKAGE #1, with all Instruction Material. Balance C.O.D.  
 Send FREE copy of your new TV Kit Catalog.

Name \_\_\_\_\_  
Address \_\_\_\_\_  
City \_\_\_\_\_ State \_\_\_\_\_

## "Frequency Meter" at No Cost

IN CONSTRUCTING tuned circuits for the standard broadcast band, experimenters often have trouble trying to figure out how many turns of wire to wind on the coil when using variable capacitors and coil forms of odd sizes. Here is a quick and easy way to determine the frequency range of a coil-and-capacitor combination intended for the standard broadcast band. This method is accurate enough for ordinary purposes and requires no expensive and complicated testing and calibrating instruments.

Assuming that you have a table radio using a loop antenna, tune in a station at about the center of the broadcast band. Hold the tuned circuit (coil and variable

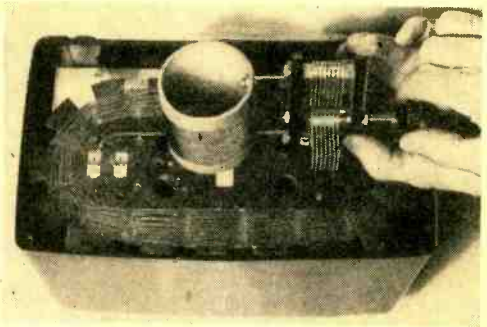

capacitor connected in parallel) close to the loop with the turns of the coil running parallel with the turns in the loop, as shown in the photo. Then turn the rotor plates of the capacitor until the radio's signal fades or disappears altogether. The tuner now resonates at the frequency of the radio's signal.

If you have the correct number of turns on the coil, the rotor plates will be about half meshed—the same as the rotor plates in the r.f. section of the capacitor gang in the radio. If the tuner's plates are too far open, you will have to remove a few turns of wire from your coil. On the other hand, if the plates are too far closed, you will have to add a few turns to the coil.

It's a good idea to check the tuner with the radio at both ends of the broadcast band to make sure that the tuner takes in the whole band without clipping off stations at either end. The principle of this "trick" is simple: the tuner acts as an absorption wavemeter which absorbs r.f. energy from the radio's loop when the tuner resonates with the radio's loop and r.f. capacitor. The farther you hold the tuner from the loop, the more accurate the frequency check. If the radio is correctly aligned, the frequency of the tuner will correspond exactly to the dial setting of the radio itself.

-30-

# LEARN TV in KG

UNIVERSAL TV FAMOUS FOR 24 YEARS

1,000's OF SUCCESSFUL GRADS COAST TO COAST



Easy, quick, fascinating. Learn TELEVISION in 36 short weeks of enjoyable companionship in shop training. Wonderful job opportunities. Graduates have choice of many jobs or can establish their own TV repair shop. YOU CAN START EARNING AS MUCH AS \$150 PER WEEK: No limit as time goes on. U.T.S. is an old established school (TV exclusive for 24 years) staffed by expert instructors, headed by one of America's first TV broadcasters. Costs so little to prepare yourself for life. No previous experience needed. Fully approved for Korean Veterans. Also fully approved course in color TV (1st in U.S.) Send coupon now for FREE BOOK on TV and Electronics opportunities.

WRITE FOR

**FREE  
CATALOG**

FILL OUT COUPON

UNIVERSAL TV SCHOOL  
1220E Admiral Boulevard, Kansas City, Missouri  
PLEASE SEND ME INFORMATION FREE

Name \_\_\_\_\_ Age \_\_\_\_\_  
Address \_\_\_\_\_  
City \_\_\_\_\_ State \_\_\_\_\_  
 Check here if Korean Veteran

# The New Model 70 UTILITY TESTER FOR REPAIRING ALL ELECTRICAL APPLIANCES MOTORS • AUTOMOBILES • TV TUBES

As an electrical trouble shooter the Model 70:

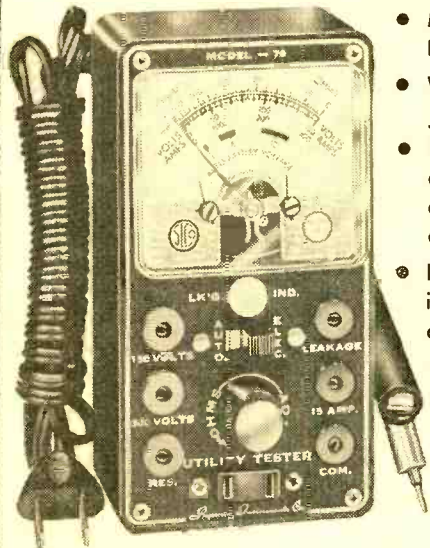

- Measures A.C. and D.C. Voltages, A.C. and D.C. Current, Resistances, Leakage, etc.
- Will measure current consumption while the appliance under test is in operation.
- Incorporates a sensitive direct-reading resistance range which will measure all resistances commonly used in electrical appliances, motors, etc.
- Leakage detecting circuit will indicate continuity from zero ohms to 5 megohms (5,000,000 ohms).
- Will test toasters, Irons, Broilers, Heating Pads, Clocks, Fans, Vacuum Cleaners, Refrigerators, Lamps, Fluorescents, Fans, Switches, Thermostats, etc.
- Will test all TV tubes for open filaments, inter-element shorts, burned out tubes, etc.

As an Automotive Tester the Model 70 will test:

- Both 6 Volt and 12 Volt Storage Batteries • Generators • Starters • Distributors • Ignition Coils • Regulators • Relays • Circuit Breakers • Cigarette Lighters • Stop Lights • Condensers • Directional Signal Systems • All Lamps and Bulbs • Fuses • Heating Systems • Horns • Also will locate poor grounds, breaks in wiring, poor connections, etc.

Handsome round-cornered molded bakelite case, 3 1/8" x 5 7/8" x 2 1/4". Complete with all test leads. Also included is a 64 page book giving detailed instructions for testing all electrical appliances, automotive equipment, TV tubes, etc. Only **15<sup>85</sup>**

## **SHIPPED ON APPROVAL NO MONEY WITH ORDER — NO C. O. D.**

Try it for 10 days before you buy. If completely satisfied then send \$3.85 and pay balance at rate of \$4.00 per month for 3 months — No Interest or Finance Charges Added! If not completely satisfied, return to us, no explanation necessary

MOSS ELECTRONIC DIST. CO., INC.

Dept. D-176, 3849 Tenth Ave., New York 34, N. Y.

Please rush 1 Model 70 I agree to pay \$3.85 within 10 days after receipt and \$4.00 per month thereafter

Name \_\_\_\_\_

Address \_\_\_\_\_

City \_\_\_\_\_

Zone \_\_\_\_\_ State \_\_\_\_\_

# BUILD YOUR OWN CODE OSCILLATOR

## LEARN MORSE CODE

### Get Your Amateur License

The New Magna-Kit Code Oscillator is a deluxe kit with all necessary parts for assembly. Simplified step-by-step instructions plus large pictorial diagrams make it easy-to-build and completely fool-proof. The chassis is cadmium plated steel, beautifully finished in baked enamel and has the entire International Morse Code permanently imprinted on its top. This set will operate up to 20 sets of headphones simultaneously or through a PM speaker. Has a separate Loudness and variable Tone Control. Tone range from 400 to 1500 cps. Complete with a 4" speaker and code key. Available in AC/DC or Battery models.

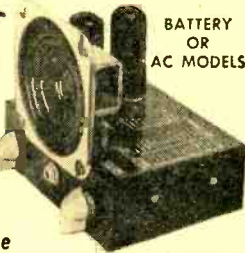

BATTERY MODEL  
**12.95**  
POSTPAID

## FREE KIT CATALOG

Write for our latest catalog showing the entire line of Magna-Kits. Get your name on our mailing list to receive regular bulletins on our exciting new developments in electronic kits.



## A & M COMPANY

DEPT. E • 616 SO. SERRANO AVENUE • LOS ANGELES 5, CALIF.

## ELECTRONIC SUPPLIES

Attn.—Lab.—School—Experimenters

## ELECTRONIC OPPORTUNITY KIT

Gov't Acquisition Cost over \$300—a wonderful opportunity to acquire a valuable selection of useful electronic components for a tiny fraction of actual cost. We include a parts list. No junk—no "Operation Cleansweep." These parts are all currently for sale in our cash & carry store. What you get: 1 Crystal Diode; 1 Relay; 1 matching Audio Transformer; 24 Ceramicons; 1 UHF Chassis, incomplete. New; 2 min IF Xformers; 6 Wafer Switches; 17 Hi Pass Filter; 1 Planetary Drive; 3 Submin. Air Trimmers; 12 Miscell Coils (Receiving & TV); 3 Min. Tube Shields; 6 pots (WW & Carbon) 3 Bathub Cond. 1—6.3V fila. Xformer; 1 Choke (150 MA); 3 Term'l Bds—Silver Plated Term'l's; 10 Ass'd Tube Sockets (Lo-Loss) no wafers; 1 Fusepost; 1 Toggle Switch; 25 1/2-1-2W Resistors (insulated); 25 Ass'd Tubulars; 1 Variable Condenser; 4 Electrolytics (Fresh); 3 Instrument Knobs; 3 25W Rheostats (Ohmic or H.H.); 25 Micra (current); 1 Line Cord; 1 DC Ammeter; Min Xformer (transistor circuits); 1 Min. Hear. Aid output Xformer; 1 60 Cycle Power Xform. with fila. winding; 1 Hank Wire; 1 Plug-In Coil; 1 Navy Test Probe; 1 Control Box; 1 Hemlok w/Schematic.

187 PIECES—Our SURPLUS retail prices for ONE (1) of these is \$5.00. WE BELIEVE THIS IS REALLY AN OPPORTUNITY KIT

**\$7.95**

### OSCILLOSCOPE

#### Model 830

Mfd for U. S. Navy

Combines a highly efficient conventional 3" oscillograph, with a thyatron linear sweep, and synchronized sweep frequency modulator or wobulator. Operates from 115VAC-60 cycles.

The perfect instrument for labs, schools, etc. Has all features of high priced lab scopes, including instruction book, at less than price of a kit. All tested.

SIZE: 10 1/2" x 14. Wt.: 23 lbs.

**\$29.95 complete**

F.O.B. N.Y. (express only)

WESTERN ELECTRIC Stepper Switch 4.5-12VDC Coil—45 Steps New ..... \$7.95

GEIGER-MULLER TUBE—Type US-CV-BS-6 Mica Window—High sensitivity—Orig. Cost \$40.00 Orig. Boxed—with spec sheet ..... \$7.95

PE-204A Portable Vibrapack for Walkie-Talkies, etc.—New V.F. spare vibrator ..... \$2.95  
Fila. Xformer 25V—2Amp \$1.95; 3/\$5.50

KING SOL Flashlight battery tester. Compare With Instructions. List price—\$7.98  
Special \$1.49; 4/\$5.00

MINIATURE TRANSFORMER. 9 porcelain term'l's. Schematic on case. As used with Transistors—98c; 10/\$9.00

SIGNAL CORPS. Telegraph Key NEW 89c; 4/\$3.00  
TUBE TYPE 1625 29c; 4/\$1.00

Include Postage With Order

## REX RADIO SUPPLY

88 CORTLAND STREET

NEW YORK 7, N. Y.

# POP'tronics



## BOOKSHELF

"ATOMS TODAY AND TOMORROW" by Margaret O. Hyde. *Whittlesey House, McGraw-Hill Book Co., Inc.*, New York, N. Y. Cloth bound. 144 pages. \$2.50.

Written for the layman, this book describes atomic energy and discusses most of its current applications, including such topics as prospecting with Geiger counters and the use of radiation in farming, medicine, transportation, etc. An analysis of atomic structure and smashing the atom is included. The text is extremely well written and numerous drawings help explain the material. Easy to read, this volume can put you on "speaking terms" with the phenomena of atomic energy.

"TV & RADIO TUBE SUBSTITUTION GUIDE" by Harry G. Cisin, Amagansett, N. Y. 24 pages. \$0.50.

This is a tube substitution guide for the replacement of tubes in television and radio sets. These suggested substitutions are extremely helpful in instances where the identical replacement type is unobtainable. All replacements suggested have characteristics similar to the tubes they are to replace. Of equal importance, they will fit in the same socket and do not require any changes in the wiring.

## Free Literature Roundup

ELECTRONIC PARTS, tubes, equipment, and accessories are listed in the new 1956 catalog announced by *Newark Electronic Co.*, 223 W. Madison St., Chicago 2, Ill. The 260-page catalog features a 64-page section on hi-fi equipment. For your free copy, write to the company.

REPORTED TO BE THE BIGGEST catalog published by an electronics distributor is the 1956 edition of *Allied's* buying guide. This 324-page book includes 128 pages in rotogravure and describes more than 26,000 electronic items. Special sections list p.a. and hi-fi equipment. All standard components and parts are shown. For your free copy, write to *Allied Radio Corp.*, 100 N. Western Ave., Chicago 80, Ill.

-30-



## Training by Home Study

(Continued from page 37)

actually represent competent training successfully completed; and they make for legitimate claims in school advertising. Schools that want to join the *NHSC* must be in existence for at least five years and must submit to a complete inspection of texts and facilities prior to acceptance. For more information on this organization, write to *National Home Study Council*, 1420 New York Ave., N.W., Washington 5, D. C.

Close contact between school heads and industry's representatives accounts for a realistic gearing of courses to meet job requirements. This contact also makes for very fruitful placement of school graduates in jobs. Many leading electronics companies promote home-study training, and in some cases actually foot the bill for such training for their employees. The *Crosley Division of AVCO Mfg. Corp.* recently paid for color TV courses taken by its personnel. In 1953, *Motovola* sponsored its distributor-service technicians through a company-financed course in television. These are only two of the many examples of the close cooperation between industry and the schools.

### Does It Pay Off?

"Success stories" of correspondence school graduates are too numerous to catalog here. Documentation is available on request to any of the schools listed in the directory appearing on page 37.

Sometimes, a trainee's success can prove slightly overwhelming. For example, an instructor at *International Correspondence Schools* received a request from a home-study trainee asking for his diploma. The student was notified that his diploma would be withheld until his final examination was completed. The student wrote again, stating that he was too busy earning money, using the knowledge he had already gained from his lessons, to have time to finish the course.

Investigation revealed that since his enrollment this student had developed a business which boasted thirty-thousand dollars worth of stock, a truck, and an assistant. He thought that until he got some slack time, in which he could complete his course, *ICS* would "lend" him the diploma so that he could have it framed and mounted above the desk in his new shop.

Naturally, this prospering student was encouraged to find the time needed to complete his school work. He did, and the diploma is now in his possession. -30-

Get your  
F.C.C. License  
QUICKLY!

FIRST CLASS  
LICENSE  
IN  
3 MONTHS  
OR LESS

### More Jobs Than We Can Fill

Jobs in radio-TV-electronics are going begging. A commercial (not amateur) F.C.C. license is your ticket to higher pay and more interesting employment. We train you quickly — then help you find the job you want!

### Learn By Mail or In Residence

Correspondence training from Washington, D. C. DAY and EVENING resident classes held in Hollywood, Calif., and Washington, D. C. Enter any course you choose.

### Grantham Training Is Best

Grantham School of Electronics specializes in preparing students to pass F.C.C. examinations. We train you quickly and well. All courses begin with basic fundamentals — NO previous training required. Beginners get 2nd class license in 8 weeks, 1st class in 4 additional weeks.

#### OUR GUARANTEE

If you should fail the FCC exam after finishing our course, we guarantee to give you additional training at NO ADDITIONAL COST. Read details in our free booklet.

#### FCC-TYPE EXAMS

FCC-type tests are used throughout the Grantham course. Constant practice with these FCC-type tests helps you prepare for the actual FCC examination.

**Here's Proof!** Recent graduates, the license they got, and how long it took them:

	Class	Weeks
V. J. Steffle, Jr., 944 Cedar, El Segundo, Calif.	1st	11
Norm Walker, 946 Post Ave., Toledo, Ohio	1st	8
Richard Johnson, WREB, Holyoke, Mass.	1st	9
Melvin Winters, RFD 1, Hummelstown, Pa.	1st	15
P. Martinez, 1013 N. Alvarado, Los Angeles	1st	13
Irvin Gemora, 5008 Pebridge, Baltimore	1st	8
J. Yeardeley, 500 Lynn Pl., Falls Church, Va.	1st	13
F. Keller, 4421 Silver Hill, Wash., D. C.	1st	15
Brent Shriver, 158 E. 136th, Hawthorne, Cal.	2nd	5

### Our Other Courses

We offer short courses in operating television studio equipment, in radio announcing and production, and in transmitter operation. The students operate an on-the-air commercial broadcast station. These short, intensive courses are open only to students who have completed our FCC license course (either by correspondence or in residence) and obtained a first class license.

**MAIL NOW TO OFFICE NEAREST YOU**

(mail in envelope or paste on postal card)

**Grantham School, Dept. 104-X**

737 11th Street, N.W. OR 5910 Sunset Blvd.  
Washington, D. C. Hollywood 28, Calif.

Please send me your free booklet, telling how I can get my commercial FCC license quickly. I understand there is no obligation and no salesman will call.

NAME.....

ADDRESS.....

CITY.....STATE.....

# AFTER CLASS

## CRYSTAL RECTIFIERS

**R**ADIO AND CRYSTAL DIODES have just about grown up together. While radio reached maturity quickly, crystals fell behind for a time; but under the impetus of a growing demand for small components, they have displayed amazing vitality and comeback power. Thanks to crystal diodes and transistors—first cousins of diodes—the day of the tubeless radio has finally arrived.

The most popular crystal diodes suitable for radio-frequency work currently available are made of germanium, a metal which is neither a very good conductor nor a very poor one. By properly fabricating a tiny chunk of germanium together with a fine "cat's whisker," the characteristics of the metal are changed so that it becomes an excellent conductor in one direction and a very poor one in the other. In short, it assumes the unidirectional nature of a rectifier. Unlike a vacuum tube, however, the crystal diode requires no filament power, is instant-heating—needing no

warm-up period, and is so tiny that half-a-dozen units can easily fit into a thimble.

Figure 1 illustrates the comparative schematic diagrams of a vacuum-tube rectifier alongside an equivalent diode circuit. The first thing one notices is the simplicity of the crystal arrangement as compared with that of the tube; the next natural step is for the reader to note the schematic symbol for the crystal diode and compare it with the tube. Remembering that electrons flow from the cathode to the plate in the vacuum tube, it can be understood why the load resistor  $R$  assumes the polarity of d.c. voltage indicated in the drawing, since the end of the resistor into which the electrons flow must become more negative than the end from which they emerge.

Although it is evident that exactly the same conditions apply to the crystal circuit, the arrowhead symbol seems to indicate that electrons should be flowing oppositely from the direction shown. This is the first lesson one must learn about diode symbols: the flat little rectangle represents the *cathode*, not the plate, and the arrowhead stands for the receiver of electrons—the equivalent of the plate in a vacuum tube. Thus, the direction of flow of electrons is actually the *reverse* of that which the symbol *seems* to indicate. Most commercial crystal diodes bear the letter "K" or a + sign on the cathode terminal.

Typical, small germanium diodes like the 1N34 are intended for use in low-current circuits, and so make ideal radio and television detectors, r.f. probe rectifiers, meter rectifiers, and noise limiters.

Figure 2B shows a complete, self-contained, batteryless broadcast radio receiver using a single 1N34 germanium diode. The tuning coil is a Ferri-loopstick or its equivalent resonated to broadcast stations by a 365- $\mu\text{fd}$ . variable capacitor. The 1N34 rectifies the incoming modulated wave, the r.f. portion of which is bypassed around the headphones by the .002- $\mu\text{fd}$ . capacitor. Modulation is then converted into sound by the headphones.

Figure 3 pictures the construction of an r.f. probe—a device which enables the  
(Continued on page 110)

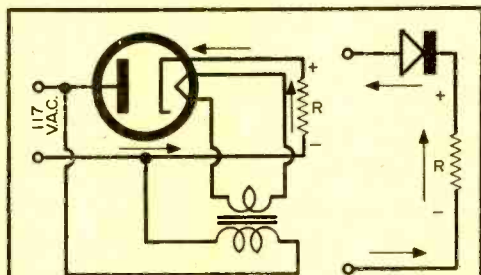
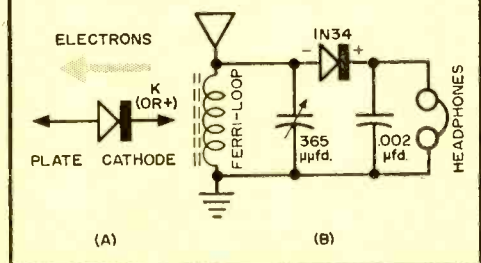

Fig. 1. Schematic of vacuum-tube rectifier (left) and crystal rectifier (right).

Fig. 2. (A) Schematic representation of crystal. (B) Complete crystal receiver.



# I WILL TRAIN YOU AT HOME FOR GOOD PAY JOBS IN RADIO-TELEVISION

J. E. SMITH has trained more men for Radio-Television than any other man. OUR 40th YEAR.



## Fast Growing Industry Offers You Good Pay-Security-Bright Future

### I Trained These Men



"I have a job working on radar equipment. Also do spare-time radio, TV servicing."

FLOYD ZAWAKE, Scranton, Pennsylvania

"I operated a successful servicing shop. Then got job with WPAQ and now am engineer for WHPE."



V. W. WORKMAN, High Point, N.C.

"I decided to quit my job and do TV work full time. I love my work and am doing all right financially."



W. F. KLINE, Cincinnati, Ohio.

"I have a good job in a Television repair shop plus a small business in my home."



VERN BARR, Toronto, Ohio.

AVAILABLE TO  
**VETERANS**  
UNDER GI BILLS

## My Training Leads to Jobs Like These



**BROADCASTING:** Chief Technician, Chief Operator, Power Monitor, Recording Operator, Remote Control Operator. **SERVICING:** Home and Auto Radios, Television Receivers, FM Radios, P.A. Systems. **IN RADIO PLANTS:** Design Assistant, Technician, Tester, Serviceman, Service Manager. **GOVERNMENT RADIO:** Operator in Army, Navy, Marine Corps, Forestry Service Dispatcher, Airways Radio Operator. **AVIATION RADIO:** Transmitter Technician, Receiver Technician, Airport Transmitter Operator. **TELEVISION:** Pick-up Operator, Television Technician, Remote Control Operator.

Approved Member, National Home Study Council.



Do you want a good pay job, a bright future, security? Or your own profitable business? Then get into the fast-growing RADIO-TELEVISION industry. Keep your job while training at home. Thousands I've trained are SUCCESSFUL Radio-Television Technicians. Most had no previous experience, many no more than grammar school education. Learn Radio-Television principles from my easy to understand, illustrated lessons; get practical experience on actual equipment I furnish.

### A Tested Way to Better Pay

Radio, even without Television, is bigger than ever. 115 million home and auto Radios create steady demand for service; 3000 Radio stations give interesting, good pay jobs to operators, technicians . . . provide good pay now, bright future later for men who qualify.

### Opportunity for Men of Action Mail Postage-Free Card

Act now to enjoy more good things of life. Take NRI training for as little as \$5 a month. Many NRI graduates make more in two weeks than the total cost of training. Mail card below today. J. E. SMITH, President, National Radio Institute, Washington 9, D.C. Over 40 years of training men.

### Television Making More Good Jobs—Prosperity

Think of the opportunities in Television. Over 30,000,000 Television homes now and the total growing rapidly. 400 Television stations on the air and hundreds more under construction. Color Television is here. This means more operators, installation men and service technicians will be needed. Now is the time to get ready for a successful career in Radio-Television. Mail the postage-free card today.



## SEE OTHER SIDE

## SAMPLE LESSON and 64-Page BOOK BOTH FREE

CUT OUT AND  
MAIL CARD NOW

Act now! Send for my DOUBLE FREE OFFER. Card entitles you to Actual Lesson on Servicing, plus my 64-page book.

**NO STAMP NEEDED — WE PAY POSTAGE**

Mr. J. E. Smith, President  
National Radio Institute, Washington 9, D.C.  
Mail me Lesson and Book, "How to Be a Success in Radio-Television." (No salesman will call. Please write plainly.)

NAME..... AGE.....

ADDRESS.....

CITY..... ZONE..... STATE.....

**VETS** write in date of discharge.....

1 2



# Train <sup>AT HOME</sup> to Jump Your Pay

## Practice Broadcasting with Parts I Send

As part of my Communications Course I send you parts to build low-power Broadcasting Transmitter at left. Use it to get practical experience. You perform procedures demanded of broadcasting station operators. An FCC Commercial Operator's License can be your ticket to a bright future. My Communications Course trains you to get your license. Mail card. Book shows other equipment you build.

## Practice Servicing with Parts I Send

Nothing takes the place of PRACTICAL EXPERIENCE. That's why NRI training is based on LEARNING BY DOING. You use parts I send to build many circuits common to Radio and Television. With my Servicing Course you build the modern Radio shown at right. You build a Multitester and use it to help make \$10, \$15 a week fixing sets in spare time while training. All equipment yours to keep. Card below will bring book showing other equipment you build.

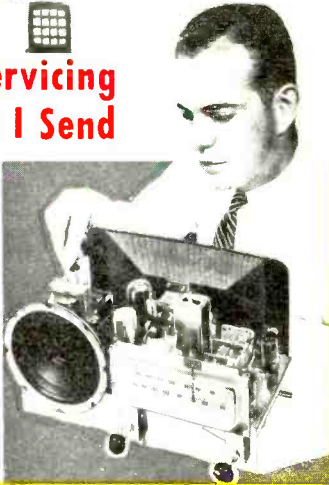

## Be a Radio-Television Technician



**J. E. SMITH**  
President  
National Radio Institute  
Washington, D. C.  
Over 40 yrs. of success training men at home

Training PLUS opportunity is the PERFECT COMBINATION for job security, good pay, advancement. When times are good, the trained man makes the BETTER PAY, gets PROMOTED. When jobs are SCARCE, the trained man enjoys GREATER SECURITY. NRI training can help assure you and your family more of the better things of life. Even without Television, Radio is bigger than ever. Television is moving ahead fast and color Television will create more jobs, more opportunity. New uses for Radio-Television principles are coming in Industry, Government, Communications.

## Start Building for Success—TODAY!

Naturally, my training includes Television. I have over the years added more and more Television information to my course and the equipment I furnish students gives experience on circuits common to BOTH Radio and Television. Get the benefit of our 40 years' experience training men. My well-illustrated lessons give you basic principles you must have to assure continued progress. Read at the left how skillfully developed kits of parts I furnish "bring to life" things you learn from my lessons.



## Find Out About Tested Way to Better Pay

Take your first step—cut out and mail the card below. Doing so involves no obligation. I even pay postage. I want to put an Actual Lesson in your hands to prove NRI home training is practical, thorough. I want you to see my 64-page book, "How to Be a Success in Radio-Television," because it tells you about my 40 years of training men and important facts about present and future Radio-Television job opportunities. You can take NRI training for as little as \$5 a month. Many graduates make more than the total cost of my training in two weeks. Mailing postage-free card can be an important step in making your future successful. J. E. Smith, President, National Radio Institute, Washington 9, D. C. 40 YEARS OF SUCCESS TRAINING MEN AT HOME.

**SEE  
OTHER  
SIDE**

**CUT OUT AND  
MAIL POSTAGE-  
FREE CARD**

FIRST CLASS  
PERMIT NO. 20-R  
(Sec. 34.9, P.L.&R.)  
WASHINGTON, D. C.

**BUSINESS REPLY CARD**

NO POSTAGE STAMP NECESSARY IF MAILED IN THE UNITED STATES

POSTAGE WILL BE PAID BY  
**NATIONAL RADIO INSTITUTE**

16th and U Sts., N.W.

Washington 9, D. C.

## Start Soon to Make \$10, \$15 a Week Extra Fixing Sets



Keep your job while training. Many NRI students make \$10, \$15 a week fixing neighbors' sets in spare time starting a few months after enrolling. E. J. STREITENBERGER, a graduate of New Boston, Ohio, writes, "By the time I graduated, had paid for my course, a car and testing equipment." Mail postage-free card now.

## Tester Revives Picture Tubes

A LOW-COST TUBE TESTER and rejuvenator—the EMC Model 209—has been announced by *Electronics Measurements Corp.*, 280 Lafayette St., New York 12, N.Y. This instrument enables the user to check vacuum tubes as well as to repair monochrome picture tubes.

The Model 209 tests tubes by using the standard, total emission method. It handles

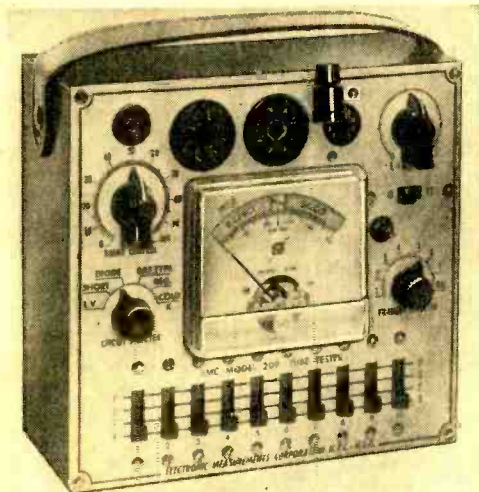

all tube base types commonly found in home sets. Accurate checks can be made for tube quality, shorts, leakages, continuity, and opens between tube elements. Featured is a meter with a 3½" scale printed in three colors.

To use the device to rejuvenate picture tubes, an additional piece of equipment is required. This is the EMC Model CRA "picture tube adapter" which sells for \$4.50. With this adapter, the Model 209 will restore brightness and emission to a TV picture tube while the tube is still inside the set.

Individual tube sockets are provided for each tube type, elements being numbered according to the RETMA Base System. Also provided is a top cap lead for tubes with grid or plate caps. Another special feature is the built-in 25-watt line voltage control that automatically adjusts for variations in voltage, insuring extremely accurate quality checks.

Handy in size (6¾" by 7½" by 4"), the Model 209 tester is supplied complete with a detailed instruction book and tube listings. It is available in three forms: wired and in a hammertone case at \$35.90; wired and in an oak carrying case at \$28.50; and as an easily assembled kit at \$25.90. For more information, see your local parts distributor, or write to the manufacturer. —30—

November, 1955

## Give POPULAR ELECTRONICS To Your Friends This Christmas

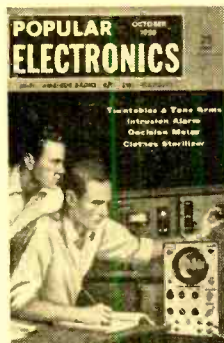

### The Perfect Gift . . . The Key To The Wonderful World of Electronics!

This year, give POPULAR ELECTRONICS—the exciting new magazine for the hobbyist, experimenter, Hi-Fi enthusiast and radio amateur.

A perfect gift—easy to order . . . inexpensive . . . sure of a warm welcome every month the year 'round.

Each issue features an exciting array of easy-to-understand construction articles . . . plus complete coverage of all that's new in the wonderful world of electronics—including TV, radio, Hi-Fi, radio control, radar, recordings, and "ham" radio activities.

### SPECIAL GIFT RATES

1st 1-yr. Gift Subscription . . . . . \$3.00  
2nd 1-yr. Gift Subscription . . . . . \$2.00  
Each addtl. 1-yr. Gift Subscription . \$1.50

*An attractive gift card will be mailed to your friends announcing your gift in time for Christmas.*

Fill in and mail the convenient postpaid order envelope facing this page for your own or gift subscriptions. List additional gift orders on an extra sheet of paper.

*(Your own new or renewal subscription may be included.)*

## POPULAR ELECTRONICS

366 Madison Avenue New York 17, N.Y.



## YOUR COPIES OF

**POPULAR  
ELECTRONICS**

**ARE VALUABLE!**

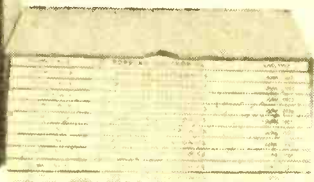

**Keep them neat . . . clean . . .**

**Ready for INSTANT REFERENCE!**

Now you can keep a year's copies of **POPULAR ELECTRONICS** in a rich-looking leatherette file that makes it easy to locate any issue for ready reference. Specially designed for **POPULAR ELECTRONICS**, this handy file—with its distinctive, washable blue Kivar cover and 16-carat gold leaf lettering—not only looks good but keeps every issue neat, clean and orderly. So don't risk tearing and soiling your copies of **POPULAR ELECTRONICS**—always a ready source of valuable information. Order several of these **POPULAR ELECTRONICS** volume files today. They are \$2.50 each, postpaid—3 for \$7.00, or 6 for \$13.00. Satisfaction guaranteed, or your money back. Order direct from:

**JESSE JONES BOX CORP., DEPT. PE**  
Box 5120, Philadelphia 41, Pa.  
(Established 1843)

## AMERICA'S FINEST VALUE "LOW-COST" HIGH FIDELITY



**30 WATT  
AMPLIFIER**  
SALE PRICE **\$29.95**

**HI-FI RESPONSE**  
30-15,000 CPS  
**PUSH-PULL 6L6's**  
**TWIN TONE  
CONTROLS**

With **CU-14Y, 12" Coax Speaker** . . . . . \$39.95  
With **CX-156, 15" Coax Speaker** . . . . . \$44.95

New, 30 watt High-Fidelity amplifier. A tremendous value at only \$29.95. Response 30 to 15,000 cps. Separate bass and treble tone controls. Inputs for microphone and crystal or variable reluctance pickup. Use with a radio tuner or any crystal or dynamic microphone. Ideal for a home High-Fidelity Music System or for background music in stores, office or factory. 30 watts power output, enough to operate 12 to 16, 8" speakers or several larger speakers. Use with any 4 or 8 ohm speaker or 250 ohm line. Chassis size, 7 3/8" x 10 1/2" x 7 1/8" high. Complete with tubes: 2-6L6, 2-6C4, 6AT6, 6AU6 and 5U4G rectifier. A terrific value. Complete ready to use at less than the cost of a comparable kit of parts. Model HF-30, 30 watt High Fidelity amplifier, shipping weight 17 lbs. Sale price, \$29.95. This amplifier is recommended for use with either of our fine coaxial speakers or 8" speakers and wall baffles. HF-30 amplifier and CU-14Y, 12" coaxial PM speaker, both for \$39.95. HF-30 amplifier and CX-156, 15" coaxial PM speaker, both for \$44.95. 8" PM speaker with leatherette covered wall baffle, \$3.95 extra, or \$3.79 in lots of 3 or more. Model CU-14Y, 12" coaxial PM speaker separately, \$12.95 each. Model CX-156, 15" coaxial PM speaker separately, \$15.95 each. JT-30 Astatic Crystal Microphone with desk stand, \$9.97 extra.

**McGEE RADIO CO., 1905 McGee St., Kansas City, Mo.**  
PRICES F.O.B. KANSAS CITY—SEND 25% DEPOSIT WITH C.O.D. ORDERS. BALANCE SENT C.O.D.

**WRITE FOR LATEST CATALOG**

## After Class

(Continued from page 106)

owner of an ordinary vacuum-tube voltmeter to measure radio-frequency voltages. The unit may be built into a Bakelite or polystyrene tube having an inside diameter of about 3/4". Capacitor *C1* isolates the probe from any d.c. that happens to be present at the point being measured; *R1* provides a return path to ground for the circuit under measurement and for the charge which builds up on *C1*; the diode rectifies the r.f. and builds up a voltage on

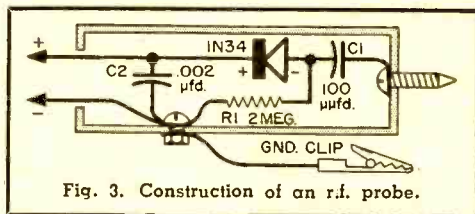

Fig. 3. Construction of an r.f. probe.

*C2* which is approximately equal to the peak r.f. voltage. This is the potential which is read off on the vacuum-tube voltmeter scale.

Germanium diodes are not designed for power rectification and so cannot replace high-current tubes like the 5U4 and 5Y3. Several other crystalline materials, particularly selenium, magnesium-copper sulfide junctions, and copper oxide, have begun to challenge the supremacy of vacuum tubes as power rectifiers.

Most three-way portable radio receivers have done away with vacuum-tube rectifiers altogether and employ instant-heating selenium units instead; such radios go to work as soon as they are turned on—using either batteries or the a.c. lines—and, in addition, run appreciably cooler on a.c. than do the sets with 117Z7 tube rectifiers. Many modern television sets now utilize selenium stacks to replace the old stand-

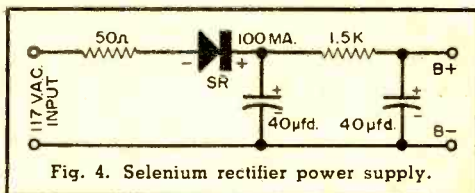

Fig. 4. Selenium rectifier power supply.

by 5U4; practically all battery chargers and battery eliminators have swung over to dry-disc rectifiers so that the Tungar type of rectifier is obsolete.

For those who are interested in construction, a typical a.c.-d.c. selenium rectifier power supply, suitable for operating a four- or five-tube radio, is given schematically in Fig. 4.

Note the different symbolism for germanium crystal rectifiers and selenium power rectifiers. The symbolism followed in POPULAR ELECTRONICS articles calls for an open arrow for germanium crystal rectifiers, and a solid arrow for power rectifiers of the selenium type.

The following quiz is intended as a self check. All of the questions can be answered correctly if the foregoing text has been mastered. Answers appear on page 124.

### QUIZ

1. If a circuit contained a 1N34 germanium diode, would you expect the function of the circuit to be that of detection or high current rectification?
2. Explain the need for capacitor C1 in Fig. 3.
3. What are the three important advantages of crystal diodes over vacuum-tube rectifiers?
4. If you were building an R/C receiver, might you use a germanium diode to trip a very sensitive relay?
5. Given a center-tapped power transformer, could you wire in two selenium rectifiers to form a full-wave power supply? Try it.

### METER SENSITIVITY

THE WIDE RANGE of prices asked for multi-test meters of apparently similar nature is often bewildering to the person who goes shopping for one of these instruments for the first time. Aside from the reputation of the manufacturer, the value of a multi-test meter is determined chiefly by its sensitivity, higher sensitivities being both more costly and more useful in general to the technician or hobbyist.

Just how good a meter movement is in this respect is dependent primarily upon the amount of current that must flow through the meter coil to produce a full-scale deflection. If the instrument requires 10 ma. (.01 amp.) for full deflection, it might be said to be a rather insensitive movement; if the needle can be moved clear across the dial by a coil current of only 50 microamperes (.00005 amperes), its sensitivity is quite high. Rather than rate their instruments in this way, manufacturers prefer ratings in terms of a quantity called "ohms-per-volt"—a very descriptive phrase if one understands exactly what it means.

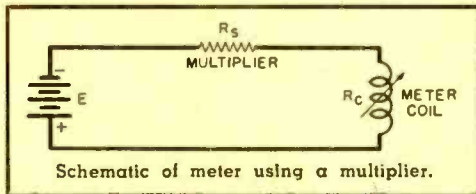

Suppose, for example, that a given meter movement is designed so that 1 ma. (.001 amp.) produces a full-scale deflection. To make it into a 0-1 volt voltmeter, a series

free!

## ALLIED'S SPECIAL 100-PAGE HI-FI CATALOG



Your guide to an easy understanding of Hi-Fi—plus the world's largest selection of Hi-Fi systems and components...

send for "this is high fidelity"

The FREE book that shows you how to SAVE MONEY on your home music system

#### DO IT YOURSELF

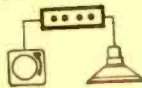

units just plug in



Install in your own fine cabinetry, in book shelves or in built-in wall

Here is the leading guide to an easy understanding of Hi-Fi. It's invaluable if you're planning a home music system. Shows you how to select a custom system to satisfy your own listening desires at lowest cost. Tells you what to look for in complete systems and individual units. Shows many handsome, practical do-it-yourself installation ideas. Offers you the world's largest selection of complete systems as well as individual amplifiers, tuners, changers, speakers, enclosures, tape recorders and accessories from which to make your money-saving choice. Before you make your selections you'll want to refer to this invaluable, informative ALLIED HI-FI book. Write for it today—it's FREE.

FREE  
HI-FI BOOK

ALLIED RADIO  
*America's Hi-Fi Center*

ALLIED RADIO CORP., Dept. JJ-115  
100 N. Western Ave., Chicago 80, Ill.

Send FREE 100-Page Hi-Fi Book

Name \_\_\_\_\_

Address \_\_\_\_\_

City \_\_\_\_\_ Zone \_\_\_\_\_ State \_\_\_\_\_

resistance called a multiplier is required which has a resistance that is just enough to permit 1 ma. to flow through the coil when 1 volt is applied to the terminals. This value is easily found by applying Ohm's law as follows:

$$R_s + R_c = E/I$$

In the foregoing example,  $E = 1$  volt and  $I = .001$  amp., so  $R_s + R_c = 1/.001 = 1000$  ohms. Since the total resistance required in this particular case is 1000 ohms to measure 1 volt, the sensitivity of the meter movement is "1000 ohms per volt," often written 1000 ohms/volt.

Take another example: a much superior meter movement is to be used as a 0-10 voltmeter. This instrument deflects full-scale for only 50 microamperes (.00005 amp.) of coil current. If 10 volts is applied, then the series resistance must be:  $R_s + R_c = 10/.00005 = 200,000$  ohms. This means that a series resistance approximating 200,000 ohms is needed for a potential of 10 volts; for 1 volt, then, the resistance would have to be 20,000 ohms. Thus, this is a 20,000 ohms/volt movement. In practically every case, the resistance of the meter coil,  $R_c$ , is so insignificantly small compared to the external resistance which must be added that it may be neglected in the calculations.

Here are some other examples of meter sensitivities:

Voltage Range	Coil Current (amp.)	Series Resistance (ohms)	Ohms/Volt Rating
0-10	.001	10,000	1,000
0-100	.001	100,000	1,000
0-100	.0005	200,000	2,000
0-50	.00005	1,000,000	20,000
0-500	.0002	2,500,000	5,000

### BLACK BOXES

Switch, S1, turns on lamp, L1, and switch, S2, turns on lamp, L2. Each switch and lamp operates independently of the other. What's inside the boxes??? Don't look at page 124 until you've tried to work it out for yourself.

-30-

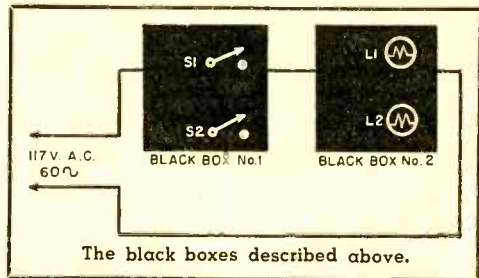

## FILAMENT TRANSFORMERS

*Do you want them?*

from 2½V - 24V or from 1 amp. to 30 amps.

*We have them in stock.*

# MERIT

see your jobber  
for immediate delivery

Coil and Transformer Corp. • 4427 N. Clark Street • Chicago 49, Illinois

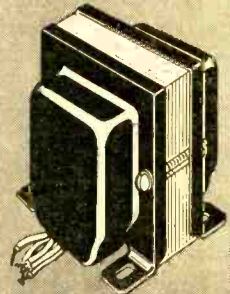

## SENSATIONAL RECORD CHANGER SALE

**DO IT YOURSELF KITS:** Send for complete catalog of all types radio, TV, Hi-Fi tuners & amplifiers & test equipment.

### 45 RPM SPINDLES

VM . . . \$2.69 Garrard . . . \$3.37  
Webster \$3.89 Collaro . . . \$3.75

### RECORD CHANGER BASES & BOARDS

Bases—\$3.89  
Mounting Boards—\$1.95  
For changers listed to right

### TRIPLE PLAY CART.

RELUCTANCE TYPE \$5.94  
GE RPX060

Free Hi-Fi equip. Cat. avail.

**WEBSTER (NEWEST MODEL):** Automatic shut off, Hi-fi Ronette cartridge with dual sapphire styli. Heavy duty 2 pole motor. Plays 7-10-12" records. Regularly \$37.50 **\$24.94**

**WEBSTER:** 3 speed hi-fi changer with GE Reluctance RPX 050 cartridge. Heavy duty 4 pole motor, Automatic shutoff. Reg. \$40.00 **\$29.49**

**VM TRIOMATIC:** 3 speed intermix with sapphire dual styli. Reg. \$34.50 **\$23.49**

**GARRARD RC 80:** 3 speed. One of the finest British changers. Automatic shutoff. Weighted turntable. 4 pole motor. Complete with plug-in head. Reg. \$50.00 **\$42.94**

**COLLARO RC 54:** 3 speed. Fine British import, automatic shut off, weighted turntable, 4 pole motor. Intermix. Complete with plug-in head. **\$38.49**

**WITH RONETTE DUAL SAPPHIRE STYLI, HI-FI CART—\$40.49**

All merchandise is brand new, factory fresh & guar. Mail & phone orders filled on receipt of certified check or MO of 20% of items as a deposit. Balance C.O.D., F.O.B. factory N. Y. Prices & specifications subject to change without notice.

**AIREX RADIO CORP., 171 Washington St., N. Y. 7**

**CO 7-5218**



# TOOLS & GADGETS

## MINIATURE SOLDERING TOOL

Weighing less than  $\frac{1}{2}$  ounce, and only 6" long, the *Oryx* Model 11 miniature soldering tool guarantees relaxed soldering—for hours on end without hand fatigue. It takes only a minute to heat and is

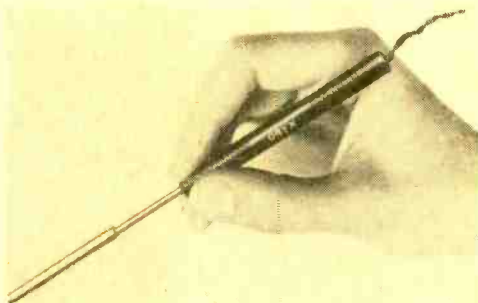

equipped with a  $\frac{5}{32}$ " pure nickel non-corrosive tip which can be easily replaced if necessary. For further details, write to the manufacturer's U. S. representatives: *Television Accessories Co.*, 1412 Great Northern Bldg., Chicago 4, Ill.

## PERMANENT-MAGNET MOTORS

A new line of d.c. motors incorporating a permanent-magnet field assembly is being offered by *Servo-Tek Products Company, Inc.* Features include a housing which is fully machined from solid aluminum, low-torque ball bearings, an anodized finish, and improved mechanical construction. These motors are notable for their

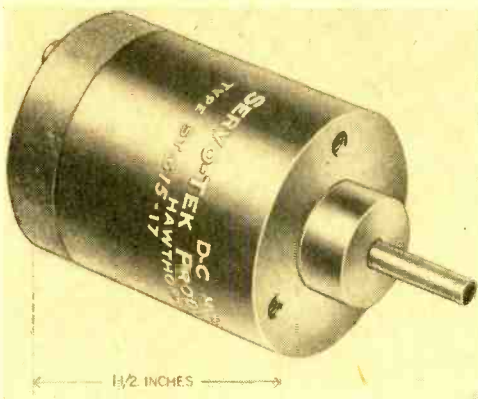

small size; over-all body length is less than  $1\frac{1}{2}$ ", and weight less than 3 ounces.

Various electrical characteristics are

November, 1955

## LEARN basic electricity electronics

THE EASY "PICTURE BOOK" WAY!



Just Released: The fabulous  
**ILLUSTRATED Training Course**  
now used by the U. S. Navy!

### You Learn by Pictures!

Over 25,000 Navy trainees have already learned Basic Electricity and Basic Electronics this easy, "Picture Book" way! Now, for the first time, YOU can master the basics of Electricity and Electronics with this same "Learn-by-Pictures" training course! Over 1,700 simple, easy-to-understand drawings explain every section—these "teaching" pictures actually make up more than half the *entire* course! No other Basic Electricity or Basic Electronics course in America uses this revolutionary illustrative technique! You learn faster and easier than you'd dream possible!

### A Complete Idea on Every Page

Here's how this easy, illustrated course works: *every page* covers one complete idea! There's at least one big illustration on that *same* page to explain it! What's more, an imaginary instructor stands figuratively at your elbow, doing "demonstrations" that make it even *easier* for you to understand. Then, at the end of every section, you'll find *review pages* that highlight the important topics you've just covered. You build a thorough, step-by-step knowledge at your own pace—as fast as you yourself want to go!

### Everyday English--A Course Anyone Can Understand

Sponsored by the Navy to turn out trained technicians in record time, this modern course presents Basic Electricity and Basic Electronics in a simple way that *everyone* can grasp—regardless of previous education! Every phase is made *instantly* clear—explained in plain, down to earth English—with hundreds of easy-to-understand illustrations to help you!

### 10 Complete Volumes

Volumes 1 and 2 of "Basic Electricity" cover DC components and circuits; Volumes 3 and 4 cover AC components and circuits; Volume 5 covers AC and DC motors and machinery.

Volume 1 of "Basic Electronics" covers Diodes & Power Supplies; Vols. 2 and 3 cover Amplifiers & Oscillators; Vols. 4 and 5 cover Transmitters & Receivers.

### Home Study Without Correspondence

This course is *so different, so complete*—there's no need for the usual letter writing, question and answer correspondence! Learn at home—at your own pace!

### 10 Day Examination--Money Back Guarantee

Send today for these exciting new training courses—you *risk nothing!* When you receive the volumes, examine them in your own home for 10 full days. If, at the end of that time, you're not completely satisfied, simply return the books to us and we'll gladly *refund your full purchase price!* Total cost for either 5-volume course is only \$9.00! In Canada, prices approximately 5% higher.

### ORDER TODAY!

These books are sold by electronics parts jobbers and book stores. If YOUR dealer doesn't have these books, mail this coupon to us!

JOHN F. RIDER PUBLISHER, INC.  
480 Canal Street, N.Y.C.

I have enclosed \$..... Please send me  
 5-vol. Basic Electricity set @ \$9 set  
 5-vol. Basic Electronics set @ \$9 set  
 Both sets. I understand I may return the books in 10 days, and receive a complete refund of the full purchase price if I am not satisfied.  
 Add state or city sales tax where applicable.

Name.....  
 Address.....  
 City & State.....P-6

# AUDIO FAIR... HI-FI

Why—What—Where to Buy

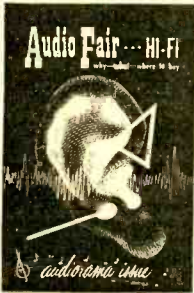

The complete directory on High Fidelity. Here at last —by wide public demand— is the book for the Hi-Fi novice, enthusiast and music lover.

Full of material on every phase of Hi-Fi plus a complete directory of WHAT and WHERE to buy EVERYWHERE.

**\$1.00**

postpaid  
anywhere

**SEND FOR YOUR  
COPY TODAY!**

AUDIO FAIR PUBLISHERS

67 West 44th St., New York 36, N. Y.

Enclosed is \$..... for..... copies of  
AUDIO FAIR... Hi-Fi.

Name .....

Address .....

City ..... State .....

## Edlie for TOP VALUES

**JUST OUT!** Newest & Best "Fix-It-Yourself" Aid  
**Edlie's E-Z TV REPAIR GUIDE**

The only Fix-It-Yourself guide made expressly for YOUR TV set!

Now you can save costly TV repairs, with this new, simplified method which includes all necessary data for just YOUR set. No confusing, unimportant information applicable to hundreds of different makes. Simplifies detection of faulty tubes in your TV receiver quickly, accurately.

It's a terrific idea—It's a terrific guide! Order today and have your set back in perfect condition at once. Be sure to send us make and model of your TV set when ordering. For most TV sets—new and old.

only  
**50¢**



Kit of 5 tubes: 12AT6, 12BA6,  
12BE6, 35W4 & 50B5... \$3.25

### 5-Tube AC/DC Superhet Radio Kit

**KIT 5:** Includes all top quality components required to construct this latest design, highly sensitive 5-tube, AC/DC superheterodyne broadcast receiver. Complete with black, glazing bakelite cabinet (excludes wire & solder).

less tubes..... **\$7.95**

### 6-Tube Radio Kit

**KIT 6:** A great value in a low-priced radio kit designed for high sensitivity and good tone qualities. Easily constructed circuit. Complete with chassis, all parts, hardware, PM speaker (except wire & solder).

Kit of 6 tubes: 25L6, 25Z6,  
6SQ7, 6SA7 &  
6SK7(2)..... **\$3.25**

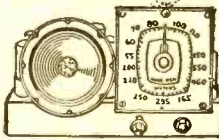

less tubes..... **\$6.95**

Write today for FREE Catalog. All mdse. shipped F.O.B. New York City, prices subject to change without notice. Include 20% deposit with C.O.D.'s.

## EDLIE ELECTRONICS

154A Greenwich St. D.I. 9-3143 New York 6, N. Y.

available with a range of operating voltages from 6 to 80 volts, no-load speeds from 3000 to 20,000 r.p.m., and power output up to 11 watts. Address requests for literature to the manufacturer at 1086 Goffle Road, Hawthorne, N. J.

### PRINTED CIRCUIT SPRAY COAT

"G-C Print-Kote," a silicon resin, comes in a convenient pressure spray can for easy application. It is said to insulate a printed circuit effectively, preventing arcing and shorting without further attention. After repairing or replacing parts in a printed circuit, the serviceman simply spray-coats the soldered connections with "Print-Kote."

A six-ounce can lists for \$3.25, with a net of \$2.17. Further information and literature may be obtained by writing direct to *General Cement Mfg. Co.*, 919 Taylor Ave., Rockford, Ill.

### V.T.V.M. FEATURES VOLTAGE REGULATION

Claimed by its manufacturer to be the first kit of its type on the market, the new Model 9071 vacuum-tube voltmeter features "true voltage regulation." Offered by *Precise Development Corp.*, Oceanside, L.I.,

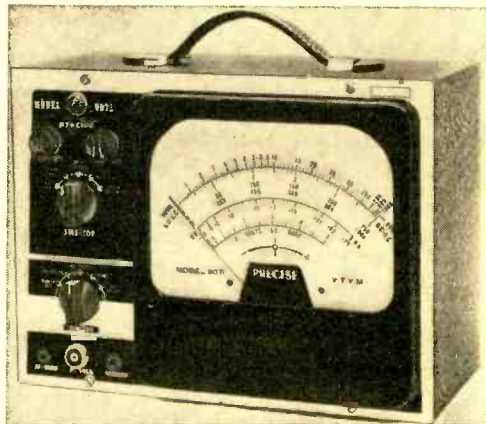

N.Y., the instrument is available as a kit for \$35.95, or factory-wired at \$49.95. The 7½" meter has readings for ohms, d.c. volts, a.c. volts, decibels, and a special scale for 5 volts a.c. only.

### AUTOMATIC PHONO SHUT-OFF

"Slumber Switch" is an accessory device that shuts off an entire hi-fi system after the last record on the changer has played. It has two a.c. receptacles for connection of amplifier, tuner, tape recorder or other powered equipment to be operated.

Fireproof, shockproof and foolproof, the unit incorporates a changer pop filter for silent changer "shut-off." It is furnished with a 3' cable for connection to a changer

switch and a 3' cable for remote or panel mounting of a defeat switch. The defeat switch restores the system to normal operation at will.

This device retails for \$7.95 postpaid. To order, or to obtain additional information, write to the manufacturer: *The Hi-Fi Center, Inc.*, 2630 N. Downer Ave., Milwaukee 11, Wis.

### R-C SUBSTITUTION BOX

A combination resistance-capacitance substitution box has been announced by *Electronics Measurements Corp.*, 280 Lafayette St., New York 12, N. Y. Known as *EMC Model 900*, it is available in kit form for \$10.25, or in completely wired form for \$17.90. The device provides, within 10% accuracy,

36 standard RETMA resistor values from 15 ohms to 10 megohms, and 18 standard RETMA capacitance values from .001  $\mu$ fd. to .22  $\mu$ fd. Complete details are available on request from the manufacturer.

### ELECTRIC DRILL ATTACHMENT

The "SUPREME VERSAMATIC" is a versatile quarter-inch electric drill attachment that boosts power and reduces speed. It can change a quarter-inch electric drill into a high-power tool with a hand-type clutch for forward and reverse. The 7:1 speed reduction steps up power proportionately. Included in the attachment kit is a slotted screwdriver, *Phillips* bit, adapter for  $\frac{1}{4}$ " socket sets (square drive), wrench pin and a 12-page instruction booklet. It is available from *Scott-Mitchell House, Inc.*, Dept. SV-1, 611 Broadway, New York 12, N. Y. Price quoted is \$14.95 postpaid.

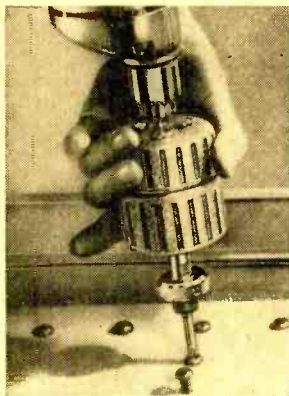

## Can you think faster than this machine?

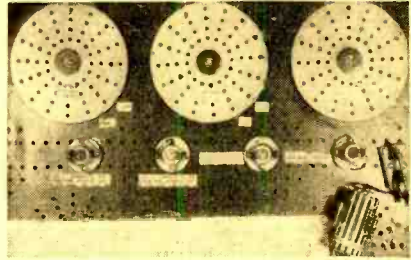

Control Panel of GENIAC set up to do a problem in check valve research.

Be careful before you answer. GENIAC the first electrical brain construction kit is equipped to play tic-tac-toe, cipher and encipher codes, convert from binary to decimal, reason (in syllogisms) as well as add, subtract, multiply and divide. Specific problems in a variety of fields—actuarial, policy claim settlement, physics, etc. can be set up and solved with the components. Connections are solderless and are completely explained with templates in the manual. This covers 33 circuits and shows how new ones can be designed.

You will find building and using GENIACS a wonderful experience; one kit user wrote us: "this kit has opened up a new world of thinking to me." You actually see how computing, problem solving, and game play (Tic-tac-toe, nim, etc.) can be analyzed with Boolean Algebra and the algebraic solutions transformed directly into circuit diagrams. You create from over 400 specially designed and manufactured components a machine that solves problems faster than you can express them.

Schools and colleges, teachers of science or math, engineering, philosophy or psychology will find these excellent demonstrators of circuitry, solutions in symbolic logic, theory of numbers, cybernetics, and automation.

Note: Teachers take advantage of our 10% discount to educational institutions and for group purchases.

### FREE CONSULTATION SERVICE FOR AMATEUR RESEARCHERS

We will help you plan your reading and research projects on computers using Geniac, at no extra charge.

Complete question and answer service available to kit buyers.

Each kit is a self contained course with materials and books.

Complete guarantee on all materials if not satisfactory returnable for full refund in one week.

SEND for your GENIAC kit now. Only \$19.95 with over four hundred components and parts, fully illustrated manual and wiring diagrams. We guarantee that if you do not want to keep GENIAC after one week you can return it for full refund plus shipping costs.

### MAIL THIS COUPON

SCIENCE KITS, Department PE4,  
Oliver Garfield Co., 546 Summit Avenue, Jersey City, N.J.

Please send me:

1 GENIAC Electric Brain Construction Kit and Manual.

\$19.95 (East of Mississippi) .....

\$20.95 (Elsewhere in United States) .....

\$21.95 (Outside the United States) .....

1 Catalog of Science Kits .....

Returnable in seven days for full refund if not satisfied.

I enclose \$..... in full payment.

My name and address are attached.

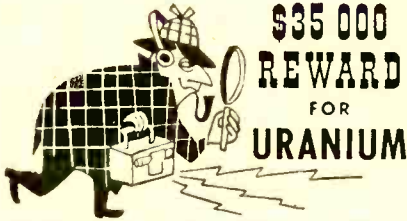

Here's your chance to "cash in!" Over \$2,500,000 in Government Bonuses have been paid for URANIUM discoveries in the past 2 years. Currently \$150,000 a month is paid to people just like you. Precision Geiger Counters and Scintillators are the finest instruments made for URANIUM prospecting. These highly sensitive instruments are compact, lightweight and ruggedly built for field use. Prices start at \$29.95.

CONTACT YOUR NEAREST DEALER or write direct to factory for FREE 12-PAGE CATALOG, describing URANIUM and Metal detectors.

PROSPECTORS



RELY ON . . . PRECISION RADIATION INSTRUMENTS, INC.

4223PT W. Jefferson Boulevard • Los Angeles 16, California  
WORLD'S LARGEST MANUFACTURER OF RADIATION INSTRUMENTS



"I'M MAKING MORE THAN \$1000 a Month



C. KAMA

Haven't Touched Bottom Yet!"



—reports Charles Kama, Texas, one of many who are "cleaning up" with orders for PRESTO, Science's New Midget Miracle Fire Extinguisher. So can YOU!

AMAZING new kind of fire extinguisher. Tiny "Presto" does job of bulky extinguishers that cost 4 times as much, are 8 times as heavy. Ends fires fast as 2 seconds. Never corrodes. Guaranteed for 20 years! 2 Million Sold! Sells for only \$3.98.

Show it to civil defense workers, owners of homes, cars, boats, farms, etc., and to stores for re-sale—make good income. H. J. Keir reports \$20 a day. Wm. Wydallis, \$15.20 an hour. Write for FREE sales kit. No obligation. (If you want a regular Presto to use as a demonstrator, send \$2.50. Money back if you wish.) MERLITE INDUSTRIES, Dept. 32-B, Presto Div., 114 East 32nd St., New York 16, N. Y. IN CANADA: Mopa Co., Ltd., 371 Dowd St., Montreal 1, P. Q.

## Repair Television Picture Tubes Without Cost or Equipment

Give new life to old or defective tubes. Remove shorts. Restore emission and brightness. Months of extra service.

Save money by fixing your own tube. Earn extra money by fixing tubes for others. Learn this easy, tried and tested method now and cash in!

Complete instructions (Pays for itself!)

ONLY \$1

TELEPARTS CO.

P. O. Box 74A

Providence 5, R. I.

## AMA-TOURING with Roger Legge

READERS who were tuning the amateur bands during the period from 1946 to 1950 will recall that the 28-mc. (10-meter) band was an outstanding DX band during those years, with lots of good DX coming through from all parts of the world. During the past several years of low sunspot numbers, propagation conditions have not been favorable for DX on this band, but with the present rapid increase in sunspot numbers, this fall and winter should see a resumption of more favorable DX conditions on the 28-mc. band.

The band covers 28.00 to 29.70 mc., with the U.S. phone portion of the band at 28.50 to 29.70 mc. As on other bands, most c.w. operation is at the low end of the band, approximately 28.00 to 28.05 mc. However, there has not been much c.w. operation on this band. Most of the foreign phone stations operate between 28.05 and 28.50 mc., but there is also

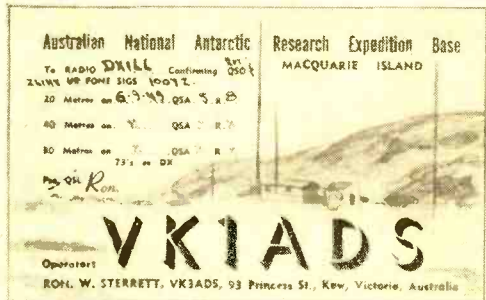

This QSL card came from the Antarctic Expedition Base on Macquarie Island.

some operation above approximately 28.80 mc.—above the heavy concentration of W/K phones at the low end of the U.S. phone band.

Best 28-mc. reception during November should be from Latin America, Africa and Oceania, during the hours indicated in this month's DX forecast. It is also possible that there may be an occasional opening to Europe. The return of good DX conditions for 28 mc. is a welcome addition to our DX bands.

### Antarctica Stations

A number of countries are operating bases in Antarctica and on adjacent islands. Amateur operation from these bases provides opportunities for hearing stations from this area.

Australia operates the Mawson Base on the Antarctic continent, the southernmost settlement in the world. VK1AWI, VK1EM and VK1RA are active from that location. There also is a base on Macquarie Island—between

Australia and Antarctica—from which VK1-DC, VK1HN and VK1ZM are operating. A former base on Heard Island is now closed.

The British have bases in Grahamland, south of the tip of South America, and also on several islands in the vicinity. Amateurs active there are VP8BD in Grahamland, and VP8AQ, VP8BF and VP8BH in the South Shetland Islands.

Argentina also has bases in Grahamland and the South Shetlands. LU amateurs operating from these bases use calls with Z following the numeral (LU1ZC, etc.). Chile operates the Base Gonzales Videla and Base O'Higgins in Antarctica. Amateurs there use CE7 calls with Z following the numeral (CE7ZA, etc.).

### 14-Mc. Phone DX

Here are the month's reports on 14-mc. phone DX. All times are 24-hour EST.

#### ASIA & OCEANIA

**Caroline Islands**—KC6AJ was heard on 14.21 mc. at 0600. (*Bobby Wilkins, Texas*)

**Ceylon**—4S7YL has been noted on 14.17 at 0900. (*Jim Moore, Calif.*)

**Fiji Islands**—VR2CW, Suva, on 14.195 mc., was picked up at 1930. (*Dennis Johnson, Calif.*)

**Indo-China**—F18AF was logged on 14.14 mc. at 0930. (*Moore*)

**Israel**—4X4DK, Jerusalem, has been heard well on 14.30 mc. at 2230 in contact with a Cuban station. (*Bill Dean, New York*)



The above QSL card is from the recent DX expedition to Corn Island, near Nicaragua —W0EIB, W0AIW, YN4CB, and YN4HA.

**Johnston Island**—KJ6FAA was observed on 14.26 at 0600. (*Don Kenny, Calif.*)

KJ6FAB, a new one on Johnston, was heard on 14.22 at 0800. He uses 90 watts and gave his address as APO 105, San Francisco, Box 11. (*RL*)

**Malaya**—VS2ER, Epoh, is now on 14.17 at 0840. (*Kenny*)

**Marianas Islands**—KG6NAA, on 14.25 mc., has been heard at 2000 on the West Coast and at 0800 on the East Coast. He gave his address as Box 97, Agana, Guam. (*Johnson*)

**Marshall Islands**—KX6AF, Kwajalein, was noted on 14.197 at 1900. (*Johnson*)

# TELTRON TUBES

**Guaranteed! Lowest Prices Ever!**

All tubes individually boxed . . . unconditionally guaranteed for one year.

**FREE!  
BONUS  
OFFER!**

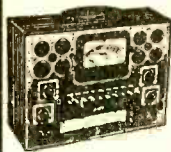

Model 625K

This Eico Tube Tester is yours FREE when you buy \$199 worth of tubes or more within 60 days at Teltron. May be bought outright from Teltron for \$34.95.

We now have a full stock of T.V. picture tubes.

You can order any size at \$1.25 per inch. All tubes RCA licensed and guaranteed for one year.

TYPE	PRICE	TYPE	PRICE	TYPE	PRICE	TYPE	PRICE	TYPE	PRICE
024	.45	6AQ5	.48	6CU6	.95	7F7	.59	25L6GT	.41
1A7GT	.55	6AR5	.48	6D6	.59	7F8	.77	25BQ6GT	.82
1B3GT	.62	6A5S	.52	6E5	.60	7N7	.52	25W4GT	.43
1H5GT	.51	6AT6	.37	6F5	.44	12AT6	.37	25Z5	.55
1L4	.51	6AU5GT	.60	6F6	.42	12AT7	.71	25Z6GT	.36
1L6	.51	6AU6	.43	6H6	.50	12AU7	.58	35A5	.48
1LC6	.49	6AV5GT	.60	6J5	.49	12AV6	.42	35B5	.48
1N5GT	.51	6AV6	.37	6J6	.61	12AV7	.73	35C5	.48
1R5	.51	6AX4GT	.60	6K5	.60	12AX4GT	.60	35L6GT	.41
1S5	.43	6AX5GT	.60	6K6GT	.39	12AX7	.61	35W4	.33
1T4	.51	6BA6	.56	6K7	.40	12AZ7	.61	35Y4	.42
1U4	.51	6BA7	.58	6L6	.78	12AZ7	.72	35Z3	.41
1U5	.43	6BC5	.48	6Q7	.40	12BA6	.46	35Z5GT	.33
1X2	.65	6BC7	.75	6S4	.41	12BA7	.58	37	.59
3A5	.65	6BE6	.46	6SRGT	.65	12BE6	.46	43	.55
3Q4	.53	6BF5	.48	6SA7	.45	12BH7	.61	45	.55
3Q5GT	.61	6BF6	.48	6SK7	.45	12BY7	.65	50A5	.49
354	.48	6BG6G	1.18	6SJ7	.45	12H6	.60	50B5	.48
3V4	.48	6BH6	.51	6SN7GT	.60	12J5	.40	50L6GT	.50
5R4	.95	6BJ6	.51	6SQ7	.40	12J7	.43	50X6	.53
5U4G	.43	6BK5	.75	6T8	.71	12Q7	.48	75	.44
5V4	.49	6BK7	.78	6U8	.76	12SA7	.45	77	.55
5V3	.30	6BL7GT	.78	6V3	.80	12SJ7	.45	80	.40
5Y4G	.37	6BN6	.90	6V6GT	.48	12SK7	.45	84	.46
6A8	.40	6BQ6GT4	.83	6W4GT	.43	12SL7	.60	117GT	1.20
6BA4	.43	6BQ7	.85	6W6GT	.53	12SN7GT	.56	117L7GT	1.20
6AC7	.65	6BSY5G	.60	6X4	.37	12SQ7	.38	117N7GT	1.20
6AG5	.52	6BZ7	.95	6X5GT	.38	14A7	.43	117P7GT	1.20
6H4GT	.65	6CA5	.41	6X8	.80	14B6	.36	117Q7GT	1.20
6AF4	1.02	6C5	.46	6Y6G	.61	14Q7	.52	117Z3	.33
6AK5	.96	6CB6	.51	7A8	.46	19B6GG	1.48	117Z6GT	.65
6AL5	.43	6CD6G	1.63	7C5	.44	19T8	.71	1629	.39

We have thousands of tube types too numerous to list here. On ordering types not listed take 75% off current list price for cost of tube.

## FREE

\$7.20 list value Bonus Box of three 6SN7 tubes and 25 assorted resistors with each order of \$25 or more.

**SAME DAY SERVICE**  
48 hour Postal Delivery to West Coast.

Repeated by Popular Demand  
Specials to Dec. 1st

1X2	.65	.55
5U4G	.43	.39
6AU6	.43	.39
6AL5	.43	.39
6BQ6GT	.83	.77
6CB6	.51	.47
6CD6G	1.63	.99
6SN7GT	.60	.55
6W4GT	.43	.39
12AT7	.71	.61
12AT7	.71	.58
12SK7	.45	.41
12SQ7	.38	.35
50L6GT	.50	.47

### NEW LIBERAL TERMS!

No minimum order. All postage paid on orders over \$10.00 in U.S.A., A.P.O.'s and Territories. 10% deposit on C.O.D.'s. 25¢ handling charges on orders under \$5.00. To our Canadian and foreign friends, please send a proximate freight—excess will be refunded. Orders subject to prior sale.

**WE WANT NEW ACCOUNTS**  
If you are rated, your credit is good with us. We are "Eico" distributors. Write us about special deals on test equipment.

# TELTRON ELECTRIC COMPANY

428 HARRISON AVE. DEPT. PE-11 Phone HUMBOLDT 4-9848 HARRISON, N. J.

## DX FORECAST FOR NOVEMBER

From	In Eastern & Central USA (EST)			In Western USA (PST)		
	14 mc.	21 mc.	28 mc.	14 mc.	21 mc.	28 mc.
Central & South America	0600-2000	0700-1700	0800-1600	0600-1900	0600-1700	0700-1600
Europe & North Africa	0600-0800 1200-1500	0800-1200	—	—	0700-1000	—
Central & South Africa	1300-1700	0600-1600	0700-1500	1500-1700	0700-1600	0800-1400
Near & Middle East	1200-1400	0800-1100	—	—	0700-0900	—
Far East	—	1600-1900	—	1900-2100	1400-1900	1400-1700
Australia & New Zealand	—	1500-1900	1700-1900	0730-0900	1100-1900	1400-1800

The 24-hour clock system is used for these forecasts. Hours from midnight until noon are shown as 0000 to 1200, hours from 1 p.m. to midnight as 1300 to 2400. EST represents Eastern Standard Time; PST is Pacific Standard Time, three hours later than EST.

**Okinawa**—KR6AF, on 14.13 mc., has been the strongest station heard from Okinawa during the period around 0700. (RL)

**Qatar**—MP4QAI, located in this rare country in the Arabian peninsula, was heard on 14.25 mc. at 0000. (Wilkins)

**Samoa**—ZM6AP, Apia, was picked up on 14.145 at 1900. (Johnson)

**Pitcairn Island**—VR6AC is now on 14.125 at 1830. He will also be operating on the 21- and 28-mc. bands. (Johnson)

**Singapore**—Stations heard at 0900-1000 were: VS1CZ, 14.14; VS1EW, 14.135; VS1FS, 14.165; and VS1GT, 14.14. (Kenny)

**Tahiti**—F08AM, Papeete, was noted on 14.19 mc. (E. G. Riggle, Ohio)

**Taiwan**—BV1US is heard at 0800-1000 on 14.25 mc. (Wilkins)

### AFRICA

**British Somaliland**—VQ6LQ is back on the air from this rare spot. Most likely time for reception in November is around 1500-1600.

**Chagos Islands**—VQ8CB states that he operates on 14.10 mc. nightly at 2215 and also about twice a week around 0800-0900.

**Libya**—5A2TL was noted on 14.10 mc. at 0745. (Jimmy Duncan, Ky.)

**Nyasaland**—ZD6BX is heard on 14.14 mc. at 2345. (Moore)

**South Africa**—ZS6TE was logged on 14.18 at 0700. (Kenny)

**Tristan da Cunha**—ZD9AC has been heard on 14.19 at 1815. (Moore)

### EUROPE

**Czechoslovakia**—OK1MB was observed on the West Coast on 14.14 at 0100. (Moore)

**Iceland**—TF2WAG, Keflavik, was heard on 14.19 at 1800. TF2WAF continues to be active and is noted around 14.19 mc. (Riggle, Terry)

**Poland**—SP5CC has been picked up on 14.16 at 2350. (Moore)

**Saar**—9S4AC was heard on 14.15 mc. at 1700. (Wilkins)

### AMERICAS

**Bolivia**—CP5EQ/CP6 is noted on 14.32 at 1900. (Kenny)

**Canadian Arctic**—Stations heard around 0700-0800 and 1800-2000 are: VE8MD, Isachsen Island, on 14.165 mc.; VE8ML, Ellesmere Island, on 14.17 mc.; and K5BZT/VE8, Resolution Island, on 14.195 mc. (RL)

**Greenland**—KG1BO is now on 14.23 at 2200. KG1AA and KG1BO are at Thule, northern

## TO HELP YOU SELECT THE CORRECT HI-FI ENCLOSURE

Send for this free booklet. It contains all the facts you need to select and install the enclosure for the discriminating... the enclosure by which all others are measured.

**AUTHORITATIVE  
GUIDE**

*The Karlson Enclosure*

**FREE**

**KARLSON  
ULTRA-FIDELITY  
ENCLOSURES**

Revised edition with complete data on the New Karlson "g"

**IDEAS**

**HELPFUL**

**FULL OF FACTS**

**COMPLETE**

KARLSON ASSOCIATES, INC.

DEPT. C

1610 Neck Road, Brooklyn 29, N. Y.

Please send copy of your latest book **The "Karlson Enclosure"** to

Name

Address

City  State

Greenland. KG1FR, who was heard on 14.27 at 0730, is at Sondrestrom. (Bill Masica, Ohio; Wilkins)

**Guatemala**—TG7CB, an unusual TG district, was heard on 14.22 at 0715.

**Haiti**—There is increased activity from here as a result of a number of new amateurs operating, including: HH4MV, 14.15; HH7AB, 14.19; HH7NM, 14.17; HH7RW, 14.16. Best reception, 1800-2100. (Johnson, Kenny, Riggle)

**Leeward Islands**—VP2KG, St. Kitts, is a new one observed on 14.165 at 1700. VP2KB and VP2KM also continue to be active.

**Peru**—Most Peruvians heard are OA4's in Lima, but stations in a number of other districts are active, including: OA1C, Negritos, 14.15; OA2A, Chilete, 14.13; OA3L, Pucallpa, 14.18; OA5G, San Juan, 14.19; and OA6M, Arequipa, 14.15 mc. Best reception is at 1700-1900.

**San Andres Island**—HK0LG, a new one, was picked up on 14.23 at 2130. (Dean)

HK0AI continues to be active, and has been noted on 14.18 mc. at 1830. (Don Alexander, Texas)

### 14-Mc. C.W.

OY7ML, Faeroes Islands, is now on 14.03 mc. at 1330. (Carey Keyser, W3YVJ)

Other c.w. DX reported includes: CP4KD, 14.07; IT1TAI, 14.07; JA5AA, 14.03; KA2GC, 14.05; KG6FAA, 14.02; SM5ANY, 14.03; SM5BPJ, 14.07; TF2WAF, 14.01; VK9WP, 14.06. (Wayne Ashworth, KN4CDZ)

### 21-Mc. Phone

Initial openings on this band indicate good DX conditions during the coming months. The following were heard: DL1HH, 21.22; DL3EA, 21.21; DL3MD, 21.27; DL6QW, 21.14; EA2DT, 21.25; F7EA, 21.24; F8MP, 21.19; ON4JN, 21.32; PA0AGR/A, 21.15; PA0ALO, 21.17; 4X4DK, 21.34; OQ5HL, 21.14; VQ4EO, 21.16; HC1FN, 21.23; HR3HH, 21.20; HR4WH, 21.16; CX2CO, 21.22; KZ5MB, 21.27; KZ5WA, 21.39; LU7DG, 21.21; PY2AKA, 21.24; KH6AFS, 21.26; and ZL2BE, 21.22. (RL)

### Last-Minute Flashes!

Watch for stations from India and Southeast Asia on 21 mc. around 0900 EST. A W0 operating mobile marine in the South China Sea was heard then, indicating openings from South Asia at that time. Additional stations heard include: EA8AX, 21.13; GC4LI, 21.29; PZ1RM, 21.15; ZS3G, 21.11 mc. (RL)

Jim Moore, California, reports the following additional 14-mc. DX: XW8AB, Laos, on 14.23, at 1145 EST; C3WV, Formosa, 14.20 at 1200; KC6UZ, Caroline Islands, on 14.255 at 0100; VK1DC, Macquarie Island, on 14.14 at 0030; VK9RC, New Guinea, on 14.14 at 0030.

KH6AR stated that MP4KAB, MP4BBF, MP4BBV, MP4QAL and VS9AL are active on 20-meter phone. VK4NC stated that there are still two VK1's operating from Heard Island; also that YJ1AR, New Hebrides, will be on the air. YJ1DL operates on phone, but is mostly on c.w.

## QUALITY KITS... BACKED BY 23 YEARS OF ELECTRONIC MANUFACTURING EXPERIENCE BY G. E. E. CO.

### Super Sensitive GEIGER COUNTER KIT AEK100

Features found only in much higher priced kits. Batteries incl. (not sold less batt.)

Geiger tube 900 volt halogen quenching type, protects against burnouts, 100 counts per min. Detects minimum radiation harmful to health; detects presence of uranium or other radio-active ores. Simple operation, rugged construction. Low cost battery replacement. High gain power amplifier, ultra sensitive geiger tube for phenomenal high sensitivity. Radio-active sample & headphone incl.



Has shoulder carrying strap, long battery life, unlimited life geiger 900 volt tube, halogen quenched, unaffected by light or temperature (-50° to 125°), finely finished all steel case.

AEK100 Geiger Counter Kit complete as above with batteries, tubes, wiring & assembly & operating instructions..... 19.65

AE100—complete factory built, ready to operate..... 32.95

### Wide Band 5 In. Oscilloscope Kit Model 555K

Compare outstanding performance with higher priced kits. For color TV & black & white. Ideal for general lab & service application.

Push pull 3 stage vertical amplifier with cathode plate follower circuit • Multivibrator type sweep generator 15 to 150,000 CPS • Compensated step type attenuator • Z axis modulation available • Anastigmatism control built in (spot size) • Retrace blanking • 5-way binding posts for all terminals • Low impedance drive from sweep coupling.



Complete, all tubes incl. 5" CR tube; illus. wiring & assembling, operating instructions. Wt. 20 lbs.

SPECIFICATIONS	VERTICAL	HORIZONTAL
Freq. Resp.	Actually useful to 4 mc.	Actually useful to 700 kc.
Max. Snst.	25 mv. per RMS inch	0.3 volts per RMS inch
Input Imp.	3.3 megohms across 30 mmfd.	500,000 ohms across 35 mmfd.
Amplifiers	Video compensated	Non-parallax deflection type output
Kit Model 555K.....	59.50	Factory wired complete.. 89.50

### 327K Tube Tester Kit

Tests all tubes in all current radio & TV sets, also color TV—new 600 ma series string-type, etc. Has line voltage regulator—"free point" obsolescence-proof element switching system—short & leakage tests—can't insert tube in wrong socket—fuses protect meter & transformer separately. New loose leaf book with indexed tube data cards—no obsolescence—new tube data quickly inserted—far ahead of rollcharts. Picture Tube Adapter \$3.95



327K Kit Complete..... 33.95  
327 Factory wired & tested..... 48.95

### 480K Multi-Tester Kit



1000 ohms per volt. Measures DC volts—AC volts—DC amp.—DC milliamps.—ohms—megohms—decibels—output meter. Molded, bakelite panel, case, battery cradle—molded in jacks—circuitry design protects against meter damage—high sensitivity.

480K kit complete with battery and all parts 12.75  
480 Factory wired and tested..... 14.85

Get these kits from your distributor. Write for literature, Dept. P-11

## GENERAL ELECTRONIC EQUIPMENT CO.

MANTUA AVE. and GLENDALE ST., EASTON, PA.

A Division of Radio City Products Co., Inc.

See What's New in  
**ELECTRONICS**  
Radio • TV • High Fidelity



**FREE!**

Send for  
**NEWARK'S 1956 CATALOG**

See the latest and finest equipment ever offered in High-Fidelity, Radio, TV, Amateur and Electronics. Select the fast, dependable way, from this new 260-page catalog.



**NEWARK**  
ELECTRIC COMPANY

Dept. P-11, 223 W. Madison, Chicago 6, Ill.

WEST COAST BRANCH  
4736 W. Century Blvd., Inglewood, Calif.

## Shrinks Hemorrhoids New Way Without Surgery

Science Finds Healing Substance That  
Relieves Pain—Shrinks Hemorrhoids

For the first time science has found a new healing substance with the astonishing ability to shrink hemorrhoids and to relieve pain—without surgery.

In case after case, while gently relieving pain, actual reduction (shrinkage) took place.

Most amazing of all—results were so thorough that sufferers made astonishing statements like "Piles have ceased to be a problem!"

The secret is a new healing substance (Bio-Dyne\*)—discovery of a world-famous research institute.

This substance is now available in *suppository* or *ointment form* under the name *Preparation H*.\* Ask for it at all drug counters—money back guarantee.

\*Reg. U. S. Pat. Off.



## LEARN MEAT CUTTING

Train quickly in 8 short weeks at Toledo for a bright future with security in the vital meat business. Big pay, full-time jobs—HAVE A PROFITABLE MARKET OF YOUR OWN! Pay after graduation. Diploma given. Job help. Thousands of successful graduates. Our 32nd Year! Send NOW for FREE catalog. No obligation. G. I. Approved.

NATIONAL SCHOOL OF MEAT CUTTING, Dept. 55-C, Toledo 4, Ohio

# TIPS and TECHNIQUES

## HOME-MADE CAPACITORS

A capacitor suitable for r.f. bypass as well as parasitic oscillation suppression can be improvised out of a large metal washer. Washer must be insulated from the chassis

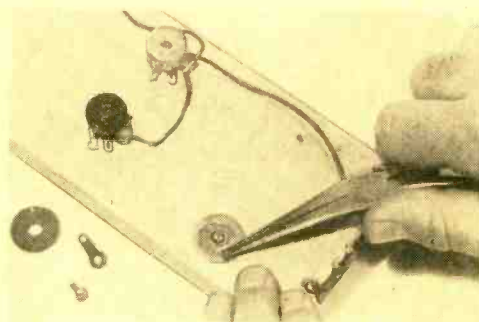

and its mounting screw by mica or plastic. The lug next to the washer is a "hot" connection; the chassis forms the other electrode.

Washers mounted on each side of the chassis, with the clamping screw passing through the clearance hole, serve as a feed-through capacitor for noise and harmonic suppression. The chassis hole should be large enough to pass the screw without contact. Lugs connecting to the washers on either side provide the through-connection.

## IMPROVISED TRANSFORMERS

Emergency substitutes for i.f., r.f. or audio transformers can be made as shown

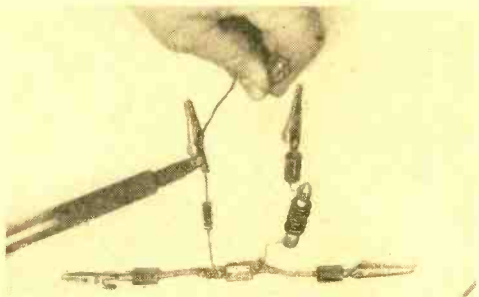

here. Component values depend upon operating frequency. For r.f. and i.f., try a choke, a 500- $\mu$ fd. capacitor, and a 500,000-



ohm resistor. Clip to transformer connections in this order, reading from left to right: plate (blue); B+ (red); ground (black); and grid (green). Values may be varied experimentally for best operation. For audio circuits, use a 100,000-ohm resistor in place of the plate choke, and a .01- $\mu$ fd. capacitor. A couple of these in the tool kit may greatly speed repair work.

### INK-BOTTLE RESISTORS

Early radio builders used India ink deposits for grid leaks and other high-value resistors. When manufactured resistors be-

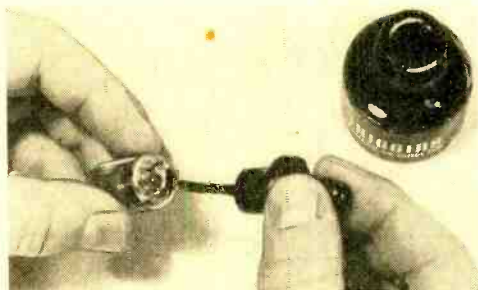

came common, the ink spots were forgotten—until the recent advent of printed circuitry.

Regular printed-circuit fluid is made in varying degrees of resistivity. You can get approximately the same effect by varying the width and thickness of an India ink line. Ink-bottle resistors can be drawn between eyelets or other hardware rigidly fixed on a card, or between tube pins as shown here. Build up layers until the dry resistance (measured with ohmmeter) is the desired value or less. Then the layer can be whittled down to bring resistance up to the desired value. Values from several megohms to around 100,000 megohms can be obtained by this method.

### TEST BENCH SPEAKER

A good test bench requires a substitute speaker which may be connected to a radio chassis being tested or repaired. For some

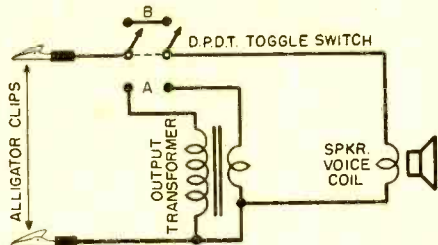

sets, the connection will have to be made directly to the voice coil; for others, an output transformer will be needed.

To handle this change-over quickly and with the least fuss, mount a double-pole,

# STOP! STOP!

DON'T PASS THESE BARGAINS BY!

AT THE  
World's Largest Distributor  
of Amateur Radio Equipment

## Quality

### GOVERNMENT SURPLUS!

(In Original Cartons - Complete With Tubes)

#### ✓ BC-455 Receiver

6 tubes, tunes 6-9.1 mc. Excellent for 40M band. Very stable. Cat. No. XA 084.

Only \$6.95

#### ✓ BC-458A VFO

Radio Xmtr., excellent for single sideband VFO. Tunes 5.3-7 mc. Cat. No. XA 082.

Only \$7.95

#### ✓ BC-459A VFO

T-22/ARC-5 Xmtr. Tunes 7-9.1 mc. Excellent as VFO for 40M. Extremely stable. Cat. No. XB 083.

Only \$7.95

#### ✓ PC-8417 Transformer (Stancor)

Pri: 117 VAC. Sec: 220V CT @ 50 MA. For receiver power supply (BC-455 above) and other Command Receivers. 6.3V—6 amp, 25.2V—.5 amp. Cat. No. 138156.

Only \$4.44



NOW AVAILABLE . . .  
The New & Improved  
**65A GLOBE SCOUT**

Completely Bandswitching  
65 watt Xmtr.

Only \$7.95 per mo. — pay just \$10.00 down

Cash price: \$99.95

**FREE 1956 CATALOG**

Listing over 15,000 top-values!

**SAVE UP TO 50%**  
on Guaranteed Recond. Equipment

Ask About **WRL's** New Code Oscillator Kit

Send for WRL's Wall-Sized **RADIO MAP** (only 25c)



All Prices Subject To Change Without Notice!



WORLD RADIO LABS  
3415 WEST BROADWAY  
COUNCIL BLUFFS, IOWA

PE-11

Please rush me your latest FREE Catalog!

Send me complete information on your

Brand New Govt. Surplus Eqpt.

65A

Globe Scout  Recond. Eqpt. List

Code

Oscillator Kit  Radio Map (25c)

Name: \_\_\_\_\_

Address: \_\_\_\_\_

City & State: \_\_\_\_\_

## MAGIC of remote RADIO CONTROL

For model airplanes, boats, cars, etc. No operator's license required.  
FREE—SEND FOR FCC FORM 505

**RADIO CONTROL BEGINNERS' SPECIAL**—Wired & Tested  
Powerful 1-Tube TRANSMITTER in 5x5x5 Case PLUS Sens.  
1-Tube RECEIVER PLUS popular ESCAPEMENT. Nothing  
to buy except batteries. . . . . \$29.85

**GYRO RADIO CONTROL TRANSMITTERS** 27.255 Mc.  
Most POWERFUL 5 Watt TRANSMITTER—LOWEST PRICE.  
Famous 2 Tube MAC II circuit, with GYRO MAGIC  
TUNING INDICATOR. Completely Tested, includes: 9 1/2  
ft. sect. Antenna. Remote "Clicker" Keying Switch.  
Meter, Gnd. Plane Booster, Beaul. Cabinet 12x7x6, with  
Built-in 2V Storage Battery, Vibrator Supply, Battery  
Charger. GYRO MODEL X1 TRANSMITTER Guaranteed.  
Complete \$39.50



**RADIO CONTROL TRANSMITTER & RECEIVER KIT**—27 1/4 mc Band—  
License Free. All Parts & Dinger. (less tubes & crystal to build  
Powerful 5 Watt Transmitter Unit & 2-Tube Receiver w. . . . . \$9.95

**SIGMA RELAY**, wound coils, drilled bases. . . . . 13.95

**LORENZ 2-TUBE RECEIVER KIT** with Tubes and Relay. . . . . 3.95

**SIGMA 4F RELAY**: 3,000 ohm, \$4.25; 11 C Escapement. . . . . 2.25

**McENTREE'S "RADIO-CONTROL HANDBOOK"**. . . . . 2.25

**CRYSTALS**: 27.255 Mc. Petersen Z9A \$3.95; HOLDER. . . . . 15

**Supersensitive RELAY**: 5000 ohm 1/2 Ma. . . . . 2.50

**Electronic STROBOSCOPE**—Stops motion—Complete. . . . . 17.95

**CRYSTAL SET Kit w. EARPHONE**. . . . . 2.61

**TELEPHONE PICK-UP Kit** (P.E. Sept. '55) w. Case, TRAN-  
SISTORS, Pick-up Coil, etc. \$9.95; PICK-UP COIL alone. . . . . 3.50

**100 Standard Assorted CARBON RESISTORS**. . . . . 1.25

**SUBMINI PARTS RELAY** 5000 ohm \$4.95; ESCAPEMENT  
Phone PLUG & JACK \$1 pr.; POTS var. sizes, \$1.00;  
EARPHONES Hi-Impedance \$1.95; 25 MF 3V. Condensers  
Mini. VIBRATOR TRIPLE GV. Imp. 90VDC. 15 Ma. . . . . 2.95

**TUBES**: XF81, 8K61, 8A4, 3A5, 1AG4, 184, 384, 3V4, 3Q4, 6K4, . . . . . 6K4

**TRANSISTORS**: New Top Brand, P.N.P. \$2.50. New Diodes  
BOOK: "TRANSISTORS," \$2.00; 2-G V. CHARGER KIT. . . . . 4.95

**Storage BATTERIES**: Mini. 1V. NTR \$2.45; 2V. 27A H. . . . . 2.75

**ALL MATERIALS GUARANTEED—FREE CATALOG "P"**  
Save C.O.D. fees, include postage, excess refunded.

### GYRO ELECTRONICS CO.

325 CANAL STREET W., NEW YORK 13, N. Y. Worth 6-1290

### LEARN

# RADAR MICROWAVES TRANSMITTERS CODE TV RADIO

Phila. Wireless Technical Institute  
1533 Pine St. Philadelphia 2, Penna.  
A Non-Profit Corp. Founded in 1908

Write for free catalog "P"

### !!!! K. & L. Bargain Box !!!!

Just came in! **NEW DOUBLE PLAY MYLAR RECORDING TAPE!**

2400 FT. on 7" REEL, Ea. . . . . \$7.50  
LONG PLAY 1,800 FT. ON 7" REEL, Ea. . . . . 4.95  
Discounts available to authorized dealers.

**SUPEREX FERRI-LOOPSTICK**, 3 for . . . . . \$1.29

**NEW ENERGIZED FERRI-LOOPSTICK**, 3 for . . . . . 1.79

**R/C CERAMIC TRIMMER** 3-10 Erie, Ea. 19c; 6 for . . . . . \$1.00

**POWER TRANSFORMER**: 115 V. pri. Secondary: 125 V.  
@ 15 MA.; 6.3 V. @ 9 amp. New. . . . . \$1.79

**SELENIUM RECTIFIER**: 20 MA., 125 V., Ea. 49c; 4 for \$1.79

**FILAMENT TRANSFORMER**: 6.3 V.C.T. @ 1.5 amp.  
New. 2 for \$2.79; Each. . . . . \$1.49

**POWER TRANSFORMER**—110 V. 60 cy. pri. Sec. 6.3 V.  
@ 2 A.; 130-0-130 V. @ 60 MA. New. Each. . . . . \$1.95

All items guaranteed. Remit with order. We pay postage.

### K. & L. RADIO PARTS CO.

1406 VENICE BLVD. LOS ANGELES 6, CALIF.

**FREE!** a copy of "Forming Sheet Metal"  
tells you how to make

**CHASSIS - BRACKETS  
CHANNELS - BOXES**

Write today for your free copy plus our  
catalog of unusual tools - shears, riveters,  
notchers, punches. Ask for Catalog 23.

TELVAC 1412 Great Northern Bldg. Chicago 4, ILL.

double-throw toggle switch on the test speaker baffle and wire it in as shown in the figure. When the switch is thrown to position A, the output transformer—which may be any standard pentode type—is connected into the circuit; in position B, the connection from the output transformer of the receiver is made directly to the voice coil of the speaker.

### NEW USES FOR PIANO STOOLS

When making experiments or testing on a low table, try an old-style rotating piano stool for seating purposes. These stools may be found in second-hand stores at a low price. Strong, serviceable and adjustable for height, they may also be used to mount table model TV sets. Once a set is secured to the stool, it can be rotated to any desired viewing position.



### PILOT LIGHT FOR TEST BENCH

A convenient and easily installed pilot lamp for a test bench may be purchased very cheaply. Any 120-volt plug-in type lamp of low wattage rating will serve. The lamp shown is a 1-watt Westinghouse "Nite Light." Plugged into one of the bench outlets, it indicates when the bench

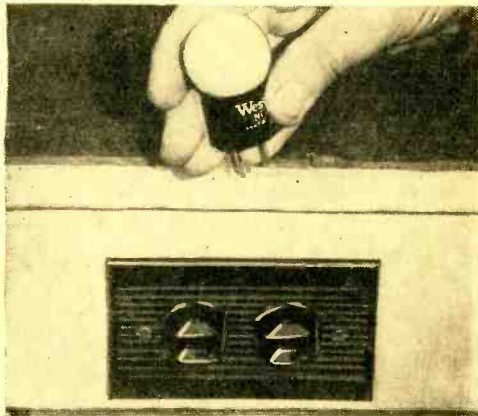

is energized. It may be removed instantly if the outlet is needed for another purpose.

### TUBE SOCKET BRACKET

When constructing compact equipment, the builder often encounters a problem in the mounting of miniature tube sockets. A handy solution is to use a socket with a center tubular contact, and a small bolt

that just fits inside the contact. Mount the bolt on an "L" bracket with a nut, and

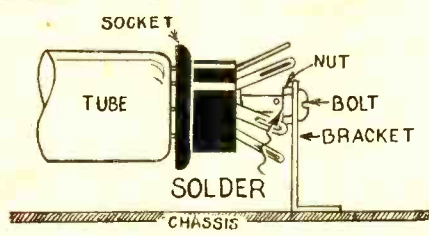

solder it into the contact. The bracket may then be bolted or soldered to the radio chassis.

**CLOTHESPIN CLAMPS**

If you have ever had wires slip from terminals at the crucial point in a solder-

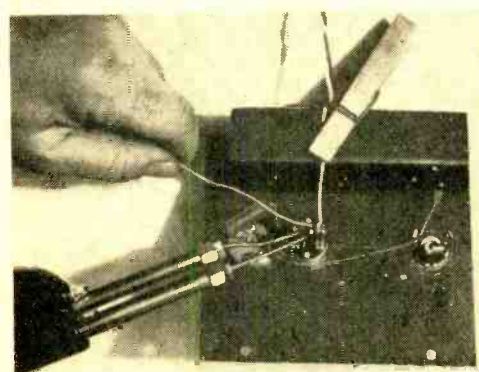

ing operation, you will appreciate this simple "kink." When you get your wire in the desired position, put some tension on it and clamp it in place with a spring-type clothespin. Use one for each wire if you are making a multiple connection.

**EYEPIECE AIDS IN IDENTIFYING PARTS**

Markings and ratings on small parts, such as capacitors, are often difficult to read with the naked eye. Observing them through a jeweler's eyepiece will aid in revealing such vital data as values of ca-

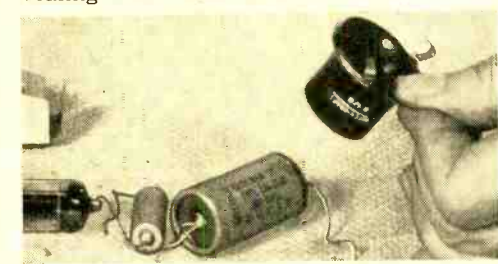

pacitance and working voltage. Innumerable other uses for the eyepiece should suggest themselves to the experimenter.

**"VISE" AIDS SMALL PARTS SOLDERING**

Don't burn your fingers when soldering small parts. Use a "plastic vise." Just

**FREE! WRITE TODAY!**  
**ELECTRONICS - TV - HiFi - KITS**  
**EXPERIMENTERS**  
**224-PAGE Mail Order CATALOG**  
 GIANT NEW 1956 ISSUE 100's of bargains like these!

**SYLVANIA 8-TUBE FM-AM CHASSIS**  
  
 Over 50% off! Needs only a speaker to use immediately; easily converted to tuner. A \$70 value. 15 lbs. incl. power supply.  
**\$31<sup>95</sup>**  
 No. PE-4244

**CRYSTAL EARPHONE**   
 Fantastic bargain! Powerful, sensitive, miniature, high impedance; may even be used as mike! 3 ft. cord. 1/4 lb. \$5.00 value!  
**RADIO SHACK \$159**  
 No. PE-9021

**20 COLUMBIA 45-RPM**   
 List \$17.80 All different, new, 45 rpm pop records, with Columbia's top artists, bands; total 40 hit songs! 3 lbs.  
**\$3<sup>99</sup>**  
 No. PE-4861

**GOV'T MAP, DRAWING CASE**   
 Cost Gov't. \$27.90. Waterproof, 14 x 18" case with many sections. 2 clear; includes drawing boards, clips, divider, protractor, rule. 5 1/2 lbs.  
**\$2<sup>90</sup>**  
 No. PE-8166

**FAIRCHILD 1/4" DRILL**   
 Reg. \$18.50, pistol grip, side lock. 1/10 hp 110-120 V a-c. d-c. motor. Save almost HALF! Ship wt. 3 lbs.  
 Reg. Chuck **\$9<sup>95</sup>**  
 No. PE-5170  
 Geared Jacobs **\$13<sup>39</sup>**  
 No. PE-5270

**ELECTRIC MODEL MOTOR**   
 Miniature 5" long out-board motor, forward and reverse, with stern clamps. Drives model boats; use any 4 1/2 V. battery or flashlight cells. List \$6.95 1/2 lb.  
**\$3<sup>50</sup>**  
 No. PE-9000

**LAPEL MICROPHONE**   
 Sensitive crystal, 15-ft. cable, swivel-clip, exclusive bargain. Ship wt. 1/4 lb. List \$20.00  
**\$3<sup>95</sup>**  
 No. PE-3454

**AUTO COMPASS**   
 Famous make, way off price! For car, boat, bike. Suction or screw mtg. with instructions. 1/4 lb.  
**\$1<sup>69</sup>**  
 No. PE-5242

**3-LENS MICROSCOPE**   
 100X - 200X - 300X, full 8" high, metal in fitted box. High powered, not a toy. \$14.95 value! 3 1/4 lbs.  
**\$5<sup>95</sup>**  
 No. PE-5007

**WESTINGHOUSE 1/4 HP MOTOR**   
 115V-60 cycle a-c, 1/2" dia. shaft, sleeve bearings, brand new current production for all power uses! 21 lbs. Reg. \$18.60.  
**\$14<sup>95</sup>**  
 No. PE-9075

**RADIO SHACK CORP.**  
 167 Washington St. Boston 8, Mass.  
 230 Crown St. New Haven 10, Conn.  
 Send FREE Catalog pe-10  
 Send .....  
 Enclose check or M.O. and est. postage.  
 NAME .....  
 ADDRESS .....

## NEW! PRINTED CIRCUIT Transistor Radio

Pocket size—works anywhere

- Features P-N-P Junction Transistor
- Permeability tuning, Diode detection
- Printed circuit eliminates extra wires
- Batteries last for months
- Expensive hearing aid headset included
- Furnished complete, nothing else to buy



Only \$9.95 Postpaid in kit form or wired and tested for only \$12.95

Here is a powerful, completely portable radio, employing the latest type of transistor audio amplification and printed circuitry. Tiny size, only 2 3/8" x 3 1/2" x 3/4" fits in pocket or purse. Uses so little current, batteries last for months. Kit can be assembled by anyone with just a soldering iron. Or furnished complete and tested, ready to use. Guaranteed to work. Comes complete with plastic case, batteries, headset, all parts. Nothing else to buy. Send for yours, today!

Send no money. Just pay postman \$9.95 plus C.O.D. charges, or send check or money order for \$9.95 and we pay postage.

TRADYNE, INC., 11 W. MONUMENT AVE., DAYTON 2, OHIO Dept. E-3

stick a lump of putty on the workbench, poke a hole in it with your finger, and push in the component to be soldered. This has

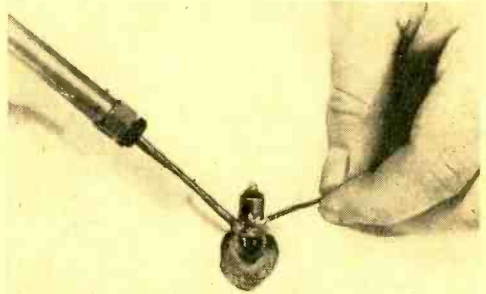

the advantage over a regular vise of not breaking brittle parts, such as those made of glass.

—50—

## TELEPHONES



Desk Stand Style  
Slightly used but in excellent condition  
Many Valuable Uses

Inter-House Phones House to Barn, etc.  
Loud Speakers Microphones  
Educational Purposes, Toys, etc.

Come complete, ready to use with wiring diagrams included. Two complete for only \$5.00.

**\$2.75** Postpaid in U.S.A.  
**TELEPHONE LAMP KIT**—with illustrated instructions for making Desk Telephone Lamp including all parts (harp, nipples, push switch, cord, plug, etc.) . . . \$6.50 Ppd. (Shade is not included).

MICROPHONE, Dept. X-207, 1760 W. Lunt Ave., Chicago 26, Ill.

### CRYSTAL RECTIFIER QUIZ

(Questions on page 111)

1. Detection.
2. It is possible for a relatively high d.c. potential to exist between the r.f. point being measured and ground. If it does, it may result in excessive current flowing through the crystal, causing it to overheat.
3. Crystal diodes (1) are small and compact, (2) are instant-heating, and (3) require no filament power.
4. Yes, although the signal picked up by an R/C antenna would probably be inadequate in most cases.
5. See diagram below.

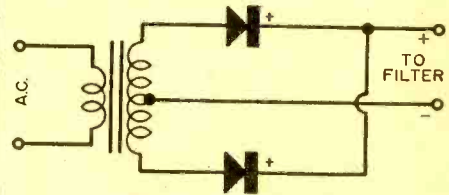

### BLACK BOXES

(Answer to question on page 112)

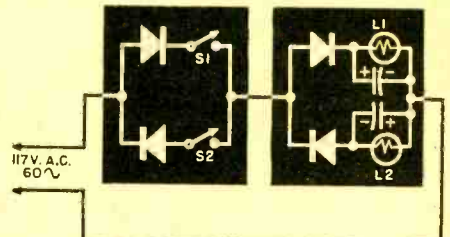

**AUDIO AMPLIFIER PRINTED CIRCUIT AND PANEL KIT**

NOW! A PRINTED CIRCUIT AND PANEL KIT. Not the conductive coating type, but real copper metal laminated to both sides of a 1/8" bakelite sheet—the universal type of the electrical and electronic industry. Replace unsightly units, even best factory models, with neat printed, etched copper circuits and panels. No more "home-made" appearing panels—since you also print it professionally. Complete illustrated instructions explain in detail how to make even one amplifier, transmitter, etc., lower in cost, higher in quality, smaller in size, lighter in weight, neater in appearance, more reliable and almost void of maintenance. 1/16" wide "wire" can easily carry 10 amps.

One kit to satisfy all—from hobbyist to product designer, basement workshop to research laboratory.

Kit includes 1 sq foot (two 6" x 12" sheets) of etching material, etching compound, printing supplies, terminals, tube sockets, hardware, parts-list and instructions.

Complete Kit \$14.75, postpaid in U.S.A. Send check or money order.

TRIPP SPECIALTY COMPANY BOX 314 SKOKIE, ILLINOIS

## LMB BOX CHASSIS Precision Engineered

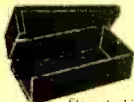

65 sizes and shapes for the laboratory, manufacturer, industrial, experimenter, builder, and general application where metal boxes are required. Stocked by all electronic and geophysical distributors. Send for free catalog.

LMB 1011 VENICE BLVD. LOS ANGELES 15, CALIF.

### PHOTO CREDITS

PAGE	CREDIT
33	International Correspondence Schools
34	RCA Institutes, Inc., Home Study Dept.
35, top and bottom	DeVry Technical Institute
35, center	National Radio Institute
36, top	Delehanty School of Television
36, bottom	Radio Television Training Ass'n.
92, center	Amplifier Corp. of America
92, bottom	Stancil-Hoffman Corp.

## Carl & Jerry

(Continued from page 65)

thimbles and rebalanced the instrument; "it is an interesting little device. Of course a 'polygraph,' as a laboratory-type lie detector is called, is quite a bit more complicated than this. It records the reaction of the person being examined to each question by means of scribing pens tracing on moving sheets of paper; and sometimes the pulse rate, respiration, and other factors are recorded as well as the skin resistance; but for our purposes—"

He turned around as he heard the outside door quietly open to admit his father.

"I'm supposed to be after another basket," Mr. Bishop announced in a hushed conspiratorial voice; "but I wanted to have a word with you two about that lie detector you've built up. A man isn't safe with a vacuum tube snitcher like that lying around. We men know that a little white lie is necessary now and then; so that thing has gotta go. What will you take to dismantle the gadget? Ten dollars?"

"Well, I don't know," Jerry said hesitantly. "After all, there is a considerable investment in parts—" Quickly, but unobtrusively, he wriggled his fingers out of the thimbles as the tell-tale meter pointer started upward.

"Okay, I'll make it fifteen dollars," Mr. Bishop said hurriedly, as he took out his wallet; "but remember this is just between us men. Not a word to your mother."

He got another basket, shot a baleful glance at the lie detector resting on the bench, and went outside again. He had barely closed the door behind him when Mrs. Bishop opened the other door.

"I was just looking for your father," she remarked casually, as she sat down on the couch from which Carl thoughtfully snatched the carcass of Old Droopy before she noticed it. "I believe I'll rest a bit, though, if you boys don't mind."

"Sure, Mom; glad to have you," Jerry said.

"You know," she commenced, in a very offhand manner, "I've been thinking about that amusing little toy you have built up; and I'm not at all sure you boys should be playing with such a thing. While we know it is just a plaything, an electronic tattletale like that *could* cause trouble. In fact, I'm afraid that it has already embarrassed your poor father; and we can't have that, now, can we? If you'll tear it up, I think I might be able to give you, say, ten dollars, to buy something really worth while for your laboratory."

"Gee, Mom, that's swell of you; and we'll certainly tear up the silly thing the first of next week," Jerry promised.

She reached into her apron pocket and handed over a ten dollar bill, then went out in search of Mr. Bishop.

"Why didn't you hold out for fifteen dollars, the way you did with your Dad?" Carl demanded.

"You don't haggle with ladies," Jerry explained chivalrously; "and anyway the twenty-five they gave us plus the twenty-five

## NOVEMBER SPECIALS!

### FAMOUS KIT KING KITS

#### BONUS!

Your choice of ANY KIT FREE with each \$10 order

#### KIT OF THE MONTH!

Best kit buy in USA! All standard parts. Separate vol., tone controls, punched chassis, cord, schematic, 2 watt output. Uses 50L6, 12SQ7 & 35Z5. For 110V. Less tubes. Wt. 2 lbs. Reg. \$3.25.

\$1

- 60 INSULATED RESISTORS. 35 popular values; 15 ohms to 20 meg.; 1/2, 1 & 2 w. Many 5%. Wt. 1/2 lb. Reg. \$1 \$1.5.
- 40 MOULDED CONDENSERS. All best known makes! .0005 to .05 mf. up to 600V. Wt. 1/2 lb. Reg. \$1
- 10 PANEL SWITCHES. Toggle, momentary push, w/10 "ON-OFF" switch plates. Wt. 1 lb. Reg. \$8.
- 15 PRECISION RESISTORS. For decade resistor boxes. Up to 1 meg. to 2 watts. 1/2 to 15 values. Wt. 1/2 lb. Reg. \$1 \$1.8.
- 1500 PIECES SPAGHETTI tubing. Ass'd. sizes. Lengths to 4'. Reg. \$1
- 150 CABLE CLAMPS. Wide variety of harness, cable & misc. clamps in ass'd. sizes. Top mfrs. Many rubber insulated. Wt. 1 lb. Reg. \$4.50.
- 60 MICA CONDENSERS. Rare bargain! Postage stamp type. 20 values; .001 to .01 mf. Many sizes. 5% off. Wt. 1/2 lb. Reg. \$1.7.
- WIRE BY THE POUND! Hundreds of different sizes, (lineal lengths 3" to 18"), ass'd. sizes, colors, insulation. Mostly 1/1 stranded. 4 lbs. Reg. \$1
- DO-IT-YOURSELF KIT #1. Threaded iron slugs and forms to make 50 matched slug-tuned coils, plus 50 extra. (lineal lengths 3" to 18"). Wt. 2 lbs. Reg. \$15.
- 25 TUBE SOCKETS. 4, 6, 8, 9, 10, 12, 14, 16, 18, 20, 25, 30, 35, 40, 50, 60, 70, 80, 90, 100, 110, 125, 150, 175, 200, 225, 250, 275, 300, 325, 350, 375, 400, 425, 450, 475, 500, 525, 550, 575, 600, 625, 650, 675, 700, 725, 750, 775, 800, 825, 850, 875, 900, 925, 950, 975, 1000. Wt. 1 lb. Reg. \$1 \$6.50.
- 15 CONTROLS. Up to 1/2 meg. 12 TV radio, 14h values, some w/switch. Concentric type, too! Wt. 2 lbs. Reg. \$12.
- 10 PANEL LITE ASSEMBLIES. Ass'd. colored jewels; some w/built-in neon lamp for 110V AC. Reg. \$8.
- 70 TERM. POSTS & STRIPS. Ass'd. ending posts, screw & lug strips (1 to 10 terms). Wt. 1/2 lb. Reg. \$5.
- 75 KNOBS for TV, radio, etc. Some worth 25¢ ea. 15 types, push-on, set screw. Wt. 1 lb. Reg. \$8.50.
- 20 POWERS. Wound. 20 values: 5 to 50w. 5 to 10,000 ohms. Candohm & tubular. Wt. 2 lbs. Reg. \$10.
- 4 POPULAR DIODES. Exclusive! Handy shop ass't.: 1N34A, 1N48, 1N58, 1N81. Order now! Reg. \$4.10.
- 10 TUBULAR ELECTROLYTICS. All different! 10 to 40 mf., up to 500V. Multiple sections, too! Wt. 2 lbs. Reg. \$1 \$8.
- TEN 25 FT. ROLLS WIRE. Plastic & cloth insulated, solid & stranded. 18 to 24 Ass'd. colors. Wt. 2 lbs. Reg. \$5.50.
- 2000 PIECES HARDWARE. Screws, nuts, lugs, grommets, washers, etc. Wt. 3 lbs. Reg. \$11.
- 100 CERAMIC INSULATORS. Hums take, stand-off, panel, bushings, etc. Wt. 3 lbs. Reg. \$15.
- 3 CAR RADIO ASSEMBLIES. Permeability-tuned front ends, cover broadcast band 450 to 1500Kcs. Push-button control. Wt. 2 lbs. Worth \$5 \$1 each.
- 50 CERAMIC CONDENSERS. Tubular, button, disc types. 20 values, 2 to 3000 mf. Wt. 1 lb. Reg. \$13.
- 40 SOCKETS & RECEPTACLES. Variety of sizes for pilot lines, AC lamps, chassis panel sockets, etc. Wt. 3 lbs. Reg. \$8.25.
- 25 CERAMIC & MICA TRIMMERS. Erie TS2A, etc., plus Flinenco mica types. Singles, duals; 12 sizes. Wt. 1 lb. Reg. \$16.
- 15 SWITCHES. Rotary, push, wide variety. Experimenters, note! Wt. 2 lbs. Reg. \$11.50.
- 15 BATHTUB & CHANNEL capacitors. Oil impregnated. .05 to 2 mf. Up to 600V. Many values. Wt. 2 lbs. Reg. \$22.
- 8-PC. NUTDRIVER KIT. Plastic handle, 3/16, 7/32, 1/4, 5/16, 11/32, 3/8, 7/16" steel socket wrenches in plastic case. Wt. 1/2 lb. \$3.50 \$1 values.
- 10 TWIST-LOCK ELECTROLYTICS. All different, all multiple sections. All popular TV & radio values. Wt. 3 lbs. Reg. \$18.
- TV ACCESSORY KIT. For 60 & 12" sets. Contains 1 ea.: 10, 7, 8, 9, 10, 12, 14, 16, 18, 20, 25, 30, 35, 40, 50, 60, 70, 80, 90, 100, 110, 125, 150, 175, 200, 225, 250, 275, 300, 325, 350, 375, 400, 425, 450, 475, 500, 525, 550, 575, 600, 625, 650, 675, 700, 725, 750, 775, 800, 825, 850, 875, 900, 925, 950, 975, 1000. Wt. 3 lbs. Reg. \$12.
- 50 TUBE SHIELDS. Wide assortment of miniature & GT tube shields. Wt. 2 lbs. Reg. \$9.
- 25 SLUG-TUNED COILS. Fifty variety of TV, radio slug-tuned units. Linearity, width, etc. Some \$1.50 ea. Wt. 1 lb. Reg. \$14.
- 50 COILS & CHOKES. Wide ass't. osc., peaking coils, RF, parasitic chokes. 20 types. Wt. 1 lb. Reg. \$21.
- 40 TUBULAR OIL CONDENSERS. Metal & paper clad. .02 to .5 mf up to 350V. Generator types, too. Wt. 3 lbs. Reg. \$1 \$22.50.
- 60 TUBULAR CONDENSERS. .00035 to 1 mf. up to 1600V, 25 values. Wt. 2 lbs. Reg. \$10.
- 50 FUSE POSTS, MOUNTINGS, CLIPS. For 3AG, 4AG & cartridge 30 amp. fuses. Unusual value! Wt. 1 lb. Reg. \$1 \$6.50.
- R/C ASSEMBLY on term. strips; 70 moulded, paper & mica capacitors, .0001 to .047, 45 1/2 w re. resistors. Wt. 1 lb. Reg. \$15.
- 125 CARBON RESISTORS. 40 values! 100 ohms to 1 meg.; 1/2, 1 & 2 w. Many 5%. Uninsulated. Wt. 1 lb. Reg. \$21.
- 200 COIL FORMS, ceramic & bakelite. Many sizes & styles, some worth \$2. \$20 \$1 value! Wt. 2 lbs.

Send check or MO, incl. sufficient postage, any excess returned. C.O.D. orders, 25% down. Rated, net 30. Simply check items wanted, fill in below & return entire ad with remittance to:

**LEKTRON SPECIALTIES** Dept. E11  
28 Gardiner Street Chelsea 50, Mass.

NAME ..... (Please print)

STREET .....

CITY ..... ZONE ..... STATE .....

I enclose \$..... for items, \$..... postage.  Ship C.O.D.

WRITE FOR BARGAIN BULLETIN.

**Find URAMIUM**

URANI-TECTOR URANIUM KIT

This is a SCIENTIFIC INSTRUMENT Not a TOY

**You CAN STRIKE IT RICH!**

is for only \$8.49 Postpaid

Now you can prospect at low cost! New invention using sun's energy! All you need for prospecting for all types of uranium! More reliable than Geiger and scintillation counters for determining uranium value! Used by professionals. Includes 4 valuable uranium ores. Postpaid. Money-back guarantee. Dept. PE-11, CMG INDUSTRIES, Box 611, Laramie, Wyoming.

**NEW! PERSONAL POCKET RADIO**

**LISTEN WHILE YOU WALK, RIDE, WORK!**

Slips in any pocket—Wt. only 8 ozs. Size 2 3/4" x 4 3/4" x 1 1/2". Beautiful Black Gold plastic case. NO HOOKUPS—NO WIRES—NO PLUG-INS! Self contained with 150 hour life flashlight batteries. (Available anywhere) and BUILT-IN ANTENNA!

**GUARANTEED RECEPTION OF RADIO STATIONS TO 50 miles—up to 1500 miles for powerful stations!** Has new Patented Super-regenerative Diode tube and transformer audio stages for sharp selectivity and sensitivity! Easy to use top controls (while walking). Almost invisible plastic foam personal earplug lets you alone listen while you walk, visit, work, ride or sleep—anytime—anywhere. **GUARANTEED TO WORK—1 year guarantee.**

**SEND ONLY \$5.00** (Ck. Mo) and pay postman \$14.95 plus postage on delivery or send \$19.95 for postpaid delivery. Get YOUR Tintone REAL pocket radio now and be ready to listen to Civil Defense alarms, news, music, sports, etc. on a moment's notice. Not a Kit! Shipped complete with batteries—Order now—today.

**WESTERN RADIO Dept. APL-11 Kearney, Nebraska**

**SUN BATTERY**

**Self Generating Selenium—Only \$1.50**

You have read about it in P.E. Now you can own one at low cost. International Self Generating Selenium B2M Sun Battery with a high output of 2 MA @ .5 volts in average sunlight. Complete with data sheet only \$1.50.

**GIANT CATALOG**

**NEW LISTINGS—1955 ELECTRONIC SPECIALS**

Listing thousands of surplus electronic and mechanical bargains for experimenters, hobbyists, engineers—10c coin or stamps.

Rectifiers @ 29c ea. Transformers @ 49c ea.  
Controls @ 29c ea. Bulbs @ 2c ea.  
Switches @ 6c ea. Motors @ 99c ea.  
Automatic Steppers @ 99c ea.

**SOUNDTRONICS LABS Dept. P-7**  
632 ARCH STREET PHILADELPHIA 6, PA.

**INVENTORS**

Learn how to protect your invention. Specially prepared "Patent Guide" containing detailed information concerning patent protection and procedure with "Record of Invention" form will be forwarded to you upon request—without obligation.

**CLARENCE A. O'BRIEN & HARVEY JACOBSON**  
Registered Patent Attorneys

59-K District National Bldg. Washington 5, D. C.

we'll get from Acme TV Service will just buy that new scope kit. There's no use in being a hog about things."

"Guess you're right," Carl agreed, "and I've got to take off my hat to you. When it comes to harvesting the old government lettuce, electronics has fish worms beat all to heck!"

-30-

**Disc and Tape Review**

(Continued from page 78)

poetically, emphasizing lyricism and smoothness of line. Both men keep the work well integrated and cohesive, and do not fall into the trap of redundancy which is the Achilles heel of this score.

In matters of sound, Paray has the most stunning realism of any version now available. The textures and brilliance of the brass are a thrilling thing to hear and the string sound is superb . . . quite clean and edgeless. The cello and contrabass, so important in this score, are imbued with a rich, dark sonority that lends tremendous weight and authority. Yet, in all this powerful framework of sound, inner detail is not subsidiary. Furtwangler has the benefit of some of London's finest "big-hall" sound. Here is a more amorphous sound, which softens and smooths the melodic line . . . the string tone of the Vienna Philharmonic is a gorgeous thing, and if the strings are less clearly defined here, this very quality adds to the totality of smoothness.

Both the Mercury and London recordings are very wide range in frequency and in dynamics, distortion is nil, and acoustic perspective is well-handled. The performance of the Vienna Philharmonic is outstanding for smooth precision, this orchestra sounding as close to its prewar perfection as it is likely to approach. The Detroit orchestra gives a first-class account of itself under the firm hand of Paray, but it lacks a little of the super-polish of the Vienna group, due more than anything else, I think, to a scarcity of top-flight first desk men. (Of course, this recording was made early in the association between Detroit and Mercury, and subsequent recordings have revealed that the lack of first desk personnel has been rectified.)

Of the remaining recordings, Ormandy's reading with the great Philadelphia orchestra is the most desirable. His good performance is just outgunned by the superexcellence of Paray and Furtwangler. The Philadelphia plays superbly as usual, and while the sound on this disc is definitely hi-fi, there is a bit of tubbiness in the bass line, and some pre- and post-echo groove distortion. These are really quite minor, and if you own the Ormandy, there is no need to feel ashamed of it, as it certainly occupies a high niche.

Here are the remaining recordings of the Franck symphony listed in descending quality of sound: Rodzinski/Westminster, Cantelli/Victor, Cluytons/Angel, Golschmann/Capitol, Munch/London, Monteaux/Victor, Van Otterloo/Epic. Remember that all of these recordings can be considered fairly well up in hi-fi, and among them are some fine performances.

## Grieg Concerto

The other musical work which seems to occupy the attention of quite a number of readers is the Grieg *Concerto in A for Piano*. Choosing the best-sounding recording of this work would indeed be a difficult task for the average person, as not only are there 13 different versions in the LP catalog but . . . within that group . . . some of the most variable quality sound of any of the more popular piano concerti! The sad fact of the matter is that not one of the recordings can really be classified as being an outstanding modern hi-fi recording. The Novaes/Vox disc comes as close to our ideals as any in the group.

Vox has a good reputation for piano recording and on this disc the repute is well deserved. Madame Novaes' piano is heard with a big solid tone, with little harshness or ringing in the transients, and with no discernible trace of wow or flutter. Recorded rather close-to, the engineers managed to escape the penalty of reproducing the hammer action and, in spite of the sharply focused sound, have maintained spacious acoustics. It is from the orchestral standpoint that the recording loses some of its luster. The strings are on the edgy side, brass is over-bright. The total effect is "thinness" . . . a lack of full-bodied support for the splendid piano of Novaes. In spite of this, it is the best we currently have available, and as an added bonus, the Novaes performance is very near the top rung.

The Curzon/London recording is next in line for sound honors. Here we also have a good clean-sounding piano tone, excellent acoustics, good orchestra. But the piano and orchestra balance is too heavily weighted to the piano, and again the orchestra support is inadequate. Curzon's performance is too fast for most tastes, and some of his ideas on dynamics are questionable.

Moura Lympany on an HMV disc gets the next best engineering, but it is hardly up to the usual HMV standard. The piano tone is fairly clean although there is considerable ringing in certain sections. Orchestral balance is good here, but suffers from the same defect as the others, namely, edgy strings and general lack of body. The Lympany performance is competent, but hardly inspired.

The redoubtable Artur Rubenstein on Victor has the No. 4 slot for his engineers' efforts. This is fairly good-sounding piano and the balance between piano and orchestra is reasonable . . . the real trouble with this recording being in its age. The somewhat restricted frequency range, the limited dynamics, and the cramped acoustics are far from mute evidence that this disc was one of the early LP's. Rubenstein definitely is not playing the score straight-away, but is indulging in some of the mannerisms which infuriate people who know what a fabulous talent is performing.

Next in line of succession are two pianistic giants . . . Walter Gieseking and the late Dinu Lipatti. Both are heard on Columbia discs and both suffer from engineering which is just good enough to be tolerable. Wow and flutter creep in here, as do transient ringing and groove distortion. Orchestral accompaniment

# BUILD 16 DIFFERENT PRINTED CIRCUIT AND METAL CHASSIS RADIO CIRCUITS

With the New Deluxe 1956 Progressive Radio "EDU-KIT"

ONLY

**\$19.95**

Complete

NOW INCLUDES  
RECEIVER, TRANSMITTER,  
SIGNAL TRACER,  
CODE OSCILLATOR,  
SIGNAL INJECTOR CIRCUITS

- Attractively Gift Packaged
- Free Soldering Iron
- Absolutely No Knowledge of Radio Necessary
- No Additional Parts Needed
- Excellent Background for Television
- 30-day Money-Back Guarantee
- School Inquiries Invited
- Used in 79 Countries
- Learn High Fidelity

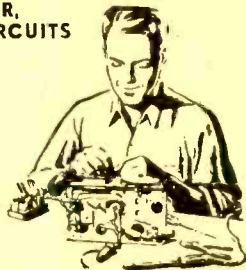

### WHAT THE "EDU-KIT" OFFERS YOU

You will learn how to identify Radio Symbols and Diagrams; how to build radios, using regular radio schematics; how to wire and solder in a professional manner. You will learn proper chassis layout. You will learn printed circuitry. You will learn the basic principles involved in radio reception, transmission and audio amplification. You will learn how to service and trouble-shoot radios. You will learn code. You will receive instructions for F.C.C. Novice license. In brief you will receive a practical basic education in Radio, worth many times the small price you pay.

### THE KIT FOR EVERYONE

It is not necessary that you have even the slightest background in science or radio. The "Edu-Kit" is used by young and old; by radio schools and clubs; by Armed Forces personnel and Veterans. No instructor is required. Instructions are complete, simple and clear.

### PROGRESSIVE TEACHING METHOD

The "Edu-Kit" uses the principle of "Learn by Doing." Therefore you will build radios, perform jobs, and conduct experiments to illustrate the principles which you learn. You begin by learning the function and theory of each of the radio parts. Then you build a simple radio. Gradually, in a progressive manner, you will find yourself constructing more advanced multi-tube radio sets, and doing work like a professional Radio Technician. The "Edu-Kit" Instruction Books are exceedingly clear in their explanations, illustrations and diagrams. These sets operate on 105-125 V. AC/DC. For use in foreign countries having 210-250 volt source, an adapter for 210-250 V. AC/DC is available.

### The Progressive Radio "EDU-KIT" Is Complete

You will receive every part necessary to build sixteen different radio circuits. The "Edu-Kit" contains all tubes, tube sockets, variable, electrolytic and paper condensers, resistors, tie strips, coils, hardware, tubing, Instruction Manuals, Printed Circuit Materials, etc. No solder or hook-up wire included. A soldering iron is included, as well as Electrical and Radio Tester. Complete, easy-to-follow instructions are provided. All parts are guaranteed, brand new, carefully selected and matched. In addition, the "Edu-Kit" now contains lessons for servicing with the Progressive Signal Tracer, High Fidelity, F.C.C. Novice instructions, quizzes.

### TROUBLE-SHOOTING LESSONS

Trouble-shooting and servicing are included. You will learn how to recognize and repair troubles. You will build and learn to operate a professional Signal Tracer and a Signal Injector. You will receive an Electrical and Radio Tester, and learn to use it for radio repairs. While you are learning in this practical way, you will be able to do many a repair job for your neighbors and friends and charge fees which will far exceed the cost of the "Edu-Kit."

### FREE EXTRAS

- ELECTRICAL & RADIO TESTER • SOLDERING IRON
- HI-FI GUIDE • TV BOOK • QUIZZES
- CONSULTATION SERVICE

PROGRESSIVE "EDU-KITS" INC., 497 Union Ave., Brooklyn 11, N.Y.

MAIL TODAY—Order shipped same day received.  
30-Day Money-Back Guarantee. INCLUDE ALL FREE EXTRAS

"EDU-KIT" Postpaid. I enclose full payment of \$19.95

"EDU-KIT" COD—I will pay \$19.95 plus postage (USA only)

Outside USA: Enclose \$20.95. "Edu-Kit" sent postpaid

Outside USA: 210-250V. AC/DC Adapter. Enclose \$2.50

More details on "EDU-KIT" Free—No Obligation

FREE Radio-TV Servicing Literature. No obligation

NAME .....

ADDRESS .....

PROGRESSIVE "EDU-KITS" INC. 497 UNION AVE.  
Room 514-D Progressive Building Brooklyn 11, N. Y.

## BCUM A HAM!

Hy fun wid ur own low cost rdn xmitter es rcvr! It's easy to pass the new FCC "mail-order" exam for your radio amateur license, when you learn the AMECO way!

**CODE COURSE** - Album of ten recordings, scientifically designed to teach you all letters, etc. and quickly have you receiving them at 8 words per minute! (Standard 78 RPM) Instruct. tion book gives secret of simplest fastest way to learn.

\$7.95

**THEORY COURSE** - Even if you don't know a dial from a tube, this complete, simplified home study course will soon have you passing your FCC Novice, Technician and General Class radio theory exams. PLUS "How to Set Up Your Own Ham Station."

\$3.95

SEND only \$1.00! Prompt, safe delivery guaranteed. Pay balance and postage to postman (Or send \$11.90 and both courses will be delivered postpaid.)

**MONEY BACK!** If you are not entirely delighted, tell us in 5 days, and you can return everything for full refund! You pay only postage.

## HARRISON RADIO (W2AVA)

225 Greenwich Street, New York 7, N. Y.  
HAM HEADQUARTERS—SINCE 1925!



AUDIO

Hi-Fi

the

TONE-MASTER

SELF powered, transistorized audio SINE WAVE generator—approx. 1200 cycle tone—variable from 0 to over .5 volts RMS output—connects directly to HiZ mike input—check AM modulation and speech equipment—ideal for audio enthusiasts—housed in compact molded case (2 3/4" x 4 1/8" x 2 5/8") with lithographed front face.

**Lakeshore INDUSTRIES**  
MANITOWOC WISCONSIN

\$12.95

## VHF AM-FM RADIO

Supersensitive sub-miniature tube set receives television, FM broadcast, CAP, and amateurs without antenna or ground. Tunes from 75 mc. to 150 mc. Similar models available in frequency bands from 27 mc. to 225 mc. Pocket size—measures only 2" x 2" x 2 3/4". Highest quality components used. Specially battery or AC model. Use with any magnetic headphone or can be connected to audio amplifier for loudspeaker operation. Thousands in use by amateurs, experimenters, and civil defense. Factory wired and tested chassis complete with special tube only \$5.98 postpaid. In kit form \$3.98. Postage extra on COD orders. New transistor audio amplifier for extra loud reception only \$2.00 including transistor.

**SPRINGFIELD ENTERPRISES**

Box 54-E

Springfield Gardens 13, N. Y.

## INVENTORS

When you are satisfied that you have invented a matter of value—write me, without obligation, for full information on what steps you should take to secure a Patent.

**PATRICK D. BEAVERS**

Registered Patent Attorney

1098 Columbian Building

Washington 1, D. C.

**STEPPING RELAY** 24 vac coils. Separate reset coil. Single pole, 50 throw or 2 pole, 25 throw. Perfect for model trains, automatic door openers, remote control—hundreds of uses. **Now \$3.95. Good used \$2.00.** Shipped post paid. 10 circuit schematics included.

**HOT SPOT DETECTOR, INC.**

214 Third Street

Des Moines, Iowa

is weak on both discs . . . mostly restrictive frequency and far from ideal acoustic perspective. It is sad that this engineering is so lackluster, because the performances are terrific. Gieseking is at the top of his form and his reading is a fluent lovely thing . . . in its unhurried pace, the strong Grieg melodic line is given full measure and the results are most pleasurable. The tragic Dinu Lipatti, who was cut off at the height of his career by leukemia, gives the finest of any performance now on LP. His tempi, his delicately modeled phrasing, his sure sense of what constitutes proper dynamics, and above all, his miraculously light touch imbue the music with a glowing warmth. In listening, you find fresh pleasures in this warhorse which has been beaten to death so often.

The other recordings of the Grieg work are either so poor in sound or so poorly performed that any consideration of them here would be ridiculous. Summing up then . . . the best-sounding recording is the Novaes/Vox, which fortunately is also one of the top performances. If you don't mind sound which isn't very hi-fi, and if you want the best performance, bar none, the Lipatti is your dish . . . with the Gieseking running a very close second.

We'll stay with the standard repertoire next month, but it may be a little shorter than usual in order to bring you a Christmas record buying guide.

### "Pop" Corner

There is not much in the "pop" bag this month except for fans of Stan Kenton. On a *Capitol H-462*, Stan and his powerhouse crew do a thing called *Portraits on Standards*. With the beautifully clean hi-fi sound on this disc, it is really something to hear.

Actually, some exceptionally good arrangements of great pop standards are included in this disc, such as *April in Paris*, *Baia*, etc. Most of the titles would be innocuous in other hands, but once Stan and his gang let loose on them, they assume very different complexions. Very few combinations of instruments can equal the Stan Kenton band in the production of fabulously exciting hi-fi sound. The stratospheric blare and scream of his massed trumpets and trombones, the super-smooth intonation of his sax choir, the free and frequent use of percussion in all its forms characterize his playing and make it unique among the big bands in this country. Throughout this disc, the frequency and dynamic range is very wide, there is virtually no distortion of any type—including pre- or post-echo, and while the acoustics are spacious and lend presence, they are not overdone.

The type of arrangement on this disc was started about three years ago, and Stan seems to be sticking to it quite closely. It is kind of unique, since it combines the elements which are quite formal and rigidized with the free form improvisation of both the various choirs and his superb sidemen. I had the pleasure of recording Stan and his men stereophonically about the time he first utilized the new style arrangements and the results were terrific! When the day comes that *Capitol* issues



stereo-tapes of the Kenton band, don't fail to hear one. In the stereophonic medium, the Kenton band is a staggering listening experience. Until then, this disc is highly recommended to you as a fair substitute.

### Hi-Fi Record of the Month

Honors this month go to William Schuman's *Symphony #6*, which is performed by Eugene Ormandy and the Philadelphia Orchestra on Columbia ML4992, 12" LP, \$4.98. This is one of Columbia's admirable Modern American Music Series discs and one of the best yet as far as I am concerned. Schuman is President of the Julliard school and his symphonic talents are considerable.

Yes, this is modern music in the normally accepted sense . . . it is dissonant, atonal, quite wild in sections. It is also a highly interesting, cleverly constructed work and a hi-fi treat par excellence. The typical Schuman trumpets and trombones sound out with brazen brilliance, the strings are quite clean although used fairly often in a high register, and there is a positively stunning collection of percussion . . . multi-timbered tympani, snarly little snares, a bass drum of noble proportion, and a brightly insistent cymbal which will be the delight of high tweeter enthusiasts.

Off the beaten track, indeed, but something you might lend an ear to, the Piston *Fourth Symphony* is heard on the reverse side and is in the same general vein as the Schuman. The last movement, entitled *Energetico*, is a roaring, pulsating orchestral tour-de-force! Try this disc for "something different." -30-

### Tape Playback and Erasure

(Continued from page 92)

Both types of bulk eraser are equally effective. In fact, many commercial recording companies which use a great many reels daily will—as part of the day's routine and as additional assurance that a reel is erased before reuse—employ such devices. This procedure also frees a complete and costly magnetic tape recorder for another job rather than tying it up for erasing. A bulk eraser does its job in less than a minute.

### Tape Transport Mechanisms

Tape transport mechanisms are to magnetic tape what the record players are to discs. A "tape transport" moves, carries, or transports the magnetic tape past the magnetic heads, just as the turntable of a record player moves the disc past the phono pickup cartridge. The tape mechanism is necessarily more complex than a phono turntable. While the disc player turntable need only stop or go, the tape player mechanism must also provide a *rewind* mode of operation, as well as a *fast forward* mode. Also, the tape mechanism has—in effect—two turntables, one for the supply

# FIX TV SETS TWICE AS FAST!



**CUT TIME  
IN HALF on  
2 jobs out of 3**

Now! Handle television receiver troubles by easy picture analysis. Let these famous PIX-O-FIX Guides tell you what is wrong . . . then show exactly how to fix it.

## PIX-O-FIX TV TROUBLE-FINDER GUIDES

Just turn the PIX-O-FIX dial until the picture in its window shows the same trouble symptoms (wavy lines, snow, no raster, "squeezing" distortion, etc., etc.) as the picture on the TV set you're repairing. PIX-O-FIX then tells the possible trouble causes and gives step-by-step repair instructions. It's as easy as that! The two PIX-O-FIX units No. 1 and No. 2 cover 47 different television troubles . . . just about anything you're likely to be called on to fix. No. 1 identifies 24 of the most common troubles and gives 192 causes and 253 remedies. No. 2 covers 23 more advanced troubles not included in No. 1. Together, they are a comprehensive guide to quick "picture analysis" servicing of any TV set. . . AND THE PRICE IS ONLY \$2.00 FOR THE TWO. Use coupon.

# DON'T THROW OLD RADIOS AWAY!



**This giant book shows exactly how to fix them . . . without a lot of previous experience!**

There's a "secret" to repairing old radios fast and profitably . . . and this big RADIO TROUBLESHOOTER'S HANDBOOK is it!

Just look up the old make and model you want to fix. This 3½ pound 744-page Ghirardi handbook tells what the trouble is likely to be . . . AND SHOWS YOU EXACTLY HOW TO FIX IT. No useless testing! No wasted time! Even beginners can handle jobs "slick as a whistle." *The only guide of its kind . . . cuts repair time in half!*

Included are common trouble symptoms and remedies for over 4,800 old models of home and auto radios and record changers. Actual case histories cover practically every model made by 202 manufacturers between 1925 and 1942—Air-line, Apex, Arvin, Atwater Kent, Belmont, Bosch, Brunswick, Clarion, Crosley, Emerson, Fada, G.E., Kolster, Majestic, Motorola, Philco, Pilot, RCA, Silvertone, Sparton, Stromberg AND DOZENS MORE. Gives how-to-do-it data on SPECIFIC jobs—NOT general theory. Includes hundreds of pages of invaluable tube and component data, service short cuts, etc. Price \$6.50. 10-day free trial.

### USE COUPON TO ORDER!

Dept. PE-115, Rinehart & Co., Inc.  
232 Madison Ave., New York 16, N. Y.

Enclosed is \$2.00 for PIX-O-FIX Nos. 1 and 2. You guarantee to refund my money if I return them in 10 days.

Send book RADIO TROUBLESHOOTER'S HANDBOOK for 10 days FREE EXAMINATION. If I like book, I will promptly send \$6.50 (plus postage) in full payment. Otherwise I will return book and owe you nothing.

Name \_\_\_\_\_

Address \_\_\_\_\_

City, Zone, State \_\_\_\_\_

RINEHART BOOKS ARE SOLD BY LEADING BOOKSTORES

EDUCATIONAL • PROFITABLE • ENJOYABLE

## Geiger Counter Kit

Combine fun with profit! Now you can build a professional model that would ordinarily sell for at least \$99.50. Comes complete with meter, latest 2 tube printed circuitry, best sensitivity, 3 position range switch, phones and flashing neon light. Compact size of 4 1/2" x 8" x 4" is best for field use. Kit includes all necessary parts, or sample and detailed instructions. Fully guaranteed. Free literature. Order now, immediate delivery!

**\$49.50**

Complete with Meter  
F.O.B. L.A.

**SIERRA SCIENTIFIC CO.** 5415 York Blvd., Dept. 3  
Los Angeles 42, Calif.

## Free! VALUABLE U.S.A!

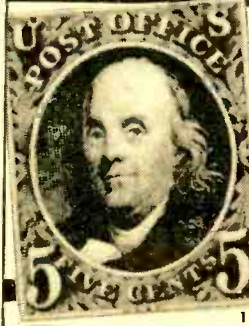

Scarce genuine postage stamp as illustrated, picturing first U.S.A. (issued in 1847); **PLUS** big collection of 30 all-different United States: 19th century, valuable \$5 stamp, etc... **PLUS** packet beautiful Commemoratives including '93 Columbian, Boy Scouts, Wild West, and many others. **EXTRA!** Big illustrated U. S. catalog; 64-page Collectors' Guide—and other attractive offers for your consideration. Send 10c for mailing costs. Act NOW!

**H. E. HARRIS & CO.**

1677 Transit Bldg., Boston 17

## CIVIL DEFENSE POCKET RADIO

NO TUBES — BATTERIES OR ELECTRIC PLUG-INS NEEDED!



Ordinary radios MAY BE USELESS DUE TO RUN-DOWN BATTERIES OR POWER FAILURES (during atomic attacks) but this NEW CD Perma-Crystal Diode Pocket Radio operates during power blackouts. Receives regular radio stations and CIVIL DEFENSE BROADCASTS. Works anywhere when used as directed. **COMPLETE SELF-CONTAINED SPEAKER PHONE GUARANTEED TO WORK** and should last for years. **BE PREPARED—GET YOUR CD POCKET RADIO NOW!** **SEND ONLY \$1.00** (cash, ck, mo) and pay postman \$3.99 C.O.D. **POSTAGE** or send \$4.99 for postpaid delivery. **COMPLETE READY TO PLAY WITH CIVIL DEFENSE INSTRUCTIONS.** By mail from—**MIDWAY COMPANY, Dept. CPL-11, Kearney, Neb.**

## WALKIE-TALKIE

Build a real wireless portable radiophone for the 2 meter amateur band with the following precision components. Factory wired and tested transmitter chassis complete with special dual tube \$6.50. UTC "ouincer" mike transformer \$ .98. High output carbon mike \$1.49. Super Alnico headphone \$1.25. 2" x 5" x 9" aluminum case \$2.00. Wiring diagram \$ .50. Uses standard batteries available at your local radio store. Please include 5% for postage. COD's require \$1.00 deposit.

**SPRINGFIELD ENTERPRISES**

Box 54-E

Springfield Gardens 13, N. Y.

## EASY TO LEARN CODE

Learn or increase speed with an Instructograph—the Radio-Telegraph Code Teacher that takes the place of an operator-instructor and enables anyone to master code without further assistance. Available tapes from beginners alphabet to typical messages on all subjects. Speed range 5 to 40 WPM. Always ready—no QRM. Thousands have "acquired the code" with the Instructograph System. Write today for convenient rental and purchase plans.



**INSTRUCTOGRAPH COMPANY**

4713-P Sheridan Road, Chicago 40, Illinois

130

reel and another for the takeup reel. They must be provided with drive motions, first in one direction, then in the other; they must also be provided with *brakes* so designed as to halt the tape motion instantly without "throwing" or "snapping" the thin tape.

Such mechanisms affect the life, performance, and even tone quality of the over-all tape equipment. The ingenuity of design engineers has been tried and tested to produce practical units. Often the engineers have failed and their designs have not been marketed. The next article in this series will discuss the problems of tape transport mechanisms, the parallels to the "wow" and "rumble" problems of record players. By becoming familiar with this aspect of tape recording equipment, the user can learn what to look for and how to recognize the tape recorder that will be his "best buy" for the kind of results desired.

—50—

## Easily Built Chassis Rack

(Continued from page 74)

With the "Handy Clamps" mounted on the rocker arm bars (use small wing nuts here), assemble the complete rocker arm to the top piece of the A-frame, employing a 1/4" wing nut and a flat washer. The completely assembled chassis rack is shown in Fig. 7. If desired, rubber feet may be mounted on the bottom angle pieces of the A-frames, but their use is optional.

**Modifications:** As shown and described, the chassis rack is designed to accommodate a wide variety of chassis sizes. Where work is limited to chassis bases of only one or two sizes, the constructor might easily modify the design of the rack to make it easier to build and to use. Shorter *Redi-Bolts* can be employed for the base assembly or, for work with a chassis of a single length, the adjustable *Redi-Bolts* might be eliminated entirely and the A-frames screwed down to a fixed wooden base plate (a length of 1" lumber or plywood should make a good base).

Rocker arms may be lengthened or shortened to meet individual requirements and, if preferred, the series of mounting holes may be replaced with a continuous 3/16" slot. The "Handy Clamps" specified in the Bill of Materials might well be replaced with either larger or smaller C-clamps.

### Using the Rack

The chassis rack may be adjusted for both the width and the length of the chassis to be mounted. Adjust for width by moving the "Handy Clamps" to different positions along the rocker arm bar. Adjust for

length by moving the A-frames along the *Redi-Bolt* base. When adjusting for length, make sure to move both sides of each A-frame the same distance—otherwise the frame may be mounted at a slight angle, placing the entire rack under a strain. Adjust for length by leaving one A-frame in a fixed position on the base and moving the other A-frame back and forth by adjusting the base wing nuts, or move both A-frames together so that the rack remains more or less centered on its *Redi-Bolt* base.

Place the chassis in position between the "Handy Clamps" and mount firmly by tightening these clamps. Once mounted, the chassis may be tilted to the desired working position by loosening the wing nuts holding the rocker arms to the top of the A-frame assemblies.

When the adjustments for length and width have been made, it requires only a minute or two to install or to remove a chassis, but several hours in working time may be saved due to the convenience of having the chassis in the best working position. —30—

## Tuning the Short-Wave Bands

(Continued from page 61)

0230-0330 and will soon extend the period an extra hour to 0430. It is also on the air at 2330-0000. The s.w. xmtr is on 6050 kc., power is 500 watts, and the call is VSZ10.

**Haiti**—The power of the new station, 4VWI, is 10 kw. 4VEH is planning a new xmtr of 5-kw. power, probably on the air in 1956 or '57. 4VWI will operate in the 19-meter band, and the call of the 1-kw. outlet on 6100 kc. has been changed to 4VEA. A rare one, being heard often at present, is 4VCM, *La Magloire B/C Circuit*, Port-au-Prince, 6165 kc. It can be noted from 1930 on, but at times is blocked by WLWO on 6155. Very few reports have been received from the USA. This one is not to be confused with *Radio Citadelle*, Cap Haitien, on 6150 kc.

**Iran**—DX'ers looking for Teheran on 15,100 kc. should be able to get it well now. They have French news at 1500-1515; music and English news at 1515-1530. Their signal is way up.

**Japan**—The latest schedule from Tokio is: 1800-1830 — JOA4 — 11,705, JOB5 — 15,235\* for Eastern North America (1); 1930-2000 — JOA4 — 11,705, JOB5 — 15,235\* for Eastern North America (2); 2230-2330 — JOB6 — 11,725\*, JOA5 — 15,225 for Pacific Coast of North America; 0030-0130 — JOB6 — 11,725, JOA5 — 15,225 for Hawaiian Islands; 0245-0345 — JOB6 — 11,725\*, JOA5 — 15,225 for New Zealand and Australia; 0415-0515 — JOB3 9675\*, JOA4 — 11,705 for South America; 0530-

\* denotes the new 100-kw. transmitters; others are 50 kw.

# Grommes

## Best Buy In Hi-Fi



### 55C "FLAT SIX" 12 WATT HIGH FIDELITY AMPLIFIER

A new concept in flat amplifier design features six tubes, six controls, separate turnover and roll off for record compensation, loudness control, and "Tri-Linear" output stage. A new low distortion figure is achieved by employing feedback around every stage from input to output. Feedback phono equalization as well as feed back bass and treble control circuits are used. Simple layout of components on chassis meet highest engineering standards. Fully enclosed for table top and shelf use or compact cabinet installation.

USERS NET—\$79.50

## G R O M M E S

Division of Precision Electronics

9101-PE King Street Franklin Park, Illinois



To Family, Friends and Yourself

It's Fun to Learn

by **LINGUAPHONE**  
World's Standard Conversational Method

FRENCH • GERMAN • JAPANESE  
SPANISH (New World or European)  
ITALIAN • RUSSIAN • MODERN GREEK  
34 languages available

A Linguaphone Language Set gives each member of your family a practical asset for professional life, business school, armed forces, culture and travel. With Linguaphone's life-like recordings, you learn to speak another language AT HOME the same, easy, natural way you learned your mother tongue long before you went to school. It's like living in a foreign land. You listen, you hear 8 to 12 of the world's best native language teachers speak in their native language about everyday matters. You understand. YOU Speak. You read and write.

Stop Wishing—Start Talking

Treat Your Family, Friends and Yourself to a Linguaphone Set—"The Gift of Language"

Used round the world by educators, governments and more than a million home-study students of all ages. FREE book, "Passport To A New World of Opportunity" gives fascinating facts—Send coupon TODAY. Linguaphone Institute, 89-115 Radio City, N. Y. 20.

SEND FOR  
**FREE**  
BOOKLET

LINGUAPHONE INSTITUTE  
89-115 Radio City, N. Y. 20

Please send me your FREE Book.

Language interest.....

Name.....

Address.....

City.....

Zone..... State.....

Leaders for Over Half a Century in Up-to-Date Modern Language Courses.

## PUZZLETRON COMPUTER KIT

### A NEW CONCEPT IN PUZZLES AND GAMES

Design and build over 100 puzzle solving, game playing, and computing machines with the complete PUZZLETRON kit.

- Anyone can do it. Absolutely no technical knowledge required. Complete instructions and easy-to-follow diagrams in big 80-page booklet—plus ideas for designing your own circuits.
- Interesting PUZZLETRON games include TIC-TAC-TOE, THREE JEALOUS HUSBANDS, MISSION, ARIES AND CANNIBALS, FARMER CIRCUIT, BATTLE OF NUMBERS, etc. etc. etc.
- Over 500 parts, precision components, and necessary tools to build any suggested puzzles or those of your own design.
- Start enjoying this new challenging hobby, now!

Complete PUZZLETRON kit—only \$17.50 (a \$24.95 value). Fully guaranteed. Money back in 7 days. Send for free "Introduction to Electronic Puzzles."

### NEW TECHNIQUES, INC.

1514 West Eleventh St. Brooklyn 4, New York

## PRINTED CIRCUIT TRANSISTOR WRIST RADIO



With the sensational new printed MULTI-CIRCUIT, build this and 10 other transistor radios only 2"x3"x3/4" for wrist or pocket use. Powerful professional-looking sets using 1, 2, or 3 transistors. No more tedious wiring. Resistance or transformer coupling. Volume control, regeneration. Civil Defense receivers, Geiger counter amplifiers, audio amplifiers, oscillators, hearing aids, headlight dimmers, rain detectors, all on the same printed circuit. Use your own transistors of any type. Essential kit consisting of precision printed and drilled MULTI-CIRCUIT, finished RADIO CASE of unbreakable plastic. INSTRUCTION MANUAL with picture diagrams \$2.98 ppd. Send cash, check, money

order today. DYNATRANS, Box 115-EK, Huntington Station, N. Y.

## INVENTORS

If you believe that you have an invention, you should find out how to protect it. We are registered Patent Attorneys. Send for copy of our Patent booklet "How to Protect Your Invention," and an "Invention Record" form. No obligation. They are yours for the asking.

### McMORROW, BERMAN & DAVIDSON

Registered Patent Attorneys

349-E Victor Building Washington 1, D. C.

## POPULAR ELECTRONIC KITS

Tech-6 converter .....	\$ 9.90
Reflex receiver .....	11.35
Etched pre-amp .....	8.10
Introduction to puzzle-tonics .....	7.85

Also hundreds of electronic parts, meters, crystals, tubes, etc., at bargain prices. 25% deposit if C.O.D. Please include postage.

### ALGERADIO ELECTRONICS CO.

236 N. Franklin St. Hempstead, N. Y.

## NEW WRIST RADIO

Amazingly powerful! Plays while you wear it. 400-mile reception using just its own antenna. No connections needed to ground, aerial, lamp, telephone, etc. Tunes entire broadcast band with sharp selectivity. **BUILD YOUR OWN**—New book has complete instructions. How-to-do-it book \$1.98 postpaid. Also a basic kit consisting of attractive pre-drilled case, "outline" chassis, and all necessary hardware \$2.98 ppd. Combination of book and basic kit, SPECIAL \$3.98 postpaid, C.O.D.'s, \$1 deposit. Huckert Electronics, Box 7400-L5, Washington 4, D.C.

## Unlimited Opportunities ENGINEERING

BACH, SC. DEGREE IN 27 MONTHS in Elect., Radio (F. V. Electronics), Mech., Civil, Chem., Aero., Adm. Engineering; Bus. Adm., Acct. Visit beautiful campus in friendly college town. See well-equipped labs. Demand for graduates exceeds supply. Effective placement service. Prep. courses. Approved for Veterans. Enter Jan., March, June, Sept. Low cost. Write Jean McCarthy for Catalog, View Book, "Your Career in Engineering or Commerce."

TRI-STATE COLLEGE, 36115 College Ave., Anglo Ind.

0730 — JOB3 — 9675, JOA4 — 11,705 for North and Central China; 0745-0845 — JOA4 — 11,705, JOB5 — 15,235\* for Indonesia and Philippines; 0900-1000 — JOA4 — 11,705, JOB5 — 15,235 for South China; 1000-1100 — JOA4 — 11,705, JOB5 — 15,235 for Indo-China, Thailand, Burma; 1115-1215 — JOB3 — 9675, JOA4 — 11,705 for India and Pakistan; 1230-1330 — JOB3 — 9675\*, JOA4 — 11,705 for the Near East; 1400-1500 — JOB3 — 9675\*, JOA4 — 11,705 for Europe.

Mexico—XEB, 1220 kc., and XEBT, 9625 kc., Mexico City, have an English news session at 1915-1930, Monday through Friday.

Mozambique—Radio Clube de Mozambique, Lourenco Marques, is now operating as follows: English network—CR7BU (4920 kc., 7½ kw.) at 2200-1600; CR7AA (7254 kc., 7½ kw.) at 0130-1000; CR7BJ (9762 kc., 7½ kw.) at 0200-1000; CR7BF (11,765 kc., 7½ kw.) at 2200-1300. Closing on Saturday is at 1700. Other frequency available: CR7AB (3480 kc., 7½ kw.). Portuguese network — 0000-0100, 0430-0630 (Sat., Sun. until 0700); 1045-1515 over CR7BV (4829 kc., 7½ kw.); CR7BG (15,285 kc., 10 kw.). Other frequencies available: CR7BM (3420 kc., 7½ kw.) and CR7BE (9804 kc., 10 kw.). The Relay Station at Nampula operates over CR7BZ (3531 kc., 600 w.) at 0500-0630, 1130-1400.

Paraguay—Radio Stentor, Paraguay, 9735 kc., is planning to increase the power of the s.w. outlet to 2500 watts.

Philippines—The Far East Broadcasting Corp., Manila, might test on 9730 kc. for Eastern North America soon. Watch for it.

Tangier—A new station in this already radio-crowded section is IBRA-Radio, being tested by Radio Africa Magreb on the current channels: 15,253 and 11,700 kc. until 1500; 15,202 kc. after 1500. It has been noted also on 9995 kc. and has been heard as early as 1200. This xmtr is being used for the Swedish religious movement called "Pingst-rerelsen." The address is IBRA-Radio, P. O. Box 822, Stockholm-I, Sweden.

Venezuela—Mr. J. N. Rodriguez, Villa San Jose, Guanare, Venezuela, sends the following list of Venezuelan station changes and to him we are thankful: 3245 — YVKT, Radio Libertador, Caracas; 3255 — YVQL, La Voz del Tigre, El Tigre; 3265 — YVOC, Ecos del Torbes, San Cristobal; 3275 — YVMC, Radio Mara, Maracaibo; 3285 — YVLE, Radio Puerto Cabello, Puerto Cabello; 3295—YVOG, Radio Trujillo, Trujillo; 3300 — YVLG, Radio Girardot, Maracay; 3315 — YVLI, Radio Maracay, Maracay; 3320 — YV, La Voz de Anzoátegui, Barcelona; 3325 — YVQG, Radio Carúpano, Carúpano; 3335 — YVQN, Ondas Porteñas, Puerto La Cruz; 3340 — YVMU, Radio Carora, Carora; 3355 — YVLD, Radio Valencia, Valencia; 3375 — YVMI, La Voz de la Fé, Maracaibo; 3385 — YVQI, Emisoras Unidas, Barcelona; 3390 — YVKK, La Voz de la Patria, Caracas; 3400 — YVKP, Radio Tropical, Caracas; 3410 — YVMK, Radio Cabimas, Cabimas; 3420 — YVOJ, Radio Universidad, Mérida; 3490 — YVRA, Radio Monagas, Maturin; 4760 — YVKV, Emisora Vargas, La Guaira; 4770 — YVMW, Ondas del Caribe, Punto Fijo; 4780 — YVLA, La Voz de Carabobo, Valencia;

4790 — YVQC, *Ecos del Orinoco*, Ciudad Bolívar; 4800 — YVME, *Ondas del Lago*, Maracaibo; 4810 — YVMG, *Radio Popular*, Maracaibo; 4820 — YVRC, *La Voz de Apure*, San Fernando; 4830 — YVOA, *La Voz del Táchira*, San Cristóbal; 4840 — YVOI, *Radio Valera*, Valera; 4850 — YVMS, *Radio Universo*, Barquisimeto; 4860 — YVPA, *Radio Yaracuy*, San Felipe; 4880 — YVKF, *Ondas Populares*, Caracas; 4890 — YVKB, *Radiodifusora Venezuela*, Caracas; 4900 — YVQE, *Radio Bolívar*, Ciudad Bolívar; 4920 — YVKR, *Radio Caracas*, Caracas; 4940 — YVMO, *Radiodifusora Occidental*, Barquisimeto; 4950 — YVMM, *Radio Coro*, Coro; 4960 — YVQA, *Radio Sucre*, Cumaná; 4970 — YVLK, *Radio Rumbos*, Caracas; 4990 — YVMQ, *Radio Barquisimeto*, Barquisimeto (15 kw.); 5030 — YVKL, *Radio Continente*, Caracas; 5040 — YVMB, *Ecos del Zulia*, Maracaibo; 5050 — YVKE, *Radio Cultura*, Caracas; 6170 — YVKO, *Radiodifusora Nacional*, Caracas; 9510 — YVXJ, *Radio Barquisimeto*, Barquisimeto; 9530 — YVMZ, *Radio Popular*, Maracaibo; and 9570 — YVOM, *Ecos del Torbes*, San Cristobal.

SWL's are being urged to send photographs of themselves or of their shacks to the DX Editor, *Radio Australia*, Melbourne, Australia. The editor is compiling a collection of RADX listeners, and we would like to help make the collection a worthwhile one. —50—

## The Transmitting Tower

(Continued from page 63)

75-meter band with a loading coil is less than 5% as efficient as a full-size antenna for the same band.

Small discrepancies in length will normally be compensated for in the tuning of the transmitter and antenna tuner, if used, and will not reduce radiating efficiency too greatly.

Going back to Fig. 2 and applying Ohm's law to the current and voltage curves shown there, it is obvious that a half-wave antenna "looks like" a high resistance at its ends and like a low resistance in the center.

The end resistance is difficult to determine with any great degree of accuracy, but is estimated to be between about 2000 and 5000 ohms. The center resistance is easily measured, and is between 50 and 75 ohms in a half-wave antenna.

As the actual ohmic resistance of the antenna wire itself is only an ohm or two at the most, the difference between the two is called the *radiation resistance*, because it represents the power lost from the antenna by radiation.

### Calculating Antenna Length

Wavelengths are always given in meters (3' 3.37"), and in the United States we measure lengths in feet and inches. Also, radio waves do not travel quite as fast on a wire as they do in free space; therefore, the electrical length of an antenna is slightly greater than its physical length. The actual difference depends upon the ratio of the wire length to its diameter and on how it is supported. It averages about 5% for half-wave wire antennas supported by insulators at each end. The

## SHOOT TV TROUBLE FAST

### With H. G. Cisin's Copyrighted RAPID "TV TROUBLE SHOOTING METHOD"

Without experience or knowledge, this guaranteed new method of servicing TV sets enables you to DIAGNOSE TV troubles as rapidly as an expert. **NO THEORY—NO MATH**—you can locate all faults in record-breaking time, regardless of make or model. "TV TROUBLE SHOOTING METHOD" is the most valuable aid to TV servicing ever written. Be a TV Trouble Diagnostician. Increase your present earnings. Open your own Profitable Business or get a high-paying skilled job.

It's all in this book . . .

#### Nothing more to Pay—Nothing else to Buy

85 picture troubles, over 58 raster and 17 sound troubles. By this unique copyrighted method you know EXACTLY WHERE the trouble is; plus step-by-step instructions, including 69 RAPID CHECKS, enabling you to find the faulty part. **13 IMPORTANT PRELIMINARY CHECKS NEED NO INSTRUMENTS!** Of the 69 Rapid Checks, **OVER 65 ALSO REQUIRE NO INSTRUMENTS!** Rapid checks include emergency checks for distorted pictures, defective tubes including PIN tube, plus 57 others. **ALL EXPLAINED IN SIMPLE LANGUAGE. PERFORMED WITHOUT INSTRUMENTS. MANY CHECKS USE THE PICTURE TUBE AS A GUIDE.**

H. G. Cisin, the author, is the inventor of the AC/DC midtest radio. He licenses RCA, AT&T, etc. He has also trained thousands of technicians now owning their own prosperous TV service organizations or holding highly paid TV positions. His years of experience are embodied in this remarkable new book.

Guaranteed. Money Back in 5 Days if Not Satisfied!

**ABSOLUTELY FREE** with each order: H. G. Cisin's newest book "TV & RADIO TUBE SUBSTITUTION GUIDE." Gives direct replacements of set and picture tubes. Most valuable servicing aid! **ACT NOW—get both books postpaid at cost of only one!**

**\$1**

Post-paid

#### RUSH COUPON NOW!

H. G. CISIN, CONSULTING ENGINEER.  
Amagansett, N. Y.

Dept. P-11

Enclosed find \$1. Rush both books.

Name .....

Address .....

City..... Zone..... State.....

## SAVE HOURS OF WORK

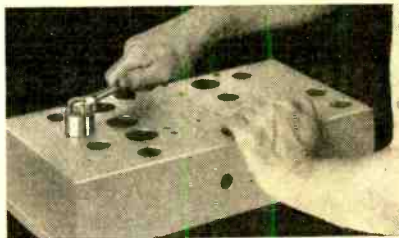

### quickly make round, square, key and "D" openings with Greenlee Radio Chassis Punches

In 1½ minutes or less you can make a smooth, accurate hole in metal, bakelite or hard rubber with a GREENLEE Punch. Easy to operate

... simply turn with an ordinary wrench. Wide range of sizes. Write for details. Greenlee Tool Co., 2391 Columbia Ave., Rockford, Ill.

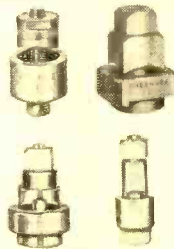

**GREENLEE**

## TRANSISTOR RADIO KIT



Not a miniature but full size transistor radio kit ready for you to assemble. Designed by transistor engineers. Its power will amaze you. Uses high quality junction transistor and radar-type diode. Operates thousands of hours on one set of small flashlight batteries! Completed kit is professional in appearance—makes excellent emergency receiver and can even operate speaker. Has variable condenser tuning! Kit comes complete with drilled chassis and everything you need—no soldering! Be the first to build this professional transistor set... ideal for learning characteristics of the transistor. Completely guaranteed. (We are also, as an introduction, offering double earphones at only \$2.25 extra.) Complete kit just \$12.95. (Send check, cash or money order and we pay postage.)

MAIL THIS TODAY

**KWIK KIT PRODUCTS**

8861 Hazard Avenue, Santa Ana, Calif.

Please send me complete kit for just \$12.95.

Name \_\_\_\_\_

Address \_\_\_\_\_

City \_\_\_\_\_

State \_\_\_\_\_

If earphones are desired enclose \$2.25 for each set.

## DO IT YOURSELF!

### SAVE ON SERVICE CALLS—

Test your own TV and Radio Tubes with the Home Service Tester

Also tests appliances for shorts and broken wires or elements, light bulbs, fuses, motors, flash bulbs, and any other electrical equipment. Same tube tester now being used by over 25,000 TV and Radio Servicemen. Quick—shock-proof—no technical knowledge required. Save Money Now—by ordering TODAY! Satisfaction guaranteed or your money back. Complete with easy instructions.

\$495

EA.

POSTPAID

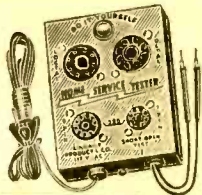

**Lindaily Products** 2626 W. 103rd Pl., Dept. PE-11  
Chicago 43, Ill.

## Catalog of 3000 Novelties 10c

Send 10c for amazing catalog of novelties, live animals, scientific supplies, hobbies, funmakers, planes & boats, looms, magic tricks, joke articles, unusual seeds, gadget time-savers, cameras, optical goods, projectors, movies, toys, lucky jewelry, religious novelties, disguises, musical instruments, stamps, coins, puzzles, fortune tellers, radios, auto & bike accessories, telescopes, magnifiers, compasses, banks, smokers' gadgets, artists' supplies, printing sets, engines, motors, shockers, knives, billfolds, fireworks, guns, rifles, sports, books, games, plants, etc. Send name, address & 10c to: **JOHNSON SMITH & CO., Dept. 107 Detroit 7, Michigan**

## GEIGER COUNTER KIT



Easily assembled. Ready to wire. Complete instructions, diagram, ore sample and government booklet provided. Model shown only \$17.50 postpaid. Same model with probe \$24.50 postpaid. Satisfaction is guaranteed. Order now.

**STOWERS & SON, Dept. 54, 804 Grand, Kansas City 6, Mo.**

## INVENTORS

Send for **PATENT INFORMATION** Book and **INVENTOR'S RECORD** without obligation

**GUSTAVE MILLER**  
115-P WARNER BUILDING  
WASHINGTON 4, D. C.

**REGISTERED PATENT ATTORNEY**

ASSOCIATE EXAMINER  
U. S. PAT. OFF. 1922-1929

Patent Attorney & Advisor  
U. S. NAVY DEPT. 1930-1947  
**PATENT LAWYER**

## GET INTO ELECTRONICS

You can enter this uncrowded, interesting field. Defense expansion, new developments demand trained specialists. Study all phases radio & electronics theory and practice: TV; FM; broadcasting; servicing; aviation, marine, police radio; 18-month course. Graduates in demand by major companies. H. S. or equivalent required. Begin Jan., March, June, Sept. Campus life. Write for Catalog.

**VALPARAISO TECHNICAL INSTITUTE**

Dept. PE

Valparaiso, Indiana

standard formula for calculating the lengths of half-wave antennas makes proper allowances for these factors. It is:

$$\text{Length (in feet)} = 468,000/\text{frequency (kc.)}$$

$$= 468/\text{frequency (mc.)}$$

To the nearest inch, the lengths of half-wave antennas for the centers of the three low-frequency Novice bands are listed below, and may be used at any frequency within the respective bands:

3700-kc. band: 125' 8"

7150-kc. band: 65' 3"

21,100-kc. band: 22' 1"

In next month's column, we will discuss a practical application of the above theory.

### News and Views

The response to the first few *Transmitting Towers* has been most gratifying. I try my level best to answer directly all letters that ask specific questions and include an address to which an answer can be sent. Those that are not answered are read just as carefully as the rest. Please continue writing.

One of the requests most repeated is for the names and addresses of radio clubs and individuals who are willing to help newcomers obtain their amateur licenses. So let me hear from you. However, do not wait until the day before the course is scheduled to start to tell me about it.

Bill Collins of Wexford, Ontario, suggests a special section of the *Transmitting Tower* for Canadian (VE) activities. Canadian reports will certainly be welcomed, as will those from other countries. Next month, I will provide information on how Canadian amateurs are licensed.

Dave, WNOYDR, reports that he was able to make only about a half-dozen contacts in several months of operation, because of receiver trouble, until he got an S-38C receiver. He is now doing much better.

Bill, KN6IYJ, reports excellent results from his *Johnson "Adventurer"* transmitter and *Hallicrafter's SX-71* receiver on 40 and 15 meters. His pet peeve is amateurs who do not confirm contacts with QSL (acknowledgment) cards.

Helen, WN9MXI, is busily studying for her General Class license and is already copying code at 20 wpm. So she is not worried about the code test. Her "Ranger" transmitter has now worked four Canadians. Helen sent a picture of her station, but I am holding out for one with her in it, too.

Lee, W7YJE, Seattle, tells us about a rather exclusive club: "The Royal Order of Hoot-owls." To become a member of this organization, it is necessary to work someone who is already a member on Saturday night between 2400 and 0100 on the 6-meter band. At this time, there are 12 certificate holders, and Lee reports that the Royal Order has stirred up quite a bit of regular 6-meter operation among the gang out there.

Bill, WN3BZR, has worked 32 states and Canada in 3½ months on the air, spending most of his time on 40 meters. But he gets on 80 and 15 meters occasionally. He reports his experiences on the last Field Day, thus: "My

friend, Bill Nagel, and I moved the entire shack, Viking II transmitter, S-40B receiver, and operating table right out on the front porch. At 4:00 p.m., we called CQ FD. Finally, about 9:00 p.m., after one local contact, I discovered that the transmitter works better with the antenna connected! After that, we made a few contacts throughout the night. Our total score was 12 points! We have a long way to go . . ."

Bob, W1EBW (15), says, "Got my General license a few weeks ago, but I am still a Novice at heart. During my four-month amateur career, I have worked 19 states. At first, I was using a 6L6 transmitter, running 20-watts input. Now, I am using a *Heathkit* AT-1 transmitter, running 35 watts on code and 25 watts on phone, using the "Simplest Modulator" described in the ARRL Radio Amateur's Handbook. My receiver is an SW-54."

Is the age of chivalry dead? Louise, W3WRE, reports that when she hinted to her husband Bill, W3WRC, that she would like a transmitter of her own, he gallantly replied, "You're a ham. Build yourself one." So Louise is gradually accumulating parts in her transmitter hope chest. She wonders what her new neighbors are going to think when they see her cavorting around on the roof, putting up antennas. Incidentally, the antenna she put up at the old location stood up under a couple of hurricanes, which she gleefully reports is more than the neighborhood TV antennas did.

From Kristinehamn, Sweden, Ullmar Kvick, SM4-1252, Romelevagan 20, reports: "I am 20 and started listening on the amateur bands after World War II. I soon learned the code, but have preferred remaining just a listener. I have been rather active reporting to amateur stations in recent years and have confirmations from 73 countries in 23 of the 40 DX zones. This record is not much, compared to my heard total of 185 countries, and all 40 zones, but I send reports with some discrimination. I like to include a letter with my card, to give the ham some details of interest, in addition to the notes on my card. I am happy to report that I obtain about a 60% return on reports sent, which I think is quite satisfactory. Though I have been hearing the more powerful amateur stations in the States on 40 and 80 meters, I have not yet heard any Novices; but I will keep trying. I would appreciate hearing from a YL over there who is a Novice or SWL."

Well, that's about all for this month. Address mail, pictures, and comments to me: Herb Brier, c/o POPULAR ELECTRONICS, 366 Madison Ave., New York 17, N. Y. Let me know, when you write, whether or not you would like your complete address printed—if your letter appears in the *Transmitting Tower*—taking into consideration that publication of your address will be an invitation to readers to write to you. As a result, you may get a lot more mail than you bargained for (POPULAR ELECTRONICS has a distribution of well over 300,000 copies), all of which you will be morally obligated to answer.

Herb, W9EGQ

not everyone does as well, but E. O. Lockin, who started a business of his own, reports . . .

for 12 months I've averaged  
**\$800 PER MONTH**  
**INCOME —**  
*most of it clear profit for me!*

● Many men have discovered how to be independent, to be free of bosses and layoffs. L. A. Eagles grossed more than \$200 his first week. Others report gross up to \$12,000 per year. How much you make depends largely on you. You need no special skill, no large investment.

**No shop necessary.** Our ELECTRIC RUG WASHER cleans rugs, carpets right on floor . . . helps to show their natural color, beauty. So efficient and safe, used by large hotels and railroads.

You take no risk. Machines fully guaranteed. Write for full information including how to make big profits in YOUR OWN business.



**MAIL COUPON TODAY FOR FREE BOOK**

VON SCHRADER MFG. CO., E44"R"PL, Racine, Wis.

Without obligation, send your FREE booklet containing information about your ELECTRIC RUG WASHER and how I can start my own permanent, profitable business.

Name \_\_\_\_\_  
 Address \_\_\_\_\_  
 City \_\_\_\_\_ Zone \_\_\_\_\_ State \_\_\_\_\_

**BA's NEW 1956 FREE CATALOG**

**YESSIR-IT'S THE KING-SIZE CATALOG—**  
**164 KING-SIZED (8 1/4 x 10 1/2) PAGES**  
 OFFERS MORE ITEMS PER PAGE--IT'S EASIER TO USE..IT'S EASIER FOR YOU TO ORDER

**COMPLETE GUIDE TO EVERYTHING IN RADIO, TV, ELECTRONICS**

**100'S OF BRAND NEW ITEMS LISTED HERE FOR THE VERY FIRST TIME**

**INCLUDES 21 BIG PAGES OF BARGAINS NOT FOUND IN ANY OTHER CATALOG**

**BURSTEIN-APPLEBEE CO.**  
 Dept. PE-1012-14 McGee St., Kansas City 6, Mo.  
 Send Free B-A Catalog No. 561.

Name \_\_\_\_\_  
 Address \_\_\_\_\_  
 City \_\_\_\_\_ State \_\_\_\_\_

# GLOSSARY OF ELECTRONIC TERMS

This glossary, which is being published in serial form, started in August. It consists of a selected group of definitions taken from the booklet "A Dictionary of Electronic Terms," published by Allied Radio Corp., 100 N. Western Ave., Chicago, Ill. The complete dictionary, containing over 3500 terms, is available from Allied at 25 cents a copy.

**Geiger-Müller counter**—A gas-filled tube consisting of a metallic cylindrical sheath having a slender wire running axially through its center, used for detecting x-rays, gamma rays, beta rays, alpha rays, etc. The tube is operated just below discharge voltage. Radiation traversing the gas causes a transient burst of discharge which actuates an amplifying or counting circuit. Also spelled **Geiger-Mueller**.

**germanium diode**—A very small type of diode employing the element germanium. Germanium diodes have wide application in detector, rectifier and converter circuits. See **diode**.

**glow lamp**—(1) A lamp in which light is produced by a glow discharge between two electrodes in an evacuated envelope into which a small quantity of gas such as neon or argon has been introduced. (2) A gas-discharge tube serving as a concentrated source of light whose brightness varies in proportion to current flow. Used in variable-density sound-on-film recording.

**grid**—An electrode mounted between the cathode and the anode of a radio or electronic tube to control the flow of electrons from cathode to anode. The grid electrode is usually either a cylindrical-shaped wire screen or a spiral of wire through which electrons can readily move.

**grid-bias cell**—A small cell used in the grid circuit of a vacuum tube to provide C bias voltage; it cannot supply current.

**grid-dip meter**—A vacuum-tube oscillator having in its grid circuit a sensitive current-indicating meter that dips (reads lower current) when energy is drawn from the oscillator by a coupled resonant circuit tuned to the oscillator frequency.

**grid leak**—A resistor used in the grid circuit of a vacuum tube to provide a discharge path in parallel with the grid coupling capacitor. The value of the resistor determines the average value of the developed grid bias.

**grid modulation**—Modulation produced by introduction of the modulating intelligence into the grid circuit of any tube in a transmitting system in which the carrier-frequency wave is present.

**groove**—The track cut in a phonograph record or other medium by the stylus during sound recording, or in which a phonograph needle rides during playback.

**ground clamp**—A metal strap or clamp used for making a good electrical connection to a ground rod or to grounded pipe. The clamp has a screw terminal or soldering lug to which the ground wire of a radio can be attached.

**ground wave**—Radio wave that is propagated near or at the surface of the earth and is affected by the resistance of the ground.

**ham**—A term applied to licensed radio operators who operate their stations as a hobby, rather than for commercial purposes.

**hard tube**—Vacuum tube that has been evacuated to a high degree.

**harmonic**—A sinusoidal wave that is an integral multiple of the fundamental frequency which is called the first harmonic. Also any function which repeats itself.

**headphone**—Small telephone receiver used either singly or in pairs for reception.

**henry**—The practical unit of self-inductance or mutual inductance. The inductance in which a current changing its rate of flow one ampere per second induces an electromotive force of 1 volt. Abbreviated **hy**, or **h**.

**heterodyne**—Pertaining to the production of a difference frequency (beat) by combining two frequencies.

**high-fidelity**—(Also **hi-fi**) A term applied to an audio component, amplifier, or system. Ideally, it is the ability to reproduce faithfully, that is, with a minimum of distortion, the full audio range of frequencies. While no universal standards have been set up, this range is generally agreed to be approximately 20-20,000 cycles. However, the term is often loosely applied to units whose range falls short of these limits.

**horizontal resolution**—The definition or clarity of a television image in a horizontal line.

**horn**—An energy-transferring device in the shape of a horn with the energy-producing device located at its throat.

**hot**—Connected, alive, energized. Said of a wire, terminal, or any ungrounded conductor. Not grounded.

**hum**—A low and constant audio frequency, usually either 60 or 120 cycles. Hum may be heard in the background of a received radio or television program or in the output of an audio amplifier. When hum is present in the video circuit of a TV receiver, it creates dark horizontal bars, picture distortion, or both. Hum is most frequently caused by a faulty filter capacitor in the power supply or heater-cathode leakage in a tube.

**hysteresis loss**—Energy loss in a magnetic substance exposed to a constantly changing magnetic field. The loss is due to internal friction, and appears as heat. It is proportional to the area enclosed in the hysteresis loop.

**ignitron**—A mercury-vapor rectifier tube with a mercury cathode. Starting is by an ignitor rod.

**image orthicon**—A television camera tube combining an image dissector, orthicon and image multiplier.

**impedance**—The total opposition that a circuit offers to the flow of alternating current or any other varying current at a particular frequency. Impedance is a combination of resistance and reactance. The symbol for impedance is **Z**, and the ohm is the unit of impedance.

**impedance match**—The condition in which the impedance of a component or circuit is equal to another impedance to which it is connected. Impedance matching is important for maximum power transfer, minimum reflection and—since reflection varies with frequency—minimum distortion.

**induced voltage**—A voltage produced in a circuit by changes in the number of magnetic lines of force which are linking or cutting across the conductors of the circuit.

**inductance**—That property of a coil or other radio part which tends to prevent any change in current flow. Inductance is effective only when varying or



alternating currents are present; it has no effect whatsoever upon the flow of direct current. Inductance is measured in henrys.

**induction heating**—Industrial and laboratory processes based on eddy currents. R.f. power is generated by spark gap or tube oscillator circuits. The power is coupled by highly efficient coils into the work which serves as a secondary or load. Process usually takes place in a vacuum or controlled atmosphere. The purpose may be that of melting (experimental alloys are melted in crucibles), welding or brazing (metal parts of vacuum tubes may be flowed together very accurately in this way), or heating ("bombarding" is standard practice in degassing vacuum tubes during exhaust).

**infrared**—The range of invisible light radiation frequencies lying between visible red and radio waves. Heat rays. See **electromagnetic spectrum**.

**insertion loss**—The ratio (expressed in decibels) of the power delivered before to the power delivered after the insertion of apparatus in a transmission system.

**instantaneous recording**—A recording that may be used immediately after cutting or embossing, without further processing.

**insulator**—Device having high electrical resistance, used for supporting or separating conductors so as to prevent undesired flow of current between conductors or to other objects.

**intercarrier system**—A television i.f. system wherein both audio and video signals go through the same i.f. stages.

**intercommunication system**—An amplifier system which provides two-way communication between two or more rooms in a building. Each station in the system contains a microphone and speaker, usually combined as a single dynamic unit; a headphone or telephone receiver is sometimes provided also for private reception of messages. The stations may be connected to each other by wire cables, or may receive and transmit messages through the electric wiring system in the building.

**interference**—(1) A variety of effects occurring when two or more wavetrains of either light or radio waves arrive at the same point simultaneously. A useful application of this phenomenon is made in heterodyne circuits and beat frequency oscillators, which may be considered as special cases of interference. (2) Undesired radio programs or noises that interfere with reception of a desired signal.

**interlock**—A safety device which automatically opens the a.c. supply circuit when the cover (as in a cabinet) or door which provides access to the circuit is opened.

**intermediate frequency amplifier**—That section of a superheterodyne receiver which is designed to amplify signals with high efficiency at a predetermined frequency called the intermediate frequency of the receiver.

**intermodulation distortion**—When a signal containing two or more frequencies is applied to the input of a nonlinear device, the output consists of waves having the original frequencies plus additional, new frequencies. These new frequencies are the result of intermodulation distortion in the nonlinear device. Undesirable in audio amplifiers.

**internal resistance**—The resistance of a battery, generator or circuit component. It acts as a series resistance.

**interstage coupling**—Coupling between vacuum-tube stages.

**inverse feedback**—A vacuum-tube circuit arrangement in which a voltage is fed back from the plate circuit to a preceding stage; used in radio-frequency circuits to improve the stability, and in audio-frequency circuits to reduce distortion and thus permit greater undistorted power output. Also called **de-generation**, **negative feedback**, and **stabilized feedback**.

**ion**—An atom or molecule which has fewer or more electrons than normal. A positive ion is one which has lost electrons, and a negative ion is one which has acquired more electrons than normal.

**ionization time**—The time required for formation of a discharge. It is shorter than de-ionization time. Time required for plasma formation in thyratrons is from a fraction of a microsecond to several microseconds. Discharge operation is rapid compared to the speed of temperature response of a filament; thus, neon glows are used in stroboscopes. There are, however, marked limitations in the use of ions as compared with electrons for high-frequency circuits.

**ionosphere**—Upper portion of the earth's atmosphere beginning at about 30 miles above the surface of the earth. The ionosphere starts with the E1 and E2 layers, commonly called the Kennelly-Heaviside layer. Above this are the F1 and F2 layers, sometimes collectively called the Appleton layer.

**ion trap**—A coil or permanent magnet placed on the neck of the cathode-ray tube for the purpose of removing ions from the electron stream. The magnetic field is able to deflect the electron stream, but has very little effect on the heavier ions. By doing this, it is able to separate the electrons from the ions, preventing the formation of ion spots on the screen.

**iron loss**—Power loss occurring in iron cores of electric machines, coils, transformers, etc., due to hysteresis and eddy currents.

**jack**—A plug-in type spring terminal widely used in radio apparatus for temporary connections. A connection is made to a jack simply by plugging into it a probe or plug attached to a flexible insulated wire or cable. Some jacks have extra contacts which are opened or closed when the probe is inserted, thereby giving automatic switching action.

**kinescope**—Name applied to a cathode-ray tube when used in a television receiver. Deflection of the electron stream is generally by magnetic means, rather than electrostatic as with cathode-ray tubes used in oscilloscopes. See **cathode-ray tube**.

**Klipsch enclosure**—A folded-horn, back-loading speaker enclosure. The Klipsch enclosure is designed specifically for installation in the corner of a room and is characterized by its ability to increase bass output substantially. It employs a built-in folded horn to load the loudspeaker from the rear. This folded horn is so mounted that it extends to the walls of the room. Thus, the walls serve as an extension of the horn to augment bass response further. Enclosures of this type output considerably less space than conventional folded-horn enclosures capable of similar efficiency at the bass frequencies. Klipsch-type enclosures are widely used in high-fidelity music systems.

**knee**—An abrupt change in direction between two fairly straight segments of a curve. Example: that region of a magnetization curve near saturation, or the top bend of a tube characteristic curve.

(To be continued next month)

# ADVERTISERS' INDEX

## NOVEMBER 1955

While every precaution is taken to insure accuracy, we cannot guarantee against the possibility of an occasional change or omission in the preparation of this index.

ADVERTISER	PAGE NO.	ADVERTISER	PAGE NO.
A & M Company	104	Merit Coil & Transformer Corp.	112
Airex Radio	112	Merlite Industries	116
Algeradio Electronics Co.	132	Microphone	124
Allied Radio Corp.	22, 111	Midway Co.	130
Audjo Fair Publishers	114	Miller, Gustave	134
Beavers, Patrick D.	128	Minnesota Mining & Mfg. Co.	8
Book of the Month Club, Inc.	9	Moss Electronics Distributing Co., Inc.	19, 103
Burstein-Appleebee Co.	135	National Radio Institute	3, 107, 108
CMG Industries	102	National School of Meat Cutting	124
Capitol Radio Engineering Institute	93	National Schools	25
Central Technical Institute	20	Newark Electric Company	120
Cisin, Consulting Engineer, H. G.	133	New Techniques	132
Cleveland Institute of Radio Electronics	17	O'Brien, Clarence & H. B. Jacobson	126
Coyne Electrical School	5, 23	Orradio Industries, Inc.	18
DeJur Amsco Corp.	95	Perma Power Company	26
Delehanty School of Television	27	Philadelphia Wireless Technical Institute	122
DeVry Technical Institute	11	Popular Electronics	109
Dynatrans	132	Precision Electronics	131
Edlie Electronics	114	Precision Radiation Instruments, Inc.	116
Electro Devices, Inc.	140	Progressive "Edu-Kits," Inc.	127
Electronic Instrument Co. Inc. (EICO)	10	RCA Institutes, Inc.	13
Electronic Measurements Corporation	16	Radio Shack of Boston	123
Esse Radio Co.	21	Radio-Television Training Association	7
G & H Wood Products Co. Inc.	2nd Cover	Raytheon Manufacturing Co.	6
General Electronic Equipment Co.	119	Rex Radio Supply	104
Granttham School of Electronics	105	Rider Publishing Co., Inc., John F.	113
Greenlee Tool Co.	133	Rinehart & Co., Inc.	129
Gyro Electronics Co.	122	Rockbar Corporation	24
Hallcrafters	4th Cover	Science Kits	115
Harris, H. E.	130	Sierra Scientific Co.	130
Harrison Radio	128	Smith & Co., Johnson	134
Heath Company	96, 97, 98, 99	Soundtronics Labs	126
Heeger, Inc.	120	Sprayberry Academy of Radio	3rd Cover
Hershel Radio Co.	26	Springfield Enterprises	128, 130
Hollywood Instrument Co.	23	Stanley Electronics Corp.	12
Hot Spot Detector, Inc.	128	Stowers & Son	134
Huckert Electronics	132	Teleparts Co.	116
Instructograph Company	130	Teltron Electric Co.	117
International Correspondence Schools	15	Telvac	122
Jones Box Corp., Jesse	110	Tetrad, Inc.	26
K & L Radio Parts Co.	122	Tradyme, Inc.	124
Karlson Associates, Inc.	118	Transvision, Inc.	102
Kwik-Kit Products	134	Tripp Specialty Company	124
Lafayette Radio	28	Tri-State College	132
Lakeshore Industries	128	U.S. Air Force	14
Lektron Specialties	125	Universal Television Schools	126
Lindaily Products	134	Valparaiso Technical College	134
Linguaphone Institute	131	Viking of Minneapolis	12
McGee Radio Co.	110	Von Schrater Mfg. Co.	135
McGraw-Hill Book Co.	12	Western Radio	126
McMorrow, Berman & Davidson	132	Whitehall Pharmacal Co.	120
Major Brand Tube Co.	20	World Radio Laboratories	121

# Classified

RATE: 50c per word—minimum 10 words

## FOR SALE

**DIAGRAMS** for repairing radios \$1.00, Television \$2.00. Give: make, model. Diagram Service, Box 672-PE, Hartford 1, Conn.

**DIAGRAMS:** Counters, Timers, Organs, Intercoms, etc., \$1.00 each. List free. Parks, 104-A S. E. 57th, Portland 15, Oregon.

**ELECTRIC Pencil:** Engraves all Metals, \$1.50. Beyer Mfg., 10511-P Springfield, Chicago 43.

**ETCHED Wire Printed Circuit Kit** \$3.75. Techniques, Inc., 135 Belmont Street, Englewood, N. J.

**USED Television sets** \$14. Jones, 1115 Rambler, Pottstown, Penna.

**"RADIOBUILDER"** Experimenter's Magazine, 25¢; 12, \$2.50. Laboratories, 328-L Fuller, Redwood City, California.

**SPECIAL:** New English Collaro RC-54 Changer, Mounting Board, Plug-In Head, \$38.75 Prepaid. Guaranteed: Diamond-Sapphire Stylus RPX-050, \$10.75. Simulated Base-Cover For All Changers, \$9.75. 3 $\frac{3}{4}$ -7 $\frac{1}{2}$ -15 Ips Dual Tracks. 30-15,000 cps English High Fidelity Tape Deck. Three 4 Pole Motors. Best Buy \$79.50 Prepaid. Write Today. Dept. PE, Fidelity Unlimited, 63-03 39th Ave., Woodside 77, N. Y.

**SECRET Beam Transmitter,** New Surplus, Five Mile Range, White & Infrared Beam, Portable, Works on Flashlight batteries. Complete with Signal Gun, Gunstock, Tripod, Infrared Goggles, Remote Control, Carrying Case Manual. Government paid over \$50. Yours for only \$10 Postpaid or \$3 Bal. C.O.D. Illustrated Signal Corps Manual 50¢. Surplus Box 118, Jersey City 4, N. J.

**BUILD Pocket Radios,** 5 selected plans 50¢. Cook, 4003 Roosevelt, Midland, Texas.

**WE Have a Very Substantial Quantity** of new, unused, dry-charged government surplus 14 volt storage batteries. 15 amp hour at  $\frac{1}{2}$  hour rate. Dimensions: 10 13/16" long x 4 7/8" wide x 8" high. D. E. Gaare, 1868 Ford Parkway, St. Paul 5, Minnesota.

**LOOK!** Any item \$1.00 Four microphone buttons; Hundred insulated carbon resistors; Single earphone telegraph key; ten electro-lytics; twelve potentiometers; 6 VDC 1RPM motor; Forty tubular condensers. Electronics, Box 72-D, Lawrence, Mass.

**SUPERSENSITIVE VHF radio** receives television, FM broadcast, special services and amateurs without antenna or ground. Factory wired and tested chassis including special tube \$5.98. In kit form \$3.98. Thousands in use by experimenters, amateurs, civil defense. Transistor audio stage complete with transistor for extra loud reception only \$2.00 extra. Springfield Enterprises, Box 54-E11, Springfield Gardens 13, New York.

**WALKIE-Talkie.** Build wireless portable radiophone for less than \$10.00. Plans for variable frequency and crystal control types, only 50¢ for both. Springfield Enterprises, Box 54E11, Springfield Gardens 13, New York.

**PRINTED Circuit materials** for Etched Preamp \$1.75. Complete advanced kit \$3.50. Guaranteed. New Techniques, 1514 West Eleventh, Brooklyn 4, N. Y.

**COLOR TV**—Simple new Colordaptor circuit converts any BW TV to receive compatible color using color wheel. Complete construction information \$2.50. Colordaptor, 3471 Ramona, Palo Alto, California.

## WANTED

**CYLINDER** and old disc phonographs, Edison Concert, Balmoral, Conqueror, Opera, and Oratorio models. Berliner Gramophones and Zono-o-phones, Columbia disc and cylinder Graphophones, Bettini micro-reproducer. Want old catalogues and literature on early phonos prior to 1919. Will pay cash or trade late hi-fi components. Popular Electronics, Box 50.

November, 1955

## HELP WANTED

**JOBS** to \$1500 Monthly, All Trades. So. America, The Islands, U.S. Fare Paid. Application Forms. Free Information, Write Dept. 72E. National, 1020 Broad, Newark, N. J.

**EXTRA Cash Spare Time!** Sell exclusive magic cushion shoes. 133 Styles. No investment. No experience. Steady repeats. Commissions to \$4.00 pair, plus bonus, paid vacations. Free outfit. Paragon Shoes, 79-E Sudbury, Boston.

**OVERSEAS Employment Opportunities!** Hiring firms' list—\$1. Sterling, Great Neck 89, N. Y.

**EARN Extra Money Selling Advertising Book Matches.** Free Sample Kit furnished. Matchcorp, Dept. EZ-3, Chicago 32, Illinois.

**RADIO-Television Service Man;** 22-30. Must have technical radio and television training, with 1-2 years of experience. Start, \$60.00 week. Live in sunny, fast growing Arizona community. Def-en-baw's, 109 East First St., Casa Grande, Arizona.

**MILITARY** or Civilian Trained Radio-Radar or Television mechanics wanting good jobs, Write Box 201, Culver City, Calif.

## INVENTIONS WANTED

**INVENTIONS** wanted. Patented; unpatented. Global Marketing Service, 2420—77th, Oakland 5, Calif.

## BUSINESS OPPORTUNITIES

**TO \$50.00 Weekly.** Sparetime, Home Operated Mail-order Business. Successful "Beginner's" Plan. Everything Supplied. Lynn, 10420-E National, Los Angeles 34.

**FREE Booklet "Money-Making Facts"** tells mechanically-inclined men how to start sparetime business at home. Lee Foley Company, Columbia Heights, Minnesota.

**WANT To Make Money At Home?** \$5 profit in an hour possible with Invisible Reworking. Make tears, holes disappear from clothing, fabrics. Steady year-round demand from cleaners, laundries, homes. Details Free. Fabricon, 8343-S Prairie, Chicago 19, Ill.

**\$200 weekly cleaning Venetian Blinds.** Free-revealing book. Burt, 2434 BU, Wichita 13, Kansas.

**OWN Profitable Spare Time home business.** Buy wholesale thousands products. Free Details. Cottage Industries, 2804-D Hanover, Omaha 12, Nebraska.

**\$70 weekly—home, spare time.** Simplified mail book-keeping. Immediate income—easy! Auditax, 34757-ANN, Los Angeles 34.

**VENDING Machines—No Selling.** Operate a route of coin machines and earn amazing profits. 32-page catalog free. Parkway Machine Corporation, Dept. 12, 715 Ensor St., Baltimore 2, Md.

**WHETHER** you have ever had any experience in the Fire Extinguisher Field—or whether you haven't—be sure and write us for the facts about this New Company that gives you the biggest opportunity a Man ever had to build up a Business of his own, with protected, exclusive Territory. The "Fire King" Company, Inc., Dept. 16, Littleton, Colorado.

## TAPE RECORDERS

**TAPE Recorders,** accessories. Best buys. Boynton Studio, 10 PE Pennsylvania, Yonkers, New York.

**RECORDERS** and tapes at lowest prices. Kerstin, 215 E. 88, N. Y. C. 28.

**TAPE Recorders,** Tapes, Accessories. Unusual values. Dressner, Box 65E, Peter Stuyvesant Station, N. Y. 9.

## INSTRUCTION

**OPPORTUNITY!** Complete high school at home in spare time with 58-year-old school. Texts furnished. No classes. Diploma. Information booklet free. American School, Dept. X856, Drexel at 58th, Chicago 37, Illinois.

Beginners

# ELECTRONIC KIT

For young and old

## 35 EXPERIMENTS

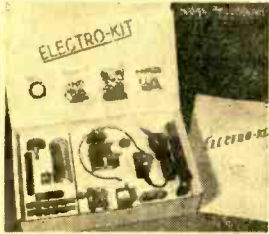

Including:

- RADIOS
- OSCILLATORS
- POWER SUPPLIES
- TEST SETS
- AMPLIFIERS
- ELECTRONIC ORGAN
- CODE SET
- MANY OTHERS

Detailed thoroughly understandable

### INSTRUCTION MANUAL

also includes interesting basic theory

### Complete, No Extras To Buy

- |                    |            |
|--------------------|------------|
| Duo Tube & Socket  | Neon Lamp  |
| Selenium Rectifier | Headset    |
| Tuning Condenser   | Resistors  |
| Crystal Detector   | Capacitors |
| Potentiometer      | Hardware   |

\$9.95 prepaid, or

Only \$1 with order pay postman  
\$8.95 plus charges

### ELECTRO KIT

Box 3468 Dept. PE-7 Maplewood 17, Mo.

## BOOKS

NATIONAL Geographic Magazines 1888-1955. Periodical Service, Box 465-PE, Wilmington, Delaware.

## STAMPS AND COINS

FREE! Catalog! About stamps. Illustrated. Free! The Stampmart, Hartford 1, Conn.

## MINERALS & PROSPECTING

ADD high sensitivity probe to your kit—operates 50 ft. cable. Also, Geiger, Amplifier, High Voltage kits. Free Information. The Raymaster Co., Box 1258, Callelo, California.

SCINTILLATION Counter. Ultra-sensitive. For information write Ute Company Inc., 200 So. 4th, Montrose, Colorado.

GEIGER Counter and Mineral Locators, Assembled and Kits. Free Geological Advice; Write for Details. Frontier Instruments, Box 276, Annandale 1, Virginia.

GEIGER Counter and Metal Detector Kits. Inexpensive, Educational. Free Literature. Electronic Applications, Dept. B, 5024 Lee Highway, Arlington 7, Va.

## ARTS AND CRAFTS

FREE! Leathercraft Catalog. Do-It-Yourself! Tandy Leather, Box 397 C-4, Tulsa, Okla.

FREE "Do-It-Yourself" Leathercraft Catalog. Tandy Leather Company, Box 791-H12, Fort Worth, Texas.

## MISCELLANEOUS

BUILD 2 Tube Loudspeaker Radio—A.C. Operated. Complete Instructions Plus Bonus Plans \$1.00. Amberlab, 159 Hermosilla, Santa Barbara, Calif.

CRYSTAL Photocells, extremely sensitive type CL-1. \$2.50 postpaid. Horton, 267 W. Eleventh Street, New York City, 14.

RECORDING Tape. Brand new—plastic base—standard brand—7 inch reel. \$2.50 Postpaid. Horton, 267 W. Eleventh Street, New York City, 14.

EXPERIMENTERS: Draw, type, print, photograph your own custom dials, name plates, etc. Have laminated in transparent plastic. Attractive—permanent. Information, sample free. Plastic Press, Box 13, St. Louis 14, Missouri.

EARPHONES: Single—1000 ohm \$1.95. Double—2000 ohm \$2.99. Bargain catalog 10¢. Morgan Electronics, Leesburg, Florida.

FREE Condenser & Resistor Code Chart! Get yours now Plus new value-packed catalogue! K. & L. Radio Parts Co., 1406 Venice Blvd., Los Angeles 6, California.

TUBES—TV, Radio, Transmitting, special purpose types—Bought, Sold, Exchanged. Send details to B. N. Gensler W2LNI, 512 Broadway, New York 12, N. Y.

NO luck finding a book publisher? Write for free booklet—EL. Vantage, 120 W. 31, New York.

HOW To live without money. Write—Cosmic, Clayton 2B, Ga.

BECOME a Radio Amateur. Free information on how to pass Code and Theory FCC examinations. American Electronics, 1203 E. Bryant Ave., New York 59, N. Y.

RULE Others With Thoughts. Full course. (Adults.) \$2. Delmar Wisdom, 846 Sunnyside, Dept. S-8, Chicago 40.

TARGET Knife, Malayan Throwing Style, 10 inches long. Leather wrapped handle, Instructions. \$1.00 or six for \$5.00 Postpaid. Surplus Box 118, Jersey City 4, New Jersey.

PSORIASIS Victims—Hopeless? New Discovery! Free Trial Offer. Write Pixacol, Box 3583-PE, Cleveland 18, Ohio.

### When you order by mail . . .

please print your name and address clearly, be specific in your order, enclose proper amount, allow ample time for delivery.

## ARE THESE IN YOUR ATTIC?

WANTED



Berliner Gramophone (illustrated).

Toy Gramophone or Phonograph (illustrated).

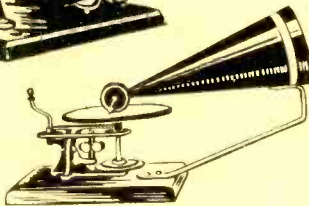

ALSO

WANTED . . .

- Columbia Grand Graphophone.
- Hill Talking Machine.
- Improved Gramophone (Zon-o-phon).
- Eagle Graphophone.
- Victor Models A, B, C & D.
- Friend Talking Machine.
- Columbia AY Disc Graphophone.
- Edison Concert Phonograph.
- Edison and Columbia Coin Machines.

AND Miscellaneous disc and cylinder phonographs with "outside" horns.

Send snapshot and description to  
POPULAR ELECTRONICS, Box 50  
366 Madison Ave., N. Y. 17, N. Y.

Learn PRACTICAL RADIO-TV  
with **25 BIG KITS**

of equipment I send you while  
you train with me . . . for valuable  
shop bench experience . . .

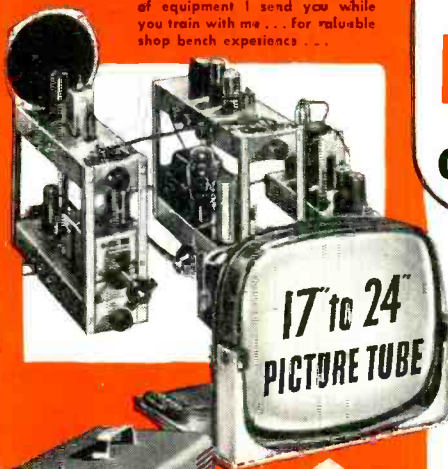

The new Sprayberry Training Television receiver, built and tested in sections.

Know offer this fine modern oscilloscope

You build this powerful 2 Band superhet radio receiver.

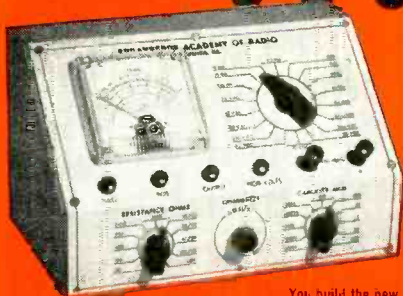
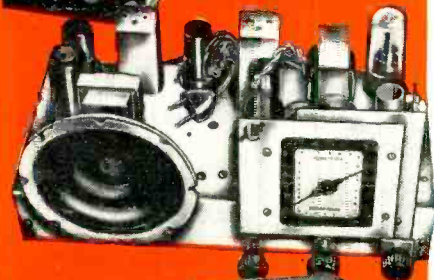

You build the new Sprayberry Tester . . . 18-range Volt-Ohm-Milliammeter readings.

In addition to modern lesson training, I also give you plenty of home practice on actual Radio-Television equipment . . . you will build and use the unit shown here plus many more. All this equipment is yours to keep . . . keep everything you need to set up your shop.

Prepare for a Good Paying Job — Or Your Own Business

"I Will Train You at Home in  
**RADIO-TELEVISION**  
on Liberal No Obligation Plan!"

New Equipment! New Lessons! Enlarged Course! The true facts are yours in my big new catalog . . . **YOURS FREE . . .**  
**JUST MAIL COUPON!**



Frank L. Sprayberry  
President, Sprayberry  
Academy of Radio

I can train and prepare you in as little as 10 months to step into the big opportunity Radio-Television service field. Train *without* signing a binding contract . . . without obligating yourself to pay any regular monthly amounts. You train entirely at home in spare hours . . . you train as fast or as slowly as you wish. You'll have your choice of **THREE SPRAYBERRY TRAINING PLANS . . .** planned for both beginners as well as the more experienced man. Get the true facts about the finest most modern Radio-Television available today . . . just mail the coupon for my big new 56 page fact-filled catalog plus sample lesson—both **FREE.**

**Train the Practical Way—with Actual Radio-Television Equipment**

**Train the Practical Way—with Actual Radio-Television Equipment**

My students do better because I train both the mind and the hands. Sprayberry Training is offered in 25 individual training units, each includes a practice giving kit of parts and equipment . . . all yours to keep. You will gain priceless practical experience building the specially engineered Sprayberry Television Training Receiver, Two-Band Radio Set, Signal Generator, Audio Tester and the new Sprayberry 18 range Multi-Tester, plus other test units. You will have a complete set of Radio-TV test equipment to start your own shop. My lessons are regularly revised and every important new development is covered. My students are completely trained Radio-Television Service Technicians.

**NEWEST DEVELOPMENTS**

Your training covers U H F, Color Television, F M, Oscilloscope Servicing, High Fidelity Sound and Transistors.

See for Yourself . . . Make Your Own Decision  
. . . Mail Coupon Today!

The coupon below brings you my big new catalog plus an actual sample Sprayberry Lesson. I invite you to read the facts . . . to see that I actually illustrate every item I include in my training. With the facts in your hands, you will be able to decide. *No salesman will call on you.* The coupon places you under no obligation. Mail it now, today, and get ready for your place in Radio-Television.

**SPRAYBERRY ACADEMY OF RADIO**

111 North Canal Street, Dept. 105-E, Chicago 6, Illinois

Mail This Coupon For Free Facts and Sample Lesson



SPRAYBERRY ACADEMY OF RADIO

Dept. 105-E, 111 N. Canal St., Chicago 6, Ill.

Please rush all information on your ALL-NEW Radio-Television Training Plan. I understand this does not obligate me and that no salesman will call upon me. Include New Catalog and Sample Lesson FREE.

Name \_\_\_\_\_ Age \_\_\_\_\_

Address \_\_\_\_\_

City \_\_\_\_\_ Zone \_\_\_\_\_ State \_\_\_\_\_



**MODEL S-38D**  
\$49.95

**COVERAGE:** Standard Broadcast from 540-1650 kc plus international reception on 3 Short-Wave Bands covering 1650 kc—32 Mc.

The radioman's idea of radio . . . This famous Hallicrafters' radio, now with smart new styling, amazes even the experts with its superior performance. Featuring the same skillful engineering found in much higher priced communications sets make the S-38D ideal for the Short-Wave listener or new radio amateur.



**MODEL S-94 or S-95**  
\$59.95

**COVERAGE:** S-94: 30-50 Mc—S-95: 152-173 Mc

For the thrill of emergency radio—Police, Fire . . . Two new high performance receivers replacing the popular Hallicrafters S-81 and S-82. Compact, easy-to-operate and covers police, fire, taxicab, bus, railroad, private telephone mobile, forestry and other industrial and emergency-service communications operating within models' frequencies. Newly engineered FM chassis provides low frequency drift and high signal-to-noise ratio.

## for hams • novices • short wave listeners...



**MODEL S-53A**  
\$89.95

**COVERAGE:** Standard Broadcast from 540-1630 kc plus four Short-Wave bands over 2.5—31 and 48—54.5 Mc.

**FEATURES:** Large easy-to-read overseas dial with international stations clearly marked. Electrical bandspread and logging scale. Five inch built-in PM speaker, jacks for headphones plus phonograph jack. Temperature compensated to reduce fading due to frequency shift. Two stages of i.f.



**MODEL S-85 or S-86**  
\$119.95

**COVERAGE:** Broadcast band 540-1680 kc plus three S/W bands 1680 kc—34 Mc.

This newly engineered Hallicrafters receiver has the 10, 11, 15, 20, 40 and 80 meter amateur bands calibrated on large easy-to-read dial. Over 1000° of calibrated bandspread for better selectivity on ham bands. Husky, full sized unit features separate bandspread tuning condenser and built-in PM 5" speaker.

## world wide enjoyment is yours with hallicrafters ...at everybody's price!



**MODEL SX-96**  
\$249.95  
Matching R-46B  
Speaker \$17.95

**COVERAGE:** Standard Broadcast; 538-1580 kc; Three S/W Bands, 1720 kc-34 Mc. Band 1: 538 kc-1580 kc—Band 2: 1720 kc-4.9 Mc—Band 3: 4.6 Mc-13 Mc—Band 4: 12 Mc-34 Mc.

**TYPE OF SIGNALS:** AM-CW-SSB

**FEATURES:** Precision gear drives are used on both main tuning and band spread dials.

Most talked about receiver on the air . . . This Hallicrafters double conversion selectable side band receiver offers major improvements in stability by the addition of temperature compensation in the high frequency oscillator circuits and the use of crystal controlled second conversion oscillators. Hallicrafters highly selectable 50 kc i-f system is used in this new precision-built receiver.



**MODEL SX-99**  
\$149.95  
Matching R-46B  
Speaker \$17.95

**COVERAGE:** Broadcast Band 540-1680 kc plus three Short-Wave Bands covers 1680 kc-34 Mc. Packed with all the features most in demand by the DX enthusiast, this model is a real stand-out in its price range. The large, very easy to read dial features over 1000 degrees of calibrated bandspread through the 10, 11, 15, 20, 40 and 80 meter amateur bands. Incorporated in the advanced design are such much-wanted components as an "S" meter, a separate bandspread tuning condenser, a crystal filter and an antenna trimmer. Grey-black steel and brushed chrome cabinet is perfectly styled for appearance and function.