

3/27C

POPULAR ELECTRONICS

ANC

APRIL
1955

25
CENTS

In U.S. and Canada

RADIO • TV • R/C • HI-FI • ELECTRONICS

USEFUL MINIATURE POWER SUPPLY
NOVICE 25 WATT TRANSMITTER
BUILDING LOW COST MICROPHONES
HOW TO SOLDER • TRANSFORMER SALVAGE
OHM'S LAW IN PHOTOS • VTVM OR VOM?

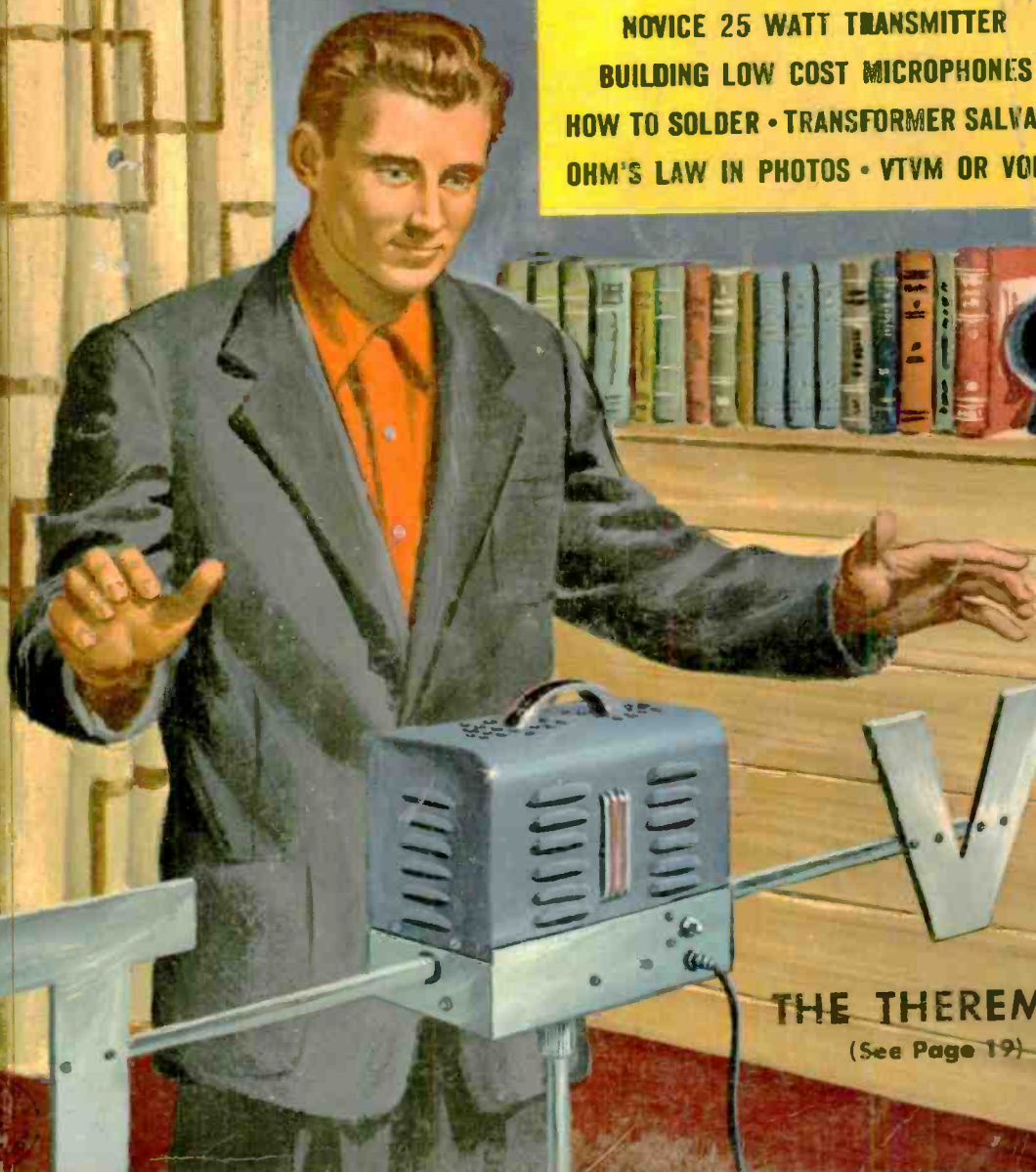

THE THEREMIN

(See Page 19)

CABINART KITS



MODEL 80
MODEL 8112
MODEL 8115

Model 80 has lift lid, removable panels. Bass reflex tuned for 12" or 15" speakers. Overall dimensions: 33½"H, 23"W, 16"D. M80 tuner section, inside: 20"H, 21¾"W, 15½"D. M8112, M8115 baffle volume: 6 cubic feet. ⅝" white pine

80	equipment cabinet kit	\$27.00
8112	12" speaker cabinet kit	18.00
8115	15" speaker cabinet kit	18.00

are acoustically engineered. Assembly and finish are up to you! Precision-cut white pine and birch key together perfectly. Assembled by anyone with only a screwdriver.



Model 61, Model 63

corner horn

12" speaker — \$19.95

15" speaker — \$23.95

Rebel* 4 KITS

FEATURING KLIPSCH-DESIGNED

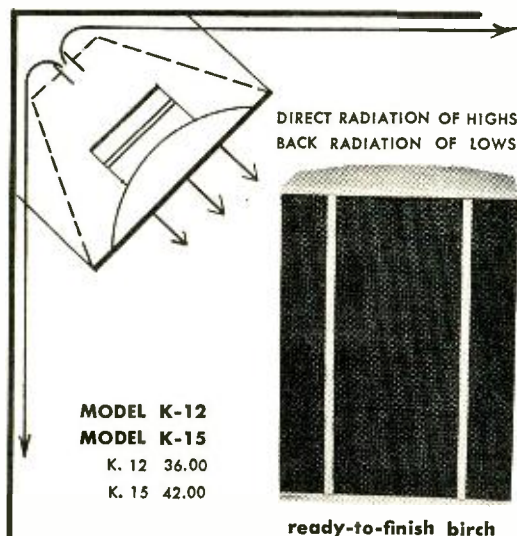

MODEL K-12

MODEL K-15

K. 12 36.00

K. 15 42.00

ready-to-finish birch

All kits precision-cut to size, baffles pre-cut for 12" or 15" speakers. Kits include Saran plastic acoustical cloth, glue, sandpaper, plastic wood, hardware, assembly instructions and finishing instructions. Write for complete catalogs and nearest Cabinart kit dealer.

REBEL enclosure development entails a cavity and slot port, to form a resonant chamber, and a horn coupled to the slot. The slot is loaded by the horn; the proportioning of slot, cavity and horn provide bass response below 100 cycles which corresponds in efficiency to the front-of-cone direct radiator response above this critical 100-cycle point. There are two ways one might consider the function of this horn. One is a bass reflex with a horn acting as a resistive load on the port. System resonances are damped by useful radiation resistance while the horn does not cost anything. It is already formed by the room corner. Again, if a full horn were added below the 100-cycle point bass response would be boomy and unnatural. But, in the Rebel enclosures, the cavity-port combination acts as an acoustic low pass filter. And its design is such that low-end response will compare with response higher in the sound scale.

all prices slightly higher west and south

* Trade Mark

CABINETS



BY CABINART

75 North 11th Street
Brooklyn, N. Y.



I Will Send You BOTH FREE

J. E. SMITH, President
National Radio Institute
Washington 9, D. C.

ACTUAL LESSON

The ABC's of SERVICING

How to be a SUCCESS in RADIO-TELEVISION

64 PAGE BOOK

See How I Train You at Home in Spare Time for Good Pay Jobs in RADIO-TELEVISION

You Practice Broadcasting with Equipment I Send



As part of my Communications Course I send you kits of parts to build the low-power Broadcasting Transmitter shown at left. You use it to get practical experience putting this station "on the air," to perform procedures required of broadcasting station operators. An FCC Commercial Operator's license can be your ticket to a better job and a bright future. My course gives you the training you need to get your license. Mail coupon below. See in my book other valuable equipment you build and keep.

You Practice Servicing with Equipment I Send

Nothing takes the place of PRACTICAL EXPERIENCE. That's why NRI training is based on LEARNING BY DOING. You use kits of parts I furnish to build many circuits common to both Radio and Television. With my Servicing Course you build the modern receiver shown at right. You also build an Electronic Multitester which you can use to help fix sets while training at home. Many students make \$10, \$15 a week extra fixing neighbors' sets in spare time, starting soon after enrolling. I send you special booklets that show you how to fix sets. Mail coupon for 64-page book and actual Servicing Lesson, both FREE.



TRAINING plus OPPORTUNITY is the PERFECT combination. The sample lesson I send will prove to you that it is practical to keep your job while TRAINING right in your own home for better pay and a brighter future. My 64-page book should convince you that Radio-Television is truly today's field of OPPORTUNITY.

TELEVISION MAKING JOBS, PROSPERITY

Radio, even without Television, is bigger than ever. 115 million home and auto Radios create steady demand for service. 3000 Radio stations give interesting, good pay jobs to operators, technicians. NOW ADD TELEVISION. 25 million Television homes and the total growing rapidly. 200 Television stations on the air and hundreds more under construction. Color Television soon to be a reality. Government, Aviation, Police, Ship, Micro-wave Relay, Two-way Communications for buses, taxis, trucks, railroads are growing fields providing good jobs for men who know Radio-Television. All this adds up to good pay now, a bright future later for men who qualify.

START SOON TO MAKE \$10, \$15 A WEEK EXTRA

An important benefit of Radio-Television training is that you can start to cash in fast. Many men I train fix neighbors' sets, make extra money, starting soon after they enroll. Multitester built with parts I send helps locate and correct set troubles. Read at left how you build actual equipment that gives you practical experience, brings to life what you learn from my lessons.



MEN OF ACTION NEEDED MAIL COUPON TODAY

Act now to enjoy more good things of life. Get the benefit of my 40 years' experience training men at home. Take NRI training for as little as \$5 a month. Many NRI graduates (some with only a grammar school education) make more in two weeks than the total cost of training. Find out about this tested way to better pay. Mail coupon below today for Actual Lesson and 64-page Book—BOTH FREE. J. E. SMITH, President, National Radio Institute, Dept. 5DD4, Washington 9, D. C. OUR 40TH YEAR.

I TRAINED THESE MEN AT HOME



"Started repairing Radios six months after enrolling. Earned \$12 to \$15 a week, spare time."—ADAM KRAMLIK, JR., Sunnyside, Pennsylvania.



"I've come a long way in Radio and Television since graduating. Have my own business on Main Street."—JOE TRAVERS, Asbury Park, New Jersey.



"Manager of meat market when I began. Answered ad for Radio serviceman. Got job. Pay increased 50% in year."—C. CARTER, San Bernardino, California.



"Am with WCOC. NRI course can't be beat. Passed exam for first class Radio-phonelicense with no trouble at all."—JESSE W. PARKER, Meridian, Miss.



"Am with WNBT as video control engineer on RCA color project. Owe a lot of my success to your textbooks."—WARREN DEEL, Malverne, N. Y.

AVAILABLE TO VETERANS UNDER GI BILLS

Good for Both—FREE

Mr. J. E. SMITH, President, Dept. 5DD4
National Radio Institute, Washington 9, D. C.

Mail me Sample Lesson and 64-page Book, FREE. (No salesman will call. Please write plainly.)

Name Age

Address

City Zone State

VETS write in date of discharge



POPULAR ELECTRONICS is published monthly by Ziff-Davis Publishing Company, William B. Ziff, Chairman of the Board (1046-1953), at 64 E. Lake St., Chicago 1, Ill. Entered as second class matter August 27, 1954 at the Post Office, Chicago, Illinois. **SUBSCRIPTION RATES:** One year U.S. and possessions, and Canada \$3.00; Pan-American Union Countries \$3.50; all other foreign countries \$4.00.

POPULAR ELECTRONICS

Registered U. S. Patent Office

CONTENTS

Electronic Music with the Theremin.....	L. E. Garner, Jr.	19
Contra-Polar Energy.....		27
The Hart-25.....	H. B. Smith, W8VVD	30
First Pocket Tape Recorder.....		35
Compact AM Tuner.....	L. B. Hust	36
Low Cost Microphones.....		40
Miniature Power Supply.....		44
A Push-Pull Transistor Audio Oscillator.....		48
R/C Reliability.....	W. Winter	51
Johnson "Adventurer" Kit.....		55
So You Want to be a Ham (Part 7).....	R. Hertzberg, W2DJJ	56
X-Ray Inspection.....	E. Bukstein	59
Loudspeaker Repairs Anyone Can Make.....		60
Save Those Defective Transformers.....		63
Cabinet Resonance.....	B. Whyte	66
Disc Review.....	B. Whyte	67
V.T.V.M. or V.O.M. A Comparison.....		68
Phono Input for Small Radios.....	B. G. Wels	71
Electronic Test Chamber.....		73
Carl & Jerry.....	J. T. Frye	74
How To Solder.....		76
Power Failure Alarm.....	H. Reed	78
Project Cyclone.....		80
Principles of D.C. Circuits.....	H. Leeper	82
Novel Transistor Code Practice Oscillator.....	R. P. Turner, K6AI	88
Electronics for Tomorrow.....		90
The World at a Twirl.....	K. R. Boord	98

DEPARTMENTS

Letters from Our Readers.....	10
R/C Notes.....	47
Book Reviews.....	96
Tools & Gadgets.....	103
After Class.....	108
Tricks of the Trade.....	117
Standardized Wiring Diagram Symbols.....	125
Glossary of Terms in This Issue.....	126
Abbreviations.....	127
Resistor Color Code.....	130
Capacitor Color Code.....	130

(Also see page 6)

APRIL 1955

VOL. 2 - NUMBER 4

EDITOR

Oliver Read, W1ETI

MANAGING EDITOR

O. P. Ferrell

TECHNICAL EDITOR

John K. Frieborn

FEATURE EDITOR

Norman Eisenberg

ASSOCIATE EDITOR

Charles Tepfer

EDITORIAL ASSISTANT

Marie Alpert

CONTRIBUTING EDITORS

J. T. Frye	L. E. Garner, Jr.
K. R. Boord	R. P. Turner
R. Hertzberg	H. Pollack

ART

Frank Sayles (Director)	
A. J. Reich	M. Whelpley
J. A. Golanek	A. A. Gons

ADVERTISING DEPARTMENT

New York (MU 7-8080)
 WM. G. McROY
 Chicago (AN 3-5200)
 M. B. CROFFORD
 Los Angeles (Mich. 9856)
 JOHN E. PAYNE



Copyright 1955
 (All Rights Reserved)

ZIFF-DAVIS PUBLISHING COMPANY

W. B. ZIFF (1898-1953) FOUNDER

Also Publishers of
 RADIO & TELEVISION NEWS
 RADIO-ELECTRONIC ENGINEERING
 Editorial and Executive Offices
 366 Madison Ave., New York 17, N.Y.

PRESIDENT

B. G. DAVIS

VICE-PRESIDENTS

H. J. MORGANROTH M. FROELICH

SECRETARY-TREASURER

G. E. CARNEY

CIRCULATION MANAGER

M. MICHAELSON

BRANCH OFFICES

Chicago (1), 64 E. Lake St.
 Los Angeles (14), Statler Center,
 900 Wilshire Blvd.

SUBSCRIPTION SERVICE:

All communications concerning subscriptions should be addressed to Circulation Dept., 64 E. Lake St., Chicago 1, Ill. Subscribers should allow at least four weeks for any change of address.

CONTRIBUTIONS:

Contributors are advised to retain a copy of their manuscripts and illustrations. Contributions should be mailed to the New York Editorial Office and must be accompanied by return postage. Contributions will be handled with reasonable care, but this magazine assumes no responsibility for their safety. Any copy accepted is subject to whatever adaptations and revisions are necessary to meet the requirements of this publication. Payment covers all author's, contributor's, and contestant's rights, title, and interest in and to the material accepted and will be made at our current rates upon acceptance. All photos and drawings will be considered as part of material purchased.

POPULAR ELECTRONICS



Train for Better
Jobs in

ELECTRICITY OR TELEVISION-RADIO

in Great
Shops of COYNE

GREAT OPPORTUNITY FIELDS

Conditions are changing. Many "one operation" jobs that have paid well will not last. Don't be satisfied with a "no future" job. Whether 17 or up to 45 years of age, train the Coyne way for a better job and a real future in **ELECTRICITY** or **TELEVISION-RADIO**, fields that offer a world of opportunities.

YOU can TRAIN in great CHICAGO SHOPS

Train on real, full-size equipment at COYNE where thousands of successful men have trained for over 55 years—largest, oldest, best equipped school of its kind—established in 1899. No advanced education or previous experience needed. **TRAINING APPROVED FOR VETERANS.**

B. W. COOKE, President

COYNE FOUNDED 1899
ELECTRICAL SCHOOL

A TECHNICAL TRADE INSTITUTE CHARTERED NOT FOR PROFIT
500 S. PAULINA STREET, CHICAGO, Dept. 45-71H

ELECTRICITY ★ RADIO ★ TELEVISION ★ REFRIGERATION ★ ELECTRONICS

START NOW—PAY LATER—Finance Plan and Easy Monthly Payment Plan. Also part-time employment help for students:

Get FREE Book

Send coupon for 48 page illustrated book "Guide to Careers in Electricity and Television-Radio." No cost; no obligation; no salesman will call. Get vital facts now!

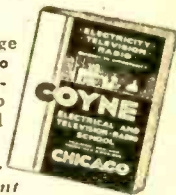

B. W. COOKE, President
COYNE ELECTRICAL SCHOOL
500 S. Paulina St., Chicago 12, Ill., Dept. 45-71H

Send **BIG FREE** book and details of your training offer. This does not obligate me and no salesman will call. I am interested in:

Electricity Television-Radio

Name _____

Address _____

City _____ State _____

**COYNE offers
LOW COST**

TELEVISION RADIO-ELECTRONICS

Training in
Spare Time **AT HOME**



The future is **YOURS** in TV-RADIO!

A fabulous field—good pay—fascinating work—a prosperous future! Good jobs, or independence in your own business!

Coyne brings you the first *truly lower cost*, **MODERN—QUALITY** Television Home Training; training designed to meet Coyne standards. Not an old Radio Course with Television "lacked on". Here is **MODERN TELEVISION TRAINING** including working knowledge of Radio. Includes UHF and **COLOR TV**. No Radio background or previous experience needed. Personal guidance by Coyne Staff. **Practical Job Guides** to show you how to do actual servicing jobs—*make money early in course*. With Coyne Television Home Training you pay only for your training, no costly "put together kits".

B. W. COOKE, President



Coyne—the Institution behind this training... the largest, oldest, best equipped residential school of its kind. Established 1899.

COYNE
ELECTRICAL SCHOOL

500 S. Paulina St., Dept. 45-HT4, Chicago 12
A TECHNICAL TRADE INSTITUTE OPERATED
NOT FOR PROFIT

SEND COUPON FOR FREE BOOK

and full details, including easy Payment Plan.

No obligation, no salesman will call.



COYNE ELECTRICAL SCHOOL

Television Home Training Div.
500 S. Paulina St., Chicago 12, Ill.,
Dept. 45-HT4

Send Free Book and details on Television Home Training. This does not obligate me and no salesman will call.

Name _____

Address _____

City _____ State _____

ITEMS OF INTEREST

This Month's Cover	8
Helicopter Finds Ideal TV Antenna Height	29
Predict Radar Maps in 1985 Aviation	29
Owner's Voice Starts Engine	29
Quick Connection Phone Plugs	34
TVI Filtering of R/C Transmitters	43
Million Watt TV Antenna Assembled Despite Snow and Ice	58
A New Tool for Cardiology	72
TV Station Sports Novel Antenna Tower	92
Home-Made Blower Cleans Tight Corners	93
"Deluxe" Neon Bulb Code Practice Oscillator	122
Special SW DX Broadcast	123
Protecting Your Antenna	123
Radio's "Sherlock Holmes"	124

NEW PRODUCTS

Musitherm Heating Control (General Electric Company, Syracuse, N. Y.)	58
Alarm Bell and Light Signal Fire in Home (Minneapolis-Honeywell Regulator Company, 2753 Fourth Avenue South, Minneapolis 8, Minn.)	92
Economical Kit Builds Hi-Fi FM Tuner (Approved Electronic Instrument Corporation, 928 Broadway, New York 10, N. Y.)	92
New Record Plan (Book-of-the-Month-Club, Inc., 345 Hudson Street, New York, N. Y.)	116
Low Cost FM Receiver (Granco Products, Inc., 36-17 20th Avenue, Long Island City, N. Y.)	116

If you are unable to find these listed products locally, write directly to the manufacturers at the addresses given. Also see the monthly review of new items of interest to the electronics hobbyist in "Tools & Gadgets" appearing on pages 103, 104, 105, 106, and 107 of this issue of POPULAR ELECTRONICS.

COMING NEXT MONTH POPULAR ELECTRONICS

A Simple Lie Detector
First Experiments With Thyratrons
Checking Your Portable Radio for Summer Fun Heat Without Flame
A Dime Oscillator
Stereophonic Sound
The Boom in Radio-Controlled Boats
Project Tinkertoy
A Precision Photographic Timer
Plus More on
High-Fidelity Audio ■ Kits ■ Radio Control
■ Short-Wave Listening ■ What's New ■
How It Works ■ How to Make It ■ How to Use It ■ Carl & Jerry

IN THIS MONTH'S RADIO & TELEVISION NEWS

(April)

A Portable Scintillation Counter
Make Ready for Transistors
An Electronic Combination Lock
Erasing Troubles in Tape Recorders
Are You Ready for Conelrad?



METERS ...with an "EXTRA MEASURE OF VALUE"

EMC voms and vtvm's feature ...

- LOWEST PRICES
- PRECISION CONSTRUCTION
- VERSATILE, ADVANCE DESIGNS
- WIDEST INSTRUMENT CHOICE

EMC MODEL 102 VOLOMETER*

• Sturdy, pocket-size case • Large, clear 3" — 1000 ohms per volt D'Arsonval-type volt meter — 2% accurate • 5 AC&DC voltage ranges, 0-3000V. • 4 DC current ranges, 0-1.2 amps. • 3 AC current ranges, 0-600 ma. • Two resistance ranges with same zero adjustment Model 102 \$14.90

EMC MODEL 104 VOLOMETER*

• 5 DC voltage ranges (20,000 ohms per V.), 0-3000 V. • 3 AC & DC current ranges
• Extra large, easy-to-read 4½", 50 microamp. meter with alnico magnet • 3 resistance ranges
• 5 DB ranges —4 to +67 • 3 AC current ranges, 0-600 ma. • 4 DC current ranges, 0-1.2 amps.
• 5 AC voltage ranges (1000 ohms per V.) 0-3000V.

*Reg. Trademark for volt-ohm milliammeter Model 104 (With carrying strap)\$26.95

EMC MODEL 106 VTVM

• Completely electronic meter cannot burn out • Dual triode balance bridge circuit • Precision 1% resistors for voltage multipliers • Zero center adjustment for TV and FM alignment • Full scale deflection of 1½ V. for AC-DC • 1 meg. isolated resistor in probe • 5 DB ranges • 5 AC & DC voltage ranges • Sturdy, compact case

MODEL 106 (With carrying strap)\$35.90

Accessory probes available MODEL 106 (In kit form)..... 23.90

"EYE LEVEL" INSTRUMENT STAND FOR ALL METERS... \$98

FREE-complete catalog of instruments ... write Dept. PE-4 TODAY!

ELECTRONIC MEASUREMENTS CORPORATION
280 LAFAYETTE STREET • NEW YORK 12, N. Y.
EXPORT DEPARTMENT 136 LIBERTY STREET, N.Y.C. 6, N.Y.

EMC



INVENTORS

Learn how to protect your invention. The U. S. Patent Laws provide that any new and useful art, machine, article of manufacture, or composition of matter, or any new and useful improvement thereof, may be patented if the act of invention is involved. Therefore, every inventor with a valuable invention should take advantage of the Patent Laws and proceed for patent protection in order to safeguard his rights.

A patent gives the inventor the exclusive right to prevent others from making, using, or selling the invention claimed in the patent for a period of seventeen years.

The Patent Laws were enacted for the benefit of the inventor to give him protection for the features of his invention which are patentable. These features must be properly and concisely set forth and claimed in a formal application for patent, in order to comply with the requirements of the Patent Laws. For that reason, unless the inventor is familiar with patent matters, he should engage a competent registered patent attorney or agent to represent him. We are registered to practice before the U. S. Patent Office and are prepared to serve you in the handling of your patent matters.

A specially prepared booklet entitled "Patent Guide for the Inventor", containing detailed information with respect to patent protection and procedure, together with a "Record of Invention" form will be promptly forwarded to you without obligation upon request.

CLARENCE A. O'BRIEN & HARVEY JACOBSON

Registered Patent Attorneys

59-D DISTRICT NATIONAL BUILDING

WASHINGTON 5, D. C.

8 TRANSISTOR CIRCUITS

You can build with



CK722

TRANSISTORS

Price now only **\$3.10**

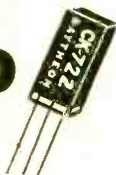

Circuitry information on the following is available free:

1. CW FILTER
2. CW MONITOR
3. TRANSISTORIZE YOUR AUDIO AMPLIFIER
4. TOY ELECTRONIC ORGAN
5. VOLT METER
6. ELECTRONIC TIMER
7. TRANSISTOR RECEIVER
8. DEMONSTRATION TRANSISTOR CIRCUITS

Order the circuit you want by number not by title, just write to Department P5. Buy low cost Raytheon CK722 Transistors from your local Raytheon Tube Supplier.



Excellence in Electronics

RAYTHEON MFG. CO.

Receiving and Cathode Ray Tube Operations
Newton 58, Massachusetts

RELIABLE SUBMINIATURE AND MINIATURE TUBES
SEMICONDUCTOR DIODES AND TRANSISTORS.
NUCLEONIC TUBES

RECEIVING AND PICTURE TUBES • MICROWAVE TUBES

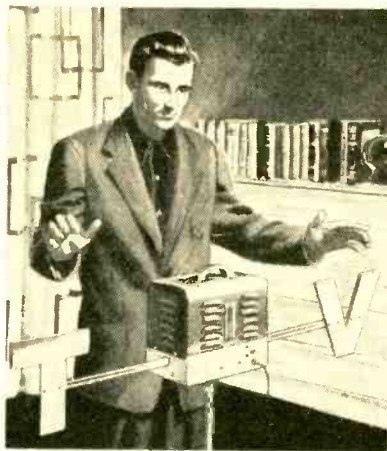

This Month's Cover

If a proper musical instrument, unlike a well-behaved child, should be heard, but not seen, then the Theremin is a very proper instrument. Its sounds occasionally are heard on TV programs where special sound effects are required, but few people ever have seen one. The Theremin is, in some ways, the most flexible of all musical instruments; a player can produce almost infinite variations in pitch and volume.

It is possible to build a Theremin by following carefully a definite procedure. The construction of a Theremin is described in the article beginning on page 19 of this issue. In order to give the builder as much help as possible, we have included more photographs and other information in this article than in any previous one. If you do undertake to build the Theremin, check each step carefully with all of the information given in the photos, the schematic and pictorial wiring diagrams, and the text.

Even with all of the help which can be given in the space available, this is not exactly a project for beginners. They are advised to watch for construction details on simpler electronic musical instruments, which will be published in future issues of POPULAR ELECTRONICS.

EDITOR

(Cover painting by Ed Valigursky)

**VETERANS!
NON-VETERANS!**



L. C. Lane, B.S., M.A.
President, Radio-Television
Training Association, Executive
Director, Pierce School of
Radio & Television.



**KEEP YOUR PRESENT
JOB AND PREPARE
FOR A BETTER ONE!**

**Train to be a Radio-Television Technician
AT HOME in your SPARE TIME**

Maybe you have a steady job now — but it isn't just what you'd like to do all the rest of your life.

The pay may be all right — but not really good enough to enable you to do all the things you'd like to do for yourself or your family. The hours may be all right — but at the end of the day you don't feel that you've gotten anywhere.

If you're in such a job you can train yourself for a better one — with all the opportunities for higher pay, satisfying work every day, job independence and security — and you don't have to give up your job or present income to do it.

Even if you've had no experience in radio you can qualify as a technician for transmitting stations or television studios, television repairman, or set up your own business.

My courses — especially prepared for home study — will prepare you for a better-paying job in the constantly expanding radio-television-electronics industry.

**ENOUGH EQUIPMENT
TO SET UP YOUR OWN
HOME LABORATORY**

Public Address System
RF Signal Generator
Super-Het Radio Receiver
C-W Telephone Transmitter
Combination Voltmeter-Ammeter-Ohmmeter

21 in.

As part of your training, I give you all the equipment you need to prepare for a BETTER PAY TV job. You build and keep a professional GIANT SCREEN TV RECEIVER complete with big picture tube (designed and engineered to take any size up to 21-inch) . . . also a Super-Het Radio Receiver, AF-RF Signal Generator, Combination Voltmeter-Ammeter-Ohmmeter, C-W Telephone Transmitter, Public Address System, AC-DC Power Supply. Everything supplied, including tubes.

EXTRA TRAINING IN NEW YORK CITY AT NO ADDITIONAL COST

You get two weeks, 50 hours, of intensive laboratory work on modern electronic equipment at our associate resident school in New York. And I give you this AT NO EXTRA COST WHATSOEVER, after you finish your home study training in the Radio-FM-TV Technician Course or the FM-TV Technician Course. However, your home study course is complete even without this two-week laboratory session. It is only one of the many Extras available to you from RTTA if you want it.

My Four FREE Aids Show You How and Where to Get a Better Pay Job in Television.

See for yourself how my simple, practical methods can make success as easy for you as for my hundreds of graduates.

Radio Television Training Association

52 EAST 19th STREET • NEW YORK 3, N. Y.

Licensed by the State of New York • Approved for Veteran Training

VETERANS!

My school fully approved to train Veterans under new Korean G.I. Bill. Write discharge date on coupon.

Radio-FM-Television Technician Training

My Radio-FM-Television Technician Course is especially prepared for men with no previous experience or training. I have trained hundreds of men for successful careers in radio-television-electronics. Many of them had only a grammar school education and no previous experience whatsoever in the field.

Expert FM-TV Technician Training

My FM-TV Technician Course lets you take full advantage of your previous experience — either civilian or Armed Forces. YOU CAN SAVE MONTHS OF TIME. Train at home with kits of parts, plus equipment to build BIG SCREEN TV RECEIVER. ALL FURNISHED AT NO EXTRA COST!

Practical TV Cameraman & Studio Technician Course

(For men with previous radio & TV training)
I train you at home for an exciting big pay job as the man behind the TV camera. Work with TV stars in the TV studios at "on location" at remote pick-ups! Available if you want it . . . one-week course of practical work on TV studio equipment at Pierce School of Radio & TV, our associate resident school in New York City.

Earn while you learn

Almost from the very start you can earn extra money while learning by repairing radio-TV sets for friends and neighbors.

FREE FCC Coaching Course

Qualifies you for Higher Pay! Given AT NO EXTRA COST after TV Theory and Practice is completed. Helps you qualify for the TOP JOBS in Radio-TV that demand an FCC license!

**MAIL THIS COUPON TODAY!
NO SALESMAN WILL CALL**

Mr. Leonard C. Lane, President
RADIO-TELEVISION TRAINING ASSOCIATION
Dept. E-4, 52 East 19th St., New York 3, N. Y.

Dear Mr. Lane: Mail me your NEW FREE BOOK, FREE SAMPLE LESSON, and FREE aid that will show me how I can make BIG MONEY IN TELEVISION. I understand I am under no obligation and no salesman will call.

(PLEASE PRINT PLAINLY)

Name _____ Age _____

Address _____

City _____ Zone _____ State _____

- I AM INTERESTED IN:
- Radio-FM-TV Technician Course
 - FM TV Technician Course
 - TV Cameraman & Studio Technician Course

VETERANS!

Write discharge date

LETTERS FROM OUR READERS

SNIPERSCOPE

"WOULD you kindly send me the improvements in the Sniperscope. . ."

Jordan Gold
Chelsea, Mass.

Write to Col. F. H. Kohloss, Editor, "The Military Engineer," Washington, D. C.



FIRST WITH MILLION WATTS

"I NOTED that the article on page 88 of your January issue states that WILK-TV in Wilkes-Barre, Pa. will be the world's first million watt u.h.f. station. About December 10th (1954), WBRE-TV, channel 28, Wilkes-Barre, Pa., began using one million watts while WILK-TV is not due to begin operation on one million watts until early in January."

Clayton Fairchild, ET2
U.S.S. Windlass
FPO New York, N. Y.

Upon checking with official representatives of both stations we learned the following: On December 10, 1954, WBRE did go on the air with a million watts. Technical difficulties forced them off after a few days at this power, but the million watts transmission was resumed January 5, 1955. WILK did not begin transmitting at a million watts until January 23. And so Reader Fairchild is right, and thank you for correcting us!



ELECTRONICS COURSE

"IN THE January issue of POPULAR ELECTRONICS, I noticed in your 'Letters from Readers' section a request that you include in each issue a lesson in electronics. I also noticed your objection and thought it was very logical. However, I have a suggestion that may overcome this objection. Make reprints of each of the lessons and then make them available at a nominal price. Later, you might combine the individual lessons and make them available in book form.

"I would also like to see you print plans for a u.h.f. converter."

Ross Harrower
Livermore, California

This letter is typical of many we've received on this subject. However, further study of the idea has substantiated our view that such a course would not be practicable. Reprints of previous installments do not appear feasible because of the costs involved. Further, the course itself would be in conflict with material already available. It is possible that at some time in the future we may publish a separate book to cover the main points of the subject.

As regards the u.h.f. converter, the cost, com-

plexity, and equipment needed properly place this item within the domain of RADIO & TELEVISION NEWS, whose editors hope to publish such material in the near future.



TAPE AND DISC SPEEDS

"IN MY opinion your January issue hit a real 'high' for its construction articles and its general interest stories. I enjoyed Celia Webster's piece 'It's All On Tape.' . . . This article raised an interesting question which nobody around here seems to have the answer to. It is simply this: why is it that the faster the tape speed, the higher the fidelity; but on records, it's the other way around, that is, a 33½ disc is slower than a 78 rpm disc and yet has higher fidelity. . . ."

J. R. Potter
Las Vegas, Nevada

There is a common fallacy implicit in the way this question has been asked that is probably fairly widespread among audiophiles of all levels of technical development. The fallacy is that the speed, as such, is the chief, if not the only, factor responsible for greater fidelity of recorded sound. Actually this is not so. In the case of tape, the higher speeds are required for higher fidelity due to the limitations of the recording tape and of the recording head. If the tape could be made with a much finer grain, and if recording head sizes could be greatly reduced, then the slower tape speed of 3¾ i.p.s. would provide high fidelity. From a practical standpoint, however, such developments are quite remote, since they involve technological advances we have not yet begun to approach. For instance, the recording head might have to be so small that you'd need a jeweler's magnifying glass to thread the tape through it. The present day tapes and recording heads represent a compromise—as must all sound reproducing equipment—between many factors such as size, quality of material, and convenience of speed for practical use.

As for discs or records: it is not the slower speed, as such, that makes LP's hi-fi. It is the vinylite material of which the long-playing discs are made that enables them to capture greater realism of sound. It is not the speed of 78's that makes them inferior to LP's; it is the shellac material of which they are made. In other words, a 78 rpm record made of vinylite would have a very high degree of fidelity; in fact its response

ERRATA

In the February, 1955, issue, in the schematic diagram on page 34 and in the pictorial diagram on page 35, the connections for the germanium crystal diode, CR₁, should be reversed.

In the March, 1955, issue, in the pictorial diagram on page 35, the connections to C₁ from C_a, R₁, L₁, and C₂ should go to one of the outer terminals (the stator plates) of C₁.

ELECTRONIC BARGAINS

SAVE BY GETTING THE BEST

SAVE BY BUYING THE LATEST

SAVE BY ELIMINATING MIDDLEMEN PROFITS

Adapters, Amateur Equipment, Antennas, Baffles, Books, Capacitors, Coaxial Cables, Coils, Connectors, Crystals, Eliminators, FM, AM, TV, etc., etc.

New Electronic products are flooding the market. Some are excellent, a few are inferior, and others so, so. A few unscrupulous individuals and sometimes equally unscrupulous firms are misrepresenting the capabilities and the work of these new products. It seems to be their philosophy "the public be hanged, get the highest price the suckers will pay." This is not in keeping with **PAT MALONE'S** business practices.

Ask the folks who depend on Pat Malone's "**ELECTRONIC BARGAINS**" for their needs. Hundreds of mid-westerners daily fill the Malone Showrooms, counter shopping, asking technical questions and buying what they want and what they need in the way of Electronic Equipment, Electronic Parts and kindred tools and equipment at **Rock Bottom Prices**.

HERE IS HOW YOU TOO CAN SAVE ON NATIONALLY KNOWN BRANDS

We want to serve Electronic fans and enthusiasts the country over. It will further increase our total annual sales **AND** enable us to serve our customers at even lower prices than ever before! The Pat Malone Policy is simply this, sell at the lowest possible price, yet make a greater annual net profit because of the greater and greater gross sales. To Pat Malone that makes Good Common Sense.

Find out if what I say here is true. **DO IT AT NOT ONE PENNY'S RISK TO YOU! IF**, you cannot visit our giant sales rooms in Elmhurst, Illinois (lovely little suburb just West of Chicago) then send for your copy of "**ELECTRONIC BARGAINS**." The prices will amaze you. All I ask is that you send your order by return mail to avoid disappointment. All items listed above are sold on a **MUST SATISFY OR RETURN FOR FULL REFUND!** In-stock items shipped within 24 hours after your order is received! Be happy —**Order Today**.

YOUR COPY OF "ELECTRONIC BARGAINS"

Crammed full of Electronic Facts—Electronic Buys—Electronic Equipment—Electronic Tools—Electronic Parts—all offered to you at low, low lower prices—will be sent to you—and "Electronic Bargains" magazine will continue to come to you month after month for one full year for only \$1.00!

OUR OFFER IS SIMPLE YOU RISK NOTHING

I want to prove to you that every word in my ad is absolutely true. That Pat Malone backs up his statements and his merchandise. **IF**, after studying your first copy of "**ELECTRONIC BARGAINS**" for 10 days you are not absolutely satisfied that you have the source that will pay you one hundred times the small sum you remitted, **THEN** drop me a postcard asking for your money back. Keep your first copy of "**ELECTRONIC BARGAINS**" but realize you will never again be permitted to re-subscribe or to have your Electronic orders filled.

PROOF OF THE VALUES IN "ELECTRONIC BARGAINS"

1. COMPLETE THEREMIN outfit. See Theremin Article elsewhere—all you need \$19.95
2. Plastic Base Recording Tape—7" (1200 Ft. Spool) 1.30
3. Schematic Diagrams for all Popular TV Sets05
4. Insulated Handle Screwdrivers—Break & Heat Resistant10
5. Phono Cartridges—Standard & Microgroove—3 Volt Output49
6. Sapphire Tipped Phono Needles—Standard & Microgroove10
7. 300 OHM Television Lead Wire 100/20—Real Heavy Duty 4.95/M
8. High Fidelity Amplifier with built-in Preampifier 11.95
9. Crystal Diodes (1N34, 1N22, 1N21, etc.)10
10. Headphones—Single Units—(2000 OHM)50
11. Picture Tube—Brand New—Guaranteed one full year—80¢ per inch (10 inch Tube would cost \$8.00, etc.)
12. Receiving Tubes—Brand New—Boxed—Code Dated—Name Brands Only. 60% to 90% off list price.
13. Famous 'Inline' Type Antenna—For TV & FM 2.00
14. Name Brand Moulded Plastic Condensers—All Standard Values—600 Volt Sizes02
15. Allen Bradley Resistors—All Standard Values—1 Watt Size05
16. Electrolytic Capacitors—Fresh Stock—Can Type—Paper Type.20
17. Electric Motors—Hobby Type 3 to 6 volt Operation47
18. Microphones—Crystal—Carbon—Dynamic 2.00
19. Transistors for the Experimenter. 1.00
20. Complete Crystal Set Kits.99
21. Complete One Tube Radio Kits. 1.99
22. 400 Ma. Selenium Rectifiers (For Motorola, G.E., etc.)89
23. Tube Sockets—All Filled Types (No Waters)—Any Size01
24. 3 Speed Automatic Record Changers—Ceramic Cartridge 9.95
25. 12 Inch Co-Ax High Fidelity Speaker 7.85
26. Pilot Lamps—All Sizes & Voltage Ratings01

MAIL COUPON TODAY!!

Pat Malone
MALONE ELECTRONICS, Elmhurst 1, Illinois

Enclosed find \$1.00. Send me "**ELECTRONIC BARGAINS**" for one full year on your 10 DAY MONEY BACK TERMS.

Name

Address

City..... Zone..... State.....

GET THE WORLD'S LEADING RADIO & TV CATALOG



free!

VALUE-PACKED

308
PAGE 1955

**ALLIED
ELECTRONIC
BUYING GUIDE**

**Builders and Experimenters:
Save on Everything in Radio & TV!**

You'll find everything you'll need for building any project in this publication in the 1955 ALLIED Catalog. Select from the world's largest stocks of parts, tubes, tools, kits, books, diagrams—plus Amateur equipment, TV components, Hi-Fi equipment, test instruments, recorders—at lowest, money-saving prices. Write for your FREE ALLIED Catalog today!

POPULAR ALLIED KITS



DOZENS OF
OTHER KITS
AVAILABLE

Famous Radio Lab Kit (10 Kits In 1)

Here's the most instructive Experimenter's kit you can buy. With it, you can build a broadcast receiver, phono amplifier, phono oscillator, signal tracer, electronic timer, photo cell relay, home broadcaster, electronic switch, etc. Fascinating, instructive. Complete with all parts, tubes, microphone, 12-page manual. Shpg. wt., 10 lbs.
83 S 265. Radio Lab Kit, only..... \$14.25

Popular "Ocean Hopper" (Amazing DX)

A remarkable Short-Wave receiver. Covers 155 to 35.0 mc with plug-in coils (below). Features bandspread; for headphone or speaker use. Easy to build. Complete with all parts, tubes, broadcast coil, hardware, full instructions. For AC-DC. Wt., 5 lbs.
83 S 740. "Ocean Hopper" kit, only \$12.75
59 J 110. 2000 ohm headset..... \$1.67
Five coils (155 kc to 35 mc)..... \$3.82

Ranger II Superhet (with Cabinet)

Learn radio while you build and enjoy this sensitive AC-DC broadcast receiver. Tunes 540-1680 kc. Includes built-in antenna, PM dynamic speaker, automatic volume control, handsome walnut plastic cabinet. Easy to assemble from detailed manual; complete with punched chassis, all parts, tubes and cabinet. Shpg. wt., 8 lbs.
83 S 735. "Ranger II" Kit, only..... \$16.75

ALLIED RADIO

ALLIED RADIO CORP., Dept. 79-D-5
100 N. Western Ave., Chicago 80, Ill.



- Send FREE 308-Page Catalog
- Send Kit No. 83 S 265 Send Kit No. 83 S 735
- Send Kit No. 83 S 740 \$.....
- Coils for above enclosed

Name _____

Address _____

City _____ Zone _____ State _____

would go up to 40,000 cycles because of its greater speed. This extreme is not necessary, however. Furthermore, the fine grain that characterizes vinylite enables records made of this material to be designed for slower speeds and still possess frequency ranges wide enough for great realism.

★ ★ ★
"ECHO BOX"

"I AM interested in constructing an 'echo box' and would appreciate information on this."

J. T. Eichelberger
Baltimore, Maryland

Thanks for the suggestion; we're looking into this and hope to have suitable material available soon.

★ ★ ★
PRICE OF TV FILTER

"THE filter to block interference to TV, described on page 79 of your February issue, looks very good to me and I'd like to purchase one. Can you tell me what it costs and what the manufacturer's address is?"

Jonah P. Kennel
Canton, Ohio

Similar requests have been pouring in steadily. The price of the filter is \$.89 and it can be ordered by mail direct from the American Electronics Company, 1203 Bryant Ave., New York 59, N. Y.

★ ★ ★
HI-FI ARTICLES

"FELT that the article 'The High Fidelity Hobby' in your January issue was too general to be of real value to a newcomer to this subject. Couldn't you cover this subject in such a way as to suggest specific points so that the uninitiated would know where to start? I'm sure many readers would like to see discussions of basic components, what accessories could be added to further improve a system, etc."

Ed R. Shetland
Portland, Oregon

Many readers have expressed similar opinions. A series of articles, covering exactly these—and other points—is planned for late spring of this year.

★ ★ ★
SCINTILLATION COUNTER

"I HAVE just completed the Geiger Counter from the plans in your January issue and am well pleased with the results. So much so that now I would like to build a portable Scintillation Counter. Is there any chance that you could help me to locate a schematic, and list of materials for one?"

G. T. Merite
Binghamton, N. Y.

In response to this, and many more letters of a similar nature, we would like to point out that the construction of a scintillation counter is a costly proposition. The basic components of these

POPULAR ELECTRONICS

NOW... Start Fixing TV and Radio Sets RIGHT AWAY

TRY IT
FREE
FOR 10 DAYS IN
YOUR OWN HOME

JOHN
MARKUS

TELEVISION AND RADIO REPAIRING

McGraw-Hill's Amazing New Low-Cost Instruction Manual Skips "Theories" and "Formulas", Tells How-to-do-it in PLAIN ENGLISH!

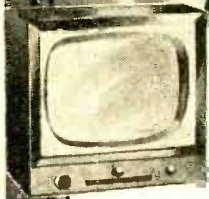

Prove It on Your Own Set

Save up to \$50 a year just by installing, repairing, and servicing your own TV set. Book tells which controls to adjust or tubes to replace if picture is entirely dark—tilted—wiggles and weaves—too pale—too black—jitters—snows—drifts—etc., etc.

PARTIAL CONTENTS
Tools Needed • How TV and Radio Sets Work • How to Remove and Replace Tubes • Testing Tubes without a Tester • Using a Tube Tester • Power-Supply Troubles • How to Test and Replace Resistors, Controls, Switches, Condensers, Coils, Transformers • Tuning Devices, Coils, Transmitters • Phono Pickups and Repair Antennas • How to Install and Repair Antennas • and MUCH MORE

TELLS HOW TO "Cash In" ON THE BIG DEMAND FOR RADIO-TV REPAIRMEN

Over 25 million TV sets over 100 million radios in this country! Shortage of skilled repairmen! You can make nice extra money just fixing sets for friends and neighbors in your spare time full-time or start your own full-time repair business with steady profits. Book tells exactly how to get started; which tubes to stock; where to get information; how to make a service call; how to start fixing sets and making money. Author tells how tough jobs can be done so you STILL make money before you're halfway through book.



... even if you have never fixed a LAMP or DOOR BELL before!

"Why hasn't somebody done this BEFORE?" That's what you'll say the minute you start browsing through this amazing new and complete one-volume instruction manual in radio and TV repairs.

For here at last a well-known EXPERT has found a way to tell you in PLAIN ENGLISH how to fix almost ANY radio or television set. (And he even tells you where you can go to have the extra-tough jobs done FOR you... at professional rates.) Right from the very first chapters you can start doing simple repairs... and before you're HALF way through the book, you can fix HALF the television and radio sets that you encounter. Surprisingly quickly you can fix your own and friends' sets... get a service shop job... even start your own money-making business right in your own home.

Why It's So EASY to Understand

No electronic formulas... no algebra... no laboratory experiments. Instead you deal only with the things that go wrong in sets—how to recognize and spot the trouble—and what to do about it. "Easy as A-B-C" directions and 700 clear photos, diagrams, and drawings show you exactly WHAT and HOW to fix, step-by-step.

The author is Associate Editor of *Electronics Magazine*. He's a long-recognized expert—not only on radio and TV—but also on making technical subjects easily understood by the average reader. He has spent FOUR years making this one-volume instruction manual so practical and easy-to-understand that even a man who never fixed a door bell before will have no trouble.

Here's everything you need to know about where and how to buy tubes and parts, where and how to get a circuit diagram for any receiver; how to choose and use basic tools; how to test tubes WITHOUT a tube tester; how to adjust 58 common TV controls; how to "diagnose" and "cure" common radio and TV troubles; how to fix or replace loudspeakers and phono pickups; how to install and check antennas; and much, much more.

SEND NO MONEY

Examine this big 556-page book for 10 days BEFORE you decide if you wish to own it. Try it out FREE on your own set. See how easy it makes your handling of repairs. Take 10 days to prove it PAYS FOR ITSELF, or don't keep it. Just mail coupon to: McGraw-Hill Book Co., Inc., Dept. PEL-4, 327 West 41st St., New York 36, N. Y.

FREE 10-DAY TRIAL COUPON

McGraw-Hill Book Co., Inc., Dept. PEL-4
327 West 41st St., New York 36, N. Y.

Please send me, for 10 days' FREE EXAMINATION, your one-volume "Television and Radio Repairing," by John Markus. If not delighted with it, I may return book, pay nothing. Otherwise, I will keep book and send only \$1.95 plus postage; followed by 3 monthly installments of \$2.00 each.

Name

Address

City.....Zone.....State.....

SAVE MONEY. Check here if enclosing full price of \$7.95 W.T.H. this coupon. Then WE will pay delivery. Same 10-day return privilege—full refund guaranteed. PEL-4

Trouble Shooting Chart Tells Where to Look for Bad Tube If:

No picture; no raster; no sound.
No picture; raster OK; no sound.
No picture; no raster; sound OK.
No picture; raster OK; sound OK.
Picture wiggles and weaves; lacks blacks, or is very black; raster OK; sound OK.
Picture jittery, double image; raster OK; sound OK.
Snow on all channels; raster OK; sound weak.

Snow on all channels, raster OK; sound OK.
Picture and raster do not fill screen; sound OK.
Picture drifts up and down but not sideways; raster OK; sound OK.
Picture muddy and gray; raster OK; sound OK.
PLUS 29 OTHER COMMON TV TROUBLES.

Want To Double Your Pay

Get into Radio-TV-Electronics



Get all 3 FREE

FIND OUT what the FCC license means

Your FCC license is recognized by employers as proof of your technical ability.

FIND OUT how the FCC license helps you get a better job or increase your pay on your present job

"Due to your Job-Finding Service, I have been getting many offers from all over the country, and I have taken a job with Capital Airlines in Chicago, as a Radio Mechanic."
Harry Clare,
4537 S. Drexel Blvd., Chicago, Ill.

"I have obtained a position at Wright-Patterson Air Force Base, Dayton, Ohio, as Junior Electronic Equipment Repairman. The Employment Application you prepared for me had a lot to do with me landing this desirable position."
Elmer Powell,
Box 247, Sparta, Tenn.



National Home Study Council
Approved Member

FIND OUT how to get your FCC license in a minimum of time

Harry G. Frame, Box 429, Charleston, W. Va.
Charles Ellis, Box 449, Charles City, Iowa
Kenneth Rue, Dresser, Wisconsin
B. L. Jordan, Seattle, Washington

License	Time
2nd Class	13 weeks
1st Class	28 weeks
2nd Class	20 weeks
1st Class	20 weeks

FIND OUT how we guarantee your FCC license

WE GUARANTEE to train and coach you at home until you pass the all-important FCC examination. . . . If you fail to pass after completing our course, we will continue your training without additional cost until you successfully obtain your commercial license.

FIND OUT how employers

make job offers like this to CIRE students every month

Letter from nationally known manufacturer of high quality AM and FM transmitters, "We are very much in need at the present time of radio-electronics technicians and would appreciate any helpful suggestions that you may be able to offer. Salary up to \$412 per month to start."

CARL E. SMITH, E.E., Consulting Engineer, President
CLEVELAND INSTITUTE OF RADIO ELECTRONICS
Desk PE-2, 4900 Euclid Bldg., Cleveland 3, Ohio

MAIL COUPON TODAY!
you'll be glad you did

CLEVELAND INSTITUTE OF RADIO ELECTRONICS
4900 Euclid Ave., Desk PE-2
Cleveland 3, Ohio

(Address to Desk No. to Avoid Delay)

I want to know the facts, without obligation, how I can get my FCC ticket in a minimum of time. Rush me your FREE booklet "How to Pass FCC License Examinations" (does not cover exams for Amateur License) as well as sample FCC-type exam and the amazing new booklet, "Money-Making FCC License Information."

PLEASE PRINT CLEARLY

Name

Address

City State

FOR PROMPT RESULTS SEND AIR MAIL

Special tuition rates to members of the U. S. Armed Forces

counters cost approximately \$100. The additional wiring and shielding will raise this cost by an equal amount. However, readers who are interested may obtain complete details in a feature article in the April 1955 issue of RADIO & TELEVISION NEWS.

★ ★ ★
MUSIC LOVER TALKS BACK

AS A lay hobbyist and music lover I was naturally pleased to note that your January issue contained for the first time a 'Disc Review.' Certainly all the technical talk and work in the world would have little meaning unless it were aimed at achieving a usable end—in the case of audio technology, this end is the enjoyment and greater appreciation of music. To me, hi-fi represents a union of science and esthetics, and it is good to see a publication that is primarily technical and scientific devoting space to the purely esthetic aspects of the field. Congratulations on adding this feature, and please do keep it running. In line with this, I would like to take exception to two of the examples of music given by Bert Whyte, which he calls 'classical' and 'romantic.' Beethoven's *Fifth Symphony* is actually as much 'romantic' as it is 'classical.' In fact, Beethoven exemplifies—more than any other single composer in history—a man at a turning point in history—musically as well as politically. And his *Fifth Symphony*, while structurally following the classical pattern in a nominal sort of way, contains in it themes and harmonies and orchestral effects

that are decidedly un-classical or anti-classical and which, as a matter of fact, have become a virtual storehouse of inspiration from which subsequent romantic composers have lifted material. I think a much better example of classical music would have been something by Haydn or Mozart, or perhaps an early Beethoven symphony like his First or Second.

"As for the *Scheherazade* of Rimsky-Korsakov, this is not at all the best example of romantic music. This composition represents a phenomenon known to musicologists as *nationalism* in which a composer uses the full resources of a modern symphony orchestra to express the idiom and character of his native culture. A far better example of 'romantic' music would have been Schubert's *Unfinished Symphony* or Schumann's *Rhenish Symphony* or Mahler's *Das Lied von der Erde*. I have no quarrel with Mr. Whyte's choice of a modern example, and I have no quarrel with the general idea embodied in a feature of this sort. In fact, it was good enough to stimulate me to write you this letter which I hope you will publish and which I trust will stimulate others to agree or disagree with me. Best wishes for continued success."

M. Pantuosco
Bronx, N. Y.

Thank you for a very thoughtful letter. Any comments on any musical controversies that may be touched off will be welcome. END

**MOLDED, FLEXIBLE COLORFUL PLASTIC WORLD MAP
IN THREE DIMENSIONS TO CONFORM WITH EARTH'S CONTOUR**



Water in vibrant turquoise; land in varying shades of sepia.

USEFUL . . . The mountains, valleys and other natural characteristics of the Earth affecting signal transmission and reception, are modeled in exact scale at their proper heights above sea level. 150 country and political boundaries are shown in red; over 1,000 reference items in black. Six distinctive symbols tell you the major seaports, airports, rail centers and population approximations.

FOR THE HAM SHACK . . . A ridge of molded plastic forms a white border and brings the overall size to 21" x 34½". The map itself is 18¾" x 33". Can be used without framing—but we suggest, to bring out its full beauty and dramatic impact, it be mounted on cardboard or plywood (using either staples or a good rubber cement), with a black mat or wood frame. Needs no glass protection. Can be cleaned with a damp cloth.

Only **\$15⁰⁰** each including all charges except NYC sales tax.

ALSO, a sturdy self-framed vinyl molded plastic map of the United States in 11 colors, 64 x 40 inches, brass grommets for immediate hanging. Shows 2,000 cities, 600 rivers, 200 mountain ranges and peaks, as well as national parks, monuments, several thousand lakes and reservoirs. Only \$45.00. F.O.B. Philadelphia, Pa.

Dun & Bradstreet's INTERNATIONAL MARKETS, Dept. PE-4, 99 Church St., N. Y., N. Y.

Please send me _____ copies of plastic world map _____ at \$15 00 each; _____ U. S. plastic maps at \$45.00 each. _____ check enclosed. _____ bill me.

NAME (Print please) _____

ADDRESS _____

CITY _____

Zone _____

STATE _____

The Model
TV-50

GENOMETER

A versatile all-inclusive GENERATOR which provides ALL the outputs for servicing:

A. M. Radio F. M. Radio Amplifiers Black and White TV Color TV

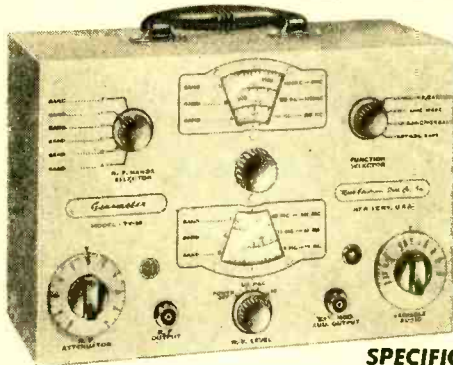

7 Signal Generators in One!

- ✓ R. F. Signal Generator for A.M.
- ✓ R. F. Signal Generator for F.M.
- ✓ Audio Frequency Generator
- ✓ Bar Generator
- ✓ Cross Hatch Generator
- ✓ Color Dot Pattern Generator
- ✓ Marker Generator

SPECIFICATIONS:

R. F. SIGNAL GENERATOR:

The Model TV-50 Genometer provides complete coverage for A.M. and F.M. alignment. Generates Radio Frequencies from 100 Kilocycles to 60 Megacycles on fundamentals and from 60 Megacycles to 180 Megacycles on powerful harmonics. Accuracy and stability are assured by use of permeability trimmed Hi-Q coils. R.F. is available separately, modulated by the fixed 400 cycle sine-wave audio or modulated by the variable 300 cycle to 20,000 cycle variable audio. Provision has also been made for injection of any external modulating source.

VARIABLE AUDIO FREQUENCY GENERATOR:

In addition to a fixed 400 cycle sine-wave audio, the Model TV-50 Genometer provides a variable 300 cycle to 20,000 cycle peaked wave audio signal. This service is used for checking distortion in amplifiers, measuring amplifier gain, trouble shooting hearing aids, etc.

BAR GENERATOR:

This feature of the Model TV-50 Genometer will permit you to throw an actual Bar Pattern on any TV Receiver Screen. Pattern will consist of 4 to 16 horizontal bars or 7 to 20 vertical bars. A Bar Generator is acknowledged to provide the quickest and most efficient way of adjusting TV linearity controls. The Model TV-50 employs a recently improved Bar Generator circuit which assures stable never-shifting vertical and horizontal bars.

CROSS HATCH GENERATOR:

The Model TV-50 Genometer will project a cross-hatch pattern on any TV picture tube. The pattern will consist of non-shifting, horizontal and vertical lines interlaced to provide a stable cross-hatch effect. This service is used primarily for correct ion trap positioning and for adjustment of linearity.

DOT PATTERN GENERATOR (For Color TV)

Although you will be able to use most of your regular standard equipment for servicing Color TV, the one addition which is a "must" is a Dot Pattern Generator. The Dot Pattern projected on any color TV Receiver tube by the Model TV-50 will enable you to adjust for proper color convergence. When all controls and circuits are in proper alignment, the resulting pattern will consist of a sharp white dot pattern on a black background. One or more circuit or control deviations will result in a dot pattern out of convergence, with the blue, red and green dots in overlapping dot patterns.

MARKER GENERATOR:

The Model TV-50 includes all the most frequently needed marker points. Because of the ever-changing and ever-increasing number of such points required, we decided against using crystal holders. We instead adjust each marker point against precise laboratory standards. The following markers are provided: 189 Kc., 262.5 Kc., 456 Kc., 600 Kc., 1000 Kc., 1400 Kc., 1600 Kc., 2000 Kc., 2500 Kc., 3579 Kc., 4.5 Mc., 5 Mc., 10.7 Mc. (3579 Kc. is the color burst frequency.)

The Model TV-50 comes absolutely complete with shielded leads and operating instructions.
Only

\$47⁵⁰
NET

SHIPPED ON APPROVAL
NO MONEY WITH ORDER — NO C.O.D.

Try it for 10 days before you buy. If completely satisfied then send \$11.50 and pay balance at rate of \$6.00 per month for 6 months. **No Interest or Finance Charges Added!** If not completely satisfied return unit to us, no explanation necessary.

MOSS ELECTRONIC DISTRIBUTING CO., INC.
Dept. D-118 3849 Tenth Ave., New York 34, N.Y.

Please rush one Model TV-50. I agree to pay \$11.50 within 10 days and to pay \$6.00 per month thereafter. It is understood there will be no finance, interest or any other charges, provided I send my monthly payments when due. It is further understood that should I fail to make payment when due, the full unpaid balance shall become immediately due and payable.

Name.....

Address.....

City..... Zone..... State.....



Superior's new
Model 670-A

SUPER METER

A COMBINATION VOLT-OHM MILLIAMMETER PLUS
CAPACITY REACTANCE INDUCTANCE AND DECIBEL MEASUREMENTS

SPECIFICATIONS:

D.C. VOLTS: 0 to 7.5/15/75/150/750/1,500/7,500 Volts
A.C. VOLTS: 0 to 15/30/150/300/1,500/3,000 Volts
OUTPUT VOLTS: 0 to 15/30/150/300/1,500/3,000 Volts
D.C. CURRENT: 0 to 1.5/15/150 Ma. 0 to 1.5/15 Amperes
RESISTANCE: 0 to 1,000/100,000 Ohms 0 to 10 Megohms
CAPACITY: .001 to 1 Mfd. 1 to 50 Mfd. (Good-Bad scale for checking quality of electrolytic condensers.)
REACTANCE: 50 to 2,500 Ohms 2,500 Ohms to 2.5 Megohms
INDUCTANCE: .15 to 7 Henries 7 to 7,000 Henries
DECIBELS: -6 to +8 +14 to +38 +34 to +58

ADDED FEATURE:

Built-in ISOLATION TRANSFORMER
reduces possibility of burning out
meter through misuse.

The Model 670-A comes housed in a rugged crackle-finished steel cabinet complete with test leads and operating instructions.

\$2840
NET



Superior's new
Model TV-11

TUBE TESTER

SPECIFICATIONS:

- ★ Tests all tubes including 4, 5, 6, 7, Octal, Lock-in, Peanut, Bantam, Heating Aid, Thyatron Miniatures, Sub-miniatures, Novalts, Sub-minars, Proximity fuse types, etc.
- ★ Uses the new self-cleaning Lever Action Switches for individual element testing. Because all elements are numbered according to pin-number in the RMA base numbering system, the user can instantly identify which element is under test. Tubes having tapped filaments and tubes with filaments terminating in more than one pin are truly tested, with the Model TV-11 as any of the pins may be placed in the neutral position when necessary.
- ★ The Model TV-11 does not use any combination type sockets. Instead individual sockets are used for each type of tube. Thus it is impossible

to damage a tube by inserting it in the wrong socket.

- ★ Free-moving built-in roll chart provides complete data for all tubes.
- ★ Newly designed Line Voltage Control compensates for variation of any Line Voltage between 105 Volts and 130 Volts.
- ★ NOISE TEST: Phono-jack on front panel for plugging in either phones or external amplifier will detect microphonic tubes or noise due to faulty elements and loose internal connections.

The model TV-11 operates on 105-130 Volt 60 Cycles A.C. Comes housed in a beautiful hand-rubbed oak cabinet complete with portable cover.

EXTRA SERVICE—The Model TV-11 may be used as an extremely sensitive Condenser Leakage Checker. A relaxation type oscillator incorporated in this model will detect leakages even when the frequency is one per minute.

\$4750
NET



SUPERIOR'S NEW MODEL TV-40

C.R.T. TUBE TESTER

★ A complete picture tube tester for little more than the price of a "make-shift" adapter!!

The Model TV-40 is absolutely complete! Self-contained, including built-in power supply, it tests picture tubes in the only practical way to efficiently test such tubes: that is by the use of a separate instrument which is designed exclusively to test the ever increasing number of picture tubes!

EASY TO USE:

Simply insert line cord into any 110 volt A.C. outlet, then attach tester socket to tube base (Ion Trap Need Not Be on Tube). Throw switch up for quality test . . . read direct on Good-Bad scale. Throw switch down for all leakage tests.

★ Tests all magnetically deflected tubes . . . in the set . . . out of the set . . . in the carton!!

- Tests ALL magnetically deflected picture tubes from 7 inch to 30 inch types.
- Tests for quality by the well established emission method. All readings on "Good-Bad" scale.
- Tests for inter-element shorts and leakages up to 5 megohms.
- Tests for open elements.

Model TV-40 C.R.T. Tube Tester comes absolutely complete—nothing else to buy. Housed in round cornered, molded bakelite case. Only

\$1585
NET

**SHIPPED ON APPROVAL
NO MONEY WITH ORDER—NO C.O.D.**

Try any of the above instruments for 10 days before you buy. If completely satisfied then send down payment and pay balance as indicated on coupon. No Interest or Finance Charges Added! If not completely satisfied return unit to us, no explanation necessary.

MOSS ELECTRONIC DISTRIBUTING CO., INC.
Dept. D-118 3849 Tenth Ave., New York 34, N.Y.

Please send me the units checked. I agree to pay down payment within 10 days and to pay the monthly balance as shown. It is understood there will be no finance, interest or any other charges, provided I send my monthly payments when due. It is further understood that should I fail to make payment when due, the full unpaid balance shall become immediately due and payable.

Name.....
Address.....
City..... Zone..... State.....

Model 670-A.....Total Price \$28.40 \$7.40 within 10 days. Balance \$3.50 monthly for 6 months. Model TV-11.....Total Price \$47.50 \$11.50 within 10 days. Balance \$6.00 monthly for 6 months. Model TV-40.....Total Price \$15.85 \$3.85 within 10 days. Balance \$4.00 monthly for 3 months.

How a Capacitor Works

(Continued from the February issue)

When voltage is applied to a capacitor it doesn't charge instantly, nor does it discharge instantly. The charging and discharging time for capacitors of identical construction and the same capacitance, but differing in the dielectric material, depends on the dielectric.

This difference is of great importance in many circuits where rapid response is necessary such as timing, integrating (voltage-adding) and wave-shaping circuits.

Charging a capacitor may be compared with stretching a spring. Mechanical energy is stored in the spring and is released when the stretching force is removed. It takes a finite time, both to stretch the spring and for it to return to its original size. This corresponds to the time required to charge and discharge electrical energy stored in a capacitor.

Differences in spring material, like differences in capacitor dielectrics, will give different responses. Unlike metal springs, however, which respond directly to a given force, the practical capacitor has a slightly delayed charge and discharge. The charge appears to be absorbed very quickly at first, and then tapers off. The converse is true on discharge. The dielectric appears to soak in part of the charge and then release it gradually. If you discharge a capacitor and then leave it for a period, you will find that a voltage will reappear across its terminals. Although this voltage will be less than the original voltage to which the capacitor was charged, it may be appreciable and even lethal in the case of high voltage paper capacitors such as those used for transmitter power supplies. And many an experimenter, building a "low voltage" 450-volt electronic photo flash power supply has been uncomfortably jolted by a 175 volt charge which reappeared on the terminals of an electrolytic capacitor discharged ten minutes previously. It is always good practice to leave a shorting bar or wire across the terminals of capacitors for a sufficient period of time to make sure that they have been completely discharged, especially when dealing with high voltages.

The capacitor dielectric which has the lowest "soak" or "dielectric hysteresis" is polystyrene. Because of this, capacitors made with polystyrene film, such as Sprague Styracon units, are finding wide use, not only in timing circuits but in the integrating circuits of certain types of electronic computers. At the other end of the scale in "soak" are the so-called aluminum electrolytic capacitors. In between in their dielectric hysteresis properties are capacitors made of other types of plastic film, metal, mica, ceramic and paper capacitors impregnated with various liquid and solid impregnants. More detailed data about them will be given later in this series.

—To be continued in June issue—



Electronics Music with the THEREMIN

By LOUIS E. GARNER, JR.

The musical instrument which is played without being touched—an advanced hobbyist can build it.

FRAMED by a spotlight, the musician stepped to the center of the stage and stood before his instrument. The expectant audience was hushed. Smiling, he lifted his arms. Eerie sounds came forth . . . wailings and howls, the call of a banshee, the rise and fall of a siren, moans and screechings. He dropped his arms and there was silence. Then he raised his arms again, and sound flooded the room. But no eerie howls or weird moans this time: instead, music, a lilting popular tune, with each note distinct and pure. . . .

Mystifying? Yes.

Fascinating? Definitely.

Unusual? Perhaps.

Impossible? No!!

Almost any one with practice can duplicate the feats described if he uses a Theremin, one of the most interesting of electronic musical instruments. For with it, it is possible to bring forth the eerie howls and moans used in suspense movies and television shows or play the pure notes of

a popular tune. And all by only waving one's arms!

The Theremin shown in the photographs is a "natural" for the home builder and electronics hobbyist. Although it provides many of the features found in complicated units and expensive commercial instruments, it is inexpensive and fairly easy to assemble. It's not a project for the beginner; for those who've "cut their teeth" on a few simple projects, this is their meat.

And, once the unit has been completely assembled, there will be lots of uses for it. Friends will applaud and enemies will admire the handiwork, for the Theremin is so mysterious to the average layman that it has an almost supernatural aura about it. And it can be used not only to play tunes, but to provide background sound effects for amateur theatricals. A complete show can be produced by combining its abilities to emit both music and sound effects.

After seeing it demonstrated, one of the first questions people ask is, "How does it work?" Let's dispose of that question right off, before discussing the construction of the instrument.

Refer to the block diagram. The operation of the Theremin depends on three basic things: (1) that the frequency of an oscillator may be changed by varying its stray



The completed Theremin in a standard amplifier foundation cabinet. If desired, a housing of wood or other material can be used instead.

capacities to ground; (2) that the output of an oscillator may be varied by changing its capacities to ground; and (3) that two signals, when combined in an electronic mixer, produce an output signal whose frequency is the *difference* frequency of the two original signals. Thus, if we combine signals of 200 kc. and 203 kc., we can obtain an output signal of 3 kc. ($203 - 200 = 3$). The sum frequency (403 kc. in the example) is also produced by mixing action, but is not used in the Theremin.

Functional block diagram of Theremin. This diagram, with a block for each vacuum tube stage and other important circuits, shows main steps in sound production and control.

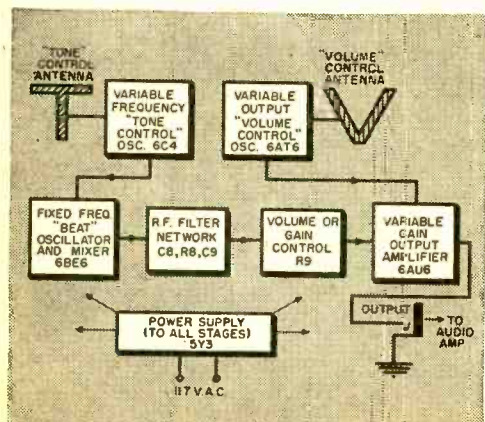

In operation, the signals from a variable frequency r.f. oscillator (the 6C4 stage) are combined with the signals from a fixed frequency r.f. oscillator in a mixer stage (6BE6). The difference frequency output, an audio frequency, is fed through a filter circuit to remove any r.f. signals that might remain and then to a variable gain amplifier (6AU6). The amount of amplification given by the 6AU6 stage depends on its grid bias and this, in turn, depends on the output of a third high frequency oscillator (6AT6). One antenna permits the operator to vary the frequency of the 6C4 oscillator ("T" or tone control antenna) and hence the pitch of the note produced. Another antenna permits the operator to vary the output of the 6AT6 oscillator ("V" or volume control antenna) and hence the loudness of the note. By moving his hands closer to and away from the two antennas, the musician changes capacities to ground in the two oscillators, and can play any note desired.

But enough of theory—here's how to build the Theremin:

Construction Hints: The Theremin shown in the photographs was assembled on a commercially available "amplifier foundation" to give the completed instrument a professional, factory-built appearance. Those who are handy with tools might prefer to design and build their own cabinets. Holes are drilled and punched in the chassis for mounting tube sockets, controls,

The Theremin chassis base, showing holes which must be cut or drilled, except holes for "V" insulator at left and parts at rear of chassis.

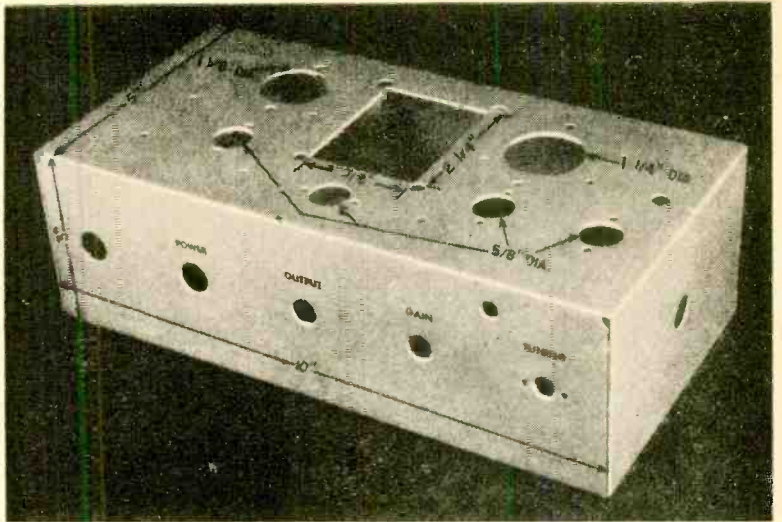

Bottom view of the chassis after all of the components except the filter choke have been mounted, but before any of the wiring is complete.

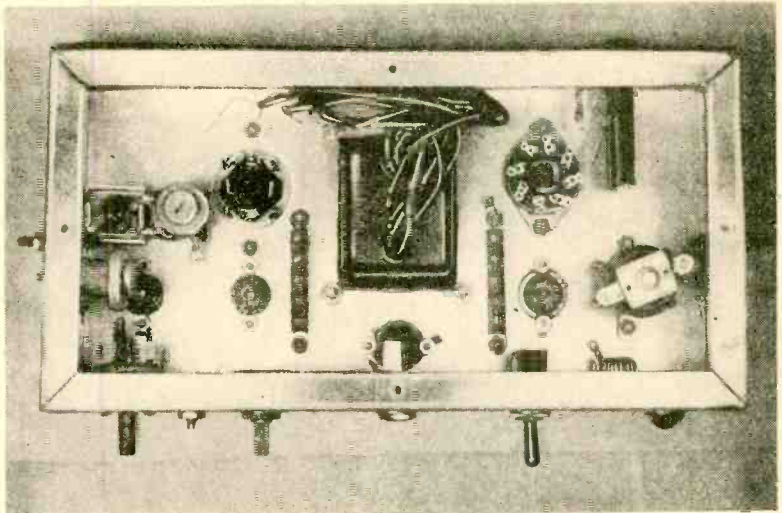

Bottom view of the chassis completely wired. See the following pages for detail photographs and schematic and pictorial diagrams.

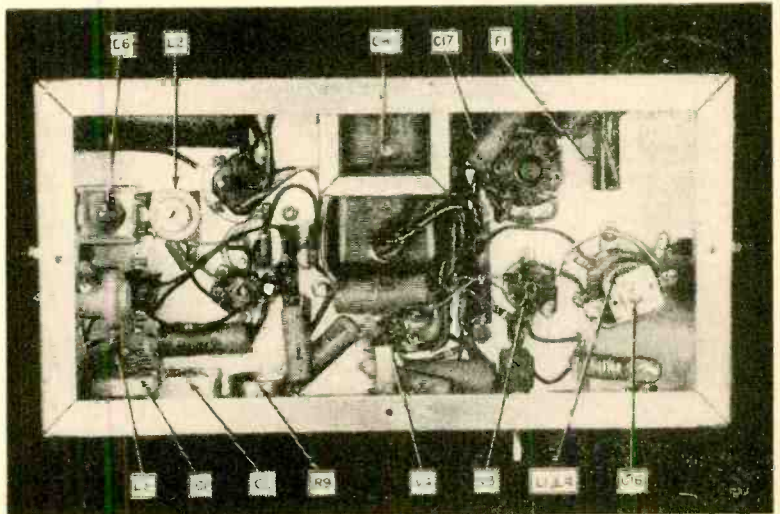

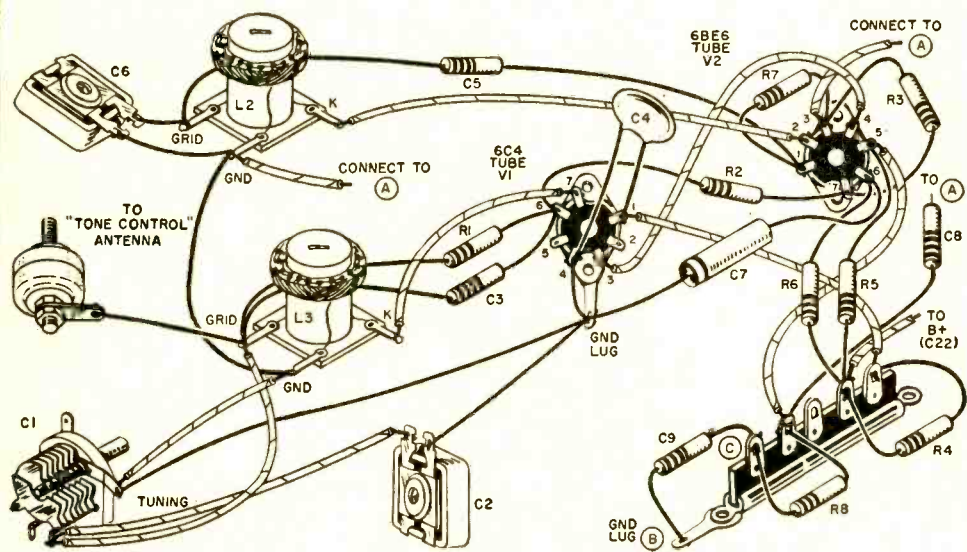
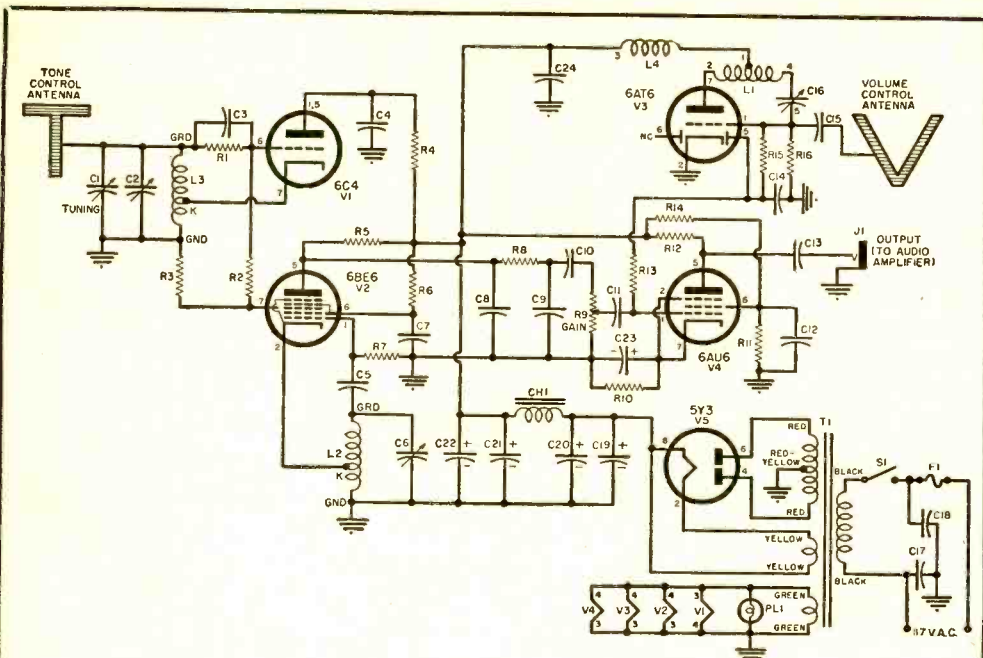

- R₁, R₆, R₇—47,000 ohm, 1/2 w. carbon res.
- R₂, R₃, R₄, R₁₂, R₁₃—100,000 ohm, 1/2 w. carbon res.
- R₅—1500 ohm, 1 w. carbon res.
- R₈—18,000 ohm, 1/2 w. carbon res.
- R₉—500,000 ohm, carbon pot., audio taper
- R₁₀—1500 ohm, 1/2 w. carbon res.
- R₁₁, R₁₄—220,000 ohm, 1/2 w. carbon res.
- R₁₃—1 megohm, 1/2 w. carbon res.
- R₁₅—150,000 ohm, 1/2 w. carbon res.
- C₁—15-30 μfd. (max.) tuning capacitor (Bud LC-2077, National PSE-25, Cardwell PL-6002, etc.)
- C₂, C₅—340 μfd. padder capacitors (Arco 303)
- C₃, C₅—100 μfd. tubular ceramic capacitors
- C₄, C₂₄—0.01 μfd. disc ceramic capacitor
- C₇—0.05 μfd., 600 v. paper tubular capacitor
- C₈, C₉—270 μfd. tubular ceramic capacitors

- C₁₀, C₁₁, C₁₃, C₁₇, C₁₈—0.01 μfd., 600 v. paper tubular capacitors
- C₁₂, C₁₄—0.1 μfd., 400 v. paper tubular capacitors
- C₁₅—500 μfd., tubular ceramic capacitor
- C₁₆—Trimmer (part of L₁ and L₄ coil assembly)
- C₁₉—40 μfd., 450 v. tubular electrolytic capacitor
- C₂₀, C₂₁, C₂₂, C₂₃—10/10/10/10 μfd., 450 v. quadruple section upright electrolytic capacitor (Mallory FP 434)
- CH₁—8.5 hy., 50 ma., 400 ohm filter choke (Merit C-2981)
- J₁—Open circuit phone jack
- L₁, L₄, C₁₆—R. f. choke, oscillator coil, and trimmer assembly (Miller 695)
- L₂, L₃—Oscillator coils (Miller 5481-K)
- S₁—S.p.s.t. toggle switch (Power)

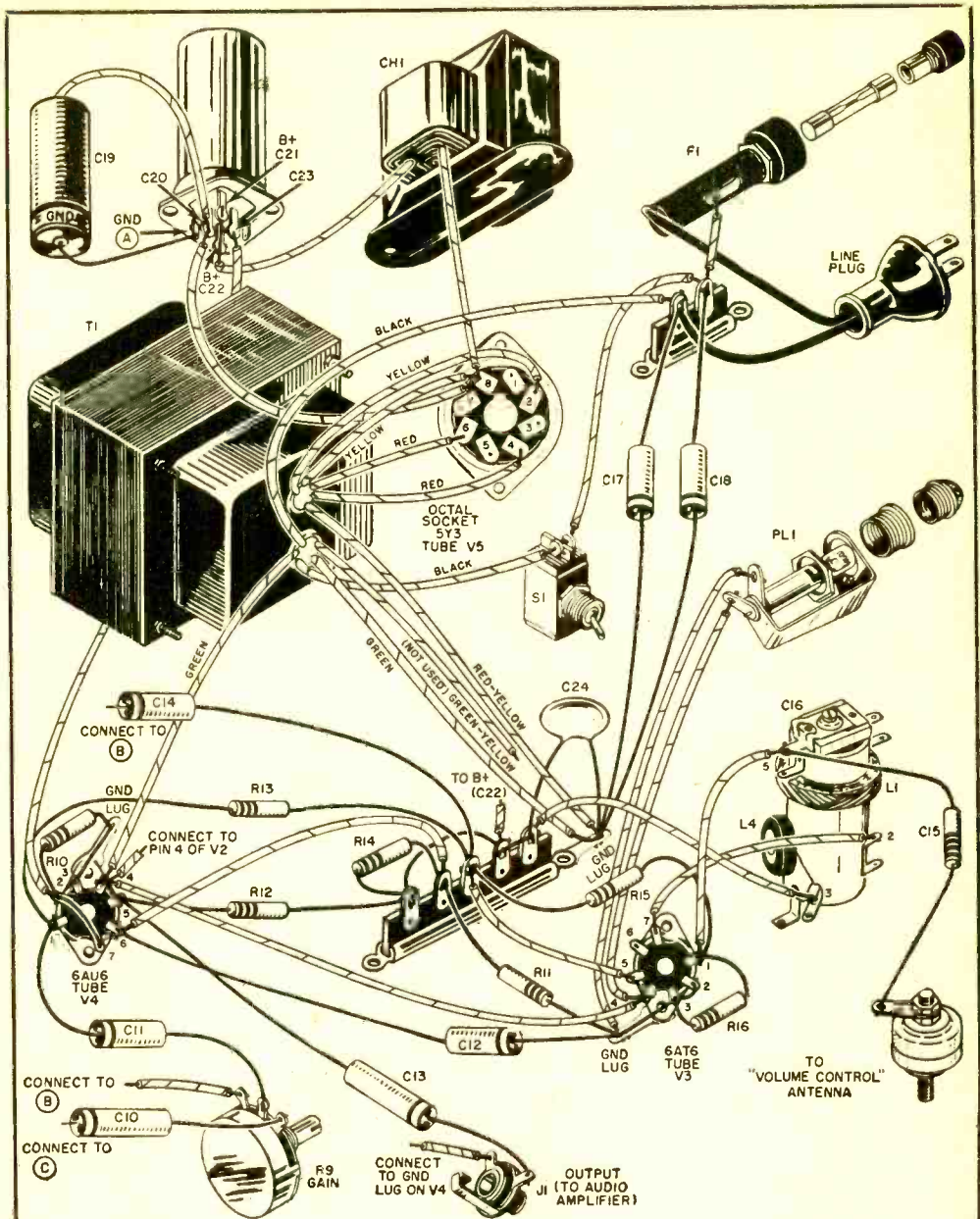

T₁—Power transformer (240-0-240 v. @ 50 ma., 5 v. @ 2 a., 6.3 v. @ 2.6 a. Merit P-2958)
V₁—6C4 tube
V₂—6BE6 tube
V₃—6AT6 tube
V₄—6AU6 tube
V₅—5Y3GT tube
Misc.—Small amplifier foundation (Bud CA-1750 or ICA 3980)
 Bottom plate to fit amplifier foundation
 Extractor fuse post and 2 ampere fuse to fit
 Pilot lamp jewel, bracket, and 6.3 volt pilot lamp bulb
 Two small feed-through insulators
 Four 7-pin miniature tube sockets
 One octal socket

Two 5-terminal tie-point strips
 One 2-terminal tie-point strip
 Two small knobs
 Two kitchen cabinet handle (unless handles are supplied with the amplifier foundation)
 One sheet Reynolds "do-it-yourself" aluminum
 One length Reynolds "do-it-yourself" U-channel aluminum
 Line cord and plug
 Rubber grommet, rivets, screws, nuts, wire, solder, ground lugs, decals, other hardware
 Microphone stand and adapter (Atlas CS-33 and AD-11)
 Shielded cable with connectors to fit phone jack and amplifier

Total cost, less amplifier and speaker: under \$40.

Close-up view showing wiring of "tone control" and fixed oscillators and mixer stage.

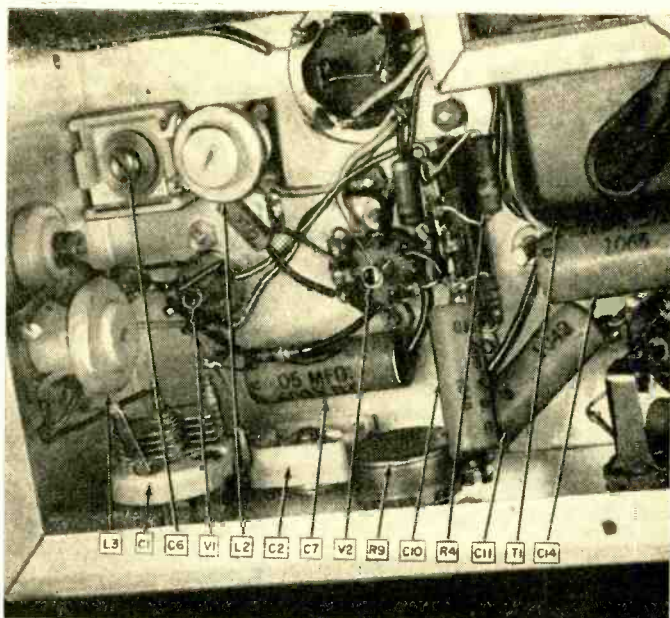

terminal strips and other components. Layout is not too critical, but the photographs and drawings should be followed fairly closely. The locations of the power transformer (T_1) and filter choke (CH_1) are especially important. The completed instrument is designed to mount on a standard microphone stand and, for maximum stability, it is essential that the heaviest weight be more or less centered on the chassis.

The sizes of some of the mounting holes will depend on the particular components obtained. This is especially true of the tuning capacitors (C_1 , C_2 , C_6), the pilot light bracket, and the feed-through insulators. So don't complete the machine work until all critical parts are on hand. Once the machine work on the chassis is completed, however, the controls can be labeled with standard decals. These should be protected with at least two coats of clear plastic, sprayed on after application and after the decals have had a chance to dry thoroughly.

Mount the carrying handle on the top of the cover. Some commercial amplifier foundations are supplied with handles, but these generally mount on the ends of the chassis, where they would interfere with the control antennas. If no handle is supplied, use a kitchen cabinet handle. These can be obtained at the nearest hardware store.

Parts are mounted with small machine screws and hex nuts. If the finished instrument is to be carried around quite a

bit, use lockwashers. The filter choke (CH_2) mounts on the back apron of the chassis but, for ease in wiring, this part should not be installed until the wiring is nearly completed. Do not draw up the nuts on the feed-through insulators too tightly; it is possible to crack the insulation and damage these components. Use the metal mounting plate furnished with the electrolytic capacitor (C_{20} , C_{21} , C_{22} , C_{23}) for mounting this part.

Wiring Suggestions: Follow the diagrams and photographs closely when wiring the unit. Use rosin core solder only. Lead dress is not too critical, but reasonably short and direct connections should be employed. Commercially available coils are used throughout, so don't worry about winding your own. The r.f. choke (L_1), "volume control" oscillator coil (CH_1), and adjustment capacitor (C_{14}) are all part of one commercially available assembly.

It is easiest to wire the Theremin by stages, whether all the work is done at one sitting, or spread over several evenings. Complete the filament, power switch and fuse, and power supply wiring first. Then wire the rest of the unit a stage at a time.

Final Steps: With the wiring completed and double-checked for accuracy, the control knobs, tubes, pilot lamp bulb, and fuse can be installed. Then set the unit aside temporarily—there are a few jobs remaining before final tests and adjustments are made.

Mount the *Atlas* AD-11 adapter in the

center of the bottom plate, using short 6-32 machine screws and hex nuts. Drill or punch a $\frac{1}{2}$ " hole in the plate, located so that it falls just below C_{16} when the bottom plate is installed. This hole may be covered with a standard "snap hole plug." The control antennas are made up by cutting large letters ("T" and "V") out of thin sheet aluminum and mounting these letters on brackets made from small U-channel aluminum. Either rivets or sheet metal screws may be used for attaching the letters to their brackets. Exact dimensions are not critical, but, in the model, the brackets are about 12" long and the letters measure approximately 10" x 10" overall.

In order to keep the circuit simple and the cost low, no audio amplifier has been incorporated into the instrument, and it is necessary that a small audio amplifier be provided as an accessory. For small get-togethers, use the amplifier described in "A Compact Public Address System" in the November, 1954, issue of POPULAR ELECTRONICS. But for the larger auditoriums, you'll want a more powerful unit. For home use, use the audio amplifier in a home radio; connect to the phono jack. But regardless of the audio amplifier used, a shielded cable will be needed to connect the Theremin and amplifier together. Use standard microphone cable and keep the length reasonably short (under 10 feet if possible). Terminate one end in a standard 'phone plug to fit the Theremin (J_1) and the other end in a connector to fit the mike input to the amplifier or the phono jack of the radio.

Adjusting the Theremin: With the bottom plate in place, install the Theremin on its mike stand. Install the control antennas,

using standard wing nuts (these permit the antennas to be removed easily whenever desired). Remove the top cover. Adjust the TUNING control, C_1 , to about half capacity. Adjust the other variable capacitors, C_2 , C_6 , and C_{16} , to full capacity by tightening the screws. Don't exert too much pressure; snugly tight is good enough. Use an insulated alignment tool when adjusting these capacitors. Connect the Theremin and the audio amplifier together with the shielded cable. Turn the GAIN controls of both units all the way up. Turn both on and allow several minutes warm-up. Later, as the preliminary adjustments are completed, the GAIN controls can be readjusted.

Using an insulated alignment tool, back off the screw of the "fixed" oscillator tuning capacitor, C_5 , about $\frac{1}{2}$ to 2 full turns. This reduces the capacity somewhat. The exact setting is not too critical, but don't use more than 2 turns.

Next, with one hand on the "V" (or volume control) antenna, and *keeping back from the "T" antenna*, gradually adjust C_2 with the alignment tool. As this capacitor is adjusted, listen for the following condition: a high pitched signal, gradually dropping in pitch to a low frequency, with the sound finally dropping out entirely (zero beat); and, as further adjustment is made, the low frequency signal being heard again, gradually increasing in pitch to a very high frequency and finally dropping out entirely. *This may occur at several points.* However, proper adjustment of C_2 is where maximum volume is obtained on either side of zero beat. Final adjustment to zero beat is made with the top cover in place, using the TUNING control, C_1 .

Close-up view showing wiring of "volume control" oscillator and part of the power supply.

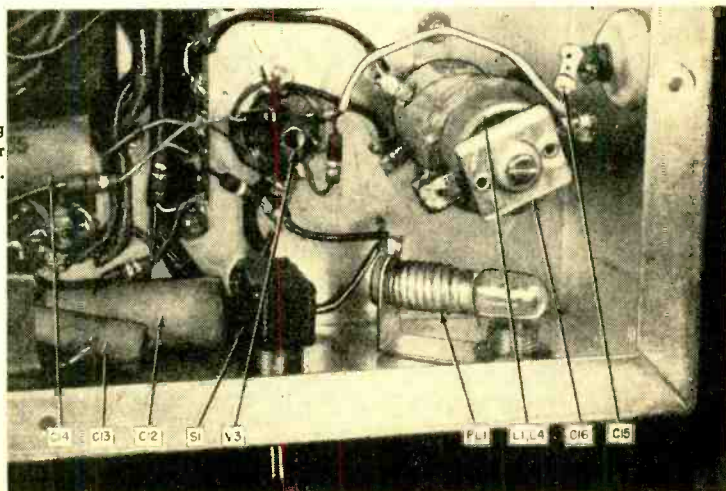

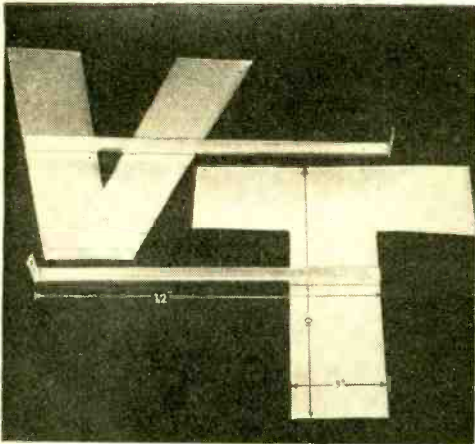

The "volume control" and "tone control" antennas: they can be fastened to the U-channels by either sheet metal screws or rivets.

To adjust C_{16} , set the TUNING control slightly off its "zero" beat position so that a steady tone is heard when the "V" antenna is touched. Next, adjust C_{16} , again using an insulated alignment tool, for the desired operation of the volume control antenna. The volume control circuit has been designed to have less sensitivity than the tone control circuit, permitting a beginner to master the instrument with a minimum of practice. When C_{16} is properly adjusted, maximum volume should be obtained just as the antenna is firmly touched with the hand. With the hand removed, and away from the antenna, the sound level should be very low, almost inaudible, if not gone entirely.

Using the Theremin: Skill in using the Theremin is acquired only through prac-

tice and familiarity with the instrument, but there are a few fundamentals which should be remembered:

1. Always make sure the instrument is properly set to "zero beat" before starting a show or playing a piece. Generally, this is done by adjusting the TUNING control, C_1 , but if the instrument has been jostled a bit or hasn't been used for some time, readjustment of C_2 and C_6 may be necessary.

2. To change volume, bring the hand up to the "V" (volume control) antenna, touching it if necessary. A wavering sound can be obtained by moving the hand back and forth.

3. To change pitch, move the hand closer to or further away from the "T" (tone control) antenna. It will be noted that it is more sensitive than the "V" antenna. The other hand must be near the "V" antenna, of course, whenever a sound is to be produced.

4. To sound individual notes, keep the hand away from the "V" antenna until the other hand is in position at the proper distance from the "T" antenna to sound the note desired; proper position is learned by experiment. Then bring the hand up to the "V" antenna, without moving the other hand (near the "T" antenna), long enough to sound the note desired. Finally, move the "V" control hand away quickly *before shifting the position of the "T" control hand.*

5. Practice! Practice! Practice! Practice!

A lot of fun can be had experimenting with the Theremin, even if you never take the time to become an accomplished musician with the instrument! **END**

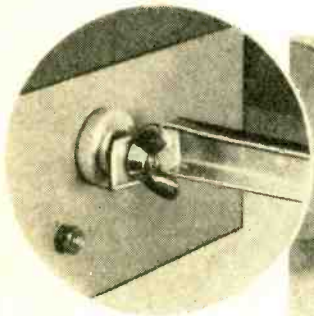

A detail view of mounting of one control antenna to its feed-through insulator.

Chassis bottom plate with adapter for mike stand and hole to reach the volume control adjustment, C_{16} .

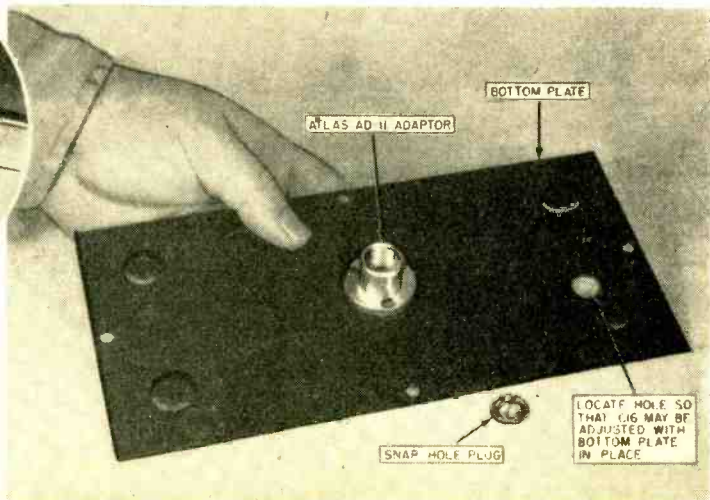

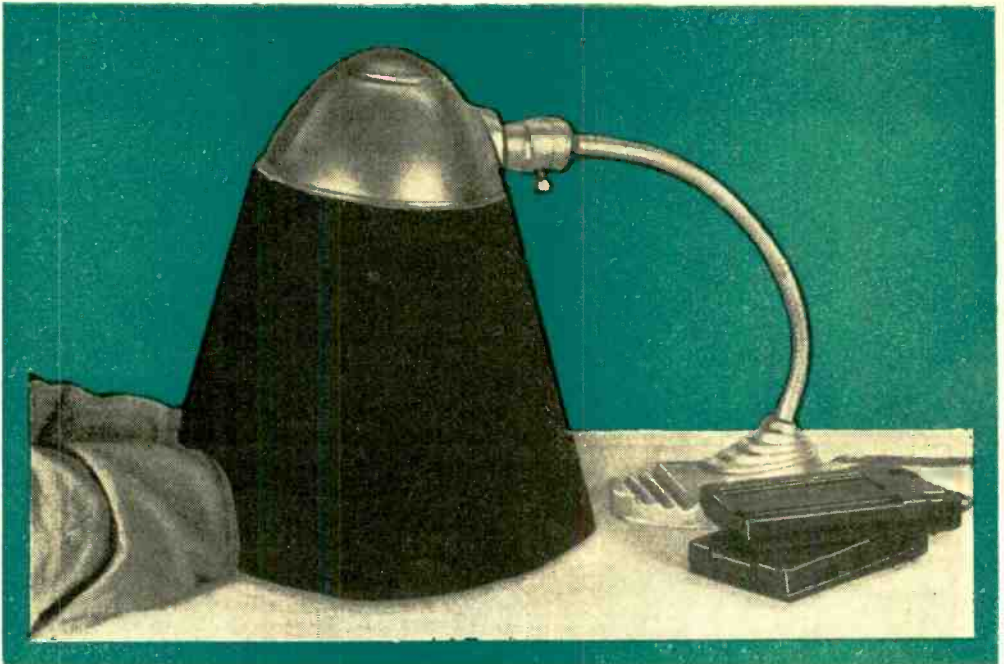

Negative light, produced by contra-polar energy, removes light from the area affected.

Contra-Polar Energy

In keeping with the first day of April

MANY developments in electronics which took place during World War II are still secret, because of the requirements of military security. However, the announced policy of the Government is not to apply security classifications to information which might be of use to the general public unless such classification will serve an actual military requirement. Also security classifications are removed when the conditions which originally necessitated them no longer exist. POPULAR ELECTRONICS is now in a position to reveal to the general public one of the most interesting phenomena yet discovered in the field of electronics—that of “contra-polar energy.”

Those who are familiar with the development of the atomic bomb will remember that the feasibility of the bomb was first demonstrated mathematically by Dr. Lise Meitner, the German mathematician, several years before World War II, and that its theoretical feasibility was first called to the attention of our Government by Dr. Albert Einstein. The problem then became one of finding out how to apply the mathematical formulae. The case of “contra-polar energy” is similar, but, since some of

our readers may be more interested in the applications of the new principle than in the mathematical basis of it, we shall defer the mathematics to the end of this article.

The photographs on these pages illustrate three simple applications of “contra-polar energy,” which are useful to the general electronic hobbyist and experimenter. In two cases, where “contra-polar energy” is applied to a soldering iron and an electric hot plate, heat is not produced, but taken away, and cold results, as proved by the formation of ice crystals on the soldering iron and freezing of water in the ice-cube tray. When “contra-polar energy” is applied to an ordinary table lamp, light is not produced, but taken away, and the area affected by the lamp becomes dark. (*Editor's Note:* This phenomenon should not be confused with “black light,” so-called, which actually is merely light without any visible elements. As far as the human eye is concerned, “black light” is equivalent to zero light; the light produced by contra-polar energy might be designated “negative light,” since it subtracts from light already present.)

One of the reasons why atomic energy

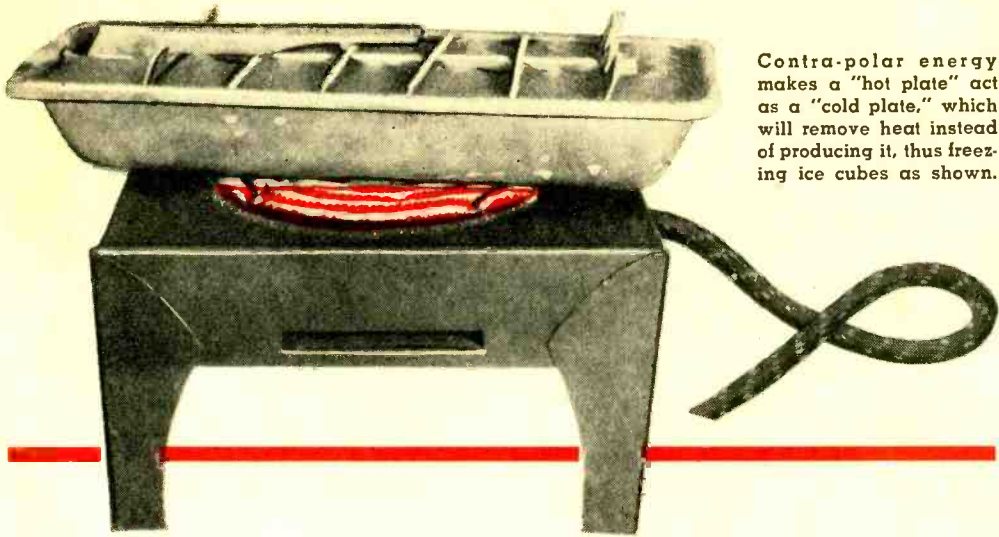

Contra-polar energy makes a "hot plate" act as a "cold plate," which will remove heat instead of producing it, thus freezing ice cubes as shown.

has not yet become popular among home experimenters is that an understanding of its production requires a knowledge of very advanced mathematics. Contra-polar energy, on the other hand, can be explained by simple algebra. Many of our readers are, no doubt, familiar with the formula for the resonant frequency of an *LC* circuit,

$$f = \frac{1}{2\pi \sqrt{LC}}$$

This formula involves a square root; elementary algebra tells us that the square root of a positive number may be either positive or negative. That is, +4 equals either +2 times +2 or -2 times -2, so the square root of +4 equals either +2 or -2. If the square root of *LC* may be either positive or negative, it follows that *f*, the resonant frequency of the circuit, may be either positive or negative.

Now, the reactance of an inductance is proportional to the frequency used; if the frequency is negative, the reactance would be negative. The current through an inductance is equal to the voltage divided by the reactance and a negative reactance would produce a negative current. A small

amount of resistance in series with the inductance would not shift the phase of the current very much and the current through the resistance would still be negative, or 180 degrees out of phase with the voltage. Power dissipated in the resistance would be equal to the voltage multiplied by the current, but if the voltage is positive and the current negative, the power would be negative. In other words, with an alternating voltage of negative frequency applied to a large inductance and a small resistance in series, the resistance would not absorb power, it would deliver power!¹ It has been known for some time that so-called "negative resistance," as in the dynatron² and transitron³, would deliver power, but this is the first indication that ordinary positive resistance also can be made to deliver power.⁴ END

¹ Those of our readers who may be unfamiliar with the foregoing mathematical relationships between electrical quantities can find an explanation of them in any standard textbook.

² Albert W. Hull, "The Dynatron—A Vacuum Tube Possessing Negative Electrical Resistance," *Proceedings of the Institute of Radio Engineers*, Vol. 6, p. 5, 1918.

³ E. W. Herold, "Negative Resistance and Devices for Obtaining It," *Proceedings of the Institute of Radio Engineers*, Vol. 23, p. 1201, 1935.

⁴ *Transactions of the Contra-Polar Energy Commission*, Vol. 45, pp. 1324-1346 (Ed. Note—A reprint of a document found in a flying saucer).

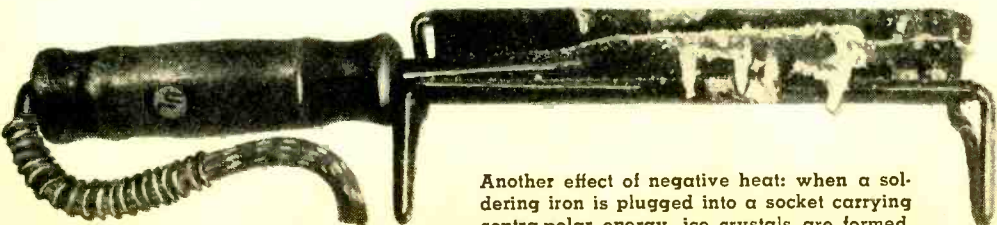

Another effect of negative heat: when a soldering iron is plugged into a socket carrying contra-polar energy, ice crystals are formed.



Helicopter Finds Ideal Antenna Height

THE German TV station at Torfhaus (Harz) solved the problem of finding the best antenna height for a new transmitter by putting a portable unit in a helicopter and hovering over the spot where the tower was to be built. The 'copter stayed at each altitude for four or five minutes while 21 receivers noted the strength of the signals and reported back to a base camp. Tests were used to find if the antenna of the new station should be as low as 150 feet, or as high as 900 feet. The tests took two weeks and saved the future station several thousand dollars in research expenses.

Predict Radar Maps in 1985 Aviation

TO CELEBRATE "Thirty Years of Service" *Trans-World Airlines* recently invited predictions and comments from leading engineers and scientists throughout the world. Optimistic reports on the next thirty years of aviation were given by Dr. Wernher von Braun, chief of Guided Missiles Development Division at the *Red Stone Arsenal*, Mr. Hall Hibbard of *Lockheed Aircraft*, and Dr. Fred L. Whipple, chairman of the Department of Astronomy, Harvard University.

Dr. Whipple predicted that by 1985 all aircraft will be provided with a new, and presently unknown, form of "radar map." This map will display a three-dimensional picture of the area surrounding the plane and will provide advance warning of impending danger, as well as coordinating its flight with those aircraft surrounding it.

TWA is also sponsoring a "Cosmic Contest" which will award \$50,000 in 1985 to



Dr. Wernher von Braun (left) of V-2 fame and Dr. Fred Whipple discuss the next thirty years in aviation at the Hayden Planetarium.

the person who can describe before July 31st of this year the most accurate picture of air transportation thirty years in the future. Further details may be obtained from TWA, Box 85, New York 46, N. Y.



His Voice Starts Engine

A SPECIAL microphone has been hooked up by Frank Toles of San Leandro, California to start the motor of his truck upon the command, "Git goin', Honey!" Toles is a master mechanic for a road construction firm and has the truck engine driving various welding and battery-charging generators. Should the engine stall while Frank is within twenty feet of the truck he can start it up again with his yell and yodel.

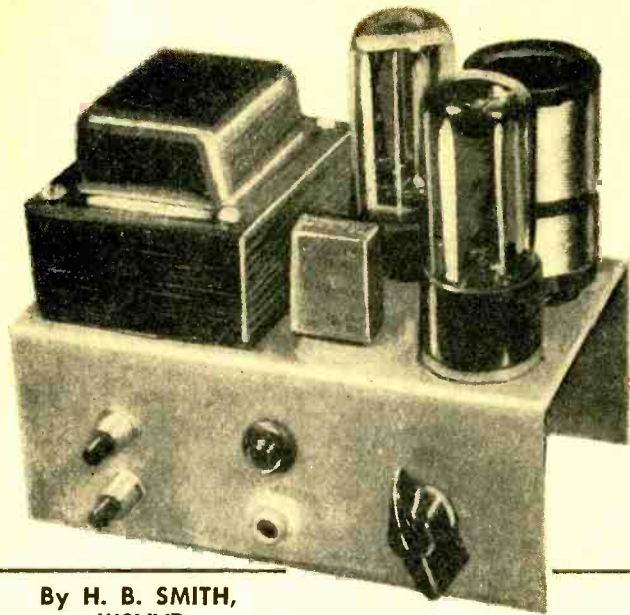

By H. B. SMITH,
W8VVD

The hart -25

Amateur transmitters can be inexpensive and simple enough for a novice to build. Here is an example.

OPERATING a novice ham station is not only interesting, but one of the few hobbies where the participants can enjoy every minute of it with an outlay of only a few dollars. Catalogue prices of radio transmitters are disheartening when the pocketbook is thin, but putting a transmitter together for the novice ham bands is not an expensive proposition. This article describes a complete, easily-constructed transmitter that costs about \$20.00—if all the parts are purchased new. Or, the novice may purchase it in kit-form to save himself the trouble of punching holes in a suitable chassis. The photographs show the appearance of the completed transmitter.

Assembling the Parts

The first step to be taken after deciding to build this transmitter is to make a list of the parts required and to take it to the nearest ham radio jobber or distributor. Ask for someone interested in ham radio—they generally have at least one ham on the staff—and get the salesclerk to take the parts out of stock, or to make suitable recommendations, if substitutions are required. Don't worry about substituting other manufacturers' parts for the ones shown in our list. Radio parts of the specifications can be used regardless of the manufacturer. In the case of the

power transformer T_1 , we strongly recommend the one specified, because of the physical size and shape. A larger transformer will require a larger chassis and a smaller one might not do the necessary work without overheating.

Wiring and Construction

This transmitter has been made very compact and the wiring procedure must be followed step-by-step. If it is not, the builder may find himself with the problem of squeezing one part into the space already occupied by another component previously soldered in place.

Punch out the chassis holes for the four tube sockets with a *Greenlee Punch*, or comparable tool. Mount all of the sockets as shown in Fig. 1 with their keyways exactly in the positions in this drawing (this is *very* important). Now mount the two rotary switches, S_1 and S_2 . The power transformer, T_1 , is put in place with the color coded leads facing the directions shown in Fig. 1. Put a small soldering lug under the mounting nut in the lower left hand corner. Then bolt down the "terminal strip" with another soldering lug—this time under the right hand nut.

Begin the wiring by twisting the two yellow leads together and then cutting and soldering them, one to pin 2, and the other to pin 8 of the 5Y3GT tube socket. Take

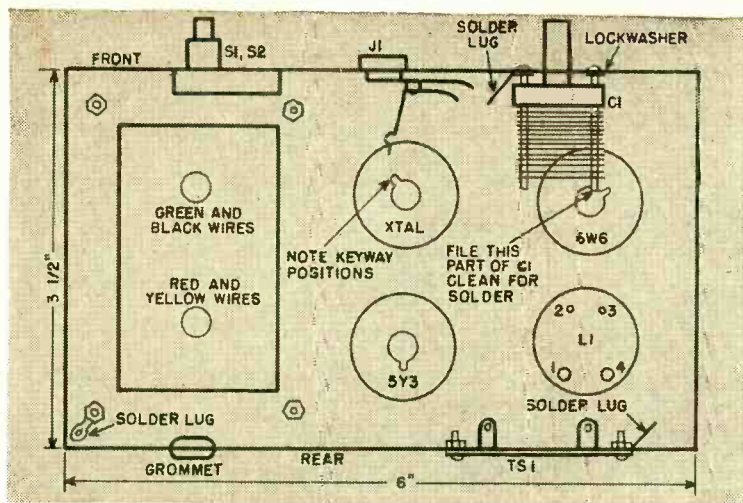

Fig. 1. This bottom view of the chassis shows the placement and orientation of the most important parts of the transmitter.

the red/yellow lead and the green/yellow lead of T_1 and solder them to the soldering lug in the corner. Now run one red lead from T_1 to pin 4 of the 5Y3GT socket and the other red lead to pin 6. Twist the two green wires together and cut and solder them, respectively, to pins 2 and 7 of the 6W6GT socket. The last step in the transformer wiring is to cut one of the black wires so that it will connect to pin 1 of the 5Y3GT socket and the other black wire to connect to pin 3. These pins are unused by this tube so it is safe to use them in place of soldering lugs.

Cut and solder one of the leads from S_1 to pin 3 of the 5Y3GT socket. The other

S_1 lead is connected to pin 5 of the 5Y3GT socket. The line cord runs through a grommet at the rear of chassis and is soldered to pins 1 and 5 of the 5Y3GT socket.

To put the filter capacitor C_3 into the circuit, solder the red positive lead to pin 8 of the 5Y3GT. The black, or negative lead is soldered to the lug near T_1 . Leave about $1\frac{1}{2}$ inches of wire on the positive lead before cutting and soldering. Now take the two resistors, R_1 and R_3 , and twist their leads together so that they are parallel to one another. Then solder one of these twisted leads to pin 8 of the 5Y3GT and the other to the soldering lug under

Fig. 2. Rear view of chassis, with 3.7 mc. band coil in place, showing antenna trimmer, C_1 , in series with transmission line.

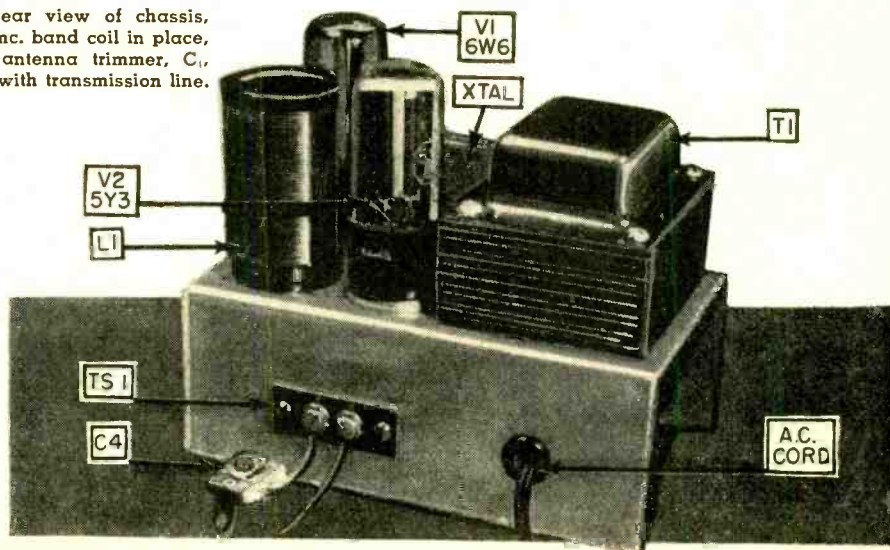

one mounting screw for the terminal strip.

With some hookup wire run a lead from pin 8 of the 5Y3GT to pin 2 of the L_1 coil socket. Another lead should run from pin 2 of L_1 to pin 4 of the 6W6GT socket. Now cut one lead of C_3 so that it is $\frac{1}{2}$ inch long and also solder it to pin 4 of the 6W6GT. Leave the other lead temporarily disconnected. Run a lead from pin 5 of the 6W6GT to pin 4 of the crystal socket. Connect together pins 1, 4, 5, and 8 of the crystal socket with a single piece of bare wire. Do the same to pins 2, 3, 6, and 7. Then solder a wire about $1\frac{1}{2}$ inch long to pin 3 of the crystal socket. Leave the other end temporarily disconnected.

Shorten one lead of R_2 (33,000 ohms) until it is $\frac{1}{2}$ inch long and solder to pin 7 of the crystal socket. Fasten one lead of RFC_1 to pin 5 of the same socket. Shorten, twist and solder the leads from R_2 and RFC_1 together.

Put a rubber grommet in the upper center hole on the front of the chassis. Press PL_1 into it until approximately $\frac{1}{4}$ inch of the glass bulb protrudes beyond the grommet (see photograph). Carefully solder to the tip of PL_1 one of the leads from switch S_2 and a short lead running to the terminal strip. The other lead of S_2 is soldered to the threaded portion of PL_1 . Also run a wire from the threaded base of PL_1 to pin 4 of the L_1 socket. Then solder a wire between pin 1 of the L_1 socket and

the last free tab on the terminal strip.

Mount C_1 with a long soldering lug under the left hand screw as shown in Fig. 1. To make sure that the rotor plates of C_1 are grounded, solder a short lead from the wiping contact to the soldering lug. Then solder in the free wire running from pin 3 of the crystal socket to this lug. One end of C_3 is still hanging free and this should also be soldered to the lug under C_1 .

Trim the leads of C_2 until it will just fit between pin 8 of the 6W6GT socket and the grounding lug under C_1 . Short pieces of spaghetti tubing should be fitted over these bare leads before they are soldered into place. Resistor R_3 now has its leads trimmed until it will fit between pin 3 of the 6W6GT socket and pin 3 of the coil L_1 socket. A short wire is then soldered between the fixed plates (stator) of C_1 and pin 3 of the coil socket. The connection to C_1 is made at the ends of one of the support arms.

The last few wiring steps include mounting J_1 and soldering a lead from unused pin 7 of the 5Y3GT socket and the springy contact of J_1 . Then trim the leads of R_1 and put on short lengths of spaghetti tubing. Solder R_1 between pins 8 of the 6W6GT socket and 7 of the 5Y3GT.

Tuning Up the Transmitter

We have now completed wiring the transmitter and it may be tested (provided of

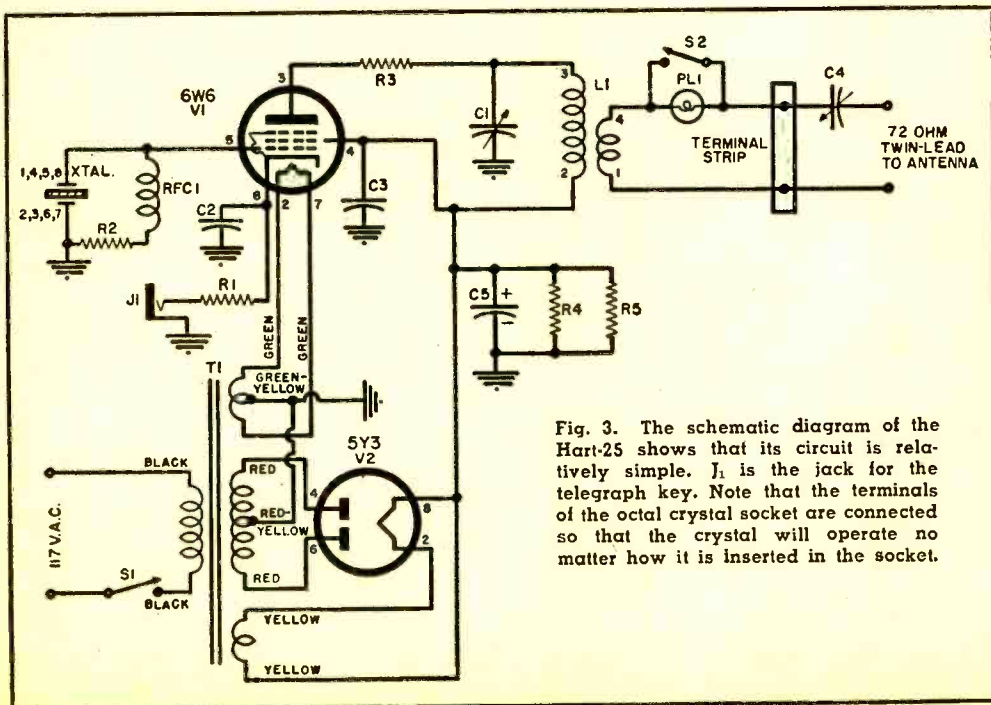

Fig. 3. The schematic diagram of the Hart-25 shows that its circuit is relatively simple. J_1 is the jack for the telegraph key. Note that the terminals of the octal crystal socket are connected so that the crystal will operate no matter how it is inserted in the socket.

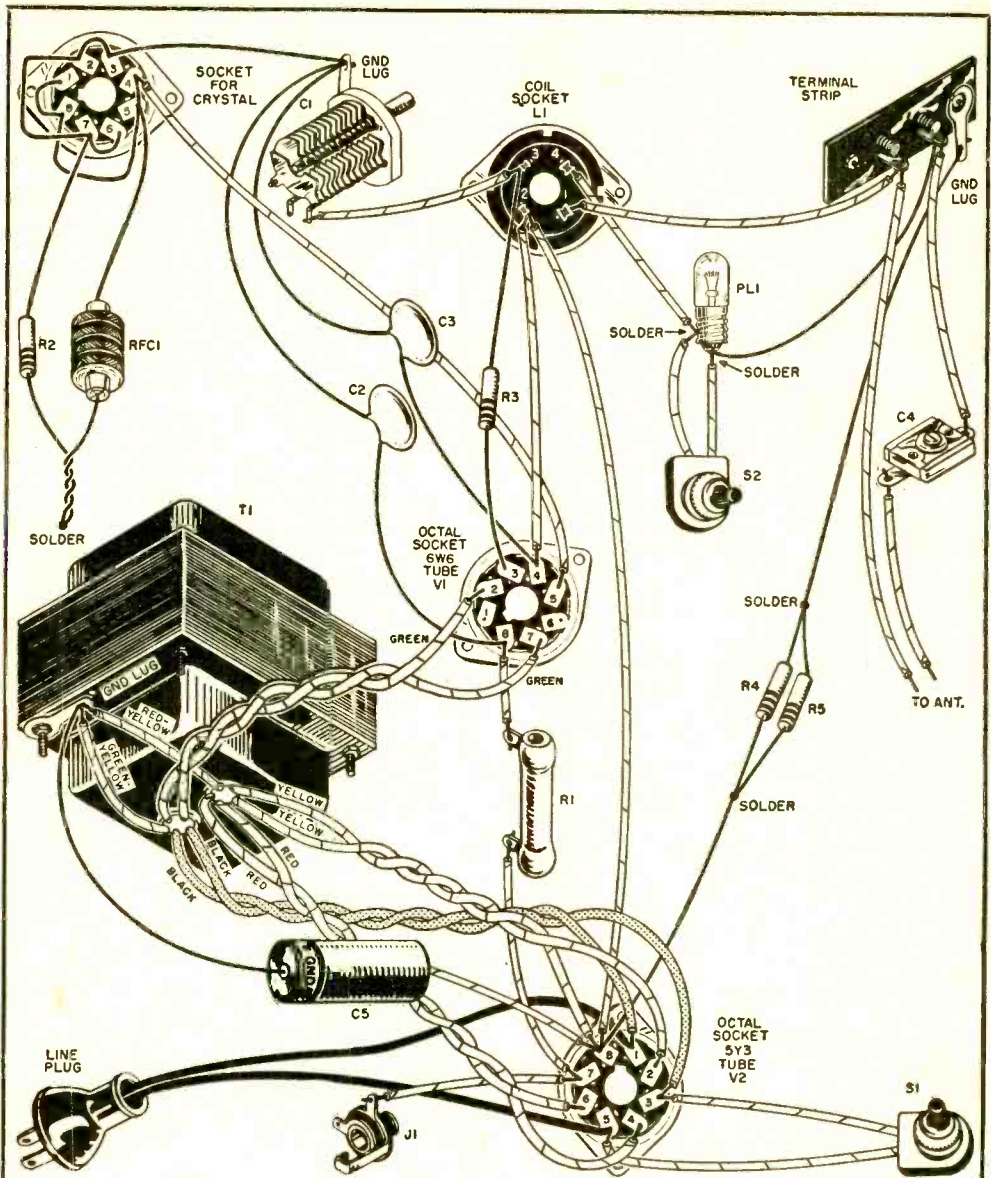

Fig. 4. The pictorial wiring diagram of the transmitter shows how the parts are connected; relative positions of the parts are not the same as on the actual chassis.

*R*₁—250 ohm, 5 w. wirewound res.
*R*₂—33,000 ohm, ½ w. res.
*R*₃—27 ohm, 1 w. res.
*R*₄, *R*₅—330,000 ohm, 1 w. res.
*C*₁—140 μfd. variable capacitor (Hammarlund APC 140 with short length of ¼" shaft added)
*C*₂, *C*₃—01 μfd. disc ceramic capacitor
*C*₄—25-280 μfd. mica padder capacitor
*C*₅—20 μfd., 500 v., electrolytic capacitor
*J*₁—Open circuit phone jack
*L*₁—3.7 mc. band; Plate coil 31 turns, #20 enamel closewound; Antenna coil 18 turns, #20 enamel closewound; ICA type 2158 coil form

*L*₁—7 mc. band; Plate coil 16 turns, #20 enamel spaced diameter of wire; Antenna coil 13 turns, #20 enamel closewound; ICA type 2158 form
*RFC*₁—2.5 mhy. r.f. choke
*S*₁, *S*₂—S.p.s.t. rotary switches (H and H type 41047)
*T*₁—Power transformer, sec 650 v.c.t. @ 40 ma., 5 v. @ 2 a., 6.3 v. @ 2.0 a. (Stancor type PM-8406)
TERMINAL STRIP—2 screw terminal strip
*V*₁—6W6GT tube
*V*₂—5Y3GT tube
*PL*₁—#46 pilot bulb
XTAL—3.7 mc. or 7 mc. transmitting crystal
 Misc.—Screws, nuts, wire, solder

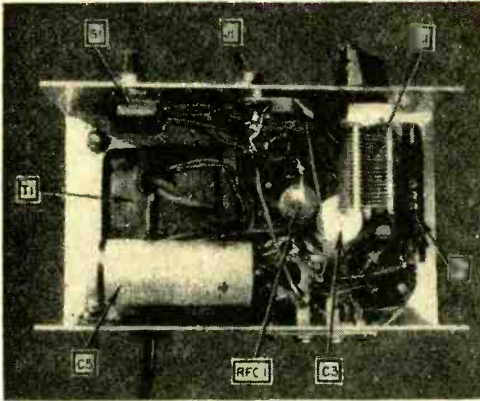

Fig. 5. Bottom view of the Hart-25 chassis. Most of the major components are visible, except the socket for V_L , the 6W6GT, which is hidden by the variable tuning capacitor, C_1 .

course, that the builder has a novice or ham ticket). Best results will always be obtained if a resonant antenna is used with this type of transmitter. Many antennas have been described in the various handbooks for amateurs. Make sure that the length of the antenna fits the operating frequency. Connect the lead from

the antenna to the "terminal strip" with capacitor C_1 in series with one lead.

Plug in the tubes, coil, crystal, and telegraph key. Turn on S_1 after the a.c. line cord is connected. Hold the key down and rotate C_1 until PL_1 glows. If the bulb does not glow it may be that S_2 is shorting it out. Throw S_2 and then attempt to make PL_1 glow. After it has started to glow, rotate C_1 and C_2 to get maximum brilliance. When it is glowing the brightest, the transmitter is drawing between 22 and 26 watts and is putting out around 9 watts of c.w.

When the transmitter is tuned, throw S_2 to short out PL_1 again. It may be used occasionally to check the tuning, but when left continuously in the circuit it will burn up valuable antenna power.

Warning: This transmitter is safe according to modern electrical standards. However, do not work on it while the a.c. line cord is connected. Electric shocks can be fatal.

A kit containing all of the parts and components used in the construction of this transmitter is available from *Hart Industries*, 467 Park Ave., Birmingham, Mich. Additional information may be obtained by writing to the above address. END

Quick Connection Phone Plugs

MANY experimenters will soon discover the person who designed the first phone plug did not do so for easy connection and disconnection of phone cord tips. Plastic salt and pepper shakers make an easy and handsome adapter to hold phone tip jacks. Empty cellulastic pill containers may also be used, although the salt shaker is shown in the accompanying photograph. Construction is simple. Unscrew the sleeve on the phone plug and attach two wires at least two inches long to the terminals. Drill a hole in the center of the

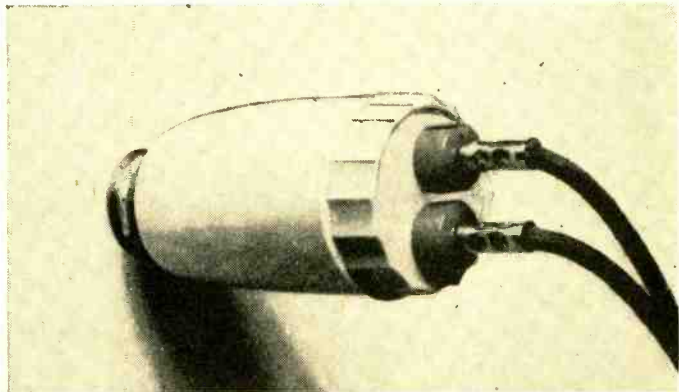

shaking end of the salt shaker. Enlarge the hole to fit snugly the threads of the phone plug. Now drill two holes $\frac{1}{4}$ -inch in diameter in the opposite end. Into these holes force fit the two tip jacks. Solder the wire leads from the plug to the tip jacks and snap the end with the jacks back into place. Now the phone tips are out in the open and easy to connect and disconnect. A.T.

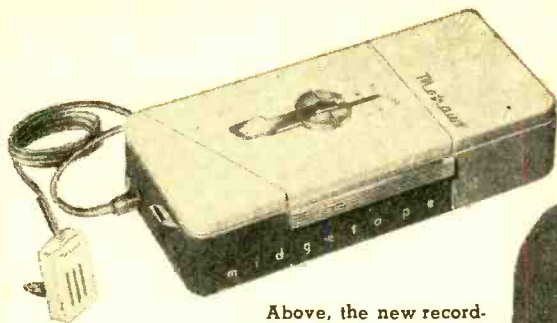

Above, the new recorder. Right, on-the-spot recording is one of its numerous applications.

First Pocket Tape Recorder

THE man on the road or the one who takes this work home can have a new electronic assistant at his side with the development of the world's first pocket tape recorder, the "Midgetape."

Battery-powered, the new recorder is the only one on the market which is cartridge-loaded. The magnetic tape is wound inside a cartridge about the size of a package of cigarettes and is inserted into the unit. Thus no tape threading is required. The "Midge-

Loading the recorder with tape cartridge is as simple as loading a camera with film.

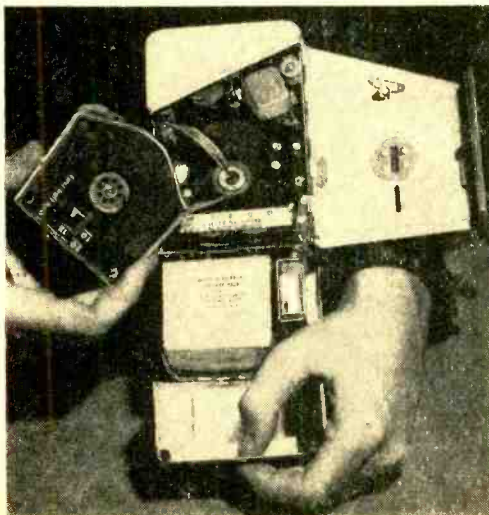

tape" has only three controls, records for one hour on dual track tape, and simultaneously erases old material as new recordings are made.

Hearing-aid type batteries, which snap-fasten into the device, have an extended life of over 45 hours. A useful feature is the battery life indicator, a small red light, which goes off when the battery has only two hours of recording time left.

Accessories add to the "Midgetape's" versatility. Among these are a wristwatch microphone, shoulder holster carrying case, and two-way telephone recording adapter. Because "Midgetape" will record anywhere, it suggests itself for a wide range of uses.

The new recorder measures 8½" long by 3⅞" wide by 1⅞" deep and weighs only 3¼ pounds. It is priced at \$229.50, which includes a recording cartridge, batteries, crystal microphone, and earphone.

Full details and descriptive literature are available from the manufacturer, the *Mohawk Business Machines Corporation*, 944 Halsey Street, Brooklyn 33, N. Y. **END**

By
LLOYD B. HUST

Compact AM Tuner

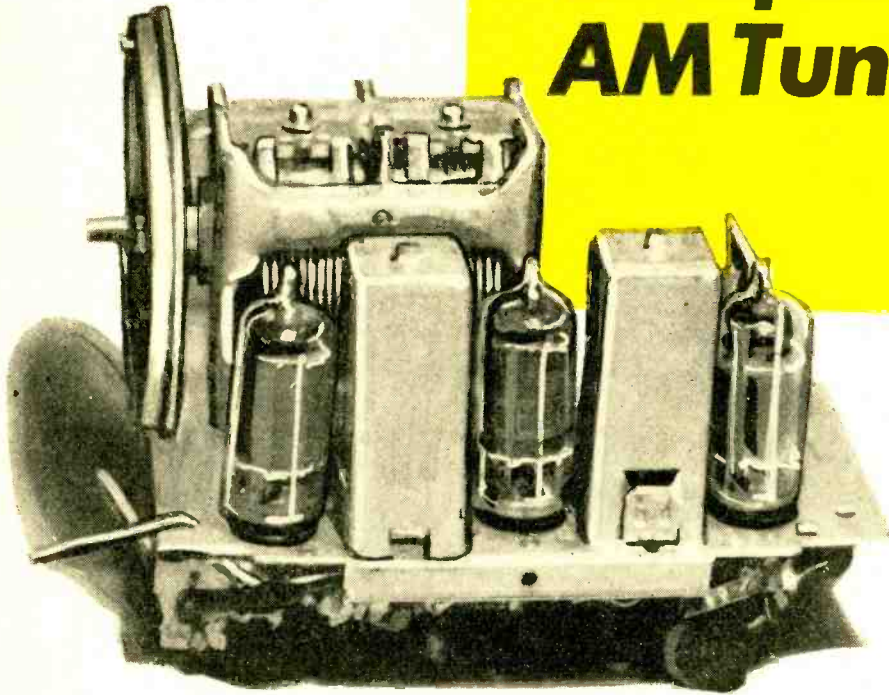

IN THE last few years the advent of FM broadcasting has made possible the reception of high quality music and one of the "musts" of the hi-fi enthusiast is a good FM tuner. However, there are still numerous areas where FM reception is not possible. Listeners in those areas must content themselves with AM radio. Although the range of music broadcasted by an AM system under present FCC standards is limited by the 10 kc. bandwidth regulation, and although AM broadcasting does not have the immunity from static and other interference that FM broadcasting does, very good results can be had from AM when necessity demands. The AM coverage of this country by good high-powered stations helps to minimize the interference difficulty, while careful standards set up by the stations and networks allow good music to be received in those areas not covered by FM, even though the bandwidth may not be so great.

This little tuner is not elaborate nor complicated in any respect. It was originally built because of the author's need for a tuner to use with his tape recorder, and it serves its purpose admirably. It was not designed to be part of so-called high fidelity equipment, but when it is used with a hi-fi

amplifier which the author possesses, the results far surpass those obtained by expensive console type radios. As an auxiliary for a tape recorder, it is very useful, and its small size makes it handy in those applications where portability is required.

Another suggested use for this tuner is in combination with a television set. Many homes now equipped with television receivers miss many good radio programs simply because of the fact that a radio and a TV set often cause overcrowding of a small room. The small size of this tuner makes it a simple matter to convert most television sets into television-radio combinations. A slight cabinet modification will allow for mounting the tuner as part of the TV set, or it can be mounted on top of the set in a small cabinet of a size convenient to house the tuner. The power needed for the tuner can be obtained from the TV set as the current drain is small, and the output of the tuner can be plugged into the phono jack provided on the TV set. In order to operate the set as a radio, the "TV-Phono" switch is merely turned to "Phono" position and the set can then be used as an ordinary radio. (Most TV sets are designed to be used with a record player and have a phono plug and switch built in.) It should be noted that

This handy tuner will make an AM broadcast receiver of any television receiver or high fidelity audio amplifier.

this tuner cannot be used conveniently with a TV set of the transformerless type.

A look at the schematic diagram will show that the tuner uses a standard superheterodyne circuit. Some may criticize this design because of the well-known fact that a wider band of frequencies can be received by a tuned r.f. circuit than with a superhet. However, nearly every area now is covered by so many stations that the interference problems which would be presented by a t.r.f. circuit would more than offset any advantage such a set might have with respect to the quality of the signal received. Furthermore, a superheterodyne type of set can easily receive the full 10 kc. bandwidth of present-day AM broadcasting if it is properly designed.

A word or two by way of description of the tuner would be of help to the prospective builder. The antenna coil is tuned by one section of the tuning capacitor and from this combination the signal is fed to the signal grid of V_1 , the 6BE6 tube. The oscillator coil is tuned by the second section of the capacitor and this combination is connected to the oscillator section of V_1 . The output of V_1 is fed to V_2 through the first i.f. transformer; V_2 is the i.f. amplifier, and its output is fed to the diode section of V_3 through the second i.f. transformer. The audio signal is developed across R_5 as is the a.v.c. voltage. The a.v.c. voltage is applied to the mixer and i.f. stage as shown in the schematic, while the audio signal is applied to the grid of V_3 , and the output of the unit is taken from the plate of V_3 through C_{10} . The use of one audio stage with this tuner makes possible its use even with amplifiers of very low gain.

The power for the tuner is taken from the device with which it is to be used. A 4-contact Jones socket can be wired into the amplifier or TV receiver with which the tuner is to be used, or any other type of connector desired by the builder can make this connection. The voltages needed are 6.3 volts a.c. or d.c. for the heater circuit, and 100 to 250 volts d.c. for the plate circuit. If a voltage supply of less than 125 is to be used, R_2 can be eliminated from the circuit. Most transformer-operated power supplies will deliver in the neighborhood of

250 volts and this will operate the device very well. The output of the tuner is fed to the input of the amplifier by a plug of the type to fit the input socket of the amplifier—in the author's case a standard phone plug was used.

Construction

The chassis for the unit is made of aluminum, and measures 3" x 5". Parts are mounted as shown in the photos. Although the various parts are placed close together, there is no difficulty in wiring the unit. Most of the resistors and capacitors have long enough leads so very little hookup wire need be used. A small amount will be needed for filament and plate wiring and for some wiring between the various coils and sockets, but most leads can be kept very short.

The r.f. coil is one of the popular "Vari-Loopsticks" and is mounted underneath the chassis on the small bracket supplied with the coil. The use of this coil makes it possible to use the tuner with just a short length of wire as an antenna and still have good sensitivity. In addition, this coil provides good selectivity characteristics, but its bandwidth is not so narrow as to cause much cutting of the sidebands. All of the capacitors in the unit except the a.v.c. capacitor and the capacitor in the plate of the audio stage are ceramic capacitors, which makes for easier wiring and more compactness than if the bulkier paper capacitors were used. Ceramic capacitors could have been used throughout.

The i.f. transformers are standard "mid-get" 456 kc. units which are low in price, efficient in operation, and small in size. The oscillator coil is of the tapped type and is available at any parts house. It should be one designed for use with 456 kc. i.f. transformers. The tuning capacitor is a standard two-section unit, with capacitance of 365 $\mu\mu\text{f.d.}$ per section. Both sections are the same—in other words, this capacitor has no special cut section for the oscillator circuit. Such a capacitor could be used if one were available with the proper cut section to track with the oscillator coil used. If a capacitor of the cut section type is used, it will not be necessary to use C_8 , the padding capacitor. The use of a capacitor with

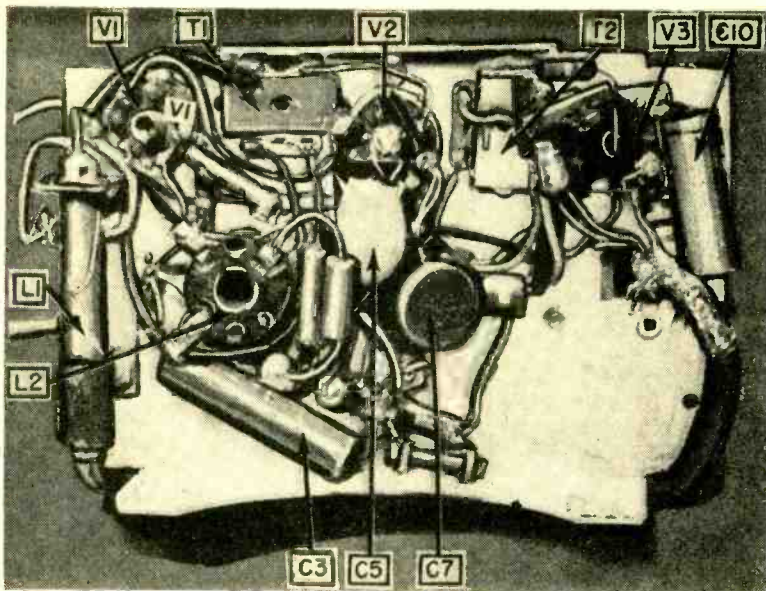

The schematic and pictorial wiring diagrams on the page opposite should be followed when wiring the Compact AM Tuner.

At left is an under-chassis view of the author's tuner, showing parts placement.

identical sections requires the use of a padding capacitor, but it eliminates any chance for poor tracking which would result if a cut section capacitor which did not match the oscillator coil were used. Since the experimenter may have many of these parts on hand, he can judge best which would be better in his particular case.

One or two observations concerning the wiring may be in order. Since one side of the filament supply or the center of the filament supply is apt to be grounded in the amplifier with which this tuner is to be used, the builder should be careful not to ground either filament lead in the tuner or a short circuit might ensue. Grounds should be made as short and direct as possible, and, if an aluminum chassis is used, grounding lugs must be provided. A couple of soldering lug strips strategically placed will lead to ease and neatness of wiring. The padder capacitor, C_6 , can be a fixed unit, or a trimmer type can be used. A fixed unit is a little more convenient. Its exact capacitance will depend on the oscillator coil used. A Miller Type 5480C coil will do nicely with a trimmer of 400 μfd .

Alignment

When the wiring has been finished and all connections to the amplifier have been made, it is necessary to make alignment adjustments. This can best be done with a signal generator using the following procedure: Connect the output from the signal generator to the variable capacitor terminal in the signal grid section of V_1 . The generator should be tuned to 456 kc. The i.f.

transformers are adjusted for greatest output as heard from the speaker, or as determined by an output meter. The generator is then tuned to 1400 kc. and the oscillator section of the tuning capacitor is adjusted to determine the calibration of 1400 kc. on the tuning dial. Then the other section of the tuning capacitor is adjusted for maximum output at this frequency. The generator is then set for 600 kc. and the dial turned until the signal is picked up. The slug of the "Vari-Loopstick" is adjusted for maximum output at this frequency. The set is now ready for operation.

If a signal generator is not available, the tuner can be aligned using a broadcast signal. The i.f. transformer settings are usually near enough to the correct frequency so that a station can be tuned in without any adjustments. These can then be adjusted for peak output. After the i.f.'s have been peaked, a station in the vicinity of 1400 kc. should be tuned in for oscillator and r.f. adjustments as outlined above. Then a station near 600 kc. can be tuned in and the "Vari-Loopstick" can be adjusted for maximum output.

Although the musical results obtained by this tuner will not equal those of a good FM tuner, nevertheless it will perform very well. It can be used in a number of applications—those mentioned here as well as others which the imaginative builder will devise. Last, but not least, it need not have too much of a deflating effect on the pocketbook. Exclusive of tubes, with a little shopping around the parts can be bought for about \$9.

END

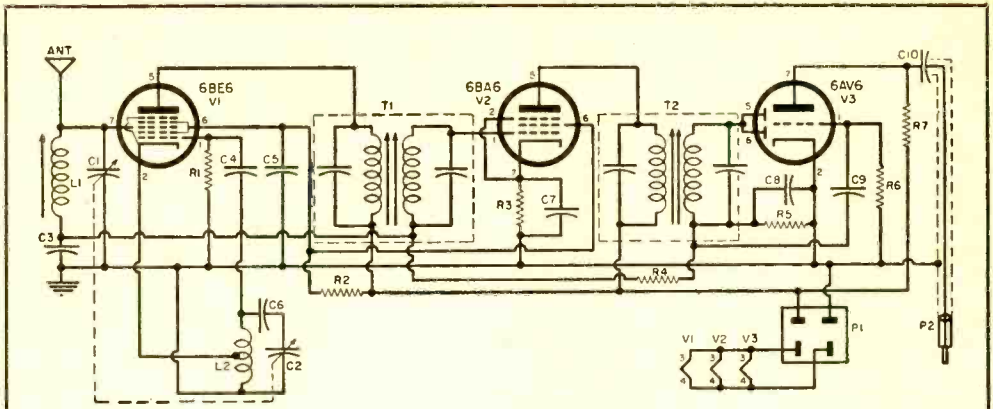

- R₁—22,000 ohm, 1/2 w. res.
- R₂—15,000 ohm, 2 w. res.
- R₃—47 ohm, 1/2 w. res.
- R₄—2 megohm, 1/2 w. res.
- R₅—220,000 ohm, 1/2 w. res.
- R₆—10 megohm, 1/2 w. res.
- R₇—220,000 ohm, 1/2 w. res.
- C₁—C₂—2-section variable capacitor, 365 μ fd.
- C₃—.05 μ fd., 400 v. paper or ceramic capacitor
- C₄—50 μ fd., 500 v. ceramic capacitor
- C₅—.01 μ fd., 500 v. paper or ceramic capacitor
- C₆—padding capacitor—see text
- C₇—.01 μ fd., 500 v. paper or ceramic capacitor
- C₈—200 μ fd., 500 v. ceramic capacitor

- C₉—.01 μ fd., 500 v. paper or ceramic capacitor
- C₁₀—.01 μ fd., 500 v. paper or ceramic capacitor
- L₁—"Vari-Loopstick" antenna coil
- L₂—tapped oscillator coil for 456 kc. i.f.
- P₁—4 prong Jones plug
- P₂—standard phono plug
- T₁, T₂—midget i.f. transformers—456 kc.
- V₁—6BE6 tube
- V₂—6BA6 tube
- V₃—6AV6 tube
- l—Aluminum chassis, approximately 3" x 5" x 1"
- (ICA Type 29080 or 29084)
- l—4-terminal tie-point strip
- Screws, nuts, wire, solder

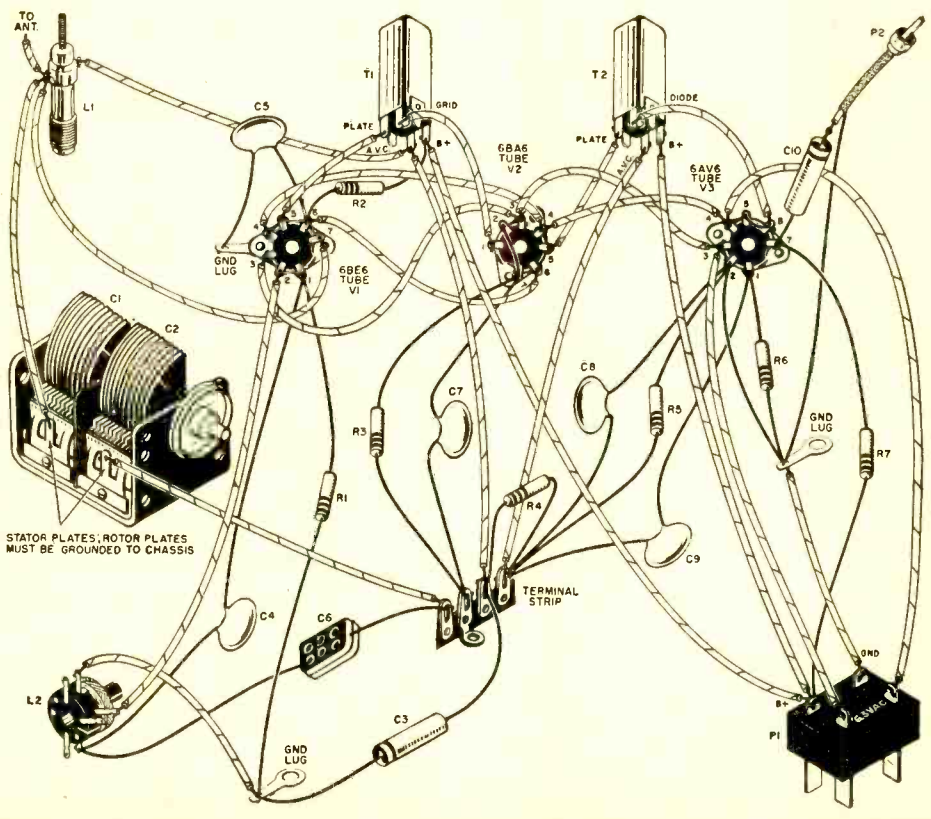

LOW COST MICROPHONES



Simple hand or lapel microphone.

Here are several ideas for the home constructor interested in building inexpensive microphones.

A MICROPHONE is a "must" accessory for many types of projects, including public address amplifiers, recorders, home broadcasters, and radio-telephone transmitters. The average experimenter has postponed a number of such projects because he didn't have a microphone on hand and didn't feel that the budget could afford one. But that should not stop him in the future. There are several solutions to the problem of obtaining an inexpensive microphone.

Perhaps the simplest is to use a basic microphone "cartridge." These are available through most parts distributors and generally cost much less than a standard microphone. Magnetic, carbon, and crystal cartridges may be obtained. Basically, they are the "heart" of their corresponding commercial units and, although electrically equivalent to their more expensive brothers, do not include such frills as a case, stand, shielded cable, or connector.

A microphone cartridge may be used "as is" or it may be mounted in a case or cabinet of the builder's choice. A metal pill



Another hand microphone complete with handle and (to the right) a PM speaker microphone and cabinet.

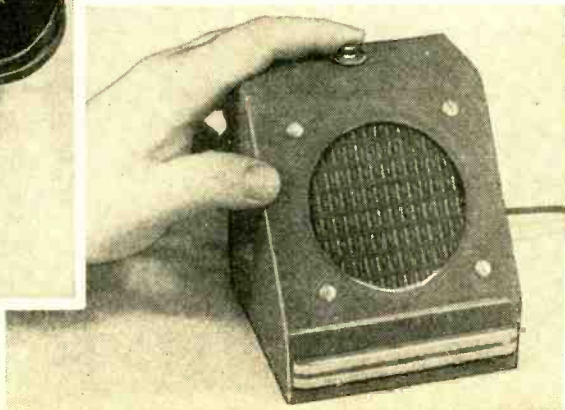

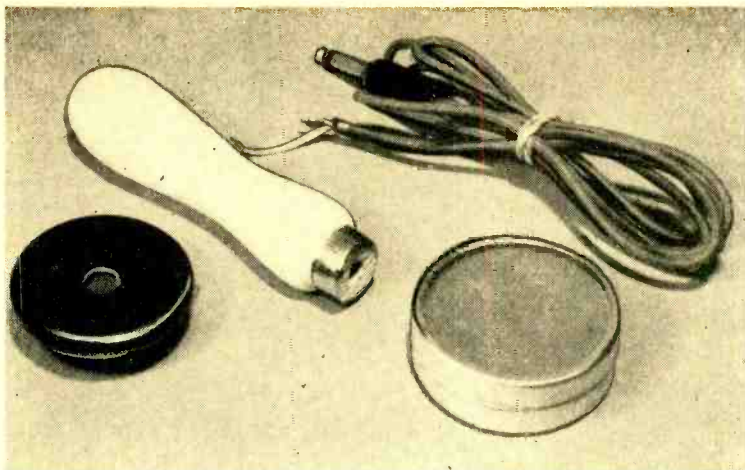

A wooden file handle, a metal pill box from the nearest druggist, and a magnetic or crystal earphone are all you need to construct a simple hand microphone. A length of shielded cable with a phone plug is shown in the background.

box, a small can, or a commercial utility or *Bud Minibox* cabinet may be used as a case. The cartridges are supplied with a rubber ring or cushion, and this should be used when mounting the unit. In addition, the experimenter must provide a shielded cable and a connector.

The builder may use any standard connector that suits his fancy. The most popular commercial types are the standard phone plug and the coaxial microphone connector. If the microphone is to be plugged into the phonograph jack of a standard radio receiver, a commercial phono plug might be used, but this should be the last choice, as such plugs are designed for semi-permanent connections and don't stand up too well when removed and reconnected many times.

Carbon Microphones

Carbon microphones have high output and, for this reason, are frequently preferred by both beginners and more advanced experimenters. With a carbon "mike," it is possible to eliminate a stage of audio amplification in either a p.a. system or in a modulator for a radio transmitter. But a carbon mike has disadvantages. In addition to having a limited frequency response and being somewhat noisy, a carbon mike requires a source of d.c. power (usually a battery) and a matching transformer. Carbon mike cartridges (often called *microphone buttons*) are available both commercially and on the surplus market, or may be salvaged from the "transmitters" of old telephones.

The basic electrical connections for a carbon microphone are shown in Fig. 1(a). The input transformer is used to match the low output impedance of the microphone (about 50 to 100 ohms) to the high input impedance of the amplifier. A suit-

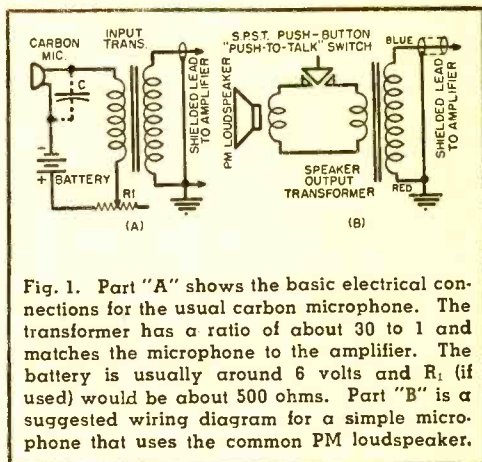

Fig. 1. Part "A" shows the basic electrical connections for the usual carbon microphone. The transformer has a ratio of about 30 to 1 and matches the microphone to the amplifier. The battery is usually around 6 volts and R_1 (if used) would be about 500 ohms. Part "B" is a suggested wiring diagram for a simple microphone that uses the common PM loudspeaker.

able transformer is the *Triad* type A-1X. Potentiometer R_1 may have a value of about 500 ohms, but is not always needed. When used, it serves to adjust the microphone current to the value specified by the manufacturer—generally about 50 to 100 ma. The microphone battery may have a rating of from 1.5 to 12 volts, with a range of 3 to 6 volts being the most popular. A small paper capacitor (C) is sometimes connected across the microphone to reduce "hiss," but its use is optional. A value of from 0.002 to 0.01 $\mu\text{fd.}$ is satisfactory in most cases. The *Shure* type R10 carbon microphone cartridge is supplied with a 0.008 $\mu\text{fd.}$, 200-volt capacitor by the manufacturer. A simple s.p.s.t. "push-to-talk" switch may be added to the microphone circuit if desired.

A Loudspeaker "Desk" Microphone

A small PM loudspeaker makes an excellent microphone if equipped with a transformer to match its low voice coil

impedance to the high input impedance of most amplifiers. The basic electrical connections are shown in Fig. 1(b). A s.p.s.t. push-button switch is shown as a "push-to-talk" control, but its use is optional. An ordinary audio output transformer will serve as a matching transformer in most applications. A suitable choice is the *Stan-cor* type A-3329. The primary or "plate" leads become the "secondary" connections when the transformer is used for input matching purposes.

For a really "deluxe" microphone, mount a 3½" PM speaker, such as the *Quam* type 3A07, in a sloping front meter case (*ICA* type 3996), using a piece of grille cloth for protection and decoration. A *Switchcraft* type 101 unit is a suitable "push-to-talk" switch. Connect a shielded single conductor lead to the red and blue wires of the output transformer. Either side may be grounded.

Any PM speaker in good condition may be used for a microphone, from a 2" midget to a 12" woofer. A speaker can be salvaged from an old radio!

A Home-Made Hand Microphone

An inexpensive file handle, a cylindrical metal pill box, a single headphone, a

shielded cable, and a phone plug are the basic parts needed to make a really professional-looking and working-hand microphone satisfactory for most experimental work. The file handle can be purchased at the local hardware store and a druggist can supply a small metal pill box.

For maximum sensitivity and best quality, use a crystal headphone. Second choice would be a single high impedance magnetic headphone. Last choice should be a 1,000 ohm magnetic phone which will work, but not as well as the first two. Or, if you prefer, insert a *Shure* type R7 crystal microphone cartridge in place of a headphone.

Punch a large hole in the cover of the metal pill box. The exact size will depend on the headphone you use, but make it at least one inch in diameter. Drill holes in the box for mounting the headphone and for mounting the box to the file handle with a wood screw. The size and location of the holes will depend on the type of phone. Exercise ingenuity in working out a mounting arrangement. Drill one final hole for the shielded cable. After all machine work on the box is finished, enamel or paint it—or leave it plain, if preferred.

Making a lapel microphone is a simple operation. Carefully solder a safety pin to the "ground" terminal. Attach to the crystal cartridge a length of thin shielded cable and terminate it at the other end with the appropriate microphone or phono connector.

These few components are all that is required to convert a PM loudspeaker into a useful microphone.

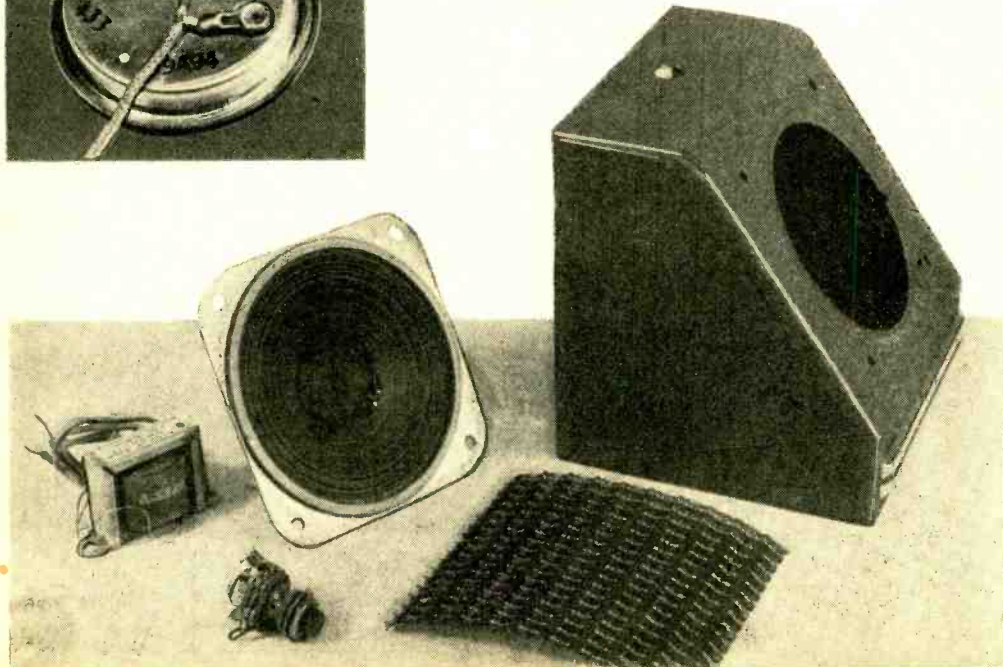
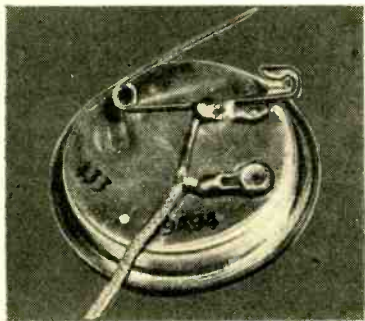

Stain or paint the file handle as it is generally of unfinished wood. Drive a small wooden dowel in the hole in the end of the handle where the metal pill box is to mount.

With all machine work and painting completed, assemble and wire the microphone. Take care when mounting the headphone. Use a small rubber grommet to protect the shielded cable where it comes through the metal box. Both a disassembled and a completed view of a home-made hand microphone are shown in the photographs.

Special Microphones

A Lapel Microphone: The experimenter can make an inexpensive lapel microphone from a *Shure* type R7 crystal microphone cartridge. Use a piece of the smallest diameter shielded wire and carefully solder the center and shield leads to the "hot" and ground terminals of the cartridge, respectively. Complete the soldering operation as quickly as possible, using a hot, well-tinned iron. Excessive heat will damage the mike cartridge. Next, tin the "back" side of a small safety pin and solder it to the ground terminal. Again, work as quickly as possible. Finally, cover the "hot" terminal of the cartridge with a piece of *Scotch* electrical tape to insulate it. Follow with a cover of aluminum foil held in place with additional pieces of tape. Make sure good contact is made between the foil and the metal case of the cartridge. The foil serves to shield the terminal.

With all work completed, slip the rubber ring in place around the cartridge and pin the finished mike to your lapel . . . or

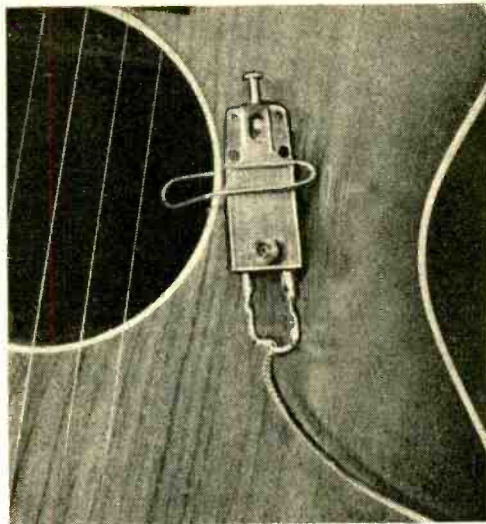

A phonograph crystal cartridge makes a satisfactory contact microphone. The metal cover has been removed to show the pin connections. A large paper clip holds the microphone in place on the musical instrument.

you can hold it in your hand as a semi-concealed "hand" mike.

A Contact Microphone: An ordinary crystal phonograph cartridge makes a satisfactory contact microphone for a guitar or other musical instrument. A large paper clip or a bent piece of spring wire may be used to hold the cartridge in place. After attaching the shielded microphone cable, cover the terminals with a small metal cap to reduce hum pick-up. The shape and size of the cap will depend entirely on the type of phonograph cartridge which the experimenter uses. END

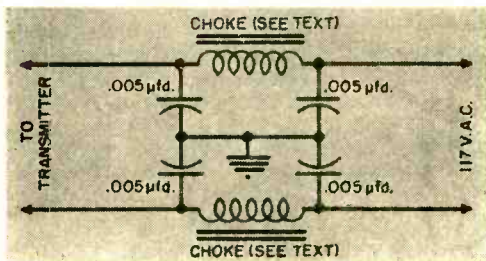

SOME older model television receivers will respond to the harmonics of 27 mc. R/C transmitting equipment. A portion of this interference is being received down the a.c. power lines. It may be prevented by simply putting *Ohmite* Z-50 chokes in series with the power line inside of the transmitter. The schematic shows how these are

TVI FILTERING of R/C Transmitters

to be connected with small disc ceramic bypass capacitors.

If the R/C experimenter does not want to go to the expense of buying these chokes he may wind his own on a short length of Lucite plastic rod. Use a piece about 2 inches long and $\frac{1}{4}$ inch in diameter. Wind on enamelled No. 27 wire close spaced for a length of $1\frac{1}{4}$ inches. Drill two holes through the Lucite rod and thread the ends of the winding in these holes. Use this filter only on low power transmitters. Sometimes a little shield around the choke will further prevent unnecessary pickup directly in the transmitter. E.M.



Miniature Power Supply

EXPERIMENTERS know the advantage of having a small test power supply. A self-contained power supply is, at one time, one of the least expensive, one of the easiest to build, and one of the most valuable instruments that a lab bench can boast. Although so small that it is almost dwarfed by a package of king-sized cigarettes, it will deliver 150 volts d.c. at 20 ma. and 6.3 volts a.c. at half an ampere. With it, you can check the operation of amplifiers, oscillators, preamps, multivibrators, regenerative detectors, and other experimental circuits. It can be used to check the operation of voltmeters, to test paper and mica capacitors for leakage, and to furnish fixed bias voltages for high powered radio transmitters and PA audio amplifiers.

The miniature power supply is so simple and easy to assemble that you should have no difficulty in wiring your own unit in a single evening. The items you'll need are specified in the parts list. Parts cost is low, all components are standard and available at both local parts distributors and through the large mail order radio supply houses.

Construction Hints: Follow the schematic and pictorial wiring diagrams and the photographs of the model when assembling your own unit. Parts layout is not critical and may be changed easily to suit your own requirements. An ICA type #29082 aluminum chassis base was used in the model but, if you prefer, you can bend your own chassis from sheet metal. Since shielding is not important, you can even make a chassis of wood if you wish (see *Nine Chassis Bases for the Home*

Builder, November, 1954, POPULAR ELECTRONICS).

Round mounting holes are drilled and punched for the tube socket, for the insulating fiber capacitor plate, for the rubber grommets, and for the transformer. The rectangular holes for the slide switches and the output terminal strip may be made by first drilling round holes and then filing to shape. Use a small flat file and scribe the rectangular outline of the holes on the chassis before starting work.

With the machine work finished, the chassis of the model was sprayed with two coats of white plastic and labeled with commercially available black decals, protected after application with two coats of clear plastic. If you prefer to leave the chassis its natural color, you can do so and still use decals for labeling the switches. They show up well against an aluminum background. But, for best results, spray on a coat of clear plastic both *before* and *after* applying the decals.

Except for the dual capacitor, all parts are mounted using small machine screws

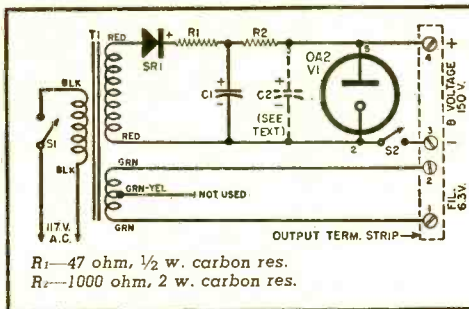

C_1, C_2 —30/50 μ fd., 150 v. dual electrolytic capacitor (Sangamo type PLD-716). A 200- or 250-volt unit is preferred if available

S_1, S_2 —S.p.s.t. slide switches

SR_1 —20 ma. selenium rectifier (Radio Receptor type 8Y1)

T_1 —Power transformer, 150 v. @ 25 ma. and 6.3 v. @ 0.5 a. (Merit type P-3046)

V_1 —OA2 or OB2 voltage regulator tube (see text)

Misc.—Chassis, 1" x 4" x 3 $\frac{1}{8}$ " (ICA #29082); 7-pin miniature tube socket; 4-terminal screw-type terminal strip; 2-terminal tie-point strip; line cord and plug; three rubber grommets; screws, nuts, wire, and solder

and hex nuts. Lockwashers are not necessary if you take care to draw up the nuts snugly. However, don't use excessive pressure on the long screw holding the selenium rectifier (SR_1) in place; you may damage this part. The capacitor is mounted on its fiber plate by three small lugs. These are twisted with a pair of pliers while the capacitor is held by hand.

Wiring Suggestions: Use standard hook-up wire and rosin-core solder for wiring the unit. Tie a knot in the line cord where it bears against the back rubber grommet. Lead dress is unimportant and no special pains need be taken. However, take care not to apply excessive heat to the lugs of the selenium rectifier or to the terminals of the electrolytic capacitor. Use a clean, hot, well-tinned soldering iron and complete these connections as quickly as possible. The filament center tap (green-yellow lead of the transformer) is not used

and is soldered to the center (shield) terminal of the tube socket to keep it out of the way.

Circuit Modifications: A dual electrolytic capacitor is used in the model and specified in the parts list. However, only the 30 μ fd. section (C_1) is connected into the circuit when the OA2 voltage regulator tube is employed. With this circuit arrangement, the voltage output is regulated to 150 volts. If the OA2 is removed and a short lead run from the free terminal of the capacitor (C_2) to pin 5 of the tube socket, the output is no longer regulated, but a somewhat higher d.c. voltage is available under "no load" conditions (about 175 to 180 volts). This "dual circuit" feature increases the utility of the miniature power supply considerably, for it may be used in both regulated and unregulated applications. However, if you don't want this feature, you can replace the dual with a single unit.

If you wish a lower output voltage, replace the OA2 with a type OB2 tube. No circuit changes are necessary, but you will obtain 108 volts (regulated) instead of 150. If you want several output voltages, you can connect a tapped resistor (or a series

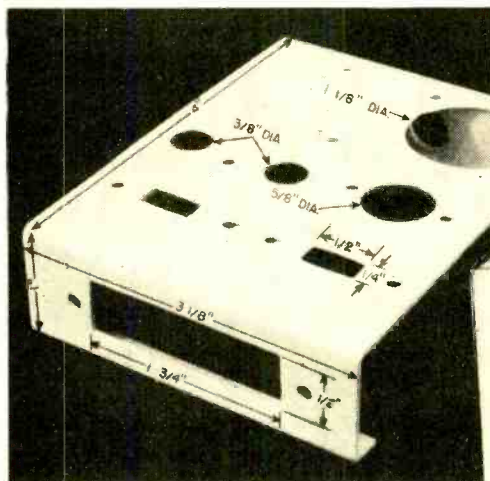

Bottom view of the miniature power supply chassis, showing wiring. See the schematic diagram for proper connections of the rectifier, SR_1 , and the transformer, T_1 .

The chassis with the needed holes cut. A hole in the center of the rear apron is provided for the line cord grommet.

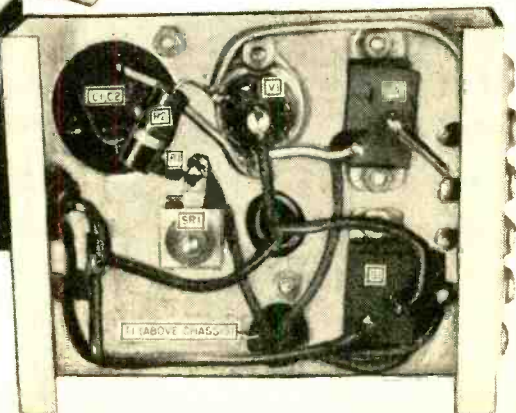

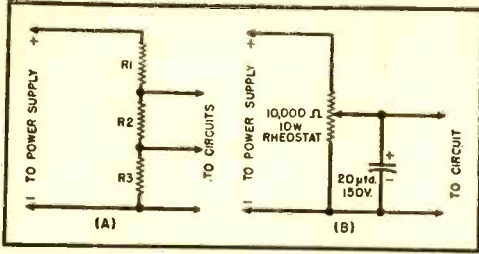

Circuits for voltages other than 150 or 108 v.

of single resistors) across the output terminals. Use at least a 10,000 ohm, 10 watt resistor, or individual resistors totaling this much. If you want a continuously variable output voltage, connect a potentiometer across the output terminals.

Note that neither side of the d.c. supply is connected to chassis ground. This permits the power supply to be used either for bias purposes (B plus grounded) or as a B voltage source (B minus grounded). Another feature is the "Standby" switch (S_2). Operating this switch permits you to remove high voltage from an experimental circuit while keeping the filaments lighted.

Using the Miniature Power Supply: The miniature unit is used like any other experimental power supply. Connections are made to the output terminal strip. It is customary to switch the "Power" switch on for a few seconds before throwing the "Standby" switch. Remember, however, that the output of the miniature power supply is limited. You can use it to test and to develop one- and two-tube experimental circuits and as a bias voltage source, but it can't be used to power a 50-watt transmitter.

To use the power supply for "forming" electrolytic capacitors that have been on a

shelf for some time, use the circuit for variable output voltage. Observe proper polarity when connecting the electrolytic across the center arm and one side of variable resistor (the 20 μ fd., 150 volt electrolytic capacitor shown in the circuit may be omitted for this operation). Starting at "0" output voltage, gradually increase the output to the maximum available, allowing from five to ten minutes between steps. From time to time, disconnect the electrolytic and check for a charge by shorting its terminals together (a spark should be obtained) or by checking its voltage with a d.c. voltmeter. If the capacitor refuses to take a charge after a reasonable "forming" period, it should be discarded. Don't try to form shorted capacitors. And remember that you can only form capacitors up to 150 volts with this unit.

Since its output is regulated, the miniature power supply is handy for checking the approximate calibration of d.c. voltmeters. Simply measure the output voltage . . . with the OA2 in place, it should measure 150 volts, with an OB2 in place, it should measure 108 volts.

To check a paper (or mica) capacitor for leakage, connect it in series with one lead of a d.c. voltmeter. Then try to measure the output voltage of the power supply, using the highest range of the voltmeter. If a fairly large capacitor is used (from 0.05 to 0.5 μ fd.), the voltmeter needle may flick up-scale momentarily. But it should return to "0" and should remain there, even when the meter is switched to a lower range. If a voltage reading is obtained, however, it indicates that the capacitor being tested is leaky and should be discarded.

As you work with the miniature power supply, you'll find many other applications for it. END

The power supply connected to provide d.c. and a.c. voltages for an experimental circuit.

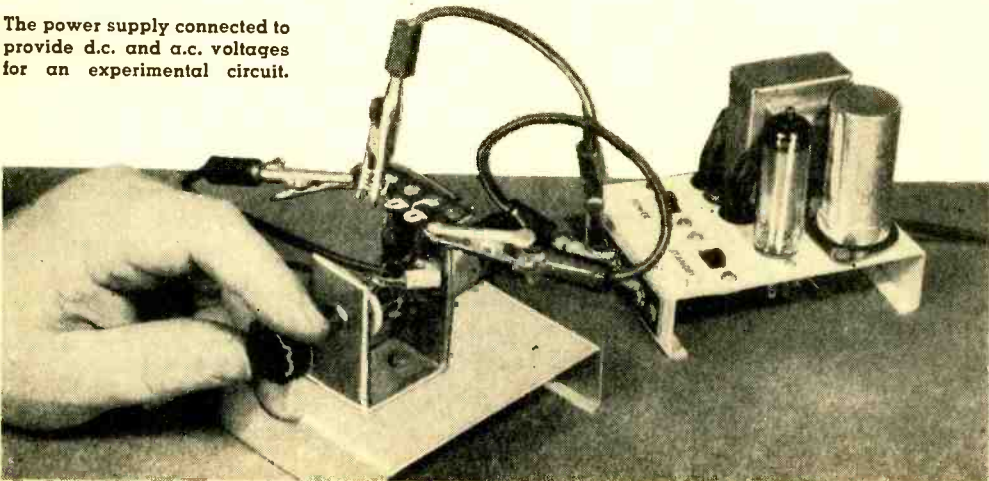

R/C NOTES

WE'VE been deluged with letters requesting a tone-modulated R/C transmitter to operate the 3-channel tone R/C receiver written up in the January 1955 issue of POPULAR ELECTRONICS. Actually, a construction article on such a transmitter will be published in a forthcoming issue of RADIO & TELEVISION NEWS magazine. However, we are hoping that we will be able to announce shortly the availability of a multi-tone modulator that will convert any crystal-controlled R/C transmitter to tone control to operate the receiver.

REMEMBER the item on an R/C sailboat which we ran in this column in the December, 1954 issue? Well, since then, lots of R/C fans have asked us where they can obtain kits for model sailboats suitable for radio control. One source that is off the beaten track is the British firm of *Model Aerodrome, Ltd.*, 141 Stratford Road, Birmingham 11, England. This company is now featuring a 36-inch model (length overall), the "Fiona," which comes fully equipped with a suit of sails, mast, steering gear, and molded keel. The price is approximately \$20. A free, colored brochure on all their kits is available on request.

An excellent and complete line of model sailboats suitable for R/C is available from

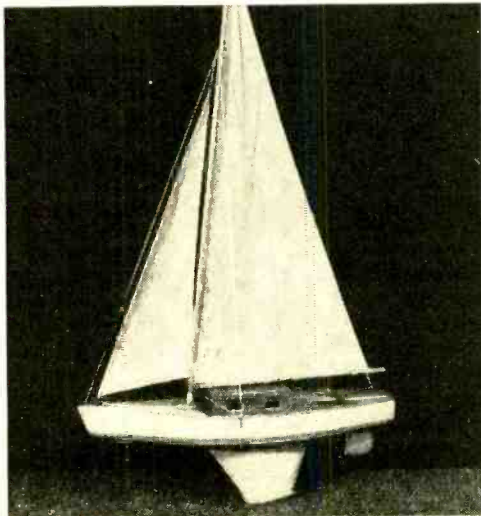

April, 1955

Ideal Aeroplane Supply Company, Inc., 22-28 West 19th Street, New York 11, N. Y. Of particular interest to the R/C fan who would like to get into model sailboat racing with an easy-to-build high performance model is the "Sail King" shown here. The hull is 22 inches overall. The model is supplied complete by *Ideal* for \$5.95.

* * *

SHOWN here is a new escapement for R/C, weighing but ½ ounce and claimed to be the smallest of its kind. It is being manufactured by the *Newx Products Company*, Box 643, Union, N. Y. The escapement will operate reliably on 1½ volts, using about

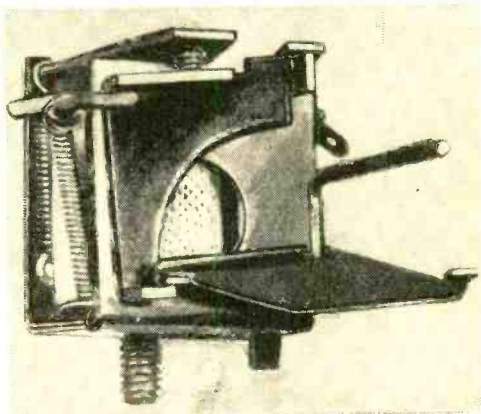

half the electrical power employed by others.

Using one loop of tightly wound 3/16" rubber, the unit was tested at 300 cycles per minute. This speed was made possible by the unique lever action between the armature and the pawl, resulting in a much greater overlap between the pawl stops and the escapement arm. The preliminary price has been set at \$6.95.

* * *

BECAUSE many of our readers are building the radio-controlled garage door opener described in the article, "A Simple Radio-Controlled Garage Door," by Vern Preston, in the February issue of POPULAR ELECTRONICS, we have been anxious to find a convenient source where our readers may obtain the surplus gear box used in the construction. We're happy to be able to refer anyone interested to the *Gyro Electronics Company*, 325 Canal Street, New York 13, N. Y. They have just obtained a considerable number of 80 to 1 reduction gear boxes of the type suitable for the garage door opener. The price is \$8.95. Another source, this one on the west coast, is the *Palley Supply Company* at 2263 E. Vernon Street, Los Angeles, Calif. END

A Push-Pull Transistor Audio Oscillator

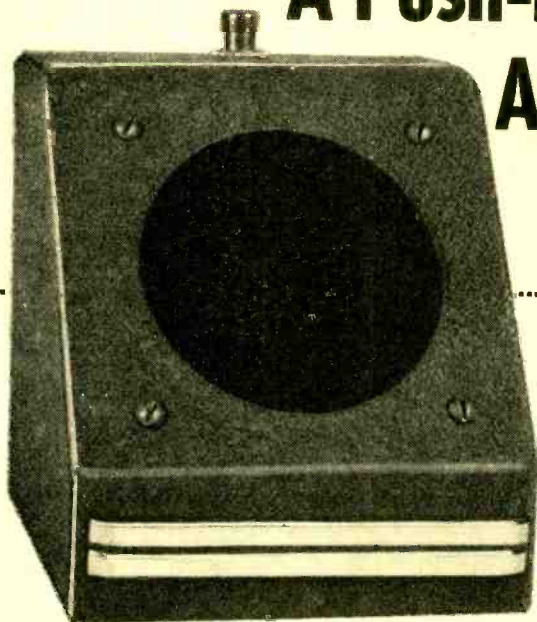

Experimenters will find many uses for this portable, compact signal source.

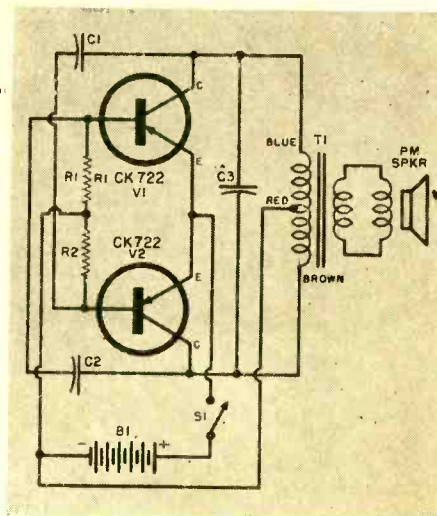

ALTHOUGH a single transistor, connected as an audio oscillator, can deliver sufficient power to operate a loudspeaker, the volume is fairly low. This is due to the comparatively low power output of commonly available transistors.

One way of increasing the available power output is to use two transistors in a push-pull oscillator circuit. With such an arrangement, ample loudspeaker volume can be easily obtained. A suitable push-pull circuit, using *p-n-p* junction transistors and commonly available components, is shown in the schematic.

The completed instrument has many potential uses in the experimenter's and technician's shop . . . from checking microphone and loudspeaker placement in a p.a. installation to use as a classroom code practice signal source. Before discussing practical applications of the unit, however, let us review circuit operation and the construction of the instrument.

Referring to the schematic diagram on this page, two Raytheon type CK722 *p-n-p* junction transistors are used in the oscillator circuit. The "grounded-emitter" connection is employed. Transformer T_1 serves two functions. It acts both as an oscillator and as an output transformer, matching the high output impedance of

the two transistors to the low impedance of the loudspeaker voice coil. Cross-feed coupling capacitors C_1 and C_2 connected between each transistor's collector and the opposite base, provide the necessary feedback signal to start and maintain oscillation.

Resistors R_1 and R_2 serve as the "base return" resistors. Connected between each transistor's base and the negative terminal of the power supply battery, these resistors serve to establish the d.c. base current, or "bias." A single battery, B_1 , controlled by a s.p.s.t. switch, S_1 , serves as the power source for the oscillator. Current drain is quite small, and does not exceed a few milliamperes.

No attempt is made in this circuit to match the high collector output impedance to the low input impedance of the base. Because of this, there is a tendency towards "blocking oscillator" action. The audio signal obtained is not a sine-wave and is quite rich in harmonics. Capacitor C_3 , connected across the primary of the transformer, bypasses the higher frequency harmonic signals, and thus reduces the "harshness" of the tone obtained from the loudspeaker.

Because of the tendency towards blocking oscillator action, C_1 , C_2 , R_1 , and R_2 all

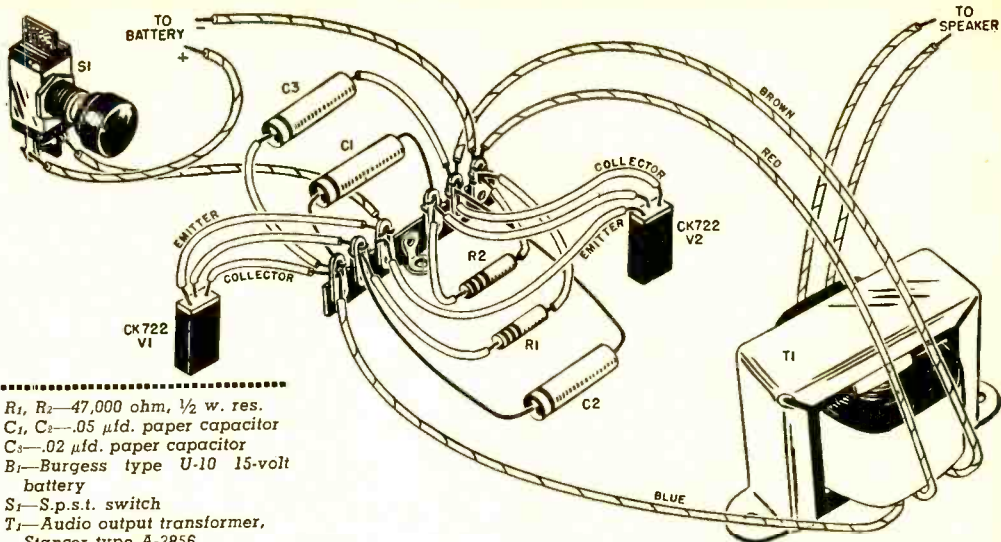

R_1, R_2 —47,000 ohm, $\frac{1}{2}$ w. res.
 C_1, C_2 —.05 μ d. paper capacitor
 C_3 —.02 μ d. paper capacitor
 B_1 —Burgess type U-10 15-volt battery
 S_1 —S.p.s.t. switch
 T_1 —Audio output transformer, Stancor type A-3856
 V_1, V_2 —P-n-p junction transistors, Raytheon type CK-722
 PM SPKR—3 $\frac{1}{2}$ " PM loudspeaker
 Misc.—Cabinet (ICA 3996 meter case); chassis (ICA 29082, 4" x 3 $\frac{1}{8}$ " x 1"); terminal strips, wire, solder, misc. hardware

All of the parts needed for the transistor oscillator are listed at left. Wiring the unit is quite simple; just follow the pictorial wiring diagram above and the schematic diagram on the opposite page.

affect the frequency of operation. Adjusting the sizes of these components provides an easy means of obtaining the desired frequency. Care must be taken that the values chosen do not result in unstable operation.

The sizes of R_1 and R_2 also affect the base and collector currents. If too small an ohmic value is chosen for these resistors, the maximum ratings of the transistors may be exceeded.

Construction Hints

The model shown in the photographs has been assembled to serve as a fixed frequency, fixed level, audible signal source. The average technician or experimenter should have no difficulty in assembling a similar or duplicate unit in a few hours.

A standard metal meter case serves as a "cabinet" for the oscillator. The 3 $\frac{1}{2}$ " PM speaker used is centered behind the "meter" opening and protected by a small piece of flocked screening. The oscillator circuit is assembled on a small aluminum chassis which also fits within the meter case. The transistors and other small components are mounted below the chassis while the transformer and battery are mounted above chassis.

Layout and parts placement are not critical and the builder should feel free to make any modifications in wiring or layout that are desirable.

In the author's model, the transistors have been soldered directly into the circuit and are mounted on a long "tie-point"

terminal strip to which other small components are also connected. If this practice is followed, care should be exercised when installing the transistors to avoid damage by excessive heat.

Do not cut the transistor leads shorter than 1"—the longer the better. Complete the soldering as quickly as possible, using a small, hot, clean, and well-tinned iron. A "soldering pencil" is excellent for this type of work.

The values for R_1 and R_2 given in the parts list should not be considered as final. Some variation in the size of these resistors may be found desirable for optimum operation, depending on the characteristics of the individual transistors employed. Where the two transistors have almost "matched" characteristics, R_1 and R_2 may have the same value. In other instances, different values for these two resistors may give better results.

To determine the proper values for R_1 and R_2 , connect resistance substitution boxes or 500,000-ohm rheostats in place of these two resistors. Insert a 0-10 milliammeter in the collector circuit of the transistors.

Next, checking to make sure that the collector current does not exceed 5 ma., gradually adjust the values of these resistors for the desired tone and for best stability of operation. Good stability is obtained when there is no wavering either of frequency or of volume, and when the same frequency and volume is obtained each time the unit is turned "off" and "on."

Finally, substitute fixed resistors for R_1

This view of the transistor oscillator chassis removed from the cabinet shows placement of all parts except the battery and transformer, which are on the other side of the chassis.

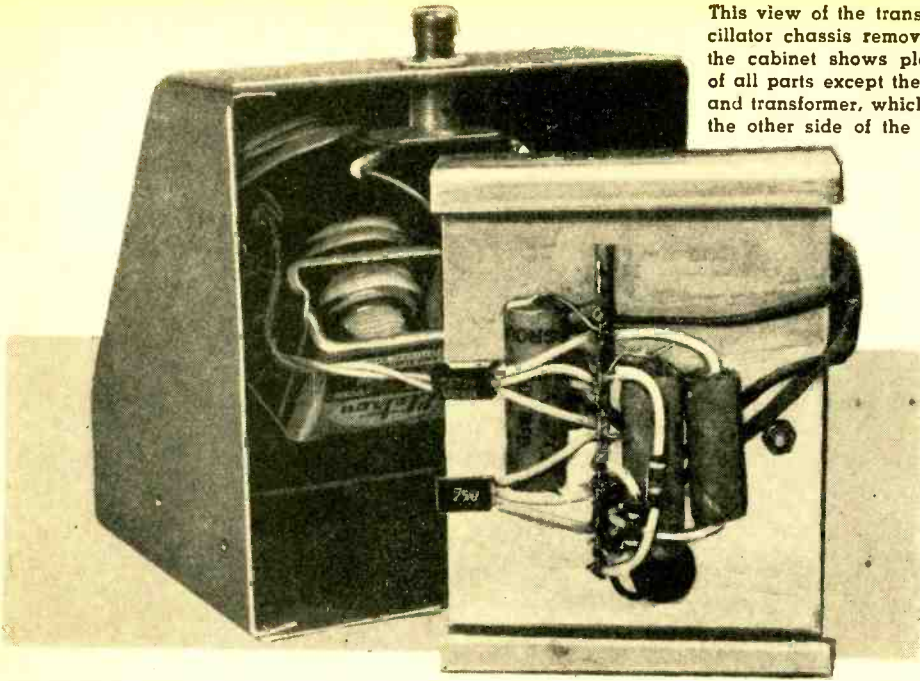

and R_2 having the values determined above.

For large changes in operating frequency, it will also be found necessary to use different values for C_1 , C_2 , and C_3 .

Applications

The number of possible applications of the completed audio oscillator depend primarily on the imagination and requirements of the user. In general, the instrument described in this article may be used wherever there is a need for a portable, compact, and lightweight signal source of moderate volume, having a fixed tone and volume level.

Comparing Microphone Sensitivity: The relative output of different types of microphones may be easily checked using the instrument described. Since a fixed level, fixed frequency audio note is supplied by the oscillator, it is only necessary to place the unit at the same fixed distance from each "mike" to be checked.

The output of the microphone is fed through a standard audio amplifier and the signal level observed, using either a standard output meter or an oscilloscope.

Checking Sound Absorption: The sound "deadening" qualities of draperies, wall board, or acoustic tile may be quickly checked on a comparative basis by using the self-contained audio oscillator in conjunction with a standard sound level meter. The oscillator may be placed at any point desired within the room and the resulting signal level quickly checked at other points.

Determining Microphone Placement: In large p.a. installations, where several microphones may be employed, it is often

desirable to locate the different "mikes" so that the pickup from a given central point is uniform. This is often done to simplify the job of the operator who "rides gain." In other cases, it may be desirable to locate each "mike" for maximum pickup from a different area—as in different parts of an orchestra.

In either case, the audio oscillator described may be used advantageously. Supplying a fixed level tone, it may be placed at any point desired, and the corresponding microphone(s) adjusted accordingly.

A somewhat similar technique may be employed in selecting loudspeaker locations. In this application, the oscillator may be placed in front of one of the microphones and the p.a. loudspeakers temporarily placed in position. The relative volume of the signal, as determined either by ear or by using a sound level meter in different parts of the projected area, will quickly show whether a location is desirable and whether adequate coverage is obtained.

Code Practice Oscillator: The audio oscillator described supplies adequate loudspeaker volume for classroom use. Use a hand-key in place of the power switch (S_1).

General Purpose Audio Signal Source: Since the completed instrument is self-contained and requires no external power source, it may be used in place of conventional signaling devices where desirable. For example, where a special and easily identified signal is desired, the oscillator may well be substituted for a buzzer, bell, or chime.

END

R/C

RELIABILITY

Escapements and Batteries

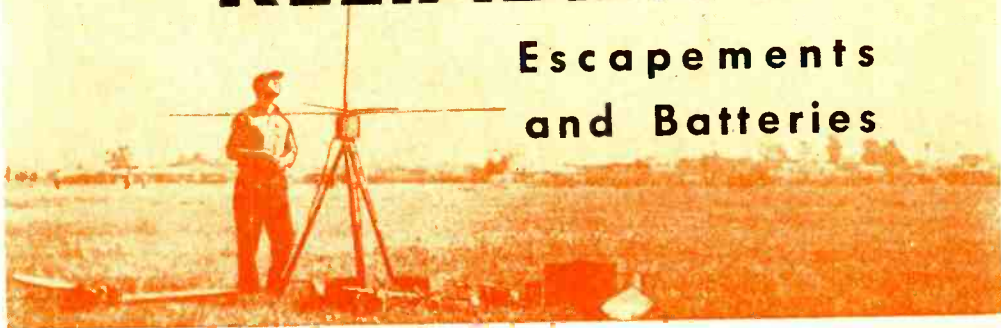

By **WILLIAM WINTER**
Editor, "Model Airplane News"

CONCLUDING last month's discussion of reliability, that taken-for-granted device, the escapement, had our attention. In the author's log, covering 15 radio control airplanes and thousands of flights, the escapement was found to be second only to the relay as a cause of erratic control. The point was made that the escapement should be considered as a relay, since it has pull-in and drop-out currents which, aside from the mechanical features, require observation, occasional adjustment, and an accessible and removable installation that enables convenient maintenance. Do not bury the escapement in a "blind" installation.

How the escapement works has been described in earlier articles of this series, as well as in Mr. Safford's articles in this magazine. Our concern now is how to keep one working. Properly installed and regularly checked, the escapement is reliable. Any new escapement should be examined and bench-tested before installation in the plane. Howard Bonner, whose SN and compound escapement types are familiar to all R/C modelers, states that the overlap of the revolving arm or claw, on the pawl, should be .015 to .020, armature pulled in. With the armature released, the claw should barely clear the pawl. Also, when armature

is pulled in, the claw should barely clear the neutral pawl position. These values apply approximately to the other familiar makes of escapements.

If the escapement functions suitably when hooked up on the bench, leave it alone; the above figures are given as a rough guide in the event that the item skips or sticks, requiring adjustment that is unlikely when new. After operating the escapement perhaps 100 times on the work bench, examine it closely for burrs that might develop where claw and pawl meet. The tiniest burr can prevent the escapement's working in the air. Usually the escapement so afflicted functions while the engine is running, but when the motor stops and vibration disappears, response to a transmitted signal does not occur. Sometimes new escapements develop burrs quickly, but once smoothed off will function properly for long periods of time.

Set up batteries similar to those in the plane, also the same size rubber strand wound to 20 per-cent excess of a single row of knots (not counting the first row of turns). It is vital to check the spring tension. Does the escapement always release when the rubber is fully wound? Does the escapement always pull in and work easily

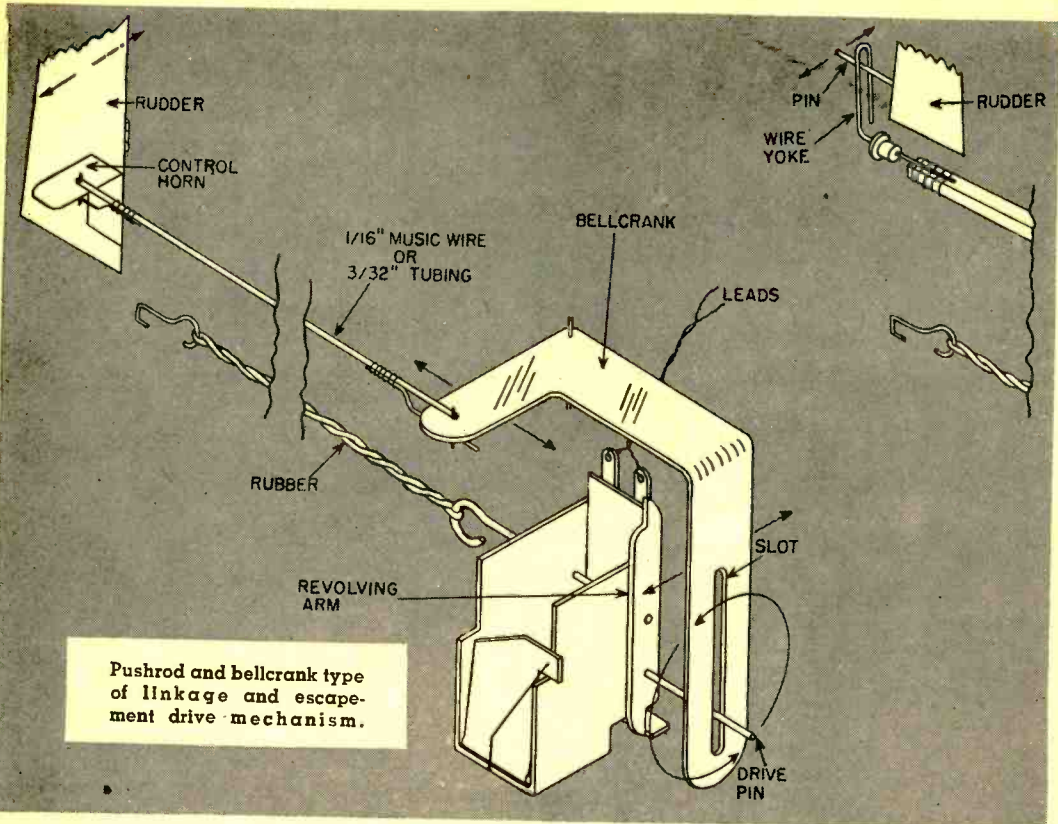

Pushrod and bellcrank type of linkage and escapement drive mechanism.

under simulated service conditions? One excellent way of checking is to hook up a set of batteries with a potentiometer in order to vary the voltage available to the escapement magnet. Increase voltage gradually until the escapement armature pulls in. Just as important, note the voltage at which the escapement releases. This was the most important lesson learned by the writer in the 1954 flying season.

The escapement should never require more than $2\frac{1}{2}$ volts to pull in and should not require a cutting off of current in order to release. First, the pull in. Under load, two new $1\frac{1}{2}$ volt pen cells in series drop off to $2\frac{3}{4}$ volts. As the no-load voltage decreases with use, the voltage then available under load may be less than the voltage required to pull in the escapement. Once during a demonstration, the writer installed a new, unchecked escapement and immediately lost control of the plane during the glide. A check revealed that the escapement required $2\frac{3}{8}$ volts to pull! It is best, therefore, to allow an adequate margin for falling voltage, especially under load, by adjusting the escapement (its spring tension is increased or decreased) to pull in at 2 to $2\frac{1}{4}$ volts.

Why is drop out so important? If spring tension is too low, the flow of current has to be cut off to allow release of the escapement armature. This is a timely tip that in the air the escapement may not release. Many a crash has been attributed to interference, sticking relays, etc., when the escapement was out of adjustment. The difficulty is that if the condition is marginal, the escapement may appear to function properly after the accident, so that cause of the accident may be undetermined. Eventually, the spin-in will be repeated. Sometimes, the plane has a mysterious tendency to come out of a turn very slowly after the rudder is released or to continue overbanking momentarily after the rudder goes back to neutral. This can be caused by a sticking relay, but also suspect that escapement.

It has been found that if the escapement will release with current caused by $\frac{1}{4}$ volt flowing through the coil, it should release reliably by spring tension in the air. The current is a measure of spring tension.

Mounting affects an escapement. Do not screw an escapement base tightly to a slightly warped piece of plywood. The frame bends, throwing adjustments out. Then the modeler may file the end of the revolving

Torsion bar type of linkage and escapement drive.

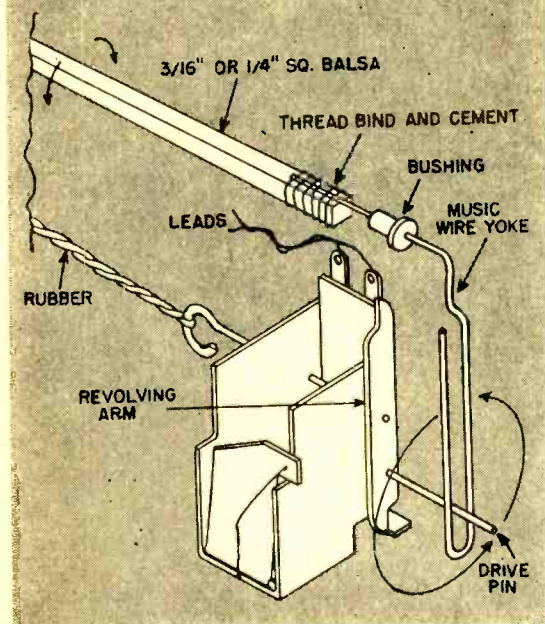

arm to make it shorter. Loosen the escapement and the frame springs back into alignment. Now the gaps are too big and the escapement is needlessly junked. So the mount must be firm (if the escapement does not incorporate its own mount), never less than $\frac{1}{8}$ inch thick plywood with the long edges reinforced with balsa strips, and it should also be warp free.

It is important to use the proper rubber strand for the escapement drive power and the correct voltages. The type of linkage affects the required size of rubber. There are two types of familiar linkages. First, the push rod connected between the rudder horn and the bellcrank, converts the rotary motion of the escapement drive pin into linear motion. The second is the torsion bar, which is rocked back and forth by the rotation of the escapement drive pin. The push rod arrangement increases the load on the escapement, especially during maneuvers (centrifugal force multiplies the weight of the rod) when the entire weight of the linkage may have to be lifted by the actuator. The torsion bar is easier to move, does not overload the escapement and, therefore, favorably affects the size of rubber which is required, in addition to es-

capement adjustment and operating currents.

With self-neutralizing escapements, $\frac{1}{8}$ inch rubber has been used with both push rod and torsion bar, although, in the author's opinion, it is decidedly marginal in the case of the push rod, particularly on a cold day when rubber loses much of its natural vitality. Therefore, it is better to use $\frac{3}{16}$ inch rubber with push rod deals. When using $\frac{3}{16}$ inch rubber, allow 20 per cent extra length over and above the distance between hooks. This prevents too much tension being placed on the escapement thrust bearing which could cause a jamming action. The compound escapement should never be used with $\frac{1}{8}$ inch rubber with a push-rod linkage. The reason is that the compound incorporates a rattle wheel to slow down the action of the escapement and allow the man on the ground enough time to get off the required number of pulses necessary for its operation. So the compound requires more drive power than the self-neutralizing escapements.

Some builders claim that the flier must have a sense of timing to pulse the compound (one, two, or three signals, depending on the desired control). Therefore, they claim it is better to use the weaker, $\frac{1}{8}$ inch rubber to slow down the escapement so that the flier can keep up with it. That is poor advice. The compound can hang up when powered by $\frac{1}{8}$ inch rubber, if only due to the drag of the electrical contacts in the third control position. Actually, it is better and easier to operate the compound with $\frac{3}{16}$ rubber, when the unit works faster instead of more slowly. With the $\frac{1}{8}$ inch rubber, timing is important, because it is possible to pulse too fast and pick up the wrong control. With the $\frac{3}{16}$ inch rubber it becomes impossible to pulse too fast with a Microswitch held in the hand. At the same time it is not hard to pulse fast enough, especially after a few practice dry runs on the bench. Even a mechanical ground control unit will not time properly the $\frac{1}{8}$ rubber driven compound. As to reliability, the compound is often criticized, but one of the author's compounds has given trouble-free operation equivalent to three self neutralizing units.

It is frequently argued that the compound does not have the ability to hold the rudder over when air speed picks up or to hold the plane in a prolonged spiral, especially in the direction of the control (usually left rudder) that requires two pulses. Supposedly, the compound is not effective on big, heavy, fast machines. The truth is that the compound is suited for all installations, provided an aerodynamic surface (see drawing) is used along with the $\frac{3}{16}$ inch rubber drive.

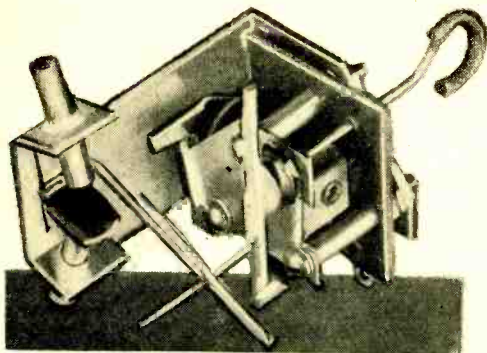

In this self-neutralizing escapement the mechanism is also used to cover and uncover air bleeds in the fuel line to control the motor.

Blaming escapement ills on batteries is both commonplace and groundless. People are forever putting 4½ and even 6 volts on a 3-volt escapement. Not only is this unnecessary under any circumstances, but it leads to further complications. To begin with, battery drain is increased greatly with higher voltages when the resistance of the coil remains the same. This is a basic law of electricity. Therefore, the batteries run down faster, not more slowly, when voltage is stepped up. A 5 ohm escapement which might function for several flying sessions on 3 volts, may make only one long flight on 6 volts! Battery life is increased by hooking batteries in parallel, not series. Most planes can carry four pen cells, instead of the standard two, for escapements. Two pen cells may give a dozen good flights, depending on how many times the control is applied and how long it is held on. Planes with slow response are rough on batteries all down the line, even in the transmitter. Excessive voltage on many escapements builds up a residual magnetism which can cause the armature to stick in the control position. Higher actuator voltages accelerate damage and dirt on the relay contacts.

With some builders, batteries may be the second or even first source of trouble. In the writer's log they happen to be third, mostly due to odd and unexpected failures, such as one abrupt failure resulting from the battery having been dropped by a clerk. A connection between cells gave way. This suggests care in the handling of "B" type batteries.

Choose battery sizes that provide adequate life and reserve, unless, of course, the plane is a midget. For example, two pen cells on filament will give an afternoon's flying on a single (gas) tube receiver. Such receivers have even been flown on one pen cell, but if the plane will carry one or two

medium flashlight cells, it is an unwise risk. A two (gas) tuber will operate on two pen cells for a busy half-day flying session, but two mediums would last for weeks. Similarly, why fly on 22½ or 30 volt hearing aid "B" batteries (in series for 45, 67, 60 volts, etc.)? A single *Burgess* XX-30 or K-45 or the equivalent in other brands will last for weeks, if not months. The typical transmitter will operate for at least a season on *Burgess* M-30's or larger (or the equivalents). Hearing aid "B" batteries certainly are not desirable for long term results with hard tube receivers that idle at 3 or 4 mils. Two mediums on an escapement may last a summer.

Possibly the gravest error made by the beginner is to measure voltages without placing a load on the batteries. The transmitter should be checked with filament turned on, Microswitch closed for "B's." It will be noted that "B" batteries may drop several volts under load, but this is normal. On the other hand, a drop of 10 volts or more from the initial reading (not new voltage necessarily) under observation means that the batteries are weak. Hold the meter probes in place for 5 to 10 seconds and watch for a slight, steady falling off in voltage. The battery is no good. Do not operate anywhere near the minimums specified by the radio manufacturer. The writer discards flight "A" batteries that read 1.4 volts or less under load, when 1.5 volts is the normal filament voltage. The voltage can drop further in the air and 1.3 volts is the safe minimum.

For 3 volt escapements, a bitter-end 2½ volt minimum under load is desirable, unless the escapement happens to be one that works on 1.5 volts, as does the *Macnabb* *Citizenship*. After a 67 volt "B" battery drops 5 volts to about 62 volts, there is no percentage in continuing it in service. Battery costs are low compared with the total cost of plane, radio, engine.

In cold weather, allowance must be made for a falling off of voltage due to temperature. Some modelers keep batteries in a warm place, as in the pocket or on a car heater. Obviously, this is inconvenient, but batteries should be allowed to recuperate between long flights. It is a good rule to allow the batteries to rest for a period twice as long as the last flight. Between flying sessions, batteries recuperate so that they almost regain the normal new voltage. After that, they should be checked after every few flights.

Make it a rule to check batteries before going out to the flying field. If they are down to a serious degree, install new ones and enjoy an outing free of concern. END



Johnson "ADVENTURER" Kit

Reviewed by the
POPULAR ELECTRONICS
Staff

NOVICES and other hams going on the air for the first time with the *E. F. Johnson* "Adventurer" will not worry about interference they might cause in neighborhood television receivers. "TVI" suppression in this new c.w. transmitter, which is sold in kit form for easy assembly and wiring, is unusually good for a small, inexpensive unit of its class. Inductance-capacitance filters are used at the a.c. power and the key leads, and low-inductance capacitors are used on the meter, heater, and cathode connections. The design of the antenna tuning system is such that it effectively suppresses most of the high-frequency harmonics of the transmitted signals that fall into the tuning range of television receivers.

Spurious radiation from the transmitter itself is prevented by thorough shielding. The metal cabinet encloses the chassis completely, and is fastened with 14 screws to form a tight electrical seal.

The "Adventurer" was designed especially for newcomers to the ham game. Rated at 50 watts input, it is crystal-controlled and band-switching from 10 through 80 meters and is completely self-contained with power supply and antenna tuner. It uses a 6AG7 oscillator, 807 power amplifier, and 5U4G rectifier. A modulator for voice transmission can be added at any time as a separate unit. The finished transmitter measures only 7% by 10% by 8% inches. The kit includes tubes, hardware, all parts, and instruction book. **END**

The unassembled kit contains all the components with the exception of crystals and a hand key. Wiring will consume two or three evenings.

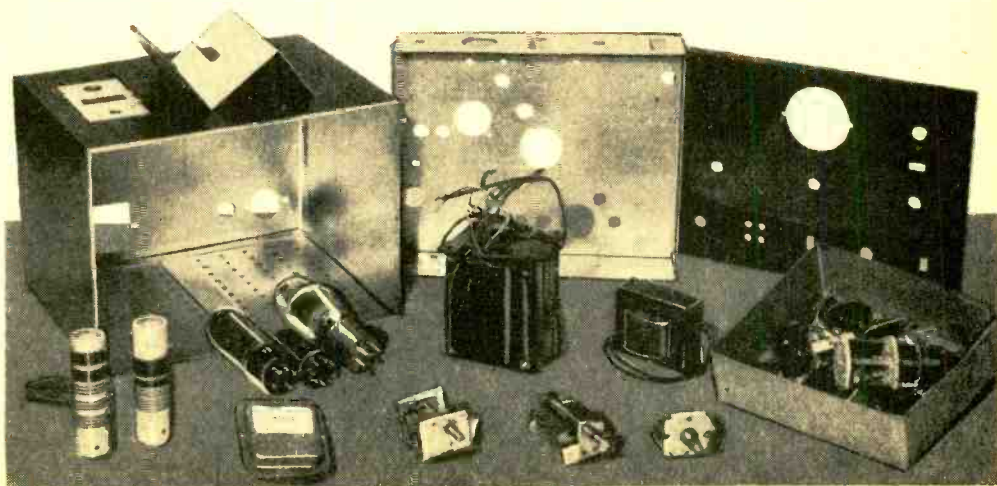

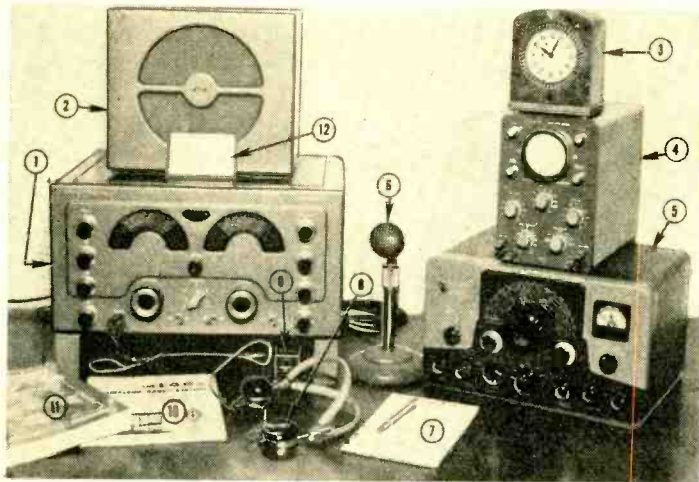

By
ROBERT HERTZBERG
W2DJJ

Ham equipment can be arranged not to crowd the operating desk. See text for explanation of numbering.

Part 7. In the concluding article of this series the author suggests convenient operating positions for your equipment.

NEWCOMERS to the amateur radio game often spread their receivers and transmitters over big tables to make the equipment look impressive. From the practical operating standpoint, however, it is much better to have a tight, compact arrangement, with everything within easy reaching distance from the chair position. It should be possible to flip switches and turn dials without getting up, moving, or excessive reaching.

A table only four feet long and about 30 inches deep will hold all the ham gear which is likely to be acquired for a couple of years. An excellent top material is $\frac{1}{8}$ inch tempered *Masonite*. Its smooth surface is fine for writing and feels good to the touch.

The accompanying photograph shows an actual ham station embodying the principles of simple layout. When the owner settles into this chair and puts his feet under the table, the world is at his finger tips. Let's examine this set-up in detail and learn a few things from it. The components are numbered for easy reference.

1) The receiver (a *National NC-183D*) is pulled forward so that the operator can manipulate its controls while he rests against the back of his chair. It is also raised above the table top by means of a couple of lengths of scrap 2 x 4 wood, well sanded and painted to match the cabinet. The space thus formed is very convenient

for storing earphones, key, papers, pencils, and other odds and ends that inevitably accumulate.

2) The loudspeaker in this position atop the receiver emits its sound directly at the operator. Since it is light, it can be removed readily if the receiver must be inspected.

3) A good electric clock is a necessity in order to record the starting and finishing times of all transmissions in your log book. (See item 10.) Check it occasionally against the time signals broadcasted by local stations or by WWV and WWVH, the stations of the National Bureau of Standards in the United States and Hawaii, respectively. If it is possible, also obtain a clock with a 24-hour face and set it for Greenwich Civil Time (GCT), also called Greenwich Mean Time (GMT), which is the basis for international schedules.

4) A small cathode-ray oscilloscope is used as a modulation indicator for voice transmission. It is a fascinating tool for electronic experimentation in general, and it also impresses visitors. The *Heathkit* Model OL-1, as illustrated, uses a three-inch tube and is light, compact, and fits neatly with the transmitter.

5) Self-contained phone and c.w. transmitter (*Johnson* "Viking Ranger") is turned at angle so that the operator can reach all controls with his right hand while his left hand covers the receiver. Alter-

Out Your Operating Table

nately, the transmitter has been used on top of the receiver, with the loudspeaker, the scope, and the clock forming a group on the right. The arrangement pictured has a more balanced look.

6) Microphone on a short table stand. The latter should have a heavy iron base to resist tipping.

7) Paper is needed to copy the other fellow's sending. Instead of using loose sheets, get a spiral bound stenographer's notebook. Its pages are smooth and take pen or pencil equally well.

8) Earphones enable the ham to hear many weak stations which would be lost against the noise of loudspeaker reproduction. Also, they permit operation of the rig without disturbing other members of the family who might prefer "I Love Lucy" to that W6 in California.

9) Telegraph key for transmitter tuning and c.w. work is also necessary. It should be positioned so that the forearm rests on the table when the fingers are on the knob.

10) According to FCC regulations, amateurs are required to record or "log" every transmission they make. Blank log books with ruled space for the necessary entries are obtainable from radio jobbers. The log is the record of ham accomplishments, and soon becomes an important document that is shown off frequently.

11) The names and addresses of licensed amateurs all over the world are printed in

The Radio Amateur Call Book Magazine, better known simply as the "Call Book." This indispensable directory of ham radio is revised four times each year and gets thicker and thicker. The current edition contains 500 pages. Every amateur should verify his listing in it and if it's not correct, the publisher should be notified. Otherwise, "QSL" (acknowledgment) cards will not be received from stations that have been worked.

Licenses are listed alphabetically by call letters, with the names and addresses following. There is no cross-listing by names. Although the United States listings dominate the book, it is noted that there are hams practically everywhere. Hams should consult their old geography books to find out where places like Reunion Island and Kazakh are located.

12) Last but by no means least, the ticket! It should be kept in a small frame or a glassine envelope to keep it clean.

The most important part of a ham station doesn't show in the picture. It is the operator. When he speaks into the microphone, he must remember that both he and ham radio are on public exhibition, and that what he says can be and usually is heard by many people other than the particular amateur with whom he is in contact. Some hams, who otherwise appear to be quite normal, act like utter idiots when they embrace a mike the first few times. Maybe the in-

A superb example of equipment arrangement for maximum operating convenience is the ham station of Ferris M. Smith, W6GZA in Van Nuys, California.

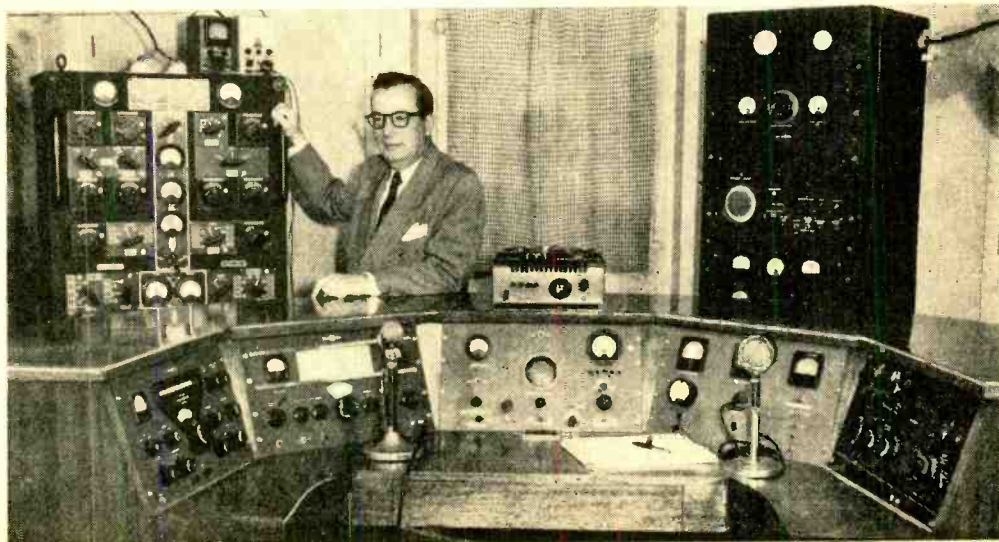

strument represents a psychological release valve to them, and enables them to blow off long-dormant inhibitions. The writer once made a tape recording of part of a soliloquy being delivered on the 20-meter phone band by a local ham of his acquaintance. He played it back to him about a month later without identifying it.

"That guy sounds loony," was the ham's comment. "Imagine uttering such rubbish on the air." When he heard the end of the transmission and realized from the call letter's that the voice was his own, he sat dumbfounded for a full minute before re-

covering his composure. When he goes on the air now he is extremely careful what he says in case someone else has a recorder.

"Good operating" is simply good sense and good manners. When on c.w., send slowly but accurately. There's nothing shameful about being a "novice"; certainly there are many on the air! When on phone, the best language should be used because it isn't a private wire line. The phone bands are and always have been crowded and interference must be expected. Working through it is all part of the game. END

Musitherm Heating Control

THE latest contribution to push-button living for the home was recently introduced by the *General Electric Co.* It is called the "Musitherm Heating Control." In addition to being a versatile thermostatic heat regulator, it has all the advantages of a clock radio.

Before retiring the user sets the "Musitherm" which will then gradually lower the temperature in the house or apartment. At a predetermined interval the next morning the thermostatic anticipating mechanism will automatically turn on the heat and raise it to room temperature. At the completion of the room warming interval the alarm feature goes into action by turning on the radio.

The manufacturer claims that this will enable many more workers to arise from the "right side" of the bed. END



Million Watt TV Antenna Assembled Despite Snow and Ice

THE super-power pylon antenna of WBRE-TV, Wilkes-Barre, Pa., was installed atop a 330-foot mast in mid-December. Cold, snow, and ice did not stop the workmen and on December 31 the transmitting antenna was in operation. This RCA installation is the first million-watt u.h.f. station in the nation. The RCA antenna weighs over seven tons and is 96 feet high. The power gain from this super pylon is nearly 50. In the photograph the workmen are connecting the sections of the pylon prior to a final ground check.

The million watt power rating of WBRE-TV conforms with the Federal Communications Commission regulations for u.h.f. TV stations. END



X-RAY INSPECTION

By
ED BUKSTEIN

Penetrating powers of x-rays help industry probe secrets of materials and new products.



Anode of this gigantic x-ray unit gets one million volts. G-E built it for Sutter Hospital, Sacramento, California.

X-RAYS are similar to radio waves in that they are electronically produced, are invisible, and travel at the speed of light. X-rays, however, are in the extremely high frequency range and have very short wavelengths. Even the shortest of radio waves, the so-called "microwaves"—are gigantic by comparison. A typical wavelength of x-ray radiation is 0.0000000001 meter (one ten-billionth of a meter). These extremely short wavelengths have great penetrating power, and can pass through substances which light cannot penetrate.

Besides their well-known use in dental and medical examinations, x-rays have many industrial applications. For example, x-ray apparatus is used to detect internal flaws in metal castings, check packaged foods for presence of foreign particles, inspect welds, check the alignment of elements in electron tubes, check the centering of the wire in insulated cables, etc.

As shown in the diagram, the x-ray tube is basically a diode. Electrons emitted from

X-rays reveal difference between straight and crooked wire reinforcements in belt.

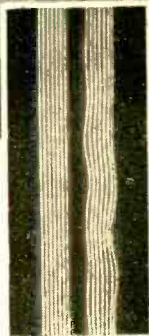

the filament are attracted down the length of the tube to the copper anode. The anode contains a tungsten insert which acts as a target for the electrons. Traveling at a very high speed, the electrons strike the target, producing the x-rays. To give the electron stream its high velocity, a large amount of voltage must be applied to the tube. Plate voltages as high as two million volts have been used in commercial x-ray units.

The object to be x-rayed is placed between the x-ray tube and a sheet of photosensitive film. The x-rays penetrate the object and strike the film. This action produces a shadow image of the internal structure of the object. For example, if the object being examined is a pulley belt with internal reinforcement wires, the x-rays will pass easily through the rubber portion of the belt, but will be obstructed by the wires. The developed film will therefore show an image of the wires (see photograph above).

In some applications, speed of inspection is an important feature and the time required to develop the film introduces an objectionable delay. In these cases, a fluorescent screen is used instead of the film. Such screens glow where they are exposed to x-rays, and thus produce an immediate image. An installation of this type is known as a fluoroscope. END

Electrons from filament hit anode at high speed; resultant radiation creates x-rays.

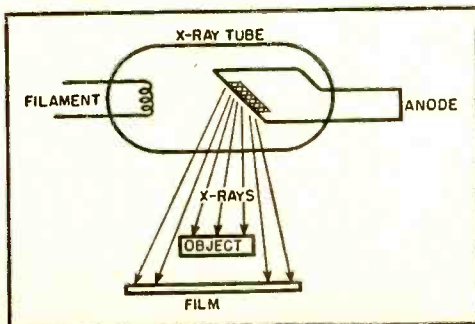

LOUDSPEAKER REPAIRS ANYONE CAN MAKE



With a minimum of equipment you can correct many speaker defects by following these instructions.

LLOUDSPEAKER defects are not too common in present-day radio and television sets but occasionally they do occur! When such faults crop up they are often due to carelessness on the part of the hobbyist who accidentally pushes through the fiber or pokes a hole in the cone itself.

Here are a few of the more common loudspeaker defects which you will encounter, along with the simple repair methods anyone can use to correct them. Before we get too involved, the author wishes to point out that he in no way encourages the repair of high-quality speakers, particularly those that are used in today's high fidelity systems. Home repair of speakers is usually a temporary expedient. Needless to say, to restore a speaker to its original performance level it is advisable to return the unit to the manufacturer for servicing.

Broken voice coil lead: This defect will cause a "dead" set. The voice coil leads

are flexible wires between the loudspeaker frame and the paper cone, and are located at the back of the speaker. See Fig. 1. Breakage usually occurs either at the terminal on the loudspeaker frame or at the connection point on the cone.

Repair a broken lead by resoldering the connection. If the break has occurred at the cone terminal, do the soldering job as quickly as possible to avoid burning the paper cone. Use a hot, clean, well-tinned soldering iron and rosin base flux.

Open cone seam: Loudspeaker cones are of two general types—the *seamless* type which are molded, and the *formed* type which have a cemented seam. Since the cement dries out gradually, the seam on the latter type may open after a period of several years. The loose edges may touch, causing a vibration that produces a papery, rattling sound.

The remedy is to put fresh cement along the seam, as shown in Fig. 2. *General*

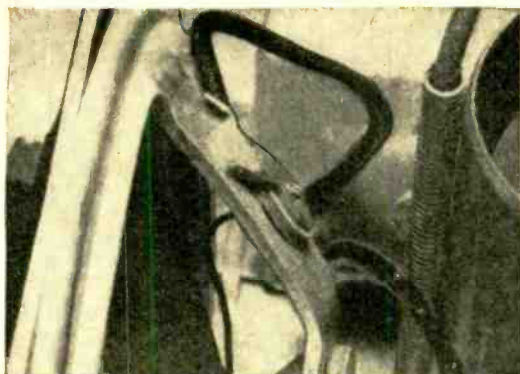

Fig. 1. Although only one is shown in photo, there are two voice coil leads on every speaker, extending from speaker frame to the cone.



Fig. 2. Correct method for applying cement to repair an open seam on outer rim of speaker. Do not use speaker until cement has hardened.

Fig. 3. Small punctures and tears in the speaker cone may also be repaired by careful application of cement over injured area.

Fig. 4. Larger tears in the paper cone of the speaker may be repaired by patching over with cheesecloth held in place by cement.

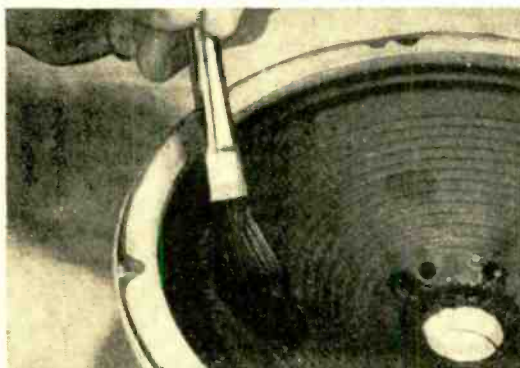

"loudspeaker cement," available at radio supply stores, may be used for the job—or, if you prefer, you can use *Duco* household cement. Don't use the loudspeaker until the cement has had time to set thoroughly.

Torn cone: Tears in the paper cone may cause symptoms similar to those encountered with an open seam, and may also cause other types of distortion.

Small "puncture" tears will result when a sharp pencil or screwdriver is pushed through the cone accidentally. These may be repaired simply by brushing on cement, as shown in Fig. 3. Gently push the torn edges together after applying the cement on both sides of the tear.

Longer tears may be repaired by patching with cement and cheese-cloth, as shown in Fig. 4.

If the tear is extensive, however, have a new cone installed. This job is not too expensive, but does require a fair amount of

skill. It can be handled best by a professional.

Off-center voice coil: This is probably the most common loudspeaker defect. If the voice coil is off center, it will rub against the pole piece and field magnet, distorting the sound.

You can check for this defect by holding the speaker by its edges and *gently* moving the cone back and forth with your thumbs, as shown in Fig. 5. Use only enough pressure to move the cone. If the cone is off center, you can easily feel the voice coil rubbing against the magnet on one side.

To re-center the cone and voice coil, you'll need several thin shims. These can be purchased in sets at your radio supply store and are available both in non-magnetic steel and in fiber. You can also cut the shims from thin card stock if you do not have the regular shim stock.

On many old style speakers, a "center-



Fig. 5. Correct procedure for testing a speaker for an off-center voice coil is shown in this photo. See text for full details.

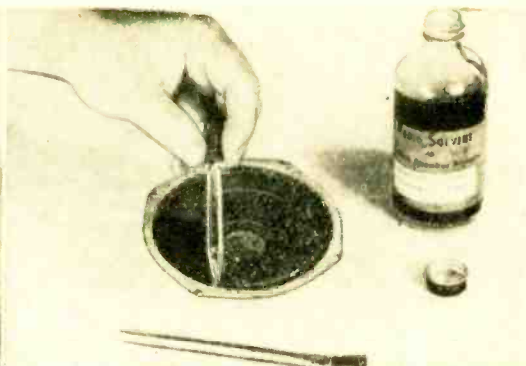

Fig. 6. To loosen the voice coil and cone assembly on speakers that do not have a centering screw, apply solvent to rim as shown.

Fig. 7. After cone assembly has been loosened, insert three shims between voice coil and pole piece. Shims must be equally spaced.

Fig. 8. Final step is replacing the felt pad over the speaker center by cementing it in place as shown. This pad keeps out dust.



ing screw" is provided. This may be located either behind the magnet or in the middle of the "spider" in the center of the cone. On most newer speakers, no such adjustment is available and the whole voice coil and cone assembly must be loosened by applying cement solvent. Use an eyedropper and brush to apply the solvent to the rim of the speaker, as shown in Fig. 6. Apply solvent to the central dust felt also and remove this piece.

You'll have to wait a short while for the solvent to loosen the cement before the cone can be freed. Proceed carefully and do not try to remove the cone until it is entirely free. Otherwise, the cone may be torn.

After loosening the cone assembly, either by adjusting the centering screw or by using solvent, insert three shims between the voice coil and the pole piece, as shown in Fig. 7. The shims should be equally spaced around the pole piece (120° apart).

With the shims inserted, retighten the centering screw or recement the cone. After the cement is thoroughly set, remove the shims carefully by pulling up on them gently but firmly.

Complete the job by cementing a new dust felt in place, as shown in Fig. 8. Exercise every caution in using the tweezers, for a careless slip on your part at this point could poke a nasty hole in the speaker cone and provide you with more problems than when you started out.

Other defects: Sometimes the speaker frame will become bent or warped, throwing the voice coil off center. This defect may often be corrected by twisting the frame by hand in the direction opposite the warp. In many cases, however, a new speaker must be installed.

An open voice coil winding requires a new cone assembly and it is a good idea to have a professional repairman handle this job for you.

END



Save Those Defective Transformers

IF YOU'RE an average experimenter, you know that iron core audio and power transformers represent a fair sized investment. Don't throw them away when they develop a defect. You may be able to repair the units without too much difficulty. If the defect can't be easily repaired, you may be able to salvage the transformers by using them in other applications.

Common transformer defects are open windings, shorts to the core, shorted windings, and shorts between separate windings. Here are hints on repairing transformers and suggested applications for units "beyond repair."

Open Windings: In a power transformer, an open secondary winding may be identified by the lack of normal a.c. voltages across the winding terminals, or by an "infinite" resistance reading when the winding is checked with an ohmmeter (*power off*). An open primary winding will remove the voltage from *all* secondary windings.

In an audio output transformer, either an open primary or an open secondary will cause a "dead" set. In addition, an open primary winding will remove the "B plus" voltage from the plate of the audio output tube, and may even cause this tube to be ruined. Plate voltage may be checked by connecting a d.c. voltmeter between the plate pin and cathode. Identify the plate pin by referring to a tube manual. Typical

output tubes are the 6V6, 6F6, 6K6, 6L6, 50L6GT, 50B5, 6AQ5, and 6AR5.

Ohmmeter or continuity tests may be used to check all windings. *Before making an ohmmeter test, make sure the power is off by unplugging the equipment.* Disconnect *all* the leads to one of the terminals of the winding to be checked. Then check the d.c. resistance by connecting the ohmmeter directly across the transformer terminals. An "infinite" reading indicates an open winding.

If the winding tests "open," check the connections at the point where the transformer wires connect to the output terminals or leads. See Fig. 1. Opens frequently occur at these points and a repair may be made simply by resoldering the connection.

In the case of transformers having leads instead of output terminals, it may be necessary to remove the outer metal shell to check these connections.

If a center-tapped winding checks "open," a further test is indicated. In many cases a center-tapped winding is obtained simply by connecting two *separate* windings in series. An open will occur if the common connection is broken. Filament windings are frequently center-tapped by bringing the two leads from the windings through a common piece of spaghetti tubing and soldering the two leads together at the end. See Fig. 2.

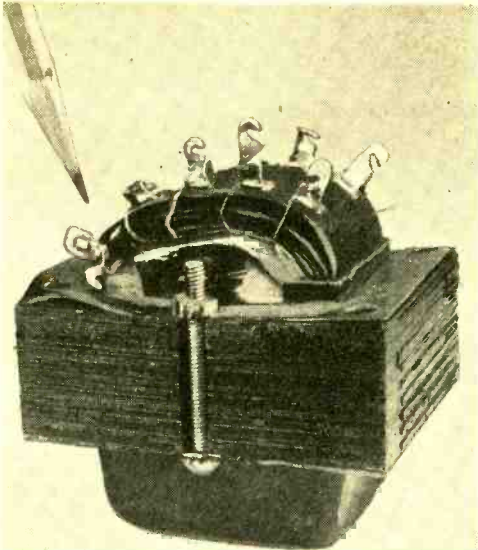

Fig. 1. Check terminal connections for "open" and "solder bridges," as shown in photograph.

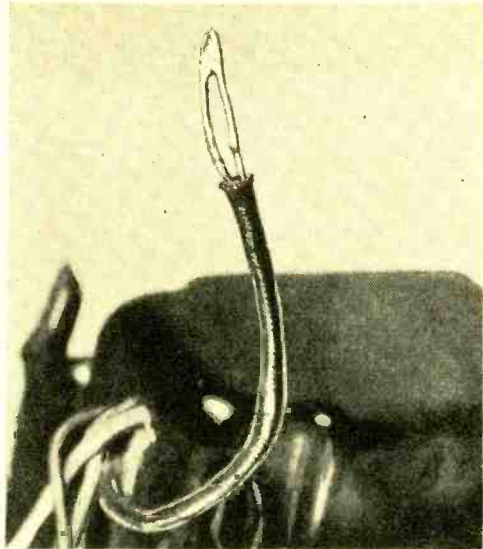

Fig. 2. Some center-tap leads consist of two wires. Disconnecting them will "open" winding.

During installation, this center-tap lead may be cut short, breaking the common connection and effectively opening the winding. A repair may be made by stripping back the insulation on the center tap lead and resoldering the two wires.

Even if an open winding can't be easily repaired, don't throw the transformer away. You may be able to use it in other applications, as we shall discuss later.

Shorts To The Core: A short between a winding and the transformer core may cause the symptoms of a shorted winding or may cause no trouble at all, depending on the connections to the transformer and where the short occurs.

For example, it is common practice to ground one side of the 6-volt filament winding and to use a single "hot" lead to the filaments of the tubes. If a short should occur between the grounded side of the winding and the core, no difficulties would be experienced. If the short occurred between the "hot" side of the winding and the core, the filament voltage would drop and the transformer would probably overheat.

In the second case, a satisfactory repair could be made by interchanging the transformer connections, so that the shorted side of the winding is connected to ground.

Where a short to the core occurs at some intermediate point on the winding, other steps are necessary.

First, make sure of the short by disconnecting *all* leads to the suspected winding and checking between this winding and the core with an ohmmeter (*power off!*).

If there is a short, remove the shell of the

transformer (Fig. 4) and try to locate the short visually. In some cases, it may be necessary to take the winding off the core (Fig. 5) before the short can be found.

Once located, the short may be repaired by using insulating varnish, *Scotch* electrical tape, or varnished cambric. When the repair has been made, the transformer may be reassembled.

In some cases you may find a bare wire inside the transformer which connects to the core or frame. If this wire does not connect to any of the windings (you can check this with an ohmmeter), it is the lead to an internal shield. *It should be left grounded.*

Shorted Windings: A partially shorted winding will cause much lower output voltages and overheating of a power transformer. In an audio output transformer, a partially shorted winding may cause low output (weak operation) and distortion.

Check first to see if the short is exter-

Fig. 3. A repair you can use where the center-tap lead of interstage transformer is open. R_1 and R_2 may be between 50,000 and 250,000 ohms.

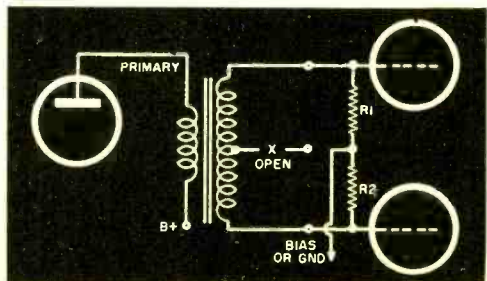

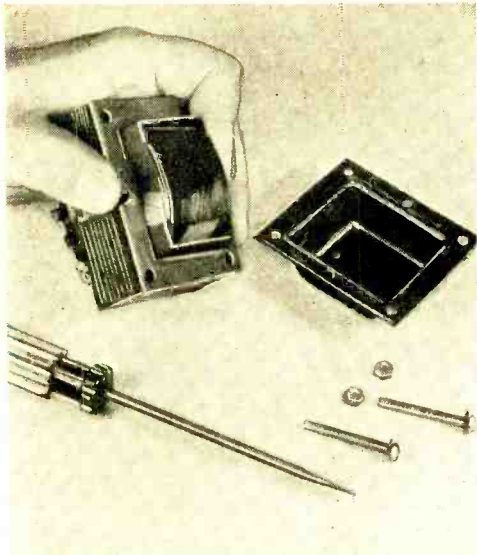

Fig. 4. Removing the shell of a transformer to check for shorts. See text for special tricks.

nal. It may be caused by a solder "bridge" across a pair of output terminals or by an actual short in wiring. If external, a repair is easily made.

If internal, the transformer should be disassembled for visual inspection and possible repair. However, in most cases, an internal short is difficult to repair without rewinding the transformer. This is no job for a beginner, even experienced hands frequently steer clear of transformer rewinding jobs.

Shorts Between Windings: As in the case of shorts to the core, whether or not trouble is encountered with this defect depends on where the short occurs. A short may be identified by ohmmeter tests between windings.

Again, shorts which may be located by visual examination or by disassembling the transformer may be cleared up easily. Internal shorts are difficult to repair, and shouldn't be tackled without considerable experience.

Applications for Power Transformers

Open High-Voltage Secondary: With this defect, the unit may be used simply as a filament transformer or as a filter choke. When used as a filter choke, connect to the primary leads.

Open Filament Winding: The transformer may still be used as a power transformer if the 5-volt filament winding is open. Either use selenium rectifiers or a rectifier tube requiring 6.3 volts (such as types 6X5 and 6X4). If both filament windings are open, the unit may be used as a "plate" transformer.

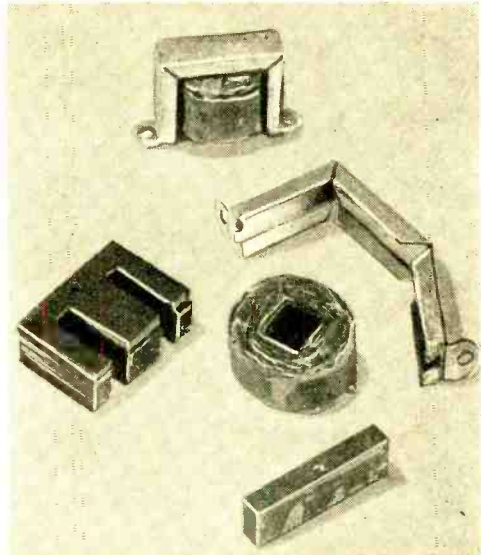

Fig. 5. A transformer core and coil may be separated, if necessary, for making visual checks.

Open Primary Winding: A power transformer with an open primary may be used as an audio output transformer in an emergency. Quality is surprisingly good in some cases. Connect the high-voltage secondary winding as the "primary" and the filament winding as the secondary (to the speaker voice coil). Use different combinations of the filament windings until best results are obtained.

Half of High-Voltage Secondary Open: Use the transformer normally, except use a half-wave rectifier instead of a full-wave circuit. "Beef up" the power supply filter circuit by increasing the size of the filter capacitors.

Audio Transformer Applications

Open Secondary Winding: Use as a small filter choke. Make connections to the primary winding.

Open Center-Tap Lead (Interstage Transformers): If only the center-tap lead itself is open, with the entire secondary winding in good condition, a resistive "center-tap" may be made by connecting two resistors in series, as shown in Fig. 3. Values of from 50,000 to 250,000 ohms may be used. The two should be equal.

A similar repair technique may be used in the case of center-tapped filament windings. Use low value (5 to 25 ohm) wire-wound resistors connected across the filament winding.

Where the transformer is beyond repair, and the techniques described cannot be employed, disassemble the unit and salvage the wire for coils, the iron core for small inductance coils and magnets. **END**

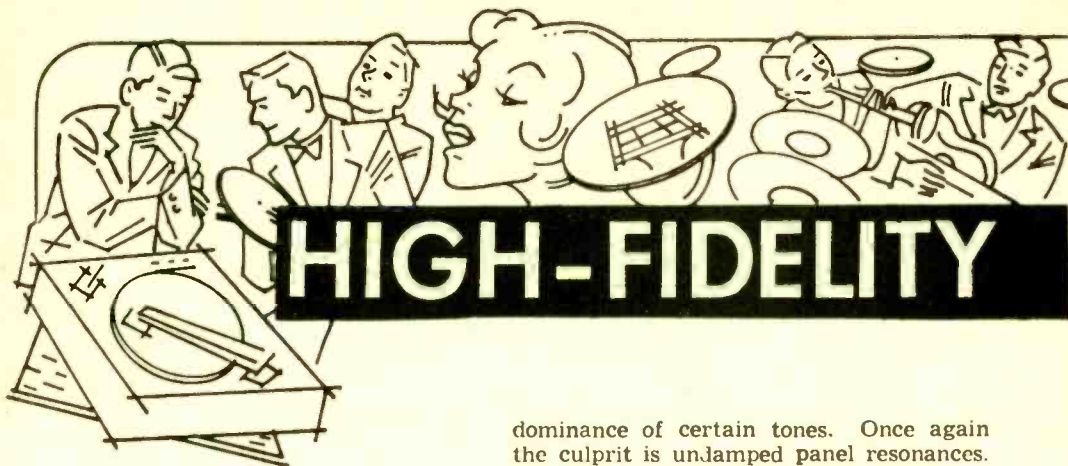

HIGH-FIDELITY

Cabinet Resonance

THIS article is directed to those who have discerning ears and an honest heart, those who have lived with a hi-fi rig and really listened to it. By now we have found that all is not golden and there is room for improvement. Previous articles in this series have dealt with and offered suggestions for the alleviation of such problems as rumble and hum. Now we come to a problem which is really man-sized—that of cabinet resonance. One of the reasons why cabinet resonance is such a formidable subject is the inability of many people to recognize this type of distortion. Someone will now ask, "Well, if the guy can't hear the distortion, why bother telling him? Ignorance is bliss." Maybe so, but I've yet to see people who couldn't tell the difference once the distortion was corrected with an anti-resonant enclosure. Furthermore they appreciated the cleaner sound and would never go back to the distorted sound.

How can resonance problems be determined? The first and easiest answer is to look instead of listen. In other words, if the loudspeaker enclosure is constructed of plywood less than $\frac{3}{4}$ inches thick, there almost certainly will be resonance. Next, listen to various sounds on the system. In male speech or singing, notice that at the lower frequencies there is a "boominess" and a tendency for a certain frequency to be predominant. This is speech coloration due to undamped panel resonances. Now get a good organ recording like the *Reubke Sonata on Columbia ML4820*. Play it at a good loud level and notice that at the lower frequencies from 100 cycles down, there is considerable vibration and a pre-

dominance of certain tones. Once again the culprit is undamped panel resonances.

There are many factors which enter into the cause of panel resonance, such as speaker cone resonance, interior acoustic damping, etc., but by far the most important factor is the method and materials of construction. Recent work has shown that even the time-honored dictum of " $\frac{3}{4}$ inch plywood and glue and screw" is not the whole answer to cabinet resonance. However, this does give us a starting point. Let us take the case of the hi-fi fan with a commercially bought enclosure, which may or may not be of sturdy $\frac{3}{4}$ inch construction. First remove the back of the enclosure and observe the interior. Do the corners and the side joints of the cabinet have stiffener blocks? Is there cross bracing on side panels? Is there cross bracing on the back panel? Is there any acoustical padding material such as felt, *Kimsul*, *Fiberglas* and how thick is it? If the answer to these questions is in the negative, proceed to correct the points mentioned.

Use 1x2 wood to make the stiffener blocks. Cut them carefully to shape, screw, and glue with casein in the proper places. Make "X" braces for side and back panels of $\frac{3}{4}$ x 2 wood, glue, and screw securely. If it will not interfere with the speaker placement, it is an excellent idea to install two 2x4 studs vertically on either side of the speaker. If the enclosure is of the reflex or infinite type, line all interior surfaces except the top with two or more layers of *Kimsul* or *Fiberglas*. Be sure that if *Fiberglas* is used, the batts are covered with a soft cloth like burlap or bark cloth. This will help prevent tiny slivers of *Fiberglas* from breaking off and entering the voice coil of the speaker where they can do considerable damage.

If the home constructor intends to build a reflex or infinite baffle enclosure for a speaker, he has a greater and better choice of construction than his friend with the

(Continued on page 115)



By BERT WHYTE

REPRODUCTION

DISC REVIEW

LAST MONTH I promised that we would investigate some recordings of large-scale choral works. This can be a dangerous subject with old and new hi-fi fans alike, because there are no "in-betweens" with choral music. You either like it very much, or dislike it intensely. However, unless you have heard really good choral recordings on *really good* equipment, you cannot judge this type of music. Nothing sounds quite as bad as a fuzzy, distorted, restricted-range recording, reproduced through poor "low-fidelity" equipment. On the other hand, possibly no other form of music can be as thrilling as a choral work when it is properly reproduced. Perhaps it would be wise to know what qualities to listen for in a modern hi-fi choral recording.

First of all there must be wide frequency response. This is most important if there is to be good articulation. Note the projection of the letters "s," "t," and "d." In a good recording, "s" and other sibilants, and "t" and "d" when used at the end of a word should be clear and distinct. Low distortion is of the utmost importance. In a work where 50 or 100, or even 200 or more voices are used, distortion can cause what is known in the trade as "choral blur."

Then there is the problem of choral-orchestral "fusion," where voice and instruments seem to run together. This is usually because of faulty microphone techniques or poor acoustics. Acoustics are, of course, one of the real bugaboos of choral recording. Since most choral works are sung in churches or other highly reverberant halls, the problem is to record enough of the reverberation to lend proper perspective and "presence," without allowing too much to be recorded so that everything becomes a meaningless blur.

Certain modern choral works, by their nature, require a "drier," more intimate, close-up type of recording, which has its own special problems. A wide dynamic range is an absolute must for a successful choral recording. Consider a solo soprano voice in a very soft *pianissimo* and then in the next moment a mighty torrent of sound as hundreds of voices, full orchestra, and even organ cut loose *fortissimo*! The choral work is the bane and challenge of engineers.

One of the most towering masterpieces of choral literature is Johann Sebastian Bach's great *Mass in B Minor*. The popularity of the work is proved

by the fact that there are no less than eight recordings of it in the LP catalogue. Of this number, only two deserve to be called, "high fidelity." The Hermann Scherchen-Vienna Symphony-Akademie Kammerchor on *Westminster* WAL-301 is the winner in the sound department with outstanding realism. A splendid balance between chorus and orchestra is achieved, along with wide dynamic and frequency response. Orchestral and vocal "fusion" is at a minimum and the recording is blessed with a fine, clean string tone and brilliant brass.

The other recording is on *Angel* 3500-C and features the redoubtable Herbert von Karajan and the Philharmonia Orchestra. This is also a splendid recording, but of a less spectacular nature than the *Westminster*. Some people will undoubtedly prefer the more rounded, "big-hall" type of recording. Choral articulation is not as good as the *Westminster*, but the microphoning of the soloists in the *Angel* is superior. In matters of performance, this is a close race. The Scherchen reading is intense and vital. The von Karajan more introspective, less athletic. Both state their cases very well. The *Angel* enjoys a big advantage in quality of choir, soloists, and orchestra. With either recording, the listener is assured of a good representation of the work. The Robert Shaw *Victor* recording should be mentioned here as a fair performance, but with somewhat "dated" sound. It has the advantage of being less expensive. The Lehmann reading on *Urania* is of very high order, but the sound is far from satisfactory.

Strictly speaking, the monumental *Ninth Symphony* of Beethoven is not a choral work. Nevertheless, the last movement is choral and it is largely because of this that the work has gained such immense popularity. Surely one of the most thrilling things in the symphonic repertoire is the almost passionate joy of this final movement. There are five recordings out of the total of eleven that can qualify as high fidelity. These are the Erich Kleiber on *London* LL632/3, the Scherchen on *Westminster* WAL-208, the Toscanini on *Victor* LM6009, the von Karajan on *Columbia* EL-51, and the Bruno Walter on *Columbia* SL-186.

The finest sound among these is on the *London* and *Westminster* set, with *London* taking top
(Continued on page 95)



A service-type vacuum-tube voltmeter—compared in this article with the non-electronic type of multimeter.



V.T.V.M. or V.O.M. A COMPARISON

THE vacuum-tube voltmeter (v.t.v.m.) and the "non-electronic" volt-ohm-milliammeter (v.o.m.) both have their places in electronic testing. The well-equipped shop or laboratory has both instruments and uses each under the most suitable conditions. However, some question arises in the mind of the electronics newcomer as to why there are two instruments instead of one general-purpose meter.

This question is answered best perhaps by explaining the main differences between the two types. First of all, the v.o.m. uses no tubes and therefore requires no power for its operation, except that a small self-contained battery supplies direct current when the instrument is used as an ohmmeter. The v.o.m. accordingly may be used in locations remote from power lines. The main disadvantage of this instrument is that it draws, for its operation, an important though small amount of current from the circuit under test, which can disturb circuit operation and thereby even change the voltage which the meter is being used to measure.

The v.t.v.m. has very high resistance and thus draws only negligible current from a test circuit. But this high input resistance is obtained through the use of

vacuum tubes which must be supplied with filament power, as well as plate power. The v.t.v.m. therefore must be connected to the power line or must have a complete set of "A" and "B" batteries, often heavy.

Comparative Characteristics

Inexpensive, service-type v.t.v.m.'s commonly have an input resistance of 11 megohms. This resistance is constant on all d.c. ranges. The resistance is somewhat less on a.c. voltage ranges and is between 0.25 and 5 megohms, depending upon manufacture, but is constant on all a.c. ranges. The v.t.v.m. measures resistance up to 1000 megohms, but ordinarily does not measure current values.

All v.o.m.'s exhibit a different input resistance for each voltage range. The "sensitivity" of the instrument is expressed as so many *ohms-per-volt*. The 20,000 ohms-per-volt type is at present the most popular for general electronic testing. This rating means simply that the input resistance is 20,000 ohms for each volt of full-scale deflection on each range. Meters rated as low as 1000 ohms-per-volt still are used, but are undesirable for testing high-resistance electronic circuits, as will be shown later. The sensitivity of the v.o.m.

COMPARISON	
V.T.V.M.	V.O.M.
Very high input resistance.	Relatively low input resistance.
Good frequency response on a.c. ranges. External probe extends response to r.f.	Frequency error usually high beyond 1000 cycles.
Usually does not measure current.	Measures microamps, milliamps, and amps.
Measure resistance up to 1000 megohms.	Resistance maximum usually 10 to 50 megohms.
Needs power supply. Uses tubes.	Requires no power, except for resistance measurement. Tubeless.
Requires zero set and drifts with time.	Driftless. No zero set, except on resistance ranges.
Sensitive to strong r.f. fields, as around radio transmitter.	Insensitive to r.f. fields.
Not damaged by electrical overload.	Easily damaged by overload.
Limited application and unsafe when both terminals must be above ground.	Performance and safety unaffected in above-ground applications.
Accuracy: voltage 5% in service types; 2% in laboratory types.	Accuracy: voltage and current 2 to 3% d.c.; 2 to 5% a.c.
Constant input resistance on all d.c. ranges. Constant (lower) input resistance on all a.c. ranges.	Input resistance changes directly with range. Lower on a.c. than d.c. ranges.
Susceptible to body capacity effects.	Not sensitive to handling.

on a.c. voltage ranges is somewhat less than d.c. For example, the 20,000 ohms-per-volt d.c. meter often is only 1000 ohms-per-volt on a.c. The v.o.m. measures resistance values, usually up to 10 to 50 megohms, considerably less than possible with the v.t.v.m. It also checks currents: microamperes, milliamperes, and amperes.

Readings in High-Resistance Circuits

The schematic diagrams show examples of the use of meters to check d.c. voltage in two typical electronic circuits, and illustrate the effect of internal meter resistance. In diagram (A), plate voltage is measured for a tube having a high value of external plate load resistance. The meter and the plate resistor will form a voltage divider. In this case, the supply voltage is 250 v. and the plate current is 0.6 ma. flowing through the 250,000-ohm plate resistor. A voltage drop is produced across the resistor by the plate current and is equal to $0.0006 \times 250,000 = 150$ v. The true plate voltage therefore is equal to $250 - 150 = 100$ v.

If M in diagram (A) is a v.t.v.m. with an input resistance of 11 megohms, the voltage divider action causes the meter to read only 99 v.—a 1 v. error.

If M is a 20,000 ohms-per-volt v.o.m. set to its 250-volt range, the input resistance of the instrument is 5 megohms. This meter reads 98 v.—a 2 v. error, twice the error of the v.t.v.m.

Now if the v.o.m. is of the low-resistance type (1000 ohms-per-volt), it will have an input resistance of 250,000 ohms when set to its 250 v. range and will read only 71 v.—a 29 v. error!

Voltmeters often must be used to measure the voltage across a high-resistance section of a voltage divider, as shown in diagram (B). The output voltage is developed across resistance section R_2 and is

equal to the input (applied) voltage multiplied by $R_2/(R_1+R_2)$. The input resistance of the meter is in parallel with R_2 , reducing the output resistance of the voltage divider just as if R_2 had fallen in value. This causes the meter to indicate a lower voltage than true value. The higher the meter resistance, the less this effect will be. For minimum error, the meter resistance should be at least 10 times R_2 . To determine the input resistance of a v.o.m., multiply its rated sensitivity (ohms-per-volt) by the figure indicating the voltage range in use. Thus, the input resistance of a 5000 ohms-per-volt meter, set to its 50-volt range, is $5000 \times 50 = 250,000$ ohms. This instrument could be used to check voltages, with good a.c. accuracy, across resistances as high as 25,000 ohms.

Sensitivity and Accuracy

So far, we have seen that a voltmeter may change the voltage we are trying to measure, but we have assumed that the meter will read the voltage exactly as it is after the meter is inserted in the circuit—for example, in diagram (A), 99 volts for the v.t.v.m., 98 volts for the 20,000 ohms-per-volt meter, and 71 volts for the 1000 ohms-per-volt meter. Actually, of course, the reading of any particular meter may vary from the exact voltage across its terminals.

The meter characteristic which accounts for the differences between the three figures just given is the sensitivity of the meter. A meter which draws relatively little current and does not disturb the circuit very much is said to be relatively sensitive. The voltage across the terminals of such a meter when it is connected in a circuit is near the voltage between the same two points in the circuit without the meter.

The accuracy of a meter, strictly speaking, is the closeness with which the meter

will read the voltage across its terminals (the actual voltage with the meter in the circuit, not the voltage in the circuit with the meter disconnected). Variations in friction, magnetization, etc. cause errors. Since the effect of these errors, in volts, will be approximately the same at any point on the meter scale, meters are rated for accuracy in terms of percentage of full-scale deflection. For example, if a meter with a 100-volt range has an accuracy of 2% of full-scale deflection, any reading on that range may be 2 volts off. Not only can a voltage which is indicated as 100 volts actually be as low as 98 volts or as high as 102 volts, and be in error by 2% of the actual voltage; also, a voltage indicated as 20 volts on the same scale actually may be as low as 18 volts or as high as 22 volts. In the second case, the error is 10% of the indicated voltage.

The accuracy of ordinary service type v.o.m.'s on d.c. voltage ranges is about 2%. Since a v.t.v.m. has all of the parts contained in a v.o.m., with their individual variations, and additional parts as well, with their variations, the accuracy of a v.t.v.m. generally is inferior to that of the v.o.m.—about 5% in ordinary service types.

The actual reading of a meter depends on both its sensitivity and its accuracy. The sensitivity determines how much the meter lowers the voltage we are trying to measure, and the accuracy determines how close to this lowered voltage the meter reading will be. In making the measurement indicated in diagram (A), the actual voltage across a v.t.v.m. would be 99 volts, but the reading may be as much as 5% of 250 volts, or 12.5 volts above or below this; the v.t.v.m., might read anywhere between 86.5 and 111.5 volts. With the 20,000 ohms-per-volt meter, the voltage across the meter is 98 volts, but the reading may be as much as 2% of 250 volts, or 5 volts, above or below this—anywhere be-



Typical non-electronic volt-ohm-milliammeter.

tween 93 and 103 volts. With the 1000 ohms-per-volt meter, the reading could be anywhere between 66 and 76 volts.

In this particular example, the 20,000 ohms-per-volt meter gives the most dependable reading; it could not be more than 7 volts off. The v.t.v.m., because of its poorer accuracy, might be as much as 13.5 volts off; the 1000 ohms-per-volt meter could be as much as 34 volts off, because of its poorer sensitivity. In other cases, the 20,000 ohms-per-volt meter might not be better than the others. In a lower-resistance circuit, the current drawn by the 1000 ohms-per-volt meter might be negligible and it could read approximately the same as the 20,000 ohms-per-volt meter. In a higher-resistance circuit, the v.t.v.m. might read nearer the actual voltage than the 20,000 ohms-per-volt meter.

See the accompanying table for a brief comparison of the v.t.v.m. and the v.o.m., including some aspects which are not fully discussed in this article.

Only the so-called service types of instruments have been considered here. Laboratory type vacuum-tube voltmeters and non-electronic meters may be both more sensitive and more accurate than the service types. However, they are seldom used by technicians or home experimenters. Laboratory instruments generally are much more expensive and less rugged than service instruments. In addition, the accuracy and sensitivity of the service types are quite adequate for general servicing and experimental work.

END

Two voltage measuring situations. See text.

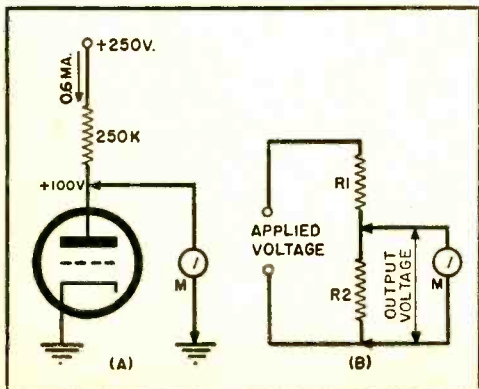

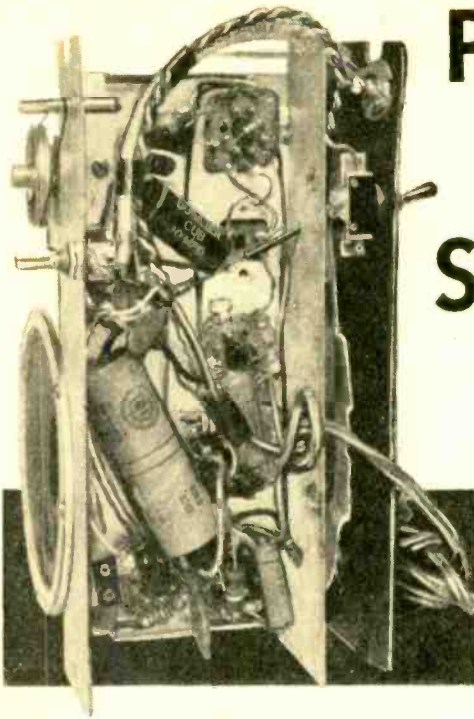

A small radio modified as described in the text. The RCA phono jack and toggle switch are mounted on the rear fiber panel.

Phono Input for Small Radios

By BYRON G. WELS

able to hear the music she had been imagining.

The alteration is quite simple, and can be done in two different ways. The simplest of these is merely to locate the volume control on the radio. This is in the input circuit to the amplifier stages. On the back of this control is a switch, which turns the set "on" and "off." This switch can be identified by the fact that it rides "piggy-back" on the volume control, and has only two lugs. The volume control has three contacts on it—a center one, and one at each end. One of the end contacts comes from an i.f. transformer, and the other end contact goes to a tube. The one that goes to the i.f. transformer is the one we are interested in. Connect a shielded wire to this contact, and solder it in place. Connect the shielding to chassis, and make sure that the shielding does not short circuit any of the other components in the chassis. It is a good idea to slip a piece of insulation over the shield. To the other end of this shielded wire, connect an RCA phono jack; connect

WHEN we decided to install a high fidelity system, we were pretty much overwhelmed by the cost of the various components that go into a decent combination. We decided to purchase the various parts piece by piece and assemble ultimately a complete home music system.

Our first investment was a record player. We chose a three-speed model with a crystal cartridge. The crystal is a stop-gap measure as we plan to replace it soon with a variable reluctance type.

Well, there we were, a beautiful phonograph, a few recordings, and no way to reproduce them. Then one day I saw my wife running the machine with a record on it, and no sound coming out—her eyes were closed ecstatically, as if she were hearing the music on the record—and I interrupted her reverie to ask what she was doing. She shut off the record player, and sighed. "Just making believe."

That did it. I dug out the old trusty soldering iron and dug into our little five-tube superhet. Every radio has an amplifier portion. My wife feared for my sanity as I muttered under my breath, wielding wire cutters unmercifully. And lo! The job was done.

I plugged in the radio, plugged the record player into it, threw a switch, and we were

Schematic of part of the circuit of a small radio; the modifications needed to add a phonograph input are shown within dotted lines. The only other parts required are shielded wire, a single-pole, double-throw switch, and (in a.c.-d.c. sets) a capacitor. (See text.)

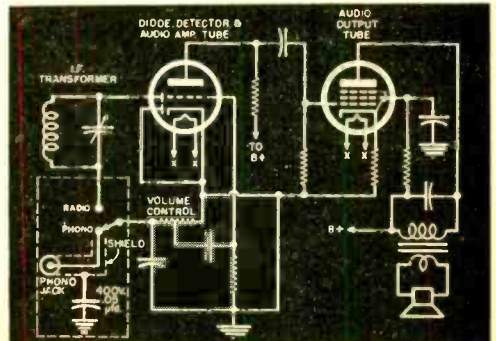

the center conductor of your wire to the center of the plug, and the shield to the outer conductor. Mount the phono jack at some convenient point on the fiber back of the radio, and you are in business.

Plug the record player into this jack, and then plug the radio and record player motor into the a.c. line. If you tune the receiver to a point on the dial where there is no signal, your record player will reproduce through the radio.

If you care to go a step further, add a small single-pole, double-throw toggle switch as shown in the diagram. With the switch in the "Phono" position, it won't matter where the tuning capacitor is set, as the tuning circuits are cut out. With the switch in the "Radio" position and the phonograph off, you will be able to hear the radio in the usual manner.

In both cases, if your radio is of the a.c.-

d.c. variety, the chassis is likely to be "hot," that is, connected to one side of the power line. This will make the metal chassis of the phono unit "hot" too, unless the a.c. plugs of the phono and radio always are inserted in their sockets a certain way. To avoid any possibility of shock from touching the phono unit, do not connect the shielding of the phono cable directly to the chassis. Use a .05 μ fd., 400-volt capacitor as shown in the diagram. Simply connect one end of the capacitor to the shield and the other end to the chassis. (The author did not use this capacitor, so it is not shown in the photograph.)

Of course, the fidelity of this system is no better than its weakest point which, in this case, is the little amplifier of the a.c. receiver. However, it served us well and is continuing to do so until we get our dream set-up completed. END

A New Tool for Cardiology

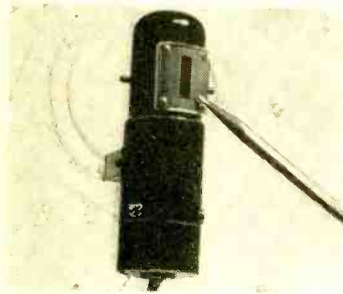

ELECTRONIC instruments which increase the range of man's senses have brought medical science out of the "dark ages" and these new and better instruments have been the tools for amazing progress in medical research.

One such tool is the electrokymograph which records the motions of the chambers of the heart and blood vessels. X-rays passing through the patient produce a pulsating silhouette of his heart on a fluoroscopic screen. This image is watched by the instrument's photoelectric "eye" while the "brain" of the machine is an electrocardiograph that "remembers" on a graphic record called an electrokymogram.

There are typical motions of the heart that are healthy and other motions that are characteristic of a diseased heart. With its electric eye and recording brain, the electrokymograph all but talks to the research worker as it watches the heart.

In the instrument shown at the left, the electron multiplier phototube is covered with a metal hood with slots in front of and behind the photo surface. The x-ray beam is then shuttered down so an area only slightly larger than the slit is exposed, thus decreasing exposure on the skin of the patient and improving the sharpness of the border being recorded.

The National Heart Institute is using this device.

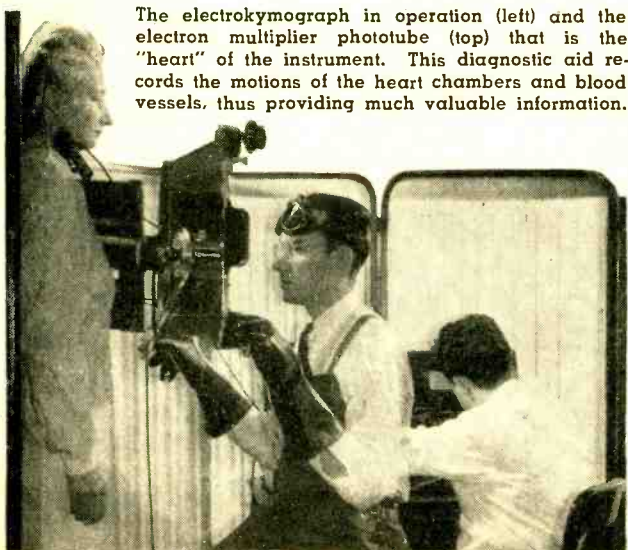

The electrokymograph in operation (left) and the electron multiplier phototube (top) that is the "heart" of the instrument. This diagnostic aid records the motions of the heart chambers and blood vessels, thus providing much valuable information.

Electronic



Test Chamber

THE figure in the winter clothing is not a man from Mars, but a U. S. Navy electronics engineer. He is type testing one of the many pieces of electronic equipment sent to the U. S. Navy Laboratory at Pt. Loma, California, by manufacturers for checking. All electronic gear undergoes various tests before production of the final model can start. The photograph shows a

stratosphere chamber capable of testing equipment at simulated altitudes up to 120,000 feet, and at temperatures ranging from 185 degrees Fahrenheit to minus 112 degrees Fahrenheit. The chamber will also simulate jungle and Arctic humidity conditions. This testing program detects faults in electronic equipment before it is permitted to be mass produced for the U. S. Navy. **END**

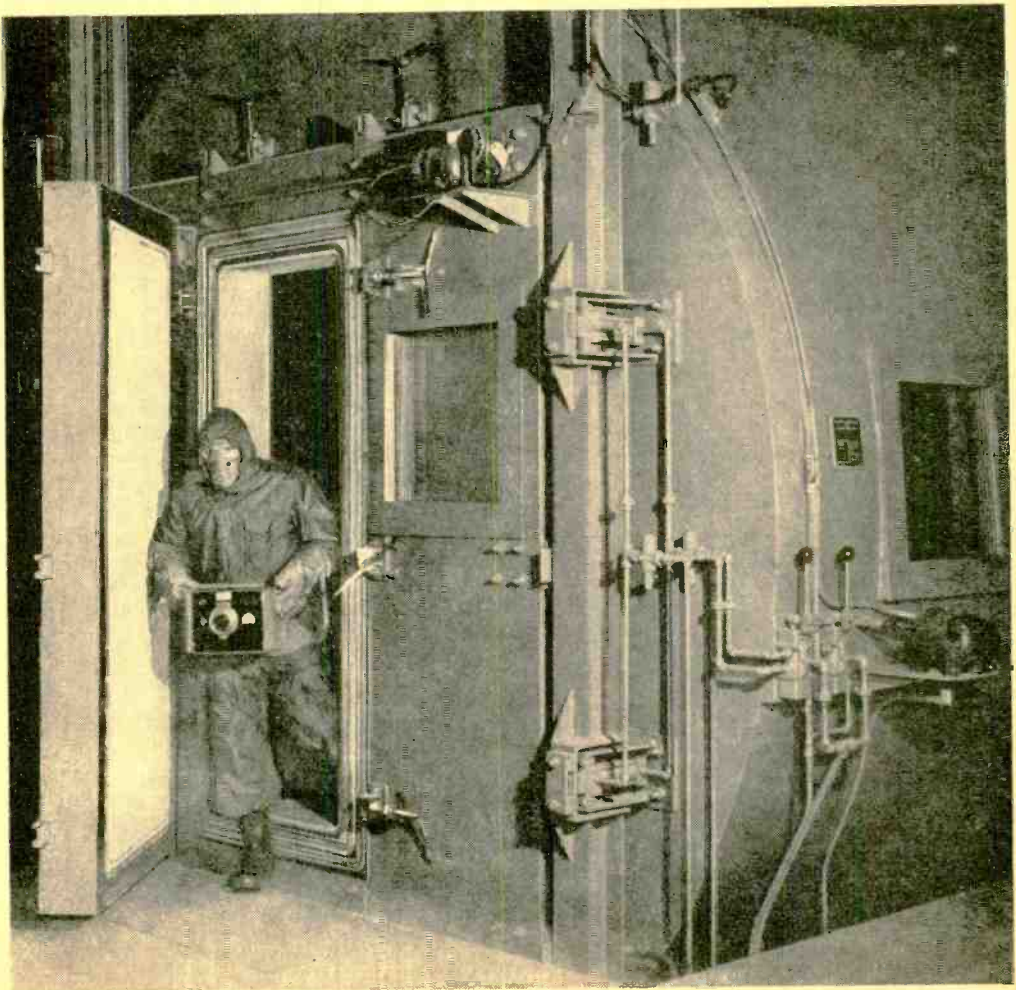



CARL & JERRY

Carl discusses the merits of his ham radio hobby and whether it is more attractive because of the technical or social aspects.

SPRING fever had infected our heroes! Carl and Jerry were busy getting the lawn furniture out of Jerry's basement and cleaning it. This chore finished, both promptly collapsed into a pair of still damp chairs in the middle of the back yard. The "churlik churlik" of busy robins filled the air and overhead a bright April sun beat down warmly upon them and induced a delicious, languorous drowsiness.

Jerry sat hunched in his chair with his chubby legs curled beneath him, his hands clasped across his stomach, and with his head slumped forward on his chest so that he resembled a sleeping Buddha. Carl's long legs were stretched out in front of him, and he had slid down in the lawn chair so that only the back of his head, the seat of his pants, and his heels dug into the freshly-green sod were supporting his lanky frame. The sun shone through the lenses of his horn-rimmed glasses upon his tightly closed eyelids and created a beautiful, formless, dark-red void for his languid inspection.

"Hey, Jer," Carl drawled feebly.

"Uh huh," Jerry answered drowsily without stirring an unnecessary muscle.

"I'm giving an oral theme Monday on 'What I Like About My Hobby.' Want to help me dream up something on ham radio?"

"I reckon you can sound off on all the reasons you can think of, and I'll add any I think you miss."

"Okey-dokey. First off, I like amateur radio because it's a hobby in which you do things. It always sounds funny to hear some of the fellows griping about there being nothing to do. You and I can't find time to do half of the things we want to.

There are always transmitters and receivers and test equipment to build and try out. New antennas to be constructed and put up and tested. New circuits must be tried, and of course there's your amateur station to operate. This last is especially important because half the fun of any hobby is talking it over with other people who are as crazy about it as you are. No matter how lonely your neighborhood is, there are always hundreds of other amateurs ready and eager to talk ham stuff with you whenever you place your transmitter on the air.

"Next, it's an exciting hobby. Every time there's a hurricane, tornado, flood, or other disaster anywhere within several hundred miles, I can have a front seat just by listening on my station receiver. What's more, I can often be of real help in relaying messages in and out of the stricken area for other ham stations who are right in the thick of things. But even when there is no emergency, operating a ham station is an exciting and suspense-filled experience. For example, when I pound out a *CQ* on twenty meters, I never know if I'm going to get an answer from half-way around the world—"

"Or perhaps from your old buddy right next door," Jerry broke in with a chuckle.

"True! But that's part of the fun. It's like fishing. You never know just what you're going to pull out. I like the challenge to skill and muscular coordination needed to handle messages at high code speeds. Your nerves must be just as steady to send good clean code as they are to make a high score in rifle shooting or in tossing free buckets in basketball. Copying a guy who's throwing it at you at thirty words a minute means your mind and muscles have

to work together as fast as lightning."

"You're making it sound pretty strenuous," Jerry yawned. "Don't you have any reasons without muscles in them?"

"Sure, my flabby friend. One thing is that it has prestige. Not just any stupe can be a ham simply by deciding he wants to be. That little old ham ticket on the wall

By
JOHN T. FRYE

says a lot of nice things about the guy who owns it. It testifies he's had the gumption to study the code, theory, and laws until he is capable of operating a complicated radio station. Who says so? Uncle Sam himself, because that license is granted by the FCC after giving a stiff examination that's no push-over, even for people who've spent their whole lives in electronics work. Many state governments, too, show what they think of hams by granting them special auto license plates with their call letters. The armed forces encourage this hobby in every way they can, even by having military stations work directly with the amateurs. They know that their best operators



and technicians will come from this group. Red Cross and Civil Defense authorities are always ready to work closely with hams. Every time there's a major disaster, you can be sure the newspapers will carry stories on the wonderful work hams perform in restoring broken communications. A ham is *somebody!*

"Another thing I like about hamming is that it allows me to acquire a lot of pretty complicated technical knowledge with hardly any pain or strain. When you're actually working with electronic equipment, reading interesting magazine articles about it, and talking about it with other guys on the air, it's amazing how much knowledge rubs off on you without your knowing it—knowledge that sticks with you, too. It's one thing to read that a parallel-tuned circuit presents maximum impedance at resonance and something entirely different to see the beautiful way in which a final amplifier plate current dips as the tank circuit is tuned through resonance."

"Now let's not get sickening about this," Jerry objected. "You're beginning to sound pretty lyrical."

"A dull clod with a slide rule for a soul!" Carl muttered. "Well, the final thing about ham radio that I like is the social side of it. By means of my amateur station I've become acquainted with all sorts of people I'd never have met otherwise. I know doctors, editors, lawyers, band leaders, radio and TV comedians, service technicians, policemen, radio station engineers, plumbers, dentists, school superintendents, and people in just about any other walk of life you'd care to mention. They call me 'Carl,' and I call them by their first names. On the ham bands it's not your age or your money or your fame that counts. All that really matters is the quality of the signal you put out with your transmitter and how good is your operating procedure.

"And," Carl concluded, "it's always mighty comforting to know I can go into any strange city and find ham friends who will welcome me into their 'shacks,' whether it be a converted clothes closet or a spacious, beautifully decorated room in a mansion. A ham has friends wherever he travels."

"That's a pretty good list of reasons you have, *Carlos, amigo mio,*" Jerry remarked as he straightened up and stretched luxuriously. "I don't have too much to add, but I might say that while you like ham radio because it gives you something to do, I like it because it gives me something to think about. Trying to understand what goes on inside the transmitter and receiver circuits makes me call on every bit of math and chemistry and physics I've ever studied and causes me to realize that I need to know even more. I'm going to learn more, too; and that's another thing in favor of the hobby. It's sort of a sweet, juicy carrot that tempts the ham along the path leading to a career in electrical or electronic engineering. At the very top of every part of these fields you'll find men who first became interested in their work through the hobby of amateur radio.

(Continued on page 94)

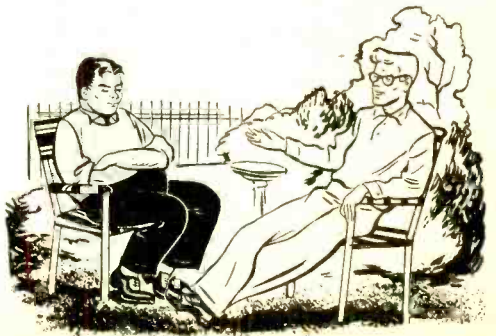



Soldering "gun" and two types of irons, along with "accessory" items.

HOW TO SOLDER

POOPLY soldered connections are often responsible for poorly functioning and inoperative equipment. Since good soldering is actually easier to do than poor soldering the amateur should do three things: he should follow the basic rules of good soldering, he should learn the difference between a poorly soldered joint and a good one, and he should practice soldering different types of connections until he acquires the "feel" of his iron.

The ten rules for good soldering are:

Select the right equipment for the job: Essential soldering tools include a soldering "gun" or soldering iron and stand, solder, paste flux, and a file.

Care should be taken to select an iron suited to the work. Too large an iron may be hard to handle and may deliver too much heat, burning the insulation. Too small an iron, on the other hand, may not deliver enough heat to the work, making it impossible to flow solder into the joint. A 60 to 100 watt iron with a $\frac{1}{4}$ " to $\frac{3}{8}$ " pyramid tip is best for most radio and electronic work. However, for work with hearing aids, miniature radios, remote control equipment, and similar small items using fine wire, a 25 to 50 watt iron or soldering "pencil" is preferred. On the other hand, for work involving large wire and considerable soldering to a chassis, a 150 to 250 watt iron may be required.

Soldering "guns," while more expensive than irons, are easier to use, use less power since they consume power only when in actual use, require virtually no warmup time, have a small tip suitable

for radio wiring, and, generally, have small lamps which spotlight the work. A 100 to 150 watt soldering gun is a good choice for electronic work.

Solder is available in many grades and in two types, wire and bar. The most popular grades are 40-60, 50-50, and 60-40. The first figure refers to the percentage of tin and the second to the percentage of lead in the alloy. In general, the higher the percentage of tin, the lower the required soldering temperature. For radio and electronic work, 50-50 or 60-40 wire solder with a rosin core is recommended. Never use acid core solder in electronic wiring.

Fluxes are used to remove the thin film of oxidized metal that forms on the surface of the work as well as to prevent additional oxidation when the metal is heated prior to soldering. Although flux core solder is used for most wiring, a small can of paste flux is handy to have around for tinning leads, tinning the iron tip, and similar work. Use a non-corrosive flux.

A small fine-cut file should be available for removing pits and smoothing the tips of soldering irons. The file should not be used unless the copper tip of the iron is pitted and then only enough of the metal should be filed away to leave a smooth, shiny surface.

Clean the metals to be soldered: All grease, dirt, corrosion, or enamel must be removed from the surface of the metal prior to soldering. Use steel wool, sandpaper, a file, a knife, wire brush, or any similar tool to remove the dirt and grease.

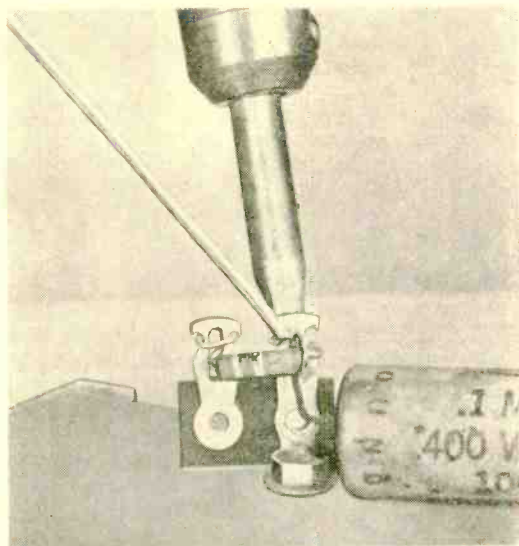

Correct soldering technique. The iron is held against part until hot enough to melt solder when applied to heated junction.

Keep the soldering iron tip clean and well tinned: If the tip of the iron is not clean, the film of oxidation formed will act as insulation and prevent the proper conduction of heat to the joint. To tin an iron, first make sure the tip is free from corrosion and pits. If the tip is badly pitted, it will have to be filed. Allow the iron to heat until its tip is hot enough to melt solder then flow solder over the end of the tip. In some cases it may be necessary to rub the tip against a metal plate (such as the top of a tin can), applying a little solder as this is done. Finally, wipe off excess solder with a heavy cloth, leaving the tip bright and shiny.

Don't tin the entire tip: When using the iron, occasionally check for proper tinning. Try to keep a thin film of solder on the tip of the iron at all times.

Heat the joint, not the solder: To solder a joint, hold the tip of the iron against the joint until the joint is hot enough to melt the solder—then apply the solder to the joint.

Don't try to solder unless the iron is



(A)
PERMANENT
JOINT

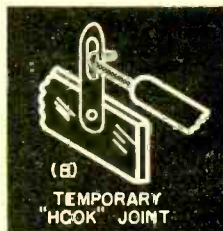

(B)
TEMPORARY
"HOOK"
JOINT



(C)
"LAP"
CONNECTION

The three types of mechanical connections used in soldering. (A) For permanent installations. (B) For work where some changes may have to be made. (C) A "lap" joint for temporary work.

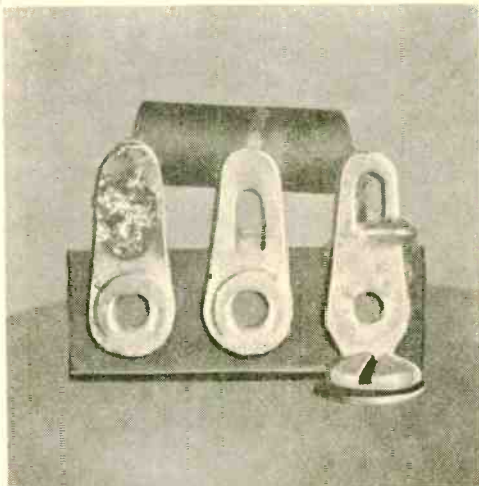

Correctly (right) and incorrectly (left) soldered connections. The latter type can cause electrical and mechanical troubles.

really hot: Make sure the iron is hot enough to melt solder instantly when it is touched to the tip *before* trying to solder a joint. Let the heat do the work. Apply only enough pressure to the work so that good contact is made between the iron tip and the joint. Then solder quickly.

For tight spots, an "extension" can be added to soldering iron by means of copper bus bar.

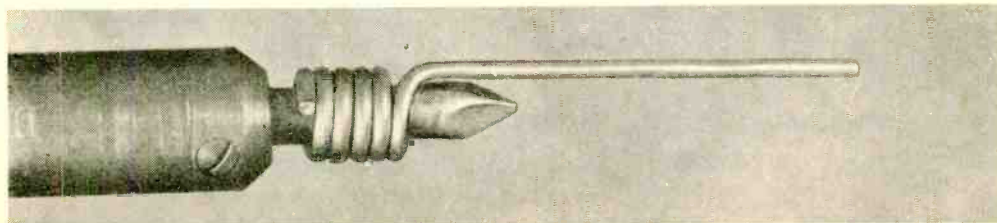

POWER

By HAROLD REED

Use a minimum of solder and flux: Too much solder will result in a poorly soldered joint rather than a better one. In addition, excessive solder may short to other terminals. Use only enough solder to cover the connection smoothly.

When paste flux is used, a thin layer should be applied to the work. Too much flux will mess up the equipment and may cause solder to flow where it is not wanted.

Use the proper type of connection: Three basic electrical connections are used in most wiring work. A permanent hook joint is used for equipment which is not to be dismantled later. The temporary hook joint is made by using an open hook in the wire. The third type, a lap joint, is used for quick test connections which are to be unsoldered immediately.

Don't depend on solder for mechanical strength. Solder is used in electronic wiring to insure good electrical connection between two conductors. It should not be used to add strength to a joint unless the joint is sufficiently strong without solder.

Don't move the work until after the solder has hardened: For a good joint the solder should be allowed to harden gradually and naturally. The leads and terminals being soldered must be immobile during this hardening period as otherwise the resulting joint may be weak. Solder which has been disturbed during hardening is likely to have a frosty white appearance and be weak and crumbly. Such a connection is called a "cold-soldered" joint. Where the wires and terminal are held together by a film of flux rather than by solder, a high-resistance joint, known as a "rosin joint" results.

A Few Final Points

If it is necessary to solder small wires or to reach back in a "tight" corner and only a standard-sized iron is available, it is often possible to make a satisfactory extension by using a heavy copper bus bar. At least #12 wire should be used. The tip is then tinned in the same manner as an iron tip.

When installing capacitors or resistors, if the original tinning on the leads has become blackened, re-tin them before making connections in a chassis, otherwise it will be hard to do a good soldering job.

Keep a little piece of canvas or a small wad of steel wool handy to wipe off excess solder on the tip. For best work the iron tip should be kept bright and shiny. Some soldering iron stands have a built-in container for steel wool—but if your stand is not so equipped—a small handful of steel wool will do the trick as well. **END**

THERE can be no doubt that semi-conducting germanium diodes and transistors will be used more and more in the home for various devices. Their minute size and low power consumption make them especially suitable for such applications. The hobbyist can employ them in many ways, not only in experiments, but in many practical ways in his home.

The simple gadget described in this article is an example of a useful device employing a germanium crystal diode. The constructor will find other uses for it but its original purpose was to warn of power failure to an electric clock.

Probably most persons today rely on an electric alarm clock to awaken them in the morning. There is no doubt about its reliability, but this little auxiliary device can be used "just in case"—just in case of power failure. It provides an additional safety margin on those occasions when it is vitally important to make that early morning train or keep an all-important appointment. It is so small that it can be taken "on the road," along with the electric clock. Those persons whose employers are not "in business" until they report for duty will recognize its advantages. The early morning radio station transmitter engineer is one example. Although power failures are not too frequent, in most areas they can be troublesome during severe electrical storms.

To place the unit in operation, it is plugged into a 117 volt a.c. convenience outlet and the clock or other equipment is plugged into the outlet on the front cover of the power failure alarm device. The power switch is then thrown "on," followed by the alarm switch. Although battery cost is very low, the alarm switch may be turned off when the device is not required in order to avoid draining the battery in case of a power failure during the absence of the user. This is an easily-remembered operation at the time the alarm clock is shut off.

This device can be constructed in any arrangement desired. The unit shown is built into a standard 4"x4"x2" metal box. Two single-pole, single-throw switches are provided, S_1 in the power circuit and S_2 in

FAILURE ALARM

The power failure alarm used with electric clock. It can be used with other home and industrial units.

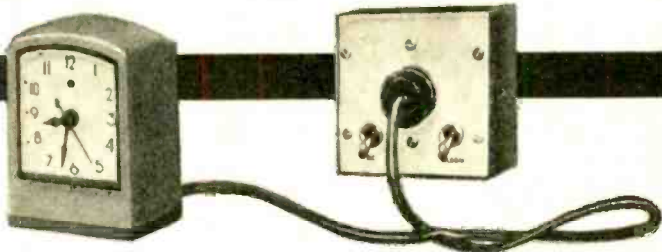

the battery-buzzer connection. *S*₁ is not absolutely essential and could be eliminated. The buzzer is an *Edwards* high-frequency miniature type. The single battery operates this buzzer loudly enough to rouse a sound sleeper but, if you are the cautious type, two batteries may be used in series to increase the sound level.

The circuit is quite simple. Two 6000-ohm resistors are connected in parallel and a 3000-ohm resistor is connected in series with these. These three resistors are connected across the 117 volt a.c. line as a voltage divider to reduce the voltage to the 1N34 crystal diode. The d.c. output of the 1N34 rectifier circuit is connected to the 8000-ohm coil of the small relay. The buzzer, battery, switch *S*₂, and the contacts of the relay that complete the circuit when the relay is in the open position, are wired in series. The outlet receptacle for the clock or other device is directly across the 117 volt a.c. line.

With an a.c. line voltage of 117 volts, the unit draws about 2.6 watts. The relay operates at 20 volts d.c. with 2.5 milliamperes flowing through the coil. Using components of the values listed in the parts list, the relay closes at an a.c. line voltage of 100 volts. This prevents the alarm from operating due to poor line voltage regulation. Once the relay pulls in, the line voltage can fluctuate from the nominal 117 volts to below 100 volts without causing the relay to drop out. **END**

Complete schematic diagram and parts list for the home-built power failure alarm.

- R*₁, *R*₄—6000 ohm, 2 w. res.
- R*₂—3000 ohm, 2 w. res.
- R*₃—8200 ohm, ½ w. res.
- C*₁—40 μfd., 150 v. elec. capacitor
- S*₁, *S*₂—S.p.s.t. switch
- RL*₁—Relay, 8000 ohm coil (Sigma 4F, Type 4F8000-S)
- Rect.—1N34 diode rectifier
- SO*₁—117 volt a.c. receptacle
- BZ*—High-frequency buzzer (*Edwards*)
- B*₁—½ volt "C" flashlight battery (*Burgess* #1)

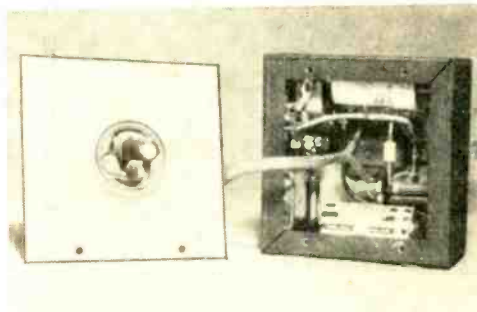

The alarm unit with rear cover removed. The small buzzer and relay are mounted on left side of box with the 1N34 mounted vertically. The a.c. plug is visible on the box cover.

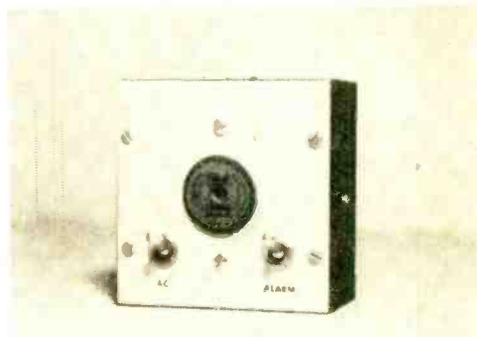

Front view of the completed unit. The switches are in their "on" positions. Switch at left is for power and the one at right turns the alarm "on" and "off." The switches should be labeled.

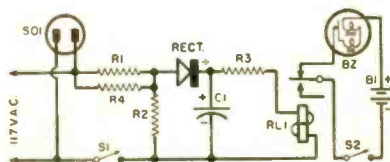

The lady builds bridges and test-flights rockets. Dr. Frances Bauer feeds data to computer, gets speedy and accurate results.



Project Cyclone

Giant computers solve industry's toughest problems and open new, lucrative field for women interested in mathematics.

THE new "Age of Automation" being ushered in by electronic computers will open up many new technical and highly remunerative fields to women.

As mathematicians who "program" or "feed" data into the electronic "brains," women will be able to build bridges and tunnels, design dams for hydroelectric plants, pre-test the flight of planes, tell automobile manufacturers what is wrong with next year's models, and maybe even forecast the weather weeks ahead of time.

A number of women have already pioneered in this new field and are finding that their sex is no barrier to their ad-

One of the largest computers in the world, "Project Cyclone" is the test center for solving three-dimensional problems involved in the design of aircraft and guided missiles.





Project director Dr. Louis Bauer (left) and Hans Meissinger, assistant, study missile's trajectory while it is computed and drawn.

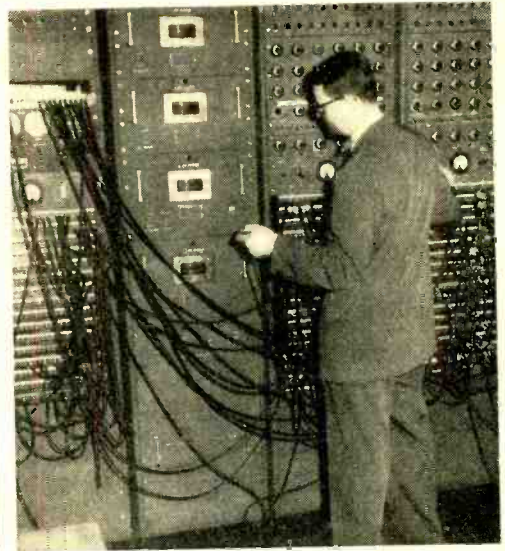

Electronics makes for safety and accuracy as Dr. Bauer watches the pull-out of a dive bomber to determine point of bomb release.

vancement. While the machines can make their calculations in minutes, often in seconds, the human "programming" or breaking down of the problems to be solved into a series of mathematical formulae so that machines can "digest" them, may take hours or even days. One of these machines, for instance, requires 963 instructions to calculate the path of a guided missile. Once these instructions are received by the computer, it can perform 1,100,000 mathematical operations in exactly two minutes. A human would probably require a year to complete the job.

One of the women pioneering in this new field is Dr. Frances Bauer, senior mathematician at *Reeves Instrument Corporation*, New York City, a subsidiary of *Claude Neon, Inc.* She assists her husband, Dr. Louis Bauer, in the operation of the famed "Project Cyclone," built and operated by *Reeves* for the U.S. Navy's Bureau of Aeronautics. She also serves as a consultant on industrial problems involving the use of the *Reeves* Analogue Computers (REAC).

A Ph. D. from Brown University and a former Research Associate in Aeronautical Structures at the Polytechnic Institute of Brooklyn, petite, blond Frances Bauer—still in her early thirties—has been called upon in the four years since she came to *Reeves* to pre-check the performance of such deadly guided missiles and military aircraft as the *Lark*, *Regulus*, *Cutlass*, and *Nike*.

Real rocket tests cost hundreds of thou-

sands of dollars but the "test flights" performed for the Navy by Dr. Bauer and her colleagues at "Project Cyclone" cost little and endanger no lives. In one instance the Navy was advised, as a result of the work at "Project Cyclone," not to try to launch certain jet fighters from the deck of a pitching carrier. The computer proved that they were much too likely to go into the drink instead of taking off safely.

Recently at *Reeves*, Dr. Bauer and her associates were called upon to help solve certain problems in the building of suspension bridges. On another occasion officials of the Tennessee Valley Authority presented certain questions on the operation of TVA's thirty-five dams.

Dr. Bauer, who says there are already several hundred women in this field, advises young women interested in mathematics who are entering college this fall and others already employed but who are looking for wider horizons, to investigate this profession of playing handmaiden to an electronic "brain." Graduate work in mathematics is advisable but not necessary. Girls with a B.A. may expect to start at \$65 to \$75 per week. Those with an M.A. may get \$85 to \$100, while the Ph.D.s will command around \$125 weekly in the industrial market. Fully qualified professionals in the field may expect anywhere from \$8,000 to \$12,000 per year and reportedly there are already a few women computer experts in the \$25,000 per year bracket. Who said figures weren't interesting?

END

Principles of D.C. Circuits

1

The common No. 6 dry cell battery will deliver slightly over 1.5 volts when purchased brand new. When in use the voltage will drop slightly, or as the battery grows older the experimenter may expect it to put out less than its rated voltage. The voltage reading may be seen on this VT voltmeter.

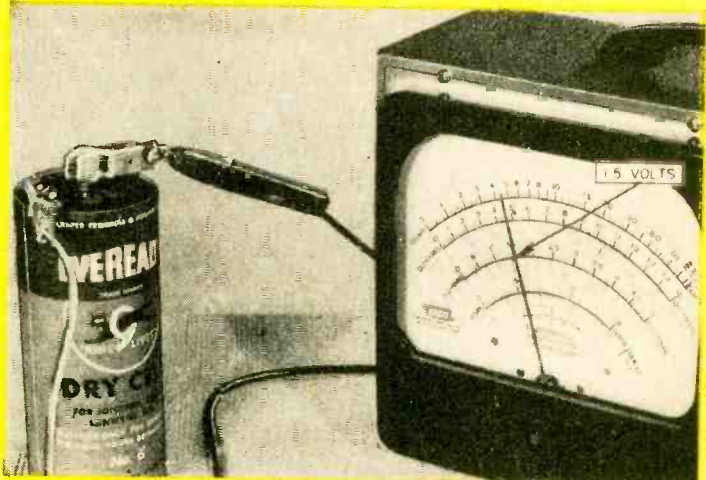

2

If two No. 6 dry cell batteries are put in series, the voltages will add. In this meter reading the voltage is just a little over 3 volts as both batteries are fresh.

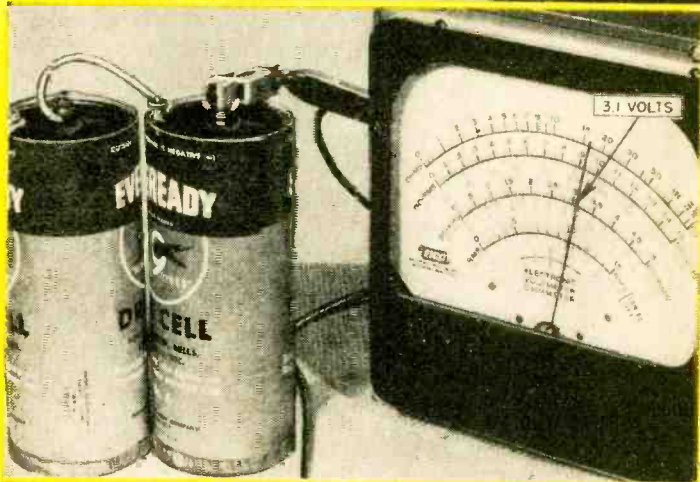

3

To provide more current output the experimenter may find it necessary to use a parallel series wiring arrangement. The voltage as seen on the meter is still 3.1 volts.



Fundamental Ohm's Law and Rules of Voltage and Current

Addition Seen With Aid of Batteries and Meter . . . H. Leeper

4

The same four dry cells can be reassembled into a series arrangement to provide about 6 volts (four times 1.5 volts). The allowable current drain is the same as with one battery, although the voltage has been multiplied.



5

The arm of this potentiometer has been turned to a point where nearly all of the resistance has been cut out. The vacuum-tube volt-ohmmeter, however, still measures 1.2 ohms. Almost all volt-ohmmeters contain circuits which measure resistance, R , according to the formula of voltage, E (internal battery), divided by current, I (shown on the meter).

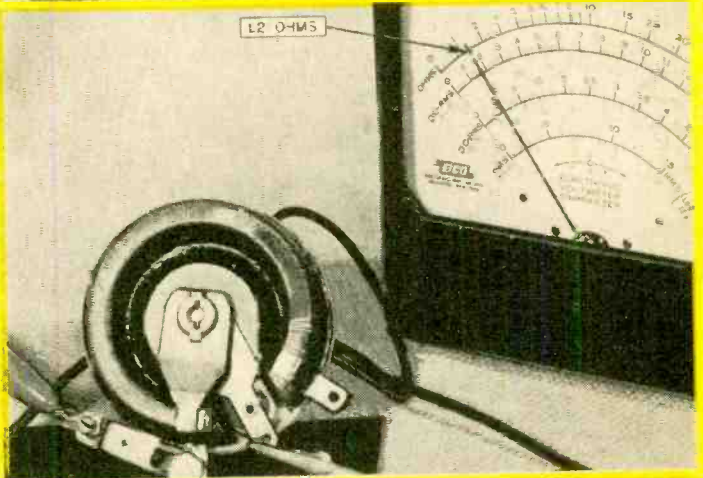

6

Although it is not recommended, we can demonstrate Ohm's Law by connecting a d.c. ammeter in series with our 1.2 ohm resistance and the battery having 6 volts output. Current, I , is equal to the voltage, E , divided by the resistance, R . In this case it is 5 amperes and is shown on the meter in the photo.



Build YOUR OWN HEATHKITS

INTERESTING—EDUCATIONAL



work has already been done for you. No cutting, drilling, or painting required. All parts fully build Heathkits.

Heathkits are fun to build with the simplified easy-to-follow Construction Manual furnished with every kit. Only basic tools are required, such as soldering iron, long-nosed pliers, diagonal cutting pliers, and screwdriver. All sheet metal furnished including tubes. Knowledge of electronics, circuits, etc., not required to success-

New charcoal gray baked enamel panel with highly readable white lettering.

New PRINTED CIRCUIT VACUUM TUBE VOLTMETER KIT

The VTVM is the standard basic voltage measuring instrument for radio and TV servicemen, engineers, laboratory technicians, experimenters, and hobbyists. Because of its extremely high input resistance (11 megohms) the loading effect on the circuit being measured, is virtually negligible. The entire instrument is easy to build from a complete kit, with a detailed step-by-step Construction Manual. Featured in this instrument is an easy-to-wire fool-proof printed circuit board which cuts assembly time in half.

CIRCUIT AND RANGES: Full wave AC input rectifier permits 7 peak-to-peak voltage ranges with upper limits of 4000 volts peak-to-peak. Just the ticket for you TV servicemen. Seven voltage ranges, 1.5, 5, 15, 50, 150, 500 and 1500 volts DC and AC RMS. Peak-to-peak ranges 4, 14, 40, 140, 400, 1400, and 4000 volts. Ohmmeter ranges X1, X10, X100, X1000, X10K, X100K, X1 meg. Additional features are a db scale, center scale zero position, and a polarity reversal switch.

IMPORTANT DESIGN FEATURES: Transformer operated—1% precision resistors—6AL5 and 12AU7 tubes—selenium power rectifier—individual AC and DC calibrations smoother improved zero adjust control action—new panel styling and color—new placement of pilot light—new positive contact battery mounting—new knobs—test leads included. Easily the best buy in kit instruments.

New peak-to-peak color scale—new harmony—new control knobs.

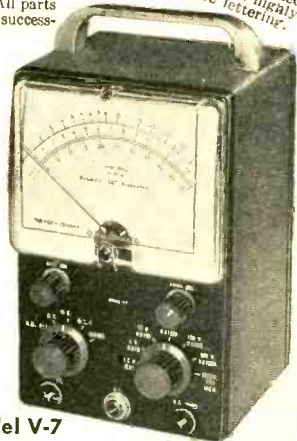

Model V-7

\$24⁵⁰

Shpg. Wt. 7 lbs.

New printed circuit board for faster, easier construction—exact duplication of Laboratory development model.

New easy-to-read open panel layout. On-on switch incorporated in selector switch.

Heathkit HANDITESTER KIT



MODEL M-1
\$14⁵⁰

Shpg. Wt. 3 lbs.

The Heathkit Model M-1 Handitester readily fulfills all requirements for a compact, portable volt-ohm-milliammeter. Its small size permits the instrument to be tucked into your coat pocket, tool box or glove compartment of your car. Always the "handitester" for those simple repair jobs. Packed with every desirable feature required in an instrument of this type. AC or DC voltage ranges, full scale 10, 30, 300, 1000 and 5000 volts. Ohmmeter ranges 0-3000 ohms and 0-300,000 ohms. DC milliammeter ranges 0-10 milliamperes and 0-100 milliamperes. Uses 400 microampere meter—1% precision resistors—hearing aid type ohms adjust control—high quality Bradley rectifier. Test leads are included.

Heathkit MULTIMETER KIT



MODEL MM-1
\$26⁵⁰ Shpg. Wt. 6 lbs.

Here is an instrument packed with every desirable service feature and all of the measurement ranges you need or want. High sensitivity 20,000 ohms per volt DC, 5000 ohms per volt AC. Has the advantage of complete portability through freedom from AC line—provides service ranges of direct current measurements from 150 microamperes up to 15 amperes—can be safely operated in RF fields without impairing accuracy of measurement.

Full scale AC and DC voltage ranges of 1.5, 5, 50, 150, 500, 1500, and 5000 volts. Direct current ranges are 150 microamperes, 15, 150, and 500 milliamperes and 15 amperes. Resistances are measured from .2 ohms to 20 megohms in three ranges and db range from -10 to +65 db. Ohmmeter batteries and necessary test leads are furnished with the kit.

HEATH COMPANY
BENTON HARBOR 10, MICHIGAN

New
PRINTED
CIRCUIT

Heathkit 3" OSCILLOSCOPE KIT



Model
OL-1

\$29.50

Shpg. Wt.
15 lbs.

Ideal for individual home work shop, ham shack, or as extra instrument for outside servicing.

Compact size, light weight, portable — perfect for service work or field operation.

New, modern styling, gray panel with white lettering, light gray knobs and red and black terminal posts.

New printed circuit for constant performance, rugged component mounting — assembly time cut in half!

Measures only 11 3/4" x 6 3/4" x 1 1/2" and weighs only 11 pounds.

USE: This brand new Utility Scope was designed especially for servicemen and radio amateurs, and is adaptable for use in all general Scope applications. Perfect for modulation monitoring, etc. Use it to tackle alignment or adjustment problems. Equally valuable in breadboard work. A must for ham shack or for outside servicing.

DESCRIPTION: Front panel controls of the Model OL-1 are "bench tested" for ease of operation and convenience. Sharp focusing 3" CRT. Printed circuit for ease of assembly and constant performance. Assembly time cut in half! High quality electronic components used. Sensitive hor. and vert. amplifiers with broad freq. response; cathode follower for isolation. Push-pull hor. and vert. output to deflection plates. Int. 60 cycle, or ext. sync. Sweep freq. range 10-100,000 cycles. Direct connection to deflection plates. Provision for Z axis input. Uses 3GPI CRT, 4-12AU7 hor. and vert. amplifiers, 1-12AX7 sweep gen., 1-6X4 LV rect., and 1-1V2 HV rect. The Heathkit Model OL-1 is a real standout value at only \$29.50, and is another example of the famous Heathkit combination: quality plus economy.

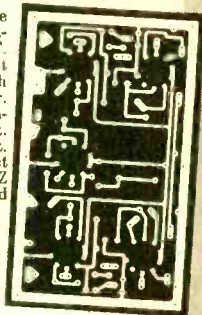

Heathkit SIGNAL GENERATOR KIT

USE: This instrument is "serviceman engineered" to fill the requirement for a reliable basic service instrument at moderate cost. Frequency coverage extends in five bands from 160 Kc to 110 Mc on fundamentals, and dial is calibrated to 220 Mc for harmonics. Pre-wound and pre-aligned coils make calibration unnecessary for service applications.

DESCRIPTION: The Heathkit Model SG-8 Signal Generator provides a stable modulated or unmodulated RF output of at least 100,000 microvolts which can be controlled by both a continuously variable and a fixed step attenuator. Internal modulation is at 400 cycles, or can be externally modulated. AF output of 2-3 volts is also available for audio testing. Uses dual purpose 12AU7 as Colpitts RF oscillator and cathode follower for stable, isolated, low impedance output, and type 6C4 tube for 400 cycle oscillator. Operation of the SG-8 is well within the frequency limits normally required for service work. Modern styling features high definition white letters on charcoal gray panel with re-designed control knobs. Modern professional appearance and Heathkit engineering know-how combine to place this instrument in the "best buy" category. Only \$19.50 complete.

New, modern panel and knob styling — professional appearance and professional performance.

Broad frequency coverage — fundamentals from 160 KC to 110 MC in 5 bands — up to 220 MC on calibrated harmonics.

Cathode follower output for good isolation — fixed step and continued variable attenuation.



MODEL SG-8

\$19.50

Shpg. Wt.
8 lbs.



MODEL
AM-1

\$14.50

Shpg. Wt.
2 lbs.

Heathkit ANTENNA IMPEDANCE METER KIT

The Model AM-1 Antenna Impedance Meter makes an ideal companion unit for the GD-1B Grid Dip Meter or a valuable instrument in its own right. Perfect for checking antenna and receiver impedance and match for optimum system operation. Use on transmission lines, halfwave, folded dipole, or beam antennas. Will double as monitor or relative field strength meter. Covers freq. range of 0-150 Mc and impedance range of 0-600 ohms. Uses 100 microampere meter and special calibrated potentiometer. A real buy at only \$14.50 complete.

Heathkit GRID DIP METER KIT

Amateurs and servicemen have proven the value of this grid dip meter many times over. Indispensable for locating parasitics, neutralizing, and aligning filters and traps in TV or Radio and for interference problems. The Model GD-1B covers from 2 Mc to 250 Mc with 5 pre-wound coils. Featuring a sensitive 500 microampere meter and phone jack, the GD-1B uses a 6AF4 or 6T4 tube. An essential tool for the ham or serviceman.



MODEL
GD-1B

\$19.50

Shpg. Wt.
4 lbs.

HEATH COMPANY
BENTON HARBOR 10, MICHIGAN

ACCESSORIES: Low freq. coverage to 355 KC with two extra coils and calibration curve. Set No. 341A for GD-1B and set No. 341 for GD-1A. Shipping weight 1 lb. Only \$3.00.

New

Heathkit VFO KIT



MODEL VF-1

\$1950

Ship. Wt. 7 lbs.

- Smooth acting illuminated and precalibrated dial.
- 6AU6 electron coupled Clapp oscillator and OA2 voltage regulator.
- 7 Band coverage, 160 through 10 meters—10 Volt RF output.
- Copper plated chassis—aluminum cabinet—easy to build—direct keying.

Here is the new Heathkit VFO you have been waiting for. The perfect companion to the Heathkit Model AT-1 Transmitter. It has sufficient output to drive any multi-stage transmitter of modern design. A terrific combination of outstanding features at a low kit price. Good mechanical

and electrical design insures operating stability. Coils are wound on heavy duty ceramic forms, using Litz or double cellulose wire coated with polystyrene cement. Variable capacitor is of differential type construction, especially designed for maximum bandspread and features ceramic insulation and double bearings.

This kit is furnished with a carefully precalibrated dial which provides well over two feet of calibrated dial scale. Smooth acting vernier reduction drive insures easy tuning and zero beating. Power requirements 6.3 volts AC at 45 amperes and 250 volts DC at 15 mills. Just plug it into the power receptacle provided on the rear of the AT-1 Transmitter Kit. The VFO coaxial output cable terminates in plastic plug to fit standard 1/4" crystal holder. Construction is simple and wiring is easy.

Open layout — easy to build — simplified wiring.

Copper plated chassis—easy to build—direct keying.

Smooth acting illuminated dial drive.

Clean appearance — rugged construction — accessible calibrating adjustments.

Ceramic coil forms — differential condenser.

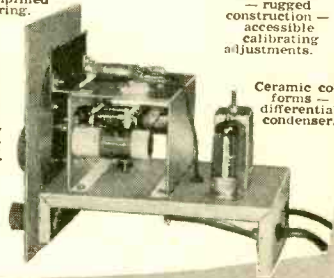

Heathkit AMATEUR TRANSMITTER KIT



MODEL AT-1

\$2950

Ship. Wt. 16 lbs.

SPECIFICATIONS:

Range 80, 40, 20, 15, 11, 10 meters.
 6AG7 Oscillator-multiplier.
 6BE6 I. F. Amplifier
 5U4G Amplifier-doubler
 6L6 Rectifier
 105-125 Volt A.C. 50-60 cycles 100 watts. Size: 8 1/4 inch high x 13 3/8 inch wide x 7 inch deep.

Crystal or VFO excitation.

Prewound coils — metered operation.

Rugged, clean construction.

Single knob band switching.

Built-in power supply.

52 ohm coaxial output.

Here is a major Heathkit addition to the Ham radio field, the AT-1 Transmitter Kit, incorporating many desirable design features at the lowest possible dollar-per-watts price. Panel mounted crystal socket, stand-by switch, key click filter, A. C. line filtering, good shielding, etc. VFO or crystal excitation—up to 35 watts input. Built-in power supply provides 425 volts at 100 MA. Amazingly low kit price includes all circuit components, tubes, cabinet, punched chassis, and detailed construction manual.

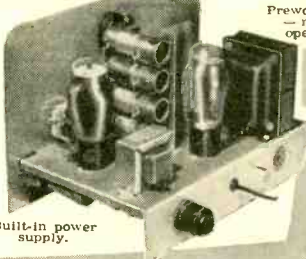

Heathkit COMMUNICATIONS RECEIVER KIT

RF Gain control with AVC or MVC.

Electrical bandspread and scale.

Stable BFO oscillator circuit.

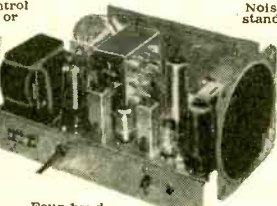

Four band operation 535 to 35 Mc.

Noise limiter—standby switch.

1/2 inch PM Speaker Headphone Jack.

Six tube transformer operation.

SPECIFICATIONS:

Range..... 535 Kc to 35 Mc
 12BE6 Mixer-oscillator
 12BA6 I. F. Amplifier
 12AV6 Detector—AVC—audio
 12A6 B. F. O. oscillator
 12A6 Beam power output
 5Y3GT Rectifier
 105-125 volts A. C. 50-60 cycles, 45 watts.

A new Heathkit AR-2 communications receiver. The ideal companion piece for the AT-1 Transmitter. Electrical bandspread scale for tuning and logging convenience. High gain miniature tubes and IF transformers for high sensitivity and good signal to noise ratio. Construct your own Communications Receiver at a very substantial saving. Supplied with all tubes, punched and formed sheet metal parts, speaker, circuit components, and detailed step-by-step construction manual.



MODEL AR-2

\$2550

Ship. Wt. 12 lbs.

CABINET:

Proxylon impregnated fabric covered plywood cabinet. Ship. weight 9 lbs. Number 91-10, \$4.50.

HEATH COMPANY
 BENTON HARBOR 10, MICHIGAN

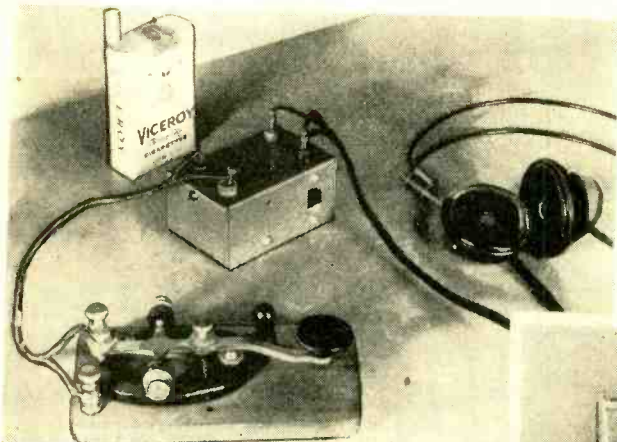

Completed transistorized oscillator (left) is not much bigger than cigarette pack.

Underchassis view of unit shows its compact wiring and relatively simple construction.

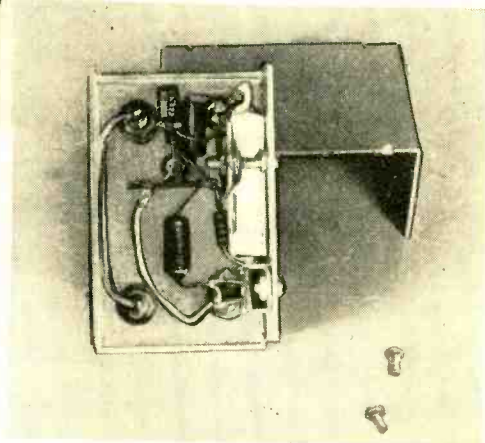

Novel Transistor Code Practice Oscillator

By RUFUS P. TURNER K6AI

THIS transistorized code-practice oscillator eliminates the need for a transformer to obtain feedback. One can build a resistance-capacitance oscillator with a single *point-contact* transistor, but point-contact units are expensive and require a higher d.c. to operate than do junction units.

The junction transistor circuit shown below oscillates *without a transformer*. A type of Colpitts circuit is used—and the headphones supply the required inductance.

The capacitance values listed provide a frequency of 750 cycles. If C_1 is held constant, increasing the value of C_2 will lower the frequency. For example, a value of $0.03 \mu\text{fd.}$ for C_2 will produce a 600 cycle tone; $0.04 \mu\text{fd.}$ will produce a 525 cycle tone, etc.

Keying is perfect. The waveform is almost purely sinusoidal. The d.c. drain on

the batteries is extremely low. If desired, a 50K potentiometer can be connected as a volume control in series with the collector lead of the transistor (the lead connected to the junction of C_2 and the key).

The photos above show the finished unit. It is completely self-contained and will fit into a small aluminum chassis box $3\frac{1}{4}$ " long by $2\frac{1}{8}$ " wide by $1\frac{1}{8}$ " deep. A smaller case can be used for real miniaturization. Point-to-point wiring is employed.

For space economy, a slide switch is used for the ON-OFF function. This switch may be seen at the front-right side of the case. Insulated pin jacks are used for headphone and key connections. The three penlight cells that furnish the power are only $\frac{3}{8}$ " in diameter and $\frac{3}{4}$ " long each. They are held in place against the inner wall of the case by a thin bakelite strip secured by two $1\frac{1}{4}$ " long 6-32 screws. END

PARTS LIST AND SCHEMATIC DIAGRAM

- R_1 —27K, $\frac{1}{2}$ w. res.
- C_1 —0.25 $\mu\text{fd.}$ capacitor
- C_2 —0.02 $\mu\text{fd.}$ capacitor
- CK722—Junction transistor
- B_1 —3 v. miniature battery (2 Eveready Type 912 penlight cells in series)
- B_2 — $1\frac{1}{2}$ v. penlight cell (Eveready Type 912)
- S_1 —S.p.s.t. slide switch
- Headset—2000-ohm magnetic (Triplett)
- Bakelite strip; 2 no. 6-32 screws, $1\frac{1}{4}$ " long, aluminum chassis box

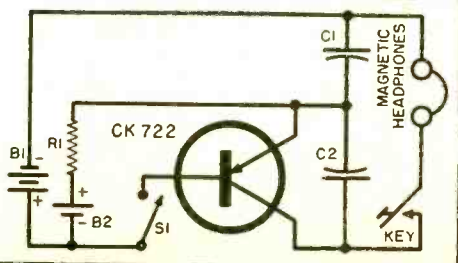

Now you CAN afford the beauty of HIGH FIDELITY!

A COMPLETE HIGH FIDELITY SYSTEM

for only
\$49.95

NET
In Mahogany or Blonde
slightly higher South
and West

amazing new *Espey*
"ANDANTE"

**3-SPEAKER
PUSH PULL BEAM POWER
AUDIO AMPLIFIER**

makes any record player, changer, tuner, microphone, etc. into a SUPERB HIGH FIDELITY SYSTEM with performance equal to equipment costing \$150 to \$200!

TWO 6½" WOOFERS



ONE 4" TWEETER

Only ESPEY PIONEER ENGINEERING could make possible the "ANDANTE". . .

Since 1927 Espey has been a world leader in the design and manufacture of electronic and audio equipment of the highest precision. Espey engineers have long concentrated on the problem of attaining high-fidelity reproduction at a price within the reach of all—have finally developed the astonishing SUPER V-5 AUDIO CHASSIS.

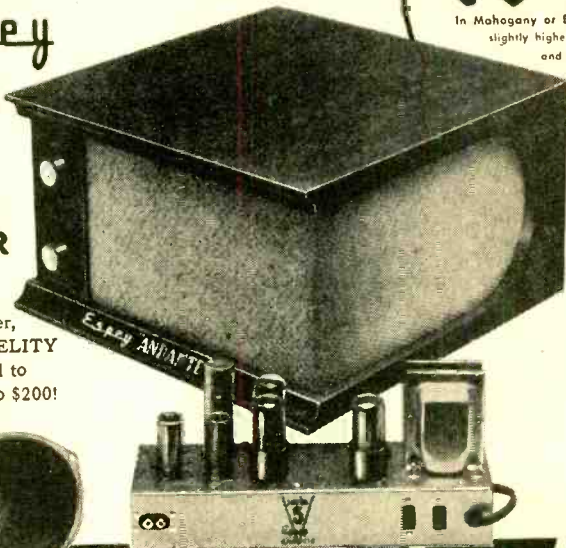

Look at all these almost-unbelievable quality features!

- PRECISION 5-TUBE AC-OPERATED PUSH-PULL BEAM POWER AMPLIFIER with power transformer.
- TUBE COMPLEMENT: 6X5GT, 12AT7, 12AX7, 2-6K6GT
- AUDIO DEGENERATION CIRCUITRY: special inverse feedback provides minimum distortion.
- AUDIO OUTPUT: 5 watts, wide range.
- OUTPUT CIRCUIT: special output transformer with crossover network for high frequency channel speaker.
- TWO SEPARATE LOW-FREQUENCY SPEAKERS: 6½-inch, side-mounted.
- ONE SEPARATE HIGH-FREQUENCY SPEAKER: 4-inch, front-mounted.
- HIGH-FIDELITY VOLUME CONTROL: automatic frequency-compensated circuitry maintains proper amount of compensation for "high" and "low" at every volume level.
- FREQUENCY RESPONSE CONTROL: enables user to adjust tone response to individual requirement of "high" and "low".
- COMPLETE UNIT AUDIO RESPONSE: 40-15,000 cps.
- CAN BE USED WITH ANY STANDARD RECORD PLAYER (RCA, Webster, VM, Columbia, etc., as well as any Tape Recorder, Tuner, Microphone, etc.)
- TWO INPUT JACKS TAKE EITHER A CRYSTAL OR MAGNETIC CARTRIDGE.
- DUAL AC OUTLET for other electrical appliances such as lamps, etc.
- CHOICE OF BEAUTIFUL FURNITURE FINISH: Mahogany or Blonde — hand-rubbed, high luster.
- COMPACT SIZE: only 8½" high x 15½" wide x 15½" deep. Shipping weight 22 lbs.
- FULLY GUARANTEED by the standard RETMA WARRANTY.

CUSTOM BUILDERS!
READY FOR MOUNTING ANYWHERE!
SUPER V-5 ESPEY CHASSIS
complete with **\$39.95** NET
3 SPEAKERS slightly higher South and West
already baffled, plus escutcheon and knobs, **LESS CABINET**

The "ANDANTE" is available at leading electronic parts distributors coast to coast. Write for name of distributor nearest you and free latest Catalog PE-4.

Espey

MANUFACTURING CO., INC.
528 East 72 Street, N. Y. 21, N. Y.

Electronics for Tomorrow



Brig. General David Sarnoff, RCA head, watches demonstration of "Electronic Light Amplifier."

MUSIC, television, recording, and air conditioning are major fields expected to benefit from new electronic developments recently demonstrated by RCA. Revealed to the public for the first time are an "Electronic Music Synthesizer," an "Electronic Light Amplifier," a new TV tape recorder, and an all-electronic cooling system.

The "Music Synthesizer" is an elaborate device that generates any tone produced by the human voice or musical instruments, as well as tones beyond the capabilities of these sources, including tones never heard

before. Capable of solo or ensemble effects, it is expected to open new horizons for composers who could take advantage of its almost limitless possibilities.

Another use of the synthesizer could be in phonograph record production. Since the unit can produce any sound imaginable, it may be used to rejuvenate old pressings into new records with full tonal range and complete freedom from noise and distortion.

In addition, the synthesizer can provide remarkably authentic renditions of older music since it can produce accurately the tones of the old instruments for which many great composers wrote. For music lovers, scholars, and historians, this feature should prove of great value.

Research and development of the synthesizer is under the direction of Dr. Harry F. Olsen, Director of Acoustical and Electro-mechanical Research at RCA's David Sarnoff Research Center, Princeton, N. J.

Equally sensational as a major development in a field followed by millions, but still largely experimental, is RCA's "Electronic Light Amplifier." Described as a new form of illumination, "electronic light" (also called "cold light") does not depend on combustion or incandescence as does conventional light. Rather it results from the excitation of electrons in certain luminescent materials. By using greatly



RCA's Dr. Harry F. Olsen operates keyboard of the new "Electronic Music Synthesizer."

amplified values of "electronic light," RCA engineers hope to perfect—by late next year—a new type of video known as "mural television" in which the present TV picture tube will be replaced by a thin, flat screen that can be hung on the wall like a picture. This development, combined with a wider use of transistors, is expected to eliminate the need for all electron tubes in TV sets and reduce its size to that of a small box, containing all the circuitry and controls needed to enjoy programs on the wall mounted screen.

Electronic light and its amplification have potential applications in other fields such as radar and x-ray work, but details on these are not yet available.

Heralded as a major step into a new era of "electronic photography" is RCA's new TV tape recorder, now installed for field tests at the *National Broadcasting Company*. Both color and black-and-white telecasts can be recorded on tape, and an unlimited number of copies made quickly and

cheaply. Ultimate uses of this device are forecast in the motion picture industry which could use the process to make movies without any photographic developing. Pictures can be viewed the instant they are taken. The new device will also aid telecasting, education, and industry in general, to say nothing of its tremendous potential for home use. TV tape recorders are expected to become as widely used as sound tape recorders.

The fourth electronic wonder at hand is an air conditioner that works without any moving parts, motors, or compressors—a completely noiseless machine. Prototype of this development is a small electronic refrigerator in which cooling is achieved by the so-called "Peltier effect" in which current through two dissimilar materials produces a cooling effect in the region of the junction, like a kind of reverse thermocouple effect. The problem here is largely one of researching the right materials to do the job. END

NEW 50-X-MINIVEX MICROSCOPE REVEALS NATURE'S HIDDEN WONDERS

This  tiny speck changes into:



2 1/4
INCHES
HIGH



this

ENLARGES
AREA UP TO
2,500
TIMES

The MINIVEX costs only 1.98—yet it gives you a "million dollars" worth of thrills. This miracle of German production reveals a New World of hidden wonders—a world of infinite variety and beauty. NOT A TOY—yet it's more thrilling than any toy—and far more educational for young & old. Get yours today on our money-back guarantee.

**IMPORTED
FROM WEST GERMANY**

1.98

NOW—thanks to German efficiency and high precision workmanship—you can own this high power microscope at an unheard of price. The 50-X-MINIVEX is pocket size . . . only 2 1/4 inches high . . . but you get terrific power! Imagine it—two thousand five hundred times area magnification! So powerful that a tiny gnat looks like a pre-historic monster!

Educational . . . Fun for Young and Old!

The 50-X-MINIVEX provides endless fun and thrills for young and old. Reveals nature's hidden wonders . . . the wondrous formations in a drop of water . . . the God-given beauty of leaves, flowers, cells, tissue, inorganic matter. Ideal for study of textiles, blood specimens, foods, minute plant life. Also for home and lab study of botany, zoology, nature, chemistry.

Optically-Ground Lenses! Super Viewing!

The powerful lenses made by German optics craftsmen give you super-sharp viewing! Durable metal construction and push-button operation. Get several now on a 5-day money back guarantee. Send check, cash or m.o. for immediate free delivery. COD's plus charges. **RUSH** order now! Remember: you must be delighted or money back quick!

INTERNATIONAL BINOCULAR CO.

352 Fourth Ave., Dept. 71-D-12 New York 10, New York

TV Station Sports Novel Antenna Tower

TELEVISION engineers chose the highest peak in the mountains surrounding the town of Stuttgart, Germany, as the site of the 483-foot broadcasting tower which will begin its operations this coming summer. Atop the 1480-foot summit of *Hoher Bopser*, the TV tower will attain a total height of 1963 feet.

The unique feature of this structure is the location of the transmitter which is directly below the antenna, but at the top of the concrete and steel spire. This circular portion above the shaft will also house television studios, beer gardens, wine rooms, kitchens, and telescope platforms to view the German Alps. The foot will contain restaurants and ultra-short-wave studios.

City officials selected the unusual needle-shaped design of Dr. Ing. Fritz Leonhardt because it will place Stuttgart on the tourists' maps as the home of a landmark completely unlike the Leaning Tower of Pisa and the Eiffel Tower in Paris.

The base diameter is 28 feet, extending 15 feet beneath the mountain's surface on a ring foundation fitted with hydraulic presses to keep the tower vertical despite the strong wind velocity.



Alarm Bell and Light Signal Fire in Home

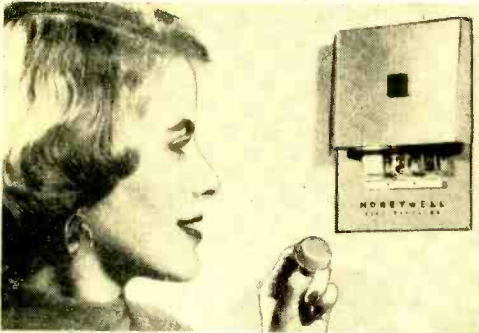

FIRE anywhere in the home is instantly signalled by *Minneapolis-Honeywell's* new fire alarm panel mounted in a bedroom, hallway, or other convenient location. The alarm is activated by temperature-sensitive elements installed in walls and ceiling in as many as 30 locations throughout the house. The instant one of the fused link elements detects any abnormal rise in temperature, the alarm bell sounds and a light on the panel indicates the area of the house in which the blaze is located. The system divides a house into three zones. List price is \$55.00.

Economical Kit Builds Hi-Fi FM Tuner

COMPANION piece to the V-5 AM tuner (*POPULAR ELECTRONICS*, February 1955, page 47) is the new V-9 FM tuner now being sold in kit form directly from the manufacturer, *Approved Electronic Instrument Corporation*, 928 Broadway, New York 10, N. Y.

The V-9 high fidelity FM tuner is recommended as one of the initial units for a hi-fi or binaural installation. Features are: a self-contained a.c. power supply; tuning range from 88 to 108 mc.; bandwidth of 200 kc.; 2 limiters and discriminator; sensitivity of 10 microvolts with 20 db of limiting; tuned r.f. stage; and a 3-section variable tuning capacitor. Dimensions are $9\frac{3}{4}'' \times 5'' \times 5\frac{7}{8}''$.

The complete kit of parts, including the



a.c. power supply, tubes, and pictorial and schematic diagrams is priced at \$29.50. Additional information and performance data are available from the manufacturer. END

HOME-MADE BLOWER CLEANS TIGHT CORNERS

WHETHER you're building a new piece of gear or repairing the family radio, it seems that metal shavings, scraps of wire, and small pieces of insulation have a habit of getting into inaccessible corners—only to come out and cause trouble when you least expect it.

A miniature blower with a fine nozzle is ideal for cleaning metal filings and scraps of wire and insulation from a chassis. You can make up a handy blower in a few minutes. All you need is an 18- to 24-inch length of soft rubber tubing and an old medicine dropper. Both dropper and tubing should be available at your neighborhood drugstore.

Remove the rubber bulb of the dropper and slip one end of the rubber tubing in place and your blower is completed! To use it, slip the free end of the rubber tubing in your mouth and blow! Direct the air stream where you want it by holding the glass dropper (which now becomes an air nozzle) in your hand.

For best results, use a dropper with a fairly narrow opening and make sure that the rubber tubing fits tightly in place. If it

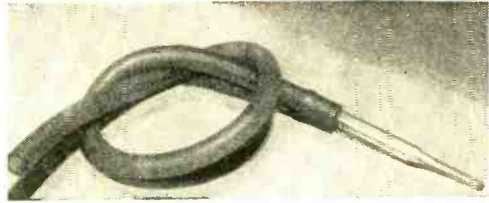

The completed blower. If the rubber tubing does not fit tightly, tie it with silk thread.

doesn't fit properly, tie the tubing tightly with a piece of silk thread. Wrap several turns around the tubing and dropper before tying the final knot to insure a good fit. **END**

Using the completed blower to clean a chassis. The dropper now becomes a miniature nozzle.

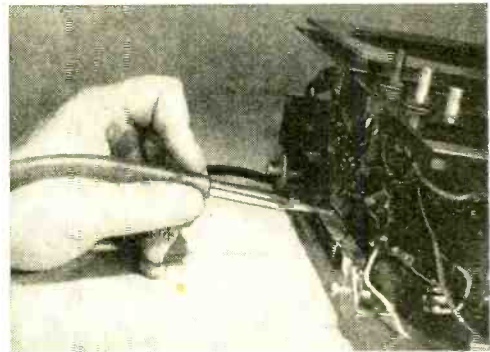

IMPORTANT TELEVISION DISCOVERY!

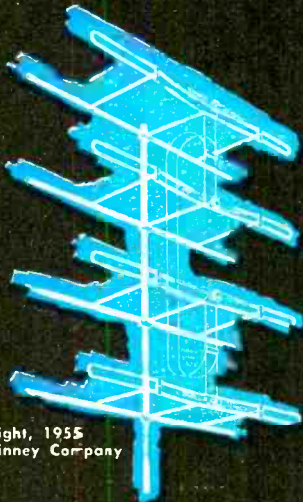

Copyright, 1955
The Finney Company

GET THE COMPLETE STORY
... Write For
Free Literature!

FINCO® F-4 Fringe Area
TV
ANTENNA
(PAT. PEND.)

with exclusive
FIDELITY PHASING...

From the world famous laboratories of FINCO has come a TV antenna that makes all other antennas on the market obsolete. The new FINCO Model F-4 is the realization of the dream of electronic scientists to find a perfect broad-band antenna — an antenna that would give superb gain on both low and high-band channels in the super-fringe area (up to 150 miles or more from station).

THE NEW FINCO F-4 WITH MIRACLE FIDELITY PHASING ACTUALLY COSTS LESS than many ordinary fringe area antennas now on the market. When you buy a new TV set or replace your present antenna, insist that your serviceman install a FINCO F-4!

THE FINNEY COMPANY • Dept. PE-45
4612 ST. CLAIR AVENUE
CLEVELAND 3, OHIO

Carl & Jerry

(Continued from page 75)

"Second, I know my hobby will never be outgrown. It has an equal fascination for all ages. Teen-agers, the middle-aged, and retired people are all represented on the ham bands. Both of us know hams who have been following the hobby for thirty or forty years and are just as enthusiastic about it now as they were when they started. One reason for this, I think, is the fact that the hobby is a live and growing thing. New techniques and equipment are constantly being discovered and put to use. I like to hear the old-timers talk about how they've stuck with their hobby from the time they built their first rotary-gap spark transmitter through self-excited vacuum-tube transmitters, crystal-controlled rigs, the first crude telephone equipment, narrow-band frequency modulated jobs, mobile installations, and now single-sideband suppressed-carrier transmitters. Several hams are actually building and using their own facsimile and television transmitters.

"And I must admit that being a ham does nice things to my ego. Here I am working with tiny electrons that can't be seen, felt, heard, tasted, or smelled; yet these powerful little 'assumptions' hop to my command and will carry my voice halfway around the world. When I try to explain what goes on in my equipment to a non-ham, he looks at me as though I were speaking an unknown foreign tongue. All this makes me feel smart and powerful.

"Another good thing about the hobby is that it's one a whole family can enjoy right at home. More and more husband and wife amateur teams are heard on the ham bands these days; and it's not at all unusual to find families in which the parents and all the children hold amateur tickets. When so many present-day forces tend to pull families apart, it is nice to discover a hobby that can draw them closer together."

"Now wait just a little minute!" Carl exploded. "If you think I'm going to stand up in front of that English class and say I'm looking forward to having a silly wife and a bunch of little brats help me work my ham rig, you've got rocks in your head. I'd never live it down. I can just hear those dizzy dames in the class snickering right now."

"All right, all right!" Jerry soothed. "Leave it out, even though it is a good point. Instead, you can sign off with this thought: as we two have just demon-

strated, one of the best things about this hobby is that it has so many different appeals. If you like to build things with your hands and watch them work, ham radio is your dish. The fellow who likes to study abstract theory will find an equal fascination here. Using code will appeal to the person who likes to master an exacting skill. If you are the social type and get your kicks out of just yakking with other people, amateur radio is the perfect hobby. The experimenter who loves to try new circuits and techniques will never run out of material in his ham shack. And the person—"

"Hold it!" Carl broke in. "I think I've got the perfect idea to close the talk. You know how hipped Miss Richason, our English teacher, is on the use of quotations. Well, I happened to be glancing through a book on Roman history in the library the other day—this was my Latin teacher's idea; not mine—and I read a couple of paragraphs in which the writer was explaining why that doll, Cleopatra, was able to snow all the guys back in her day. As he saw it, she could do this because her personality had so many different forms. As he put it rather neatly, taking a line from the Bible, she was 'All things to all men.' How's about my saying that this is a perfect description of ham radio? All of us are in love with our hobby and never grow tired of it because it is 'All things to all men.'"

"Perfect!" Jerry applauded. "If that doesn't wangle an 'A' for you, I'll eat my log book. And now we've talked about ham radio so much that I'm beginning to feel a nasty surge of ambition. What say we go down into the basement and put in a few licks on that two-meter rig of mine?"

"I'm with you," Carl exclaimed as he jumped to his feet. "Let's go!" END

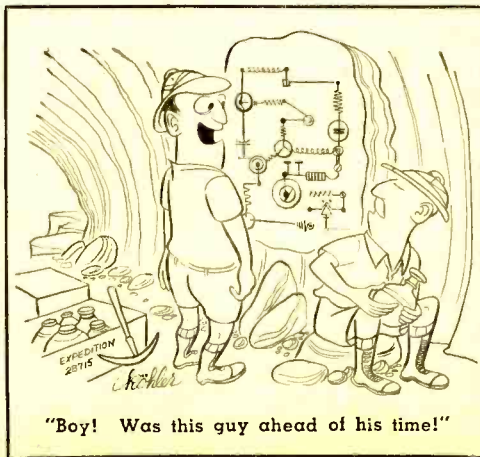

Disc Review

(Continued from page 67)

honors by a hair. The *London* sound is hugely proportioned, with superb string tone and by far the best percussion. The *Westminster* is a little wiry at times, but takes top honors for orchestral balance. The Toscanini is considered the great performance, but unhappily, while the sound is generally good, it does not measure up to the *London* or *Westminster* and the Toscanini talent is poorly served. The principal fault is in the acoustic treatment and the vocal articulation. The von Karajan recording is considered by many to be the best and he certainly gives much evidence to support these contentions. Balance, tempi, dynamics—all are excellent but they are not helped by a sound quality which betrays its 78 rpm origin. The Walter is an odd one. The *Columbia SL-156* gives splendid performance with fair sound. The *Columbia SL-186* has the same Walter performance with the difference being that the last movement was re-recorded at a later date with sound far superior to the rest of the set. Summing up, for the last word in the sound department the *London* would be the choice. The Toscanini is the recording of choice for the best performance with reasonably hi-fi sound.

For a modern choral work, there is an absolutely magnificent score, *Belshazzar's Feast* by the contemporary British composer, Sir William Walton. Fortunately, the sole recording is one of the finest of its type. Sir Adrian Boult gives a stunning performance on *Westminster* 5248. Always a popular work in England, it has gained a wide

audience in this country since the recording became available. It is really exciting with some of the most shattering choral climaxes ever recorded. This is the way all choral recordings should sound. The choral blur and "fusion" is at a minimum and the delineation of the vocal line is extraordinary. Throughout, the recording is extremely wide range, with little distortion and with fabulous dynamics. String tone is generally good, brass is particularly bright and weighty, and percussion is a hi-fi delight. There is plenty of it from the crash of cymbals to the thunder of tympani and bass drum. Acoustic perspective is perhaps the most exceptional feature of this recording and lends "presence" to the chorus and orchestra that is uncanny. Sir Adrian and the London Philharmonic Choir and Promenade Orchestra do nobly with the complexities of this difficult score. An outstanding recording, particularly recommended to those who still are not convinced that choral works can be among the most satisfying of musical experiences.

Next month, back to the symphonic, straight orchestral repertoire, with reviews of some of the more important tone poems. END

AUDIO FANS!

Keep up with the latest record releases on all labels by reading Bert Whyte's monthly "Certified Record Revue" in our sister publication, **RADIO & TELEVISION NEWS**. Available at all newsstands!

Get This Valuable Book

FREE



Just for Examining COYNE'S New 6-Volume Set

"Applied Practical Radio-Television"

ON 7 DAY
FREE
TRIAL!



Yes, you get this big, brand new book, "150 Radio-Television Picture Patterns and Diagrams Explained", absolutely FREE! Just off the press! Gives complete wiring circuits and diagrams on the latest Radio and Television Sets. Easy-to-read, large 8½ x 11" pages, with full instructions on how to read and use the diagrams. A "must" in every Radio and Television service-man's repair kit. You get this valuable book as a FREE Gift for asking to see Coyne's great new 6-book set, "Applied Practical Radio-Television"!

Here's "Know-How" That Makes You Worth More!

Coyne's great new 6-volume set gives you all the answers to servicing problems—quickly! For basic "know-how" that is easy to understand, you'll find everything you want in volumes 1 to 5 which contain over 5000 practical facts and data. They cover every step from principles to installing, servicing, trouble-shooting and aligning all types of radio and TV sets. So up-to-date it includes COLOR TV and UHF, adaptors and converters. Also covers very latest information on TRANSISTORS.

900-Page Television Cyclopedia Included

And then, for speedy on-the-job use, you get volume 6—the famous COYNE TELEVISION CYCLOPEDIA. It answers today's television problems on servicing, alignment, installation and others. In easy-to-find ABC order, cross indexed. Use this 6 volume TV-RADIO LIBRARY free for 7 days; get the valuable Servicing Book ABSOLUTELY FREE!

SEND NO MONEY! Just mail coupon for 6-volume set on 7 days free trial. We'll include book of 150 TV-Radio Patterns & Diagrams. If you keep the set, pay \$2 in 7 days and \$2 per month until \$22.50 plus postage is paid. (Cash price \$20.95). Or you can return the library at our expense in 7 days and owe nothing. **YOU BE THE JUDGE.** Either way, the book of TV-Radio Patterns is yours FREE to keep! Offer is limited. Act NOW!

FREE BOOK—FREE TRIAL COUPON!

Coyne Electrical School, Educational Book Publ. Div., Dept. 45-PE
500 S. Paulina St., Chicago 12, Ill.

YES! Send 6-volume "Applied Practical Radio-Television" for 7 days FREE TRIAL per your offer. Include TV-Radio Patterns & Diagram Book FREE.

Name..... Age.....

Address.....

City..... Zone..... State.....

Where Employed.....

() Check here if you want library sent COD. You pay postman \$20.95 plus COD postage on delivery. 7-day money-back guarantee.

COYNE

Educational Book Publishing Division

ELECTRICAL SCHOOL

500 S. Paulina St., Dept. 45-PE Chicago 12, Ill.

MIDGETS

that
do

a
Giant Job

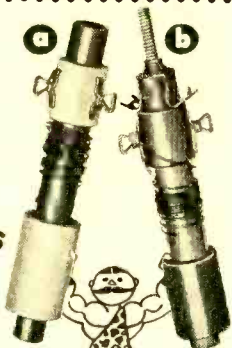

(A) Grayburne FERRI-LOOPSTICK
World's most sensitive, compact, efficient
small radio antenna..... **75¢**

(B) Grayburne VARI-LOOPSTICK
Same as Ferri-Loopstick with variable
micrometer adjustment..... **1.00**

Give your radio new life with this famous, proven replacement for old fashioned, inefficient loop antennas. Improves performance up to 5 times that of loop . . . brings in more stations sharp and clear. You'll be amazed with the results! Contains detailed, illustrated instructions for quick, easy installation.

DON'T ACCEPT IMITATIONS!

Ask for the Ferri-Loopstick and Vari-Loopstick by name at your local dealer.

SupereX ELECTRONICS CORP. successor to Grayburne
6 Radford Pl., Yonkers, N.Y.

EXPERIMENTERS • HAMS • TECHNICIANS

**MAKE YOUR OWN
PRINTED CIRCUITS**

Complete Kit **\$19.55**
ppd.

- USE MODERN TECHNIQUES
- MAKE CIRCUIT BOARDS TO YOUR OWN DESIGN AND LAYOUT
- CONTAINS ALL MATERIALS NEEDED TO MAKE SEVERAL BOARDS
- COMPLETE, STEP-BY-STEP INSTRUCTIONS
- SIMPLE EASY PROCEDURE FOR DESIGN LAYOUT

Make your newest design idea and layout in printed circuit techniques. Build complete, light-weight circuitry with professional appearance and finish. Kit contains complete materials and equipment—nothing else to buy. **MONEY BACK GUARANTEE.**

Send Check or Money Order to Dept. P-1

TELE-DIAGNOSIS CO.
155 WEST 72 STREET NEW YORK 23, N. Y.

BOOK REVIEWS

"QRD? SNOHOMISH" by Conrad Burns. Published by Pageant Press, N.Y., N.Y. 137 pages. Price \$2.50. Cloth bound.

Just to make things clear at the outset, "QRD?" is radiotelegraphy shorthand for "Where are you bound and where are you from?" "Snohomish" is the name of a fabulous tugboat. And Conrad Burns, the author, served aboard as radio operator ("Sparks" in the book).

This is the tale of the "longest towing voyage ever made out of the Northwest Coast of North America"—in which a 40-year old tug towed a cut-down LST with 6 modern steel-hulled tow-boats perched atop from Seattle to Buenos Aires. Told from the viewpoint of the radioman, the story is a chronicle of events ranging from the ridiculous to the perilous. "Sparks" was only 20 years old, still a probationer with his ticket unendorsed, but he helped roll the old ship down to Rio despite such handicaps as defective equipment, violent sea storms, and an old salt of a master who tended to trust the power of his lungs more than radio equipment as a means of communication.

This book should appeal to lovers of sea yarns. Moreover, it gives a revealing picture of what goes on in the wireless shack, framed in the kind of talkative and sincere humor that characterizes the professional radioman.

* * *

"RADIO-CONTROL HANDBOOK" by Howard G. McEntee, W2SI. Published by Gernsback Publications, Inc., N.Y., N.Y. 192 pages. Price \$2.25. Paper bound.

R/C fans who have a working knowledge of fundamentals will find this book a source of detailed information on the actual construction of many practical units. Also covered are troubleshooting, installation of equipment, and the choice of equipment for various needs. Very little theory is given; this book is aimed at those who may have a fair knowledge of electronics and possibly model design and construction, and want some practical hints for tying the two together. Most of the systems covered are for use in aircraft models, but fortunately, they may be easily adapted to other models, such as boats and vehicles. Clearly written and fully illustrated, this volume—despite its lack of an alphabetical index—should be of great value to the R/C builder.

"UNDERSTANDING HIGH FIDELITY" by Louis Biancolli and Lester H. Bogen. Published by *David Bogen Co., Inc.*, N.Y., N.Y. 56 pages. Price \$.25. Paper bound.

This is the second edition, revised and enlarged, of an earlier pamphlet issued by the *Bogen* organization about a year ago. Within its limitations as a "digest" version of a relatively complex subject about which volumes have been written, this little tome manages to furnish a good deal of basic information. And it does so in remarkably clear language that avoids engineering terms. The illustrations, while naturally emphasizing *Bogen* equipment, cover examples of other units as well as some attractive home installations.

Especially valuable is the booklet's emphasis on correct loudspeaker housing. Too often the speaker enclosure is neglected in quasi-sales presentations of hi-fi units. If the discussion, in this book, of enclosures and speaker placement helps make a point with the many newcomers to hi-fi, then the book will have performed a distinct service.

* * *

"A DICTIONARY OF ELECTRONIC TERMS" edited by Prof. Gordon R. Partridge. Published by *Allied Radio Corporation*, Chicago. 72 pages. Price \$0.25. Paper bound.

More than 3000 terms, abbreviations, and letter-symbols in radio, TV, and electronics are defined. This specialized lexicon indicates the extent to which the field of electronics has grown—to the point of creating its own language which requires standardization. Numerous illustrations enhance the book's value.

* * *

Free Literature Roundup

From time to time various organizations make available free literature of interest to POPULAR ELECTRONICS readers. Information on new pamphlets, etc. will be noted here as we are advised of them.

Hi-fi fans will want the new, attractive 30-page book on the *Karlson* loudspeaker enclosure. Amply illustrated, including do-it-yourself plans, the book should merit serious consideration by all audiophiles. For a free copy, write to *Karlson Associates, Inc.*, 1483 Coney Island Avenue, Brooklyn 30, N. Y., requesting "Booklet P80."

The new *Automation Dictionary* issued by *Minneapolis-Honeywell* defines over 75 terms used in automatic control. The growing importance of this field well warrants a booklet of this type, and this organization has performed a real service in preparing it. For a copy, write to the *Minneapolis-Honeywell Regulator Company*, Industrial Division, Wayne & Windrim Avenues, Philadelphia 44, Pa.

END

April, 1955



NEW low-cost CRYSTAL MICROPHONE



the modern
"926"

E-V quality features in handsome new slim design for public address, home tape recorders and communications. Frequency response is smooth peak-free 70-8000 cps. Assures faithful reproduction and clear QSO's. Output level -60 db. Hi-Z. Omnidirectional. Moisture - Sealed crystal. $\frac{5}{8}$ "-27 thread stand coupler. Tiltable, die cast case, finished in Satin Chromium. Size 1 $\frac{5}{16}$ " x 6 $\frac{3}{4}$ " including swivel mount. 18 ft. cable. Net wt., 11 oz.

List Price \$24⁵⁰

Ask your E-V Distributor
or write for literature.

NO FINER CHOICE THAN

Electro-Voice

BUCHANAN • MICHIGAN
Export: 13 E. 40th, N. Y. 16, U.S.A. Cables: Arlab

THE WORLD AT A TWIRL

By K. R. BOORD

THIS month features "Best Bets for the Beginner and the Experienced SWL," especially compiled on a geographic basis for this column by monitors for the International Short-Wave Department of RADIO & TELEVISION NEWS.

Items preceded by an asterisk (*) are intended primarily for experienced DX-ers—but that does not mean that beginning SWL's cannot log them by careful tuning, patience, and perseverance! These compilations refer to stations that should be heard during the spring months. However, don't forget that short-wave reception conditions vary from day to day. For certain stations found on summertime schedules, subtract one hour from the listings. Many stations make seasonal changes in their schedules with little or no advance notice. Be on the alert for announcements concerning new schedules and/or frequencies. Remember, time listed is in American EST! (See footnote).

Eastern North America

**Albania*—Worth many "tries" is ZAA, 7.850A, "Radio Tirana," with English 1530. . . . *Argentina*—LRY1, 9760A, Buenos Aires, "Radio Belgrano," should be good level 2100-2130. . . . *Australia*—VLB9, 9.615, Melbourne, is good level, slight QRM during daily transmission to Eastern North America 0700-0845; news 0715, 0815; has FB DX news session Sunday 0830; listen for distinctive sign-on with call of the Kookaburra Bird. . . . **Belgian Congo*—Try for OTM2, 9.380, Leopoldville, "Radio Congo Belge," around 0000-0100 in French. . . . *Belgium*—ORU, 6.085A, Brussels, has news 2000-2008 in English session to North America which runs 2000-2200 closedown. . . . *Brazil*—ZYK3, 9.565, Recife, has musical session 2000-2030; weekdays this is in

English and is called "Brazil Calling." . . . *Bulgaria*—"Radio Sofia," 6.070, is a powerhouse signal in English for North America 1930-2000.

**Canary Islands*—EA8AB, measured 7.505, Tenerife, noted 1729 in Spanish. . . . *Ceylon*—The "Commercial Service of Radio Ceylon," 9.520, Colombo, has local news 0745, BBC news relay 0800; runs to 1200 or 1230 on this (best) channel; verifies with an attractive, large QSL card. . . . **China*—If you're extremely lucky and persistent, perhaps you can pick up "Radio Peking" on its currently best channel, 11.300, in Asiatic-language session 1730-2030, and by use of greatest possible usable selectivity, you might log this real Asiatic DX "catch" during one of its English sessions—2200-2230, 0400-0430, 0930-1000. . . . *Costa Rica*—TIFC, 9.647 (best) and 6.037, San Jose, "The Lighthouse of the Caribbean," has religious sessions in English daily 2300-2400A. . . . *Cuba*—COCQ, 9.670A, Havana, has musical session 1830-1930; Spanish language. . . . *Czechoslovakia*—"Radio Prague," 7.255V and 9.550, can be heard with English to North America at 1930 and again at 2300; the 7.255V channel may suffer ham QRM at times.

Haiti—"Radio Commerce," 4VC, 9.485, Port-au-Prince, has English on Sunday only 1700-1730; and over 4VB, 6.091A, Wednesday only 2200-2215. . . . *Holland*—"Radio Nederland," 11.730A, Hilversum, has English 1645-1725; was one of the world's earliest short-wave stations. . . . *Hungary*—Radio Budapest, 6.248A, parallel 9.833A, can be logged easily at 1700-1730 in English. . . . *India*—New Delhi, 9.840, offers a good chance to log and verify the Asiatic continent at 0830 when opens in English for Southeast Asia; news 0835; runs to 0945. . . . *Israel*—Tel Aviv, 9.009A, has news daily 1515; is usually good level then, but should be better at 1615-1715A when takes the "Voice of Zion" relay from Jerusalem (English Edition).

Italy—Rome, 9.575A, parallel 6.010, has English to North America 1915-1935. . . . *Jamaica*—"Radio Jamaica," 4.950, Kingston, is good daily around 0800 when relays

NOTE: Unless otherwise stated, all time herein is expressed in American EST (Eastern Standard Time); add 5 hours for GMT (Greenwich Mean Time). "News" refers to newscast in the English language. To avoid confusion, the 24-hour clock has been used in designating the times of broadcasts. The hours from midnight until noon are shown as 0000 to 1200, while from 1 p.m. to midnight they are shown as 1300 to 2400. The symbol "V" following a listed frequency or a time schedule indicates "varying." "A" means that frequency—or time schedule—is approximate.

BBC news from London; is fair to good on 3.360 evenings to 2300 closedown. . . .

**Japan*—With careful tuning and patience, you may be able to tune in JOB3, 9.675, Tokyo, with news 0700. . . . **Liberia*—Another nice catch would be ELBC, 6.022A, Monrovia, heard recently at fair level 1800, but with heavy QRM; closes 1845; English.

**Madagascar*—For real DX, also try 9.515 at 2230 for the sign-on, in French, of "Radio Tananarive." . . . **Mexico*—XEWV, 9.500, Mexico City, is an easy one, very strong 1600-2400 in Spanish. . . . **Monaco*—3AM4, 7.349, "Radio Monte Carlo," should be logged easily around 1700 when identifies in French as "Ici Monte Carlo"; irregularly has English (religious) sessions 1700-1730 or later. . . . **Peru*—OAX4Z, 6.082A, Lima, has news 2300-2315, closes 2400. . . . **Poland*—You may be able to get "Radio Warsaw" out of the QRM on 6.025 around 2130-2200 when has English for North America. . . . **Portugal*—"Emissora Nacional," 15.050AV, Lisbon, should be logged 0600-1000 in Portuguese; is usually fine level in North American beam, also all-Portuguese, 1900-2100 over 9.746A; has fine music.

Turkey—TAP, 9.465, is usually good level with English to Western Europe, British Isles 1600-1645, parallel TAS, 7.285 (later in summer will probably replace 7.285 with 15.160). TAT, 9.515, is consistently strong in beam in English, with typical Turkish music, news, commentaries, daily to North America 1815-1900. . . . **USSR*—Try 5.965 or 5.930 at 1330 for newscast. . . . **Vatican*—Tune HVJ, 11.685, at 1000 when has news. . . . **Yugoslavia*—"Radio Belgrade," 6.100, should be good level with news 1715-1730.

Midwest, Southwest, Mountain Areas

**Angola*—CR6RC, 11.862A, Luanda, may be heard like a "local" in Indiana before closes 1600 or later; weak in Texas 1600. . . . **Argentina*—LRA, 9.690, Buenos Aires, "Radio del Estado," is easily identified around 1930; LRV1, 9.760, "Radio Belgrano," is local-like in Ind. 1945; best in Texas 1330-2300. . . . **Australia*—Try for "Radio Australia" on 11.760 around 1530; is consistently good in Indiana. Tune VLB9, 9.615, during the Eastern North American beam 0700-0845, news 0715, 0815; DX news session Sunday 0830. Most of the year you should be able to log VLM4, 4.920, Brisbane, Queensland, around 0800 when relays BBC news, followed by ABC news. VLI9, 6.090, Sydney, New South Wales, should be good level when closes 0830. . . . **Belgian Congo*—Try 9.655 for OTC, Leopoldville,

April, 1955

FIX TV SETS TWICE AS FAST!

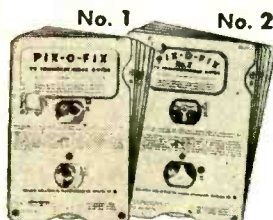

PIX-O-FIX TV TROUBLE- FINDER GUIDES

Just turn the PIX-O-FIX dial until the picture in its window shows the same trouble symptoms (wavy lines, snow, no raster, "squeezing" distortion, etc., etc.) as the picture on the TV set you're repairing. PIX-O-FIX then tells the possible trouble causes and gives step-by-step repair instructions. It's as easy as that! The two PIX-O-FIX units No. 1 and No. 2 cover 47 different television troubles . . . just about anything you're likely to be called on to fix. No. 1 identifies 24 of the most common troubles and gives 192 causes and 253 remedies. No. 2 covers 23 more advanced troubles not included in No. 1. Together, they are a comprehensive guide to quick "picture analysis" servicing of any TV set . . . AND THE PRICE IS ONLY \$2.00 FOR THE TWO. Use coupon to order.

**CUT TIME
IN HALF on
2 jobs out of 3**

Now! Handle television receiver troubles by easy picture analysis. Let these famous PIX-O-FIX Guides tell you what is wrong . . . then show exactly how to fix it.

Just turn the PIX-O-FIX dial until the picture in its window shows the same trouble symptoms (wavy lines, snow, no raster, "squeezing" distortion, etc., etc.) as the picture on the TV set you're repairing. PIX-O-FIX then tells the possible trouble causes and gives step-by-step repair instructions. It's as easy as that!

The two PIX-O-FIX units No. 1 and No. 2 cover 47 different television troubles . . . just about anything you're likely to be called on to fix. No. 1 identifies 24 of the most common troubles and gives 192 causes and 253 remedies. No. 2 covers 23 more advanced troubles not included in No. 1. Together, they are a comprehensive guide to quick "picture analysis" servicing of any TV set . . . AND THE PRICE IS ONLY \$2.00 FOR THE TWO. Use coupon to order.



HIGH FIDELITY TECHNIQUES

by John H. Newitt

The book that says goodbye to guesswork in choosing, building and servicing hi-fi equipment.

512 pages
203 pictures
Price \$7.50

PUT THE HIGH IN HIGH FIDELITY!

Whether you specialize in high fidelity service, custom building or simply want to build a top-notch "hi-fi" outfit for yourself, this big 512-page book will guide you every step of the way.

Helps you get better results at less cost. Shows what to do . . . what mistakes to avoid. Gives a full understanding of the different methods, circuits, designs, equipment, components and other subjects that are debated whenever hi-fi fans get together.

High Fidelity Techniques is complete, authentic and easy to understand. From beginning to end, it is chock-full of hints, custom-building ideas and data, charts and diagrams of the most helpful sort.

USE COUPON TO ORDER!

Dept. PE-45, Rinehart & Co., Inc.
232 Madison Ave., New York 16, N. Y.

Enclosed is \$2.00 for PIX-O-FIX Nos. 1 and 2. You guarantee to refund my money if I return them in 10 days.

Send book HIGH FIDELITY TECHNIQUES for 10 days FREE EXAMINATION. If I like book, I will promptly send \$7.50 (plus postage) in full payment. Otherwise I will return book postpaid and owe you nothing.

Name _____

Address _____

City, Zone, State _____

when it relays ORU, Brussels, in English to North America 2000-2200 closedown. *OTM1, Leopoldville, "Radio Congo Belge," on new channel 6.140A is often audible with intriguing interval signal and actual sign-on 0000. . . . *Belgium*—ORU, 6.085, Brussels, should be good signal in 2000-2200 English beam for North America. . . . **China*—"Radio Peking," 11.300, is sometimes fair level 1900 with new interval signal easily recognized by "Red March." Heard in mountain area on 11.930, 11.300 with English 2200-2230. *Costa Rica*—TIDCR, 9.618A, San Jose, "La Voz de La Victor," can be logged at good level 2200. YIFC, 9.647, has strong signal 2200-2400A closedown; has English last hour. *Ecuador*—HCJB, 11.915A, Quito, is good level 1900-2400 or later. . . . *Egypt*—"Radio Cairo," 9.475, often shows at 1300 sign-on; news 1330; the 7.045A channel is often strong level with Arabic 0015-0030. *Germany*—"Deutsche Welle," Cologne, "Overseas Service," can be logged on 5.980 during North American beam 2030-2330; some English. . . . *Guatemala*—TGWA, 9.765A, is good signal around 0900-1900. . . . *Haiti*—"Radio Commerce," Port-au-Prince, noted with English feature, "Glimpses of Haiti," on Sunday only 1730-1745; has English Wednesday only over

6.091A at 2200. . . . *India*—AIR, 9.840, New Delhi, is good signal opening in English 0830; news 0835, closes 0845. . . . *Israel*—4XB31, 9.008, Tel Aviv, is an easy mark by 1600 and usually has English 1615-1715A. . . . *Italy*—"Radio Italiana," 9.575A, Rome, is good level with English 1920A to North America. . . . **Philippines*—DZH7, 9.730, Manila, noted 1000 in English. . . . *Portugal*—"Emissora Nacional," Lisbon, is noted around 0730, good level on 11.996A, parallel 15.050AV; all-Portuguese. . . . *Spain*—Madrid, 9.363AV, is strong level around 2015. . . . *Surinam*—PZC, 15.405A, Paramaribo, radiates a strong signal, as a rule, by 1830 and, at times, may be found with English for short periods; most sessions, however, are in Dutch. . . . *Sweden*—"Radio Sweden," 9.535, is good level 0900, with English for Western North America 1100. . . . *Switzerland*—Berne, 9.535, is fair around 2030 when opens to Eastern North America; in Texas is much stronger by 2330. . . . *Thailand*—HSK9, 11.670, Bangkok, is one of the most consistent of the Far East outlets with strong level (although with bad QRM and CW QRM at times), when identifies in English 0800 opening Thai (native) transmission; also identifies 0900; should have English session 0530-0625A. . . . *USSR*—A good "Ra-

<p>R/C MODELS for BEGINNER AND EXPERT</p>	<p>MULTI-SERVOS POWERFUL-DEPENDABLE MOTOR DRIVEN R/C ACTUATORS</p>	<p>FOR ADVANCED FLYING:</p>
<p>FOR BEGINNERS:</p> <p>48" SPAN</p>  <p>LIVE WIRE "TRAINER" WORLDS MOST POPULAR R/C MODEL</p> <p>A quickly built model of medium size, stable, rugged and simple to fly. Features a removable R/C PRE-FAB. unit. KIT \$6.95</p>	<p>Ample power to move any model control. A great models, one for every purpose.</p> <p>2oz. CAP.</p>  <p>Positive-Flow FUEL TANK</p> <p>Gives perfect fuel flow under all flight attitudes, upright or inverted. The tank with the internal swivel.</p> <p>DESCRIPTIVE LITERATURE FREE SERVO INFO BOOKLET75c</p> <p>\$11.95 TO \$14.95 \$1.29</p>	<p>65" SPAN</p>  <p>LIVE WIRE "CRUISER" FOR THE ULTIMATE IN R/C FLYING</p> <p>A big, high performance, realistic model capable of carrying the heaviest of equipment with ease. Has elevators and a re-movable R/C unit. KIT \$14.95</p> <p>deBOLT MODEL ENGINEERING CO. BOX 73 WILLIAMSVILLE, N. Y.</p>

EASY! BUILD your own Professional Electronic Instruments with EICO KITS! SAVE 50%

• Complete easy-to-follow instructions • Fully guaranteed

<p>3" PUSH-PULL OSCILLOSCOPE</p>  <p>KIT \$44.95 WIRED \$79.95</p>	<p>VACUUM TUBE VOLTMETER</p>  <p>KIT \$25.95 WIRED \$39.95</p>	<p>1,000 Ohms/Volt MULTIMETER</p>  <p>KIT \$12.90 WIRED \$14.90</p> <p><small>Prices 5% higher on West Coast.</small></p>	<p>6V & 12V BATTERY ELIMINATOR & CHARGER</p>  <p>KIT \$29.95 WIRED \$39.95</p>
---	---	--	--

Write now for FREE Catalog PE-4 describing 38 EICO Kits.

EICO ELECTRONIC INSTRUMENT CO., INC.
84 Withers St., Brooklyn 11, N. Y.

dio Moscow" channel is 7.250A, noted with English to North America around 1800-2400.

The Far West

Canada—CFRX, 6.070, Toronto, Ont., usually is good strength on West Coast when opens 0500. . . . **Ceylon**—For the "Commercial Service of Radio Ceylon," Colombo, tune 9.520 at 0630-1230 closedown; 15.120 at 2030-2200, with BBC news relay from London 2100. . . . **China**—For "Radio Peking," tune 11.960, 15.060, or 15.380 at 2200-2230; 11:300, 11:650A, 15.100A, 0930-1000—both these sessions are in English. The Home Service is heard in Calif. opening in Chinese on 7.170 at 0355, parallel with 5.970, 6.103A, 7.500, 9.080A.

France—"Paris-Inter," 6.200, noted at good level with news in French 0315; is usually good signal 0200-0400; the 7.220 Paris channel is heard after 0300, but is usually cut up badly by ham QRM; is not parallel with 6.200 then. . . . **Fr. Equatorial Africa**—For news from "Radio Brazzaville," try the new channels of 9.625A and 9.725A, along with the old standby, 11.970, at 1745-1800. . . . **Germany**—"Radio Free Europe," 9.750, 9.695, 9.655, 7.145, is heard on West Coast with strong signals 1800-1900; lately has had a little English. . . . **Haiti**—Tune 4VB, 6.091, on Wed. at 2200-2215 when has English. . . . ***Indo-China**—"Radio France-Asie," 9.765AV, Saigon, should be heard around 0830-1130; news 0900. ***"La Voix de Vietnam,"** 9.625, Saigon, noted with English Lesson some days 0640, fair signal; 7.263 is audible at same time but with separate session in native.

***Iraq**—Try for "Radio Baghdad," HNG, 11.702A, around 1124 when has Arabic vocal music, native instruments. At some seasons, may be audible 1415-1500 close-down when has English session. . . . **Japan**—For "Radio Japan," Tokyo, try JOA3, 9.695, and JOB4, 11.780, 0000-0100, when beam is for Western North America; and at 0200-0300 when beam is to Hawaii. For the "Far East Network" (AFRTS), Tokyo, tune 11.750 at 1600-0445; 6.160 at 0500-1000; carries English with AFRTS news 1700, 0500, 0945. . . . **Malaya**—The "British Far Eastern Broadcasting Service," 9.690, Singapore, opens 0415 to Indonesia; at 1100 relays BBC news, parallel with 7.120; closes 1135. Other channels you can "try" between 0415-1135 are 15.435, 11.820. . . . ***Mozambique**—Tune CR7BU, 4.920A, Lourenco Marques, opening 2300 in English with popular request session, commercials, and frequent time checks (7 hours ahead of EST; 10 hours ahead of PST).

New Caledonia—"Radio Noumea," 6.035, is usually high level around 0215-0230 with classical music, announcements by man in French. . . . **Okinawa**—For the Voice of

LEARN basic electricity electronics

THE EASY "PICTURE BOOK" WAY!



Just Released: The fabulous ILLUSTRATED Training Course now used by the U. S. Navy!

You Learn by Pictures

Over 25,000 Navy trainees have already learned Basic Electricity and Basic Electronics this easy, "Picture Book" way! Now, for the first time, YOU can master the basics of Electricity and Electronics with this same "Learn-by-Pictures" training course! Over 1,700 simple, easy-to-understand drawings explain every section—these "teaching" pictures actually make up more than half the *entire* course! No other Basic Electricity or Basic Electronics course in America uses this revolutionary illustrative technique! You learn faster and easier than you'd dream possible!

A Complete Idea on Every Page

Here's how this easy, illustrated course works: *every page* covers one complete idea! There's at least one big illustration on that *same* page to explain it! What's more, an imaginary instructor stands figuratively at your elbow, doing "demonstrations" that make it even *easier* for you to understand. Then, at the end of every section, you'll find *review pages* that highlight the important topics you've just covered. You build a thorough, step-by-step knowledge at your own pace—as fast as you yourself want to go!

Everyday English—A Course Anyone Can Understand

Sponsored by the Navy to turn out trained technicians in record time, this modern course presents Basic Electricity and Basic Electronics in a simple way that *everyone* can grasp—regardless of previous education! Every phase is made *instantly* clear—explained in plain, down to earth English—with hundreds of easy-to-understand illustrations to help you!

10 Complete Volumes

Volumes 1 and 2 of "Basic Electricity" cover DC components and circuits; Volumes 3 and 4 cover AC components and circuits; Volume 5 covers AC and DC motors and machinery.

Volume 1 of "Basic Electronics" covers Diodes & Power Supplies; Vols. 2 and 3 cover Amplifiers & Oscillators; Vols. 4 and 5 cover Transmitters & Receivers.

Home Study Without Correspondence

This course is so *different*, so *complete*—there's no need for the usual letter writing, question and answer correspondence! Learn at home—at your own pace!

10 Day Examination—Money Back Guarantee

Send today for these exciting new training courses—you *risk nothing*! When you receive the volumes, examine them in your own home for 10 full days. If, at the end of that time, you're not completely satisfied, simply return the books to us and we'll gladly *refund your full purchase price*! Total cost for either 5-volume course is only \$9.00! In Canada, prices approximately 5% higher.

ORDER TODAY!

These books are sold by electronics parts jobbers and book stores. If YOUR dealer doesn't have these books, mail this coupon to us!

JOHN F. RIDER PUBLISHER, INC.
480 Canal Street, N.Y.C.

Please RUSH me _____ sets of "Basic Electricity" @ \$9.00 per set, and _____ sets of "Basic Electronics" @ \$9.00 per set. I understand that I may return the books within 10 days and receive a complete refund of my full purchase price.

Name _____

Address _____

City & State _____ P

THESE HI-FI SECRETS WILL SAVE YOU HUNDREDS OF DOLLARS



Expert Rebels Against High-Fi Prices! Shows How, Where to Buy Low-Cost Components—How to Install, Assemble Professional Way—How to Build Cabinets and Enclosures Better Than Factory-Made, at a Fraction of Cost!

HIGH FIDELITY Home Music Systems

by William Wellman, author of Elementary Radio Servicing, Elementary Industrial Electronics, co-author of Home Mechanic's TV Servicing.

Don't spend a nickel for hi-fi equipment till you've read this revealing, practical, most easy-to-understand, most complete book on hi-fi ever written—filled with easy-to-follow guidance on choosing and building the right parts and cabinets. Here are . . .

CHOICE NUGGETS FROM THIS 208-PAGE GOLDMINE

what to look for in a hi-fi system—what not to pay—what specifications not to trust—how to choose an amplifier, speaker, pre-amplifier—COMPLETE INSTRUCTIONS FOR BUILDING CUSTOM ENCLOSURE AT LOW COST—explanation of terms—simple explanation of loudspeaker and diagram of components—performances to insist on—where to locate speakers—how to phase & assemble separate speakers—STEP-BY-STEP PICTURE-CAPTIONS ON BUILDING & INSTALLING BAFFLES AND CABINETS—how to choose phonograph parts—what to look for in a radio tuner—how to make, assemble, install antennas—GIANT CHAPTER ON TAPE RECORDERS! SELECTED LIST OF DEALERS & MANUFACTURERS WHERE YOUR DOLLAR IS WORTH MORE! CHARTS—DIAGRAMS—PHOTOS—HIGHLIGHTS—TO MAKE SELECTING, ASSEMBLING AND INSTALLING HI-FI SYSTEM FOOLPROOF, INEXPENSIVE! SEND NO MONEY—USE 10 DAYS FREE!

MAIL COUPON TODAY!

D. VAN NOSTRAND CO.,
Dept. PE, 250 Fourth Ave. New York 3, N. Y.
Rush me "HIGH FIDELITY Home Music Systems," for 10 days' free trial. At the end of 10 days I will either send you \$3.95 plus postage—or return book and owe nothing.

Name

Address

City..... Zone..... State.....

SAVE! We'll pay postage if you send money with order!

America" relay, Naha, try 9.630, 7.160, 6.145, or 6.010 at 0530-1200; English 1030-1100. . . . *Pakistan—A good time to try to log "Radio Pakistan," Karachi, is 0900-1015 on 7.010; news 0945. . . . Philippines—Check the "Far East Broadcasting Co.," Manila, "The Call of the Orient," a non-commercial missionary broadcaster, over DZH7, 9.730; DZH9, 11.855, and/or DZH8, 15.300 at 1600-2000, 0400-1200; news at 0500, 1100. This station is particularly eager for reports on the performance of its new Collins Model 21M, 10 kw., transmitter, now scheduled on the 9.730 channel at 0400-1200 and at (new time) 1600-2400; has printed up reception report forms for anyone interested in reporting regularly; QRA (address) is Box 2041, Manila, P. I.

Taiwan (Formosa)—Try BED3, 15.235, BED6, 11.735, Taipei, during Western North American beam 2300-0100; news 2300, 0015. . . . Tangier — VOA Relay, 11.830, noted 0300-0500, good level; identifies in English 0329. . . . USI (Indonesia) —YDF6, 9.710, Djakarta, should be logged 0600-1100; English 0615-0700 and 0930-1030. *A new outlet to try for is on 6.145, opens in Dutch at 0430; at times has bad QRM; location is not certain, and might be in Dutch New Guinea rather than in Indonesia. . . . JSSR—"Radio Moscow," 6.160A, noted at good level in English 0130-0159 closedown. Moscow opens at 1600 to the Far East in Asiatic languages on 9.545, 9.635; a new channel for the Far East is 5.980, heard 0330-1000 in parallel with 5.995, 6.050, 6.085, 6.165, 7.280, all very powerful signals.

Best bet for QRA's of any of the stations just listed would be the 1955 Edition of World Radio Handbook available for \$2.00 from Gilfer Associates, P.O. Box 239, Grand Central Station, New York 17, New York.

Acknowledgments

For their special efforts, I am particularly indebted to Cox, Delaware; Ferguson, North Carolina; Hill, New Hampshire; Scheiner, New Jersey; Saylor, Churchill, Virginia; Niblack (short-wave editor, Universal Radio DX Club), Indiana; Rosener, Foster, Illinois; Swenson, Minnesota; Sutton, Ohio; Stark, Peterson, Texas; Kippel, Colorado; McDaniel, Idaho; Balbi, Kapp, Morgan, Russell, Winch, California; Callarman, Oregon, and Adam, British Columbia.

That winds it up for this month. Next time I'll have some interesting data about radio clubs. In the meantime, the very best in successful DXing as you "twirl to tune the world!"

(Continued next month)

Perma-Power Radio Controlled Garage Door Opener

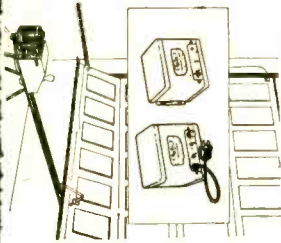

DOOR . . . modern garage doors are either one piece fill-up or sectional roll-up type up to 18" wide. The PERMA-POWER GARAGE DOOR OPENER will operate these doors when equipped with horizontal roller track and a 2 1/2" ceiling clearance is available.

MOTOR MECHANISM . . . Operating force is obtained from an electric motor (1/2 H.P., 117-Volts) coupled to the door through a driving arrangement. Limit switches included to stop door in fully open or fully closed position. In fully closed position, coupling provides self-locking. A quick disconnect device allows for manual door operation in case of power or unit failure. Mechanism includes a light which is on whenever door is open.

PERMA-POWER REMOTE (PUSH BUTTON) CONTROL . . . Installed in auto motor compartment is a one tube radio transmitter sending a 27.255 MC signal (authorized by F.C.C.) when push button is actuated. Installed with motor mechanism is two tube receiver which operates the motor. Signal from transmitter opens closed door or closes open door. Door may also be operated with a wall mounted switch.

Available through recognized electronic parts suppliers
Perma-Power COMPANY 4727 N. DAMEN AVE., ILL.
 Manufacturers of electronic equipment since 1928

- Everyone can afford this modern convenience!
- It's really simple to install . . . one man can do it easily!
- Takes just an afternoon with an after-hand tool; no soldering.
- Complete instructions assure professional-type installation.

TOOLS & GADGETS

SHOCKPROOF PLIERS

The "Probe-O-Pliers" is a new versatile tool designed to enable technicians to work in the smallest quarters on live units without danger of shock. The "Probe-O-Pliers" has, at one end, a needle nose pliers with 1/4 inch jaw opening which is conveniently operated by push-button action. The pliers grip like a vise on the slightest button pressure. At the other end of the tool is a spade-shaped probe for scraping solder and checking high voltages, with neon glow warning bulb. The tool is 9 1/2 inches long



and is molded of high-impact plastic. Dealer net is \$1.98. *Rytel Electronics*, 7100 Avalon Blvd., Los Angeles 3, Calif., is the manufacturer.

POCKET SIZE VOLTOHMMETER

Heralded as the world's smallest practical

pocket-size volt ohmmeter is *Simpson's* new "Midgetester," Model 355. Although it measures only 2 3/4" x 4 1/2" x 1" it includes fourteen measurement ranges: five for a.c. voltages; five for d.c. voltages; and four for d.c. resistances. Sensitivity is 10,000

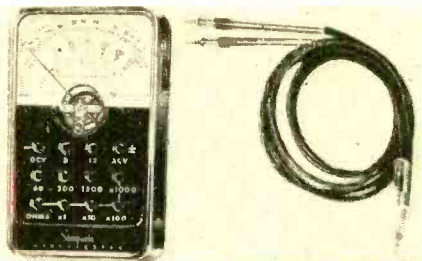

ohms per volt on both a.c. and d.c. Accuracy is specified at 3 percent for d.c. and 5 percent for a.c. A full wave bridge type rectifier is used for the a.c. ranges. The new meter, which can fit into a shirt-pocket, is priced at \$29.95 and is available at electronic parts jobbers. For further information, request form A-55 from the manufacturer, *Simpson Electric Company*, 5200 W. Kinzie St., Chicago 44, Ill.

VERSATILE LOW COST VISE

A low cost home workshop vise capable of solving any workholding problem in the home, garage, or shop has been modeled

BUILD YOUR OWN HI-FI

3-SPEED RECORD PLAYER

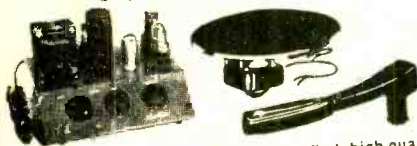

Another Concord Money Saver!! The first high-quality low-priced 5 watt amplifier on the market! Complete with built-in preamplifier for GE variable reluctance cartridge. One look at these features will convince you that this is the finest Hi-Fi value ever offered. Frequency response 60 to 15,000 cycles. 1 db. To 40 cycles at 2 db. down. Inputs for variable reluctance cartridge, crystal cartridge and microphone. Gives 5 watts of undistorted power with sensationally low hum level - 55 db. Separate controls for Mike volume, phono volume, bass-treble control. Hi-Fi output transformer for either 3.2 or 8 ohms. Tubes - 6SJ7, 6SC7, 6V6 and 6X5. For 110 V. Ac operation. Amplifier completely wired and ready to go. Shpg. wt. 10 lbs.

Stock No. F-VRX-5..... Only \$20.95

COMPLETE HI-FI RECORD PLAYER KIT

Includes Amplifier described above complete with tubes; 3 speed heavy duty rim drive motor with beautiful velvet finish turntable; high quality pick-up arm with GE RPX-050 triple play variable reluctance cartridge and high fidelity 12" Speaker. Speaker alone worth \$9.95!!!

Stock No. F-VRX5K... Shpg. wt. 18 lbs.... \$34.95

Make Your Own Clock Radio

Genuine TELECHRON
Switch Timer Clocks

\$3.95

\$3.85 Lots of 3

Brand New, individually boxed TELECHRON (GE) Switch Timers at a fraction of their original price. Will turn appliances on at any pre-set time up to 12 hours. Operates on 115 Volts 60 cycle AC. Appliance switch rated at 115 V. 15 Amps. Has 3 control knobs, -on-off-auto knob for controlling appliances. Auto Set knob for pre-setting turn-on time, and Time-set knob. Clock mounts in a 3 1/2" hole. Comes complete with handsome easy-to-read bezel

Stock No. 99-G-C40B-G7... Shpg. Wt. 1 1/2 lbs..... \$3.95

CONCORD RADIO

55 Vesey St., N. Y. 7

MINIMUM ORDER \$5.00 20% deposit with C.O.D.

Please send NEW 1955 CONCORD Catalog!

NAME _____

ADDRESS _____

CITY _____ ZONE _____ STATE _____

Concord Radio

55 Vesey Street, New York 7, N. Y. Digby 9-1132

IT'S NEW! IT'S FREE!

1955 Walter Ashe Catalog of Radio, Electronics and TV



The Treasure Chest of Values!

Features all the leading brands of Communication Equipment, Test Instruments, Build-it-Yourself Kits, Hi-fi, Sound and Recording Equipment, Radio, Electronics and TV Parts and Supplies for every conceivable need . . . in stock — ready for immediate delivery. A "must" for experimenters, amateurs, servicemen, engineers, builders and "hi-fiers."

Walter Ashe
RADIO CO.
1125 PINE ST. • ST. LOUIS 1, MO.

Send for your
FREE Copy

MAIL COUPON TODAY!

WALTER ASHE RADIO CO.
1125 Pine St., St. Louis 1, Mo.

PE-4-55

Rush FREE Copy of New 1955 Catalog.

Name _____

Address _____

City _____ Zone _____ State _____

YOU CAN GET MUSIC RIGHT OUT OF
A BLANK WALL WITH THE



NEW 'KARLSON 12'

Now you can build the world's finest speaker cabinet in a jiffy with the KARLSON SELF-ASSEMBLING ENCLOSURE KIT. All you need is a hammer and some glue to assemble the unit, due to the interlocking construction of the dozens of intricately cut pieces.

The "Karlson 12" is the first enclosure ever designed with adjustments to match the speaker used and the liveness of your room.

It has a separate base so it can be used vertically or lying down for "Aural-Optics." Size: 25" x 17" x 14"; Weight 35 lbs.

Self-assembling kit with full finishing instructions only \$37.50.

Available finished for \$99.60.

Send for Booklet "12"

32 Pages Full of Valuable Information

KARLSON ASSOCIATES, INC.

DEPT. M

1483 Coney Island Ave., Brooklyn 30, N. Y.

after the noted line of *AMF* Float-Lock Safety Vises for industry and introduced by *American Machine & Foundry Company*. The flexibility of the new *AMF* "Float-

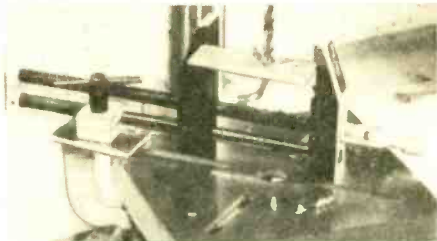

Lock Mity 7 Vise" eliminates the need for at least a half dozen specialized tools. In addition to its use as a drill press, bench and bandsaw vise, "Mity 7" has many other applications in sawing, wrenching, clamping, and plumbing work. All-steel construction and precision-manufacturing assure "Mity 7" a long, trouble-free life. It includes a mounting bracket for machines, and anchor plate and screws for bench mounting and retails for \$9.98. Inquiries should be directed to *Float-Lock Corp.*, *AMF* Building, 261 Madison Avenue, New York 16, N. Y.

A.C. PANEL VOLTMETER

A.C. voltage readings accurate to .5 percent over the frequency range of 50 to 2000 cps are obtained with a new "Expanded Scale Panel Voltmeter."

Use of a thermal bridge permits the indication of a narrow voltage range. The scale is expanded about a given normal



voltage which may be as low as 6.25 volts with a span of ± 0.25 volts, or as high as 230 volts with a span of ± 30 volts. A complete line of 3½" and 4½" diameter models is supplemented by square (3½") and rectangular (4"x6") models. For more information contact *Arga Division, Beckman Instruments, Inc.*, South Pasadena, Calif., Attn.: Publicity.

BREADBOARD SOCKETS

Designed for electronic experimental and development work in laboratories, schools, and industry, is *Pomona's* new line of "Breadboard Sockets." Mounting is simple, requiring only a ⅜" diameter hole in the breadboard chassis. Circuits can be wired on top of the chassis with ease and speed,

POPULAR ELECTRONICS

thus cutting the cost and time on experimental projects. Each socket is equipped with a ground lug attached to the socket mounting, further simplifying circuit wiring. The silver-plated phosphor bronze



socket connections are numbered for easy identification. "Breadboard Sockets" come in two different sizes: XS-7, seven pin miniature; and XS-9, nine pin miniature. Net price of the units, complete with mounting hardware, is \$0.49 each. For further information contact a local electronic parts jobber, or write to *Pomona Electronics Co., Inc.*, 524 W. 5th Avenue, Pomona, Calif.

PHONO NEEDLE BRUSHES

Shown here are two new brushes, each of which is designed to remove dust from phono needles and to prevent dust picked up from records from accumulating on the



needle. They both operate in the same way; the brush is mounted on the base of the record player by means of an adhesive pad under its base. Each time the tone arm is moved from its normal resting place to its position on a record, it has to pass across the bristles of the brush, which wipe the needle clean. On the left is pictured the "KLeeNeeDLE" brush, manufactured by *Robins Industries Corp.*, Bellerose, N. Y. and priced at \$1.59. The brush at the right is the "Gramercy Hi-Fi Needle Brush." A product of *Prosound Corp.*, New York, N. Y., it sells for \$1.00.

MULTIVOLTER SHOP AID

Variable d.c. and a.c. voltages, useful for test and experiment applications, are furnished by the *A.M.S.* Model No. 301 Multivolter Power Supply. Weighing only two pounds and measuring 3 3/4"x6 1/4"x2", the unit provides a range of variable d.c. voltages from minus 135 through 0 to plus 135, as well as an a.c. range of 0 to 135. An



Fix your TV Set YOURSELF!

**BUY YOUR TV TUBES
AT WHOLESALE!**

100% GUARANTEED! BRANDED! SAME DAY SERVICE!

1A4P	.29	6BD5	.59	7F8	.59
1A7	.49	6BE6	.39	7J7	.59
1B3	.59	6BG6	.99	7K7	.59
1B4P	.79	6BH6	.49	7U5	.49
1C6	.29	6BJ6	.49	7Z4	.39
1C7	.29	6BK7	.69	12AL5	.39
1E7GT	.39	6BL7	.69	12AT6	.39
1F5G	.29	6BN6	.99	12AT7	.69
1H5	.49	6BQ6	.79	12AU6	.39
1L4	.49	6BQ7	.79	12AU7	.59
1L6	.59	6BY5G	.59	12AV6	.39
1LA6	.39	6BZ7	.79	12AV7	.69
1LCS	.39	6C4	.39	12AX7	.59
1LC6	.39	6CB6	.49	12BA6	.39
1N5	.49	6CD6	.99	12BA7	.59
1R5	.49	6CU6GT	.99	12BE6	.39
1S5	.39	6F6	.39	12BH7	.59
1T4	.49	6F7	.69	12SA7	.49
1T5GT	.69	6J6	.59	12SK7	.49
1U4	.49	6J8	.79	12SN7	.59
1U5	.39	6K6	.39	12SL7	.59
1X2	.59	6L6	.69	12SQ7	.39
2A3	.29	6N6	.69	1457	.79
2A7	.29	6S4	.39	19B6G	.99
3AGT	.99	6S8	.59	19T8	.69
3Q4	.49	6SA7	.49	25BQ6	.79
3Q5	.59	6SD7	.49	25L6GT	.39
3S4	.49	6SK7	.49	25W4GT	.39
3V4	.49	6SL7	.59	25Z6	.39
5U4	.39	6SN7	.59	35B5	.39
5Y4	.49	6SQ7	.39	35C5	.39
5Y3	.29	6SR7	.49	35W4	.29
5Y4	.49	6T8	.69	35Z3	.29
5Z3	.29	6U8	.69	35Z5	.29
6A8A	.39	6V6	.49	35/51	.29
6AG5	.49	6W4GT	.39	36	.29
6AJ5	.69	6X4	.29	37	.29
6AK5	.69	6X5	.29	39/44	.29
6AL5	.39	7A4/XXL	.39	49	.29
6AQ5	.49	7A6	.49	50B5	.49
6AS5	.49	7A7	.49	50C5	.49
6AT6	.39	7A8	.49	50L6	.49
6AU6	.39	7AK7	.79	75	.29
6AV6	.39	7B4	.49	76	.29
6B7	.79	7B5	.49	77	.29
6BA6	.49	7B6	.49	80	.29
6BA7	.59	7B7	.49	117L7GT	.99
6BC5	.49	7F7	.59	117Z3	.29

Minimum Order \$7.00

25% deposit with order. Balance C.O.D. if full remittance is sent, please include postage. Excess money will be refunded. Quantity users — write for special discounts!

FREE!

with every order of \$20 or more — famous "Ox-wall" magnetic screw driver kit. Includes all sizes — Phillips head, long handles to get in those tight spots, etc. 7 screwdrivers in all. May be purchased outright. List value \$4.89 — \$1.99 each; 3 for \$5.50.

Mail Your Order to

VIDEO
ELECTRIC COMPANY
79 CLINTON PL.
NEWARK, N. J.

NEW!

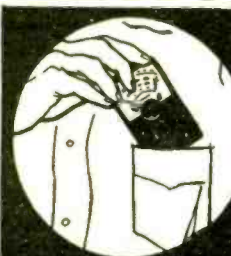

**A VOLT-OHMMETER
THAT FITS IN YOUR SHIRT POCKET**

Simpson MIDGETESTER

SELF SHIELDED! The world's first and smallest instrument of its type. Ideal for appliance maintenance, radio-TV service, and electrical experimenters. Sensitivity of 10,000 ohms per volt AC and DC. *Fourteen* ranges: *five* for AC voltages, *five* for DC voltages, and *four* for DC resistances.

MODEL 355
\$29.95

See your Electronics Parts Distributor, or write

SIMPSON ELECTRIC COMPANY

5227 W. Kinzie St., Chicago 44, Ill. • ES16brook 9-1121

(Feb. 55)
Preston GARAGE DOOR RADIO CONTROL

TRANSMITTER KIT: All parts, tube, 6 V Dyna., Instr. . . \$16.95
RECEIVER KIT: All parts, tube, relay, Instructions . . . 14.95
GEAR BOX (for Garage Door): 80/1 ratio reduction . . . 8.95

GYRO RADIO CONTROL TRANSMITTER

IMMEDIATE DELIVERY. The most POWERFUL (5 Watt) TRANSMITTER at the LOWEST PRICE. Famous 2 Tube MAC 11 circuit, featuring GYRO MAGIC TUNING INDICATOR. Completely wired & tested, includes 9 1/2 ft. sectional Antenna, remote "clicker" Keying Switch, Interlocking Ground Plane Booster, Shorting Plug. Beautiful Cabinet: 12" x 7" x 6". Available in the following models—all with money-back GUARANTEE.



GYRO X1 TRANSMITTER, as described with built-in 2 volt Storage Battery, 2 Volt Vibrator Supply, Battery Charger. Nothing else to buy. **GUARANTEED—Complete . . . \$39.95**

GYRO X2 TRANSMITTER, as described, with built-in dynamotor for operating from 6 Volt Auto battery. **GUARANTEED—Complete (less battery) . . . \$33.95**

GYRO X3 TRANSMITTER, as described, but for dry battery operation, and using Powerful 1-tube, 4.8 Watt, low-drain circuit. **GUARANTEED—Complete (less batteries) . . . \$23.95**

Model Radio Control Transmitter & Receiver Kit

27 1/2 Mc Band License Free. All Parts & Diagrams (less tubes & crystal) to build Powerful 5 Watt Transmitter Unit & 2-Tube Supersensitive lightweight Receiver, including

SIGMA 10,000 ohm Relay . . . \$9.95
LORENZ 61 RECEIVER KIT: with tube and relay . . . \$14.95
LORENZ RECEIVER KIT: 2 tubes and relay . . . 14.35
wired & tested add \$5.00.

LORENZ 1 Tube TRANSMITTER KIT with cabn. crystal & tube 10.65

RELAYS SIGMA 4F 8,000 ohm. . . \$4.95; SIGMA 26F CDS . . . 8.50

MCENTEE'S "RADIO CONTROL HANDBOOK" . . . 2.25

CRYSTALS: 27.25 Mc, Peterson Z9A, \$4.75; holder15

FLEAWEIGHT HOOKUP WIRE: 25 feet, 5 colors25

MULTITESTER: Brand New!—3 1/2" x 4 1/4" x 1 1/4" DC/AC Volts: 0-15, 75, 300, 750, 3000—DC MA: 0-15, 150, 75 ma. Resistance: 0-10,000, 100,000 ohms. Complete with battery test leads. . . **\$9.95**

TUBES: LOWEST PRICES: XFG1, RK01, 9A4, 3A5, 1A4G, 6A9S, 1S4.

Clockwork ELECTRIC TIMER: 1/2 to 24 min. . . \$1.00

GENERATOR: 12-24V DC, 13 amps. 1/6 h.p. or larger motor with pulleys . . . \$3.25

ALL MATERIAL GUARANTEED—FREE CATALOG "P"
Save C.O.D. fees, include postage, excess refunded.

GYRO ELECTRONICS CO.

325 CANAL STREET W., NEW YORK 13, N. Y. WOrth 6-1290

added feature provides 1 ampere of 6.3 filament voltage at separate terminals. A neon lamp indicates current output, extinguishing when 20 ma. is drawn. The device is recommended for a.v.c., a.g.c., a.f.c.



bias, and amplifier gain measurements, bridge voltage source, component tester, power supply, etc. For additional information, write to the manufacturer, *Authorized Manufacturers Service Co., Inc.*, 919 Wyckoff Avenue, Brooklyn 27, N. Y.

NEW CAPACITOR SUBSTITUTION BOX

Especially designed to help the technician, the new *EICO* Capacitance Substitution Box enables rapid substitution of a wide range of RETMA capacitance values in an operating circuit to determine the value needed for optimum performance. It also helps to find the value of badly damaged or otherwise illegible capacitors by substitution. Model 1120K, a kit, is \$5.95. Model 1120, factory wired, is \$9.95. For complete details on this unit and the rest of the *EICO* line of 38 kits and 42 factory wired instruments, write directly to *EICO*, 84 Withers Street, Brooklyn 11, N. Y.



BANTAMWEIGHT SOLDERING IRON

Weighing only 3 ounces, *Hexacon's* bantamweight "hatchet" soldering iron is recommended for fast soldering of instruments, small equipment, etc. The design of the iron assures perfect balance which makes the iron effortless to hold and gives accurate control of soldering. The bantamweight "hatchet" is said to be more pow-

erful than its wattage rating indicates, and its tiny tips are reputed to out-perform larger and heavier models. Irons are available in 25 watts with $\frac{1}{8}$ " tip, or 30 watts



with $\frac{3}{16}$ " tip. Either iron lists at \$5.50. For additional information, contact the manufacturer, *Hexaco Electric Company*, 569 W. Clay Avenue, Roselle Park, N. J.

TOOL AND HOLDER SET

A new series of low-cost tools and holders, offered by the *Plomb Tool Company*, Los Angeles, California, enables the craftsman to assemble a master set of tools as his budget permits.

Known as "PROTO Adda-Units," each group of tools is mounted on a plastic holder which secures the tools when not in use. Tool numbers and wrench-opening sizes are printed on the holders to simplify tool selection. Holes permit the holder to

be mounted on any type of panel. The photo shows the units mounted on a sheet of perforated "Masonite."

Included in the first five units are: No. 9931, with five open-end wrenches; No. 9937, with six combination box and open-end wrenches; No. 9942, with two adjustable wrenches and two pipe wrenches; No. 9950, with a hinge handle and ten $\frac{1}{2}$ "-drive socket wrenches; and No. 9953, with a thin-nose plier, midjet plier, compound leverage

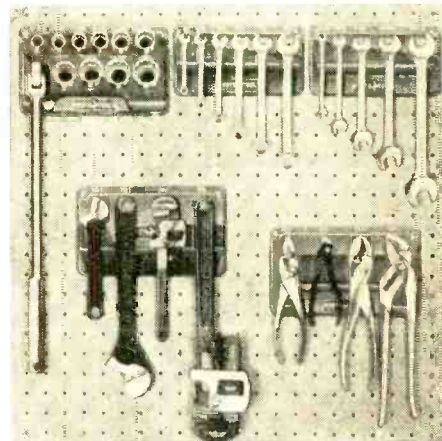

plier, and general utility plier. For further information, contact the manufacturer. END

LAFAYETTE'S

WESTERN ELECTRIC HEARING AID

Brand new, in original Western Electric's jeweler's case. Supplied with receiver cord, battery cord and plug (less batteries). Money back guarantee. Act now while they last! Uses Burgess X350E and 8B batteries at \$1.55 per set.



Reg. Price ~~185.00~~ Our Price 14.95

PRECISION GEIGER COUNTER

29.95



Geiger counter featuring high sensitivity to radioactive substances and extremely compact design. Detects uranium ore, cosmic rays, radium and X-rays by instantly producing a loud series of clicks in earphone. Uses a miniature amplifier tube, one 22.5V hearing aid battery and one flashlight battery. Strong plastic case $1\frac{1}{2}$ " x $3\frac{1}{2}$ " x $5\frac{1}{2}$ ". Supplied complete with headset, batteries, radio-cable and instructions. Shpg. Wt. 3 lbs.

Model 108 29.95

WELDER SOLDERING KIT

Kit includes 250 watt instant heat — dual sporthite Weller gun — ample supply of Kester solder — soldering tip — smoothing tip — two interchangeable wrench — two instruction booklets — sturdy metal case. Shpg. Wt. 5 lbs. Weller 8250-AK Net 10.99



PRECISION DRAFTING SET

11 Pieces — Fitted Felt-Lined Case. Made in Germany of heavy nickel plated and polished. Instruments include $5\frac{1}{2}$ " Compass with pencil and pen points and leveling bar. $5\frac{1}{2}$ " Divider three $3\frac{1}{2}$ " bow dividers with needle point, pen point and pencil point. $5\frac{1}{2}$ " Ruling pen, extra handle for pen or pencil, capsule with extra leads. Four money back — if this set is not worth twice our price!



2.75

F-13 NET 2.75

BARGAIN SALE!

TIMER-SWITCH SALE 3.95

Automatically turns on radio, television sets, toasters, coffee makers, etc. — at any pre-set time within 12 hour period; also tells time. Requires $3\frac{1}{2}$ " diameter round hole. Depth behind dial face $2\frac{1}{4}$ ". Shpg. wt. $1\frac{1}{2}$ lbs. #5682 for 110V/60 Cy AC



NEW POCKET AC-DC VOM MULTITESTER

1,000 ohms per Volt



AC-DC MULTITESTER. An ideal portable unit that meets the need for a compact, yet rugged test instrument. Uses full $3\frac{1}{2}$ " rectangular meter with large easy to read scale. Uses 1% precision resistors, jeweled D'Arsonval microamp meter movement. Ranges: AC-DC and output volts 0-5, 0-25, 0-250, 0-1000V. DC current 0-1, 0-10, 0-100. MA. Resistance 0-10K and 0-100K ohms. Size: $4\frac{3}{4}$ " x $3\frac{1}{4}$ " x $1\frac{3}{4}$ ". Supplied complete with test leads and batteries. Shpg. Wt. $2\frac{1}{2}$ lbs. MODEL RW-27C Complete — Singly, ea. 9.95 In lots of 3, ea. 9.45

3 LENS TURRET MICROSCOPE

100X-200X-300X 6.75

Precision built for accuracy and long lasting service. Triple position turret holds 3 achromatic color-corrected objectives for magnification of 100X, 200X and 300X power! Dual knob focusing. High-grade micro-optics used throughout. Complete with fitted wood carrying case and sides. Shpg. Wt. $3\frac{1}{2}$ lbs. F-10 NET 6.75



30 POWER TELESCOPE

● All metal — Chrome trimmed! Precision machined body. Hand ground, hard coated, achromatic lenses. Sharp, clear, brilliant images. In the same manner as fine binoculars. Brings objects 30 times closer! Smooth, easy sliding focusing. Collapses to $7\frac{1}{2}$ " — extends to $14\frac{1}{2}$ ". As always you must be satisfied — or return for immediate refund. Shpg. Wt. 9 lbs. F-59 NET 7.50



EXPERIMENTERS MULTI-PURPOSE KIT

13.95

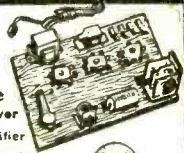

10 Kits in One

1. Broadcaster Receiver
2. Microphone Amplifier
3. Photo Oscillator
4. Home Broadcast Station
5. Code Practice Oscillator
6. Capacity Operated Relay
7. Signal Tracer
8. Electronic Timer
9. Electronic Switch
10. Photo Cell Relay

You can play your phonograph through your radio, broadcast your voice through your radio, etc. Kit is complete with breadboard, microphone, 3 tubes and all necessary parts for construction, with 12 page manual of instructions and schematic and pictorial diagrams. Less headphones, photo cell and socket, wire and solder. Shpg. Wt. 10 lbs.

KT-36 Net 13.95

Photo Electric Cell type 868 Net 2.50

Amphenol 77MIP4 Socket for above Net 7¢

BINOCULARS NEVER BEFORE AT THIS PRICE

Imported Direct
Prism-Coated Lenses
with order, Add 10% Fed. Tax

- All-Metal Construction
- Individual Focus
- Complete with Leather Case & Straps



- F-105, 8 x 30 with case NET 19.95
- F-15, 7 x 35 with case NET 22.50
- F-103, 7 x 50 with case NET 24.95
- F-104, 12 x 50 with case NET 32.50

Lafayette Radio

100 SIXTH AVE. NEW YORK, N. Y.
DEPT. PE3 Write for FREE Catalog
BRONX, N. Y. 542 E. Fordham Rd.
NEWARK, N. J. 24 Central Ave.
PLAINFIELD, N. J. 139 West 2nd St.
BOSTON, MASS. 110 Federal St.
Include postage with order.

AFTER CLASS

CAPACITANCE UNITS AND COMBINATIONS

CAPACITORS (also called condensers) are available in a wide range of standard values for different applications. The basic unit is the *farad*. However, a capacitor to give this amount of capacitance would be physically extremely large. Fortunately, the amounts of capacitance usually needed in practical circuits are very much smaller. Therefore, fractional units are used: the microfarad, or one-millionth of a farad, and the micromicrofarad, or one-millionth of one-millionth of a farad. Several different abbreviations are used for the names of these units: $\mu\text{fd.}$, $\mu\text{f.}$, mfd. , and mf. for microfarad and $\mu\mu\text{fd.}$, $\mu\mu\text{f.}$, mmfd. , and mmf. for micromicrofarad.

Combinations of two or more capacitors in series or in parallel often are used in electronic circuits. Therefore, it is useful to be able to compute the total capacitance of such combinations. Capacitors in parallel are easy to handle: the total capacitance is simply the sum of the individual values.

The only difficult cases of parallel capacitance circuits are those in which some capacitors specified in microfarads are combined with others specified in micromicrofarads. For example, two parallel capacitors may have the values of .001 microfarads and 330 micromicrofarads. This may be handled in either of two ways: by changing the first value to micromicrofarads or by changing the second value to microfarads. To change a number of microfarads to micromicrofarads, multiply by 1,000,000: $.001 \times 1,000,000 = 1000$ micromicrofarads. The total of the two capacitors would then be 1330 micromicrofarads. To change a number of micromicrofarads to microfarads, divide by 1,000,000: $330 \div 1,000,000 = .000330$ microfarads. The total of the two capacitors then would be .001330 microfarads. Note that the total value of capacitance actually is the same, whichever way it is expressed: .001330, the number of microfarads, multiplied by 1,000,000 equals 1330, the number of micromicrofarads.

The total capacitance of capacitors in series is a bit more difficult to figure. The rule is that the total capacitance is "the reciprocal of the sum of the reciprocals" of the individual capacitances. In mathe-

matical form, C_T , the total capacitance of three capacitances, C_1 , C_2 , and C_3 , in series, is given by the formula,

$$C_T = \frac{1}{\frac{1}{C_1} + \frac{1}{C_2} + \frac{1}{C_3}}$$

The values of all of the capacitors must be in the same units. As an example, compute the total capacitance of three capacitors, of .002 $\mu\text{fd.}$, 500 $\mu\mu\text{fd.}$, and 100 $\mu\mu\text{fd.}$, in series. The capacitance values which are expressed in $\mu\mu\text{fd.}$ can be converted to $\mu\text{fd.}$ by dividing by 1,000,000: 500 $\mu\mu\text{fd.}$ equals .0005 $\mu\text{fd.}$ and 100 $\mu\mu\text{fd.}$ equals .0001 $\mu\text{fd.}$ Substituting the proper values in the formula, we have

$$C_T = \frac{1}{\frac{1}{.002} + \frac{1}{.0005} + \frac{1}{.0001}}$$

$$C_T = \frac{1}{500 + 2000 + 10,000}$$

$$C_T = \frac{1}{12,500}$$

$$C_T = .00008 \mu\text{fd.}$$

$$C_T = 80 \mu\mu\text{fd.}$$

For two capacitors in series, the formula given above may be used by omitting the fraction which includes C_3 . An alternative formula for two capacitors, which sometimes may be easier to use, is

$$C_T = \frac{C_1 \times C_2}{C_1 + C_2}$$

For example, if we have capacitors of 500 $\mu\mu\text{fd.}$ and 100 $\mu\mu\text{fd.}$ in series,

$$C_T = \frac{500 \times 100}{500 + 100}$$

$$C_T = 83\frac{1}{3} \mu\mu\text{fd.}$$

Note that in both examples the total capacitance of the combination is less than the capacitance of the smallest capacitor. This is always true of a series combination. Note also that the formula for series capacitance is of the same form as the formula for parallel resistance.

The following quiz is intended as a self check. You should be able to answer all

of the questions correctly if you have mastered the foregoing text. The answers appear on page 128.

QUIZ

1. What is the total capacitance of a combination of three capacitors, .05 $\mu\text{fd.}$, .001 $\mu\text{fd.}$, and .01 $\mu\text{fd.}$, in parallel?
(a) .061 $\mu\text{fd.}$; (b) .07 $\mu\text{fd.}$; (c) .0511 $\mu\text{fd.}$
2. What is the total capacitance of three capacitors in parallel, having individual values of .002 $\mu\text{fd.}$, 3300 $\mu\mu\text{fd.}$, and .05 $\mu\text{fd.}$?
(a) 4000 $\mu\mu\text{fd.}$; (b) .0553 $\mu\text{fd.}$; (c) 8500 $\mu\mu\text{fd.}$
3. What is the total capacitance of two capacitors in series, of 140 $\mu\mu\text{fd.}$ and 365 $\mu\mu\text{fd.}$?
(a) 505 $\mu\mu\text{fd.}$; (b) 253 $\mu\mu\text{fd.}$; (c) 101 $\mu\mu\text{fd.}$
4. What is the total capacitance of the series combination of three capacitors having values of .01 $\mu\text{fd.}$, .02 $\mu\text{fd.}$, and .05 $\mu\text{fd.}$?
(a) .08 $\mu\text{fd.}$; (b) .00588 $\mu\text{fd.}$; (c) .000125 $\mu\text{fd.}$
5. If a capacitor of 1 microfarad capacitance were placed in series with a 1-micromicrofarad capacitor, the total capacitance would be:
(a) slightly less than 1 $\mu\text{fd.}$; (b) slightly less than 1 $\mu\mu\text{fd.}$; (c) larger than either capacitor.

D.C. AMPLIFIERS

ORDINARY signal amplifiers are coupled to each other inductively through transformers or capacitively by means of blocking capacitors; in either case, the coupling device prevents the positive plate voltage of one stage from being impressed on the grid of the following one.

In medical and industrial circuits, tiny d.c. or very low frequency a.c. voltages which require amplifications of several hundredfold are often encountered, for which a standard, a.c. amplifier is useless. These voltages come from tiny thermocouples, phototubes, devices for measuring mechanical strain, or even electrodes for determining differences in human skin potential during emotional stress. D.c. amplifiers are used in some television receivers, although the signal voltages involved in this case are not small.

Direct current amplifiers have been known for a long time, but they present some problems not found in ordinary a.c. amplifiers. The main trouble lies in the tendency of a d.c. amplifier to drift and, since the voltage being amplified is direct, even a tiny amount of drift in the input circuit appears to the amplifier as a change in *input signal strength* which it will amplify, producing false results. This problem has been partially overcome by special circuits using drift in one tube to cancel the drift in the other.

Of greater importance to the reader who is just becoming acquainted with d.c. amplifiers is the question of how direct coupling from plate to grid is accomplished without having the positive plate voltage of the first tube completely ruin the performance of the second tube when applied to its grid. One of the earliest coupling

The Record Changer with

JPF*

Collaro

RC-54 3 Speeds
Fully Automatic



* Get the whole story

ROCKBAR CORPORATION, Dept. TD-18
215 East 37th Street, New York 16, N.Y.

Tell me about JPF and the Collaro RC-54

Name.....

ADDRESS.....

City.....Zone.....State.....

SEE THE LATEST IN
Electronics
EQUIPMENT



FREE

Send for
Newark's 1955 Catalog

Select the fast, easy, dependable way from the New Electronics Reference Book—full of the latest releases and largest selections of High Fidelity, Radio, TV, Amateur and Electronics equipment.



Dept. P-4, 223 W. Madison, Chicago 6, Ill.

ELECTRONIC SUPPLIES

For Experimenters—Service—Industry

Clean useful items sold on satisfaction

Guaranteed basis. **WHOLESALE OR RETAIL**

Miniature Hearing Aid Crystal Microphone (postage stamp size) extremely sensitive. Thousands of applications. Famous Make—Worth over \$8.00. \$1.49 ea.

ELECTRONIC REMOTE CONTROL UNIT

Contains tube sockets, condensers, resistors, panel lamp, 3,000 Ohm SENSITIVE PLATE RELAY (worth over \$4.00), transformer. We include schematic instruction sheet. TO CLOSE OUT REMAINING QUANTITY. 79c ea. 4 for \$3.00 Western Electric Stepping Switches 6 or 12VDC Coil—48 steps worth over \$30. \$7.95 ea.

Miniature Xformer 8 pore. term'ls. schematic on case—used with Transistors 1 1/2x 3/4x3/4. .98c ea. 10 for \$9.00 Motor Westinghouse 1/16 H.P. L.N. 7,000 RPM. \$1.95 RETRACTABLE PHONE CORD 4 Cond.—worth over \$4.00 ea. Over 6' long. Brand New. .98c ea.

ABK UHF Receiver complete w/10 tubes 18VDC dynamotor. Case—excellent cond. Gov't cost \$250. complete. \$6.95 GERMANIUM OR SILICON DIODES—Br. New—IN22. 49c ea.; 5 for \$2.00 IN34. .50c ea.; 6 for \$2.75

TUBE VALUES
1629 Magic Eye Tube. 7 for \$1.00
3A5 Dual Triode RCA. 3 for \$1.00
1625 Beam Pentode. 4 for \$1.00
1628 Triode. .4 for \$1.00
6AK5 Sylvania. .4 for \$3.00
807 Beam Pentode. 2 for \$2.50
12AY7 G.E. \$1.00 ea.; 3 for \$2.50
Hearing Aid Subminiature, unbranded. New. 5 for \$1.00

Include Postage with Order

REX RADIO SUPPLY

88 Cortlandt Street, New York 7, N. Y., CO 7-1617

methods used is shown in the accompanying drawing. A voltage divider consisting

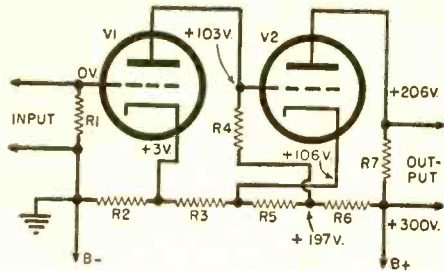

of four sections is tapped to provide the voltages indicated (with respect to B-). The cathode of V₁ is slightly more positive than the grid of the same tube (3 volts), thereby applying the needed bias; the plate of V₁ is returned to a point of higher positive potential through its load resistor so that proper plate-to-cathode voltage is obtained (103-3 = 100 volts). The grid of V₂, being directly coupled to the plate of V₁, is now 103 volts above ground, but the cathode of the same tube is 106 volts above ground, making the grid 3 volts negative with respect to the cathode. Again, this is the correct voltage relationship between these electrodes for bias. Lastly, the plate of V₂ is returned to the highest point on the divider and has a potential of 206 volts, thereby establishing a plate-to-cathode voltage of 100 volts for V₂. The amplified output voltage is taken from the plate load resistor of V₂.

This system has its disadvantages: for a few additional stages in cascade, a high voltage d.c. power source is required; also, it is often difficult to connect this amplifier to external apparatus because of the high potential in the final plate circuit. Another difficulty is that a change in the power supply voltage changes the d.c. voltage at the plate of the final tube, just as a change in the input signal would do. A perfect d.c. amplifier of this type therefore would require a perfect power supply.

Other direct coupling methods have been devised and are now in use in practical d.c. amplifiers. They are rather complex, however, and usually very tricky in adjustment.

PHASE-SHIFT OSCILLATOR

THIS little-discussed but highly stable form of R-C oscillator finds many applications in industry and military electronics where a good sine wave output is desired at relatively low cost. It is particularly well-adapted for devices which require low frequencies—in and about the audio range—for their operation. One manufacturer uses more than eight separate and different

phase-shift oscillators in certain test equipment used for checking-out procedures in the manufacture and maintenance of a new guided missile.

In its simplest form, the circuit looks like that given in the accompanying fig-

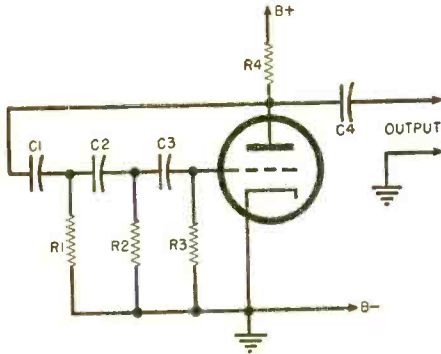

ure. Like any other oscillator, some random change in circuit voltage is needed to start oscillation and, to sustain the oscillation thus initiated, there must be amplification and positive feedback.

Assume that the control grid picks up a few electrons and begins to go negative. The plate current, influenced by the negative-going grid, begins to drop at the same time, so that the voltage drop across the plate load resistor R_1 becomes smaller. This leaves more voltage between the plate and cathode of the tube and we may say that the plate is, therefore, positive-going.

The increase in plate voltage is coupled back into the combination of C_1 and R_1 . Since the current through a capacitor always leads the voltage, the voltage across R_1 is out of phase with the original positive-going plate voltage by some quantity between zero and 90° . Let's arbitrarily assume a shift of 60° in this first pair. This shifted voltage is next coupled to the $C_2 - R_2$ combination where a second 60° shift of phase occurs, making a total of 120° thus far; finally, the third pair (C_3 and R_3) produce another phase-shift of 60° , thereby feeding a voltage to the grid of the tube which is a full 180° out of phase with the voltage change at the plate.

Now consider all the events together: we assumed the grid as negative-going; this produced a positive-going plate; the capacitor-resistor network shifted the phase through 180° bringing the pulse fed to the grid right back to negative-going. This fed-back pulse therefore assists the grid in going still further negative until the tube cuts off and starts on its upward swing. On the next half-cycle of oscillation, the grid receives a similar "assist" from the returned pulse to produce sustained oscillation.

Here's Your Coupon

for bigger values...
at lower prices!

FROM THE WORLD'S LARGEST DISTRIBUTOR OF AMATEUR RADIO EQUIPMENT

JUST CHECK THE ITEMS BELOW THAT YOU'RE INTERESTED IN! CLIP AND MAIL! WE'LL RUSH INFORMATION!
 LATE RECONDITIONED EQPT. LIST
 BANDSWITCHING GLOBE SCOUT
 AMATEUR RADIO KITS! FREE 1955 CATALOG!
 GIANT RADIO MAP (25c)
 TEN DAY FREE TRIAL PLAN
 TRANSMITTER \$29.40 Complete
 RECEIVER \$14.70 Complete

PE-4
World Radio LABORATORIES
 WORLD'S MOST PERSONALIZED RADIO SUPPLY HOUSE.
 3415 W. BROADWAY, CH. BLUFFS, IA. Phone 2-0277



RECEIVER \$14.70 Complete



TRANSMITTER \$29.40 Complete

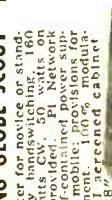

ONLY \$795 mo. or \$10.00 DOWN or \$99.95 CASH

Send Information to:
 Name _____
 Address _____
 City and State _____



Build your own transmitter on the air... with this complete kit... Complete kit only \$43.22... Designed for power supply included with transmitter. Units made of metal. Write for full details.

SAVE UP TO 85% ON GOV'T SURPLUS!

**GOV'T SURPLUS E.E.B
SIGNAL CORPS
FIELD TELEPHONE**

A private phone or intercom system. Easy to operate. Use any place that portable, 2-way communication is desired. Gives clear reception up to 15 miles. Operates on two standard batteries. Several phones may be used on the same line. Set contains a ringing generator, leather carrying case and phone. Each set is reconditioned & checked-out.

**14.95 EA.
2.95**

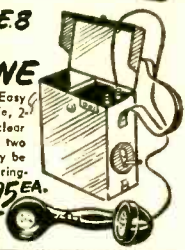

Complete circuit - Set of 2

Pay by Money Order or Check. P.O.'s accepted from D&B firms. 50% deposit with C.O.D.'s. Prices F.O.B. Los Angeles.

WORLD'S MOST AMAZING BARGAIN CATALOG

OVER 320 PAGES

SAVE UP TO 85% ON WAR SURPLUS
Packed with **SENSATIONAL VALUES** in WAR SURPLUS. **FACTORY CLOSE-OUTS** and **GENERAL MERCHANDISE!**

Fully Illustrated. Packed with thousands of Bargains in Hand & Power Tools, Radio Speakers, Ear Phones, Electronics, Gadgets, Electric Motors & Blowers, all types of Hydraulic Equipment, Outdoor & Sports Equip., Cameras, Precision Instruments, Microscopes, plus many, many more.



Send **50c** To cover the cost of Handling and Mailing. CREDITED to your first order.

PALLEY SUPPLY CO. 2263 E. VERNON AVE., DEPT. PL-4
Los Angeles 58, California



FREE! INFORMATION YOU SHOULD KNOW NOW ABOUT

URANIUM PROSPECTING

Uranium is making fortunes overnight. The Government pays up to \$35,000 bonus for uranium finds. But, there is information you should know about uranium prospecting. Get it FREE in a valuable booklet by Dr. Benjamin Schloss, well known scientist who worked on the original wartime atomic bomb project. "How to Make Money Prospecting for Uranium", how to find; how to sell; legal aspects; etc. We'll send this booklet, along with a Geiger Comparator Chart: "How to Select a Geiger Counter" FREE—write today. NUCLEONIC CO. OF AMERICA, 196 DeGraw St., Brooklyn 31, N. Y. Dept. PE-54



**\$2100 and MORE YOURS!
IN A WEEK!**

New Refrigerator Defroster Sells Itself on Sure-Fire FREE TRIAL!
NOTHING ELSE LIKE IT! 8 out of ten housewives buy amazing D-Frost-O-Matic after daring FREE TRIAL. Pocket \$15.00, \$20.00 and more in few hours full or spare time, up to \$210.00 in a week!

FREE! RUSH POSTCARD now for big profit facts, sure-fire FREE TRIAL Plan. Everything free, no obligation. Write TODAY!

D-FROST-O-MATIC, 173 W. Madison, Dept. C-54 Chicago 2, Ill.

EASY TO LEARN CODE

Learn or increase speed with an Instructograph—the Radio-Telegraph Code Teacher that takes the place of an operator-instructor and enables anyone to master code without further assistance. Available tapes from beginners alphabet to typical messages on all subjects. Speed range 5 to 40 WPM. Always results—no GROT. Thousands have "acquired the code" with the Instructograph System. Write today for convenient rental and purchase plans.



INSTRUCTOGRAPH COMPANY
4713-P Sheridan Road, Chicago 40, Illinois

One more thing! At what frequency will the circuit oscillate? Here's where our assumed 60° phase shift comes into the picture because the whole sequence forms an unbroken circle like the mythical serpent with his tail in his mouth: the C-R network must shift the phase exactly 180° to maintain oscillation; assuming equal phase shift in each pair; there must be three shifts of 60° each; there is only one frequency for which a given pair will yield a shift of exactly 60°; therefore, the circuit will oscillate at this frequency only!

In commercial circuits, the frequency may be varied to some degree by making one of the resistors variable. Also, calculation shows that a minimum tube gain of about 8 times is necessary to sustain oscillation, so most designers add an additional stage to make sure that oscillation is strong and stable. **END**

AUDIO QUIZ

(Answers on page 128)

- Negative feedback added to an amplifier will:**
 - increase the gain;
 - decrease the gain;
 - not change the gain
- An amplifier which provides more gain for high-level signals and less gain for low-level signals is known as:**
 - a volume expander;
 - a volume compressor
- When two separate loudspeakers are used, one for the high frequencies and the other for the low frequencies, the high frequency speaker is known as:**
 - woofer;
 - flutter;
 - tweeter
- One of the main advantages of a push-pull amplifier is that it cancels:**
 - even harmonic distortion;
 - odd harmonic distortion;
 - both even and odd harmonic distortion
- The purpose of a bass boost circuit is:**
 - to increase low frequency response;
 - to increase high frequency response;
 - to increase both low and high frequency response
- A type of distortion resulting from operating tubes beyond the straight-line portion of their characteristic curves is:**
 - frequency distortion;
 - phase distortion;
 - harmonic distortion
- Which of the following types of pick-ups is piezo-electric?**
 - strain gauge;
 - dynamic;
 - crystal
- The DB gain of an amplifier whose voltage gain is 100 is:**
 - 2 DB;
 - 40 DB;
 - 100 DB
- The purpose of a crossover network is to:**
 - permit switching from radio to phono without causing a click in the loudspeaker;
 - permit playing of both 78 and 45 RPM records on the same turntable without changing turntable speed;
 - channel signal frequencies to the proper loudspeaker in a system using more than one speaker
- The audio frequency range extends, approximately, from:**
 - 20 to 2000 cycles per second;
 - 2000 to 20,000 cycles per second;
 - 20 to 20,000 cycles per second

TELEMETERING

EVERY electronics enthusiast eventually encounters this term in the literature and he is likely to become quite confused if he attempts to translate it literally.

The prefix "tele" almost universally represents an activity involving "a distance." The suffix "metering" unquestionably means "measuring." Thus, "telemetering" should mean "taking a measurement over a distance."

In many applications, this is exactly what it does mean. For instance, under telemetering applications one might find: an electronic circuit which enables an airplane pilot to measure his rate of fuel consumption by means of a flow-meter on his panel; a radiosonde transmitter sent up in a weather balloon for transmitting information back to the weather station concerning wind velocity, temperature, humidity, and so on; or an electronic ammeter for reading a radio transmitter's antenna current at remote point.

On the other hand, some engineers now include remote control systems of all types as telemetering systems. In its new broad sense, telemetering means the transmission of measuring or controlling information over a distance, usually by means of electricity or electronics. Included under this definition one may now discover cir-

cuits for the control of guided missiles, remote tuning of receivers, opening and closing garage doors by radio, and radio control of model planes and ships.

So—remember: the next time you're out with your R/C plane or ship, you're "telemetering!"

THE SATURABLE REACTOR IN INDUSTRIAL ELECTRONICS

ALTHOUGH not an electronic device in itself, the saturable reactor forms an integral part of many industrial electronic control circuits which cannot be understood or explained without a fundamental comprehension of the reactor.

Imagine that the speed of many large motors, or the intensity of a large bank of high-powered lights is to be accurately controlled. This might be done with a series variable resistor, but the size needed might be prohibitive in cost since the resistor would have to dissipate a tremendous amount of power.

The saturable reactor makes use of the principle that alternating current may be held to a very low figure by means of inductive reactance, a method which may involve very small power dissipation. In the figure, consider that no d.c. is flowing through the d.c. winding and that the re-

NOT 40% . . . NOT 50% . . . NOT 60% but . . .
SAVE 70%, 80% and 90% OFF LIST PRICES!

NAME BRAND TUBES SAME DAY SERVICE
ALL TUBES RTMA GUARANTEED FOR ONE FULL YEAR

- Hallicrafters • Admiral • Stewart-Warner • Zenith
- Philco • Crosley • Motorola • Stantron • Sonora
- American • Muntz

Several or one of these brands will be sent on your order.

All tubes individually boxed. We also carry a full line of all special purpose tubes. Send us your requirements.

FREE: All new customers will receive free as our introductory offer, combination kit of resistors, condensers, volume control and line cords—retail value \$2.95. (May be purchased separately, if desired.)

FREE with each \$25 or more order, 5-Pc. Sylvania Repair Kit. Value \$4.95. Includes: flashlight head, Phillips screwdriver, flat head screwdriver, alignment tool and polystyrene case.



SPECIALS:

FOR A LIMITED TIME ONLY

1L4	6AC7	59¢
1L5	6AF4	
1L6	6AG7	
2X2	6AL7	
3B7	12B4	
3D6	19T8	

TERMS: 25% deposit required on all orders, balance C.O.D. Orders under \$5.00, 50¢ service charge. Postage paid in USA on all orders accompanied by full remittance. All unused money refunded with order.

Send for Complete Tube Listing

0A2	.70	3A4	.53	6BJ6	.49	6TR	.70	14A5	.59
0A4G	.60	3B7	.57	6BK5	.70	6V6GT	.48	14A7	.45
0B2	.70	3D6	.45	6BK7A	.78	6W4GT	.40	14B5	.40
0C3	.90	3L4	.66	6BN6	.59	6W6GT	.56	14Q7	.52
0D3	.90	3Q4	.48	6BL7GT	.77	6X4	.35	19B6GG	1.18
0Z4	.45	3Q5GT	.59	6BQ6GT	.80	6X5GT	.35	19J6	.66
1A4P	.35	354	.48	6B7A	.80	6X7A	.57	19T8	.70
1A7GT	.45	3V4	.58	6BZ7	.90	6X8	.75	24A	.40
1B3GT	.68	5R4GY	.75	6BY5G	.60	7A4-XXL	.47	25A7GT	1.50
1C5GT	.43	5T4	.79	6C4	.33	7A5G	.55	25AV5GT	.80
1D5GP	.45	5U4G	.44	6CS	.36	7A6	.47	25BQ6GT	.80
1E7GT	.43	5V4	.60	6CB6	.51	7A7	.45	25L6GT	.48
1G6GT	.43	5X4G	.44	6CD6G	1.18	7A8	.46	25Y5	.45
1H4G	.43	5Y3GT	.32	6D6	.57	7B5G	.41	25Z5	.38
1HSGT	.49	5V4G	.37	6E5	.46	7B7	.43	25Z6GT	.38
1J6GT	.49	5Z3	.42	6F5GT	.39	7B8	.47	27	.23
1L4	.43	5Z4	.54	6F6	.40	7C4	.40	32L7GT	.40
1L6	.59	6A7	.59	6GG6	.42	7C5	.44	35A5	.48
1LA4	.59	6A8	.59	6HG6T	.40	7C6	.45	35B5	.52
1LA6	.49	6A8A	.44	6J4	2.00	7E5	.35	35C5	.51
1L84	.59	6AC7	.70	6J5GT	.40	7F8	.70	35L6GT	.48
1LCS	.51	6AF4	.80	6J6	.49	7Y4	.35	35W4	.35
1L6C	.49	6AG5	.51	6J7	.45	12A6	.40	35Y4	.35
1L05	.50	6AG7	.70	6K8	.57	12AT6	.41	35Z3	.41
1L3	.59	6AH6	.70	6K6GT	.39	12AT7	.68	35Z5GT	.35
1L6S	.59	6AJ5	.70	6K7	.44	12AU6	.43	45Z5GT	.40
1LH4	.66	6AK5	.55	6K8	.67	12AU7	.55	50A5	.48
1N5	.49	6AL5	.40	6L6GA	.70	12AV6	.37	50B5	.52
1NSGT	.51	6A4S	.48	6L7	.44	12AV7	.69	50C5	.51
1PSGT	.50	6A5S	.50	6N7	.61	12AX7	.50	50L6GT	.45
1R5	.65	6A5E	1.75	6O7	.45	12BY7	.90	70L7GT	.60
1RS	.57	6A5TG	2.25	6R7	.49	12BA6	.48	75	.44
1S4	.53	6AT6	.40	6S4	.41	12B4	.70	77	.39
1S5	.49	6AV6	.40	6S7G	.47	12BE6	.50	78	.39
1T4	.58	6AU6	.43	6SA7GT	.48	12BH7	.61	80	.35
1T5GT	.58	6AV5GT	.75	6SCT	.50	12BY7	.68	83V	.60
1U4	.49	6AV6	.40	6S7G	.43	125GT	.49	117L7GT	.40
1US	.50	6AX5GT	.59	6SH7	.45	12K8	.48	117N7GT	1.10
1V	.43	6B4G	.54	6SJ7GT	.45	12SA7	.48	117P7GT	1.10
1X2A	.63	6B8	.70	6SK7	.48	12SH7	.47		
2A5	.59	6AL6	.49	6SL7GT	.45	12SJ7GT	.45		
2A7	.23	6BC5	.49	6SN7GT	.57	12SK7	.48		
2B7	.89	6BE6	.50	6SQ7GT	.50	12SL7GT	.59		
2D21	1.00	6BFS	.41	6SR7GT	.47	12SN7GT	.57	117Z3	.37
2V3A	.80	6B6GG	1.18	6SS7	.43	12SQ7GT	.40	117Z6GT	.62
2X2A	1.00	6H86	1.61	6T7G	.63	12Z3	.25	2051	1.25
								2051	1.25
								9001	1.50

Stanley ELECTRONICS CORP.

935 MAIN AVENUE - PASSAIC, N. J.

BUILD YOUR OWN RADIO OR ELECTRONIC EQUIPMENT *with the* SPEED-CHASSIS

Save time and money...simplify assembly, improve appearance with a SPEED-CHASSIS. This flexible breadboard assembly of modular construction is ideal for testing, designing, modification or permanent equipment. SPEED-CHASSIS is provided with interchangeable socket arrangements; one grounded and four insulated tie point strips; interchangeable plates, with pre-punched holes, are available to meet all needs. Cover and panel make your successful equipment designs both permanent and neat. SPECIFICATIONS: Chassis 5" wide x 5 1/4" deep x 1 6/8" long; 20 gauge cad. plated steel.



CK-200 (Chassis Kit plus ass't plates), **\$9.95**

CK-300 (Chassis Super-Kit: CK-200 plus rack panel and cover), \$18.95

WRITE FOR FREE LITERATURE AND PRICE LIST DESCRIBING CHASSIS, PLATES, DUST COVERS, PANELS, BRACKETS, AND POWER SUPPLIES.

Enclose full amount with order. No C.O.D.'s please.

SPECIFIC PRODUCTS

14515 Dickens Street • Sherman Oaks 7, California

Something New! LEARN While You WORK!

Transistor Cir-Kit

This interesting, instructive kit includes a special designed chassis on which is mounted the necessary components to build 12 fundamental circuits using the transistor. You also get two transistor manuals giving general information on transistors and outlining the various experiments made possible with the complete kit. There's a wealth of education and excitement here for only\$17.50

For further information, or your Transistor Cir-Kit, see your local electronic parts jobber, or write direct to—

Sutton Electronic Co.

426 W. Short

Lexington, Ky.

actor has been wound using very heavy wire for the a.c. coils. When correctly de-

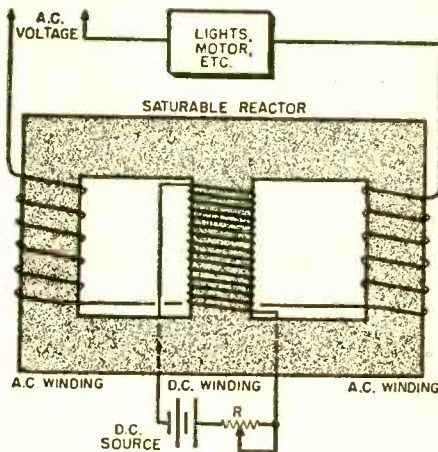

signed, the inductive reactance of the system may be so high as to limit the a.c. current flow to a very tiny figure—insufficient to light the lamps or to permit the motors to run.

The d.c. winding has many turns of wire; if a small amount of direct current is now allowed through this winding, the core will begin to approach magnetic saturation and will reach complete saturation when enough direct current is flowing.

Inductive reactance depends upon a changing magnetic field (flux), but, the closer the magnetic field approaches saturation for a given core, the less it can vary. Therefore the magnitude of inductive reactance decreases as saturation is approached, until, ultimately, the reactor offers practically no opposition to the flow of a.c. when it is fully saturated. Thus, the more d.c. that flows, the greater the magnitude of the alternating current permitted through the reactor. Here, then, is a case where a very small d.c. source and a 2- or 3-watt potentiometer may control hundreds of amperes!

Saturable reactors may be found in some types of battery chargers in which they control the charging rate to correspond with the state of charge of the battery, in theater light-dimming systems, in electric furnace heating controls, and in countless other industrial applications.

A particularly interesting application of the principle of the saturable reactor is the magnetic amplifier. In that device, a varying a.c. input signal can be used to control a similar, but larger, output signal. The effect is somewhat similar to that of a vacuum tube amplifier; the magnetic amplifier is more rugged, but limited to low signal frequencies. END

Cabinet Resonance

(Continued from page 66)

"store-bought" cabinet. For one thing, he can emulate a manufacturer who recently put some cabinets on the market in New York made of 1¼-inch plywood. This size is now obtainable in most lumberyards. There is just one catch. It comes only in fir, which the little woman would promptly toss out of her living room. The manufacturer mentioned solved the problem by bonding veneer flitches of mahogany, walnut, etc. to the fir. Perhaps the home constructor can do the same, but nothing can be guaranteed. If the fir is used, follow the screw- and glue-type of construction and the procedures outlined previously, but eliminate the 2 x 4 uprights. If a reflex is built, use a model recommended by the speaker manufacturer and scale up the interior dimensions slightly to allow for the greater wood thickness. When building an infinite, make the unit at least 12 cubic feet or better, if space allows. With less than 10 cubic feet, a reflex would be better.

There are several better methods of constructing anti-resonant baffles, but these are mostly for the free and the brave. Who else but the free and the brave would dare to construct a baffle in the living room corner made of brick and mortar? It's been done and the bass from these units is fabulous in its cleanness. Again, just follow the plans and scale up to allow for the thickness of the brick. Some true believers have even made forms and poured themselves concrete baffles. An alternative which some lucky people have is to brick up an unused fireplace and use this as a baffle. This is said to work very well. Admittedly these are drastic procedures and highly impractical for most people.

However, for the enthusiast who wishes to rid himself of cabinet resonance distortion, there is a not too difficult solution. This is the construction of an enclosure utilizing sand-filled panels. This has been advocated and put into practice for some years by the British speaker authority, G. A. Briggs. Because the sand does most of the work of damping, much thinner plywood panels can be used. It is recommended that all panels be formed from two pieces of ¼ inch plywood separated from each other by numerous 1 x 1¼ inch wood spacer blocks. The corner joints should all be well strengthened with stiffener blocks. The top of the enclosure should be made from plywood no less than ¾ inch thick, with spacer bars all around

BUILD *the New* TRANSVISION TV KIT

\$15⁰⁰
ONLY gets you started*

Designed so
that **COLOR**
can be added

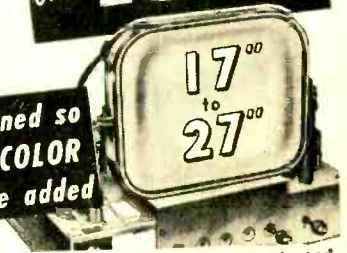

* THIS MODEST INVESTMENT gets you started on a most fascinating project — assembling the new "E" type Transvision TV Kit in easy stages. For \$15 you get PACKAGE #1 (standard first package for all new "E" Kits). This package gives you the BASIC CHASSIS and required first-stage TV COMPONENTS, with complete instructions. When ready, you order the next stage (pkg. #2), etc.

YOU PROFIT 3 WAYS:

- 1 **Learn TV** the practical way — by doing.
No previous technical knowledge is required.
- 2 **Save up to 50%**
- 3 **Prepare for COLOR TV**



**FREE
CATALOG**

Shows 8 Great TV Kits:

EXCLUSIVE. Only Transvision TV Kits are adaptable to UHF. Ideal for FRINGE AREAS. No Previous Technical Knowledge required. Write now!

TRANSVISION
THE OLDEST NAME IN TV KITS

NEW ROCHELLE, N. Y.

MAIL THIS COUPON-TODAY

Educational Director

TRANSVISION, INC., NEW ROCHELLE, N. Y. Dept. PE 4

I'm enclosing \$ _____ deposit. Send standard kit

PACKAGE #1, with all Instruction Material. Balance C.O.D.

Send FREE copy of your new TV Kit Catalog.

Name _____

Address _____

City _____ State _____

INTERCOM SPECIAL!

STEVE-EL (House of Bargains) HAS DONE IT AGAIN

This intercom comes housed in wooden cabinets completely wired and ready to operate.

Outfit consists of one master, one sub station and fifty feet of two wire cable. Ideal for home or baby sitter. Perfect for office or factory. Order now as quantities are limited.



Now you can own an intercom that has a thousand uses at a price you would normally pay for a kit.



YOUR COST COMPLETE ONLY.....

\$15⁹⁵

FREE BARGAIN CATALOG • WRITE DEPT. PE-4

STEVE-EL Electronics Corp.

61 Reade St.

New York 7, N. Y.



WHAT IS?

the "Video Probe Meter"

- Is this truly the first meter designed for General Testing of a T.V. set?
- Is it an accurate instrument made with precision?
- Can the Meter trace the R.F. & I.F. & Video Signal from Tuner to Pix Tube? Can it measure voltage?
- With the attached coil, can the Meter show the signal by placing coil over I.F. or Video Tube? Is a ground return necessary? Who manufactures the Meter? What is the price of the meter?

RESEARCH, INVENTIONS & MFG.

617 "F" ST. N. W.

WASHINGTON 1, D. C.

Inventors

Send today for our instructive booklet, "Patent Protection for Inventors" outlining preliminary steps to take toward patent protection, also for convenient "Evidence of Invention" form.

VICTOR J. EVANS & CO.
139-D MERLIN BUILDING, WASHINGTON 6, D. C.

GET INTO ELECTRONICS

You can enter this uncrowded, interesting field. Defense expansion, new developments demand trained specialists. Study all phases radio & electronics theory and practice. TV, FM, broadcasting, servicing; aviation, marine, police radio. 18-month course. Graduates in demand by major companies. H. S. or equivalent required. Begin Jan., March, June, Sept. Campus life. Write for Catalog.

VALPARAISO TECHNICAL INSTITUTE

Dept. PE

Valparaiso, Indiana

the outside, made slightly smaller than the sand-space, so that a tight fit will be ensured. Position cabinet where it is to be used and pour in the sand. There is a fine, free-running beach type of sand that can be purchased from most contractors, which is most suitable. The beauty of these sand-filled enclosures is that while they are thoroughly anti-resonant, by pouring out the sand they can be easily moved. All this business of killing cabinet resonance is admittedly a lot of work. But if you get a chance to hear identical speakers in some hi-fi salon, one of which is mounted in a baffle of conventional construction and the other mounted in one of the new 1 1/4 inch plywood baffles, I'm sure you will agree the difference in quality is worth the effort.

END

NEW RECORD PLAN

OF INTEREST to music lovers of all ages and degrees of musical sophistication is the announcement by *Music-Appreciation Records* (a division of *Book-of-the-Month Club, Inc.*) of a new monthly record plan whereby classical selections are recorded on one side of a 12" 33 1/3 rpm. long-play record and the analysis of the music is carried on the reverse side.

For those owning good recordings of the selections offered, the Club provides a separate 10" record carrying the analysis only. These analyses are prepared by a board of critics with the spoken commentary amplified by illustrative passages from the recording.

END

LOW COST FM RECEIVER

A REALLY low-cost FM receiver incorporating its own antenna has been announced by *Granco Products, Inc.* Named the "Music Hall" by the manufacturer, this new product is ultra compact. It has an audio system comparable to the usual AM broadcast band radio and a price in the upper twenty-dollar range to match.

The performance of the "Music Hall" is reported to be very good and due in part to the coaxial tuner that the manufacturer has used for several years in TV boosters. More information from 36-17-20th Ave., Long Island City, N. Y.

END



TRICKS of the TRADE

CHEAP PILOT LIGHTS

PILOT light jewel and bracket assemblies dress up home-built equipment, but are fairly expensive. You can make satisfactory pilot lights at low cost by painting a pilot lamp bulb with fingernail polish and mounting it in a large rubber grommet.

You can also save the cost of a socket



by soldering connections directly to the bulb itself!

* * *

IMPROVISED PHONE TIP JACKS

PIN jacks for panels can be easily improvised by using Fahnestock clips. The photograph shows a piece of plastic to which the clips have been fastened with

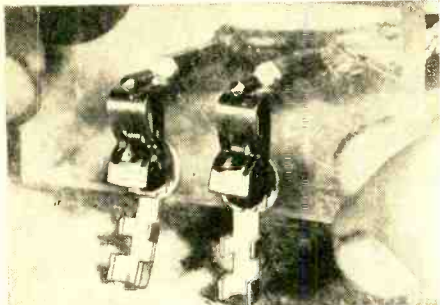

bolts. Holes for the phone tips are drilled so that the ends of the tips will contact the rounded spring end of the clips.

* * *

SOLDER FORMS OWN HANDLE

SOLDER is much easier to handle if used like twine which is pulled from the center of the ball. Instead of having to stop work to uncoil the solder, you can give it just a pull to get more length. Simply

April, 1955

HERSHEL'S "KIT" SPECIALS

ALL-PURPOSE FIL. TRANSFORMER

For Model Trains, Welding, Transmitters, etc.
PRI. 117 v. 60 cyc. sec.

6.4 v. 12A
6.4 v. 10A
5 v. 3A
5 v. 3A
5 v. 3A
2.5 v. 1.75A

\$495

MYSTERY PACKAGE ELECTRONIC PARTS

The Surprise of Your Life

25 pounds of BRAND NEW USABLE GOVT. SURPLUS. Ideal gift for the ham, etc.

Worth 550.
Our Price
\$495

KIT 1. HARDWARE

Over 1,000 pieces, 2½ lbs. of assorted RADIO & TV HARDWARE.

\$149

KIT 5. RESISTORS

100 ASSORTED TYPES. Range from 1 ohm to 15 meg. ½ to 5 watt.

\$198

KIT 2. CERAMICONS

100 ASSORTED. Range from .75 mfd. to 6,000 mfd.

\$350

KIT 6. R.F. CHOKES

25 ASSORTED. Range from .5 mh. to 25 mh.

\$195

Kit 3. Volume Controls

25 ASSORTED Range from 2 ohm to 3 meg. Some with switch.

\$475

KIT 7. TOGGLE & SLIDE SWITCHES

25 ASSORTED. DPST, DPDT, SPST, etc.

\$495

Kit 4. Rotary Switches

25 ASSORTED TYPES. A Real Buy at only.

\$475

KIT 8. PAPER & CAN CONDENSERS

25 ASSORTED. Range from 4 mfd. 150 v. to 80 mfd. 450 v.

\$350

FIND YOUR KIT PARTS HERE FOR POPULAR ELECTRONICS KITS

- TRANSFORMER—Pri. 110 V. 60 Cy. Sec. 6.3 V. 1 Amp. 95c
- TRANSFORMER—Pri. 110 V. 60 Cy. Sec. 400 VCT. 6.3 V. 1 Amp. 5 V. 2 Amp. 20 Ma. \$1.49
- SCOPE TRANSFORMER—Pri. 110 V. 60 Cy. Sec. 4000 V. 10 Ma. \$2.95
- TRANSFORMER—Pri. 110 V. 60 Cy. Sec. 600 VCT. 6.3 V. 3 Amp. 5 V. 2 Amp. 70 Ma. \$2.45
- RELAY D.P.D.T.—110 VAC. 8 Amp. contacts \$1.69
- RELAY D.P.D.T.—3 VDC. 11 ohm coil cont. 1.5 Amp. 110 V. Gold Plated 95c
- KEY—J38 Telegraph key 95c
- LIP MIKE—With Head band cord and switch \$1.29
- CHOKE—2.5 Mh. 125 Ma. 35c
- CHOKE—1.5 Mh. 100 Ma. 15c
- COIL—Plug in type 4, 5, 6, Prong Type 29c
- OUTPUT TRANSFORMER—6V6 to 3.2 Voice Coil 39c
- OUTPUT TRANSFORMER—P.P. 6V6 to 3.2 Voice Coil 59c
- OUTPUT TRANSFORMER—50L6 to 3.2 Voice Coil 35c
- CHOKE—AC-DC. Type. 8 H. 80 Ma. 49c
- COIL—Ignition Type. Pri. 3 V. Sec. 15,000 VDC. Ideal for Photo Flash Triggering \$1.29
- GLOW-LITE—2½ Watt Argon Lite 110 VAC. 29c
- MOTOR—From Gun Camera 24 VDC. Will Run on 110 VAC. 95c
- CABINET—RCA Speaker Cabinet. Plastic for 8 inch Round Speaker \$1.95
- RHEOSTAT—30 ohm 50 Watt 95c

HI GAIN DYNAMIC MIKE KIT

Uses UTC. Transformer and Western Electric Mike. Ideal for Hams, PA. CAP, Recording, Mobile Equip.

—50 DB/80-1500 CPS.
Diagram Furnished

\$195

HERSHEL RADIO CO.

5245 Grand River, Detroit 8, Mich.

Terms: Cash with order or 25% DOWN—Balance will be shipped C.O.D.

ALL ITEMS SHIPPED F.O.B. DETROIT

1954=168 PAGES

Yes, during 1954 we issued 10 Electronic Sales Bulletins totaling 168 pages just chocked full of bargains for the electronics experimenter and hobbyist. 1955 will bring you even more values. Just a very few of our current values include:

BLACK LIGHT KIT

Includes 4 W. bulb, ballast, starter, starter socket, lamp mounting, switch, line cord & plug, and schematic.

No. P4517 \$2.50
Same as above, except with 8 W. bulb. . . . No. P4519 \$2.95

G. E. 1 RPM "SYNC" MOTOR

115 V. 60 cy. Suitable for timing applications. Size: 2 1/4 H. x 3/8" thick. . . . No. P4212 each \$1.25 10 for \$11.00

500 WATT STRIP HEATER

Flat type, 115 V. AC/DC Metal Clad 1 1/2 W. x 24 L. x 3/8" thick. . . . No. P4505 \$1.50

TAYLOR IMMERSION THERMOMETER

Floating mercury column type. Range -10° to +50° C. Size: 10 1/4 L. x 3/8" dia. . . . No. P4291 2 for \$1.00

ASTRO COMPASS

Spertl. Brand New For Navigation and Astronomy. With Base. . . . No. P4431 \$17.95

AUTO CLOCK

6 Volt D.C. Dashboard Type. . . . No. P2934 \$2.50

60 MINUTE MINIATURE TIMER

Mechanical. Strikes bell at end of preset time, from 1 to 60 minutes. . . . No. P4273X \$1.95

MEDICAL STETHOSCOPE

Combination cone & diaphragm type with tubing and ear pieces. . . . No. P4394 \$3.95

ALL ITEMS ARE SHIPPED F.O.B. PHILADELPHIA

Just 25c will bring you the next 12 issues. Be sure to get your copies. . . . Send us your name and address, together with 25c. . . . Do it Today.

HERBACH & RADEMAN, INC.

1204 ARCH STREET PHILADELPHIA 7, PENNA.

GEIGER COUNTER KIT

You can assemble it yourself in about an hour. All holes drilled and ready for wiring. No special tools required. Full instructions and easy to follow diagram included. Government booklet "Prospecting with a Counter" and radioactive sample provided free with kit. Full price including tubes, headset and batteries only \$17.50 postpaid. Send check or money order to

Stowers & Son, 804 Grand, Kansas City, Missouri

Sigma 4F 8000 ohm Relay in Aluminum Dust Cover with 5 prong base. Relay can be removed for lighter weight. . . . \$3.95
Peterson Z9A Crystal 27.255Mc. . . . \$4.75

We maintain large stocks of High Fidelity Equipment, parts, tubes. Send for our latest catalogs. Trades accepted.

Please include sufficient postage, excess will be refunded.

SPERA ELECTRONIC SUPPLY

37-10 33 St. L. I. C., N. Y.

"SHOOPER" GEIGER COUNTER



2995
COMPLETE

Super-sensitive! Only 1 1/4 lbs. Fits pocket—uses flashlight battery. Find a fortune in uranium. Order Now! Send \$5.00, balance C.O.D. MONEY BACK GUARANTEE. FREE CATALOG—scintillator and larger uranium and metal detectors. DEALERS WANTED.

PRECISION RADIATION INSTRUMENTS
2235PT S. La Brea, Los Angeles 16, Cal.

INVENTORS

When you are satisfied that you have invented a matter of value—write me, without obligation, for full information on what steps you should take to secure a Patent.

PATRICK D. BEAVERS

Registered Patent Attorney

1098 Columbian Building Washington 1, D. C.

make 3 or 4 coils one on top of the other about 2 inches long. Then with fingers or

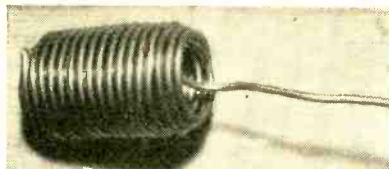

pliers pull the inside end out and you're ready to go. You'll be surprised how much this speeds soldering jobs.

* * *

TRANSPARENT STORAGE

SMALL storage boxes, made of clear plastic, have a secure latch and can be used to hold many small parts. You can see at a glance where everything is and yet keep parts from any set separated from other hardware. These boxes are available at most hardware stores.

* * *

COIL DRYING RACK

A USEFUL rack for drying your hand-wound coils can be made by driving several finishing nails into a piece of hardboard or plywood. Use 6- or 8-penny nails, driving them at a slight angle. Nails should be spaced about three to four inches apart.

When you've finished winding a coil, and have given it a coating of "dope," hang it on a nail to dry. Drying can be speeded by warm air from an electric hair dryer.

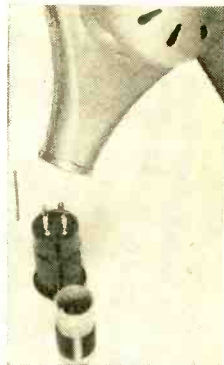

* * *

DRILLING LEVEL HOLES

A LINE and surface level is a handy attachment for your power drill and is easily fastened with rubber bands or tape.

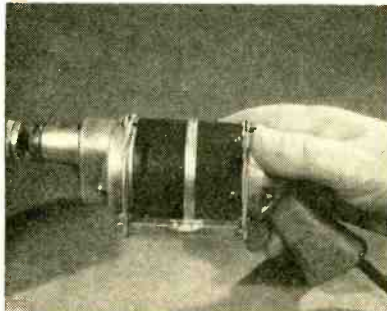

To drill horizontal holes in upright work, adjust the level so it is parallel with the

drill; for other angles, hold the drill at the angle required, then adjust the level until the bubble shows in the window. Keep it in that position while drilling.

SAVE CRT CARTON

WHERE a cathode-ray tube is used in experimental circuits as a picture tube or in an oscilloscope, it is worthwhile to save the original tube container for use when the test circuit is dismantled.

The 3-inch tube shown came in a small

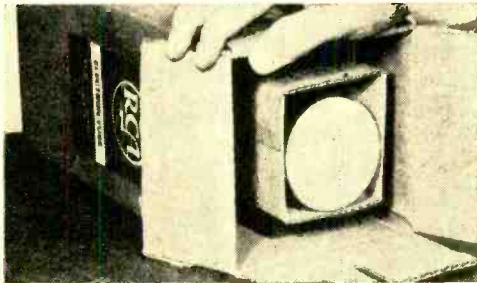

box with packing around this box inside the larger box shown. Such arrangement provides an ideal storage box for the tube when not in use.

RENEWING DIAL MARKING

A QUICK and effective way of restoring the legibility of faded dial markings, such as the etched numbers on radio dials, camera shutters, or kitchen stove controls is to rub a white marking crayon over the entire surface and then wipe with a cloth (moistened if necessary). The result will



be that the whitening remains in the markings and makes them show up distinctly.

DON'T LOSE IT; TAPE IT

PLASTIC or Lucite radio and TV adjusting tools which are transparent are difficult to locate on the service bench.

White adhesive tape wrapped at a couple of places on the tool makes it easy to find and, in addition, improves your grip on the tool.

AUTOMATIC WIRE STRIPPER

FOR the experimenter who is making many wire connections, one of the automatic wire strippers—which returns to nor-

BUILD 15 RADIOS

AT HOME

With the New Improved 1955 Progressive Radio "EDU-KIT"

ONLY
\$19.95

Complete

NOW INCLUDES
HIGH FIDELITY, SIGNAL TRACER, CODE OSCILLATOR

- Attractively Gift Packed
- Free Soldering Iron
- Absolutely No Knowledge of Radio Necessary
- No Additional Parts Needed
- Excellent Background For Television
- 30-Day Money-Back Guarantee
- School Inquiries Invited
- Used in 79 Countries



WHAT THE PROGRESSIVE RADIO "EDU-KIT" OFFERS YOU

You will learn how to identify Radio Symbols and Diagrams; how to build radios, using regular radio schematics; how to wire and solder in a professional manner. You will learn how to operate Receivers, Transmitters, and Audio Amplifiers. You will learn how to service and trouble-shoot radios. You will learn code. You will receive instructions for F.C.C. Novice license. In brief you will receive a practical basic education in Radio, worth many times the small price you pay.

THE KIT FOR EVERYONE

It is not necessary that you have even the slightest background in science or radio. The "Edu-Kit" is used by young and old; by radio schools and clubs; by Armed Forces personnel and Veterans. No instructor is required. Instructions are complete, simple and clear.

PROGRESSIVE TEACHING METHOD

The "Edu-Kit" uses the principle of "Learn by Doing." Therefore you will build radios, perform jobs, and conduct experiments to illustrate the principles which you learn. You begin by learning the function and theory of each of the radio parts. Then you build a simple radio. Gradually, in a progressive manner, you will find yourself constructing more advanced multi-tube radio sets, and doing work like a professional Radio Technician. The "Edu-Kit" Instruction Books are exceedingly clear in their explanations, illustrations and diagrams. These sets operate on 105-125 V. AC/DC. Adapter for 210-250 V. AC/DC available.

The Progressive Radio "EDU-KIT" is Complete

You will receive every part necessary to build fifteen different radio circuits. Our kits contain tubes, tube sockets, chassis, variable condensers, electrolytic condensers, mica condensers, paper condensers, resistors, line cords, selenium rectifiers, tie strips, coils, hardware, tubing, Instruction Manuals, etc. A soldering iron is included, as well as an Electrical and Radio Tester. Complete, easy-to-follow instructions are provided. All parts are guaranteed, brand new, carefully selected and matched. In addition, the "Edu-Kit" now contains lessons for servicing with the Progressive Signal Tracer, High Fidelity, F.C.C. instructions, quizzes.

TROUBLE-SHOOTING LESSONS

Trouble-shooting and servicing are included. You will be taught to recognize and repair troubles. You will build and learn to operate a professional Signal Tracer. You receive an Electrical and Radio Tester, and learn to use it for radio repairs. While you are learning in this practical way, you will be able to do many a repair job for your neighbors and friends and charge fees which will far exceed the cost of the "Edu-Kit."

FREE EXTRAS

• Electric-Radio Tester • Soldering Iron • TV Book • Quizzes
PROGRESSIVE "EDU-KIT" INC., 497 Union St., Brooklyn 11, N.Y.
MAIL TODAY—Order shipped same day received.
30-Day Money-Back Guarantee. INCLUDE ALL FREE EXTRAS.

- RUSH ME the following—Include all Free Extras:
- "EDU-KIT" Postpaid. I'll enclose full payment of \$19.95
 - "EDU-KIT" C.O.D.—I'll pay \$19.95 plus postage, 11, N.Y.
 - Outside USA: Enclose \$20.95. "Edu-Kit" sent postpaid.
 - Outside USA: 210-250V, AC/DC Adapter. Enclose \$2.50
 - More details on "EDU-KIT". Free—No Obligation
 - FREE Radio-TV Servicing Literature. No obligation

NAME _____
ADDRESS _____

PROGRESSIVE "EDU-KITS" INC. 497 UNION AVE.
Room 507D, Progressive Bldg. Brooklyn 11, N. Y.
(On shipments to New York City address add 6% sales tax)

Edlie for TOP VALUES

JUST OUT! Newest & Best "Fix-It-Yourself" Aid Edlie's E-Z TV REPAIR GUIDE

The only Fix-It-Yourself guide made expressly for YOUR TV set! Now you can save costly TV repairs with this new, simplified method which includes all necessary data for just YOUR set. No confusing, unimportant information applicable to hundreds of different makes. Simplifies detection of faulty tubes in your TV receiver quickly, accurately. It's a terrific idea—It's a terrific guide! Order today and have your set back in perfect condition at once. Be sure to send us make and model of your TV set when ordering.

only
50¢



5-Tube AC/DC Superhet Radio Kit

KIT 5 includes all top quality components required to construct this latest design, highly sensitive 5-tube, AC/DC superheterodyne broadcast receiver. Complete with black, glistening bakelite cabinet (excludes wire & solder).

Kit of 5 tubes: 12AT6, 12BA6, 12BE6, 35W4 & 50B5... \$3.25

less tubes \$7.95

6-Tube Radio Kit

KIT 6: A great value in a low-priced radio kit designed for high sensitivity and good tone qualities. Easily constructed circuit. Complete with chassis, all parts, hardware, PM speaker (except wire & solder).

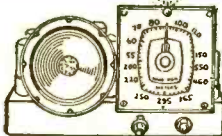

Kit of 6 tubes: 25L6, 25Z6, 6SQ7, 6SA7 & 6SK7 (2) \$3.25

less tubes \$6.95

Write today for FREE Catalog. All mdse. shipped F.O.B. New York City, prices subject to change without notice, include 20% deposit with C.O.D.'s.

EDLIE ELECTRONICS

154 Greenwich St. DI. 9-3143 New York 6, N. Y.

mal position after stripping insulation—will speed up the work and prevent nicks made by knife or similar tools. Such wire

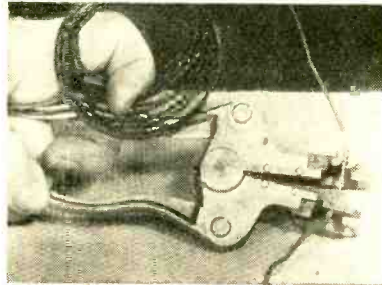

strippers may be purchased for various ranges of wire sizes, such as 10-20, 14-30, 12-20 gauge wire.

INEXPENSIVE RELAY COVER

PLASTIC refrigerator dishes with screw tops make excellent removable covers for sensitive relays operating in exposed or dusty locations.

Mount the cover of the dish and the relay

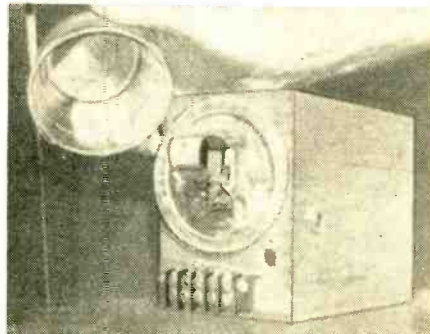

in the desired place and screw the dish to the lid as shown.

SAVE TUBE SOCKET "PUNCH-OUTS"

THE next time you're drilling and punching a metal chassis, save the tube socket "punch-outs." These may be de-burred,

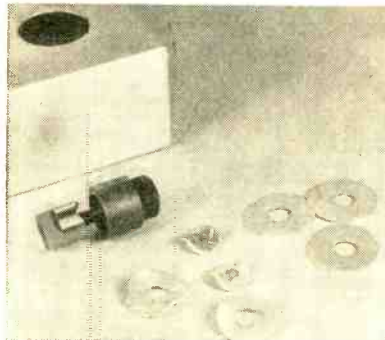

then flattened in a vise to make excellent oversize washers.



HANDS TIED?

—because you lack a HIGH SCHOOL DIPLOMA

• You can qualify for an American School Diploma *in spare time at home!* If you have left school, write or mail coupon for FREE booklet that tells how. No obligation of any kind.

OUR 58TH YEAR

AMERICAN SCHOOL, Dept. V456
Drexel at 58th, Chicago 37, Illinois

Please send FREE High School booklet.

Name.....

Address.....

City & State.....

Canadian Residents: Complete Canadian Course Available.
Write American School, 1610 Sherbrooke St. West, Montreal.

INVENTORS

Send for
PATENT INFORMATION
Book and
INVENTOR'S RECORD
without obligation

GUSTAVE MILLER
45-PE WARNER BUILDING
WASHINGTON 4, D. C.

REGISTERED PATENT
ATTORNEY

ASSOCIATE EXAMINER
U.S. PAT. OFF. 1922-1929

Patent Attorney & Advisor
U. S. NAVY DEPT. 1930-1947
PATENT LAWYER

If you ever need a mounting ring, you can make these from the flattened "punch-outs" by re-punching a smaller hole in them. The width of the ring obtained is equal to one-half the difference between the diameter of the "punch-out" used and the smaller punch. Thus, a 1½-inch "punch-out" re-punched with a 1-inch hole will give a ring width of ¼-inch and an i.d. of 1-inch.

* * *

DIAL CORD REPAIR

MANY radios and television sets use variable tuning capacitors which are turned by a remote dial. A length of cord con-

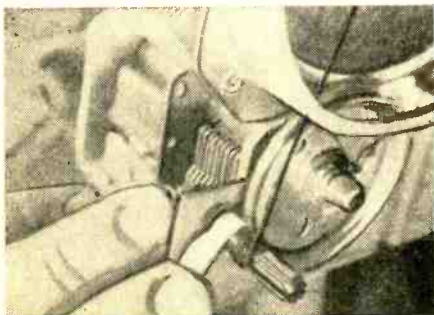

nects the capacitor pulley to the tuning knob pulley. After considerable use this cord may stretch and will no longer op-

erate the capacitor. When this happens the cord must be replaced—no easy job—or the slack taken up in some way. The slack can be removed merely by increasing the diameter of the tuning knob shaft through the addition of a strip of adhesive (medical) tape as shown in the illustration. One layer of tape will enlarge the diameter, give the cord a new bearing surface, and effectively prevent slippage.

* * *

TAPE IMPROVES SCREWDRIVER

THE screw-holding screwdriver is very handy for starting screws and bits. Unfortunately, only a common screwdriver may be available on the job. A temporary expedient is to jam the screwdriver blade against the sides of the screw slot with friction tape. If friction tape is not handy, almost any other type of tape may be used



such as drafting or masking tape. Even paper makes a good emergency substitute; if one thickness does not suffice, fold over several thicknesses of whatever material is used. **END**

FREE Bonus Offer!



Model 625K
• Illum. gear-driven "Speed Roll-chart"
• New lever-action switches for individual testing of every element
• Tests all conventional and TV tubes

This Eico Tube Tester is yours **FREE** when you buy \$100 worth of tubes or more within 60 days at Teltron.

May be bought outright from Teltron for \$34.95.

SPECIALS!

TYPE	PRICE
1K2	.57
504G	.38
6A05	.41
6BA6	.49
6BK7	.67
6BQ6GT	.75
6CD6G	.99
6SA7	.39
6SK7	.39
6SQ7	.34
6W6GT	.37
12A7	.67
12AX7	.55
25B06GT	.71
35Z5GT	.29
50C5	.41
50L6GT	.41
1629	.25

TELTRON TUBES

Guaranteed! Lowest Prices Ever!

All tubes individually boxed . . . unconditionally guaranteed for one year.

GIFT OFFER!
One 6BQ6 tube will be shipped **FREE** with any \$10 order accompanying this ad.

TYPE	PRICE	TYPE	PRICE	TYPE	PRICE	TYPE	PRICE	TYPE	PRICE
1A7GT	.53	6AC7	.65	6BQ7	.85	6V3	.80	12BZ7	.63
1B3GT	.62	6AF4	1.02	6BL7GT	.78	6V6GT	.48	12SA7	.45
1H5GT	.51	6AG5	.52	6BY5G	.60	6W6GT	.53	12SL7GT	.60
1L4	.51	6AH4GT	.65	6BZ7	.95	6X4	.37	12SK7	.45
1L6	.49	6AK5	.96	6C4	.41	6X5GT	.38	12SQ7	.38
1L6C	.51	6AL5	.43	6CU6	.95	6X8	.80	12SN7GT	.56
1N5GT	.51	6AR5	.48	6F6	.42	7F8	.49	19T8	.71
1R5	.51	6AU5GT	.60	6F5GT	.44	7N7	.52	25C06	1.09
1T4	.51	6AV5GT	.60	6H6	.50	12AL5	.43	25L6GT	.41
1U4	.51	6AV6	.37	6J5GT	.49	12AT6	.37	25Z5	.55
1U5	.43	6AX4GT	.60	6J6	.61	12AU6	.43	25Z6GT	.36
2A3	.35	6AX5GT	.60	6K6GT	.39	12AU7	.58	35B5	.48
2A7	.35	6BA7	.58	6K7	.40	12AV7	.73	35C5	.48
3Q4	.53	6BC5	.48	6L6	.78	12AX4GT	.60	35L6GT	.41
3Q5GT	.61	6BE6	.46	6Q7	.40	12AZ7	.65	35W4	.33
3S4	.48	6BF5	.48	6S4	.41	12B4	.72	35Y4	.42
3V4	.48	6BG6G	1.18	6S8GT	.65	12BA6	.46	50A5	.49
5V4G	.49	6BH6	.51	6SL7GT	.60	12BA7	.58	50B5	.48
5Y3GT	.30	6BJ6	.51	6SN7GT	.60	12BE6	.46	117L7GT	1.20
5Y4G	.40	6BK5	.75	6T8	.71	12BH7	.61	117Z3	.33
6A8	.40	6BN6	.90	6U8	.76	12BY7	.65	117Z6GT	.60
								80	.40

SAME DAY SERVICE
48 Hour Postal Delivery
To West Coast

TERMS: Save all freight and postage charges. All orders accompanied by full remittance will be shipped **POSTAGE PAID** anywhere in the continental U.S.A. 25% deposit required on C.O.D.'s. \$1.00 handling charge on orders under \$10. Open accounts to rated firms only.

FREE \$7.20 list value Bonus Box of three 6SN7 tubes and 25 assorted resistors with each order of \$25 or more.

TELTRON ELECTRIC COMPANY

428 HARRISON AVE. DEPT. PE-4 Phone HUmboldt 4-9848 HARRISON, N. J.



SUBMINIATURE POCKET TESTER

MODEL A-1000

- Low voltage tester (0-1000 volts) A.C., D.C.
- High voltage tester (50 K.V.)
- Signal tracer
- Audio Oscillator
- Condenser tester
- A.G.C. substitution voltage supply
- Visual output meter
- Continuity tester
- 3" x 4" x 1 1/4"

SEE YOUR DEALER
OR WRITE . . .

EBY SALES CO. of N. Y.
130 Lafayette St., NYC 13, NY

Get Your F. C. C. LICENSE Quickly!

Correspondence or residence preparation for F.C.C. examinations. Results guaranteed.

An FCC commercial operator license means greater opportunities and higher pay. We are specialists in preparing you, in a MINIMUM OF TIME, to pass FCC examinations for all classes of licenses. Beginners get 2nd class license in 5 weeks and 1st class in 3 additional weeks. Write for free booklet.

GRANTHAM School of Electronics

Dept. 104G, 6064 Hollywood Blvd., Hollywood 28, Calif.
Phone: Hollywood 2-1411

SOUND-OFF!

Build fully automatic electronic brain. The MUSICON cuts out commercials. Lets any radio, TV play only music! Priceless possession for home, business, office. Work, study, read, relax with music. Simple, low-cost construction. 2-tubes. Booklet, full instructions, schematic, PLUS special component, \$3.50 with order. Free literature.

NORMAN ELECTRONICS COMPANY
P.O. Box 733 Brooklyn 1, N.Y.

EYE GLASSES by MAIL As low as \$1.95

WRITE FOR FREE
CATALOG with 14
LENS SAMPLE CARD

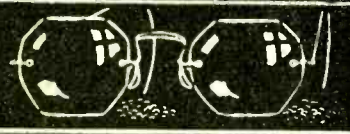

Thousands
Customers
Est. 1939

QUALITY READING-MAGNIFYING OR
BIFOCAL GLASSES FOR FAR AND NEAR
ADVANCE SPECTACLE COMPANY, Inc.
537 S. Dearborn St., Dept. PE-2 Chicago 5, Illinois

FREE!
GET IT
TODAY!

REQUEST PORTFOLIO 950

TO EVERY TV
SERVICEMAN

TV accessories and parts
catalogs, literature,
data sheets, etc. Yours
for the asking!



Vidaire

ELECTRONICS MFG. CORP

576 WEST MERRICK ROAD LYNBROOK, N.Y.

CONTACT SPRINGS for ORGAN KEYBOARDS WITH HARDWARE 5¢ EACH

Send 10¢ for giant new 16 page catalog listing hundreds of surplus bargains for experimenters.

SOUNDTRONICS LABS, 632 Arch St., Dept. P-3, Phila. 6, Pa.

"DELUXE" NEON BULB CODE PRACTICE OSCILLATOR

THE CIRCUIT shown will deliver a clean note to several pairs of headphones at once—from one to six—of either the low impedance or the high impedance type.

Power supply is built-in, using a selenium rectifier off the 117-volt line. Current drain is in the microamperes, so any size rectifier will do. An audio transformer serves to improve the note and also to isolate the key and phone circuit from the line. It is very important to eliminate the hazard of shock. The transformer is a regular junk-box 3-to-1 interstage unit as used in old-fashioned radios. When more than one pair of phones are used, connect them in series.

The potentiometer R_2 serves to control the pitch. The lower the resistance in series with the neon bulb, the higher the pitch of the note. The bulb stops oscillating, however, if the total series resistance is lower than about 1 megohm.

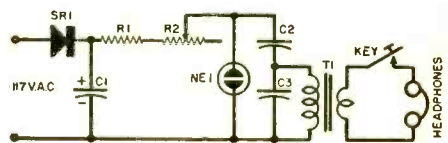

- R_1 —470 K., 1/2 w. res.
- R_2 —5 meg. pot.
- C_1 —10 μ d., 150 v. elec. capacitor
- C_2 —.001 μ d., 400 v. capacitor
- C_3 —.01 μ d., 400 v. capacitor
- NE1—Type NE-2 neon glow lamp
- SR1—Selenium rectifier
- T1—Interstage audio trans.
- 1—Standard telegraph key
- 1—Pair headphones

Schematic diagram and complete parts list.

Other power supplies or even "B" batteries will do for power instead of the selenium rectifier and filter capacitor shown. At least 90 volts is required, but the current drain is so low that old or outdated batteries will usually work. The higher the voltage, the higher the resistance setting of the pot, R_2 , for best results.

Operation of the circuit is similar to that of the basic glow lamp relaxation oscillator, with C_2 being the capacitor which is charged and discharged. Addition of C_3 and the transformer in series with C_2 does not change the operation of the basic circuit much, but it does allow some of the signal to be coupled to the phones when the key is closed.

The NE-2 bulb is the little ten-cent job without any base, available at radio parts dealers and surplus houses.

GEORGE BERRY

SPECIAL SW DX BROADCAST

IN a special DX broadcast, Ken Boord, author of "The World At A Twirl" in POPULAR ELECTRONICS, will present a half-hour program of Holy Week and Easter organ melodies over TGNEB, 9.668, and TGNC, 11.850 mc. on Saturday, April 9, at 2330-2400 EST. The station will verify all correct reports with their QSL card and would appreciate an International Reply Coupon with each report, to help defray cost of postage. To send a QSL card via airmail from Guatemala, the station should have three IRC's. Address reports to TGNA, Apartado 601, Guatemala City, Guatemala, Central America.

PROTECTING YOUR ANTENNA

HAVE trouble with your antenna breaking in heavy wind?

One way to prevent it is to use ¼-inch screen door spring. This will protect a 100-foot antenna.

Insulate the antenna at the ends as usual, but fasten the door spring between the antenna mast and the insulator. Then the spring will serve as slack to be taken up by the wind when it blows hard.

For winds of more than 45 m.p.h. the antenna will require a home-made spring as well. This can be made by using ½-inch iron wire, which farmers call "baling wire." Wind this closely and tightly around a broom-stick handle and then slip it off.

If there is a hole or pulley at the top of the mast, a piece of wire can be passed through it and led down 2 feet from the top of the mast. This wire is attached to the home-made spring and another wire is led from the spring and fastened to the mast at any convenient place.

In high winds the home-made spring will stretch to give added slack and prevent the antenna from snapping.

PHOTO CREDITS

Page	Credit
29	Center, Trans-World Airlines
30, 31, 34	Hart Industries
35	Mohawk Business Machines Corp.
55	E. F. Johnson
58	Left, General Electric Co. Right, Radio Corporation of America
59	General Electric Co.
72	National Heart Institute
73	U. S. Navy
80, 81	Claude Neon, Inc.
90, 91	Radio Corporation of America
92	Middle, Minneapolis-Honeywell Regulator Company Bottom, Approved Electronic Instrument Corporation
116	Granco Products
124	Radio Receptor Co.

CAPACITANCE QUIZ

(Questions on page 109)

1. a 2. b 3. c 4. b 5. b

BUILD YOUR OWN AMATEUR TRANSMITTER

from this easy to assemble kit!

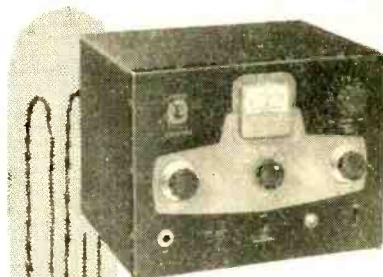

Start your hobby off right with this professional CW transmitter kit. 50 Watts input on 80, 40, 20, 15 and 11-10 meters. Packs enough power for world-wide radio contacts with just a simple antenna. No antenna tuner needed—single knob band-switching—crystal controlled oscillator—powerful 807 transmitting type output tube. Easy to build—safe to operate! Kit is furnished complete with built-in power supply, tubes, cabinet, wiring instructions and antenna suggestions.

Cat. No. 240-181-1—Viking "Adventurer" Kit, less crystal and key \$54.95

JOHNSON KEYS AND PRACTICE SETS

STANDARD KEY—Heavy die cast base. Smooth adjustable bearings. Provision for plugging in semi-automatic keys. Contacts are ⅛" coin silver. A high quality key at a low cost. 114-310 . . . \$2.60 Net Price

PRACTICE KEY—an inexpensive practice key—perfect in design for the average beginner. All the metal parts are nickel plated except the base. Furnished with an adjustable key arm spring and smooth action bearings. Contacts are of ⅛" coin silver. 114-300 . . . \$1.75 Net Price

PRACTICE SET—Constant frequency buzzer and key on a 4"x6" molded Bakelite base. May be used singly or in pairs for code practice. 114-450 . . . \$4.25 Net Price

For more information on the Viking "Adventurer" or Johnson's complete line of keys—see your electronic parts distributor or write to:



E. F. JOHNSON COMPANY

3013 Second Ave. S.W., Waseca, Minn.

PUT CANCER ON THE DEFENSIVE

together we can
strike back

Give to
**AMERICAN
CANCER SOCIETY**

DELUXE POCKET RADIO



Satisfied users report up to 1500 mile range. **Electron tube model** uses standard radio parts built to last. No hearing aid parts used. You can assemble this neatly engineered kit in one hour with simple directions. Batteries and parts fit in case. Tube included. **FULLY GUARANTEED.** Eveready Batteries \$1.15 per set. Radio headphone \$1.69. High imp. reg. \$10 hearing aid earset only \$4.95, or use own earphone. MODEL 3V4, factory-wired (set only) available at \$8.95. If C.O.D. please mail \$1 deposit.

\$395
Post
Paid

WESTERN RADIO CO., Box 1526, Sacramento 14, Calif.



Radio's "Sherlock Holmes"

INTERFERENCE to radio and TV reception caused by nearby factories equipped with high frequency equipment is doomed by a new kind of mobile detective.

Instrument-equipped station wagons now standing guard over the air lanes can make spot measurements of interfering signals. The two-man team then quickly determines if the signals are within channels authorized by the FCC. The level and source of disturbance are also determined. A two-way radio-telephone link between field cars and the plant helps in the work. If the plant is blameless, owners and operators of the mobile units (*Radio Receptor Corp., N.Y.C.*) are authorized to file certificates of compliance with the FCC. If there is interference, plant officials are given suggestions or methods of shielding to eliminate the trespass.

The station wagon houses all equipment, including two sets of instruments behind the driver's seat that cover the range from 15 to 300 mc. On its top is mounted a dual antenna system. To permit fast travel on any road, and without structural interference, the low-frequency antenna is an adjustable dipole. It is mounted on a retractable mast which swings into position vertically when in use. Manipulating a few controls sets it into horizontal position for fast travel.

END

Secrets of VENTRILOQUISM Now Revealed!

Easy to learn in 60 to 90 days with our Home Study Course. **RESULTS GUARANTEED.** Make Money! Be Popular! Have Fun! Big Opportunity! Radio, Television, Stage Appearances! For FREE information regarding price and terms, WRITE. You must state your age. Dummy Catalog 25c.

FRED MAHER SCHOOL OF VENTRILOQUISM
Box 36, Studio PE-4 Kensington Station
Detroit 24, Michigan

STANDARDIZED WIRING DIAGRAM SYMBOLS

<p style="text-align: center;"><u>ANTENNAS</u></p> <div style="display: flex; justify-content: space-around;"> </div> <p style="font-size: small; text-align: center;">GENERAL DIPOLE LOOP FERRITE TYPE</p>	<p style="text-align: center;"><u>MICROPHONE</u></p> <div style="display: flex; justify-content: space-around;"> </div> <p style="font-size: small; text-align: center;">SINGLE BUTTON DOUBLE BUTTON CAPACITOR</p> <div style="display: flex; justify-content: space-around;"> </div> <p style="font-size: small; text-align: center;">DYNAMIC VELOCITY CRYSTAL</p>	<p style="text-align: center;"><u>TELEGRAPH KEY</u></p>
<p style="text-align: center;"><u>BATTERIES</u></p> <div style="display: flex; justify-content: space-around;"> </div> <p style="font-size: small; text-align: center;">SINGLE-CELL MULTI-CELL</p>	<p style="text-align: center;"><u>NEON BULB</u></p>	<p style="text-align: center;"><u>PILOT LIGHT</u></p>
<p style="text-align: center;"><u>BELL</u></p>	<p style="text-align: center;"><u>PHONO PICKUPS</u></p> <div style="display: flex; justify-content: space-around;"> </div> <p style="font-size: small; text-align: center;">CRYSTAL MAGNETIC</p>	
<p style="text-align: center;"><u>BUZZER</u></p>	<p style="text-align: center;"><u>PLUG OR SOCKET</u></p>	
<p style="text-align: center;"><u>CAPACITORS</u></p> <div style="display: grid; grid-template-columns: repeat(3, 1fr); gap: 10px;"> </div> <p style="font-size: small; text-align: center;">FIXED MICA OR PAPER ELECTROLYTIC VARIABLE CAPACITORS GANGED</p> <p style="font-size: small; text-align: center;">TRIMMER OR PADDER SPLIT-STATOR FEED-THRU</p> <p style="font-size: x-small; text-align: center;">T-DESIGNATES TRIMMER OR PADDER</p>	<p style="text-align: center;"><u>RECEPTACLE 117 V.</u></p>	<p style="text-align: center;"><u>RECORDING HEAD</u></p> <p style="font-size: small; text-align: center;">MAGNETIC</p>
<p style="text-align: center;"><u>COILS</u></p> <div style="display: grid; grid-template-columns: repeat(3, 1fr); gap: 10px;"> </div> <p style="font-size: small; text-align: center;">FIXED R.F. COIL COIL WITH FIXED TAP COIL WITH VARIABLE TAP</p> <p style="font-size: small; text-align: center;">IRON CORE OR CHOKE BIFILAR VARIABLE COIL OR CHOKE</p> <p style="font-size: small; text-align: center;">SLUG-TUNED COIL</p>	<p style="text-align: center;"><u>RECTIFIER</u></p> <p style="font-size: small; text-align: center;">SELENIUM TYPE</p>	
<p style="text-align: center;"><u>CRYSTALS</u></p> <div style="display: flex; justify-content: space-around;"> </div> <p style="font-size: small; text-align: center;">CRYSTAL DETECTOR PIEZOELECTRIC CRYSTAL</p>	<p style="text-align: center;"><u>RELAYS</u></p> <div style="display: flex; justify-content: space-around;"> </div> <p style="font-size: small; text-align: center;">S.P.S.T. NORMALLY OPEN S.P.S.T. NORMALLY CLOSED S.P.D.T.</p>	
<p style="text-align: center;"><u>FUSE</u></p>	<p style="text-align: center;"><u>RESISTORS</u></p> <div style="display: flex; justify-content: space-around;"> </div> <p style="font-size: small; text-align: center;">GENERAL TAPPED OR ADJUSTABLE</p> <p style="font-size: small; text-align: center;">POTENTIOMETER OR RHEOSTAT CONTINUOUSLY VARIABLE</p>	
<p style="text-align: center;"><u>HEADPHONES</u></p> <div style="display: flex; justify-content: space-around;"> </div> <p style="font-size: small; text-align: center;">DOUBLE SINGLE</p>	<p style="text-align: center;"><u>SHIELDING</u></p> <p style="font-size: x-small; text-align: center;">DOTTED LINES INDICATE SHIELDING. COULD BE AROUND ANY COMPONENT OR GROUPS</p>	<p style="text-align: center;"><u>SPEAKERS</u></p> <div style="display: flex; justify-content: space-around;"> </div> <p style="font-size: small; text-align: center;">P.M. ELECTRO-MAGNETIC</p>
<p style="text-align: center;"><u>JACKS</u></p> <div style="display: flex; justify-content: space-around;"> </div> <p style="font-size: small; text-align: center;">OPEN CIRCUIT CLOSED CIRCUIT SHORTING TYPE 2 CIRCUIT</p> <p style="font-size: small; text-align: center;">PHONE PLUG PIN PLUG PIN JACK</p>	<p style="text-align: center;"><u>SWITCHES</u></p> <div style="display: flex; justify-content: space-around;"> </div> <p style="font-size: small; text-align: center;">S.P.S.T. S.P.D.T. PUSH-BUTTON</p> <p style="font-size: x-small; text-align: center;">D.P.S.T. D.P.D.T. BOTH TYPES GANGED</p> <p style="font-size: x-small; text-align: center;">ROTARY TYPE S.P.S.T. WAFER</p>	
<p style="text-align: center;"><u>METER</u></p>	<p style="text-align: center;"><u>TUBES</u></p> <div style="display: grid; grid-template-columns: repeat(3, 1fr); gap: 10px;"> </div> <p style="font-size: small; text-align: center;">DIODE OR FILS. PLATE CATHODE TRIODE TETRODE</p> <p style="font-size: small; text-align: center;">DIODE PLATE SURPRESSOR SCREEN CONTROL GRID CAP PLATE CAP</p> <p style="font-size: small; text-align: center;">PENTODE DUO TRIODE COLD CATHODE PHOTO-ELECTRIC</p> <p style="font-size: x-small; text-align: center;">DESIGNATES GAS FILLED</p>	
<p style="text-align: center;"><u>MOTOR</u></p>	<p style="text-align: center;"><u>TRANSISTOR (JUNCTION)</u></p> <p style="font-size: x-small; text-align: center;">BASE COLLECTOR EMITTER</p> <p style="font-size: x-small; text-align: center;">P-N-P TYPE N-P-N TYPE SAME SYMBOL EXCEPT ARROW IS REVERSED</p>	
<p style="text-align: center;"><u>VIBRATOR</u></p>	<p style="text-align: center;"><u>WIRES</u></p> <div style="display: flex; justify-content: space-around;"> </div> <p style="font-size: small; text-align: center;">CONNECTION NO CONNECTION</p>	

GLOSSARY

a.f.c.—Automatic frequency control: (1) control of the frequency of the local oscillator in a superheterodyne to keep the receiver in tune with a desired station; (2) control of the frequency of the horizontal oscillator in a television receiver to keep the horizontal deflection in step with the horizontal deflection at the television studio and thus to keep the picture steady horizontally.

a.g.c.—Automatic gain control, control of the amplification of an amplifier so that its output is approximately constant in spite of variations in the input signal; especially such control in television receivers to reduce variations in picture contrast produced by variations in r.f. signal strength.

a.v.c.—Automatic volume control (a.v.c. used in radio receivers to reduce variations in sound volume produced by variations in r.f. signal strength).

choke—An inductance used especially to present a high impedance to a wide range of frequencies. Filter chokes are used in rectifier-type power supplies to remove from the d.c. output hum components equal to the power line frequency and its harmonics; audio-frequency chokes are used in audio amplifiers and radio-frequency chokes are used in r.f. and i.f. amplifiers, to present a high impedance load to a vacuum tube or to block unwanted signals.

crystal—1. Rectifying crystal, one which passes electric current more easily in one direction than in the other and thus can be used to change alternating current to pulsating direct current; made of such materials as germanium, silicon, copper oxide, galena, and carborundum. 2. Piezo-electric crystal, one which transforms mechanical energy to electrical and vice versa. Such crystals, made of Rochelle salt or barium titanate, are used in microphones and phonograph pickups. When cut to a certain size and shape, a piezo-electric crystal, usually made of quartz, can be used as a resonant circuit, to control the frequency of an oscillator or as a frequency-selective filter.

decibel—A measure of the ratio between two power levels or of a power level with respect to a designated reference level. Basically, the number of decibels is ten times the logarithm of a power ratio. One decibel is approximately the smallest difference in sound power which can be detected by the average human ear.

db of feedback—The number of decibels by which inverse feedback in an amplifier reduces its over-all gain and distortion.

detector—A circuit used to recover an audio or video signal from a modulated radio signal.

electrolytic capacitor—A type of capacitor in which the dielectric or insulator is a thin film of oxide deposited on one aluminum or tantalum plate and an electrolyte is used between the insulator and the other plate. This type of capacitor provides a larger capacitance in a given volume than any other type. However, except for special a.c. electrolytics, this type can be used only in circuits where voltage of constant polarity is applied to it.

elevator—Control surface of an aircraft which regulates its pitch attitude (level, climbing, or diving).

feedback—Returning part of the output of an amplifier stage to the input of the same or a previous stage. Negative or inverse (out-of-phase) feedback decreases the gain and distortion of the amplifier; positive (in-phase) feedback increases gain and distortion and may produce oscillation.

frequency response—The relative ability of an amplifier, loudspeaker, or other device to respond to different frequencies.

glow plug—A type of internal-combustion engine used in models, in which starting is assisted by a filament in the combustion chamber, which is energized by an external battery.

harmonic distortion—Distortion consisting of addition to the signal of components whose frequencies are multiples (harmonics) of the original signal frequency. It is produced by an amplifier or other device which is nonlinear (does not give the same ratio of output to input for all input amplitudes).

heterodyne—A different frequency (beat) produced by combining two frequencies.

hole—Absence of an electron normally present in an atom; a positive charge. The action of some transistors often is explained by referring to movement of holes or positive charges, rather than movement in the opposite direction of electrons or negative charges.

microammeter—A meter for the measurement of current flow, which is calibrated in microamperes, or millionths of an ampere.

milliampere—One-thousandth of an ampere.

modulated—Varied in amplitude, frequency, or some other quality. Radio-frequency signals are modulated in order to carry signals of lower frequency, such as sound or picture signals.

multitester—A meter which is a combination of a voltmeter, an ohmmeter, and (often) an ammeter.

octal—Designation of one of the standard types of tube base or the socket to fit it. The base has eight equally spaced pins and a centrally located boss, which is made of insulating material and has a key to prevent improper insertion of the tube in the socket. The loctal tube base is similar, except that its pins are smaller in diameter and the central boss is of metal and has a groove which fits a one-turn spring in the socket, to hold the tube.

oscillator—A vacuum-tube or transistor circuit or other device which produces an alternating-current power output without mechanical rotation.

plate dissipation—The part of the power applied to the plate circuit of a vacuum tube which does not appear as signal output, but is dissipated as heat in the plate of the tube.

push-pull—An arrangement of two vacuum tubes in an amplifier so that the input signal is applied in opposite phases to the two tubes and the signal outputs are combined in phase. This arrangement reduces even-harmonic distortion.

regeneration—Positive feedback in detectors and amplifiers. Increases gain and distortion and may produce oscillation.

saturate—To reach the maximum possible value of some quantity, such as magnetization in the core of an inductor or electron flow in a vacuum tube from cathode to plate.

servo-motor—A special electric, hydraulic, or other type of motor used in control apparatus to convert a small movement into one of greater amplitude or greater force.

signal generator—A test instrument providing electrical power substantially similar in amplitude, frequency, and other qualities, to signals found in electronic equipment.

signal tracer—A test instrument for detecting the presence of a signal in electronic equipment and, with some signal tracers, measuring its amplitude, frequency, or other qualities.

superheterodyne—A receiver in which all incoming radio-frequency signals are mixed with the output of an oscillator to produce a heterodyne or beat frequency. The oscillator frequency is variable so that the beat produced with any desired signal can be adjusted to a certain frequency. The beat-frequency

signal is fed to a fixed-frequency (intermediate-frequency) amplifier, where greater and more uniform gain and selectivity can be obtained than at the original radio frequency.

superregenerative—A type of regenerative detector in which the tendency to oscillation is controlled by a quenching voltage of ultrasonic frequency which periodically allows the gain to increase, then reduces it. The quenching voltage can be produced by the detector tube itself or by a separate oscillator. This type of detector has great sensitivity, but poor selectivity.

tone control—1. In a radio receiver or an audio amplifier, means provided to change the relative response to audio signals of different frequencies; effects which can be produced are treble boost or attenuation and bass boost or attenuation. 2. In radio control of models, a system wherein the radio signal is modulated by audio tones and control is achieved by keying the modulating tones on and off, instead of keying the r.f. carrier.

v.t.v.m.—Vacuum-tube voltmeter, a voltmeter using one or more vacuum tubes to increase the sensitivity of the basic meter movement, so that measurements can be made in a circuit without drawing much current and without disturbing very much the normal operating conditions of the circuit. May also be a combination voltmeter, ohmmeter, and ammeter. END

ABBREVIATIONS

a.c.—alternating current
a.f.—audio frequency
a.f.c.—automatic frequency control
a.g.c.—automatic gain control
AM—amplitude modulation
amp.—ampere
ARRL—American Radio Relay League
a.v.c.—automatic volume control
BCI—interference with broadcast reception
b.f.o.—beat frequency oscillator
cps—cycles per second
c.t.—center-tapped
c.w.—continuous wave
db—decibel
dbm—decibels above one milliwatt
d.c.—direct current
d.c.c.—double cotton covered (wire)
d.p.d.t.—double-pole, double-throw
d.p.s.t.—double-pole, single-throw
DX—distance
elec.—electrolytic
FCC—Federal Communications Commission
FM—frequency modulation
freq.—frequency
GMT—Greenwich Mean Time
hi fi—high fidelity (of sound reproduction)
hy.—henry
i.f.—intermediate frequency
K—kilo (one thousand)
kc.—kilocycle
M—mega (one million)
ma.—milliampere
mc.—megacycle
meg.—megohm
mike—microphone, microfarad
mil—milliampere
m.o.p.a.—master oscillator, power amplifier
mu—amplification factor
 μ fd.—microfarad

μ fd.—micromicrofarad
mw.—milliwatt
m.w.—medium wave
PA—power amplifier
p.a.—public address
PM—phase modulation, permanent magnet (speaker)
pos.—position (of a switch)
pot.—potentiometer
pri.—primary
R-C—resistance-coupled
R/C—radio control
rect.—rectifier
res.—resistor
RETMA—Radio-Electronics-Television Manufacturers Association
r.f.—radio frequency
r.m.s.—root mean square
sec.—secondary
SN—self-neutralizing (escapement)
s.p.d.t.—single-pole, double-throw
spkr.—loudspeaker
s.p.s.t.—single-pole, single-throw
s.w.—short-wave
SWL—short-wave listener
sync.—synchronization
t.—turns (of a coil)
trans.—transformer
TV—television
TVI—interference with television reception
u.h.f.—ultra high frequency
v.—volt
v.f.o.—variable frequency oscillator
v.h.f.—very high frequency
VR—voltage regulator
v.t.v.m.—vacuum-tube voltmeter
vu—volume unit
w.—watt
wpm—words per minute
xmtr.—transmitter

HUDSON HAS 'EM!

COMPLETE PARTS KITS for FEATURE PROJECTS in this Magazine

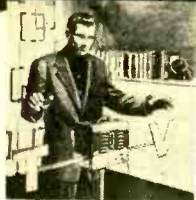

We've put together FROM OUR REGULAR STOCKS OF STANDARD BRAND PARTS, complete kits as shown in the parts lists of feature projects in this issue of Popular Electronics. These components are all BRAND NEW, FULLY GUARANTEED, and SPECIALLY LOW PRICED FOR THESE PROJECTS!

- THEREMIN Electronic Organ**
Complete Kit of Parts (less Amplifier & Speaker) **\$26.54**
Special
- Mike Stand and Adapter **\$8.60**
Amplifier and Speaker Catalog on request
- TRANSISTOR P.P. AUDIO OSCILLATOR**
Complete Kit of Parts Special **\$10.81**
- MINIATURE POWER SUPPLY**
Complete Kit of Parts Special **\$6.93**
- COMPACT AM TUNER**
Complete Kit of Parts Special **\$13.55**



PLEASE INCLUDE
20% DEPOSIT WITH
C.O.D. ORDERS

Mail Order Dept. PE-4
48 West 48th Street
New York 36, N. Y.

Beginners ELECTRONIC KIT

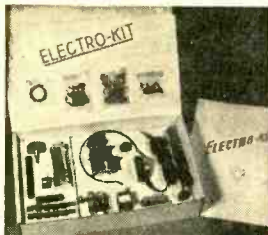

For young and old
35 EXPERIMENTS

Complete, no extras to buy. Build 5 radios, audio amplifier and oscillator, electronic organ, 2 power supplies plus many others. Kit has duo-purpose tube, selenium rectifier, headphone, crystal, all necessary resistors, condensers, hardware, etc.

Only \$1 with order, pay postman \$8.95 plus charges or \$9.95 prepaid.

ELECTRO KIT

Box 3468 Dept. PE-5 Maplewood 17, Mo.

hundreds of exciting ELECTRONIC BUYS!

FREE! CATALOG!

Harjo Sales Co.

Dept. P1, 4109 BURBANK BLVD., BURBANK, CALIF.
Phone Victoria 9-2411

CLEAR-VUE AMAZING VEST-POCKET SIZE TV ANTENNA ONLY \$1.00

Can be hidden from view. Use instead of bulky rabbit ears. 10 Day Money Back Guarantee. Enclose \$1.00 for regular or \$2.00 for deluxe model. Name and address with this ad to

G. DALAMANGO
160-26 26 Avenue, Flushing 58, N. Y.

INDEX OF ADVERTISERS

Advertiser	Page
Advance Spectacle Co., Inc.	122
Allied Radio Corp.	12
American School	120
Ashe, Radio Co., Walter	104
Beavers, Patrick D.	118
Business Information Corp.	129
Cleveland Institute of Radio Electronics	14
Concord Radio	103
Coyne Electrical School	5, 95
deBolt Model Engineering Co.	100
G. Dalamango	128
D-Frost-O-Matic	112
Dun & Bradstreet International Markets	15
Eby Sales	122
Edlie Electronics	120
Electro Kit	128
Electronic Instrument Co., Inc. EICO	100
Electronic Measurements Corporation	6
Electro-Voice	97
Espey Manufacturing Co.	89
Evans, Victor J.	116
Finney Company, The	93
G & H Wood Products Co.	2nd Cover
Grantham School of Electronics	122
Gyro Electronics Co.	106
Hallcrafters	4th Cover
Harjo Sales Co.	128
Heath Company	84, 85, 86, 87
Herback & Rademan, Inc.	118
Hershel Radio Co.	117
Hudson Radio & Television Corp.	128
International Binocular Co.	91
Instructograph Company	112
Johnson, E. F.	123
Karlson Associates, Inc.	104
Lafayette Radio	107
Maher School of Ventriloquism, Fred	124
Malone Electronics	11
Miller, Gustave	120
Moss Electronics Distributing, Inc.	16, 17
McGraw-Hill Book Co., Inc.	13
National Radio Institute	3
National Schools	3rd Cover
Newark Electric Company	110
Norman Electronics Company	122
Nucleonic Co. of America	112
O'Brien, Clarence & H. B. Jacobson	7
Palley Supply Co.	112
Perma Power Company	102
Precision Radiation Instruments	118
Progressive "Edu-Kits," Inc.	119
Radio-Television Training Association	9
Raytheon Manufacturing	8
Research Invention & Mfg.	116
Rex Radio Supply	110
Rider Publishing Co., Inc., John F.	101
Rinehart & Co., Inc.	99
Rockbar Corporation	109
Simpson Electric Company	106
Soundronics Labs	122
Specific Products	114
Spera Electronic Supply	118
Sprague Products Co.	18
Stanley Electronics Corp.	112
Steve-El Electronics Corp.	116
Stower & Son	118
Superex Electronics Corp.	96
Sutton Electronic Company	114
Tele-Diagnosis Co.	96
Teltron Electric Company	121
Transistor-Photo Products	129
Transvision, Inc.	115
Valparaiso Technical Institute	116
Van Nostrand Company, Inc., D.	102
Vidaire Electronics Mfg. Corp.	122
Video Electronics Company	105
Western Radio Co.	124
World Radio Laboratories	111

AUDIO QUIZ

(Questions on page 112)

- | | | | | |
|------|------|------|------|-------|
| 1. b | 2. a | 3. c | 4. a | 5. a |
| 6. c | 7. c | 8. b | 9. c | 10. c |

Classified

FOR SALE

GEIGER Counter Kit—Only \$64. assembled \$76. more sensitive than most counters and scintillometers. Counter Diagrams, 50 cents. Uranium, 1.00% U_s Os, \$1.00. Determine ore values with this accurate sample. T. Barrett, 22319 Kathryn Ave., Torrance, Calif.

ELECTRIC Pencil: Engraves all Metals, \$1.50. Beyer Mfg., 10511-P Springfield, Chicago 43.

THOUSAND "Quality" Business Cards \$3.95. Stickers \$2.95. Postpaid. Trowbridge, 312-C W. 75th, Chicago 21.

ELECTRICAL fires needn't worry you. Effective compact fire extinguisher with wall bracket. Brass \$3.98; Chrome \$4.95. Box 161, Bridge Station, Niagara Falls, New York.

REAR Seat Speaker Kits, large 6x9 speaker, cover plate, 3 way control, only \$5.95 postpaid, Keltronic's, P.O. Box 92, Ventura, Calif.

GEIGER counter kit. Complete \$17.50 postpaid. Easily assembled. Send cash with order to Stowers & Son, 804 Grand, Kansas City, Mo.

DIAGRAMS for repairing radios \$1.00 Television \$2.00. Give; make, model. Diagram Service, Box 672-PE, Hartford 1, Conn.

24 PAGE Plans "18 Crystal Sets" (SW Record 5800 miles) 25¢, including "Radiobuilder," catalog. Laboratories, 328-L Fuller, Redwood City, California.

CRYSTALS—FT-243's—3500 to 8700 KC, \$1.00 each; .01% setting \$2.00 each. Hundley Crystal Co., P.O. Box 422, Kansas City 4, Kansas.

40 NEW Condensers and Resistors—\$1.00 postpaid. Bigelow Electronics, Beulah, Michigan.

CODE Practice Oscillators. Electronic Audio-Visual Trainer, codes, instructions, year warranty \$4.00 Postpaid. Details Free. Stout, 2241A E. Broadway, Muskegon, Michigan.

RESISTORS, condensers, micas, electrolytics, tubulars, thousands of new latest types, each piece new, usable, some short leads. 10 lbs., \$9.50, Prepaid, Cagan Sales, Box 1152, Rochester, New York.

WHOLESALE Speaker Reconing. Send for dealer price list. Prompt service. C. Bernard Smith, 920 So. Euclid Ave., Pasadena 5, Calif.

BUY Surplus Radio, Electronic, Equipment Supplies from Government. List \$1.00. Box 169ZF, East Htd. 8, Conn.

INVENTIONS WANTED

INVENTIONS wanted. Patented; unpatented. Global Marketing Service, 1404 Mitchell, Oakland 1, Calif.

INSTRUCTION

HIGH School—no Classes. Study at home. Spare time. Diploma awarded. Write for Free Catalog HET-6, Wayne School, 2527 Sheffield, Chicago 14, Ill.

BUSINESS OPPORTUNITIES

TRADE - Business - Vocational - Diversion Magazines. Late copies. Get-acquainted service. More than 5,000 publications—all fields. Current Lists Free. Commercial Engraving Publishing Company, 34BW North Ritter, Indianapolis 19, Indiana.

RECAST Old batteries into new. Latest achievements. Battery Laboratories, Minneapolis.

TELEVISION Jobs—Names and addresses of companies to contact. \$1.00. Fitzgerald, Dept. A-22, 815 Countryside Drive, Wheaton, Illinois.

MISCELLANEOUS

PUBLISH Your Own Magazine. Details 10¢ Waco, Box 854, Spokane, Washington.

BUILD at no cost: amplifier from radio, doesn't damage radio; intercoms; tube-testers; radios; soldering iron; polarity, volt-ohmmeters; switches; more. Book tells, \$1.00. Dept. C1G3M2X, Clifford M. Gatzaway, Garland, Kans.

NOTICE: Inventors and Smaller Industries. Will design and build special electronic test or experimental equipment to your requirements. For information write Box 1191, Dept. B, Minneapolis, Minn.

FREE diagram. Amazingly inexpensive Geiger Counter, Kits Available. Columbia Distributors, Box 599, Camas, Washington.

BUILD super crystal radios, Electrotomic crystal, detector, instructions 50¢. Electrotomics, Box 98-E, Dixon, Missouri.

STOP television interference. Interference filter described on page 79 February Popular Electronics only \$1 postpaid; money back guarantee. American Electronics, 1203 Bryant, N. Y. 59, N. Y.

RECORDISTS! Exchange talking and musical tapes internationally. Box 1404-PE, San Francisco 1.

BECOME A Radio Amateur. Free information on how to pass Code and Theory FCC examinations. American Electronics, 1205½ Bryant Ave., New York 59, N. Y.

MODEL and Builder vs the atmosphere; money prizes; free manual, Mariotti Model Company, Box 655, Fontana, California.

"CRYSTAL Set beginners—Free gifts for stamp." Mailmart, Box 92, Paramus, N. J.

FREE Condenser and Resistor Code Charts. Largest stock of parts and tubes in West. We can save you money. K & L Radio Parts Co., 1406 Venice Blvd., Los Angeles 6, Calif.

TUBES—TV, Radio, Transmitting, special purpose types—Bought, Sold, Exchanged. Send details to B. N. Gensler W2LNI, 136 Liberty St., New York 6, N. Y.

IT WILL PAY YOU

to read and answer the ads in this section or to place your own ad at these thrifty rates.
50c per word—minimum 10 words

TRANSISTORS!!!

EXPERIMENTERS Hurry • limited quantity, marvels of electronics • build your own audio oscillators, personal radios, hearing aids etc. • Transistor \$3.00 • Lead Sulphide Photo-cell in plastic \$1.00 • Cadmium Sulphide Cell \$2.00 • Lead Sulphide Cell in Glass \$1.00 • Learn by doing • Act now
BARGAIN OFFER—Entire kit, 2 Lead, 1 Cadmium Cells and 1 Transistor ONLY \$5.00 postpaid, including booklet of information and circuits.
TRANSISTOR - PHOTO PRODUCTS
Geneva, Illinois

**ADDRESS
POSTCARDS
AT HOME!!**

write BOX 14, BELMONT, MASS.

RESISTOR COLOR CODE

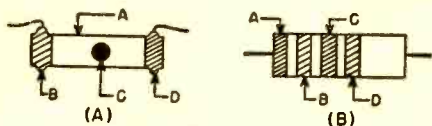

RETMA COLOR CODE CHART

COLOR	VALUE	MULTIPLIER
Black	0	1
Brown	1	10
Red	2	100
Orange	3	1000
Yellow	4	10,000
Green	5	100,000
Blue	6	1,000,000
Violet	7	10,000,000
Grey	8	100,000,000
White	9	1,000,000,000

TOLERANCE CODE

Gold—±5%	Silver—±10%
No Color—±20%	

The ohmic value of a resistor can be determined by means of the color code. There are two standard methods of indicating this value.

In Fig. A, the body (A) and end (B) indicate the first and second digits of the value while the dot (C) indicates the multiplier to be used. The tolerance of the unit is indicated by the end color (D). For example, if the body (A) is green the number is 5; if the end (B) is grey the second number is 8. If the dot (C) is red the multiplier is 100 or two zeros should be added. The resistor is then a 5800 ohm unit. If the end (D) has no color, the tolerance is ±20%.

In Fig. B, the first two stripes indicate the first two digits; the third stripe the multiplier; the fourth stripe the tolerance. Thus, if stripe (A) is green, (B) is grey, (C) is red, and (D) is silver, the resistor is a 5800 ohm, ±10% unit.

CAPACITOR COLOR CODE

Color	MOLDED PAPER		MOLDED MICA		CERAMIC	
	Multiplier	Tolerance	Multiplier	Tolerance	Multiplier	Tolerance
Black	1	20%	1	20%	1	20% or 2.0μfd.*
Brown	10		10	10	10	1%
Red	100	5%	100	2%	100	2%
Orange	1000		1000	3% (RETMA)	1000	2.5% (RETMA)
Yellow	10,000	10%	10,000	5% (RETMA)	10,000	5% or 0.5μfd.*
Green						
Blue		10%		5% (JAN)	0.01	0.25μfd.*
Violet						0.1
Gray		20%		10%		
White	0.1		0.1			
Gold			0.01			
Silver						
None						

*Capacitance less than 10μfd.

Capacitance is given in μfd. Colors have same values as on resistors, except as indicated in tables. Colors (A) and (B) are for first two digits; (C) is for multiplier. (D) is for tolerance. (E) and (F) give voltage rating in hundreds of volts; (E) is used only for ratings less than 1000 volts, (E) and (F) for first two digits of ratings 1000 volts or more. Values of colors for (E) and (F) are same as in resistance values. (G) is class or characteristic of capacitor, (H), (I), and (J) give temperature coefficient. (G), (H), (I), and (J) are not listed in the tables, since this information is seldom needed by the average home builder.

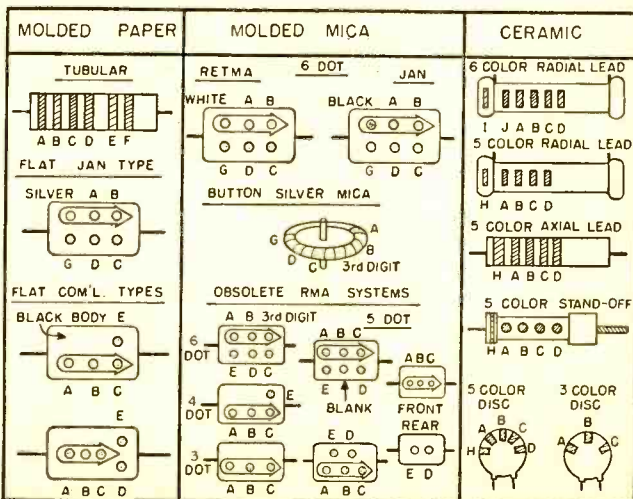



Get more money!
More security! More out of life!

Learn

TELEVISION • RADIO • ELECTRONICS

Get the best!

Get National Schools' SHOP-METHOD HOME TRAINING!

Start now! Why wait around for that raise or promotion that may never come? Get started *now* in high-paying TV-Radio-Electronics! National Schools' SHOP METHOD Home Training prepares you for success in a top-salary job or in your own business. You learn *all three*... Television, Radio, Electronics... in one complete course. Our Shop-Tested lessons and manuals help you master all phases in shortest possible time! Send coupon, find out today!

WHY NATIONAL SCHOOLS LEADS THE FIELD

Located in the "Television Center" of the world, our staff is in close touch with latest developments and opportunities. We give you personalized job placement assistance. We also give you confidential help with both technical and personal problems relating to your training. We show you how to make Part Time Earnings as you progress. Whether you live 30 miles away, or 3,000, you will always be pleased with our prompt, friendly service!

DRAFT AGE? Our home training helps you achieve specialized ratings and higher pay grades if you go in service.

We send you this precision-tested Multitester! Plus parts to build Oscillators, Receivers, Signal Generator, Continuity Checker, Combination Short Wave and Standard

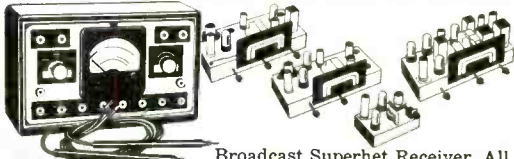

Broadcast Superhet Receiver. All this equipment is part of your National Schools course. **NO EXTRA CHARGES!** Send coupon for free books!

NATIONAL SCHOOLS, world-famous technical trade school. Now entering our 50th year!



NATIONAL SCHOOLS

TECHNICAL TRADE TRAINING SINCE 1905

LOS ANGELES 37, CALIFORNIA

In Canada: 811 W. Hastings St., Vancouver, B. C.

• APPROVED FOR G. I. TRAINING

• BOTH HOME STUDY AND RESIDENT COURSES OFFERED

30 MILLION TV SETS

need regular repair! Color TV means more sets than ever before. NOW is the golden opportunity to cash in on this multi-billion-dollar industry. Or "write your own ticket" in broadcasting, manufacturing, and other specialized phases!

**YOUR AGE
IS NO
OBSTACLE!**

Send for
FREE LESSON!
FREE BOOK & SAMPLE LESSON
will convince you!
SEND COUPON TODAY!

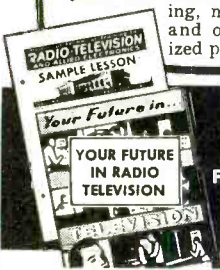

MAIL NOW TO OFFICE NEAREST YOU!

(mail in envelope or paste on postal card)

NATIONAL SCHOOLS, DEPT. R2G-45

4000 SOUTH FIGUEROA STREET OR 323 WEST POLK STREET
LOS ANGELES 37, CALIFORNIA CHICAGO 7, ILLINOIS

Please rush **FREE BOOK**, "My Future in Radio-Television-Electronics," and **FREE LESSON** at once. I understand there is no obligation, and no salesman will call.

NAME _____ BIRTHDAY _____ 19 _____

ADDRESS _____

CITY _____ ZONE _____ STATE _____

Check if interested ONLY in Resident Training at Los Angeles.

VETERANS: Give date of discharge _____

Again, Two New Leaders Bear a Famous Brand*

We're proud of our name and the twenty years of electronic leadership it represents. Our brand new communications line is in keeping with the high standards we have always maintained. Hallicrafters respects the recognition it has achieved by never compromising quality for price or sacrificing craftsmanship for mass production. These new models are the ultimate in precision-built communications equipment.

W. J. Halligan

Bird Halligan, Jr.

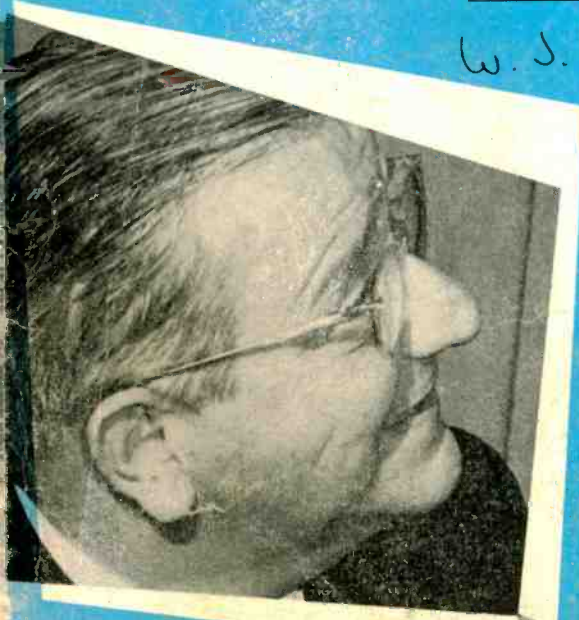

This new receiver reflects the dependable performance of 500,000 Hallicrafters radios with basically this chassis now in the field. Covers Broadcast Band 540-1650 kc plus three short-wave bands from 1650 kc—32 Mc. Electrical bandspread operates over large, easy-to-read dial. Headphone tip jacks on rear and built-in PM speaker. Oscillator for reception of code signals.

Gray steel cabinet with silver frame trim 12 $\frac{1}{8}$ " x 7" x 7 $\frac{1}{4}$ ". Shipping weight 13 lbs.. Four tubes plus rectifier. 105/125 V. 50/60 cycle AC/DC \$49.95



Model S-38D

These two new Civil Patrol receivers replacing the popular S-81 and S-82 are over ten times as sensitive, have greater increased audio power output, and include an extremely reliable *built-in relay squelch system*. This type of squelch system *completely* disables the entire audio system so that not a murmur is heard from the speaker until a signal is received making the unit perfect for monitoring of police, fire, taxi, mobile-telephone, forestry, civil defense. The S-94 covers from 30—50 Mc and the S-95 from 150—173 Mc. Built-in speaker and provisions for headphones. Gray steel cabinet with silver trim panel and red pointer. 12 $\frac{1}{8}$ " x 7" x 7 $\frac{1}{4}$ ". Shipping weight approximately 12 $\frac{1}{2}$ lbs. Eight tubes plus rectifier. 105/125 V. 50/60 cycle AC/DC \$59.95



CHICAGO 24, ILLINOIS



Model S-94 (S-95)

* hallicrafters