

CHROME

B H O R O M E 2

THE CYBERPUNK STYLE GUIDE VOL. 2



CYBERPUNK

R. TALSORIAN
GAMES, INC.

CYBERPUNK HOME 2

The Cyberpunk Style Guide Vol. 2



R. TALSORIAN
GAMES, INC.

CYBERPUNK®

STAFF

CONTRIBUTING WRITERS

Ben Wright
 Mike Roter
 Jeff Hexter
 Marcus Pregel
 Craig Sheeley
 Mike MacDonald
 Ross Winn
 Mike Pondsmith
 Colin Tipton
 Michael Todd

CONTRIBUTING EDITORS

Derek Quintanar
 David Ackerman
 Mike Pondsmith
 Mike MacDonald
 Lisa Pondsmith

ARTISTS

Ben Wright
 Gloria Yuh Jenkins
 Harrison Fong
 Tim Eldred

COVER

Mike Ebert

ART DIRECTION

Matthew Anacleto

GRAPHICS

Mike Pondsmith
 David Ackerman
 Matthew Anacleto

**R. TALSORIAN
 GAMES, INC.**

Published by R. Talsorian Games
 P.O. Box 7356
 Berkeley, CA 94707

Copyright 1992 by R. Talsorian Games Inc.
 Cyberpunk® and Chromebook 2 are trademarks
 of R. Talsorian Games Inc. All Rights Reserved.

CONTENTS

CYBERWARE 3
EQUIPMENT 10
WEAPONS 35
TEAMS 51
FULL BODY REPLACEMENT 63
VEHICLES 86
EXOTICS 101
INDEX 111

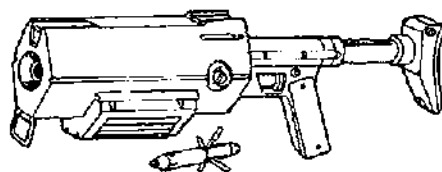

MILITECH URBAN
 MISSILE LAUNCHER PG. 41

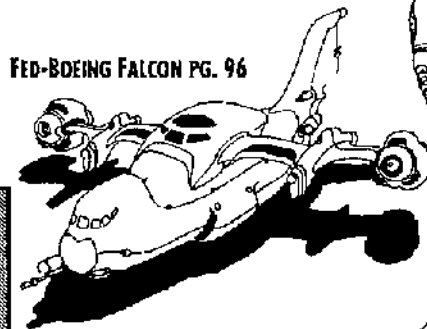

FED-BOEING FALCON PG. 96

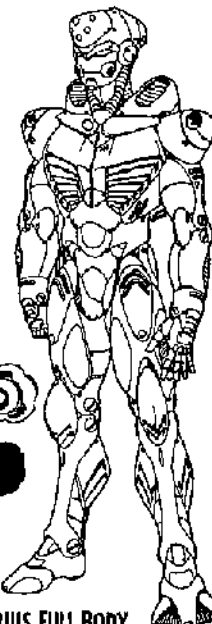

AQUARIUS FULL BODY
 CONVERSION PG. 67

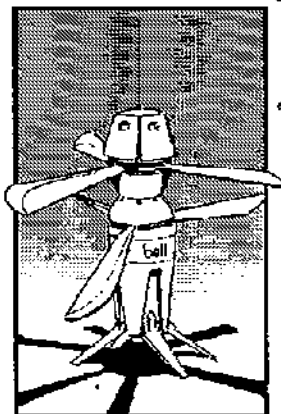

BELL REMOTE
 ROTOCRAFT PG. 31



DYNALAR QUICK CHANGE MOUNTS PG. 4

CYBERWARE

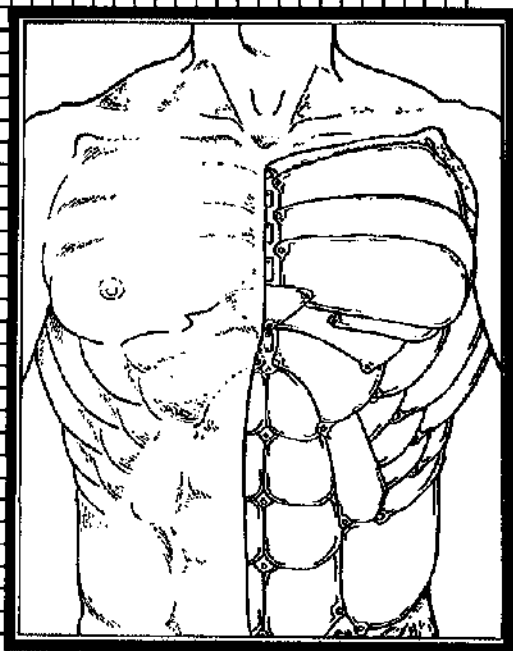
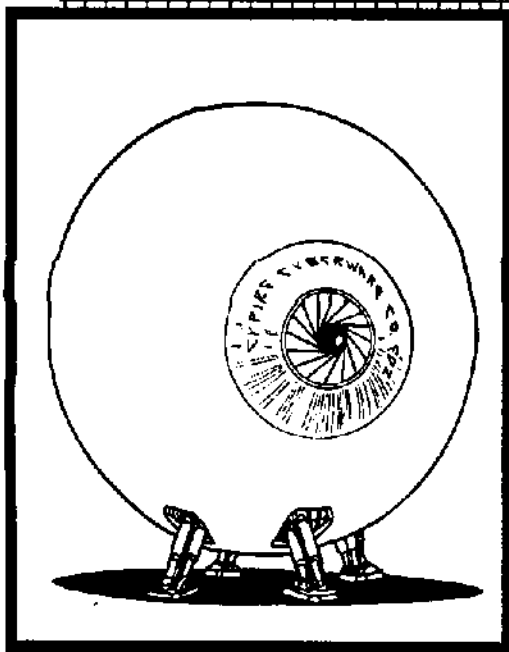

"Court the Chrome, become one with it. You need it, and it needs you. You will become stronger in the bonding."

—**Quess**

"Once you're sure you've got the Chrome on the inside then you can take care of the exterior. If you don't have the interior instinct, don't bother with the trappings."

—**Akira Takahashi**

"The quintessential 'punk needs quintessential warez. It's a necessity, chombatta."

—**Gil Myxx**

"Hey, Cyberware's just like factory options for humanity, y'know? Heh."

—**Blitz**

**DYNALAR
TECHNOLOGIES
"DIGITS"
CYBERFINGERS**



The latest line of cyberfingers from the minds at Dynalar Technologies. Compatible with any standard cybernetic hand or arm; easily installed in the privacy of your own home.

QUICK CHANGE MOUNT **150EB**
A handy click-and-turn mount installed at the knuckle of the cyberhand. Any Dynalar cyberfinger can be modified for use with a quick change mount for 20eb. HC=1

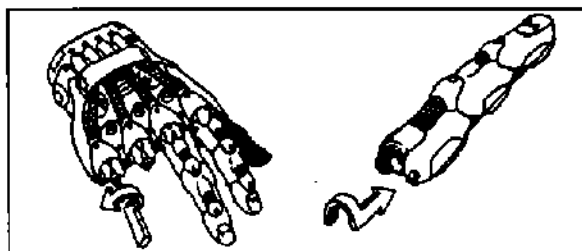

CHANGE MOUNT ▲

VIDCAM **400EB**
Designed in conjunction with Kiroshi Optics, this cyberfinger contains a miniature video camera designed to transmit its input to a Kiroshi Video Imager (*Chromebook 1*, pg.39). This cyberfinger is ideal for peering around corners unobtrusively. HC=2 The vidcam can have **one** of the following options.

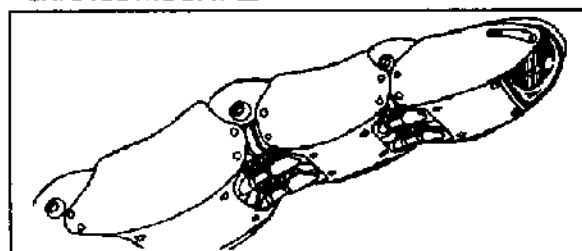

VIDCAM ▲

- Passive IR 200eb
- Teleoptics (10x) 225eb
- Lowlite 100eb

SELF-PROPELLED GRENADE **200EB**
The first joint of the cyberfinger is a self-propelled grenade (7m range). 2D6 damage to all targets in a 2m diameter. Replacement grenades cost 25eb. each. Caution: Black market cyberware in most judicial regions. HC=2

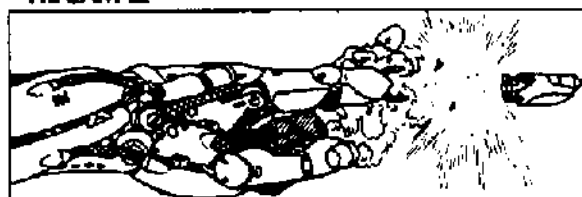

GRENADE ▲

AIR HYPO **200EB**
Miniature "Bones McCoy". Drug container plugs into a socket below the knuckle. Enough compressed air for 4 injections. Replacement air containers are 3eb. each. See CP2020, pg. 112 for available drugs. HC=1

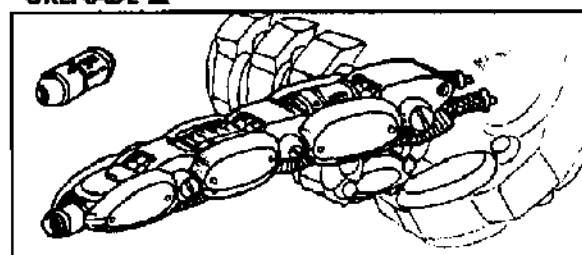

HYPO ▲

TRACKING DEVICE **300EB**
Another cyberfinger designed in conjunction with Kiroshi Optics. This cyberfinger contains a tracking device with a range of 3km. It transmits the direction and distance to a TimesSquare display. This cyberfinger holds 2 magnetized tracer bugs that it can launch at targets up to 3m away. Extra bugs are 10eb each. HC=0.5

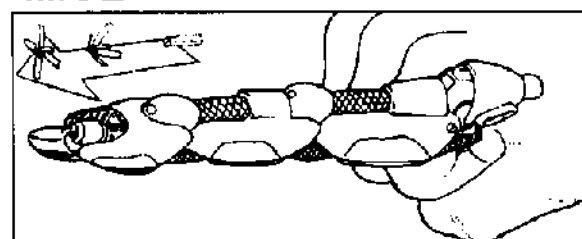

TRACKER ▲

LIGHTER **25EB**
A miniature flame lighter. It has fuel enough for 2 hours of continuous use. Extra fuel 1 eb/refill. HC=2



LIGHTER ▲

KIROSHI OPTISHIELD OPTIONS

There's no need for cyberoptics with Kiroshi's new OptiShield options. This line of options are exactly the same as the standard cyberoptic upgrades (2 options per OptiShield).



KIROSHI

- Times Square 250eb
- TimesSquare Plus 500eb
- Teleoptics 150eb
- Lowlite 200eb
- Infrared 250eb
- Time/day display
(uses no options) 100eb

Game notes: See CP2020, pg.67 for descriptions; HC is at 1/2 normal. See Chromebook 1, pg.38 for TimesSquare Plus, pg. 31 for OptiShields.

WINCH 500EB

Cyberarm option. A winch is installed in the arm. The winch has a hook and a 15m cable which is driven by a powerful motor. The winch's motor is capable of pulling up to 1 ton. Uses all option spaces. HC=1D6+3.

Game notes: Of course, the user wouldn't be capable of pulling a ton without anchoring himself in some way. Muscle/bone lace or a linear frame is required to gain full use of this cyberoption. You can operate at only 33-50% of capacity without them. If the limits are exceeded, the character takes 1D6 damage and his BOD is reduced by 1 for 1D6 days due to muscle/ligament strain.

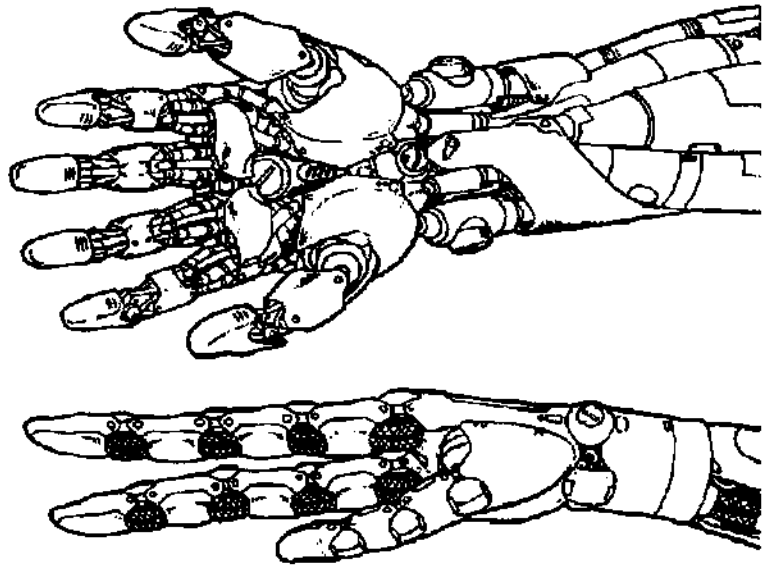

CYTECH CUSTOM CYBERHANDS 900EB

The latest line of cyberhands from Cytech includes three, four, and six-fingered hands, as well as cyberhands with joints that can bend in either direction. Do you think your cyberarm is too drab and ordinary? Cytech can help you rise above the crowd.

Game notes: The primary game effect these cyberhands have is in the realm of cyberfinger capacity. Double-jointedness gives +1 to Dodge/Escape skill attempts when escaping from bindings. Cytech offers a service to customize cyberhands, including plating the hand with precious metals and configuring the joints and fingers to specifications. The HC is unchanged. Special effects are up to the Referee.

ANCHORING CYBERFEET 400EB

This cyberleg option (uses 2 spaces) has anchoring spikes with fold-out hooks. The spikes can penetrate anything with an SP of 12 or less. These cyberfeet can be used to adhere to a surface or to avoid being knocked down. The anchor spike detaches when you wish to move again. This device can be used 4 times before the spikes must be replaced. Cost: 120eb. HC=3

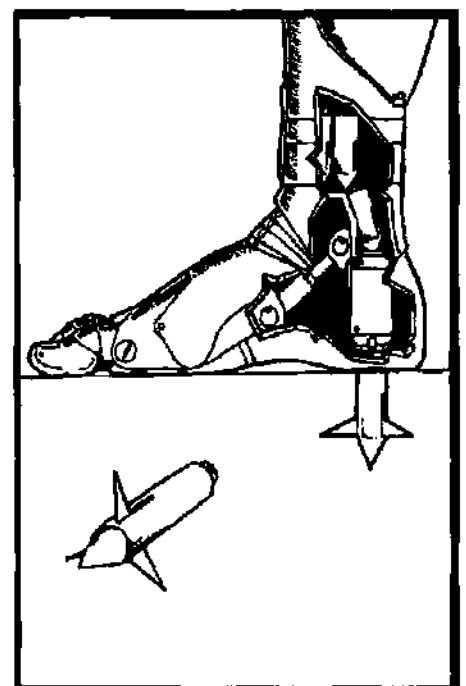

**QUICKDRAW ARMHOLSTER
200EB**

This cyberarm option consists of a concealed, spring-loaded holster installed in the forearm. The holster launches anything the size of a light pistol (P class concealment) or a knife into the hand of the cyberarm (adds an extra +2 to Initiative when a fast draw is declared). Uses 1 option space. HC=0

KILL DISPLAY 100EB

Sure you've got a lot of kills, but those street punks still keep hasslin' ya. What do you do? Maybe you should advertise your expertise some to get the boosters off your back. Similar to a skinwatch, a Kill Display shows in prominent glowing letters and numbers "KILLS: xxx" (any three-digit number you enter with a special key). The display can be any size from 2" X 2" up to 6" X 6" and placed anywhere. The actual number displayed is on the honor system, but if they have any doubts as to the veracity of the total, why don't they ask you, eh? HC=1, Surgery: N

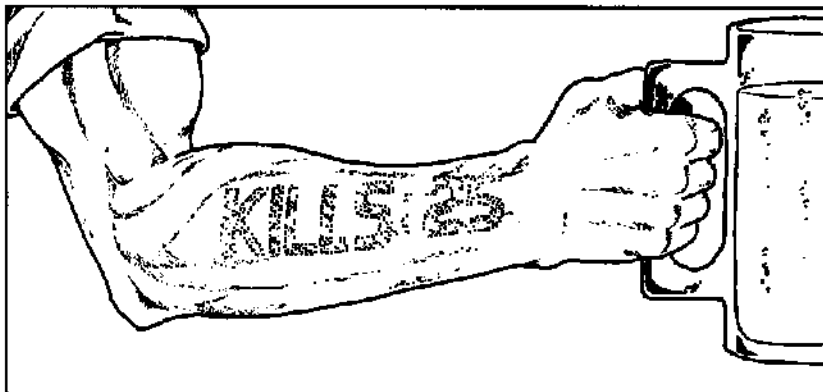

**COLOR GLAND
CONTROL
250EB**

There's a little gland in the back of your eye that generally works only once in your life; changing your eye color from blue (the color ALL human babies' eyes are) to your adult color six to eight weeks after birth. With the color gland control unit (a small electrical unit which stimulates the gland's functioning), you can change the color of your eyes to almost every color in the spectrum without having to have cyberoptics. The shift takes 1D6 minutes to affect and the colors must be pre-programmed in. HC=1, Surgery: M

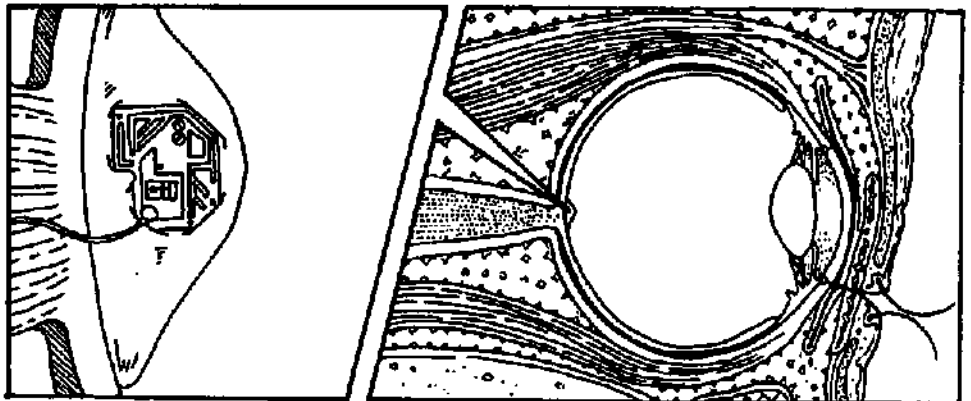

**TRI-DART
LAUNCHER 300EB**

CYBERE Three dart launchers are installed between the knuckles of the cyberhand. Each launcher contains 1 dart that will inflict 1D6/2 damage (armor is at 1/3). All three darts may be fired simultaneously or separately. They are silent, and can be poisoned or drugged. HC=1D6/2

**WETDRIVE
ACCESS LINK
200EB**

This co-processor will allow the owner of a Wetdrive memory unit to mentally link to the wetdrive memory without external interface cables, calling up information as desired. The information is not "known" as with MRAM chips, but has to be called up exactly like a computer. A character is essentially "studded in" when accessing and as such, is relatively helpless. HC=1D6/2, Surgery: M



GRADIATED SUBDERMAL ARMOR (TORSO)

Adapted from the old version (CP 2020), and slightly altered to give those who prefer discretion the opportunity to be discreet about their personal enhancements, subdermal armor can come in a variety of SP ratings and thicknesses. All require CRITICAL surgery. The Attractiveness loss is permanent and cannot be remedied with plastic surgery. The reflex penalty has been known to be removed by using high-tech orbital materials. (Approx. 8x cost for each -1 REF you want to remove at GM's call.)

SP	HC	COST	DIFFICULTY TO SPOT	ATTR LOSS	REF LOSS
6	1D6/3	350	Impossible (35+)	None	None
8	1D6/2	500	Impossible (32)	None	None
10	1D6/2+1	650	Impossible (30)	None	None
12	1D6	800	Very difficult (25)	None	None
14	1D6+2	1000	Very difficult (25)	None	None
16	1D6+3	1100	Difficult (20)	None	None
18	2D6	1200	Difficult (20)	-1(50%)	None
20	2D6+2	1450	Average (15)	-1	-1
22	3D6	1750	Easy (10)	-2	-2

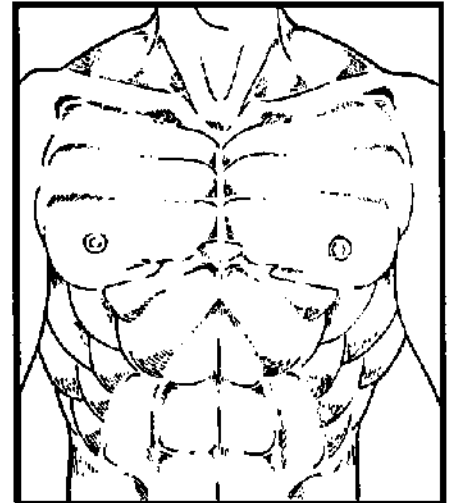

Chest (Exterior View)

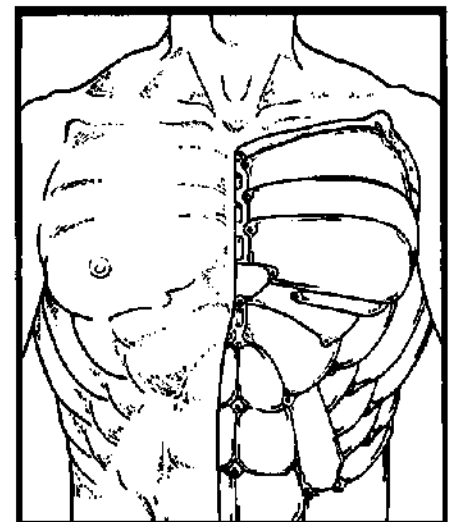

Chest (Surgical View)



SUBDERMAL ARMOR (SKULL)

Hey, your skull doesn't have any moving parts, at least not in the important places, like right over your brain! So why not get subdermal plating on your main cranium? It protects like a helmet in every way (there's a 1-4 on 1D10 chance any head attack hits an unprotected part—like your face or neck; subject to Ref's ruling). Requires MA surgery.

Game Notes: Subdermal armor on your *face* and *neck* also sounds like a great idea; right? Not so. Average skin thickness on your face is less than half an inch. Adding a 1/4 inch thick rigid kevlar weave to your torso and skull is possible, but not on your face.

SP	HC	COST	CHANCE TO SPOT	ATTR LOSS
4	1D6/3	300	Impossible (35)	None
6	1D6/2	550	Impossible (30)	None
8	1D6	750	Very difficult (25)	None
10	1D6+2	1000	Difficult (20)	None
12	1D6+3	1200	Average (15)	-1(50%)*
14	2D6	1400	Easy (10)	-1

*Chance of loss

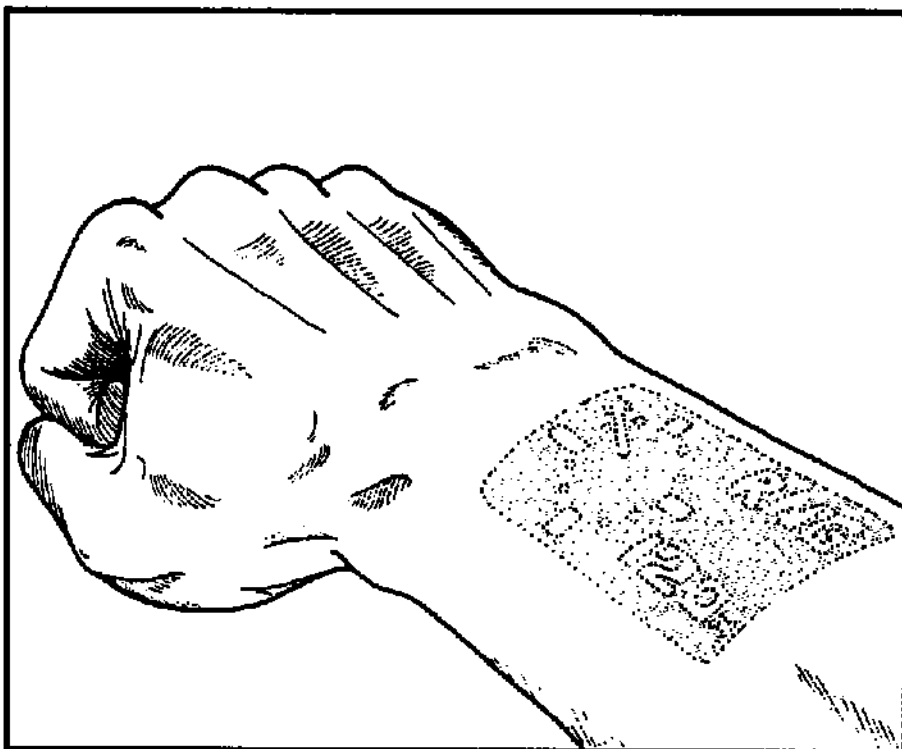

**SUBDERMAL
VIEWSCREEN
250EB**

For those without the benefit of a standard Times Square Marquee, or any other of the multitude of readout options, a small glowing LCD screen is inserted under the flesh of an easily accessible area, usually a forearm. It can be read in bright glowing letters that pan by, showing up to five lines of type at one time. This unit will not work with Times Square Plus or the Video Imager. HC=1D6/2, Surgery: M

ZETATECH BODYCOMP 1,750EB

PERSONAL COMPUTING TAKEN TO THE LOGICAL EXTREME!



The BodyComp is the latest in microcomputing; a computer so small it can be implanted in the human body, yet as powerful as an E-Book! A unit the size of a large lighter is implanted in the torso, and links are run to the user's Neural Processor by nanomachines. Power is supplied by a pair of microfine blood turbines, implanted in the pulmonary and femoral arteries.

The BodyComp has functions and capabilities equal to a E-Book. (No chipslot, but it can read from the player's Chipware socket or a chip player plugged into an Interface Plug.) It requires Times Square Plus (or Video Imager) and Cyberaudio to operate (it can be plugged into a Kiroshi Optics HUD, but without audio). Hardened systems are available, but this option cannot be retrofitted. BodyComps can be outfitted with all CompuMods and other modifications, but the sensors are separate; they can be installed in a cyberlimb (usually taking up about 1/3 of an option space each) or carried separately and jacked in with a special cable and multi-processor (50eb). For an additional 125eb, the unit can be hooked up to a character's Wet Drive, allowing for extra memory (and an easy way to see what you're carrying).

Game notes: If the unit is not EMP hardened, a hit by a microwaver will usually (70% chance) wipe the BodyComp's memory (but not an attached Wet Drive) and will inflict an additional 1D6-2 damage in feedback and burns. HC: 1D6+4, Surgery: MA

**NANOOPTICAL
UPGRADE
1500EB**

For those of you loathe to replace your natural orbs, you can have specialized Nanosurgeons rebuild your retinas and optic nerves for a song! These nanosurgeons work ONLY on natural eyes. They give the character capacity for Infrared and Ultraviolet spectrum pickup and allow +2 to night vision. **Game Notes:** Reduces darkness penalties; see CP2020, pg.32) The process takes 1 week and the character is blind for 5D10 hours after the treatment (blindness begins 2D6 hours after injection) due to the fact that the nanosurgeons are taking your retina apart and rebuilding a partially fiber-optic coated LCD latticework into it. HC=1D6/2, Surgery: N

RETRACTABLE VAMPIRES

Created on request by Sycust several times, the resulting patents were transferred to a subsidiary mass-production cyberware company, Cyphire Cyberware. The entire upper and lower jaw must be removed/rebuilt with new spring housings inside. Extended bite versions are also available, modifying the jaws to open wide enough to stick a baseball in comfortably. All retractable teeth are between 3/4" and 1" long. **Note:** extended bite = knife for AP effects.

- Retractable vampires or sharkgrin: Cost: 500eb, HC=2D6+2, Surgery: MA
- Extended Canines (1D6/2+1 dam. due to deeper bite): Cost 1000eb, HC=3D6+2, Surgery: CR
- Sharkgrin Special Extended (1D6 dam.): Cost: 1400eb, HC=4D6, Surgery: CR

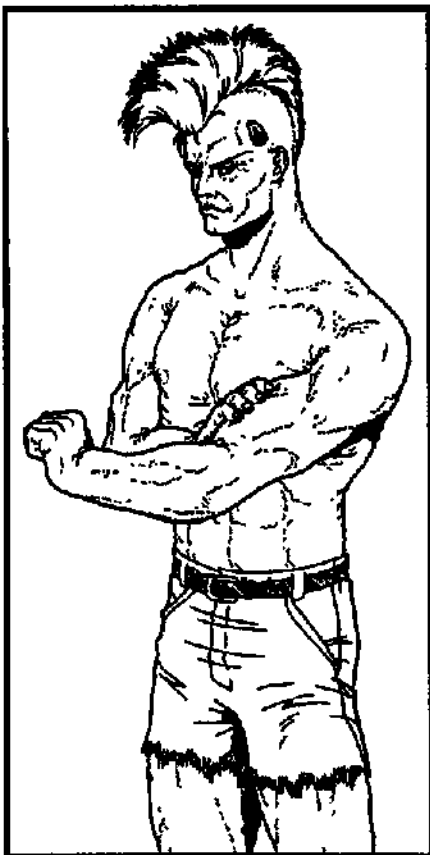

TOTAL BODY PLATING 6,800EB

This is a fully-armored exoskeletal "shell," with no internal reconstruction. The entire body is covered in a damage-resistant, hybrid ceramic material which is porous so that the body can breathe. The entire body receives SP20 armor (and is gas/flash-resistant due to filters), but suffers a -3 to REF. -1 to Stealth. Nanotechnological micromachines heal penetration damage to the armor at the rate of 1 point per day. Total body plating is very obvious, making the cyborg look like a metallic or plastic person (visual features and effects vary). Appearance reduced by 1/2; can be regained by body sculpt/design. Because of the nanotech support mechanisms, this form of 'plating can only be done to the entire body. HC=8D6, Surgery: 2xCR; yearly maintenance 680 eb.

REMOTE EYE 1500EB

A strange and particularly disturbing idea created by the Cyphire Cyberwear company. Upon internal command, the eye detaches and can be placed in a small mount with magnetic and velcro feet (standard equipment that comes with the eye). It then transmits back to the user as if he/she were seeing from that position! You must have a receiver set or Video Imager in your other eye. Only ONE option space is open for the Remote Eye. Transmission range is 100 meters. HC=3D6 per eye, Surgery: MA

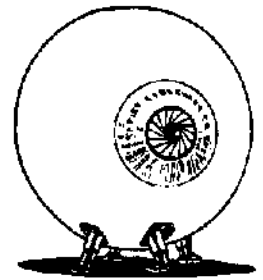

UPGRADED SKINWEAVE

Skinweave of lighter or tougher stopping powers is available almost everywhere standard skinweave is found. Below are costs and HC for differing armor values. Also listed is the Awareness difficulty to notice the skinweave. Attractiveness loss cannot be remedied with bodysculpting, because the woven skin looks and feels like tough rubber or plastic.

Skinweave can be upgraded to different levels at the full cost of the new level. (e.g., you have 8SP and want 12SP, you pay full 12SP price) Remember, skinweave cannot be downgraded or removed without undergoing a treatment equal in price and time to the original treatment, so choose carefully!

SP	HC	Cost	SPOTTING CHECK	ATTR loss
6	1D6	1000	Impossible (35+)	none
8	1D6+1	1250	Impossible (30)	none
10	1D6+3	1600	Very diff. (25)	none
12	2D6	2000	Difficult (20)	-1(50%)*
14	2D6+2	2400	Difficult (20)	-1
16	2D6+4	2750	Average (15)	-2

*Chance of loss

EQUIPMENT

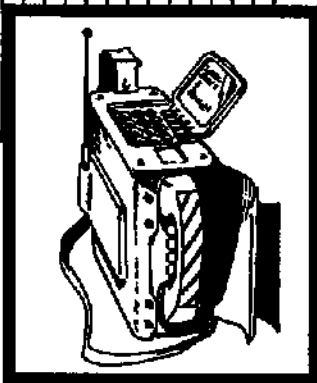
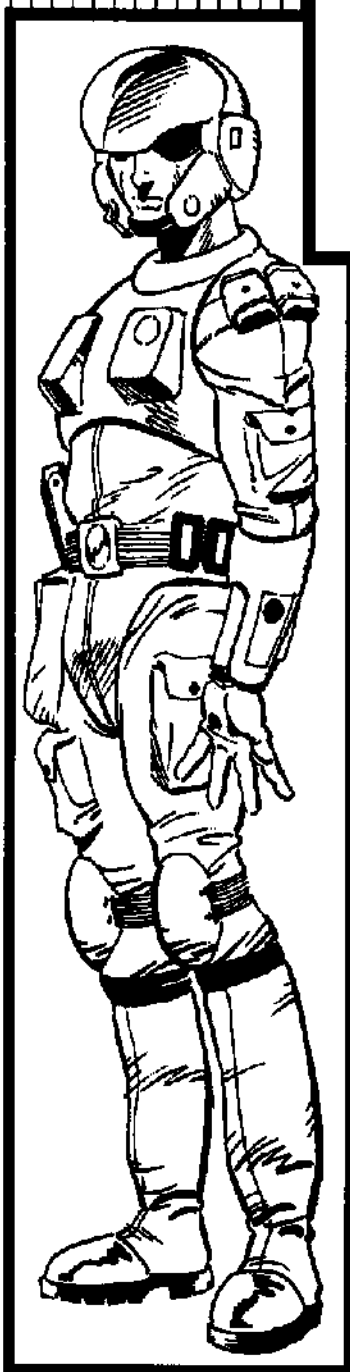

“Whatever you need, you can find it here. The latest Chromebook has all the necessities for the street. There’s crucial programs for the Netrunners. For all the Rockerboys and girls there’s rhythm boxes and programmable axes. The deadliest of weapons are available for the Solos. New Campods for the Medias, and streetlethal corpwear for the executive with an attitude. If you’re a Cyberpunk, then you need Chrome. If you have the Edge on the inside, then you need the meanest Edge that euro can buy on the outside.”

**—The Chromebook,
downloaded for June, 2020**

“Hey, can you spare some euro for a fellow ‘punk who’s down on his luck?”

**-The Bogie, leader of the
Bogarts poser gang**

BIOTECHNICA NUTRISUPPLEMENT 10EB

This nutrient-rich drink produced by Biotechnica will provide alternative sustenance for those who don't have time to bother with food. The Nutrisupplement will not only provide all essential vitamins, it will also negate hunger. Just drink one bottle of Nutrisupplement a day and you won't need any other sustenance. Comes in a variety of flavors. Weight 0.5kg.

Game notes: The Nutrisupplement can only be used for a week at a time, because it does not sufficiently meet all of the body's requirements. After that time, the character will lose 1 point of BOD every week.

BIOTECHNICA**NYMPH PERFUME 200EB**

Finally a perfume that goes beyond the aesthetic. Our new Nymph perfume contains special pheromones that will stimulate the sexual centers of the brain. Any member of the opposite sex that inhales your scent will instantly become attracted to you. Available in fragrances for men and women. Nymph perfume is the closest that Biotechnica has come to a love potion.

Game notes: +2 to the use of Persuasion/Seduction skills against members of the opposite sex.

GEOTECH**ENVIROSCANNER 400EB**

This compact, hand-held unit is capable of detecting and indentifying the level and direction of radioactive and biological contamination within 7m. The Enviros scanner also provides a constant reading of the purity of the oxygen in the area. The scanner has an auditory warning system, so there's no need to constantly monitor it. The scanner has an AC adapter and a rechargeable 12 hour battery. Weight 1kg.

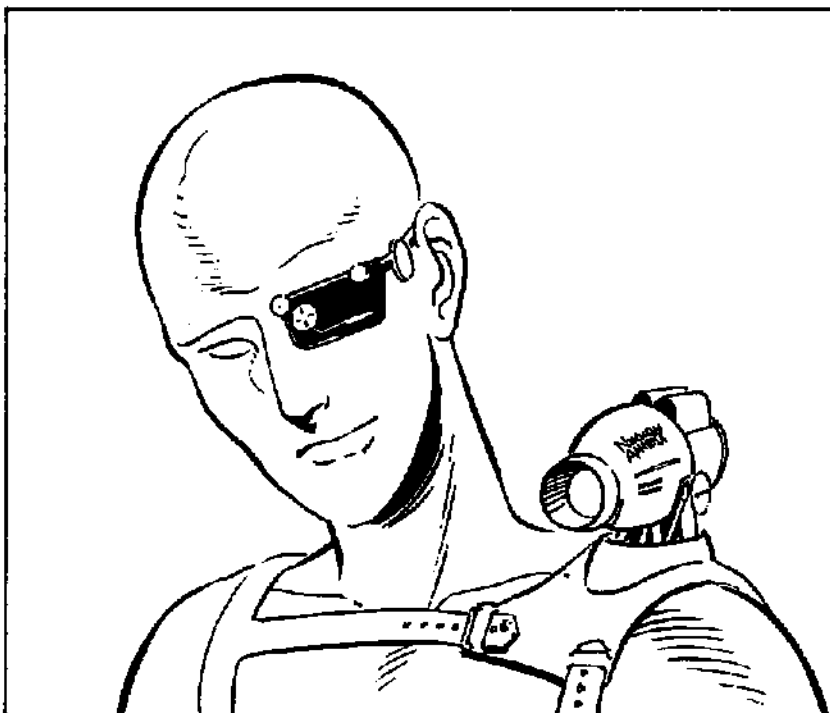
NIKON AMERICA CAMPOD 1,000EB

Nikon's new Campod isn't the old head-mounted variety; it mounts on the user's shoulder. The user wears a cordless viewfinder monocular that displays the Campod's input. If the user turns his head then the Campod will automatically follow his view. It may also be left in a fixed position while the user looks elsewhere. Since the viewfinder is cordless, the Campod may be detached from its shoulder harness and left somewhere or used to look around corners. The Campod is ideal for field reporters on the trail of a hot story. It has a rechargeable battery with a life of 12 hours. Weight 2kg.

Game notes: The cordless viewfinder has a range of 15m. The Campod is made to take quite a beating, so it has an SP of 8.

EQUIPMENT



SECSYSTEMS PROTECTION FIELD 750EB

Rockers! Tired of being mobbed by overzealous fans? Try SecSystem's Protection Field on for size. The Field consists of a thin, lightweight harness that is worn under your clothing. The device emits a high-voltage static field in a 2m diameter. If anyone comes within range they will receive a mildly discouraging shock (no damage, make Average COOL to approach again). If they come within 0.5m they will receive something much more considerable (1D6/3 damage, Difficult COOL roll). The Protection Field does not affect the wearer. (The same cannot be said for any electronic devices he might be using at the time. Effects are at GM's discretion.) The batteries hold enough power for 5 hours of continuous use. Replacement batteries are 6eb each. Weight 1.5kg

MEAD ELECTRONIC NOTEBOOK 860EB

This souped-up lapcomp has 6MegB RAM, a 30MB hard drive, a full page color display, an internal cellular fax machine, a digital dictating machine, and an external hand scanner for copying documents or pictures into memory. It is very durable (SP=4), and has an AC adapter and a rechargeable 12 hour battery. Weight 2.5kg.

DATATEL 2350A VIDPHONE 150EB

More than just a phone, the Vidphone sends visual images as well. This model Vidphone has a call screening feature, a focus and zoom control, a built-in fax, and an answering machine. **Game notes:** Vidphones come in a variety of sizes; they can be as small as a laptop, or they can fill a whole wall (400eb).



MICROTECH VIRTUAL REALITY BBS 10,000EB

Tired of tying up the memory in your own deck for a virtual reality? Now you have an alternative. Microtech's VR-BBS is a cybermodem specifically designed for use as a Virtual Reality generator. This cyberdeck has a specialized Creator program that makes it easier to generate a virtual reality. When using the specialized programs treat the realism multipliers as being 1 level less. Weight 8kg.

Game notes: (MU40, Speed +1, Data Walls +3, only 10MU can be used for active running, the rest is VR storage.)

FROSTECH PORTABLE CRYOGENIC CASE **250EB**

The Frostech CryoCase is a 2'x 2'x 1' case that is ideal for moving and preserving organs and tissue. Perfect for body bank couriers or Trauma Team members, the CryoCase can maintain and preserve human tissue for up to 12 hours. It has a 24 hour rechargeable battery, and may also plug into any standard outlet. The CryoCase is highly durable and damage resistant. Weight 2kg. **Game notes:** SDP=5, SP=10

PORTABLE ELECTROPACK

100EB

This is a hand-held power pack that can provide 6 hours of power for any 110 volt device. The recharge pack itself is rechargeable. It reaches full charge in 2 hours. Now you can make any of your appliances fully portable. Weight 2kg.

KIROSHI OPTICS REMOTE

CYBERCAM 20 **350EB**

Perfect for surveillance or security, the remote CyberCam is designed to work in tandem with Kiroshi's Video Imager cyberware (*Chromebook 1*, pg.39). The CyberCam sends its video image directly to the Video Imager. This is perfect for being in two places at once. The CyberCam is about the size of a fist and has a range of 2km. It can be plugged into any standard outlet and also has a rechargeable battery with a 24 hour life. Weight 1kg.

SECSYSTEMS DETENTION

COLLAR **260EB**

No need to worry about troublesome prisoners with SecSystem's Detention Collar. This highly durable collar locks into place around the prisoner's neck. You hold the remote for the collar which can cause it to deliver a considerable shock (1D6/2 damage). Or it can deliver a dose of a paralysis or relaxant drug (Difficult BOD check to avoid effects, unmoving/unconscious for 1D10 minutes otherwise). If the prisoner moves beyond the range of the remote (10m) the collar automatically delivers the shock and/or the drug. The collar has a rechargeable battery with a 48 hour life; 5 drug doses can be injected. Weight 0.5kg.

DDI PRAYERWARE **120EB**

Because God can't wait and you shouldn't have to!

Times and technologies change. Like everything else,

Religion has been

forced to adapt. In

the old days, people

had time to spare to

visit places of wor-

ship. Today's rushed

lifestyles leave little

time for the plea-

tures of spiritual re-

newal. Now, Digital

Divinity Incorporated

brings the House

of God to you. Each

wallet-sized Prayer-

Ware unit instantly

connects its user to

an ordained minis-

ter of the user's faith.

The small video screen allows for personalized religious

guidance. DDI's patented PrayerWare is approved by

the World Interfaith Council.

"Once, when I was pinned down in this alley, I used my PrayerWare to call my priest for spiritual help. And help me he did—'specially when he showed up with the Holy Fathers of the Perpetual Railgun to save my heathen soul. Religion sure can be a comfort to a believin' man.

—Ripperjack

SECSYSTEMS MAGLOCK

300EB (+80EB FOR CAMERA)

If you find yourself spending the night in an unsafe place, then you need SecSystem's new Maglock. This durable, portable magnetic clamp lock is usable with any door. As an option, it can have a fiberoptic camera that allows you to see what's on the other side of the door. The fiberoptic camera can run off solar power or a rechargeable 12 hour battery. There won't be any nasty surprises with the SecSystems Maglock. Weight 1kg.

Game notes: SP=15, Difficulty level to break through =25+

COMPUTERS & PERIPHERALS

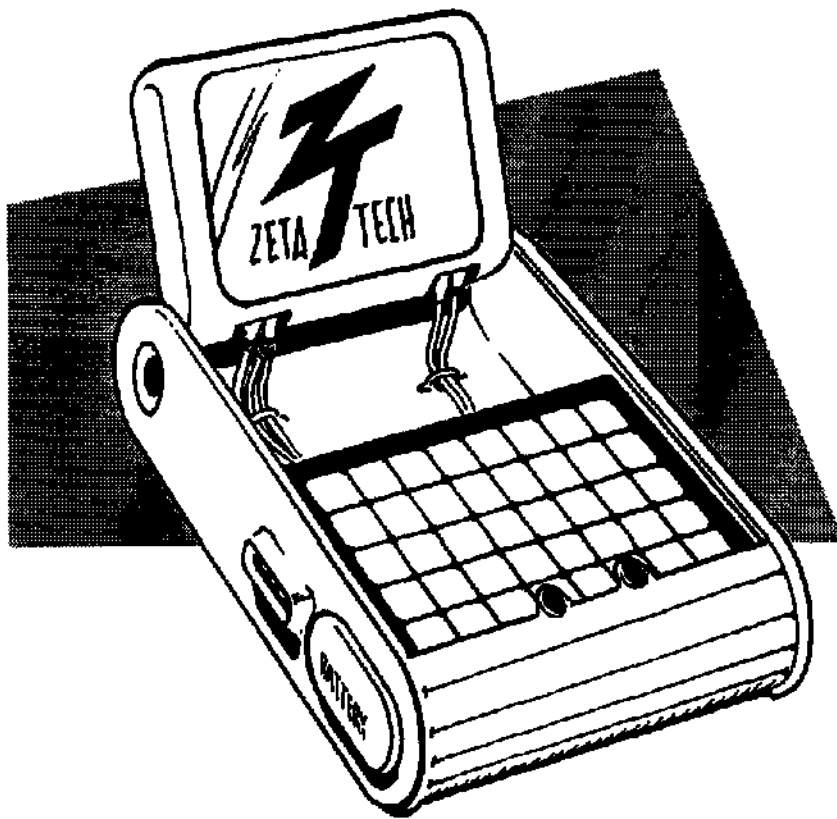
**ZETATECH "E-BOOK"****MICROCOMP 100EB**

Maximum data, minimum bulk!

As important as a wallet, as common as a wristwatch, Zetatech's E-Book series (and hundreds of other models from a host of competitors) can be found almost everywhere in 2020. The E-Book is a 15.4cm by 7.6cm by 1.3cm pocket computer with a keypad and one chipslot, housed in a hardened ceramic housing (designer colors are available). Able to function for 5 hours before its batteries need to be replaced, this entirely portable system uses a liquid crystal processor (a CPU with an effective INT of 1) boasting 12MU of programmable memory. The liquid crystal CPU can run one program at a time, but netrunning is impossible with an E-Book. The chipslot can accept digital audio chips as well as standard datachips, and it can even process video (although the screen is a bit small for this.) A cybernetic version is available for a 40% increase in price (140eb), and adds +2 to any INT/TECH skill roll. Capable of accepting a multitude of attachments, many custom versions can be found on the street, functioning as bug detectors, encryption units, biomonitors and codebreakers. Perfect for the edgerunner on the go!

EBM "PCX"**MINICOMP 900EB**

Still the most powerful, still the most popular!

This common portable system is housed in a lightweight impact-resistant plastic casing (available in several colors) with a folding handle for easy transport, and the entire package measures 5.1 cm by 35.6cm by 51 cm and weighs one kilogram. It can run off house current or an internal 2-hour rechargeable battery. The processing core of the PCX is a multitasking superchip (treat as a CPU with an INT of 2) driving a 25 Memory Unit storage bank. The superchip can run two programs at a time, but this unit cannot be used for netrunning. The unit's dual datachip ports can accept and play any kind of digital chip, allowing the PCX to double as an audio/video player. The touch-sensitive keyboard and high-definition screen can be folded away for transport, or removed to be replaced with other peripherals. EBM also markets a factory-standard cybernetic-interface version of the PCX, available for a 40% increase in price (Cyber-PCX is 1200eb and adds +1 to any INT or TECH skill rolls that can be computer-assisted). Arguably the most popular laptop model computer in the 21st century, EBM's PCX series still has some competition from similar products marketed by Microtech, ARC, Mitsubishi and others. Just about every home has a minicomp like this one, and many a sweatshop and underground weapons factory have made use of these babies as well!

MICROTECH IIKL-4 WORKSTATION 1200EB

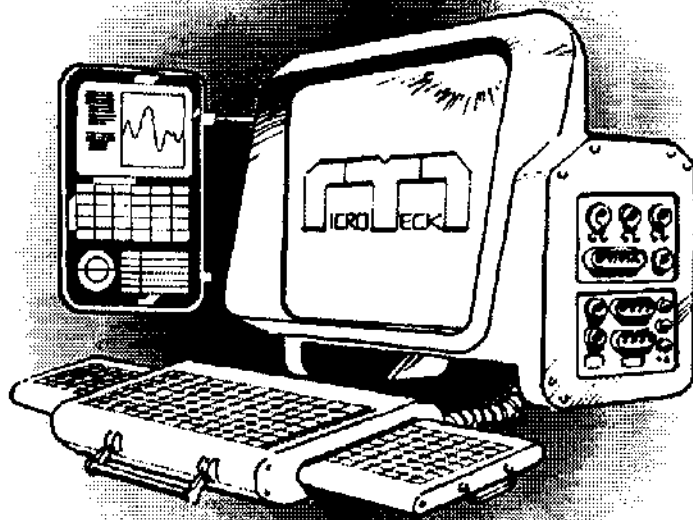

Mainframe power on your desktop!

Considered by some to be the most versatile personal computer on the market today, the IIKL uses an advanced optical 90689 multiprocessing chip (treat as INT 3) as its processing core, making it one of the most powerful personal computers on the market today. With 40MU and the ability to run up to three programs simultaneously (No, you can't use this one as a cybermodem either, poser.), the IIKL is popular for high power CADaM and illustration. With two chipslots, ports for Two SCSI-4 chains and on-board protocols that can read and write data for audio, video, and braindance chips, the IIKL is also popular

with underground recording studios, as it can control the entire studio through its MIDI port, and encode on up to 20 chipreaders at once! The IIKL comes with a 2'x2' video board, full stereo output and an extended keyboard. A cybernetically controlled version is also available (+40% to cost), as are a wide number of peripherals. **Note:** the IIKL is about the size of a modern desktop computer...it's portable, but only in a large case. Very common in pirate radio stations, underground studios and publishers.

TELECTRONICS "BLACK BOOK"

MICROCOMP 250EB

The portable police processor that puts perps in their place!

Designed as a compact computer system for urban patrol officers, the Black Book is the size and shape of a common pocket computer, and can be found on the hip of almost every 2020 cop (sometimes it is built into the dash of a patrol car). The Black Book has all the capabilities of a standard microcomp (see Zetat-tech's E-Book, page 14), and is packed with police modifications. It has a cellular communications link for immediate access to police Net-based databases. Its left side has a slot for reading the magnetic strips of driver and weapon licenses, and the front end has a heat-sensitive optical scanner for fingerprint identification. The small videoscreen can be used to call up criminal records, and a tiny laser-printer can be used to run off a ticket or summons in seconds. Although the Black Book comes chipped for interface, it has a small keypad as backup. Housed in a nearly-indestructible kevlar frame, the Black Book can withstand a hit from a .357 Magnum (SP15) and is also shielded against microwaves and EMP!

LANGUAGE

PROCESSORS

Bring your system into the 4th generation!

Microtech is now offering aftermarket retrofits for any and all computer systems, allowing them full voice recognition and language comprehension ability. Take your unit to your nearest Parts N' Programs, and for 40% of your computer's original cost, you can do away with keyboards and protocols entirely! **Note:** Microtech markets its own versions of the PCX and E-Book with these processors already included (cost is only 20% more than normal). The processors can also be bought separately and installed in 1D6/2+2 hours on an electronics roll of 25.

EQUIPMENT

WORLD SAT COMMUNICATIONS

FLOPSCREEN™

400EB

PER

SQ.

FOOT

*Molecular
memory for versa-
tile video!*

WorldSat takes advantage of recent advances in memory plastics and fiber-optics to bring you the Flopscreen. The

Flopscreen operates exactly like a videoboard when unfolded, but it can be rolled up and stowed in a pocket, or what have

you. It has small adhesive surfaces on the

back which allow it to be stuck onto a wall or floor (or

ceiling) for display when connected to a computer. The Flopscreen can even be used while hanging on a rack or piled in a heap, although image distortion will occur.

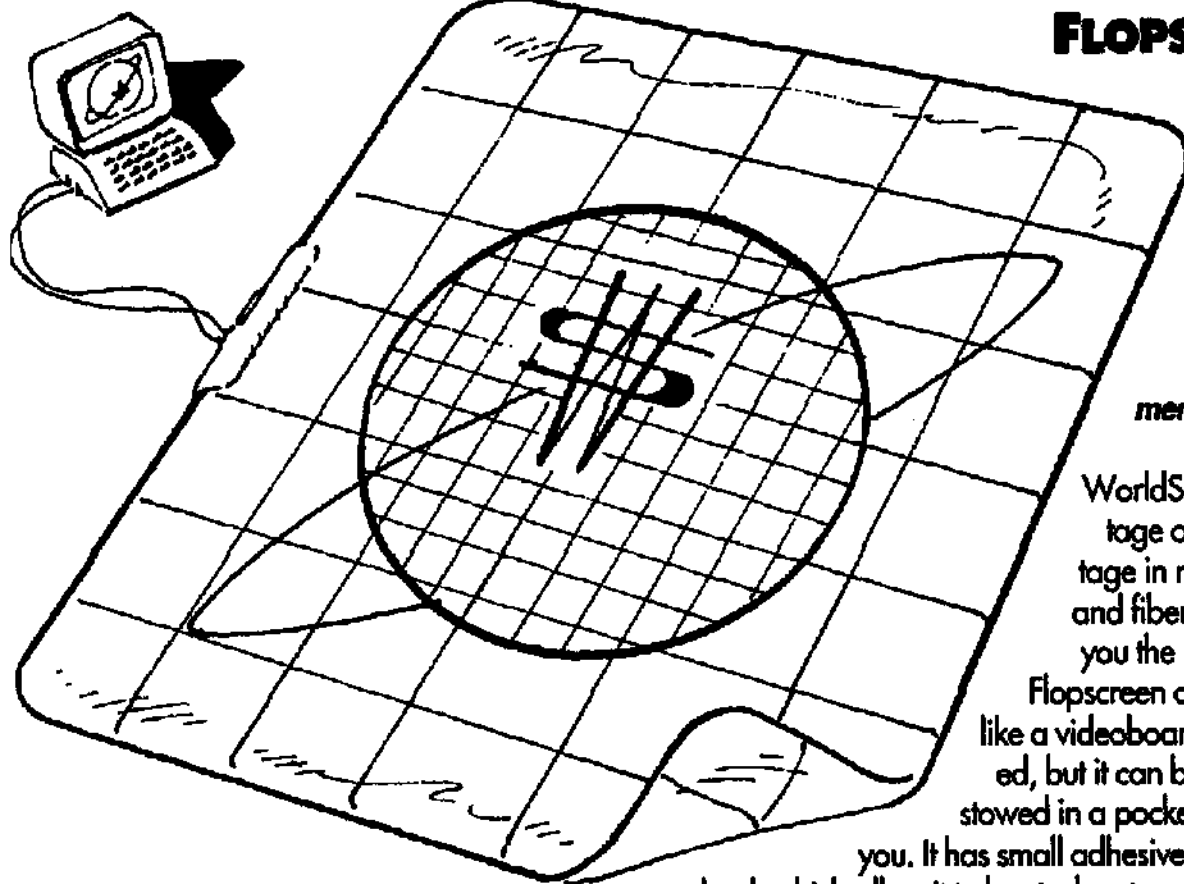

DIRECT DATAWARE EXPERT SERIES COMPUTER

SKILL PROGRAMS

These programs come prepackaged in small plastic boxes, complete with an instruction booklet and software stored on standard datachips (1MU per chip, each skill level uses one MU). Because of their MU size, the programs must be stored on a computer's memory unit to be usable. These skill programs will add to the user's INT skills, but they take time to run (one second per level of skill), unlike MRAM skillchips. Skill programs available include *Accounting, Anthropology, Botany, Chemistry, Corporate Policy, Diagnose Illness, Expert* (subjects vary), *Geology, History, Language, Library Search, Mathematics, Physics, System Knowledge, and Zoology*. Note: Desktop computers can also run Netrunner Utility programs (which function and cost as described in the *Cyberpunk* rulebook), Visual Recognition Chips (*Chromebook 1*, pg. 76), and can even store small virtual realities! Base 200eb for Level 4, +100eb per added +1 up to Level 8.

DATATEL "TREASURER" DATAWATCH 55EB

Elegantly styled, finished in gloss black, the Treasurer is an environment-proof 26-function digital watch (calendar, world time, stopwatch, lunar phases, thermometer, pressure gauge...) which contains a high-density storage microchip (1MU). Capable of being connected via fiber-optic cable to any computer, the Treasurer can be used to store sensitive data in a very safe spot. Note that this datawatch cannot run skill or utility programs, because it has no processor.

TRITECH DATASHIELDING (20% COST OF COMPUTER)*Makes electronic warfare a thing of the past!*

Tritech now offers datashielding as an aftermarket option for your computer system. By replacing the housing of your unit with a lead and hybrid alloy frame, and hardening sensitive electronics, your computer can be made immune to the effects of EMP, Microwaves, and Tempest equipment. This service can be performed at your local Parts N' Programs (or in 1D6+2 hours on an electronics roll of 25).

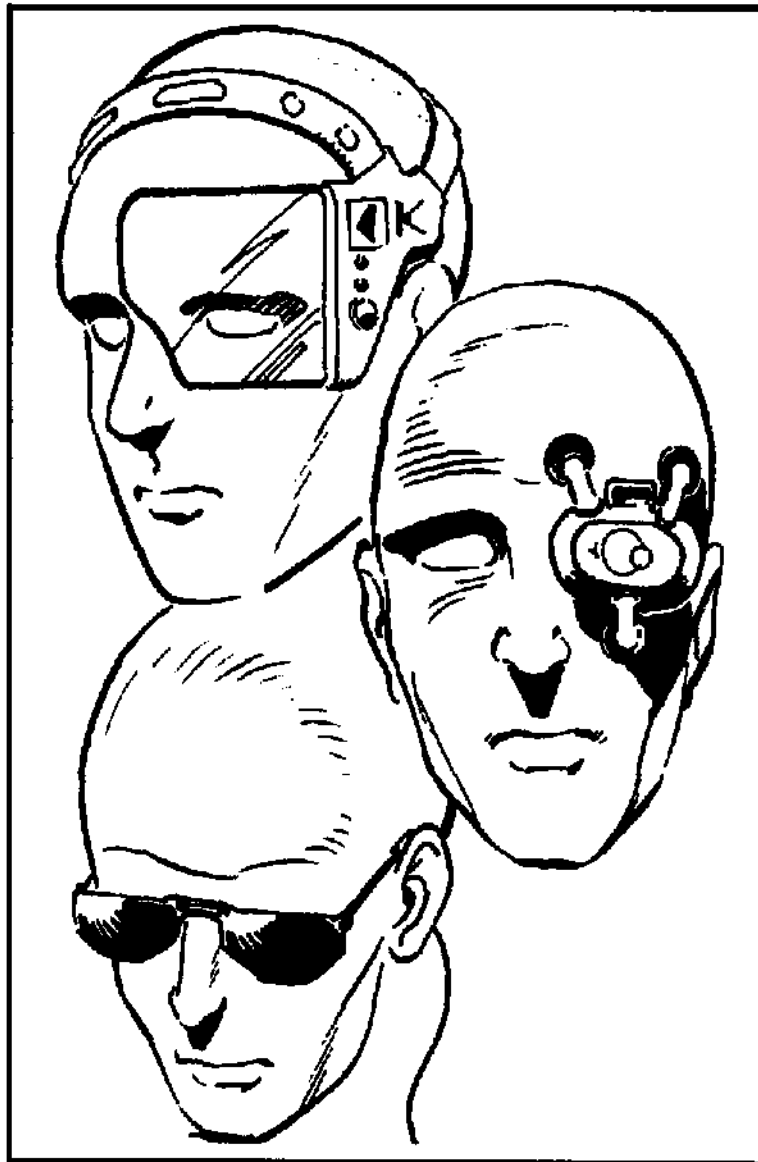
**KIROSHI OPTICS****HEADS-UP DISPLAY****(150EB FOR GOGGLES,
200EB FOR MONOCLE)**

Kiroshi's Heads-Up Displays can be connected to any computer system for totally accessible visual readouts. Both the headset and monocle models display a color image in the user's field of vision, but do not obscure the outside world. This allows full access to computing power without requiring the user to look away from what he is doing. Endorsed by Trauma Team medics (who connect heads-up monocles to their medscanner units) as "a life saver." Also useful for technicians, surgeons, assembly line workers, and many others who need to have access to visual information while keeping track of their task. The display reduces Awareness skill checks by -3. A special version of the Heads-Up Display is available for corporate security operatives (and on the black market) for 300eb: a heads-up display which looks exactly like a pair of mirrorshades. Connected to a pocket computer by a tiny wire from the ear-piece, these will pass casual inspection (Awareness vs 20 to spot wire).

DATATEL MODEM UNITS**(OPTICAL FIBER LINK 200EB, CELLULAR LINK 1200EB)**

For the ultimate in universal access, Datatel's modems are what you need! By adding on a cable jack or cellular transmitter, your computer can connect with the Net and access databases, bulletin boards, the DataTerm network, Infocomp services, and an almost infinite selection of electronic media. Pay-per-view videos, electronic publishing, games, online rocker jams, and across-the-world shareware are all yours for the taking with this aftermarket add-on. **Note:** even if your computer is chipped for interface, you still cannot perform netrunning with this unit. Buy a cybermodem already!

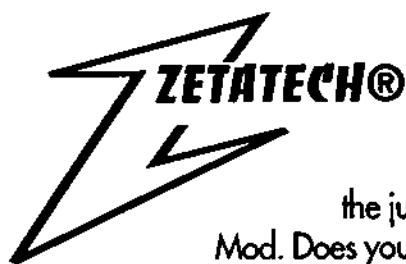

ZETATECH COMPUMODS™ STERIODS FOR YOUR COMPUTER!

Now you can modify your computer to suit your lifestyle! Worried that the junior manager in the next office has bugged your desk? You need a CompuMod. Does your genetically-tailored pet seem sick? You need a CompuMod. Is that pesky electronic lock holding up your black op? CompuMod. These computer modification packages are interchangeable, cheap, and completely legal in most states! Usable with most laptop or pocket computers.

Voice Stress Analyzer Package (200eb): This package includes a 3MU program and a tiny microphone add-on. Adds +2 to *Human Perception* and *Interrogation* after appropriate sampling of the unstressed voice.

Lie Detector Package (400eb): This package includes a 3MU program, a sensor pad, and a tiny needle probe. Attach the sensor and probe to the informant's arm, and red or green lights will go off. This heart rate and blood flow analyzer has 65% reliability. Use of the Voice Stress Analyzer in conjunction raises the reliability to 75%.

Bug Detector Package (200eb): This package consists of a 2MU program and a signal scanner add-on. It will detect and locate line taps and bugs (if they are transmitting) in a 6m radius with 80% reliability.

Bug Jammer Package (200eb): This package consists of a 1MU program and a transmitter add-on. Broadcasting electronic noise over a wide band of frequencies, it overrides any signals a bug may be sending. Operates within 10m radius; 80% reliability.

Radar Detector Package (150eb): This package consists of a 2MU program and a signal scanner add-on. This package will emit a beep if it detects any radar signal, and locates the source. It is 60% reliable.

Signal Tracker Package (300eb): This package consists of a 2MU program and a signal scanner add-on. The highly sensitive handheld-scanner will search out signals sent from line taps and bugs (if they are transmitting), following them to the listening source with 80% reliability.

Medscanner Package (250eb): Consisting of a 5MU database and a compact array of sensor add-ons; this package gives readouts for body temperature, heart rate, blood pressure, respiration, and blood sugar levels. The chipped database adds +1 to your *Diagnose* skill.

Techscanner Package (250eb): Including a 5MU database and an assortment of circuit tester and computer-linkage jacks, this package can be hooked up to the diagnostic systems of most vehicles, appliances and personal electronics to determine possible problems and troubleshoot break-downs. Reliability is 60%. On a successful roll, the difficulty of the task is reduced by -3. (You know what's wrong; you just have to fix it.)

Drug Analyzer Package (75eb): This package includes a 4MU database and an intelligent multi-analysis sensor port. It will determine the purity of a drug with a known composition, or identify the molecular makeup and possible effects of an unknown substance that is similar to a drug already in its database. Reliability is 75%. Popular with cops—they add it to their Black Book microcomps.

Credit Transactor Package (250eb): Consisting of a 1MU program and a special chipslot, this unit can be used to make electronic money transactions to and from bank accounts. (A modem of some kind is needed to do this.) Although technically you must have a legitimate business license to have one of these, a fixers can usually manage to get ahold of one for his pocket computer (*Streetwise* or *Streetdeal* vs 22).

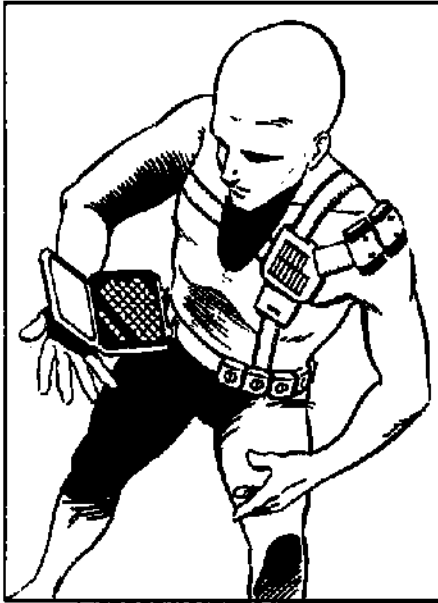

HYBRID™ WEARABLE COMPUTER

1000EB/1400EB CHIPPED

Blurring the line between body and machine!

Mitsubishi and Raven Microcyb takes portability to the ultimate level with their new Hybrid™ line of wearable computer systems. The standard model functions as a portable computer (see EBM PCX, page 14), but is worn over the shoulders and around the waist. The 25MU memory storage is housed on the shoulders, along with the battery pack and backup solar cells. A specially-arranged keyboard is arrayed around the waist along with a flip-down display screen, keeping the user's hands free when the keyboard isn't being used. This section can be removed and replaced with heads-up displays and voice-recognition or cybernetic operating systems for total hands-free operation. This remarkable 2.1 kg system is housed in a lightweight impact-proof plastic casing (available

in several stylish color schemes), and is popular with reporters, medics, and warehouse inventory personnel. There are many models tailored for specific applications, such as an over-the-shoulder unit with a barcode optical scanner on the forearm (used for inventory purposes) and a flip-down mirror for using the liquid-crystal display screen. Another special version is the Hybrid MedicWear, which does away with the waist component and instead uses a language processor core and a set of heads-up display goggles with headphones, a vocal pickup mike and a digital video recorder. An armpack contains a track-ball and body sensors, while the back unit houses a satellite link for communication with hospitals. The MedicWear costs 2,500eb, and functions as a Medscanner as well as a portable computer.

MEDICGEAR COMBAT

MEDICAL ARMOR 3400EB

Lifesaving protection!

Utilizing the latest in computer, medical, and armor technology, MedicGear by Body-weight Systems is designed to assist medics everywhere. Endorsed by Trauma Team, Inc. and the Night City Search and Rescue service! MedicGear starts with SP20 hard-shell armor, then starts loading on the goodies. Incorporated into the structure is a Hybrid MedicWear computer, with a few additional functions. Sensors and software are added that allow it to function as drug analyzer and a techscanner (see appropriate CompuMods), giving you the ability to see just what he's on, and what cyberware he's got! A drug injector is built into an extending stalk on the left arm (5 doses each of 10 different drugs are stored in the wrist/forearm assembly. A pack on the waist includes various pressure bandages and other supplies, as well as a mask and small canister of oxygen (about 30 minutes worth). A sprayskin applier is mounted on the right wrist, and a dermal stapler is also available. For extreme cases, the palms of the gloves can be electrified, allowing them to be used as a resuscitator (they can also be used as a taser, at -2 to hit). Enough charge is carried for 3 attempts. A number of storage pouches and cargo containers are available to allow the medic to further customize his load. Finally, an anesthetic gun can be mounted alongside the right wrist (or on the right hip), allowing you to knock out especially unruly patients! (Treat as p-1135, CP 2020, pg.52, but 1/2 range, 8 shots, and ACC 0. Usually loaded with anesthetic/sleep darts.) Medic gear has an EV of -3. It adds a +2 to all "on-the-spot" medical rolls, due to the wealth of information and tools available.

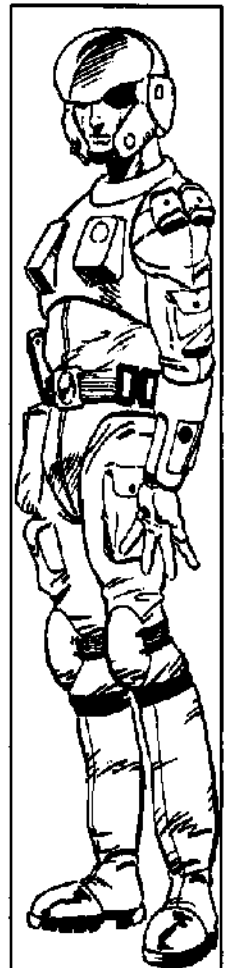

SECURITY SCANNERS & EQUIPMENT

TELECTRONICS TATTLETALE® VOICE STRESS ANALYZER 200EB

Your very own pocket-size snitch!

This hand-held unit registers minute changes in vocal patterns and tones and cross-references them with preset parameters. Once the unit has sampled the subject's voice while he/she is telling the truth or is un-stressed, it will recognize variations in vocal modulation. The unit is the size of a pack of cigarettes, and uses a small screen to display the vocal deviations, thereby adding +1 to the user's *Human Perception and Interrogation* skills. An interfaced version (250eb) can display through Times Square Marquee, so that the user would not need to have the unit out in the open as long as it was chipped into his/her plug (works best with wrist plugs).

CCI BRL-3014

WINDOW TREMBLER 120EB

Handiest vibrator ever. (NOT!)

Tired of people listening in on your conversation through the windows? Sick and tired of people using laser-mikes to record everything you say? No problem. The window trembler (by the nice folks at Communications Control Incorporated), is a small device that when stuck on a window (using the re-usable adhesive patch on the back), will set up a microscopic vibration in the glass (or plexiglass, or armorcrys...) that effectively scrambles the vibrations that a laser microphone uses to "hear" you. So you can speak with candor over dinner, thanks to CCI!

ARASAKA "KOMAKU" LASER MIKES 250EB (350 FOR FIXED VERSION)

Can't get in to drop a microbug? Have they got a window? No problem. With the new Komaku laser-transduction microphone system, you can hear them as plain as day! The Komaku bounces an ultraclear low power laser beam off of the window, picking up the vibrations made by any conversation. A powerful CPU then translates these vibrations back into human speech. The Komaku is so accurate that you can tell accents, tone, and even shadings in speech patterns. Three versions are available. The first is stylized to resemble an indeterminate polymer one-shot, and has a range of 50m. The second is capable of being mounted on a wall or ledge, has a 4 hour recorder built in, and has a range of 75m. The third is mountable in a cyberarm (1d6+2HC, 400eb, 60m range). Its input can be routed to cyberaudio and/or internal or external recorders.

The Komaku can be used to make *Human Perception* rolls on any conversation that are overheard with it, due to the powerful processor (these are at a -5, due to the lack of visual cues). Komaku mikes are usually a *DIFF Streetwise* (or *Streetdeal*) roll to acquire (AVG Resource roll), due to their utility. Corps don't like people listening in.

• BUG DETECTOR

• 200EB

• *Forget Big Brother — everyone's watching you!*
• Communications Control Incorporated's handheld bug scanner will detect line taps and bugs (if they are actively transmitting) in a 6m radius with 80% reliability, telling the user if they are "hot" or "cold" with varying-pitched tones. It is the size of a pack of cigarettes.

• BUG JAMMER

• 200EB

• *Kills bugs dead!*
• This handheld transmitter from the friendly folks at Communications Control Incorporated broadcasts random electronic noise over a wide band of frequencies, overriding any signals a bug may be sending (it will also garble any radio broadcasts other than tight-beam transmissions). It operates within a 10m radius with 80% reliability, and is the size of a cigarette pack.

OMEGA™ PHONE TAP BY TRITECH 1400EB

The last word in surveillance equipment!

The Omega is the top of the line in phone surveillance equipment (besides owning the phone company, of course). When plugged into the phone switching box for a building, it can monitor up to 10 lines simultaneously and record up to 24 hours of conversations onto a standard datachip (8 hours of video phone or data transmission). The Omega can even listen in on and record conversations in any room containing a phone! Best yet, because the unit is self-powered and does not draw any power from the line in use, it is more difficult to detect than other run of the mill line taps. Omega...even when your target is expecting surveillance, he can't hide from the Omega!

The Omega really is all it seems to be, and more. The thing can even shunt a copy of every conversation off to another line (like yours) when the datachip is full, or fire off a burst transmission (compressed data at high speed, takes 1 minute of phone time) to any dedicated receiver. When the lines are checked with a line tap detector, roll a D10. On a 1-6, the line tap detector has failed to find the Omega. Of course, anyone going downstairs to check the phone switching box will find it (it's about the size of a Walkman), but who's ever that physical?

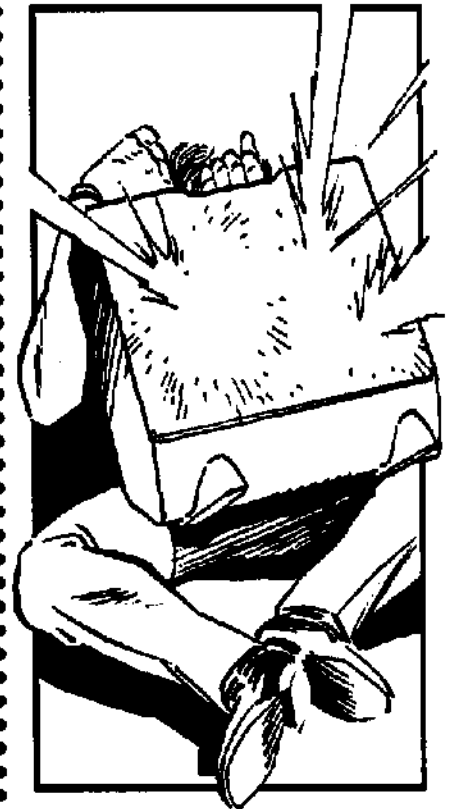

ARASAKA OMNITEC RADAR DETECTOR 250EB

Use their own sensors against them!

This sophisticated system emits a warning tone whenever a radar beam is detected. Considering the specificity of radar transmissions, this function is completely reliable. This unit can also be used to locate the source of the radar by triangulation; when the direction of the beam is ascertained, the tone changes to a rapid chirping (this function has a 60% chance of success). The unit has a 100m range and is the size of a pack of cigarettes.

TELETRONICS "SCOUT"

SIGNAL TRACKER 300EB

They can hear, but they can't hide!

This is a specially-tuned, highly sensitive handheld radio transceiver which can search out signals sent from line taps and bugs (if they are actively transmitting), and then follow them to their listening source with 80% reliability. A digital, compass-style pointer indicates the direction of the listening source, and a tone indicates whether you are "hot or cold." It is the size and shape of a handheld radio (like a "walkie-talkie").

ARASAKA JETSETTER EXECUTIVE BRIEFCASE 2000EB

Carry out your business with style and security!

A lavishly styled, superior-quality attache case for the security-minded corporate. Built from composite materials stronger than steel (SDP=10, SP=30), the JetSetter disguises its toughness with an exterior of real leather! A maximum level (difficulty 30) Smartlock keeps your documents safe, and the patented AcidErase™ security assurance system prevents your work from falling into the wrong hands. For an extra 200eb, a silent alarm and Nachtlager gas trap can be installed (Very Difficult BOD roll or unconscious for 6D10+10 min).

EQUIPMENT

WORLD SAT COMMUNICATIONS

LINEAR BEAM COMMLINK 200EB

WorldSat offers this tight beam radio linkage system for all brands and types of radio communications gear. Once installed in your radio, this will allow untappable, eavesdrop-proof communication for up to one mile, as long as both parties are within line of sight of each other and are not blocked by any object thicker than one foot. With a Linear Beam Link at each end of a conversation, no-one else can tap in or eavesdrop, ensuring secure communications for your black op! **Note:** installation requires a Difficult Electronics task and takes about a half an hour. This service can be performed at any Radio Shack or other electronics shop.

.....

ARASAKA ECM COMM-SCRAMBLER 100EB

Radio Silence? Never again!

In an age where information is power, private communications are as important as armor! Arasaka's ECM module, when attached to any radio or telephone unit, scrambles all communicated messages according to a preset pattern. Only another comm-scrambled radio or phone set to the same combination can then understand the message. Arasaka guarantees that their Scrambler package will stump any decryption system on the market today for at least 300 seconds. Since the scrambler only consists of a small assortment of microchips and a small control panel, the entire unit is very small (capable of fitting inside most handheld radios or phones) and requires a Difficult Electronics roll to install in one hour.

.....

TRITECH "MUMBLER" WHITE NOISE GENERATOR 3500EB

It's sonic camouflage!

Gone are the days when a whispered conversation around a table in a crowded, noisy dance club was the only way to ensure that you are not overheard. Trittech now offers the Mumbler, for total privacy in any environment. This "white noise" generator is a sophisticated electronic broadcaster, about the size of a paperback book. It emits random noise at a level which is barely audible to human ears but will confound listening devices with 90% reliability. Anything within a 3-meter radius of the Mumbler will be "camouflaged" by the white noise, thereby allowing private conversation and defeating eavesdropping.

.....

TELECTRONICS SCANMAN™

FULL IDENTITY SCANNER 2100EB

Know your enemy!

This pan-spectrum scanning system employs ultrasound, thermographics, magnetic resonance, and optical sensors to fully analyze, digitize, and categorize all identifying physical features for total identity parameters. The ScanMan™ can assess as well as recognize the features of whatever person it is turned upon, allowing for positive identification. This unit has three main functions: first, it can be programmed to recognize a certain person's features, and when used in this way it will be able to recognize the person even if they have undergone body sculpting (33% chance). Second, it can be used to scan a subject and then compare collected information with a database (either chipped for a small number of suspects, or connected to a microcomp or mainframe for access to full institutional records). However, it is only effective if the subject already has a ScanMan™ record to be accessed. The ScanMan™ can be operated with its own separate scanning devices, or as an analysis package for detection equipment already in place (such as Arasaka's Scanway Gates). It is currently in use with several police departments, the CIA, Interpol, and many powerful corporations.

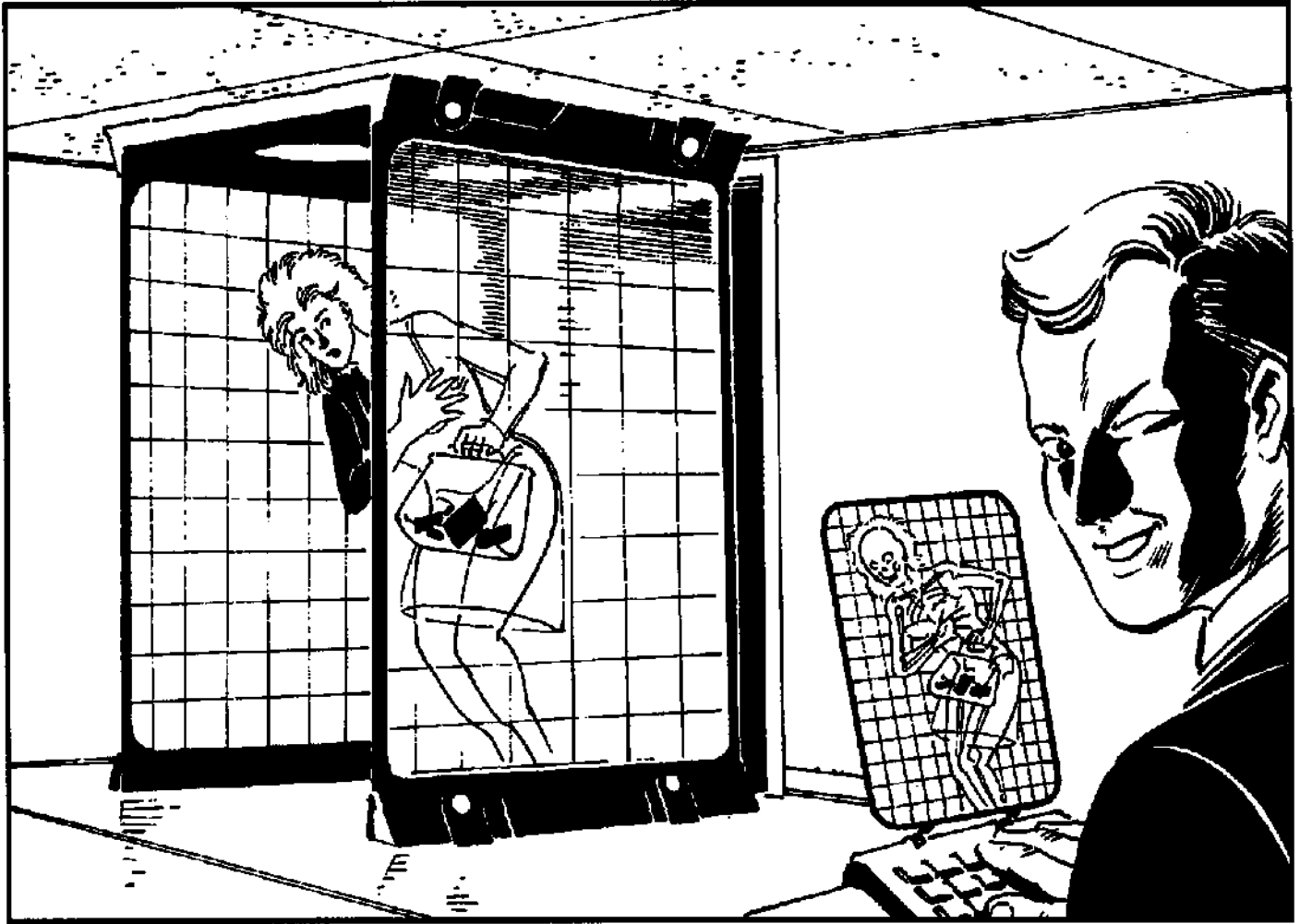

ARASAKA "SCANWAY" SCANNER GATES

(2,800EB, 5400EB FOR DELUXE MODEL)

Arasaka knows that dealing with the public can be difficult. One never knows what a customer or visitor may be hiding beneath their clothes (or in their cyberlimbs!). Protect your premises with an Arasaka Scanway.

Placed in a doorway, the frame of a Scanway will scan anyone who walks through it. Three models are available: a weapons detector, a cyberware detector, and a chemicals and explosives detector. All function with 95% reliability, and a deluxe model Scanway (which can be set to scan for any, or all, of the three anomalies) is available. The total package consists of a 7' tall, 3-4' wide (adjustable) frame (500eb. large screen optional) packed with sophisticated sensor systems and a small terminal with controls for programming scan parameters and monitoring scans. Scanway frames are available in an assortment of colors and styles, allowing them to blend in with your decor or stand out (black and yellow Danger-Striping® is our most popular pattern for this purpose). Along with being displayed on the terminal's screen, the results of the scans can be custom-programmed — an obvious or silent alarm could be set off, the police could be called, a remote weapon could be initiated; it's all up to you!

**If you have
a door, you need
a Scanway!**

CYBERDECKS & NET-STUFF

RAVEN MICROCYB NET-VISION™ IG-ALGORITHM GLASSES 900EB

Now you too can own a pair of Net-Vision™ glasses, originally designed by Raven Microcybemetics for Netwatch. This mirrorshades-style eyewear uses a cellular 'trade link' which allows you to have a Net's-eye-view of your realspace location! (25% chance of losing contact when in a moving vehicle; not all places have cellular connections to their systems.) Drawing information from the Net's own Ihara-Grubb Transformation Algorithms, these glasses show the wearer how their surroundings appear in the Net.

Electronic surveillance of ICE and other computer security can now be done from the safety of realspace, without the danger of actually jacking in. Remember, though, that you will still have an icon representing you in the Net (unless chipped for Invisibility; add 300eb), and you won't be able to penetrate Code Gates or Data Walls. **Notes:** with these glasses, the wearer can see Net icons and determine Net locations, but even if you are inside the Arasaka tower, you won't see the inside of their Data Fortress; the Data Walls and Code Gates keep your perceptions "outside." Remember, you are not a Netrunner, only an observer.

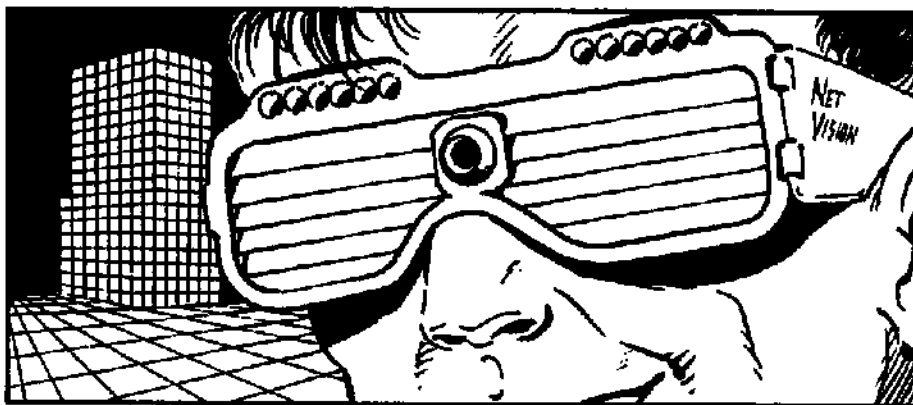

Now you can see what you've been missing!

DECKMATE + YOUR CYBERDECK = YOUR COMPLETE COMMUNICATIONS SOLUTION



ZETATECH®

DECKMATE

100EB

Expand your electronic horizons!

Although they are very advanced systems, almost all off-the-shelf cybermodems are dedicated computers which exclusively support the capability to perform netrunning. The hard-working engineers at Zetatech have solved this limitation with the DeckMate! The addition of this plug-in option gives your deck the processing power of a pocket computer, allowing your cybermodem to perform all the functions of a multi-purpose micro-computer. The DeckMate incorporates an INT 1 liquid-crystal processor core (capable of performing one task at a time), a small keypad and LCD screen (for use without interface plugs), and a datachip port which can run audio, video or information media. The DeckMate has no memory of its own, instead it uses the deck's memory, but it allows your deck to perform all the functions of a Zetatech E-Book, including the use of CompuMods or other computer options.

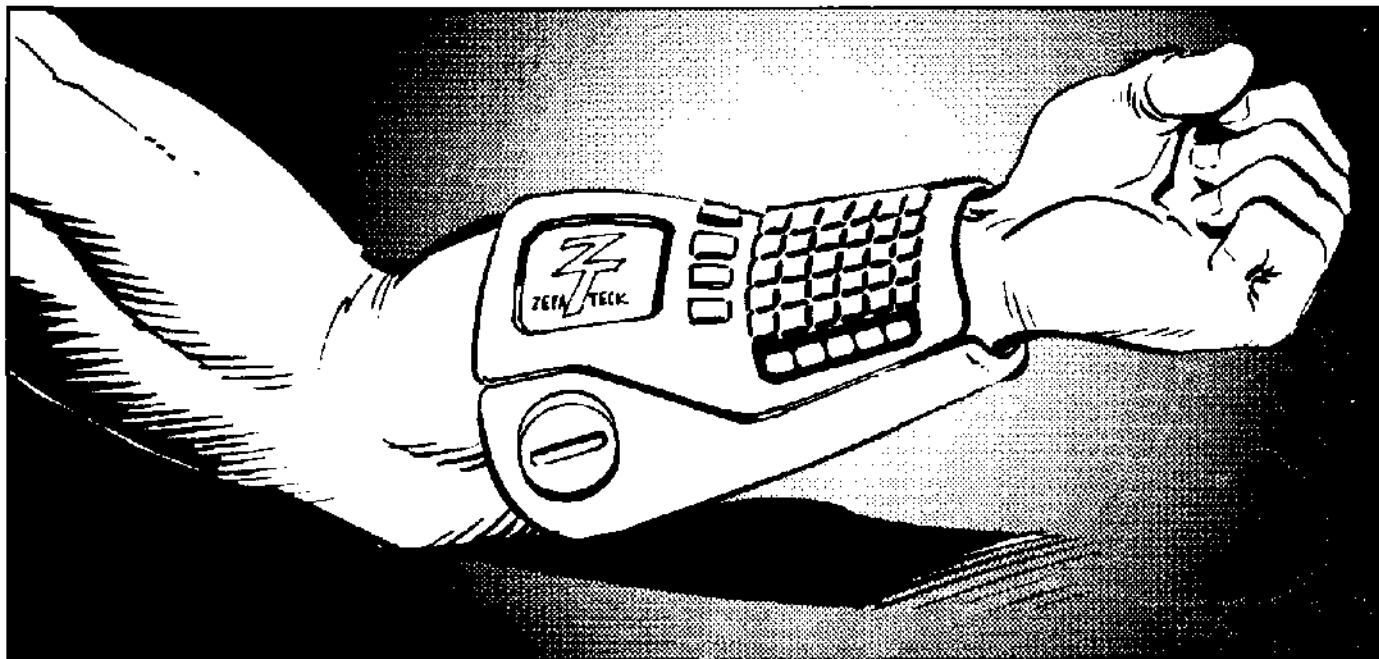

ZETATECH D2-3000 ARMDECK 5,000EB

The only universal system for hands-on integration.

Zetatech proudly presents the D2-3000 "Armdeck," the only true all-purpose cybernetic computer system on the market. Incorporating a gigabit superconductive microprocessor and a cybernetic operating system, the Armdeck can perform a variety of functions for the edgerunner who's on the move! Housed in a impact-resistant molyporcelain shell, the Armdeck has adjustable straps which allow it to be worn comfortably on the user's forearm. It's profile is so slim that it can even fit comfortably beneath the wearer's sleeve (Difficulty 18 to spot it)! It incorporates all the functions of a state-of-the-art micro-computer and a portable cybermodem, supporting a wide range of applications, from quick calculations to electronic intrusion! **Game notes:** for computer functions, see Zetatech E-Book (page 14). Cybermodem has 15MU, Speed +2, Data Walls +4, and includes Flip Switch option.

MUSIC-TECH & INSTRUMENTATION

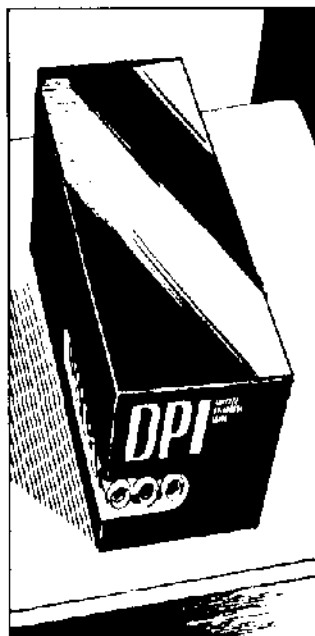

DPI "BLACK BOX"

BACKUP SYNTHAMP

800EB

Jam with the legends!

Digital Products Incorporated's Black Box is a highly sophisticated programmable vocal synthesizer. Specific voices are available on datachips for 10eb each, containing the completely digitized vocal patterns of many famous performers. The digitizations are so precise that they are indistinguishable from the real thing without painstaking analysis (even a Voice Stress Analyzer couldn't tell the difference). Once loaded with a selected voice, the Black Box can be programmed to sing pre-programmed lyrics along with a pre-programmed selection of music. The vocal synthesizing is so complete that a Black Box would make the same mistakes that the original artist would. Imagine; you can have anyone from the Beatles to Kerry Eurodyne as your backing singers! **Game notes:** A Black Box is the size of a shoebox, and must be connected to a synthesizer and speakers in order to function.

DPI BODY RHYTHM™ DANCE BRACELETS (400EB PER PAIR, PLUS 250EB FOR AMP)

Music in motion!

These neural-interface bracelets are chipped to translate muscle-activity impulses into musical patterns. The type of sound which the bracelets will synthesize must be pre-programmed beforehand, giving the bracelets the ability to sound like any one instrument; anything from a violin to a xylophone. The musical patterns are then broadcast via radiolink to a mini-amp (max range 15m) which then pumps the music out through a separate speaker system. With these bracelets, the user's body language actually creates the music! Many have likened a Body Rhythm performance to a hypnotic dance which borders on a new language. **Notes:** with a set of DPI's Body Rhythm™ dance bracelets, the performer can use either his/her Play Instrument (Synthesizer) or Dance skill, whichever is highest! To use the Bracelets, one must have wrist-located interface plugs.

WASHBURN SOUNDMACHINE GUITAR 1,000EB

Who needs a band when you have the Washburn Soundmachine? The Soundmachine has an internal rhythm box (with the full range of drums, cymbals and bass notes) and has a 100 beat loopable memory. It also has a memory for the notes played on the guitar; you can play a riff of up to 100 notes and the Soundmachine will loop it. Weight 3.5kg. **Game notes:** +1 to use of the *Perform* skill when not playing with a band.

"Okay, so I thought this was a joke—in fact, when my input slammed me a Washburn for my birth/incept date, I had to stop myself from laughing. But it grew on me...late nights on the tour, I found I could use it to work out new ideas, or get in a few hours of practice."

—Jack Entropy



CHAMELEON CLOTHING AND STEALTH ARMOR

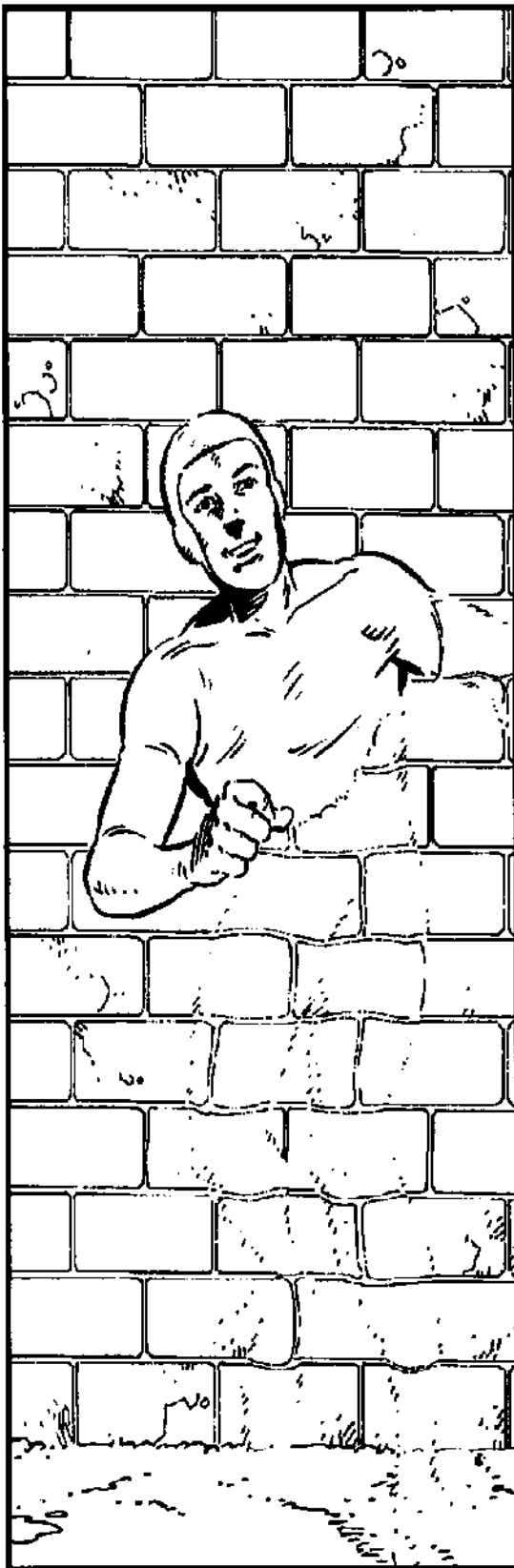

MILITECH M96 "GHOSTSUIT"

CHAMELEON CLOTHING 5300EB

Winner of the #2 spot on *Solo of Fortune* magazine's Top Ten Most Useful Newtech Tools of 2020! The Ghostsuit is a full-body coverall made of materials incorporating liquid crystal technology and a multi-faceted fiber-optic digitization system. Stealthier than a Sneaksuit, and smarter than Mirage Gear, the Ghostsuit actually blends into its surroundings. There are no preset restrictions; the Ghostsuit uses its computerized liquid crystal system to formulate the perfect camouflage for any situation. Just pull on the Ghostsuit, chip into the operator's interface via your plugs, don the visor and you're ready to vanish. The suit's liquid crystal exterior is composed of a matrix of cameras and projectors which cover the body. Through the interface, the wearer chooses the angle to which their camouflage will apply (i.e., the front of the suit will look like what is behind you; the right side will look like what's on your left; the back of the suit will look like what you're laying on). Then the suit's on-board computer carries out the user's wish. The effect is that the wearer is "painted" with the chosen background.

Game notes: Movement causes a lag in processing time, resulting in a blur effect (the normal bonus is -4 to any observers's Awareness, but only -2 if you're moving — all bonuses increase by -1/10 meters of distance between the wearer and the observer). The Ghostsuit cannot make you invisible, rather, your background is mapped onto your body. Therefore, you cannot emulate more than one background at once, and you can't fool two or more observers who have different points of view. Militech recommends that for best results, press up against (or lie down on) a surface, flattening against it so that you do not disturb the contours of your background. In such a case, multiple observers may be fooled. The Ghostsuit has an EV of -1 and provides 10SP of armor. For every two levels of protection the armor is damaged, there is a +1 penalty on the Awareness modifier. The hood features a set of eye-covering lenses for total protection. A fully-enclosed SP16 Combat Helmet (EV 0) can also be bought for an additional 600eb.

EQUIPMENT

GIBSON BATTLEGEAR "SNEAK SUIT"

560EB

Make the shadows your home!

Gibson Battlegear's sneak suit — the most popular brand of stealth garb in the world. This tight, black, light absorbent bodysuit (composed of PhotoCarbon™) sports a hood and an ultra-light trifilament weave for lightly armored protection. It also reduces the wearer's infrared signature, giving an overall -4 to an observer's Awareness rolls (visual or infrared) to spot anyone wearing a sneak suit in darkness, shadows or low-light conditions (this bonus compounds by -1/10 meters of distance between the wearer and the observer). The sneak suit has an EV of 0, and provides 10SP of armor. The hood features a set of eye-covering lenses for total protection. An SP16 Flak Vest (EV -1) with webgear and assorted pockets is available for 375eb, and a fully-enclosed SP18 Combat Helmet (EV 0) can also be bought for 185eb. Gibson also manufactures a space sneak-suit in cooperation with Mitsubishi/Koryidanshu; the Light Maneuver Sneak-Suit, a rubberized SP8 coverall with a 40 minute air supply (2,500eb, EV -2). Sonar-baffling diving suits made with the help of the Hydrosubsidium are also available (3,500eb, EV-2). **Manufacturers Warning:** Gibson Battlegear recommends that the Sneak Suit not be exposed to daylight for more than 10 consecutive minutes, as the photocarbon will overheat and melt. Be aware that lasers and other heat-based weapons will have a similar effect (any hit doing 20 points or more of damage will overheat the suit, making it inoperative).

.....

MILITECH M73 "MIRAGE GEAR"

ENVIRONMENTAL ASSIMILATION SYSTEM

1050EB

Adaptability is survivability.

Militech's new Mirage Gear revolutionizes the science of camouflage. Employing liquid crystal technology, the Environmental Assimilation System allows you to match your camouflage to your surroundings. The system consists of a full-body coverall whose patterning and coloration can be selected by the wearer. The Mirage Gear's internal memory stores 24 different camouflage patterns (desert, urban, snow, etc) as well as flat black and olive drab coloration, selectable by the wearer via a keypad on the inner wrist. Observers are at -2 Awareness if the wearer remains still, -1 if they're moving (this bonus compounds by -1/10 meters of distance between the wearer and the observer). Mirage Gear has an SP of 12, weighs 1.5kg, and has an EV of -1 (the hood includes an eye-covering visor for total protection). An SP24 Combat Helmet (EV -1) with transparent face shield can be bought for 140eb, and an SP18 Flak Vest (EV -1) with utility harness is available for 275eb.

.....

ARMORED STOCKINGS 110EB/PAIR

New—from Fashiondrome®

Because Beauty Never Goes Out of Style

The armored stocking, new for 2020 from Fashiondrome, the ultimate in elegant form and useful functionality. These stockings, made from new Nylon23, Militech's revolutionary new armor polymer, provides useful protection, with a minimum of bulky encumbrance. These stockings are just as silky and elegant as others on the market, but the new Nylon23 will stop the penetration of any thing up to a .38cal bullet. Now your legs can be well protected, even with the tiniest of mini-skirts. The stockings come in blue, basic black, white, red and beige. Styles include plain, fishnet, lace and circuit-board designs.

Game notes: 6SP protection on each leg. EV: 0. Garter or panty-hose styles both available.

HOLOGRAPHY

HOLOSCREEN

HOLOGRAPHIC VIEWERS

(2X BASIC PRICE)

A window on a new dimension.

At last, 3-D enters the mainstream. Supplanting the older generation of holographic generators (see Holo Generator, *Cyberpunk 2020* pg.59), whose screens could only supply simulated 3-D images, the new Holo-screens have unmatched clarity and resolution. Making use of KodaGraphix and other similar imaging technologies, holographic viewers allow high-quality projection of 3-D images. Many different models are available, such as videoboards, video/audio tape players, pocket TVs (note that only about 4% of TV broadcasts are in 3-D), computers, cyberoptic video imagers and cybermodem screen options. Holo-screens can only show 3-D images if they were recorded in 3-D, but they are fully capable of playing 2-D images as well.



DATATEL HOLOTANKS (500EB, 1000EB, 5000EB)

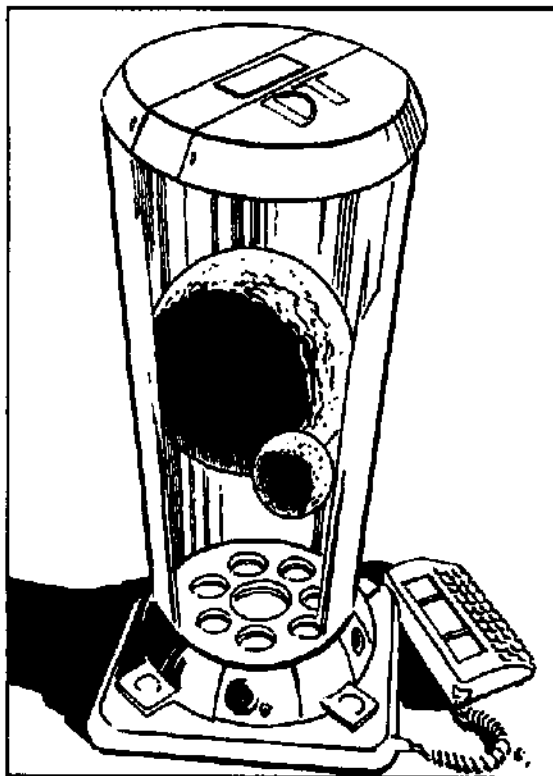

The holotank reestablishes the art of visual modelling. Consisting of a clear cylinder capped at both ends with super high-definition laser projectors, a Holotank is filled with a highly-reflective, non-toxic gas into which a hologram is projected. The hologram can be static or animated, and its positioning can be manipulated by a remote keypad. Walk around the tank, and you can see all sides of the image (also called a "model"). To film a model, three holographic cameras are necessary; the image to be recorded must be in the middle of the three cameras. This makes holotanks inefficient for TV shows or other highly active models — usually individual, static images are best for holotanks (however holotanks are often used when one person will be speaking or dancing). Three models of holotanks are available: the tabletop model measures 12" diameter & 18" tall, the desktop model is 24" diameter & 36" tall, and the display size holotank is 4' diameter & 7' tall. Holotanks are most popular for computer modelling purposes, but are also seeing use as programmable fashion mannequins for clothing stores (as well as walk-in models which serve as instant clothing "try-on" booths), holographic video games, visual teleconferencing, battlefield strategic analysis, weather prediction, and for air traffic control displays.

EQUIPMENT

EASTMAN KODAGRAPHIX HOLOGRAPHIC CAMERAS (2X BASIC PRICE)

Give your images more depth!

Eastman-Kodak's new holographic imaging technology allows you to create flatscreen images with realistic depth. Using advanced laser-rangefinding systems, regular photography or film procedure with Kodagraphix yields flat pictures with a simulated 3rd dimension. All camera types are available as holographic models, including headsets, multiformat news cameras, pocket units and cyberarm options; they have the same statistics, but cost 100% more than normal versions.

.....

EASTMAN ARTS MINDSCAPE® CYBERHOLO ART IMAGER 600EB

Bringing art into the 3rd dimension!

Eastman-Kodak's Arts division removes the middleman with Mindscape®. This advanced holographic imager employs the latest in cybernetic and hologram technology to render the pad and the palette obsolete. With Mindscape®, anyone can be an artist—just stud into the unit with a set of interface plugs, and let your imagination do the work. Whatever you can visualize, Mindscape® can model in 5792-color 3-D!

Game notes: this unit will indeed draw pictures from your mind's eye, but it takes more control than its makers would have you believe. Stream of consciousness and train of thought must be under strict control to maintain an image for recording to memory, so the Mindscape® merely adds +1 to Paint or Draw skill (but your picture is in 3D).

.....

REMOTES & DRONES

REMOTE CONTROL SYSTEMS

There are several remote control systems for remote vehicles, all requiring the use of either the new skill Remote Systems Operation (REF/INT average based) or the Netrunner special ability Interface. This is modified by the remote's Control Modifier for tricky, delicate, or combat maneuvers (as well as the control systems modifier). The most basic design is a manual version, which costs 300eb and has a control modifier of -2. A more advanced control system uses a virtual reality heads-up-display helmet with a dataglove and keypad. This system costs 500eb and has a control modifier of -1. The most advanced control system available for remotes is a cybernetic control deck (CCD) which the operator simply chips into in order to control the remote; a CCD costs 800eb and has a control modifier of 0 or +1 depending on quality. These three units are available either in stationary panel style or compact portable versions—the cost is the same, but control range is sacrificed for portability: a stationary unit with repeaters can have up to a 100km range, while many portable versions have a mere 15km, tops.

"Netrunners moan all the time about how they can't stand with the Solos when combat comes. I never needed more than a couple assassin remotes or a handy Robo-Cab™ to level any opposition."

—Rache Bartmoss

BELL "BUMBLEBEE" REMOTE ROTOCRAFT 4,000EB

The classic remote vehicle; a design that has been in service since the 1980's. The Bumblebee is the latest refinement of the "peanut" rotorwing—the light, ceramic body consists of two bulbs, with two counter-rotating blades spinning around the central body between the bulbs. A meter tall and weighing 35kg, it can easily be launched from the deck of any ship (or from the trunk of your car). Its lower bulb, which sports the landing skids, can be fitted with a variety of cameras, sensor systems and other electronics (such systems are doubled in cost). Some have even been armed (with capacitor lasers, micro-missiles, SMGs), but this is a rare occurrence; anything bigger than an SMG is too big, heavy and has too much recoil. The ultimate multi-purpose remote. **Game notes:** Control Modifier -2, SDP=25, SP=6, maximum speed 120mph, operational range 250 miles.

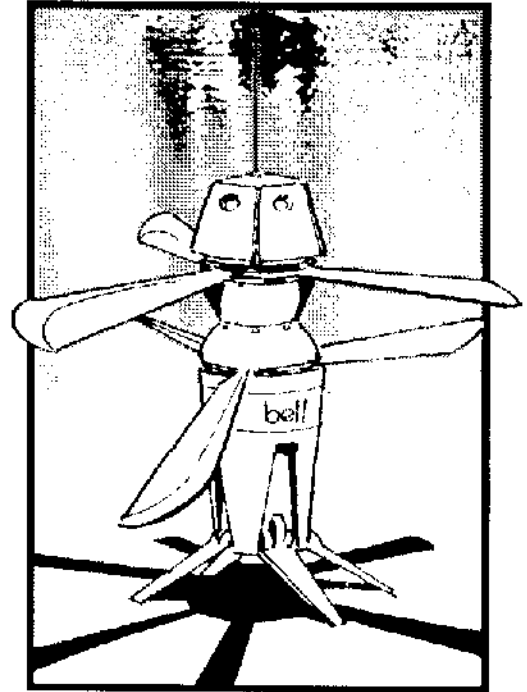

MITSUBISHI "ROVER" WHEELED REMOTE 9,000EB

The driverless jeep! Rover's primary purpose is perimeter patrol and other security tasks. It has a small CHOOH-powered combustion engine driving its 6 independent-suspension wheels, and its body is sturdy enough to take the punishment of any job. It normally patrols an area autonomously, following a pre-programmed route, alerting an operator when a security anomaly is detected. It is lightly armored, equipped with a small turret for sensors or weapons, and can run for six hours. Rover is 4 feet long, 2 feet wide, and 2 feet tall—weighing 60kg, it is too big to be used indoors, and forget about kicking it over! The turret sports a audio-visual, light-intensification and IR sensor suite, and there are two spaces which can be used for more sensors or weapons systems (each space can hold a rifle-sized weapon). Rover has very limited threat engagement and isn't too smart, but it's reliable and loyal. **Game notes:** Control Modifier -3, SDP=35, SP=20, maximum speed 45mph; its Awareness, Targeting & Initiative rolls are at 10+1D10.

MILITECH RPV-400 LIGHT COMBAT TILTROTOR REMOTE

Designed to be a light, easily-deployed unit. Capable of carrying a wide variety of munitions and options, mounted on 4 wing and one centerline hard point. Integral weaponry consists of a 2-barrel 12.7mm rapid-fire machine gun, firing from a dual box feed mechanism. Each box holds 1500 rounds; usually one is loaded with LAPHE (light AP/HE), while the other is loaded with anti-personnel fragmenting rounds (treat as DP ammo), and a flare chaff launcher which can fire 10 flares or chaff pods (-30% to be hit by radar homing or heat seeking missiles. only a 60% chance of deployment when under self control). The RPV-400 is capable of remote operation, using the new VRSU-23 control helmet (or cybernetically), and can also control itself, thanks to a pre-programmed set of responses and orders (orders can be loaded in before mission, or they can be selected from a pre-programmed list). **Game notes:** Control Modifier +2, SDP 65, SP25, Maximum Speed 210mph, Operational Radius 450 miles. 12.7mm Chaingun: HVY•+2•N•P•12.7mm/4D10+2• 1500x2•150•STD, Range 1km. Note: armor is 1/2 vs. LAPHE ammo, but penetrating damage is not reduced.

EQUIPMENT

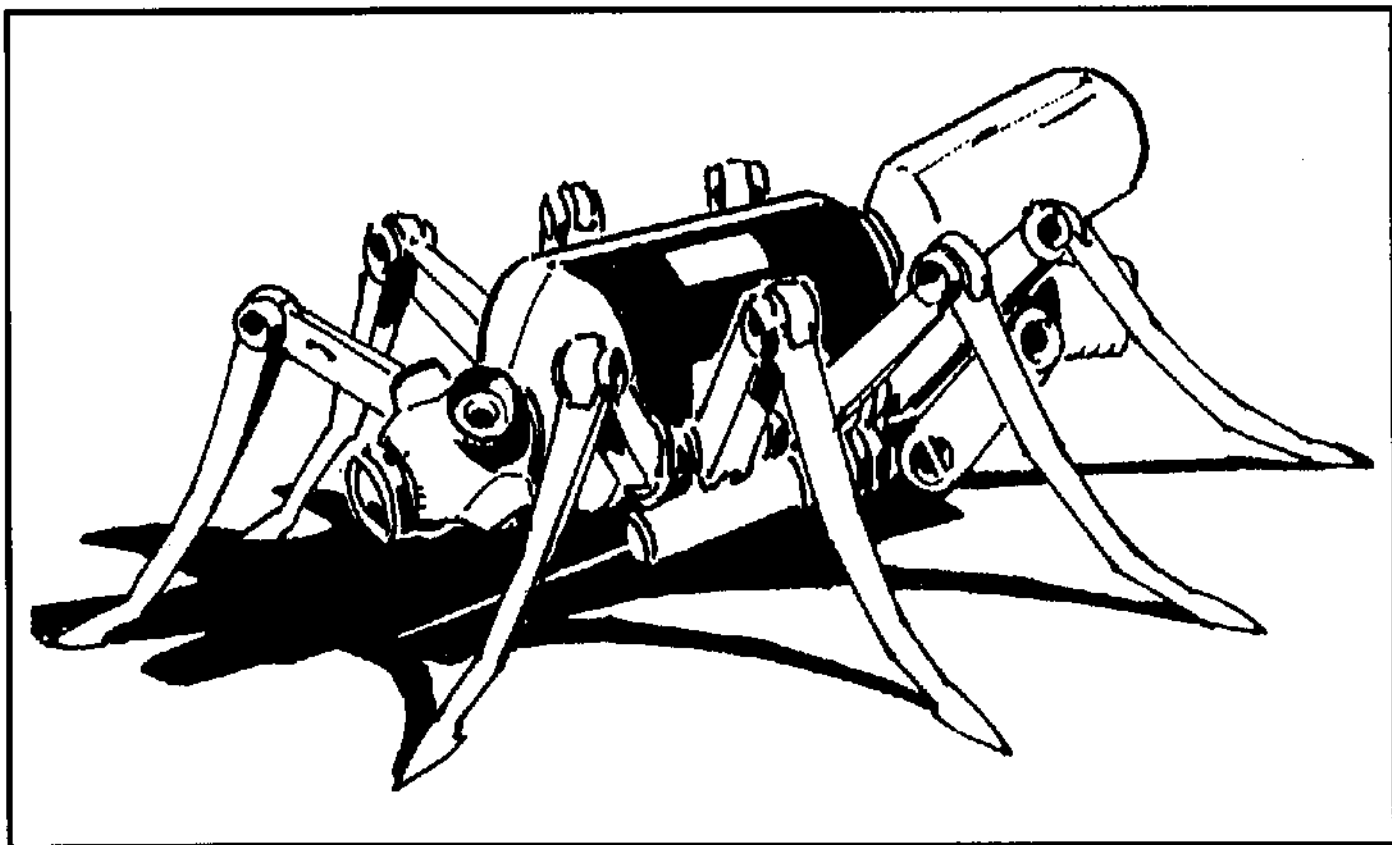

ARASAKA RDAK SPY &

ASSASSIN REMOTE

12,000EB

An advanced synthesis of robotics and state-of-the-art remote technology, the Remotely Deployed Arachnoid Killer is Arasaka's premier entry in the field of remote weaponry. Designed for stealthy urban reconnaissance, sabotage and assassinations, RDAKs (also known on the streets as "Spiders") have eight thin, highly

"Killer bugs. I hate those things. They can hide under a piece of paper, waiting to blow yer face off. Or watch you from the corner of the ceiling with their beady lil' eyes till your back is turned..."

—Ripperjack

maneuverable legs which can also function as crude manipulators. Its small body (about the size of a paperback book) has a multipositionable "head" which is packed with audiovisual, low-light, and thermal microsensors as well as a set of small wirecutter "teeth." The abdomen unit has a space for including a single pistol-size weapon system such as a handgun, needler, squirtgun, capacitor laser, etc. (Note: all handgun-type weapons will have 1/2 normal magazine capacity and 1/2 basic range. Capacitor lasers will be 1-shot. All weapons are Acc 0.) RDAKs are very sophisticated, but also quite durable for their size; for example, a Spider can easily withstand a fall down a flight of stairs or from a 2nd story window without harm. Each RDAK has a 5-dose hypodermic "stinger" built into it, and the ends of its legs are tipped with molecular adhesive which allows it to climb walls and walk on ceilings. Available in a variety of colors and camouflage patterns. Their ceretronic systems (the combined silicon microcircuitry and vat-grown organic neural tissue that functions as a "brain") are less vulnerable to a Microwaver than most cyberware: 1-3/ no effect; 4-5/ motor malfunction—runs in random circles for 1D10 combat

(10sec.) turns; 6/total breakdown—it just sits, twitches, and smolders. On 4-6, if it has a ranged weapon, there's a 25% chance it will fire once at random. An EMP grenade or MagField generator has normal effect. **Game notes:** Control Modifier -1, SDP T0, SP10, MA 12, battery time: 5 hours, control range: 300m. Remember, Arasaka normally only sells these little beauties to *friendly* corporate entities.

CONSUMER ELECTRONICS

AUTOTANNER™ 200EB

The greatest invention since lotion. Wanted to get a tan, but couldn't get to the parlor? Ever since the holes in the ozone made it hazardous to get extended exposure, people have wanted new ways to get that bronzed look. Well now, thanks to the design staff at RelCo, you can get that look any time you want. Simply touch the chemical injector to your skin and voila! Instant tan. Be the envy of all your neighbors and get the Autotanner™ today. 30-day money back guarantee if not completely satisfied. Your look means a lot to us.

Game notes: Device gives the player a +1 to ATT for a period of 1D6 days.

PHONE

UPGRADES

(COST VARIES)

The following items and services are designed to make your cellular phone work for you.

VOICEMAIL 20EB/MONTH

Another way to avoid the ring. Now, they can leave a message on your private voicemail service. Any number of messages can be recorded. The Phone Company maintains the equipment, all you pay for is the service.

FAX INTERFACE 75EB

This device allows the attachment of a fax machine directly to your cellular. Fax in that proposal while heading to the airport. Why wait to use a stationary fax machine, when you can carry yours along for the trip? Very handy.

DIGITAL RECORDER 75EB

Allows one to record that special conversation for later. Record up to 2hrs before replacing the chip. Extra chips are available for a mere 10eb each. Note: Some areas consider this device a form of "bug" and is illegal. We do not condone the practice of breaking the law.

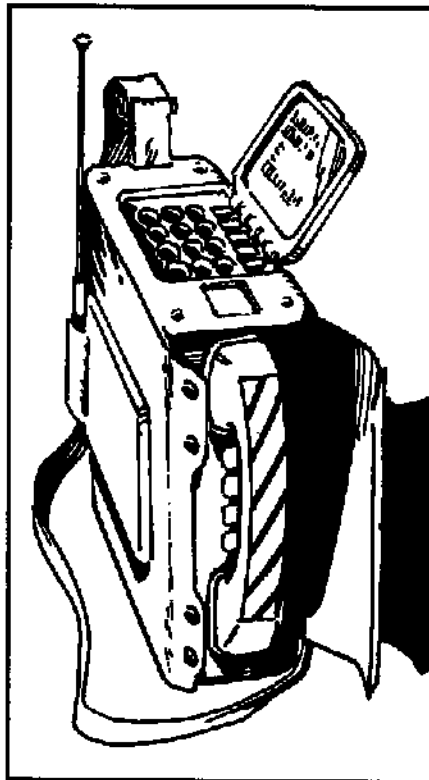

ECM SCRAMBLER 50EB

Allows for private phone calls to another likewise equipped unit.

VIDEO OPTION 150EB

2"x2" screen and a mini digital camera to allow you to see, and be seen by, whomever you are speaking to. Not available for microcellular models.

EMERGENCY AUTODIALER 25EB

A memory for emergency numbers. Allows one-touch dialing of Police, Fire Dept, and either Trauma Team or REO Meatwagon rescue services. 6 preset numbers.

CONFERENCE CALLING 5EB/MONTH

Owner can call 2 separate lines and have all talking to one another. For each additional 5eb/month you spend, you can have 1 more line added.

SPLIT LINE 50EB

Owner has 2 separate numbers for the same phone. Each line is billed separately. Like having 2 phones in one.

CYBERMODEM INTERFACE 500EB

Turns any plain cyberdeck into a cellular model. Never again will your netrunner need to buy an overpriced cellular job, when for hundreds less, he/she can buy a phone with Zetatech's new Cyberbaud 7 cellular deck upgrade.

Note: Due to extra circuitry, a -1 penalty to the netrunner's Interface skill is applied.

PRIVACY PLUS™ 300EB

For the discreet businessman. Privacy Plus™ provides the caller with ECM, a built-in bug detector, and a display of the number calling you. This display flashes each time the phone rings. For an additional 50eb, a memory of up to 20 numbers can be installed and will list the name of the person calling, as well as the number.

EQUIPMENT

RUSH® VIRTUAL ENTERTAINMENT SYSTEM 500EB

SegAtari has just recently dropped the price of it's home Virtual Reality unit, Rush®. Using a combination of Virtual and Braindance technology, Rush® is the ultimate home video game experience. Already gaining notoriety, Rush® is setting the industry standard for home entertainment. Over 300 games have been released so far and the list just keeps growing. Check out *Brainburner*, it's a wild ride! A guaranteed favorite!

Game notes: Interface plugs and basic processor required for use.

: RUSH® VR UNIT UPGRADES

• These items allow you to improve the system you purchased (smuggled, stole, whatever) to maximize game play and enjoyment.

• **TOTAL ENVIRONMENT™**
• The Total Environment™ allows far more realistic sensations than the basic Rush® unit. When chipped into a Total Environment™/Rush® system, you are given complete freedom of movement for maximum enjoyment. Comes with 16 games designed specifically for the To-

tal Environment™ unit. If you like excitement, Total Environment™ is for you! 1000eb

MULTI-PLAYER ADAPTOR

Allows up to 4 other Rush® players to join in. With multiple adaptors, you could have an unlimited number of players. (Software permitting). 100eb.

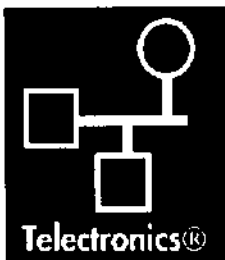

VIDEO WALL™ 3500EB

New from Teletronics Ltd comes

the masterpiece of visual stimulation: The Video Wall. Transforms any size wall into a 2-D or 3-D movie screen. Great for watching the classics! A must for either the movie buff or the person with money to burn. Hooks up to any standard video machine or game system with ease. Try Rush® *Kung Fu Fighter VI* on this baby! WOW!!!!!!

Note: Requires at least a 6'x6' space of wall to be effective.

: SEGATARI VIRTUAL VILLAINS 150EB

• Battle the greatest villains of all time with SegAtari's Virtual Villains. This Rush® system game chip contains a virtual reality with photorealistic portrayal of a medieval castle. It's there that you have a showdown with the greatest of evils. The game deck has a massive collection of historical and fictional villains. You and up to nine of your friends can do battle with the likes of Hitler, Genghis Khan, and Captain Hook! There is also a large assortment of weapons, both modern and archaic. Live the game with Seg-Atari!

"Karkong the Impaler. Worst of the lot. Makes Atilla the Hun look like a poser. I don't know how many Virtual games I've lost to that fuckin' SOB. I don't even wanna know. It's humiliating to get your butt kicked by a virtual algorithm."

—Rache Bartmoss

SCHOLAR™ HOME LEARNING SYSTEM 750EB

The Scholar™ Home Learning System has recently been added to SegAtari's long list of breakthrough hardware. By use of Virtual/Braindance Technology, you can learn languages, history, mathematics, just about anything. And in your own home! No more are you required to take long, boring classes. No more lectures. All you need to do is jack in to the Scholar™ upgrade package for your Rush® home virtual reality unit.

Game note: Any skill requiring hands-on experience requires you to have a Total Environment upgrade. Maximum skill level learnable is +2. Cannot be used to improve skills already known. Skill is learned at a rate of +1 per 6-hour lesson; plus 1 day of practice per lesson.

WEAPONS

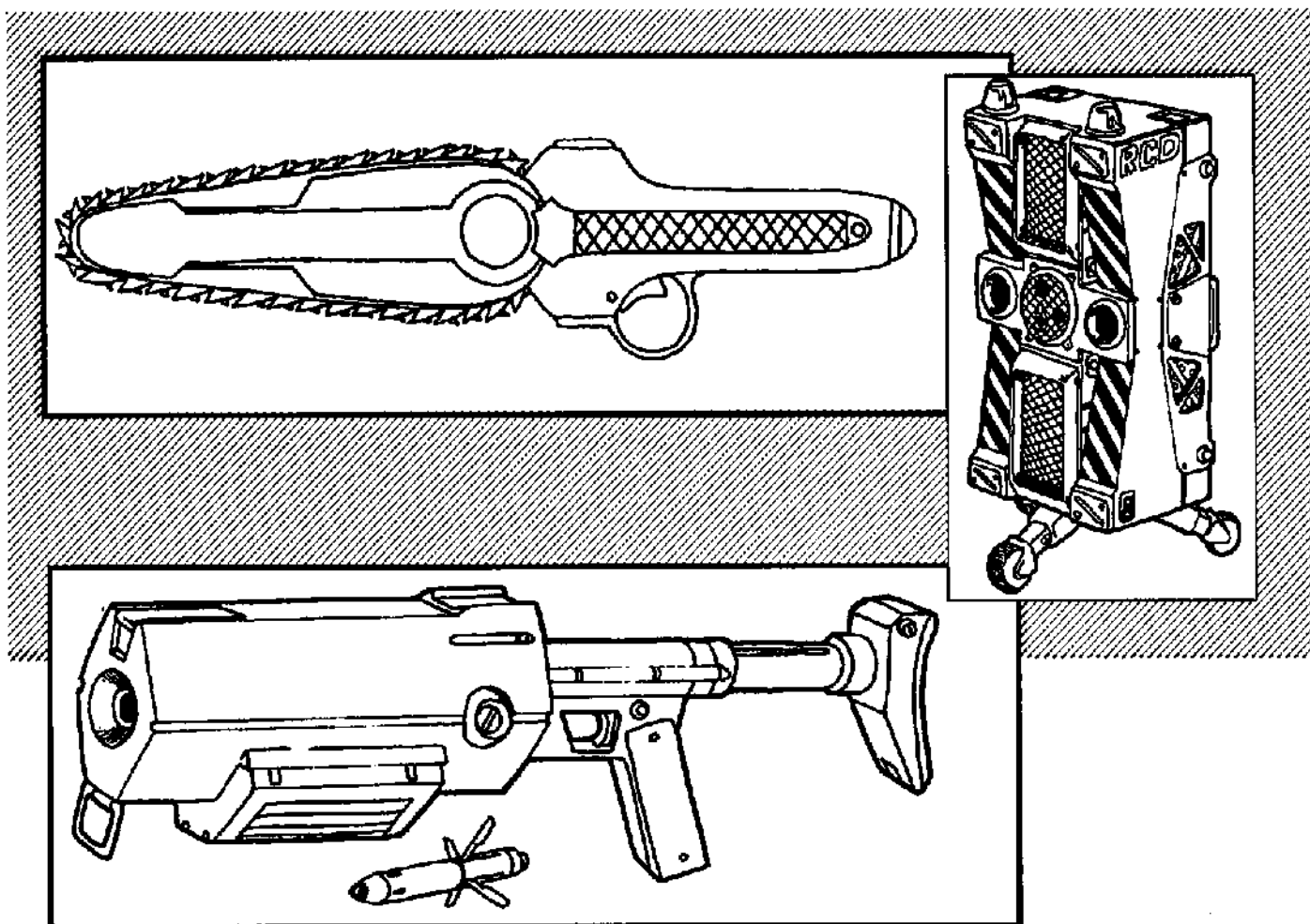

Let's not kid ourselves. As Solos, we use guns to kill. They may have other uses, but that is no concern of ours. So, with that in mind, you must agree that we need a wide variety of weapons for a wide variety of situations. And you must also agree that the best weapons are the ones that kill with the most efficiency and speed."

-Jake Takada

WEAPONS

TSUNAMI ARMS RAMJET RIFLE 1,230EB

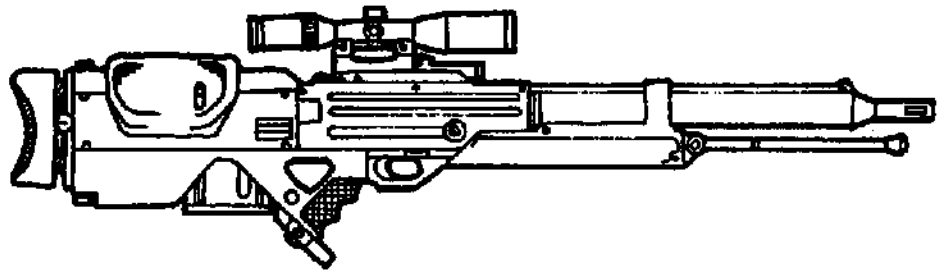

RIF +3 N P 8.5MM RAMJET 9 3
VR 800M

"Tsunami Arms - Better Than The Best." The top-secret Japanese weapons design firm once again lives up to its motto with their Ramjet Rifle, a remarkable new weapon which is fitted well to the roles of sniper, counter-sniper and light anti-armor weapons system. What makes this rifle special is the bullets it fires—not a normal slug, flechette or gyrojet, these 8.5mm projectiles are small ramjet engines! Fired from the rifle at a velocity of 3,200 feet per second, the supersonic bullets have a conical aperture in their nose into which the incoming air is compressed. This jet of hot air ignites the solid fuel in the center of the bullet; the exhaust blasts out of the back, accelerating the round until it runs out of fuel. This results in a constant increase of the velocity and energy of the shell until it reaches its maximum range, making the Ramjet Rifle a harder hitter the further away it is from its target. The gun is a semiautomatic, caseless ammo-firing bullpup made of lightweight polymers, boasting an adjustable grip and stock as well as an adjustable bipod and a free-floating heavy barrel. For superior accuracy at long ranges, the Ramjet Rifle comes equipped with a 4x telescopic laser-reflex smartgun interlock, which paints the target with a laser and then uses microprocessor-controlled liquid lenses to determine the range and the proper elevation to hit the target at that range by moving the aimpoint, causing the shooter to bring it to the correct angle. **Game Notes:** the 8.5mm Ramjet rounds do 5D6+3 at Close range, 6D6+1 at Medium range, 7D6 at long range and 7D6+3 at Extreme range.

POLYMER ONE-SHOT CANNON 90EB

"So like, he came at me, and like, I pulled the trigger and — ewwww—lunch meat..."

—Random
mail brat

RIF -2 L C 4D6+2 (13MM)
1 1 UR 100M

Heavy firepower in a disposable package! This plastic blaster from Kang Tao is the ultimate last-chance weapon—after all, you're not going to need more than one explosive 13mm bullet to get

the toughest pursuer off your tail! To keep costs down, the "One-Cannon" is made from inexpensive materials, and the shell is filled with stable explosive materials. **Game Notes:** The 13mm shell is a low-velocity HEP (High-Explosive Plastic, cratering) round which does 4D6+2. Damage is 1/2 real, 1/2 stun only—armor has no effect and is damaged 2 M_s. The gun is so poorly made that if it jams, it breaks—if a 1 is rolled, the weapon explodes, doing 2D6 to the firer's arm!

MILITECH CYBORG RIFLE 800EB



RIF +1 N P 7D6+3AP (.300WM) 30 2 ST 500M

They say that if you want good weapons, you buy Militech. The Cyborg Rifle is no exception. Made for 'borg fighting, the Cyborg Rifle can be relied on to drop a metalhead at any range. A massive bullpup, this rifle was designed around the .300 Winchester Magnum hunting cartridge, which is normally used for hunting big game. The .300WM was chosen for its versatility under a variety of conditions, ranges and targets. Militech is fully licensed to use this round, since they bought out most of the Winchester holdings many years ago! An assortment of .300WM ammunition has been produced for the Cyborg Rifle; among these is a teflon-coated armor-piercing bullet, which has proven to be sufficiently effective against most Body Plating. To enhance controllability, the barrel of the rifle is surrounded by a hydro-pneumatic recoil sleeve. Even so, this weapon is most often used by combat 'borgs themselves, as most unaugmented soldiers find its bulk taxing (loaded weight is 7.5kg).

STEIN & WASSERMAN "TRI-STAR" REVOLVER 375EB

P 0 J C 2D6 (#000) 6 1 ST 50M

S & W designed this special-load revolver as a "compact yet practical multi-munitions delivery system." What this means (in plain English) is that the Tri-Star is a big, double-action revolver-style handgun which fires .410 shotgun ammo. Although it is capable of firing shotshells (2D6/1D6+2/1D6) and slugs (3D6+1 AP), the Tri-Star is best known for loading Triplex shells which pack three #000 buckshot pellets. When using this load, treat each shot as a "3-round burst," rolling 1D6/2 to see how many buckshot hit and then rolling each hit randomly (2D6 damage each). Stein & Wasserman also markets a 100eb lasersight which is specially made for Tri-Stars packing the #000 Triplex: the sight projects a red dot which marks the point of aim, and a surrounding circle which marks the area into which the three pellets will spread. Because of the visually distinct style of these sights, the Tri-Star has seen a great deal of use in media entertainment.

"I like this gun. It's a little old fashioned, but it has a certain kind of charm. And S&W knows how to make a good revolver too.

"Yeah, I really like it. Thanks for letting me blow your head off so I could keep it."

—conversation in the Aftermath night club, six seconds after a firefight.

PURSUIT SECURITY INCORPORATED WEBGUN 250EB

RIF +1 N C ENTANGLE 1 1 ST 30M

P.S.I. continues its popular line of non-lethal weapons systems with their Webgun, the "long-range mantrap."

This single-shot weapon has a shock-absorbing stock, a pistolgrip and forend-grip arrangement, and an optical sight. The "Webber's" conical muzzle has four blast-directing "barrels," each of which propels an elliptical weight, attached to a spiderweb-like nylon net. Fired by a single cartridge, the net is pulled open by the radiating trajectories of the weights, ensnaring the target in a fast-moving, hard-pulling tangle. In police tests it has been 95% effective in rendering a person helpless. **Notes:** The web is large enough to encompass any size assailant. The victim must make Near Impossible BOD and REF checks to escape. Failure of both rolls means the target is captured; 1/2 REF for Initiative and actions, and a non-moving target for attacks. A single failure means the target will escape in 10-(BOD or REF) minutes (whichever is shorter). While stretchy and tough, the material can easily be cut by any decent blade the victim has in hand.

For an additional 100eb, the Webber can be outfitted with a carbosteel wire net and the integral taser mount to charge it. P.S.I. assumes no responsibility for the safety of those caught by the device. If web is equipped with taser charging, use Taser rules (CP2020, pg.97)

Also available is the FEN Dz-55 Det-Web (450eb/net): Designed as a new anti-Borg net-projectile for the P.S.I. Webgun, the Det-Web replaces the net's nylon strands with strips of Detcord. These directional explosive charges in strip form can make instantaneous, precision cuts through just about anything (burns through up to SP40 armor like a cutting torch in 1 combat round) when detonated. In effect, anything caught in a Detweb will take a 40-point AP hit to every body location, which will all but shred anything but the most monstrous of combat Borgs. Accuracy and range for the carbosteel net and the Det-Web are 0 • 25m.

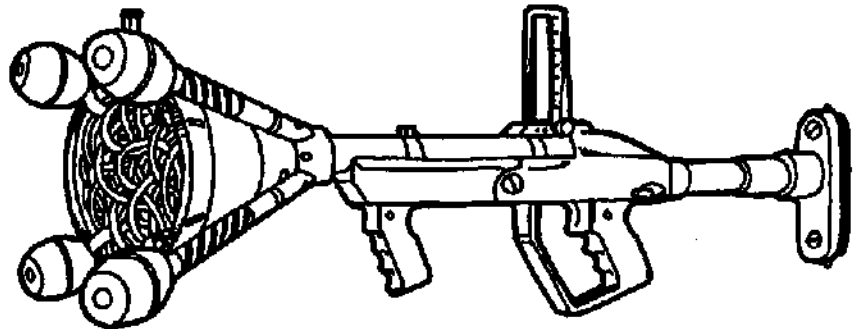

WEAPONS

RHINEMETALL EMG-85 KINETIC ENERGY RAILGUN 11,370EB

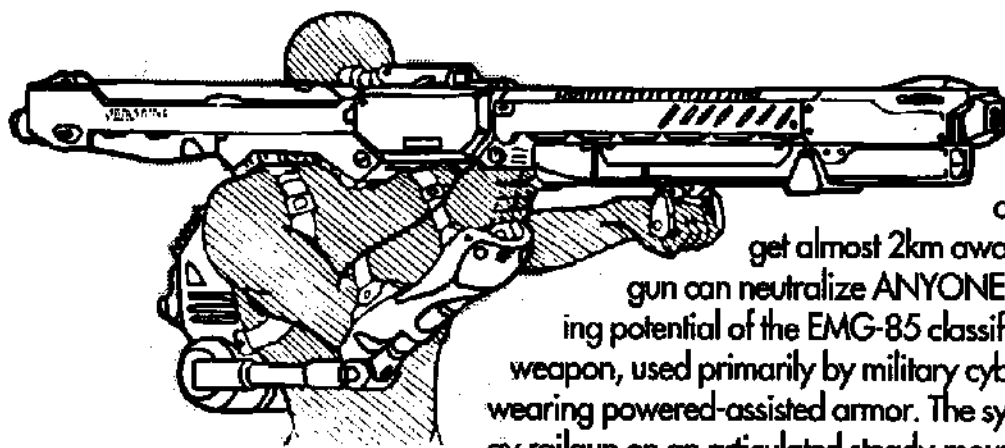

**HVY +3 NR 5D10+10
(EAP) 5 1/2 ST 1,500M**

The ultimate weapon in the war on cyberpsychosis. Delivering a nickel-ferrous slug at hypersonic velocity to a target almost 2km away, the new Rhinemetall Rail-

gun can neutralize ANYONE! The appalling multi-level killing potential of the EMG-85 classifies it as a special-purpose weapon, used primarily by military cyborgs and C-SWAT troops wearing powered-assisted armor. The system consists of a kinetic energy railgun on an articulated steady-mount harness with a computer-

ized fire-control system. This electro-magnetic gun (or EMG) uses superconducting technology to launch a special 15-gram Mylar-coated metal projectile at 8,000 feet per second! This projectile is not only utterly lethal to the human body, but it can also punch through all but the toughest vehicular armor plating. The fire-control system acts as a sophisticated smartgun, allowing for rapid target acquisition and engagement. The weapon has a built-in magazine with 5 superconductor power loops and a 5-round projectile pack (weight 1kg.). The ammo unit (plus power charging) costs 1200eb. Militech hopes to have a competing model, the XR-1 Mag-Pulse Gun in 12/5mm Sabot (with removable ammo/power pack) out in 18 months.

Game Notes: Due to the sheer weight and recoil, a minimum BOD of 11 is required to fire the gun without a linear frame or powered armor. The gyrostabilized mount-harness negates all modifiers for movement, but has an EV of -1 and negates the use of a Smartlink. The Extra-AP effect of the ammo is 1/4 to armor, but only 1/2 to penetrating damage. Short range extends out to approx. 375m, and maximum range is 3000m, similar to most HMGs and light cannon. Weapon weight: 35kg (77 pounds) fully loaded. The weapon requires 1 combat round to realign the magnets before a second shot can be fired. Interface plugs and a Smartgun Link can be used by themselves instead of the harness, but shooter's MA is at -1; EV is -2, and the minimum BOD requirement becomes 12.

Only found with authorized C-SWAT teams, military armories, and sometimes mounted on vehicles, the EMG-85 is incredibly rare, expensive, and illegal. Black-Market purchases should only be available with a Near Impossible Streetdeal roll. (And a critical success at that!)

LUIGI FRANCHI "KING BUCK" MULTI-MAGNUM 800EB

SHG -1 N P 6D6/5D6/4D6 (10-GAUGE) 4 2/4 VR

The Italian-made King Buck is a four-barreled pepperbox-style shotgun, made for hunting big game. It has four separate barrels and chambers, and they can be fired one at a time, or (if you want to be really gross) you can fire all four at once! This magnum shotgun fires 10-Gauge 3" Magnum shells, and can load buckshot and slugs. A huge, unusual and exceptionally heavy weapon (7 kilos), which is considered a collector's item.

"You'll love this. A large gun but simple to operate. One pull of the trigger, and BOOM, his head falls off. A very fine instrument. We make excellent instruments in Italy, yes?"

—Giovanni Stratelibre, Eurosolo

UNDERBARREL CAPACITOR LASERS/ MICROWAVERS 950/500EB

U-B CAPACITOR LASER RIF +2 * R 3D6 2 2 UR 25M

U-B MICROWAVER EX 0 * P 1D6 4 2 ST 20M

Advanced weapons from the genius at Tsunami Arms, these capacitor weapons negate the need for bulky power units by using advanced superconducting capacitor packs instead. Accuracy and hitting power in a ceramic and polymer tube that will fit under your weapon's barrel! You can even plug them into a hip power pack, giving you more shots. They are designed for sub-machine guns and rifles (medium SMG or larger).

The power pack costs 250eb, weighs 4kg, and doubles the number of shots (it also adds 5m to the microwaver range). The capacitor lasers mount in an underbarrel position, and look like older laser sights (DIFF Awareness to spot the difference). Note: the laser is an advanced version of the cyberarm weapon (CP2020, pg.82)

"By my second or third op, I was slinging all kinds of hardware under the muzzle; flashlights to spot, lasers to pinpoint... Now I've settled on a combination that works for me; a Militech grenade launcher and a Tsunami microwaver in tandem. I call it Shake and Bake."

—Morgan Blackhand

TECHTRONICA M40 "PULSE RIFLE" 3,500EB

RIF 0 N R EMP 6 1/2 ST 50M

Techntronica's milspec Electro-Magnetic Pulse cannon is quickly proving itself to be the ultimate electronics-killer. Utilizing new breakthroughs in multi-band electromagnetic beam propagation systems, the M40 is a rugged weapon designed to disrupt, defeat and otherwise destroy electronics and computer systems of all kinds. This stubby, rifle-shaped weapon (which uses liquid metal storage cells), is fully insulated against its own effects—which are devastating! At Close range, the weapon can permanently fry electronics of all kinds (from computers to cyberware), and incapacitate people for hours.

Game Notes: This a tight-beam weapon, affecting one target per shot (body locations are irrelevant), and because of its charging cycle it can only fire once every other turn.

Warning: a Point-Blank shot

can be lethal to the human nervous system. At Point Blank range it has a 50% chance that it will ruin electronics even through shielding, and people must make a Death Save at -3 (if they succeed, they will be unconscious for 2D6x30min). At Close range, any unshielded electronics or cyberware are immediately disabled (but can be repaired) and people must make a Stun Save at -5 or pass out of 1D6x10 minutes. At Medium range, any unshielded electronics or cyberware are disabled for 1D6/2 hours, and people must make a Stun Save at -3 or pass out for 2D6 minutes. At Long range, any unshielded electronics or cyberware have a 70% chance of being disabled for 2D10 minutes, and people must make a Stun Save at -1 or pass out of 1D6 minutes. At Extreme range, any unshielded electronics or cyberware have a 30% chance of being disabled for 1D10 turns, and people must make a Stun Save or pass out for 1D6 combat turns.

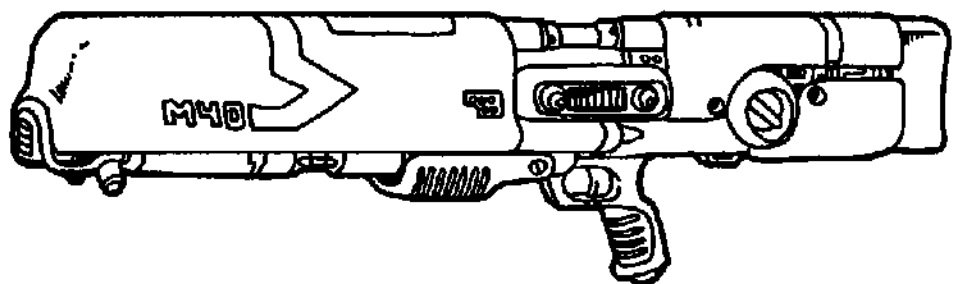

WEAPONS

NOVA .338 CITYGUN 460EB

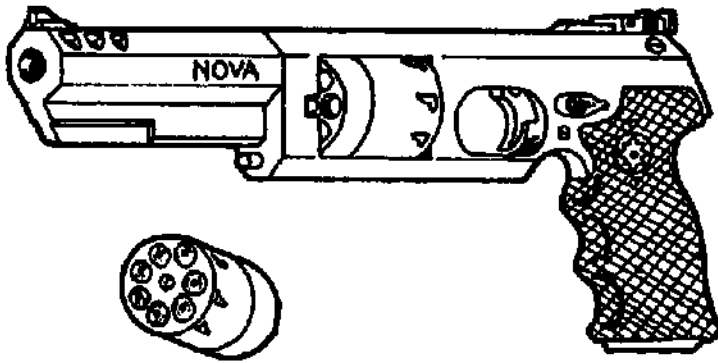

P +1 J P 3D6 (.338) 7 3 VR 50M

The double-action Citygun is Nova Arms' attempt to bring the revolver up to date. Rather than employing a traditional cylinder, it uses Nova's patented "Ammo Cassettes." These are disposable cylinders composed of superstrong composite ceramics, preloaded with seven .338 Nova cartridges. To reload, one simply drops out the empty cassette and slaps in a fresh one, thus doing away with clumsy re-

loading of individual rounds. The Citygun is packed with modern features, sporting a nonreflective matte-black finish, a octagonal barrel which has an underbarrel universal scope-mount, an adjustable trigger, and twin triple-porting on the barrel, which serves as a sophisticated muzzle compensator (the compensator aids in quick recovery for follow-up shots, increasing the ROF to 3). Nova also includes two spare ammo cassettes with every Citygun. Durable, reliable, and capable of placing seven high-velocity slugs in a two-inch pattern as fast as you can pull the trigger, the Citygun is indisputably the most advanced wheelgun on the market today. **Note:** .338 Nova—This rimmed, brass-cased cartridge fires a 98-grain bullet at 1695 fps. This places Nova's new cartridge around the .357 Magnum, making it an ideal mid-range load. Ammo is available for 15eb (per box of 50 rounds), and disposable

COLT-MAUSER M2X CANNON 3,050EB

HVY 0 NR 4D10+6 (20MM EHI) 8 1 ST 600M

The undeservingly world-famous Barrett-Asasaka "Light 20" has a 20mm bore diameter but fires sabot subcaliber penetrators of depleted uranium; it's a cheap cop-out, a "20mm" rifle any wimp can fire. The Colt and Mauser arms companies have recently joined forces to produce the M-2x, a true 20mm rifle! This massively powerful semiautomatic is fired over the shoulder, much like a WWII bazooka, and uses the same 20mm shells as those in the Vulcan guns on aircraft like the F-36. The magazine housing is built into the shoulder brace, bullpup-style, and the long-travel recoil absorbing rod goes over the firer's shoulder. Despite composite construction and hydraulic shock-absorption systems, the M-2 requires an Average BOD roll (difficulty 15) to avoid taking 1D6/3 in bruise damage to the firing arm (a critical failure also results in the gun being dropped). A 4x telescopic sight in the carrying handle is standard equipment, and the M-2 weighs 23kg fully loaded.

EHI: Extra High Impact ammo (for rounds in the 20-30mm range)—armor is at 1/4, penetrating damage is not reduced. If the damage is stopped, but exceeds 1/2 the armor's SP, the target takes 1/4 damage from sheer kinetic impact. Brittle cover (i.e., cinderblock walls) will shatter if the cover's SP is exceeded by the shell's damage.

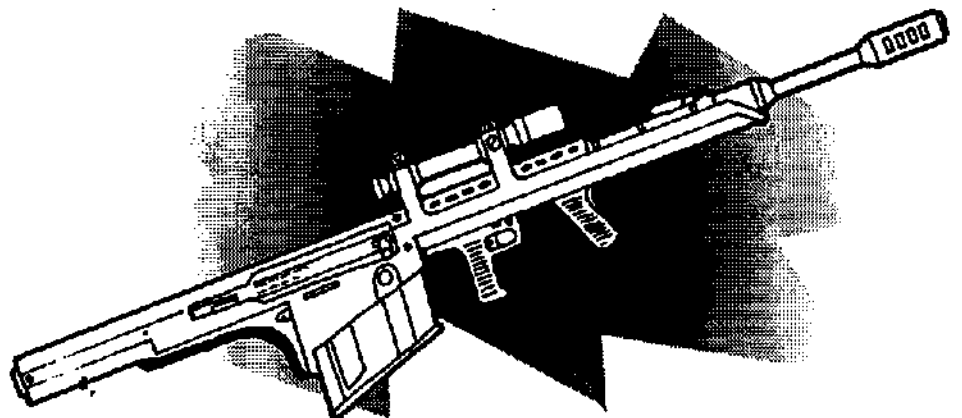

MILITECH AM-3 "ANTI-MATTER RIFLE" 6,000EB

HVY 0/+1 NR 6D10+12 (30MMEH) 5 1 ST 1600M

The return of the Anti-Tank Rifle! Militech's 30mm recoilless rifle is the only man-portable weapons system capable of taking on a main battle tank. More commonly, this high-power cannon is used to smash combat borgs, powered armor, and sensitive targets such as bunkers, radar stations and armored fighting vehicles. It fires Militech's patented 30mm rocket-propelled depleted-uranium shells to avoid the crushing recoil that ac-

"Okay, so it doesn't really use anti-matter. We just call it that because it uses depleted uranium."

— Marlo (Militech Rep)

"Right. I say you call it that because you can use it to knock the frackin' Starship Enterprise outa orbit."

— Axeman (Freelancer)

companies a standard 30mm cartridge (these are the same shells used in Militech's aircraft-mounted gatling cannon). Nonetheless, this rifle is by no means recoilless, and it is made of high-strength ceramics in order to withstand the tremendous pressures and reduce overall weight. Equipped with a hydro-pneumatic recoil absorption system, an advanced muzzle brake, and a telescoping shock-absorbing stock and bipod, the AM-3's recoil is still punishing: it requires an Average BOD roll (difficulty 15) to avoid taking 1D6/2 in bruise damage to the firing arm (a critical failure also results in the gun being dropped). Warning: do not try firing this thing standing up unless you have a linear frame of at least Beta class, or you will be knocked down and the bruise damage doubled! Equipped with a Cyberoptic Triangulation smartgun interlock and a 2-10x telescopic sighting system with low-light and thermal imaging

capabilities, this rifle has incredible range potential. Strictly a military weapon, this gun is incredibly illegal. What's more, the Depleted Uranium rounds (which are rated Extra High Impact, see Colt-Mausser M-2x) cost 100eb each! Because the round is low-velocity with rocket boost, there is a "safe zone" of 160m in which the weapon has Acc 0 and does 1/3 damage; it does 1/2 damage, Acc +1 between 160-800m, and full damage, Acc 0 after that.

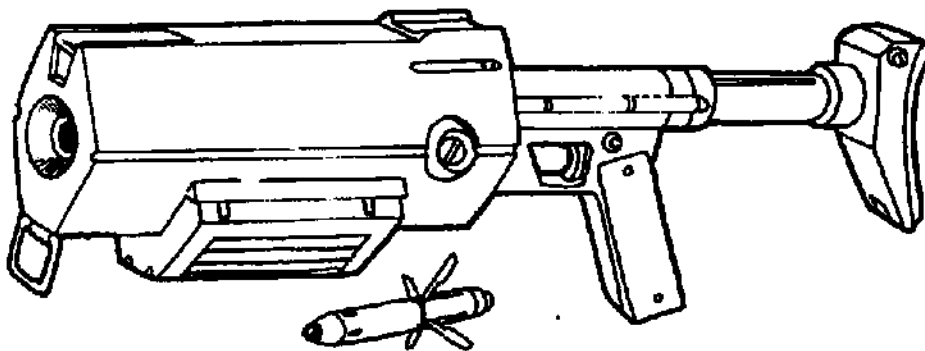

MILITECH URBAN MISSILE LAUNCHER 900EB

HVY +2 LP 4D6 (MICROMISSILE) 12 2 ST 200M
MM-POD: HVY +1 * P 4D6 (MICROMISSILE) 1 1 ST 200M

The most advanced urban weapon ever to hit the streets! This magazine-fed weapon, which resembles an oversized SMG, fires the same self-guided heat-seeking explosive-tipped rocket-propelled projectiles as the cyberarm Micromissile Launcher. However, its large box magazine allows for high firepower and rapid reloading. With an Urban Missile Launcher, the average corporate solo becomes a fearsome hunter-killer! Also available from Militech is the Micro-Missile Pod, a muzzle-loading 1-shot micromissile launcher designed to be mounted on any shoulder firearm, from a carbine to a machinegun (this unit costs 200eb, and can be mounted on any weapon for 50eb). **Notes:** see Micromissiles, pg. 49, for rules on using these weapons.

WEAPONS

MILITECH PDU-3 MULTI-PURPOSE PERIMETER DEFENSE UNIT 150EB PER UNIT

HVY O P P 2D6+5 1 1 ST (2.5M
BLAST RADIUS)

These small devices are one of the most compact sensor-deterrent units on the market today. The PDU-3 is a unit about 3" square by .75" thick, with a sensor, controls, and a small panel for insertion of a single microcell (to power the sensor and controls). Designed to be used as a part of a perimeter, or to be sown to dissuade pursuit, these units contain a small, but potent, explosive charge. The casing is made of a light ceramic that shatters into long, sharp shards, providing a fragmentation effect. The PDU-3 can be set to fire from a variety of triggers, and can be set for almost any time delay. While the unit will accept input from most military sensors, it is equipped with a PIR (Passive Infra-Red) motion sensor, a magnetic door contact (about the same size as a matchstick), and a tripwire. Each unit has a small amount of charge-activated molecular glue on it's back, allowing for solid adhesion with almost any surface. The PDU is state of the art in man-portable area denial weaponry! Versions adapted to throw gas are usually bursting types with a similar radius.

TSUNAMI ARMS "AIRHAMMER" 5.3 MM AIR PISTOL 325-400EB

P+1 J SPECIAL (5.3MM AIRJET/VARIES) 5/7 2 ST

An unusual design for an unusual purpose. Tsunami was asked by Crystal Palace Security to design a weapon that would penetrate the light armor (like skinweave) commonly encountered on the Palace, while still avoiding the problems of hull penetration and threats to bystanders. The answer was the AirHammer, which fires a 5.3x19mm cartridge, using a compressed gas cannister for propulsion. The low velocity of the air gun limits penetration, and reduces recoil. A simple switch on the bottom of the barrel controls how much gas is used. The gun has three settings: "Target," "Combat," and "Overload." A variety of rounds are available for this weapon, but the most common is a fragmenting flechette made by Kendachi that has minimal penetration versus solid surfaces but excellent stopping power. Other rounds include flechette, gas, gel, and practice rounds. The AirHammer is available in two versions: the first has a 5-round cylinder, a laser sight, and mounts a 10-shot gun camera as integral equipment. HighRider solos prefer this weapon, as it gives positive proof that the user was unable to close with the victim. The second version (the Mark 2) has a seven-round cylinder and an integral smartgun rig. This is usually issued to Security personnel and bodyguards.

The AirHammer is Very Difficult (25) to find on Earth, but Average (15) at any Spacer facility (although they may not sell one to a Groundhog). "Target" is used when performance is not necessary, and only delivers 1/2 damage. "Combat" is the normal setting for the weapon, and no modifiers are applied. When the pistol is set for "Overload," its reliability drops to UR. It also does +3 damage. The gun's air reservoir holds 15 units of air—each target shot uses 1/2 a unit, each combat 1, and overload uses 3. Replacing the cylinder is a 1 turn (10sec) operation, and requires a REF roll vs 15 (to keep from dropping something). This roll can be skipped by taking an extra turn. The Z-G Recoil Modifier is +1 so the base REF roll to maintain position in Z-G while firing this weapon is 16+.

MUNITIONS LIST

Kendachi Fragmentation Flechette—does 1d6+2 damage, uses special ceramic darts.

Flechette—1D6+2 AP. Uses bioplastic or ceramic darts. Shreds soft armor (reduces SP by 1/4), but shatters against solid surfaces.

JellSluggs—2D6+2 damage (see rubber bullets, pg. 47). The gel rounds splat against walls or hard armors.

Gas—Throws out a 2m gas cloud when it impacts a solid surface (usually sleep gas, but any gas is usable). Persistence is 2 rounds.

Practice—1D6-1 damage, uses a plastic slug.

**TECHRONICA
MODEL 009
VOLT PISTOL
950EB**

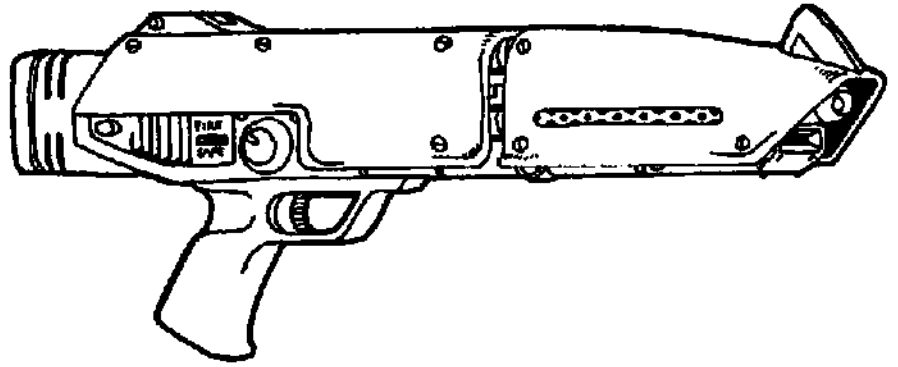

P+1J R 3D6 6 1 ST 25M

A dynamic new weapon from the masters of electronic warfare! Inside the sleek metallic frame of the Volt Pistol is a low-intensity laser projector, which ionizes the air when fired. Then the 009's high-capacitance liquid metal batteries release an electrical charge along that path, resulting in an artificially-generated, directed "lightning bolt." (damage is 1/2 real, 1/2 stun) Since this is an electrical discharge weapon, any cyberlimb hit by a Volt Pistol will be shorted out for 1D6+3 turns (if a critical success is rolled, the limb is permanently shorted out and must be repaired) unless shielded (20% chance). Even if the target is hit in a meat part, adjacent cyberware is treated as if hit by a microwaver with a +1 on the effect roll (a critical TO HIT success means any effects are permanent until repaired). Of course, most armor is not grounded against electrical impulse (this is 50% the cost of the armor, and negates the gun's effects), so normal armor offers no protection against the blast! Utilizing advanced technology, the Volt Pistol is comparable in size to a large SMG, and is powered by an energy pack (reloads cost 25eb) which attaches to the rear of the weapon.

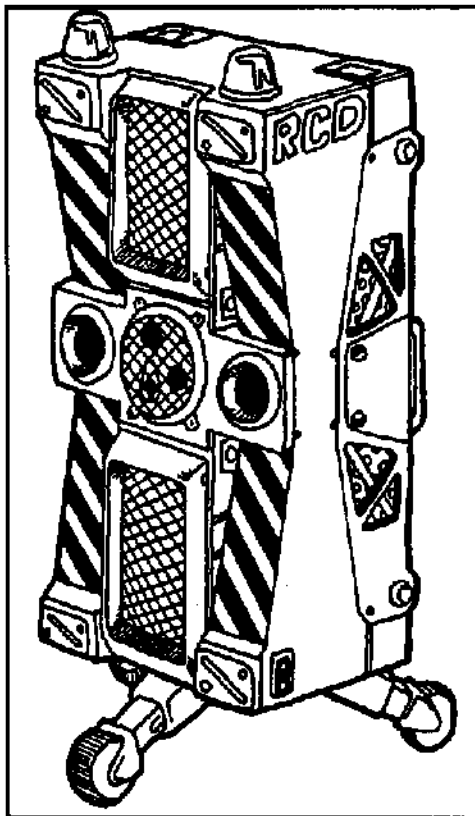

**ARASAKA "NAUSEATOR" RIOT
CONTROL DEVICE™ 1900EB**

EX 0 N P SPECIAL 10 1 ST

The latest in large-scale crowd control. Police forces take note: the "Nauseator" (as it was dubbed at last year's LawTech convention), has proven itself as an effective way to cool down an otherwise ugly situation without unnecessary bloodshed. No need to hose down a field with expensive 30mm ammo. Just dose 'em with ultrasound and watch those poor souls puke their guts out. The mess is certainly less than that of blood on the streets.

- All targets within range must make a Very Difficult BOD check to avoid the disorientation, headaches and nausea/vomiting.
- If check was made: Debilitation (-4 to all actions for 1D6 rounds)
- If check failed by 1-3: Incapacitation (REF and MA reduced to 1 for 1D6+1 rounds)
- If save failed by 4+: Serious Incapacitation (unconscious for 1D6 minutes)

Target must be hit for a minimum of 2 consecutive rounds before being subdued. Range is a shotgun pattern 1.5m deep and 2.5m wide.

The following cyberaudio options increase the BOD check one level: Amplified Hearing, Increased Hearing Range. These options make you immune to the effects: Sound Editing, Level Damper. Special headsets or earplugs reduce the BOD check by one level. Note: the device is a field generator (0.6m wide x 1.7m tall), not a hand-held weapon.

WEAPONS

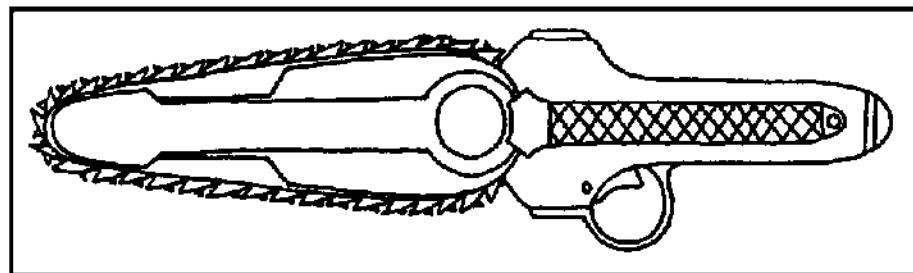

IMI "CHAINKNIFE" 120EB

M +0 J P 2D6+1 NA NA VR

Designed and manufactured in Israel, the ChainKnife has seen a great deal of use with Mossad agents. Shaped somewhat like a survival knife, this is a battery-powered (2 hours) hand-held combat saw (similar to the Buzzsaw cyber-option; *Solo of Fortune*, pg32) which can chew through armor like cheesecloth (1/2 SP, soft armors are reduced 2 pts/hit)!

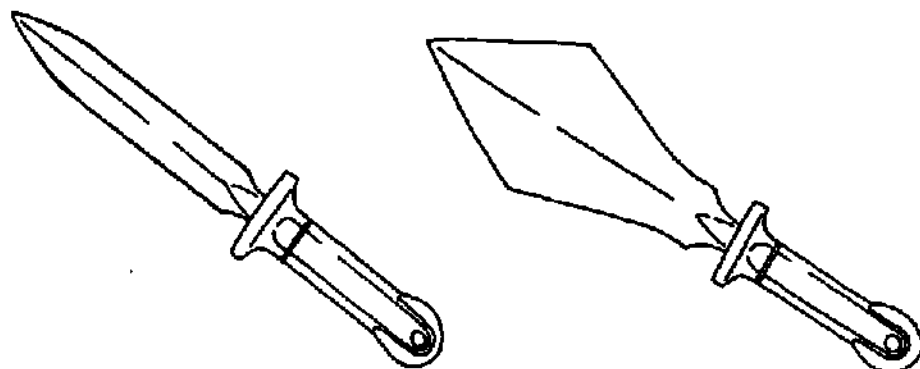

SLAMDANCE INC. SPAWNBLADE 450EB

M 0(+1 THROWN) J P 1D6+BOD/1D6+4 NA NA ST

With the Spawnblade, SlamDance Inc. puts the "combat" back into the combat knife! To the naked eye, the Spawnblade just looks much like any combat knife that has been balanced for throwing (1D6+BOD modifier damage). The differences manifest only in combat: once the safety is disabled, the Spawnblade's memory-metal blade has the ability to "fan out" its cutting edges. On any combat hit that does more than 4 points of damage (including BOD bonuses to damage, but before BTM) and gets past your opponent's armor, the Spawnblade can be triggered. The blade spreads into a razor-sharp 50° spatula—inside your opponent's body! This does an additional 1D6+3 (armor won't help). Once opened, the Spawnblade can only be safely removed with a Medtech roll of 20; any other means of removal will cause the victim another 1D6/2 damage. The Spawnblade comes with a safety sheath in a choice of ten designer colors.

KENDACHI MONOWHIP 350EB

M 0 J P 2D6 NA NA ST 1-3M

Following in the tradition of the popular cyberweapon, Kendachi's Monowhip houses a spool of mono-filament wire in an ergonomically-designed handle. The wire has a small weight at one end for balance and swing, and can be extended up to 4m in length or reeled in at the push of a switch. The Monowhip can therefore be used as a garotte, cutter, or razor-sharp grapple. The monomolecular wire will cut through almost any organic material as well as most plastics, doing 2D6 damage (double damage on a critical success). **Note:** Monoweapons, unless noted otherwise, allow only 1/3 armor protection vs. both hard and soft armors.

KENDACHI MONOWIRE 60EB PER METER

String it at neck level, and watch your pursuit go to pieces; string it at ankle level, and watch intruders lose their footing! Available in varying lengths, Kendachi's monomolecular wires are capped with synthetic bulbs at either end for safe handling. The ultimate trap element, and ideal for slicing your cheese, too. **Note:** Monowire does 3D6/cut damage, while reducing armor values to 1/3rd.

**TASER
WALLET
65EB**

New from Pursuit Security Inc. comes their complete line of personal object protection devices. Thieves got you down? Try our little toys. Each wallet,

billfold, and purse is rigged with a 1000-volt charge that activates when removed more than 2m from the transmitter chip hidden on your person. The unwary pickpocket is unable to hold onto the object for more than a few seconds. Discreet and non-lethal, these are designed to discourage so called "five-finger discounts" of your personal belongings.

Note: Beyond 2m the thief must make a Very Difficult BOD roll each round to hold onto the stolen item. An Average COOL check is recommended to avoid crying out.

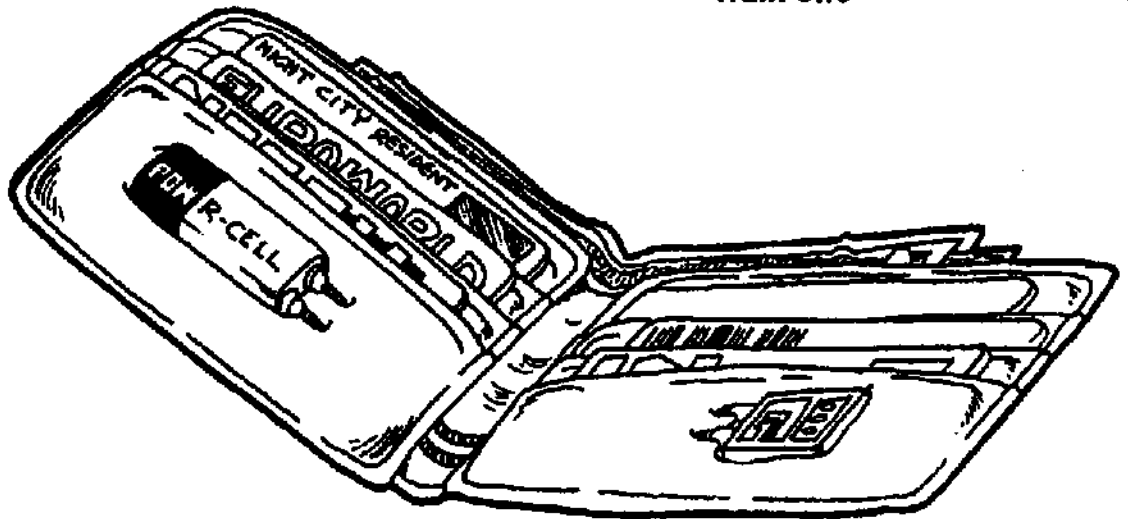

**MYSTIC TECHNOLOGIES
SPRING KNIFE 125EB**

MEL O P C 1D6 NA NA ST 1M/5M

On first inspection this knife appears to be the standard survival variety, but in fact its blade can be released and launched via a high-powered spring. The blade has a range of 5m and inflicts 1D6 points of damage. The knife takes 2 rounds to reload.

DRUG-A-THUG™ 150EB

EX O P C CHEMICAL 5 1 VR

The latest thing to hit the streets of 2020 is the Petrochem Drug-a-Thug™. This handy-dandy little device delivers a solid dose of any paralyzing or sleep-inducing drug that the wielder chooses. Compact, it is capable of fitting into most pockets and purses. Only slightly larger than a touch taser, the Drug-a-Thug™ is perfect for those who wish to be discreetly armed.

Any target struck must make a Very Difficult BOD check (plus Resist Drugs skill) to avoid it's effects. Reloads cost from 10-20eb per dose. Capable of being loaded with any drug. The device will not penetrate armor.

TASER II™ 100EB

EX O P C STUN 4 2 VR

The newest in personal protection for the non-violent person. This little friend is capable of delivering a 15,000 volt charge to a touched target. Reach out and say hello to that perp with the modern answer to crime. The new Taser II™, brought to you by the people at Militech. Because we care about your safety.

Note: Target must make a Stun Save with an additional -1 to avoid its effects. See taser rules in CP2020, pg.97 for more details.

SKUNKER™ 70EB

EX -1 P E GAS 4 1 VR

Armament for the non-violent person. Delivers up to 4 doses of non-lethal gas (Purchaser's choice) to a target 2m away. One target only, but enough to discourage any allies he/she may have. At 6 inches long and 1 inch around, it fits in any purse or jacket pocket. Comes in 6 designer colors. For 5-10eb more, the gas can be mixed with odiferous chemicals creating additional effect equal to Stench Bomb (see entry).

Note: See gas rules CP2020, pg 100 for details.

AMMUNITION

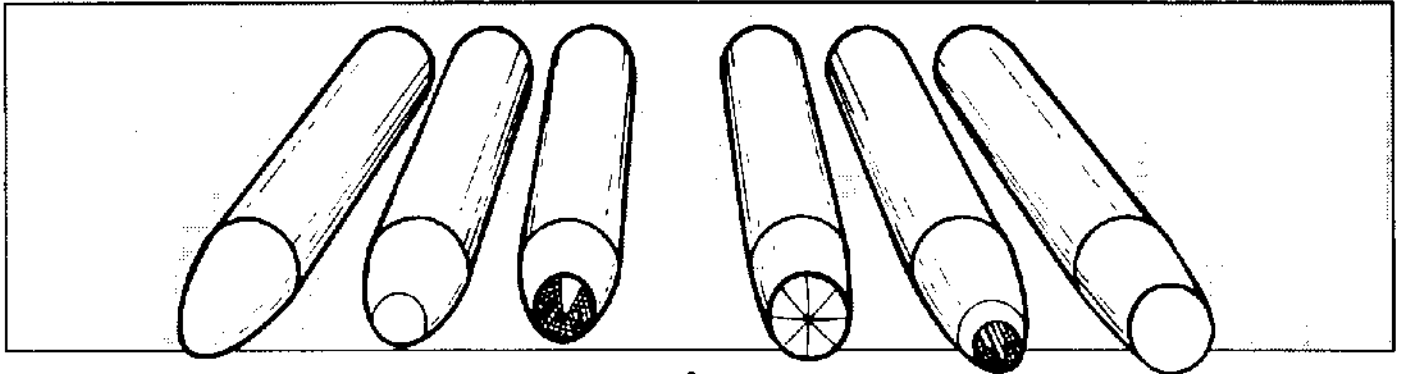

DUAL-PURPOSE ROUNDS (4X BASIC COST)

Gone are the days when you might accidentally bring AP bullets to a nudist colony, or normal ammo to a Body Armor manufacturer's convention. Dual-Purpose ammo gives you the best ballistics for the best situation; DP rounds consist of a dense, sub-caliber penetrator core of tungsten steel wrapped in a sheath of soft, quickly-mushrooming lead. When these rounds hit armor, the lead sheath strips away while the penetrator continues through to your target. However, when these rounds hit flesh, the lead squashes out to cause a massive wound cavity. In any situation, Dual-Purpose rounds leave little to be desired. **Notes:** when DP rounds hit an armored target, they treat it as 1/2SP but do 1/2 damage to flesh. If the target is unarmored, they do 1.5x normal damage.

API - ARMOR-PIERCING INCENDIARY (4X COST)

In the old days, guns were called "heaters." That name applies once again, thanks to the remarkable new API rounds. These cartridges fire metal-jacketed, sharp-nosed slugs which cut through most armor with ease, but these slugs pack a surprise: each bullet is composed of a solid chemical compound which combusts in reaction to high-pressure impacts. The overall effect is a bullet which, upon impact, becomes incredibly hot, searing the insides of its target! Just try not to get into a firefight in a paper factory... **Notes:** API ammo acts as normal AP ammo (armor SP is halved but so is damage vs. flesh), but if the bullet penetrates its target's armor, it does an extra 1D6 damage the first turn, and 1D6/2 damage the second turn. API rounds may ignite any flammables they hit (50% chance). Cannot be fired from guns with ElectroThermal Enhancement

KENDACHI FRAGMENTATION FLECHETTES (5X COST)

This ammunition, manufactured by the Kendachi Corporation, consists of a synthetic-cased or caseless cartridge which fires a subcaliber alloy flechette. These sabotaged, fin-stabilized arrows travel at impressive speeds (up to 4,000 feet per second), giving them superior armor penetration ability. They are also injected with a near-microscopic filling of a C6-style plastic explosive, and are chemically time-delayed to detonate a micro-second after impact. Using this design, the needle-like projectiles are able to successfully penetrate armor without suffering from overpenetration. The classic problem with flechettes is this: being of very small diameter and traveling at extremely high velocity, a flechette may pass directly through the target and leave only a tiny (and ineffective) hole in the body. To overcome this, Kendachi's fragmentation flechettes pack just enough explosive to break themselves apart once they enter the body, thereby creating a devastating wound cavity. **Notes:** Kendachi's Fragmentation Flechette ammo is available for any weapon at 5x the cost of regular rounds; they treat soft armor as 1/2SP and do normal damage to flesh. Beware — these rounds are Rare availability and very illegal. Usually found with orbital weapons. Cannot be fired from weapons with ElectroThermal Enhancement.

LESS-THAN-LETHAL™ AMMUNITION (COST VARIES)

Many ammunition manufacturers have produced a variety of Less-Than-Lethal ammunition as well as utility rounds for shotguns. They can not be called non-lethal, as many are very dangerous if not used at the proper ranges. These are just a few of the types available to the public.

RUBBER BULLETS 1/3 NORMAL PRICE BOX OF 50
Damage is Stun only beyond 3m. Below that range, 1/2 is real, 1/2 is Stun.

STINGER SHOTGUN SHELLS, 12 GAUGE 15EB BOX OF 25
Damage is Stun only beyond 3m. Damage is 4d6 under that range.

STINGER SHOTGUN SHELLS, 10 GAUGE 20EB BOX OF 25
Damage is Stun only beyond 9m. Damage is 5d6 under that range.

GAS SHOTGUN SHELLS 20EB/25EB BOX OF 25
Damage is by gas type used. Area of effect is 2m circle.

FLARE SHOTGUN SHELLS 25EB/30EB BOX OF 25
Lights up an area of 30m diam. Causes 2d6+2 and 1d6/2 per round fire damage if fired as a regular shell.

SMOKE SHOTGUN SHELLS 15EB/20EB BOX OF 25
No damage, but obscures a 3m circle with dense smoke.

FLASH SHOTGUN SHELLS 30EB/35EB BOX OF 25
Act as a flashbang grenade in a shotgun pattern 25m deep by 3m wide. (see Flashbang Grenade)

**"Non-lethal
ammo only?
Geez, Morgan.
You're really a
killjoy, y'know
that?"**
—Ripper jack

**PROPELLED/
HAND GRENADE TYPES**

**URBAN TECHNOLOGIES
SLASHER 75EB EACH**

Another lethal toy from the madmen at Urban Technologies! They've come up with an antipersonnel shell (available in 12 or 10 ga., 25mm, 30mm, and 40mm shells) that strings monowire between two specially-weighted slugs. As the slugs travel, they spread apart, pulling the monowire taut and slicing everything that passes between them in half!

The Slasher delivers a single attack if it hits, doing 4d6 damage at 1/3 armor SP. The only difference is the length of the monowire...the 12/10ga has a 1m wire, while larger shells have longer wires (25mm= 2m, 30mm= 2.5m, 40mm= 3m wire). The shell can attack any target in that area, similar to a shotgun blast.

**SPLATHELL (10EB PLUS
COST OF SPLATBALLS)**

One of the most unique riot control weapons to ever come down the pike, the SplatShell is a submunitions dispenser of a different sort. Loading 20 16mm splatball rounds into a special sabot (for 30mm/40mm launched grenades), the SplatShell can spray a 10 meter area with your favorite splatballs...virtually guaranteeing a hit!

The SplatShell is treated just like a shotgun blast, but all pattern sizes are doubled (2m at Close range, etc.), and any target will be hit with 1d6 splat balls...which can be of any type, but must be selected ahead of time. Munitions can be mixed... Referee's discretion as to which types hit whom.

WEAPONS

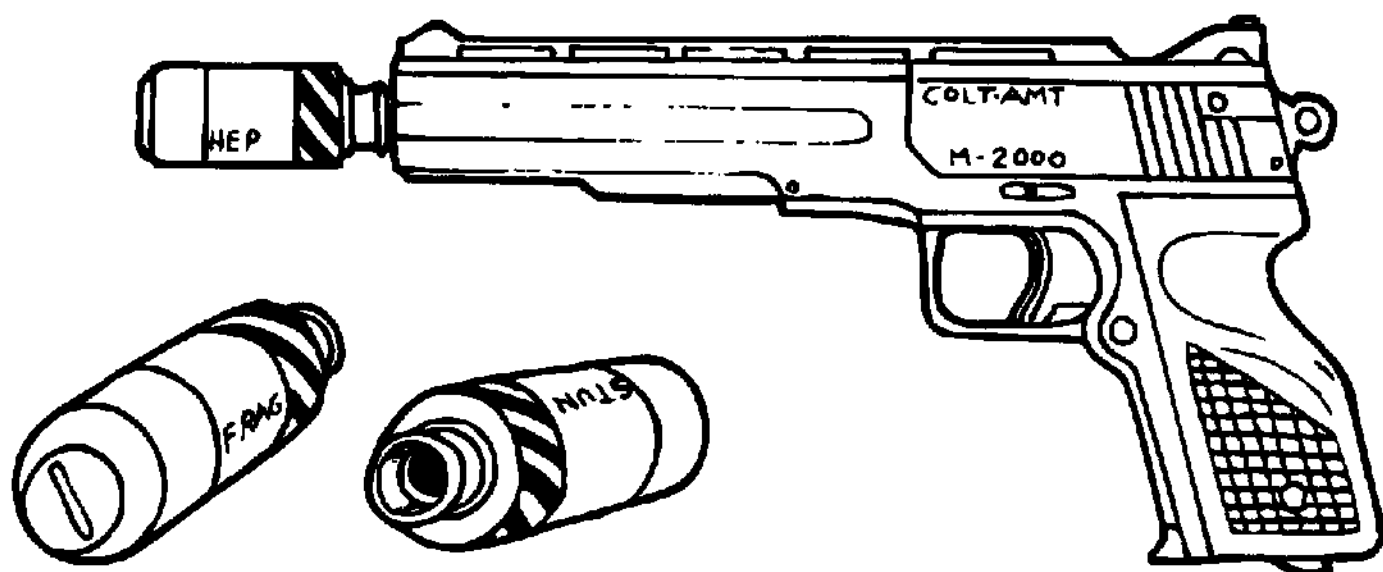

MILITECH 25MM PISTOL-GRENADES

15-30EB EACH

These are similar to DCR's rifle-fired grenades, but they are designed to be fired from pistol-caliber weapons. Any pistol or submachinegun's barrel can be fitted with a Militech-produced muzzle adaptor (200eb) in the appropriate caliber by a weaponsmith or techie (for about 50eb). The adaptor's bullet trap design allows the shooter to fire a conventional round to launch the pistol grenade up to 100m away. These small, barrel-shaped (25x50mm) projectiles carry warheads with capabilities equal to standard 25mm Mini-Grenades. Note: Pistol-Grenades cannot be launched by weapons of less power than 9mm, and 9mm through .45-caliber weapons will only have an Extreme Range of 30m! .357, 10mm and other, more powerful rounds will have an Extreme Range of 100m. Bullet trap launcher cannot be used on guns with ElectroThermal Enhancement.

GRENADE TYPE	LONG RANGE 9MM/.45	LONG RANGE .357/10MM+	BLAST RADIUS/DAM	COST EA.
HEP (Cratering) - Damage is 1/2 real, 1/2 stun only; armor has no effect and is damaged 2 levels.	15m	50m	- /5D6	30eb
INCENDIARY - 4D6 first turn, 2D6 second turn, 1D6 third turn; flammables in 1m radius burn. Soft armors reduced two levels/hit.	15M	50M	1M/ 4-2-1D6	30EB
OFFENSIVE FRAG - High-explosive fragmentation; very messy in closed areas.	15M	50M	3M/5D6	25EB
DEFENSIVE FRAG - Reduced explosive; safer for use in tight confines (like rooms, hallways, etc).	15M	50M	3M/2D6+1	20EB
SMOKE/TEAR GAS - See CP rules for clouds; Tear Gas causes tearing & -2 REF, Smoke can't be seen thru.	15M	50M	3M/VARIES	20EB
CONCUSSION - 3D6 damage is stun only, armor protects at only 1/3 effectiveness.	15M	50M	4M/3D6	15EB
FLASH BOMB - 1/2 Stun Save per person with -4 to REF & Awareness for 5 turns.	15M	50M	5M/-4REF/AWA	15EB

MICROMISSILES 50EB EACH

75EB FOR ANTI-ARMOR, 200EB FOR HEP

CYBERLIMB LAUNCHER (900EB):

HVY +2 * P 4D6 4 2 UR 200M

These miniature missiles are explosive-tipped rocket-propelled rounds with heat-seeking guidance and steering vents. They can be programmed to track objects by their specific IR signature (vehicle engines and human body heat are the most common choices), and explode on impact. The missiles are self-guided, and once locked onto a target they can follow it through one direction change of 90 degrees or less, giving them the ability to track around corners and obstacles (with a 3 in 10 chance of losing the target). Attacks are resolved in the following manner: first, the firer makes an attack roll, adding the Missile's +2 accuracy and ignoring cover and line of sight modifiers. If the attack roll is greater than the difficulty for the listed range, then the missile has hits its target. If the attack fails, then the firer rolls 1D10: on a 4-10, the Micro-missile corrects its path and a second attack roll, just like the first, can be made. A failed roll means that the micromissile was distracted and struck something or someone else at random, with no possibility to hit the target (use the Grenade Table on page 89 of *Cyberpunk 2020* to determine where the missile went). However, if your first shot misses your target, you may always fire at him again with your next shot(s) — even if he's under complete cover! Micromissiles have a minimum range of 10 meters, and they must be aimed at a partially exposed target — if they are fired blindly they will fail to initialize a target and will fly in straight paths like normal projectiles. Micromissiles normally do 4D6 damage in a 2m radius, but Anti-Armor Micromissiles (which treat the target's armor as 1/2SP, 1m radius) are available for a 50% increase in price. Missiles can be fitted with HEP warheads for 4x normal price. (4D6+4 damage, no radius; effects equal to S&W Model F)

SCATTER GRENADE 70EB

GRN O P C SPECIAL 1 1 VR
This grenade closely resembles a standard frag grenade. It has a 6 second delay after the pin is pulled. When the grenade discharges, it fills a 5m radius with smoke and harmless particles. The cloud is not only impenetrable to normal sight, it also makes IR and thermal imaging useless. The cloud lasts for 5 rounds in calm winds.

STENCH BOMB 20EB

Best weapon to clear a room with. Few, if any, can stand the putrid odor that emits from the bomb after activation. The cloud covers a 5x5m area and sticks to any surface. Surfaces must be cleaned to remove the odor.
Note: All those in area of effect not in protective gear (gas mask, nasal filters, etc.) must make a Very Difficult COOL or BOD check or leave the area.

FLASHBANG GRENADE 40EB

GRN O P P 4D10 (STUN) 1 1 VR
The perfect weapon for those delicate jobs requiring that the target be returned alive. Put two or three of these babies in their laps and watch 'em drop. No one can stand up to a concussion blast as well as three 1,000,000-candlepower flashes delivered in under a second. Even the most borged-out loon gets bounced around when a flashbang goes off in his lap. Minimal damage is accrued to surroundings and no permanent structural damage is incurred. The only thing you need to worry about is the bill from the glass men.

The flash effect is similar to that of Flashbulb (*Chrome Book*, pg.35). Soft armor has NO EFFECT against the stun damage; hard armor is at 1/4. Total time out is 1D10 minutes. Flash affects anyone who looks at the blast. Concussion effects all in 5m diam. circle. Glass is shattered up to 10m away if in an enclosed area, like a building.

SPRAYPAINT GRENADE 20EB

Good for the 'punk with a sense of humor. Upon any sharp impact the grenade will "detonate," sending paint all over a 3m area. Paint comes in 15 vibrant colors.
Note: Can blind a target for 1D6/3 minutes if caught dead center of "blast".

WEAPON MODIFICATIONS

NINE-ELEVEN CHIP 175EB : SECURITY CHIPPING

250EB

Now you can rely on the cops.

How likely is it that the police will even know about, let alone respond to, a firefight which you happen to get mixed up in? With the Nine-Eleven chip, it's a sure thing! This modification to your handgun (which does not require a smartgun interlock) installs a small, high-power cellular phone-link which calls the local police (or anyone else you choose) the instant you pull the trigger. Law enforcement agents (or whoever you have selected) are almost guaranteed to respond within 1D10+2 minutes. GMs' discretion on how likely the cops are to respond. **Note:** do not expect any help if you use this item in the Combat Zone.

- **Keep your gun out of the wrong hands.**
- This aftermarket chipping for your smartgun establishes a coded lock on the weapon's firing mechanism. In order to use the weapon, you must first jack into your weapon and then "think" the correct password or combination to the gun's on-board computer. Only after the correct code has been given will the weapon operate. A Very Difficult (25) Electronic Security roll is required to break the lock.

GUN-CAM 100EB

This modification to your handgun (which does not require a smartgun interlock) mounts a tiny digital camera aimed parallel with the barrel. Whenever your gun fires, it takes a picture, giving you instant evidence for your self-defense plea. Its internal memory can hold 10 "shots" to aid in your defense, downloadable to any computer or display system. **Note:** many states now require that registered guns have Gun-Cams.

ELECTROTHERMAL AMMO ENHANCEMENT (50% OF WEAPON'S BASE COST)

Overcome the laws of physics! The maximum speed a bullet can be accelerated with gunpowder (around 6,500 feet per second) and the pressure spike created by a gunpowder gas explosion have always limited the capabilities of firearms technology—until now. Take your firearms beyond the limitations of the last century with ElectroThermal Enhancement. By modifying the breechlock, adding a micro-battery pack, insulating the weapon and using high-tech ammunition, a firearm's muzzle energy can be doubled! (Without blowing apart, too!) ElectroThermal (ET) ammunition has the same cartridge dimensions as regular cased loads, but instead of a primer and powder, ET guns employ an electrical pulse and a liquid working fluid. This liquid can be anything from methanol to water, but it must be primed with around 100,000 amps. This energy pulse causes the liquid to combust, changing state to plasma, which pushes the bullet down the barrel at incredible velocities. ET guns can also modulate barrel pressure with a throttle, controlling the energy in the priming process with a safe time/pressure trace. As an example, a 5.56mm bullet has a muzzle energy of 1330 foot-pounds, while an ET 5.56mm has a muzzle energy of 2764 ft-lbs! ET enhancement insulates the gun against electrical surges, modifies it to accept a 100-shot battery (10eb each), and replaces the hammer with an electrode: the result is that the gun does 50% more damage! the procedure can be performed by many arms factories and some gunsmiths (**Poor** availability, Weaponsmith vs. 25), usually costs a couple of hundred euro, and adds .5kg to the weapon — note that only weapons which use cased ammo can take advantage of ET enhancement (this generally means 20th-century guns). ET ammo costs 2x normal, and can be combined with some of the other ammo types (AP, etc).

TEAMS

lifetime
escort
service

ES



ORION

AUTOJOKS

"Hire some help?
Hell no! I can
handle those
Arasaka goons myself!"

**—epitaph of an
unknown Solo.**

"No, I won't cut our
price in half. Do
you want only
half of a daughter in exchange?"

**—Orion Contract
Agent**

SAFETY IN NUMBERS

For those times in life when a single street ronin isn't enough, or the giants of Lazarus and Arasaka just aren't *subtle* enough, only a small team of dedicated professionals will do.

Teams can provide a discrete "escort" for a safe (and enjoyable) night on the town, to secure, expedited, shipments anywhere in the world! For employment opportunities or assistance, these organizations may just save your life. Well worth the Euro at any price!

TERMS



SPHERE...

IF IT

NEEDS

TO GET THERE;

ANYWHERE.

Sphere Courier is the world's finest transportation company. From LEO to Lyon, Tycho to Topeka, secure, prompt delivery is our specialty. Other companies may compete, but none can compare. Worried about your shipment? Sleep tight—call SPHERE.

We move any size package, from a data chip to a mainframe. Our staff will help with planning, threat determination, packing, and handle all security while in transport. Our overland trucks use state of the art ECM suites, anti-personnel weapons and real human pilots to ensure against hijackers. Our aircraft are all rated at Mach 2 or better, and are under full human control. Codelock Safeboxes™ protect all but the largest of our cargoes with armor to SP40. Self-destruct is standard. A typical SPHERE operation includes a netrunner or expert system to check for spooks, a driver/pilot, an ECM tech and a security guard. On larger vehicles a weapon operator may also be required. Crews differ slightly on air cargo and LEO flights but operational capabilities remain constant.

While there is no standardized rate system

(threat, size, distance and mode of transport all affect the cost of service), it is however, safe to assume costs will fall within three basic price ranges. **Low threat cargo** costs about 50eb per kilo, overland. **Air Cargo** starts at about 120eb per kilo and **LEO** at 300eb (down) and 1500eb (up), per kilo. **Threat level increases** cost by 2-50 times. Delivery distances greater than 6000 kilometers double the price (except for LEO travel).

SPHERE has offices in every major city and arcology in the world (define major city as anything over 100,000 ppl.), with its headquarters in Capetown, Azania. Feeder service is available in all other locations at no extra charge, just call OSPHERE-CAAZ and one of our representatives will consult with you free.

SPHERE. Expensive. Cocky. But the best. How do we know we're this good? Our customers keep coming back.

Background Notes: SPHERE became a reality in 2004 when several antiquated courier services (DHL, Roadway, etc.) were co-opted by famed

corporate raider, Peter X. In one of the most widely televised corporate eliminations in history, sixteen major stockholders were assassinated at the 2005 World Cup Soccer semifinals. (The event was sponsored by Federated Transport, a progenitor of SPHERE. In 2010, the company was sold to the employees for an undisclosed sum.)

This is not the only scandal associated with SPHERE's checkered past. The company is still trying to live down its nickname, *The Blackball Express*, coined by a pirate vidchannel after a highly publicized incident where a mid-level EBM manager tried to mail himself to Haiti (after he was blackballed and targeted for "retirement"). The executive was delivered; he was even still alive, and almost made it across the street before he was retired (earning the corporation the sobriquet *Blackball Express*. The Company's logo, a black sphere, was not a help here).

SPHERE DRIVER/REPRESENTATIVE

INT 6 REF 8 TECH 6 COOL 6
ATR 5 LUCK 6 MA 5 BOD 7 EMP 8

SKILLS: Family+3, Awareness+5, Melee+2, Rifle (or SMG)+3, Drive+6, Pilot (varies)+2, Pilot(also varies)+2, Basic tech+4, Wilderness (or Urban) Survival+2, Brawling+4, Athletics+4, Education+3, Math (or Business Sense)+2

EQUIPMENT: Sternmeyer S-10 w/50rnds, Lt. Armorjack, Notebook Computer, Personal Commlink (as in C-TEAM), Delivery Vehicle (varies).
Cyberware: Neural Processor with Vehicle-link, Dataterm-link, Plug set; +1 Kerenzikov; Chipsocket; Cyb-optics with IE, TE, AD, LL.



It's a dangerous world out there. Everyone has enemies, and no one has the time to watch them all. Today's security problems call for tough solutions. For thousands of people, Lifetime Escort Services provides the solutions for their day-to-day security needs. And we can help YOU.

Our bodyguards and security teams cover nearly the full gamut of armed force. From a sophisticated lady or gentleman companion (who won't raise an eyebrow at that luncheon meeting); to a full-time staff of uniformed bodyguards, capable and obvious, LES gives you all the options for personal security and peace of mind.

And you can count on us to be discrete. A single escort can be disguised as a romantic involvement, a long time friend, a personal secretaries or chauffeur. Or, if you prefer, an obvious and heavily armed personal Cyborg Attendant can be provided. (Why does every nineteen year-old netrunner in the world think that it's really cool to have your own full-on 'borg as a doorstep?)

Most security needs are met by the aforementioned options: the single escort (the most common); the three man team: escort, driver, ECM specialist, and the security squad (coordinator, driver, ECM specialist, technician, three escorts and a netrunner). Daily rates run about 150eb/day average for a single escort, with experts running from 400-20,000eb. A three man team will start at 4000EB a day. A car will cost between 75eb (for a basic sedan with no extras, like the T-C Omega; CP2020, pg.171) to about 500eb (for a limousine, or a low-end APC). AV-4's start at about 800eb per day. A fully equipped security team with armored vehicle (usually an armored van; SP20, SDP200, tires SP20, SDP20, glass also armored to SP20. The

TEAMS

van seats ten and is equipped with all-around firing ports and a top hatch with weapon mount.) Starts at 2000eb per day for an average unit. As with all services, highly trained experts with big reputations will cost a lot extra (4-20 times). Some discounts may apply for larger groups but most local escort services top out at forty operatives. Weekly rates for the three options are 900eb, 2400eb, and 12000eb. An easy formula for weekly services is buy six days, get the seventh one free. The easy monthly formula is half-off the fourth week. This sets monthly rates at 3200eb, 8800eb, and 42,000eb. Use the same formula for long term vehicle rental. These rates assume you pay for all room and board. There is also usually a slight surcharge on AV fuel and maintenance (long term rentals or excessive use only).

Local talent is critically important in security work and as a nationwide franchise specializing in the use of local operatives, LES has the edge over other out-of-town security forces (if your high-power, imported Meat Boys don't know what local trouble looks like, it makes their job that much harder). For discretionary assignments, operatives can also easily be brought in from offices outside your region.

Conveniently accessed via Data Term, through our franchised storefront operations, or our high tech Regional Clearing Exchange Offices—your local office is always nearby.

Reliable, bonded and discrete. Lifetime Escort Service. Count on us.

AVERAGE ESCORT (SOLO)

INT 5 REF 7 TECH 5 COOL 6
ATR 4 MA 6 BOD 7 EMP 5

SKILLS: Combat Sense+5 Awareness+3, SMG+3, Handgun+4, Social+3, Human Perception+4, Intimidate+5, Elec.Security+3, Personal Grooming+3, Wardrobe & Style+2, Driving+4, MA (judo)+4, Melee+4, Streetwise+5, Fast Talk+3, Education+2, First Aid+2, Hide/Evade+3

CYBERWARE: Nasal Filters, Rippers, Cyberoptic w/TimeSquare Plus and Vis. Rec. chipware is good idea; maybe some Fashionware. Remember, the bodyguard/escort is a people person; having low/no empathy is usually a bad idea

EQUIPMENT: Colt Alpha/Omega with silencer and laser sight in shoulder rig w/3 mags, HK MP-2013 with laser sight in breakaway holster w/5 magazines, Monoknife, Tonfa, Gibson Armortrench (SP14, EV 1), Eji action jeans, Arasaka-Nike TacTrainers.

WHEN YOU
NEED MORE
THAN A MAN TO
GET THE JOB
DONE.



When you need more than a man to do the job, C-TEAM gives you more than a man. At C-TEAM we supply top-of-the-line cybermercs for a price you can afford. A team of six men will give all the flexibility and force options of most units twice the size.

Our standard six man team consists of a Team Leader (with over five years of experience, guaranteed!), a comms/ECM expert, three line infantrymen (cross trained or chipped in a specialty you choose) and a heavy weapons expert/certified demolitions tech. Most special equipment is included. However, due to recent de-

TEAMS

mand, air-mobile teams have a slight surcharge. Many other types of cyber teams are also available. Air Cav, ground support aircraft, full-plated bodyguard teams, even custom operatives made to order. C-TEAM does it all.

C-TEAM was founded in 2015 by Len Carrington, a highly decorated officer in the U.S. Air Force who has served in cyber-augmented forces since the Pittman 2 project in 1999. An expert in small unit tactics and counter-insurgency with over thirty successful missions in the Central American Conflicts, Carrington saw a definite need for the kind of tough soldier that the big corporations would not employ. C-TEAM was his solution; it's probably yours, too!

To contact C-TEAM, just dial CTEAM-2NEB on your local dataterm, or feel free to visit our

training center in Omaha, Nebraska. Offices or representatives are located in most American cities; no matter how remote your location, we can have a team on duty in 48 hours (some charges may apply, custom teams are exempt). Periodically, supply exceeds demand, so make your reservations early.

A standard six man team starts at only 1000eb per day or 3500eb weekly with extra weeks as low as 3000eb. Monthly rates can start at 12,000eb and only 11,000eb per extra month. Air-mobile units start at 12,500 per week plus fuel with a standard AV-4; a pilot and a technician are also included. Monthly rates start at 45,000eb flat rate, fuel extra. Supply and Transport charges may apply. All rates subject to availability. For custom teams or larger units please call for a quote.

STANDARD C-TEAM LEADER (SOLO)

INT 6 REF 10 TECH 5 COOL 6
ATR ? LUCK 5 MA 6 BOD 9 EMP 2

SKILLS: Combat Sense+5, Aware+5, Handgun+3, SMG+4, Brawling (or MA)+3, Melee+2, Weap. tech+3, Athletics+4, Rifle+4, Stealth+3, Cyber tech+2, Exp: tactics+4, Intimidate+2, Leader+3, Wild. Survival+2, Heavy Weapons+1

Equipment: Assault rifle w/15 mags, tactical computer, Sidearm w/5 mags, portable braindance unit, etc.

CYBERWARE: Neural Processor with Boosterware+2, Pain Ed., Weap. Link, Plug set x2; Chipsocket; Muscle/Bone Lace or Graft. Muscle; Nanosurg.; Cyb-optic x2 with IE, TA, AD, LL; Cyb-audio with RL, SC, SE, EH, LD; Cyb-arm x2 with THK, RJ, MSR, ARM, RPH (right) and THK, RJ, MSR, ARM, GRP (left); Cyb-leg x2 with THK, RJ, ARM, GRPF; Body Plating: SKUL, FACE, TORS

HVY WEAPON/DEMO TROOPER (SOLO)

INT 6 REF 11 TECH 7 COOL 8
ATR ? LUCK 7 MA 5 BOD 11 EMP 3

SKILLS: Combat Sense+4, Aware +5, Handgun+2, Rifle+6, Hvy. wpn.+5, Demo.+4, Brawl (or MA)+3, Weap. tech+4, Athletics+3, SMG+2, stealth+1, Exp: combat engineer+3, Oper. Hvy. Machine +2

EQUIP: Any SAW w/800 mnds, or Grenade Launcher w/25 mnds, SMG w/7 mags, demolitions kit, long range multichannel encrypted radiodetonator, etc. Σ-series linear frame, Metalgear.

CYBERWARE: Neural Processor with Boosterware+2, Pain Ed., Weap. Link, Plug set x2; Chipsocket; Nasal Filters, Independ. Air, Adren. Boost; Muscle/Bone Lace; Nanosurg.; Cyb-optic x2 with IE, TA, AD, IR; Cyb-audio with RL, SC, SE, RD, LD; (optional) Cyb-arm with MSR, ARM, MML

TEAMS

"Meatboys are fine for some things...like getting perforated. If you want survivability, choose the Metal."

Anonymous C-Team Squad Leader

COMMO/ECM TROOPER (SOLO)

INT 7 INT 10 INT 7 COOL 6
ATR ? LUCK 7 MA 6 BOD 8 EMP 4

SKILLS: Jury Rig+5, Aware+5, Basic tech+5, Cyber tech+2, Teach+3, Educ.+3, Electronics+4, Weap. tech+1, Elect. security+4, ECM+5, Exp: commo+3, Exp: cryptology +3, Math+3, Remote Sys. Op.+3

EQUIPMENT: Assault rifle w/10 mags, tactical computer with crypto software, electronic maintenance tools, drone-control terminal (optional), cybernetic repair kit(optional), weapon tool kit(optional)

CYBERWARE: As Team Leader without the Cyb-leg mods, adding a special radio-uplink/ECM unit in all leg spaces, instead. No THK, RJ in Cyb-arms. Radio/Cellular Booster Station (Interface #2, pg. 19): full radio-phone station, sat-capable; the equivalent of an Army backpack radio. 160 hours operation on a charge; has power-tap extension, signal-boosting fins; can be attached to portable antenna. Comes with standard channel-jumping encryption. Uses all spaces in one standard cyberleg; 2950eb. An equivalent electronic counter-measures emitter is mounted in the other leg; 2650eb

COMMON TROOPER (SOLO)

INT 5 REF 9 TECH 5 COOL 5
ATR? MA 5 LUCK 5 BOD 8 EMP3/4

SKILLS: standard Solo career package with all at +4

Equipment: Assault rifle w/20 mags, 1 RAW, 4 frag grenades, 3 smoke/gas grenades, etc.

CYBERWARE: Same as team leader without the Cyb-limb options: THK, RJ; x2 Wolverers instead of GRP/RPH; and no Muscle/Bone Lace or Grafted Muscle; Body Plating: SKUL and TORS only. All members carry a personal commlink (with global positioning, beeper), bayonet/utility tool (M-9), E-tool, field gear/supplies for 2 weeks, and a weapon cleaning kit. Armor is usually issued only to non-plated personnel.

"I assure you Mr. Henderson, one squad will be more than enough for this operation. You want the building standing when it's over, correct?"

Leonard Barton—C-Team contact Agent

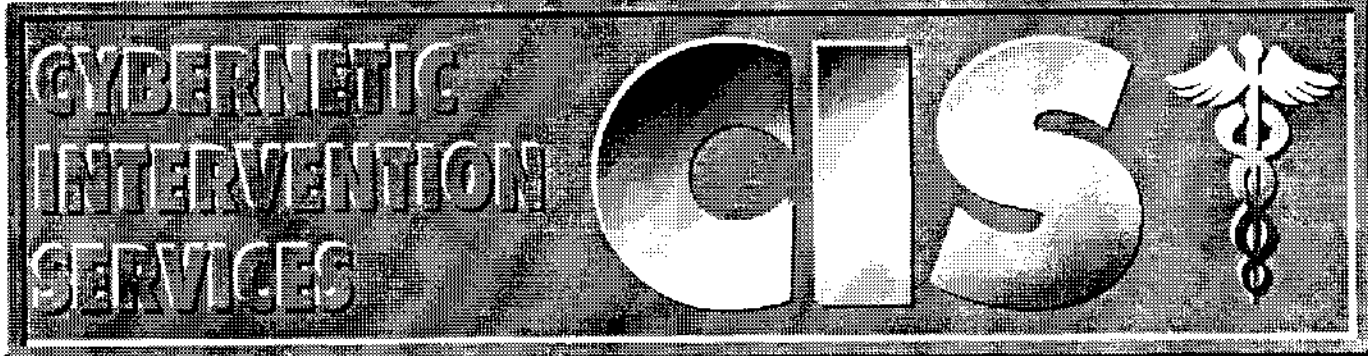

Cyberpsychosis. A word that strikes fear into the hearts of families across America. Each year, thousands succumb to its ravages. Until now.

When your friend or loved one finally goes over the Edge, we can prevent the final solution. Cybernetic Intervention Services is one of the most experienced innovators in the field of restorative intervention techniques. As a wholly owned subsidiary of C-TEAM International, we have more experience with C-Psychos than anyone in the world. And if we don't beat MaxTac, you get a full refund.

Capture is our first objective, but our services don't end there. Our state-of-the-art Cyberpsychosis Rehabilitation Center in Omaha, Nebraska, is one of the finest in America. Upon recovery, your friend or loved one will be immediately jacked into the finest virtual world available. While their mind is being healed by one of our certified therapists, a team of surgeons will remove the patient's cyberware and replace it with real biological parts. Only the patient's Neural Processor and coprocessors (if any) will remain (CIS does not remove neuralware, internal organs, nanotech of any kind, or anything that may cause harm to the client. CIS does not accept any liability for cortex bombs or tailored binary toxins). For a small additional fee, we can also install a T-Maxx "cyber liver" to limit the patients' use of controlled substances. After a nine-week stay in our virtual therapy and regen facility, we will deliver him or her to you anywhere in the U.S.A.

CIS is automatically available in any city with a C-TEAM office, and can be on station anywhere in the world in 24 hours. Our teams are fully-equipped with a tactical vehicle (usually an AV-4) and state of the art weapons and restraint equipment (EMP gre-

nades, Static field nets, Gauss projectors and other non-lethal equipment).

So when a loved one calls out to you from the depths of cybernetic addiction, call us. Cybernetic Intervention Services. We Care, Because You Care. Call us at CTEAM-2NEB for a quote.

Game Background: A Standard CIS contract calls for a *minimum* charge of 250,000eb in the Continental U.S.A. There is an extra charge of 50,000eb outside the Continental U.S. If you don't have a verifiable credit rating, then pay up-front. If you don't have the cash for a full rehabilitation, the client can be captured and delivered to you (inside the U.S.) for only 100,000eb. How you control them once they wake up is not CIS's problem. If the rehabilitation requires an extraction, then the cost triples. The phrase, "at what price friendship" comes to mind...

CIS automatically co-opts the offending hardware once a capture has been made. An astute customer should ask for credit to the account for all cyberware removed (or the company will take it anyway). There are no refunds; as a matter of fact, the only thing that C-Team offers refunds for is a missed target. As the contract reads, "If, for any reason we fail to locate our client, or the client is located and subdued by any other party, CIS agrees to refund the full amount within 24 hours."

Each eight man team has the same makeup as a standard C-TEAM, with a variety of chipped skills, and the extra equipment below:

EMP GRENADE (CHROMEBOOK 1, PG.47)
GRN O P R ELECT. 1 1 VARIES

These grenades are usually deployed as a rifle grenade, or a limpet-type round. The Intervention Team

"WE CARE, BECAUSE YOU CARE."

TERMS

is very cautious about using these, as they are almost as heavily-augmented as the client.

BIOTECH-ASKARI MOTION RESTRAINT BOMBS (CHROMEBOOK 1, PG.48)

EX 0 P P SPECIAL 1 1 UR

Every line trooper on a Team carries 3 or 4 of these. The bigger 'borgs rip right out, but they're good for subduing lesser psychos with a minimum of fuss.

SHARPWIRE NET UNDER-BARREL MOUNT (INTERFACE #1, PG.26)

EX +2 N P NET 1 1 STD 10M RANGE 450EB/NET

A one-use cannister mounted under an assault rifle; it launches a macro-filament wire net. If target fails Dodge skill roll (or Athletics at -1), MA is reduced to 0. If an attempt to escape is made using force, divide target's BOD by 2 (round up); apply this as damage (1/2 armor, don't reduce penetrating damage) as filament cuts in. If target uses cutting weapon to escape, it will take 12-REF in combat rounds.

PURSUIT SECURITY, INC. WEBGUN (SEE WEAPONS SECTION, PG.37)

TECHTRONICA M-40 PULSE RIFLE (SEE WEAPONS SECTION, PG.39)

GAUSS FIELD PROJECTOR EX +2 N R MAG. FIELD 10 1 ST 10,000EB

This weapon projects a magnetic field strong enough to disrupt the electrical signals of the brain. It is quite large (200kg), and is usually mounted on a vehicle or set up in a trap. The shots are charges lasting about 30 seconds. The disorientation lasts for (BOD-2)x10 minutes. If the target can make a Strength Feat or Dodge/Escape skill roll of 25+, he can throw himself out of the field during the first second of the shot (the chances of that are minimal).

WARNING: THE GAUSS FIELD UNIT WORKS ON EVERYBODY—BE CAREFUL

ORION

America: held hostage. Terrorists, psychopaths, disgruntled employees, and the gangboy streets-cum; they all hunt us relentlessly. You forget to check the door lock one night and your children disappear. You trust the security at an expensive hotel, and the maid kidnaps your top particle physicist. Who can you call, when the spectre of corporate kidnapping and terrorist extortion threatens your family or business?

Call us. ORION—the Hunters. We use the most talented people in the extraction business to do the job right in any kind of "hostage-rescue" situation.

Founder Orion Hunter is a decorated veteran of SOG Panama and has served in over twenty successful extraction and hostage-rescue missions. Shortly after Hunter's retirement, MA&F

Corporate Director Howard Merrill was trapped in his home by a group of the infamous "Iron Sights" street gang. Assembling a dedicated team of experienced solos, Hunter swiftly accomplished the rescue with minimal loss of life. That team has become the core group that has evolved into ORION's elite cadre of experts; a team that we can put to work for YOU.

In the rare event that ORION cannot handle the type of operation that you need (or you prefer to utilize your own corporate extraction teams), we can still help. We maintain a worldwide database of operatives and can construct any type of specialized team for you. Air assault—no problem. Underground hideout—it's handled. At ORION we never say die. ORION (and its sister companies; C-TEAM

TEAMS

and Cybernetic Intervention Services) have offices across America. We can be anywhere, ready to go in twenty-four hours, guaranteed. Contact us; ask one of our efficient consultants to take down all of your information and compile a mission prospectus.

Once the victim is located, we move swiftly to the planning phase of our contract. We keep you involved at each step. Even though our mission planners are the best in the world, only you will be able to tell us about the client. How will they react? Are they expecting rescue? How can we prove to them that we are on their side?

All missions are accomplished with state-of-the-art weapons and equipment. An aerodyne with on-board trauma unit is standard. When the mission is complete, we can deliver the target directly to you, anywhere in the world. Most operations are completed in less than 72 hours. Your associate or loved one will be returned to you safe and sound. We guarantee it.

Initial investigation is only 10,000eb. Low-threat rescues, like gang abductions and white slavery, start at only 20,000eb (Continental U.S.) and 30,000eb (Western Hemisphere). Some missions cost more, but all are tax-deductible.

Game Notes: Although Orion's "hostage recovery" pitch sounds altruistic, the flip side is that they also specialize in corporate kidnapping as well (this is as bold as a company specializing in extraction can be and still operate legally). Why go to this kind of trouble when the big corporations, like Arasaka, have their own black ops teams? It's simple; Arasaka won't take outside clients. No one in Corporate America wants to admit that they actually perform extractions on a regular basis. They certainly aren't going to risk their reputations for a third party.

Deniability and secrecy are very important in high-level extraction, and most Corporations work outside through services like this one. The best operatives are freelance and they don't work cheap. They live in the shadows, work through double cut-outs, and stay invisible. Most of the time the Corporations consider them a necessary evil, but paranoia rules. A full biosculpt after every mission does wonders for your survival.

If you really want to extract a "Top Man," you had better have deep pockets; these operations cost between 1.5 and 2 million eb depending on the tar-

get and the threat. Terms will be dictated in extreme secrecy and through many levels of cutouts. You won't see these people or talk to them. You won't pay them until delivery. You'll probably only talk to their fixer's fixer. You'll pay them in gold or other stable non-currency.

They won't even leave a footprint in the sand.

TEAM LEADER (SOLO)

INT 9	REF 10	COOL 9
TECH 6	ATR 8	LUCK 6
MA 8	BOD 10	EMP 5

Skills: Combat Sense+7, Awareness+6, Handgun+4, MA (Aikido)+6, Melee+4, Weap. Tach+3, Rifle+3, Athletics+6, SMG+5, Stealth+7, Exp: Extraction+4, Streetwise+5, Exp: Tactics+4, Leader+6, Elect. Security+4, Endurance+4, Social+3, Wardrobe/Style+3, Grooming+3, Dodge/Escapes+4, Hide/Evade+7, Education+4, Math+2, Corporate Policy+4, Business Sense+3 [Carp. Policy and Busin. Sense skill are in Solo of Fortune, pg. 31]

Cyberware: Neural Processor w/Vehicle, Smartgun, Dataterm links; Speedware +3, Tactile and Olfac. boosts, Pain Ed., Plug Set x2; Chipsocket; Skinweave and Lifesaver weave, Musc./Bone Lace, Tox. Binders, Nanosurg.

Equipment: Notebook computer, cellular phone, Arasaka WSA smartpistol w/silencer and 3 extra mags, Smartgoggles w/Targeting and Lowlight; CommLink, Tanaka Suit w/ matching briefcase, Kendachi Sword Cane, low impedance interfacecables, Metalgear, Militech Smart "Bulldog" CAW w/ 5 mags(saboted slug)

TEAMS

"They kidnapped my wife. By the time I called Orion and got her back, she needed a full body rebuild. So I hired Orion to get the terrorists out of a Mossad prison. And hand them over to my wife and her bodyguards..."

—An EBM Manager

MEDTECH

INT 8 REF 8 COOL 8 TECH 10
ATTR 5 LUCK 6 MA 9 BOD 8 EMP 6

SKILLS: Medical Tech+8, Aware.+6, Diagnose+8, Education+6, Cryotank Ops+8, Library Search+6, Pharmaceuticals+5, Zoology+3, Cyber tech+6, First Aid+5, Biology+6, Exp: Loyalty Devices+6*, SMG+3 (chip), Melee+3 (chip), Exp: Surgery+4 (chip), Stealth+3 (chip), Basic tech+4(chip)* This skill specializes in the devices implanted to prevent disloyalty/extraction

CYBERWARE: Neural Processor with all links except Cybermodem, Tactile Boost, Plug Set x2; Chipsocket; Skinweave, Tox. Binders, Nanosurg.; Cyb-hand w/Medical Module (Interface#2)

EQUIPMENT: Malorian Smart SMG w/5 mags, Commlink, MedicGear combat med armor, Smartgoggles (IE,AD,ME,TH options), portable trauma unit and cryotank (in get-away vehicle), interface cables

BASIC OPERATIVE (SOLO)

INT 7 REF 10 COOL 8 TECH 7
ATTR 7 LUCK 6 MA 8 BOD 10 EMP 5

SKILLS: Combat Sense+5, Awareness+6, Athletics+5, Handgun+3, SMG+4, Rifle+6, MA (Thai)+5, Melee+4, Weap. tech+5, Stealth+6, Endurance+3, Basic tech+3, Streetwise+4, Grooming+2, Wardrobe+2 Education+2, Math+2

CYBERWARE: Neural Processor with Weap. Link, Plug Set x1; Chipsocket; Graft. Muscle; Rippers x2

EQUIPMENT: Metalgear, commlink, Smarted FedArms Lt. Assault-15 w/10 mags AP ammo, 4 Dazzle, 4 Frag, 4 Sonic, 2 EMP grenades

NETRUNNER

INT 10 REF 9 COOL 8 TECH 9
ATTR 7 LUCK 7 MA 6 BOD 7 EMP 6

SKILLS: Interface+8, Aware.+8, Sys.Know.+8, Composition+6 Program+9, Basic Tech+5, Electronics+5, Cyber Tech+5, Cyberdeck Design+7, Education+6, Math+6, Elect. Security+6, SMG+3 (chip), Stealth+4 (chip), Grooming+3, Wardrobe+3 (chip), Exp: Computer Systems (mainframes)+4 (chip)

CYBERWARE: Neural Processor with all links, Plug Set x3, Pain Ed., Tactile Boost, Speedware +3

EQUIPMENT: Cybermodem Utility Suit with custom cellular combat deck, armor t-shirt, metalgear (legs), backup custom portable deck, Viper SMG w/5 mags

AUTOBOOKS

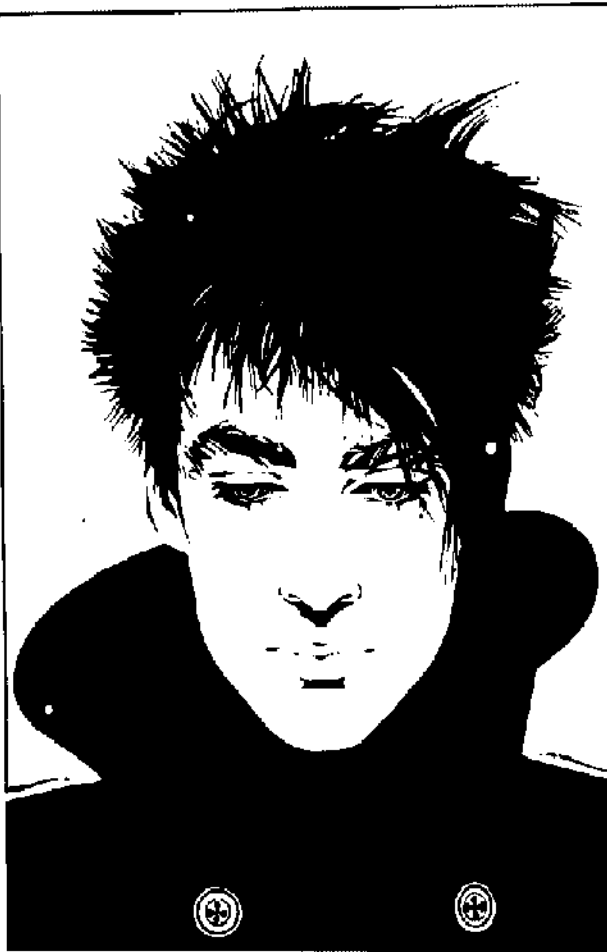

"Why do all the Meat Boys get the credit? Sure, they got smartguns, but they haven't got the right smarts. They can pull trigger on a guy, or even a bunch of guys. They don't have any real power. I do; I can make you wish you were dead. I mean, we're sitting here in this nice cafe, havin' tea. In about three minutes, I can make your car, your wife, your Cred-Card... disappear. Pfft, gone, see ya'. We can do anything and you can't even touch us. Sure, you can do me, but the Joks will know and we look after our own." She ends the diatribe to light a cigarette.

"The Net is a wild place, a wilderspace/ So much can happen in the 'face/ The speed of it, the light of it/ My brain disintegrates bit by bit/ IN...THE...NET..."

"IN THE NET", THE SINNTHETIKS FROM THEIR DISK CHAINSAW INTERFACE, ©2018, INTERROGATION RECORDS.

You really didn't think your boss was serious. You are sitting across the table from a skinny girl, about sixteen year sold. Her techhair is iridescent green and she wears this ugly blue armorjack with a picture of Gibson on it. Her six plugs make a neat row across her forehead. Your boss needs a shrink. This kid doesn't stand a chance of breaking the other guy. She probably watches too much vid. But hey, you're sitting here, so let the kid feed you her pitch....

"So this run, you got a shopping list or you just want I should crash the system. Hey! You listening?" You turn your datacase around, showing her the screen. She blinks a couple of times as she looks at it, then you hit the erase macro. "This is gonna take some time, The files are ease but that 'frame has pretty thick ICE. I'm gonna'

TEAMS

need 15K up front for software. The balance will run you, let's say 145K on delivery."

Yeah. Right. You smile. "No deal," you say. "The price is 100K on delivery, take it and that's that. The time frame is sixteen hours. Seventeen and the deal's off."

She looks for a moment at you with eyes that seem inhuman, then she speaks. "Check. Sixteen hours, but the price just became 150K. Time is money. Without a day to plan, this is gonna' be a stone bitch." She gets up and sticks out her hand, you nod and smile, shaking it. "By the way, this whole meeting has been recorded," she says. "Try to stiff us and you get to become a deniable asset, on national television." As she walks away, you smile to yourself. The boss gave you a budget of 200K; if she pulls it off you are going to have a great vacation.

Meeting an AUTOJOKS rep is probably the toughest part of a desperate executive's life. These people don't advertise. They don't take out ads on the DataTerm. According to most fixers they're a myth. The truth is—no one wants to know the truth. That a syndicate of subzero netcriminals are hiring themselves out to the highest bidder...too freaky. But if you know the right kind of people (and ask obtuse enough

questions) you might get a call in the middle of night. A call not logged on your (or anyone else's) monthly bill. A call that will get the job done, for the right price (Ref's call).

Not quite a gang and not quite a mafia: AUTOJOKS.

The network sprang up a year ago, or maybe two. Some young kid was nervous about his first run. They say he asked an older Netrunner, some guy he once worked joeboy for, to keep an eye out. When the kid disappeared—so did the client.

An idea was born. Things are getting pretty tight now. Watching over each other in a kind of voyeuristic way. This isn't all "hearts and flowers;" everyone gets a cut. Older runners sometimes coordinate several contracts with the same company, cutting costs. Most AUTOJOKS sleep soundly. Sometimes being alone can really stink. Now, they never have to be.

Not all netrunners are AUTOJOKS. Most don't want to be that connected to other people. Some are asked and some just find their way. A side note: a new vid show that glorifies netcrime is getting decent ratings on 54. It's called AUTOJOKS; poser gangs are popping up already.

No camouflage like publicity.

A TYPICAL AUTOJOK (YEAH, RIGHT)

INT 10	REF 7	TECH 9
COOL 7	ATR 5	LUCK 7
MA 5	BOD 5	EMP 7-4

SKILLS: Interface+6, Aware.+6, Basic tech+4, Educ.+4, Sys. Know.+7, Cyberdeck Des.+7, Composition+5, Electronics+6, Programming+6, Math+4, Library Search+6, Streetwise+4, Wardrobe and Style+4, Culture+2, Elect. Security+3, MA (Tai Chi)+4(chip), Handgun+4 (chip), Melee+2 (chip), PhotoRAM chip, Stress chip, "Fish n' Chips" chip [Culture skill is in *Solo of Fortune*, pg.31]

CYBERWARE: Neural Processor with all links except Smartgun, Kerenzikov +2, Tactile Boost, Plug set x3, Pain Ed. (option); Chipsocket; Digit. Recorder, Contracept. Impl., various Fashionware (usually Techhair); Cyb-optics x2 with ME, IE, TS Plus, Vid. Imager. Some have Cyb-legs x2 (orbital crystal) with ARM, custom CMD, LCD, HOL, TOLF (right), STDF (left)

EQUIPMENT: A ton of programs, Eji Armorjack SP14, Chanel handbag, Arasaka WSA pistol (in leg holster), spare magazines (in bag), CredCard, three complete passports and two driver licences, Frag grenade, a great deal of random junk.

FULL BODY REPLACEMENT

TOTAL CONVERSION FOR THE TOTAL CYBERPUNK

"There I was, trapped on the third floor of the burning apt-block—thick smoke and fire everywhere... I couldn't tell *which* way was out. A blazing section of ceiling had fallen on the last fireman who tried to rescue me. I figured I was burnt toast for sure, ready to flatline. Suddenly, the burning wall to my left exploded as a metallic form charged through it. Emergency lights flashed on its shoulders, and it marched straight through the inferno surrounding me. No foolin, choomba, this thing just scooped me up like a mother collecting her kid. Before I knew what was happening, it leapt out the window and we hurtled to the ground. When I came to, it told me that her name was Samantha."

—*Johnny Silverhand.*

"Full Conversion—because sometimes meat just can't cut it."

—*Advertisement*

Borg is a four letter word. As early as 2005, various military forces were experimenting with fully cybernetic body conversions. It was during these early experiments that "Cyberpsychosis" was first identified and diagnosed. In 2020, "full borgs," as they are colloquially referred to, are becoming an increasingly common sight. Construction workers, fighter pilots, space explorers and even firemen are opting to supplant their human bodies with mechanical replacements which will help them do their jobs better. The full potential of this technology has yet to be realized, but becoming a full borg is far from a standard procedure.

Such a conversion is the ultimate step in cybernetic enhancement. By supplanting a skeletal system with a metal endoskeleton interlaced with a myomar fiber musculature, incorporating fully cybernetic limbs and covering the entire body with armor, you can become the "classic" cyborg of science fiction. A full borg can lift and throw a small car, tear down brick walls with his bare hands, and walk through machinegun fire. His body has effectively been fully replaced, giving him all the equivalent abilities and structural damages of cyberlimbs and more. He is reinforced and armored, with a full body SP of 25. His cybernetic nervous system and interlaced synthetic muscle fibers give him incredible reflexes and movement speed. Heavier combat models also utilize electromagnetic pistons, commonly referred to as "Hydraulics," which are stronger and faster. A combat borg is almost unstoppable, capable of withstanding massed machinegun fire and light anti-tank weapons. Full borg conversions are still rare (and frequently illegal) new-tech. One reason for this is that by the time the

FULL BODY REPLACEMENT

arduous and expensive process is over, much of the intangible "humanness" of the person is lost, sometimes creating a cold, merciless, machinelike personality. Physically speaking, the character becomes so "unhuman" that he takes Structural Damage Points rather than wound damage.

There is some hope for those who undergo full conversion... because full body replacement is performed all at once, there is less trauma to the individual. If a person were to get all the components of a full borg separately, she/he would suffer a massive loss of humanity (usually over 100 HC!) This is because there would be several operations, repeated physical and psychological trauma, and a sort of "slow chipping away at the body and soul" of the patient. A full borg conversion, however, is an all-in-one procedure which is less like an operation performed on the body and more like a transplant. In such a case, the patient's brain, a portion of the spinal cord, and the few organs which cannot be replaced (collectively known as the "Biosystem") are transplanted into a "robotic" body. Most of the functions performed by internal organs (such as a digestive tract, lungs and heart) are taken up by cybernetic analogs. For instance, the lungs are replaced with a high-efficiency filtration and oxygenation system; for this reason, a full borg is immune to any kind of gas. In fact, a full borg has a pressurized air storage cell which it "charges" twice a day, eliminating the need to breathe almost entirely. The

case is similar for eating and drinking, although for psychological reasons all full borgs are capable of regular eating (it is unavoidable that most full borgs cannot engage in sexual activity or have children). For psychological reasons, a full borg must sleep and is not normally able to turn off his sense of touch — thus they are susceptible to pain (but many have built-in Pain Editors). Being mechanical in nature, a full borg body cannot heal damage without repairs. Full body conversion imparts improved physical capabilities (supplanting the patient's original REF, ATT, MA & BOD with new ones based upon the functions of the body). Additionally, full borg bodies have many option spaces which can accept any of the standard cyberlimb options and many new systems.

Although full borgs enjoy massively increased physical abilities and the capability to totally customize the body, they have some serious disadvantages as well. Aside from the obvious humanity costs, full borgs (sometimes referred to as "Metalheads") suffer from a strong social stigma against them. Many people are fearful of their potential for cyberpsychosis, while others are jealous of a Metalhead's physical capabilities and perceived wealth. (Full borgs have many more job opportunities than normals because of their bodies, which are quite simply...superior.) Although opinions vary, most full borgs find themselves the victims of discrimination and prejudice—this has resulted in a sort of brother-

hood among borgs, which is not always understood by others (some see it as a secret club or conspiracy, leading to more fear and hatred). For obvious reasons, every city's C-SWAT division requires all full borgs to register (see page 64 of *Cyberpunk 2020* "Registered Cybers"), and often corporate sponsorship is also needed for complete legitimization.

Corporate sponsorship is, in fact, the most common route for attaining a full body conversion. Many corporations will offer a contract for full conversion to those who satisfy the extensive screening and testing procedures (which are structured to determine psychological profile and stability—usually a minimum EMP of 8 is required to pass these tests). A corporation will offer an employee a full body conversion on a 10- to 25-year basis, during which time the employee will be able to perform at fantastic levels, thereby making the corp a lot of money. Once the contracted time has expired, the employee has the option to keep the body or have it downgraded to a "naturalized" body (one that is more human in appearance/function). There have been rumors that the best borgs can have their brains transplanted to clone bodies after their term of service. Corporate (or Military) sponsorship can be chosen as an option in character creation similar to selling out (see *Cyberpunk 2020* pg. 83-4), but there is only a 20% chance that you'll be given a full borg body. (No luck can be

FULL BODY REPLACEMENT

added to this roll, so don't skimp on your stats, because if you don't get the body, you're stuck with your original one. You only get a basic body, and all options must still be paid for.) Although most borgs are corporate or military creations, there have been a few cases of "street" Borgs—most of these jobs have been sloppy and unreliable (as well as being psychotic and short-lived). Once in a blue moon, a custom borg does show up, but they are incredibly rare and expensive. In

any event, whether you have sponsorship or get a custom body, the transplant operation has a Surgery Code of 2x CRITICAL (see *Cyberpunk 2020* p.70 for more on surgery).

There are rumors on the street of exotic experiments focusing on full body conversions, and they aren't pretty. Interchangeable braincases are a reality (though rare), but there are supposed to be projects involving inserting such braincases into tanks and fighter planes, and there are even rumors of

human brains in robohound bodies. Even more speculative and exotic is the rumor that Microtech can electronically transfer a mind from a human body into a borg housing an implanted clone brain. These rumors are unconfirmed, but many experts say it is possible. The implications are enormous...

Note: We suggest you use the Therapy rules from the Exotics Section (pgs.101-102) with these conversions. HC for high Stats or special Options is marked by asterisks: *N*

TOTAL-BODY CYBERWARE:

To illustrate the point of how a Full Borg is made, a list has been provided showing the relative costs (in Humanity and Eurodollars) for the component parts of a total cyborg

INDIVIDUAL COMPONENTS	HC	Cost
Neural Processor (required)	1D6	1000eb
Interface Plugs (assumed)	1D6	200eb
Cyberoptics (no options)	2D6/2D6	500eb/500eb
Cyberaudia (no options)	2D6	500eb
-HEADWARE TOTAL-	-8D6-	-2,700eb-
Cyberarms (basic)	2D6/2D6	3000eb/3000eb
Hands (standard)	0/0	150eb/150eb
Arm Armor (SP25)	0/0	250eb/250eb
Cyberlegs (basic)	2D6/2D6	2000eb/2000eb
Feet (standard)	0/0	200eb/200eb
Leg Armor (SP25)	0/0	250eb/250eb
-CYBERLIMBS TOTAL-	-8D6-	-11,700eb-
Cowl (skull SP25)	1D6	200eb
Faceplate (face SP25)	4D6	400eb
Torso Plate (torso SP25)	3D6	2000eb
-BODY PLATING TOTAL-	-8D6-	-2,600eb-
BODY REPLACEMENT*		
(H30/T40/SP25)	8D6 (was 5D6)	20,000eb (was 8,000eb)
-REPLACEMENT TOTAL-	-8D6-	-20,000eb-
TOTALLED SEPARATE COSTS	-32D6-	-37,000eb-

The list above covers all the basic components required to make a full borg. The "Body Replacement" is not a standard cybernetic item — it is only available as part of a full borg conversion. However, for reference's sake, it has been itemized in the complete list. Compare these costs to the Alpha body which represents a basic full borg conversion.

FULL BODY REPLACEMENT

ALPHA CLASS

INTERNATIONAL ELECTRIC CYBERNETICS
FULL CYBERNETIC CONVERSION

40,000EB

IEC, as one of the largest and most successful manufacturers of cybernetics in the world, offers many full conversion packages. Their "Alpha Class" is considered to be the industry standard, and as such can be regarded as one of many "generic" designs. Similar models are also offered by Raven Microcyb, Cybermatrix Inc, Militech Cybernetics International, Dynalar Technologies, and Noveltech Ltd. Composed of durable, ultra-light polyceramics, foamed alloys and other hybrid materials, an Alpha Class body is designed to bear a strong resemblance to the human form. It is anthropomorphically structured to integrate with standard human ergonomics with little or no difficulty. Following this design concept, an Alpha Class stands about 6'6" tall, weighs approximately 350lbs, and is built like a linebacker or world-class bodybuilder.

Once a patient's brain is transplanted into the head and the few required bio-systems are wired into

the body, all the physical functions (oxygenation, digestion, blood circulation, etc.) of the body are performed by cybernetic components. The internal systems of an Alpha Class body consist of a cybernetic nervous system, an alloy endoskeleton actuated by a myomar fiber musculature, and a covering of an ultra-light plating of woven carbon-beryllium fibers in a plastic base. The

Alpha Class body's physical abilities are easily equivalent to the human maximum, with strength and lifting power being even higher. Because the cybernetic reconstruction is so complete, an Alpha Class body takes Structural Damage Points rather than wound damage.

Although an Alpha Class (or similar model) body comes essentially "stripped," (except for Interface Plugs, of course) it has many option spaces to accept subsystems for customization. Most custom-built or otherwise non-corporate/military bodies will be similar to an Alpha Class, with assorted options built-in to serve the patient's (or creator's) own purposes. Similarly, when an individual manages to get together enough money to buy himself a full body conversion, he will usually get an Alpha Class body with a customized suite of options (such as improved physical capabilities, sensors and weapons systems, aesthetics and stylization, etc).

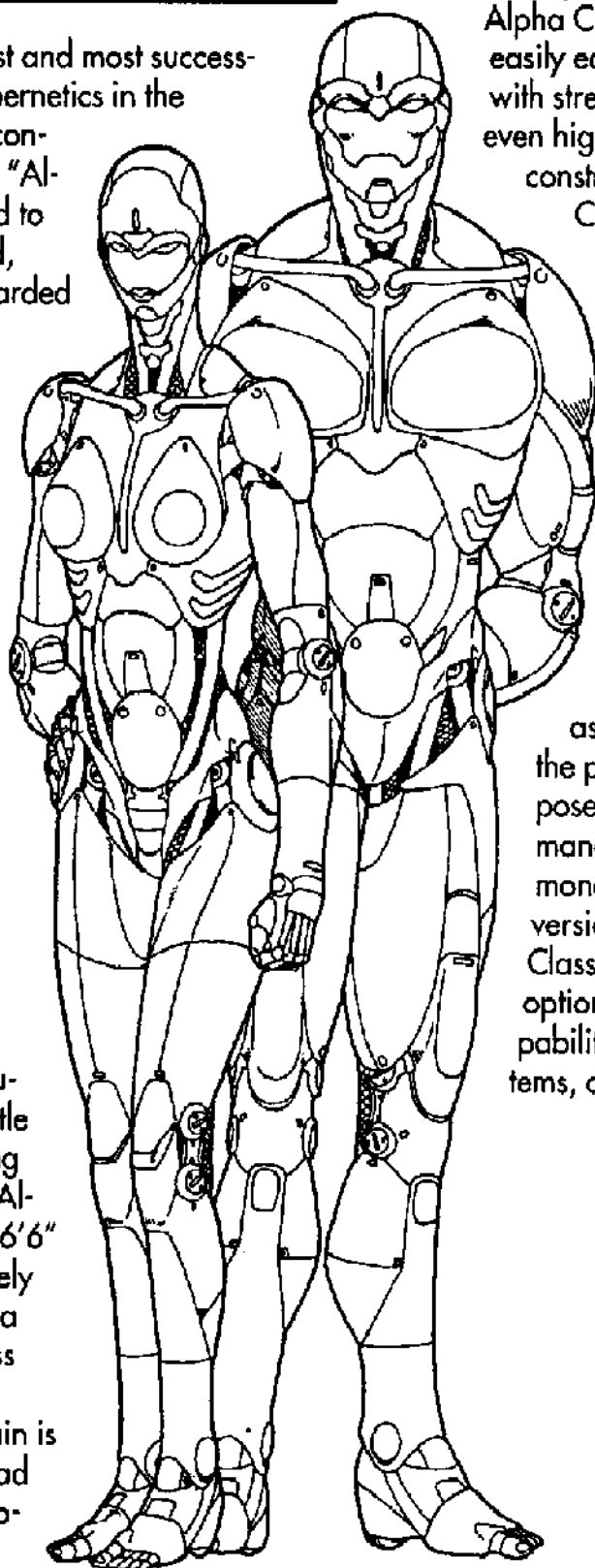

FULL BODY REPLACEMENT

ALPHA CLASS PHYSICAL STATS

REFLEC: 10
 ATTRACTIVENESS: NA
 MOVEMENT ALLOWANCE: 10
 M/turn: 30m MPH: 20mph
 Jump (up): 6m (broad): 8m

Body: 12
 Lift: 480kg Throw: 120m
 Damage Mod: +4

HAND-TO-HAND:

Punch: 1D6+4 Kick: 2D6+4

OPTION PACKAGES

Sensor Options: None installed
 Weapon Subsystems: None installed
 Other Options: None installed

PHYSICAL STRUCTURE

HEAD

SP: 25
 SDP: 20 (disabled), 30 (destroyed)
 Options (Optic): 4 & 4
 Options (Audio): 6

RIGHT ARM W/ HAND	TORSO	LEFT ARM W/ HAND
SP: 25	SP: 25	SP: 25
SDP: 20/30	SDP: 30/40	SDP: 20/30
Options: 3	Options: 4	Options: 3

RIGHT LEG W/ FOOT	LEFT LEG W/ FOOT
SP: 25	SP: 25
SDP: 20/30	SDP: 20/30
Options: 2	Options: 2

TOTAL PACKAGE COSTS

Eurodollars: 40,000
 Humanity Cost: 16D6

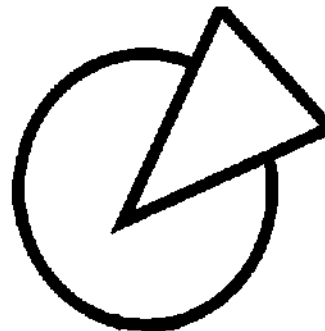
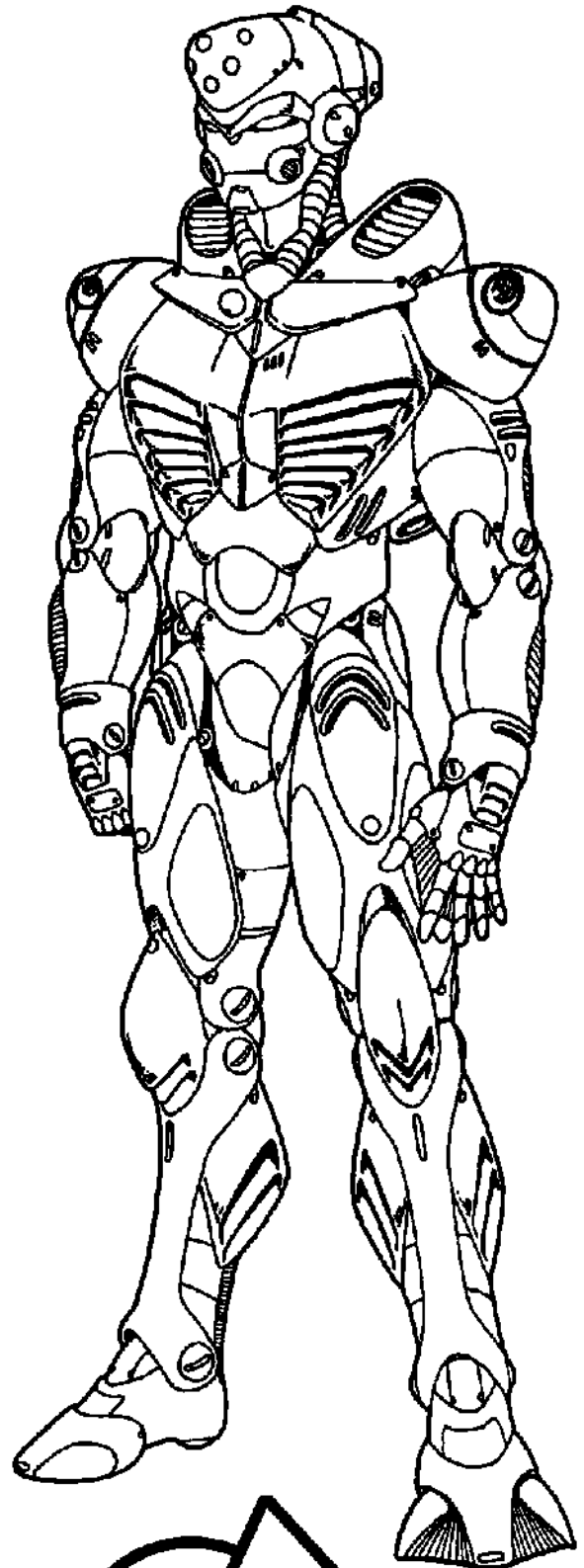

DYNALAR

AQUARIUS

DYNALAR TECHNOLOGIES
 SUB-MARINE FULL CONVERSION

50,000EB

The only way to dive deeper than Bryan LeShawn (who dove to a record 12,645 feet on July 13, 2011) is with Dynalar Technologies' "Aquarius" full body conversion. Designed for use in underwater environments (both fresh and salt water), Aquarius is superior to any diving system. It is ideal for undersea exploration, mining, aquaculture, construc-

FULL BODY REPLACEMENT

Don't let your frail, organic frame keep you from exploring a bold new frontier. See another world—with your body as your vessel... Aquarius
—Advertisement

tion, and covert operations. Endorsed by the Cousteau Society, the U.S. Navy SEALs, the Hydrosubsidium and OTEC; Aquarius can operate underwater for up to 16 hours, and at depths of up to 16,000 feet! Remember, it was an Aquarius cyborg that explored the Marianas Trench!

The Aquarius is built using corrosion-proof materials, and is waterproofed to protect all internal systems. The body is carefully weighted for neutral buoyancy (its density is equal to that of water), allowing easier maneuvering. Rather than using the standard oxygen cell, Aquarius employs a solid oxygen battery which must be recharged approximately every 16 hours. Its motive system forgoes standard myomar technologies, instead using a high-speed hydraulic system, which has fewer difficulties than myomars when submerged, and boasts a higher strength factor. Supplementing its normal locomotion, Aquarius has a set of miniaturized "caterpillar" drives for high-speed propulsion. These electromagnetic engines (manufactured by the Hydrosubsidium) charge and propel water through their lengths, granting high speed and energy efficiency with minimal audio signature or pollution.

To better function in the alien environment of the deepest waters, Aquarius has several specialized sensor systems. In addition to the standard audio-visual array, a powerful head-mounted Sonar system allows accurate ranging and detection out to 1 km. Built into multipositionable housings in the shoulders are two 1,000,000-candela spotlights, capable of penetrating the murky depths up to 100m (depending on conditions). Communications is provided by a long-range, ULF multichannel radio link (range 50km) so that contact can be maintained with the surface and other units. For defense, Aquarius takes after the Electric Eel, being capable of charging its hull with a high-voltage electric current; no need to worry about shark attacks!

AQUARIUS PHYSICAL STATS

REFLEX: 10 (- TO REFLEXES WHEN SUBMERGED GM'CALL)
ATTRACTIVENESS: NA
MOVEMENT ALLOWANCE: 10 (1/2 MA WHEN SUBMERGED)
M/turn: 30m/15m MPH: 20mph/10mph
Jump (up): 6m/3m (broad): 8m/4m
Body: 15 *6*
Lift: 600kg Throw: 150/15m underwater
Damage Mod: +8

HAND-TO-HAND:

Punch: 1D6+8 Kick: 2D6+8

PHYSICAL STRUCTURE

HEAD

SP: 25
SDP: 20 (disabled), 30 (destroyed)
Options (Optic): 4 & 4
Options (Audio): 4

RIGHT ARM W/ HAND	TORSO	LEFT ARM W/ HAND
SP: 25	SP: 25	SP: 25
SDP: 20/30	SDP: 30/40	SDP: 20/30
Options: 2	Options: 2	Options: 2

RIGHT LEG W/ FOOT	LEFT LEG W/ FOOT
SP: 25	SP: 25
SDP: 20/30	SDP: 20/30
Options: 2	Options: 2

OPTION PACKAGES

SENSOR OPTIONS:

Sonar - 1 km range. Note that if a full power Sonar pulse ("Ping") is directed at a human at close range (20m), the person must make a Stun Save at -2 or be deafened & disoriented for 1D6+3 full combat turns. This only works underwater. *2*

Spotlights - 100m range, varies depending on conditions. Note that when used at close ranges, can function in the same way as a Dazzle grenade (blinds for 4 turns). This only works above water. *2*

WEAPON SUBSYSTEMS:

Electrified Hull - A contact weapon which will do 1D6+2 in electrical burn damage and also requires a Stun Save at -3. This electrifies the entire surface of the borg. *1*

OTHER OPTIONS:

Caterpillar Drive - Maximum speed is 30mph (MA 15) underwater. Being electrically powered, these have no maximum range or duration. These only work underwater! *2*

Long-Range Radio - Range 50km, with 10 channels. *2*

TOTAL PACKAGE COSTS

EURODOLLARS: 50,000
HUMANITY COST: 18D6+2 (16D6+14)

COPERNICUS

CYBERMATRIX INCORPORATED
SPACE-USE FULL CONVERSION

60,000EB

There is no environment more hostile than the cold vacuum of space. Radiation constantly bombards those who venture outside of man's fragile artificial habitats, and many have fallen prey to the unique accidents of an orbital environment. Cybermatrix Incorporated offers the Copernicus body conversion to make you a native inhabitant of the final frontier. From EVA construction to deep-space exploration, Copernicus is the ideal body conversion.

As a standard feature, this body is fully protected against radiation, EMP and Microwaves with fully-shielded materials and hardened electronics; cosmic rays and electromagnetic storms are no threat to Copernicus. In addition, all exposed surfaces are highly reflective so as not to absorb heat from the glaring light of the sun's unobstructed rays. For added reliability, Copernicus' reaction time has been increased beyond the normal human threshold, making it possible to avoid or avert those zero-G accidents which can occur in a split-second. Because of the unique nature of Full Borg biosystems, minimal reconstruction was required to make this body fully vacuum-proofed; a 12-hour stint of EVA is standard for this cybersystem (after which time the borg must return to a human-friendly environment to recharge air). An internal gyroscope gives excellent balance and level-headedness, despite the lack of any kind of "up" or "down."

By no means a helpless observer, Copernicus can do much more than simply survive in space: 36 micro-verniers are clustered across the body in retractable housings, enabling this Full Borg to perform maneuvers without needing to push off against any surfaces (this effectively adds +2 to Zero-G Maneuver skill). A central fuel storage pod, which is loaded into a receptacle in the borg's lower back, allows enough fuel for 12

FULL BODY REPLACEMENT

hours of EVA maneuvering. In addition to these maneuver rockets, Copernicus has one main thruster nozzle built into the back of the upper body: this compact rocket-propulsion system (usable only in zero-G) can grant acceleration of 5 meters per second squared (or an ever increasing speed of about 10mph per second). Its replaceable solid fuel supply has enough fuel for 20 seconds of burn, giving Copernicus the ability to get up to 200mph if it's really necessary. Just in case, a 20m grapple-line with an Electro-Stick Pad (fired by a spring-launcher) is housed in the left

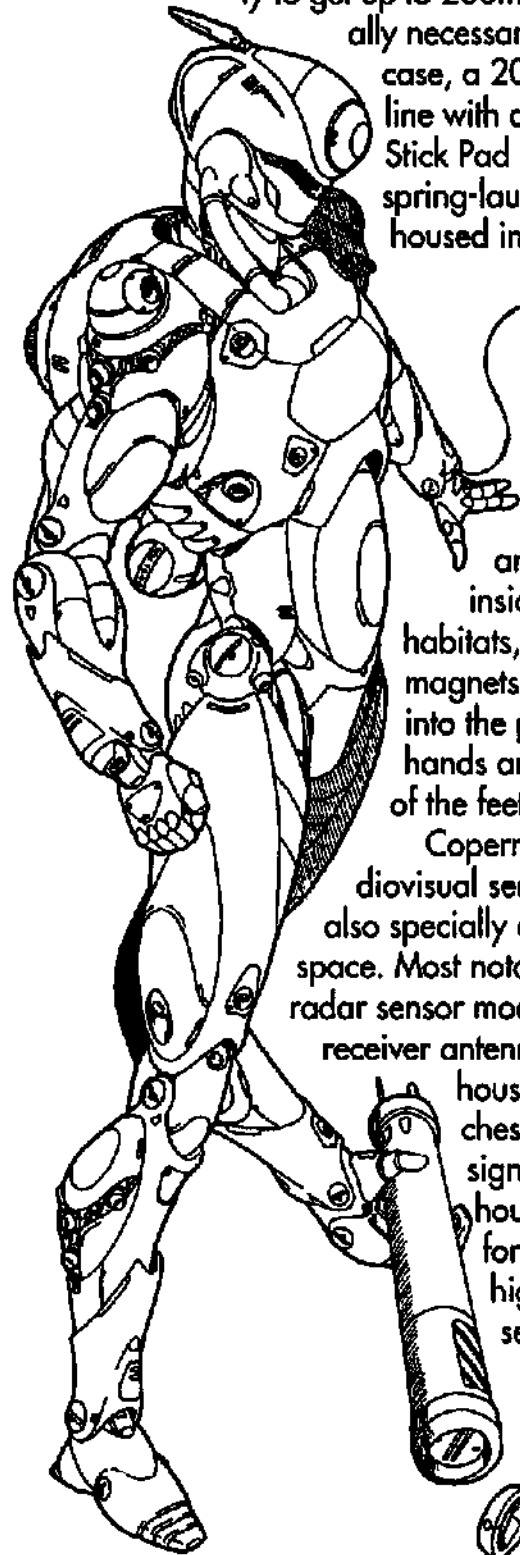

arm, for secure tethering to metal surfaces. For reliable traction and stability inside orbital habitats, electromagnets are built into the palms of the hands and the soles of the feet.

Copernicus' audiovisual sensor suite is also specially adapted for space. Most notable is the radar sensor module, whose receiver antenna is housed in the chest, with the signal emitter housed in the forehead. This high-power sensor has a 2km range, giving the Full Borg an unparalleled

unparalleled

FULL BODY REPLACEMENT

leed awareness of his environment. A radio link is spliced into the audio systems, and both optics are fully protected from bright lights with integral flare-compensation capability. A radio beacon with a 100km range is also standard, in case the borg gets separated from his station. To enhance visibility in the blackness of space, two 1,000,000-candela spotlights are built into multipositionable housings in the shoulders.

In addition to, all these necessities, Copernicus is packed with additional features which make this Full Borg the equal of any Space Suit or Work Module. Although this body's legs can perform all the normal functions that those of the human body can, they can also act as a supplementary set of arms. Copernicus' legs are literally double-jointed, and the feet can unfold into rudimentary hands, the toes extending into finger-like digits which can manipulate objects. These dual-purpose limbs can act just like arms, but at a -3 penalty to reflexes due to their inferior dexterity. Another utility is the 3-shot Goop Ball launcher in the right arm, whose spring-launcher has a 10m range. Goop Balls are ping pong sized plastic spheres filled with a fluid which can harden to patch holes up to 2 inches wide in structures. For convenience, the left hand has several tools useful in zero-G, allowing many small repairs to be done without any additional equipment.

COPERNICUS PHYSICAL STATS

REFLEX: 11 *2*
 ATTRACTIVENESS: NA
 MOVEMENT ALLOWANCE: 10
 M/turn: 30m MPH: 20mph
 Jump (up): 6m (broad): 8m

BODY: 12
 Lift: 480kg Throw: 120m
 Damage Mod: +4

HAND-TO-HAND:

Punch: 1D6+4 Kick: 2D6+4

PHYSICAL STRUCTURE

HEAD
 SP: 25
 SDP: 20 (disabled), 30 (destroyed)
 Options (Optic): 3 & 3
 Options (Audio): 4

RIGHT ARM w/ HAND	TORSO	LEFT ARM w/ HAND
SP: 25	SP: 25	SP: 25
SDP: 20/30	SDP: 30/40	SDP: 20/30
Options: 2	Options: 0	Options: 1

RIGHT LEG w/ FOOT	LEFT LEG w/ FOOT
SP: 25	SP: 25
SDP: 20/30	SDP: 20/30
Options: 0	Options: 0

OPTION PACKAGES

SENSOR OPTIONS:

Radar Sensor: 2km range. *1*
 Radio Beacon: 100km range. *1*
 Flare Compensation: Works just like Anti-Dazzle. *1*
 Spotlights: 500m range.

Note that when used at close ranges, can function in the same way as a Dazzle grenade (blinds for 4 turns). *2*

WEAPON SUBSYSTEMS: NONE INSTALLED

OTHER OPTIONS:

Toolhand - contains a power-screwdriver, a vac-solderer, a micro-probe, and a small wirecutter. *2*

Dual-Purpose Limbs - these can act just like arms, but at a -3 penalty to reflexes due to their inferior dexterity. *2*

Goop Ball Launcher - 10m range, 3 shots, each shot can patch a 2" hole. *1*

Gyroscope (+2 on Space Sickness rolls, +1 on Zero-G Maneuver skill, +2 on any roll REF involving balance). *1*

Maneuver Verniers and Back Thruster: this system adds +2 to Zero-G Maneuver skill, and allows acceleration up to 5m/sec², or a 10mph (5MA) increase in speed each second. There are 20 seconds of burn for the thruster, and 12 hours of maneuvering for the verniers. Refueling pods cost 50eb each. *2*

Grapple line: 20m range, -1 accuracy. *1*

Magnetic hands & feet. *0*

Electromagnetic Shielding—Hardened circuitry and heat-reflective surface. *1*

TOTAL PACKAGE COSTS

EURODOLLARS: 60,000
 HUMANITY COST: 19D6 (16D6+17)



CYBERMATRIX

ECLIPSE

MILITECH CYBERNETICS INTERNATIONAL
COVERT OPERATIONS FULL CONVERSION

65,000 EB

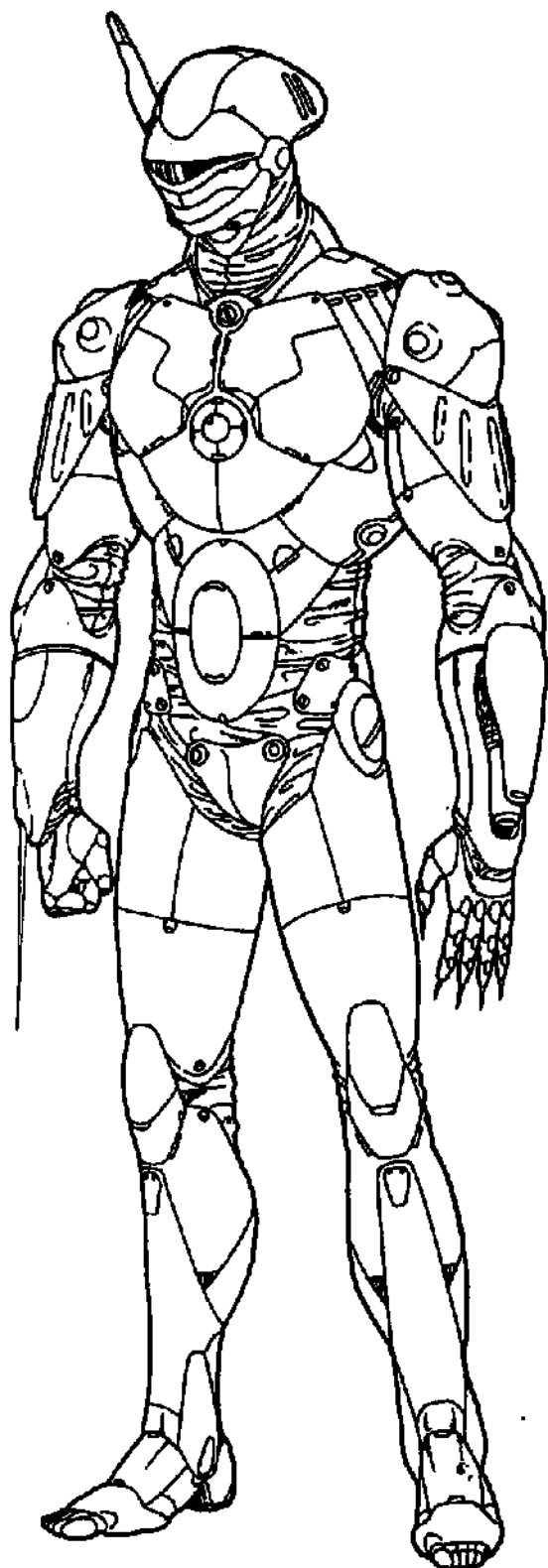

FULL BODY REPLACEMENT

In normal circumstances it takes six highly trained men to form an effective black ops cell. In such cases, you have versatility and firepower, but six men can only be so stealthy. Now, Eclipse offers maximum versatility, firepower and stealth in one compact package. Ideal for assassinations, intrusion, sabotage, kidnapping and information collection. A mix of advanced cybernetics, high-tech weaponry and stealth technology, the Eclipse Cyber System puts any ninja to shame.

As a superior black ops full conversion, the Eclipse uses jump-wired cybernetic reflexes to excel in its field. These reflexes feed directly into the high efficiency Myomar musculature, for increased speed, and a custom integrated gyro-stabilization unit, for near-perfect balance in any situation. Eclipse also comes standard with a pain editor, a pair of independently focusing optics and an on-board ambidexterity sub-processor. Eclipse's physical capabilities guarantee the greatest level of lethality.

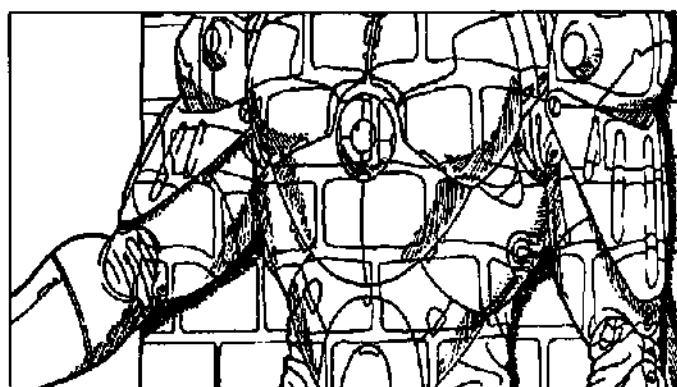

Eclipse chameleon system in action

What would a black ops 'borg be without stealth technology? The Eclipse's exterior incorporates a chameleon system, which employs liquid crystal technology and a multi-faceted fiber-optic digitization system. The visual effects of Eclipse's "skin" are complemented by a negative-noise sound canceller, which uses a complex sound array and fuzzy-logic processors to cancel out any noises made by the cyborg. Its stealth capabilities are supplemented by a high power ECM generator and IR Thermal Dam. Eclipse's foot modules have sound absorbing pads on their soles, which are covered in a tacky rubberized material for increased traction, and the toes can extend and curl around objects to aid in climbing.

FULL BODY REPLACEMENT

The Eclipse's optical array includes Thermal imaging, Lowlite enhancement, an auto-step feature, and an integrated heads-up display with targeting system. The audio package is equally impressive, featuring amplified audio pickups, a decibel leveling system, and a scrambled multifrequency radio with the ability to lock on to homing tracers. As a back-up, the Eclipse has a sensor boom capable of looking around corners.

Eclipse's sensory and physical abilities are backed up by a formidable selection of subtle yet effective weapons. The fingers of one hand contain retractable hypodermic needles (See *Venomhand*, *Corpbook 1*, pg. 70). The other hand is a modular unit which comes standard with a dartgun, a lockpick, a finger bomb, and a gas sprayer. The left arm is equipped with a silenced 10mm pop-up auto-loader and the right arm with a retractable 12" monoblade. Secret spaces in the legs are perfect for additional gear.

ECLIPSE PHYSICAL STATS

REFLEX: 13 *6*
 ATTRACTIVENESS: NA
 MOVEMENT ALLOWANCES: 13 *6*
 M/turn: 39m MPH: 26mph
 Jump (up): 6m (broad): 10m

BOAR: 12
 Lift: 480kg Throw: 120m
 Damage Mod: +4

HAND-TO-HAND:

Punch: 1D6+4 Kick: 2D6+4

PHYSICAL STRUCTURE

HEAD

SP: 25
 SDP: 20 (disabled), 30 (destroyed)
 Options (Optic): 0 & 0 (3 in boom)
 Options (Audio): 1 (2 in boom)

RIGHT ARM W/ HAND	TORSO	LEFT ARM W/ HAND
SP: 25	SP: 25	SP: 25
SDP: 20/30	SDP: 30/40	SDP: 20/30
Options: 2	Options: 0	Options: 2
RIGHT LEG W/ FOOT		LEFT LEG W/ FOOT
SP: 25		SP: 25
SDP: 20/30		SDP: 20/30
Options: 1		Options: 1

OPTION PACKAGES

SENSOR OPTIONS:

Audios: Amplified Hearing (+2 to audio Awareness rolls), Level

Damper (prevents deafening), Radio w/ Scrambler (1 km range) and Homing Tracer (4 bugs included). *4*

Optics: Thermographic Sensor, Targeting Scope (+1 to Smart-guns), Low-Lite (night vision), AntiDazzle (prevents blinding) and Times Square Plus (Heads-Up Display) *6*

Sensory Boom ("Rabbit Ear"): Normal A-V systems, can look around corners. *3*

WEAPON SUBSYSTEMS:

Retractable Monoblade - This does 2d6+7 damage, including BOD, 1/3 to armor. *2*

Silenced pop-up gun (P +2 na na 2d6+3(10mm) 10 2 VR 50m) w/Limblink- Any Awareness roll to hear it fire is at -10. *2*

Modular Cyberhand; Dartgun, Gas Sprayer, Finger-Bomb and Lockpick fingers (see *ChromeBook 1*, pg. 32). *1*

Venomhand (4 drug-injecting needles, 1d6-1 damage if used in a slash) for more detail, see *Corpbook 1*, pg. 70. *2*

OTHER OPTIONS:

Secret Spaces - There is one in each leg (2" x 6" x 2"). *1*

Gyro-Balancer - This adds +1 to all rolls involving balance. See *Chromebook 1*, pg. 38. *1*

Grip Foot - This adds +2 to all Climbing rolls. *2*

Stealth Foot - This adds +1 to Stealth rolls. *1*

Pain Editor- This negates heat, cold, and pain on command. *2*

Chameleon Covering - This is a built-in digital camouflage system which makes the cyborg blend into its surroundings, granting -4 to Awareness. (See *Militech Ghostsuit*, Page 27). *0*

ECM Generator - This on-board electronics scrambler will jam any Radar or Sonar sensor, motion detectors, and any form of radio communications (except for tight-beam transmissions). Its sphere of influence is adjustable, ranging from 5-100m. *2*

Sound Canceller - This system incorporates an array of sensitive audio pickups, noise generators and a matrix of fuzzy-logic microprocessors. This unit can analyze the sounds being made by the cyborg (such as footsteps, hands touching things, etc) and instantly emit the "opposite" of that sound; this anti-noise effectively cancels out the original sound, resulting in virtually no sound at all (this causes a -3 modifier to any listener's Awareness rolls). *2*

IR Thermal Dam - This system absorbs IR emissions until they can be safely bled off; this is done in a random pattern, so that it does not appear to come from a humanoid source. This translates into a -5 to any IR-based Awareness rolls. *2*

TOTAL PACKAGE COSTS

EURODOLLARS: 65,000
 HUMANITY COST: 21D6+3 (16D6+33)

ENFORCER

MILITECH CYBERNETICS INTERNATIONAL
POLICE & SECURITY FULL CONVERSION

55,000 EB

Militech knows that cops are on the run in our cities. That's why they've created the Enforcer, a full body cybernetics package designed especially for the Police and Security community. Militech's own contracted police services proudly include several Enforcers in each of their precincts, and Militech security divisions are often supplemented by Enforcers to better guarantee the safety of your premises. Now available for any police group, public or private, the Enforcer is sure to become a familiar sight where you live.

With streetgangs and organized crime becoming better armed all the time, the Enforcer package is well-armed, capable of withstanding almost any small arms fire. Since the scene on the street (or during a security breach) can change in an instant, the Enforcer's nervous system is hardwired for superior response time, and no perpetrator can outrun this cyborg, since its ground speed matches that of most electrically-powered vehicles! Of course, any good cop knows that intimidation is the better part of crime prevention, and to that end the Enforcer is built on a large, heavy-duty chassis which can soak up a good deal of damage, but also scare the most "chilled" of intruders into surrendering.

FULL BODY REPLACEMENT

The Enforcer's audiovisual systems are configured to aid officers of the law no matter what department they're with, from street patrol, to investigations, to the Psycho Squad. This full body conversion's cyberoptics feature a targeting system, a video recorder (for filming evidence), a thermographic sensor (to check suspicious types for hidden weapons and cyberware), as well as low-light and flare compensation capability. The audio system includes a radio link, a recorder (for taking statements), and a voice stress analyzer (to see if those statements are true). The left forearm also stores a Black Book micro-computer (see Electronics section) for instant access to police databases.

When the time comes to get serious, the Enforcer conversion is more than ready. First, there are light bars mounted on the cyborg's shoulders to ensure that you legally identify yourself, but we all know that it takes more than lights to stop a Black Lace addict. That's why each of the Enforcer's legs has a storage space: the right leg houses a pop-out weapon holster, while the left leg has space for three hand grenades (Stun and Gas bombs are good choices). For hand-to-hand combat and subduing antsy criminals, both hands have built-in tasers. Once the job is done, the striptape dispenser in the right arm keeps the catch under wraps.

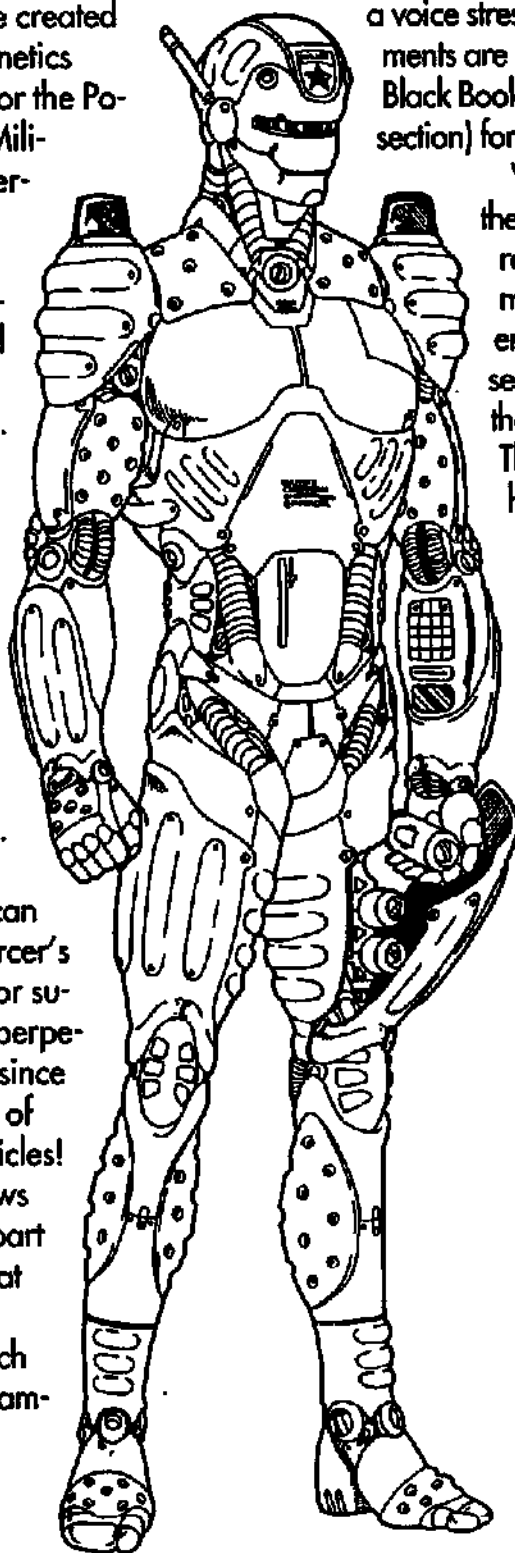

FULL BODY REPLACEMENT

ENFORCER PHYSICAL STATS

REFLEX: 12 *4*
 ATTRACTIVENESS: NA
 MOVEMENT ALLOWANCE: 15 *10*
 M/turn: 45m MPH: 40mph
 Jump (up): 6m (broad): 11m
 Body: 12
 Lift: 480kg Throw: 120m
 Damage Mod: +4

HAND-TO-HAND:

Punch: 1D6+4 Kick: 2D6+4

PHYSICAL STRUCTURE

HEAD

SP: 30
 SDP: 25 (disabled), 35 (destroyed)
 Options (Optic): 1 & 1
 Options (Audio): 3

RIGHT ARM W/ HAND	TORSO	LEFT ARM W/ HAND
SP: 30	SP: 30	SP: 30
SDP: 25/35	SDP: 35/45	SDP: 25/35
Options: 1	Options: 4	Options: 1

RIGHT LEG W/ FOOT	LEFT LEG W/ FOOT
SP: 30	SP: 30
SDP: 25/35	SDP: 25/35
Options: 1	Options: 1

OPTION PACKAGES

SENSOR OPTIONS:

Cyberoptics: Targeting Scope (odds +1 to Smartguns only), Video recorder (can record up to 20 minutes of video), Thermograph Sensor, Lowlite and Antidozzle. *4*

Cyberaudio: Voice Stress Analyzer (+2 to Human Perception & Interrogation), Radio Link (1km range) and Digital Recording Link (can record up to 2 hours). *3*

WEAPON SUBSYSTEMS:

Leg Holster - This can hold a Heavy Pistol, Medium SMG or a folding shotgun, as well as one spare clip of ammo (weapons not included). *1*

Grenade Storage - This space can hold three hand grenades or bombs of any type. *1*

Taser Grips - Each hand can be treated as having a built-in Taser. *2*

OTHER OPTIONS:

Black Book Micro-Computer - built into the left arm. See the Equipment section for specifications and details. *1*

Striptape Dispenser - 12 one-use lengths of plastic tape which serve as temporary handcuffs (Very Difficult to break), this dispenser is reloadable. *1*

Light Bars - These cannot be used as blinders, just as signals. *1*

TOTAL PACKAGE COSTS

EURODOLLARS: 55,000
 HUMANITY COST: 21D6-2 (16D6+28)

BRIMSTONE

DYNALAR TECHNOLOGIES
 FIRE-FIGHTER FULL CONVERSION

47,000 EB

Throughout time, fire has been man's greatest tool as well as his greatest enemy. Firefighting, an art that has evolved for centuries, now reaches its pinnacle with Dynalar's Brimstone full body conversion. Immune to the hazards of smoke inhalation, burns and rapidly-changing pressures, Brimstone can do the work of an entire company of regular firemen. Originally deployed in London, Brimstone cyborgs are now a regular sight in many major cities throughout the world.

As a necessity, the Brimstone package is fully fireproofed and insulated, making it capable of enduring the searing heat of almost any blazing inferno. It is also protected by extra-thick layers of laminate armor, allowing it to survive such catastrophes as collapsing ceilings, falling rubble and explosive backdrafts. The musculature of the Brimstone system mixes thickened myomar fibers with magnetic piston actuators, giving it the strength it needs to break through doors and walls to reach trapped civilians. An improved response time in the cybernetic nervous system also makes sure that Brimstone can react quickly to the crisis situations it was designed for, and an automatic pain editing feature keeps the cyborg from feeling the searing heat that may surround him.

Since the intense heat of blazing fires will scramble IR and thermal imagers, and smoke will obscure any other visual sensors, the Brimstone conversion includes a low-power radar sensor.

FULL BODY REPLACEMENT

The signal emitter is housed in the chest, with the receiver mounted in the forehead, allowing the cyborg to navigate through the thickest smoke without difficulty. This conversion's audio package includes a radio link, so that communications can be maintained with the command structure and other firefighters. Amplified hearing range, sound editing, and acoustic level dampers make it possible to hear the calls of trapped victims through the loudest explosions and blazes.

For active anti-blaze and rescue duty, the Brimstone cybersystem has a CO₂ fire extinguisher built into its left arm, and the right arm has a tubular conductor

for water drawn in through a high-pressure pump in the back. To complete the package, dual revolving-style emergency light bars (in yellow and white) are mounted on the shoulders, accompanied by a siren to let bystanders know that the authorities have arrived.

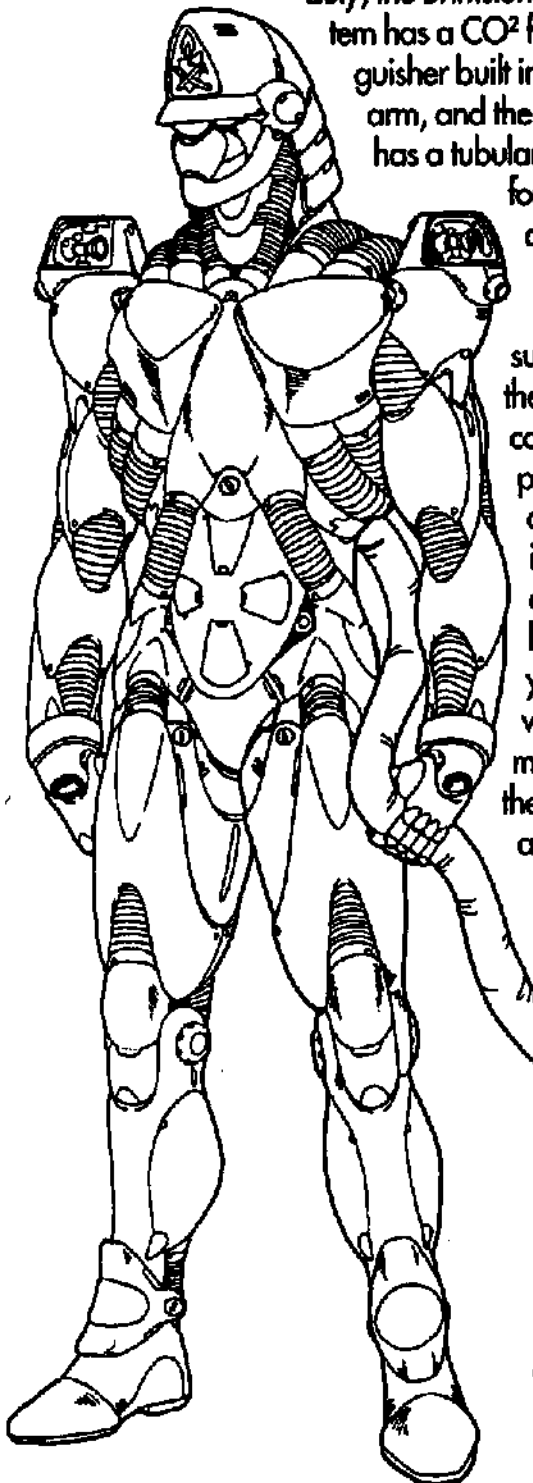

BRIMSTONE PHYSICAL STATS

REFLEX: 11 *2*
 ATTRACTIVENESS: NA
 MOVEMENT ALLOWANCE: 10
 M/turn: 30m MPH: 20mph
 Jump (up): 6m (broad): 8m
 Body: 14 *4*
 Lift: 560kg Throw: 140m
 Damage Mod: +6

HAND-TO-HAND:

Punch: 1D6+6 Kick: 2D6+6

PHYSICAL STRUCTURE

Head

SP: 30
 SDP: 20 (disabled), 30 (destroyed)
 Options (Optic): 4 & 4
 Options (Audio): 6

RIGHT ARM w/ HAND	TORSO	LEFT ARM w/ HAND
SP: 30	SP: 30	SP: 30
SDP: 20/30	SDP: 30/40	SDP: 20/30
Options: 3	Options: 4	Options: 3

RIGHT LEG w/ FOOT	LEFT LEG w/ FOOT
SP: 30	SP: 30
SDP: 20/30	SDP: 20/30
Options: 2	Options: 2

OPTION PACKAGES

Sensor Options:

Radar Sensor - 100m range, very reliable. *2*

Audio Systems: Radio link with 1km range, Amplified Hearing (+2 to audio Awareness rolls), Level Damper (prevents deafening), Sound Editor (selective sound sensor, adds +1 to audio Awareness rolls). *3*

WEAPON SUBSYSTEMS: NONE INSTALLED

OTHER OPTIONS:

Waterhose System - A high-pressure pump in the back draws in water from a firehose, which can be attached to a sleeve in the back. A duct leads through to the arm, which has an adjustable nozzle in the wrist. The water can reach up to 50m, and has very high pressure (Very Difficult BOD roll to withstand it). *2*

CO₂ Fire Extinguisher - 5m range, fueled by a replaceable 10-turn canister. If used as a weapon, target must make a Difficult REF roll to avoid being blinded for 1D6/2 turns. *1*

Pain Editor - This system tunes out heat, cold and pain. *2*

Light Bars - These cannot be used to blind, just as signals. *1*

TOTAL PACKAGE COSTS

EURODOLLARS: 47,000
 HUMANITY COST: 19D6 (16D6+17)

FULL BODY REPLACEMENT

G E M I N I

RAVEN MICROCYBERNETICS
HUMANOID FULL CONVERSION

55,000 EB

Full Body Conversions have a multitude of advantages: superhuman strength, speed, and durability, heightened reflexes, the ability to alter the body at will and even an increased lifespan. However, being a Full Borg sets you apart. Society brands you as a "Metalhead," and people treat you like a machine—even a tool. The sad truth is that if you look like a robot, no matter how you behave, people will tend to treat you like a robot. So, if you want the advantages of a full conversion without the societal baggage, Gemini is the package for you.

The Gemini cybersystem is a full-body conversion that simulates the human body in both form and function. Its chassis is designed in a similar manner to the human skeletal structure, and its myomar muscle system is arranged to physically mimic the human musculature. With this carefully-tailored layout, the Gemini cleverly imitates the anatomy of a normal person without sacrificing the superior capabilities for which full body conversions are so well-known. To complete the effect, Gemini's entire surface is covered with ExoDerm®, a synthetic surface which looks and feels like almost exactly like human skin (assorted skin tones, textures and hairstyles are available).

The Gemini's capability to pass for a normal human is impressive. Its built-in "Pinocchio" sub-processor automatically maintains body temperature (through the use of a heating system integrated into the ExoDerm®), expands and contracts the upper torso to create the illusion of breathing, and even

blinks the eyes occasionally. What's more, the entire body is composed of lightweight carbon-carbon synthetics and other composite materials, resulting in a mere 10-pound deviation from the average weight for a similar-size person. However, it should be kept in mind that ExoDerm® can be cut, punctured, and burnt as easily as real skin. (Although it does not bleed!)

It is a Nearly Impossible (Diff 30) Awareness roll to determine that a Gemini is a Full Borg through any of the five senses. However, a Thermograph sensor, a highly sensitive Radar scanner, a Scanman™ (see Scanman, in Equipment section, page 23) or similar material-sensitive detectors

will reveal the Gemini's true nature. The apparent Body Type can be chosen (Average, Strong or Very Strong) without affecting the true strength of the Borg. However, the actual BOD cannot be boosted, nor can additional SDP or SP be added (the ExoDerm® already integrates a high-density "skinweave"); if the ExoDerm® becomes damaged, it must be "patched" by a competent Cybertechician.

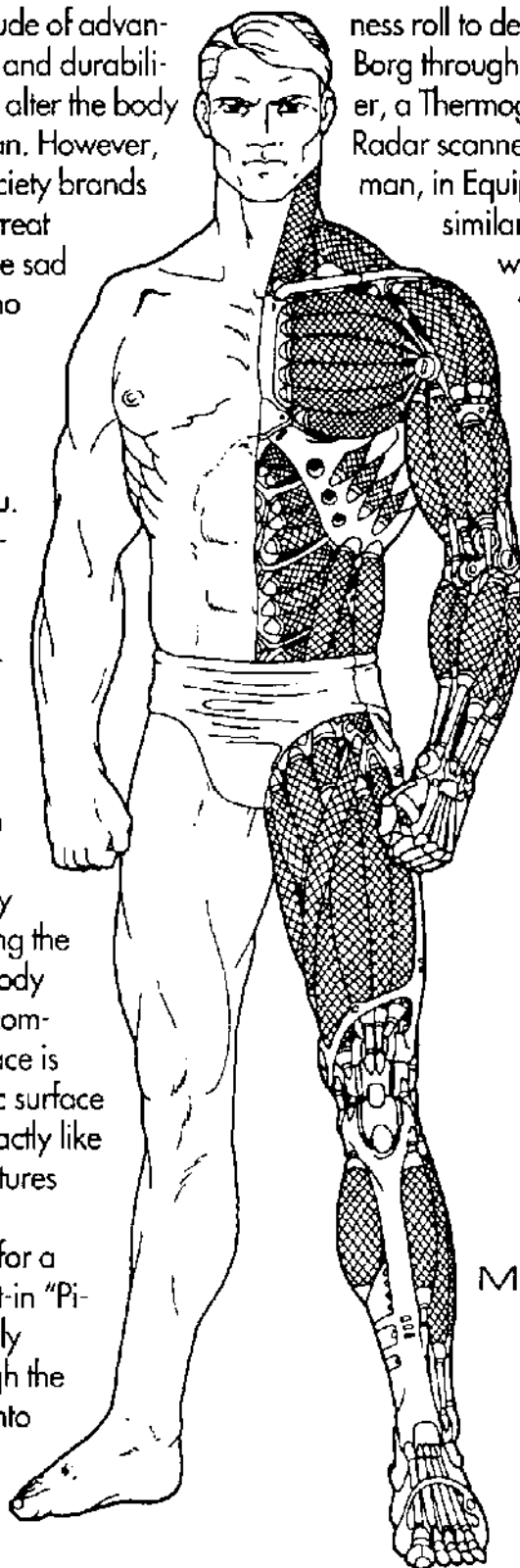

As an option, Gemini can be equipped with an added "disguise" feature, wherein tiny microsurfaces can be used to change the cyborg's facial features, and a chemskin-type modification to the ExoDerm® allows the skin tone to be altered at will. This is a popular option for infiltration and espionage, roles to which the Gemini cybersystem is well-suited.

GEMINI PHYSICAL STATS

REFLEX: 10
 ATTRACTIVENESS: 2-10 (THIS CAN BE CHOSEN BY THE PURCHASER)
 MOVEMENT ALLOWANCE: 10
 M/turn: 30m MPH: 20mph
 Jump (up): 6m (broad): 8m
 Body: 12
 Lift: 480kg Throw: 120m
 Damage Mod: +4
 HAND-TO-HAND:
 Punch: 1D6+4 Kick: 2D6+4

PHYSICAL STRUCTURE

HEAD
 SP: 25
 SDP: 20 (disabled), 30 (destroyed)
 Options (Optic): 4 & 4
 Options (Audio): 6

RIGHT ARM W/ HAND	TORSO	LEFT ARM W/ HAND
SP: 25	SP: 25	SP: 25
SDP: 20/30	SDP: 30/40	SDP: 20/30
Options: 1	Options: 2	Options: 1

RIGHT LEG W/ FOOT	LEFT LEG W/ FOOT
SP: 25	SP: 25
SDP: 20/30	SDP: 20/30
Options: 1	Options: 1

OPTION PACKAGES

SENSOR OPTIONS: NONE INSTALLED
 WEAPON SUBSYSTEMS: NONE INSTALLED

OTHER OPTIONS:

Sexual Implant - Treat as a Mr. Studd or Midnight Lady. Can't pass for a human being without one of these! (HC2)

"Disguise" Option - This allows the cyborg to alter its skin tone and facial features, effectively adding +5 to any Disguise roll. This is not a standard feature, but can be purchased for 1000eb (HC2)

TOTAL PACKAGE COSTS

EURODOLLARS: 55,000
 HUMANITY COST: 16D6+2 (+2 FOR DISGUISE FEATURE)

FULL BODY REPLACEMENT

W I N G M A N

INTERNATIONAL ELECTRIC CYBERNETICS
 FIGHTER PILOT FULL CONVERSION

54,000 EB

For decades, modern fighter planes have had the ability to outperform their pilots. The G-forces caused by acceleration and high-speed maneuvers have been the cause of many pilot fatalities. It stands to reason that when the machine outperforms the flesh, you get rid of the flesh. IEC, with the Wingman full body conversion, has finally enabled pilots to take their fighter to the limit. Designed to withstand even the fifteen G's pumped out by the F-36 Fire-shark cyberfighter, Wingman takes air combat to new, undreamt-of heights.

Wingman's responses are as fast as a computer—they have to be. With AI-guided missiles and hypervelocity projectiles filling the air, every microsecond counts. Along with a "greased" nervous system, the Wingman body has six interface plugs, allowing for maximum interface with any cybernetically-controlled aircraft. To further aid in dogfighting and maneuvering, an advanced gyro-stabilizer is built into the skull, preventing any dizziness due to sudden changes in orientation; very little can disturb the concentration of a Wingman. Employing specially buffered biosystems and a high-performance, high-stress blood pump, Wingman can effectively ignore the problems normally associated with acceleration. Blackouts and red-outs become a thing of the past.

All the reflexes in the world won't help in an air war if you can't sense your environment effectively. To this end, Wingman's visual sensor suite includes everything a fighter pilot could want: flare compensation, telescopic systems, high-resolution visual enhancement and a visual marquee for heads-up information. There comes a time, however, when you have to leave your plane behind. For such contingencies, this full-body conversion includes an on-board parachute. A weapon holster and multi-purpose blade are also included for when you reach the ground, and a locator beacon ensures that the rescue team will be able to find you. Remember: any cyborg body you can walk away in is a good one.

FULL BODY REPLACEMENT

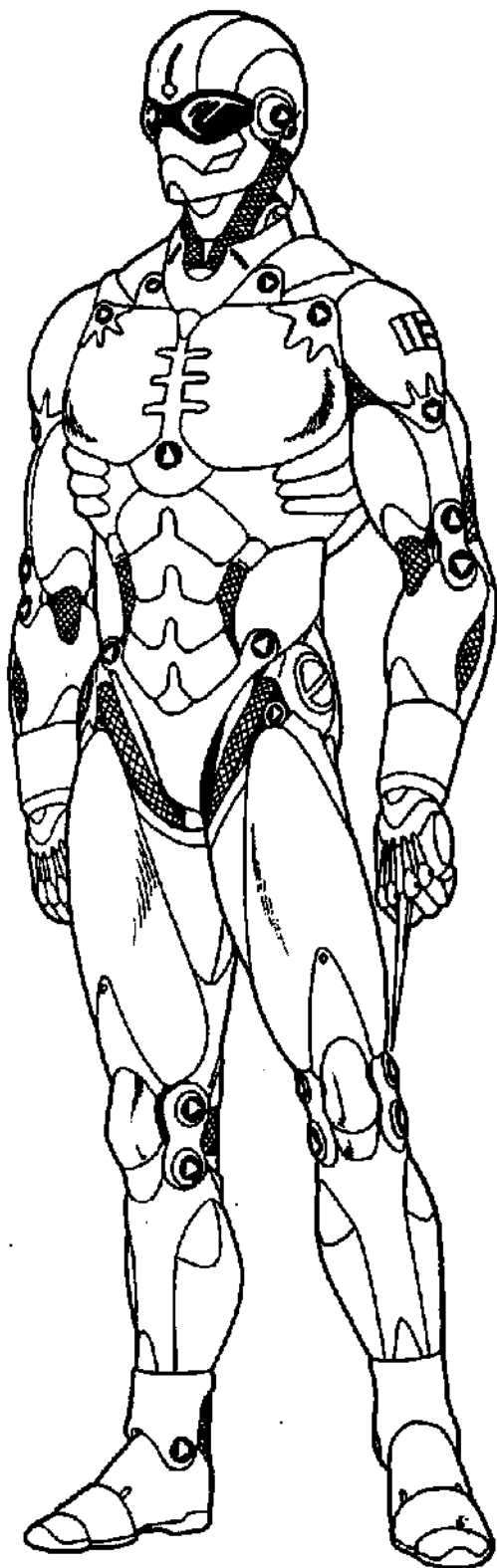

WINGMAN PHYSICAL STATS

REFLEX: 15 *10*
 ATTRACTIVENESS: NA
 MOVEMENT ALLOWANCE: 10
 M/turn: 30m MPH: 20mph
 Jump (up): 6m (broad): 8m

Body: 12
 Lift: 480kg Throw: 120m
 Damage Mod: +4

HAND-TO-HAND:

Punch: 1D6+4 Kick: 2D6+4

PHYSICAL STRUCTURE

HEAD

SP: 25
 SDP: 20 (disabled), 30 (destroyed)
 Options (Optic): 0 & 0
 Options (Audio): 5

RIGHT ARM w/ HAND	TORSO	LEFT ARM w/ HAND
SP: 25	SP: 25	SP: 25
SDP: 20/30	SDP: 30/40	SDP: 20/30
Options: 2	Options: 3	Options: 3

RIGHT LEG w/ FOOT	LEFT LEG w/ FOOT
SP: 25	SP: 25
SDP: 20/30	SDP: 20/30
Options: 1	Options: 2

OPTION PACKAGES

SENSOR OPTIONS:

Locator Beacon - a radio signal unit with a 100km range, because you want to protect your investment. *1*

Visual Systems: Teleoptics (20x magnifications), Image Enhancement (+2 to visual Awareness rolls), AntiDazzle, Times Square Plus. *4*

WEAPON SUBSYSTEMS:

Survival Blade - A wrist blade which extends between the knuckles, doing 1D6+7 damage (BOD included). *2*

Leg Holster - This can hold a Heavy Pistol, Light SMG or a Folding Shotgun, as well as one spare clip of ammo (weapons not included). *1*

OTHER OPTIONS:

Parachute - This internally-stored back unit compresses the 'chute into a tiny package, and blasts it out with gas pressure: cannot work under 200 feet. *2*

Gyroscope - (+2 on Sickness rolls, +1 to high-G maneuvers, +2 on any REF roll involving balance). *1*

Two extra sets of Interface Plugs, making three pairs total. *2*

TOTAL PACKAGE COSTS

EURODOLLARS: 54,000
 HUMANITY COST: 20D6 (16D6+23)

SAMSON

NOVELTECH LIMITED

INDUSTRIAL-USE FULL CONVERSION

50,000 EB

Imagine a perfect worker: tireless, incredibly strong, and capable of surviving almost any accident. This is the Samson full body conversion. Designed for construction, loading, and "hazmat" duty (dealing with hazardous materials and environments), Samson is as effective as an entire crew of union hardhats! Samson is equally at home hundreds of stories above the ground as a welder on high steel, or hundreds of feet below the surface of the Earth in a mining tunnel. Samson's other areas of expertise include logging, oil drilling, toxic waste disposal and any other industrial application you can think of.

Like his namesake, this full body conversion is unparalleled in strength. Using a mix of super-dense myomar fibers and high-powered magnetic pistons, Samson is brawny enough to load and unload almost any cargo, reshuffle steel girders, and demolish old tenements with his bare hands. This full conversion is also tough enough to withstand the many accidents which plague construction sites, and can be relied upon to rescue any co-worker who is so unlucky.

Since he has to work with his hands, Samson's own are packed with every tool he could ever need. He can cut wires, twist in screws, test circuits, manipulate microsensors, tighten (or loosen) any bolt, drill a hole through a 2" steel plate, and link up with any electronic device's diagnostic systems. On top of this impressive array of equip-

FULL BODY REPLACEMENT

ment, Samson's right arm has an industrial-strength arc-welder and cutting torch which is powerful enough to work on battleship armor plating. Since it wouldn't do for any cyborg to be blinded by his own torch, Samson's optics have auto-stepdown flare compensation as a standard feature.

In order to do the job better, Samson has an interactive heads-up display which can access assorted databases and information systems through the cyborg's interface plugs, or from special chipware (such as Techie Visual Recognition Chips). This display is often used in concert with a cyber-chipped micro-computer (which stores blueprints, diagrams, etc.) worn around the waist on a belt, and it also ties directly into the tech-scanner which is built into the left forearm. This device can be hooked up (through connectors in Samson's fingers) to the diagnostic systems of most vehicles, appliances and personal electronics to determine possible problems and troubleshoot breakdowns.

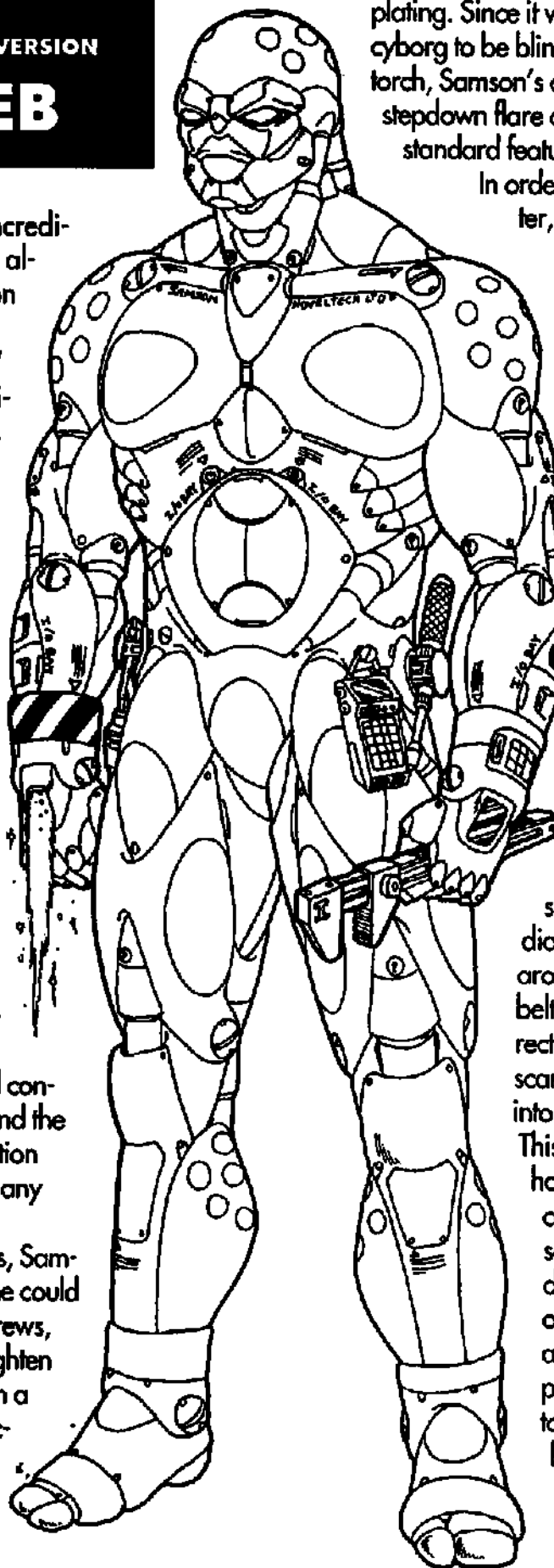

FULL BODY REPLACEMENT

Being more than human, Samson truly shines in the field of hazardous material handling and hostile environment duty. Already immune to the effects of toxic gasses, this body also has a special lead-lined biosystem housing which protects Samson's organic components from radiation poisoning. Further enhancing Samson's Hazmat capabilities is a built-in radmeter which can detect radiation in a 10m radius, determine its intensity and extrapolate the dangers of continued exposure. He just has remember to get "cleaned" of radioactivity before going to the bar after work!

SAMSON PHYSICAL STATS

REFLEX: 10
 ATTRACTIVENESS: NA
 MOVEMENT ALLOWANCE: 1 0
 M/turn: 30m MPH: 20mph
 Jump (up): 6m (broad): 8m
 Body: 18 *12*
 Lift: 720kg Throw: 180m
 Damage Mod: +8

HAND-TO-HAND:

Punch: 1D6+8 Kick: 2D6+8

PHYSICAL STRUCTURE

HEAD

SP: 25
 SDP: 20 (disabled), 30 (destroyed)
 Options (Optic): 1 & 3
 Options (Audio): 6

RIGHT ARM W/ TOOLHAND	TORSO	LEFT ARM W/ TOOLHAND
SP: 25	SP: 25	SP: 25
SDP: 20/30	SDP: 30/40	SDP: 20/30
Options: 2	Options: 3	Options: 2

RIGHT LEG W/ FOOT	LEFT LEG W/ FOOT
SP: 25	SP: 25
SDP: 20/30	SDP: 20/30
Options: 2	Options: 2

OPTION PACKAGES

Sensor Options:

Times Square Plus - This interactive heads-up display can integrate with databases through interface plugs and chipware. It is usually used in concert with a plug-in micro-computer (which stores blueprints, diagrams, etc) worn around the waist on a belt. *2*

Anti-Dazzle - Both optics are equipped with stepdown flare compensation, so that the glaring light from the arc-welder won't blind the cyborg. *1*

Radiation Detector - Very useful for Hazmat duty, this unit is built into the torso and has a 10m range. Data is displayed on the Times Square Plus. *2*

WEAPON SUBSYSTEMS: NONE INSTALLED

OTHER OPTIONS:

Arc-Welder - Built into the right arm, his super-high-powered thermite lance has a foot-long flame which can weld together anything you want, and can burn through up to SP50 in one turn. It does 4D6+2, halving the SP of any armor, if used as a weapon. *2*

Techscanner - Built into the left arm, this microcomputer has various I/O connectors and probes to connect with assorted electronic systems. It adds +3 to any TECH rolls by running diagnostics, identifying and examining malfunctioning components, and displaying schematics on the Times Square Plus. *1*

Toolhand (right) - Wirecutters, power screwdriver, micro tools, wrench. *2*

Toolhand (left) - Mini-drill, I/O Connector (for Techscanner), probe (for Techscanner), socket wrench. *2*

Radiation Shielding - This protects the biosystem from suffering from any harmful side-effects due to exposure to radioactive material. Handy for Hazmat duty. *1*

TOTAL PACKAGE COSTS

EURODOLLARS: 50,000
 HUMANITY COST: 20D6+1 (16D6+25)

DRAGON

INTERNATIONAL ELECTRIC CYBERNETICS
 MILITARY-USE FULL CONVERSION

120,000 EB

The modern battlefield sees many impressive weapons—remote-controlled drones, STOVL stealth fighters, minitanks, combat bikes, anti-tank vehicles, power-assisted infantry armor, and AV-type ground attack craft. However, the ultimate multi-role land-deployed combat unit is the "Dragon" cybersystem. IEC, holders of the U.S. military cybernetics contract, designed the Dragon to be the most deadly weapon any army could have. Variants of the Dragon have, predictably, sold well overseas. Being a strictly military weapon, the Dragon is absolutely impossible to buy on the open market, and even the most powerful of corporations have a hard time getting ahold of these (except for IEC, that is). Measuring over 8 feet in height, and weighing in at

FULL BODY REPLACEMENT

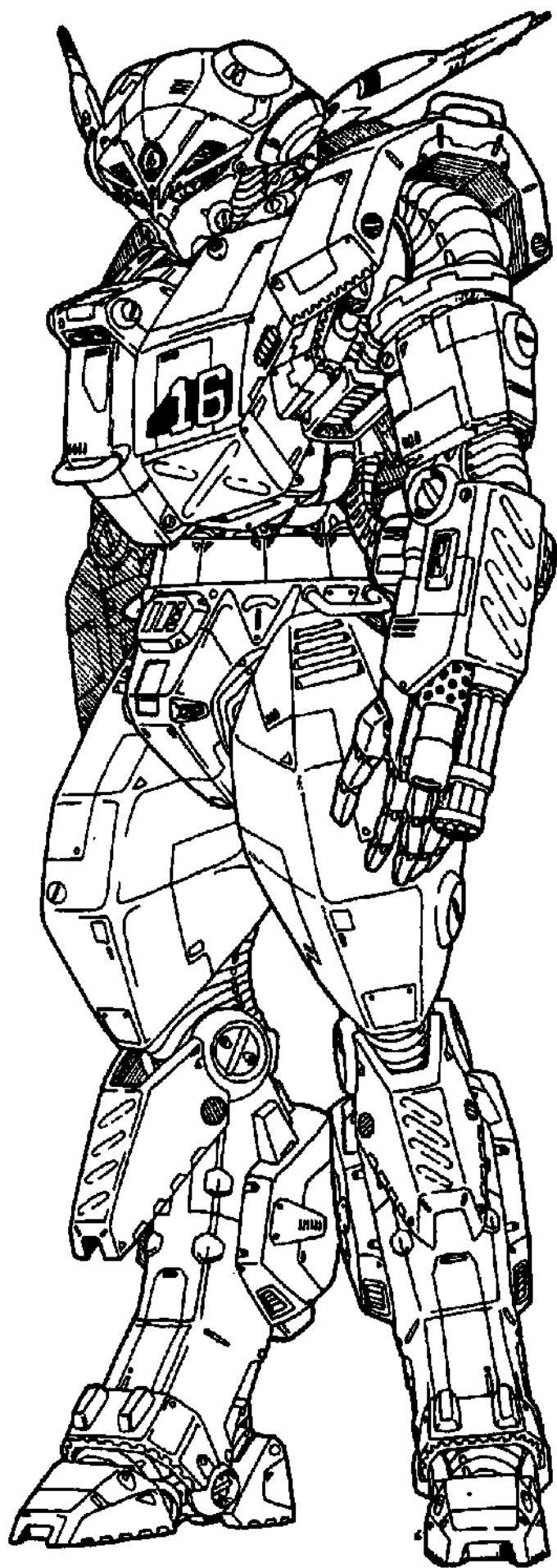

"Personally, they give me the creeps. It's like standing next to a 7 foot, steel-encased, cannon-toting, basket case. Give me your good, old-fashioned, armed nuclear weapon any day."

—Infantry Sgt. James R. Teal

620 pounds, the Dagoon is arguably the most powerful full conversion in existence.

The Dagoon's advantage over all other land-based combat units is its humanoid form. It is capable of taking maximum advantage of terrain, it can enter buildings, hold territory and perform every part of a military operation, from guerilla warfare to anti-aircraft artillery. Its performance levels give it equal speed (and superior all-terrain capability) to a 4x4 combat car, while it can go where no car ever could: treetops, maintenance tunnels, even vehicle cockpits. Combined with this unbeatable mobility is the Dagoon's inherent toughness: its armor plating consists of a monocrystalline ceramic composite with an ablative layer of heat-displacing ceramics and foamed metal (full SP vs lasers, etc), while its critical system redundancies and raw ability to soak damage make it the rough equivalent of an AFV. In this respect, the Dagoon can easily function as a perimeter patrol and defense unit, as well as an anti-site fast-attack system. It is also a fearsome opponent to troops and vehicles.

FULL BODY REPLACEMENT

As a military weapon, Dragoon has many subsystems which are vital on the battlefield as standard features. It has a wide array of detection, acquisition and designation systems, backup sensors, environmental scanners and communications gear which maximize its chances of getting that most precious of commodities: current data on your foe. However, the Dragoon is not a dedicated design; rather, its modular construction allows it to custom-tailor its equipment to suit almost any role. All four of its limbs are interchangeable, allowing it to mount almost any type of weaponry, from a suppressed SMG for special ops to a heavy machinegun or railcannon for anti-vehicular combat. The Dragoon is also fully protected against nuclear, biological, chemical and electronic warfare, giving it greatly enhanced staying power in an extended engagement.

The most immediately obvious problem with such a full body conversion package is the almost guaranteed development of devastating cyberpsychosis. It is true that a human brain, implanted in such a body, cannot easily cope with so many new senses and capabilities. IEC overcame this problem: the Dragoon, being a restricted, combat-use body, comes with an interchangeable biopod. This biopod, which houses the cyborg's biosystems, normally inhabits an "off-duty body," usually an Alpha Class. The Dragoon is only fitted with the biopod, and the human mind within, when it is actively performing missions. To ensure reliable performance from the Dragoon, a Behavioral Inhibitor Program in the cyborg's on-board computer (operating in concert with a chemical injection system loaded with psychoactives) restrict the Borg's thought processes, turning it into a loyal soldier. Battle-proven in the Brushfire Wars of 2018, the Dragoon's prowess and dependability are assured.

Note: The Behavioral Inhibitor Program and its battery of psychoactives do, indeed, keep the cyborg from going cyberpsycho (in the conventional sense). Basically, anyone whose biopod is in this body will act like a robot, unimaginative and literal minded. The borg's commanding officer says "Do this," and the Dragoon says "Yes, sir..." and does it. Because Dragooons are so straightforward-thinking, they are given very spe-

cific orders with carefully-laid out parameters. They are also easy to trick, so truly sensitive work is still left to more human operatives. A common mission would be to send a Dragoon into a sector which has been cleared of friendly forces and have it kill anyone it finds, then return. Those soldiers who have been the "minds" of Dragooons are not comfortable with the experience, likening it to being in a dream (or nightmare).

DRAGOON PHYSICAL STATS

REFLEX:	1	5'10"
ATTRACTIVENESS:	NA	
MOVEMENT ALLOWANCE:	25'30"	
M/turn:	75m	MPH: 50mph
Jump (up):	6m	(broad): 19m
BODY:	20'16"	
Lift:	800kg	Throw: 200m
Damage Mod:	+8	

HAND-TO-HAND:

Punch: 1D6+8 Kick: 2D6+8

PHYSICAL STRUCTURE

HEAD

SP:	40
SDP:	40 (disabled), 50 (destroyed)
Options (Optic):	0
Options (Audio):	0

RIGHT ARM W/O HAND	TORSO	LEFT ARM W/O HAND
SP: 40	SP: 40	SP: 40
SDP: 40/50	SDP: 50/60	SDP: 40/50
Options: 4	Options: 0	Options: 4
RIGHT LEG W/ FOOT		LEFT LEG W/ FOOT
SP: 40		SP: 40
SDP: 40/50		SDP: 40/50
Options: 2		Options: 2

OPTION PACKAGES

Sensor Options:

- Front Optic Mount with 5 cyberoptics: "23"
- (Night-Vision Optic) Lowlight, Image Enhancement, Anti-Dazzle, Targeting Scope.
 - (Thermal Optic) Thermographics, Image Enhancement, Anti-Dazzle, Targeting Scope.
 - (Long-Range Optic) Teleoptics, Image Enhancement, Anti-Dazzle, Targeting Scope.
 - (IR-Vision Optic) Infrared, Image Enhancement, Anti-Dazzle, Targeting Scope.
 - (Heads-Up Display Optic) Times Square Plus, Anti-Dazzle.

Cyberaudio: Amplified Hearing (+2 Awareness) with Level Damper and Enhanced Hearing Range, Long-Range Radio (25km) with 6 frequencies and Scrambler, Radar Detector (automatically detects Radar beam, 40% chance of fixing source). *5*

Twin Sensory Booms: *6*
(Right) Optic with Video Transmitter (transmits what the optic is seeing, live), Audio with Audio Transmitter (transmits what the mike is hearing, live). *2*

(Left) Optic with Video Imager (can show video images from recordings, transmissions and through Interface Plugs), Audio with Tight Beam Transmitter (unjammable within line of sight). *3*

"Sniffer" - Built into the head, consisting of an Olfactory Booster (which adds +2 to smell Awareness rolls, and has a 50% chance of picking up a scent and adding +2 to Shadow/Track skill) and a Chemical Analyzer (which can analyze chemical traces in the air and break them down into their components). Data is displayed on the Times Square Plus. *4*

Sonar Scanner - Built into the skull, this ultrasound sensor accurately measures distance to, and dimensions of, the nearest solid object. It also serves as a motion sensor with a 120m radius. Data is displayed on the Times Square Plus. *2*

Radar Sensor - This 1km range sensor has its emitter in the skull, and its receiver in the chest area. Data is displayed on the Times Square Plus. *2*

Radiation Detector - Built into the torso, this unit has a 10m range. Data is displayed on the Times Square Plus. *2*

WEAPON SUBSYSTEMS:

None installed, but all four limbs have Quick-Change Mounts, allowing the Dragoon to suit its weapon suite to its mission; anything from a .22 pistol to a grenade launcher or railcannon can be mounted. *8*

OTHER OPTIONS:

Interchangeable Biopod - This allows the cyborg's biosystems to inhabit different bodies for different purposes. The Dragoon body is only inhabited by a biopod when it is active, and a Behavioral Inhibitor Program keeps the semi-cyberpsycho borg from getting out of line. *3D6*

Chipware Socket - If a Dragoon cyborg needs any extra skills in the battlefield, it's able to use them without filling up its Interface Plugs. *1*

Pain Editor - Cuts out heat, cold and pain on command. A must for a combat borg! *2*

Ambidexterity Sub-Processor - This allows Dragoon to use either arm with equal effectiveness, and at the same time. *1*

Combat Crystal - This system allows 5 or more Dragoons to coordinate their actions; making sure that their vision covers 360°, covering each other, and generally using teamwork. This does not promote much individual action, but it grants maximum

FULL BODY REPLACEMENT

efficiency. When used, it adds +1 to Initiative and Attack rolls, +2 to Awareness and Defense rolls. *4*

Chronometer - Dragoon has a built-in timekeeping unit with stopwatch and alternate time-zone functions, displayed on the Times Square Plus. *0*

IR Thermal Dam - This system absorbs IR emissions until they can be safely bled off; this is done in a random pattern, so that it does not appear to come from a humanoid source. This translates into a -5 to any IR-based Awareness rolls. *2*

Black Box Recorder - This is a built-in Braindance recorder, recording on chip everything the 'Borg experiences during its mission. It is used for post-mission analysis and debriefing, and it records what happened to those borgs who didn't make it. *1*

Environmental Assimilation System - Dragoon's exterior patterning and coloration can be selected. Internal memory stores 24 different camouflage patterns (desert, urban, snow, etc) as well as flat black and olive drab coloration, selectable by the 'Borg. Observers are at -2 Awareness if the wearer remains still, -1 if they're moving (This bonus compounds for each 10 meters of distance between the wearer and the observer). See Militech Mirage Gear, Equipment section, page 28. *2*

Autoinjector - This is a small, refillable drug injector which can dose the brain with psychoactive drugs. Black Lace derivatives are a common choice. *1*

Ammo Hopper - This is a back-mounted ammo container with an electrically-powered belt feed. It can be modified to carry almost any type of ammo, and holds 20x the weapon's standard magazine capacity. *2*

Locator Beacon - a radio signal unit with a 100km range, because you want to protect your investment. *1*

IFF Transponder - This emits a coded, Identify Friend-or-Foe signal so that friendly patrols, smart mines, and air support won't mistake a Dragoon for the enemy. *0*

Satellite Link - This high-powered microwave communication system (which uses "rabbit ears" as antennae) allows communication with friendly satellites, giving instant access to battlefield data, intelligence, and updated orders. It also has a Global Positioning System which can pinpoint Dragoon's True Earth location to within 5m. *3*

Micro-Computer - An on-board fuzzy-logic subprocessor with capabilities equivalent to a pocket computer (see EBM PCX, Equipment section page 14). *2*

Shielding - Dragoon is fully protected against electromagnetic pulse, electrical surges and microwave attacks. *6*

TOTAL PACKAGE COSTS

EURODOLLARS: 120,000
HUMANITY COST: 42D6+3 (19D6+141)

OPTIONS FOR FULL BODY CONVERSIONS:

Full Borgs, by their very nature, have the advantage of being able to accept a wider variety of options than any enhanced human. These cyborgs can use any Cyberware mentioned in any of the rules: most Bioware and Organware would be superfluous, but all Cyberlimb, Optic and Audio Options, as well as other systems, are perfectly acceptable. The only limitations come from the potential humanity costs, and the number of option spaces the cyborg has. As a rule, all option components cost the minimum HC. Ex: Rippers (3D6) would cost 3 Humanity points. Any options added at the same time as the full body package (ie, it is included in the body at the time that the person's biosystems are implanted into it) have their minimized HC costs added together and broken into dice plus modifiers. Example: six 2-point options would total 12HC, so they would become 2D6HC. Options which are built into the body at a later time simply cost minimum HC, but they are not broken into dice values.

Stylization (Price varies): Most full body conversions are "standard" models, with no unique features to set them apart from another body of the same series. Since individuality is the essence of being cyberpunk, customization is a common occurrence among Full Borgs. Some are sculpted to look sleek and graceful, others are made more fearsome looking. Such stylization varies in cost, depending upon what the effect is. However, certain choices can affect skill rolls: a monstrous appearance might add +2 (or more) to Intimidation, while a smooth "sexy robot" appearance might actually give you a chance at a Seduction roll. Attractiveness really cannot be changed; Personal Grooming skill is a moot point, while Wardrobe and Style skill can simply be used, as its own "Stat." (What, you thought Metalheads didn't wear clothes?)

Increased SP (2000eb, HCO): Monocrystalline matrices, latticed plating, chitin-ceramics, carbon polyalloys and other hybrid materials can all be employed to increase the overall Stopping Power of the cyborg's armor plating. Each +5 increase in the overall SP of the body (+5 to arms, legs, head and torso) costs 2000eb, adding 10lbs for +5SP, 25lbs for +10SP and 50lbs for +15. An overall SP of 40 is the maximum. SP must be applied to the body as a whole not just to specific parts.

Increased SDP (1500eb, HCO): Reinforced joints, denser myomars, metallic matrix materials and redundant construction can all contribute to increasing a cyborg's Structural Damage Points. Each +5 increase in the overall SDP of the body (+5 to arms, legs, head and torso) costs 1500eb,

FULL BODY REPLACEMENT

adds 55 pounds, and may increase overall size slightly. Remember that the maximum is +20SDP.

Increased Stats (Cost varies, HC2): By hardwiring faster response times, replacing myomars with magnetic-powered hydraulics, and supercharging micromotors, the Borg's physical stats can be increased. Reflexes cost 2000eb per +1 (Maximum 15), MA costs 1500eb per +1 (1MA equals 3mpt/2mph, Maximum 25), and Body costs 1000eb per +1 (Maximum 20). Humanity cost is 2 per +1 increase in any stat.

Shielding (2000eb, HC6): Placed internally, this "hardened" sheathing protects the cyborg from the effects of electromagnetic pulse, electrical surges, and microwave attacks. A very useful item, since one shot from a Techtronica M40 Pulse Rifle at close range is enough to turn the toughest Metalhead into the equivalent of a broken toaster.

Quick-Change Mounts (200eb, HC2): All Full Borgs (except the Gemini) may purchase Quick-Change mounts for any or all of their limbs, as well as for their hands and feet. If an arm does not have a hand installed, that space may be used for some other option, and it becomes possible to install Rifles (2 spaces) and Heavy Weapons (3 spaces) in the limb. Keep in mind that your Humanity index will change depending upon what limb you have mounted. Don't even think about getting a Quick-Change Head, you poser.

Interchangeable Biopod (20,000eb, 18D6): This drastic option for full-body conversions allows the purchaser to effectively have an assortment of interchangeable bodies! When the transplant operation is performed, the patient's biosystem (the brain and the few organs which cannot be replaced) is not built into a cybernetic body; rather, the biosystem is placed in a compact life-support module. This Biopod (which is about two cubic feet in size) can then be interfaced with any cyborg body which has been fitted with the correct receptacle, thereby allowing the Biopod to be switched from body to body, depending on what

duty it intends to perform. However, it can only be put in a cyborg body which was designed to accept an Interchangeable Biopod (these bodies cost the same amount as normal ones, but cannot be used by anything but a Biopod). When the Biopod is removed, it is often jacked into a braindance recording in order to provide stimulus for the brain while it waits for the next body to be prepped for installation. Those cyborgs who can afford it often buy human-looking bodies for everyday life, and also buy other bodies for their "work." Theoretically, it would be possible to place such a Biopod inside a specially-modified vehicle (or other non-humanoid body), thus granting the brain unmatched versatility. However, the alien nature of these bodies would probably incur catastrophic humanity loss. An Interchangeable Biopod can only be bought at the time of the subject's transplant operation, and the Humanity Cost is 18D6 (rather than 16D6 for the basic Full Body Conversion); the humanity index will vary depending upon which body the Biopod is using. This is determined by the total HC of the body, less 16D6.

Longevity Module (15,000eb, HC1): This module, which can be installed in any full body conversion system, consists of an advanced medical computer (which functions like a Medscanner and Biomonitor), a chemical synthesizer, and a vast supply of free-roaming nanosurgeons. Once installed in the body of a cyborg, the Longevity Module monitors the status of the Borg's biosystems (ie, the brain and its few support organs) and maintains upkeep of their health. The nanosurgeons isolate local brain degeneration and stimulate deteriorating cells to regenerate. The medical computer diagnoses any illnesses or dysfunctions in the biosystems and synthesizes chemicals and catalyst enzymes to heal any problems. Although this system has not been on the market long enough to prove its full capabilities, it makes the cyborg all but immune to disease and will theoretically triple its lifespan (this based on computer projections). This is a popular choice among those who have a Gemini body.

VEHICLES

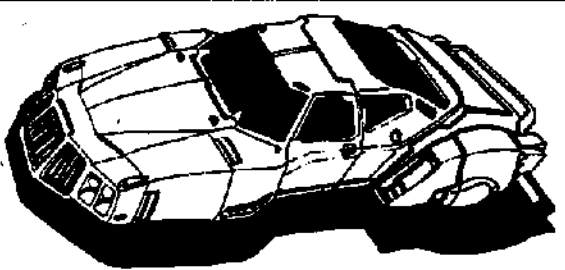
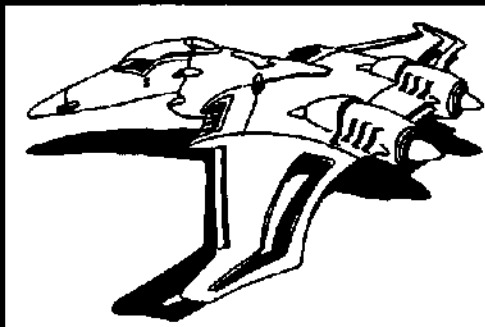

"Ares combat bike . . . A Nomad's dream. Rock 'n roll, babe!"

-Donya West, Demoracer and Braindance Star

"A Punk's ride is an extension of his attitude. And we all know attitude is everything."

-Gil Myxx

"Who cares what it looks like; how fast is it?"

-Jake Takada

AERODYNES

Aerodynes (vectored thrust vehicles) are airframes without lifting surfaces (wings or rotors) that can fly by virtue of vectoring jet engine thrust to counteract gravity. They are true Vertical Take-Off and Landing (VTOL) aircraft.

Aerodynes are a familiar sight in the *Cyberpunk 2.0.2.0* universe, largely represented by the ugly, bulbous AV-4. There are drawbacks to their versatility: if an aerodyne is flipped on its side or back, it loses all lift and plummets until it can point its jets at the ground again. Aerodynes also use jet engines which produce lots of heat; heat that attracts IR-homing missiles in combat (including most SAMs). Finally, jet engines can't use alcohol fuel (the octane is far too low) and must use Avgas or Kerosene, expensive petroleum derivatives. Avgas is available at airports and other aerodyne/helicopter ports, and costs (2D6 x 10)+50 eb per gallon (70-170 eb/gallon).

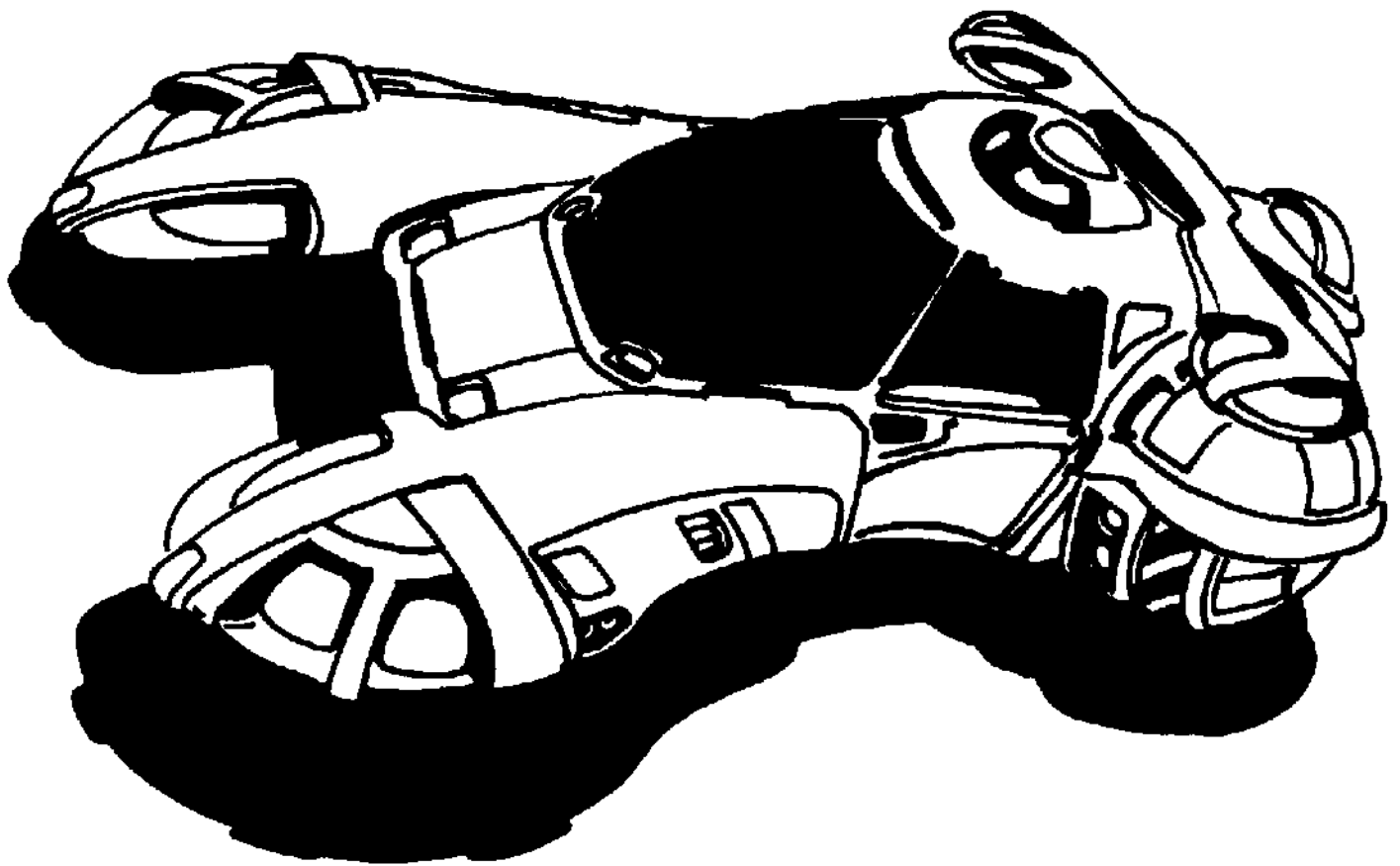

AV-3 "AEROCOP"

The AV-3 "Aerocop" (as it is known) is a familiar sight in any metropolitan area in the world. It is the standard for police departments the world over, with good armor, good performance, and versatility. The Aerocop functions just like a normal police car, except that it can fly as well as "roll".

The turret machinegun mount owes its existence to the AV-3's design concept as a military scouting vehicle. Rejected in favor of the all-purpose AV-4 and the assault AV-6, the AV-3 was then sold to police departments the world over. Some departments dismount the turret; others keep it, and even vary the weaponry from the standard machinegun to heavy machineguns, light autocannons and missiles. The AV-3 is possibly unique in that it has retained ground wheels for surface maneuvering, another legacy of military requirements that it be able to go to ground and operate in surface mode: This comes in very handy for police operating in areas where tall surface clutter precludes flight.

Maneuver Speed: 250 mph
 Acc/Dec: 50 mph per phase
 Top Speed: 350 mph
 Fuel Efficiency: 1 mpg
 Passengers: 5
 Fuel Capacity: 300 gallons avgas
 SDP: 50
 Maneuverability: +1 to all rolls
 SP: 20
 Cost: 500,000 eb

Special Equipment: Radio, computer link to police headquarters, crash webbing (counts as 15 SP for passengers in crashes and collisions), ejection seats for front passengers (passengers then drift to ground on individual parachutes), secure back seat (20 SP armorplastic barrier between front and back seat), spotlight, police strobe lights, loudspeaker.

Game Notes: The AV-3 has a Maneuvering Speed of 60 mph, a Top Speed of 150 mph, Maneuverability of +0 to all rolls and Acc/Dec 10 mph per phase when on the ground.

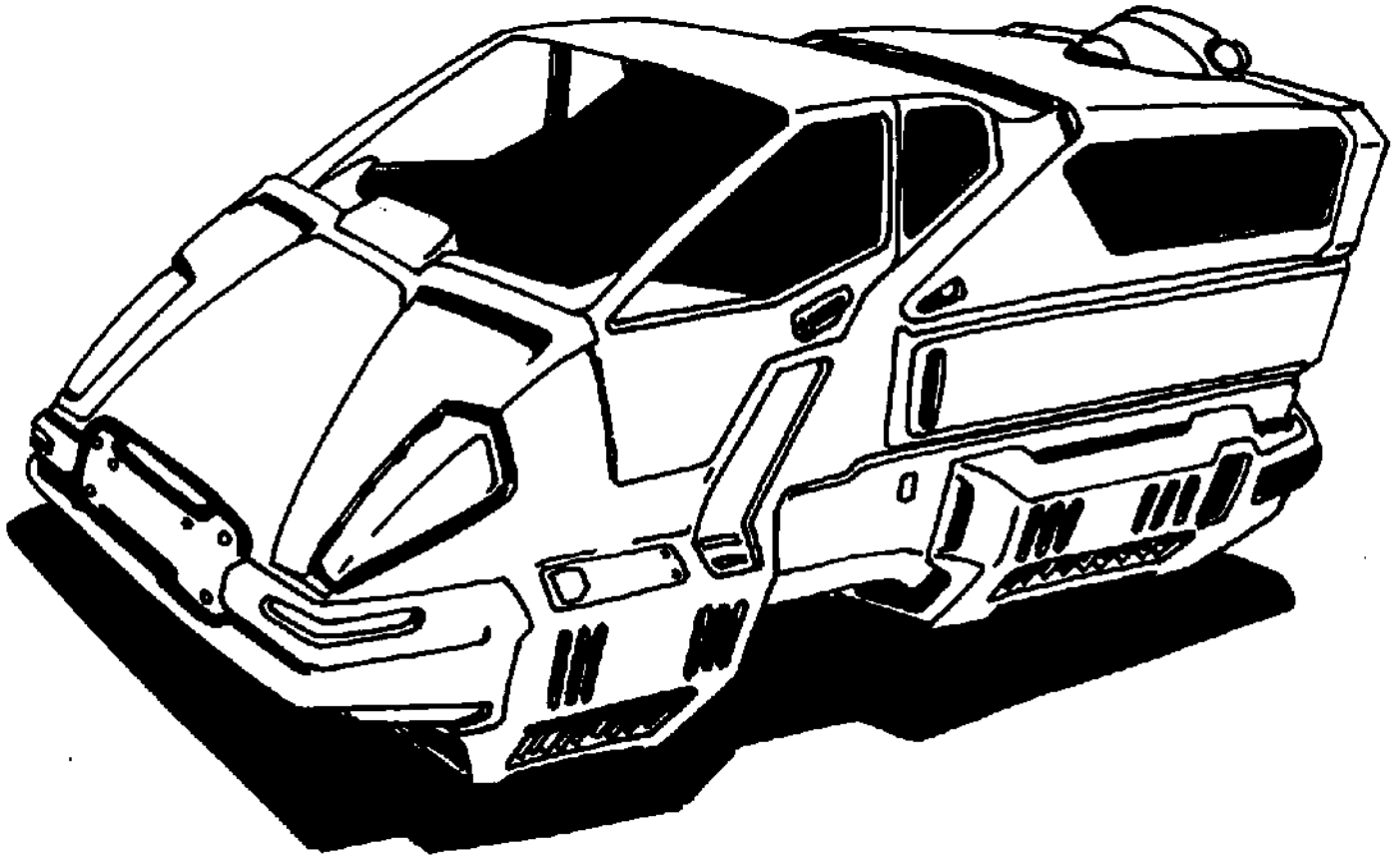

THE FAMILY FLIER

For years, the AV series has been the epitome of fast transport, a vehicle that can take off and land without the need of a runway and flit to its destination at aircraft speeds, avoiding ground clutter and traffic congestion. But it's always been beyond the reach of any but the most filthy rich.

No longer! VMW now introduces its new export model of their popular EEC military airjeep, the Family Flier. Priced to sell, the Family Flier is available to the middle-class family, at reasonable interest rates (10% APR). It's easy to fly, cheap to maintain, and has one of the highest fuel mileage rates of any aerodyne on the market. The Family Flier: Safe, fast, inexpensive, convenient. Head on down to your VMW dealership today and take to the skies!

Maneuver Speed: 75 mph
Acc/Dec: 25 mph per phase

Top Speed: 150 mph
Fuel Efficiency: > 2 mpg
Passengers: 6
Fuel Capacity: 100 gallons avgas
SDP: 50
Maneuverability: -2 to all rolls
SP: 15
Cost: 50,000eb

Special Equipment: Crash bags for passengers (counts as SP20 for resisting crash and collision damage to passengers)..

Game Notes: The Family Flier is underpowered (thus its slow speed, sluggish maneuverability and high fuel efficiency). It can hold up to six people (including the driver) and another 100 kilograms of cargo in a cargo bay

THE NISSAN FORD FANMASTER

Can't afford avgas? Why not try a cheaper and more low tech alternative? The FanMaster is a common sight both in the city and outside city limits (especially in areas where roads are limited or non-existent). Its large cargo capacity, reliability and durability make this hovertruck the perfect vehicle for the outdoorsperson on the go, or for an intercity trip with the furniture.

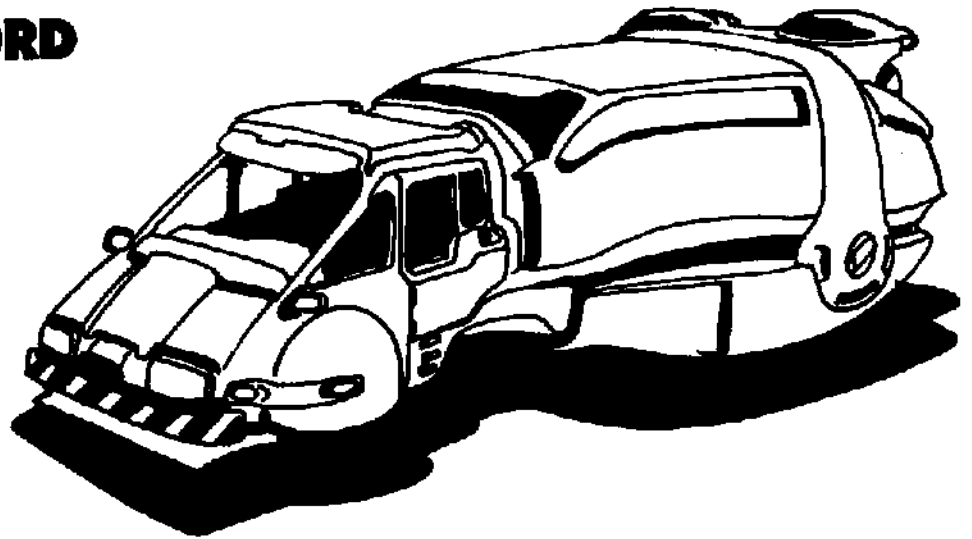

Built to military suspension specifications, if you can get there on a hoverfan, the FanMaster will get you there! It's even fully amphibious!

Maneuver Speed: 25 mph

Fuel Efficiency: 20 mph

Fuel Capacity: 25 gallons CHOOH2

Cost: 20,000 eb

Acc/Dec: 12 mph per phase

Passengers: 3

Maneuverability: -2 to all rolls

Top Speed: 100 mph

SDP: 75

SP: 15

Special Equipment: The FanMaster can carry 750 kg of cargo in the back bed. Enclosed rear vans are available (add 2,000 eb to cost) for in-city vans and runaboats.

Game Notes: The FanMaster is also a fully amphibious, hoverfan vehicle (although it can't fly). As long as it is not carrying more than 250 kg of cargo, it can drive right into water and float. Its low-power fan blade system allows it to drive at 5 mph speed (Acc/Dec 1 mph per phase) overwater. Its maneuvering is terrible, though: -3 to all maneuvering rolls while in water.

THE MACH

The AV series is popular. It's reliable. It's useful. It's everywhere. And every vehicle in the series looks like it was designed by a truck-builder. An AV looks about as fast as a gum eraser, and has the same sex appeal. You can get

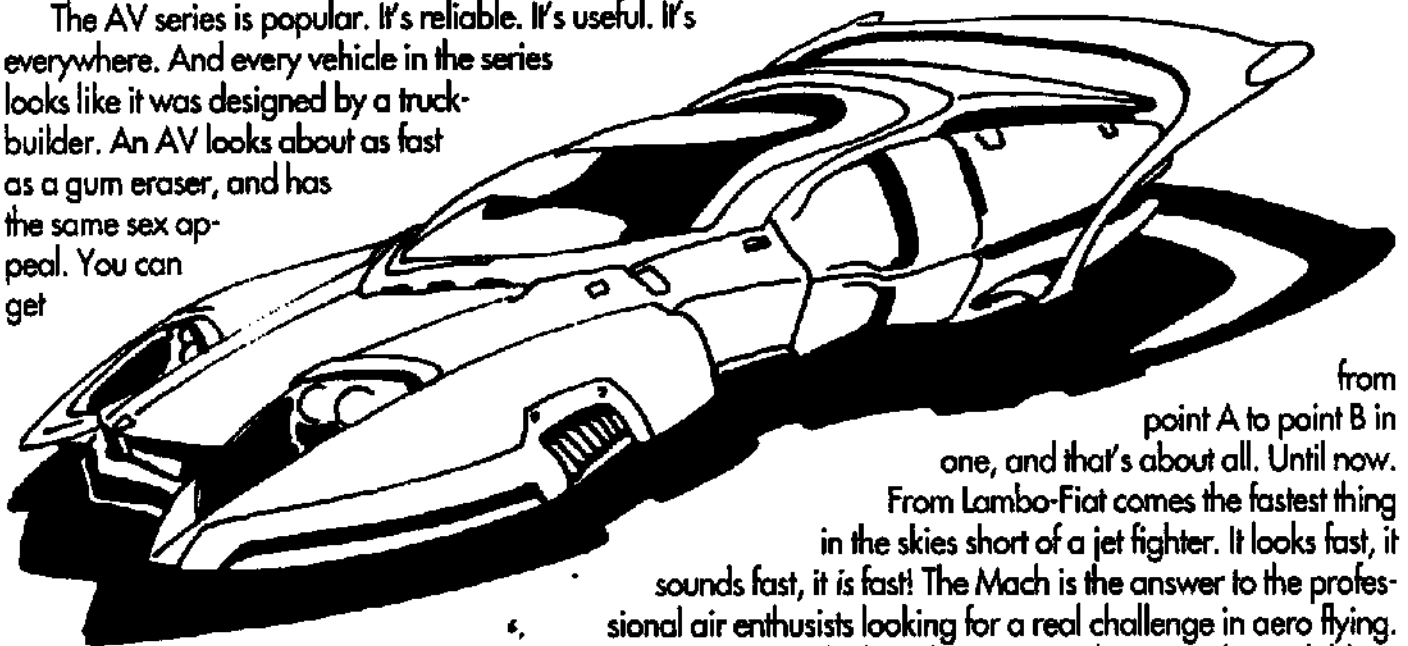

from point A to point B in one, and that's about all. Until now. From Lambo-Fiat comes the fastest thing in the skies short of a jet fighter. It looks fast, it sounds fast, it is fast! The Mach is the answer to the professional air enthusiasts looking for a real challenge in aero flying. And it's the sexiest vehicle in the air or on the ground. Available in black with red interior or red with black interior.

VEHICLES

Maneuver Speed: 200 mph

Fuel Efficiency: 1 mpg

SDP: 40

Cost: 650,000 eb

Acc/Dec: 150 mph per phase

Passengers: 2

Maneuverability: +2 to all rolls

Top Speed: 500 mph

Fuel Capacity: 300 gallons avgas

SP: 10

Special Equipment: Autopilot and computer navigation systems can fly the car to any destination, as long as the destination is programmed into the computer and satellite navigation systems can be accessed. The autopilot makes all maneuvers at skill Pilot (Vector Thrust) 5. The Mach comes equipped with top quality compact audio and video entertainment systems.

Game Notes: The Mach is a very unforgiving aircraft. Unless the pilot has a Pilot (Vector Thrust) skill of 5+, the Mach's maneuverability drops from +2 to all rolls to -5 to all rolls.

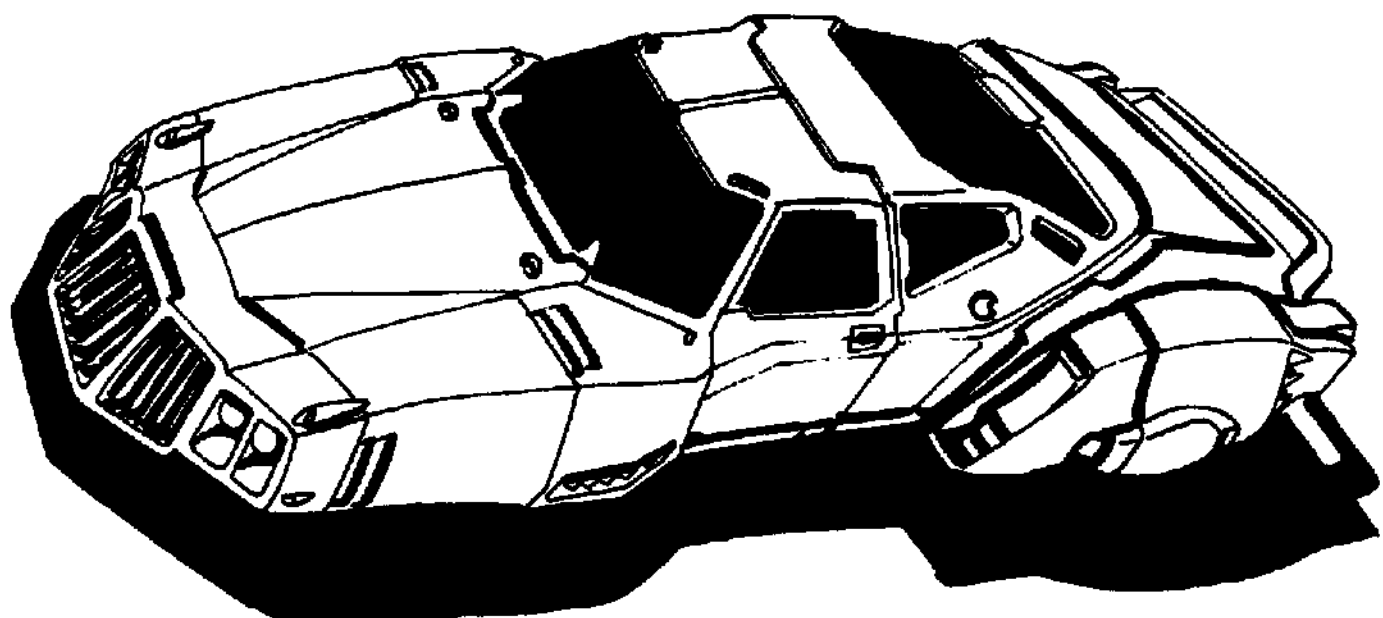

THE SWAN

For the executive on the go, who doesn't want to bother with the pressures of traffic, road repairs, and obscene interest payments, the aircraft and automotive manufacturers of Scandinavia offer the Swan. Performance, high speed, maneuverability, reliability and safety combined with a look that says "You're a success."

The Swan is equipped with the latest in autopilot and computer navigation systems, as well as the top of the line in safety and control equipment. The Swan. Elegance, dependability, and performance.

Maneuver Speed: 100 mph

Fuel Efficiency: 1.5 mpg

Fuel Capacity: 300 gal. avgas

Cost: 200,000 eb

Acc/Dec: 50 mph per phase

Passengers: 3

Maneuverability: -1 to maneuver rolls

Top Speed: 200 mph

SDP: 65

SP: 20

Special Equipment: Crash bags and restraint equipment for passengers (counts as SP 40 to passengers in case of crash or collision). Autopilot and computer navigation systems can literally fly the Swan to any destination, as long as the destination is programmed into the computer and satellite navigation systems can be accessed. The autopilot makes all maneuvers at skill Pilot (Vector Thrust) 5. If the Swan suffers control loss, compensator systems add +5 to Pilot die rolls to regain control. The Swan can carry 100 kg of cargo if the third passenger is not carried.

GROUND CARS

Most ground cars are simple devices very much like those available in the late 20th Century. They almost always have digital readouts and heads-up displays projected onto the windshields, and all-wheel drive/steering. And they almost always run on CHOOH₂ alcohol fuel, or electrical storage/flywheel systems.

THE CROWDER

The New American Motors Crowder is one of the most popular electric citycars in North America, and is even made by license overseas (Japan being the country with the next largest quantity of Crowders). The Crowder's popularity over its closest rival, the Honda Metrocar, comes from its electrical power system. Electricity is available almost anywhere, at a lower cost than CHOOH₂. A Metrocar fillup with CHOOH₂ costs about 15 eb, while a Crowder recharge costs only 10 eb in most cities where electricity is readily available.

For the Green citizen, the Crowder is the only alternative. Make your impact on the environment! Send a message to polluters, and save on fuel costs at the same time.

Maneuver Speed: 20
mph
Acc/Dec: 3 mph per
phase

Top Speed: 40 mph

Fuel Efficiency: 1 hour per power unit

Passengers: 2

Fuel Capacity: 5 power units

SDP: 25

Maneuverability: -1 on all rolls

SP: 10

Cost: 3,000 eb

Game Notes: The Crowder takes 1 hour per power unit to charge when connected to at least a 220-volt power output. A regular 110-volt house power plug charges the battery in 10 hours.

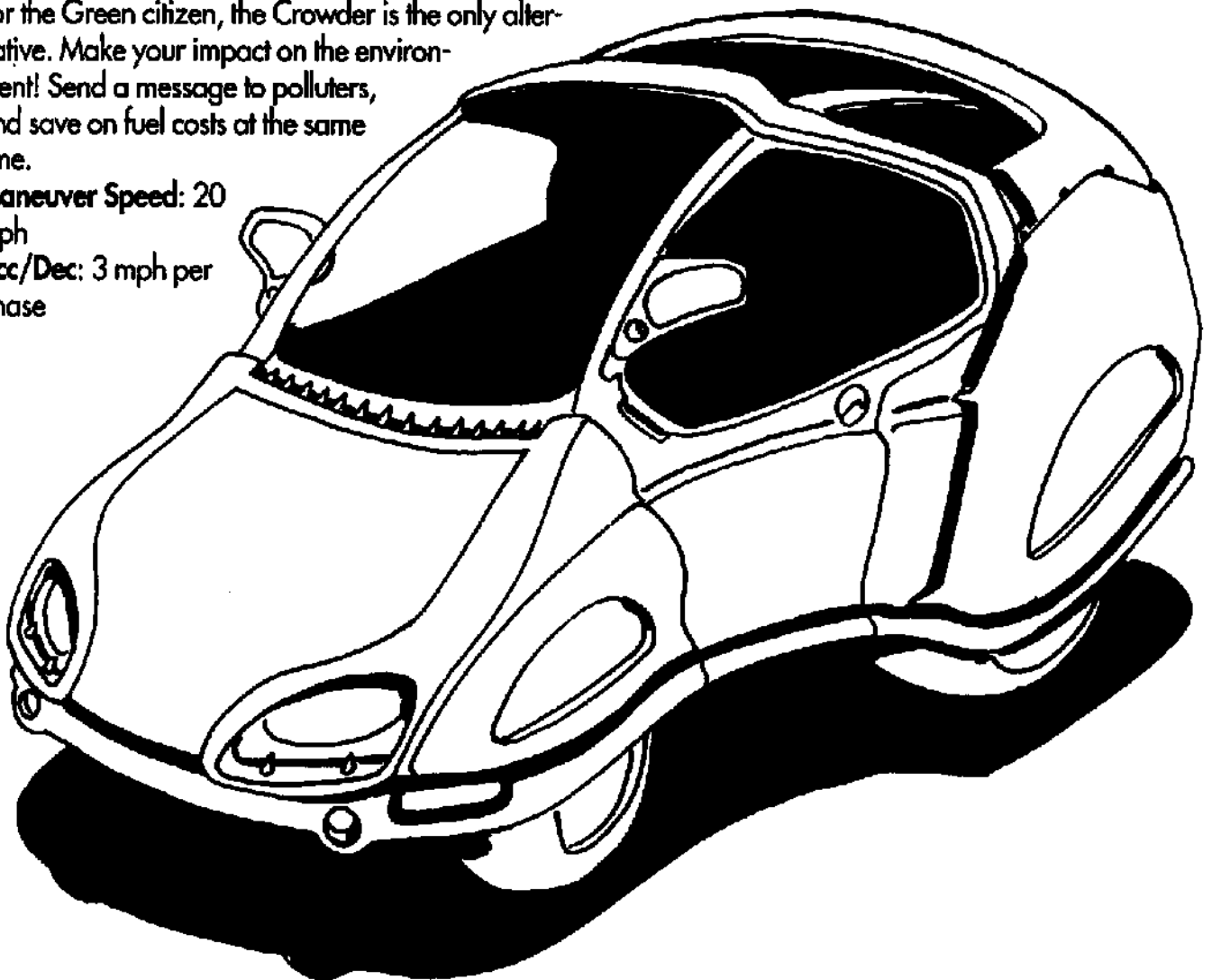

VEHICLES

THE MAX INTERCEPTOR

Used by intercity police the world over! Faster than anything but an aero, tougher than anything but a tank, with the acceleration to make it count and the endurance to maintain long-range high-speed chases, the Max Interceptor is now available to the public. Official chase car of the United States Highway Marshals.

Maneuver Speed: 50 mph

Acc/Dec: 12 mph per phase

Top Speed: 180 mph

Fuel Efficiency: 20 mpg

Passengers: 4

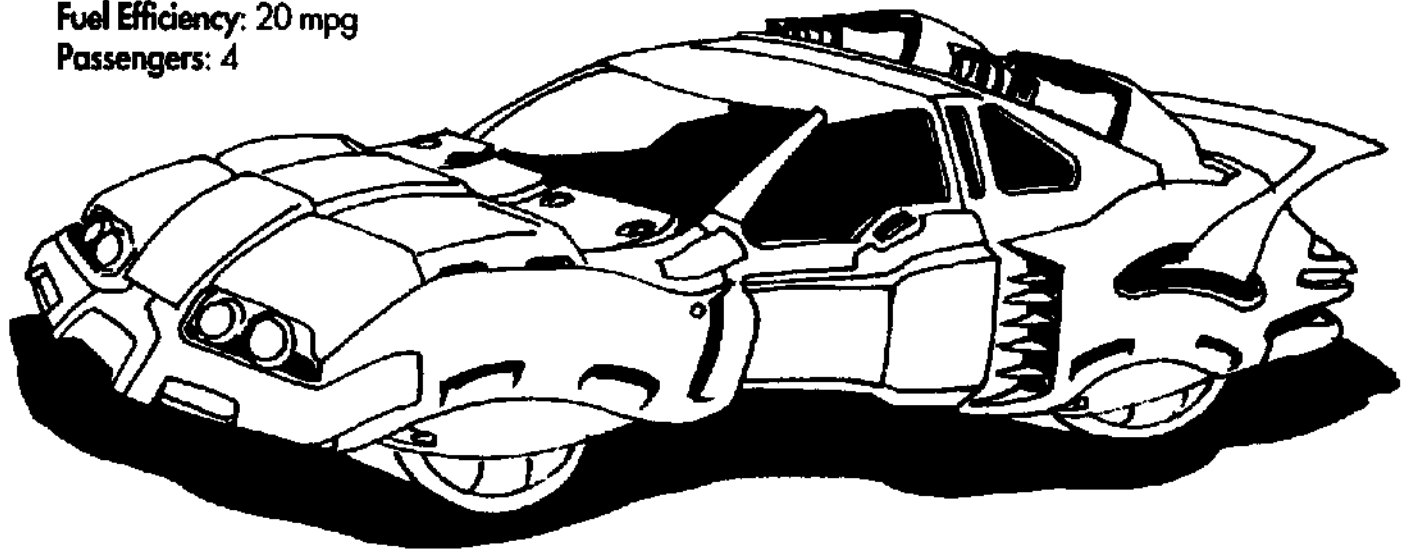

Fuel Capacity: 40 gallons CHOOH_2 SDP: 60 Maneuverability: +1 on all rolls SP: 15
Cost: 40,000 eb

Special Equipment: Police radio, satellite uplink for onboard computer, fire extinguisher, crash webbing (counts as 15 SP for passengers in crashes and collisions), secure back seat (20 SP armorplastic barrier between front and back seat), spotlight, police strobe lights, loudspeaker. **Game notes:** Sometimes this car is armed with a machinegun turret like the AV-3 "Aerocop."

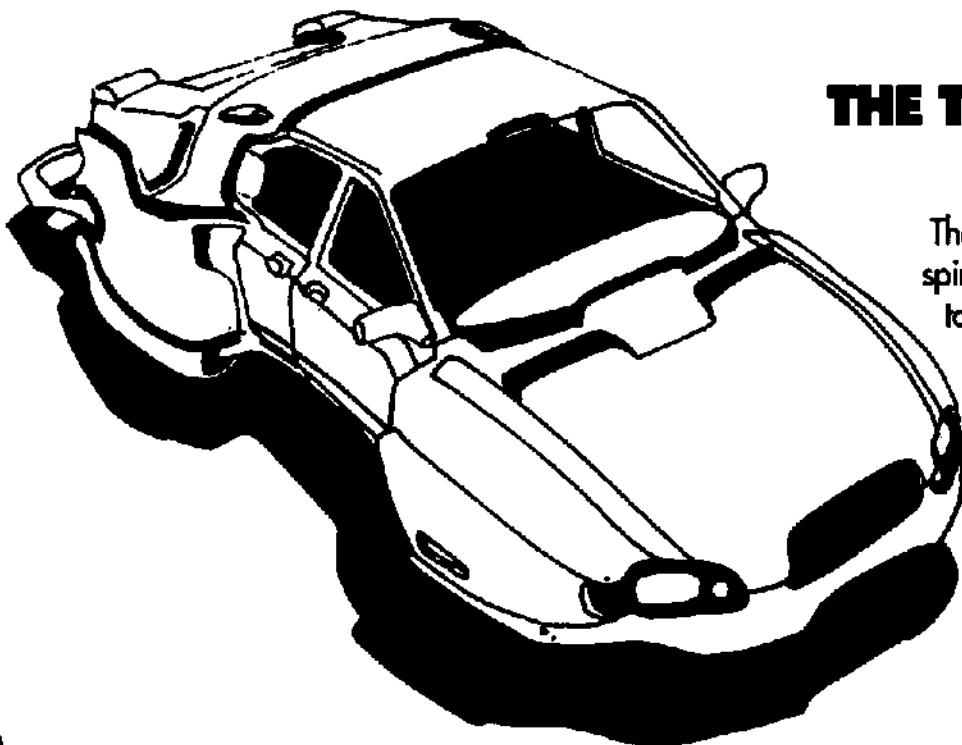

THE TOYO-CHEVROLET '17 CHEVY

The '17 Chevy is possibly the least inspired automobile in the history of automobiles. It is virtually a copy of every selling feature seen on every rival passenger sedan on the market. Intended as a marketing ploy, the imitation instead made the '17 Chevy nearly invisible; it has no distinct look that sets it apart from any of its competitors.

Maneuver Speed: 30 mph

Acc/Dec: 3 mph per phase

Top Speed: 90 mph
 Fuel Efficiency: 30 mpg
 Passengers: 4
 Fuel Capacity: 10 gallons CHOOH2
 SDP: 50
 Maneuverability: +0 to all rolls
 SP: 10
 Cost: 10,000 eb

Game Notes: The '17 Chevy (and its competitors) can haul 150 kg of cargo in addition to its passengers. If not carrying cargo, it can haul up to 5 passengers (provided that the three in the back are very friendly with one another).

MOTORCYCLES

Ever popular with the younger crowd, in the year 2020 sometimes a good cycle is all the transport you can afford. Still, a cycle isn't a bad option — it gets great gas mileage, is easy to maintain, and looks cool. And, after all, isn't image what life is all about?

THE ASHIGARU

The Mitsuuzuki Ashigaru is just the thing for the city rider. Classic lines, clean handling, and the bonus of electrical power make the Ashigaru the perfect city transport, with enough speed to get you where you're going and enough acceleration to get you out of trouble, fast.

Maneuver Speed: 30 mph
 Acc/Dec: 4 mph per phase
 Top Speed: 70 mph
 Fuel Efficiency: 1 hour per power unit
 Passengers: 1
 Fuel Capacity: 8 power units
 SDP: 20
 Maneuverability: +1 on all rolls
 SP: 0
 Cost: 1,750 eb
Special Equipment:
 The Ashigaru can carry 25 kg of cargo in its cargo boot.

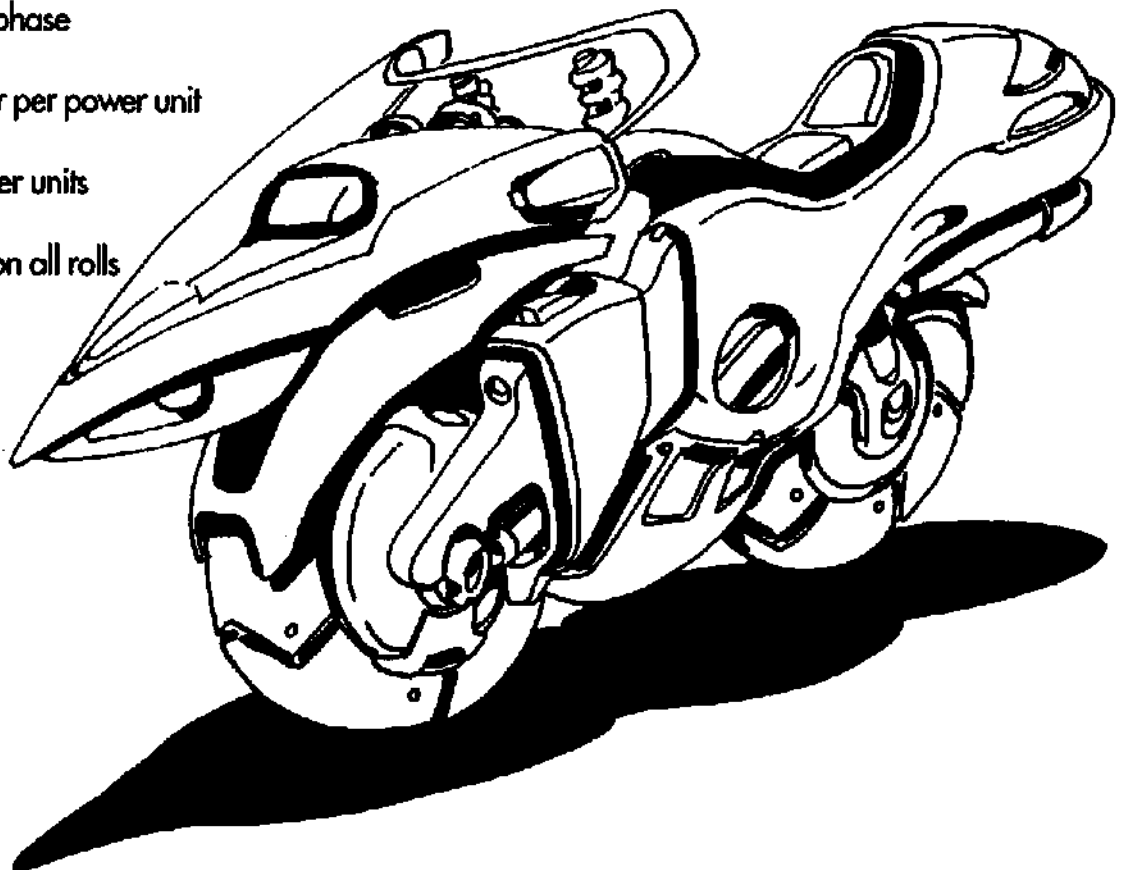

VEHICLES

THE BERMUDA

Bermuda, home to the most dangerous triangle on the high seas. Only fitting that it lend its name to the most dangerous triangle on the roads. The Delta Motors Bermuda is a new concept on the roads—a tricycle instead of a bike. Faster, more maneuverable, steadier, longer-ranged and just plain more comfortable to ride. Enter the Triangle. The Bermuda awaits.

Maneuver Speed: 45 mph
Acc/Dec: 4 mph per phase
Top Speed: 155 mph
Fuel Efficiency: 60 mpg
Passengers: 1
Fuel Capacity: 5 gallon CHOOH₂
SDP: 40
Maneuverability: +2 all rolls
SP: 0
Cost: 3,000 eb

Special Equipment: CB radio. The Bermuda can be fitted with a special seat to allow carrying 100 kg of cargo, or another passenger. This modification costs an additional 200 eb.

Game Notes: The Bermuda functions as well off-road as it does on pavement.

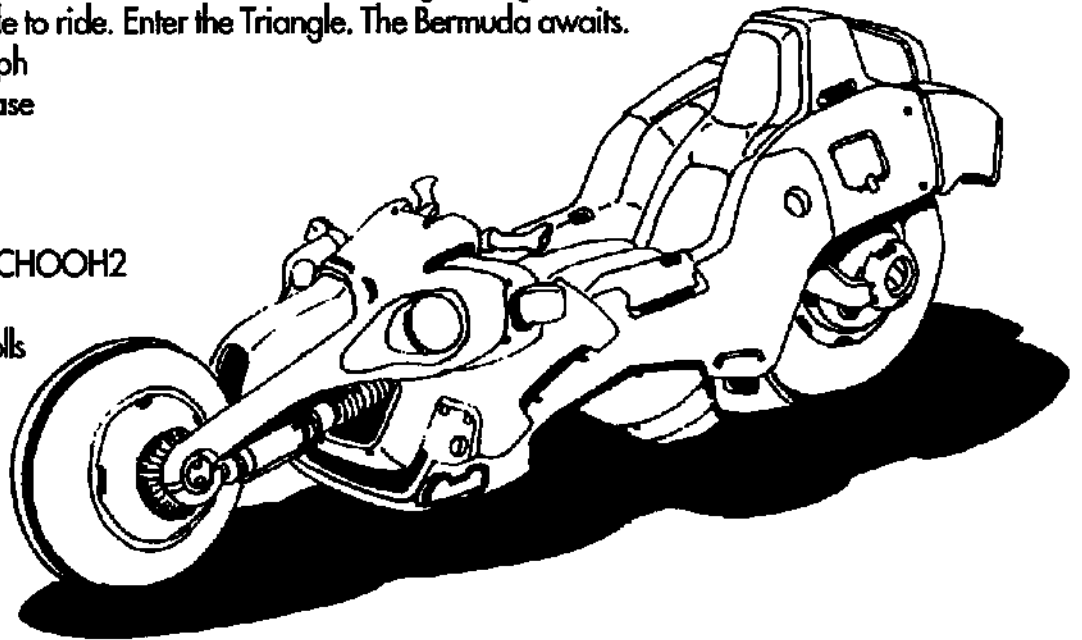

THE DARKWING

The Darkwing is Harley's latest entry into the off-road cycle market. It's not as fast as a Shiva, nor does it haul as much as a Thundergod. It doesn't have to be that fast, or haul that much. Because the Darkwing will go anywhere you can take it. It'll go places a tank can't get to, and brave country that will have any other bike in pieces. So if you have to access the inaccessible, get on the Darkwing and go!

From Harley. Bikes built for Americans, by Americans.

Maneuver Speed: 30 mph
Acc/Dec: 3 mph per phase
Top Speed: 100 mph
Fuel Efficiency: 75 mpg
Passengers: 1

Fuel Capacity: 5 gallon CHOOH₂
SDP: 35
Maneuverability: +3 when off-road
SP: 5

Cost: 4,500 eb

Special Equipment: CB radio, halogen headlights. Can be outfitted for cybernetic use at a cost of an additional 1,000 eb.

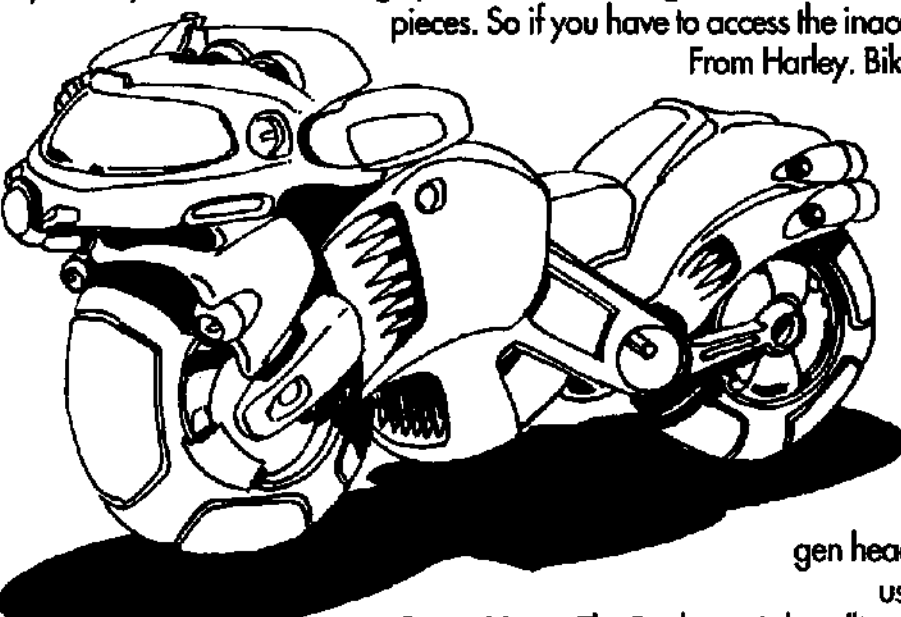

Game Notes: The Darkwing's handling is only fair on pavement. Off-road, in dirt, sand, mud and other similar conditions, all maneuvering rolls are +3 with the Darkwing. Darkwings have been used by military organizations, and are armed with fixed-forward SAW light machineguns (treat as a Ronin Light Assault rifle with #Shots as 150) and a rear-firing smoke projector.

AIRCRAFT AND MINI-JETS

Most aircraft are limited to airports in order to support their long takeoff and landing requirements. There are a number of VTOL aircraft that don't have this problem. Ospreys and their tilt-jet cousins operate from building roofs, helipads and other restricted areas. They can't go places that an aerodyne can, but they can usually go farther.

Unfortunately for the prospect of Everyman owning a tilt-plane, the high power requirements of this method of flight require jets or jet-engine power, meaning that these aircraft (again) use some variant of Avgas for fuel.

Some of the vehicles listed below (Wasp & Comet), belong to a special category known as **minijets**. Since even governments find it difficult to stockpile enough jet fuel to operate the fuel-gobbling monsters of old, most corporate armies don't use full-sized jet fighters. Instead, smaller is better—small jets can carry lethal weaponry, are more maneuverable, and use less fuel.

GD F-36 COMET

General Dynamics introduces the Comet. Faster than the Wasp, more maneuverable than the Wasp, better than the Wasp. Ride the wave of the future; leave the insects behind and rocket to the skies!

Maneuver Speed: 625 mph

Acc/Dec: 15 mph per phase

Top Speed: 1,400 mph

Fuel Efficiency: 1 mpg

Passengers: 1

Fuel Capacity: 500 gallons avgas

SDP: 175

Maneuverability: +10 to all rolls

SP: 20

Cost: 45,000,000 eb

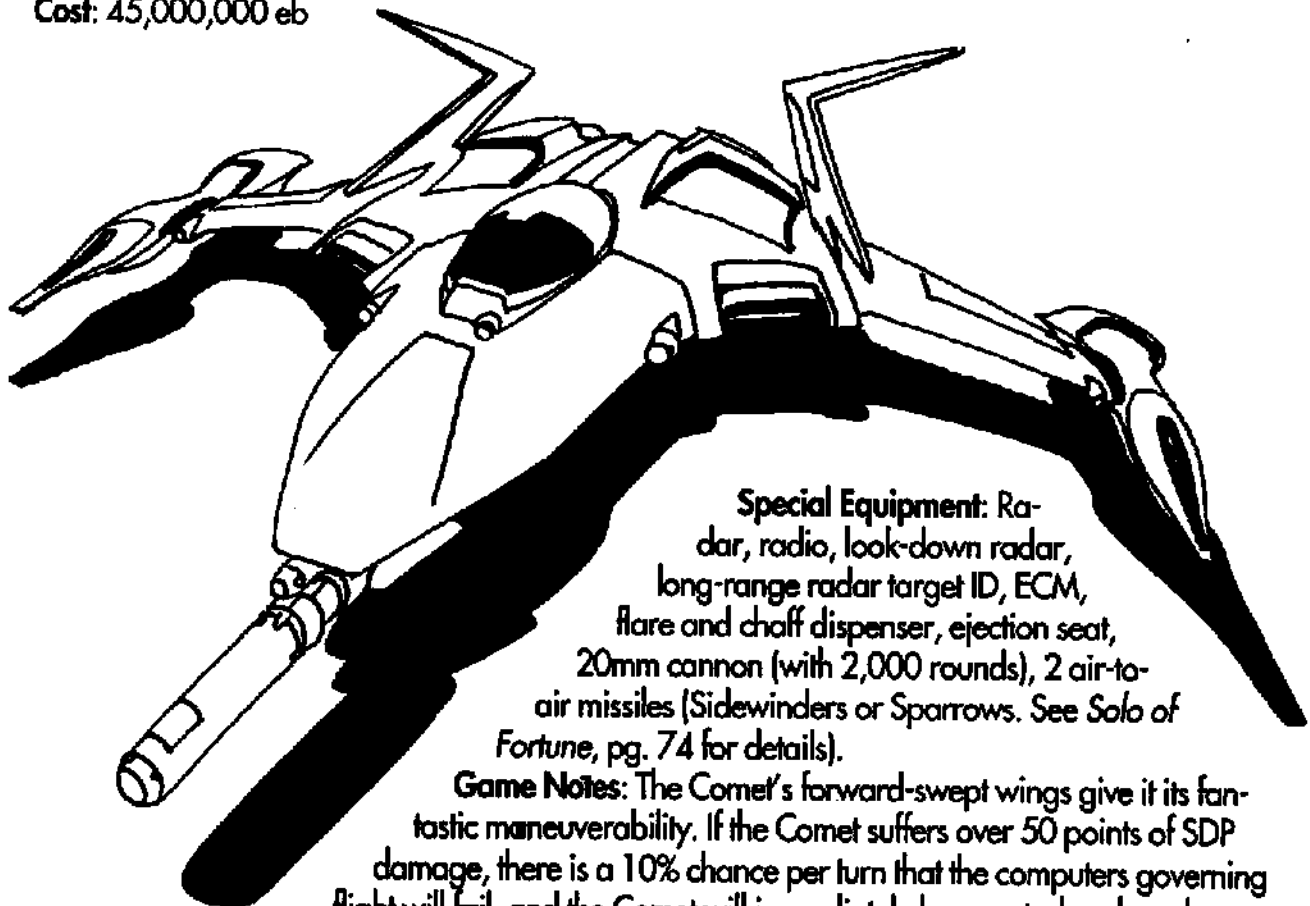

Special Equipment: Radar, radio, look-down radar, long-range radar target ID, ECM, flare and chaff dispenser, ejection seat, 20mm cannon (with 2,000 rounds), 2 air-to-air missiles (Sidewinders or Sparrows. See *Solo of Fortune*, pg. 74 for details).

Game Notes: The Comet's forward-swept wings give it its fantastic maneuverability. If the Comet suffers over 50 points of SDP damage, there is a 10% chance per turn that the computers governing flight will fail, and the Comet will immediately lose control and crash.

VEHICLES

MDD F-33 WASP

The F-33 Wasp is MacDonal-Douglass' current market leader in fast interceptors. Weighing in at a mere 6,800 kg, the Wasp can reach Mach 1.8, has an extended range of 1,000 miles, and carries four air-to-air missiles as well as the internal gun.

Maneuver Speed: 550 mph

Acc/Dec: 15 mph per phase

Top Speed: 1,250 mph

Fuel Efficiency: 1.5 mpg **Passengers:** 1

Fuel Capacity: 670 gallons avgas

SDP: 250 **SP:** 20

Maneuverability: +3 to all rolls

Cost: 35,000,000eb

Special Equipment: Radar, radio, ECM, chaff and flare dispenser, look-down radar, long-range radar target ID, ejection seat, 30mm cannon (with 1,000 rounds), 4 air-to-air missiles (either Sidewinders or Sparrows, or a mix of both).

Game Notes: The Sparrow missile is a radar-guided missile, doing 6D10 damage, with a 90% hit probability. Effected by chaff and ECM jamming. (See Solo, pg. 74, for Sidewinder and cannon details)

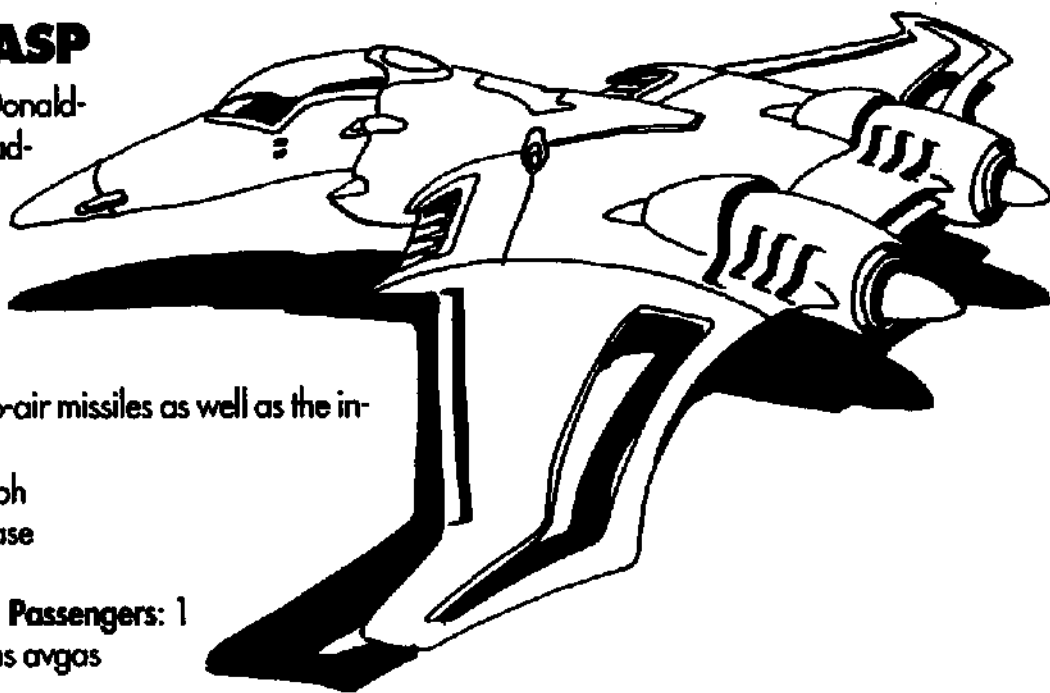

THE FED-BOEING FALCON

Swooping from the sky like its namesake, the Falcon stoops to deliver its cargo rather than slashing its prey. Fed-Boeing is proud to supply the world with this fine transport, continuing the line of top-quality Fed-Boeing aircraft.

Maneuver Speed: 100 mph

Acc/Dec: 10 mph per phase

Top Speed: 300 mph

Fuel Efficiency: 5 mpg

Passengers: 10

Fuel Capacity: 150-gallon avgas

SDP: 100

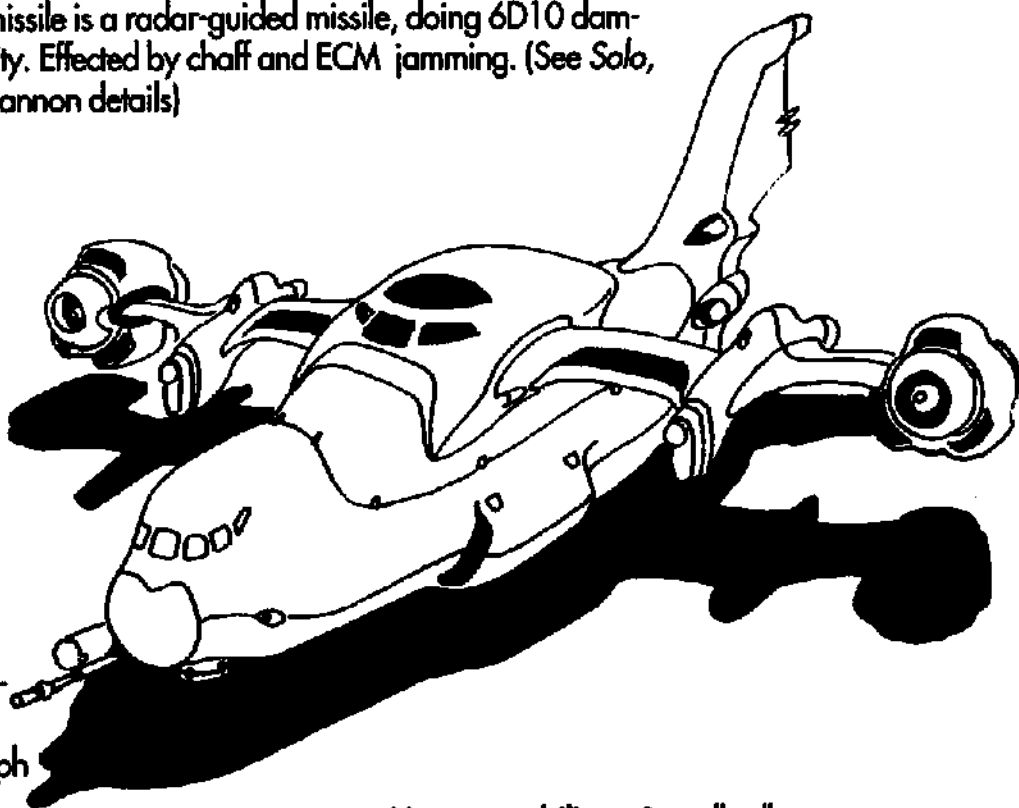

Maneuverability: +0 to all rolls

SP: 10

Cost: 1,250,000 eb

Special Equipment: Radar, long-range radio.

Game Notes: The Falcon needs at least 30 meters of open space to land or take off.

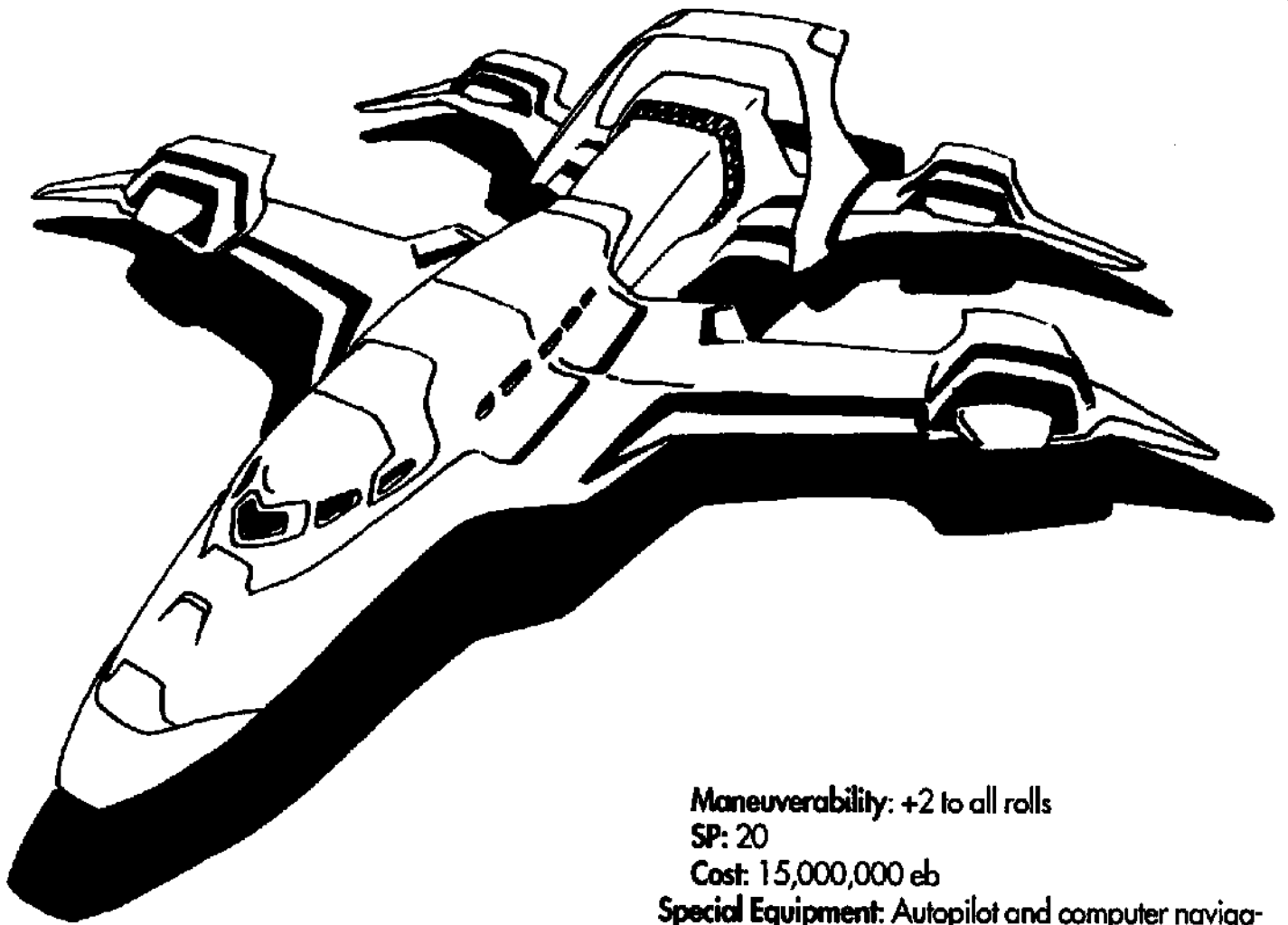

GD HUMMINGBIRD

Airships are too slow. Aerodynes don't have the range. Passenger scramjets just too expensive — after all, you're just going across the country, not LEO. So what can get you there when you absolutely, positively have to be there in a few hours?

The Hummingbird can. Combining the virtues of winged speed with tilt-wing vectored thrust, the Hummingbird can land on a helipad, and take off from one* as well. Fast, agile, comfortable ... That's the Hummingbird.

*With catapult assist.

Maneuver Speed: 300 mph

Acc/Dec: 10 mph per phase

Top Speed: 600 mph

Fuel Efficiency: 0.75 mpg

Passengers: 10

Fuel Capacity: 1,000 gallons avgas

SDP: 100

Maneuverability: +2 to all rolls

SP: 20

Cost: 15,000,000 eb

Special Equipment: Autopilot and computer navigation systems can fly the craft to any destination, as long as the destination is programmed into the computer and satellite navigation systems can be accessed. The autopilot makes all maneuvers at skill Pilot (Vector Thrust) 5. Mini-computer (see the Laptop computer in *Cyberpunk 2020*), a wet-bar, complete environment control, cellular visiphone, satellite up-link, telefax, radio, television, document shredder, fire extinguisher, radar, thermographic sensors, radar detector, laser detector and on-board ECM systems (see *Solo of Fortune* for details).

Game Notes: The Hummingbird is a tilt-wing, not a tilt-engine design. It is actually a very short Short Take-Off and Landing (STOL) aircraft. Landing it without a runway is a Difficult task; the airplane's size requires a minimum of a 20 meter radius to land it without harming the wing-mounted engines. The Hummingbird requires a 150 by 40 meter runway, or a catapult assist to take off. A crazed pilot could take off from a skyscraper roof, by taxiing over the edge and plummeting to gain speed! This is a Very Difficult task, and requires at least 100 meters of fall to build up speed.

VEHICLES

LOCKHEED-CESSNA

PINTO

There's a target on the ground. The jet fighters whizz past at 400+ miles per hour, firing. Missed! Not enough fire to take it out; the jet went by too fast. Call in the gunships! Oops, they're not fast enough to make it to the target zone in time. When a jet is too fast, and a helicopter is too slow, and an AV is too vulnerable, you have to turn to the old standby: The prop plane.

The Pinto is a STOL weapons platform. It has the speed to get to the target area, the rough-landing capability to lurk on the ground behind the lines, waiting for action, and the loiter time to hover around the battlefield.

The Pinto. It's not another one-trick pony.

Maneuver Speed: 200 mph

Acc/Dec: 5 mph per phase

Top Speed: 450 mph

Fuel Efficiency: 3 mpg

Passengers: 4

Fuel Capacity: 500 gallons avgas

SDP: 150

Maneuverability: +2 to all rolls

SP: 20

Cost: 10,500,000 eb

Special Equipment: Radio, radar, thermographic vision, painting laser rangefinder, ejection seats, chaff and flare dispenser, ECM, two 20mm cannons fixed forward (each has 2,000 rounds. See Solo, pg. 74). The Pinto can carry 1,400 kg of ordnance.

Game Notes: The laser rangefinder can guide Hellfire missiles (Solo, pg. 74) and other laser-guided munitions. It also gives a +3 to cannon fire at Long and Extreme ranges. Ordnance weights: Hellfire missile 45 kg, 7-shot rocket pod 250 kg, 19-shot rocket pod 650 kg, Sidewinder missile 85 kg, bombs as per weight (115, 230, 340 or 455 kg). Bombs do explosive damage equal to 1D10 per kilogram of bomb weight with a radius of 1 meter per 10 kg, rounded down, of bomb weight. There is a further blast radius of 1 meter per 5 kg, rounded down, of bomb weight, where the bomb does 1D10 damage per 5 kg of bomb weight.

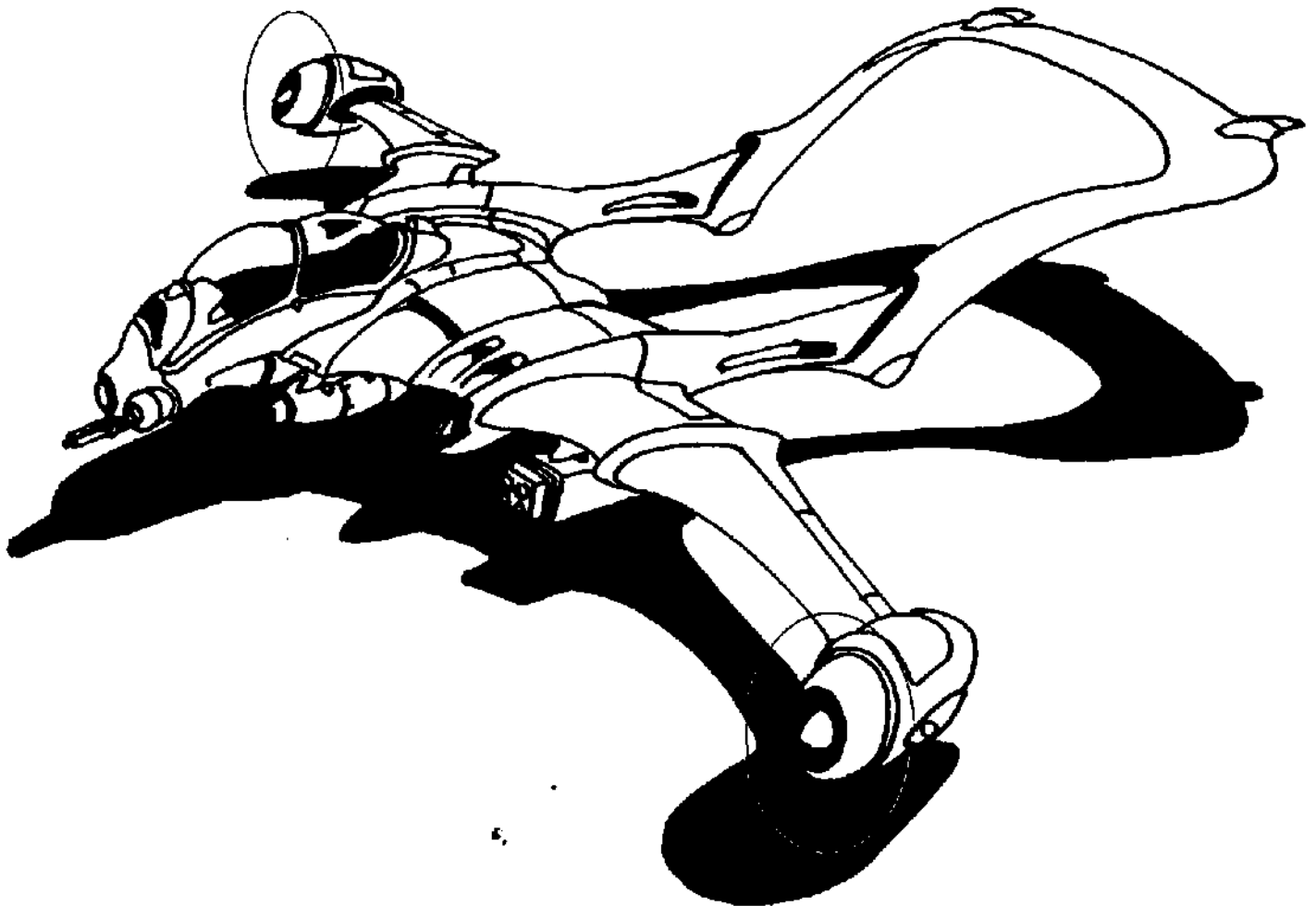

AIRSHIPS

With the price of aviation fuel so high, the jetliners that roamed the skies of the 20th Century are gone. In their place are the slower, quieter, more dignified lighter-than-air airships. Filled with helium, fueled by CHOOH_2 , these mammoth fliers drift across the world, conveying people and cargo without effort. And since they've got so much more cubic space when compared to airliners, they can afford luxuries for the passengers. You may not get there as fast on an airship, but you'll enjoy the ride!

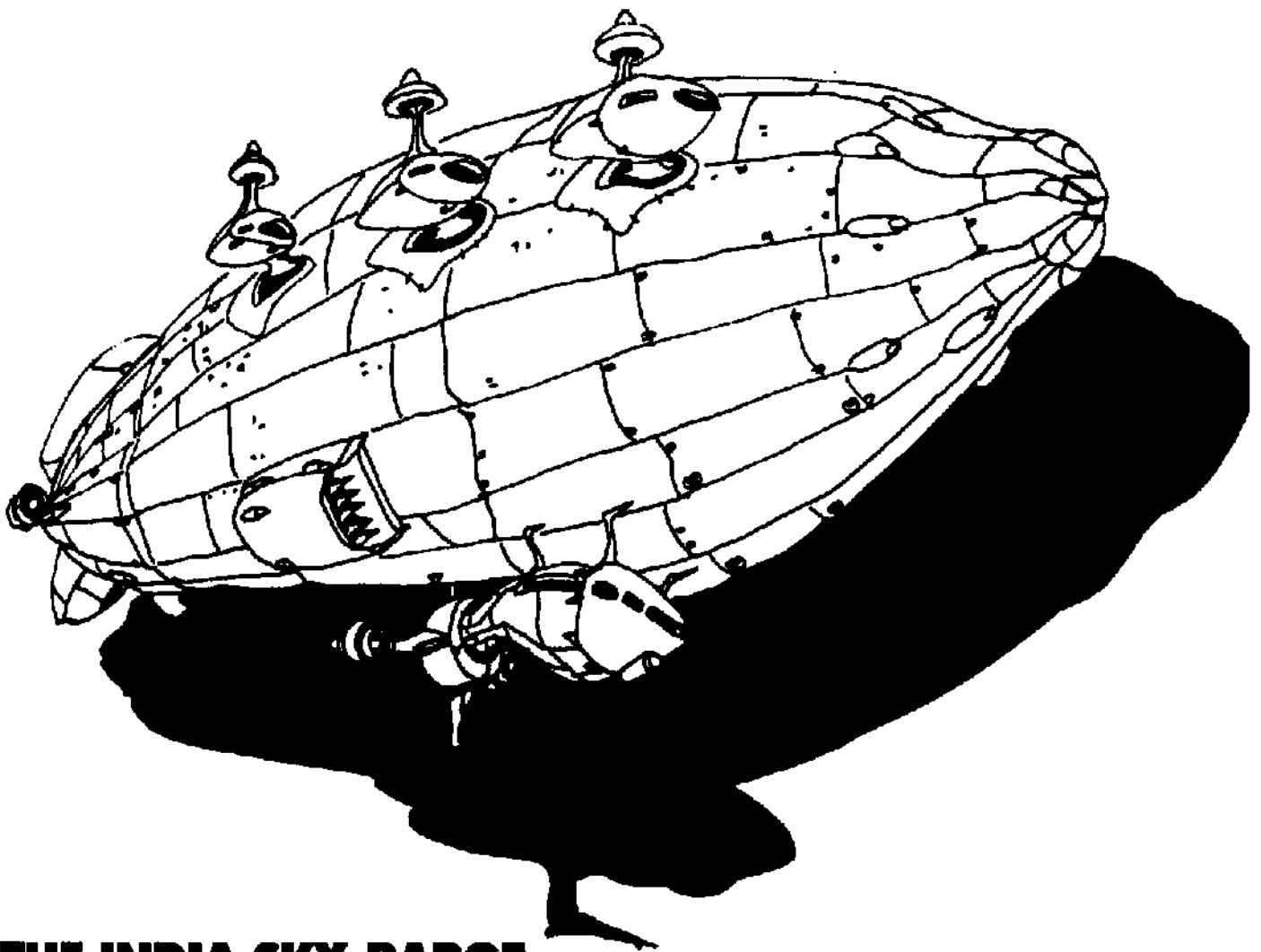

THE INDIA SKY-BARGE

Cargo-hauler *par excellence*. With the Sky-Barge, you can fly over the countryside, without having to brave the anarchy of the unsupervised country or endure the poor road system running from city to city. Rated at over 150 metric tons, the Sky-Barge is the cheap answer to moving goods.

Maneuver Speed: 30 mph
Acc/Dec: 1 mph per phase
Top Speed: 60 mph
Fuel Efficiency: 0.33 mpg

Passengers: 6
Fuel Capacity: 3,000 gallons CHOOH_2
SDP: 750
Maneuverability: -3 to all rolls
SP: 0
Cost: 10,000,000eb

Special Equipment: Radio, radar. The Sky-Barge can haul up to 150 metric tons at full speed. It can haul up to 250 tons at a top speed of 45 mph.

VEHICLES

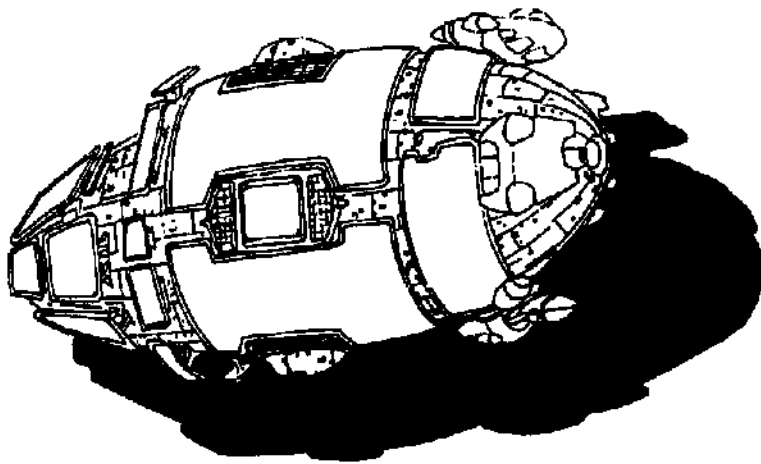

THE "MADISON AVENUE" ADVERTBLIMP

Madison Avenue, once the hub of North American advertising. This remote-controlled LTA vehicle is a tribute to that stretch of street. A flying billboard, the "Mad Ave," as it's known, is the perfect attention-getter. Its video screens are fully programmable from any computer that can run the software (software

included with purchase), and the blimp can be set for pre-programmed routes or directly guided with a joystick and video monitor.

Maneuver Speed: 15 mph

Fuel Efficiency: 1 mpg

Fuel Capacity: 500 gallons CHOOH₂

Cost: 2,500,000 eb

Acc/Dec: 1 mph per phase

Passengers: 2

Maneuverability: -3 to all rolls

Top Speed: 35 mph

SDP: 500

SP: 0

Special Equipment: Video cameras, spotlights, 6 meter by 12 meter electronic projection screens.

Game Notes: In a pinch, two people can squeeze into the emergency cockpit and fly the vessel.

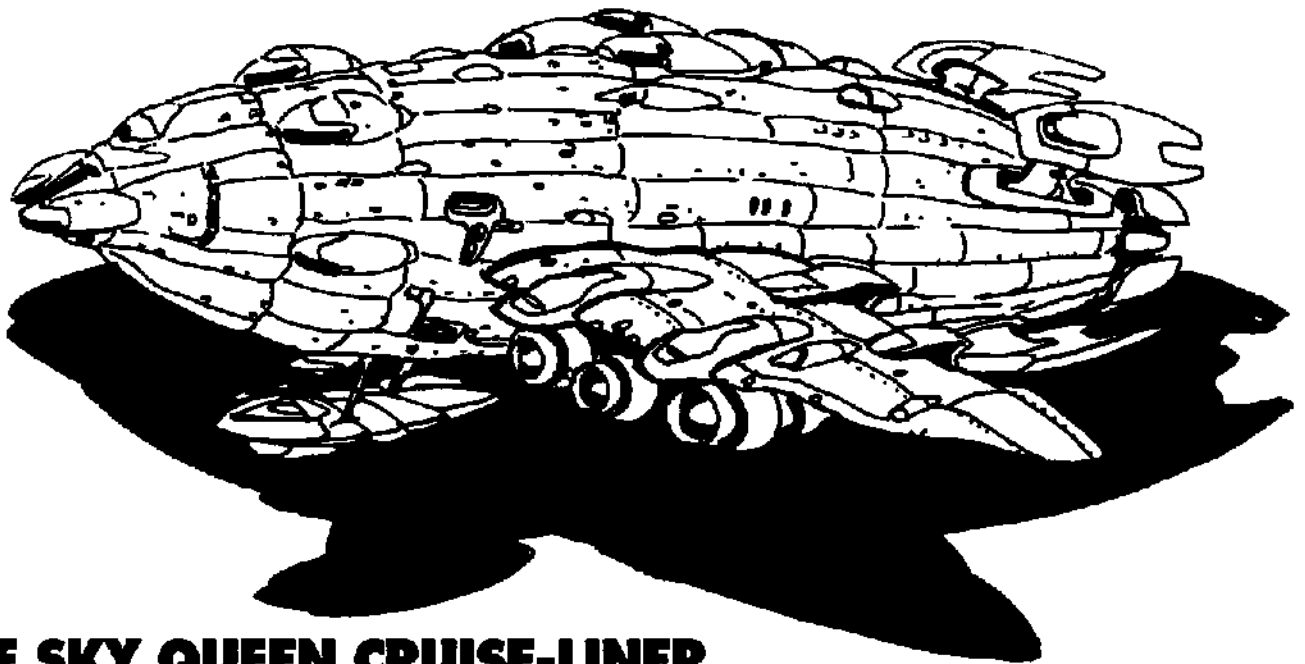

THE SKY QUEEN CRUISE-LINER

The Dayton Sky-Queen, regal ruler of the North American skies. Comfort, safety and convenience in trans-continental transport. Fly the floating skies with the Sky-Queen!

Maneuver Speed: 40 mph

Fuel Efficiency: 0.25 mpg

Fuel Capacity: 8,000 gallons CHOOH₂

Cost: 20,000,000 eb

Acc/Dec: 1 mph per phase

Passengers: 170

Maneuverability: -1 to all rolls

Top Speed: 100 mph

SDP: 1,000

SP: 0

Special Equipment: Radio, radar, ECM, flare and chaff dispenser, sleeping accommodations for 150, 3 bars, 2 restaurants, crew compartment for 20, 37.5 metric tons cargo capacity, 6 Sidewinder AA missiles (Solo, pg. 74).

Game Notes: The Sky-Queen usually cruises at 60 mph, taking approximately one full day to go from coast to coast. The high SDP rating reflects the difficulty of downing the compartmented, self-sealing gasbag.

EXOTICS

Exotic: Foreign; having the charm of fascination or the unfamiliar; strangely beautiful; enticing. **Slang:** A human biosculpted with nonhuman elements: fur, long fangs, tails, etc.

In the world of 2020, practically anything is available—for a price. With sophisticated plastic surgery techniques, a person can have his or her appearance changed to nearly any specification. Bodysculpting is popular, relatively inexpensive and available on a “while you wait” basis.

So what do the wealthy do to show that they’re wealthy? Once upon a time, plastic surgery was a symbol of the filthy rich. Now it’s *passee*. A new line of bodysculpting is available for those with the euro. Why bother being one of the beautiful people when you don’t have to be “people” at all?

Biotechnica is proud to unveil its new line of Bioexotics™. With nanosurgery, cloning, gene matching and grafting, there’s nothing you can’t become!

Disclaimer: Biotechnica accepts no responsibility for the misuse of its exotic technology. For best results, a full psychological therapy program should be implemented before, during and after exotic biosculpting. Only Biotechnica-licensed clinics guarantee official implantation and exotisculpting procedures.

THERAPY PROGRAMS

Biotechnica-licensed clinics and hospitals also provide therapy programs to ease the transition from mere human to your new form. (Game Note: Other hospitals also provide therapy for recovery from accident and cybernetic implantation.) Therapy costs money and time, but it’s worth it in the end!

Therapy is a regimen (referred to as “torture” by patients) designed to assist the patient in recovering use of damaged muscles and nerves. In game terms, therapy lowers the humanity loss from any injury/implant as the patient is helped to understand what has happened and how to use his/her new parts; and is given practice in using them.

There are three levels of therapy: Outpatient, where the patient attends therapy sessions at the clinic/hospital; Inpatient, where the patient lives in the hospital and practices every day under medical supervision; and Intensive Care Therapy, where the patient not only lives in the facility but has his/her nervous system and psyche probed each day for “fine-tuning” (in essence, a trained psychological team rebuilds the patient’s personality into one that minimizes identity loss. By the time they’re done, the psych team knows more about the person than the person does, so you’d better trust these people with all of your innermost secrets).

The time needed for successful therapy is based on the complexity of the operations performed. Add up the surgery codes as follows:

4 Negligible = 1 Minor

2 Minor = 1 Major

2 Major = 1 Critical

The time needed for each kind of therapy is listed below. The surgeries add together, so the therapy time for multiple surgeries is determined by the surgery total. For instance, a patient who experienced 1 Major surgery and 3 Minor surgeries would treat therapy time as if he had had 1 Critical and one Minor surgery (1 Major + (3 Minors/2))=22 weeks of outpatient therapy or 11 weeks of inpatient/IC therapy.

EXOTICS

THERAPY

Surgery	Out	Inpatient/ICT
Negligible	2 weeks	1 week
Minor	6 weeks	3 weeks
Major	8 weeks	4 weeks
Critical	16 weeks	8 weeks

THERAPY COSTS AND EFFECTS

Therapy	Cost/Week	Time Required	HPT
Outpatient	1,000 eb	14 hours/week	25%
Inpatient	5,000 eb	168 hours/week*	33%
ICT	10,000 eb	168 hours/week*	50%

* In these sorts of therapy, you live in the facility 24

hours a day and they don't want to let you out...
† Humanity Points Regained

SURGERY ADDENDA AND NOTES

When a person is undergoing surgery, the surgeons will work on only one area of the body at a time (divided up into head, torso, abdomen, arms and legs). All work in that area will be done at the same time—for instance, installing a cyberhand on one arm and putting rippers in the other hand will be done simultaneously. The operation costs are all still separate, of course. (What, you expect otherwise? Not on your bankbook, chum!)

EXOTIC CYBERWARE

(COSTS DO NOT INCLUDE SURGERY AND HOSPITALIZATION FOR RECOVERY.)

ITEM	SURGERY	HL	COST	NOTES
MINOR FACIAL MODIFICATIONS	M	1d6/2	1,000 EB	
MAJOR FACIAL MODIFICATIONS	M	1d6	2,000 EB	
MUZZLE, SHORT	M	1d6	2,000 EB	
MUZZLE, LONG	MA	2d6	2,500 EB	A
MANDIBLES, EXTENDED	MA	3d6	4,000 EB	B
NATURAL FANGS (DO 1D6 IN COMBAT)	N	2d6	500 EB	C
NATURAL CLAWS (DO 1D6 IN COMBAT)	N	1d6+1	1,000 EB (PER LIMB)	D
RETRACTABLE CLAWS (DO 1D6 IN COMBAT)	M	2d6	1,000 EB (PER LIMB)	
SCRATCHERS	N	1d6	500 EB (PER LIMB)	E
RIPPERS	M	2d6	750 EB (PER LIMB)	E
TAIL	MA	2d6	1,500 EB	F
COMBAT TAIL	MA	3d6	2,500 EB	G
DIGITIGRADE LEGS	CR	6d6	4,000 EB	H
FUR/SCALES/SKINCHANGE	N	3d6	10,000 EB	I
HEAVY SCALES	N	3d6	12,000 EB	J
EXOSKELETON	CR	4d6	20,000 EB	K
FRAME ALTERATION	CR	2d6	8,000 EB	L
BEHAVIOR CHIP	N	1d6/2	1,000 EB	M
NEW BIOTECH:				
ARMORWEAVE	N	1d6	4,000 EB	N
SPEED GRAFTS	MA	1d6	750 EB	O

EXPLANATION OF "NOTES" (ABOVE)

A: Like a dog's or horse's muzzle.

B: Mandibles are semi-prehensile grasping "jaws" extended from the facial bone structure. They are usually sharp and strong, and can inflict 1D6 damage in grappling combat.

C: Only when the person with fangs has grappled its opponent.

D: Grown from the bones via nanotech. +3 to manipulation skill rolls (anything requiring use of fingertips—typing, delicate tool use, writing).

E: Low HC loss is due to implantation in a good hospital environment.

F: Mobile but weak—can only exert about 3 lbs. of force.

G: A heavily-muscled tail, usually tipped with spikes, spines or a bony knob. Does 1D6 + Body Damage Modifier in hand-to-hand combat. Some combat tails have poison stingers added, doing damage like a knife and injecting appropriate drugs/toxins. A stinger tail costs 500eb more than a regular combat tail.

- H: Dog-legs, jack-legs, etc. Animal-style hind legs, with a short foot and 3 joints instead of 2. This option replaces both legs. If acquired without a tail, the recipient is at -2 MA and -1 REF whenever on his/her feet. If acquired with a tail, digitigrade legs increase MA by 1.
- I: This changes the bearer's skin to the desired texture. There is a 10% chance of developing cancer from the genetic implant. The cancer can be cured, but the skinchange will have to be removed and curing the cancer will take 1-6 months and cost 2,000-12,000 eb. (roll 1d6 for months and multiply by 2,000eb for cost)
- J: This is actually Skinchange with Skinweave thrown in, for SP 12 protection. Same cancer risk as Skinchange.
- K: A rigid exoskeleton provides SP 18 protection, but reduces MA and REF by 2! Same cancer risk as Skinchange.
- L: Frame alteration can make the patient shorter, taller, fatter, thinner, etc., up to 25% change from patient's actual body size.
- M: Behavior chips are personality modifiers. Some rigidly lock a person into a single set of pre-programmed behavior (these are largely used by correction authorities to control prisoners), others simply provide a strong urge to act in certain ways when presented with certain stimuli. These chips can alter moods—want to be the life of the party? Simply slip in a chip and you're fun-loving for the rest of the night! (Or until the chip comes out.) Want to be the board-room terror? Slip in the Dominator chip and bully your partners into submission. Want to be a real Romeo? The Maximum Lover chip just gives the techniques. Use the Romance chip and feel the emotional high. Any emotion you want, any state of mind you crave, Behavioral chips can provide. The high price is for precise adjustment to your neural system (thus the visit to the clinic).
Warning: These chips can become addictive. Prisoner-correction chips can't be removed with-

out special equipment; the others can be slipped in or out like a regular chip. But you might not want to take it out! The chip produces constant emotion patterns that many people find hard to give up—they know the second the chip comes out, they return to normal thought chaos. Removing a chip requires a Cool/Will roll vs. +15 difficulty. If you fail, you fight having the chip removed by anybody. Each time you fail, you can try again in five minutes, but the next test is against +5 more each time you fail (maximum difficulty +30). If you spend over 48 hours under the influence of a Behavior Chip, you're mentally addicted. Once the chip is removed, the person has to roll under his/her Cool each hour to avoid fits of depression, shaking, and anxiety, overlaid by a compulsion to acquire the chip again.

Behavior Chips are legal, but using them on someone against their will is not. In addition, the person for whom the chip is made (they are, after all, individualized) signs a waiver when the chip is made. This waiver exempts the chip-producer from any legal obligations arising from use of the chip.

The stronger Behavior Chips that lock the subject into specific actions for specific stimuli cost 2,000eb, and are illegal for use by anyone except correctional and mental health institutions. (Sure. We all know that corporations would never do something illegal and use these. Right.)

- N: ArmorWeave is an addition to SkinWeave and Muscle/Bone Lace. It is a subcutaneous endoskeletal "carapace" woven into the subject's skin layers, linking the floating ribs with the pelvis and allowing cybernetically-strengthened people to use their full lifting power without breaking their backs! It adds +1 to BOD, increases the subjects SkinWeave armor factor to SP 18 and permanently subtracts 1 from REF and MA. The subject must already have SkinWeave and Muscle/Bone Lace to buy ArmorWeave.
- O: Speed Grafts improve the subject's MA by +2.

MINOR EXOTIC PACKAGE DEALS

So you don't want to go all the way down the evolutionary scale? Take too much time, too much money, too scary? Well, there's no reason to change yourself too far. Almost any Biotechnica-licensed walk-in clinic can handle a minor exotic change. Here are some of the favorites:

Me-yow! Feeling catty? The KatNip™ package includes pointed ears, whiskers, proper synthiskin to mimic fur patterns, cat claws, bio-contacts for that cat-eyed look, and voice-box modifications for those who truly want to yowl! Here, kitty, kitty, kitty...

Game Statistics: Minor Facial Modification (slit-eyes, pointed ears, whiskers, modified hairstyle), Scratchers, Tail, Synthiskin. 3,400eb total. Surgeries: 1 Major, 1 Minor, 2 Negligible (2,200eb). HC=4 1/2D6.

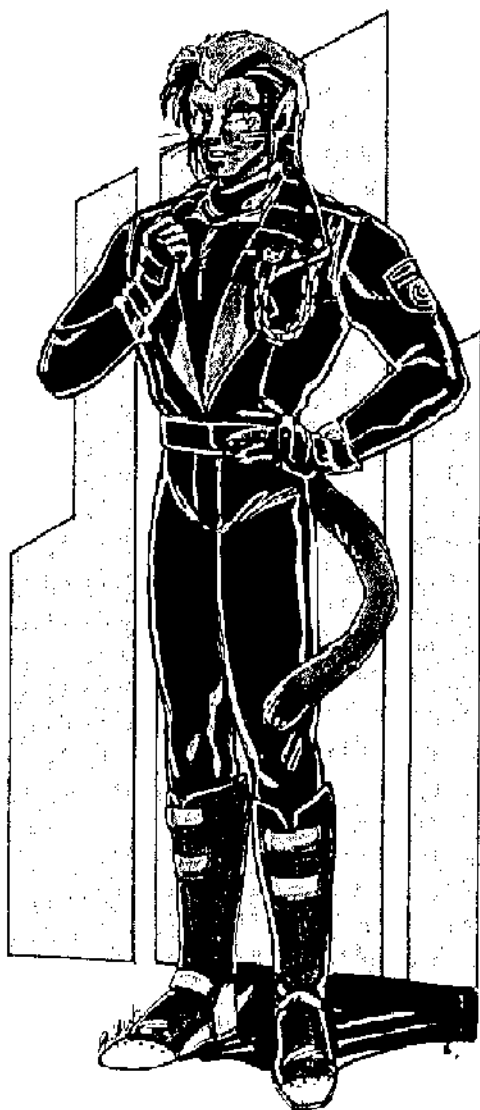

Hickory, dickory, dock: If you just don't like cats, why not be a mouse? An anthropomorphism made popular by a certain unnamed mouse (you know who; our lawyers won't let us say his name), and countless animation and graphic works, the mouse is always popular at parties. For those really interested in deception, psychological studies indicate that people are less threatened by mice than by any other exotic. What better way to conceal your true nature... until they find that you're the mouse that roars! (Other rodent forms—chipmunks, minks and ferrets, rats, etc. are also possible with this package.)

Game Statistics: Minor Facial Modification (ears enlarged, face somewhat pointed, button nose, overlarge eyes), Synthiskin. 1,400eb total. Surgeries: 1 Minor, 1 Negligible (700eb). HC=1 1/2D6

EXOTICS



Do the Bunny Hop! Be your own good luck charm! And what could be a better lover than a bunny? (Everyone knows about rabbits', uh, activities.) And girls, remember, men world-wide have been conditioned for over half a century to regard the "bunny" as the epitome of feminine sexuality. Okay, so they won't think you're likely to win any Nobel prizes, but you'll be popular!

Game Statistics: Minor Facial Surgery (bunny ears, optional button nose and whiskers; some like buck teeth). Bunny Tail (not nearly as traumatic a process as the listed tail; Minor surgery, HC=2 points, costs 250eb) 1,250eb total. Surgeries: 2 Minor (500eb). HC=1D6.

Hiss-s-s-s-s: Mammals not appealing? Are you cold, calculating; reptilian and proud of it? Are you accused of speaking with a forked tongue? Want to be the best french-kisser in your circle? Serpentine yourself. There's nothing so seductive as the original tempter!

Game Statistics: Minor Facial Modification (eyes, removal of outside ears, long tongue, olfactory boost, nose reduced to slits), Natural Fangs, Synthskin. 2,000eb total. Surgeries: 1 Minor, 3 Negligible (1,100eb) HC=4D6



Fantasy Packages: No, not that kind of fantasy! If you're looking into exotics, you're beyond that anyway. This is "classic" fantasy, as made famous by obscure 60's writers, and the time-honored art of role-playing games that now forms the basis for braindance and netgames. Be someone who walked out of a novel, or even the Elfines™ series!

Elf: Minor Facial Modification (pointed ears, up-turned eyebrows, thin face). 1,000eb total. 1 Minor Surgery (500eb). HC=1/2D6. Popular options include enhanced cyberears.

Dwarf or Halfling: Minor Facial Modification (broader features), Frame Alteration (shorter, stockier). MA is -2 because of shorter legs. 9,000eb total. Surgeries: 1 Critical, 1 Minor (3,000eb). HC=2 1/2D6. Popular options include grafted muscle or bone and muscle lace. Skin-weave is also popular.

EXOTICS



Ork/Goblin: Major Facial Modification (broad features, squint eyes, big nose), Natural Fangs, Frame Alteration (wider, longer arms), Synthiskin (green, brown, black, etc.). 10,900eb. Surgeries: 1 Critical, 1 Minor, 2 Negligible (3,400eb). HC=6D6. Popular options include red shift-tacts or enhanced cybereyes, grafted muscle, scratchers, dermal armor and skinweave.

Troll/Ogre: Minor Facial Modification, Natural Fangs, Frame Alteration (taller), grafted muscle, muscle and bone lace. 12,000eb total. Surgeries: 1 Critical, 1 Major, 1 Minor, 2 Negligible (4,900eb). HC=7D6.

Fishman: Gills, Synthiskin, Webbing (minor alterations to hands and feet; equivalent to Minor Facial Modifications), Custom Contacts (to keep water out of the eyes and facilitate easier vision along the blue-green spectrum). 2,000eb total. Surgeries: 1 Major, 1 Minor, 2 Negligible (2,400eb). HC=4 1/2D6.

GRAFTABLES

They are available for that discerning patron who doesn't want the whole look, but just parts of it! This is a very popular line for many people who calculate their appearance to startle, to amaze, to intrigue. The sample given here is the package adopted by Zark Nartanq, the famous dirty-combat star of the *Urban Nightmare* vids.

Game Statistics: Natural Fangs, Wolverers, Combat Tail with stinger, SkinWeave, Bone & Muscle Lace, ArmorWeave, Speed Grafts. 12,350eb total. Surgeries: 2 Major, 1 Minor, 4 Negligible (4,300eb). HC=12 1/2d6+1.

MAJOR EXOTIC PACKAGES

THE BEAR NECESSITIES

The bear can be an effective form. It shares the dual advantages of being cuddly and *big*. (Even in this age of high-tech toys and games, the old teddy bear is a comforting constant.) Perfect for that easy-going personality; but when you need to get tough, people listen!

Game Statistics: Major Facial Modification, Muzzle (short), Natural Fangs, Retractable Claws, Fur Skinchange, Frame Alteration (taller, bigger), Grafted Muscle. 24,500eb total. Surgeries: 1 Critical, 1 Major, 3 Minor, 2 Negligible (5,900eb). HC=13d6.

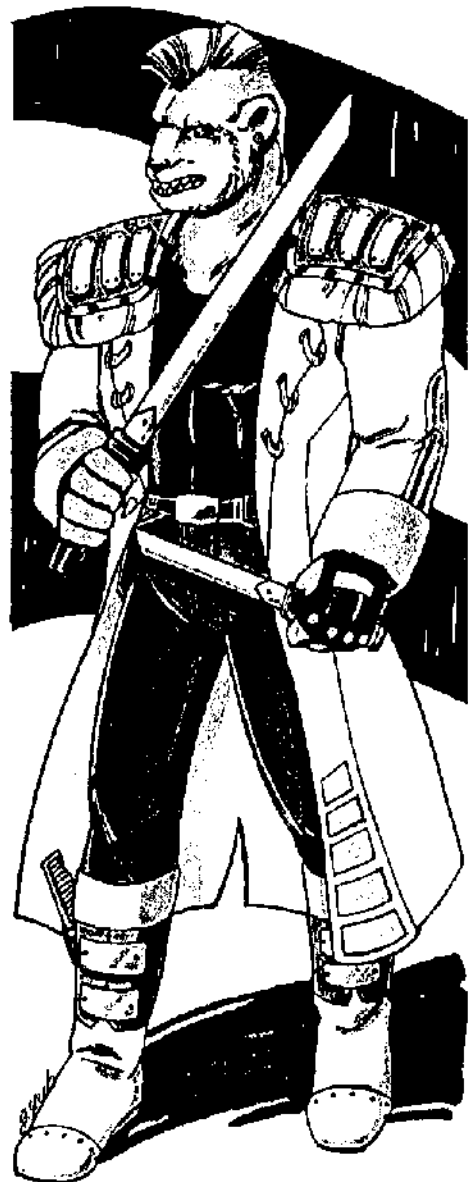

THE SUPERMAN

Some people like to think of themselves as evolution in action, preferring to step up the evolutionary chain instead of down. Thanks to gene-splicing nanotech, cloning, chemical enhancement and bionics, you can be an Übermensch, the future of humanity!

Game Statistics: Grafted Muscle and/or Bone/ Muscle Lace, Speed Grafts, Neural Processor, Kerenzikov Boost +2, Pain Editor, Biomonitor, Skin-Weave, Lifesaver weave, Toxin Binders, Nanosurgeons, Pacesetter 2000 Heart, Rebreather Lungs, NanoOptical rebuild (see Cyberware section, pg. 8). 19,735eb total. Surgeries: 1 Critical, 3 Major, 1 Minor, 8 Negligible (8,900eb). HC=13D6.

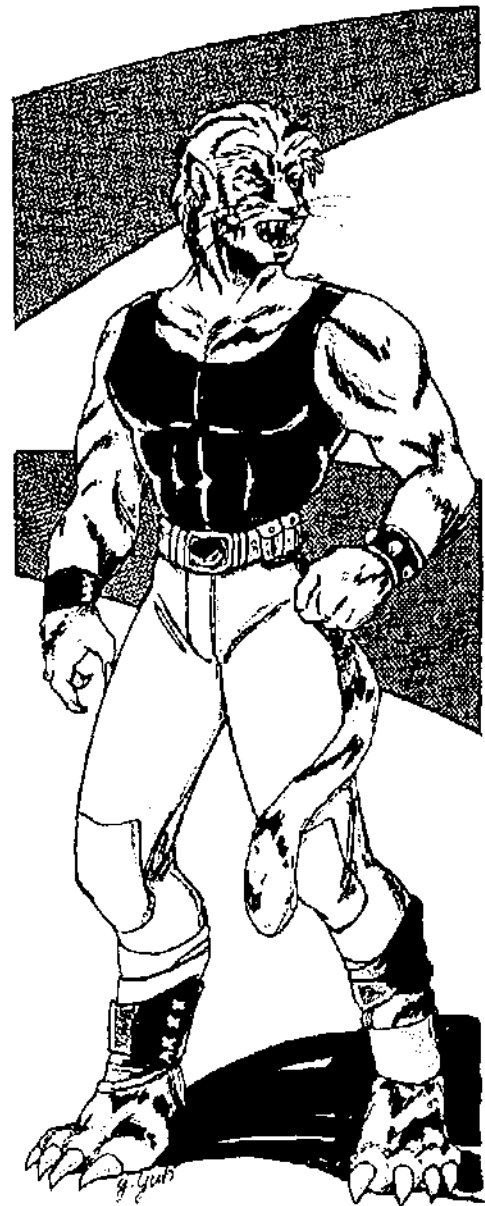
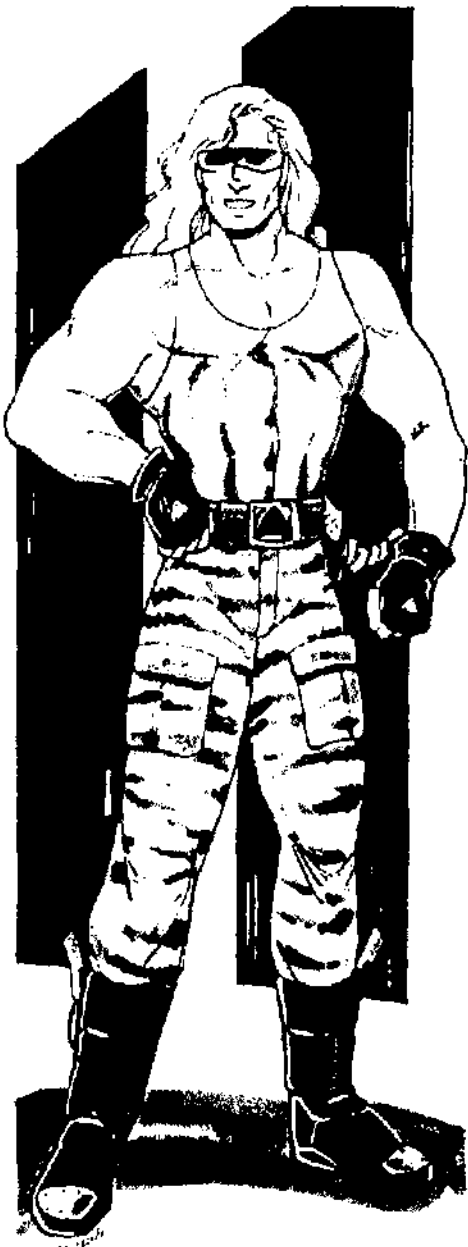

HOLD THAT TIGER!

For the truly feline, nothing less than the BigKatt™ package will do. After *this* transformation, you can stalk with the tigers, run with the lions, chase with the cheetahs, or prowl with the pumas! Exotic, erotic, seductive, mysterious— become the newest predator in the concrete jungle.

Game Statistics: Major Facial Modification, Muzzle (short), Natural Fangs, Retractable Claws (or Rippers), Tail, Digitigrade Legs, Skinchange (fur). 21,000eb total. Surgeries: 1 Critical, 1 Major, 3 Minor, 1 Negligible (5,700eb). HC=19D6. Popular options include enhanced cybereyes, enhanced cyberears, grafted muscles, boosted reflexes.

EXOTICS

BUG OUT!

Why not take a step sideways on the evolutionary scale? For those who are looking for a rare and truly exotic look, take a lesson from some of the most satisfied lifeforms on the planet—the insects! We can make you look like something that crawled out of Franz Kafka's imagination, or a creation from another planet, or just a bit "buggy." For the closet aliens among us.

Slightly Buggy: This creates a bug-headed human. Major Facial Modification (bug-eyes, plating the face with bony chitin, adding antennae, etc.), slightly scaly Synthiskin, Custom Cybereyes. 3,400eb total. Surgeries: 1 Major, 1 Minor, 1 Negligible (2,200eb). HC=6d6.

Bughouse: Major Facial Modification (as above), Mandibles, Frame Alteration (to change the body shape, hands and feet), Custom Cybereyes, Exoskeleton, Scratchers. 35,500eb

total. Surgeries: 2 Critical, 2 Major, 1 Minor, 1 Negligible (8,700eb). HC: 15d6. Extremely

popular options include enhanced vision in the cybereyes, boosted reflexes, enhanced olfactory sense and cyberears. Some "Bughouse" patients even have Cybersnakes (or worse) installed in oversized head housings.

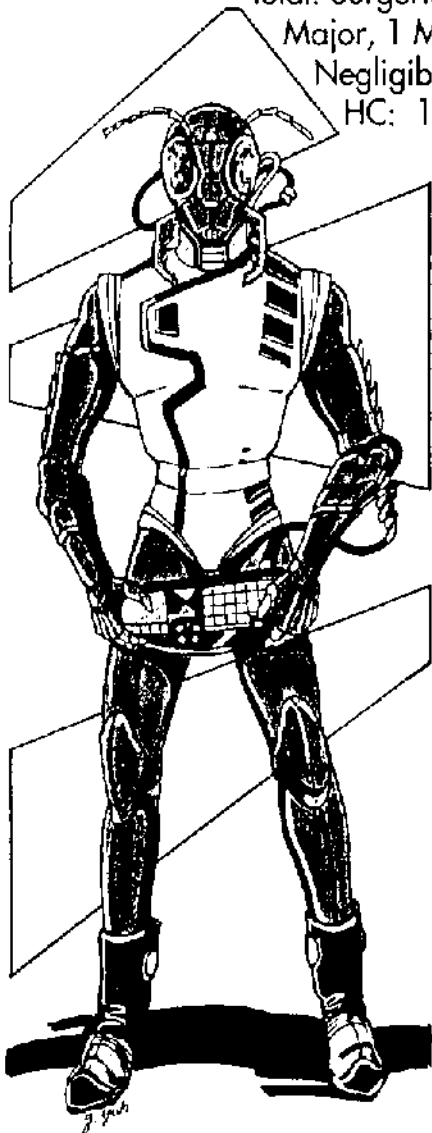

AQUAFORMS

Almost seventy percent of the Earth's surface is covered by water. And almost all of Earth's population is ill-equipped to deal with it. Break out of the evolutionary track, return to our watery origins, and merge with the liquid of life once again. **Note:** custom designed gills for exotics have two times the duration of standard cybergills.

Merman: The classic aquaform. Not too useful out of the water, but while you're in the water, you're in your element.

Game Statistics: Gills, Skinchange, double Frame Alteration (rebuilding the legs into a "fish-tail"), Custom Contacts (for underwater vision), Sonar. 18,900eb total. Surgeries: 2 Critical, 1 Major, 1 Minor, 2 Negligible (12,900eb). HC=10 1/2D6.

Sharkman: Popular with lawyers, this resembles nothing so much as a two-legged shark. It's also a functioning aquaform, with full underwater capability; useful as well as being decorative (and intimidating).

Game Statistics: Gills, Sonar, Skinchange, Skinweave, Muzzle (long), Natural Fangs, Major Facial/Frame Modification (includes dorsal fin and webbed hands/feet as well as shaping face into shark's). 17,700eb total. Surgeries: 2 Major, 2 Minor, 3 Negligible (4,600eb). HC=12D6.



THE FAITHFUL DOG

Man's best friend has touched the hearts of mankind for untold centuries. The cat walks by herself, but the dog has long been heralded for his steadfastness, his empathy, his friendliness. Maybe you want to cash in on this marvelous reputation (and the emotional content attached to it), or maybe you just really like dogs.

But remember, there's a darker side to the canine story. The Big Bad Wolf has long been a bogeyman; the fox and the coyote are classic tricksters, and there are few animals with a worse reputation than the pit-bull, the Tasmanian Devil of the canine world. Who says being a dog means you're harmless, happy-go-lucky and always faithful? Whether you want to be your own best friend or the fox in the henhouse, the LupaForm™ package is for you!

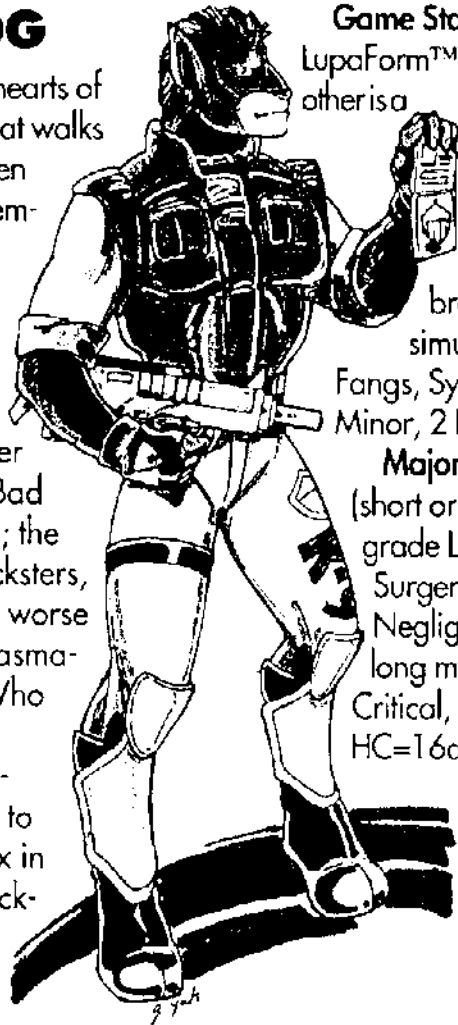

Game Statistics: There are two versions of the LupaForm™ package. One is relatively minor, the other is a full-form modification. The package elements can be mixed and matched to order.

Minor: Minor Facial Modification (pointed ears, dog-nose, big brown eyes; pugs and bull-dogs can be simulated with this procedure), Natural Fangs, Synthiskin. 1,900eb total. Surgeries: 1 Minor, 2 Negligible (900eb). HC=3 1/2D6.

Major: Major Facial Modification, Muzzle (short or long), Natural Fangs, Tail, Digitigrade Legs, Fur Skinchange. 20,000eb total. Surgeries: 1 Critical, 1 Major, 2 Minor, 2 Negligible (5,400eb). HC=15D6. (With long muzzle, 21,000eb total., Surgeries: 1 Critical, 2 Major, 1 Minor, 2 Negligible., HC=16d6.)

Popular Options: Enhanced cyberears, enhanced olfactories, grafted muscle (for the bull-dog bullies and big muscle dogs.)

HERE THERE BE DRAGONS

Voted the most intimidating exotic form on public display, the Dragon-Man is perfect for those wanting to deliver a message on sight. An armored colossus, nothing stands in the way of a Dragon-Man. So you can't spit fire. Big deal. Who needs fire when you have an H&K MP in your fist? This form means that you likely won't need to use it!

Tempted, but afraid to scare off the girls? Don't worry! Independent research has found that Dragon-Men rate on a sexuality scale alongside and sometimes even higher than the felines! There's something about an inhuman tower of strength and teeth that sends a guilty thrill deep into the human psyche. After all, everyone loves dinosaurs!

The Thunder Lizards walk the Earth again. Join their ranks as the *Humanisaurus Rex!*

Game Statistics: Major Facial Modification, Muzzle (short), Natural Fangs, Tail, Scale Skinchange. 16,000eb total. Surgeries: 1 Major, 2 Minor, 2 Negligible (2,900eb). HC=9d6. Popular options include heavy scales, natural claws (or retractables), combat tail, enhanced olfactory sense, thermograph eyes, and grafted muscles. Some like digitigrade legs for the dinosaurian look.



EXOTICS

PLAYBEING

They are the true life of any party. The "erotic exotic" is always a welcome and popular guest. And what makes a playbeing different from a normal exotic? Those "special extras under the hood," so to speak. Lose your inhibitions. Become a master (or mistress) of the arts of physical pleasure. Who needs drugs or pleasure-center wireheading? Please yourself and others at the same time, with just a few "enhancements."

Disclaimer: The rumors of persons being converted to exotic playbeings against their will by Biotechnica are false; as can easily be seen below, Biotechnica requires a legal waiver indicating intent and protecting against unfounded legal action before allowing any person to purchase a playbeing accessory package for installation. Any proven incidents of playbeing "manufacture" are due to unscrupulous agencies not related to Biotechnica.

Warning: Biotechnica refuses to install the playbeing package in any person without a signed waiver indicating that the applicant wishes to become a playbeing and absolves Biotechnica of all legal responsibility for any psychological aberrations or problems arising from the playbeing package.

Game Statistics: The playbeing package is usually added to an existing exotic conversion, but can be purchased without exotic conversions. Playbeings usually have their ATT scores raised to a minimum of 10, up to a maximum of 12. The package includes a "Mr. Studd/Midnight Lady™" implant, Tactile Boost (hardwired into the sexual implant), Chipware socket with the Maximum Lover chip and a Behavior chip—specific behavioral slant is chosen by the user to correspond to his/her emotional patterns and wishes, in any case the chip stimulates the libido; plus a Contraceptive Implant. 3,000eb total. Surgeries: 1 Major, 4 Negligible (2,300eb). HC=3 1/2d6. Optionally, the pleasure impulses from sexual activity can be tied into the Tactile Boost for an additional 150eb. This can lead to addiction to such activity, as well as nervous or physical overload.



INDEX

CYBERWARE 3

Anchoring Cyberfeet	5
Color Gland Control	6
Cytech Custom Cyberhands	5
Dynalar Cyberfingers	4
Gradiated Subdermal Armor (torso)	7
Kill Display	6
Kiroshi OptiShield	5
NanoOptical upgrade	8
QuickDraw Armholster	6
Remote Eye	9
Retractable Vampires	9
Subdermal Armor (skull)	7
Subdermal Viewscreen	8
Total Body Plating	9
Tri-dart Launcher	6
Upgraded Skinweave	9
Weirdrive Access Link	6
Winch	5
Zetatech BodyComp	8

EQUIPMENT 10

Arasaka "Komaku" Laser Mikes	20
Arasaka "Scanway" Scanner Gates	23
Arasaka ECM Comm-Scrambler	22
Arasaka JetSetter Executive Briefcase	21
Arasaka OmniTec Radar Detector	21
Arasaka RDAK Spy & Assassin Remote	32
Armored Stockings	28
Autotanner™	33
Bell "Bumblebee" Remote Rotocraft	31
Bug Detector	20
Bug Jammer	20
CCI BR-3014 Window Trembler	20
DataTel 2350AVidphone	12
DataTel Holotanks	29
Datotel "Treasurer" Datawatch	16
Datotel Modem Units	17
DDI PrayerWare	13
DeckMate	24
Direct Dataware EXPERT Series Programs	16
DPI "Black Box" Backup Synthamp	25
DPI Body Rhythm™ Dance Bracelets	26
Eastman Arts Mindscape®	
Cyberhelo Art Imager	30
Eastman KodaGraphix	
Holographic Cameras	30
EBM "PCX" Minicomp	14
Frostech Portable Cryogenic Case	13

Geotech EnviroScanner	11
Gibson Bottlegear "Sneak Suit"	28
Holoscreen holographic viewers	29
Hybrid™ Wearable Computer	19
Kiroshi Optics Heads-Up Display	17
Kiroshi Optics Remote CyberCam 20	13
Language Processor	15
Mead Electronic Notebook	12
MedicGear Combat Medical Armor	19
Microtech IINK-4 WorkStation	15
Microtech Virtual Reality BBS	12
Militech M73 "Mirage Gear"	
Environmental Assimilation System	28
Militech M96 "Ghostsuit"	27
Millitech RPV-400 Light	
Combat Tiltrotor Remote	31
Mitsubishi "Rover" Wheeled Remote	31
Multi-Player Adaptor	34
Nikken America Campod	11
Nutrisupplement	11
Nymph Perfume	11
OMEGA™ phone tap by Trittech	21
Portable Electropack	13
Raven Microcyb Net-Vision™	
IG-Algorithm Glasses	24
Remote Control Systems	30
Scholar™ Home Learning System	34
SecSystems Detention Collar	13
SecSystems Maglock	13
SecSystems Protection Field	12
SegAtari Virtual Villains	34
Soundmachine Guitar	26
Teletronics "Black Book" Microcomp	15
Teletronics "Scout" Signal Tracker	21
Teletronics ScanMan™	
Full Identity Scanner	22
Teletronics Tattletale®	
Voice Stress Analyzer	20
Total Environment™	34
Trittech "Mumbler" White Noise Generator	22
Trittech DataShielding	17
Video Wall™	34
Virtual Reality Entertainment System	34
VR Unit Upgrades	34
WorldSat Communications Flopscreen™	16
WorldSat Communications	
Linear Beam CommLink	22
Zetatech "E-Book" Microcomp	14
Zetatech CompuMods™	18

INDEX

Zetatech D2-3000 Armdeck 25

WEAPONS 35

API - Armor-Piercing Incendiary.....	46
Arasaka "Nauseator" Riot Control Device™.....	43
Colt-Mauser M2x Cannon.....	40
Drug-a-Thug™.....	45
Dual-Purpose rounds.....	46
ElectroThermal Ammo Enhancement.....	50
Flare Shotgun Shells.....	47
Flash Shotgun Shells.....	47
Flashbang Grenade.....	49
Gas Shotgun Shells.....	47
Gun-Cam.....	50
IMI "ChainKnife".....	44
Kendachi Fragmentation Flechettes.....	46
Kendachi Monowhip.....	44
Kendachi Monowire.....	44
Luigi Franchi "King Buck" Multi-Magnum.....	38
Micromissiles.....	49
Militech 25mm Pistol-Grenades.....	48
Militech AM-3 "Anti-Matter Rifle".....	41
Militech Cyborg Rifle.....	36
Militech PDU-3 Multi-Purpose	
Perimeter Defense Unit.....	42
Militech Urban Missile Launcher.....	41
Mystic Technologies Spring Knife.....	45
Nine-Eleven Chip.....	50
Nova 338 Citygun.....	40
Polymer One-Shot Cannon.....	36
Pursuit Security Incorporated Webgun.....	37
Rhinemetall EMG-85 Kinetic Energy Railgun.....	38
Rubber Bullets.....	47
Scatter Grenade.....	49
Security Chipping.....	50
Skunker™.....	45
SlamDance Inc. Spawnblade.....	44
Smoke Shotgun Shells.....	47
SplatShell.....	47
Spraypaint Grenade.....	49
Stein & Wasserman "Tri-Star" Revolver.....	37
Stench Bomb.....	49
Stinger Shotgun Shells, 10 Gauge.....	47
Stinger Shotgun Shells, 12 Gauge.....	47
Taser II™.....	45
Taser Wallet.....	45
Techtronica M40 "Pulse Rifle".....	39
Techtronica Model 009 Volt Pistol.....	43
Tsunami Arms	
"AirHammer" 5.3 mm Air pistol.....	42
Tsunami Arms Ramjet Rifle.....	36
UnderBarrel Capacitor	
Lasers/Microwavers.....	39
Urban Technologies Slasher.....	47

TEAMS 51

Autojok.....	61
C-Team.....	54

Cybernetic Intervention Services.....	57
Lifetime Escort Services.....	53
Orion.....	58
Sphere.....	52

FULL BODY REPLACEMENT 63

Alpha Class.....	66
Aquarius.....	67
Brimstone.....	74
Copernicus.....	69
Dragoon.....	80
Eclipse.....	71
Enforcer.....	73
Gemini.....	76
Options for Full Body Conversions.....	84
Samson.....	79
Wingman.....	77

VEHICLES 86

AV-3 "Aerocop".....	87
Ashigaru.....	93
Bermuda.....	94
GD F-36 Comet.....	95
Crowdar.....	91
Darkwing.....	94
Family Flier.....	88
Fed-Boeing Falcon.....	96
GD Hummingbird.....	97
India Sky-Barge.....	99
Lockheed-Cessna Pinto.....	98
MDD F-33 Wasp.....	96
Mach.....	89
"Madison Avenue" Advertblimp.....	100
Max Interceptor.....	92
Nissan Ford FanMaster.....	89
Sky Queen Cruise-Liner.....	100
Swan.....	90
Toyo-Chevrolet '17 Chevy.....	92

EXOTICS 101

Aquaforms.....	108
Bear Necessities.....	106
Bug Out!.....	108
Bunny.....	105
Dwarf/Halfling.....	105
Elf.....	105
Faithful Dog.....	109
Fishman.....	106
Graftables.....	106
Hold That Tiger!.....	107
Katnip™.....	104
Ork/Goblin.....	106
Playbeings.....	110
Rodent.....	104
Snake.....	105
Superman.....	107
Therapy Costs and Effects.....	102
Troll/Ogre.....	106

IT'S HERE...

This year's issue of THE style guide for the 21st Century...

CHROMEBOOK 2

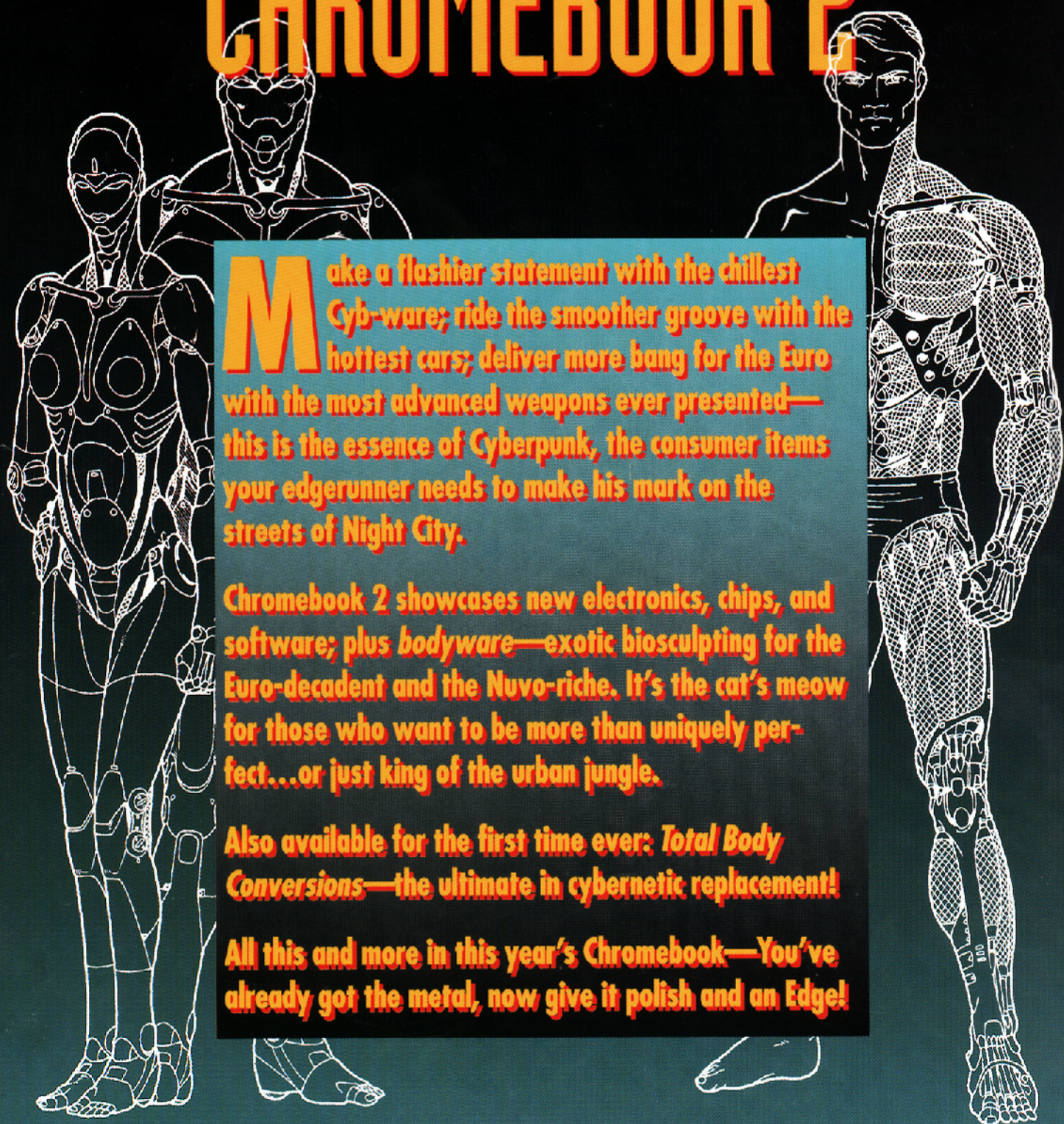

Make a flashier statement with the chilliest Cyb-ware; ride the smoother groove with the hottest cars; deliver more bang for the Euro with the most advanced weapons ever presented—this is the essence of Cyberpunk, the consumer items your edgerunner needs to make his mark on the streets of Night City.

Chromebook 2 showcases new electronics, chips, and software; plus *bodyware*—exotic biosculpting for the Euro-decadent and the Nuvo-riche. It's the cat's meow for those who want to be more than uniquely perfect...or just king of the urban jungle.

Also available for the first time ever: *Total Body Conversions*—the ultimate in cybernetic replacement!

All this and more in this year's Chromebook—You've already got the metal, now give it polish and an Edge!



A SUPPLEMENT FOR CYBERPUNK

**R. TALSORIAN
GAMES, INC.**

Published by R. Talsorian Games
P.O. Box 7356

Berkeley, CA 94707

Copyright 1992 by R. Talsorian Games Inc.

Cyberpunk® and Chrome book 2 are trademarks of R. Talsorian Games Inc. All Rights Reserved.

CP 3181

ISBN # 0-937279-29-8



7 37216 31810 9