

***Reconstructing
Clothes***
FOR
DUMMIES®

by Miranda Caroligne Burns



Wiley Publishing, Inc.

***Reconstructing
Clothes***
FOR
DUMMIES®

by Miranda Caroligne Burns



Wiley Publishing, Inc.

Reconstructing Clothes For Dummies®

Published by
Wiley Publishing, Inc.
111 River St.
Hoboken, NJ 07030-5774
www.wiley.com

Copyright © 2007 by Wiley Publishing, Inc., Indianapolis, Indiana

Published simultaneously in Canada

No part of this publication may be reproduced, stored in a retrieval system, or transmitted in any form or by any means, electronic, mechanical, photocopying, recording, scanning, or otherwise, except as permitted under Sections 107 or 108 of the 1976 United States Copyright Act, without either the prior written permission of the Publisher, or authorization through payment of the appropriate per-copy fee to the Copyright Clearance Center, 222 Rosewood Drive, Danvers, MA 01923, 978-750-8400, fax 978-646-8600. Requests to the Publisher for permission should be addressed to the Legal Department, Wiley Publishing, Inc., 10475 Crosspoint Blvd., Indianapolis, IN 46256, 317-572-3447, fax 317-572-4355, or online at <http://www.wiley.com/go/permissions>.

Trademarks: Wiley, the Wiley Publishing logo, For Dummies, the Dummies Man logo, A Reference for the Rest of Us!, The Dummies Way, Dummies Daily, The Fun and Easy Way, Dummies.com and related trade dress are trademarks or registered trademarks of John Wiley & Sons, Inc. and/or its affiliates in the United States and other countries, and may not be used without written permission. All other trademarks are the property of their respective owners. Wiley Publishing, Inc., is not associated with any product or vendor mentioned in this book.

LIMIT OF LIABILITY/DISCLAIMER OF WARRANTY: THE PUBLISHER AND THE AUTHOR MAKE NO REPRESENTATIONS OR WARRANTIES WITH RESPECT TO THE ACCURACY OR COMPLETENESS OF THE CONTENTS OF THIS WORK AND SPECIFICALLY DISCLAIM ALL WARRANTIES, INCLUDING WITHOUT LIMITATION WARRANTIES OF FITNESS FOR A PARTICULAR PURPOSE. NO WARRANTY MAY BE CREATED OR EXTENDED BY SALES OR PROMOTIONAL MATERIALS. THE ADVICE AND STRATEGIES CONTAINED HEREIN MAY NOT BE SUITABLE FOR EVERY SITUATION. THIS WORK IS SOLD WITH THE UNDERSTANDING THAT THE PUBLISHER IS NOT ENGAGED IN RENDERING LEGAL, ACCOUNTING, OR OTHER PROFESSIONAL SERVICES. IF PROFESSIONAL ASSISTANCE IS REQUIRED, THE SERVICES OF A COMPETENT PROFESSIONAL PERSON SHOULD BE SOUGHT. NEITHER THE PUBLISHER NOR THE AUTHOR SHALL BE LIABLE FOR DAMAGES ARISING HEREFROM. THE FACT THAT AN ORGANIZATION OR WEBSITE IS REFERRED TO IN THIS WORK AS A CITATION AND/OR A POTENTIAL SOURCE OF FURTHER INFORMATION DOES NOT MEAN THAT THE AUTHOR OR THE PUBLISHER ENDORSES THE INFORMATION THE ORGANIZATION OR WEBSITE MAY PROVIDE OR RECOMMENDATIONS IT MAY MAKE. FURTHER, READERS SHOULD BE AWARE THAT INTERNET WEBSITES LISTED IN THIS WORK MAY HAVE CHANGED OR DISAPPEARED BETWEEN WHEN THIS WORK WAS WRITTEN AND WHEN IT IS READ.

For general information on our other products and services, please contact our Customer Care Department within the U.S. at 800-762-2974, outside the U.S. at 317-572-3993, or fax 317-572-4002.

For technical support, please visit www.wiley.com/techsupport.

Wiley also publishes its books in a variety of electronic formats. Some content that appears in print may not be available in electronic books.

Library of Congress Control Number: 2007926404

ISBN: 978-0-470-12767-4

Manufactured in the United States of America

10 9 8 7 6 5 4 3 2 1



About the Author

Miranda Caroligne Burns (San Francisco, CA) has donned a variety of hats in her young years: physical therapist, event producer, community activist, installation artist, author, performance artist, philosopher, and fashion designer. Mentored by her mother, Miranda has been sewing and creating her own clothing since she could hold a needle. Over time she developed a zest for re-use and heartfelt desire for truly unique design. This ethos is masterfully woven together to recall the forms of yesteryear with an otherworldly edge — a philosophy she calls “neoarchaic.”

Miranda’s life has been a bi-coastal artistic evolution. She became active in the alternative arts scene in Boston, where she introduced “living construction,” a live sewing performance piece staged in gallery window fronts.

Relocating to San Francisco in 2005, she quickly emerged as a bright new star in a constellation of provocative artist-designers. Her fashion shows are known for their performance-art quality, embodying political, artistic, and personal statements. These shows include Catwalk on the Wild Side (U.N. World Environment Day Gala “Walk the Talk”), Love Fest VIP Event (San Francisco City Hall), and Maker Faire (Swaporamarama and *Make* magazine). She has also had various individual performance art appearances at Supperclub San Francisco, San Jose Museum of Art, and Burningman.

Meander through San Francisco’s Mission-Deco Ghetto neighborhood and you’ll find Miranda reconstructing in the window-front of her boutique, *miranda caroligne — a living construction boutique* (www.mirandacaroligne.com), 485 14 Street @ Guerrero. You’re sure to be delighted by the local art and design, and step forward with the inspiration to do it yourself!

Dedication

This book is dedicated to you. Yes, you! You are a living, breathing work of art in full construction and reconstruction every day. Shed your fear and take off the blinders. Live fully in truth, clarity, and consciousness. Free yourself of waste and find time for your passion in life. Be inspired by the re-use artists and entrepreneurs in this book. Be an inspiration for others.

Author's Acknowledgments

The rebel in me is pulled to write something unusual but I honestly must express immense gratitude to my parents. Not only did they teach me about sewing and textiles, but also how to create a livelihood from “hobbies.” They never restricted my creativity and exploration of new ideas, even when I cut up my turtlenecks for miniskirts! Still they managed to instill a core ethic of hard work, humanity, and environmental responsibility. Thank you.

Much thanks to the trail of wonderful people who made this book happen: Lindsay Lefevere and Jennifer Connolly, my editors at Wiley Publishing, for your ever-positive spirit, guidance, and advocacy; Wendy Tremayne of Swaporamarama, for sending Lindsay my way; Steven Raspa for introducing me to Wendy (as well as being his inspiring self!); and the folks at *Make* magazine for supporting the Swap and DIY textile arts at their Maker Faire.

Thank you to my fellow artists for ideas, help in the boutique, signature hair-coloring breaks, coffee, and emergency computer aid: Anastazia Louise of Bad Unkl Sista, Dida Cudrnak of Dida Jewelry, Marc Scheff of Dangermarc, Mariefrance of Madusalon, Rachel Hospodar of Medium Reality, Rebecca Vandersteen of Venus Superstar, and Tammy “Tamo” Hulva of Greengirl and Wildlife Works. To Del Greger and Honne Heller; you are the divas of graceful play and I am truly humbled to receive your wisdom, brownies, and old clothes.

I owe my eyes to Loren Earle-Cruikshanks for his photographic genius in making the boring projects appealing and the good ones infinitely better. On the other side of the lens, thanks to Tamara Ja, Amy Leblanc, Lauren Borowski, Chris Ray Collins, and Ocean for your strength of character. Much thanks to the following artists for accessorizing the shoots: www.aikojewelry.com, www.didajewelry.com, www.fluidance.com, www.orelafey.com, www.rengaarts.com, www.venussuperstar.com, and www.zacharypryor.com.

We all owe a debt of gratitude to the people behind the shoot locations: Building Resources and for keeping building materials in circulation of use rather than in our landfills; Jens-Peter Jungclaussen, The Teacher With The Bus, for his veggie oil fueled mobile classroom; artist Nome Edonna for his work in found objects as an artist-in-residence at Sunset Scavenger; artists and all-around exemplary human beings Marcus Guillard, Melvin Occasio, and Chris Ray Collins for creating beauty with the scraps in their own backyard. Thank you for allowing me to share your work with others and to show the variety of ways we can *all* diminish waste for a more sustainable future.

Thanks to my community for being fantastic beings of inspiration and endless support. So many others to thank for their smiles, patience, needles, adventure kidnappings, healing hands, glitchy beats, hugs 'n clown kisses, open hearts, and bright eyes to swim in . . . you know, all that gushy stuff!

Publisher's Acknowledgments

We're proud of this book; please send us your comments through our Dummies online registration form located at www.dummies.com/register/.

Some of the people who helped bring this book to market include the following:

Acquisitions, Editorial, and Media Development

Project Editor: Jennifer Connolly

Acquisitions Editor: Lindsay Lefevere

Copy Editor: Jennifer Connolly

Technical Editor: Rachel Hopsdar

Editorial Manager: Michelle Hacker

Editorial Supervisor: Carmen Krikorian

Editorial Assistants: Erin Calligan, Joe Niesen,
Leeann Harney

Cover and Interior Photos: LEC Photo, Inc.

Cartoons: Rich Tennant
(www.the5thwave.com)

Composition Services

Project Coordinator: Lynsey Osborn

Layout and Graphics: Jonelle Burns,
Denny Hager, Joyce Haughey,
Stephanie Jumper, Shelley Norris,
Laura Pence, Alicia B. South,
Christine Williams

Anniversary Logo Design: Richard Pacifico

Proofreaders: Laura Albert, Cynthia Fields,
Susan Moritz, Aptara

Indexer: Aptara

Publishing and Editorial for Consumer Dummies

Diane Graves Steele, Vice President and Publisher, Consumer Dummies

Joyce Pepple, Acquisitions Director, Consumer Dummies

Kristin A. Cocks, Product Development Director, Consumer Dummies

Michael Spring, Vice President and Publisher, Travel

Kelly Regan, Editorial Director, Travel

Publishing for Technology Dummies

Andy Cummings, Vice President and Publisher, Dummies Technology/General User

Composition Services

Gerry Fahey, Vice President of Production Services

Debbie Stailey, Director of Composition Services

Contents at a Glance

<i>Introduction</i>	1
<i>Part I: Let the Reconstruction Begin! But First . . .</i>	9
Chapter 1: The Ins, Outs, and Inside-Outs of This Book	11
Chapter 2: Reconstruction Reasons.....	23
Chapter 3: Scoping Stuff with an Eye for Design	33
Chapter 4: Deconstructing 101: Taking Stuff Apart	49
Chapter 5: Reconstructing 101: The Very Basics of Sewing.....	63
<i>Part II: Shirts: Sluggish to Spectacular</i>	87
Chapter 6: Transforming T-shirts	89
Chapter 7: Redefining Boring Button-downs	107
Chapter 8: Pullover Overhaul	125
<i>Part III: Breathing Life into Dead Pants</i>	147
Chapter 9: Basic Slacks Brought Back	149
Chapter 10: Regenerating Jeans	169
Chapter 11: The Existential Stretch Pant	183
<i>Part IV: Salvation for Your Sweaters and Other Knits ...</i>	199
Chapter 12: Do It Again with Your Cardigan	201
Chapter 13: Pullover Sweaters Pulled in All Directions.....	217
Chapter 14: Afghan Today, What Tomorrow?	235
<i>Part V: Skirts and Dresses (re)Done Right</i>	249
Chapter 15: Bridesmaid's Redemption	251
Chapter 16: Second Life For Your Skirt.....	269
Chapter 17: Addressing That Tired Old Dress.....	281
<i>Part VI: Now What to Do with All These Scraps?</i>	295
Chapter 18: Brand New Bedding	297
Chapter 19: Deck the Halls with Lots of Scraps.....	315
Chapter 20: Decorative (re)Touches.....	327

<i>Part VII: The Part of Tens</i>	339
Chapter 21: Ten General Tips	341
Chapter 22: Ten Fix-a-Stain Tricks	347
<i>Index</i>	353

Table of Contents

.....

<i>Introduction</i>	1
About This Book.....	1
How to Use This Book	2
Conventions Used in This Book	3
Foolish Assumptions	4
How This Book Is Organized.....	5
Part I: Let the Reconstruction Begin! But First . . .	5
Part II: Shirts: Sluggish to Spectacular.....	5
Part III: Breathing Life into Dead Pants.....	6
Part IV: Salvation for Your Sweaters and Other Knits	6
Part V: Skirts and Dresses (re)Done Right	6
Part VI: Now What to Do with All These Scraps?	6
Part VII: The Part of Tens	6
Icons Used in This Book.....	7
Where to Go From Here.....	7

Part 1: Let the Reconstruction Begin! But First**9**

Chapter 1: The Ins, Outs, and Inside-Outs of This Book11

Reconstructed Clothing Defined	12
Clothes of a different color	13
Mind-altering alterations	14
Clothing for cloth	15
Trash to treasure.....	16
Just Who Do You Think You Are?	17
The dabbler	17
The environmentalist.....	18
The student	18
The artist-designer	19
Perusing This Book For Your Best Interest.....	20

Chapter 2: Reconstruction Reasons23

Reduce.....	24
Reuse	25
Recycle	26
Reaping Financial Gain	27
Rescuing Old Favorites	29
Redeeming Closet Space	30
Representing Your Self	31

Chapter 3: Scoping Stuff with an Eye for Design 33

Shopping Your Own Shelves	34
Lifting the Thrifting Veil.....	34
The ease of city selection.....	35
Stocking up in the suburbs	36
You'd be surprised what you'd find here	37
Updated Optimism on Dated Styles.....	38
Playing the Numbers	39
Giving Ill-Fitting Clothes a Second Chance	40
Damaged But Not Done Yet.....	40
Good stains versus bad stains.....	41
Deals on decent damages.....	41
Wear 'n tear worn well	41
Feel-Good Fabric	42
Best Bet Basics	43
ABC's to Avoid	43
Armpit issues	44
Beadwork and other tempting adornments.....	44
Critters and creepies.....	45
Depilatory delusions.....	46
Expectations of supernatural proportion	47
Fragrant fabrics — if you have to hold your nose, put it back!.....	47

Chapter 4: Deconstructing 101: Taking Stuff Apart 49

Creating Space to Minimize Waste.....	50
Neat freak	50
Chaos theory.....	52
Organized chaos	52
Getting the “Gotta-Have-Its”	53
The seam ripper — a holistic alternative in anger management	53
Scissor happy.....	54
Safety pins to save your soles	54
Taking It Up a Notch with More Tools	54
The rolling cutter — a love/hate relationship	54
Suck it up!	55
No fuss lint brush	55
Leaving Caution (and Washing) to the Wind	56
Washing woes.....	56
Making your life, and allergies, a whole lot easier	57
The miraculous marvels of modern washing	57
Dryer be damned.....	57
Making the Most of Flaws.....	58
Stains.....	58
Tears and holes.....	59
Deconstructing Like a Pro.....	61
Sightseeing seams	61
To be or not to be a seam.....	62
Get over it and get started	62

Chapter 5: Reconstructing 101: The Very Basics of Sewing 63

Stocking Up On Sewing Essentials	64
Thread in your head.....	64
On pins and needles.....	64
Keeping it clean	66
Setting Up Your Workspace	66
Don't rock the boat	66
Posture perfect	67
Happiness (and everything else) is within your reach	69
Going Unplugged — Sewing By Hand	69
Third eye of the needle.....	70
Knot enough.....	72
Basic basting	74
Run with the running stitch	74
Blanket stitch or bust	75
Hemming and hawing	75
Moving Up To Machine Sewing	77
Key features	77
Tried and true tricks for affordability.....	78
Salvation through servicing	78
Stitch essentials.....	79
Beyond the basic stitch.....	80
Oh Holy Overlock Machine.....	81
What is this thing?.....	81
Key features	81
Making the financial plunge with buoyancy	82
Stay smart and service me.....	82
Starting and stopping with security.....	83
Hungry puckers and differential feeding.....	84
Go raw	84
In a Pinch Tricks.....	85
The heat is on	85
No sew hems	86
Decorative cover-up.....	86

Part 11: Shirts: Sluggish to Spectacular* 87*Chapter 6: Transforming T-shirts 89**

Giving Your T-shirt Some TLC	89
Pre-construction care	90
Post-construction care	90
Upside-Down Skirt in a Topsy-Turvy World.....	91
Materials	92
Directions	92
Variations.....	97

No-Stop Halter Top.....	98
Materials.....	99
Directions.....	99
Variations.....	102
Diminishing Waste with Waistbands.....	103
Materials.....	103
Directions.....	104
Chapter 7: Redefining Boring Button-downs	107
Prepping, Priming, and Post Care for Your Button-downs.....	107
Busting Out the Neck Bustles.....	108
Materials.....	109
Directions.....	109
Variations.....	111
Bridging the Sweater Gap Top.....	112
Materials.....	114
Directions.....	114
Variations.....	118
Getting Crafty With Cuffs.....	118
Preciously Painted Cuffs.....	118
Buttoned-Up Bracelets.....	121
Chapter 8: Pullover Overhaul	125
Prepping, Priming, and Post Care for Your Pullover.....	125
The usual suspects.....	126
Circumventing circumstantial stains and such.....	126
Running Circles Around Crop Tops.....	126
All-Season Crop Top.....	126
Crop Inversion Top.....	130
Tails of Two Crops Top.....	136
Wrap to Write Home About.....	140
Materials.....	141
Directions.....	141
<i>Part III: Breathing Life into Dead Pants.....</i>	147
Chapter 9: Basic Slacks Brought Back	149
Prepping, Priming, and Post Care for Your Pants.....	149
The usual suspects.....	149
Wearing to watch out for.....	150
Renaissance Repairs Jeans.....	150
Materials.....	150
Directions.....	151
Skirts and Such.....	153
So Easy Split Skirt.....	153
Detachable Bustle Skirt.....	158

Surprise Fly Top163
 Materials164
 Directions164
 Variations.....167

Chapter 10: Regenerating Jeans169

Prepping, Priming, and Post Care for Your Jeans169
 The usual suspects.....170
 Potential pitfalls to prepare for170
 Repetition Editions Jeans.....170
 Materials171
 Directions171
 Oh-So-Hip Hip Belt173
 Materials.....174
 Directions174
 Variations.....177
 It's in the Bag Shoulderbag179
 Materials179
 Directions180
 Variations.....182

Chapter 11: The Existential Stretch Pant183

Prepping, Priming, and Post Care for Your Stretch Pants183
 The usual suspects.....184
 Pulls and pills in all the wrong places184
 Bare and Flare Skirt.....184
 Materials185
 Directions185
 Variations.....189
 Layering the Leggings.....190
 Materials191
 Directions191
 Variations.....193
 From Flat to Hat.....194
 Materials195
 Directions195
 Variations.....198

Part IV: Salvation for Your Sweaters and Other Knits ... 199

Chapter 12: Do It Again with Your Cardigan201

Prepping, Priming, and Post Care for Your Cardigan201
 The usual suspects.....202
 Cleaning your cardigan.....202
 Buttons be gone.....203
 Running Wild.....204

Bad Unkl Sista Sweater	205
Materials	205
Directions	206
Variations.....	208
Making a Case for Pillowcases.....	209
Materials	210
Directions	210
Variations.....	212
A Twist on the Upside-Down Skirt	213
Materials	214
Directions	214
Variations.....	216

Chapter 13: Pullover Sweaters Pulled in All Directions 217

Prepping, Priming, and Post Care for Your Pullover Sweaters	218
The usual suspects.....	218
A bad pill you don't have to swallow.....	218
Take Two On the Tees	219
Upside-Down Skirt	219
No Stopping the Halter Top.....	220
New Cut on Crops.....	223
Wrap for a New Way of Life	224
Sleek 'n' Sneaky Sleeves	226
Materials	227
Directions	227
Variations.....	229
Bag Ladies Shoulderbag.....	230
Materials	231
Directions	231
Variations.....	234

Chapter 14: Afghan Today, What Tomorrow? 235

Prepping, Priming, and Post Care for Your Afghan	235
The usual suspects.....	236
Bang for your buck.....	236
Fringe fallout	236
Pimping the Poncho.....	237
Materials	237
Directions	238
Variations.....	241
Vestcoat Investments.....	241
Materials	242
Directions	242
Variations.....	247

***Part V: Skirts and Dresses (re)Done Right*.....249**
Chapter 15: Bridesmaid's Redemption251

Prepping, Primping, and Post Care for Your Dress	251
The usual suspects.....	252
Dry clean or bust.....	252
A Little Heat Gun Goes a Long Way Dress.....	252
Materials.....	253
Directions	253
Variations.....	256
Split Skirt Stick-Up.....	256
Materials.....	256
Directions	257
Variations.....	260
Cape — from Costume to Couture	261
Materials.....	262
Directions	262
Variations.....	264
Whip Up a Wine Bag.....	265
Materials.....	266
Directions	266
Variations.....	268

Chapter 16: Second Life For Your Skirt269

Prepping, Primping, and Post Care for Your Skirt.....	269
The usual suspects.....	270
Freeform and Frill Skirt.....	270
Materials.....	271
Directions	271
Variations.....	275
Business Skirt Gone Badass.....	275
Materials.....	276
Directions	276
Variations.....	278
Cutting-Edge Cowl Neck Top	278
Materials.....	279
Directions	280

Chapter 17: Addressing That Tired Old Dress281

Prepping, Primping, and Post Care for Your Dress	281
The usual suspects.....	281
Showing Some Skin Dress	282
Materials.....	283
Directions	283
Variations.....	285

Raw the Right Way Dress	287
Materials	288
Directions	288
Variations.....	290
Sets of All Sorts Top/Skirt	291
Materials	291
Directions	292
Variations.....	292

Part VI: Now What to Do with All These Scraps?295

Chapter 18: Brand New Bedding297

Save-It-All Stuffing	297
Materials	298
Directions	298
Variations.....	300
Casing Your Cozies Pillowcases	300
Materials	301
Directions	302
Variations.....	306
Quintessential Quilt	307
Materials	308
Directions	309
Variations.....	313

Chapter 19: Deck the Halls with Lots of Scraps315

Sachet Simplicity	315
Materials	316
Directions	317
Variations.....	319
Pragmatic Potholders	320
Materials	321
Directions	322
Variations.....	325

Chapter 20: Decorative (re)Touches327

Deco from Garbage to Gorgeous	327
Materials	328
Directions	328
Variations.....	330
Choker Chop-Up	330
Materials	331
Directions	331
Variations.....	333

Put Your Money Where Your Scraps Are Wallet.....	334
Materials.....	334
Directions.....	335
Variations.....	337
<i>Part VII: The Part of Tens.....</i>	339
Chapter 21: Ten General Tips	341
Don't Be Afraid to Cut It.....	341
Let Go Of Your Inner Perfectionist.....	341
Get in the Groove of a Good Pair of Scissors.....	342
Enjoying Evolution.....	342
You Are Your Own Model.....	343
Stains Can Be Your Guide.....	343
Clever Closures.....	344
Pinning for Winning.....	344
Lock into a Good Overlock.....	345
No Salvation for Armpit Stains.....	345
Chapter 22: Ten Fix-a-Stain Tricks	347
Brushing Up on Your Painting.....	347
Dye Do-overs.....	348
Drawing 101 — Sharpie Style.....	348
Patchwork Pride.....	349
Turning the Dial to Decorative Stitching.....	349
Seemingly a Mere Seam.....	349
Deco-Serge Splurge.....	350
Worn with Purpose.....	350
Exemplary Embroidery.....	350
Buttons and Beads That Can't Be Beat.....	351
<i>Index.....</i>	353

XX

Reconstructing Clothes For Dummies

Introduction

The projects in this book all develop from one essential story. Let me illustrate: Have you ever kept a sweater because it had some significant meaning to you? Maybe at one time it carried the scent of a loved one, or it reminded you of adventures you had in Paris? It may have even been passed down from your favorite grandpa. The clothes you wear are an extension of yourself and all that happens to you. The projects in this book are my way of recycling those moments and integrating them together into a new form. Just as we individuals are transformed by these life-altering experiences, our clothes can be a reflection of those transformations as well.

Although reconstructing clothing is a new hot trend these days, I really hope it sticks. I have been chopping up my clothes since I was a kid and have always been showered with compliments from people of all walks of life. In both my commission work as well as my “living construction” live sewing performances, I have interacted with everyone from CEOs to people living on the street. Everyone I come across is intrigued in some way by this concept. Reconstructing existing clothes is an easy and affordable way to customize and individualize a garment to your own special size and style needs. Reconstructing clothes is truly for everyone

Beyond the practical perks of reconstructing old clothing, there are many environmentally sound aspects as well. With every piece you reconstruct, you are helping to diminish waste in a world overflowing with it. On top of that, every time you wear a reconstructed garment you are promoting re-use and sustainable living philosophies to every person you meet and even the ones who just pass by you on the street. While it may seem cliché, it’s true that we never know the full impact we have on this world. Make it a positive one!

About This Book

I think of this book as a group effort. I like to learn something from everyone I meet, and then put my own spin on it. *Reconstructing Clothes For Dummies* is a culmination of my experience up to this point, with so many avenues yet to explore.

This book provides you with the basics of taking things apart and reworking them to yield a brand new look. There are a slew of projects, and oh-so-many more in my head. The project instructions are simplified to provide you with the basics. Honestly it was a struggle for my creative self to keep it as bare-bones as possible for you. But I did this intentionally to allow for your own creativity to rise to the occasion. Part of reconstruction is, after all, making something unique and fully individualized.

I've included a list of decorative variations, either variations to the instructions or decorative touches to finish off the project. The variations I list are just my ideas so please don't think of this list as complete.

Most of the projects in this book require sewing. Whenever applicable, no-sew options to certain steps within the directions have been emphasized. There are also lots of decorative variations that do not involve sewing at all. Additional variations touch on other needlecraft and textile art techniques that you might be interested in exploring further. I encourage you to take this as a platform to spring off of with your own ideas and creativity. Always feel free to expand on the variations with your own personal talents and interests. The possibilities are endless!

Beyond the basics and practical projects, I've plugged in conscious reminders of sustainable living practices. I think it's important to have fun with what you're doing, but also know *why* you're doing it. While Chapter 2 discusses some of the reasons to reconstruct clothing, I've also embedded my own experiences and intentions throughout the book. I don't necessarily just want you to regurgitate my feelings, but I hope to inspire you to look into yourself and figure out your own intentions and aspirations for living a fulfilling life. It won't necessarily change the look of your piece, but will certainly affect how good you feel in it!

How to Use This Book

This book is not meant to be read cover to cover. If you are anything like me, you just don't have the time or patience for that! Personally, I like to figure things out with logical thought and what seems to me as common sense. With that, I completely understand others who work in the same manner and don't feel compelled to read anything more than the directions of their chosen project. While you might be able to swing this, it will make your life a lot easier to take a quick glance through the chapter in which your project is located. While mistakes and mishaps can be fun adventures to lead you in a new direction, they can also be daunting, especially to the perfectionist. I want you to find success in this reconstruction adventure so I urge you to read a bit and learn new lessons from my mistakes rather than having to make them on your own.

If you are a proficient sewer, have a solid handle on textiles and how to care for them, feel free to just dive right into the projects. In doing so, it's helpful to refer to the Part of Tens for some quick tips, do's and don'ts that are special to reconstructing clothing. If you are new to sewing, reconstruction, or just need a refresher, I recommend reading Part I before you begin the projects.

Whenever I talk to people about reconstructing clothes, often a light of realization comes across their eyes. Just about everyone seems to have *something* in their closet that they don't wear anymore but can't bear throwing or giving away for whatever reason. Because of this, I've organized this book by the starting garment. This may be pants, a skirt, or an old favorite sweater. On the flip side, there are before/after photos, as well as a color photo insert for you to check out and choose a desired project. From that point, you can either search your own closet or your local thrift store for the starting garment.

Conventions Used in This Book

In the throes of creation, you can easily lose attention with a tangential idea. Not all of us have the luxury of a private studio or workspace free of distractions: ringing phones, hungry pets, playful children and other loved ones. With this in mind, I've used a few conventions to help keep your mind and projects organized.

- ✔ **Every chapter starts off with care instructions.** This care section often references Chapter 4 for general care instructions, but I note within each chapter individual differences among the garments that are important to take note of.
- ✔ **Every project includes a before photo and ends with an after photo.** The before photo is located after the introductory paragraph of each project, while the after photo is located after the instructions and before the list of variations for that project. Please note that these project photos are for the barebones basic version with no variations. In other words, some of them are ugly. The artist in me apologizes. The teacher in me hopes that you appreciate the clarity. In some cases, some “fix-a-stain” or “making the most of wear and tear” tricks have been implemented to create a functionally sound piece.
- ✔ **Every project includes a list of necessary materials presented in bulleted format for easy reference and check-off.** I confess that I don't use all of these materials. If you are proficient with these tools and feel okay substituting, go for it! If not, it's best to have everything on the list ready to go, and wait to fudge it until you have more practice with reconstructing.

- ✔ **Directions for each project are listed in numbered steps, making it easy to keep your place.** Each step begins with boldface text telling you the general action for that step — the text following the boldface text explains the step in more detail. Feel free to write in this book, make your own notes in the white space and margins, and check the steps off as you go along. This book is for using, not putting on a shelf somewhere to look pretty.
- ✔ **At the end of each project is a bulleted list of variations for that project.** These can be repetitive and in no way include all of the possibilities for decorative variations. I've simply compiled some creative ideas that I tend to use and plugged them into the projects that they work best with. Do not let this list limit you. If you are compelled to try the stripey spray-paint technique on a knit — go for it! Just because it isn't listed in the variations, don't assume that it's not an option. You are always free to try new things as long as you are willing to accept the consequences that it might not turn out so hot.
- ✔ **The projects photographed for this book have been completed with an overlock machine whenever this method is an option.** While I love using an overlock because of its capacity to create the visibly constructed look that I prefer, I in no way want you to feel that you have to go out and buy an overlock just to complete these projects. I chose to use the overlock for these projects so that it was easier for you to see the seams and better understand how things are constructed. It is my primary tool, and thus I must apologize for the horrific sewing on the regular sewing machine. I am not exactly what you would call a good sewer!

Foolish Assumptions

I've assumed a few things about you in writing this book:

- ✔ You are open-minded, creative, and excited to try new things!
- ✔ You are not a complete novice to sewing. While this book provides brief sewing lessons, it is not a “how-to” book for sewing skills. It is about using those skills, as well as a collection of other techniques, in a novel way.
- ✔ You either are familiar with the tools, materials and verbiage of this craft *or*
- ✔ You are capable of becoming familiar with the tools, materials and verbiage of this craft via the Internet, library, local craft/fabric store, and so on.
- ✔ You have heard about reconstructing clothing and want to play around with it in your own personal wardrobe.

- ✔ You want some clear and simple instructions to get you started on reconstructing clothing. You may even have a particular garment in mind already.
- ✔ You live on this planet and care about its future.
- ✔ You're tired of your sweetie's holey T-shirts and underwear and are determined to do something with them besides making them into rags.

Sound like you? Great . . . let's get on with it!

How This Book Is Organized

I have broken this book up into seven parts. The first part includes introductory chapters for sewing basics, deconstructing and reconstructing. The following five parts are organized by the type of garment you are starting with in your reconstruction project. Finally, the Part of Tens is a *For Dummies* staple that provides you with some quick tips to refer to in a pinch.

Part I: Let the Reconstruction Begin! But First . . .

This is the part in which you will find out the who, what, where, when, why, and how about reconstructing. Okay, well maybe not the “who,” because that’s you and you know that already. As far as “when,” well, that’s easy too . . . *right now*.

Part I lays out the basics of this book. In it you will find the reasons behind reconstructing, how to find good stuff to start with, what to look for, where to find it and how to take it apart. Last is a quickie sewing review of the techniques you can use to put it all back together in a new form.

Part II: Shirts: Sluggish to Spectacular

What a better place to start than at the top! This part is all about reconstruction projects you can do with commonplace shirt styles: T-shirts, button-downs, and pullovers.

Part III: Breathing Life into Dead Pants

Pants come in all shapes and sizes, and this part lets you know what you can do with all of them. Jeans are turned into all sorts of creations, while basic slacks and stretch pants find new life in your wardrobe.

Part IV: Salvation for Your Sweaters and Other Knits

Sweaters and knits provide unique sewing challenges. I present these challenges and show you how to conquer them, amid a slew of projects for both cardigans and pullover sweaters. I even include a chapter to help you figure out what to do with those old afghans!

Part V: Skirts and Dresses (re)Done Right

This part is all about revamping old skirts and dresses. I show you some projects for several styles of skirts, that hideous bridesmaid dress, and multiple options for any old dress.

Part VI: Now What to Do with All These Scraps?

If you are a sewer, or just an all-around pack-rat, you likely have lots of fabric scraps taking up space in your life. Being both of these things, I have not only gotten my own collection, but a virtual family tree of scraps passed down from generation to generation. In this part, you can find lots of ideas for lots of different sizes and types of scraps. It includes chapters on home décor projects and accessories for your own personal wardrobe.

Part VII: The Part of Tens

The Part of Tens is a good quickie referral section of this book. Bring it along with you on thrift-store scavenging trips to find out what to avoid. Trust me, after years of perusing thrift stores there are some definite trends and pitfalls, and I've got stacks of them in storage unable to be used but too fantastic to cut up for scraps! It's often hard to say no when you should. Having this book on hand can help you sort it all out. It's also a succinct reference for general tips and clever ways to fix stains.

Icons Used in This Book

These cute little drawings are not just here for your entertainment. They serve to emphasize important points. Think of them as a big flashing sign begging for your attention.



The Tip icon points out just that, tips! Next to this icon you will find additional suggestions for either doing something better, faster or beyond the basics in some way.



Eeek! Forget to read this and you may lose a finger! But seriously, there are some dangers in reconstructing clothing, whether to yourself, your tools or your garment. Read this to avoid injury!



Sometimes we forget, being human and all. This icon points out areas in which this might be common, and helps keep you on track!



There are few projects that can be completed without at least *some* sewing. Many, however, have components in the main pattern and even more variations that can be done without a needle and thread. You can find all of these easily just by keeping your eyes peeled for this icon.



Three cheers for recycling! Saving your scraps from these projects can propel you onto yet another project. This icon is next to every opportunity to do this. It lists at least one suggestion for the particular scrap. The option is always open to use your scraps in any way you choose as long as they are kept in circulation and out of our landfills as long as possible!

Where to Go from Here

While there are a growing number of books with ideas and patterns for reconstructing clothing, I encourage you to explore your own ideas. Think about what is lacking in clothing for you, either in the fit or the style. Are sleeves always too short? Do you love fleece but the styles are always too sporty? Or do you find yourself saying, "I love this top but I just wish it was *<insert adjective here>*." Well find those garments and then plop open the pages to the applicable chapter to find some projects to get started on pronto.

If you're wanting to know more about reconstructing clothes before you begin hacking away at your own pieces, just turn to Part I. This book is a great way to get a hold of some basics and get a running start on inspiration.

My other hope with this book is that it will get you thinking about all sorts of ways you can re-use and diminish waste in your daily life. While the problems of the environment can seem overwhelming and just too much to make a difference as an individual, every little bit helps. Wearing reconstructed clothing is a publicly visible reminder of re-use ethics. It's also a great trigger for conversations about creative re-use. I've included lots of references, especially within the color photo insert, to re-use facilities, programs and individuals: an artist-in-residence program at my local dump, two facilities that sell salvaged building materials (great stuff like antique claw-foot bathtubs!), a revamped veggie oil school bus, and a variety of artists working with recycled materials. These types of things *are* within your reach to take part in, if not establish, in your own community. Your children will thank you.

Part I

Let the Reconstruction Begin! But First . . .

The 5th Wave

By Rich Tennant

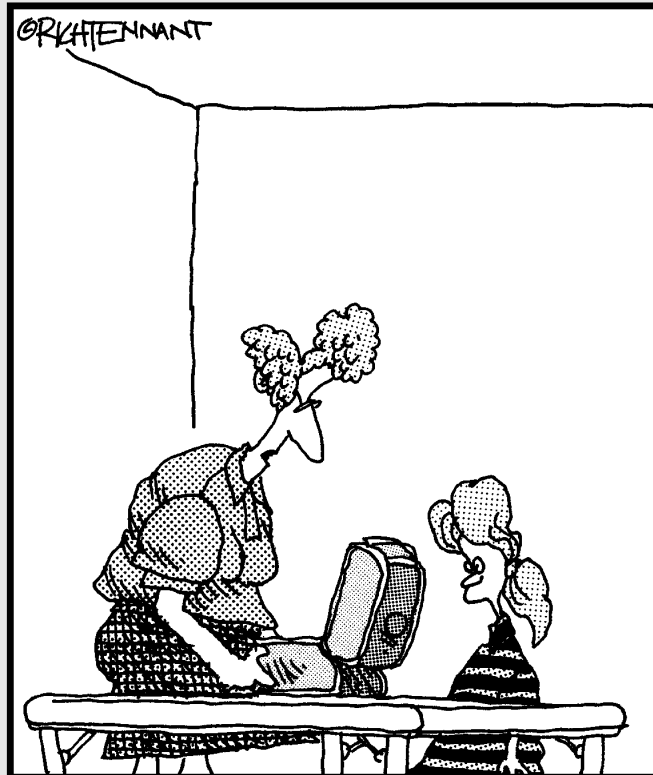

"It's a beginner's sewing kit I put together for you. There's scissors, needles, bandaids, gauze, antiseptic..."

In this part . . .

In Part I, I lay out the prep you need to start your reconstruction projects successfully. You discover not only how to use this book to your best interests, but also develop some realistic expectations and inspiration in reconstructing clothes. You become privy to my most precious secrets in finding good starting material . . . shhhh . . . it's just between you and me and thousands of other readers. With this knowledge and a pile o' clothes you can read on to find out the best ways to take garments apart and put them all back together again.

Chapter 1

The Ins, Outs, and Inside-Outs of This Book

In This Chapter

- ▶ Understanding how it all began
 - ▶ Defining reconstruction methods
 - ▶ Discovering which method is best for you
 - ▶ Playing with ideas and projects
 - ▶ Figuring out where you're coming from and where you want to go
 - ▶ Checking out some ethically sound eye candy
-

Before I knew what reconstructing clothing was, I was doing it. Heck, I was doing it as soon as I knew how to use a pair of scissors and thread a needle! Just as my dolls all had crew cuts, they also had tricked-out reconstructed clothing.

Like most reconstruction creatrixes, my initial impetus for heading down this path was a desire to do things differently. Patterns bored me and made me feel boxed in tight to someone else's rules. Existing clothes that I found at the mall (my only choice for shopping) were always lacking. They were especially lacking the individuality that I was compelled to express. I wasn't a rebellious troublemaker, the opposite in fact. I was a little bit of everything and thus not fully able to be defined or stereotyped. I like to think of my clothing in the same way.

Reconstructed clothing is not limited to a certain style, culture, or peer group. Reconstructed clothing is for each and every individual. It is a mish-mash of styles. It is about dismantling mass-production, both in what we put on our bodies and how we function as a community unit, as well as an individual in that same community.

Sample sales a.k.a. trunk shows!

When I lived in Boston I attempted, in vain, to put together a trunk show. I soon realized that nobody even knew what this was. Because of this experience, I feel that it is important to share this amazing thing with you in hopes that you can produce and/or support them in your own community. Trunk shows, also known as sample sales, can range in size and location but generally involve local clothing and accessory designers gathering to present and sell their creations to the public. Word on the underground design street is that they started as true “sample” sales, a sample being the initial garment that a designer sews together to test out the design prior to

production. This has broadened to designers bringing their entire collections, samples or not. The perks to this are beneficial to not only the designer, but the consumer as well. It provides a means for even the smallest designer to test the waters on selling their work. It also allows for them to clear out their samples and other pieces that aren’t suitable for retail shops for whatever reason. For the consumer, it’s a great way to get good deals (usually half of the retail price) on fantastic stuff. Typically the designers present their work in person, which allows for a direct relationship to form, increasing support for the artist and customization for the consumer.

Reconstructed Clothing Defined

As reconstructed clothing is becoming more widespread, it is also subject to definition. Personally, I think we should all have our *own* personal dictionaries that express our *own* unique use of language. While definitions provide clarity in communication, they also have an inherent tendency towards limitation.



Limitation is blasphemy in the dictionary of the creative mind! Blow it open!

Clothing is a very accessible form of art and self-expression. Think about it. You sculpt and paint yourself every day with the clothing you put on your body. Clothing defines who we are to the outside world, as well as to ourselves. At times there is comfort to be found in dressing in a manner that defines you as part of a commonly-known stereotype. However, on the path of life and self-actualization, shouldn’t you start defining this for your true self?

While not everyone can be their own fashion designer, you can start making more conscious choices. You can start demanding more of what you want to express yourself. You can start supporting local designers in your community over mass-produced mirror images of your neighbor. You can start combining clothes in unique ways. And finally, you can start cutting up those clothes and re-making them into completely unique clothes that work for you!

Clothes of a different color

The most common definition of reconstructed clothing is the practice of creating new clothes from existing garments. This can take on a wide variety of extremes. Many of the projects in this book fall into this category of reconstruction.

Some examples of this include the following:

- ✓ Adding a simple hood to a jacket
- ✓ Cutting the sleeves off a T-shirt
- ✓ Shredding your sheets and turning them into a ruffled skirt.
- ✓ Cropping a sweater
- ✓ Creating a couture evening gown from an old duvet cover
- ✓ Cutting the pant legs of your jeans to create “Daisy Dukes”
- ✓ Doing the same thing, with a bit more discretion, to create long shorts/short pants a la *Dirty Dancing*

This is a good method for people of all levels of sewing skill. It is especially helpful for creative types who don’t like to use patterns, like me! It is also helpful for those who have yet to figure out how to make patterns for their own designs.

By starting with an intact garment, the framework is already in place. It is this framework that is often boring for me in creating clothes from flat fabric (the “normal” way). Even with my own patterns, when I have to cut the same shape and sew the same seams repeatedly I feel like my soul is being sucked out of me. My pseudo-mass production limit is 10 pieces. I’m not much of a sweatshop!

Shop therapy!

I had a really bad breakup in my early twenties. *Really* bad! I found myself in a sea of not knowing who I was without my “boyfriend” and our pre-planned life together all spelled out for me. Ugh, even that sentence alone is just filled with societal definitions, expectations, and limitations! How did I handle it? Shopping! With my girlfriend in tow, or vice versa, I spent a major chunk of my student loan money for the

semester in a single corporate-owned chain store! I walked out with nearly an entire new wardrobe, a virtual replica of the TV sitcom starlet of the times, as well as just about every other mainstream female age 18–35. I needed it. I needed the stability of some sort of definition of who I was, even if it wasn’t truly *me*! Clothing can provide this therapeutic function at times. There’s nothing wrong with that!



Don't be fooled into thinking that starting with an intact garment makes clothing construction any easier! Patterns and instructions are laid out in a certain systematic order, like engineering. For this reason, it is actually much harder to alter a garment after its initial construction is complete. On the flip side, it is a lot more fun!

Mind-altering alterations

Sometimes clothing is just fine in its present form, but it just needs a little something. I usually come across people who just want a little pizzazz and individuality added to their garment. However, this may also be your choice of reconstruction to fix a poor fit, hide away stains or spruce up a worn 'n torn favorite piece.

With my sewing machine in the window front of my boutique, I am often asked that dreaded question, “do you do alterations?” While I like to help my neighbors and friends out with most quick-fix-its, it's not all that exciting to my creative spirit to just take up a regular hem. My compromise has been to do what I call “creative alterations.” These types of interesting alterations are visible and thus take the garment to a new level of style. Some tricks to push it up a notch include:

- ✓ Sewing a hem with contrasting color thread
- ✓ Taking in a seam with the seam placed externally
- ✓ Decorative patching on wear 'n tear
- ✓ Decorative stitching on patches as well as on hems
- ✓ Decorative painting over stains

This type of reconstructing clothing is exciting for all levels of skill and creativity. It is the best way for the novice to get started and get some practice with the basics of reconstruction. There are a lot of no-sew options with this method. For those who don't have a machine, this type of reconstruction can allow for a little bit of hand-sewing to go a long way.



These little reconstruction touches are perfect for those pieces that you are on the fence about cleaning out of your closet!

Lots of clothing is functionally well-made and practical. But it can also be boring, not to mention looking exactly like every other piece that was mass-produced from the same factory! These types of less intense reconstruction techniques serve to elevate your ho-hum hoodie to a truly unique piece of self-expression!

Regretful give-aways

A couple friends of mine have a playful banter back and forth about clothing. They tease each other on who got the hottest new thing off the rack first (all local designer racks mind you!) They also hand things off to each other from time to time. Yay! Hand-me-downs for adults! Recently I did some creative alterations on a zip-up fleece for one of them. It was a beautiful color but huge and boxy and altogether boring! Turns out it was a hand-me-down from the other

woman. A few weeks later she taunted her friend, “how’s that big old fleece working out for you?” She was utterly dismayed to hear about the fantastic new form it had taken. She, herself, could have been the proud new owner of this tricked-out fleece if only she’d remembered about reconstructing. Don’t let this happen to you — always remember the possibilities with creative alterations.

Clothing for cloth

I very rarely use this type of reconstruction, but it is a valuable option. This type involves dismantling the existing garment and salvaging the cloth for other projects. You may choose to do this for a variety of reasons:

- ✔ The fabric is gorgeous but the garment is horrible
- ✔ The garment shape is unable to be maintained due to style or other pitfalls
- ✔ The garment is excessively large
- ✔ The fabric is an *oh so precious* vintage
- ✔ The fabric is of high quality, such as silks
- ✔ The fabric has extensive beadwork or other embellishments that you would like to save
- ✔ The garment has sentimental significance, but the style and fit are not for you

In taking apart existing clothing to make use of the fabric, the skill level needed depends highly on the intended project for it. Because the garment is being transformed first to flat fabric, the use of a flat pattern is appropriate, and thus familiarity with using patterns is helpful. However, there are several projects in this book that make use of flat fabric scraps in this way. Here’s a list to refer to:

- ✔ Renaissance Repairs Pants — Chapter 9
- ✔ Detachable Bustle Skirt — Chapter 9
- ✔ Repetition Editions Jeans — Chapter 10
- ✔ From Flat to Hat — Chapter 11

- ✓ Whip Up a Wine Bag — Chapter 15
- ✓ Freeform and Frill Skirt — Chapter 16
- ✓ Casing Your Cozies Pillowcases — Chapter 18
- ✓ Quintessential Quilt — Chapter 18
- ✓ Sachet Simplicity — Chapter 19
- ✓ Pragmatic Potholders — Chapter 19
- ✓ Put Your Money Where Your Scraps Are Wallet — Chapter 20

What do you do when your heart can't let go of a piece, but it can't bear to watch it hang wastefully in the storage closet? In creating flat fabric from these pieces you can incorporate them into a quilt to curl up with and cherish those memories. I've heard examples of this done with retired work shirts and special occasion dresses.



This type of reconstructing clothing is actually a great way to learn about garment construction. By taking things apart you can figure out how they were put together!

Trash to treasure

There is still yet another form of reconstruction that takes it all to a whole new level. Turning trash into garments is a much more extreme form of reconstructing clothes. Basically, this technique involves recycling non-clothing items, trash, and refashioning it into articles of clothing and accessories.

For a variety of reasons, this particular method is not explored much among the projects of this book. From Garbage to Gorgeous in Chapter 20, is the only project that even remotely comes close to characterizing this method. Even then, its inclusion is debatable since the trash component is textile scraps.

While I have seen found objects and other “trash” items recycled into the decoration of a wearable clothing item or accessory, I have yet to see a fully recycled trash piece that is functionally wearable. Hence the reason why I haven't presented projects of this sort for you in this book. The projects in this book are for wearing, using and re-using as much as possible!

Reconstructed trash pieces fall in a range closer to artwork than clothing. They make statements on recycling, often using small items that we never even think twice about tossing away:

- ✓ Plastic grocery bags
- ✓ Candy wrappers
- ✓ Music cassette tapes
- ✓ Bottle tops
- ✓ Paperclips
- ✓ CAUTION or DANGER tape used by police, firemen, and construction workers
- ✓ Bicycle tire inner tubes

I must say that while these reconstructed pieces are intriguing and often whimsical, their lack in functionality leaves me wanting something more. I'd like to see functional pieces and practical uses of these recycled materials. Accessories and outerwear hold more hope for this, as their need for washing is significantly less than daily wear. I don't mean to discourage you from experimenting with this method, but I do encourage you to make it as viable as you possibly can.

Just Who Do You Think You Are?

This book is written to reach a wide variety of people while still maintaining and honoring my own unique self and my community. In this section I will discuss a bit of my assumptions about who you might be as well. In this, you can read this book in a different light of understanding, taking pleasure in the points that are catered to your special needs, and thus having tolerance for seemingly unnecessary points meant for others. This section holds some specific messages for you that might not apply to every reader of this book. So pay close attention!



You are not a fixed entity! You may move between these groups at different points in your life, or you may be a combination of several at any single point in time!

The dabbler

You are a creative sort. You likely have a career, be it a job or other responsibility, that doesn't necessarily make full use of your creative spirit. Therefore, you spend your extracurricular time doing things that fulfill this part of you. You are a hobbyist. You like to dabble in lots of different activities, or maybe specialize solely in textiles and crafts.

Your sewing skills may be limited, out-of-practice, or nonexistent. In the next few chapters I provide a brief refresher of these skills. I also mention a variety of other options in the “Variations” section of each project. You, in particular, are encouraged to explore the realm of these variations. If there is a new technique, such as silk-screening, that you are learning, I want you to feel free to play with it in these projects even if it is not mentioned. Heck, I don’t know *everything!*

The environmentalist

You are concerned about this planet and the waste we lay upon it. You live consciously. You continue to explore and make changes in your life to diminish waste. You recycle. You purchase products with minimal packaging to avoid even having to recycle it from the start. You are familiar with the terms “living green” and “sustainability.” This is a way of life for you, not just a hip new trend with a cute logo!

You likely know a lot more about the environment than I do. For a variety of reasons, I choose for my education to come from person-to-person sources and thus I am not always on top of the latest goings-on. Therefore I can almost guarantee that the points in this book are incomplete. Forgive me and feel free to inform me about it!

You may be a complete novice to sewing and crafts. For this reason I have included quick reference instructions on basic sewing skills and tools of the trade. I have made reference to a lot of techniques that you may not be familiar with, such as embroidery. I did this not to confuse you, but to open the door of possibility. I am a firm believer in awareness. If you don’t know what you don’t know you are unable to learn it.

The student

You are interested in clothing design as a career path. You may or may not have sewing and design skills yet. You see self-taught designers like myself and wonder “is fashion school necessary?” I am often asked this question and here are my responses (The following statements come only from my own experience. I am certain that there are exceptions):

- ✔ It depends on your philosophy, heart and intent.
- ✔ Personally, I don’t see an absolute need for fashion school. Ages ago, mentoring and apprenticing were the means of learning. Why they aren’t valued just as highly in our society is beyond me.

- ✔ I've been sewing ever since I could hold a needle. My mom and grandma taught me. What they didn't teach me, I taught myself. I figure things out. And someday, I might just take a pattern-making class to check in on those skills. I might just read that "Complete Book of Sewing" that I received last Christmas.
- ✔ But is it *necessary*?

Obviously you need to learn certain skills, but school is just one of many ways to do this. I think that the difference (self-taught versus school) is in the comprehension and resulting adaptation of the skill. When one is taught in school, usually things are presented and perceived as *the correct way* with little exception. This applies to any area of study, not just fashion design. Lessons are like a recipe book of step 1, step 2, and so on. You just do it and get graded on how much you adhere to the rules. So within those hard and fast rules, where does the creativity come in?

A fashion school graduate once said to me, "the first thing they teach you in design school is that nothing is original. Everything has been done before." Logically this argument is false. Unfortunately it yields ethical permission to copy. To further compound this, I've heard many students say that their fashion school teaches them to find inspiration and ideas by looking at other clothing. We certainly influence and inspire each other, but to be taught to seek it out and duplicate it in such a way really disturbs me.

This type of "inspiration" prohibits the evolution of fashion as an art form. I believe that clothing can be the most accessible form of art to the masses. Not only that . . . but it is a means of self-expression. Thus it needs to breathe and evolve rather than be stuck in a box of re-visitation and reinterpretation of design.

In the end, make sure you have a means to feed yourself, pay for shelter, and so on. Then follow your heart and create your heart's vision. You will be happy.

The artist-designer

You have made clothing for yourself and for other people. You are well-versed in sewing and clothing construction skills. You may be in fashion school or a fashion school graduate and thus I may have insulted you in the previous section. Whoops! Like I said, I am certain that there are exceptions to what I have been exposed to. No hard feelings, eh?

You are reading this book to learn more about reconstructing clothing. You may be practiced in this and just looking for new ideas to play with. On the other hand, you may work strictly in pattern-drafting and therefore reconstructing clothing is completely new to you.

The patterns in this book are kept intentionally basic. This is done not only to make it easier for the novice, but also so that you can put your own creative spin on it. Whether you have a style all your own that you can incorporate, or you are interested in playing with variations to develop this style, I wholeheartedly encourage this personalization. With your unique clothing construction skills, you can even vary the patterns themselves to suit your own style.



The projects in this book are meant for individual use only, not for mass-production and/or for-profit!

Perusing This Book for Your Best Interest

This book is intentionally set up for easy use. It is most important to me that you leave it with an understanding of individual expression and conscious living. The projects are merely icing on the cake of reconstruction temptation!

Seriously, I hope for you to use this book in whatever way serves you best. In that, my goal of inspiring your individuality is achieved. Whether you choose to read it cover to cover is up to you.

There are a fair bit of anecdotal stories inserted within the text. These stories serve to provide examples from my life of the information being presented. They are “extra” and while not essential to completing the project, they are what drives and feeds me to continue creating this form of art. The people I’ve worked with express much appreciation for these stories and how they can relate to them. It helps to make this process human and well within your reach of success.

In this book I’ve presented some of the basics of taking things apart, washing care and sewing skills. If you are already competent in this, you are well-equipped to jump into the projects. If not, give it a good review and maybe even supplement your knowledge with *Sewing For Dummies* (Wiley).

Amid the project chapters you will find a color photograph insert. This photography was done with much conscious intent and thus I hope for you to pay specific attention to it. The photographs represent many of the projects in this book, including their variations. They serve to demonstrate how to wear some pieces and how to combine them together in fun and functional ways.

Beyond this, it is important for me to share some points with you about how these photos were completed:

- ✔ I used a local photographer, supporting my local artist community.
- ✔ I used local artists' work to accessorize the outfits.
- ✔ I didn't use mannequins because these clothes are made for *real* bodies . . . your bodies!
- ✔ I used real people, actually very intelligent and strong women, rather than models. I must confess here that in deciding this, the possibility of having one model was considered. In researching that option, I found a prevalent underweight trend even among amateur models! As a designer, I can understand the ease of having this clothes-hanger-type frame to drape clothes on and not worry about "real" flaws. But also, as a designer, I feel a responsibility not to promote this unrealistic and unhealthy trend.
- ✔ All locations of the photo shoots are working in "green" ways:
 - **Building Resources** is San Francisco's only source for reusable and recycled building materials, supplied with donations exclusively from the local community. It is a source of inspiration for artists and contractors alike, as well as a place to donate tax deductible material from building and demolition (www.buildingresources.org).
 - **Teacher With The Bus** a.k.a. **DasFrachtgut** is a veggie oil converted school bus, pioneered by Jens-Peter Jungclaussen, with an environmental message that fosters education, entertainment, and sustainability (www.TeacherWithTheBus.com).
 - **Sunset Scavenger Artist-in-Residence Program** uses art to inspire people to recycle more and conserve natural resources. The company provides selected local artists, such as Nome Edonna, with the opportunity to create art using materials they gather from San Francisco's refuse (www.nomeedonna.com and www.sunsetscavenger.com/AIR).
 - San Francisco artists **Marcus Guillard** and **Chris Ray Collins** with visiting artist **Melvin Occasio** (Atlanta) are the innovative creators of **The Pegicorn**, an interactive sculpture made from scraps in their own backyard (www.marcusguillard.com).

Chapter 2

Reconstruction Reasons

In This Chapter

- ▶ Feeling good about reconstructing clothes
 - ▶ Understanding the environmental ethics of reconstructing clothes
 - ▶ Feeling the financial perks
 - ▶ Salvaging sentimental items
-

The reconstructed look is becoming increasingly popular across all walks of life. While I have a tendency to rebel against most things deemed “trendy” or “popular,” I think I’ll stick with reconstructing clothing for all the same reasons that I originally got into it. I hope you come away from this book feeling the same way.



Be aware that even if something looks reconstructed, it may not be. Read your labels and know your design companies. Many designers are just mass-producing this style without encompassing the environmental ethos of it. However, there are other design companies that are working hard to create environmentally sustainable products. It is important to support and shop wisely!

This chapter explores a variety of reasons behind why I like to reconstruct clothing. I started out with just making use of the materials available to me. These materials would have otherwise just gone to waste. As years passed by, I developed more of a sentimentality towards reconstructing. Special pieces that no longer fit suddenly came to life again with just a bit of creative assistance. The financial savings in this process were obvious, although not always the number one draw for me. Above and beyond any reason, I have always been compelled to do this for purposes of self-expression and individualization.



I don’t give you these reasons as a means to preach any particular agenda. Instead, my reasons serve to inspire you to begin or do more reconstructing of clothes as well as encourage you to develop your own intentions and reasons for why *you* choose to reconstruct. After all, it’s all about you!

Reduce

Reducing waste is the first chain in the link of sustainable living. It is the most important. By reducing the demand for new “stuff,” the initial production of that “stuff” will be reduced.



It is especially important to avoid stuff in lots of unnecessary packaging meant to make you “ooh” and “ahh” and “look how pretty” and “Mommy I want” and *buy* it, whether you need it or not. Don’t fall prey to marketing schemes!

By reducing this production, energy is saved and raw materials are sustained. You will also be reducing its eventual waste by the lack of its production in the first place! Why fluster over how to best deal with waste after-the-fact when you can eliminate it from the beginning?

In reconstructing clothing, you are reducing waste by choosing alternate ways of clothing yourself. You are reducing demand for new clothing production by reusing and recycling clothing that has already been manufactured. You are creating a new style from this clothing, and making a statement in doing so.

In wearing reconstructed clothing, you are supporting these philosophies and helping to create awareness in everyone you meet. Trust me, you will get compliments on your creations! You will have a precious opportunity to share these reasons and educate others.

While “recycle” is the most common mainstream buzzword when it comes to sustainable living, it is actually the *third* step in the desired hierarchy of sustainability:

- ✓ Reduce
- ✓ Reuse
- ✓ Recycle

What does this hierarchy mean? The first step in sustainable living, a necessary practice for all of us, is to reduce the amount of waste we produce. Is your recycling bin overflowing every week? Take a look at the amount of garbage you produce and try to imagine where it goes. Try to imagine what in that garbage bag or recycle bin could have been avoided in the first place. Here are some ideas:

- ✔ Using rags rather than paper towels
- ✔ Using cloth napkins rather than paper ones
- ✔ Using cloth diapers rather than disposables
- ✔ Bagged foods rather than boxed and bagged, a double whammy!
- ✔ Using refillable containers
- ✔ Using your own coffee mug rather than paper “to go” cups
- ✔ Using a sturdy water bottle, such as a Nalgene, rather than disposable containers.
- ✔ Re-using grocery bags, or even better, bringing your own re-usable bags for your groceries
- ✔ Reading newspapers and magazines online rather than producing the paper
- ✔ Using e-bills (electronic billing) rather than paper bills
- ✔ Avoiding junk mail with one of several services like greendimes.com

Reuse

Reuse is the second best way to diminish waste. It involves reusing manufactured materials in their original form. Some common examples of this include refilling water bottles and re-using grocery bags. Reuse is different from recycling in that it does not involve reprocessing of the product, nor the energy consumed and the waste created from that reprocessing.

In regards to clothing, the practice of reuse can take several forms:

- ✔ Hand-me-downs among siblings, friends with children of the same size, and even among adult friends as well!
- ✔ Clothing exchange parties with your community of friends, neighbors, family and/or other community organization.
- ✔ Donating to thrift/second-hand stores
- ✔ Shopping at thrift/second-hand stores
- ✔ Holding onto old clothes for rags, play-clothes, paint smocks, and so on.

Depending on your point of view, the projects in this chapter may be considered “reuse” or “recycling.” While an entirely new product is created, its production does not entail the standard reprocessing techniques involved in recycling. The energy consumed in their reprocessing is primarily *your* energy. And I don’t think you put off hazardous waste when you sew, do you?

An unfortunate outcome

I was recently asked to attend a critique at a local art school fashion program. Their project was to investigate the re-use clothing processes involved at a major nonprofit organization. Lead members of this organization were also present to brainstorm, critique, and share information and ideas. While the intentions of the organization are wonderful, the students unveiled some unfortunate outcomes of their process. Being such a large donation center, they receive massive amounts of clothing. After several levels of providing this clothing for local use, the leftovers

are packed up into giant bins and donated to underdeveloped countries. While this seems like a charitable thing to do, it is actually quite detrimental to the local culture and economy. The students who saw these bins, which are packed and sent weekly, were utterly shocked at the quantity of clothing being sent off. Together we brainstormed ways to reduce this, including implementing methods of reconstructing the clothing into more viable garments that could be used by the local community.

Recycle

What is recycling? The general definition of recycling involves taking an existing product and reprocessing it into a completely new and different product. Common recyclables include:

- ✓ Glass
- ✓ Paper
- ✓ Aluminum
- ✓ Asphalt
- ✓ Iron
- ✓ Textiles
- ✓ Plastics
- ✓ Biodegradable waste (food waste) via composting

Recycling is important not only to reduce waste but also to save energy in the production of new materials. Reducing the amount of waste needing disposal reduces the harmful environmental effects of common disposal processes. These processes include incineration, pyrolysis (heat process), and landfill.



If you have never seen a landfill, dump, or barge filled with garbage sent out to sea, you should make an effort to do this. If you can't experience it in person, try looking up "landfill" online or at your local library. Putting a visual meter on this helps reinforce the need to reduce your own personal waste. You can make a difference!

However, there are some prevalent arguments that recycling does not in fact save energy. The energy demanded by the reprocessing is debatable as to its environmentally sound practice. This is not to say that it is worthless. It merely should not be used as a crutch in lieu of other means of dealing with waste, such as reduce and reuse, as discussed previously in this chapter.

How does all of this relate to reconstructed clothing? Many of the projects in this book fall into the category of "recycled." Clothing items that have already been manufactured and used, are reprocessed into a new and different item of clothing, accessory or other product.

From an environmental standpoint, clothing should be reconstructed repeatedly. You might start with a button-down shirt, turn it into a pillowcase and finally the stuffing for the pillowcase. In its last breath, textiles can be recycled into paper, yarns and other products.

Reaping Financial Gain

When it comes to saving cashola, re-using and reconstructing clothes just can't be beat. You can still spend a pretty penny for pieces in a fancy vintage store, and even some of the more boutique-like thrift or second-hand stores in the city. But in comparison to what you would be paying for new clothes at boutiques and major stores, it's a bargain bonanza!

The savings just keep racking up when you reconstruct your own clothes! Keep your mind open and your closet organized to make this easy to bring to fruition. If you're just too bored with your own clothes, trade them with a friend!



Rather than sticking stuff in storage, get into the habit of reconstructing it right away. It's easy to forget about pieces once they are hidden away. There's truth to the old saying "Out of sight, out of mind!"

If you are really into the financial perks of reconstructing clothes, here are some tips to get the most for your money when shopping outside of your own closet!

- ✔ **Take advantage of yard sales.** Get 'em before they get donated!
- ✔ **Know your price points.** Arm yourself with knowledge of what common items usually sell for in your area. Pieces generally fall into the following categories:
 - Pants
 - Skirts
 - Sweaters
 - Dresses
 - Suits
 - Outerwear/coats
 - Men's shirts
 - Linens
 - Blouses
 - T-shirts
 - Children's clothing
 - Undergarments
- ✔ **Hold your ground.** Don't be afraid to ask for a discount, especially if you really need it. You are also more likely to get a discount when you are buying multiple items, and when you are familiar with pricing as described above.
- ✔ **Hit the small towns over big cities.** In my shopping experience, the city shops charge double the price of suburban shops. More trendy city shops, vintage boutiques, and antique shops are even more expensive!
- ✔ **Take a run through the children's section.** Children's clothes are always cheaper! Kids playful T-shirts and pullovers are especially fun to reconstruct! Other adorable pieces might make a sweet little handbag ala the It's in the Bag project (Chapter 10) and the Bag Ladies project (Chapter 13.)
- ✔ **Remember the linens.** The linens section has some fantastic treasures for mere pocket change!
- ✔ **Stock up on seasonal sales.** Like any other store, second-hand shops tend to display garments related to the current season. They also usually have sales and discounted prices for items that are going out of season. Feel free to ask about these types of sales at your local shop. Don't worry about being perceived as cheap. You might just be giving them a great idea of a way to avoid the trouble of storing it for a whole year!
- ✔ **Give estate sales a go.** Get it before the vintage dealers do!

I once was lost . . .

. . . but now I'm found by someone else who needs me! Did you ever wonder what happened to the item you lost but can't remember where? Chances are, it's in an ambiguous lost and found somewhere in your travels. When I was still in school I worked at a movie theater in a rather touristy area. Our lost and found box was overflowing with items that would never find their

rightful owner halfway across the country! Because of this, lots of places have a timeframe on the amount of time they will hold onto something awaiting the owner's return. I don't recommend randomly asking around to peruse through these things. But if you happen to have a friend that works in such a place, why not put the word out?



I find that I save the most money by not spending it at all. Lots of people are happy to bring me their old clothes as opposed to giving them away to thrift store never-never land! Put the word out to friends and neighbors that you've got a new hobby and the clothes will come rolling in!



My personal philosophy is about balance. In saving money on clothing from second-hand stores, I then have more money to spend on local designers, artists, organic food, and even mass-produced clothing made in an ethically responsible way (such as Wildlife Works) as opposed to sweatshop labor (such as Wal-mart and Nike) just to save a buck.

Rescuing Old Favorites

It might be scary to take the scissors to that sentimental piece. Okay, it's downright frightening! But it will do the both of you lots of good. Fond memories are not meant to be hidden away in a closet time capsule. Live in the present and relish in their beauty! Holding onto the past is a sure-fire way to get stale and prickly!

But what can you do when your favorite old boyfriend's sweater is two sizes too big? Don't let your memory turn frumpy or forgotten. By reconstructing it you can give it life. Integrate it into your present life and your current needs. Let it evolve in the same way that you evolve as a human being.

Here's a list of some sentimental pieces that you might have hanging around just waiting for a second chance at strutting their stuff:

- ✓ Inherited items
 - Cozy grandpa sweaters
 - Vintage dresses
 - Suits
 - Linens and dainty things
 - Costume jewelry (make it deco!)
- ✓ Concert or event T-shirts
- ✓ Gifts from loved ones
- ✓ Children's clothes
- ✓ Special occasion clothes
 - Wedding gown
 - Bridesmaid dress
 - Prom dress
 - Graduation gown
 - Baptismal, Bar and Bat Mitzvah, or other religious ceremonial clothing
 - Interview suit

Redeeming Closet Space

Are you just dying for new clothes but your closets are overflowing? Reconstructing your own clothes can help this common fashionista foible! Depending on the projects that you choose, you can add more breathing room in your closet. At the very least, it's an even trade!

Here's some clever ways to redeem the most space with reconstructing clothing projects:

- ✓ Upside-Down Skirt in a Topsy-Turvy World (Chapter 6): Use one T-shirt for the waistband, one T-shirt for the skirt body, and frill up the bottom edge with a few more.
- ✓ Bridging the Sweater Gap (Chapter 7): Turn two garments into one with a sweater *and* a button-down shirt.
- ✓ So-Easy Split Skirt (Chapter 9): Free up a pants hanger by taking two pairs of pants and reconstructing them into a single new skirt.

- ✔ Detachable Bustle Skirt (Chapter 9): Transform those extra pieces into scrap fabric for this project.
- ✔ Surprise Fly Top (Chapter 9): Turn two garments into one with a pullover *and* a pair of pants.
- ✔ Bare and Flare Skirt (Chapter 11): Keep the frills coming by chopping up more T-shirts, pullovers and stretch pants for this project.
- ✔ Making a Case for Pillowcases (Chapter 12): Get that cardigan out of your closet and onto your couch by turning it into a pillowcase to be proud of.
- ✔ A Twist on The Upside-Down Skirt (Chapter 12): Turn a T-shirt, cardigan and additional sweaters into this one fantastic skirt.
- ✔ Upside-Down Skirt (Chapter 13): Yet another version of the upside-down skirt, making use of a T-shirt, pullover sweater and as many other sweaters as you can manage to frill up.
- ✔ Split Skirt Stick-Up (Chapter 15): Get rid of that gown you'll never wear again by pairing it with a pair of pants or jeans to make room for something that will actually get worn.
- ✔ Freeform and Frill Skirt (Chapter 16): Make use of those blouses and other forgotten items by chopping them up for decorative frills on this skirt.
- ✔ Cutting Edge Cowl Necks (Chapter 16): Another two-for-one, or one-for-two. A skirt and any old top make a great space-saving combination with this project.
- ✔ Save-It-All Stuffing and Casing Your Cozies Pillowcases (Chapter 18): Make more room in your closet and more comfort elsewhere in your home by turning old clothes into pillows, coverings and cases.
- ✔ Quintessential Quilt (Chapter 18): This project is the ultimate creator of space! With layers of patchwork you can not only use up a lot of old clothes, but bring it out of the closet and onto the bed as well.

Representing Your Self

My reasons for reconstructing all come together with this one. In reconstructing your own clothes you create something entirely unique for you and you alone! In wearing this you demonstrate much more than your own style and personality. You also demonstrate all the ideals, philosophies and reasons discussed in this chapter!

The *real* new trend is consciousness! Wearing clothing is one thing that all human beings have in common. Being conscious about what you wear and encouraging the same thing in others can make a huge difference in this world!

Many people are making the choice to go entirely re-used in their wardrobe! Think about the volume of shopping bags you bring home every week, every month, every year. Think about what this amounts to in a lifetime. Now think about that same quantity being buried in landfills? Or tied up in bins and sent off to developing countries. Think about tribal dress replaced by Nike track suits!

Others who can't quite manage to have an entire re-used wardrobe can still be smart about where their money goes. Buying local is important for your community. Did you know that for every \$100 you spend at a locally owned independent business, \$68 of that goes back into your local economy? National chains only return \$43 of that \$100! Who do you want to give *your* money to?

Another trend that is here to stay is being aware about how your clothes are made. In reconstructing your own clothes you can thwart any possibility of supporting sweatshop labor. In buying local you also have some assurance in this. Still it's always good to educate yourself. The easiest way to do this is to find a list of businesses that adhere to sustainable living practices. Once you know where to shop, it's easy to have confidence in where your money is going, and what it is going to support. Sites like www.greenopia.com work hard to compile lists to help you in this process. Make sure your clothes aren't coming from a sweatshop!



Check out the National Labor Committee Web site www.nlcnet.org for the latest on human and labor rights.

In stepping off the soapbox, I accept that you may not be as hyped up about the environmental and ethically responsible perks of reconstructing clothing. But at the very least, I want you to be aware that it's icing on the cake of a cool way to express yourself.

In making the leap to chop up clothes that don't work for you, you are opening a door. You are now able to take positive action in your self-expression. You no longer have to make due with what you can find. You are no longer victim to someone else's style. You can make it yourself, and make it how *you* want it to be!

Chapter 3

Scoping Stuff with an Eye for Design

In This Chapter

- ▶ Finding the good stuff
 - ▶ Knowing what to look for
 - ▶ Running fast and furious from the nasty stuff
 - ▶ Changing your point of view and your price points
 - ▶ Understanding what you can work with and what's just too much work
 - ▶ Searching for sure finds for any fashionista
-

The key to the most successful reconstruction feats is to begin with good starting pieces. Especially when you are first learning the ins and outs of reconstruction, it is tough to make treasure out of trash. But taking interesting garments and making them even more interesting is a piece of cake!

With time and practice you will get to know what you can work with and what things are just beyond your reach. You will also start to figure out what favorite tricks and techniques you like to use to create your very own personal reconstruction style. Once you know what you can do, you will be better able to scope out and choose starting garments based on your skills and capabilities.

In the meantime, this chapter provides you with some of my secrets of spying stuff for reconstruction. Even with this knowledge, it's often hard to stay focused when presented with a bevy of reconstruction treasures at your fingertips. Feel free to bring this book along with you on your shopping trips.

Shopping Your Own Shelves

Are your drawers difficult to shut? Are your shelves overflowing with who knows what? Is half of your closet a virtual never-never land? Or are you one of those lucky, or unlucky, clothes mongers with enough storage space in your cedar closet to hold onto things for centuries?

If you have answered yes to even just one of these questions, it is time to stop buying and start shopping in your own wardrobe. Forget perusing through the second-hand stores! You are a perfect recruit for reconstruction rehab!

A good rule to follow is that if you haven't worn it in a year, it's time to do something about it. If it's not a good candidate for reconstruction based on the tips in this chapter, be sure to donate it to a charitable organization that you would like to support.



I prefer small local charitable organizations that accept clothing rather than the large-scale ones. These larger entities often receive such massive quantities of stuff that they are forced to do all sorts of not-so-great stuff with the leftovers.

Lifting the Thrifting Veil

In case you've been living under a rock for the past few years, here's a tip: Shopping at thrift stores is no longer just for people on a budget! The vintage look came into vogue quite some time ago, almost to the point that it's "out" now. Whatever! In or out, who cares. Your look is your own, and recycling is always in style.

Even if the vintage look isn't your thing, you can still find gobs of interesting and always unique pieces at thrift stores. It could be as simple as a black T-shirt to go underneath that crocheted top, or a hoodie for that random back-packing trip. On the other hand, this might be just the place to find a goldmine of mismatched bridesmaid's dresses. Halloween costume-hunting is always made easier with one simple shopping trip. The creative costumer need not be reminded of the inspiration that lies beyond the front door of the local thrift shop!



Often when starting a new job, you don't get paid for some time due to the accounting cycle. In the meantime, especially in an office, you are expected to have a whole new wardrobe of appropriate work attire! Instead of racking up your credit cards on a slew of new clothes that will only see the fluorescent light of a cubicle, hit your local thrift store for all your office-wear needs!

Tag-a-longs!

Here in San Francisco, it's commonplace to put your unwanted items out on the street for scavenging. On the same note, scavenging is fairly common, even among more affluent members of the population. While the bedbug bonanza in Boston has reduced me to a squirming germa-phobe in regards to picking up clothes on the street, I'm certainly not opposed to accepting stuff from friends and neighbors, and neighbors of friends. Such was the case not too long ago

when a friend of mine arrived with four gigantic bags full of clothes from a neighbor. It was enough to start my own thrift store! What appalled us was that most of the clothes looked as though they'd never been worn. Many of them even still had tags on them! While I'm sure we've all purchased something, or received something as a gift, that we've never worn, the massive quantities of this particular shop-a-holic collection simply blew my mind!

With the reconstruction tips and fun new projects right here waiting, your second-hand shopping adventures are sure to take on new meaning. You will soon be able to scan things with a discerning eye as well as an air of inspiration!

One point of caution: Thrift-store shopping can be addictive!

The ease of city selection

My first experience with thrift-store shopping in a city occurred in Boston. There was only one place to go but it was *huge!* I was amazed at the selection and the organization of it all. Like most things in a fast-paced city, it was quick and easy to find exactly what I was looking for. Instant gratification!

Here in San Francisco there's a myriad of thrift stores to choose from, large and small, charitable and, egads, for profit! Some are packed with a wide variety of stuff. Other shops specialize in vintage with a pretty price tag to boot!

For the ease of city thrift-store shopping, you *do* pay the price. For those of us without transportation, time, and energy to head outside of the city, this is often an even exchange. You just pay more for someone else to hand-pick the good stuff, organize it, and even make it look pretty in a fancy window-front display.

But what happens when you just want to browse? Where's the adventure of digging through heaps of random stuff? What fun is it to discover fantastic new things when they are all utterly fantastic! It's fairly obvious that this fun is had by professional shoppers with a keen eye for rummaging the less popular thrift stores of the suburbs.

Here's a quick reference list of the perks and poohs of city thrifting:

✔ Perks:

- Good selection.
- Well organized.
- Clean clothes (usually).
- Easy to find what you are looking for.
- Easy to get to without a car.

✔ Poohs:

- More expensive than the suburbs.
- Lacking in that treasure-hunting adventure.
- For stocking up on large loads with no car, public transport can be a nightmare.

Stocking up in the suburbs

Being a country girl at heart, I tend to stick to my roots and keep my major thrift-store shopping extravaganzas, at least for the fun stuff, in the small towns. I think it is nice to walk into a place, spend money, and know where it goes. Small locally-run places tend to have defined organizations that they support such as the local senior center, high school band or after-school programs.



It's good to spend your hard earned cash on local businesses. Local businesses give more money back to their community than nationally-owned businesses!

Not only are the suburban and small-town thrift stores more affordable, but in my opinion they are just more fun! Of course, I like the Russian roulette adventure of these disheveled and overstuffed nooks. I like finding treasures amid nasty old sweatshirts and golf pants. Actually, the golf pants are pretty cool too!

You may disagree with me. I've met others who prefer to find what they want when they go shopping. This is not guaranteed when you step into a small-town shop. You will likely be rummaging through a whole lot of old clothes, maybe even your own. The smell is often reminiscent of mothballs or your grandmother's attic. Items likely haven't been washed, so you might have to make a judgment call with stains. Some come right out with simple washing, and others are candidates for more intensive care and repair. It's an adventure!

Cut-throat thrifting!

One of my new favorite spots in the city is quickly becoming my most dreaded experience. Professional shoppers have taken over the place and developed their own set of rules. Bins of unsorted clothes are guarded heavily. Fierce stares and sharp tongues await anyone daring to step inside this gang-like cult. On several occasions I have stood in the middle of it all,

utterly frustrated, “you mean I can’t even look at the clothes?” The last time I was there I dared to touch an old Singer put aside by a woman. I merely wanted to show her the bobbin case, a beautiful piece of engineering. She took no gratitude in this gesture. In fact, I think I was lucky to leave alive!

Here’s a quick reference list of the perks and poohs of suburban and small-town thrifting:

✔ Perks:

- Great prices!
- Getting there by car, you can stock up on larger loads.
- Fun to find treasures among the trash.
- Your money is typically pushed forward to local charitable causes.

✔ Poohs:

- No guarantees that you’ll find exactly what you seek.
- Clothes aren’t always cleaned.
- The adventure of rummaging is often accompanied by odors of extraordinary proportion.
- For city dwellers, you need a car to get here.

You’d be surprised what you’d find here

After years of thrift-store shopping, this fantastic opportunity had never dawned on me. I was stuck in a pattern of checking out certain sections. I looked for certain things. I kept focused on the basics of these reconstruction projects.

Then one day a friend came with me on my thrift-store adventure. He led me to a whole new section of the store that never made sense to me. A new light was shed upon me on that day. It was the day I discovered the linens department!

Who needs to buy fabric when you can cut up old curtains? For fancier or more costumeey fashionistas, the ruffling and decorative details are to die for! Personally, I found a window dressing with giant grommets that made a hot new belt-like thing. Quilters can't go wrong with the plethora of sheets, dainty hankies and other beautiful bits of wonderfulness to work with!

Here's some other novel ways to get your hands on some good stuff!

- ✓ Yard sales
- ✓ Online community boards such as www.craigslist.org and www.freecycle.org.
- ✓ Swaporamarama events: www.swaporamarama.org
- ✓ Organize your own clothing exchange among friends or open it up to your larger community.
- ✓ Put the word out to fashionista friends that you're on the hunt for reconstructables.



People love to give stuff away when they know where it's going. You may soon get overwhelmed with donations. Try to encourage your friends to reconstruct as well, keeping your storage down and more clothes in reconstruction circulation!

Updated Optimism on Dated Styles

Do you like to strut your stuff in the hottest new styles? Do you pour through stacks of fashion magazines for the latest trends? While this in itself is a fun pastime, it can get rather expensive to replace your entire wardrobe with the "must-haves" of every passing season. Meanwhile, what do you do with all of *last* season's clothes that, in the blink of an eye, are suddenly "have-nots?"



When you create your own aesthetic that fully expresses yourself, rather than mimicking the fashion magazines, you are *always* in style. I find that no matter what I wear, as long as I carry it with confidence I get compliments galore!

Most "trends" are often reminiscent of a previous style or time period. In perusing thrift stores or your own bevy of forgotten clothing, you can often find pieces that with just a little repair and updating can be hip once again! Isn't it always better to be in an original, rather than some washed out discounted, or overpriced, knockoff?



Mixing and matching the old and new, the vintage with the trendy staples, can give you a look to hold your head high.

Playing the Numbers

Personally I do not like to haggle over prices, especially when that money is going to a charitable cause. It just feels insulting. But if you are on an honestly tight budget, you can often work out an acceptable discount at the smaller second-hand shops. Unfortunately, the for-profit stores, the ones that I *would* feel okay haggling with, generally are not amenable to this mode of purchase. Pooh!



Get to know the general price range for common items in your area so you have some bargaining ground to stand on.

It's hard to put a price on used clothing. It depends highly on the knowledge of the person doing the pricing, as well as their own personal taste. When our society is built around dollar number representation of value, it's only natural to price an item that you like higher than something you don't.

It's also natural to price something lower when you don't have an understanding of how it was made. I think there was a period of time in which the knowledge of textile arts and crafts was dwindling in our culture, as machines developed to do these things faster and cheaper. Thankfully, with the resurgence of DIY (do-it-yourself) these skills are finding their way back into mainstream culture!

I commonly find the following hand-made pieces in thrift stores at absurdly low prices.

- ✓ Afghans
- ✓ Doilies
- ✓ Handkerchiefs
- ✓ Ladies' gloves
- ✓ Embroidered blouses

It breaks my heart to see an afghan that took someone months to make by hand, on sale for \$2! Linen hankies for a quarter! I encourage everyone to make good reconstruction use of these handiworks, not just because of their inexpensive price, but in order to bring some appreciation back to the fact that a *real* person worked very hard to create them!

Giving Ill-Fitting Clothes a Second Chance

When shopping for clothes, no matter how much you like it, if it doesn't fit quite right it doesn't make it into the shopping bag. If you're shopping for new clothes you might not want to take the pricey risk of buying it anyway and having it altered, either by yourself or a professional tailor. However, with less expensive re-used clothing this risk is not such a huge leap of faith.

Sometimes reused garments do not fit so well based on the size. They may be from a vintage era in which sizing standards were different, or they might have just been thrown in the dryer too long.

Other times the fit is a wee bit off due to the style. In either predicament you can fix it up to fit you right on with the tips and tricks in this book. When it comes to sizing, I like to use the term "creative alterations" to describe my self-taught tailoring techniques.



It's important to realize that many of these tricks are visible alterations, and thus the garment will not look like a tailored version of its former self. Go to a tailor for that! This isn't *Tailoring for Dummies*, it's *Reconstructing Clothes For Dummies*.

When it's the style that is thwarting your fit, it might be time to get out the scissors for some serious transformation. Flaws in a garment can spur your creativity to new levels. Many projects in this book take existing pieces and turn them into other things. Feel free to play with the components you like, and leave out steps that don't work for you based on your starting garment. Have fun!

Damaged But Not Done Yet

Even the smallest tear or stain can send a garment packing. Personally, I like to keep these as-is for "play clothes" like I had as a kid. Actually, I think most all of my clothes have turned into play clothes by now! If they are too nice to play in, I generally don't ever wear them!

For most people, however, life doesn't allow for you to walk into the office with a torn suit. I understand and sympathize. But instead of giving up on that garment, give it a whirl through the world of reconstruction! What's the worst that can happen?

Good stains versus bad stains

Some stains are great left as is. Paint stains are a perfect example. I often have people mistakenly compliment me on my hand-painted skirt. Certain liquid spills and splatters can also be enhanced with the techniques in this book to create an intentional look.

However, one of the greatest skills in reconstructing clothes is knowing the limit to this raw look. Some stains should only be covered up or cut out! Here's a good list to refer to:

- ✓ Food spills down the front of a shirt will always make you look like a messy eater.
- ✓ Grease and dirt only work for an overall grungy style.
- ✓ Bodily fluids, especially armpits, collars, and cuffs stained over time are never worthy of salvage!

Deals on decent damages

Because some people just don't have the technical skill, or the artistic eye, to see how to repair or make a damaged garment work for them, they deem it worthless. As with any seemingly worthless thing, they thus price it accordingly. This is where you can pick up some great stuff for minimal pocket-change! Your knowledge of reconstruction can work to your favor not only at second-hand shops, but in regular shops as well. Even larger discount stores tend to have a standard markdown for damaged items, so be sure to ask for this!

I hate to promote shopping at a large retail chain store. But for things like this it can be tolerable. Besides, not every part of the country, or the world for that matter, has the variety of shopping choices that I have within walking distance from my own front door. Large discount chains may be the only place for you to go, at least until you demand something better to support your local economy and community. Maybe you should start your own thrift store, eh?

Wear 'n tear worn well

At some point in our fashion history, the worn 'n torn look became stylish. It was no longer reserved for "work clothes" or children's "play clothes." From rock stars and rebels to models and fashion magnates, the intentionally distressed look seems to be sticking around.

Dropping jaws

In my last year of school I had a job hand-painting clothing in the window front of a shop located on busy Thames Street in Newport, Rhode Island. It was fascinating and beautiful and inspiring to both myself, customers, and the tourists passing by. Years later I had another job painting murals in a gigantic theater-turned-nightclub/concert venue in Boston. Due to a ridiculously tight timeframe, my friend Ryan and I often had to paint during the events and concerts, always to the dismay of the management. I still find it funny that what I once was paid to do as a public display, was deemed a nuisance by these less-than-artistically-minded folks. Anyway, one night during a fashion show the

area in which we were painting was turned into a dressing area for the models. This was no local indy designer show, but rather a major-label presentation with lots of bright white smiles directed my way “oh, you’re painting!” followed by audible whispers to staff, “but the paint . . . and the clothes . . . what if they get *ruined*?” Again I found it hilarious that what this woman deemed “ruined,” other people actually paid me money to create for them. So how did I respond to this complete ignorance and false bright smile? I turned directly towards the woman, getting her attention, and smeared my brush-full of black paint clear across the front of my white shirt. She just about fell over!

Nowadays you can pay astronomical amounts of money for a team of people to sand-blast, stone-wash, paint and otherwise destroy a once perfect pair of jeans. One option is to wait until the person who spent gobs on that pair has to jump on the newest trend and thus gives away their “old” pair. But even more fun than that is to become your own sand-blasting distress designer team!

You can start out with any garment in any stage of perfection or destruction. It can be from your own closet or handed down from someone else’s. Keep it as is, further distress it, or visibly repair it with a variety of techniques right here in your hot little hands!

Feel-Good Fabric

There is one characteristic of clothing that softens me to any other flaws it may possess. Fabric that feels good to the touch is an all-around winner. So how do you determine this?

You could take a class on textiles and memorize the fiber content and methods of weaving that create a pleasingly soft texture. Then peruse each and every clothing label, assuming they’re intact, to find out what the garments are made from.

On the flip side, the side called common sense, here is a neat little trick. Take your hand and put it on the garment. Feel it with your fingers. Ask yourself “does this feel good?” If the answer is yes, it’s a winner! Simple as that!



To save time, close your eyes or just fleetingly glance at the rack of clothes. Run your fingers along each hanger or sleeve as you walk along. Pull out anything that feels good. Do this through the entire shop. When you’re done, peruse through the pile, checking price tags, condition and other deciding factors in your purchase.

Best Bet Basics

I have amassed bins and bins of vintage treasures that I either adore too much to tear up, or just don’t have the time to brainstorm a brand new creation from them. But they do serve as inspiration, not just for other projects, but for keeping focused on the best basics for reconstruction. So now I have also amassed bins and bins of basics as well!

If you are not sure where to begin and what to salvage, here are a few sure things:

- ✓ Sweaters, especially thinner ones
- ✓ Pants and skirts that fit in the waist
- ✓ Anything in a fabric that feels good
- ✓ Large-sized items in a fabric that you like



Keep similar items, such as those listed above, packed together in clear plastic bins. Label the bins with the items inside so that you can find exactly what you need with relative ease!

ABC's to Avoid

If you are used to shopping at regular stores you are not accustomed to checking for some of the flaws typically found in re-used clothing. Normally you would look at the style, the color, the size and the price. Now you can add a few things to that checklist of essentials. Just as there are sure things in life, there are sure things to steer clear of as well. Here’s a list of issues to avoid at all costs.

Armpit issues

Second-hand shops hold a plethora of tempting tops that just beg for you to take them home. But before you succumb to this common “whoops!” take a peek at what lies beneath that sleeve.

- ✓ Torn underarm seam
- ✓ Sweat stains
- ✓ Deodorant stains
- ✓ Pills (not drugs, I’m talking about that yucky balled-up effect that clothes get when they’re rubbed together)
- ✓ Stinky pit



There are lots of vintage tops in gorgeous prints from the '60s and '70s. However, many of these are made from polyester, a big contributor to stinky pit syndrome!

Beadwork and other tempting adornments

When it comes to reconstruction, it’s nice to start with a clean slate. This book gives you instructions for basic versions of a myriad of projects. If you are just starting out, this is enough to comprehend. Throwing curve balls into the mix, like working around decorative beadwork, is just too much to expect of yourself.

You might be wondering why this is a problem. The problem doesn’t necessarily lie in the beadwork but in its potential interference with the cut lines and its proximity to sewing lines. Cutting through a section of beadwork typically cuts through the thread and knots that keep it secure. Not only will this result in a loss of beads, but a loss of continuity in the beading design as well.



Cutting through beadwork can ruin your good sewing scissors.

Just as there are precautions with sewing multiple thick layers of fabrics due to potential needle breakage, the same reasoning applies to sewing thickened areas of beadwork. On top of that, beads can also get stuck in the foot of your machine, preventing forward movement of the stitching. These points may seem obvious, but the ramifications are just too ugly to let go unmentioned.

Here are some other things to avoid for similar reasons:

- ✔ Sequins
- ✔ Thick embroidery
- ✔ Embroidery with metallic thread
- ✔ Embedded mirrors

Unless the adornments are well out of range of any area that I might be cutting up, I tend to steer clear of these garments. Honestly, it's rare that I even find beadwork that is attractive to me so it's never too much of a temptation. Still, sometimes these items find their way into my hands, whether by exception, donation or just plain oversight. In that case, I find that the best use is to cut the entire beaded section out and use it as a patch on another garment.

Critters and creepies

I am fairly germaphobic. I admit it. I wash my hands vigorously after touching door handles, being on public transportation and shaking hands with someone who seems to be under the weather. I also rarely get sick, likely because of these precautions!

But in my own defense, there *are* nasty things out there that can get at you and infest your home via used clothing! Just as I have tried and true rules to my health, I have these rules to live by when it comes to scavenging for used clothing:

- ✔ Never pick clothes up off the street!
- ✔ Be savvy of your thrift stores and how they handle donations
- ✔ Know what's going on in your neighborhood. If there's a bedbug problem, play it safe and hold off on any used clothing from an unknown source.
- ✔ Wash all clothing before handling or storing it away for future projects

Bedbugs are not the only critters that can make a nightmare of your reconstruction dream. Boxes, bags and undisturbed piles of clothing, fabric and scraps are a virtual palace for mice. Here are some tips to thwarting the four-legged furries:

- ✔ Keep storage to a minimum. The longer something sits idle, the more safe and homey it becomes to mice.
- ✔ Pack items in tight-sealing hard plastic containers free of cracks.



It only takes an open area the size of a pencil eraser for a mouse to make its way in!

- ✓ Keep storage containers on shelves, making them harder to reach (for the mice, not for you!)
- ✓ Keep storage in a well-lit, well-traveled area
- ✓ If your storage is in a dark, undisturbed place, check on it at least once a week.
- ✓ Make your home mice-unfriendly by keeping it free of entry, tidy and clean, especially of food waste. If the mice have no reason to be there (in other words, no food, water, or safe shelter) they'll find someplace else to go.

Depilatory delusions

It's easy to have grand plans, hopes and dreams when you are still in the second-hand shop. It's a whole other ball of wax when you get stuff home. Often things don't look so bad on first sight, especially if there's bad lighting. But upon further consideration, sometimes too late, you'll be wishing you thought twice about it. Sweaters and fleece with pills (that balled-up look where the fabric rubs together) easily and often fall into this category for me.

The best advice I can give you is to take a good look at the garment. A once-over glance is not enough. Trust me! Pills are most common in the following locations

- ✓ Underarm area where the sleeve brushes the side of the garment.
- ✓ Under the breast
- ✓ On the back where the back rests on a chair
- ✓ For pants: between the thighs

Sometimes a sweater or fleece is particularly prone to pilling. Other times it has been washed improperly. In these cases it may be covered with pills. There's really no hope of remedy for the complete pill. Chances are you'll probably come down with a case of carpal tunnel syndrome before you're even halfway through.

For the partial pills, give it a test-fix. Pinch one of the pills between your fingers and see if it pulls off easily. If so, the garment might be worthy of salvaging!



Sometimes pills are a different color than the original garment. Such is often the case with dark sweaters and fleece washed with lighter fluffy items such as socks. In these cases, once you get pulling at the pills you will soon realize the infinite array of fuzz attached to your garment. Keep an eye out for these particularly pill-y problems and try to avoid falling into this predicament in the first place!

Expectations of supernatural proportion

Be realistic. You are just starting out. It's easy to get excited about a new idea and forget about the work involved. It's also easy to get daunted by a project that is just beyond your beginner capacity and throw in the towel completely!

I don't want you to give up that easy!

Getting the basic sewing skills and concepts under your belt with some simple projects will help get the ball rolling. Once you've got a good handle on this you can start pushing yourself a bit further. Here's a good list of beginner projects to start you off on the right foot:

- ✓ Busting Out the Neck Bustles: Chapter 7
- ✓ Getting Crafty With Cuffs: Chapter 7
- ✓ All-Season Crop Top: Chapter 8
- ✓ Oh-So-Hip Hip Belt: Chapter 10
- ✓ It's in the Bag: Chapter 10
- ✓ Layering the Leggings: Chapter 11
- ✓ From Flat to Hat: Chapter 11
- ✓ Making a Case for Pillowcases: Chapter 12
- ✓ Sleek 'n' Sneaky Sleeves: Chapter 13
- ✓ Bag Ladies Shoulderbag: Chapter 13
- ✓ Cape: From Costume to Couture: Chapter 15
- ✓ Whip Up a Wine Bag: Chapter 15
- ✓ Business Skirt Gone Badass: Chapter 16
- ✓ Raw the Right Way Dress: Chapter 17
- ✓ Save-It-All Stuffing: Chapter 18
- ✓ Casing Your Cozies Pillowcases: Chapter 18
- ✓ Deco from Garbage to Gorgeous: Chapter 20

Fragrant fabrics — if you have to hold your nose, put it back!

Second-hand clothes sometimes are ridden with odors that you just can not get rid of. Even after repeated runs through the wash cycle and dousing them with all sorts of odor removing miracles, there is still no hope for your nose.

Whether the odors are reminiscent of the wearer or from eons of storage in a damp basement, these pieces are worthy of investigation by the Clean Air Act!

Don't kid yourself. Odors on re-used clothes hold no guarantee whatsoever for departure. It's best just to steer clear of them. Save your sense of smell and keep your friends close by!

Here's a list of some odors that are particularly difficult to get rid of, and best to leave behind:

- ✓ Mildew
- ✓ Mothballs
- ✓ Perspiration
- ✓ Perfume
- ✓ Pets

Chapter 4

Deconstructing 101: Taking Stuff Apart

In This Chapter

- ▶ Setting up your workspace to work for you
 - ▶ Tooling up
 - ▶ Prepping garments
 - ▶ Getting started: Ready, set, rip
-

I'm not sure why cutting up my precious clothing was never a problem for me. Maybe it was because I started so young, before I was buying my own clothes and had an understanding of their monetary value. But then again, I was like this with everything! I once asked my mom why this was so, and she told me that I'd always been like that — if there was something I wanted to do I just did it.

But with age and “maturity” this openness has waned. Thus I have developed tricks and techniques to make deconstruction more doable, which often breaks down to a few simple words to live by.



If a garment is not being worn, it's just going to waste. No matter what something costs, or how sentimentally valuable it is to you, don't let it sit idle and unappreciated.

Okay so ripping stuff apart may not sound so hard to you. But you'd be surprised by the sentimentality that blocks you when it's just you, the scissors, and your grandpa's old sweater. “What if I screw it up?” are words often spoken by the reconstruction novice. Here's where I can give you a lot of tips to make it easier. This chapter gets you over that initial hurdle of deconstructing a garment and makes you comfortable with taking the scissors to your special old clothes.

Creating Space to Minimize Waste

Your workspace can make all the difference in your enjoyment of the reconstruction process. You may have a studio of your own to let your projects sit safely midway through reconstruction. Or you may be working out of your bedroom in which everything has to be packed up and put away every night in order for you to sleep with out becoming a human pincushion.

Whether you are working in a spacious loft or a tiny nook, it is helpful to consider the conditions in which you work best. Accept these conditions and don't judge yourself for being overly messy or incredibly anal with cleanliness. You are who you are. As long as you don't impose it on others, life is good!



Communicate your particular style with the people you share your space with. Being open about your style helps them understand your, well, let's call them quirks, and communication always helps to minimize potential frustration over the clashing of organizational style — or lack thereof.

In the next sections, I provide you with methods to work with your space and organizational style whether your prefer to keep things clean and tidy, to let it all hang out, or to take a little from both sides of the organizational fence.

Neat freak

So you're a neat freak. There are worse things in life that you could be. The important thing to remember in being clean conscious is to balance your creation time with your cleaning time. If you are cleaning more than you are creating, it's time to get a housecleaner, or pick up a part-time job doing this yourself!

I thoroughly enjoy cleaning. More exactly, I thoroughly enjoy accomplishing things. Cleaning gives immediate feedback for your efforts. This bursting sense of accomplishment often can spur you on to new ideas and fresh energy for your creative projects . . . coffee helps, too!

Here are some tips for the neat freak to minimize waste in their space:

- ✓ Keep all clothing and fabric in clear plastic bins with visible labels as to what is inside:
 - T-shirts
 - Pullovers
 - Button-downs
 - Pants



- Jeans
- Stretch pants
- Cardigans
- Pullover sweaters
- Other knits
- Dresses
- Skirts
- Large scraps (for projects)
- Small scraps (for filling pillows or decorative touches)
- Flat fabric (by type of course!)

- ✓ Store these bins on shelves so that you can easily grab the bin you want without having to unstack them. Shelving units on wheels make this even easier, as you can stack items double wide and still get to all the bins with just a little push.
- ✓ Write your name on your tools with a sharpie marker.
- ✓ Keep tools organized in clear plastic boxes or in labeled drawers — rolling clear plastic sets of drawers are great for tool storage.
- ✓ Keep three garbage cans next to your workspace for:
 - Garbage
 - Small scraps
 - Large scraps
- ✓ Keep decorative touches, buttons and beads, in labeled containers — pill boxes are great for this.
- ✓ Keep thread visible, accessible and pretty by making a display board of nails for them to slide on to.

Pre-clean prep!

When I first moved to San Francisco I lived in a closet. It was a beautiful closet with a window and everything, but still it was a closet. And being that the house was filled with the most smelly animals you could ever imagine, I spent most of my time in my “room.” I sewed in there, slept in there and often ate meals in there as well, usually as I was sewing. Obviously it had to

be kept neat, being such a small space. But more pressing, I found that I needed a delineation of some sort from sleep time to creation time. Cleaning served this function. Cleaning helped me to not only prepare the space for work, but prepare myself to be in a different headspace. It is a habit that I have carried on, even living outside of the closet.

Chaos theory

The opposite of the neat freak, some people work best in what would be deemed by most as a messy environment. At times, I fluctuate towards this. I find myself saying those words often uttered by teenagers “I know where everything is. Don’t touch (a.k.a. clean) my stuff!”

My reasoning for working in this manner is to create a palette. The larger the space I have the larger my palette becomes. I work best when I can lay out fabric and clothing in a visual array. I then mix and match pieces, brainstorming ideas as I move through the masses.

Just as neat freaks are often criticized for their compulsive cleanliness, those adhering to the chaos theory also fall under a discerning eye. My dad once shared with me a fun comparison to make light of it all: In answer to the seemingly clever criticism of “a cluttered desk indicates a cluttered mind,” my dad replied, “What then does an empty desk indicate?”

Here are some tips for the chaos theorist to minimize waste in their space:



- ✓ Keep all clothing and fabric in clear plastic garbage bags.
 - Watch out for mice. They can get through garbage bags easily and will just love making nests inside. Refer to Chapter 3 for more information.
- ✓ Make your tools easy to spot in a mess:
 - Spray paint them orange.
 - Tie something large to them (like the bathroom key at a diner or gas station).
- ✓ Keep a garbage can next to your workspace. Put everything in it and separate it later into:
 - Garbage
 - Small scraps
 - Large scraps
- ✓ Keep thread, notions, decorative touches, buttons and beads, in visible containers — save your spaghetti jars for this.

Organized chaos

Somewhere between the creative madness and the diligent do-gooder is a wonderful concept of organized chaos. Functioning in organized chaos allows for acceptance of imperfections and thus an opening of one’s mind to new ideas. It is a less rigid way of working, while still functional for most people.

In this manner of working, there are different styles in and of themselves. You may start out a project organized and get progressively messy as the creative ideas come into fruition. You may start out each work session with a cleaning and organizational frenzy, followed by the ensuing creative brainstorm. Or you may live in a constant state of organization that may only be navigable by you.



Organizing in a way recognized only by you isolates you and your work. If nobody else can find her way around your things, it's hard for anyone to help you when you need it. And if you're anything like me, if someone doesn't put something back where they found it, or hand it to you directly, it can be lost in the abyss for centuries! When you can't find your tools, it's immensely frustrating to everyone involved!

For tips on minimizing wasted space in organized chaos, look through the preceding sections and pick out what works best for your particular space and style of working.

Getting the “Gotta-Have-Its”

When you are embarking on your hobby of reconstructing clothes, there are a few things that you just can't get by without. These are things that it's important not to be stubborn about. I'm sure there are MacGyvers out there who want to make do with whatever tools happen to be within reach, but please, I beg you, just get these few small things!

The seam ripper — a holistic alternative in anger management

The seam ripper is a fun tool, while still having a dangerous edge to it. I find that men especially like to use this tool, possibly due to its similarity to the knife and thus the whole hunter-gatherer thing. But seriously, the satisfaction in ripping a clean cut seam can't be beat!

This tool is quite useful for a number of tasks. Obviously, its intended purpose is for quickly ripping out seams without risk to cutting or tearing the fabric. It is also great for removing buttonholes, beads, patches and other decorative embellishments. Minimal embroidery can disappear in a snap with your seam ripper. For creating that worn-'n-torn look, the seam ripper can achieve that naturally jagged look you're looking for!



Always point the seam ripper away from you and anyone else nearby! It is quite sharp, despite its seemingly innocent appearance.

Scissor happy

You need scissors. Real scissors! Don't fool yourself into thinking you can get by with that old crappy pair in your desk drawer. You can't bother with the safety scissors from your child's art kit either. You need to get yourself a real pair of scissors that you only use for fabric. Trust me. Do it and you'll see the difference immediately.

You have two options. Ideally you can afford to splurge \$30 on a good pair of fabric scissors from your local fabric or craft store. If you're not up for this kind of investment, you can get a less expensive but still decent pair for under \$7. Either way, these scissors are special and are only to be used on fabric.

Safety pins to save your soles

Always have safety pins on hand. Not only do safety pins help you make quick adjustments, but you can leave them in without worrying about them falling out when you pack up your projects halfway through the reconstruction process.

I grew up in a house with a mom who sewed often. Between her sewing and my brother and my fascination with the brightly colored common pins, there were more than a few stuck in our carpet. Considering how we tended to walk around in bare feet most all of the time, I'm sure my dad would have much preferred for me to come to the understanding of "safety" pins much earlier in my life!

Taking It Up a Notch with More Tools

The novice reconstructrix may not need these tools, but I bet it won't take too much prodding for you to recognize how the tools in the following sections will make your life oh-so-much easier.

The rolling cutter — a love/hate relationship

I received a rolling cutter and cutting mat as an unrequested gift. I had no idea what it was or how to use it. I soon learned that this is the best thing in the world!

Don't deny the danger

A fellow designer once asked me for some help in cutting some pants (flat pattern). I offered to bring over my rotary cutter and mat, which she discouraged in preference of scissors. I still brought it over, wanting to share this fantastic thing with her, and preferring not to threaten carpal tunnel syndrome with repeated scissoring. After some time, she acknowledged the

effectiveness of this method. I could even keep up with *her*, the queen of quickness! Within a week she had herself her own brand new cutting mat and rotary cutter! Within another week I saw her with hands bandaged — she had cut herself with the rotary cutter . . . both hands. Be careful with this thing, folks! Even the professionals can get nicked now and then!

The rolling cutter is similar to a pizza cutter. It's a round blade with a handle that you roll along the flat fabric (on the cutting mat) for a clean and easy cut. It cuts through several layers at one time (for mass-production). It is sharp and it is fast!



The rolling cutter can rival any samurai sword in its sharpness. Always keep the safety on when not in use. Warn any others who might come in contact with it. Keep it out of reach of small children. I'm serious on this one!

Suck it up!

Having a vacuum on hand and ready to use makes clean up a breeze! Shop vacs in particular are very useful as they don't have a rotating brush mechanism that is often tangled, twisted and jammed up by long threads and shreds of fabric!



Clean your vacuum brush regularly to free it of the threads that bind up the mechanism.

No fuss lint brush

When you are done with your reconstruction, you'll likely be in a bit of a fuzzy field of threads and shreds of fabric. To make your new piece *look* like a new piece, having a lint brush on hand can come in handy! Lint brushes are also a lifesaver if your fabric is accessible to furry four-legged friends. There is nothing they love better than to curl up in a cozy pile of clothes ready to reconstruct!

Leaving Caution (and Washing) to the Wind

Your best bet with washing is to stick to the laundering instructions on the label. If you have to cut it out either by personal choice or because of the reconstruction pattern, be sure to read it thoroughly and make a mental note of the instructions. If there's a chance you might forget, keep the label intact and in a safe place for future reference when the time comes to clean your reconstructed garment.



Pin the laundering instruction label onto an index card with a description of the reconstruction project. Keep this card posted by your washer.

Washing woes

If your garment contains any of the following materials, it should always be professionally cleaned:

- ✓ **Bead-work, sequins or other appliqué:** These dainty details may fall off, break, or melt in the washer or dryer. This is not only bad for your garment, but for your machine as well.
- ✓ **Fancy or fragile buttons:** Vintage, painted, leather, woven, glass, or other fragile buttons could be destroyed by agitation in the washing machine.
- ✓ **Animal products:** Suede, leather, fur, feathers, or other animal products that make up any part of the garment are not safe in water unless you want to look like beef jerky.

Washing inspiration!

I lived in Boston when I first started making clothes for other people. I soon found that my style was much too outrageous and playful for such a conservative city. Daunted, I turned to muted tones of black, grey, and brown for the bulk of my creations. I was thoroughly uninspired. Then, during the neighborhood open studios, I came across a rack of clothing by a local art student. I left with a T-shirt, paying the young woman at least \$30 *more* than what she was asking because it was so amazing! However, it had a large splotch of water-based paint on the

back, laden with glitter. It was fun and lovely but I knew it wouldn't survive the washer. I wore the shirt as long as I could without washing it. When the day finally came to throw it in the washer, I did so reluctantly. When it came out, I was even more amazed. Beneath the paint, the young woman had scrawled a message onto the T-shirt: The remaining lyrics of the sentiment she had patched and stitched into the front of the shirt. It blew my mind and immediately made me stop second-guessing the art that I was drawn to create.

If you're in that gambling mood . . .

My personal philosophy regarding labels and laundry is fairly low maintenance and highly experimental. I tend to throw caution to the wind, throwing almost everything in a cold gentle wash cycle. But I must also confess that

I often throw my knits, even my woolens, into the dryer on a low setting for 15–20 minutes before laying them out to completely dry. There is almost always an evolution of the piece which I find to be rather charming.

Making your life, and allergies, a whole lot easier

Often times your old clothes have been sitting idle for some time. They may have been in storage and collected a bit of the musties. Second-hand clothes can come to the same fate. Second-hand clothes may have also been subject to nuisances and noses unlike yours. They can sometimes reek of perfume and mothballs as well as pets.

Washing old clothes before you start handling them can clear them of this not-so-delightful odor. Working with a freshly laundered garment will keep your head clear and fresh as well. For those of you with allergies, this is a must!

The miraculous marvels of modern washing

You might be working with vintage clothes that haven't seen the light of day for decades! Remember that washing was different back then *before* you give up on a seemingly stained garment. Make these modern advances work for you! Throw on some stain remover and give it a go through your newfangled washing machine. You might just be amazed at what comes out!

Dryer be damned

The dryer can be the downfall of many a garment! It generally adds life, as in "aged," in an exponential way. Some items shrink while others pill. Stretchy fabrics can lose their elasticity with a single spin! The general rule is to avoid it whenever possible!

Making the Most of Flaws

I find flaws exciting. They push your creative boundaries, giving you a chance to do some creative problem-solving. You can revitalize your garments by keeping them as is and just doing one or more of the tricks listed in this section to fix the flaws. However, if you are going to be using a garment as a base for one of the projects, it's a lot easier to fix the flaws *after* you've reconstructed it. Who knows, that nasty spaghetti stain that wouldn't come out in the wash might just be in exactly the right spot to be cut out of the pattern anyway!

Stains

Generally, you can either cover up or enhance stains. Take your pick!



Some stains you just can't work with, unless you've got a high tolerance for ickiness. For shirts, this includes armpit and collar stains. For bottoms, ahem, stains in the crotch area. These stains may be more tolerable if you're working with your own garment, but when the garment is second-hand, it's just too yucky for me to stomach. I recommend either cutting these parts out completely, or scrapping the whole project.

In covering up a stain, here are a few ideas:

- ✓ **Patch it.** Sew a patch on that is large enough to cover the stain. Your patch can be any shape. Don't feel boxed in to the standard square! Sew it on by stitching around the edges or get creative by randomly stitching in a decorative pattern over the patch.
- ✓ **Sew it.** This technique is most appropriate with a small stain less than an inch in diameter. With hand sewing, machine sewing, or even embroidery floss, decoratively sew repeatedly over the stain. Use swirls, zigzags, circles, flowers, or other shapes.
- ✓ **Paint it.** Using a fabric paint or marker, cover up the stain with a drawing. Swirls, zigzags and other abstract shapes are easy and look great. Using a stamp and embossing powder is another option. Visit your local craft, fabric or art supply store for materials and instructions on these techniques.



When painting on a garment be sure to have a scrap surface directly beneath the layer you are painting, thus protecting the opposite layer, as well as the table you are working on. A good re-use idea for a scrap surface is old magazines or junk mail catalogs. Also make sure that as the paint dries it doesn't stick to the paper. Nonstick options are plastic wrap or metal.



- ✓ **Cut it.** Literally cut the stain out of the garment. This will leave a hole that you can either patch from behind, or leave as is.

Cut several holes in the same area for a tattered & worn look. Instead of holes, you can also cut several parallel slits through the stain (½ inch apart and 1–3 inches long), giving it a slashed effect while disguising the stain.

- ✓ **Dye it.** Dyeing is my favorite method simply because it’s so obvious, yet so shocking, whenever I tell people. Dyes were originally made from organic matter, some of the same organic matter that people deem “stained.” So why not just dye, or stain, your entire garment in the same stuff it was stained with! This works with wine, juice, tea, and other liquids. Of course, you can also dye it with a commercial product.

Be sure to wash the garment both before and after dyeing!

In my experience the stains take on commercial dye more than other parts of a garment. Therefore it’s best to keep the dyeing process imperfect, such as with tie-dyeing or bleach-work after dyeing.

- ✓ **Do them all.** If you can’t decide which technique to use, feel free to do a couple, three, or all of them. I like to do multiple layers of all of the flaw-disguising tricks. I start with a fabric patch or two. Next I do a patched layer of ribbon or a scrap of bias tape. I top that off with some decorative stitching, either by machine or by hand. Finally I finish up with a stamp or hand-painted detail. Feel free to mix it up and find what tricks and techniques you like to mix and match most often.

Tears and holes

You may be able to incorporate certain tears and holes into your design. For example:

- ✓ Cutting a tear through to the edge of the garment might make a good slit.
- ✓ Holes, which can often occur along the edges of garments, can just be cut out to make a wavy neckline, bottom edge, or cuff.
- ✓ Tears along seams can be restitched along the seam to maintain the original garment.

But these fixes are boring. To rev up your look, use one of the following techniques for any tear, regardless of its location:

- ✓ **Patch it.** Sew a patch on either side of the garment as described above for “stains.” Sewing a patch on top will hide the tear, while sewing it beneath will create a little window of fabric peeking out from within the tear. This little window technique works well with lots of decorative stitching on top of it. See Figure 4-1.



- ✓ **Hand stitch.** Using a complimentary colored thread or embroidery floss, make visible stitches of ¼-inch length across the tear to sew it closed. Making the stitches messy gives it a fun child-like look.
- ✓ **Machine stitch.** Create a zigzag or decorative stitch across the length of the tear. Add additional stitching detail for decorative effect.
- ✓ **Use the overlock.** Create a decorative external seam by serging a seam along the length of the garment, incorporating the tear.

Using this technique of running a serged seam along the length of a garment will make the garment smaller! Also, this technique only works if the tear is in a straight line. For tears with a curved shape, use another technique, or cut it open to make it into a hole and use one of the techniques for creatively repairing holes.

When repairing holes, it is best to try on the garment to determine where the hole falls and whether it's an area that needs to be covered or not. If it needs to be covered, you can do any of the patching techniques described above. If it doesn't need to be covered, you can make it decorative (see the section "Stains," earlier in this chapter and follow the "cut it" option).

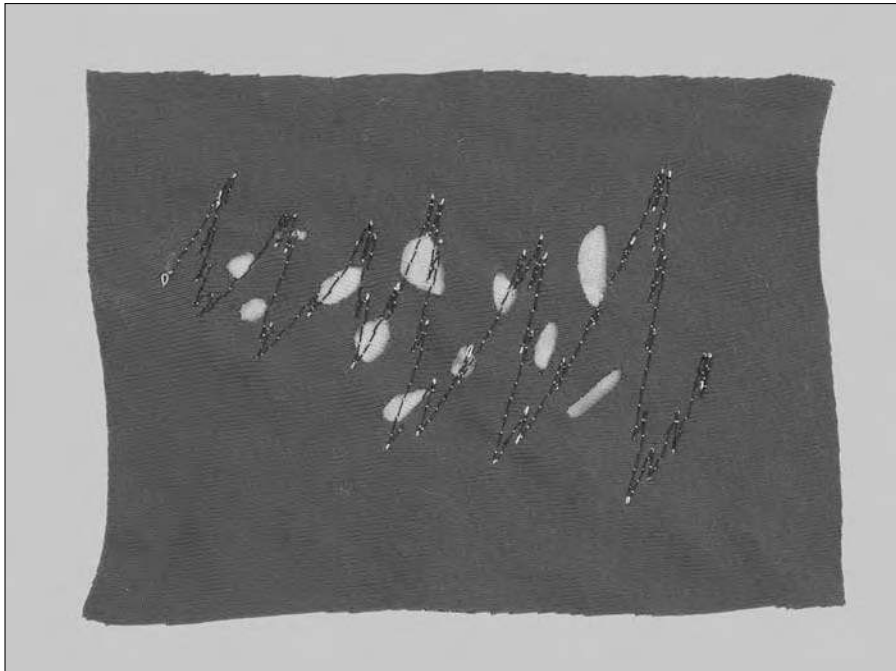

Figure 4-1:
Decoratively
patching the
underside
of tears
and holes.

Deconstructing Like a Pro

By now you've got your work space prepped, your tools in hand and your garment clean and ready to go. So what's next? Rip it all up . . . the smart way.

Sightseeing seams

The seam is where the pieces of a garment are sewn together, and thus where you can take it apart (see Figure 4-2). The easiest way to spot a seam is to turn the garment inside-out. Seams are typically found in these locations:

- ✓ **For shirt body:**
 - At side: Armpit to waist
 - At shoulder: From neck to top of shoulder
- ✓ **For shirt sleeve:**
 - Under arm: Armpit to wrist
 - At shoulder: In a circle around the shoulder and under the armpit
- ✓ **For pants:**
 - At side of leg: waist to ankle
 - At inside of leg: crotch to ankle
 - At belly and buttocks: waist to crotch
- ✓ **For skirts:** waist to hem
- ✓ **For dresses:** same as shirt but extending to hem of dress

Figure 4-2:
Sightseeing
seams.

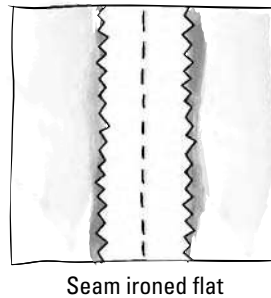
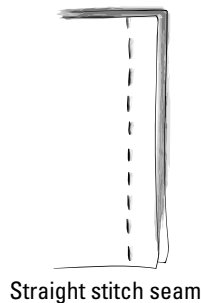

To be or not to be a seam

When determining whether to open up a seam, read through the next sections, which give you a few things to take into consideration.

Repair, reshape, or rip it out!

Sometimes a seam just needs to be repaired. In this case leave the seam intact and just sew up the hole, overlapping with the existing stitching. Ironing the seam flat will make it easier to stitch a new seam cleanly.

Sometimes the seam just needs to be taken in to fit better, or give the garment an updated shape. In this case, turn the garment inside out and pin a new seam according to your needs. You can keep the old seam intact and just cut it out after sewing your new seam.

Other times, you'll want to rip the seam out altogether to completely transform the piece into something else. Seam-rip all seams and then iron the fabric flat to start fresh!

Clean-cut and easy going

Rather than seam-ripping a seam open, you can cut it off. This is especially handy when converting a garment into flat fabric scraps. Using a rolling cutter and mat is immensely helpful in this; however, good scissors can work just as well to cut through both layers at once.



When a top is just a wee bit tight in the armpit, upper arm and body, you can rip open the seam and sew in a length of fabric (2–4 inches wide as needed). This not only gives you more breathing room, but creates a sharp sporty stripe!

Get over it and get started

With the basics of taking things apart and getting them prepped for reconstruction, it's time to just do it. One of the biggest hurdles is your own head, really. Don't worry about screwing up. What's the worst that can happen? If your intended desire for reconstructing your mother's wedding dress is thwarted by a slip of the scissors, that's okay! Maybe it was meant to happen that way!

Use mistakes to your advantage. Change your point of view and see them as challenges and even guides to push you in new directions with your creativity. At the very least you can always take a screwed up project and reconstruct it into a pillowcase, quilt, wine bag or one of the many other scrap projects presented in Part VI of this book!

Chapter 5

Reconstructing 101: The Very Basics of Sewing

In This Chapter

- ▶ Getting started with sewing — reconstruction style
 - ▶ Creating an environment conducive for creation
 - ▶ Exploring all your sewing options with quickie instructions
-

I got my first sewing machine in 5th grade. I vaguely remember using it. However, I do remember getting very annoyed with the tension controls and jamming threads. Not so ironically, this is about the same time that raw edges came into vogue for my wardrobe. I stuck to hand-stitching small projects for quite some time, about 15 years in fact. It actually wasn't until I finished graduate school and got a full-time job that I pulled out my old sewing machine again. I soon found that with regular use and annual tune-ups it zipped along without any of its former issues. I must say, fully free of my stubborn tendencies, that it also really helps to read the instruction manual *and* do what it says!

While there are some projects in this book that are completely of the “no-sew” variety, most of them require some basic sewing skills. In this chapter, I not only give you the basics of sewing, but I also give you instructions for sewing by hand, by machine, as well as with an overlock. Of course, the better your skills are, the easier these projects become. Using a machine makes things easier, but is not essential for any of the projects. So do not get daunted early on. With more sewing practice, both you and your machine will run more smoothly.



Balance the enjoyment of a new challenge with your capacity for mastering it. If it is not fun, it is not worth your energy!

Stocking Up On Sewing Essentials

There is nothing more daunting than trying to do a project without the correct tools. You are extremely limited in your capabilities unless you have the tools you need to do the job right. Trust me, there is only so much you can rig up. Getting a bunch of new stuff may seem like a commitment, but this chapter will ease your mind and wallet, filling you in on the essentials and not so essentials.



Trying to sew without the right tools is like trying to cook a nice dinner with only canned tuna and ketchup in your cupboards!

Thread in your head

No surprise. In order to sew you will need thread. While certain types of thread work best with certain types of material, I tend to stick with the all-purpose dual duty, especially for hand and machine sewing.

Do not try to get away with one of those travel sewing kits. They are meant for sewing up a tear or a button, not for an actual sewing project! You can find thread at fabric and most craft stores of course. If you are not picky about the color, you can also typically get the standard white at major pharmacies and grocery stores.

However, if you are using an overlock, you need cone thread. No question about it! Cone thread can be found at fabric stores. It is special because it pulls straight off of the top of the spool rather than with the spinning motion of regular thread.

You might have a collection of old thread at your disposal. You might also come across some at yard sales or in thrift stores. In these cases, be sure to check the thread quality carefully. It might be frayed, rotted, or decayed from exposure to the sun or other nasty elements. Bad thread will cause you more problems that you can imagine!

Think of thread as compared with flossing your teeth. The floss needs to move smoothly between your teeth, just as thread needs to move smoothly between the parts of the machine. Fuzzy or unevenly woven (lumpy) thread can bind up, break, and cause all sorts of tension problems in your machine. Ouch!

On pins and needles

Personally, I am pretty frugal when it comes to pins. I hang on to them all, bent out of shape or not! However, I do not recommend this practice. I have broken many a needle in my stubbornness. Using straight common pins will help hold

your fabric in place, flat and easy to run through the machine. Bent pins tend to get caught up in the machine, break needles, and cause all sorts of havoc.



Always place pins perpendicular to the line of sewing so the machine can sew over them easier. If you choose not to sew over your pins, this method of placement makes them easy to remove as you are sewing.

Regarding hand-sewing needles, use a needle appropriate to the project you are working on. In general the finer needles are used for fine fabric, and vice versa. However, you can really use any needle as long as it does not pierce the thread of the fabric, causing a hole or pull in the material. Craft needles are larger in size as well as having a larger eye for threading ribbon, yarn, and other crafty cording.

I usually buy a variety pack of needles. I keep one pack on hand for regular stitching and another pack for crafts.

Regarding machine-sewing needles, the same general sizing rules apply as for hand sewing: fine needles for fine fabric and more heavyweight needles for heavyweight fabric. Now pay close attention. This can make or break, literally, your sewing experience. Here are a few “for sure” tips in choosing needles:

- ✓ Write down the machine brand and model number to bring with you when choosing a needle.
- ✓ Take out the needle that is currently in the machine and bring it with you.
- ✓ Pack up your project or swatches of fabric from your project and bring it along as well.
- ✓ Ask a salesperson for help in choosing a needle.



Do not be afraid to ask “why” the salesperson is choosing a particular needle. This is a great way to learn how to do it yourself the next time you’re in need of needles!

Here’s a quick list to refer to when figuring out what kind of needle is best for your project:

- ✓ For general sewing, use a Universal needle
 - Size 12/80 for most fabric types
 - Size 70/10 for lighter weight fabrics
 - Size 90/14 for heavyweight fabrics (such as the sweater projects)
- ✓ For sewing stretch fabrics, use a stretch needle. It really does make a difference!
- ✓ For sewing thin leather, use a leather needle.

Both of these specialty needles come in the same packaging as the Universal. Look closely and ask for help as you need it.

“I don’t know why but it does . . .”

This is what I told my friend about the stretch needle. He was my only designer-ish friend in Boston. We bonded immediately when we met, falling into an hour-long discussion about, what else, making clothes! In telling me about his latest projects involving some sweet stretchy fabric he complained about threads breaking and bunching up in to massive tangles . . . all the

typical symptoms. I was very familiar with this, and like him, was once very resistant to using a stretch needle. I didn’t see how it could make a difference. It looked just like the other needles. But one day I caved and it was a day of salvation! I shared this with him, just as I’m sharing it with you now. I don’t know why it works but it just does!

Keeping it clean

While annual servicing by a professional is needed, it is also important to keep your machine clean on your own. Refer to your owner’s manual for full instructions on this. Generally you will want to keep moving parts oiled and free of dust (thread buildup). The feed dogs do not need to be oiled but they definitely need to be kept dust-free. Be sure to keep areas that are in contact with the fabric free of oil.



When oiling your machine, only use oil made for sewing machines.

Setting Up Your Workspace

Having a workspace that works for you can make your life a lot easier. This does not mean you need a separate room, or a private studio to get some good sewing done. But there are some key elements that will make any space much more conducive for you.

Don’t rock the boat

Your machine can get off balance, whether working on a tilted surface or on a surface that wiggles while the machine is running. Therefore, you will need a sturdy table for your machine. If you find your machine moving or rotating from its original position while you are sewing, this is a sure sign that something is off balance. First check your table for any tilt or rocking motion. Try to fix the table as best as possible. Next, check your owner’s manual for ways that you can make adjustments on the machine to further correct any tilt.



If your table is not able to be fixed, I hate to break the news but you will have to get a new one.

When seeking out a new sewing table, place your hands flat on the top and try to wiggle it. If it moves, check the legs to see if there are any screws that can be tightened in order to increase the stability. Tighten these. If the table still wiggles, it is not any good for your sewing machine. You'll need to continue on your search for the perfect table.

Once you have a sturdy table, set it up where you would like it to be. Check for any tilt in the floor or table. A fun and easy trick to do this is to place a marble or other smooth, round object on the table top in various locations. If it rolls, the table is not level. Fix the tilt by placing padding under one or more legs. Some machines also allow you to fix the tilt on the machine itself!

Posture perfect

I couldn't write this book without some sort of nod to the other "hat" I wear as a Physical Therapist. Extended sewing can cause overuse injuries, such as carpal tunnel syndrome, tension headaches, and a myriad of back problems. Having good posture at your machine can help immensely in the prevention of these ailments. Here are the basics of good working posture, refer to Figure 5-1 for a visual representation of these.

✓ Chair characteristics

- Lumbar support
- Back rest at least the height of your shoulders
- Seat length so that there is 2–4 inches between the edge of the seat and the back of your knees when sitting properly

✓ How to sit properly in your chair

- Hips all the way at the back of the chair
- Hips and knees at the same height
- Shoulders resting on backrest
- Feet flat on the floor (lower seat or raise floor with a book)
- Room for feet to move freely

✓ Table characteristics

- Table top is at the height of your elbows
- 2–3 inches between the table top and the tops of your thighs



Do not rely on good posture to solve all your aches and pains. It is also important to take regular breaks to change position, walk around and stretch your muscles:

- ✔ Touch your toes, or close to it. Keep your knees straight.
- ✔ Stretch your arms over your head.
- ✔ With arms over your head, lean side to side.
- ✔ Move your head side to side (ear to shoulder), left to right, front and back (tucking chin).
- ✔ Roll your shoulders in circles.



Listen to your body. It will tell you what needs to be stretched. Sit down on a warm floor and just move around. If a muscle needs to be stretched it will feel like a good pulling. If something causes you pain that makes you wince, don't push it! Stretching should feel good!

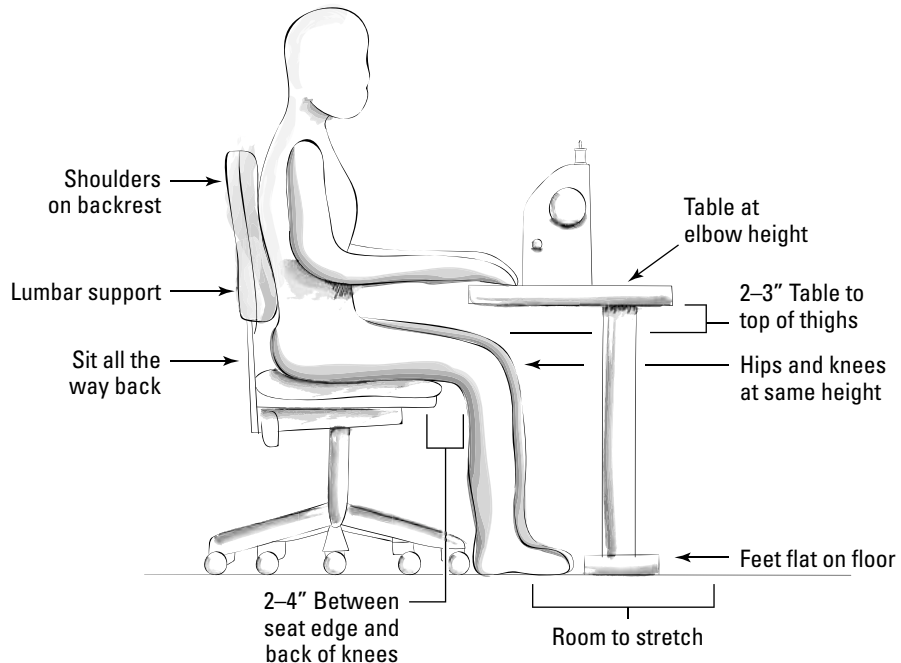

Figure 5-1:
Perfect
posture.

Happiness (and everything else) is within your reach

It will make your sewing move more smoothly if you have everything you need nearby. I tend to keep this pile of necessities close at hand on my sewing table:

- ✓ Scissors
- ✓ Needles
- ✓ Pins
- ✓ Sewing machine tools
 - Tweezers
 - Cleaning brush
 - Oil
 - Screwdrivers
- ✓ Thread
- ✓ Threaded bobbins
- ✓ Tape measure

If your table is not big enough to achieve this, there are a couple other good solutions. You may choose to store these items on shelves within arm's reach of your workspace. Be sure these shelves are at the level of your table and higher so that you are not hunching over to get to things.

Another handy solution is to keep items in a rolling storage cart. You can hide this away when not in use. Just roll it out in a good position next to your workspace when you're ready to sew.

Going Unplugged — Sewing By Hand

I really enjoy sewing by hand. It is utterly meditative for me. However, it is slow-going, which can often be daunting when facing a more involved project. If you are sewing by hand, choose your projects wisely and plan your time accordingly! It is not impossible, but it is important to have appropriate expectations!

Third eye of the needle

Threading a needle can be difficult for the novice. But once you get some practice under your belt, you will be able to do this basic sewing task in your sleep!

1. **Cut a length of thread 18–24 inches long. Use sharp scissors!**
2. **Wet the tip of the thread in your mouth to make a clean point.**
3. **Hold the thread approximately $\frac{1}{4}$ inch away from the tip, holding with your thumb and forefinger.**
4. **Poke the tip of the thread through the eye of the needle. The tip, being a bit wet, should be easy to grab and pull through the eye completely.**

If you have trouble threading needles, have no fear. A needle threader can help save the day, and your eyesight! To use this terrific tool, start by pushing the pointed part of the wire through the eye of the needle. Poke the end of the thread through the loop of wire. Pull the needle threader wire back out of the eye, pulling the thread along with it. Refer to Figure 5-2 for a visual of these instructions.

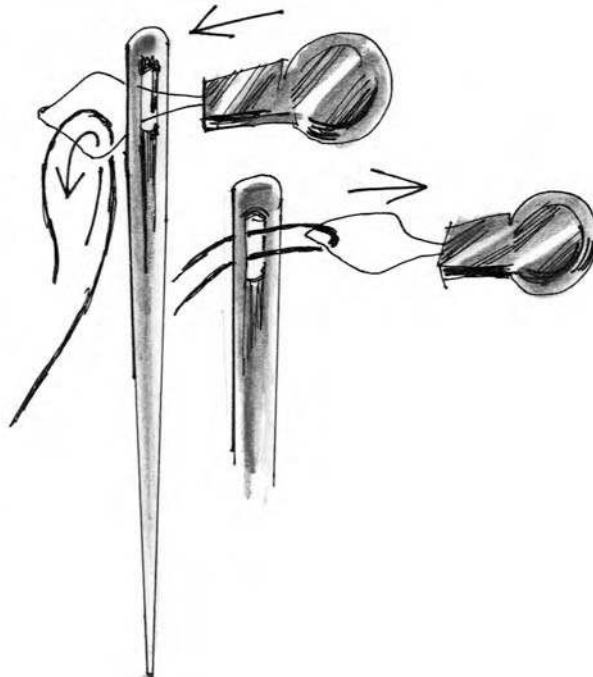

Figure 5-2:
Threading a
needle with
a needle
threader.

You may also choose to use a self-threading needle to make this task easier. Hold the thread taut in the notch of the needle's eye. Snap the thread into the eye and voila! You've threaded it! Refer to Figure 5-3 for a visual of these instructions.

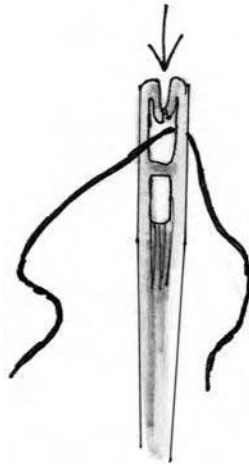

Figure 5-3:
Threading
a self-
threading
needle.

When threading yarn or embroidery floss, it is often difficult to get a clean cut edge that you can poke easily through the eye without fraying the ends. A nice trick to avoid this futile threading attempt is to fold the end of the yarn or floss and push the folded part through the eye. Refer to Figure 5-4 for a visual of these instructions.

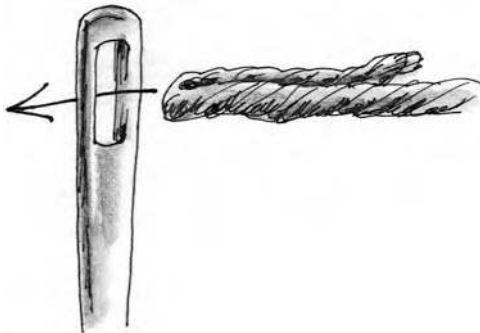

Figure 5-4:
Getting
yarn or
embroidery
floss
through a
tapestry
needle.

Knot enough

I recently learned a new trick to knot tying. I had always tied knots in my sewing thread just as you would any other pretzel shaped knot. Then a friend came into my shop one day and ever-so-proudly showed me a trick passed down from his mom. Ironically, it is the same method described in *Sewing For Dummies!* Guess I missed out on this one as a kid! What happened there, mom?



If you have a method of knot tying that works for you, stick with it. No need to fix something that is not broken!

After threading your needle, always tie a knot at the end of your thread. This will prevent the thread from slipping through the fabric as you start hand sewing. It also serves to secure the first stitch as you start hand sewing your seam.

I typically knot the two ends of the thread together after threading the needle. This allows for double strength in your thread and in your stitches. For fine fabrics and blind hems, just use one strand of thread and thus tie a knot in only one end of the thread.

The instructions listed below are for both right and left-handed knot tying. Choose your hand according to what feels most comfortable for you.

1. **Hold the thread between your thumb and index fingers and wrap a loop of thread around the tip of your opposite index finger, as shown in Figure 5-5.**
2. **Roll the loop between your finger and against your thumb so that the loop twists, as shown in Figure 5-6.**

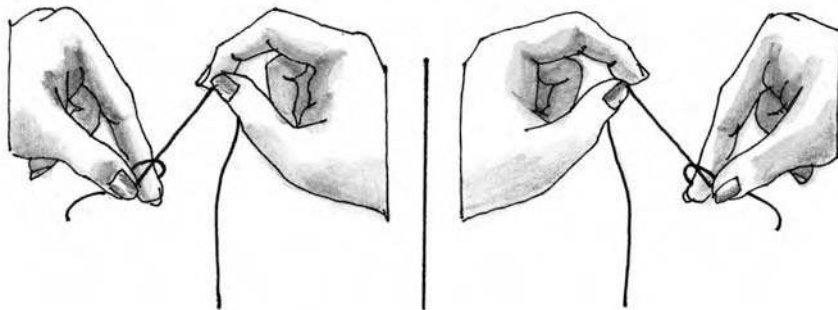

Figure 5-5:
Make a
loop.

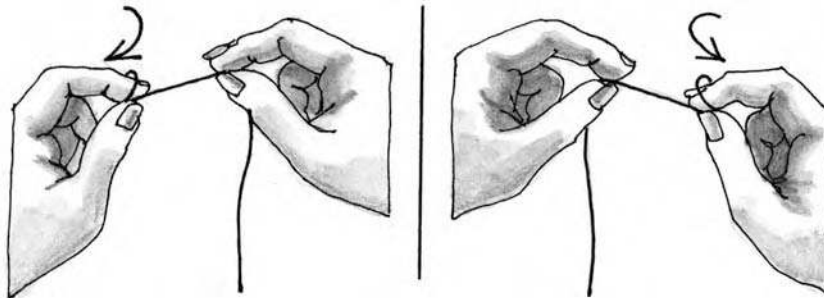

Figure 5-6:
Twist the
loop.

3. Slide your index finger back while rolling the thread until the loop is almost off your finger, as shown in Figure 5-7.
4. Bring your middle finger to the twisted end of the loop, remove your index finger, and firmly place the middle finger in front of the twisted thread against the thumb, as shown in Figure 5-8.
5. Pull on the thread with the opposite hand to close the loop and form the knot.

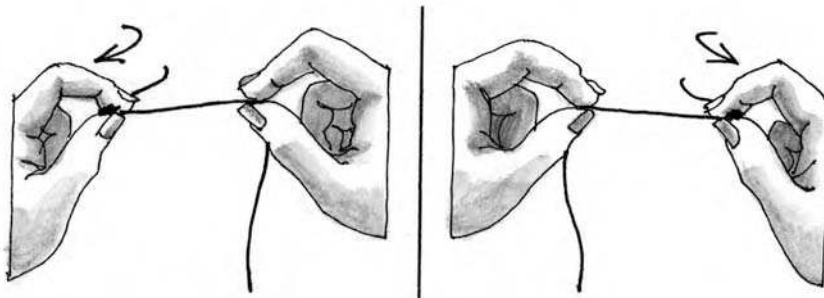

Figure 5-7:
Roll the loop
to the end of
your finger.

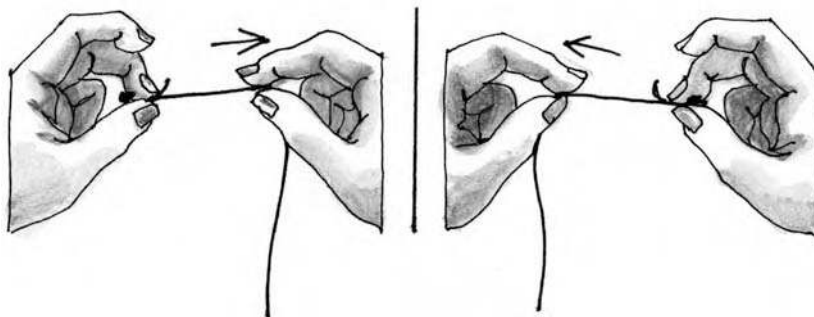

Figure 5-8:
Secure the
loop end
with your
middle
finger and
then tighten
the knot.



Do not forget to tie a knot at the end of your thread when you are done with your seam as well! It is best to make the knot by passing the needle through and catching the loop of the last stitch you made. Repeat this step for extra security.

Basic basting

Basting is a quick stitch used to temporarily hold layers of fabric together. Basting stitches are removed after permanent stitches are completed. Basting is also used in the knit projects of this book to assist in preventing runs in the knit while you are working with it.



Basting layers together, such as quilt pieces, is an essential part of the process.

Use a contrasting color thread to make the basting stitches apparent when it comes time to take them out. Weave the needle in and out of the fabric, with stitches approximately $\frac{1}{4}$ inch in length. Refer to Figure 5-9 for a visual of these instructions. No worries if these stitches are messy. This is just a temporary fix.

Figure 5-9:
You baste by simply weaving the needle in and out of the fabric.

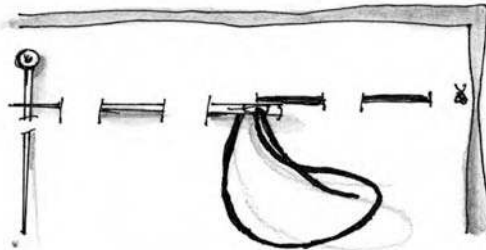

Run with the running stitch

The running stitch may look similar to the basting stitch in its instruction, but it is very different. Not only is this a permanent stitch, but the stitches are shorter in length (about $\frac{1}{16}$ -inch), even and clean. You can weave the needle in and out of the fabric in the same manner as basting, but only if you are in a hurry, as in the case of a quick seam repair. Refer to Figure 5-10 for a visual of these instructions.

For the cleanest stitching, pass the needle completely through the fabric before re-entering the fabric on the other side. In this manner, the needle is perpendicular to the fabric and thus pierces each layer of fabric in exactly the same place. This results in less visibility of the thread when the seam is ironed, as well as a stronger stitch.

Figure 5-10:
Use short,
even
stitches
when
fashioning
running
stitches.

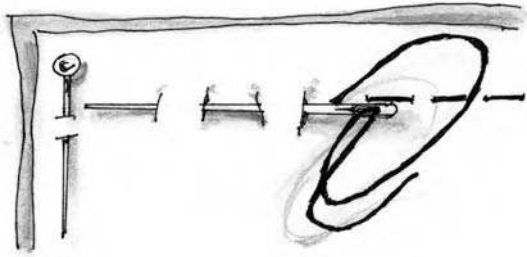

Blanket stitch or bust

This is my favorite hand-sewing stitch. It is not only a strong and secure stitch, but it involves weaving the threads in a way that can be used as a decorative external seam. I typically stitch $\frac{1}{4}$ -inch-long blanket stitches, but you can make them closer together for a more secure stitch (such as needed for knits).

The blanket stitch is completed by piercing the fabric through the same side on each stitch. This creates a loop that goes over the edge of the fabric. After piercing the fabric front to back, catch this loop with the needle (from the back of the thread to the front) and pull the stitch taut. Refer to Figure 5-11 for a visual of these instructions.

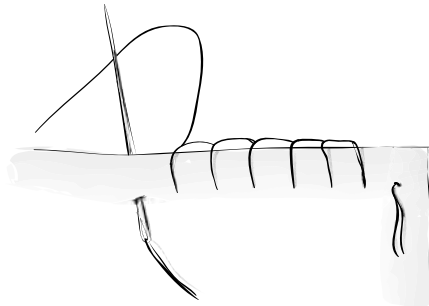

Figure 5-11:
Blanket
stitch.

Hemming and hawing

Knowing how to sew your own hems is a valuable skill. Once you are well-versed in this technique, you too will be appalled at the money you have spent having a tailor or seamstress do this for you! It is about time that you take it into your own hands, literally!

Blinded by the hem

Blind hems are invisible (ish) on the outside layer of the garment. This invisibility, or blind appearance, is enhanced by using a fine needle and a single strand of fine thread.

Start by ironing your hem. Fold the hem allowance back $\frac{3}{8}$ -inch. Start stitching on the hem allowance, $\frac{1}{4}$ -inch from the cut edge. Take a short stitch in the hem allowance, then move the needle to catch a single thread of the outside layer (the facing layer of the garment). Repeat with stitches approximately $\frac{1}{2}$ -inch apart. Refer to Figure 5-12 for a visual of these instructions.

Figure 5-12:
Blind hems
require fine
stitches
about
 $\frac{1}{2}$ -inch
apart.

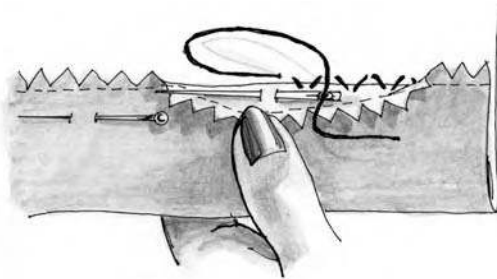

This skill comes in really handy for those bridesmaid dress alterations! Save yourself from wasting even more cashola on a dress you'll never wear again by taking up your own blind hem!

Quick 'n slanted

This is typically the type of hemming that I do, for time-saving reasons only. This is not a very durable hem, but for me the ease and quickness make up for this.

Secure your stitch at the hem allowance. Then, in one motion, catch a single thread of the outside layer (the facing layer of the garment) and continue the needle into the hem allowance for another stitch. Refer to Figure 5-13 for a visual of these instructions.



If you're really in a hurry, make several stitches before pulling the thread completely through.

Slippery little slipstitch

Do not let the heading fool you, there is nothing slippery about this slipstitch. It is a durable stitch that is used when hemming a folded edge. Start and secure your stitch in the folded hem allowance. Move the needle to catch a single thread of the outside layer (the facing layer of the garment). Take another stitch in the folded hem and repeat. Refer to Figure 5-14 for a visual of these instructions.

Figure 5-13:
The slant
stitch is
quick and
easy but not
too durable.

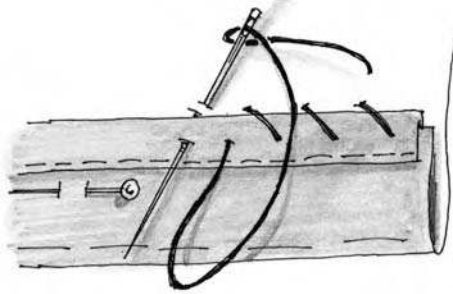
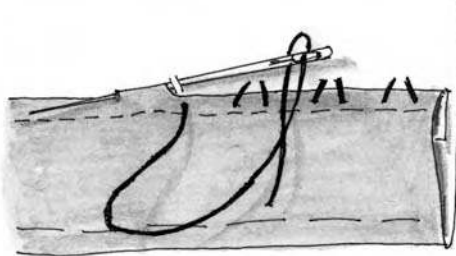

Figure 5-14:
The
hemming
slipstitch is
very durable
and nearly
invisible.



Moving Up To Machine Sewing

You will greatly increase your speed of working with machine sewing. However, with the advent of modern machinery is the increased risk for mistakes and machine mishaps. Make sure you know a bit about what you're doing on a machine before you jump in blindly.

Get your machine in good working order before you start messing around with a project that you're excited about. Feel free to practice on scrap cloth to get the tension set correctly. Don't be stubborn about this. It *does* make a difference!

Key features

I am a fan of the basics. Sometimes the more you have to choose from, the more complicated life can become. Here is a basic list of must-haves for your sewing machine:

- ✓ **Backstitch or reverse control:** For stitching backwards to secure the start and end of a length of stitching.
- ✓ **Free arm:** For stitching around tubular areas such as cuffs.
- ✓ **Metal parts:** Be a metal head and avoid plastic parts at all costs.

Tried and true tricks for affordability

Especially for beginners, I recommend getting a used machine. Not only is this affordable, but in my opinion you have a better chance of getting something that will last. I often hear stories about people happily using their grandmother's machine, or like me, the machine I got for Christmas in 5th grade. They made stuff that lasted back then. It wasn't the disposable society that we live in today!

You can find very good old machines at second-hand stores, yard sales and even online for as little as \$10–\$25. I have found this to be true on both coasts! My little collection of machines, like my clothing, is a mish-mash of gifts, hand-me-downs, salvaged finds, and thrift-store treasures. With a little TLC they all work beautifully!

Be sure that the machine has the key features listed above. Give it a test run before buying, or at least ask the person selling it about its working condition. Accept that you are taking a chance with this. Don't be naïve. Never spend more money than you are willing to part with.

Bring your “new” machine to your local repair shop for a tune-up. Let them know that you bought it used so that they can check its functionality first. This way they can order any necessary parts ahead of time. On the other hand, they might tell you it is a dud and unable to be repaired. Prepare to spend approximately \$70 on the tune-up. At this point your machine, and you, should be ready to go!



Sewing machine repair shops are often listed under “sewing and vacuum” in the yellow pages.

Salvation through servicing

Just as you go to the doctor for regular checkups, it is important to bring your machine in for regular servicing. While you can keep it clean over the course of the year, it's essential to still give it a good annual overhaul by a professional.

The pros can let you know how your machine is doing, what is wearing out and what you might be doing wrong with it. Like I said, it is just like going to the doctor!

Dirty little secrets

So I'm a rather aggressive sewer. So what! So I tend to break needles before they're ready to be replaced. What of it? Well, at one point I found that I was having some annoyingly unidentifiable problems with my machine. By the time I took it in for service it was at its last breath. I remember standing there with the technician across the counter. He held something in his hand, my needleplate, and tapped it

in his hands knowingly. I dare say he even swaggered as he said, "you break a lot of needles, eh?" I felt like a kid who had just been sent to the principal's office (an experience that I never actually had as a kid!) That man was like a detective! In one quick glance at my machine, the trail of the unidentifiable problem was identified, and I was at the end of it!

Stitch essentials

Lots of new machines have all sorts of fancy stitches, at all sorts of fancy prices. With computers coming into play, good old-fashioned sewing is being taken to a whole new level of geekdom. Maybe I am a stick in the mud or maybe I am just jealous, but I prefer to keep it simple. The projects in this book just require the straight stitch and the zigzag, the bare necessities that you can find on any old machine (see Figure 5-15 for examples).

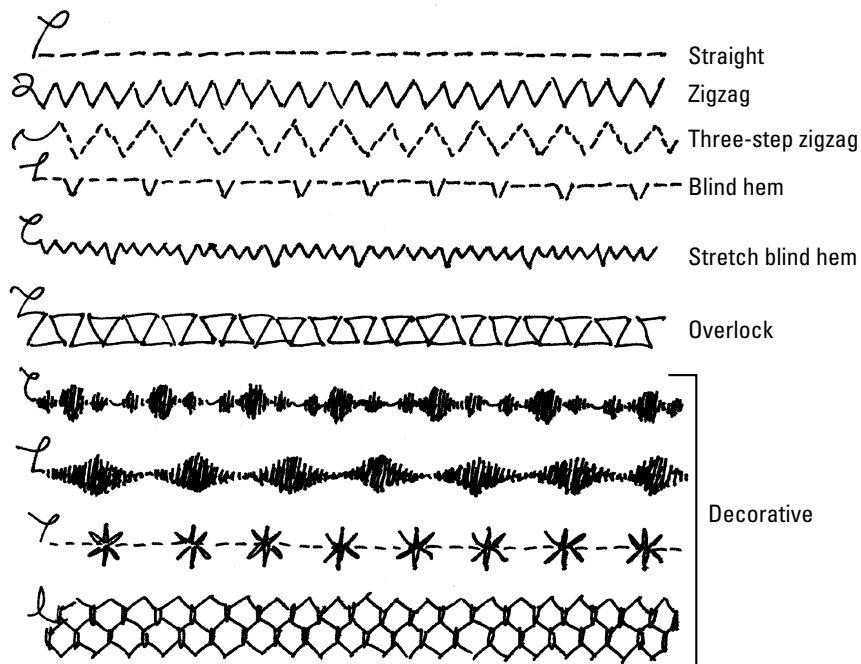

Figure 5-15:
Basic
machine
stitches.

Straight up

The straight stitch is the basic sewing machine stitch found on even the oldest machines. You can make the stitches longer and shorter, but otherwise, it is just straight and simple. This stitch is used for basting (long stitches), seaming and topstitching.

Zig my zag

The zigzag stitch looks exactly how it sounds. On older machines, this stitch is created by increasing the width. Oh how I have spent many a befuddled moment figuring this one out! On other machines, it often has its very own spot on the dial. This stitch is used for adhering patches, decorative topstitching, rough-edged seams, securing the edges of knit fabric, making buttonholes and even sewing buttons on!

Beyond the basic stitch

While you can complete any of the projects in this book with just a simple straight and zigzag stitch, it is likely that your machine has many more to choose from. Feel free to substitute these other stitches according to your skill and comfort level.

One stitch forward, two stitches back

Backwards, or reverse, stitching is usually noted by a button or lever on your machine. It is an essential component to securing the start and finish of any line of stitching. But it is also useful when doing decorative stitching to work yourself out of corners and other tight nooks.

Function and form

The stretch blind hem stitch not only looks really cool as a decorative stitch, but as the name implies it is very functional for stitching blind hems in knits and other stretchy fabrics.

Three times your average zigzag

The three step zigzag stitch achieves the functionality of a zigzag stitch without the tunneling effect created by too-tight tension with a too-wide-zigzag stitch setting. This stitch is good for finishing raw edges as well as for decorative effects.

Blinding hemlines

The blind hem stitch is another functional stitch that makes a decent decoration as well. In case you could not tell by the name, this stitch is used for machine sewing blind hems.

Over the top overlock

The overlock stitch found on regular sewing machines is meant to mimic the stitch and finish effect of the overlock machine. I do not recommend using this in lieu of an overlock machine, especially if this is a desired technique for your style.

Do it up deco style

Decorative stitches can vary widely. Try out the types on your machine with a piece of scrap fabric before giving it a go on your garment, quilt, or potholder.

Oh Holy Overlock Machine

I praise the day I got my overlock! It was a very serendipitous occasion. My mom had been prompting me to get one for some time, after seeing the type of work I was creating. Prior to my overlock I was zigzagging patches together in a rather painfully tedious sort of way. Still I was stubborn about “needing” something else. Then I came across a man who was in the middle of changing his career and getting rid of a brand new overlock. His story was a beautiful one and thus I was honored to be part of his evolution from designer to painter.

What is this thing?

An overlock machine stitches and finishes the seam all in one. It cuts the fabric as it goes along, as threads wrap around the cut edge as well as create a straight stitch. It is commonly found in the interior seams of sweatshirts and other ready-to-wear garments.

Key features

What key features do you want to look for in an overlock machine? The biggest pitfall I hear about is difficulty in threading. Therefore, the best advice I can give you is to get a machine that claims to be easy to thread, has a color-coded diagram of how to thread it and in what order it should be threaded.



Never take a marketing claim to be truth. Ask for personal recommendations either from friends or from the salespeople in the store. Sewing machine salespeople are not like car salespeople. They generally want you to find a machine that works for your skill level so that you can enjoy sewing as much as they do!

Another key feature for a good overlock, especially for these projects, is the ability to sew heavyweight fabrics. Do not be fooled by cheapo machines making “heavyweight” claims. Make sure you get a good personal referral on this!

Making the financial plunge with buoyancy

My best advice in buying a serger is to find one that you like either by test-driving at a store or searching online by searching the keyword “overlock reviews.” Look at the machines in the \$600 range and choose a couple brand and model options from that list based on the reviews and personal recommendations.

The next step in finding an overlock that fits in your budget is to search online shopping Web sites. Search for your desired brand and model. There are often lots of machines that are up to a couple hundred dollars cheaper, even when purchased brand new! Be patient and diligent with this process and you will come up a winner!

Stay smart and service me

Your overlock machine needs to be kept clean and oiled between projects. If you are working on a particularly long project, or a rather dusty one (knits), you may have to give it a cleaning mid-way. Refer to your owner’s manual for how to do this. It is not hard and it will save you such headache and money in the long run.



Overlock repairs are pricey. A cleaning brush and oil are much cheaper!

Beyond your regular cleaning, the overlock will need an annual tune-up at your local repair shop. Be sure to call ahead to make sure they have the capacity to do overlock machines. Don’t mess around with people that don’t know what they’re doing. This is a serious machine that needs proficient professionals to take care of it!

Starting and stopping with security

The overlock stitch is often referred to as a chain, as it looks like a chain when run off the fabric. If the beginning and end points of your serged stitch-line are going to be finished, either with the overlock or by hemming, don't worry about starting and stopping securely. Otherwise, you will need to learn a few tricks of the trade to take care of this.

To secure the start of your serged seam, make just two to three stitches with the machine. With the needles raised, lift the presser foot and bring the chain around to the front of the needles and cutter. Bring the presser foot back down and resume serging. The chain will be bound in the stitching and cut off by the blade. Refer to Figure 5-16 for a visual representation of this.

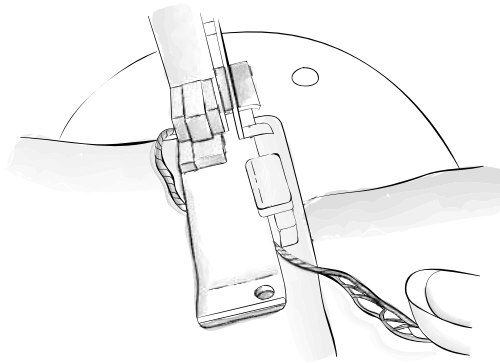

Figure 5-16:
Starting
your serged
seam.

To secure the end of your serged seam, stitch one stitch off the edge of the fabric and stop. With the needles raised and presser foot lifted, gently pull the fabric to allow for some slack in the threads. Move the fabric forward enough so that you can serge over your serged seam again 2-3 stitches. Continue stitching off the fabric. Cut the chain close to the fabric for a clean look.



There's a chance that this could still unravel a bit depending on your tension, stitch length, and other stitch characteristics.

Depending on your tension and other variables, this method of finishing a serged seam may still unravel a bit. I like to play it double safe by tying a knot in the end of my seam. Do this by cutting the chain just a bit further away from the edge of the fabric, approximately $\frac{1}{4}$ inch. Untangle the chain by gently pulling the two threads that wrap around the edge of the fabric (the upper and lower looper threads). Tie a double knot with these two threads. Cut off excess thread.

Figure 5-17:
Finishing
your serged
seam.

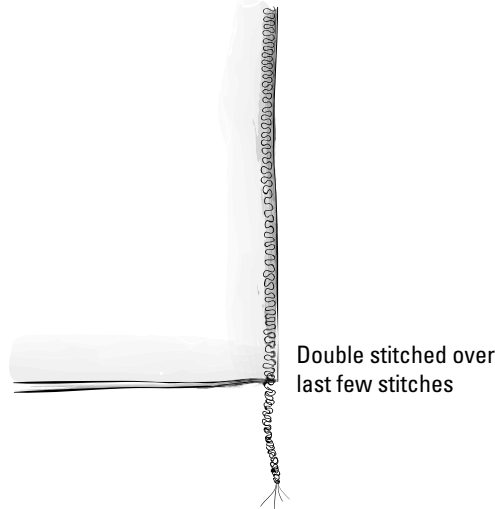

If you are an avid overlock user and finishing a lot of seams with double knots, it's a good tip to keep your thumbnails a bit on the long side so that you can maneuver the knotting with ease.

Hungry puckers and differential feeding

Some overlock machines have a feature called differential feeding. This feature changes the way the fabric feeds in the machine, thus eliminating the overstretched wavering edges that occur in some knits as well as eliminating puckers.



By some perspectives, differential feed is meant to fix imperfections. I like to use it to push the limit further in creating these “imperfections” as a decorative effect.

Go raw

The raw look is “in” and an overlock machine is one of many ways to achieve this. For me, I like to use the overlock seams as visible decoration and sculpting effects. Others choose to do solely the inside-out look with their seams. Either way, it is definitely a new technique that you can have lots of fun playing around with!

Not so self-explanatory

I've been doing this exposed external seam and decorative stitching bit for a while now. Lots of independent designers are doing it. On top of that I've even seen it in the flashy fashion magazines in waiting rooms (the only times I even glance at them). So when I sent a box of clothes out for a fashion show, *with* pictures of how they should be worn, I never thought there

would be a problem. When the clothes were returned to me, they were all inside out. I thought to myself, "no, they wouldn't have worn them like this. They just must have taken them off quickly." But sure enough, when the pictures came in the faux-pas was revealed. All the girls were on the runway, tags sticking out of the clothes with seams on the inside! Sacrilege!

In a Pinch Tricks

So you don't really care about perfect seams and invisible hems. You are in a hurry! You are either on-the-go or too busy to even think about whether you are coming or going. No fear, there are tricks to do for your fast-paced life as well!

The heat is on

A heat gun is normally used for embossing and other craft projects. However, it can also be a quick trick to seal the edge of synthetic fabrics. Keep in mind that this is a very rough look meant only for costuming or rather edgy dressing individuals.

Warm up your heat gun according to the instructions that came with it. Taking care to keep your hands out of the direct line of the heat gun, aim it at an angle towards the cut edge. Keep the heat gun at least 3 inches from the fabric. Keep it moving back and forth within an inch along the edge. This area should start to melt within a few seconds. When it starts to melt, move the heat gun smoothly along the edge, continuing the melting process as you go.



Be sure to work in a well-ventilated area. Your work surface should be heat resistant and free of other items that might melt while you are working with the heat gun. Keep the area free of other hazards, children, and animals that may trip up the cord and cause your heat gun to move or fall off the work surface.

No sew hems

Finding yourself in need of a hem repair on the go! No thread and needle at your disposal? No-sew hem tape is your new best friend. This tape can be found at any fabric store, but it's good to keep it handy in your travel sewing kit for emergency occasions. You just cut the amount you need and iron it on to affix it to your hem.

Decorative cover-up

If you have got a stain with no hope of washing out, there are some solutions for you. These ideas can be done in a jiffy for a temporary fix, or serve as a permanent alteration.

- ✓ Iron-on patch
- ✓ Sew-on patch
- ✓ Put on a patch with safety pins (on the outside for an obviously rough look)
- ✓ Beads and buttons sewn on over the stain
- ✓ Painting or drawing over the stain

Part II

Shirts: Sluggish to Spectacular

The 5th Wave

By Rich Tennant



In this part . . .

In this part, I show you what you can do with your old shirts. T-shirts are transformed. Button-downs turn into some down-low accessories. Pullover tops go over the top and upside-down!

Chapter 6

Transforming T-shirts

In This Chapter

- ▶ Caring properly for your T-shirt — before and after you rip it to shreds
 - ▶ Bringing out the beauty in flaws
 - ▶ Discovering sweet new clothes and practical ideas for old T-shirts
-

Okay, admit it: You've got at least one old T-shirt, probably more. It could be from a favorite concert or left behind by an old love. Or better yet, it might just be the softest darn thing you've ever felt, but you've worn it to the point that even your dog cringes at the sight of it!

In this chapter you can find ways to revitalize this prized possession. I'm not talking just making it sleeveless or fringed (eek!) or any number of the standard simple tricks. The projects in this chapter give you a fresh idea to run on and explore your own creativity.

These projects include a top, bottom, and the stuff in between. The Upside-Down Skirt is a clever and easy way to keep the coziness of your T-shirt close to you. The No-Stop Halter Top has lots of variations to perfectly express and flatter yourself. Finally, a use for that T-shirt that's too beat up for anything else, but too loved to scrap: Diminishing Waste with Waistbands!

Giving Your T-shirt Some TLC

Whether you're starting out with your own T-shirt or one you bought from a thrift shop, you may discover some surprises about its laundering care. In this section, I give you the ins and outs of how to take care of your tee, before and after reconstruction.

Part of your prep may include fixing flaws. Refer to Chapter 4 to make the most of the flaws. You may choose to do only these techniques to reconstruct your T-shirt. However, if you do plan on proceeding with a project, hold off on fixing flaws until you are done with the project.

Pre-construction care

Typically, T-shirts turn out just fine in a regular washer and dryer (check out Chapter 4 for the exceptions to this general rule). Still, refer to the laundering label for exact instructions. Some newer styles with spandex or lycra mixed with the cotton of the fabric require special attention to keep them in tip-top shape. If your label is missing, play it safe by washing the T-shirt in cold water on the gentle cycle and no dryer!



In reconstructing, sometimes you forget why you put that old T-shirt away in the first place. So be sure to check every inch of your T-shirt thoroughly for stains and other wear and tear *before* you wash it. You may be able to get rid of some of the stains with a spot treatment, and washing on the gentle cycle may prevent further wear and tear to T-shirts that have seen a better day. So keep an eye out for the following to save yourself a bit of time and energy working around the flaws later:

- ✓ Stains and other wear and tear on the cuffs of long-sleeved T-shirts
- ✓ Collar tearing away from the body of the T-shirt
- ✓ Armpit and collar stains
- ✓ Spill stains. You can usually find spill stains on the front of the T-shirt, but you also may find some around the hip area where some people have a habit of wiping their hands (ew!!!) or leaning up against a counter.



For ways to work with stains, see Chapter 4.

Post-construction care

After you've done all this repairing and/or reconstructing, how in the world do you clean it? Unless you've used leather, fragile vintage buttons or other appliqué that is obviously not machine-washable, I recommend throwing it a gentle cold wash and flat dry to see what happens. This is always an exciting part of the process for me as the materials have a way of blending together and becoming one. But if you're not such a risk taker, have your reconstructed T-shirt dry cleaned.



One thing I can tell you for certain is that if you have used red embroidery floss on a light colored shirt, or red fabric to patch your garment, it will bleed and turn your garment a pinkish hue. Avoid this pitfall by dry cleaning.

Upside-Down Skirt in a Topsy-Turvy World

The Upside-Down Skirt is a T-shirt turned upside down and worn as a skirt. Okay, there's a bit more to it than just that. One of my favorite things about this project is how it preserves every bit of the original fabric, as well as how it can incorporate scraps of other fabric.

I first made this skirt a while back and grabbed it off the clothing rack in my boutique in a mad frenzy of needing something to put on quick to head out for the night. I'm thrilled that I gave myself such a treat because I absolutely live in it! It's as comfy as a T-shirt, but has a flare to it that puts it on the dressy side depending on what you pair it with. I layer it with tights and boots on chilly days. On its own it's as breathable as a summer sundress!

Overall, this project is fairly easy. You start by cutting open the shoulders from the neck down to the hem of the sleeve on each side. Turn it upside down. Take it in or let it out if you need to. Add a waistband and voila! You've got a new skirt!

Check out the T-shirt prior to reconstruction in Figure 6-1.



Figure 6-1:
Before —
Upside-
Down Skirt
in a Topsy-
Turvy World.

Materials

- ✓ T-shirt
- ✓ 1 yard of stretchy fabric *or* another T-shirt of complementary color
- ✓ Safety pins
- ✓ Common pins
- ✓ Tape measure
- ✓ Tailor's chalk (substitute with laundry marker)
- ✓ Needle (for hand sewing) or sewing machine
- ✓ Thread that matches the T-shirt
- ✓ Waistband material:
 - Drawstring (allow 20 inches of additional length for tying)
 - $\frac{3}{4}$ -inch-wide elasticized band or $\frac{1}{4}$ yard of stretch fabric that measures the width of your waist
- ✓ Scissors

Directions

1. **Prep.** Wash and dry your T-shirt according to the label instructions, or, if the shirt has no laundering label, use a gentle wash and dry it flat.
2. **Orient yourself.** While your T-shirt is still intact, take a look at it. When I use the word *length* I am referring to the distance and direction from neck to waist on the body, and from shoulder towards hand on the sleeve. *Width* is the distance and direction from side to side across the body and across the arm (for the sleeve). See Figure 6-2 for a visual representation.

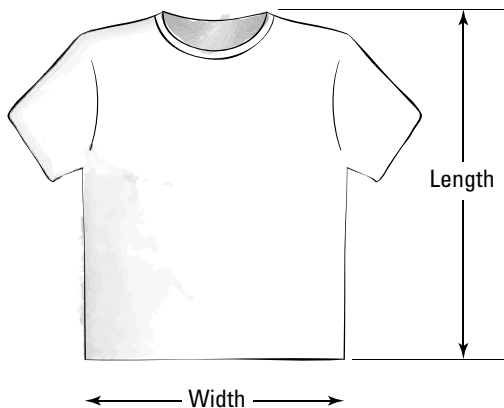
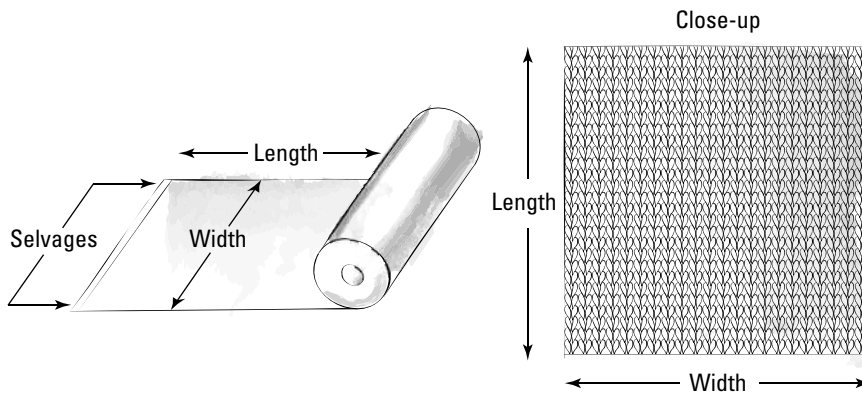

Figure 6-2:
T-shirt
length and
width.



When referring to fabric, *length* is the yardage and the direction in which that yardage is measured (also referred to as “with the grain”). *Width* is the distance and direction perpendicular to this, running from selvage (finished edge) to selvage (also referred to as “against the grain”). Note that I have come across some very rare and odd fabrics that are woven opposite to this, so it is helpful to be able to determine this by visual inspection. Functionally, it’s even more important to feel the fabric and stretch it in each of these directions. The direction that stretches more is the width. See Figure 6-3 for assistance in identifying length and width in reference to the T-shirt fabric.

Figure 6-3:
Fabric
length and
width.



3. **Cut.** Cut along the shoulder seams, starting at the neck and continuing in a straight line along the length of the sleeve. Cut off the collar and hem of the sleeve. If you don’t feel comfortable cutting free-hand, mark each of the cuts with tailor’s chalk prior to cutting.
4. **Turn it out and try it on.** Turn the T-shirt inside out. Hold it upside down and step into it. Pull the waist edge of the T-shirt up to your waist. Does it fit comfortably over your bottom, hips and belly?



If you are sewing by hand or standard machine, your options for waistbands are limited to a drawstring or elasticized band. Be sure to leave an extra 2½-inch length at the waist for this. Also, be sure that the width of the fabric at the waist is at least the width of your hips. Measure the largest part of your hips using the tape measure.

5. See how it fits.

If it’s too big:

1. Fold the extra fabric and pin it with your safety pins as shown in Figure 6-4.



2. Take off the skirt and cut off extra fabric that you have just folded and pinned, $\frac{1}{2}$ -inch away from the pinning.

Save your scraps to add frill to the bottom of the skirt!

Hand and Machine Sewing

Circumference equal
to hip circumference

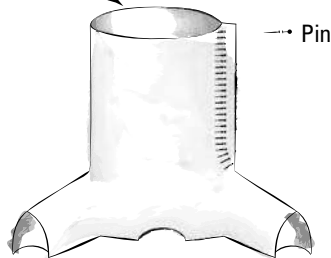
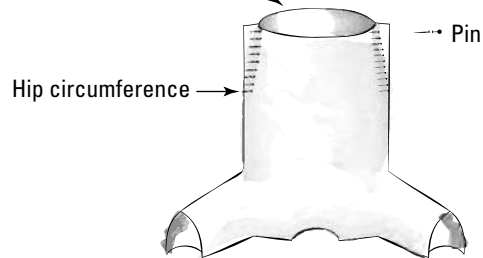

Figure 6-4:
Pinning your
“too big”
T-shirt.

Overlock Machine

Circumference
to fit waist



If it's too small, you have to fit and pin the T-shirt (see Figure 6-5 for a detailed view of the following steps):

1. Cut the entire shirt open along the length.
2. Starting at the waist, line up a length of stretchy fabric (or a length of fabric from another T-shirt) with the cut edge of the original T-shirt.
3. Safety pin together with right sides facing and a $\frac{1}{2}$ -inch seam allowance.
4. Wrap the T-shirt around your waist (inside out as in Step 4).
5. Safety pin the edges together to fit you comfortably, right sides facing and a $\frac{1}{2}$ -inch seam allowance.
6. Take off the skirt and cut off any extra fabric from the seam that you have just pinned, as well as any extra length of fabric.

Save your scraps for Renaissance Repairs in Chapter 9!



Figure 6-5:
Fitting and
pinning your
“too small”
T-shirt.

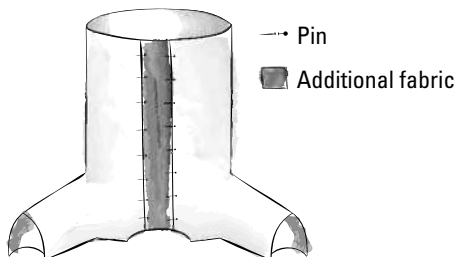



This technique for too-small T-shirts also comes in handy to get rid of logos. Cut out the entire length of the piece with the logo. Refer to Figure 6-6. Proceed with the directions for “too small” T-shirts.

Figure 6-6: Cutting out logos and other unwanted pictures.

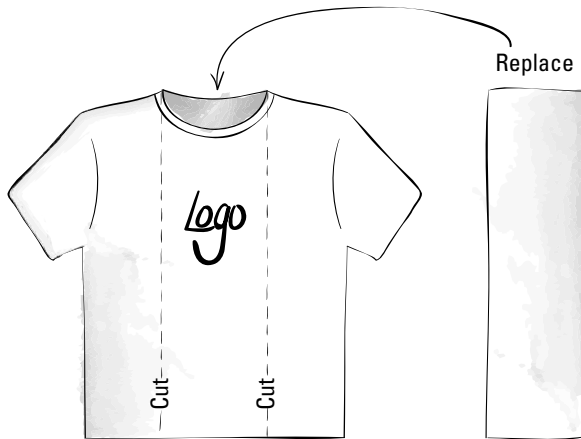

6. **Replace safety pins.** Replace the safety pins with common pins, placing them perpendicular to the cut edge every 2 inches.
7. **Sew, using the method below that matches your sewing method.** The instructions depend highly on whether you are hand sewing, machine sewing, or using an overlock machine.
 - **Sewing by hand:** Refer to Chapter 5 for hand-sewing techniques. Running stitch all vertical seams with a ½-inch seam allowance. Hem the bottom edge using the quick-hem technique.
 - **Sewing by machine:** Straight stitch all vertical seams using a ½-inch seam allowance. Hem the edge using the quick-hem technique described in Chapter 5.
 - **Sewing with an overlock:** Serge all vertical seams using a ½-inch seam allowance. Hem the edge using the quick-hem technique described in Chapter 5.



Instead of sewing a finished hem, you can use no-sew hem tape. This tape is just ironed on. You can find it in your local fabric or craft store, online, or even in major supermarkets and department stores.

8. **Repair.** Refer to Chapter 4 to repair any tears, holes, and stains as needed.

9. **Make the waistband.** If you are using an overlock machine, refer to another project in this chapter, “Diminishing Waste with Waistbands.” Otherwise, do the following:
1. Fold 1½ inches of the top edge towards the inside of the garment.
 2. Using common pins, pin the two layers together, with the pins placed perpendicular to and 1 inch in from the folded edge.
 3. Using a running stitch (hand sewing) or a zigzag stitch (machine sewing), sew the waist 1 inch from the folded edge. (See Figure 6-7.)
 4. Remove pins and proceed with the waistband by referring to the directions for elasticized waistbands and drawstring waistbands in the project, “Diminishing Waste with Waistbands” later in this chapter.

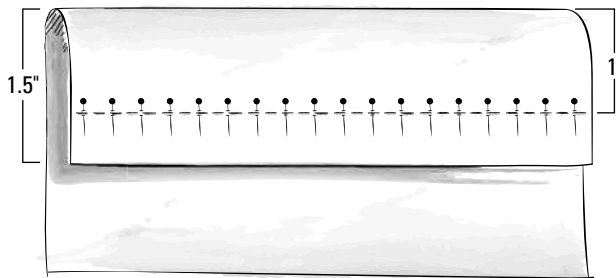

Figure 6-7:
Making your
waistband
work.

Check out the T-shirt after reconstruction in Figure 6-8.



Figure 6-8:
After —
Upside-
Down Skirt
in a Topsy-
Turvy World.

Powerful perspective

When fitting for this or any of the projects in this book, it is not *you* who is too small or too big, it is the garment! Don't let the garment, and some arbitrary number assigned to it, have power over how you feel about yourself!

Variations

For a decorative effect, try some of these ideas:

- ✔ **Raw look:** For external seams, skip Step 4, keeping the T-shirt right side out. Instead of finishing the edge with a hem, leave out this step and blanket stitch (hand sewing), zigzag stitch (machine sewing) or serge the edge (overlock) for a raw finish.
- ✔ **Bias tape:** Instead of hemming the edge or leaving it raw, you can cover it with a decorative bias tape. This can be found in any sewing goods or fabric store, usually near the zippers in the “Notions” area. Bias tape comes in a variety of colors and can be either hand-sewn or machine sewn on to cover the edge (follow the instructions on the package).
- ✔ **More frill:** Add more length and frill to your skirt by adding scraps of material onto the bottom edge prior to hemming. Pleating (folding) or ruffling the scrap piece makes this extra fun! See Figure 6-9 for a visual.
- ✔ **Thick stitches:** Complete all stitches by hand sewing with embroidery floss.
- ✔ **Thicker stitches:** Hand sewing over pre-sewn and secured edges with yarn or ribbon.
- ✔ **Mix colors:** Use a thread color that doesn't match, but complements the color of the skirt. With a sewing machine you can also use a different color for the bobbin thread. With an overlock machine, you can get really creative and use four to five different colors.
- ✔ **No-sew deco techniques:** You can leave the edge completely unstitched and raw. Running it through the washer and dryer will help the edges fray and bind together to complete the “unfinished” look. Other no-sew ideas include painting, grommeting, riveting, bedazzling, dyeing, and drawing with fabric markers or even a sharpie marker. Make stripes on your skirt with gaffer's or masking tape. Spray a light coat of spray paint over it, let dry and remove the tape to reveal super-hot stripes!



Figure 6-9:
Methods for
more frill.

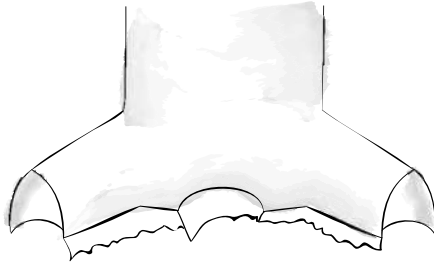

No-Stop Halter Top

The No-Stop Halter Top is a clever way to alter your T-shirt just enough to take it from plain to pretty in just a few easy steps. It's a perfect piece for a beach or poolside cover-up. With a quick change you can add a skirt and head right out for dinner or a sunset stroll.

This project is easy. You just cut up your T-shirt and bind the edges. Extra decorative effects add fun to both the piece and to the process of making it.

Check out the T-shirt prior to reconstruction in Figure 6-10.



Figure 6-10:
Before —
No-Stop
Halter Top.

Materials

- ✓ T-shirt that fits you well
- ✓ Safety pins
- ✓ Common pins
- ✓ Tape measure
- ✓ Needle (for hand sewing) or sewing machine
- ✓ Thread that matches the T-shirt
- ✓ Tailor's chalk (substitute with laundry marker)
- ✓ Scissors

Directions

1. **Prep.** Wash and dry your T-shirt according to the label instructions, or, if the T-shirt has no laundering label, use a gentle wash and dry it flat.
2. **First cut.** Cut your T-shirt across the back, armpit to armpit, and along the inside of the sleeve up to the shoulder seam. You will continue this cut line in Step 4. See Figure 6-11. (If you don't feel comfortable cutting free-hand, mark each of the cuts with tailor's chalk prior to cutting.)
3. **Second cut.** Cut lengthwise from the center of the top back piece, up through the collar. Cut the collar off with a scoop at the neck as shown in Figure 6-12.

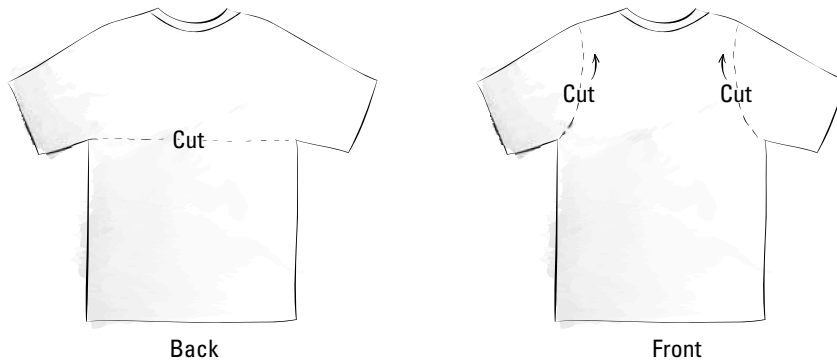

Figure 6-11:
First cut.

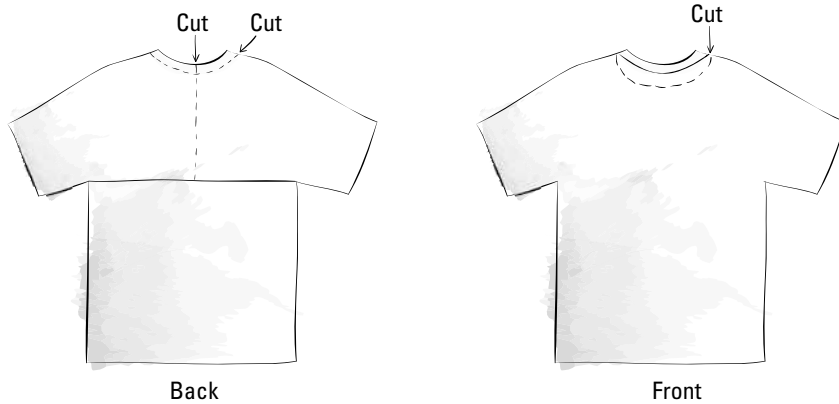

Figure 6-12:
Second cut.

4. **Third cut — making dangles.** Cut off the underarm seam, from armpit down to the hem of the sleeve. Then continue the cut from the shoulder (Step 2) through the material in a spiral, creating a long dangling strap for your halter top. Do this on each side. See Figure 6-13.

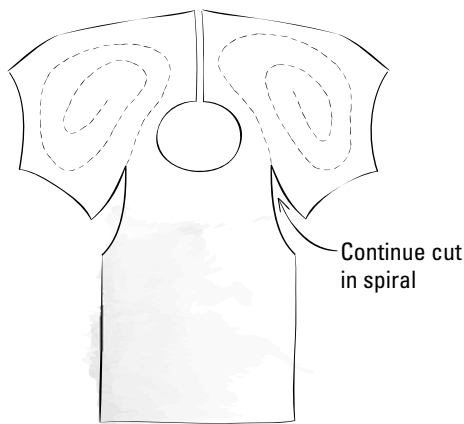

Figure 6-13:
Making
dangles.

5. **Try it on.** Put your T-shirt halter on, tying the dangles behind your neck comfortably. Is the collar too tight or too high on your neck? If so, cut off more fabric in front of the neck, using Figure 6-14 as a guide.



If you started out with a T-shirt that fit well, the halter top should fit well. If it does not, you can use the same techniques for fitting a too-small or too-big skirt in the project earlier in this chapter, “Upside-Down Skirt in a Topsy-Turvy World.”

6. **Repair.** Refer to Chapter 4 to repair any tears, holes, and stains as needed.

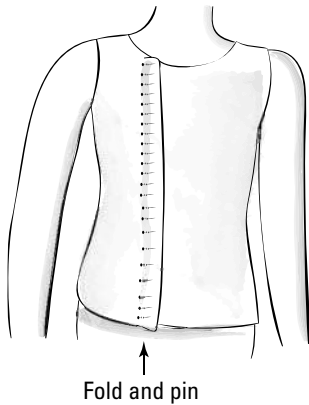

Figure 6-14:
Fitting a too-
big top.

7. Sew, using the method below that matches your sewing method and desired finish. The instructions depend highly on whether you are hand sewing, machine sewing, or using an overlock machine.

- **Sewing by hand for a clean look:** Refer to Chapter 5 for hand-sewing techniques. Hem all cut edges using the quick-hem technique.
- **Sewing by machine for a rough look:** Zigzag stitch all cut edges with a $\frac{1}{4}$ -inch seam allowance.
- **Sewing with an overlock for a rougher look:** Serge all cut edges with a $\frac{1}{4}$ -inch seam allowance.



Instead of sewing a finished hem, you can use no-sew hem tape. This tape is just ironed on! You can find it in your local fabric or craft store, online, or even in major supermarkets and department stores.

Check out the T-shirt after reconstruction in Figure 6-14.



Figure 6-15:
After —
No-Stop
Halter Top.

Variations

For a decorative effect, try some of these ideas:

- ✓ **Raw look, bias tape, thick stitches, thicker stitches, mix colors, and no-sew deco:** You can find instructions for these options in the “Variations” section for the “Upside-Down Skirt in a Topsy-Turvy World” project earlier in this chapter.
- ✓ **More dangles:** Get creative with Step 4. Cut multiple dangles, either along the length of the strap or from the point where it attaches to the body of the halter top. Sew on more scraps of fabric for even more dangles! See Figure 6-16 for ideas.
- ✓ **Necklines:** Alter your neckline by altering the cut line, adding more straps or even sewing on some ruffling scraps. See Figure 6-17 for ideas.

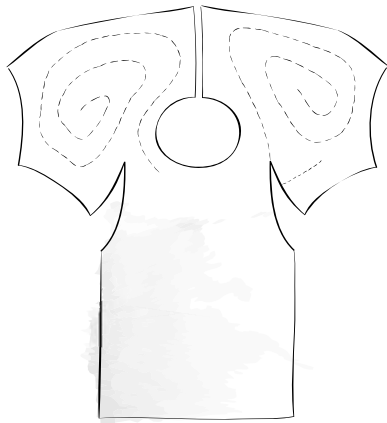
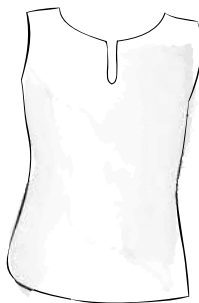

Figure 6-16:
More
dangles.



Slice cut



Deep neck

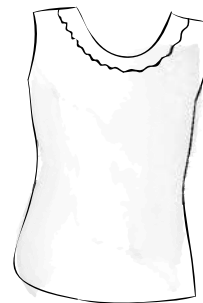

Ruffled

Figure 6-17:
Neckline
variations.

Diminishing Waste with Waistbands

Some T-shirts are just worn to their last thread, well, almost! This project is for those T-shirts that are past the point of revamping into a garment but not quite ready for the rag pile. Check out the T-shirt prior to reconstruction in Figure 6-18.



Figure 6-18:
Before —
Diminishing
Waste with
Waistbands.

Materials

- ✓ T-shirt that fits around your hips and waist
- ✓ Common pins
- ✓ Safety pins
- ✓ Tape measure
- ✓ Needle (for hand sewing) or sewing machine
- ✓ Thread that matches the T-shirt
- ✓ Drawstring *or* $\frac{3}{4}$ -inch-wide elasticized band with a length equal to the width of your waist. For drawstring, allow 20 inches of additional length for tying.
- ✓ Scissors

Directions

There are three waistbands presented in this project: an elasticized waistband, a drawstring waistband, and a stretchy fabric waistband. All are easy but depend highly on the material and your method of sewing. The elasticized waistband and drawstring waistband can be done with any method of sewing and any type of T-shirt fabric. The stretchy waistband can only be done with an overlock machine and with stretchy fabric. Read the instructions thoroughly prior to starting to make sure that you are choosing a project that works for you.

Elasticized waistbands

1. **Cut.** Cut a 3-inch strip across the T-shirt, yielding a tube of T-shirt material 3 inches wide.
2. **Fold.** Fold this piece in half, raw edges together, resulting a folded tube piece of 1½ inches wide.
3. **Pin.** Pin the two layers of this piece together, with the pins placed perpendicular to and 1 inch in from the folded edge.
4. **Sew.** Refer to Chapter 5 for instructions on hand sewing. Using a running stitch (hand sewing) or a zigzag stitch (machine sewing), sew the waist 1 inch from the folded edge.
5. **Insert elastic.** Cut a small ½-inch slit into the inside of the waistband. Pin a safety pin to the end of the elastic. Insert the elastic, using the safety pin as a needle to guide the elastic through the waistband. When you reach the other end, pin them together, making sure that the elastic lies flat within the waistband.



Tie a knot in the end of the elastic to be sure it doesn't slip through.

6. **Fit.** Try on the waistband. Cinch the elastic to a tightness that is comfortable for you. Pin the elastic together at this point.
7. **Sew.** Refer to Chapter 5 for hand-sewing techniques. Using a running stitch, hand-stitch the elastic together where it is pinned. Cut off any extra length. Blanket stitch the slit you cut in Step 5.

Drawstring waistbands

1. Refer to Steps 1 through 4 in the earlier section "Elasticized waistbands."
2. For Step 5, cut two slits in the outside of the waistband, 1 inch apart from each other.
3. Blanket stitch around the edges of each of these slits from Step 3.
4. Thread the drawstring as described in Step 5 of "Elasticized waistbands," starting it through one hole and bringing it out the second hole.

Stretchy waistbands

Stretchy waistbands can only be done with an overlock machine. They require fabric that stretches along the width. Old workout tops are great for this!

- 1. Cut.** Cut the entire shirt horizontally, from armpit to armpit. You will be using the bottom piece for your waistband. It should be at least 6 inches long.
- 2. Fit.** Try on the waistband. If it is too big, cinch it to a tightness that is comfortable for you. Pin it together at this point. Remove the waistband and serge a seam along the length at this point, removing pins as you go.
- 3. Fold.** Fold this piece in half, raw edges together.
- 4. Sew.** Serge the raw edges of the waistband directly onto your garment.

Check out the T-shirt after reconstruction in Figure 6-19.



Figure 6-19:
After —
Diminishing
Waste with
Waistbands.

Chapter 7

Redefining Boring Button-downs

In This Chapter

- ▶ Caring for and handling of your button-down
 - ▶ Making multiple items from a single shirt
-

Button-downs are plentiful in thrift shops. Most are men's style, although there are some tailored versions for women in fewer numbers. Many of the button-downs that I have come across are fairly standard and downright boring. On occasion, especially in more vintage-oriented thrift stores, you can find some fabulous colors, interesting collars, and other detail work. But for the most part, they are white, or at least they used to be.

In this chapter, you can find solutions and salvation for button-downs in any condition. Creative accessories for the neck and wrists make use of one part of the shirt, while the remaining body of the shirt can be paired with a sweater for a unique twist on the boring old button-down.

Prepping, Primping, and Post Care for Your Button-downs

Button-downs are generally cotton and thus wash just fine in the washing machine. Check the laundering label and wash the shirt prior to your reconstruction project, being sure to take special spot-cleaning care of "the usual suspects" listed below. If your label is missing, refer to Chapter 4 for guidelines on when to have the shirt professionally cleaned. You can also play it safe by washing your shirt in cold water on the gentle cycle and laying it flat to dry.

Personally, I'm very picky about starting with items in good condition, particularly when it comes to body stains. Button-downs are generally low on my list of "good finds" in respect to this. It's difficult to find one that doesn't have these usual suspects but most of the projects in this chapter are very forgiving of these things. Still, be aware of these common flaws and choose within your comfort zone.

Re-addressing the business dress code!

Men just don't have a lot of options, especially when it comes to dressing for business. I seem to have a fair amount of friends these days who are leaving their desk jobs to pursue a career that is more devoted to their art. In the midst of this shift, they are left with clothes, particularly button-downs, that have absolutely no use to

them in the outside world. With just a quick trip under the sewing machine needle, they are fit for viewing in a whole new light. This trick, that ironically I refer to as "tricking out," allows for individuality to be expressed while still retaining some semblance of professionalism.



Always check for these common button-down flaws:

- ✓ Armpit and collar stains
- ✓ Stains and other wear and tear on the cuffs
- ✓ Torn underarm seams

Refer to Chapter 4 for what to look for and how to make it work for you. Some button-downs do well with just a bit of patching and sprucing up with some decorative stitching. If it has a decent shape, consider this an option.

Busting Out the Neck Bustles

The neck bustle was requested by a friend and fellow shop-owner in San Francisco. We both adore a romantic aesthetic, expressing the strength, mystery, and beauty of women. Bustling is a vision of elegance and decorum that has gone lacking in our current society. I love bringing back the bustle in whatever way that I can. Sometimes it takes on a more traditional form with a modern functionality (Detachable Bustles in Chapter 9), and other times it's much more subtle (Tails of Two Crops in Chapter 8.)

This project can vary in difficulty, depending on whether you keep it simple or dive into decorating with the variations. Generally it involves removal of the collar from the button-down, finishing the edges and decorating it!

Check out the button-down prior to reconstruction in Figure 7-1.

Figure 7-1:
Before —
Busting Out
the Neck
Bustles.



Materials

- ✓ Button-down
- ✓ Safety pins
- ✓ Common pins
- ✓ Tailor's chalk (substitute with a laundry marker)
- ✓ Tape measure
- ✓ Needle (for hand sewing) or sewing machine
- ✓ Thread that matches the button-down
- ✓ Scissors

Directions

1. **Prep.** Wash and dry your button-down according to the label instructions, or have it professionally cleaned if there's no label.
2. **Mark and cut.** Turn up the collar of your button-down. Locate the seam of the collar with the body of the shirt. Using your tape measure, measure $1\frac{1}{2}$ inches from the seam into the body of the shirt. Mark this point with your tailor's chalk. Repeat this measurement every 1–2 inches around the collar in order to mark an even cut line. Connect the dots with your tailor's chalk. Cut along this line. Refer to Figure 7-2.

Save the cuffs for projects later in this chapter, and save the scrap of the shirt body as a case for Save-It-All Stuffing or Making a Case for Pillowcases, both in Chapter 18.



Figure 7-2:
Cut line for
your neck
bustle.

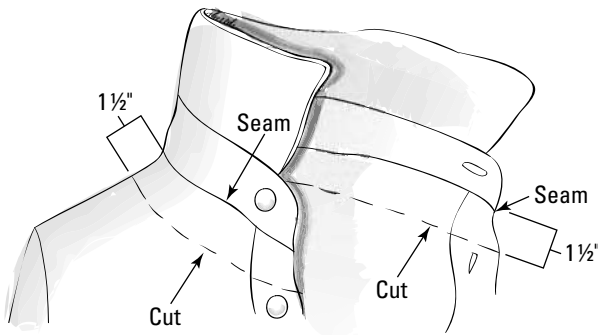

3. Sew, using the method below that matches your sewing method. The instructions depend highly on whether you are hand sewing, machine sewing or using an overlock machine.

- **Sewing by hand — for a clean look:** Refer to Chapter 5 for hand-sewing techniques. Hem the cut edge using the quick hem technique.
- **Sewing by machine — for a rough look:** Zigzag stitch the entire cut edge with a $\frac{1}{4}$ -inch seam allowance.
- **Sewing with an overlock — for a rougher look:** Serge the entire cut edge with a $\frac{1}{4}$ -inch seam allowance.



Instead of sewing a finished hem, you can use no-sew hem tape. This tape is just ironed on! You can find it in your local fabric or craft store, online, or even in major supermarkets and department stores.

Check out the button-down after reconstruction in Figure 7-3.

Figure 7-3:
After —
Busting Out
the Neck
Bustles.



Variations

For a decorative effect, try some of these ideas:

- ✓ **Bias tape:** Instead of hemming the edge or leaving it rough, you can cover it with a decorative bias tape. This can be found in any sewing goods or fabric store, usually near the zippers in the Notions area. Bias tape comes in a variety of colors and can be either hand sewn or machine sewn on to cover the edge (instructions on package).
- ✓ **More ruffling:** Cut further away from the collar for a longer ruffle.
- ✓ **Thick stitches:** Complete all stitching by hand sewing with embroidery floss.
- ✓ **Thicker stitches:** Hand sewing over pre-sewn and secured edges with yarn or ribbon.
- ✓ **Mix colors:** Use a thread color that doesn't match, but complements the color of the shirt. With a sewing machine you can also use a different color for the bobbin thread. With an overlock machine, you can get really creative and use four to five different colors.
- ✓ **Stitching everywhere:** Decoratively stitch on the neck bustle, marking with tailor's chalk first if necessary. Decorative stitches include embroidery or deco stitches on your machine (see Figure 7-4).
- ✓ **Buttons:** Sew decorative buttons onto the neck bustle. This is a great way to make use of those odds and ends buttons. Keep within a color scheme, or within a certain style (art deco, fabric, glass, carved) for a complete look.
- ✓ **No-sew deco techniques:** You can leave the edge completely unstitched and raw. Running it through the washer and dryer will help the edges fray and bind together to complete the "unfinished" look. Some other no-sew ideas include hot gluing items (nonwashable), painting, grommeting, riveting, bedazzling, dyeing, drawing with fabric markers or even sharpie markers. Make stripes on your neck bustle with gaffer's or masking tape. Spray a light coat of spray paint over it, let dry and remove the tape to reveal super-hot stripes!



Of course, constructing the neck bustle is one thing . . . wearing it is another. See Figure 7-5 for how to wear a neck bustle.

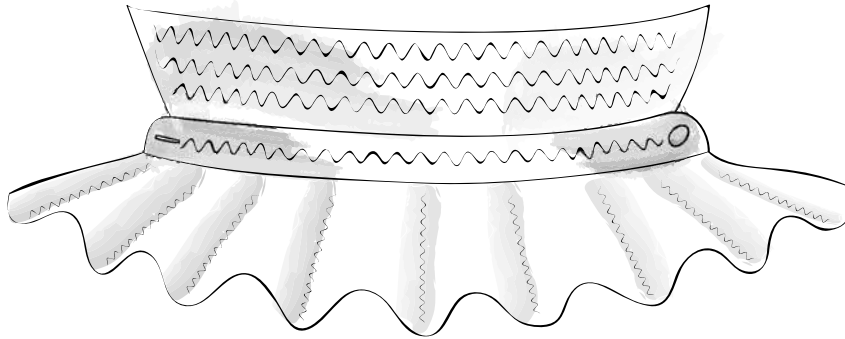

Figure 7-4:
Stitching
detail for
your neck
bustle.

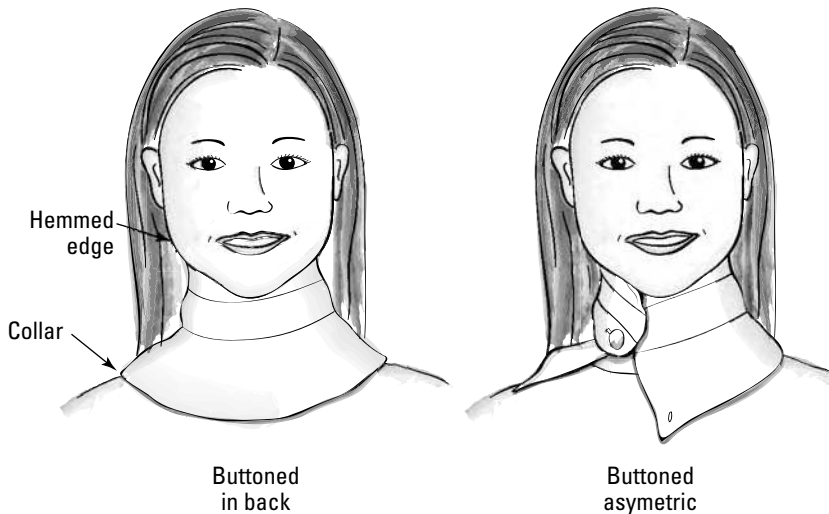

Figure 7-5:
How to
wear your
neck bustle.

Buttoned
in back

Buttoned
asymmetric

Bridging the Sweater Gap Top

This project recycles two pieces into one. Sometimes things have unfixable flaws in certain areas, but in chopping them up and putting them together you can make good use of both!

The Bridging the Sweater Gap project utilizes the body of the button-down and pairs it with the sleeves and other parts of a cardigan sweater. It's great as a cozy piece on its own, and even better for layering under a coat. It reduces the bulk of wearing a full sweater, while keeping you warm in all the right places.



Any difficulty in this project only arises in measuring and fitting the sleeves. Otherwise, it is simple in both concept and construction.

Check out the button-down and cardigan prior to reconstruction in Figures 7-6 and 7-7.

Figure 7-6:
Button-down
before —
Bridging the
Sweater
Gap Top.



Figure 7-7:
Cardigan
before —
Bridging the
Sweater
Gap Top.



Materials

- ✓ Button-down that fits well
- ✓ Cardigan sweater with long sleeves
- ✓ Common pins
- ✓ Safety pins
- ✓ Tape measure
- ✓ Needle (for hand sewing) or sewing machine
- ✓ Thread that matches the button-down
- ✓ Tailor's chalk (substitute with laundry marker)
- ✓ Scissors

Directions

1. **Prep.** Wash and dry your button-down and sweater according to the label instructions, or have it professionally cleaned if there's no label.
2. **Mark the cut line for the cardigan.** Lie your cardigan flat. Using it as a straight-edge, run your tape measure from armpit to armpit. Mark this line with your tailor's chalk. Measure the sleeve length, marking the point 14 inches from the cuff. Mark a line at this point that runs parallel to the cuff. Refer to Figure 7-8.

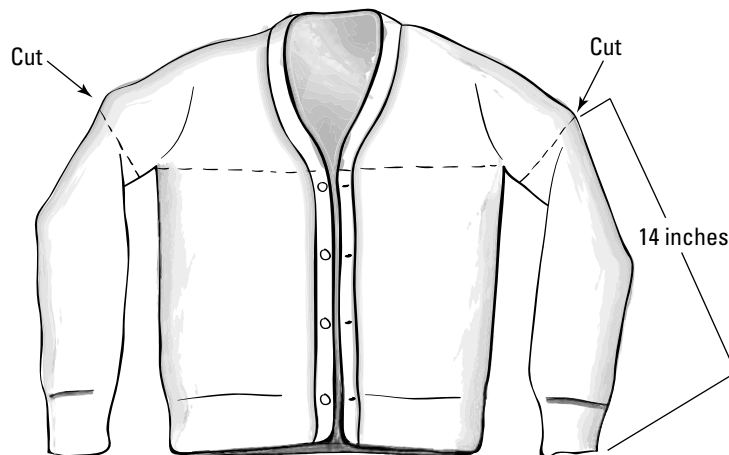

Figure 7-8:
Cardigan
cut line.

3. **Mark the cut line for the button-down.** Measure and mark the sleeve length of the button-down as you did for the cardigan. Refer to Figure 7-8.
4. **Secure edges of cardigan.** Refer to Running Wild in Chapter 12 and hand-baste or zigzag machine stitch on each side of the cut lines to prevent runs.
5. **Cut.** Cut the material along the lines you just made with the tailor's chalk.
Save your cardigan scrap for a choker chop-up in Chapter 20. Save your button-down sleeves for the cuff projects later in this chapter.
6. **Fit and pin the sleeve.** Turn the button-down inside out. Place the cardigan sleeves (right side out) inside the sleeves of the button-down, aligning the cut edges and underarm seams (see Figure 7-9).

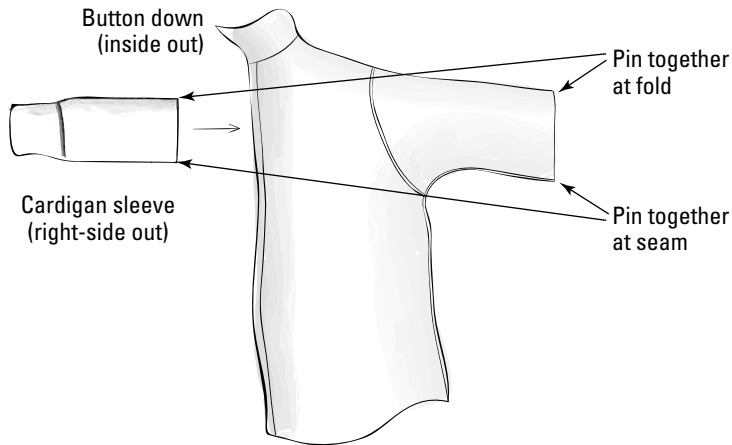

Figure 7-9:
Fitting and
pinning the
sleeve
together.

Does your cardigan sleeve fit perfectly inside your button-down sleeve? Can it be stretched so that the two fabrics lie flat against each other? If the answer is “yes,” continue pinning it every 1 inch and then proceed to Step 7. If not, see either of the following steps depending on your particular circumstance:

1. **Fitting a “too big button-down”:** If the button-down is too big, gather the extra fabric within an inch around the folded point you pinned in Step 6.
2. **Fitting a “too big cardigan”:** If the cardigan sleeve is too big, you have two choices. You can make it more narrow by taking it in, being sure to secure the stitches of the knit (Running Wild, Chapter 12). An easier method is to unpin the cut edge, flip the cardigan sleeve around and re-pin (Step 6) at the cuff edge.



If you flip the cardigan sleeve around you will have a cut edge of sweater at the new cuff. Finish this edge in the same manner described in Step 6 for the Bad Unkl Sista Sweater in Chapter 12.

- 7. Fit and pin the collar.** Lay your button-down flat. Lay the body of the cardigan above it, cut edge closest to the button-down collar. Locate the button side of the button-down collar. Pin the corresponding cut edge corner of the cardigan to the base of the collar at the button side. Continue to pin the cut edge of the cardigan around the base of the button-down collar. Let the remaining part of the cardigan hang free. Refer to Figure 7-10.



For this project, you can *not* use an overlock machine to adhere the cardigan to the collar of the button-down. But it is useful to serge the cut edge of the body of the cardigan before pinning it to the button-down collar. This will help prevent runs in the knit.

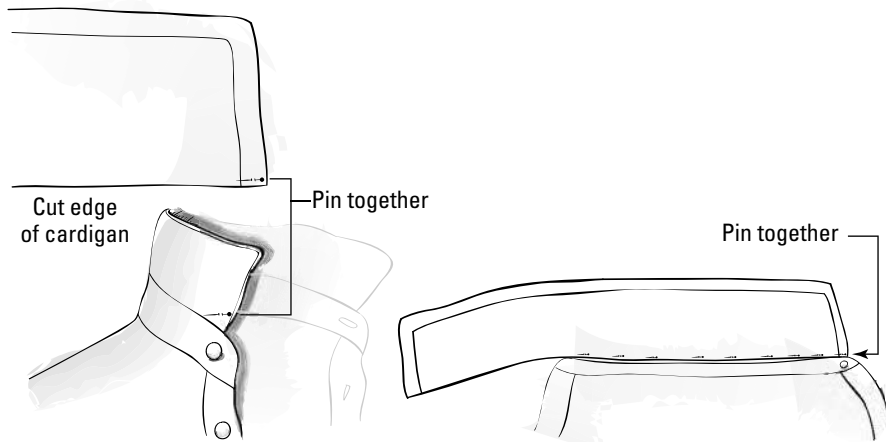

Figure 7-10:
Fitting and
pinning the
collar.

- 8. Repair.** Refer to Chapter 4 to repair any tears, holes, and stains as needed.
- 9. Sew, using the method below that matches your sewing method.**
- **Sewing by hand:** Refer to Chapter 5 for hand-sewing techniques. Running stitch the edge of the button-down collar to the cardigan as shown in Figure 7-11. Blanket stitch the free hanging cut edge of the cardigan. Hem this free hanging piece using the quick hem technique. Blanket stitch the pinned seam on each sleeve, securing the cardigan sleeve to the button-down.

- **Sewing by machine:** Zigzag stitch the edge of the button-down collar to the cardigan as shown in Figure 7-11. Continue this zigzag stitch along the free hanging cut edge of the cardigan. Hem this free hanging piece using the quick hem described in Chapter 5. Zigzag stitch the pinned seam on each sleeve.
- **Sewing with an overlock:** You cannot adhere the collar using an overlock machine. You must use either the hand or machine-sewing techniques described above. Be sure to serge the cut edge of the cardigan body before pinning and sewing it. This will secure the knit, including the free hanging piece. Serge the pinned seam on each sleeve, removing the pins before running it through the machine.

Check out the button-down and cardigan after reconstruction in Figure 7-12.

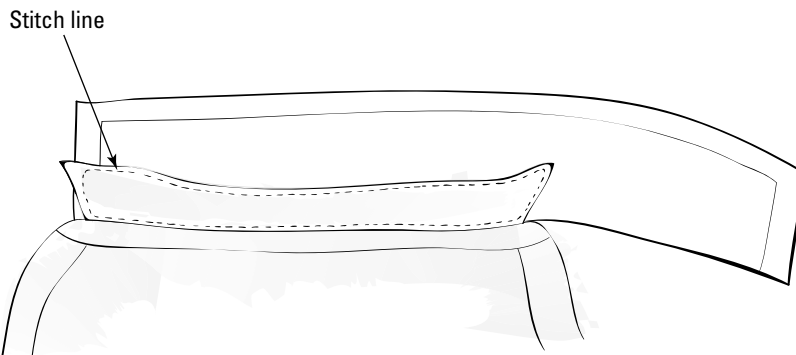

Figure 7-11:
Sewing the
collar.



Figure 7-12:
After —
Bridging the
Sweater
Gap Top.

Variations

For a decorative effect, try some of these ideas:

- ✓ **Raw look:** For external seams, skip Step 6, keeping the button-down right side out, and turn the cardigan sleeve inside out instead.
- ✓ **Bias tape:** Instead of hemming the edge or leaving it raw, you can cover it with a decorative bias tape. This can be found in any sewing goods or fabric store, usually near the zippers in the Notions area. Bias tape comes in a variety of colors and can be either hand sewn or machine sewn on to cover the edge (instructions on package).
- ✓ **Thick stitches:** Hand sewing with embroidery floss.
- ✓ **Thicker stitches:** Hand sewing over secured edge with yarn or ribbon.
- ✓ **Mix colors:** Use a thread color that doesn't match, but complements the color of the button-down or cardigan. With a sewing machine you can also use a different color for the bobbin thread. With an overlock machine, you can get really creative and use four to five different colors.

Getting Crafty With Cuffs

Cuffs are a great accessory for both men and women. Reconstructing them in this way is not only affordable, but personal and completely unique! You can stud it with rivets for a businessman gone bad-boy look; or embroider it with rosettes for your sweet grandmother. I like to layer cuffs over other sleeves, such as the Sleek 'n' Sneaky Sleeves in Chapter 13. However, cuffs are just as good on their own, worn as a set, two on one wrist or just a solo cuff on one wrist as you would typically wear a watch or bracelet.

Preciously Painted Cuffs

These painted cuffs are a great project for nonsewers. The minimal sewing involved can easily be replaced by no-sew hem tape or by just leaving a raw edge! Years ago I actually used to seal my raw edges by painting them. The look is hot, but sacrifices some comfort as painted edges are often a bit scratchy!

This project is very easy. All you have to do is cut the cuff from the button-down, finish the cut edge and decorate. Being such a small project, this one is great for parties and crafty get-togethers! Have everyone bring an old button-down and random craft supplies (have the essentials stocked up). Throw it all in a big heap, put on some music, and have a blast.



I have witnessed a few near-misses when mixing finger-foods and craft supplies in the same area. People get really focused and next thing you know someone has a mouthful of yarn. Be careful!

Check out the button-down prior to reconstruction in Figure 7-13.



Figure 7-13:
Before —
Preciously
Painted
Cuffs.

Materials

- ✓ Button-down
- ✓ Common pins
- ✓ Tape measure
- ✓ Needle (for hand sewing) or sewing machine
- ✓ Thread that matches the button-down
- ✓ Tailor's chalk (substitute with laundry marker)
- ✓ Scissors
- ✓ Paintbrushes
- ✓ Fabric paint

Directions

1. **Prep.** Wash and dry your button-down according to the label instructions, or have it professionally cleaned if there's no label.
2. **Mark and cut.** Locate the seam of the cuff with the sleeve of the button-down. Using your tape measure, measure 1½ inches from the seam into the body of the shirt. Mark this point with your tailor's chalk. Repeat this measurement every 1–2 inches around the cuff in order to mark an even cut line. Connect the dots with your tailor's chalk. Cut along this line.



Save the collar for the neck bustle earlier in this chapter, and save the scrap of the shirt body as a case for Save-It-All Stuffing or Making a Case for Pillowcases, both in Chapter 18.



3. **Sew, using the method below that matches your sewing method.** The instructions depend highly on whether you are hand sewing, machine sewing or using an overlock machine.

- **Sewing by hand — for a clean look:** Refer to Chapter 5 for hand-sewing techniques. Hem the cut edge using the quick hem technique.

Instead of sewing a finished hem, you can use no-sew hem tape.

This tape is just ironed on! You can find it in your local fabric or craft store, online, or even in major supermarkets and department stores.

- **Sewing by machine — for a rough look:** Zigzag stitch the entire cut edge with a $\frac{1}{4}$ -inch seam allowance.
- **Sewing with an overlock — for a rougher look:** Serge the entire cut edge with a $\frac{1}{4}$ -inch seam allowance.

4. **Paint.** Using your brush and fabric paint, paint your design onto the cuff. I like to do abstract and asymmetric designs freehand. You can buy or make your own stencils as well. Paper doilies also make a great stencil to achieve a lace-like effect.



Pay attention to the instructions on the paint. Some paints need to be heat set and others are fine without setting.

Check out the button-down after reconstruction in Figure 7-14.

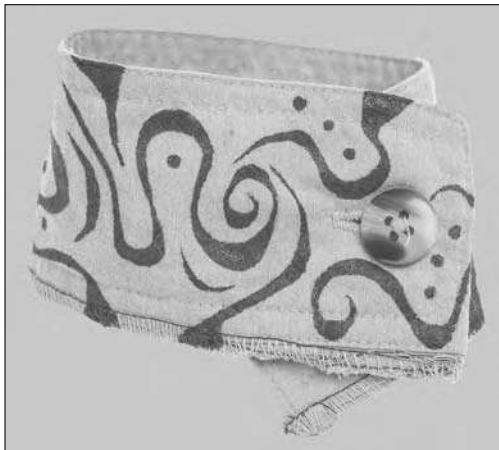

Figure 7-14:
After —
Preciously
Painted
Cuffs.

Variations

For a decorative effect, try some of these ideas:

- ✔ **Bias tape:** Instead of hemming the edge or leaving it rough, you can cover it with a decorative bias tape. This can be found in any sewing goods or fabric store, usually near the zippers in the Notions area. Bias tape comes in a variety of colors and can be either hand sewn or machine sewn on to cover the edge (instructions on package).
- ✔ **More ruffling:** Cut further away from the cuff for a longer ruffle.
- ✔ **Thick stitches:** Hand sewing with embroidery floss.
- ✔ **Thicker stitches:** Hand sewing over secured edge with yarn or ribbon.
- ✔ **Mix colors:** Use a thread color that doesn't match, but complements the color of the shirt. With a sewing machine you can also use a different color for the bobbin thread. With an overlock machine, you can get really creative and use four to five different colors.
- ✔ **Stitching everywhere:** Decoratively stitch on the cuff, marking with tailor's chalk first if necessary. Decorative stitches include embroidery or deco-stitches on your machine.
- ✔ **No-sew deco techniques:** You can leave the edge completely unstitched and raw. Running it through the washer and dryer will help the edges fray and bind together to complete the "unfinished" look. Some other no-sew ideas include hot gluing items (non-washable), painting, grommeting, riveting, bedazzling, dyeing, drawing with fabric markers or even a sharpie marker. Make stripes on your neck bustle with gaffer's or masking tape. Spray a light coat of spray paint over it, let dry and remove the tape to reveal super-hot stripes!
- ✔ **Other painting ideas.** Instead of fabric paint you can use a light coat of spray paint. Use repeated coats for a darker shade, letting the cuff dry completely in between. Other paint ideas include fabric paint pens, puffy paints and other craft paints in applicator tubes, stamping and embossing (you will need a heat gun for this).



Buttoned-Up Bracelets

Buttoned-up Bracelets, like *Preciously Painted Cuffs* (see the project earlier in this chapter), is a fun and easy project to do with friends. This project can be a little more difficult because it requires a fair bit of hand sewing, but generally this project is impossible to screw up!

Check out the button-down prior to reconstruction in Figure 7-15.



Figure 7-15:
Before —
Buttoned-
Up
Bracelets.

Materials

- ✓ Button-down
- ✓ Common pins
- ✓ Tape measure
- ✓ Needle (for hand sewing) or sewing machine
- ✓ Thread that matches the button-down
- ✓ Tailor's chalk (substitute with laundry marker)
- ✓ Scissors
- ✓ Safety pins
- ✓ Buttons

Directions

1. **Prep and then some!** Follow Steps 1 through 3 for *Preciously Painted Cuffs* (see project earlier in this chapter).
2. **Choose and place buttons.** Some ideas for decorating with buttons include keeping to a color theme (such as a particular color and its shades, warm tones, cool tones) or within a certain style (such as art deco, fabric, glass, antique.) Lay your cuff flat. Arrange buttons as you would like them sewn onto the cuff. Slide them off the cuff, keeping them in place.



If you have a digital camera, take a photo of the arrangement on the cuff. If you have a good view window, you won't even need to load the photo onto the computer to view it for reference when you are sewing the buttons on.

- 3. Sew.** Using a hand needle and matching thread, sew buttons in place. Since these buttons are not functional, you can get away with a quick trick. Thread two lengths of thread through the needle, doubling it over so that you are sewing with four strands. With such a thickness, you only need to make one or two passes through the button to secure it.

Check out the button-down after reconstruction in Figure 7-16.



Figure 7-16:
Buttoned-
Up
Bracelets.

Variations

For a decorative effect, refer to the Variations for the preceding project, *Preciously Painted Cuffs*, as well as use multiple buttons: Sew several buttons stacked on top of each other for a dangling effect.

Chapter 8

Pullover Overhaul

In This Chapter

- ▶ Prepping before cutting, cropping, wrapping, and twisting
 - ▶ Picking out a good one
 - ▶ Sealing up the loose ends in your wardrobe
-

Pullovers come in all types, shapes, and sizes. They range from a long sleeved T-shirt to a velvet holiday top to a near sweater-like ribbed turtleneck. All of these have a use that is far better than filling the garbage can, and all of them can be incorporated into the projects in this chapter. No fear, the solution to your overflowing closet is here!

For me, pullovers tend to be a staple item worn often with lots of different variations and layers. Thus, being worn often, it shows wear and becomes stale more quickly than other things. This chapter will provide you with solutions to alleviate any feelings of mediocrity in your pullover.

These projects include several variations of fun crops as well as a wrap to layer over the pullovers you have yet to reconstruct. The All-Season Crop is a basic crop while the Crop Inversion gives a little more coverage, as well as making good use of the entire pullover. Let your creativity shine with Tails of Two Crops, a crop with a bit more to flaunt in the back. A Wrap to Write Home About is a simple way to convert your pullover into something you can throw on and fun-up just about anything.

Prepping, Primping, and Post Care for Your Pullover

Pullovers can vary widely in fabric content and construction. Check the laundering label and wash it prior to your reconstruction project. If your label is missing, play it safe by washing in cold water on the gentle cycle and no dryer! Refer to Chapter 4 for guidelines of when to have it professionally cleaned.

The usual suspects

Depending on the style of the pullover and where you got it, you can expect some typical wear and tear trends. Check it over thoroughly in order to determine whether it's perfect, needs some repairs, or if it's just too much to salvage.



Always check for these common pullover flaws:

- ✓ Stains and other wear and tear on the cuffs
- ✓ Armpit stains
- ✓ Collar stains
- ✓ Spill stains. These are usually on the front of the pullover, but you also might find some around the hip area where someone might have a habit of wiping their hands (ew!!!)
- ✓ Fraying or torn hems at collar, cuff and bottom hem
- ✓ Torn underarm seam

Circumventing circumstantial stains and such

Stains and such flaws might be the downfall of your beloved pullover in its current state of affairs. But when reconstructing, these things serve as divine inspiration! Pullovers are very similar to T-shirts in regards to ways to fix up flaws. Refer to Chapter 4 for details and ideas on this.

Running Circles Around Crop Tops

I am a big fan of crop tops layered over longer, more tailored or snug-fit tops. They are also great over vintage slips and similar styled slim-fit and mid-length dresses. This allows for extra warmth and style without adding extra bulk to your mid-section.

All-Season Crop Top

The All-Season Crop is a basic cropped version of your existing pullover. I started making these as an active pedestrian in the cold Boston winter. Merely walking a few blocks on the snow-laden sidewalks was sometimes

a major hiking expedition! Such a workout while wearing my warm winter duds often resulted in a lovely “drowned rat” look by the time I finally made it to my destination. By cropping my sweater, I was able to easily take it off and tie it onto the straps of my bag. My other favorite option was to pull it over my head while leaving the sleeves on to form a sort of “shrug.”

This project is a cinch. All you have to do is cut your pullover short and finish the cut edge. Voila! You’re a reconstruction genius!

Check out the pullover prior to reconstruction in Figure 8-1.



Figure 8-1:
Before —
All-Season
Crop Top.

Materials

- ✓ Pullover
- ✓ Safety pins
- ✓ Common pins
- ✓ Tailor’s chalk (substitute with laundry marker)
- ✓ Tape measure
- ✓ Needle (for hand sewing) or sewing machine
- ✓ Thread that matches the pullover
- ✓ Scissors

Directions

- 1. Prep.** Wash and dry your pullover according to the label instructions, or have it professionally cleaned if there's no label.
- 2. Identify the cut line.** For most women, a flattering length for crops is 1 inch below the lowest border of the breast. Some men can pull off the cropped look as well, particularly with slim-fit pullovers. My personal preference for men is to go shorter, at least one inch above the nipple line, which sometimes requires the cut line to arch up from the under-arm seam. Refer to Figure 8-2. To help determine where your cut line should be, put the pullover on and mark the desired length with a safety pin. Take the pullover off. Add another inch to this length, moving the safety pin down an inch, in order to account for the hem.

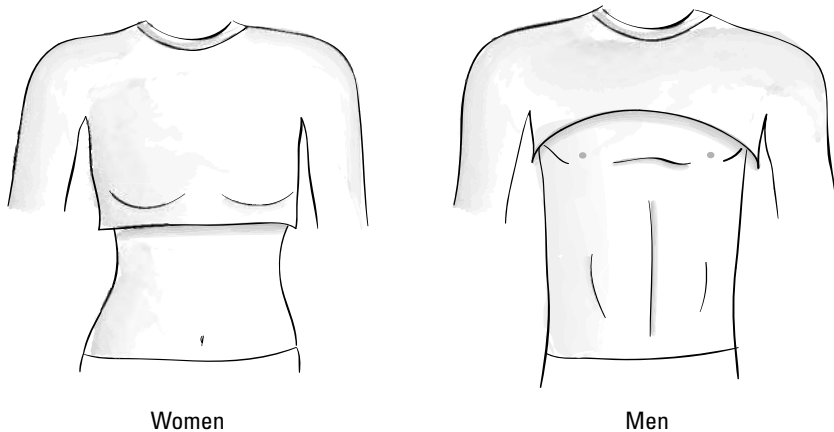

Figure 8-2:
Cut lines
for crops.



If you are unsure of how long to make your crop, err on the longer side. You can always cut off more fabric and make it shorter. However, if you cut it too short, it's not so easy to make it long again.

- 3. Mark the cut line.** Using your tape measure, measure the length from the bottom of the pullover to the safety pin. Note this length, and mark this point with tailor's chalk. Measure and mark the pullover every 5 inches along the bottom of the pullover. Connect the dots made by the tailor's chalk to draw a straight horizontal line.
- 4. Cut.** Cut the material along the line you just made with the tailor's chalk. Save your scrap for extra frill in the Upside-Down Skirt in a Topsy-Turvy World project in Chapter 6, or Quintessential Quilt pieces in Chapter 18.
- 5. Repair.** Refer to Chapter 4 to repair any tears, holes, and stains as needed.



6. **Sew, using the method below that matches your sewing method.** The instructions depend highly on whether you are hand sewing, machine sewing or using an overlock machine.

- **Sewing by hand — for a clean look:** Refer to Chapter 5 for hand-sewing techniques. Hem the cut edge using the quick hem technique.
- **Sewing by machine — for a rough look:** Cut $\frac{3}{4}$ inches off the bottom edge. Zigzag stitch the cut edge with a $\frac{1}{4}$ -inch seam allowance.
- **Sewing with an overlock — for a rougher look:** Cut $\frac{3}{4}$ inches off the bottom edge. Serge the cut edge with a $\frac{1}{4}$ -inch seam allowance.



Instead of sewing a finished hem, you can use no-sew hem tape. This tape is just ironed on! You can find it in your local fabric or craft store, online, or even in major supermarkets and department stores.

Check out the pullover after reconstruction in Figure 8-3.



Figure 8-3:
After —
All-Season
Crop Top.

Variations

For a decorative effect, try some of these ideas:

- ✓ **Raw look:** You can also get a rough look by cutting off the extra inch of fabric and blanket-stitching the cut edge.
- ✓ **Bias tape:** Instead of hemming the edge or leaving it raw, you can cover it with a decorative bias tape. This can be found in any sewing goods or fabric store, usually near the zippers in the Notions area. Bias tape comes in a variety of colors and can be either hand-sewn or machine-sewn on to cover the edge (instructions on package).



- ✓ **Flared edge:** When machine or overlock sewing, gently stretch the fabric as it is feeding into the machine for a flared edge.

It is important not to pull too hard when stretching the fabric or you will break a needle. This trick is for experienced sewers who are very familiar with the feeding of their machine. Refer to your sewing manual for tips on your machine's capacity to create this flared edge on its own (in other words, differential feeding mechanism on some overlock machines).

- ✓ **Thick stitches:** Complete all stitching by hand sewing with embroidery floss.
- ✓ **Thicker stitches:** Hand sewing over pre-sewn and secured edges with yarn or ribbon.
- ✓ **Mix colors:** Use a thread color that doesn't match, but complements the color of the pullover. With a sewing machine you can also use a different color for the bobbin thread. With an overlock machine, you can get really creative and use four to five different colors.
- ✓ **Stitching everywhere:** Decoratively stitch other areas of the crop, marking with tailor's chalk first if necessary. Decorative stitches include embroidery or deco-stitches on your machine
- ✓ **Buttons:** Sew decorative buttons onto the edge or neckline of the crop. This is a great way to make use of those odds and ends buttons. Keep within a color scheme, or within a certain style (art deco, fabric, glass, carved) for a complete look.
- ✓ **No-sew deco techniques:** You can leave the edge completely unstitched and raw. Running it through the washer and dryer will help the edges fray and bind together to complete the "unfinished" look. Some other no-sew ideas include creatively cutting the bottom edge, hot-gluing items (nonwashable), painting, grommets, riveting, bedazzling, dyeing, drawing with fabric markers or even a sharpie marker. Use a heat gun to seal raw edges (for synthetic fabrics), referring to the instructions on the heat gun project in Chapter 15. Make stripes on your crop with gaffer's or masking tape. Spray a light coat of spray paint over it, let dry and repeat until you get the desired color saturation. Remove the tape to reveal super-hot stripes!



Crop Inversion Top

The Crop Inversion project is a nice way to add some dimension and warmth to your crop. Essentially, the body of the pullover becomes a cowl neck. If your pullover is long, the neckline might even extend far enough to become a hood!

This project is just a bit more difficult than the All-Season Crop, taking just a wee little bit of measuring skill and patience to fit the neckline in just right.

Check out the pullover prior to reconstruction in Figure 8-4.



Figure 8-4:
Before —
Crop
Inversion
Top.

Materials

- ✓ Pullover that fits well
- ✓ Common pins
- ✓ Safety pins
- ✓ Tape measure
- ✓ Needle (for hand sewing) or sewing machine
- ✓ Thread that matches the pullover
- ✓ Tailor's chalk (substitute with laundry marker)
- ✓ Scissors

Directions

1. **Prep and then some!** Follow Steps 1 through 4 for the All-Season Crop project. Hold off on any repairs and save your scrap piece.
2. **Measure.** Using your tape measure, measure the circumference of the neckline. Measure the circumference of the scrap piece of the body. Refer to Figure 8-5.

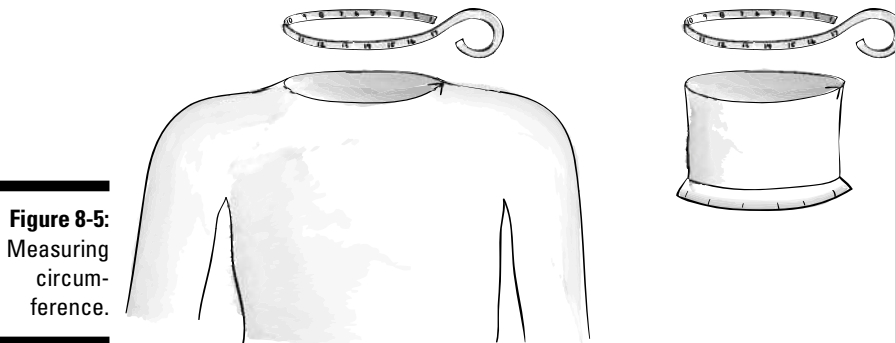

Figure 8-5:
Measuring
circum-
ference.

- 3. Design decision.** Can the body of the pullover fit into the neckline as it is? In other words, is the circumference measurement of the neckline equal to the circumference measurement of the body? Can the neckline be stretched to the circumference measurement of the body? If the answer is “no,” get out your scissors and follow Step 1 below. If the answer is “yes,” proceed to Step 2 below.



Always make the neckline bigger when you are starting with a turtleneck, mock turtleneck, or other neckline that fits tight to the base of your neck.

- 1. Cut.** Cut open the neckline by making it wider and lower in the front. Use Figure 8-6 as a guide.

Save this little scrap for From Garbage to Gorgeous in Chapter 20.

Be conservative! You can always cut more to make the neckline bigger, but if you cut too much you'll be stuck with an off-the-shoulder 80's version of the All Season Crop.

- 2. Turn it out.** Turn the pullover inside out. Keep the scrap piece from the body right side out.

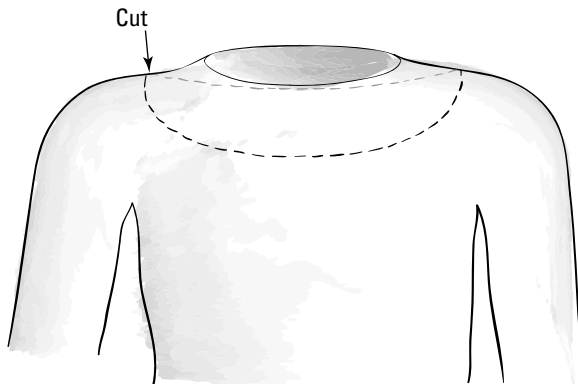

Figure 8-6:
Cutting a
wider
neckline.



4. **Finding centers.** Fold the neckline of the pullover in half, lining up the shoulder seams. The folds designate the center front and center back of the pullover. Fold the body of the pullover in the same manner, lining up the side seams. Mark the centers with tailor's chalk.

I like to mark the centers by putting a safety pin in at each folded edge. Just make sure to remove the safety pins before sewing!

5. **Line up.** Place the body inside the crop so that the right sides are facing each other. Line up the centers.
6. **Pin.** Pin the center front of the neckline to the center front of the body. Pin the center back of the neckline to the center back of the body. Refer to Figure 8-7 for a schematic of this process. Be sure to place pins perpendicular to the cut edge and continue pinning every 1 inch along the edge.

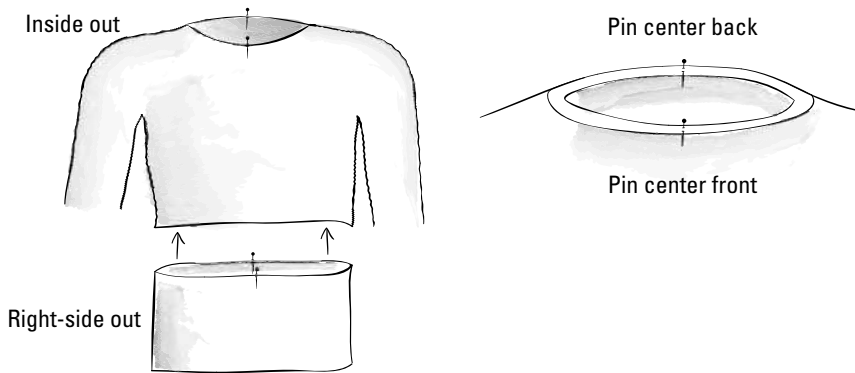

Figure 8-7:
Aligning
neckline
and body.

7. **Sew, using the method below that matches your sewing method.** The instructions depend highly on whether you are hand sewing, machine sewing or using an overlock machine.

- **Sewing by hand:** Refer to Chapter 5 for hand-sewing techniques. Blanket stitch the entire cut edge, attaching the neckline to the body. Hem the cut edge using the quick hem technique. Turn the crop right-side-out.
- **Sewing by machine:** Zigzag stitch the entire cut edge, attaching the neckline to the body. Hem the cut edge using the quick hem technique described in Chapter 5 (hand sewing). Turn the crop right-side out.

Use a zigzag as opposed to a straight stitch so that the neckline can stretch a bit.



- **Sewing with an overlock:** Serge the entire cut edge, attaching the neckline to the body. Hem the cut edge using the quick hem technique described in Chapter 5 (hand sewing.) Turn the crop right-side out.

In a pinch!

Okay, I know this is a little gross but it works. When marking spots that don't have to be exact, such as the neckline centers for the Crop Inversion, you can use what nature gave you, your saliva. Especially when folding edges like

this, it's easy and quick to just take the fabric between your teeth and wet it a bit to mark the spot. It's marked with both the wetness, which often darkens the fabric, and sometimes even holds the fold where you held it in your teeth.



- **No sew:** Instead of sewing a finished hem, you can use no-sew hem tape. This tape is just ironed on! You can find it in your local fabric or craft store, online, or even in major supermarkets and department stores.

8. Repair. Refer to Chapter 4 to repair any tears, holes, and stains as needed.

Check out the pullover after reconstruction in Figure 8-8.



Figure 8-8:
After —
Crop
Inversion
Top.

Variations

For a decorative effect, try some of these ideas:

- ✓ **Raw look:** For external seams, keep the pullover right side out in Step 5 and turn the body of the pullover inside out instead. Instead of finishing the edge with a hem, leave out this step and blanket stitch (hand sewing), zigzag stitch (machine sewing) or serge the edge (overlock) for a raw finish.



✔ **Bias tape:** Instead of hemming the edge or leaving it raw, you can cover it with a decorative bias tape. This can be found in any sewing goods or fabric store, usually near the zippers in the Notions area. Bias tape comes in a variety of colors and can be either hand-sewn or machine-sewn on to cover the edge (instructions on package).

✔ **Flared edge:** When machine or overlock sewing, gently stretch the fabric as it is feeding into the machine for a flared edge.

It is important not to pull too hard when stretching the fabric or you will break a needle. This trick is for experienced sewers who are very familiar with the feeding of their machine. Refer to your sewing manual for tips on your machine's capacity to create this flared edge on its own (as in, differential feeding mechanism on some overlock machines).

✔ **Thick stitches:** Complete all stitching by hand sewing with embroidery floss.

✔ **Thicker stitches:** Hand sewing over pre-sewn and secured edges with yarn or ribbon

✔ **Mix colors:** Use a thread color that doesn't match, but complements the color of the pullover. With a sewing machine you can also use a different color for the bobbin thread. With an overlock machine, you can get really creative and use four to five different colors.

✔ **Stitching everywhere:** Decoratively stitch other areas of the crop, marking with tailor's chalk first if necessary. Decorative stitches include embroidery or deco stitches on your machine

✔ **Buttons:** Sew decorative buttons onto the edge or neckline of the crop. This is a great way to make use of those odds and ends buttons. Keep within a color scheme, or within a certain style (art deco, fabric, glass, carved) for a complete look.



✔ **No-sew deco techniques:** You can leave the edge completely unstitched and raw. Running it through the washer and dryer will help the edges fray and bind together to complete the "unfinished" look. Some other no-sew ideas include creatively cutting the bottom edge, hot-gluing items (non-washable), painting, grommeting, riveting, bedazzling, dyeing, drawing with fabric markers or even a sharpie marker. Use a heat gun to seal raw edges (for synthetic fabrics), referring to the instructions on the heat gun project in Chapter 15. Make stripes on your crop with gaffer's or masking tape. Spray a light coat of spray paint over it, let dry and repeat until you get the desired color saturation. Remove the tape to reveal super-hot stripes!

Tails of Two Crops Top

This is a really fun top for those who prefer a little more flair in their wardrobe. It's also a fun piece to get creative with, both in its construction, as well as the various ways to wear it! The basic shape is cropped in the front, with the remaining fabric left dangling in the back for a bustling or tailed effect.

This project is fairly easy. It requires a lot of tedious finishing of edges, depending on how intricate your cut line is. Otherwise, the most difficult component of it is getting over the fear of screwing up the cut line.



You cannot screw up the creative process. Go for it and accept the result gracefully. If you hate it, you can always reconstruct it into something else!

Check out the pullover prior to reconstruction in Figure 8-9.



Figure 8-9:
Before —
Tails of Two
Crops.

Materials

- ✓ Pullover
- ✓ Common pins
- ✓ Safety pins
- ✓ Tape measure
- ✓ Needle (for hand sewing) or sewing machine
- ✓ Thread that matches the pullover
- ✓ Tailor's chalk (substitute with laundry marker)
- ✓ Scissors

Directions

- 1. Prep.** Wash and dry your pullover according to the label instructions, or have it professionally cleaned if there's no label.
- 2. Identify the cut line.** For most women, a flattering length for crops is 1 inch below the lowest border of the breast. To help determine where your cut line should be, put the pullover on and mark the desired length with a safety pin. Take the pullover off. Add another inch to this length, moving the safety pin down an inch, in order to account for the hem.



If you are unsure of how long to make your crop, err on the longer side. You can always cut off more fabric and make it shorter. However, if you cut it too short, it's not so easy to make it long again.

- 3. Mark the cut line on the front of the pullover.** Using your tape measure, measure the length from the bottom of the pullover to the safety pin. Note this length, and mark this point with tailor's chalk. Measure and mark the pullover every 5 inches along the bottom of the pullover. Do this only across the front of the pullover. Connect the dots made by the tailor's chalk to draw a straight horizontal line.
- 4. Mark the cut line on the back of the pullover.** Refer to Figure 8-10 for sample cut lines. Mark your desired cut line with your tailor's chalk.

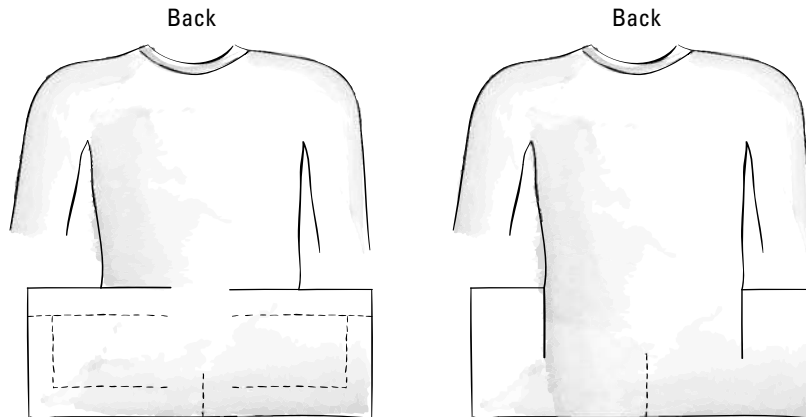

Figure 8-10:
Cut lines for
Tails of Two
Crops.

- 5. Cut.** Cut the material along the chalk line you just made with the tailor's chalk.

Save your scraps for the Bare and Flare Skirt in Chapter 11, or sew them onto your tails before finishing the edges to get more frills!



- 6. Repair.** Refer to Chapter 4 to repair any tears, holes and stains as needed

7. **Sew, using the method below that matches your sewing method.** The instructions depend highly on whether you are hand sewing, machine sewing or using an overlock machine.



- **Sewing by hand — for a clean look:** Refer to Chapter 5 for hand-sewing techniques. Hem the cut edge using the quick hem technique.
- **No sew:** Instead of sewing a finished hem, you can use no-sew hem tape. This tape is just ironed on! You can find it in your local fabric or craft store, online, or even in major supermarkets and department stores.
- **Sewing by machine — for a rough look:** Cut $\frac{3}{4}$ inches off the front bottom edge. Zigzag stitch the cut edge with a $\frac{1}{4}$ -inch seam allowance.
- **Sewing with an overlock — for a rougher look:** Cut $\frac{3}{4}$ inches off the front bottom edge. Serge the cut edge with a $\frac{1}{4}$ -inch seam allowance.

Check out in the pullover after reconstruction in Figure 8-11.



Figure 8-11:
After —
Tails of Two
Crops Top.

Variations

For a decorative effect, try some of these ideas:

- ✓ **Raw look:** You can also get a rough look by cutting off the extra inch of fabric on the front and blanket-stitching the cut edge.
- ✓ **Bias tape:** Instead of hemming the edge or leaving it raw, you can cover it with a decorative bias tape. This can be found in any sewing goods or fabric store, usually near the zippers in the Notions area. Bias tape comes in a variety of colors and can be either hand-sewn or machine-sewn on to cover the edge (instructions on package).



- ✓ **Flared edge:** When machine or overlock sewing, gently stretch the fabric as it is feeding into the machine for a flared edge.

It is important not to pull too hard when stretching the fabric or you will break a needle. This trick is for experienced sewers who are very familiar with the feeding of their machine. Refer to your sewing manual for tips on your machine's capacity to create this flared edge on its own (as in, differential feeding mechanism on some overlock machines).

- ✓ **Get creative with the cut line:** While Figure 8-10 gives you an idea for the cut line, feel free to experiment with your own ideas. Get creative with curves and other shapes, as well as the placement of the dangling tails of your pullover.
- ✓ **More frill:** Add more length and frill to your tails by adding scraps of material prior to finishing the edges.
- ✓ **Thick stitches:** Complete all stitching by hand sewing with embroidery floss.
- ✓ **Thicker stitches:** Hand sewing over pre-sewn and secured edges with yarn or ribbon.
- ✓ **Mix colors:** Use a thread color that doesn't match, but complements the color of the pullover. With a sewing machine you can also use a different color for the bobbin thread. With an overlock machine, you can get really creative and use four to five different colors.
- ✓ **Stitching everywhere:** Decoratively stitch other areas of the crop and along the tails, marking with tailor's chalk first if necessary. Decorative stitches include embroidery or deco stitches on your machine
- ✓ **Buttons:** Sew decorative buttons onto the edge, neckline or along the tails of the crop. Sewing them onto the tails will give a weight and fun swing to the motion of the tails. This is a great way to make use of those odds and ends buttons. Keep within a color scheme, or within a certain style (art deco, fabric, glass, carved) for a complete look.
- ✓ **No-sew deco techniques.** You can leave the edge completely unstitched and raw. Running it through the washer and dryer will help the edges fray and bind together to complete the "unfinished" look. Some other no-sew ideas include creatively cutting the bottom edge, hot-gluing items (nonwashable), painting, grommeting, riveting, bedazzling, dyeing, drawing with fabric markers or even a sharpie marker. Use a heat gun to seal raw edges (for synthetic fabrics), referring to the instructions on the heat gun project in Chapter 15. Make stripes on your crop with gaffer's or masking tape. Spray a light coat of spray paint over it, let dry and repeat until you get the desired color saturation. Remove the tape to reveal super-hot stripes!



How to wear it? There are many ways to wear your Tails of Two Crops. This depends highly on the cut pattern you have chosen. See Figure 8-12 for ideas, but feel free to experiment with your own as well.

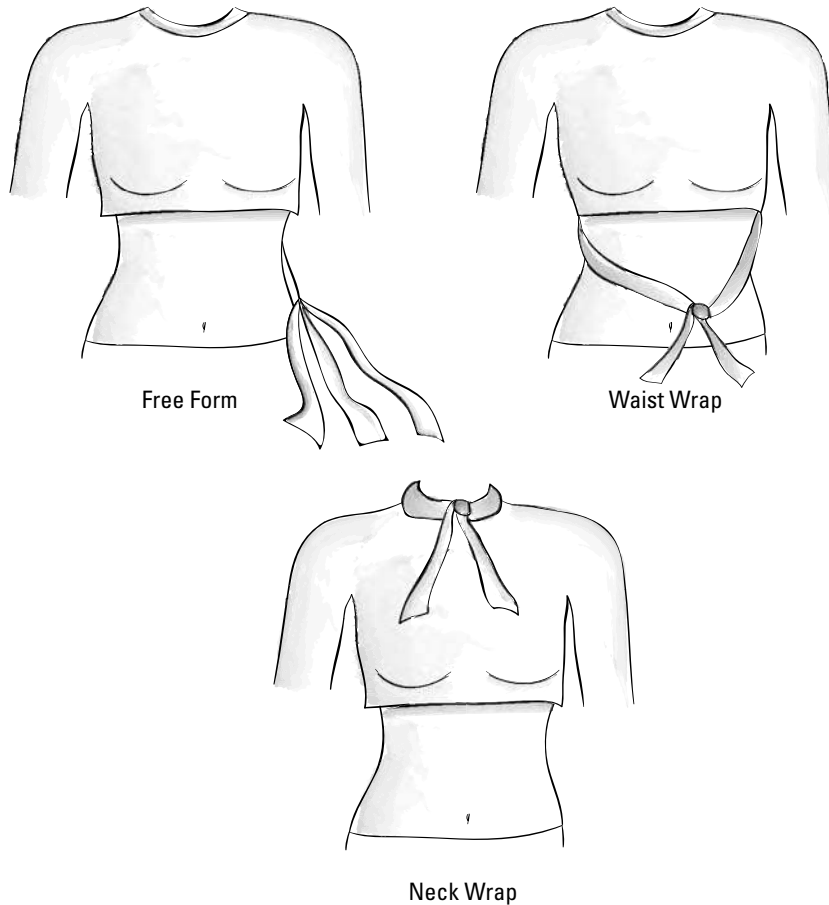

Figure 8-12:
How to
wear your
Tails of Two
Crops.

Wrap to Write Home About

Some pullovers, while great in so many ways, just get boring after a while. Turning your pullover into a wrap is a fantastic way to give it new life. Wraps are a wonderful way to spruce up an outfit, adding just a bit more warmth and coziness. Depending on the fabric and style of your original pullover, this can be a rather elegant piece suitable for a fancy dinner, or it can be casual enough for the gym.

This is a fairly easy project. It involves cutting some ties out of the front and finishing the edges. Simple as that!

Check out the pullover before reconstruction in Figure 8-13.



Figure 8-13:
Before —
Wrap to
Write Home
About.

Materials

- ✓ Pullover
- ✓ Common pins
- ✓ Tape measure
- ✓ Needle (for hand sewing) or sewing machine
- ✓ Thread that matches the T-shirt
- ✓ Scissors

Directions

1. **Prep.** Wash and dry your pullover according to the label instructions, or have it professionally cleaned if there's no label.
2. **Identify the center.** Fold your pullover in half lengthwise, aligning side seams and aligning shoulder seams at the neckline. The fold designates the center of the pullover. See Figure 8-14.

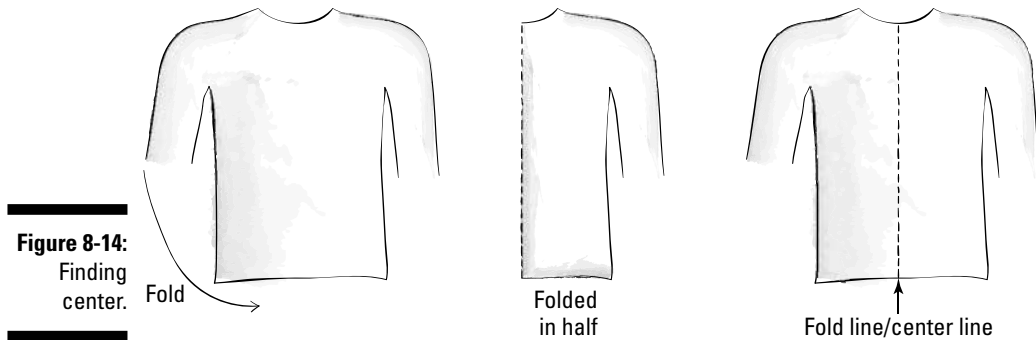

Figure 8-14:
Finding
center.

3. **Mark the cut line on the front of the pullover.** Using your tailor's chalk, draw a line down the center along the fold. Unfold the pullover and lie it flat as shown in the before photo for this project. Using your tape measure, measure a set of points two inches from the bottom and two inches from the center. Draw a straight line, one on each side of the center line, from the marked point to the side of the neckline. Refer to Figure 8-15.
4. **Cut.** Cut the material along the line you just made with the tailor's chalk.
5. **Repair.** Refer to Chapter 4 to repair any tears, holes, and stains as needed.
6. **Sew, using the method below that matches your sewing method.** The instructions depend highly on whether you are hand sewing, machine sewing or using an overlock machine:
 - **Sewing by hand — for a clean look:** Refer to Chapter 5 for hand-sewing techniques. Hem the cut edge using the quick hem technique.
 - **No sew:** Instead of sewing a finished hem, you can use no-sew hem tape. This tape is just ironed on! You can find it in your local fabric or craft store, online, or even in major supermarkets and department stores.
 - **Sewing by machine — for a rough look:** Cut $\frac{3}{4}$ inches off the front bottom edge. Zigzag stitch the cut edge with a $\frac{1}{4}$ -inch seam allowance.
 - **Sewing with an overlock — for a rougher look:** Cut $\frac{3}{4}$ inches off the front bottom edge. Serge the cut edge with a $\frac{1}{4}$ -inch seam allowance.



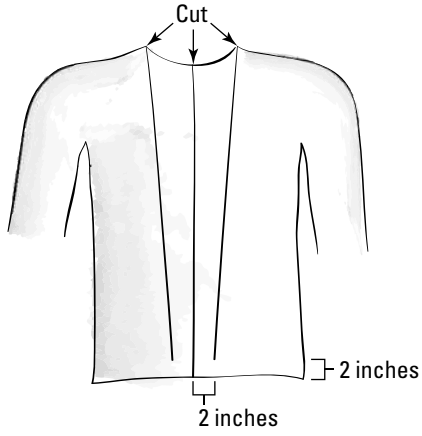

Figure 8-15:
Cut line.

Check out the pullover after reconstruction in Figure 8-16.



Figure 8-16:
After —
Wrap to
Write Home
About.

Variations

For a decorative effect, try some of these ideas:



- ✓ **Raw look:** You can also get a rough look by blanket-stitching the cut edge (refer to Chapter 5 for hand-sewing techniques).
- ✓ **Bias tape:** Instead of hemming the edge or leaving it raw, you can cover it with a decorative bias tape. This can be found in any sewing goods or fabric store, usually near the zippers in the Notions area. Bias tape comes in a variety of colors and can be either hand-sewn or machine-sewn on to cover the edge (instructions on package).
- ✓ **Flared edge:** When machine or overlock sewing, gently stretch the fabric as it is feeding into the machine for a flared edge.

It is important not to pull too hard when stretching the fabric or you will break a needle. This trick is for experienced sewers who are very familiar with the feeding of their machine. Refer to your sewing manual for tips on your machine's capacity to create this flared edge on its own (as in, differential feeding mechanism on some overlock machines).

- ✓ **Thick stitches:** Complete all stitching by hand sewing with embroidery floss.
- ✓ **Thicker stitches:** Hand sewing over pre-sewn and secured edges with yarn or ribbon.
- ✓ **Mix colors:** Use a thread color that doesn't match, but complements the color of the pullover. With a sewing machine you can also use a different color for the bobbin thread. With an overlock machine, you can get really creative and use four to five different colors.
- ✓ **Crop it:** Make a cropped version of this wrap! After Step 4, cut it as you would any of the crop projects in this chapter. Be sure to keep the front ties intact!
- ✓ **Stitching everywhere:** Decoratively stitch other areas of the wrap, marking with tailor's chalk first if necessary. Good ideas are along the cuffs, collar and front edges and along the ties. Decorative stitches include embroidery or deco stitches on your machine
- ✓ **Buttons:** Sew decorative buttons onto the front edges, neckline, and ties of the wrap. This is a great way to make use of those odds and ends buttons. Keep within a color scheme, or within a certain style (art deco, fabric, glass, carved) for a complete look.
- ✓ **No-sew deco techniques:** You can leave the edge completely unstitched and raw. Running it through the washer and dryer will help the edges fray and bind together to complete the "unfinished" look. Some other no-sew ideas include creatively cutting the bottom edge, hot-gluing



items (nonwashable), painting, grommeting, riveting, bedazzling, dyeing, drawing with fabric markers or even a sharpie marker. Use a heat gun to seal raw edges (for synthetic fabrics), referring to the instructions on the heat gun project in Chapter 15. Make stripes on your crop with gaffer's or masking tape. Spray a light coat of spray paint over it, let dry and repeat until you get the desired color saturation. Remove the tape to reveal super-hot stripes!

How to wear it? There are at least two ways to wear your Wrap To Write Home About. See Figure 8-17 for ideas, but feel free to experiment with your own as well.

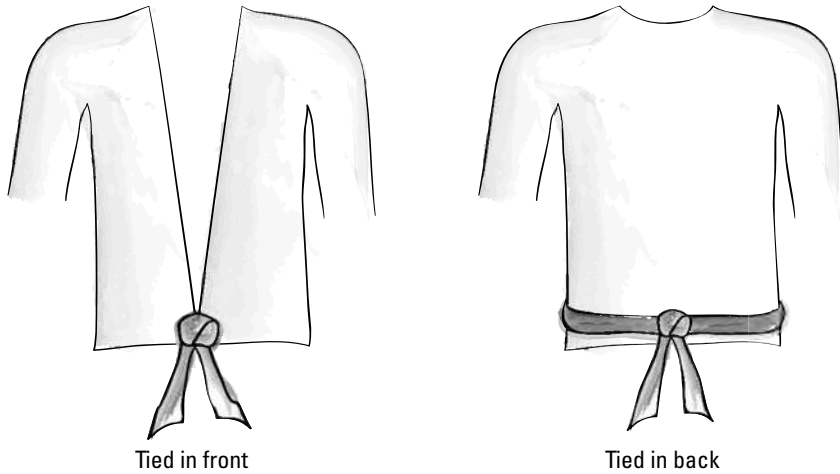

Figure 8-17:
How to
wear your
Wrap to
Write Home
About.

Part III

Breathing Life into Dead Pants

The 5th Wave

By Rich Tennant



"If it's any consolation, you hemmed the length on this leg perfectly."

In this part . . .

In Part III, I delve into the dilemma of old pants. Be it tears, bad pleats, or the workout pants you never wear . . . you can find the solution for these pant problems right here!

Do you have a tendency to work your butt off, or party it off for that matter? Your pants can have a second life with some quick repair tricks, or a full overhaul. You can find lots of options in these projects.

Chapter 9

Basic Slacks Brought Back

In This Chapter

- ▶ Caring for your pants
 - ▶ Watching out for pant problems
 - ▶ Exploring a plethora of projects
-

Pants get a lot of wear. Unfortunately, they're not so forgiving when it comes to wear and tear. While we can skin the knees of jeans and continue to wear them, slacks just can't swing it. But that doesn't mean their life is over just yet! The projects in this chapter range from creative repair, to a bevy of skirts to a combo piece that will bust your mind wide open!

Prepping, Primping, and Post Care for Your Pants

Pants vary widely in their fabric content. Check the laundering label and wash prior to your project. If your label is missing, refer to Chapter 4 for guidelines of when to have it professionally cleaned, and when it might be safe to just gently wash it in cold water and dry flat (no dryer).

The usual suspects

The biggest flaw for pants is often the fit and style, particularly in the waist. Start with pants that fit well, and use those that don't for the Detachable Bustle and Surprise Fly Top, as well as for the extra fabric for the So Easy Split Skirt. All of these projects can be found later in this chapter.



Always check for these common flaws in pants:

- ✓ Torn inseam (crotch), rear end and knees
- ✓ Stains and other wear and tear on the cuffs
- ✓ Stains on the knees and rear end (be sure to check inside too)
- ✓ Broken zipper, missing snap, button or other closure
- ✓ Bad pleats. Yes, this is a flaw in my book!

Wearing to watch out for

Refer to Chapter 4 for ways to make the wear and tear work for you. Some pants do well with just a bit of patching and decorative stitching, such as discussed in Renaissance Repairs. Others, particularly those with issues in the rear end, are best left for scrap additions for other projects such as those discussed in Part VI.

Renaissance Repairs Pants

I can't even begin to count the number of people who have come to me, sometimes near tears, telling me about how much they love a certain pair of pants but have worn them to the point of mutilation, Velveteen Rabbit-style.

This project can be difficult depending on the location of the worn spot. It is important to realize that this is a visible repair job turned decorative.

Check out the pants prior to reconstruction in Figure 9-1.

Materials

- ✓ Pants
- ✓ Stretchy fabric large enough to cover the tear and/or worn spot
- ✓ Common pins
- ✓ Needle (for hand sewing) or sewing machine
- ✓ Thread that matches the pants
- ✓ Scissors



Figure 9-1:
Before —
Renaissance
Repairs
Pants.

Directions

- 1. Prep.** Wash and dry your pants according to the label instructions, or have them professionally cleaned if there's no label. Turn the pants inside-out and lie flat so that the worn spot is fully visible.
- 2. Cut.** Cut a patch of stretchy fabric to completely cover the tear and/or worn spot. It should be at least an inch larger than any visible tear.

It's best to orient the fabric to stretch along the stress lines of the pants. Typically this is lengthwise at the knee and widthwise at the rear end.
- 3. Pin.** Pin the patch into place. Place pins diagonally at each corner and perpendicular to the edge every $\frac{1}{2}$ inch.
- 4. Hand sew for security.** Refer to Chapter 5 for hand-sewing techniques. Using a hand-sewing needle and matching thread, sew a running stitch along the edge of the patch as well as along the edge of the tear or perimeter of the worn area. Turn the pants right side out.
- 5. Decorative sewing using the method below that matches your sewing method.** The instructions depend on whether you are hand sewing or machine sewing. An overlock machine is not useful for this project.
 - **Sewing by hand:** Refer to Chapter 5 for hand-sewing techniques. Use any of these techniques to decoratively sew around the patch, while extending the stitching pattern beyond the patch and throughout the pants. You can even sew a faux patch in another area to disguise the repair work. Refer to Figure 9-2 for ideas.



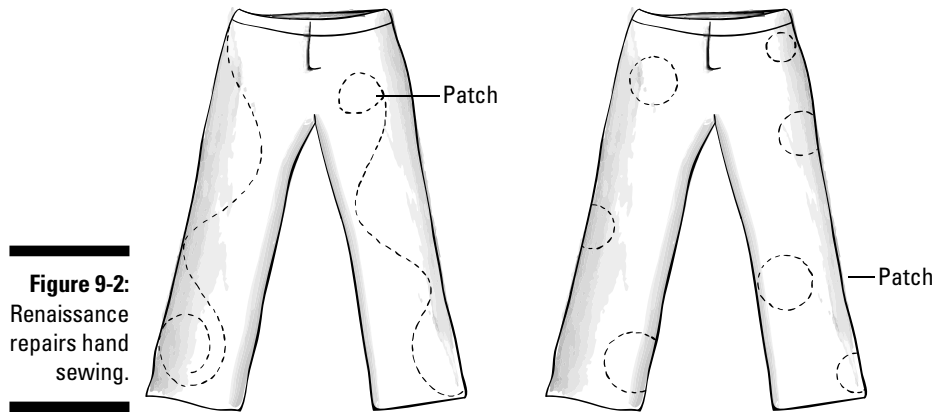

Figure 9-2:
Renaissance
repairs hand
sewing.

- **Sewing by machine:** Use any stitch you like to decoratively sew around the patch, while extending the stitching pattern beyond the patch and throughout the pants. You can even sew a faux patch in another area to disguise the repair work. See Figure 9-3.

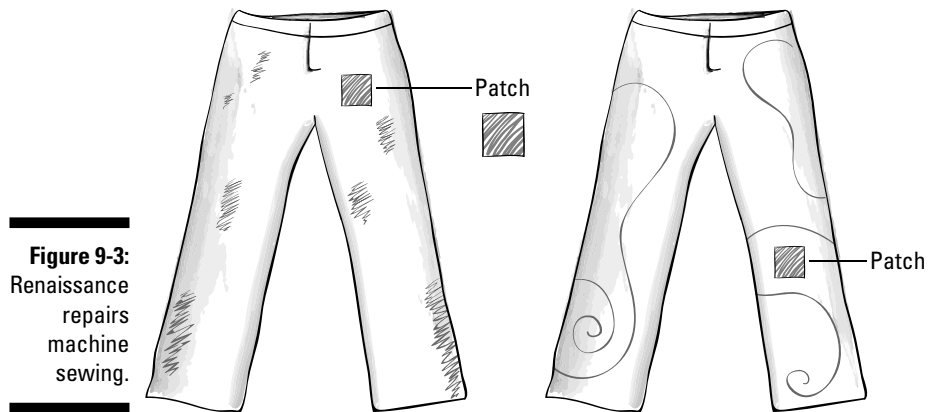

Figure 9-3:
Renaissance
repairs
machine
sewing.

Check out the pants after reconstruction in Figure 9-4.



Figure 9-4:
After —
Renaissance
Repairs
Pants.

Skirts and Such

I'm a huge fan of skirts. They are comfortable, easy to wear, fun to layer and they always look “dressed up” no matter how scruffy they are!

So Easy Split Skirt

The only bad thing about skirts is the stigma against men wearing them. With this in mind, I made a version of the So Easy Split Skirt using men's pants. While the barrier hasn't been totally broken, it's enough for more adventurous men to make the plunge. They look simply *gorgeous*.

This project easy. You just cut the inseam of two pairs of pants, using one for the base and the other for filler. Sew them together and you're done!

Check out the two pairs of pants prior to reconstruction in Figure 9-5 and 9-6.



Figure 9-5:
Base pants
before —
So Easy
Split Skirt.



Figure 9-6:
Insert pants
before —
So Easy
Split Skirt.

Materials

- ✓ Pants that fit well in the waist
- ✓ Pants of a complementary color/style (don't need to fit well)
- ✓ Common pins
- ✓ Tape measure
- ✓ Needle (for hand sewing) or sewing machine
- ✓ Thread that matches the pants

- ✓ Tailor's chalk (substitute with laundry marker)
- ✓ Seam ripper
- ✓ Scissors

Directions

1. **Prep.** Wash and dry your pants according to the label instructions, or have them professionally cleaned if there's no label.
2. **Locate the inseams.** Refer to Figure 9-7 to locate the inseam.

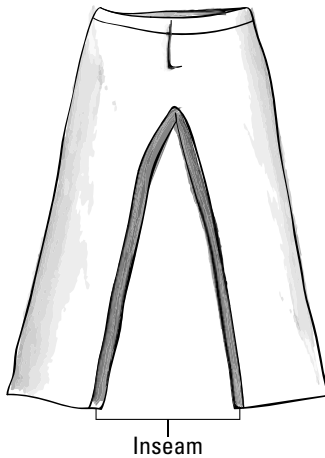

Figure 9-7:
Locating the
inseams.



3. **Rip it.** Using your seam ripper, rip open the inseams of both pairs of pants. Also rip open or cut off any cuffs on the pants.

Save your cuff scraps for Save-It-All Stuffing in Chapter 18.

4. **Marking the cut line.** Using the pair of pants that will become the scrap fabric, fold them in half and lie them flat as shown in Figure 9-8. Using your tape measure as a straight edge, and your tailor's chalk, draw a line perpendicular to the length of the pants (parallel to the cuff) at the height of the crotch. Using the pair of pants that will become your base skirt, also fold them in half and lie them flat. Using your tape measure as a straight edge, and your tailor's chalk, draw a line from a point 1 inch below the base of the zipper to the corner of the cuff. Draw a similar line on the back side, from the back seam before it starts to curve out, to the bottom cuff.

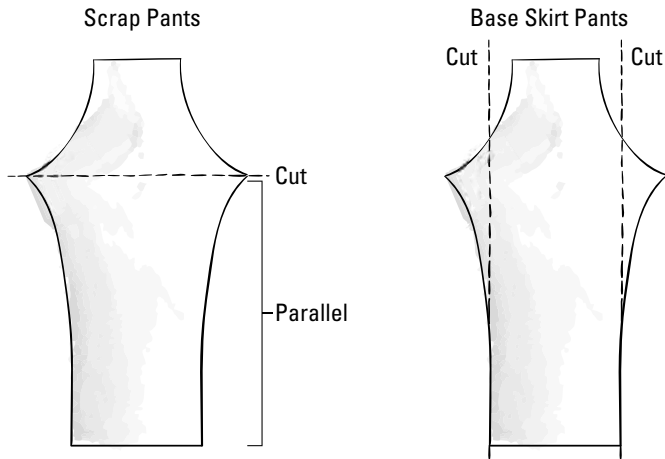

Figure 9-8:
Marking cut lines.



- 5. Cut and turn.** Keeping both pairs of pants folded, cut through both layers along the lines you just made. Turn both pairs of pants inside-out.

Save your waist scraps for the Surprise Fly Top later in this chapter.

- 6. Align and pin.** Line up the bottom cuff corner of a scrap pant leg with the wedge-shape (formerly the inseam) beneath the zipper of the base pants/skirt. With right sides facing each other, pin the cuff edge to one side of the wedge, and the long pant-leg length edge to the other. Place pins perpendicular to the edge every 1 inch. Repeat with the backside and remaining pant-leg. Refer to Figure 9-9.

- 7. Repair.** Refer to Chapter 4 to repair any tears, holes, and stains as needed.

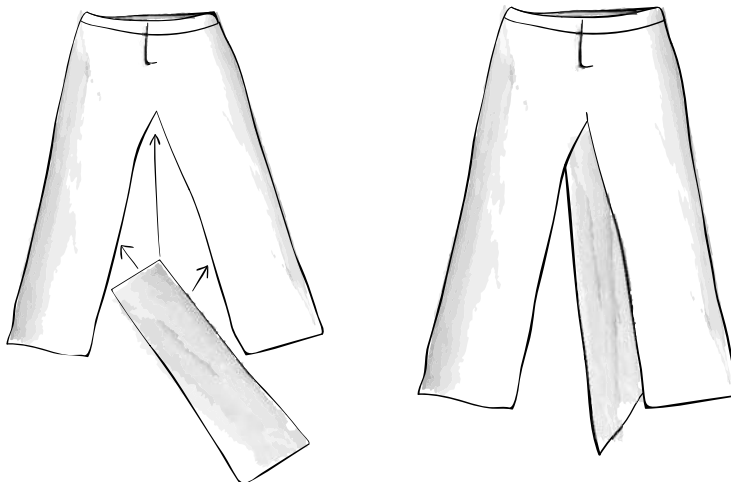

Figure 9-9:
Lining up
and pinning.

8. **Sew, using the method below that matches your sewing method.** The instructions depend highly on whether you are hand sewing, machine sewing or using an overlock machine.

- **Sewing by hand:** Refer to Chapter 5 for hand-sewing techniques. Blanket stitch the pinned seams. Hem the edge using the quick hem technique.
- **Sewing by machine:** Straight stitch the pinned seams with a ½-inch seam allowance. Hem the edge by hand using a quick hem technique described in Chapter 5.
- **Sewing with an overlock:** Serge the pinned seams, removing the pins before running it through the overlock. Hem the edge by hand using a quick hem technique described in Chapter 5.
- **No sew:** Instead of sewing a finished hem, you can use no-sew hem tape. This tape is just ironed on! You can find it in your local fabric or craft store, online, or even in major supermarkets and department stores.



Check out the pants after reconstruction in Figure 9-10.



Figure 9-10:
After —
So Easy
Split Skirt.

Variations

For a decorative effect, try some of these ideas:

- ✓ **Raw look:** For external seams, keep the pants right-side-out in Step 5. Instead of finishing the edge with a hem, leave out this step and blanket stitch (hand sewing), zigzag stitch (machine sewing) or serge the edge (overlock) for a raw finish.

- ✔ **Bias tape:** Instead of hemming the edge or leaving it raw, you can cover it with a decorative bias tape. This can be found in any sewing goods or fabric store, usually near the zippers in the Notions area. Bias tape comes in a variety of colors and can be either hand-sewn or machine-sewn on to cover the edge (instructions on package).
- ✔ **Thick stitches:** Complete all stitching by hand sewing with embroidery floss.
- ✔ **Thicker stitches:** Hand sewing over pre-sewn and secured edges with yarn or ribbon
- ✔ **Mix colors:** Use a thread color that doesn't match, but complements the color of the pants. With a sewing machine you can also use a different color for the bobbin thread. With an overlock machine, you can get really creative and use four to five different colors.

Detachable Bustle Skirt

The Detachable Bustle is a more traditional yet functional version of the bustle. I just love the giggle when people try these on. There is some tedious finishing work on this project, but otherwise it's moderately easy. You just cut the pants away from the front waistband, add fabric, and bustle it all.

Check out the pants prior to reconstruction in Figure 9-11.



Figure 9-11:
Before —
Detachable
Bustle Skirt.

Materials

- ✓ Pants with a waistband that fits
- ✓ Scrap fabric of complementary colors and/or 1 yard of tulle/netting
- ✓ Common pins
- ✓ Safety pins
- ✓ Tape measure
- ✓ Needle (for hand sewing) or sewing machine
- ✓ Thread that matches the pants
- ✓ Tailor's chalk (substitute with laundry marker)
- ✓ Scissors

Directions

1. **Prep.** Wash and dry your pants according to the label instructions, or have it professionally cleaned if there's no label.
2. **Mark the first cut line.** Locate the seam of the waistband with the body of the pants. Using your tape measure, measure 1½ inches from the seam into the body of the pants. This measure may be made longer in order to avoid cutting through belt loops.
3. **Mark this point with your tailor's chalk.** Repeat this measurement on the front half of the pants every 1–2 inches around the waistband in order to mark an even cut line. Connect the dots with your tailor's chalk. Refer to Figure 9-12.



If your pants do not have a waistband, draw a line such as described in Step 2, 2 inches below the button or other closure. If your pants have no closure (elastic or drawstring waist), draw a line 1.5 inches below the band holding the elastic or drawstring. For any other type of pant, a safe bet is to draw a line 4 inches from the top border of the waist.

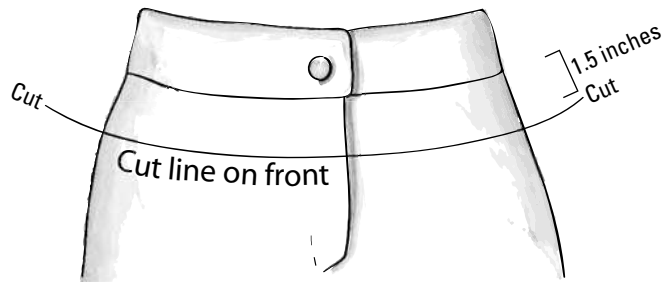
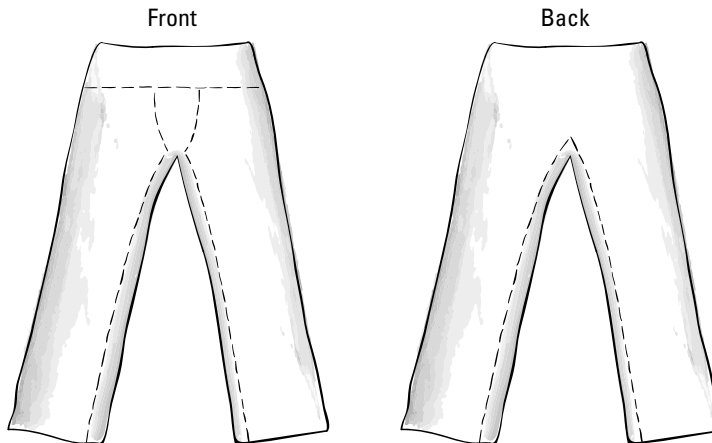

Figure 9-12:
First cut
line.

4. **Cut and trim.** Cut the fabric along the cut line you just made on the front half of the pants. Cut around the top of the zipper, removing it from the waistband portion. For the lower portion, the body of the pants, cut out the fly completely and open the inseams from crotch to cuff. Cut the thick inseams and cuffs off of the pants. Refer to Figure 9-13.

Figure 9-13:
Cut and trim your detachable bustle.



5. **Mark the second cut line.** Using your tape measure, measure the width of the cuff. Divide this number by three to get the width of the strips you will be marking along the pant legs. Using your tailor's chalk, mark the cuff at these points. Measure the width of the pant-leg at the height of the crotch. Repeat the same division by three and marking. Repeat this entire step on the other pant leg. Draw two lines on each pant leg, connecting the cuff dots to the dots at crotch height. Refer to Figure 9-14.

Figure 9-14:
Second cut line.

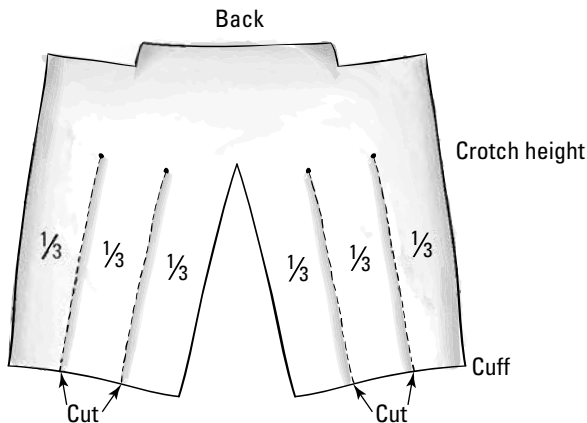

6. **Cut.** Cut the fabric along the cut lines you just made. If you are using scrap fabric as filler, cut it in similar width strips. Tulle and/or netting do not need to be cut!
7. **Repair.** Refer to Chapter 4 to repair any tears, holes, and stains as needed.
8. **Sew.** Hem the cut edges by hand using a slant hem technique described in Chapter 5. Do this for any scrap fabric you are using as well. Tulle and/or netting do not need to be hemmed. Alternatives for a rough edge are hand sewing a blanket stitch, machine sewing a zigzag stitch, or serging the cut edges with an overlock machine.



Instead of finishing the cut edge with sewing, you can use no-sew hem tape. This tape is just ironed on! You can find it in your local fabric or craft store, online, or even in major supermarkets and department stores.

9. **Pinning with scrap fabric.** Lie the pants flat, with the back on top. Arrange the scrap pieces lengthwise, with half of the length of each piece above the waistband, and half below, so that the center point of the length lies on the waistband. Arrange them evenly, overlapping as necessary along the back of the waistband. Using common pins, pin the scrap fabric to the waistband, placing pins perpendicular to the waistband every inch. Refer to Figure 9-15.



Be sure to keep roughly the same thickness of fabrics along the waistband, especially if you are machine sewing. It is best to use lightweight scrap fabrics in order to make this easier.

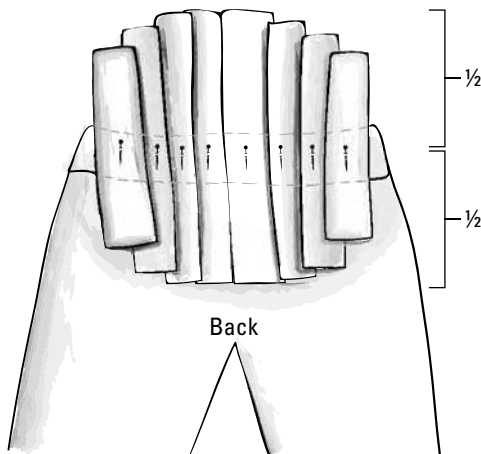

Figure 9-15:
Pinning your
bustle with
scrap fabric.

- 10. Pinning with tulle/netting.** Lie the pants flat, with the back on top. Arrange the tulle/netting lengthwise, with a $\frac{1}{2}$ yard above the waistband, and $\frac{1}{2}$ below, so that the center point of the length lies on the waistband. Pin the side edges of the tulle/netting 3 inches in from the side seams. Gather the width of the tulle/netting evenly and pin to the waistband, placing pins perpendicular to the waistband every inch. Refer to Figure 9-16.



Instead of pinning with common pins, pin with safety pins so that you can try the bustle on. Dance, jump, wiggle, and do whatever you need to do to see if it moves well and looks good!

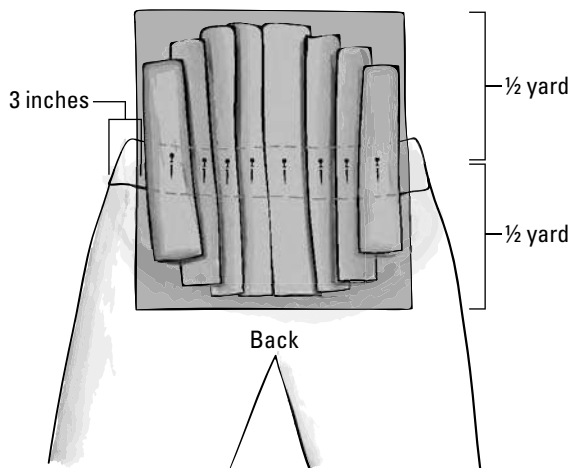

Figure 9-16:
Pinning your
bustle with
tulle/netting.

- 11. Pin the pant-leg strips.** With the pants still lying flat, fold the pant-leg strips back up to the waistband. Pin the outermost strips to the waistband with 5–10 inches of the strip lying above the waistband. Pin the center two strips to the waistband at the cuff edge. Place pins perpendicular to the waistband every 1 inch.
- 12. Sew, using the method below that matches your sewing method.** The instructions depend highly on whether you are hand sewing or machine sewing. An overlock is not appropriate.
- **Sewing by hand:** Refer to Chapter 5 for hand-sewing techniques. Running stitch along the waistband to secure the strips of fabric, tulle and/or netting to the waistband.
 - **Sewing by machine:** Refer to your sewing manual for instructions on sewing multiple thicknesses. Straight stitch along the waistband to secure the strips of fabric, tulle and/or netting to the waistband.

Check out the pants after reconstruction in Figure 9-17.



Figure 9-17:
After —
Detachable
Bustle Skirt.

Surprise Fly Top

Apparently there's something unusual about one's head coming out of the waist of a pair of pants! This is a great project to make use of those pants you love but they just don't fit right, simply paired with just about any shirt that fits well.

The construction of this project is similar to the Crop Inversion in Chapter 8, taking a bit of measuring skill and patience to fit the neckline just right.

Check out the pants and pullover prior to reconstruction in Figure 9-18 and 9-19.



Figure 9-18:
Pants
before —
Surprise
Fly Top.



Figure 9-19:
Pullover
before —
Surprise
Fly Top.

Materials

- ✓ Pants
- ✓ Pullover that fits well
- ✓ Common pins
- ✓ Safety pins
- ✓ Tape measure
- ✓ Needle (for hand sewing) or sewing machine
- ✓ Thread that matches the pullover
- ✓ Tailor's chalk (substitute with laundry marker)
- ✓ Scissors

Directions

1. **Prep.** Wash and dry your pants and pullover according to the label instructions, or have them professionally cleaned if there's no label.
2. **Marking the cut line.** Fold the pants in half, hip to hip, and lie them flat. Using your tape measure as a straight edge and your tailor's chalk, draw a horizontal line (parallel with the waistband) 2 inches above the crotch. Refer to Figure 9-20.

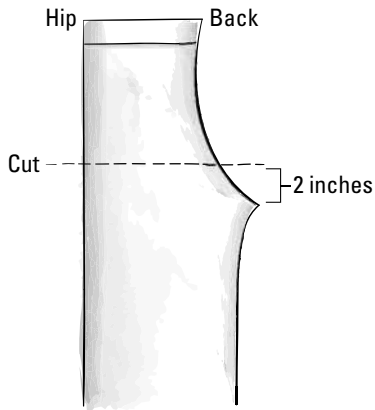

Figure 9-20:
Marking the
cut line.



Be sure to avoid cutting through any pockets.

- 3. Cut.** Cut through all four thicknesses along the line you just made with your tailor's chalk. Open the pants up and make the cut line even by cutting off any angular points made by the curve of the crotch seam.

Save the scrap pant legs to make a Pragmatic Potholder in Chapter 19.



- 4. Measure.** Using your tape measure, measure the circumference of the piece you just cut. Also measure the circumference of the neckline of the pullover. Refer to Figure 9-21.

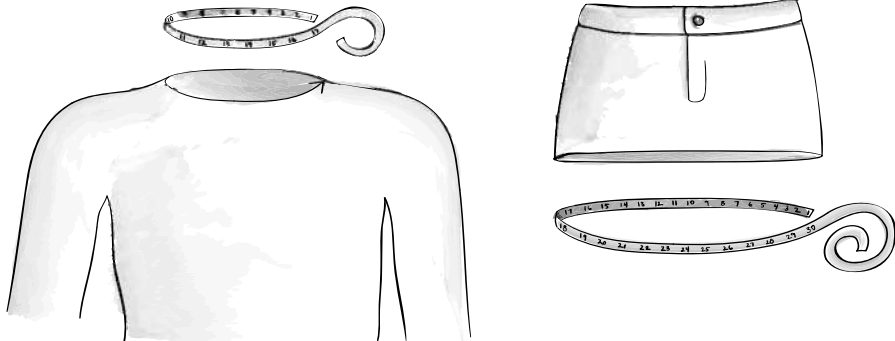

Figure 9-21:
Measuring circum-
ference.

- 5. Design decision.** Can the cut edge of the pants fit into the neckline? Can the neckline be stretched to fit the circumference of the pants? If the answer is “no,” see Step 1 below. If “yes,” see Step 2 below.

- 1. Cut and turn.** Cut open the neckline by making it wider and lower in the front. See Figure 9-22. Turn the pullover inside out.

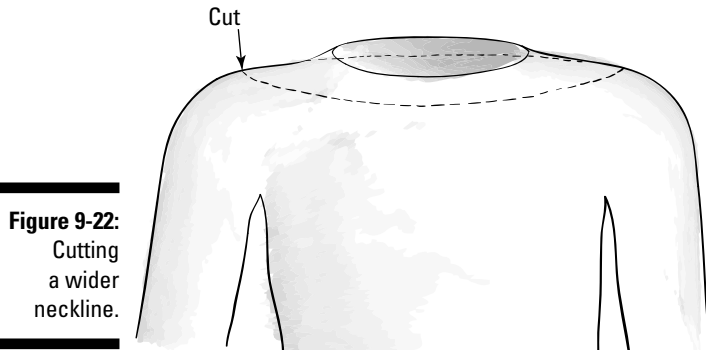

Figure 9-22:
Cutting
a wider
neckline.



Be conservative! You can always cut more to make the neckline bigger.

- 2. Line up.** Place the pants inside the crop so that the right sides are facing each other. I like to have the fly (center front of pants) a few inches off to the side as shown in Figure 9-23, but you can choose to align this wherever you like.
- 6. Pin.** Pin the cut edge of the pants evenly into the neckline, placing pins perpendicular to the cut edge every 1 inch.

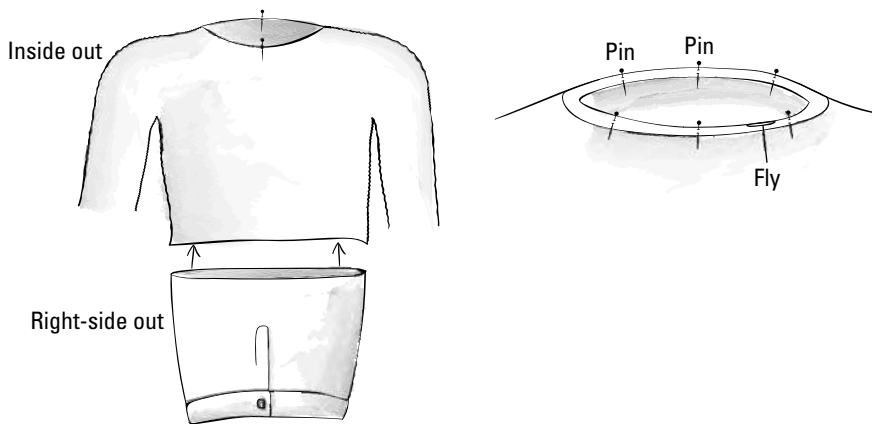

Figure 9-23:
Aligning and
pinning the
neckline.

7. **Repair.** Refer to Chapter 4 to repair any tears, holes, and stains as needed.
8. **Sew, using the method below that matches your sewing method.** The instructions depend highly on whether you are hand sewing, machine sewing or using an overlock machine. Turn the top right-side out when you are done.
 - **Sewing by hand:** Refer to Chapter 5 for hand-sewing techniques. Blanket stitch the entire cut edge, attaching the neckline to the pants/collar.
 - **Sewing by machine:** Zigzag stitch the entire cut edge, attaching the neckline to the pants/collar.
 - **Sewing with an overlock:** Serge the entire cut edge, attaching the neckline to the pants/collar.

Check out the pants and pullover after reconstruction in Figure 9-24.



Figure 9-24:
After —
Surprise
Fly Top.

Variations

For a decorative effect, try some of these ideas:

- ✓ **Raw look:** For external seams, instead of turning the pullover inside out, turn the pants inside out. This will result in an external raw seam at the neck.
- ✓ **Thick, thicker, mixed:** Refer to the “Variations” section for the first project in this chapter for ideas on these deco stitching techniques.

Chapter 10

Regenerating Jeans

In This Chapter

- ▶ Caring for your jeans
 - ▶ Finding flaws and pitfalls
 - ▶ Laying new looks on your jeans
-

What would life be like without our tried and true denim friend? Jeans are a wardrobe staple in most closets. Sturdier than slacks, they hang on through tougher times. But when they finally go it tends to be in a dramatic fashion. At one time, ripped jeans were “in.” Even *I* was known to layer leggings or boxers under a pair of dilapidated denims with a big old hole in the butt! No more!

I’ve had many people come to me, jeans in hand, with a desperate look on their face, wondering whether can anything be done. This is usually followed by an embarrassing story of how their trusty jeans finally “went.” Thankfully something can be done, lots of things actually. But if you want to save your jeans before the breaking point, check out the Repetition Editions project in this chapter. Beyond that, you still have many options to convert your jeans into a variety of items, none of which involve your rear-end or knees exposed to the elements!

Prepping, Primping, and Post Care for Your Jeans

In reconstructing jeans you will likely be dealing with jeans that have already been washed and dried, and therefore any potential shrinking is minimal. A regular wash cycle and dryer is typically fine for jeans. However, some jeans may have some stretch to them, detail work, or other adornments that would render special attention. Therefore, always check the laundering label to wash your jeans prior to your reconstruction project. If your label is missing, refer to Chapter 4 for guidelines of when to have it professionally cleaned, and when it might be safe to just gentle wash it in cold water and dry flat (no dryer).

The usual suspects

Based on your project of choice, different flaws may be ok or not. Some projects, such as the Oh-So-Hip Hip Belt cut off the entire pant legs, while others make use of every last bit of the jeans. Review the list below to figure out where to begin and what hurdles you may have to jump over before embarking on your reconstruction project.



Always check for these common flaws in jeans:

- ✓ Torn or worn rear end, fly and knees
- ✓ Stains and other wear and tear on the cuffs
- ✓ Stains on the knees and rear end
- ✓ Broken zipper
- ✓ Torn belt loop
- ✓ Holes in pockets (or other forgotten goodies)

Potential pitfalls to prepare for

Denim, the fabric that jeans are made from, is thick. Even just two layers are difficult to sew through. When sewing through an existing seam it's even more difficult, if not impossible. When working with these or other jean reconstruction projects, try to arrange the fabric so that you have minimal layers to sew through. For example, don't line up two seams so that you have to sew through four or more layers at a time! Be sure to use a thimble if you are hand sewing, and needles of appropriate thickness. Don't push or pull fabric through the machine. In general, be gentle with yourself and your machine.



Don't be afraid to ask questions, especially when shopping for needles. It can be confusing, especially with machine needles. In looking at them with the naked eye they don't seem all that different, but they are! Having the right needle will save you a world of trouble in the end. Make sure you have several needles on-hand with these projects as the likelihood is great that you will break at least one!

Repetition Editions Jeans

This project is a “repetition” of “Renaissance Repairs” in Chapter 9, with special instructions for denim. Blow-outs are part of the life expectancy of any pair of jeans. Ideally you can use this technique before the full blow-out and save yourself a lot of effort and embarrassment.

This project can be somewhat difficult depending on where the tear and/or worn spot is located. Blowouts in the crotch area are rather difficult, sometimes requiring multiple patches. It is important to realize that this is a *visible* repair job with a decorative twist.

Check out the jeans prior to reconstruction in Figure 10-1.



Figure 10-1:
Before —
Repetition
Editions
Jeans.

Materials

- ✓ Jeans
- ✓ Stretchy fabric scrap large enough to cover the tear and/or worn spot
- ✓ Common pins
- ✓ Needle (for hand sewing) or sewing machine
- ✓ Thread that matches the jeans, or complements decoratively
- ✓ Scissors

Directions

1. **Prep.** Wash and dry your jeans according to the label instructions, or gentle wash and dry flat if there's no label.
2. **Turn it out.** Turn the jeans inside out. Lie them flat so that the tear or worn area is fully visible.



- 3. Cut.** Cut a patch of stretchy fabric to completely cover the tear and/or worn spot. It should be at least an inch larger than any visible tear, worn or threadbare areas. Being sure to cover any threadbare areas will save you the trouble of repairing yet another denim blow-out in the future.

It is best to orient the fabric with the stretch running along the stress lines of the jeans. Typically this is perpendicular to the tear, and lengthwise at the knee and widthwise at the rear end.

- 4. Pin.** Pin the patch to the denim. Place pins perpendicular to the edge of the patch, and thus, perpendicular to the stitch line in Step 3.
- 5. Hand sew for security.** Refer to Chapter 5 for hand-sewing techniques. Using a hand-sewing needle and matching thread, running stitch along the edge of the patch as well as along the edge of the tear or perimeter of the worn area.
- 6. Turn it out.** Turn the jeans right side out. Remove the common pins.
- 7. Decorative sewing using the method below that matches your sewing method.** The instructions depend on whether you are hand sewing or machine sewing. An overlock machine is not appropriate for this project.

- **Sewing by hand:** Refer to Chapter 5 for hand-sewing techniques. Use any of these techniques to decoratively sew around the patch, while extending the stitching pattern beyond the patch and throughout the jeans. You can even sew a faux patch in another area to disguise the repair work. Refer to Figure 9-2 in Chapter 9 for ideas.
- **Sewing by machine:** Use any stitch you like to decoratively sew around the patch, while extending the stitching pattern beyond the patch and throughout the jeans. You can even sew a faux patch in another area to disguise the repair work. Refer to Figure 9-3 in the Chapter 9 for ideas.



This is a decorative stitch and therefore should be visible. Use a contrasting but complementary color thread when completing the decorative part of this project.

Check out the jeans after reconstruction in Figure 10-2.



Figure 10-2:
After —
Repetition
Editions
Jeans.

Oh-So-Hip Hip Belt

One thing that is great about jeans is their ability to go with almost anything! This is why it makes a perfect transition into an accessory. Hip belts, which are simply the waistband of the jeans with the pockets still attached, combine function and style in a way that “fanny packs” never quite achieved. It might just have been the name. Who really wants to pack their fanny? But a hip reconstructed hip belt is whole different story!

This project easy. I've kept the instructions for a rough look because sewing through multiple layers of denim, especially around all the seams of the waistband is not only difficult on you, but on your machine as well. I also find that finishing jeans with a clean edge just plain looks funny! So for this project, you just cut the waistband of the jeans, keeping the pockets you want attached and cutting off the pockets you don't want! Leave it raw (no sew!) or finish with a rough stitching technique as described.

Check out the jeans prior to reconstruction in Figure 10-3.



Figure 10-3:
Before —
Oh-So-Hip
Hip Belt.

Materials

- ✓ Jeans with a waistband that fits on your hips
- ✓ Common pins
- ✓ Tape measure
- ✓ Needle (for hand sewing) or sewing machine
- ✓ Thread that matches the jeans
- ✓ Tailor's chalk (substitute with laundry marker)
- ✓ Scissors

Directions

1. **Prep.** Wash and dry your jeans according to the label instructions, or gentle wash and dry flat if there's no label.
2. **Design decision.** Decide which pockets you want to keep.
If undecided, keep more pockets on. If you change your mind, you can always cut more off, but sewing them back on is much more difficult.
3. **Turn it out.** Turn your jeans inside out and lie flat. Flatten and pin down all pockets with interior lining.



TIP

4. **Measure and mark the first cut line.** Locate the lowest border of the pockets. Using your tape measure, measure 1 inch below this point. Mark this point with your tailor's chalk. Using your tape measure as a straight edge, draw a line at this point that runs across the pant leg and parallel to the cuff. Do this on both legs. Refer to Figure 10-4.
5. **Cut.** Cut the entire pant leg at the line you just made. Then cut out the inseam, cutting on each side of this thick seam. Refer to Figure 10-5.

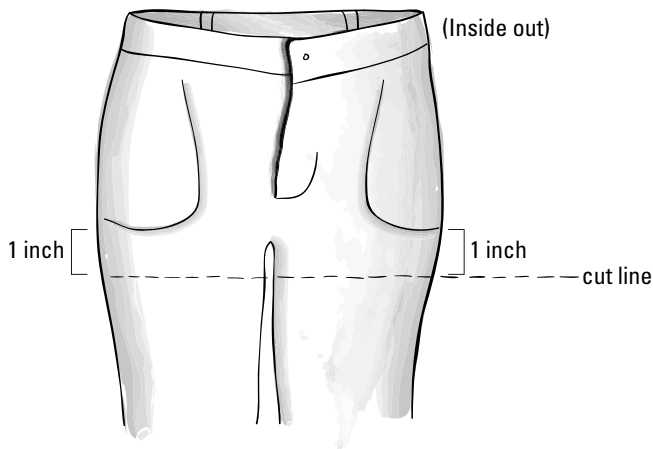

Figure 10-4:
First cut
line.

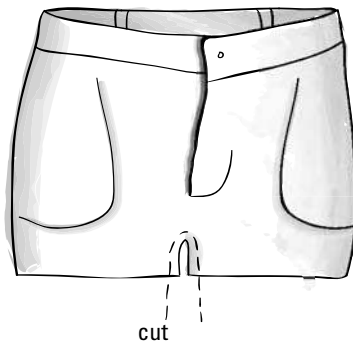

Figure 10-5:
Cutting the
inseam.

6. **Measuring and marking the second cut line.** With your jeans still turned inside out, locate the seam of the back pockets, as well as the border of the front pockets that you have pinned down. With your tape measure and tailor's chalk, measure and mark $\frac{1}{2}$ inch around the borders of the pockets that you are keeping. Using your tailor's chalk, continue the vertical lines to the seam of the waistband (or the closest horizontal seam depending on the style of your jeans). Continue marking your cut line horizontally, $\frac{1}{2}$ inch below the seam/waistband. This $\frac{1}{2}$ -inch measure is flexible, depending on the style of your jeans. It might have to be longer to get around belt loops, and it might have to be shorter to avoid cutting through the zipper. See Figure 10-6.

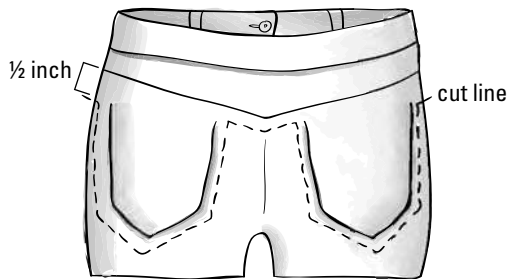

Figure 10-6:
Second cut
line.

7. **Cut and stuff.** Cut along the line you just made in Step 6. Remove the common pins. Turn the jeans right side out.
- Save the pant leg scraps to use for Put Your Money Where Your Scraps Are in Chapter 20.
8. **Repair.** Refer to Chapter 4 to repair any tears, holes, and stains as needed.
- Be sure to check for holes in the pockets and fix them up before you lose your stuff!
9. **Sew, using the method below that matches your sewing method.** The instructions depend highly on whether you are hand sewing, machine sewing or using an overlock machine.



- **Sewing by hand:** Refer to Chapter 5 for hand-sewing techniques. Blanket stitch the entire cut edge.
- **Sewing by machine:** Be sure to use a needle made for denim. Don't force multiple thicknesses of the jeans through the machine. In an area such as the zipper and seams, either run the machine manually, or just leave this area unstitched as shown in Figure 10-7. Zigzag stitch the entire cut edge, getting as close to the edge as possible.
- **Sewing with an overlock:** Serge the entire cut edge, taking caution in areas of multiple thicknesses.



You can leave the edge completely unstitched and raw. Running it through the washer and dryer will help the edges fray and bind together to complete the “unfinished” look.

Figure 10-7:
Getting
around
multiple
thicknesses.

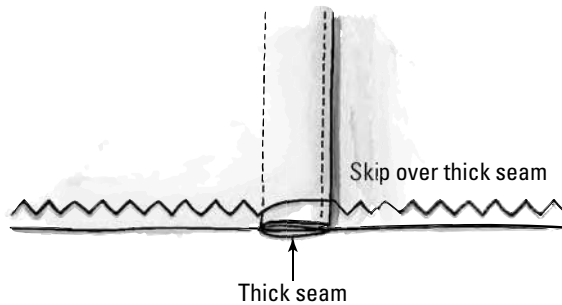

Check out the jeans after reconstruction in Figure 10-8.



Figure 10-8:
After —
Oh-So-Hip
Hip Belt.

Variations

For a decorative effect, try some of these ideas:

- ✔ **Bias tape:** Instead of hemming the edge or leaving it raw, you can cover it with a decorative bias tape. This can be found in any sewing goods or fabric store, usually near the zippers in the Notions area. Bias tape comes in a variety of colors and can be either hand-sewn or machine-sewn on to cover the edge (instructions on package).
- ✔ **Thick stitches:** Complete all stitching by hand sewing with embroidery floss.

- ✔ **Thicker stitches:** Hand sewing over pre-sewn and secured edges with yarn, ribbon or cord.
- ✔ **Mix colors:** Use a thread color that doesn't match, but complements the color of the jeans. With a sewing machine you can also use a different color for the bobbin thread. With an overlock machine, you can get really creative and use four to five different colors.
- ✔ **Stitching everywhere:** Decoratively stitch other areas of the jeans, marking with tailor's chalk first if necessary (pocket edges, seams and/or patching holes or other wear and tear). Decorative stitches include embroidery or deco stitches on your machine.
- ✔ **Buttons:** Sew decorative buttons onto hip belt. This is a great way to make use of those odds and ends buttons. Keep within a color scheme, or within a certain style (art deco, fabric, glass, carved) for a complete look.
- ✔ **Get creative with the cut line.** Instead of keeping the cut line tight to the perimeter of the pocket and waist seams, get creative with curves and other shapes. Refer to Figure 10-9 for ideas.
- ✔ **No-sew deco techniques.** You can leave the edge completely unstitched and raw. Running it through the washer and dryer will help the edges fray and bind together to complete the "unfinished" look. Some other no-sew ideas include creatively cutting the bottom edge, painting, grommeting, riveting, bedazzling, hot-gluing items (nonwashable), bleaching, dyeing, drawing with fabric markers or even a sharpie marker. Make stripes on your hip belt with gaffer's or masking tape. Spray a light coat of spray paint over it, let dry and repeat until you get the desired color saturation. Remove the tape to reveal super-hot stripes!

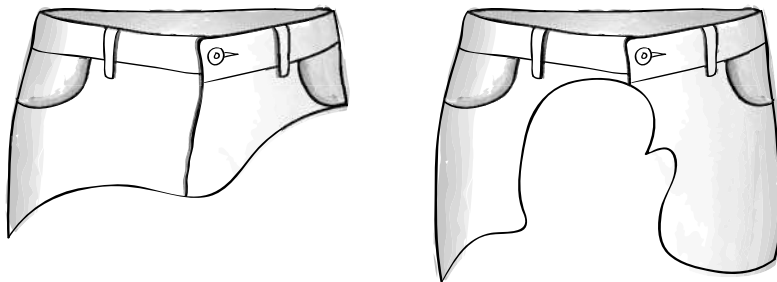

Figure 10-9:
Creative cut
lines.

It's in the Bag Shoulderbag

Jeans are so durable, it only makes sense that they would make a great day-bag to throw your stuff in and head off on an adventure. This bag takes your every-day jeans and turns them upside down to make an over the shoulder bag with fly access.

This project is easy, requiring no cutting and very little hand or machine sewing. All you do is sew the waist shut, sew the cuffs together, turn it upside-down and there you have it: It's in the bag!

Check out the jeans prior to reconstruction in Figure 10-10.

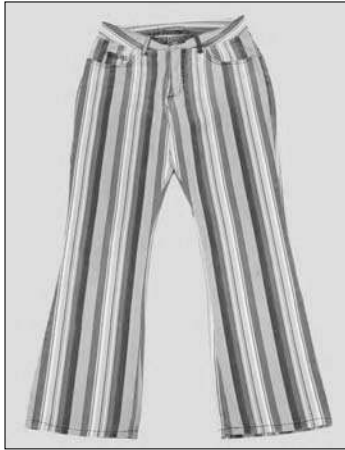

Figure 10-10:
Before —
It's in
the Bag
Shoulder-
bag.

Materials

- ✓ Jeans with at least a 6-inch zipper/fly
- ✓ Common pins
- ✓ Tape measure
- ✓ Needle (for hand sewing) or sewing machine
- ✓ Thread that matches the jeans
- ✓ Scissors

Directions

- 1. Prep.** Wash and dry your jeans according to the label instructions, or gentle wash and dry flat if there's no label.
- 2. Repair.** Refer to Chapter 4 to repair any tears, holes, and stains as needed.
- 3. Waist pinning.** Lie your jeans flat with the front and back parts of the waistband at even heights as shown in Figure 10-11. Pin the front center to the back center. Place pins diagonally at each corner and perpendicular to the edge every 1 inch.

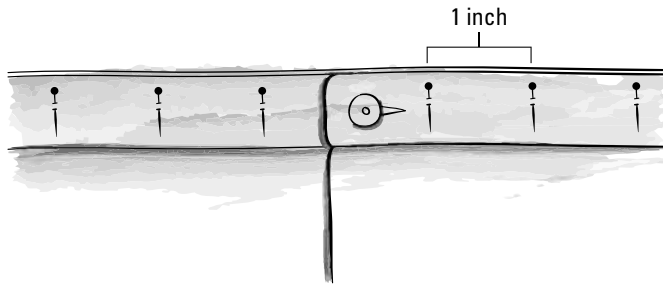

Figure 10-11:
Waistband
pinning.

- 4. Folding the cuffs.** Fold each cuff so that the inseam and outside seam are just approximately centered as shown in Figure 10-12.

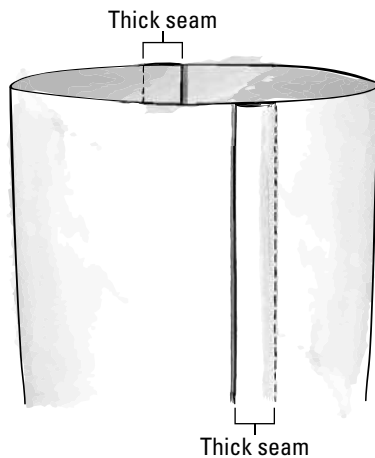

Figure 10-12:
Folding
cuffs.

- 5. Cuff pinning.** Place one cuff inside the other, overlapping 2 inches. Arrange the seams just off-center to minimize the thicknesses of denim. Pin into place, with pins placed every 1 inch perpendicular to the cuff edge. See Figure 10-13.

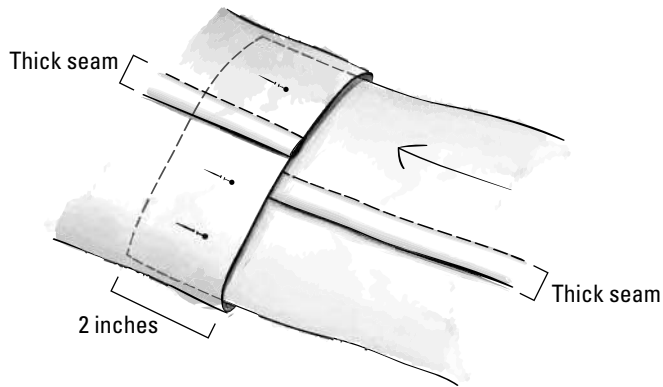

Figure 10-13:
Cuff pinning.

6. Sew, using the method below that matches your sewing method. The instructions depend highly on whether you are hand sewing or machine sewing. An overlock machine is not appropriate for this project.

- **Sewing by hand:** Refer to Chapter 5 for hand-sewing techniques. Running stitch along the top edge of the waistband, securing the front and back of the waistband together. At the cuffs, also use a running stitch parallel to the cuff edge to sew the cuffs together. Refer to Figure 10-14 for a visual on where to sew.
- **Sewing by machine:** Be sure to use the appropriate needle size and pressure for optimal feeding. Refer to your sewing manual for instructions on sewing multiple thicknesses. Straight stitch along the top edge of the waistband, securing the front and back of the waistband together. At the cuffs, also use a straight stitch parallel to the cuff edge to sew the cuffs together. Refer to Figure 10-14 for a visual on where to sew.

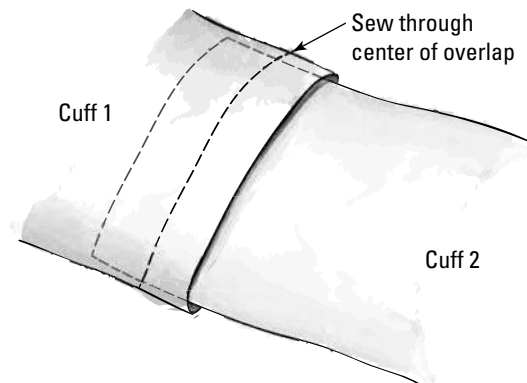

Figure 10-14:
Where to sew.

Check out the jeans after reconstruction in Figure 10-15.



Figure 10-15:
After —
It's in
the Bag
Shoulder-
bag.

Variations

For a decorative effect, try some of these ideas:

- ✓ **Thick stitches:** Complete all stitching by hand sewing with embroidery floss.
- ✓ **Thicker stitches:** Hand sewing over pre-sewn and secured edges with yarn, ribbon or cord.
- ✓ **Mix colors:** Use a thread color that doesn't match, but complements the color of the jeans. With a sewing machine you can also use a different color for the bobbin thread. With an overlock machine, you can get really creative and use four to five different colors.
- ✓ **Stitching everywhere:** Decoratively stitch other areas of the jeans, marking with tailor's chalk first if necessary (pocket edges, seams and/or patching holes or other wear and tear). Decorative stitches include embroidery or deco stitches on your machine.
- ✓ **Buttons:** Sew decorative buttons onto the bag. This is a great way to make use of those odds and ends buttons. Keep within a color scheme, or within a certain style (art deco, fabric, glass, carved) for a complete look.
- ✓ **No-sew deco techniques:** Some no-sew ideas include painting, grommeting, riveting, bedazzling, hot-gluing items (nonwashable), bleaching, dyeing, drawing with fabric markers or even a sharpie marker. Make stripes on your bag with gaffer's or masking tape. Spray a light coat of spray paint over it, let dry and repeat until you get the desired color saturation. Remove the tape to reveal super-hot stripes!



Chapter 11

The Existential Stretch Pant

In This Chapter

- ▶ Keeping the stretch in your stretch pants
 - ▶ Getting around not-so-nice surprises
 - ▶ Doing projects that will bring out the flash-dancer in anyone!
-

Stretch pants and leggings come and go in the fashion world. Really they should just go, only to be revealed in a dance studio, gym or accompanied by sneakers in some other physical environment. So what do we do with these worn out wonders of fashion? Thankfully, there's hope! The projects in this chapter make use of the comfort and versatility of the stretch pant while keeping the look playful, athletic, and functional.

The projects in this chapter range from frilly dancing skirts and leggings, to a hat to keep you warm when you step out of the studio.

Prepping, Primping, and Post Care for Your Stretch Pants

Stretch pants need special care. The materials that make them stretchy are especially delicate and susceptible to harsh washing as well as the heat of the dryer. Always gently wash your stretch pants in cold water and dry flat. Do not put your stretch pants in the dryer no matter how much of a hurry you are in! Check the laundering label for complete instructions, but this is an item that I wouldn't take any chances with. The results of improper care, as discussed below, are simply frightening!

The usual suspects

Stretch pants generally show their wear pretty quickly. With the nature of their use (in other words, working out) it's not something I personally seek out in a thrift store to reconstruct. Instead, think of these projects as creative ways to evolve the stretch pants that already exist in your wardrobe. With that in mind, you will not only be making use of your own item, but keeping it out of the masses of clothing in thrift stores that go unclaimed, and then sent off to an unspeakable fate. However, if you *are* looking for a pair in a thrift store, keep your eyes out for common flaws. The projects listed in this chapter are flexible with flaws in a focused area. Even the leggings are feasible to complete with stretch pants that have overall damage and wear.



Always check for these common flaws in stretch pants:

- ✓ Places that have lost their stretch (knees, rear end)
- ✓ Torn inseam (crotch)
- ✓ Overstretched and torn waistband
- ✓ Stains on the knees and rear end (be sure to check inside too, these are a tight-fitting item)
- ✓ Pilling in specific areas and even over the entire garment

Pulls and pills in all the wrong places

Depending what the stretch pants were worn for and worn with, they may have a fair bit of pilling. Check them over carefully. Areas of particular attention include the crotch and inner thigh, where activities like walking or running would cause some wear. Also check around the waist, where certain jackets or, eek, fanny-packs might have caused some damage.

Bare and Flare Skirt

The Bare and Flare Skirt can be as short or as long as you like it. The basic pattern is for a shorter, “bare” version, however you can easily continue adding more scrap fabric to make it longer. Like the Upside-Down Skirt, one of my favorite things about it is how it makes use of every bit of original material, while having the capacity to incorporate even more scrap material. The minimal version of this skirt is great over a leotard for dance class, then layered over longer skirts or pants on other occasions.

This project is moderately easy. You just cut off the legs, cut up the scraps and sew them back on for some flare. Hem the edge, or even leave it raw, and you're done.

Check out the stretch pants prior to reconstruction in Figure 11-1.



Figure 11-1:
Before —
Bare and
Flare Skirt.

Materials

- ✓ Stretch pants with an intact waist that fits well
- ✓ Common pins
- ✓ Tape measure
- ✓ Needle (for hand sewing) or sewing machine
- ✓ Thread that matches the stretch pants
- ✓ Tailor's chalk (substitute with laundry marker)
- ✓ Scissors

Directions

1. **Prep.** Wash and dry your stretch pants according to the label instructions, or gentle wash and dry flat if there's no label.

- 2. Marking the cut line.** Fold the pants in half, hip to hip, and lay them flat. Using your tape measure as a straight edge and your tailor's chalk, draw a horizontal line (parallel with the waistband) 1 inch above the crotch. Refer to Figure 11-2.

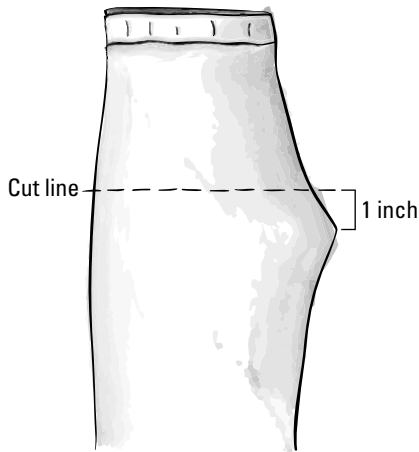

Figure 11-2:
Marking the
cut line.

- 3. Cut.** Cut through all four thickness along the line you just made with your tailor's chalk. With the remaining scrap leg pieces, cut off the crotch, inseam and cuffs to yield two pieces of fabric. Cut each of these pieces of fabric in half lengthwise.
- 4. Repair.** Refer to Chapter 4 to repair any tears, holes, and stains as needed.
- 5. Turn it out.** Turn the waist portion of the stretch pants inside out.
- 6. Align and pin.** Line up one corner of a scrap piece with the center front (crotch) point of the waist portion as shown in Figure 11-3. Be sure that the right sides are facing each other and pin together. Continue pinning the length of the scrap piece to the cut edge of the waist portion. Place pins perpendicular to the edge every 1 inch.
- 7. Sew, using the method below that matches your sewing method.** The instructions depend highly on whether you are hand-sewing, machine sewing or using an overlock machine.
 - **Sewing by hand:** Refer to Chapter 5 for hand-sewing techniques. Blanket stitch the pinned seams with a $\frac{1}{2}$ -inch seam allowance. Remove the pins.

- **Sewing by machine:** Use a stretch needle for this project. Zigzag stitch the pinned seams with a ½-inch seam allowance. Remove the pins.
- **Sewing with an overlock:** Serge the pinned seams, removing the pins before running it through the overlock.

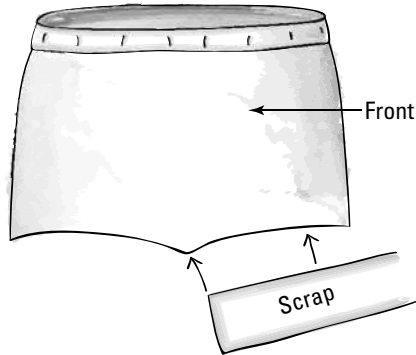

Figure 11-3:
Pinning the
first scrap.

- 8. Cut.** Cut off any excess fabric, either from the scrap or from the waist portion, whichever is longer. Cut in a direction that will keep an even line with the remaining edge. Refer to Figure 11-4 for each of these techniques.

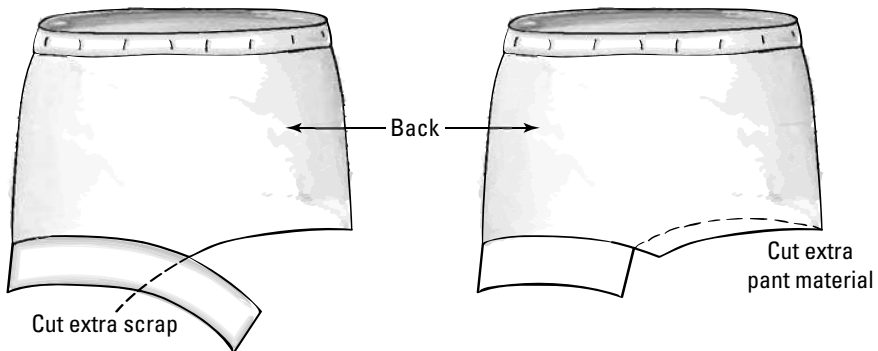

Figure 11-4:
Cutting off
excess
fabric.



Save your scraps for From Garbage to Gorgeous in Chapter 20.

- 9. Repeat Steps 6 through 8.** Repeat Steps 6 through 8 with each of the three remaining pieces of scrap fabric. Refer to Figure 11-5 to line up the next piece of scrap fabric with the bottom corner of the first piece you sewed in.

Figure 11-5:
Pinning
additional
scraps.

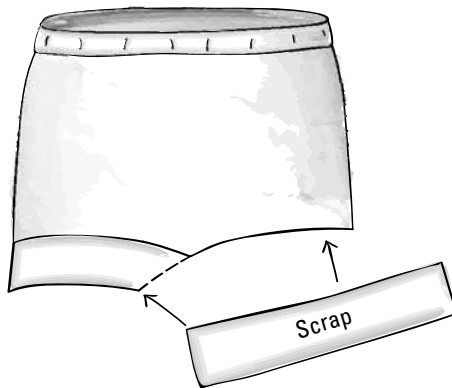

- 10. Turn it out.** Turn your skirt right-side out.

- 11. Finish the hem, using the method below that matches your sewing method.** The instructions depend highly on whether you are hand-sewing, machine sewing or using an overlock machine.



Instead of hemming the edge, you can leave it raw. Many stretch pants are made of a material that will hold its finish without a hem, and even do a cool curled edge effect when stretched. You can also avoid sewing a hem by using no-sew hem tape. This tape is just ironed on. You can find it in your local fabric or craft store online, or even in major supermarkets and department stores.

- **Sewing by hand — for a finished look:** Refer to Chapter 5 for hand-sewing techniques. Hem the bottom edge with a quick hem technique.
- **Sewing by machine — for a rough look:** Zigzag stitch the bottom edge with a ½-inch seam allowance.
- **Sewing with an overlock — for a rough look:** Be sure to use the appropriate needle size and pressure for optimal feeding. Serge the entire bottom edge.

Check out the pants after reconstruction in Figure 11-6. Note that the skirt is worn sideways in this photo, but you can wear it any way that you like.



Figure 11-6:
After —
Bare and
Flare Skirt.

Variations

For a decorative effect, try some of these ideas:

- ✓ **Raw look:** For external seams, skip Step 5, keeping the waist portion of the stretch pants right side out. Pin wrong sides together in Step 6, as well as successive pinning of the scraps.
- ✓ **Hand-stitched raw edge:** Stitch the bottom edge with a blanket stitch instead of a finished hem.
- ✓ **Bias tape:** Instead of hemming the edge or leaving it raw, you can cover it with a decorative bias tape. This can be found in any sewing goods or fabric store, usually near the zippers in the Notions area. Bias tape comes in a variety of colors and can be either hand-sewn or machine-sewn on to cover the edge (instructions on package).
- ✓ **Get creative with the cut line:** Instead of keeping the bottom edge cut straight, get creative with curves and other shapes.
- ✓ **More frill:** Add more length and frill to your skirt by adding scraps of material onto the bottom edge prior to hemming. Pleating (folding) or ruffling the scrap piece makes this extra fun!
- ✓ **Flared edge:** When machine or overlock sewing, gently stretch the fabric as it is feeding into the machine for a flared edge.

It is important not to pull too hard when stretching the fabric or you will break a needle. This trick is for experienced sewers who are very familiar with the feeding of their machine.



Refer to your sewing manual for tips on your machine's capacity to create this flared edge on its own (as in, differential feeding mechanism on some overlock machines.)

- ✔ **Thick stitches:** Complete all stitching by hand-sewing with embroidery floss.
- ✔ **Thicker stitches:** Hand-sewing over pre-sewn and secured edges with yarn or ribbon
- ✔ **Mix colors:** Use a thread color that doesn't match, but complements the color of the stretch pants. With a sewing machine you can also use a different color for the bobbin thread. With an overlock machine, you can get really creative and use four to five different colors.
- ✔ **Stitching everywhere:** Decoratively stitch other areas of the skirt, particularly on the scrap pieces prior to sewing them into place. Mark the decorative design with your tailor's chalk first if necessary. Decorative stitches include embroidery or deco-stitches on your machine.
- ✔ **No sew:** You can leave the edge completely unstitched and raw. Some other no-sew deco techniques include creatively cutting the bottom edge, weaving ribbon or cord through the edge of the skirt, painting, grommeting, riveting, bedazzling, drawing with fabric markers or even a sharpie marker. Use a heat gun to seal the raw edges of synthetic fabrics, referring to the instructions on the heat gun project in Chapter 15. Make stripes on your skirt with gaffer's or masking tape. Spray a light coat of spray paint over it, let dry and repeat until you get the desired color saturation. Remove the tape to reveal super-hot stripes!



Layering the Leggings

While stretch pants as a single item are utterly unattractive, somehow with a snip of the scissors and a slouch of the fabric, leggings are created to not only keep you warm but look incredibly hot under layers.

This project is easy. All you do is cut the stretch-pant legs off, and maybe the cuffs as well, finish the cut edges and you're done!

Check out the stretch pants prior to reconstruction in Figure 11-7.



Figure 11-7:
Before —
Layering the
Leggings.

Materials

- ✓ Stretch pants
- ✓ Common pins
- ✓ Tape measure
- ✓ Needle (for hand sewing) or sewing machine
- ✓ Thread that matches the stretch pants
- ✓ Tailor's chalk (substitute with laundry marker)
- ✓ Scissors

Directions

1. **Prep.** Wash and dry your stretch pants according to the label instructions, or gentle wash and dry flat if there's no label.
2. **Marking the cut line.** Fold the stretch pants in half, hip to hip, and lay them flat. Using your tape measure as a straight edge and your tailor's chalk, draw a horizontal line (parallel with the waistband) 1 inch below the crotch. Refer to Figure 11-8.

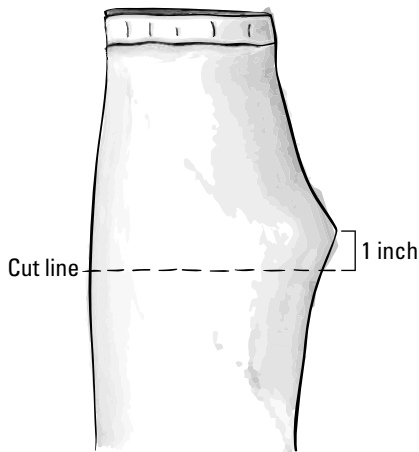

Figure 11-8:
Marking the
cut line.



- 3. Cut.** Cut through all four thickness along the line you just made with your tailor's chalk.

Save the waist portion of this project and use it for either the Bare and Flare Skirt earlier in this chapter, or leave it as is for a pair of hot pants.

- 4. Repair.** Refer to Chapter 4 to repair any tears, holes, and stains as needed.

- 5. Sew, using the method below that matches your sewing method.**

Because this is a casual piece that needs to maintain its ability to stretch, all of the instructions below are for a rough look. The instructions depend highly on whether you are hand-sewing, machine sewing or using an overlock machine.



Instead of finishing the edge, you can leave it raw. Many stretch pants are made of a material that will not fray or run. It is a good idea to just hand-sew the edges of the cut seam, or tie a knot in the existing threads of the seam so that it doesn't open up. You can also avoid sewing a hem by using no-sew hem tape. This tape is just ironed on! You can find it in your local fabric or craft store online, or even in major supermarkets and department stores.

- **Sewing by hand:** Refer to Chapter 5 for hand-sewing techniques. Using a hand-sewing needle and matching thread, blanket stitch the entire cut edge. Keep the stitches close together and a bit loose so that the fabric can still stretch. Check the capacity for stretching as you go.



Hand-sewing is not a preferred method for this project since the edge you are sewing needs to stretch.



- **Sewing by machine:** Using a stretch needle, zigzag stitch the entire cut edge with a ½-inch seam allowance. Refer to the variations listed below for ideas on decorative techniques.

Use a zigzag as opposed to a straight stitch so that the legging can stretch a bit.

- **Sewing with an overlock:** Serge the entire cut edge.

Check out the stretch pants after reconstruction in Figure 11-9.



Figure 11-9:
After —
Layering the
Leggings.

Variations

For a decorative effect, try some of these ideas:

- ✓ **Bias tape:** Instead of hemming the edge or leaving it raw, you can cover it with a decorative bias tape. This can be found in any sewing goods or fabric store, usually near the zippers in the Notions area. Bias tape comes in a variety of colors and can be either hand-sewn or machine-sewn on to cover the edge (instructions on package).
- ✓ **Thick stitches:** Complete all stitching by hand-sewing with embroidery floss.
- ✓ **Thicker stitches:** Hand-sewing over pre-sewn and secured edges with yarn or ribbon.
- ✓ **Mix colors:** Use a thread color that doesn't match, but complements the color of the leggings. With a sewing machine you can also use a different color for the bobbin thread. With an overlock machine, you can get really creative and use four to five different colors.



- ✓ **Stitching everywhere:** Decoratively stitch other areas of the leggings, marking with tailor's chalk first if necessary. Decorative stitches include embroidery or deco-stitches on your machine.
- ✓ **No sew:** You can leave the edge completely unstitched and raw. Running it through the washer and dryer will help the edges fray and bind together to complete the "unfinished" look. Some other no-sew ideas include weaving ribbon or cord through the fabric, painting, grommeting, riveting, bedazzling, bleaching, dyeing, drawing with fabric markers or even a sharpie marker. Make stripes on your leggings with gaffer's or masking tape. Spray a light coat of spray paint over it, let dry and remove the tape to reveal super-hot stripey leggings.

Figure 11-10 shows you how to wear your leggings.

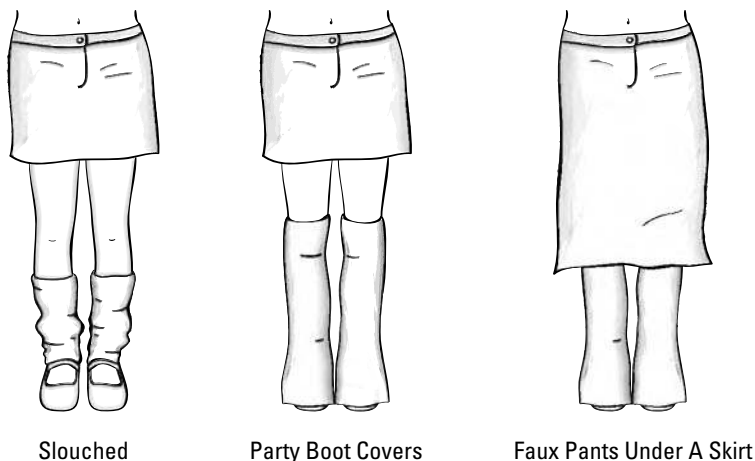

Figure 11-10:
How to wear
Layering the
Leggings.

Slouched

Party Boot Covers

Faux Pants Under A Skirt

From Flat to Hat

It might seem a little strange to put your pants on your head, but this is a project that will do it up right! Stretch pants can be transformed into a variety of hat shapes, so feel free to play around with this concept. This particular project is not only simple but versatile. It can be kept simple or made extravagantly creative with just a few easy alterations. In its most basic form, it resembles a skull cap, while the creative version incorporates a long tail of treasures!

This project is easy and can even be done without a bit of sewing! You just cut off the pant leg and tie off one end. Cut off the extra length for a skull cap or keep it in long strands. Add in more fabric and other adornments if you like, creating a fantastic ponytail. One of the great things about this project is that if you screw up, you have another pant leg to try again!

Check out the stretch pants prior to reconstruction in Figure 11-11.



Figure 11-11:
Before —
From Flat
to Hat.

Materials

- ✓ Stretch pants
- ✓ Rubber band
- ✓ Tape measure
- ✓ Needle (for hand sewing) or sewing machine
- ✓ Thread that matches the stretch pants
- ✓ Scissors

Directions

1. **Prep.** Wash and dry your stretch pants according to the label instructions, or gentle wash and dry flat if there's no label.
2. **Marking the cut line.** Fold the stretch pants in half, hip to hip, and lay them flat. Using your tape measure as a straight edge and your tailor's chalk, draw a horizontal line (parallel with the waistband) just below the crotch. Refer to Figure 11-12.
3. **Cut.** Cut through all four thickness along the line you just made with your tailor's chalk.

Save the waist portion of this project and use it for either the Bare and Flare Skirt earlier in this chapter, or leave it as is for a pair of hot pants.

4. **Repair.** Refer to Chapter 4 to repair any tears, holes, and stains as needed.



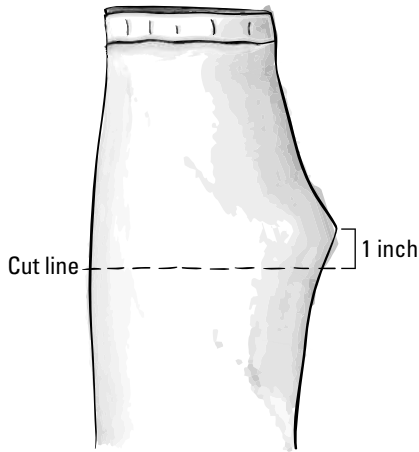

Figure 11-12:
Marking the
cut line.

5. **Try it on.** Put the cut edge of the pant leg on your head like a hat, folding the edge for style and security. A standard stretch pant should fit fine; however, if it is too small or too big you can either add in a length of fabric or take in a seam. Refer to Chapter 6, Upside-Down Skirt in a Topsy-Turvy World, Step 5 for instructions on how to do this.
6. **Fit the crown.** With the hat on (inside out for a skull cap, right side out for a fun hat), gather the extra fabric on the top into a ponytail of sorts and secure with a rubber band. Remove the hat.
7. **Cut for skull cap.** For a skull cap, cut 2 inches away from the rubber band as shown in Figure 11-13.



Be sure to cut the ponytail side of the rubber band, not the skull cap side!

8. **Cut for both caps.** Cut the length of fabric tied off with the rubber band into 4 equal lengths, stopping $\frac{1}{2}$ inch from the rubber band. Refer to Figure 11-13.

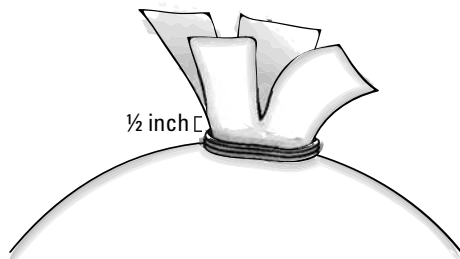

Figure 11-13:
Next step
cutting.

9. **Tie.** With the rubber band still in place, make two knots in the fabric lengths, tying opposite sections together. Pull the knot tight.

- 10. Finish.** Turn the skull cap inside out to finish. For the fun ponytail version, tie in additional lengths of scrap fabric, weaving them into the existing knots.
- 11. Sew, using the method below that matches your sewing method.** Because this is a casual piece that needs to maintain its ability to stretch, all of the instructions below are for a rough look. The instructions depend highly on whether you are hand-sewing, machine sewing or using an overlock machine.



Instead of finishing the edge, you can leave it raw. Many stretch pants are made of a material that will not fray or run. It is a good idea to just hand-sew the edges of the cut seam, or tie a knot in the existing threads of the seam so that it doesn't open up.

- **Sewing by hand:** Refer to Chapter 5 for hand-sewing techniques. Using a hand-sewing needle and matching thread, blanket stitch the entire cut edge. Keep the stitches close together and a bit loose so that the fabric can still stretch. Check the capacity for stretching as you go. Refer to the variations listed below for ideas on decorative techniques.



Hand-sewing is not a preferred method for this project since the edge you are sewing needs to stretch.

- **Sewing by machine:** Using a stretch needle, zigzag stitch the entire cut edge with a 1/2-inch seam allowance.

Use a zigzag as opposed to a straight stitch so that the legging can stretch a bit.



- **Sewing with an overlock:** Serge the entire cut edge.

Check out the stretch pants after reconstruction in Figure 11-14.



Figure 11-14:
After —
From Flat
to Hat.

Variations

For a decorative effect, try some of these ideas:

- ✓ **Get creative with the cut line:** Instead of cutting straight lines in the lengths of fabric of the ponytail version, get creative with curves and other shapes.
- ✓ **Thick stitches:** Complete all stitching by hand-sewing the edge with embroidery floss.
- ✓ **Thicker stitches:** Hand-sewing pre-sewn and secured edges with yarn or ribbon.
- ✓ **Mix colors:** Use a thread color that doesn't match, but complements the color of the hat. With a sewing machine you can also use a different color for the bobbin thread. With an overlock machine, you can get really creative and use four to five different colors.
- ✓ **Stitching everywhere:** Decoratively stitch other areas of the hat, especially the dangles of the ponytail version, marking with tailor's chalk first if necessary. Decorative stitches include embroidery or deco-stitches on your machine.
- ✓ **Buttons:** Sew decorative buttons onto the edge of the hat, in a cluster, or on to the ends of the ponytail dangles. This is a great way to make use of those odds and ends buttons. Keep within a color scheme, or with in a certain style (art deco, fabric, glass, carved) for a complete look.
- ✓ **No Sew!** You can leave the edge completely unstitched and raw. Running it through the washer and dryer will help the edges fray and bind together to complete the "unfinished" look. Some other no-sew ideas include weaving ribbon or cord through the hat, hot-gluing items (non-washable), painting, grommeting, riveting, bedazzling, dyeing, drawing with fabric markers or even a sharpie marker. Use a heat gun to seal the raw edges of synthetic fabrics in the ponytail scraps, referring to the instructions of the heat gun project in Chapter 15. Make stripes on your hat with gaffer's or masking tape. Spray a light coat of spray paint over it, let dry and repeat until you get the desired color saturation. Remove the tape to reveal super-hot stripes!



Part IV

Salvation for Your Sweaters and Other Knits

The 5th Wave

By Rich Tennant

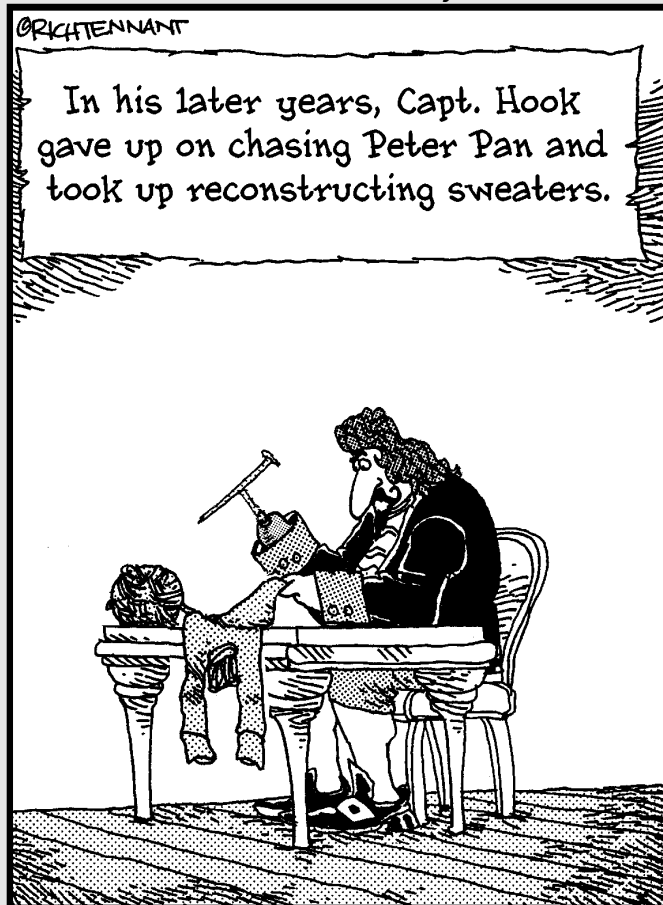

In this part . . .

In Part IV, I present to you some of my favorite projects. I just love working with sweaters, although my machines would beg to differ. Whether you're starting with a cardigan, a pullover, or those ever-so-memorable afghans . . . you're sure to find a project you can enjoy right here!

Read on and discover some tricks to working with knits and their particular pickiness to being cut apart. Personally, I'm drawn to the tattered look of a frayed sweater, moth-eaten holes, and dangling threads. But not everyone is, so I've shared with you the how-to's on how to prevent these issues from cropping up.

Chapter 12

Do It Again with Your Cardigan

In This Chapter

- ▶ Prepping before shredding
 - ▶ Exploring common pitfalls and fix-it tricks
 - ▶ Using cardigans from top to bottom
-

There is just something wonderfully comforting about wrapping yourself up in a cardigan. It's like a big hug from a dear old friend. But when that hug comes with moth-eaten holes and makes you look like a sack of potatoes, there's nothing comforting about it!

In this chapter you will take that nasty old cardigan to new levels. No longer will it remain hidden in the drawer, only to be taken out for those most cozy moments curled up with a good book and a box of tissues. After reading this chapter, your cardigan will take on new visibility not only in your wardrobe, but in your home as well.

The projects in this chapter range from something for your top as well as your bottom, and even a place to rest your head when you are finished. For your top, there is the Bad Unkl Sista Sweater, a year-round staple in my personal wardrobe. For your bottom, a twist on the Upside-Down Skirt presented in Chapter 6. For a simple project, a pillowcase, which not only allows you a good place to begin learning, but a great place for a nap when you are done.

Prepping, Primping, and Post Care for Your Cardigan

While all garments have their peculiarities, knits, particularly cardigans, have some special considerations to take note of.

The usual suspects

When picking out your cardigan, check it over thoroughly in order to determine whether it's perfect, needs some repairs, or if it's just too much to salvage. Chapter 4 will help you decide which of these pitfalls you are willing to take on for repairs, and which are just beyond saving.



Always check for these common cardigan pitfalls, using Figure 12-1 for reference:

- ✓ Missing, mismatched or poorly replaced buttons
- ✓ Stains and other wear and tear on the cuffs
- ✓ Armpit and collar stains
- ✓ Spill stains. These are usually on the front of the cardigan, but you also might find some around the hip area where someone might have a habit of wiping their hands (ew!!!)
- ✓ Overall pilling and pulls, especially under the arms & sometimes on the back if the wearer sat in a chair often.
- ✓ Holes and runs. Stretching the material along the width can make these easier to find (see arrows in Figure 12-1)

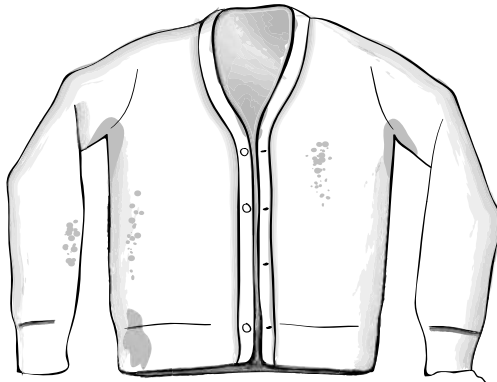

Figure 12-1:
Common
cardigan
pitfalls.

Stretch to look for holes and runs

Cleaning your cardigan

Even after years of handling fabrics and knits, I still stumble across garments from time to time that surprise me. Knits are especially particular! Because of this, I recommend sticking to the laundering instructions on the label. If the laundering instruction label is missing, check for a material content label. Woolens need to be professionally cleaned. Angora, cashmere or other

softy-knits are highly susceptible to pilling and therefore should also be professionally cleaned. Refer to Chapter 4 for other special cases. All other materials are okay to hand-wash in cold water and dry flat (no dryer).



Knits hold their shape best when dried on a flat surface as opposed to hanging on a line or drying rack.

Buttons be gone

Yikes! You've got the perfect cardigan but it's missing a button! Or the buttons are just so hideous that you can't bear the sight of them! Easy fix!

For a missing button, first check the inside seam for extras. If not, you can usually fudge it with the bottom-most or top-most button. Here's how:

1. **Remove the button with your seam ripper.** Insert the sharp point of the seam ripper into the thread loop holding the button in place. See Figure 12-2. Be careful not to catch any parts of the sweater in the blade hook of the seam ripper. Push the blade hook against the thread to cut the button free.



Point the seam ripper away from you so as not to gouge yourself. Ouch!

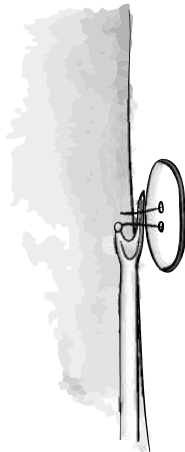

Figure 12-2:
Button
removal via
seam ripper.

2. **Remove loose threads from the sweater.** Carefully cut any knots with scissors or your seam ripper. Pull threads from the material.
3. **Locate the new location for the button.** Button the sweater and mark the missing button location revealed by its complementary buttonhole.
4. **Sew.** Hand sew the button into place, referring to Chapter 5. Sew the extra buttonhole shut by hand or machine zigzag stitch.



If you have to shop for replacement buttons, it is easiest to bring an old button along with you to check for size, just like light bulbs!

Running Wild

After prepping your cardigan for take-off, you have one essential point to consider before getting started: will the sweater run when you cut it?



Wool holds together better than synthetic, more slippery, yarns. Looser knits, the ones with larger holes, run more than tighter knits. Elaborate knit-work such as Irish knit sweaters, also tend to run easily.

If there is any uncertainty, hand-baste or machine sew a zigzag stitch line just inside your cutting line. See Chapter 5 for sewing how-tos. Next, cut the material outside of the zigzag line away from the remaining body of the sweater. See Figure 12-3.



Baste or zigzag stitch on *each* side of the cutting line when saving your cut scraps for other projects!

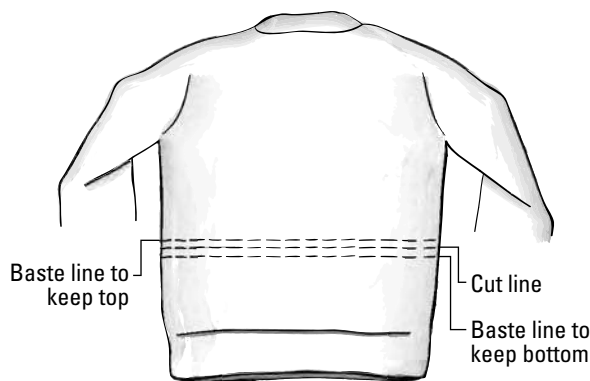

Figure 12-3:
Basting to
prevent
runs.

This technique will help prevent runs while you are working on your project — it's not a substitute for the edge-securing instructions within each pattern. The pattern instructions will all include a “hand baste or machine sew the cut edge to avoid runs” step, but you can choose to opt out of this step if your knit doesn't run easily based on the tips described above.



Stretching the cut material will cause it to run so be careful with your handling of the sweater. Don't stretch it and don't leave it uncut and unattended, especially among pets, children or other potential pullers.

Bad Unkl Sista Sweater

The Bad Unkl Sista Sweater, a design by my friend and fellow designer Anastazia, is a cropped sweater that retains the button closures along the full length of the original sweater. This results in a piece with the function of ties or belting. Not only does it retain the coziness of its former cardigan self, but you can wear it in a variety of ways to keep wardrobe boredom at bay. It functions equally well accompanied by fleece sweatpants and a cup of hot chocolate as it does paired with a cocktail dress at an art opening.

Overall, this project is fairly easy. Basically, you mark a cutting line, baste it, cut it and bind it by sewing. From that point, you can elaborate with suggested variations or decorative repair.

Check out the cardigan prior to reconstruction in Figure 12-4.



Figure 12-4:
Before —
Bad Unkl
Sista
Sweater.

Materials

- ✓ Cardigan
- ✓ Safety pins
- ✓ Tape measure
- ✓ Needle (for hand sewing) or sewing machine
- ✓ Thread that matches the cardigan
- ✓ Tailor's chalk (substitute with laundry marker)
- ✓ Scissors

Directions

1. **Prep.** Wash and dry your cardigan according to the label instructions, or have it professionally cleaned if there is no laundering label. Replace and/or move any buttons (See “Buttons be gone” above).
2. **Identify the cut line.** For most women, a flattering length for cropped sweaters, including this one, is 1 inch below the lowest border of the breast. Add another inch to this length in order to account for the hem.

For thicker sweaters, add another half inch to this length to account for the difference.

Put the sweater on, and then put a safety pin in the sweater to mark this point. Take the sweater off.

If you are unsure of how long to make your sweater, err on the longer side. You can always cut off more fabric and make it shorter. However, if you cut it too short, it's not so easy to make it long again.

3. **Mark the cut line.** Using your tape measure, measure the length from the bottom of the sweater to the safety pin. Note this length, and mark this point with tailor's chalk. Measure and mark the cardigan every 5 inches along the bottom of the sweater. Connect the dots made by the tailor's chalk to draw a straight horizontal line, starting 1 inch in from the edging of the buttonholes, and ending 1 inch in from the edging of the buttons.

Buttons and buttonholes are almost always centered on an edging that is distinctively different from the rest of the cardigan. If your sweater is not like this, you can still find the edge. Using your tape measure, measure the distance from the button center to the border edge of the cardigan. Note this distance. Measure the same distance from the center of the button toward the body of the cardigan. This is the point in which the edging would typically end, and where you will measure an inch further in towards the body of the cardigan to mark your cutting line.

Using the guide in Figure 12-5, extend the line down along the edges of the buttons and buttonholes. This is the cut line.

4. **Baste edge.** Using the guideline of your tailor's chalk line, hand-baste or machine sew a zigzag stitch just inside the cutting line shown in Figure 12-5 *before* cutting it in order to prevent runs.
5. **Cut.** Cut the material outside of the zigzag line away from the remaining body of the sweater.

Save your scrap for Choker Chop-Ups in Chapter 20.

6. **Sew, using the method below that matches your sewing method.** The instructions depend highly on whether you are hand sewing, machine sewing or using an overlock machine. Regardless of the method, the goal is to bind the cut edge completely, catching every loop of the knit in order to avoid runs.



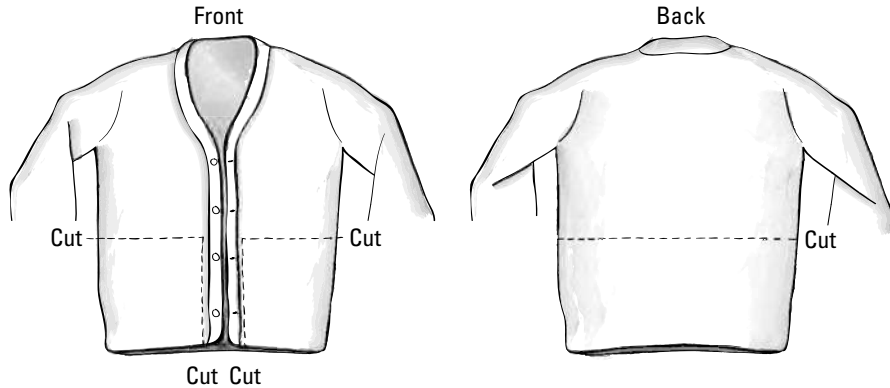

Figure 12-5:
Cut line.



This step is in addition to basting the edge. Basting and a single zigzag stitch are temporary solutions to runs, while this is a more precise and finished step.

- **Sewing by hand:** Refer to Chapter 5 for hand-sewing techniques. Blanket stitch the entire cut edge. Hem the edge using the quick hem technique described in Chapter 5.
- **Sewing by machine:** Zigzag stitch the entire cut edge. Try to get the stitch as close to edge as possible without the stitches falling off the edge. Check the edge to be sure you've caught all loops of the knit securely. If not, run it through the machine again until this is secure. Hem the edge using the quick hem technique described in Chapter 5.
- **Sewing with an overlock:** Serge the entire cut edge. Hem the edge using the quick hem technique described in Chapter 5.

Check out the cardigan after reconstruction in Figure 12-6.



Figure 12-6:
After —
Bad Unkl
Sista
Sweater.

Variations

For a decorative effect, try some of these ideas:

- ✓ **Raw look:** Instead of finishing the edge with a hem, leave out this step and blanket stitch (hand sewing) for a raw finish.
- ✓ **Bias tape:** Instead of hemming the edge or leaving it raw, you can cover it with a decorative bias tape. This can be found in any sewing goods or fabric store, usually near the zippers in the Notions area. Bias tape comes in a variety of colors and can be either hand-sewn or machine-sewn on to cover the edge (instructions on package).
- ✓ **Get creative with the cut line:** Change the look and feel of the sweater by altering the cut line. See Figure 12-7.
- ✓ **Thick stitches:** Complete all stitching by hand sewing with embroidery floss.
- ✓ **Thicker stitches:** Hand sewing over pre-sewn and secured edges with yarn or ribbon.
- ✓ **Mix colors:** Use a thread color that doesn't match, but complements the color of the cardigan. With a sewing machine you can also use a different color for the bobbin thread. With an overlock machine, you can get really creative and use four to five different colors.

Now that you've completed this fabulous creation — how do you wear it? Tie it in the front. Cross the ties, wrap and button behind your back. Cross them on a diagonal, one over the shoulder, and button behind your back. See Figure 12-8.

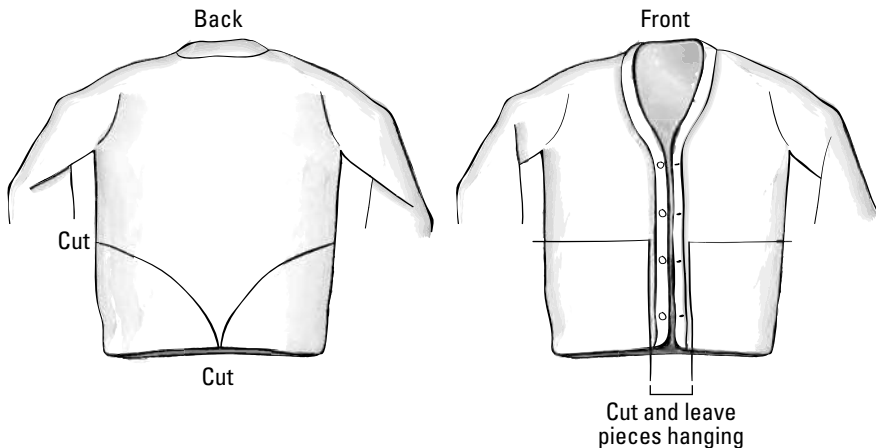

Figure 12-7:
Variations
on the
cut line

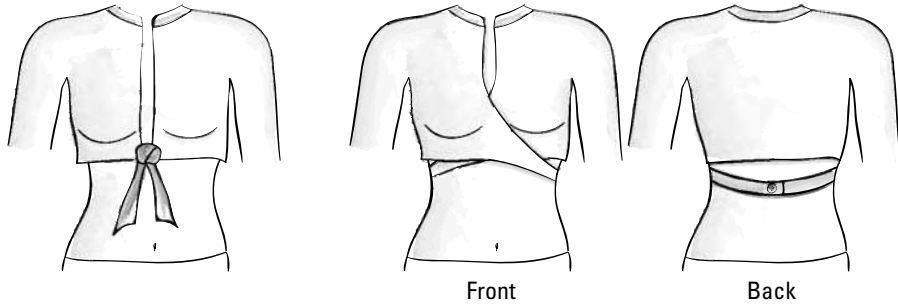
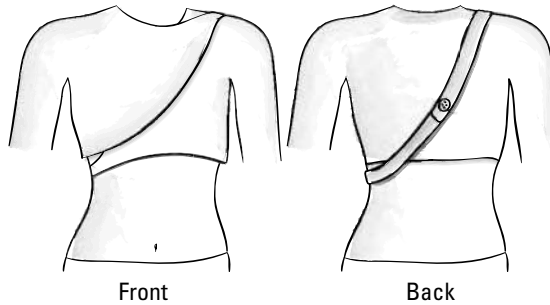

Figure 12-8:
How to wear
your Bad
Unkl Sista
Sweater.



Not all of these methods will work with all sweater styles and all body types. It's important, and fun, to find what works best for you!

Making a Case for Pillowcases

Cardigans make great pillowcases because they already have the closures built in! No longer do you have to pain over nostalgic pieces. With a few stitches you can turn that baby sweater into a tooth fairy pillow!

This project is very easy. You can make either a square or rectangular pillow case. First you determine the size of the pillow based on a pre-made pillow form, or a customized pillow that you make yourself (Chapter 18). Then you mark, baste, cut, bind and sew four straight seams.

Check out the cardigan prior to reconstruction in Figure 12-9.



Figure 12-9:
Before —
Making a
Case for
Pillowcases.

Materials

- ✓ Cardigan
- ✓ Common pins
- ✓ Tape measure
- ✓ Needle (for hand sewing) or sewing machine
- ✓ Thread that matches the cardigan
- ✓ Tailor's chalk (substitute with laundry marker)
- ✓ Scissors

Directions

1. **Prep.** Wash and dry your cardigan according to the label instructions, or have it professionally cleaned if there's no label. Replace and/or move any buttons (see "Buttons be gone" earlier in this chapter). Keeping it buttoned, turn your cardigan inside out and flatten it to prep for cutting.
2. **Identify the pillow and case size.** A store bought pillow form will have the dimensions listed on the packaging. In all other cases, pull the seams of the pillow taut and use your measuring tape to find the dimensions. Add one inch to each of these numbers to determine the dimensions of the pillow case. This allows for a ½-inch-wide seam.



For thicker sweaters, add another half inch to this length to give yourself some breathing room.



- 3. Mark the cut line.** With the buttons centered as shown in Figure 12-10, use your measuring tape, pillowcase dimensions found in Step 2, and tailor's chalk to mark the square or rectangular shape of the pillow.

You can only make a pillow case as large as your cardigan is. Measure the length and width of your cardigan (buttoned up) as shown in Figure 12-10 before you purchase or make a pillow that's too big for the case.

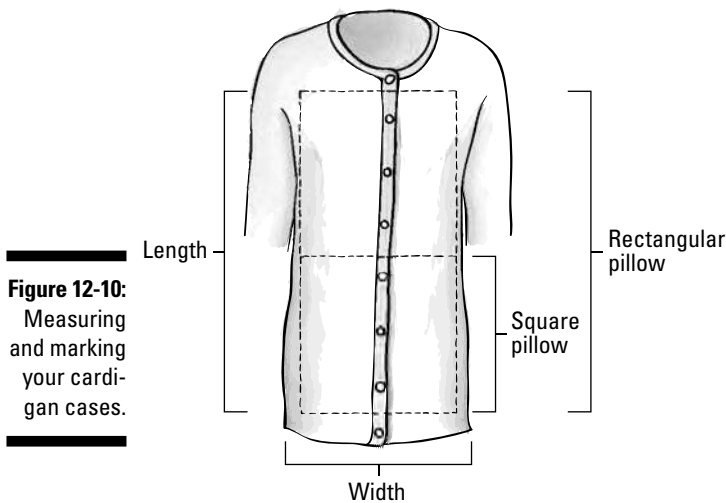

Figure 12-10:
Measuring
and marking
your cardi-
gan cases.

- 4. Pin.** Pin both layers together. Place common pins diagonally at each corner and every 1 inch along the inside of the cutting line.
- 5. Baste edge.** Using the guideline of your tailor's chalk line, hand-baste or machine sew a zigzag stitch through both layers just inside the cutting lines *before* cutting it in order to prevent runs. Remove pins.
- 6. Cut.** Cut through both layers along the cutting line.

Save your scrap for Sleek and Sneaky Sleeves in Chapter 13.



- 7. Sew using the method below that matches your sewing method.** The instructions depend highly on whether you are hand sewing, machine sewing or using an overlock machine. Regardless of the method, the goal is to bind the cut edge completely, catching every loop of the knit in order to avoid runs.



This step is in addition to basting the edge. Basting and a single zigzag stitch are temporary solutions to runs, while this is a more precise and finished step.

- **Sewing by hand:** Refer to Chapter 5 for hand-sewing techniques. Blanket stitch along the entire cut edge with a ½-inch seam. Turn right side out.
- **Sewing by machine:** Using a ½-inch seam, zigzag stitch along the entire cut edge. Check the edge to be sure you've caught all loops of the knit securely. If not, run it through the machine again until this is secure. Turn right side out.
- **Sewing with an overlock:** Serge along the entire cut edge with a ½-inch seam. Turn right side out.

8. Repair. Refer to Chapter 4 to repair any tears, holes, and stains as needed.

Check out the cardigan after reconstruction in Figure 12-11.



Figure 12-11:
After —
Making a
Case for
Pillowcases.

Variations

For a decorative effect, try some of these ideas:

- ✓ **Raw look:** For external seams, leave the cardigan right side out in Step 1, and blanket stitch (hand sew) the edge.
- ✓ **Thick stitches:** Complete all stitching by hand sewing with embroidery floss.

- ✔ **Thicker stitches:** Hand sew over pre-sewn and secured edges with yarn or ribbon.
- ✔ **Mix colors:** Use a thread color that doesn't match, but complements the color of the cardigan. With a sewing machine you can also use a different color for the bobbin thread. With an overlock machine, you can get really creative and use four to five different colors.
- ✔ **Buttons.** Sew decorative buttons along the edge of the pillow or clustered in the corners. This is a great way to make use of those odds and ends buttons. Keep within a color scheme, or within a certain style (art deco, fabric, glass, carved) for a complete look. You can also have fun positioning the buttons of the cardigan by cutting your cardigan with the buttons off center or even running on a diagonal.

A Twist on the Upside-Down Skirt

While the T-shirt upside-down skirt in Chapter 6, and the sweater version in Chapter 13 are fun, they don't have the capacity for a peek-a-boo effect when you're feeling flirty. By un-buttoning just a few buttons, you'll suddenly go from solemn to seductress!

This project is a bit hard. You will primarily refer to the instructions for the upside-down skirt in Chapter 6, with a few variations. First you determine the size. Then you sew the button edge partially closed, and make and attach a waistband. Then you mark, baste, cut, bind and sew the bottom edge.

Check out the cardigan prior to reconstruction in Figure 12-12.



Figure 12-12:
Before —
A Twist on
the Upside-
Down Skirt.

Materials

- ✓ Cardigan
- ✓ Common pins
- ✓ Tape measure
- ✓ Needle (for hand sewing) or sewing machine
- ✓ Thread that matches the cardigan
- ✓ Tailor's chalk (substitute with laundry marker)
- ✓ Scissors

Directions

1. **Size it up.** The easiest way to check the size is to try it on. Turn your buttoned up cardigan upside down so that your feet step through the neckline. Does it fit around your hips? If it doesn't, you'll need to forgo it for this particular project. Find another cardigan that is at least the width of your hips, preferably 3-6 inches larger.



Sometimes our dimensions, ahem, shift a bit when we sit down. If you have some curves in this area, be sure to test fit in sitting as well!

2. **Prep.** Wash and dry your cardigan according to the label instructions, or have it professionally cleaned if there's no label. Replace and/or move any buttons (see "Buttons be gone," earlier in this chapter).
3. **Sew buttons closed.** Using a running stitch (Chapter 5), hand sew the buttons closed, starting at the waist edge and finishing where you would like your slit to begin. You can also use a zigzag machine stitch with a zipper foot to get as close as possible to the buttons.
4. **Make and attach waistband.** Refer to Upside-Down Skirt in a Topsy-Turvy World (Chapter 6).
5. **Identify the cut line.** Refer to Upside-Down Skirt in a Topsy-Turvy World (Chapter 6).
6. **Mark the cut line.** Refer to Upside-Down Skirt in a Topsy-Turvy World (Chapter 6).
7. **Baste the edge.** Using the guideline of your tailor's chalk line, hand-baste or machine sew a zigzag stitch along each side of the cutting line *before* cutting it in order to prevent runs.

8. **Cut.** Cut the material on the cutting line.
9. **Sew, using the method below that matches your sewing method.** The instructions depend highly on whether you are hand sewing, machine sewing or using an overlock machine. Regardless of the method, the goal is to bind the cut edge completely, catching every loop of the knit in order to avoid runs.



This step is in addition to basting the edge. Basting and a single zigzag stitch are temporary solutions to runs, while this is a more precise and finished step.

- **Sewing by hand:** Refer to Chapter 5 for hand-sewing techniques. Blanket stitch the entire cut edge. Hem the edge using the quick hem technique described in Chapter 5.
 - **Sewing by machine:** Zigzag stitch the entire cut edge. Try to get the stitch as close to edge as possible without the stitches falling off the edge. Check the edge to be sure you've caught all loops of the knit securely. If not, run it through the machine again until this is secure. Hem the edge using the quick hem technique described in Chapter 5.
 - **Sewing with an overlock:** Serge along the entire cut edge. Hem the edge using the quick hem technique described in Chapter 5.
10. **Repair.** Refer to Chapter 4 to repair any tears, holes, and stains as needed.

Check out the cardigan after reconstruction in Figure 12-13.



Figure 12-13:
After —
A Twist on
the Upside-
Down Skirt.

Variations

For a decorative effect, try some of these ideas:

- ✔ **Raw look:** Instead of finishing the edge with a hem, leave out this step and blanket stitch (hand sewing) for a raw finish.
- ✔ **Bias tape:** Instead of hemming the edge or leaving it raw, you can cover it with a decorative bias tape. This can be found in any sewing goods or fabric store, usually near the zippers in the Notions area. Bias tape comes in a variety of colors and can be either hand-sewn or machine-sewn on to cover the edge (instructions on package).
- ✔ **Get creative with the cut line.**
- ✔ **More frill:** Add more length and frill to your skirt by adding scraps of material (from the sleeves) onto the bottom edge prior to hemming.
- ✔ **Thick stitches:** Hand sewing the bottom edge with embroidery floss.
- ✔ **Thicker stitches:** Hand sewing over pre-sewn and secured edges with yarn or ribbon.
- ✔ **Mix colors.** Use a thread color that doesn't match, but complements the color of the cardigan. With a sewing machine you can also use a different color for the bobbin thread. With an overlock machine, you can get really creative and use four to five different colors.

Chapter 13

Pullover Sweaters Pulled in All Directions

In This Chapter

- ▶ Prepping and preventing pitfalls
 - ▶ Projects that revisit the tees
 - ▶ Accessories to warm your precious parts
-

Pullover sweaters are one of those basics that you either love or hate. Either way, it will have its day suitable for reconstruction. I like the one year rule: “if you haven’t worn it in a year, it’s time to get rid of it.” But instead of getting rid of it, you now have a choice, many choices in fact!

My most favorite of these projects is also the easiest: Sleek and Sneaky Sleeves. After my hands had a frightening reaction to being overworked in San Francisco’s damp and cold winter, I started wearing woolen sleeves over vintage gloves. Paired with a little acupuncture and traditional Chinese medicine and *voilà!* My hands were back in action! The combo looked so adorable (the sleeves, not the needles) that I soon got into the habit of wearing them literally *all* the time! Thankfully they are so easy to make that I can whip another pair up in a few minutes whenever I feel the need for a fresh new(ish) pair!

The projects in this chapter revisit several of the T-shirt projects from Chapter 6, as well as including a variety of accessories to curl up with!

Prepping, Priming, and Post Care for Your Pullover Sweaters

Pullover sweaters vary widely in their fabric content. Read the tips in Chapter 12 for more information on knit content, laundering foibles, and pre-cutting prep. Check the laundering label and wash your sweater prior to your reconstruction project. If your label is missing, refer to Chapter 4 for guidelines of when to have it professionally cleaned, and when it might be safe to just gentle wash it in cold water and dry flat (no dryer).

The usual suspects

You are likely working from your own sweater, and are well-aware of its flaws. In fact those flaws are probably the reason you're not wearing it anymore! But if you are looking for a sweater to reconstruct from a thrift store, keep a keen eye on the fit, especially if you are making a garment as opposed to an accessory. Always be aware of some usual suspects to watch out for.



Always check for these common flaws in pullover sweaters:

- ✓ Stains and other wear and tear on the cuffs
- ✓ Collar ripping away from its binding
- ✓ Armpit stains
- ✓ Collar stains
- ✓ Spill stains. These are usually on the front of the sweater, but you also might find some around the hip area where someone might have a habit of wiping their hands (ew!!!)
- ✓ Overall pilling and pulls, especially under the arms and sometimes on the back if the wearer sat in a chair often. Also think about the material's tendency in general to pilling.
- ✓ Holes and runs. Stretching the material along its width can make these easier to find.

A bad pill you don't have to swallow

Pullover sweaters are aplenty in any large thrift store. Certainly if there's a darling little vintage find that you've just got to have, you'll take it home flaws and all. However, if you are just looking on a more broad spectrum, the number one thing to look out for is pilling. Mild pilling and pills in a focused area can

be taken care of. However, if a sweater has major pilling all over it there's not much you can do to make it look clean and fresh again. Sometimes the fiber content of the sweater is simply prone to pilling. In this case, it's best to move on to another sweater, or use the bad pill to make a smaller accessory.



For badly pillared sweaters, try turning it inside out! If you're ok with external seams, this is sometimes a clever option to the pilling dilemma.

Take Two On the Tees

Pullover sweaters function very much like T-shirts in their capacity for reconstruction, and therefore can be incorporated into many of the same projects with just some minor changes and prep to prevent runs in the knit.

Upside-Down Skirt

This sweater skirt is not only cozy but also very flattering! It's a fitted skirt with a flare from knee to mid-calf. While it is rather flirty, the sweater material makes it more elegant and fun than slinky and seductive.

This project is moderately easy. It is just a bit more difficult and time consuming than the T-shirt version because the edges need to be basted to prevent runs in the knit. Otherwise, it's snip, flip, and finish for a brand new Upside-Down Skirt . . . sweater style!

Check out the sweater prior to reconstruction in Figure 13-1.



Figure 13-1:
Before —
Upside-
Down Skirt.

Materials

- ✓ Pullover sweater
- ✓ 1 yard of stretchy fabric or another sweater of complementary color
- ✓ Safety pins
- ✓ Common pins
- ✓ Tape measure
- ✓ Needle (for hand sewing) or sewing machine
- ✓ Thread that matches the sweater
- ✓ Waistband material: drawstring, $\frac{3}{4}$ -wide elasticized band or $\frac{1}{4}$ -yard of stretch fabric that measures the width of your waist. For drawstring, allow 20 inches of additional length for tying.
- ✓ Scissors

Directions

Follow the directions for the Upside-Down Skirt in Chapter 6. Baste or zigzag stitch, referring to “Running Wild” in Chapter 12, on each side of the cutting lines prior to cutting. This will prevent runs in the knit. Only use a drawstring waist or elastic waistband if your sweater is very thin. Another alternative is to weave the drawstring through the loops of the knit rather than folding the edge over.



Be sure to use appropriate needle and pressure for knits. Minimize the thicknesses you put through your machine, and always precut before putting sweaters through the overlock.

Check out the sweater after reconstruction in Figure 13-2.

No Stopping the Halter Top

A halter top made out of a sweater couldn't be the more perfect thing for warm summer evenings! If the sweater is made of cotton it's even better as a swimsuit cover-up in the day. Put it away for the winter or pair it under layers, using the dangles of the halter ties as a scarf. I love surprising people with all the ways you can weave and play with these dangles!

This project is more tedious than it is difficult. It requires a lot of basting and hemming of the edges, but otherwise it has much room for your own creativity to creep in and have fun with!



Figure 13-2:
After —
Upside-
Down Skirt.

Check out the sweater prior to reconstruction in Figure 13-3.



Figure 13-3:
Before —
No Stopping
the Halter
Top.

Materials

- ✓ Sweater that fits you well
- ✓ Common pins
- ✓ Tape measure
- ✓ Needle (for hand sewing) or sewing machine
- ✓ Thread that matches the sweater
- ✓ Tailor's chalk (substitute with laundry marker)
- ✓ Scissors

Directions

Follow the directions for the No Stop Halter Top in Chapter 6. Baste or zigzag stitch, referring to “Running Wild” in Chapter 12, on each side of the cutting lines prior to cutting. This will prevent runs in the knit. Note that you are not able to use no-sew hem tape with the sweater . . . it's just too thick!



Cut the sleeves off first and use them for Sleek & Sneaky Sleeves, later in this chapter.



Be sure to use appropriate needle and pressure for knits. Minimize the thicknesses you put through your machine, and always precut before putting sweaters through the overlock.

Check out the sweater after reconstruction in Figure 13-4.



Figure 13-4:
After —
No Stopping
the Halter
Top.

New Cut on Crops

Let me just say how much I love crop sweaters. I can still remember the one I had in 7th grade and I still love it! Of course back then I wore it with a bare belly, while now the look has graduated to a shorter crop with a longer slim top or vintage slip underneath.

For years I've been playing with different versions of crops, changing it up as the seasons go by. And for years people have been telling me, "I wear this *all* the time." You've got to love clothes that just become a part of you like that!

The difficulty of this project varies from easy (basic crop) to more tedious (tails crop). Either way, it's worth it. You will love your new crop.

Check out the sweater prior to reconstruction in Figure 13-5.



Figure 13-5:
Before —
New Cut
on Crops.

Materials

- ✓ Pullover sweater that fits well
- ✓ Safety pins
- ✓ Common pins
- ✓ Tailor's chalk (substitute with laundry marker)
- ✓ Tape measure
- ✓ Needle (for hand sewing) or sewing machine
- ✓ Thread that matches the sweater
- ✓ Scissors

Directions

Follow the directions for any of the crop projects in Chapter 8. Baste or zigzag stitch, referring to “Running Wild” in Chapter 12, on each side of the cutting lines prior to cutting. This will prevent runs in the knit. Note that you are not able to use no-sew hem tape with the sweater . . . it’s just too thick!



Save your scraps from the crops to make Sleek and Sneaky Sleeves in this chapter, or leave them as is for a scarf!



Be sure to use appropriate needle and pressure for knits. Minimize the thicknesses you put through your machine, and always precut before putting sweaters through the overlock.

Check out the sweater after reconstruction in Figure 13-6.



Figure 13-6:
After —
New Cut
on Crops.

Wrap for a New Way of Life

For those of you who can’t wear the crop sweaters because you don’t like pull-overs, *what’s your problem?* No, really, I’m surprised how many people I meet that feel this way. So for you, there’s a solution, a Wrap For a New Way Of Life!

This project, a sweet sweater version of the Wrap To Write Home About in Chapter 8, is fairly easy, with minimal basting to prevent runs. It’s also great in that it makes use of the entire sweater with not a scrap to spare.

Check out the sweater prior to reconstruction in Figure 13-7.



Figure 13-7:
Before —
Wrap for a
New Way
of Life.

Materials

- ✓ Pullover sweater
- ✓ Common pins
- ✓ Tape measure
- ✓ Needle (for hand sewing) or sewing machine
- ✓ Thread that matches the sweater
- ✓ Scissors

Directions

Follow the directions for the Wrap to Write Home About in Chapter 8. Baste or zigzag stitch, referring to “Running Wild” in Chapter 12, on each side of the cutting lines prior to cutting. This will prevent runs in the knit. Note that you are not able to use no-sew hem tape with the sweater . . . it’s just too thick!



Be sure to use appropriate needle and pressure for knits. Minimize the thicknesses you put through your machine, and always precut before putting sweaters through the overlock.

Check out the sweater after reconstruction in Figure 13-8.



Figure 13-8:
After —
Wrap for
a New Way
of Life.

Sleek 'n' Sneaky Sleeves

Sleek 'n' Sneaky Sleeves are a staple in my everyday attire. They are a simple thing, merely cut off sleeves of a sweater. But when finished off and decorated up a bit they can be unique statement all their own.

These sleeves are more than just a stylish accessory. Who needs those anyway? As discussed in the beginning of this chapter, I rely on mine for warmth in lieu of gloves when working with my hands. They are also great for biking, and for long days when you don't know where you'll end up! Pull them out from too-short jacket sleeves to cover cold hands when there's a sudden change of weather, or when you cross the street here in San Francisco!

This project is easy. You just cut off the sleeves and bind the edge. The hardest part is figuring out what to do with the rest of the sweater.

Check out the sweater prior to reconstruction in Figure 13-9.



Figure 13-9:
Before —
Sleek 'n'
Sneaky
Sleeves.

Materials

- ✓ Pullover sweater with narrow sleeve
- ✓ Common pins
- ✓ Tape measure
- ✓ Needle (for hand sewing) or sewing machine
- ✓ Thread that matches the pullover sweaters
- ✓ Tailor's chalk (substitute with laundry marker)
- ✓ Scissors

Directions

1. **Prep.** Wash and dry your pullover sweaters according to the label instructions, or have it professionally cleaned if there's no label.
2. **Marking the cut line.** Lay your sweater flat. Using your tape measure, measure the sleeve length, marking the point 10 inches from the cuff. Using your tape measure as a straight edge, mark a line at this point that runs parallel to the cuff. Use your tailor's chalk to mark this line. Do this for each sleeve. Refer to Figure 13-10.

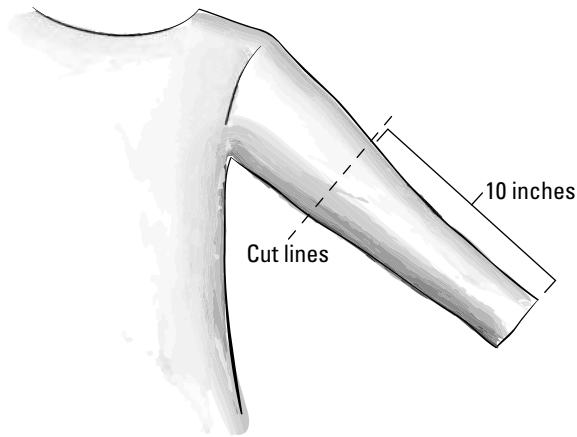

Figure 13-10:
Marking the
cut line.



3. **Baste edge.** Using the guideline of your tailor's chalk line, hand-baste or machine sew a zigzag stitch on each side of the cutting line shown in Figure 13-10 *before* cutting it in order to prevent runs.
4. **Cut.** Cut the material along the lines you just made with the tailor's chalk.
Save your scraps for an Upside-Down Skirt (earlier in this chapter) or just leave it as is for a short sleeved sweater!
5. **Repair.** Refer to Chapter 4 to repair any tears, holes and stains as needed.
6. **Sew, using the method below that matches your sewing method.** The instructions depend highly on whether you are hand sewing, machine sewing or using an overlock machine.
 - **Sewing by hand:** Refer to Chapter 5 for hand-sewing techniques. Blanket stitch along the entire cut edge, making sure to catch every loop of the knit to prevent runs. Hem the edge with a quick hem.
 - **Sewing by machine:** Be sure to use the appropriate needle size and pressure for optimal feeding. Refer to your sewing manual for instructions on sewing multiple thicknesses. Zigzag stitch along the entire cut edge, making sure to catch every loop of the knit to prevent runs. Run it through the machine twice to be sure. Hem the edge by hand using the quick hem technique described in Chapter 5.
 - **Sewing with an overlock:** Be sure to use the appropriate needle size and pressure for optimal feeding. Serge the entire cut edge, making sure to catch every loop of the knit to prevent runs. Hem the edge by hand using the quick hem technique described in Chapter 5.

Check out the sweater after reconstruction in Figure 13-11. You can see how to wear the sleeves in Figure 13-12.



Figure 13-11:
Sleek 'n'
Sneaky
Sleeves.

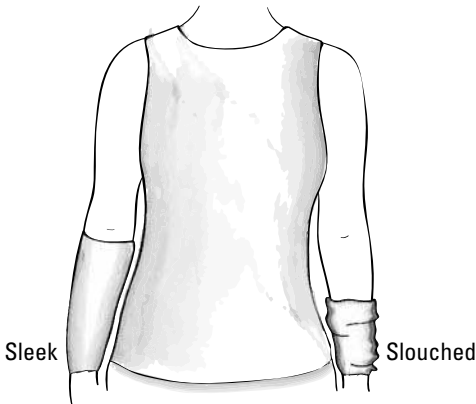

Figure 13-12:
Wearing
your Sleek
'n' Sneaky
Sleeves.

Variations

For a decorative effect, try some of these ideas:

- ✔ **Raw look.** Leave out the hemming for a raw finish.
- ✔ **Bias tape.** Instead of hemming the edge or leaving it raw, you can cover it with a decorative bias tape. This can be found in any sewing goods or fabric store, usually near the zippers in the Notions area. Bias tape comes in a variety of colors and can be either hand-sewn or machine-sewn on to cover the edge (instructions on package).
- ✔ **Get creative with the cut line.** Instead of cutting a straight line, get creative with curves and other shapes.



- ✓ **Flared edge.** When machine or overlock sewing, gently stretch the knit as it is feeding into the machine for a flared edge.

For knits, this trick only works well on thin material. It is important not to pull too hard when stretching the fabric or you will break a needle. This trick is for experienced sewers who are very familiar with the feeding of their machine.

Refer to your sewing manual for tips of your machine's capacity to create this flared edge on its own (as in, differential feeding mechanism on some overlock machines).

- ✓ **Thick stitches:** Complete all stitching by hand sewing with embroidery floss.
- ✓ **Thicker stitches.** Hand sewing over pre-sewn and secured edges with yarn or ribbon.
- ✓ **Mix colors:** Use a thread color that doesn't match, but complements the color of the sweater. With a sewing machine you can also use a different color for the bobbin thread. With an overlock machine, you can get really creative and use four to five different colors.
- ✓ **Stitching everywhere:** Decoratively stitch other areas of the sleeves, marking with tailor's chalk first if necessary. Decorative stitches include embroidery or deco-stitches on your machine.
- ✓ **Buttons:** Sew decorative buttons onto the sleeves. This is a great way to make use of those odds and ends buttons. Cluster a few together at the cuff or resemble a vintage glove with a row of tiny buttons and the wrist.
- ✓ **No-sew deco techniques:** For wool sweaters, you can leave the edge completely unstitched and raw. These cut edges can be bound by felting the sweater: washing it in hot water. Note that this will shrink the sleeve, so start with a piece that is too big, or take care to stretch it to size while it's still wet. Some no-sew ideas include weaving ribbon or cord through the knit, grommeting, riveting, bedazzling and hot-gluing items (nonwashable).



Bag Ladies Shoulderbag

Bag Ladies is a softie shoulder bag perfect for your knitting projects! Bring it traveling and it doubles as a pillow! It's a simple bag, similar to the one in Chapter 10 in that the cuffs are sewn together to form a single strap while the waist is closed up to form the bottom of the bag. The neckline serves as easy access to get to your lovely cozies inside!

This project is a cinch! There's no cutting and minimal sewing. Just line it up, sew the waist together, sew the cuffs together and maybe add a little deco to make it a bit more unique and you're done.

Check out the sweater prior to reconstruction in Figure 13-13.



Figure 13-13:
Before —
Bag Ladies
Shoulder-
bag.

Materials

- ✓ Pullover sweater
- ✓ Common pins
- ✓ Tape measure
- ✓ Needle (for hand sewing) or sewing machine
- ✓ Thread that matches the sweater
- ✓ Tailor's chalk (substitute with laundry marker)
- ✓ Scissors

Directions

1. **Prep.** Wash and dry your sweater according to the label instructions, or have it professionally cleaned if there's no label.
2. **Repair.** Refer to Chapter 4 to repair any tears, holes, and stains as needed.
3. **Waist pinning.** Lay the waist of your sweater flat with the left and right side seams together and the waistband level as shown in Figure 13-14. Pin the seams together, slightly off center so as not to have multiple thicknesses at the seam. Continue pinning every 2 inches, placing pins perpendicular to the waistband edge.

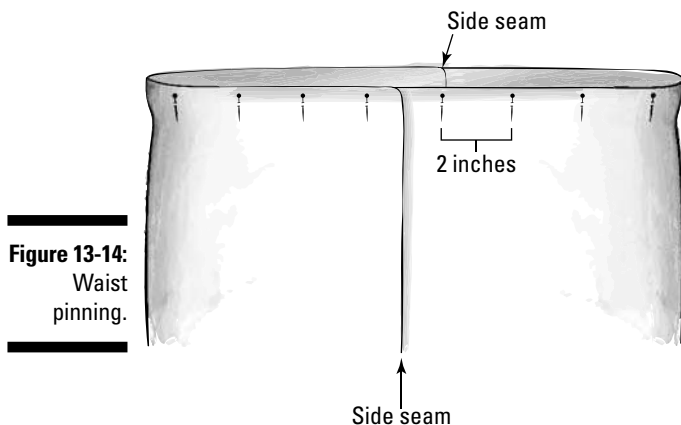

Figure 13-14:
Waist
pinning.

4. **Folding the cuffs.** Fold each cuff so that the underarm seam is approximately centered as shown in Figure 13-14.
5. **Cuff pinning.** Place one cuff inside the other, overlapping 2 inches. Arrange the seams just off-center to minimize the thicknesses of knit. Pin into place, with pins perpendicular to the cuff edge. Refer to Figure 13-15.
6. **Sew, using the method below that matches your sewing method.** The instructions depend highly on whether you are hand sewing or machine sewing. An overlock machine is not appropriate for this project.
 - **Sewing by hand:** Refer to Chapter 5 for hand-sewing techniques. Blanket stitch along the edge of the waistband, securing both sides of the waistband together. At the cuffs, also use a running stitch parallel to the cuff edge to sew the cuffs together at the midline of their overlap. Refer to Figure 13-15 for a visual on where to sew.

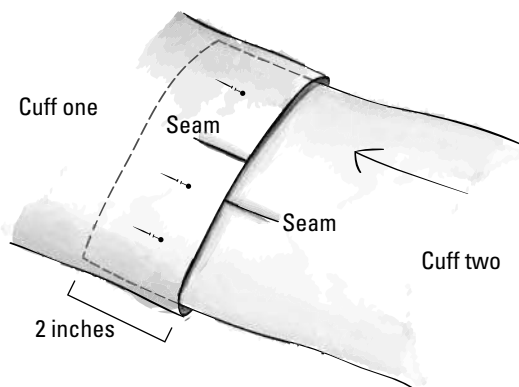

Figure 13-15:
Folding and
pinning
cuffs.

- **Sewing by machine:** Be sure to use the appropriate needle size and pressure for optimal feeding. Refer to your sewing manual for instructions on sewing multiple thicknesses. Using a zigzag stitch and a ½-inch seam allowance, sew along the edge of the waistband, securing both sides of the waistband together. At the cuffs, use a zigzag stitch parallel to the cuff edge to sew the cuffs together at the midline of their overlap. Refer to Figure 13-16 for a visual on where to sew.

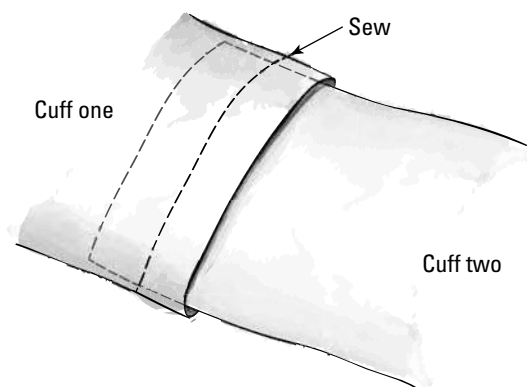

Figure 13-16:
Where
to sew.

- **Sewing with an overlock:** Be sure to use the appropriate needle size and pressure for optimal feeding. Serge along the edge of the waistband, securing both sides of the waistband together. Remove the cuffs from their overlapped position and sew edges together in a circle, forming a long tube of one sleeve running into the other.

Check out the sweater after reconstruction in Figure 13-17.



Figure 13-17:
After —
Bag Ladies
Shoulder-
bag.

Variations

For a decorative effect, try some of these ideas:

- ✔ **Thick stitches:** Complete all stitching by hand sewing with embroidery floss.
- ✔ **Thicker stitches:** Hand sewing over pre-sewn and secured edges with yarn or ribbon.
- ✔ **Mix colors:** Use a thread color that doesn't match, but complements the color of the sweater. With a sewing machine you can also use a different color for the bobbin thread. With an overlock machine, you can get really creative and use four to five different colors.
- ✔ **Stitching everywhere:** Decoratively stitch other areas of the bag, marking with tailor's chalk first if necessary. Decorative stitches include embroidery or deco-stitches on your machine.
- ✔ **Buttons:** Sew decorative buttons onto the bag. This is a great way to make use of those odds and ends buttons. Cluster a few together in a corner or line the seam with a row of buttons for a cleaner look. Keep within a color scheme, or within a certain style (art deco, fabric, glass carved) for a complete look.
- ✔ **No-sew deco techniques:** Some no-sew ideas include weaving ribbon or cord through the knit, grommeting, riveting, bedazzling and hot-gluing items (non-washable).



Chapter 14

Afghan Today, What Tomorrow?

In This Chapter

- ▶ Getting your afghan in good shape and keeping it that way
 - ▶ Investigating afghan incentives
 - ▶ Putting together projects to curl up and burrow into
-

Afghans are something that we're all familiar with but their value often goes overlooked. They are typically knitted or crocheted by hand, thus requiring hours of craftsmanship. Because it's a bit of a lost art, the afghans that you find in thrift stores or in your grandmother's house are often in a color scheme that's wretchedly dated. But revisiting this old treasure and giving it a new form can update this piece and finally evoke the appreciation it so deserves!

The projects in this chapter include fix-it tricks, as well as a couple lovely pieces to nuzzle into, ideally next to a cozy crackling fire!

Prepping, Primping, and Post Care for Your Afghan

Most afghans that I come across are made from acrylic yarns, but there's no guarantee. Since these pieces are likely hand-made, they won't have fabric content or laundering labels either. So it's best to start off by reading some of the care tips in Chapter 12 for more information on knit content, laundering foibles, and pre-cutting prep. Then bring your afghan to a dry-cleaner unless you are absolutely certain of its content and tolerance to washing in the machine. The dry-cleaner may also have some expertise and suggestions for future care of your afghan.

The usual suspects

The afghans that I have found thrift shopping are generally in great condition. Still check for these pitfalls and decide whether it's worth the plunge or not.



Always check for these common flaws in afghans:

- ✓ Smell (musty, smoke, or animal smells in particular)
- ✓ Torn or unraveled areas
- ✓ Stains and other wear and tear

Bang for your buck

It's a sin really. Afghans, while taking so many hours to create by hand, are generally one of the least expensive things I've found in thrift stores. Typically I've seen them priced between \$2 and \$5! From a reconstructing standpoint, this is a huge amount of raw material for virtually no cost!

Fringe fallout

Some afghans have fringe on the edges. It's typically composed of short lengths of yarn. If you will be using the fringed edge for your project and it's either old or has fallen out, you'll need to replace it. Unravel or untie one of the fringe sections and bring the yarn to the store with you to find a matching skein of yarn. If you can't find one that matches, you will have to replace all the fringe with a different, but complementing yarn. Cut the new yarn in lengths equivalent to the piece you unraveled. Use at least 3 pieces of yarn for each fringe section. Fold the yarn in half and insert the folded end through the edge of the afghan. Pull the loose ends of the yarn through the loop created by the fold. Pull tight. Refer to Figure 14-1.

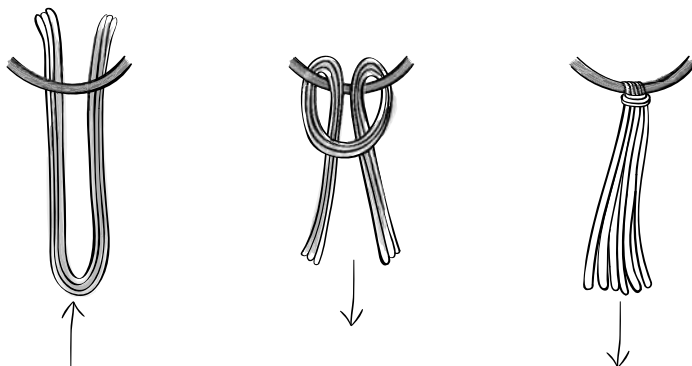

Figure 14-1:
Replacing
fringe.

Pimping the Poncho

Fear not! This is not your ordinary poncho. I dared for a moment to give you instructions on the standard poncho, but thankfully I smartened up and came up with a whole new design just for the readers of this book! This is a short poncho that can be slumped around the shoulders with a hood to snuggle up in!

This project easy. You start by basting and cutting a length of your afghan off. Spiral it around in a tube, pin and sew and that's it! All you have to do after that is enjoy it!

Check out the afghan prior to reconstruction in Figure 14-2.



Figure 14-2:
Before —
Pimping the
Poncho.

Materials

- ✓ Afghan with minimum dimensions of 17 x 60 inches
- ✓ Safety pins
- ✓ Tape measure
- ✓ Needle (for hand sewing) or sewing machine
- ✓ Thread that matches the afghan
- ✓ Tailor's chalk
- ✓ Scissors

Directions

- 1. Prep.** Have your afghan professionally cleaned.
- 2. Locate edge.** Lay the afghan out flat and find the edges (typically opposite edges) that have interesting detail such as fringe or scalloped (wavy) edges.
- 3. Marking your cut line.** Using your measuring tape, measure 17 inches along the fringed edge on each side. Mark these point with your tailor's chalk or a safety pin. Using your measuring tape as a straight edge, draw a line between the two points, fringed edge to fringed edge. Again substitute marking with safety pins if your tailor's chalk doesn't leave a mark on your afghan. Refer to Figure 14-3.



I like to use safety pins instead of common pins in afghans because of the loose knit. I find that common pins tend to slip out. They also have a tendency to get caught up in the bulk of the afghan while you are handling it.

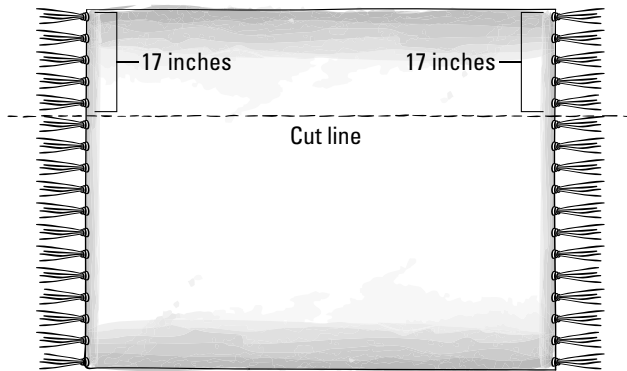

Figure 14-3:
Marking the
cut line.

- 4. Baste.** Refer to Chapter 5 for instructions on basting. Hand-baste or machine zigzag stitch on each side of the line you marked in Step 3.
- 5. Cut.** Cut along the line you just made.

Save the remaining piece of the afghan for a vestcoat later in this chapter, another poncho, or Sleek 'n' Sneaky Sleeves in Chapter 13.



6. **Repair.** Refer to Chapter 4 to repair any tears, holes, and stains as needed
7. **Pin in a spiral.** Lay the afghan flat with the basted edge closest to you. Measure 50 inches along the basted edge, starting at the left side. Mark this point with a safety pin. Fold the top left corner to the safety pin. Pin together. Continue rolling the top edge along the bottom edge and safety pinning every 5 inches until you reach the opposite fringed edge. Refer to Figure 14-4.

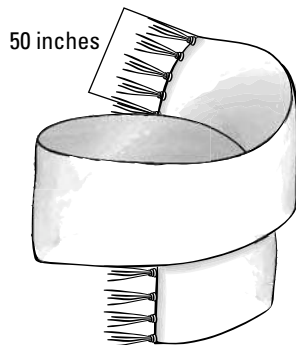

Figure 14-4:
Pinning in
a spiral.



If you are particularly narrow or wide in the shoulders, try the poncho on while it's pinned before you put in all the effort to sew it into place. Tighten up the spiral to make it smaller, or loosen it up to make it bigger.

8. **Sew using the method below that matches your sewing method.** The instructions depend highly on whether you are hand sewing, machine sewing or using an overlock machine.
 - **Sewing by hand:** Refer to Chapter 5 for hand-sewing techniques. Blanket stitch the pinned seam with a $\frac{1}{2}$ -inch seam allowance, making sure to catch every loop of the knit to prevent runs.
 - **Sewing by machine:** Zigzag stitch the pinned seam with a $\frac{1}{2}$ -inch seam allowance, making sure to catch every loop of the knit to prevent runs.
 - **Sewing with an overlock:** Be sure to use the appropriate needle size and pressure for optimal feeding. Serge the pinned seams, removing the pins before running it through the overlock. Be sure to catch every loop of the knit to prevent runs.

Check out the afghan after reconstruction in Figure 14-5. Figure 14-6 shows you how you can wear it.



Figure 14-5:
After —
Pimping the
Poncho.



Figure 14-6:
Wearing the
poncho.



Variations

- ✓ **Bias tape:** Cover your stitched seam with a decorative bias tape. This can be found in any sewing goods or fabric store, usually near the zippers in the Notions area. Bias tape comes in a variety of colors and can be either hand-sewn or machine-sewn on to cover the edge (instructions on package).
- ✓ **Thick stitches:** Complete all stitching by hand-sewing with embroidery floss.
- ✓ **Thicker stitches:** Hand sewing over pre-sewn and secured edges with yarn or ribbon.
- ✓ **Mix colors:** Use a thread color that doesn't match, but complements the color of the afghan. With a sewing machine you can also use a different color for the bobbin thread. With an overlock machine, you can get really creative and use four to five different colors.
- ✓ **Stitching everywhere:** Decoratively stitch other areas of the dress, marking with tailor's chalk first if necessary. Decorative stitches include embroidery or deco-stitches on your machine.
- ✓ **Buttons:** Sew decorative buttons onto the poncho. This is a great way to make use of those odds and ends buttons. Cluster a few together at the bottom corner or at the neckline. Sew a line of buttons on along the seam to emphasize the spiraling effect of the poncho! Keep within a color scheme, or within a certain style (art deco, fabric, glass, carved) for a complete look.
- ✓ **No-sew deco techniques:** Some no-sew ideas include weaving ribbon or cord through the knit, grommeting, riveting, bedazzling and hot-gluing items (non-washable).



Vestcoat Investments

In reconstructing and design, I love to take seemingly dissimilar things and blend them together. This project is a perfect example of this. Vestcoat Investments is a full-length sleeveless sweater that somehow brings the old country-looking afghan to new heights of elegance.

This project is moderately easy. It involves some fitting of the afghan first. But once you have that all set you can seam up the shoulders, then baste, cut and finish the arm-holes and you're all done!

Check out the afghan prior to reconstruction in Figure 14-7.

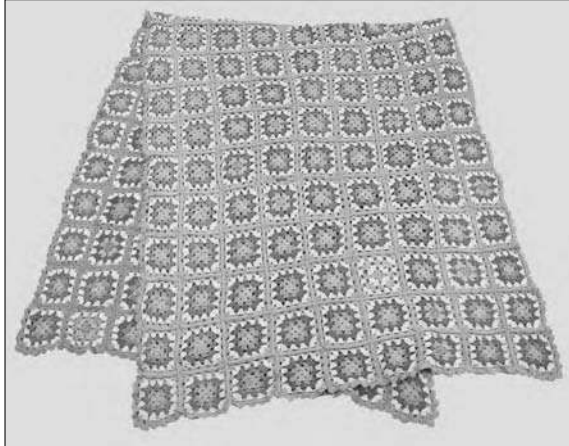

Figure 14-7:
Before —
Vestcoat
Investments.

Materials

- ✓ Afghan, ideally with fringe or an interesting edge
- ✓ Common pins
- ✓ Safety pins
- ✓ Tape measure
- ✓ Needle (for hand sewing) or sewing machine
- ✓ Thread that matches the afghan
- ✓ Tailor's chalk (substitute with laundry marker)
- ✓ Scissors

Directions

1. **Prep.** Have your afghan professionally cleaned.
2. **Locate edge.** Lay the afghan out flat and find the edges (typically opposite edges) that have interesting detail. These edges will be the front of your vestcoat. Refer to Figure 14-8.

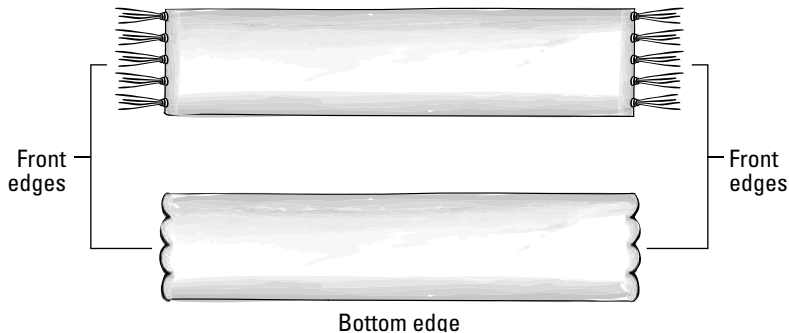

Figure 14-8:
Finding the
edges.

3. **Finding center.** Fold the afghan in half, front edges (found in Step 2) together. The fold is the center of the afghan. Mark this point at the top edge by putting a safety pin in it. Unfold the afghan.
4. **Measuring shoulder width on you.** Using your tape measure, measure the width of your shoulders, armpit to armpit across the back. Divide this number in half and make note of it.



It's much easier to have a friend measure your shoulders!

5. **Measure shoulder width on the afghan.** Using your tape measure and the number you found in Step 4, measure this amount from each side of the afghan center. Fold the afghan towards the center at each of these points. Safety pin the layers together at the fold and every two inches towards the center until you are three inches from the center. Refer to Figure 14-9.

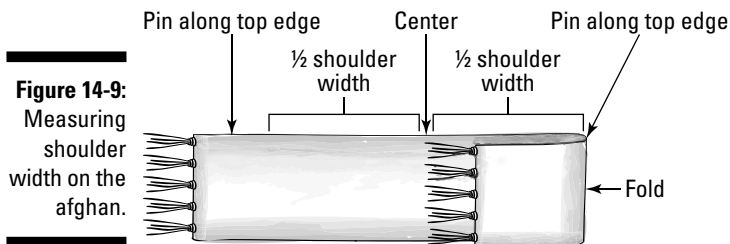

Figure 14-9:
Measuring
shoulder
width on the
afghan.

6. **Try it on.** Drape the afghan over your shoulders, the folded points being at the tip of your shoulder. There are two questions to answer with this. *Is there too much fabric left in the front*, as in, more than 1 foot on after the last pin? If so, use your tape measure to measure how much excess

length you would like to remove on each side. *Is it too long?* If so, mark the length at which you would like it to be by placing safety pins on the sides and back. Take the afghan off. Refer to Figure 14-10.

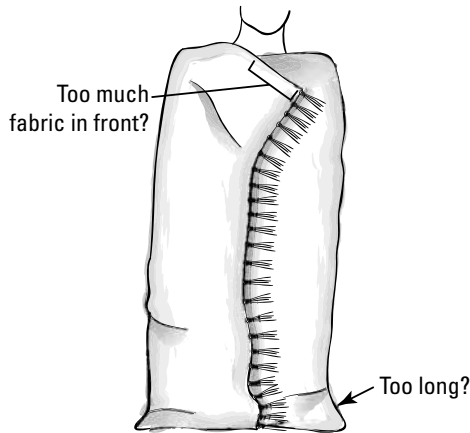

Figure 14-10:
Test-fitting.



- 1. Too long?** Remove the pins running between the two layers at the shoulders and lay the afghan flat.

Do not remove the pin that marks the center of the afghan!

Note the safety pins you placed to mark the desired length. Using your tape measure, measure each of these and determine an average number between them. Remove the pins. Measure the amount you determined from the bottom at two points. Mark each of these points with your tailor's chalk (or with a safety pin if tailor's chalk won't work on your afghan). Using your tape measure as a straight edge, draw a line across the entire width of the afghan, through these two points. If the tailor's chalk doesn't work to mark this line, place safety pins every 5 inches. Hand-baste or machine-zigzag stitch on each side this line, removing the safety pins as you go. Cut along the line to remove the excess fabric.

Save this lower edge scrap and turn it into Sleek 'n' Sneaky Sleeves (Chapter 13) or leave it as is for a fun scarf!





- 2. Too wide (too much fabric in front?)** If you haven't done so already, remove the pins in the shoulders, leaving the center point marked with a pin. Fold the afghan in half again as you did in Step 3. Using your tape measure, measure the half the total excess amount determined in Step 6 from the folded edge. Place a safety pin at this point. Make the same measure further down the length, marking with a safety pin through both layers. Using your tape measure as a straight edge, draw a line across the entire length of the afghan, through these two points. Mark the line by placing safety pins every 5 inches through both layers. Hand-baste or machine-zigzag stitch on this line, removing the safety pins as you go. Cut excess fabric off on the fold side of the line.

Save this scrap and use it as flare for the Upside-Down Skirt (Chapter 13) or finish the edges for a fun scarf!

- 7. Make arm holes.** Using your tape measure and the number you found in Step 4, measure this amount from each side of the afghan center. Mark each of these points with a safety pin. Mark a 6-inch vertical line at this point. Hand-baste or machine zigzag stitch around this line as shown in Figure 14-11. Cut along this line.

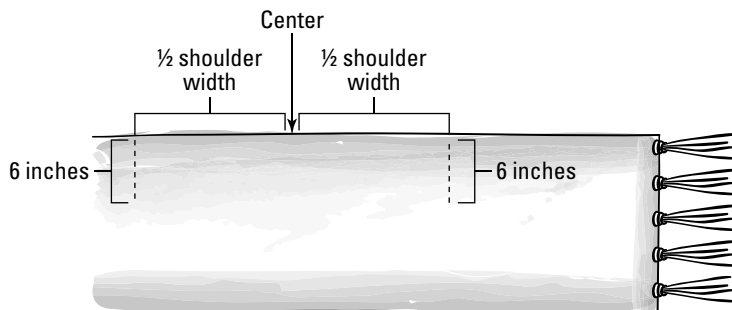

Figure 14-11:
Making arm
holes.

- 8. Make shoulders.** Repeat Steps 5 and 6, pinning the shoulders as close to the neck as you like.
- 9. Sew, using the method below that matches your sewing method.** The instructions depend highly on whether you are hand sewing, machine sewing or using an overlock machine.

- **Sewing by hand:** Refer to Chapter 5 for hand-sewing techniques. First blanket stitch the edge of the arm hole, then the back seam and then the bottom edge. Hem each of these in the same order, being sure to keep all seams on the inside. Finish by blanket stitching the shoulder seams. When sewing, be sure to catch every loop of the knit to prevent runs.
- **Sewing by machine:** Be sure to use the appropriate needle size and pressure for optimal feeding. Refer to your sewing manual for instructions on sewing multiple thicknesses. First zigzag stitch the edge of the arm hole, then the back seam and then the bottom edge. Refer to the hand-sewing techniques in Chapter 5 to hem each of these in the same order, being sure to keep all seams on the inside. Finish by zigzag stitching the shoulder seams together. When sewing, be sure to catch every loop of the knit to prevent runs. Run the knit through the machine twice to be sure.
- **Sewing with an overlock:** Be sure to use the appropriate needle size and pressure for optimal feeding. First serge the edge of the arm hole, then the back seam and then the bottom edge. Refer to the hand-sewing techniques in Chapter 5 to hem each of these in the same order, being sure to keep all seams on the inside. Finish by serging the shoulder seams together. When serging, be sure to catch every loop of the knit to prevent runs.

Check out the afghan after reconstruction in Figure 14-12.

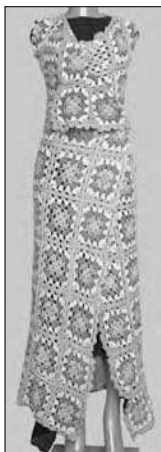

Figure 14-12:
After —
Vestcoat
Investments.

Variations

For a decorative effect, try some of these ideas:

- ✔ **Raw look:** Leave out the hemming for a raw finish.
- ✔ **Bias tape:** Cover your seams and hems with a decorative bias tape. This can be done to just neaten up the interior, or turn the seams inside out for a decorative seam. Bias tape can be found in any sewing goods or fabric store, usually near the zippers in the Notions area. Bias tape comes in a variety of colors and can be either hand-sewn or machine-sewn on to cover the edge (instructions on package).
- ✔ **Get creative with the cut line:** Instead of keeping the edges of your vestcoat straight, get creative with cutting curves and other shapes into it. Cut it short, asymmetrical or with tails as in the Tails of Two Crops in Chapter 8.
- ✔ **More frill:** Add frill to the edge of a short vestcoat by adding scraps of material on to the bottom edge prior to hemming.
- ✔ **Thick stitches:** Complete all stitching by hand-sewing with embroidery floss.
- ✔ **Thicker stitches:** Hand-sewing over pre-sewn and secured edges with yarn or ribbon.
- ✔ **Mix colors.** Use a thread color that doesn't match, but complements the color of the afghan. With a sewing machine you can also use a different color for the bobbin thread. With an overlock machine, you can get really creative and use four to five different colors.
- ✔ **Stitching everywhere:** Decoratively stitch different areas of the vestcoat, marking with tailor's chalk first if necessary. Good areas to focus on include the collar and edges. Decorative stitches include embroidery or deco-stitches on your machine.
- ✔ **Buttons:** Sew decorative buttons onto the edges of the vestcoat. This is a great way to make use of those odds and ends buttons. Keep within a color scheme, or within a certain style (art deco, fabric, glass, carved) for a complete look.
- ✔ **No-sew deco techniques:** Some no-sew ideas include weaving ribbon or cord through the knit, grommeting, riveting, bedazzling and hot-gluing items (non-washable).



Part V

Skirts and Dresses (re)Done Right

The 5th Wave

By Rich Tennant

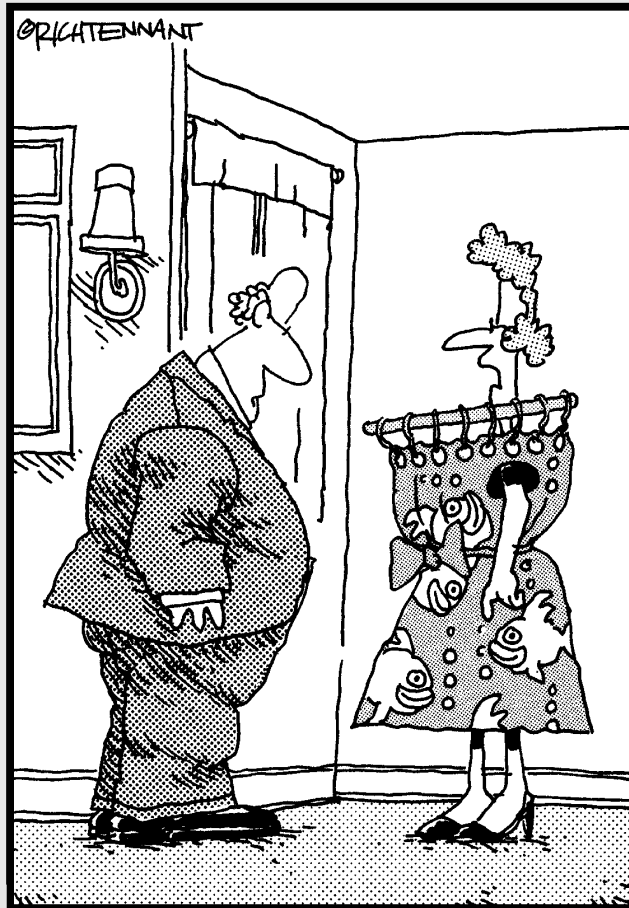

"Maybe a shower curtain wasn't the best thing to try and make into an evening dress."

In this part . . .

I made sure in this part that you can find a project to equal any chick-flick-'n'-chocolate session: tearing apart that bridesmaid dress! No need to wait in vain for some reason to wear it again. Trust me, you can have much more fun chopping it up!

In addition to the projects for the bridesmaid dress, you can find lots of ideas for not only dresses but skirts as well. Some are just simple decorative accents to make your co-workers give you a double-take. Others border on more costume-like adventures . . . so get your guts up and go for it!

Chapter 15

Bridesmaid's Redemption

In This Chapter

- ▶ Handling that bridesmaid dress before and after you give it a new look
 - ▶ Keeping a keen eye out for mishaps
 - ▶ Completing projects to wear yourself and give away
-

The bridesmaid dress, and its equivalently horrible mother-of-the-bride, mother-of-the-groom and prom dresses are, more often than not, very expensive one-wear-wonders. It's unfortunate that such lovely occasions are tainted with such wastefulness. No more! It's time to release these old dresses from the shackles of their garment bags stuffed at the far end of the closet. Why make them continue to wait in vain for another public viewing that will never come, at least not in their present shape? It's downright criminal!

I've personally had my fill of pastel wonders in satin. I've also had some fantastic Halloween costumes as a result! I find the dominating obstacle in reconstructing these prized pieces is the idea of ripping apart something that cost so much money. But if it's only hanging in the closet anyway, there's only profit to be gained in reconstructing it. At the very least, even if you screw it up beyond any salvation, it will give you more closet space. The other obstacle is the sentimental connection. But like all connections, things evolve. Your dress is welcome to evolve as well. On the other hand, if it was a hideous dress, or a hideous engagement, tearing it up can be immensely therapeutic!

The projects in this chapter range from costume to conventional, both simple to complete and completely pleasurable to rip to shreds!

Prepping, Primping, and Post Care for Your Dress

These dresses can be rather high maintenance. But with a little knowledge and flexibility, they don't always have to be this way.

The usual suspects

These dresses are aplenty in larger thrift stores. I've even heard of entire bridal parties *finding* matching dresses in a single thrift shop! Now *that's* a clever alternative to forking out mad cash on something you only wear once! Whether you are working from your own dress or seeking one out elsewhere, you'll need one that fits well for the A Little Heat Gun Goes A Long Way project. Everything else is forgiving in regards to fit, so just keep in mind some usual bridesmaid mishaps.



Always check for these common flaws in bridesmaid dresses:

- ✓ Torn or dirty hem (especially for outdoor weddings)
- ✓ Stains (makeup, wine and food are most prevalent on the front of the dress, or lipstick might be on the inside as well)
- ✓ Armpit stains
- ✓ Missing or loose decorative beading and appliqué
- ✓ Snags and pulls (usually at hips or rear-end from sitting)

Dry clean or bust

I have yet to come across a bridesmaid dress that wasn't "dry clean only." However, I haven't always paid heed to that, especially when I plan to reconstruct it into something intentionally distressed. Projects that have this capacity include the Split Skirt Stick-Up and Whip Up a Wine Bag. For these projects you may be okay with hand-washing in cold and drying flat (no dryer). Refer to Chapter 4 for more specific guidelines on when it might be okay to get away with passing over professional cleaning.

A Little Heat Gun Goes a Long Way Dress

I got a heat gun a few years ago for purposes of embossing stamped effects into my garments. Through a fortunate accident, I discovered its capacity for gently melting synthetic fabrics and thus heat-sealing seams! Soon this developed into a decorative effect resembling a war-ravaged version of the dress's former design.

This project easy. It's a rather unique piece, best suited for costuming or the daring unique individual who wears "costume" every day. You can choose to melt just the existing edges, or cut the dress into shreds for lots of edges!

Check out the dress prior to reconstruction in Figure 15-1.



Figure 15-1:
Before —
A Little Heat
Gun Goes a
Long Way
Dress.



This is entirely a no-sew project!

Materials

- ✓ Dress that fits well (synthetic fabric, not silk, cotton, linen or other natural fibers)
- ✓ Heat gun
- ✓ Scissors

Directions

1. **Prep.** Have your dress professionally cleaned.
2. **Repair.** Refer to Chapter 4 to repair any tears, holes, and stains as needed.

3. **Design decision.** Decide whether you would like to raw up just the bottom edges or scrap up more of the garment.
4. **Cut.** Using your scissors, cut the hem off. Continue to cut any other edges you would like to heat-seal. Refer to Figure 15-2 for ideas on more simple looks. Refer to Figure 15-3 for ideas on more ravaged costume looks.

Figure 15-2:
Simple
ideas for
cut-lines.

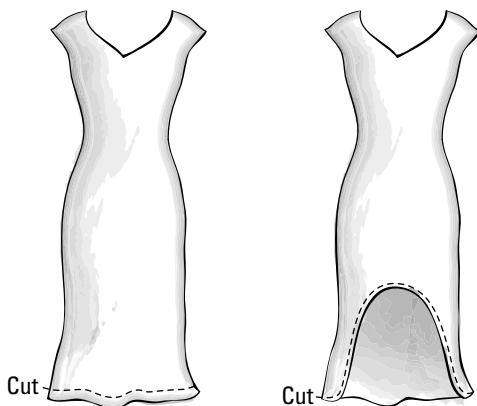
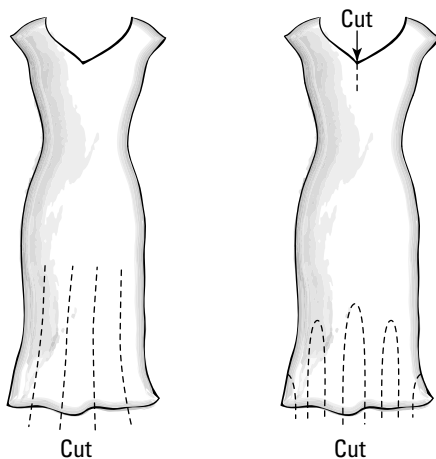

Figure 15-3:
Costume
ideas for
cut lines.



5. **Prep work area.** Be sure to work in a well-ventilated area. Your work surface should be heat resistant and free of other items that might melt while you are working with the heat gun. Keep the area free of other hazards, children, and animals that may trip up the cord and cause your heat gun to move or fall off the work surface.
6. **Heat seal.** Warm up your heat gun according to the instructions that came with it. Taking care to keep your hands out of the direct line of the heat

gun, aim it at an angle towards the edge you just cut. Keep the heat gun at least approximately 3 inches from the fabric. Keep it moving back and forth within an inch along the edge. This area should start to melt within a few seconds. When it starts to melt, move the heat gun smoothly along the edge, continuing the melting process as you go. Refer to Figure 15-4.

Figure 15-4:
Heat sealing
the edges.

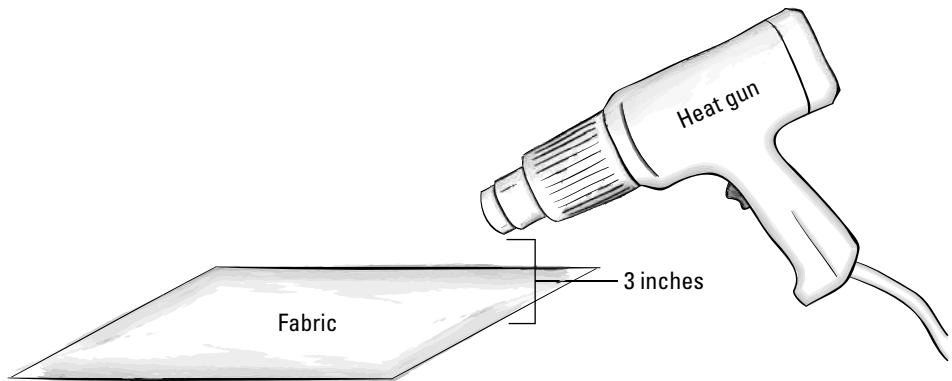

Check out the dress after reconstruction in Figure 15-5.



Figure 15-5:
After —
A Little Heat
Gun Goes a
Long Way
Dress.

Variations

For a decorative effect, try cutting holes in the middle of the fabric to heat seal. You can also point the heat cut directly onto the solid fabric to create crimping and holes. I like to create a crimped area and then stretch it out to tear open a hole.

Split Skirt Stick-Up

Being that the fabrics of bridesmaid dresses are so lovely and fancy, I like to blend them with less formal fabrics to balance them out. The Split Skirt Stick-Up is a good example of this. An all-pants version of the split skirt is in Chapter 9. This version makes use of the pants as a base, with a length of dress fabric sewn into both the front and back.

This project is moderately easy. You just cut the inseam of a pair of pants, trimming off the crotch. Then you patch in the scrap fabric from the bridesmaid dress, hem the whole skirt and you're done!

Check out the dress and pants/jeans prior to reconstruction in Figures 15-6 and 15-7.



Figure 15-6:
Split Skirt
Stick-Up.

Materials

- ✓ Bridesmaid dress
- ✓ Pants or jeans that fit well in the waist and complement the color of the dress

- ✓ Common pins
- ✓ Tape measure
- ✓ Needle (for hand sewing) or sewing machine
- ✓ Thread that matches the dress
- ✓ Tailor's chalk (substitute with laundry marker)
- ✓ Seam ripper
- ✓ Scissors



Figure 15-7:
Split Skirt
Stick-Up.

Directions

1. **Prep.** Have your dress professionally cleaned. Wash and dry your pants according to the label instructions, or have them professionally cleaned if there's no label.



If you are feeling daring, you can try hand-washing in cold and flat-dry (no dryer). Refer to Chapter 4 for more information on whether this is a feasible option for you.

2. **Cut.** Cut two rectangles of material from the dress, approximately 20 inches wide by 30 inches long.

In choosing where to cut these rectangles, you can work your way around stains, snags and other mishaps.

Save your scrap pieces for Wine Bags later in this chapter.



3. **Repair.** Refer to Chapter 4 to repair any remaining tears, holes, and stains in the dress material.
4. **Locate the inseam.** Refer to Figure 15-8 to locate the inseam of the pants.

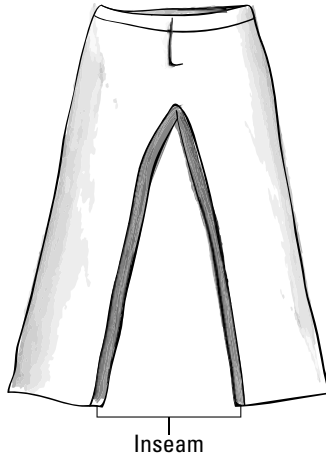

Figure 15-8:
Locating the
inseam.

5. **Rip it.** Using your seam ripper, rip open the inseams of the pants. Also rip open any cuffs on the pants, or cut them off completely.
6. **Marking the cut line.** Fold the pants in half and lie them flat. Using your tape measure as a straight edge, and your tailor's chalk, draw a line from a point 1 inch below the base of the zipper to the corner of the cuff. Draw a similar line on the back side, from the back seam before it starts to curve out, to the bottom cuff. Refer to Figure 15-9.
7. **Cut.** Keeping the pants folded, cut both layers along the lines you made with your tailor's chalk.
8. **Repair.** Refer to Chapter 4 to repair any tears, holes, and stains in the pants as needed.
9. **Turn it out.** Turn the pants inside out.

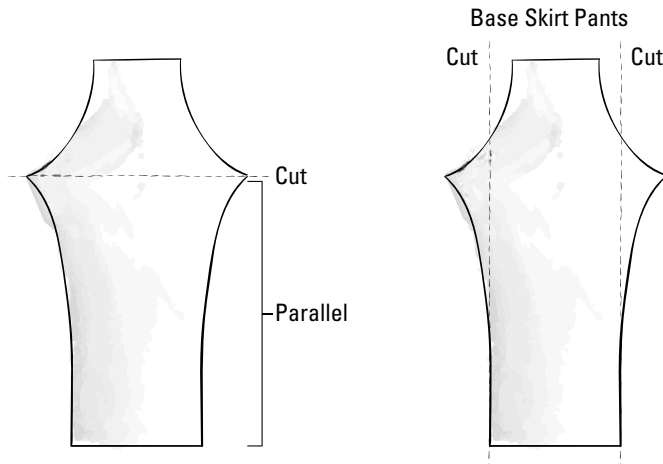

Figure 15-9:
Cut line for
pants.

- 10. Align and pin.** Line up the corner of the dress material with the wedge-shape (formerly the inseam) beneath the zipper of the pants. With right sides facing each other and a ½-inch seam allowance, pin the edges together. Place pins diagonally at each corner and perpendicular to the edge every 1 inch. Repeat with the back side and second piece of dress material. Refer to Figure 15-10.



Corners such as this are tricky. The safest bet is to leave extra dress material (approximately 1 inch) in this corner so that you have something to work with. And never be afraid to ask a more experienced sewer for help.

- 11. Sew, using the method below that matches your sewing method.** The instructions depend highly on whether you are hand sewing, machine sewing or using an overlock machine.

- **Sewing by hand:** Refer to Chapter 5 for hand-sewing techniques. Blanket stitch the pinned seams with a ½-inch seam allowance. Then hem the edge using the quick hem technique. Turn the skirt right side out.
- **Sewing by machine:** Straight stitch the pinned seams with a ½-inch seam allowance. Hem the bottom edge by hand using a quick hem technique described in Chapter 5. Turn the skirt right-side out.
- **Sewing with an overlock:** Be sure to use the appropriate needle size and pressure for optimal feeding. Serge the pinned seams, removing the pins before running it through the overlock. Hem the bottom edge by hand using a quick hem technique described in Chapter 5. Turn the skirt right side out.



Instead of sewing a finished hem, you can use no-sew hem tape. This tape is just ironed on! You can find it in your local fabric or craft store, online, or even in major supermarkets and department stores.

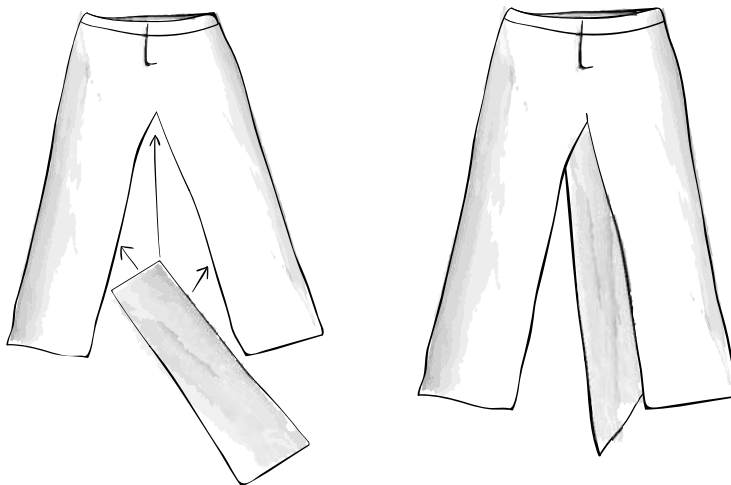

Figure 15-10:
Lining up
and pinning
your pants
and dress
together.

Check out the dress after reconstruction in Figure 15-11.



Figure 15-11:
After —
Split Skirt
Stick-Up.

Variations

For a decorative effect, try some of these ideas:

- ✓ **Raw look:** Skip Step 9 and pin with wrong sides facing. This will result in an external raw seam. Instead of finishing the edge with a hem, leave out this step and blanket stitch (hand sewing), zigzag stitch (machine sewing) or serge the edge (overlock.)
- ✓ **Bias tape:** Instead of hemming the edge or leaving it raw, you can cover it with a decorative bias tape. This can be found in any sewing goods or fabric store, usually near the zippers in the Notions area. Bias tape comes in a variety of colors and can be either hand-sewn or machine-sewn on to cover the edge (instructions on package).
- ✓ **Get creative with the cut line:** Instead of keep the bottom edge straight, get creative with curves or other shapes.
- ✓ **Thick stitches:** Complete all stitching by hand sewing with embroidery floss.
- ✓ **Thicker stitches:** Hand sewing over pre-sewn and secured edges with yarn or ribbon.
- ✓ **Mix colors:** Use a thread color that doesn't match, but complements the color of the pants and/or dress. With a sewing machine you can also use a different color for the bobbin thread. With an overlock machine, you can get really creative and use four to five different colors.



- ✔ **Stitching everywhere:** Decoratively stitch other areas of the skirt, marking with tailor's chalk first if necessary. Decorative stitches include embroidery or deco-stitches on your machine.
- ✔ **No-sew deco techniques:** Some no-sew ideas include painting, grommeting, riveting, bedazzling, dyeing, bleaching, drawing with fabric markers or even sharpie markers. Make stripes on your skirt with gaffer's or masking tape. Spray a light coat of spray paint over it, let dry and repeat until you get the desired color saturation. Remove the tape to reveal super-hot stripes!

Cape — from Costume to Couture

Capes are an elegant evening cover-up for those dressy occasions when you just don't have the right coat. They also make great superhero/heroine accessories! This particular cape incorporates a wrapped method of wearing it, for increased elegance.

This project is fairly easy. You start by cutting the dress at the waist. Then cut off a length of the bottom, reattaching it at the more narrow waist part. Finish the seams and you've got a new cape!

Check out the dress prior to reconstruction in Figure 15-12.



Figure 15-12:
Before —
Cape —
from
Costume to
Couture.

Materials

- ✓ Bridesmaid dress
- ✓ Common pins
- ✓ Tape measure
- ✓ Needle (for hand sewing) or sewing machine
- ✓ Thread that matches the dress
- ✓ Tailor's chalk (substitute with laundry marker)
- ✓ Scissors

Directions

1. **Prep.** Have your dress professionally cleaned.
2. **Mark the cut-line.** Lie the dress flat. Using your tape measure, measure from the armpit down to a point at the waist on each side. Mark these points with your tailor's chalk. Using the tape measure as a straight edge, draw a horizontal line connecting the two points. Next, measure 10 inches from the bottom seam and mark the point with your tailor's chalk. Repeat this measure every 5 inches from the bottom edge. Using your tape measure as a straight edge, draw a line connecting these points. Refer to Figure 15-13.



By laying the dress flat with the bottom hem even, you can cut your work time in half by measuring and marking the top half of the dress, and then carefully cutting through two layers at a time.

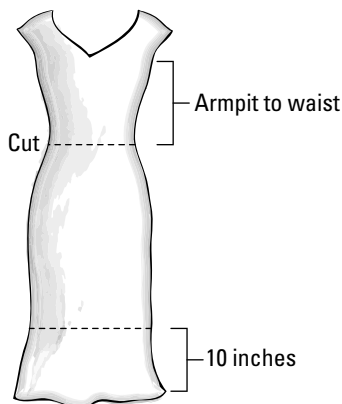

Figure 15-13:
Marking the
cut line.

3. **Cut.** Cut along the lines you just made. Cut open the back seam.



Use the upper scrap portion of the dress for scrap material in the Detachable Bustle in Chapter 9.

4. **Finding centers.** Fold both pieces of the skirt in half. Mark the fold, the center of each piece, using your tailor's chalk. Mark the waist edge of the larger piece, and the cut edge of the 10-inch-wide piece.
5. **Pin.** Pin the marked points of each piece together, right sides facing as shown in Figure 15-14. Place pins diagonally at each corner and perpendicular to the edge every 1 inch.

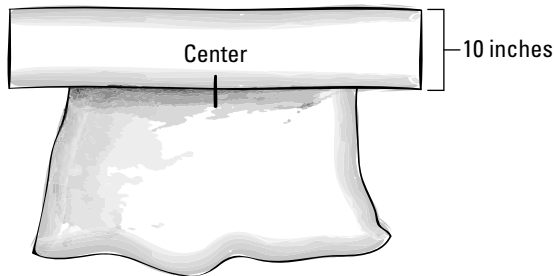

Figure 15-14:
Pinning
your cape.

6. **Sew, using the method below that matches your sewing method.** The instructions depend highly on whether you are hand sewing, machine sewing or using an overlock machine.
 - **Sewing by hand:** Refer to Chapter 5 for hand-sewing techniques. Quick hem the vertical seams (formerly the back seam) first. Then use a running stitch ($\frac{1}{2}$ -inch seam allowance) to sew the two pieces together at the pinned seam. Hem the cut edges (the lower portion of the wrap and the bottom of the cape).
 - **Sewing by machine:** Quick hem the vertical seams (formerly the back seam) first, referring to Chapter 5 for hand-sewing techniques. Then use a straight machine stitch ($\frac{1}{2}$ -inch seam allowance) to sew the two pieces together at the pinned seam. Hem the cut edges (the lower portion of the wrap and the bottom of the cape).
 - **Sewing with an overlock:** Quick hem the vertical seams (formerly the back seam) first, referring to Chapter 5 for hand-sewing techniques. Then serge the two pieces together at the pinned seam. Hem the cut edges (the lower portion of the wrap and the bottom of the cape).



Instead of sewing a finished hem, you can use no-sew hem tape. This tape is just ironed on! You can find it in your local fabric or craft store, online, or even in major supermarkets and department stores.

7. **Repair.** Refer to Chapter 4 to repair any tears, holes, and stains as needed.

Check out the dress after reconstruction in Figure 15-15.



Figure 15-15:
After —
Cape —
from
Costume to
Couture.

Variations

For a decorative effect, try some of these ideas:

- ✔ **Raw look:** Instead of finishing the edge with a hem, leave out this step and blanket stitch (hand sewing), zigzag stitch (machine sewing) or serge the edge (overlock) for a raw finish.
- ✔ **Bias tape:** Instead of hemming the edge or leaving it raw, you can cover it with a decorative bias tape. This can be found in any sewing goods or fabric store, usually near the zippers in the Notions area. Bias tape comes in a variety of colors and can be either hand-sewn or machine-sewn on to cover the edge (instructions on package).
- ✔ **Get creative with the cut line:** Instead of keeping the edges straight, get creative with curves and other shapes.
- ✔ **Thick stitches:** Complete all stitching by hand sewing with embroidery floss.
- ✔ **Thicker stitches:** Hand sewing over pre-sewn and secured edges with yarn or ribbon.
- ✔ **Mix colors:** Use a thread color that doesn't match, but complements the color of the dress. With a sewing machine you can also use a different color for the bobbin thread. With an overlock machine, you can get really creative and use four to five different colors.
- ✔ **Stitching everywhere:** Decoratively stitch other areas of the cape, on just the corners, just the wrap portion, or all over the whole piece! Mark

the area with your tailor's chalk first if necessary. Decorative stitches include embroidery or deco-stitches on your machine.

- ✓ **Buttons:** Sew decorative buttons onto the edges or wrap portion of your cape. This is a great way to make use of those odds and ends buttons. Keep within a color scheme, or within a certain style (art deco, fabric, glass, carved) for a complete look.
- ✓ **No-sew deco techniques.** Some no-sew ideas include painting, grommeting, riveting, bedazzling, dyeing, bleaching, drawing with fabric markers or even sharpie markers. Use a heat gun to seal the raw edges of synthetic fabrics, referring to the instruction on the heat gun project earlier in this chapter. Make stripes on your cape with gaffer's or masking tape. Spray a light coat of spray paint over it, let dry and repeat until you get the desired color saturation. Remove the tape to reveal super-hot stripes!



Whip Up a Wine Bag



The Whip Up A Wine Bag project is not only a good use of your scraps, but it's a good incentive to give a gift! This particular wine bag is a very basic tube of fabric sealed at the bottom and tied with a ribbon. With such elegant fabric you can pull off simplicity with grace!

This project is easy. Basically you just cut a rectangle of fabric, fold it and sew together two of three edges. Add a ribbon (or cluster of deco scraps if you're feeling crafty) and you're ready to be the hit of the party. Oh, and don't forget to put the wine bottle in first!

Check out the dress prior to reconstruction in Figure 15-16.



Figure 15-16:
Before —
Whip Up a
Wine Bag.

Materials

- ✓ Bridesmaid dress
- ✓ Ribbon (minimum 20 inches long)
- ✓ Common pins
- ✓ Tape measure
- ✓ Needle (for hand sewing) or sewing machine
- ✓ Thread that matches the dress
- ✓ Tailor's chalk (substitute with laundry marker)
- ✓ Scissors

Directions



1. **Prep.** Have your dress professionally cleaned.

If you are feeling daring, you can try hand-washing in cold and flat-dry (no dryer.) Refer to Chapter 4 for more information on whether this is a feasible option for you.

2. **Marking the cut line.** Using your tailor's chalk, mark a point on the hem. Using your tape measure, measure 15 inches across the hem of the dress. Mark the second point. Measure 20 inches straight down from each point, marking two more points 15 inches apart from each other. Using your tape measure as a straight edge, connect the marks for a rectangle. Refer to Figure 15-17. Check the length of the diagonals to see if your rectangle is really a rectangle; they should be pretty similar if not the same.

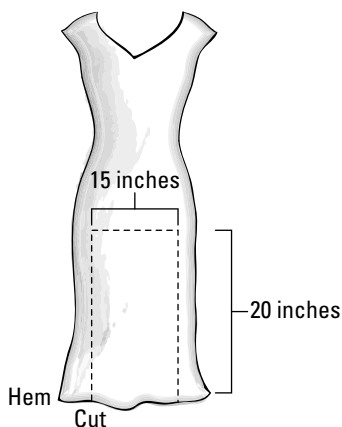

Figure 15-17:
Marking the
cut line.



In choosing where to mark the cutting line, you can work your way around stains, snags and other mishaps. Save time and effort by cutting material for several wine bags at once!

3. **Cut.** Cut along the lines you just made.
Save your scrap for the Freeform and Frill skirt in Chapter 16!
4. **Repair.** Refer to Chapter 4 to repair any remaining tears, holes, and stains in the dress material.
5. **Fold and pin.** Fold the rectangle in half, right sides facing each other. Using common pins, pin the layers together along the cut edge. Place pins diagonally at each corner and perpendicular to the edge every 1 inch.
6. **Sew, using the method below that matches your sewing method.** The instructions depend highly on whether you are hand sewing, machine sewing or using an overlock machine.
 - **Sewing by hand:** Refer to Chapter 5 for hand-sewing techniques. Running stitch the entire cut edge.
 - **Sewing by machine:** Straight stitch the entire cut edge.
 - **Sewing with an overlock:** Be sure to use the appropriate needle size and pressure for optimal feeding. Serge the entire cut edge.
7. **Post-prep.** Turn the bag right side out. Put your wine bottle in it and tie a ribbon around the top, with the neck of the wine bottle tied securely in the ribbon as well. Dress up the ribbon with scraps, flowers or other decorative accents.

Check out the dress after reconstruction in Figure 15-18.



Figure 15-18:
After —
Whip Up a
Wine Bag.

Variations

For a decorative effect, try some of these ideas:

- ✓ **Raw look:** Create a raw finish on the top edge by blanket stitching (hand sewing), zigzag stitching (machine sewing) or serging (overlock) the top edge of the wine bag.
- ✓ **Bias tape:** Instead of creating a raw finish on the top edge, you can cover it with a decorative bias tape. This can be found in any sewing goods or fabric store, usually near the zippers in the Notions area. Bias tape comes in a variety of colors and can be either hand-sewn or machine-sewn on to cover the edge (instructions on package.)
- ✓ **Thick stitches:** Complete all stitching by hand sewing with embroidery floss.
- ✓ **Thicker stitches:** Hand sewing over pre-sewn and secured edges with yarn or ribbon.
- ✓ **Mix colors:** Use a thread color that doesn't match, but complements the color of the wine bag. With a sewing machine you can also use a different color for the bobbin thread. With an overlock machine, you can get really creative and use four to five different colors.
- ✓ **Stitching everywhere:** Decoratively stitch other areas of the wine bag, marking with tailor's chalk first if necessary. Decorative stitches include embroidery or deco-stitches on your machine.
- ✓ **Buttons:** Sew decorative buttons onto the wine bag. Make vertical lines of buttons or random clusters. Keep within a color scheme, or within a certain style (art deco, fabric, glass, carved) for a complete look.
- ✓ **No-sew deco techniques:** Some no-sew ideas include painting, grommeting, riveting, bedazzling, dyeing, bleaching, drawing with fabric markers or even sharpie markers. Make stripes on your wine bag with gaffer's or masking tape. Spray a light coat of spray paint over it, let dry and repeat until you get the desired color saturation. Remove the tape to reveal super-hot stripes!



Chapter 16

Second Life For Your Skirt

In This Chapter

- ▶ Caring for and handling of your skirt
 - ▶ Making pleasing things from unsightly flaws!
 - ▶ Perusing projects from head to toe
-

I love skirts! On rare occasions, usually close to laundry day, I can be found wearing a pair of pants. But most every morning I climb into layers of skirts. Not only are they comfortable, but for some reason everyone thinks you're "dressed up" in a skirt, even when it's torn to shreds and covered in paint like most of mine.

While there are certain items that can be found en masse in thrift stores, the quality is not always top notch. Skirts, however, are generally in great condition. The problems with them lie more in their outdated style and fit. This chapter will help solve these problems and expand your wardrobe.

The projects in this chapter include two ways to flare up your skirt and one to wrap your head around!

Prepping, Primping, and Post Care for Your Skirt

Skirts vary widely in their fabric content. Check the laundering label and wash it prior to your reconstruction project. If your label is missing, refer to Chapter 4 for guidelines of when to have it professionally cleaned, and when it might be safe to just gentle wash it in cold water and dry flat (no dryer).

Working your butt off!

Every so often a friend gives me a rather sentimental piece of their clothing to “do my thing” with. It usually comes with a story, and I involve that story into what I create from it. I honor clothing that represents our evolution in it, even when the result appears tattered to the naked eye. One such example occurred with a friend and her old business suit. It was a beautiful custom-tailored red suit that she was forbidden to wear after her employer of many years sold out to a big corporation. From that point on she was required to wear a boxy dark suit, stripped

of personality, similar to the new format of the company. After continuing to wear the red suit, soon enough my friend was fired from her position. When she gave me the suit I noticed that the lining had been worn to nearly nothing in some parts. She had literally worked her butt off for a company for 20 years, only to be shut out when it sold out and didn't care about *people* anymore. In reconstructing the suit I removed the worn sections and patched them onto the front of the coat to fully honor her life's work and the beauty she created with it.

The usual suspects

When thrift shopping for skirt, the fit, particularly in the waist, can be the biggest flaw. Skirts are constantly changing styles and most can be reckoned with in reconstruction. But a too-high or too-low fitting waist is not something you want to mess with. Start with one that fits well, and then take a peek for flaws that you may or may not be able to work with. When all fails in the fit, you always have the option of turning it into a cowl neck, the last project in this chapter.



Always check for these common flaws in skirts:

- ✓ Torn or worn rear end (check the lining too!)
- ✓ Holes in pockets
- ✓ Distorted and worn waist
- ✓ Torn hem on long skirts
- ✓ Stains at the hips and hem
- ✓ Broken zipper
- ✓ Missing snap, button or other closure

Freeform and Frill Skirt

This skirt is basically permission for you to play! There's really no wrong way to screw it up. Experimenting is encouraged within the guidelines of the simplest form: a skirt with slits of other fabric patched into it.

This project is easy. You start by cutting out rounded sections of the skirt, sewing in lengths of fabric, and continue cutting and sewing in fabric as you like!

Check out the skirt prior to reconstruction in Figure 16-1.



Figure 16-1:
Before —
Freeform
and Frill
Skirt.

Materials

- ✓ Skirt that fits well in the waist
- ✓ Scrap fabric, minimum of 3 lengths at least twice the length of the skirt and 10 inches wide
- ✓ Common pins
- ✓ Tape measure
- ✓ Needle (for hand sewing) or sewing machine
- ✓ Thread that matches the skirt
- ✓ Tailor's chalk (substitute with laundry marker)
- ✓ Scissors

Directions

1. **Prep.** Wash and dry your skirt according to the label instructions, or have it professionally cleaned if there's no label.
2. **Mark the cut line.** The number of lengths of scrap fabric you have, and your own design decision, will determine the number rounded sections you cut out of the skirt. Using your tape measure, measure around the width of the bottom hem. Divide this number by the number of sections you wish to make. This number is the bottom width of each section.

Using your tailor's chalk, mark a point on the hem of the skirt where you would like to start a section. I usually start this on the side seam. Measure the section width from this point and mark a second point. Repeat until all the points are marked. Using your tailor's chalk, draw an arch into the skirt, starting at one point and ending at the next point. The top of the arch should be no more than 5 inches below the waist. Continue drawing arches between all points. Refer to Figure 16-2.



Five inches from the waist is a minimum measure. If you would like a more conservative skirt, or would like your frills concentrated at the bottom, make the top of the arch lower (further from the waist.)

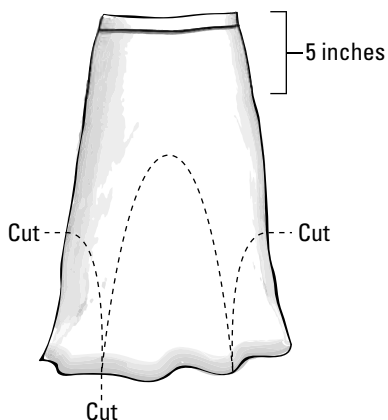

Figure 16-2:
Marking cut
lines.



3. Cut. Cut the lines you just made.

Save your scrap for Sachet Simplicity in Chapter 19.

4. Turn it out. Turn the skirt inside out.

5. Align and pin. With right sides facing each other, line up the bottom corner of a cut arch with the corner of the scrap fabric. Pin the two layers together. Continue pinning the length of the scrap piece to the cut edge of the arch, placing the pins perpendicular to the cut edge every 1 inch as shown in Figure 16-3.

6. Sew, using the method below that matches your sewing method. The instructions depend highly on whether you are hand sewing, machine sewing or using an overlock machine.

- **Sewing by hand:** Refer to Chapter 5 for hand-sewing techniques. Running stitch the pinned seam with a ½-inch seam allowance. Remove the pins.
- **Sewing by machine:** Straight stitch the pinned seam with a ½-inch seam allowance. Remove the pins.
- **Sewing with an overlock:** Serge the pinned seam, removing the pins before running it through the overlock.

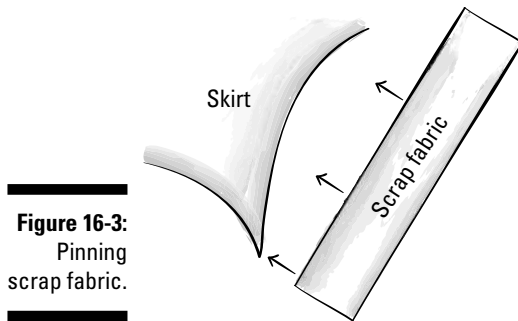

Figure 16-3:
Pinning
scrap fabric.



- 7. Cut.** Cut off any excess scrap fabric. Cut in a direction that will keep an even line with the remaining edge. Refer to Figure 16-4.

Save your scrap for Save It All Stuffing in Chapter 18.

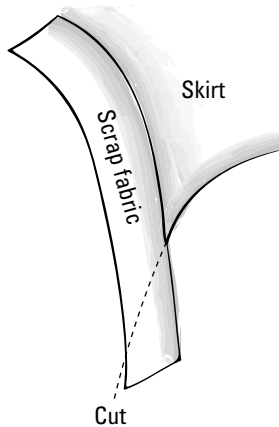

Figure 16-4:
Cutting off
excess
fabric.

- 8. Repeat Steps 5 through 7.** Repeat Steps 5 through 7 with each of the remaining pieces of scrap fabric. Refer to Figure 16-5 to line up the next piece of scrap fabric with the bottom corner of the first piece you sewed in.
- 9. Turn it out.** Turn your skirt right-side out.
- 10. Finish the hem, using the method below that matches your sewing method.** The instructions depend highly on whether you are hand sewing, machine sewing, or using an overlock machine. Refer to the sewing instructions listed below.
- **Sewing by hand for a finished look:** Refer to Chapter 5 for hand-sewing techniques. Using a hand-sewing needle and matching thread, hem the bottom edge. Refer to the variations listed below for ideas on decorative techniques.

- **Sewing by machine for a rough look:** Using a zigzag stitch and a $\frac{1}{2}$ -inch seam, sew the bottom edge. Refer to the variations listed below for ideas on decorative techniques.
- **Sewing with an overlock for a rough look:** Be sure to use the appropriate needle size and pressure for optimal feeding. Serge the entire bottom edge.



Instead of sewing a finished hem, you can use no-sew hem tape. This tape is just ironed on! You can find it in your local fabric or craft store, online, or even in major supermarkets and department stores.

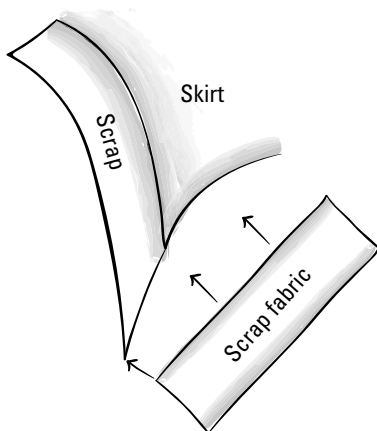

Figure 16-5:
Pinning
additional
scraps on

Check out the skirt after reconstruction in Figure 16-6.



Figure 16-6:
After —
Freeform
and Frill
Skirt.

Variations

For a decorative effect, try some of these ideas:

- ✓ **Raw look:** For external seams, skip Step 4 and pin the wrong sides together. Instead of finishing the edge with a hem, leave out this step and blanket stitch (hand sewing), zigzag stitch (machine sewing) or serge the edge (overlock) for a raw finish.
- ✓ **Bias tape:** Instead of hemming the edge or leaving it raw, you can cover it with a decorative bias tape. This can be found in any sewing goods or fabric store, usually near the zippers in the Notions area. Bias tape comes in a variety of colors and can be either hand-sewn or machine-sewn on to cover the edge (instructions on package).
- ✓ **Get creative with the cut line:** Instead of keeping the bottom edge as is, get creative with curves and other shapes.
- ✓ **More frill:** Add more length and frill to your skirt by adding scraps of additional material on to the bottom edge prior to hemming. Pleating (folding) or ruffling the scrap piece makes this extra fun!
- ✓ **Thick stitches:** Complete all stitching by hand sewing with embroidery floss.
- ✓ **Thicker stitches:** Hand sewing over pre-sewn and secured edges with yarn or ribbon.
- ✓ **Mix colors:** Use a thread color that doesn't match, but complements the color of the material. With a sewing machine you can also use a different color for the bobbin thread. With an overlock machine, you can get really creative and use four to five different colors.
- ✓ **No-sew deco techniques.** Some no-sew ideas include painting, grommeting, riveting, bedazzling, dyeing, drawing with fabric markers or even sharpie markers. Use a heat gun to seal the raw edges of synthetic fabrics, referring to the instruction on the heat gun project in Chapter 15. Make stripes on your skirt pieces with gaffer's or masking tape. Spray a light coat of spray paint over it, let dry and repeat until you get the desired color saturation. Remove the tape to reveal super-hot stripes!



Business Skirt Gone Badass

The Business Skirt Gone Badass project is a simple way to add subtle or not so subtle personality to your office-wear. This skirt is a decked out, stitched, patched, painted version of your former skirt.

This project is easy. It merely involves adding stitching or other decorative variations to your existing skirt.

Check out the skirt prior to reconstruction in Figure 16-7.



Figure 16-7:
Before —
Business
Skirt Gone
Badass.

Materials

- ✓ Skirt that fits well
- ✓ Common pins
- ✓ Needle (for hand sewing) or sewing machine
- ✓ Thread in a color that complements the skirt
- ✓ Tailor's chalk (substitute with laundry marker)
- ✓ Scissors

Directions

1. **Prep.** Wash and dry your skirt according to the label instructions, or have it professionally cleaned if there's no label.
2. **Mark the stitching.** Using your tailor's chalk, mark the areas of the skirt that you would like to decorate. The simplest version is to just stitch along the hem. Refer to Figure 16-8 for ideas.
3. **Sew, using the method below that matches your sewing method.** The instructions depend highly on whether you are hand sewing, machine sewing or using an overlock machine.

- **Sewing by hand:** Refer to Chapter 5 for hand-sewing techniques. Use any stitch you like to decoratively stitch in the areas you've marked. The simplest version is to blanket stitch along the bottom hem.
- **Sewing by machine:** Use any stitch you like to decoratively stitch in the areas you've marked. The simplest version is to zigzag stitch along the bottom hem.
- **Sewing with an overlock:** Serge the entire bottom hem.

When sewing with an overlock, you can only serge the bottom hem for decoration.



Figure 16-8:
Sample
stitching
areas.

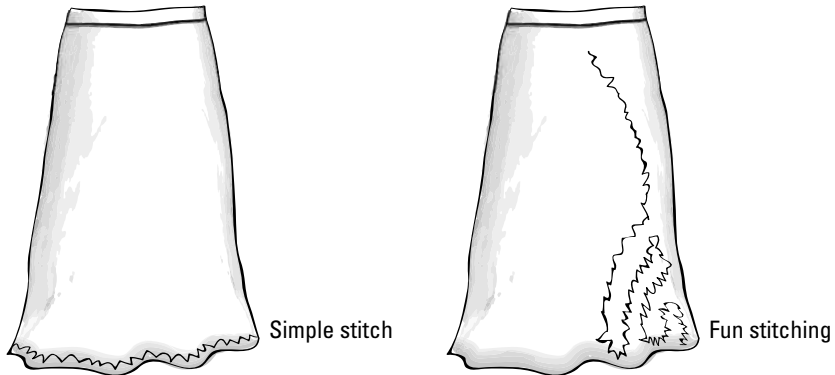

Check out the skirt after reconstruction in Figure 16-9.

Figure 16-9:
After —
Business
Skirt Gone
Badass.



Variations

For a decorative effect, try some of these ideas:

- ✓ **Raw look:** Open the bottom hem or cut it off to leave a raw edge that you can then blanket stitch (by hand) or zigzag stitch (by machine).
- ✓ **Bias tape:** Cover the bottom hem with decorative bias tape. This can be found in any sewing goods or fabric store, usually near the zippers in the notions area. Bias tape comes in a variety of colors and can be either hand-sewn or machine-sewn on to cover the edge (instructions on package).
- ✓ **Thick stitches:** Complete all stitching by hand sewing with embroidery floss.
- ✓ **Thicker stitches:** Hand sewing over pre-sewn and secured edges with yarn or ribbon.
- ✓ **Buttons:** Sew decorative buttons onto the edge of the skirt. This is a great way to make use of those odds and ends buttons. Keep within a color scheme, or within a certain style (art deco, fabric, glass, carved) for a complete look.
- ✓ **No-sew deco techniques:** Some no-sew ideas include painting, grommeting, riveting, bedazzling, dyeing, drawing with fabric markers or even a sharpie marker. Make stripes on your skirt with gaffer's or masking tape. Spray a light coat of spray paint over it, let dry and repeat until you get the desired color saturation. Remove the tape to reveal super-hot stripes!



Cutting-Edge Cowl Neck Top

This project is very similar to the Surprise Fly Top in Chapter 9 except it is even easier! With no messy pant legs or crotches to work around, you can make the cowl neck (the skirt) part of your pullover as long as you like.

This project is moderately easy. The hardest part is fitting the skirt into the pullover neckline. You start by cutting the skirt to the length you'd like for your cowl. Make sure the neckline of your pullover is wide enough and then sew the skirt into for a surprisingly chic look!

Check out the skirt and top prior to reconstruction in Figures 16-10 and 16-11.



Figure 16-10:
Skirt
before —
Cutting-
Edge Cowl
Neck Top.



Figure 16-11:
Top
before —
Cutting-
Edge Cowl
Neck Top.

Materials

- ✓ Skirt
- ✓ Pullover that fits well (pullover sweater used in this example)
- ✓ Common pins
- ✓ Safety pins
- ✓ Tape measure

- ✓ Needle (for hand sewing) or sewing machine
- ✓ Thread that matches the pullover
- ✓ Tailor's chalk (substitute with laundry marker)
- ✓ Scissors

Directions

1. **Prep.** Wash and dry your skirt and pullover according to the label instructions, or have them professionally cleaned if there's no label.
2. **Marking the cut line for your skirt.** Decide how long you want your cowl neck to be. I usually do 24 inches to be able to wear it as a hood. Lay the skirt flat. Measure this amount down from the waist on each side and mark the points with your tailor's chalk. Using your measuring tape as a straight edge, draw a line connecting the two points.
3. **Cut.** Cut the skirt through both layers along the line you just made.
Save any scraps to add into the Freeform and Frill Skirt project earlier in this chapter.
4. **Proceed as with the Surprise Fly Top (Chapter 9).** Refer to Steps 5 onward, including variations, for the Surprise Fly Top in Chapter 9.



Check out the skirt after reconstruction in Figure 16-12.



Figure 16-12:
After—
Cutting-
Edge Cowl
Neck Top.

Chapter 17

Addressing That Tired Old Dress

In This Chapter

- ▶ Doing right by your dress
 - ▶ Protecting yourself against pitfalls
 - ▶ Update your outdated dilemma of a dress with a variety of projects
-

I'm sure you have at least one dress in your closet that you never wear but hold on to just in case you need it for *something!* Dresses can get dated quickly, especially if you're a trendy buyer. While vintage dresses are adorable, the fit is not always quite right and you can often end up looking like you raided Grandma's closet.

This chapter will help you fix up these dilapidated darlings. The projects range from some simple seam realignment to complete redesigns. Whether you are looking for a subtle change or a whole new piece for your wardrobe, you'll find the solution in the next few pages.

Prepping, Primping, and Post Care for Your Dress

Dresses vary widely in their fabric content. Check the laundering label and wash it prior to your reconstruction project. If your label is missing, refer to Chapter 4 for guidelines of when to have it professionally cleaned, and when it might be safe to just gently wash it in cold water and dry flat (no dryer).

The usual suspects

Dresses, particularly vintage dresses, can have some typical dilemmas to be aware of. Whether you are using your own old dress, or thrift shopping for a great reconstruction find, keep your eyes peeled for a few things. Note that the fit is important for the following reconstruction projects. So unless you are particularly handy with alterations, stick to a dress that fits well already.



Always check for these common flaws in dresses:

- ✓ Torn hem
- ✓ Spill stains (especially in party dresses!)
- ✓ Armpit stains
- ✓ Broken zipper or other closure
- ✓ Smell, especially in vintage and polyester pieces

Showing Some Skin Dress

Changing the neckline and hem on a dress can significantly change the look of it. While it doesn't affect how it fits you, it can have a significant effect on how often you wear it! My favorite neckline alteration is turning things into halters, which this project does. I just love the draping dangles of fabric that hang down the back.

This project is moderately easy, depending on the style of your dress. You start off by cutting the dress into a halter by cutting across the back and making straps. Finish the cut edges and you're done.

Check out the dress prior to reconstruction in Figure 17-1.

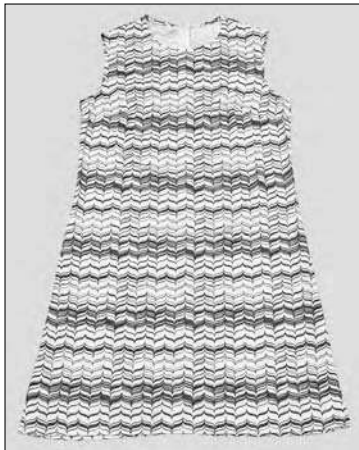

Figure 17-1:
Before —
Showing
Some Skin
Dress.

Materials

- ✓ Dress that fits well
- ✓ Safety pin
- ✓ Common pins
- ✓ Tape measure
- ✓ Needle (for hand sewing) or sewing machine
- ✓ Thread that matches the dress
- ✓ Tailor's chalk (substitute with laundry marker)
- ✓ Scissors

Directions



1. **Prep.** Wash and dry your dress according to the label instructions, or have it professionally cleaned if there's no label.

If you don't feel comfortable cutting free-hand, mark each of the following cuts with tailor's chalk prior to cutting.

2. **First cut.** Cut your dress across the back, armpit to armpit, and continue under the arm and around the front of the shoulder. See Figure 17-2.

If your dress has a zipper, unzip it before cutting. Keep it from zipping back up, and losing your zipper-pull, by safety-pinning the zipper-pull in place.

3. **Second cut.** Next, cut a vertical line through the center of the upper back piece. See Figure 17-3.

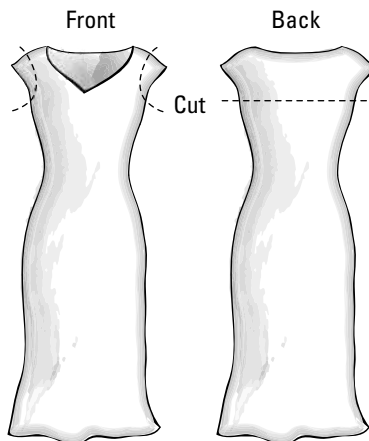

Figure 17-2:
First cut.



Figure 17-3:
Second cut.

- 4. Third cut — making dangles.** If your dress has sleeves, cut open the underarm seam. Next continue the cut from the shoulder in a spiral through the remaining material, creating one long piece measuring approximately 2 inches wide. Do this on each side. These are the ties that will tie around your neck to hold your halter top up. See Figure 17-4 for a cutting diagram.
- 5. Try it on.** Put your halter dress on, tying the dangles behind your neck comfortably. Is the neckline too tight or too high on your neck? If so, proceed with Step 6 and/or refer to the Variations section of this project. Otherwise, continue on to Step 7.
- 6. Neckline issues?** Cut off more fabric in front of the neck, using Figure 17-7 as a guide, if necessary.

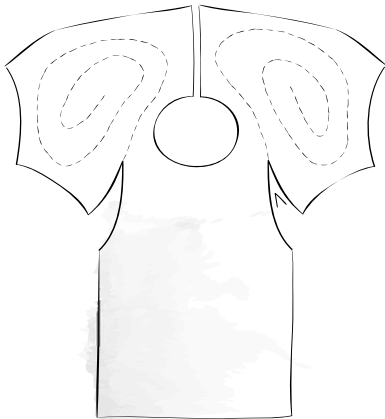

Figure 17-4:
Making
dangles.

7. **Sew, using the method below that matches your sewing method.** The instructions depend highly on whether you are hand sewing, machine sewing or using an overlock machine.
 - **Sewing by hand:** Refer to Chapter 5 for hand-sewing techniques. Hem all cut edges using the quick hem technique. If you have cut through a zipper, stitch the cut edge down securely, making multiple wraps around the teeth edge so that the zipper-pull cannot be pulled off. You may have to sew on a hook-and-eye closure if your zipper does not self-lock. You can use the hook-and-eye on the original portion of the dress. Use the original placement as a guide in placing and sewing the hook-and-eye into its new location.
 - **Sewing by machine — for a rough look:** Zigzag stitch all cut edges, stitching as close to the edge as possible without the stitches falling off the edge. Refer to the instructions on hand sewing to fix the top of a zipper.
 - **Sewing with an overlock — for a rougher look:** Serge all cut edges. Refer to the instructions on hand sewing to fix the top of a zipper.
8. **Repair.** Refer to Chapter 4 to repair any tears, holes, and stains as needed.

Check out the dress after reconstruction in Figure 17-5.



Figure 17-5:
After —
Showing
Some Skin
Dress.

Variations

For a decorative effect, try some of these ideas:

- ✓ **Raw look:** When hand sewing, instead of finishing the edge with a hem, blanket stitch the cut edge for a raw finish.

- ✔ **Bias tape:** Instead of hemming the edge or leaving it raw, you can cover it with a decorative bias tape. This can be found in any sewing goods or fabric store, usually near the zippers in the Notions area. Bias tape comes in a variety of colors and can be either hand-sewn or machine-sewn to cover the edge (instructions on package).
- ✔ **Get creative with the cut line:** Make the bottom hem of your dress more interesting by cutting a curvy cut line and then hemming.
- ✔ **Thick stitches:** Complete all stitching by hand sewing with embroidery floss.
- ✔ **Mix colors:** Use a thread color that doesn't match, but complements the color of the dress, or its decorative components. With a sewing machine you can also use a different color for the bobbin thread. With an overlock machine, you can get really creative and use four to five different colors.
- ✔ **Stitching everywhere:** Decoratively stitch other areas of the dress, marking with tailor's chalk first if necessary. Decorative stitches include embroidery or deco-stitches on your machine.
- ✔ **More dangles:** Get creative with Step 4. Cut multiple dangles, either along the length of the strap or from the point where it attaches to the body of the halter top. Sew on more scraps of fabric for even more dangles! See Figure 17-6 for ideas.
- ✔ **Necklines:** Alter your neckline by altering the cut line, adding more straps or even sewing on some ruffling scraps. See Figure 17-7 for ideas.
- ✔ **No-sew deco techniques:** You can leave the edge completely unstitched and raw. Running it through the washer and dryer will help the edges fray and bind together to complete the "unfinished" look. Some other no-sew ideas include painting, grommeting, riveting, bedazzling, dyeing, drawing with fabric markers or even a sharpie. Make stripes on your dress with gaffer's or masking tape. Spray a light coat of spray paint over it, let dry and repeat until you get the desired color saturation. Remove the tape to reveal super-hot stripes!

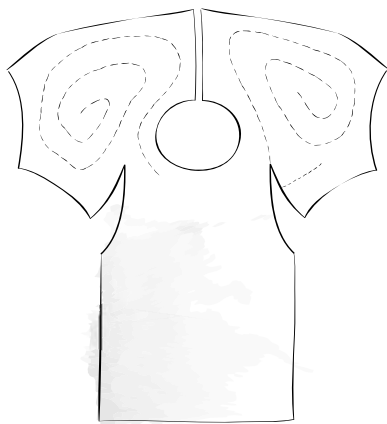

Figure 17-6:
More
dangles!

Figure 17-7:
Neckline
variations.



Raw the Right Way Dress

This is a good solution for a dress you like but are just bored with. It's also a great option for those vintage frocks that need some sprucing up. The dress looks the same, except the seams, certain seams mind you, are inside out.

This project is easy. All you do is rip open the desired seams and restitch them with the wrong sides facing each other. Adding decorative touches can be fun with this project as well.

Check out the dress prior to reconstruction in Figure 17-8.



Figure 17-8:
Before —
Raw the
Right Way
Dress.

Looking inward, or outward . . .

My personal design aesthetic involves exposing the construction and development by exposing the seams. It's a style that some people understand, but still trips others up. I once sent a few outfits out for a fashion show, complete with pictures to demonstrate how to wear them.

When I got the clothes back they were all inside out. I hoped that this was just an oversight in sending them back in a rush. It wasn't. When the pictures finally came through, sure enough, all the clothes were shown inside out, complete with tags hanging out and everything!

Materials

- ✓ Dress that fits well
- ✓ Common pins
- ✓ Seam ripper
- ✓ Needle (for hand sewing) or sewing machine
- ✓ Thread that matches the dress
- ✓ Scissors

Directions

1. **Prep.** Wash and dry your dress according to the label instructions, or have it professionally cleaned if there's no label.
2. **Identify desired seams.** Find the seams on your dress. Turn it inside out if necessary. Pick out the ones that you would like to expose. I like to keep things elongated by working only with the vertical seams, not the horizontal seams. Refer to Figure 17-9.
3. **Rip.** Using your seam ripper and scissors as needed, rip open the desired seams carefully.
4. **Pin.** Pin the seams back together with the wrong sides facing. Start pinning at one edge and place pins diagonally at each corner and perpendicular to the edge every 1 inch. Be sure to line up any obvious points that should be in line, such as a waist seam. Refer to Figure 17-10.
5. **Sew, using the method below that matches your sewing method.** The instructions depend highly on whether you are hand sewing, machine sewing or using an overlock machine.

- **Sewing by hand:** Refer to Chapter 5 for hand-sewing techniques. Blanket stitch the pinned seams with the same seam allowance as the original seam. Remove pins.
- **Sewing by machine:** Zigzag stitch the pinned seams with the same seam allowance as the original seam. Remove pins.
- **Sewing with an overlock:** Serge the pinned seams, removing the pins before running them through the overlock. Refer to the variations listed below for ideas on decorative techniques.

Check out the dress after reconstruction in Figure 17-11.

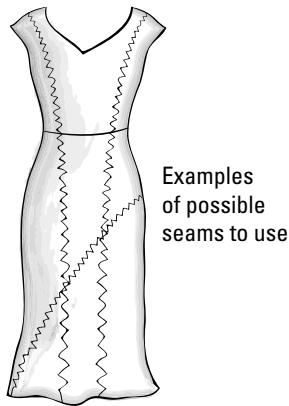

Figure 17-9:
Picking out
seams to
play with.

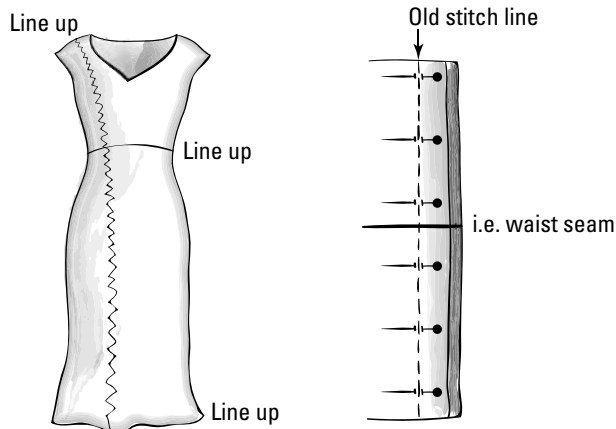

Figure 17-10:
Re-pinning
seams the
wrong way.



Figure 17-11:
After —
Raw the
Right Way
Dress.

Variations

For a decorative effect, try some of these ideas:

- ✓ **Bias tape:** Cover the external seams and/or hem with decorative bias tape. This can be found in any sewing goods or fabric store, usually near the zippers in the Notions area. Bias tape comes in a variety of colors and can be either hand-sewn or machine-sewn on to cover the edge (instructions on package).
- ✓ **Thick stitches:** Complete all hand-sewing with embroidery floss.
- ✓ **Thicker stitches:** Hand-sewing over pre-sewn and secured edges with yarn or ribbon.
- ✓ **Mix colors.** Use a thread color that doesn't match, but complements the color of the dress. With a sewing machine you can also use a different color for the bobbin thread. With an overlock machine, you can get really creative and use four to five different colors.
- ✓ **Stitching everywhere:** Decoratively stitch other areas of the dress, marking with tailor's chalk first if necessary. Decorative stitches include embroidery or deco-stitches on your machine.
- ✓ **Buttons:** Enhance your external seam by sewing decorative buttons along the border of the seam. This is a great way to make use of those odds and ends buttons. Keep within a color scheme, or within a certain style (art deco, fabric, glass, carved) for a complete look.
- ✓ **No-sew deco techniques:** Some no-sew ideas include painting, grommeting, riveting, bedazzling, dyeing, drawing with fabric markers or even a sharpie marker. Make stripes on your dress with gaffer's or masking tape. Spray a light coat of spray paint over it, let dry and repeat until you get the desired color saturation. Remove the tape to reveal super-hot stripes!



Sets of All Sorts Top/Skirt

Sometimes it's hard to find things that match. But when you are cutting a dress into two pieces, it can't *not* match! The simplest version of this project involves making the dress into a top and skirt that look fairly similar to their previous form. However, with other options you can get creative with other projects in this book.

This project varies in difficulty depending what you choose to do. The simplest version is easiest. Other versions depend on the project you choose to incorporate.

Check out the dress prior to reconstruction in Figure 17-12.



Figure 17-12:
Before —
Sets of
All Sorts
Top/Skirt.

Materials

- ✓ Dress
- ✓ Waistband material: drawstring, $\frac{3}{4}$ -inch wide elasticized band or $\frac{1}{4}$ yard of stretch fabric that measures the width of your waist. For drawstring, allow 20 inches of additional length for tying.
- ✓ Common pins
- ✓ Safety pins
- ✓ Tape measure
- ✓ Needle (for hand sewing) or sewing machine
- ✓ Thread that matches the dress
- ✓ Tailor's chalk (substitute with laundry marker)
- ✓ Scissors

Directions

1. **Prep.** Wash and dry your dress according to the label instructions, or have it professionally cleaned if there's no label.
2. **Mark cutting line.** Try your dress on. Decide how long you would like the top. Put a safety pin in this point at the side seam. Take the dress off and lay it flat. Using your measuring tape, measure the distance from the armpit to the pin. Mark this point with your tailor's chalk. Repeat on the other side seam. Using your measuring tape as a straight edge, draw a horizontal line connecting the two points.
3. **Cut.** Cut through both layers on the line you just made.
4. **Waistband.** Refer to the Diminishing Waste With Waistbands project in Chapter 6 for instructions on making a waistband for the skirt portion of your dress.
5. **Sew, using the method below that matches your sewing method.** The instructions depend highly on whether you are hand sewing, machine sewing or using an overlock machine.
 - **Sewing by hand:** Refer to Chapter 5 for hand-sewing techniques. Hem the bottom edge of the top.
 - **Sewing by machine for a rough look:** Zigzag stitch the entire bottom edge of the top.
 - **Sewing with an overlock for a rough look:** Serge the entire bottom edge of the top.

Instead of sewing a finished hem, you can use no-sew hem tape. This tape is just ironed on! You can find it in your local fabric or craft store, online, or even in major supermarkets and department stores.
6. **Repair.** Refer to Chapter 4 to repair any tears, holes, and stains as needed.



Check out the dress after reconstruction in Figure 17-13.

Variations

If the simplest version doesn't quite work for your dress, or you just want a different look, try these options:

- ✓ **Skirt options:** Use the remaining skirt part of the dress as scraps in an upside-down skirt (Chapters 6, 12, 13), split skirt (Chapter 9), Bare and Flare Skirt (Chapter 11) or Freeform and Frill Skirt (Chapter 16)
- ✓ **Top options:** Turn your top into a No-Stop Halter Top (Chapter 6), crop it (Chapter 8), or get creative with cowl necks (Chapter 16).

For a decorative effect, try some of these ideas:

- ✓ **Raw look:** When hand sewing, instead of finishing the edge with a hem, blanket stitch the cut edge for a raw finish.
- ✓ **Bias tape:** Instead of hemming the edge or leaving it raw, you can cover it with a decorative bias tape. This can be found in any sewing goods or fabric store, usually near the zippers in the Notions area. Bias tape comes in a variety of colors and can be either hand-sewn or machine-sewn on to cover the edge (instructions on package).
- ✓ **Thick stitches:** Complete all hand-sewing with embroidery floss.
- ✓ **Thicker stitches:** Hand-sewing over pre-sewn and secured edges with yarn or ribbon.
- ✓ **Mix colors:** Use a thread color that doesn't match, but complements the color of the dress. With a sewing machine you can also use a different color for the bobbin thread. With an overlock machine, you can get really creative and use four to five different colors.
- ✓ **Stitching everywhere:** Decoratively stitch other areas of the dress, marking with tailor's chalk first if necessary. Decorative stitches include embroidery or deco-stitches on your machine.
- ✓ **No-sew deco techniques.** Some no-sew ideas include painting, grommeting, riveting, bedazzling, dyeing, drawing with fabric markers or even a sharpie marker. Make stripes on your dress with gaffer's or masking tape. Spray a light coat of spray paint over it, let dry and repeat until you get the desired color saturation. Remove the tape to reveal super-hot stripes!



Figure 17-13:
After —
Sets of
All Sorts
Top/Skirt.

Part VI

Now What to Do with All These Scraps?

The 5th Wave

By Rich Tennant

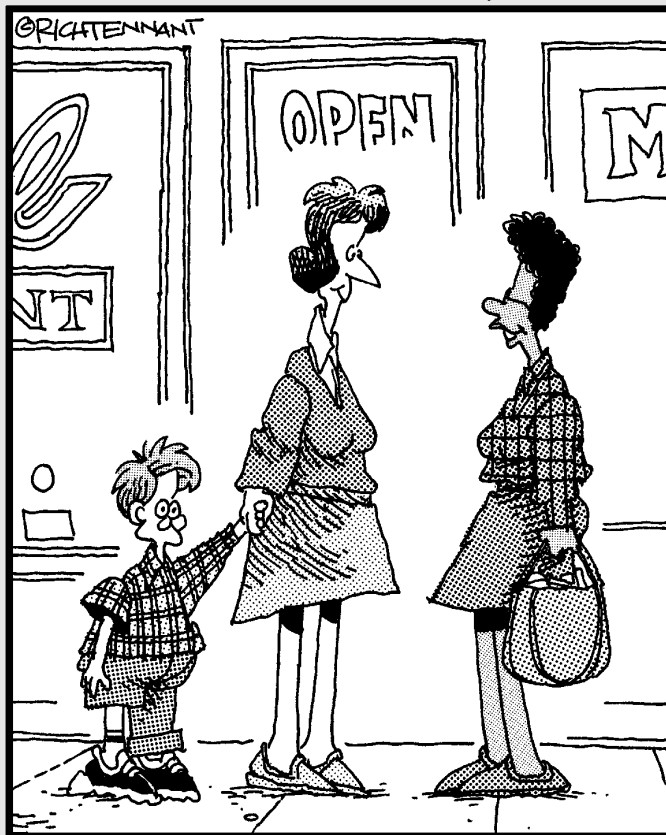

"I see that you're still collecting scraps
for your reconstructing projects."

In this part . . .

In Part VI, I give you a reason to throw a party! Gather your scraps, your friends, your scrappy friends and have a reconstruction roo-ha-ha!

Find out how to make use of all sorts of scraps with simple and quick projects that don't require a lot of space or attention. I also include more involved projects, including a quilt that's forgiving enough in style that even I can pull it off!

Chapter 18

Brand New Bedding

In This Chapter

- ▶ Bedecking your bedroom with recycled scraps
 - ▶ Stuffing, casing, and covering your bed
-

Bedding and bedding accessories are great projects for beginners. These projects are especially perfect because they are made from scraps! So there's really no risk of ruining a piece! The size and fit of bedding is forgiving, and realistically who is going to see it if you mess up? You can always put that not-so-perfect side of the pillow on the bottom, or hide it behind other pillows.

For the same unseen reasons, these projects also allow for more creativity than you can sometimes get away with in your clothing. You can make use of those sentimental pieces, favorite colors and prints that are simply unsuitable for your daily attire!

The projects in this chapter cover most bed linen basics. Not only will you learn how to make a pillow, but a case for it as well. You will also learn how to make a scrap quilt, and quick hints for duvet covers!

Save-It-All Stuffing

The more you reconstruct, the more you learn that scraps come in all shapes, sizes, and textures. For this project you can use it ALL! Actually, the only exception is anything hard, such as thick leather, buttons, or other decorative components that you wouldn't want to rest your head on.

This project is easy. All you have to do is sew together a casing from a large scrap, leave a hole and stuff it with the rest of the scraps. Oh, and don't forget to sew the hole back up when you're done.



Sometimes in reconstructing items, pins are forgotten and left in the scraps. Be sure to check your scraps for pins before stuffing. With this project in particular, you are sure to get pricked!

Check out the scraps prior to reconstruction in Figure 18-1.

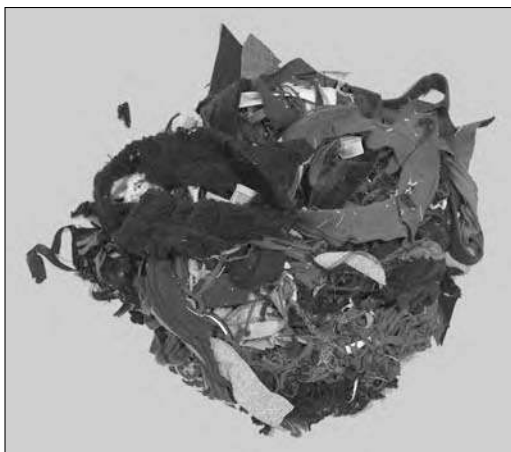

Figure 18-1:
Before —
Save-It-All
Stuffing.

Materials

- ✓ Scrap material large enough for a casing
- ✓ Scrap material of soft texture
- ✓ Common pins
- ✓ Tape measure
- ✓ Needle (for hand sewing) or sewing machine
- ✓ Thread
- ✓ Tailor's chalk (substitute with laundry marker)
- ✓ Scissors

Directions

1. **Identify the pillow size.** This project is for a square or rectangular pillow. Your pillow size is determined by either the decorative pillow case you are putting it in, such as in the “Casing Your Cozies” project in this chapter, your personal preference, or the size of the scrap you have to make a casing for your stuffing.

You need two pieces of fabric of the same size, one for each side of the pillow.

2. **Mark the cut line.** Using your measuring tape and tailor's chalk, mark a square or rectangle on one layer of the scrap fabric equal to the pillow-case dimensions found in Step 1.





3. **Line up.** Place the marked fabric on top of the second piece of scrap fabric, keeping the markings visible.
4. **Pin.** Using common pins, pin both layers together just inside of the cutting line. Place the pins diagonally at each corner and perpendicular to the cut-line every 1 inch.

5. **Cut.** Cut both layers of fabric along the marked cutting line.

Save scraps for more pillow stuffing.

6. **Sew using the method below that matches your sewing method.** The instructions depend highly on whether you are hand sewing, machine sewing or using an overlock machine:

- **Sewing by hand:** Refer to Chapter 5 for hand-sewing techniques. Using a ½-inch seam allowance, blanket stitch both layers together along the entire cut edge. Leave 4 inches at the center of a seam unsewn. Refer to Figure 18-2.
- **Sewing by machine:** Using a ½-inch seam allowance, straight stitch both layers together along the entire cut edge. Leave 4 inches at the center of a seam unsewn. Refer to Figure 18-2.
- **Sewing with an overlock:** Serge both layers together along the cut edge. Leave 4 inches at the center of a seam unsewn. Refer to Figure 18-2.

7. **Turn it out.** Turn the casing right-side out. Poke out the corners.

8. **Stuff it.** Stuff the casing, starting with smaller scrap material stuffed solidly into the corners. This will give the corners shape. From that point on, stuff the casing as loosely or as solidly as you like.

The more full you stuff the casing, the harder it will be to sew. I like to stuff it to my desired amount, then push the stuffing as far away from the open seam as possible.

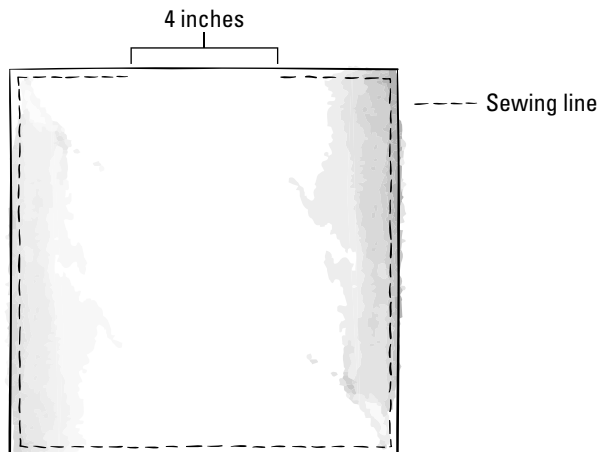

Figure 18-2:
Sewing line
for your
casing.

9. **Sew the hole.** Using a needle and thread, hand sew the seam shut by folding the raw edges inside and using a blanket stitch (Chapter 5).

Check out the scraps after reconstruction in Figure 18-3.



Figure 18-3:
After —
Save-It-All
Stuffing.

Variations

Try some of these ideas:

- ✓ **Scented pillows:** Add scent to your pillow. Visit your local herb shop, or research online for the variety of ways you can do this.
- ✓ **Playful pillows:** This is great for kids and pets. Stuff the pillow casing with crunchy plastic grocery bags, squeak toys, or caged bells for a whole new experience!

Casing Your Cozies Pillowcases

So you've made a pillow, now it's time to make it a case. Using scraps to do this creates a fun and interesting look that not only looks great in your home, but makes an extra special homemade gift as well.

I have a pillow that I made out of scraps years ago. I have a ribbon sewn onto it, not just for decoration but also to tie it onto my bags when I travel. It saves room in my luggage and is super-easy to get to, not to mention being the envy of every weary traveler's eye!

This project is moderately easy. It is very similar to the first few steps of the previous project, while keeping one side open to slip the pillow in and ribbon closures to seal it up tight. Note that these instructions are for a square or rectangle pillow case only.

Check out the scraps prior to reconstruction in Figure 18-4.



Figure 18-4:
Before —
Casing Your
Cozies
Pillowcases.

Materials

- ✓ 2 pieces of scrap material larger than the pillow or scrap material sewn together that is larger than the pillow
- ✓ Ribbon of complementary color (20 inches)
- ✓ Common pins
- ✓ Tape measure
- ✓ Needle (for hand sewing) or sewing machine
- ✓ Thread
- ✓ Tailor's chalk (substitute with laundry marker)
- ✓ Scissors
- ✓ Iron

Directions

- 1. Identify the pillow and case size.** A pre-made pillow form bought from a store will have the dimensions listed either on the packaging or the tag. In all other cases, pull the seams of the pillow taut and use your measuring tape to determine the dimensions. Add one inch to each of these numbers to determine the dimensions of the pillow case you will be making. This allows for a ½-inch-wide seam.
- 2. Measure.** Is your scrap big enough? Using your measuring tape, measure the dimensions of each piece of your scrap material. Referring to the dimensions determined in Step 1, determine whether the pieces are big enough as they are or if you need to sew more fabric on to make them big enough. If you do, you have two choices, straight lines (Step 3) or patchwork (Step 4). If you do not need to sew on more fabric, proceed to Step 5.



Patching in additional scraps of material can add an interesting look to your pillowcase. While the instructions refer to it as a solution for size, this may also be a design choice!

- 3. Sewing on more fabric — straight lines.** The easiest way to add more fabric is to sew straight edges together. Place your scrap pieces together, right sides facing, lining up existing straight edges whenever possible. Pin the pieces together along the straight edge, pins perpendicular to the edge and 2 inches apart. If the edges are not straight, use your measuring tape as a straight edge, and your tailor's chalk to draw a straight line. Pin the pieces together just inside the line (pins perpendicular to the line, 2 inches apart). Cut through both layers along the line. Sew the pieces together along the straight edge using the method below that matches your sewing method. The instructions depend highly on whether you are hand sewing, machine sewing or using an overlock machine. Open up the pieces and iron the seam flat (for hand and machine sewn.)

Refer to Figure 18-5. Measure again and sew on more fabric in the same manner until the piece is at least the dimensions found in Step 1.

Proceed to Step 5.

Save your scraps for additional patching of the case, for stuffing (earlier in this chapter), or for a myriad of other projects in Part VI.

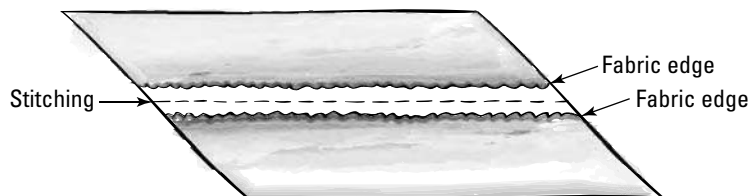
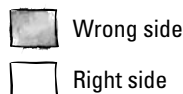

Figure 18-5:
Ironing the
seam flat.





Remember that the pillow case has two sides, so be sure to have two pieces prepared to the correct size.

- **Sewing by hand:** Refer to Chapter 5 for hand-sewing techniques. Using a hand-sewing needle, matching thread and $\frac{1}{4}$ -inch seam, running stitch the seam.
- **Sewing by machine:** Using a $\frac{1}{4}$ -inch seam, straight stitch along the seam.
- **Sewing with an overlock:** Be sure to use the appropriate needle size and pressure for optimal feeding. Remove the pins from the edge and serge the layers together along the seam.

4. **Sewing on more fabric — patchwork style.** While this method of adding fabric makes use of the whole scrap and yields a rough constructed look that I like, it is more difficult. Start by finding scraps that almost fit together as puzzle pieces. Overlap their edges by at least $\frac{1}{2}$ inch and pin together. Place the pins at every corner and at least 1 inch apart. Be sure to pin along the edge of each scrap layer. Refer to Figure 18-6. Sew the pieces together along each edge using the method below that matches your sewing method. The instructions depend highly on whether you are hand sewing, machine sewing or using an overlock machine. Measure again and sew on more fabric in the same manner until the piece is at least the dimensions determined in Step 1.

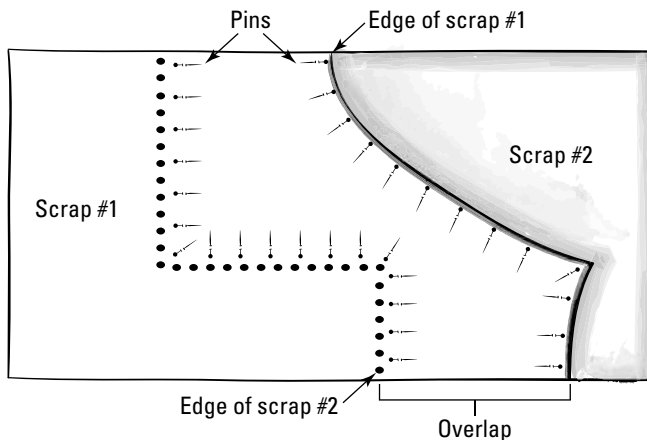

Figure 18-6:
Placing and
pinning
scraps.



Remember that the pillow case has two sides, so be sure to have two pieces prepared to the correct size.

- **Sewing by hand:** Refer to Chapter 5 for hand-sewing techniques. Using a hand-sewing needle and matching thread, secure each edge with a stitch similar to the slant hem, but do a full stitch on the underside rather than just catching a single thread.

- **Sewing by machine:** Zigzag stitch through both layers just inside the cut edge of each edge.
- **Sewing with an overlock:** The overlock is not appropriate for sewing the scrap pieces together for this project. However, serging along the edges of each piece will not only help keep the fabric from fraying, but it will be a nice decorative effect as well.

5. **Mark the cut line.** Using your measuring tape and tailor's chalk, mark one layer of the scrap fabric equal to the dimensions found in Step 1. Be sure to mark the wrong side of the fabric.

6. **Line up.** Place the marked fabric on top of the second piece of scrap fabric, keeping the right sides together and the markings visible.

7. **Pin.** Using common pins, pin the layers together just inside of the cutting line. Place the pins diagonally at each corner and perpendicular to the cut-line every 1 inch.

8. **Cut.** Cut both layers of fabric along the marked cutting line.

Save any scrap for stuffing (earlier in this chapter) or other projects in Part VI.

9. **Prep open edge.** Remove the pins from one edge of the pillow case. This is the edge that will remain open to insert the pillow. Using your measuring tape, fold the edge of each layer back $\frac{1}{2}$ inch. Pin the folded edge of each layer. Remove the pins from the other edges. Iron the folded edges flat. Pin a length of ribbon at least 10 inches long, to the center of each folded edge. Refer to Figure 18-7.

10. **Sew the open edge using the method below that matches your sewing method.** The instructions depend highly on whether you are hand sewing, machine sewing or using an overlock machine.

- **Sewing by hand:** Refer to Chapter 5 for hand-sewing techniques. Hem the folded edge of each layer, using one of the hem stitches described in Chapter 5. Secure the ribbon in place by sewing it down in a square pattern with a running stitch. Refer to Figure 18-8.
- **Sewing by machine:** Using a $\frac{1}{4}$ -inch seam, straight stitch the folded edge of each layer, sewing over the ribbon as well. Further secure the ribbon by sewing it down in a square pattern. Refer to Figure 18-8.
- **Sewing with an overlock:** Remove the pins from the folded edge on each layer. Unfold the edge and cut off the extra $\frac{1}{2}$ inch on each layer. Serge along the cut edge of each layer. Sew the ribbon into place using either the hand sewing or machine sewing technique described above.

11. **Realign.** With the right sides facing and hemmed edges together, put the layers together so that the edges are even.



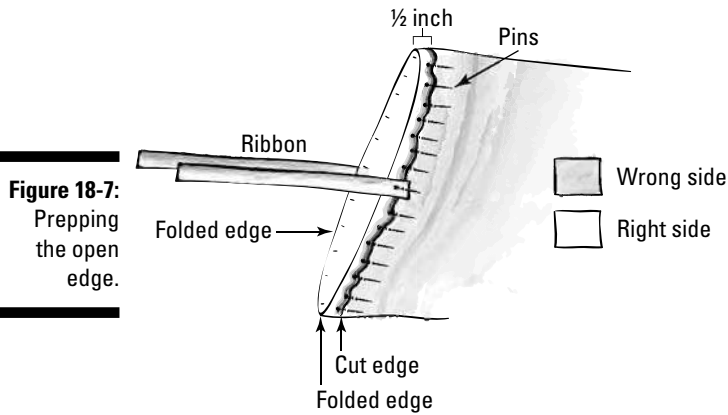

Figure 18-7:
Prepping
the open
edge.

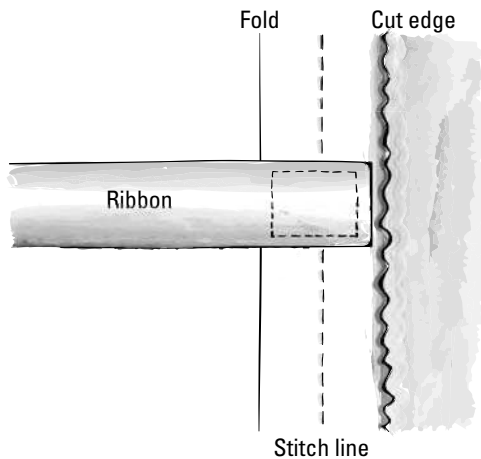

Figure 18-8:
Sewing on
the ribbon.



12. **Pin.** Using common pins, pin the layers together. Place the pins diagonally at each corner and perpendicular to the cut edge every 1 inch.

Since you will not be sewing the hemmed edges together, you do not need to pin this side together.

13. **Sew,** using the method below that matches your sewing method. The instructions depend highly on whether you are hand sewing, machine sewing or using an overlock machine.

- **Sewing by hand:** Refer to Chapter 5 for hand-sewing techniques. With a $\frac{1}{2}$ -inch seam allowance, running stitch along pinned edges, securing both layers together. Turn your pillow case inside-out.
- **Sewing by machine:** Be sure to use the appropriate needle size and pressure for optimal feeding. With a $\frac{1}{2}$ -inch seam allowance straight stitch along the pinned edges, securing both layers together. Turn your pillow case inside-out.

Exponentially expanding dimensions . . .

This might be obvious, but sometimes obvious things can be overlooked in this ever-stimulating world. With this, and all the projects in this book, I encourage you to open your mind to new adaptation and ideas. In regards to the pillow and pillow case project in this chapter, increasing the

dimensions can yield a whole new world. At about 4 feet square you will have a wonderful floor pillow for you or your furry friends. Making the pillow case even larger suddenly turns it into a duvet cover!

- **Sewing with an overlock:** Using a ½-inch seam, serge along the cut edges, cutting off the extra fabric as you serge. Be sure to remove the pins prior to running them through the machine. Turn your pillowcase inside-out.

Check out the scraps after reconstruction in Figure 18-9.



Figure 18-9:
After —
Casing Your
Cozies
Pillowcases.

Variations

For a decorative effect, try some of these ideas:

- ✓ **Raw look:** When realigning in Step 8, keep the wrong sides of the fabric together for an external raw seam. It can be stitched raw with a blanket stitch (hand sewing), zigzag stitch (machine sewing) or serged edge (overlock.) You can also incorporate raw edges into any patchwork you might be doing in creating a large enough piece for your pillow case.

- ✔ **Bias tape:** Cover the external raw seam with decorative bias tape. This can be found in any sewing goods or fabric store, usually near the zippers in the Notions area. Bias tape comes in a variety of colors and can be either hand-sewn or machine-sewn on to cover the edge (instructions on package).
- ✔ **Thick stitches:** Complete all stitching by hand sewing with embroidery floss.
- ✔ **Thicker stitches:** Hand sewing over pre-sewn and secured edges with yarn or ribbon.
- ✔ **Mix colors:** Use a thread color that doesn't match, but complements the color of the pillow case. With a sewing machine you can also use a different color for the bobbin thread. With an overlock machine, you can get really creative and use four to five different colors.
- ✔ **Stitching everywhere:** Decoratively stitch on other parts of the pillowcase, marking with tailor's chalk if necessary. Decorative stitches include embroidery or deco-stitches on your machine.
- ✔ **Buttons:** Sew decorative buttons onto the pillowcase. This is a great way to make use of those odds and ends buttons. Keep within a color scheme, or within a certain style (art deco, fabric, glass, carved) for a complete look.
- ✔ **More ribbons:** Rather than just having one ribbon, sew on several pairs. You can even leave the opposite side of the case open to sew on even more ribbons for a more symmetrical look.
- ✔ **No-sew deco techniques:** Some no-sew ideas include painting, grommeting, riveting, bedazzling, dyeing, drawing with fabric markers or even a sharpie marker. Make stripes on your pillowcase with gaffer's or masking tape. Spray a light coat of spray paint over it, let dry and repeat until you get the desired color saturation. Remove the tape to reveal super-hot stripes!



Quintessential Quilt

Quilting is an art unto itself. I am always awed by the work, the precise and patient skill of the quilter. Some quilts I've seen have boggled my mind in regards to the intricate blending of color palettes and fractal patterns. However, quilting, like brain surgery, is a talent that I do not expect to ever possess in my lifetime, and therefore I bow down humbly to the quilter.

So what does a crafty girl do when she's got a pile of scraps and no patience to make a "real" quilt? While you can pick up a book on quilting and use your scraps to make a variety of quilts, this project is a little more freeform. Choosing color palettes is just about the only thing the Quintessential Quilt has in common with these other quilts.

This project is rather difficult and time-consuming, even in its simplest form. Basically you start by patching together small sections and back them to make mini-quilts. Then you sew these mini-quilts together and finish by lining the entire piece.

Check out the scraps prior to reconstruction in Figure 18-10.



Figure 18-10:
Before —
Quintessen-
tial Quilt.

Materials

- ✓ Large pieces of scrap fabric (minimum 4 inch diameter)
- ✓ Fabric for backing (10 x 10 squares; total dimensions equal to the size of your finished quilt)
- ✓ Batting (10 x 10 squares; total dimensions equal to the size of your finished quilt)
- ✓ Fabric for lining (size of finished quilt)
- ✓ Blanket binding or long strips of 6-inch-wide scrap fabric equal to the perimeter measurement of your quilt)
- ✓ Common pins
- ✓ Tape measure
- ✓ Needle (for hand sewing) or sewing machine
- ✓ Matching thread
- ✓ Tailor's chalk (substitute with laundry marker)
- ✓ Iron
- ✓ Scissors

Directions

1. **Make a design decision.** Decide how large you want your quilt to be. Being made up of 10 x 10 inch squares, determine how many squares you will need to make your quilt. For example, for a 60 x 50 inch quilt you will be laying 5 rows of 6 squares across, totaling 30 squares.
2. **Creating the top layer of the square — straight edges.** Refer to Step 3 in the previous project “Casing Your Cozies.” Proceed to Step 4 of this project.
3. **Creating the top layer of the square — patchwork style.** Refer to Step 4 of the previous project “Casing Your Cozies.” Proceed to Step 4 of this project.
4. **Mark the cut line.** Using your measuring tape and tailor’s chalk, mark a 10 x 10 inch square on the right side of the patched fabric.
5. **Line up.** Sandwich the batting between the marked fabric and the backing fabric, wrong sides facing the batting. Line up any corners and edges with the marked line, so as not to waste fabric.
6. **Pin.** Using common pins, pin the layers together just inside of the cutting line. Place the pins diagonally at each corner and perpendicular to the cut-line every 1 inch.
7. **Cut.** Cut through all layers along the cut line.



Save your scraps for pillow stuffing (earlier in this chapter) or other projects in Part VI.

8. **Baste.** Refer to Chapter 5 for instructions on hand sewing. Baste the square from the center out with a vertical line, horizontal line, and two diagonal lines (connecting opposite corners). Refer to Figure 18-11.

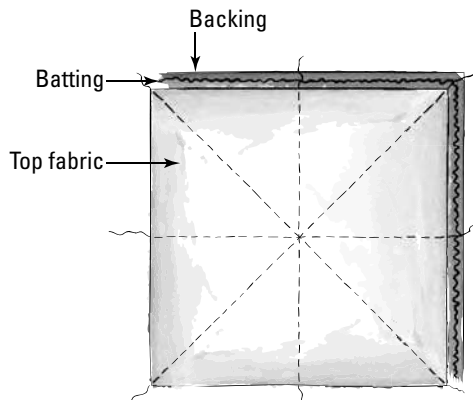

Figure 18-11:
Basting your
square.

9. **Sew your square, using the method below that matches your sewing method.** The instructions depend highly on whether you are hand sewing or machine sewing. An overlock machine is not appropriate for this step.
- **Sewing by hand:** Refer to Chapter 5 for hand-sewing techniques. Running stitch a desired pattern through all three layers. Be sure that the layers are bound together along the edges and across the center, as the basting stitches bind it together. Refer to Figure 18-12 for examples. Remove the pins and basting stitches.
 - **Sewing by machine:** Using any of the stitches on your machine, stitch a desired pattern through all three layers. Be sure that the layers are bound together along the edges and across the center, as the basting stitches bind it together. Refer to Figure 18-12 for examples. Remove the pins and basting stitches.
10. **Repeat.** Repeat Steps 2–9 for additional squares.
11. **Line up and pin.** Lay out your squares into a pleasing arrangement. Pin squares together into rows with the right sides of the patchwork layer facing, pins placed perpendicular to the edge every 1 inch. Refer to Figure 18-13.

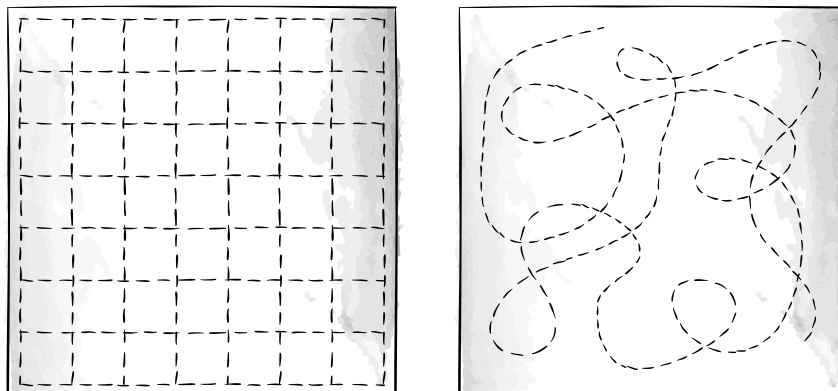
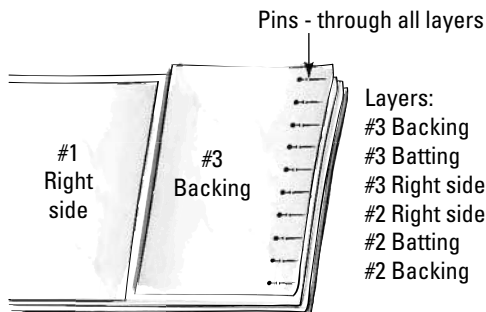

Figure 18-12:
Stitching
patterns.

Sample quilt

#1	#2	#3		
				Row 1
				Row 2
				Row 3
				Row 4
				Row 5
				Row 6

Figure 18-13:
Pinning
squares into
rows.



12. **Sew squares into rows, using the method below that matches your sewing method.** The instructions depend highly on whether you are hand sewing or machine sewing. An overlock machine is not appropriate for this step.
 - **Sewing by hand:** Refer to Chapter 5 for hand-sewing techniques. With a ½-inch seam allowance, running stitch through all layers along the pinned edge. Remove the pins.
 - **Sewing by machine:** Straight stitch with a ½-inch seam through all layers along the pinned edge. Remove the pins.
13. **Pin rows.** Pin rows together into the full quilt with the right sides of the patchwork layer facing, pins placed perpendicular to the edge every 1 inch.
14. **Sew rows together, using the method below that matches your sewing method.** The instructions depend highly on whether you are hand sewing or machine sewing. An overlock machine is not appropriate for this step.
 - **Sewing by hand:** Refer to Chapter 5 for hand-sewing techniques. With a ½-inch seam allowance, running stitch through all layers along the pinned edge. Remove the pins.
 - **Sewing by machine:** Straight stitch with a ½-inch seam through all layers along the pinned edge. Remove the pins.
15. **Line up and pin the lining.** Lay your quilt face down. Lay the lining fabric on top, aligning the edges and corners. Pin from the center out, placing a pin at each corner of the squares. Refer to Figure 18-14.
16. **Sew.** Using a hand-sewing needle and matching thread, stitch through all layers at each pin location (corner of the squares). Make your stitches in a star shape with each stitch starting and finishing at the center as shown in Figure 18-15.

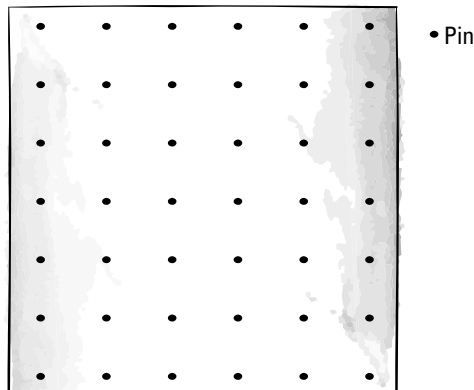

Figure 18-14:
Pinning the
lining on.

Sample quilt: 6 rows, 5 squares/row

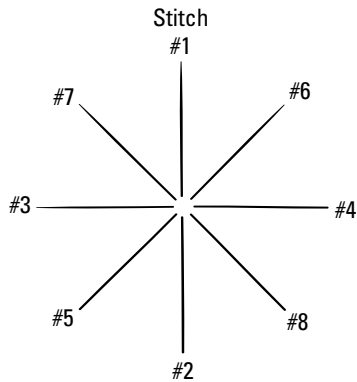

Figure 18-15:
Sewing on
the lining
with stars.

17. **Place and pin the binding.** If you are using strips of scrap fabric, fold the long edges in 1 inch and iron. Then fold the scrap strip in half lengthwise and iron flat to create a binding strip. Line up your binding along the edge of the quilt, with the folded crease at the edge of the quilt and the binding wrapping around either side of the quilt. Fold the binding neatly at the corners. Refer to Figure 18-16. Pin as you go, placing pins diagonally at each corner and perpendicular to the edge every 1 inch.
18. **Sew using the method below that matches your sewing method.** The instructions depend highly on whether you are hand sewing or machine sewing. An overlock machine is not appropriate for this step.
 - **Sewing by hand:** Refer to Chapter 5 for hand-sewing techniques. Running stitch along the edge, $\frac{1}{4}$ -inch in from the edge of the binding, securing the binding to the quilt. Remove the pins.

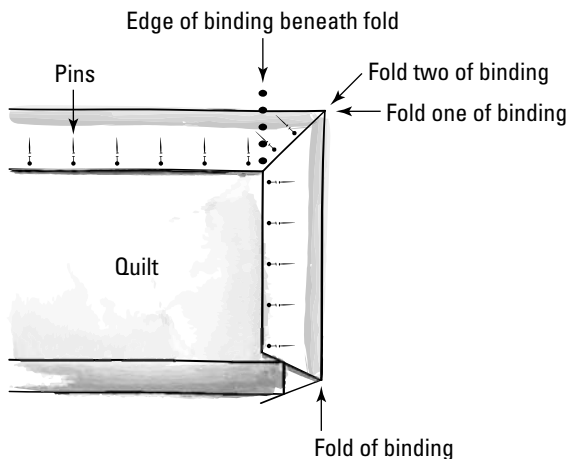

Figure 18-16:
Placing the
binding.

- **Sewing by machine:** Straight stitch along the edge, $\frac{1}{4}$ inch in from the edge of the binding, securing the binding to the quilt. Remove the pins.

Check out the scraps after reconstruction in Figure 18-17.

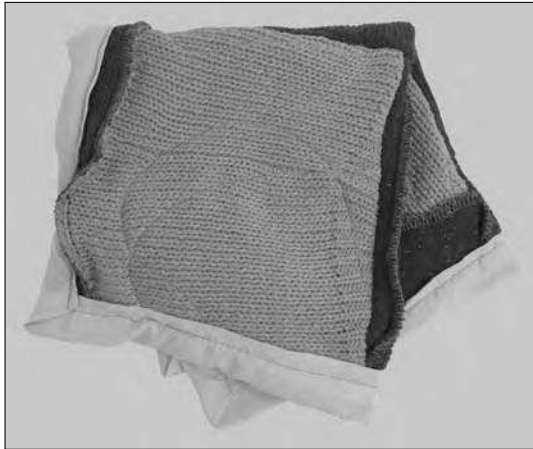

Figure 18-17:
After —
Quintessen-
tial Quilt.

Variations

For a decorative effect, try some of these ideas:

- ✓ **Raw edge:** In Step 2, sew the scraps together with the wrong sides facing, using a blanket stitch (hand sewing), zigzag stitch (machine) or serge to create an external raw seam.
- ✓ **Thick stitches:** Complete all hand sewing with embroidery floss.
- ✓ **Thicker stitches:** Hand sewing over pre-sewn and secured edges with yarn or ribbon.
- ✓ **Mix colors:** Use a thread color that doesn't match, but complements the color of the quilt. With a sewing machine you can also use a different color for the bobbin thread.
- ✓ **Buttons:** Sew decorative buttons onto the quilt, ideally where you have sewn the stars in Step 16. This is a great way to make use of those odds and ends buttons. Keep within a color scheme, or within a certain style (art deco, fabric, glass, carved) for a complete look.

Chapter 19

Deck the Halls with Lots of Scraps

In This Chapter

- ▶ Tempting your nose while re-using old clothes
 - ▶ Sprucing up your stovetop with practical projects
 - ▶ Using tricks to expand your skills for more home projects
-

Using scraps for home décor is ever so much more practical than putting them in the garbage and consuming more new stuff made by someone you will never lay eyes upon in your lifetime. Take it a step further and bring your friends and neighbors together for a scrap craft party! For those times when you've over-committed your creative talents, bring a personal touch to mass production with a group of friends, bottle of wine and pile o' craft supplies. You'll have those bridal shower sachets made in no time, and with no distressing thoughts of "if I have to make another one of these %^#@\$ sachets I'm going to gag on this scrap fabric!"

The projects in this chapter are small enough and quick enough to do in the midst of conversation, tea, and nibbles. I find it a fascinating way to see new characteristics of people, get to know each other better and develop a deeper level of friendship and understanding. You can learn new tricks, share your own skills and make cool recycled projects all at the same time!

The projects in this chapter include two extremes: a decorative sachet to indulge your luxurious side; and a practical potholder to keep your mitts safe while slaving over a hot stove. At the end of the chapter you will also find helpful hints and warm encouragement to take these projects to new levels of creative home décor.

Sachet Simplicity

As a child I had such a fondness for all things ladylike and romantic. On breaks from seaweed wars with my brother and cousins, I was enamored with wild roses, hand-made lace, and lavender sachets we'd find at local craft shows.

Sachets, while once seeming a rare and indulgent treat to the senses, are now prevalent not only to hold scoops of lavender, but bath salts, candies, jewelry, crystals and just about anything that can fit in a 3-x-5-inch drawstring baggie. So with this surging popularity, why not jump on the luxury train and give it a recycled twist?

This project easy. The hardest part is finding scraps of fabric that are pretty enough for such a delightful project. The construction is simple, involving only some simple folding, ironing and stitching. After the sewing is complete all you do is run a ribbon through the top and you're done!

Check out the scraps prior to reconstruction in Figure 19-1.



Figure 19-1:
Before —
Sachet
Simplicity.

Materials

- ✓ Scrap material of a pretty fabric, measuring 6 x 5 inches
- ✓ 10-inch length of ribbon
- ✓ Common pins
- ✓ Tape measure
- ✓ Needle (for hand sewing) or sewing machine
- ✓ Thread that matches the scrap
- ✓ Tailor's chalk (substitute with laundry marker)
- ✓ Scissors
- ✓ Seam ripper
- ✓ Iron

Directions



1. **Mark the cut line.** Using your tape measure and tailor's chalk, measure and mark a rectangle of 6 x 5 inches.
2. **Cut.** Cut along the line you just made with the tailor's chalk.
Save your scrap for Save-It-All Stuffing in Chapter 18.
3. **Fold.** Fold the rectangle scrap in half lengthwise, right sides facing so that it measures 3 x 5 inches.
4. **Pin.** Pin the edges of the folded rectangle together, place pins diagonally at each corner and perpendicular to the edge every 1 inch.
5. **Sew using the method below that matches your sewing method.** The instructions depend highly on whether you are hand sewing, machine sewing or using an overlock machine.
 - **Sewing by hand:** Refer to Chapter 5 for hand-sewing techniques. Blanket stitch the pinned seams with a $\frac{1}{4}$ -inch seam allowance, leaving a 3-inch wide side open. Refer to Figure 19-2.
 - **Sewing by machine:** Straight stitch the pinned seams with a $\frac{1}{4}$ -inch seam allowance, leaving a 3-inch-wide side open. Refer to Figure 19-2.
 - **Sewing with an overlock:** Serge the pinned seams, removing the pins before running it through the overlock. Leave a 3-inch-wide side open. Refer to Figure 19-2.
6. **Fold top edge and pin.** Keeping the sachet inside out, fold down the open top edge 1 inch. Pin the edge, placing pins perpendicular to the edge every 1 inch.
7. **Iron.** Iron the folded edge flat.

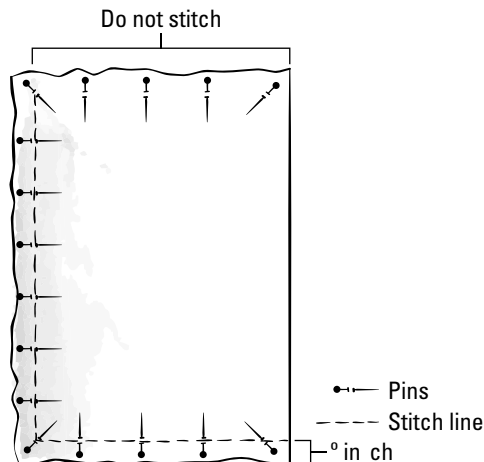

Figure 19-2:
Sewing your
sachet.

8. **Sew using the method below that matches your sewing method.** The instructions depend highly on whether you are hand sewing or machine sewing. An overlock is not appropriate for this step.

- **Sewing by hand:** Refer to Chapter 5 for hand-sewing techniques. Running stitch the folded layers together along the pinned edge. Leave a $\frac{3}{4}$ -inch seam allowance.
- **Sewing by machine:** Using a straight stitch and a $\frac{3}{4}$ -inch seam, sew the folded layers together along the pinned edge.



This step might be easier to complete by hand, depending on your sewing machine features as well as your experience in using the machine.

9. **Turn it out.** Turn the sachet right-side-out.
10. **Rip it.** Using your seam ripper, cut through the few stitches on the outer layer of the upper edge. Refer to Figure 19-3.
11. **Sew for security.** Refer to Chapter 5 for tips on hand sewing. Using a hand-sewing needle and matching thread, blanket stitch around the opening you just created with the seam ripper. Refer to Figure 19-4.

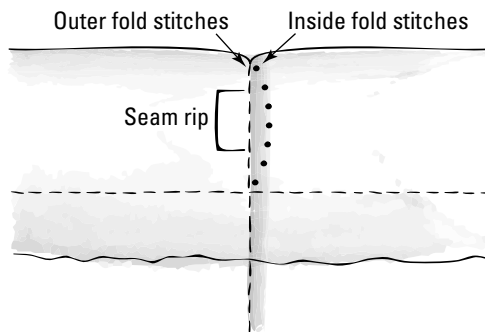

Figure 19-3:
Seam-rip
the opening.

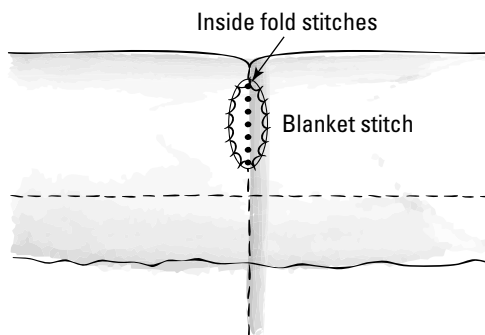

Figure 19-4:
Secure the
opening.



Lots of decorative sachets are made with fabric that doesn't run when you cut it. If your fabric is like this, you can save time and skip Steps 10 and 11. Instead, just cut a hole in the fabric on either side of the seam for the ribbon to enter and exit the top edge.

12. **Lacing the ribbon.** Put a safety pin through the end of the ribbon. Use the safety pin as you would use a needle to guide the ribbon into the opening, through the folded seam along the upper edge of the sachet, and out of the same opening. Remove the safety pin.
13. **Tie off.** Tie a knot in each end of the ribbon to prevent it from fraying. Refer to the variations listed below for other decorative ideas on finishing the ribbon ends.
14. **Fill it.** You may choose to fill your sachet with a variety of different things: lavender, potpourri, bath salts, travel-size bath products, or even small food items.



Lavender buds will eventually lose their fresh scent and need occasional drops of oil to refresh them. Start out by adding a few drops of lavender oil to the lavender in your sachet.

Check out the scraps after reconstruction in Figure 19-5.



Figure 19-5:
After —
Sachet
Simplicity.

Variations

For a decorative effect, try some of these ideas:

- ✓ **Thick stitches:** Hand sew the top edge with embroidery floss.
- ✓ **Thicker stitches:** Hand sew over pre-sewn and secured top edge with yarn or ribbon.

- ✓ **Mix colors:** Use a thread color that doesn't match, but complements the color of the sachet. With a sewing machine you can also use a different color for the bobbin thread. With an overlock machine, you can get really creative and use four to five different colors.
- ✓ **Stitching everywhere:** Before you start sewing the sachet together, stitch decoratively throughout the lower part of the fabric. You can do this by hand or regular machine. With an overlock it will be best to do the decorative stitching before cutting your piece to size.
- ✓ **Lace:** Sew on lace to the uppermost part of the top edge, leaving enough room for the ribbon to still go through.
- ✓ **Buttons:** Sew small decorative buttons onto the sachet. This is a great way to make use of those odds and ends buttons. Keep within a color scheme, or within a certain style (art deco, fabric, glass, carved) for a complete look. Sew them in clusters, in a line up the edge or across the bottom, or just have one especially beautiful button centered at the top edge (leaving room for the ribbon to go through).
- ✓ **Beads and buttons on the ribbon:** String a bead or button onto the ends of the ribbon. Make sure the hole in the bead or button is large enough for the ribbon to pass through.



To help pass the ribbon through the button/bead hole, you can thread it onto a large craft sewing needle. I have also had luck with knotting a double strand of thread (on small needle) through the edge of the ribbon and threading it through the bead or button in that way.

Pragmatic Potholders

I seem to have inherited a knack for destroying dishtowels and potholders. I make good use of them and thus turn them into rags fairly quickly. But still there are those times when you want to have something nice and pretty in your kitchen. My mom always just bought new ones, hiding the old rags under the sink for backup, or giving them to my dad for his own messy projects. So where does the cycle of consumption end? How many car-washing rags does one really need?

Starting the cycle with reconstructed scrap material, as discussed in this project, will take a bit of the burden off of things. And as long as your potholder doesn't start to smell, you can always just give it a fresh look by sewing on a new layer of fabric! Give them as gifts with the caveat of doing the same updating for your friends. Not only will you be creating a beautiful homemade gift and promoting re-use ethics, but it will provide an opportunity for you to have a creative moment with your friend in the future when their potholder needs revamping!

This project is moderately easy. You are basically making a small quilt with layers of heat-resistant fabric.

Check out the scraps prior to reconstruction in Figure 19-6.



Figure 19-6:
Before —
Pragmatic
Potholders.

Materials



- ✓ Scrap material that won't melt (at least two 6-x-6-inch pieces)
Not sure if it will melt? Hold it with an oven mitt or potholder to protect your hand. Push it against a hot pan as you would if you were using it as a potholder. Natural materials, such as cotton, linen, and especially wool, are ideal for this project.
- ✓ Cotton batting (minimum 6 x 6 inches; can substitute with thick scrap material such as cotton sweaters)
- ✓ Bias tape (minimum 25 inches)
- ✓ Common pins
- ✓ Tape measure
- ✓ Needle (for hand sewing) or sewing machine
- ✓ Matching thread
- ✓ Tailor's chalk (substitute with laundry marker)
- ✓ Scissors
- ✓ Iron

Directions

1. **Measuring scraps.** Using your measuring tape, measure the dimensions of each piece of your scrap material. Are the pieces at least 6 x 6 inches square? If so, proceed to Step 4. If not, you need to patch together additional scraps to make it big enough. You have two choices, straight lines (Step 2) or patchwork (Step 3).



Patching in additional scraps of material can add an interesting look to your potholder. While the instructions refer to it as a solution for size, this may also be a design choice!

2. **Sewing on more fabric — straight lines.** Refer to Step 3 of “Casing Your Cozies” in Chapter 18. Proceed to Step 4.
3. **Sewing on more fabric — patchwork style.** Refer to Step 4 of the “Casing Your Cozies” project in Chapter 18. Proceed to Step 4.
4. **Mark the cut line.** Using your measuring tape and tailor’s chalk, mark a 6-x-6-inch square on the right side of the patched fabric.
5. **Line up.** Sandwich the batting between the marked fabric and the second piece of fabric, wrong sides facing the batting. Line up any corners and edges with the marked line, so as not to waste fabric.
6. **Pin.** Using common pins, pin the layers together just inside of the cutting line. Place the pins diagonally at each corner and perpendicular to the cut line every 1 inch.
7. **Cut.** Cut through all layers along the cut line.
Save your scraps for pillow stuffing (Chapter 18) or other projects in Part IV.
8. **Baste.** Refer to Chapter 5 for instructions on hand sewing. Baste the square from the center out with a vertical line, horizontal line and two diagonal lines (connecting opposite corners). Refer to Figure 19-7.

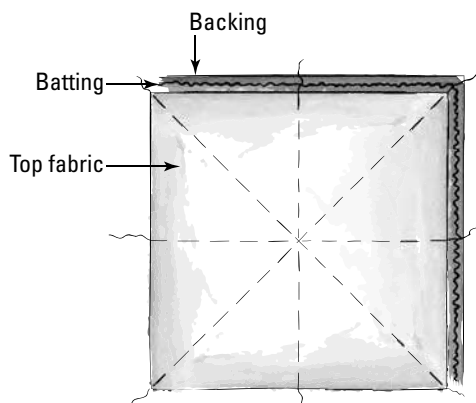

Figure 19-7:
Basting your square.

9. **Sew your square, using the method below that matches your sewing method.** The instructions depend highly on whether you are hand sewing or machine sewing. An overlock machine is not appropriate for this step.

- **Sewing by hand:** Refer to Chapter 5 for hand-sewing techniques. Running stitch a desired pattern through all three layers. Be sure that the layers are bound together along the edges and across the center, as the basting stitches bind it together. Refer to Figure 19-8 for examples. Remove the pins and basting stitches.
- **Sewing by machine:** Using any of the stitches on your machine, stitch a desired pattern through all three layers. Be sure that the layers are bound together along the edges and across the center, as the basting stitches bind it together. Refer to Figure 19-8 for examples. Remove the pins and basting stitches.

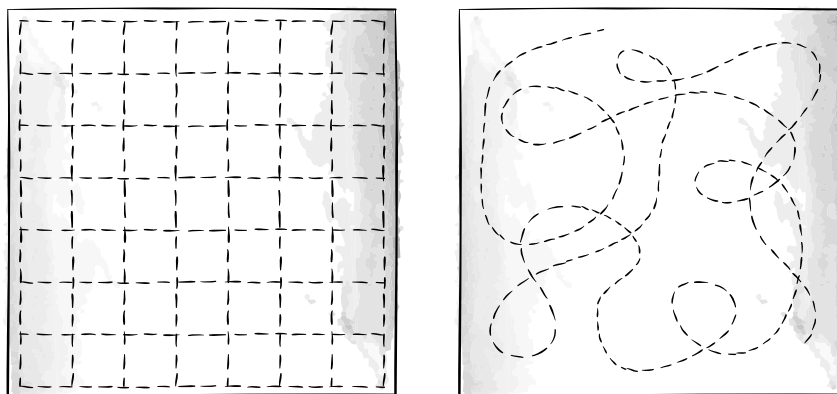

Figure 19-8:
Stitching
patterns.

10. **Place and pin the bias tape.** Line up your bias tape along the edge of the potholder, with the folded crease at the edge of the potholder and the bias tape wrapping around either side of the potholder. Fold the bias tape neatly at the corners. Refer to Figure 19-9. Pin as you go, placing pins diagonally at each corner and perpendicular to the edge every 1 inch. Overlap the ends of the bias tape 1 inch.
11. **Sew using the method below that matches your sewing method.** The instructions depend highly on whether you are hand sewing or machine sewing. An overlock machine is not appropriate for this step.
- **Sewing by hand:** Refer to Chapter 5 for hand-sewing techniques. Running stitch along the edge with a $\frac{1}{4}$ -inch seam allowance, securing the bias tape to the potholder. Remove the pins.
 - **Sewing by machine:** Straight stitch along the edge with a $\frac{1}{4}$ -inch seam allowance, securing the bias tape to the potholder. Remove the pins.

Next level

In the same way you can turn a pillow case into a duvet cover (Chapter 18), you can do the same with the potholder. Always feel free to take it to the next level. Following the same instructions for the potholder, but at approximately 12 x 16 inches gives you a lovely placemat. Leaving out the batting with yield a napkin, or dish towel.

Making this even larger, similar to the quilt in Chapter 18, will give you a tablecloth. Take the tablecloth vertical and either add grommets or a top seam such as in the sachet project earlier in this chapter, and you've got a curtain. Don't ever fear your imagination!

Check out the scraps after reconstruction in Figure 19-10.

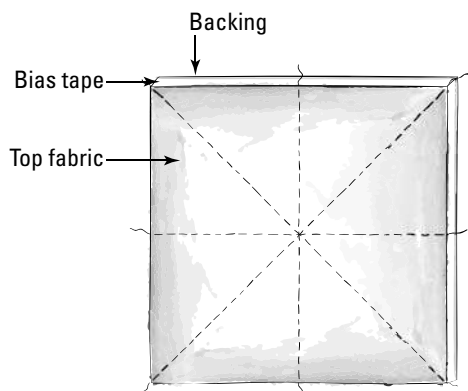

Figure 19-9:
Placing the
bias tape.



Figure 19-10:
After —
Pragmatic
Potholders.

Variations

For a decorative effect, try some of these ideas:



- ✓ **Raw edge:** Skip Step 11, adhering bias tape to the edge. Instead, create a raw edge by sewing the edge with a blanket stitch (hand sew), zigzag stitch (machine sew) or serge it with an overlock.
- ✓ **Scrappy raw edge:** Skip Steps 5 through 8, cutting the potholder into a square. Instead, just pin the layers together, baste and stitch for a scrappy-edged potholder.

Be careful when using this potholder. The edges beyond the 6-x-6-inch square will be of varying thickness and will not protect from heat effectively.
- ✓ **Thick stitches.** Complete all stitching by hand-sewing with embroidery floss.
- ✓ **Thicker stitches.** Hand-sewing over pre-sewn and secured edges with yarn or ribbon.
- ✓ **Mix colors.** Use a thread color that doesn't match, but complements the color of the potholder. With a sewing machine you can also use a different color for the bobbin thread. With an overlock machine, you can get really creative and use four to five different colors.
- ✓ **Bias stripes.** Sew on leftover lengths of bias tape to create random stripes on the potholder.
- ✓ **Ribbon stripes.** Sew on leftover lengths of ribbon to create random stripes on the potholder.
- ✓ **Hang it.** Using a length of bias tape or heat-resistant ribbon, sew a loop on to one corner of the potholder. This will make a nice way to hang it up. Make it even easier by just sewing on the midpoint of a 10-inch length of ribbon or bias tape. Then you can tie the potholder onto any open handle or door pull as well . . . no hook needed!

Chapter 20

Decorative (re)Touches

In This Chapter

- ▶ Discovering creative re-uses for even the smallest scraps
 - ▶ Adorning just about anything
 - ▶ Accessorizing in style and statement
-

Don't sweat the small scraps! There's hope for them yet! While stuffing pillows is a great solution (Chapter 18), there's only so many pillows you really need. This chapter gives you fresh ideas to make use of these scraps. In writing this, I've rediscovered old ideas and fun techniques inspired by digging through my sewing trash. It's a good idea to keep a separate wastebasket just for this purpose. At my shop I'm often at odds over what to throw in, knowing that my 7-year-old neighbor could come in at any time and relinquish me of my scrap treasures in the blink of an inspired eye!

The projects in this chapter include decorative ideas serving no function other than to make a visible statement on recycling. Other projects will keep your neck warm and body healthy, and still others will remind you of diminishing waste in our society each and every time you pull out your wallet!

Deco from Garbage to Gorgeous

Someone once proposed “if you could make your own fabric, what would it look like?” This project is what it would be: scraps and bits of thread and fabric (see Figure 20-1 for the before shot) sewn together in an amalgamation of textiles reminiscent of all the creative ideas that they came forth from. Yea, that would be my fabric of life!

This project is easy. The hardest part is being okay with making a mess. It can also get a bit tricky on the machine to keep your foot from catching loops of scraps. But this project is very forgiving in its mash-up of textile scraps. You start by sprinkling and arranging a thin layer of scraps onto the desired flat fabric that you wish to decorate. Then sew it on to keep it in place.

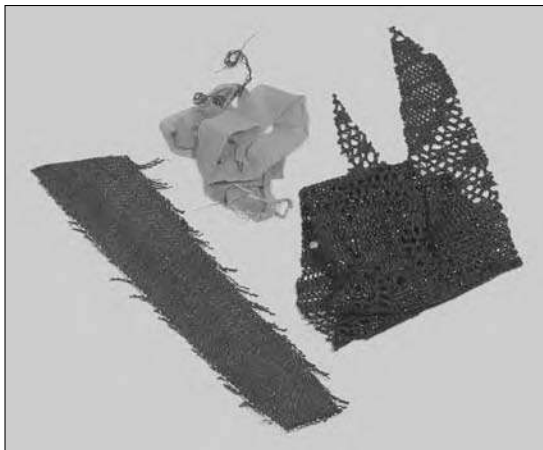

Figure 20-1:
Before —
Deco from
Garbage to
Gorgeous.

Materials

- ✓ Small scraps of material, no larger than 3 x 3 inches, although long thin pieces are okay
- ✓ Item you wish to decorate
- ✓ Common pins
- ✓ Needle (for hand sewing) or sewing machine
- ✓ Thread of a complementary color
- ✓ Scissors

Directions

1. **Make a design decision.** Choose the area on the item that you want to decorate. Try it on to make this easier. Use your tailor's chalk to outline areas or designs.
2. **Arrange scrap material — messy.** Take a pinch of scrap material and sprinkle it onto the item in the location chosen in Step 1. Arrange it so that the layers are approximately even in thickness, and it is within any boundaries that you drew with your tailor's chalk. Proceed to Step 4.
3. **Arrange scrap material — intentionally.** Place a larger scrap, right side up, on the item in the location chosen in Step 1. Place 3–5 smaller pieces on top with minimal overlap between them. Refer to Figure 20-2 for an approximation of this. Proceed to Step 4.

Figure 20-2:
Scrap
arrange-
ment.

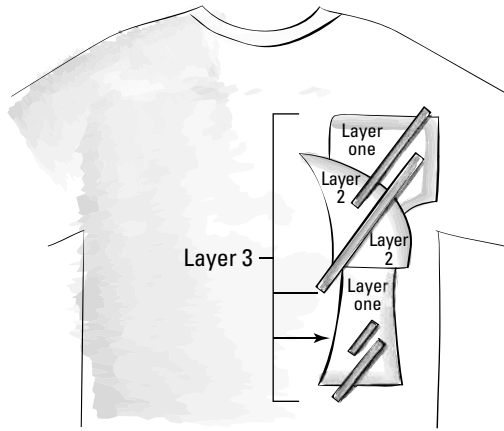

4. **Pin.** Pin the scraps to the item, focusing on edges that you want to keep in place and overlapped areas.
5. **Sew, using the method below that matches your sewing method.** The instructions depend highly on whether you are hand sewing or machine sewing. An overlock is not appropriate for this project.
 - **Sewing by hand:** Refer to Chapter 5 for hand-sewing techniques. Running stitch a decorative pattern throughout the messy scrap pile, or along the edges of the intentional arrangement.
 - **Sewing by machine:** Using any decorative stitch on your machine, stitch a decorative pattern throughout the messy scrap pile, or along the edges of the intentional arrangement.

Check out the scraps after reconstruction in Figure 20-3.



Figure 20-3:
After —
Deco from
Garbage to
Gorgeous.

Variations

For a decorative effect, try some of these ideas:

- ✔ **Thick stitches:** Complete all stitching by hand sewing with embroidery floss.
- ✔ **Thicker stitches:** Hand sewing over pre-sewn and secured edges with yarn or ribbon.
- ✔ **Mix colors:** Use a thread color that doesn't match, but complements the color of the item and scraps. With a sewing machine you can also use a different color for the bobbin thread.
- ✔ **Buttons:** Sew decorative buttons within the scrap deco. This is a great way to make use of those odds and ends buttons. Keep within a color scheme, or within a certain style (art deco, fabric, glass, carved) for a complete look.
- ✔ **Beads:** Sew on beads in the same way described above for buttons.
- ✔ **Stripes:** Make stripes with ribbon or bias tape scraps.
- ✔ **No-sew deco techniques:** Some no-sew ideas include painting, grommeting, riveting, bedazzling, dyeing, drawing with fabric markers or even a sharpie marker. Hot-glue all sorts of things on, as long as you don't have to wash it. Make stripes on your choker with gaffer's or masking tape. Spray a light coat of spray paint over it, let dry and repeat until you get the desired color saturation. Remove the tape to reveal super-hot stripes!



Choker Chop-Up

I have an obsession with keeping my neck warm. It started on a trip to Paris when I got a chill that I just couldn't shake. I soon noticed that nearly everyone had a scarf on, even if they were just wearing a T-shirt. I grew up in New England where you only wore a scarf to go sledding, and even then your mom had to stealthily lasso it around your neck as you were heading out the door. But in letting go of my stubborn assumptions, I got myself a scarf and enjoyed the rest of the trip in comfort. I've been addicted ever since.

This project is fairly easy. You just wind a long strip of sweater material (or other stretchy material) into a spiral, sewing it together and binding the edges.

Check out the scraps prior to reconstruction in Figure 20-4.



Figure 20-4:
Before —
Choker
Chop-Up.

Materials



- ✓ Long strip of sweater/stretchy material (minimum 2 inches wide and 35 inches long)
The material must be able to stretch along the length or you will not be able to pull it over your head!
- ✓ Common pins
- ✓ Safety pins
- ✓ Tape measure
- ✓ Needle (for hand sewing) or sewing machine
- ✓ Thread that matches the scrap
- ✓ Tailor's chalk (substitute with laundry marker)
- ✓ Scissors

Directions

1. **Baste.** When using knits (sweater fabric) they sometimes run. Securing the edges with basting or other stitching can prevent this. If the edges of your scrap are not already secured, hand-baste or machine zigzag stitch along the edge. Refer to Chapter 5 for instructions on basting.
2. **Measure length.** Using your tape measure and tailor's chalk, measure 18 inches from the edge of the scrap and mark this point.
If the tailor's chalk doesn't mark the scrap, place a safety pin there instead.

3. **Pin in a spiral.** Lay the scrap flat. Bring the corner opposite the mark/pin to it. Pin right sides facing together. Continue spiraling the edges together, safety pinning every 2 inches until you reach the end of the scrap. Refer to Figure 20-5.



I like to use safety pins instead of common pins in sweater scraps because of the loose knit. I find that common pins tend to slip out. They also have a tendency to get caught up in other parts of the scrap while you are handling it.

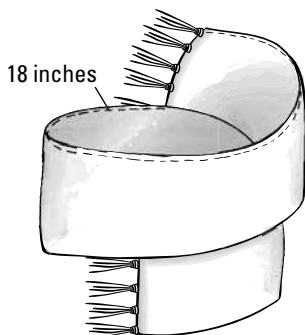

Figure 20-5:
Pinning in
a spiral.



If you have a particularly large head that needs to pass through the choker, try it on before sewing. Tighten up the spiral to make it smaller, or loosen it up to make it bigger.

4. **Sew using the method below that matches your sewing method.** The instructions depend highly on whether you are hand sewing, machine sewing or using an overlock machine.
- **Sewing by hand:** Refer to Chapter 5 for hand-sewing techniques. Blanket stitch the pinned seam together as well as the along the cut edges, making sure to catch every loop of the knit to prevent runs. Remove any basting. Turn the choker right side out.
 - **Sewing by machine:** Zigzag stitch the pinned seam together as well as along the cut edges, making sure to catch every loop of the knit to prevent runs. Run it through the machine a second time to be sure. Remove any basting. Turn the choker right side out.
 - **Sewing with an overlock:** Serge the pinned seam together, removing the pins before running it through the overlock. Serge the edges as well. Be sure to catch every loop of the knit to prevent runs. Remove any basting. Turn the choker right side out.

Check out the scraps after reconstruction in Figure 20-6.



Figure 20-6:
After —
Choker
Chop-Up.

Variations

For a decorative effect, try some of these ideas:

- ✓ **Raw look:** For external seams, pin the wrong sides facing together in Step 3.
- ✓ **Thick stitches:** Complete all stitching by hand sewing with embroidery floss.
- ✓ **Thicker stitches:** Hand sewing over pre-sewn and secured edges with yarn or ribbon.
- ✓ **Mix colors:** Use a thread color that doesn't match, but complements the color of the choker. With a sewing machine you can also use a different color for the bobbin thread. With an overlock machine, you can get really creative and use four to five different colors.
- ✓ **Buttons:** Sew decorative buttons onto the choker. This is a great way to make use of those odds and ends buttons. Keep within a color scheme, or within a certain style (art deco, fabric, glass, carved) for a complete look.
- ✓ **Lace and ribbon:** Sew in a length of lace or ribbon along the seam and/or edges of the choker.
- ✓ **No-sew deco techniques:** You can leave the edge completely unstitched and raw. Running it through the washer and dryer will help the edges fray and bind together to complete the "unfinished" look. Some other no-sew ideas include painting, grommeting, riveting, bedazzling, dyeing, drawing with fabric markers or even a sharpie marker. Make stripes on your choker with gaffer's or masking tape. Spray a light coat of spray paint over it, let dry and repeat until you get the desired color saturation. Remove the tape to reveal super-hot stripes!



Put Your Money Where Your Scraps Are Wallet

This project, a wallet, is a great way to re-use scraps from those old jeans as well as bring a conscious reminder to how you choose to spend your money. You can trick it out in lots of different ways to give it a personal touch.

This project is moderately easy. You start by making a change pocket on one layer of denim, and then sew it to another layer, leaving one seam open to put in your wads of cash.

Check out the scraps prior to reconstruction in Figure 20-7.



Figure 20-7:
Before —
Put Your
Money
Where Your
Scraps Are
Wallet.

Materials

- ✓ Denim scrap material measuring at least 9 x 6 inches (2 pieces), and 2½ x 4 inches (1 piece)
- ✓ Bias tape (approximately 35 inches long)
- ✓ Common pins
- ✓ Tape measure
- ✓ Needle (for hand sewing) or sewing machine
- ✓ Matching thread
- ✓ Tailor's chalk (substitute with laundry marker)
- ✓ Scissors

Directions

1. **Mark the cut line.** Using your tape measure and tailor's chalk, measure and mark a 9-x-6-inch rectangle on two pieces, and a 2½-x-4-inch rectangle on the smaller piece of denim.
2. **Cut.** Cut along the lines you just made with the tailor's chalk.
3. **Place and pin the bias tape.** Line up your bias tape along the edge of the small rectangle, with the folded crease at the edge and the bias tape wrapping around either side of the denim. Fold the bias tape neatly at the corners. Refer to Figure 20-8. Pin as you go, placing pins diagonally at the corners and perpendicular to the edge every 1 inch. Overlap the ends of the bias tape ½ inch.

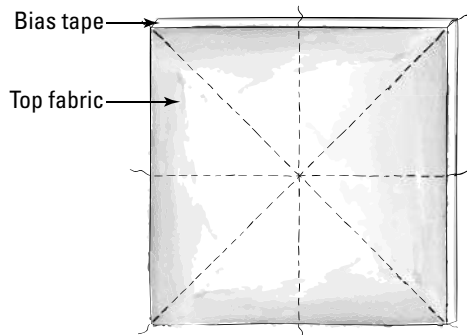
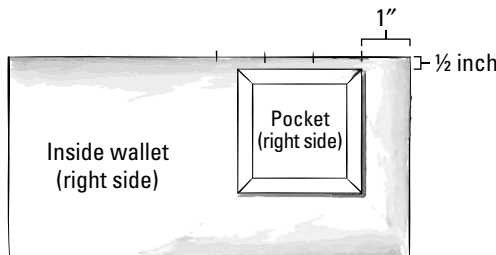

Figure 20-8:
Placing the
bias tape on
your pocket.

4. **Sew using the method below that matches your sewing method.** The instructions depend highly on whether you are hand sewing or machine sewing. An overlock machine is not appropriate for this step.
 - **Sewing by hand:** Refer to Chapter 5 for hand-sewing techniques. Using a hand-sewing needle and matching thread, running stitch along the edge with a ¼-inch seam, securing the bias tape to the denim. Remove the pins.
 - **Sewing by machine:** Straight stitch along the edge with a ¼-inch seam, securing the bias tape to the denim. Remove the pins.
5. **Place and pin the pocket.** Place the pocket on the large scrap of denim that you will be using for the inside of the wallet (wrong side of pocket facing right side of wallet). Place the top edge of the pocket ½ inch from the top of the inside-wallet piece. Move the pocket to one side, 1 inch from the edge. Pin the pocket to the denim scrap, placing pins diagonally at each corner and perpendicular to the edge every 1 inch. Refer to Figure 20-9.

Figure 20-9:
Placement
of your
pocket.



6. **Sew using the method below that matches your sewing method.** The instructions depend highly on whether you are hand sewing or machine sewing. An overlock machine is not appropriate for this step.
 - **Sewing by hand:** Refer to Chapter 5 for hand-sewing techniques. Secure the pocket to the denim using a running stitch along the same line you stitched to adhere the bias tape. Remove the pins.
 - **Sewing by machine:** Using a straight stitch, secure the pocket to the denim along the same line you stitched to adhere the bias tape. Remove the pins.
7. **Crease it.** Fold the other piece of denim in half, wrong sides facing.
8. **Pin.** Pin at the fold with pins placed perpendicular to the folded edge and 1 inch apart.
9. **Sew using the method below that matches your sewing method.** The instructions depend highly on whether you are hand sewing, machine sewing or using an overlock.
 - **Sewing by hand:** Refer to Chapter 5 for hand-sewing techniques. Blanket stitch along the folded crease with a $\frac{1}{8}$ -inch seam allowance. Remove the pins.
 - **Sewing by machine:** Straight stitch along the folded crease with a $\frac{1}{8}$ -inch seam allowance. Remove the pins.
 - **Sewing with an overlock:** Be sure to use the appropriate needle size and pressure for optimal feeding. Serge along the folded crease, removing the pins before running it through the overlock.
10. **Place and pin the wallet pieces.** Place the two large rectangles together, edges even and right sides facing. Pin corners and along sides and bottom edge, placing pins diagonally at each corner and perpendicular to the edge and every 1 inch.



The side of the wallet with the crease in the center will be slightly shorter than the other piece. Keep it centered and make seam measurements from the longer piece.

11. **Sew using the method below that matches your sewing method.** The instructions depend highly on whether you are hand sewing, machine sewing or using an overlock.
 - **Sewing by hand:** Refer to Chapter 5 for hand-sewing techniques. Running stitch along the sides and bottom edges with $\frac{1}{4}$ -inch seam allowance. Remove the pins. Turn your wallet right side out.
 - **Sewing by machine:** Straight stitch along the sides and bottom edges with a $\frac{1}{4}$ -inch seam allowance. Remove the pins. Turn your wallet right side out.
 - **Sewing with an overlock:** Serge along the sides and bottom edge, removing the pins before running it through the overlock. Turn your wallet right side out.
12. **Place and pin the bias tape.** Line up your bias tape along the top edge of the wallet, arranging and sewing it in place as you did in Steps 3 and 4.

Check out the scraps after reconstruction in Figure 20-10.



Figure 20-10:
After — Put
Your Money
Where Your
Scraps Are
Wallet.

Variations

For a decorative effect, try some of these ideas:

- ✓ **Raw look:** For external seams, pin with the wrong sides facing in Step 10. Instead of binding the edge with bias tape, leave out this step and blanket stitch (hand sewing), zigzag stitch (machine sewing) or serge the edge (overlock) for a raw finish.
- ✓ **Thick stitches:** Complete all stitching by hand sewing with embroidery floss.



- ✔ **Thicker stitches:** Hand sewing over pre-sewn and secured edges with yarn or ribbon.
- ✔ **Mix colors:** Use a thread color that doesn't match, but complements the color of the wallet. With a sewing machine you can also use a different color for the bobbin thread. With an overlock machine, you can get really creative and use four to five different colors.
- ✔ **Stitching and tricking everywhere:** Before sewing the large rectangles together (Step 10), decorate the outside, creased wallet piece. Trick it out with decorative stitching, (see the Garbage to Gorgeous project earlier in this chapter) or any of the other variations listed.
- ✔ **No-sew deco techniques:** Some no-sew ideas include painting, grommeting, riveting, bedazzling, dyeing, drawing with fabric markers or even a sharpie marker. Hot-glue all sorts of things on, as long as you don't have to wash it. Make stripes with gaffer's or masking tape. Spray a light coat of spray paint over it, let dry and remove the tape to reveal super-hot stripes!

Part VII

The Part of Tens

The 5th Wave

By Rich Tennant

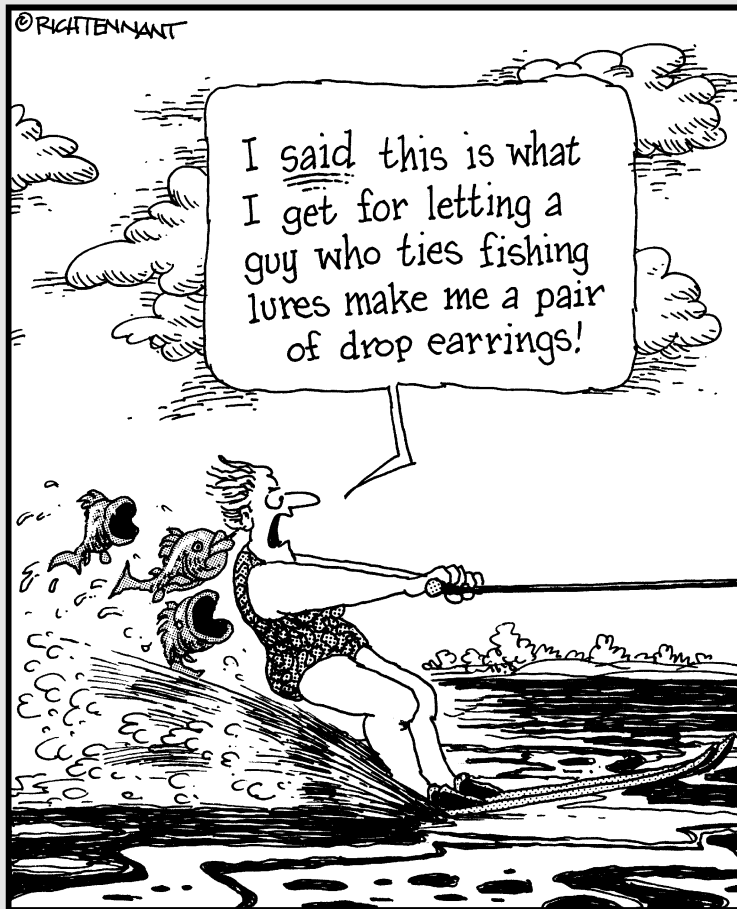

In this part . . .

Find the basics at your fingertips in this part. Experienced sewers and trained professionals may balk at my creative renderings and quick tips, but, hey, this is reconstruction — break the mold that boxes you in!

In this part, I share some general tips and emotional support for common hurdles. I understand it's not always easy to start cutting up your family heirlooms. I'm there for you . . . with scissors in hand! I've also listed tips to fix stains in ways you'd never expect. I like to think that nothing is ever ruined, stains and other wear and tear are merely a challenge to your creativity.

Chapter 21

Ten General Tips

In This Chapter

- ▶ Living by tried-and-true tips
 - ▶ Breaking rules and knowing which ones to follow
 - ▶ Gathering equipment essentials
-

If you're stubborn, like me, and like to figure things out on your own, here's a quickie list to start you off in the right direction. These quick tips will help you avoid the downhill spiral of frustration while still allowing you creative license to do it your own way. This chapter touches on some things that I've learned over the years and encourage others to take mind of. During my course of time in live sewing performances and alternative reconstructive sewing lessons, these are the things that come up consistently.

Don't Be Afraid to Cut It

A good part of my commissions for reconstructions are from people who are simply afraid to cut up the original garment. Regardless of their skill level or complexity of the project, that first step prohibits them from ever starting. My rule of thumb is that if the garment isn't being worn or appreciated in some way, it's just taking up the space of something that could.

Let Go of Your Inner Perfectionist

Reconstruction is not about being perfect. It's about being creative. It's about being you. In my eyes, nobody is perfect without at least one imperfection. So it's okay if your clothes aren't so perfect either. Changing your perspective on things can make all the difference.

My own clothes tend to be tattered rags. I find something I like and I wear it to shreds. Of course, these remnants and hand-me-downs are usually layered with my own designs, equally full of imperfections, or those of other local designers. Typically the whole ensemble comes together with a slew of paint stains and safety pins, not as a style choice but more out of function and laziness to change my clothes before embarking on painting projects. But because I embrace the imperfections and feel as though they reflect who I am and the adventures I embark upon in life, often it is mistaken for a purposeful “look.” I suppose it is in a way, but no, I didn’t lay that skirt down and paint it messy on purpose. It became like that while I was working on some murals and didn’t have a paint rag!

Get in the Groove of a Good Pair of Scissors

Don’t kill yourself over a dull pair of scissors! A decent sharp pair is only a few dollars. Splurge on a new pair and save your hands from all sorts of horrible fates. If you are doing a lot of sewing, I recommend getting good scissors made specifically for cutting fabric. You can find these for \$20 to \$30 at your local fabric store, or on the Internet.

Regardless of the type of scissors you choose, make sure they are only used on fabric. I know, it still baffles me too. How does something as thin as paper dull your scissors? I do not know but it does! If your scissors are at the mercy of other hands grabbing them up in a hasty cutting need, hide them! In addition to hiding them, label them with your name or a clever warning, “not yours!” Of course it is of utmost importance to communicate directly with any potential guilty parties and make it absolutely clear that the fabric scissors cannot be used on *anything* but fabric.

This may seem like a silly thing that you could overlook. But in reality, the comparison is phenomenal. It is like putting on glasses after not seeing clearly all of your life. The ease of a good pair of scissors is not only better for your hands, but better for your fabric as well. Having a clean straight cut to start with makes a world of difference!

Enjoying Evolution

One of my favorite things is working with flaws and other mishaps. What most people think of as “ruined” I see as an adventure in creativity. In reconstructing clothing, it is important to realize that you are not fixing or mending

the garment so that it looks like it used to. You are not tailoring an old style to be an updated version of its former self. You are changing it. You are creating something new. You are creating sometimes drastic change in the piece. It will not look like it used to and that's okay. Change is part of life!

You Are Your Own Model

I don't size things. People ask me, "how do I know if it fits?" I respond simply with, "try it on and see how it feels." Different pieces fit different people in different ways. It's important to get in touch with yourself, accept yourself, and get an understanding of what flatters you.

It's the same thing when making and reconstructing clothes. The best way to see how something is going to fit is not to read it in a book or from a pattern. Just put it on your body! Feel it! Are you comfortable? Can you move as you like to?

Don't let a number box you in. Sizes change greatly over time and even at the same time between different manufacturers. They are merely a guideline and they do not define you! Define yourself and decide for yourself what looks good on you as opposed to letting some stranger in a magazine tell you what looks good.

Stains Can Be Your Guide

Stains are often seen as the grand finale to a garment's existence. I am actually really excited, with some exceptions, when I have a starting piece that is stained. It breaks the standard step by step process and challenges my creativity.

Using the stain as your guide and inspiration on a piece is a fun way of accepting its evolution. Depending on where the stain is and how it came about, you may want to either cover it up or incorporate it into the piece. For example, I once spilled wine on a very special one-of-a-kind silk vest. The standard response would be to freak out, head straight for the dry-cleaners and hope for the best. Instead, I decided that I loved how the stain came about, at a friends' wedding celebration. So instead of hiding it, I enhanced it by dyeing the entire vest in wine!

Clever Closures

My personal style is for garments to be variable in their size, style and fit. I like to change things up. I like pieces that I can wear in different ways. I like layers that I can take off mid-stride and tie onto my purse, backpack, or other accessory.

Closures such as zippers tend to lock in a size and method of wearing a garment. Because of this, I rarely use zippers. Snap tape and buttons can achieve the same fit as a zipper with a little more variability in how to wear it. This variability comes in buttoning or snapping asymmetrically, achieving a sculptural swoop at the neckline and an asymmetrically flattering triangle of fabric at the bottom.

My favorite methods of closure are long dangling lengths of fabric or ribbon that double in function and style. These pieces can either be tied, wrapped around (a la wrap-around skirt style), or woven through D hooks for an adjustable fit! Still another favorite is using giant safety pins, diaper pins, vintage hat pins, brooches, or any other similar pinning mechanism to achieve a perfect fit that perfectly varies with your ever-changing body.

Pinning for Winning

Common pins are the common way to tailor garments. I'm a little too aggressive for that! They can fall out or get pulled out by getting stuck on other things. After sticking my old landlord with a pin forgotten in a floor pillow, I learned my lesson. Common pins are just not for me!

Safety pins, however, are my best friend. As you are trying on a garment to test the fit, you can pin and re-pin them easily. They are great for test-fitting the movement of a piece before you sew it, something that is just not realistic with common pins. They are also, according to their name, just plain safer to play around with.

There are some drawbacks to safety pins that you should be aware of. They are generally thicker than common pins and therefore should be used carefully, or not at all, with delicate fabrics such as silks. Also, unlike common pins, you cannot sew over them with a regular machine. For this reason, whenever it's necessary to do this I will replace the safety pins with common pins when it's time to sew. Of course, neither common pins or safety pins can go through an overlock!

Lock into a Good Overlock

People often ask me for recommendations on machines, where to buy them, what to look for, good brands, etc. When it comes to overlocks, you just do not want to mess around with a mediocre one, even if you are on a budget. I made this mistake once and the darn thing busted the second time I used it! I confess to being hard on my machines, but that is just unacceptable! Knowing it was a \$200 repair, the same price I paid for the machine, I promptly returned it to the store. So think of it this way, for the cost of what it takes to repair the cheapo overlocks, you can get a good one from the very beginning.

While I do have certain brands and models that I like, and don't like, I refrain from recommending any particular one because I have not used every brand available. It just wouldn't be fair. There are some good Web sites that you can refer to with "overlock reviews." My rule of thumb is to look at the machines in the \$600 range and choose a couple options from that based on the reviews. The next step is to search for your desired brand and model online. If you are not Web-savvy, try your local library for some help! Shopping auction Web sites, you can find lots of machines that are generally up to a couple hundred dollars cheaper, even when purchased brand new!

If you are purchasing a used machine, get a warranty or return policy that you can live with. Remember that a standard tune-up can be up to \$80 and a common repair, at least for me, runs at about \$200. So if you are taking a leap of faith, budget this possibility into a price that you can live with. You don't want to be one of those people with a broken machine in their closet or trying to hock it on an auction Web site to screw some other poor sucker. Be smart and treat yourself fairly!

No Salvation for Armpit Stains

Please, I beg of you, let me save you from this fate. There are some fantastically tempting treasures out there: vintage print shirts, sweet little sweaters and tons of button-downs! Trust me, I've got loads of them! But unless you are going to completely cut out the entire armpit area, do not *ever* fool yourself into believing that you can salvage, sanitize, de-stinkify or cover up armpit stains!

Armpit stains are not only unsightly, but fairly disturbing when it comes to vintage. It's bad enough to have your own sweat stain a shirt, but someone else's is just plain disgusting. Often times they still stink, too! Ew! I've tried all different means of cleaning, covering up, transforming into a different garment and it's still just bad news.

Even my favorite fix-a-flaw tricks don't work on this nasty business. While dyeing is a great cover up for most stains, when it comes to the armpit it's still obviously an armpit stain. It actually just gets worse by taking on the dye bath more than the rest of the shirt. Ick! My other tried and true technique of chopping up into a halter doesn't even work. In order to get the stain out you just have to cut too much to get a good line for the halter.

So unless you're steering clear of this area in your reconstruction projects, don't kid yourself. There's no salvation for armpit stains!

Chapter 22

Ten Fix-a-Stain Tricks

In This Chapter

- ▶ Discovering clever ideas that never crossed your mind
 - ▶ Trying your hand at new techniques
 - ▶ Finding inspiration to save what you thought was lost forever
-

My mother and I used to have a knack for wearing white whenever we went out for Italian food, red sauce in particular. While some stains can be cleaned up and cleared out entirely, others hang on for dear life. Red sauce on a white shirt is just one of these, albeit a common dilemma in my own childhood experience. As I grew older, this culprit changed to red wine. But with age comes wisdom, and thus in more recent years I have learned to appreciate the stain-free salvation of sake!

But aside from changing your lifestyle, what else can you do to save your clothes from the ruin of stains? This chapter lists ten creative tips to disguising that stain you just can't get out in the wash. I actually like to think of stains as a guide. They are a challenge to one's creativity, depending on their location, size, and shape. Some can be incorporated into the reconstructed garment. Others might be small enough to erase or cover up entirely with a slew of tactical maneuvers enough to rival any spaghetti-toting ninja army.

Brushing Up on Your Painting

From fine art to finger paint, regardless of your skill level, painting over a stain is a sure-fire way to cover it up completely! Even just a single splotch or brushstroke can add super-style to your piece. Many of my clothes have doubled as paint rags in their lifetime, and they are often mistaken for purposeful decorative techniques. Fancy that!

Start off with fabric paint in a desired color. Follow the instructions on the paint in regards to any heat-setting that might be required. If you have a specific design in mind, it's best to practice it on paper or scrap fabric first.

I recommend keeping things abstract, such as swirls, dots and stripes. Another key point is to be careful of covering too large an area with your deco-paint masterpiece. Paint can stiffen up a garment, even fabric paint, and who wants to look stiff!?

Dye Do-Overs

This is not your ordinary tie-dye! Dying a garment or a portion of a garment is a fun experiment in covering up stains. In my experience, most often the stain takes on the dye bath more than the rest of the fabric. In other words, the stain comes out darker than the whole garment.

For this reason, I play around with a lot of different dyeing techniques. I confess that I am a self-taught novice with this, so feel free to seek out your own techniques as well. My favorite is grading the shades of the dye bath by suspending the garment partway in the bath, and slowly removing it, or lowering it further, in successive time increments. This is also fun to do with two colors. Twisting, knotting, and tying with rubber bands, the standard “tie-dye” techniques can be altered in such a way to not scream “hi, I’m tie-dyed!” I like to twist the whole garment and tie it into a knot on itself before placing it in the dye bath. Dyeing it a second time without twisting further subdues the tie-dye effect, but leaves variations in shades that mask most any stubborn stain!

Drawing 101 — Sharpie Style

I love sharpie markers! But really, you could use any permanent marker to achieve this effect. I’ve found that black works best to cover up stains and still look good. The colored markers, even fabric markers, tend to fade and look dull even from the start. Besides, a clean black outline drawing just looks so hot!

Like painting, if you have a specific design be sure to practice it first. Unlike painting, there’s no need to keep this artistic feat simple! Go nuts graffiti-style! Personally, I generally keep to my basic abstract lines and dots. I’ve even nonchalantly outlined stains with my sharpie (oh the things you do when you’re on hold with customer service!) and ironically this emphasis of the stain has drawn some surprising compliments.

You want a really good idea? Throw a stain cover-up party with friends. Commission a local artist to do it up. Even your idle-handed teenager could give it a whirl!

Patchwork Pride

This cover-up technique makes good new use of your old scraps. Just plop on a patch large enough to cover the stain and you're good to go. Layer multiple patches, smaller ones on top of larger ones, for a layered effect. Who knows, people may never even suspect what lies beneath!

This trick can get a bit scrappy if that's a look you want to play with. In Chapter 20 I've included a project, "From Garbage to Gorgeous," that tells you some fun ways to mash up even your smallest scraps into a decorative adornment.

Some stains are in locations that you don't necessarily want to emphasize with a patch. In this case, feel free to extend the patching technique to create a stripe of several patches along the garment. Another option is to sew on additional patched areas to take the emphasis away from the singular stained area.

Turning the Dial to Decorative Stitching

I was a big fan of decorative stitching. I emphasize "was." One afternoon I was dragged into a mall and *blam*, there it was: a mass-produced uber-designer shirt almost identical to one I had just done for a friend! From that point on, any decorative stitching that I do is generally intentionally messy and over-the-top, using massive amounts of thread, which actually works perfectly to cover up stains.

Go deco all over the place, either combined with a patch or solely on its own merits. Play around with layering different colors of thread. At the same time you can layer different types of stitches in those different colors. Another eye-catching (or stain-distracting) trick is using an alternate color bobbin thread while tightening the upper tension of the machine, and loosening the bobbin tension if needed. The bobbin thread will pull through to the top, leaving surprise dots of color in its wake.

Seemingly a Mere Seam

For small stains, such as those lovely spaghetti splatter stains, taking up the fabric in a faux external seam is a neat trick. You run the seam evenly through the whole garment, avoiding difficult angles like the armpit. Another option is to go extreme and only run the seam through the actual stain, tying the threads off midway through a garment. This will result in a puckered look, which is fun to combine with other elements: patchwork and decorative sewing especially.

It's important to remember that taking in a faux seam will make your garment smaller! Be careful!

Deco-Serge Splurge

This fix-a-stain trick is very similar to the above technique but with the use of an overlock machine rather than a regular sewing machine. I like to use this when I have several small stains . . . connect the dots! It's also useful to cover up splatters from a larger stain. Combine it with some of the other techniques to cover the large stain as well as the splattering.

These lines can travel anywhere within the garment . . . on angles, vertically and horizontally. Cross these lines to create a patchwork effect in the garment. You can have even more fun by painting or drawing in the different windows made with these intersecting serge lines!

Worn with Purpose

Cut your stain out of the picture with a worn look. I know this is trendy nowadays. I've had people ask me to hem their absurdly overpriced "designer" jeans that look astonishingly similar to a pair my dad used to wear to work in the garden. It's so silly what a little marketing will do to empty people's pockets.

Stepping off that soapbox, here's some tricks and tips to do it yourself at home, without wasting your money on nonsense and manipulation! What's even better is that at the same time you'll be salvaging that stained garment from its garbage can destiny.

How to? Well, it's time to hit my favorite place for inspiration: the hardware store! Combining these tools and techniques works best to achieve the amount of wear and tear, and stain repair, that you're looking for. For thick fabric such as denim, cut all or part of the stain with dull scissors or rough up the edges of a cut with the scissor blade or other sharp-edged tool. Rubbing the area, cut or not, with rough sandpaper on a hard surface achieves a very natural worn 'n torn look. If you've got one lying around, or can wrangle one up from your local handy-person, an electric palm-sander will ease the hard labor, scrapes and finger cramping sometimes involved in this creative endeavor.

Exemplary Embroidery

I just love embroidery. While there are fancy machines that do this, it is actually one of the first textile arts I learned to do by hand as a child. It's actually very odd for me to think of it as a machine technique when doing it by hand was so beautiful. When I was a kid, it was pretty limited to flowers and scrolling and other kitschy scenes that I soon grew tired of. But now, it's

making a comeback in a whole new way. Embroidery mavens are expressing their skill and creative license with skulls, hand-lettered phrases, and just about whatever they feel like.

Embroidery can be used to cover up stains or disguise them via enhancement. You can try to give it a shot freehand, but it's easiest to avoid puckers by using an embroidery hoop. Stitch around the border of a stain to create a circle or odd shape. French knots are handy for little stains and splatters. Combined with beading, sewing on sequins or other adornments, embroidery stitchwork can bring about a whole different look to your otherwise useless garment.

Buttons and Beads That Can't Be Beat

Depending on where your stain is, sewing on some decorative adornments can be a fun solution. This is also a great way to make use of those odds 'n ends buttons and beads that have fallen off other garments.

Keep in mind the thickness of your material and the weight of the buttons and beads. If necessary, place a scrap of backing fabric or interfacing on the inside of the area you are working on.

Some beads have tiny holes that are much too small for a sewing needle to pass through. In this case, alternate your stitching through the fabric with threading through the bead with a beading needle. This is rather tedious and thus you should mete out your beading expectations accordingly. If you're really into gobs of beads, try recycling sections from old wedding gowns or, egads, buying a pre-beaded appliqué to sew on as you would for a patch.

I like keeping buttons clustered together in some sort of thematic presentation. I have a drawer full of buttons collected and handed down from generations. There are definite trends in which to play with: cloth covered, glass, braided leather, vintage, and of course color!

Combining buttons with embroidery can yield fun looks, especially for kids, or the kid in us! Buttons make great eyes for fun animal faces, wheels for cars and even leaves on a tree! Have fun with it!

Index

• A •

afghan
 care tips, 235–236
 poncho creation, 237–241
 vestcoat creation, 241–247
allergy, 57
alteration
 dress neckline redo, 282–287
 reconstruction definition, 14
animal product, 56
armpit stain
 clothing search, 44, 46
 general tips, 345–346
artist-designer, 19–20

• B •

basting, 74, 104
beadwork
 clothing search, 44–45
 damaged clothing workarounds, 351
 laundering tips, 56
bedbug, 45
bedding
 overview, 297
 pillowcase, 209–213, 300–307
 quilt, 307–313
 stuffing, 297–300
belt, 173–178
bias tape, 111
bin, 50–51
blanket. *See* afghan; quilt
blanket stitch, 75
blind hem, 76, 80
bracelet, 121–123
bridesmaid dress
 cape creation, 261–265
 care tips, 251–252

 overview, 251
 shredded-edge dress creation, 252–256
 split skirt creation, 256–261
 wine bag creation, 265–268
Building Resources (sustainable organization), 21
business skirt, 275–278
bustle
 neck, 109–112
 pants, 158–163
button
 cardigan care, 203–204
 damaged clothing workarounds, 351
 general tips, 344
 laundering tips, 56
button-down shirt
 bracelet creation, 121–123
 care tips, 107–108
 cuff creation, 118–121
 neck bustle creation, 109–102
 sweater-shirt combo creation, 112–118

• C •

cape, 261–265
cardigan. *See also* sweater
 care tips, 201–204
 cropped sweater creation, 205–209
 pillowcase creation, 209–213
 skirt creation, 213–216
care instructions
 afghans, 235–236
 bridesmaid dress, 251–252
 button-down shirts, 107–108
 cardigans, 201–204
 casual dresses, 281–282
 general laundering tips, 56–57
 jeans, 169–170
 pants, 149–150, 183–184

care instructions (*continued*)
 pullover shirts, 125–126
 pullover sweaters, 218–219
 skirts, 269–270
 T-shirts, 90

chain store, 41

chair, 67–68

chaos, 52–53

children's clothing, 28

choker, 330–333

city store, 35–36

cleaning clothes
 afghans, 235
 bridesmaid dress, 252
 cardigans, 202–203
 dresses, 281
 general instructions, 56–57
 jeans, 169
 pants, 149, 183
 pullover shirts, 125, 126
 pullover sweaters, 218
 skirts, 269
 T-shirts, 90

closet space, 30–31, 34

closure, 344

clothing, damaged
 clothing search, 40–42
 general tips, 342–343
 workarounds, 58–60, 347–351

clothing repairs
 jeans, 170–173
 pants, 150–153
 seams, 62
 workarounds, 58–60, 347–351

clothing search
 damaged clothes, 40–42
 fabric scraps, 42–43
 ill-fitting clothes, 40
 inspirational items, 43
 personal closet, 34
 style, 38
 thrift stores, 34–38, 39
 used clothing issues, 43–48

clothing size, 343

Collins, Chris Ray (artist), 21

consciousness, 32

cowl neck top
 pullover redo, 130–135
 skirt redo, 278–280

craigslist.com (Web site), 38

creativity
 alterations, 14
 personal style, 12
 personality, 17–20
 workspace, 52–53

crocheted blanket
 care tips, 235–236
 poncho creation, 237–241
 vestcoat creation, 241–247

crop top
 cowl neck top, 130–135
 tailed top, 136–140

cropped sweater
 cardigan redo, 205–209
 pullover sweater redo, 223–224

cuff project, 118–121

cutting fabric, 59, 341



dabbler, 17–18

damaged clothing
 clothing search, 40–42
 general tips, 342–343
 workarounds, 58–60, 347–351

DasFrachtgut (sustainable organization), 21

daybag
 jeans redo, 179–182
 sweater redo, 230–234

deconstruction
 overview, 49
 seam locations, 61
 seam ripping, 62
 tools, 53–55
 workspace organization, 50–53

decorative fabric, 327–330

decorative stitch, 58, 81, 349

deep neck cut, 287

designer
 fake reconstructions, 23
 personality, 19–20
 sample sales, 12

differential feeding, 84
 discount, 28
 drawing, 348
 dress. *See also specific types*
 care tips, 281–282
 matched set creation, 291–293
 neckline alteration, 282–287
 raw seam design, 287–290
 dry cleaning, 252
 dryer, 57
 dyeing, 59, 348

● E ●

embroidery, 45, 350–351
 environmental issues
 personality, 18
 photo shoot locations, 21
 purpose of reconstruction, 1, 24–27, 32
 ergonomics, 66–69

● F ●

fabric care
 afghans, 235–236
 bridesmaid dress, 251–252
 button-down shirts, 107–108
 cardigans, 201–204
 casual dresses, 281–282
 general laundering tips, 56–57
 jeans, 169–170
 pants, 149–150, 183–184
 pullover shirts, 125–126
 pullover sweaters, 218–219
 skirts, 269–270
 T-shirts, 90
 fabric scraps
 bedding stuffing, 297–300
 choker, 330–333
 clothing search, 42–43
 decorative fabric, 327–330
 painting tips, 58
 pillowcase, 300–307
 quilt, 307–313
 reconstruction definition, 15–16

 sachet, 315–320
 wallet, 334–338
 favorite clothing, 29–30
 feathers, 56
 financial issues
 clothing search, 39, 41
 reconstruction purpose, 27–29, 32
 fit, clothing, 40
 fitted T-shirt, 103–105
 flare skirt
 cardigan redo, 113–116
 pants redo, 184–190
 flat fabric
 bedding stuffing, 297–300
 choker, 330–333
 clothing search, 42–43
 decorative fabric, 327–330
 painting tips, 58
 pillowcase, 300–307
 quilt, 307–313
 reconstruction definition, 15–16
 sachet, 315–320
 wallet, 334–338
 fly top, 163–167
 freecycle.org (Web site), 38
 frill skirt, 270–275
 fringe, 236

● G ●

garbage
 decorative fabrics, 327–330
 purpose of reconstruction, 24–27
 reconstruction definition, 16–17
 garbage can, 51, 52
 greenopia.com (Web site), 32
 Guillard, Marcus (artist), 21

● H ●

halter top
 pullover sweater redo, 220–222
 T-shirt redo, 99–102
 hand sewing
 basting, 74
 blanket stitch, 75

hand sewing (*continued*)
 hemming, 75–77
 knots, 72–74
 needle threading, 70–71
 overview, 69
 running stitch, 74–75
 torn clothing workaround, 60

hand-made crafts, 39
 hand-me-downs, 15
 hand-washing, 252
 hat, 194–198
 heat gun, 85, 252–256
 hemming
 hand sewing tips, 75–77
 machine sewing tips, 79–80
 quick fixes, 86
 holes, 59–60
 home décor
 overview, 315
 potholder, 320–325
 sachet, 315–320
 human rights, 32

• I •

inside-out clothing, 288

• J •

jeans. *See also* pants
 belt creation, 173–178
 care tips, 169–170
 daybag creation, 179–182
 repair creation, 170–173

• K •

knot, 72–74

• L •

label, clothing, 56
 landfill, 26–27
 laundering clothes
 afghans, 235
 bridesmaid dress, 252

cardigans, 202–203
 dresses, 281
 general instructions, 56–57
 jeans, 169
 pants, 149, 183
 pullover shirts, 125, 126
 pullover sweaters, 218
 skirts, 269
 T-shirts, 90
 leather, 65
 leggings, 190–194
 linen, 28
 lint brush, 55
 lost-and-found items, 29
 lycra, 90

• M •

machine sewing
 damaged clothing workaround, 58, 60
 machine features, 77
 machine maintenance, 66, 78–79
 machine purchasing tips, 78
 overview, 77
 stitches, 79–81
 workspace tips, 66–69
 marker, 348
 mice, 45–46, 52
 mistake, 62
 money
 clothing search, 39, 41
 reconstruction purpose, 27–29, 32
 musty clothing, 57

• N •

National Labor Committee, 32
 neatness, 50–53
 neck bustle, 109–112
 neckline, 282–287
 needles
 overview, 64–65
 threading tips, 70–71
 no-sew tips
 hems, 86, 95
 reconstruction definition, 14

• O •

Occasio, Melvin (artist), 21
 odor
 armpit problems, 44, 345–346
 clothing search, 44, 47–48
 laundering tips, 57
 Ohmega Salvage (sustainable organization), 21
 organization, 50–53
 overlock machine
 damaged clothing workaround, 60, 350
 differential feeding, 84
 features, 81–82
 general tips, 345
 maintenance, 82
 overview, 81
 purchasing tips, 82
 raw look, 84, 85
 serged seams, 83–84
 overlock stitch, 83–84

• P •

paint
 clothing search, 42
 cuff project, 118–121
 damaged clothing workarounds, 58, 347–348
 laundering tips, 56
 pants. *See also* jeans; stretch pants
 bustle creation, 158–163
 care tips, 149–150
 fly top creation, 163–167
 repair creation, 150–153
 seam location, 61
 split skirt creation, 153–158
 patch
 damaged clothing workarounds, 58, 59, 349
 hem fix, 86
 pattern, sewing, 13–14
 The Pegicorn (artwork), 21
 perfection, 341–342
 personality, 17–20
 pet hair, 55

photograph, 20–21
 pill, clothing, 46, 184, 219
 pillow
 cases, 209–213, 300–307
 stuffing, 297–300
 pins
 general tips, 344
 overview, 64–65
 polyester, 44
 poncho, 237–241
 posture, 67–68
 potholder, 320–325
 professional appearance, 108
 pullover shirt
 care tips, 125–126
 cowl neck creation, 130–135, 278–280
 fly top creation, 163–167
 seasonal crop top creation, 126–130
 tailed top creation, 136–140
 wrap top creation, 140–145
 pullover sweater. *See also* sweater
 care tips, 218–219
 cowl neck creation, 278–280
 halter top creation, 220–222
 overview, 217
 skirt creation, 219–220
 sleeve creation, 227–230
 wrap top creation, 224–226

• Q •

quilt
 instructions, 309–313
 materials, 308
 overview, 307–308
 variations, 313

• R •

raw look
 dress design, 287–290
 overlock machine, 84, 85
 reconstructing clothing
 overview, 12–17
 personality types, 17–20
 purpose, 1, 23–32

- recycling, 26–27
 - reducing waste, 24–25
 - remnants
 - bedding stuffing, 297–300
 - choker, 330–333
 - clothing search, 42–43
 - decorative fabric, 327–330
 - painting tips, 58
 - pillowcase, 300–307
 - quilt, 307–313
 - reconstruction definition, 15–16
 - sachet, 315–320
 - wallet, 334–338
 - repairs
 - jeans, 170–173
 - pants, 150–153
 - seams, 62
 - workarounds, 58–60, 347–351
 - reuse, 25–26
 - reverse stitch, 80
 - ribbon, 344
 - ripping seams, 53, 62
 - rolling cutter, 54–55
 - rotary cutter, 55
 - ruffled neck, 287
 - running stitch, 74–75
 - running sweater, 104
- S ●
- sachet, 315–320
 - safety pin, 54, 344
 - sample sale, 12
 - scavenging, 35
 - scissors, 54, 342
 - scrap surface, 58
 - scraps
 - bedding stuffing, 297–300
 - choker, 330–333
 - clothing search, 42–43
 - decorative fabric, 327–330
 - painting tips, 58
 - pillowcase, 300–307
 - quilt, 307–313
 - reconstruction definition, 15–16
 - sachet, 315–320
 - wallet, 334–338
 - seam
 - deconstruction, 62
 - exposure, 288
 - location, 61
 - repair, 62
 - ripper, 53
 - serging process, 83–84
 - stain fix, 349
 - seasonal clothing, 126–130
 - seasonal sale, 28
 - self-identity, 13
 - sequins, 56
 - serged seam, 83–84
 - serger
 - damaged clothing workarounds, 60, 350
 - differential feeding, 84
 - features, 81–82
 - general tips, 345
 - maintenance, 82
 - overview, 81
 - purchasing tips, 82
 - raw look, 84, 85
 - serged seams, 83–84
 - sewing, hand
 - basting, 74
 - blanket stitch, 75
 - hemming, 75–77
 - knots, 72–74
 - needle threading, 70–71
 - overview, 69
 - running stitch, 74–75
 - torn clothing workarounds, 60
 - Sewing For Dummies* (Wiley Publishing), 20, 72
 - sewing machine
 - damaged clothing workarounds, 58, 60
 - features, 77
 - maintenance, 66, 78–79
 - overview, 77
 - purchasing tips, 78
 - stitches, 79–81
 - torn clothing workarounds, 60
 - workspace tips, 66–69

- sewing room
 ergonomics, 66–69
 organization, 50–53
 shelving, 51
 shirt, 61. *See also specific types*
 shopping
 damaged clothes, 40–42
 fabric scraps, 42–43
 ill-fitting clothes, 40
 inspirational items, 43
 personal closet, 34
 style, 38
 thrift stores, 34–38, 39
 used clothing issues, 43–48
 shoulder bag
 jeans redo, 179–182
 sweater redo, 230–234
 sizing clothes, 343
 skirt, reconstructed
 business skirt, 275–278
 cowl neck top, 278–280
 frill skirt, 270–275
 matched set, 291–293
 skirt creations. *See also specific skirt types*
 cardigan redo, 213–216
 care tips, 269–270
 dress redo, 291–293
 leggings redo, 190–194
 overview, 269
 pants redo, 153–158, 184–190
 pullover sweater redo, 219–220
 seam location, 61
 T-shirt redo, 91–98
 slacks. *See also specific types*
 bustle creation, 158–163
 care tips, 149–150
 fly top creation, 163–167
 repair creation, 150–153
 seam location, 61
 split skirt creation, 153–158
 slanted hem, 76
 sleeves, 226–230
 slice cut neckline, 287
 slipstitch, 76–77
 snap tape, 344
 spandex, 90
 split skirt
 bridesmaid dress redo, 256–261
 pants redo, 153–158
 stain
 clothing search, 41, 44
 general tips, 343, 345–346
 laundering tips, 57
 pullover shirt care, 126
 T-shirt care, 90
 workarounds, 58–59, 347–351
 stitch. *See also specific types*
 hand sewing, 74–77
 machine sewing, 79–81
 straight stitch, 80
 stretch fabric, 65, 66
 stretch pants. *See also pants care tips*, 183–184
 flare skirt creation, 184–190
 hat creation, 194–198
 student, 18–19
 stuffing, 297–300
 style
 clothing search, 38, 40
 creativity, 12
 therapy, 13
 suburban store, 36–37
 suede, 56
 suit, 270
 Sunset Scavenger Artist-in-Residence Program (sustainable organization), 21
 sustainable living
 personality, 18
 photo shoot locations, 21
 purpose of reconstruction, 1, 24–27, 32
 Swaporamarama event, 38
 sweater. *See also cardigan; pullover sweater*
 button-down combo creation, 112–118
 cropped sweater creation, 205–209
 pillowcase creation, 209–213
 sweatshop labor, 32
- **T** •
- table, 66–67
 tailed top, 136–140

tape, no-sew, 95

Teacher With The Bus a.k.a. DasFrachtgut
(sustainable organization), 21

thread

knots, 72–74

needle threading, 70–71

organized workspace, 51, 52

overview, 64

thrift store, 34–37, 39

tools. *See also specific tools*

necessities, 53–55, 64–66

organization, 51–53, 69

overview, 53

quick fixes, 85–86

top overlock stitch, 81

torn clothing

clothing search, 41–42

workarounds, 59–60

trash

decorative fabrics, 327–330

purpose of reconstruction, 24–27

reconstruction definition, 16–17

trendy clothing, 38

trunk show, 12

T-shirt

care tips, 89–90

fitted waistband creation, 102–105

halter top creation, 99–102

skirt creation, 91–98

• U •

vacuum, 55

vestcoat, 241–247

• W •

waistband, 103–105

wallet, 334–338

Wiley Publishing (*Sewing For Dummies*),
20, 72

wine bag, 265–268

workspace

ergonomics, 66–69

organization, 50–53

worn clothing, 41–42, 350

wrap top

pullover shirt, 140–145

sweater, 224–226

• Y •

yard sale, 28, 38

• Z •

zigzag stitch, 80

zipper, 344

BUSINESS, CAREERS & PERSONAL FINANCE



0-7645-9847-3

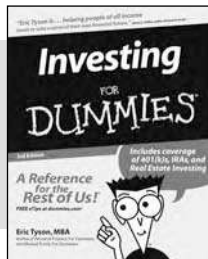

0-7645-2431-3

Also available:

- ✓ Business Plans Kit For Dummies 0-7645-9794-9
- ✓ Economics For Dummies 0-7645-5726-2
- ✓ Grant Writing For Dummies 0-7645-8416-2
- ✓ Home Buying For Dummies 0-7645-5331-3
- ✓ Managing For Dummies 0-7645-1771-6
- ✓ Marketing For Dummies 0-7645-5600-2

- ✓ Personal Finance For Dummies 0-7645-2590-5*
- ✓ Resumes For Dummies 0-7645-5471-9
- ✓ Selling For Dummies 0-7645-5363-1
- ✓ Six Sigma For Dummies 0-7645-6798-5
- ✓ Small Business Kit For Dummies 0-7645-5984-2
- ✓ Starting an eBay Business For Dummies 0-7645-6924-4
- ✓ Your Dream Career For Dummies 0-7645-9795-7

HOME & BUSINESS COMPUTER BASICS

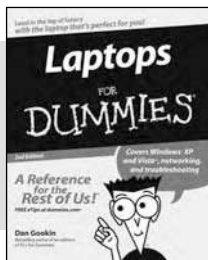

0-470-05432-8

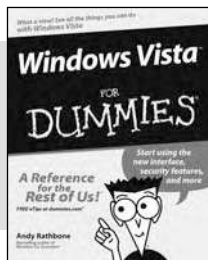

0-471-75421-8

Also available:

- ✓ Cleaning Windows Vista For Dummies 0-471-78293-9
- ✓ Excel 2007 For Dummies 0-470-03737-7
- ✓ Mac OS X Tiger For Dummies 0-7645-7675-5
- ✓ MacBook For Dummies 0-470-04859-X
- ✓ Macs For Dummies 0-470-04849-2
- ✓ Office 2007 For Dummies 0-470-00923-3

- ✓ Outlook 2007 For Dummies 0-470-03830-6
- ✓ PCs For Dummies 0-7645-8958-X
- ✓ Salesforce.com For Dummies 0-470-04893-X
- ✓ Upgrading & Fixing Laptops For Dummies 0-7645-8959-8
- ✓ Word 2007 For Dummies 0-470-03658-3
- ✓ Quicken 2007 For Dummies 0-470-04600-7

FOOD, HOME, GARDEN, HOBBIES, MUSIC & PETS

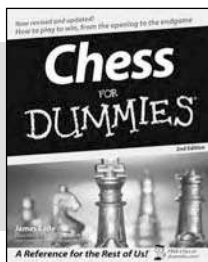

0-7645-8404-9

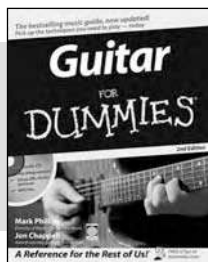

0-7645-9904-6

Also available:

- ✓ Candy Making For Dummies 0-7645-9734-5
- ✓ Card Games For Dummies 0-7645-9910-0
- ✓ Crocheting For Dummies 0-7645-4151-X
- ✓ Dog Training For Dummies 0-7645-8418-9
- ✓ Healthy Carb Cookbook For Dummies 0-7645-8476-6
- ✓ Home Maintenance For Dummies 0-7645-5215-5

- ✓ Horses For Dummies 0-7645-9797-3
- ✓ Jewelry Making & Beading For Dummies 0-7645-2571-9
- ✓ Orchids For Dummies 0-7645-6759-4
- ✓ Puppies For Dummies 0-7645-5255-4
- ✓ Rock Guitar For Dummies 0-7645-5356-9
- ✓ Sewing For Dummies 0-7645-6847-7
- ✓ Singing For Dummies 0-7645-2475-5

INTERNET & DIGITAL MEDIA

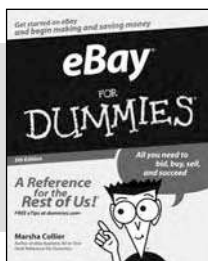

0-470-04529-9



0-470-04894-8

Also available:

- ✓ Blogging For Dummies 0-471-77084-1
- ✓ Digital Photography For Dummies 0-7645-9802-3
- ✓ Digital Photography All-in-One Desk Reference For Dummies 0-470-03743-1
- ✓ Digital SLR Cameras and Photography For Dummies 0-7645-9803-1
- ✓ eBay Business All-in-One Desk Reference For Dummies 0-7645-8438-3
- ✓ HDTV For Dummies 0-470-09673-X

- ✓ Home Entertainment PCs For Dummies 0-470-05523-5
- ✓ MySpace For Dummies 0-470-09529-6
- ✓ Search Engine Optimization For Dummies 0-471-97998-8
- ✓ Skype For Dummies 0-470-04891-3
- ✓ The Internet For Dummies 0-7645-8996-2
- ✓ Wiring Your Digital Home For Dummies 0-471-91830-X

* Separate Canadian edition also available

† Separate U.K. edition also available

Available wherever books are sold. For more information or to order direct: U.S. customers visit www.dummies.com or call 1-877-762-2974. U.K. customers visit www.wiley.com or call 0800 243407. Canadian customers visit www.wiley.ca or call 1-800-567-4797.



SPORTS, FITNESS, PARENTING, RELIGION & SPIRITUALITY

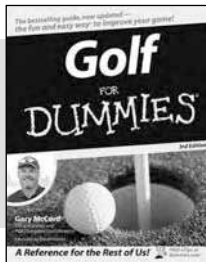

0-471-76871-5

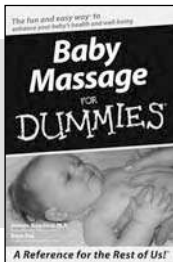

0-7645-7841-3

Also available:

- ✓ Catholicism For Dummies 0-7645-5391-7
- ✓ Exercise Balls For Dummies 0-7645-5623-1
- ✓ Fitness For Dummies 0-7645-7851-0
- ✓ Football For Dummies 0-7645-3936-1
- ✓ Judaism For Dummies 0-7645-5299-6
- ✓ Potty Training For Dummies 0-7645-5417-4
- ✓ Buddhism For Dummies 0-7645-5359-3
- ✓ Pregnancy For Dummies 0-7645-4483-7 †
- ✓ Ten Minute Tone-Ups For Dummies 0-7645-7207-5
- ✓ NASCAR For Dummies 0-7645-7681-X
- ✓ Religion For Dummies 0-7645-5264-3
- ✓ Soccer For Dummies 0-7645-5229-5
- ✓ Women in the Bible For Dummies 0-7645-8475-8

TRAVEL

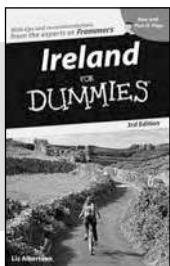

0-7645-7749-2

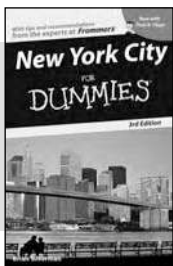

0-7645-6945-7

Also available:

- ✓ Alaska For Dummies 0-7645-7746-8
- ✓ Cruise Vacations For Dummies 0-7645-6941-4
- ✓ England For Dummies 0-7645-4276-1
- ✓ Europe For Dummies 0-7645-7529-5
- ✓ Germany For Dummies 0-7645-7823-5
- ✓ Hawaii For Dummies 0-7645-7402-7
- ✓ Italy For Dummies 0-7645-7386-1
- ✓ Las Vegas For Dummies 0-7645-7382-9
- ✓ London For Dummies 0-7645-4277-X
- ✓ Paris For Dummies 0-7645-7630-5
- ✓ RV Vacations For Dummies 0-7645-4442-X
- ✓ Walt Disney World & Orlando For Dummies 0-7645-9660-8

GRAPHICS, DESIGN & WEB DEVELOPMENT

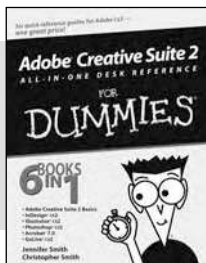

0-7645-8815-X

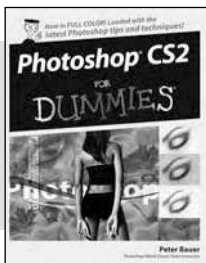

0-7645-9571-7

Also available:

- ✓ 3D Game Animation For Dummies 0-7645-8789-7
- ✓ AutoCAD 2006 For Dummies 0-7645-8925-3
- ✓ Building a Web Site For Dummies 0-7645-7144-3
- ✓ Creating Web Pages For Dummies 0-470-08030-2
- ✓ Creating Web Pages All-in-One Desk Reference For Dummies 0-7645-4345-8
- ✓ Dreamweaver 8 For Dummies 0-7645-9649-7
- ✓ InDesign CS2 For Dummies 0-7645-9572-5
- ✓ Macromedia Flash 8 For Dummies 0-7645-9691-8
- ✓ Photoshop CS2 and Digital Photography For Dummies 0-7645-9580-6
- ✓ Photoshop Elements 4 For Dummies 0-471-77483-9
- ✓ Syndicating Web Sites with RSS Feeds For Dummies 0-7645-8848-6
- ✓ Yahoo! SiteBuilder For Dummies 0-7645-9800-7

NETWORKING, SECURITY, PROGRAMMING & DATABASES

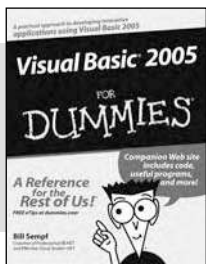

0-7645-7728-X

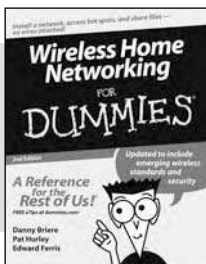

0-471-74940-0

Also available:

- ✓ Access 2007 For Dummies 0-470-04612-0
- ✓ ASP.NET 2 For Dummies 0-7645-7907-X
- ✓ C# 2005 For Dummies 0-7645-9704-3
- ✓ Hacking For Dummies 0-470-05235-X
- ✓ Hacking Wireless Networks For Dummies 0-7645-9730-2
- ✓ Java For Dummies 0-470-08716-1
- ✓ Microsoft SQL Server 2005 For Dummies 0-7645-7755-7
- ✓ Networking All-in-One Desk Reference For Dummies 0-7645-9939-9
- ✓ Preventing Identity Theft For Dummies 0-7645-7336-5
- ✓ Telecom For Dummies 0-471-77085-X
- ✓ Visual Studio 2005 All-in-One Desk Reference For Dummies 0-7645-9775-2
- ✓ XML For Dummies 0-7645-8845-1

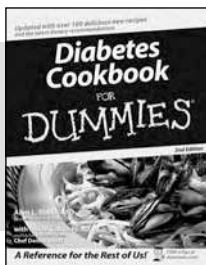

0-7645-8450-2

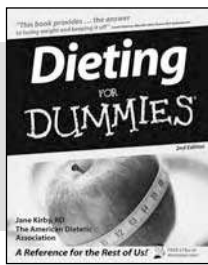

0-7645-4149-8

Also available:

- ✔ Bipolar Disorder For Dummies
0-7645-8451-0
- ✔ Chemotherapy and Radiation For Dummies
0-7645-7832-4
- ✔ Controlling Cholesterol For Dummies
0-7645-5440-9
- ✔ Diabetes For Dummies
0-7645-6820-5* †
- ✔ Divorce For Dummies
0-7645-8417-0 †

- ✔ Fibromyalgia For Dummies
0-7645-5441-7
- ✔ Low-Calorie Dieting For Dummies
0-7645-9905-4
- ✔ Meditation For Dummies
0-471-77774-9
- ✔ Osteoporosis For Dummies
0-7645-7621-6
- ✔ Overcoming Anxiety For Dummies
0-7645-5447-6
- ✔ Reiki For Dummies
0-7645-9907-0
- ✔ Stress Management For Dummies
0-7645-5144-2

EDUCATION, HISTORY, REFERENCE & TEST PREPARATION

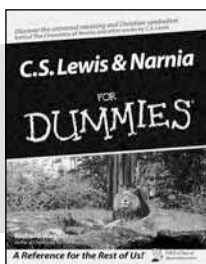

0-7645-8381-6

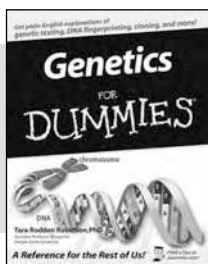

0-7645-9554-7

Also available:

- ✔ The ACT For Dummies
0-7645-9652-7
- ✔ Algebra For Dummies
0-7645-5325-9
- ✔ Algebra Workbook For Dummies
0-7645-8467-7
- ✔ Astronomy For Dummies
0-7645-8465-0
- ✔ Calculus For Dummies
0-7645-2498-4
- ✔ Chemistry For Dummies
0-7645-5430-1
- ✔ Forensics For Dummies
0-7645-5580-4

- ✔ Freemasons For Dummies
0-7645-9796-5
- ✔ French For Dummies
0-7645-5193-0
- ✔ Geometry For Dummies
0-7645-5324-0
- ✔ Organic Chemistry I For Dummies
0-7645-6902-3
- ✔ The SAT I For Dummies
0-7645-7193-1
- ✔ Spanish For Dummies
0-7645-5194-9
- ✔ Statistics For Dummies
0-7645-5423-9

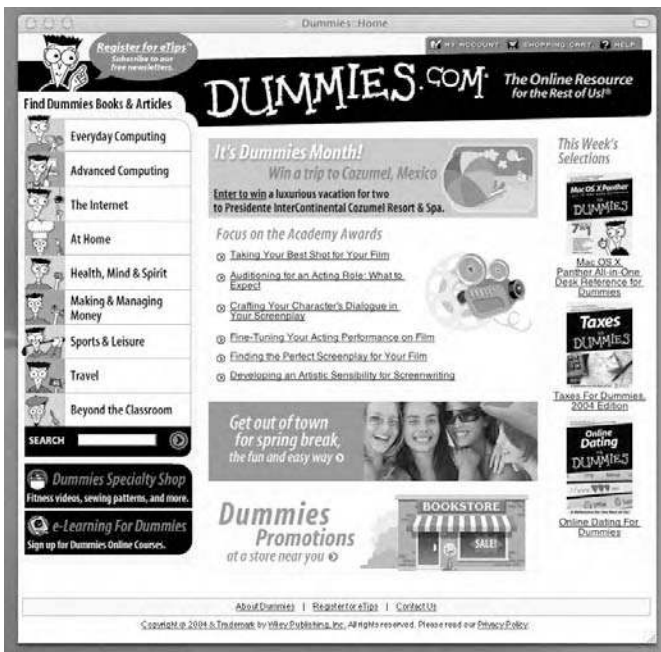

Get smart @ dummies.com®

- Find a full list of Dummies titles
- Look into loads of FREE on-site articles
- Sign up for FREE eTips e-mailed to you weekly
- See what other products carry the Dummies name
- Shop directly from the Dummies bookstore
- Enter to win new prizes every month!



* Separate Canadian edition also available

† Separate U.K. edition also available

Available wherever books are sold. For more information or to order direct: U.S. customers visit www.dummies.com or call 1-877-762-2974. U.K. customers visit www.wileyurope.com or call 0800 243407. Canadian customers visit www.wiley.ca or call 1-800-567-4797.

Do More with Dummies



**Instructional DVDs • Music Compilations
Games & Novelties • Culinary Kits
Crafts & Sewing Patterns
Home Improvement/DIY Kits • and more!**

Check out the Dummies Specialty Shop at www.dummies.com for more information!

 **WILEY**



Showing Some Skin Dress (Chapter 17)



Deco spray-paint stripes on hat, jacket, and jeans by Chris Ray Collins (Variations section of most projects)



shirt: No-Stop Halter Top (Chapter 6); *skirts:* Detachable Bustle Skirt and So-Easy Split Skirt (Chapter 8); *neckpiece:* Choker Chop-Ups (Chapter 20); *armpieces:* Sleek 'n' Sneaky Sleeves (Chapter 13)



A Little Heat Gun Goes a Long Way Dress (Chapter 16)

shirt (top): Crop Inversion Top
(Chapter 8); *shirt (bottom):*
No-Stop Halter Top (Chapter 6)



shirt (top): New Cut on Crops —
Tails of Two Crops Top variation
(Chapter 13); *headpiece:* Choker
Chop-Ups worn as headband
(Chapter 20); *shirt (bottom):*
No-Stop Halter Top (Chapter 6)

shirt: Take Two on the
Tees and No Stopping
the Halter Top (Chapter
13); *skirt:* Split Skirt
Stick-Up (Chapter 15)





shirts: two variations of No-Stop Halter Top (Chapter 6); waistpiece: Oh-So-Hip Hip Belt variation (Chapter 10)

On left: *sweater: New Cut on Crops – Crop Inversion Top (Chapter 13); neckpiece: Upside-Down Skirt worn as a shawl (Chapter 13); skirt: Upside-Down Skirt in a Topsy-Turvy World (Chapter 6); on right:* *sweater: Bad Unkl Sista Sweater (Chapter 12); shirt: No-Stop Halter Top (Chapter 6); skirt (top): Bare-and-Flare Skirt (Chapter 11); skirt (bottom): A Twist on the Upside-Down Skirt (Chapter 12)*





skirt: Upside-Down Skirt (Chapter 13);
shirt: Tails of Two Crops Top (Chapter 8)

Variation on how to wear Tails of
Two Crops Top (Chapter 8)

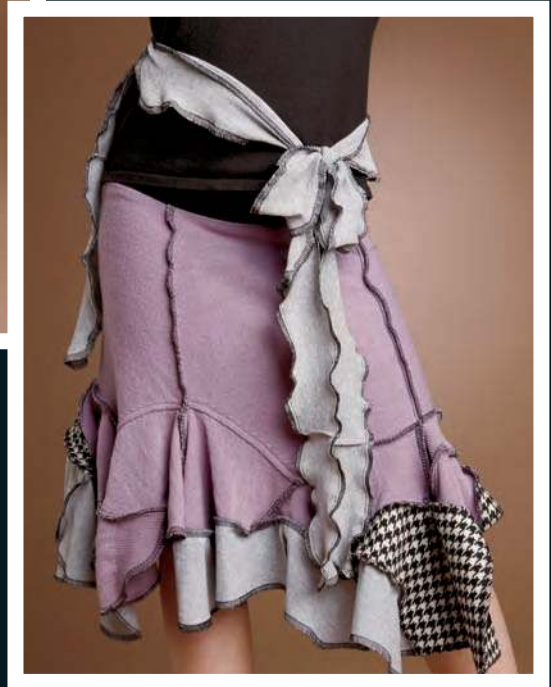

neckpiece: Busting Out the Neck Bustles
(Chapter 7); *armpieces:* Getting Crafty with
Cuffs variation (Chapter 7); *skirt:* Freeform-
and-Frill Skirt variation (Chapter 16)



*shirt (top): All-Season Cropping Top (Chapter 8);
shirt (bottom): Making the Most of Flaws on a
T-shirt (Chapter 4); armpieces: Sleek 'n' Sneaky
Sleeves (Chapter 13)*



*shirt: From Garbage to Gorgeous deco on a
T-shirt (Chapter 20); skirt: Freeform-and-Frill
Skirt (Chapter 16)*



*shirt: Surprise Fly Top (Chapter 9); shoulderbag: It's
in the Bag Shoulderbag (Chapter 10)*

dress: Raw the Right Way Dress (Chapter 17); **sweater:** Wrap For a New Way of Life (Chapter 13); **shoulderbag:** Bag Ladies Shoulderbag (Chapter 13)



armpiece (left): Getting Crafty with Cuffs variation (Chapter 7); **armpiece (right):** Sleek 'n' Sneaky Sleeves (Chapter 13)



shirt: Bridging the Sweater Gap Top (Chapter 7)



top and skirt: Sets of All Sorts Top/Skirt (Chapter 17)