

COBOL

From Micro to Mainframe

Preparing for the New Millennium



ROBERT T. GRAUER
CAROL VAZQUEZ VILLAR
ARTHUR R. BUSS

THIRD EDITION

Micro Focus™ Coverage Included
Free Fujitsu Compiler Included



COBOL

From Micro to Mainframe

Preparing for the New Millennium

THIRD EDITION

GRAUER / VAZQUEZ VILLAR / BUSS

The third edition of *COBOL From Micro to Mainframe* is designed to satisfy all of your COBOL needs—on multiple platforms. The textbook covers all basic COBOL elements, with additional chapters on the Year 2000 problem, structured programming and design, debugging, subprograms, table processing, sorting, screen I/O, sequential file maintenance, indexed files, and object-oriented COBOL. The third edition teaches programming as it is practiced in the real world, with programming tips that go beyond the syntactical rules of COBOL and that make programs easier to maintain and run more efficiently.

Best-selling author Robert T. Grauer and co-authors Carol Vazquez Villar and Arthur R. Buss provide you with a complete learning package—available with the Micro Focus® Personal COBOL™ for Windows™ compiler—that will prepare you for success with COBOL programming.

Look for these enhancements in the third edition:

- **NEW**—Our most important revision is an entirely new chapter on the Year 2000 problem that discusses the nature of changes that need to be made to existing COBOL programs.
- **NEW**—A second new chapter is devoted to Object-Oriented COBOL Programming, an emerging technology of increased importance in the COBOL world.
- **NEW**—Availability of the Micro Focus Personal COBOL for Windows with the third edition. A new appendix has been added with more than 83 screen shots describing how to use the software.
- **NEW and REVISED**—Appendix with more than 100 programming projects. Data for the projects are available for download from www.prenhall.com/grauer_cobol.

Dr. Robert T. Grauer is an Associate Professor in the Department of Computer Information Systems at the University of Miami, where he has been honored with the Outstanding Teacher Award in the School of Business. A prolific author known for his unparalleled pedagogy, reader-friendly writing style, and Exploring Windows series, Dr. Grauer has written 30 books on programming and information systems, and has more than a million books in print. Dr. Grauer can be reached at rgrauer@sba.miami.edu.

Carol Vazquez Villar, an instructor in the Department of Computer Information Systems at University of Miami for eight years, currently works for Andersen Consulting. She has developed and trained high performance teams on team building and communications and is currently planning and developing leadership training seminars.

Dr. Arthur R. Buss is Associate Professor of Computer Studies at William Jewell College, where he teaches Information Technology courses. Prior to coming to Jewell, he worked at Kmart Corporation and McDonnell Douglas as a programmer, systems analyst, and project leader. He is currently conducting studies in the Year 2000 problem and in Object-Oriented COBOL.

PRENTICE HALL
Upper Saddle River, NJ 07458
<http://www.prenhall.com>

ISBN 0-13-790817-2



9 780137 908172

Software and Supplements

The following software and supplements are available from Prentice Hall:

- **SOFTWARE**—Micro Focus Personal COBOL for Windows 3.1 with object-orientation and Personal Dialog System. Compatible with Windows95 and WindowsNT, Personal COBOL provides all the tools to help you learn and use COBOL. The software includes an integrated editor, compiler and animator for creating, debugging and executing COBOL programs. Prentice Hall offers an affordable package of *COBOL: From Micro to Mainframe, Third Edition* with the Micro Focus Personal COBOL Compiler. Please order ISBN 0-13-975178-5.
- **WEB SITE**—Download every COBOL program in the text as well as data files for the nearly on hundred student projects from the *COBOL: From Micro to Mainframe* web site at: http://www.prenhall.com/grauer_cobol.
- **Instructor's Resource Manual** (ISBN# 0-13-081513-6)
- **Prentice Hall Custom Test**. Based on the powerful testing technology developed by Engineering Software Associates, Inc. (EAS), Prentice Hall Custom Test allows the educator to create and tailor the exam to their own needs. Please order ISBN# 0-13-081515-2

Acknowledgments

We are especially grateful to our editors at Prentice Hall, Laura Steele, Alan Apt, and Marcia Horton, without whom this project would not have been possible. We also want to thank the many other individuals who helped produce the third edition. Irwin Zucker, who supervised the production, Kate Kaibni, editorial assistant, who worked hard to provide us with timely chapter reviews, and Joel Berman, our marketing manager at Prentice Hall, who developed the innovative campaign to make this book a success.

We also want to acknowledge our reviewers, who through their comments and constructive criticism, made this a far better book:

Robert V. Binder, Robert Binder Systems Consulting, Inc.
 Dinon Boyer, University of Akron
 Georgia Brown, Northern Illinois University
 Jan De Lassen, Brigham Young University
 Ida M. Flynn, University of Pittsburgh
 Frank T. Gergelyi, NJIT
 Ken Goldsmith, University of Miami
 Tom Gorecki, St. Charles Community College
 Carol C. Grimm, Palm Beach Community College
 Monica Holmes, Central Michigan University
 Ann W. Houck, Pima Community College
 David Lee
 James W. Payne, Kellogg Community College
 Nicholas Ross, University of Illinois at Chicago
 Wendell I. Pope, Utah State University
 Daniel H. Rindfleisch, Computer Specialist with Federal Government
 Daniel R. Rota, Robert Morris College
 Richard H. Saracusa, Northeastern University
 Ron Teemley, DeVry Institute of Technology
 Donat Valcourt, Northeastern University
 Ron Williams, McLennon Community College
 Jackie Zucker, University of Miami

A final word of thanks to you, our readers, for choosing this book. Please feel free to contact us with any comments or suggestions via email.

Robert Grauer
rgrauer@umiami.miami.edu

Carol Vazquez Villar

Arthur R. Buss
bussa@william.jewell.edu

Contents

Preface iii

Chapter 1: Introduction 1

| | | | |
|----------------------------|----|---------------------------|----|
| Overview | 2 | Test Data | 13 |
| The First Problem | 2 | Elements of COBOL | 13 |
| Programming Specifications | 3 | Reserved Words | 13 |
| Required Logic | 5 | Programmer-Supplied Names | 14 |
| Flowcharts | 6 | Literals | 15 |
| Pseudocode | 8 | Symbols | 16 |
| A First Look at COBOL | 9 | Level Numbers | 16 |
| Identification Division | 11 | Picture Clauses | 17 |
| Environment Division | 11 | A Second Look at COBOL | 17 |
| Data Division | 11 | Summary | 19 |
| Procedure Division | 12 | Fill-in | 20 |
| | | True/False | 20 |
| | | Problems | 21 |

Chapter 2: From Coding Form to Computer 25

| | | | |
|---|----|-------------------------|----|
| Overview | 26 | Errors in Compilation | 33 |
| From Coding Form to Computer | 26 | Errors in Execution | 35 |
| The COBOL Coding Form | 28 | Errors in Data Input | 37 |
| Use of an Editor | 28 | Evolution of COBOL | 38 |
| The Compile, Link, and Execute Sequence | 30 | There's Always a Reason | 40 |
| Learning by Doing | 32 | Summary | 41 |
| Errors in Entering the Program | 33 | Fill-in | 41 |
| Errors in Operating System Commands | 33 | True/False | 42 |
| | | Problems | 43 |

Chapter 3: A Methodology for Program Development 47

| | | | |
|--------------------------------|----|-------------------------------------|----|
| Overview | 48 | Sufficiency of the Basic Structures | 56 |
| The Tuition Billing Problem | 48 | Expressing Logic | 57 |
| Structured Design | 50 | The Traditional Flowchart | 57 |
| Evaluating the Hierarchy Chart | 52 | Pseudocode | 57 |
| Completeness | 53 | Warnier-Orr Diagrams | 59 |
| Functionality | 54 | Top-Down Testing | 61 |
| Span of Control | 54 | Summary | 66 |
| Structured Programming | 54 | Fill-in | 67 |
| | | True/False | 68 |
| | | Problems | 68 |



Chapter 4: The Identification, Environment, and Data Divisions 73

Overview 74
 COBOL Notation 74
 Identification Division 75
 Environment Division 76
 CONFIGURATION SECTION 76
 INPUT-OUTPUT SECTION 76
 Data Division 77
 FILE SECTION 77
 WORKING-STORAGE SECTION 82
 The Tuition Billing Program 84
 Programming Specifications 84
 COBOL Entries 87
 Limitations of COBOL-74 90
 Summary 90
 Fill-in 92 True/False 92 Problems 93

Chapter 5: The Procedure Division 97

Overview 98
 OPEN 98
 CLOSE 99
 READ 99
 Placement of the READ Statement 100
 WRITE 100
 STOP RUN 102
 MOVE 102
 Restrictions on the Move Statement 103
 Alphanumeric Field to Alphanumeric Field 103
 Numeric Field to Numeric Field 104
 Group Moves 105
 PERFORM 105
 IF 106
 The ELSE Clause 106
 Indentation 106
 EVALUATE 109
 Arithmetic Statements 109
 The ROUNDED Clause 109
 The SIZE ERROR Clause 110
 COMPUTE 110
 ADD 112
 SUBTRACT 112
 MULTIPLY 114
 DIVIDE 115
 Programming Tip: Use the COMPUTE Statement 116
 Assumed Decimal Point 117
 The Tuition Billing Program 118
 Test Data 126
 Hierarchy Chart 127
 COBOL Program Skeleton 128
 Limitations of COBOL-74 128
 Summary 130
 Fill-in 131 True/False 132 Problems 133

Chapter 6: Debugging 139

Overview 140
 Errors in Compilation 140
 Common Compilation Errors 149
 Errors in Execution 151
 File Status Codes 156
 Another Run Time Error 158
 Logic Errors 159
 Tips for Debugging 160
 DISPLAY Statement 161
 The Structured Walkthrough 162
 Summary 163
 Fill-in 164 True/False 165 Problems 165

Chapter 7: Editing and Coding Standards 169

| | | | |
|--------------------------------|-----|--|-----|
| Overview | 170 | BLANK WHEN ZERO Clause | 177 |
| Editing | 170 | The Tuition Billing Program Revisited | 178 |
| The Decimal Point | 172 | Coding Standards | 179 |
| Zero Suppression | 172 | Data Division | 179 |
| Dollar Signs | 174 | Programming Tip: Avoid Literals | 180 |
| Comma | 174 | Procedure Division | 181 |
| Asterisks for Check Protection | 175 | Programming Tip: Use Scope Terminators | 182 |
| Insertion Characters | 175 | Both Divisions | 183 |
| Synopsis | 175 | A Well-Written Program | 184 |
| Signed Numbers | 176 | Summary | 189 |
| CR and DB | 176 | Fill-in | 190 |
| Plus and Minus Signs | 177 | True/False | 191 |
| | | Problems | 191 |

Chapter 8: Data Validation 195

| | | | |
|--|-----|------------------------------|-----|
| Overview | 196 | ACCEPT Statement | 206 |
| System Concepts: Data Validation | 196 | Calculations Involving Dates | 206 |
| The IF Statement | 197 | The Stand-Alone Edit Program | 207 |
| Relational Condition | 198 | Programming Specifications | 208 |
| Class Test | 199 | Error Messages | 211 |
| Sign Test | 200 | Pseudocode | 211 |
| Condition-Name Test (88-Level Entries) | 200 | Hierarchy Chart | 212 |
| Compound Test | 200 | The Completed Program | 212 |
| Hierarchy of Operations | 201 | Limitations of COBOL-74 | 221 |
| Implied Conditions | 203 | Summary | 223 |
| Nested IFs | 203 | Fill-in | 224 |
| NEXT SENTENCE | 205 | True/False | 224 |
| | | Problems | 225 |

Chapter 9 : More About the Procedure Division 229

| | | | |
|--|-----|----------------------------|-----|
| Overview | 230 | STRING | 238 |
| PERFORM | 231 | UNSTRING | 240 |
| TEST BEFORE/TEST AFTER | 231 | Reference Modification | 240 |
| In-line Perform | 232 | ACCEPT | 242 |
| Performing Sections | 232 | Duplicate Data Names | 243 |
| PERFORM THRU | 232 | Qualification | 244 |
| Programming Tip: Perform Paragraphs, Not | | MOVE CORRESPONDING | 245 |
| Sections | 233 | The Car Billing Program | 246 |
| READ | 234 | Programming Specifications | 246 |
| False-Condition Branch | 234 | Program Design | 248 |
| READ INTO | 235 | The Completed Program | 249 |
| WRITE FROM | 236 | Limitations of COBOL-74 | 258 |
| INITIALIZE | 236 | Summary | 258 |
| String Processing | 237 | Fill-in | 259 |
| INSPECT | 237 | True/False | 260 |
| | | Problems | 260 |

Chapter 10: Screen I-O 265

Overview 266

ACCEPT 266

 Programming Tip: Micro Focus Level 78—The Use of COBOL Constants 267

DISPLAY 269

The Tuition Billing Program Revisited 270

 Programming Specifications 270

 Hierarchy Chart 271

 Pseudocode 271

 The Completed Program 273

 Programming Tip: The Hidden Power of the Alt key 274

Car Validation and Billing Program 278

 Programming Specifications 279

 The Screen Section 280

 Hierarchy Chart 284

 Pseudocode 284

 The Completed Program 287

Limitations of COBOL-74 297

Summary 297

Fill-in 298 True/False 299 Problems 299

Chapter 11: Introduction to Tables 301

Overview 302

Introduction to Tables 302

 OCCURS Clause 303

 Processing a Table 304

 PERFORM VARYING 304

A Second Example 306

 Problems with the OCCURS Clause 308

 Rules for Subscripts 308

 Relative Subscripting 308

 USAGE Clause 309

OCCURS DEPENDING ON 310

The Student Transcript Program 311

 Programming Specifications 311

 Program Design 313

 The Completed Program 314

Indexes versus Subscripts 321

 The SET Statement 322

Limitations of COBOL-74 322

Summary 325

Fill-in 326 True/False 326 Problems 327

Chapter 12: Table Lookups 331

Overview 332

System Concepts 332

 Types of Codes 333

 Characteristics of Codes 333

 Sequential Table Lookup 334

 Binary Table Lookup 335

 Positional Organization and Direct Lookups 336

Initializing a Table 336

 Hard Coding 336

 Input-Loaded Tables 338

Table Lookups 339

 PERFORM VARYING Statement 340

 SEARCH Statement 340

 Programming Tip—Restrict Subscripts and Switches to a Single Use 342

SEARCH ALL Statement 344

 Direct Lookup 344

 Range-Step Tables 345

A Complete Example 347

 Programming Specifications 347

 Program Design 349

 The Completed Program 350

Limitations of COBOL-74 357

Summary 357

Fill-in 358 True/False 359 Problems 360

Chapter 13: Multilevel Tables

363

Overview 364

System Concepts 364

COBOL Implementation 366

One-Level Tables 366

 PERFORM VARYING 366

Two-Level Tables 368

 Errors in Compilation 369

 PERFORM VARYING 370

A Sample Program 373

 Programming Specifications 373

 Program Design 375

 The Completed Program 375

Three-Level Tables 380

 PERFORM VARYING 382

A Sample Program 384

 Programming Specifications 384

 The Completed Program 386

Table Lookups 390

A Calorie Counter's Delight 392

 Programming Specifications 392

 Range-Step Tables 392

 The Completed Program 394

Limitations of COBOL-74 398

Summary 398

Fill-in 399 True/False 399 Problems 400

Chapter 14: Sorting

403

Overview 404

System Concepts 405

Collating Sequence 405

 Embedded Sign 406

COBOL Implementation 408

 SORT Statement 409

 SD (Sort Description) 410

 RELEASE and RETURN 410

 Programming Specifications 411

 USING/GIVING Option 414

INPUT PROCEDURE/OUTPUT PROCEDURE

 Option 419

Comparing Options 426

MERGE Statement 426

Limitations of COBOL-74 428

Summary 428

Fill-in 429 True/False 430 Problems 431

Chapter 15: Control Breaks

435

Overview 436

System Concepts 436

 Running versus Rolling Totals 440

One-Level Control Breaks 443

 Programming Specifications 443

 Hierarchy Chart 444

 Pseudocode 446

 The Completed Program 446

Two-Level Control Breaks 451

 Hierarchy Chart 451

 Pseudocode 452

 The Completed Program 454

Three-Level Control Breaks 460

 Hierarchy Chart 460

 Pseudocode 462

 The Completed Program 463

 Programming Tip: How to Write a Control Break

 Program 470

Limitations of COBOL-74 471

Summary 471

Fill-in 472 True/False 472 Problems 473

Chapter 16: Subprograms**475**

- Overview 476
- Subprograms 477
 - Called and Calling Programs 477
 - COPY Statement 479
 - Calling BY CONTENT and BY REFERENCE 480
 - Programming Tip: Use COPY to Pass Parameters 481
- INITIAL Clause 482
- A System for Physical Fitness 482
 - Programming Specifications 482
 - Hierarchy Chart 485
 - Pseudocode 485
- The Completed Programs 486
 - Main Program (FITNESS) 486
 - Input Program (INPUTSUB) 490
 - Weight-Range Program (WGTSUB) 495
 - Training Program (TRAINSUB) 498
 - Display Program (DSPLYSUB) 498
 - Time Program (TIMESUB) 503
- The Linkage Editor 504
 - Problems with the Linkage Editor 505
- Limitations of COBOL-74 506
- Summary 508
 - Fill-in 509
 - True/False 509
 - Problems 510

Chapter 17: Sequential File Maintenance**515**

- Overview 516
- System Concepts 516
 - Sequential versus Nonsequential Processing 518
 - Periodic Maintenance 518
- Data Validation 519
 - Programming Specifications 520
 - Designing the Program 523
 - The Completed Program 524
- Sequential File Maintenance 528
 - Programming Specifications 528
 - The Balance Line Algorithm 529
 - Designing the Hierarchy Chart 531
- Top-Down Testing 535
 - The Stubs Program 535
 - The Completed Program 540
- Summary 545
 - Fill-in 546
 - True/False 546
 - Problems 547

Chapter 18: Indexed Files**549**

- Overview 550
- System Concepts 550
- COBOL Implementation 554
- Creating an Indexed File 556
 - Programming Specifications 556
 - Pseudocode 557
 - The Completed Program 557
- Additional COBOL Elements 559
 - OPEN 559
 - READ 560
 - WRITE 562
 - REWRITE 562
 - DELETE 562
- Maintaining an Indexed File 563
 - Programming Specifications 563
 - Hierarchy Chart 564
 - Pseudocode 566
 - The Completed Program 566
- Alternate Record Key 570
 - Programming Specifications 570
- Concatenated Key 573
 - The START Statement 574
- Limitations of COBOL-74 574
- Summary 576
 - Fill-in 577
 - True/False 578
 - Problems 578



Chapter 19: The Year 2000 Problem 583

| | | | |
|------------------------------------|-----|------------------------------|-----|
| Overview | 584 | Leap-Year Problem | 594 |
| The Year 2000 Problem | 584 | Retirement Program Revisited | 594 |
| Date Arithmetic | 590 | Summary | 599 |
| COBOL Intrinsic Calendar Functions | 591 | Fill-in | 600 |
| | | True/False | 600 |
| | | Problems | 601 |

Chapter 20: Object-Oriented COBOL Programming 603

| | | | |
|--|-----|-----------------------------------|-----|
| Overview | 604 | The StudentDM Class | 621 |
| The Next Generation of COBOL | 605 | The StudentDM Instance Definition | 625 |
| The Development of Structured Programming | 606 | The Student Class | 627 |
| Terminology | 607 | The Person Class | 630 |
| The Object-Oriented versus Structured Paradigm | 608 | The Student UI Class | 633 |
| Student-Look-UP Program | 612 | The Student PRT Class | 635 |
| The Registrar Class | 616 | Conclusion | 639 |
| Classes and Inheritance | 619 | Summary | 640 |
| ProcessRequests Method | 619 | Fill-in | 641 |
| | | True/False | 641 |
| | | Problems | 642 |

Appendix A: Micro Focus Personal COBOL for Windows: Users Guide and Tutorial 643

Appendix B: Getting Started 697

Appendix C: Reserved Words 709

Appendix D: COBOL-85 Reference Summary 711

Appendix E: COBOL 1997, 1998, 1999, 2000, or ...? 737

Appendix F: Answers to Odd-Numbered Exercises 745

Appendix G: Projects 753

Index 893

Introduction

CHAPTER OUTLINE

Overview

The First Problem

Programming Specifications

Required Logic

Flowcharts

Pseudocode

A First Look at COBOL

Identification Division

Environment Division

Data Division

Procedure Division

Test Data

Elements of COBOL

Reserved Words

Programmer-Supplied Names

Literals

Symbols

Level Numbers

PICTURE Clauses

A Second Look at COBOL

Summary

Fill-in

True/False

Problems

OBJECTIVES

After reading this chapter you will be able to:

- Define the terms: field, record, and file.
- Name two techniques used to express program logic.
- Identify the four divisions of a COBOL program.
- State the six COBOL language elements.
- State the rules for creating a programmer-supplied name; distinguish between examples of valid and invalid names.
- State the difference between numeric and nonnumeric literals; recognize valid and invalid examples of each.
- Follow the logic of a simple program as expressed in a flowchart or pseudocode.

OVERVIEW

This book is about computer programming. In particular, it is about COBOL, a widely used commercial programming language. Programming involves the translation of an algorithm (a precise means of solving a problem) into a form the computer can understand. Programming is necessary because, despite reports to the contrary, computers cannot think for themselves. Instead, they do exactly what they have been instructed to do, and these instructions take the form of a computer program. The advantage of the computer stems from its speed and accuracy. It does not do anything that a human being could not do, given sufficient time and memory capacity.

We begin our study of computer programming by describing a simple problem and then developing the logic and COBOL program to solve it. This rapid entrance into COBOL is somewhat different from the approach followed by most textbooks, but we believe in learning by doing. There is nothing very mysterious about COBOL programming, so let's get started.

The First Problem

Our first problem is set in the context of a university, and involves a set of student records, one record per student. Each record contains the student's name, number of completed credits, and major. Implicit in this statement are the definitions of three fundamental terms: field, record, and file. A *field* is a basic fact, such as the name, address, major, grade point average, or number of completed credits. A *record* is a set of fields, and a *file* is a set of records. Thus, if there were 1,000 students, there would be 1,000 records (one for each student), each consisting of five fields, and comprising a single student file.

To clarify this relationship, we create four hypothetical students for our problem: John Adams, Amelia Earhart, Orville Wright, and Georgia O'Keeffe. There are many facts about each of our students, but our problem utilizes only three:

Figure 1.1 Fields, Records, and Files

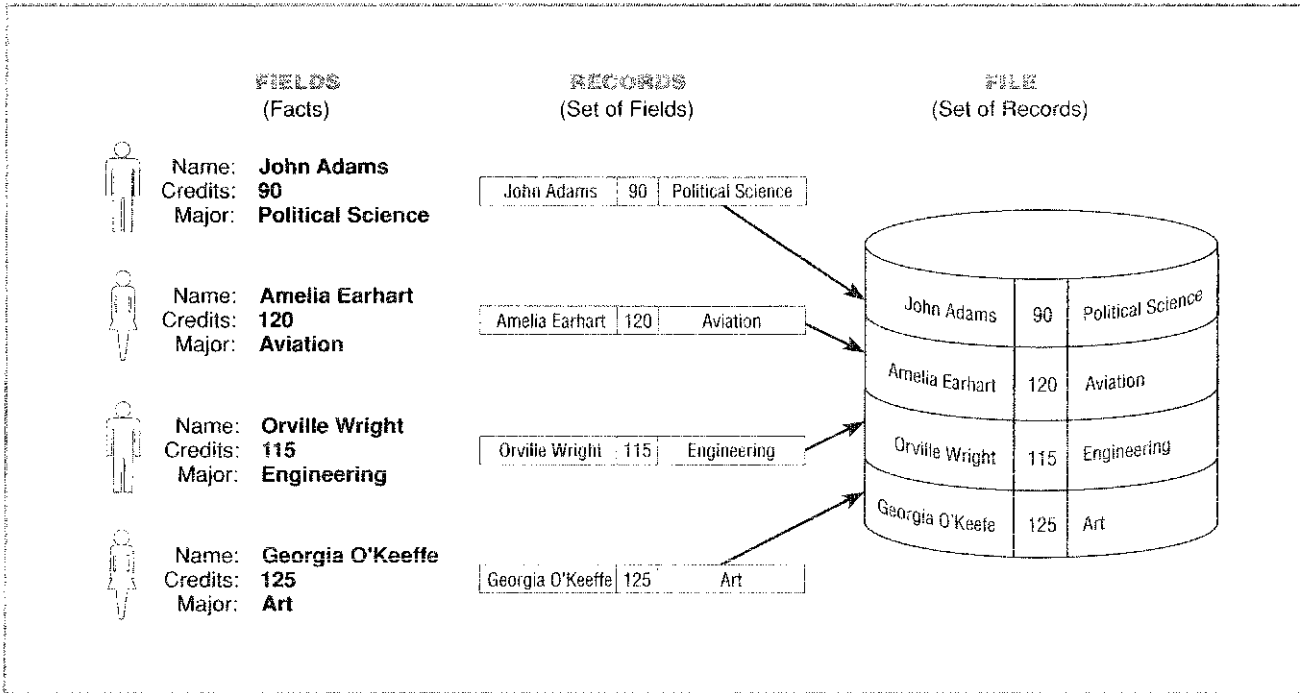

name, major, and credits completed. Figure 1.1 represents these concepts in pictorial fashion. Each fact about each student comprises a single field. The three fields collectively make up that student's record. The four records (one for each of our students) compose the student file.

The problem is to process the file of student records and produce a list of engineering students who have completed more than 110 credits. It is a typical problem, in that its solution will address the three elements common to all computer applications: input, processing, and output. As shown in Figure 1.2, the student file, just defined, is the *input*; this file is *processed* by determining which students are engineering majors with more than 110 credits; and consequently, a report is created as *output*, reflecting these students.

The input to a computer program; that is, the precise arrangement of the various fields in each incoming record, has to be specified exactly. Figure 1.3a is a common way to communicate this information, and shows that the student's name is contained in positions 1–25, the number of credits in positions 26–28, and the student's major in positions 29–43. Note too, that every record in a given file must have the identical record layout.

In similar fashion, the report produced as output is also precisely designed. Figure 1.3c shows a print layout chart, in which descriptive information appears on line one, with the names of selected students in columns 9–33 of subsequent lines. Observe also that the location of the name field is different in the input and output records (positions 1–25 and 9–33, respectively), and that each input record contains three fields, but that each line of output has been designed to contain only one field.

Programming Specifications

It is important that programming specification—that is, the input, processing, and output requirements—be presented in a clear and unambiguous fashion.

Accordingly, the authors have adopted the format shown below, and use it throughout the text for both illustrative programs and student assignments. The programming specifications begin with the program name and a brief narrative, followed by a detailed description of the various requirements. Note, too, that the specification document is entirely self-contained, and that if the person preparing the specifications has done a complete job, there will be little need for the programmer to seek additional information.

PROGRAMMING SPECIFICATIONS

Program Name: Engineering Senior Program

Narrative: This program processes a file of student records and prints the name of every student who is an engineering major with more than 110 credits.

Input File(s): STUDENT-FILE

Input Record Layout: See Figure 1.3a

Test Data: See Figure 1.3b

Report Layout: See Figure 1.3c

Processing Requirements:

1. Print a heading line.
2. Read a file of student records.
3. For every record, determine whether that student has a major of engineering and has completed more than 110 credits.
4. Print the name of every student who satisfies the requirements in item 3 above. Single-space the output.

Required Logic

Let us imagine momentarily that the student records are physically in the form of manila folders, stored in a filing cabinet, and further that a clerk is available to do our work. Our problem is to instruct the clerk on how to go through the folders. We would say something to the following effect:

Repeat steps 1 through 4 until there are no more folders:

1. Select a folder.
2. Examine the folder to see if that student is an engineering major *and* has more than 110 credits.
3. If the student meets both qualifications, write the student's name on a running list.
4. Return the folder to the file cabinet.

Stop

In essence, we have prepared a series of instructions for the clerk to follow. If our instructions are correct and if they are followed exactly, then the clerk will produce the desired results.

A **computer program** is a set of instructions, written according to a precise set of rules, which the computer interprets and subsequently executes. Unlike the clerk, however, the computer always follows our instructions exactly. In other words, *the computer does what we tell it to do, which is not necessarily what we want it to do*. A human clerk, on the other hand, has a mind of his or her own and can question or alter erroneous instructions. Since the computer does precisely what it is told, it is imperative that you strive to write logically correct programs. Accordingly, you must expend significant effort *prior to actual coding* to develop a program's logic correctly. Two common techniques for expressing that logic are **flowcharts** and **pseudocode**.

Flowcharts

A flowchart is a pictorial representation of the logic inherent in a program. It is the translation of a problem statement into a logical blueprint that is subsequently incorporated into the COBOL program. A flowchart to list the engineering students with more than 110 credits is shown in Figure 1.4.

A flowchart uses blocks with specific shapes to indicate the nature of an operation. Using Figure 1.4 as a guide, we see that a diamond-shaped block indicates a decision, a parallelogram depicts input or output, an ellipse shows the beginning or end, and a rectangle implies straightforward processing. A rectangle with vertical lines implies that the processing within the rectangle will be expanded into a flowchart of its own.

To understand the flowchart in Figure 1.4, consider the nature of a READ statement. The function of a READ instruction is to obtain a record, but there will always be a point when a READ is attempted and no record is found, that is, when all the records in the file have already been read. Since one does not know in advance how many records a file contains, the READ instruction must also test for the *end-of-file* condition. Thus, if a file contains two records, it is actually read three times (once for each record, and once to sense the end-of-file condition).

The flowchart in Figure 1.4 begins with a start block (block 1), and continues with various housekeeping blocks. Housekeeping consists of statements that are done once at the start of processing, for example, opening files (block 2), reading the first record (block 3), and writing a heading at the start of a report (block 4). Control then passes through a connector block (block 5) to a decision statement (block 6).

If the end-of-file has not been reached, control goes to the PROCESS-RECORDS block, which is expanded in the right side of the figure. Each incoming record is checked in block 9 to determine if it meets both qualifications. If so, that student's name is written to the output report in block 10; if not, control goes directly to the connector in block 11. (Note that both the true and false branches for the condition in block 9 meet at a single connector in block 11.) The next record is read in block 12, and the PROCESS-RECORDS block is finished. Control then moves to the left side of the figure, to the connector in block 5 to the end-of-file test in block 6. Eventually, when the end-of-file has been reached, control will pass to close files (block 7), then to the stop statement in block 8.

To better understand how the flowchart works, we can use the test data of Figure 1.1 and play computer, by running the data through the flowchart. Execution begins by opening the files, reading the first record (John Adams), and writing the heading line. The end-of-file has not been reached, so block 6 directs flow to block 9, the test for engineering majors with more than 110 credits. John Adams fails the test, so control passes to the connector in block 11, to the READ in block 12, whereupon the data for Amelia Earhart are read into memory. Control flows through

Figure 1-4 Flowchart to Select Engineering Seniors

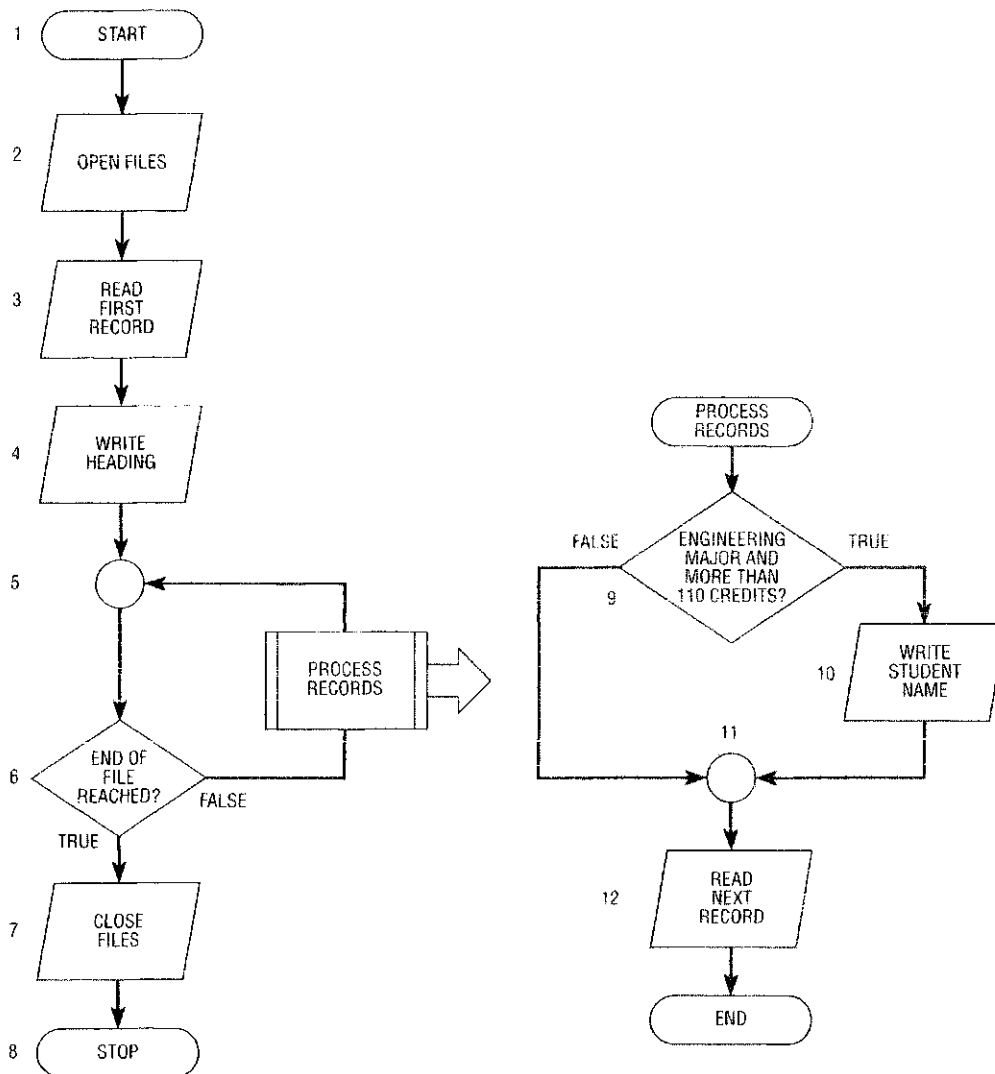

(a) Overall Flowchart

(b) Detail of PROCESS RECORDS

the connector of block 5, to the end-of-file test in block 6, and then to the qualification test in block 9. Amelia Earhart fails the test, again passing control to the connector in block 11, to the READ in block 12, at which point Orville Wright is read into memory. However, Wright is an engineering major with more than 110 credits, so he passes the test and his name is written in block 10.

The data for Georgia O’Keeffe are read in block 12, and control flows once more to the connector in block 5, to the end-of-file test in block 6. Realize, however, that even though O’Keeffe is the last record, the end-of-file condition has *not* yet been detected. O’Keeffe fails the qualification test, whereupon control flows to the READ in block 12. This time the end-of-file is detected so that, when control again reaches the end-of-file test in block 6, processing will be directed to the CLOSE FILES and STOP statements in blocks 7 and 8.

TABLE 1.1 The Flow chart and Test Data

| | | | |
|-----------|------------------|---|---|
| 1 | Start | 1 | At beginning of program |
| 2 | Open files | 1 | At beginning of program |
| 3 | Initial read | 1 | Reads the first record (Adams) |
| 4 | Write heading | 1 | At beginning of program |
| 5 | Connector | 5 | Entered five times |
| 6 | End-of-file test | 5 | Once for each of four records; once to sense end-of-file condition |
| 7 | Close files | 1 | Once, before execution stops |
| 8 | Stop | 1 | Executed once, at program's end |
| 9 | Qualifying test | 4 | Once for each student |
| 10 | Write | 1 | Executed for Wright only |
| 11 | Connector | 4 | Entered four times |
| 12 | Read | 4 | Reads every record but the first, and detects the end-of-file condition |

It is useful to summarize this discussion by tabulating the number of times each block in Figure 1.4 is executed. This is shown in Table 1.1.

Pseudocode

Pseudocode expresses a program's logic more concisely than a flowchart. One definition of pseudocode is *neat notes to oneself*, and since programmers do this naturally, pseudocode has replaced the traditional flowchart in many installations. Consider Figure 1.5, which contains identical logic to the flowchart in Figure 1.4, albeit in a more concise fashion.

As shown in Figure 1.5, the logic of most programs can be divided into three major portions: **initialization**, **processing**, and **termination**. Initialization is done once at the start of processing—for example, opening files, reading the first record in a file, and writing a heading. This is followed by a series of instructions that are executed repeatedly, once for each incoming record; e.g., each record is evaluated for an engineering major with the requisite number of credits. If both conditions are met, the name will be written on the registrar's list; if the conditions are not met,

FIGURE 1.5 Pseudocode

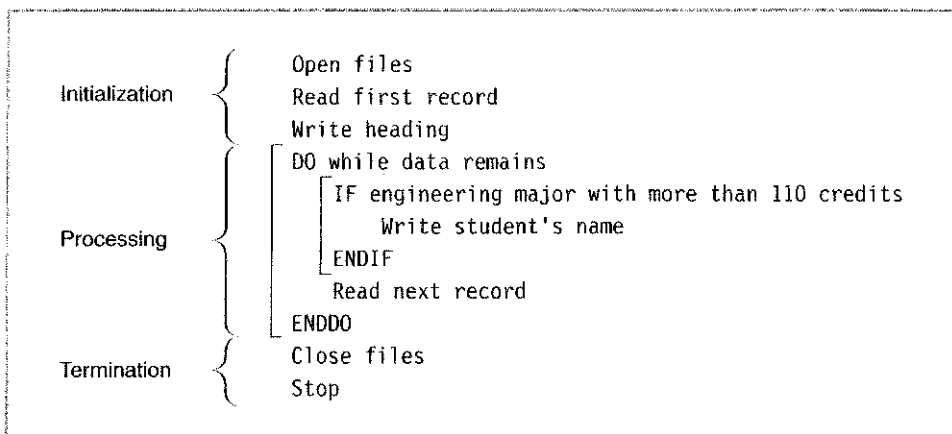

nothing further is done with the particular record. When *all* of the records in the file have been read, the loop is finished, and a termination routine is entered to print a total or simply stop processing.

Figure 1.5 also contains vertical lines connecting the words IF and ENDIF, and DO and ENDDO. This notation indicates two of the basic building blocks (*selection* and *iteration*) of a discipline known as *structured programming* which is fully explained in Chapter 3.

Pseudocode uses instructions similar to those of a computer language to describe program logic, but is *not* bound by precise syntactical rules found in formal programming languages. For example, the vertical lines referred to previously are the authors' convention and do not necessarily appear in the pseudocode of others. Nor is pseudocode bound by any rules for indentation, which is done strictly at the discretion of the person using it. The purpose of pseudocode is simply to convey program logic in a straightforward and easily followed manner.

A First Look at COBOL

We proceed to the COBOL program in Figure 1.6, which corresponds to the flowchart in Figure 1.4 and the pseudocode in Figure 1.5. The syntactical rules for COBOL are extremely precise, and you are certainly *not* expected to remember them after a brief exposure to Figure 1.6. The authors believe, however, *that immediate exposure to a real program is extremely beneficial in stripping the mystical aura that too often*

Figure 1.6 The First COBOL Program

```

1  IDENTIFICATION DIVISION.
2  PROGRAM-ID.        SENIOR.
3  AUTHOR.            ROBERT GRAUER.
4
5  ENVIRONMENT DIVISION.
6  INPUT-OUTPUT SECTION.
7  FILE-CONTROL.
8      SELECT STUDENT-FILE ASSIGN TO 'A:\CHAPTR02\SENIOR.DAT'
9      ORGANIZATION IS LINE SEQUENTIAL.
10     SELECT PRINT-FILE
11     ASSIGN TO PRINTER.
12
13  DATA DIVISION.
14  FILE SECTION.
15  FD  STUDENT-FILE
16     RECORD CONTAINS 43 CHARACTERS
17     DATA RECORD IS STUDENT-IN.
18  01  STUDENT-IN.
19     05  STU-NAME           PIC X(25).
20     05  STU-CREDITS        PIC 9(3).
21     05  STU-MAJOR          PIC X(15).
22

```

Figure 1.6 (continued)

```
23      FD  PRINT-FILE
24          RECORD CONTAINS 132 CHARACTERS
25          DATA RECORD IS PRINT-LINE.
26      01  PRINT-LINE          PIC X(132).
27
28      WORKING-STORAGE SECTION.
29      01  DATA-REMAINS-SWITCH  PIC X(2)    VALUE SPACES.
30
31      01  HEADING-LINE.
32          05  FILLER          PIC X(10)    VALUE SPACES.
33          05  FILLER          PIC X(12)    VALUE 'STUDENT NAME'.
34          05  FILLER          PIC X(110)   VALUE SPACES.
35
36      01  DETAIL-LINE.
37          05  FILLER          PIC X(8)     VALUE SPACES.
38          05  PRINT-NAME      PIC X(25).
39          05  FILLER          PIC X(99)    VALUE SPACES.
40
41      PROCEDURE DIVISION.
42      PREPARE-SENIOR-REPORT.
43          OPEN INPUT  STUDENT-FILE
44              OUTPUT PRINT-FILE.
45          READ STUDENT-FILE
46              AT END MOVE 'NO' TO DATA-REMAINS-SWITCH
47          END-READ.
48          PERFORM WRITE-HEADING-LINE.
49          PERFORM PROCESS-RECORDS
50              UNTIL DATA-REMAINS-SWITCH = 'NO'.
51          CLOSE STUDENT-FILE
52              PRINT-FILE.
53          STOP RUN.
54
55      WRITE-HEADING-LINE.
56          MOVE HEADING-LINE TO PRINT-LINE.
57          WRITE PRINT-LINE.
58
59      PROCESS-RECORDS.
60          IF STU-CREDITS > 110 AND STU-MAJOR = 'ENGINEERING'
61              MOVE STU-NAME TO PRINT-NAME
62              MOVE DETAIL-LINE TO PRINT-LINE
63              WRITE PRINT-LINE
64          END-IF.
65          READ STUDENT-FILE
66              AT END MOVE 'NO' TO DATA-REMAINS-SWITCH
67          END-READ.
```

Data Division

Procedure Division

surrounds programming. Further, Figure 1.6 will become easier to understand after some brief explanation.

Every COBOL program consists of four divisions, which must appear in the following order:

| | |
|-------------------------|--|
| IDENTIFICATION DIVISION | The Identification Division contains the program name and author's name. |
| ENVIRONMENT DIVISION | The Environment Division associates the file names referenced in a program to the input and output (I/O) devices recognized by the operating system. |
| DATA DIVISION | The Data Division describes the record layout of the incoming record(s) and the location of data in the generated report. |
| PROCEDURE DIVISION | The Procedure Division contains the program logic, that is, the instructions the computer is to execute in solving the problem. |

Since COBOL is intended to resemble English, you may be able to get an overall sense of what is happening, merely by reading the program. We provide an intuitive explanation and reiterate that, at this time, you should in no way be concerned with the precise syntax of the language; that is, our present intent is to teach COBOL by example, with the short-term objective of achieving a conceptual understanding of a COBOL program.

The Identification Division

The IDENTIFICATION DIVISION (Lines 1–3) appears at the beginning of every program. It serves to identify the program (SENIOR) and the author (Robert Grauer). There is nothing complicated about this division, and it has no effect on the results of the program.

The Environment Division

The ENVIRONMENT DIVISION (lines 5–11) contains the INPUT-OUTPUT SECTION, which describes the files used by the program. The engineering senior program uses two files, an input file containing the student records and an output file for the report. Both of these files are defined in SELECT statements.

The names chosen by the programmer for these files (that is, STUDENT-FILE and PRINT-FILE) are assigned to logical devices known to the operating system, by the SELECT statement and associated ASSIGN clause. Line 8, for example, ties the incoming STUDENT-FILE to the file SENIOR.DAT; this tells the operating system to read the file containing the incoming student records from the file SENIOR.DAT. (The format of the file name is installation dependent and varies from computer to computer.) The clause ORGANIZATION IS LINE SEQUENTIAL is required to properly process sequential files on personal computers. Mainframe sequential files have a different format and do not require this clause.

The Data Division

The DATA DIVISION (lines 13–39) describes all data elements used by the program. It is divided into two sections, the FILE SECTION (lines 14–26) and the WORKING-STORAGE SECTION (lines 28–39).

The **FILE SECTION** contains file description (FD) entries for files previously defined in **SELECT** statements. The FD for **STUDENT-FILE** extends from line 15 to line 17 and contains clauses that describe the physical characteristics of the file. The FD is followed by a *record description*, which defines the various fields within the record (lines 18–21).

The statements within the record description are preceded by *level numbers*, in this example, 01 and 05. The level number 01 is special and indicates the beginning of a *record description* entry. The fields within a record are defined through a series of **PICTURE** clauses (**PIC** is an acceptable abbreviation), which indicate the *type* and *size* of the field. A picture of 9's indicates a numeric field, whereas a picture of X's signifies an alphanumeric field. The number in parentheses indicates the size of the field; for example, **PIC 9(3)** indicates a three-position numeric field, and **PIC X(25)** is a 25-position alphanumeric field. The **PICTURE** clauses in lines 19–21 of Figure 1.6 are consistent with the record description in the original problem statement.

The **WORKING-STORAGE SECTION** (lines 28–39) is used to define any data names that do not appear in an input or output file. The programming specifications called for two distinct print lines (a heading line and a detail line), each of which contains a different format as per the print layout of Figure 1.3. Accordingly, two different 01 entries are defined, **HEADING-LINE** and **DETAIL-LINE**, each with a different layout. The function of **DATA-REMAINS-SWITCH** will be made clearer after an examination of the Procedure Division.

The Procedure Division

The **PROCEDURE DIVISION** (lines 41–67) contains the logic required to solve the problem. The Procedure Division is divided into *paragraphs*, with each paragraph consisting of one or more sentences.

The first paragraph, **PREPARE-SENIOR-REPORT**, extends from line 42 to line 53. It begins by opening the files, then reading the first student record. The **PERFORM** statement in line 48 transfers control to the paragraph **WRITE-HEADING-LINE** (lines 55–57), which prints the heading, then returns control back to line 49 in the **PREPARE-SENIOR-REPORT** paragraph. This too is a **PERFORM** statement, which transfers control to the paragraph **PROCESS-RECORDS** (lines 59–67), which processes incoming student records until the data file is exhausted.

The **IF** statement in line 60 determines whether an incoming record meets both qualifications, that is, whether the student is an engineering major and has more than 110 credits. If both conditions are met, that student's name is written to the output report. The **IF** statement extends to the **END-IF scope terminator** in line 64; that is, if the condition in line 60 is met, *every* statement between the condition and the **END-IF** in line 64 will be executed. Note, too, that three **COBOL** statements are required to produce a detail line; the incoming name is moved to the output name in line 61, the detail line is moved to the print line in line 62, and the line is written in line 63.

The action of the **PERFORM** statement is explained with the aid of Figure 1.7. The **PERFORM** statement in line 49 transfers control to the paragraph **PROCESS-RECORDS**, until **DATA-REMAINS-SWITCH = 'NO'**, that is, until the data file is empty. Accordingly, the last statement of the performed routine is a **READ** statement to read the next record. When the end-of-file is reached, the **AT END** clause of the **READ** statement will move 'NO' to **DATA-REMAINS-SWITCH** to terminate the **PERFORM**; the **READ** statement itself is ended by the **END-READ** scope terminator. Control then returns to the statement under the **PERFORM** statement (to line 51), which closes the files, and finally to the **STOP RUN** statement, which terminates the program.

Figure 1.6 Procedure Division Logic

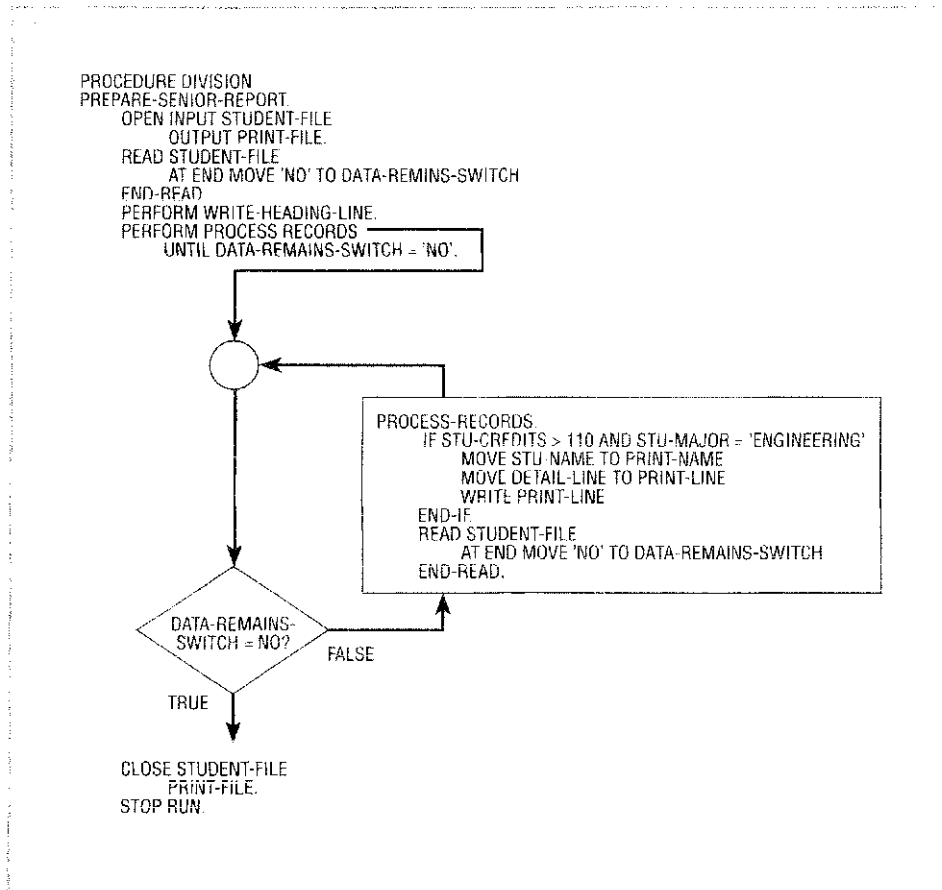

Test Data

Figure 1.8 contains test data and the associated output produced by the program in Figure 1.6. (Five more records have been added to provide additional examples.) You should be able to state the reasons why individual records were not selected for the output report; for example, Amelia Earhart and Alex Bell were rejected for the wrong major and an insufficient number of credits, respectively. (Can you identify all nine of our famous students?)

lements of COBOL

Although you are not yet expected to write a COBOL program, you should be able to follow simple programs like the one in Figure 1.6 intuitively. This section begins a formal discussion of COBOL so that you will eventually be able to write an entire program.

COBOL consists of six language elements: reserved words, programmer-supplied names, literals, symbols, level numbers, and pictures.

Reserved Words

Reserved words have special significance to COBOL and are used in a rigidly prescribed manner. They must be spelled correctly, or the compiler will not be able

Figure 1.8 Test Data and Associated Output

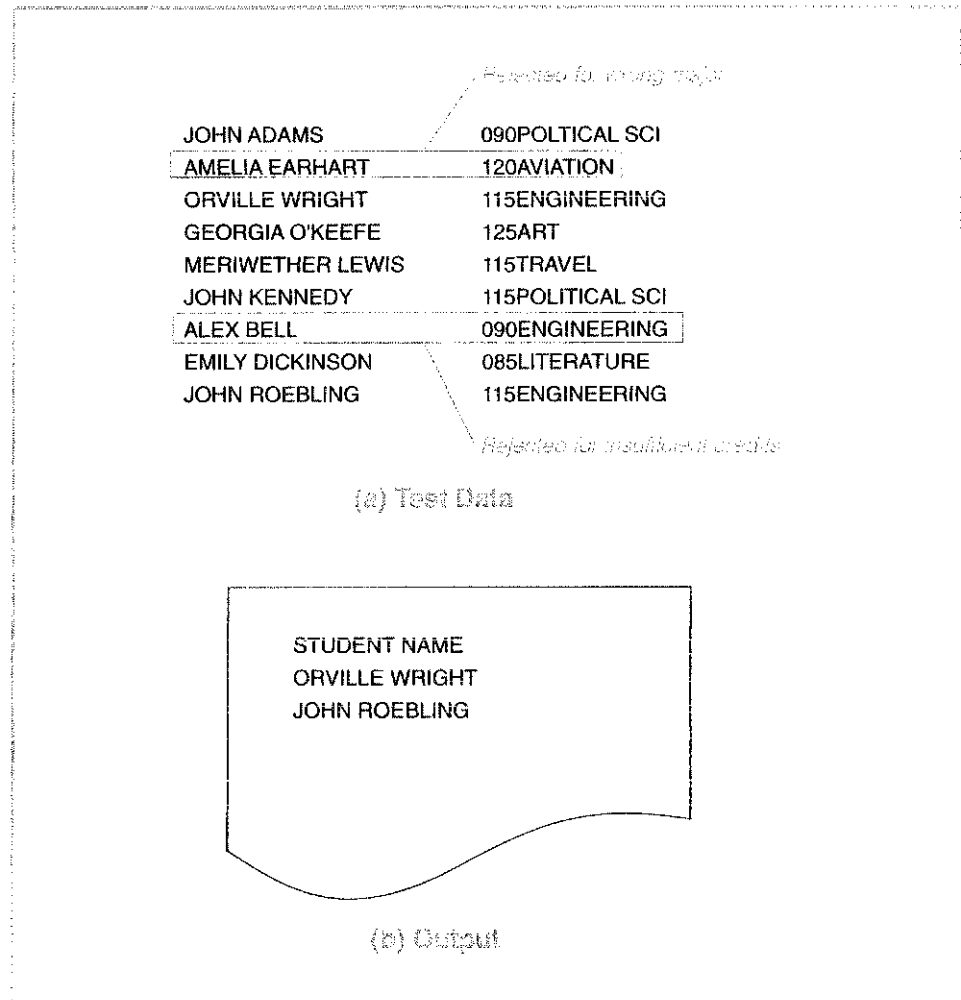

to recognize them. The list of reserved words varies from compiler to compiler. A comprehensive list of reserved words is given in Appendix C. The beginner is urged to refer frequently to this appendix for two reasons: (1) to ensure the proper spelling of reserved words used in his or her program; and (2) to avoid the inadvertent use of reserved words as programmer-supplied names.

Programmer-Supplied Names

You, the programmer, supply names for paragraphs, data elements, and files. A **paragraph name** is a tag to which the program refers, for example, PROCESS-RECORDS or PREPARE-SENIOR-REPORT in Figure 1.6. **Data names** are the elements on which instructions operate, for example, STU-NAME, STU-CREDITS, and STU-MAJOR in Figure 1.6. **File names** are specified in several places throughout a COBOL program, but their initial appearance is in the Environment Division, for example, STUDENT-FILE and PRINT-FILE in Figure 1.6. All programmer-supplied names are chosen according to the following rules:

1. A programmer-supplied name may contain the letters A to Z, the digits 0 to 9, and the hyphen; no other characters are permitted, not even blanks.

2. A programmer-supplied name may *not* begin or end with a hyphen.
3. A programmer-supplied name must be 30 characters or fewer in length.
4. A reserved word may *not* be used as a programmer-supplied name.
5. Data names must contain at least one letter.
6. Paragraph names may be all numeric.

Table 1.2 illustrates examples of the rules associated with programmer-supplied names.

TABLE 1.2 Programmer-Supplied Names

| | |
|-------------------------------------|--|
| SUM | Invalid —reserved word |
| SUM-OF-X | Valid |
| SUM OF X | Invalid —contains blanks |
| SUM-OF-X- | Invalid —ends with a hyphen |
| SUM-OF-ALL-THE-XS | Valid |
| SUM-OF-ALL-THE-XS-IN-ENTIRE-PROGRAM | Invalid —more than 30 characters |
| GROSS-PAY-IN-\$ | Invalid —contains a \$ |
| 12345 | Valid as a paragraph name but <i>invalid</i> as a data name |

Literals

A *literal* is an exact value or constant. Literals are of two types, *numeric* (a number) or *nonnumeric* (a character string). Literals of both types appear throughout a program and are used to compare the value of a data name to a specified constant. Consider line 60 of Figure 1.6:

```
IF STU-CREDITS > 110 AND STU-MAJOR = 'ENGINEERING'
```

In the first portion of the statement, STU-CREDITS is compared to 110, a numeric literal. Numeric literals adhere to the following rules:

1. A numeric literal can be up to 18 digits long.
2. A numeric literal may begin with a leading (leftmost) plus or minus sign.
3. A numeric literal may contain a decimal point, but it may *not* end with a decimal point.

The second part of the IF statement contains a nonnumeric literal, 'ENGINEERING'. Nonnumeric literals adhere to the following rules:

1. A nonnumeric literal is enclosed in apostrophes (or quotation marks) as specified by the compiler.
2. A nonnumeric literal may be up to 160 characters in length.
3. A nonnumeric literal may contain anything, including blanks, numbers, and reserved words, but not another apostrophe (or quotation mark).

Examples of both numeric and nonnumeric literals are shown Table 1.3.

TABLE 1.3 Numeric and Nonnumeric Literals

| | |
|---------------------------|---|
| 123.4 | Valid numeric literal |
| '123.4' | Valid nonnumeric literal |
| +123 | Valid numeric literal |
| 'IDENTIFICATION DIVISION' | Valid nonnumeric literal |
| 123. | Invalid numeric literal—may not end with a decimal point |
| 123- | Invalid numeric literal—the minus sign must be in the leftmost position |

Symbols

Symbols are of three types—punctuation, arithmetic, and relational, as listed in Table 1.4.

TABLE 1.4 Symbols

| | | |
|-------------|--------|------------------------------------|
| Punctuation | . | Denotes end of COBOL entry |
| | , | Defines clauses |
| | ' or " | Sets off nonnumeric literals |
| | () | Encloses subscripts or expressions |
| Arithmetic | + | Addition |
| | - | Subtraction |
| | * | Multiplication |
| | / | Division |
| | ** | Exponentiation |
| Relational | = | Equal to |
| | > | Greater than |
| | < | Less than |
| | >= | Greater than or equal to |
| | <= | Less than or equal to |

The use of relational and arithmetic symbols is described in detail later in the text, beginning in Chapter 4. A period terminates an entry, and its omission (in the absence of a scope terminator) can cause difficulty. A comma, on the other hand, is entirely optional, and its omission (or inclusion) has no effect whatsoever on the program. The use of commas is discouraged, however, as a comma can be mistaken for a period on older printers, which tend to blur the output.

Level Numbers

Level numbers describe the relationship of items in a record. For example, under STUDENT-FILE in Figure 1.6, there was a single 01-level entry and several 05-level entries. In general, the higher (numerically) the level number, the less significant the entry; thus 05 is less important than 01. Entries with higher numeric values are said to belong to the levels above them. Thus, in Figure 1.6 the several 05-level entries belong to their respective 01-level entries.



PICTURE Clauses

Pictures describe the nature of incoming or outgoing data. A picture of 9's means the entry is numeric; a picture of X's means the entry is alphanumeric, that is, it can contain letters, numbers, and special characters. (Alphabetic pictures, with a picture of A, are seldom used; even names can contain apostrophes or hyphens, which are alphanumeric rather than alphabetic in nature.) Level numbers and pictures are discussed more fully in Chapter 4.

A Second Look at COBOL

Figure 1.9 contains a relabeled version of the Engineering Senior Program and represents a second look at COBOL. This time our intention is to emphasize the various COBOL elements as they appear in a complete program.

Figure 1.9 The Engineering Senior Program (A Second Look)

```

1  IDENTIFICATION DIVISION.
2  PROGRAM-ID.        SENIOR.
3  AUTHOR.            ROBERT GRAUER.
4
5  ENVIRONMENT DIVISION.
6  INPUT-OUTPUT SECTION.
7  FILE-CONTROL.
8      SELECT STUDENT-FILE ASSIGN TO 'A:\CHAPTR02\SENIOR.DAT'.
9          ORGANIZATION IS LINE SEQUENTIAL.
10     SELECT PRINT-FILE
11         ASSIGN TO PRINTER.
12
13  DATA DIVISION.
14  FILE SECTION.
15  FD STUDENT-FILE
16     RECORD CONTAINS 43 CHARACTERS
17     DATA RECORD IS STUDENT-IN.
18  01 STUDENT-IN.
19     05 STU-NAME          PIC X(25).
20     05 STU-CREDITS       PIC 9(3).
21     05 STU-MAJOR         PIC X(15).
22
23  FD PRINT-FILE
24     RECORD CONTAINS 132 CHARACTERS
25     DATA RECORD IS PRINT-LINE.
26  01 PRINT-LINE          PIC X(132).
27
28  WORKING-STORAGE SECTION.
29  01 DATA-REMAINS-SWITCH PIC X(2)    VALUE SPACES.
30

```

Programmer-supplied file name appears in several places (see lines 8, 10, 11, and 65)

PICTURE clauses describe incoming record and are consistent with the data in Figure 1.3

Reserved word's

Figure 1.9 (continued)

```

31      01 HEADING-LINE.
32          05 FILLER                PIC X(10)    VALUE SPACES.
33          05 FILLER                PIC X(12)    VALUE 'STUDENT NAME'.
34          05 FILLER                PIC X(110)   VALUE SPACES.
35
36      01 DETAIL-LINE.
37          05 FILLER                PIC X(8)     VALUE SPACES.
38          05 PRINT-NAME            PIC X(25)    .
39          05 FILLER                PIC X(99)    VALUE SPACES.
40
41      PROCEDURE DIVISION.
42      PREPARE-SENIOR-RFPOR.
43          OPEN INPUT STUDENT-FILE
44              OUTPUT PRINT-FILE.
45          READ STUDENT-FILE
46              AT END MOVE 'NO' TO DATA-REMAINS-SWITCH
47          END-READ.
48          PERFORM WRITE-HEADING-LINE.
49          PERFORM PROCESS-RECORDS
50              UNTIL DATA-REMAINS-SWITCH = 'NO'.
51          CLOSE STUDENT-FILE
52              PRINT-FILE.
53          STOP RUN.
54
55      WRITE-HEADING-LINE.
56          MOVE HEADING-LINE TO PRINT-LINE.
57          WRITE PRINT-LINE.
58
59      PROCESS-RECORDS.
60          IF STU-CREDITS > 110 AND STU-MAJOR = 'ENGINEERING'
61              MOVE STU-NAME TO PRINT-NAME
62              MOVE DETAIL-LINE TO PRINT-LINE
63              WRITE PRINT-LINE
64          END-IF.
65          READ STUDENT-FILE
66              AT END MOVE 'NO' TO DATA-REMAINS-SWITCH
67          END-READ.

```

Annotations in the original image:

- Reserved words:** PROCEDURE, DIVISION, PREPARE-SENIOR-RFPOR, OPEN, INPUT, STUDENT-FILE, OUTPUT, PRINT-FILE, READ, STUDENT-FILE, AT END, MOVE, 'NO', TO, DATA-REMAINS-SWITCH, END-READ, PERFORM, WRITE-HEADING-LINE, STOP, RUN.
- Programmer-supplied paragraph name:** PROCESS-RECORDS (used in lines 49 and 59).
- Numeric literal:** 110 (in line 60).
- Nonnumeric literal:** 'ENGINEERING' (in line 60).

Observe, for example, the definition of a *file name*, STUDENT-FILE, in the SELECT statement of line 8, and its subsequent appearance in the FD of line 15, and the OPEN, READ, and CLOSE statements of lines 43, 45, 51, and 65. Notice the definition of the various *data names* in lines 19–21 (accomplished through level numbers and PICTURE clauses) and the subsequent appearances in the Procedure Division. Note the consistency of the paragraph name in the PERFORM statement of line 49 and the paragraph header in line 59. Observe that literals appear in the IF statement of line 60 and in the AT END clause of the READ statement (lines 46 and 66). Finally, note the abundant use of COBOL reserved words (PROCEDURE, DIVISION, WORKING-STORAGE, SECTION, and so on) throughout.

U M M A R Y

Points to Remember

- A field is a basic fact, such as the name, address, major, grade point average, or number of completed credits. A record is a set of fields, and a file is a set of records.
- Every computer application consists of input, processing, and output.
- The computer cannot think for itself but must be told precisely what to do. This is done through a series of instructions known as a program.
- The computer does not do anything that a human being could not do if given sufficient time. The advantages of a computer stem from its speed and accuracy.
- A flowchart and/or pseudocode represent the logic embodied in a computer program.
- Every COBOL program contains four divisions, which appear in the sequence: Identification, Environment, Data, and Procedure.
- COBOL contains six language elements; reserved words, programmer-supplied names, literals, symbols, level numbers, and pictures.

Key Words and Concepts

| | |
|--------------------|----------------------------|
| Alphabetic data | Processing |
| Alphanumeric data | Programmer-supplied name |
| Arithmetic symbol | Programming specifications |
| End-of-file | Pseudocode |
| Field | Punctuation symbol |
| File | Record |
| Flowchart | Record description |
| Initialization | Relational symbol |
| Level number | Reserved words |
| Nonnumeric literal | Scope terminator |
| Numeric data | Symbol |
| Numeric literal | Termination |
| Paragraph | Test Data |

COBOL Elements

| | |
|-------------------------|-------------------------|
| DATA DIVISION | INPUT-OUTPUT SECTION |
| ENVIRONMENT DIVISION | PICTURE |
| FILE SECTION | PROCEDURE DIVISION |
| IDENTIFICATION DIVISION | WORKING-STORAGE SECTION |

FILL-IN

1. All computer applications consist of _____, _____, and _____.
2. The divisions of a COBOL program appear in the order: _____, _____, _____, and _____.
3. A _____ is a pictorial representation of the logic in a program.
4. _____ may be described as neat notes to oneself.
5. A diamond-shaped block in a flowchart indicates a _____.
6. _____ have special significance to COBOL and must be used in a rigidly prescribed manner and be spelled correctly.
7. A _____ may contain the letters A to Z, the digits 0 to 9, and the hyphen.
8. ** is the COBOL symbol for _____.
9. =, >, and < are examples of _____ symbols in COBOL.
10. A _____ is a set of records.
11. A record consists of one or more _____.
12. A _____ is a set of instructions to a computer.

TRUE/FALSE

1. Nonnumeric literals may not contain numbers.
2. Numeric literals may not contain letters.
3. A data name may not contain any characters other than letters or numbers.
4. The rules for forming paragraph names and data names are exactly the same.
5. A data name may not consist of more than 30 characters.
6. A nonnumeric literal may not contain more than 30 characters.
7. A numeric literal may contain up to 18 digits.
8. There are four divisions in a COBOL program.
9. The divisions of a COBOL program may appear in any order.
10. Data description appears in the Identification Division.
11. A record contains one or more fields.
12. A file is a set of records.
13. Computers can think for themselves.
14. No statement in a computer program may be executed more than once.
15. A rectangle is the standard flowchart symbol for a decision block.
16. Reserved words may appear in a nonnumeric literal.
17. Reserved words may be used as data names.

18. Pseudocode serves the same function as a flowchart.
19. Pseudocode must be written according to precise syntactical rules.
20. The COBOL compiler needs to be installed every time a program is executed.

PROBLEMS

1. Indicate whether the entries below are valid as data names. If any entry is invalid, state the reason.
 - a. NUMBER-OF-TIMES
 - b. CODE
 - c. 12345
 - d. ONE TWO THREE
 - e. IDENTIFICATION-DIVISION
 - f. IDENTIFICATION
 - g. HOURS
 - h. GROSS-PAY
 - i. GROSS-PAY-IN-\$
2. Classify the entries below as being valid or invalid literals. For each valid entry, indicate whether it is numeric or nonnumeric; for each invalid entry, state why it is invalid.
 - a. 567
 - b. 567.
 - c. -567
 - d. +567
 - e. +567.
 - f. '567.'
 - g. 'FIVE SIX SEVEN'
 - h. '-567'
 - i. 567-
 - j. 567+
 - k. '567+'
3.
 - a. Which division(s) contain paragraph names?
 - b. Which division(s) contain the SELECT statement(s)?
 - c. Which division(s) contain level numbers?
 - d. Which division(s) contain data names?
 - e. Which division(s) contain reserved words?
 - f. Which division(s) contain PICTURE clauses?
 - g. Which division(s) do not contain file names?
4. Given the COBOL program in Figure 1.6, indicate what changes would have to be made if
 - a. We wanted music students rather than engineering students.
 - b. We wanted students with 60 or fewer credits.
 - c. The student major was contained in columns 60–74 of the incoming record.
 - d. We wanted engineering students *or* students with 110 credits or more.Note: Treat parts (a), (b), (c), and (d) independently.

5. Which division in a COBOL program contains
 - a. The File Section?
 - b. Statements to open and close files?
 - c. The description of incoming data?
 - d. The description of outgoing data?
 - e. The author's name?
 - f. The program's name?
 - g. Statements to read information?
 - h. Statements to write information?
6. Your programming supervisor has drawn a flowchart for you to code. He left the flowchart on his dining room table at home, and unfortunately his three-year-old son, Benjy, cut it up into pieces with a pair of scissors. Your supervisor has collected the pieces (shown in Figure 1.10) and has asked you to rearrange them properly into a correct flowchart; do so. The flowchart is to read a file with each record containing three unequal numbers, A, B, and C. Write out the greater of the two sums $(A + B)$ and $(B + C)$ for each record only if A is less than 50. Develop the equivalent pseudocode.
7. World Wide Sales, Inc., wishes to promote one of its employees to head the South American Division. The selected employee must speak Spanish, be 40 or younger, and hold a college degree. The programming manager has prepared the necessary flowchart (see Figure 1.11), but unfortunately Benjy and his scissors got to it first (see Problem 6). Your job is to put the flowchart together. Note that there may be more than one employee who qualifies for the position. Accordingly, the flowchart includes the necessary logic to count and print the number of qualified employees and to print the name of every such employee. Develop the equivalent pseudocode.
8. Figure 1.12 contains a COBOL program to process a file of employee records and print the names of programmers under 30. Using Figure 1.6 as a guide, restore the missing information so that the program will run as intended.

Figure 1.10 Flowchart Blocks for Problem 6

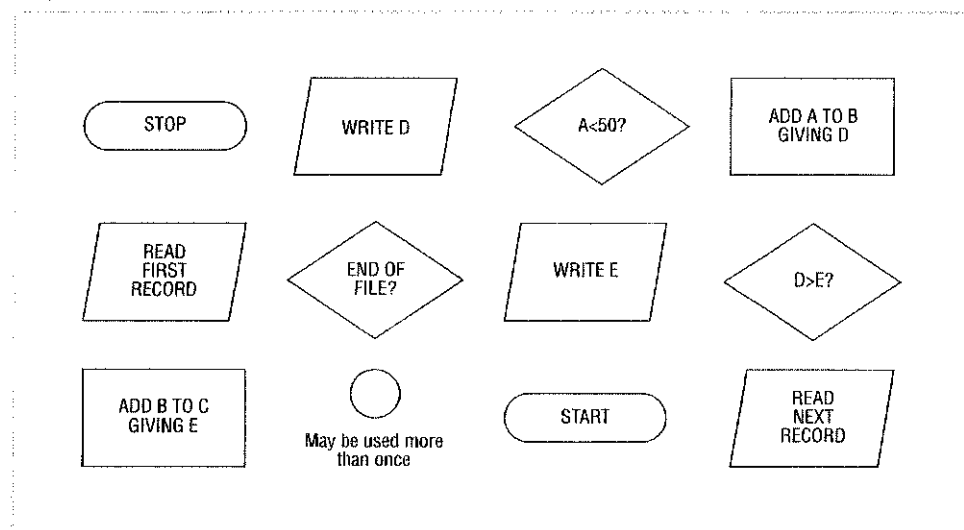

Figure 1.11 Flowchart Blocks for Problem 7

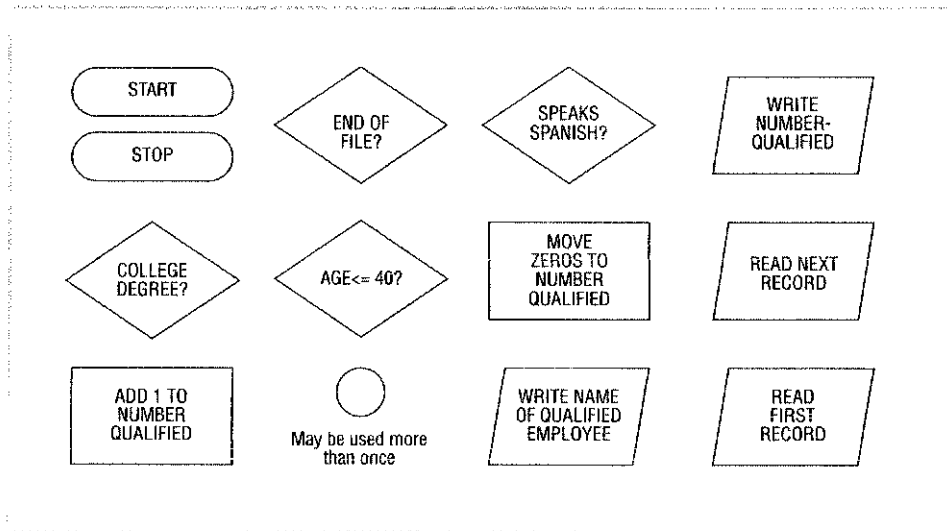

Figure 1.12 COBOL Listing for Problem 8

```

1  IDENTIFICATION DIVISION.
2  PROGRAM-ID.  FIRSTTRY.
3          GRAUER.
4
5  ENVIRONMENT DIVISION.
6  INPUT-OUTPUT SECTION.
7  FILE-CONTROL.
8      SELECT EMPLOYEE-FILE ASSIGN TO 'A:\CHAPTR02\FIRSTTRY.DAT'
9          ORGANIZATION IS LINE SEQUENTIAL.
10     PRINT-FILE
11     ASSIGN TO PRINTER.
12
13
14  FILE SECTION.
15  FD  EMPLOYEE-FILE
16     RECORD CONTAINS 44 CHARACTERS
17     DATA RECORD IS EMPLOYEE-RECORD.
18  01  EMPLOYEE-RECORD.
19     05  EMP-NAME           PIC X(25).
20     05  EMP-TITLE         PIC X(10).
21     05  EMP-AGE           PIC 99.
22     05  FILLER            PIC XX.
23     05  EMP-SALARY        PIC 9(5).
24

```

Figure 1.12 COBOL Listing for Problem 8 (continued)

```

25     FD EMPLOYEE-FILE
26     RECORD CONTAINS 132 CHARACTERS
27     DATA RECORD IS PRINT-LINE.
28     01 PRINT-LINE.
29         05 FILLER                PIC X.
30         05 PRINT-NAME            PIC X(5).
31         05 FILLER                PIC X(2).
32         05 PRINT-AGE             PIC 99.
33         05 FILLER                PIC X(3).
34         05 PRINT-SALARY          PIC 9(5).
35         05 FILLER                PIC X(94).
36
37     01 END-OF-DATA-FLAG          PIC X(3).
38     PROCEDURE DIVISION.
39     MAINLINE.
40         800 INPUT EMPLOYEE-FILE
41             OUTPUT PRINT-FILE.
42         MOVE SPACES TO PRINT-LINE.
43         MOVE 'SALARY REPORT FOR PROGRAMMERS UNDER 30' TO PRINT-LINE.
44         WRITE PRINT-LINE
45             AFTER ADVANCING 2 LINES.
46         READ EMPLOYEE-FILE
47             AT END MOVE 'YES' TO END-OF-DATA-FLAG
48         END-READ.
49     900 PROCESS-EMPLOYEE-RECORDS
50         UNTIL END-OF-DATA-FLAG = 'YES'.
51     CLOSE EMPLOYEE-FILE
52         PRINT-FILE.
53     STOP RUN.
54
55     PROCESS-EMPLOYEE-RECORDS.
56     IF EMP-TITLE = 'PROGRAMMER' AND EMP-AGE < 30
57         MOVE SPACES TO PRINT-LINE
58         MOVE EMP-NAME TO PRINT-NAME
59         MOVE EMP-AGE TO PRINT-AGE
60         MOVE EMP-SALARY TO PRINT-SALARY
61         WRITE PRINT-LINE
62     END-IF.
63     READ EMPLOYEE-FILE
64         AT END MOVE 'YES' TO END-OF-DATA-FLAG
65     END-READ.
66

```

From Coding Form to Computer

CHAPTER OUTLINE

Overview

From Coding Form to Computer

The COBOL Coding Form

Use of an Editor

The Compile, Link, and Execute Sequence

Learning by Doing

Errors in Entering the Program

Errors in Operating System Commands

Errors in Compilation

Errors in Execution

Errors in Data Input

Evolution of COBOL

There's Always a Reason

Summary

Fill-in

True/False

Problems

OBJECTIVES

After reading this chapter you will be able to:

- State the rules associated with the COBOL coding sheet, and enter a program appropriately.
- Distinguish between compilation and execution; describe the function of a link program.
- Describe the environmental differences between a PC and a mainframe as they relate to execution of COBOL programs.
- Compile, link, and execute a COBOL program.
- Find and correct simple errors in compilation or execution.

OVERVIEW

This chapter continues with the engineering senior program of Chapter 1, describing how to actually run a COBOL program. We discuss the COBOL coding form and its associated rules, the use of an editor (or word processor) to create COBOL programs and/or data files, and the procedure for submission to the computer. We describe the compile, link, and execute sequence. We also prepare you for the errors you will inevitably make, discuss fundamentals of debugging, and alert you to the subtle differences between the two standards in use today, COBOL-74 and COBOL-85.

At the conclusion of the chapter we ask you to run the engineering senior program of Chapter 1. *Seeing is believing* may be a cliché, but it is only after you have seen output from your own program that the material truly begins to make sense. Suffice it to say then, that the sooner you are on the computer, the sooner you will appreciate the subtleties inherent in programming.

From Coding Form to Computer

Chapter 1 ended with presentation of a completed COBOL program, and a discussion of the elements that make up the COBOL language. The program, however, is not yet in a form suitable for execution on the computer, and much has to be done in order for this to be accomplished. That is the overriding objective of this chapter.

The flowchart in Figure 2.1 depicts the various steps in solving a problem through use of a computer. The first step is to obtain a clear statement of the problem, containing a complete description of the input and desired output. The problem statement should also contain detailed processing specifications. It is not enough, for example, to say calculate a student's grade point average; instead the method for calculating the average must be provided as well.

Once the input, output, and processing specifications have been enumerated, a hierarchy chart (see Chapter 3) is created, then a flowchart or pseudocode is developed. Careful attention to these steps will simplify the subsequent program and increase the likelihood it will be correct.

Coding is the translation of the hierarchy chart, flowchart, and/or pseudocode into COBOL. Coding must be done within the well-defined rules of COBOL regarding

Figure 2.1 The Programming Process

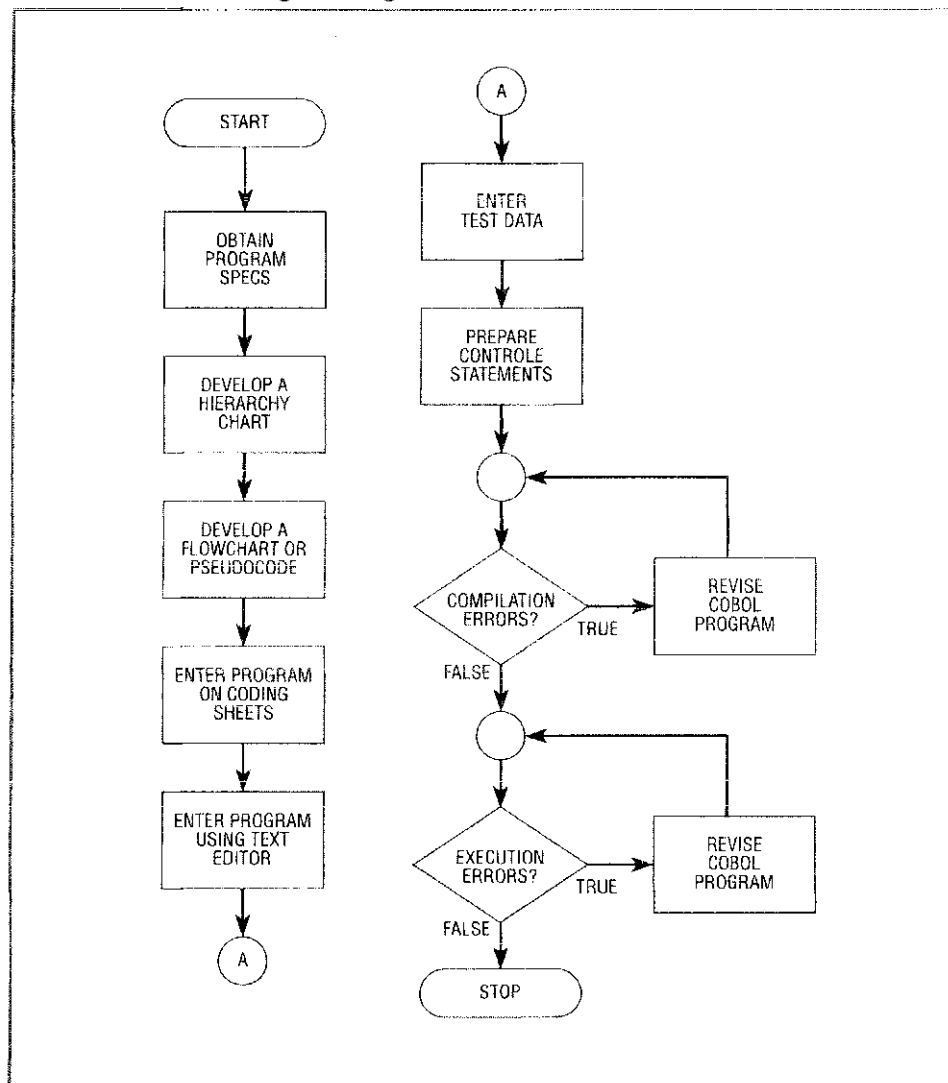

the placement of various statements in specific areas of the coding form. After coding, the program is entered into a file suitable for input to a computer through use of an editor.

The program is then submitted to the computer in conjunction with a set of control statements. The latter provide information to the operating system as to the location of the COBOL program and/or its associated data. The control statements vary greatly from installation to installation.

Next comes compilation in which the COBOL program is translated into machine language. Initial attempts at compilation are apt to identify several errors, due to misspellings, missing periods, misplaced parentheses, etc. Corrections are made, and the program is recompiled. Only after the compilation has been successfully completed can we proceed to execution.

During execution the computer does exactly what it was instructed to do, which may be different from what you want it to do. For example, if OR were substituted for AND in line 60 of the engineering senior program, the program would select *either* engineering majors *or* seniors. Either way, it would function differently from the original, logically correct version, although the program would

still compile cleanly. Corrections are made, the program is recompiled, and testing continues.

The presence of the two decision blocks in Figure 2.1 indicates the iterative nature of the entire process. Few, if any, programs compile correctly on the first try—hence the need to recode specific statements. Similarly, programs may not execute properly on the first attempt, and thus the need to revise the program, recompile, reexecute, and so on.

The COBOL Coding Form

The COBOL compiler is very particular about the information it receives, and requires a program to be written within its well-defined syntax. For example, division and section headers are required to begin between columns 8 and 11, whereas most other statements begin in or past column 12. There are additional rules for continuation (what happens if a statement does not fit on one line), comments, optional sequencing of source statements in columns 1–6, and program identification in columns 73–80.

The rules of the coding sheet are summarized in Table 2.1, and illustrated in Figure 2.2. The latter shows completed forms for the engineering senior problem of Chapter 1. Several features in Figure 2.2 bear mention. Note in particular the wavy line under various PIC entries to indicate that identical information is to be entered on subsequent lines. Of greatest import, however, is the conformity between the entries in Figure 2.2 and the COBOL requirements of Table 2.1.

Coding sheets are not mandatory and you can use ordinary paper instead. You will find, however, that programming is much easier, if you are well organized. A good start is to have the program neatly entered in appropriate columns before sitting down at the computer.

Use of an Editor

Once a program has been written on coding sheets, it is entered through an editor (or word processor) into a file for subsequent input to the computer. In all likelihood you are already familiar with a word processor, and can use that to create and edit COBOL programs as well. Accordingly, be sure you can do all of the following:

1. Save the program as an unformatted (ASCII text) file, with a file name of your own choosing, consistent with the computer on which you will execute the program.
2. Retrieve the file, then resave it after making additional modifications.
3. Toggle between the insertion and replacement modes to change characters within a statement, and/or to insert and/or delete statements within a program.
4. Print a listing of the file.

You will also find it useful to learn the commands to:

1. Set tabs to move to designated columns; for example, columns 8 and 12 for the A and B margins, respectively.
2. Search and/or replace character strings.
3. Move to specified places within the program; for example, the beginning or end, a particular line, the start of the Procedure Division, and so on.

The availability of an on-line editor facilitates programming to an extent that was unimaginable to tens of thousands of COBOL programmers of the 1960s and

TABLE 2.1 Rules for the COBOL Coding Form

- 1-6 **Optional sequence numbers:** If this field is coded, the compiler performs a sequence check on incoming COBOL statements by flagging any statements out of order. Although some commercial installations encourage this option, we advise against it, especially since you are entering your own programs, and the more you type, the more chance for error.
- 7 An asterisk in column 7 indicates a **comment**, while a hyphen is used for the **continuation of nonnumeric literals** (described further on page 180). Comments may appear anywhere in a program; they are shown on the source listing but are otherwise ignored.
- 8-11 Known as the **A margin**, Division headers, section headers, paragraph names, FD's, and 01's all begin in the A margin.
- 12-72 Known as the **B margin**, All remaining entries begin in or past column 12. COBOL permits considerable flexibility here, but individual installations have their own requirements. We, for example, begin PICTURE clauses in the same column, for example, column 37, for better readability. (We shall discuss this further in Chapter 7.)
- 73-80 **Program identification:** a second optional field, which is ignored by the compiler. Different installations have different standards regarding use of this field.

Figure 2.2 The COBOL Coding Form

| Program | | Requested by | | Page | | |
|-----------------|--------|--------------|---|---------------------------------|------------------------------------|--|
| SENIOR | | | | 1 of 3 | | |
| Programmer | | Date | | Identification | | |
| ROBERT GRAUER | | 9/10/93 | | | | |
| Sequence (Page) | Column | A | B | COBOL Statement | | |
| 01 | 7 | | | IDENTIFICATION DIVISION | | |
| 02 | 7 | | | PROGRAM-ID | SENIOR | |
| 03 | 7 | | | AUTHOR | ROBERT GRAUER | |
| 04 | 7 | | | ENVIRONMENT DIVISION | | |
| 05 | 7 | | | INPUT-OUTPUT SECTION | | |
| 06 | 7 | | | FILE-CONTROL | | |
| 07 | 7 | | | SELECT STUDENT-FILE | ASSIGN TO 'A:\CHAPTR02\SENIOR.DAT' | |
| 08 | 7 | | | ORGANIZATION IS LINE SEQUENTIAL | | |
| 09 | 7 | | | SELECT PRINT-FILE | | |
| 10 | 7 | | | ASSIGN TO PRINTER | | |
| 11 | 7 | | | | | |
| 12 | 7 | | | DATA DIVISION | | |
| 13 | 7 | | | FILE SECTION | | |
| 14 | 7 | | | FD STUDENT-FILE | | |
| 15 | 7 | | | RECORD CONTAINS 43 CHARACTERS | | |
| 16 | 7 | | | DATA RECORD IS STUDENT-IN | | |
| 17 | 7 | | | 01 STUDENT-IN | | |
| 18 | 7 | | | 05 STU-NAME | PIC X(25) | |
| 19 | 7 | | | 05 STU-CREDITS | PIC 9(3) | |
| 20 | 7 | | | 05 STU-MAJOR | PIC X(15) | |
| 21 | 7 | | | | | |
| 22 | 7 | | | FD PRINT-FILE | | |
| 23 | 7 | | | RECORD CONTAINS 132 CHARACTERS | | |
| 24 | 7 | | | DATA RECORD IS PRINT-LINE | | |
| 25 | 7 | | | 01 PRINT-LINE | PIC X(132) | |
| 26 | 7 | | | | | |

(Division, section, and paragraph headers; FD and 01 entries begin in column 7)

PICTURE clauses begin anywhere after data names end; column 37 was chosen

Figure 2.3 (continued)

| Program | | Requested by | | Page 2 of 3 | | |
|---------------|--------|--------------|----|---|-----------------|------------------|
| Programmer | | Date | | Identification | | |
| SENIOR | | | | 73 | | |
| ROBERT GRAUER | | 9/10/93 | | 80 | | |
| Sequence | (Page) | (Serial) | A | B | COBOL Statement | |
| 0.1 | 1 | 1 | | | | |
| 0.2 | | 2 | 01 | DATA-REMAINS-SWITCH | PIC X(2) | VALUE SPACES |
| 0.3 | | 3 | | | | |
| 0.4 | | 4 | 01 | HEADING-LINE | | |
| 0.5 | | 5 | 05 | FILLER | PIC X(10) | VALUE SPACES |
| 0.6 | | 6 | X | X | X(12) | X 'STUDENT NAME' |
| 0.7 | | 7 | X | X | X(10) | X SPACES |
| 0.8 | | 8 | | | | |
| 0.9 | | 9 | 01 | DETAIL-LINE | | |
| 1.0 | | 10 | 05 | FILLER | PIC X(8) | VALUE SPACES |
| 1.1 | | 11 | X | PRINT-NAME | X(25) | |
| 1.2 | | 12 | X | FILLER | X(99) | VALUE SPACES |
| 1.3 | | 13 | | | | |
| 1.4 | | 14 | | PROCEDURE DIVISION | | |
| 1.5 | | 15 | | PREPARE-SENIOR-REPORT | | |
| 1.6 | | 16 | | OPEN INPUT STUDENT-FILE | | |
| 1.7 | | 17 | | OUTPUT PRINT-FILE | | |
| 1.8 | | 18 | | READ STUDENT-FILE | | |
| 1.9 | | 19 | | AT END MOVE 'NO' TO DATA-REMAINS-SWITCH | | |
| 2.0 | | 20 | | END-READ | | |
| 2.1 | | 21 | | PERFORM WRITE-HEADING-LINE | | |
| 2.2 | | 22 | | PERFORM PROCESS-RECORDS | | |
| 2.3 | | 23 | | UNTIL DATA-REMAINS-SWITCH = 'NO' | | |
| 2.4 | | 24 | | CLOSE STUDENT-FILE | | |
| 2.5 | | 25 | | PRINT-FILE | | |
| 2.6 | | 26 | | STOP RUN | | |

early 1970s. COBOL itself is over 30 years old, and for much of its existence the punched card and batch processing (often with turnaround times of several hours or more) was the way in which programs were submitted. Students today are far more fortunate in the available technology, taking for granted the ability to execute a program many times in a single session, instead of having to wait hours (or days) to retrieve a single run, wait hours more for the next run, etc.

The Compile, Link, and Execute Sequence

The material on the coding sheet and use of an editor is straightforward, and should pose little difficulty. The execution of a COBOL program, however, is more complex, and is explained in conjunction with Figure 2.3. The figure shows the execution of three distinct programs, a *compiler*, *linker* (or linkage-editor on IBM mainframes), and *load module*, each of which is necessary to produce the list of engineering seniors. Realize, too, that the process described in Figure 2.3 is required for any COBOL program, even one as simple as the engineering senior example.

Figure 2.2 (continued)

| Program | | Requested by | | Page 3 of 3 | |
|---------------|--|--------------|--|----------------|--|
| Programmer | | Date | | Identification | |
| SENIOR | | | | 73 | |
| ROBERT GRAUER | | 9/10/93 | | 80 | |

| Sequence (Page) | Serial | COBOL Statement |
|-----------------|--------|--|
| 0 1 | 1 | WRITE HEADING-LINE |
| 0 2 | 2 | MOVE HEADING-LINE TO PRINT-LINE |
| 0 3 | 3 | WRITE PRINT-LINE |
| 0 4 | 4 | |
| 0 5 | 5 | PROCESS RECORDS |
| 0 6 | 6 | IF STU-CREDITS > 110 AND STU-MAJOR = 'ENGINEERING' |
| 0 7 | 7 | MOVE STU-NAME TO PRINT-NAME |
| 0 8 | 8 | MOVE DETAIL-LINE TO PRINT-LINE |
| 0 9 | 9 | WRITE PRINT-LINE |
| 1 0 | 10 | END-IF |
| 1 1 | 11 | READ STUDENT-FILE |
| 1 2 | 12 | AT END MOVE 'NO' TO DATA-REMAINS-SWITCH |
| 1 3 | 13 | END-READ |
| 1 4 | 14 | |
| 1 5 | 15 | |
| 1 6 | 16 | |
| 1 7 | 17 | |
| 1 8 | 18 | |
| 1 9 | 19 | |
| 2 0 | 20 | |
| 2 1 | 21 | |
| 2 2 | 22 | |
| 2 3 | 23 | |
| 2 4 | 24 | |
| 2 5 | 25 | |
| 2 6 | 26 | |

The procedure begins with the COBOL *compiler*, a program that accepts a COBOL (source) program as input, and produces a machine-language (object) program as output. The result of the compilation, the object program, is input into a second program called the *linker*, that combines the object program with subroutines and other object modules to produce a load module. Execution of the compiled COBOL program takes place in the third step as the *load module* accepts input data and produces an output report.

The execution of the various programs in Figure 2.3 does not happen through wishful thinking, but through specification of commands to the *operating system* to describe these programs and their associated data files. Every operating system has its own specific commands, but the underlying concept is the same, namely that three different programs (a compiler, linker, and load module) are required. It will be necessary, therefore, to learn the commands for your particular configuration in order to compile, link, and execute a COBOL program.¹

1. Appendices A and B describe the Micro Focus Personal COBOL for Windows that may accompany this text.

Figure 2.3 Compile, Link, and Execute Sequence

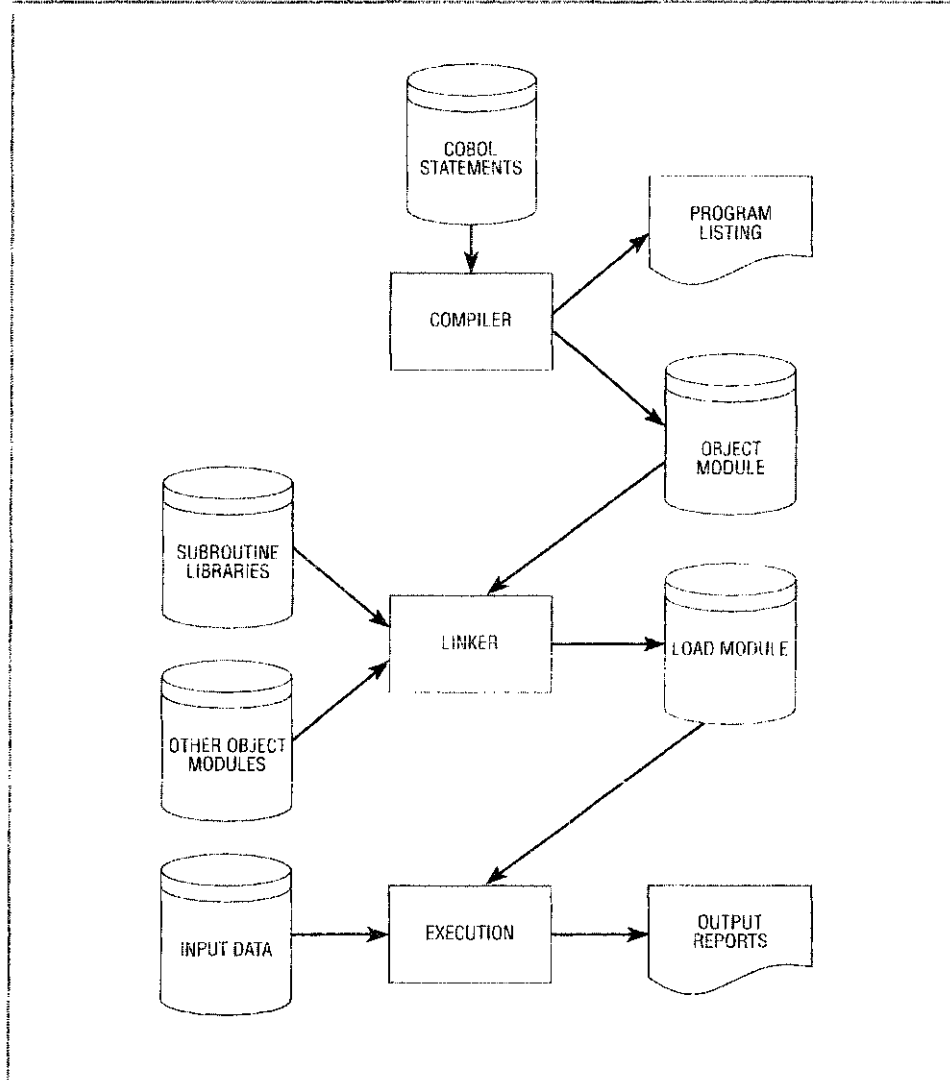

Learning by Doing

One learns by doing. This time-worn axiom is especially true for programming. We have covered a lot of material since you first began reading Chapter 1. Now it is time to put everything together and actually run your first program. Enter the program on the coding sheets in Figure 2.2, using the appropriate editor. Prepare the necessary control statements for the operating system. Create your own test data, or use Figure 1.8a. Submit the job and retrieve your output.

We believe—in fact we are very sure—that after you receive your first computer printout, many things will fall into place. Nevertheless, the first program is in many ways the most difficult you will attempt, and you should be prepared for problems along the way. The difficulty is not in the program's complexity (the engineering senior program is logically trivial). Nor is it in the COBOL syntax, in that the program uses only a fraction of the COBOL features you will eventually employ. The problems arise in interacting with the computer, using the editor, entering the proper commands to the operating system, and so on. Murphy's Law is perhaps the most eloquent statement of what to expect, and thus you should be prepared for any or all of the ensuing errors.

Errors in Entering the Program

The errors that occur as you enter the program are potentially the most damaging, especially if you spend hours entering the program and then forget to save it, save it incorrectly, or delete it unintentionally. A suggested course of action for your first attempt is to enter only the first two lines of the program, save these, log off the system, then log on and retrieve the file. In this way you are sure you know how to use the editor. Other frequent errors are to enter information in the wrong columns, to misuse a tab key, and so on.

Errors in Operating System Commands

The syntax of operating system commands has to be followed exactly, in order for the system to do your bidding. Simple mistakes result in baffling errors; for example, *Bad command or file name*, when you misspell an MS-DOS command, and/or fail to indicate the proper subdirectory where the command is located. In similar fashion the control statements submitted on a mainframe must be syntactically correct, or everything else will fail. Invalid job streams result in the system being unable to execute the job, leaving you with the most frustrating of all messages, *Job not run due to JCL error*.

Errors in Compilation

A **compilation error** occurs whenever you violate a rule of COBOL, for example, misspelling a reserved word or misplacing a period. The result of the error is that the compiler is unable to translate a portion of the COBOL program to machine language, and any subsequent attempt at execution will (most likely) be incorrect.

Consider, for example, Figure 2.4a, which contains a slightly modified version of the Engineering Senior Program of Figure 1.6, in which lines 59–64 have been

Figure 2.4 Engineering Senior Program with Compilation Errors

```

1  IDENTIFICATION DIVISION.
2  PROGRAM-ID.      SENIORCE.
3  AUTHOR.         ROBERT GRAUER.
4
5  ENVIRONMENT DIVISION.
6  INPUT-OUTPUT SECTION.
7  FILE-CONTROL.
8      SELECT STUDENT-FILE  ASSIGN TO 'A:\CHAPTER02\SENIOR.DAT'
9          ORGANIZATION IS LINE SEQUENTIAL.
10     SELECT PRINT-FILE
11         ASSIGN TO PRINTER.
12
13  DATA DIVISION.
14  FILE SECTION.
15  FD  STUDENT-FILE
16      RECORD CONTAINS 43 CHARACTERS
17      DATA RECORD IS STUDENT-IN.
18  01  STUDENT-IN.
19      05  STU-NAME          PIC X(25).

```

Figure 2.4 (continued)

```

20      05 STU-CREDITS      PIC 9(3).
21      05 STU-MAJOR       PIC X(15).
22
23      FD PRINT-FILE
24          RECORD CONTAINS 132 CHARACTERS
25          DATA RECORD IS PRINT-LINE.
26      01 PRINT-LINE      PIC X(132).
27
28      WORKING-STORAGE SECTION.
29      01 DATA-REMAINS-SWITCH  PIC X(2)      VALUE SPACES.
30
31      01 HEADING-LINE.
32          05 FILLER          PIC X(10)      VALUE SPACES.
33          05 FILLER          PIC X(12)      VALUE 'STUDENT NAME'.
34          05 FILLER          PIC X(110)     VALUE SPACES.
35
36      01 DETAIL-LINE.
37          05 FILLER          PIC X(8)       VALUE SPACES.
38          05 PRINT-NAME     PIC X(25).
39          05 FILLER          PIC X(99)     VALUE SPACES.
40
41      PROCEDURE DIVISION.
42      PREPARE-SENIOR-REPORT.
43          OPEN INPUT  STUDENT-FILE
44              OUTPUT PRINT-FILE.
45          READ STUDENT-FILE
46              AT END MOVE 'NO' TO DATA-REMAINS-SWITCH
47          END-READ.
48          PERFORM WRITE-HEADING-LINE.
49          PERFORM PROCESS-RECORDS
50              UNTIL DATA-REMAINS-SWITCH = 'NO'.
51          CLOSE STUDENT-FILE
52              PRINT-FILE.
53          STOP RUN.
54
55      WRITE-HEADING-LINE.
56          MOVE HEADING-LINE TO PRINT-LINE.
57          WRITE PRINT-LINE.
58
59      PROCESS-RECORDS
60          IF STU-CREDITS > 110 AND STU-MAJOR = 'ENGINEERING'
61              MOVE STU-NAME TO PRINT-NAME
62              MOVE DETAIL-LINE TO PRINT-LINE
63              WRTE PRINT-LINE.
64          END-IF.
65          READ STUDENT-FILE
66              AT END MOVE 'NO' TO DATA-REMAINS-SWITCH
67          END-READ.

```

Period missing after paragraph header

*WRITE is misspelled
Period does not belong before END-IF terminator*

(a) COBOL Listing

Figure 2.4 (continued)

| LINE | ERR# | LVL | ERROR TEXT |
|------|------|-----|--|
| 60 | 0138 | W | Period assumed before 'IF' |
| 63 | 0787 | E | Undefined symbol 'WRTE' |
| 64 | 0593 | E | No corresponding active scope for 'END-IF' |

seniorce has 1 Warning + 2 E Level messages

(b) COBOL Diagnostics

changed to produce compilation errors. Figure 2.4b shows the resulting compiler diagnostics. The error message associated with line 60 is caused by the missing period (after the paragraph header) in line 59. The diagnostic in line 63 resulted from misspelling a reserved word, and the diagnostic in line 64 is produced by the superfluous period in line 63.

Compiler diagnostics are discussed fully in Chapter 6. Corrections are made, and the program is recompiled. Only after the compilation has been successfully completed should we proceed to execution.

Errors in Execution

Execution errors occur after compilation and are generally due to errors in logic. Figure 2.5a contains yet another version of the engineering senior program in which the credits test was *deliberately* omitted in line 60. The program is syntactically correct and will compile without error; it is, however, logically incorrect and hence the associated output in Figure 2.5b is wrong. (Review the original program specifications and test data; Alex Bell should not be selected because of an insufficient number of credits.)

Figure 2.5 Engineering Senior Program with Execution Errors

```

1 IDENTIFICATION DIVISION.
2 PROGRAM-ID. SENIOREE.
3 AUTHOR. ROBERT GRAUER.
4
5 ENVIRONMENT DIVISION.
6 INPUT-OUTPUT SECTION.
7 FILE-CONTROL.
8 SELECT STUDENT-FILE ASSIGN TO 'A:\CHAPTR02\SENIOR.DAT'
9 ORGANIZATION IS LINE SEQUENTIAL.
10 SELECT PRINT-FILE
11 ASSIGN TO PRINTER.
12
13 DATA DIVISION.
```

Figure 2.5 (continued)

```

14     FILE SECTION.
15     FD  STUDENT-FILE
16         RECORD CONTAINS 43 CHARACTERS
17         DATA RECORD IS STUDENT-IN.
18     01  STUDENT-IN.
19         05  STU-NAME             PIC X(25).
20         05  STU-CREDITS         PIC 9(3).
21         05  STU-MAJOR          PIC X(15).
22
23     FD  PRINT-FILE
24         RECORD CONTAINS 132 CHARACTERS
25         DATA RECORD IS PRINT-LINE.
26     01  PRINT-LINE             PIC X(132).
27
28     WORKING-STORAGE SECTION.
29     01  DATA-REMAINS-SWITCH   PIC X(2)    VALUE SPACES.
30
31     01  HEADING-LINE.
32         05  FILLER             PIC X(10)   VALUE SPACES.
33         05  FILLER             PIC X(12)   VALUE 'STUDENT NAME'.
34         05  FILLER             PIC X(110)  VALUE SPACES.
35
36     01  DETAIL-LINE.
37         05  FILLER             PIC X(8)    VALUE SPACES.
38         05  PRINT-NAME         PIC X(25).
39         05  FILLER             PIC X(99)   VALUE SPACES.
40
41     PROCEDURE DIVISION.
42     PREPARE-SENIOR-REPORT.
43         OPEN INPUT  STUDENT-FILE
44             OUTPUT PRINT-FILE.
45         READ STUDENT-FILE
46             AT END MOVE 'NO' TO DATA-REMAINS-SWITCH
47         END-READ.
48         PERFORM WRITE-HEADING-LINE.
49         PERFORM PROCESS-RECORDS
50             UNTIL DATA-REMAINS-SWITCH = 'NO'.
51         CLOSE STUDENT-FILE
52             PRINT-FILE.
53         STOP RUN.
54
55     WRITE-HEADING-LINE.
56         MOVE HEADING-LINE TO PRINT-LINE.
57         WRITE PRINT-LINE.
58
59     PROCESS-RECORDS.
60         IF STU-MAJOR = 'ENGINEERING'
61             MOVE STU-NAME TO PRINT-NAME
62             MOVE DETAIL-LINE TO PRINT-LINE
63             WRITE PRINT-LINE

```

Credits text missing

Figure 2.5 (continued)

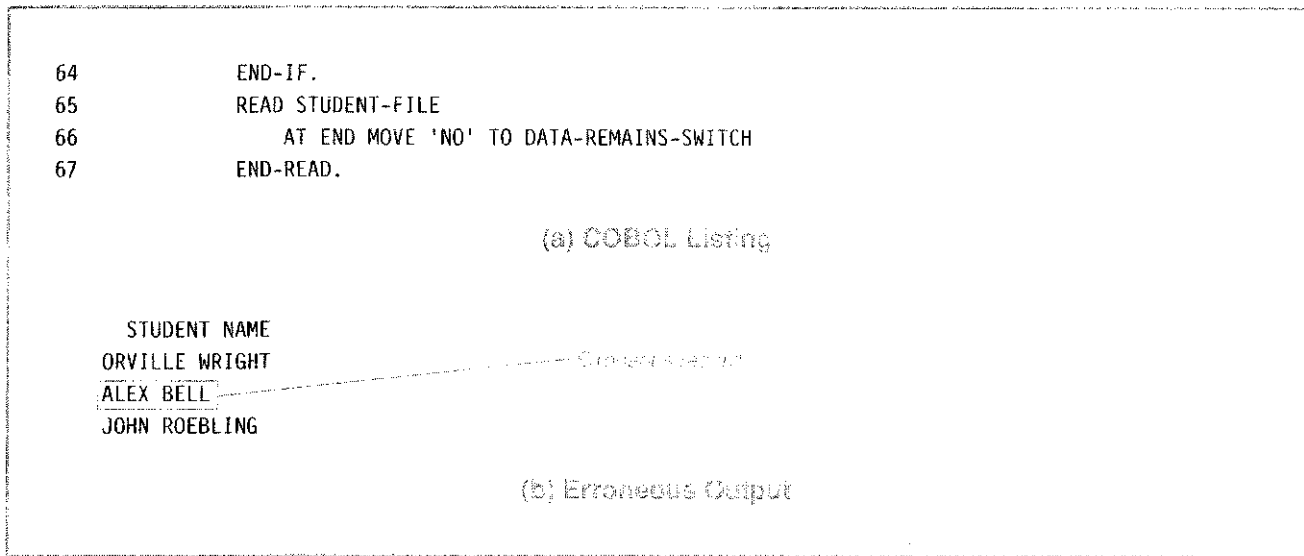

It is important to remember, therefore, that *a computer does exactly what it is instructed to do, which may be different from what you want it to do*. In other words if you (incorrectly) tell the computer to ignore the credits test, then that is precisely what the program will do.

Errors in Data Input

A program may also produce erroneous output, even if it is logically correct, when the data on which the program operates are invalid. If, for example, the *erroneous* data in Figure 2.6 are submitted to the *valid* program in Figure 2.2, neither Orville Wright nor John Roebing will be selected! Wright's major appears in the data as ENGINEER, whereas line 60 in the program is looking for ENGINEERING. Roebing's credits are entered in the wrong column. In other words, a computer operates on data exactly as it is submitted, with no regard for its correctness. Stated another way, the output produced by a program is only as good as its input, or put even more simply, *garbage in, garbage out*, giving rise to the well known acronym, *GIGO*.

Figure 2.6 Erroneous Input Data

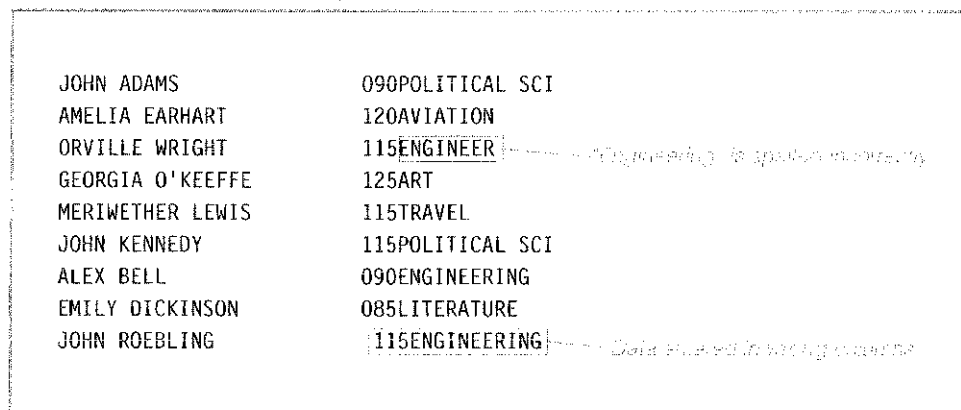

Evolution of COBOL

COBOL was introduced in 1959 through the efforts of Captain Grace Murray Hopper of the United States Navy. It was designed to be an open ended language, capable of accepting change and amendment. It was also intended to be a highly portable language; i.e., a COBOL program written for an IBM mainframe computer should run equally well on any other computer with a COBOL compiler. Over the years the needs of an evolving language, and the desire for compatibility among vendors have given rise to several COBOL standards, two of which are in common use today, *COBOL-74* and *COBOL-85*.

All of the listings in this text are written to take advantage of features in the newest standard, COBOL-85. We think it important to emphasize COBOL-85 (de-emphasize COBOL-74) because COBOL-85 has been the current standard for several years. Industry, however, is slow to change, and even as this book is written in 1993, many (perhaps most) of industry's currently running COBOL programs adhere to COBOL-74. The reason for the slow conversion is the subtle *incompatibilities* that exist between the two compilers. In theory, a program written under the earlier compiler is supposed to run without modification under the later compiler. In practice, however, this is not always the case.

Consider, for example, the incompatibility brought about by the introduction of new features and associated new reserved words, words such as CONTENT, EVALUATE, FALSE, OTHER, TEST, and so on. A programmer writing under COBOL-74 could logically have used any or all of these words as data names, which posed no problem under the older compiler, but which produces numerous compilation errors under COBOL-85. Thus, a blanket conversion by an installation of its hundreds (thousands, or tens of thousands) of COBOL programs, would prove disastrous, unless each program was manually checked for compatibility with the new standard.

Many installations support both compilers, using COBOL-74 to maintain existing programs and COBOL-85 for new development. It is important, therefore, that you become aware of the differences between the two standards. Accordingly, we end most chapters with a section describing differences between the standards as they relate to the program discussed in that chapter.

Figure 2.7 represents our final look at the engineering senior program as it would be implemented in COBOL-74. Note the following differences between this program and the COBOL-85 implementation of Figure 1.6:

Figure 2.7 Engineering Senior Program (COBOL-74 Implementation)

```

1  IDENTIFICATION DIVISION.
2  PROGRAM-ID.      SENIOR74.
3  AUTHOR.         ROBERT GRAUER.
4
5  ENVIRONMENT DIVISION.
6  CONFIGURATION SECTION.
7  SOURCE-COMPUTER.  IBM-PC.
8  OBJECT-COMPUTER.  IBM-PC.
9  INPUT-OUTPUT SECTION.
10 FILE-CONTROL.
11     SELECT STUDENT-FILE ASSIGN TO UT-S-SYSIN.
13     SELECT PRINT-FILE
14         ASSIGN TO UT-S-SYSOUT.
15
16 DATA DIVISION.
```

Figure 2.1 (continued)

```

17     FILE SECTION.
18     FD  STUDENT-FILE
19         LABEL RECORDS ARE STANDARD
20         RECORD CONTAINS 43 CHARACTERS
21         DATA RECORD IS STUDENT-IN.
22     01  STUDENT-IN.
23         05  STU-NAME           PIC X(25).
24         05  STU-CREDITS       PIC 9(3).
25         05  STU-MAJOR        PIC X(15).
26
27     FD  PRINT-FILE
28         LABEL RECORDS ARE STANDARD
29         RECORD CONTAINS 132 CHARACTERS
30         DATA RECORD IS PRINT-LINE.
31     01  PRINT-LINE           PIC X(132).
32
33     WORKING-STORAGE SECTION.
34     01  DATA-REMAINS-SWITCH PIC X(2)    VALUE SPACES.
35
36     01  HEADING-LINE.
37         05  FILLER           PIC X(10)   VALUE SPACES.
38         05  FILLER           PIC X(12)   VALUE 'STUDENT NAME'.
39         05  FILLER           PIC X(110)  VALUE SPACES.
40
41     01  DETAIL-LINE.
42         05  FILLER           PIC X(8)    VALUE SPACES.
43         05  PRINT-NAME      PIC X(25).
44         05  FILLER           PIC X(99)   VALUE SPACES.
45
46     PROCEDURE DIVISION.
47     PREPARE-SENIOR-REPORT.
48         OPEN INPUT  STUDENT-FILE
49             OUTPUT PRINT-FILE.
50         READ STUDENT-FILE
51             AT END MOVE 'NO' TO DATA-REMAINS-SWITCH.
52         PERFORM WRITE-HEADING-LINE.
53         PERFORM PROCESS-RECORDS
54             UNTIL DATA-REMAINS-SWITCH = 'NO'.
55         CLOSE STUDENT-FILE
56             PRINT-FILE.
57         STOP RUN.
58
59     WRITE-HEADING-LINE.
60         MOVE HEADING-LINE TO PRINT-LINE.
61         WRITE PRINT-LINE.
62
63     PROCESS-RECORDS.
64         IF STU-CREDITS > 110 AND STU-MAJOR = 'ENGINEERING'
65             MOVE STU-NAME TO PRINT-NAME
66             MOVE DETAIL-LINE TO PRINT-LINE
67             WRITE PRINT-LINE.
68         READ STUDENT-FILE
69             AT END MOVE 'NO' TO DATA-REMAINS-SWITCH.

```

LABEL RECORDS ARE STANDARD

IF STU-CREDITS > 110 AND STU-MAJOR = 'ENGINEERING'

1. COBOL-74 requires a CONFIGURATION SECTION with both a SOURCE-COMPUTER and an OBJECT-COMPUTER paragraph, to indicate the computer on which the program will compile and execute. The CONFIGURATION SECTION is optional in COBOL-85, and since these entries are treated as comments by the compiler, they are omitted in the COBOL-85 listing.
2. COBOL-74 requires the LABEL RECORDS clause in a file description to indicate whether standard, nonstandard, or no labels are in effect. (A label contains information about a file such as the date it was created and the intended expiration date.) The clause is optional in COBOL-85 where its omission defaults to LABEL RECORDS ARE STANDARD.
3. Scope terminators (END-IF and END-READ) are not permitted in COBOL-74 and hence do not appear in Figure 2.7. Scope terminators are optional in COBOL-85, but are used throughout the text because of advantages that will be clearly explained in Chapter 7.

Despite these differences the COBOL-74 implementation of the engineering senior program is upward compatible with COBOL-85; that is, the program in Figure 2.7 will run *without* modification under the new compiler. The converse is not true; the COBOL-85 listing in Figure 1.6 will not run under the earlier standard.

There's Always a Reason

We expect that you completed the chapter with little difficulty and that you were able to successfully run the engineering senior program. There will be times, however, when not everything will go as smoothly and so we relate a favorite anecdote ("Mystery of the Month," PC World Magazine, April 1983) that is as relevant today as when it was written. As you read our tale, remember that a computer does exactly what you tell it to do, which is not necessarily what you want it to do. It is a source of wonderful satisfaction when everything works, but also the cause of nearly unbelievable frustration when results are not what you expect.

Our story concerns a manager who purchased a PC and began to use it enthusiastically. Unfortunately, the feeling did not rub off on his assistant, who was apprehensive of computers in general, but who finally agreed to try the new technology.

As is frequently the case, the assistant's experience with the computer was as frustrating as the manager's was rewarding. Every time the assistant tried using the computer an error message appeared, yet when the manager tried the same procedure it worked fine. Finally, manager and assistant went through a systematic comparison of everything they did: turning the machine on and off, handling disks, using the keyboard, etc. They could find no difference in their procedures and could not account for the repeated disk errors which plagued the assistant but left the manager alone.

Just as they were about to give up the manager noticed that his assistant was wearing a charm bracelet. He looked closely, and sure enough one of the charms was a tiny magnet containing just enough force to interfere with reading the disk. The assistant stored the bracelet in a drawer and the machine has been fine ever since.

The point of our story is that there is always a logical reason for everything a computer does or does not do, although discovering that reason may be less than obvious. You are about to embark on a wonderful journey toward the productive use of a computer, with a virtually unlimited number of potential applications. Be patient, be inquisitive, and enjoy.

S U M M A R Y

Points to Remember

- ☛ The A margin consists of columns 8–11 whereas the B margin is defined as columns 12–72. Division and section headers, paragraph names, FD's, and 01-level entries must begin in the A margin; all other entries begin in the B margin (that is, in or past column 12).
- ☛ The execution of a COBOL program is a three part process, involving three distinct programs—a compiler, a linker, and the resultant load module. The means of communicating information about these programs (and their associated files) is dependent on the operating system.
- ☛ A compiler is a computer program that translates a higher-level (problem-oriented) language such as COBOL into machine language; the input to a compiler is referred to as a source program, whereas the output is an object program.
- ☛ The linker combines the output produced by the compiler, with additional object modules (such as subroutines and/or Input/Output modules) to produce a load module.
- ☛ Execution of the COBOL program occurs when the load module processes the input file(s) to produce the required reports.
- ☛ COBOL-74 is intended to be upward compatible with COBOL-85 although subtle incompatibilities do exist between the two standards. The converse is not true, as COBOL-85 programs will not run under the earlier standard.

Key Words and Concepts

| | |
|-------------------|------------------|
| A margin | Debugging |
| ASCII file | Editor |
| B margin | Execution error |
| COBOL-74 | GIGO |
| COBOL-85 | Incompatibility |
| Coding form | Load module |
| Comments | Object program |
| Compilation error | Operating system |
| Compiler | Source program |
| Continuation | Test data |

F I L L - I N

1. A _____ translates a _____ language into an _____ language.
2. _____ is the most recently approved COBOL standard, but _____ is still widely used in industry.

3. The _____ is in columns 8 to 11 of the coding sheet.
4. A comment is indicated by an _____ in column _____.
5. Entries that are not required to begin in the A margin may begin anywhere in columns _____ to _____.
6. Division headers and paragraph names must begin in the _____.
7. An _____ is used to enter programs into the computer.
8. The compile, link, and execute process requires the execution of _____ distinct programs.
9. _____ is the process of finding and correcting errors in a program.
10. Picture clauses may begin anywhere within the _____ margin.
11. The output of compilation is input to a second program called the _____.
12. A clean compile (does/does not) guarantee that the resulting program execution will be correct.
13. Different mainframe computers will most likely use (different/identical) COBOL compilers.
14. Misspelling a reserved word will result in a _____ error.
15. Entering test data in the wrong columns will result in an _____ error.

TRUE / FALSE

1. A compiler translates a machine-oriented language into a problem-oriented language.
2. A well-written program will always produce correct results, even with bad data.
3. A compiler is a computer program.
4. The COBOL compiler for an IBM mainframe is identical to the compiler for a PC.
5. A COBOL program can run on a variety of computers.
6. Division headers must begin in the A margin.
7. Division headers must begin in column 8.
8. Section headers must begin in column 12.
9. Paragraph names must begin in column 8.
10. PICTURE clauses may appear in column 12 or after.
11. If a program compiles correctly, then it must execute correctly.
12. Columns 1–6 are never used on the coding sheet.
13. The use of columns 73–80 is optional.
14. Column 8 is used as a continuation column.
15. All editors have identical commands.
16. All computers use the same operating system.
17. Successful execution of the COBOL compiler produces a load module.

PROBLEMS

- Figure 2.8a contains data for the COBOL program in Figure 2.8b, which will process a file of employee records and print the names of all programmers under 30.

Figure 2.8 COBOL Program and Associated Data for Problems 1 & 2

| | | |
|---------------|--------------|-------|
| WALT BECHTEL | PROGRAMMER34 | 39700 |
| NELSON KERBEL | PROGRAMMER23 | 30000 |
| MARGOT HUMMER | PROGRAMMER30 | 45000 |
| CATHY BENWAY | DATA BASE 23 | 50000 |
| JUD MCDONALD | DATA BASE 29 | 55000 |
| JACKIE CLARK | PROGRAMMER22 | 47500 |
| LOUIS NORIEGA | PROGRAMER 24 | 42500 |
| JEFF SHEESLEY | ANALYST 28 | 46400 |

(a) Data

```

1  IDENTIFICATION DIVISION.
2  PROGRAM-ID.  FIRSTTRY.
3  AUTHOR.      GRAUER.
4
5  ENVIRONMENT DIVISION.
6  INPUT-OUTPUT SECTION.
7  FILE-CONTROL.
8      SELECT EMPLOYEE-FILE ASSIGN TO 'A:\CHAPTR02\FIRSTTRY.DAT'
9      ORGANIZATION IS LINE SEQUENTIAL.
10     SELECT PRINT-FILE
11     ASSIGN TO PRINTER.
12
13  DATA DIVISION.
14  FILE SECTION.
15  FD  EMPLOYEE-FILE
16     RECORD CONTAINS 44 CHARACTERS
17     DATA RECORD IS EMPLOYEE-RECORD.
18  01  EMPLOYEE-RECORD.
19     05  EMP-NAME           PIC X(25).
20     05  EMP-TITLE         PIC X(10).
21     05  EMP-AGE           PIC 99.
22     05  FILLER            PIC XX.
23     05  EMP-SALARY        PIC 9(5).
24
25  FD  PRINT-FILE
26     RECORD CONTAINS 132 CHARACTERS
27     DATA RECORD IS PRINT-LINE.
28  01  PRINT-LINE.

```

Figure 2.3 (continued)

```

29         05 FILLER                PIC X.
30         05 PRINT-NAME            PIC X(25).
31         05 FILLER                PIC X(2).
32         05 PRINT-AGE             PIC 99.
33         05 FILLER                PIC X(3).
34         05 PRINT-SALARY          PIC 9(5).
35         05 FILLER                PIC X(94).
36
37     WORKING-STORAGE SECTION.
38     01 END-OF-DATA-FLAG          PIC X(3)    VALUE SPACES.
39     PROCEDURE DIVISION.
40     PREPARE-PROGRAMMER-REPORT.
41         OPEN INPUT EMPLOYEE-FILE
42             OUTPUT PRINT-FILE.
43         MOVE SPACES TO PRINT-LINE.
44         MOVE 'SALARY REPORT FOR PROGRAMMERS UNDER 30' TO PRINT-LINE.
45         WRITE PRINT-LINE
46             AFTER ADVANCING 2 LINES.
47         READ EMPLOYEE-FILE
48             AT END MOVE 'YES' TO END-OF-DATA-FLAG
49         END-READ.
50         PERFORM PROCESS-EMPLOYEE-RECORDS
51             UNTIL END-OF-DATA-FLAG = 'YES'.
52         CLOSE EMPLOYEE-FILE
53             PRINT-FILE.
54         STOP RUN.
55
56     PROCESS-EMPLOYEE-RECORDS.
57         IF EMP-TITLE = 'PROGRAMMER' AND EMP-AGE < 30
58             MOVE SPACES TO PRINT-LINE
59             MOVE EMP-NAME TO PRINT-NAME
60             MOVE EMP-AGE TO PRINT-AGE
61             MOVE EMP-SALARY TO PRINT-SALARY
62             WRITE PRINT-LINE
63         END-IF.
64         READ EMPLOYEE-FILE
65             AT END MOVE 'YES' TO END-OF-DATA-FLAG
66         END-READ.

```

(b) COBOL Program

- a. Compile, link, and execute the COBOL program, using the appropriate commands for your system. (The program is on the data disk that accompanies this book.)
- b. Are any potential problems introduced by checking age rather than date of birth?
- c. Would processing be simplified if the employee records contained an abbreviated title code (for example, 010) rather than an expanded title (for example, programmer)? Are there any other advantages to storing codes rather than expanded values?

2. Modify the program in Figure 2.8b to accommodate all of the following.
 - a. Employee age is stored in positions 38 and 39 of the incoming record.
 - b. The report should list all employees under age 30 who earn at least \$30,000, regardless of title.
 - c. The report should include the title of all selected employees in positions 41-52.

3. Match each item with its proper description.

| | |
|---|--|
| <ul style="list-style-type: none"> ___ 1. A Margin ___ 2. B Margin ___ 3. Comment ___ 4. IDENTIFICATION DIVISION ___ 5. PROCEDURE DIVISION ___ 6. Hyphen ___ 7. Nonnumeric literal ___ 8. Reserved word ___ 9. Compiler ___ 10. Literal | <ul style="list-style-type: none"> a. An asterisk in column 7 b. First line of any COBOL program c. Often appears in data names d. Columns 12 through 72 e. Contains the logic of a program f. Limited to 160 characters, and enclosed in quotes or apostrophes g. Where division, section, and paragraph headers begin h. Translates COBOL to machine language i. Preassigned meaning j. A constant; may be numeric or nonnumeric |
|---|--|

4. Indicate the starting column (or columns) for each of the following.
 - a. Division headers
 - b. Comments
 - c. Paragraph names
 - d. Statements in the Procedure Division (except paragraph names)
 - e. WORKING-STORAGE SECTION
 - f. FD
 - g. 01 entries
 - h. 05 entries
 - i. PICTURE clauses
 - j. OPEN statement
 - k. WRITE statement
 - l. SELECT statement

5. Explain how it is possible for a program to compile perfectly, be logically correct, and still produce invalid results; provide specific examples in conjunction with the engineering senior program.

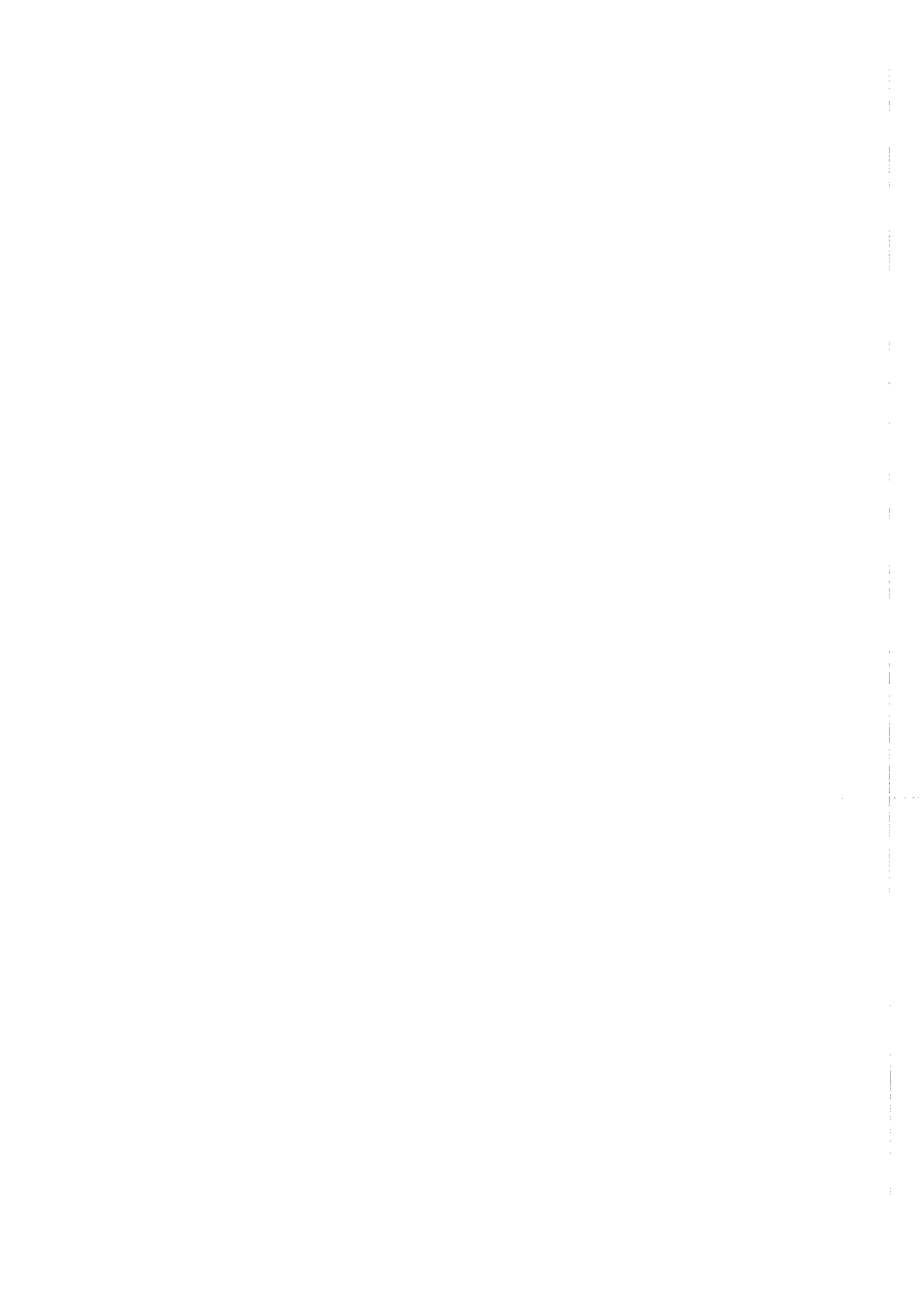

A Methodology for Program Development

CONTENTS

Overview

The Tuition Billing Problem

Structured Design

Evaluating the Hierarchy Chart

Completeness

Functionality

Span of Control

Structured Programming

Sufficiency of the Basic Structures

Expressing Logic

The Traditional Flowchart

Pseudocode

Warnier-Orr Diagrams

Top-Down Testing

Summary

Fill-in

True/False

Problems

OBJECTIVES

After reading this chapter you will be able to:

- 1. Describe how a hierarchy chart is developed; discuss three criteria for evaluating a completed hierarchy chart.
- 2. Define structured programming; describe its three fundamental building blocks and an optional extension.
- 3. Explain the one entry point/one exit point philosophy of structured programming.
- 4. Differentiate between structured programming and structured design; distinguish between a functionally oriented technique and one that is procedurally oriented.
- 5. Describe what is meant by top down design and implementation.

OVERVIEW

We stated at the outset that programming is best learned by doing, and so our objective in the first two chapters was to put you on the computer as quickly as possible. Thus, we jumped immediately into COBOL, without giving much thought to the underlying logic of the program you developed. While that approach works well initially, it is also important for you to learn how to properly design programs, so that they will work correctly, and further so that they can be easily read and maintained by someone other than yourself.

Accordingly, this chapter presents a methodology for program development, embracing the techniques of structured design, structured programming, and top down testing. We stress that structured design is functionally oriented and describes what is to be accomplished; structured programming, on the other hand, is procedurally oriented and focuses on how the objectives of the program will be realized. The discussion includes hierarchy charts, pseudocode, flowcharts, and Warnier-Orr diagrams.

The presentation is of a practical nature, and stresses application rather than theory. Accordingly, we introduce a new program at the beginning of the chapter, and develop the methodology in the context of that program. We begin with presentation of the program specifications.

The Tuition Billing Program

This section contains the specifications for a new problem, known simply as the tuition billing program. The requirements are straightforward and parallel those of many other COBOL programs, namely to print a heading line(s) at the start of processing, one or more detail lines for every record processed, and a total line(s) at the end of processing. As simple as these specifications may be, it is critical that you avoid the temptation to rush immediately into COBOL, and concentrate instead on designing the program you will eventually write.

The approach we follow begins with a determination of the most general function the program is to accomplish, then divides that task into smaller and smaller pieces, until the requirements of each piece are clearly recognized. Initially the design process may seem superfluous in that you are confident of your ability to begin coding immediately. Rest assured, however, that design is productive work, and does in fact pay dividends in the long run. A well-designed program is far more likely to be correct than one written off-the-cuff. Moreover, and this may be the argument that most appeals to you, a well-designed program will ultimately be completed in less time than one that is poorly designed or one that has no design at all.

PROGRAMMING SPECIFICATIONS

Program Name: Tuition Billing Program

Narrative: This program processes a file of student records, computes and prints the tuition bill for each student, and prints the total amounts for all students.

Input File(s): STUDENT-FILE

Input Record Layout: See Figure 3.1a

| | | |
|-------------------|-------------|--------------|
| Test Data: | SMITH | JB15Y0000230 |
| | JAMES | HR15 0500245 |
| | BAKER | SR09 0500350 |
| | PART-TIMER | JR03Y0000300 |
| | JONES | PL15Y0000280 |
| | HEAVYWORKER | HM18 0000200 |
| | LEE | BL18 0000335 |
| | CLARK | JC06 0000310 |
| | GROSSMAN | SE07 0000215 |
| | FRANKEL | LF10 0000350 |
| | BENWAY | CT03 0250395 |
| | KERBEL | NB04 0000100 |

Report Layout: See Figure 3.1b

- Processing Requirements:**
1. Print a suitable heading at the beginning of the report.
 2. Read a file of student records.
 3. Process each record read by:
 - a. Computing an individual bill, equal to the sum of tuition, union fee, and activity fee, minus a scholarship (if any), by:
 - i. Calculating the tuition due, at a rate of \$200 per credit.
 - ii. Billing the student \$25 for the union fee, if there is a "Y" in the Union Member position.
 - iii. Computing the activity fee based on the number of credits taken:

| | |
|--------------|--------------|
| ACTIVITY FEE | CREDITS |
| \$25 | 6 or fewer |
| \$50 | 7 - 12 |
| \$75 | more than 12 |

Figure 3.1 Record Layouts for Tuition Billing Program

| | | | | | | | | | | | | | | | | | | | | | | | | | | |
|--------------|---|---|---|---|---|---|---|---|----|----|----|----|----|----|----------|----|---------|----|--------------|----|-------------|----|-----|----|----|----|
| STUDENT NAME | | | | | | | | | | | | | | | INITIALS | | CREDITS | | UNION MEMBER | | SCHOLARSHIP | | GPA | | | |
| LAST | | | | | | | | | | | | | | | | | | | | | | | | | | |
| 1 | 2 | 3 | 4 | 5 | 6 | 7 | 8 | 9 | 10 | 11 | 12 | 13 | 14 | 15 | 16 | 17 | 18 | 19 | 20 | 21 | 22 | 23 | 24 | 25 | 26 | 27 |

(a) Input Record Layout

| STUDENT NAME | CREDITS | TUITION | UNION FEE | ACT FEE | SCHOLARSHIP | TOTAL BILL |
|-----------------------|---------|------------------|-----------------|-----------------|-----------------|------------------|
| XXXXXXXXXXXXXXXXXX XX | 99 | \$\$, \$\$\$ | \$\$9 | \$\$9 | \$. \$\$\$ | \$\$, \$\$\$ |
| XXXXXXXXXXXXXXXXXX XX | 99 | \$\$, \$\$\$ | \$\$9 | \$\$9 | \$. \$\$\$ | \$\$, \$\$\$ |
| UNIVERSITY TOTALS | | \$\$\$\$, \$\$\$ | \$\$\$, \$\$\$ | \$\$\$, \$\$\$ | \$\$\$, \$\$\$ | \$\$\$\$, \$\$\$ |

(b) Report Format

- iv. Awarding a scholarship equal to the amount in the incoming record if, and only if, the GPA is greater than 2.5. (Observe that in the test data on the previous page James does *not* qualify for the \$500 scholarship he would otherwise have been awarded.)
- v. Incrementing the university totals for tuition, union fee, activity fee, scholarship, and overall total.
- b. Printing a detail line for each record read.
- 4. Print a total line at the end of the report.

Structured Design

Structured design identifies the tasks a program is to accomplish, then relates those tasks to one another in a *hierarchy chart*. Figure 3.2 contains a very basic example, applicable to any COBOL program. The hierarchy chart divides the program into its functional components, for example, initialization, processing, and termination,

and indicates the manager/subordinate relationships between these components. In this example all three modules are subordinate to the module labeled any COBOL program.

To better appreciate the significance of a hierarchy chart and its role in program development, consider Figure 3.3, depicting the hierarchy chart for the tuition billing program. The development takes place in stages, beginning at the top and working down to the bottom. At every level, the major function(s) are subdivided into other functions that are placed on the next lower level in the hierarchy chart. Those functions are in turn further subdivided into still other functions, until finally the lowest-level functions cannot be further subdivided.

The specifications for the tuition billing problem suggest a suitable name for the highest-level module, PREPARE-TUITION-REPORT. This in turn is divided into its basic functions of initialization (consisting of WRITE-HEADING-LINE and READ-STUDENT-FILE), processing (PROCESS-STUDENT-RECORD), and termination (WRITE-UNIVERSITY-TOTALS). Levels 1 and 2 of the hierarchy chart are shown in Figure 3.3a.

Of these four modules, only one, PROCESS-STUDENT-RECORD, needs to be subdivided. In other words ask yourself which additional lower-level functions should be included under PROCESS-STUDENT-RECORD in order to process individual student records. The program specifications contain the requirement to compute the individual's bill, increment the university totals to include the amount just computed, and write a detail line for the particular student. Each of these tasks requires its own module as indicated in Figure 3.3b. In addition, PROCESS-STUDENT-RECORD must also read the next record so that the program can continue. (The module READ-STUDENT-FILE appears twice in the hierarchy chart; on level two to read the first record, and on level three to read all subsequent records. The necessity for the dual appearance stems from a limitation in COBOL-74 rather than a requirement of structured design).

The development of a hierarchy chart continues until its lowest-level modules cannot be further subdivided, that is, until the designer believes they can be easily translated into programming statements. The decision is *subjective* in that there is no single correct answer; you could, for example, stop at three levels or continue to a fourth level as in Figure 3.3c. We chose to divide COMPUTE-INDIVIDUAL-BILL into four additional modules: COMPUTE-TUITION, COMPUTE-UNION-FEE, COMPUTE-ACTIVITY-FEE, and COMPUTE-SCHOLARSHIP.

The hierarchy chart is now complete and consists of four levels, each of which will correspond to a PERFORM statement in the eventual COBOL program;

Figure 3.2 Overall COBOL Hierarchy Chart

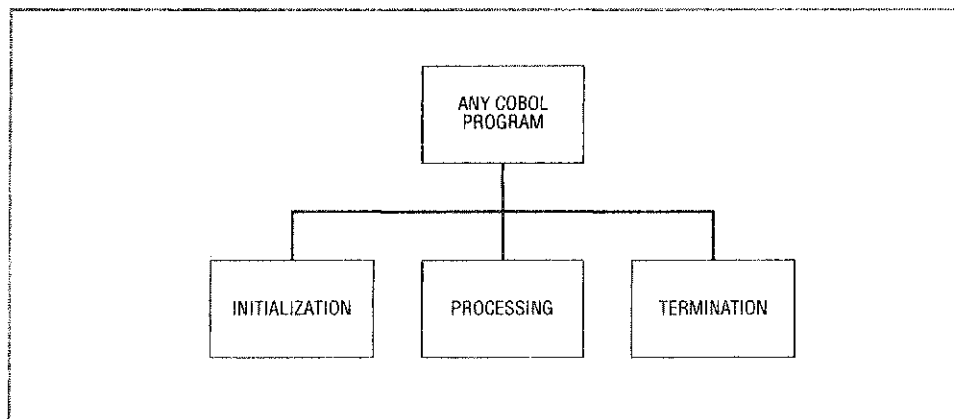
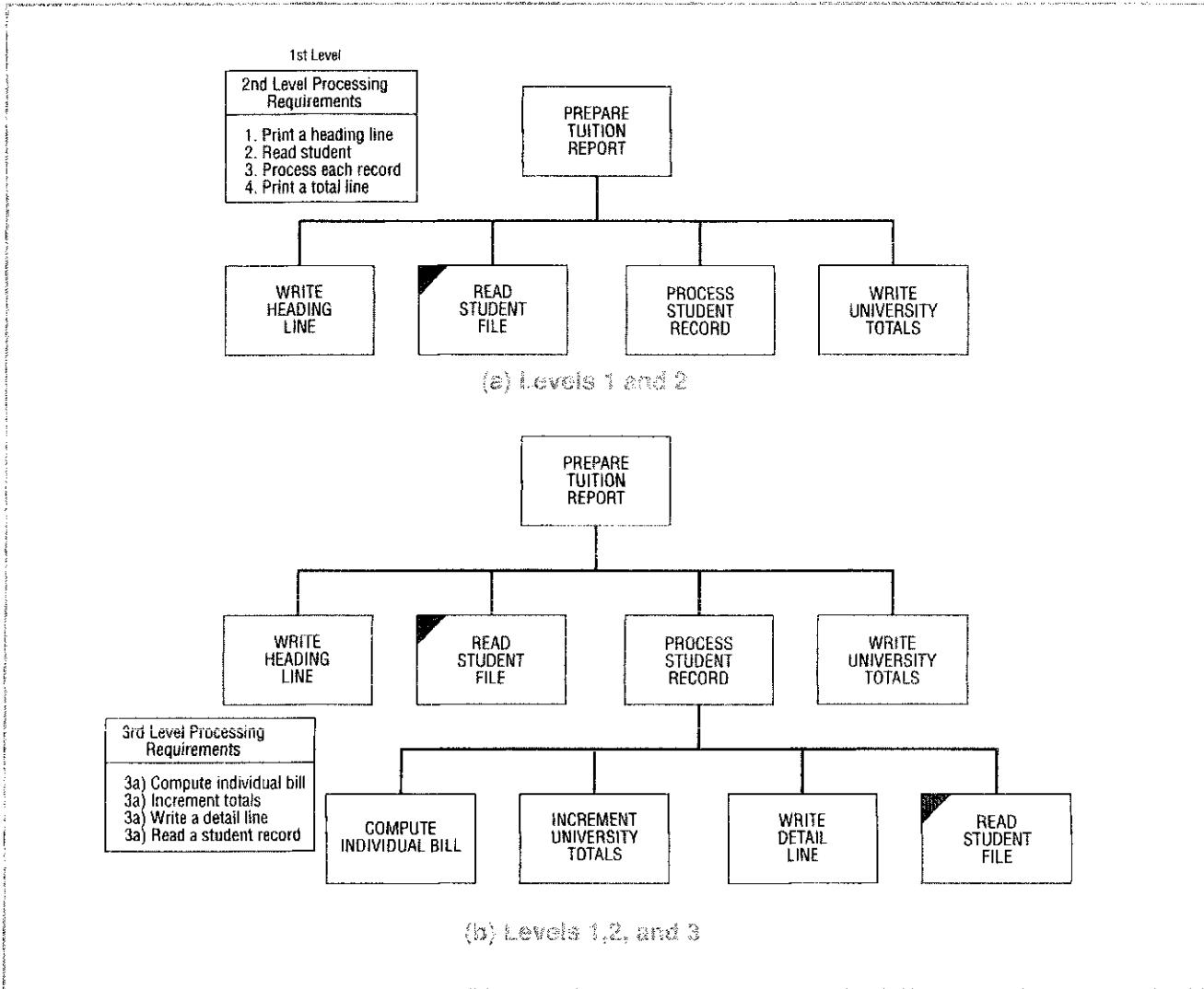

Figure 3.3 Hierarchy Chart for Tuition Billing Program



that is, the module (paragraph) on level one will perform the modules (paragraphs) on level two, those on level two will perform the modules on level three, and so on. The hierarchy chart does not specify how often these paragraphs will be called, nor does it indicate the conditions for calling one subordinate in lieu of another. In other words, the hierarchy chart indicates only what functions are necessary, but not when they are executed. It contains no decision-making logic, nor does it imply anything about the order or frequency in which various paragraphs within a program are executed. That, in turn, is specified within the logic of the program, developed according to the discipline of structured programming as discussed later in the chapter.

Evaluating the Hierarchy Chart

As we have already indicated, the decision of how many modules to include in a hierarchy chart and how they should be related to one another is necessarily subjective. Nevertheless, there are certain evaluation criteria that result in selecting one design over another. Among these are the following:

Figure 3.3 (continued)

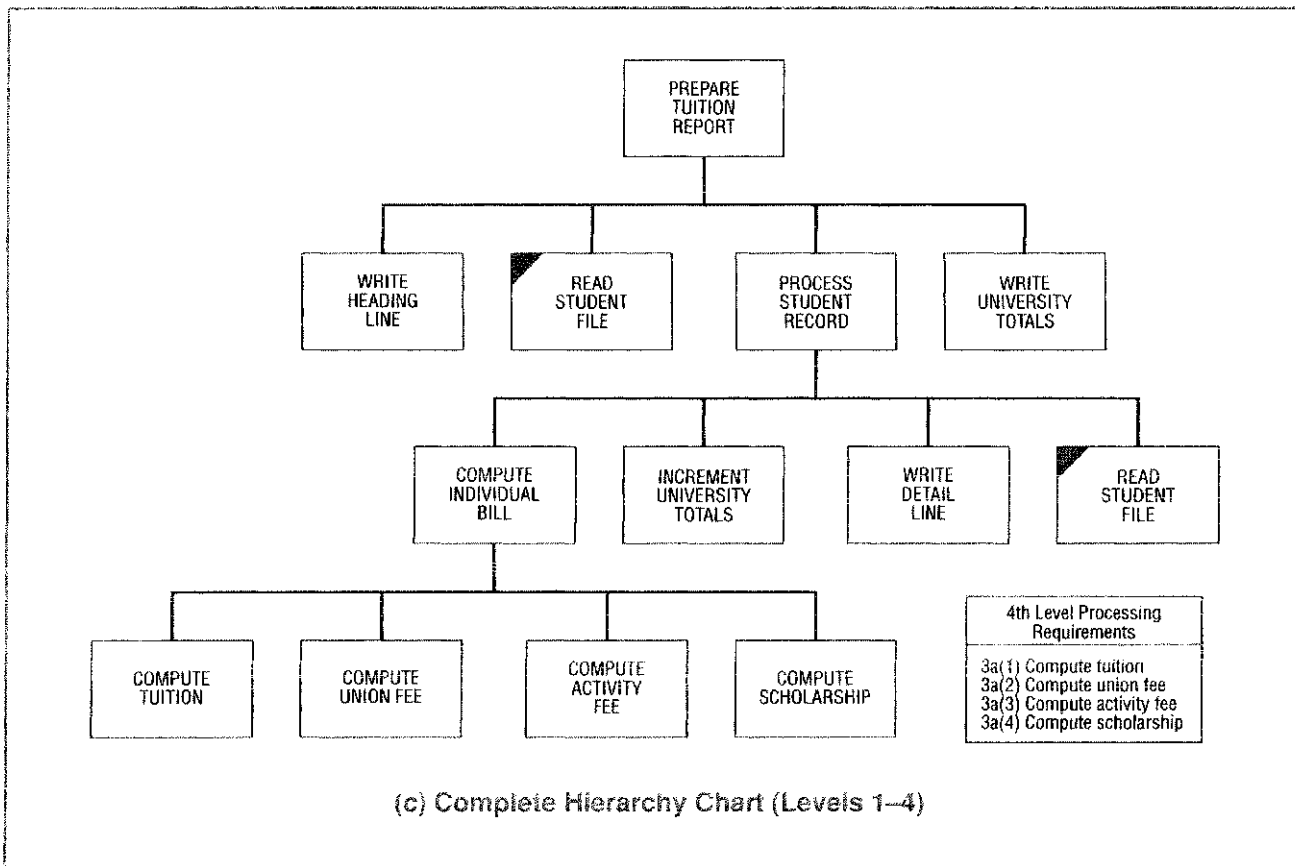

1. Is the hierarchy chart complete?
2. Are the modules functional?
3. Is there effective span of control?

Completeness

A hierarchy chart must be complete; that is, it has to provide for every function required by the program as specified in the programming specifications. You test for completeness level by level, starting at the top of the hierarchy chart, and working your way down, one level at a time, by asking the question, "Do the subordinate modules at the next level completely develop their corresponding modules at this level?" If the answer is yes, move to the next module on the present level, or to the first module on the next level, and repeat the question. If the answer is no, add functions as necessary and continue to the next module.

For example, begin with the completed hierarchy chart of Figure 3.3c and ask yourself whether the modules on level two are adequate to expand the single module of level one; that is, do the four modules on level two completely expand the PREPARE-TUITION-REPORT module to which they are subordinate? The answer is yes, so you move to level three and see whether the modules on this level adequately expand the PROCESS-STUDENT-RECORD module from level two. Once again the answer is yes, and so you progress to level four. The process continues until you have checked every module on every level and are satisfied that all necessary functions are included.

Functionality

Every module in a hierarchy chart should be dedicated to a *single* function, the nature of which should be clear from examining the module's name. Each of the module names in Figure 3.3 consists of a verb, adjective (or two), and an object—for example, COMPUTE-INDIVIDUAL-BILL or WRITE-DETAIL-LINE. Indeed, if a module cannot be named in this way, its function is probably not well defined and thought should be given to revising the hierarchy chart.

Stated another way, you should reject (or redesign) any module that does not appear to be functional; that is, modules whose names contain:

1. More than one verb—for example, READ-AND-WRITE.
2. More than one object—for example, EDIT-NAME-AND-ACCOUNT-DATA.
3. Nondescriptive or time-related terms—for example, HOUSEKEEPING, TERMINATION-ROUTINE, INITIALIZATION, or MAINLINE.

Another way of expressing the need for functional modules is to strive for module independence; that is, the internal workings of one module should not affect those of another. Perhaps you have already been associated with a working program in which changes were implemented, only to have some other, apparently unrelated, portion of the program no longer work properly. The problem may be due to paragraphs in the program being unnecessarily dependent on one another.

What we are saying is that in an ideal situation, changes made to one paragraph should not affect the results of any other. In a more practical sense, the paragraphs have to be somewhat related, otherwise they would not be parts of the same program; however, the amount of interdependence between paragraphs should be minimized to the greatest extent possible. With respect to Figure 3.3, for example, a change in the procedure for computing the union fee should not affect how the activity fee is determined. That is because the modules COMPUTE-UNION-FEE and COMPUTE-ACTIVITY-FEE are functional in their own right, and consequently are independent of one another.

Span of Control

The *span of control* of a module is the number of subordinates it contains. In Figure 3.3, for example, the span of control of both PREPARE-TUITION-REPORT and COMPUTE-INDIVIDUAL-BILL is four. An effective span of control (for hierarchy charts associated with COBOL programs) is generally from two or three to seven, although that may vary depending on the situation. You should, however, avoid extremes in either direction. Programs with ineffective spans of control (too many subordinates or too few) are poorly designed and difficult to follow and/or maintain.

Structured Programming

Let us pause for a moment to see what has been accomplished. We have taken the original problem and divided it into a series of manageable pieces, each of which describes a particular job that needs to be accomplished. In other words, we have said what needs to be done to solve the problem, but have not as yet said how we will solve it. That in essence is the difference between structured design and structured programming.

A structured program is one consisting entirely of three types of logic structures: sequence, selection (a decision), and iteration (a loop). The fact that these structures

(or basic building blocks) are sufficient to express any desired logic was first postulated in a now-classic paper by Bohm and Jacopini.¹

The elementary building blocks of structured programming are shown in flowchart form in Figure 3.4. Flowcharts use special symbols to communicate information. A rectangle indicates a processing statement, a diamond indicates a decision, and a small circle connects portions of the flowchart. All of the flowcharts have one key feature in common, namely, a *single entry point* and a *single exit point*; that is, there is only one way to enter each structure and only one way to leave.

The *sequence* structure in Figure 3.4a specifies that the program statements are executed sequentially, in the order in which they appear. The two blocks, A and B, may denote anything from single statements to complete programs, and it is clear that there is a single entry point and a single exit point to the structure.

¹ Bohm and Jacopini, "Flow Diagrams, Turing Machines and Languages with Only Two Formation Rules," *Communications of the ACM* (May 1966).

Figure 3.4 The Building Blocks of Structured Programming

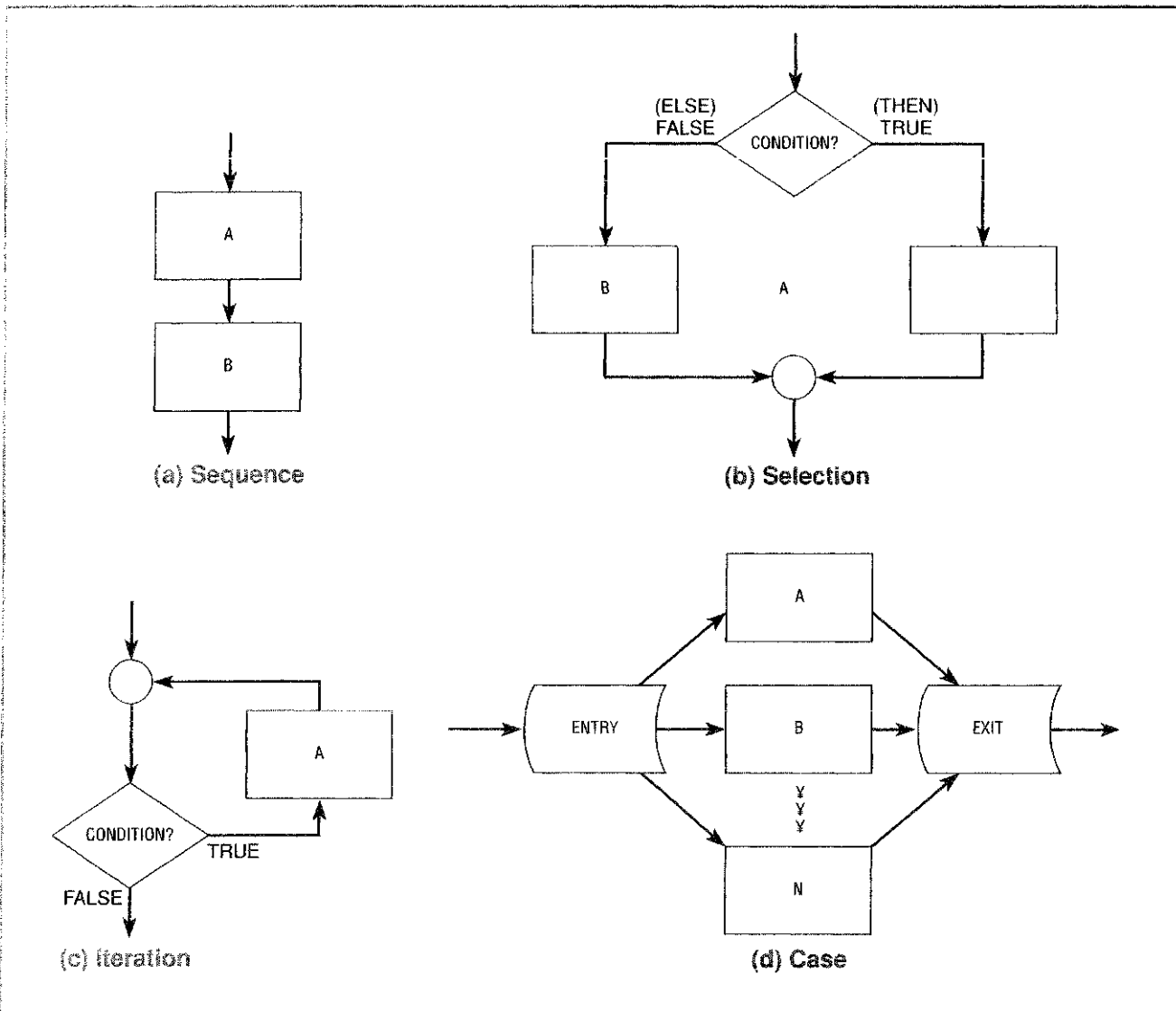

The *selection* (or IF . . . THEN . . . ELSE) structure in Figure 3.4b specifies a choice between two actions. A condition is tested with one of two outcomes; if the condition is true, block A is executed, while if it is false, block B is executed. The condition itself is the single entry point, and both paths meet to form a single exit point.

The *iteration* (or DO . . . WHILE) structure in Figure 3.4c specifies repeated execution of one or more statements while a condition is true. A condition is tested and, if it is true, block A is executed after which the condition is retested. If, however, the condition is false, control passes to the next sequential statement after the iteration structure. Again, there is a single entry point and a single exit point from the structure.

The *case structure* in Figure 3.4d expresses a multibranch situation. Although case is actually a special instance of selection, it is convenient to extend the definition of structured programming to include this fourth type of building block. The case structure evaluates a condition and branches to one of several paths, depending on the value of the condition. As with the other building blocks, there is one entry point and one exit point.

Sufficiency of the Basic Structures

The theory of structured programming says simply that an appropriate combination of the basic building blocks may be derived to solve any problem. This is possible because an entire structure (sequence, selection, iteration, or case) may be *substituted* anywhere block A or B appears. Figure 3.5 shows a combination of the basic structures to illustrate this concept.

Figure 3.5 is essentially a selection structure. However, instead of specifying a single statement for the true or false branches, as was done in Figure 3.4, a complete building block is used instead. Thus, if condition-1 is true, an iteration structure is entered, whereas, if it is false, a sequence structure is executed. Both the iteration and sequence structures meet at a single exit point which becomes the exit point for the initial selection structure.

Figure 3.5 Sufficiency of the Basic Structures

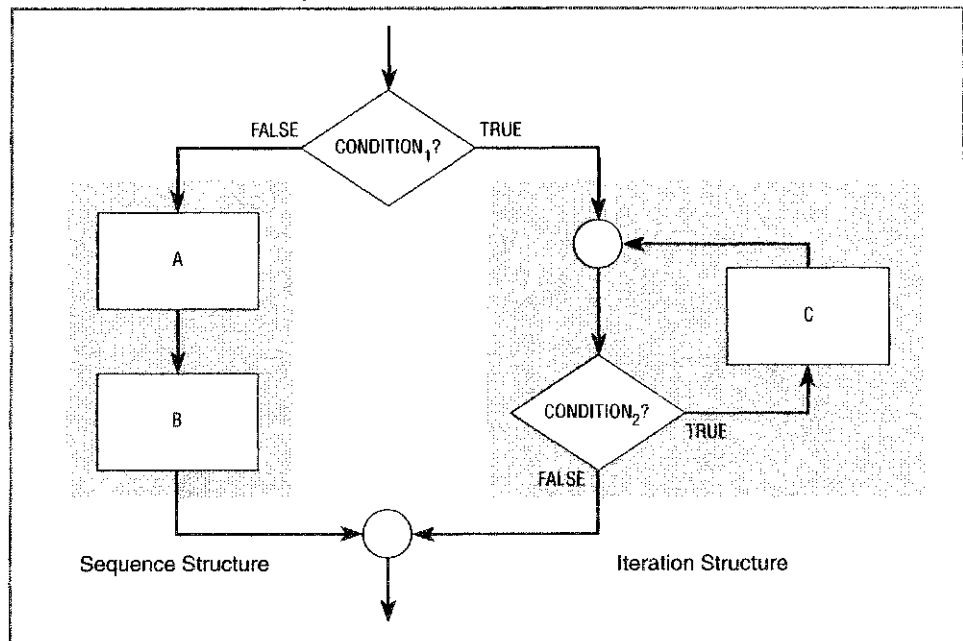

We now turn our attention to ways in which programmers express logic, to themselves and to others. We begin with the traditional flowchart, then move to newer techniques more closely associated with structured programming: pseudocode and Warnier-Orr diagrams.

The Traditional Flowchart

Every programmer is familiar with the traditional *flowchart* as described in Chapter 1. Although flowcharts have declined in popularity, they remain in widespread use, primarily for documentation. Our personal preference is to use pseudocode, but we include Figure 3.6 for completeness. The decision as to which technique to use is between you and your instructor.

Pseudocode

The fact that most programmers write simple notes to themselves prior to coding a program gave rise to *pseudocode*, a technique associated with structured programming. As we indicated in Chapter 1, pseudocode is defined simply as neat notes to yourself, and uses statements similar to computer instructions to describe logic. Figure 3.7 represents the building blocks of structured programming as they would be written in pseudocode and corresponds to the flowcharts shown in Figure 3.4.

Pseudocode comes into play after the design phase of a program has been completed, and prior to actual coding. Recall that a hierarchy chart is *functional* in nature and indicates *what* has to be done, but not necessarily *when* or *how*. Pseudocode, on the other hand, is *procedural* and contains sequence and decision-making logic. In other words, pseudocode connects the modules in a hierarchy chart through loops and decision making.

To better appreciate how pseudocode expresses programming logic, consider Figure 3.8, which contains pseudocode for the tuition billing program. Two versions of the pseudocode are presented—an initial attempt in Figure 3.8a, and an expanded (more detailed) version in Figure 3.8b. Both versions are equally appropriate, with the choice between them depending entirely on the individual, and the level of detail he or she desires.

The logic is straightforward and begins with the steps for initialization; to open files, write a heading line(s), and read the first record. Then, a loop (or iteration structure) is entered in which the program computes the student's bill (tuition plus union and activity fees minus scholarship), increments the university totals to include this amount, writes a detail line, and finally reads the next student record. The statements in the loop are executed continually until all the records have been read, at which point university totals are written, and the program terminates.

Pseudocode has a distinct block structure that is conducive to structured programming. It is not, however, bound by formal syntactical rules (although some organizations have implemented standards), nor does it have specific rules of indentation, which is done strictly at the programmer's discretion. Its only limitation is a restriction to the building blocks of structured programming (sequence, selection, iteration, and case).

With practice, pseudocode can be developed quickly and easily. Good pseudocode should be sufficiently precise to be a real aid in writing a program, while informal enough to be understood by nonprogrammers. The informality of

Figure 3.6 Flowchart for Tuition Billing Program

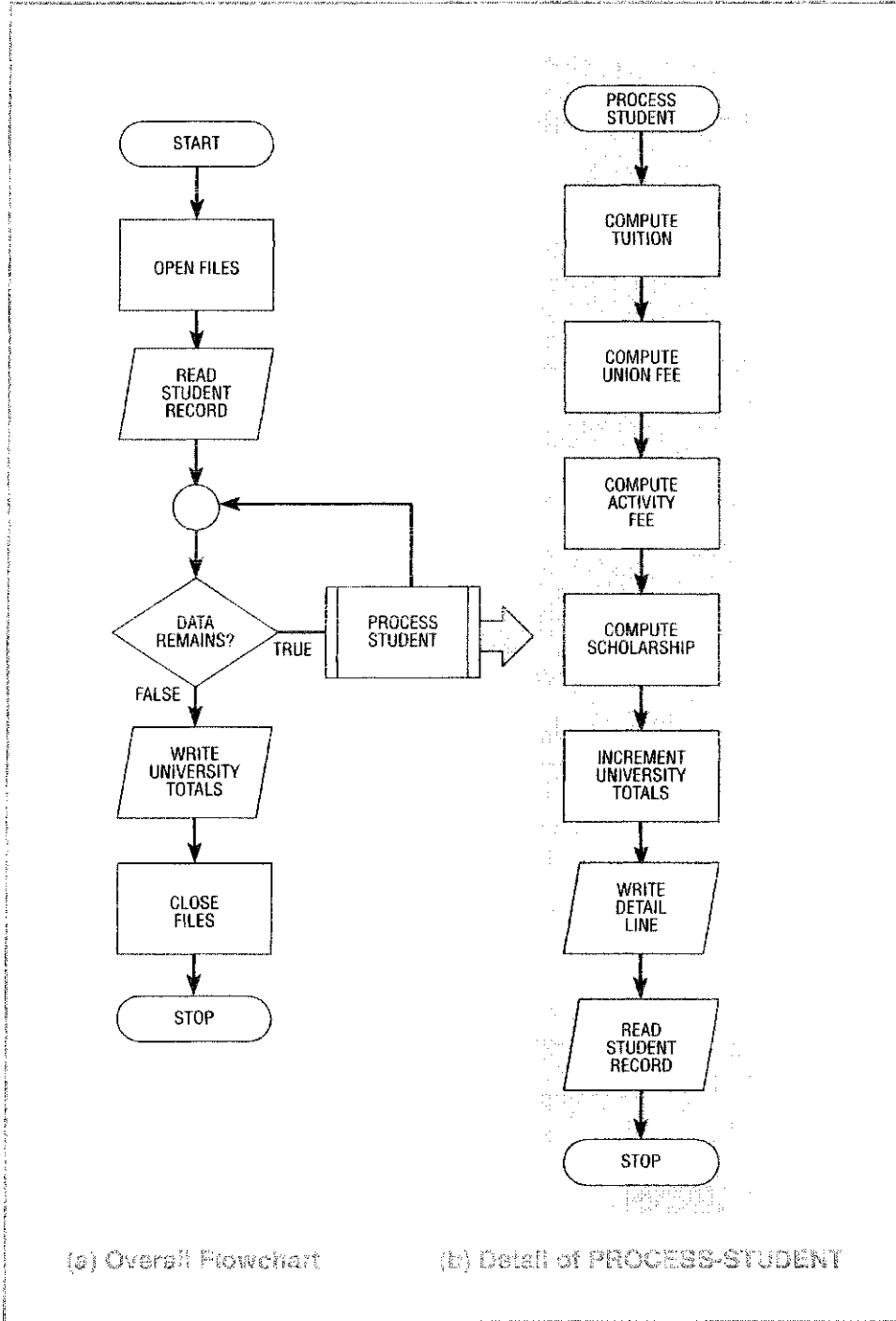

the technique precludes exact rules, but we urge the use of consistent conventions to make it easier to read. Our suggestions:

1. Indent for readability.
2. Use ENDIF, ENDDO, and ENDCASE to indicate the end of a logic structure; use vertical lines to indicate the extent of a block.

Figure 3.7 Pseudocode for Building Blocks

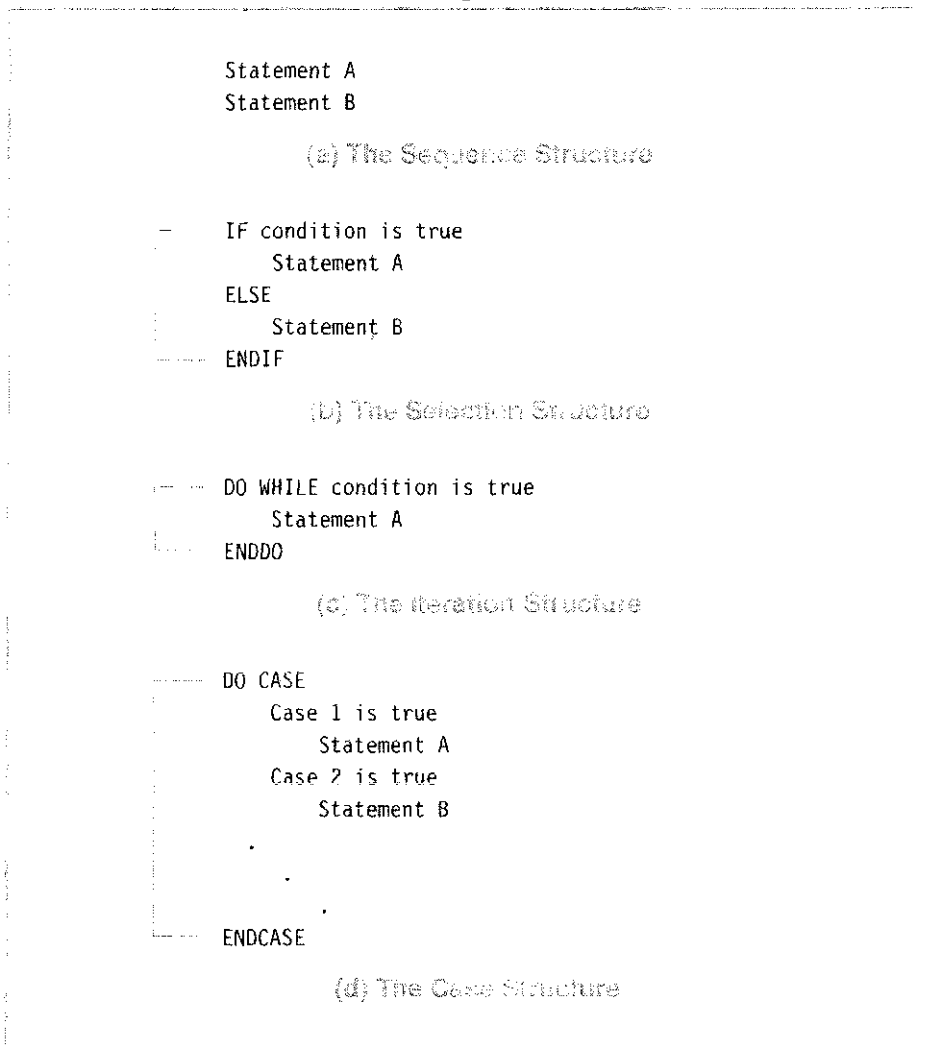

3. Use parenthetical expressions to clarify statements associated with the ELSE portion of an IF statement.
4. Minimize or avoid the use of adjectives and adverbs.

Warnier-Orr Diagrams

Warnier-Orr diagrams (named for their co-developers, Jean-Dominique Warnier and Kenneth Orr) combine elements of structured design and structured programming. The diagrams use specific symbols to represent the basic building blocks of structured programming, then combine these elements in hierarchical fashion.

Figure 3.9 shows how the basic building blocks of structured programming would be represented in a Warnier-Orr diagram. Sequential statements (Figure 3.9a) are listed vertically, one under the other, and are grouped in braces. A plus sign enclosed in a circle indicates selection, and is placed between the true and false conditions of the selection structure (a bar denotes the false condition). Parentheses indicate iteration (Figure 3.9c), with the number inside the parentheses indicating

Figure 3.8 Pseudocode for Tuition Billing Program

```

Open files
Write heading line(s)
Read STUDENT-FILE at end indicate no more data
DO WHILE data remains
    Compute tuition
    Compute union fee
    Compute activity fee
    Compute scholarship
    Compute bill
    Increment university totals
    Write detail line
    Read STUDENT-FILE at end indicate no more data
ENDDO
Write university totals
Close files
Stop run

```

(a) Initial attempt

```

Open files
Write heading line(s)
Read STUDENT-FILE at end indicate no more data
DO WHILE data remains
    Compute tuition = 200 * credits
    IF union member
        Union fee = $25
    ELSE
        Union fee = 0
    ENDIF
    DO CASE
        CASE credits <= 6
            Activity fee = 25
        CASE credits > 6 and <= 12
            Activity fee = 50
        CASE credits > 12
            Activity fee = 75
    END CASE
    IF gpa > 2.5
        Scholarship = Scholarship amount
    ELSE (no scholarship)
        Scholarship = 0
    ENDIF
    Compute Bill = Tuition + Union fee + Activity fee - Scholarship
    Increment university totals
    Write detail line
    Read STUDENT-FILE at end indicate no more data
ENDDO
Write university totals
Close files
Stop run

```

(b) Detailed pseudocode

Figure 3.9 Warnier-Orr Diagrams for Building Blocks

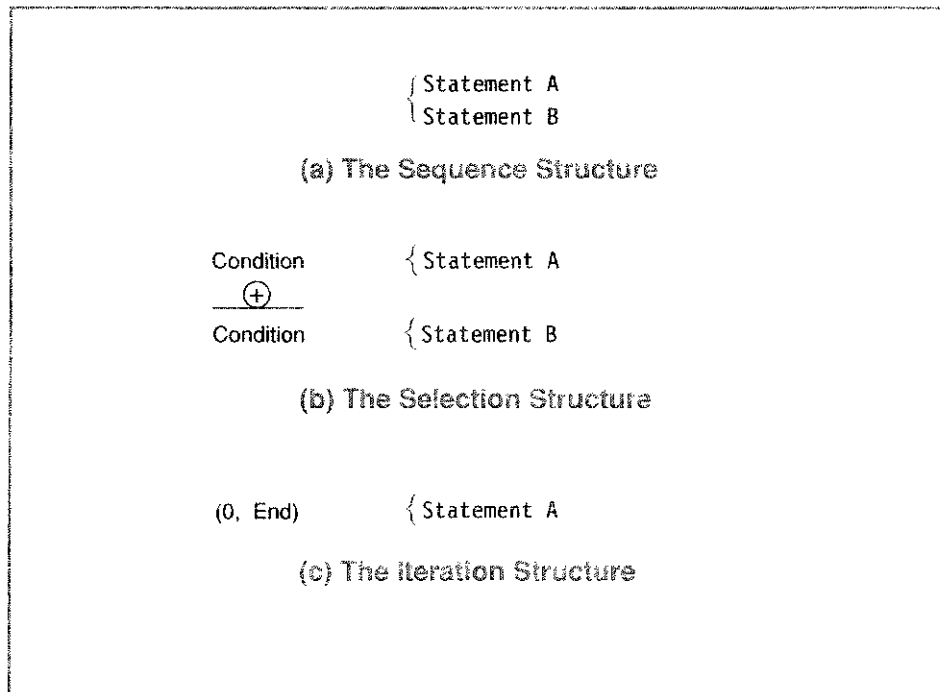

how often the loop is to be performed. A variable number of iterations is implied by enclosing two numbers, for example (0, End) to indicate execution until an end-of-file condition is reached. There is no specific notation for the case construct.

Figure 3.10 contains a Warnier-Orr diagram for the tuition billing program. The diagram depicts the same manager/subordinate relationships as the hierarchy chart of Figure 3.3c, but unlike the hierarchy chart, is read from left to right rather than from top to bottom. The diagram also contains additional information not found in the hierarchy chart, namely the logic to indicate how often, and in what sequence, subordinate modules are executed.

Top-Down Testing

All programs require extensive testing to ensure that they conform to the original specifications. However, the question of when coding ends and testing begins is not as straightforward as it may appear, and gives rise to the philosophy of *top-down testing*.

Top-down testing suggests that coding and testing are parallel activities, and espouses the philosophy that testing begins even before a program is completely finished. This is accomplished by initially coding the intermediate- and/or lower-level paragraphs as *stubs*, that is, partially coded paragraphs whose purpose is to indicate only that the paragraph has been executed. The stub paragraphs do no useful work per se, and are used only to test the overall flow of the program. The rationale is that the highest (and most difficult) modules should be tested earlier and more often than the lower-level routines; the latter contain detailed but often trivial logic, and are least important with respect to the overall program flow.

Figure 3.11 is an example of such a program. It is *complete* in the sense that it contains a paragraph for every module in the hierarchy chart of Figure 3.3, yet *incomplete* in that most of its paragraphs consist of a single DISPLAY statement.

Figure 3.10 Warnier-Orr Diagram for Tuition Billing Program

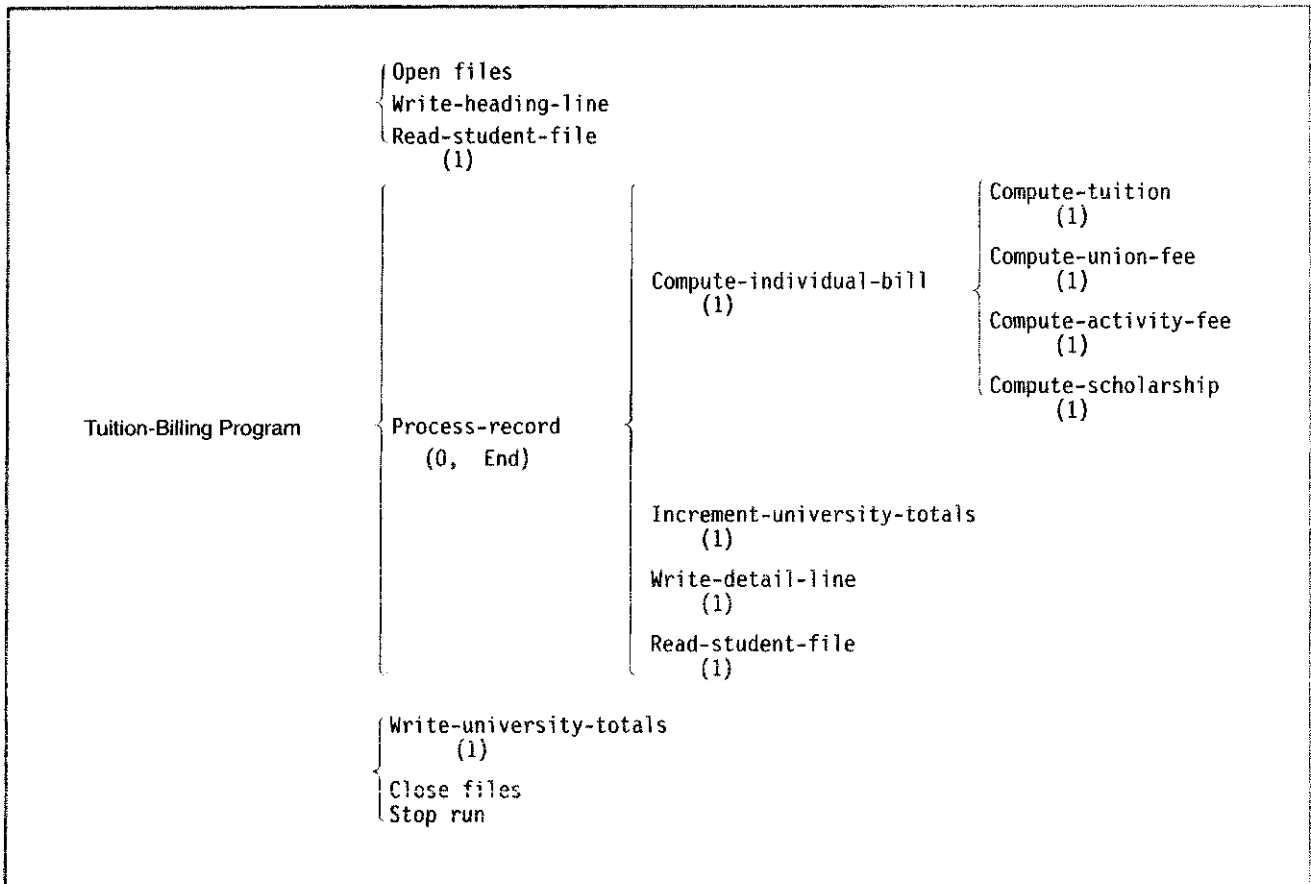

(DISPLAY is one of the most useful statements in COBOL as it allows the programmer to print a message on the screen—for example, DISPLAY “COMPUTE-INDIVIDUAL-BILL paragraph has been entered”—or to print the contents of a data name—for example, DISPLAY STUDENT-RECORD—without having to open a file. The DISPLAY statement is covered in Chapter 6.)

The program in Figure 3.11 was tested with the data of Figure 3.12a, and produced the output of Figure 3.12b. You may not think that much has been accomplished, but closer examination shows that all of the paragraphs in the program were executed, and further that they were executed in the correct sequence. The testing has demonstrated that the overall program flow is correct.

Execution began with the paragraph PREPARE-TUITION-REPORT followed by the the paragraph WRITE-HEADING-LINE. The record for the first student (JB Smith) was read, and the paragraph PROCESS-STUDENT-RECORD was entered. The paragraph COMPUTE-INDIVIDUAL-BILL was executed next, and called its four subordinates to compute the tuition, union fee, activity fee, and scholarship. The paragraphs to increment university totals and to write a detail line were also called. The data for the second student (HR James) was read, and PROCESS-STUDENT-RECORD (and all its subordinates) were re-executed. Eventually the end of file was reached, the paragraph WRITE-UNIVERSITY-TOTALS was executed, and the program ended.

Yes, the program requires additional development, but the hardest part is over. Any errors that may have existed in the highest-level modules have already

Figure 3.11 Tuition Billing Program with Stubs

```
1 IDENTIFICATION DIVISION.  
2 PROGRAM-ID. TUITION3.  
3 AUTHOR. CAROL VAZQUEZ VILLAR.  
4  
5 ENVIRONMENT DIVISION.  
6 INPUT-OUTPUT SECTION.  
7 FILE-CONTROL.  
8 SELECT STUDENT-FILE ASSIGN TO 'A:\CHAPTR03\TUITION.DAT'  
9 ORGANIZATION IS LINE SEQUENTIAL.  
10  
11 DATA DIVISION.  
12 FILE SECTION.  
13 FD STUDENT-FILE  
14 RECORD CONTAINS 27 CHARACTERS.  
15 01 STUDENT-RECORD PIC X(27).  
16  
17 WORKING-STORAGE SECTION.  
18 01 DATA-REMAINS-SWITCH PIC X(2) VALUE SPACES.  
19  
20 PROCEDURE DIVISION.  
21 PREPARE-TUITION-REPORT.  
22 DISPLAY 'PREPARE-TUITION-REPORT paragraph entered'.  
23 OPEN INPUT STUDENT-FILE.  
24 PERFORM WRITE-HEADING-LINE.  
25 PERFORM READ-STUDENT-FILE.  
26 PERFORM PROCESS-STUDENT-RECORD  
27 UNTIL DATA-REMAINS-SWITCH = 'NO'.  
28 PERFORM WRITE-UNIVERSITY-TOTALS.  
29 CLOSE STUDENT-FILE.  
30 STOP RUN.  
31  
32 WRITE-HEADING-LINE.  
33 DISPLAY 'WRITE-HEADING-LINE paragraph entered'.  
34  
35 READ-STUDENT-FILE.  
36 READ STUDENT-FILE  
37 AT END MOVE 'NO' TO DATA-REMAINS-SWITCH  
38 END-READ.  
39  
40 PROCESS-STUDENT-RECORD.  
41 DISPLAY ' '.  
42 DISPLAY 'PROCESS-STUDENT-RECORD paragraph entered'.  
43 DISPLAY 'Student record being processed: ' STUDENT-RECORD.  
44 PERFORM COMPUTE-INDIVIDUAL-BILL.  
45 PERFORM INCREMENT-UNIVERSITY-TOTALS  
46 PERFORM WRITE-DETAIL-LINE.  
47 PERFORM READ-STUDENT-FILE.  
48
```

Display statement shows current record

Figure 3.11 (continued)

```
49     COMPUTE-INDIVIDUAL-BILL.  
50     DISPLAY ' COMPUTE-INDIVIDUAL-BILL paragraph entered'.  
51     PERFORM COMPUTE-TUITION.  
52     PERFORM COMPUTE-UNION-FEE.  
53     PERFORM COMPUTE-ACTIVITY-FEE.  
54     PERFORM COMPUTE-SCHOLARSHIP.  
55  
56     COMPUTE-TUITION.  
57     DISPLAY ' COMPUTE-TUITION paragraph entered'.  
58  
59     COMPUTE-UNION-FEE.  
60     DISPLAY ' COMPUTE-UNION-FEE paragraph entered'.  
61  
62     COMPUTE-ACTIVITY-FEE.  
63     DISPLAY ' COMPUTE-ACTIVITY-FEE paragraph entered'.  
64  
65     COMPUTE-SCHOLARSHIP.  
66     DISPLAY ' COMPUTE-SCHOLARSHIP paragraph entered'.  
67  
68     INCREMENT-UNIVERSITY-TOTALS.  
69     DISPLAY ' INCREMENT-UNIVERSITY-TOTALS paragraph entered'.  
70  
71     WRITE-DETAIL-LINE.  
72     DISPLAY ' WRITE-DETAIL-LINE paragraph entered'.  
73  
74     WRITE-UNIVERSITY-TOTALS.  
75     DISPLAY ' '.  
76     DISPLAY 'WRITE-UNIVERSITY-TOTALS paragraph entered'.
```

Program stub

been found, and were easier to correct than had testing been deferred. Of course, later versions of the program can still contain bugs, but these errors will occur in lower level modules where correction is generally easier. The more difficult problems will already have been resolved in the initial tests, and that is precisely the goal of top-down testing.

We urge you to implement the top-down approach to program testing, and offer Figure 3.13 as our last word on the subject. In the traditional mode of Figure 3.13a, no testing is done until the weekend before the program goes live (or your assignment is due). Inevitably last-minute panic sets in, giving rise to overtime and chaos, an environment unlikely to produce logically correct programs. By contrast, the top down approach of Figure 3.13b provides a more uniform testing pattern, beginning almost immediately with the project's inception and continuing throughout its duration. The results are vastly superior.

Figure 5.12 Testing the Tuition Billing Program

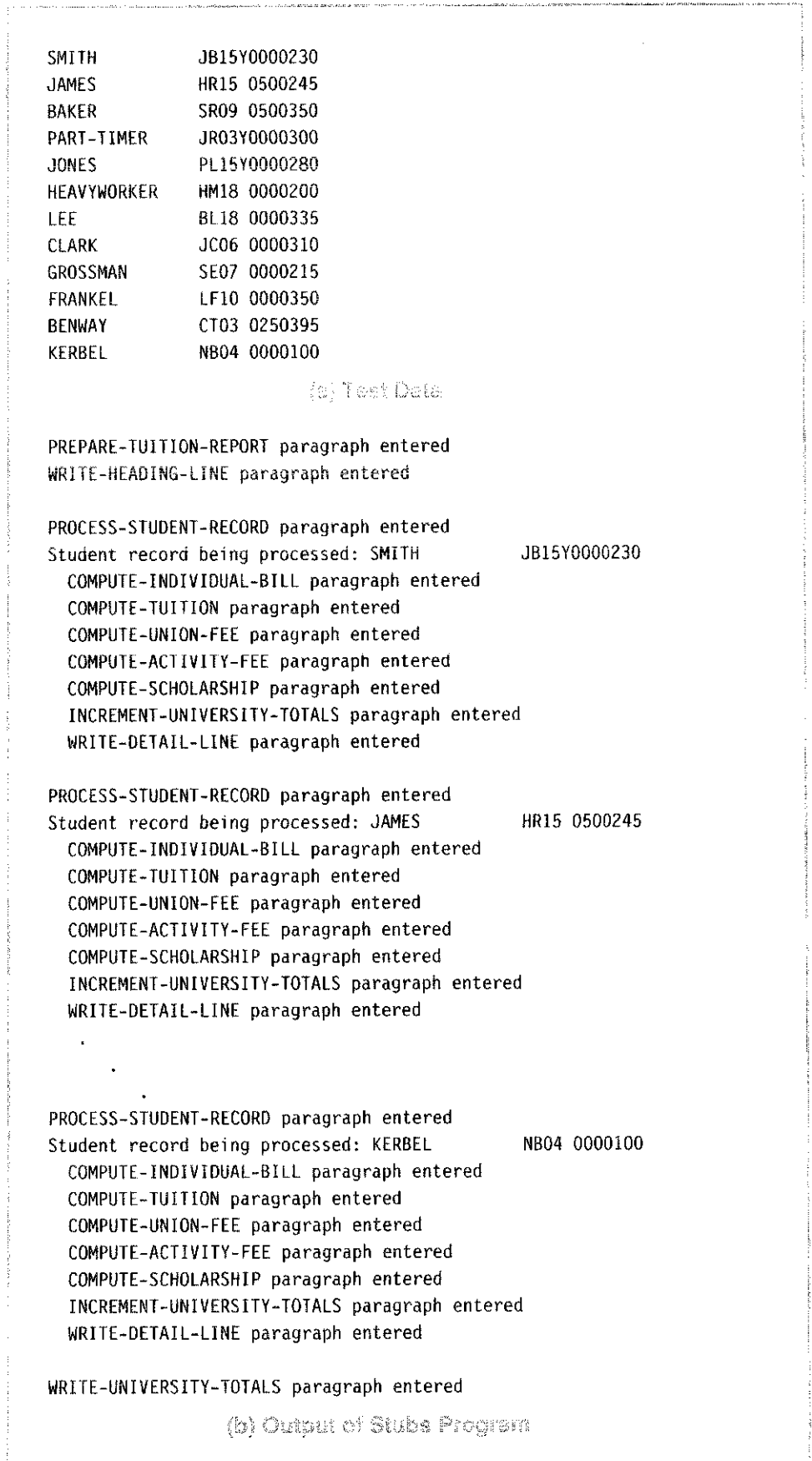
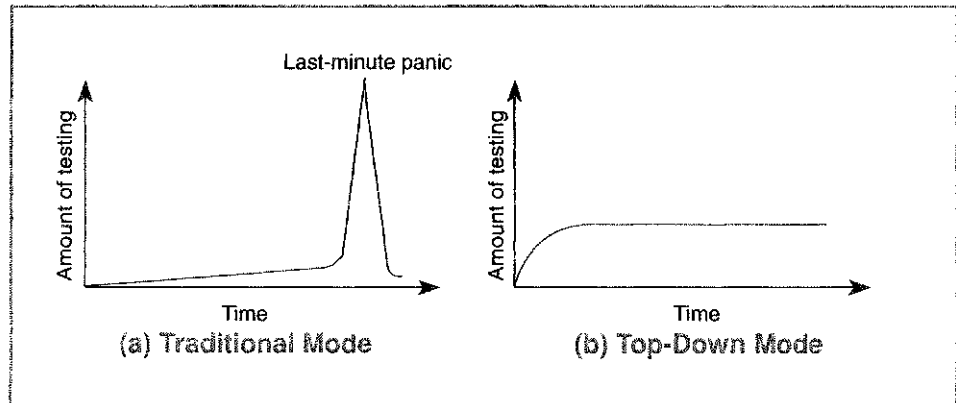

Figure 3.13 Advantages of Top-Down Testing

S U M M A R Y

Points to Remember

- ☛ Structured design is a functionally oriented technique that identifies the tasks a program is to accomplish, then relates those tasks to one another in a hierarchy chart.
- ☛ The modules in a hierarchy chart correspond one to one with paragraphs in a COBOL program. A module (paragraph) can be entered only from the module immediately above it, and must return control to that module when execution is complete.
- ☛ A hierarchy chart is evaluated for completeness, functionality, and span of control.
- ☛ Structured programming is procedural in nature and contains decision-making logic depicting the sequence in which the program tasks will be executed.
- ☛ A structured program consists entirely of the basic building blocks of sequence, selection, and iteration; a fourth construct, case, is commonly included in the definition of structured programming.
- ☛ Each of the elementary building blocks in structured programming has one entry point and one exit point.
- ☛ Flowcharts and/or pseudocode (defined as neat notes to yourself) describe the logic in a program. Warnier-Orr diagrams combine elements of structured design and structured programming.
- ☛ Top down testing begins early in the development process, even before a program is completely coded; it is accomplished through the use of program stubs.

Key Words and Concepts

| | |
|--------------------------------|------------------------|
| Bohm and Jacopini | Pseudocode |
| Case structure | Selection structure |
| Flowchart | Sequence structure |
| Functional technique | Span of control |
| Hierarchy chart | Structured design |
| Iteration structure | Structured programming |
| One entry point/one exit point | Top-down development |
| Procedural technique | Warnier-Orr diagram |
| Program stub | |

FILL - IN

- The fundamental building blocks of structured programming are: _____, _____, and _____.
- The _____ construct is a fourth structure, which is convenient for expressing multibranch situations.
- All of the basic building blocks of structured programming have _____ entry point and _____ exit point.
- In the iteration, or DO WHILE construct, the condition is tested (before/after) the procedure is executed.
- The primary tool of structured design is the _____.
- _____ diagrams combine elements of a hierarchy chart and pseudocode.
- A hierarchy chart is evaluated according to the criteria of _____, _____, and _____.
- Structured design is a _____ oriented technique, whereas structured programming is _____ in nature.
- _____, rather than flowcharting, is the most common technique for expressing program logic.
- Each module in a _____ represents a _____ in a COBOL program.
- _____ is the management term for the number of subordinate modules.
- A well-chosen paragraph name should indicate the function of that paragraph, and consist of a _____, _____, and _____.
- _____ and _____ are the individuals credited with first postulating the structured theorem.
- Structured (programming/design) is intended to produce a _____ solution with the same components and relationships as the problem it is intended to solve.
- A program should be tested from the (top down/bottom up).

TRUE/FALSE

1. A structured program is guaranteed not to contain logical errors.
2. Structured programming can be implemented in a variety of programming languages.
3. INITIALIZATION and TERMINATION are good module names.
4. The logic of any program can be expressed as a combination of only three types of logic structures.
5. The one entry/one exit philosophy is essential to structured programming.
6. Decision making should generally occur in higher-level, rather than lower-level, modules.
7. The case construct is one of the three basic logic structures.
8. A flowchart is the only way to communicate program logic.
9. Pseudocode has precise syntactical rules.
10. A program's hierarchy chart is developed from the bottom up.
11. A program must be completely coded before testing can begin.
12. A Warnier-Orr diagram combines elements of structured design and structured programming.
13. READ-WRITE-AND-COMPUTE is a good module name.
14. A single COBOL paragraph should accomplish many functions for optimal efficiency.
15. Program testing should be concentrated in the last 25% of the development phase.
16. A span of control from 15 to 25 COBOL paragraphs is desirable for the highest-level modules.
17. The optimal number of modules in a system is equal to the number of programmers available for coding.
18. A module in a hierarchy chart can be called from another module on its own level.

PROBLEMS

1. Given the flowchart in Figure 3.14, respond "true" or "false" to the following on the basis of the flowchart.
 - a. If $X > Y$ and $W > Z$, then *always* add 1 to B.
 - b. If $X < Y$, then *always* add 1 to D.
 - c. If $Q > T$, then *always* add 1 to B.
 - d. If $X < Y$ and $W < Z$, then *always* add 1 to D.
 - e. There are no conditions under which 1 will be added to both A and B simultaneously.
 - f. If $W > Z$ and $Q < T$, then *always* add 1 to C.
2. Assume that a robot is sitting on a chair, facing a wall a short distance away. Restricting yourself to the basic building blocks of structured programming, develop the necessary logic to have the robot walk to the wall and return to its initial position. Express your solution in pseudocode. The robot understands the following commands:

Figure 3.14 Flowchart for Problem 1

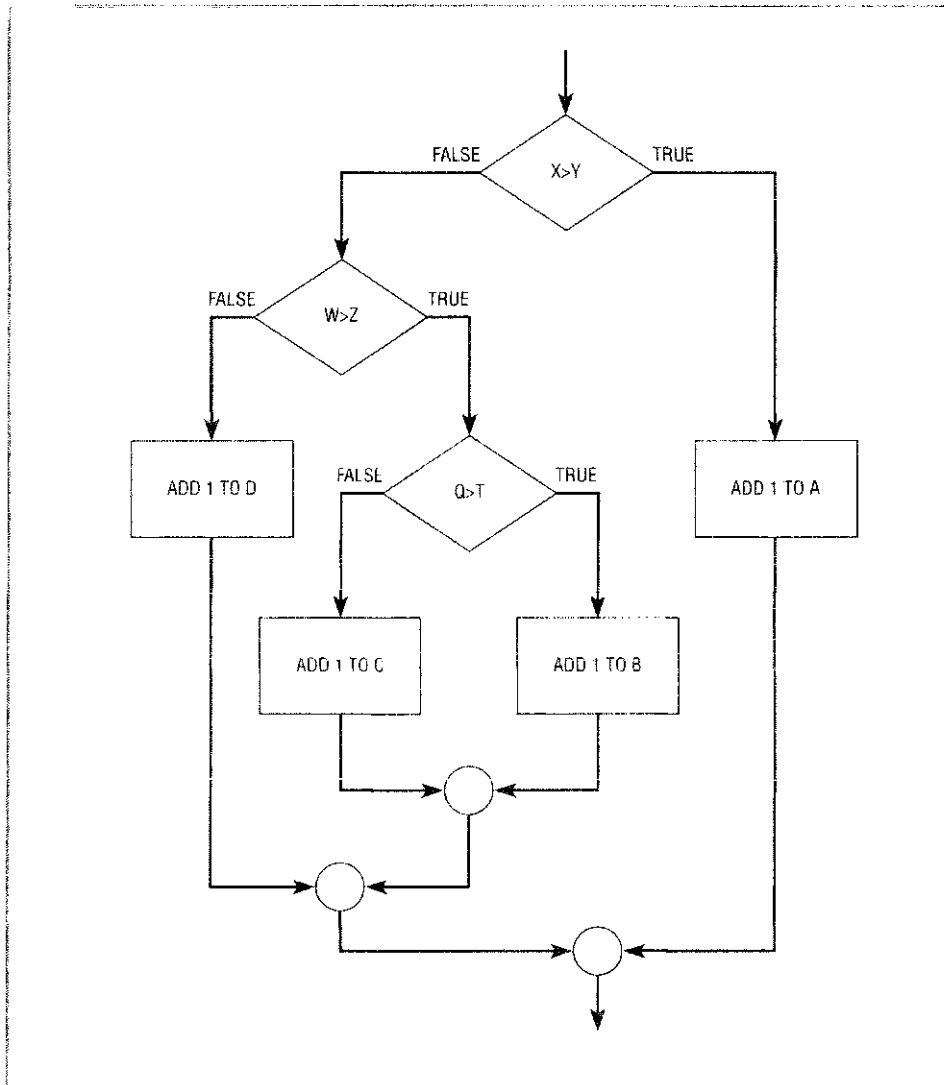

- STAND
- SIT
- TURN (turns right 90 degrees)
- STEP

In addition, the robot can raise its arms and sense the wall with its fingertips. (However, it cannot sense the chair on its return trip, since the chair is below arm level.) Accordingly the robot must count the number of steps to the wall or chair by using the following commands:

- ADD (increments counter by 1)
- SUBTRACT (decrements counter by 1)
- ZERO COUNTER (sets counter to zero)
- ARMS UP
- ARMS DOWN

The wall is assumed to be an integer number of steps away. Select a volunteer to act as the robot, and see whether the submitted solutions actually accomplish the objective.

Figure 3.15 Flowchart for Problem 3

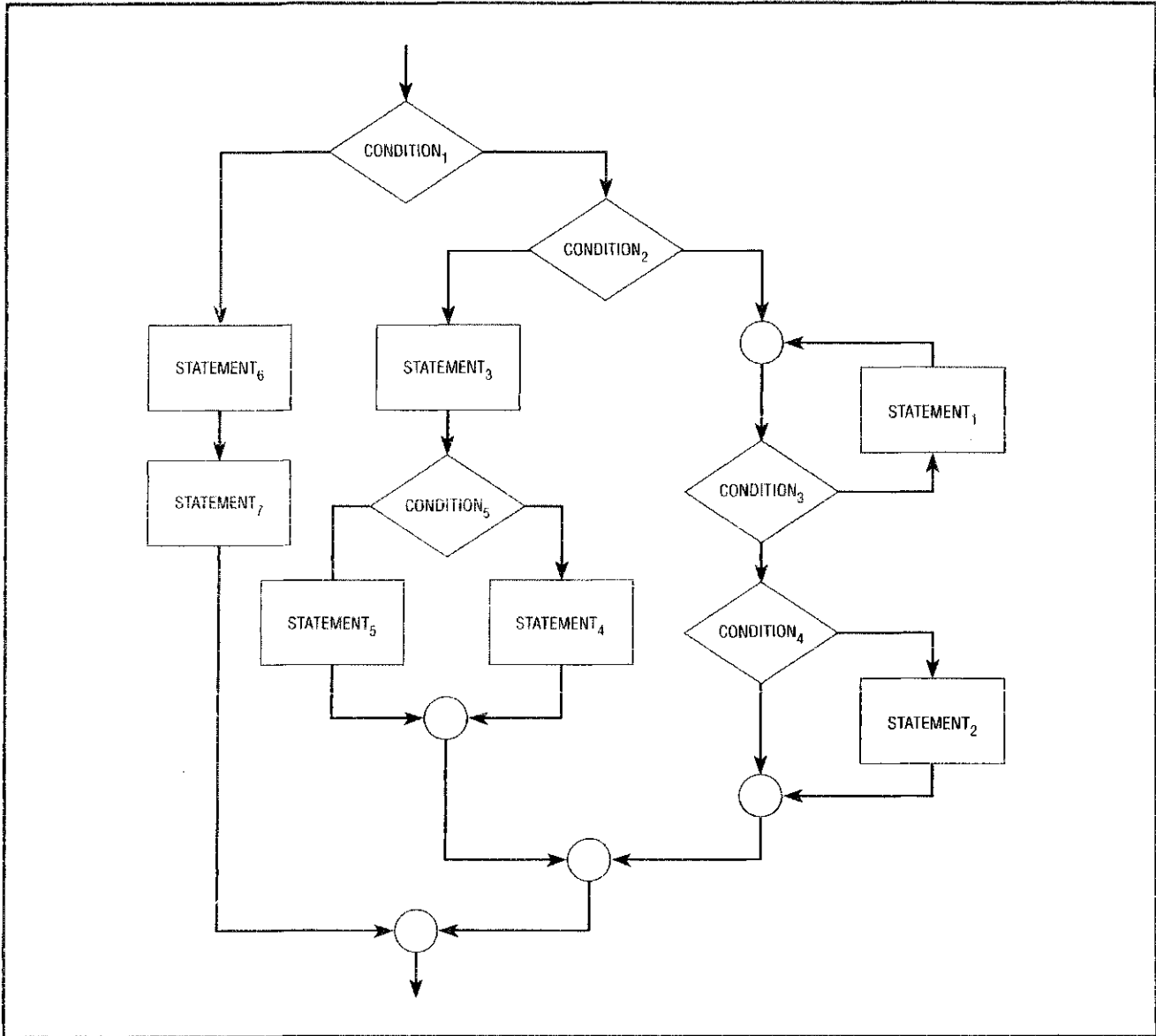

3. Identify the elementary building blocks in Figure 3.15. Be sure you get all of them (the authors can find eight).
4. Indicate the output that will be produced by each of the following DISPLAY statements.
 - a. DISPLAY 'STUDENT RECORD'.
 - b. DISPLAY STUDENT-RECORD.
 - c. DISPLAY 'STUDENT RECORD IS ' STUDENT-RECORD.
 - d. DISPLAY.
 - e. DISPLAY STUDENT-NAME, SOC-SEC-NUM.
5. This non-data-processing problem specifically avoids a business context, and was chosen because you are unlikely to have a preexisting bias toward a solution.

Develop a hierarchy chart to allow a user to play a series of tic-tac-toe games interactively against a computer. The following modules were used in the author's solution: PLAY-SERIES, PLAY-GAME, CLEAR-BOARD, GET-USER-MOVE, VALIDATE-USER-MOVE, CHECK-FOR-WINNER, UPDATE-BOARD, GET-COMPUTER-MOVE, DISPLAY-BOARD, DISPLAY-MESSAGE. (The last module, DISPLAY-MESSAGE, may be called from several places.) The module names should in themselves be indicative of the module functions.

6. Again we have chosen a nonbusiness problem to give you further practice with structured design. This time you are asked to develop a hierarchy chart for the game of blackjack (also known as "21"). The game is played with a deck of 52 cards (or more commonly with multiple decks). The player places a bet, and the player and dealer are each dealt two cards. Both of the player's cards are face up (showing), but one of the dealer's cards is hidden. The player is asked whether he or she wishes to draw additional card(s), after which the dealer has the same option (provided the player has not gone over 21). The player closest to 21 (without going over) wins. The rules of the game require the dealer to draw with 16 or less, and stand (not draw) with 17 or more. Your hierarchy chart should contain the necessary modules to keep a running total of the player's winnings (or losses) as well as the following special situations:
 - a. Doubling down—if the player's first two cards total 11, he or she may double the bet and receive one additional card.
 - b. Purchasing insurance—if the dealer's "up" card is an ace, the player may place an additional side bet. If the dealer has "blackjack," the player receives a payout of 2 to 1 on the side bet, but loses the initial bet. If the dealer does not have blackjack, the side bet is lost and play continues.
 - c. Splitting pairs—if the player has a pair, he or she may double the bet and play two hands.



4

The Identification, Environment, and Data Divisions

CHAPTER OUTLINE

Overview

COBOL Notation

IDENTIFICATION DIVISION

ENVIRONMENT DIVISION

CONFIGURATION SECTION

INPUT-OUTPUT SECTION

DATA DIVISION

FILE SECTION

File Description (FD)

Record Description

PICTURE Clause

Level Numbers

Assumed Decimal Point

WORKING-STORAGE SECTION

VALUE Clause

The Tuition Billing Program

Programming Specifications

COBOL Entries

Limitations of COBOL-74

Summary

Fill-in

True/False

Problems

OBJECTIVES

After reading this chapter you will be able to:

- Describe the COBOL notation and determine the appropriate syntax for any statement.
- Complete the Identification Division of a COBOL program.
- Complete the Environment Division of a COBOL program.
- Code a record description to show hierarchical relationships among fields containing numeric and alphanumeric entries.
- Code a Working-Storage Section to define various print lines.
- Explain the use of an assumed decimal point.

OVERVIEW

The overall approach of this book is to provide a rapid introduction to computer programming; thus we presented a complete COBOL program in Chapter 1. Our objective at that time was to put you on the computer immediately, without too much concern for the syntactical rules, which you must eventually master.

We move now to a formal study of COBOL, beginning with a notation that fully explains the variations permitted within any COBOL statement. The chapter focuses on the Identification, Environment, and Data Divisions, and concludes with a COBOL listing expanding on this material.

COBOL Notation

COBOL is an English-like language with inherent flexibility in the way a particular entry may be expressed. In other words, there are a number of different, but equally acceptable, ways to say the same thing. It is necessary, therefore, to develop a standard notation to provide a clear and unambiguous means of indicating precisely what is, and is not, permitted within any given statement. The notation is illustrated in Figure 4.1 and adheres to the following conventions:

1. Lowercase letters signify programmer-supplied information—for example, identifier-1 or literal-1.
2. Uppercase letters indicate reserved words—for example, IF, GREATER, or THAN.
3. Uppercase letters that are underlined are required; uppercase letters that are not underlined are optional reserved words.
4. Brackets [] symbolize an optional entry—for example, [NOT].
5. Braces { } imply that one of the enclosed items must be chosen—for example, a choice is required between identifier-1, literal-1, and arithmetic expression-1.
6. Three dots . . . mean that the last syntactical unit can be repeated an arbitrary number of times.

Figure 4.1 COBOL Notation

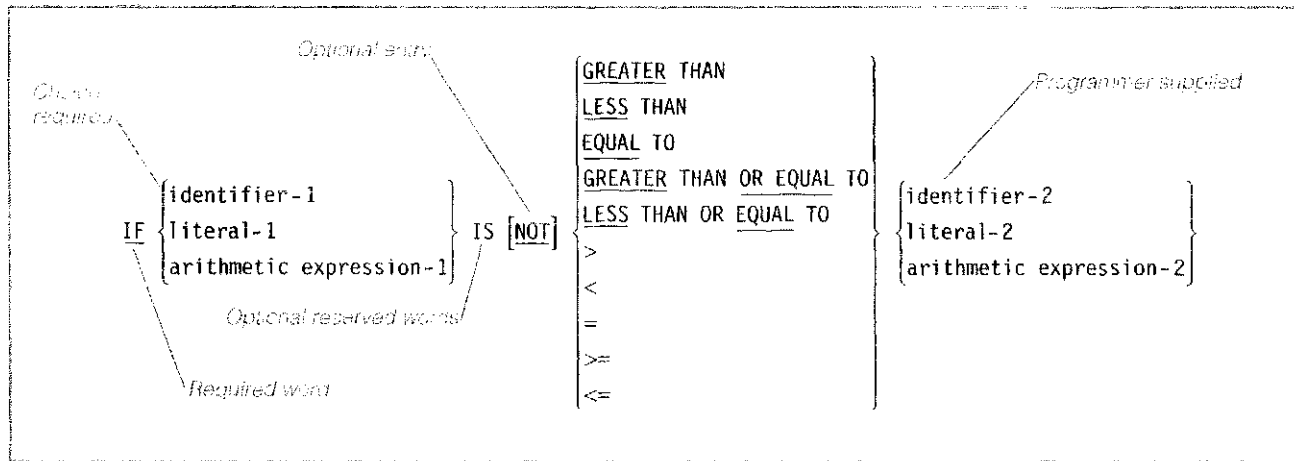

The example in Figure 4.1 is associated with the condition portion in the IF statement. IF is underlined and appears in capital letters, indicating it is a required reserved word. It is followed by a set of braces containing three options, one of which must be chosen. The reserved word IS appears in uppercase letters but is not underlined, meaning its use is optional. The brackets surrounding NOT imply that the clause is optional, but if the clause is chosen, NOT is required because it is underlined.

The next set of braces indicates a second mandatory choice among five relationships: GREATER THAN, GREATER THAN OR EQUAL TO, LESS THAN, LESS THAN OR EQUAL TO, or EQUAL TO. The reserved words THAN and TO are not underlined and are, therefore, optional. Alternatively, you can choose the appropriate symbol: >, >=, <, <=, or = instead of spelling out the relationship. The third set of braces indicates yet another choice, this time from the entries identifier-2, literal-2, and arithmetic expression-2.

Returning to the engineering senior problem of Chapter 1, in which STU-MAJOR is compared to engineering, we see that all of the following are acceptable as the condition portion of the IF statement:

```
IF STU-MAJOR IS EQUAL TO 'ENGINEERING'
IF STU-MAJOR EQUAL 'ENGINEERING'
IF 'ENGINEERING' IS EQUAL TO STU-MAJOR
IF STU-MAJOR = 'ENGINEERING'
```

Identification Division

The IDENTIFICATION DIVISION is the first of the four divisions in a COBOL program. Its function is to provide identifying information about the program, such as author, date written, and security. The division consists of a division header and up to six paragraphs:

```
IDENTIFICATION DIVISION.
PROGRAM-ID.          program-name.
AUTHOR.             [comment-entry] ... ]
INSTALLATION.      [comment-entry] ... ]
DATE-WRITTEN.       [comment-entry] ... ]
DATE-COMPILED.     [comment-entry] ... ]
SECURITY.           [comment-entry] ... ]
```

The division header and PROGRAM-ID paragraph are the only required entries. The five remaining paragraphs are optional (as indicated by the COBOL notation), and only the DATE-COMPILED paragraph merits special mention. If the paragraph is specified, the compiler will insert the current date during program compilation. (The paragraph is redundant, however, since most compilers automatically print the date of compilation on the top of each page.) A completed Identification Division is shown:

```
IDENTIFICATION DIVISION.
PROGRAM-ID.           FIRSTTRY.
AUTHOR.              ROBERT T. GRAUER.
INSTALLATION.        UNIVERSITY OF MIAMI.
DATE-WRITTEN.        MARCH 16, 1993.
DATE-COMPILED.       The compiler supplies compilation date.
SECURITY.            TOP SECRET-INSTRUCTORS ONLY.
```

Coding for the Identification Division follows the general rules described in Chapter 2. The division header and paragraph names begin in the A margin, with all corresponding entries beginning in or past column 12 (B margin).

Environment Division

The ENVIRONMENT DIVISION contains two sections:

1. The CONFIGURATION SECTION identifies the computers for compiling and executing the program, usually one and the same.
2. The INPUT-OUTPUT SECTION associates the files in the COBOL program with the files known to the operating system.

The nature of these functions makes the Environment Division dependent on the computer on which you are working; that is, the Environment Division for a program on a VAX is different from that for a program on an IBM mainframe.

Configuration Section

The CONFIGURATION SECTION is enclosed in brackets within the COBOL notation and is therefore optional. An abbreviated format is shown below:

```
[CONFIGURATION SECTION.
SOURCE-COMPUTER. computer-name.]
[OBJECT-COMPUTER. computer-name.]]
```

The section header and paragraph names begin in the A margin whereas the computer-name entries begin in or past column 12. The CONFIGURATION SECTION does little to enhance (the documentation of) a COBOL program and is typically omitted.

Input-Output Section

The INPUT-OUTPUT SECTION associates the files in a COBOL program with files known to the operating system. It contains a FILE-CONTROL paragraph, which in turn contains a SELECT statement for every file in the program. Syntactically it has the format:

INPUT-OUTPUT SECTION.FILE-CONTROL.

```
SELECT file-name-1 ASSIGN TO implementor-name.]
```

A program may be written without any files and hence the INPUT-OUTPUT section is optional. (See Chapter 10 on screen I/O for an example of a program written without any files.)

The section header (INPUT-OUTPUT SECTION) and paragraph name (FILE-CONTROL) begin in the A margin (columns 8 through 11). The SELECT statements for the individual files begin in the B margin (column 12 and beyond).

The precise format of the *implementor-name* in the SELECT statement varies from compiler to compiler, with the example below taken from lines 8 through 11 in the engineering senior problem.

```
INPUT-OUTPUT SECTION.
FILE-CONTROL.
SELECT STUDENT-FILE  ASSIGN TO 'A:\CHAPTR03\TUITION.DAT'
      ORGANIZATION IS LINE SEQUENTIAL.
SELECT PRINT-FILE
      ASSIGN TO PRINTER.
```

The dependence of the Environment Division on the individual computer installation bears repeating. You should consult either your instructor or your computer center for the proper statements to use in your program.

Data Division

The Data Division describes the data items that appear in a program. It contains several sections, two of which, the FILE SECTION and the WORKING-STORAGE SECTION, will be discussed in this chapter. Two other sections, the SCREEN SECTION and the LINKAGE SECTION, are presented in later chapters.

File Section

The FILE SECTION is the first section in the Data Division and contains a file description (FD) for every file previously defined in a SELECT statement in the Environment Division. (If, however, a program is written without any files, then the FILE SECTION will not appear.) The file description is followed by the associated record description which is accomplished through PICTURE clauses and level numbers. Each of these elements is discussed in turn.

File Description (FD) The *file description* (FD) provides information about the physical characteristics of a file. It contains four clauses, all of which are optional, and which may appear in any order. The final entry, however, must be terminated by a period. An abbreviated format for the file description is as follows:

```
FD file-name
[BLOCK CONTAINS integer-1 RECORDS ]
[RECORD CONTAINS integer-1 CHARACTERS]
[ LABEL {RECORDS ARE} {OMITTED}
        {RECORD IS } {STANDARD} ]
[DATA RECORD IS data-name-1].
```

The BLOCK CONTAINS clause is used to speed up input/output operations for files on tape or disk, by reducing the number of physical records (blocks) in a file,

and thus reducing the number of times the input/output device is accessed. In other words, it is more efficient to access a disk once and read a block containing 10 records, than it is to access the disk 10 times and read each record individually. The **blocking factor** is defined as the number of **logical records** in a **physical record**. The concept is illustrated in Figure 4.2 where the records of Figure 4.2a are unblocked, whereas those in Figures 4.2b and 4.2c have blocking factors of 2 and 3, respectively.

The higher the blocking factor, the fewer the number of physical records, and the more efficient the processing. Thus, the blocking factor should always be as high as possible, within the limitations of the physical device. The actual determination of the blocking factor need not concern us now; what is important is the implementation of blocking in a COBOL program.

Assume, for example, a blocking factor of 5, with the associated entry, BLOCK CONTAINS 5 RECORDS. The initial execution of the READ statement places a block of 5 logical records in memory, with only the first record available to the program. The second (third, fourth, and fifth) execution of the READ statement makes a new logical record available, without a corresponding physical operation taking place. In similar fashion the sixth execution of the READ statement will bring a new physical record into the I/O area, with new logical records made available on the seventh through tenth executions of the READ statement. All of this is automatically done for the programmer as long as the BLOCK CONTAINS statement is specified in the COBOL FD.

Figure 4.2 Blocked versus Unblocked Records

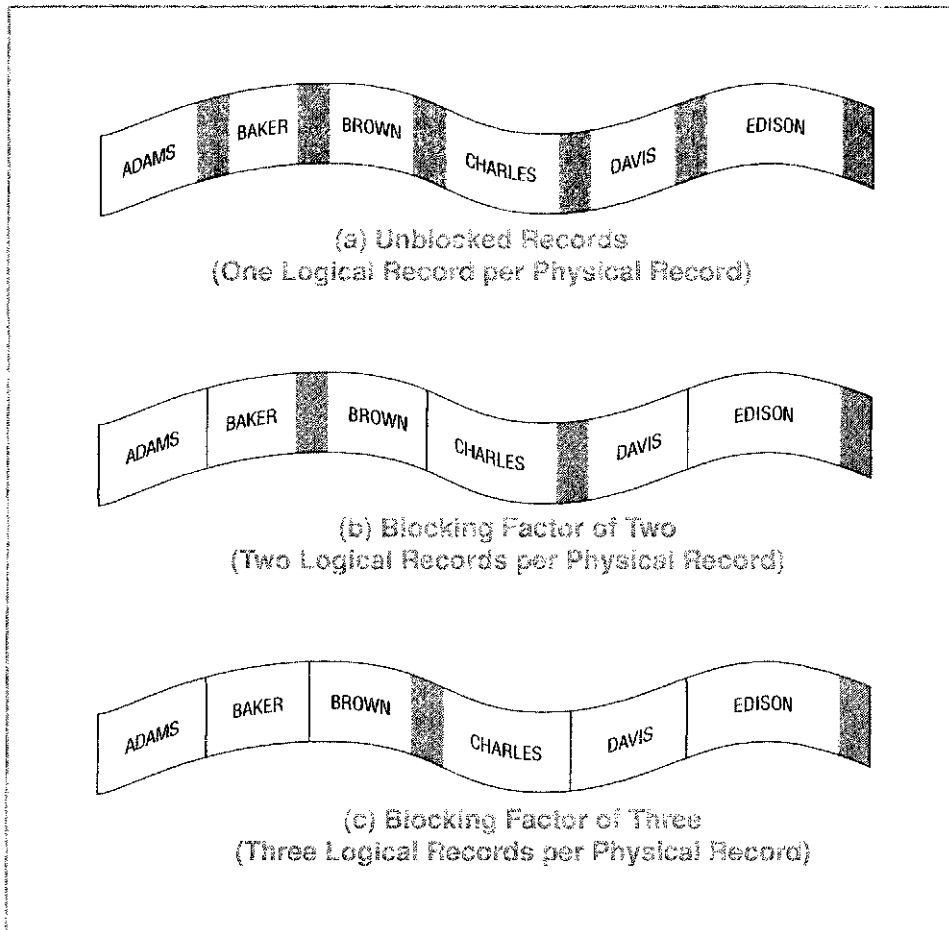

COBOL programs that are written to run on an IBM mainframe typically contain the entry, `BLOCK CONTAINS 0 RECORDS`. This entry does not mean what it says literally, but rather that the block size will be entered at execution time.

The `RECORD CONTAINS` clause indicates the number of characters in a record and is useful for documentation. The clause also causes the compiler to verify that the sizes of the individual data items sum to the stated value.

The `LABEL RECORDS` clause determines whether or not label processing is to take place. Label records appear at the beginning and end of files stored on tape or disk, and contain information about the file, such as the date created, the logical record size and the block size. Label records are created automatically whenever a file is opened as output and are checked automatically whenever a file is opened as input. Label processing is necessary to ensure that the proper file is being processed. The `LABEL RECORDS` clause is optional and its omission defaults to standard labels.

The `DATA RECORD` clause specifies the name of the 01 entry (or entries) associated with the particular file. It has limited value in documentation and has no other function. An example of a completed FD is shown below:

```
FD STUDENT-FILE
   BLOCK CONTAINS 10 RECORDS
   RECORD CONTAINS 43 CHARACTERS
   LABEL RECORDS ARE STANDARD
   DATA RECORD IS STUDENT-IN.
```

Record Description A file description is followed by an associated *record description* that conveys the following information:

1. The size and type of each field within a record
2. The order in which the fields appear
3. The relationship of the fields to one another

through a combination of `PICTURE` clauses and level numbers.

PICTURE Clause A `PICTURE` clause describes the size and type of a field. The *size* of a field is equivalent to the number of characters (positions) in the field. The *type* of field is either numeric or alphanumeric, and is denoted by a 9 or an X, respectively, in the associated `PICTURE` clause. A *numeric item* can contain the numbers 0–9, whereas an *alphanumeric item* may contain A–Z (alphabetic), 0–9 (numeric), and/or special characters.

The size of a field is indicated by the number of times the 9 or X is repeated. A data item with a picture of `XXXX` or `X(4)` is a four-position alphanumeric field. In similar fashion `999` or `9(3)` denotes a three-position numeric field. (Alphabetic data items, denoted by an A in the associated `PICTURE` clause, are seldom used because even a field as simple as a person's name can contain apostrophes or hyphens, which are alphanumeric rather than alphabetic in nature.)

Level Numbers *Level numbers* describe the relationships that exist between fields within a record. Each field is classified as either a group item or an elementary item. A *group item* is a field that can be further divided—an *elementary item* can not.

Consider, for example, Figure 4.3, which depicts a student examination record. The field `STUDENT-NAME` is a group item because it is divided into three fields: `LAST-NAME`, `FIRST-NAME`, and `INIT`. `LAST-NAME`, `FIRST-NAME`, and `INIT`, however, are elementary items, since they are not further divided. In similar fashion, `SS-NUM` is an elementary item. `EXAM-SCORES` is a group item, as are `MATH` and `ENGLISH`. `ALG`, `GEO`, `READ`, etc., are elementary items.

Figure 4.3 Student Exam Record

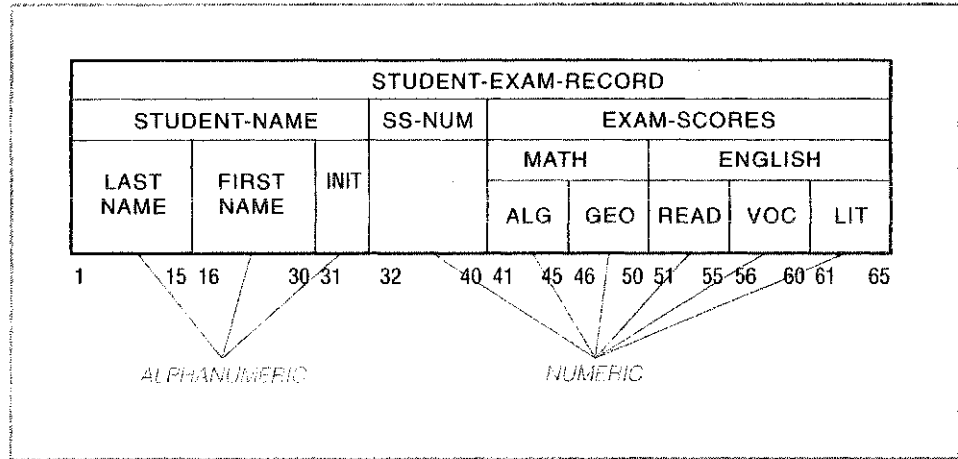

Level numbers and PICTURE clauses are used in Figure 4.4 to define a record corresponding to the STUDENT-EXAM-RECORD in Figure 4.3. Two equivalent sets of COBOL statements (Figures 4.4a and 4.4b) are presented and follow the rules below:

1. The level numbers within a record description can assume any value from 01 to 49 inclusive.
2. The level number 01 denotes the record as a whole.
3. Any level number from 02 to 49 can be used for field(s) within the record, so long as elementary items have a numerically higher number than the group item to which they belong.
4. An elementary item *must* have a PICTURE clause—a group item *cannot* have a PICTURE clause.

In Figure 4.4 STUDENT-EXAM-RECORD has a level number of 01 to indicate the record as a whole. STUDENT-NAME is a subfield of STUDENT-EXAM-RECORD; hence it has a higher level number (05). LAST-NAME, FIRST-NAME, and MID-INITIAL are subordinate to STUDENT-NAME and thus have a higher level number (10). SOC-SEC-NUM and EXAM-SCORES are also subfields of STUDENT-EXAM-RECORD and have the same level number as STUDENT-NAME. EXAM-SCORES is subdivided into two group items, MATH and ENGLISH, which in turn are further subdivided into elementary items.

Every elementary item must have a PICTURE clause, whereas a group item cannot have a PICTURE clause. Thus, LAST-NAME has the entry PICTURE IS X(15) to denote a 15-position alphanumeric field; STUDENT-NAME, however, is a group item and does not have a PICTURE clause. The parentheses in a PICTURE clause imply repetition; that is, the entry 9(5) for ALGEBRA depicts a 5-position numeric field.

There is considerable latitude within COBOL as to the specification of level numbers and PICTURE clauses. You can, for example, choose any level numbers from 02 to 49 to describe subordinate fields; for example, 04, 08, and 12 are used in Figure 4.4b as opposed to the levels 05, 10, and 15 in Figure 4.4a. The 01 level is used in both figures for the record as a whole.

Figure 4.4 Level Numbers and PICTURE Clauses

```

01 STUDENT-EXAM-RECORD.
   05 STUDENT-NAME.
      10 LAST-NAME          PICTURE IS X(15).
      10 FIRST-NAME         PICTURE IS X(15).
      10 MID-INITIAL        PICTURE IS X.
   05 SOC-SEC-NUM          PICTURE IS 9(9).
   05 EXAM-SCORES.
      10 MATH.
         15 ALGEBRA          PICTURE IS 9(5).
         15 GEOMETRY         PICTURE IS 9(5).
      10 ENGLISH.
         15 READING          PICTURE IS 9(5).
         15 VOCABULARY       PICTURE IS 9(5).
         15 LITERATURE        PICTURE IS 9(5).

```

(a) Initial Coding

```

01 STUDENT-EXAM-RECORD.
   04 STUDENT-NAME.
      08 LAST-NAME          PIC X(15).
      08 FIRST-NAME         PIC X(15).
      08 MID-INITIAL        PIC X.
   04 SOC-SEC-NUM          PIC 9(9).
   04 EXAM-SCORES.
      08 MATH.
         12 ALGEBRA          PIC 99999.
         12 GEOMETRY         PIC 99999.
      08 ENGLISH.
         12 READING          PIC 99999.
         12 VOCABULARY       PIC 99999.
         12 LITERATURE        PIC 99999.

```

(b) Alternative Specification

The PICTURE clause itself can assume any one of four forms: PICTURE IS, PICTURE, PIC IS, or PIC. Parentheses may be used to signal repetition of a picture type; that is, X(3) is equivalent to XXX. Figure 4.4b is the exact equivalent of Figure 4.4a with emphasis on the aforementioned flexibility.

Assumed Decimal Point Incoming numeric data may not contain *actual* decimal points. On first reading, that statement may be somewhat hard to accept. How, for example, does one read a field containing dollars and cents? The answer is an assumed (implied) decimal point as illustrated in the COBOL entry:

```
05 HOURLY-RATE PICTURE IS 99V99.
```

Everything is familiar except the V embedded in the PICTURE clause. The V means an *implied decimal point*; that is, HOURLY-RATE is a four-digit (there are

Figure 4.5 Assumed Decimal Point

| INCOMING RECORD: | DATA DIVISION RECORD DESCRIPTION: | VALUES: |
|-----------------------|-----------------------------------|---------|
| 9 87 65 4 3 210 | 01 INCOMING-DATA-RECORD. | |
| | 05 FIELD-A PIC 9V99. → | 9.87 |
| | 05 FIELD-B PIC 99V9. → | 65.4 |
| | 05 FIELD-C PIC 9. → | 3 |
| | 05 FIELD-D PIC V999. → | .210 |

four 9's) numeric field, with two of the digits coming after the decimal point. Simply stated, the V indicates the position of the decimal point.

To check your understanding, assume that 9876543210 is found in positions 1–10 of an incoming record and that the following Data Division entries apply:

```

01 INCOMING-DATA-RECORD.
   05 FIELD-A          PIC 9V99.
   05 FIELD-B          PIC 99V9.
   05 FIELD-C          PIC 9.
   05 FIELD-D          PIC V999.
    
```

The values of FIELD-A, FIELD-B, FIELD-C, and FIELD-D are 9.87, 65.4, 3, and .210, respectively, as shown in Figure 4.5. FIELD-A is contained in the first three positions with two of the digits to the right of the decimal point. FIELD-B is contained in the next three positions (i.e., 6, 5, and 4) with one digit to the right of the decimal point. FIELD-C is contained in position 7 with no decimal places. Finally, FIELD-D is contained in positions 8, 9, and 10, with all three to the right of the decimal.

Working-Storage Section

The WORKING-STORAGE SECTION defines any data name that was not previously referenced in the FILE SECTION, that is, any data name that does not appear in a file. The WORKING-STORAGE SECTION contains data names to store the results of calculations, switches to control the execution of performed paragraphs, and/or data names to hold constants needed by the program. The WORKING-STORAGE SECTION will also define various print lines (a heading, detail, and/or total line) required by a program.

Figure 4.6 contains a WORKING-STORAGE SECTION for an expanded version of the engineering senior program to count the number of qualified students. There are separate record descriptions for the counters and constants needed by the program, as well as a separate record description (01 entry) for each type of print line.

A FILLER entry defines a field that is not referenced elsewhere in the COBOL program. The layout of DETAIL-LINE, for example, begins with eight spaces, followed by the value of PRINT-NAME, an additional 10 spaces, the value of PRINT-MAJOR, and a final set of 74 spaces to complete the print line. The three fields containing spaces are not referenced anywhere else in the program yet need to be accounted for—hence the FILLER entry.

The word FILLER is optional, however, and could be omitted as shown in the definition of TOTAL-LINE. The entries under TOTAL-LINE look strange initially, but make perfect sense when you realize that the “missing” FILLER entries are not

Figure 4.6 The Working-Storage Section

| WORKING-STORAGE SECTION. | | | |
|---------------------------|---------------------|------------|-------------------------|
| 01 COUNTERS-AND-SWITCHES. | | | |
| 05 | TOTAL-STUDENTS | PIC 9(3) | VALUE ZEROS. |
| 05 | DATA-REMAINS-SWITCH | PIC X(2) | VALUE SPACES. |
| 01 PROGRAM-CONSTANTS. | | | |
| 05 | REQUIRED-CREDITS | PIC 999 | VALUE 110. |
| 05 | REQUIRED-MAJOR | PIC X(10) | VALUE 'ENGINEERING'. |
| 05 | REQUIRED-GPA | PIC 9V99 | VALUE 3.00. |
| 01 HEADING-LINE. | | | |
| 05 | FILLER | PIC X(10) | VALUE SPACES. |
| 05 | FILLER | PIC X(12) | VALUE 'STUDENT NAME'. |
| 05 | FILLER | PIC X(110) | VALUE SPACES. |
| 01 DETAIL-LINE. | | | |
| 05 | FILLER | PIC X(8) | VALUE SPACES. |
| 05 | PRINT-NAME | PIC X(25). | |
| 05 | FILLER | PIC X(10) | VALUE SPACES. |
| 05 | PRINT-MAJOR | PIC X(15). | |
| 05 | FILLER | PIC X(74) | VALUE SPACES. |
| 01 TOTAL-LINE. | | | |
| 05 | | PIC X(4) | VALUE SPACES. |
| 05 | | PIC X(14) | VALUE 'TOTAL STUDENTS'. |
| 05 | | PIC X(2) | VALUE SPACES. |
| 05 | TOT-STUDENTS | PIC 9(3) | VALUE ZEROS. |
| 05 | | PIC X(110) | VALUE SPACES. |
| 01 DASHED-LINE | | | |
| 05 | FILLER | PIC X(132) | VALUE ALL '-'. |

FILLER IS OPTIONAL IN COBOL-85

referenced in the Procedure Division, and hence their omission has no effect on the remainder of the program.

VALUE Clause The **VALUE** clause initializes the contents of a data name within the **WORKING-STORAGE SECTION** and has the general form:

VALUE IS literal

Literals are of three types—numeric, nonnumeric, and figurative constants. Numeric literals—for example, 110 or 3.00—contain a number and are used in calculations. Nonnumeric literals, such as 'ENGINEERING', contain a character string and are enclosed in apostrophes or quotations marks. (Additional rules for numeric and nonnumeric literals were presented in Chapter 1.)

A **figurative constant** (**ZERO** or **SPACE**) is a COBOL reserved word with a pre-assigned value. The singular and plural forms of a figurative constant are interchangeable; that is, one can use **SPACE** or **SPACES**, or **ZERO**, **ZEROS**, or **ZEROES**.

Figurative constants are *not* enclosed in quotation marks. COBOL also permits the use of the ALL literal to repeat a character string.

The VALUE clause associated with a particular data name must be consistent with the corresponding PICTURE clause; that is, it is *incorrect* to use a nonnumeric literal with a numeric picture clause or a numeric literal with a nonnumeric picture. Consider:

| | | | |
|------------------|-----------|----------------------|-----------|
| REQUIRED-CREDITS | PIC 999 | VALUE 110. | (valid) |
| REQUIRED-MAJOR | PIC X(10) | VALUE 'ENGINEERING'. | (valid) |
| REQUIRED-CREDITS | PIC 999 | VALUE '110'. | (invalid) |
| REQUIRED-MAJOR | PIC X(10) | VALUE ENGINEERING. | (invalid) |

REQUIRED-CREDITS is defined as a numeric item and must have a numeric value. In similar fashion, REQUIRED-MAJOR is defined as alphanumeric and requires an alphanumeric VALUE clause.

The Tuition Billing Program

The tuition billing program was introduced in Chapter 3 in conjunction with structured programming and design. The stubs program did not, however, show the detailed output as presented in the programming specifications, because the objective at that time was only to test the overall flow of the program. It is necessary, therefore, to return to the original specifications to develop the Identification, Environment, and Data Divisions. We will, however, amplify the development of the Data Division by presenting three figures that relate various portions of the programming specifications to their associated COBOL entries.

Programming Specifications

Figure 4.7a displays the input record layout from the programming specifications; Figure 4.7b shows the corresponding FD and record description. STUDENT-RECORD corresponds to the record as a whole and thus is assigned the level number 01. STUDENT-RECORD in turn is divided into the subordinate fields STU-NAME (which is further divided into STU-LAST-NAME and STU-INITIALS), STU-CREDITS, STU-UNION-MEMBER, and STU-SCHOLARSHIP. STUDENT-RECORD and STU-NAME are group items and do not have a PICTURE clause; all of the other data names are elementary items and have a PICTURE clause. An implied decimal point appears within the PICTURE clause for STU-GPA.

Figure 4.8a excerpts the processing specifications for the computation of a student's bill; Figure 4.8b shows the associated record description as it appears in WORKING-STORAGE. The entries in Figure 4.8b are not required by COBOL per se, and are included to facilitate documentation and maintenance. It would be possible, for example, to use the constants 200 and 25 in the Procedure Division rather than the corresponding data names PRICE-PER-CREDIT and UNION-FEE. The data names, however, facilitate program maintenance; that is, a change in the value of a constant is easier to implement in the Data Division than (in multiple statements) in the Procedure Division.

Figure 4.9a contains the programming specifications for the heading and detail lines; Figure 4.9b shows the associated COBOL entries. Note carefully the exact correspondence between the COBOL entries and report layout. The print layout calls for 10 spaces between the literals STUDENT NAME and CREDITS; thus there is a 10 position FILLER entry between these literals within the COBOL entries.

Figure 4.7 Development of a COBOL Program (File Section)

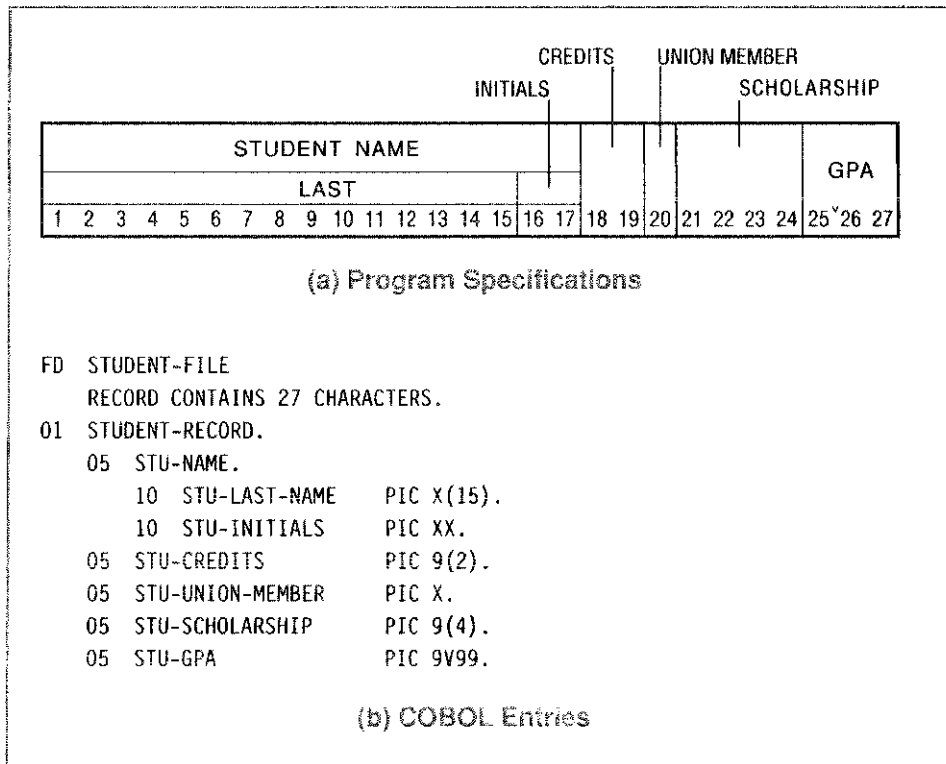

Figure 4.8 Development of a COBOL Program (Constants and Rates)

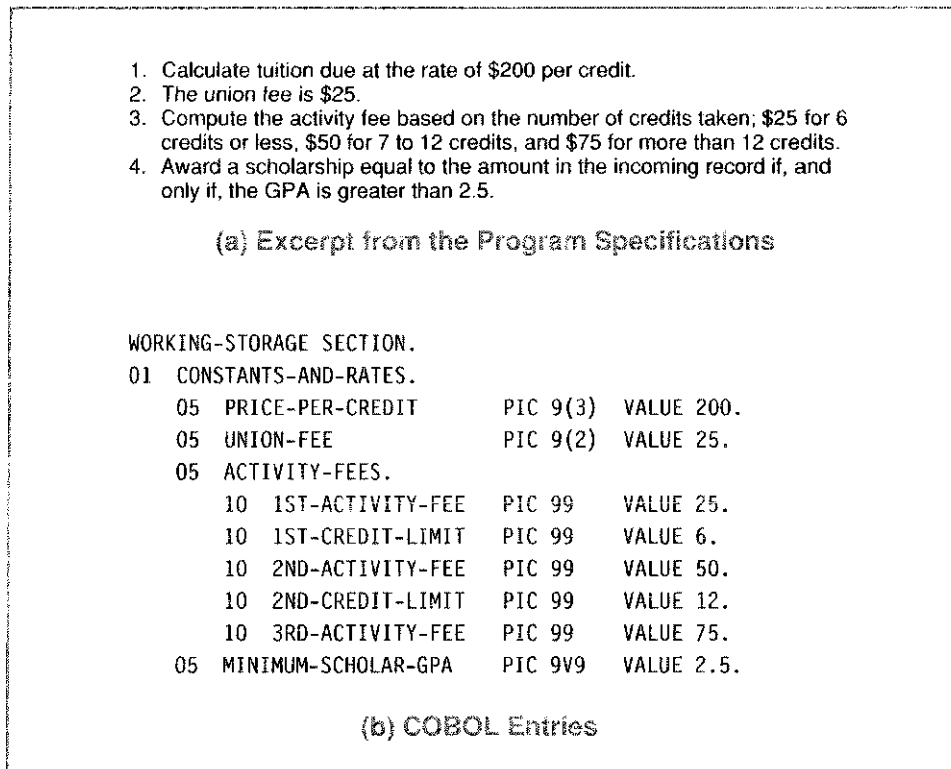

Figure 4.9 Development of a COBOL Program (Print Lines)

| STUDENT NAME | CREDITS | TUITION | UNION FEE | ACT FEE | SCHOLARSHIP | TOTAL BILL |
|------------------|---------|---------|-----------|---------|-------------|------------|
| XXXXXXXXXXXXXXXX | 99 | 999999 | 999 | 999 | 99999 | 999999 |
| XXXXXXXXXXXXXXXX | XX | 999999 | 999 | 999 | 99999 | 999999 |

(a) Report Layout

```

01 HEADING-LINE.
   05 FILLER          PIC X          VALUE SPACES.
   05 FILLER          PIC X(12)     VALUE 'STUDENT NAME'.
   05 FILLER          PIC X(10)     VALUE SPACES.
   05 FILLER          PIC X(7)      VALUE 'CREDITS'.
   05 FILLER          PIC X(2)      VALUE SPACES.
   05 FILLER          PIC X(7)      VALUE 'TUITION'.
   05 FILLER          PIC X(2)      VALUE SPACES.
   05 FILLER          PIC X(9)      VALUE 'UNION FEE'.
   05 FILLER          PIC X(2)      VALUE SPACES.
   05 FILLER          PIC X(7)      VALUE 'ACT FEE'.
   05 FILLER          PIC X(2)      VALUE SPACES.
   05 FILLER          PIC X(11)     VALUE 'SCHOLARSHIP'.
   05 FILLER          PIC X(2)      VALUE SPACES.
   05 FILLER          PIC X(10)     VALUE 'TOTAL BILL'.
   05 FILLER          PIC X(48)     VALUE SPACES.

01 DETAIL-LINE.
   05 FILLER          PIC X          VALUE SPACES.
   05 DET-LAST-NAME   PIC X(15).
   05 FILLER          PIC X(2)      VALUE SPACES.
   05 DET-INITIALS    PIC X(2).
   05 FILLER          PIC X(5)      VALUE SPACES.
   05 DET-CREDITS     PIC 9(2).
   05 FILLER          PIC X(6)      VALUE SPACES.
   05 DET-TUITION     PIC 9(6).
   05 FILLER          PIC X(7)      VALUE SPACES.
   05 DET-UNION-FEE   PIC 9(3).
   05 FILLER          PIC X(6)      VALUE SPACES.
   05 DET-ACTIVITY-FEE PIC 9(3).
   05 FILLER          PIC X(8)      VALUE SPACES.
   05 DET-SCHOLARSHIP PIC 9(5).
   05 FILLER          PIC X(6)      VALUE SPACES.
   05 DET-IND-BILL    PIC 9(6).
   05 FILLER          PIC X(49)     VALUE SPACES.
    
```

(b) COBOL Entries

COBOL Entries

Figure 4.10 contains the completed entries for the first three divisions. (The completed Procedure Division appears at the end of Chapter 5.) The Identification Division is unchanged from the stubs program in Chapter 3 and contains only the required PROGRAM-ID paragraph and an optional AUTHOR paragraph. The Environment Division has expanded slightly to include an additional SELECT statement for the print file (lines 10 and 11).

The Data Division, however, has grown significantly. The FILE SECTION contains the FD for the incoming student record (lines 15 and 16) followed by the associated record description in lines 17 through 24. A file description has also been added for PRINT-FILE. Note, too, the correspondence between the SELECT statements in the Environment Division and the associated FD entries in the Data Division.

The programming specifications call for multiple calculations for each student (tuition, union fee, activity fee, scholarship) as well as university totals for each item. Each of these calculations requires a separate data name in WORKING-STORAGE to store the result. Observe, therefore, the definition of the elementary items IND-TUITION, IND-ACTIVITY-FEE, and so on, which appear together (for convenience) under the group item INDIVIDUAL-CALCULATIONS (line 33). In similar fashion, the elementary items UNI-TUITION, UNI-ACTIVITY-FEE, and so on, appear under the group item UNIVERSITY-TOTALS (line 40). There is also a separate 01 entry to hold the constants and rates required by the program (lines 47–56).

The program requires several different types of print lines—a heading line, a detail line, and a total line, each with a different format. Thus, there are separate 01 entries for HEADING-LINE (lines 58–73), DETAIL-LINE (lines 75–92), and TOTAL-LINE in lines 107–121. Note, too, the separate entry for DASH-LINE (lines 94–105), which makes use of the ALL literal to establish a row of dashes. Look carefully at the use of the FILLER and associated VALUE clauses in each of these print lines, to create the necessary literal information, and the correspondence between these entries and the COBOL specifications.

Figure 4.10 Identification, Environment, and Data Divisions for Tuition Billing Program

```

1  IDENTIFICATION DIVISION.
2  PROGRAM-ID.    TUITION5.
3  AUTHOR.       CAROL VAZQUEZ VILLAR.
4
5  ENVIRONMENT DIVISION.
6  INPUT-OUTPUT SECTION.
7  FILE-CONTROL.
8      SELECT STUDENT-FILE ASSIGN TO 'A:\CHAPTR05\TUITION.DAT'
9          ORGANIZATION IS LINE SEQUENTIAL.
10     SELECT PRINT-FILE
11         ASSIGN TO PRINTER.
12

```

Figure 4.10 Identification, Environment, and Data Divisions for Tuition Billing Program (continued)

```

13      DATA DIVISION.
14      FILE SECTION.
15      FD STUDENT-FILE
16         RECORD CONTAINS 27 CHARACTERS.
17      01 STUDENT-RECORD.
18         05 STU-NAME.
19            10 STU-LAST-NAME    PIC X(15).
20            10 STU-INITIALS    PIC XX.
21         05 STU-CREDITS        PIC 9(2).
22         05 STU-UNION-MEMBER   PIC X.
23         05 STU-SCHOLARSHIP    PIC 9(4).
24         05 STU-GPA            PIC 9V99.
25
26      FD PRINT-FILE
27         RECORD CONTAINS 132 CHARACTERS.
28      01 PRINT-LINE            PIC X(132).
29
30      WORKING-STORAGE SECTION.
31      01 DATA-REMAINS-SWITCH  PIC X(2) VALUE SPACES.
32
33      01 INDIVIDUAL-CALCULATIONS.
34         05 IND-TUITION        PIC 9(4) VALUE ZEROS.
35         05 IND-ACTIVITY-FEE   PIC 9(2) VALUE ZEROS.
36         05 IND-UNION-FEE      PIC 9(2) VALUE ZEROS.
37         05 IND-SCHOLARSHIP    PIC 9(4) VALUE ZEROS.
38         05 IND-BILL           PIC 9(6) VALUE ZEROS.
39
40      01 UNIVERSITY-TOTALS.
41         05 UNI-TUITION        PIC 9(6) VALUE ZEROS.
42         05 UNI-UNION-FEE     PIC 9(4) VALUE ZEROS.
43         05 UNI-ACTIVITY-FEE  PIC 9(4) VALUE ZEROS.
44         05 UNI-SCHOLARSHIP   PIC 9(6) VALUE ZEROS.
45         05 UNI-IND-BILL      PIC 9(6) VALUE ZEROS.
46
47      01 CONSTANTS-AND-RATES.
48         05 PRICE-PER-CREDIT  PIC 9(3) VALUE 200.
49         05 UNION-FEE         PIC 9(2) VALUE 25.
50         05 ACTIVITY-FEES.
51            10 1ST-ACTIVITY-FEE PIC 99 VALUE 25.
52            10 1ST-CREDIT-LIMIT PIC 99 VALUE 6.
53            10 2ND-ACTIVITY-FEE PIC 99 VALUE 50.
54            10 2ND-CREDIT-LIMIT PIC 99 VALUE 12.
55            10 3RD-ACTIVITY-FEE PIC 99 VALUE 75.
56         05 MINIMUM-SCHOLAR-GPA PIC 9V9 VALUE 2.5.
57
58      01 HEADING-LINE.
59         05 FILLER            PIC X VALUE SPACES.
60         05 FILLER            PIC X(12) VALUE 'STUDENT NAME'.
61         05 FILLER            PIC X(10) VALUE SPACES.
62         05 FILLER            PIC X(7) VALUE 'CREDITS'.

```

STU-NAME is a group item with two elementary items

Implied decimal point

VALUE clauses initialize data names

Separate areas for heading and detail lines

Figure 4.10 (continued)

```

63      05 FILLER          PIC X(2) VALUE SPACES.
64      05 FILLER          PIC X(7) VALUE 'TUITION'.
65      05 FILLER          PIC X(2) VALUE SPACES.
66      05 FILLER          PIC X(9) VALUE 'UNION FEE'.
67      05 FILLER          PIC X(2) VALUE SPACES.
68      05 FILLER          PIC X(7) VALUE 'ACT FEE'.
69      05 FILLER          PIC X(2) VALUE SPACES.
70      05 FILLER          PIC X(11) VALUE 'SCHOLARSHIP'.
71      05 FILLER          PIC X(2) VALUE SPACES.
72      05 FILLER          PIC X(10) VALUE 'TOTAL BILL'.
73      05 FILLER          PIC X(48) VALUE SPACES.
74

```

75 01 **DETAIL-LINE.** *Separate areas for heading and detail lines*

```

76      05 FILLER          PIC X      VALUE SPACES.
77      05 DET-LAST-NAME   PIC X(15).
78      05 FILLER          PIC X(2)  VALUE SPACES.
79      05 DET-INITIALS    PIC X(2).
80      05 FILLER          PIC X(5)  VALUE SPACES.
81      05 DET-CREDITS     PIC 9(2).
82      05 FILLER          PIC X(6)  VALUE SPACES.
83      05 DET-TUITION     PIC 9(6).
84      05 FILLER          PIC X(7)  VALUE SPACES.
85      05 DET-UNION-FEE   PIC 9(3).
86      05 FILLER          PIC X(6)  VALUE SPACES.
87      05 DET-ACTIVITY-FEE PIC 9(3).
88      05 FILLER          PIC X(8)  VALUE SPACES.
89      05 DET-SCHOLARSHIP PIC 9(5).
90      05 FILLER          PIC X(6)  VALUE SPACES.
91      05 DET-IND-BILL    PIC 9(6).
92      05 FILLER          PIC X(49) VALUE SPACES.
93

```

94 01 **DASH-LINE.** *Separate areas for dash and total lines*

```

95      05 FILLER          PIC X(31) VALUE SPACES.
96      05 FILLER          PIC X(8)  VALUE ALL '-'.
97      05 FILLER          PIC X(2)  VALUE SPACES.
98      05 FILLER          PIC X(8)  VALUE ALL '-'.
99      05 FILLER          PIC X(2)  VALUE SPACES.
100     05 FILLER          PIC X(7)  VALUE ALL '-'.
101     05 FILLER          PIC X(6)  VALUE SPACES.
102     05 FILLER          PIC X(7)  VALUE ALL '-'.
103     05 FILLER          PIC X(5)  VALUE SPACES.
104     05 FILLER          PIC X(7)  VALUE ALL '-'.
105     05 FILLER          PIC X(49) VALUE SPACES.
106

```

107 01 **TOTAL-LINE.**

```

108     05 FILLER          PIC X(8)  VALUE SPACES.
109     05 FILLER          PIC X(17)
110     VALUE 'UNIVERSITY TOTALS'.
111     05 FILLER          PIC X(8)  VALUE SPACES.
112     05 TOT-TUITION     PIC 9(6).

```

Figure 4.10 (continued)

| | | | | |
|-----|----|------------------|-----------|---------------|
| 113 | 05 | FILLER | PIC X(6) | VALUE SPACES. |
| 114 | 05 | TOT-UNION-FEE | PIC 9(4). | |
| 115 | 05 | FILLER | PIC X(5) | VALUE SPACES. |
| 116 | 05 | TOT-ACTIVITY-FEE | PIC 9(4). | |
| 117 | 05 | FILLER | PIC X(7) | VALUE SPACES. |
| 118 | 05 | TOT-SCHOLARSHIP | PIC 9(6). | |
| 119 | 05 | FILLER | PIC X(6) | VALUE SPACES. |
| 120 | 05 | TOT-IND-BILL | PIC 9(6). | |
| 121 | 05 | FILLER | PIC X(49) | VALUE SPACES. |

LIMITATIONS OF COBOL-74

The CONFIGURATION SECTION, SOURCE-COMPUTER, and OBJECT-COMPUTER entries are optional in COBOL-85 but are required in COBOL-74. The LABEL RECORDS clause is optional in COBOL-85 but is required in COBOL-74.

The BLOCK CONTAINS clause is optional in both compilers, but its omission has different effects. Omitting the clause in COBOL-85 causes the system to take the blocking factor from the operating environment (and is equivalent to the IBM entry BLOCK CONTAINS 0 RECORDS). Omission of the clause in COBOL-74 defaults to the implementor-designated number, regardless of what was specified in the control statements to the operating system.

COBOL-85 allows two new relationships, GREATER THAN OR EQUAL TO and LESS THAN OR EQUAL TO, in the condition portion of an IF statement. These were not allowed in COBOL-74, which used NOT LESS THAN as the equivalent of GREATER THAN OR EQUAL TO.

The word FILLER is optional in COBOL-85, whereas it is required in COBOL-74.

S U M M A R Y

Points to Remember

- COBOL notation is the standardized form used to express permissible COBOL formats. Uppercase letters indicate COBOL reserved words, whereas lowercase letters denote programmer-supplied information. Brackets [] imply an optional entry, whereas braces { } indicate a choice between required entries. Any underlined item is required.
- The PROGRAM-ID paragraph is the only required entry in the Identification Division; the AUTHOR paragraph is strongly recommended. The

Environment Division contains the FILE-CONTROL paragraph that defines the files used in a program through SELECT statements.

- The FILE SECTION contains a file description for every file previously defined in a SELECT statement in the Environment Division. The file description is followed by a record description to describe the fields within a file.
- The PICTURE clause indicates the size and type of a data name. An elementary item always has a PICTURE clause, whereas a group item does not. Level numbers assume values from 01 to 49 inclusive, with 01 assigned to the record as a whole. Level numbers need not be assigned consecutive values.
- The WORKING-STORAGE SECTION contains additional record descriptions for data names not found in the FILE SECTION. VALUE clauses assign an initial value to a data name of a numeric literal, a nonnumeric literal, or a figurative constant.

Key Words and Concepts

| | |
|---------------------------------|--------------------|
| Alphanumeric item | Group item |
| Assumed (implied) decimal point | Heading line |
| Blocking factor | Level numbers |
| Braces | Logical record |
| Brackets | Numeric item |
| COBOL notation | Physical record |
| Detail line | Record description |
| Elementary item | Size |
| Figurative constant | Total line |
| File description | Type |

COBOL Elements

| | |
|----------------------|-------------------------|
| ALL | INSTALLATION |
| ASSIGN | LABEL RECORDS |
| AUTHOR | PICTURE |
| BLOCK CONTAINS | PROGRAM-ID |
| DATA RECORD IS | RECORD CONTAINS |
| DATE-COMPILED | SECURITY |
| DATE-WRITTEN | SELECT |
| FD | SPACES |
| FILE SECTION | VALUE |
| FILE-CONTROL | WORKING-STORAGE SECTION |
| FILLER | ZEROS |
| INPUT-OUTPUT SECTION | |

FILL-IN

1. The _____ Division is the first division in a COBOL program.
2. The _____ paragraph is the only required entry in the Identification Division.
3. In the COBOL notation, _____ indicate that one of the enclosed elements must be included.
4. Required reserved words are written in _____ letters and are _____.
5. Lowercase letters indicate _____ information.
6. The Environment Division contains _____ sections.
7. The _____ statement ties a programmer-chosen file name to a system name.
8. A _____ item is divided into one or more elementary items.
9. An elementary item always has a _____ clause.
10. Level numbers appearing under a 01 record may range from _____ to _____.
11. The Data Division contains the _____ and _____ sections.
12. The presence of a V in a numeric picture indicates an _____ decimal point.
13. Incoming numeric fields (may/may not) contain an actual decimal point.
14. _____ denotes a field that is not referenced by name.
15. The _____ specifies the number of _____ records in one _____ record.

TRUE/FALSE

1. The Identification Division may contain up to six paragraphs.
2. The PROGRAM-ID paragraph is the only required paragraph in the Identification Division.
3. Square brackets indicate a required entry.
4. Braces imply that one of the enclosed entries must be chosen.
5. A COBOL program that runs successfully on a PC would also run successfully on a mainframe with no modification whatever.
6. A level number may assume any value from 01 to 49.
7. A 01-level entry cannot have a PICTURE clause.
8. All elementary items have a PICTURE clause.
9. A group item may have a PICTURE clause.
10. 01-level entries may appear in both the File and Working-Storage Sections of the Data Division.

11. A data name at the 10 level will always be an elementary item.
12. A data name at the 05 level may or may not have a PICTURE clause.
13. PICTURE, PICTURE IS, PIC, and PIC IS are all acceptable forms of the PICTURE clause.
14. PICTURE IS 9(3) and PICTURE IS 999 are equivalent entries.
15. The File Section is required in every COBOL program.
16. An incoming numeric field may contain an actual decimal point.
17. The RECORD CONTAINS clause is required in an FD.

P R O B L E M S

1. Consider the accompanying time card. Show an appropriate record description for this information in COBOL; use any PICTURE clauses you think appropriate.

| Time-Record | | | | | | | |
|-------------|--------|------|--------|------|----|----|-------|
| Name | | | Number | Date | | | Hours |
| First | Middle | Last | | MO | DA | YR | |
| | | | | | | | |

2. In which division(s) do you find the
 - a. PROGRAM-ID paragraph?
 - h. DATE-COMPILED paragraph?
 - b. FILE-CONTROL paragraph?
 - i. INPUT-OUTPUT SECTION?
 - c. CONFIGURATION SECTION?
 - j. File names?
 - d. WORKING-STORAGE SECTION?
 - k. Level numbers?
 - e. FILE SECTION?
 - l. SELECT statements?
 - f. FD's?
 - m. VALUE clauses?
 - g. AUTHOR paragraph?
 - n. PICTURE clauses?

3. Given the following record layout:

```

01 EMPLOYEE-RECORD.
   05 SOC-SEC-NUMBER          PIC 9(9).
   05 EMPLOYEE-NAME.
      10 LAST-NAME           PIC X(12).
      10 FIRST-NAME          PIC X(10).
      10 MIDDLE-INIT         PIC X.
   05 FILLER                  PIC X.
   05 BIRTH-DATE.
      10 BIRTH-MONTH         PIC 99.
      10 BIRTH-DAY           PIC 99.
      10 BIRTH-YEAR          PIC 99.
   05 FILLER                  PIC X(3).
    
```

```

05 EMPLOYEE-ADDRESS.
  10 NUMBER-AND-STREET.
    15 HOUSE-NUMBER PIC X(6).
    15 STREET-NAME PIC X(10).
  10 CITY-STATE-ZIP.
    15 CITY PIC X(10).
    15 STATE PIC X(4).
    15 ZIP PIC 9(5).
05 FILLER PIC X(3).
    
```

- a. List all group items.
- b. List all elementary items.
- c. State the record positions in which the following fields are found:
 - * SOC-SEC-NUMBER
 - * EMPLOYEE-NAME
 - * LAST-NAME
 - * FIRST-NAME
 - * MIDDLE-INIT
 - * BIRTH-DATE
 - * BIRTH-MONTH
 - * BIRTH-DAY
 - * BIRTH-YEAR
 - * EMPLOYEE-ADDRESS
 - * NUMBER-AND-STREET
 - * HOUSE-NUMBER
 - * STREET-NAME
 - * CITY-STATE-ZIP
 - * CITY
 - * STATE
 - * ZIP
4. Given the following record layout (assume that FIELD-I is the last entry under FIELD-A),

```

01 FIELD-A
  05 FIELD-B
    10 FIELD-C
    10 FIELD-D
  05 FIELD-E
  05 FIELD-F
    10 FIELD-G
    10 FIELD-H
    10 FIELD-I
    
```

answer true or false.

- a. FIELD-C is an elementary item.
- b. FIELD-E is an elementary item.
- c. FIELD-E should have a picture.
- d. FIELD-F should have a picture.
- e. FIELD-B must be larger than FIELD-C.
- f. FIELD-C must be larger than FIELD-D.
- g. FIELD-C must be larger than FIELD-H.

- h. FIELD-B and FIELD-D end in the same column.
 - i. FIELD-A and FIELD-I end in the same column.
 - j. FIELD-E could be larger than FIELD-F.
 - k. FIELD-D could be larger than FIELD-E.
 - l. FIELD-F and FIELD-G start in the same column.
5. Use the COBOL notation introduced at the beginning of the chapter and the general format of the FD entry to determine whether the following are valid FD entries.
- a. FD EMPLOYEE-FILE.
 - b. FD EMPLOYEE-FILE
BLOCK CONTAINS 10 RECORDS
RECORD CONTAINS 100 CHARACTERS
LABEL RECORDS ARE STANDARD
DATA RECORD IS EMPLOYEE-RECORD.
 - c. FD EMPLOYEE-FILE
BLOCK 10 RECORDS
RECORD 100 CHARACTERS
LABEL RECORDS STANDARD
DATA RECORD EMPLOYEE-RECORD.
6. Indicate whether each of the following entries is spelled correctly and whether it is syntactically valid.
- a. ENVIRONMENT DIVISION
 - b. WORKING-STORAGE-SECTION
 - c. IDENTIFICATION-DIVISION
 - d. WRITTEN-BY
 - e. DATA-DIVISION
 - f. FILE SECTION
 - g. PROGRAM ID
 - h. DATE-WRITTEN
 - i. DATE-EXECUTED
 - j. INPUT-OUTPUT SECTION
 - k. FILE-CONTROL SECTION
 - l. DATE DIVISION
 - m. COMMENTS



The Procedure Division

CHAPTER OUTLINE

Overview

OPEN

CLOSE

READ

Placement of the READ Statement

WRITE

STOP RUN

MOVE

Restrictions on the MOVE Statement

Alphanumeric Field to

Alphanumeric Field

Numeric Field to Numeric Field

Group Moves

PERFORM

IF

The ELSE Clause

Indentation

EVALUATE

Arithmetic Statements

The ROUNDED Clause

The SIZE ERROR Clause

COMPUTE

ADD

SUBTRACT

MULTIPLY

DIVIDE

Programming Tip: Use the

COMPUTE Statement

Assumed Decimal Point

The Tuition Billing Program

Test Data

Hierarchy Chart

COBOL Program Skeleton

Limitations of COBOL-74

Summary

Fill-in

True/False

Problems

OBJECTIVES

After reading this chapter you will be able to:

- Write the OPEN, CLOSE, READ, and WRITE statements necessary for sequential file processing.
- Describe the purpose of the priming (initial) READ statement, and place it correctly in the Procedure Division.
- Discuss the rules of the MOVE statement as they apply to numeric and alphanumeric fields.
- Describe the PERFORM statement; show how this statement is used to process a file until all of its records have been read.
- Describe the IF statement and how it is used with and without an ELSE clause; explain the significance of the END-IF scope terminator.
- Use the EVALUATE statement to implement a case (multibranch) construct.
- State the hierarchy of operations for a COMPUTE statement; describe the individual arithmetic statements, ADD, SUBTRACT, MULTIPLY, and DIVIDE.
- Describe the ROUNDED and SIZE ERROR options as they apply to any of the arithmetic statements.
- Explain the relationship between a Procedure Division and its associated hierarchy chart.

OVERVIEW

This is a long chapter—the longest in the text. It focuses on the Procedure Division, which is the portion of a COBOL program that contains the logic. The chapter is long because it presents the many statements needed to write a basic program such as the tuition billing program introduced in Chapter 3.

We begin with the COBOL statements used for I/O (input/output) operations; OPEN, CLOSE, READ, and WRITE, and continue with the STOP RUN statement to terminate program execution. We learn about the PERFORM statement to implement a loop, the IF statement to implement the selection structure, and the EVALUATE statement to implement a case structure. We study the MOVE statement to copy data from one location to another and end with the arithmetic statements: COMPUTE, ADD, SUBTRACT, MULTIPLY, and DIVIDE.

The chapter concludes with the completed COBOL listing for the tuition billing program of Chapter 3.

OPEN

The **OPEN** statement initiates processing for a file. It indicates the nature of the file (input or output) and ensures that a specific device is available for the I/O operations. The **OPEN** statement also performs validation functions in conjunction with the **LABEL**

RECORDS clause of the FD; for example, if label records are specified for an input file, the OPEN statement checks the header label of that file to ensure that the proper file is available for processing. An abbreviated format of the OPEN statement is:

$$\text{OPEN } \left\{ \begin{array}{l} \text{INPUT} \\ \text{OUTPUT} \end{array} \right\} \text{ file-name-1 . . . } \left\} . . .$$

The syntax of the OPEN statement indicates a mandatory selection for the type of file—INPUT is used for a file that is read, whereas OUTPUT is used for a file that is written to. The brackets and ellipsis associated with file-name-2 imply that multiple files can be opened in the same statement as was done in lines 43 and 44 of the engineering senior program in Figure 1.6:

```
OPEN INPUT STUDENT-FILE
      OUTPUT PRINT-FILE.
```

Each file referenced in an OPEN statement must have been previously defined in a SELECT statement in the Environment Division, and in a corresponding FD in the Data Division. All files must be opened before they can be accessed; the operating system will terminate execution of a COBOL program that attempts to read (or write) an unopened file.

CLOSE

The CLOSE statement is executed when access to a file is no longer necessary, such as when all records have been read from an input file or when all records have been written to an output file. The CLOSE statement releases the I/O devices associated with the file; it also writes trailer labels at the end of files on disk or tape in conjunction with the LABEL RECORDS clause of the FD. All open files should be closed before processing terminates. The format of the CLOSE is simply:

```
CLOSE file-name-1 [, file-name-2 ...]
```

The brackets and ellipsis associated with file-name-2 indicate that multiple files can be closed in the same statement. The type of file, INPUT or OUTPUT, is not specified when the file is closed because the distinction between input and output is no longer important. Lines 51 and 52 in the engineering senior program provide an example:

```
CLOSE STUDENT-FILE
      PRINT-FILE.
```

A CLOSE statement can appear anywhere within a program but typically appears immediately before the program terminates, that is, immediately before the STOP RUN statement.

READ

The READ statement transfers data from an open file into memory, provided a record is available. If, however, no record is present—that is, the *end-of-file* condition has been reached—control passes to the statement(s) following the AT END clause. An abbreviated format of the READ statement is shown below:

```
READ file-name
      AT END statement
      [END-READ]
```

The END-READ scope terminator is optional but strongly recommended. The READ statement is illustrated in lines 45–47 of the engineering senior program.

```

READ STUDENT-FILE
  AT END MOVE 'NO' TO DATA-REMAINS-SWITCH
END-READ.

```

Placement of the READ Statement

The engineering senior program in Figure 1.6 contained two distinct READ statements. There was an initial, or priming, READ in lines 45–47 and a second READ statement as the *last* instruction of the performed paragraph (lines 65–67). The necessity for *both* statements is explained by considering Figure 5.1, which shows correct and incorrect ways to process a file of transactions.

Figure 5.1a, the *incorrect* implementation, causes the last record of INPUT-FILE to be processed twice. To see how this happens, consider a file with only two records, A and B, realizing that such a file is read three times—once for each record and once to sense the end of file. Realize, too, that the PERFORM statement evaluates the UNTIL condition *before* branching (a detailed description of the PERFORM statement is found in an upcoming section).

In Figure 5.1a, record A is read the first time PROCESS-RECORDS is performed, with execution continuing through the remainder of the PROCESS-RECORDS paragraph, at which point DATA-REMAINS-SWITCH is still set to 'YES'. Hence, PROCESS-RECORDS is executed a second time, during which time it reads and processes record B. Since DATA-REMAINS-SWITCH is still set to 'YES', PROCESS-RECORDS is executed a third time, during which the end-of-file condition is sensed immediately. Execution continues, however, to the end of the paragraph, causing the last record (record B) to be processed twice.

In the *correct* implementation of Figure 5.1b, an initial (priming) READ is executed *before* performing the paragraph PROCESS-RECORDS, which also contains a READ statement. The first time PROCESS-RECORDS is performed, it processes record A, and its *last* statement reads record B. Since DATA-REMAINS-SWITCH is still set to 'YES', PROCESS-RECORDS is executed a second time to process record B, with the ending READ statement sensing the end-of-file condition. DATA-REMAINS-SWITCH is set to 'NO', which in turn terminates the PERFORM statement.

WRITE

The WRITE statement transfers data from memory to the printer (or other open output device). Consider:

```
WRITE record-name
```

$$\left[\begin{array}{l} \text{AFTER} \\ \text{BEFORE} \end{array} \right] \text{ADVANCING} \left\{ \begin{array}{l} \text{integer} \\ \text{PAGE} \end{array} \right. \left[\begin{array}{l} \text{LINE} \\ \text{LINES} \end{array} \right] \left. \right\}$$

The ADVANCING option controls the line spacing on a printer; for example, specification of AFTER ADVANCING 3 LINES produces triple spacing (the printer skips two lines and writes on the third). Conversely, specification of the BEFORE option first writes the line, then skips the designated amount. Specification of

Figure 5.1 Placement of the READ Statement

PREPARE-TUITION-REPORT.

.
.

MOVE 'YES' TO DATA-REMAINS-SWITCH.
PERFORM PROCESS-RECORDS
 UNTIL DATA-REMAINS-SWITCH = 'NO'.

.
.

PROCESS-RECORDS.

READ INPUT-FILE
 AT END MOVE 'NO' TO DATA-REMAINS-SWITCH
END-READ.

First statement of performed paragraph is the READ

(a) Incorrect Implementation

PREPARE-TUITION-REPORT.

.
.

MOVE 'YES' TO DATA-REMAINS-SWITCH.

READ INPUT-FILE
 AT END MOVE 'NO' TO DATA-REMAINS-SWITCH
END-READ.

Initial READ is executed once and only once

PERFORM PROCESS-RECORDS
 UNTIL DATA-REMAINS-SWITCH = 'NO'.

.
.

PROCESS-RECORDS.

.
.

READ INPUT-FILE
 AT END MOVE 'NO' TO DATA-REMAINS-SWITCH
END-READ.

Last statement of performed paragraph is another READ

(b) Correct Implementation

PAGE, in lieu of LINES, will cause output to begin on top of a new page. Omission of the ADVANCING option defaults to single spacing. The examples below

```
WRITE PRINT-LINE.
WRITE PRINT-LINE
    AFTER ADVANCING 2 LINES.
WRITE PRINT-LINE
    AFTER ADVANCING PAGE.
```

will single space, double space, and advance to the top of a new page, respectively.

The WRITE statement contains a *record* name, whereas the READ statement contains a *file* name. The record name in the WRITE statement will appear as a 01 entry in the File Section of the Data Division. The file in which it is contained will appear in SELECT, FD, OPEN, and CLOSE statements.

STOP RUN

The format of the STOP RUN statement is simply:

```
STOP RUN
```

The STOP RUN statement terminates execution of a COBOL program and returns control to the operating system. [STOP RUN need not be (and typically is not) the last physical statement in the program.] All files should be closed prior to executing the STOP RUN statement.

MOVE

The MOVE statement copies data from one location to another; for example, the statement MOVE A TO B copies the value in location A to location B. The value of A is in two places after the move has taken place, while the initial value of B is gone (having been replaced by the value of A). The syntax of the MOVE statement is:

$$\underline{\text{MOVE}} \left\{ \begin{array}{l} \text{identifier-1} \\ \text{literal-1} \end{array} \right\} \underline{\text{TO}} \text{identifier-2} [\text{identifier-3}] \dots$$

Consider the following examples:

1. MOVE 200 TO PRICE-PER-CREDIT.
2. MOVE 'ABC UNIVERSITY' TO SCHOOL-NAME.
3. MOVE STU-NAME TO PRINT-NAME.
4. MOVE ZEROS TO TOTAL-NUMBER.
5. MOVE SPACES TO PRINT-LINE.

Example one moves a numeric literal, 200, to the data name PRICE-PER-CREDIT. Example two moves a nonnumeric literal, 'ABC UNIVERSITY', to SCHOOL-NAME. Example three copies data from an input area to an output area for subsequent printing. Examples four and five use the figurative constants, ZEROS and SPACES, to initialize a counter and print line, respectively.

The brackets and ellipsis associated with identifier-3 in the COBOL syntax indicate the same item can be moved to multiple data names. Thus the single statement:

```
MOVE 10 TO FIELD-A FIELD-B FIELD-C.
```

is equivalent to the three individual statements:

```
MOVE 10 TO FIELD-A.
MOVE 10 TO FIELD-B.
MOVE 10 TO FIELD-C.
```

Restrictions on the MOVE Statement

The results of a MOVE statement depend on the type of data in the sending and/or receiving field. We concentrate initially on MOVE statements involving only elementary items, since these statements are by far the most common. Recall (from Chapter 4) that elementary data items may be of four types:

- Numeric Numeric data items, numeric literals, and the figurative constants, ZERO, ZEROS, or ZEROES.
- Alphabetic Alphabetic data items and the figurative constants, SPACE and SPACES
- Alphanumeric Alphanumeric data items, nonnumeric literals and the figurative constants, SPACE and SPACES
- Numeric Edited Numeric edited data items (to be discussed in Chapter 7)

In theory a MOVE statement could involve any combination of these four types; in actuality, however, certain types of moves are not permitted as indicated by Table 5.1. (You do not have to commit the table to memory; simply be aware that certain restrictions exist, and know where to turn should questions arise later.)

TABLE 5.1 Rules of the MOVE Statement (Elementary Data Items)

| | ALPHABETIC | ALPHANUMERIC | NUMERIC | NUMERIC EDITED |
|-----------------------|------------|---------------|---------|----------------|
| Alphabetic | Valid | Valid | Invalid | Invalid |
| Alphanumeric | Invalid | Valid | Invalid | Invalid |
| Numeric | Invalid | Integers only | Valid | Valid |
| Numeric Edited | Invalid | Valid | Valid | Invalid |

At first glance Table 5.1 seems overwhelming, but a second look shows it to make intuitive sense. You cannot, for example, move an alphanumeric field to an alphabetic field (because the alphanumeric field may contain numbers, which are invalid in an alphabetic field). You can, however, do the move in the opposite direction; that is, you can move an alphabetic field to an alphanumeric field.

Even Table 5.1 does not tell us everything we need to know about the MOVE statement. What happens, for example, when moves with like fields (an alphanumeric sending field to an alphanumeric receiving field) involve PICTURE clauses of different lengths? Additional explanation is required as explained in the next two sections.

Alphanumeric Field to Alphanumeric Field

Data moved from an alphanumeric field to an alphanumeric field are moved one character at a time from left to right. If the receiving field is larger than the sending field, it is padded on the right with blanks; if the receiving field is smaller than the sending field, the rightmost characters are truncated.

Alphanumeric moves are illustrated in Table 5.2. Example (a) is trivial, in that the sending and receiving fields have the same picture clause. In example (b) the sending field is one character longer than the receiving field; hence the rightmost

character is truncated. Data are moved from left to right one character at a time; thus A, B, C, and D are moved in that order, and E is dropped. In example (c), however, the receiving field is one character longer than the sending field. A, B, C, D, and E are moved in that order, and a blank is added at the right.

TABLE 5.2 Illustration of the MOVE Statement: Alphanumeric Sending Field to Alphanumeric Receiving Field

| PICTURE | CONTENTS | PICTURE | CONTENTS |
|----------|-----------|---------|-----------|
| (a) X(5) | A B C D E | X(5) | A B C D E |
| (b) X(5) | A B C D E | X(4) | A B C D |
| (c) X(5) | A B C D E | X(6) | A B C D E |

Numeric Field to Numeric Field

All moves involving numeric fields maintain decimal alignment. If the integer portion of the receiving field is larger than that of the sending field, high-order (insignificant) zeros are added to the receiving field. If, however, the integer portion of the receiving field is smaller than that of the sending field, the high-order (significant) digits of the sending field are truncated.

In similar fashion if the decimal portion of the receiving field is larger than that of the sending field, low-order zeros are added. And finally, if the decimal portion of the receiving field is smaller than that of the sending field, the extra positions are truncated. These points are clarified in Table 5.3.

TABLE 5.3 Illustration of the MOVE Statement: Numeric Sending Field to Numeric Receiving Field

| PICTURE | CONTENTS | PICTURE | CONTENTS |
|-------------|-----------|---------|-------------|
| (a) 9(5) | 1 2 3 4 5 | 9(5) | 1 2 3 4 5 |
| (b) 9(5) | 1 2 3 4 5 | 9(4) | 2 3 4 5 |
| (c) 9(5) | 1 2 3 4 5 | 9(6) | 0 1 2 3 4 5 |
| (d) 9(3)V99 | 1 2 3 4 5 | 9(3) | 1 2 3 |
| (e) 9(3)V99 | 1 2 3 4 5 | 9V99 | 3 4 5 |
| (f) 9(3) | 1 2 3 | 9(3)V99 | 1 2 3 0 0 |

Example (a) is trivial. Example (b) attempts to move a five-position field to a four-position field. Since decimal alignment is always maintained, the leftmost digit (i.e., the *most significant* digit) is truncated. Example (c) moves a five-position sending field to a six-position receiving field, causing the addition of a leading (nonsignificant) zero. The sending field in example (d) has two digits after the decimal point, but the receiving field has none. Hence the 4 and 5 do not appear in the receiving field. Example (e) truncates the most significant digits. Example (f) adds two nonsignificant zeros to the receiving field.

Group Moves

The preceding discussion concerned MOVE statements in which the receiving field was an elementary item. The results are very different if a group item is involved, because *if the receiving field is a group item, the move takes place as though the receiving field were an alphanumeric item, with padding or truncation on the right as necessary*. MOVE statements involving group items often produce unexpected results and should be avoided.

The PERFORM statement transfers control to a procedure (paragraph) elsewhere in the program, allowing the program to be divided into functional modules. An abbreviated format of the PERFORM statement is:

```
PERFORM procedure-name
      [UNTIL condition]
```

Consider first the statement *without* an UNTIL clause as illustrated below:

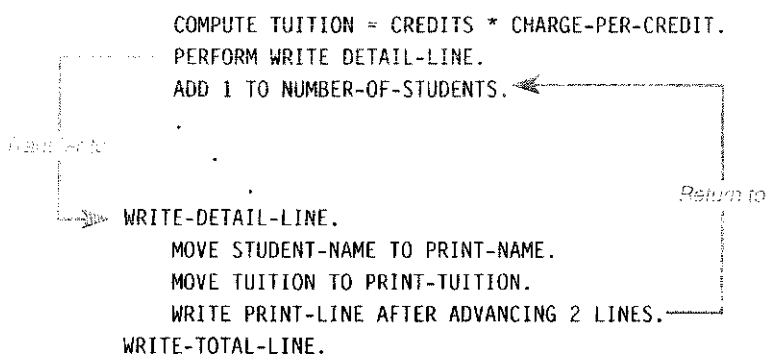

The statement PERFORM WRITE-DETAIL-LINE transfers control to the first statement in the paragraph WRITE-DETAIL-LINE. When every statement in WRITE-DETAIL-LINE has been executed (i.e., when the next paragraph name is encountered), control returns to the statement immediately after the original PERFORM, in this case, to the ADD statement.

A loop (iteration) is implemented through inclusion of an UNTIL clause. The condition in the UNTIL clause is tested *before* the paragraph is executed, and if the condition is not met, control is transferred to the designated paragraph. When the paragraph has completed execution, the condition is retested, and if it (the condition) is still not met, the paragraph is executed a second time. The process continues until the condition is finally satisfied. Consider:

```

PERFORM PROCESS-RECORDS
      UNTIL DATA-REMAINS-SWITCH = 'NO'.
.
.
.
PROCESS-RECORDS.
.
.
.
READ STUDENT-FILE
  AT END MOVE 'NO' TO DATA-REMAINS-SWITCH
END-READ.

```

The paragraph PROCESS-RECORDS is executed repeatedly until DATA-REMAINS-SWITCH equals 'NO', that is, until there are no more incoming records. The last statement of the performed paragraph is a READ statement, so that when the end of file is reached, DATA-REMAINS-SWITCH will be set to 'NO'. This causes the next test of the UNTIL condition to be successful and prevents further execution of the PROCESS-RECORDS paragraph.

IF

The IF statement is one of the most powerful statements in COBOL. Our present concern, however, is with only a few of the available options, with additional consideration deferred to Chapter 8. An abbreviated format of the IF statement is

```
IF condition THEN
    statement-1
[ELSE
    statement-2 ]
[END-IF]
```

The IF statement is terminated by the optional (but highly recommended) END-IF scope terminator and/or a period. Consider:

```
IF STU-CREDITS > 110 AND STU-MAJOR = 'ENGINEERING'
    MOVE STU-NAME TO PRINT-NAME
    MOVE STU-CREDITS TO PRINT-CREDITS
    MOVE STU-GPA TO PRINT-GPA
    WRITE PRINT-LINE
END-IF.
```

If the condition is true, then *every* statement between the IF (condition) and the END-IF (and/or period) will be executed. Hence, when an engineering senior is processed, three MOVE statements and one WRITE statement are executed. If, however, the condition is false, then all four statements—three MOVES and a WRITE—are bypassed.

As indicated, the IF statement is terminated by the END-IF scope terminator and/or a period, and the inclusion of both appears redundant. (Many programmers do, however, use both entries.) END-IF, despite the fact that it is an optional entry, has distinct advantages (as will be explained in Chapter 7) and should be used in every instance.

The ELSE Clause

The ELSE clause is optional as implied by the square brackets in its syntax. Figure 5.2a contains an ELSE clause, whereas it is omitted in Figure 5.2b. If the condition in Figure 5.2a is true, statement-1 is executed; whereas if it is false, statement-2 is executed—in either case execution continues with statement-3. Figure 5.2b, however, omits the ELSE clause so that if the condition is false, the IF statement is terminated immediately.

Indentation

Indentation in an IF statement is extremely important to emphasize a programmer's understanding of a statement's intended effect. Consider Figure 5.3, which contains a flowchart and corresponding COBOL code.

Figure 5.2 The IF Statement

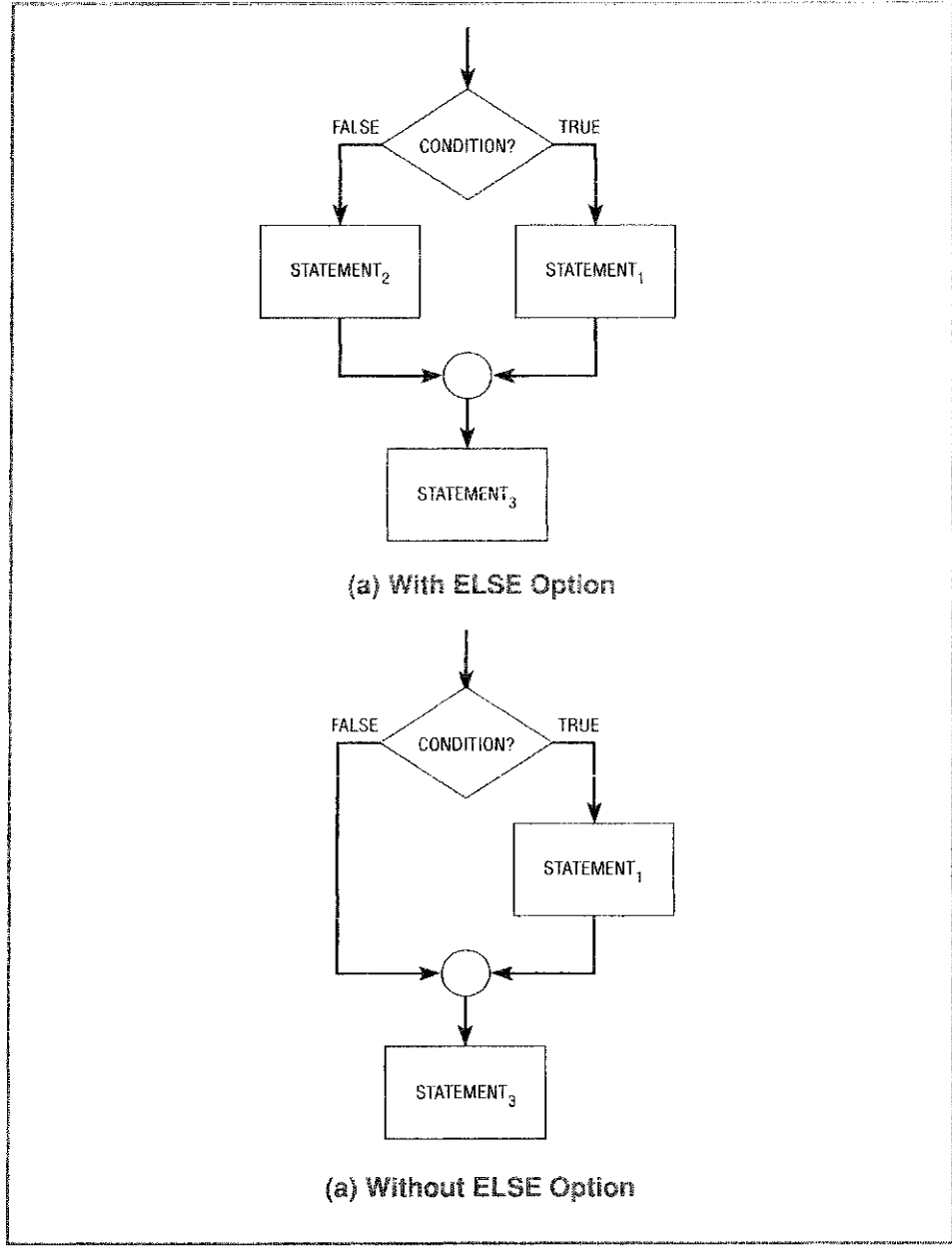

The flowchart in Figure 5.3a indicates that if the condition $A = B$ is true, the statements MOVE 1 TO C and MOVE 1 TO D are to be executed. If, however, the condition is false, then the statements MOVE ZERO TO C and MOVE ZERO TO D are to be executed instead. In either case—that is, whether the condition is true or false—we are to write a detail line. The latter is indicated by the IF and ELSE branches meeting in a common exit point, which leads to the final WRITE statement.

The COBOL code in Figure 5.3b is carefully aligned to reflect this interpretation. Recall that the rules of COBOL require only that an IF statement appear in the B margin, that is, in columns 12–72. Hence the indentation in Figure 5.3b is done solely for the purpose of making a program easier to read, rather than to satisfy a

Figure 5.3 The ELSE Clause/II

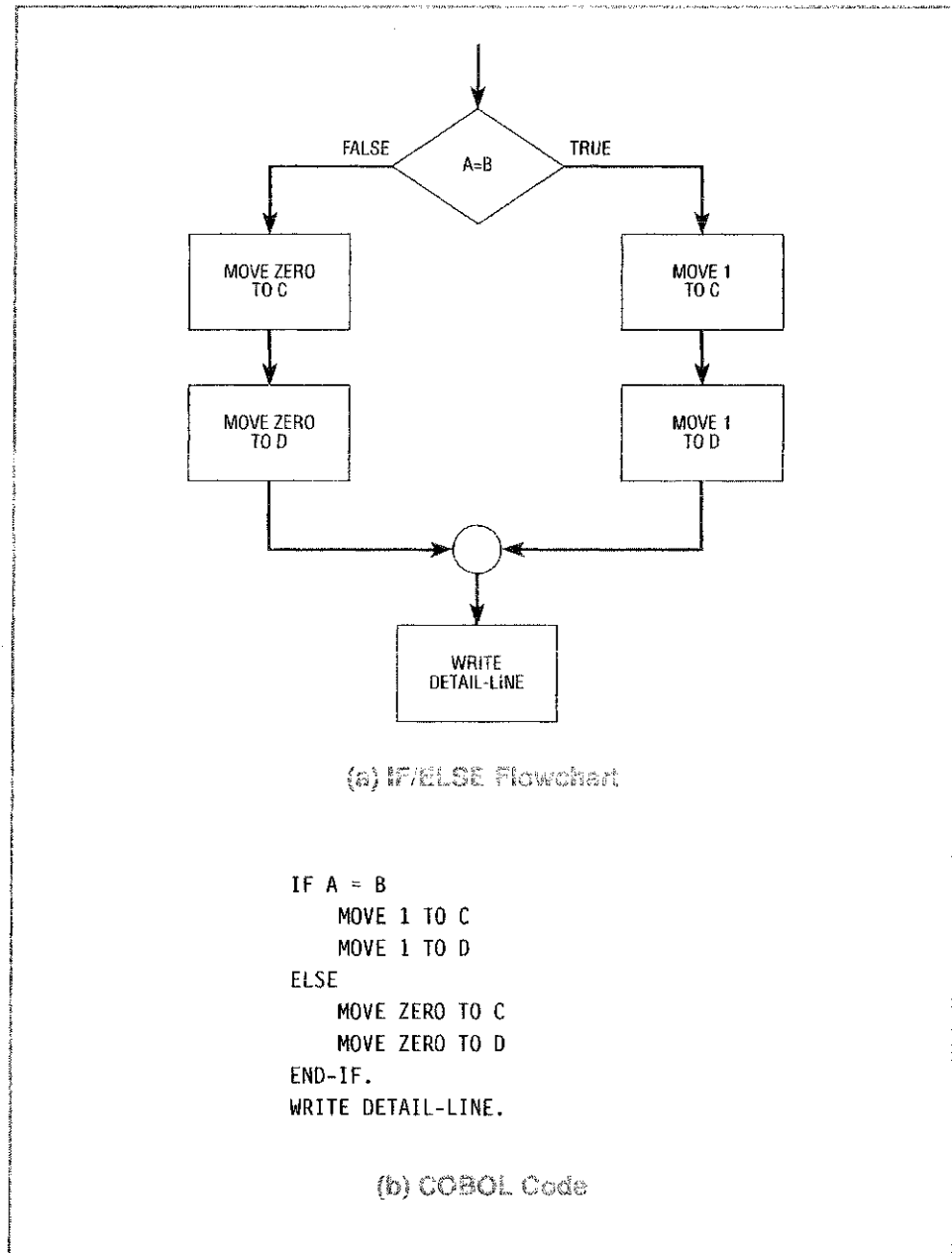

rule of COBOL. Nevertheless, proper indentation is essential and goes a long way to improve the quality of your work. Accordingly, we suggest the following guidelines:

1. Begin the IF statement in column 12.
2. Put the word ELSE on a line by itself and directly under the IF.
3. Indent detail lines associated with either the IF or ELSE four columns.
4. Put END-IF on a line by itself directly under the IF statement.

EVALUATE

The **EVALUATE** statement implements the case (multibranch) construct of structured programming. It has what first appears to be a rather complicated syntax, but in actuality is quite easy to use. Consider:

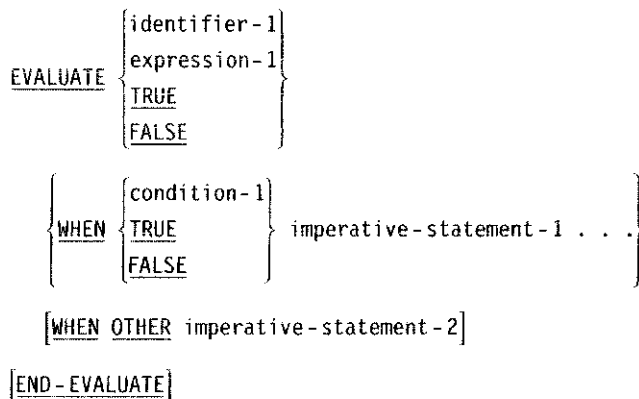

An example of the **EVALUATE** statement is shown below in conjunction with the tuition billing program presented in Chapter 3. The specifications for the program indicate that activity fee is dependent on the number of credits (\$25 for 6 credits or fewer, \$50 for 7 to 12 credits, and \$75 for 13 credits or more). Consider:

```

EVALUATE TRUE
  WHEN STU-CREDITS <= 6
    MOVE 25 TO IND-ACTIVITY-FEE
  WHEN STU-CREDITS > 6 AND STU-CREDITS <= 12
    MOVE 50 TO IND-ACTIVITY-FEE
  WHEN STU-CREDITS > 12
    MOVE 75 TO IND-ACTIVITY-FEE
END-EVALUATE.
    
```

The different conditions (i.e., the ranges for the number of student credits) are presented in the various **WHEN** clauses. The **END-EVALUATE** scope terminator is a required entry.

Arithmetic Statements

COBOL does arithmetic in one of two ways. It has individual statements for the basic arithmetic operations (addition, subtraction, multiplication, and division), and a **COMPUTE** statement that combines multiple operations into one statement. As you shall see, the **COMPUTE** statement is generally easier to use, and so we begin with it. Note, too, that all of these statements have optional **ROUNDED** and **SIZE ERROR** clauses, which are discussed prior to the individual statements.

The ROUNDED Clause

The **ROUNDED** clause (in any arithmetic statement) causes COBOL to carry a calculation to one more decimal place than is specified in the result field. If the value of the extra decimal place is 5 or larger, the answer is rounded up; if it is 4 or less, the answer is unchanged. If the **ROUNDED** clause is omitted, COBOL truncates any extra decimal positions regardless of their value. Table 5.4 shows the effect of the **ROUNDED** option in which the values of A and B are added to produce a value for C.

TABLE 5.4 The ROUNDED Clause

| PICTURE | 9V99 | 9V99 | 5V9 |
|--------------------------|------|------|--------------|
| Value before execution | 123 | 456 | (immaterial) |
| Value after execution of | | | |
| ADD A B GIVING C | 123 | 456 | 57 |
| ADD A B GIVING C ROUNDED | 123 | 456 | 58 |

Both of the examples in Table 5.4 add the same numbers (1.23 and 4.56) to produce a sum of 5.79. Both examples also specify the same PICTURE clause for the sum, which contains only a single decimal place. The first statement, however, does not contain the ROUNDED clause, and hence the .09 is truncated, leaving 5.7 as the final answer. The second example contains the ROUNDED clause, producing a more accurate 5.8.

The SIZE ERROR Clause

The SIZE ERROR clause is available for all arithmetic statements and produces a warning when the result of calculation is too large for the designated field. Consider:

```
05 HOURLY-RATE      PIC 99.
05 HOURS-WORKED    PIC 99.
05 GROSS-PAY       PIC 999.
```

```
COMPUTE GROSS-PAY = HOURLY-RATE * HOURS-WORKED.
```

Let us assume that HOURLY-RATE and HOURS-WORKED are 25 and 40, respectively. The result of the multiplication should be 1,000. GROSS-PAY, however, is defined as a three-position numeric field and is too small to hold the result. Hence its value is *truncated* and only the three rightmost digits are retained; in other words, GROSS-PAY becomes 000.

The situation is prevented by the inclusion of the SIZE ERROR clause:

```
COMPUTE GROSS-PAY = HOURLY-RATE * HOURS-WORKED
ON SIZE ERROR PERFORM ERROR-ROUTINE
END-COMPUTE.
```

This time, if the results of the computation are too large and exceed the size allotted in the PICTURE clause, control passes to the statement(s) following the SIZE ERROR clause. The latter contains an error routine to display an error message or take other corrective action.

COMPUTE

The COMPUTE statement combines multiple arithmetic operations into a single statement of the form:

```
COMPUTE {identifier-1 [ROUNDED]}...= expression-1
[ON SIZE ERROR imperative-statement-1]
[END-COMPUTE]
```

The COMPUTE statement first calculates the value of the expression on the right side of the equal sign, then stores that value in the data name on the left. The

expression within the COMPUTE statement consists of data names, numeric literals, arithmetic symbols, and parentheses. Spaces should precede and follow arithmetic symbols. A space is also required before a left parenthesis and after a right parenthesis.

Parentheses are used to clarify, and in some cases, alter the sequence of, operations within an expression, but anything contained within parentheses must also be a valid expression. Expressions are evaluated according to the following rules:

1. Anything contained in parentheses is evaluated first as a separate expression.
2. The symbols +, -, *, /, and ** denote addition, subtraction, multiplication, division, and exponentiation, respectively. Exponentiation is done first, then multiplication or division, then addition or subtraction.
3. If rule 2 results in a tie (e.g., if both multiplication and division are present), then evaluation proceeds from left to right.

Table 5.5 contains examples to illustrate the formation and evaluation of expressions in a COMPUTE statement.

TABLE 5.5 The COMPUTE Instruction

| | | | | |
|--------------------------|---|---|----|--------------------------------|
| Value before execution | 2 | 3 | 10 | Initial Values |
| Value after execution of | | | | |
| COMPUTE C = A + B. | 2 | 3 | 5 | Simple addition |
| COMPUTE C = A + B * 2. | 2 | 3 | 8 | Multiplication before addition |
| COMPUTE C = (A + B) * 2. | 2 | 3 | 10 | Parenthesis evaluated first |
| COMPUTE C = A ** B. | 2 | 3 | 8 | Algebraically, $c = a^b$ |
| COMPUTE C = B ** A. | 2 | 3 | 9 | Algebraically, $c = b^a$ |

Table 5.6 should further clarify the use of this all-important statement. This table contains several algebraic expressions and the corresponding COMPUTE statements to accomplish the intended logic.

TABLE 5.6 The COMPUTE Instruction (continued)

| | |
|-----------------------------|---|
| $x = a + b$ | COMPUTE X = A + B. |
| $x = \frac{a+b}{2}$ | COMPUTE X = (A + B) / 2. |
| $x = \frac{(a+b)c}{2}$ | COMPUTE X = (A + B) * C / 2. |
| $x = \frac{a+b}{2c}$ | COMPUTE X = (A + B) / (2 * C). |
| $x = \sqrt{a}$ | COMPUTE X = A ** .5. |
| $x = \frac{a^2 + b^2}{c^2}$ | COMPUTE X = (A ** 2 + B ** 2) / C ** 2. |

ADD

The **ADD** statement has two basic formats:

```
ADD {identifier-1} . . . TO {identifier-2 [ROUNDED]} . . .
    [ON SIZE ERROR imperative-statement-1]
[END-ADD]
```

```
ADD {identifier-1} . . . TO {identifier-2}
    {literal-1} . . . TO {literal-2}
    GIVING {identifier-3 [ROUNDED]} . . .
    [ON SIZE ERROR imperative-statement-1]
[END-ADD]
```

In the first format the value of identifier-2 is *replaced* by the result of the addition; in the second format the value of identifier-2 is *unchanged*, because the result is stored in identifier-3 (and beyond). The word **TO** is *required* in the first format, but *optional* in the second. The three dots in either format indicate that identifier-1 or literal-1 can be repeated as many times as necessary (so that multiple items can be added together.)

Examples 5.1 and 5.2 illustrate the **ADD** statement. The first instruction adds the values of A and B (5 and 10) to the value of C (20), and puts the sum of 35 back into C. Example 5.2, however, does not include the initial value of C in the calculation; it adds the values of A and B (5 and 10), and places the sum of 15 in C.

Example 5.1 ADD A B TO C

| | A | B | C |
|-------------------|---|----|----|
| Before execution: | 5 | 10 | 20 |
| After execution: | 5 | 10 | 35 |

Example 5.2 ADD A TO B GIVING C

| | A | B | C |
|-------------------|---|----|----|
| Before execution: | 5 | 10 | 20 |
| After execution: | 5 | 10 | 15 |

Table 5.7 contains additional examples of the **ADD** statement, with all examples operating on the *initial* values of A, B, and C (5, 10, and 30, respectively). The last example changes the values of both B and C.

TABLE 5.7 The ADD Instruction

| | | | |
|--------------------------|---|----|----|
| Value before execution | 5 | 10 | 30 |
| Value after execution of | | | |
| ADD A TO C. | 5 | 10 | 35 |
| ADD A B TO C. | 5 | 10 | 45 |
| ADD A TO B GIVING C. | 5 | 10 | 15 |
| ADD A 18 B GIVING C. | 5 | 10 | 33 |
| ADD A 18 B TO C. | 5 | 10 | 63 |
| ADD 1 TO B C. | 5 | 11 | 31 |

SUBTRACT

The **SUBTRACT** statement has two formats:

```

SUBTRACT {identifier-1} . . . FROM {identifier-2 [ROUNDED]} . . .
        [ON SIZE ERROR imperative-statement-1]
[END - SUBTRACT]
    
```

```

SUBTRACT {identifier-1} . . . FROM {identifier-2}
        GIVING {identifier-3 [ROUNDED]} . . .
        [ON SIZE ERROR imperative-statement-1]
[END - SUBTRACT]
    
```

In the first format the initial value of identifier-2 is replaced by the result of the subtraction. In the second format the initial value of either identifier-2 or literal-2 is unchanged, as the result is stored in identifier-3 (and beyond).

Examples 5.3 and 5.4 illustrate the **SUBTRACT** statement. In Example 5.3 the **SUBTRACT** statement causes the value of A (5) to be subtracted from the initial value of B (15) and the result (10) to be stored in B. Only the value of B was changed.

In the **FROM . . . GIVING** format of Example 5.4 the value of A (5) is subtracted from the value of B (15), and the result (10) is placed in C. The values of A and B are unchanged, and the initial value of C (100) is replaced by 10. Table 5.8 contains additional examples.

Example 5.3 SUBTRACT A FROM B

| | A | B |
|-------------------|---|----|
| Before execution: | 5 | 15 |
| After execution: | 5 | 10 |

Example 5.4 SUBTRACT A FROM B GIVING C

| | A | B | C |
|-------------------|---|----|-----|
| Before execution: | 5 | 15 | 100 |
| After execution: | 5 | 15 | 10 |

TABLE 5.8 The SUBTRACT Instruction

| DATA NAME | A | B | C | D |
|--|---|----|----|-----|
| Value before execution | 5 | 10 | 30 | 100 |
| Value after execution of SUBTRACT A FROM C. | 5 | 10 | 25 | 100 |
| SUBTRACT A B FROM C. | 5 | 10 | 15 | 100 |
| SUBTRACT A B FROM C GIVING D. | 5 | 10 | 30 | 15 |
| SUBTRACT 10 FROM C D. | 5 | 10 | 20 | 90 |

MULTIPLY

The **MULTIPLY** statement has two formats:

```

MULTIPLY {identifier-1}
         {literal-1} BY {identifier-2 [ROUNDED]} . . .
         [ON SIZE ERROR imperative-statement-1]
[END-MULTIPLY]

```

```

MULTIPLY {identifier-1}
         {literal-1} BY {identifier-2}
         {literal-2}
         GIVING {identifier-3 [ROUNDED]} . . .
         [ON SIZE ERROR imperative-statement-1]
[END-MULTIPLY]

```

If **GIVING** is used, then the result of the multiplication is stored in **identifier-3** (and beyond). If **GIVING** is omitted, then the result is stored in **identifier-2** (and beyond).

Example 5.5 MULTIPLY A BY B

| | A | B |
|-------------------|----|-----|
| Before execution: | 10 | 20 |
| After execution: | 10 | 200 |

Example 5.6 MULTIPLY A BY B GIVING C

| | A | B | C |
|-------------------|----|----|-----|
| Before execution: | 10 | 20 | 345 |
| After execution: | 10 | 20 | 200 |

Table 5.9 contains additional examples of the MULTIPLY statement. As in the previous examples, the instructions operate on the initial values of A, B, and C.

TABLE 5.9 The MULTIPLY Instruction

| | | | |
|---|----|----|----|
| Value before execution | 5 | 10 | 30 |
| Value after execution of MULTIPLY B BY A GIVING C. | 5 | 10 | 50 |
| MULTIPLY A BY B GIVING C. | 5 | 10 | 50 |
| MULTIPLY A BY B. | 5 | 50 | 30 |
| MULTIPLY B BY A. | 50 | 10 | 30 |
| MULTIPLY A BY 3 GIVING B C. | 5 | 15 | 15 |

DIVIDE

The **DIVIDE** statement has two formats. In the second format, the primary distinction is between the words **BY** and **INTO**, which determine whether identifier-2 is the divisor or the dividend. As with the other arithmetic statements, the **GIVING** option implies that the result is stored in identifier-3 so that the initial value of identifier-2 or literal-2 is unchanged. Only the second format makes explicit provision for storing the remainder.

DIVIDE { identifier-1 } **INTO** { identifier-2 [**ROUNDED**] } . . .

[**ON SIZE ERROR** imperative-statement-1]

[**END-DIVIDE**]

DIVIDE { identifier-1 } { **INTO** } { identifier-2 } **GIVING** { identifier-3 [**ROUNDED**] } . . .

[**REMAINDER** identifier-4]

[**ON SIZE ERROR** imperative-statement-1]

[**END-DIVIDE**]

In Example 5.7 the value of B (50) is divided by the value of A (10), and the quotient (5) replaces the initial value of B. In Example 5.8, which uses the **GIVING** option, the quotient goes into C, the remainder into D, and the values of A and B are

PROGRAMMING TIP**Use the COMPUTE Statement
for Multiple Arithmetic Operations**

The COMPUTE statement should always be used when multiple arithmetic operators are involved. Consider two sets of equivalent code:

Poor Code:

```
MULTIPLY B BY B GIVING B-SQUARED.
MULTIPLY 4 BY A GIVING FOUR-A.
MULTIPLY FOUR-A BY C GIVING FOUR-A-C.
SUBTRACT FOUR-A-C FROM B-SQUARED GIVING RESULT-1.
COMPUTE RESULT-2 = RESULT-1 ** .5.
SUBTRACT B FROM RESULT-2 GIVING NUMERATOR.
MULTIPLY 2 BY A GIVING DENOMINATOR.
DIVIDE NUMERATOR BY DENOMINATOR GIVING X.
```

Improved Code:

```
COMPUTE X = (-B + (B ** 2 - (4 * A * C)) ** .5) / (2 * A).
```

Both sets of code apply to the quadratic formula,

$$X = \frac{-B + \sqrt{B^2 - 4AC}}{2A}$$

It is fairly easy to determine what is happening from the single COMPUTE statement, but next to impossible to realize the cumulative effect of the eight arithmetic statements. Interpretation of the unacceptable code is further clouded by the mandatory definition of data names for intermediate results, RESULT-1, RESULT-2, etc.

Parentheses are often required in COMPUTE statements to alter the normal hierarchy of operations; for example, parentheses are required around $2 * A$ in the denominator. If they had been omitted, the numerator would have been divided by 2 and then the quotient would have been multiplied by A. Sometimes the parentheses are optional to the compiler but should be used to clarify things for the programmer. The parentheses around $4 * A * C$ do not alter the normal order of operations and hence are optional.

Individual arithmetic statements are preferable to the COMPUTE statement when only a *single* operation is required. Hence, ADD 1 TO COUNTER is easier to read than COMPUTE COUNTER = COUNTER + 1.

unaffected. Example 5.9 parallels 5.8 except that BY replaces INTO, resulting in a quotient of zero and a remainder of 10. Table 5.10 contains additional examples of the DIVIDE statement.

Example 5.7 DIVIDE A INTO B.

| | A | B |
|-------------------|----|----|
| Before execution: | 10 | 50 |
| After execution: | 10 | 5 |

Example 5.8 DIVIDE A INTO B GIVING C REMAINDER D.

| | A | B | C | D |
|-------------------|----|----|----|----|
| Before execution: | 10 | 51 | 13 | 17 |
| After execution: | 10 | 51 | 5 | 1 |

Example 5.9 DIVIDE A BY B GIVING C REMAINDER D.

| | A | B | C | D |
|-------------------|----|----|----|----|
| Before execution: | 10 | 51 | 13 | 17 |
| After execution: | 10 | 51 | 0 | 10 |

TABLE 5.10 The DIVIDE Instruction

| | | | |
|---------------------------------------|---|----|----|
| Value before execution | 5 | 10 | 30 |
| Value after execution of | | | |
| DIVIDE 2 INTO B. | 5 | 5 | 30 |
| DIVIDE 2 INTO B GIVING C. | 5 | 10 | 5 |
| DIVIDE B BY 5 GIVING A. | 2 | 10 | 30 |
| DIVIDE A INTO B C. | 5 | 2 | 6 |
| DIVIDE A INTO B GIVING C. | 5 | 10 | 2 |
| DIVIDE 3 INTO A GIVING B REMAINDER C. | 5 | 1 | 2 |

Assumed Decimal Point

Arithmetic is performed on decimal as well as integer fields. You must be aware of the decimal point, and in particular, *be sure to define the field holding the result with a sufficient number of decimal places.* Consider Example 5.10, in which A and B have pictures of 99 and 99V9, respectively.

Example 5.10 ADD A TO B.

| | A | B |
|-------------------|-----|-------|
| Before execution: | 1 2 | 3 4 5 |
| After execution: | 1 2 | 4 6 5 |

In the example, field B is stored with an implied decimal point. The compiler generates instructions to add an integer number (12) to a number with one decimal place (34V5). It maintains decimal alignment, obtains 46V5 as an answer, and stores the result in field B.

Now consider what happens if the operation is reversed, that is, ADD B TO A. The result of the addition is still 46V5; however, the field that stores the sum, A, is defined without a decimal point; hence, the .5 will be truncated. *It is critical, therefore, to define the receiving field with a sufficient number of decimal places.* Table 5.11 contains additional examples. In each instance the instruction is assumed to operate on the initial values of A, B, and C.

TABLE 5.11 Arithmetic on Fields with Assumed Decimal Points

| PICTURE | 99 | 99V5 | 99V99 |
|--------------------------|----|------|-------|
| Value before execution | 12 | 345 | 4712 |
| Value after execution of | | | |
| ADD B TO A. | 46 | 345 | 4712 |
| ADD A TO B. | 12 | 465 | 4712 |
| ADD B TO C. | 12 | 345 | 8162 |
| ADD C TO B. | 12 | 816 | 4712 |
| ADD C TO A. | 59 | 345 | 4712 |
| ADD A TO C. | 12 | 345 | 5912 |

The Tuition Billing Program

The tuition billing program was first presented in Chapter 3, where we produced the hierarchy chart, pseudocode, and stubs program. We continued the development of the program in Chapter 4, with specifics of the Identification, Environment, and Data divisions. Now we are able to write the Procedure Division and complete the program.

We emphasize, however, that the Procedure Division is not written from scratch, but is developed from work already done in Chapters 3 and 4. Consider, therefore, Figure 5.4, which contains the hierarchy chart and detailed pseudocode, and most importantly the *already working* stubs program. The stubs program is complete in the sense that it contains all of the paragraphs needed for the eventual program; it is incomplete because many of its paragraphs exist as one sentence DISPLAY statements that need to be expanded to perform the indicated task. The most difficult work has already been done, however, because the testing in Chapter 3 demonstrated that the overall program flow is correct.

Thus, it is relatively simple to expand the various stub paragraphs in favor of more detailed Procedure Division statements presented in this chapter. The paragraphs can be implemented one (or several) at a time; for example, begin with the paragraph to write a heading line, expand it, then test it to be sure it executes correctly. Develop the paragraph to write a detailed line, then expand the paragraphs to compute the individual amounts (tuition, union fee, activity fee, and scholarship), testing each paragraph to be sure it works properly. Finally, add the paragraphs to increment the university totals and write the summary line at the end of the report.

The completed program is shown in Figure 5.5. The Identification, Environment, and Data divisions were developed at the end of Chapter 4 and are

Figure 5.4 Developing the Procedure Division

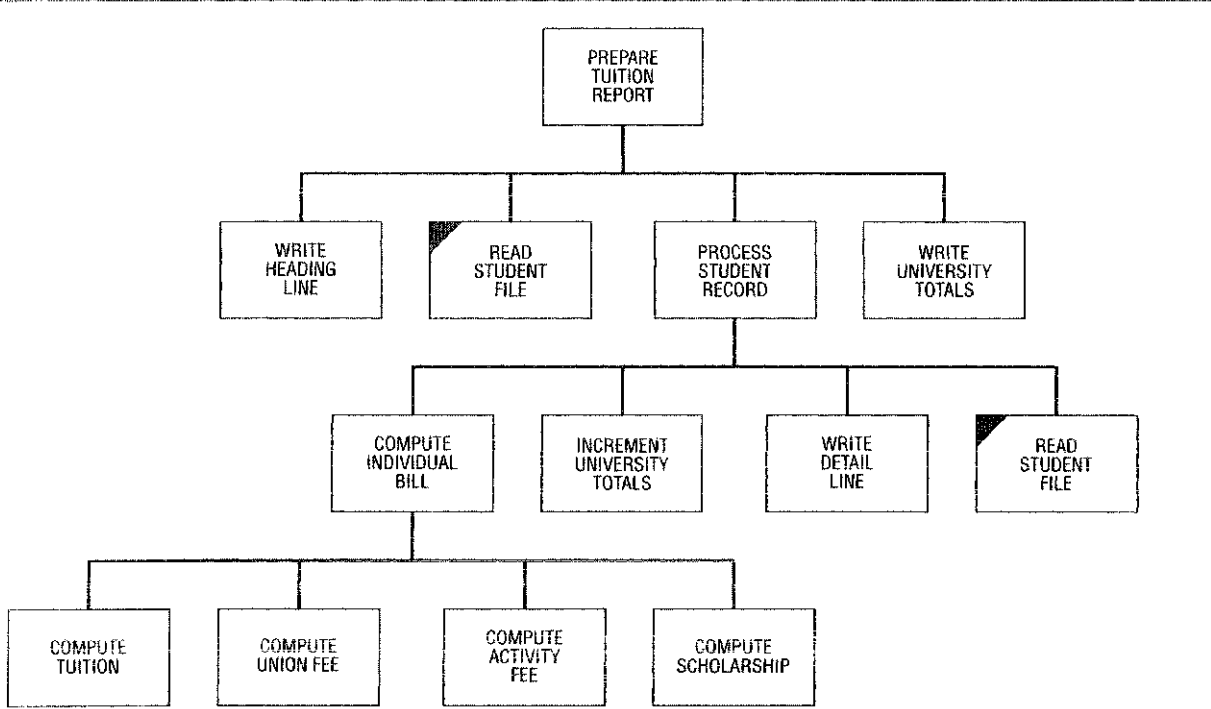

(a) Hierarchy Chart

```

Open files
Write heading line(s)
Read STUDENT-FILE at end indicate no more data
DO WHILE data remains
  Compute tuition = 200 * credits
  IF union member
    Union fee = $25
  ELSE
    Union fee = 0
  ENDIF
  DO CASE
    CASE credits <= 6
      Activity fee = 25
    CASE credits > 6 and <= 12
      Activity fee = 50
    CASE credits > 12
      Activity fee = 75
  END CASE
  IF gpa > 2.5
    Scholarship = Scholarship amount
  ELSE (no scholarship)
    Scholarship = 0
  ENDIF
  Compute Bill = Tuition + Union fee + Activity fee - Scholarship
  Increment university totals
  Write detail line
  Read STUDENT-FILE at end indicate no more data
ENDDO
Write university totals
Close files
Stop run
    
```

(b) Detailed Pseudocode

Figure 5.4 (continued)

```

PROCEDURE DIVISION.
PREPARE-TUITION-REPORT.
  DISPLAY 'PREPARE-TUITION-REPORT paragraph entered'.
  OPEN INPUT STUDENT-FILE.
  PERFORM WRITE-HEADING-LINE.
  PERFORM READ-STUDENT-FILE.
  PERFORM PROCESS-STUDENT-RECORD
    UNTIL DATA-REMAINS-SWITCH = 'NO'.
  PERFORM WRITE-UNIVERSITY-TOTALS.
  CLOSE STUDENT-FILE.
  STOP RUN.
WRITE-HEADING-LINE.
  DISPLAY 'WRITE-HEADING-LINE paragraph entered'.

READ-STUDENT-FILE.
  READ STUDENT-FILE
    AT END MOVE 'NO' TO DATA-REMAINS-SWITCH
  END-READ.

PROCESS-STUDENT-RECORD.
  DISPLAY ' '.
  DISPLAY 'PROCESS-STUDENT-RECORD paragraph entered'.
  DISPLAY 'Student record being processed: ' STUDENT-RECORD.
  PERFORM COMPUTE-INDIVIDUAL-BILL.
  PERFORM INCREMENT-UNIVERSITY-TOTALS
  PERFORM WRITE-DETAIL-LINE.
  PERFORM READ-STUDENT-FILE.

COMPUTE-INDIVIDUAL-BILL.
  DISPLAY ' COMPUTE-INDIVIDUAL-BILL paragraph entered'.
  PERFORM COMPUTE-TUITION.
  PERFORM COMPUTE-UNION-FEE.
  PERFORM COMPUTE-ACTIVITY-FEE.
  PERFORM COMPUTE-SCHOLARSHIP.

COMPUTE-TUITION.
  DISPLAY ' COMPUTE-TUITION paragraph entered'.

COMPUTE-UNION-FEE.
  DISPLAY ' COMPUTE-UNION-FEE paragraph entered'.

COMPUTE-ACTIVITY-FEE.
  DISPLAY ' COMPUTE-ACTIVITY-FEE paragraph entered'.

COMPUTE-SCHOLARSHIP.
  DISPLAY ' COMPUTE-SCHOLARSHIP paragraph entered'.

INCREMENT-UNIVERSITY-TOTALS.
  DISPLAY ' INCREMENT-UNIVERSITY-TOTALS paragraph entered'.

WRITE-DETAIL-LINE.
  DISPLAY ' WRITE-DETAIL-LINE paragraph entered'.

WRITE-UNIVERSITY-TOTALS.
  DISPLAY ' '.
  DISPLAY 'WRITE-UNIVERSITY-TOTALS paragraph entered'.

```

(c) Stubs Program

Figure 5.5 The Tuition Billing Program

```

1      IDENTIFICATION DIVISION.
2      PROGRAM-ID.    TUITION5.
3      AUTHOR.       CAROL VAZQUEZ VILLAR.
4
5      ENVIRONMENT DIVISION.
6      INPUT-OUTPUT SECTION.
7      FILE-CONTROL.
8          SELECT STUDENT-FILE ASSIGN TO 'A:\CHAPTR05\TUITION.DAT'
9              ORGANIZATION IS LINE SEQUENTIAL.
10         SELECT PRINT-FILE
11             ASSIGN TO PRINTER.
12
13     DATA DIVISION.
14     FILE SECTION.
15     FD  STUDENT-FILE
16         RECORD CONTAINS 27 CHARACTERS.
17     01  STUDENT-RECORD.
18         05  STU-NAME.
19             10  STU-LAST-NAME    PIC X(15).
20             10  STU-INITIALS     PIC XX.
21         05  STU-CREDITS          PIC 9(2).
22         05  STU-UNION-MEMBER    PIC X.
23         05  STU-SCHOLARSHIP     PIC 9(4).
24         05  STU-GPA             PIC 9V99.
25
26     FD  PRINT-FILE
27         RECORD CONTAINS 132 CHARACTERS.
28     01  PRINT-LINE              PIC X(132).
29
30     WORKING-STORAGE SECTION.
31     01  DATA-REMAINS-SWITCH    PIC X(2) VALUE SPACES.
32
33     01  INDIVIDUAL-CALCULATIONS.
34         05  IND-TUITION          PIC 9(4) VALUE ZEROS.
35         05  IND-ACTIVITY-FEE     PIC 9(2) VALUE ZEROS.
36         05  IND-UNION-FEE        PIC 9(2) VALUE ZEROS.
37         05  IND-SCHOLARSHIP      PIC 9(4) VALUE ZEROS.
38         05  IND-BILL            PIC 9(6) VALUE ZEROS.
39
40     01  UNIVERSITY-TOTALS.
41         05  UNI-TUITION          PIC 9(6) VALUE ZEROS.
42         05  UNI-UNION-FEE        PIC 9(4) VALUE ZEROS.
43         05  UNI-ACTIVITY-FEE     PIC 9(4) VALUE ZEROS.
44         05  UNI-SCHOLARSHIP      PIC 9(6) VALUE ZEROS.
45         05  UNI-IND-BILL         PIC 9(6) VALUE ZEROS.
46
47     01  CONSTANTS-AND-RATES.
48         05  PRICE-PER-CREDIT     PIC 9(3) VALUE 200.
49         05  UNION-FEE            PIC 9(2) VALUE 25.
50         05  ACTIVITY-FEES.

```

Figure 5.5 (continued)

```

51          10 1ST-ACTIVITY-FEE PIC 99    VALUE 25.
52          10 1ST-CREDIT-LIMIT PIC 99    VALUE 6.
53          10 2ND-ACTIVITY-FEE PIC 99    VALUE 50.
54          10 2ND-CREDIT-LIMIT PIC 99    VALUE 12.
55          10 3RD-ACTIVITY-FEE PIC 99    VALUE 75.
56          05 MINIMUM-SCHOLAR-GPA PIC 9V9 VALUE 2.5.
57
58      01 HEADING-LINE.
59          05 FILLER                PIC X    VALUE SPACES.
60          05 FILLER                PIC X(12) VALUE 'STUDENT NAME'.
61          05 FILLER                PIC X(10) VALUE SPACES.
62          05 FILLER                PIC X(7)  VALUE 'CREDITS'.
63          05 FILLER                PIC X(2)  VALUE SPACES.
64          05 FILLER                PIC X(7)  VALUE 'TUITION'.
65          05 FILLER                PIC X(2)  VALUE SPACES.
66          05 FILLER                PIC X(9)  VALUE 'UNION FEE'.
67          05 FILLER                PIC X(2)  VALUE SPACES.
68          05 FILLER                PIC X(7)  VALUE 'ACT FEE'.
69          05 FILLER                PIC X(2)  VALUE SPACES.
70          05 FILLER                PIC X(11) VALUE 'SCHOLARSHIP'.
71          05 FILLER                PIC X(2)  VALUE SPACES.
72          05 FILLER                PIC X(10) VALUE 'TOTAL BILL'.
73          05 FILLER                PIC X(48) VALUE SPACES.
74
75      01 DETAIL-LINE.
76          05 FILLER                PIC X    VALUE SPACES.
77          05 DET-LAST-NAME          PIC X(15).
78          05 FILLER                PIC X(2)  VALUE SPACES.
79          05 DET-INITIALS          PIC X(2).
80          05 FILLER                PIC X(5)  VALUE SPACES.
81          05 DET-CREDITS           PIC 9(2).
82          05 FILLER                PIC X(6)  VALUE SPACES.
83          05 DET-TUITION           PIC 9(6).
84          05 FILLER                PIC X(7)  VALUE SPACES.
85          05 DET-UNION-FEE         PIC 9(3).
86          05 FILLER                PIC X(6)  VALUE SPACES.
87          05 DET-ACTIVITY-FEE     PIC 9(3).
88          05 FILLER                PIC X(8)  VALUE SPACES.
89          05 DET-SCHOLARSHIP       PIC 9(5).
90          05 FILLER                PIC X(6)  VALUE SPACES.
91          05 DET-IND-BILL          PIC 9(6).
92          05 FILLER                PIC X(49) VALUE SPACES.
93
94      01 DASH-LINE.
95          05 FILLER                PIC X(31) VALUE SPACES.
96          05 FILLER                PIC X(8)  VALUE ALL '-'.
97          05 FILLER                PIC X(2)  VALUE SPACES.
98          05 FILLER                PIC X(8)  VALUE ALL '-'.
99          05 FILLER                PIC X(2)  VALUE SPACES.
100         05 FILLER                PIC X(7)  VALUE ALL '-'.

```

Figure 5.8 (continued)

```

101         05 FILLER                PIC X(6) VALUE SPACES.
102         05 FILLER                PIC X(7) VALUE ALL '-'.
103         05 FILLER                PIC X(5) VALUE SPACES.
104         05 FILLER                PIC X(7) VALUE ALL '-'.
105         05 FILLER                PIC X(49) VALUE SPACES.
106
107     01 TOTAL-LINE.
108         05 FILLER                PIC X(8) VALUE SPACES.
109         05 FILLER                PIC X(17)
110             VALUE 'UNIVERSITY TOTALS'.
111         05 FILLER                PIC X(8) VALUE SPACES.
112         05 TOT-TUITION            PIC 9(6).
113         05 FILLER                PIC X(6) VALUE SPACES.
114         05 TOT-UNION-FEE          PIC 9(4).
115         05 FILLER                PIC X(5) VALUE SPACES.
116         05 TOT-ACTIVITY-FEE      PIC 9(4).
117         05 FILLER                PIC X(7) VALUE SPACES.
118         05 TOT-SCHOLARSHIP        PIC 9(6).
119         05 FILLER                PIC X(6) VALUE SPACES.
120         05 TOT-IND-BILL           PIC 9(6).
121         05 FILLER                PIC X(49) VALUE SPACES.
122
123     PROCEDURE DIVISION.
124     PREPARE-TUITION-REPORT.
125         OPEN INPUT STUDENT-FILE
126             OUTPUT PRINT-FILE.
127         PERFORM WRITE-HEADING-LINE.
128         PERFORM READ-STUDENT-FILE.
129         PERFORM PROCESS-STUDENT-RECORD
130             UNTIL DATA-REMAINS-SWITCH = 'NO'.
131         PERFORM WRITE-UNIVERSITY-TOTALS.
132         CLOSE STUDENT-FILE
133             PRINT-FILE.
134         STOP RUN.
135
136     WRITE-HEADING-LINE.
137         MOVE HEADING-LINE TO PRINT-LINE.
138         WRITE PRINT-LINE
139             AFTER ADVANCING PAGE.
140         MOVE SPACES TO PRINT-LINE.
141         WRITE PRINT-LINE.
142
143     READ-STUDENT-FILE.
144         READ STUDENT-FILE
145             AT END MOVE 'NO' TO DATA-REMAINS-SWITCH
146             END-READ.
147
148     PROCESS-STUDENT-RECORD.
149         PERFORM COMPUTE-INDIVIDUAL-BILL.
150         PERFORM INCREMENT-UNIVERSITY-TOTALS
151         PERFORM WRITE-DETAIL-LINE.

```

indicated by #128 in the next

Figure 5.5 (continued)

```

152     PERFORM READ-STUDENT-FILE.
153
154     COMPUTE-INDIVIDUAL-BILL.
155         PERFORM COMPUTE-TUITION.
156         PERFORM COMPUTE-UNION-FEE.
157         PERFORM COMPUTE-ACTIVITY-FEE.
158         PERFORM COMPUTE-SCHOLARSHIP.
159         COMPUTE IND-BILL = IND-TUITION + IND-UNION-FEE +
160             IND-ACTIVITY-FEE - IND-SCHOLARSHIP.
161
162     COMPUTE-TUITION.
163         COMPUTE IND-TUITION = PRICE-PER-CREDIT * STU-CREDITS.
164
165     COMPUTE-UNION-FEE.
166         IF STU-UNION-MEMBER = 'Y'
167             MOVE UNION-FEE TO IND-UNION-FEE
168         ELSE
169             MOVE ZERO TO IND-UNION-FEE
170         END-IF.
171
172     COMPUTE-ACTIVITY-FEE.
173         EVALUATE TRUE
174             WHEN STU-CREDITS <= 1ST-CREDIT-LIMIT
175                 MOVE 1ST-ACTIVITY-FEE TO IND-ACTIVITY-FEE
176             WHEN STU-CREDITS > 1ST-CREDIT-LIMIT
177                 AND STU-CREDITS <= 2ND-CREDIT-LIMIT
178                 MOVE 2ND-ACTIVITY-FEE TO IND-ACTIVITY-FEE
179             WHEN STU-CREDITS > 2ND-CREDIT-LIMIT
180                 MOVE 3RD-ACTIVITY-FEE TO IND-ACTIVITY-FEE
181             WHEN OTHER
182                 DISPLAY 'INVALID CREDITS FOR: ' STU-NAME
183         END-EVALUATE.
184
185     COMPUTE-SCHOLARSHIP.
186         IF STU-GPA > MINIMUM-SCHOLAR-GPA
187             MOVE STU-SCHOLARSHIP TO IND-SCHOLARSHIP
188         ELSE
189             MOVE ZERO TO IND-SCHOLARSHIP
190         END-IF.
191
192     INCREMENT-UNIVERSITY-TOTALS.
193         ADD IND-TUITION      TO UNI-TUITION.
194         ADD IND-UNION-FEE   TO UNI-UNION-FEE.
195         ADD IND-ACTIVITY-FEE TO UNI-ACTIVITY-FEE.
196         ADD IND-SCHOLARSHIP TO UNI-SCHOLARSHIP.
197         ADD IND-BILL        TO UNI-IND-BILL.
198
199     WRITE-DETAIL-LINE.
200         MOVE STU-LAST-NAME TO DET-LAST-NAME.
201         MOVE STU-INITIALS TO DET-INITIALS.
202         MOVE STU-CREDITS TO DET-CREDITS.

```

Compute individual bill, including union fee and activity fee

If student is member of union, add union fee to individual bill; otherwise, add zero

Use EVALUATE to compute activity fee based on number of credits

Compare student's GPA to minimum GPA required for scholarship

Figure 5.5 (continued)

```

203      MOVE IND-TUITION TO DET-TUITION.
204      MOVE IND-UNION-FEE TO DET-UNION-FEE.
205      MOVE IND-ACTIVITY-FEE TO DET-ACTIVITY-FEE.
206      MOVE IND-SCHOLARSHIP TO DET-SCHOLARSHIP.
207      MOVE IND-BILL TO DET-IND-BILL.
208      MOVE DETAIL-LINE TO PRINT-LINE.
209      WRITE PRINT-LINE
210          AFTER ADVANCING 1 LINE.
211
212      WRITE-UNIVERSITY-TOTALS.
213      MOVE DASH-LINE TO PRINT-LINE.
214      WRITE PRINT-LINE.
215      MOVE UNI-TUITION TO TOT-TUITION.
216      MOVE UNI-UNION-FEE TO TOT-UNION-FEE.
217      MOVE UNI-ACTIVITY-FEE TO TOT-ACTIVITY-FEE.
218      MOVE UNI-SCHOLARSHIP TO TOT-SCHOLARSHIP.
219      MOVE UNI-IND-BILL TO TOT-IND-BILL.
220      MOVE TOTAL-LINE TO PRINT-LINE.
221      WRITE PRINT-LINE
222          AFTER ADVANCING 1 LINE.

```

Building a University

copied directly from Figure 4.10. The completed program appears somewhat formidable the first time you see it, but it has been developed over the last three chapters, and you should have no difficulty in following. We suggest you take it in pieces and review sections of the text as you need them with respect to the following:

1. The Identification Division in lines 1–3 contains only the PROGRAM-ID and AUTHOR paragraphs.
2. The Environment Division in lines 5–11 contains the SELECT statements for the two required files.
3. The FD's in lines 15–16 and 26–28 correspond to the SELECT statements in the Environment Division.
4. The description for the incoming data in lines 17–24 matches the program specifications of Chapter 3.
5. Separate 01 entries are defined for individual and total calculations (lines 33–38 and 40–45); also data names for the constants and rates are established in lines 47–56.
6. Heading, detail, dashed, and total lines are described separately in WORKING-STORAGE (lines 58–73, 75–92, 94–105, and 107–121, respectively); note the use of VALUE clauses to initialize the various print lines.
7. The paragraphs in the Procedure Division correspond one to one with the blocks in the hierarchy chart of Figure 5.4a.
8. An initial READ statement in line 128 is followed by the PERFORM statement in lines 129 and 130 to execute PROCESS-STUDENT-RECORD (lines 148–152) until there are no more records. The last statement of the performed paragraph is a second READ statement. The combination of these statements implements the overall logic in the pseudocode of Figure 5.4b.

9. An EVALUATE statement in lines 173–183 computes the activity fee according to the number of credits taken.
10. Separate paragraphs in the Procedure Division compute an individual bill (lines 154–160), increment university totals (lines 192–197), and write a detail line (lines 199–210).
11. Multiple MOVE statements are required within the paragraph to write a detailed line (lines 199–210), with each statement moving a computed value (such as IND-TUITION) to the corresponding entry in the print line (DET-TUITION). The need for both data names will be more apparent after the material on editing in Chapter 7. The paragraph to write university totals requires similar treatment.
12. Multiple ADD statements are needed within the paragraph to increment university totals (lines 193–197). Each total is stored in a separate field and thus must be incremented separately.

Figure 5.6 Test Data and Output

| | | | | | | |
|-------------------|-------------|--------------|-----------|---------|-------------|------------|
| | SMITH | JB15Y0000230 | | | | |
| | JAMES | HR15 0500245 | | | | |
| | BAKER | SR09 0500350 | | | | |
| | PART-TIMER | JR03Y0000300 | | | | |
| | JONES | PL15Y0000280 | | | | |
| | HEAVYWORKER | HM18 0000200 | | | | |
| | LEE | BL18 0000335 | | | | |
| | CLARK | JC06 0000310 | | | | |
| | GROSSMAN | SE07 0000215 | | | | |
| | FRANKEL | LF10 0000350 | | | | |
| | BENWAY | CT03 0250395 | | | | |
| | KERBEL | NB04 0000100 | | | | |
| (a) Test Data | | | | | | |
| STUDENT NAME | CREDITS | TUITION | UNION FEE | ACT FEE | SCHOLARSHIP | TOTAL BILL |
| SMITH | JB 15 | 003000 | 025 | 075 | 00000 | 003100 |
| JAMES | HR 15 | 003000 | 000 | 075 | 00000 | 003075 |
| BAKER | SR 09 | 001800 | 000 | 050 | 00500 | 001350 |
| PART-TIMER | JR 03 | 000600 | 025 | 025 | 00000 | 000650 |
| JONES | PL 15 | 003000 | 025 | 075 | 00000 | 003100 |
| HEAVYWORKER | HM 18 | 003600 | 000 | 075 | 00000 | 003675 |
| LEE | BL 18 | 003600 | 000 | 075 | 00000 | 003675 |
| CLARK | JC 06 | 001200 | 000 | 025 | 00000 | 001225 |
| GROSSMAN | SE 07 | 001400 | 000 | 050 | 00000 | 001450 |
| FRANKEL | LF 10 | 002000 | 000 | 050 | 00000 | 002050 |
| BENWAY | CT 03 | 000600 | 000 | 025 | 00250 | 000375 |
| KERBEL | NB 04 | 000800 | 000 | 025 | 00000 | 000825 |
| | | 024600 | 0075 | 0625 | 000750 | 024550 |
| UNIVERSITY TOTALS | | | | | | |
| (b) Output | | | | | | |

Test Data

The test data and associated output are shown in Figures 5.6a and 5.6b, respectively. The test data are identical to those used in the original stubs program; the output, however, is different and reflects the expanded Procedure Division of Figure 5.5. Note, too, the correspondence between individual records in the input data file and the associated lines in the printed report.

Observe, for example, that JB Smith, JR Part-Timer, and PL Jones each have a Y in column 20 of their input records, and that these are the only individuals who are charged a Union Fee. In similar fashion, James, Baker, and Benway are the only students with potential scholarships in the incoming data; James, however, does not have the requisite average and so he does not receive a scholarship. The student file has 12 records, and hence 12 students appear in the printed report.

In retrospect, the output produced isn't very pretty as it is unformatted and contains extraneous zeros throughout. (Editing is presented in Chapter 7 together with a final version of the program.)

Hierarchy Chart

The hierarchy chart was introduced initially as a design aid and developed before the program was written; it is also used as a documentation technique after coding is completed to better understand the overall program structure. The hierarchy chart depicts the functions inherent in a program, and is closely tied to the paragraphs in the Procedure Division. Observe therefore, the properties of the hierarchy chart in Figure 5.4a as they relate to the COBOL program in Figure 5.5.

1. Every box (module) in the hierarchy chart corresponds to a paragraph in the COBOL program. There are twelve different modules (the READ appears twice) in the hierarchy chart, and twelve paragraphs in the program.
2. Each paragraph in the COBOL program contains as many PERFORM statements as there are modules in the next lower level of the hierarchy chart. Thus the paragraph at the highest level, PREPARE-TUITION-REPORT, contains four PERFORM statements, one for each subordinate paragraph.
3. A paragraph can be entered only from the paragraph directly above it and must eventually return control to that paragraph. Hence, PROCESS-STUDENT-RECORDS is entered via a PERFORM statement in PREPARE-TUITION-REPORT. PROCESS-STUDENT-RECORDS in turn invokes four lower level paragraphs, each of which returns control to PROCESS-STUDENT-RECORDS, which eventually returns control to PREPARE-TUITION-REPORT.
4. Every module in a hierarchy chart (paragraph within a program) should be dedicated to a single function. The nature of that function should be apparent from the module's name and should consist of a verb, one or two adjectives, and an object.

Remember, too, that a hierarchy chart is very different from flowcharts or pseudocode. A hierarchy chart shows what has to be done, but not when; it contains no decision-making logic. Flowcharts and pseudocode, on the other hand, specify when and if a given block of code is executed. We say that hierarchy charts are *functional* in nature; they contain the tasks necessary to accomplish the specifications but do not indicate an order for execution. Pseudocode and flowcharts are *procedural* and specify logic.

Our objective is for you to write meaningful COBOL programs, not to memorize what must appear to be an endless list of rules. You must eventually remember certain things, but we have found the best approach is to pattern your first few COBOL programs after existing examples such as the tuition billing program. Everything you need to get started is contained in that program (Figure 5.5) if you will look at it carefully. As a further aid, Figure 5.7 contains a skeleton outline of a COBOL program and some helpful hints. Consider:

1. The four divisions must appear in the order: Identification, Environment, Data, and Procedure. Division headers begin in the A margin and always appear on a line by themselves.
2. The Environment and Data Divisions contain sections with fixed names. The Identification Division does not contain any sections. (The Procedure Division may contain programmer-defined sections; however, this is usually not done in beginning programs.)
3. The Data Division is the only division without paragraph names. In the Identification and Environment Divisions, the paragraph names are fixed. In the Procedure Division they are determined by the programmer. Paragraph names begin in the A margin.
4. Any entry not required to begin in the A margin begins in the B margin—that is, in or past column 12.
5. The program executes instructions sequentially, as they appear in the Procedure Division, unless a transfer-of-control statement such as PERFORM is encountered.
6. Every file must be opened and closed. A file name will appear in at least four statements: SELECT, FD, OPEN, and CLOSE. The READ statement also contains the file name of an input file, whereas the WRITE statement contains the record name of an output file.

LIMITATIONS OF COBOL-74

Scope terminators (e.g., END-IF, and END-READ) did not exist in COBOL-74; hence all scope terminators in Figure 5.5 must be removed for the program to compile under COBOL-74. The advantage of including scope terminators is explained further in Chapter 7.

The EVALUATE statement is also new to COBOL-85 and hence an alternative way to compute the activity fee (e.g., multiple IF statements) is required to develop the program under the older compiler.

The word TO is permitted as an optional reserved word in the GIVING form of the ADD statement in COBOL-85; it was not allowed in COBOL-74. THEN is an optional reserved word in the IF statement in COBOL-85 but was not allowed in COBOL-74.

Figure 5.7 Skeleton Outline of a COBOL Program

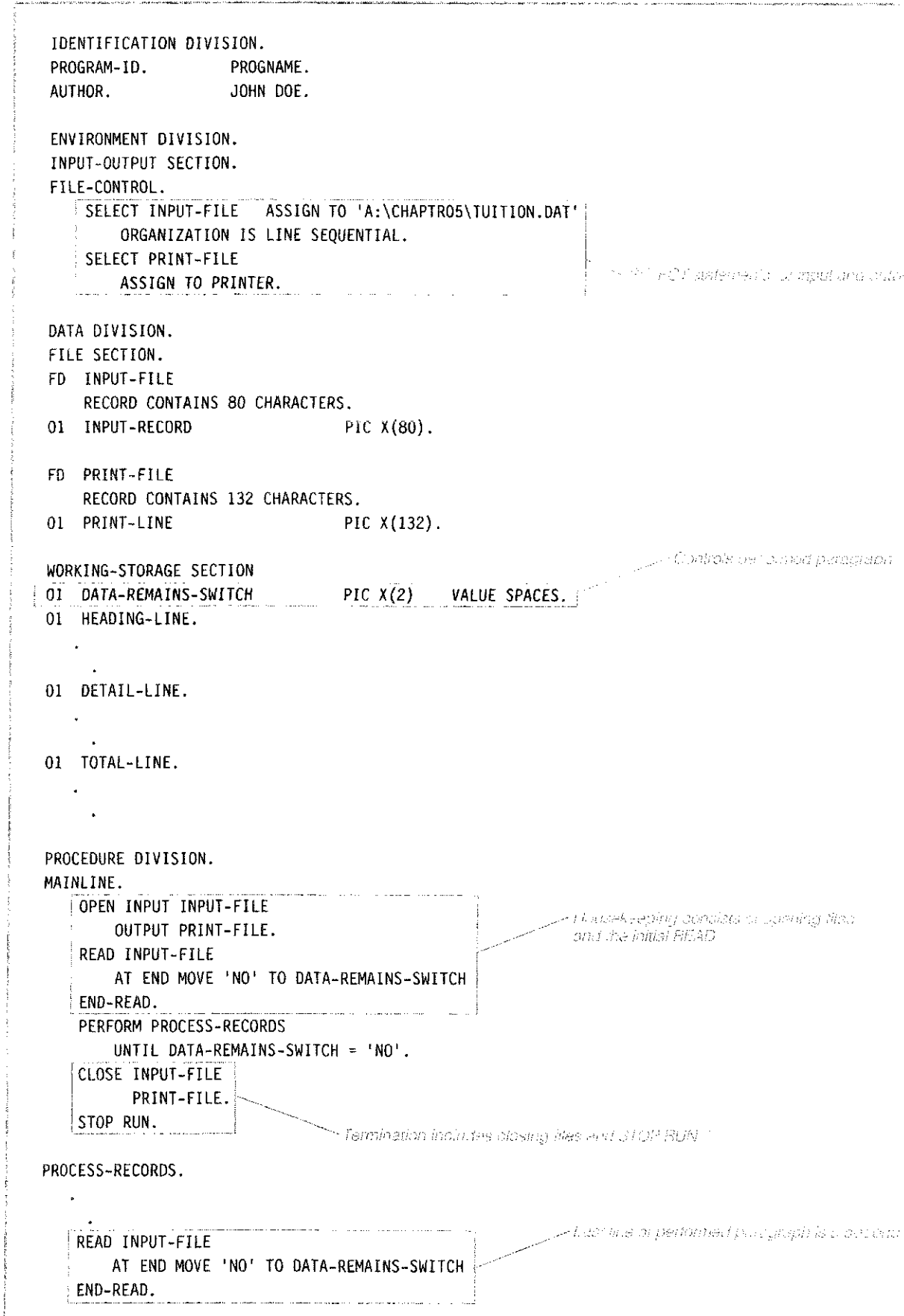

S U M M A R Y

Points to Remember

- ☛ The READ statement typically appears twice in a COBOL program; as an initial (priming) read, and as the last statement of a performed paragraph to process a file until its records are exhausted.
- ☛ The PERFORM statement may be used with or without an UNTIL clause; the latter is used to implement a loop.
- ☛ The IF statement may be used with or without an ELSE clause; indentation is optional, but strongly suggested, in order to clarify intent.
- ☛ The EVALUATE statement implements the case structure and is used instead of multiple IF statements.
- ☛ The MOVE statement has several precisely defined rules, which govern the use of sending and receiving fields of different lengths and/or data types.
- ☛ Arithmetic is done in one of two ways: either through individual statements such as ADD, SUBTRACT, MULTIPLY, and DIVIDE, or through a COMPUTE statement which combines multiple operations.
- ☛ Parentheses may clarify and/or alter the normal sequence of operations; exponentiation, multiplication or division, addition or subtraction (and from left to right, if a tie).
- ☛ The hierarchy chart can be used as a design aid before a program is written, and as a documentation technique afterward.

Key Words and Concepts

| | |
|---------------------------------|-------------------------------|
| Assumed (implied) decimal point | Hierarchy of operations |
| Decimal alignment | Indentation |
| Design aid | Priming (initial) read |
| Documentation | Pseudocode |
| Exponentiation | Receiving (destination) field |
| Group move | Scope terminator |
| Hierarchy chart | Source (sending) field |

COBOL Elements

| | | | |
|-----------|--------------|----------|------------|
| ADD | END-COMPUTE | EVALUATE | READ |
| ADVANCING | END-DIVIDE | GIVING | ROUNDED |
| CLOSE | END-EVALUATE | IF | SIZE ERROR |
| COMPUTE | END-IF | MOVE | STOP RUN |
| DIVIDE | END-MULTIPLY | MULTIPLY | SUBTRACT |
| ELSE | END-READ | OPEN | UNTIL |
| END-ADD | END-SUBTRACT | PERFORM | WRITE |

1. The _____ statement permits multiple arithmetic operations in a single statement.
2. Most arithmetic statements have _____ distinct formats.
3. Specification of the _____ clause causes a calculation to be carried to one more place than is specified in the result field.
4. Exponentiation is indicated by _____.
5. In the absence of parentheses exponentiation comes (before/after) multiplication.
6. If both multiplication and division are present, computation proceeds from _____ to _____.
7. The IF statement (does/does not) require an ELSE clause.
8. The effect of an IF statement is terminated by the presence of a _____ or the presence of an _____ clause.
9. _____ is normally the last statement that is executed in any COBOL program.
10. A typical COBOL program usually has _____ distinct READ statements.
11. A file containing N records is generally read _____ times.
12. In COBOL, one reads a _____ and writes a _____.
13. Specification of _____ in a WRITE statement causes the next line of output to begin on top of a new page.
14. The type of file—that is, INPUT or OUTPUT—appears in an _____, but not in a _____ statement.
15. When an alphanumeric field is moved to an alphanumeric field, data are moved _____ character at a time, from _____ to _____.
16. If a five position alphanumeric field is moved to a four position alphanumeric field, the low order character is _____.
17. A numeric move always maintains _____.
18. A PERFORM UNTIL statement always tests the condition (before/after) performing the designated paragraph.
19. A numeric field (may/may not) be moved to an alphabetic field.
20. If a numeric field with PIC 999 is moved to a numeric field with PIC 99, the (most/least) significant digit will be truncated.
21. The _____ option is available for all arithmetic statements, and indicates when the result of a computation is larger than its designated PICTURE clause.
22. The _____ statement has been introduced to express a multibranch situation.

TRUE / FALSE

1. One ADD instruction can change the value of more than one data name.
2. Both GIVING and TO may be present in the same ADD instruction.
3. A valid ADD instruction may contain neither GIVING nor TO.
4. Both FROM and GIVING may appear in the same SUBTRACT instruction.
5. The use of GIVING is optional in the MULTIPLY statement.
6. The reserved word INTO must appear in a DIVIDE statement.
7. In the DIVIDE statement, the dividend is always identifier-1.
8. Multiplication and division can be performed in the same MULTIPLY statement.
9. Multiplication and addition can be performed in the same COMPUTE statement.
10. In a COMPUTE statement with no parentheses, multiplication is always done before subtraction.
11. In a COMPUTE statement with no parentheses, multiplication is always done before division.
12. Parentheses are sometimes required in a COMPUTE statement.
13. The COMPUTE statement changes the value of only one data name.
14. The IF statement must always contain the ELSE option.
15. The PERFORM statement transfers control to a paragraph elsewhere in the program.
16. A program may contain more than one STOP RUN statement.
17. STOP RUN must be the last statement in the Procedure Division.
18. The ADVANCING option is mandatory in the WRITE statement.
19. The READ statement contains a record name.
20. The WRITE statement contains a record name.
21. The OPEN and CLOSE statements are optional.
22. The END-IF scope terminator has little effect in an IF statement.
23. An IF statement can cause the execution of several other statements.
24. If the ELSE clause is satisfied in an IF statement, it can cause execution of several statements.
25. The ROUNDED clause is required in the COMPUTE statement.
26. The SIZE ERROR option is allowed only in the COMPUTE statement.
27. The SIZE ERROR option is required in the COMPUTE statement.
28. The EVALUATE statement facilitates implementation of the case construct.

PROBLEMS

1. Some of the following arithmetic statements are invalid. Identify those, and state why they are unacceptable.
 - a. ADD A B C.
 - b. SUBTRACT 10 FROM A B.
 - c. SUBTRACT A FROM 10.
 - d. ADD A TO B GIVING C.
 - e. SUBTRACT A ROUNDED FROM B ROUNDED GIVING C.
 - f. MULTIPLY A BY 10.
 - g. MULTIPLY 10 BY A ROUNDED.
 - h. MULTIPLY A BY 10 GIVING B C.
 - i. DIVIDE A BY B.
 - j. DIVIDE A INTO B.
 - k. DIVIDE A INTO B GIVING C.
 - l. DIVIDE B BY A GIVING C.
 - m. COMPUTE X ROUNDED = A + B.
 - n. COMPUTE X = 2(A + B).
 - o. COMPUTE V = 20 / A - C.

2. Complete the table below. In each instance, refer to the *initial* values of A, B, C, and D.

| DATA NAME | A | B | C | D |
|--|---|---|----|-------|
| Value before execution | 4 | 8 | 12 | 2 |
| Value after execution of | | | | |
| a. ADD 1 TO D B. | | | | _____ |
| b. ADD A B C GIVING D. | | | | _____ |
| c. ADD A B C TO D. | | | | _____ |
| d. SUBTRACT A B FROM C. | | | | _____ |
| e. SUBTRACT A B FROM C GIVING D. | | | | _____ |
| f. MULTIPLY A BY B C. | | | | _____ |
| g. MULTIPLY B BY A. | | | | _____ |
| h. DIVIDE A INTO C. | | | | _____ |
| i. DIVIDE C BY B GIVING D REMAINDER A. | | | | _____ |
| j. COMPUTE D = A + B / 2 * D. | | | | _____ |
| k. COMPUTE D = (A + B) / (2 * D). | | | | _____ |
| l. COMPUTE D = A + B / (2 * D). | | | | _____ |
| m. COMPUTE D = (A + B) / 2 * D. | | | | _____ |
| n. COMPUTE D = A + (B / 2) * D. | | | | _____ |

3. Indicate the logical errors inherent in the following COBOL fragment:

```

FILE SECTION.
FD EMPLOYEE-FILE
.
.
.
FD PRINT-FILE
.
.
.
WORKING-STORAGE SECTION.
01 END-OF-FILE-SWITCH      PIC X(3)      VALUE 'YES'.
.
.
.
PROCEDURE DIVISION.
PREPARE-EMPLOYEE-REPORT.
    MOVE HEADING-LINE TO PRINT-LINE.
    WRITE PRINT-LINE
        AFTER ADVANCING PAGE.
    OPEN INPUT EMPLOYEE-FILE
        OUTPUT PRINT-FILE.
    PERFORM PROCESS-RECORDS
        UNTIL END-OF-FILE-SWITCH = 'YES'.
    CLOSE EMPLOYEE-FILE.
    STOP RUN.
PROCESS-RECORDS.
    READ EMPLOYEE-FILE
        AT END MOVE 'YES' TO END-OF-FILE-SWITCH
    END-READ.
.
.
.

```

4. Some of the following statements are invalid. Indicate those, and state why they are invalid. (Assume FILE-ONE and FILE-TWO are file names and RECORD-ONE is a record name.)
- OPEN INPUT RECORD-ONE.
 - OPEN INPUT FILE-ONE OUTPUT FILE-TWO.
 - OPEN INPUT FILE-ONE.
 - CLOSE OUTPUT FILE-ONE.
 - READ FILE-ONE.
 - READ FILE-ONE AT END PERFORM END-OF-JOB-ROUTINE.
 - READ RECORD-ONE AT END PERFORM END-OF-JOB.
 - WRITE RECORD-ONE.
 - WRITE RECORD-ONE AFTER ADVANCING TWO LINES.
 - WRITE RECORD-ONE BEFORE ADVANCING TWO LINES.
 - CLOSE FILE-ONE FILE-TWO.
 - WRITE FILE-ONE.
 - WRITE RECORD-ONE AFTER ADVANCING PAGE.

5. Write COBOL COMPUTE statements to accomplish the intended logic:

a. $x = a + b + c$

b. $x = \frac{a + bc}{2}$

c. $x = a^2 + b^2 + c^2$

d. $x = \frac{a + b}{2} - c$

e. $x = a + b$

f. $x = \sqrt{\frac{a^2 + b^2}{2c}}$

g. $f = p(1 + i)^n$

h. $f = \frac{(1 + i)^n - 1}{i}$

i. $x = \frac{(a + b)^c}{(d + e)^f}$

6. Given the following Procedure Division:

PROCEDURE DIVISION.

FIRST-PARAGRAPH.

MOVE ZEROS TO FIELD-A FIELD-B.

PERFORM SECOND-PARAGRAPH.

PERFORM THIRD-PARAGRAPH.

PERFORM SECOND-PARAGRAPH.

STOP RUN.

SECOND-PARAGRAPH.

ADD 10 TO FIELD-A.

ADD 20 TO FIELD-B.

THIRD-PARAGRAPH.

MULTIPLY FIELD-A BY FIELD-B GIVING FIELD-C.

DIVIDE FIELD-A INTO FIELD-B GIVING FIELD-D.

- What are the final values for FIELD-A, FIELD-B, FIELD-C, and FIELD-D?
- How many times is each paragraph executed?

7. Complete the following table, showing the contents of the receiving field.

| SENDING FIELD | | RECEIVING FIELD | |
|---------------|----------|-----------------|----------|
| PICTURE | CONTENTS | PICTURE | CONTENTS |
| a. X(4) | H O P E | X(4) | |
| b. X(4) | H O P E | 9(4) | |
| c. X(4) | H O P E | X(3) | |
| d. X(4) | H O P E | X(5) | |
| e. 9(4) | 6 7 8 9 | X(4) | |
| f. 9(4) | 6 7 8 9 | 9(3) | |
| g. 9(4) | 6 7 8 9 | 9(5) | |
| h. 999V9 | 6 7 8 9 | 9(4) | |
| i. 999V9 | 6 7 8 9 | 9(4)V9 | |
| j. 999V9 | 6 7 8 9 | 9(3)V99 | |
| k. 999V9 | 6 7 8 9 | 99V99 | |

8. Supply Procedure Division statements as indicated:

- Code two equivalent statements, an ADD and a COMPUTE, to add 1 to the counter NUMBER-QUALIFIED-EMPLOYEES.
- Code a COBOL statement to add the contents of five fields, MONDAY-SALES, TUESDAY-SALES, WEDNESDAY-SALES, THURSDAY-SALES, and FRIDAY-SALES, storing the result in WEEKLY-SALES.
- Code a COBOL statement to subtract the fields FED-TAX, STATE-TAX, FICA, and VOLUNTARY-DEDUCTIONS, from GROSS-PAY, and put the result in NET-PAY.
- Code a single COBOL statement to calculate NET-AMOUNT-DUE, which is equal to the GROSS-SALE minus a 2% discount.
- Recode part (d), using two statements (a MULTIPLY and a SUBTRACT).
- Code a COBOL statement to compute GROSS-PAY, which is equal to HOURS-WORKED times HOURLY-RATE.
- Code a single COBOL statement to compute GROSS-PAY, which is equal to REG-HOURS-WORKED times HOURLY-RATE plus OVERTIME-HOURS times HOURLY-RATE times 1.5.
- Code a COBOL statement to determine AVERAGE-SALARY by dividing TOTAL-SALARY by NUMBER-OF-EMPLOYEES.
- Code a COBOL Compute statement equivalent to the algebraic formula.

$$x = \frac{(a + b)c}{de}$$

- Code a COBOL Compute statement equivalent to the algebraic formula.

$$x = \frac{-b + \sqrt{b^2 - 4ac}}{2a}$$

9. Write Procedure Division code for the flowchart in Figure 5.8.

Figure 5.6 Flowcharts for Problem 9

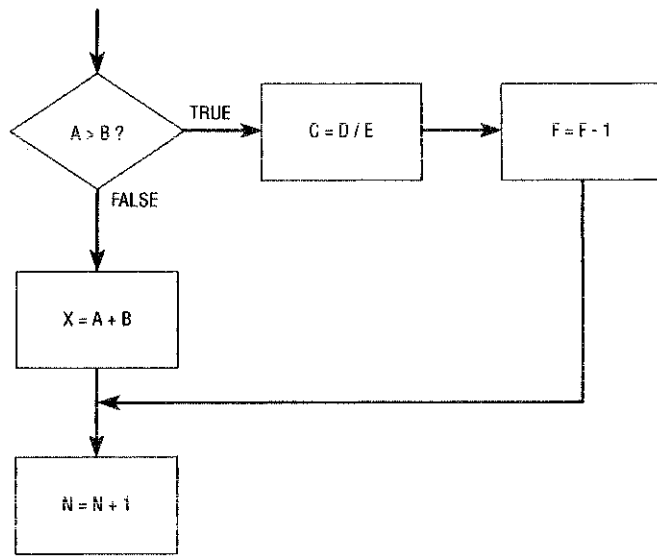

(a)

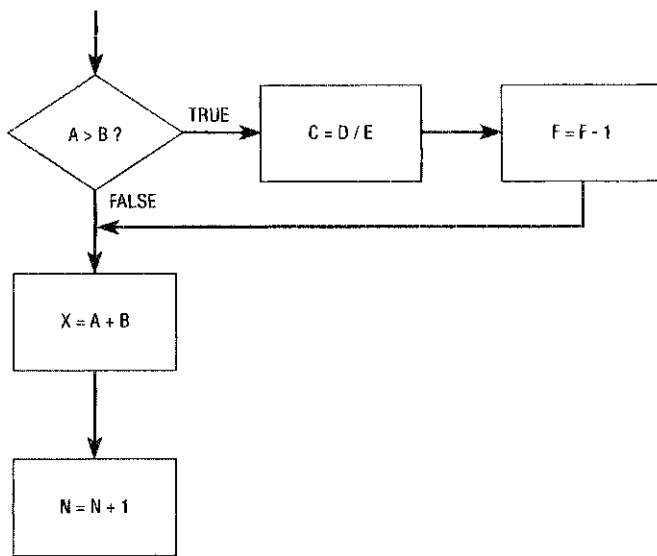

(b)

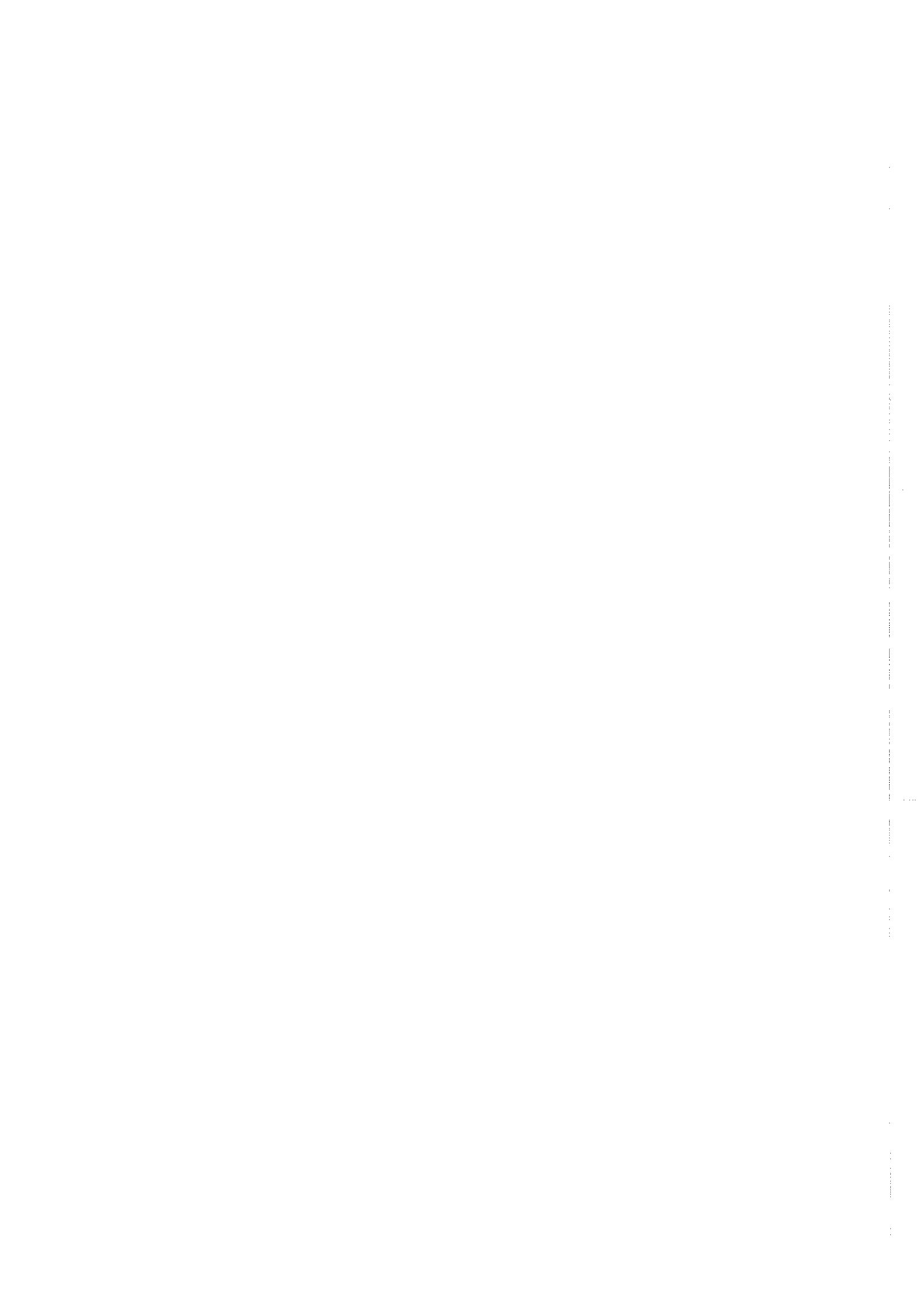

Debugging

CHAPTER OUTLINE

Overview

Errors in Compilation

Common Compilation Errors

Errors in Execution

File Status Codes

Tips for Debugging

Cross-Reference Listing

DISPLAY Statement

Interactive Debugger

The Structured Walkthrough

Summary

Fill-in

True/False

Problems

OBJECTIVES

After reading this chapter you will be able to:

- ✦ Distinguish between errors in compilation and execution; correct typical compilation errors.
- ✦ Use the DISPLAY statement as a debugging tool.
- ✦ Explain how an interactive debugger can be used to find and correct execution errors.
- ✦ Describe the use of file status codes in correcting data management errors.
- ✦ Explain what is meant by a structured walkthrough; be able to participate as reviewer, reviewee, moderator, or secretary.

OVERVIEW

Very few computer programs run successfully on the first attempt. Indeed, the programmer is realistically expected to make errors, and an important test of a good programmer is not whether he or she makes mistakes, but how quickly he or she is able to detect and correct the errors. Since this process is such an integral part of programming, an entire chapter is devoted to debugging. We consider errors in both compilation and execution.

Compilation errors occur during the translation of COBOL to machine language and are caused by a mistake in COBOL syntax, for example, a missing period or an entry in a wrong column. Execution errors result after the program has been translated to machine language and produce results that are different from what the programmer expected or intended.

Compilation errors are easy to find because the compiler produces an explicit error message. Execution errors are more difficult to detect and may require the use of additional debugging tools, such as the insertion of DISPLAY statements into a program and/or the use of an interactive debugger. The chapter also considers the structured walkthrough as a means of reducing errors before they occur.

Errors in Compilation

Compilation is the process of translating a source (COBOL) program into machine language. Any mistake in COBOL syntax causes the compiler to make an assumption in the interpretation of the statement in which the error occurs, or, worse yet, makes it impossible for the compiler to interpret the statement at all. Either way a *compilation error* results.

Some errors are less severe than others; for example, the compiler is generally able to guess the programmer's intent when periods are omitted in the Data Division, whereas it is unable to decipher a misspelled reserved word. Accordingly, most compilers provide different levels of *compiler diagnostics* (error messages) according to the severity of the error. Micro Focus Personal COBOL for Windows, for example, produces five types of error messages, which are listed in order of increasing severity. Other compilers have similar classifications. Consider:

| | | |
|---|---------------------------|---|
| I | Informational Diagnostics | Indicates a coding inefficiency or other condition (for example, an incompatibility with the ANS standard). The program will compile correctly. |
| W | Warning Diagnostics | The statement is syntactically correct, but the source of a potential problem. A program can compile and execute with several W-level diagnostics present; however, ignoring these messages could lead to errors in execution. |
| E | Error Diagnostics | The statement is incorrect as written, and requires the compiler to make an assumption in order to complete the compilation. You may wish to correct the program in case the compiler's assumption is not what you intended. |
| S | Severe Diagnostics | A severe error in that the compiler cannot make corrections and therefore cannot generate object instructions. Any statement flagged as an S-level error is ignored and treated as if it were not present in the program. |
| U | Unrecoverable Diagnostics | An error of such severity that the compiler does not know what to do and cannot continue. U-level diagnostics are extremely rare, and you practically have to submit a Visual BASIC program to the COBOL compiler to cause a U-level message. |

The COBOL compiler tends to rub salt in a wound in the sense that an error in one statement can cause error messages in other statements that appear correct. For example, should you have an S-level error in a SELECT statement, the compiler will flag the error, ignore the SELECT statement, and then flag any other statements that reference that file even though those other statements are correct.

Often simple mistakes such as omitting a line or misspelling a reserved word can lead to a long and sometimes confusing set of error messages. The only consolation is that compiler errors can disappear as quickly as they occurred. Correction of the misspelled word or insertion of the missing statement will often eliminate several errors at once.

Proficiency in debugging comes from experience—the more programs you write, the better you become. You may correct the errors in the order they appear

(our preference), or in the order of severity (from Unrecoverable, Severe, Error, Warning, to Informational), or even haphazardly as you find them. Whichever way you choose, try to find the mistakes as quickly as possible and without wasting time. Moreover, don't spend too much time on any single error; instead, if you are stuck, skip the error temporarily and continue to the next, eliminating as many errors as you can before you recompile.

Figure 6.1 Tuition Billing Program with Compilation Errors

```

1  IDENTIFICATION DIVISION.
2  PROGRAM-ID.      TUIT6COM.
3  AUTHOR.          CAROL VAZQUEZ VILLAR.
4
5  ENVIRONMENT DIVISION.
6  INPUT-OUTPUT SECTION.
7  FILE-CONTROL.
8      SELECT STUDENT-FILE  ASSIGN TO 'A:\CHAPTR06\TUITION.DAT'
9          ORGANIZATION IS LINE SEQUENTIAL.
10     SELECT PRINT-FILE
11         ASSIGN TO PRINTER.
12
13  DATA DIVISION.
14  FILE SECTION.
15  FD STUDENT-FILE
16     RECORD CONTAINS 27 CHARACTERS.
17  01 STUDENT-RECORD.
18     05 STU-NAME.
19         10 STU-LAST-NAME  PIC X(15).
20         10 STU-INITIALS   PIC XX.
21         05 STU-CREDITS    PIC 9(2).
22         05 STU-UNION-MEMBER  PIC X.
23         05 STU-SCHOLARSHIP PIC 9(4).
24         05 STU-GPA        PIC 9V99.
25
26  FD PRINT-FILE
27     RECORD CONTAINS 132 CHARACTERS.
28  01 PRINT-LINE          PIC X(132).
29
30  WORKING-STORAGE SECTION.
31  01 DATA-REMAINS-SWITCH  PIC X(2) VALUE SPACES.
32
33  01 INDIVIDUAL-CALCULATIONS.
34     05 IND-TUITION        PIC 9(4) VALUE ZEROS.
35     05 IND-ACTIVITY-FEE   PIC 9(2) VALUE ZEROS.
36     05 IND-UNION-FEE      PIC 9(2) VALUE ZEROS.
37     05 IND-SCHOLARSHIP    PIC 9(3) VALUE ZEROS.
38     05 IND-BILL           PIC 9(6) VALUE ZEROS.
39
40  01 UNIVERSITY-TOTALS.
41     05 UNI-TUITION        PIC 9(6) VALUE ZEROS.
42     05 UNI UNION FEE      PIC 9(4) VALUE ZEROS.

```

Hyphens missing

Figure 6.1 (continued)

```

43      05 UNI-ACTIVITY-FEE      PIC 9(4) VALUE ZEROS.
44      05 UNI-SCHOLARSHIP      PIC X(6) VALUE ZEROS.
45      05 UNI-IND-BILL          PIC 9(6) VALUE ZEROS.
46
47      01 CONSTANTS-AND-RATES.
48          05 PRICE-PER-CREDIT  PIC 9(3) VALUE 200.
49          05 UNION-FEE         PIC 9(2) VALUE 25.
50          05 ACTIVITY-FEES.
51              10 1ST-ACTIVITY-FEE PIC 99 VALUE 25.
52              10 1ST-CREDIT-LIMIT PIC 99 VALUE 6.
53              10 2ND-ACTIVITY-FEE PIC 99 VALUE 50.
54              10 2ND-CREDIT-LIMIT PIC 99 VALUE 12.
55              10 3RD-ACTIVITY-FEE PIC 99 VALUE 75.
56          05 MINIMUM-SCHOLAR-GPA PIC 9V9 VALUE 2.5.
57
58      01 HEADING-LINE.
59          05 FILLER              PIC X VALUE SPACES.
60          05 FILLER              PIC X(12) VALUE 'STUDENT NAME'.
61          05 FILLER              PIC X(10) VALUE SPACES.
62          05 FILLER              PIC X(7) VALUE 'CREDITS'.
63          05 FILLER              PIC X(2) VALUE SPACES.
64          05 FILLER              PIC X(7) VALUE 'TUITION'.
65          05 FILLER              PIC X(2) VALUE SPACES.
66          05 FILLER              PIC X(9) VALUE 'UNION FEE'.
67          05 FILLER              PIC X(2) VALUE SPACES.
68          05 FILLER              PIC X(7) VALUE 'ACT FEE'.
69          05 FILLER              PIC X(2) VALUE SPACES.
70          05 FILLER              PIC X(11) VALUE 'SCHOLARSHIP'.
71          05 FILLER              PIC X(2) VALUE SPACES.
72          05 FILLER              PIC X(10) VALUE 'TOTAL BILL'.
73          05 FILLER              PIC X(48) VALUE SPACES.
74
75      01 DETAIL-LINE.
76          05 FILLER              PIC X VALUE SPACES.
77          05 DET-LAST-NAME       PIC X(15).
78          05 FILLER              PIC X(2) VALUE SPACES.
79          05 DET-INITIALS        PIC X(2).
80          05 FILLER              PIC X(5) VALUE SPACES.
81          05 STU-CREDITS          PIC 9(2).
82          05 FILLER              PIC X(6) VALUE SPACES.
83          05 DET-TUITION         PIC 9(6).
84          05 FILLER              PIC X(7) VALUE SPACES.
85          05 DET-UNION-FEE       PIC 9(3).
86          05 FILLER              PIC X(6) VALUE SPACES.
87          05 DET-ACTIVITY-FEE    PIC 9(3).
88          05 FILLER              PIC X(8) VALUE SPACES.
89          05 DET-SCHOLARSHIP     PIC 9(5).
90          05 FILLER              PIC X(6) VALUE SPACES.
91          05 DET-IND-BILL        PIC 9(6).
92          05 FILLER              PIC X(49) VALUE SPACES.
    
```

05 UNI-SCHOLARSHIP PIC X(6) VALUE ZEROS.

05 FILLER PIC X(10) VALUE SPACES.

05 STU-CREDITS PIC 9(2).

Figure 6.1 (continued)

```

93
94     01 DASH-LINE.
95         05 FILLER             PIC X(31) VALUE SPACES.
96         05 FILLER             PIC X(8)  VALUE ALL '-'.
97         05 FILLER             PIC X(2)  VALUE SPACES.
98         05 FILLER             PIC X(8)  VALUE ALL '-'.
99         05 FILLER             PIC X(2)  VALUE SPACES.
100        05 FILLER             PIC X(7)  VALUE ALL '-'.
101        05 FILLER             PIC X(6)  VALUE SPACES.
102        05 FILLER             PIC X(7)  VALUE ALL '-'.
103        05 FILLER             PIC X(5)  VALUE SPACES.
104        05 FILLER             PIC X(7)  VALUE ALL '-'.
105        05 FILLER             PIC X(49) VALUE SPACES.
106
107        01 TOTAL-LINE.
108            05 FILLER             PIC X(8)  VALUE SPACES.
109            05 FILLER             PIC X(17)
110                VALUE 'UNIVERSITY TOTALS'.
111            05 FILLER             PIC X(8)  VALUE SPACES.
112            05 TOT-TUITION         PIC 9(6).
113            05 FILLER             PIC X(6)  VALUE SPACES.
114            05 TOT-UNION-FEE       PIC 9(4).
115            05 FILLER             PIC X(5)  VALUE SPACES.
116            05 TOT-ACTIVITY-FEE    PIC 9(4).
117            05 FILLER             PIC X(7)  VALUE SPACES.
118            05 TOT-SCHOLARSHIP     PIC 9(6).
119            05 FILLER             PIC X(6)  VALUE SPACES.
120            05 TOT-IND-BILL        PIC 9(6).
121            05 FILLER             PIC X(49) VALUE SPACES.
122
123        PROCEDURE DIVISION. Reserved word used as paragraph name
124        START.
125            OPEN INPUT STUDENT-FILE
126                OUTPUT PRINT-FILE.
127            PERFORM WRITE-HEADING-LINE.
128            PERFORM READ-STUDENT-FILE.
129            PERFORM PROCESS-STUDENT-RECORD
130                UNTIL DATA-REMAINS-SWITCH = 'NO'.
131            PERFORM WRITE-UNIVERSITY-TOTALS.
132            CLOSE STUDENT-FILE
133                PRINT-FILE.
134            STOP RUN.
135
136        WRITE-HEADING-LINE.
137            MOVE HEADING-LINE TO PRINT-LINE.
138            WRITE PRINT-LINE
139                AFTER ADVANCING PAGE.
140            MOVE SPACES TO PRINT-LINE.
141            WRITE PRINT-LINE.
142

```

Figure 6.1 (continued)

```

143 READ-STUDENT-FILE.
144 READ STUDNET-FILE
145 AT END MOVE 'NO' TO DATA-REMAINS-SWITCH
146 END-READ.
147
148 PROCESS-STUDENT-RECORD.
149 PERFORM COMPUTE-INDIVIDUAL-BILL.
150 PERFORM INCREMENT-UNIVERSITY-TOTALS
151 PERFORM WRITE-DETAIL-LINE.
152 PERFORM READ-STUDENT-FILE.
153
154 COMPUTE-INDIVIDUAL-BILL.
155 PERFORM COMPUTE-TUITION.
156 PERFORM COMPUTE-UNION-FEE.
157 PERFORM COMPUTE-ACTIVITY-FEE.
158 PERFORM COMPUTE-SCHOLARSHIP.
159 COMPUTE IND-BILL = IND-TUITION + IND-UNION-FEE + IND-ACTIVITY
160 - IND-SCHOLARSHIP.
161
162 COMPUTE-TUITION.
163 COMPUTE IND-TUITION = PRICE-PER-CREDIT * STU-CREDITS.
164
165 COMPUTE-UNION-FEE.
166 IF STU-UNION-MEMBER = 'Y'
167 MOVE UNION-FEE TO IND-UNION-FEE
168 ELSE
169 MOVE ZERO TO IND-UNION-FEE
170 END-IF.
171
172 COMPUTE-ACTIVITY-FEE.
173 EVALUATE TRUE
174 WHEN STU-CREDITS <= 1ST-CREDIT-LIMIT
175 MOVE 1ST-ACTIVITY-FEE TO IND-ACTIVITY-FEE
176 WHEN STU-CREDITS > 1ST-CREDIT-LIMIT
177 AND STU-CREDITS <= 2ND-CREDIT-LIMIT
178 MOVE 2ND-ACTIVITY-FEE TO IND-ACTIVITY-FEE
179 WHEN STU-CREDITS > 2ND-CREDIT-LIMIT
180 MOVE 3RD-ACTIVITY-FEE TO IND-ACTIVITY-FEE
181 WHEN OTHER
182 DISPLAY 'INVALID CREDITS FOR: ' STU-NAME
183 END-EVALUATE.
184
185 COMPUTE-SCHOLARSHIP.
186 IF STU-GPA > MINIMUM-SCHOLAR-GPA
187 MOVE STU-SCHOLARSHIP TO IND-SCHOLARSHIP
188 ELSE
189 MOVE ZERO TO IND-SCHOLARSHIP
190 END-IF.
191
192 INCREMENT-UNIVERSITY-TOTALS.

```

Annotations:
 - Line 144: *STUDNET-FILE*
 - Line 157: *ACTIVITY-FEE*
 - Line 163: *PRICE-PER-CREDIT * STU-CREDITS*
 - Line 174: *Multiple references to lines 175-180*
 - Line 187: *STU-SCHOLARSHIP*

Figure 6.1 (continued)

```

193     ADD IND-TUITION      TO UNI-TUITION.
194     ADD IND-UNION-FEE    TO UNI-UNION-FEE.
195     ADD IND-ACTIVITY-FEE TO UNI-ACTIVITY-FEE.
196     ADD IND-SCHOLARSHIP TO UNI-SCHOLARSHIP.
197     ADD IND-BILL        TO UNI-IND-BILL.
198
199 WRITE-DETAIL-LINE.
200     MOVE STU-LAST-NAME TO DET-LAST-NAME.
201     MOVE STU-INITIALS  TO DET-INITIALS.
202     MOVE STU-CREDITS TO DET-CREDITS.
203     MOVE IND-TUITION TO DET-TUITION.
204     MOVE IND-UNION-FEE TO DET-UNION-FEE.
205     MOVE IND-ACTIVITY-FEE TO DET-ACTIVITY-FEE.
206     MOVE IND-SCHOLARSHIP TO DET-SCHOLARSHIP.
207     MOVE IND-BILL TO DET-IND-BILL.
208     MOVE DETAIL-LINE TO PRINT-LINE.
209     WRITE PRINT-FILE
210         AFTER ADVANCING 1 LINE.
211
212 WRITE-UNIVERSITY-TOTALS.
213     MOVE DASH-LINE TO PRINT-LINE.
214     WRITE PRINT-LINE.
215     MOVE UNI-TUITION TO TOT-TUITION.
216     MOVE UNI-UNION-FEE TO TOT-UNION-FEE.
217     MOVE UNI-ACTIVITY-FEE TO TOT-ACTIVITY-FEE.
218     MOVE UNI-SCHOLARSHIP TO TOT-SCHOLARSHIP.
219     MOVE UNI-IND-BILL TO TOT-IND-BILL.
220     MOVE TOTAL-LINE TO PRINT-LINE.
221     WRITE PRINT-LINE
222         AFTER ADVANCING 1 LINE.

```

Put hyphens in Working Storage definition line 42
PIC X(9) used in definition
Multiple dashes in line 19 and 21
Not defined in working storage
Should be PRINT-LINE
Put hyphens in Working Storage definition line 42
PIC X(9) used in definition

To give you a better feel of what to expect from your programs, we have taken the Tuition Billing program from Chapter 5 and deliberately changed several of the statements to cause compilation errors as shown in Figures 6.1 and 6.2. The Personal COBOL Animator highlights each error line in the original code and coordinates the error line with the error messages listed in the Syntax Errors window shown in Figure 6.2. The error messages include the assigned number of the error and the error level. For example, 233-S means that this is error message 233 and its error level is Severe. The statement is ignored but the program cannot be compiled. The error message also contains a brief explanation of the error. Some of the errors will be immediately obvious; others may require you to look up the message number in Syntax Check Error Messages in Animator Help. This help feature is included in the Standard COBOL Reference entry in the Help menu. Still other errors may require you to seek help. As you progress through this book and gain practical experience, you will become increasingly self-sufficient.

Figure 6.2 Compilation Errors

```

Syntax Error: a:\happ00\CVI\5005.sno
223-S unknown data description qualifier UNION
1014-E Period missing. Period assumed.
13-S User-name required
12-S Operand STUDNET-FILE is not declared
564-S A scope-delimiter did not have a matching verb and was discarded.
12-S Operand IND-ACTIVITY is not declared
5-S User-name STU-CREDITS not unique
5-S User-name STU-CREDITS not unique
5-S User-name STU-CREDITS not unique
5-S User-name STU-CREDITS not unique
12-S Operand UNI-UNION-FEE is not declared
34-S Operand UNI-SCHOLARSHIP should be numeric
5-S User-name STU-CREDITS not unique
330-S Not a record name
12-S Operand UNI-UNION-FEE is not declared

```

Let us examine the errors:

```
223-S unknown data description qualifier UNION
```

This error results from the first omitted hyphen in the definition of UNI UNION FEE in line 42; that is, the compiler does not know how to handle what it thinks are two data names in a row (UNI and UNION) and hence the error. In this case, the compiler has found a S-level error and ignores the rest of the statement. The compiler does not detect the missing hyphen between UNION and FEE. If only the first hyphen is inserted, on the next recompilation, the compiler will then discover the second hyphen is missing. Sometimes, one syntax error hides others so that the compiler is not able to detect them.

Correction: Insert hyphens to read UNI-UNION-FEE.

```
1014-E Period missing. Period assumed
```

A level number must follow a completed statement, but the period ending line 61 has been removed. In this instance, the compiler assumes that the period is present, so no harm is done, but it is poor programming to permit such E-level diagnostics to remain. Moreover, there are situations in which a missing period can be very damaging.

Correction: Insert a period at the end of line 61.

```
13-S user-name required
```

This error in line 124 is a subtle one that typically sends the beginner for help. START is intended as a paragraph name, and paragraph names must begin in the A-margin, so what's the problem? The difficulty is that START is a reserved word and cannot be used as a paragraph name.

Correction: Choose another name—for example, START-THE-PROGRAM.

```
12-S Operand STUDNET-FILE is not declared
```

The compiler was expecting a valid file name but didn't find one because line 144 references STUDNET-FILE rather than STUDENT-FILE. You know they are the same, but the compiler does not and hence the error.

Correction: Change the file name to STUDENT-FILE in statement 144.

564-S A scope-delimiter did not have a matching verb and was discarded.

This error in line 146 will disappear with the correction to the previous READ statement.

Correction: None required beyond the correction to line 144.

12-S Operand IND-ACTIVITY is not declared

The error is subtle because the program file contains IND-ACTIVITY-FEE in line 35, yet the data name IND-ACTIVITY appears on the listing and is flagged as an error. The problem is that the COMPUTE statement in line 159 extends beyond column 72, into columns 73–76, which are not interpreted by the compiler; that is, the compiler reads IND-ACTIVITY rather than IND-ACTIVITY-FEE.

Correction: Reformat the COMPUTE statement so that IND-ACTIVITY-FEE appears on the next line.

5-S User-name STU-CREDITS not unique

This message appears four times in a row and is associated with lines 163, 174, 176, and 179. This error message implies that two or more data names are the same; in this instance STU-CREDITS is defined in line 21 and again in line 81 (the latter should be DET-CREDITS), and the compiler does not know which is which.

Correction: Restore uniqueness to the data name in line 81, by changing STU-CREDITS to DET-CREDITS.

12-S Operand UNI-UNION-FEE is not declared

The error message references UNI-UNION-FEE as an undefined symbol and is another example of how one error can cause several others. Hyphens were omitted in the definition of UNI-UNION-FEE in line 42, and thus (as far as the compiler is concerned) the data name UNI-UNION-FEE does not exist.

Correction: This diagnostic will disappear with the correction to line 42.

34-S Operand UNI-SCHOLARSHIP should be numeric

Arithmetic is permitted only on numeric data names. UNI-SCHOLARSHIP, however, was defined in line 44 as an alphanumeric rather than a numeric data name, and hence the error.

Correction: Change the PICTURE clause in line 44 from X(6) to 9(6).

5-S User-name STU-CREDITS not unique

This error is identical to the earlier non-unique message from lines 163, 174, 175, 177, and 179. This error disguises another error. DET-CREDITS has not been defined and should be flagged. In this case, the same correction fixes both problems.

Correction: This error will disappear after changing STU-CREDITS to DET-CREDITS in line 81.

330-S Not a record name

A WRITE statement, such as the one in line 209, requires a record name rather than a file name.

Correction: Change line 209 to WRITE PRINT-LINE instead of WRITE PRINT-FILE.

12-S Operand UNI-UNION-FEE is not declared

This error is identical to the one in line 194 and is due to the omitted hyphens in the definition of UNI-UNION-FEE.

Correction: None required beyond the previous correction to line 42.

These are all of the compilation errors detected by the Animator. This example was prepared for an earlier edition of the book and a different compiler. In making the conversion to Personal COBOL we found two errors that the Animator did not flag. The first was in line 163, where there is no space between the "=" and PRICE-PER-CREDIT. COBOL requires spaces before and after arithmetic operators, but evidently the Animator tolerates this error. You should always make it a habit to put spaces before and after arithmetic operators. Other compilers will not be as forgiving.

The second error the Animator did not flag was in line 187. The MOVE statement moves the value of STU-SCHOLARSHIP (a four-position numeric field) to IND-SCHOLARSHIP (a three-position numeric field). The problem is that the sending field is larger than the receiving field, and thus the leftmost (most significant) digit may be truncated. This error could cause problems and should have had an I-level or possibly W-level message.

Common Compilation Errors

Compilation errors are a fact of life. Don't be discouraged if you have many compilation errors in your first few attempts, and don't be surprised if you have several pages of diagnostics. Remember that a single error in a COBOL program can result in many error messages, and that several errors often can be made to disappear with one correction. Before leaving the subject, it is worthwhile to review a list of common errors and suggested ways to avoid them:

Nonunique data names. This error occurs because the same data name is defined in two different records or twice within the same record. For example, CREDITS might be specified as an input field in STUDENT-FILE and again as output in a detail line. You can avoid the problem by prefixing every data name within a record by a unique prefix as shown below:

```
01 STUDENT-RECORD
   05 STU-NAME
       10 STU-LAST-NAME
       10 STU-INITIALS
   05 STU-CREDITS
   05 STU-UNION-MEMBER
   05 STU-SCHOLARSHIP
   05 STU-GPA
```

Omitted (or extra) periods. Every COBOL sentence should have a period. Omission in the first three divisions often results in the compiler's assumption of a period where one belongs, and such errors are generally harmless. The effect is far more serious in the Procedure Division, where missing and/or extra periods affect the generated logic.

Omitted space before or after an arithmetic operator. The arithmetic operators, **, *, /, +, and - all require a space before and after (a typical error for BASIC programmers, since the space is not required in that language).

Invalid picture clause for numeric entry. All data names used in arithmetic statements must have numeric picture clauses consisting of 9's, an implied decimal point, and an optional sign.

Conflicting picture and value clause. Numeric pictures must have numeric values (no quotes); nonnumeric pictures must have nonnumeric values (enclosed in quotes). Both entries below are *invalid*.

```
05 TOTAL    PIC 9(3) VALUE '123'.
05 TITLE    PIC X(3) VALUE 123.
```

Inadvertent use of COBOL reserved words. COBOL has a list of some 300 reserved words that can be used only in their designated sense; any other use results in one or several diagnostics. Some reserved words are obvious, for example, WORKING-STORAGE, IDENTIFICATION, ENVIRONMENT, DATA, and PROCEDURE. Others—such as CODE, DATE, START, and REPORT—are less obvious. Instead of memorizing the list or continually referring to it, we suggest this simple rule of thumb: *Always use a hyphen in every data name you create.* This will work more than 99% of the time.

Conflicting RECORD CONTAINS clause and FD record description. This is a common error, even for established programmers. It can stem from careless addition in that the sum of the pictures in the FD does not equal the number of characters in the RECORD CONTAINS clause. It can also result from other errors within the Data Division, for example, when an entry containing a PICTURE clause is flagged. (Remember that if an E-level diagnostic occurs, that entry will be ignored, and the count is thrown off.)

Receiving field too small to accommodate sending field. This is an extremely common error, often associated with edited pictures (editing is discussed in Chapter 7). Consider the entries:

```
05 PRINT-TOTAL-PAY    PIC $$,$$$.
```

```
05 WS-TOTAL-PAY       PIC 9(5).
```

```
MOVE WS-TOTAL-PAY TO PRINT-TOTAL-PAY.
```

The MOVE statement would generate the warning that the receiving field may be too small to accommodate the sending field. The greatest possible value for WS-TOTAL-PAY is 99,999; the largest possible value that could be printed by PRINT-TOTAL-PAY is \$9,999. Even though the picture for the print field contains five \$'s, one \$ must always be printed along with the numeric characters, hence the warning.

Omitted (or extra) hyphens in a data name. This is a careless error, but one that occurs too often. If, for example, we define PRINT-TOTAL-PAY in the Data Division and then reference PRINT TOTAL-PAY in the Procedure Division, the compiler catches the inconsistency. It doesn't state that a hyphen was omitted, but indicates that PRINT and TOTAL-PAY are undefined.

A related error is the insertion of extra hyphens where they don't belong, for example, WORKING-STORAGE-SECTION or DATA-DIVISION.

Misspelled data names or reserved words. Too many COBOL students are poor spellers. Sound strange? How do you spell *environment*? One or many errors can result, depending on which word was spelled incorrectly.

Reading a record name or writing a file name. The COBOL rule is very simple—read a file and write a record—but many people get it confused. Consider:

```
FD STUDENT-FILE
   DATA RECORD IS STUDENT-RECORD.
```

```
FD PRINT-FILE
   DATA RECORD IS PRINT-RECORD.
```

Correct entries:

```
READ STUDENT-FILE . . .
WRITE PRINT-RECORD . . .
```

Incorrect entries:

```
READ STUDENT-RECORD . . .
WRITE PRINT-FILE . . .
```

Going past column 72. This error can cause any of the preceding errors as well as a host of others. A COBOL statement must end in column 72 or before; columns 73–80 are left blank or used for program identification. (The 72-column restriction does not apply to data.)

Errors in Execution

After a program has been successfully compiled, it can proceed to execution, and therein lies the strength and weakness of the computer. The primary attractiveness of the machine is its ability to perform its task quickly; its weakness stems from the fact that it does exactly what it has been instructed to do. The machine cannot think for itself; the programmer must think for the machine. If you were to inadvertently instruct the computer to compute tuition by charging \$20 instead of \$200 per credit, then that is what it would do.

To give you an idea of what can happen, we have deliberately altered the original tuition billing program of Chapter 5 and created a new program, shown in Figure 6.3. Incorporated into this program are two types of errors: run time errors and logic errors. Run time errors prevent the program from carrying out its task even though the program compiled properly. Logic errors do not stop the program, but they cause invalid output from the program.

Figure 6.3 Tuition Billing Program with Execution Errors

```
1 IDENTIFICATION DIVISION.
2 PROGRAM-ID. TUIT6EXE.
3 AUTHOR. CAROL VAZQUEZ VILLAR.
4
5 ENVIRONMENT DIVISION.
6 INPUT-OUTPUT SECTION.
7 FILE-CONTROL.
8 SELECT STUDENT-FILE ASSIGN TO 'A:\CHAPTR06\TUITIION.DAT'
9 ORGANIZATION IS LINE SEQUENTIAL.
10 SELECT PRINT-FILE
```

Figure 6.3 (continued)

```

11          ASSIGN TO PRINTER.
12
13  DATA DIVISION.
14  FILE SECTION.
15  FD  STUDENT-FILE
16     RECORD CONTAINS 27 CHARACTERS.
17  01  STUDENT-RECORD.
18     05  STU-NAME.
19         10  STU-LAST-NAME    PIC X(15).
20         10  STU-INITIALS    PIC XX.
21     05  STU-CREDITS          PIC 9(2).
22     05  STU-UNION-MEMBER     PIC X.
23     05  STU-SCHOLARSHIP      PIC 9(4).
24     05  STU-GPA              PIC 999.
25
26  FD  PRINT-FILE
27     RECORD CONTAINS 132 CHARACTERS.
28  01  PRINT-LINE              PIC X(132).
29
30  WORKING-STORAGE SECTION.
31  01  DATA-REMAINS-SWITCH    PIC X(2) VALUE SPACES.
32
33  01  INDIVIDUAL-CALCULATIONS.
34     05  IND-TUITION          PIC 9(4) VALUE ZEROS.
35     05  IND-ACTIVITY-FEE     PIC 9(2) VALUE ZEROS.
36     05  IND-UNION-FEE        PIC 9(2) VALUE ZEROS.
37     05  IND-SCHOLARSHIP      PIC 9(4) VALUE ZEROS.
38     05  IND-BILL             PIC 9(6) VALUE ZEROS.
39
40  01  UNIVERSITY-TOTALS.
41     05  UNI-TUITION          PIC 9(6) VALUE ZEROS.
42     05  UNI-UNION-FEE        PIC 9(4) VALUE ZEROS.
43     05  UNI-ACTIVITY-FEE     PIC 9(4) VALUE ZEROS.
44     05  UNI-SCHOLARSHIP      PIC 9(6) VALUE ZEROS.
45     05  UNI-IND-BILL         PIC 9(6) VALUE ZEROS.
46
47  01  CONSTANTS-AND-RATES.
48     05  PRICE-PER-CREDIT     PIC 9(3) VALUE 200.
49     05  UNION-FEE            PIC 9(2) VALUE 25.
50     05  ACTIVITY-FEES.
51         10  1ST-ACTIVITY-FEE PIC 99    VALUE 25.
52         10  1ST-CREDIT-LIMIT PIC 99    VALUE 6.
53         10  2ND-ACTIVITY-FEE PIC 99    VALUE 50.
54         10  2ND-CREDIT-LIMIT PIC 99    VALUE 12.
55         10  3RD-ACTIVITY-FEE PIC 99    VALUE 75.

```

Implied decimal place missing

Figure 6.3 (continued)

```

56          05 MINIMUM-SCHOLAR-GPA PIC 9V9 VALUE 2.5.
57
58      01 HEADING-LINE.
59          05 FILLER PIC X VALUE SPACES.
60          05 FILLER PIC X(12) VALUE 'STUDENT NAME'.
61          05 FILLER PIC X(10) VALUE SPACES.
62          05 FILLER PIC X(7) VALUE 'CREDITS'.
63          05 FILLER PIC X(2) VALUE SPACES.
64          05 FILLER PIC X(7) VALUE 'TUITION'.
65          05 FILLER PIC X(2) VALUE SPACES.
66          05 FILLER PIC X(9) VALUE 'UNION FEE'.
67          05 FILLER PIC X(2) VALUE SPACES.
68          05 FILLER PIC X(7) VALUE 'ACT FEE'.
69          05 FILLER PIC X(2) VALUE SPACES.
70          05 FILLER PIC X(11) VALUE 'SCHOLARSHIP'.
71          05 FILLER PIC X(2) VALUE SPACES.
72          05 FILLER PIC X(10) VALUE 'TOTAL BILL'.
73          05 FILLER PIC X(48) VALUE SPACES.
74
75      01 DETAIL-LINE.
76          05 FILLER PIC X VALUE SPACES.
77          05 DET-LAST-NAME PIC X(15).
78          05 FILLER PIC X(2) VALUE SPACES.
79          05 DET-INITIALS PIC X(2).
80          05 FILLER PIC X(5) VALUE SPACES.
81          05 DET-CREDITS PIC 9(2).
82          05 FILLER PIC X(6) VALUE SPACES.
83          05 DET-TUITION PIC 9(6).
84          05 FILLER PIC X(7) VALUE SPACES.
85          05 DET-UNION-FEE PIC 9(3).
86          05 FILLER PIC X(6) VALUE SPACES.
87          05 DET-ACTIVITY-FEE PIC 9(3).
88          05 FILLER PIC X(8) VALUE SPACES.
89          05 DET-SCHOLARSHIP PIC 9(5).
90          05 FILLER PIC X(6) VALUE SPACES.
91          05 DET-IND-BILL PIC 9(6).
92          05 FILLER PIC X(49) VALUE SPACES.
93
94      01 DASH-LINE.
95          05 FILLER PIC X(31) VALUE SPACES.
96          05 FILLER PIC X(8) VALUE ALL '-'.
97          05 FILLER PIC X(2) VALUE SPACES.
98          05 FILLER PIC X(8) VALUE ALL '-'.
99          05 FILLER PIC X(2) VALUE SPACES.
100         05 FILLER PIC X(7) VALUE ALL '-'.

```

Figure 6.3 (continued)

```

101      05 FILLER                PIC X(6) VALUE SPACES.
102      05 FILLER                PIC X(7) VALUE ALL '-'.
103      05 FILLER                PIC X(5) VALUE SPACES.
104      05 FILLER                PIC X(7) VALUE ALL '-'.
105      05 FILLER                PIC X(49) VALUE SPACES.
106
107      01 TOTAL-LINE.
108      05 FILLER                PIC X(8) VALUE SPACES.
109      05 FILLER                PIC X(17)
110          VALUE 'UNIVERSITY TOTALS'.
111      05 FILLER                PIC X(8) VALUE SPACES.
112      05 TOT-TUITION            PIC 9(6).
113      05 FILLER                PIC X(6) VALUE SPACES.
114      05 TOT-UNION-FEE          PIC 9(4).
115      05 FILLER                PIC X(5) VALUE SPACES.
116      05 TOT-ACTIVITY-FEE       PIC 9(4).
117      05 FILLER                PIC X(7) VALUE SPACES.
118      05 TOT-SCHOLARSHIP        PIC 9(6).
119      05 FILLER                PIC X(6) VALUE SPACES.
120      05 TOT-IND-BILL           PIC 9(6).
121      05 FILLER                PIC X(49) VALUE SPACES.
122
123      PROCEDURE DIVISION.
124      PREPARE-TUITION-REPORT.
125          OPEN INPUT STUDENT-FILE
126              OUTPUT PRINT-FILE.
127          PERFORM WRITE-HEADING-LINE.
128          PERFORM READ-STUDENT-FILE.
129          PERFORM PROCESS-STUDENT-RECORD
130              UNTIL DATA-REMAINS-SWITCH = 'NO'.
131          PERFORM WRITE-UNIVERSITY-TOTALS.
132          CLOSE STUDENT-FILE
133              PRINT-FILE.
134          STOP RUN.
135
136      WRITE-HEADING-LINE.
137          MOVE HEADING-LINE TO PRINT-LINE.
138          WRITE PRINT-LINE
139              AFTER ADVANCING PAGE.
140          MOVE SPACES TO PRINT-LINE.
141          WRITE PRINT-LINE.
142
143      READ-STUDENT-FILE.
144          READ STUDENT-FILE
145              AT END MOVE 'NO' TO DATA-REMAINS-SWITCH

```

Figure 6.3 (continued)

```

146         END-READ.
147
148     PROCESS-STUDENT-RECORD.
149         PERFORM READ-STUDENT-FILE.
150         PERFORM COMPUTE-INDIVIDUAL-BILL.
151         PERFORM INCREMENT-UNIVERSITY-TOTALS
152         PERFORM WRITE-DETAIL-LINE.
153
154     COMPUTE-INDIVIDUAL-BILL.
155         PERFORM COMPUTE-TUITION.
156         PERFORM COMPUTE-UNION-FEE.
157         PERFORM COMPUTE-ACTIVITY-FEE.
158         PERFORM COMPUTE-SCHOLARSHIP.
159         COMPUTE IND-BILL = IND-TUITION + IND-UNION-FEE +
160             IND-ACTIVITY-FEE - IND-SCHOLARSHIP.
161
162     COMPUTE-TUITION.
163         COMPUTE IND-TUITION = PRICE-PER-CREDIT * STU-CREDITS.
164
165     COMPUTE-UNION-FEE.
166         IF STU-UNION-MEMBER = 'Y'
167             MOVE ZERO TO IND-UNION-FEE
168         ELSE
169             MOVE UNION-FEE TO IND-UNION-FEE
170         END-IF.
171
172     COMPUTE-ACTIVITY-FEE.
173         EVALUATE TRUE
174             WHEN STU-CREDITS <= 1ST-CREDIT-LIMIT
175                 MOVE 1ST-ACTIVITY-FEE TO IND-ACTIVITY-FEE
176             WHEN STU-CREDITS > 1ST-CREDIT-LIMIT
177                 AND STU-CREDITS <= 2ND-CREDIT-LIMIT
178                 MOVE 2ND-ACTIVITY-FEE TO IND-ACTIVITY-FEE
179             WHEN STU-CREDITS > 2ND-CREDIT-LIMIT
180                 MOVE 3RD-ACTIVITY-FEE TO IND-ACTIVITY-FEE
181             WHEN OTHER
182                 DISPLAY 'INVALID CREDITS FOR: ' STU-NAME
183         END-EVALUATE.
184
185     COMPUTE-SCHOLARSHIP.
186         IF STU-GPA > MINIMUM-SCHOLAR-GPA
187             MOVE STU-SCHOLARSHIP TO IND-SCHOLARSHIP
188         ELSE
189             MOVE ZERO TO IND-SCHOLARSHIP

```

READ statement is processed second

Value of IF data that is revealed

Figure 6.3 (continued)

```

190         END-IF.
191
192     INCREMENT-UNIVERSITY-TOTALS.
193         ADD IND-TUITION      TO UNI-TUITION.
194         ADD IND-ACTIVITY-FEE TO UNI-ACTIVITY-FEE.
195         ADD IND-SCHOLARSHIP TO UNI-SCHOLARSHIP.
196         ADD IND-BILL        TO UNI-IND-BILL.
197
198     WRITE-DETAIL-LINE.
199         MOVE STU-LAST-NAME TO DET-LAST-NAME.
200         MOVE STU-INITIALS TO DET-INITIALS.
201         MOVE STU-CREDITS TO DET-CREDITS.
202         MOVE IND-TUITION TO DET-TUITION.
203         MOVE IND-UNION-FEE TO DET-UNION-FEE.
204         MOVE IND-ACTIVITY-FEE TO DET-ACTIVITY-FEE.
205         MOVE IND-SCHOLARSHIP TO DET-SCHOLARSHIP.
206         MOVE IND-BILL TO DET-IND-BILL.
207         MOVE DETAIL-LINE TO PRINT-LINE.
208         WRITE PRINT-LINE
209             AFTER ADVANCING 1 LINE.
210
211     WRITE-UNIVERSITY-TOTALS.
212         MOVE DASH-LINE TO PRINT-LINE.
213         WRITE PRINT-LINE.
214         MOVE UNI-TUITION TO TOT-TUITION.
215         MOVE UNI-UNION-FEE TO TOT-UNION-FEE.
216         MOVE UNI-ACTIVITY-FEE TO TOT-ACTIVITY-FEE.
217         MOVE UNI-SCHOLARSHIP TO TOT-SCHOLARSHIP.
218         MOVE IND-BILL TO TOT-IND-BILL.
219         MOVE TOTAL-LINE TO PRINT-LINE.
220         WRITE PRINT-LINE
221             AFTER ADVANCING 1 LINE.

```

File Status Codes

Input/Output operations occur throughout the execution of a COBOL program and consequently are a source of frequent run-time errors. The window shown in Figure 6.4a represents one of the most common types of errors—attempting to read from a file that doesn't exist.

After we click on OK, the Animator shows us the line where the error was detected, as in Figure 6.4b. The OPEN statement relates to the SELECT ... ASSIGN statements in the Environment Division. The COBOL SELECT statement ties a programmer-chosen file name to an implementor name. In Windows-based COBOL compilers the ASSIGN clause allows the definition of a file name. The combination of SELECT and ASSIGN associates a COBOL file, such as STUDENT-FILE, with a file on disk such as TUITION.DOT in Figure 6.4c, line 8.

The problem is that TUITION.DOT does not exist; look carefully at the properties of TUITION in Figure 6.4d. The file extension is *DAT* rather than *DOT*. In other words, the COBOL program is attempting to read from a file that isn't there, an impossible situation for the program that leads to an execution or *run time system* (RTS) error.

Figure 6.4 File Status Errors

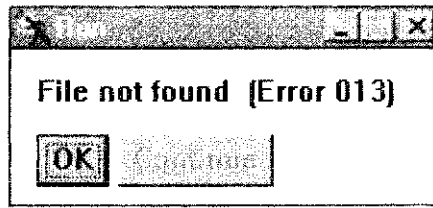

(a) File not found message

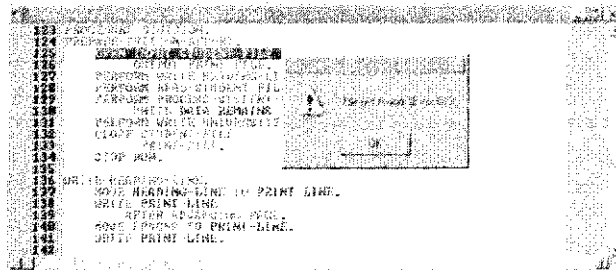

(b) Location where error detected.

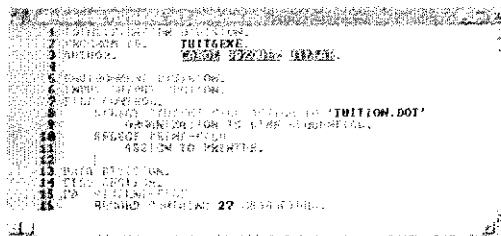

(c) Error in SELECT statement

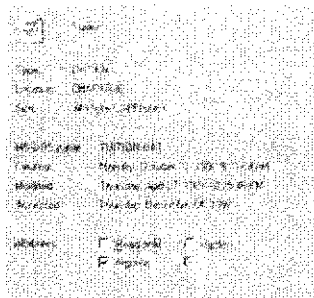

(d) Tuition File Properties

The Animator is very picky about file names. For example, even if you spell the name correctly but do not correctly specify the path, the Animator may not be able to find the file. If the program specifies only the name and extension, but the actual file is in a working directory other than that expected by the Animator, the program will not be able to find the file. Appendix B shows you how to make sure that the Animator knows where to look for files.

Another Run Time Error

After correcting the file name, we recompiled the program and ran it again, this time with the results in Figure 6.5. Figure 6.5a shows another common RTS error, “Illegal Character in Numeric Field.” This error almost always comes from having spaces in a numeric field. One cause of those spaces is when the program reads a data file that actually has spaces in the field. In other words, if the field has a PICTURE of 9(5) and the actual contents are “123”, the program will fail if it tries to use this field in a computation. This problem is a data problem rather than a program problem. When you create test data, be sure to type in leading zeros for any numeric fields. In this case the field should have been “00123”.

A second reason for spaces in a numeric field is when the program attempts to read beyond the end of a file. The incorrect placement of the READ in line 149 of Figure 6.3 causes this condition. Figure 6.5b shows the line where the error was detected. We clicked on each data name in the statement, and the Animator showed us the current contents of the field. STU-CREDITS contains only spaces and caused the error. In this case, when the program read beyond the end of the file, COBOL inserted spaces into STUDENT-RECORD (line 17), including STU-CREDITS. To correct the problem we restored the READ to the end of PROCESS-STUDENT-RECORD, recompiled the program, and reran it. This action corrects the run-time errors, but there are still logic errors to deal with.

Figure 6.5 Illegal Character Run Time Error

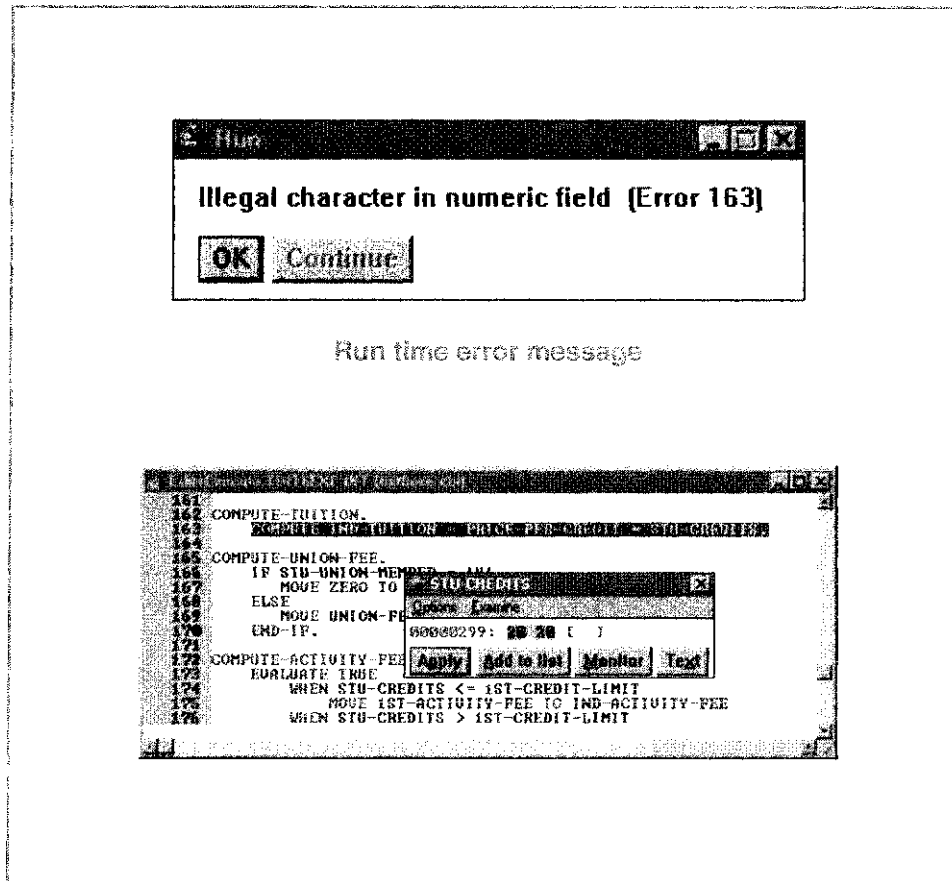

Logic Errors

There are several subtle errors in Figure 6.6:

1. The university total for union fees is zero rather than a computed amount.
2. The sum of the individual bills in the total line appears as 850 (the amount for the last record), rather than a running total of 24550.
3. The union fees are reversed for each student. For example, James and Baker are charged \$25 when they should be charged nothing; conversely, Part-Timer and Jones are charged nothing when their fee is \$25.
4. James was erroneously awarded a scholarship of \$500; James, however, does not qualify because his average is below 2.5.

We emphasize that these logic errors are not contrived but are typical of students and beginning programmers. Even the accomplished practitioner can be guilty of similar errors when rushed or careless. Realize also that logic errors occur without fanfare. There are no compiler diagnostics or RTS error messages to warn of impending trouble. The program has compiled cleanly and runs smoothly to the end; there is nothing to indicate a problem.

The errors in Figure 6.3 are errors in execution, rather than in compilation. The program compiled cleanly because it is *syntactically correct*, but it executed improperly because it is *logically incorrect*. Nevertheless, the program did precisely what it was instructed to do, which, unfortunately, is not what the programmer wanted it to do. It is necessary, therefore, to find the source of each logic error, as discussed below.

1. The totals for the university are computed in the paragraph INCREMENT-UNIVERSITY-TOTALS (lines 192–196), in which the individual amounts for the student being processed are added to the running university totals. Note, however, that the ADD statement for UNI-UNION-FEE is conspicuously absent, and hence the value of UNI-UNION-FEE remains unchanged throughout the program.
2. UNI-IND-BILL is defined in line 45 and correctly incremented for each record in line 196; so far, so good. However, when the total line is built in line 218, IND-BILL rather than UNI-IND-BILL is moved to TOT-IND-BILL, causing the individual last bill (for Kerbel) to be printed as the total.
3. IND-UNION-FEE is calculated in a simple IF statement in lines 166–170, in which the IF and ELSE clauses are reversed; that is, the union fee is \$25 for students who belong to the union as indicated by a Y in the appropriate incoming field.
4. The definition STU-GPA in line 24 incorrectly omits the implied decimal point in the PICTURE clause. Hence all incoming averages will be interpreted as ten times their true value (i.e., 2.5 will be stored as 25). Thus, all students will have an average greater than 2.5, and hence all students with potential scholarships will receive the award.

Figure 6.6 Tuition Billing Report Comparisons—Invalid and Valid

| STUDENT NAME | CREDITS | TUITION | UNION FEE | ACT FEE | SCHOLARSHIP | TOTAL BILL | |
|-------------------|---------|---------|-----------|---------|-------------|------------|--------|
| SMITH | JB | 15 | 003000 | 000 | 075 | 00000 | 003075 |
| JAMES | HR | 15 | 003000 | 025 | 075 | 00500 | 002600 |
| BAKER | SR | 09 | 001800 | 025 | 050 | 00500 | 001375 |
| PART-TIMER | JR | 03 | 000600 | 000 | 025 | 00000 | 000625 |
| JONES | PL | 15 | 003000 | 000 | 075 | 00000 | 003075 |
| HEAVYWORKER | HM | 18 | 003600 | 025 | 075 | 00000 | 003700 |
| LEE | BL | 18 | 003600 | 025 | 075 | 00000 | 003700 |
| CLARK | JC | 06 | 001200 | 025 | 025 | 00000 | 001250 |
| GROSSMAN | SE | 07 | 001400 | 025 | 050 | 00000 | 001475 |
| FRANKEL | LF | 10 | 002000 | 025 | 050 | 00000 | 002075 |
| BENWAY | CT | 03 | 000600 | 025 | 025 | 00250 | 000400 |
| KERBEL | NB | 04 | 000800 | 025 | 025 | 00000 | 000850 |
| UNIVERSITY TOTALS | | 024600 | 0000 | 0625 | 001250 | 000850 | |

(a) Invalid Output

Annotations for (a):

- [1] Union fees are reversed (pointing to 000 in Union Fee column for SMITH)
- [2] Should not have a scholarship (pointing to 00000 in Scholarship column for SMITH)
- [3] Total is incorrect (pointing to 000850 in Total Bill column for UNIVERSITY TOTALS)
- [4] Union fee was not summed (pointing to 0000 in Union Fee column for UNIVERSITY TOTALS)

| STUDENT NAME | CREDITS | TUITION | UNION FEE | ACT FEE | SCHOLARSHIP | TOTAL BILL | |
|-------------------|---------|---------|-----------|---------|-------------|------------|--------|
| SMITH | JB | 15 | 003000 | 025 | 075 | 00000 | 003100 |
| JAMES | HR | 15 | 003000 | 000 | 075 | 00000 | 003075 |
| BAKER | SR | 09 | 001800 | 000 | 050 | 00500 | 001350 |
| PART-TIMER | JR | 03 | 000600 | 025 | 025 | 00000 | 000650 |
| JONES | PL | 15 | 003000 | 025 | 075 | 00000 | 003100 |
| HEAVYWORKER | HM | 18 | 003600 | 000 | 075 | 00000 | 003675 |
| LEE | BL | 18 | 003600 | 000 | 075 | 00000 | 003675 |
| CLARK | JC | 06 | 001200 | 000 | 025 | 00000 | 001225 |
| GROSSMAN | SE | 07 | 001400 | 000 | 050 | 00000 | 001450 |
| FRANKEL | LF | 10 | 002000 | 000 | 050 | 00000 | 002050 |
| BENWAY | CT | 03 | 000600 | 000 | 025 | 00250 | 000375 |
| KERBEL | NB | 04 | 000800 | 000 | 025 | 00000 | 000825 |
| UNIVERSITY TOTALS | | 024600 | 0075 | 0625 | 000750 | 024550 | |

(b) Valid Output (from Chapter 5)

Tips for Debugging

It was easy to find the execution errors just discussed because we created them in the first place, and hence we knew exactly where to look. In practice, however, it is not so easy. Fortunately, the Personal COBOL Animator provides some powerful tools to help

with debugging programs. Appendix A gives an extended discussion of the Animator and even has a short debugging tutorial. However, we can provide a few tips here as well.



1. Step through the program using the Watch Button. This button shows the contents of each field in the current statement.
2. Use breakpoints to stop the program at critical junctures in the program. By using breakpoints, you can run the program at full speed until the breakpoint is encountered and then step through the questionable code.
3. To save paper, write your output to the screen rather than the printer. When you are actually ready to print the report, a simple change to the ASSIGN will accomplish the task. For example:
To print to screen: SELECT PRINT-FILE ASSIGN TO PRINTER 'CON'.
To print to printer: SELECT PRINT-FILE ASSIGN TO PRINTER.
4. Double-clicking on any data name will bring up the current value of the field, whether it is in the current execution line or not.
5. Using the Find option in the Edit Menu will highlight all occurrences of a data name in the program.

There are many other features in the Animator to help with debugging, and as you gain proficiency in programming you will see how to use them.

DISPLAY Statement

It is often helpful to display intermediate results of a program as the program is being executed. One way to accomplish this is through the insertion of **DISPLAY** statements at strategic points in the program. The statement enables you to print the value of one or more data names and/or one or more literals without having to format a record description. Consider:

$$\text{DISPLAY } \left\{ \begin{array}{l} \text{identifier-1} \\ \text{literal-1} \end{array} \right\} \left[\left\{ \begin{array}{l} \text{identifier-2} \\ \text{literal-2} \end{array} \right\} \right] \dots$$

The **DISPLAY** statement produces the contents of each item listed in the order shown. For example,

1. DISPLAY STUDENT-RECORD.
2. DISPLAY 'Record being processed: ' STUDENT-RECORD.
3. DISPLAY 'COMPUTE-TUITION paragraph is entered'
4. DISPLAY 'Student data: ' STU-NAME STU-CREDITS.

Examples one and two both display the value of the data name **STUDENT-RECORD**; the second example, however, precedes the data name with a literal to facilitate interpretation of the output. Example three displays just a literal but could be used (in conjunction with similar **DISPLAY** statements in other paragraphs) to show the flow of program execution. Example four displays a literal and two data names.

The Structured Walkthrough

Although it is reasonable to expect errors, the programmer is also expected (reasonably) to find and correct them. Until recently, error detection and correction was a lonely activity. A programmer was encouraged to *desk check*—that is, read and reread the code—in an attempt to discern logical errors before they occurred. Desk checking is still an important activity, but it is frequently supplemented by a newer technique, the *structured walkthrough*.

The walkthrough brings the evaluation into the open. It requires a programmer to have his or her work reviewed formally and periodically by a peer group. The theory is simple—a programmer is too close to his or her work to see potential problems adequately and evaluate them objectively. The purpose of the walkthrough is to ensure that all specifications are met, and that the logic and its COBOL implementation are correct.

The earlier an error is found, the easier it is to correct and thus the single most important objective of a walkthrough is *early error detection*. Walkthroughs occur at several stages during a project, beginning in the analysis phase, where the purpose is to ensure that the systems analyst has understood the user's requirements. Walkthroughs occur again during the design phase, after the programmer has developed a hierarchy chart and/or associated pseudocode. Finally, walkthroughs occur during the implementation phase, during which the programmer presents actual code prior to testing.

Walkthroughs are scheduled by the person being reviewed, who also selects the reviewers. The programmer distributes copies of the work (for example, a hierarchy chart, pseudocode, or a COBOL program) prior to the session. Reviewers are supposed to study the material in advance so that they can discuss it intelligently. At the walkthrough itself, the programmer presents the material objectively, concisely, and dispassionately. He or she should encourage discussion and be genuinely glad when errors are discovered.

One of the reviewers should function as a *moderator* to keep the discussion on track. Another should act as a *secretary* and maintain an *action list* of problems uncovered during the session. At the end of the walkthrough the action list is given to the programmer, who in turn is expected to correct the errors and notify attendees accordingly. The objective of the walkthrough is to find errors, not to correct them. The latter is accomplished by the programmer upon receipt of the action list.

The preceding discussion may read well in theory, but programmers often dislike the walkthrough concept. The probable reason is that they dislike having their work reviewed and regard criticism of code as a personal affront, intended or otherwise. This attitude is natural and stems from years of working as individuals.

In addition, walkthroughs can and have become unpleasant and ego-deflating experiences. "Structured walkover" and "stomp through" are terms that have been applied to less-than-successful sessions. Only if the atmosphere is kept open and nondefensive, only if the discussion is restricted to major problems rather than trivial errors, and only if personality clashes are avoided can the walkthrough be an effective technique. To have any chance of success, programmers who function as both reviewer and reviewee must adhere to the following guidelines:

1. *The program, and not the programmer, is reviewed.* Structured walkthroughs are intended to find programming problems; they will not be used by management as an evaluation tool. No one should keep count of how many

errors are found in an individual's work or how many errors one finds in someone else's. It is quite logical, therefore, to exclude the project manager—that is, the individual in charge of salaries and promotions—from review sessions.

2. *Emphasis is on error detection, not correction.* It is assumed that the individual being reviewed will take the necessary corrective action. Reviewers should not harp on errors by discussing how to correct them; indeed, no corrections whatever are made during a walkthrough.
3. *Everyone, from senior analyst to trainee, has his or her work reviewed.* This avoids singling out an individual and further removes any stigma from having one's work reviewed. It also promotes the give-and-take atmosphere that is so vital to making the concept work.
4. *A list of well-defined objectives for each session should be specified in advance.* Adherence to this guideline keeps the discussion on track and helps to guarantee productive discussions. Another guideline is to impose a predetermined time limit, from half an hour to two hours. Walkthroughs will eventually cease to be productive and degenerate into a discussion of last night's ball game, the new manager, the latest rumor, or some other "hot" topic. The situation should be anticipated and avoided, perhaps by scheduling walkthroughs an hour before lunch. If all of the walkthrough's objectives have not been met when the deadline is reached, schedule a second session.
5. *Participation must be encouraged and demanded from the reviewers.* A walkthrough will indeed become a waste of time if no one has anything to say. Let it be known in advance that each reviewer will be expected to make at least two comments, one positive and one negative. Alternatively, require each reviewer to come to the session with a list of at least three questions.

S U M M A R Y

Points to Remember

- ❖ Compilation errors occur in the translation of COBOL to machine language and result from a violation of COBOL syntax—for example, a misspelled data name or an entry in the wrong column.
- ❖ Run time and execution errors develop after compilation has taken place, and are caused by improper logic and/or improper COBOL implementation of valid logic.
- ❖ A program may compile cleanly and be logically correct, yet still fail to execute if there are problems with the associated data files. Run time errors will occur and generate RTS error messages to help determine the cause of such data management errors.
- ❖ Sometimes data file problems are not the fault of the program, but are from the data file itself. The most common problem occurs when a numeric field includes spaces rather than zeroes.

- ☛ The Animator provides many tools for debugging and can be quite helpful in tracking both syntax and logic errors.
- ☛ A structured walkthrough is an open evaluation of an individual's work by a group of his or her peers, with the primary objective of detecting errors as soon as possible in the development cycle.

Key Words and Concepts

| | |
|-------------------------|------------------------|
| Action list | Execution error |
| Compilation error | File status codes |
| Compiler option | Interactive debugger |
| Cross-reference listing | Moderator |
| Debugging | Run Time System |
| Desk checking | Secretary |
| Early error detection | Structured walkthrough |

COBOL Element

DISPLAY

F I L L - I N

1. _____ errors occur in the translation of COBOL to machine language.
2. _____ errors occur after a program has been successfully translated to machine language.
3. Incorrect translation of valid pseudocode into COBOL will most likely produce _____ errors.
4. Misspelling a reserved word will most likely produce a _____ error.
5. If a program _____ cleanly, it means only that the program has been successfully translated into machine language.
6. _____ errors are accompanied by some type of error message, whereas _____ errors are frequently undetected by the computer.
7. The process of peer review is known as a _____.
8. The errors that are detected during a _____ are entered on an _____, which is maintained by the secretary.
9. The emphasis in a structured walkthrough is on error _____, not error _____.
10. One suggestion for conducting successful walkthroughs is to remember that the _____, and not the _____, is reviewed.

11. _____ cause a program to stop processing even though it is syntactically correct.
12. _____ are helpful in detecting errors in execution that pertain to data management.

TRUE / FALSE

1. If a program compiles with no diagnostics, it must execute correctly.
2. If a program compiles with warning diagnostics, execution will be suppressed.
3. If a program contains logical errors but not syntactical errors, the compiler will print appropriate warnings.
4. A COBOL program is considered data by the COBOL compiler.
5. An error in one COBOL statement can cause errors in several other, apparently unrelated, statements.
6. There are several different levels (of severity) of compilation errors.
7. Paragraph names begin in the A margin.
8. Spaces are required before and after arithmetic symbols.
9. Spaces are required before and after punctuation symbols.
10. A data name that appears in a COMPUTE statement can be defined with a picture of X's.
11. Data names may contain blanks.
12. The contents of columns 73-80 are ignored by the compiler.
13. In a COBOL program one reads a record name and writes a file name.
14. The emphasis in a structured walkthrough is on error detection rather than error correction.
15. Walkthroughs should be held for trainees only, as these are the individuals most likely to make mistakes.
16. Managers typically do not attend walkthroughs.
17. A walkthrough generally takes a minimum of two hours.
18. Walkthroughs should be restricted to the coding phase of a project.

PROBLEMS

1. Has your work ever been the subject of a structured walkthrough? Was the experience helpful or a waste of time, or worse? Are you looking forward to your next walkthrough?
2. Do you agree with banning managers from walkthroughs? Is it possible that the role of moderator in a walkthrough might best be filled by the project manager?

3. Do you agree with the authors' suggestions for successful walkthroughs? Are there any guidelines you wish to add to the list? To remove from the list?
4. Identify the syntactical errors in the COBOL fragment in Figure 6.8.
5. Identify the logical errors in the COBOL fragment in Figure 6.9. (Assume there are no other READ statements in the program.)
6. The COBOL fragment in Figure 6.10a is taken from a program that compiled cleanly but failed to execute. The error message is in Figure 6.10b. Explain the problem.

Figure 6.8 COBOL Fragment for Problem 4

```

IDENTIFICATION DIVISION.
PROGRAM ID. ERRORS.
ENVIRONMENT DIVISION.
INPUT-OUTPUT SECTION.
SELECT EMPLOYEE-FILE ASSIGN TO 'A:\CHAPTR06\EMP.DAT'
    ORGANIZATION IS LINE SEQUENTIAL.
DATA DIVISION.
FILE SECTION.
FD EMPLOYEE-FILE
    RECORD CONTAINS 50 CHARACTERS
    DATA RECORD IS EMPLOYEE-RECORD.
    EMPLOYEE-RECORD.
    05 EMP-NAME                PIC X(20).
    05 EMP-NUMBER              PIC X(9).
    05 FILLER                  PIC X(20).
WORKING STORAGE SECTION.
10 END-OF-FILE-SWITCH        PIC X(3)    VALUE BLANKS.

```

Figure 6.9 COBOL Fragment for Problem 5

```

WORKING-STORAGE SECTION.
01 END-OF-FILE-SWITCH        PIC X(3)    VALUE 'YES'.
.
.
PROCEDURE DIVISION.
MAINLINE.
.
.
    PERFORM PROCESS-RECORDS
        UNTIL END-OF-FILE-SWITCH = 'YES'
.
.
PROCESS-RECORDS.
    READ EMPLOYEE-FILE
        AT END MOVE 'YES' TO END-OF-FILE-SWITCH
    END-READ.

```

COBOL Fragment for Problem 6

```
SELECT STUDENT-FILE ASSIGN TO 'A:\CHAPTR06\TUITION.DAT'  
    ORGANIZATION IS LINE SEQUENTIAL.  
SELECT PRINT-FILE  
    ASSIGN TO PRINTER.  
  
PROCEDURE DIVISION.  
PREPARE-SENIOR-REPORT.  
    READ STUDENT-FILE  
        AT END MOVE 'NO' TO DATA-REMAINS-SWITCH  
    END-READ.  
    OPEN INPUT STUDENT-FILE  
        OUTPUT PRINT-FILE.  
    PERFORM WRITE-HEADING-LINE.  
    PERFORM PROCESS-RECORDS  
        UNTIL DATA-REMAINS-SWITCH = 'NO'.  
    CLOSE STUDENT-FILE  
        PRINT-FILE.  
STOP RUN.
```

(a) COBOL Fragments

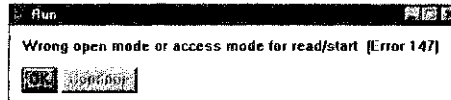

(b) Error Message

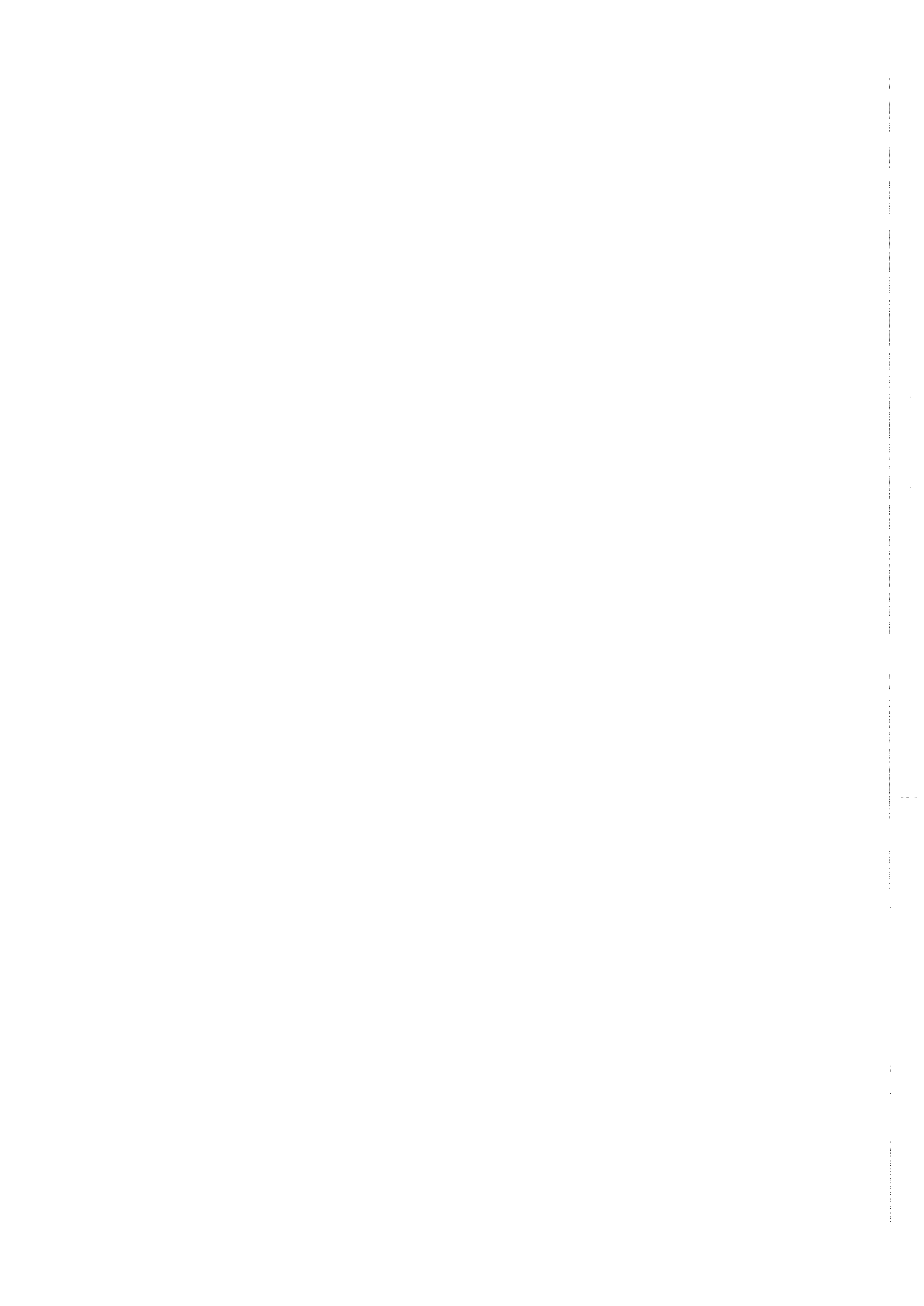

7 Editing and Coding Standards

CHAPTER OUTLINE

Overview

Editing

The Decimal Point

Zero Suppression

Dollar Signs

Commas

Asterisks for Check Protection

Insertion Characters

Synopsis

Signed Numbers

CR and DB

Plus and Minus Signs

BLANK WHEN ZERO Clause

The Tuition Billing Program Revisited

Coding Standards

Data Division

Procedure Division

Both Divisions

Programming Tip: Avoid Literals

Programming Tip: Use Scope Terminators

A Well-Written Program

Summary

Fill-in

True/False

Problems

OBJECTIVES

After reading this chapter you will be able to:

- List the complete set of COBOL editing characters.
- Differentiate between a numeric field and a numeric-edited field; predict the results when a numeric field is moved to a numeric-edited field.
- Understand the difference between an implied decimal point and an actual decimal point; state the role of each in editing.
- Describe the rules for signed numbers and the editing characters +, -, CR, and DB.
- Describe the rationale for coding standards that go beyond the syntactical requirements of COBOL.

OVERVIEW

The chapter introduces editing—the ability to dress up printed reports by inserting dollar signs, decimal points, and so on, into numeric fields prior to printing. The chapter also introduces the concept of signed numbers and the use of CR and DB, or a plus and minus sign, to indicate positive or negative results. All of this material is incorporated into the tuition billing program from Chapter 5.

The second half of the chapter develops the rationale for coding standards, or requirements imposed by an installation to increase the readability (and maintainability) of COBOL programs. We present a series of typical standards and show how they are incorporated into existing programs.

Editing

The importance of editing is best demonstrated by comparing outputs from two programs. Figure 7.1a contains the original (unedited) output produced by the tuition billing program of Chapter 5. Figure 7.1b contains edited output, produced by a modified version of the program, which is presented later in the chapter. The last line of Figure 7.1b displays a new student, Lucky One, whose scholarship grant exceeds the total amount of his bill, producing a credit of \$150. (Lucky One is not shown in Figure 7.1a as the original program did not address signed numbers.) The superiority of the edited output speaks for itself.

The *editing characters* of Table 7.1 enable the kind of output shown in Figure 7.1b. Editing is achieved by incorporating these characters into the various PICTURE clauses within a COBOL program.

The editing characters are not associated with the numeric fields used in computations, as these fields may contain only digits, an implied decimal point, and an optional sign. Additional data names, known as *numeric-edited fields*, are necessary within the program, and it is the picture clauses for the latter that contain editing characters from Table 7.1. In other words, arithmetic is performed on numeric fields, whose computed values are subsequently moved to numeric-edited fields, and the latter are printed.

Figure 7.1 Comparison of Outputs

| STUDENT NAME | | CREDITS | TUITION | UNION FEE | ACT FEE | SCHOLARSHIP | TOTAL BILL |
|-------------------|----|---------|---------|-----------|---------|-------------|------------|
| SMITH | JB | 15 | 003000 | 025 | 075 | 00000 | 003100 |
| JAMES | HR | 15 | 003000 | 000 | 075 | 00000 | 003075 |
| BAKER | SR | 09 | 001800 | 000 | 050 | 00500 | 001350 |
| PART-TIMER | JR | 03 | 000600 | 025 | 025 | 00000 | 000650 |
| JONES | PL | 15 | 003000 | 025 | 075 | 00000 | 003100 |
| HEAVYWORKER | HM | 18 | 003600 | 000 | 075 | 00000 | 003675 |
| LEE | BL | 18 | 003600 | 000 | 075 | 00000 | 003675 |
| CLARK | JC | 06 | 001200 | 000 | 025 | 00000 | 001225 |
| GROSSMAN | SE | 07 | 001400 | 000 | 050 | 00000 | 001450 |
| FRANKEL | LF | 10 | 002000 | 000 | 050 | 00000 | 002050 |
| BENWAY | CT | 03 | 000600 | 000 | 025 | 00250 | 000375 |
| KERBEL | NB | 04 | 000800 | 000 | 025 | 00000 | 000825 |
| UNIVERSITY TOTALS | | | 024600 | 0075 | 0625 | 000750 | 024550 |

(a) Without Editing

| STUDENT NAME | | CREDITS | TUITION | UNION FEE | ACT FEE | SCHOLARSHIP | TOTAL BILL |
|-------------------|----|---------|----------|-----------|---------|-------------|------------|
| SMITH | JB | 15 | \$3,000 | \$25 | \$75 | | \$3,100 |
| JAMES | HR | 15 | \$3,000 | | \$75 | | \$3,075 |
| BAKER | SR | 9 | \$1,800 | | \$50 | \$500 | \$1,350 |
| PART-TIMER | JR | 3 | \$600 | \$25 | \$25 | | \$650 |
| JONES | PL | 15 | \$3,000 | \$25 | \$75 | | \$3,100 |
| HEAVYWORKER | HM | 18 | \$3,600 | | \$75 | | \$3,675 |
| LEE | BL | 18 | \$3,600 | | \$75 | | \$3,675 |
| CLARK | JC | 6 | \$1,200 | | \$25 | | \$1,225 |
| GROSSMAN | SE | 7 | \$1,400 | | \$50 | | \$1,450 |
| FRANKEL | LF | 10 | \$2,000 | | \$50 | | \$2,050 |
| BENWAY | CT | 3 | \$600 | | \$25 | \$250 | \$375 |
| KERBEL | NB | 4 | \$800 | | \$25 | | \$825 |
| LUCKY ONE | FR | 9 | \$1,800 | | \$50 | \$2000 | \$150CR |
| UNIVERSITY TOTALS | | | \$26,400 | \$75 | \$675 | \$2,750 | \$24,400 |

(a) With Editing

Student has been added to the original data

TABLE 7.1 Editing Characters

| | | | |
|----|----------------------|----|------------------|
| . | Actual decimal point | B | Blank |
| Z | Zero suppression | / | Slash |
| \$ | Dollar sign | CR | Credit character |
| , | Comma | DB | Debit character |
| * | Check protection | + | Plus sign |
| 0 | Zero | - | Minus sign |

The relationship between numeric fields and numeric-edited fields is illustrated in Figure 7.2, which depicts the calculation of tuition as credits times the rate (\$200 per credit). The incoming student record contains the field STU-CREDITS, with the calculated result defined in Working-Storage as IND-TUITION. The two fields are numeric, and do not contain any editing characters.

On the other hand, DETAIL-LINE contains two numeric-edited fields (DET-CREDITS and DET-TUITION), each of which holds one or more editing characters from Table 7.1. It is not necessary for you to know the precise function of the various editing characters at this time; you need only perceive the difference between numeric and numeric-edited fields.

The calculations within Figure 7.2 are done with the numeric fields (IND-TUITION and STU-CREDITS). Then, just prior to printing, the values in the numeric fields are moved to the corresponding numeric-edited fields, which are printed.

Let us consider the various editing characters from Table 7.1, in turn.

The Decimal Point

The *actual decimal point* is the most basic editing character. In reviewing this and other examples, it is essential that you remember that *any move of a numeric field to a numeric-edited field maintains decimal alignment*. Consider:

```
05 FIELD-A          PIC 9V99.
05 FIELD-A-EDITED  PIC 9.99.
```

FIELD-A is a numeric field, with two digits after an *implied* decimal point. FIELD-A-EDITED is a numeric-edited field containing an *actual* decimal point. All calculations are done using FIELD-A, which is moved to FIELD-A-EDITED prior to printing by means of the statement MOVE FIELD-A TO FIELD-A-EDITED. Thus:

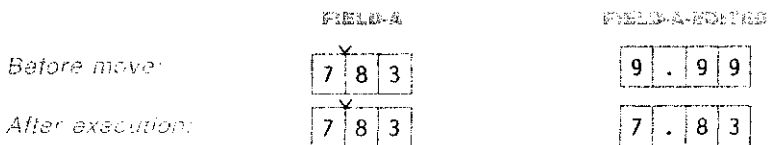

The decimal point requires a position in FIELD-A-EDITED, but not in FIELD-A; that is, FIELD-A-EDITED is a *four*-position field, whereas FIELD-A requires only *three* positions.

Zero Suppression

One of the simplest editing requirements is to eliminate high-order (insignificant) zeros. For example, consider a numeric field defined with a PICTURE clause of 9(5), but whose value is 00120; in other words the two high-order positions contain insignificant zeros. It is likely that you would prefer the printed output to appear as 120, rather than 00120, which is accomplished by the statement MOVE FIELD-B TO FIELD-B-EDITED as shown:

```
05 FIELD-B          PIC 9(5).
05 FIELD-B-EDITED  PIC ZZZZ9
```

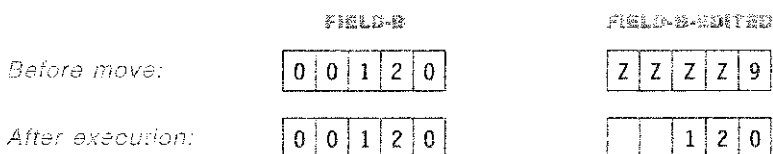
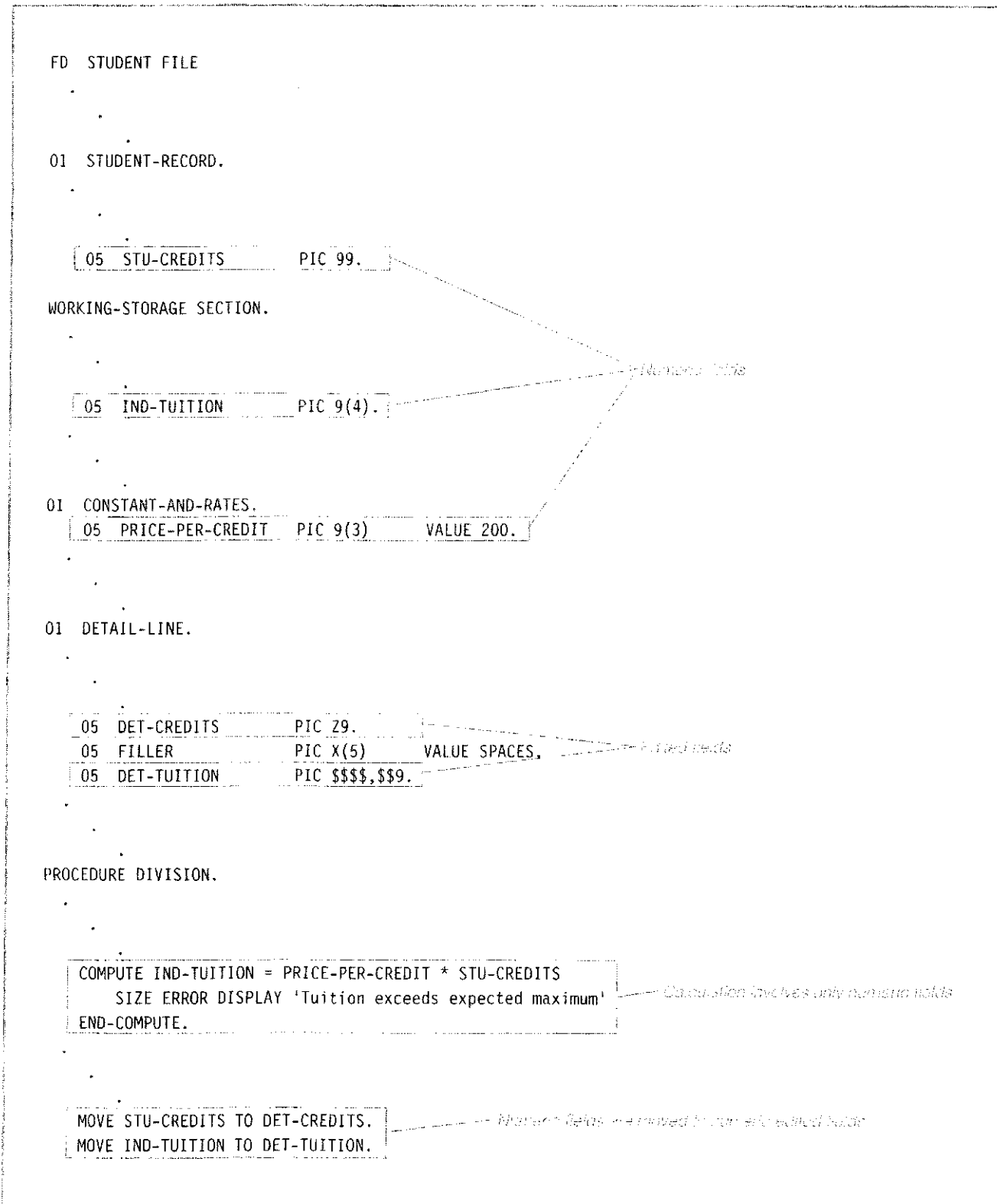

Figure 7.2 Numeric and Numeric-Edited Fields



The editing character *Z* indicates *zero suppression*, and prevents the printing of leading zeros. However, as soon as the first significant digit is reached (the 1 in this example), all subsequent digits are printed. Note, too, that the picture for FIELD-B-EDITED has a 9 as the low-order character, to print a zero, rather than blank out the field entirely, in the event of a zero value.

Dollar Signs

The dollar sign is used as an editing character in one of two ways, either in a *fixed* or *floating* position. A single dollar sign in the numeric-edited picture will always print the dollar sign in the same (fixed) position. Consider the following data names with the statement MOVE FIELD-C TO FIELD-C-EDITED:

```
05 FIELD-C          PIC 9(4).
05 FIELD-C-EDITED  PIC $ZZZ9.
```

| | FIELD-C | FIELD-C-EDITED |
|------------------|---------|----------------|
| Before move: | 0 0 4 3 | \$ Z Z Z 9 |
| After execution: | 0 0 4 3 | \$ 4 3 |

A floating dollar sign is obtained by using multiple dollar signs in the edited field. Consider the following data names in conjunction with the statement MOVE FIELD-D TO FIELD-D-EDITED:

```
05 FIELD-D          PIC 9(4).
05 FIELD-D-EDITED  PIC $$$9.
```

| | FIELD-D | FIELD-D-EDITED |
|------------------|---------|----------------|
| Before move: | 0 0 2 3 | \$ \$ \$ \$ 9 |
| After execution: | 0 0 2 3 | \$ 2 3 |

A single (floating) dollar sign is printed before the first significant digit in the edited field, with the leading zero digits, if any, replaced by blanks. In other words, the floating dollar sign has the same effect as zero suppression. Note, too, that the receiving field must be at least one character longer than the sending field to accommodate the dollar sign; otherwise, a compiler warning results.

Comma

A *comma* used as an editing character causes a comma to be printed, provided a significant digit appears to the left of the comma. The comma will be suppressed, however, if it is preceded by leading zeros. Consider the following data names in conjunction with the statement MOVE FIELD-E TO FIELD-E-EDITED:

```
05 FIELD-E          PIC 9(4).
05 FIELD-E-EDITED  PIC $$,$9.
```

| | FIELD-E | FIELD-E-EDITED |
|------------------|---------|-----------------|
| Before move: | 8 7 6 5 | \$ \$. \$ \$ 9 |
| After execution: | 8 7 6 5 | \$ 8 . 7 6 5 |

The comma is printed in the indicated position. Suppose, however, that the contents of the sending field are less than 1,000, and that the statement MOVE FIELD-F TO FIELD-F-EDITED is executed in conjunction with the fields:

```
05 FIELD-F          PIC 9(4).
05 FIELD-F-EDITED  PIC $$,$$9.
```

| | FIELD-F | FIELD-F-EDITED |
|------------------|---------|-----------------|
| Before move: | 0 0 8 7 | \$ \$. \$ \$ 9 |
| After execution: | 0 0 8 7 | \$ 8 7 |

The comma is suppressed because it was not preceded by a significant digit. Observe also how the comma is used in conjunction with a floating dollar sign.

Asterisks for Check Protection

The *asterisk* is used as a fill character to avoid blanks between a fixed dollar sign and the first significant digit as in \$***87. Consider the following fields in conjunction with the statement MOVE FIELD-G TO FIELD-G-EDITED:

```
05 FIELD-G          PIC 9(5).
05 FIELD-G-EDITED  PIC $**,**9.
```

| | FIELD-G | FIELD-G-EDITED |
|------------------|-----------|----------------|
| Before move: | 0 0 0 8 7 | \$ * * . * * 9 |
| After execution: | 0 0 0 8 7 | \$ * * * * 8 7 |

The dollar sign will print in its fixed position, with asterisks replacing leading zeros. The use of the asterisk as a fill character is commonly referred to as *check protection*.

Insertion Characters

The slash, blank, and zero (/, B, and 0, respectively) are *insertion characters*, meaning that they are printed exactly where they appear in an edited field. Consider the following fields together with the statement MOVE FIELD-H TO FIELD-H-EDITED:

```
05 FIELD-H          PIC 9(6).
05 FIELD-H-EDITED  PIC 99/99/99.
```

| | FIELD-H | FIELD-H-EDITED |
|------------------|-------------|-----------------|
| Before move: | 0 3 1 6 8 9 | 9 9 / 9 9 / 9 9 |
| After execution: | 0 3 1 6 8 9 | 0 3 / 1 6 / 8 9 |

FIELD-H-EDITED is an eight-position field and is typical of how a date field may be edited. Blanks and zeros may be inserted in similar fashion. Note, however, that the hyphen is *not* an insertion character and cannot be used to place hyphens within a social security number.

Synopsis

Table 7.2 provides an effective review of the editing characters covered so far. Each entry in the table shows the result of a MOVE statement of a numeric source field to a numeric-edited receiving field. All of the examples maintain decimal alignment as required. (The ø which appears in several examples indicates a space.)

TABLE 7.2 Review of Editing Characters

| PICTURE | VALUE | PICTURE | EDITED RESULT |
|------------|-----------|---------------|---------------|
| a. 9(4) | 0678 | Z(4) | Ø678 |
| b. 9(4) | 0678 | \$9(4) | \$0678 |
| c. 9(4) | 0678 | \$Z(4) | \$Ø678 |
| d. 9(4)V99 | 123456 | 9(4).99 | 1234.56 |
| e. 9(4)V99 | 123456 | \$9(4).99 | \$1234.56 |
| f. 9(4)V99 | 123456 | \$9,999.99 | \$1,234.56 |
| g. 9(4) | 0008 | \$\$,\$\$\$9 | ØØØØ\$8 |
| h. 9(4)V9 | 12345 | 9(4) | 1234 |
| i. 9(4)V9 | 12345 | 9(4).99 | 1234.50 |
| j. 9(5) | 00045 | \$****9 | \$***45 |
| k. 9(9) | 123456789 | 999B99B9999 | 123Ø45Ø6789 |
| l. 9(4) | 1234 | \$\$,\$\$9.00 | \$1,234.00 |
| m. 9(6) | 080594 | 99/99/99 | 08/05/94 |
| n. 9(6) | 080594 | Z9/99/99 | Ø8/05/94 |

Signed numbers

Thus far we have considered only positive numbers, a rather unrealistic limitation. Numeric fields with negative values require an S in their PICTURE clause to indicate a *signed field*, that is, a field that may contain either positive or negative values. If the sign (the S in the PICTURE clause) is omitted, the value of the data name will always be converted to a positive number, regardless of the result of the computation. Consider:

```

05 FIELD-A      PIC S99  VALUE -20.
05 FIELD-B      PIC 99   VALUE 15.
05 FIELD-C      PIC S99  VALUE -20.
05 FIELD-D      PIC 99   VALUE 15.
    
```

```

ADD FIELD-B TO FIELD-A.
ADD FIELD-C TO FIELD-D.
    
```

Numerically, the sum of -20 and +15 is -5, and there is no problem when the result is stored in FIELD-A as in the first command. In the second command, however, the sum is stored in FIELD-D (an unsigned field), and thus it will assume a value of +5. Accordingly many programmers adopt the habit of always using signed fields to avoid any difficulty. Signed numbers require additional editing characters.

CR and DB

Financial statements use either the credit (CR) or debit (DB) character to indicate a negative number. In other words, the representation of a negative number can be either CR or DB, and depends entirely on the accounting system in use; some systems use CR, whereas others will use DB.

Table 7.3 contains four examples that should clarify the matter. In each instance, CR or DB appears only when the sending field is negative [examples (b)

and (d)]. If the source field is positive or zero, CR and/or DB are replaced by blanks. The essential point is that COBOL treats CR and DB identically, and the determination of which negative indicator to use depends on the accounting system.

TABLE 7.3 CR and DB Editing Characters

| | PICTURE | VALUE | PICTURE | EDITED RESULT |
|----|---------|--------|---------------|---------------|
| a. | S9(5) | 98765 | \$\$\$,999CR | \$98,765 |
| b. | S9(5) | -98765 | \$\$\$,999CR | \$98,765CR |
| c. | S9(5) | 98765 | \$\$\$,999DB | \$98,765 |
| d. | S9(5) | -98765 | \$\$\$,999DB | \$98,765DB |

Plus and Minus Signs

Table 7.4 illustrates the use of plus and minus signs. The repetition of a (plus or minus) sign within the edited PICTURE clause denotes a *floating* (plus or minus) *sign*, which will appear in the printed field immediately to the left of the first significant digit. A single (plus or minus) sign, however, indicates a *fixed* (plus or minus) *sign*, which prints in the indicated position.

Specification of a (fixed or floating) plus sign displays the sign of the edited field if the number is positive, negative, or zero [examples (a), (b), and (c)]. Specification of a minus sign, however, displays the sign only when the edited result is negative. The receiving field must be at least one character longer than the sending field to accommodate the sign; otherwise, a compiler warning results.

TABLE 7.4 Floating Plus and Minus Sign

| | PICTURE | VALUE | PICTURE | EDITED RESULT |
|----|---------|-------|---------|---------------|
| a. | S9(4) | 1234 | ++,+++ | +1,234 |
| b. | S9(4) | 0123 | ++,+++ | ØØ+123 |
| c. | S9(4) | -1234 | ++,+++ | -1,234 |
| d. | S9(4) | 1234 | --,--- | Ø1,234 |
| e. | S9(4) | 0123 | --,--- | ØØØ123 |
| f. | S9(4) | -1234 | --,--- | -1,234 |
| g. | S9(4) | 1234 | ZZ,ZZ9+ | Ø1,234+ |
| h. | S9(4) | -1234 | ZZ,ZZ9+ | Ø1,234- |

BLANK WHEN ZERO Clause

The **BLANK WHEN ZERO** clause produces a blank field when the associated numeric value is zero. Although the same effect can be achieved with certain editing strings, such as ZZZZ or \$\$\$\$, there are times when the clause is essential. A field with dollars and cents—for example, \$\$\$9.99, formatted to print a digit immediately to the left of the decimal point—will print \$0.00. In similar fashion it might be desirable to blank out a date field with PIC Z9/Z9/Z9 if the values are unavailable. The inclusion of **BLANK WHEN ZERO** at the end of the PICTURE clause in all three instances will accomplish the desired result.

The Tuition Billing Program Revisited

We return once more to Figure 7.1, the example with which we began the chapter. The earlier version of the tuition billing program in Chapter 5 did not include editing characters, and so produced the output in Figure 7.1a. Now we incorporate the material just presented into a revised version of the program to produce the edited output of Figure 7.1b.

The necessary changes are highlighted in Figure 7.3, which compares edited and unedited PICTURE clauses. The changes affect only the detail (7.3a) and total

Figure 7.3 Edited versus Unedited PICTURE Clauses

| | EDITED FIELDS | | UNEDITED FIELDS | |
|----|------------------|----------------------------------|----------------------------|---------------|
| 01 | DETAIL-LINE. | | | |
| 05 | FILLER | PIC X VALUE SPACES. | PIC X | VALUE SPACES. |
| 05 | DET-LAST-NAME | PIC X(15). | PIC X(15). | |
| 05 | FILLER | PIC X(2) VALUE SPACES. | PIC X(2) | VALUE SPACES. |
| 05 | DET-INITIALS | PIC X(2). | PIC X(2). | |
| 05 | FILLER | PIC X(5) VALUE SPACES. | PIC X(5) | VALUE SPACES. |
| 05 | DET-CREDITS | PIC Z9. | PIC 9(2). | |
| 05 | FILLER | PIC X(4) VALUE SPACES. | PIC X(6) | VALUE SPACES. |
| 05 | DET-TUITION | PIC \$\$\$,\$\$9. | PIC 9(6). | |
| 05 | FILLER | PIC X(6) VALUE SPACES. | PIC X(7) | VALUE SPACES. |
| 05 | DET-UNION-FEE | PIC \$\$\$9 BLANK WHEN ZERO. | PIC 9(3). | |
| 05 | FILLER | PIC X(5) VALUE SPACES. | PIC X(6) | VALUE SPACES. |
| 05 | DET-ACTIVITY-FEE | PIC \$\$\$9 BLANK WHEN ZERO. | PIC 9(3). | |
| 05 | FILLER | PIC X(6) VALUE SPACES. | PIC X(8) | VALUE SPACES. |
| 05 | DET-SCHOLARSHIP | PIC \$\$,\$\$\$9 BLANK WHEN ZERO | PIC 9(5). | |
| 05 | FILLER | PIC X(4) VALUE SPACES. | PIC X(6) | VALUE SPACES. |
| 05 | DET-IND-BILL | PIC \$\$\$,\$\$9CR. | PIC 9(6). | |
| 05 | FILLER | PIC X(47) VALUE SPACES. | PIC X(49) | VALUE SPACES. |
| | | (a) Detail Line | | |
| 01 | TOTAL-LINE. | | | |
| 05 | FILLER | PIC X(8) VALUE SPACES. | PIC X(8) | VALUE SPACES. |
| 05 | FILLER | PIC X(17) | PIC X(17) | |
| | | VALUE 'UNIVERSITY TOTALS'. | VALUE 'UNIVERSITY TOTALS'. | |
| 05 | FILLER | PIC X(6) VALUE SPACES. | PIC X(8) | VALUE SPACES. |
| 05 | TOT-TUITION | PIC \$\$\$,\$\$9. | PIC 9(6). | |
| 05 | FILLER | PIC X(2) VALUE SPACES. | PIC X(6) | VALUE SPACES. |
| 05 | TOT-UNION-FEE | PIC \$\$\$,\$\$9. | PIC 9(4). | |
| 05 | FILLER | PIC X VALUE SPACES. | PIC X(5) | VALUE SPACES. |
| 05 | TOT-ACTIVITY-FEE | PIC \$\$\$,\$\$9. | PIC 9(4). | |
| 05 | FILLER | PIC X(5) VALUE SPACES. | PIC X(7) | VALUE SPACES. |
| 05 | TOT-SCHOLARSHIP | PIC \$\$\$,\$\$9. | PIC 9(6). | |
| 05 | FILLER | PIC X(4) VALUE SPACES. | PIC X(6) | VALUE SPACES. |
| 05 | TOT-IND-BILL | PIC \$\$\$,\$\$9CR. | PIC 9(6). | |
| 05 | FILLER | PIC X(47) VALUE SPACES. | PIC X(49) | VALUE SPACES. |
| | | (b) Total Line | | |

(7.3b) lines. Computations are made within the program using the unedited PICTURE clauses found in INDIVIDUAL-CALCULATIONS and UNIVERSITY-TOTALS, then moved to edited PICTURE clauses found in DETAIL-LINE and TOTAL-LINE, respectively.

All of the calculations and editing are accomplished as illustrated earlier in Figure 7.2. The computed value of tuition, for example, is stored in the data name IND-TUITION with PIC 9(6), then moved to the edited field DET-TUITION with a PIC \$\$\$\$,\$\$9 prior to printing.

Observe the presence of a CR within the PICTURE clauses for both DET-IND-BILL and TOT-IND-BILL in Figures 7.3a and 7.3b, respectively. The CR is blanked out when students owe money to the university, but appears when the student is due a credit (Lucky One in Figure 7.1b). Note, too, the various BLANK WHEN ZERO clauses throughout Figure 7.3, which produce the more appealing edited output of Figure 7.1b contrasted to the zeros in Figure 7.1a.

A good program is easily read and maintained by someone other than the author. Indeed, continuing success in a commercial installation depends on someone other than the author being able to maintain a program. Most installations impose a set of *coding standards*, such as those described here, which go beyond the requirements of the COBOL compiler. These standards are optional for the student, but typical of what is required in the real world.

The next several pages suggest a series of coding standards for you to use. However, there are no absolute truths—no right or wrong—insofar as programming style is concerned. Different programmers develop slightly or even radically different styles that are consistent with the rules of COBOL and with the programmer's objective. The discussion that follows reflects the viewpoint of the authors and is necessarily subjective.

We begin with suggestions for the Data Division.

Data Division

Choose meaningful names. Avoid taking the easy way out with two- or three-character data names. It is impossible for the maintenance programmer, or even the original author, to determine the meaning of abbreviated data names. The usual student response is that this adds unnecessarily to the burden of writer's cramp. Initial coding, however, takes only 5–10% of the total time associated with a program (maintenance, testing, and debugging take the vast majority), and the modest increase in coding time is more than compensated by improvements in the latter activities.

Prefix all data names within the same FD or 01 with two or three characters unique to the FD; for example, OM-LAST-NAME, OM-BIRTH-DATE. The utility of this guideline becomes apparent in the Procedure Division if it is necessary to refer back to the definition of a data name.

Begin all PICTURE clauses in the same column. Usually in columns 36–48, but the choice is arbitrary. Do not be unduly disturbed if one or two entries stray from the designated column, because of long data names and/or indentation of level numbers.

Choose one form of the PICTURE clause. Choose PIC, PIC IS, PICTURE, or PICTURE IS and follow it consistently. PIC is the shortest and is as good as any.

PROGRAMMING TIP

Avoid Literals

The constant (literal) portion of a print line should be defined in Working-Storage, rather than moved to the print line in the Procedure Division. Consider the following:

Poor Code:

```
MOVE 'STUDENT NAME      SOC SEC NUM CREDITS TUITION
- 'SCHOLARSHIP FEES' TO PRINT-LINE.
```

WRITE PRINT-LINE.

Hyphen required to continue nonnumeric literal

Improved Code:

```
01  HEADING-LINE.
    05                PIC X(12)    VALUE 'STUDENT NAME'
    05                PIC X(10)    VALUE SPACES.
    05                PIC X(11)    VALUE 'SOC SEC NUM' .
    05                PIC X(2)     VALUE SPACES.
    05                PIC X(7)     VALUE 'CREDITS' .
    05                PIC X(2)     VALUE SPACES.
    05                PIC X(7)     VALUE 'TUITION' .
    05                PIC X(3)     VALUE SPACES.
    05                PIC X(11)    VALUE 'SCHOLARSHIP' .
    05                PIC X(2)     VALUE SPACES.
    05                PIC X(4)     VALUE 'FEES' .
```

WRITE PRINT-LINE FROM HEADING-LINE.

The poor code illustrates continuation of a nonnumeric literal. The first line begins with an apostrophe before **STUDENT NAME** and ends *without a closing apostrophe* in column 72. The continued line contains a hyphen in column 7, and both a beginning and ending apostrophe.

The improved code may appear unnecessarily long in contrast to the poor code. However, it is an unwritten law that users will change column headings, and/or spacing at least twice before being satisfied. Such changes are easily accommodated in the improved code but often tedious in the original solution. Assume, for example, that four spaces are required between **CREDITS** and **TUITION**, rather than the two that are there now. Modification of the poor code requires that both lines in the **MOVE** statement be completely rewritten, whereas only a **PICTURE** clause changes in the improved version. Note, too, that the improved code can be rewritten to reduce the number of **FILLER** entries, and also to eliminate the word **FILLER**, as shown below.

```
01  HEADING-LINE.
    05                PIC X(22)    VALUE 'STUDENT NAME' .
    05                PIC X(13)    VALUE 'SOC SEC NUM' .
    05                PIC X(9)     VALUE 'CREDITS' .
    05                PIC X(10)    VALUE 'TUITION' .
    05                PIC X(13)    VALUE 'SCHOLARSHIP' .
    05                PIC X(4)     VALUE 'FEES' .
```

In this example each **VALUE** clause contains fewer characters than the associated **PICTURE** clause. Accordingly, alignment is from left to right, with the extra (low-order) positions padded with blanks.

Indent successive level numbers under a 01 consistently. For example, two or four columns. Leave gaps between adjacent levels (for example, 01, 05, 10, 15 or 01, 04, 08, 12) instead of using consecutive numbers; that is, avoid 01, 02, 03 (as discussed in Chapter 4). Use the same level numbers from FD to FD to maintain consistency within a program.

Avoid 77-level entries. 77-level entries have not been mentioned in the text, because current programming practice argues for their elimination. Nevertheless, they are apt to be found in existing programs and are discussed now for that reason.

A 77-level entry was originally defined as an independent data name with no relationship to any other data name in a program. (77-level entries are coded as elementary items in Working-Storage.) However, few if any data names are truly independent, and 77-level entries should be avoided for that reason. The authors, for example, have gotten along quite nicely by grouping related entries under a common 01 description. Consider the following:

Poor Code:

```
77 TUITION          PIC 9(4)V99  VALUE ZEROS.
77 ACTIVITY-FEE    PIC 9(2)     VALUE ZEROS.
77 UNION-FEE       PIC 9(2)     VALUE ZEROS.
```

Improved Code:

```
01 INDIVIDUAL-CALCULATIONS.
   05 IND-TUITION      PIC 9(4)V99  VALUE ZEROS.
   05 IND-ACTIVITY-FEE PIC 9(2)     VALUE ZEROS.
   05 IND-UNION-FEE    PIC 9(2)     VALUE ZEROS.
```

The improved code also uses a common prefix, which reflects the similarities among the related items. There is simply no reason to use the older approach of independent data items.

Procedure Division

Develop functional paragraphs. Every statement in a paragraph should be related to the overall function of that paragraph, which in turn should be reflected in the paragraph name. A well-chosen name will consist of a verb, one or two adjectives, and an object; for example, READ-STUDENT-FILE, WRITE-HEADING-LINE, and so on. If a paragraph cannot be named in this manner, it is probably not functional, and consideration should be given to redesigning the program and/or paragraph.

Sequence paragraph names. Programmers and managers alike accept the utility of this guideline to locate paragraphs in the Procedure Division quickly. However, there is considerable disagreement on just what sequencing scheme to use: all numbers, a single letter followed by numbers, and so on. We make no strong argument for one scheme over another, other than to insist that a consistent sequencing rule be followed. Some examples are A010-WRITE-NEW-MASTER-RECORD and 100-PRODUCE-ERROR-REPORT.

Avoid commas. The compiler treats a comma as noise; it has no effect on the generated object code. Many programmers have acquired the habit of inserting commas to increase readability. Though this works rather well with prose, it can have just the opposite effect in COBOL, because of blurred print chains, which make it difficult to distinguish a comma from a period. The best solution is to try to avoid commas altogether.

Use scope terminators. END-IF (see programming tip on page 182) is one of several scope terminators included in COBOL-85 that should be used whenever possible to

PROGRAMMING TIP

Use Scope Terminators

Scope terminators are one of the most powerful enhancements in COBOL-85, and in the opinion of the authors, justify in and of themselves, conversion to the new standard. In its simplest role a scope terminator is used in place of a period to end a conditional statement—for example, **END-IF** to terminate an **IF** statement. (A scope terminator and a period should not appear together unless the period also ends the sentence.)

One of the most important reasons for using scope terminators is that they eliminate the very subtle *column 73* problem which has always existed, and which is depicted below. The intended logic is straightforward, and is supposed to apply a discount of two percent on an order of \$2,000 or more. The amount due (**NET**) is equal to the amount ordered less the discount (if any).

COBOL code

```
IF AMOUNT-ORDERED-THISWEEK < 2000
  MOVE ZEROS TO CUSTOMER-DISCOUNT
ELSE
  COMPUTE CUSTOMER-DISCOUNT = AMOUNT-ORDERED-THISWEEK * .02.
  COMPUTE NET = AMOUNT-ORDERED-THISWEEK - CUSTOMER-DISCOUNT.
```

Output

| Amount ordered | Discount | Net |
|----------------|----------|------|
| 3000 | 60 | 2940 |
| 4000 | 80 | 3920 |
| 1000 | 0 | 3920 |
| 5000 | 100 | 4900 |
| 1500 | 0 | 4900 |

The period is in column 73.

COMPUTE NET is not executed for orders less than \$2,000 because of the ELSE clause.

Net amount is incorrect and shown as the value of the previous order.

The COBOL statements appear correct, yet the output is wrong! In particular, *the net amounts are wrong for any order less than \$2,000* (but valid for orders of \$2,000 or more). The net amount for orders less than \$2,000 equals the net for the previous order (that is, the net for an order of \$1,000 is incorrectly printed as \$3,920, which was the correct net for the preceding order of \$4,000). The net amount for an order of \$1,500 was printed as \$4,900, and so on. Why?

The only possible explanation is that the **COMPUTE NET** statement is not executed for net amounts less than \$2,000. The only way that can happen is if the **COMPUTE NET** statement is taken as part of the **ELSE** clause, and that can happen only if the **ELSE** is not terminated by a period. The period is present, however, so we are back at ground zero—or are we? *The period is present, but in column 73, which is ignored by the compiler.* Hence the visual code does not match the compiler interpretation, and the resulting output is incorrect. Replacing the period by the **END-IF** delimiter will eliminate this and similar errors in the future. (Remember, a period may appear *at the end of the sentence* after the **END-IF** terminator.)

terminate a conditional statement. The END-READ terminator should be used in similar fashion to end the conditional AT END clause in the READ statement.

Indent. Virtually all programmers indent successive level numbers in the Data Division, yet many of these same individuals do not apply a similar principle in the Procedure Division. The readability of a program is enhanced significantly by indenting subservient clauses under the main statements. Some examples:

```

READ STUDENT-FILE
  AT END MOVE 'NO' TO DATA-REMAINS-SWITCH
END-READ.

PERFORM 0020-PROCESS-A-RECORD
  UNTIL DATA-REMAINS-SWITCH = 'NO'.

IF STU-UNION-MEMBER = 'Y'
  MOVE UNION-FEE TO IND-UNION-FEE
ELSE
  MOVE ZERO TO IND-UNION-FEE
END-IF.

COMPUTE IND-TUITION = PRICE-PER-CREDIT * STU-CREDITS
  SIZE ERROR DISPLAY 'Size error for individual tuition'
END-COMPUTE.

```

Both Divisions

Space attractively. The adoption of various spacing conventions can go a long way toward improving the appearance of a program. The authors believe very strongly in the insertion of blank lines throughout a program to highlight important statements. Specific suggestions include a blank line before all paragraphs, FDs, and 01 entries.

You can also force various portions of a listing to begin on a new page, by putting a slash in column 7 of a separate statement.

Avoid constants. A significant portion of maintenance programming (and headaches) could be avoided if a program is written with an eye toward change. Consider:

Poor Code

```
COMPUTE IND-TUITION = 200 * STU-CREDITS.
```

Improved Code:

```

WORKING-STORAGE SECTION.
01  CONSTANTS-AND-RATES.
    05  PRICE-PER-CREDIT          PIC 9(4)    VALUE 200.
.
.
.
PROCEDURE DIVISION.
.
.
.
COMPUTE IND-TUITION = PRICE-PER-CREDIT * STU-CREDITS.

```

The improved code is easy to modify when (not if) the tuition rate changes as the only required modification is to the VALUE clause in Working Storage. The poor

code requires changes to the appropriate Procedure Division statement(s), and if the constant 200 appears more than once in the Procedure Division, it is very easy to miss some of the statements in which the change is required. There is less possibility for error in the improved code.

Don't overcomment. Contrary to popular belief, the mere presence of comments does not ensure a well-documented program, and poor comments are sometimes worse than no comments at all. The most common fault is redundancy with the source code. Consider:

```
*   CALCULATE NET PAY
    COMPUTE NET-PAY = GROSS-PAY - FED-TAX - VOL-DEDUCT.
```

The comment detracts from the readability of the statement because it breaks the logical flow as you read the Procedure Division. Worse than redundant, comments may be obsolete or inconsistent with the associated code, as is the case when program statements are changed during maintenance, and the comments are not correspondingly altered.

The authors certainly do not advocate the elimination of comments altogether, but argue simply that care, more than is commonly exercised, should be applied to developing them. One guideline is to provide a comment whenever the purpose of a program statement is not immediately obvious. Imagine, for example, that you are turning the program over to someone else for maintenance, and insert a comment whenever you would explain a statement to the other person. Comments should be used only to show *why* you are doing something, rather than *what* you are doing. Assume that the maintenance programmer is as competent in COBOL as you are; avoid using comments to explain how a particular COBOL statement works.

Well-Written Program

Figure 7.4 is our final pass at the tuition billing program, with attention drawn to the application of the coding standards just developed. All data names within a 01 entry are given a common prefix: STU for entries in STUDENT-RECORD (lines 17–24), IND for data names under INDIVIDUAL-CALCULATIONS (lines 34–38), and so on. This guideline applies equally well to record descriptions in both the File and Working-Storage Sections.

Blank lines highlight 01 entries in the Data Division and paragraph headers in the Procedure Division. All PICTURE clauses are vertically aligned. Indentation is stressed in the Procedure Division with subservient clauses four columns under the associated statements.

Paragraph headers are sequenced and functional in nature. All statements within a paragraph pertain to the function of that paragraph, as indicated by its name. We have chosen a three-digit numerical sequencing scheme, in which the first digit reflects the hierarchy chart level and the remaining two digits reflect the order in which the paragraphs are performed.

Figure 7.4 A Well-Written COBOL Program

```

1  IDENTIFICATION DIVISION.
2  PROGRAM-ID.    TUITION7.
3  AUTHOR.       CAROL VAZQUEZ VILLAR.
4
5  ENVIRONMENT DIVISION.
6  INPUT-OUTPUT SECTION.
7  FILE-CONTROL.
8      SELECT STUDENT-FILE ASSIGN TO 'A:\CHAPTR07\TUITION.DAT'
9      ORGANIZATION IS LINE SEQUENTIAL.
10     SELECT PRINT-FILE
11     ASSIGN TO PRINTER.
12
13  DATA DIVISION.
14  FILE SECTION.
15  FD STUDENT-FILE
16     RECORD CONTAINS 27 CHARACTERS.
17  01 STUDENT-RECORD.
18     05 STU-NAME.
19         10 STU-LAST-NAME    PIC X(15).
20         10 STU-INITIALS    PIC XX.
21     05 STU-CREDITS          PIC 9(2).
22     05 STU-UNION-MEMBER    PIC X.
23     05 STU-SCHOLARSHIP     PIC 9(4).
24     05 STU-GPA              PIC 9V99.
25
26  FD PRINT-FILE
27     RECORD CONTAINS 132 CHARACTERS.
28  01 PRINT-LINE              PIC X(132).
29
30  WORKING-STORAGE SECTION.
31  01 DATA-REMAINS-SWITCH    PIC X(2)    VALUE SPACES.
32
33  01 INDIVIDUAL-CALCULATIONS.
34     05 IND-TUITION          PIC 9(4)    VALUE ZEROS.
35     05 IND-ACTIVITY-FEE     PIC 9(2)    VALUE ZEROS.
36     05 IND-UNION-FEE        PIC 9(2)    VALUE ZEROS.
37     05 IND-SCHOLARSHIP     PIC 9(4)    VALUE ZEROS.
38     05 IND-BILL             PIC S9(6)   VALUE ZEROS.
39
40  01 UNIVERSITY-TOTALS.
41     05 UNI-TUITION          PIC 9(6)    VALUE ZEROS.
42     05 UNI-UNION-FEE        PIC 9(4)    VALUE ZEROS.
43     05 UNI-ACTIVITY-FEE     PIC 9(4)    VALUE ZEROS.
44     05 UNI-SCHOLARSHIP     PIC 9(6)    VALUE ZEROS.
45     05 UNI-IND-BILL         PIC S9(6)   VALUE ZEROS.
46
47  01 CONSTANTS-AND-RATES.
48     05 PRICE-PER-CREDIT     PIC 9(3)    VALUE 200.
49     05 UNION-FEE            PIC 9(2)    VALUE 25.
50     05 ACTIVITY-FEES.

```

Data names within 01 have common prefix

Blank lines appear before 01 entries

Figure 7.4 (continued)

| | | | | |
|-----|----|---------------------|---------------------|-----------------------|
| 51 | 10 | 1ST-ACTIVITY-FEE | PIC 99 | VALUE 25. |
| 52 | 10 | 1ST-CREDIT-LIMIT | PIC 99 | VALUE 6. |
| 53 | 10 | 2ND-ACTIVITY-FEE | PIC 99 | VALUE 50. |
| 54 | 10 | 2ND-CREDIT-LIMIT | PIC 99 | VALUE 12. |
| 55 | 10 | 3RD-ACTIVITY-FEE | PIC 99 | VALUE 75. |
| 56 | 05 | MINIMUM-SCHOLAR-GPA | PIC 9V9 | VALUE 2.5. |
| 57 | | | | |
| 58 | 01 | HEADING-LINE. | | |
| 59 | 05 | FILLER | PIC X | VALUE SPACES. |
| 60 | 05 | FILLER | PIC X(12) | VALUE 'STUDENT NAME'. |
| 61 | 05 | FILLER | PIC X(10) | VALUE SPACES. |
| 62 | 05 | FILLER | PIC X(7) | VALUE 'CREDITS'. |
| 63 | 05 | FILLER | PIC X(2) | VALUE SPACES. |
| 64 | 05 | FILLER | PIC X(7) | VALUE 'TUITION'. |
| 65 | 05 | FILLER | PIC X(2) | VALUE SPACES. |
| 66 | 05 | FILLER | PIC X(9) | VALUE 'UNION FEE'. |
| 67 | 05 | FILLER | PIC X(2) | VALUE SPACES. |
| 68 | 05 | FILLER | PIC X(7) | VALUE 'ACT FEE'. |
| 69 | 05 | FILLER | PIC X(2) | VALUE SPACES. |
| 70 | 05 | FILLER | PIC X(11) | VALUE 'SCHOLARSHIP'. |
| 71 | 05 | FILLER | PIC X(2) | VALUE SPACES. |
| 72 | 05 | FILLER | PIC X(10) | VALUE 'TOTAL BILL'. |
| 73 | 05 | FILLER | PIC X(48) | VALUE SPACES. |
| 74 | | | | |
| 75 | 01 | DETAIL-LINE. | | |
| 76 | 05 | FILLER | PIC X | VALUE SPACES. |
| 77 | 05 | DET-LAST-NAME | PIC X(15). | |
| 78 | 05 | FILLER | PIC X(2) | VALUE SPACES. |
| 79 | 05 | DET-INITIALS | PIC X(2). | |
| 80 | 05 | FILLER | PIC X(5) | VALUE SPACES. |
| 81 | 05 | DET-CREDITS | PIC Z9. | |
| 82 | 05 | FILLER | PIC X(4) | VALUE SPACES. |
| 83 | 05 | DET-TUITION | PIC \$\$\$,\$\$9. | |
| 84 | 05 | FILLER | PIC X(6) | VALUE SPACES. |
| 85 | 05 | DET-UNION-FEE | PIC \$\$\$9 | BLANK WHEN ZERO. |
| 86 | 05 | FILLER | PIC X(5) | VALUE SPACES. |
| 87 | 05 | DET-ACTIVITY-FEE | PIC \$\$\$9 | BLANK WHEN ZERO. |
| 88 | 05 | FILLER | PIC X(6) | VALUE SPACES. |
| 89 | 05 | DET-SCHOLARSHIP | PIC \$,\$\$\$9 | BLANK WHEN ZERO. |
| 90 | 05 | FILLER | PIC X(4) | VALUE SPACES. |
| 91 | 05 | DET-IND-BILL | PIC \$\$\$,\$\$9CR. | |
| 92 | 05 | FILLER | PIC X(47) | VALUE SPACES. |
| 93 | | | | |
| 94 | 01 | DASH-LINE. | | |
| 95 | 05 | FILLER | PIC X(31) | VALUE SPACES. |
| 96 | 05 | FILLER | PIC X(8) | VALUE ALL '-'. |
| 97 | 05 | FILLER | PIC X(2) | VALUE SPACES. |
| 98 | 05 | FILLER | PIC X(8) | VALUE ALL '-'. |
| 99 | 05 | FILLER | PIC X(2) | VALUE SPACES. |
| 100 | 05 | FILLER | PIC X(7) | VALUE ALL '-'. |

Figure 7.4 (continued)

```

101      05 FILLER                PIC X(6)    VALUE SPACES.
102      05 FILLER                PIC X(7)    VALUE ALL '-'.
103      05 FILLER                PIC X(5)    VALUE SPACES.
104      05 FILLER                PIC X(7)    VALUE ALL '-'.
105      05 FILLER                PIC X(49)   VALUE SPACES.
106
107      01 TOTAL-LINE.
108      05 FILLER                PIC X(8)    VALUE SPACES.
109      05 FILLER                PIC X(17)
110          VALUE 'UNIVERSITY TOTALS'.
111      05 FILLER                PIC X(6)    VALUE SPACES.
112      05 TOT-TUITION            PIC $$$,$$9.
113      05 FILLER                PIC X(2)    VALUE SPACES.
114      05 TOT-UNION-FEE         PIC $$$,$$9.
115      05 FILLER                PIC X      VALUE SPACES.
116      05 TOT-ACTIVITY-FEE     PIC $$$,$$9.
117      05 FILLER                PIC X(5)    VALUE SPACES.
118      05 TOT-SCHOLARSHIP       PIC $$$,$$9.
119      05 FILLER                PIC X(4)    VALUE SPACES.
120      05 TOT-IND-BILL          PIC $$$,$$9CR.
121      05 FILLER                PIC X(47)   VALUE SPACES.
122
123      PROCEDURE DIVISION.
124      100-PREPARE-TUITION-REPORT.
125          OPEN INPUT STUDENT-FILE
126              OUTPUT PRINT-FILE.
127          PERFORM 210-WRITE-HEADING-LINE.
128          PERFORM 230-READ-STUDENT-FILE.
129          PERFORM 260-PROCESS-STUDENT-RECORD
130              UNTIL DATA-REMAINS-SWITCH = 'NO'.
131          PERFORM 290-WRITE-UNIVERSITY-TOTALS.
132          CLOSE STUDENT-FILE
133              PRINT-FILE.
134          STOP RUN.
135
136      210-WRITE-HEADING-LINE.
137          MOVE HEADING-LINE TO PRINT-LINE.
138          WRITE PRINT-LINE
139              AFTER ADVANCING PAGE.
140          MOVE SPACES TO PRINT-LINE.
141          WRITE PRINT-LINE.
142
143      230-READ-STUDENT-FILE.
144          READ STUDENT-FILE
145              AT END MOVE 'NO' TO DATA-REMAINS-SWITCH
146          END-READ.
147
148      260-PROCESS-STUDENT-RECORD.
149          PERFORM 310-COMPUTE-INDIVIDUAL-BILL.
150          PERFORM 330-INCREMENT-UNIVER-TOTALS

```

DATA DIVISION

PROCEDURE DIVISION

101
102
103
104
105
106
107
108
109
110
111
112
113
114
115
116
117
118
119
120
121
122
123
124
125
126
127
128
129
130
131
132
133
134
135
136
137
138
139
140
141
142
143
144
145
146
147
148
149
150

Figure 7.4 (continued)

```

151     PERFORM 360-WRITE-DETAIL-LINE.
152     PERFORM 230-READ-STUDENT-FILE.
153
154     290-WRITE-UNIVERSITY-TOTALS.
155         MOVE DASH-LINE TO PRINT-LINE.
156         WRITE PRINT-LINE.
157         MOVE UNI-TUITION TO TOT-TUITION.
158         MOVE UNI-UNION-FEE TO TOT-UNION-FEE.
159         MOVE UNI-ACTIVITY-FEE TO TOT-ACTIVITY-FEE.
160         MOVE UNI-SCHOLARSHIP TO TOT-SCHOLARSHIP.
161         MOVE UNI-IND-BILL TO TOT-IND-BILL.
162         MOVE TOTAL-LINE TO PRINT-LINE.
163         WRITE PRINT-LINE
164             AFTER ADVANCING 1 LINE.
165
166     310-COMPUTE-INDIVIDUAL-BILL.
167         PERFORM 410-COMPUTE-TUITION.
168         PERFORM 430-COMPUTE-UNION-FEE.
169         PERFORM 460-COMPUTE-ACTIVITY-FEE.
170         PERFORM 490-COMPUTE-SCHOLARSHIP.
171         COMPUTE IND-BILL = IND-TUITION + IND-UNION-FEE +
172             IND-ACTIVITY-FEE - IND-SCHOLARSHIP.
173
174     330-INCREMENT-UNIVER-TOTALS.
175         ADD IND-TUITION      TO UNI-TUITION.
176         ADD IND-UNION-FEE   TO UNI-UNION-FEE.
177         ADD IND-ACTIVITY-FEE TO UNI-ACTIVITY-FEE.
178         ADD IND-SCHOLARSHIP TO UNI-SCHOLARSHIP.
179         ADD IND-BILL        TO UNI-IND-BILL.
180
181     360-WRITE-DETAIL-LINE.
182         MOVE STU-LAST-NAME TO DET-LAST-NAME.
183         MOVE STU-INITIALS TO DET-INITIALS.
184         MOVE STU-CREDITS TO DET-CREDITS.
185         MOVE IND-TUITION TO DET-TUITION.
186         MOVE IND-UNION-FEE TO DET-UNION-FEE.
187         MOVE IND-ACTIVITY-FEE TO DET-ACTIVITY-FEE.
188         MOVE IND-SCHOLARSHIP TO DET-SCHOLARSHIP.
189         MOVE IND-BILL TO DET-IND-BILL.
190         MOVE DETAIL-LINE TO PRINT-LINE.
191         WRITE PRINT-LINE
192             AFTER ADVANCING 1 LINE.
193
194     410-COMPUTE-TUITION.
195         COMPUTE IND-TUITION = PRICE-PER-CREDIT * STU-CREDITS.
196
197     430-COMPUTE-UNION-FEE.
198         IF STU-UNION-MEMBER = 'Y'
199             MOVE UNION-FEE TO IND-UNION-FEE
200         ELSE

```

Paragraph names are functional, i.e., verb, adjective, object

Comment line is indented

Paragraph names are functional, i.e., verb, adjective, object

IF-ELSE statement indented and ends with END-IF scope terminator

Figure 7.4 (continued)

```

201     MOVE ZERO TO IND-UNION-FEE
202     END-IF.
203
204     460-COMPUTE-ACTIVITY-FEE.
205         EVALUATE TRUE
206             WHEN STU-CREDITS <= 1ST-CREDIT-LIMIT
207                 MOVE 1ST-ACTIVITY-FEE TO IND-ACTIVITY-FEE
208             WHEN STU-CREDITS > 1ST-CREDIT-LIMIT
209                 AND STU-CREDITS <= 2ND-CREDIT-LIMIT
210                 MOVE 2ND-ACTIVITY-FEE TO IND-ACTIVITY-FEE
211             WHEN STU-CREDITS > 2ND-CREDIT-LIMIT
212                 MOVE 3RD-ACTIVITY-FEE TO IND-ACTIVITY-FEE
213             WHEN OTHER
214                 DISPLAY 'INVALID CREDITS FOR: ' STU-NAME
215         END-EVALUATE.
216
217     490-COMPUTE-SCHOLARSHIP.
218         IF STU-GPA > MINIMUM-SCHOLAR-GPA
219             MOVE STU-SCHOLARSHIP TO IND-SCHOLARSHIP
220         ELSE
221             MOVE ZERO TO IND-SCHOLARSHIP
222         END-IF.

```

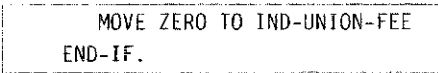
+ Block alignment inserted and ends with END-IF scope terminator

S U M M A R Y

Points to Remember

- A numeric field contains digits, an (optional) implied decimal point, and/or an optional sign. A numeric-edited field may contain any editing character. All calculations in a COBOL program are done on numeric fields, whose computed values are moved to numeric-edited fields prior to printing.
- Any move involving a numeric field and a numeric-edited field maintains decimal alignment.
- Only a signed numeric field can hold a negative value; that is, a numeric field cannot retain a negative value unless it has been defined with an S in its PICTURE clause.
- Coding standards are intended to improve the readability and maintainability of COBOL programs. They are imposed by individual installations and go beyond the requirements of COBOL.

Key Words and Concepts

| | |
|----------------------|----------------------------|
| Actual decimal point | Implied decimal point |
| Check protection | Indentation |
| Coding standards | Insertion characters |
| CR | Maintainability |
| DB | Numeric field |
| Decimal alignment | Numeric-edited field |
| Editing | Prefixing data names |
| Editing characters | Readability |
| Fixed dollar sign | Receiving field |
| Floating dollar sign | Sequencing paragraph names |
| Floating minus sign | Signed numbers |
| Floating plus sign | Source (sending) field |
| Functional paragraph | Zero suppression |

COBOL Element

BLANK WHEN ZERO

F I L L - I N

- _____ are a set of rules unique to each installation, which go beyond the rules of COBOL, to improve the readability of a COBOL program.
- The editing characters, _____ and _____, will appear if and only if the sending field is _____ and are suppressed otherwise.
- The presence of multiple dollar signs in the PICTURE clause of an edited field indicates a _____ dollar sign, whereas a single dollar sign indicates a _____ dollar sign.
- The _____ is the character used for check protection.
- The PICTURE clause of a numeric field may consist of 9's, a _____ to indicate an implied decimal point, and the letter _____ to indicate a signed field.
- Continuation of a _____ literal requires a _____ in column _____.
- A well-chosen paragraph name consists of a _____, _____, and _____ to indicate the function of that paragraph.
- All data names within the same 01 record should begin with a common _____.
- _____ of COBOL statements within the B margin does not affect compiler interpretation but goes a long way toward improving the readability of a program.
- _____ may be left before 01 records and paragraph names to enhance readability.



11. If a numeric field is defined without an S in its PICTURE clause, the field will never assume a _____ value.
12. All calculations in a COBOL program are performed on (numeric/numeric-edited) fields.

TRUE/FALSE

1. Indentation within the B margin affects compiler interpretation.
2. Blank lines are not permitted within a COBOL program.
3. The COBOL coding standards for AT&T and IBM are apt to be identical.
4. COBOL requires that paragraph names be sequenced.
5. Data names should be as short as possible to cut down on the coding effort.
6. Indentation in COBOL is a waste of time.
7. A well-commented COBOL program should contain half as many comment lines as Procedure Division statements.
8. All continued statements require a hyphen in column 7.
9. COMPUTE-AND-WRITE is a good paragraph name.
10. Heading, detail, and total lines may be established as separate 01 entries in Working-Storage.
11. Every PICTURE clause requires a corresponding VALUE clause.
12. Arithmetic may be done on numeric-edited fields.
13. A positive field should always be defined with a CR in its PICTURE clause, whereas a negative field requires DB.
14. A single numeric-edited field may contain a dollar sign, comma, decimal point, asterisk, and the character string CR in its PICTURE clause.
15. The same numeric-edited field may contain both CR and DB in its PICTURE clause.
16. Hyphens may be used as insertion characters in a social security number.
17. Slashes may be used as insertion characters in a date.
18. The presence of CR or DB in a numeric-edited field implies that the sending field is signed.
19. Zero is a valid insertion character.

PROBLEMS

1. Supply PICTURE clauses for the receiving fields needed to accomplish the following:
 - a. A floating dollar sign, omission of cents, printing (or suppression) of commas as appropriate, and a maximum value of \$9,999,999.
 - b. A fixed dollar sign, asterisk fill for insignificant leading zeros, printing (or suppression) of commas as appropriate, a maximum value of \$9,999, and a trailing DB if the sending field is negative.

- c. A fixed dollar sign, zero suppression of insignificant leading zeros, omission of commas in all instances, and a maximum value of \$99,999.99.
- d. A floating dollar sign, printing (or suppression) of commas as appropriate, a maximum value of \$9,999.00, and a trailing CR if the sending field is negative.

2. Show the value of the edited result for each of the following entries:

| | SOURCE FIELD | | RECEIVING FIELD | |
|----|--------------|--------|-------------------|---------------|
| | PICTURE | VALUE | PICTURE | EDITED RESULT |
| a. | 9(6) | 123456 | 9(6) | _____ |
| b. | 9(6) | 123456 | 9(8) | _____ |
| c. | 9(6) | 123456 | 9(6).99 | _____ |
| d. | 9(4)V99 | 123456 | 9(6) | _____ |
| e. | 9(4)V99 | 123456 | 9(4) | _____ |
| f. | 9(4)V99 | 123456 | \$\$\$\$9.99 | _____ |
| g. | 9(4)V99 | 123456 | \$\$,\$\$9.99 | _____ |
| h. | 9(6) | 123456 | \$\$\$\$,\$\$9.99 | _____ |
| i. | 9(6) | 123456 | Z(8) | _____ |
| j. | 9(4)V99 | 123456 | \$ZZ,ZZZ.99 | _____ |

3. Show the edited results for each entry:

| | SOURCE FIELD | | RECEIVING FIELD | |
|----|--------------|---------|---------------------|---------------|
| | PICTURE | VALUE | PICTURE | EDITED RESULT |
| a. | S9(4)V99 | 45600 | \$\$\$\$.99CR | _____ |
| b. | S9(4)V99 | 45600 | \$\$,\$\$\$9.99DB | _____ |
| c. | S9(4) | 4567 | \$\$,\$\$\$0.00 | _____ |
| d. | S9(6) | 122577 | 99B99B99 | _____ |
| e. | S9(6) | 123456 | ++++,+++ | _____ |
| f. | S9(6) | -123456 | ++++,+++ | _____ |
| g. | S9(6) | 123456 | ----,--- | _____ |
| h. | S9(6) | -123456 | ----,--- | _____ |
| i. | 9(4)V99 | 567890 | \$\$\$\$,\$\$\$9.99 | _____ |
| j. | 9(4)V99 | 567890 | \$ZZ,ZZZ.99 | _____ |
| k. | 9(4)V99 | 567890 | \$***,\$**9.99 | _____ |

4. What, if anything, is wrong (either syntactically or logically) with the following PICTURE clauses?

- a. \$,\$\$\$,\$\$9.99
- b. 9999999999
- c. \$\$\$\$,\$\$\$,\$\$\$
- d. \$ZZZ.ZZ
- e. \$999V99
- f. \$999,999,999.99
- g. \$\$\$\$\$,\$\$9.99

5. Do you agree with all of the coding standards suggested by the authors? Can you suggest any others? Do you think the imposition of coding standards within an installation impinges on the creativity of individual programmers? Are coding standards worth the extra time and trouble they require?

6. Consider the following code:

```
01 AMOUNT-REMAINING      PIC 9(3)    VALUE 100.  
01 WS-INPUT-AREA.  
   05 QUANTITY-SHIPPED   PIC 99.  
   05 REST-OF-A-RECORD   PIC X(50).
```

```
READ TRANSACTION-FILE INTO WS-INPUT-AREA  
  AT END MOVE 'YES' TO EOF-SWITCH  
END-READ.  
PERFORM PROCESS-TRANSACTIONS  
  UNTIL EOF-SWITCH = 'YES'.
```

```
PROCESS-TRANSACTIONS.
```

```
  SUBTRACT QUANTITY-SHIPPED FROM AMOUNT-REMAINING.  
  READ TRANSACTION-FILE INTO WS-INPUT-AREA  
    AT END MOVE 'YES' TO EOF-SWITCH  
  END-READ.
```

- a. Why will AMOUNT-REMAINING never be less than zero?
- b. What will be the final value of AMOUNT-REMAINING, given successive values of 30, 50, 25, and 15 for QUANTITY-SHIPPED?

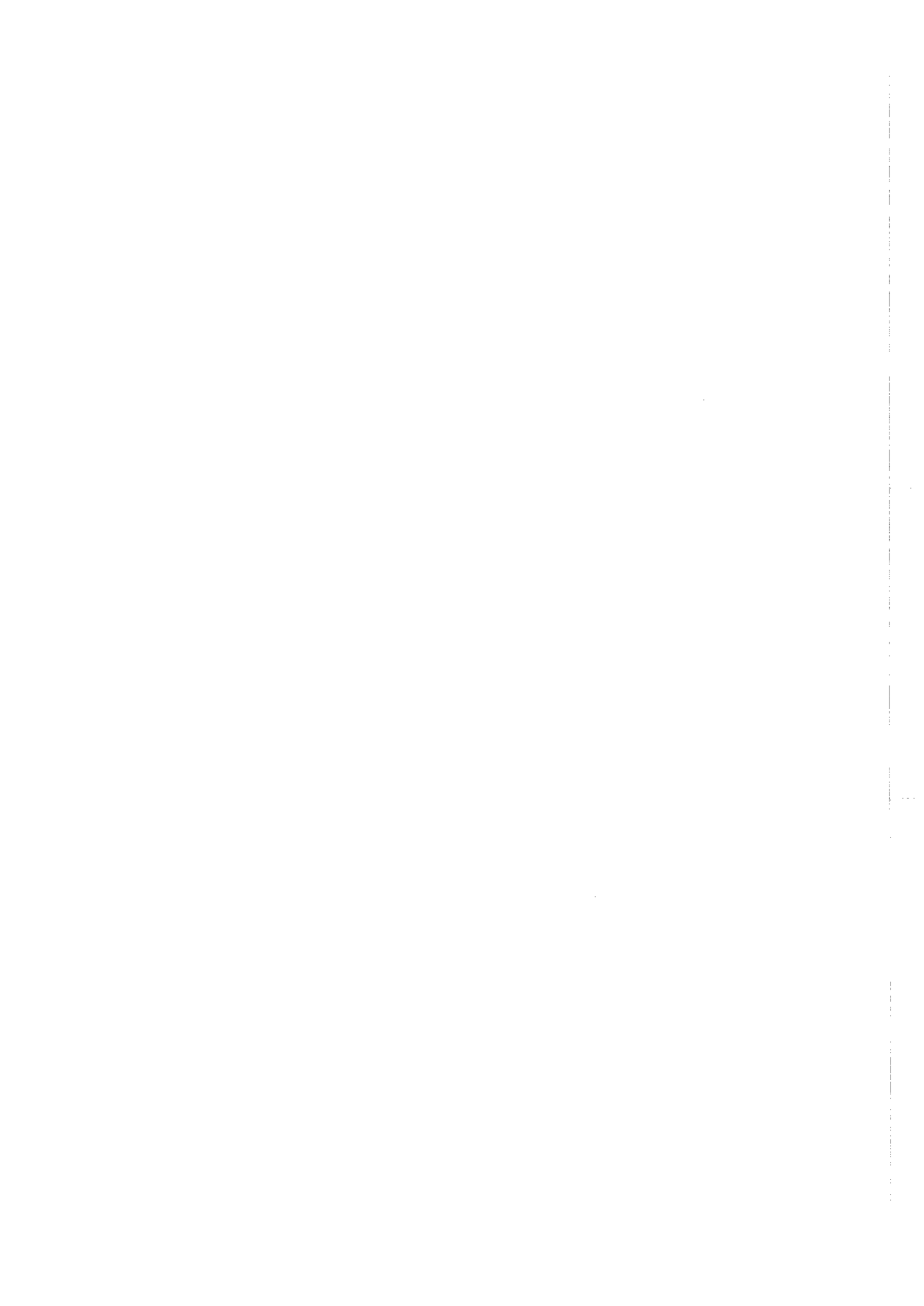

Data Validation

CHAPTER OUTLINE

Overview

System Concepts: Data Validation

The IF Statement

- Relational Condition
- Class Test
- Sign Test
- Condition-Name Test (88-Level Entries)
- Compound Test
 - Hierarchy of Operations
- Implied Conditions
- Nested IFs
- NEXT SENTENCE

ACCEPT Statement

- Calculations Involving Dates

Stand-Alone Edit Program

- Programming Specifications
- Error Messages
- Pseudocode
- Hierarchy Chart
- The Completed Program

Limitations of COBOL-74

Summary

Fill-in

True/False

Problems

OBJECTIVES

After reading this chapter you will be able to:

- ✱ Describe the importance of data validation and its implementation in a stand-alone edit program.
- ✱ Define the following validity tests: numeric test, alphabetic test, consistency check, sequence check, completeness check, date check, and subscript check.
- ✱ Describe the various types of conditions in an IF statement.
- ✱ Define a nested IF; indicate guidelines for proper indentation in coding such statements.
- ✱ Describe the advantages of the END-IF scope terminator; show how the scope terminator eliminates the need for the NEXT SENTENCE clause.
- ✱ Obtain the date (calendar and Julian) and time of execution; implement date checking in a program to ensure that the day and month are consistent.

OVERVIEW

This chapter introduces the concept of data validation, the process of ensuring that data entered into a system is as error-free as possible. It begins by describing various types of error checking, then focuses on the IF statement, the means by which data validation is implemented in COBOL. We cover the different types of conditions that exist within an IF statement (relation, class, sign, and condition name), the concept of a nested IF, and the importance of the END-IF scope terminator.

The second half of the chapter develops a stand-alone edit program to illustrate the implementation of data validation. The program is designed to process a file of incoming transactions, reject invalid transactions with appropriate error messages, and write valid transactions to an output file. The latter is then input to a reporting (or other) program.

Systems Concepts: Data Validation

A well-written program is not limited to merely computing answers, but must also validate the data on which those answers are based. Failure to do so results in programs that produce meaningless or inaccurate information, a situation described by the cliché GIGO (Garbage In, Garbage Out). It is the job of the programmer or analyst to ensure that a system remains as error-free as possible and that the “garbage” does not enter the system in the first place.

Incoming data may be validated within the program in which it is used or in a separate stand-alone edit program. The essential point is that incoming data *must*

be checked; when and how this is done is of secondary importance. The following are typical types of data validation:

Numeric test. Ensures that a numeric field contains numeric data. Commas, dollar signs, decimal points, blanks, or other alphabetic characters are not numeric, and will cause problems in execution.

Alphabetic test. Analogous to a numeric test, except that alphabetic fields should contain only alphabetic data. Any errors detected here are typically less serious than for numeric fields.

Reasonableness (limit or range) check. Ensures that a number is within expected limits; that is, that a value does not exceed a designated upper or lower extreme.

Consistency check. Verifies that the values in two or more fields are consistent, for example, salary and job title. Other examples of consistency checks are an individual's credit rating and the amount of credit a bank is willing to extend, or (as used by the Internal Revenue Service) an individual's reported income and the zip code.

Existing code check. One of the most important tests, the omission of which produces countless errors. Consider:

```
IF SEX = 'M'
    ADD 1 TO NUMBER-OF-MEN
ELSE
    ADD 1 TO NUMBER-OF-WOMEN
END-IF.
```

It is decidedly poor practice to assume that an incoming record is female if it is not male. Both codes should be explicitly checked, and if neither occurs, a suitable error should be printed.

Sequence check. Ensures that incoming records are in proper order. It can also be used when one record is continued over several lines to ensure that the lines within a record are in proper sequence.

Completeness check. Verifies that data in all required fields are present; this check is normally used when new records are added to a file.

Date check. Ensures that an incoming date is acceptable—for example, that the day is from 1 to 31, the month from 1 to 12, and the year within a designated period, often just the current year. A further check is that the month and day are consistent with one another—for example, a date of April 31 is invalid.

Subscript check. Validates that a subscript or index is within a table's original definition. (Table processing is discussed fully in Chapter 11.)

Diligent application of data validation (sometimes referred to as defensive programming) minimizes the need for subsequent debugging. It assumes that errors will occur and takes steps to make them apparent to the programmer and/or user *before* a program terminates. Is it worth the extra time? Emphatically yes, especially if you have ever been called at two in the morning to hear that your program “bombed” because of invalid data.

The importance of the *IF* statement is obvious, yet the large number of options make it one of the more difficult statements to master. Essential to any *IF* statement, however, is the condition, the portion of the statement that is evaluated as either

true or false. Four types of conditions are possible: relational, class, sign, and condition-name, each of which is discussed in a separate section.

Relational Condition

The *relational condition* is the most common type of condition and has appeared throughout the book. As you already know there is considerable variation in the way the relational operator may be expressed. In all instances, however, the condition compares the quantities on either side of the relational operator to determine whether (or not) the condition is true.

The data type of the quantities being compared must be the same; for example, a numeric data item must be compared to a numeric literal and a nonnumeric data item to a nonnumeric literal. Failure to do so produces a syntax error during compilation. The relational condition is illustrated in Figure 8.1.

Figure 8.1 The Relational Condition

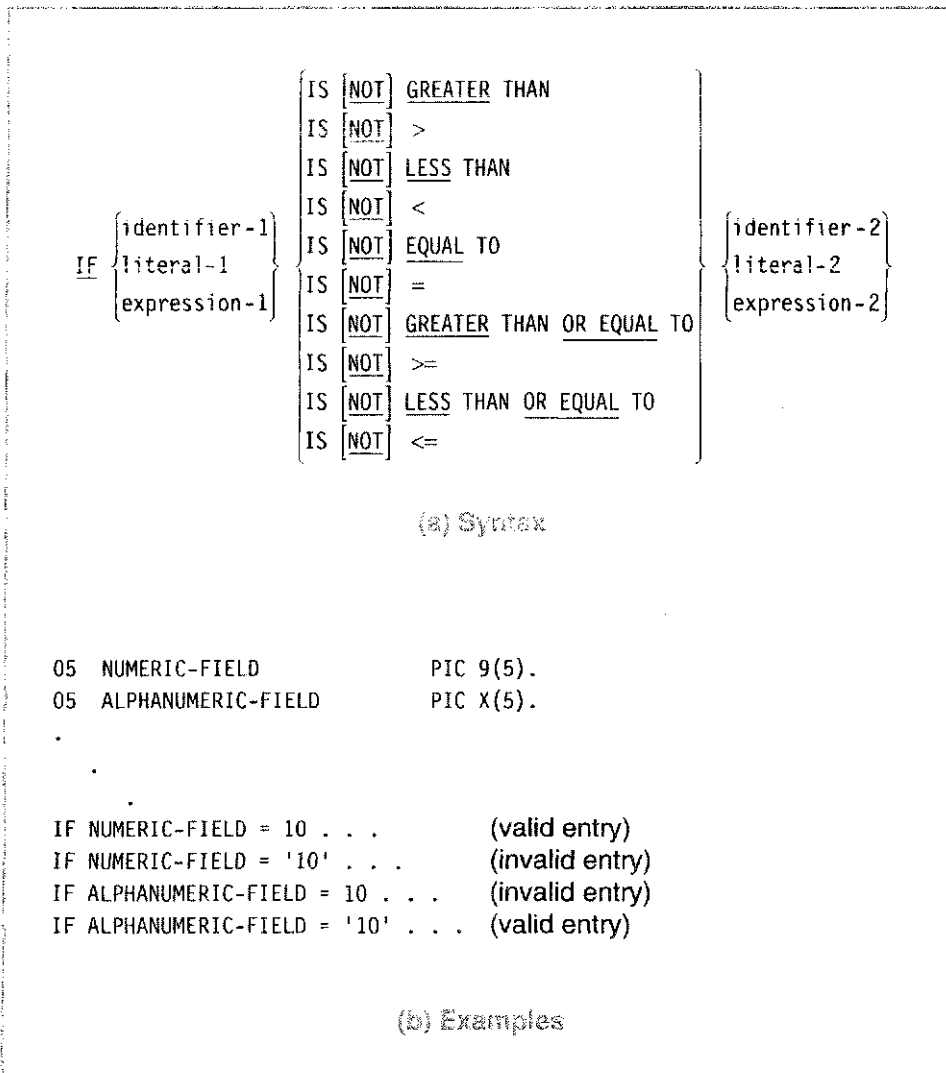

Class Test

The *class test* ensures that a field contains numeric or alphabetic data in accordance with its PICTURE clause. A valid numeric field will contain only the digits 0 to 9 (a sign is optional); blanks, decimal points, commas, and other editing characters are not valid as numeric characters. A valid alphabetic field will contain the letters A to Z (upper or lower case) and/or blanks. An alphanumeric field may contain any character; letters, numbers, and/or special characters.

The class test cannot be used indiscriminately; that is, a numeric test cannot be used for data names defined as alphabetic, nor can an alphabetic test be used for numeric data names. Either test, however, may be performed on alphanumeric items. The class test is illustrated in Figure 8.2

Figure 8.2 The Class Test

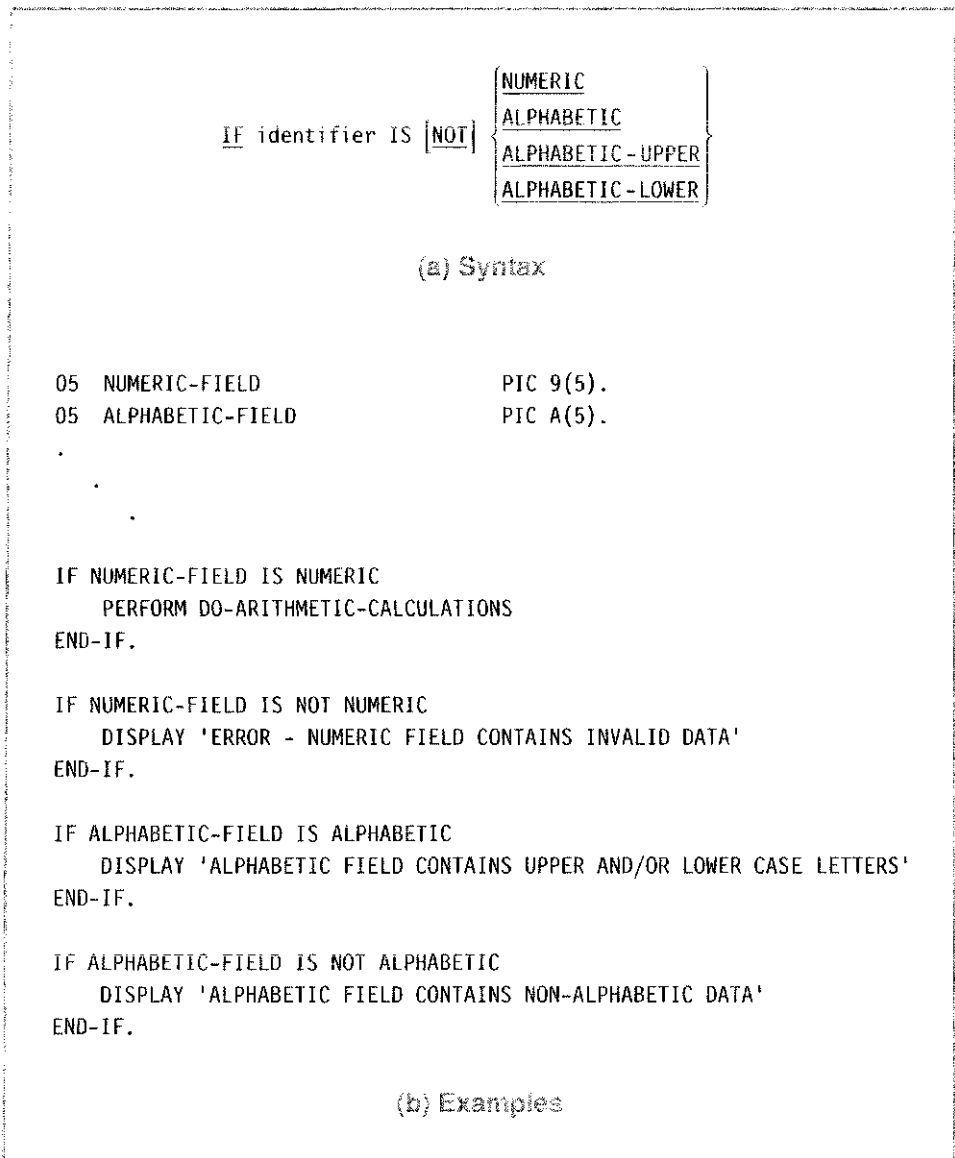
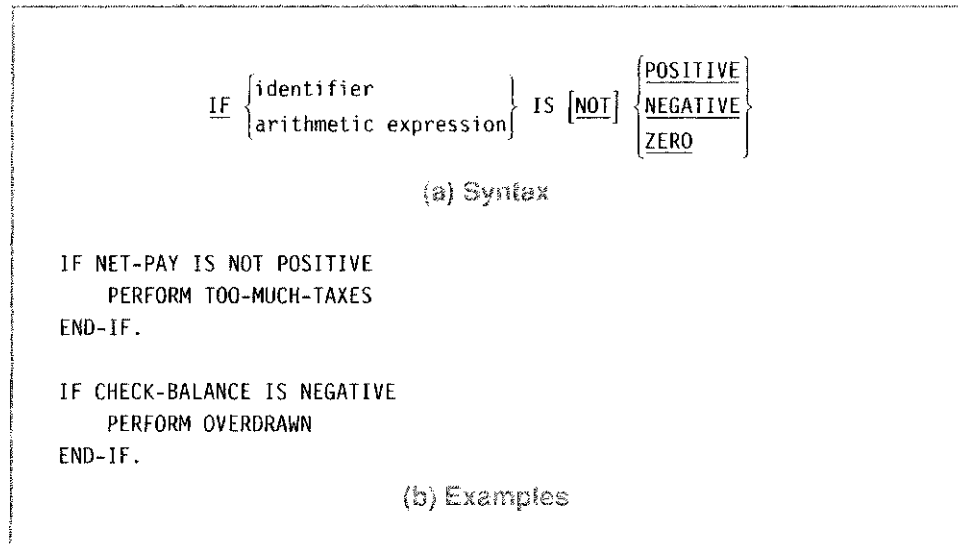

Figure 8.3 The Sign Test



Sign Test

The *sign test* determines whether a numeric field is positive, negative, or zero. The test is of limited value and could in fact be replaced with the equivalent relational condition. Nevertheless, the sign test is illustrated in Figure 8.3.

Condition-Name Test

A *condition name* (88-level entry) is a special way of writing a relational condition that makes it (the condition) easier to read. Condition names are defined in the Data Division, then referenced in the Procedure Division as shown in Figure 8.4. Condition names are used for elementary items only.

The definition of a condition name in the Data Division simplifies subsequent coding in the Procedure Division; for example, IF FRESHMAN is equivalent to IF YEAR-CODE = 1. 88-level entries provide improved documentation in that IF FRESHMAN is inherently clearer than IF YEAR-CODE = 1.

The use of an 88-level entry also allows multiple codes to be grouped under a single data name; for example, VALID-CODES is defined as any value from 1 to 8. This in turn makes it possible to test for an invalid code with a simple IF statement as shown in Figure 8.4b. Note, too, that condition names permit a given value to appear under more than one classification; for example, records containing a 3 belong to JUNIOR, UPPER-CLASSMAN, and VALID-CODES.

Compound Test

Any two simple tests may be combined to form a *compound test* through the logical operators AND and OR. AND implies that both conditions must be satisfied for the IF to be considered true, whereas OR requires that only one of the conditions be satisfied. A flowchart is shown in Figure 8.5a depicting the AND condition. It requires that *both* A be greater than B *and* C be greater than D in order to proceed to TRUE. If either of these tests fails, the compound condition is judged false. The general format is:

$$\text{IF condition-1 } \left\{ \begin{array}{l} \text{AND} \\ \text{OR} \end{array} \right\} \text{ condition-2 } \dots$$

Figure 8.4 Condition Names (88-level entries)

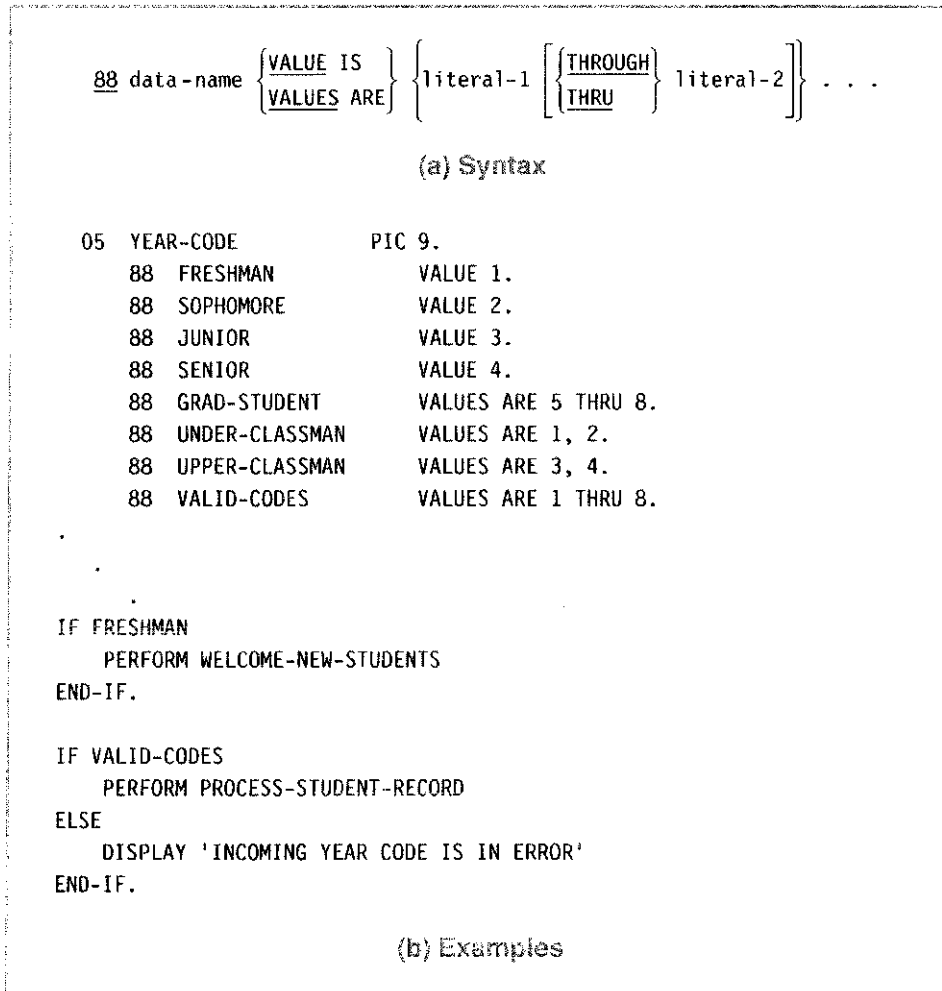

Figure 8.5b contains a flowchart for a compound OR in which only one of two conditions needs to be met for the condition to be considered true. Thus, if either A is greater than B or C is greater than D, processing is directed to TRUE.

Hierarchy of Operations

IF statements containing compound conditions can become difficult to interpret; for example, in the statement,

```
IF X > Y OR X = Z AND X < W ...
```

which takes precedence, AND or OR? To provide an unequivocal evaluation of compound conditions, the following hierarchy for evaluation is established:

1. Arithmetic expressions
2. Relational operators
3. NOT condition
4. AND (from left to right if more than one)
5. OR (from left to right if more than one)

Figure 8.5 Compound Conditions

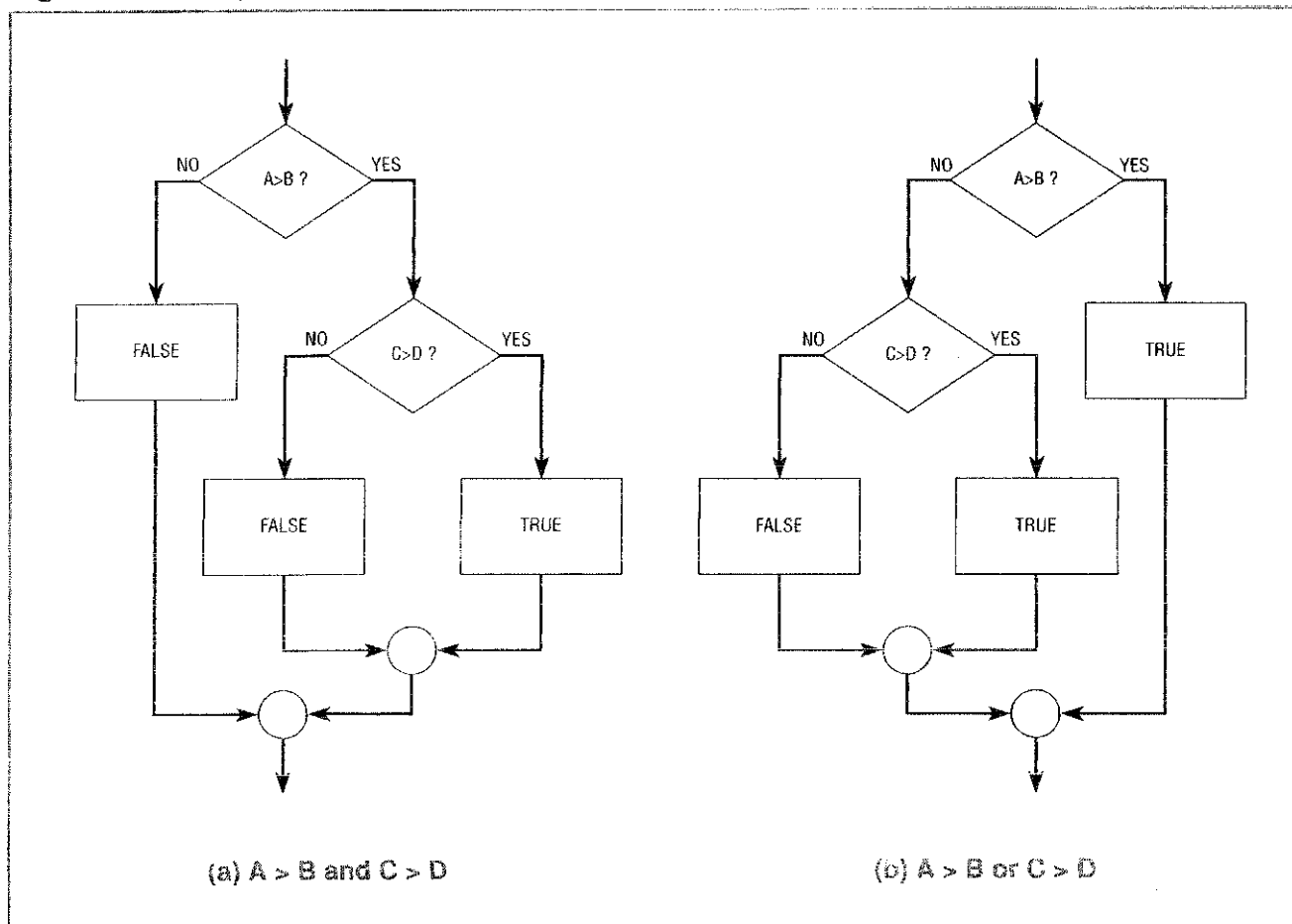

Thus, for the preceding statement to be true, either

$X > Y$

or

$X = Z$ and $X < W$

Parentheses can (and should) be used to clarify the programmer's intent and the preceding statement is made clearer if it is rewritten as

IF $X > Y$ OR ($X = Z$ AND $X < W$) . . .

Parentheses can also *alter* the outcome in that the expression in parentheses is evaluated first. The following statement is *logically different* from the original statement:

IF ($X > Y$ OR $X = Z$) AND $X < W$. . .

In this example the condition in parentheses ($X > Y$ OR $X = Z$) is evaluated first, after which X is compared to W . Both conditions (the one in parentheses and $X < W$) must be true for the compound condition to be considered true.

Implied Conditions

The simple conditions within a compound condition often have the same subject as in the statement:

```
IF SALARY > 30000 AND SALARY < 40000
```

A more concise way of expressing this logic is with an *implied condition*, which requires only the first occurrence of the subject; that is,

```
IF SALARY > 30000 AND < 40000
```

is equivalent to the earlier entry. If both the subject and relational operator are the same, then only the first occurrence of both needs to be written; that is,

```
IF DEPARTMENT = 10 OR 20
```

is equivalent to

```
IF DEPARTMENT = 10 OR DEPARTMENT = 20
```

Implied conditions are often confusing and the following are provided as additional examples:

| | | |
|--------------------|------------------|----------------------------|
| IF X = Y OR Z | is equivalent to | IF X = Y OR X = Z |
| IF A = B OR C OR D | is equivalent to | IF A = B OR A = C OR A = D |
| IF A = B AND C | is equivalent to | IF A = B AND A = C |

Nested IFs

The general format of the IF statement is:

```
IF condition-1 THEN { statement-1... } { ELSE statement-2... [END-IF] }
                   { NEXT SENTENCE } { ELSE NEXT SENTENCE }
                   { END-IF }
```

A *nested IF* results when either statement-1 or statement-2 is itself another IF statement, that is, when there are two or more IFs in one sentence. For example, consider

```
IF A > B
  IF C > D
    MOVE S TO W
    MOVE X TO Y
  ELSE
    ADD 1 TO Z
  END-IF
END-IF.
```

The ELSE clause is associated with the closest previous IF that is not already paired with another ELSE. Hence, in this example, Z is incremented by 1 if A is greater than B, but C is not greater than D. If, however, A is not greater than B, control passes to the statement immediately following the period with no further action being taken. (The END-IF scope terminator is optional in both instances, but is included as per our coding standard of Chapter 7 of always specifying the scope terminator.)

Figure 8.6 shows a flowchart and corresponding COBOL code to determine the largest of three quantities A, B, and C. (They are assumed to be unequal numbers.) Observe how the true and false branches of each decision block meet in a single exit point and how this corresponds to the COBOL code. Notice also how the indentation

Figure 8.6 Nested IF Statements

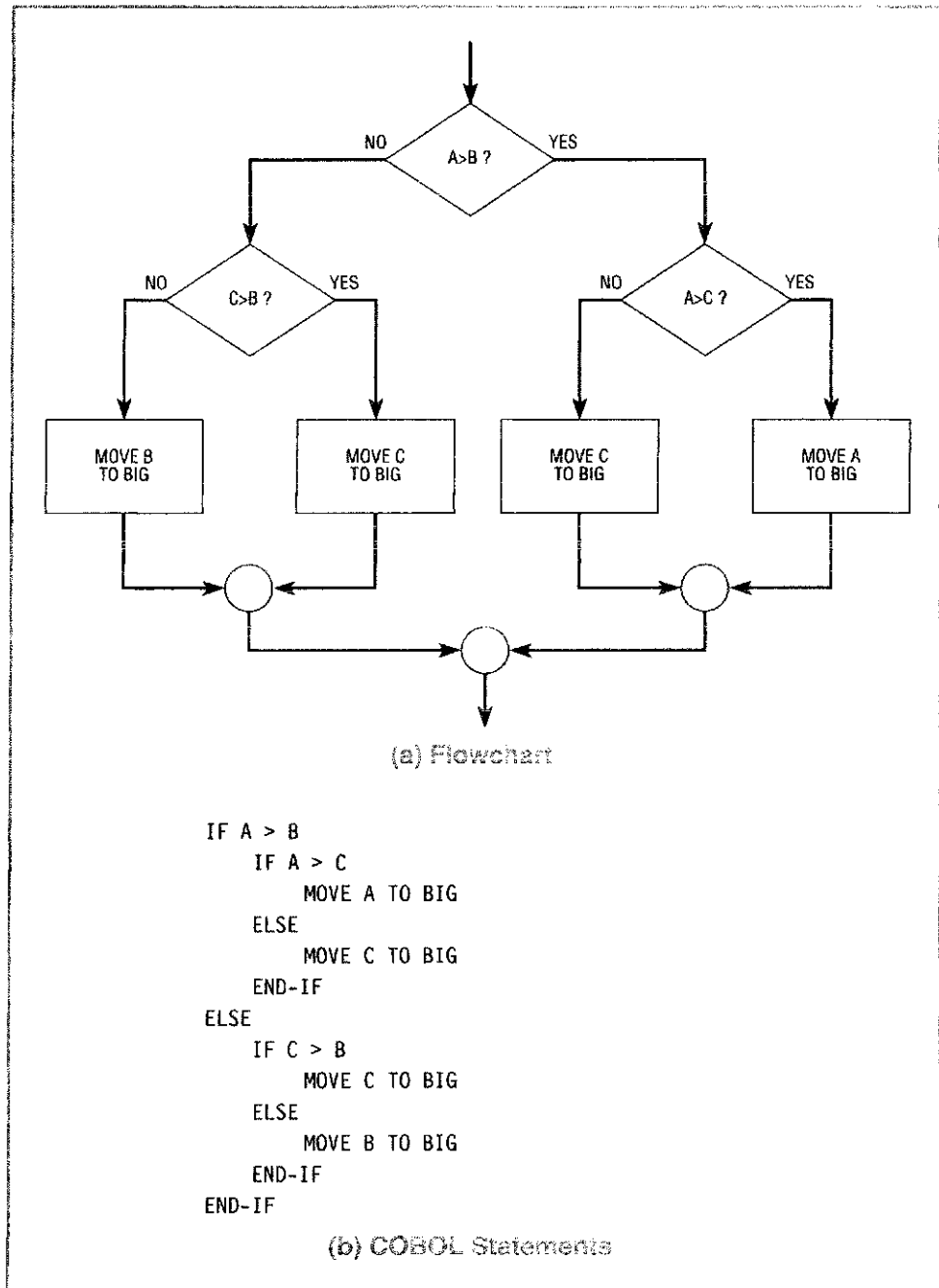

in the COBOL statement facilitates interpretation of the statement. (The compiler pays no attention to the indentation, which is done strictly for programmer convenience.)

We advocate careful attention to indentation and recommend the following guidelines:

1. Each nested IF should be indented four columns from the previous IF.
2. ELSE should appear on a line by itself directly under its associated IF.
3. Detail lines should be indented four columns under both IF and ELSE.

- The END-IF scope terminator should always be used and appear on a line by itself directly under its associated IF.

These guidelines were used in Figure 8.6.

NEXT SENTENCE

The NEXT SENTENCE clause directs control to the statement following the period in an IF statement. It was an essential clause in COBOL-74 to implement certain types of nested IF statements, but is no longer needed due to the the END-IF scope terminator in COBOL-85. The use of NEXT SENTENCE is compared to the scope terminator in Figure 8.7.

Figure 8.7 Nested IF Statements/II

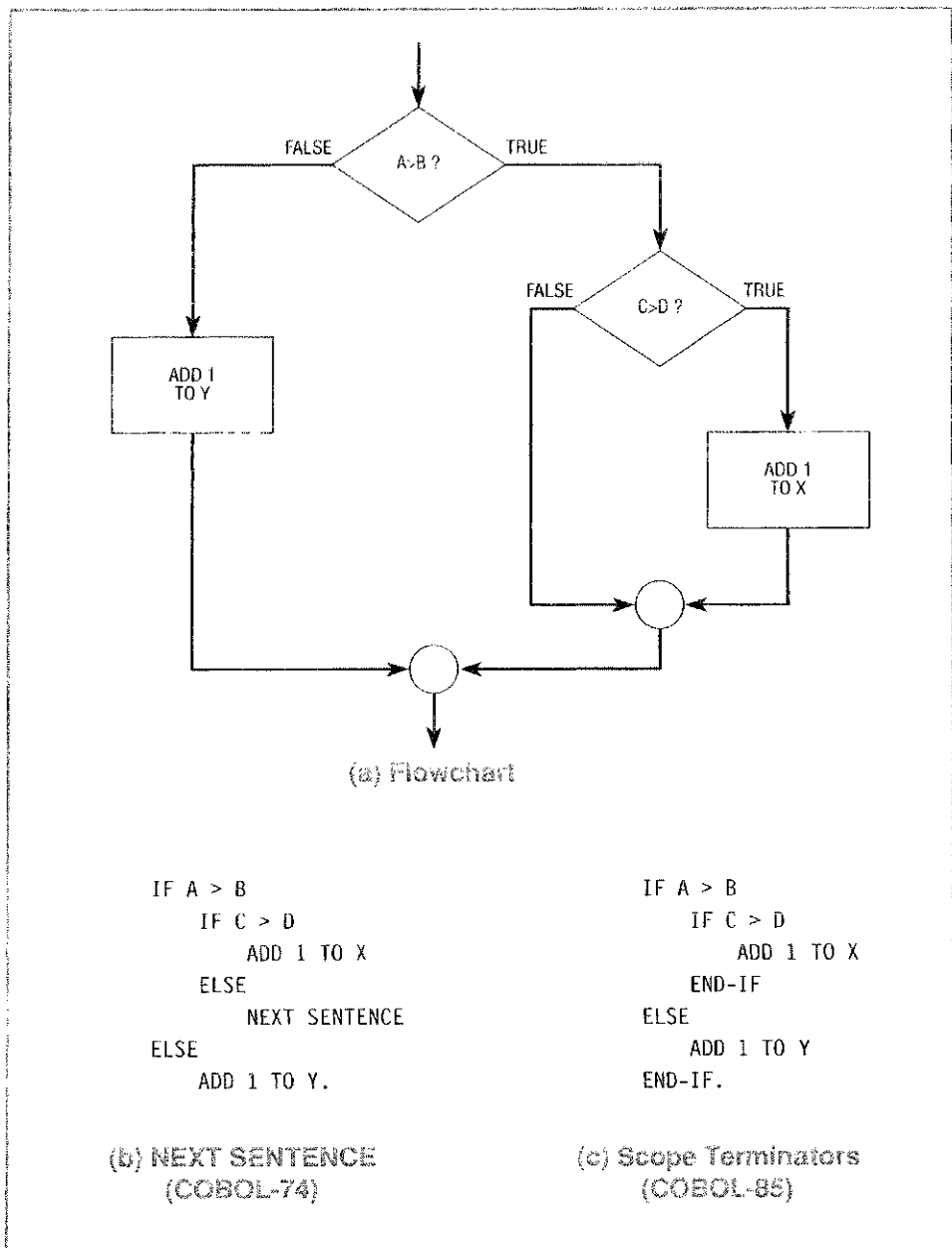

The intended logic is to add 1 to X if A is greater than B and C is greater than D; if, however, A is greater than B, but C is not greater than D, no further action is to be taken. The NEXT SENTENCE clause in Figure 8.7b terminates the IF statement if the second condition ($C > D$) is not met. The identical effect is achieved by the END-IF scope terminator in Figure 8.7c.

ACCEPT statement

The ACCEPT statement is used to obtain the day of the week, date, and/or time of program execution. Consider:

```
ACCEPT identifier-1 FROM {
    DAY-OF-WEEK
    DATE
    DAY
    TIME
}
```

Identifier-1 is a programmer-defined work area that holds the information being accepted such as the DAY-OF-WEEK, DATE, DAY, or TIME. The DAY-OF-WEEK is returned as a single digit, from one to seven inclusive, corresponding to Monday through Sunday. (See Figure 9.8 in the next chapter.) DATE and DAY both reflect the current date, but in different formats. Specification of DATE places a six-digit numeric field into identifier-1 in the form *yymmdd*; the first two digits contain year; the next two, month; and the last two, the day of the month; for example, 930316, denotes March 16, 1993.

Specification of DAY, rather than DATE, returns a five-digit numeric field to the work area. The first two digits represent year and the last three the day of the year, numbered from 1 to 365 (366 in a leap year). March 16, 1993, would be represented as 93075, but March 16, 1992, as 92076, since 1992 is a leap year. (A date written in this format is known as a *Julian date*.)

TIME returns an eight-digit numeric field, *hhmmsshh*, in a 24-hour system. It contains the number of elapsed hours, minutes, seconds, and hundredths of seconds after midnight, in that order, from left to right. 10:15 A.M. would return as 10150000, 10:15 P.M. as 22150000.

Calculations Involving Dates

Once the date of execution is obtained, it can be used for various types of date validation such as checking that an employee's hire date is within the current year. It can also be used in various calculations, for example, to compute an employee's age, or to determine which accounts haven't been paid in 30 days. Figure 8.8 illustrates how an employee's age may be calculated from the date of execution and the employee's birth date.

You should verify that the COMPUTE statement in Figure 8.8 works as intended, and further that it works for all combinations of data. This is best accomplished by "playing computer" and plugging in numbers. Accordingly, consider two examples:

Example 8.1

Date of birth: 3/73

Date of execution: 6/93

Expected age: 20 1/4

Calculation: $93 - 73 + (6 - 3)/12 = 20 + 3/12 = 20.25$

Figure 8.8 The ACCEPT Statement

```

WORKING-STORAGE SECTION.

01 EMPLOYEE-RECORD.
.
.
.
05 EMP-DATE-OF-BIRTH.
    10 EMP-BIRTH-MONTH      PIC 99.
    10 EMP-BIRTH-YEAR       PIC 99.

01 EMPLOYEE-AGE              PIC 99V99.

01 DATE-WORK-AREA.
    05 TODAYS-YEAR          PIC 99.
    05 TODAYS-MONTH        PIC 99.
    05 TODAYS-DAY          PIC 99.
.
.

PROCEDURE DIVISION.

.
.
.
ACCEPT DATE-WORK-AREA FROM DATE.

.
.

COMPUTE EMPLOYEE-AGE = TODAYS-YEAR - EMP-BIRTH-YEAR
+ (TODAYS-MONTH - EMP-BIRTH-MONTH) / 12.
    
```

Example 8.2

Date of birth: 9/73
 Date of execution: 6/93
 Expected age: 19 3/4
 Calculation: $93 - 73 + (6 - 9)/12 = 20 + -3/12 = 19.75$

The calculations are correct, and they work for both combinations of data; it doesn't matter whether the month of execution is before or after the birth month. (For simplicity only month and year were used in the calculation of age.)

The Stand-Alone Edit Program

The validation of incoming data is often done in a stand-alone edit program as opposed to the reporting program that processes the data. The sequence is shown in Figure 8.9. A transaction file is input to the edit program, which checks each incoming record for validity. Invalid transactions are rejected with an appropriate error message(s), whereas valid transactions are written to an output file. The valid transaction file (i.e., the output file from the edit program) is then input to a reporting program.

Figure 8.9 The Stand-Alone Edit Program

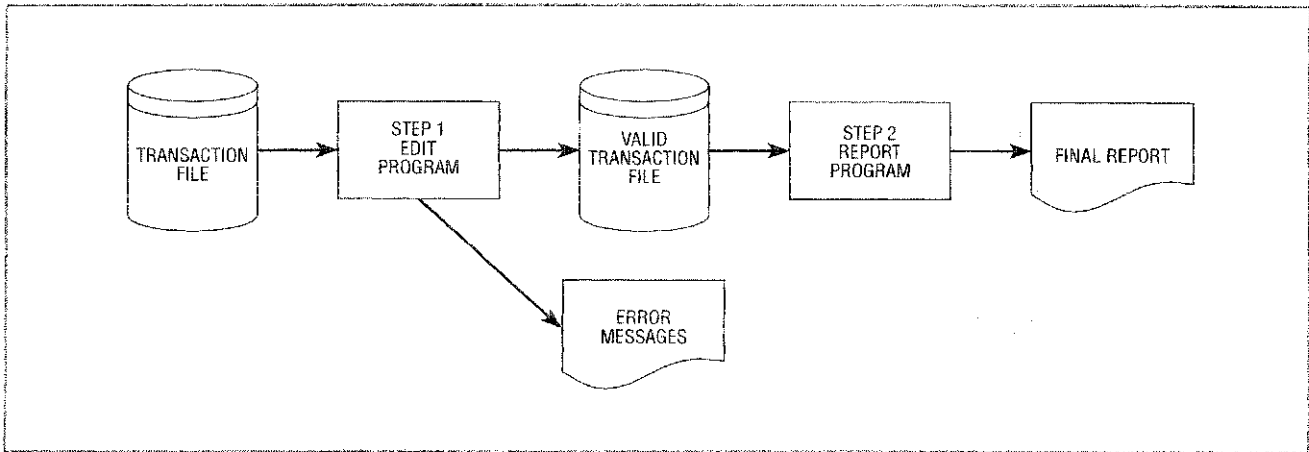

The flowchart in Figure 8.9 serves as an effective blueprint for the *combination* of programs that are developed in this chapter and the next. The programs are related to one another in that the output of the edit program in this chapter will be input to the reporting program in Chapter 9. Specifications for the edit program are given below, whereas the requirements of the reporting program are presented in Chapter 9.

PROGRAMMING SPECIFICATIONS

Program Name: Car Rental Validation

Narrative: The specifications describe a stand-alone edit program for car rental transactions, each of which is subject to multiple validity checks. Invalid transactions are to be rejected with appropriate error message(s), whereas valid transactions are to be written in their entirety to an output file; the latter will be input to a reporting program developed in the next chapter.

Input File(s): RENTAL-RECORD-FILE

Input Record Layout:

```

01 RENTAL-RECORD-IN.
   05 REN-CONTRACT-NO      PIC 9(6).
   05 REN-NAME.
       10 REN-LAST-NAME    PIC X(15).
       10 REN-FIRST-NAME   PIC X(10).
       10 REN-INITIAL      PIC X.
   05 REN-RETURNED-DATE.
       10 REN-RETURNED-YEAR PIC 9(2).
       10 REN-RETURNED-MONTH PIC 9(2).
       10 REN-RETURNED-DAY  PIC 9(2).
   05 REN-CAR-TYPE         PIC X.
   05 REN-DAYS-RENTED      PIC 99.
   05 REN-MILEAGE.
       10 REN-MILES-IN      PIC 9(6).
       10 REN-MILES-OUT     PIC 9(6).
       10 REN-MILEAGE-RATE  PIC 99.
   05 REN-INSURANCE        PIC X.
  
```



Test Data: See Figure 8.10a (Four errors are identified.)

Report Layout: See Figure 8.10b

- Processing Requirements:**
1. Read a file of car rental records.
 2. Validate each input record for all of the following:
 - a. A numeric contract number; print the message *Nonnumeric Contract Number* for any nonnumeric contract.
 - b. The presence of both a first and last name; print the message *Missing last name* or *Missing first name* for a record missing either field. A middle initial is not required, but if present, the initial must be alphabetic; print the message *Nonalphabetic initial* as appropriate.
 - c. A valid car type where the code is one of five values; E, C, M, F, or L. Print the message *Car type must be: E, C, M, F, or L* for any record with an invalid car type.
 - d. Valid dates:
 - (1) A valid month; that is, a month must be from 1 to 12; print the message *Month must be between 1 and 12* for any invalid month.
 - (2) A valid day; that is, the day cannot exceed the maximum days in the corresponding month; print the message *Invalid Day* for any date that is inconsistent with the month—for example, April 31.
 - (3) A valid date; that is, a date that is less than or equal to the system date; print the message *Date has not yet occurred* for any date in the future.
 - e. A valid number of days rented where the number of days is numeric, is greater than zero, and less than or equal to 35. Print appropriate error messages for any condition that is not met; e.g., *Days rented must be numeric*, *Days rented must be > zero*, or *Refer to Long-Term Leasing*.

Figure 8.10 Transaction Files and Error Reports

| | | | |
|-------------------|--------|---------------------------|---------------------------|
| 123459BAKER | ROBERT | G930431F0500670000664025X | 1 Invalid date |
| 987651BROWN | PETER | G930112M1000353000352000N | |
| 999999JONES | TOM | J931309E3500450000460005Y | 2 Invalid contract number |
| 987655BROWNING | PAULA | J93102400700240000252500Y | |
| 999777ELSINOR | TERRY | R921126F0500168000159005N | |
| 655443FITZPATRICK | DAN | T930532L0701000000987000C | |
| 987654SMITH | PAUL | G921213M0300510000500502Y | |
| PINNOCK | | 1931012F1000342400331000N | 3 Nonnumeric car type |
| X93477BUTLER | JOHN | H930631C0000423000419075N | |
| 354679KERBEL | NORMAN | X930331E1000340000324300Y | |
| 264805CLARK | JANE | S921101F0700561500551200N | 4 Invalid car type |
| 846440 | SAM | 921231X1500182300169802N | |
| 233432BEINHORN | CATHY | B921122M0200123400113402Y | |
| 556564HUMMER | MARGO | R920815C0800234500123403Y | |
| 677844MCDONALD | JAMES | 930123C0500423500402300N | |
| 886222VOGEL | JANICE | D930518F1200634500612302Y | |
| 008632TOWER | DARREN | R930429L0900700200689300N | |

(a) Transaction File

Figure 8.10 (continued)

ERROR REPORT AS OF 07/03/93

| CONTRACT # | LAST NAME | ERROR MESSAGE & FIELD | CONTENTS |
|------------|-------------|------------------------------------|------------------------|
| 123459 | BAKER | INVALID DAY | 04/31 |
| 123459 | BAKER | INSURANCE CODE MUST BE Y OR N | X |
| 987651 | BROWN | MILES DRIVEN UNREASONABLY LOW | DAYS: 10 MILES: 000010 |
| 999999 | JONES | MONTH MUST BE BETWEEN 1 AND 12 | 13 |
| 999999 | JONES | MILEAGE IN LESS THAN MILEAGE OUT | IN: 004500 OUT: 004600 |
| 999999 | JONES | NON-NUMERIC MILEAGE RATE | 05 |
| 987655 | BROWNING | CAR TYPE MUST BE: E, C, M, F, OR L | 0 |
| 987655 | BROWNING | DATE HAS NOT YET OCCURRED | 10/24/93 |
| 987655 | BROWNING | NON-NUMERIC MILES IN | 002400 |
| 655443 | FITZPATRICK | INVALID DAY | 05/32 |
| 655443 | FITZPATRICK | INSURANCE CODE MUST BE Y OR N | C |
| | PINNOCK | NON-NUMERIC CONTRACT NUMBER | |
| | PINNOCK | MISSING FIRST NAME | |
| | PINNOCK | NON ALPHABETIC INITIAL | 1 |
| | PINNOCK | DATE HAS NOT YET OCCURRED | 10/12/93 |
| | PINNOCK | NON-NUMERIC MILES OUT | 003310 |
| X93477 | BUTLER | NON-NUMERIC CONTRACT NUMBER | X93477 |
| X93477 | BUTLER | INVALID DAY | 06/31 |
| X93477 | BUTLER | DAYS RENTED MUST BE > ZERO | 00 |
| X93477 | BUTLER | MILEAGE RATE OUT OF RANGE | 75 |
| 846440 | | NON-NUMERIC CONTRACT NUMBER | 846440 |
| 846440 | | MISSING LAST NAME | |
| 846440 | | CAR TYPE MUST BE: E, C, M, F, OR L | X |
| 846440 | | DAYS RENTED MUST BE NUMERIC | 15 |
| 846440 | | MILES DRIVEN UNREASONABLY LOW | DAYS: 15 MILES: 000125 |

(b) Error Report

| | | | |
|--------|----------|--------|---------------------------|
| 999777 | EL SINOR | TERRY | R921126F0500168000159005N |
| 987654 | SMITH | PAUL | G921213M0300510000500502Y |
| 354679 | KERBEL | NORMAN | X930331E1000340000324300Y |
| 264805 | CLARK | JANE | S921101F0700561500551200N |
| 233432 | BEINHORN | CATHY | B921122M0200123400113402Y |
| 556564 | HUMMER | MARGO | R920815C0800234500123403Y |
| 677844 | MCDONALD | JAMES | 930123C0500423500402300N |
| 886222 | VOGEL | JANICE | D930518F1200634500612302Y |
| 008632 | TOWER | DARREN | R930429L0900700200689300N |

(c) Valid Transaction File

- f. Valid values for the mileage in and out:
 - (1) The values for both miles in and miles out must be numeric; print the message *Nonnumeric miles in or nonnumeric miles out*, respectively.
 - (2) The mileage reported when the car is turned in cannot be less than the mileage when the car was taken out; print the message *Mileage in less than mileage out* as appropriate.
 - (3) The number of miles driven must pass a reasonableness test of 10 miles or more per day; Display the message, *Miles driven unreasonably low* as appropriate.
 - g. The mileage rate must be numeric and less than or equal to 50 cents per day; print the message *Mileage rate out of range* for an invalid rate.
 - h. The value of the insurance field must be either Y or N; print the message *Insurance code must be Y or N* for an invalid value.
3. Any record that fails any validity test is to be rejected and omitted from the valid record file. It is quite possible that a given record may contain more than one error, and all errors are to be printed except where noted.
 4. Valid records are to be written to a file.

Error Messages

The utility of a data validation program is determined by the number of potential errors that it can detect as well as the clarity of the resulting error messages. A truly useful program must check for a variety of errors and explain to the user the nature of any errors that are detected. These concepts are illustrated in Figure 8.10. The incoming transaction file is shown in Figure 8.10a, the associated error messages (in conjunction with the programming specifications) in Figure 8.10b, and the valid transaction file in Figure 8.10c.

The numbered callouts in Figure 8.10 highlight some of the erroneous transactions and the corresponding error message; for example, the date of April 31 is highlighted in the first transaction of Figure 8.10a as is the corresponding error message in Figure 8.10b. Three other erroneous transactions are similarly highlighted.

The individual error messages are fully descriptive and list both the contract number and last name of the associated transaction. In addition, the contents of the erroneous field(s) are shown to the right of the error message, making it even easier to correct the invalid transaction. Note, too, that the program can also detect *multiple* errors for the same transaction; for example, three errors are identified in the single transaction for Jones.

Pseudocode

The pseudocode in Figure 8.11 begins with statements to obtain the date of execution, write the heading for the error report, and read the first record. The main loop of the program is executed next and does the following:

1. The incoming transaction is assumed to be valid by moving 'YES' to a valid-record-switch.
2. The incoming transaction is subject to all of the individual validity checks, any one of which can set the valid-record-switch to 'NO'. Note, too, that since each transaction record is subject to *every* validity check, multiple errors can be detected for a single transaction.
3. The valid-record-switch is checked to see if the record is still valid, and if so, the transaction is written to the valid record file. If, on the other hand, the record is no longer valid, a blank line is written to the error report, which double spaces between the error messages for one transaction and the next.

Figure 8.11 Pseudocode

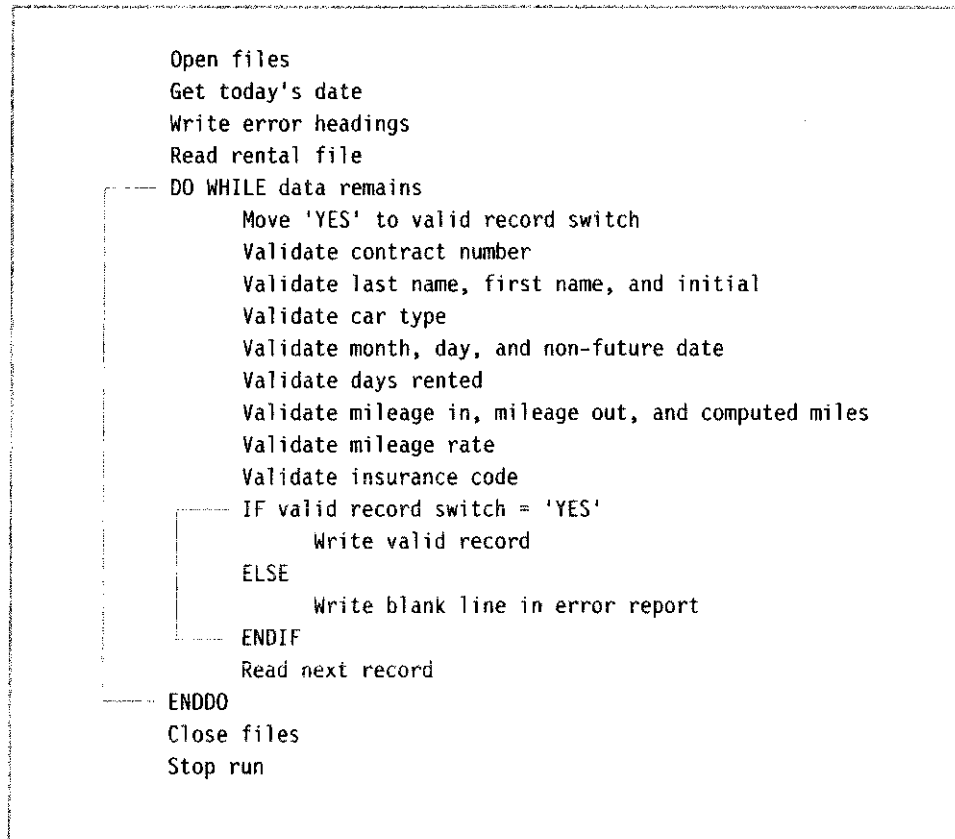

4. The next record is read and the loop continues until the transaction file is exhausted.

The pseudocode is concise in that the specific nature of each error check is not shown; nevertheless it (the pseudocode) is an effective aid in writing the program.

Hierarchy Chart

The hierarchy chart for the data validation program is shown in Figure 8.12. The module CREATE-VALID-FILE sits at the top of the hierarchy chart and invokes four subordinates, one of which is PROCESS-RENTAL-RECORDS, which implements the main loop of the program.

PROCESS-RENTAL-RECORDS in turn has three subordinates, VALIDATE-RENTAL-RECORD to perform the individual error checks, WRITE-VALID-RECORD to write valid transactions to the output file, and READ-RENTAL-RECORD to read the next transaction. Each of the required validity checks is implemented in its own module, and all of these modules call a common routine to write an error message.

The Completed Program

The completed program is shown in Figure 8.13. It is considerably longer than the tuition billing program of the previous chapters, but nonetheless straightforward

Figure 8.12 Hierarchy Chart for Validation Program

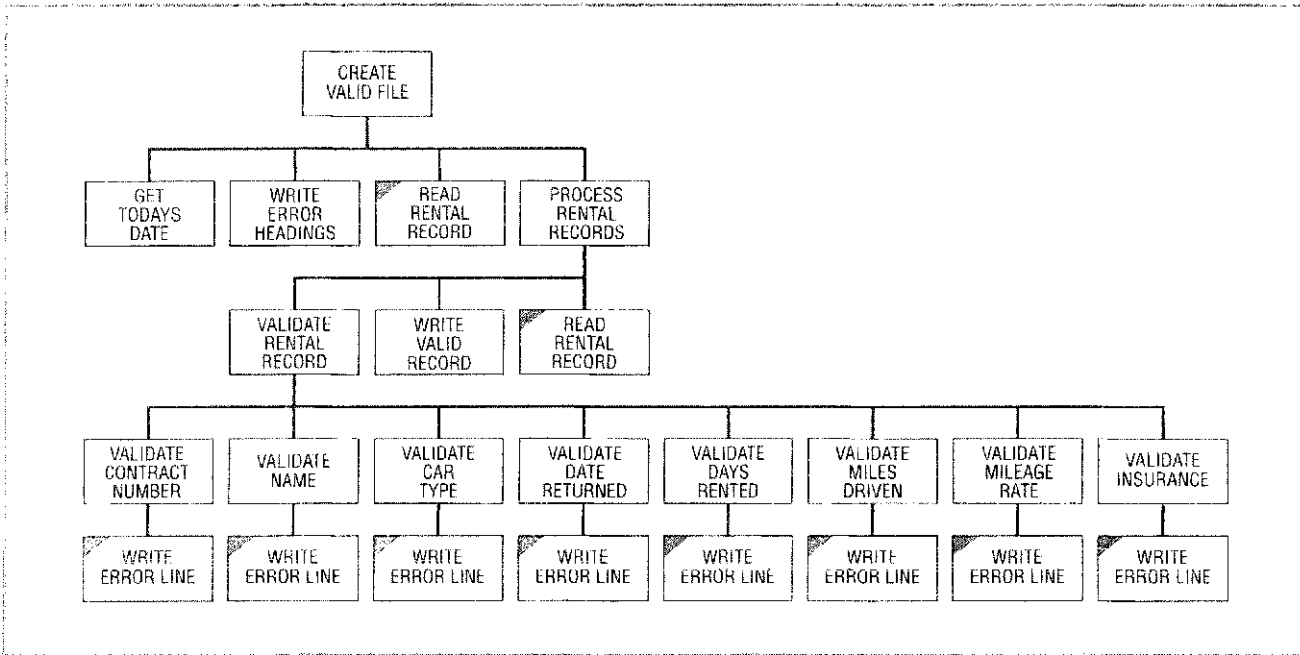

Figure 8.13 Data Validation Program

```

1  IDENTIFICATION DIVISION.
2  PROGRAM-ID.      VALCARS8.
3  AUTHOR.         CVV.
4
5  ENVIRONMENT DIVISION.
6  INPUT-OUTPUT SECTION.
7  FILE-CONTROL.
8      SELECT RENTAL-FILE  ASSIGN TO 'A:\CHAPTR08\VALCARS.DAT'
9          ORGANIZATION IS LINE SEQUENTIAL.
10     SELECT VALID-RENTAL-FILE  ASSIGN TO 'A:\CHAPTR08\VALRENT.DAT'
11         ORGANIZATION IS LINE SEQUENTIAL.
12     SELECT ERROR-FILE
13         ASSIGN TO PRINTER.
14
15  DATA DIVISION.
16  FILE SECTION.
17  FD  RENTAL-FILE
18     RECORD CONTAINS 56 CHARACTERS.
19  01  RENTAL-RECORD.
20     05  REN-CONTRACT-NO          PIC 9(6).
21     05  REN-NAME.
22         10  REN-LAST-NAME        PIC X(15).
23         10  REN-FIRST-NAME       PIC X(10).
    
```

Figure 8.13 (continued)

```

24         10 REN-INITIAL          PIC X.
25     05  REN-RETURNED-DATE.
26         10 REN-RETURNED-YEAR    PIC 9(2).
27         10 REN-RETURNED-MONTH  PIC 9(2).
28         88 VALID-MONTHS        VALUES 1 THRU 12.
29         88 FEBRUARY            VALUE 2.
30         88 30-DAY-MONTH        VALUES 4 6 9 11.
31         88 31-DAY-MONTH        VALUES 1 3 5 7 8 10 12.
32         10 REN-RETURNED-DAY    PIC 9(2).
33     05  REN-CAR-TYPE           PIC X.
34         88 VALID-CAR-TYPES     VALUES 'E' 'C' 'M' 'F' 'L'.
35     05  REN-DAYS-RENTED        PIC 99.
36         88 ZERO-DAYS-RENTED    VALUE 0.
37         88 VALID-DAYS-RENTED   VALUES 1 THRU 35.
38     05  REN-MILEAGE.
39         10 REN-MILES-IN        PIC 9(6).
40         10 REN-MILES-OUT       PIC 9(6).
41         10 REN-MILEAGE-RATE    PIC 99.
42         88 VALID-MILEAGE-RATES  VALUES 00 THRU 50.
43     05  REN-INSURANCE          PIC X.
44         88 VALID-INSURANCE     VALUES 'Y' 'N'.
45
46     FD  VALID-RENTAL-FILE
47         RECORD CONTAINS 56 CHARACTERS.
48     01  VALID-RENTAL-RECORD    PIC X(56).
49
50     FD  ERROR-FILE
51         RECORD CONTAINS 132 CHARACTERS.
52     01  ERROR-RECORD          PIC X(132).
53
54     WORKING-STORAGE SECTION.
55     01  PROGRAM-SWITCHES.
56         05  NO-DATA-REMAINS-SWITCH  PIC XXX VALUE SPACES.
57         88  NO-DATA-REMAINS        VALUE 'NO'.
58         05  VALID-RECORD-SWITCH    PIC X(3).
59         88  VALID-RECORD           VALUE 'YES'.
60
61     01  VALIDATION-CONSTANTS-AND-CALCS.
62         05  MILES-PER-DAY-FACTOR    PIC 99 VALUE 10.
63         05  EXPECTED-MILES         PIC 9(6).
64         05  ACTUAL-MILES           PIC 9(6).
65
66     01  ERROR-REASONS.
67         05  NON-NUMERIC-CONTRACT-MSG PIC X(40)
68             VALUE 'NON-NUMERIC CONTRACT NUMBER'.
69         05  LAST-NAME-MSG          PIC X(40)
70             VALUE 'MISSING LAST NAME'.
71         05  FIRST-NAME-MSG        PIC X(40)
72             VALUE 'MISSING FIRST NAME'.
73         05  INITIAL-MSG           PIC X(40)

```

88-valid miles driven with values

Table of error messages

Figure 8.13 (continued)

| | | | |
|-----|----|---|-------------------------------|
| 74 | | VALUE 'NON ALPHABETIC INITIAL'. | |
| 75 | 05 | CAR-TYPE-MSG | PIC X(40) |
| 76 | | VALUE 'CAR TYPE MUST BE: E, C, M, F, OR L'. | |
| 77 | 05 | MONTH-MSG | PIC X(40) |
| 78 | | VALUE 'MONTH MUST BE BETWEEN 1 AND 12'. | |
| 79 | 05 | DAY-MSG | PIC X(40) |
| 80 | | VALUE 'INVALID DAY'. | |
| 81 | 05 | FUTURE-DATE-MSG | PIC X(40) |
| 82 | | VALUE 'DATE HAS NOT YET OCCURRED'. | |
| 83 | 05 | NON-NUM-DAYS-RENTED-MSG | PIC X(40) |
| 84 | | VALUE 'DAYS RENTED MUST BE NUMERIC'. | |
| 85 | 05 | ZERO-DAYS-MSG | PIC X(40) |
| 86 | | VALUE 'DAYS RENTED MUST BE > ZERO'. | |
| 87 | 05 | LEASING-MSG | PIC X(40) |
| 88 | | VALUE 'REFER TO LONG-TERM LEASING'. | |
| 89 | 05 | NON-NUM-MILES-IN-MSG | PIC X(40) |
| 90 | | VALUE 'NON-NUMERIC MILES IN'. | |
| 91 | 05 | NON-NUM-MILES-OUT-MSG | PIC X(40) |
| 92 | | VALUE 'NON-NUMERIC MILES OUT'. | |
| 93 | 05 | LESS-THAN-MILES-MSG | PIC X(40) |
| 94 | | VALUE 'MILEAGE IN LESS THAN MILEAGE OUT'. | |
| 95 | 05 | INVALID-MILES-MSG | PIC X(40) |
| 96 | | VALUE 'MILES DRIVEN UNREASONABLY LOW'. | |
| 97 | 05 | NON-NUM-RATE-MSG | PIC X(40) |
| 98 | | VALUE 'NON-NUMERIC MILEAGE RATE'. | |
| 99 | 05 | MILEAGE-RATE-MSG | PIC X(40) |
| 100 | | VALUE 'MILEAGE RATE OUT OF RANGE'. | |
| 101 | 05 | INSURANCE-MSG | PIC X(40) |
| 102 | | VALUE 'INSURANCE CODE MUST BE Y OR N'. | |
| 103 | | | |
| 104 | 01 | TODAYS-DATE. | |
| 105 | 05 | TODAYS-YEAR | PIC 99. |
| 106 | 05 | TODAYS-MONTH | PIC 99. |
| 107 | 05 | TODAYS-DAY | PIC 99. |
| 108 | | | |
| 109 | 01 | HEADING-ERROR-LINE-ONE. | |
| 110 | 05 | FILLER | PIC X(26) VALUE SPACES. |
| 111 | 05 | FILLER | PIC X(19) |
| 112 | | VALUE 'ERROR REPORT AS OF '. | |
| 113 | 05 | HDG-DATE. | |
| 114 | 10 | HDG-MONTH | PIC 99/. |
| 115 | 10 | HDG-DAY | PIC 99/. |
| 116 | 10 | HDG-YEAR | PIC 99. |
| 117 | 05 | FILLER | PIC X(79) VALUE SPACES. |
| 118 | | | |
| 119 | 01 | HEADING-ERROR-LINE-TWO. | |
| 120 | 05 | FILLER | PIC X(10) VALUE 'CONTRACT #'. |
| 121 | 05 | FILLER | PIC XX VALUE SPACES. |
| 122 | 05 | FILLER | PIC X(9) VALUE 'LAST NAME'. |
| 123 | 05 | FILLER | PIC X(8) VALUE SPACES. |

Table of error messages

Figure 8.13 (continued)

```

124      05 FILLER                                PIC X(21)
125          VALUE 'ERROR MESSAGE & FIELD'.
126      05 FILLER                                PIC X(21) VALUE SPACES.
127      05 FILLER                                PIC X(8)  VALUE 'CONTENTS'.
128      05 FILLER                                PIC X(46) VALUE SPACES.
129
130      01 ERROR-LINE.
131          05 FILLER                                PIC XX  VALUE SPACES.
132          05 ERR-CONTRACT-NO                      PIC 9(6).
133          05 FILLER                                PIC X(4)  VALUE SPACES.
134          05 ERR-LAST-NAME                        PIC X(15).
135          05 FILLER                                PIC XX  VALUE SPACES.
136          05 ERR-MESSAGE                          PIC X(40).
137          05 FILLER                                PIC XX  VALUE SPACES.
138          05 ERR-CONTENTS                         PIC X(23).
139          05 FILLER                                PIC X(38) VALUE SPACES.
140
141      01 ERROR-DETAILS.
142          05 ERR-MILES-IN-OUT.
143              10 FILLER                            PIC X(4) VALUE 'IN: '.
144              10 ERR-MILES-IN                      PIC 9(6).
145              10 FILLER                            PIC X(6) VALUE ' OUT: '.
146              10 ERR-MILES-OUT                    PIC 9(6).
147          05 ERR-RETURNED-DATE.
148              10 ERR-RETURNED-MONTH-DAY.
149                  15 ERR-RETURNED-MONTH          PIC 99.
150                  15 ERR-RETURNED-DAY            PIC /99.
151              10 ERR-RETURNED-YEAR                PIC /99.
152          05 ERR-EXPECTED-MILES.
153              10 FILLER                            PIC X(6) VALUE 'DAYS: '.
154              10 ERR-DAYS-RENTED                  PIC 99.
155              10 FILLER                            PIC X(9) VALUE ' MILES: '.
156              10 ERR-MILES                        PIC 9(6).
157
158      PROCEDURE DIVISION.
159      000-CREATE-VALID-RENTAL-FILE.
160          OPEN INPUT RENTAL-FILE
161              OUTPUT VALID-RENTAL-FILE
162              ERROR-FILE.
163          PERFORM 100-GET-TODAYS-DATE.
164          PERFORM 200-WRITE-ERROR-HEADINGS.
165          PERFORM 300-READ-RENTAL-RECORD.
166          PERFORM 400-PROCESS-RENTAL-RECORDS
167              UNTIL NO-DATA-REMAINS.
168          CLOSE RENTAL-FILE
169              VALID-RENTAL-FILE
170              ERROR-FILE.
171          STOP RUN.
172
173      100-GET-TODAYS-DATE.

```

Separate output files for error messages and valid records

Figure 8.13 (continued)

```

174 ACCEPT TODAYS-DATE FROM DATE.
175 MOVE TODAYS-MONTH TO HDG-MONTH.
176 MOVE TODAYS-DAY TO HDG-DAY.
177 MOVE TODAYS-YEAR TO HDG-YEAR.
178
179 200-WRITE-ERROR-HEADINGS.
180 MOVE HEADING-ERROR-LINE-ONE TO ERROR-RECORD.
181 WRITE ERROR-RECORD
182 AFTER ADVANCING PAGE.
183 MOVE HEADING-ERROR-LINE-TWO TO ERROR-RECORD
184 WRITE ERROR-RECORD
185 AFTER ADVANCING 2 LINES.
186 MOVE SPACES TO ERROR-RECORD.
187 WRITE ERROR-RECORD.
188
189 300-READ-RENTAL-RECORD.
190 READ RENTAL-FILE
191 AT END MOVE 'NO' TO NO-DATA-REMAINS-SWITCH
192 END-READ.
193
194 400-PROCESS-RENTAL-RECORDS.
195 MOVE 'YES' TO VALID-RECORD-SWITCH.
196 PERFORM 500-VALIDATE-RENTAL-RECORD.
197 PERFORM 600-WRITE-VALID-RECORD.
198 PERFORM 300-READ-RENTAL-RECORD.
199
200 500-VALIDATE-RENTAL-RECORD.
201 PERFORM 510-VALIDATE-CONTRACT-NO.
202 PERFORM 520-VALIDATE-NAME.
203 PERFORM 530-VALIDATE-CAR-TYPE.
204 PERFORM 540-VALIDATE-DATE-RETURNED.
205 PERFORM 550-VALIDATE-DAYS-RENTED.
206 PERFORM 560-VALIDATE-MILES-DRIVEN
207 PERFORM 570-VALIDATE-MILEAGE-RATE.
208 PERFORM 580-VALIDATE-INSURANCE.
209
210 510-VALIDATE-CONTRACT-NO.
211 IF REN-CONTRACT-NO NOT NUMERIC
212 MOVE NON-NUMERIC-CONTRACT-MSG TO ERR-MESSAGE
213 MOVE REN-CONTRACT-NO TO ERR-CONTENTS
214 PERFORM 599-WRITE-ERROR-LINE
215 END-IF.
216
217 520-VALIDATE-NAME.
218 IF REN-LAST-NAME = SPACES
219 MOVE LAST-NAME-MSG TO ERR-MESSAGE
220 MOVE SPACES TO ERR-CONTENTS
221 PERFORM 599-WRITE-ERROR-LINE
222 END-IF.
223 IF REN-FIRST-NAME = SPACES

```

Obtain system date

If rental records are assumed to be valid

Class test for numeric data

Figure 8.13 (continued)

```

224         MOVE FIRST-NAME-MSG TO ERR-MESSAGE
225         MOVE SPACES TO ERR-CONTENTS
226         PERFORM 599-WRITE-ERROR-LINE
227     END-IF.
228     IF REN-INITIAL NOT ALPHABETIC
229         MOVE INITIAL-MSG TO ERR-MESSAGE
230         MOVE REN-INITIAL TO ERR-CONTENTS
231         PERFORM 599-WRITE-ERROR-LINE
232     END-IF.
233
234 530-VALIDATE-CAR-TYPE.
235     IF NOT VALID-CAR-TYPES
236         MOVE CAR-TYPE-MSG TO ERR-MESSAGE
237         MOVE REN-CAR-TYPE TO ERR-CONTENTS
238         PERFORM 599-WRITE-ERROR-LINE
239     END-IF.
240
241 540-VALIDATE-DATE-RETURNED.
242     IF VALID-MONTHS
243         IF 30-DAY-MONTH AND REN-RETURNED-DAY <= 30 OR
244            31-DAY-MONTH AND REN-RETURNED-DAY <= 31 OR
245            FEBRUARY AND REN-RETURNED-DAY <= 29
246             IF REN-RETURNED-DATE > TODAYS-DATE
247                 MOVE FUTURE-DATE-MSG TO ERR-MESSAGE
248                 MOVE REN-RETURNED-MONTH TO ERR-RETURNED-MONTH
249                 MOVE REN-RETURNED-DAY TO ERR-RETURNED-DAY
250                 MOVE REN-RETURNED-YEAR TO ERR-RETURNED-YEAR
251                 MOVE ERR-RETURNED-DATE TO ERR-CONTENTS
252                 PERFORM 599-WRITE-ERROR-LINE
253             END-IF
254         ELSE
255             MOVE DAY-MSG TO ERR-MESSAGE
256             MOVE REN-RETURNED-MONTH TO ERR-RETURNED-MONTH
257             MOVE REN-RETURNED-DAY TO ERR-RETURNED-DAY
258             MOVE ERR-RETURNED-MONTH-DAY TO ERR-CONTENTS
259             PERFORM 599-WRITE-ERROR-LINE
260         END-IF
261     ELSE
262         MOVE MONTH-MSG TO ERR-MESSAGE
263         MOVE REN-RETURNED-MONTH TO ERR-CONTENTS
264         PERFORM 599-WRITE-ERROR-LINE
265     END-IF.
266
267 550-VALIDATE-DAYS-RENTED.
268     IF REN-DAYS-RENTED NOT NUMERIC
269         MOVE NON-NUM-DAYS-RENTED-MSG TO ERR-MESSAGE
270         MOVE REN-DAYS-RENTED TO ERR-CONTENTS
271         PERFORM 599-WRITE-ERROR-LINE
272     ELSE
273         IF ZERO-DAYS-RENTED

```

Class test for alphabetic data

Needed IF to implement class validation

Figure 8.13 (continued)

```

274             MOVE ZERO-DAYS-MSG TO ERR-MESSAGE
275             MOVE REN-DAYS-RENTED TO ERR-CONTENTS
276             PERFORM 599-WRITE-ERROR-LINE
277         ELSE
278             IF NOT VALID-DAYS-RENTED
279                 MOVE LEASING-MSG TO ERR-MESSAGE
280                 MOVE REN-DAYS-RENTED TO ERR-CONTENTS
281                 PERFORM 599-WRITE-ERROR-LINE
282             END-IF
283         END-IF
284     END-IF.
285
286 560-VALIDATE-MILES-DRIVEN.
287     IF REN-MILES-IN NOT NUMERIC
288         MOVE NON-NUM-MILES-IN-MSG TO ERR-MESSAGE
289         MOVE REN-MILES-IN TO ERR-CONTENTS
290         PERFORM 599-WRITE-ERROR-LINE
291     ELSE
292         IF REN-MILES-OUT NOT NUMERIC
293             MOVE NON-NUM-MILES-OUT-MSG TO ERR-MESSAGE
294             MOVE REN-MILES-OUT TO ERR-CONTENTS
295             PERFORM 599-WRITE-ERROR-LINE
296         ELSE
297             IF REN-MILES-IN < REN-MILES-OUT
298                 MOVE LESS-THAN-MILES-MSG TO ERR-MESSAGE
299                 MOVE REN-MILES-IN TO ERR-MILES-IN
300                 MOVE REN-MILES-OUT TO ERR-MILES-OUT
301                 MOVE ERR-MILES-IN-OUT TO ERR-CONTENTS
302                 PERFORM 599-WRITE-ERROR-LINE
303             ELSE
304                 COMPUTE EXPECTED-MILES =
305                     MILES-PER-DAY-FACTOR * REN-DAYS-RENTED
306                     SIZE ERROR DISPLAY 'SIZE ERROR EXPECT MILES'
307                 END-COMPUTE
308                 COMPUTE ACTUAL-MILES =
309                     REN-MILES-IN - REN-MILES-OUT
310                     SIZE ERROR DISPLAY 'SIZE ERROR ACTUAL MILES'
311                 END-COMPUTE
312                 IF ACTUAL-MILES < EXPECTED-MILES
313                     MOVE INVALID-MILES-MSG TO ERR-MESSAGE
314                     MOVE REN-DAYS-RENTED TO ERR-DAYS-RENTED
315                     MOVE ACTUAL-MILES TO ERR-MILES
316                     MOVE ERR-EXPECTED-MILES TO ERR-CONTENTS
317                     PERFORM 599-WRITE-ERROR-LINE
318                 END-IF
319             END-IF
320         END-IF
321     END-IF.
322
323 570-VALIDATE-MILEAGE-RATE.

```

SIZE ERROR / Issue in anticipation of unexpectedly large reads

Figure 8.13 (continued)

```

324     IF REN-MILEAGE-RATE NOT NUMERIC
325         MOVE NON-NUM-RATE-MSG TO ERR-MESSAGE
326         MOVE REN-MILEAGE-RATE TO ERR-CONTENTS
327         PERFORM 599-WRITE-ERROR-LINE
328     ELSE
329         IF NOT VALID-MILEAGE-RATES
330             MOVE MILEAGE-RATE-MSG TO ERR-MESSAGE
331             MOVE REN-MILEAGE-RATE TO ERR-CONTENTS
332             PERFORM 599-WRITE-ERROR-LINE
333         END-IF
334     END-IF.
335
336 580-VALIDATE-INSURANCE.
337     IF NOT VALID-INSURANCE
338         MOVE INSURANCE-MSG TO ERR-MESSAGE
339         MOVE REN-INSURANCE TO ERR-CONTENTS
340         PERFORM 599-WRITE-ERROR-LINE
341     END-IF.
342
343 599-WRITE-ERROR-LINE.
344     MOVE 'NO ' TO VALID-RECORD-SWITCH.
345     MOVE REN-CONTRACT-NO TO ERR-CONTRACT-NO.
346     MOVE REN-LAST-NAME TO ERR-LAST-NAME.
347     MOVE ERROR-LINE TO ERROR-RECORD.
348     WRITE ERROR-RECORD.
349
350 600-WRITE-VALID-RECORD.
351     IF VALID-RECORD
352         MOVE RENTAL-RECORD TO VALID-RENTAL-RECORD
353         WRITE VALID-RENTAL-RECORD
354     ELSE
355         MOVE SPACES TO ERROR-RECORD
356         WRITE ERROR-RECORD
357     END-IF.

```

Common error routine sets switch to indicate invalid record and write error message

Valid transactions are written to a valid file, the ELSE clause writes a blank line before each group of invalid transactions

and easy to follow. The logic in the program parallels that of the pseudocode just developed, whereas the paragraphs in the Procedure Division correspond one to one with the modules in the hierarchy chart. The program complies completely with the processing requirements and also illustrates the various COBOL features presented earlier. Consider:

1. The use of condition names within the FD for RENTAL-RECORD (e.g., lines 28–31, 34, 36–37, etc.) to define valid values for the various input fields.
2. A table of error messages in lines 66–102; grouping the error messages in this way makes it easy to determine precisely which error checks are implemented. It also facilitates uniform formatting of the various error messages.

3. The ACCEPT statement in line 174 to obtain the system date; also the definition of TODAYS-DATE in WORKING-STORAGE to hold the date after it is read.
4. The MOVE statement to initialize VALID-RECORD-SWITCH to 'YES' for each incoming transaction record (line 195). A second MOVE statement in the WRITE-ERROR-LINE paragraph (line 344) to reset the switch to 'NO' if the current transaction fails any one of the validity tests.
5. Various class tests for numeric and alphabetic data as in lines 211 and 228.
6. A nested IF statement in lines 242-265 to implement the various types of date validation. A second nested IF statement in lines 287 through 321 performs the various checks on the incoming, outgoing, and computed mileage.
7. SIZE ERROR clauses within the COMPUTE statements, lines 306 and 310, in anticipation of unexpectedly large fields.
8. The IF statement in lines 351-357 that determines whether the transaction is written to the valid file. Note, too, the ELSE clause within this IF statement, which writes a blank line for every invalid record, which in turn puts a blank line before each group of invalid transactions in the error report.

EVOLUTIONS OF COBOL

COBOL-85 introduced two additional relational conditions into the IF statement, GREATER THAN OR EQUAL TO and LESS THAN OR EQUAL TO; these conditions were not allowed in COBOL-74, which used NOT LESS THAN as the equivalent of GREATER THAN OR EQUAL TO and NOT GREATER THAN for LESS THAN OR EQUAL TO.

COBOL-85 enables the testing of upper- and/or lowercase letters through expansion of the alphabetic class test. In COBOL-85 the ALPHABETIC test is true for uppercase letters, lowercase letters, and the space character; the ALPHABETIC-UPPER test is true for uppercase letters and the space character; and the ALPHABETIC-LOWER test is true for lowercase letters and the space character. There were no UPPER/LOWER tests in COBOL-74 and the ALPHABETIC test was true only for uppercase letters and space characters.

The most significant change, however, is the introduction of the END-IF scope terminator, which did not exist in COBOL-74. We have already seen how the scope terminator eliminates the column-73 problem in conjunction with a "missing period" (page 182) and how it eliminates the need for the NEXT SENTENCE clause (Figure 8.7). The scope terminator also facilitates the nesting of conditional statements as shown in Figure 8.14.

Consider, for example, the flowchart of Figure 8.14a, and the contrasting implementations in COBOL-85 and COBOL-74 in Figures 8.14b and 8.14c, respectively. The END-IF terminator transforms a conditional statement to an imperative (complete) statement, making it possible to express the required logic as a single IF statement in COBOL-85. By contrast, the COBOL-74 implementation requires an additional PERFORM statement and is more difficult to follow.

Figure 8.14 Limitations of COBOL-74

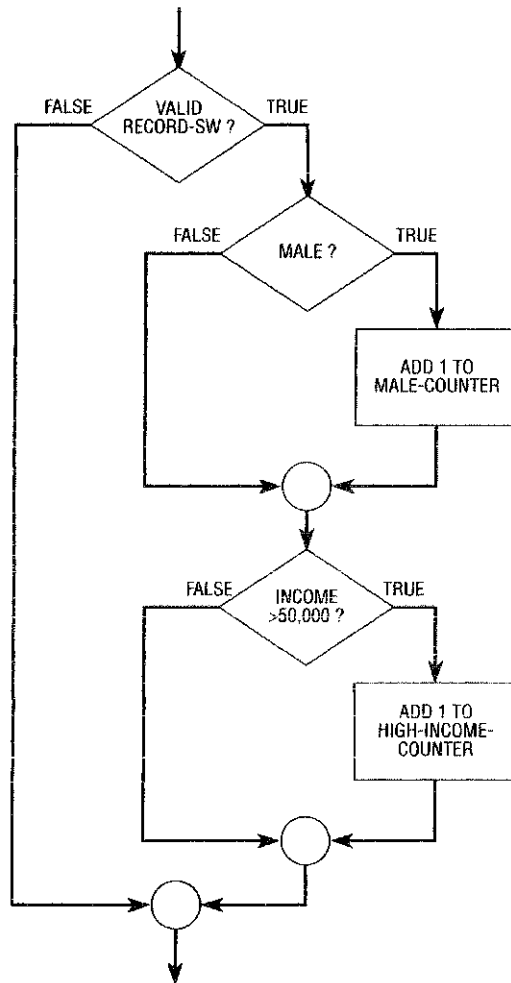

(a) Flowchart

```

IF VALID-RECORD-SW = 'Y'
  IF SEX = 'M'
    ADD 1 TO MALE-COUNTER
  END-IF
  IF INCOME > 50000
    ADD 1 TO HIGH-INCOME-CTR
  END-IF
END-IF.
  
```

(b) COBOL-85

```

IF VALID-RECORD-SW = 'Y'
  PERFORM DO-MORE-TESTS.
DO-MORE-TESTS.
  IF SEX = 'M'
    ADD 1 TO MALE-COUNTER.
  IF INCOME > 50000
    ADD 1 TO HIGH-INCOME-CTR.
  
```

(c) COBOL-74

U M M A R Y

Points to Remember

- Data validation is a critical portion of any system, as the output produced by any program is only as good as its input.
- Data validation is often done in a stand-alone edit program as opposed to the reporting program that processes the data; that is, the valid transaction file produced as output by the edit program becomes the input file to the reporting program.
- The ACCEPT statement is used to obtain the date of execution for use in implementing various types of date checks.
- There are four types of conditions in the IF statement: relation, class, sign, and condition name (88-level entries).
- Any two simple conditions may be combined to form a compound condition using the logical operators AND and OR. An IF statement may also use implied conditions, in which the subject and/or operation is understood.
- A nested IF statement contains two or more IF statements within a sentence. The scope of the condition in the IF statement is terminated by the ELSE clause, the END-IF scope terminator, and/or a period. The scope terminator is optional but strongly recommended in all instances.
- Indentation within an IF statement is not required by the compiler but recommended to facilitate the programmer's interpretation.
- The NEXT SENTENCE clause directs control to the statement immediately following the period and is required (in COBOL-74) to implement certain types of nested conditional statements. The END-IF scope terminator, introduced in COBOL-85, eliminates the need for the NEXT SENTENCE clause in all instances.

Key Words and Concepts

| | |
|---------------------|----------------------|
| 88-level entry | Implied condition |
| Alphabetic test | Limit check |
| Class test | Nested IF |
| Completeness check | Numeric test |
| Compound test | Range check |
| Condition name | Reasonableness check |
| Consistency check | Scope terminator |
| Data validation | Sequence check |
| Date check | Sign test |
| Edit program | Subscript check |
| Existing code check | |

COBOL Elements

| | |
|-------------|---------------|
| ACCEPT | END-IF |
| AND | IF |
| DATE | NEXT SENTENCE |
| DAY | NOT |
| DAY-OF-WEEK | OR |
| ELSE | TIME |

FILL-IN

1. Incoming data should be _____ prior to being used in computations.
2. The valid transaction file produced as output by an edit program is _____ to a reporting program.
3. A _____ test ensures that numeric fields do in fact contain numeric data.
4. A _____ check tests that a value does not exceed a designated upper or lower bound.
5. A _____ check verifies that all required fields are present.
6. In evaluating a compound condition, AND comes (before/after) OR.
7. A condition name is also known as an _____-level entry.
8. The _____ clause directs control to the statement immediately following the period.
9. The _____ scope terminator eliminates the need for the NEXT SENTENCE clause.
10. The statement, ACCEPT DATE-WORK-AREA FROM DATE requires specification of a user-defined work area in the form, _____.

TRUE/FALSE

1. Output from a reporting program is typically input to an edit program.
2. The numeric class test can be applied to alphanumeric data.
3. The alphabetic class test can be applied to alphanumeric data.
4. The numeric class test can be applied to alphabetic data.
5. The alphabetic class test can be applied to numeric data.
6. A nested IF statement contains two or more IF statements within a single sentence.
7. The NEXT SENTENCE clause may be associated with either an IF or an ELSE.
8. The END-IF scope terminator eliminates the need for a NEXT SENTENCE clause.
9. The ACCEPT statement is used to obtain the date of execution.
10. DATE is a COBOL reserved word, containing the date of execution in the form yymmdd.
11. DAY and DATE produce the same results.
12. TIME returns a six-digit numeric field, indicating the time of program execution.

PROBLEMS

1. Recode the following statements to include scope terminators and proper indentation with the ELSE clause indented under the relevant IF.
 - a. IF A > B, IF C > D, MOVE E TO F,
ELSE MOVE G TO H.
 - b. IF A > B, IF C > D, MOVE E TO F,
ELSE MOVE G TO H, ELSE MOVE X TO Y.
 - c. IF A > B, IF C > D, MOVE E TO F,
ADD 1 TO E, ELSE MOVE G TO H,
ADD 1 TO G.
 - d. IF A > B, MOVE X TO Y, MOVE Z TO W,
ELSE IF C > D MOVE 1 TO N,
ELSE MOVE 2 TO Y, ADD 3 TO Z.

2. Given the nested IF statement:

```

IF SEX = 'M'
    PERFORM PROCESS-MALE-RECORD
ELSE
    IF SEX = 'F'
        PERFORM PROCESS-FEMALE-RECORD
    ELSE
        PERFORM WRITE-ERROR-MESSAGE
    END-IF
END-IF.
  
```

and the logically equivalent code:

```

IF SEX = 'M'
    PERFORM PROCESS-MALE-RECORD
END-IF.
IF SEX = 'F'
    PERFORM PROCESS-FEMALE-RECORD
END-IF.
IF SEX NOT = 'M' AND SEX NOT = 'F'
    PERFORM WRITE-ERROR-MESSAGE
END-IF.
  
```

- a. Discuss the relative efficiency of the two alternatives.
 - b. What would be the effect of changing AND to OR in the third IF of the second set of statements?
 - c. What would be the effect of removing the word ELSE wherever it occurs in the first set of IF statements?
3. Are the two IF statements logically equivalent?

Statement 1:

```

IF A > B
    IF C > D
        ADD 1 TO X
    ELSE
        ADD 1 TO Y
    END-IF
END-IF.
  
```

Statement 2:

```

IF A > B AND C > D
  ADD 1 TO X
ELSE
  ADD 1 TO Y
END-IF.

```

Try the following sets of values to aid in answering the question:

- a. A = 5, B = 1, C = 10, D = 15.
 - b. A = 1, B = 5, C = 10, D = 15.
4. Company XYZ has four corporate functions: manufacturing, marketing, financial, and administrative. Each function in turn has several departments, as shown:

| FUNCTION | DEPARTMENTS |
|----------------|-----------------------|
| MANUFACTURING | 10, 12, 16-30, 41, 56 |
| MARKETING | 6-9, 15, 31-33 |
| FINANCIAL | 60-62, 75 |
| ADMINISTRATIVE | 1-4, 78 |

Establish condition-name entries so that, given a value of EMPLOYEE-DEPARTMENT, you can determine the function. Include an 88-level entry, VALID-CODES, to verify that the incoming department is indeed a valid department (any department number not shown is invalid).

5. Given the following COBOL definitions:

```

05 LOCATION-CODE          PIC 99.
   88 NEW-YORK             VALUE 10.
   88 BOSTON               VALUE 20.
   88 CHICAGO              VALUE 30.
   88 DETROIT              VALUE 40.
   88 NORTH-EAST           VALUES 10 20.

```

Are the following entries valid as the condition portion of an IF statement?

- a. IF LOCATION-CODE = '10'
- b. IF LOCATION-CODE = 40
- c. IF NEW-YORK
- d. IF LOCATION-CODE = 10 OR 20 OR 30
- e. IF NEW-YORK OR BOSTON OR CHICAGO
- f. IF DETROIT = 40

Would the following be valid examples of MOVE statements?

- g. MOVE 20 TO BOSTON.
- h. MOVE 20 TO LOCATION-CODE.
- i. MOVE '20' TO LOCATION-CODE.

6. Given the following pairs of IF statements, indicate whether the statements in each pair have the same effect:
- a. IF A > B OR C > D AND E = F
IF A > B OR (C > D AND E = F)
 - b. IF A > B OR C > D AND E = F
IF (A > B OR C > D) AND E = F
 - c. IF A > B OR A > C OR A > D
IF A > B OR C OR D
 - d. IF A > B
IF A NOT < B OR A NOT = B

7. Consider the following code, intended to calculate an individual's age from a stored birth date and the date of execution.

```

01 EMPLOYEE-RECORD.
  05 EMP-BIRTH-DATE.
    10 BIRTH-MONTH PIC 99.
    10 BIRTH-YEAR PIC 99.
01 DATE-WORK-AREA.
  05 TODAYS-MONTH PIC 99.
  05 TODAYS-DAY PIC 99.
  05 TODAYS-YEAR PIC 99.

PROCEDURE DIVISION.
  ACCEPT DATE-WORK-AREA FROM DATE.
  .
  .
  .
  COMPUTE EMPLOYEE-AGE = TODAYS-YEAR - BIRTH-YEAR
    + TODAYS-MONTH - BIRTH-MONTH.
  
```

There are two distinct reasons why the code will not work as intended. Find and correct the errors.

8. Implement the logic in Figure 8.15 with and without scope terminators, corresponding to the implementations in COBOL-74 and COBOL-85. Do you see any distinct advantages to the latter compiler?

Figure 8.15 Flowcharts for Problem 8

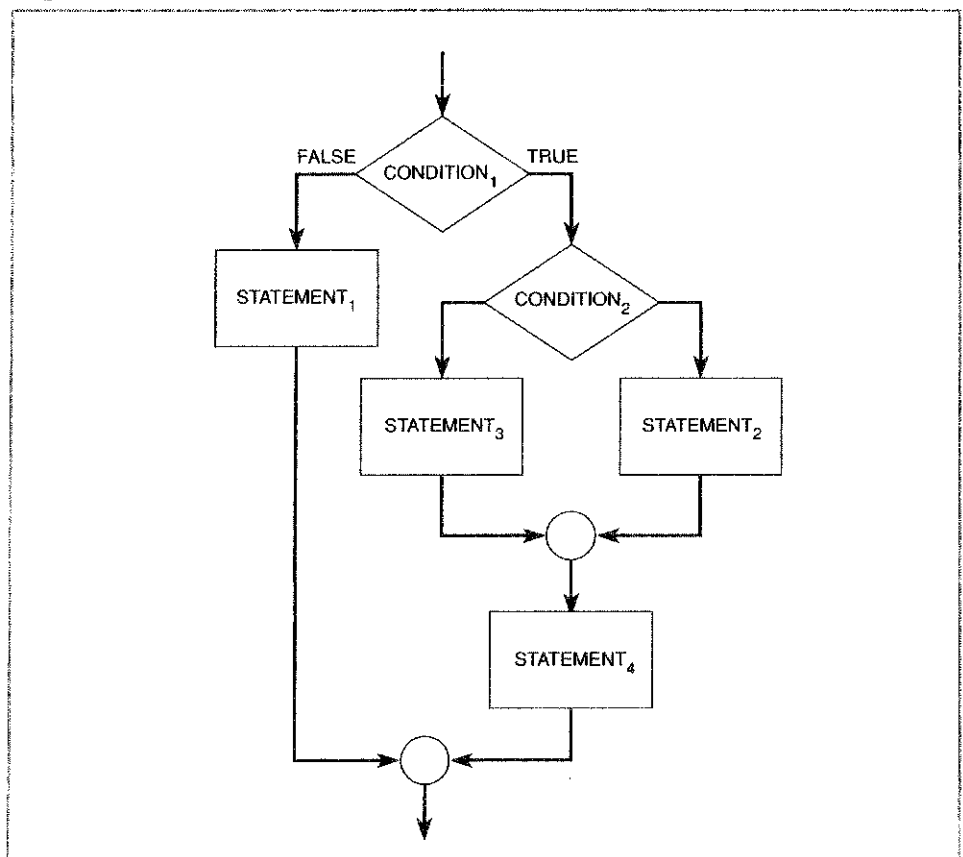

More About the Procedure Division

CHAPTER 10

Overview

PERFORM

TEST BEFORE/TEST AFTER

In-line Perform

Performing Sections

PERFORM THRU

Programming Tip: Perform Paragraphs, Not Sections

READ

False-Condition Branch

READ INTO

WRITE FROM

INITIALIZE

String Processing

INSPECT

STRING

UNSTRING

Reference Modification

ACCEPT

Duplicate Data Names

Qualification

MOVE CORRESPONDING

The Car Billing Program

Programming Specifications

Program Design

The Completed Program

Limitations of COBOL-74

Summary

Fill-in

True/False

Problems

OBJECTIVES

After reading this chapter you will be able to:

- ☛ Differentiate between the DO WHILE and DO UNTIL structures; describe how each is implemented in conjunction with a PERFORM statement.
- ☛ Define an in-line perform and a false-condition branch; explain how the combination of these features eliminates the need for a priming read statement.
- ☛ Differentiate between a paragraph and a section.
- ☛ Code the READ INTO and WRITE FROM statements in the Procedure Division.
- ☛ Use the INITIALIZE statement.
- ☛ Perform basic string processing operations through use of the INSPECT, STRING, and UNSTRING statements.
- ☛ Define a duplicate data name and use qualification to eliminate ambiguity; describe the use of the MOVE CORRESPONDING statement.

OVERVIEW

This chapter completes the two-program sequence begun in Chapter 8 by developing the reporting program for the valid transaction file. The program is also intended to illustrate a series of advanced Procedure Division statements that are presented in the chapter. Many of the statements are new to COBOL-85 and were not available in COBOL-74.

We begin with the PERFORM statement and include material on the TEST BEFORE and TEST AFTER clauses which correspond to the DO WHILE and DO UNTIL constructs of structured programming. The in-line perform is presented, as is the THROUGH clause, to perform multiple paragraphs; the use of sections in lieu of paragraphs is also covered. The READ INTO and WRITE FROM clauses are introduced to combine the effects of a MOVE statement with the indicated I/O operation. The ACCEPT statement is expanded to include the DAY-OF-WEEK clause, and the INITIALIZE statement establishes values for multiple data names in a single statement. The INSPECT, STRING, and UNSTRING statements are introduced to implement string processing operations. Duplicate data names, qualification, and the MOVE CORRESPONDING statement are introduced as well.

The program at the end of the chapter is designed very differently from the programs presented thus far as it uses an in-line perform and a false-condition branch to eliminate the priming read used in earlier programs. The program also makes extensive use of scope terminators throughout the Procedure Division.

A simple form of the PERFORM statement has been used throughout the text to implement the iteration construct of structured programming:

```
PERFORM procedure-name UNTIL condition
```

The condition in the UNTIL clause is tested *before* the procedure is executed, and if the condition is not met, control is transferred to the designated procedure. When the procedure has completed execution, the condition is retested, and if it (the condition) is still not met, the procedure is executed a second time. The process continues indefinitely until the condition is finally satisfied.

In actuality the PERFORM statement is considerably more complex with many additional options. Consider:

```
PERFORM [ procedure-name-1 [ { THROUGH } { THRU } procedure-name-2 ] ]
        [ WITH TEST { BEFORE } { AFTER } UNTIL condition-1 ]
        [ imperative-statement-1 END-PERFORM ]
```

TEST BEFORE/TEST AFTER

The optional TEST BEFORE/TEST AFTER clause is explained in conjunction with Figure 9.1. Figure 9.1a depicts the DO WHILE structure that has been used

Figure 9.1 The Iteration Structure

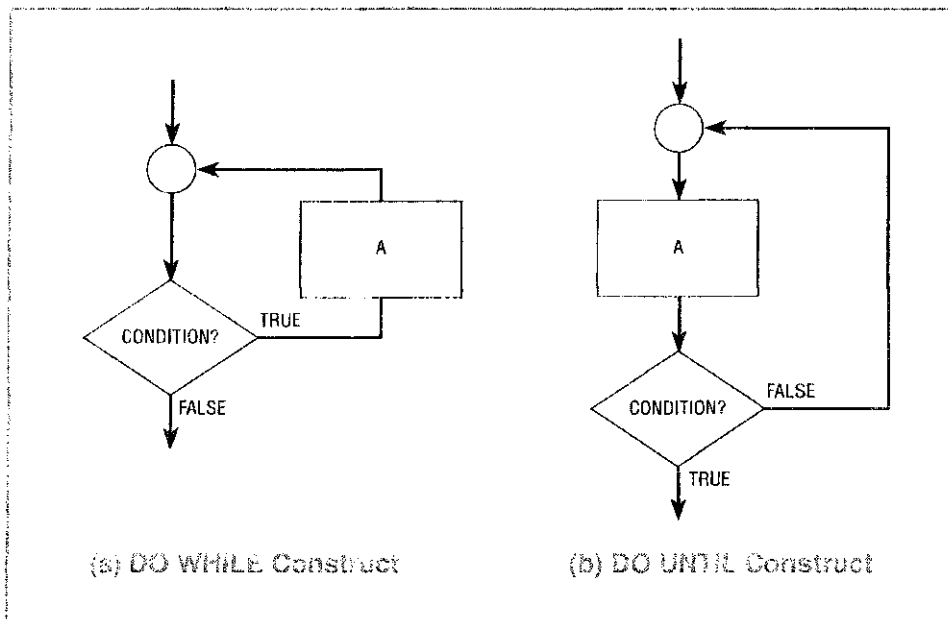

throughout the book, while Figure 9.1b illustrates the slightly different DO UNTIL structure. The difference between the two (aside from the semantics of switching the true and false branches) pertains to the sequence in which the condition and statement are executed.

The DO WHILE structure of Figure 9.1a tests the condition *before* executing Block A; the DO UNTIL structure in Figure 9.1b tests the condition *after* executing Block A. The DO WHILE structure does not execute Block A if the condition is initially false, whereas DO UNTIL guarantees that Block A is executed at least once.

The PERFORM statement includes the TEST BEFORE and TEST AFTER phrases, corresponding to a DO WHILE and DO UNTIL, respectively. Specification of TEST BEFORE tests the condition before performing the procedure, and corresponds to the DO WHILE. Specification of TEST AFTER performs the procedure and then tests the condition, and corresponds to a DO UNTIL. Omission of both TEST BEFORE and TEST AFTER (as has been done throughout the text) defaults to TEST BEFORE.

In-line PERFORM

The procedure-name is enclosed within brackets within the syntax of the PERFORM statement and thus is an *optional* entry. Omission of the procedure name produces an *in-line perform*, where the statements to be executed appear immediately below the PERFORM statement itself, as opposed to the out-of-line execution of a designated procedure elsewhere in the program. For example:

```
PERFORM
    Statement 1
    Statement 2
    .
    . Other statements to be executed
    .
END-PERFORM
```

An in-line perform functions just as a regular PERFORM, except that the statements to be executed are contained entirely within the statement—that is, between PERFORM and END-PERFORM. Omission of the procedure name (that is, specification of an in-line perform) requires the END-PERFORM delimiter; conversely, the END-PERFORM may *not* be specified in conjunction with performing a paragraph.

Performing Sections

The procedure name in the PERFORM statement can be either a *paragraph* or a *section*. A paragraph consists of one or more sentences, whereas a section is made up of one or more paragraphs. Paragraph headers are required to begin in the A-margin (columns 8–11), whereas sentences begin in the B-margin (columns 12–72). The compiler recognizes the end of one paragraph when it senses the beginning of the next paragraph—that is, when it finds the next entry in the A-margin. Section headers also begin in the A-margin and are distinguished from paragraph headers by the reserved word SECTION.

When a paragraph is performed, control is transferred to the first sentence in that paragraph and remains in that paragraph until the next paragraph is reached. In similar fashion, if the procedure name in a PERFORM statement refers to a section (rather than a paragraph), control is transferred to the first paragraph in that section and remains in that section until the next section is reached.

The authors suggest that you avoid sections altogether (see tip on page 233); the material is included here because sections appear in many older COBOL programs.

PROGRAMMING TIP

Perform Paragraphs, Not Sections

The motivation behind this guideline is best demonstrated by example. Given the following Procedure Division, what will be the final value of X?

PROCEDURE DIVISION.

MAINLINE SECTION.

MOVE ZERO TO X.
 PERFORM A.
 PERFORM B.
 PERFORM C.
 PERFORM D.
 STOP RUN.

A SECTION.

ADD 1 TO X.
 B.
 ADD 1 TO X.
 C.
 ADD 1 TO X.
 D.
 ADD 1 TO X.

The correct answer is 7, not 4. A common error made by many programmers is a misinterpretation of the statement **PERFORM A**. Since **A** is a *section* and not a *paragraph*, the statement **PERFORM A** invokes *every* paragraph in that section, namely, paragraphs B, C, and D, in addition to the unnamed paragraph immediately after the section header.

A **PERFORM** statement specifies a *procedure*, which is *either* a section *or* a paragraph, yet there is no way of telling the nature of the procedure from the **PERFORM** statement itself. Consequently, when a section is specified as a procedure, the unfortunate result is too often execution of unintended code. Can't happen? Did you correctly compute the value of X?

PERFORM THRU

The **THROUGH (THRU)** clause executes all statements *between* the specified procedure names. The procedures may be paragraphs or sections, but procedure-name-1 must be physically before procedure-name-2 within the COBOL program.

A common practice is to make procedure-name-2 a single-sentence paragraph consisting of the word **EXIT**. The **EXIT** statement causes no action to be taken; its function is to delineate the end of the **PERFORM**. Consider:

PERFORM PROCESS-RECORDS THRU PROCESS-RECORDS-EXIT.

PROCESS-RECORDS.

```
PROCESS-RECORDS-EXIT.
EXIT.
```

The only practical reason to use a PERFORM THRU statement with an EXIT paragraph is to enable *downward* branching to the EXIT statement depending on a condition within the paragraph. Although an argument could be made for this usage in limited instances, the need for such statements as GO TO PROCESS-RECORDS-EXIT should generally be avoided.

READ

The READ statement includes two important clauses—INTO and NOT AT END—that were not previously presented. Consider:

```
READ file-name RECORD [ INTO identifier ]
    [ AT END imperative-statement-1 ]
    [ NOT AT END imperative-statement-2 ]
END-READ
```

Figure 9.2 Structure of a COBOL Program

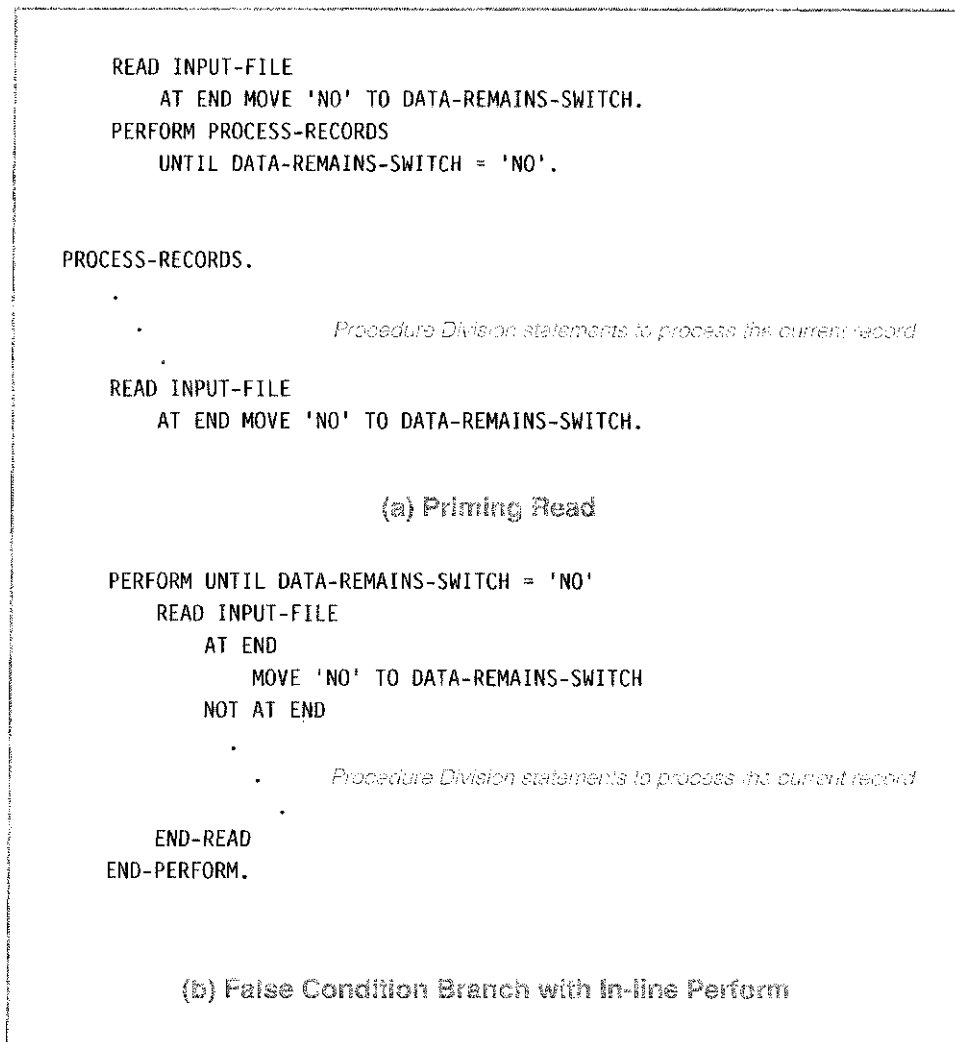

False-Condition Branch

The **NOT AT END** clause specifies an action for the false branch of a conditional statement; it is commonly used in conjunction with a scope terminator and an in-line perform to eliminate the priming read, as shown in Figure 9.2.

The choice between the priming read in Figure 9.2a and the equivalent logic in Figure 9.2b is one of personal preference. The earlier listings (e.g., the tuition billing program in Chapter 5) used the priming read because it was required in COBOL-74 as the earlier compiler had neither the false-condition branch nor the in-line perform. Many programmers are, in fact, so accustomed to the priming read that they continue to use it even though it is no longer necessary. We prefer the in-line perform and false-condition branch, but both techniques are equally acceptable.

READ INTO

The **READ INTO** phrase causes the input record to be stored in two places: in the I/O area of the designated file *and* in the identifier name specified in the INTO phrase in Working-Storage. The statement is illustrated in Figure 9.3, where the input data are available in both **EMPLOYEE-RECORD** and **WS-EMPLOYEE-RECORD**. **READ INTO** is equivalent to the combination of a **READ** statement and a **MOVE** statement as shown:

```

READ EMPLOYEE-FILE
  AT END
    MOVE 'NO' TO DATA-REMAINS-SWITCH
  NOT AT END

```

Figure 9.3 The READ INTO Statement

```

FD EMPLOYEE-FILE
  DATA RECORD IS EMPLOYEE-RECORD.
01 EMPLOYEE-RECORD          PIC X(60).
.
.
.
WORKING-STORAGE SECTION.
01 FILLER                   PIC X(14)   VALUE 'WS BEGINS HERE'.
01 WS-EMPLOYEE-RECORD.
   05 EMP-NAME              PIC X(25).
.
.
.
PROCEDURE DIVISION.
.
.
.
  READ EMPLOYEE-FILE INTO WS-EMPLOYEE-RECORD
    AT END
      MOVE 'NO' TO DATA-REMAINS-SWITCH
    NOT AT END
      PERFORM PROCESS-THIS-RECORD
  END-READ.

```

The brackets indicate that all parameters are optional; that is, INITIALIZE in and of itself is a valid statement that initializes all numeric items in a program to zeros, and all nonnumeric items to spaces. You can also restrict the INITIALIZE statement to one (data name or more,) initialize only specific categories of data names, and/or initialize to values other than zeros or spaces. Thus given the COBOL fragment:

```
01 GROUP-ITEM.
   05 NUMERIC-FIELD-1      PIC 9(4).
   05 NUMERIC-FIELD-2      PIC 9(4).
   05 ALPHANUMERIC-FIELD-1 PIC X(15).
   05 ALPHANUMERIC-FIELD-2 PIC X(20).
```

The statement INITIALIZE GROUP-ITEM is equivalent to:

```
MOVE ZEROS TO NUMERIC-FIELD-1.
MOVE ZEROS TO NUMERIC-FIELD-2.
MOVE SPACES TO ALPHANUMERIC-FIELD-1.
MOVE SPACES TO ALPHANUMERIC-FIELD-2.
```

In similar fashion, INITIALIZE GROUP-ITEM REPLACING NUMERIC BY ZERO is equivalent to:

```
MOVE ZEROS TO NUMERIC-FIELD-1.
MOVE ZEROS TO NUMERIC-FIELD-2.
```

And finally, INITIALIZE GROUP-ITEM REPLACING ALPHANUMERIC BY SPACES is equivalent to:

```
MOVE SPACES TO ALPHANUMERIC-FIELD-1.
MOVE SPACES TO ALPHANUMERIC-FIELD-2.
```

It is often necessary to operate on individual characters within a field, when the field is alphanumeric. Operations of this type are called *string processing* operations, and are accomplished with the INSPECT, STRING, and UNSTRING statements in COBOL. Each of these statements is discussed in detail.

INSPECT

The INSPECT statement is a convenient way to replace one character (or character string) with another. Consider:

INSPECT identifier-1 REPLACING

$$\left(\begin{array}{l} \text{CHARACTERS BY } \left\{ \begin{array}{l} \text{identifier-2} \\ \text{literal-1} \end{array} \right\} \left[\begin{array}{l} \text{BEFORE} \\ \text{AFTER} \end{array} \right] \text{INITIAL } \left\{ \begin{array}{l} \text{identifier-3} \\ \text{literal-2} \end{array} \right\} \dots \\ \left[\begin{array}{l} \text{ALL} \\ \text{LEADING} \\ \text{FIRST} \end{array} \right] \left\{ \begin{array}{l} \text{identifier-4} \\ \text{literal-3} \end{array} \right\} \text{ BY } \left\{ \begin{array}{l} \text{identifier-5} \\ \text{literal-4} \end{array} \right\} \left[\begin{array}{l} \text{BEFORE} \\ \text{AFTER} \end{array} \right] \text{INITIAL } \left\{ \begin{array}{l} \text{identifier-6} \\ \text{literal-5} \end{array} \right\} \dots \end{array} \right)$$

The INSPECT statement can be used with the editing characters of Chapter 7 as illustrated in Figure 9.4. Assume, for example, that social security number is stored as a nine-position field (with no hyphens) in the input record, but is to appear with hyphens in the printed report. The MOVE statement transfers the incoming social security number to an 11-position field containing two blanks

Figure 9.4 The INSPECT Statement

```

01 RECORD-IN.
   05 SOC-SEC-NUM          PIC 9(9).
   .
   .
01 PRINT-LINE.
   05 SOC-SEC-NUM-OUT      PIC 999B99B9999.
   .
   .
PROCEDURE DIVISION.
   .
   .
   MOVE SOC-SEC-NUM TO SOC-SEC-NUM-OUT.
   INSPECT SOC-SEC-NUM-OUT REPLACING ALL ' ' BY '-'.

```

(denoted by B in the PICTURE clause). The INSPECT statement replaces every occurrence of a blank in SOC-SEC-NUM-OUT by the desired hyphen.

Another frequent use of the INSPECT statement is the elimination of leading blanks in numeric fields. (Numeric fields in COBOL should not contain anything other than the digits 0 to 9 and a sign over the rightmost (low-order) position.) Leading blanks can be replaced with zeros as follows:

```
INSPECT FIELD-WITH-BLANKS REPLACING LEADING ' ' BY '0'.
```

STRING

The STRING statement joins (concatenates) one or more fields and/or one or more literals into a single field. Thus a STRING statement has the same effect as a series of MOVE statements, except that the destination fields are one and the same. An abbreviated form of the COBOL notation for the STRING follows:

```

STRING { identifier-1 } [ literal-1 ] { identifier-2 } [ literal-2 ] . . . DELIMITED BY { identifier-3 } [ literal-3 ] [ SIZE ] . . .
      INTO identifier-4 [ WITH POINTER identifier-5 ]
[ END-STRING ]

```

The above notation can be simplified, for our discussion, in the following manner:

```
STRING sending item INTO receiving field
```

A sending item may be either an identifier or a literal. Each sending item must be accompanied by a delimiting clause, which indicates when to stop moving characters from the sending field. The delimiter can take one of three forms:

1. An identifier name that contains the delimiting character(s),
2. A figurative literal or constant whose value is the delimiting character(s), or
3. SIZE, which transfers the entire contents of the sending item.

The delimiting character(s) itself is *not* transferred. Figure 9.5 contains an example of the STRING statement in which the components of an individual's name are stored separately, then put together to form a single character string. The application is not unusual in that a program often requires a person's name in two formats. It is easy, for example, to visualize the name (John H. Smith) as a single entity as it might appear on an address label. You would not, however, want to store the name as a single field as that would preclude the ability to obtain an alphabetical

Figure 9.5 The STRING Statement

```

05 NAME-IN-PIECES.
   10 LAST-NAME      PIC X(16)
   10 FIRST-NAME     PIC X(10)
   10 MIDDLE-INITIAL PIC X.
    
```

```

05 ENTIRE-NAME      PIC X(29)
    
```

(a) Working-Storage Holding Areas

```

MOVE SPACES TO ENTIRE-NAME.
STRING FIRST-NAME DELIMITED BY SPACE
      ' ' DELIMITED BY SIZE
      MIDDLE-INITIAL DELIMITED BY SPACE
      ' ' DELIMITED BY SIZE
      LAST-NAME DELIMITED BY SPACE
      INTO ENTIRE-NAME
    
```

(b) STRING Statement

Before Execution

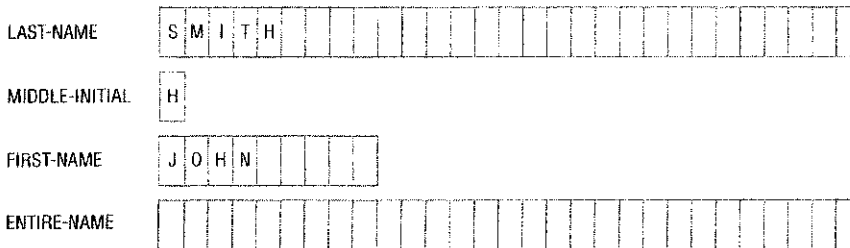

Execution steps:

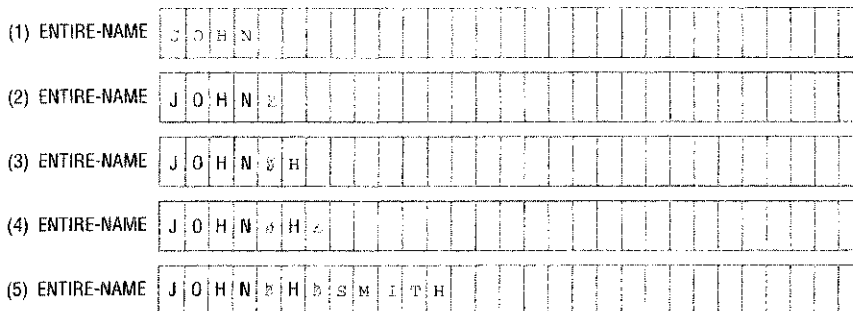

(c) Sequence of Transfer

list on last name; that is you must have access to last name as a separate entity, in order to alphabetize a list. (See problem 3.)

The Data Division entries in Figure 9.5a define NAME-IN-PIECES to hold the individual fields, and ENTIRE-NAME to hold the concatenated result. Five distinct steps are required to string the individual fields together to form a single name:

1. Move FIRST-NAME to ENTIRE-NAME.
2. Move a space to ENTIRE-NAME after the first name.
3. Move MIDDLE-INITIAL to ENTIRE-NAME after the space.
4. Move a space to ENTIRE-NAME after the initial.
5. Move LAST-NAME to ENTIRE-NAME after the second space.

The STRING statement in Figure 9.5b accomplishes all five tasks and is illustrated in Figure 9.5c. The STRING statement executes as follows:

1. The characters in the FIRST-NAME field are moved (from left to right) to ENTIRE-NAME until a space is encountered (the delimiter), or the entire contents of FIRST-NAME are transferred.
2. The literal ' ' (delimiter is SIZE) is moved to the position following the last character of FIRST-NAME.
3. The MIDDLE-INITIAL is moved.
4. The literal ' ' (delimiter is SIZE) is moved to the position following the MIDDLE-INITIAL.
5. Finally, each character in LAST-NAME is moved until either a space is encountered (the delimiter), or the entire field is transferred.

UNSTRING

The UNSTRING statement breaks a concatenated field into its components and is the opposite of the STRING statement. An abbreviated form of the COBOL notation for the UNSTRING follows:

$$\begin{array}{l} \text{UNSTRING identifier-1} \left[\text{DELIMITED BY} \left\{ \begin{array}{l} \text{identifier-2} \\ \text{literal-1} \end{array} \right\} \left[\text{OR} \left\{ \begin{array}{l} \text{identifier-3} \\ \text{literal-2} \end{array} \right\} \right] \dots \right] \\ \text{INTO identifier-4} \\ \text{[END-UNSTRING]} \end{array}$$

We reverse the previous example and divide ENTIRE-NAME into its three components, FIRST-NAME, MIDDLE-INITIAL, and LAST-NAME, as shown in Figure 9.6. The UNSTRING statement operates from left to right on ENTIRE-NAME, moving characters into FIRST-NAME until a space is encountered, then into MIDDLE-INITIAL, and finally into LAST-NAME.

Reference modification

Reference modification enables you to address a character string that was not explicitly defined—that is, a character string within an existing data name. This is done by specifying the leftmost (starting) position of the string within the data name and the length of the string, separating the parameters by a colon. The format for reference modification is shown below and is illustrated in Figure 9.7.

Figure 9.6 The UNSTRING Statement

```

05 NAME-IN-PIECES.
   10 LAST-NAME      PIC X(16).
   10 FIRST-NAME     PIC X(10).
   10 MIDDLE-INITIAL PIC X.
.
.
.
05 ENTIRE-NAME      PIC X(31).
    
```

(a) Working-Storage Holding Areas

```

MOVE SPACES TO NAME-IN-PIECES.
UNSTRING ENTIRE-NAME DELIMITED BY ' '
  INTO FIRST-NAME MIDDLE-INITIAL LAST-NAME.
    
```

(b) UNSTRING Statement

Before UNSTRING

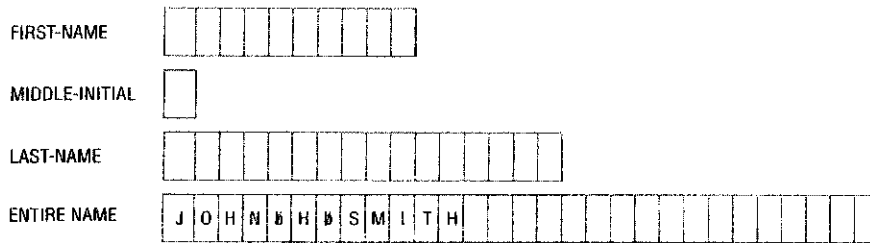

During UNSTRING

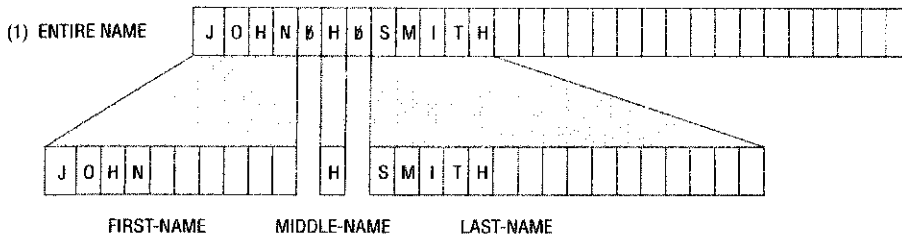

(c) Execution of UNSTRING

data-name (leftmost position: [length])

In Figure 9.7 TELEPHONE-NUMBER is defined as a 10 position field within an incoming record. Portions of this field are then moved to EDITED-PHONE-NUMBER through reference modification; for example, TELEPHONE-NUMBER (4:3) refers to positions 4, 5, and 6 within TELEPHONE-NUMBER. The specification of length is optional, and its omission defaults to the end of the data name; i.e., TELEPHONE-NUMBER (7:4) and TELEPHONE-NUMBER (7:) are equivalent.

Figure 9.7 Reference Modification

```

01 INCOMING-RECORD.
.
.
05 TELEPHONE-NUMBER      PIC X(10).
.
.

01 EDITED-PHONE-NUMBER.
05 FILLER                 PIC X   VALUE '('.
05 AREA-CODE              PIC X(3).
05 FILLER                 PIC X   VALUE ')'.
05 EXCHANGE               PIC X(3).
05 FILLER                 PIC X   VALUE '-'.
05 DIGITS                 PIC X(4).
.
.

MOVE TELEPHONE-NUMBER (1:3) TO AREA-CODE.
MOVE TELEPHONE-NUMBER (4:3) TO EXCHANGE.
MOVE TELEPHONE-NUMBER (7:4) TO DIGITS.

```

ACCEPT

The **ACCEPT** statement was introduced in Chapter 8 to obtain the date of execution and implement various forms of date validation. The statement is expanded in this chapter to include the day of the week as well as the date. Consider:

```

ACCEPT identifier-1 FROM { DAY-OF-WEEK
                        DATE
                        DAY
                        TIME }

```

The **DAY-OF-WEEK** clause returns an integer from 1 to 7 representing the day according to the following table:

| INTEGER | DAY |
|---------|-----------|
| 1 | Monday |
| 2 | Tuesday |
| 3 | Wednesday |
| 4 | Thursday |
| 5 | Friday |
| 6 | Saturday |
| 7 | Sunday |

The **ACCEPT** statement is illustrated in Figure 9.8. The user defines a data name in Working-Storage—for example, **DAY-CODE-VALUE** in Figure 9.8a—then accepts

Figure 9.8 The ACCEPT Statement

```

01 DAY-CODE-VALUE          PIC 9.

01 TODAYS-DATE.
  05 TODAYS-YEAR           PIC 99.
  05 TODAYS-MONTH         PIC 99.
  05 TODAYS-DAY           PIC 99.

01 HDG-LINE.
  05 HDG-DAY-OF-WEEK      PIC X(9).
  05 FILLER                PIC XX VALUE ' '.
  05 HDG-DATE             PIC X(8).

```

(a) Working-Storage Entries

```

ACCEPT DAY-CODE-VALUE FROM DAY-OF-WEEK.
EVALUATE DAY-CODE-VALUE
  WHEN 1 MOVE ' Monday' TO HDG-DAY-OF-WEEK
  WHEN 2 MOVE ' Tuesday' TO HDG-DAY-OF-WEEK
  WHEN 3 MOVE 'Wednesday' TO HDG-DAY-OF-WEEK
  WHEN 4 MOVE ' Thursday' TO HDG-DAY-OF-WEEK
  WHEN 5 MOVE ' Friday' TO HDG-DAY-OF-WEEK
  WHEN 6 MOVE ' Saturday' TO HDG-DAY-OF-WEEK
  WHEN 7 MOVE ' Sunday' TO HDG-DAY-OF-WEEK
END-EVALUATE.

```

(b) DAY-OF-WEEK Clause

```

ACCEPT TODAYS-DATE FROM DATE.
STRING TODAYS-MONTH '/' TODAYS-DAY '/' TODAYS-YEAR
  DELIMITED BY SIZE INTO HDG-DATE
END-STRING.

```

(c) DATE Clause

the value from DAY-OF-WEEK into that data name. The subsequent EVALUATE statement expands the one-position code to a literal day.

The DATE and DAY clauses were described in Chapter 8 and represent the date (in the form yymmdd) and Julian date (in the form yyddd), respectively. The DATE clause is illustrated in Figure 9.8c for purposes of review.

Most programs require that the output contain some of the input, for example, name and social security number. COBOL permits the definition of *duplicate data names* in the Data Division, provided all Procedure Division references to duplicate names use the appropriate *qualification*. We prefer *not* to use duplicate names because they violate the prefix coding standard discussed in Chapter 7, but they are used in older programs, and are covered here for completeness.

Qualification

The Data Division entries in Figure 9.9a contain several data names that appear in both STUDENT-RECORD and PRINT-LINE—for example, CREDITS—and any Procedure Division reference to CREDITS will produce a compiler error indicating a *nonunique data name*. This is because the compiler cannot determine which CREDITS (in STUDENT-RECORD or PRINT-LINE) is referenced. One solution is

Figure 9.9 Duplicate Data Names

```

01 STUDENT-RECORD.
   05 STUDENT-NAME          PIC X(20).
   05 SOCIAL-SECURITY-NUM   PIC 9(9).
   05 STUDENT-ADDRESS.
       10 STREET            PIC X(15).
       10 CITY-STATE        PIC X(15).
   05 ZIP-CODE              PIC X(5).
   05 CREDITS               PIC 9(3).
   05 MAJOR                 PIC X(10).
   05 FILLER                PIC X(3).
.
.
.
01 PRINT-LINE.
   10 STUDENT-NAME          PIC X(20).
   10 FILLER                PIC XX.
   10 CREDITS               PIC ZZ9.
   10 FILLER                PIC XX.
   10 TUITION               PIC $$,$$9.99.
   10 FILLER                PIC XX.
   10 STUDENT-ADDRESS.
       15 STREET            PIC X(15).
       15 CITY-STATE        PIC X(15).
       15 ZIP-CODE          PIC X(5).
   10 FILLER                PIC XX.
   10 SOCIAL-SECURITY-NUM   PIC 999B99B9999.
   10 FILLER                PIC X(47).

```

(a) Duplicate Data Names

```
MOVE CORRESPONDING STUDENT-RECORD TO PRINT-LINE.
```

(b) MOVE CORRESPONDING Statement

```

MOVE STUDENT-NAME OF STUDENT-RECORD
  TO STUDENT-NAME OF PRINT-LINE.
MOVE SOCIAL-SECURITY-NUM OF STUDENT-RECORD
  TO SOCIAL-SECURITY-NUM OF PRINT-LINE.
MOVE STREET OF STUDENT-RECORD
  TO STREET OF PRINT-LINE.
MOVE CITY-STATE OF STUDENT-RECORD
  TO CITY-STATE OF PRINT-LINE.
MOVE CREDITS OF STUDENT-RECORD
  TO CREDITS OF PRINT-LINE.

```

(c) Equivalent MOVE Statements

to *qualify* the data name, using **OF** or **IN**, and refer to CREDITS OF STUDENT-RECORD or CREDITS IN STUDENT-RECORD.

Qualification is sometimes necessary over several levels. For example, the use of STREET OF STUDENT-ADDRESS in the statement below is still ambiguous.

```
MOVE STREET OF STUDENT-ADDRESS TO OUTPUT-AREA.
```

The qualifier STUDENT-ADDRESS appears in both 01 records and thus the ambiguity was not resolved. Two levels of qualification are necessary to make the intent clear:

```
MOVE STREET OF STUDENT-ADDRESS OF STUDENT-RECORD TO OUTPUT-AREA.
```

Alternatively, you could skip the intermediate level and rewrite the statement as:

```
MOVE STREET IN STUDENT-RECORD TO OUTPUT-AREA.
```

OF and IN can be used interchangeably. Duplicate data names offer the advantage of not having to invent different names for the same item—for example, an employee name appearing in both an input record and output report. They also permit use of the MOVE CORRESPONDING statement which is *not* recommended by the authors, but which is covered for completeness.

MOVE CORRESPONDING

The syntax of the MOVE CORRESPONDING statement is:

```
MOVE { CORRESPONDING } identifier-1 TO identifier-2
     { CORR }
```

The MOVE CORRESPONDING statement in Figure 9.9b is the equivalent of the individual MOVE statements in Figure 9.9c; that is, the single MOVE CORRESPONDING statement has the same effect as the five individual MOVE statements. The CORRESPONDING option searches every data name in STUDENT-RECORD for a matching (duplicate) data name in PRINT-LINE, then generates an individual MOVE statement whenever a match is found. It is very convenient because you have to code only the single MOVE CORRESPONDING statement.

The level numbers of the duplicate data names in Figure 9.9a do not have to match for a move to be generated—only the data names must be the same. The order of the data names in the 01 records is also immaterial; for example, SOCIAL-SECURITY-NUM is the second field in STUDENT-RECORD, and the next to last in PRINT-LINE. Two other conditions must be satisfied, however, in order for a move to be generated:

1. At least one item in each pair of CORRESPONDING items must be an elementary item; that is, STUDENT-ADDRESS of STUDENT-RECORD is not moved to STUDENT-ADDRESS of PRINT-LINE. (The elementary items STREET and CITY-STATE are moved instead.)
2. Corresponding elementary items are moved only if they have the same name and qualification, up to but not including identifier-1 and identifier-2. ZIP-CODE, for example, belongs directly to STUDENT-RECORD, but has an intermediate qualifier (STUDENT-ADDRESS) in PRINT-LINE, and thus ZIP-CODE is not moved.

The Car Billing Program

Our fundamental approach throughout the text is to learn by doing. To that end we have developed a complete COBOL program that incorporates the various statements presented in the chapter. Specifications follow in the usual format.

PROGRAMMING SPECIFICATIONS

Program Name: Car Billing Program

Narrative: This program processes the file of valid car rental records that was created in the validation program of Chapter 8 to produce a report reflecting the amounts owed by individual customers.

Input File(s): RENTAL-FILE

```

01 RENTAL-RECORD-IN.
   05 REN-CONTRACT-NO          PIC 9(6).
   05 REN-NAME.
      10 REN-LAST-NAME         PIC X(15).
      10 REN-FIRST-NAME       PIC X(10).
      10 REN-INITIAL          PIC X.
   05 REN-RETURNED-DATE.
      10 REN-RETURNED-YEAR    PIC 9(2).
      10 REN-RETURNED-MONTH   PIC 9(2).
      10 REN-RETURNED-DAY     PIC 9(2).
   05 REN-CAR-TYPE            PIC X.
   05 REN-DAYS-RENTED         PIC 99.
   05 REN-MILEAGE.
      10 REN-MILES-IN         PIC 9(6).
      10 REN-MILES-OUT        PIC 9(6).
      10 REN-MILEAGE-RATE     PIC V99.
   05 REN-INSURANCE          PIC X.
```

Test Data: The input file used by this program was created by the data validation program of Chapter 8 and was shown earlier as Figure 8.10c. The data are repeated below for convenience:

| | | | |
|--------|----------|--------|---------------------------|
| 999777 | ELSINOR | TERRY | R921126F0500168000159005N |
| 987654 | SMITH | PAUL | G921213M0300510000500502Y |
| 354679 | KERBEL | NORMAN | X930331E1000340000324300Y |
| 264805 | CLARK | JANE | S921101F0700561500551200N |
| 233432 | BEINHORN | CATHY | B921122M0200123400113402Y |
| 556564 | HUMMER | MARGO | R920815C0800234500123403Y |
| 677844 | MCDONALD | JAMES | 930123C0500423500402300N |
| 886222 | VOGEL | JANICE | D930518F1200634500612302Y |
| 008632 | TOWER | DARREN | R930429L0900700200689300N |

Report Layout: See Figure 9.10.

Processing Requirements: 1. Read the file of valid car rental records that was produced by the editing program of Chapter 8. No further validation is required in this program.

2. Calculate the amount due for each incoming record as a function of car type, days rented, miles driven, mileage rate, and insurance.
 - a. The mileage rate is different for each customer and appears as a field in the incoming record; the mileage total is the mileage rate times the number of miles driven.
 - b. The daily rate is a function of the type of car rented. Economy cars cost \$15 a day, compact cars \$20 a day, mid-size cars \$24 a day, full-size cars \$28 a day, and luxury cars \$35 a day. The daily total is the daily rate times the number of days rented.
 - c. Insurance is optional and is indicated by a 'Y' in the appropriate position in the incoming record. Insurance is \$10.50 a day (for customers who choose it), regardless of the type of car rented.
 - d. A customer's total bill consists of the mileage total, daily total, and insurance total as described in parts (a), (b), and (c).
3. A heading is required at the top of every page, as shown in Figure 9.10. Detail lines are to be double-spaced and limited to five per page.
4. A total line for all computed fields is required at the end of the report.

Figure 9.10 Car Rental Report

| Mavis Car Rental Report | | | | | | | | | | | Saturday - 07/03/93 | | Page 2 |
|-------------------------|--------------------|---------------|----------|-------------|--------------|--------------|--------------|---------------|-----------------|------------|---------------------|--|--------|
| Contract Number | Name | Date Returned | Car Type | Days Rented | Rental Total | Miles Driven | Mileage Rate | Mileage Total | Insurance Total | Amount Due | | | |
| 5-565-64 | HUMMER, MARGO R. | 08/15/92 | C | 8 | 160.00 | 1,111 | .03 | 33.33 | 84.00 | 277.33 | | | |
| 6-778-44 | MCDONALD, JAMES | 01/23/93 | C | 5 | 100.00 | 212 | .00 | 0.00 | | 100.00 | | | |
| 8-862-22 | VOGEL, JANICE D. | 05/18/93 | F | 12 | 336.00 | 222 | .02 | 4.44 | 126.00 | 466.44 | | | |
| | | | | | | | | | | | 315.00 | | |
| Mavis Car Rental Report | | | | | | | | | | | Saturday - 07/03/93 | | Page 1 |
| Contract Number | Name | Date Returned | Car Type | Days Rented | Rental Total | Miles Driven | Mileage Rate | Mileage Total | Insurance Total | Amount Due | | | |
| 9-997-77 | ELSINOR, TERRY R. | 11/26/92 | F | 5 | 140.00 | 90 | .05 | 4.50 | | 144.50 | | | |
| 9-876-54 | SMITH, PAUL G. | 12/13/92 | M | 3 | 72.00 | 95 | .02 | 1.90 | 31.50 | 105.40 | | | |
| 3-546-79 | KERBEL, NORMAN X. | 03/31/93 | E | 10 | 150.00 | 157 | .00 | 0.00 | 105.00 | 255.00 | | | |
| 2-648-05 | CLARK, JANE S. | 11/01/92 | F | 7 | 196.00 | 103 | .00 | 0.00 | | 196.00 | | | |
| 2-334-32 | BEINHORN, CATHY B. | 11/22/92 | M | 2 | 48.00 | 100 | .02 | 2.00 | 21.00 | 71.00 | | | |
| | | | | | | | | | | | \$1,930.67 | | |

Program Design

The car billing program has two objectives: to complete the two-program sequence begun in Chapter 8 and to illustrate the Procedure Division statements presented in this chapter. Both objectives impact the design of the pseudocode and associated hierarchy chart.

The hierarchy chart in Figure 9.11 is written *without* the priming read of earlier programs. The highest-level module, PREPARE-RENTAL-REPORT, has three subordinates: GET-TODAYS-DATE, PROCESS-RENTAL-RECORDS, and WRITE-RENTAL-TOTALS. PROCESS-RENTAL-RECORDS in turn is the driving module of the program and performs four lower-level paragraphs: COMPUTE-INDIVIDUAL-BILL, WRITE-HEADING-LINES, WRITE-DETAIL-LINE, and INCREMENT-RENTAL-TOTALS. COMPUTE-INDIVIDUAL-BILL has three subordinate modules, COMPUTE-MILEAGE-TOTAL, COMPUTE-DAILY-TOTAL, and COMPUTE-INSURANCE-TOTAL to compute the components of a customer's bill.

The paragraph WRITE-HEADING-LINES is subordinate to PROCESS-RENTAL-RECORDS, which differs from an earlier hierarchy chart (page 119) that placed the heading routine on a higher level. The earlier structure, however, produced only a single heading at the start of processing, whereas the current requirement is to produce a heading at the top of every page; hence the heading routine will be executed several times and is subordinate to processing a record.

The pseudocode in Figure 9.12 takes advantage of the in-line perform and false-condition branch to eliminate the priming read used in earlier examples. The pseudocode also implements the required page heading routine by initializing the line counter to six and testing its value prior to writing each detail line. The heading

Figure 9.11 Hierarchy Chart

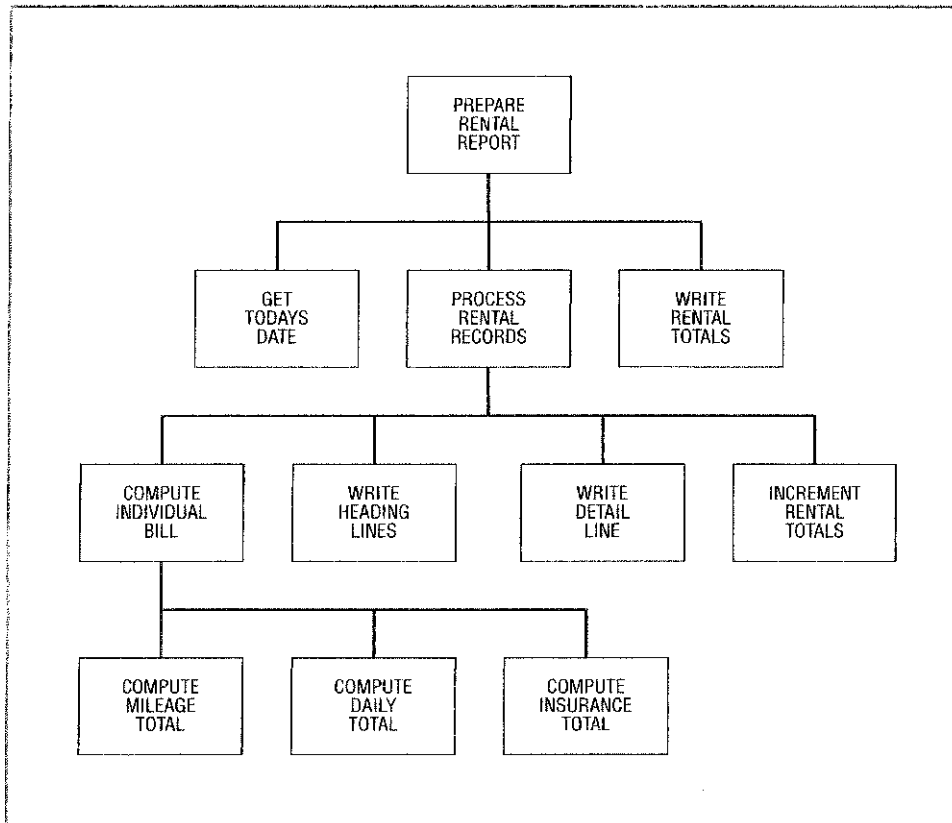

Figure 9.12 Pseudocode

```

Open Files
Get today's date
DO WHILE data remains
  Read Rental File
  AT END
    Indicate no more data
  NOT AT END
    Initialize individual calculations
    Compute miles driven = miles in - miles out
    DO CASE
      Car Type E - Move economy rate to mileage rate
      Car Type C - Move compact rate to mileage rate
      Car Type M - Move midsize to mileage rate
      Car Type F - Move fullsize rate to mileage rate
      Car Type L - Move luxury rate to mileage rate
    END CASE
    Compute mileage total = miles driven * mileage rate
    Compute daily total = days rented * daily rate
    IF insurance taken
      Compute insurance = insurance rate * days rented
    END-IF
    Compute total bill = mileage amount + daily amount + insurance
    IF line count greater than 5
      Initialize line count to 1
      Increment page count
      Write heading lines
    END-IF
    Write detail line
    Add 1 to line count
    Increment rental totals
  END READ
ENDDO
Write rental totals
Close files
Stop run

```

will be written prior to the first detail record because it (the line counter) is greater than five (the desired number of lines per page). The line counter is then reset to one so that the heading will be produced for every fifth record.

The Completed Program

The completed program in Figure 9.13 illustrates many of the statements presented in the chapter. The logic of the program is straightforward and parallels the pseudocode just discussed. Several features of the program merit attention:

1. The combination of the in-line perform and false-condition branch (lines 209–216) to eliminate the priming read used in all previous programs.

Figure 9.10 The Completed Program

```

1 IDENTIFICATION DIVISION.
2 PROGRAM-ID. CARSRPT.
3 AUTHOR. CVV.
4
5 ENVIRONMENT DIVISION.
6 INPUT-OUTPUT SECTION.
7 FILE-CONTROL.
8 SELECT RENTAL-FILE ASSIGN TO 'A:\CHAPTR09\VALCARS.DAT'
9 ORGANIZATION IS LINE SEQUENTIAL.
10 SELECT PRINT-FILE
11 ASSIGN TO PRINTER.
12
13 DATA DIVISION.
14 FILE SECTION.
15 FD RENTAL-FILE
16 RECORD CONTAINS 56 CHARACTERS.
17 01 RENTAL-RECORD PIC X(56).
18
19 FD PRINT-FILE
20 RECORD CONTAINS 132 CHARACTERS.
21 01 PRINT-LINE PIC X(132).
22
23 WORKING-STORAGE SECTION.
24 01 FILLER PIC X(14)
25 VALUE 'WS BEGINS HERE'.
26
27 01 RENTAL-RECORD-IN.
28 05 REN-CONTRACT-NO PIC 9(6).
29 05 REN-NAME.
30 10 REN-LAST-NAME PIC X(15).
31 10 REN-FIRST-NAME PIC X(10).
32 10 REN-INITIAL PIC X.
33 05 REN-RETURNED-DATE.
34 10 REN-RETURNED-YEAR PIC 9(2).
35 10 REN-RETURNED-MONTH PIC 9(2).
36 10 REN-RETURNED-DAY PIC 9(2).
37 05 REN-CAR-TYPE PIC X.
38 05 REN-DAYS-RENTED PIC 99.
39 05 REN-MILEAGE.
40 10 REN-MILES-IN PIC 9(6).
41 10 REN-MILES-OUT PIC 9(6).
42 10 REN-MILEAGE-RATE PIC V99.
43 05 REN-INSURANCE PIC X.
44
45 01 PROGRAM-SWITCHES.
46 05 DATA-REMAINS-SWITCH PIC XX VALUE SPACES.
47 05 NAME-POINTER PIC 999 VALUE 1.
48
49 01 PAGE-AND-LINE-COUNTERS.
50 05 LINE-COUNT PIC 9(2) VALUE 6.

```

Definition of line counter in comparison to the opening routine

Figure 8.18 (continued)

| | | | | |
|-----|----|----------------------------------|--------------|-------------------|
| 51 | 05 | PAGE-COUNT | PIC 9(2) | VALUE ZEROS. |
| 52 | 05 | LINES-PER-PAGE | PIC 9(2) | VALUE 5. |
| 53 | | | | |
| 54 | 01 | DAILY-RATES. | | |
| 55 | 05 | ECONOMY-RATE | PIC 9(3)V99 | VALUE 15. |
| 56 | 05 | COMPACT-RATE | PIC 9(3)V99 | VALUE 20. |
| 57 | 05 | MID-RATE | PIC 9(3)V99 | VALUE 24. |
| 58 | 05 | FULL-RATE | PIC 9(3)V99 | VALUE 28. |
| 59 | 05 | LUXURY-RATE | PIC 9(3)V99 | VALUE 35. |
| 60 | 05 | INSURANCE-RATE | PIC 99V99 | VALUE 10.50. |
| 61 | | | | |
| 62 | 01 | IND-BILL-INFORMATION. | | |
| 63 | 05 | IND-MILES-DRIVEN | PIC 9(5). | |
| 64 | 05 | IND-DAILY-RATE | PIC 9(3)V99. | |
| 65 | 05 | IND-DAILY-TOTAL | PIC 9(4)V99. | |
| 66 | 05 | IND-MILEAGE-TOTAL | PIC 9(3)V99. | |
| 67 | 05 | IND-INSURANCE-TOTAL | PIC 9(3)V99. | |
| 68 | 05 | IND-AMOUNT-DUE | PIC 9(4)V99. | |
| 69 | | | | |
| 70 | 01 | TOTALS-FOR-REPORT. | | |
| 71 | 05 | TOTAL-DAYS-RENTED | PIC 9(4) | VALUE ZEROS. |
| 72 | 05 | TOTAL-DAILY-RENTAL | PIC 9(6)V99 | VALUE ZEROS. |
| 73 | 05 | TOTAL-MILES-DRIVEN | PIC 9(6) | VALUE ZEROS. |
| 74 | 05 | TOTAL-MILEAGE | PIC 9(4)V99 | VALUE ZEROS. |
| 75 | 05 | TOTAL-INSURANCE | PIC 9(4)V99 | VALUE ZEROS. |
| 76 | 05 | TOTAL-AMOUNT-DUE | PIC 9(6)V99 | VALUE ZEROS. |
| 77 | | | | |
| 78 | 01 | TODAYS-DATE-AREA. | | |
| 79 | 05 | TODAYS-YEAR | PIC 99. | |
| 80 | 05 | TODAYS-MONTH | PIC 99. | |
| 81 | 05 | TODAYS-DAY | PIC 99. | |
| 82 | | | | |
| 83 | 01 | DAY-CODE-VALUE | PIC 9. | |
| 84 | | | | |
| 85 | 01 | HEADING-LINE-ONE. | | |
| 86 | 05 | FILLER | PIC X(20) | VALUE SPACES. |
| 87 | 05 | FILLER | PIC X(25) | |
| 88 | | VALUE 'Mavis Car Rental Report'. | | |
| 89 | 05 | FILLER | PIC X(16) | VALUE SPACES. |
| 90 | 05 | HDG-DAY | PIC X(9). | |
| 91 | 05 | FILLER | PIC X(3) | VALUE ' - '. |
| 92 | 05 | HDG-DATE | PIC X(8). | |
| 93 | 05 | FILLER | PIC X(41) | VALUE SPACES. |
| 94 | 05 | FILLER | PIC X(5) | VALUE 'Page '. |
| 95 | 05 | HDG-PAGE-NUMBER | PIC Z9. | |
| 96 | 05 | FILLER | PIC X(3) | VALUE SPACES. |
| 97 | | | | |
| 98 | 01 | HEADING-LINE-TWO. | | |
| 99 | 05 | FILLER | PIC X(8) | VALUE 'Contract'. |
| 100 | 05 | FILLER | PIC X(38) | VALUE SPACES. |

05 VALUE 5. or page count is 5. (injection with no edit) online

Figure 9.13 (continued)

```

101      05 FILLER                PIC X(4) VALUE 'Date'.
102      05 FILLER                PIC X(5) VALUE SPACES.
103      05 FILLER                PIC X(3) VALUE 'Car'.
104      05 FILLER                PIC X(3) VALUE SPACES.
105      05 FILLER                PIC X(4) VALUE 'Days'.
106      05 FILLER                PIC X(6) VALUE SPACES.
107      05 FILLER                PIC X(6) VALUE 'Rental'.
108      05 FILLER                PIC X(4) VALUE SPACES.
109      05 FILLER                PIC X(5) VALUE 'Miles'.
110      05 FILLER                PIC X(2) VALUE SPACES.
111      05 FILLER                PIC X(7) VALUE 'Mileage'.
112      05 FILLER                PIC X(2) VALUE SPACES.
113      05 FILLER                PIC X(7) VALUE 'Mileage'.
114      05 FILLER                PIC X(2) VALUE SPACES.
115      05 FILLER                PIC X(9) VALUE 'Insurance'.
116      05 FILLER                PIC X(6) VALUE SPACES.
117      05 FILLER                PIC X(6) VALUE 'Amount'.
118      05 FILLER                PIC X(5) VALUE SPACES.
119
120      01 HEADING-LINE-THREE.
121      05 FILLER                PIC X      VALUE SPACES.
122      05 FILLER                PIC X(6) VALUE 'Number'.
123      05 FILLER                PIC X(4) VALUE SPACES.
124      05 FILLER                PIC X(4) VALUE 'Name'.
125      05 FILLER                PIC X(29) VALUE SPACES.
126      05 FILLER                PIC X(8) VALUE 'Returned'.
127      05 FILLER                PIC X(2) VALUE SPACES.
128      05 FILLER                PIC X(4) VALUE 'Type'.
129      05 FILLER                PIC X(2) VALUE SPACES.
130      05 FILLER                PIC X(6) VALUE 'Rented'.
131      05 FILLER                PIC X(6) VALUE SPACES.
132      05 FILLER                PIC X(5) VALUE 'Total'.
133      05 FILLER                PIC X(3) VALUE SPACES.
134      05 FILLER                PIC X(6) VALUE 'Driven'.
135      05 FILLER                PIC X(4) VALUE SPACES.
136      05 FILLER                PIC X(4) VALUE 'Rate'.
137      05 FILLER                PIC X(4) VALUE SPACES.
138      05 FILLER                PIC X(5) VALUE 'Total'.
139      05 FILLER                PIC X(6) VALUE SPACES.
140      05 FILLER                PIC X(5) VALUE 'Total'.
141      05 FILLER                PIC X(9) VALUE SPACES.
142      05 FILLER                PIC X(3) VALUE 'Due'.
143      05 FILLER                PIC X(6) VALUE SPACES.
144
145      01 DETAIL-LINE.
146      05 DET-CONTRACT-NO       PIC 9B999B99.
147      05 FILLER                PIC X(3) VALUE SPACES.
148      05 DET-NAME              PIC X(30).
149      05 FILLER                PIC X(3) VALUE SPACES.
150      05 DET-RETURN-DATE       PIC X(8).

```

Blanks are replaced in the INSPECT
statement of line 146.

Figure 9.13 (continued)

| | | | |
|-----|----|---------------------|-----------------------------|
| 151 | 05 | FILLER | PIC X(4) VALUE SPACES. |
| 152 | 05 | DET-CAR-TYPE | PIC X. |
| 153 | 05 | FILLER | PIC X(5) VALUE SPACES. |
| 154 | 05 | DET-DAYS-RENTED | PIC Z9. |
| 155 | 05 | FILLER | PIC X(5) VALUE SPACES. |
| 156 | 05 | DET-DAILY-TOTAL | PIC Z,ZZ9.99. |
| 157 | 05 | FILLER | PIC X(3) VALUE SPACES. |
| 158 | 05 | DET-MILES-DRIVEN | PIC ZZ,ZZ9. |
| 159 | 05 | FILLER | PIC X(5) VALUE SPACES. |
| 160 | 05 | DET-MILEAGE-RATE | PIC .99. |
| 161 | 05 | FILLER | PIC X(5) VALUE SPACES. |
| 162 | 05 | DET-MILEAGE-TOTAL | PIC ZZ9.99. |
| 163 | 05 | FILLER | PIC X(4) VALUE SPACES. |
| 164 | 05 | DET-INSURANCE-TOTAL | PIC ZZ9.99 BLANK WHEN ZERO. |
| 165 | 05 | FILLER | PIC X(4) VALUE SPACES. |
| 166 | 05 | DET-AMOUNT-DUE | PIC Z,ZZ9.99. |
| 167 | 05 | FILLER | PIC X(5) VALUE SPACES. |
| 168 | | | |
| 169 | 01 | TOTAL-DASH-LINE. | |
| 170 | 05 | FILLER | PIC X(59) VALUE SPACES. |
| 171 | 05 | FILLER | PIC X(5) VALUE ALL '- '. |
| 172 | 05 | FILLER | PIC X(3) VALUE SPACES. |
| 173 | 05 | FILLER | PIC X(10) VALUE ALL '- '. |
| 174 | 05 | FILLER | PIC XX VALUE SPACES. |
| 175 | 05 | FILLER | PIC X(7) VALUE ALL '- '. |
| 176 | 05 | FILLER | PIC X(11) VALUE SPACES. |
| 177 | 05 | FILLER | PIC X(8) VALUE ALL '- '. |
| 178 | 05 | FILLER | PIC XX VALUE SPACES. |
| 179 | 05 | FILLER | PIC X(8) VALUE ALL '- '. |
| 180 | 05 | FILLER | PIC XX VALUE SPACES. |
| 181 | 05 | FILLER | PIC X(10) VALUE ALL '- '. |
| 182 | 05 | FILLER | PIC X(5) VALUE SPACES. |
| 183 | | | |
| 184 | 01 | TOTAL-LINE. | |
| 185 | 05 | FILLER | PIC XX VALUE SPACES. |
| 186 | 05 | FILLER | PIC X(6) VALUE 'Totals'. |
| 187 | 05 | FILLER | PIC X(51) VALUE SPACES. |
| 188 | 05 | TOT-DAYS-RENTED | PIC Z,ZZ9. |
| 189 | 05 | FILLER | PIC X(2) VALUE SPACES. |
| 190 | 05 | TOT-DAILY-RENTAL | PIC \$\$\$,\$\$9.99. |
| 191 | 05 | FILLER | PIC XX VALUE SPACES. |
| 192 | 05 | TOT-MILES-DRIVEN | PIC ZZZ,ZZ9. |
| 193 | 05 | FILLER | PIC X(9) VALUE SPACES. |
| 194 | 05 | TOT-MILEAGE | PIC \$\$\$,\$\$9.99. |
| 195 | 05 | FILLER | PIC X VALUE SPACES. |
| 196 | 05 | TOT-INSURANCE | PIC \$\$,\$\$9.99. |
| 197 | 05 | FILLER | PIC X VALUE SPACES. |
| 198 | 05 | TOT-AMOUNT-DUE | PIC \$\$\$,\$\$9.99. |
| 199 | 05 | FILLER | PIC X(5) VALUE SPACES. |
| 200 | | | |

Figure 9.13 (continued)

```

201      01 FILLER                                PIC X(12)
202          VALUE 'WS ENDS HERE'.
203
204      PROCEDURE DIVISION.
205      000-PREPARE-RENTAL-REPORT.
206          OPEN INPUT RENTAL-FILE
207              OUTPUT PRINT-FILE.
208          PERFORM 100-GET-TODAYS-DATE.
209          PERFORM UNTIL DATA-REMAINS-SWITCH = 'NO'
210              READ RENTAL-FILE INTO RENTAL-RECORD-IN
211              AT END
212                  MOVE 'NO' TO DATA-REMAINS-SWITCH
213              NOT AT END
214                  PERFORM 200-PROCESS-RENTAL-RECORDS
215          END-READ
216      END-PERFORM.
217      PERFORM 700-WRITE-RENTAL-TOTALS.
218      CLOSE RENTAL-FILE
219          PRINT-FILE.
220      STOP RUN.
221
222      100-GET-TODAYS-DATE.
223          ACCEPT TODAYS-DATE-AREA FROM DATE.
224          STRING TODAYS-MONTH '/' TODAYS-DAY '/' TODAYS-YEAR
225              DELIMITED BY SIZE INTO HDG-DATE
226          END-STRING.
227          ACCEPT DAY-CODE-VALUE FROM DAY-OF-WEEK.
228          EVALUATE DAY-CODE-VALUE
229              WHEN 1 MOVE ' Monday' TO HDG-DAY
230              WHEN 2 MOVE ' Tuesday' TO HDG-DAY
231              WHEN 3 MOVE ' Wednesday' TO HDG-DAY
232              WHEN 4 MOVE ' Thursday' TO HDG-DAY
233              WHEN 5 MOVE ' Friday' TO HDG-DAY
234              WHEN 6 MOVE ' Saturday' TO HDG-DAY
235              WHEN 7 MOVE ' Sunday' TO HDG-DAY
236          END-EVALUATE.
237
238      200-PROCESS-RENTAL-RECORDS.
239          PERFORM 300-COMPUTE-IND-BILL.
240          IF LINE-COUNT > LINES-PER-PAGE
241              PERFORM 400-WRITE-HEADING-LINES
242          END-IF.
243          PERFORM 500-WRITE-DETAIL-LINE.
244          PERFORM 600-INCREMENT-TOTALS.
245
246      300-COMPUTE-IND-BILL.
247          INITIALIZE IND-BILL-INFORMATION.
248          PERFORM 320-COMPUTE-MILEAGE-TOTAL.
249          PERFORM 340-COMPUTE-DAILY-TOTAL.
250          PERFORM 360-COMPUTE-INSURANCE-TOTAL.
    
```

In the context of this procedure, DATA-REMAINS-SWITCH is a data name.

ACCEPT statement starts data of execution

Scope limitations are used throughout the Procedure Division

INITIALIZE statement resets initial values

Figure 9.13 (continued)

```

251      COMPUTE IND-AMOUNT-DUE ROUNDED
252          = IND-MILEAGE-TOTAL + IND-DAILY-TOTAL
253          + IND-INSURANCE-TOTAL
254      SIZE ERROR DISPLAY 'SIZE ERROR ON AMOUNT DUE FOR '
255          REN-CONTRACT-NO
256      END-COMPUTE.
257
258      320-COMPUTE-MILEAGE-TOTAL.
259      COMPUTE IND-MILES-DRIVEN
260          = REN-MILES-IN - REN-MILES-OUT
261      END-COMPUTE.
262      COMPUTE IND-MILEAGE-TOTAL ROUNDED
263          = IND-MILES-DRIVEN * REN-MILEAGE-RATE
264      SIZE ERROR
265          DISPLAY 'COMPUTED BILL EXCESSIVELY LARGE'
266      END-COMPUTE.
267
268      340-COMPUTE-DAILY-TOTAL.
269      EVALUATE REN-CAR-TYPE
270          WHEN 'E' MOVE ECONOMY-RATE TO IND-DAILY-RATE
271          WHEN 'C' MOVE COMPACT-RATE TO IND-DAILY-RATE
272          WHEN 'M' MOVE MID-RATE TO IND-DAILY-RATE
273          WHEN 'F' MOVE FULL-RATE TO IND-DAILY-RATE
274          WHEN 'L' MOVE LUXURY-RATE TO IND-DAILY-RATE
275          WHEN OTHER MOVE ZEROES TO IND-DAILY-RATE
276      END-EVALUATE.
277      MULTIPLY IND-DAILY-RATE BY REN-DAYS-RENTED
278          GIVING IND-DAILY-TOTAL
279      SIZE ERROR DISPLAY 'SIZE ERROR ON RENTAL TOTAL'
280      END-MULTIPLY.
281
282      360-COMPUTE-INSURANCE-TOTAL.
283      IF REN-INSURANCE = 'Y'
284          MULTIPLY INSURANCE-RATE BY REN-DAYS-RENTED
285          GIVING IND-INSURANCE-TOTAL
286          SIZE ERROR DISPLAY 'SIZE ERROR ON INSURANCE TOTAL'
287      END-MULTIPLY
288      END-IF.
289
290      400-WRITE-HEADING-LINES.
291      MOVE 1 TO LINE-COUNT.
292      ADD 1 TO PAGE-COUNT.
293      MOVE PAGE-COUNT TO HDG-PAGE-NUMBER.
294      WRITE PRINT-LINE FROM HEADING-LINE-ONE
295          AFTER ADVANCING PAGE.
296      WRITE PRINT-LINE FROM HEADING-LINE-TWO
297          AFTER ADVANCING 2 LINES.
298      WRITE PRINT-LINE FROM HEADING-LINE-THREE.
299
300      500-WRITE-DETAIL-LINE.

```

Size error on amount due for
REN-CONTRACT-NO

When other move zeroes to
IND-DAILY-RATE

Size error on insurance
total

Figure 9.13 (continued)

```

301     MOVE REN-CONTRACT-NO TO DET-CONTRACT-NO.
302     INSPECT DET-CONTRACT-NO REPLACING ALL ' ' BY '-'.
303     MOVE 1 TO NAME-POINTER.
304     MOVE SPACES TO DET-NAME.
305     STRING REN-LAST-NAME DELIMITED BY ' '
306           ', ' DELIMITED BY SIZE
307     REN-FIRST-NAME DELIMITED BY ' '
308     INTO DET-NAME POINTER NAME-POINTER
309     END-STRING.
310     IF REN-INITIAL NOT = SPACES
311       STRING ' ' REN-INITIAL '.' DELIMITED BY SIZE
312       INTO DET-NAME POINTER NAME-POINTER
313       END-STRING
314     END-IF.
315     STRING REN-RETURNED-MONTH '/' REN-RETURNED-DAY '/'
316           REN-RETURNED-YEAR DELIMITED BY SIZE
317     INTO DET-RETURN-DATE
318     END-STRING.
319     MOVE REN-CAR-TYPE TO DET-CAR-TYPE.
320     MOVE REN-DAYS-RENTED TO DET-DAYS-RENTED.
321     MOVE IND-DAILY-TOTAL TO DET-DAILY-TOTAL.
322     MOVE IND-MILES-DRIVEN TO DET-MILES-DRIVEN.
323     MOVE REN-MILEAGE-RATE TO DET-MILEAGE-RATE.
324     MOVE IND-MILEAGE-TOTAL TO DET-MILEAGE-TOTAL.
325     MOVE IND-INSURANCE-TOTAL TO DET-INSURANCE-TOTAL.
326     MOVE IND-MILEAGE-TOTAL TO DET-MILEAGE-TOTAL.
327     MOVE IND-AMOUNT-DUE TO DET-AMOUNT-DUE.
328     WRITE PRINT-LINE FROM DETAIL-LINE
329     AFTER ADVANCING 2 LINES.
330     ADD 1 TO LINE-COUNT.
331
332 600-INCREMENT-TOTALS.
333     ADD REN-DAYS-RENTED TO TOTAL-DAYS-RENTED
334     SIZE ERROR DISPLAY 'SIZE ERROR ON TOTAL DAYS RENTED'
335     END-ADD.
336     ADD IND-DAILY-TOTAL TO TOTAL-DAILY-RENTAL
337     SIZE ERROR DISPLAY 'SIZE ERROR ON TOTAL RENTAL'
338     END-ADD.
339     ADD IND-MILES-DRIVEN TO TOTAL-MILES-DRIVEN
340     SIZE ERROR DISPLAY 'SIZE ERROR ON TOTAL MILES DRIVEN'
341     END-ADD.
342     ADD IND-MILEAGE-TOTAL TO TOTAL-MILEAGE
343     SIZE ERROR DISPLAY 'SIZE ERROR ON TOTAL MILEAGE'
344     END-ADD.
345     ADD IND-INSURANCE-TOTAL TO TOTAL-INSURANCE
346     SIZE ERROR DISPLAY 'SIZE ERROR ON TOTAL INSURANCE'
347     END-ADD.
348     ADD IND-AMOUNT-DUE TO TOTAL-AMOUNT-DUE
349     SIZE ERROR DISPLAY 'SIZE ERROR ON TOTAL AMOUNT DUE'
350     END-ADD.
351

```

STRING statement joins last name and first name

Line counter is incremented

Figure 9.13 (continued)

| | | |
|-----|--|-----------------------|
| 352 | 700-WRITE-RENTAL-TOTALS. | |
| 353 | WRITE PRINT-LINE FROM TOTAL-DASH-LINE | |
| 354 | AFTER ADVANCING 2 LINES. | |
| 355 | MOVE TOTAL-DAYS-RENTED TO TOT-DAYS-RENTED. | |
| 356 | MOVE TOTAL-DAILY-RENTAL TO TOT-DAILY-RENTAL. | |
| 357 | MOVE TOTAL-MILES-DRIVEN TO TOT-MILES-DRIVEN. | |
| 358 | MOVE TOTAL-MILEAGE TO TOT-MILEAGE. | |
| 359 | MOVE TOTAL-INSURANCE TO TOT-INSURANCE. | |
| 360 | MOVE TOTAL-AMOUNT-DUE TO TOT-AMOUNT-DUE. | |
| 361 | WRITE PRINT-LINE FROM TOTAL-LINE. | WRITE FROM statements |

(A period may not be present after the END-READ scope terminator because it is nested within the in-line perform statement. See problem 2 at the end of the chapter.)

- The use of scope terminators throughout the Procedure Division—for example, END-READ in line 215, END-COMPUTE in lines 256 and 266, and END-IF in lines 242, 288, and 314.
- The establishment of a heading routine (lines 290–298) and the associated definition of counters in Working-Storage, LINE-COUNT and PAGE-COUNT in lines 50 and 51. LINE-COUNT is tested prior to writing a detail line (lines 240–242). Since it was initialized to six (a value greater than the desired number of detail lines per page), a heading is written prior to the first detail record. The heading routine resets the line counter (line 291), which is subsequently incremented after every detail line is written (line 330). The page counter is also incremented in the heading routine (line 292), so that the page number can appear on the top of every page in the report.
- The ACCEPT statement (line 223) to obtain the date of execution and again to accept the corresponding day of the week (line 227). The EVALUATE statement of lines 228–236 converts the numeric DAY-OF-WEEK code to its literal equivalent.
- The INITIALIZE statement in line 247 to initialize the six data names defined under IND-BILL-INFORMATION.
- The READ INTO statement in line 210 and the associated WS BEGINS HERE literal at the start of Working-Storage (lines 24–25) to facilitate debugging. The WRITE FROM statement is used throughout the Procedure Division with various print lines.
- The indentation of subservient clauses throughout the Procedure Division to enhance the readability of the program. AT END and NOT AT END are indented under READ, AFTER ADVANCING is indented under WRITE, and so on. Blank lines are used throughout the program and appear before 01 entries in the Data Division and before paragraph headers in the Procedure Division.
- The STRING statements in lines 305–309 and 311–313; the latter statements use the POINTER phrase to place the middle initial (if one is present) after the first name.

The chapter focused on advanced statements in the Procedure Division, many of which were not available in COBOL-74. The most significant enhancements include scope terminators, the in-line perform, and false-condition branch, all of which are new to COBOL-85. The TEST BEFORE and TEST AFTER clauses are also new, as are the INITIALIZE statement and DAY-OF-WEEK clause.

The statements for string processing (INSPECT, STRING, and UNSTRING) were previously available in COBOL-74; reference modification, however, is new to COBOL-85. Duplicate data names, qualification, and the MOVE CORRESPONDING statement are unchanged from the earlier compiler.

S U M M A R Y

Points to Remember

- The PERFORM statement contains the optional TEST BEFORE and TEST AFTER clauses, corresponding to the DO WHILE and DO UNTIL iteration structures.
- The combination of an in-line PERFORM and false-condition branch within the READ statement eliminates the need for a priming read.
- The procedure-name in a PERFORM statement may be either a paragraph or a section. The THRU clause enables the execution of multiple procedures, which typically include an EXIT paragraph.
- READ INTO and WRITE FROM combine the effects of a MOVE statement with the indicated I/O operation. READ INTO is also used in conjunction with the literal WS BEGINS HERE to facilitate debugging.
- String processing is accomplished through the INSPECT, STRING, and UNSTRING statements, which provide flexibility in character manipulation.
- The ACCEPT statement includes the DAY and DAY-OF-WEEK clauses to obtain the date and corresponding day of the week on which a program executes.
- The INITIALIZE statement sets multiple data names to initial values in a single statement.
- Duplicate data names may be defined (but are *not* recommended) provided all Procedure Division references to the duplicate names use appropriate qualification. The MOVE CORRESPONDING statement is the equivalent of several individual MOVE statements.

Key Words and Concepts

| | |
|---------------------------------|------------------------|
| DO UNTIL structure | Procedure name |
| DO WHILE structure | Qualification |
| Duplicate (nonunique) datanames | Reference modification |
| False-condition branch | Section |
| In-line perform | String processing |

COBOL Elements

| | |
|--------------------|---------------|
| ACCEPT | OF |
| DAY | PERFORM THRU |
| DAY-OF-WEEK | PERFORM UNTIL |
| EXIT | READ INTO |
| IN | STRING |
| INITIALIZE | TEST AFTER |
| INSPECT | TEST BEFORE |
| MOVE CORRESPONDING | UNSTRING |
| NOT AT END | WRITE FROM |

FILL-IN

1. The READ INTO statement causes each incoming record to be moved to _____ areas.
2. The WRITE FROM statement is the equivalent of two statements, a _____ and a _____.
3. A _____ consists of one or more paragraphs.
4. The _____ statement causes no action to be taken and is often used to delineate the end of a PERFORM THRU statement.
5. Nonunique data names within a COBOL program may be _____ using the reserved words _____ or _____.
6. The _____ statement is a convenient way to replace leading blanks in a field with zeros.
7. String processing operations are accomplished through the _____, _____, and _____ statements.
8. The READ statement includes an optional false-condition branch implemented by the _____ clause.
9. The DO WHILE and DO UNTIL constructs of structured programming are implemented with the TEST _____ and TEST _____ clauses in the PERFORM statement.
10. _____ makes it possible to address a string of characters contained within another string.

11. Omission of the procedure name in a PERFORM statement creates an _____ perform.
12. The _____ statement enables the initialization of multiple data types in a single statement.

TRUE / FALSE

1. The INSPECT statement facilitates the elimination of leading blanks.
2. A paragraph consists of one or more sections.
3. A PERFORM statement must include a procedure (paragraph or section) name.
4. Qualification over a single level will always remove ambiguity of duplicate data names.
5. The CORRESPONDING option is required if duplicate data names are used.
6. The STRING statement is used to combine several fields together.
7. For the CORRESPONDING option to work, both duplicate names must be at the same level.
8. The UNSTRING statement is used to separate a field into a maximum of three distinct fields.
9. The EXIT statement is required to delineate the end of a performed routine.
10. A PERFORM statement must specify either TEST BEFORE or TEST AFTER.
11. The READ statement may include both an AT END and a NOT AT END clause.
12. The READ statement must be terminated by an END-READ scope terminator.

PROBLEMS

1. Given the code:

```

PROCEDURE DIVISION.
MAINLINE SECTION.
FIRST-PARAGRAPH.
    PERFORM SEC-A.
    PERFORM PAR-C THRU PAR-E.
    MOVE 1 TO N.
    PERFORM PAR-G
        WITH TEST AFTER
        UNTIL N > 2.
STOP RUN.
SEC-A SECTION.
    ADD 1 TO X.
    ADD 1 TO Y.
    ADD 1 TO Z.
PAR-B.
    ADD 2 TO X.
PAR-C.
    ADD 10 TO X.
```

```

PAR-D.
  ADD 10 TO Y
  ADD 20 TO Z.
PAR-E.
  EXIT.
PAR-F.
  MOVE 2 TO N.
PAR-G.
  ADD 1 TO N
  ADD 5 TO X.

```

- a. How many times is each paragraph executed?
 - b. What are the final values of X, Y, and Z? (Assume they were all initialized to 0.)
 - c. What would happen if the statement ADD 1 TO N were removed from PAR-G?
2. Figure 9.14a contains a slightly modified version of the first paragraph in the car reporting program in which two periods have been added to produce the indicated compilation errors. Indicate the erroneous periods and explain why they produce the error messages.

Figure 9.14 COBOL Listing for Problem 2

```

204     PROCEDURE DIVISION.
205     000-PREPARE-RENTAL-REPORT.
206         OPEN INPUT RENTAL-FILE
207             OUTPUT PRINT-FILE.
208     PERFORM 100-GET-TODAYS-DATE.
209     PERFORM UNTIL DATA-REMAINS-SWITCH = 'NO'
210         READ RENTAL-FILE INTO RENTAL-RECORD-IN
211             AT END
212                 MOVE 'NO' TO DATA-REMAINS-SWITCH.
213             NOT AT END
214                 PERFORM 200-PROCESS-RENTAL-RECORDS.
215     END-READ.
216     END-PERFORM.
217     PERFORM 700-WRITE-RENTAL-TOTALS.
218     CLOSE RENTAL-FILE
219         PRINT-FILE.
220     STOP RUN.

```

(a) Modified Procedure Division

```

209 W Explicit scope terminator END- 'PERFORM' assumed present
213 E AT END exception only valid for READ or SEARCH verbs
215 E No corresponding active scope for 'END-READ'
216 E No corresponding active scope for 'END-PERFORM'

```

(b) Error Messages

3. Is the following list of names in alphabetical order?

Joel Stutz
Maryann Barber
Shelly Parker

Your answer depends on the record layout, that is, whether Name is a single field or whether Last Name, First Name, and Middle Initial are defined as individual fields. Can you see the need to define separate fields for these items? Can you appreciate the utility of the STRING statement to concatenate the fields together when necessary?

4. Given the following Data Division entries:

```
01 EMPLOYEE-RECORD.
   05 EMP-NAME.
      10 EMP-LAST-NAME      PIC X(16).
      10 EMP-FIRST-NAME    PIC X(10).
      10 EMP-MIDDLE-INITIAL PIC X.
   05 ADDRESS.
      10 EMP-STREET-ADDRESS PIC X(20).
      10 EMP-CITY           PIC X(20).
      10 EMP-STATE         PIC XX.
      10 EMP-ZIP           PIC X(5).
```

Write the necessary STRING statements to create a mailing label with the format:

First-Name Middle-Initial Last-Name
Street-Address
City, State Zip

5. Given the following COBOL fragment:

```
01 DATE-WORK-AREA-1.
   05 YEAR-1          PIC 99.
   05 MONTH-1        PIC 99.
   05 DAY-1          PIC 99.
01 DATE-WORK-AREA-2.
   05 YEAR-2          PIC 99.
   05 DAY-2          PIC 999.
01 DATE-WORK-AREA-3.
   05 DAY-3          PIC 9.
```

```
ACCEPT DATE-WORK-AREA-1 FROM DATE.
ACCEPT DATE-WORK-AREA-2 FROM DAY.
ACCEPT DATE-WORK-AREA-3 FROM DAY-OF-WEEK.
```

Indicate the stored values of each of the elementary items in the program. Assume a date of execution of March 16, 1993 (a Tuesday).

6. Given the following COBOL fragment:

```
01 DATE-WORK-AREA          PIC X(6).
01 EDITED-DATE.
   05 EDIT-MONTH          PIC XX.
   05 FILLER              PIC X   VALUE '/'.
   05 EDIT-DAY            PIC XX.
   05 FILLER              PIC X   VALUE '/'
   05 EDIT-YEAR           PIC XX.
```

```
ACCEPT DATE-WORK-AREA FROM DATE.
MOVE DATE-WORK-AREA (3:2) TO EDIT-MONTH.
MOVE DATE-WORK-AREA (5:2) TO EDIT-DAY.
MOVE DATE-WORK-AREA (1:2) TO EDIT-YEAR.
```

Indicate the stored values of EDIT-MONTH, EDIT-DAY, and EDIT-YEAR. (Assume the same date as in the previous problem.)

7. Given the following COBOL definition:

```
01 GROUP-ITEM
   05 NUMERIC-FIELD-1      PIC 9(4).
   05 NUMERIC-FIELD-2      PIC 9(4).
   05 ALPHANUMERIC-FIELD-1 PIC X(15).
   05 ALPHANUMERIC-FIELD-2 PIC X(20).
```

What difference (if any) is there between the following statements?

- a. INITIALIZE.
- and
- INITIALIZE GROUP-ITEM.
- b. INITIALIZE GROUP-ITEM.
- and
- INITIALIZE GROUP-ITEM
- REPLACING NUMERIC DATA BY ZERO
- ALPHANUMERIC DATA BY SPACES.
- c. INITIALIZE GROUP-ITEM.
- and
- MOVE ZEROS TO NUMERIC-FIELD-1 NUMERIC-FIELD-2.
- MOVE SPACES TO ALPHANUMERIC-FIELD-1 ALPHANUMERIC-FIELD-2.

10

Screen I-O

CHAPTER OUTLINE

Overview

ACCEPT

Programming Tip: The Use of COBOL Constants

DISPLAY

The Tuition Billing Program Revisited

Programming Specifications

Hierarchy Chart

Pseudocode

The Completed Program

Programming Tip: The Hidden Power of the Alt Key

Car Validation and Billing Program

Programming Specifications

The Screen Section

Hierarchy Chart

Pseudocode

The Completed Program

Limitations of COBOL-74

Summary

Fill-in

True/False

Problems

OBJECTIVES

After reading this chapter you will be able to:

- Discuss the concept of screen I-O versus the file-oriented approach of earlier chapters.
- Describe the ACCEPT and DISPLAY statements; discuss at least three optional clauses for each statement.
- Describe the SCREEN SECTION and indicate why its use may be preferable to individual ACCEPT and DISPLAY statements.
- Differentiate between the background and foreground colors; implement a color scheme using ACCEPT and DISPLAY statements and/or the Screen Section.
- Describe how interactive data validation is implemented in a screen I-O program; contrast this technique to the batch-oriented procedure in Chapter 8.

OVERVIEW

The proliferation of the PC has increased the importance of screen I-O, whereby input to a program is received from the keyboard and output is displayed on the monitor. The specific options (color, highlighting, positioning, and so on) vary according to the particular keyboard or monitor (display terminal) and are *not* part of the COBOL-85 standard. Virtually all compilers, however, include these capabilities as an *extension* to the 85 standard, and hence we do our best to describe them in general fashion. The syntax is that of Micro Focus Personal COBOL that accompanies this text. (Personal COBOL conforms to the X-Open standard, developed by of a consortium of software vendors including Microsoft, and has been proposed as an official extension to the 2000 standard.)

The chapter begins with the ACCEPT and DISPLAY statements that are used for low-volume input and output and that reference specific line and column positions. Both statements contain an abundance of optional clauses that are illustrated in a final version of the tuition-billing program that first appeared in Chapter 5.

The second half of the chapter focuses on the Screen Section to define an entire screen as opposed to individual lines. We combine the data validation and reporting programs of Chapters 8 and 9 to produce an interactive program that validates data as it is entered, and produces an on-screen result.

ACCEPT

The **ACCEPT** statement enables data to be entered in specific positions according to a precise format. The statement contains a required identifier—that is, a data

name to hold the input data, followed by optional clauses that can be entered in any order.

As indicated, the specific implementation for screen I-O is not defined in the COBOL-85 standard, but has been proposed as an extension to that standard. Our examples follow the syntax of Personal COBOL that accompanies this text. Consider:

```
ACCEPT identifier [AT]
[LINE NUMBER {identifier-1} ] [ {COLUMN}
  {integer-1} ] [ {COL} NUMBER {identifier-2}
  {integer-2} ]
[WITH [AUTO] [BACKGROUND-COLOR IS integer-3] [ {BELL}
  {BEEP} ] [BLINK]
[FOREGROUND-COLOR IS integer-4] [HIGHLIGHT] [SECURE] [REVERSE-VIDEO]
[CONTROL IS {identifier-3}]
[ {LEFT-JUSTIFY} {SPACE-FILL} ] [TRAILING SIGN] [UNDERLINE] [UPDATE]
[ {RIGHT-JUSTIFY} {ZERO-FILL} ] ]
```

The **LINE** and **COLUMN** clauses provide the location for the data. (The typical screen displays 25 lines of 80 columns.) Both clauses are optional with default actions as follows. Omission of the **LINE** clause defaults to line one if a previous screen element has not been defined, or to the existing line otherwise. Omission of the **COLUMN** clause defaults to column one if the **LINE** clause is also specified, and to the next column (after the last screen element) if the **LINE** clause is also omitted.

The **BACKGROUND-COLOR** and **FOREGROUND-COLOR** clauses specify the background and foreground colors, respectively, with the available colors listed in Table 10.1. Any of the sixteen listed colors may be specified for the foreground, but only the first eight (numbered from zero to seven) may be specified as the background. The default colors for the background and foreground are black and white, respectively, corresponding to white text on a black background. In Personal COBOL the integer or a constant representing that integer must be used. A data name does *not* work. See Programming Tip on Micro Focus constants.

PROGRAMMING TIP

Micro Focus Level 78 - The Use of COBOL Constants

in Micro Focus's version of the Screen Section, the **ACCEPT** and **DISPLAY** verbs require the use of an integer to specify **BACKGROUND-COLOR** and **FOREGROUND-COLOR**. Specifying colors by number rather than name can be confusing. Fortunately, there is a way to meet the requirements of using an integer while maintaining the clarity of a color name. Micro Focus provides for a new level number - 78-level. The 78-level is a way of defining and naming a constant value. The syntax for a 78-level is similar to that of the 88-level, but only one literal can be specified.

78 DATA-NAME VALUE LITERAL.

The 78-level does not need a PIC clause since the compiler will allocate space on the basis of the data format of the literal. Examples:

```
78 MAGENTA           VALUE 5.
78 YES               VALUE 'Y'.
78 ERROR-1          VALUE 'Entry must be Y or N'.
```

Wherever each of these entries are referenced the constant values are used. Constants are particularly useful when a literal must be used. The BACKGROUND-COLOR and FOREGROUND-COLOR clauses for defining ACCEPT and DISPLAY statements are the prime examples.

Level-78s are standalone data-items and the compiler does not treat them as subordinate to any group item. Therefore, if you wish to group the items as in line 16-34 of Figure 10-4, the 01-level must have a PIC clause. The PIC has no effect on the following level-78s. Without the PIC, COBOL thinks that the 01-level has no length.

You should remember that level-78s are not standard COBOL entries. We have introduced them simply to make the screen I-O programs more readable.

TABLE 10.1 Foreground and Background Colors

| | |
|----|-----------------------|
| 0 | Black |
| 1 | Blue |
| 2 | Green |
| 3 | Cyan |
| 4 | Red |
| 5 | Magenta |
| 6 | Brown |
| 7 | White |
| 8 | Bright black (gray) |
| 9 | Bright blue |
| 10 | Bright green |
| 11 | Bright cyan |
| 12 | Bright red |
| 13 | Bright magenta |
| 14 | Bright brown (yellow) |
| 15 | Bright white |

The **AUTO** clause terminates the ACCEPT statement when the last character in the data item has been entered; the user does not have to press the return key for processing to continue. If, however, multiple data names are entered into the same ACCEPT statement, the AUTO clause moves the cursor to the first character of the next item.

The **HIGHLIGHT**, **REVERSE-VIDEO**, **BLINK**, and **UNDERLINE** clauses are used for emphasis, and their intended effects are apparent: **BLINK** causes characters to blink on and off, **UNDERLINE** underlines each character as it is displayed on the screen, and **HIGHLIGHT** displays a field at its highest intensity. The **REVERSE-VIDEO** clause displays light characters on a dark background; that is, the characters are dark and the area surrounding the characters is light. The synonymous **BELL** and **BEEP** clauses sound the system's audio tone when the referenced data item is processed during execution of the ACCEPT statement.

The **CONTROL** option allows any of the other clauses to be specified in an identifier. The identifier can be changed by the program allowing flexibility in appearance of the entry.

The **ZERO-FILL** option displays a numeric item with high-order zeros, whereas the (default) **SPACE-FILL** clause displays data with zero suppression. The **RIGHT-JUSTIFY** clause makes operator-keyed characters align in the rightmost character position of the field and is for elementary items only. **LEFT-JUSTIFY** (the default) is for documentation only and has no effect. The **SPACE-FILL**, **ZERO-FILL**, **LEFT-JUSTIFY**, and **RIGHT-JUSTIFY** clauses are allowed only for elementary items.

The **UPDATE** option displays the initial value of the data item before the operator is prompted for new input, and if no new data are entered, the initial data are treated as though they were operator keyed. **UPDATE** is not allowed for a numeric-edited item.

The **SECURE** clause prevents the accepted data item from appearing on the screen and is useful in implementing *password protection* and/or other security considerations.

SPLAY

The **DISPLAY** statement was introduced in Chapter 3 in conjunction with top-down testing and referenced again in Chapter 6 for use in debugging. In both instances the simplest form of the statement was used at strategic points in a program, to display messages and/or intermediate results to help monitor program execution. The **DISPLAY** statement also has many additional options to enhance its output. Consider:

```

DISPLAY { identifier-1 }
        { literal-1 }
        [ AT LINE NUMBER { identifier-2 } ] [ COLUMN NUMBER { identifier-3 } ]
        [ WITH [ BACKGROUND-COLOR IS integer-3 ] [ BELL ] [ BEEP ] [ BLINK ] ]
        [ FOREGROUND-COLOR IS integer-4 ] [ HIGHLIGHT ] [ REVERSE-VIDEO ]
        [ CONTROL IS { identifier-4 } ]
        [ UNDERLINE ] [ BLANK { SCREEN } ]

```

Many of the clauses in the **DISPLAY** statement have been explained in conjunction with the **ACCEPT** statement; for example, you can use the **LINE** and **COLUMN** clauses to control the specific position where the displayed output is to appear. You can also emphasize the displayed message by blinking, beeping, underlining, or reverse video. You can (on a color monitor) implement a variety of color schemes for both the foreground (text) and background.

The **DISPLAY** statement also enables you to clear all or a portion of the screen prior to displaying a data element. The **BLANK SCREEN** clause clears the entire screen and leaves the cursor positioned in line 1, column 1. The **BLANK LINE** clause blanks the associated line beginning in column 1 unless a column is specified. Specification of either entry, **BLANK SCREEN** or **BLANK LINE**, also reactivates the default background and foreground colors.

The Tuition Billing Program Revisited

The tuition-billing program has appeared several times throughout the text. It was first presented in Chapter 3 in conjunction with structured methodology, used in Chapters 4 and 5 to introduce basic COBOL statements, and expanded in Chapter 7 to include editing characters. We continue now with one final version to illustrate screen I-O, whereby student data are accepted for one student at a time, after which the computed bill (for that student) is displayed on the monitor.

The programming specifications parallel the original problem statement on page 49 with minor modifications to reflect the interactive nature of screen I-O. Thus, unlike the original file-based program, which processed students until the input file was exhausted, the screen-based program accepts data for one student at a time, then asks the user whether data for another student are to be entered. The screen I-O program also imposes the requirement for a valid password prior to processing the first student, and it eliminates the calculation of university totals. The formal specifications follow in the usual format.

PROGRAMMING SPECIFICATIONS

Program Name: Tuition Billing Program (Screen Version)

Narrative: This program modifies the specifications for the original tuition billing program to accommodate screen I-O. Incoming records are to be entered one at a time via the keyboard with computed results for each student displayed as they are calculated.

Screen Layouts: The password is to be masked and entered as per the screen in Figure 10.1a, student data are to be entered according to the screen in Figure 10.1b, and the computed results displayed as in Figure 10.1c.

- Processing Requirements:**
1. Develop an *interactive program* to accept student data, then compute and display the student's bill. The program is to execute continually until it receives a response indicating that no more students are to be processed.
 2. The program is to check for a valid password prior to accepting data for the first student. (The password is COBOL in either all upper- or all lowercase letters) The user is allowed a maximum of two tries to enter the password correctly, after which the program is to terminate with an appropriate error message.
 3. The specifications for computing an individual student's bill are the same as in the original program:
 - a. Compute the individual bill as the sum of tuition, union fee, and activity fee, minus a scholarship (if any).
 - b. The tuition is \$200 per credit.
 - c. The union fee is \$25.
 - d. The activity fee is based on the number of credits taken:

| ACTIVITY FEE | CREDITS |
|--------------|--------------|
| \$25 | 6 or less |
| \$50 | 7-12 |
| \$75 | more than 12 |
 - e. Award a scholarship equal to the amount in the incoming record if the GPA is greater than 2.5.
 4. The requirement to compute university totals has been deleted.

Figure 10.1 Tuition Billing Program (Screen I-O)

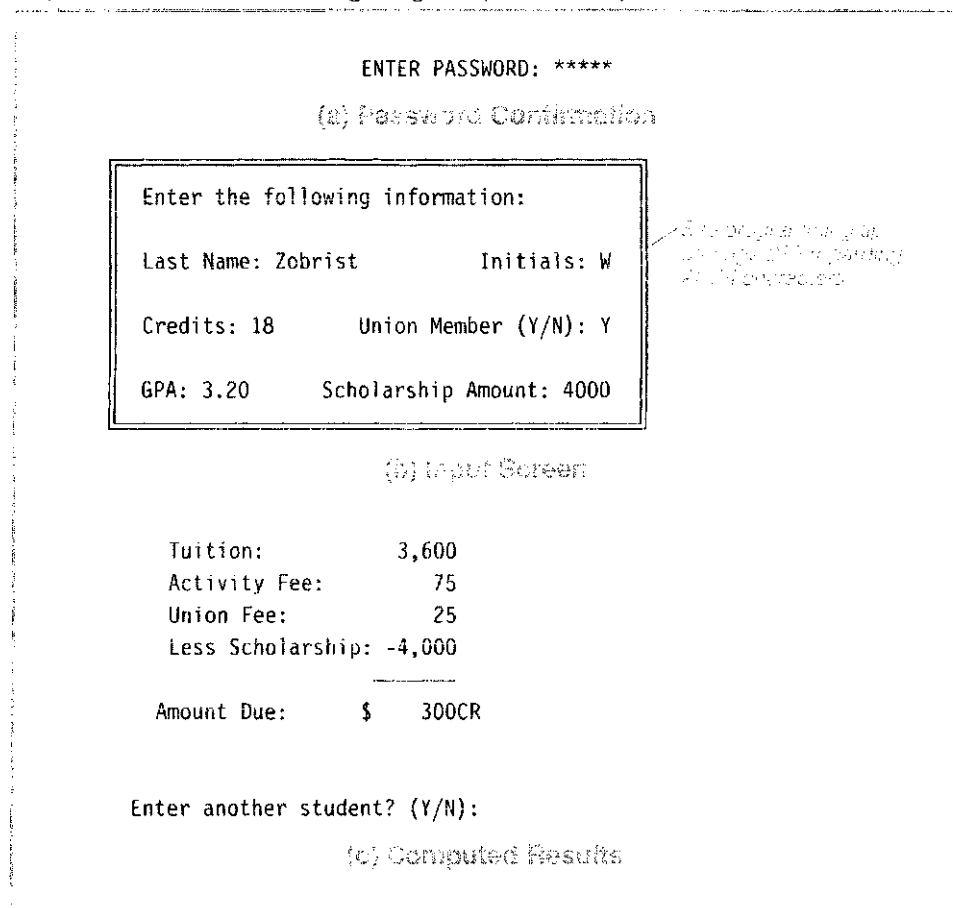

Hierarchy Chart

The hierarchy chart for the screen version of the tuition billing program is shown in Figure 10.2. The highest-level module, PROCESS-STUDENT-DATA, has four subordinates: PROCESS-PASSWORD, INPUT-STUDENT-INFO, COMPUTE-INDIVIDUAL-BILL, and DISPLAY-STUDENT-BILL. COMPUTE-STUDENT-BILL has four subordinates of its own: COMPUTE-TUITION, COMPUTE-UNION-FEE, COMPUTE-ACTIVITY-FEE, and COMPUTE-SCHOLARSHIP, all of which appeared in the original hierarchy chart.

The requirement to compute university totals has been dropped from the programming specifications, and thus the modules associated with this function that appeared in the original hierarchy chart (Figure 3.3) have been dropped from the current version.

Pseudocode

The pseudocode in Figure 10.3 contains two iterative structures, a DO UNTIL associated with obtaining the password, and a DO WHILE to process student data. The difference between the two is significant and was explained previously in Chapter 9 (see Figure 9.1). Recall, therefore, that the DO UNTIL structure tests the condition *after* executing the indicated statements and thus ensures that those statements are executed at least once. A DO WHILE, however, tests the condition *before* executing the statements, and hence the indicated statements need not be executed at all.

Figure 10.2 Hierarchy Chart for Tuition Billing Program (Screen Version)

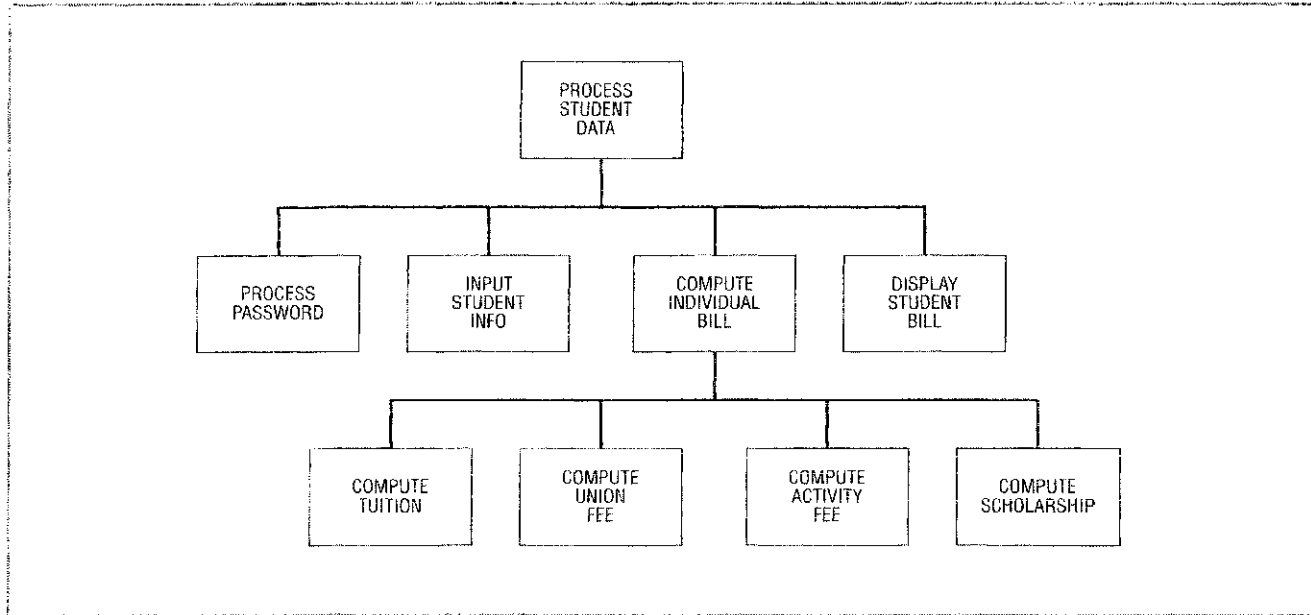
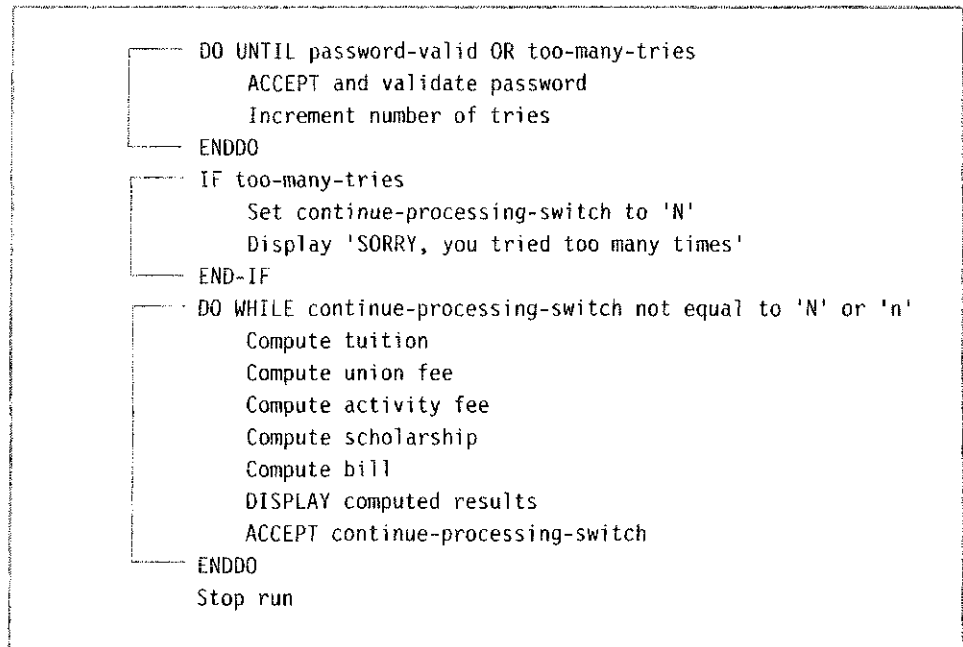

Figure 10.3 Pseudocode for Tuition Billing Program (Screen Version)



The user must be given *at least* one try to enter the password and hence the DO UNTIL structure is used to accept and validate (reject) the user's entry. If the user fails to enter the correct password within the allocated number of tries, the continue-processing-switch will be set to 'N', which prevents the execution of statements within the DO WHILE loop; that is, the program terminates without processing a student record.

The Completed Program

The completed program is shown in Figure 10.4 and reflects the hierarchy chart and pseudocode just discussed. It is different from all previous programs in that input is received from the keyboard and output is displayed on the monitor. Thus, there are no files in this program, and hence no need for an Environment Division (and the associated SELECT statements), nor for the File Section in the Data Division. The absence of all files also means that the Procedure Division does not contain the familiar OPEN, CLOSE, READ, and WRITE statements that were present in all previous programs.

All I-O is screen based and accomplished through ACCEPT and DISPLAY statements with LINE and COLUMN clauses to control the location of the displayed fields. Different colors are used for different areas of the screen as implemented through the COLOR clauses that appear throughout the program; the available colors are defined as data names in lines 16–34, then referenced as necessary in the various ACCEPT and DISPLAY statements.

The imposition of a password is accomplished through the in-line PERFORM statement in lines 80–89, which uses the TEST AFTER clause to give the user two chances to enter the password correctly. The SECURE clause, in the ACCEPT statement of lines 87 and 88, prevents the user's response from appearing on the screen, and the AUTO clause saves the user from having to press the return key. The BLANK SCREEN clause in line 84 clears the screen before requesting the password. The program accepts either COBOL or cobol as a valid password according to the 88-level entry in line 38; it will not, however, recognize a combination of upper- and lowercase letters.

Once a valid password has been entered, the program processes students one at a time through the in-line PERFORM statement in lines 72–76, which invokes three lower-level paragraphs for each student: 200-INPUT-STUDENT-INFO, 310-COMPUTE-INDIVIDUAL-BILL, and 500-DISPLAY-STUDENT-BILL. The latter paragraph ends by obtaining the user response regarding another student (lines 189–191). Note, too, the provision for both upper- and lowercase data entry as the CONTINUE-PROCESSING-SWITCH in line 72 is compared to both 'N' and 'n'.

One last comment concerns the double line that appeared around the user's input in the screen of Figure 10.1b. This was accomplished by including the necessary ASCII (graphics) characters in the DISPLAY statements of lines 99 through 117. (See programming tip on the Alt key and numeric keypad.)

PROGRAMMING TIP

The Hidden Power of the Alt Key

Newcomers to the computer recognize the Alt key as the middle key in the Ctrl, Alt, and Del sequence to reboot the computer. It has many more uses, however, one of which is to reproduce any character within the 256 ASCII character set shown in the table below.

| | | | | | | | | | | |
|----|---|---|---|---|---|---|----|---|---|---|
| 00 | 0 | 1 | 2 | 3 | 4 | 5 | 6 | 7 | 8 | 9 |
| 01 | ☐ | ☉ | ☊ | ♥ | ♦ | ♣ | ♠ | • | ■ | ○ |
| 02 | ☒ | ♂ | ♀ | ♪ | ♫ | * | ▶ | ◀ | † | ‡ |
| 03 | ☓ | § | - | ‡ | † | ↓ | → | ← | ┌ | ↕ |
| 04 | ▲ | ▼ | * | ! | " | # | \$ | % | & | ' |
| 05 | (|) | * | + | , | - | . | / | 0 | 1 |
| 06 | < | = | > | ? | @ | A | B | C | D | E |
| 07 | F | G | H | I | J | K | L | M | N | O |
| 08 | P | Q | R | S | T | U | V | W | X | Y |
| 09 | Z | [| \ |] | ^ | _ | ` | a | b | c |
| 10 | d | e | f | g | h | i | j | k | l | m |
| 11 | n | o | p | q | r | s | t | u | v | w |
| 12 | x | y | z | { | | } | ~ | À | Á | Â |
| 13 | é | â | ä | À | Á | Â | Ë | È | É | Ê |
| 14 | î | ì | Ë | Ö | Ü | Ç | æ | Ë | ô | ö |
| 15 | û | ù | Ï | Ö | Ü | Ç | æ | Ë | ô | ö |
| 16 | á | í | ó | ú | ñ | Ñ | • | ° | ¸ | ˆ |
| 17 | ˜ | ½ | ¼ | ı | « | » | ı | ı | ı | ı |
| 18 | ı | ı | ı | ı | ı | ı | ı | ı | ı | ı |
| 19 | ı | ı | ı | ı | ı | ı | ı | ı | ı | ı |
| 20 | ı | ı | ı | ı | ı | ı | ı | ı | ı | ı |
| 21 | ı | ı | ı | ı | ı | ı | ı | ı | ı | ı |
| 22 | ı | ı | ı | ı | ı | ı | ı | ı | ı | ı |
| 23 | ı | ı | ı | ı | ı | ı | ı | ı | ı | ı |
| 24 | ı | ı | ı | ı | ı | ı | ı | ı | ı | ı |
| 25 | ı | ı | ı | ı | ı | ı | ı | ı | ı | ı |

The double vertical line, for example, is found in row 18, column 6 of the table, and thus, is ASCII character 186; it is entered into a program file by *holding the Alt key down, and typing 1, 8, and 6, from the numeric keyboard*. In similar fashion, a double horizontal line is found in row 20, column 5, and thus is ASCII character number 205. Four other characters, corresponding to the four corners, are required to complete the box.

The printer, however, is a limiting factor, because while all of the 256 symbols will appear on an ordinary monitor, they are not necessarily supported on every printer.

Figure 10.4 Screen Version of Tuition Billing Program

```

1  IDENTIFICATION DIVISION.
2  PROGRAM-ID.    SCRNTUIT.
3  AUTHOR.       CAROL VAZQUEZ VILLAR.
4
5  DATA DIVISION.
6  WORKING-STORAGE SECTION.
7  01 STUDENT-DATA.
8     05 STU-NAME.
9         10 STU-LAST-NAME    PIC X(15).
10        10 STU-INITIALS    PIC XX.
11     05 STU-CREDITS        PIC 9(2).
12     05 STU-UNION-MEMBER   PIC X.
13     05 STU-SCHOLARSHIP    PIC 9(4).
14     05 STU-GPA            PIC 9V99.
15
16     01 SCREEN-COLORS      PIC S9(4) COMP-5.
17     * COLORS FOR FOREGROUND AND BACKGROUND
18         78 BLACK          VALUE 0.
19         78 BLUE           VALUE 1.
20         78 GREEN         VALUE 2.
21         78 CYAN          VALUE 3.
22         78 RED           VALUE 4.
23         78 MAGENTA       VALUE 5.
24         78 BROWN         VALUE 6.
25         78 WHITE         VALUE 7.
26     * ADDITIONAL COLORS FOR FOREGROUND ONLY
27         78 BRIGHT-BLACK  VALUE 8.
28         78 BRIGHT-BLUE   VALUE 9.
29         78 BRIGHT-GREEN  VALUE 10.
30         78 BRIGHT-CYAN   VALUE 11.
31         78 BRIGHT-RED    VALUE 12.
32         78 BRIGHT-MAGENTA VALUE 13.
33         78 BRIGHT-BROWN  VALUE 14.
34         78 BRIGHT-WHITE  VALUE 15.
35
36     01 PASSWORD-VARIABLES.
37         05 PASSWORD-ENTERED PIC X(5).
38         88 VALID-PASSWORD  VALUE 'COBOL' 'cobol'.
39         05 TRIES-COUNTER   PIC 9.
40         88 TOO-MANY-TRIES  VALUE 3.
41
42     01 CONTINUE-PROCESSING-SWITCH PIC X VALUE 'Y'.
43
44     01 INDIVIDUAL-CALCULATIONS.
45         05 IND-TUITION     PIC 9(4) VALUE ZEROS.
46         05 IND-ACTIVITY-FEE PIC 9(2) VALUE ZEROS.
47         05 IND-UNION-FEE   PIC 9(2) VALUE ZEROS.
48         05 IND-SCHOLARSHIP PIC 9(4) VALUE ZEROS.
49         05 IND-BILL        PIC S9(6) VALUE ZEROS.
50
51     01 DISPLAY-CALCULATIONS.

```

SCREEN-COLORS
PIC S9(4) COMP-5

ADDITIONAL COLORS FOR FOREGROUND ONLY
VALUE 8-15

Figure 10.4 (continued)

```

52         05 DIS-TUITION             PIC Z,ZZ9.
53         05 DIS-ACTIVITY-FEE       PIC Z9.
54         05 DIS-UNION-FEE          PIC Z9.
55         05 DIS-SCHOLARSHIP        PIC Z,ZZ9.
56         05 DIS-BILL               PIC $$$,ZZ9CR.
57
58     01 CONSTANTS-AND-RATES.
59         05 PRICE-PER-CREDIT        PIC 9(3) VALUE 200.
60         05 UNION-FEE              PIC 9(2) VALUE 25.
61         05 ACTIVITY-FEES.
62             10 1ST-ACTIVITY-FEE    PIC 99 VALUE 25.
63             10 1ST-CREDIT-LIMIT    PIC 99 VALUE 6.
64             10 2ND-ACTIVITY-FEE    PIC 99 VALUE 50.
65             10 2ND-CREDIT-LIMIT    PIC 99 VALUE 12.
66             10 3RD-ACTIVITY-FEE    PIC 99 VALUE 75.
67         05 MINIMUM-SCHOLAR-GPA     PIC 9V9 VALUE 2.5.
68
69     PROCEDURE DIVISION.
70     000-PROCESS-STUDENT-DATA.
71         PERFORM 100-PROCESS-PASSWORD.
72         PERFORM UNTIL CONTINUE-PROCESSING-SWITCH = 'N' OR 'n'
73             PERFORM 200-INPUT-STUDENT-INFO
74             PERFORM 310-COMPUTE-INDIVIDUAL-BILL
75             PERFORM 500-DISPLAY-STUDENT-BILL
76         END-PERFORM.
77     STOP RUN.
78
79     100-PROCESS-PASSWORD.
80         PERFORM WITH TEST AFTER
81             VARYING TRIES-COUNTER FROM 1 BY 1
82             UNTIL VALID-PASSWORD OR TOO-MANY-TRIES
83             DISPLAY 'ENTER PASSWORD: ' LINE 12 COLUMN 30
84                 WITH BLANK SCREEN
85                 FOREGROUND-COLOR BRIGHT-GREEN
86                 BACKGROUND-COLOR MAGENTA
87             ACCEPT PASSWORD-ENTERED LINE 12 COLUMN 46
88                 WITH REVERSE-VIDEO AUTO SECURE
89         END-PERFORM.
90     IF TOO-MANY-TRIES
91         MOVE 'N' TO CONTINUE-PROCESSING-SWITCH
92         DISPLAY 'SORRY, You tried too many times'
93             LINE 24 COLUMN 22 WITH BLINK
94             FOREGROUND-COLOR WHITE
95             BACKGROUND-COLOR RED
96     END-IF.
97
98     200-INPUT-STUDENT-INFO.
99         DISPLAY '#####'
100            AT LINE 2 COLUMN 5 WITH BLANK SCREEN
101            FOREGROUND-COLOR BRIGHT-BROWN
102            BACKGROUND-COLOR BLUE.

```

Initial screen output of program divided into three sections.

TEST AFTER clause ensures that in-line statements are executed at least once.

Use of color in screen output.

Figure 10.4 (continued)

```

103     DISPLAY '~ Enter the following information:           '~
104         AT LINE 3 COLUMN 5.
105     DISPLAY '~                                           '~
106         AT LINE 4 COLUMN 5.
107     DISPLAY '~ Last Name:                               Initials: '~
108         AT LINE 5 COLUMN 5.
109     DISPLAY '~                                           '~
110         AT LINE 6 COLUMN 5.
111     DISPLAY '~ Credits:                               Union Member (Y/N): '~
112         AT LINE 7 COLUMN 5.
113     DISPLAY '~                                           '~
114         AT LINE 8 COLUMN 5.
115     DISPLAY '~ GPA:                                   Scholarship Amount: '~
116         AT LINE 9 COLUMN 5.
117     DISPLAY '~ ~~~~~~'
118         AT LINE 10 COLUMN 5.
119     ACCEPT STU-LAST-NAME AT LINE 5 COLUMN 18.
120     ACCEPT STU-INITIALS AT LINE 5 COLUMN 45.
121     ACCEPT STU-CREDITS AT LINE 7 COLUMN 16.
122     ACCEPT STU-UNION-MEMBER AT LINE 7 COLUMN 45 WITH AUTO.
123     ACCEPT STU-GPA AT LINE 9 COLUMN 16 WITH AUTO.
124     ACCEPT STU-SCHOLARSHIP AT LINE 9 COLUMN 45.
125
126     310-COMPUTE-INDIVIDUAL-BILL.
127         PERFORM 410-COMPUTE-TUITION.
128         PERFORM 430-COMPUTE-UNION-FEE.
129         PERFORM 460-COMPUTE-ACTIVITY-FEE.
130         PERFORM 490-COMPUTE-SCHOLARSHIP.
131         COMPUTE IND-BILL = IND-TUITION + IND-UNION-FEE +
132             IND-ACTIVITY-FEE - IND-SCHOLARSHIP
133         SIZE ERROR DISPLAY 'SIZE ERROR FOR INDIVIDUAL BILL'
134     END-COMPUTE.
135
136     410-COMPUTE-TUITION.
137         COMPUTE IND-TUITION = PRICE-PER-CREDIT * STU-CREDITS
138         SIZE ERROR DISPLAY 'SIZE ERROR FOR INDIVIDUAL TUITION'
139     END-COMPUTE.
140
141     430-COMPUTE-UNION-FEE.
142     IF STU-UNION-MEMBER = 'Y' or 'y'
143         MOVE UNION-FEE TO IND-UNION-FEE
144     ELSE
145         MOVE ZERO TO IND-UNION-FEE
146     END-IF.
147
148     460-COMPUTE-ACTIVITY-FEE.
149     EVALUATE TRUE
150         WHEN STU-CREDITS <= 1ST-CREDIT-LIMIT
151             MOVE 1ST-ACTIVITY-FEE TO IND-ACTIVITY-FEE
152         WHEN STU-CREDITS > 1ST-CREDIT-LIMIT
153             AND STU-CREDITS <= 2ND-CREDIT-LIMIT

```

IF statement checks for upper and lower case

Figure 10.4 (continued)

```

154             MOVE 2ND-ACTIVITY-FEE TO IND-ACTIVITY-FEE
155             WHEN STU-CREDITS > 2ND-CREDIT-LIMIT
156             MOVE 3RD-ACTIVITY-FEE TO IND-ACTIVITY-FEE
157             WHEN OTHER
158             DISPLAY 'INVALID CREDITS FOR: ' STU-NAME
159             END-EVALUATE.
160
161 490-COMPUTE-SCHOLARSHIP.
162     IF STU-GPA > MINIMUM-SCHOLAR-GPA
163     MOVE STU-SCHOLARSHIP TO IND-SCHOLARSHIP
164     ELSE
165     MOVE ZERO TO IND-SCHOLARSHIP
166     END-IF.
167
168 500-DISPLAY-STUDENT-BILL.
169     MOVE IND-TUITION TO DIS-TUITION.
170     DISPLAY 'Tuition:' AT LINE 12 COLUMN 10.
171     DISPLAY DIS-TUITION AT LINE 12 COLUMN 29.
172
173     MOVE IND-ACTIVITY-FEE TO DIS-ACTIVITY-FEE.
174     DISPLAY 'Activity Fee:' AT LINE 13 COLUMN 10.
175     DISPLAY DIS-ACTIVITY-FEE AT LINE 13 COLUMN 32.
176
177     MOVE IND-UNION-FEE TO DIS-UNION-FEE.
178     DISPLAY 'Union Fee:' AT LINE 14 COLUMN 10.
179     DISPLAY DIS-UNION-FEE AT LINE 14 COLUMN 32.
180
181     MOVE IND-SCHOLARSHIP TO DIS-SCHOLARSHIP.
182     DISPLAY 'Less Scholarship: -' AT LINE 15 COLUMN 10.
183     DISPLAY DIS-SCHOLARSHIP AT LINE 15 COLUMN 29.
184
185     DISPLAY '-----' AT LINE 16 COLUMN 27.
186     MOVE IND-BILL TO DIS-BILL.
187     DISPLAY 'Amount Due:' AT LINE 17 COLUMN 9.
188     DISPLAY DIS-BILL AT LINE 17 COLUMN 26.
189     DISPLAY 'Enter another student? (Y/N):'
190     AT LINE 20 COLUMN 7.
191     ACCEPT CONTINUE-PROCESSING-SWITCH AT LINE 20 COLUMN 37.

```

LINE and COLUMN clause control screen output

Contains response for next student

Car Validation and Billing Program

The concept of *data validation* was introduced in Chapter 8 in the form of a stand-alone edit program that processed a file of incoming transactions, rejected invalid transactions with appropriate error message(s), and wrote valid transactions to a new file; the latter was then input to a reporting program that was developed in Chapter 9. This chapter combines the data validation and reporting programs into a single program to validate data as they are entered and produce an on-screen result.

The biggest difference between this program and its predecessor(s) is that the data are validated *interactively* as they are entered, as opposed to the *batch-oriented* approach in Chapter 8. The advantage of the interactive program is that the user is

given the opportunity to correct the invalid transaction at the time the error is detected, as opposed to receiving a report listing the errors. Realize, however, that interactive (screen-based) programs are restricted to low-volume applications and that their execution is far more time consuming than programs that are file-driven. Specifications follow in the usual format.

PROGRAMMING SPECIFICATIONS

Program Name: Car Validation and Billing Program (Screen Version)

Narrative: This program combines the specifications for data validation and reporting as presented earlier in Chapters 8 and 9. The fields in each incoming transaction are accepted and validated one at a time, after which the bill is computed and displayed on the screen. Valid transactions are also written to an output file.

Screen Layout: See Figure 10.5 (page 280).

- Processing Requirements:**
1. Develop an interactive program to accept and validate car rental data, then compute and display the associated bill. The program is to execute continually until it receives a response indicating that no more records are to be processed.
 2. Each incoming field is to be validated as it is entered; that is, the user cannot move to the next field until valid data have been entered in the current field. The requirements for validation were presented in Chapter 8 and are summarized below. Each transaction is to be checked for the following:
 - a. A numeric contract number.
 - b. The presence of both a first and last name; a middle initial is not required, but if present, the initial must be alphabetic.
 - c. A valid car type where the code is one of five values; E, C, M, F, or L.
 - d. A valid date in which the month is between 1 and 12, the day is consistent with the month (e.g., April 31 should be rejected), and the date is less than or equal to the system date.
 - e. A valid number of days rented that is greater than zero and less than or equal to 35.
 - f. Numeric values for the mileage in and out; and further, that the mileage reported when the car is turned in is greater than the mileage when the car was taken out. The number of miles driven must also pass a reasonableness test of 10 miles or more per day.
 - g. A numeric mileage rate less than or equal to 50 cents per day.
 - h. An insurance field of either Y or N.
 3. Write the validated transaction to a file as per the original program in Chapter 8.
 4. Calculate the customer's bill after all fields have been validated. The amount due is a function of car type, days rented, miles driven, mileage rate, and insurance.
 - a. The mileage rate is different for each customer and appears as a field in the incoming transaction; the mileage total is the mileage rate times the number of miles driven.
 - b. The daily rate is a function of the type of car rented. Economy cars cost \$15 a day, compact cars \$20 a day, mid-size cars \$24 a day, full-size cars \$28 a day, and luxury cars \$35 a day. The daily total is the daily rate times the number of days rented.
 - c. Insurance is optional at \$10.50, regardless of the type of car rented.

- d. A customer's total bill consists of the mileage total, daily total, and insurance total as described in parts (a), (b), and (c).
5. Display the computed bill on the screen as per the screen layout of Figure 10.5.
6. The requirement to compute totals has been deleted.

The Screen Section

The tuition billing program illustrated the use of ACCEPT and DISPLAY statements within the Procedure Division. This approach is useful to display individual lines and/or to accept a limited number of fields as input, but awkward when you need to fill an entire screen. A second limitation of individual ACCEPT and DISPLAY statements is that they are scattered throughout the Procedure Division, making it difficult to reproduce consistent screens from program to program within a system.

The **Screen Section** specifies the characteristics of an entire screen in the Data Division, then accepts or displays that screen in a single statement in the Procedure Division. The Screen Section is physically the *last* section in the Data Division, and its structure is similar to that of the File and/or Working-Storage Sections. Consider:

```

level-number {screen-name} [ BLANK {SCREEN} ] {BELL} [BLINK]
           {FILLER}          [ LINE ] [BEEP]

[ HIGHLIGHT ] [ REVERSE - VIDEO ] [ UNDERLINE ]

[ BACKGROUND COLOR IS {integer-1} ] [ FOREGROUND - COLOR IS {integer-2} ]
  {data-name-1}                    {data-name-2}

[ LINE NUMBER {identifier-1} ] [ COLUMN NUMBER {identifier-2} ]
  {integer-3}                  {integer-4}

[ VALUE IS literal-1 ]

{PICTURE} IS {FROM identifier-4 TO identifier-5}
{PIC}       {USING identifier-6}

[ CONTROL IS {literal-1} ]
             {identifier-7}

[AUTO] [SECURE]

```

An appreciation for the Screen Section can best be gained by viewing sample screens and the associated COBOL entries. Consider now Figure 10.5, which displays three screens from the car validation and billing program to be developed later in the chapter. Figure 10.5a displays the opening screen, consisting entirely of prompts for the various fields. Figure 10.5b displays a completed screen for Janice Vogel with valid entries in all fields, and Figure 10.5c displays the computed results.

The screens are produced in the sequence shown; that is, the system displays the opening screen of Figure 10.5a and the user enters the fields one at a time. Each field is validated as it is entered; the user cannot move to the next field until he or she has entered a valid value for the current field. Once all fields have been entered the system computes the bill and displays the results.

An abbreviated Screen Section, extracted from the completed program at the end of the chapter, is shown in Figure 10.6. The entries in the Screen Section are similar to those in the File or Working-Storage Section; that is, they consist of group items divided into elementary items. The entry at the 01 level must specify a screen-name—for example, OPENING-SCREEN and UPDATE-SCREEN in Figure 10.6. The



Figure 10.5 Screen Layouts

```

Mavis Car Rental Company      07/03/98

Contract No: 
Customer Information:
  Last Name   First   Initial
  (blank)    (blank) (blank)
Car Information:
  Type Code:  (Compact, Economy, Midsize, Fullsize, Luxury)
  Date Returned:
  Days Rented:
  Mileage:
  Miles In:
  Miles Out:      Mileage Rate:
  Insurance:      (Y/N)

Above information correct?
(Y - Yes, N - No)

```

(a) Opening Screen (No Data Entered)

```

Mavis Car Rental Company      07/03/98

Contract No: 886222
Customer Information:
  Last Name   First   Initial
  VOGEL      JANICE  D
Car Information:
  Type Code: F (Compact, Economy, Midsize, Fullsize, Luxury)
  Date Returned: 05/18/93
  Days Rented: 12
  Mileage:
  Miles In: 6,345
  Miles Out: 6,123      Mileage Rate: .02
  Insurance: Y (Y/N)

Above information correct? Y
(Y - Yes, N - No)

```

(b) Validated Record

Figure 10.5 (continued)

| Mavis Car Rental Company | | 07/03/98 |
|--|----------|-------------------------|
| Contract No: 886222 | | |
| Customer Information: | | |
| Last Name | First | Initial |
| VOGEL | JANICE | D |
| Car Information: | | |
| Type Code: F (Compact, Economy, Midsize, Fullsize, Luxury) | | |
| Date Returned: | 05/18/93 | Totals |
| Days Rented: | 12 | Rental Rate: \$28.00 |
| | | \$336.00 |
| Mileage: | | |
| Miles In: | 6,345 | Miles Driven: 222 |
| Miles Out: | 6,123 | Mileage Rate: .02 |
| | | \$4.44 |
| Insurance: Y (Y/N) | | Insurance Rate: \$10.50 |
| | | \$126.00 |
| Amount Due: | | \$466.44 |
| Enter another record? N | | |
| (Y - Yes, N - No) | | |

(c) Computer Bill

Figure 10.6 Abbreviated Screen Section

```

SCREEN SECTION.
01 OPENING-SCREEN.
05 BLANK SCREEN
   BACKGROUND-COLOR BLUE  FOREGROUND-COLOR WHITE.
05 SCREEN-PROMPTS.
   .
   10 LINE 3 COLUMN 7 VALUE 'Contract No:'.
   10 LINE 5 COLUMN 7 VALUE 'Customer Information:'.
   10 LINE 6 COLUMN 9 VALUE 'Last Name'.
   10           COLUMN 25 VALUE 'First'.
   10           COLUMN 36 VALUE 'Initial'.
   10 LINE 9 COLUMN 6 VALUE 'Car Information:'.
   10 LINE 10 COLUMN 12 VALUE 'Type Code:'.
   .
05 SCREEN-INPUTS.
   10 SCR-CONTRACT-NO  PIC 9(6) USING REN-CONTRACT-NO
   LINE 3 COLUMN 20 REVERSE-VIDEO.

```

Figure 10.6 (continued)

```

10 SCR-LAST-NAME      PIC X(15) USING REN-LAST-NAME
   LINE 7 COLUMN 9 REVERSE-VIDEO.
10 SCR-FIRST-NAME    PIC X(10) USING REN-FIRST-NAME
   LINE 7 COLUMN 25 REVERSE-VIDEO.
10 SCR-INITIAL       PIC X      USING REN-INITIAL
   LINE 7 COLUMN 36 REVERSE-VIDEO.
10 SCR-CAR-TYPE      PIC X      USING REN-CAR-TYPE
   LINE 10 COLUMN 23 REVERSE-VIDEO AUTO.

01 UPDATE-SCREEN.
05 LINE 11 COLUMN 67  VALUE 'Totals' HIGHLIGHT.
05 LINE 12 COLUMN 38  VALUE 'Rental Rate:' HIGHLIGHT.
05 UPD-DAILY-RATE    PIC $$$9.99 FROM IND-DAILY-RATE
   LINE 12 COLUMN 50  HIGHLIGHT.
05 UPD-DAILY-TOTAL   PIC $$$,$$9.99 FROM IND-DAILY-TOTAL
   COLUMN 63         HIGHLIGHT.
05 LINE 14 COLUMN 37  VALUE 'Miles Driven:' HIGHLIGHT.
05 UPD-MILES-DRIVEN  PIC ZZZ,ZZ9 FROM IND-MILES-DRIVEN
   COLUMN 50         HIGHLIGHT.
05 UPD-MILEAGE-TOTAL PIC $$,$$9.99
   FROM IND-MILEAGE-TOTAL
   LINE 15 COLUMN 64 HIGHLIGHT.
05 LINE 16 COLUMN 35  VALUE 'Insurance Rate:' HIGHLIGHT.
05 UPD-INSURANCE-RATE PIC $$9.99 FROM INSURANCE-RATE
   LINE 16 COLUMN 51  HIGHLIGHT.
05 UPD-INSURANCE-TOTAL PIC $$,$$9.99
   FROM IND-INSURANCE-TOTAL
   COLUMN 64         HIGHLIGHT.
05 LINE 17 COLUMN 63  VALUE '-----' HIGHLIGHT.
05 LINE 18 COLUMN 48  VALUE 'Amount Due: ' HIGHLIGHT.
05 UPD-AMOUNT-DUE    PIC $$$,$$9.99 FROM IND-AMOUNT-DUE
   COLUMN 62         HIGHLIGHT.

```

screen (data) name is optional at any other level; for example, the first 05-level entry in Figure 10.6 omits the screen (data) name and specifies a blank screen with a blue background and white foreground. The next 05-level entry includes a data name, SCREEN-PROMPTS, which is divided into multiple elementary items, each of which omits the data name.

If a screen (data) name or FILLER is specified, then it must be the first word following the level name. The remaining clauses can appear in any order, but each elementary item must contain at least one of the following clauses: BELL, BLANK LINE, BLANK SCREEN, COLUMN, LINE, PICTURE, or VALUE. (The VALUE and PICTURE clauses are mutually exclusive in the Screen Section.) Any clause that appears on a group item applies to all elementary items within the group where it is allowed. If the same clause is specified at multiple levels in the hierarchy, the *lowest* level takes effect. The various optional clauses are illustrated in Figure 10.6 and function as explained previously in conjunction with the ACCEPT and DISPLAY statements.

Note, too, the correspondence between the line and column positioning within SCREEN-PROMPTS and SCREEN-INPUT; for example, a prompt for 'Contract No:' appears on line 3 and extends from column 7 to 18; the data name SCR-CONTRACT-NO is subsequently accepted in column 20 on the same line. The action of the LINE and COLUMN clauses is the same as with individual ACCEPT and DISPLAY statements: omission of the LINE clause defaults to the same line as the previously specified element. Thus the prompt for last name is displayed on line 6, column 9 followed by the prompt for first name in column 25 of the same line, followed by the initial in column 36 of the same line.

The Screen Section makes possible the definition of multiple screens within the same program as implied by the screen in Figure 10.5c, in which the computed results are displayed on the same (expanded) screen as the original inputs. Thus the Screen Section in Figure 10.6 contains a second 01 entry, UPDATE-SCREEN, with multiple entries that display both text and computed information; the latter is displayed after all data have been entered and the bill has been computed.

The TO clause in a screen description entry indicates an input field; the FROM clause indicates an output field. The USING clause—for example, USING REN-CONTRACT-NO—is equivalent to the combination of FROM and TO clauses each specifying the same data name. In this instance the screen input in line 3, column 20 is accepted from and/or moved to the data name SCR-CONTRACT-NO, which is defined elsewhere in the Data Division.

Unlike the ACCEPT and DISPLAY statements, SCREEN SECTION FOREGROUND-COLOR and BACKGROUND-COLOR can use identifiers as well as integers. Level-78 can be used as well. However, the BRIGHT colors are not acceptable. Using values 0–7 and HIGHLIGHT is the equivalent of 8–15.

Hierarchy Chart

The hierarchy chart in Figure 10.7 combines the functions of the data validation and reporting programs of Chapters 8 and 9. The second-level module, PROCESS-RENTAL-RECORDS, effectively drives the program and contains subordinates to VALIDATE-RENTAL-RECORD, COMPUTE-IND-BILL, WRITE-VALID-RECORD, and INPUT-SCREEN-CONFIRM.

The validation module, VALIDATE-RENTAL-RECORD, contains a lower-level module for every validity check (identical to those in Chapter 8), each of which calls a common routine that displays the indicated error message or clears the error line. The computation module, COMPUTE-IND-BILL, has three subordinates of its own: COMPUTE-MILEAGE-TOTAL, COMPUTE-DAILY-TOTAL, and COMPUTE-INSURANCE-TOTAL. The remaining modules under PROCESS-RENTAL-RECORDS write the validated record, then determine whether another record is to be processed.

Pseudocode

The pseudocode in Figure 10.8 is driven by an overall loop to process transactions until the user elects to quit. Each new transaction begins with validation of individual fields, which continues until the user indicates that the entire screen is accurate; that is, the user is given the opportunity to change any field that has been previously validated. Within this loop, each field is validated interactively; that is, the user cannot enter the next field until the current field has been accepted as valid.

Once all fields have been entered and validated, the program moves to the computation of the bill according to the specifications presented earlier. The computed bill is displayed on the screen, the validated record is written to a valid record file, and the user is given the opportunity to process another transaction.

Figure 10.7 Hierarchy Chart

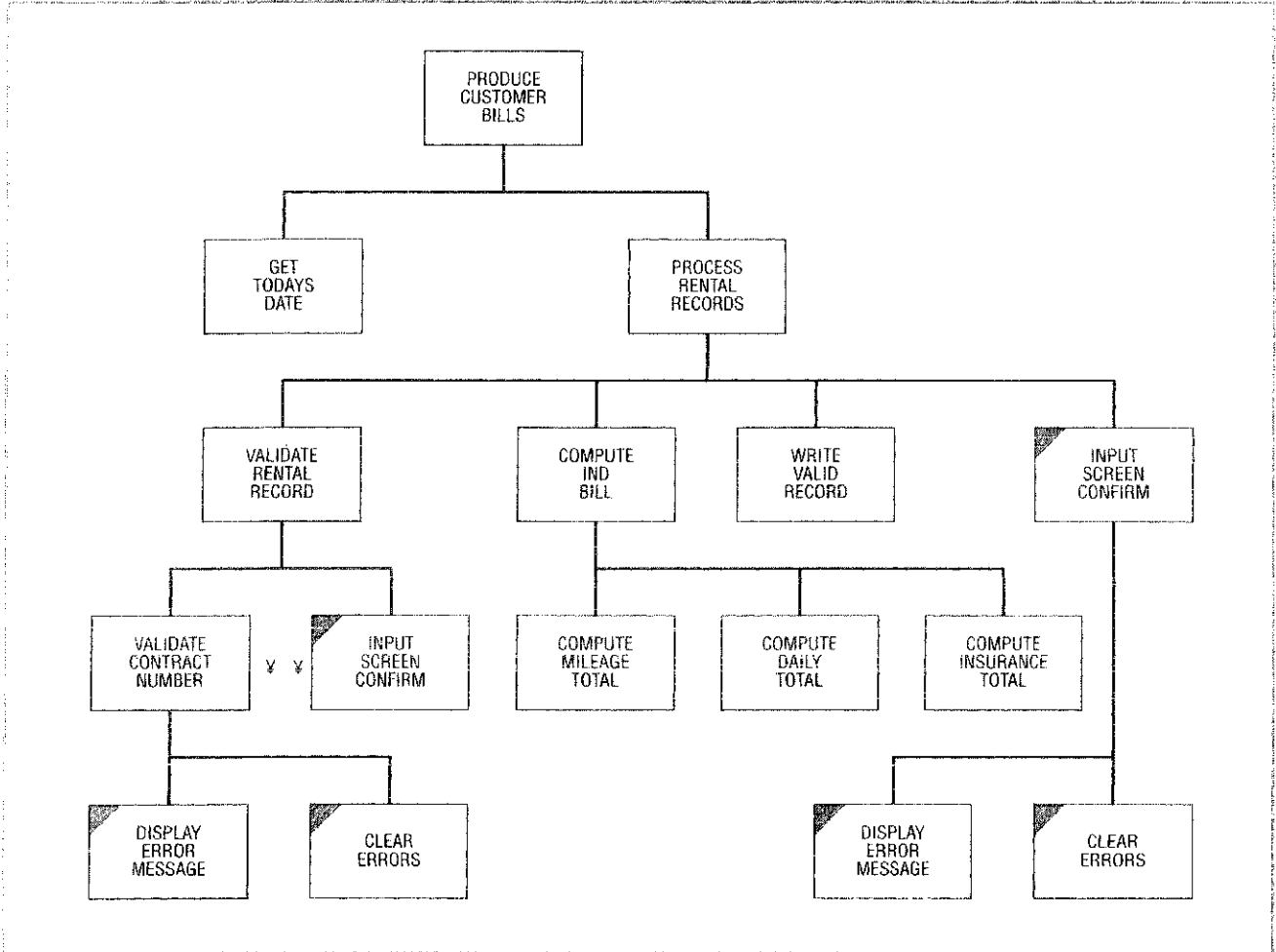

Figure 10.8 Pseudocode for Car Validation and Billing Program (Screen Version)

```

Open valid-rental-file
Get today's date
DO WHILE another record is desired
  DO UNTIL information correct
    DO UNTIL valid-field-switch = spaces
      Accept contract number
      IF contract number = zeros
        Display 'Contract number must not be zero'
        Move 'NO' to valid-field-switch
      ELSE
        Move spaces to valid-field-switch
      ENDIF
    ENDDO
  ENDDO

```

Figure 10.8 (continued)

```

DO UNTIL valid-field-switch = spaces
  Accept last-name
  IF last-name = spaces
    Display 'Error - Missing last name'
    Move 'NO' to valid-field-switch
  ELSE
    Move spaces to valid-field-switch
  ENDIF
ENDDO
. . . Validation checks for remaining fields
Display information correct message
DO UNTIL valid confirmation ("Y", "y", "N", or "n")
  Accept confirm-switch
  IF valid confirmation
    Clear previous error message
  ELSE
    Display 'Must be "Y" or "N"'
  ENDIF
ENDDO
ENDDO
Compute miles driven = miles in - miles out
DO CASE
  Car Type E - Move economy rate to mileage rate
  Car Type C - Move compact rate to mileage rate
  Car Type M - Move midsize to mileage rate
  Car Type F - Move fullsize rate to mileage rate
  Car Type L - Move luxury rate to mileage rate
END CASE
Compute mileage total = miles driven * mileage rate
Compute daily total = days rented * daily rate
IF insurance taken
  Compute insurance = insurance rate * days rented
END-IF
Compute total bill = mileage amount + daily amount + insurance
Display computed bill
Write valid record to valid record file
Display Another record message
DO UNTIL valid confirmation ("Y", "y", "N", or "n")
  Accept confirm-switch
  IF valid confirmation
    Clear previous error message
  ELSE
    Display 'Must be "Y" or "N"'
  ENDIF
ENDDO
ENDDO
Close valid-rental-file
Stop run

```

The Completed Program

The completed program is shown in Figure 10.9 and includes many statements from the earlier programs in Chapters 8 and 9. The most significant difference is that I-O is screen based, with transactions entered via the keyboard and computed results displayed on the monitor, as provided through the extended Screen Section (lines 135–244). The program also creates a VALID-RENTAL-FILE as output, illustrating that the same program can contain both a File Section and a Screen Section

Figure 10.9 Car Validation and Billing Program

```

1  IDENTIFICATION DIVISION.
2  PROGRAM-ID.      SCRNCARS.
3  AUTHOR.         CVV.
4
5  ENVIRONMENT DIVISION.
6  INPUT-OUTPUT SECTION.
7  FILE-CONTROL.
8      SELECT VALID-RENTAL-FILE    ASSIGN TO 'A:\CHAPTR10\VALRENT.DAT'
9      ORGANIZATION IS LINE SEQUENTIAL.
10
11 DATA DIVISION.
12 FILE SECTION.
13 FD VALID-RENTAL-FILE.
14 01 VALID-RENTAL-RECORD          PIC X(57).
15
16 WORKING-STORAGE SECTION.
17 01 RENTAL-RECORD-IN.
18     05 REN-CONTRACT-NO          PIC 9(6).
19     05 REN-NAME.
20         10 REN-LAST-NAME        PIC X(15).
21         10 REN-FIRST-NAME       PIC X(10).
22         10 REN-INITIAL          PIC X.
23     05 REN-RETURNED-DATE.
24         10 REN-RETURNED-YEAR    PIC 9(2).
25         10 REN-RETURNED-MONTH   PIC 9(2).
26         88 VALID-MONTHS         VALUES 1 THRU 12.
27         88 FEBRUARY             VALUE 2.
28         88 30-DAY-MONTH         VALUES 4 6 9 11.
29         88 31-DAY-MONTH         VALUES 1 3 5 7 8 10 12.
30         10 REN-RETURNED-DAY     PIC 9(2).
31     05 REN-CAR-TYPE             PIC X.
32         88 VALID-CAR-TYPES      VALUES 'E' 'C' 'M' 'F' 'L'.
33     05 REN-DAYS-RENTED          PIC 99.
34         88 ZERO-DAYS-RENTED     VALUE 0.
35         88 VALID-DAYS-RENTED    VALUES 1 THRU 35.
36     05 REN-MILEAGE.
37         10 REN-MILES-IN         PIC 9(6).
38         10 REN-MILES-OUT        PIC 9(6).

```

Figure 10.9 (continued)

```

39         10 REN-MILEAGE-RATE    PIC V99.
40         88 VALID-MILEAGE-RATES  VALUES 00 THRU .50.
41     05 REN-INSURANCE          PIC X.
42         88 VALID-INSURANCE      VALUE 'Y' 'y' 'N' 'n'.
43         88 INSURANCE            VALUE 'Y' 'y'.
44
45     01 PROGRAM-SWITCHES-AND-CONSTANTS.
46     05 MILES-PER-DAY-FACTOR    PIC 99  VALUE 10.
47     05 VALID-FIELD-SWITCH      PIC XX.
48         88 VALID-FIELD          VALUE SPACES.
49     05 CONFIRM-SWITCH          PIC X  VALUE SPACES.
50         88 INFO-CORRECT          VALUE 'Y' 'y'.
51         88 NO-MORE-RECORDS       VALUE 'N' 'n'.
52         88 VALID-CONFIRMED       VALUE 'N' 'n' 'Y' 'y'.
53
54     01 TODAYS-DATE-INFORMATION.
55     05 TODAYS-DATE.
56         10 TODAYS-YEAR          PIC 99.
57         10 TODAYS-MONTH         PIC 99.
58         10 TODAYS-DAY           PIC 99.
59     05 SCREEN-DATE             PIC X(8).
60
61     01 CONFIRM-MESSAGES.
62     05 CONFIRM-MESSAGE          PIC X(27).
63     05 INFO-CORRECT-MESSAGE     PIC X(27)
64         VALUE 'Above information correct? '.
65     05 ANOTHER-RECORD-MESSAGE  PIC X(27)
66         VALUE '   Enter Another Record? '.
67
68     01 ERROR-MESSAGES.
69     05 ERROR-MESSAGE            PIC X(40).
70     05 ZERO-CONTRACT-NO-MSG     PIC X(40)
71         VALUE '   CONTRACT NUMBER MUST NOT BE ZERO'.
72     05 LAST-NAME-MSG            PIC X(40)
73         VALUE '   MISSING LAST NAME'.
74     05 FIRST-NAME-MSG           PIC X(40)
75         VALUE '   MISSING FIRST NAME'.
76     05 INITIAL-MSG              PIC X(40)
77         VALUE '   NON ALPHABETIC INITIAL'.
78     05 CAR-TYPE-MSG             PIC X(40)
79         VALUE '   CAR TYPE MUST BE:  E, C, M, F, OR L'.
80     05 MONTH-MSG                PIC X(40)
81         VALUE '   MONTH MUST BE BETWEEN 1 AND 12'.
82     05 DAY-MSG                  PIC X(40)
83         VALUE '   INVALID DAY'.
84     05 FUTURE-DATE-MSG          PIC X(40)
85         VALUE '   DATE HAS NOT YET OCCURRED'.
86     05 NON-NUM-DAYS-RENTED-MSG  PIC X(40)
87         VALUE '   DAYS RENTED MUST BE NUMERIC'.
88     05 ZERO-DAYS-MSG            PIC X(40)

```

User may enter upper- or lowercase response

Table of error messages is explained in Working Storage

Figure 10.9 (continued)

```

89         VALUE '      DAYS RENTED MUST BE > ZERO'.
90     05 LEASING-MSG          PIC X(40)
91         VALUE '      REFER TO LONG-TERM LEASING'.
92     05 NON-NUM-MILES-IN-MSG PIC X(40)
93         VALUE '      NON-NUMERIC MILES IN'.
94     05 NON-NUM-MILES-OUT-MSG PIC X(40)
95         VALUE '      NON-NUMERIC MILES OUT'.
96     05 LESS-THAN-MILES-MSG  PIC X(40)
97         VALUE '      MILEAGE IN LESS THAN MILEAGE OUT'.
98     05 INVALID-MILES-MSG    PIC X(40)
99         VALUE '      MILES DRIVEN UNREASONABLY LOW'.
100    05 NON-NUM-RATE-MSG      PIC X(40)
101        VALUE '      NON-NUMERIC MILEAGE RATE'.
102    05 MILEAGE-RATE-MSG      PIC X(40)
103        VALUE '      MILEAGE RATE OUT OF RANGE'.
104    05 INSURANCE-MSG        PIC X(40)
105        VALUE '      INSURANCE CODE MUST BE Y OR N'.
106    05 YES-NO-MSG           PIC X(40)
107        VALUE '      MUST BE "Y" OR "N"'.
108
109    01 DAILY-RATES.
110        05 ECONOMY-RATE      PIC 9(3)V99 VALUE 15.
111        05 COMPACT-RATE      PIC 9(3)V99 VALUE 20.
112        05 MID-RATE          PIC 9(3)V99 VALUE 24.
113        05 FULL-RATE         PIC 9(3)V99 VALUE 28.
114        05 LUXURY-RATE       PIC 9(3)V99 VALUE 35.
115        05 INSURANCE-RATE    PIC 99V99  VALUE 10.50.
116
117    01 IND-BILL-INFORMATION.
118        05 IND-MILES-DRIVEN  PIC 9(6).
119        05 IND-DAILY-RATE    PIC 9(3)V99.
120        05 IND-DAILY-TOTAL   PIC 9(5)V99.
121        05 IND-MILEAGE-TOTAL PIC 9(4)V99.
122        05 IND-INSURANCE-TOTAL PIC 9(4)V99.
123        05 IND-AMOUNT-DUE    PIC 9(6)V99.
124
125    01 SCREEN-COLORS.
126        05 BLUE              PIC S9(4) COMP-5 VALUE 1.
127        05 CYAN              PIC S9(4) COMP-5 VALUE 3.
128        05 RED                PIC S9(4) COMP-5 VALUE 4.
129        05 MAGENTA           PIC S9(4) COMP-5 VALUE 5.
130        05 WHITE             PIC S9(4) COMP-5 VALUE 7.
131        05 BRIGHT-GREEN     PIC S9(4) COMP-5 VALUE 10.
132        05 BRIGHT-MAGENTA   PIC S9(4) COMP-5 VALUE 13.
133        05 BRIGHT-WHITE     PIC S9(4) COMP-5 VALUE 15.
134
135    SCREEN SECTION.
136    01 OPENING-SCREEN.
137        05 BLANK SCREEN
138        BACKGROUND-COLOR BLUE FOREGROUND-COLOR WHITE.
    
```

Data items used instead of Level 75

Screen Section follows Working-Storage Section

Figure 10.9 (continued)

```

139      05 SCREEN-PROMPTS.
140      10 LINE 1 BLANK LINE BACKGROUND-COLOR MAGENTA.
141      10      COLUMN 20 VALUE 'Mavis Car Rental Company'
142      BACKGROUND-COLOR MAGENTA
143      FOREGROUND-COLOR BRIGHT-GREEN.
144      10 SCR-DATE      PIC X(8) FROM SCREEN-DATE
145      COLUMN 55 BACKGROUND-COLOR MAGENTA
146      FOREGROUND-COLOR BRIGHT-GREEN.
147      10 LINE 3 COLUMN 7 VALUE 'Contract No:'.
148      10 LINE 5 COLUMN 7 VALUE 'Customer Information:'.
149      10 LINE 6 COLUMN 9 VALUE 'Last Name'.
150      10      COLUMN 25 VALUE 'First'.
151      10      COLUMN 36 VALUE 'Initial'.
152      10 LINE 9 COLUMN 6 VALUE 'Car Information:'.
153      10 LINE 10 COLUMN 12 VALUE 'Type Code:'.
154      10      COLUMN 25
155      VALUE '(Compact, Economy, Midsize, Fullsize, Luxury)'
156      FOREGROUND-COLOR CYAN.
157      10      COLUMN 26 VALUE 'C' HIGHLIGHT.
158      10      COLUMN 35 VALUE 'E' HIGHLIGHT.
159      10      COLUMN 44 VALUE 'M' HIGHLIGHT.
160      10      COLUMN 53 VALUE 'F' HIGHLIGHT.
161      10      COLUMN 63 VALUE 'L' HIGHLIGHT.
162      10 LINE 11 COLUMN 8 VALUE 'Date Returned:'.
163      10      COLUMN 23 VALUE 'mm/dd/yy'
164      FOREGROUND-COLOR BRIGHT-WHITE.
165      10 LINE 12 COLUMN 10 VALUE 'Days Rented:'.
166      10 LINE 13 COLUMN 10 VALUE 'Mileage:'.
167      10 LINE 14 COLUMN 13 VALUE 'Miles In:'.
168      10 LINE 15 COLUMN 12 VALUE 'Miles Out:'.
169      10      COLUMN 37 VALUE 'Mileage Rate:'.
170      10 LINE 16 COLUMN 12 VALUE 'Insurance:'.
171      10      COLUMN 25 VALUE '(Y/N)'
172      FOREGROUND-COLOR CYAN.
173
174      05 SCREEN-INPUTS.
175      10 SCR-CONTRACT-NO PIC 9(6) USING REN-CONTRACT-NO
176      LINE 3 COLUMN 20 REVERSE-VIDEO.
177      10 SCR-LAST-NAME   PIC X(15) USING REN-LAST-NAME
178      LINE 7 COLUMN 9 REVERSE-VIDEO.
179      10 SCR-FIRST-NAME  PIC X(10) USING REN-FIRST-NAME
180      LINE 7 COLUMN 25 REVERSE-VIDEO.
181      10 SCR-INITIAL     PIC X      USING REN-INITIAL
182      LINE 7 COLUMN 36 REVERSE-VIDEO.
183      10 SCR-CAR-TYPE    PIC X      USING REN-CAR-TYPE
184      LINE 10 COLUMN 23 REVERSE-VIDEO AUTO.
185      10 SCR-RETURNED-MONTH PIC 99 USING REN-RETURNED-MONTH
186      LINE 11 COLUMN 23 REVERSE-VIDEO AUTO.
187      10 SCR-RETURNED-DAY PIC 99 USING REN-RETURNED-DAY
188      LINE 11 COLUMN 26 REVERSE-VIDEO AUTO.

```

Figure 10.6 (continued)

```

189          10 SCR-RETURNED-YEAR PIC 99 USING REN-RETURNED-YEAR
190          LINE 11 COLUMN 29 REVERSE-VIDEO AUTO.
191          10 SCR-DAYS-RENTED PIC 99 USING REN-DAYS-RENTED
192          LINE 12 COLUMN 23 REVERSE-VIDEO AUTO.
193          10 SCR-MILES-IN PIC ZZZ,ZZ9 USING REN-MILES-IN
194          LINE 14 COLUMN 23 REVERSE-VIDEO.
195          10 SCR-MILES-OUT PIC ZZZ,ZZ9 USING REN-MILES-OUT
196          LINE 15 COLUMN 23 REVERSE-VIDEO.
197          10 SCR-MILEAGE-RATE PIC .99 USING REN-MILEAGE-RATE
198          LINE 15 COLUMN 54 REVERSE-VIDEO.
199          10 SCR-INSURANCE PIC X USING REN-INSURANCE
200          LINE 16 COLUMN 23 REVERSE-VIDEO AUTO.
201          05 LINE 24 BLANK LINE.
202          05 LINE 25 BLANK LINE.
203
204          01 UPDATE-SCREEN.
205              05 LINE 11 COLUMN 67 VALUE 'Totals' HIGHLIGHT.
206              05 LINE 12 COLUMN 38 VALUE 'Rental Rate:' HIGHLIGHT.
207              05 UPD-DAILY-RATE PIC $$$9.99 FROM IND-DAILY-RATE
208              LINE 12 COLUMN 50 HIGHLIGHT.
209              05 UPD-DAILY-TOTAL PIC $$$,$$9.99 FROM IND-DAILY-TOTAL
210              COLUMN 63 HIGHLIGHT.
211              05 LINE 14 COLUMN 37 VALUE 'Miles Driven:' HIGHLIGHT.
212              05 UPD-MILES-DRIVEN PIC ZZZ,ZZ9 FROM IND-MILES-DRIVEN
213              COLUMN 50 HIGHLIGHT.
214              05 UPD-MILEAGE-TOTAL PIC $$,$$9.99
215              FROM IND-MILEAGE-TOTAL
216              LINE 15 COLUMN 64 HIGHLIGHT.
217              05 LINE 16 COLUMN 35 VALUE 'Insurance Rate:' HIGHLIGHT.
218              05 UPD-INSURANCE-RATE PIC $$9.99 FROM INSURANCE-RATE
219              LINE 16 COLUMN 51 HIGHLIGHT.
220              05 UPD-INSURANCE-TOTAL PIC $$$,$$9.99
221              FROM IND-INSURANCE-TOTAL
222              COLUMN 64 HIGHLIGHT.
223              05 LINE 17 COLUMN 63 VALUE '-----' HIGHLIGHT.
224              05 LINE 18 COLUMN 48 VALUE 'Amount Due: ' HIGHLIGHT.
225              05 UPD-AMOUNT-DUE PIC $$$,$$9.99 FROM IND-AMOUNT-DUE
226              COLUMN 62 HIGHLIGHT.
227
228          01 ERROR-LINE.
229              05 LINE 25 BLANK LINE BACKGROUND-COLOR RED.
230              05 PIC X(40) FROM ERROR-MESSAGE
231              COLUMN 20 HIGHLIGHT BLINK BEEP
232              FOREGROUND-COLOR BRIGHT-WHITE BACKGROUND-COLOR RED.
233
234          01 CONFIRM-SCREEN.
235              05 LINE 24 BLANK LINE BACKGROUND-COLOR MAGENTA.
236              05 PIC X(27) FROM CONFIRM-MESSAGE
237              LINE 24 COLUMN 25
238              BACKGROUND-COLOR MAGENTA FOREGROUND-COLOR BRIGHT-GREEN.
    
```

Screen name is displayed on line 110

Figure 10.9 (continued)

```

239         05          PIC X USING CONFIRM-SWITCH
240         LINE 24 COLUMN 52      BLINK AUTO
241         BACKGROUND-COLOR MAGENTA FOREGROUND-COLOR BRIGHT-GREEN.
242         05 LINE 25 BLANK LINE BACKGROUND-COLOR MAGENTA.
243         05 LINE 25 COLUMN 32    VALUE '(Y - Yes, N - No)'
244         BACKGROUND-COLOR MAGENTA FOREGROUND-COLOR BRIGHT-GREEN.
245
246 PROCEDURE DIVISION.
247 000-CREATE-VALID-RENTAL-FILE.
248     OPEN OUTPUT VALID-RENTAL-FILE.
249     PERFORM 100-GET-TODAYS-DATE.
250     PERFORM 200-INPUT-RENTAL-RECORDS
251         UNTIL NO-MORE-RECORDS.
252     CLOSE VALID-RENTAL-FILE.
253     STOP RUN.
254
255 100-GET-TODAYS-DATE.
256     ACCEPT TODAYS-DATE FROM DATE.
257     STRING TODAYS-MONTH '/' TODAYS-DAY '/' TODAYS-YEAR
258         DELIMITED BY SIZE INTO SCREEN-DATE.
259
260 200-INPUT-RENTAL-RECORDS.
261     INITIALIZE RENTAL-RECORD-IN.
262     PERFORM 400-VALIDATE-RENTAL-RECORD WITH TEST AFTER
263         UNTIL INFO-CORRECT.
264     PERFORM 500-COMPUTE-IND-BILL.
265     DISPLAY UPDATE-SCREEN.
266     PERFORM 600-WRITE-VALID-RECORD.
267     MOVE ANOTHER-RECORD-MESSAGE TO CONFIRM-MESSAGE.
268     PERFORM 700-INPUT-SCREEN-CONFIRM.
269
270 400-VALIDATE-RENTAL-RECORD.
271     DISPLAY OPENING-SCREEN.
272     PERFORM 410-VALIDATE-CONTRACT-NO.
273     PERFORM 420-VALIDATE-NAME.
274     PERFORM 430-VALIDATE-CAR-TYPE.
275     PERFORM 440-VALIDATE-DATE-RETURNED
276         WITH TEST AFTER UNTIL VALID-FIELD.
277     PERFORM 450-VALIDATE-DAYS-RENTED.
278     PERFORM 460-VALIDATE-MILES-DRIVEN.
279     PERFORM 470-VALIDATE-MILEAGE-RATE.
280     PERFORM 480-VALIDATE-INSURANCE.
281     MOVE INFO-CORRECT-MESSAGE TO CONFIRM-MESSAGE.
282     PERFORM 700-INPUT-SCREEN-CONFIRM.
283
284 410-VALIDATE-CONTRACT-NO.
285     PERFORM WITH TEST AFTER UNTIL VALID-FIELD
286         ACCEPT SCR-CONTRACT-NO
287         IF REN-CONTRACT-NO = ZEROES
288         MOVE ZERO-CONTRACT-NO-MSG TO ERROR-MESSAGE

```

Combination of foreground and background colors for emphasis

DISPLAY statement (line 271) only in Screen Section

Figure 10.9 (continued)

```

289         PERFORM 499-DISPLAY-ERROR-MESSAGE
290     ELSE
291         PERFORM 498-CLEAR-ERRORS
292     END-IF
293 END-PERFORM.
294
295 420-VALIDATE-NAME.
296     PERFORM WITH TEST AFTER UNTIL VALID-FIELD
297     ACCEPT SCR-LAST-NAME
298     IF REN-LAST-NAME = SPACES
299         MOVE LAST-NAME-MSG TO ERROR-MESSAGE
300         PERFORM 499-DISPLAY-ERROR-MESSAGE
301     ELSE
302         PERFORM 498-CLEAR-ERRORS
303     END-IF
304 END-PERFORM.
305     PERFORM WITH TEST AFTER UNTIL VALID-FIELD
306     ACCEPT SCR-FIRST-NAME
307     IF REN-FIRST-NAME = SPACES
308         MOVE FIRST-NAME-MSG TO ERROR-MESSAGE
309         PERFORM 499-DISPLAY-ERROR-MESSAGE
310     ELSE
311         PERFORM 498-CLEAR-ERRORS
312     END-IF
313 END-PERFORM.
314     PERFORM WITH TEST AFTER UNTIL VALID-FIELD
315     ACCEPT SCR-INITIAL
316     IF REN-INITIAL NOT ALPHABETIC
317         MOVE INITIAL-MSG TO ERROR-MESSAGE
318         PERFORM 499-DISPLAY-ERROR-MESSAGE
319     ELSE
320         PERFORM 498-CLEAR-ERRORS
321     END-IF
322 END-PERFORM.
323
324 430-VALIDATE-CAR-TYPE.
325     PERFORM WITH TEST AFTER UNTIL VALID-FIELD
326     ACCEPT SCR-CAR-TYPE
327     IF NOT VALID-CAR-TYPES
328         MOVE CAR-TYPE-MSG TO ERROR-MESSAGE
329         PERFORM 499-DISPLAY-ERROR-MESSAGE
330     ELSE
331         PERFORM 498-CLEAR-ERRORS
332     END-IF
333 END-PERFORM.
334
335 440-VALIDATE-DATE-RETURNED.
336     PERFORM WITH TEST AFTER UNTIL VALID-FIELD
337     ACCEPT SCR-RETURNED-MONTH
338     IF VALID-MONTHS

```

TEST AFTER UNTIL clause ensures that in the statements in a selection at least once

TEST AFTER UNTIL clause ensures that in the statements in a selection at least once

Figure 10.9 (continued)

```

339         PERFORM 498-CLEAR-ERRORS
340     ELSE
341         MOVE MONTH-MSG TO ERROR-MESSAGE
342         PERFORM 499-DISPLAY-ERROR-MESSAGE
343     END-IF
344 END-PERFORM.
345 PERFORM WITH TEST AFTER UNTIL VALID-FIELD
346     ACCEPT SCR-RETURNED-DAY
347     IF 30-DAY-MONTH AND REN-RETURNED-DAY > 0 AND <= 30 OR
348        31-DAY-MONTH AND REN-RETURNED-DAY > 0 AND <= 31 OR
349        FEBRUARY AND REN-RETURNED-DAY > 0 AND <= 29
350         PERFORM 498-CLEAR-ERRORS
351     ELSE
352         MOVE DAY-MSG TO ERROR-MESSAGE
353         PERFORM 499-DISPLAY-ERROR-MESSAGE
354     END-IF
355 END-PERFORM.
356 PERFORM WITH TEST AFTER UNTIL VALID-FIELD
357     ACCEPT SCR-RETURNED-YEAR
358     IF REN-RETURNED-DATE > TODAYS-DATE
359         MOVE FUTURE-DATE-MSG TO ERROR-MESSAGE
360         PERFORM 499-DISPLAY-ERROR-MESSAGE
361     ELSE
362         PERFORM 498-CLEAR-ERRORS
363     END-IF
364 END-PERFORM.
365
366 450-VALIDATE-DAYS-RENTED.
367     PERFORM WITH TEST AFTER UNTIL VALID-FIELD
368         ACCEPT SCR-DAYS-RENTED
369         IF ZERO-DAYS-RENTED
370             MOVE ZERO-DAYS-MSG TO ERROR-MESSAGE
371             PERFORM 499-DISPLAY-ERROR-MESSAGE
372         ELSE
373             IF NOT VALID-DAYS-RENTED
374                 MOVE LEASING-MSG TO ERROR-MESSAGE
375                 PERFORM 499-DISPLAY-ERROR-MESSAGE
376             ELSE
377                 PERFORM 498-CLEAR-ERRORS
378             END-IF
379         END-IF
380 END-PERFORM.
381
382 460-VALIDATE-MILES-DRIVEN.
383     PERFORM WITH TEST AFTER UNTIL VALID-FIELD
384         ACCEPT SCR-MILES-IN
385         ACCEPT SCR-MILES-OUT
386         IF REN-MILES-IN < REN-MILES-OUT
387             MOVE LESS-THAN-MILES-MSG TO ERROR-MESSAGE
388             PERFORM 499-DISPLAY-ERROR-MESSAGE

```

TEST AFTER clause ensures that in-line statement is executed at least once

Figure 10.9 (continued)

```

389         ELSE
390             IF REN-MILES-IN - REN-MILES-OUT <
391                 MILES-PER-DAY-FACTOR * REN-DAYS-RENTED
392                 MOVE INVALID-MILES-MSG TO ERROR-MESSAGE
393                 PERFORM 499-DISPLAY-ERROR-MESSAGE
394             ELSE
395                 PERFORM 498-CLEAR-ERRORS
396             END-IF
397         END-IF
398     END-PERFORM.
399
400 470-VALIDATE-MILEAGE-RATE.
401     PERFORM WITH TEST AFTER UNTIL VALID-FIELD
402     ACCEPT SCR-MILEAGE-RATE
403     IF NOT VALID-MILEAGE-RATES
404         MOVE MILEAGE-RATE-MSG TO ERROR-MESSAGE
405         PERFORM 499-DISPLAY-ERROR-MESSAGE
406     ELSE
407         PERFORM 498-CLEAR-ERRORS
408     END-IF
409     END-PERFORM.
410
411 480-VALIDATE-INSURANCE.
412     PERFORM WITH TEST AFTER UNTIL VALID-FIELD
413     ACCEPT SCR-INSURANCE
414     IF NOT VALID-INSURANCE
415         MOVE INSURANCE-MSG TO ERROR-MESSAGE
416         PERFORM 499-DISPLAY-ERROR-MESSAGE
417     ELSE
418         PERFORM 498-CLEAR-ERRORS
419     END-IF
420     END-PERFORM.
421
422 498-CLEAR-ERRORS.
423     INITIALIZE VALID-FIELD-SWITCH.
424     DISPLAY ' ' LINE 25 WITH BLANK LINE.
425
426 499-DISPLAY-ERROR-MESSAGE.
427     MOVE 'NO' TO VALID-FIELD-SWITCH.
428     DISPLAY ERROR-LINE.
429
430 500-COMPUTE-IND-BILL.
431     PERFORM 520-COMPUTE-MILEAGE-TOTAL.
432     PERFORM 540-COMPUTE-DAILY-TOTAL.
433     PERFORM 560-COMPUTE-INSURANCE-TOTAL.
434     COMPUTE IND-AMOUNT-DUE ROUNDED
435         = IND-MILEAGE-TOTAL + IND-DAILY-TOTAL
436         + IND-INSURANCE-TOTAL
437     SIZE ERROR DISPLAY 'SIZE ERROR ON AMOUNT DUE FOR '
438         REN-CONTRACT-NO
439     END-COMPUTE.

```

TEST AFTER clause ensures that input statements are executed at least once.

Figure 10.9 (continued)

```

440
441     520-COMPUTE-MILEAGE-TOTAL.
442         COMPUTE IND-MILES-DRIVEN
443             = REN-MILES-IN - REN-MILES-OUT
444         END-COMPUTE.
445         COMPUTE IND-MILEAGE-TOTAL ROUNDED
446             = IND-MILES-DRIVEN * REN-MILEAGE-RATE
447         SIZE ERROR
448             DISPLAY 'COMPUTED BILL EXCESSIVELY LARGE'
449         END-COMPUTE.
450
451     540-COMPUTE-DAILY-TOTAL.
452         EVALUATE REN-CAR-TYPE
453             WHEN 'E' MOVE ECONOMY-RATE TO IND-DAILY-RATE
454             WHEN 'C' MOVE COMPACT-RATE TO IND-DAILY-RATE
455             WHEN 'M' MOVE MID-RATE TO IND-DAILY-RATE
456             WHEN 'F' MOVE FULL-RATE TO IND-DAILY-RATE
457             WHEN 'L' MOVE LUXURY-RATE TO IND-DAILY-RATE
458             WHEN OTHER MOVE ZEROES TO IND-DAILY-RATE
459         END-EVALUATE.
460         MULTIPLY IND-DAILY-RATE BY REN-DAYS-RENTED
461             GIVING IND-DAILY-TOTAL
462         SIZE ERROR DISPLAY 'SIZE ERROR ON RENTAL TOTAL'
463         END-MULTIPLY.
464
465     560-COMPUTE-INSURANCE-TOTAL.
466         IF INSURANCE
467             MULTIPLY INSURANCE-RATE BY REN-DAYS-RENTED
468                 GIVING IND-INSURANCE-TOTAL
469             SIZE ERROR DISPLAY 'SIZE ERROR ON INSURANCE TOTAL'
470             END-MULTIPLY
471         ELSE
472             MOVE ZEROES TO IND-INSURANCE-TOTAL
473         END-IF.
474
475     600-WRITE-VALID-RECORD.
476         WRITE VALID-RENTAL-RECORD FROM RENTAL-RECORD-IN.
477
478     700-INPUT-SCREEN-CONFIRM.
479         DISPLAY CONFIRM-SCREEN.
480         PERFORM WITH TEST AFTER UNTIL VALID-CONFIRMED
481             ACCEPT CONFIRM-SCREEN
482             IF VALID-CONFIRMED
483                 PERFORM 498-CLEAR-ERRORS
484             ELSE
485                 MOVE YES-NO-MSG TO ERROR-MESSAGE
486                 PERFORM 499-DISPLAY-ERROR-MESSAGE
487             END-IF
488         END-PERFORM.

```

The requirements for the validation of individual fields parallel those in Chapter 8, and thus the table of error messages (lines 68–107) is repeated from the validation program. The validation process is different, however, as each field is checked interactively, so that the user cannot move to the next field until a valid value has been entered for the current field.

Consider, for example, the validation of car type in lines 324–333. The TEST AFTER clause guarantees that the performed statements are executed at least once; that is, the car type is accepted into SCR-CAR-TYPE (defined in lines 183–184), then tested by the IF statement in lines 327–332. A valid car type will reset VALID-FIELD-SWITCH to 'NO', which in turn satisfies the condition in the PERFORM statement in line 325. An invalid response, however, displays the appropriate error message, then requests a new response from the user. A similar process is followed for the other fields in each transaction. An appreciation for the interactive nature of the program can best be gained by executing the program as it exists on the accompanying data disk.

The remainder of the Procedure Division is straightforward with applicable paragraphs copied from the earlier programs—for example, COMPUTE-MILEAGE-TOTAL, COMPUTE-DAILY-TOTAL, and COMPUTE-INSURANCE-TOTAL.

LIMITATIONS OF COBOL-74

The Screen Section and extended options of the ACCEPT and DISPLAY statements are *not* included in either the COBOL-74 or COBOL-85 standard, and thus there are no limitations per se in the earlier compiler. In other words, any differences that do exist are due to vendor-specific extensions, which vary significantly from compiler to compiler.

S U M M A R Y

Points to Remember

- ☛ The extended screen handling capabilities in the Screen Section and the ACCEPT and DISPLAY statements are not part of the COBOL-85 standard. The examples in this chapter follow the syntax of the Classroom COBOL compiler that accompanies the text, which conforms to the X-Open standard.
- ☛ The ACCEPT and DISPLAY statements display individual lines and/or accept a limited number of fields as input. Both statements contain an abundance of optional clauses, the functions of which are generally apparent from the clause itself: BLINK, BEEP, BACKGROUND-COLOR, FOREGROUND-COLOR, and so forth.
- ☛ The Screen Section facilitates the production of uniform screens within a system as an entire screen may be easily copied from one program to the next. This is in contrast to individual ACCEPT and DISPLAY statements that are scattered throughout the Procedure Division.

- ☛ The format of the Screen Section parallels that of the File and Working-Storage sections in the Data Division; that is, it consists of 01-level entries that are further divided into group and elementary items. The Screen Section must be the last section in the Data Division.
- ☛ Data validation may be implemented interactively through an in-line perform and through TEST AFTER clauses, which accept a data name, perform the indicated validation, then repeat the process until a valid field has been entered.

Key Words and Concepts

| | |
|------------------------|---------------------|
| All key | Interactive program |
| ASCII characters | Password protection |
| Background color | Prompt |
| Batch-oriented program | Reversed video |
| Data validation | Screen attribute |
| Foreground color | Screen-name |

COBOL Elements

| | |
|------------------|----------------|
| ACCEPT | HIGHLIGHT |
| AUTO | LINE |
| BACKGROUND-COLOR | REVERSE-VIDEO |
| COLUMN | SCREEN SECTION |
| DISPLAY | SECURE |
| FOREGROUND-COLOR | TO |
| FROM | USING |

F I L L - I N

1. The Screen Section (_____) part of the COBOL-85 standard.
2. The typical screen displays _____ lines of _____ columns each.
3. The _____ clause in the ACCEPT statement prevents the user's response from being displayed on the monitor.
4. The LINE and COLUMN clauses (_____) required in the ACCEPT and/or DISPLAY statements
5. The Screen Section is the (_____) section in the Data Division.
6. The _____ key, in conjunction with the numeric keyboard, can be used to enter any of the 256 _____ characters into a program.
7. In general, the foreground and background colors (_____) be the same.

8. The (_____) statement is often used in conjunction with top-down testing and/or debugging.
9. An in-line PERFORM statement, coupled with the (_____) clause, is used to implement interactive data validation.
10. The _____ facilitates the production of uniform screens within a system in that its entries can be easily copied from program to program.
11. Screen I-O makes possible the implementation of (_____) programs.
12. An in-line perform, in conjunction with the TEST AFTER clause, can be used to _____ a field as it is entered.

TRUE / FALSE

1. The same COBOL program cannot contain a Screen Section and a File Section.
2. The File Section is required in every program.
3. The LINE and/or COLUMN clauses are required in the DISPLAY statement.
4. The Screen Section is required in all programs that display output on the monitor.
5. The ACCEPT and DISPLAY statements are used for low-volume output.
6. The options and syntax for screen I-O are unlikely to change from one compiler to the next.
7. Text is typically displayed on screens in which the foreground and background colors are the same.
8. COBOL-85 makes little provision for screen I-O, and thus its implementation varies greatly from compiler to compiler.
9. The optional clauses in the ACCEPT statement can appear in any order.
10. Interactive data validation cannot be implemented in programs with extensive screen I-O.

PROBLEMS

1. Which clause is used to implement the following in an ACCEPT and/or DISPLAY statement?
 - a. Invert the specified or default background and foreground colors
 - b. Prevent the referenced field from being displayed on the screen
 - c. Require that at least one character is entered in the referenced field
 - d. Automatically position the cursor to the first character of the next field after the last character of the current field has been entered
 - e. Clear the screen before accepting (displaying) a data element
 - f. Emphasize the displayed field (multiple clauses are acceptable)

2. Indicate the exact effect of each of the following DISPLAY statements. Note, however, that some of the statements are invalid syntactically, in which case you should indicate the nature of the error. Other statements are valid syntactically, but most probably do not do what the programmer intended.
 - a. DISPLAY
 - b. DISPLAY 'COMPUTE-TUITION paragraph is entered'
 - c. DISPLAY 'TUITION = IND-TUITION'
 - d. DISPLAY 'TUITION = ', IND-TUITION
 - e. DISPLAY 'Initials: AT LINE 5 COLUMN 5'
 - f. DISPLAY 'Initials:' AT LINE 5 COLUMN 5
 - g. The two statements, DISPLAY 'Less Scholarship' AT LINE 15 COLUMN 10 followed by DISPLAY 'Amount due' AT LINE 15 COLUMN 16
3. Modify the tuition billing program to accommodate the following:
 - a. A new password, RTG, which should be accepted as valid in all uppercase, all lowercase, or any combination of upper- and lowercase letters.
 - b. Data validation as you see fit; the program as presently written does no validation whatsoever. Suggest and implement validation checks for at least three fields.
 - c. Display a total screen at the conclusion of processing that contains the number of students processed and the corresponding totals for total tuition, total activity fee, total union fee, total scholarship awarded, and the total amount due.
 - d. Create a valid record file as output—that is, a file containing the valid student records that could be input into the edited version of the tuition billing program in Chapter 7.
4. Answer the following with respect to the car validation and billing program:
 - a. Is the program case-sensitive; that is, is there any difference between entering an upper- or lowercase C to denote a compact car?
 - b. What changes (if any) have to be made to VALUE clauses in the Data Division to make the program case-insensitive for car type?
 - c. What changes (if any) have to be made in the Procedure Division to support those made in the Data Division in part (b)?
 - d. What other changes (if any) are needed to make the program case-insensitive to other data names?
5. The car validation and billing program makes extensive use of the in-line PERFORM statement to validate data as it is entered.
 - a. What is the minimum number of times the statements within an in-line perform (e.g., lines 305–313) will be executed?
 - b. Do the PERFORM statements (e.g., lines 305–313) implement a DO WHILE or a DO UNTIL structure?
 - c. What is the effect (if any) of substituting TEST BEFORE for TEST AFTER in line 305?
 - d. What is the effect (if any) of removing the TEST clause in line 305?

Introduction to Tables

Overview

Introduction to Tables

OCCURS Clause

Processing a Table

PERFORM VARYING

A Second Example

Problems with the OCCURS Clause

Rules for Subscripts

Relative Subscripting

USAGE Clause

OCCURS DEPENDING ON

The Student Transcript Program

Programming Specifications

Program Design

The Completed Program

Indexes versus Subscripts

The SET Statement

Limitations of COBOL-74

Summary

Fill-in

True/False

Problems

OBJECTIVES

After reading this chapter you will be able to:

- ☛ Define a table and describe its use in programming.
- ☛ Use the OCCURS (at either the group or elementary level) to implement a table in COBOL.
- ☛ Use the PERFORM VARYING statement to process a table.
- ☛ Distinguish between fixed and variable length records; use the OCCURS DEPENDING ON clause to implement a variable length table.
- ☛ State the purpose of the USAGE clause.
- ☛ Differentiate between a subscript and an index.

OVERVIEW

This is the first of three chapters that deal exclusively with tables, a topic of major importance in any programming language. A table is a grouping of similar data whose values are stored in consecutive storage locations and assigned a single data name. Any reference to an individual element within a table is accomplished by a subscript or an index.

The present chapter introduces the basic statements for table processing. We begin with the OCCURS clause to define a table and show how it can be used at both the group and elementary levels. We discuss the DEPENDING ON phrase to specify a variable-length table and the concept of relative subscripting. We cover the PERFORM VARYING statement to process the elements in a table by repeatedly executing a paragraph or a series of in-line statements. We also differentiate between an index that is specified in an INDEXED BY clause and a subscript defined in Working-Storage. All of this material is summarized by the illustrative program at the end of the chapter.

Introduction to Tables

The motivation for using a table comes from examination of Figure 11.1. Let us assume that a company tabulates its sales on a monthly basis and that the sales of each month are to be referenced within a COBOL program. Without tables, as in the brute force approach of Figure 11.1a, 12 different data names are required: JAN-SALES, FEB-SALES, and so on. A table, however, enables you to define a single data name such as SALES, then subsequently refer to individual months by an appropriate subscript. SALES (2), for example, refers to the sales for the second month, February.

Figure 11.1 The Table Concept

```

01 ANNUAL-SALES-DATA.
05 JAN-SALES      PIC 9(6).
05 FEB-SALES      PIC 9(6).
05 MAR-SALES      PIC 9(6).
05 APR-SALES      PIC 9(6).
05 MAY-SALES      PIC 9(6).
05 JUN-SALES      PIC 9(6).
05 JUL-SALES      PIC 9(6).
05 AUG-SALES      PIC 9(6).
05 SEP-SALES      PIC 9(6).
05 OCT-SALES      PIC 9(6).
05 NOV-SALES      PIC 9(6).
05 DEC-SALES      PIC 9(6).
    
```

(a) Brute Force

```

01 ANNUAL-SALES-DATA.
05 SALES OCCURS 12 TIMES      PIC 9(6).
    
```

(b) OCCURS Clause

| ANNUAL-SALES-DATA | | | | | | | | | | | | | | | | | |
|-------------------|--|--|--|--|--|-----------|--|--|--|--|--|-----------|--|--|--|--|--|
| SALES (1) | | | | | | SALES (2) | | | | | | SALES (3) | | | | | |
| | | | | | | | | | | | | ... | | | | | |

(c) Storage Schematic

OCCURS Clause

The **OCCURS** clause defines the number of entries in a table and is covered in detail later in the chapter. For the time being, however, we consider only its simplest form:

```
OCCURS integer TIMES
```

The **OCCURS** clause is illustrated in Figure 11.1b to define a table of 12 elements, with each element in the table having the identical format; that is, each element is a six-position numeric field. The entire table takes a total of 72 positions (12 entries x 6 positions per entry), as shown in the schematic of Figure 11.1c. As indicated, individual entries in the table are referenced by the table name, **SALES**, and an appropriate subscript—for example, **SALES (1)** to refer to the first element (January sales), **SALES (2)** to refer to the second element (February sales), and so on.

The **OCCURS** clause is not permitted at the 01 level and thus the sales table was defined under the entry **ANNUAL-SALES-DATA** in Figure 11.1b. The 12 elements may be referenced collectively by the data name **ANNUAL-SALES-DATA** although such a reference is unlikely to be used.

Processing a Table

After a table has been defined, we shall want to sum the 12 monthly totals to produce an annual total. There are several approaches, the first of which is brute force:

```

COMPUTE ANNUAL-TOTAL
  = SALES (1) + SALES (2) + SALES (3)
  + SALES (4) + SALES (5) + SALES (6)
  + SALES (7) + SALES (8) + SALES (9)
  + SALES (10) + SALES (11) + SALES (12)
END-COMPUTE.

```

This technique is cumbersome to code, and defeats the purpose of defining the table in the first place, but it does explicitly illustrate the concept of table processing. Fortunately, however, there is a better way through the `PERFORM VARYING` statement.

PERFORM VARYING

The `PERFORM VARYING` statement causes repeated execution of a designated procedure or series of in-line statements and is the most common means of processing a table. Consider:

```

PERFORM [procedure-name-1]
      [WITH TEST {BEFORE | AFTER}]
      VARYING identifier-1 FROM {literal-1 | identifier-2} BY {literal-2 | identifier-3}
      UNTIL condition-1
      [imperative-statement-1 END-PERFORM]

```

The `TEST BEFORE/TEST AFTER` clause is new to COBOL-85 and was explained in Chapter 9. The clause is optional and typically omitted; the default is `TEST BEFORE` and corresponds to the COBOL-74 implementation.

The `PERFORM VARYING` statement (with test before) *initializes* a variable, *tests a condition*, and if the condition is not satisfied, enters a loop to *execute* a procedure, *increment* a variable, and *retest* the condition (condition-1). The loop is executed repeatedly until the condition is finally satisfied, at which point the `PERFORM VARYING` statement ends, and control passes to the next sequential statement in the program. The sequence just described is illustrated in Figure 11.2 and is restated below:

1. Identifier-1 is initialized to the value in the `FROM` clause
2. Condition-1 is evaluated and is either true or false:
 - a. If the condition is true, the `PERFORM VARYING` is terminated and control passes to the next sequential statement.
 - b. If the condition is false, procedure-name-1 or imperative-statement-1 is executed, after which identifier-1 is incremented with the value in the `BY` clause. Condition-1 is reevaluated as either true or false with subsequent action as just described.

Figure 11.2 PERFORM VARYING (with TEST BEFORE)

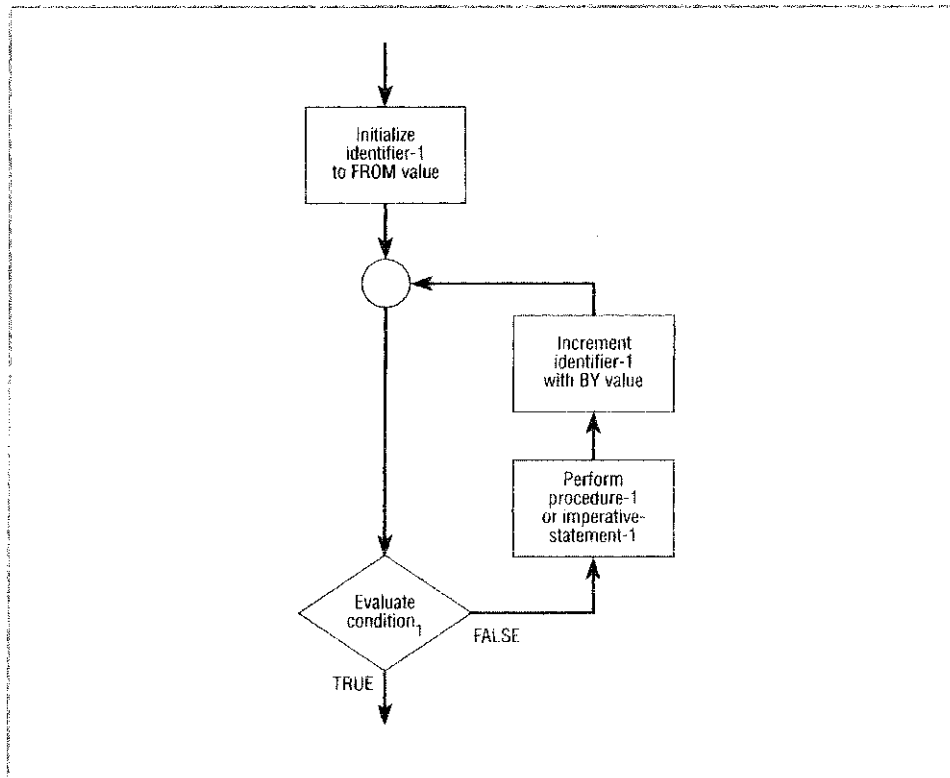

The condition in the PERFORM VARYING statement typically includes a greater than sign, rather than an equal sign, to execute the designated procedure an integer number of times; for example, the statement

```

PERFORM COMPUTE-PAYMENT
  VARYING SUBSCRIPT FROM 1 BY 1
  UNTIL SUBSCRIPT > 3
  
```

executes the procedure COMPUTE-PAYMENT three times. The sequence is explained as follows:

1. SUBSCRIPT is initially set to 1 and the condition SUBSCRIPT > 3 is evaluated. The condition is not true, so the designated procedure, COMPUTE-PAYMENT, is executed the first time.
2. SUBSCRIPT is incremented to 2 and the condition is retested. The condition is still not satisfied, so COMPUTE-PAYMENT is executed a second time.
3. SUBSCRIPT is incremented to 3, but the condition is still false—3 is not greater than 3—and hence COMPUTE-PAYMENT is executed a third (and final) time.
4. SUBSCRIPT is incremented to 4, satisfying the condition in the UNTIL clause and terminating the PERFORM statement. (Note that, had the condition been specified as SUBSCRIPT = 3, COMPUTE-PAYMENT would have been executed only twice.)

Extending this reasoning to the general case of executing a procedure N times requires a statement of the form:

```
PERFORM PARAGRAPH
  VARYING SUBSCRIPT FROM 1 BY 1
  UNTIL SUBSCRIPT > N.
```

The data name used to monitor execution—for example, SUBSCRIPT—must be explicitly defined in Working-Storage.

The PERFORM VARYING statement is illustrated a final time in Figure 11.3. The choice between performing a paragraph as in Figure 11.3a, or using an in-line perform as in Figure 11.3b, is one of personal preference. Both techniques are equally acceptable and achieve identical results.

Figure 11.3 Processing a Table

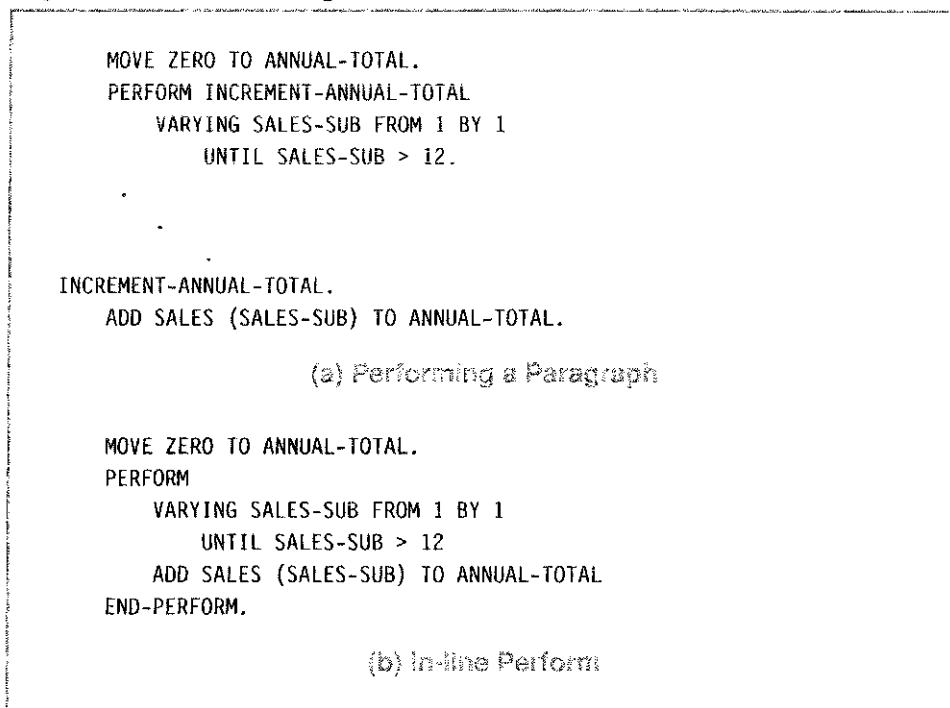

Second example

Let us consider a second example in which three sets of salary data are kept for each employee; that is, each employee record contains the employee's present salary and date on which it became effective, the previous salary and date, and the second previous salary and date. (Not all employees have all three salaries.)

It is, of course, possible to develop unique data names for each occurrence of salary information, for example,

```
05 SALARY-DATA.
10 PRESENT-SALARY          PIC 9(6).
10 PRESENT-SALARY-DATE    PIC 9(4).
10 PREVIOUS-SALARY        PIC 9(6).
10 PREVIOUS-SALARY-DATE  PIC 9(4).
10 SECOND-PREVIOUS-SALARY PIC 9(6).
10 SECOND-PREVIOUS-SALARY-DATE PIC 9(4).
```

Figure 11.4 OCCURS Clause at the Group Level

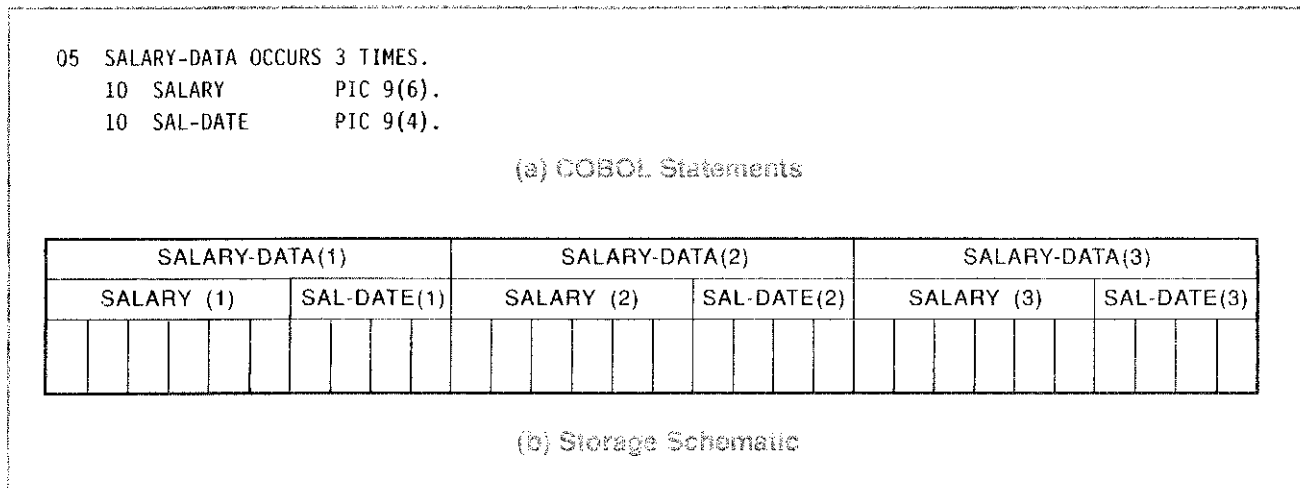
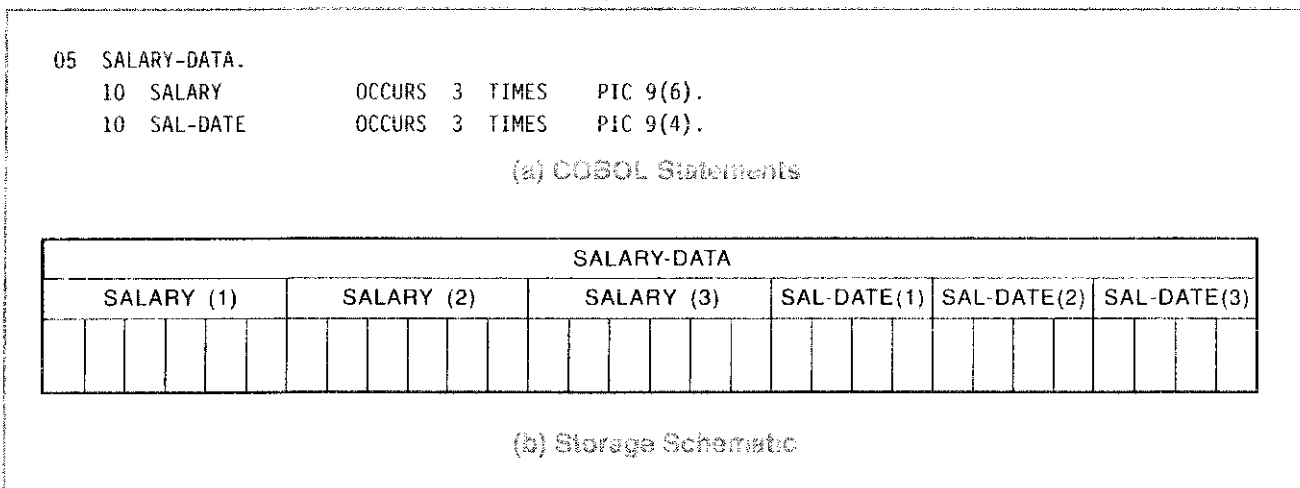

Figure 11.5 OCCURS Clause at the Elementary Level



What if, however, it were suddenly decided that four, five, or even ten levels of historical data were required? The situation is neatly circumvented by establishing a table that enables the programmer to define logically similar elements under a common name, and to reference the desired entry subsequently by an appropriate subscript. Hence SALARY (1) denotes the present salary, SALARY (2) the previous salary, SALARY (3) the second previous salary, and so on. Figure 11.4 shows the COBOL statements and corresponding storage allocation for such a scheme.

Figure 11.4 depicts a total of 30 storage positions for the table SALARY-DATA, with the OCCURS clause at the group level. Positions 1-6 refer to SALARY (1), positions 7-10 refer to SAL-DATE (1), and positions 1-10 collectively to SALARY-DATA (1). In similar fashion, positions 11-16 refer to SALARY (2), positions 17-20 refer to SAL-DATE (2), and positions 11-20 collectively to SALARY-DATA (2). Whenever a subscript is used, it is enclosed in parentheses.

Figure 11.5 contains an alternate implementation with two OCCURS clauses at the elementary level. A total of 30 storage positions are still assigned to the table, but the storage allocation is different; i.e., positions 1-6 contain SALARY (1), positions 7-12 contain SALARY (2), and positions 13-18 contain SALARY (3). In similar fashion,

positions 19–22 correspond to SAL-DATE (1), positions 23–26 to SAL-DATE (2), and positions 27–30 to SAL-DATE (3). Either arrangement, Figure 11.4 or Figure 11.5, is appropriate; the choice is up to the programmer.

Problems with the OCCURS Clause

The most common error associated with tables is the omission of a subscript where one is required, or the inclusion of a subscript where it is not needed. The rule is very simple. *Any data name that has been defined with an OCCURS clause, or any data name subservient to a group item containing an OCCURS clause, must always be referenced with a subscript.* Failure to do so results in a compilation error. Thus all of the following are valid references with respect to the table definition of Figure 11.4: SALARY-DATA (2), SALARY (2), and SAL-DATE (2).

In the table definition of Figure 11.5, however, the OCCURS clause exists at the elementary, rather than the group, level. SALARY-DATA is referenced *without* a subscript and refers collectively to the 30 bytes in the table. SALARY and SAL-DATE are both defined with OCCURS clauses and require subscripts: SALARY (2) and SAL-DATE (2), for example.

The compiler checks only for the existence of a subscript, but not its value; for example, the entry SALARY (20) is syntactically correct in that a subscript is present, but logically incorrect as the OCCURS clause defines only three elements. The error would not be detected during compilation; it would pose a problem during execution as it references an invalid storage location with unpredictable results. Some compilers offer the option of including a *subscript check* whereby an error message will be produced during execution if an invalid subscript is referenced.

Rules for Subscripts

COBOL subscripts may be either variable or constant, but in either case must adhere to the following:

1. At least one space is required between the data name and the left parenthesis.

| | |
|-----------------|------------|
| <i>Valid:</i> | SALES (2) |
| <i>Invalid:</i> | SALES(SUB) |
| <i>Invalid:</i> | SALES(2) |

2. A space may not follow the left parenthesis nor precede the right parenthesis.

| | |
|-----------------|-------------|
| <i>Valid:</i> | SALES (SUB) |
| <i>Valid:</i> | SALES (2) |
| <i>Invalid:</i> | SALES(2) |
| <i>Invalid:</i> | SALES(2) |

3. A subscript can be a data name or a numeric literal with an integer value. Relative subscripting—that is, a data name plus or minus an integer—is also permitted.

| | |
|-----------------|-----------------|
| <i>Valid:</i> | SALES (SUB + 1) |
| <i>Invalid:</i> | SALES (1.2) |

Relative Subscripting

Relative subscripting—that is, the ability to add or subtract an integer from a subscript—is a tremendous convenience in certain situations. The report in Figure

Figure 11.6 Relative Subscribing

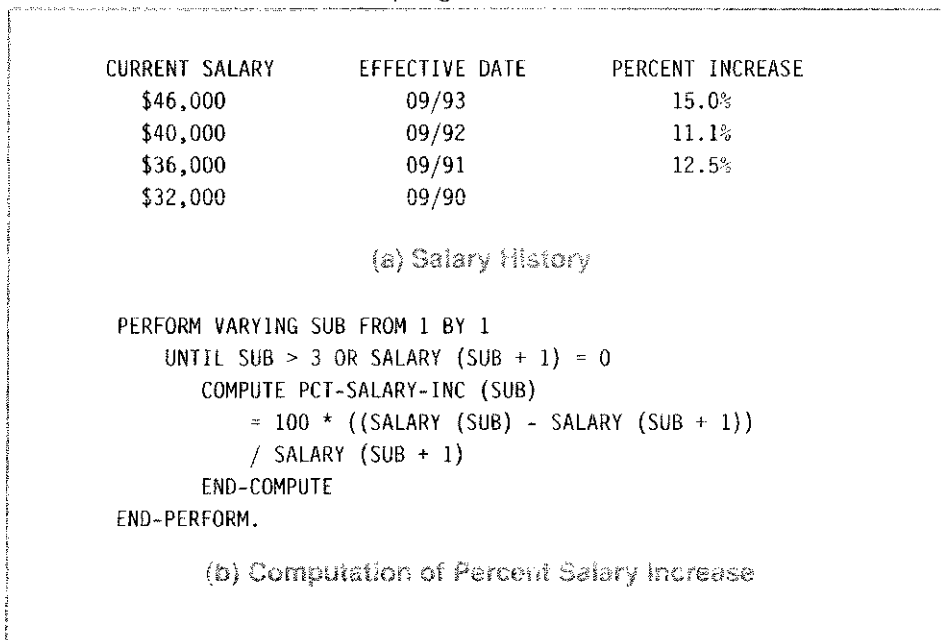

11.6a displays four levels of salary, the date on which each salary became effective, and the associated percent increase for each pair of salaries. (The percent increase is not calculated for the last salary.) Percent increase is computed according to the general formula:

$$\text{Percent Salary Increase} = \frac{\text{New Salary} - \text{Old Salary}}{\text{Old Salary}} \times 100$$

The current salary of \$46,000 in Figure 11.6a reflects a 15 percent increase over the previous salary of \$40,000 and was computed as follows:

$$\text{Percent Salary Increase} = \frac{46,000 - 40,000}{40,000} \times 100 = .15$$

The percent salary increase is a repetitive calculation that is required for each pair of salaries stored within the salary table. One (tedious) approach is to use a different formula for each pair of salaries—that is, one formula to reference SALARY (1) and SALARY (2), a second formula to reference SALARY (2) and SALARY (3), and so on. A more elegant solution is to develop a general formula that references SALARY (SUB) and SALARY (SUB + 1) as shown in Figure 11.6b.

The COMPUTE statement is executed three times if all four salaries are present. Newer employees will not have a complete salary history, however, and hence the second condition in the UNTIL clause will cease execution if an earlier salary is not present; that is, the latter condition prevents a division by zero when an earlier salary is not available.

USAGE Clause

The USAGE clause is intended to make a program more efficient. The clause is entirely optional as the presence (or absence) of a USAGE clause does not alter the logic of a program, but affects only the generated object code. A true understanding, therefore, requires a knowledge of assembler fundamentals which is beyond the

present discussion. Suffice it to say that subscripts are best defined with a USAGE clause in one of four equivalent formats as follows:

```
05 SUBSCRIPT-1    PIC S9(4)    USAGE IS COMPUTATIONAL.
05 SUBSCRIPT-2    PIC S9(4)    COMPUTATIONAL.
05 SUBSCRIPT-3    PIC S9(4)    USAGE IS COMP.
05 SUBSCRIPT-4    PIC S9(4)    COMP.
```

OCCURS DEPENDING ON

We began the chapter with the simplest form of the OCCURS clause to define a table. The clause has several additional options, however, as shown below:

```
OCCURS {integer-1 TO integer-2 TIMES [DEPENDING ON data-name-1]}
       {integer-2 TIMES}

       { [ASCENDING]
         [DESCENDING] } KEY IS data-name-2 [data-name-3] . . .

       [INDEXED BY index-name-1 [index-name-2] . . . ]
```

The DEPENDING ON clause defines a *variable-length table*. This in turn produces a *variable-length record*, which is reflected in the RECORD CONTAINS clause of the FD as shown in Figure 11.7.

The records in STUDENT-TRANSCRIPT-FILE will vary in length from 42 to 1,131 characters, depending on the number of courses a student has completed. The minimum record length is 42 characters; 30 for name, 10 for major, and 2 for the number of courses. The records for incoming freshmen will contain the minimum 42 characters, whereas the records for upperclassmen contain an additional 11 bytes for every completed course. An arbitrary maximum of 99 courses is permitted in a record.

The advantage of *variable-length records* is that they allocate only as much space as necessary in the storage medium. *Fixed-length records*, on the other hand, assign the same (maximum) amount of disk space to every record in the file.

Figure 11.7 Variable-length Records

```
FD STUDENT-TRANSCRIPT-FILE
   RECORD CONTAINS 42 TO 1131 CHARACTERS
   DATA RECORD IS STUDENT-RECORD.
01 STUDENT-RECORD.
   05 ST-NAME                               PIC X(30).
   05 ST-MAJOR                              PIC X(10).
   05 ST-COURSES-COMPLETED                 PIC 99.
   05 ST-COURSE-GRADE OCCURS 0 TO 99 TIMES
      DEPENDING ON ST-COURSES-COMPLETED.
   10 ST-COURSE-NUMBER                     PIC 9(6).
   10 ST-GRADE                             PIC X.
   10 ST-COURSE-DATE                       PIC 9(4).
```

What, then, is the maximum number of courses? Is it five per semester, times 8 semesters, or 40 courses? What about the student who fails a course or the one with two majors, or the one who remains in the university to pursue a master's or doctoral degree? Perhaps we should allocate space for 100 courses, just to be safe. If we do, every student record will require 1,100 bytes (11 bytes per course times 100 courses). But at any given time the average student probably has completed twenty or fewer courses (that is, there are freshmen, sophomores, juniors, and seniors in the file), and hence most records would require only 220 (20 x 11) or fewer characters. In other words, approximately 900 bytes per record would be wasted in the storage medium. Multiply this by the number of students in the university, and you can quickly see the inefficiency of fixed-length records in certain applications.

Variable-length records, on the other hand, allow only as much space in each record as is actually required. Each variable-length record contains a specific field from which the length of the record can be calculated—for example, the number of completed courses, which becomes the data name specified in the OCCURS DEPENDING ON clause.

The INDEXED BY clause is covered later in this chapter (on page 321). The ASCENDING/DSCENDING KEY clause is presented in Chapter 12 in conjunction with table lookups.

The Student Transcript Program

We are ready to incorporate the basic material on table processing into an illustrative program. Specifications follow in the usual format.

PROGRAMMING SPECIFICATIONS

Program Name: Student Transcript Program

Narrative: This program processes a file of student records to produce a set of student transcripts. Each incoming record contains a variable-length table with the student's grades from the preceding semester. The program computes the grade point average for every student, prints individual transcripts for each student, and produces a table of students on the dean's list at the end of processing.

Input File(s): STUDENT-FILE

Input Record Layout:

| | | |
|----|--|------------|
| 01 | STUDENT-RECORD. | |
| 05 | ST-NAME | PIC X(19). |
| 05 | ST-NUMBER-OF-COURSES | PIC 99. |
| 05 | ST-COURSE-INFO OCCURS 1 TO 8 TIMES DEPENDING ON ST-NUMBER-OF-COURSES. | |
| 10 | ST-COURSE-NUMBER | PIC X(3). |
| 10 | ST-COURSE-GRADE | PIC X. |
| 10 | ST-COURSE-CREDITS | PIC 9. |

Test Data: See Figure 11.8a.

Report Layout: See Figure 11.8b and 11.8c.

Processing Requirements: 1. Read a file of student records.

Figure 11.8 Test Data and Required Output

BENJAMIN, L 05111A3222A2333A3444A3555B3
 BORROW, J 04666B3777B3888B3999B4
 MILGROM, M 06123C4456C4789C4012C4345C3678C4

(a) Test Data

NAME: BENJAMIN, L OFFICIAL TRANSCRIPT

| COURSE # | CREDITS | GRADE |
|----------|---------|-------|
| 111 | 3 | A |
| 222 | 2 | A |
| 333 | 3 | A |
| 444 | 3 | A |
| 555 | 3 | B |

AVERAGE: 3.79 *DEANS LIST*

NAME: BORROW, J OFFICIAL TRANSCRIPT

| COURSE # | CREDITS | GRADE |
|----------|---------|-------|
| 666 | 3 | B |
| 777 | 3 | B |
| 888 | 3 | B |
| 999 | 4 | B |

AVERAGE: 3.00

NAME: MILGROM, M OFFICIAL TRANSCRIPT

| COURSE # | CREDITS | GRADE |
|----------|---------|-------|
| 123 | 4 | C |
| 456 | 4 | C |
| 789 | 4 | C |
| 012 | 4 | C |
| 345 | 3 | C |
| 678 | 4 | C |

AVERAGE: 2.00

(b) Individual Transcripts

STUDENTS ON THE DEANS LIST

| NAME | TOTAL COURSES | TOTAL CREDITS | QUALITY POINTS | GPA |
|-------------|---------------|---------------|----------------|------|
| BENJAMIN, L | 5 | 14 | 53 | 3.79 |

(c) The Dean's List

Figure 11.9 Calculation of Grade Point Average

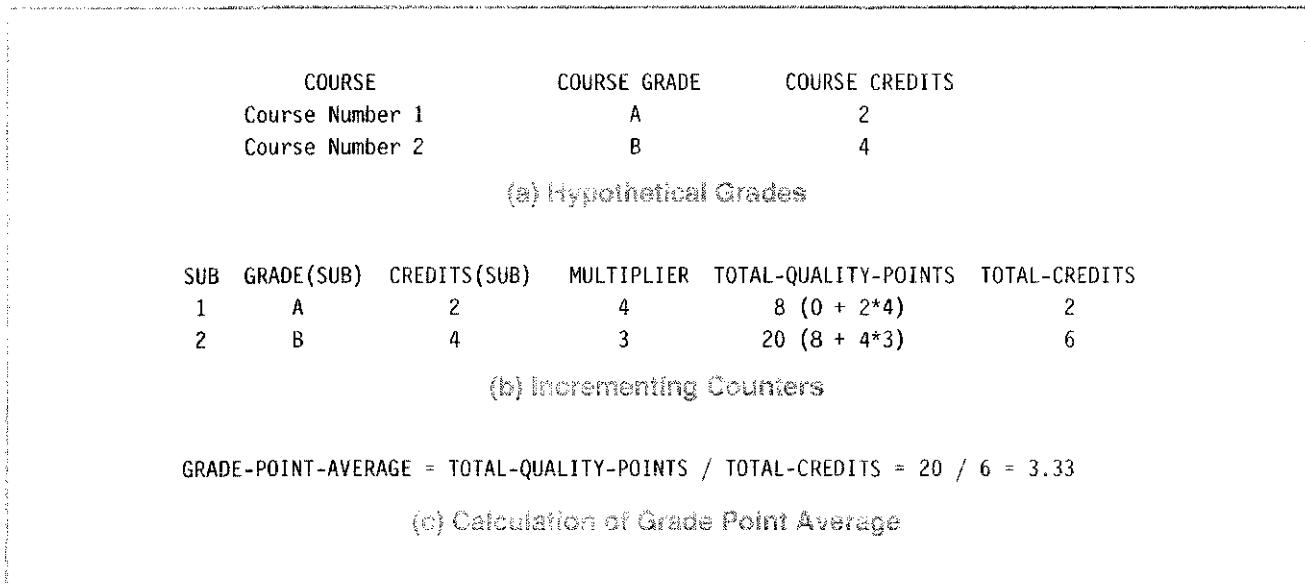

2. For every record read,
 - a. Calculate the grade point average (GPA) according to a four-point scale with grades of A, B, C, D, and F, worth 4, 3, 2, 1, and 0, respectively. Courses are weighted according to their credit value in computing the GPA. The number of quality points for a given course is equal to the number of credits for that course times the numeric value of that grade. The GPA is equal to the total number of quality points (for all courses) divided by the total number of credits. The computation of the GPA is further illustrated in Figure 11.9.
 - b. Print the student's name, list of courses with associated grades, and computed grade point average according to the format in Figure 11.8b. Every transcript is to begin on a new page.
 - c. Determine whether the student qualifies for the dean's list, which requires a GPA of 3.5 or higher; if so, print the dean's list designation on the last line of the transcript.
3. Print a list of all students on the dean's list at the end of processing as shown in Figure 11.8c.

Program Design

The development of this (or any other) program begins with a hierarchy chart that includes all necessary functions to implement the processing requirements. The output in Figure 11.8 shows individual transcripts and a composite dean's list, both of which represent major tasks to be fully expanded; thus the highest-level module in the hierarchy chart will have two subordinates, CREATE-TRANSCRIPT and WRITE-DEANS-LIST, corresponding to the major functions. Each of these is expanded further as shown in the hierarchy chart of Figure 11.10.

The CREATE-TRANSCRIPT module has four subordinates: WRITE-TRANS-HEADING, PROCESS-COURSES, WRITE-GPA, and ADD-TO-DEANS-LIST. PROCESS-COURSES, in turn, has two subordinates: INCREMENT-COUNTERS and WRITE-DETAIL-LINE. WRITE-DEANS-LIST also has two subordinates: WRITE-DEANS-LIST-HEADING and WRITE-DEANS-LIST-DETAILS. The hierarchy chart is straightforward and easy to follow with the functions of all modules readily apparent from the module names.

Figure 11.10 Hierarchy Chart for Transcript Program

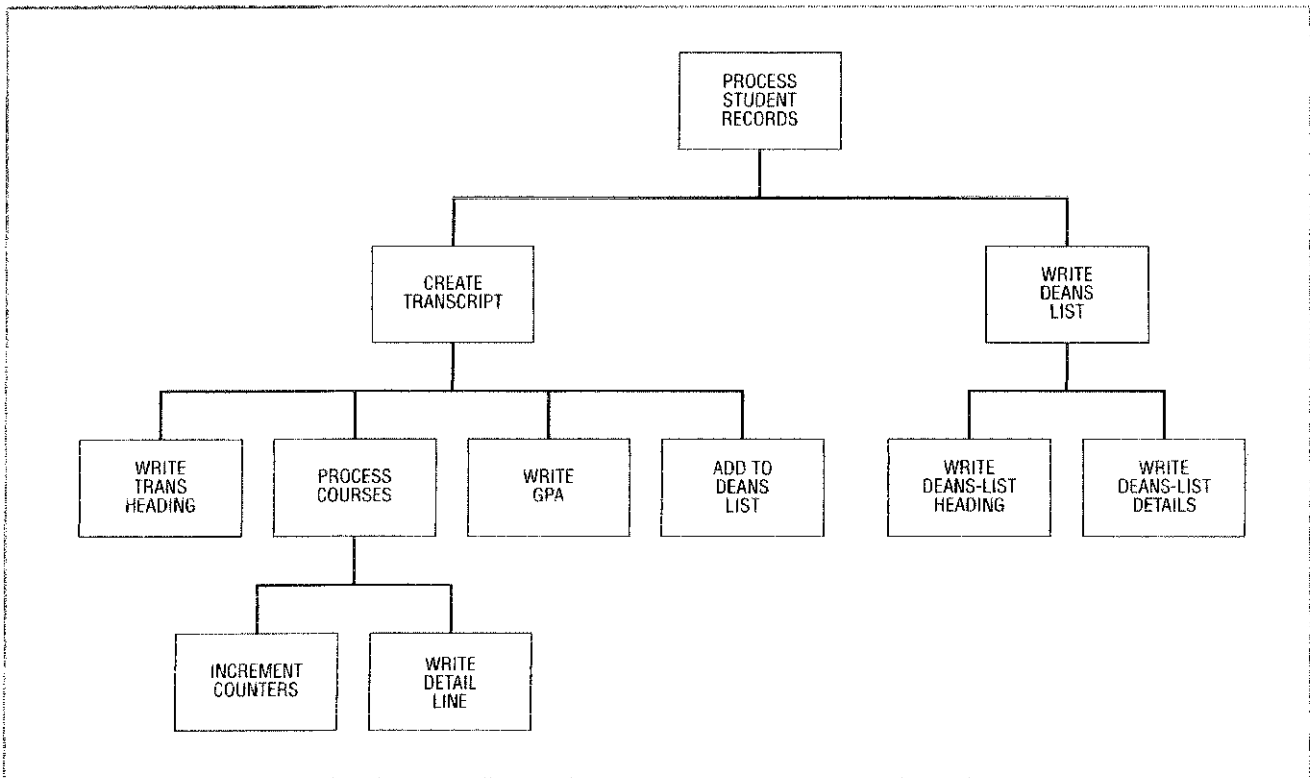

The pseudocode in Figure 11.11 uses an in-line perform to eliminate the priming read used in earlier programs. The false-condition branch in the read statement drives the program and contains the logic to compute an individual's grade point average, produce the transcript, and determine whether the individual qualifies for the dean's list.

The processing of each incoming record focuses on the production of a transcript, a process that begins with the initialization of two counters, for total quality points and total credits, respectively. Next, an inner loop is executed for every course in the current record, to determine the appropriate multiplier for the course (4 for an A, 3 for a B, and so on), to increment the counters for quality points and credits, and to write the detail line. This loop terminates after all courses (for one student) have been processed, after which the grade point average is computed by dividing the total quality points by the total number of credits.

The pseudocode next determines whether the student qualifies for the dean's list, and if so, increments the number of students on the dean's list, then moves the student's data to the appropriate place in a dean's list table. The table containing the students on the dean's list is written at the end of processing.

The Completed Program

The completed program is shown in Figure 11.12. The paragraphs in the Procedure Division correspond one to one with the modules in the hierarchy chart, and its logic in the program parallels that of the pseudocode just developed. The program complies with the processing requirements and also illustrates the various COBOL features presented earlier. Note the following:

Figure 11.14 Pseudocode for Transcript Program

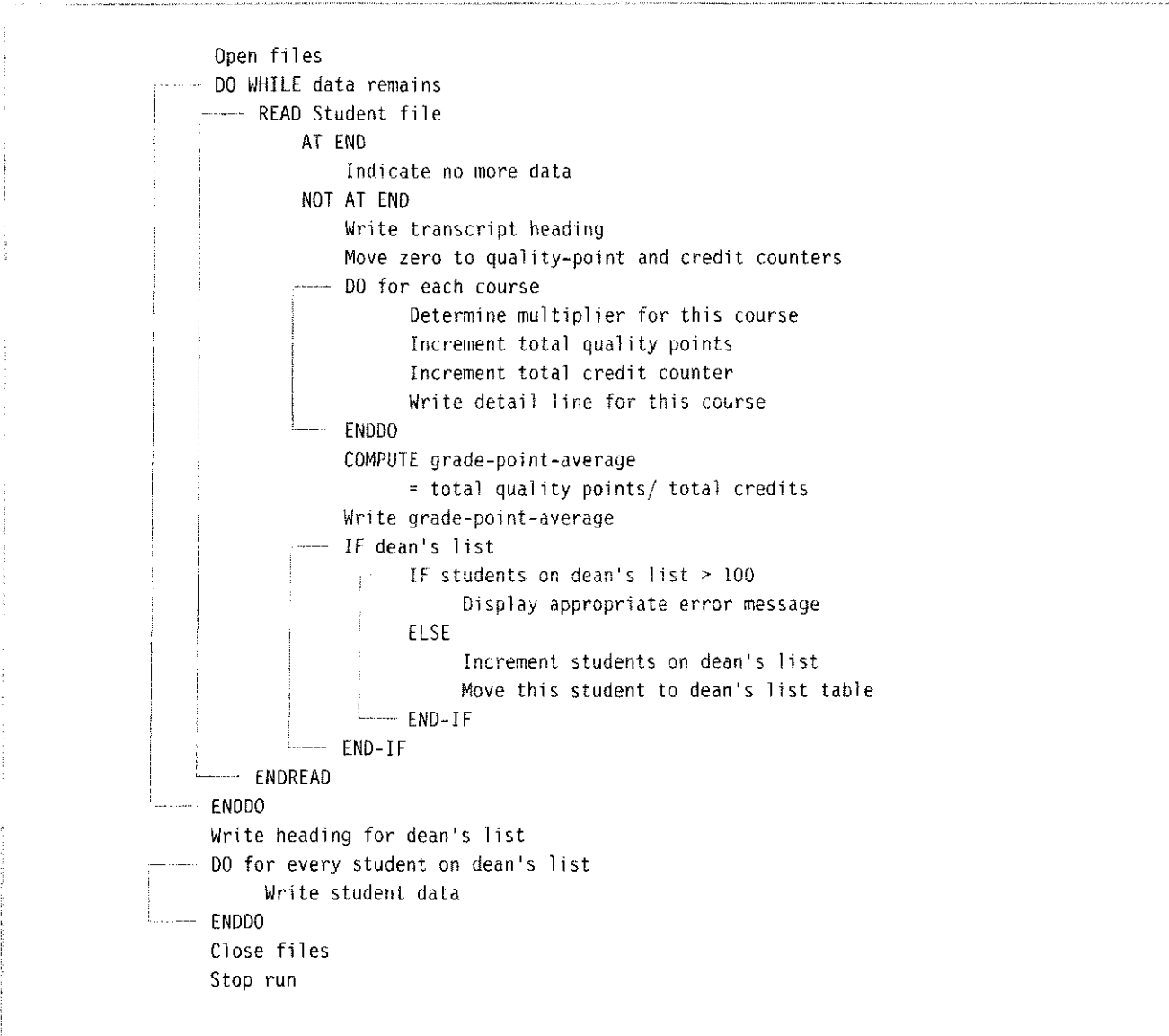

1. The OCCURS DEPENDING ON clause in lines 21 and 22 defines a variable-length table for the number of courses, which in turn produces a variable-length record in lines 15–17 of the FD for STUDENT-FILE.
2. The definition of two subscripts in Working-Storage—COURSE-SUB and DEAN-SUB—both of which contain the (USAGE IS) COMP clause for efficiency.
3. The in-line PERFORM statement of lines 133-140, coupled with the false-condition branch in the READ statement, drives the program by performing the paragraph 200-CREATE-TRANSCRIPT (lines 146–159) for every record in the file. This critical paragraph computes the grade point average, produces the transcript, and determines whether the student qualifies for the dean's list.

Figure 11.12 The Student Transcript Program

```

1  IDENTIFICATION DIVISION.
2  PROGRAM-ID.    TRANSCR.
3  AUTHOR.       ROBERT GRAUER.
4
5  ENVIRONMENT DIVISION.
6  INPUT-OUTPUT SECTION.
7  FILE-CONTROL.
8      SELECT STUDENT-FILE ASSIGN TO 'A:\CHAPTR11\STUDENT.DAT'
9          ORGANIZATION IS LINE SEQUENTIAL.
10     SELECT PRINT-FILE
11         ASSIGN TO PRINTER.
12
13  DATA DIVISION.
14  FILE SECTION.
15  FD STUDENT-FILE
16     RECORD CONTAINS 26 TO 61 CHARACTERS
17     DATA RECORD IS STUDENT-RECORD.
18  01 STUDENT-RECORD.
19     05 ST-NAME                PIC X(19).
20     05 ST-NUMBER-OF-COURSES   PIC 99.
21     05 ST-COURSE-INFO OCCURS 1 TO 8 TIMES
22         DEPENDING ON ST-NUMBER-OF-COURSES.
23         10 ST-COURSE-NUMBER  PIC X(3).
24         10 ST-COURSE-GRADE   PIC X.
25         10 ST-COURSE-CREDITS PIC 9.
26
27  FD PRINT-FILE
28     RECORD CONTAINS 132 CHARACTERS
29     DATA RECORD IS PRINT-LINE.
30  01 PRINT-LINE                PIC X(132).
31
32  WORKING-STORAGE SECTION.
33  01 SUBSCRIPTS.
34     05 COURSE-SUB             PIC S9(4)
35     05 DEAN-SUB              PIC 9(3)   VALUE ZERO
36
37  01 SWITCHES-AND-COUNTERS.
38     05 END-OF-FILE-SWITCH    PIC X(3)   VALUE 'NO '.
39     05 STUDENTS-ON-DEANS-LIST PIC 9(3)   VALUE ZERO.
40
41  01 INDIVIDUAL-GPA-VARIABLES.
42     05 IND-TOTAL-CREDITS     PIC 999.
43     05 IND-TOTAL-QUAL-POINTS PIC 999.
44     05 IND-MULTIPLIER        PIC 9.
45     05 IND-GRADE-POINT-AVERAGE PIC S9V99.
46     88 DEANS-LIST           VALUES 3.5 THRU 4.
47
48  01 DEANS-LIST-TABLE.
49     05 DEANS-LIST-INFO OCCURS 100 TIMES.
50     10 DL-NAME              PIC X(19).

```

Defines a variable-length table.

COMPUTATIONAL clause increases efficiency of compiled program

Figure 11.12 (continued)

| | | | |
|-----|----|-------------------------------------|-----------------------------|
| 51 | 10 | DL-COURSES | PIC 99. |
| 52 | 10 | DL-CREDITS | PIC 999. |
| 53 | 10 | DL-QUAL-POINTS | PIC 999. |
| 54 | 10 | DL-GPA | PIC S9V99. |
| 55 | | | |
| 56 | 01 | TRANS-HEADING-LINE-ONE. | |
| 57 | 05 | FILLER | PIC X(6) VALUE ' NAME:'. |
| 58 | 05 | HDG-NAME | PIC X(15). |
| 59 | 05 | FILLER | PIC X(10) VALUE SPACES. |
| 60 | 05 | FILLER | PIC X(19) |
| 61 | | VALUE 'OFFICIAL TRANSCRIPT'. | |
| 62 | 05 | FILLER | PIC X(82) VALUE SPACES. |
| 63 | | | |
| 64 | 01 | TRANS-HEADING-LINE-TWO. | |
| 65 | 05 | FILLER | PIC X(10) VALUE SPACES. |
| 66 | 05 | FILLER | PIC X(9) VALUE 'COURSE # '. |
| 67 | 05 | FILLER | PIC X(9) VALUE 'CREDITS '. |
| 68 | 05 | FILLER | PIC X(5) VALUE 'GRADE'. |
| 69 | 05 | FILLER | PIC X(99) VALUE SPACES. |
| 70 | | | |
| 71 | 01 | DETAIL-LINE. | |
| 72 | 05 | FILLER | PIC X(13) VALUE SPACES. |
| 73 | 05 | DET-COURSE | PIC X(3). |
| 74 | 05 | FILLER | PIC X(9) VALUE SPACES. |
| 75 | 05 | DET-CREDITS | PIC 9. |
| 76 | 05 | FILLER | PIC X(5) VALUE SPACES. |
| 77 | 05 | DET-GRADE | PIC X. |
| 78 | 05 | FILLER | PIC X(100) VALUE SPACES. |
| 79 | | | |
| 80 | 01 | LAST-LINE. | |
| 81 | 05 | FILLER | PIC X(16) VALUE SPACES. |
| 82 | 05 | FILLER | PIC X(9) VALUE 'AVERAGE: '. |
| 83 | 05 | LAST-GPA | PIC 9.99. |
| 84 | 05 | FILLER | PIC X(4) VALUE SPACES. |
| 85 | 05 | LAST-DEANS-LIST | PIC X(12) VALUE SPACES. |
| 86 | 05 | FILLER | PIC X(87) VALUE SPACES. |
| 87 | | | |
| 88 | 01 | DEANS-LIST-HEADING-LINE-ONE. | |
| 89 | 05 | FILLER | PIC X(20) VALUE SPACES. |
| 90 | 05 | FILLER | PIC X(26) |
| 91 | | VALUE 'STUDENTS ON THE DEANS LIST'. | |
| 92 | 05 | FILLER | PIC X(86) VALUE SPACES. |
| 93 | | | |
| 94 | 01 | DEANS-LIST-HEADING-LINE-TWO. | |
| 95 | 05 | FILLER | PIC X(25) VALUE SPACES. |
| 96 | 05 | FILLER | PIC X(5) VALUE 'TOTAL'. |
| 97 | 05 | FILLER | PIC X(5) VALUE SPACES. |
| 98 | 05 | FILLER | PIC X(5) VALUE 'TOTAL'. |
| 99 | 05 | FILLER | PIC X(4) VALUE SPACES. |
| 100 | 05 | FILLER | PIC X(7) VALUE 'QUALITY'. |

Figure 11.12 (continued)

```

101      05 FILLER                PIC X(81)  VALUE SPACES.
102
103      01 DEANS-LIST-HEADING-LINE-THREE.
104      05 FILLER                PIC X    VALUE SPACES.
105      05 FILLER                PIC X(4)  VALUE 'NAME'.
106      05 FILLER                PIC X(19) VALUE SPACES.
107      05 FILLER                PIC X(7)  VALUE 'COURSES'.
108      05 FILLER                PIC X(3)  VALUE SPACES.
109      05 FILLER                PIC X(7)  VALUE 'CREDITS'.
110      05 FILLER                PIC X(4)  VALUE SPACES.
111      05 FILLER                PIC X(6)  VALUE 'POINTS'.
112      05 FILLER                PIC X(5)  VALUE SPACES.
113      05 FILLER                PIC X(3)  VALUE 'GPA'.
114      05 FILLER                PIC X(73) VALUE SPACES.
115
116      01 DEANS-LIST-DETAIL-LINE.
117      05 FILLER                PIC X    VALUE SPACES.
118      05 DL-DET-NAME            PIC X(19).
119      05 FILLER                PIC X(7)  VALUE SPACES.
120      05 DL-DET-TOT-COURSES    PIC Z9.
121      05 FILLER                PIC X(7)  VALUE SPACES.
122      05 DL-DET-TOT-CREDITS    PIC Z9.
123      05 FILLER                PIC X(8)  VALUE SPACES.
124      05 DL-DET-TOT-QUAL-POINTS PIC Z9.
125      05 FILLER                PIC X(6)  VALUE SPACES.
126      05 DL-DET-GPA            PIC 9.99.
127      05 FILLER                PIC X(72) VALUE SPACES.
128
129      PROCEDURE DIVISION.
130      100-PROCESS-STUDENT-RECORDS.
131          OPEN INPUT  STUDENT-FILE
132                OUTPUT PRINT-FILE.
133          PERFORM UNTIL END-OF-FILE-SWITCH = 'YES'
134              READ STUDENT-FILE
135              AT END
136                  MOVE 'YES' TO END-OF-FILE-SWITCH
137              NOT AT END
138                  PERFORM 200-CREATE-TRANSCRIPT
139          END-READ
140          END-PERFORM.
141          PERFORM 300-WRITE-DEANS-LIST.
142          CLOSE STUDENT-FILE
143                PRINT-FILE.
144          STOP RUN.
145
146      200-CREATE-TRANSCRIPT.
147          PERFORM 210-WRITE-TRANS-HEADING.
148          MOVE ZERO TO IND-TOTAL-QUAL-POINTS IND-TOTAL-CREDITS.
149          PERFORM 220-PROCESS-COURSES
150              VARYING COURSE-SUB FROM 1 BY 1
151              UNTIL COURSE-SUB > ST-NUMBER-OF-COURSES.

```

In line PERFORM statement and until-condition which gives the program

PERFORM VARYING statement processes all entries in course table

Figure 11.12 (continued)

```

152      COMPUTE IND-GRADE-POINT-AVERAGE ROUNDED
153          = IND-TOTAL-QUAL-POINTS / IND-TOTAL-CREDITS
154          SIZE ERROR DISPLAY 'SIZE ERROR ON GPA'
155      END-COMPUTE.
156      PERFORM 250-WRITE-GPA.
157      IF DEANS-LIST
158          PERFORM 260-ADD-TO-DEANS-LIST
159      END-IF.
160
161      210-WRITE-TRANS-HEADING.
162          MOVE ST-NAME TO HDG-NAME.
163          WRITE PRINT-LINE FROM TRANS-HEADING-LINE-ONE
164              AFTER ADVANCING PAGE.
165          WRITE PRINT-LINE FROM TRANS-HEADING-LINE-TWO
166              AFTER ADVANCING 2 LINES.
167
168      220-PROCESS-COURSES.
169          PERFORM 230-INCREMENT-COUNTERS.
170          PERFORM 240-WRITE-DETAIL-LINE.
171
172      230-INCREMENT-COUNTERS.
173          EVALUATE ST-COURSE-GRADE (COURSE-SUB)
174              WHEN 'A'
175                  MOVE 4 TO IND-MULTIPLIER
176              WHEN 'B'
177                  MOVE 3 TO IND-MULTIPLIER
178              WHEN 'C'
179                  MOVE 2 TO IND-MULTIPLIER
180              WHEN 'D'
181                  MOVE 1 TO IND-MULTIPLIER
182              WHEN OTHER
183                  MOVE 0 TO IND-MULTIPLIER
184                  DISPLAY 'INVALID COURSE GRADE'
185          END-EVALUATE.
186          COMPUTE IND-TOTAL-QUAL-POINTS = IND-TOTAL-QUAL-POINTS
187              + ST-COURSE-CREDITS (COURSE-SUB) * IND-MULTIPLIER
188              SIZE ERROR DISPLAY 'SIZE ERROR ON TOTAL QUALITY POINTS'
189          END-COMPUTE.
190          ADD ST-COURSE-CREDITS (COURSE-SUB) TO IND-TOTAL-CREDITS
191              SIZE ERROR DISPLAY 'SIZE ERROR ON TOTAL CREDITS'
192          END-ADD.
193
194      240-WRITE-DETAIL-LINE.
195          MOVE ST-COURSE-NUMBER (COURSE-SUB) TO DET-COURSE.
196          MOVE ST-COURSE-CREDITS (COURSE-SUB) TO DET-CREDITS.
197          MOVE ST-COURSE-GRADE (COURSE-SUB) TO DET-GRADE.
198          WRITE PRINT-LINE FROM DETAIL-LINE.
199
200      250-WRITE-GPA.
201          MOVE IND-GRADE-POINT-AVERAGE TO LAST-GPA.

```

Course 'B' writes during
the call to WRITE-DETAIL-LINE

Figure 11.12 (continued)

```

202     IF DEANS-LIST
203         MOVE '*DEANS LIST*' TO LAST-DEANS-LIST
204     ELSE
205         MOVE SPACES TO LAST-DEANS-LIST
206     END-IF.
207     WRITE PRINT-LINE FROM LAST-LINE
208         AFTER ADVANCING 2 LINES.
209
210 260-ADD-TO-DEANS-LIST.
211     IF STUDENTS-ON-DEANS-LIST > 100
212         DISPLAY 'DEAN LIST TABLE EXCEEDED'
213     ELSE
214         ADD 1 TO STUDENTS-ON-DEANS-LIST
215         ADD 1 TO DEAN-SUB
216         MOVE ST-NAME TO DL-NAME (DEAN-SUB)
217         MOVE ST-NUMBER-OF-COURSES TO DL-COURSES (DEAN-SUB)
218         MOVE IND-TOTAL-CREDITS TO DL-CREDITS (DEAN-SUB)
219         MOVE IND-TOTAL-QUAL-POINTS TO DL-QUAL-POINTS (DEAN-SUB)
220         MOVE IND-GRADE-POINT-AVERAGE TO DL-GPA (DEAN-SUB)
221     END-IF.
222
223 300-WRITE-DEANS-LIST.
224     PERFORM 310-WRITE-DEANS-LIST-HEADINGS.
225     PERFORM 320-WRITE-DEANS-LIST-DETAILS
226         VARYING DEAN-SUB FROM 1 BY 1
227         UNTIL DEAN-SUB > STUDENTS-ON-DEANS-LIST.
228
229 310-WRITE-DEANS-LIST-HEADINGS.
230     WRITE PRINT-LINE FROM DEANS-LIST-HEADING-LINE-ONE
231         AFTER ADVANCING PAGE.
232     WRITE PRINT-LINE FROM DEANS-LIST-HEADING-LINE-TWO
233         AFTER ADVANCING 2 LINES.
234     WRITE PRINT-LINE FROM DEANS-LIST-HEADING-LINE-THREE.
235     MOVE SPACES TO PRINT-LINE.
236     WRITE PRINT-LINE.
237
238 320-WRITE-DEANS-LIST-DETAILS.
239     MOVE DL-NAME (DEAN-SUB) TO DL-DET-NAME.
240     MOVE DL-COURSES (DEAN-SUB) TO DL-DET-TOT-COURSES.
241     MOVE DL-CREDITS (DEAN-SUB) TO DL-DET-TOT-CREDITS.
242     MOVE DL-QUAL-POINTS (DEAN-SUB) TO DL-DET-TOT-QUAL-POINTS.
243     MOVE DL-GPA (DEAN-SUB) TO DL-DET-GPA.
244     WRITE PRINT-LINE FROM DEANS-LIST-DETAIL-LINE.

```

increments number of entries in variable-length table

Prints the dean's list

4. The computation of the grade point average is described as follows:
 - a. The counters IND-TOTAL-QUALITY-POINTS and IND-TOTAL-CREDITS are set to zero by the MOVE ZERO statement in line 148.
 - b. The PERFORM VARYING statement in lines 149–151 executes the paragraph 220-PROCESS-COURSES, which in turn performs two lower-level paragraphs for every course in the current record, one course at a time.
 - c. Each time the paragraph 230-INCREMENT-COUNTERS is executed, the course multiplier is determined (4 for an A, 3 for a B, and so on), after which the cumulative values of the quality points and credits are updated.
 - d. The PERFORM VARYING terminates, after which the GPA is determined in lines 152–155.
5. The definition of a counter STUDENTS-ON-DEANS-LIST (line 39) and the definition of the associated DEANS-LIST-TABLE in lines 48–54 to hold data for qualifying students. The IF statement in lines 157–159 determines whether the current student qualifies for the dean's list, then executes paragraph 260-ADD-TO-DEANS-LIST (lines 210–221) to increment the counter and move the student's values to the appropriate place in the table.
6. The PERFORM VARYING statement in lines 225–227 to produce the dean's list based on the number of students (i.e., the final value of STUDENTS-ON-DEANS-LIST) and the entries in the table.

Indexes Versus Subscripts

The transcript program just completed illustrates the basics of table processing, and as such goes a long way toward increasing your proficiency in COBOL. There is, however, a good deal more to learn about tables, and so we return to the syntax of the OCCURS clause shown earlier in the chapter.

The OCCURS clause includes an optional INDEXED BY entry to define an *index* for use with a particular table. An index is conceptually the same as a subscript in that both reference an entry in a table. Indexes, however, produce more efficient object code and are preferred (by some programmers) for that reason. The difference is subtle; an index represents a *displacement* (the number of positions into a table), whereas a subscript indicates an occurrence. Consider:

```

05 ST-COURSE-INFO OCCURS 10 TIMES
   INDEXED BY COURSE-INDEX.
   10 ST-COURSE-NUMBER          PIC X(3).
   10 ST-COURSE-GRADE          PIC X.
   10 ST-COURSE-CREDITS        PIC 99.

```

The COBOL statements establish a table with 10 entries which occupy a total of 60 positions in memory. Valid subscripts for ST-COURSE-INFO are 1, 2, 3, . . . 10, because the table entries occur 10 times. The first occurrence of ST-COURSE-INFO is at the start of the table (displacement zero), the second occurrence begins 6 bytes into the table, the third occurrence 12 bytes into the table, and so on. The value of the index is the value of the displacement, that is, the number of positions into a table to the entry in question; hence valid displacements for ST-COURSE-INFO are 0, 6, 12, . . . 54.

Fortunately, you need not be concerned with the actual value (displacement) of an index, and can regard it conceptually as a subscript. In other words, you will

indicate index values of 1, 2, 3, and so on, which will be converted by the compiler to internal displacements of 0, 6, 12, and so on. Indexes can not, however, be initialized with a MOVE statement, nor can they be incremented with an ADD statement. The SET statement is used instead.

The SET Statement

The SET statement has two formats and is used only with indexes.

Format 1

$$\text{SET } \left\{ \begin{array}{l} \text{identifier-1 [, identifier-2] . . .} \\ \text{index-name-1 [, index-name-2] . . .} \end{array} \right\} \text{ TO } \left\{ \begin{array}{l} \text{identifier-3} \\ \text{index-name-3} \\ \text{integer-1} \end{array} \right\}$$

Format 2

$$\text{SET index-name-4 [, index-name-5] . . . } \left\{ \begin{array}{l} \text{UP BY} \\ \text{DOWN BY} \end{array} \right\} \left\{ \begin{array}{l} \text{identifier-4} \\ \text{integer-2} \end{array} \right\}$$

Figures 11.13 and 11.14 compare indexes and subscripts. Figure 11.13a depicts the definition of a table without an index, which in turn requires the definition of a subscript elsewhere in the Data Division. Figure 11.13b uses a PERFORM VARYING statement to manipulate this table (in conjunction with COURSE-SUBSCRIPT), while Figure 11.13c shows the PERFORM TIMES statement to accomplish the same objective. The latter is yet another form of the PERFORM statement and performs the designated procedure (or in-line statement) the indicated number of times. It is less convenient than a comparable PERFORM VARYING statement as the programmer has to vary the subscript (index) explicitly.

Figure 11.14 contains parallel code, except that the table is defined in Figure 11.14a with an index (so there is no need to define a subscript). Figure 11.14b is virtually identical to its predecessor in that the PERFORM VARYING statement can manipulate either subscripts or indexes. Finally, Figure 11.14c shows the alternate (less desirable) way to process the table. Observe, therefore, the use of SET statements to initialize and increment the index (as opposed to the MOVE and ADD statements in Figure 11.13c).

Indexing is not required in COBOL, and thus you can choose between subscripts and indexes in any given application. Indeed, you may wonder why bother with indexes at all, if they provide the same capability as subscripts. The answer is twofold:

1. Indexes provide more efficient object code than subscripts.
2. Indexes are required for SEARCH and SEARCH ALL, two powerful statements that are presented in Chapter 12.

Differences between indexes and subscripts are summarized in Table 11.1.

Table 11.1 Indexes versus Subscripts

| | |
|--|--|
| Defined with a specific table; can be used only with the table with which they are defined | Defined in Working-Storage; the same subscript can be used with multiple tables although this is not recommended |
| Initialized and incremented via the SET statement; can also be manipulated in PERFORM statements | May not be used with SET statements (MOVE and ADD are used instead); can also be manipulated in PERFORM statements |
| Provide more efficient object code than subscripts | USAGE IS COMPUTATIONAL makes subscripts more efficient, although indexes are still faster |

Figure 11.13 Indexes versus Subscripts (Subscripts)

```

05 ST-NUMBER-OF-COURSES      PIC 99.
05 ST-COURSE-INFO OCCURS 1 TO 8 TIMES
   DEPENDING ON ST-NUMBER-OF-COURSES.
   10 ST-COURSE-NUMBER      PIC X(3).
   10 ST-COURSE-GRADE      PIC X.
   10 ST-COURSE-CREDITS    PIC 99.

```

```

05 COURSE-SUBSCRIPT        PIC S9(4) COMP.

```

Subscript data is registered in Working-Storage

(a) Table Definition

```

PERFORM WRITE-COURSE-DATA
   VARYING COURSE-SUBSCRIPT FROM 1 BY 1
   UNTIL COURSE-SUBSCRIPT > ST-NUMBER-OF-COURSES.

```

```

WRITE-COURSE-DATA.
   MOVE ST-COURSE-NUMBER (COURSE-SUBSCRIPT) TO PL-NUMBER.
   MOVE ST-COURSE-GRADE (COURSE-SUBSCRIPT) TO PL-GRADE.
   WRITE PRINT-LINE FROM PRINT-LINE-ONE
   AFTER ADVANCING 1 LINE.

```

(b) PERFORM VARYING

```

MOVE 1 TO COURSE-SUBSCRIPT.
PERFORM WRITE-COURSE-DATA ST-NUMBER-OF-COURSES TIMES.

```

```

WRITE-COURSE-DATA.
   MOVE ST-COURSE-NUMBER (COURSE-SUBSCRIPT) TO PL-NUMBER.
   MOVE ST-COURSE-GRADE (COURSE-SUBSCRIPT) TO PL-GRADE.
   WRITE PRINT-LINE FROM PRINT-LINE-ONE
   AFTER ADVANCING 1 LINE.
   ADD 1 TO COURSE-SUBSCRIPT.

```

(c) PERFORM TIMES

Figure 11.14 Indexes versus Subscripts (Indexes)

```

05 ST-NUMBER-OF-COURSES      PIC 99.
05 ST-COURSE-INFO OCCURS 1 TO 8 TIMES
   DEPENDING ON ST-NUMBER-OF-COURSES
   INDEXED BY COURSE-INDEX.
10 ST-COURSE-NUMBER         PIC X(3).
10 ST-COURSE-GRADE         PIC X.
10 ST-COURSE-CREDITS       PIC 99.

```

Index is defined in table

(a) Table Definition

```

PERFORM WRITE-COURSE-DATA
   VARYING COURSE-INDEX FROM 1 BY 1
   UNTIL COURSE-INDEX > ST-NUMBER-OF-COURSES.

```

```

WRITE-COURSE-DATA.
  MOVE ST-COURSE-NUMBER (COURSE-INDEX) TO PL-NUMBER.
  MOVE ST-COURSE-GRADE (COURSE-INDEX) TO PL-GRADE.
  WRITE PRINT-LINE FROM PRINT-LINE-ONE
  AFTER ADVANCING 1 LINE.

```

(b) PERFORM VARYING

```

SET COURSE-INDEX TO 1.
PERFORM WRITE-COURSE-DATA ST-NUMBER-OF-COURSES TIMES.

```

Index is initialized by a SET statement

```

WRITE-COURSE-DATA.
  MOVE ST-COURSE-NUMBER (COURSE-INDEX) TO PL-NUMBER.
  MOVE ST-COURSE-GRADE (COURSE-INDEX) TO PL-GRADE.
  WRITE PRINT-LINE FROM PRINT-LINE-ONE
  AFTER ADVANCING 1 LINE.
  SET COURSE-INDEX UP BY 1.

```

(c) PERFORM TIMES

COBOL-85 introduced several minor changes in conjunction with table processing. The new compiler allows seven levels of subscripting as opposed to the earlier limit of three, but given that the typical programmer seldom uses three-level tables, this extension is of little practical benefit. (Multiple-level tables are covered in Chapter 13.) The OCCURS DEPENDING ON clause may specify a value of zero, whereas at least one occurrence was required in COBOL-74.

A more significant change is the introduction of relative subscripting (as explained in Figure 11.6), enabling the reference DATA-NAME (SUBSCRIPT \pm integer). Relative subscripting was not permitted in COBOL-74 (although relative indexing was).

SUMMARY

Points to Remember

- ❑ A table is a grouping of similar data whose values are stored in contiguous storage locations and assigned a single name. Tables are implemented in COBOL through the OCCURS clause with subscripts or indexes used to reference individual items in a table. The OCCURS DEPENDING ON clause implements a variable-length table.
- ❑ An index is conceptually the same as a subscript but provides more efficient object code. Indexes are manipulated with the SET statement, whereas subscripts are initialized with a MOVE statement and incremented with an ADD statement.
- ❑ The PERFORM VARYING statement manipulates an index or a subscript to execute a procedure or series of in-line statements. Omission of the TEST BEFORE and TEST AFTER clauses defaults to TEST BEFORE and corresponds to the COBOL-74 implementation.
- ❑ The PERFORM TIMES statement also provides for repeated execution of a procedure or in-line statement, but requires the programmer to explicitly vary the value of the subscript or index.
- ❑ The optional USAGE IS COMPUTATIONAL clause is used to improve the efficiency of a program's generated object code, but does not affect its logic.

Key Words and Concepts

| | |
|-----------------------|------------------------|
| Displacement | Subscript |
| Fixed-length record | Table |
| Index | Variable-length record |
| Relative indexing | Variable-length table |
| Relative subscripting | |

COBOL Elements

| | |
|---------------------|------------------------|
| BY | PERFORM VARYING |
| FROM | SET |
| INDEXED BY | TEST AFTER |
| OCCURS | TEST BEFORE |
| OCCURS DEPENDING ON | UNTIL |
| PERFORM TIMES | USAGE IS COMPUTATIONAL |

F I L L - I N

1. A table is defined through the _____ clause.
2. Entries in a table may be referenced by either a _____ or an _____.
3. A _____ length table is defined by the _____ clause.
4. The USAGE clause is a (required/optional) entry for a subscript.
5. A table (must/may) be defined with an index.
6. (Subscripts/indexes) are manipulated with a SET statement.
7. Arithmetic (is/is not) permitted for subscripts and indexes.
8. _____ levels of subscripting are permitted in COBOL-85.
9. The TEST BEFORE clause (changes/does not change) the effect of a PERFORM VARYING statement.
10. The OCCURS DEPENDING ON, ASCENDING/DESCENDING KEY, and INDEXED BY clauses are (optional/required) entries in an OCCURS clause.

T R U E / F A L S E

1. Tables are established by a DIMENSION statement.
2. The same entry may not contain both an OCCURS clause and a PICTURE clause.
3. When using subscripts, a space is required between a data name and the left parenthesis.
4. The USAGE clause is required when defining a subscript in Working-Storage.
5. The entry, DATA-NAME (0) would not cause a compilation error, provided that an OCCURS clause had been used in the associated definition.

6. The same subscript can be used to reference different tables.
7. The same index can be used to reference different tables
8. A subscript may be a constant or a variable.
9. All records in the same file must be the same length.
10. The SET statement is used to manipulate subscripts or indexes.
11. An index may be modified by either an ADD or a MOVE statement.
12. The PERFORM VARYING statement may manipulate both subscripts and indexes.

P R O B L E M S

1. Indicate which entries are incorrectly subscripted. Assume that SUB1 has been set to 5, and that the following entry applies:
05 SALES-TABLE OCCURS 12 TIMES PIC 9(5).
 - a. SALES-TABLE (1)
 - b. SALES-TABLE (15)
 - c. SALES-TABLE (0)
 - d. SALES-TABLE (SUB1)
 - e. SALES-TABLE(SUB1)
 - f. SALES-TABLE (5)
 - g. SALES-TABLE (SUB1, SUB2)
 - h. SALES-TABLE (3)
 - i. SALES-TABLE (3)
 - j. SALES-TABLE (SUB1 + 1)
2. How many times will PARAGRAPH-A be executed by each of the following PERFORM statements?
 - a. PERFORM PARAGRAPH-A
VARYING SUBSCRIPT FROM 1 BY 1
UNTIL SUBSCRIPT > 5.
 - b. PERFORM PARAGRAPH-A
VARYING SUBSCRIPT FROM 1 BY 1
WITH TEST BEFORE
UNTIL SUBSCRIPT > 5.
 - c. PERFORM PARAGRAPH-A
VARYING SUBSCRIPT FROM 1 BY 1
WITH TEST AFTER
UNTIL SUBSCRIPT > 5.
 - d. PERFORM PARAGRAPH-A
VARYING SUBSCRIPT FROM 1 BY 1
UNTIL SUBSCRIPT = 5.
 - e. PERFORM PARAGRAPH-A
VARYING SUBSCRIPT FROM 1 BY 1
WITH TEST BEFORE
UNTIL SUBSCRIPT = 5.

```
f. PERFORM PARAGRAPH-A
   VARYING SUBSCRIPT FROM 1 BY 1
   WITH TEST AFTER
   UNTIL SUBSCRIPT = 5.
```

3. Given the following Working-Storage entries:

```
01 SAMPLE-TABLES.
   05 FIRST-TABLE OCCURS 10 TIMES
     INDEXED BY FIRST-INDEX.
     10 FIRST-TABLE-ENTRY      PIC X(5).
   05 SECOND-TABLE OCCURS 10 TIMES
     INDEXED BY SECOND-INDEX.
     10 SECOND-TABLE-ENTRY     PIC X(5).

01 SUBSCRIPT-ENTRIES.
   05 FIRST-SUBSCRIPT          PIC 9(4).
   05 SECOND-SUBSCRIPT         PIC 9(4).
```

Indicate whether the following table references are valid syntactically.

- a. FIRST-TABLE-ENTRY (FIRST-INDEX)
- b. FIRST-TABLE-ENTRY (FIRST-SUBSCRIPT)
- c. SECOND-TABLE-ENTRY (FIRST-INDEX)
- d. SECOND-TABLE-ENTRY (SECOND-INDEX)
- e. SECOND-TABLE-ENTRY (FIRST-SUBSCRIPT)
- f. SECOND-TABLE-ENTRY (SECOND-SUBSCRIPT)
- g. FIRST-TABLE-ENTRY (FIRST-INDEX + 1)
- h. FIRST-TABLE-ENTRY (FIRST-SUBSCRIPT + 1)

Indicate whether the following Procedure Division statements are valid.

- i. MOVE 1 TO FIRST-SUBSCRIPT
 - j. SET FIRST-SUBSCRIPT TO 1
 - k. MOVE 1 TO FIRST-INDEX
 - l. SET FIRST-INDEX TO 1
 - m. SET FIRST-INDEX UP BY 1
 - n. ADD 1 TO FIRST-INDEX
4. Use the general format of the OCCURS clause to determine whether the following are valid entries (the level number has been omitted in each instance):
- a. TABLE-ENTRY OCCURS 4 TIMES.
 - b. TABLE-ENTRY OCCURS 4.
 - c. TABLE-ENTRY OCCURS 3 TO 30 TIMES
DEPENDING ON NUMBER-OF-TRANS.
 - d. TABLE-ENTRY OCCURS 5 TIMES
INDEXED BY TABLE-INDEX.
 - e. TABLE-ENTRY OCCURS 5 TIMES
SUBSCRIPTED BY TABLE-SUBSCRIPT.

- f. TABLE-ENTRY OCCURS 5 TO 50 TIMES
DEPENDING ON NUMBER-OF-TRANSACTIONS
INDEXED BY TABLE-INDEX.
- g. TABLE-ENTRY OCCURS 6 TIMES
ASCENDING KEY TABLE-CODE
INDEXED TABLE-INDEX.
- h. TABLE-ENTRY OCCURS 6 TIMES
ASCENDING KEY TABLE-CODE-1
DESCENDING KEY TABLE-CODE-2 INDEXED BY TABLE-INDEX.
5. How many storage positions are allocated for each of the following table definitions?
Show an appropriate schematic indicating storage assignment for each table.
- a. 01 STATE-TABLE.
05 STATE-NAME OCCURS 50 TIMES PIC X(15).
05 STATE-POPULATION OCCURS 50 TIMES PIC 9(8).
- b. 01 STATE-TABLE.
05 NAME-POPULATION OCCURS 50 TIMES.
10 STATE-NAME PIC X(15).
10 STATE-POPULATION PIC 9(8).
6. Show Procedure Division statements to determine the largest and smallest population in POPULATION-TABLE. (Assume the table has been initialized elsewhere.) Move these values to BIGGEST and SMALLEST, respectively. Move the state names to BIG-STATE and SMALL-STATE, respectively. POPULATION-TABLE is defined as follows:
- 01 POPULATION-TABLE.
05 POPULATION-AND-NAME OCCURS 50 TIMES
INDEXED BY POP-INDEX.
10 POPULATION PIC 9(8).
10 STATE-NAME PIC X(15).

Table Lookups

Overview

System Concepts

Types of Codes

Characteristics of Codes

Sequential Table Lookup

Binary Table Lookup

Positional Organization and Direct Lookups

Initializing a Table

Hard Coding

Input-loaded Tables

Programming Tip—Restrict Subscripts and Switches to a Single Use

Table Lookups

PERFORM VARYING Statement

SEARCH Statement

SEARCH ALL Statement

Direct Lookup

Range-Step Tables

A Complete Example

Programming Specifications

Program Design

The Completed Program

Limitations of COBOL-74

Summary

Fill-in

True/False

Problems

OBJECTIVES

After reading this chapter you will be able to:

- ☛ Define a table lookup and describe why it is used.
- ☛ Distinguish between a numeric, alphabetic, and alphanumeric code; describe several attributes of a good coding system.
- ☛ Distinguish between a sequential table lookup, a binary table lookup, and direct access to table entries.
- ☛ Distinguish between a table that is hard coded versus one that is input loaded.
- ☛ State the purpose of the VALUE, OCCURS, and REDEFINES clauses as they pertain to table definition and initialization.
- ☛ Define a range-step table.
- ☛ Code SEARCH and SEARCH ALL statements to implement table lookups.

OVERVIEW

One-level tables, subscripts, and indexes were introduced in Chapter 11. This chapter extends that information to include table lookups—the conversion of incoming data from a concise, coded format to a descriptive and more meaningful result.

The System Concepts section begins with a discussion of codes, then proceeds to techniques for table organization, table initialization, and table lookups. The body of the chapter covers the COBOL implementation of the conceptual material, and includes the REDEFINES, VALUE, and OCCURS clauses, and the SEARCH and SEARCH ALL statements. All of this material is effectively summarized in a COBOL program at the end of the chapter.

System Concepts

Figure 12.1 depicts a table of student major *codes* and the associated descriptions. Records in the storage medium contain a two-position code, whereas printed reports display the descriptive (expanded) value. The conversion is accomplished through a *table lookup*, with the obvious advantage that less space is required to store codes rather than descriptive values. (Consider the implications for large files with thousands, perhaps millions of records.)

A second, perhaps more important, reason for using codes is to assign records to consistent classes. It is a simple matter for a data-entry clerk to look up a *unique* code for a Computer Information Systems major (e.g., 24 in Figure 12.1), and different clerks will always obtain the same code for the same major. It is far less likely that different clerks will always use identical spellings for a given major; even the same individual is apt to use different spellings at different times, especially when one begins to abbreviate. By assigning a code, rather than a descriptive value, individuals

Figure 12.1 Table of Major Codes

| | |
|----|-------------------|
| 02 | ART HISTORY |
| 04 | BIOLOGY |
| 19 | CHEMISTRY |
| 21 | CIVIL ENGINEERING |
| 24 | COMP INF SYS |
| 32 | ECONOMICS |
| 39 | FINANCE |
| 43 | MANAGEMENT |
| 49 | MARKETING |
| 54 | STATISTICS |

with the same major will have a common identifying characteristic that can be subsequently processed by a program.

Types of Codes

The codes in a table may be *numeric*, *alphabetic*, or *alphanumeric*. A numeric code consists entirely of digits; for example, the zip code is a numeric code familiar to all Americans. A three-digit numeric code has 1,000 possible values (from 0 through 999). In similar fashion, four- and five-digit numeric codes have 10,000 and 100,000 values, respectively.

Alphabetic codes contain only letters—for example, state abbreviations. A two-position alphabetic code has 676 possible values. (Each character can assume one of 26 values, A through Z. Thus, a two-position alphabetic code has $26 \times 26 = 26^2 = 676$ possible values. In similar fashion, a three-position alphabetic code has $26^3 = 17,576$ possible values.)

Alphanumeric codes contain both letters and numbers—for example, license plates. Alphanumeric codes offer the advantage of providing a greater number of combinations than either pure numeric or pure alphabetic codes. A three-digit numeric code has 1,000 (10^3) variations, a three-digit alphabetic code has 17,576 (26^3) possibilities, but a three-position alphanumeric code (in which each character can be either a letter or number) has 46,656 (36^3) choices. Table 12.1 summarizes the various types of codes.

TABLE 12.1 Types of Table Codes

| CODE TYPE | USED | 1 POSITION | 2 POSITIONS | n POSITIONS |
|--------------|----------|-------------|----------------|-------------|
| Numeric | 0-9 | $10^1 = 10$ | $10^2 = 100$ | 10^n |
| Alphabetic | A-Z | $26^1 = 26$ | $26^2 = 676$ | 26^n |
| Alphanumeric | A-Z, 0-9 | $36^1 = 36$ | $36^2 = 1,296$ | 36^n |

Characteristics of Codes

A good coding system is *precise*, *mnemonic*, and *expandable*. A precise code is unique; that is, it should not be possible to select alternative choices from a table of codes for a given entry. Indeed, codes are often assigned because the original

attribute is not unique. Universities, for example, assign student numbers because different students may have the same name.

Good codes are mnemonic, that is, easy to remember. State abbreviations are alphabetic rather than numeric for this reason. Thus NY and TX are inherently easier to learn as abbreviations for New York and Texas than random two-digit numbers.

A coding system should also be expandable so that future additions can be easily handled. It is poor design, for example, to allocate only two positions in a record for a numeric branch office code, if 98 unique branch offices already exist.

Sequential Table Lookup

A *table lookup* occurs when an incoming code is compared to entries in a table in order to convert the code to an expanded value. In a *sequential* table lookup the entries in the table are checked in order, as shown in Figure 12.2.

Figure 12.2 Sequential Table Lookup

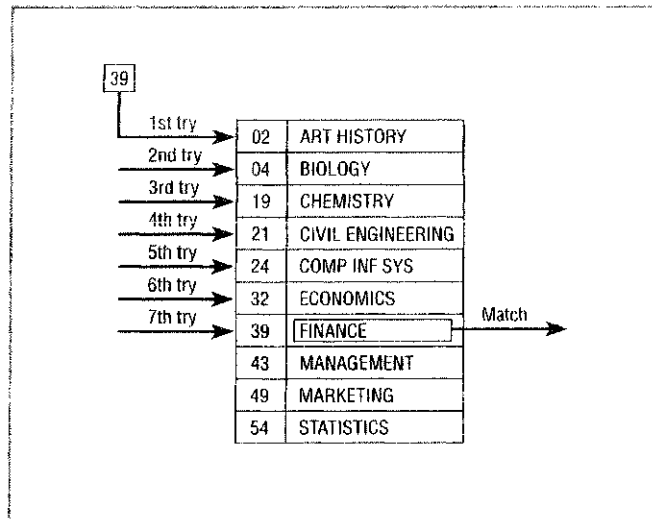

Assume, for example, an incoming code of 39. A sequential lookup begins with the first entry, then the second entry, and so on until a match is found or the table is exhausted. In this instance, 7 tries are required. On the average, a sequential table lookup requires $N/2$ tries (where N is the number of entries in the table) to find a match, assuming that each entry is equally likely.

The codes in Figure 12.2 were arranged sequentially. An alternative form of table organization, by *frequency of occurrence*, is sometimes used to reduce the number of trials needed to find a match in a sequential lookup. Assume, for example, that Computer Information Systems is the most common major, followed by Management. It is reasonable, therefore, to list these majors first and second in the table. In other words, majors are listed according to the likelihood of finding a match, rather than by a strict numeric sequence. The codes in the table are still examined in order, but the table itself has been rearranged.

Many tables follow a so-called 80/20 rule; that is, 80% of the matches come from 20% of the entries. (For example, 80% of the questions raised in class may come from 20% of the students; 80% of the United States population lives in 20% of the states, and so on. The numbers 80 and 20 are approximate, but the concept is valid over a surprising number of applications.)

Organization by frequency of occurrence requires a knowledge of code probabilities that is often unavailable. Sequential organization is therefore more common.

Binary Table Lookup

A binary lookup makes the number of comparisons relatively independent of where in the table the match occurs, but requires that the entries in the table be in sequence (either ascending or descending). The action of a binary lookup is illustrated in Figure 12.3.

Figure 12.3 Binary Lookup

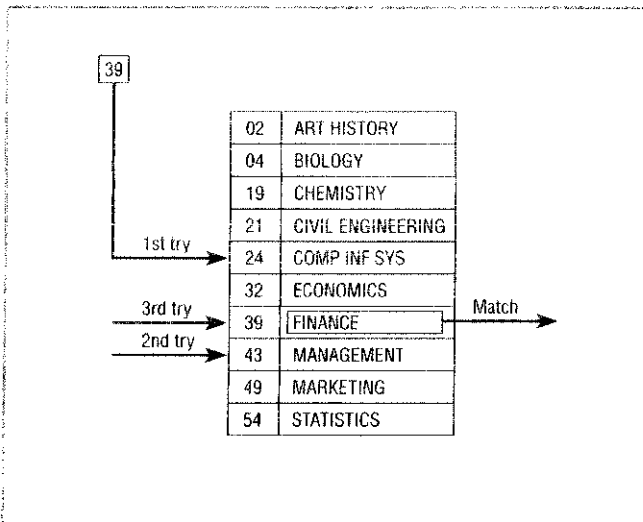

A binary search begins in the *middle* of the table, for example, at the fifth entry in Figure 12.3, and eliminates half the table with every comparison. The search then proceeds as follows:

1. Is the value of the incoming entry (the code you want to find) greater than the middle entry in the table? The answer is yes in this example in that 39 (the incoming code) is greater than 24 (the value of the middle entry). The search algorithm therefore eliminates table entries one through five.
2. There are five remaining entries (positions 6–10) that could yet contain a value equal to the incoming code. The middle (eighth) entry is selected and the comparison is made again; that is, is the value of incoming code 39 greater than the value of the eighth (middle) entry of 43? It isn't, which eliminates table entries eight through 10.
3. There are two remaining entries (positions 6–7). The middle (seventh) entry is selected, and its value of 39 matches that of the incoming code. The search is terminated.

A total of three comparisons was required to match the incoming code, 39. (If 32 had been the incoming entry, four comparisons would have been needed, but this is the *maximum* number that would ever be required for a 10-position table.) A sequential lookup, on the other hand, required seven comparisons until a match was found on 39.

If all 10 entries in a table have an equal chance of occurring, the *average* number of comparisons for a sequential search on a table of 10 entries is five. This is greater than the *maximum* number for a binary search. Indeed, as table size increases, the advantage of the binary search increases dramatically. Table 12.2 shows the maximum number of comparisons for tables with 8 to 4,095 entries.

TABLE 12.2 Required Number of Comparisons for Binary Search

| | | |
|-----------|------------------------------|----|
| 8-15 | (less than 2 ⁴) | 4 |
| 16-31 | (less than 2 ⁵) | 5 |
| 32-63 | (less than 2 ⁶) | 6 |
| 64-127 | (less than 2 ⁷) | 7 |
| 128-255 | (less than 2 ⁸) | 8 |
| 256-511 | (less than 2 ⁹) | 9 |
| 512-1023 | (less than 2 ¹⁰) | 10 |
| 1024-2047 | (less than 2 ¹¹) | 11 |
| 2048-4095 | (less than 2 ¹²) | 12 |

Positional Organization and Direct Lookups

A *positional table* is a sequential table with a *consecutive* set of numeric codes. It permits immediate retrieval of a table value at the expense of unused storage space. Figure 12.4 depicts positional organization and the associated *direct lookup*.

The table in Figure 12.4 is considerably larger than the sequential table in Figures 12.2 and 12.3. Fifty-four entries are present in Figure 12.4, as opposed to 10 in the earlier tables. Observe also that codes are not stored in a positional table; that is, the value of the associated code is the position of the descriptive value within the table. Hence, ART HISTORY is stored in the second position and has an associated code of 2; BIOLOGY is stored in the fourth position with an associated code of 4; and so forth. As can be seen, this arrangement results in considerable empty (wasted) space, as only 10 of the 54 table entries contain descriptive values.

The advantage of a positional table is that a match is found immediately; for example, to obtain the descriptive value for an incoming code of 39, you go *directly* to the 39th entry in the table. (Prudent practice dictates that the programmer ensure the incoming code is valid, that is, within the table's range, before attempting a direct lookup.)

A table is initialized in one of two ways, by hard coding it into a program, or by reading its values from a file. (A table may also be initialized through the COPY statement, which is presented in Chapter 16.) Both techniques are discussed in detail.

Hard Coding

A table may be *hard-coded* directly in a program as shown in Figure 12.5. This is accomplished through a combination of the VALUE, OCCURS, and REDEFINES clauses, which are explained below:

- VALUE Assigns an initial value to a specified area in memory.
- REDEFINES Assigns another name to previously allocated memory locations.

Figure 12.4 Positional Organization and Direct Lookup

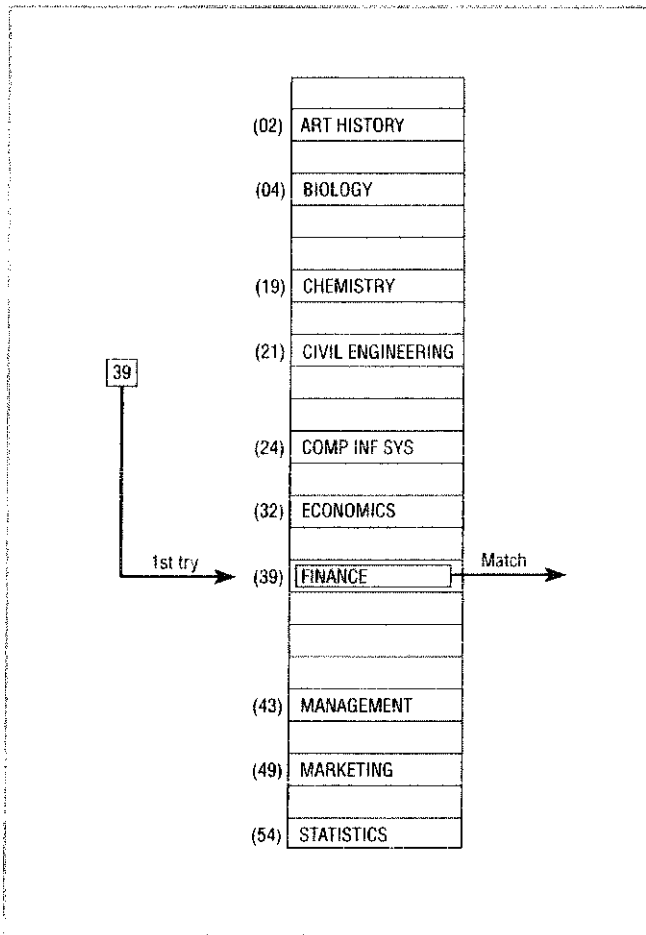

Figure 12.5 Initialization via Hard Coding

```

01 MAJOR-VALUE.
   05 FILLER          PIC X(14)  VALUE '02ART HISTORY'.
   05 FILLER          PIC X(14)  VALUE '04BIOLOGY'.
   05 FILLER          PIC X(14)  VALUE '19CHEMISTRY'.
   05 FILLER          PIC X(14)  VALUE '21CIVIL ENG'.
   05 FILLER          PIC X(14)  VALUE '24COMP INF SYS'.
   05 FILLER          PIC X(14)  VALUE '32ECONOMICS'.
   05 FILLER          PIC X(14)  VALUE '39FINANCE'.
   05 FILLER          PIC X(14)  VALUE '43MANAGEMENT'.
   05 FILLER          PIC X(14)  VALUE '49MARKETING'.
   05 FILLER          PIC X(14)  VALUE '54STATISTICS'.

01 MAJOR-TABLE REDEFINES MAJOR-VALUE.
   05 MAJORS OCCURS 10 TIMES.
       10 MAJOR-CODE  PIC 9(2).
       10 EXP-MAJOR   PIC X(12).
    
```

Figure 12.6 Table Initialization (Storage Schematic)

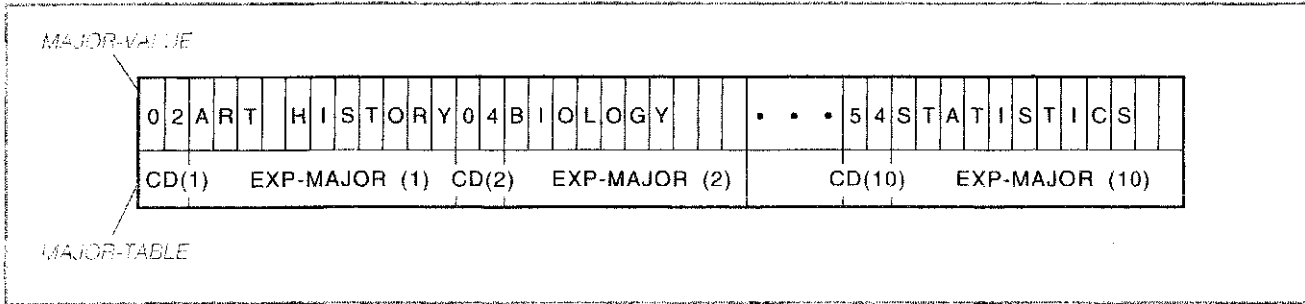

OCCURS Establishes a table, that is, permits different locations to be referenced by the same data name, but with different subscripts.

The need for the VALUE and OCCURS clauses is somewhat intuitive, whereas the REDEFINES clause is more obscure. The 01 entry MAJOR-VALUE contains 10 successive FILLER entries, each with a different VALUE clause, which collectively initialize 140 consecutive positions with the indicated values. The first two positions under MAJOR-VALUE contain 02, positions 3–14 contain ART HISTORY, positions 15 and 16 contain 04, positions 17–28 contain BIOLOGY, and so on.

The REDEFINES clause assigns a different name (MAJOR-TABLE) to these same 140 positions, and the subsequent OCCURS clause creates a table with 10 occurrences. The first two positions in the table are designated MAJOR-CODE (1) and contain 02, the first major code. Positions 3–14 are known as EXP-MAJOR (1) and contain ART HISTORY, and so on. The conceptual view of these storage locations is shown in Figure 12.6.

Input-loaded Tables

Initialization of a table through hard coding is a commonly used technique, but one that presents problems in program maintenance when the table changes. Any change to a hard-coded table requires a corresponding change in the program, which in turn requires that the program be recompiled and retested. Moreover, if the same table is used in multiple programs, then the same change has to be made in *every* program that uses the table, a time-consuming and error-prone procedure.

A better technique is to initialize the table dynamically, by reading values from a file when the program is executed. This is known as an *input-loaded table* and is illustrated in Figure 12.7. The Data Division entries in Figure 12.7a establish space for the variable-length major table without assigning values; the latter is accomplished at execution time by the Procedure Division entries in Figure 12.7b. (The statements in Figure 12.7b use the in-line PERFORM statement and false-condition branch of the READ statement to process a file until its records are exhausted.)

The process is further illustrated by Figure 12.8, in which records from the external file (containing the table codes and descriptive values) are read one at a time and moved to the appropriate table entries. The first record in MAJOR-CODE-FILE contains the first code and descriptive value, 02 and ART HISTORY, respectively, which are moved into MAJOR-CODE (1) and EXP-MAJOR (1). Subsequent table values are moved in similar fashion.

The advantage of an input-loaded table (over one that is hard coded) is that any change to the table is accommodated by modifying the file that contains the table values. The program (or programs) that access that table are unaffected.

Figure 12.7 Input-Loaded Table

```

FD MAJOR-CODE-FILE
RECORD CONTAINS 14 CHARACTERS
DATA RECORD IS MAJOR-CODE-RECORD.
01 MAJOR-CODE-RECORD.
   05 INCOMING-FILE-CODE    PIC 9(2).
   05 INCOMING-FILE-NAME    PIC X(12).

WORKING-STORAGE SECTION.
01 MAJOR-TABLE.
   05 MAJORS OCCURS 1 TO 10 TIMES
      DEPENDING ON NUMBER-OF-MAJORS
      INDEXED BY MAJOR-INDEX.
      10 MAJOR-CODE          PIC 9(2).
      10 EXP-MAJOR           PIC X(12).

01 NUMBER-OF-MAJORS          PIC 99    VALUE ZERO.

```

(a) Data Division Entries

```

OPEN INPUT MAJOR-CODE-FILE.
PERFORM VARYING MAJOR-INDEX FROM 1 BY 1
  UNTIL MAJOR-INDEX > 10
    OR END-OF-MAJOR-FILE = 'YES'
  READ MAJOR-CODE-FILE
  AT END
    MOVE 'YES' TO END-OF-MAJOR-FILE
  NOT AT END
    ADD 1 TO NUMBER-OF-MAJORS
    MOVE INCOMING-FILE-CODE TO MAJOR-CODE (MAJOR-INDEX)
    MOVE INCOMING-FILE-NAME TO EXP-MAJOR (MAJOR-INDEX)
  END-READ
END-PERFORM.
IF MAJOR-INDEX > 10
  DISPLAY 'MAJOR TABLE TOO SMALL'
END-IF.
CLOSE MAJOR-CODE-FILE.

```

(b) In-Line Perform

Table Lookups

Once a table has been established, the table lookup procedure is coded in the Procedure Division. We illustrate four alternative COBOL techniques: PERFORM VARYING, SEARCH, SEARCH ALL, and Direct Access to table entries.

Figure 12.9 Input-Loaded Tables

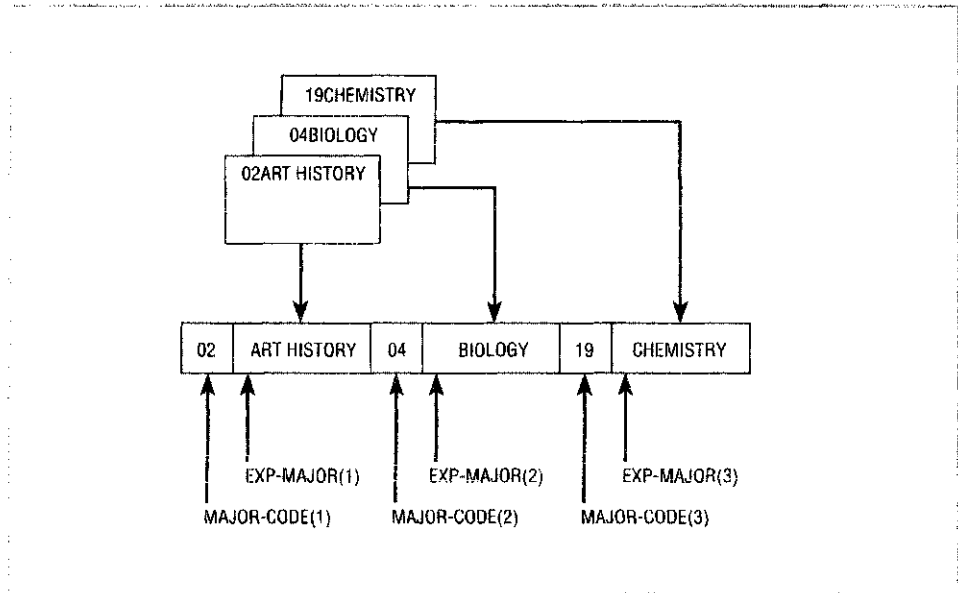

Figure 12.9 Input-Loaded Tables

Figure 12.9 contains the COBOL statements to implement the sequential table lookup of Figure 12.2. Entries in the table are compared sequentially to the incoming code ST-MAJOR-CODE with one of two outcomes. Either a match is found, in which case the corresponding descriptive value is moved to the output area, or the incoming code is not in the major table, which produces an appropriate error message.

The check for an invalid code is accomplished by comparing the value of the subscript WS-MAJOR-SUB, to the number of entries in the table. This type of error checking is extremely important and is one way of distinguishing between professional work and sloppy coding. (What would happen if the check were not included and an unknown code did appear?) Observe also the need to initialize both switches prior to the lookup, and how the switches are reset when the search is terminated.

SEARCH Statement

The SEARCH statement implements a sequential table lookup and is easier to use than the corresponding PERFORM VARYING statement. SEARCH has the following syntax:

```

SEARCH identifier-1 [ VARYING { index-name-1 }
                    { identifier } ]
                    [ AT END imperative-statement-1 ]
                    WHEN condition-1 { imperative-statement-2 }
                                     { NEXT SENTENCE }
                    [ WHEN condition-2 { imperative-statement-3 }
                      { NEXT SENTENCE } ] . . .
[ END-SEARCH ]

```

Figure 12.9 Sequential Lookup with PERFORM VARYING

WORKING-STORAGE SECTION.

01 TABLE-PROCESSING-ELEMENTS.

| | | | |
|----|------------------------|-----------|----------------|
| 05 | WS-MAJOR-SUB | PIC S9(4) | USAGE IS COMP. |
| 05 | WS-FOUND-MAJOR-SWITCH | PIC X(3) | VALUE 'NO' |
| 05 | WS-END-OF-TABLE-SWITCH | PIC X(3) | VALUE 'NO'. |

01 MAJOR-VALUE.

| | | | |
|----|--------|-----------|-------------------------|
| 05 | FILLER | PIC X(14) | VALUE '02ART HISTORY'. |
| 05 | FILLER | PIC X(14) | VALUE '04BIOLOGY'. |
| 05 | FILLER | PIC X(14) | VALUE '19CHEMISTRY'. |
| 05 | FILLER | PIC X(14) | VALUE '21CIVIL ENG'. |
| 05 | FILLER | PIC X(14) | VALUE '24COMP INF SYS'. |
| 05 | FILLER | PIC X(14) | VALUE '32ECONOMICS'. |
| 05 | FILLER | PIC X(14) | VALUE '39FINANCE'. |
| 05 | FILLER | PIC X(14) | VALUE '43MANAGEMENT'. |
| 05 | FILLER | PIC X(14) | VALUE '49MARKETING'. |
| 05 | FILLER | PIC X(14) | VALUE '54STATISTICS'. |

01 MAJOR-TABLE REDEFINES MAJOR-VALUE.

| | | | |
|----|-------------------------|------------|--|
| 05 | MAJORS OCCURS 10 TIMES. | | |
| 10 | MAJOR-CODE | PIC 9(2). | |
| 10 | EXP-MAJOR | PIC X(12). | |

PROCEDURE DIVISION.

```

MOVE 'NO' TO WS-FOUND-MAJOR-SWITCH WS-END-OF-TABLE-SWITCH.
PERFORM FIND-MAJOR
    VARYING WS-MAJOR-SUB FROM 1 BY 1
        UNTIL WS-END-OF-TABLE-SWITCH = 'YES'
            OR WS-FOUND-MAJOR-SWITCH = 'YES'.

```

FIND-MAJOR.

```

IF WS-MAJOR-SUB > 10
    MOVE 'YES' TO WS-END-OF-TABLE-SWITCH
    MOVE 'UNKNOWN' TO HDG-MAJOR
ELSE
    IF ST-MAJOR-CODE = MAJOR-CODE (WS-MAJOR-SUB)
        MOVE 'YES' TO WS-FOUND-MAJOR-SWITCH
        MOVE EXP-MAJOR (WS-MAJOR-SUB) TO HDG-MAJOR
    END-IF
END-IF.

```

PROGRAMMING TIP***Restrict Subscripts and Switches to a Single Use***

Data names defined as switches and/or subscripts should be restricted to a single use. Consider:

Poor Code

```
01  SUBSCRIPT          PIC S9(4)  COMP.
01  EOF-SWITCH        PIC X(3)   VALUE SPACES.
```

```
PERFORM INITIALIZE-TITLE-FILE
  UNTIL EOF-SWITCH = 'YES'.
MOVE SPACES TO EOF-SWITCH.
PERFORM PROCESS-EMPLOYEE-RECORDS
  UNTIL EOF-SWITCH = 'YES'.
PERFORM COMPUTE-SALARY-HISTORY
  VARYING SUBSCRIPT FROM 1 BY 1
  UNTIL SUBSCRIPT > 3.
PERFORM FIND-MATCH-TITLE
  VARYING SUBSCRIPT FROM 1 BY 1
  UNTIL SUBSCRIPT > 100.
```

Improved Code

```
01  PROGRAM-SUBSCRIPTS.
05  TITLE-SUBSCRIPT    PIC S9(4)  COMP.
05  SALARY-SUBSCRIPT  PIC S9(4)  COMP.
01  END-OF-FILE-SWITCHES.
05  END-OF-TITLE-FILE-SWITCH PIC X(3)  VALUE SPACES.
05  END-OF-EMPLOYEE-FILE-SWITCH PIC X(3)  VALUE SPACES.
```

```
PERFORM INITIALIZE-TITLE-FILE
  UNTIL END-OF-TITLE-FILE-SWITCH = 'YES'.
PERFORM PROCESS-EMPLOYEE-RECORDS
  UNTIL END-OF-EMPLOYEE-FILE-SWITCH = 'YES'.
PERFORM COMPUTE-SALARY-HISTORY
  VARYING SALARY-SUBSCRIPT FROM 1 BY 1
  UNTIL SALARY-SUBSCRIPT > 3.
PERFORM FIND-MATCHING-TITLE
  VARYING TITLE-SUBSCRIPT FROM 1 BY 1
  UNTIL TITLE-SUBSCRIPT > 100.
```

At the very least, the improved code offers superior documentation. By restricting data names to a single use, one automatically avoids such nondescript entries as EOF-SWITCH or SUBSCRIPT. Of greater impact, the improved code is more apt to be correct in that a given data name is modified or tested in fewer places within a program. Finally, if bugs do occur, the final values of the unique data names (TITLE-SUBSCRIPT and SALARY-SUBSCRIPT) will be of much greater use than the single value of SUBSCRIPT.

Identifier-1 in the SEARCH statement designates a table that contains both the OCCURS and INDEXED BY clauses. AT END is optional, but strongly recommended, to detect invalid or unknown codes. The WHEN clause specifies both a condition and an imperative sentence; the latter is executed when the condition is satisfied (that is, when a match is found.) Control passes to the statement immediately following the SEARCH statement after the WHEN condition is satisfied or the AT END clause is reached. (The VARYING option is covered in Chapter 13.)

The SEARCH statement is illustrated in Figure 12.10 (which implements the identical logic of Figure 12.9). The table definition includes the INDEXED BY clause, which is required by the SEARCH statement, and establishes values through hard coding.

The SEARCH statement compares, in sequence, entries in the MAJORS table to ST-MAJOR-CODE. If no match is found (that is, if the AT END condition is

Figure 12.10 SEARCH Statement (Sequential Lookup)

```

01 MAJOR-VALUE.
   05 FILLER          PIC X(14)  VALUE '02ART HISTORY'.
   05 FILLER          PIC X(14)  VALUE '04BIOLOGY'.
   05 FILLER          PIC X(14)  VALUE '19CHEMISTRY'.
   05 FILLER          PIC X(14)  VALUE '21CIVIL ENG'.
   05 FILLER          PIC X(14)  VALUE '24COMP INF SYS'.
   05 FILLER          PIC X(14)  VALUE '32ECONOMICS'.
   05 FILLER          PIC X(14)  VALUE '39FINANCE'.
   05 FILLER          PIC X(14)  VALUE '43MANAGEMENT'.
   05 FILLER          PIC X(14)  VALUE '49MARKETING'.
   05 FILLER          PIC X(14)  VALUE '54STATISTICS'.

01 MAJOR-TABLE REDEFINES MAJOR-VALUE.
   05 MAJORS OCCURS 10 TIMES
     INDEXED BY MAJOR-INDEX.
     10 MAJOR-CODE   PIC 9(2).
     10 EXP-MAJOR    PIC X(12).

PROCEDURE DIVISION.

   SET MAJOR-INDEX TO 1.
   SEARCH MAJORS
     AT END
       MOVE 'UNKNOWN' TO HDG-MAJOR
     WHEN ST-MAJOR-CODE = MAJOR-CODE (MAJOR-INDEX)
       MOVE EXP-MAJOR (MAJOR-INDEX) TO HDG-MAJOR
   END-SEARCH.

```

INDEXED BY clause required in table definition

SET statement establishes starting point

reached), then UNKNOWN is moved to HDG-MAJOR. However, if a match does occur, [that is, if ST-MAJOR-CODE = MAJOR-CODE (MAJOR-INDEX)], the appropriate major is moved to HDG-MAJOR. The search is terminated, and control passes to the statement following the SEARCH.

The statement SET MAJOR-INDEX TO 1 is necessary to indicate the point in the table where the search is to begin, and appears before the SEARCH statement. Recall also that the SET statement must be used to modify an index; that is, it is *incorrect* to say MOVE 1 TO MAJOR-INDEX.

SEARCH ALL Statement

The SEARCH ALL statement implements a binary lookup, and is presented below:

```
SEARCH ALL identifier-1
      [AT END imperative-statement-1]
      WHEN condition-1 {imperative-statement-2}
                       {NEXT SENTENCE}
      [END SEARCH]
```

As with a sequential search statement, SEARCH ALL requires the associated table be defined with an index. In addition, *the codes in the table must be in sequence* (either ascending or descending).

The implementation of a binary search is shown in Figure 12.11, and is very similar in appearance to Figure 12.10. Observe, however, the KEY clause in the table definition to indicate the sequence in which codes appear. (In the event that codes in the table are out of sequence, COBOL will not indicate an explicit error, but the results of the search will be incorrect.) Note too that since SEARCH ALL determines its own starting position in the table, a SET statement is not used in conjunction with a binary lookup. The differences between SEARCH and SEARCH ALL are summarized in Table 12.3.

TABLE 12.3 SEARCH versus SEARCH ALL

| | |
|--|---|
| Implements a sequential lookup | Implements a binary lookup |
| Requires a SET statement prior to SEARCH, to establish the initial position in the table | Does not require an initial SET statement (calculates its own starting position) |
| Does not require codes in the table to be in any special sequence | Requires codes to be in (ascending or descending) sequence on the associated KEY clause in the table definition |
| Contains an optional VARYING clause (See Figure 13.18) | Does not contain a VARYING clause |
| May specify more than one WHEN clause | Restricted to a single WHEN clause |

Direct Lookup

A positional table results in wasted space but permits a far faster table lookup in that you go *directly* to the appropriate table entry. Implementation of a direct lookup is shown in Figure 12.12.

Figure 12.13a SEARCH ALL Statement (Binary Lookup)

```

01 MAJOR-VALUE.
05 FILLER          PIC X(14)  VALUE '02ART HISTORY'.
05 FILLER          PIC X(14)  VALUE '04BIOLOGY'.
05 FILLER          PIC X(14)  VALUE '19CHEMISTRY'.
05 FILLER          PIC X(14)  VALUE '21CIVIL ENG'.
05 FILLER          PIC X(14)  VALUE '24COMP INF SYS'.
05 FILLER          PIC X(14)  VALUE '32ECONOMICS'.
05 FILLER          PIC X(14)  VALUE '39FINANCE'.
05 FILLER          PIC X(14)  VALUE '43MANAGEMENT'.
05 FILLER          PIC X(14)  VALUE '49MARKETING'.
05 FILLER          PIC X(14)  VALUE '54STATISTICS'.

01 MAJOR-TABLE REDEFINES MAJOR-VALUE.
05 MAJORS OCCURS 10 TIMES
   ASCENDING KEY IS MAJOR-CODE
   INDEXED BY MAJOR-INDEX.
10 MAJOR-CODE     PIC 9(2).
10 EXP-MAJOR      PIC X(12).

PROCEDURE DIVISION.

SEARCH ALL MAJORS
  AT END
    MOVE 'UNKNOWN' TO HDG-MAJOR
  WHEN MAJOR-CODE (MAJOR-INDEX) = ST-MAJOR-CODE
    MOVE EXP-MAJOR (MAJOR-INDEX) TO HDG-MAJOR
  END-SEARCH.

```

The codes themselves are not stored in the table of descriptive values as the *position* of an entry within the table corresponds to its associated code. The direct lookup is in essence a single MOVE statement in which the descriptive value in the indicated table position is chosen. The associated IF statement ensures that the incoming code lies within the range of the table.

Range-Step Tables

A *range-step table* is used when the same table value is applicable to multiple search arguments—that is, when there is no longer a one-to-one correspondence between a table value and the search argument. The computation of federal income tax is a well-known example as the same tax rate is applied to an entire tax bracket; that is, there is one tax rate for all incomes less than \$20,000, a different rate for incomes between \$20,000 and \$40,000, and so on.

The scholarship table in Figure 12.13a is another example of a range-step table in which the amount of financial aid depends on a student's grade point

Figure 12.12 Direct Access to Table Entries

```

01 MAJOR-VALUE.
   05 FILLER          PIC X(12)  VALUE 'UNKNOWN'.
   05 FILLER          PIC X(12)  VALUE 'ACCOUNTING'.
   05 FILLER          PIC X(12)  VALUE 'UNKNOWN'.
   05 FILLER          PIC X(12)  VALUE 'BIOLOGY'.
   .
   .
   05 FILLER          PIC X(12)  VALUE 'STATISTICS'.

01 MAJOR-TABLE REDEFINES MAJOR-VALUE.
   05 MAJORS OCCURS 54 TIMES PIC X(12).

PROCEDURE DIVISION.
   .
   .
   IF ST-MAJOR-CODE > 0 AND ST-MAJOR-CODE < 55
      MOVE MAJORS (ST-MAJOR-CODE) TO HDG-MAJOR
   ELSE
      MOVE 'UNKNOWN' TO HDG-MAJOR
   END-IF.

```

Positional organization results in wasted space

Check to ensure valid code

Figure 12.13 Range-step Table

| Grade Point Average | Scholarship Percentage |
|---------------------|------------------------|
| 3.75 - 4.00 | 100 |
| 3.50 - 3.74 | 75 |
| 3.25 - 3.49 | 50 |
| 3.00 - 3.24 | 33 |
| 2.75 - 2.99 | 25 |
| 2.50 - 2.74 | 15 |

(a) Scholarship Table

average. Students with a GPA between 2.50 and 2.74 receive a scholarship of 15%, students with a GPA between 2.75 and 2.99 an award of 25%, and so on.

The COBOL implementation is shown in Figure 12.13b. The scholarship table is hard coded and parallels the earlier example in Figure 12.5. The GPA table includes the minimum grade point average and corresponding scholarship amount for each of the six table entries. (There is no need to include the corresponding maximum grade point average).

Figure 12.13 (continued)

```

01 SCHOLARSHIP-TABLE.
05 GPA-SCHOLARSHIP-PERCENTAGES.
   10 FILLER          PIC X(6)    VALUE '375100'.
   10 FILLER          PIC X(6)    VALUE '350075'.
   10 FILLER          PIC X(6)    VALUE '325050'.
   10 FILLER          PIC X(6)    VALUE '300033'.
   10 FILLER          PIC X(6)    VALUE '275025'.
   10 FILLER          PIC X(6)    VALUE '250015'.
05 GPA-TABLE REDEFINES GPA-SCHOLARSHIP-PERCENTAGES
   OCCURS 6 TIMES
   INDEXED BY GPA-INDEX.
   10 GPA-MINIMUM     PIC 9V99.
   10 SCHOLARSHIP-PCT PIC 999.

SET GPA-INDEX TO 1.
SEARCH GPA-TABLE
  AT END
    MOVE ZERO TO SCHOLARSHIP-AWARD
  WHEN STUDENT-GPA >= GPA-MINIMUM (GPA-INDEX)
    MOVE SCHOLARSHIP-PCT (GPA-INDEX) TO SCHOLARSHIP-AWARD
END-SEARCH.

```

(b) COBOL Implementation

The SEARCH statement implements a sequential search similar to the earlier example in Figure 12.10. Note, however, that the WHEN condition uses a greater than or equal condition in accordance with the definition of the range-step table.

A Complete Example

We are ready now to incorporate the material on table lookups and initialization procedures into a complete example. Specifications are as follows:

PROGRAMMING SPECIFICATIONS

Program Name: Tables

Narrative: This program fully illustrates table processing. Two distinct means for initialization (hard coding and input loaded tables) are shown, as are three techniques for table lookups (sequential, binary, and direct access to table entries).

Input File(s): EMPLOYEE-FILE

TITLE-FILE

| Employee Record: | COLUMNS | FIELD | PICTURE |
|-------------------------|----------------|-----------------|----------------|
| | 1-20 | Name | X(20) |
| | 21-24 | Title Code | X(4) |
| | 25-27 | Location Code | X(3) |
| | 28 | Education Code | 9 |
| | 29-34 | Employee Salary | 9(6) |

| Title Record: | COLUMNS | FIELD | PICTURE |
|----------------------|----------------|-------------------|----------------|
| | 1-4 | Title Code | X(4) |
| | 5-19 | Descriptive Value | X(15) |

Test Data: See Figure 12.14a for TITLE-FILE. See Figure 12.14b for EMPLOYEE-FILE.

Report Layout: See Figure 12.14c.

- Processing Requirements:**
1. Process an employee file, with each record containing the employee's salary as well as *coded* data on an employee's location, education, and title.
 2. The table of location codes is to be hard-coded into the program and expanded via a sequential search. Location codes and their descriptive values are shown below:

| CODE | CITY |
|-------------|---------------|
| ATL | Atlanta |
| BOS | Boston |
| CHI | Chicago |
| DET | Detroit |
| KC | Kansas City |
| LA | Los Angeles |
| MIN | Minneapolis |
| NY | New York |
| PHI | Philadelphia |
| SF | San Francisco |

3. The education codes are to be stored in a positional table and expanded via a direct lookup. Education codes and their descriptive values are shown below:

| CODE | EDUCATION |
|-------------|---------------------|
| 1 | Some high school |
| 2 | High school diploma |
| 3 | Two-year degree |
| 4 | Four-year degree |
| 5 | Some graduate work |
| 6 | Master's degree |
| 7 | Doctorate degree |
| 8 | Other |

4. The table of title codes is to be read from a file and expanded via a binary search. The title codes and their descriptive values were shown earlier in Figure 12.14a.
5. The amount of life insurance is determined by the employee's salary according to the following range-step table:

Figure 12.14 Test Data and Report

1000PROGRAMMER
 1500DATA BASE
 2000OPERATOR
 2999SYSTEMS ANALYST
 3499DATA DICTIONARY

(a) Title File

JACKIE CLARK 2999CHI4025000
 MARGOT HUMMER 1000LA 6080000
 PERCY GARCIA 2999IND3015000
 CATHY BENWAY 3499ATL5110000
 LOUIS NORIEGA 0100NC 9035000
 JUD MCDONALD 1500ATL3065000
 NELSON KERBEL 1000PHI3038000

(b) Employee File

| EMPLOYEE | LOCATION | TITLE | EDUCATION | SALARY | LIFE INS |
|---------------|--------------|-----------------|------------|-----------|-----------|
| JACKIE CLARK | CHICAGO | SYSTEMS ANALYST | 4YR DEGREE | \$25,000 | \$80,000 |
| MARGOT HUMMER | LOS ANGELES | PROGRAMMER | MASTERS | \$80,000 | \$250,000 |
| PERCY GARCIA | UNKNOWN | SYSTEMS ANALYST | 2YR DEGREE | \$15,000 | \$40,000 |
| CATHY BENWAY | ATLANTA | DATA DICTIONARY | SOME GRAD | \$110,000 | \$500,000 |
| LOUIS NORIEGA | UNKNOWN | UNKNOWN | UNKNOWN | \$35,000 | \$80,000 |
| JUD MCDONALD | ATLANTA | DATA BASE | 2YR DEGREE | \$65,000 | \$175,000 |
| NELSON KERBEL | PHILADELPHIA | PROGRAMMER | 2YR DEGREE | \$38,000 | \$80,000 |

(c) Report

| SALARY RANGE | LIFE INSURANCE |
|-----------------------|----------------|
| <= \$ 20,000 | \$ 40,000 |
| \$ 20,001-\$ 40,000 | \$ 80,000 |
| \$ 40,001-\$ 75,000 | \$ 175,000 |
| \$ 75,001-\$ 100,000 | \$ 250,000 |
| \$ 100,001-\$ 200,000 | \$ 500,000 |

6. Print a detail line for each employee with descriptive information for location, education, title, and life insurance. Single-space this report.

Program Design

The hierarchy chart for the table lookup is shown in Figure 12.15. The highest-level module, PRODUCE-EMPLOYEE-REPORT, contains three subordinates to initialize the title table (the specifications called for an input-loaded table), write a heading

Figure 12.15 Hierarchy Chart for Table-Lookup Program

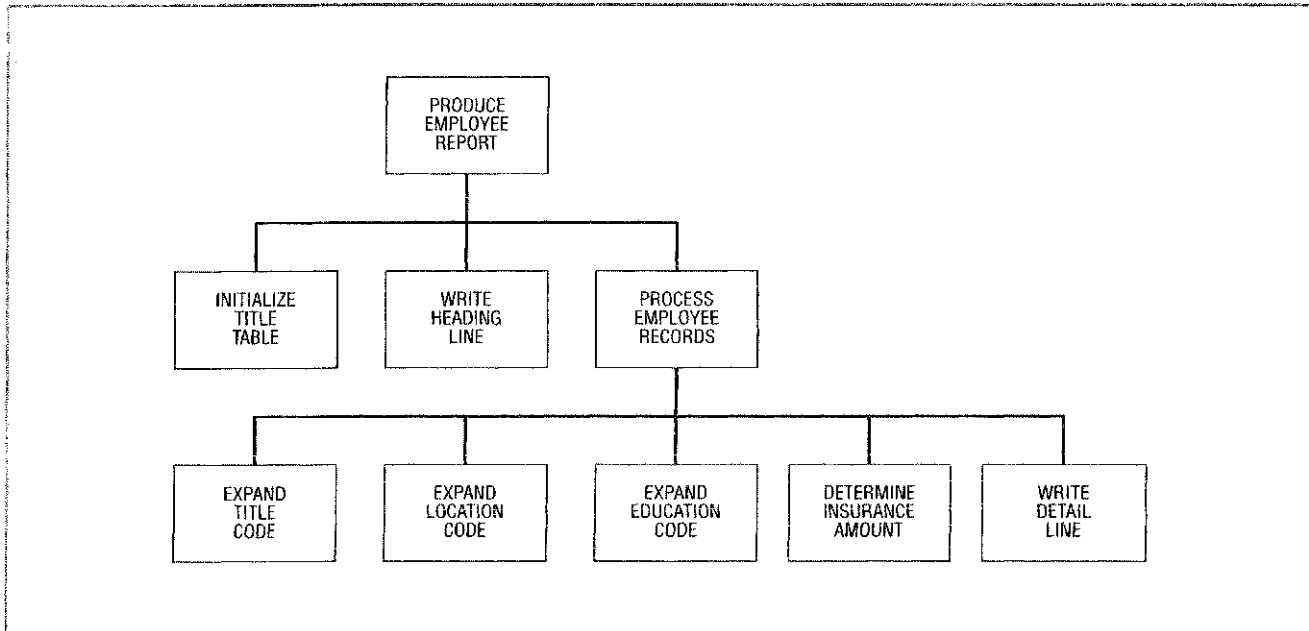

line, and process employee records; the latter includes four lower modules for the four table lookups.

The associated pseudocode is shown in Figure 12.16 and uses the in-line perform and false-condition branch first to process both the title and employee files. The title file is processed first and includes a check to ensure that the size of the title table is not exceeded. After the last record from the title file has been read, the employee file is opened and processed in its entirety. Each incoming employee record has its title, location, and education codes expanded, the amount of insurance determined, and a detail line written.

The Completed Program

The completed program is shown in Figure 12.17. The paragraphs in the Procedure Division correspond one to one with the modules in the hierarchy chart, and its logic in the program parallels that of the pseudocode just developed. The program complies with the processing requirements and also illustrates the various COBOL features presented earlier. Note the following:

1. The use of three SELECT statements for EMPLOYEE-FILE, PRINT-FILE, and TITLE-FILE; the latter is used to dynamically load the title table.
2. Omission of all optional clauses in the FD entries in the Data Division; that is, the FD contains only the file name. The optional reserved word FILLER is also omitted throughout the Data Division (see Limitations of COBOL-74 on page 357).
3. The use of READ INTO and WRITE FROM throughout the Procedure Division; this is not a requirement of table processing per se, but a coding style used throughout the text.
4. The definition of the location table in lines 43–59 through combination of the VALUES, OCCURS, and REDEFINES clauses. The location table includes the INDEXED BY clause as required by the SEARCH statement in lines 190–196.

Figure 12.16 Pseudocode for Table-Lookup Program

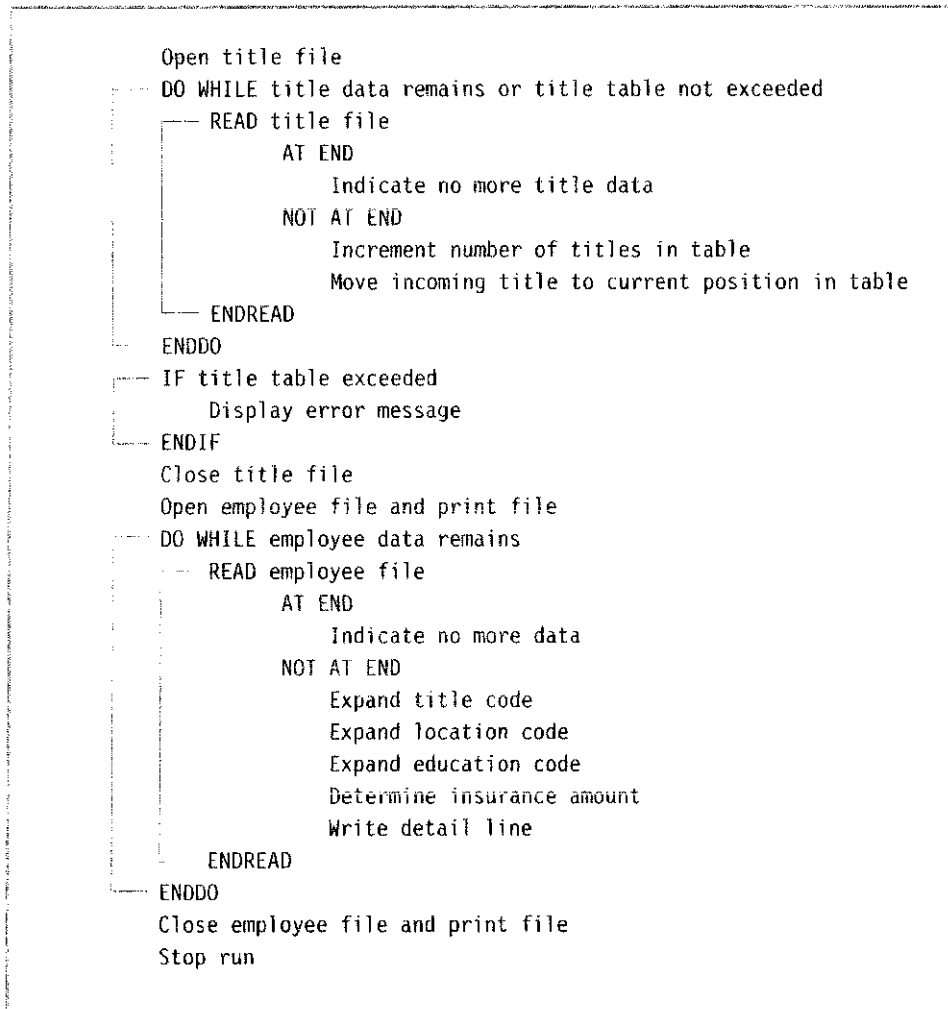

Figure 12.17 Table-Lookup Program

```

1  IDENTIFICATION DIVISION.
2  PROGRAM-ID.    TABLES.
3  AUTHOR.       ROBERT GRAUER
4
5  ENVIRONMENT DIVISION.
6  INPUT-OUTPUT SECTION.
7  FILE-CONTROL.
8      SELECT EMPLOYEE-FILE  ASSIGN TO 'A:\CHAPTR12\TABLES.DAT'
9          ORGANIZATION IS LINE SEQUENTIAL.
10     SELECT PRINT-FILE
11         ASSIGN TO PRINTER.
12     SELECT TITLE-FILE     ASSIGN TO 'A:\CHAPTR12\TITLES.DAT'
13         ORGANIZATION IS LINE SEQUENTIAL.
14
15  DATA DIVISION.
  
```

Separate file is used to initialize title table

Figure 12.17 (continued)

```

16 FILE SECTION.
17 FD TITLE-FILE.
18 01 TITLE-IN PIC X(19).
19
20 FD EMPLOYEE-FILE.
21 01 EMPLOYEE-RECORD PIC X(34).
22
23 FD PRINT-FILE.
24 01 PRINT-LINE PIC X(132).
25
26 WORKING-STORAGE SECTION.
27 01 PIC X(14)
28 VALUE 'WS BEGINS HERE'.
29
30 01 PROGRAM-SWITCHES-AND-COUNTERS.
31 05 END-OF-TITLE-FILE PIC X(3) VALUE 'NO '.
32 05 END-OF-EMP-FILE PIC X(3) VALUE 'NO '.
33 05 NUMBER-OF-TITLES PIC 999 VALUE ZEROS.
34
35 01 TITLE-TABLE.
36 05 TITLES OCCURS 1 TO 999 TIMES
37 DEPENDING ON NUMBER-OF-TITLES
38 ASCENDING KEY IS TITLE-CODE
39 INDEXED BY TITLE-INDEX.
40 10 TITLE-CODE PIC X(4).
41 10 TITLE-NAME PIC X(15).
42
43 01 LOCATION-VALUE.
44 05 PIC X(16) VALUE 'ATLANTA'.
45 05 PIC X(16) VALUE 'BOSTON'.
46 05 PIC X(16) VALUE 'CHICAGO'.
47 05 PIC X(16) VALUE 'DETROIT'.
48 05 PIC X(16) VALUE 'KC KANSAS CITY'.
49 05 PIC X(16) VALUE 'LA LOS ANGELES'.
50 05 PIC X(16) VALUE 'MINNEAPOLIS'.
51 05 PIC X(16) VALUE 'NY NEW YORK'.
52 05 PIC X(16) VALUE 'PHILADELPHIA'.
53 05 PIC X(16) VALUE 'SF SAN FRANCISCO'.
54
55 01 LOCATION-TABLE REDEFINES LOCATION-VALUE.
56 05 LOCATIONS OCCURS 10 TIMES
57 INDEXED BY LOCATION-INDEX.
58 10 LOCATION-CODE PIC X(3).
59 10 LOCATION-NAME PIC X(13).
60
61 01 EDUCATION-TABLE.
62 05 EDUCATION-VALUES.
63 10 PIC X(10) VALUE 'SOME HS'.
64 10 PIC X(10) VALUE 'HS DIPLOMA'.

```

Different switches are defined for different files

ASCENDING KEY clause required for subsequent binary search

Location table is initialized through combination of OCCURS, VALUES, and REDEFINES clauses

Figure 12.17 (continued)

```

65          10          PIC X(10)    VALUE '2YR DEGREE'.
66          10          PIC X(10)    VALUE '4YR DEGREE'.
67          10          PIC X(10)    VALUE 'SOME GRAD'.
68          10          PIC X(10)    VALUE 'MASTERS'.
69          10          PIC X(10)    VALUE 'PH. D.'.
70          10          PIC X(10)    VALUE 'OTHER'.
71          05  EDU-NAME REDEFINES EDUCATION-VALUES
72              OCCURS 8 TIMES    PIC X(10).
73
74          01  SALARY-INSURANCE-TABLE.
75              05  INSURANCE-VALUES.
76                  10          PIC X(12)    VALUE '020000040000'.
77                  10          PIC X(12)    VALUE '040000080000'.
78                  10          PIC X(12)    VALUE '075000175000'.
79                  10          PIC X(12)    VALUE '100000250000'.
80                  10          PIC X(12)    VALUE '200000500000'.
81              05  INSURANCE-TABLE REDEFINES INSURANCE-VALUES
82                  OCCURS 5 TIMES
83                  INDEXED BY INSURANCE-INDEX.
84                  10  SALARY-MAXIMUM    PIC 9(6).
85                  10  INSURANCE-AMOUNT PIC 9(6).
86
87          01  HEADING-LINE.
88              05          PIC X(2)    VALUE SPACES.
89              05          PIC X(10)   VALUE 'EMPLOYEE'.
90              05          PIC X(10)   VALUE SPACES.
91              05          PIC X(8)    VALUE 'LOCATION'.
92              05          PIC X(7)    VALUE SPACES.
93              05          PIC X(5)    VALUE 'TITLE'.
94              05          PIC X(12)   VALUE SPACES.
95              05          PIC X(10)   VALUE 'EDUCATION'.
96              05          PIC X(4)    VALUE SPACES.
97              05          PIC X(6)    VALUE 'SALARY'.
98              05          PIC X(3)    VALUE SPACES.
99              05          PIC X(8)    VALUE 'LIFE INS'.
100             05          PIC X(47)   VALUE SPACES.
101
102          01  DASHED-LINE.
103             05          PIC X(85)   VALUE ALL '-'.
104             05          PIC X(47)   VALUE SPACES.
105
106          01  DETAIL-LINE.
107             05  DET-NAME    PIC X(20).
108             05          PIC XX      VALUE SPACES.
109             05  DET-LOCATION PIC X(13).
110             05          PIC XX      VALUE SPACES.
111             05  DET-TITLE  PIC X(15).
112             05          PIC XX      VALUE SPACES.
113             05  DET-EDUCATION PIC X(10).
114             05          PIC XXX     VALUE SPACES.

```

Figure 12.17 (continued)

```

115      05 DET-SALARY          PIC $$$$.$$$ .
116      05                    PIC XX          VALUE SPACES.
117      05 DET-INSURANCE      PIC $$$$.$$$ .
118      05                    PIC X(47)      VALUE SPACES.
119
120      01 WS-EMPLOYEE-RECORD.
121      05 EMP-NAME           PIC X(20) .
122      05 EMP-TITLE-CODE     PIC X(4) .
123      05 EMP-LOC-CODE      PIC X(3) .
124      05 EMP-EDUC-CODE     PIC 9 .
125      05 EMP-SALARY        PIC 9(6) .
126
127      01 WS-TITLE-RECORD.
128      05 TITLE-IN-CODE     PIC X(4) .
129      05 TITLE-IN-NAME     PIC X(15) .
130
131      PROCEDURE DIVISION.
132      100-PRODUCE-EMPLOYEE-REPORT.
133          PERFORM 200-INITIALIZE-TITLE-TABLE.
134          OPEN INPUT EMPLOYEE-FILE
135              OUTPUT PRINT-FILE.
136          PERFORM 300-WRITE-HEADING-LINES.
137          PERFORM UNTIL END-OF-EMP-FILE = 'YES'
138              READ EMPLOYEE-FILE INTO WS-EMPLOYEE-RECORD
139                  AT END
140                      MOVE 'YES' TO END-OF-EMP-FILE
141                  NOT AT END
142                      PERFORM 400-PROCESS-EMPLOYEE-RECORDS
143          END-READ
144          END-PERFORM.
145          CLOSE EMPLOYEE-FILE
146              PRINT-FILE.
147          STOP RUN.
148
149      200-INITIALIZE-TITLE-TABLE.
150          OPEN INPUT TITLE-FILE.
151          PERFORM VARYING TITLE-INDEX FROM 1 BY 1
152              UNTIL END-OF-TITLE-FILE = 'YES'
153                  OR TITLE-INDEX > 999
154              READ TITLE-FILE INTO WS-TITLE-RECORD
155                  AT END
156                      MOVE 'YES' TO END-OF-TITLE-FILE
157                  NOT AT END
158                      ADD 1 TO NUMBER-OF-TITLES
159                      MOVE TITLE-IN-CODE TO TITLE-CODE (TITLE-INDEX)
160                      MOVE TITLE-IN-NAME TO TITLE-NAME (TITLE-INDEX)
161          END-READ
162          END-PERFORM.
163          IF TITLE-INDEX > 999
164              DISPLAY 'SIZE OF TITLE TABLE IS EXCEEDED'

```

IF: code is initialized dynamically

Checks that table size is not exceeded

Figure 12.17 (continued)

```

165         END-IF.
166         CLOSE TITLE-FILE.
167
168     300-WRITE-HEADING-LINES.
169         WRITE PRINT-LINE FROM HEADING-LINE
170             AFTER ADVANCING PAGE.
171         WRITE PRINT-LINE FROM DASHED-LINE
172             AFTER ADVANCING 1 LINE.
173
174     400-PROCESS-EMPLOYEE-RECORDS.
175         PERFORM 420-EXPAND-TITLE-CODE.
176         PERFORM 430-EXPAND-LOCATION-CODE.
177         PERFORM 440-EXPAND-EDUCATION-CODE.
178         PERFORM 450-DETERMINE-INSURANCE-AMOUNT.
179         PERFORM 470-WRITE-DETAIL-LINE.
180
181     420-EXPAND-TITLE-CODE.
182         SEARCH ALL TITLES
183             AT END
184                 MOVE 'UNKNOWN' TO DET-TITLE
185                 WHEN TITLE-CODE (TITLE-INDEX) = EMP-TITLE-CODE
186                 MOVE TITLE-NAME (TITLE-INDEX) TO DET-TITLE
187         END-SEARCH.
188
189     430-EXPAND-LOCATION-CODE.
190         SET LOCATION-INDEX TO 1.
191         SEARCH LOCATIONS
192             AT END
193                 MOVE 'UNKNOWN' TO DET-LOCATION
194                 WHEN EMP-LOC-CODE = LOCATION-CODE (LOCATION-INDEX)
195                 MOVE LOCATION-NAME (LOCATION-INDEX) TO DET-LOCATION
196         END-SEARCH.
197
198     440-EXPAND-EDUCATION-CODE.
199         IF EMP-EDUC-CODE < 1 OR > 8
200             MOVE 'UNKNOWN' TO DET-EDUCATION
201         ELSE
202             MOVE EDU-NAME (EMP-EDUC-CODE) TO DET-EDUCATION
203         END-IF.
204
205     450-DETERMINE-INSURANCE-AMOUNT.
206         IF EMP-SALARY IS NUMERIC
207             SET INSURANCE-INDEX TO 1
208             SEARCH INSURANCE-TABLE
209                 AT END
210                     MOVE ZERO TO DET-INSURANCE
211                     WHEN EMP-SALARY <= SALARY-MAXIMUM (INSURANCE-INDEX)
212                     MOVE INSURANCE-AMOUNT (INSURANCE-INDEX)
213                         TO DET-INSURANCE
214         END-SEARCH

```

Binary search

Sequential search

Direct access to table entries

Range step loop uses <= condition

Figure 12.17 (continued)

```

215         ELSE
216             DISPLAY 'INCOMING SALARY NOT NUMERIC'
217             MOVE ZERO TO DET-INSURANCE
218         END-IF.
219
220     470-WRITE-DETAIL-LINE.
221     MOVE SPACES TO PRINT-LINE.
222     MOVE EMP-NAME TO DET-NAME.
223     MOVE EMP-SALARY TO DET-SALARY.
224     WRITE PRINT-LINE FROM DETAIL-LINE
225         AFTER ADVANCING 1 LINE.

```

5. The definition of the education table (lines 61–72) as a positional table; that is, the education codes themselves (1, 2, ... ,8) are *not* entered in the table, and the incoming employee education code is expanded via direct access to a table entry in the MOVE statement of line 202. (The IF statement in line 199 is executed prior to the MOVE to ensure a valid education code.)
6. The definition of the insurance table (lines 74–85), which includes an INDEXED BY clause as required by the subsequent SEARCH statement. Note, too, the WHEN clause in line 211 includes a less than or equal condition consistent with the implementation of a range-step table.
7. The definition of the title table as input loaded in lines 35–41; that is, the OCCURS clause merely allocates spaces for the table but does not assign values to it; the latter is done dynamically in lines 150–166 of the Procedure Division. Note, too, the inclusion of the INDEXED BY and ASCENDING KEY clauses that are required by the SEARCH ALL statement in lines 182–187.

The flow in the Procedure Division is straightforward and easy to follow. The PERFORM statement in line 133 initializes the title table, after which the employee and print files are opened and a heading line is written. The combination of the in-line perform and false-condition branch in lines 137 through 144 processes employee records until the file is exhausted.

A P P L I C A T I O N S O F C O B O L - 8 5

The optional END-SEARCH scope terminator is new to COBOL-85 and terminates the conditional portion of the SEARCH and SEARCH ALL statements.

The word FILLER is optional, making possible Data Division entries of the form:

```

01 MAJOR-VALUE.
   05                PIC X(14)  VALUE '02ART HISTORY'.
   05                PIC X(14)  VALUE '04BIOLOGY'.
   05                PIC X(14)  VALUE '19CHEMISTRY'.

```

The entries look strange initially, but make perfect sense when you realize that data names defined as FILLER are not referenced in the Procedure Division; that is, omission of the word FILLER has no effect on the remainder of a program.

S U M M A R Y

Points to Remember

- ✦ Codes may be alphabetic, numeric, or alphanumeric. A good coding system will be precise, mnemonic, and expandable.
- ✦ The VALUE, OCCURS, and REDEFINES clauses are used in combination to define and initialize a table within a COBOL program.
- ✦ A table lookup may be implemented sequentially, in binary fashion, or through direct access to table entries.
- ✦ A range-step table occurs when there is no one-to-one correspondence between a table value and the search argument.
- ✦ Tables may be initialized through hard coding or dynamically loaded at execution time.
- ✦ A SEARCH statement is used to implement a sequential lookup. The statement requires the INDEXED BY clause in the table definition.
- ✦ A SEARCH ALL statement is used to implement a binary lookup. The statement requires the INDEXED BY and KEY clauses in the table definition, and requires the keys in the table to be in either ascending or descending sequence.

Key Words and Concepts

| | |
|--------------------------------|-------------------------|
| Alphabetic code | Numeric code |
| Alphanumeric code | Positional organization |
| Binary table lookup | Precise code |
| Direct access to table entries | Range-step table |
| Hard coding | Sequential table lookup |
| Index | Subscript |
| Input-loaded table | Table lookup |
| Mnemonic code | |

COBOL Elements

| | |
|-----------------|------------|
| ASCENDING KEY | REDEFINES |
| AT END | SEARCH |
| DESCENDING KEY | SEARCH ALL |
| END-SEARCH | SET |
| INDEXED BY | VALUE |
| OCCURS | WHEN |
| PERFORM VARYING | |

FILL-IN

1. A two-position numeric code has _____ combinations; a two-position alphabetic code has _____; and a two-position alphanumeric code has _____.
2. A _____ table lookup does not require its entries to be in any special order, whereas a binary table lookup requires that the entries be in either _____ or _____ sequence.
3. If a table is _____, then the program in which it is found must be recompiled in order to change the table.
4. An _____ table makes it possible to change entries in the table without recompiling the program.
5. Direct access to table entries is possible only if the table has _____ organization.
6. A sequential table lookup in a table of 500 elements could require as many as _____ tries, whereas a binary lookup for the same table would take no more than _____ tries.
7. The _____ clause gives another name to previously allocated space.
8. A sequential table lookup is implemented by the _____ statement, whereas a binary lookup is implemented by _____.
9. The ASCENDING/DESCENDING _____ clause is required in the table definition if a binary table lookup is to be implemented.
10. The _____ statement appears before a sequential search, but is not used prior to a binary search.
11. The _____ clause is required in a table's definition if either a sequential or binary search is used.

12. The REDEFINES clause (must/may) be used when initializing a table.
13. If the wrong number of subscripts are used with a particular data name, a (compilation/execution) error will result.
14. A SET statement (is/is not) used before a SEARCH ALL statement, as the binary algorithm calculates its own starting position.
15. A _____ table occurs when there is no longer a one-to-one correspondence between a table value and the search argument.

TRUE/FALSE

1. A binary search over a table of 500 elements requires 9 or fewer comparisons.
2. A sequential search over a table of 500 elements could require 500 comparisons.
3. Direct access to table entries requires no comparisons.
4. The SEARCH statement requires an index.
5. SEARCH ALL denotes a binary search.
6. There are no additional requirements of table organization in order to implement a binary rather than a sequential search.
7. An index (that is, displacement) of zero refers to the first element in a table.
8. A subscript of zero refers to the first element in a table.
9. An index cannot be manipulated by a MOVE statement.
10. PERFORM VARYING can manipulate both indexes and subscripts.
11. A SEARCH statement can contain only a single WHEN clause.
12. The ASCENDING (DESCENDING) KEY clause is required whenever the SEARCH statement is applied to a table.
13. The INDEXED BY clause is required whenever the SEARCH statement is applied to a table.
14. The same index can be applied to many tables.
15. The same subscript can be applied to many tables.
16. An index and a subscript can be applied to the same table.
17. The REDEFINES clause provides another name for previously allocated space.
18. The REDEFINES clause must be used in initializing a table.
19. A binary search could be applied to a table if its elements were arranged in descending (rather than ascending) sequence.
20. A numeric code of four digits provides a greater number of possibilities than a three-digit alphabetic code.
21. Codes are used for reasons other than to conserve space.
22. Alphabetic codes are more likely to be mnemonic than numeric codes.
23. Numeric codes, such as Social Security numbers, should not be unique to accommodate individuals with the same last name.
24. Positionally organized tables require the first code to begin at 1.

25. Positionally organized tables require numeric codes.
26. Positionally organized tables often result in large amounts of wasted space.
27. A range-step table requires a one-to-one correspondence between the table value and search argument.
28. The federal income tax table is an example of a range-step table.

PROBLEMS

1. How many unique codes can be developed from a four-position numeric code? From a four-position alphabetic code? From a four-position alphanumeric code?
2. Ask a friend to pick a number from 1 to 2,000. What is the maximum number of guesses required to find the number if
 - a. a binary search is used?
 - b. a sequential search is used?
 Answer parts (a) and (b), if the selected number is between 1 and 4,000.
3. What, if anything, is wrong with the following table definition?

```
01 MONTH-TABLE.
   05 MONTH OCCURS 12 TIMES          PIC X(4).
   05 MONTH-VALUES REDEFINES MONTH  PIC X(36)
      VALUE 'JANFEBMARAPRMAYJUNJULAUGSEPOCTNOVDEC'.
```
4. The DAY-OF-WEEK phrase was introduced in Chapter 9 (page 242) to obtain a one-position code corresponding to the day of the week. An alternate way of expanding the code (as opposed to the EVALUATE statement in Chapter 9) is to use a positional table and direct lookup.
 - a. Use the data names in Figure 12.18 to write the appropriate ACCEPT statement.
 - b. Write the necessary statements to implement a direct lookup on the table of Figure 12.18.

Figure 12.18 DAY-OF-WEEK Table

```
01 DAY-CODE-VALUE          PIC 9.

01 DAY-HEADING.
   05 FILLER                PIC X(9)    VALUE 'TODAY IS '.
   05 TODAYS-DAY            PIC X(9).

01 DAY-OF-WEEK-VALUE.
   05 FILLER                PIC X(9)    VALUE 'MONDAY'.
   05 FILLER                PIC X(9)    VALUE 'TUESDAY'.
   05 FILLER                PIC X(9)    VALUE 'WEDNESDAY'.
   05 FILLER                PIC X(9)    VALUE 'THURSDAY'.
   05 FILLER                PIC X(9)    VALUE 'FRIDAY'.
   05 FILLER                PIC X(9)    VALUE 'SATURDAY'.
   05 FILLER                PIC X(9)    VALUE 'SUNDAY'.

01 DAY-OF-WEEK-TABLE REDEFINES MAJOR-VALUE.
   05 DAY OCCURS 7 TIMES    PIC X(9).
```

5. Given the following table definition:

```

01 LOCATION-VALUE.
   05 FILLER          PIC X(16) VALUE '010ATLANTA'.
   05 FILLER          PIC X(16) VALUE '020BOSTON'.
   05 FILLER          PIC X(16) VALUE '030CHICAGO'.
   05 FILLER          PIC X(16) VALUE '040DETROIT'.
   05 FILLER          PIC X(16) VALUE '050KANSAS CITY'.
   05 FILLER          PIC X(16) VALUE '060LOS ANGELES'.
   05 FILLER          PIC X(16) VALUE '070NEW YORK'.
   05 FILLER          PIC X(16) VALUE '080PHILADELPHIA'.
   05 FILLER          PIC X(16) VALUE '090SAN FRANCISCO'.
   05 FILLER          PIC X(16) VALUE '045DENVER'.
01 LOCATION-TABLE REDEFINES LOCATION-VALUE.
   05 LOCATION OCCURS 10 TIMES
      ASCENDING KEY IS LOCATION-CODE
      INDEXED BY LOCATION-INDEX.
      10 LOCATION-CODE PIC X(3).
      10 LOCATION-NAME PIC X(13).

```

and the following Procedure Division code:

```

SET LOCATION-INDEX TO 1.
SEARCH LOCATION
  AT END
    DISPLAY '*ERROR IN SEQUENTIAL SEARCH FOR DENVER'
    WHEN LOCATION-CODE (LOCATION-INDEX) = '045'
    DISPLAY 'SEQUENTIAL SEARCH OK FOR DENVER'
END-SEARCH.
SEARCH LOCATION
  AT END
    DISPLAY '*ERROR IN SEQUENTIAL SEARCH FOR NEW YORK'
    WHEN LOCATION-CODE (LOCATION-INDEX) = '070'
    DISPLAY 'SEQUENTIAL SEARCH OK FOR NEW YORK'
END-SEARCH.

```

- a. Indicate the output that will be produced.
- b. Code a binary search statement to expand code 045 for Denver. Do you expect any trouble in the execution of that statement?

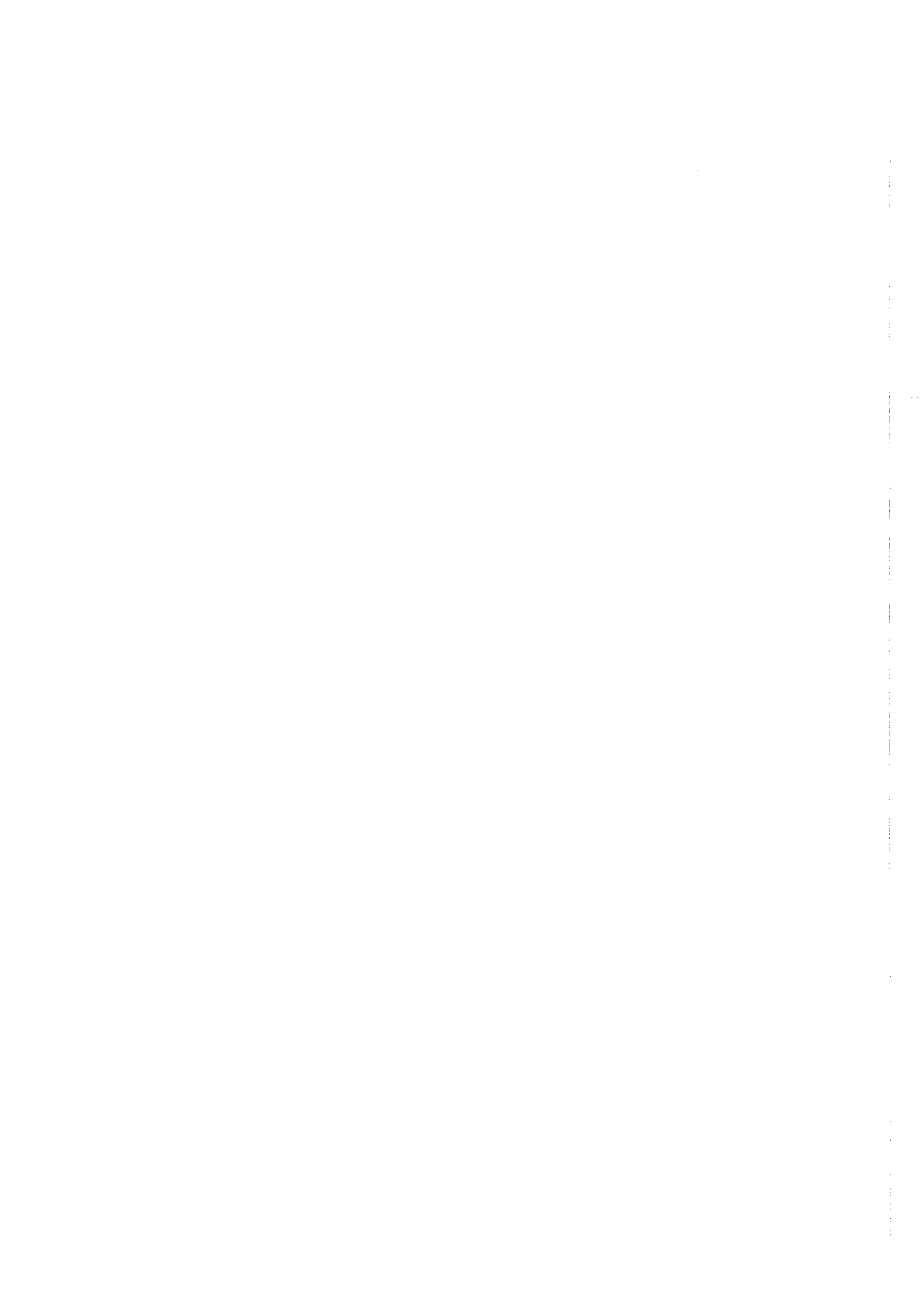

Multilevel Tables

CHAPTER OUTLINE

Overview

System Concepts

COBOL Implementation

One-Level Tables

PERFORM VARYING

Two-Level Tables

Errors in Compilation

PERFORM VARYING

A Sample Program

Programming Specifications

Program Design

The Completed Program

Three-Level Tables

PERFORM VARYING

A Sample Program

Programming Specifications

The Completed Program

Table Lookups

A Calorie Counter's Delight

Programming Specifications

Range-Step Tables

The Completed Program

Limitations of COBOL-74

Summary

Fill-in

True/False

Problems



OBJECTIVES

After reading this chapter you will be able to:

- ✱ Describe a conceptual (user's) view of one-, two-, and three-level tables; implement (that is, define and initialize) one-, two-, and three-level tables in COBOL.
- ✱ Differentiate between the VALUE, OCCURS, and REDEFINES clauses as they relate to table definition and initialization.
- ✱ Distinguish between errors in compilation versus errors in execution; give an example of each as it pertains to multilevel table processing.
- ✱ Explain the operation of a PERFORM VARYING statement; develop suitable examples to process tables in one, two, and three dimensions.
- ✱ Use the VARYING option of the SEARCH statement; nest SEARCH statements within one another for multilevel-table lookups.

OVERVIEW

COBOL-85 allows multilevel tables of up to seven dimensions as opposed to the earlier limit of three in COBOL-74. Most applications do not require anything beyond a three-level table, and thus our coverage is limited to two- and three-level tables. The underlying concepts are identical regardless of a table's complexity, and hence our approach to multilevel tables will be a simple extension of the single-level problem.

We begin with a one-level example and develop it completely. This material reviews some discussion from the previous chapter, but is included nonetheless, in order to build the parallel between one-, two-, and three-level examples. Our presentation reexamines the OCCURS, VALUE, and REDEFINES clauses in the Data Division, and the PERFORM VARYING statement in the Procedure Division. We then extend the discussion to two and three dimensions and present complete programs to illustrate all statements.

The chapter concludes with a third program to implement table lookups in a multilevel table. The example introduces the VARYING option of the SEARCH statement and also nests SEARCH statements within one another.

System Concepts

Figure 13.1a depicts the user's view of a table of starting salaries within a company. In this example, an employee starts at one of 10 salaries, depending on the responsibility level for his or her job. A junior account executive, for example, may be designated as having a responsibility level of 1, whereas a divisional manager may be assigned level 10. The 10 salaries together comprise a salary table, with individual values designated by a subscript. The starting salary at responsibility level four, for example, is \$30,000.

Figure 13.1 Multilevel Tables

| | | |
|----------------|----|--------|
| Responsibility | 1 | 26,000 |
| | 2 | 27,000 |
| | 3 | 28,000 |
| | 4 | 30,000 |
| | 5 | 32,000 |
| | 6 | 34,000 |
| | 7 | 36,000 |
| | 8 | 39,000 |
| | 9 | 42,000 |
| | 10 | 46,000 |

(a) One-Level Table

| | | | | | | |
|----------------|----|--------|--------|--------|--------|--------|
| Experience | | 1 | 2 | 3 | 4 | 5 |
| Responsibility | 1 | 26,000 | 27,000 | 28,000 | 29,000 | 30,000 |
| | 2 | 27,000 | 28,000 | 29,000 | 30,000 | 31,000 |
| | 3 | 28,000 | 29,000 | 30,000 | 31,000 | 32,000 |
| | 4 | 30,000 | 32,000 | 34,000 | 36,000 | 38,000 |
| | 5 | 32,000 | 34,000 | 36,000 | 38,000 | 40,000 |
| | 6 | 34,000 | 36,000 | 38,000 | 40,000 | 42,000 |
| | 7 | 36,000 | 39,000 | 42,000 | 45,000 | 48,000 |
| | 8 | 39,000 | 42,000 | 45,000 | 48,000 | 51,000 |
| | 9 | 42,000 | 45,000 | 48,000 | 51,000 | 54,000 |
| | 10 | 46,000 | 50,000 | 54,000 | 58,000 | 62,000 |

(b) Two-Level Table

| | | | | | | | | | | | |
|----------------|--|------------|--------|--------|--------|--------|--------|--------|--------|--------|--------|
| Region 2 | | Experience | | 1 | 2 | 3 | 4 | 5 | | | |
| Responsibility | | 1 | 28,000 | 29,000 | 30,000 | 31,000 | 32,000 | | | | |
| | | 2 | 29,000 | 30,000 | 31,000 | 32,000 | 33,000 | | | | |
| | | 3 | 30,000 | 31,000 | 32,000 | 33,000 | 34,000 | | | | |
| | | 4 | 32,000 | 34,000 | 36,000 | 38,000 | 40,000 | | | | |
| Region 1 | | Experience | | 1 | 2 | 3 | 4 | 5 | 6 | 7 | |
| Responsibility | | 1 | 26,000 | 27,000 | 28,000 | 29,000 | 30,000 | 31,000 | 32,000 | 33,000 | 34,000 |
| | | 2 | 27,000 | 28,000 | 29,000 | 30,000 | 31,000 | 32,000 | 33,000 | 34,000 | 35,000 |
| | | 3 | 28,000 | 29,000 | 30,000 | 31,000 | 32,000 | 33,000 | 34,000 | 35,000 | 36,000 |
| | | 4 | 30,000 | 32,000 | 34,000 | 36,000 | 38,000 | 40,000 | 42,000 | 44,000 | 46,000 |
| | | 5 | 32,000 | 34,000 | 36,000 | 38,000 | 40,000 | 42,000 | 44,000 | 46,000 | 48,000 |
| | | 6 | 34,000 | 36,000 | 38,000 | 40,000 | 42,000 | 44,000 | 46,000 | 48,000 | 50,000 |
| | | 7 | 36,000 | 39,000 | 42,000 | 45,000 | 48,000 | 51,000 | 54,000 | 57,000 | 60,000 |
| | | 8 | 39,000 | 42,000 | 45,000 | 48,000 | 51,000 | 54,000 | 57,000 | 60,000 | 63,000 |
| | | 9 | 42,000 | 45,000 | 48,000 | 51,000 | 54,000 | 57,000 | 60,000 | 63,000 | 66,000 |
| | | 10 | 46,000 | 50,000 | 54,000 | 58,000 | 62,000 | 66,000 | 70,000 | 74,000 | 78,000 |

(c) Three-Level Table

Figure 13.1b extends the user's view to two dimensions, in which salary is a function of two variables, responsibility and experience. The additional variable enables individuals with the same responsibility to be assigned different salaries, depending on experience. An individual at responsibility level four, for example, earns one of five salaries (\$30,000, \$32,000, \$34,000, \$36,000, or \$38,000), depending

on his or her experience level (which varies from one to five, respectively.) Two subscripts are necessary to designate a specific value in a two-level table; it should be apparent that the order of the subscripts is important; that is, the entry in row 4, column 1 (\$30,000) is different from the entry in row 1, column 4 (\$29,000).

Figure 13.1c extends the user's view to a third dimension, region, in which salary is a function of three variables; region (based on cost of living), responsibility, and experience. Any reference to a specific entry in a three-level table requires three subscripts, and again the order is important. Look again at Figure 13.1c and verify that the salary for region 1, responsibility 4, and experience 1 is \$30,000, while the entry in region 2, responsibility 4, and experience 1 is \$32,000.

COBOL Implementation

A table is initialized either by hard-coding it in a program or by dynamically loading it at execution time. Once initialized, the entries in a table can be accessed through a `PERFORM VARYING` or `SEARCH` statement, and these statements are applicable to tables in one, two, or three dimensions. We have, however, for the sake of simplicity, chosen to focus on hard-coding and the `PERFORM VARYING` statement. As previously indicated, our approach will be to develop the material for the simplest application (one-level tables), and then extend the concepts to two and three dimensions.

One-Level Tables

Figure 13.2 depicts three different views of the one-level table shown earlier in Figure 13.1. Figure 13.2a repeats the user's view in which salary is a function of responsibility, Figure 13.2b contains the COBOL statements to define and initialize the table in COBOL, and Figure 13.2c shows the resulting storage allocation.

Figure 13.2b creates the 01 entry `SALARY-VALUES` with 10 successive `VALUE` clauses that initialize 50 consecutive locations in memory. The first five locations contain 26000, the next five contain 27000, and so on.

The `REDEFINES` clause assigns another name, `SALARY-TABLE`, to these same 50 locations, and the subsequent `OCCURS` clause establishes the table. (The `OCCURS` clause cannot appear on the 01 level and hence `SALARY` is defined under `SALARY-TABLE`.) The first five positions in `SALARY-VALUES` are renamed `SALARY (1)` and contain 26000, the starting salary for responsibility level one. The next five positions are renamed `SALARY (2)` and contain 27000, and so on. The conceptual view of the storage allocation is shown in Figure 13.2c.

PERFORM VARYING

The `PERFORM VARYING` statement (explained previously in Chapter 11) processes the elements in a table. For example, the statement

```
PERFORM WRITE-STARTING-SALARY
      VARYING RESPONSIBILITY-SUB FROM 1 BY 1
      UNTIL RESPONSIBILITY-SUB > 10
```

executes the procedure `WRITE-STARTING-SALARY` 10 times, changing the value of `RESPONSIBILITY-SUB` each time the procedure is executed. The `PERFORM VARYING` statement initializes (increments) a subscript (index), tests a condition, then performs the designated procedure, depending on whether the condition is true. In the example, `RESPONSIBILITY-SUB` is initialized to 1, and the condition

Figure 14.2 One-level Table

| | | |
|----------------|----|--------|
| Responsibility | 1 | 26,000 |
| | 2 | 27,000 |
| | 3 | 28,000 |
| | 4 | 30,000 |
| | 5 | 32,000 |
| | 6 | 34,000 |
| | 7 | 36,000 |
| | 8 | 39,000 |
| | 9 | 42,000 |
| | 10 | 46,000 |

Responsibility level = 4

(a) User's View

```

01 SALARY-VALUES.
   05 FILLER PIC X(5) VALUE '26000'.
   05 FILLER PIC X(5) VALUE '27000'.
   05 FILLER PIC X(5) VALUE '28000'.
   05 FILLER PIC X(5) VALUE '30000'.
   05 FILLER PIC X(5) VALUE '32000'.
   05 FILLER PIC X(5) VALUE '34000'.
   05 FILLER PIC X(5) VALUE '36000'.
   05 FILLER PIC X(5) VALUE '39000'.
   05 FILLER PIC X(5) VALUE '42000'.
   05 FILLER PIC X(5) VALUE '46000'.

01 SALARY-TABLE REDEFINES SALARY-VALUES.
   05 SALARY OCCURS 10 TIMES PIC 9(5).
    
```

(b) Initialization via the REDEFINES and VALUES Clauses

| SALARY-TABLE | | | | | | | | | |
|---------------|------------|------------|------------|------------|------------|------------|------------|------------|-------------|
| SALARY (1) | SALARY (2) | SALARY (3) | SALARY (4) | SALARY (5) | SALARY (6) | SALARY (7) | SALARY (8) | SALARY (9) | SALARY (10) |
| 26000 | 27000 | 28000 | 30000 | 32000 | 34000 | 36000 | 39000 | 42000 | 46000 |
| SALARY-VALUES | | | | | | | | | |

(c) Storage Schematic

RESPONSIBILITY-SUB > 10 is evaluated. The condition is not satisfied, so the designated procedure, WRITE-STARTING-SALARY, is executed for the first time. RESPONSIBILITY-SUB is incremented to 2, and the condition is retested. The condition is still false, so WRITE-STARTING-SALARY is executed a second time. The loop (testing, executing, and incrementing) continues for values of RESPONSIBILITY-SUB of 3, 4, 5, and so on, until RESPONSIBILITY-SUB reaches 10. Even then the condition is still not satisfied, because 10 is *not greater than* 10, and so WRITE-STARTING-SALARY is executed a tenth (and last) time. RESPONSIBILITY-SUB is incremented to 11, the condition is finally satisfied (11 > 10), and the PERFORM VARYING is terminated.

Two-Level Tables

All of this material is easily extended to two levels as shown in Figure 13.3. Figure 13.3a repeats the user's view of the table in which salary is a function of both responsibility and experience, Figure 13.3b shows the COBOL definition and initialization, and Figure 13.3c depicts the storage allocation.

Figure 13.3 Two-level Tables

| Experience | | 1 | 2 | 3 | 4 | 5 |
|----------------|----|--------|--------|--------|--------|--------|
| Responsibility | 1 | 26,000 | 27,000 | 28,000 | 29,000 | 30,000 |
| | 2 | 27,000 | 28,000 | 29,000 | 30,000 | 31,000 |
| | 3 | 28,000 | 29,000 | 30,000 | 31,000 | 32,000 |
| | 4 | 30,000 | 32,000 | 34,000 | 36,000 | 38,000 |
| | 5 | 32,000 | 34,000 | 36,000 | 38,000 | 40,000 |
| | 6 | 34,000 | 36,000 | 38,000 | 40,000 | 42,000 |
| | 7 | 36,000 | 39,000 | 42,000 | 45,000 | 48,000 |
| | 8 | 39,000 | 42,000 | 45,000 | 48,000 | 51,000 |
| | 9 | 42,000 | 45,000 | 48,000 | 51,000 | 54,000 |
| | 10 | 46,000 | 50,000 | 54,000 | 58,000 | 62,000 |

*Responsibility level = 1
Experience level = 4*

*Responsibility level = 4
Experience level = 1*

(a) User's View

```

01 SALARY-VALUES.
  05 FILLER PIC X(25) VALUE '2600027000280002900030000'.
  05 FILLER PIC X(25) VALUE '2700028000290003000031000'.
  05 FILLER PIC X(25) VALUE '2800029000300003100032000'.
  05 FILLER PIC X(25) VALUE '3000032000340003600038000'.
  05 FILLER PIC X(25) VALUE '3200034000360003800040000'.
  05 FILLER PIC X(25) VALUE '3400036000380004000042000'.
  05 FILLER PIC X(25) VALUE '3600039000420004500048000'.
  05 FILLER PIC X(25) VALUE '3900042000450004800051000'.
  05 FILLER PIC X(25) VALUE '4200045000480005100054000'.
  05 FILLER PIC X(25) VALUE '4600050000540005800062000'.
    
```

```

01 SALARY-TABLE REDEFINES SALARY-VALUES.
  05 RESPONSIBILITY OCCURS 10 TIMES.
    10 EXPERIENCE OCCURS 5 TIMES.
      15 SALARY PIC 9(5).
    
```

(b) Initialization via the REDEFINES and VALUES Clauses

| SALARY-TABLE | | | | | | | | | | | | | | | | | | | | | | | | | | | | | | | | | | | | | | | | | | | | | | | | | |
|--------------------|---------|---------|---------|---------|---|---------|---------|---------|---------|---------------------|---|---|---|---|---|---|---|---|---|---|---|---|---|---|---|---|---|---|---|---|---|---|---|---|---|---|---|---|---|---|---|---|---|---|---|---|---|---|---|
| RESPONSIBILITY (1) | | | | | | | | | | RESPONSIBILITY (10) | | | | | | | | | | | | | | | | | | | | | | | | | | | | | | | | | | | | | | | |
| Exp (1) | Exp (2) | Exp (3) | Exp (4) | Exp (5) | | Exp (1) | Exp (2) | Exp (3) | Exp (4) | Exp (5) | | | | | | | | | | | | | | | | | | | | | | | | | | | | | | | | | | | | | | | |
| 2 | 6 | 0 | 0 | 0 | 2 | 7 | 0 | 0 | 0 | 2 | 8 | 0 | 0 | 0 | 2 | 9 | 0 | 0 | 0 | 3 | 0 | 0 | 0 | 0 | 4 | 6 | 0 | 0 | 0 | 5 | 0 | 0 | 0 | 0 | 5 | 4 | 0 | 0 | 0 | 5 | 8 | 0 | 0 | 0 | 6 | 2 | 0 | 0 | 0 |

SALARY-VALUES

(c) Storage Schematic

Establishment of a two-level table requires two OCCURS clauses, each at a different level, in the table definition as shown:

```
01 SALARY-TABLE.
   05 RESPONSIBILITY OCCURS 10 TIMES.
      10 EXPERIENCE OCCURS 5 TIMES.
         15 SALARY PIC 9(5).
```

The above entries establish a 50-element table (10 rows and 5 columns) with each element assigned five memory locations (according to the PICTURE clause). There are a total of 250 memory locations (10 x 5 x 5) allocated to the table as shown in Figure 13.3c. The first 25 locations contain the salaries for the five experience levels at the first responsibility level. Locations 1-5 contain the salary at responsibility level 1, experience level 1; locations 6-10 contain the salary at responsibility level 1, experience level 2; and so on. In similar fashion, locations 26-50 refer to the salaries for the five experience levels at responsibility level 2; locations 51-75 to the salaries at the five experience levels for responsibility level 3; and so on.

As in the one-level example, the table is initialized through combination of the OCCURS, VALUE, and REDEFINES clauses. This time, however, each VALUE clause fills an entire row (consisting of five experience levels or 25 positions in all). The first VALUE clause fills the first 25 locations (corresponding to the five experience levels for responsibility one), the second VALUE clause fills locations 26-50 (the five experience levels for responsibility two), and so on. The order of the VALUE clauses is critical and coincides with Figure 13.3a. The resulting storage allocation is shown in Figure 13.3c and further clarifies the discussion.

Errors in Compilation

Newcomers to multilevel tables find it all too easy to use the wrong number of subscripts, specify subscripts in improper sequence, and/or supply an invalid subscript value (that is, a value beyond the definition in the OCCURS clause.) The rule is very simple, namely that the number of subscripts is equal to the number of OCCURS clauses used to define the entry and further, that the order of subscripts corresponds to the order of the OCCURS clauses.

Consider again the table definition in Figure 13.3b, observing that SALARY is subordinate to EXPERIENCE, that EXPERIENCE is subordinate to RESPONSIBILITY, and that both RESPONSIBILITY and EXPERIENCE were defined with an OCCURS clause. In other words an OCCURS clause appears in *both* group items prior to the definition of SALARY, and thus *two* subscripts will be required for all Procedure Division references to SALARY. Any reference to SALARY that does not include two subscripts will be flagged during compilation. SALARY (1,4) is a valid reference to indicate the element in row 1, column 4 of the two-level table; SALARY (1) is *invalid* and will be flagged accordingly.

The compiler, however, is concerned only with syntax (namely that the proper number of subscripts is supplied), and not with the values of those subscripts. In other words, a reference to SALARY (20, 20) would not produce a compilation error, because it contains two subscripts and is syntactically valid. It would, however, cause problems during execution as the subscript values are inconsistent with the table definition. (The execution results are unpredictable.)

COBOL also allows reference to data names at different *hierarchical levels* of a table (although such reference may not make sense logically). Thus the definition of a two-dimensional table automatically allows reference to other one-dimensional tables. Refer again to the storage schematic of Figure 13.3c and/or the examples below to clarify the issue.

| | |
|--------------------|--|
| SALARY (6, 5) | A valid entry in all respects, which refers to salary responsibility level 6, experience level 5. The data name SALARY must always be referenced with two subscripts. |
| SALARY (5, 6) | Syntactically correct in that SALARY has two subscripts. The entry will compile cleanly but will cause problems in execution because it refers to responsibility and experience levels of 5 and 6, respectively, which are inconsistent with the table definition. |
| SALARY-TABLE | Refers to the entire table of 50 elements (250 locations). SALARY-TABLE is referenced without any subscripts. |
| RESPONSIBILITY (1) | Refers collectively to the five experience levels for the first level of salary responsibility; RESPONSIBILITY is referenced with a single subscript. |
| EXPERIENCE (6, 5) | A valid entry equivalent to SALARY (6,5); the entries are equivalent because SALARY is the only elementary item defined under the group item EXPERIENCE. |

PERFORM VARYING

The PERFORM VARYING statement was introduced in Chapter 11 in conjunction with processing a one-level table. Its syntax is easily extended to process a two-level table as shown below. Consider:

```

PERFORM [procedure-name-1] [WITH TEST {BEFORE
                                         AFTER}]
      VARYING {identifier-1} FROM {identifier-2
                                  index-name-2} BY {literal-2
                                                    identifier-3}
      UNTIL condition-1
      [AFTER {identifier-4} FROM {identifier-5
                                  index-name-3} BY {identifier-6
                                                    literal-5}]
      UNTIL condition-2
      [imperative-statement-1 END PERFORM]

```

The PERFORM VARYING statement accommodates a two-level table through inclusion of the AFTER clause that varies two subscripts (indexes) simultaneously. As in the case of a one-level table, the TEST BEFORE/TEST AFTER clause is optional and is typically omitted; the default is TEST BEFORE and corresponds to the COBOL-74 implementation.

The PERFORM VARYING statement executes a designated procedure as in Figure 13.4a, or the statements in an in-line perform as in Figure 13.4b. Either way two subscripts are used as shown in Figure 13.4c. RESPONSIBILITY-SUB is varied from 1 to 10, in conjunction with EXPERIENCE-SUB changing from 1 to 5, so that the performed statements are executed 50 times in all.

The *bottom* subscript (EXPERIENCE-SUB in this example) is varied first. Thus RESPONSIBILITY-SUB is initially set to 1 while EXPERIENCE-SUB is varied from 1 to 5. RESPONSIBILITY-SUB is then incremented to 2, while EXPERIENCE-SUB

Figure 13.4 PERFORM VARYING with Two Subscripts

```
PERFORM INITIALIZE-SALARIES
  VARYING RESPONSIBILITY-SUB FROM 1 BY 1
    UNTIL RESPONSIBILITY-SUB > 10
  AFTER EXPERIENCE-SUB FROM 1 BY 1
    UNTIL EXPERIENCE-SUB > 5.
```

```
INITIALIZE-SALARIES.
  MOVE ZERO TO SALARY (RESPONSIBILITY-SUB, EXPERIENCE-SUB).
```

(a) Performing a Paragraph

```
PERFORM
  VARYING RESPONSIBILITY-SUB FROM 1 BY 1
    UNTIL RESPONSIBILITY-SUB > 10
  AFTER EXPERIENCE-SUB FROM 1 BY 1
    UNTIL EXPERIENCE-SUB > 5
    MOVE ZERO TO SALARY (RESPONSIBILITY-SUB, EXPERIENCE-SUB)
END-PERFORM.
```

(b) In-Line Perform

| Responsibility Subscript | Experience Subscript |
|--------------------------|----------------------|
| 1 | 1 |
| 1 | 2 |
| 1 | 3 |
| 1 | 4 |
| 1 | 5 |

RESPONSIBILITY-SUB is set to 1 while EXPERIENCE-SUB varies from 1 to 5

| | |
|---|---|
| 2 | 1 |
| 2 | 2 |
| 2 | 3 |
| 2 | 4 |
| 2 | 5 |

RESPONSIBILITY-SUB is set to 2 while EXPERIENCE-SUB varies from 1 to 5

| | |
|----|---|
| 10 | 1 |
| 10 | 2 |
| 10 | 3 |
| 10 | 4 |
| 10 | 5 |

RESPONSIBILITY-SUB reaches 10 and EXPERIENCE-SUB varies from 1 to 5

(c) Variation of Subscripts

Figure 13.5 Varying Column and/or Row Subscripts

Question: What is the average salary for responsibility level three?

Answer: Sum the five salaries in row three of the salary table, then divide that total by five.

```
MOVE ZERO TO TOTAL-SALARY.
PERFORM
    VARYING EXPERIENCE-SUB FROM 1 BY 1
        UNTIL EXPERIENCE-SUB > 5
            ADD SALARY (3, EXPERIENCE-SUB) TO TOTAL-SALARY
END-PERFORM.
COMPUTE AVERAGE-SALARY = TOTAL-SALARY / 5.
```

(a) Varying a Column Subscript

Question: What is the average salary for experience level four?

Answer: Sum the 10 salaries in column four of the salary table, then divide that total by 10.

```
MOVE ZERO TO TOTAL-SALARY.
PERFORM
    VARYING RESPONSIBILITY-SUB FROM 1 BY 1
        UNTIL EXPERIENCE-SUB > 10
            ADD SALARY (RESPONSIBILITY-SUB, 4) TO TOTAL-SALARY
END-PERFORM.
COMPUTE AVERAGE-SALARY = TOTAL-SALARY / 10.
```

(b) Varying a Row Subscript

Question: What is the average salary over all responsibility and experience levels?

Answer: Sum all 50 salaries in the table, then divide that total by 50.

```
MOVE ZERO TO TOTAL-SALARY.
PERFORM
    VARYING RESPONSIBILITY-SUB FROM 1 BY 1
        UNTIL RESPONSIBILITY-SUB > 10
        AFTER EXPERIENCE-SUB FROM 1 BY 1
            UNTIL EXPERIENCE-SUB > 5
                ADD SALARY (RESPONSIBILITY-SUB, EXPERIENCE-SUB) TO TOTAL-SALARY
END-PERFORM.
COMPUTE AVERAGE-SALARY = TOTAL-SALARY / 50.
```

(c) Varying Both Subscripts

is again varied from 1 to 5. The process continues until all 50 combinations have been reached.

It is not necessary to always vary both subscripts in a two-level table; that is, you can hold the row constant and vary the column, or keep the column constant and vary the row. Indeed, different types of information are obtained according to

the subscript that is used. Figure 13.5a, for example, varies the column subscript (EXPERIENCE-SUB) while keeping the row constant, to obtain the average starting salary at the third responsibility level. In similar fashion, Figure 13.5b varies the row subscript (RESPONSIBILITY-SUB) while keeping the column constant, to obtain the average starting salary for the fourth experience level. Figure 13.5c varies both subscripts to compute the average salary over all 50 row-column combinations.

A Sample Program

We incorporate the material on two-level tables into a COBOL program. Specifications follow in the usual format.

PROGRAMMING SPECIFICATIONS

Program Name: Two-Level Tables

Narrative: This program illustrates the definition, initialization, and processing of two-level tables, building directly on the examples just presented. The specifications call for the processing of an employee file and the printing of each individual's salary, based on his or her responsibility and experience. In addition, the number of employees in each responsibility/experience combination is to be computed.

Input File(s): EMPLOYEE-FILE

Input Record Layout:

| | | |
|----|--------------------------|------------|
| 01 | EMPLOYEE-RECORD. | |
| 05 | EMP-NAME | PIC X(15). |
| 05 | EMP-SALARY-DETERMINANTS. | |
| 10 | EMP-RESP | PIC 99. |
| 10 | FILLER | PIC X. |
| 10 | EMP-EXP | PIC 99. |
| 10 | FILLER | PIC X(3). |
| 05 | FILLER | PIC X(5). |

Test Data:

| | | |
|----------|----|----|
| ADAMS | 04 | 01 |
| BAKER | 01 | 04 |
| BROWN | 08 | 02 |
| CHARLES | 09 | 02 |
| DAVIDSON | 09 | 04 |
| DAVIS | 10 | 04 |
| EPSTEIN | 04 | 05 |
| FRANKEL | 03 | 03 |
| GOODMAN | 03 | 03 |
| GULFMAN | 03 | 05 |
| HATHAWAY | 07 | 02 |
| INGLES | 03 | 01 |
| JACKSON | 06 | 03 |
| JORDAN | 06 | 03 |
| KING | 07 | 02 |
| LIPMAN | 07 | 01 |
| LOWELL | 01 | 04 |

Report Layout: See Figure 13.6.

- Processing Requirements:**
1. Read a file of employee records, and for each record:
 - a. Determine the employee's starting salary as a function of responsibility and experience.
 - b. Print a detail line for this employee showing his or her name and starting salary.
 2. Compute the number of employees for each responsibility-experience combination. This requires creation of a 10-by-5 table to store the number of individuals in each responsibility-experience combination, and implies that as each employee record is

Figure 13.6 Output of Two-Level Program

| STARTING SALARIES OF ALL NEW EMPLOYEES | | | | | |
|--|----------|--|--|--|--|
| ADAMS | \$30,000 | | | | |
| BAKER | \$29,000 | | | | |
| BROWN | \$42,000 | | | | |
| CHARLES | \$45,000 | | | | |
| DAVIDSON | \$51,000 | | | | |
| DAVIS | \$58,000 | | | | |
| EPSTEIN | \$38,000 | | | | |
| FRANKEL | \$30,000 | | | | |
| GOODMAN | \$30,000 | | | | |
| GULFMAN | \$32,000 | | | | |
| HATHAWAY | \$39,000 | | | | |
| INGLES | \$28,000 | | | | |
| JACKSON | \$38,000 | | | | |
| JORDAN | \$38,000 | | | | |
| KING | \$39,000 | | | | |
| LIPMAN | \$36,000 | | | | |
| LOWELL | \$29,000 | | | | |

(a) Detail Report

| STARTING SALARY SUMMARY REPORT | | | | | |
|--------------------------------|------------|---|---|---|---|
| RESPONSIBILITY | EXPERIENCE | | | | |
| | 1 | 2 | 3 | 4 | 5 |
| 1 | 0 | 0 | 0 | 2 | 0 |
| 2 | 0 | 0 | 0 | 0 | 0 |
| 3 | 1 | 0 | 2 | 0 | 1 |
| 4 | 1 | 0 | 0 | 0 | 1 |
| 5 | 0 | 0 | 0 | 0 | 0 |
| 6 | 0 | 0 | 2 | 0 | 0 |
| 7 | 1 | 2 | 0 | 0 | 0 |
| 8 | 0 | 1 | 0 | 0 | 0 |
| 9 | 0 | 1 | 0 | 1 | 0 |
| 10 | 0 | 0 | 0 | 1 | 0 |

(b) Summary Report

read, the corresponding table entry (the particular responsibility-experience combination) has to be incremented by one.

3. When all employees have been processed, print the table containing the number of employees in each category as shown in Figure 13.6b.

Program Design

The report layout in Figure 13.6 requires both a *detail report* containing a line for every employee, as well as a *summary report* displaying the total number of employees in each of the 50 responsibility-experience combinations. The program will evaluate each incoming record to determine in which of the 50 categories the employee fits, then increment the appropriate counter. At the conclusion of processing—after all employee records have been read—the table of 50 totals will be printed as the summary report.

The functions needed in the eventual program are shown in the expanded hierarchy chart of Figure 13.7. The purpose of the individual modules should be apparent from the module name and/or the eventual COBOL program (shown later in the chapter).

The pseudocode in Figure 13.8 is succinct and is restricted to the basic building blocks of structured programming. The initial statements open the files and write an appropriate heading. The program is driven by a loop that determines the appropriate responsibility/experience combination for each employee record, writes the detail line, and increments the appropriate counter. The summary report is written after this loop has ended (when all employee records have been processed).

The Completed Program

Much of the completed program in Figure 13.9 is already familiar as it repeats the COBOL statements used in the explanation of two-level tables. The COBOL statements to define the salary table (lines 42–57), appeared earlier in Figure 13.3b and were discussed fully at that time. A second two-level table, for the number of employees in each category, is defined in lines 59–62; the definition uses the OCCURS

Figure 13.7 Hierarchy Chart for Two-Level Program

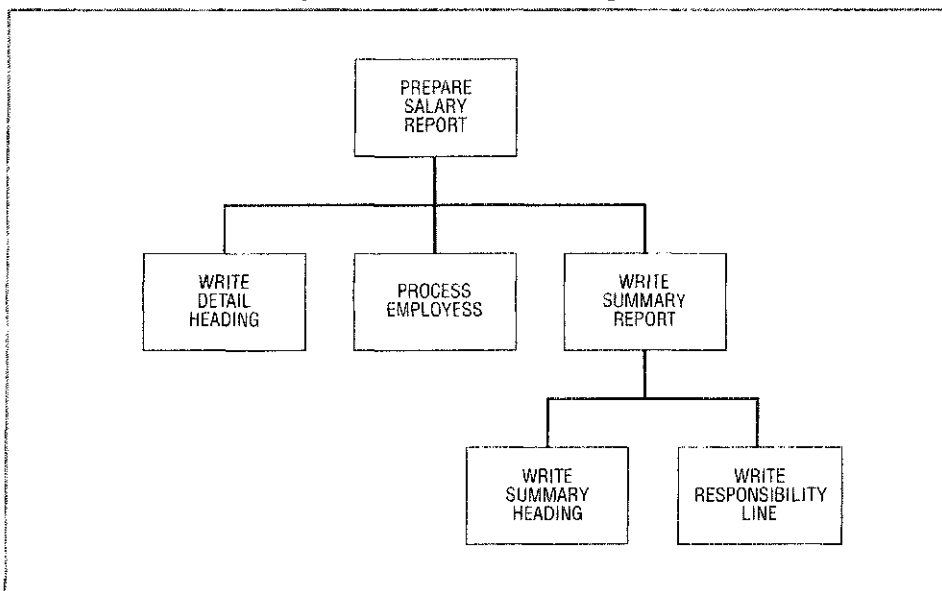

Figure 13.8 Pseudocode for Two-Level Program

```

Open files
Write heading lines
DO WHILE data remains
  READ employee file
  AT END
    Indicate no more data
  NOT AT END
    Determine responsibility/experience combination
    Increment number of employees in that combination
    Write detail line
  END-READ
ENDDO
Write summary report
Close files
Stop run

```

Figure 13.9 Two-Level Program

```

1  IDENTIFICATION DIVISION.
2  PROGRAM-ID.    2LVTABLE.
3  AUTHOR.       ROBERT T. GRAUER.
4
5  ENVIRONMENT DIVISION.
6  INPUT-OUTPUT SECTION.
7  FILE-CONTROL.
8      SELECT EMPLOYEE-FILE  ASSIGN TO 'A:\CHAPTR13\TABLES.DAT'
9          ORGANIZATION IS LINE SEQUENTIAL.
10     SELECT PRINT-FILE
11         ASSIGN TO PRINTER.
12
13  DATA DIVISION.
14  FILE SECTION.
15  FD  EMPLOYEE-FILE
16     DATA RECORD IS EMPLOYEE-RECORD.
17     01  EMPLOYEE-RECORD                PIC X(23).
18
19  FD  PRINT-FILE
20     DATA RECORD IS PRINT-LINE.
21     01  PRINT-LINE                    PIC X(132).
22
23  WORKING-STORAGE SECTION.
24     01  FILLER                        PIC X(14)
25         VALUE 'WS BEGINS HERE'.
26
27     01  WS-EMPLOYEE-RECORD.
28         05  EMP-NAME                  PIC X(15).

```

Figure 13.9 (continued)

```

29      05 EMP-SALARY-DETERMINANTS.
30      10 EMP-RESP          PIC 99.
31      10 FILLER            PIC X.
32      10 EMP-EXP          PIC 99.
33      10 FILLER            PIC X(3).
34
35      01 PROGRAM-SUBSCRIPTS.
36      05 RESP-SUB          PIC S9(4) COMP.
37      05 EXP-SUB           PIC S9(4) COMP.
38
39      01 WS-END-OF-DATA-SWITCH          PIC X(3)  VALUE SPACES.
40      88 END-OF-DATA                    VALUE 'YES'.
41
42      01 SALARY-VALUES.
43      05 FILLER PIC X(25)  VALUE '2600027000280002900030000'.
44      05 FILLER PIC X(25)  VALUE '2700028000290003000031000'.
45      05 FILLER PIC X(25)  VALUE '2800029000300003100032000'.
46      05 FILLER PIC X(25)  VALUE '3000032000340003600038000'.
47      05 FILLER PIC X(25)  VALUE '3200034000360003800040000'.
48      05 FILLER PIC X(25)  VALUE '3400036000380004000042000'.
49      05 FILLER PIC X(25)  VALUE '3600039000420004500048000'.
50      05 FILLER PIC X(25)  VALUE '3900042000450004800051000'.
51      05 FILLER PIC X(25)  VALUE '4200045000480005100054000'.
52      05 FILLER PIC X(25)  VALUE '4600050000540005800062000'.
53
54      01 SALARY-TABLE REDEFINES SALARY-VALUES.
55      05 RESPONSIBILITY OCCURS 10 TIMES.
56      10 EXPERIENCE OCCURS 5 TIMES.
57      15 SALARY          PIC 9(5).
58
59      01 NUMBER-OF-EMPLOYEES-TABLE.
60      05 NUMBER-RESPONSIBILITY OCCURS 10 TIMES.
61      10 NUMBER-EXPERIENCE OCCURS 5 TIMES.
62      15 NUMB-EMP        PIC 99  VALUE ZERO.
63
64      01 DETAIL-REPORT-HEADING-LINE.
65      05 FILLER          PIC X(9)  VALUE SPACES.
66      05 FILLER          PIC X(39)
67      VALUE 'STARTING SALARIES OF ALL NEW EMPLOYEES'.
68      05 FILLER          PIC X(82) VALUE SPACES.
69
70      01 DETAIL-LINE-1.
71      05 FILLER          PIC X(12) VALUE SPACES.
72      05 DET-EMP-NAME    PIC X(15).
73      05 FILLER          PIC X(4)  VALUE SPACES.
74      05 DET-SALARY      PIC $99,999.
75      05 FILLER          PIC X(94) VALUE SPACES.
76
77      01 SUMMARY-REPORT-HEADING-LINE-1.
78      05 FILLER          PIC X(24) VALUE SPACES.
    
```

Used as subscripts into summary table

Individual salary is hard coded

Two-level summary table is defined and initialized to zero

Figure 13.9 (continued)

```

79      05 FILLER                PIC X(39)
80          VALUE 'STARTING SALARY SUMMARY REPORT'.
81      05 FILLER                PIC X(69) VALUE SPACES.
82
83      01 SUMMARY-REPORT-HEADING-LINE-2.
84      05 FILLER                PIC X(36) VALUE SPACES.
85      05 FILLER                PIC X(10) VALUE 'EXPERIENCE'.
86      05 FILLER                PIC X(86) VALUE SPACES.
87
88      01 SUMMARY-REPORT-HEADING-LINE-3.
89      05 FILLER                PIC X(5)  VALUE SPACES.
90      05 FILLER                PIC X(14) VALUE 'RESPONSIBILITY'.
91      05 FILLER                PIC X(48)
92          VALUE '      1      2      3      4      5'.
93      05 FILLER                PIC X(65) VALUE SPACES.
94
95      01 SUMMARY-LINE-1.
96      05 FILLER                PIC X(9).
97      05 SUMMARY-RESPONSIBILITY PIC Z(4).
98      05 FILLER                PIC X(4)  VALUE SPACES.
99      05 SUMMARY-TOTAL-VALUES OCCURS 5 TIMES.
100         10 FILLER            PIC X(4).
101         10 SUMMARY-NUMBER    PIC Z(4)9.
102      05 FILLER                PIC X(70).
103
104      PROCEDURE DIVISION.
105      100-PREPARE-SALARY-REPORT.
106          OPEN INPUT EMPLOYEE-FILE
107              OUTPUT PRINT-FILE.
108          PERFORM 200-WRITE-DETAIL-REPORT-HDG.
109          PERFORM UNTIL END-OF-DATA
110              READ EMPLOYEE-FILE INTO WS-EMPLOYEE-RECORD
111                  AT END
112                      MOVE 'YES' TO WS-END-OF-DATA-SWITCH
113                      NOT AT END
114                          PERFORM 300-PROCESS-EMPLOYEES
115          END-PERFORM.
116          PERFORM 400-WRITE-SUMMARY-REPORT.
117          CLOSE EMPLOYEE-FILE
118              PRINT-FILE.
119          STOP RUN.
120
121      200-WRITE-DETAIL-REPORT-HDG.
122          WRITE PRINT-LINE FROM DETAIL-REPORT-HEADING-LINE
123              AFTER ADVANCING PAGE.
124          MOVE SPACES TO PRINT-LINE.
125          WRITE PRINT-LINE.
126
127      300-PROCESS-EMPLOYEES.
128          ADD 1 TO NUMB-EMP (EMP-RESP, EMP-EXP).

```

Program driven by inline perform and loop-condition branch

increments number of employees in summary table

Figure 13.9 (continued)

```

129     MOVE EMP-NAME TO DET-EMP-NAME.
130     MOVE SALARY (EMP-RESP, EMP-EXP) TO DET-SALARY.
131     WRITE PRINT-LINE FROM DETAIL-LINE-1.
132
133     400-WRITE-SUMMARY-REPORT.
134         PERFORM 500-WRITE-SUMMARY-HEADING.
135         PERFORM 520-WRITE-RESPONSIBILITY-LINE
136             VARYING RESP-SUB FROM 1 BY 1
137             UNTIL RESP-SUB > 10.
138
139     500-WRITE-SUMMARY-HEADING.
140     WRITE PRINT-LINE FROM SUMMARY-REPORT-HEADING-LINE-1
141         AFTER ADVANCING PAGE.
142     WRITE PRINT-LINE FROM SUMMARY-REPORT-HEADING-LINE-2
143         AFTER ADVANCING 2 LINES.
144     WRITE PRINT-LINE FROM SUMMARY-REPORT-HEADING-LINE-3.
145     MOVE SPACES TO PRINT-LINE.
146     WRITE PRINT-LINE.
147
148     520-WRITE-RESPONSIBILITY-LINE.
149     MOVE SPACES TO SUMMARY-LINE-1.
150     PERFORM VARYING EXP-SUB FROM 1 BY 1
151         UNTIL EXP-SUB > 5
152         MOVE NUMB-EMP (RESP-SUB, EXP-SUB)
153             TO SUMMARY-NUMBER (EXP-SUB)
154     END-PERFORM.
155     MOVE RESP-SUB TO SUMMARY-RESPONSIBILITY.
156     WRITE PRINT-LINE FROM SUMMARY-LINE-1.

```

Print a detail line for each employee

Write summary headings

In the detail moves the experience, the 10 responsibility into

clauses to allocate space for the table, but omits the REDEFINES clause, because (unlike the salary table) the number of employees is computed during processing. The 50 elements in the table are initialized to zero by the VALUE ZERO clause in line 62. (See limitations of COBOL-74 at the end of the chapter.)

The Procedure Division follows both the hierarchy chart and pseudocode. The key to the program is the ADD statement in line 128, which increments the number of employees for the particular responsibility-experience combination. The subscript values in this statement are taken directly from the incoming employee record, which defines EMP-RESP and EMP-EXP in lines 30 and 32, respectively. The detail line for the individual employee is written in lines 129-131.

The summary report is produced after the end of file has been reached by the PERFORM WRITE-SUMMARY-REPORT statement of line 116. The heading lines are written in lines 140-146, after which the paragraph WRITE-RESPONSIBILITY-LINE is executed 10 times (once for each responsibility level) in lines 148-156. The latter paragraph contains its own PERFORM VARYING statement to write each of the five experience totals for each of the 10 responsibility levels.

Three-Level Tables

The material on two-level tables is easily extended to a third dimension. We continue therefore with our two-level example, in which salary is a function of responsibility and experience, but this time add a third determinant, region (due to different costs of living in different areas of the country). Figure 13.10a depicts the user's view showing salary as a function of three variables (region, responsibility, and experience), Figure 13.10b contains the COBOL definition, and Figure 13.10c shows the storage allocation.

Establishment of a three-level table requires three OCCURS clauses in the table definition:

```
01 SALARY-TABLE.
   05 REGION OCCURS 2 TIMES.
      10 RESPONSIBILITY OCCURS 10 TIMES.
         15 EXPERIENCE OCCURS 5 TIMES.
            20 SALARY PIC 9(5).
```

These entries establish a 100-element table (2 x 10 x 5) with each element assigned five memory locations (according to the PICTURE clause). Thus there are a total of 500 memory locations allocated to the table as indicated in Figure 13.10c. The first 25 locations refer to the five experience levels at the first responsibility level in the first region; the next 25 locations to the five experience levels at the second responsibility level in the first region, and so on.

As in the two-level example, the table is initialized through combinations of the OCCURS, VALUE, and REDEFINES clauses. Each VALUE clause fills an entire row (consisting of five experience elements or 25 positions in all), with 20 such statements needed to initialize all 500 storage locations. The first VALUE clause fills the first 25 locations (corresponding to the five experience levels for responsibility one in region one), the second VALUE clause fills locations 26–50 (the five experience levels for responsibility two in region one), and so on. The order of the VALUE clauses is critical and coincides with Figure 13.10a. The resulting storage allocation is shown in Figure 13.10c and further clarifies the discussion.

Once again you must be careful to use the correct number of subscripts, as well as specify the subscripts in the proper order. The rule is the same as for two-level tables, namely that the number of subscripts is equal to the number of OCCURS clauses used to define the entry, and further, that the order of the subscripts corresponds to the order of the OCCURS clauses.

Return to the table definition of Figure 13.10b, observing that three OCCURS clauses are associated with SALARY, and hence three subscripts are necessary; that is, SALARY is subordinate to REGION, RESPONSIBILITY, and EXPERIENCE, each of which was defined with its own OCCURS clause. Hence any Procedure Division reference to SALARY must include three subscripts—for example, SALARY (2, 4, 1) to indicate the salary for region 2, responsibility 4, and experience 1.

As is the case with one- and two-level tables, the compiler is concerned only with syntax (that the proper number of subscripts is supplied), and not with the values of those subscripts. A reference to SALARY (3, 1, 1) would not produce a compilation error because it is syntactically valid. It would, however, cause problems during execution because the subscript value for region 3 is inconsistent with the table definition. The execution results are unpredictable.

COBOL also permits reference at different hierarchical levels, so that the definition of a three-level table automatically allows reference to other one- and two-dimensional tables (although such references may not make sense logically). Refer again to the storage schematic in Figure 13.10c and/or the examples below to further clarify this discussion.

Figure 13.10 Three-level Tables

| Region 2 | | Experience | | | | |
|----------------|---|------------|--------|--------|--------|--------|
| | | 1 | 2 | 3 | 4 | 5 |
| Responsibility | 1 | 28,000 | 29,000 | 30,000 | 31,000 | 32,000 |
| | 2 | 29,000 | 30,000 | 31,000 | 32,000 | 33,000 |
| | 3 | 30,000 | 31,000 | 32,000 | 33,000 | 34,000 |
| | 4 | 32,000 | 34,000 | 36,000 | 38,000 | 40,000 |

| Region 1 | | Experience | | | | | |
|----------------|----|------------|--------|--------|--------|--------|--------|
| | | 1 | 2 | 3 | 4 | 5 | |
| Responsibility | 1 | 26,000 | 27,000 | 28,000 | 29,000 | 30,000 | 44,000 |
| | 2 | 27,000 | 28,000 | 29,000 | 30,000 | 31,000 | 50,000 |
| | 3 | 28,000 | 29,000 | 30,000 | 31,000 | 32,000 | 53,000 |
| | 4 | 30,000 | 32,000 | 34,000 | 36,000 | 38,000 | 56,000 |
| | 5 | 32,000 | 34,000 | 36,000 | 38,000 | 40,000 | 64,000 |
| | 6 | 34,000 | 36,000 | 38,000 | 40,000 | 42,000 | |
| | 7 | 36,000 | 39,000 | 42,000 | 45,000 | 48,000 | |
| | 8 | 39,000 | 42,000 | 45,000 | 48,000 | 51,000 | |
| | 9 | 42,000 | 45,000 | 48,000 | 51,000 | 54,000 | |
| | 10 | 46,000 | 50,000 | 54,000 | 58,000 | 62,000 | |

(a) User's View

```

01 SALARY-VALUES.
05 REGION-ONE.
10 FILLER PIC X(25) VALUE '2600027000280002900030000'.
10 FILLER PIC X(25) VALUE '2700028000290003000031000'.
10 FILLER PIC X(25) VALUE '2800029000300003100032000'.
10 FILLER PIC X(25) VALUE '3000032000340003600038000'.
10 FILLER PIC X(25) VALUE '3200034000360003800040000'.
10 FILLER PIC X(25) VALUE '3400036000380004000042000'.
10 FILLER PIC X(25) VALUE '3600039000420004500048000'.
10 FILLER PIC X(25) VALUE '3900042000450004800051000'.
10 FILLER PIC X(25) VALUE '4200045000480005100054000'.
10 FILLER PIC X(25) VALUE '4600050000540005800062000'.
05 REGION-TWO.
10 FILLER PIC X(25) VALUE '2800029000300003100032000'.
10 FILLER PIC X(25) VALUE '2900030000310003200033000'.
10 FILLER PIC X(25) VALUE '3000031000320003300034000'.
10 FILLER PIC X(25) VALUE '3200034000360003800040000'.
10 FILLER PIC X(25) VALUE '3400036000380004000042000'.
10 FILLER PIC X(25) VALUE '3600038000400004200044000'.
10 FILLER PIC X(25) VALUE '3800041000440004700050000'.
10 FILLER PIC X(25) VALUE '4100044000470005000053000'.
10 FILLER PIC X(25) VALUE '4400047000500005300056000'.
10 FILLER PIC X(25) VALUE '4800052000560006000064000'.

01 SALARY-TABLE REDEFINES SALARY-VALUES.
05 REGION OCCURS 2 TIMES.
10 RESPONSIBILITY OCCURS 10 TIMES.
15 EXPERIENCE OCCURS 5 TIMES.
20 SALARY PIC 9(5).
    
```

(b) Initialization via the REDEFINES and VALUES Clauses



(c) Storage Schematic

| | |
|-----------------------|--|
| SALARY (1, 2, 3) | A valid reference in all respects, which refers to the salary for region 1, responsibility 2, and experience 3. SALARY must always be referenced with three subscripts. |
| SALARY (2, 12, 7) | Syntactically correct in that SALARY has three subscripts. The entry compiles cleanly but will cause problems in execution, because it refers to responsibility and experience levels of 12 and 7, respectively, which are inconsistent with the table definition. |
| SALARY-TABLE | Refers to the entire table of 100 elements (500 memory locations in all). SALARY-TABLE is referenced without any subscripts. |
| REGION (1) | Refers collectively to the 10 responsibility levels, each containing five experience levels associated with the first region; REGION is referenced with a single subscript. |
| RESPONSIBILITY (1, 2) | Refers collectively to the five experience levels for responsibility level 2 for region 1; RESPONSIBILITY is referenced with two subscripts. |
| EXPERIENCE (1, 2, 3) | A valid entry equivalent to SALARY (1, 2, 3); the entries are equivalent because SALARY is the only elementary item defined under the group item EXPERIENCE. |

PERFORM VARYING

The syntax of the PERFORM VARYING statement shows the AFTER clause enclosed in brackets and followed by three dots to indicate the clause can be repeated. Accordingly, three-level tables are processed with a PERFORM VARYING statement that includes two AFTER clauses as shown in Figure 13.11. The statement may execute either a designated procedure as in Figure 13.11a, or a series of in-line statements as in Figure 13.11b.

As in the two-level example, all possible combinations of the three subscripts are executed, causing the designated statements to be executed a total of 100

Figure 13.11 PERFORM VARYING with Three Subscripts

```
PERFORM INITIALIZE-SALARIES
  VARYING REGION-SUB FROM 1 BY 1
    UNTIL REGION-SUB > 2
  AFTER RESPONSIBILITY-SUB FROM 1 BY 1
    UNTIL RESPONSIBILITY-SUB > 10
  AFTER EXPERIENCE-SUB FROM 1 BY 1
    UNTIL EXPERIENCE-SUB > 5.
```

INITIALIZE-SALARIES.

MOVE ZERO TO SALARY (REGION-SUB, RESPONSIBILITY-SUB, EXPERIENCE-SUB).

(a) Performing a Paragraph

Figure 13.11 (continued)

```

PERFORM
  VARYING REGION-SUB FROM 1 BY 1
    UNTIL REGION-SUB > 2
  AFTER RESPONSIBILITY-SUB FROM 1 BY 1
    UNTIL RESPONSIBILITY-SUB > 10
  AFTER EXPERIENCE-SUB FROM 1 BY 1
    UNTIL EXPERIENCE-SUB > 5
    MOVE ZERO TO SALARY (REGION-SUB, RESPONSIBILITY-SUB, EXPERIENCE-SUB)
END-PERFORM.
    
```

(b) In-Line Perform

| Region Subscript | Responsibility Subscript | Experience Subscript |
|------------------|--------------------------|----------------------|
| 1 | 1 | 1 |
| 1 | 1 | 2 |
| 1 | 1 | 3 |
| 1 | 1 | 4 |
| 1 | 1 | 5 |

REGION-SUB and RESPONSIBILITY-SUB are both set to 1 while EXPERIENCE-SUB varies from 1 to 5

| | | |
|---|---|---|
| 1 | 2 | 1 |
| 1 | 2 | 2 |
| 1 | 2 | 3 |
| 1 | 2 | 4 |
| 1 | 2 | 5 |

REGION-SUB remains at 1 while RESPONSIBILITY-SUB is incremented to 2 and EXPERIENCE-SUB is again varied from 1 to 5

| | | |
|---|----|---|
| 1 | 10 | 1 |
| 1 | 10 | 2 |
| 1 | 10 | 3 |
| 1 | 10 | 4 |
| 1 | 10 | 5 |

At the 50th iteration, REGION-SUB is still set to 1, but RESPONSIBILITY-SUB has reached 10

| | | |
|---|---|---|
| 2 | 1 | 1 |
| 2 | 1 | 2 |
| 2 | 1 | 3 |
| 2 | 1 | 4 |
| 2 | 1 | 5 |

REGION-SUB is incremented to 2, RESPONSIBILITY-SUB is reset to 1 while EXPERIENCE-SUB varies from 1 to 5

| | | |
|---|----|---|
| 2 | 10 | 1 |
| 2 | 10 | 2 |
| 2 | 10 | 3 |
| 2 | 10 | 4 |
| 2 | 10 | 5 |

At the 100th iteration, REGION-SUB reaches 2, RESPONSIBILITY-SUB reaches 10 and EXPERIENCE-SUB reaches 5

(c) Variation of Subscripts

($2 \times 10 \times 5$) times. The *bottom* subscript (EXPERIENCE-SUB in the example) is varied first, then the middle subscript (RESPONSIBILITY-SUB), and finally the top subscript (REGION-SUB). The sequence in which the 100 combinations are executed is shown in Figure 13.11.

A Sample Program

We incorporate the material on three-level tables into our previous sample COBOL program on two-level tables. The specifications have been updated and are presented in their entirety.

PROGRAMMING SPECIFICATIONS

Program Name: Three-Level Tables

Narrative: This program extends the example on two-level tables to a third dimension in that salary is now a function of three variables (region, responsibility, and experience). As in the earlier program, a detail report is required showing the salary of each employee. In addition a summary report containing the number of employees in each region/responsibility/experience combination is to be produced.

Input File(s): EMPLOYEE-FILE

Input Record Layout:

| | | |
|----|--------------------------|----------------|
| 01 | EMPLOYEE-RECORD. | |
| 05 | EMP-NAME | PIC X(15). |
| 05 | EMP-SALARY-DETERMINANTS. | |
| 10 | EMP-RESP | PIC 99. |
| 10 | FILLER | PIC X. |
| 10 | EMP-EXP | PIC 99. |
| 10 | FILLER | PIC X(3). |
| 10 | EMP-REGION | PIC 99. |
| 05 | FILLER | PIC X(5). |

Test Data:

| | |
|----------|----------|
| ADAMS | 04 01 01 |
| BAKER | 01 04 01 |
| BROWN | 08 02 02 |
| CHARLES | 09 02 02 |
| DAVIDSON | 09 04 02 |
| DAVIS | 10 04 01 |
| EPSTEIN | 04 05 02 |
| FRANKEL | 03 03 01 |
| GOODMAN | 03 03 01 |
| GULFMAN | 03 05 01 |
| HATHAWAY | 07 02 01 |
| INGLES | 03 01 01 |
| JACKSON | 06 03 01 |
| JORDAN | 06 03 01 |
| KING | 07 02 01 |
| LIPMAN | 07 01 01 |
| LOWELL | 01 04 02 |

Report Layout: See Figure 13.12.



Figure 13.12 Output of Three-Level Program

| STARTING SALARIES OF ALL NEW EMPLOYEES | | | | | |
|--|--|--|--|--|----------|
| ADAMS | | | | | \$30,000 |
| BAKER | | | | | \$29,000 |
| BROWN | | | | | \$44,000 |
| CHARLES | | | | | \$47,000 |
| DAVIDSON | | | | | \$53,000 |
| DAVIS | | | | | \$58,000 |
| EPSTEIN | | | | | \$40,000 |
| FRANKEL | | | | | \$30,000 |
| GOODMAN | | | | | \$30,000 |
| GULFMAN | | | | | \$32,000 |
| HATHAWAY | | | | | \$39,000 |
| INGLES | | | | | \$28,000 |
| JACKSON | | | | | \$38,000 |
| JORDAN | | | | | \$38,000 |
| KING | | | | | \$39,000 |
| LIPMAN | | | | | \$36,000 |
| LOWELL | | | | | \$31,000 |

(a) Total Report

| STARTING SALARY SUMMARY REPORT - REGION 1 | | | | | |
|---|------------|---|---|---|---|
| RESPONSIBILITY | EXPERIENCE | | | | |
| | 1 | 2 | 3 | 4 | 5 |
| 1 | 0 | 0 | 0 | 1 | 0 |
| 2 | 0 | 0 | 0 | 0 | 0 |
| 3 | 1 | 0 | 2 | 0 | 1 |
| 4 | 1 | 0 | 0 | 0 | 0 |
| 5 | 0 | 0 | 0 | 0 | 0 |
| 6 | 0 | 0 | 2 | 0 | 0 |
| 7 | 1 | 2 | 0 | 0 | 0 |
| 8 | 0 | 0 | 0 | 0 | 0 |
| 9 | 0 | 0 | 0 | 0 | 0 |
| 10 | 0 | 0 | 0 | 1 | 0 |

| STARTING SALARY SUMMARY REPORT - REGION 2 | | | | | |
|---|------------|---|---|---|---|
| RESPONSIBILITY | EXPERIENCE | | | | |
| | 1 | 2 | 3 | 4 | 5 |
| 1 | 0 | 0 | 0 | 1 | 0 |
| 2 | 0 | 0 | 0 | 0 | 0 |
| 3 | 0 | 0 | 0 | 0 | 0 |
| 4 | 0 | 0 | 0 | 0 | 1 |
| 5 | 0 | 0 | 0 | 0 | 0 |
| 6 | 0 | 0 | 0 | 0 | 0 |
| 7 | 0 | 0 | 0 | 0 | 0 |
| 8 | 0 | 1 | 0 | 0 | 0 |
| 9 | 0 | 1 | 0 | 1 | 0 |
| 10 | 0 | 0 | 0 | 0 | 0 |

(b) Summary Report

- Processing Requirements:**
1. Read a file of employee records, and for each record:
 - a. Determine the employee's starting salary as a function of region, responsibility, and experience.
 - b. Print a detail line for this employee showing his or her name and starting salary.
 2. Compute the number of employees for each *region-responsibility-experience* combination. This requires creation of a 2 x 10 x 5 table to store the number of individuals in each region-responsibility-experience combination, and implies that as each employee record is read, the corresponding table entry is incremented by one.
 3. When all employees have been processed, print the table containing the number of employees in each category as shown in Figure 13.12b.

The Completed Program

The extension of the original program from two to three dimensions is so direct that the hierarchy chart and pseudocode are virtually unchanged. The completed program is shown in Figure 13.13, and should already appear familiar, as it repeats the COBOL statements used in the explanation of three-level tables. The COBOL statements to define the salary table (lines 44–73), appeared earlier in Figure 13.10b and were discussed fully at that time. Observe also the definition of a second

Figure 13.13 Three-Level Program

```

1  IDENTIFICATION DIVISION.
2  PROGRAM-ID.      3LVTABLE.
3  AUTHOR.         ROBERT T. GRAUER.
4
5  ENVIRONMENT DIVISION.
6  INPUT-OUTPUT SECTION.
7  FILE-CONTROL.
8      SELECT EMPLOYEE-FILE  ASSIGN TO 'A:\CHAPTR13\TABLES.DAT'
9          ORGANIZATION IS LINE SEQUENTIAL.
10     SELECT PRINT-FILE
11         ASSIGN TO PRINTER.
12
13  DATA DIVISION.
14  FILE SECTION.
15  FD  EMPLOYEE-FILE
16     DATA RECORD IS EMPLOYEE-RECORD.
17  01  EMPLOYEE-RECORD                PIC X(23).
18
19  FD  PRINT-FILE
20     DATA RECORD IS PRINT-LINE.
21  01  PRINT-LINE                      PIC X(132).
22
23  WORKING-STORAGE SECTION.
24  01  FILLER                          PIC X(14)
25     VALUE 'WS BEGINS HERE'.
26
27  01  WS-EMPLOYEE-RECORD.
```

Figure 10.10 (continued)

```

28      05 EMP-NAME                PIC X(15).
29      05 EMP-SALARY-DETERMINANTS.
30          10 EMP-RESP             PIC 99.
31          10 FILLER               PIC X.
32          10 EMP-EXP              PIC 99.
33          10 FILLER               PIC X.
34          10 EMP-REG              PIC 99.
35
36      01 PROGRAM-SUBSCRIPTS.
37          05 RESP-SUB             PIC S9(4) COMP.
38          05 EXP-SUB             PIC S9(4) COMP.
39          05 REG-SUB             PIC S9(4) COMP.
40
41      01 WS-END-OF-DATA-SWITCH   PIC X(3)  VALUE SPACES.
42          88 END-OF-DATA         VALUE 'YES'.
43
44      01 SALARY-VALUES.
45          05 REGION-ONE.
46              10 FILLER PIC X(25) VALUE '2600027000280002900030000'.
47              10 FILLER PIC X(25) VALUE '2700028000290003000031000'.
48              10 FILLER PIC X(25) VALUE '2800029000300003100032000'.
49              10 FILLER PIC X(25) VALUE '3000032000340003600038000'.
50              10 FILLER PIC X(25) VALUE '3200034000360003800040000'.
51              10 FILLER PIC X(25) VALUE '3400036000380004000042000'.
52              10 FILLER PIC X(25) VALUE '3600039000420004500048000'.
53              10 FILLER PIC X(25) VALUE '3900042000450004800051000'.
54              10 FILLER PIC X(25) VALUE '4200045000480005100054000'.
55              10 FILLER PIC X(25) VALUE '4600050000540005800062000'.
56
57          05 REGION-TWO.
58              10 FILLER PIC X(25) VALUE '2800029000300003100032000'.
59              10 FILLER PIC X(25) VALUE '2900030000310003200033000'.
60              10 FILLER PIC X(25) VALUE '3000031000320003300034000'.
61              10 FILLER PIC X(25) VALUE '3200034000360003800040000'.
62              10 FILLER PIC X(25) VALUE '3400036000380004000042000'.
63              10 FILLER PIC X(25) VALUE '3600038000400004200044000'.
64              10 FILLER PIC X(25) VALUE '3800041000440004700050000'.
65              10 FILLER PIC X(25) VALUE '4100044000470005000053000'.
66              10 FILLER PIC X(25) VALUE '4400047000500005300056000'.
67              10 FILLER PIC X(25) VALUE '4800052000560006000064000'.
68
69      01 SALARY-TABLE REDEFINES SALARY-VALUES.
70          05 REGION OCCURS 2 TIMES.
71              10 RESPONSIBILITY OCCURS 10 TIMES.
72                  15 EXPERIENCE OCCURS 5 TIMES.
73                      20 SALARY                PIC 9(5).
74
75      01 NUMBER-OF-EMPLOYEES-TABLE.
76          05 NUMBER-REGION OCCURS 2 TIMES.
77              10 NUMBER-RESPONSIBILITY OCCURS 10 TIMES.
    
```

Used as subscript in summary table

Used as subscript in table

Figure 13.11 (continued)

```

78           15 NUMBER-EXPERIENCE OCCURS 5 TIMES.
79           20 NUMB-EMP           PIC 99     VALUE ZERO.
80
81     01  DETAIL-REPORT-HEADING-LINE.
82       05  FILLER                 PIC X(9)   VALUE SPACES.
83       05  FILLER                 PIC X(39)
84           VALUE 'STARTING SALARIES OF ALL NEW EMPLOYEES'.
85       05  FILLER                 PIC X(82)  VALUE SPACES.
86
87     01  DETAIL-LINE-1.
88       05  FILLER                 PIC X(12)  VALUE SPACES.
89       05  DET-EMP-NAME           PIC X(15).
90       05  FILLER                 PIC X(4)   VALUE SPACES.
91       05  DET-SALARY             PIC $99,999.
92       05  FILLER                 PIC X(94)  VALUE SPACES.
93
94     01  SUMMARY-REPORT-HEADING-LINE-1.
95       05  FILLER                 PIC X(24)  VALUE SPACES.
96       05  FILLER                 PIC X(39)
97           VALUE 'STARTING SALARY SUMMARY REPORT - REGION'.
98       05  SUM-REGION-NUMBER      PIC ZZZ9.
99       05  FILLER                 PIC X(65)  VALUE SPACES.
100
101    01  SUMMARY-REPORT-HEADING-LINE-2.
102      05  FILLER                 PIC X(36)  VALUE SPACES.
103      05  FILLER                 PIC X(10)  VALUE 'EXPERIENCE'.
104      05  FILLER                 PIC X(86)  VALUE SPACES.
105
106    01  SUMMARY-REPORT-HEADING-LINE-3.
107      05  FILLER                 PIC X(5)   VALUE SPACES.
108      05  FILLER                 PIC X(14)  VALUE 'RESPONSIBILITY'.
109      05  FILLER                 PIC X(48)
110          VALUE '      1      2      3      4      5'.
111      05  FILLER                 PIC X(65)  VALUE SPACES.
112
113    01  SUMMARY-LINE-1.
114      05  FILLER                 PIC X(9).
115      05  SUMMARY-RESPONSIBILITY  PIC Z(4).
116      05  FILLER                 PIC X(4)   VALUE SPACES.
117      05  SUMMARY-TOTAL-VALUES  OCCURS 5 TIMES.
118          10  FILLER             PIC X(4).
119          10  SUMMARY-NUMBER     PIC Z(4)9.
120      05  FILLER                 PIC X(70).
121
122    PROCEDURE DIVISION.
123    100-PREPARE-SALARY-REPORT.
124      OPEN INPUT EMPLOYEE-FILE
125          OUTPUT PRINT-FILE.
126      PERFORM 200-WRITE-DETAIL-REPORT-HDG.

```

Figure 13.13 (continued)

```

127     PERFORM UNTIL END-OF-DATA
128         READ EMPLOYEE-FILE INTO WS-EMPLOYEE-RECORD
129         AT END
130             MOVE 'YES' TO WS-END-OF-DATA-SWITCH
131         NOT AT END
132             PERFORM 300-PROCESS-EMPLOYEES
133     END-PERFORM.
134     PERFORM 400-WRITE-SUMMARY-REPORT
135         VARYING REG-SUB FROM 1 BY 1
136         UNTIL REG-SUB > 2.
137     CLOSE EMPLOYEE-FILE
138     PRINT-FILE.
139     STOP RUN.
140
141     200-WRITE-DETAIL-REPORT-HDG.
142     WRITE PRINT-LINE FROM DETAIL-REPORT-HEADING-LINE
143     AFTER ADVANCING PAGE.
144     MOVE SPACES TO PRINT-LINE.
145     WRITE PRINT-LINE.
146
147     300-PROCESS-EMPLOYEES.
148     ADD 1 TO NUMB-EMP (EMP-REG, EMP-RESP, EMP-EXP).
149     MOVE EMP-NAME TO DET-EMP-NAME.
150     MOVE SALARY (EMP-REG, EMP-RESP, EMP-EXP) TO DET-SALARY.
151     WRITE PRINT-LINE FROM DETAIL-LINE-1.
152
153     400-WRITE-SUMMARY-REPORT.
154     MOVE REG-SUB TO SUM-REGION-NUMBER.
155     PERFORM 500-WRITE-SUMMARY-HEADING.
156     PERFORM 520-WRITE-RESPONSIBILITY-LINE
157     VARYING RESP-SUB FROM 1 BY 1
158     UNTIL RESP-SUB > 10.
159
160     500-WRITE-SUMMARY-HEADING.
161     WRITE PRINT-LINE FROM SUMMARY-REPORT-HEADING-LINE-1
162     AFTER ADVANCING PAGE.
163     WRITE PRINT-LINE FROM SUMMARY-REPORT-HEADING-LINE-2
164     AFTER ADVANCING 2 LINES.
165     WRITE PRINT-LINE FROM SUMMARY-REPORT-HEADING-LINE-3.
166     MOVE SPACES TO PRINT-LINE.
167     WRITE PRINT-LINE.
168
169     520-WRITE-RESPONSIBILITY-LINE.
170     MOVE SPACES TO SUMMARY-LINE-1.
171     PERFORM VARYING EXP-SUB FROM 1 BY 1
172     UNTIL EXP-SUB > 5
173         MOVE NUMB-EMP (REG-SUB, RESP-SUB, EXP-SUB)
174         TO SUMMARY-NUMBER (EXP-SUB)
175     END-PERFORM.
176     MOVE RESP-SUB TO SUMMARY-RESPONSIBILITY.
177     WRITE PRINT-LINE FROM SUMMARY-LINE-1.

```

Program driven by in-line perform
 loop condition branch

In-line add to number of employees
 in summary table

Prints a detail line for each emp

invoked twice - once for each r

invoked 10 times - once for each responsibility level

In-line perform moves five
 experience levels to appropriate
 region and responsibility

three-level table, for the number of employees in each category in lines 75–79; the definition uses the OCCURS clauses to allocate space for the table, but omits the REDEFINES clause, because (unlike the salary table) the number of employees is computed during processing. The 100 elements in the table are initialized to zero by the VALUE ZERO clause in line 79. (See limitations of COBOL-74 at the end of the chapter.)

The Procedure Division of Figure 13.13 follows both the hierarchy chart and pseudocode. The key to the program is the ADD statement of line 148, which increments the number of employees for the particular region/responsibility/experience combination. The subscript values in this statement are taken directly from the incoming employee record, which define EMP-REG, EMP-RESP, and EMP-EXP. The detail line for the individual employee is created in lines 149–151.

The summary report is produced after the end of file has been reached by the PERFORM statement of lines 134–136, which executes the paragraph WRITE-SUMMARY-REPORT twice, once for each region. The heading lines are written (statements 160–167), after which the paragraph WRITE-RESPONSIBILITY-LINE is executed 10 times (once for each responsibility level) in lines 171–175. The latter paragraph contains its own PERFORM VARYING statement to write the five experience totals for each responsibility level.

Table Lookups

The examples thus far took advantage of a direct lookup in which the table elements were referenced directly by the value of the subscript; that is, the examples used numeric subscripts for responsibility and experience that corresponded directly to the row and column of the table. This is not always true as indicated by the example in Figure 13.14.

The table in Figure 13.14a depicts a user's view in which quarterly sales are recorded for every branch within the corporation. The COBOL implementation in Figure 13.14b establishes BRANCH as a one-level table with 25 rows; it also establishes QUARTERLY-SALES as a two-level table consisting of 25 rows and 4 columns. Any reference to BRANCH-NAME requires a single subscript (index)—for example, BRANCH-NAME (2) to obtain the branch-name in the second row. Any reference to QUARTERLY-SALES requires two subscripts (indexes) to indicate the branch and quarter—for example, QUARTERLY-SALES (2, 1), QUARTERLY-SALES (2, 2), QUARTERLY-SALES (2, 3), and QUARTERLY-SALES (2, 4) to reference the four sales figures for the branch in row two. Figure 13.14c shows the corresponding storage schematic.

Assume now that we want to obtain the annual sales for a specific branch, for example, Boston. An individual could tell at a glance that the data for Boston are in the second row of the table and would know automatically to sum the figures in row two to obtain the annual sales. The computer, however, has to first search the table of branch names to locate the proper row before summing the quarterly sales. The process is illustrated in Figure 13.4d, which contains the Procedure Division statements necessary to obtain the annual sales for Boston.

The SET statement is required prior to a sequential search in order to begin the search in row one of the BRANCH table. The SEARCH statement varies BRANCH-INDEX until a match is found on branch name; the WHEN clause includes a PERFORM VARYING statement that varies QUARTERLY-INDEX from one to four in the appropriate (BRANCH-INDEX) row in order to obtain the annual total. Note, too, the use of scope terminators (END-ADD, END-PERFORM, and END-SEARCH) and how the various statements are nested within one another.

Figure 13.14 Two-Level Table Lookup

| Branch Name | 1st Quarter | 2nd Quarter | 3rd Quarter | 4th Quarter |
|-------------|-------------|-------------|-------------|-------------|
| Atlanta | \$100,000 | \$200,000 | \$300,000 | \$400,000 |
| Boston | \$50,000 | \$150,000 | \$250,000 | \$350,000 |
| Chicago | \$150,000 | \$165,000 | \$400,000 | \$275,000 |
| San Diego | \$25,000 | \$50,000 | \$75,000 | \$100,000 |

(a) User's View

```

01 SALES-TABLE REDEFINES SALES-DATA.
05 BRANCH OCCURS 25 TIMES
   INDEXED BY BRANCH-INDEX.
10 BRANCH-NAME                PIC X(12).
10 QUARTERLY-SALES OCCURS 4 TIMES
   INDEXED BY QUARTERLY-INDEX PIC 9(6).
    
```

(b) Table Definition

| SALES-TABLE | | | | | | | | |
|-----------------|-----------------------|-----|-----------------------|-----|------------------|------------------------|-----|------------------------|
| BRANCH (1) | | | | ... | BRANCH (25) | | | |
| BRANCH NAME (1) | QUARTERLY SALES (1,1) | ... | QUARTERLY SALES (1,4) | | BRANCH NAME (25) | QUARTERLY SALES (25,1) | ... | QUARTERLY SALES (25,4) |
| PIC X(12) | PIC 9(6) | | PIC 9(6) | | PIC X(12) | PIC 9(6) | | PIC 9(6) |

(c) Storage Schematic

```

MOVE ZEROS TO ANNUAL-TOTAL.
SET BRANCH-INDEX TO 1.
SEARCH BRANCH
  AT END
    DISPLAY 'Boston not in table'
  WHEN BRANCH-NAME (BRANCH-INDEX) = 'Boston'
    PERFORM VARYING QUARTERLY-INDEX FROM 1 BY 1
      UNTIL QUARTERLY-INDEX > 4
        ADD QUARTERLY-SALES (BRANCH-INDEX, QUARTERLY-INDEX)
          TO ANNUAL-TOTAL
        SIZE ERROR
        DISPLAY 'ANNUAL TOTAL TOO LARGE'
    END-ADD
  END-PERFORM
END-SEARCH.
    
```

(d) SEARCH Statement

A Calorie**Counter's
Delight**

We come now to our final example, which ties together material from several previous chapters. The specifications call for an interactive program that accepts information from the console and displays the results on the monitor. Specifications follow in the usual format.

PROGRAMMING SPECIFICATIONS

Program Name: A Calorie Counter's Delight

Narrative: Develop a program that will prompt the operator for an age and weight, then display the number of calories needed to maintain that weight. The table of daily maintenance calories is given in the second processing requirement.

Input File(s): None; input will be accepted from the console.

Report Layout: None; output will be displayed on the monitor.

Processing Requirements:

1. Prompt the user for age and weight; validate the parameters immediately as they are input and prompt the user continually until valid values are received. Age must be between 18 and 75 years, inclusive; weight between 90 and 165 pounds, inclusive.
2. Display the calories required to maintain the indicated weight according to the table below.

| WEIGHT (LBS.) | | AGE RANGE (Y. P.) | | |
|---------------|-----|-------------------|-------|-------|
| FROM | TO | 18-25 | 26-35 | 36-45 |
| 90 | 99 | 1,700 | 1,500 | 1,300 |
| 100 | 110 | 1,850 | 1,650 | 1,400 |
| 111 | 121 | 2,000 | 1,750 | 1,550 |
| 122 | 128 | 2,100 | 1,900 | 1,600 |
| 129 | 132 | 2,150 | 1,950 | 1,650 |
| 133 | 143 | 2,300 | 2,050 | 1,800 |
| 144 | 154 | 2,400 | 2,150 | 1,850 |
| 155 | 165 | 2,550 | 2,300 | 1,950 |

3. Ask the user whether s/he wishes to input another set of parameters: if yes, repeat steps one and two above; if not, terminate the program.

Range-Step Tables

The concept of a range-step table was introduced in the previous chapter and is essential to the solution of the present problem. A range-step table occurs when the same table value—for example, 1,700 calories—is applicable to many search arguments—for example, any weight between 90 and 99 pounds coupled with any age between 18 and 35. We need to recognize, therefore, that two range-step tables, for weight and age, are necessary in addition to the calorie maintenance table.

Figure 16.16 Range-step Tables

| | | | | |
|-----|-------|-------|-------|------------------------|
| | 35 | 55 | 75 | <i>Age-limit table</i> |
| 99 | 1,700 | 1,500 | 1,300 | <i>Calorie table</i> |
| 110 | 1,850 | 1,650 | 1,400 | |
| 121 | 2,000 | 1,750 | 1,550 | |
| 128 | 2,100 | 1,900 | 1,600 | |
| 132 | 2,150 | 1,950 | 1,650 | |
| 143 | 2,300 | 2,050 | 1,800 | |
| 154 | 2,400 | 2,150 | 1,850 | |
| 165 | 2,550 | 2,300 | 1,950 | |

(a) User's View

```

01 CALORIE-VALUES.
05 FILLER          PIC X(12) VALUE '170015001300'.
05 FILLER          PIC X(12) VALUE '185016501400'.
05 FILLER          PIC X(12) VALUE '200017501550'.
05 FILLER          PIC X(12) VALUE '210019001600'.
05 FILLER          PIC X(12) VALUE '215019501650'.
05 FILLER          PIC X(12) VALUE '230020501800'.
05 FILLER          PIC X(12) VALUE '240021501850'.
05 FILLER          PIC X(12) VALUE '255023001950'.

01 CALORIE-TABLE REDEFINES CALORIE-VALUES.
05 CALORIE-WEIGHTS OCCURS 8 TIMES
   INDEXED BY CAL-WGT-INDEX.
10 CALORIE-AGES OCCURS 3 TIMES
   INDEXED BY CAL-AGE-INDEX.
15 CALORIES       PIC 9(4).

01 WEIGHT-LIMIT-VALUES.
05 FILLER          PIC X(3)  VALUE '099'.
05 FILLER          PIC X(3)  VALUE '110'.
05 FILLER          PIC X(3)  VALUE '121'.
05 FILLER          PIC X(3)  VALUE '128'.
05 FILLER          PIC X(3)  VALUE '132'.
05 FILLER          PIC X(3)  VALUE '143'.
05 FILLER          PIC X(3)  VALUE '154'.
05 FILLER          PIC X(3)  VALUE '165'.

01 WEIGHT-TABLE REDEFINES WEIGHT-LIMIT-VALUES.
05 WEIGHT-LIMIT OCCURS 8 TIMES
   INDEXED BY WEIGHT-INDEX  PIC 9(3).

01 AGE-LIMIT-VALUES.
05 FILLER          PIC XX   VALUE '35'.
05 FILLER          PIC XX   VALUE '55'.
05 FILLER          PIC XX   VALUE '75'.

01 AGE-TABLE REDEFINES AGE-LIMIT-VALUES.
05 AGE-LIMIT OCCURS 3 TIMES
   INDEXED BY AGE-INDEX  PIC 99.
    
```

(b) COBOL Implementation

Figure 13.16 Hierarchy Chart

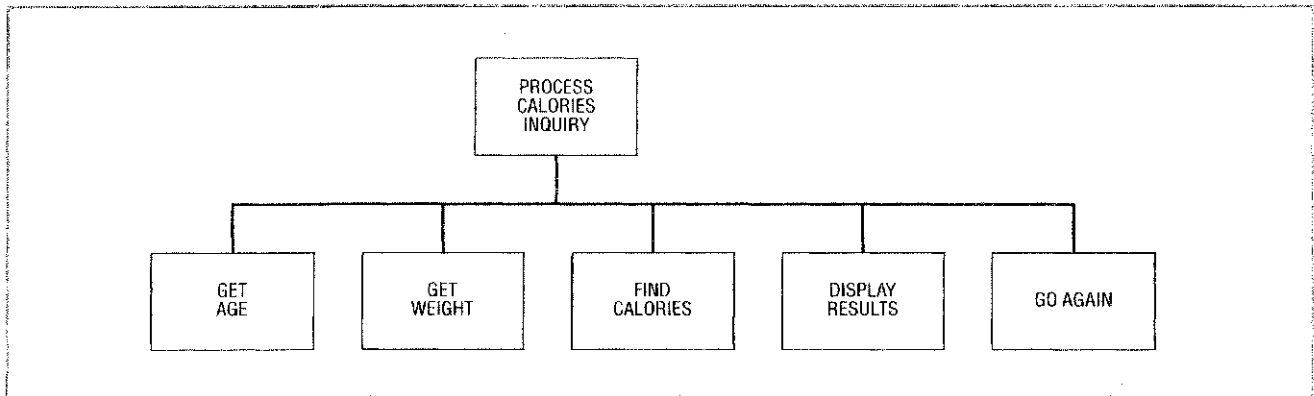

Our solution is shown in Figure 13.15. The user's view of the three tables is shown in Figure 13.15a and the COBOL implementation in Figure 13.15b. The definition of the CALORIE-TABLE is straightforward and uses the OCCURS, VALUE, and REDEFINES clauses as explained earlier. The WEIGHT-LIMIT table stores only the upper limit for each weight class because the ranges overlap from one class to the next—that is, 90–99 pounds, 100–110 pounds, 111–121 pounds, and so on. In similar fashion the age-limit table stores only the upper limit for each age class.

The hierarchy chart in Figure 13.16 contains the modules to get the user's age and weight, determine the number of calories, display the results, then determine whether the entire process is to be repeated. The pseudocode in Figure 13.17 continually prompts the user until a valid age is received, then prompts the user for a valid weight. The *nested search* statement mimics the process a person would follow to determine the number of calories based on weight and age—that is, to search the weight limits in the various rows, then go across the appropriate row to search the age limits for that weight. Note, too, the less than or equal condition in the search argument, which checks only the upper limit in each weight (age) class.

The Completed Program

The completed program is shown in Figure 13.18 and parallels the pseudocode and hierarchy chart just discussed. Several features of the program merit attention.

1. The definition of CALORIE-TABLE in lines 17–32 as a two-level 8 x 3 table; the indexes CAL-WGT-INDEX and CAL-AGE-INDEX are defined with the table to reference the row and column, respectively.
2. The definition of two range-step tables for weight and age limits in lines 34–46 and lines 48–55, and referenced by WEIGHT-INDEX and AGE-INDEX, respectively.
3. The *nested SEARCH statements* in lines 82–94, which identify the row containing the weight limit (from the one-level weight-limit table), the column containing the age limit (from the one-level age-limit table), then reference the corresponding row and column in the calorie table to display the answer.
4. The SET statement in line 81 that initializes WEIGHT-INDEX (from the weight-limit table) and CAL-WGT-INDEX (from the two-level calorie table); the

Figure 13.17 Pseudocode

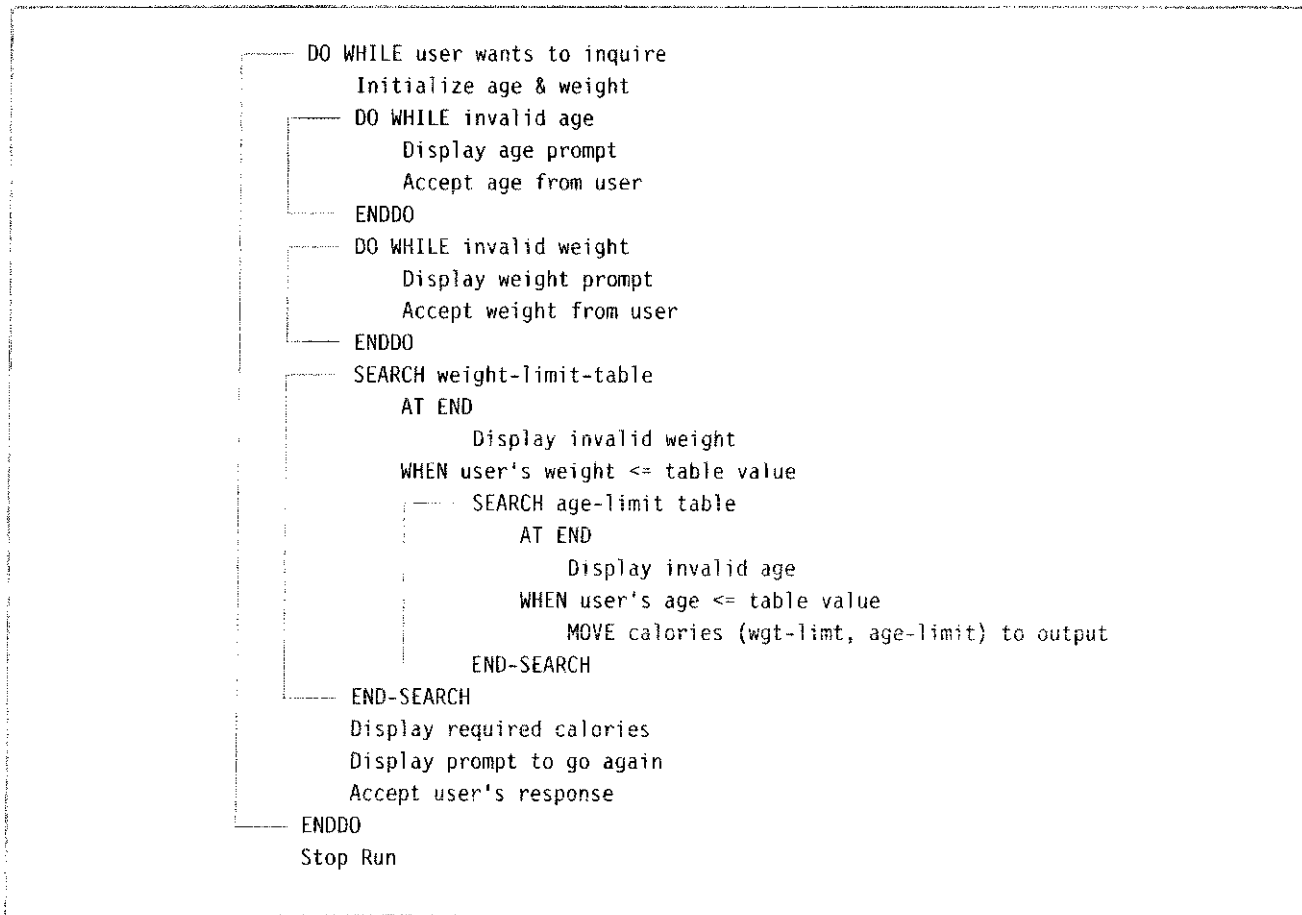

Figure 13.18 Calories Program

```

1  IDENTIFICATION DIVISION.
2  PROGRAM-ID.    CALORIE.
3  AUTHOR.       CVV.
4
5  DATA DIVISION.
6  WORKING-STORAGE SECTION.
7  01 INDIVIDUAL-DATA.
8     05 IND-AGE          PIC 99.
9     88 VALID-AGE       VALUE 18 THRU 75.
10    05 IND-WEIGHT       PIC 9(3).
11    88 VALID-WEIGHT     VALUE 90 THRU 165.
12
13    01 PROGRAM-VARIABLES.
14    05 CALORIES-NEEDED  PIC Z,ZZ9 VALUE ZEROS.
15    05 GO-AGAIN-SWITCH PIC X.
16
17    01 CALORIE-VALUES.
18    05 FILLER           PIC X(12) VALUE '170015001300'.
  
```

Definition of two-level table

Figure 13.16 (continued)

```

19      05 FILLER                PIC X(12) VALUE '185016501400'.
20      05 FILLER                PIC X(12) VALUE '200017501550'.
21      05 FILLER                PIC X(12) VALUE '210019001600'.
22      05 FILLER                PIC X(12) VALUE '215019501650'.
23      05 FILLER                PIC X(12) VALUE '230020501800'.
24      05 FILLER                PIC X(12) VALUE '240021501850'.
25      05 FILLER                PIC X(12) VALUE '255023001950'.
26
27      01 CALORIE-TABLE REDEFINES CALORIE-VALUES.
28          05 CALORY-WEIGHTS OCCURS 8 TIMES
29              INDEXED BY CAL-WGT-INDEX.
30          10 CALORY-AGES OCCURS 3 TIMES
31              INDEXED BY CAL-AGE-INDEX.
32          15 CALORIES            PIC 9(4).
33
34      01 WEIGHT-LIMIT-VALUES.
35          05 FILLER                PIC X(3)  VALUE '099'.
36          05 FILLER                PIC X(3)  VALUE '110'.
37          05 FILLER                PIC X(3)  VALUE '121'.
38          05 FILLER                PIC X(3)  VALUE '128'.
39          05 FILLER                PIC X(3)  VALUE '132'.
40          05 FILLER                PIC X(3)  VALUE '143'.
41          05 FILLER                PIC X(3)  VALUE '154'.
42          05 FILLER                PIC X(3)  VALUE '165'.
43
44      01 WEIGHT-TABLE REDEFINES WEIGHT-LIMIT-VALUES.
45          05 WEIGHT-LIMIT OCCURS 8 TIMES
46              INDEXED BY WEIGHT-INDEX      PIC 9(3).
47
48      01 AGE-LIMIT-VALUES.
49          05 FILLER                PIC XX    VALUE '35'.
50          05 FILLER                PIC XX    VALUE '55'.
51          05 FILLER                PIC XX    VALUE '75'.
52
53      01 AGE-TABLE REDEFINES AGE-LIMIT-VALUES.
54          05 AGE-LIMIT OCCURS 3 TIMES
55              INDEXED BY AGE-INDEX      PIC 99.
56
57      PROCEDURE DIVISION.
58      PROCESS-CALORIE-INQUIRY.
59          PERFORM UNTIL GO-AGAIN-SWITCH = 'n' OR 'N'
60              MOVE ZEROS TO IND-AGE IND-WEIGHT
61              PERFORM GET-AGE
62                  UNTIL VALID-AGE
63              PERFORM GET-WEIGHT
64                  UNTIL VALID-WEIGHT
65              PERFORM FIND-CALORIES
66              PERFORM DISPLAY-RESULTS
67              PERFORM GO-AGAIN
68          END-PERFORM.
69          DISPLAY 'May all your calories be non-fat'.

```

Definition of two-level table

Prompts user continually until valid age and weight are entered

Figure 13.10 (continued)

```

70      STOP RUN.
71
72      GET-AGE.
73      DISPLAY 'Enter Age (18-75): ' NO ADVANCING.
74      ACCEPT IND-AGE.
75
76      GET-WEIGHT.
77      DISPLAY 'Enter Weight (90-165): ' NO ADVANCING.
78      ACCEPT IND-WEIGHT.
79
80      FIND-CALORIES.
81      SET WEIGHT-INDEX CAL-WGT-INDEX TO 1.
82      SEARCH WEIGHT-LIMIT VARYING CAL-WGT-INDEX
83      AT END
84          DISPLAY 'Weight not found in table'
85      WHEN IND-WEIGHT <= WEIGHT-LIMIT (WEIGHT-INDEX)
86          SET AGE-INDEX CAL-AGE-INDEX TO 1
87          SEARCH AGE-LIMIT VARYING CAL-AGE-INDEX
88      AT END
89          DISPLAY 'Age not found in table'
90      WHEN IND-AGE <= AGE-LIMIT (AGE-INDEX)
91          MOVE CALORIES (CAL-WGT-INDEX, CAL-AGE-INDEX)
92          TO CALORIES-NEEDED
93      END-SEARCH
94  END-SEARCH.
95
96      DISPLAY-RESULTS.
97      DISPLAY ' '.
98      DISPLAY CALORIES-NEEDED ' calories/day will maintain '
99      'a weight of ' IND-WEIGHT ' pounds at age ' IND-AGE.
100     DISPLAY ' '.
101
102     GO-AGAIN.
103     DISPLAY 'Go again? (Y/N) ' NO ADVANCING.
104     ACCEPT GO-AGAIN-SWITCH.

```

SEARCH VARYING statement in line 82 manipulates these indexes in conjunction with one another so that when the weight limit is found in the first table, the corresponding row is set in the second table. The **SET** statement in line 86 and the **SEARCH VARYING** statement in line 87 function in similar fashion for the age limit and corresponding column in the calorie table.

5. The **MOVE** statement in line 91 is a direct lookup that uses values of **CAL-WGT-INDEX** and **CAL-AGE-INDEX** established by the nested **SEARCH** statements.
6. The various **ACCEPT** and **DISPLAY** statements throughout the program that utilize screen I-O.

LIMITATIONS OF COBOL-74

Seven levels of subscripting are permitted in COBOL-85 as opposed to the earlier limit of three; most applications, however, do not require even three-level tables.

COBOL-85 facilitates the initialization of a table in which all elements have the same value by allowing the VALUE clause to be specified in the same entry as an OCCURS clause. (The technique was illustrated in lines 61–62 of Figure 13.9.) This was not permitted in COBOL-74, which required a PERFORM VARYING statement or REDEFINES clause to achieve the same result.

The optional END-SEARCH scope terminator is new to COBOL-85 and terminates the conditional portion of the SEARCH and SEARCH ALL statements; the scope terminator makes it possible to nest SEARCH statements.

SUMMARY

Points to Remember

- Multilevel tables of up to seven levels are possible in COBOL-85 although most applications use tables of only one, two, or three dimensions.
- The entries in multiple-level tables may be referenced in different hierarchical levels. The number of subscripts (indexes) needed is equal to the number of OCCURS clauses in the entry definition.
- Tables at any level may be initialized through a combination of the OCCURS, VALUES, and REDEFINES clauses. The OCCURS clause allocates space for the table, the VALUE clause places data in these locations, and the REDEFINES clause assigns another name to previously allocated space.
- Multilevel tables can be manipulated by using the PERFORM VARYING statement with the addition of the appropriate AFTER clause(s). The bottom subscript (index) is always manipulated first.
- The SEARCH VARYING statement manipulates the indexes in two tables in conjunction with one another; the technique is often used with range-step tables, in which the table arguments are stored in a separate table.

Key Words and Concepts

| | |
|-------------------------|-------------------|
| Compilation error | Range-step table |
| Detail report | Summary report |
| Execution error | Three-level table |
| Hierarchical level | Two-level table |
| Nested search statement | User view |



COBOL Elements

| | |
|-----------------|----------------|
| AFTER | REDEFINES |
| BY | SEARCH VARYING |
| END-SEARCH | UNTIL |
| OCCURS | VALUE |
| PERFORM VARYING | |

FILL-IN

1. A two-level table requires two _____ clauses in its definition.
2. In a PERFORM VARYING statement with two subscripts, the (bottom/top) subscript is varied first.
3. COBOL-85 permits a maximum of _____ subscripts.
4. If a Procedure Division reference is made to FIELD-ONE (SUB1, SUB2), SUB1 refers to the _____ level OCCURS clause, whereas SUB2 refers to the _____ level OCCURS clause.
5. In COBOL-74 a VALUE clause (may/may not) be used in conjunction with an _____ clause to initialize a table, and so a _____ clause is used as well.

6. The statement:

```

PERFORM PARAGRAPH-A
  VARYING SUB1 FROM 1 BY 1 UNTIL SUB1 > 5
  AFTER SUB2 FROM 1 BY 1 UNTIL SUB2 > 6.

```

will perform PARAGRAPH-A a total of _____ times.

7. The PERFORM statement of question 6 begins execution by setting SUB1 to 1, and varying SUB2 from _____ to _____, after which SUB1 will be incremented to _____, and SUB2 will again vary from _____ to _____.
8. Given the COBOL definition:

```

01 CORPORATION.
  05 REGION OCCURS 4 TIMES.
    10 STATE OCCURS 5 TIMES.
      15 CITY OCCURS 6 TIMES PIC 9(6).

```

A total of _____ elements are present in the table.

9. Answer with respect to the table of question 8. Any reference to REGION requires _____ subscript(s), a reference to STATE requires _____ subscript(s), and a reference to CITY requires _____ subscript(s).

TRUE/FALSE

1. A maximum of seven OCCURS clauses in a given table is permitted in COBOL-85.
2. A given entry may contain both an OCCURS clause and a PICTURE clause.
3. A given entry may contain both an OCCURS clause and a VALUE clause.

4. The REDEFINES clause is required whenever a table is initialized.
5. A PERFORM VARYING statement may vary indexes as well as subscripts.
6. Referencing a data name with two subscripts, when only a single OCCURS clause appears in the table definition, produces a compilation error.
7. Referencing a data name with a subscript value of 50, when the OCCURS clause indicates only 10 entries, produces a compilation error.
8. SEARCH statements may be nested.
9. The VARYING, FROM, BY, and AFTER clauses are mandatory in a PERFORM statement.
10. A PERFORM VARYING statement will always execute the designated procedure at least once.

PROBLEMS

1. Write out the 12 pairs of values that will be assumed by SUB-1 and SUB-2 as a result of the statement:

```
PERFORM 10-PROCESS-TABLE
  VARYING SUB-1 FROM 1 BY 1
    UNTIL SUB-1 > 4
  AFTER SUB-2 FROM 1 BY 1
    UNTIL SUB-2 > 3.
```

2. Indicate the 24 sets of values that will be assumed by SUB-1, SUB-2, and SUB-3 as a result of the following statement. Remember that the bottom subscript is varied first.

```
PERFORM 10-PROCESS-TABLE
  VARYING SUB-1 FROM 1 BY 1
    UNTIL SUB-1 > 3
  AFTER SUB-2 FROM 1 BY 1
    UNTIL SUB-2 > 2
  AFTER SUB-3 FROM 1 BY 1
    UNTIL SUB-3 > 4.
```

3. Given the following table definition:

```
01 CORPORATE-DATA.
   05 COMPANY OCCURS 10 TIMES.
      10 DIVISION-NAME          PIC X(15).
      10 YEARLY-FINANCIAL-DATA OCCURS 4 TIMES.
         15 REVENUE              PIC 9(7)
         15 NET-INCOME           PIC 9(7).
```

- a. Indicate an appropriate storage schematic.
- b. State whether the following are valid or invalid references, and if invalid, indicate whether the problem occurs during compilation or execution:
 - i. CORPORATE-DATA
 - ii. COMPANY
 - iii. COMPANY (8)
 - iv. DIVISION-NAME (8)
 - v. DIVISION-NAME (12)

- vi. YEARLY-FINANCIAL-DATA (4)
 - vii. REVENUE (10, 4)
 - viii. NET-INCOME (10,4)
 - ix. REVENUE (4, 10)
4. A corporation monitors monthly sales for its six branch offices according to the following table definition:
- ```

01 CORPORATE-SALES-TABLE.
 05 BRANCH-OFFICE OCCURS 6 TIMES.
 10 BRANCH-NAME PIC X(10).
 10 MONTHS OCCURS 12 TIMES.
 15 SALES-AMOUNT PIC 9(6).

```
- a. Indicate the appropriate storage schematic.
  - b. Write a PERFORM VARYING statement to determine the annual sales for the third branch office.
  - c. Write a PERFORM VARYING statement to determine the corporate sales for May.
  - d. Write a PERFORM VARYING statement to determine the corporate sales for the entire year.
  - e. Develop an FD, corresponding record description, and associated Procedure Division statements, to read the data for CORPORATE-SALES-TABLE from a file of six records; that is, each incoming record has the 12 monthly sales for a particular branch office.
  - f. Develop an FD, corresponding record description, and associated Procedure Division statements, to read the data for CORPORATE-SALES-TABLE from a file of 12 records; that is, each incoming record has the six branch office amounts for a particular month.
5. Your professor has two sections of COBOL. Each section has 40 students. Each student is expected to submit six projects and take three examinations. Develop a file structure suitable to all of this data in a single table.
6. The following table was suggested to tabulate enrollments for the various colleges within a university. Each college, such as the College of Engineering, has multiple majors: Mechanical Engineering, Electrical Engineering, and so on.
- ```

01 ENROLLMENT-DATA.
   05 COLLEGE OCCURS 3 TIMES.
      10 MAJOR OCCURS 50 TIMES.
         15 YEAR OCCURS 4 TIMES.
            20 NUMBER-OF-STUDENTS PIC 9(4).

```
- a. Indicate an appropriate storage schematic.
 - b. State whether the following are valid or invalid references, and if invalid, indicate whether the problem occurs during compilation or execution:
 - i. ENROLLMENT-DATA
 - ii. COLLEGE (1)
 - iii. MAJOR (1)
 - iv. YEAR (1)
 - v. NUMBER-OF-STUDENTS (1)
 - vi. NUMBER-OF-STUDENTS (1, 2, 3)
 - vii. NUMBER-OF-STUDENTS (4, 5, 6)

- c. Write PERFORM VARYING statements to determine:
- i. The total number of students in the university.
 - ii. The total number of seniors in the first college.
 - iii. The total number of students in the first major of the first college.
 - iv. The total number of freshmen (year 1) in the first college.
 - v. The total number of freshmen in the university.

Sorting

CHAPTER OUTLINE

Overview

System Concepts

Collating Sequence

Embedded Sign

COBOL Implementation

SORT Statement

SD (Sort Description)

RELEASE and RETURN

Programming Specifications

USING/GIVING Option

INPUT PROCEDURE/OUTPUT PROCEDURE Option

Comparing Options

MERGE Statement

Limitations of COBOL-74

Summary

Fill-in

True/False

Problems

OBJECTIVES

After reading this chapter you will be able to:

- ✱ Distinguish between an internal sort, a utility sort, and the COBOL SORT statement.
- ✱ Differentiate between an ascending and a descending sort; between major, intermediate, and minor keys; and between primary, secondary, and tertiary keys.
- ✱ Define collating sequence; discuss the most significant differences between EBCDIC and ASCII and how the collating sequence affects fields with an embedded sign.
- ✱ Explain the syntax of the COBOL SORT statement, and the supporting RELEASE, RETURN, and SD statements.
- ✱ Explain the use of INPUT PROCEDURE to sort on a calculated field, and/or to selectively pass records to the sort work file.
- ✱ Distinguish between a merge and a sort.

OVERVIEW

Sorting (the rearrangement of data) is one of the most frequent operations in data processing, making it possible to present data in a variety of sequences according to the analysis required. Transactions may be listed alphabetically, alphabetically by location, in ascending or descending sequence by account balance, and so on. The sorting procedure itself is accomplished in one of three ways:

1. An internal sort, in which the programmer develops his or her own logic within the application program. (This approach is typically not used by the COBOL programmer.)
2. A utility sort, in which an independent sort program is executed outside of the application program as a separate step.
3. The COBOL SORT statement, in which control is passed to the independent sort program from within the COBOL program. (Our discussion deals exclusively with this approach.)

We begin the chapter by developing the general concepts associated with sorting, then present the necessary statements to implement sorting within a COBOL program. We develop two parallel programs to illustrate variations within the SORT statement and conclude with a brief discussion of merging, which is a special case of sorting.

System Concepts

A *sort key* is a field within a record that determines how the file is to be arranged. Several keys may be specified in a single sort, as in the case of a departmental census in which employees are to appear alphabetically within department. In other words, the file is to be rearranged (that is, sorted) so that all employees in the same department appear together, and further, so that employees in the same department appear alphabetically. Department is a more important key than employee name; thus department is considered the *major key* and employee name the *minor key*. (Other, equally correct, terminology refers to department as the *primary key* and name as the *secondary key*.)

Sorting is done in one of two sequences: *ascending* (low to high) or *descending* (high to low). Listing employees in increasing order of salary is an example of an ascending sort, whereas listing them in decreasing order (that is, with the highest salary first) represents a descending sort. *Any sort on an alphabetic field, (employee name, for example) is always perceived as an ascending sort.* (An ascending sort is assumed if the sequence is not specified.)

To be absolutely sure of this terminology, consider Figure 14.1. Figure 14.1a lists unsorted data for 12 students. Figure 14.1b displays these records after they have been sorted by name only. Figure 14.1c shows a primary sort on year (descending) and a secondary sort on name. Thus, all students in year four are listed first (in alphabetical order), then all students in year three, and so on. Finally, Figure 14.1d illustrates primary, secondary, and tertiary sorts. All business majors are listed first, then all engineering majors, and finally all liberal arts majors. Within each major, students are listed by year in descending order and are also listed alphabetically within year.

Collating Sequence

The sequencing of numeric items is done strictly according to their algebraic values; for example, -10 is less than $+5$, which is less than $+10$. The length of a numeric field does not enter into the comparison; for example, a four-digit integer field equal to 0099 is less than a three-digit field equal to 100.

The sequencing of alphabetic and/or alphanumeric fields is more subtle with fields of different length—for example, GREEN and GREENFIELD. The sorting algorithm compares the two names one character at a time, from left to right and determines that the first five letters, G, R, E, E, and N, are the same in both names. The shorter field (GREEN in the example) is then extended with blanks so that comparison may continue. A blank, however, is always considered smaller than any other letter, so that GREEN will be placed ahead of GREENFIELD.

The sorting of alphanumeric fields is further complicated when the sort key contains letters and numbers. Comparison still proceeds from left to right, but which alphanumeric key should come first, 111 or AAA? Surprisingly, either answer could be correct, depending on the *collating sequence* in effect. Collating sequence is defined as the ordered list (from low to high) of all valid characters and is a function of manufacturer; IBM mainframes use EBCDIC, whereas almost every other computer, including the PC, uses ASCII. Both sequences are shown in Figure 14.2 for selected characters.

As can be seen from Figure 14.2, the number one 1 comes *after* the letter A in EBCDIC, but *before* the letter A in ASCII. In other words, in an alphanumeric sort a key of 111 will precede a key of AAA under the ASCII collating sequence, but follow it under EBCDIC. It is imperative, therefore, that you be aware of the collating sequence in effect when alphanumeric keys are specified. This is especially true in a

Figure 14.1 Sorting Vocabulary

| | | | Primary Key: Name (Ascending) | | |
|----------|------|--------------|-------------------------------|------|--------------|
| NAME | YEAR | MAJOR | NAME | YEAR | MAJOR |
| Smith | 1 | Liberal arts | Adams | 3 | Business |
| Jones | 4 | Engineering | Benjamin | 4 | Business |
| Adams | 3 | Business | Crawford | 2 | Engineering |
| Howe | 2 | Liberal arts | Deutsch | 4 | Business |
| Frank | 1 | Engineering | Epstein | 2 | Engineering |
| Epstein | 2 | Engineering | Frank | 1 | Engineering |
| Zev | 4 | Business | Grauer | 3 | Liberal arts |
| Benjamin | 4 | Business | Howe | 2 | Liberal arts |
| Grauer | 3 | Liberal arts | Jones | 4 | Engineering |
| Crawford | 2 | Engineering | Makoske | 1 | Business |
| Deutsch | 4 | Business | Smith | 1 | Liberal arts |
| Makoske | 1 | Business | Zev | 4 | Business |

(a) Unsorted Data (b) Sorted Data, One Key

| | | | Primary Key: Major (Ascending) Secondary Key: Year (Descending) Tertiary Key: Name (Ascending) | | |
|----------|------|--------------|--|------|--------------|
| NAME | YEAR | MAJOR | NAME | YEAR | MAJOR |
| Benjamin | 4 | Business | Benjamin | 4 | Business |
| Deutsch | 4 | Business | Deutsch | 4 | Business |
| Jones | 4 | Engineering | Zev | 4 | Business |
| Zev | 4 | Business | Adams | 3 | Business |
| Adams | 3 | Business | Makoske | 1 | Business |
| Grauer | 3 | Liberal arts | Jones | 4 | Engineering |
| Crawford | 2 | Engineering | Crawford | 2 | Engineering |
| Epstein | 2 | Engineering | Epstein | 2 | Engineering |
| Howe | 2 | Liberal arts | Frank | 1 | Engineering |
| Frank | 1 | Engineering | Grauer | 3 | Liberal arts |
| Makoske | 1 | Business | Howe | 2 | Liberal arts |
| Smith | 1 | Liberal arts | Smith | 1 | Liberal arts |

(c) Sorted Data, Two Keys (d) Sorted Data, Three Keys

multivendor environment, as when on-site mini- or microcomputers offload to an IBM mainframe.

Embedded Sign

The collating sequence has yet an additional consequence with signed numeric fields. Arithmetic operations require positive and negative numbers, and hence, when we do arithmetic with pencil and paper, we precede the numbers with plus

Figure 14.4 Embedded Signs (ASCII versus EBCDIC)/II

| Name | Account Balance |
|---------------|-----------------|
| John Doe | \$1,005 |
| Mary Smith | \$1,005CR |
| Frank Coulter | \$2,000 |
| Erik Parker | \$2,000CR |

(a) Report

| | |
|---------------|------|
| John Doe | 1005 |
| Mary Smith | 100u |
| Frank Coulter | 2000 |
| Erik Parker | 200z |

(b) Data (ASCII)

| | |
|---------------|------|
| John Doe | 100E |
| Mary Smith | 100N |
| Frank Coulter | 200{ |
| Erik Parker | 200} |

(c) Data (EBCDIC)

The effect of the collating sequence is seen in Figure 14.4. Figure 14.4a contains a simple report in which John Doe and Mary Smith have positive and negative balances of \$1,005. The data that produce the report are shown in Figure 14.4b for ASCII and in Figure 14.4c for EBCDIC. The record for Mary Smith contains a percent sign in the lower-order digit under ASCII according to the character for -5 in Figure 14.3a, but an upper case N under EBCDIC as indicated in Figure 14.3b.

The optional **SIGN** clause (entered after the **PICTURE** clause) makes it possible to embed the sign as the leading rather than the trailing character, and/or to establish a separate position for the sign. Consider:

$$\left[\text{[SIGN IS]} \left\{ \begin{array}{l} \text{LEADING} \\ \text{TRAILING} \end{array} \right\} \text{[SEPARATE CHARACTER]} \right]$$

The vast majority of applications, however, embed the sign as the trailing character (the default action taken by COBOL) as was illustrated in Figure 14.4.

COBOL Implementation

The COBOL requirements for implementing a sort center on the **SORT** statement. In addition, you must be familiar with an **SD** (sort description) and with the **RELEASE** and **RETURN** statements.

SORT Statement

The syntax for the **SORT** statement is as follows:

SORT file-name-1

```

{ ON { DESCENDING
      ASCENDING } KEY { data-name-1 } . . . } . . .
[ WITH DUPLICATES IN ORDER ]
[ COLLATING SEQUENCE IS alphabet-name ]
[ INPUT PROCEDURE IS procedure-name-1 [ THRU
  USING { file-name-2 }                THROUGH ] procedure-name-2 ]
[ OUTPUT PROCEDURE IS procedure-name-3 [ THRU
  GIVING { file-name-3 }                THROUGH ] procedure-name-4 ]

```

Multiple sort keys are listed in the order of importance, with the major (primary) key listed first. Thus, the statement:

```

SORT STUDENT-FILE
  ASCENDING KEY STUDENT-MAJOR
  DESCENDING KEY YEAR-IN-SCHOOL
  ASCENDING KEY STUDENT-NAME

```

corresponds to the order of the keys in Figure 14.1d. (STUDENT-MAJOR is the primary key, YEAR-IN-SCHOOL is the secondary key, and STUDENT-NAME is the tertiary key.) As can be seen from the general syntax, KEY is an optional reserved word, so that the preceding statement could have been written as:

```

SORT STUDENT-FILE
  ASCENDING STUDENT-MAJOR
  DESCENDING YEAR-IN-SCHOOL
  ASCENDING STUDENT-NAME

```

When consecutive keys have the same sequence (both ascending or both descending), ASCENDING (or DESCENDING) need not be repeated. Hence, if it were necessary to obtain a master list of students in ascending order by year in school, and alphabetically within year, you could code:

```

SORT STUDENT-FILE
  ASCENDING YEAR-IN-SCHOOL
  STUDENT-NAME

```

The **WITH DUPLICATES IN ORDER** phrase in the SORT statement ensures that the sequence of records with duplicate keys in the output file will be identical to the sequence of the records in the input file. The phrase is illustrated in Figure 14.9, which appears later in the chapter.

The **COLLATING SEQUENCE** clause allows you to change the collating sequence; that is, you can specify ASCII on an IBM mainframe or EBCDIC on a PC. (Implementation of an alternate collating sequence is less than straightforward, and you should consult an appropriate vendor manual if you wish to use one.)

The SORT statement requires a choice between **INPUT PROCEDURE** and **USING**, and between **OUTPUT PROCEDURE** and **GIVING**, resulting in four possible combinations: **USING/GIVING**, **USING/OUTPUT PROCEDURE**, **INPUT PROCEDURE/GIVING**, and **INPUT PROCEDURE/OUTPUT PROCEDURE**. The choice between the different options depends on the specific application. (The chapter contains two listings for **USING/GIVING** and **INPUT PROCEDURE/OUTPUT PROCEDURE**.)

The difference between **USING** and **INPUT PROCEDURE** is that **INPUT PROCEDURE** requires the programmer to do the I/O to and from the sort utility, whereas the **USING** option does the I/O automatically. **INPUT PROCEDURE** is thus a more general technique in that it permits sorting on a *calculated field*, a field not contained in the input record. Assume, for example, that an employee record contains the present and previous salary, but not the percent of salary increase. The **USING** option can sort on either salary, but not on the salary increase because the latter is a calculated field that it is not present in the input record.

The **INPUT PROCEDURE** also allows you to *selectively* pass records to the sort utility, a desirable practice in instances where only some of the records in an input file are to appear in a subsequent report. Sorting is time consuming and thus, it is highly inefficient to sort an entire file only to eliminate records after sorting. It is far better to select the records prior to the sort by using the **INPUT PROCEDURE**.

The difference between **OUTPUT PROCEDURE** and **GIVING** is the status of the sorted file. The **OUTPUT PROCEDURE** uses a *temporary* work file, which disappears after the program ends so that the results of the sort are lost. The **GIVING** option creates a *permanent* file containing the sorted results that remains after the program has ended.

SD (Sort Description)

The first file in the SORT statement references the *sort work file* that was previously defined in an **SD** (Sort Description) statement in the Data Division. The **SD** is analogous to an **FD** except that it refers to a sort work file, rather than an ordinary file used for I/O. The **SD** has the general syntax:

SD file-name-1

[**RECORD** CONTAINS [integer-1 TO] integer-2 CHARACTERS]

[**DATA** {**RECORD IS**
RECORDS ARE} {data-name-1} . . .]

RELEASE and RETURN

The **RELEASE** and **RETURN** statements are required in the **INPUT** and **OUTPUT PROCEDURE**, respectively. The **RELEASE** statement is analogous to a **WRITE** statement and writes a record to the sort work file (the file defined in the **SD**).

RELEASE record-name [**FROM** identifier]

The **RELEASE** statement appears in the **INPUT PROCEDURE**. The **RETURN** statement, on the other hand, is analogous to a **READ** statement and appears in the **OUTPUT PROCEDURE**. It has the format:

```

RETURN file-name [INIQ identifier]
      [AT END imperative-statement-1]
      [NOT AT END imperative-statement-2]
[END-RETURN]

```

The RETURN statement reads a record from the sort work file (the file defined in the SD) for subsequent processing in the program.

The SORT statement and its related statements can be integrated into any COBOL program. We proceed to develop a typical application, with specifications in the usual format. In actuality we present two separate programs, to illustrate both the INPUT PROCEDURE/OUTPUT PROCEDURE and USING/GIVING options of the SORT statement.

PROGRAMMING SPECIFICATIONS

Program Name: Sort Programs

Narrative: The specifications call for *two* programs to illustrate the USING/GIVING and INPUT PROCEDURE/OUTPUT PROCEDURE options of the SORT statement. The programs use the same data file but produce different reports.

Input File(s): SALES-FILE

Input Record Layout:

| | | |
|----|-----------------------|------------|
| 01 | SALES-RECORD-IN. | |
| 05 | SR-ACCOUNT-NUMBER | PIC 9(6). |
| 05 | FILLER | PIC X. |
| 05 | SR-NAME | PIC X(15). |
| 05 | SR-SALES | PIC S9(4). |
| 05 | FILLER | PIC XX. |
| 05 | SR-COMMISSION-PERCENT | PIC V99. |
| 05 | FILLER | PIC XX. |
| 05 | SR-LOCATION | PIC X(15). |
| 05 | SR-REGION | PIC X(11). |

Test Data: See Figure 14.5.

Report Layout: See Figure 14.6a and 14.6b. The report layout—the heading, detail, and total lines—is the same for both programs, but the contents of the reports—the specific records as well as the sequence of those records—are different.

- Processing Requirements:**
1. Develop two parallel programs, each of which processes a file of sales records and computes the commission due for each incoming transaction. The amount of the commission is equal to the sales amount times the commission percentage.
 2. The first program is to use the USING/GIVING option to produce a master list of *all* incoming records. The records are to be in sequence by region, location, and name as shown in Figure 14.6a.
 3. The second program is to use the INPUT PROCEDURE/OUTPUT PROCEDURE option and list only the transactions with a commission greater than \$100. The records are to appear in decreasing order of commission as shown in Figure 14.6b.

Figure 14.5 Test Data (ASCII Format)

| | | | | | |
|--------|-----------|------|----|----------------|-----------|
| 000069 | BENWAY | 023q | 10 | CHICAGO | MIDWEST |
| 000100 | HUMMER | 010w | 05 | CHICAGO | MIDWEST |
| 000101 | CLARK | 1500 | 10 | TRENTON | NORTHEAST |
| 000104 | CLARK | 0500 | 03 | TRENTON | NORTHEAST |
| 100000 | JOHNSON | 030s | 06 | ST. PETERSBURG | SOUTHEAST |
| 130101 | CLARK | 3200 | 20 | TRENTON | NORTHEAST |
| 203000 | HAAS | 8900 | 05 | ST. LOUIS | MIDWEST |
| 248545 | JOHNSON | 0345 | 14 | ST. PETERSBURG | SOUTHEAST |
| 277333 | HAAS | 009x | 08 | ST. LOUIS | MIDWEST |
| 400000 | JOHNSON | 070y | 08 | ST. PETERSBURG | SOUTHEAST |
| 444333 | ADAMS | 100v | 01 | NEW YORK | NORTHEAST |
| 444444 | FEGEN | 0100 | 02 | ST. PETERSBURG | SOUTHEAST |
| 475365 | HAAS | 0333 | 05 | ST. LOUIS | MIDWEST |
| 476236 | FEGEN | 037v | 03 | ST. PETERSBURG | SOUTHEAST |
| 476530 | BENWAY | 023u | 05 | CHICAGO | MIDWEST |
| 555555 | FEGEN | 0304 | 05 | ST. PETERSBURG | SOUTHEAST |
| 555666 | ADAMS | 2003 | 20 | NEW YORK | NORTHEAST |
| 576235 | CLARK | 0100 | 03 | TRENTON | NORTHEAST |
| 583645 | KARLSTROM | 0145 | 04 | BALTIMORE | NORTHEAST |
| 649356 | HUMMER | 0345 | 05 | CHICAGO | MIDWEST |
| 694446 | HUMMER | 0904 | 10 | CHICAGO | MIDWEST |
| 700039 | MARCUS | 0932 | 10 | BALTIMORE | NORTHEAST |
| 750020 | MARCUS | 0305 | 05 | BALTIMORE | NORTHEAST |
| 800396 | KARLSTROM | 3030 | 09 | BALTIMORE | NORTHEAST |
| 878787 | JOHNSON | 1235 | 12 | ST. PETERSBURG | SOUTHEAST |
| 987654 | ADAMS | 2005 | 10 | NEW YORK | NORTHEAST |
| 988888 | BENWAY | 0450 | 01 | CHICAGO | MIDWEST |
| 999340 | BENWAY | 0334 | 30 | CHICAGO | MIDWEST |

Figure 14.6 Sorted Reports

| SALES ACTIVITY REPORT | | | 04/21/93 | PAGE 1 | |
|-----------------------|-----------|--------|-----------|---------|------------|
| REGION | LOCATION | NAME | ACCOUNT # | SALES | COMMISSION |
| MIDWEST | CHICAGO | BENWAY | 000069 | \$ 231- | \$ 23- |
| MIDWEST | CHICAGO | BENWAY | 476530 | \$ 235- | \$ 12- |
| MIDWEST | CHICAGO | BENWAY | 988888 | \$ 450 | \$ 5 |
| MIDWEST | CHICAGO | BENWAY | 999340 | \$ 334 | \$ 100 |
| MIDWEST | CHICAGO | HUMMER | 000100 | \$ 107- | \$ 5- |
| MIDWEST | CHICAGO | HUMMER | 649356 | \$ 345 | \$ 17 |
| MIDWEST | CHICAGO | HUMMER | 694446 | \$ 904 | \$ 90 |
| MIDWEST | ST. LOUIS | HAAS | 203000 | \$8,900 | \$ 445 |
| MIDWEST | ST. LOUIS | HAAS | 277333 | \$ 98- | \$ 8- |
| MIDWEST | ST. LOUIS | HAAS | 475365 | \$ 333 | \$ 17 |

(a) By Region, Location, and Name (All Records)

Figure 14.6 (continued)

| SALES ACTIVITY REPORT | | | | 04/21/93 | PAGE 3 |
|-----------------------|----------------|---------|-----------|----------|------------|
| REGION | LOCATION | NAME | ACCOUNT # | SALES | COMMISSION |
| NORTHEAST | TRENTON | CLARK | 576235 | \$ 100 | \$ 3 |
| SOUTHEAST | ST. PETERSBURG | FEGEN | 444444 | \$ 100 | \$ 2 |
| SOUTHEAST | ST. PETERSBURG | FEGEN | 476236 | \$ 376- | \$ 11- |
| SOUTHEAST | ST. PETERSBURG | FEGEN | 555555 | \$ 304 | \$ 15 |
| SOUTHEAST | ST. PETERSBURG | JOHNSON | 100000 | \$ 303- | \$ 18- |
| SOUTHEAST | ST. PETERSBURG | JOHNSON | 248545 | \$ 345 | \$ 48 |

| SALES ACTIVITY REPORT | | | | 04/21/93 | PAGE 2 |
|-----------------------|-----------|-----------|-----------|----------|------------|
| REGION | LOCATION | NAME | ACCOUNT # | SALES | COMMISSION |
| NORTHEAST | BALTIMORE | KARLSTROM | 583645 | \$ 145 | \$ 6 |
| NORTHEAST | BALTIMORE | KARLSTROM | 800396 | \$3,030 | \$ 273 |
| NORTHEAST | BALTIMORE | MARCUS | 700039 | \$ 932 | \$ 93 |
| NORTHEAST | BALTIMORE | MARCUS | 750020 | \$ 305 | \$ 15 |
| NORTHEAST | NEW YORK | ADAMS | 444333 | \$1,005- | \$ 10- |
| NORTHEAST | NEW YORK | ADAMS | 555666 | \$2,003 | \$ 401 |
| NORTHEAST | NEW YORK | ADAMS | 987654 | \$2,005 | \$ 201 |
| NORTHEAST | TRENTON | CLARK | 000101 | \$1,500 | \$ 150 |
| NORTHEAST | TRENTON | CLARK | 000104 | \$ 500 | \$ 15 |
| NORTHEAST | TRENTON | CLARK | 130101 | \$3,200 | \$ 640 |

57-
148
2,540

(a) By Region, Location, and Name (All Records)

| SALES ACTIVITY REPORT | | | | 04/21/93 | PAGE 1 |
|-----------------------|----------------|-----------|-----------|-----------|------------|
| REGION | LOCATION | NAME | ACCOUNT # | SALES | COMMISSION |
| NORTHEAST | TRENTON | CLARK | 130101 | \$3,200 | \$ 640 |
| MIDWEST | ST. LOUIS | HAAS | 203000 | \$8,900 | \$ 445 |
| NORTHEAST | NEW YORK | ADAMS | 555666 | \$2,003 | \$ 401 |
| NORTHEAST | BALTIMORE | KARLSTROM | 800396 | \$3,030 | \$ 273 |
| NORTHEAST | NEW YORK | ADAMS | 987654 | \$2,005 | \$ 201 |
| NORTHEAST | TRENTON | CLARK | 000101 | \$1,500 | \$ 150 |
| SOUTHEAST | ST. PETERSBURG | JOHNSON | 878787 | \$1,235 | \$ 148 |
| *** COMPANY TOTAL = | | | | \$ 21,873 | \$ 2,258 |

(b) By Decreasing Commission (Commission > \$100)

USING/GIVING Option

The specifications are similar to those of any other reporting program that requires a combination of heading, detail, and total lines. The hierarchy chart and pseudocode for the USING/GIVING option are shown in Figures 14.7 and 14.8, respectively. The hierarchy chart contains many of the modules found in earlier programs—for example, GET-TODAYS-DATE, WRITE-HEADING-LINES, and WRITE-DETAIL-LINE. In addition, it contains the module SORT-SALES-FILE to sequence records in the sales file.

Figure 14.7 Hierarchy Chart (USING/GIVING)

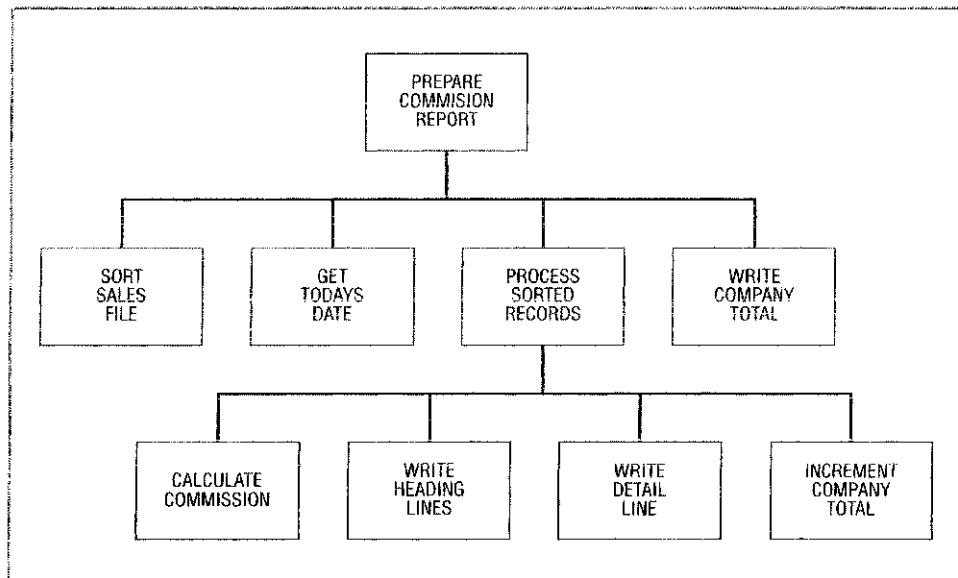
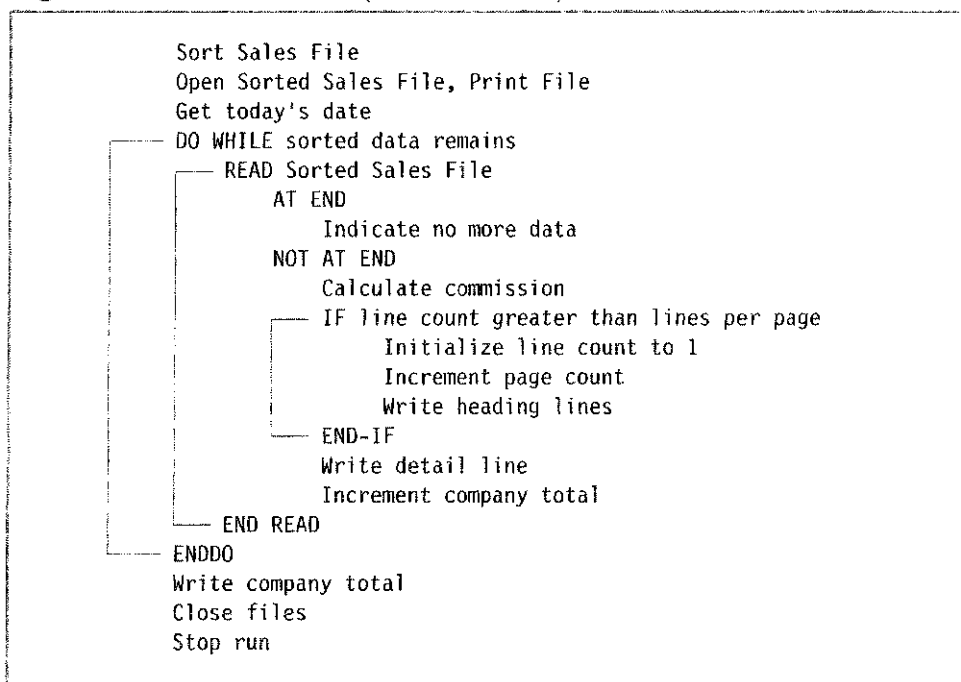

Figure 14.8 Pseudocode (USING/GIVING)



The pseudocode in Figure 14.8 contains a sort statement prior to the main loop, which contains the in-line perform and false-condition branch used in all other programs. The sales commission is calculated for each incoming record, a detail line is written, and the company total is incremented. The pseudocode also contains the logic to implement a page heading routine as explained previously in Chapter 9.

The USING/GIVING format is illustrated in Figure 14.9. The SORT statement in lines 149-155 references three files—SORT-WORK-FILE, SALES-FILE, and SORTED-SALES-FILE—each of which has the identical record layout. The SORT statement implicitly opens SALES-FILE and reads every record in that file, releasing each record as it is read to the sort work file. It then sequences the sort work file according to designated keys and writes the newly ordered file to SORTED-SALES-FILE. The programmer does not open or close SORT-WORK-FILE or SALES-FILE as this is done by the SORT statement.

Figure 14.9 SORT Program (USING/GIVING)

```

1  IDENTIFICATION DIVISION.
2  PROGRAM-ID.  SORT1.
3  AUTHOR.      CVV.
4
5  ENVIRONMENT DIVISION.
6  INPUT-OUTPUT SECTION.
7  FILE-CONTROL.
8      SELECT SALES-FILE  ASSIGN TO 'A:\CHAPTR14\SORTIN.DAT'
9          ORGANIZATION IS LINE SEQUENTIAL.
10     SELECT PRINT-FILE
11         ASSIGN TO PRINTER.
12     SELECT SORT-WORK-FILE
13         ASSIGN TO 'A:\CHAPTR14\SORWK.DAT'.
14     SELECT SORTED-SALES-FILE  ASSIGN TO 'A:\CHAPTR14\SORTOUT.DAT'
15         ORGANIZATION IS LINE SEQUENTIAL.
16
17  DATA DIVISION.
18  FILE SECTION.
19  FD SALES-FILE
20     RECORD CONTAINS 58 CHARACTERS
21     DATA RECORD IS SALES-RECORD.
22  01 SALES-RECORD          PIC X(58).
23
24  FD PRINT-FILE
25     RECORD CONTAINS 132 CHARACTERS
26     DATA RECORD IS PRINT-LINE.
27  01 PRINT-LINE          PIC X(132).
28
29  SD SORT-WORK-FILE
30     RECORD CONTAINS 58 CHARACTERS
31     DATA RECORD IS SORT-RECORD.
32  01 SORT-RECORD.
33     05 SORT-ACCOUNT-NUMBER  PIC 9(6).
    
```

Sort work file is defined by primary SELECT statement

Sort work file is defined as SD

Sort keys present in heading record

Figure 14.9 (continued)

```

34      05 FILLER                                PIC X.
35      05 SORT-NAME                            PIC X(15).
36      05 FILLER                                PIC X(10).
37      05 SORT-LOCATION                          PIC X(15).
38      05 SORT-REGION                          PIC X(11).
39
40      FD SORTED-SALES-FILE
41          RECORD CONTAINS 58 CHARACTERS
42          DATA RECORD IS SORTED-SALES-RECORD.
43      01 SORTED-SALES-RECORD                    PIC X(58).
44
45      WORKING-STORAGE SECTION.
46      01 FILLER                                PIC X(14)
47          VALUE 'WS BEGINS HERE'.
48
49      01 SALES-RECORD-IN.
50          05 SR-ACCOUNT-NUMBER                  PIC 9(6).
51          05 FILLER                            PIC X.
52          05 SR-NAME                          PIC X(15).
53          05 SR-SALES                          PIC S9(4).
54          05 FILLER                            PIC XX.
55          05 SR-COMMISSION-PERCENT             PIC V99.
56          05 FILLER                            PIC XX.
57          05 SR-LOCATION                        PIC X(15).
58          05 SR-REGION                        PIC X(11).
59
60      01 TODAYS-DATE-AREA.
61          05 TODAYS-YEAR                       PIC 99.
62          05 TODAYS-MONTH                     PIC 99.
63          05 TODAYS-DAY                       PIC 99.
64
65      01 PROGRAM-SWITCHES.
66          05 DATA-REMAINS-SWITCH              PIC X(3)    VALUE 'YES'.
67          88 NO-DATA-REMAINS                  VALUE 'NO'.
68
69      01 PAGE-AND-LINE-COUNTERS.
70          05 LINE-COUNT                        PIC 9(2)    VALUE 11.
71          05 PAGE-COUNT                       PIC 9(2)    VALUE ZEROS.
72          05 LINES-PER-PAGE                   PIC 9(2)    VALUE 10.
73
74      01 INDIVIDUAL-CALCULATIONS.
75          05 IND-COMMISSION                    PIC S9(4).
76
77      01 COMPANY-TOTALS.
78          05 COMPANY-SALES-TOT                PIC S9(6)    VALUE ZEROES.
79          05 COMPANY-COMM-TOT                PIC S9(6)    VALUE ZEROES.
80
81      01 HDG-LINE-ONE.
82          05 FILLER                            PIC X(25)    VALUE SPACES.
83          05 FILLER                            PIC X(21)

```

Sort keys present in incoming record

Figure 14.9 (continued)

```

84          VALUE 'SALES ACTIVITY REPORT'.
85          05 FILLER                PIC X(8)  VALUE SPACES.
86          05 HDG-DATE              PIC X(8).
87          05 FILLER                PIC X(10) VALUE SPACES.
88          05 FILLER                PIC X(5)  VALUE 'PAGE '.
89          05 HDG-PAGE              PIC Z9.
90          05 FILLER                PIC X(53) VALUE SPACES.
91
92          01 HDG-LINE-TWO.
93          05 FILLER                PIC X(7)  VALUE ' REGION'.
94          05 FILLER                PIC X(5)  VALUE SPACES.
95          05 FILLER                PIC X(8)  VALUE 'LOCATION'.
96          05 FILLER                PIC X(11) VALUE SPACES.
97          05 FILLER                PIC X(4)  VALUE 'NAME'.
98          05 FILLER                PIC X(10) VALUE SPACES.
99          05 FILLER                PIC X(11) VALUE 'ACCOUNT # '.
100         05 FILLER                PIC X(5)  VALUE SPACES.
101         05 FILLER                PIC X(5)  VALUE 'SALES'.
102         05 FILLER                PIC X(3)  VALUE SPACES.
103         05 FILLER                PIC X(10) VALUE 'COMMISSION'.
104         05 FILLER                PIC X(53) VALUE SPACES.
105
106         01 DETAIL-LINE.
107         05 DET-REGION             PIC X(11).
108         05 FILLER                PIC X     VALUE SPACES.
109         05 DET-LOCATION            PIC X(15).
110         05 FILLER                PIC X(3)  VALUE SPACES.
111         05 DET-NAME              PIC X(15).
112         05 FILLER                PIC X(2)  VALUE SPACES.
113         05 DET-ACCOUNT-NUMBER    PIC 9(6).
114         05 FILLER                PIC X(5)  VALUE SPACES.
115         05 DET-SALES             PIC $Z,ZZ9-.
116         05 FILLER                PIC X(7)  VALUE SPACES.
117         05 DET-COMMISSION        PIC $Z,ZZ9-.
118         05 FILLER                PIC X(50) VALUE SPACES.
119
120         01 COMPANY-TOTAL-LINE.
121         05 FILLER                PIC X(31) VALUE SPACES.
122         05 FILLER                PIC X(25)
123             VALUE '*** COMPANY TOTAL = '.
124         05 COMPANY-SALES-TOTAL   PIC $Z(3),ZZ9-.
125         05 FILLER                PIC X(5)  VALUE SPACES.
126         05 COMPANY-COMM-TOTAL   PIC $Z(3),ZZ9-.
127         05 FILLER                PIC X(51) VALUE SPACES.
128
129         PROCEDURE DIVISION.
130         100-PREPARE-COMMISSION-REPORT.
131         PERFORM 210-SORT-SALES-RECORDS.
132         OPEN INPUT SORTED-SALES-FILE
133             OUTPUT PRINT-FILE.

```

Opens the sorted file to produce report

Figure 14.9 (continued)

```

134     PERFORM 230-GET-TODAYS-DATE.
135     PERFORM UNTIL NO-DATA-REMAINS
136         READ SORTED-SALES-FILE INTO SALES-RECORD-IN
137         AT END
138             MOVE 'NO' TO DATA-REMAINS-SWITCH
139         NOT AT END
140             PERFORM 250-PROCESS-SORTED-RECORDS
141     END-READ
142     END-PERFORM.
143     PERFORM 290-WRITE-COMPANY-TOTAL.
144     CLOSE SORTED-SALES-FILE
145     PRINT-FILE.
146     STOP RUN.
147
148     210-SORT-SALES-RECORDS.
149         SORT SORT-WORK-FILE
150             ASCENDING KEY SORT-REGION
151                 SORT-LOCATION
152                 SORT-NAME
153             WITH DUPLICATES IN ORDER
154             USING SALES-FILE
155             GIVING SORTED-SALES-FILE.
156
157     230-GET-TODAYS-DATE.
158     ACCEPT TODAYS-DATE-AREA FROM DATE.
159     STRING TODAYS-MONTH '/' TODAYS-DAY '/' TODAYS-YEAR
160     DELIMITED BY SIZE INTO HDG-DATE.
161
162     250-PROCESS-SORTED-RECORDS.
163     PERFORM 310-CALCULATE-COMMISSION.
164     IF LINE-COUNT > LINES-PER-PAGE
165         PERFORM 330-WRITE-HEADING-LINES
166     END-IF.
167     PERFORM 350-WRITE-DETAIL-LINE.
168     PERFORM 370-INCREMENT-COMPANY-TOTAL.
169
170     290-WRITE-COMPANY-TOTAL.
171     MOVE COMPANY-SALES-TOT TO COMPANY-SALES-TOTAL.
172     MOVE COMPANY-COMM-TOT TO COMPANY-COMM-TOTAL.
173     WRITE PRINT-LINE FROM COMPANY-TOTAL-LINE
174     AFTER ADVANCING 2 LINES.
175
176     310-CALCULATE-COMMISSION.
177     COMPUTE IND-COMMISSION ROUNDED =
178         SR-SALES * SR-COMMISSION-PERCENT
179     SIZE ERROR DISPLAY 'SIZE ERROR ON COMMISSION FOR '
180         SR-NAME
181     END-COMPUTE.
182
183     330-WRITE-HEADING-LINES.

```

Figure 14.9 (continued)

```

184      MOVE 1 TO LINE-COUNT.
185      ADD 1 TO PAGE-COUNT.
186      MOVE PAGE-COUNT TO HDG-PAGE.
187      WRITE PRINT-LINE FROM HDG-LINE-ONE
188          AFTER ADVANCING PAGE.
189      WRITE PRINT-LINE FROM HDG-LINE-TWO
190          AFTER ADVANCING 2 LINES.
191
192      350-WRITE-DETAIL-LINE.
193          MOVE SR-REGION TO DET-REGION.
194          MOVE SR-LOCATION TO DET-LOCATION.
195          MOVE SR-NAME TO DET-NAME.
196          MOVE SR-ACCOUNT-NUMBER TO DET-ACCOUNT-NUMBER.
197          MOVE SR-SALES TO DET-SALES.
198          MOVE IND-COMMISSION TO DET-COMMISSION.
199          WRITE PRINT-LINE FROM DETAIL-LINE.
200          ADD 1 TO LINE-COUNT.
201
202      370-INCREMENT-COMPANY-TOTAL.
203          ADD SR-SALES TO COMPANY-SALES-TOT.
204          ADD IND-COMMISSION TO COMPANY-COMM-TOT.
    
```

Three keys—SORT-REGION, SORT-LOCATION, and SORT-NAME—are specified in lines 150–152 as the primary, secondary, and tertiary key, respectively. The WITH DUPLICATES IN ORDER phrase keeps records with duplicate keys in the same sequence as the input file. Note, therefore, that since the input file in Figure 14.5 is already in sequence by account number, records with the same region, location, and name will be in sequence by account number as well.

After the file has been sorted, control returns to the OPEN statement in line 132, which opens SORTED-SALES-FILE as input and PRINT-FILE as output. The remainder of the Procedure Division reads records from the sorted file in order to produce the report of Figure 14.6a. Its logic parallels that of any other reporting program that produces a combination of heading, detail, and total lines.

**INPUT
PROCEDURE/
OUTPUT
PROCEDURE
Option**

The hierarchy chart to implement the INPUT PROCEDURE/OUTPUT PROCEDURE option is shown in Figure 14.10. It contains the identical modules as its predecessor for the USING/GIVING option, but the placement of the modules (the subordinate relationships and associated span of control) is significantly different.

The most obvious change is the sort module itself, which sits atop the hierarchy chart in Figure 14.10, but which is subordinate to PREPARE-COMMISSION-REPORT in Figure 14.7. This is because the SORT statement effectively drives the INPUT PROCEDURE/OUTPUT PROCEDURE option as it calls the respective procedures. A second major change is the placement of CALCULATE-COMMISSION, which is subordinate to the sort module in Figure 14.10, because the commission is calculated

Figure 14.10 Hierarchy Chart (INPUT PROCEDURE/OUTPUT PROCEDURE)

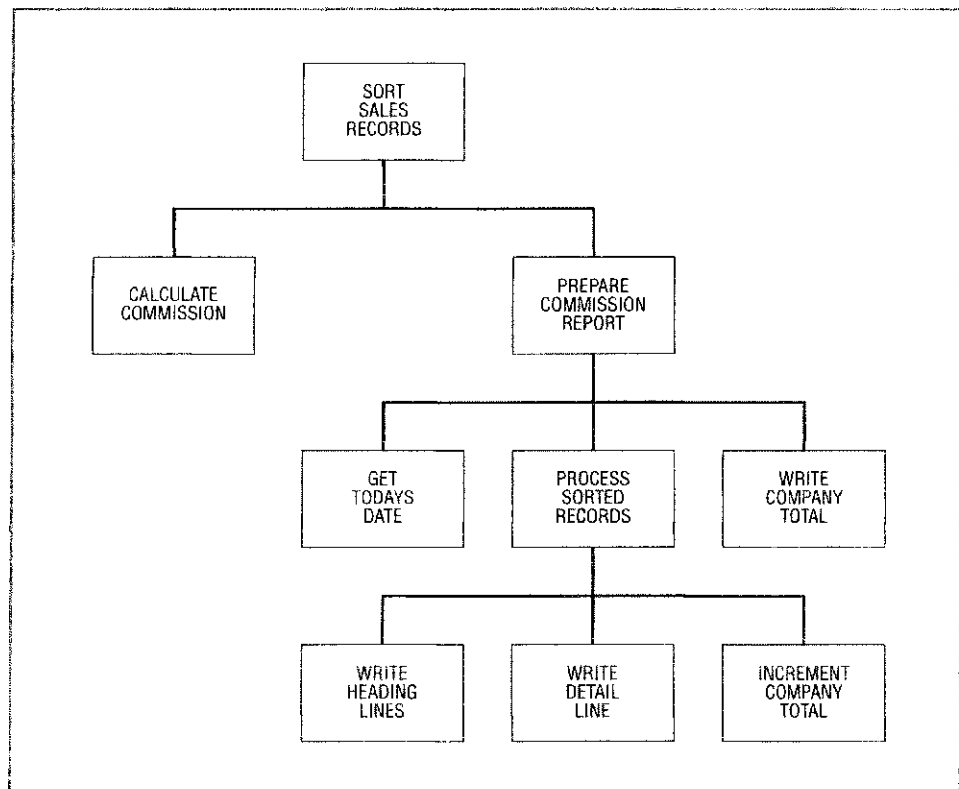

prior to sorting, and only those records with sufficient commission are written to the sort work file. In the earlier hierarchy chart, however, every record in the incoming file appears in the report; the commission is calculated after sorting so that CALCULATE-COMMISSION is subordinate to PROCESS-SORTED-RECORDS.

The pseudocode in Figure 14.11 contains two loops, whereas its predecessor in Figure 14.8 contained only one. This is because the USING/GIVING option does the I/O for the programmer and thus is transparent to the programmer. However, INPUT PROCEDURE/OUTPUT PROCEDURE requires the programmer to do the I/O and this is reflected in the pseudocode. The initial loop opens the (unsorted) sales file, calculates the commission for each incoming record, then selectively releases records to the sort work file. The second loop (which corresponds to the only loop in Figure 14.8) reads records from the sorted file and prepares the report.

The program containing the INPUT PROCEDURE/OUTPUT PROCEDURE format is illustrated in Figure 14.12. Explanation begins with the SORT statement itself, lines 125–128, which references a sort work file defined in an SD in lines 27–37 of the Data Division. SORT-WORK-FILE is to be sorted on SORT-COMMISSION, a calculated field that is not contained in the incoming sales record.

The INPUT PROCEDURE/OUTPUT PROCEDURE involves several implicit transfers of control as follows:

1. Control passes from the SORT statement to the INPUT PROCEDURE, which reads records from an input file and builds the sort work file.
2. When the INPUT PROCEDURE is finished, control passes to the sort utility, which sorts the work file created by the INPUT PROCEDURE.

Figure 14.11 Pseudocode (INPUT PROCEDURE/OUTPUT PROCEDURE)

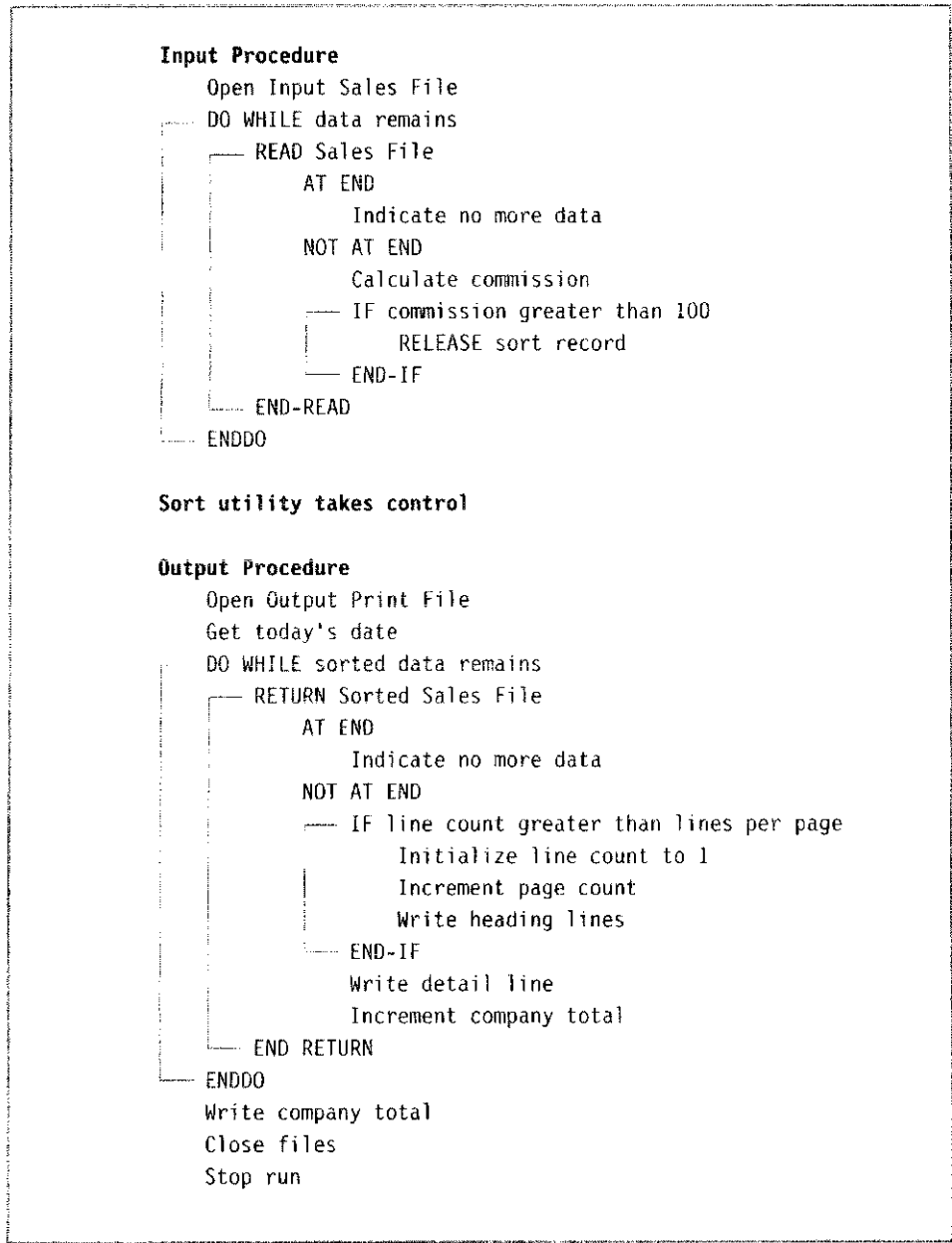

3. After the sort has taken place, control passes to the OUTPUT PROCEDURE, which reads records from the sorted file in order to produce the required report.
4. When the OUTPUT PROCEDURE is finished, control returns to the statement directly (physically) following the actual SORT statement.

The INPUT PROCEDURE is the paragraph 100-CALCULATE-COMMISSION and extends from lines 131 to 148. It begins by opening SALES-FILE, after which the combination of the in-line PERFORM and false condition branch processes records until the file is empty. The commission is calculated for each incoming record, and

Figure 14.12 SORT Program (INPUT PROCEDURE/OUTPUT PROCEDURE)

```

1  IDENTIFICATION DIVISION.
2  PROGRAM-ID.  SORT2.
3  AUTHOR.      CVV.
4
5  ENVIRONMENT DIVISION.
6  INPUT-OUTPUT SECTION.
7  FILE-CONTROL.
8      SELECT SALES-FILE  ASSIGN TO 'A:\CHAPTR14\SORTIN.DAT'
9          ORGANIZATION IS LINE SEQUENTIAL.
10     SELECT PRINT-FILE
11         ASSIGN TO PRINTER.
12     SELECT SORT-WORK-FILE
13         ASSIGN TO 'A:\CHAPTR14\SORTWK.DAT'.
14
15  DATA DIVISION.
16  FILE SECTION.
17  FD SALES-FILE
18     RECORD CONTAINS 57 CHARACTERS
19     DATA RECORD IS SALES-RECORD.
20  01 SALES-RECORD                PIC X(57).
21
22  FD PRINT-FILE
23     RECORD CONTAINS 132 CHARACTERS
24     DATA RECORD IS PRINT-LINE.
25  01 PRINT-LINE                  PIC X(132).
26
27  SD SORT-WORK-FILE
28     RECORD CONTAINS 62 CHARACTERS
29     DATA RECORD IS SORT-RECORD.
30  01 SORT-RECORD.
31     05 SORT-ACCOUNT-NUMBER      PIC 9(6).
32     05 FILLER                    PIC X.
33     05 SORT-NAME                 PIC X(15).
34     05 FILLER                    PIC X(10).
35     05 SORT-LOCATION              PIC X(15).
36     05 SORT-REGION              PIC X(11).
37     05 SORT-COMMISSION          PIC S9(4).
38
39  WORKING-STORAGE SECTION.
40  01 FILLER                       PIC X(14)
41     VALUE 'WS BEGINS HERE'.
42
43  01 SALES-RECORD-IN.
44     05 SR-ACCOUNT-NUMBER        PIC 9(6).
45     05 FILLER                    PIC X.
46     05 SR-NAME                  PIC X(15).
47     05 SR-SALES                 PIC S9(4).
48     05 FILLER                    PIC XX.
49     05 SR-COMMISSION-PERCENT    PIC V99.
50     05 FILLER                    PIC XX.
51     05 SR-LOCATION                PIC X(15).

```

SD defines sort work file

Calculated field not found in input record

Figure 14.12 (continued)

| | | | | |
|-----|----|--------------------------------|------------|---------------------|
| 52 | 05 | SR-REGION | PIC X(11). | |
| 53 | 05 | SR-COMMISSION | PIC S9(4). | |
| 54 | | | | |
| 55 | 01 | TODAYS-DATE-AREA. | | |
| 56 | 05 | TODAYS-YEAR | PIC 99. | |
| 57 | 05 | TODAYS-MONTH | PIC 99. | |
| 58 | 05 | TODAYS-DAY | PIC 99. | |
| 59 | | | | |
| 60 | 01 | PROGRAM-SWITCHES. | | |
| 61 | 05 | DATA-REMAINS-SWITCH | PIC X(3) | VALUE 'YES'. |
| 62 | 88 | NO-DATA-REMAINS | | VALUE 'NO'. |
| 63 | 05 | SORTED-DATA-REMAINS-SW | PIC X(3) | VALUE 'YES'. |
| 64 | 88 | NO-SORTED-DATA-REMAINS | | VALUE 'NO'. |
| 65 | | | | |
| 66 | 01 | PAGE-AND-LINE-COUNTERS. | | |
| 67 | 05 | LINE-COUNT | PIC 9(2) | VALUE 11. |
| 68 | 05 | PAGE-COUNT | PIC 9(2) | VALUE ZEROS. |
| 69 | 05 | LINES-PER-PAGE | PIC 9(2) | VALUE 10. |
| 70 | | | | |
| 71 | 01 | COMPANY-TOTALS. | | |
| 72 | 05 | COMPANY-SALES-TOT | PIC S9(6) | VALUE ZEROES. |
| 73 | 05 | COMPANY-COMM-TOT | PIC S9(6) | VALUE ZEROES. |
| 74 | | | | |
| 75 | 01 | HDG-LINE-ONE. | | |
| 76 | 05 | FILLER | PIC X(25) | VALUE SPACES. |
| 77 | 05 | FILLER | PIC X(21) | |
| 78 | | VALUE 'SALES ACTIVITY REPORT'. | | |
| 79 | 05 | FILLER | PIC X(8) | VALUE SPACES. |
| 80 | 05 | HDG-DATE | PIC X(8). | |
| 81 | 05 | FILLER | PIC X(10) | VALUE SPACES. |
| 82 | 05 | FILLER | PIC X(5) | VALUE 'PAGE'. |
| 83 | 05 | HDG-PAGE | PIC Z9. | |
| 84 | 05 | FILLER | PIC X(53) | VALUE SPACES. |
| 85 | | | | |
| 86 | 01 | HDG-LINE-TWO. | | |
| 87 | 05 | FILLER | PIC X(7) | VALUE ' REGION'. |
| 88 | 05 | FILLER | PIC X(5) | VALUE SPACES. |
| 89 | 05 | FILLER | PIC X(8) | VALUE 'LOCATION'. |
| 90 | 05 | FILLER | PIC X(11) | VALUE SPACES. |
| 91 | 05 | FILLER | PIC X(4) | VALUE 'NAME'. |
| 92 | 05 | FILLER | PIC X(10) | VALUE SPACES. |
| 93 | 05 | FILLER | PIC X(11) | VALUE 'ACCOUNT #'. |
| 94 | 05 | FILLER | PIC X(5) | VALUE SPACES. |
| 95 | 05 | FILLER | PIC X(5) | VALUE 'SALES'. |
| 96 | 05 | FILLER | PIC X(3) | VALUE SPACES. |
| 97 | 05 | FILLER | PIC X(10) | VALUE 'COMMISSION'. |
| 98 | 05 | FILLER | PIC X(53) | VALUE SPACES. |
| 99 | | | | |
| 100 | 01 | DETAIL-LINE. | | |
| 101 | 05 | DET-REGION | PIC X(11). | |
| 102 | 05 | FILLER | PIC X | VALUE SPACES. |

Figure 14.12 (continued)

```

103      05 DET-LOCATION          PIC X(15).
104      05 FILLER              PIC X(3)  VALUE SPACES.
105      05 DET-NAME            PIC X(15).
106      05 FILLER              PIC X(2)  VALUE SPACES.
107      05 DET-ACCOUNT-NUMBER  PIC 9(6).
108      05 FILLER              PIC X(5)  VALUE SPACES.
109      05 DET-SALES           PIC $Z,ZZ9-.
110      05 FILLER              PIC X(7)  VALUE SPACES.
111      05 DET-COMMISSION       PIC $Z,ZZ9-.
112      05 FILLER              PIC X(50) VALUE SPACES.
113
114      01 COMPANY-TOTAL-LINE.
115      05 FILLER              PIC X(31) VALUE SPACES.
116      05 FILLER              PIC X(25)
117          VALUE '*** COMPANY TOTAL = '.
118      05 COMPANY-SALES-TOTAL  PIC $Z(3),ZZ9-.
119      05 FILLER              PIC X(5)  VALUE SPACES.
120      05 COMPANY-COMM-TOTAL  PIC $Z(3),ZZ9-.
121      05 FILLER              PIC X(51) VALUE SPACES.
122
123      PROCEDURE DIVISION.
124      0000-SORT-SALES-RECORDS.
125          SORT SORT-WORK-FILE
126              DESCENDING KEY SORT-COMMISSION
127              INPUT PROCEDURE 100-CALCULATE-COMMISSION
128              OUTPUT PROCEDURE 200-PREPARE-COMMISSION-REPORT.
129          STOP RUN.
130
131      100-CALCULATE-COMMISSION.
132          OPEN INPUT SALES-FILE.
133          PERFORM UNTIL NO-DATA-REMAINS
134              READ SALES-FILE INTO SALES-RECORD-IN
135              AT END
136                  MOVE 'NO' TO DATA-REMAINS-SWITCH
137              NOT AT END
138                  COMPUTE SR-COMMISSION ROUNDED =
139                      SR-SALES * SR-COMMISSION-PERCENT
140                      SIZE ERROR DISPLAY 'ERROR ON COMMISSION FOR '
141                      SR-NAME
142                  END-COMPUTE
143                  IF SR-COMMISSION > 100
144                      RELEASE SORT-RECORD FROM SALES-RECORD-IN
145                  END-IF
146          END-READ
147          END-PERFORM.
148          CLOSE SALES-FILE.
149
150      200-PREPARE-COMMISSION-REPORT.
151          OPEN OUTPUT PRINT-FILE.
152          PERFORM 230-GET-TODAYS-DATE.

```

Sales are sorted by descending commission
Control returns here after SORT statement
INPUT PROCEDURE
RELEASE statement writes record to work file
Records are conditionally written to work file
OUTPUT PROCEDURE

Figure 14.12 (continued)

```

153     PERFORM UNTIL NO-SORTED-DATA-REMAINS
154         RETURN SORT-WORK-FILE INTO SALES-RECORD-IN
155         AT END
156             MOVE 'NO' TO SORTED-DATA-REMAINS-SW
157         NOT AT END
158             PERFORM 250-PROCESS-SORTED-RECORDS
159         END-RETURN
160     END-PERFORM.
161     PERFORM 290-WRITE-COMPANY-TOTAL.
162     CLOSE PRINT-FILE.
163
164     230-GET-TODAYS-DATE.
165         ACCEPT TODAYS-DATE-AREA FROM DATE.
166         STRING TODAYS-MONTH '/' TODAYS-DAY '/' TODAYS-YEAR
167             DELIMITED BY SIZE INTO HDG-DATE.
168
169     250-PROCESS-SORTED-RECORDS.
170         IF LINE-COUNT > LINES-PER-PAGE
171             PERFORM 330-WRITE-HEADING-LINES
172         END-IF.
173         PERFORM 350-WRITE-DETAIL-LINE.
174         PERFORM 370-INCREMENT-COMPANY-TOTAL.
175
176     290-WRITE-COMPANY-TOTAL.
177         MOVE COMPANY-SALES-TOT TO COMPANY-SALES-TOTAL.
178         MOVE COMPANY-COMM-TOT TO COMPANY-COMM-TOTAL.
179         WRITE PRINT-LINE FROM COMPANY-TOTAL-LINE
180             AFTER ADVANCING 2 LINES.
181
182     330-WRITE-HEADING-LINES.
183         MOVE 1 TO LINE-COUNT.
184         ADD 1 TO PAGE-COUNT.
185         MOVE PAGE-COUNT TO HDG-PAGE.
186         WRITE PRINT-LINE FROM HDG-LINE-ONE
187             AFTER ADVANCING PAGE.
188         WRITE PRINT-LINE FROM HDG-LINE-TWO
189             AFTER ADVANCING 2 LINES.
190
191     350-WRITE-DETAIL-LINE.
192         MOVE SR-REGION TO DET-REGION.
193         MOVE SR-LOCATION TO DET-LOCATION.
194         MOVE SR-NAME TO DET-NAME.
195         MOVE SR-ACCOUNT-NUMBER TO DET-ACCOUNT-NUMBER.
196         MOVE SR-SALES TO DET-SALES.
197         MOVE SR-COMMISSION TO DET-COMMISSION.
198         WRITE PRINT-LINE FROM DETAIL-LINE.
199         ADD 1 TO LINE-COUNT.
200
201     370-INCREMENT-COMPANY-TOTAL.
202         ADD SR-SALES TO COMPANY-SALES-TOT.
203         ADD SR-COMMISSION TO COMPANY-COMM-TOT.

```

← IFV statement reads record from sort work file

only those records with a commission greater than \$100 are written (released) to the sort work file. The INPUT PROCEDURE ends by closing SALES-FILE, after which control passes to the sort utility. The sort work file is neither opened nor closed explicitly by the programmer as that is done by the sort utility.

The OUTPUT PROCEDURE is the paragraph 200-PREPARE-COMMISSION-REPORT and extends from lines 150 to 162. It begins by opening PRINT-FILE, after which the combination of the in-line PERFORM and false-condition branch processes records until the sort work file is empty. The report is produced by using many of the identical paragraphs from the earlier program. The OUTPUT PROCEDURE ends by closing PRINT-FILE after which control passes to the STOP RUN statement in line 129 immediately under the SORT statement.

Comparing Options

The differences between the two COBOL programs is highlighted by comparing the generated reports in Figure 14.6. Figure 14.6a was produced by the USING/GIVING option and lists *all records* in sequence by region, location, and name. Figure 14.6b lists a subset of *selected records* in decreasing order of commission, a calculated field. The following are other differences between the two programs:

1. Figure 14.9 sorts on three fields, SORT-REGION, SORT-LOCATION, and SORT-NAME, each of which is contained in the incoming record. Figure 14.12 sorts on SORT-COMMISSION, a calculated field not found in the incoming record.
2. The USING option in Figure 14.9 does the I/O for the programmer; that is, it opens SALES-FILE, reads and writes every record from this file to the sort work file, then closes SALES-FILE when the sort work file has been created.
3. The INPUT PROCEDURE in Figure 14.12 requires the programmer to do the I/O; that is, the programmer has to open SALES-FILE, read records from the input file and write (release) them to the sort work file, then close the input file.
4. The GIVING option in Figure 14.9 creates a permanent file, SORTED-SALES-FILE, that contains the results of the sort; the OUTPUT PROCEDURE in Figure 14.12 creates a temporary work file that disappears when the program terminates. The GIVING option uses an extra file; that is, four files are present in Figure 14.9 versus three in Figure 14.12.
5. The OUTPUT PROCEDURE uses a RETURN statement in lines 154–159 because the sorted records are read from the sort work file. This is in contrast to the READ statement in lines 136–141 of Figure 14.9, which reads records from SORTED-SALES-FILE, an ordinary file defined in an FD.
6. The record lengths in Figure 14.9 of SORT-FILE, SALES-FILE, and SORTED-SALES-FILE, must be the same (58 characters). The record lengths of SORT-FILE and SALES-FILE in Figure 14.12 are different.

MERGE Statement

Merging files is a special case of sorting. The MERGE statement takes several input files, which have identical record formats and which have been sorted in the same sequence, and combines them into a single output file (device type and blocking may differ for the various files). A merge achieves the same results as sorting, but

more efficiently; that is, the several input files to a merge could also be concatenated as a single input file to a sort. The advantage of the merge over a sort is in execution speed; a merge will execute faster because its logic realizes that the several input files are already in order.

The format of the MERGE statement is as follows:

```

MERGE file-name-1
    { ON { DESCENDING } KEY { data-name-1 } . . . } . . .
    { ON { ASCENDING } KEY { data-name-1 } . . . } . . .
    [ COLLATING SEQUENCE IS alphabet-name ]
    USING file-name-2 [ file-name-3 ] . . .
    [ OUTPUT PROCEDURE IS procedure-name-1 [ { THRU } procedure-name-2 ] ]
    [ GIVING { file-name-4 } . . . ]

```

File-name-1 must be specified in an SD. Rules for ASCENDING (DESCENDING) KEY, COLLATING SEQUENCE, USING/GIVING, and OUTPUT PROCEDURE are identical to those of the SORT statement.

Unlike the SORT statement, however, there is no INPUT PROCEDURE option. In other words you must specify USING, and list all files from which incoming records will be chosen. Hence every record in every file specified in USING will appear in the merged file. However, you do have a choice between GIVING and OUTPUT PROCEDURE.

None of the files specified in a MERGE statement can be open when the statement is executed, as the merge operation implicitly opens them. In similar fashion, the files will be automatically closed by the MERGE.

An example of a MERGE statement is shown below:

```

MERGE WORK-FILE
    ON ASCENDING CUSTOMER-ACCOUNT-NUMBER
       DESCENDING AMOUNT-OF-SALE
    USING
       MONDAY-SALES-FILE
       TUESDAY-SALES-FILE
       WEDNESDAY-SALES-FILE
       THURSDAY-SALES-FILE
       FRIDAY-SALES-FILE
    GIVING
       WEEKLY-SALES-FILE.

```

WORK-FILE is defined in a COBOL SD. WEEKLY-SALES-FILE, MONDAY-SALES-FILE, TUESDAY-SALES-FILE, and so on are each specified in both FD and SELECT statements. These files must be in sequence and are both opened and closed by the merge operation.

The primary key is CUSTOMER-ACCOUNT-NUMBER (ascending), and the secondary key is AMOUNT-OF-SALE (descending). All records with the same account number will be grouped together with the highest sale for each account number listed first. Records with identical keys in one or more input files will be listed in the order in which the files appear in the MERGE statement itself. Hence, in the event of a tie on both account number and amount of sale, Monday's transactions will appear before Tuesday's, and so on.

LIMITATIONS OF COBOL-74

The SORT statement in COBOL-74 is significantly more restrictive than its counterpart in COBOL-85. In particular:

1. The INPUT (OUTPUT) PROCEDURE in COBOL-74 was required to be a *section* rather than a paragraph, which necessitated that other paragraphs in the program be organized into sections as well.
2. The INPUT (OUTPUT) PROCEDURE in COBOL-74 could not transfer control to points outside the designated procedure, requiring the use of a GO TO statement within the procedure. The GO TO statement was directed to an EXIT paragraph at the end of the section.

Both of these restrictions have been removed from COBOL-85 as illustrated in the INPUT PROCEDURE/OUTPUT PROCEDURE example in Figure 14.12. An additional change in COBOL-85 is the introduction of the WITH DUPLICATES IN ORDER phrase, which was not present in the earlier compiler.

S U M M A R Y

Points to Remember

- ✱ Sorting is done in one of two sequences, ascending or descending. Multiple sort keys are listed in order of importance— primary, secondary, and tertiary; or major, intermediate, and minor.
- ✱ Two collating sequences are in common use, EBCDIC (on IBM mainframes) and ASCII (on the PC and other mainframes). The difference is significant when an alphanumeric key is used and/or with an embedded sign in a numeric field.
- ✱ The SORT statement has four combinations: INPUT PROCEDURE/OUTPUT PROCEDURE, USING/GIVING, USING/OUTPUT PROCEDURE, and INPUT PROCEDURE/GIVING.
- ✱ The INPUT PROCEDURE requires the programmer to do the I/O associated with the sort work file, whereas the USING option does the I/O automatically. The advantage of the INPUT PROCEDURE is the ability to sort on a calculated field and/or to selectively pass records to the sort work file.
- ✱ The INPUT PROCEDURE contains a RELEASE statement to transfer (write) records to the sort work file; the OUTPUT PROCEDURE contains a RETURN statement to read the sorted data.
- ✱ The GIVING option specifies a permanent file that remains after the program has ended and that contains the sorted results; the OUTPUT PROCEDURE uses a temporary work file, which is deleted after the program has ended.



- ☐ Regardless of which option is chosen, file-name-1 of the SORT statement must be described in an SD. Further, each key (that is, data name) appearing in the SORT statement must be described in the sort record.
- ☐ If the USING / GIVING option is used, file-name-2 and file-name-3 each require an FD. The record sizes of file names 1, 2, and 3 must all be the same.

Key Words and Concepts

- | | |
|--------------------|----------------------|
| ASCII | Minor key |
| Ascending sort | Primary key |
| Calculated field | Secondary key |
| Collating sequence | Sort key |
| Descending sort | Sort work file |
| EBCDIC | Temporary work file |
| Embedded sign | Tertiary key |
| Intermediate key | Utility sort program |
| Major key | |

COBOL Elements

- | | |
|---------------------|-------------------------------------|
| ASCENDING KEY | RELEASE |
| DESCENDING KEY | RETURN |
| DUPLICATES IN ORDER | SD |
| GIVING | SIGN IS LEADING SEPARATE CHARACTER |
| INPUT PROCEDURE | SIGN IS TRAILING SEPARATE CHARACTER |
| MERGE | SORT |
| OUTPUT PROCEDURE | USING |

F I L L - I N

1. A sort _____ is a field within a record that determines how the file is to be arranged.
2. The most important key is known as the _____ or _____ key.
3. _____ and _____ are widely used collating sequences.
4. If records in a file have been sorted by salary so that the employee with the highest salary appears first, the records are in _____ sequence by salary.
5. If a file has been sorted by state, city within state, and employee within city, then state, city, and name are the _____, _____, and _____ keys, respectively.
6. In a sort on an alphanumeric part number, AAA would precede 111 using the _____ collating sequence, but follow it under _____.
7. The USING option may be used with either _____ or _____.

8. The _____ statement is analogous to WRITE and appears in the _____.
9. A sort work file must be defined in a _____ statement in the Environment Division and in an _____ in the Data Division.
10. An embedded sign (requires/does not require) an extra position within a signed field.
11. The default placement of a sign is as the (leading/trailing) character in a(n) (embedded/separate) position.
12. The _____ may be used to sort on a _____ field, and also to _____ pass records to the sort work file to increase efficiency.
13. The MERGE statement requires that its input files have _____ record layouts.
14. The MERGE statement (does/does not) permit the INPUT PROCEDURE option.

TRUE / FALSE

1. The SORT statement cannot be used on a calculated field.
2. If USING is specified in the SORT statement, then GIVING must also be specified.
3. If INPUT PROCEDURE is specified in the SORT statement, then OUTPUT PROCEDURE is also required.
4. Only one ascending and one descending key are permitted in the SORT statement.
5. Major key and primary key are synonymous.
6. Minor key and secondary key are synonymous.
7. RELEASE and RETURN are associated with the USING/GIVING option.
8. RELEASE is present in the INPUT PROCEDURE.
9. RETURN is specified in the OUTPUT PROCEDURE.
10. If a record is released, it is written to the sort file.
11. If a record is returned, it is read from the sort file.
12. If USING/GIVING is used, the sorted file must contain every record in the input file.
13. If INPUT PROCEDURE/OUTPUT PROCEDURE is used, the sorted file must contain every record in the input file.
14. XYZ will always come before 123 in an alphanumeric sort.
15. ADAMS will always appear before ADAMSON, regardless of collating sequence.
16. The file specified immediately after the word MERGE must be defined in an MD rather than an SD.
17. The MERGE statement can specify INPUT PROCEDURE/OUTPUT PROCEDURE.
18. The MERGE statement can specify USING/GIVING.
19. The MERGE statement can be applied to input files with different record layouts.
20. The sort work file (the file defined in the SD) is a temporary file and does not exist after the COBOL program has finished execution.

O B L E M S

1. Given the following data:

| Name | Location | Department |
|----------|-------------|------------|
| Milgrom | New York | 1000 |
| Samuel | Boston | 2000 |
| Isaac | Boston | 2000 |
| Chandler | Chicago | 2000 |
| Lavor | Los Angeles | 1000 |
| Elsinor | Chicago | 1000 |
| Tater | New York | 2000 |
| Craig | New York | 2000 |
| Borow | Boston | 2000 |
| Kenneth | Boston | 2000 |
| Renaldi | Boston | 1000 |
| Gulfman | Chicago | 1000 |

Rearrange the data according to the following sorts:

- Major field: department (descending); minor field: name (ascending).
 - Primary field: department (ascending); secondary field: location (ascending); tertiary field: name (ascending).
2. Given the statement

```

SORT SORT-FILE
      ASCENDING KEY STUDENT-MAJOR DESCENDING YEAR-IN-SCHOOL
      ASCENDING STUDENT-NAME
USING FILE-ONE
GIVING FILE-TWO.

```

- What is the major key?
 - What is the minor key?
 - Which file will be specified in an SD?
 - Which file will contain the sorted output?
 - Which file(s) will be specified in a SELECT?
 - Which file contains the input data?
 - Which file must contain the data names STUDENT-NAME, YEAR-IN-SCHOOL, and STUDENT-MAJOR?
3. The following code is intended to sort a file of employee records in order of age, listing the oldest first:

```

FD EMPLOYEE-FILE
.
.
01 EMPLOYEE-RECORD.
   05 EMP-NAME           PIC X(25).
   05 EMP-BIRTH-DATE.
      10 EMP-BIRTH-MONTH PIC 99.
      10 EMP-BIRTH-YEAR  PIC 99.
   05 FILLER             PIC X(51).

```

```

SD SORT-FILE
.
.
01 SORT-RECORD.
   05 FILLER                PIC X(20).
   05 SORT-BIRTH-DATE.
       10 SORT-BIRTH-MONTH  PIC 99.
       10 SORT-BIRTH-YEAR   PIC 99.
   05 FILLER                PIC X(56).

PROCEDURE DIVISION.
SORT SORT-FILE
   DESCENDING KEY SORT-BIRTH-MONTH SORT-BIRTH-YEAR
   USING EMPLOYEE-FILE
   GIVING ORDERED-FILE.

```

There are three distinct reasons why the intended code will not work. Find and correct the errors.

4. The registrar has asked for a simple report listing students by year, and alphabetically within year. Thus all freshmen are to appear first, followed by all sophomores, juniors, seniors, and graduate students. The incoming record has the following layout:

```

01 STUDENT-RECORD.
   05 ST-NAME                PIC X(15).
   05 ST-MAJOR               PIC X(15).
   05 ST-YEAR                PIC XX.
   05 ST-CREDITS             PIC 99.
   05 ST-COLLEGE            PIC X(10).

```

The ST-YEAR field uses the codes, FR, SO, JR, SR, and GR for freshman, sophomore, junior, senior, and graduate student, respectively. Develop the Procedure Division code to accomplish the desired sort. (It is not as easy as it looks.)

5. Indicate the form of the SORT statement (USING, INPUT PROCEDURE, GIVING, OUTPUT PROCEDURE) that would most likely be used for the following applications:
- Conversion of an incoming inventory file that has its part numbers in ASCII sequence to a new file, having its numbers in EBCDIC sequence.
 - Preparation of a report to select all graduating seniors (those with completed credits totaling 90 or more), listed in order of decreasing grade point average.
 - A data-validation program that reads unedited transactions, rejects those with invalid data, and prepares a sorted transaction file containing only valid records.
 - A program to prepare mailing labels in zip code order from a customer list.
6. Given the statement:

```

MERGE WORK-FILE
   ASCENDING ACCOUNT-NUMBER
   DESCENDING AMOUNT-OF-SALE
USING
   JANUARY-SALES
   FEBRUARY-SALES
   MARCH-SALES
GIVING
   FIRST-QUARTER-SALES.

```

- a. Which file(s) are specified in an SD?
 - b. Which file(s) are specified in an FD?
 - c. Which file(s) contain the key ACCOUNT-NUMBER?
 - d. What is the primary key?
 - e. What is the secondary key?
 - f. If a record on the JANUARY-SALES file has the identical ACCOUNT-NUMBER as a record on the FEBRUARY-SALES file, which record would come first on the merged file?
 - g. If a record on the JANUARY-SALES file has the identical AMOUNT-OF-SALE as a record on the FEBRUARY-SALES file, which record would come first on the merged file?
 - h. If a record on the JANUARY-SALES file has the identical AMOUNT-OF-SALE and ACCOUNT-NUMBER as a record on the FEBRUARY-SALES file, which record would come first on the merged file?
7. Given the following COBOL definition:
- ```
05 TRANSACTION-DATE.
 10 TRANS-MONTH PIC 99.
 10 TRANS-DAY PIC 99.
 10 TRANS-YEAR PIC 99.
```

Write a portion of the SORT statement necessary to put transactions in sequence with the earliest transaction listed first. Are there any problems in your solution when the century changes? Should you be concerned about those problems now?

8. The registrar requires an alphabetical list of graduating seniors. The report will be generated from the student master file, which contains every student in the school, in social security number sequence.
- Two approaches have been suggested. The first uses the USING/GIVING option to sort the file alphabetically, after which the desired records are selected for inclusion in the report. The second selects the desired records in the INPUT PROCEDURE, after which the file is sorted and the report prepared in the OUTPUT PROCEDURE.
- Both approaches will produce a correct report. Is there any reason to choose one over the other?



# Control Breaks

## CHAPTER OUTLINE

---

Overview

**System Concepts**

Running versus Rolling Totals

**One-Level Control Breaks**

Programming Specifications

Hierarchy Chart

Pseudocode

The Completed Program

**Two-Level Control Breaks**

Hierarchy Chart

Pseudocode

The Completed Program

**Three-Level Control Breaks**

Hierarchy Chart

Pseudocode

The Completed Program

Limitations of COBOL-74

Summary

Fill-in

True/False

Problems



## OBJECTIVES

---

After reading this chapter you will be able to:

- Define control break; distinguish between a single control break and a multilevel control break.
- Explain the relationship between sorting and control breaks.
- Design a hierarchy chart and pseudocode to implement any number of control breaks; evaluate the hierarchy chart with respect to completeness, functionality, and span of control.
- Use a general purpose algorithm to write a COBOL program for any number of control breaks.
- Develop COBOL programs for one-, two-, and three-level control breaks.
- Distinguish between rolling and running totals.

## OVERVIEW

---

This chapter does not introduce any new COBOL per se, but uses the COBOL you already know to present one of the most important applications in data processing, that of control breaks. A control break is defined as a change in a designated field, which in turn requires that the incoming file be in sequence by the designated field. There is, therefore, a close relationship between sorting and control breaks, a relationship that will be stressed throughout the chapter.

The logic associated with control breaks is more complex than many of the examples presented earlier in the text. The difficulty, if any, stems from a rush into coding a program, without giving suitable thought to its design. Accordingly, we emphasize the importance of proper design, and the use of hierarchy charts and pseudocode, to simplify the eventual coding.

Control breaks may be implemented at several levels, just as a file may be sorted on multiple keys. The system concepts section distinguishes between one-, two-, and three-level control breaks, each of which is developed in a separate program.

---

### System Concepts

This chapter continues the example of Chapter 14, beginning with a review of the file in Figure 15.1 (shown previously as Figure 14.5). Six fields are present in every record: account number, salesperson, sales amount, commission percentage, location, and region. The sales amount contains an embedded sign to reflect negative numbers (i.e., returns rather than sales) as previously discussed. Recall, too, that the commission amount is determined by multiplying the commission percentage (contained in the record) by the sales amount.

**Figure 15.1** Transaction File ( The sales amount shows ASCII rather than EBCDIC characters.)

| Acct Num | Salesperson | Sales Amount | Comm Pct | Location       | Region    |
|----------|-------------|--------------|----------|----------------|-----------|
| 000069   | BENWAY      | 023q         | 10       | CHICAGO        | MIDWEST   |
| 000100   | HUMMER      | 010w         | 05       | CHICAGO        | MIDWEST   |
| 000101   | CLARK       | 1500         | 10       | TRENTON        | NORTHEAST |
| 000104   | CLARK       | 0500         | 03       | TRENTON        | NORTHEAST |
| 100000   | JOHNSON     | 030s         | 06       | ST. PETERSBURG | SOUTHEAST |
| 130101   | CLARK       | 3200         | 20       | TRENTON        | NORTHEAST |
| 203000   | HAAS        | 8900         | 05       | ST. LOUIS      | MIDWEST   |
| 248545   | JOHNSON     | 0345         | 14       | ST. PETERSBURG | SOUTHEAST |
| 277333   | HAAS        | 009x         | 08       | ST. LOUIS      | MIDWEST   |
| 400000   | JOHNSON     | 070y         | 08       | ST. PETERSBURG | SOUTHEAST |
| 444333   | ADAMS       | 100v         | 01       | NEW YORK       | NORTHEAST |
| 444444   | FEGEN       | 0100         | 02       | ST. PETERSBURG | SOUTHEAST |
| 475365   | HAAS        | 0333         | 05       | ST. LOUIS      | MIDWEST   |
| 476236   | FEGEN       | 037v         | 03       | ST. PETERSBURG | SOUTHEAST |
| 476530   | BENWAY      | 023u         | 05       | CHICAGO        | MIDWEST   |
| 555555   | FEGEN       | 0304         | 05       | ST. PETERSBURG | SOUTHEAST |
| 555666   | ADAMS       | 2003         | 20       | NEW YORK       | NORTHEAST |
| 576235   | CLARK       | 0100         | 03       | TRENTON        | NORTHEAST |
| 583645   | KARLSTROM   | 0145         | 04       | BALTIMORE      | NORTHEAST |
| 649356   | HUMMER      | 0345         | 05       | CHICAGO        | MIDWEST   |
| 694446   | HUMMER      | 0904         | 10       | CHICAGO        | MIDWEST   |
| 700039   | MARCUS      | 0932         | 10       | BALTIMORE      | NORTHEAST |
| 750020   | MARCUS      | 0305         | 05       | BALTIMORE      | NORTHEAST |
| 800396   | KARLSTROM   | 3030         | 09       | BALTIMORE      | NORTHEAST |
| 878787   | JOHNSON     | 1235         | 12       | ST. PETERSBURG | SOUTHEAST |
| 987654   | ADAMS       | 2005         | 10       | NEW YORK       | NORTHEAST |
| 988888   | BENWAY      | 0450         | 01       | CHICAGO        | MIDWEST   |
| 999340   | BENWAY      | 0334         | 30       | CHICAGO        | MIDWEST   |

The records in Figure 15.1 are in sequence by account number, so that the transactions associated with any particular salesperson are scattered throughout the file. What if, however, we wanted to know the total sales and/or commission amount for a particular salesperson or for every salesperson? The easiest way to produce such a report would be to sort the file by salesperson so that all of the transactions for each salesperson appear together. It would then be a simple matter to look at all the transactions for Adams in order to compute his total sales and commission, then look at the transactions for Benway, then for Clark, etc. This is precisely what is meant by control break processing.

The records in Figure 15.2a have been sorted by salesperson in order to produce the report of Figure 15.2b. A *control break*, defined as a change in a *control field* (salesperson in the example), occurs when the value of the control field changes from record to record—for example, when we go from the last transaction for Adams to the first transaction for Benway, and again from the last transaction for Benway to the first transaction for Clark. The detection of a control break signals the creation of one or more *control totals*, which in this example would be the sales and commissions for a given salesperson.

Figure 15.2 One-Level Control Break

|        |           |      |    |                         |
|--------|-----------|------|----|-------------------------|
| 444333 | ADAMS     | 100v | 01 |                         |
| 555666 | ADAMS     | 2003 | 20 |                         |
| 987654 | ADAMS     | 2005 | 10 | One-level control break |
| 000069 | BENWAY    | 023q | 10 |                         |
| 476530 | BENWAY    | 023u | 05 |                         |
| 988888 | BENWAY    | 0450 | 01 |                         |
| 999340 | BENWAY    | 0334 | 30 | One-level control break |
| 000101 | CLARK     | 1500 | 10 |                         |
| 000104 | CLARK     | 0500 | 03 |                         |
| 130101 | CLARK     | 3200 | 20 |                         |
| 576235 | CLARK     | 0100 | 03 |                         |
| 444444 | FEGEN     | 0100 | 02 |                         |
| 476236 | FEGEN     | 037v | 03 |                         |
| 555555 | FEGEN     | 0304 | 05 |                         |
| 203000 | HAAS      | 8900 | 05 |                         |
| 277333 | HAAS      | 009x | 08 |                         |
| 475365 | HAAS      | 0333 | 05 |                         |
| 000100 | HUMMER    | 010w | 05 |                         |
| 649356 | HUMMER    | 0345 | 05 |                         |
| 694446 | HUMMER    | 0904 | 10 |                         |
| 100000 | JOHNSON   | 030s | 06 |                         |
| 248545 | JOHNSON   | 0345 | 14 |                         |
| 400000 | JOHNSON   | 070y | 08 |                         |
| 878787 | JOHNSON   | 1235 | 12 |                         |
| 583645 | KARLSTROM | 0145 | 04 |                         |
| 800396 | KARLSTROM | 3030 | 09 |                         |
| 700039 | MARCUS    | 0932 | 10 |                         |
| 750020 | MARCUS    | 0305 | 05 |                         |

(a) Sorted Data (by Salesperson)

| SALES ACTIVITY REPORT |          |            | PAGE 3 |
|-----------------------|----------|------------|--------|
| SALESPERSON: CLARK    |          |            |        |
| ACCOUNT #             | SALES    | COMMISSION |        |
| SALES ACTIVITY REPORT |          |            | PAGE 2 |
| SALESPERSON: BENWAY   |          |            |        |
| ACCOUNT #             | SALES    | COMMISSION |        |
| SALES ACTIVITY REPORT |          |            | PAGE 1 |
| SALESPERSON: ADAMS    |          |            |        |
| ACCOUNT #             | SALES    | COMMISSION |        |
| 444333                | 1,005-   | 10-        |        |
| 555666                | 2,003    | 401        |        |
| 987654                | 2,005    | 201        |        |
| ** SALESPERSON TOTAL  |          |            |        |
|                       | \$ 3,003 | \$ 592     |        |

(b) Partial Output

A *two-level control break* is illustrated in Figure 15.3. The data in Figure 15.3a have been sorted by location, and by salesperson within location, in order to produce the report in Figure 15.3b. All salespersons in the same location appear together, as do all transactions for the same salesperson. A one-level control break occurs from Karlstrom to Marcus as salesperson changes, but location does not. A two-level control break occurs from Marcus to Benway, when the values of two control fields, salesperson and location, change simultaneously. The two-level control break produces two sets of control totals: the sales and commission totals for Marcus, as well as the sales and commission totals for all salespersons in Baltimore.

A *three-level control break* is shown in Figure 15.4. The data in Figure 15.4a have been sorted by region, location within region, and salesperson within location, in order to produce the report of Figure 15.4b. A one-level control break occurs from Benway to Hummer as salesperson changes, but location and region do not. A two-level control break occurs from Hummer to Haas when salesperson and location change simultaneously but regions remains constant, and a three-level control break occurs from Haas to Karlstrom as all three fields change together.

There is no theoretical limit to the number of control breaks that can be computed; there is a practical limit, however, in that most people lose track after three (or at most four) levels. Regardless of the number of control breaks in effect, the file used to create the control totals must be in sequence according to the designated control fields.

Figure 15.3 Two-Level Control Break

|        |           |      |    |                |                         |
|--------|-----------|------|----|----------------|-------------------------|
| 583645 | KARLSTROM | 0145 | 04 | BALTIMORE      |                         |
| 800396 | KARLSTROM | 3030 | 09 | BALTIMORE      |                         |
| 700039 | MARCUS    | 0932 | 10 | BALTIMORE      | one-level control break |
| 750020 | MARCUS    | 0305 | 05 | BALTIMORE      |                         |
| 000069 | BENWAY    | 023q | 10 | CHICAGO        | two-level control break |
| 476530 | BENWAY    | 023u | 05 | CHICAGO        |                         |
| 988888 | BENWAY    | 0450 | 01 | CHICAGO        |                         |
| 999340 | BENWAY    | 0334 | 30 | CHICAGO        |                         |
| 000100 | HUMMER    | 010w | 05 | CHICAGO        |                         |
| 649356 | HUMMER    | 0345 | 05 | CHICAGO        |                         |
| 694446 | HUMMER    | 0904 | 10 | CHICAGO        |                         |
| 444333 | ADAMS     | 100v | 01 | NEW YORK       |                         |
| 555666 | ADAMS     | 2003 | 20 | NEW YORK       |                         |
| 987654 | ADAMS     | 2005 | 10 | NEW YORK       |                         |
| 203000 | HAAS      | 8900 | 05 | ST. LOUIS      |                         |
| 277333 | HAAS      | 009x | 08 | ST. LOUIS      |                         |
| 475365 | HAAS      | 0333 | 05 | ST. LOUIS      |                         |
| 444444 | FEGEN     | 0100 | 02 | ST. PETERSBURG |                         |
| 476236 | FEGEN     | 037v | 03 | ST. PETERSBURG |                         |
| 555555 | FEGEN     | 0304 | 05 | ST. PETERSBURG |                         |
| 100000 | JOHNSON   | 030s | 06 | ST. PETERSBURG |                         |
| 248545 | JOHNSON   | 0345 | 14 | ST. PETERSBURG |                         |
| 400000 | JOHNSON   | 070y | 08 | ST. PETERSBURG |                         |
| 878787 | JOHNSON   | 1235 | 12 | ST. PETERSBURG |                         |
| 000101 | CLARK     | 1500 | 10 | TRENTON        |                         |
| 000104 | CLARK     | 0500 | 03 | TRENTON        |                         |
| 130101 | CLARK     | 3200 | 20 | TRENTON        |                         |
| 576235 | CLARK     | 0100 | 03 | TRENTON        |                         |

(a) Sorted Data (by Location and Salesperson)

Figure 15.3 (continued)

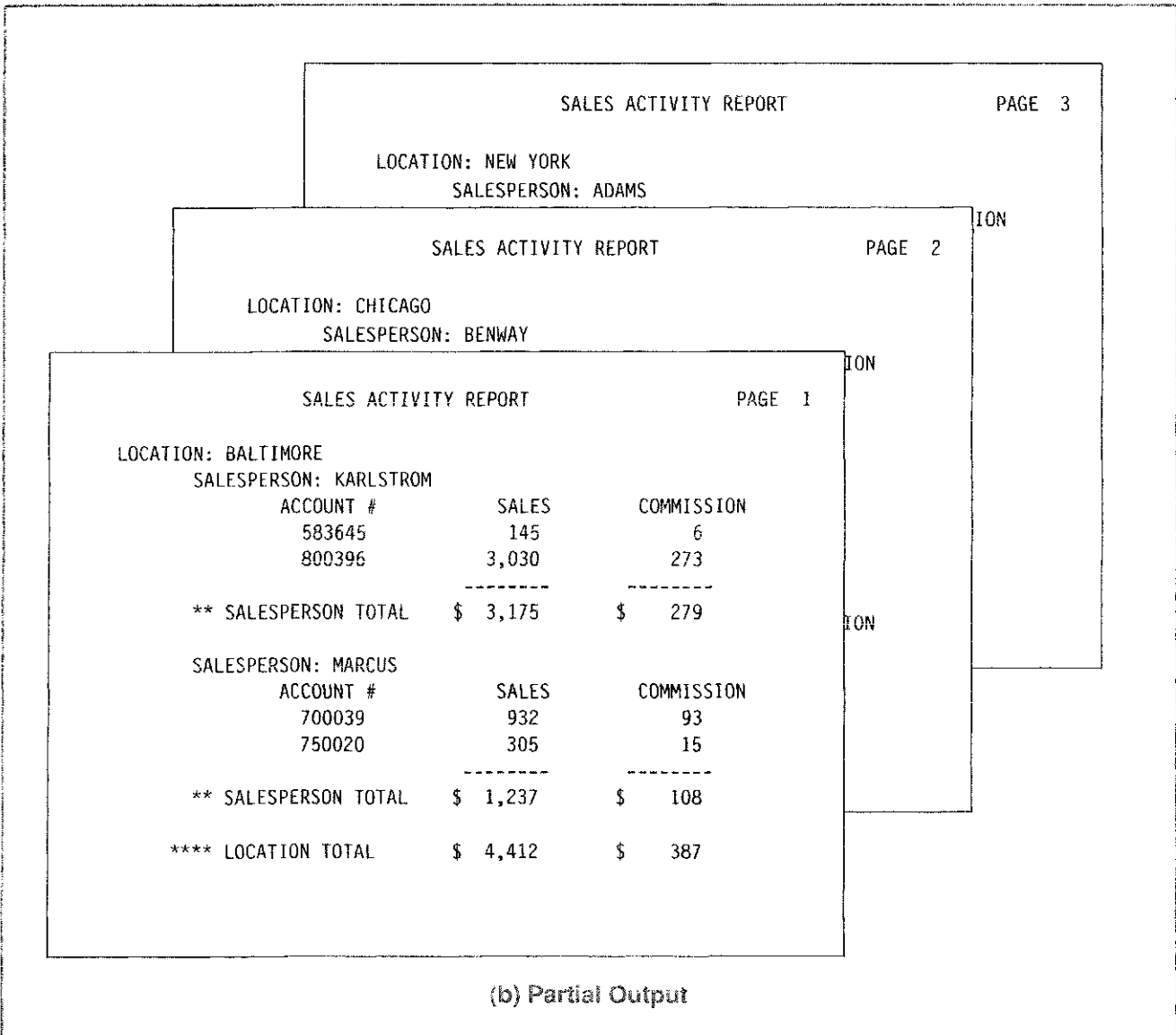

### Running versus Rolling Totals

Each of the reports in Figures 15.2 through 15.4 computes totals at one or more levels (at salesperson, location, region, and company), according to the number of control breaks. The company totals are printed at the end of processing and appear on the last page of each report, but are not visible in the individual figures. (The total sales for the company and corresponding commission are \$23,906 and \$2,540, respectively.)

Consider for a moment how the computations might be accomplished in the one-level report of Figure 15.2b. There is only one way to compute the total for individual salespersons—by initializing the total for each new salesperson to zero, then adding the amount on every transaction for that salesperson to his or her total. There are, however, two ways to compute the company total—by adding the value for every transaction to a *running company total*, or by waiting for a break on

salesperson and then adding, or *rolling*, the salesperson total to the company total. The latter is more efficient in that fewer additions are performed.

Similar reasoning applies to the two-level report of Figure 15.3b, in which the location total can be computed two different ways—by adding the value of each incoming transaction to a running location total, or by waiting for a control break on salesperson, then rolling the salesperson total to the location total. In similar fashion, the company total may be obtained in three ways. First, by adding the value of every incoming transaction to a running company total. Second, by rolling the salesperson total into the company total after a one-level break on salesperson. Or third, by rolling the location total into the company total after a two-level break on location. The third approach is the most efficient.

You should be able to extend this logic to the three-level report of Figure 15.4b, which maintains a running total for each salesperson, then rolls the salesperson total into the location total (after a break on salesperson), rolls the location total into the region total (after a break on location), and finally rolls the region total into the company total (after a break on region).

Figure 15.4 Three-Level Control Break

|        |           |      |    |                |           |                           |
|--------|-----------|------|----|----------------|-----------|---------------------------|
| 000069 | BENWAY    | 023q | 10 | CHICAGO        | MIDWEST   |                           |
| 476530 | BENWAY    | 023u | 05 | CHICAGO        | MIDWEST   |                           |
| 988888 | BENWAY    | 0450 | 01 | CHICAGO        | MIDWEST   |                           |
| 999340 | BENWAY    | 0334 | 30 | CHICAGO        | MIDWEST   |                           |
| 000100 | HUMMER    | 010w | 05 | CHICAGO        | MIDWEST   | One-level control break   |
| 649356 | HUMMER    | 0345 | 05 | CHICAGO        | MIDWEST   |                           |
| 694446 | HUMMER    | 0904 | 10 | CHICAGO        | MIDWEST   |                           |
| 203000 | HAAS      | 8900 | 05 | ST. LOUIS      | MIDWEST   | Two-level control break   |
| 277333 | HAAS      | 009x | 08 | ST. LOUIS      | MIDWEST   |                           |
| 475365 | HAAS      | 0333 | 05 | ST. LOUIS      | MIDWEST   |                           |
| 583645 | KARLSTROM | 0145 | 04 | BALTIMORE      | NORTHEAST | Three-level control break |
| 800396 | KARLSTROM | 3030 | 09 | BALTIMORE      | NORTHEAST |                           |
| 700039 | MARCUS    | 0932 | 10 | BALTIMORE      | NORTHEAST |                           |
| 750020 | MARCUS    | 0305 | 05 | BALTIMORE      | NORTHEAST |                           |
| 444333 | ADAMS     | 100v | 01 | NEW YORK       | NORTHEAST |                           |
| 555666 | ADAMS     | 2003 | 20 | NEW YORK       | NORTHEAST |                           |
| 987654 | ADAMS     | 2005 | 10 | NEW YORK       | NORTHEAST |                           |
| 000101 | CLARK     | 1500 | 10 | TRENTON        | NORTHEAST |                           |
| 000104 | CLARK     | 0500 | 03 | TRENTON        | NORTHEAST |                           |
| 130101 | CLARK     | 3200 | 20 | TRENTON        | NORTHEAST |                           |
| 576235 | CLARK     | 0100 | 03 | TRENTON        | NORTHEAST |                           |
| 444444 | FEGEN     | 0100 | 02 | ST. PETERSBURG | SOUTHEAST |                           |
| 476236 | FEGEN     | 037v | 03 | ST. PETERSBURG | SOUTHEAST |                           |
| 555555 | FEGEN     | 0304 | 05 | ST. PETERSBURG | SOUTHEAST |                           |
| 100000 | JOHNSON   | 030s | 06 | ST. PETERSBURG | SOUTHEAST |                           |
| 248545 | JOHNSON   | 0345 | 14 | ST. PETERSBURG | SOUTHEAST |                           |
| 400000 | JOHNSON   | 070y | 08 | ST. PETERSBURG | SOUTHEAST |                           |
| 878787 | JOHNSON   | 1235 | 12 | ST. PETERSBURG | SOUTHEAST |                           |

(a) Sorted Data (by Region, Location, and Salesperson)

Figure 15.4 (continued)

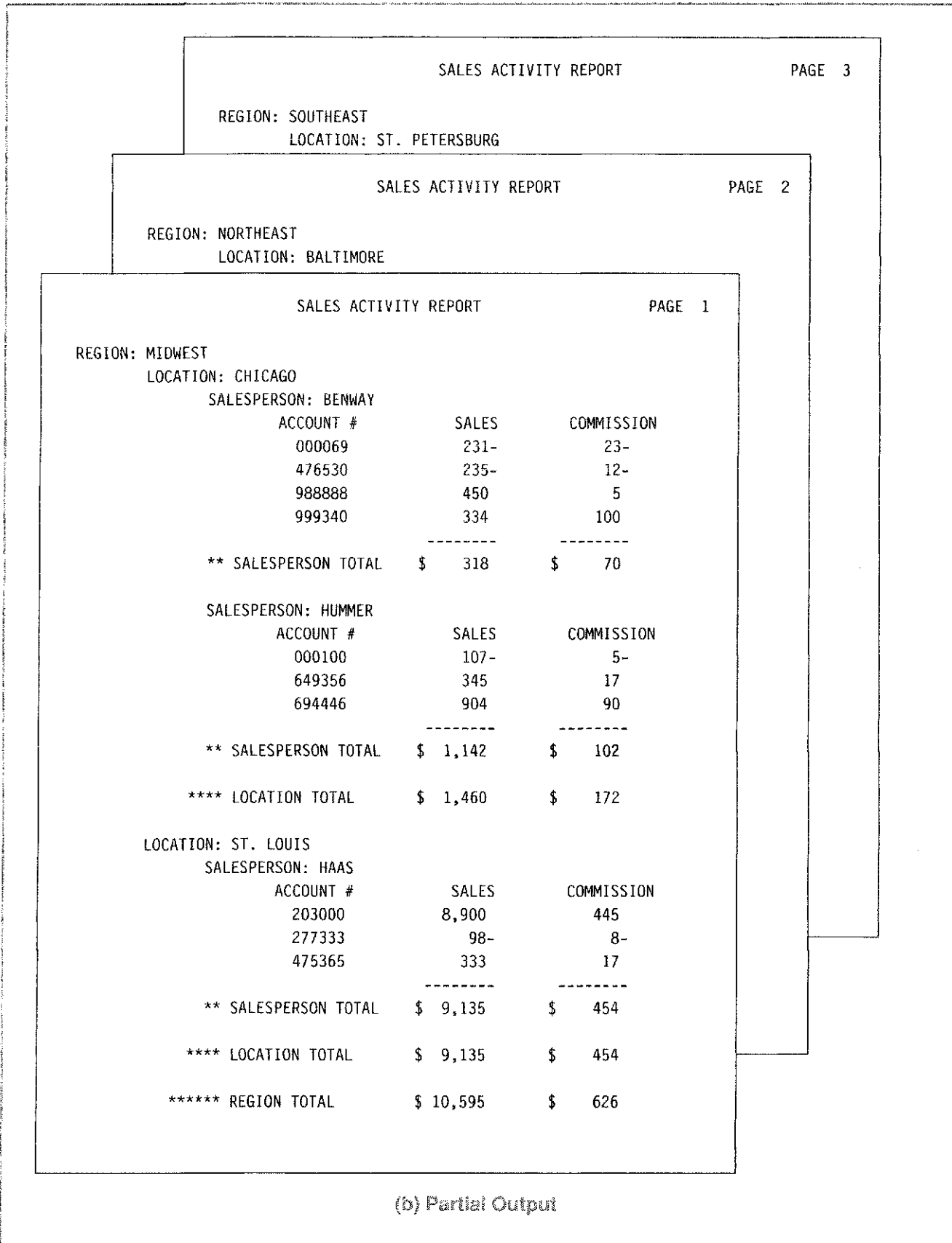

## One-Level Control Breaks

The development of the one- (two- and three-) level programs is not difficult given a clear understanding of the requirements and the distinction between running and rolling totals. We begin with the specifications for the one-level program.

### PROGRAMMING SPECIFICATIONS

**Program Name:** One-Level Control Break

**Narrative:** The specifications are for the one-level control break program. Changes to the specifications to accommodate two- and three-level control breaks are provided later in the chapter.

**Input File(s):** SALES-FILE

**Input Record Layout:**

|    |                       |            |
|----|-----------------------|------------|
| 01 | SALES-RECORD-IN.      |            |
| 05 | SR-ACCOUNT-NUMBER     | PIC 9(6).  |
| 05 | FILLER                | PIC X.     |
| 05 | SR-NAME               | PIC X(15). |
| 05 | SR-SALES              | PIC S9(4). |
| 05 | FILLER                | PIC XX.    |
| 05 | SR-COMMISSION-PERCENT | PIC V99.   |
| 05 | FILLER                | PIC XX.    |
| 05 | SR-LOCATION           | PIC X(15). |
| 05 | SR-REGION             | PIC X(11). |

**Test Data:** See Figure 15.1.

**Report Layout:** See Figure 15.2b.

- Processing Requirements:**
1. Sort the incoming transaction file by salesperson; use the WITH DUPLICATES IN ORDER phrase of the SORT statement to keep the sorted file in sequence by transaction number within salesperson.
  2. Process transactions until a control break is encountered on salesperson, then for each new salesperson:
    - a. Initialize the total sales and commission for that salesperson to zero.
    - b. Print a heading for this salesperson on a new page.
  3. Process all transactions for each salesperson as follows:
    - a. Compute the commission for each transaction by multiplying the amount of the sale by the commission percentage.
    - b. Print a detail line for each transaction containing the account number, sales amount, and computed commission.
    - c. Increment the total sales and commissions for that salesperson by the corresponding amounts for this transaction.
  4. Print a total line for each salesperson whenever salesperson changes. Print dashes as indicated between the last detail line and the total line.
  5. Increment the company totals with the salesperson's accumulated totals as salesperson changes.
  6. Print the company totals after all records have been processed.



### Hierarchy Chart

The report in Figure 15.2b contains a heading line prior to the first transaction for each salesperson, detail lines containing the sales and commission for the individual transactions, and a total line after all transactions for each salesperson. The company total appears at the end of the report (but is not visible in Figure 15.2b).

All of these functions are recognized in the hierarchy chart of Figure 15.5a, which was developed in stages, beginning at the top and working down to the bottom. The functions at every level in the hierarchy chart are divided into component functions that appear on the next lower-level. The lower-level functions are further subdivided into other functions on a still lower-level, until finally the lowest-level functions cannot be further subdivided.

The module at the top (or first level) of the hierarchy chart, PREPARE-SALES-REPORT, depicts the overall program function. It is divided into four subordinate functions, each of which was taken directly from the programming specifications. These modules are placed on the second level of the hierarchy chart:

1. SORT-TRANSACTION-FILE to sort the transaction file (as indicated in item 1 of the processing requirements)
2. READ-SORTED-SALES-FILE to read a record from the sorted file
3. PROCESS-ONE-SALESPERSON to process each salesperson (from items 2 through 5 of the processing requirements)
4. WRITE-COMPANY-TOTAL to write the company total (from item 6 of the processing requirements)

Each of these modules is considered for further subdivision, but only PROCESS-ONE-SALESPERSON is divided into component functions for the next level. Once again, we use the processing requirements as a guide to determine the subordinate functions for the third level:

1. INITIALIZE-SALESPERSON to initialize the sales and commission amounts for this salesperson (item 2a of the processing requirements)
2. WRITE-SALESPERSON-HEADING to write a heading for each salesperson (item 2b of the processing requirements)
3. PROCESS-ONE-TRANSACTION to process the transaction (item 3 of the processing requirements)
4. WRITE-SALESPERSON-TOTAL to print the salesperson total (item 4 of the processing requirements)
5. INCREMENT-COMPANY-TOTAL to increment the company total (item 5 of the processing requirements)

Each function is evaluated for further subdivision, but only PROCESS-ONE-TRANSACTION is developed further. Repeating the earlier procedure, and again using the processing requirements, we obtain the modules for the fourth and final level:

1. CALCULATE-COMMISSION to calculate the commission for the transaction (item 3a of the processing requirements)
2. WRITE-DETAIL-LINE to write a detail line for each transaction (item 3b of the processing requirements)
3. INCREMENT-SALESPERSON-TOTAL to increment the salesperson's total (item 3c of the processing requirements)
4. READ-SORTED-SALES-FILE to read the next record and avoid an endless loop

Figure 15.5 One-Level Algorithm

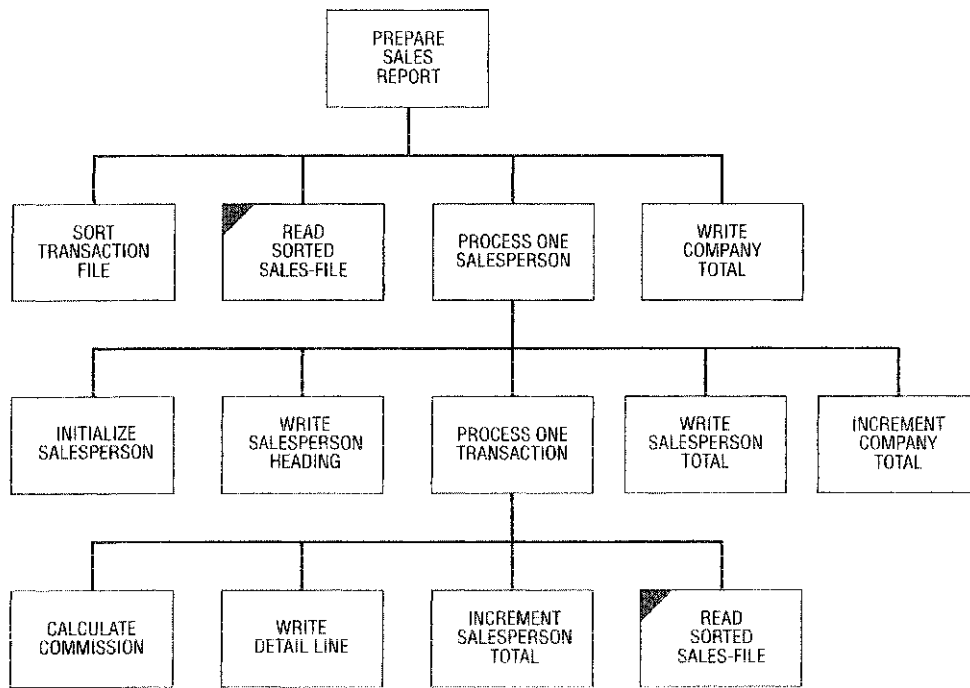

(a) Hierarchy Chart

```

Sort transaction file on salesperson
Open sorted-file, print-file
Read first record
PERFORM UNTIL no more data
 Initialize salesperson totals
 Move SR-NAME to PREVIOUS-NAME
 Write salesperson headings
 PERFORM UNTIL SR-NAME NOT = PREVIOUS-NAME
 or no more data
 Calculate commission
 Write detail line
 Increment salesperson totals
 Read next record
 ENDPERFORM
 Write salesperson totals
 Increment company totals by salesperson totals
ENDPERFORM
Write company totals
Close files
Stop run

```

(b) Pseudocode

The completed hierarchy chart is evaluated according to the criteria presented in Chapter 3—completeness, functionality, and span of control. The hierarchy chart is complete because it contains a module corresponding to every processing requirement. Its modules are functional (i.e., each module accomplishes a single task) as can be implied from the module names that consist of a verb, an adjective or two, and an object—for example, INCREMENT-SALESPERSON-TOTAL or WRITE-DETAIL-LINE.

Finally, the span of control (number of subordinate modules) is reasonably set at three or four throughout the hierarchy chart, and the relationship of the modules to one another appears to be correct. Observe, for example, that WRITE-DETAIL-LINE, INCREMENT-SALESPERSON-TOTAL, and READ-SORTED-SALES-FILE are subordinate to PROCESS-ONE-TRANSACTION, which in turn is subordinate to PROCESS-ONE-SALESPERSON, which is subordinate to PREPARE-SALES-REPORT. There is no other reasonable way to relate these functions, all of which are required to maintain completeness.

### Pseudocode

The pseudocode in Figure 15.5b introduces specific COBOL data names, such as SR-NAME and PREVIOUS-NAME, that enable the program to detect a control break. In other words, a COBOL statement cannot simply process records until a control break occurs, but must specify precisely how to determine when the value of salesperson changes. Thus in order to detect a control break, the program compares the name on the record just read to the name on the previous record; that is, it compares SR-NAME to PREVIOUS-NAME, and detects a break when the values are different.

The pseudocode sorts the transaction file according to salesperson, reads the first transaction record, then executes the statements in the outer loop for every salesperson until the entire file has been processed. The (sales and commission) totals for each new salesperson are initialized, then an inner loop is executed until a control break is detected. The inner loop processes all transactions for the current salesperson by calculating the commission amount, writing a detail line, and incrementing the running salesperson totals. The inner loop is terminated by the control break—that is, when SR-NAME is not equal to PREVIOUS-NAME—after which the sales and commission totals for the salesperson are written and rolled into the corresponding company totals.

It is now a simple matter to write the required program.

### The Completed Program

The completed program in Figure 15.6 is straightforward and easy to follow, especially after the preceding discussion on hierarchy charts and pseudocode. Note especially the relationship of the hierarchy chart in Figure 15.5a to the paragraphs in the Procedure Division. The modules in the hierarchy chart correspond one to one with the paragraphs in the program. Observe also that each level in the hierarchy chart corresponds to a COBOL PERFORM statement.

The Working-Storage Section contains multiple 01 entries for the various print lines required by the program. There are multiple heading lines, a detail line, and two total lines. Working-Storage also contains separate counters for the salesperson and company totals, as well as a switch, PREVIOUS-NAME, to detect the control break on salesperson.

The SORT statement (lines 151–156) specifies SORT-NAME as the primary key in accordance with the requirements of the control break on salesperson. The

WITH DUPLICATES IN ORDER phrase keeps the transactions for a given salesperson in sequence by account number because the input file (Figure 15.1) was already in sequence by this field.

Figure 15.6 One-Level Control Break Program

```

1 IDENTIFICATION DIVISION.
2 PROGRAM-ID. ONELEVEL.
3 AUTHOR. CVV.
4
5 ENVIRONMENT DIVISION.
6 INPUT-OUTPUT SECTION.
7 FILE-CONTROL.
8 SELECT SALES-FILE ASSIGN TO 'A:\CHAPTR15\SORTIN.DAT'
9 ORGANIZATION IS LINE SEQUENTIAL.
10 SELECT PRINT-FILE
11 ASSIGN TO PRINTER.
12 SELECT SORT-WORK-FILE
13 ASSIGN TO 'A:\CHAPTR15\SORTWK.DAT'.
14 SELECT SORTED-SALES-FILE ASSIGN TO 'A:\CHAPTR15\SORTOUT.DAT'
15 ORGANIZATION IS LINE SEQUENTIAL.
16
17 DATA DIVISION.
18 FILE SECTION.
19 FD SALES-FILE
20 RECORD CONTAINS 58 CHARACTERS
21 DATA RECORD IS SALES-RECORD.
22 01 SALES-RECORD PIC X(58).
23
24 FD PRINT-FILE
25 RECORD CONTAINS 132 CHARACTERS
26 DATA RECORD IS PRINT-LINE.
27 01 PRINT-LINE PIC X(132).
28
29 SD SORT-WORK-FILE
30 RECORD CONTAINS 58 CHARACTERS
31 DATA RECORD IS SORT-RECORD.
32 01 SORT-RECORD.
33 05 SORT-ACCOUNT-NUMBER PIC 9(6).
34 05 FILLER PIC X.
35 05 SORT-NAME PIC X(15).
36 05 FILLER PIC X(10).
37 05 SORT-LOCATION PIC X(15).
38 05 SORT-REGION PIC X(11).
39
40 FD SORTED-SALES-FILE
41 RECORD CONTAINS 58 CHARACTERS
42 DATA RECORD IS SORTED-SALES-RECORD.
43 01 SORTED-SALES-RECORD PIC X(58).

```

Figure 15.6 (continued)

```

44
45 WORKING-STORAGE SECTION.
46 01 FILLER PIC X(14)
47 VALUE 'WS BEGINS HERE'.
48
49 01 SALES-RECORD-IN.
50 05 SR-ACCOUNT-NUMBER PIC 9(6).
51 05 FILLER PIC X.
52 05 SR-NAME PIC X(15).
53 05 SR-SALES PIC S9(4).
54 05 FILLER PIC XX.
55 05 SR-COMMISSION-PERCENT PIC V99.
56 05 FILLER PIC XX.
57 05 SR-LOCATION PIC X(15).
58 05 SR-REGION PIC X(11).
59
60 01 PROGRAM-SWITCHES-AND-COUNTERS.
61 05 DATA-REMAINS-SW PIC X(3) VALUE 'YES'.
62 88 NO-DATA-REMAINS VALUE 'NO'.
63 05 PREVIOUS-NAME PIC X(15) VALUE SPACES.
64 05 PAGE-COUNT PIC 99 VALUE ZEROS.
65
66 01 CONTROL-BREAK-TOTALS.
67 05 INDIVIDUAL-TOTALS.
68 10 IND-COMMISSION PIC S9(4).
69 05 SALESPERSON-TOTALS.
70 10 SALESPERSON-SALES-TOT PIC S9(6).
71 10 SALESPERSON-COMM-TOT PIC S9(6).
72 05 COMPANY-TOTALS.
73 10 COMPANY-SALES-TOT PIC S9(6) VALUE ZEROS.
74 10 COMPANY-COMM-TOT PIC S9(6) VALUE ZEROS.
75
76 01 REPORT-HEADING-LINE.
77 05 FILLER PIC X(25) VALUE SPACES.
78 05 FILLER PIC X(21)
79 VALUE 'SALES ACTIVITY REPORT'.
80 05 FILLER PIC X(19) VALUE SPACES.
81 05 FILLER PIC X(5) VALUE 'PAGE '.
82 05 HDG-PAGE PIC Z9.
83 05 FILLER PIC X(60) VALUE SPACES.
84
85 01 SALESPERSON-HEADING-LINE-ONE.
86 05 FILLER PIC X(15) VALUE SPACES.
87 05 FILLER PIC X(13)
88 VALUE 'SALESPERSON: '.
89 05 HDG-NAME PIC X(15).
90 05 FILLER PIC X(89) VALUE SPACES.
91
92 01 SALESPERSON-HEADING-LINE-TWO.
93 05 FILLER PIC X(23) VALUE SPACES.

```

Signed fields are used  
in all computations

Figure 15.6 (continued)

```

94 05 FILLER PIC X(11) VALUE 'ACCOUNT .
95 05 FILLER PIC X(9) VALUE SPACES.
96 05 FILLER PIC X(5) VALUE 'SALES'.
97 05 FILLER PIC X(8) VALUE SPACES.
98 05 FILLER PIC X(10) VALUE 'COMMISSION'.
99 05 FILLER PIC X(66) VALUE SPACES.
100
101 01 DETAIL-LINE.
102 05 FILLER PIC X(25) VALUE SPACES.
103 05 DET-ACCOUNT-NUMBER PIC 9(6).
104 05 FILLER PIC X(9) VALUE SPACES.
105 05 DET-SALES PIC Z(3),ZZ9-.
106 05 FILLER PIC X(7) VALUE SPACES.
107 05 DET-COMMISSION PIC Z(3),ZZ9-.
108 05 FILLER PIC X(69) VALUE SPACES.
109
110 01 DASHED-LINE.
111 05 FILLER PIC X(40) VALUE SPACES.
112 05 FILLER PIC X(8) VALUE ALL '-'.
113 05 FILLER PIC X(7) VALUE SPACES.
114 05 FILLER PIC X(8) VALUE ALL '-'.
115 05 FILLER PIC X(69) VALUE SPACES.
116
117 01 SALESPERSON-TOTAL-LINE.
118 05 FILLER PIC X(15) VALUE SPACES.
119 05 FILLER PIC X(21)
120 VALUE '** SALESPERSON TOTAL'.
121 05 FILLER PIC X(3) VALUE SPACES.
122 05 SALESPERSON-SALES-TOTAL PIC $Z(3),ZZ9-.
123 05 FILLER PIC X(6) VALUE SPACES.
124 05 SALESPERSON-COMM-TOTAL PIC $Z(3),ZZ9-.
125 05 FILLER PIC X(69) VALUE SPACES.
126
127 01 COMPANY-TOTAL-LINE.
128 05 FILLER PIC X(9) VALUE SPACES.
129 05 FILLER PIC X(22)
130 VALUE '***** COMPANY TOTAL'.
131 05 FILLER PIC X(8) VALUE SPACES.
132 05 COMPANY-SALES-TOTAL PIC $Z(3),ZZ9-.
133 05 FILLER PIC X(6) VALUE SPACES.
134 05 COMPANY-COMM-TOTAL PIC $Z(3),ZZ9-.
135 05 FILLER PIC X(69) VALUE SPACES.
136
137 PROCEDURE DIVISION.
138 100-PREPARE-SALES-REPORT.
139 PERFORM 200-SORT-TRANSACTION-FILE.
140 OPEN INPUT SORTED-SALES-FILE
141 OUTPUT PRINT-FILE.
142 PERFORM 220-READ-SORTED-SALES-FILE.
143 PERFORM 240-PROCESS-ONE-SALESPERSON

```

Editing reflects sorted sales

Highest-level routine in hierarchy of sort

Figure 15.6 (continued)

```

144 UNTIL NO-DATA-REMAINS.
145 PERFORM 260-WRITE-COMPANY-TOTAL.
146 CLOSE SORTED-SALES-FILE
147 PRINT-FILE.
148 STOP RUN.
149
150 200-SORT-TRANSACTION-FILE.
151 SORT SORT-WORK-FILE
152 ASCENDING KEY
153 SORT-NAME
154 WITH DUPLICATES IN ORDER
155 USING SALES-FILE
156 GIVING SORTED-SALES-FILE.
157
158 220-READ-SORTED-SALES-FILE.
159 READ SORTED-SALES-FILE INTO SALES-RECORD-IN
160 AT END MOVE 'NO' TO DATA-REMAINS-SW
161 END-READ.
162
163 240-PROCESS-ONE-SALESPERSON.
164 PERFORM 300-INITIALIZE-SALESPERSON.
165 PERFORM 320-WRITE-SALESPERSON-HEADING.
166 PERFORM 340-PROCESS-ONE-TRANSACTION
167 UNTIL SR-NAME NOT EQUAL PREVIOUS-NAME
168 OR NO-DATA-REMAINS.
169 PERFORM 360-WRITE-SALESPERSON-TOTAL.
170 PERFORM 380-INCREMENT-COMPANY-TOTAL.
171
172 260-WRITE-COMPANY-TOTAL.
173 MOVE COMPANY-SALES-TOT TO COMPANY-SALES-TOTAL.
174 MOVE COMPANY-COMM-TOT TO COMPANY-COMM-TOTAL.
175 WRITE PRINT-LINE FROM COMPANY-TOTAL-LINE
176 AFTER ADVANCING 2 LINES.
177
178 300-INITIALIZE-SALESPERSON.
179 MOVE SR-NAME TO PREVIOUS-NAME.
180 INITIALIZE SALES-PERSON-TOTALS.
181
182 320-WRITE-SALESPERSON-HEADING.
183 ADD 1 TO PAGE-COUNT.
184 MOVE PAGE-COUNT TO HDG-PAGE.
185 WRITE PRINT-LINE FROM REPORT-HEADING-LINE
186 AFTER ADVANCING PAGE.
187 MOVE SR-NAME TO HDG-NAME.
188 WRITE PRINT-LINE FROM SALES-PERSON-HEADING-LINE-ONE
189 AFTER ADVANCING 2 LINES.
190 WRITE PRINT-LINE FROM SALES-PERSON-HEADING-LINE-TWO
191 AFTER ADVANCING 1 LINE.
192
193 340-PROCESS-ONE-TRANSACTION.
194 PERFORM 400-CALCULATE-COMMISSION.

```

Sort statement required to place transactions in sequence

Heading written prior to each new salesperson

Detection of control break

Total for this salesperson written after control break is detected

Figure 15.6 (continued)

```

195 PERFORM 420-WRITE-DETAIL-LINE.
196 PERFORM 440-INCRMENT-SALESPERSON-TOTAL.
197 PERFORM 220-READ-SORTED-SALES-FILE.
198
199 360-WRITE-SALESPERSON-TOTAL.
200 WRITE PRINT-LINE FROM DASHED-LINE
201 AFTER ADVANCING 1 LINE.
202 MOVE SALESPERSON-SALES-TOT TO SALESPERSON-SALES-TOTAL.
203 MOVE SALESPERSON-COMM-TOT TO SALESPERSON-COMM-TOTAL.
204 WRITE PRINT-LINE FROM SALESPERSON-TOTAL-LINE
205 AFTER ADVANCING 1 LINE.
206 MOVE SPACES TO PRINT-LINE.
207 WRITE PRINT-LINE
208 AFTER ADVANCING 1 LINE.
209
210 380-INCREMENT-COMPANY-TOTAL.
211 ADD SALESPERSON-SALES-TOT TO COMPANY-SALES-TOT.
212 ADD SALESPERSON-COMM-TOT TO COMPANY-COMM-TOT.
213
214 400-CALCULATE-COMMISSION.
215 COMPUTE IND-COMMISSION ROUNDED =
216 SR-SALES * SR-COMMISSION-PERCENT
217 SIZE ERROR DISPLAY 'SIZE ERROR ON COMMISSION FOR '
218 SR-NAME
219 END-COMPUTE.
220
221 420-WRITE-DETAIL-LINE.
222 MOVE SR-ACCOUNT-NUMBER TO DET-ACCOUNT-NUMBER.
223 MOVE SR-SALES TO DET-SALES.
224 MOVE IND-COMMISSION TO DET-COMMISSION.
225 WRITE PRINT-LINE FROM DETAIL-LINE.
226
227 440-INCRMENT-SALESPERSON-TOTAL.
228 ADD SR-SALES TO SALESPERSON-SALES-TOT.
229 ADD IND-COMMISSION TO SALESPERSON-COMM-TOT.

```

*Salesperson totals are rolled into company totals*

*Salesperson totals are accumulated through running totals*

## Two-Level Control Breaks

The reports in Figures 15.2, 15.3, and 15.4 presented a logical progression of one, two, and three control breaks—for salesperson; location and salesperson; and region, location, and salesperson, respectively. This section extends the hierarchy chart, pseudocode, and COBOL program for the one-level application to include a second control break.

### Hierarchy Chart

The development of the two-level hierarchy chart is best accomplished as an extension of its existing one-level counterpart. One easy way to anticipate the changes is to compare the one- and two-level reports in Figures 15.2b and 15.3b,



then consider the following questions with respect to the hierarchy chart of Figure 15.5a:

1. What additional (i.e., new) modules are necessary?
2. Which existing modules (if any) have to be modified?
3. Which existing modules (if any) have to be deleted?

Every module that appeared in the one-level hierarchy chart will also appear in its two-level counterpart; that is, no modules will be deleted because every function in the one-level application is also required in the two-level example. In addition, several new functions have to be added to accommodate the control break on location. These include:

1. PROCESS-ONE-LOCATION to process all salespersons in one location
2. INITIALIZE-LOCATION to initialize the sales and commission amounts for this location
3. WRITE-LOCATION-HEADING to print a location heading prior to each new location
4. INCREMENT-LOCATION-TOTAL to increment the sales and commission totals for each location
5. WRITE-LOCATION-TOTAL to print the location totals after a control break on location

Changes will also be required in the logic of some existing modules; for example, the module SORT-TRANSACTION-FILE must now reflect a sort on location and salesperson within location. A more subtle change is in WRITE-SALESPERSON-HEADING, which previously began the report for each salesperson on a new page, but which now lists all salespersons in one location on the same page.

The computation of the company total changes as well. The one-level example waited for a control break on salesperson, then rolled the salesperson total into the company total. Although the same approach could be used in the two-level example, it is more efficient to wait for a control break on location, then roll the location total into the company total.

The hierarchy chart for the two-level problem is shown in Figure 15.7a, with the additional and/or modified modules shaded for emphasis. The placement of the new modules is important, and you should notice that the module PROCESS-ONE-LOCATION appears on the second level of the hierarchy chart; this in turn forces the existing module PROCESS-ONE-SALESPERSON, and all of its subordinates, down a level.

Figure 15.7b is subject to the same design considerations as its predecessor, namely, completeness, functionality, and span of control. All design criteria appear satisfactory and the hierarchy chart is finished.

### **Pseudocode**

The pseudocode for the one-level control example is expanded to its two-level counterpart in Figure 15.7b. New and/or modified statements are highlighted to be consistent with the associated hierarchy chart.

The sort statement includes location as an additional key as previously indicated. The major change, however, is the modification of the outer loop to include a series of repetitive statements for each new location that initialize the location totals, write the location heading, and process all salespersons in that location. The detection of a control break on location occurs when SR-LOCATION is unequal to PREVIOUS-LOCATION, and produces the location total, which is then rolled into the company total.

Figure 15.7 Two-Level Algorithm

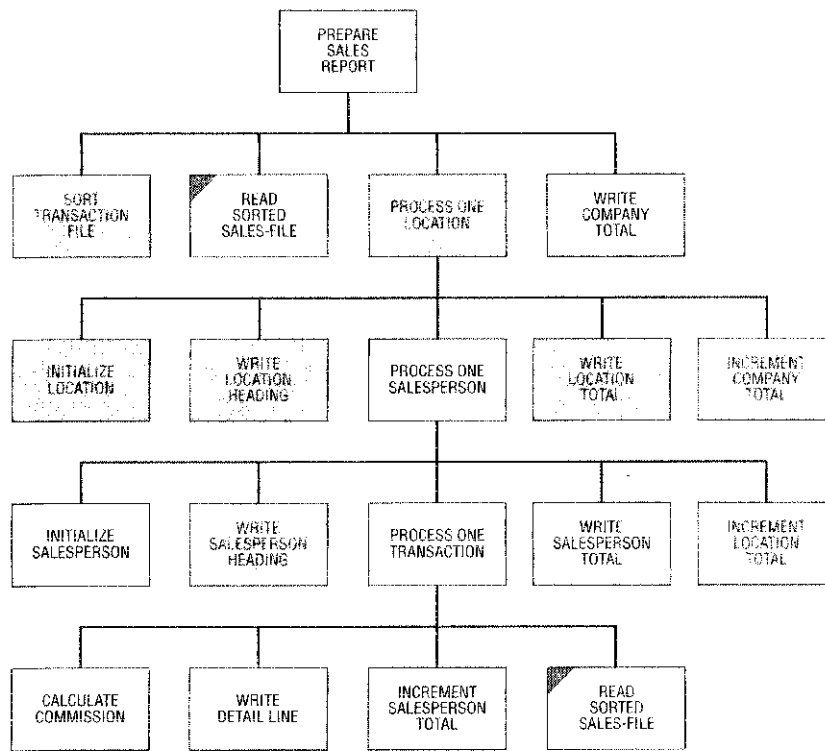

(a) Hierarchy Chart

Sort transaction file on location, salesperson.  
 Open sorted-file, print-file  
 Read first record

```

PERFORM UNTIL no more data
 Initialize location totals
 MOVE SR-LOCATION to PREVIOUS-LOCATION
 Write location headings
 PERFORM UNTIL SR-LOCATION NOT EQUAL PREVIOUS-LOCATION
 or no more data
 Initialize salesperson totals
 MOVE SR-NAME to PREVIOUS-NAME
 Write salesperson headings
 PERFORM UNTIL SR-NAME NOT EQUAL PREVIOUS-NAME
 or SR-LOCATION NOT EQUAL PREVIOUS-LOCATION
 or no more data
 Calculate commission
 Write detail line (if any)
 Increment salesperson totals
 Read next record
 ENDPERFORM
 Write salesperson totals
 Increment location totals
 ENDPERFORM
 Write location totals
 Increment company totals by location totals
ENDPERFORM
Write company totals
Close files
Stop run

```

(b) Pseudocode

Within each location, there is a second loop (carried over from the one-level application) to process all salespersons in that location. Note, however, the *compound condition* in the test for a control break on salesperson that now includes both salesperson and location. This dual test is necessary in the unusual instance where the last salesperson in the current location and the first salesperson in the next location have the same name. (A general rule for the detection of a control break requires a compound condition, which includes a check for the level you are on, as well as any levels above the current level.)

### The Completed Program

The completed program is shown in Figure 15.8 and reflects all of the indicated changes. Once again, we call your attention to the relationship between the hierarchy chart in Figure 15.7a and the paragraphs in the Procedure Division. The modules in the hierarchy chart correspond one to one with the paragraphs in the program. Observe also that each level in the hierarchy chart can be matched with a COBOL PERFORM statement.

Figure 15.8 Two-Level Control Break Program

```

1 IDENTIFICATION DIVISION.
2 PROGRAM-ID. TWOLEVEL.
3 AUTHOR. CVV.
4
5 ENVIRONMENT DIVISION.
6 INPUT-OUTPUT SECTION.
7 FILE-CONTROL.
8 SELECT SALES-FILE ASSIGN TO 'A:\CHAPTR15\SORTIN.DAT'
9 ORGANIZATION IS LINE SEQUENTIAL.
10 SELECT PRINT-FILE
11 ASSIGN TO PRINTER.
12 SELECT SORT-WORK-FILE
13 ASSIGN TO 'A:\CHAPTR15\SORTWK.DAT'.
14 SELECT SORTED-SALES-FILE ASSIGN TO 'A:\CHAPTR15\SORTWK.DAT'
15 ORGANIZATION IS LINE SEQUENTIAL.
16
17 DATA DIVISION.
18 FILE SECTION.
19 FD SALES-FILE
20 RECORD CONTAINS 58 CHARACTERS
21 DATA RECORD IS SALES-RECORD.
22 01 SALES-RECORD PIC X(58).
23
24 FD PRINT-FILE
25 RECORD CONTAINS 132 CHARACTERS
26 DATA RECORD IS PRINT-LINE.
27 01 PRINT-LINE PIC X(132).
28
29 SD SORT-WORK-FILE
30 RECORD CONTAINS 58 CHARACTERS
31 DATA RECORD IS SORT-RECORD.

```

Figure 15.8 (continued)

```

32 01 SORT-RECORD.
33 05 SORT-ACCOUNT-NUMBER PIC 9(6).
34 05 FILLER PIC X.
35 05 SORT-NAME PIC X(15).
36 05 FILLER PIC X(10).
37 05 SORT-LOCATION PIC X(15).
38 05 SORT-REGION PIC X(11).
39
40 FD SORTED-SALES-FILE
41 RECORD CONTAINS 58 CHARACTERS
42 DATA RECORD IS SORTED-SALES-RECORD.
43 01 SORTED-SALES-RECORD PIC X(58).
44
45 WORKING-STORAGE SECTION.
46 01 FILLER PIC X(14)
47 VALUE 'WS BEGINS HERE'.
48
49 01 SALES-RECORD-IN.
50 05 SR-ACCOUNT-NUMBER PIC 9(6).
51 05 FILLER PIC X.
52 05 SR-NAME PIC X(15).
53 05 SR-SALES PIC S9(4).
54 05 FILLER PIC XX.
55 05 SR-COMMISSION-PERCENT PIC V99.
56 05 FILLER PIC XX.
57 05 SR-LOCATION PIC X(15).
58 05 SR-REGION PIC X(11).
59
60 01 PROGRAM-SWITCHES-AND-COUNTERS.
61 05 DATA-REMAINS-SW PIC X(3) VALUE 'YES'.
62 88 NO-DATA-REMAINS VALUE 'NO'.
63 05 PREVIOUS-NAME PIC X(15) VALUE SPACES.
64 05 PREVIOUS-LOCATION PIC X(15) VALUE SPACES.
65 05 PAGE-COUNT PIC 99 VALUE ZEROES.
66
67 01 CONTROL-BREAK-TOTALS.
68 05 INDIVIDUAL-TOTALS.
69 10 IND-COMMISSION PIC S9(4).
70 05 SALESPERSON-TOTALS.
71 10 SALESPERSON-SALES-TOT PIC S9(6).
72 10 SALESPERSON-COMM-TOT PIC S9(6).
73 05 LOCATION-TOTALS.
74 10 LOCATION-SALES-TOT PIC S9(6).
75 10 LOCATION-COMM-TOT PIC S9(6).
76 05 COMPANY-TOTALS.
77 10 COMPANY-SALES-TOT PIC S9(6) VALUE ZEROES.
78 10 COMPANY-COMM-TOT PIC S9(6) VALUE ZEROES.
79
80 01 REPORT-HEADING-LINE.
81 05 FILLER PIC X(25) VALUE SPACES.

```

Used to detect control break in location

Location columns are added to the level program

Figure 15.6 (continued)

```

82 05 FILLER PIC X(21)
83 VALUE 'SALES ACTIVITY REPORT'.
84 05 FILLER PIC X(19) VALUE SPACES.
85 05 FILLER PIC X(5) VALUE 'PAGE '.
86 05 HDG-PAGE PIC Z9.
87 05 FILLER PIC X(60) VALUE SPACES.
88
89 01 LOCATION-HEADING-LINE.
90 05 FILLER PIC X(8) VALUE SPACES.
91 05 FILLER PIC X(10)
92 VALUE 'LOCATION: '.
93 05 HDG-LOCATION PIC X(19) VALUE SPACES.
94 05 FILLER PIC X(95) VALUE SPACES.
95
96 01 SALESPERSON-HEADING-LINE-ONE.
97 05 FILLER PIC X(15) VALUE SPACES.
98 05 FILLER PIC X(13)
99 VALUE 'SALESPERSON: '.
100 05 HDG-NAME PIC X(15).
101 05 FILLER PIC X(89) VALUE SPACES.
102
103 01 SALESPERSON-HEADING-LINE-TWO.
104 05 FILLER PIC X(23) VALUE SPACES.
105 05 FILLER PIC X(11) VALUE 'ACCOUNT # '.
106 05 FILLER PIC X(9) VALUE SPACES.
107 05 FILLER PIC X(5) VALUE 'SALES'.
108 05 FILLER PIC X(8) VALUE SPACES.
109 05 FILLER PIC X(10) VALUE 'COMMISSION'.
110 05 FILLER PIC X(66) VALUE SPACES.
111
112 01 DETAIL-LINE.
113 05 FILLER PIC X(25) VALUE SPACES.
114 05 DET-ACCOUNT-NUMBER PIC 9(6).
115 05 FILLER PIC X(9) VALUE SPACES.
116 05 DET-SALES PIC Z(3),ZZ9-.
117 05 FILLER PIC X(7) VALUE SPACES.
118 05 DET-COMMISSION PIC Z(3),ZZ9-.
119 05 FILLER PIC X(69) VALUE SPACES.
120
121 01 DASHED-LINE.
122 05 FILLER PIC X(40) VALUE SPACES.
123 05 FILLER PIC X(8) VALUE ALL '-'.
124 05 FILLER PIC X(7) VALUE SPACES.
125 05 FILLER PIC X(8) VALUE ALL '-'.
126 05 FILLER PIC X(69) VALUE SPACES.
127
128 01 SALESPERSON-TOTAL-LINE.
129 05 FILLER PIC X(15) VALUE SPACES.
130 05 FILLER PIC X(21)
131 VALUE '** SALESPERSON TOTAL'.

```

*Location heading is added  
to two-level program*

Figure 4.6 (continued)

```

132 05 FILLER PIC X(3) VALUE SPACES.
133 05 SALESPERSON-SALES-TOTAL PIC $Z(3),ZZ9-.
134 05 FILLER PIC X(6) VALUE SPACES.
135 05 SALESPERSON-COMM-TOTAL PIC $Z(3),ZZ9-.
136 05 FILLER PIC X(69) VALUE SPACES.

```

```

138 01 LOCATION-TOTAL-LINE.
139 05 FILLER PIC X(13) VALUE SPACES.
140 05 FILLER PIC X(19)
141 VALUE '**** LOCATION TOTAL'.
142 05 FILLER PIC X(7) VALUE SPACES.
143 05 LOCATION-SALES-TOTAL PIC $Z(3),ZZ9-.
144 05 FILLER PIC X(6) VALUE SPACES.
145 05 LOCATION-COMM-TOTAL PIC $Z(3),ZZ9-.
146 05 FILLER PIC X(69) VALUE SPACES.

```

Location total line is added to the program

```

147
148 01 COMPANY-TOTAL-LINE.
149 05 FILLER PIC X(9) VALUE SPACES.
150 05 FILLER PIC X(22)
151 VALUE '***** COMPANY TOTAL'.
152 05 FILLER PIC X(8) VALUE SPACES.
153 05 COMPANY-SALES-TOTAL PIC $Z(3),ZZ9-.
154 05 FILLER PIC X(6) VALUE SPACES.
155 05 COMPANY-COMM-TOTAL PIC $Z(3),ZZ9-.
156 05 FILLER PIC X(69) VALUE SPACES.

```

```

157
158 PROCEDURE DIVISION.
159 100-PREPARE-SALES-REPORT.
160 PERFORM 200-SORT-TRANSACTION-FILE.
161 OPEN INPUT SORTED-SALES-FILE
162 OUTPUT PRINT-FILE.
163 PERFORM 220-READ-SORTED-SALES-FILE.
164 PERFORM 240-PROCESS-ONE-LOCATION
165 UNTIL NO-DATA-REMAINS.
166 PERFORM 260-WRITE-COMPANY-TOTAL.
167 CLOSE SORTED-SALES-FILE
168 PRINT-FILE.
169 STOP RUN.

```

```

170
171 200-SORT-TRANSACTION-FILE.
172 SORT SORT-WORK-FILE
173 ASCENDING KEY
174 SORT-LOCATION
175 SORT-NAME
176 WITH DUPLICATES IN ORDER
177 USING SALES-FILE
178 GIVING SORTED-SALES-FILE.

```

keys in SORT statement match control breaks

```

179
180 220-READ-SORTED-SALES-FILE.
181 READ SORTED-SALES-FILE INTO SALES-RECORD-IN

```

Figure 15.6 (continued)

```

182 AT END MOVE 'NO' TO DATA-REMAINS-SW
183 END-READ.
184
185 240-PROCESS-ONE-LOCATION.
186 PERFORM 300-INITIALIZE-LOCATION.
187 PERFORM 320-WRITE-LOCATION-HEADING.
188 PERFORM 340-PROCESS-ONE-SALESPERSON
189 UNTIL SR-LOCATION NOT EQUAL PREVIOUS-LOCATION
190 OR NO-DATA-REMAINS.
191 PERFORM 360-WRITE-LOCATION-TOTAL.
192 PERFORM 380-INCREMENT-COMPANY-TOTAL.
193
194 260-WRITE-COMPANY-TOTAL.
195 MOVE COMPANY-SALES-TOT TO COMPANY-SALES-TOTAL.
196 MOVE COMPANY-COMM-TOT TO COMPANY-COMM-TOTAL.
197 WRITE PRINT-LINE FROM COMPANY-TOTAL-LINE
198 AFTER ADVANCING 2 LINES.
199
200 300-INITIALIZE-LOCATION.
201 MOVE SR-LOCATION TO PREVIOUS-LOCATION.
202 INITIALIZE LOCATION-TOTALS.
203
204 320-WRITE-LOCATION-HEADING.
205 ADD 1 TO PAGE-COUNT.
206 MOVE PAGE-COUNT TO HDG-PAGE.
207 WRITE PRINT-LINE FROM REPORT-HEADING-LINE
208 AFTER ADVANCING PAGE.
209 MOVE SR-LOCATION TO HDG-LOCATION.
210 WRITE PRINT-LINE FROM LOCATION-HEADING-LINE
211 AFTER ADVANCING 2 LINES.
212
213 340-PROCESS-ONE-SALESPERSON.
214 PERFORM 400-INITIALIZE-SALESPERSON.
215 PERFORM 420-WRITE-SALESPERSON-HEADING.
216 PERFORM 440-PROCESS-ONE-TRANSACTION
217 UNTIL SR-NAME NOT EQUAL PREVIOUS-NAME
218 OR SR-LOCATION NOT EQUAL PREVIOUS-LOCATION
219 OR NO-DATA-REMAINS.
220 PERFORM 460-WRITE-SALESPERSON-TOTAL.
221 PERFORM 480-INCREMENT-LOCATION-TOTAL.
222
223 360-WRITE-LOCATION-TOTAL.
224 MOVE LOCATION-SALES-TOT TO LOCATION-SALES-TOTAL.
225 MOVE LOCATION-COMM-TOT TO LOCATION-COMM-TOTAL.
226 WRITE PRINT-LINE FROM LOCATION-TOTAL-LINE
227 AFTER ADVANCING 1 LINE.
228 MOVE SPACES TO PRINT-LINE.
229 WRITE PRINT-LINE
230 AFTER ADVANCING 1 LINE.
231
232 380-INCREMENT-COMPANY-TOTAL.

```

*Location heading written for each new location*

*Location total written after control break detected*

*Detects control break if salespersons in two locations have the same name*

Figure 15.8 (continued)

```

233 ADD LOCATION-SALES-TOT TO COMPANY-SALES-TOT.
234 ADD LOCATION-COMM-TOT TO COMPANY-COMM-TOT.
235
236 400-INITIALIZE-SALESPERSON.
237 MOVE SR-NAME TO PREVIOUS-NAME.
238 INITIALIZE SALESPERSON-TOTALS.
239
240 420-WRITE-SALESPERSON-HEADING.
241 MOVE SR-NAME TO HDG-NAME.
242 WRITE PRINT-LINE FROM SALESPERSON-HEADING-LINE-ONE
243 AFTER ADVANCING 1 LINE.
244 WRITE PRINT-LINE FROM SALESPERSON-HEADING-LINE-TWO
245 AFTER ADVANCING 1 LINE.
246
247 440-PROCESS-ONE-TRANSACTION.
248 PERFORM 500-CALCULATE-COMMISSION.
249 PERFORM 520-WRITE-DETAIL-LINE.
250 PERFORM 540-INCRMENT-SALESPERSON-TOTAL.
251 PERFORM 220-READ-SORTED-SALES-FILE.
252
253 460-WRITE-SALESPERSON-TOTAL.
254 WRITE PRINT-LINE FROM DASHED-LINE
255 AFTER ADVANCING 1 LINE.
256 MOVE SALESPERSON-SALES-TOT TO SALESPERSON-SALES-TOTAL.
257 MOVE SALESPERSON-COMM-TOT TO SALESPERSON-COMM-TOTAL.
258 WRITE PRINT-LINE FROM SALESPERSON-TOTAL-LINE
259 AFTER ADVANCING 1 LINE.
260 MOVE SPACES TO PRINT-LINE.
261 WRITE PRINT-LINE
262 AFTER ADVANCING 1 LINE.
263
264 480-INCREMENT-LOCATION-TOTAL.
265 ADD SALESPERSON-SALES-TOT TO LOCATION-SALES-TOT.
266 ADD SALESPERSON-COMM-TOT TO LOCATION-COMM-TOT.
267
268 500-CALCULATE-COMMISSION.
269 COMPUTE IND-COMMISSION ROUNDED =
270 SR-SALES * SR-COMMISSION-PERCENT
271 SIZE ERROR DISPLAY 'SIZE ERROR ON COMMISSION FOR '
272 SR-NAME
273 END-COMPUTE.
274
275 520-WRITE-DETAIL-LINE.
276 MOVE SR-ACCOUNT-NUMBER TO DET-ACCOUNT-NUMBER.
277 MOVE SR-SALES TO DET-SALES.
278 MOVE IND-COMMISSION TO DET-COMMISSION.
279 WRITE PRINT-LINE FROM DETAIL-LINE.
280
281 540-INCRMENT-SALESPERSON-TOTAL.
282 ADD SR-SALES TO SALESPERSON-SALES-TOT.
283 ADD IND-COMMISSION TO SALESPERSON-COMM-TOT.

```

Location totals are rolled into company totals.

Commission totals are rolled into location totals.



The Working-Storage Section contains every statement from the previous program plus additional entries to accommodate the second control break. The location heading and total lines are defined in lines 89–94 and 138–146, respectively. There are new counters for the location totals, LOCATION-SALES-TOT, and LOCATION-COMM-TOT, and a new data name, PREVIOUS-LOCATION, to detect the control break on location. The new entries are shaded in the listing for emphasis.

The SORT statement (lines 172–178) specifies two keys, SORT-LOCATION and SORT-NAME, to sort the transaction file by location and salesperson within location. The WITH DUPLICATES IN ORDER phrase keeps the transactions for a given salesperson in sequence by account number since the input file (Figure 15.1) was already in sequence by account number.

The remaining statements in the Procedure Division are straightforward and easy to follow, given the earlier discussion of the hierarchy chart and associated pseudocode. Observe, for example, the paragraph to increment the company totals (lines 232–234), in which location totals are rolled into the company totals. Note, too, the compound condition in the PERFORM statement of lines 216–219 to detect a control break on salesperson.

## Three-Level Control Breaks

We return to the reports of Figures 15.2, 15.3, and 15.4, which showed the progression of one-, two-, and three-level control breaks. This time, we will expand the hierarchy chart, pseudocode, and COBOL program from two to three levels.

### Hierarchy Chart

The three-level hierarchy chart will be developed as an extension of the existing two-level hierarchy chart. Accordingly, we will compare the two- and three-level reports in Figures 15.3b and 15.4b, then consider the following questions with respect to the existing chart:

1. What additional (i.e., new) modules are necessary?
2. Which existing modules (if any) have to be modified?
3. Which existing modules (if any) have to be deleted?

Every module that appeared in the two-level hierarchy chart will also appear in the three-level version; no modules will be deleted because every function from the two-level example is also required in the three-level example. Several new functions are necessary to accommodate the control break on region. These include:

1. PROCESS-ONE-REGION to process all locations in one region
2. INITIALIZE-REGION to initialize the sales and commission totals for this region
3. WRITE-REGION-HEADING to print a region heading for each new region
4. INCREMENT-REGION-TOTAL to increment the sales and commission totals for each region
5. WRITE-REGION-TOTAL to print region totals after a break on region

Changes will also be required in the logic of some existing modules—for example, a change in SORT-TRANSACTION-FILE to reflect a sort on region, location within region, and salesperson within location. It will also be necessary to change WRITE-LOCATION-HEADING, which previously began the report for

each location on a new page, but which now lists all locations in the same region on the same page.

The computation of the company totals also changes. The two-level example waited for a control break on location, then rolled the location total into the company total. The same approach could be used in the three-level example, but it is more efficient to wait for a control break on region, then roll the region total into the company total.

The hierarchy chart for the three-level problem is shown in Figure 15.9a, with the additional and/or modified modules shaded for emphasis. The placement of the new modules is important, and you should notice that the module PROCESS-ONE-REGION appears on the second level of the hierarchy chart, which in turn forces the existing module PROCESS-ONE-LOCATION, and all of its subordinates, down a level.

Figure 15.9b is subject to the same design considerations as its predecessor, namely, completeness, functionality, and span of control. All design criteria appear satisfactory and the hierarchy chart is finished.

Figure 15.9 Three-Level Algorithm

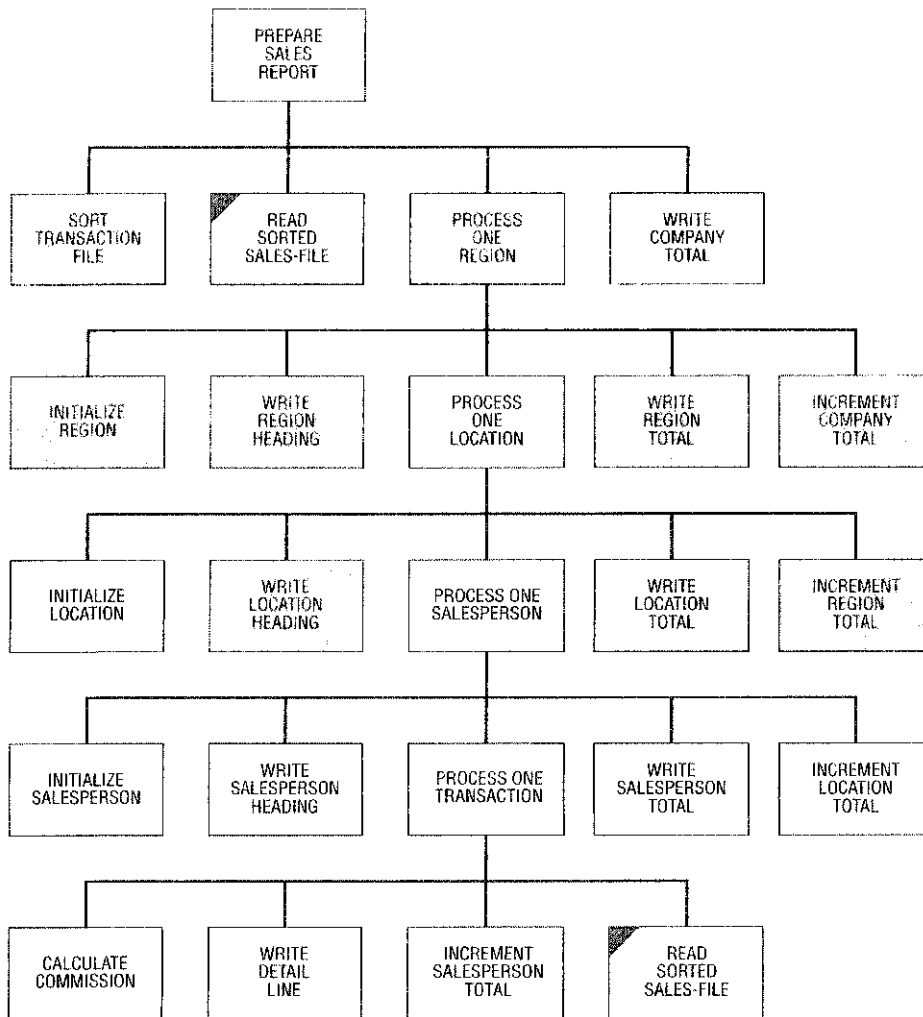

(a) Hierarchy Chart

Figure 15.9 (continued)

```

Sort transaction file on region, location, and salesperson
Open sorted-file, print-file
Read first record
— PERFORM UNTIL no more data
 Initialize region totals
 MOVE SR-REGION to PREVIOUS-REGION
 Write region heading
 PERFORM UNTIL REGION NOT EQUAL PREVIOUS-REGION
 or no more data
 Initialize location totals
 MOVE SR-LOCATION to PREVIOUS-LOCATION
 Write location heading
 — PERFORM UNTIL SR-LOCATION NOT EQUAL PREVIOUS-LOCATION
 or SR-REGION NOT EQUAL PREVIOUS-REGION
 or no more data
 Initialize salesperson totals
 MOVE SR-NAME to PREVIOUS-NAME
 Write salesperson heading
 — PERFORM UNTIL SR-NAME NOT EQUAL PREVIOUS-NAME
 or SR-LOCATION NOT EQUAL PREVIOUS-LOCATION
 or SR-REGION NOT EQUAL PREVIOUS-REGION
 or no more data
 Calculate commission
 Write detail line
 Increment salesperson totals
 Read next record
 — ENDPERFORM
 Write salesperson totals
 Increment location totals
 — ENDPERFORM
 Write location totals
 Increment region totals
 — ENDPERFORM
 Write region totals
 Increment company totals by region totals
— ENDPERFORM
Write company totals
Close files
Stop run

```

(b) Pseudocode

**Pseudocode**

The pseudocode for the two-level control break is expanded to its three-level counterpart in Figure 15.9b. New and/or modified statements are highlighted to be consistent with the associated hierarchy chart.

The sort statement includes region as an additional key as previously indicated. The major change, however, is the modification of the outer loop to include a series of repetitive statements for each new region that initialize the region totals, write the region heading, and process all locations in that region. The detection of a control break on region occurs when SR-REGION is unequal to PREVIOUS-REGION, and produces the region total, which is then rolled into the company total.

Within each region, there is a second loop (carried over from the two-level application) to process all locations in that region. A compound condition, that includes location and region, is necessary to detect a control break on location in the unusual instance where the last location in the current region and the first location in the next region have the same name. (This is in accordance with the general rule to detect a control break, which includes a compound condition that checks the level you are on, as well as any levels above the current level. Note, therefore, the compound condition associated with a control break on salesperson that includes salesperson, location, and region.)

### The Completed Program

The completed program is shown in Figure 15.10 and reflects all of the indicated changes. Once again, we call your attention to the relationship between the hierarchy chart in Figure 15.9a and the paragraphs in the Procedure Division. The modules in the hierarchy chart correspond one to one with the paragraphs in the program. Observe also that each level in the hierarchy chart can be matched with a COBOL PERFORM statement.

The Working-Storage Section contains every statement from the previous program plus additional entries to accommodate the second control break. The region heading and total lines are defined in lines 93–96 and 157–165, respectively. There are new counters for the region totals, REGION-SALES-TOT, and REGION-COMM-TOT, and a new data name, PREVIOUS-REGION, to detect the control break on region. The new entries are shaded in the listing for emphasis.

The SORT statement (lines 191–198) specifies three keys—SORT-REGION, SORT-LOCATION, and SORT-NAME—to sort the transaction file by region, location within region, and salesperson within location. The WITH DUPLICATES IN ORDER phrase keeps the transactions for a given salesperson in sequence by account number since the input file (Figure 15.1) was already in sequence by account number.

The remaining statements in the Procedure Division are straightforward and easy to follow given the earlier discussion of the hierarchy chart and associated pseudocode. Observe, for example, the paragraph to increment the company totals (lines 249–251), in which region totals are rolled into the company totals. Note, too, the compound condition in the PERFORM statement of lines 236–239 to detect a control break on salesperson.

Figure 15.10 Three-Level Control Break Program

```

1 IDENTIFICATION DIVISION.
2 PROGRAM-ID. THRLEVEL.
3 AUTHOR. CVV.
4
5 ENVIRONMENT DIVISION.
```

Figure 15.10 (continued)

```

6 INPUT-OUTPUT SECTION.
7 FILE-CONTROL.
8 SELECT SALES-FILE ASSIGN TO 'A:\CHAPTR15\SORTIN.DAT'
9 ORGANIZATION IS LINE SEQUENTIAL.
10 SELECT PRINT-FILE
11 ASSIGN TO PRINTER.
12 SELECT SORT-WORK-FILE
13 ASSIGN TO 'A:\CHAPTR15\SORTWK.DAT'.
14 SELECT SORTED-SALES-FILE ASSIGN TO 'A:\CHAPTR15\SORTOUT.DAT'
15 ORGANIZATION IS LINE SEQUENTIAL.
16
17 DATA DIVISION.
18 FILE SECTION.
19 FD SALES-FILE
20 RECORD CONTAINS 58 CHARACTERS
21 DATA RECORD IS SALES-RECORD.
22 01 SALES-RECORD PIC X(58).
23
24 FD PRINT-FILE
25 RECORD CONTAINS 132 CHARACTERS
26 DATA RECORD IS PRINT-LINE.
27 01 PRINT-LINE PIC X(132).
28
29 SD SORT-WORK-FILE
30 RECORD CONTAINS 58 CHARACTERS
31 DATA RECORD IS SORT-RECORD.
32 01 SORT-RECORD.
33 05 SORT-ACCOUNT-NUMBER PIC 9(6).
34 05 FILLER PIC X.
35 05 SORT-NAME PIC X(15).
36 05 FILLER PIC X(10).
37 05 SORT-LOCATION PIC X(15).
38 05 SORT-REGION PIC X(11).
39
40 FD SORTED-SALES-FILE
41 RECORD CONTAINS 58 CHARACTERS
42 DATA RECORD IS SORTED-SALES-RECORD.
43 01 SORTED-SALES-RECORD PIC X(58).
44
45 WORKING-STORAGE SECTION.
46 01 FILLER PIC X(14)
47 VALUE 'WS BEGINS HERE'.
48
49 01 SALES-RECORD-IN.
50 05 SR-ACCOUNT-NUMBER PIC 9(6).
51 05 FILLER PIC X.
52 05 SR-NAME PIC X(15).

```

Figure 15.10 (continued)

```

53 05 SR-SALES PIC S9(4).
54 05 FILLER PIC XX.
55 05 SR-COMMISSION-PERCENT PIC V99.
56 05 FILLER PIC XX.
57 05 SR-LOCATION PIC X(15).
58 05 SR-REGION PIC X(11).
59
60 01 PROGRAM-SWITCHES-AND-COUNTERS.
61 05 DATA-REMAINS-SW PIC X(3) VALUE 'YES'.
62 88 NO-DATA-REMAINS VALUE 'NO'.
63 05 PREVIOUS-NAME PIC X(15) VALUE SPACES.
64 05 PREVIOUS-LOCATION PIC X(15) VALUE SPACES.
65 05 PREVIOUS-REGION PIC X(11) VALUE SPACES.
66 05 PAGE-COUNT PIC 99 VALUE ZEROES.
67
68 01 CONTROL-BREAK-TOTALS.
69 05 INDIVIDUAL-TOTALS.
70 10 IND-COMMISSION PIC S9(4).
71 05 SALESPERSON-TOTALS.
72 10 SALESPERSON-SALES-TOT PIC S9(6).
73 10 SALESPERSON-COMM-TOT PIC S9(6).
74 05 LOCATION-TOTALS.
75 10 LOCATION-SALES-TOT PIC S9(6).
76 10 LOCATION-COMM-TOT PIC S9(6).
77 05 REGION-TOTALS.
78 10 REGION-SALES-TOT PIC S9(6).
79 10 REGION-COMM-TOT PIC S9(6).
80 05 COMPANY-TOTALS.
81 10 COMPANY-SALES-TOT PIC S9(6) VALUE ZEROS.
82 10 COMPANY-COMM-TOT PIC S9(6) VALUE ZEROS.
83
84 01 REPORT-HEADING-LINE.
85 05 FILLER PIC X(25) VALUE SPACES.
86 05 FILLER PIC X(21)
87 VALUE 'SALES ACTIVITY REPORT'.
88 05 FILLER PIC X(19) VALUE SPACES.
89 05 FILLER PIC X(5) VALUE 'PAGE '.
90 05 HDG-PAGE PIC Z9.
91 05 FILLER PIC X(60) VALUE SPACES.
92
93 01 REGION-HEADING-LINE.
94 05 FILLER PIC X(8) VALUE 'REGION: '.
95 05 HDG-REGION PIC X(11) VALUE SPACES.
96 05 FILLER PIC X(113) VALUE SPACES.
97
98 01 LOCATION-HEADING-LINE.
99 05 FILLER PIC X(8) VALUE SPACES.

```

Region is an additional control field

Used to adjust control break on region

Region totals are added to three-level program

Region heading is added to three-level program

Figure 15.10 (continued)

|     |    |                               |                  |                  |
|-----|----|-------------------------------|------------------|------------------|
| 100 | 05 | FILLER                        | PIC X(10)        |                  |
| 101 |    | VALUE 'LOCATION: '.           |                  |                  |
| 102 | 05 | HDG-LOCATION                  | PIC X(19)        | VALUE SPACES.    |
| 103 | 05 | FILLER                        | PIC X(95)        | VALUE SPACES.    |
| 104 |    |                               |                  |                  |
| 105 | 01 | SALESPERSON-HEADING-LINE-ONE. |                  |                  |
| 106 | 05 | FILLER                        | PIC X(15)        | VALUE SPACES.    |
| 107 | 05 | FILLER                        | PIC X(13)        |                  |
| 108 |    | VALUE 'SALESPERSON: '.        |                  |                  |
| 109 | 05 | HDG-NAME                      | PIC X(15).       |                  |
| 110 | 05 | FILLER                        | PIC X(89)        | VALUE SPACES.    |
| 111 |    |                               |                  |                  |
| 112 | 01 | SALESPERSON-HEADING-LINE-TWO. |                  |                  |
| 113 | 05 | FILLER                        | PIC X(23)        | VALUE SPACES.    |
| 114 | 05 | FILLER                        | PIC X(11)        | VALUE 'ACCOUNT . |
| 115 | 05 | FILLER                        | PIC X(9)         | VALUE SPACES.    |
| 116 | 05 | FILLER                        | PIC X(5)         | VALUE 'SALES'.   |
| 117 | 05 | FILLER                        | PIC X(8)         | VALUE SPACES.    |
| 118 | 05 | FILLER                        | PIC X(10)        | VALUE MMISSION'. |
| 119 | 05 | FILLER                        | PIC X(66)        | VALUE SPACES.    |
| 120 |    |                               |                  |                  |
| 121 | 01 | DETAIL-LINE.                  |                  |                  |
| 122 | 05 | FILLER                        | PIC X(25)        | VALUE SPACES.    |
| 123 | 05 | DET-ACCOUNT-NUMBER            | PIC 9(6).        |                  |
| 124 | 05 | FILLER                        | PIC X(9)         | VALUE SPACES.    |
| 125 | 05 | DET-SALES                     | PIC Z(3),ZZ9-.   |                  |
| 126 | 05 | FILLER                        | PIC X(7)         | VALUE SPACES.    |
| 127 | 05 | DET-COMMISSION                | PIC Z(3),ZZ9-.   |                  |
| 128 | 05 | FILLER                        | PIC X(69)        | VALUE SPACES.    |
| 129 |    |                               |                  |                  |
| 130 | 01 | DASHED-LINE.                  |                  |                  |
| 131 | 05 | FILLER                        | PIC X(40)        | VALUE SPACES.    |
| 132 | 05 | FILLER                        | PIC X(8)         | VALUE ALL '-'.   |
| 133 | 05 | FILLER                        | PIC X(7)         | VALUE SPACES.    |
| 134 | 05 | FILLER                        | PIC X(8)         | VALUE ALL '-'.   |
| 135 | 05 | FILLER                        | PIC X(69)        | VALUE SPACES.    |
| 136 |    |                               |                  |                  |
| 137 | 01 | SALESPERSON-TOTAL-LINE.       |                  |                  |
| 138 | 05 | FILLER                        | PIC X(15)        | VALUE SPACES.    |
| 139 | 05 | FILLER                        | PIC X(21)        |                  |
| 140 |    | VALUE '** SALESPERSON TOTAL'. |                  |                  |
| 141 | 05 | FILLER                        | PIC X(3)         | VALUE SPACES.    |
| 142 | 05 | SALESPERSON-SALES-TOTAL       | PIC \$Z(3),ZZ9-. |                  |
| 143 | 05 | FILLER                        | PIC X(6)         | VALUE SPACES.    |
| 144 | 05 | SALESPERSON-COMM-TOTAL        | PIC \$Z(3),ZZ9-. |                  |
| 145 | 05 | FILLER                        | PIC X(69)        | VALUE SPACES.    |
| 146 |    |                               |                  |                  |

Figure 15.10 (continued)

```

147 01 LOCATION-TOTAL-LINE.
148 05 FILLER PIC X(13) VALUE SPACES.
149 05 FILLER PIC X(19)
150 VALUE '**** LOCATION TOTAL'.
151 05 FILLER PIC X(7) VALUE SPACES.
152 05 LOCATION-SALES-TOTAL PIC $Z(3),ZZ9-.
153 05 FILLER PIC X(6) VALUE SPACES.
154 05 LOCATION-COMM-TOTAL PIC $Z(3),ZZ9-.
155 05 FILLER PIC X(69) VALUE SPACES.

```

```

157 01 REGION-TOTAL-LINE.
158 05 FILLER PIC X(11) VALUE SPACES.
159 05 FILLER PIC X(19)
160 VALUE '***** REGION TOTAL'.
161 05 FILLER PIC X(9) VALUE SPACES.
162 05 REGION-SALES-TOTAL PIC $Z(3),ZZ9-.
163 05 FILLER PIC X(6) VALUE SPACES.
164 05 REGION-COMM-TOTAL PIC $Z(3),ZZ9-.
165 05 FILLER PIC X(69) VALUE SPACES.

```

*Region total line is added to three-level program.*

```

166
167 01 COMPANY-TOTAL-LINE.
168 05 FILLER PIC X(9) VALUE SPACES.
169 05 FILLER PIC X(22)
170 VALUE '***** COMPANY TOTAL'.
171 05 FILLER PIC X(8) VALUE SPACES.
172 05 COMPANY-SALES-TOTAL PIC $Z(3),ZZ9-.
173 05 FILLER PIC X(6) VALUE SPACES.
174 05 COMPANY-COMM-TOTAL PIC $Z(3),ZZ9-.
175 05 FILLER PIC X(69) VALUE SPACES.

```

```

176
177 PROCEDURE DIVISION.
178 100-PREPARE-SALES-REPORT.
179 PERFORM 200-SORT-TRANSACTION-FILE.
180 OPEN INPUT SORTED-SALES-FILE
181 OUTPUT PRINT-FILE.
182 PERFORM 220-READ-SORTED-SALES-FILE.
183 PERFORM 240-PROCESS-ONE-REGION
184 UNTIL NO-DATA-REMAINS.
185 PERFORM 260-WRITE-COMPANY-TOTAL.
186 CLOSE SORTED-SALES-FILE
187 PRINT-FILE.
188 STOP RUN.

```

```

189
190 200-SORT-TRANSACTION-FILE.
191 SORT SORT-WORK-FILE
192 ASCENDING KEY
193 SORT-REGION

```

*Keys in SORT statement match control breaks*



Figure 15.10 (continued)

```

194 SORT-LOCATION
195 SORT-NAME
196 WITH DUPLICATES IN ORDER
197 USING SALES-FILE
198 GIVING SORTED-SALES-FILE.
199
200 220-READ-SORTED-SALES-FILE.
201 READ SORTED-SALES-FILE INTO SALES-RECORD-IN
202 AT END MOVE 'NO' TO DATA-REMAINS-SW
203 END-READ.
204
205 240-PROCESS-ONE-REGION.
206 PERFORM 300-INITIALIZE-REGION.
207 PERFORM 320-WRITE-REGION-HEADING.
208 PERFORM 340-PROCESS-ONE-LOCATION
209 UNTIL SR-REGION NOT EQUAL PREVIOUS-REGION
210 OR NO-DATA-REMAINS.
211 PERFORM 360-WRITE-REGION-TOTAL.
212 PERFORM 380-INCREMENT-COMPANY-TOTAL.
213
214 260-WRITE-COMPANY-TOTAL.
215 MOVE COMPANY-SALES-TOT TO COMPANY-SALES-TOTAL.
216 MOVE COMPANY-COMM-TOT TO COMPANY-COMM-TOTAL.
217 WRITE PRINT-LINE FROM COMPANY-TOTAL-LINE
218 AFTER ADVANCING 2 LINES.
219
220 300-INITIALIZE-REGION.
221 MOVE SR-REGION TO PREVIOUS-REGION.
222 INITIALIZE REGION-TOTALS.
223
224 320-WRITE-REGION-HEADING.
225 ADD 1 TO PAGE-COUNT.
226 MOVE PAGE-COUNT TO HDG-PAGE.
227 WRITE PRINT-LINE FROM REPORT-HEADING-LINE
228 AFTER ADVANCING PAGE.
229 MOVE SR-REGION TO HDG-REGION.
230 WRITE PRINT-LINE FROM REGION-HEADING-LINE
231 AFTER ADVANCING 2 LINES.
232
233 340-PROCESS-ONE-LOCATION.
234 PERFORM 400-INITIALIZE-LOCATION.
235 PERFORM 420-WRITE-LOCATION-HEADING.
236 PERFORM 440-PROCESS-ONE-SALESPERSON
237 UNTIL SR-LOCATION NOT EQUAL PREVIOUS-LOCATION
238 OR SR-REGION NOT EQUAL PREVIOUS-REGION
239 OR NO-DATA-REMAINS.
240 PERFORM 460-WRITE-LOCATION-TOTAL.

```

SORT-LOCATION  
 SORT-NAME  
 WITH DUPLICATES IN ORDER  
 USING SALES-FILE  
 GIVING SORTED-SALES-FILE.

Keys in SORT statement match control breaks

Region heading written for each new region

Region total written after control break detected

Figure 15.10 (continued)

```

241 PERFORM 480-INCREMENT-REGION-TOTAL.
242
243 360-WRITE-REGION-TOTAL.
244 MOVE REGION-SALES-TOT TO REGION-SALES-TOTAL.
245 MOVE REGION-COMM-TOT TO REGION-COMM-TOTAL.
246 WRITE PRINT-LINE FROM REGION-TOTAL-LINE
247 AFTER ADVANCING 1 LINE.
248
249 380-INCREMENT-COMPANY-TOTAL.
250 ADD REGION-SALES-TOT TO COMPANY-SALES-TOT.
251 ADD REGION-COMM-TOT TO COMPANY-COMM-TOT.
252
253 400-INITIALIZE-LOCATION.
254 MOVE SR-LOCATION TO PREVIOUS-LOCATION.
255 INITIALIZE LOCATION-TOTALS.
256
257 420-WRITE-LOCATION-HEADING.
258 MOVE SR-LOCATION TO HDG-LOCATION.
259 WRITE PRINT-LINE FROM LOCATION-HEADING-LINE
260 AFTER ADVANCING 1 LINE.
261
262 440-PROCESS-ONE-SALESPERSON.
263 PERFORM 500-INITIALIZE-SALESPERSON.
264 PERFORM 520-WRITE-SALESPERSON-HEADING.
265 PERFORM 540-PROCESS-ONE-TRANSACTION
266 UNTIL SR-NAME NOT EQUAL PREVIOUS-NAME
267 OR SR-LOCATION NOT EQUAL PREVIOUS-LOCATION
268 OR SR-REGION NOT EQUAL PREVIOUS-REGION
269 OR NO-DATA-REMAINS.
270 PERFORM 560-WRITE-SALESPERSON-TOTAL.
271 PERFORM 580-INCREMENT-LOCATION-TOTAL.
272
273 460-WRITE-LOCATION-TOTAL.
274 MOVE LOCATION-SALES-TOT TO LOCATION-SALES-TOTAL.
275 MOVE LOCATION-COMM-TOT TO LOCATION-COMM-TOTAL.
276 WRITE PRINT-LINE FROM LOCATION-TOTAL-LINE
277 AFTER ADVANCING 1 LINE.
278 MOVE SPACES TO PRINT-LINE.
279 WRITE PRINT-LINE
280 AFTER ADVANCING 1 LINE.
281
282 480-INCREMENT-REGION-TOTAL.
283 ADD LOCATION-SALES-TOT TO REGION-SALES-TOT.
284 ADD LOCATION-COMM-TOT TO REGION-COMM-TOT.
285
286 500-INITIALIZE-SALESPERSON.
287 MOVE SR-NAME TO PREVIOUS-NAME.

```

Region totals are rolled into company

Location totals are rolled into region

Figure 15.10 (continued)

```

288 INITIALIZE SALESPERSON-TOTALS.
289
290 520-WRITE-SALESPERSON-HEADING.
291 MOVE SR-NAME TO HDG-NAME.
292 WRITE PRINT-LINE FROM SALESPERSON-HEADING-LINE-ONE
293 AFTER ADVANCING 1 LINE.
294 WRITE PRINT-LINE FROM SALESPERSON-HEADING-LINE-TWO
295 AFTER ADVANCING 1 LINE.
296
297 540-PROCESS-ONE-TRANSACTION.
298 PERFORM 600-CALCULATE-COMMISSION.
299 PERFORM 620-WRITE-DETAIL-LINE.
300 PERFORM 640-INCREMENT-SALESPERSON-TOTAL.
301 PERFORM 220-READ-SORTED-SALES-FILE.
302
303 560-WRITE-SALESPERSON-TOTAL.
304 WRITE PRINT-LINE FROM DASHED-LINE
305 AFTER ADVANCING 1 LINE.
306 MOVE SALESPERSON-SALES-TOT TO SALESPERSON-SALES-TOTAL.
307 MOVE SALESPERSON-COMM-TOT TO SALESPERSON-COMM-TOTAL.
308 WRITE PRINT-LINE FROM SALESPERSON-TOTAL-LINE
309 AFTER ADVANCING 1 LINE.
310 MOVE SPACES TO PRINT-LINE.
311 WRITE PRINT-LINE
312 AFTER ADVANCING 1 LINE.
313
314 580-INCREMENT-LOCATION-TOTAL.
315 ADD SALESPERSON-SALES-TOT TO LOCATION-SALES-TOT.
316 ADD SALESPERSON-COMM-TOT TO LOCATION-COMM-TOT.
317
318 600-CALCULATE-COMMISSION.
319 COMPUTE IND-COMMISSION ROUNDED =
320 SR-SALES * SR-COMMISSION-PERCENT
321 SIZE ERROR DISPLAY 'SIZE ERROR ON COMMISSION FOR '
322 SR-NAME
323 END-COMPUTE.
324
325 620-WRITE-DETAIL-LINE.
326 MOVE SR-ACCOUNT-NUMBER TO DET-ACCOUNT-NUMBER.
327 MOVE SR-SALES TO DET-SALES.
328 MOVE IND-COMMISSION TO DET-COMMISSION.
329 WRITE PRINT-LINE FROM DETAIL-LINE.
330
331 640-INCRMENT-SALESPERSON-TOTAL.
332 ADD SR-SALES TO SALESPERSON-SALES-TOT.
333 ADD IND-COMMISSION TO SALESPERSON-COMM-TOT.

```

*Salesperson totals are rolled into location totals*

**PROGRAMMING TIP****How to Write a Control Break Program**

The algorithm for one-, two-, and three-level control breaks follows a general pattern that can be adopted for any control break application and/or any number of levels. We suggest, therefore, that you review the hierarchy chart, pseudocode, and/or COBOL programs that were developed in this chapter and see how those examples fit a general pattern.

Start by determining the number of levels in the application, their relative importance (sort order), and corresponding field names. Identify the field names that will be used to detect a control break at each level—for example, **SR-REGION**, **SR-LOCATION**, and **SR-NAME** in the three-level example used in the text.

Modify the hierarchy chart, pseudocode, and COBOL listings from the chapter to accommodate your specific application. Begin with the highest (most important) level and do the following for every level:

1. Initialize the control totals for this level
2. Initialize the field name to detect a control break at this level with the previous value
3. Write the heading for this level (if any)
4. Process this level until the field name at this level is not equal to the previous value  
OR the field name at a higher level is not equal to the previous value  
OR no data remains
5. Write this level's total (if required)
6. Increment the next higher level's total (rolling total)

At the lowest (transaction) level:

1. Perform the necessary calculations (if any)
2. Write a detail line (if any)
3. increment the lowest level's total (running total)
4. Read the next record

**EVOLUTION OF COBOL**

There are no specific enhancements in COBOL-85 intended to facilitate the processing of control breaks. Accordingly, all of the listings in this chapter could be made to run under COBOL-74 with only minor modification, such as the removal of the **END-READ** scope terminator, and the **WITH DUPLICATES** clause in the sort statement; the latter would require an additional sort key on account number.

## S U M M A R Y

---

### Points to Remember

- ☒ A control break is a change in a designated (control) field; any file used to process control breaks must be in sequence according to the control field.
- ☒ Control breaks may occur at multiple levels; for example, a two-level control break occurs when two control fields change simultaneously; in similar fashion a three-level control break occurs when three control fields change simultaneously.
- ☒ There is no theoretical limit to the number of control breaks; there is a practical limit, however, in that most people lose track after three (or at most four) levels.
- ☒ Programs for one-, two-, and three-level control breaks are developed according to a general algorithm; the importance of a hierarchy chart and pseudocode in the design process cannot be over-emphasized.
- ☒ A running total is incremented by the value of the corresponding field in every transaction; a rolling total is incremented by a lower-level-control total only after a control break has occurred; rolling totals are more efficient than running totals.

### Key Words and Concepts

|                         |                           |
|-------------------------|---------------------------|
| Compound condition      | Pseudocode                |
| Control field           | Rolling total             |
| Control total           | Running total             |
| Control break           | Three-level control break |
| Hierarchy chart         | Two-level control break   |
| One-level control break |                           |

## F I L L - I N

---

1. A \_\_\_\_\_ in a designated field is known as a \_\_\_\_\_.
2. Any file used to process control breaks must be in \_\_\_\_\_ according to the control fields.
3. It (is/is not) possible for data in a given record to produce a control break on more than one field.
4. Control break processing (is/is not) limited to one level.
5. A program's hierarchy chart is best developed (before/after) the program is written.
6. The more significant field in a two-level control break application is known as the \_\_\_\_\_ field, whereas the less significant field is the \_\_\_\_\_ field.

7. (Pseudocode/hierarchy charts) depict a program's logic and decision-making sequence.
8. A COBOL program to process control breaks (requires/does not require) the file to be in sequence.
9. Running totals are (more/less) efficient than rolling totals.
10. A \_\_\_\_\_ total increments the value of a counter after every record.
11. A \_\_\_\_\_ total increments the value of a counter after a control break.

## TRUE / FALSE

---

1. Control break processing is restricted to a single level.
2. Input to a control break program need not be in any special order.
3. Modules in a hierarchy chart and paragraphs in a COBOL program correspond one to one.
4. A hierarchy chart depicts decision-making logic.
5. Each level in a hierarchy chart corresponds to a COBOL PERFORM statement.
6. A two-level control break occurs when two control fields change simultaneously.
7. A three-level control break implies the occurrence of one- and two-level control breaks as well.
8. A three-level control breaks requires that three control totals be computed at each level.
9. Rolling totals is a more efficient means of computation than running totals
10. A rolling total increments a counter for every transaction.

## PROBLEMS

---

1. Return once more to the two-level program in Figure 15.8 and note that the PERFORM statement to detect a break in salesperson (lines 188–190) includes the clause SR-LOCATION NOT EQUAL PREVIOUS-LOCATION. Why? (What would happen if this clause were not present and the last salesperson in one location had the same name as the first salesperson in the next location?) State a generalized rule for the compound condition in PERFORM statements that is needed to detect control breaks.
2. What would be the consequences of omitting the SORT statement in the one-level control break program of Figure 15.6; that is, describe the appearance of the resulting report if the unsorted transaction file of Figure 15.1 were used in lieu of the sorted file in Figure 15.2a. Explain in general terms the consequences of omitting the SORT statement in any of the programs contained in the chapter.
3. The one-level program of Figure 15.6 uses the data names SALESPERSON-SALES-TOT and COMPANY-SALES-TOT to accumulate totals.
  - a. Which data name(s) are computed as a *running* total? When, and by what amount, is the total incremented?
  - b. Which data name(s) are computed as a *rolling* total? When, and by what amount, is the total incremented?

- c. Repeat parts (a) and (b) for the two-level program of Figure 15.8. Answer for the data names SALESPERSON-SALES-TOT, LOCATION-SALES-TOT, and COMPANY-SALES-TOT.
  - d. Repeat parts (a) and (b) for the three-level program of Figure 15.10. Answer for the data names SALESPERSON-SALES-TOT, LOCATION-SALES-TOT, REGION-SALES-TOT, and COMPANY-SALES-TOT.
4. The hypothetical Continental University is composed of multiple colleges, with each college divided into multiple departments. The central administration wants to know the total number of students in a variety of categories and uses a university-wide ENROLLMENT-FILE to compute the desired totals. The following fields are present in each enrollment record: COLLEGE, DEPARTMENT, YEAR, NUMBER-OF-STUDENTS. Identify the control fields and sorting sequence to produce each of the following reports. (Each report is to be treated independently.)
- a. The number of students in each year
  - b. The number of students in each department
  - c. The number of students in each college
  - d. The number of students in each college and within college, the number of students in each department
  - e. The number of students in each college and within college, the number of students in each year

# Subprograms

## CHAPTER OUTLINE

---

Overview

### **Subprograms**

Called and Calling Programs

COPY Statement

Calling BY CONTENT and BY REFERENCE

### **INITIAL Clause**

### **A System for Physical Fitness**

Programming Specifications

Hierarchy Chart

Pseudocode

### **The Completed Programs**

Main Program (FITNESS)

Input Program (INPUTSUB)

Weight-Range Program (WGTSUB)

Training Program (TRAINSUB)

Display Program (DSPLYSUB)

Time Program (TIMESUB)

### **The Linkage Editor**

Problems with the Linkage Editor

Limitations of COBOL-74

Summary

Fill-in

True/False

Problems



## OBJECTIVES

---

After reading this chapter you will be able to:

- Define a subprogram and describe its implementation in COBOL.
- Distinguish between a called and calling program; describe the use of a hierarchy chart to show the relationship of programs within a system.
- State the purpose of the COPY statement; indicate where it may be used within a program and how it can be used to pass a parameter list.
- Distinguish between the BY CONTENT and BY REFERENCE clauses as they relate to subprograms.
- Explain the function of the INITIAL phrase in the PROGRAM-ID paragraph.
- Describe the purpose of the linkage-editor; explain the meaning of an unresolved external reference.

## OVERVIEW

---

This chapter introduces the concept of subprograms in order to develop a system of programs associated with physical fitness. Each program is compiled as a separate entity, after which the individual object programs are linked together to produce a single load module. The chapter includes material on all necessary COBOL elements as well as a conceptual discussion on the role of the link program (linkage-editor).

The COBOL presentation begins with the CALL statement and associated parameter list in the calling program, then presents the relationship with data names defined in the LINKAGE SECTION of the called program. It describes the different ways of passing parameters, either BY REFERENCE or BY CONTENT, and introduces the COPY statement as a means of simplifying program development.

The chapter also serves as an effective review of earlier material in that the various subprograms utilize many features from previous chapters. Thus, we once again emphasize the importance of data validation from Chapter 8, illustrate advanced statements from the Procedure Division as covered in Chapter 9, review the screen I/O capabilities presented in Chapter 10, and incorporate material on both one- and two-level tables from Chapters 11 through 13.

## Subprograms

The PERFORM statement has been used throughout the text to divide a program into functional paragraphs, each of which is executed as necessary from elsewhere within the program. The individual paragraphs are developed in stages and implemented in hierarchical fashion through top-down testing. The individual paragraphs are, in effect, subroutines that are written, compiled, and executed within the main program.

Alternatively, the performed routines may be developed as independent entities, known as *subprograms*, that are written and compiled separately from the *main (calling) program*. The subprograms within the same system may even be written by different programmers, but they are always executed under control of the main program. Subprograms bring to a system all the advantages of modularity that functional paragraphs bring to a program; for example, a change in one subprogram should not affect the internal workings of another subprogram nor the overall flow of the system. And, like the paragraphs in a program, the subprograms in a system may be developed and tested in top-down fashion.

A subprogram contains the four divisions of a regular program, and in addition, a LINKAGE SECTION in its Data Division to hold the data passed to and from the calling program. Figure 16.1 contains statements extracted from the listings at the end of the chapter to illustrate the use of subprograms. In this example, the calling program contains the logic to accept personal data from a user regarding the individual's height, age, and sex. It passes control to the sub (called) program WGTSUB, which determines the ideal range for the person's weight based on the data received. The CALL statement in the calling program matches the entry in the PROGRAM-ID paragraph of the called program (WGTSUB).

The CALL statement transfers control to the first executable statement in the called program. The CALL statement contains a USING clause, which specifies the data on which the called program is to operate. The called program in turn contains a USING clause in its Procedure Division header, indicating which data it is to receive from the calling program. The data names in either USING clause are known collectively as the *parameter or argument list*.

The data names in the two parameter lists can (but need not) be the same, but the order and structure of data names within the list is critical. The first item in the parameter list of the calling program is FITNESS-RECORD, and corresponds to the first item in the parameter list of the called program, which is also called FITNESS-RECORD. In similar fashion, the second and third items in the calling program (WEIGHT-FROM and WEIGHT-TO) correspond to the second and third items in the subroutine (LS-WEIGHT-FROM and LS-WEIGHT-TO). The picture clauses of the individual parameters (arguments) are the same, but the data names are different.

The arguments in the calling program are defined either in the File Section or in Working-Storage, whereas the arguments in the called program must be defined in the *Linkage Section*. The parameters in either program must be defined as 01 or elementary items; that is, group items (other than 01 entries) cannot be passed to a subprogram.

Execution of the CALL statement in the main program transfers control to the first executable statement of the subprogram, which executes exactly as a regular COBOL program; the latter is terminated by an EXIT PROGRAM statement that returns control to the calling program at the statement immediately after the CALL.

### Called and Calling Programs

The example in Figure 16.1 included only two programs, one calling program and one called program. More complex arrangements are also possible, for example:

Figure 16.1 COBOL Statements for a Subprogram

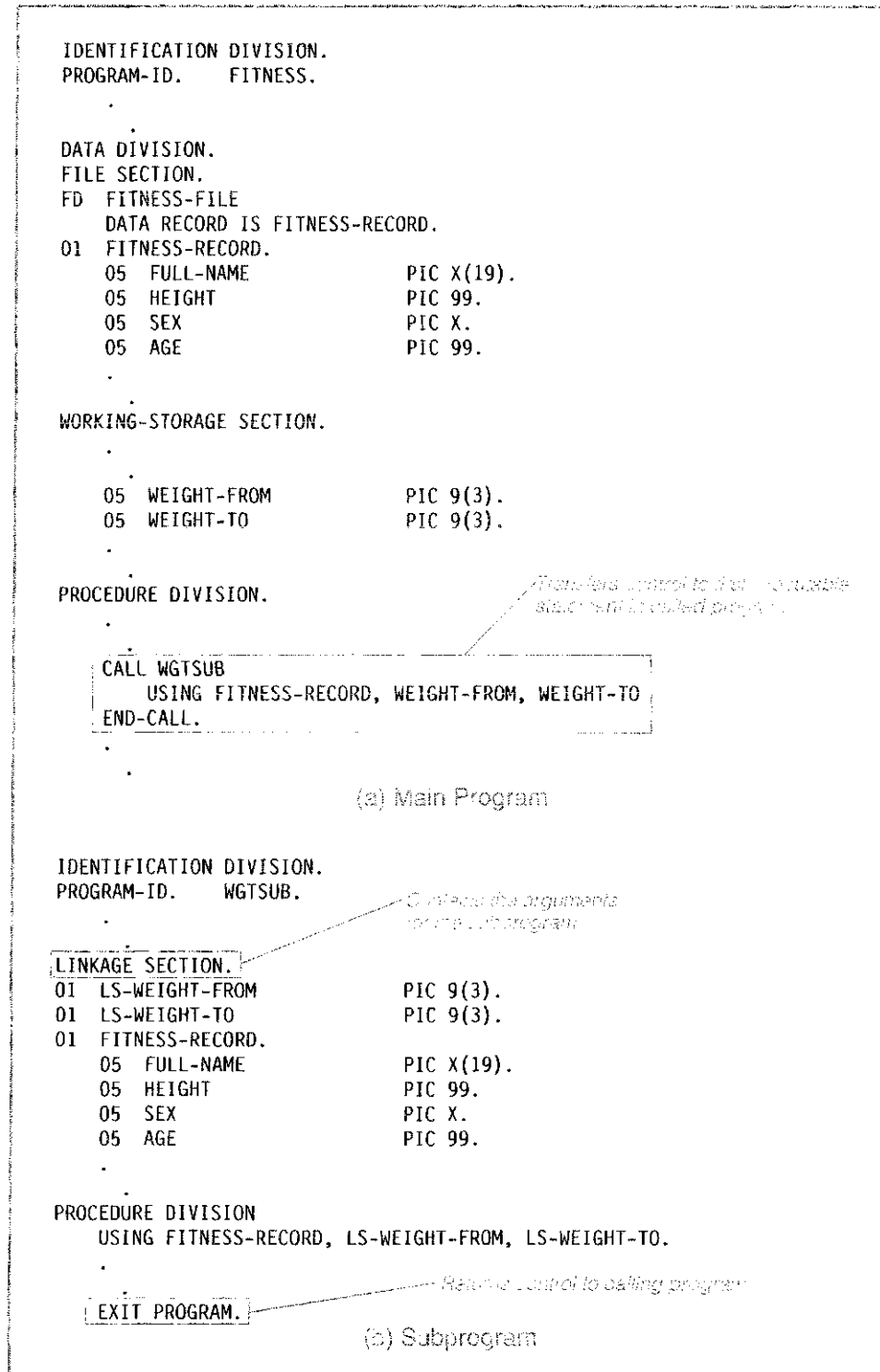

1. One program can call multiple subprograms; for example, program A can call programs B, C, D, and E.
2. One program can be called from different programs; for example, program F can be called from programs B and C.

3. The same program can be both a called and calling program; for example, program A calls program B, which in turn calls program F. (Program B is both a called and calling program.)

A hierarchy chart depicts the relationship of various programs to one another within a system, just as it shows the relationship of paragraphs within a program. The hierarchy chart in Figure 16.2, for example, illustrates the relationships just expressed. Thus, program A sits at the top of the hierarchy chart and calls programs B, C, D, and E. Program F is shown twice in the hierarchy chart, indicating that it (program F) is called from programs B and C. Programs B and C function as both called and calling programs; they are called from program A and in turn call program F.

Figure 16.2 Called and Calling Programs

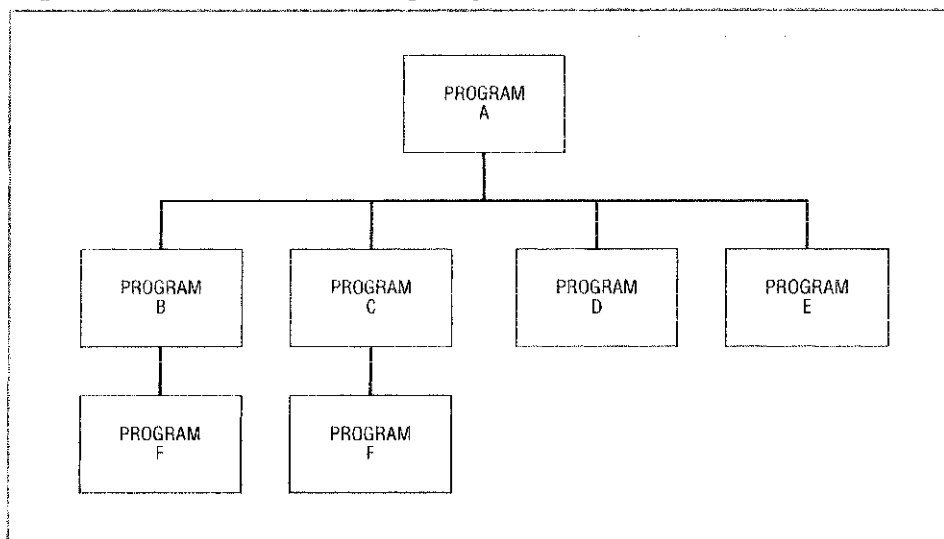

### The COPY Statement

The data names used within different programs of the same system are often interrelated because the same file is apt to be referenced by several programs. The COPY statement facilitates the development of such programs by allowing the programmer to code a one-line COPY statement, which brings the associated entries into the COBOL program.

Figure 16.3 contains a COPY statement in which the programmer coded the line COPY TRAINCPY in line 27. The COBOL compiler locates the file TRAINCPY, and brings in lines 28–34 as though the programmer had coded them explicitly. The compiler inserts a C after the statement number in the source listing to indicate a copied statement.

A COPY statement may be used anywhere within a COBOL program, *except that the text being copied cannot contain another COPY*. The syntax of the COPY statement is simply:

`COPY text-name`

Figure 16.3 The COPY Statement

|     |    |                     |           |
|-----|----|---------------------|-----------|
| 27  |    | COPY TRAINCOPY.     |           |
| 28C | 01 | TRAINING-ARGUMENTS. |           |
| 29C | 05 | TRAINING-INPUTS.    |           |
| 30C | 10 | TRAIN-AGE           | PIC 99.   |
| 31C | 10 | TRAIN-FITNESS-LEVEL | PIC X.    |
| 32C | 05 | TRAINING-RANGES.    |           |
| 33C | 10 | TRAIN-OVERALL-RANGE | PIC X(5). |
| 34C | 10 | TRAIN-FITNESS-RANGE | PIC X(5). |

where text-name is the name of a file (member, or element) that exists independently of the COBOL program. A COPY statement is not restricted to subprograms; it can be used with any COBOL program. COPY statements offer the following advantages:

1. Individual programmers need not code the extensive Data Division entries that can make COBOL so tedious; a programmer can code a one-line COPY statement, and the compiler will bring the proper entries into the program.
2. Any change that affects multiple programs is made only once, in the library version of the COPY element. Subsequent compilations of all programs containing a COPY statement for that element will automatically bring in the updated version.
3. Programming errors are reduced through standardization and common definition of data elements. All fields within a record description (or other copied element) in one program will always be correct and consistent with the definition in other programs using the same copied element.

### Calling BY CONTENT and BY REFERENCE

One of the most important principles of structured design is program independence, which minimizes (eliminates) the effect one program has on another. The optional USING BY CONTENT phrase prevents the values of parameters created in the calling program from being changed by the called program. Consider:

```
CALL program [USING { [BY REFERENCE] identifier-2 . . . } . . .]
 [BY CONTENT identifier-3 . . .]
[END-CALL]
```

and an example:

```
CALL 'SUBRIN' USING FIELD-A
 BY CONTENT FIELD-B FIELD-C
 BY REFERENCE FIELD-D.
```

The CALL statement passes four arguments, FIELD-A, FIELD-B, FIELD-C, and FIELD-D, to a subprogram that manipulates any or all of these parameters (referring to them by its own data names as defined in its LINKAGE SECTION). However, the USING BY CONTENT phrase will restore the values of FIELD-B and FIELD-C to their initial values when control is returned to the calling program, despite any changes made to the corresponding parameters by the called program.

**PROGRAMMING TIP****Use COPY To Pass Parameters**

The order of arguments in the **CALL USING** and **PROCEDURE DIVISION USING** clauses of the calling and called programs is critical. You can reduce the chance for error by using a **COPY** clause to pass parameters as shown. Consider:

*Poor Code:*

```
CALL 'WGTSUB'
 USING HEIGHT, SEX, AGE, WEIGHT-FROM, WEIGHT-TO
END-CALL.
```

## PROCEDURE DIVISION

```
 USING LS-HEIGHT, LS-SEX, LS-AGE, LS-WGT-FROM, LS-WGT-TO.
```

*Improved Code:*

```
 COPY WGTLSST.
01 WEIGHT-TABLE-ARGUMENTS.
 05 WT-HEIGHT PIC 99.
 05 WT-SEX PIC X.
 05 WT-AGE PIC 99.
 05 WT-FROM PIC 9(3).
 05 WT-TO PIC 9(3).

CALL 'WGTSUB'
 USING WEIGHT-TABLE-ARGUMENTS
END-CALL.
```

## LINKAGE SECTION.

```
 COPY WGTLSST.
01 WEIGHT-TABLE-ARGUMENTS.
 05 WT-HEIGHT PIC 99.
 05 WT-SEX PIC X.
 05 WT-AGE PIC 99.
 05 WT-FROM PIC 9(3).
 05 WT-TO PIC 9(3).
```

## PROCEDURE DIVISION

```
 USING WEIGHT-TABLE-ARGUMENTS.
```

Use of the single 01 parameter facilitates coding in the **USING** clauses and also makes them immune to change. Use of the same **COPY** member in both programs eliminates any problem with listing arguments in the wrong order or inconsistent definition through different pictures.

No such restriction is placed on the value of **FIELD-A**, which will retain any value computed in the called program. The value of **FIELD-D** will also reflect changes made by the called program, as it (**FIELD-D**) was specified in a **USING BY REFERENCE** phrase; that is, **USING BY REFERENCE** is equivalent to a **CALL** statement with neither phrase.

**INITIAL Clause**

The **INITIAL** clause in the **PROGRAM-ID** paragraph restores a program to its initial state each time it is called; that is, all data names in Working-Storage are reset to their original values via any **VALUE** clauses that are present. Consider:

```
PROGRAM-ID. program-name [IS INITIAL PROGRAM].
```

The **INITIAL** clause makes it possible to start with an original (unmodified) copy of a called program every time it is executed. Alternatively, omission of the phrase causes every execution of a called program to begin with the values established in the latest (previous) execution.

**A System for  
Physical  
Fitness**

The material on subprograms will be incorporated into a system for physical fitness that obtains input from a user, determines various aspects of the individual's fitness, then displays the results at the end of processing. The individual programs illustrate the transfer of control and passing of parameters between a called and calling program, and also review COBOL material from earlier chapters as described in the chapter overview.

## PROGRAMMING SPECIFICATIONS

**Program Name:** Physical Fitness System

**Narrative:** The specifications call for a series of programs that constitute a system for physical fitness. A screen I/O program will accept and verify various inputs from a user, such as age, sex, and height, then pass control to a series of subprograms to compute the desired weight and target heart range at different levels of fitness.

**Input Files:** There are no input or output files as all data are entered and displayed interactively via screen I/O. Figure 16.4 contains a sample screen for a hypothetical individual named Mr. Fit. The inputs provided by Mr. Fit are highlighted in the top half of the screen. The diagnostic messages produced by the system show Mr. Fit's weight of 185 to be within the desired range for his age, sex, and height. The system also suggests a target (10-second) heart rate (after exercise) between 27 and 30 in accordance with his advanced fitness level.

**Processing Requirements:**

1. Develop a series of programs that constitute a system for physical fitness as described below:
  - a. A main program to govern the overall system and pass control to various subprograms as appropriate
  - b. A subprogram to accept and validate an individual's personal data
  - c. A subprogram to compute a goal weight based on an individual's sex, height, and age.
  - d. A subprogram to compute a target heart rate (after sustained cardiovascular exercise) based on age and fitness level
  - e. A subprogram to display the computed results for weight and target heart rate
2. The main program is to control the overall system by passing (receiving) control from the various subprograms. The system is to execute continually—that is, for multiple individuals—until it receives a response that no one else wishes to use the system.

3. The input program is to accept the following fields as indicated in Figure 16.4: Name, Age, Sex, Weight, Height, and Fitness level. Validation checks are required as follows:
  - a. A name must be entered
  - b. Age must be 18 or higher
  - c. Sex must be male or female; the system should accept both upper- and lowercase letters as valid characters.
  - d. Height is to be entered in inches and must be consistent with the tables available to the system; valid male heights are between 60 and 76 inches; valid female heights must be between 54 and 74 inches.
  - e. The fitness level should be entered as a single letter, B, I, or A, corresponding to Beginner, Intermediate, or Advanced. The system should accept both upper- and lowercase letters as valid characters.

The input program is to display appropriate prompts and error messages for each of these fields. In addition, it should also display the current time as shown in the upper right portion of Figure 16.4.

4. The goal weight is determined from a person's sex, height, and age as shown in the tables of Figure 16.5.
5. The minimum and maximum target (training) heart ranges, expressed for a 10-second period after exercise, are determined from an individual's age according to the formulas:

$$\text{Minimum target (10 seconds)} = .60 * (220 - \text{AGE}) / 6$$

$$\text{Maximum target (10 seconds)} = .90 * (220 - \text{AGE}) / 6$$

The target range can also be adjusted according to the individual's fitness level and the range between the maximum and minimum values; that is, those at a beginner's level of fitness should aim for a target heart range in the lower third of the interval, those with intermediate fitness in the middle third, and those at an advanced level in the upper third.

Figure 16.4 Fitness Screen

```

Personal Fitness Evaluation 11:53:10

Full Name: Mr. Fit

Age: 22 Weight: 185 Fitness Level: A
Sex (M/F): M Height: 74 B - Beginner
 I - Intermediate
 A - Advanced

Your Goal Weight Range: 163-196
CONGRATULATIONS! You are within the range

Training Heart Rate Range Information (10 Second)
Overall Heart Rate Range: 20-30
Adjusted for Fitness Level: 27-30

Another Person (Y/N):

```



Figure 16.5 Table of Goal Weights

| Height<br>(in inches) | Age (in years) |         |         |         |           |
|-----------------------|----------------|---------|---------|---------|-----------|
|                       | 18             | 19-20   | 21-22   | 23-24   | 25 & Over |
| 54                    | 83-99          | 84-101  | 85-103  | 86-104  | 88-106    |
| 55                    | 84-100         | 85-102  | 86-104  | 88-105  | 90-107    |
| 56                    | 86-101         | 87-103  | 88-105  | 90-106  | 92-108    |
| 57                    | 89-102         | 90-104  | 91-106  | 92-108  | 94-110    |
| 58                    | 91-105         | 92-106  | 93-109  | 94-111  | 96-113    |
| 59                    | 93-109         | 94-111  | 95-113  | 96-114  | 99-116    |
| 60                    | 96-112         | 97-113  | 98-115  | 100-117 | 102-119   |
| 61                    | 100-116        | 101-117 | 102-119 | 103-121 | 105-122   |
| 62                    | 104-119        | 105-121 | 106-123 | 107-125 | 108-126   |
| 63                    | 106-125        | 107-126 | 108-127 | 109-129 | 111-130   |
| 64                    | 109-130        | 110-131 | 111-132 | 112-134 | 114-135   |
| 65                    | 112-133        | 113-134 | 114-136 | 116-138 | 118-139   |
| 66                    | 116-137        | 117-138 | 118-140 | 120-142 | 122-143   |
| 67                    | 121-140        | 122-142 | 123-144 | 124-146 | 126-147   |
| 68                    | 123-144        | 124-146 | 126-148 | 128-150 | 130-150   |
| 69                    | 130-148        | 131-150 | 132-152 | 133-154 | 134-155   |
| 70                    | 134-151        | 135-154 | 136-156 | 137-158 | 138-159   |
| 71                    | 138-155        | 139-158 | 140-160 | 141-162 | 142-163   |
| 72                    | 142-160        | 143-162 | 144-164 | 145-166 | 146-167   |
| 73                    | 146-164        | 147-166 | 148-168 | 149-170 | 150-171   |
| 74                    | 150-168        | 151-170 | 152-172 | 153-174 | 154-175   |

(a) Goal Weights for Women

| Height<br>(in inches) | Age (in years) |         |         |         |           |
|-----------------------|----------------|---------|---------|---------|-----------|
|                       | 18             | 19-20   | 21-22   | 23-24   | 25 & Over |
| 60                    | 109-122        | 110-133 | 112-135 | 114-137 | 115-138   |
| 61                    | 112-126        | 113-136 | 115-138 | 117-140 | 118-141   |
| 62                    | 115-130        | 116-139 | 118-140 | 120-142 | 121-144   |
| 63                    | 118-135        | 119-143 | 121-145 | 123-147 | 124-148   |
| 64                    | 120-145        | 122-147 | 124-149 | 126-151 | 127-152   |
| 65                    | 124-149        | 125-151 | 127-153 | 129-155 | 130-156   |
| 66                    | 128-154        | 129-156 | 131-158 | 133-160 | 134-161   |
| 67                    | 132-159        | 133-161 | 134-158 | 136-165 | 138-166   |
| 68                    | 135-163        | 136-165 | 138-167 | 140-169 | 142-170   |
| 69                    | 140-163        | 141-169 | 142-171 | 144-173 | 146-174   |
| 70                    | 143-170        | 144-173 | 146-175 | 148-178 | 150-179   |
| 71                    | 147-177        | 148-179 | 150-181 | 152-183 | 154-184   |
| 72                    | 151-180        | 152-184 | 154-186 | 156-188 | 158-189   |
| 73                    | 155-187        | 156-189 | 158-190 | 160-193 | 162-194   |
| 74                    | 160-192        | 161-194 | 163-196 | 165-198 | 167-199   |
| 75                    | 165-198        | 166-199 | 168-201 | 170-203 | 172-204   |
| 76                    | 170-202        | 171-204 | 173-206 | 175-208 | 177-209   |

(b) Goal Weights for Men

## Hierarchy Chart

The hierarchy chart has been used throughout the text to indicate the required functions within a COBOL program. It can also be used to indicate the relationship of programs within a system as shown in Figure 16.6.

Figure 16.6 Hierarchy Chart of the Overall System

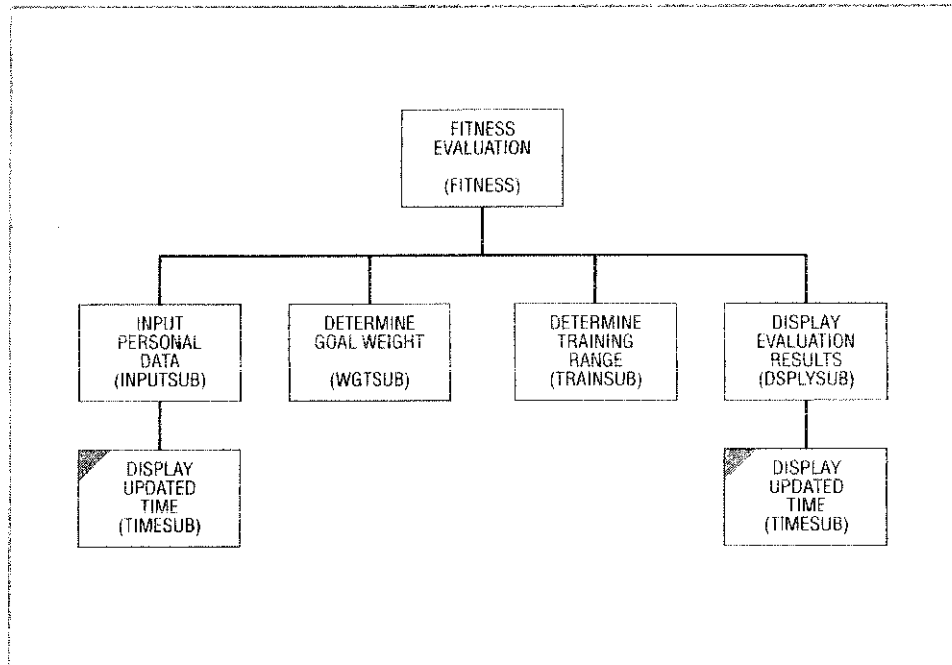

The module at the top of the hierarchy chart, FITNESS-EVALUATION, is the main program for the overall system; it has four subordinates (subprograms) in accordance with the processing specifications: INPUT-PERSONAL-DATA, DETERMINE-GOAL-WEIGHT, DETERMINE-TRAINING-RANGE, and DISPLAY-EVALUATION-RESULTS. (The entries in parentheses correspond to the name of the program as it appears in the PROGRAM-ID paragraph.) A sixth program, DISPLAY-UPDATED-TIME, is subordinate to the programs to accept and display the data.

## Pseudocode

The logic for the overall system (main program) is contained in the pseudocode of Figure 16.7. The main program is driven by a single loop to process multiple individuals (as per the second processing specification) until a negative response is received regarding continuation. This is consistent with the corresponding prompt at the bottom of Figure 16.4, which asks whether there is another user.

The logic within the loop is straightforward and passes control from one subprogram to the next in sequential fashion. Note, however, the requirement to establish a parameter list prior to calling each subprogram, and further, how the parameter lists for the different subprograms contain different variables. Observe also that the parameter list for the last program references *another-person-switch*, which determines whether execution is to continue.

Figure 16.7 Pseudocode

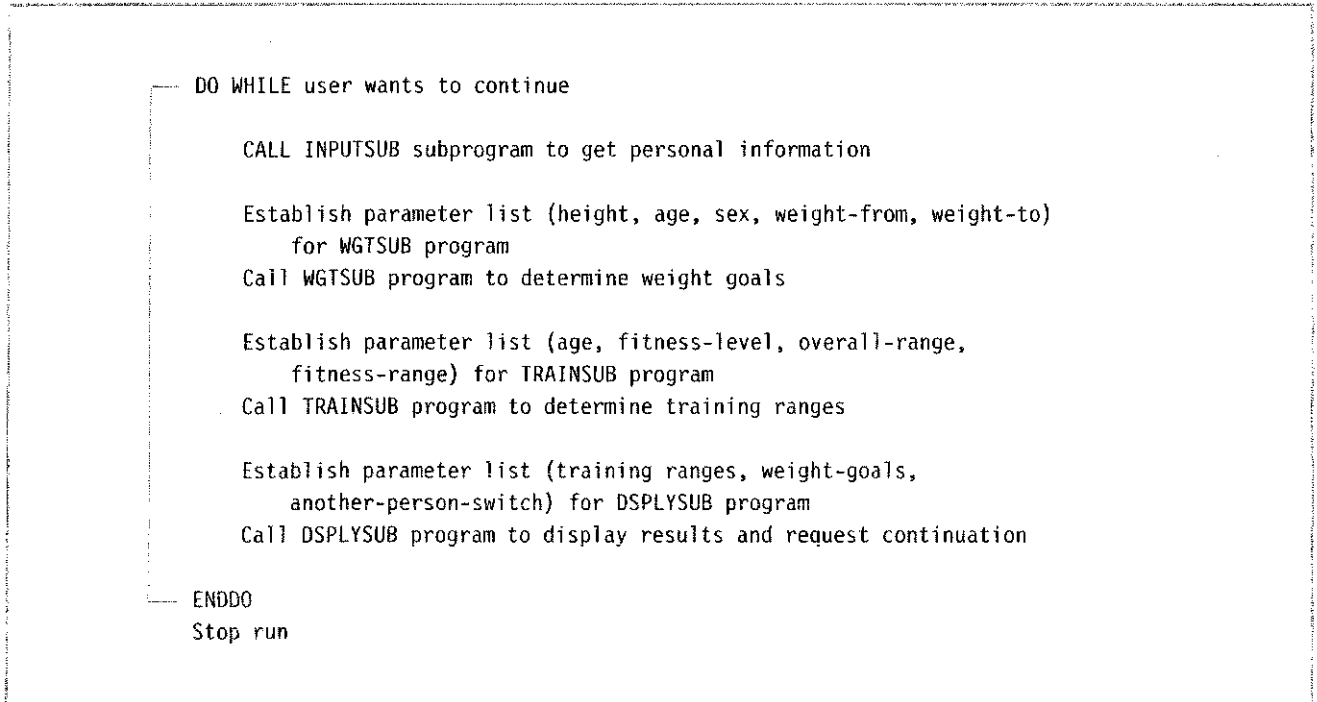

## The Completed Programs

The next several pages contain listings for the completed programs according to the description in Table 16.1. We have, however, in the interest of space, omitted the pseudocode and hierarchy chart for the individual programs.

### Main Program (FITNESS)

The main program in Figure 16.8 contains neither an Environment Division nor a File Section as all input/output operations are accomplished via the screen. The Working-Storage Section consists largely of four COPY statements corresponding to the parameter lists for each of the four called programs. The programmer codes a single statement, such as COPY INPUTREC in line 10. The compiler locates the file INPUTREC and brings in lines 11 through 26 as though the programmer had coded them explicitly.

The mainline paragraph in lines 69–76 corresponds exactly to the pseudocode in Figure 16.7. The INITIALIZE statement in line 79 clears the parameters passed to the input program and is necessary so that the input values from one user are not carried over to the next user. The CALL statement in lines 80–82 transfers control to the input subprogram, using a single parameter, INPUT-INFORMATION, which is copied into both programs.

A different parameter list is created immediately prior to calling each of the remaining subprograms; for example, lines 85–87 move the data names for age, height, and sex—obtained from the input subprogram—to the corresponding data names in the parameter list for the weight program. Observe also how the CALL statement uses a single 01 entry, WEIGHT-ARGUMENTS, as the parameter list and further, how the entry is copied into the program (line 40). The same technique is used prior to the CALL statement for the training program in lines 95–97, and prior to the CALL statement for the final display program in lines 105–107.

The Completed Programs

Figure 16.7 Physical Fitness System

|          |                                                |              |                                                                                                                                                                                                                                                                                                                                         |
|----------|------------------------------------------------|--------------|-----------------------------------------------------------------------------------------------------------------------------------------------------------------------------------------------------------------------------------------------------------------------------------------------------------------------------------------|
| FITNESS  | Calls INPUTSUB, WGTSUB, TRAINSUB, and DSPLYSUB | Figure 16.8  | The main program governs the overall system; it passes control to the input subprogram, which accepts input from the user, passes control to the weight and training programs, then passes control to the display subprogram that displays the calculated results. The main program executes continually until the user elects to exit. |
| INPUTSUB | Called from FITNESS; calls TIMESUB             | Figure 16.9  | The input subprogram obtains all required inputs from the user (name, age, sex, height, and fitness level), validating each field as it is entered. The program reviews the screen section that was first presented in Chapter 10.                                                                                                      |
| WGTSUB   | Called from FITNESS                            | Figure 16.10 | The weight subprogram accepts an individual's sex, height, and age, then determines a range for the person's desired weight. The program reviews two-level tables as presented in Chapter 12.                                                                                                                                           |
| TRAINSUB | Called from FITNESS                            | Figure 16.11 | The training subprogram determines an individual's target heart rate according to age and fitness level. The program reviews various Procedure Division statements and scope terminators from earlier chapters.                                                                                                                         |
| DSPLYSUB | Called from FITNESS; calls TIMESUB             | Figure 16.12 | The display subprogram updates the original screen created by the input program, using various options for the ACCEPT and DISPLAY statements, thus reviewing additional material from Chapter 10.                                                                                                                                       |
| TIMESUB  | Called from INPUTSUB and DSPLYSUB              | Figure 16.13 | The time subprogram is included to show that a subprogram need not contain a Linkage Section, and further that it can be called from multiple calling programs. It also illustrates the means of obtaining the current time from the system and reference modification.                                                                 |

Figure 16.8 Fitness Program

```

1 IDENTIFICATION DIVISION.
2 PROGRAM-ID. FITNESS.
3 AUTHOR. CVV.
4
5 DATA DIVISION.
6 WORKING-STORAGE SECTION.
7 01 FILLER PIC X(36)
8 VALUE 'WS BEGINS HERE FOR FITNESS PROGRAM'.
9

```

Figure 16.8 (continued)

```

10 COPY INPUTREC.
STCPY> 01 INPUT-INFORMATION.
12 05 INP-FULL-NAME PIC X(30).
13 88 MISSING-NAME VALUE SPACES.
14 05 INP-AGE PIC 99.
15 88 INVALID-AGES VALUES 0 THRU 17.
16 05 INP-SEX PIC X.
17 88 VALID-SEX VALUES 'M' 'm' 'F' 'f'.
18 88 MALE VALUES 'M' 'm'.
19 88 FEMALE VALUES 'F' 'f'.
20 05 INP-HEIGHT PIC 99.
21 05 INP-WEIGHT PIC 9(3).
22 88 INVALID-WEIGHTS
23 VALUES 0 THRU 70 500 THRU 999.
24 05 INP-FITNESS-LEVEL PIC X.
25 88 VALID-FITNESS-LEVELS
EDCPY> VALUES 'B' 'I' 'A' 'b' 'i' 'a'.

27
28 COPY TRAINCPY.
STCPY> 01 TRAINING-ARGUMENTS.
30 05 TRAINING-INPUTS.
31 10 TRAIN-AGE PIC 99.
32 10 TRAIN-FITNESS-LEVEL PIC X.
33 88 BEGINNER VALUE 'B' 'b'.
34 88 INTERMEDIATE VALUE 'I' 'i'.
35 88 ADVANCED VALUE 'A' 'a'.
36 05 TRAINING-RANGES.
37 10 TRAIN-OVERALL-RANGE PIC X(5).
EDCPY> 10 TRAIN-FITNESS-RANGE PIC X(5).

39
40 COPY WGTCPY.
STCPY> 01 WEIGHT-ARGUMENTS.
42 05 WEIGHT-TABLE-INPUTS.
43 10 WGT-HEIGHT PIC 99.
44 10 WGT-AGE PIC 99.
45 10 WGT-SEX PIC X.
46 88 MALE VALUE 'M' 'm'.
47 88 FEMALE VALUE 'F' 'f'.
48 05 WEIGHT-GOALS.
49 10 GOAL-WGT-FROM PIC 999.
EDCPY> 10 GOAL-WGT-TO PIC 999.

51
52 COPY DISPCPY.
STCPY> 01 DISPLAY-ARGUMENTS.
54 05 DISP-TRAINING-RANGES.
55 10 DISP-TRAIN-OVERALL-RANGE PIC X(5).
56 10 DISP-TRAIN-FITNESS-RANGE PIC X(5).
57 05 DISP-WEIGHT-GOALS.
58 10 DISP-GOAL-WGT-FROM PIC ZZ9.
59 10 DISP-GOAL-WGT-TO PIC ZZ9.

```

*Record description is copied into program*

*Lowercase responses are accepted*

*Start of COPY AREA*

*End of COPY AREA*

Figure 16.8 (continued)

```

60 05 DISP-INPUT-WEIGHT PIC 9(3).
61 05 ANOTHER-PERSON-SWITCH PIC X VALUE SPACES.
62 88 NO-MORE-PERSONS VALUE 'N' 'n'.
EDCPY> 88 VALID-ANOTHER VALUE 'N' 'n' 'Y' 'y'.
64
65 01 FILLER PIC X(32)
66 VALUE 'WS ENDS HERE FOR FITNESS PROGRAM'.
67
68 PROCEDURE DIVISION.
69 000-FITNESS-EVALUATION.
70 PERFORM UNTIL NO-MORE-PERSONS
71 PERFORM 100-INPUT-PERSONAL-DATA
72 PERFORM 200-GOAL-WEIGHT-RANGE
73 PERFORM 300-TRAIN-RATE-RANGE
74 PERFORM 400-DISPLAY-RESULTS
75 END-PERFORM.
76 STOP RUN.
77
78 100-INPUT-PERSONAL-DATA.
79 INITIALIZE INPUT-INFORMATION.
80 CALL 'INPUTSUB'
81 USING INPUT-INFORMATION
82 END-CALL.
83
84 200-GOAL-WEIGHT-RANGE.
85 MOVE INP-AGE TO WGT-AGE.
86 MOVE INP-HEIGHT TO WGT-HEIGHT.
87 MOVE INP-SEX TO WGT-SEX.
88 CALL 'WGTSUB'
89 USING WEIGHT-ARGUMENTS
90 END-CALL.
91
92 300-TRAIN-RATE-RANGE.
93 MOVE INP-AGE TO TRAIN-AGE.
94 MOVE INP-FITNESS-LEVEL TO TRAIN-FITNESS-LEVEL.
95 CALL 'TRAINSUB'
96 USING TRAINING-ARGUMENTS
97 END-CALL.
98
99 400-DISPLAY-RESULTS.
100 MOVE TRAIN-OVERALL-RANGE TO DISP-TRAIN-OVERALL-RANGE.
101 MOVE TRAIN-FITNESS-RANGE TO DISP-TRAIN-FITNESS-RANGE.
102 MOVE GOAL-WGT-FROM TO DISP-GOAL-WGT-FROM.
103 MOVE GOAL-WGT-TO TO DISP-GOAL-WGT-TO.
104 MOVE INP-WEIGHT TO DISP-INPUT-WEIGHT.
105 CALL 'DSPLYSUB'
106 USING DISPLAY-ARGUMENTS
107 END-CALL.

```

CALL statement transfers control to callor (sub)program

CALL statement transfers control to callor (sub)program

## Input Program (INPUTSUB)

The input program in Figure 16.9 reviews data validation and screen I/O as presented in Chapter 10. It also functions as a subprogram, and hence the Linkage Section in lines 53–70 which defines the data names passed from the calling (fitness) program. Note the relationship between the CALL statement in the calling program (lines 80–82 in Figure 16.8) and the Procedure Division header in line 120 of this program, both of which contain the 01 entry, INPUT-INFORMATION. The latter is copied into both programs in accordance with the programming tip on page 481.

The input program also contains a second COPY statement, COPY COLORCPY, to define the various colors available with screen I/O. The Screen Section defines an input screen consistent with the display shown earlier in Figure 16.4; it also utilizes various features of screen I/O (line and column positioning, reverse video, and underlining) as presented in Chapter 10.

The Procedure Division accepts and validates the input parameters, one at a time, in accordance with the table of error messages defined in lines 37–48. Each parameter is processed in a separate paragraph, which utilizes the DO UNTIL (TEST AFTER) construct described earlier in Chapters 9 and 10.

Figure 16.9 Input Subprogram

```

1 IDENTIFICATION DIVISION.
2 PROGRAM-ID. INPUTSUB.
3 AUTHOR. CVV.
4
5 DATA DIVISION.
6 WORKING-STORAGE SECTION.
7 01 FILLER PIC X(38)
8 VALUE 'WS BEGINS HERE FOR SUBPROGRAM INPUTSUB'.
9
10 01 PROGRAM-SWITCHES.
11 05 VALID-FIELD-SWITCH PIC XX.
12 88 VALID-FIELD VALUE SPACES.
13 05 CONFIRM-SWITCH PIC X.
14 88 ALL-DATA-VALID VALUE 'Y' 'y'.
15
16 COPY COLORCPY.
17 STCPY> 01 SCREEN-COLORS. PIC S9(4) COMP-5.
18 * COLORS FOR FOREGROUND AND BACKGROUND
19 78 BLACK VALUE 0.
20 78 BLUE VALUE 1.
21 78 GREEN VALUE 2.
22 78 CYAN VALUE 3.
23 78 RED 4.
24 78 MAGENTA 5.
25 78 BROWN 6.
26 78 WHITE 7.
27 * ADDITIONAL COLORS FOR FOREGROUND ONLY
28 78 BRIGHT-BLACK 8.
29 78 BRIGHT-BLUE 9.
30 78 BRIGHT-GREEN 10.
31 78 BRIGHT-CYAN 11.

```

*Entry: PROGRAM-ID configuration parameter CALL statement in calling (FITNESS) program*

Figure 10.6 (continued)

```

32 78 BRIGHT-RED 12.
33 78 BRIGHT-MAGENTA 13.
34 78 BRIGHT-BROWN 14.
EDCPY> 78 BRIGHT-WHITE 15.
36
37 01 ERROR-VALUES-TABLE.
38 05 ERROR-MESSAGE-VALUES.
39 10 PIC X(30) VALUE ' Name must be Entered'.
40 10 PIC X(30) VALUE ' Age must be over 17'.
41 10 PIC X(30) VALUE ' Sex must be M or F'.
42 10 PIC X(30) VALUE ' Weight must be > 70 & < 500'.
43 10 PIC X(30) VALUE ' Male Height must be 60"-76"'.
44 10 PIC X(30) VALUE ' Female Height must be 54"-74"'.
45 10 PIC X(30) VALUE ' Fitness Level must be B I or A'.
46 05 ERROR-MESSAGE-TABLE REDEFINES ERROR-MESSAGE-VALUES.
47 10 ERROR-MESSAGE OCCURS 7 TIMES
48 INDEXED BY ERROR-INDEX PIC X(30).
49
50 01 FILLER PIC X(36)
51 VALUE 'WS ENDS HERE FOR SUBPROGRAM INPUTSUB'.
52
53 LINKAGE SECTION.
54 COPY INPUTREC.
STCPY> 01 INPUT-INFORMATION.
56 05 INP-FULL-NAME PIC X(30).
57 88 MISSING-NAME VALUE SPACES.
58 05 INP-AGE PIC 99.
59 88 INVALID-AGES VALUES 0 THRU 17.
60 05 INP-SEX PIC X.
61 88 VALID-SEX VALUES 'M' 'm' 'F' 'f'.
62 88 MALE VALUES 'M' 'm'.
63 88 FEMALE VALUES 'F' 'f'.
64 05 INP-HEIGHT PIC 99.
65 05 INP-WEIGHT PIC 9(3).
66 88 INVALID-WEIGHTS
67 VALUES 0 THRU 70 500 THRU 999.
68 05 INP-FITNESS-LEVEL PIC X.
69 88 VALID-FITNESS-LEVELS
EDCPY> VALUES 'B' 'I' 'A' 'b' 'i' 'a'.
71
72 SCREEN SECTION.
73 01 INPUT-SCREEN.
74 05 BLANK SCREEN FOREGROUND-COLOR WHITE
75 BACKGROUND-COLOR BLUE.
76 05 SCREEN-PROMPTS.
77 10 LINE 1 COLUMN 9
78 VALUE 'Personal Fitness Evaluation'.
79 10 LINE 3 COLUMN 4 VALUE 'Full Name:'.
80 10 LINE 5 COLUMN 4 VALUE 'Age:'.
81 10 LINE 5 COLUMN 22 VALUE 'Weight:'.

```



Figure 16.9 (continued)

```

82 10 LINE 5 COLUMN 44 VALUE 'Fitness Level:'.
83 10 LINE 6 COLUMN 4 VALUE 'Sex (M/F):'.
84 10 LINE 6 COLUMN 22 VALUE 'Height:'.
85 10 LINE 6 COLUMN 45 VALUE 'B - Beginner '
86 FOREGROUND-COLOR BLACK BACKGROUND-COLOR CYAN.
87 10 LINE 7 COLUMN 45 VALUE 'I - Intermediate'
88 FOREGROUND-COLOR BLACK BACKGROUND-COLOR CYAN.
89 10 LINE 8 COLUMN 45 VALUE 'A - Advanced '
90 FOREGROUND-COLOR BLACK BACKGROUND-COLOR CYAN.
91
92 05 SCREEN-INPUTS.
93 10 SCR-FULL-NAME LINE 3 COLUMN 15 PIC X(30)
94 USING INP-FULL-NAME REVERSE-VIDEO.
95 10 SCR-AGE LINE 5 COLUMN 9 PIC 99
96 USING INP-AGE REVERSE-VIDEO REQUIRED AUTO.
97 10 SCR-WEIGHT LINE 5 COLUMN 30 PIC 999
98 USING INP-WEIGHT REVERSE-VIDEO REQUIRED AUTO.
99 10 SCR-FITNESS-LEVEL LINE 5 COLUMN 59 PIC X
100 USING INP-FITNESS-LEVEL REVERSE-VIDEO AUTO.
101 10 SCR-SEX LINE 6 COLUMN 15 PIC X
102 USING INP-SEX REVERSE-VIDEO AUTO.
103 10 SCR-HEIGHT LINE 6 COLUMN 30 PIC 99
104 USING INP-HEIGHT REVERSE-VIDEO REQUIRED AUTO.
105
106 01 CONFIRM-SCREEN HIGHLIGHT.
107 05 LINE 23 COLUMN 13 UNDERLINE
108 FOREGROUND-COLOR GREEN
109 BACKGROUND-COLOR MAGENTA
110 VALUE 'Is the above information correct? '.
111 05 LINE 24 COLUMN 21
112 FOREGROUND-COLOR GREEN
113 BACKGROUND-COLOR MAGENTA
114 VALUE ' (Y - Yes, N - No) '.
115 05 SCR-CONFIRM LINE 23 COLUMN 49 PIC X
116 FOREGROUND-COLOR MAGENTA
117 BACKGROUND-COLOR GREEN
118 USING CONFIRM-SWITCH.
119
120 PROCEDURE DIVISION USING INPUT-INFORMATION.
121 000-INPUT-PERSONAL-DATA.
122 INITIALIZE PROGRAM-SWITCHES.
123 PERFORM UNTIL ALL-DATA-VALID
124 DISPLAY INPUT-SCREEN
125 CALL 'TIMESUB'
126 PERFORM 200-VALIDATE-DATA
127 PERFORM 300-CONFIRM-INPUT-SCREEN
128 END-PERFORM.
129 EXIT PROGRAM.
130
131 200-VALIDATE-DATA.

```

*INITIALIZE statement resets all program switches*

*EXIT PROGRAM returns control to calling program*

Figure 16.9 (continued)

```

132 PERFORM 210-VALIDATE-NAME.
133 PERFORM 220-VALIDATE-AGE.
134 PERFORM 230-VALIDATE-SEX.
135 PERFORM 240-VALIDATE-WEIGHT.
136 PERFORM 250-VALIDATE-HEIGHT.
137 PERFORM 260-VALIDATE-FITNESS-LEVEL.
138
139 210-VALIDATE-NAME.
140 PERFORM WITH TEST AFTER UNTIL VALID-FIELD
141 ACCEPT SCR-FULL-NAME
142 IF MISSING-NAME
143 SET ERROR-INDEX TO 1
144 PERFORM 299-DISPLAY-ERROR-MESSAGE
145 ELSE
146 PERFORM 288-CLEAR-ERRORS
147 END-IF
148 END-PERFORM.
149
150 220-VALIDATE-AGE.
151 PERFORM WITH TEST AFTER UNTIL VALID-FIELD
152 ACCEPT SCR-AGE
153 IF INVALID-AGES
154 SET ERROR-INDEX TO 2
155 PERFORM 299-DISPLAY-ERROR-MESSAGE
156 ELSE
157 PERFORM 288-CLEAR-ERRORS
158 END-IF
159 END-PERFORM.
160
161 230-VALIDATE-SEX.
162 PERFORM WITH TEST AFTER UNTIL VALID-FIELD
163 ACCEPT SCR-SEX
164 IF VALID-SEX
165 PERFORM 288-CLEAR-ERRORS
166 ELSE
167 SET ERROR-INDEX TO 3
168 PERFORM 299-DISPLAY-ERROR-MESSAGE
169 END-IF
170 END-PERFORM.
171
172 240-VALIDATE-WEIGHT.
173 PERFORM WITH TEST AFTER UNTIL VALID-FIELD
174 ACCEPT SCR-WEIGHT
175 IF INVALID-WEIGHTS
176 SET ERROR-INDEX TO 4
177 PERFORM 299-DISPLAY-ERROR-MESSAGE
178 ELSE
179 PERFORM 288-CLEAR-ERRORS
180 END-IF
181 END-PERFORM.

```

PERFORM WITH TEST AFTER UNTIL VALID-FIELD clause  
 is the same as the one in the previous

Figure 16.9 (continued)

```

182
183 250-VALIDATE-HEIGHT.
184 PERFORM WITH TEST AFTER UNTIL VALID-FIELD
185 ACCEPT SCR-HEIGHT
186 EVALUATE TRUE ALSO INP-HEIGHT
187 WHEN MALE ALSO NOT 60 THRU 76
188 SET ERROR-INDEX TO 5
189 PERFORM 299-DISPLAY-ERROR-MESSAGE
190 WHEN FEMALE ALSO NOT 54 THRU 74
191 SET ERROR-INDEX TO 6
192 PERFORM 299-DISPLAY-ERROR-MESSAGE
193 WHEN OTHER
194 PERFORM 288-CLEAR-ERRORS
195 END-EVALUATE
196 END-PERFORM.
197
198 260-VALIDATE-FITNESS-LEVEL.
199 PERFORM WITH TEST AFTER UNTIL VALID-FIELD
200 ACCEPT SCR-FITNESS-LEVEL
201 IF VALID-FITNESS-LEVELS
202 PERFORM 288-CLEAR-ERRORS
203 ELSE
204 SET ERROR-INDEX TO 7
205 PERFORM 299-DISPLAY-ERROR-MESSAGE
206 END-IF
207 END-PERFORM.
208
209 288-CLEAR-ERRORS.
210 INITIALIZE VALID-FIELD-SWITCH.
211 DISPLAY ' ' LINE 24 WITH BLANK LINE.
212
213 299-DISPLAY-ERROR-MESSAGE.
214 CALL 'TIMESUB'.
215 MOVE 'NO' TO VALID-FIELD-SWITCH.
216 DISPLAY ERROR-MESSAGE (ERROR-INDEX)
217 LINE 24 COLUMN 25 WITH HIGHLIGHT BLINK BEEP
218 FOREGROUND-COLOR BRIGHT-WHITE
219 BACKGROUND-COLOR RED.
220
221 300-CONFIRM-INPUT-SCREEN.
222 DISPLAY CONFIRM-SCREEN.
223 ACCEPT SCR-CONFIRM.

```

### Weight-range Program (WRTSUB)

The weight-range program in Figure 16.10 reviews material on multilevel programs as presented in Chapter 13. The Working-Storage Section defines two tables, for

men and women's weights, in accordance with the user's view as presented in Figure 16.5. Subsequent statements in the Procedure Division determine the suggested range for an individual's weight, based on sex, height, and age.

The sex, height, and age are contained within the 01 entry WEIGHT-ARGUMENTS that is passed as an argument to the subprogram by the CALL statement in lines 88-90 of the fitness (main) program in Figure 16.8, and which coincides with the Procedure Division header in line 101 of this program. The parameter list consists of a single 01 entry, which is copied into both the calling and called program. Note the COPY statement in the Linkage Section of this program (lines 89-99,) and the corresponding COPY statement in the fitness program (lines 40-50 in Figure 16.8). Note, too, the use of COPY statements to initialize and define the tables for male and female weights, in lines 10 and 38, respectively.

Figure 16.10 Weight Subprogram

```

1 IDENTIFICATION DIVISION.
2 PROGRAM-ID. WGTSUB.
3 AUTHOR. CVV.
4
5 DATA DIVISION.
6 WORKING-STORAGE SECTION.
7 01 FILLER PIC X(36)
8 VALUE 'WS BEGINS HERE FOR SUBPROGRAM WGTSUB'.
9
10 COPY MALEWGT.
STCPY> 01 MALE-WEIGHT-VALUES.
12 05 PIC X(30) VALUE '109122110133112135114137115138'.
13 05 PIC X(30) VALUE '112126113136115138117140118141'.
14 05 PIC X(30) VALUE '115130116139118140120142121144'.
15 05 PIC X(30) VALUE '118135119143121145123147124148'.
16 05 PIC X(30) VALUE '120145122147124149126151127152'.
17 05 PIC X(30) VALUE '124149125151127153129155130156'.
18 05 PIC X(30) VALUE '128154129156131158133160134161'.
19 05 PIC X(30) VALUE '132159133161134158136165138166'.
20 05 PIC X(30) VALUE '135163136165138167140169142170'.
21 05 PIC X(30) VALUE '140163141169142171144173146174'.
22 05 PIC X(30) VALUE '143170144173146175148178150179'.
23 05 PIC X(30) VALUE '147177148179150181152183154184'.
24 05 PIC X(30) VALUE '151180152184154186156188158189'.
25 05 PIC X(30) VALUE '155187156189158190160193162194'.
26 05 PIC X(30) VALUE '160192161194163196165198167199'.
27 05 PIC X(30) VALUE '165198166199168201170203172204'.
28 05 PIC X(30) VALUE '170202171204173206175208177209'.
29
30 01 MALE-WEIGHT-TABLE REDEFINES MALE-WEIGHT-VALUES.
31 05 MALE-HEIGHTS OCCURS 17 TIMES
32 INDEXED BY MALE-HGT-INDEX.
33 10 MALE-AGES OCCURS 5 TIMES
34 INDEXED BY MALE-AGE-INDEX.
35 15 MALE-WGT-FROM PIC 9(3).
EDCPY> 15 MALE-WGT-TO PIC 9(3).

```

Entry to PROGRAM ID is given by the CALL statement in the fitness program

Male weights are copied into a table

Figure 16.10 (continued)

```

37
38 COPY FEMWGT.
STCPY> 01 FEMALE-WEIGHT-VALUES.
40 05 PIC X(30) VALUE '083099084101085103086104088106'.
41 05 PIC X(30) VALUE '084100085102086104088105090107'.
42 05 PIC X(30) VALUE '086101087103088105090106092108'.
43 05 PIC X(30) VALUE '089102090104091106092108094110'.
44 05 PIC X(30) VALUE '091105092106093109094111096113'.
45 05 PIC X(30) VALUE '093109094111095113096114099116'.
46 05 PIC X(30) VALUE '096112097113098115100117102119'.
47 05 PIC X(30) VALUE '100116101117102119103121105122'.
48 05 PIC X(30) VALUE '104119105121106123107125108126'.
49 05 PIC X(30) VALUE '106125107126108127109129111130'.
50 05 PIC X(30) VALUE '109130110131111132112134114135'.
51 05 PIC X(30) VALUE '112133113134114136116138118139'.
52 05 PIC X(30) VALUE '11613/117138118140120142122143'.
53 05 PIC X(30) VALUE '121140122142123144124146126147'.
54 05 PIC X(30) VALUE '123144124146126148128150130150'.
55 05 PIC X(30) VALUE '130148131150132152133154134155'.
56 05 PIC X(30) VALUE '134151135154136156137158138159'.
57 05 PIC X(30) VALUE '138155139158140160141162142163'.
58 05 PIC X(30) VALUE '142160143162144164145166146167'.
59 05 PIC X(30) VALUE '146164147166148168149170150171'.
60 05 PIC X(30) VALUE '150168151170152172153174154175'.
61
62 01 FEMALE-WEIGHT-TABLE REDEFINES FEMALE-WEIGHT-VALUES.
63 05 FEMALE-HEIGHTS OCCURS 21 TIMES
64 INDEXED BY FEMALE-HGT-INDEX.
65 10 FEMALE-AGES OCCURS 5 TIMES
66 INDEXED BY FEMALE-AGE-INDEX.
67 15 FEMALE-WGT-FROM PIC 9(3).
EDCPY> 15 FEMALE-WGT-TO PIC 9(3).
69
70 01 AGE-LIMIT-VALUES.
71 05 PIC 99 VALUE 18.
72 05 PIC 99 VALUE 20.
73 05 PIC 99 VALUE 22.
74 05 PIC 99 VALUE 24.
75 05 PIC 99 VALUE 99.
76 01 AGE-TABLE REDEFINES AGE-LIMIT-VALUES.
77 05 AGE-LIMIT OCCURS 5 TIMES
78 INDEXED BY AGE-INDEX PIC 99.
79
80 01 CONSTANTS-AND-VARIABLES.
81 05 MALE-HGT-ADJUST-CONSTANT PIC 99 VALUE 59.
82 05 FEMALE-HGT-ADJUST-CONSTANT PIC 99 VALUE 53.
83 05 ADJUSTED-HEIGHT PIC 99.
84
85 01 FILLER PIC X(34)
86 VALUE 'WS ENDS HERE FOR SUBPROGRAM WGTSUB'.

```

Figure 16.10 (continued)

```

87
88 LINKAGE SECTION.
89 COPY WGTCOPY.
STCPY> 01 WEIGHT-ARGUMENTS.
91 05 WEIGHT-TABLE-INPUTS.
92 10 WGT-HEIGHT PIC 99.
93 10 WGT-AGE PIC 99.
94 10 WGT-SEX PIC X.
95 88 MALE VALUE 'M' 'm'.
96 88 FEMALE VALUE 'F' 'f'.
97 05 WEIGHT-GOALS.
98 10 GOAL-WGT-FROM PIC 999.
EDCPY> 10 GOAL-WGT-TO PIC 999.
100
101 PROCEDURE DIVISION USING WEIGHT-ARGUMENTS.
102 FIND-GOAL-WEIGHT.
103 EVALUATE TRUE
104 WHEN MALE
105 PERFORM FIND-MALE-WEIGHT-RANGE
106 WHEN FEMALE
107 PERFORM FIND-FEMALE-WEIGHT-RANGE
108 WHEN OTHER
109 DISPLAY 'INVALID SEX ENTERED'
110 INITIALIZE WEIGHT-GOALS
111 END-EVALUATE.
112 EXIT PROGRAM.
113
114 FIND-MALE-WEIGHT-RANGE.
115 COMPUTE ADJUSTED-HEIGHT =
116 WGT-HEIGHT - MALE-HGT-ADJUST-CONSTANT
117 SIZE ERROR DISPLAY 'SIZE ERROR ADJUSTED HEIGHT'
118 END-COMPUTE.
119 SET MALE-AGE-INDEX AGE-INDEX TO 1.
120 SET MALE-HGT-INDEX TO ADJUSTED-HEIGHT.
121 SEARCH AGE-LIMIT VARYING MALE-AGE-INDEX
122 AT END DISPLAY 'MALE AGE NOT FOUND'
123 INITIALIZE WEIGHT-GOALS
124 WHEN
125 WGT-AGE <= AGE-LIMIT (AGE-INDEX)
126 SET MALE-AGE-INDEX TO AGE-INDEX
127 MOVE MALE-WGT-FROM (MALE-HGT-INDEX, MALE-AGE-INDEX)
128 TO GOAL-WGT-FROM
129 MOVE MALE-WGT-TO (MALE-HGT-INDEX, MALE-AGE-INDEX)
130 TO GOAL-WGT-TO
131 END-SEARCH.
132
133 FIND-FEMALE-WEIGHT-RANGE.
134 COMPUTE ADJUSTED-HEIGHT =
135 WGT-HEIGHT - FEMALE-HGT-ADJUST-CONSTANT
136 SIZE ERROR DISPLAY 'SIZE ERROR ADJUSTED HEIGHT'

```

Figure 16.10 (continued)

```

137 END-COMPUTE.
138 SET FEMALE-AGE-INDEX AGE-INDEX TO 1.
139 SET FEMALE-HGT-INDEX TO ADJUSTED-HEIGHT.
140 SEARCH AGE-LIMIT VARYING FEMALE-AGE-INDEX
141 AT END DISPLAY 'FEMALE AGE NOT FOUND'
142 INITIALIZE WEIGHT-GOALS
143 WHEN
144 WGT-AGE <= AGE-LIMIT (AGE-INDEX)
145 SET FEMALE-AGE-INDEX TO AGE-INDEX
146 MOVE FEMALE-WGT-FROM
147 (FEMALE-HGT-INDEX, FEMALE-AGE-INDEX)
148 TO GOAL-WGT-FROM
149 MOVE FEMALE-WGT-TO
150 (FEMALE-HGT-INDEX, FEMALE-AGE-INDEX)
151 TO GOAL-WGT-TO
152 END-SEARCH.

```

*SEARCH VARYING used with two level table*

### Training Program (TRAINSUB)

The training program in Figure 16.11 calculates an individual's target heart rate (after exercise) according to the formulas given in the programming specifications. The program uses the SIZE ERROR phrase and associated END-COMPUTE scope terminator in several places in the Procedure Division. It also uses the EVALUATE statement to determine the specific training range according to the user's fitness level.

The means for passing parameters between this program and the fitness program, which calls it, parallels the procedure for the other subprograms. Thus, the Linkage Section contains a COPY statement (line 29) to define the 01 parameters that constitute the parameter list; note, too, the correspondence between the Procedure Division header in this program and the CALL statement in the fitness program.

### Display Program (DSPLYSUB)

The display program in Figure 16.12 uses DISPLAY statements rather than a Screen Section to control the displayed output in accordance with earlier material from Chapter 10. The means for passing parameters between this program and the fitness program parallel the procedure for the other subprograms. The Linkage Section contains a COPY statement (line 57) to define the single 01 parameter, which constitutes the parameter list in the Procedure Division header of lines 70–71.

Observe also the presence of the identical COPY statement found in the input program (line 21) to obtain the definition of foreground and background colors.

Figure 18.11 Training Subprogram

```

1 IDENTIFICATION DIVISION.
2 PROGRAM-ID. TRAINSUB.
3 AUTHOR. CVV.
4
5 DATA DIVISION.
6 WORKING-STORAGE SECTION.
7
8 01 FILLER PIC X(38)
9 VALUE 'WS BEGINS HERE FOR SUBPROGRAM TRAINSUB'.
10
11 01 RATES-AND-CONSTANTS.
12 05 TRAIN-CONSTANT PIC 999 VALUE 220.
13 05 LOW-RATE PIC V9 VALUE .6.
14 05 HIGH-RATE PIC V9 VALUE .9.
15
16 01 RANGE-CALCULATIONS.
17 05 OVERALL-RANGES.
18 10 OVERALL-HIGH PIC 99.
19 10 OVERALL-LOW PIC 99.
20 05 FITNESS-RANGES.
21 10 FITNESS-HIGH PIC 99.
22 10 FITNESS-LOW PIC 99.
23 05 RANGE-INTERVAL PIC 9.
24
25 01 FILLER PIC X(36)
26 VALUE 'WS ENDS HERE FOR SUBPROGRAM TRAINSUB'.
27
28 LINKAGE SECTION.
29 COPY TRAINCPY.
30
31 01 TRAINING-ARGUMENTS.
32 05 TRAINING-INPUTS.
33 10 TRAIN-AGE PIC 99.
34 10 TRAIN-FITNESS-LEVEL PIC X.
35 88 BEGINNER VALUE 'B' 'b'.
36 88 INTERMEDIATE VALUE 'I' 'i'.
37 88 ADVANCED VALUE 'A' 'a'.
38 05 TRAINING-RANGES.
39 10 TRAIN-OVERALL-RANGE PIC X(5).
40 10 TRAIN-FITNESS-RANGE PIC X(5).
41
42 PROCEDURE DIVISION
43 USING TRAINING-ARGUMENTS.
44 FIND-TRAIN-RANGE.
45 PERFORM COMPUTE-OVERALL-RANGES.
46 PERFORM COMPUTE-FITNESS-RANGES.
47 EXIT PROGRAM.

```

*Constants used for no hanging*

*Program parameters are copied into Linkage section*

*EXIT PROGRAM returns control to calling program*



Figure 16.11 (continued)

```

47
48 COMPUTE-OVERALL-RANGES.
49 COMPUTE OVERALL-LOW ROUNDED =
50 (TRAIN-CONSTANT - TRAIN-AGE) * LOW-RATE / 6
51 SIZE ERROR DISPLAY 'SIZE ERROR ON LOW RANGE'
52 END-COMPUTE.
53 COMPUTE OVERALL-HIGH ROUNDED =
54 (TRAIN-CONSTANT - TRAIN-AGE) * HIGH-RATE / 6
55 SIZE ERROR DISPLAY 'SIZE ERROR ON HIGH RANGE'
56 END-COMPUTE.
57 STRING OVERALL-LOW '-' OVERALL-HIGH DELIMITED BY SIZE
58 INTO TRAIN-OVERALL-RANGE
59 END-STRING.
60
61 COMPUTE-FITNESS-RANGES.
62 COMPUTE RANGE-INTERVAL =
63 (OVERALL-HIGH - OVERALL-LOW) / 3
64 SIZE ERROR DISPLAY 'SIZE ERROR ON RANGE INTERVAL'
65 END-COMPUTE.
66 EVALUATE TRUE
67 WHEN BEGINNER
68 MOVE OVERALL-LOW TO FITNESS-LOW
69 COMPUTE FITNESS-HIGH ROUNDED =
70 OVERALL-LOW + RANGE-INTERVAL
71 SIZE ERROR DISPLAY 'SIZE ERROR HIGH FITNESS'
72 END-COMPUTE
73 WHEN INTERMEDIATE
74 COMPUTE FITNESS-LOW ROUNDED =
75 OVERALL-LOW + RANGE-INTERVAL
76 SIZE ERROR DISPLAY 'SIZE ERROR LOW FITNESS'
77 END-COMPUTE
78 COMPUTE FITNESS-HIGH ROUNDED =
79 OVERALL-HIGH - RANGE-INTERVAL
80 SIZE ERROR
81 DISPLAY 'SIZE ERROR HIGH FITNESS'
82 END-COMPUTE
83 WHEN ADVANCED
84 COMPUTE FITNESS-LOW ROUNDED =
85 OVERALL-HIGH - RANGE-INTERVAL
86 SIZE ERROR DISPLAY 'SIZE ERROR LOW FITNESS'
87 END-COMPUTE
88 MOVE OVERALL-HIGH TO FITNESS-HIGH
89 WHEN OTHER
90 DISPLAY 'INVALID FITNESS LEVEL SEE VALIDATION'
91 END-EVALUATE.
92 STRING FITNESS-LOW '-' FITNESS-HIGH DELIMITED BY SIZE
93 INTO TRAIN-FITNESS-RANGE
94 END-STRING.

```

Figure 16.12 Display Subprogram

```

1 IDENTIFICATION DIVISION.
2 PROGRAM-ID. DSPLYSUB.
3 AUTHOR. CVV.
4
5 DATA DIVISION.
6 WORKING-STORAGE SECTION.
7 01 FILLER PIC X(38)
8 VALUE 'WS BEGINS HERE FOR SUBPROGRAM UPDTESUB'.
9
10 01 DISPLAY-MESSAGES.
11 05 OVER-WEIGHT-COMMENT PIC X(41)
12 VALUE ' OH! NO! Your weight exceeds the range'.
13 05 UNDER-WEIGHT-COMMENT PIC X(41)
14 VALUE ' EAT UP! Your weight is below the range'.
15 05 IN-WEIGHT-COMMENT PIC X(41)
16 VALUE 'CONGRATULATIONS! You are within the range'.
17 05 WEIGHT-COMMENT PIC X(41).
18 05 ANOTHER-MESSAGE PIC X(14)
19 VALUE 'Must be Y or N'.
20
21 COPY COLORCPY.
STCPY> 01 SCREEN-COLORS. PIC S9(4) COMP-5.
23 * COLORS FOR FOREGROUND AND BACKGROUND
24 78 BLACK VALUE 0.
25 78 BLUE VALUE 1.
26 78 GREEN VALUE 2.
27 78 CYAN VALUE 3.
28 78 RED VALUE 4.
29 78 MAGENTA VALUE 5.
30 78 BROWN VALUE 6.
31 78 WHITE VALUE 7.
32 * ADDITIONAL COLORS FOR FOREGROUND ONLY
33 78 BRIGHT-BLACK VALUE 8.
34 78 BRIGHT-BLUE VALUE 9.
35 78 BRIGHT-GREEN VALUE 10.
36 78 BRIGHT-CYAN VALUE 11.
37 78 BRIGHT-RED VALUE 12.
38 78 BRIGHT-MAGENTA VALUE 13.
39 78 BRIGHT-BROWN VALUE 14.
EDCPY> 78 BRIGHT-WHITE VALUE 15.
41
42 01 MESSAGE-COLORS.
43 05 COLOR-CONTROL PIC X(50).
44 05 MAGENTA-BLACK PIC X(50).
45 VALUE 'BACKGROUND-COLOR 5 FOREGROUND-COLOR 0'.
46 05 RED-BLACK PIC X(50).
47 VALUE 'BACKGROUND-COLOR 4 FOREGROUND-COLOR 0'.
48 05 GREEN-BLACK PIC X(50).
49 VALUE 'BACKGROUND-COLOR 2 FOREGROUND-COLOR 0'.

```

Screen colors are copied into program.

Color controls to facilitate display message.

Figure 16.12 (continued)

```

50
51 01 GOAL-WEIGHT-RANGE PIC X(7).
52
53 01 FILLER
54 VALUE 'WS ENDS HERE FOR SUBPROGRAM UPDTESUB'.
55
56 LINKAGE SECTION.
57 COPY DISPCPY.
STCPY> 01 DISPLAY-ARGUMENTS.
59 05 DISP-TRAINING-RANGES.
60 10 DISP-TRAIN-OVERALL-RANGE PIC X(5).
61 10 DISP-TRAIN-FITNESS-RANGE PIC X(5).
62 05 DISP-WEIGHT-GOALS.
63 10 DISP-GOAL-WGT-FROM PIC ZZ9.
64 10 DISP-GOAL-WGT-TO PIC ZZ9.
65 05 DISP-INPUT-WEIGHT PIC 9(3).
66 05 ANOTHER-PERSON-SWITCH PIC X VALUE SPACES.
67 88 NO-MORE-PERSONS VALUE 'N' 'n'.
EDCPY> 68 88 VALID-ANOTHER VALUE 'N' 'n' 'Y' 'y'.
69
70 PROCEDURE DIVISION
71 USING DISPLAY-ARGUMENTS.
72 000-UPDATE-PERSONAL-DATA.
73 PERFORM 100-DETERMINE-WEIGHT-COMMENT.
74 PERFORM 200-UPDATE-SCREEN.
75 CALL 'TIMESUB'. ----- Call to another subprogram
76 PERFORM 300-INPUT-ANOTHER-PERSON.
77 EXIT PROGRAM.
78
79 100-DETERMINE-WEIGHT-COMMENT.
80 EVALUATE TRUE
81 WHEN DISP-INPUT-WEIGHT < DISP-GOAL-WGT-FROM
82 MOVE UNDER-WEIGHT-COMMENT TO WEIGHT-COMMENT
83 MOVE MAGENTA-BLACK TO COLOR-CONTROL
84 WHEN DISP-INPUT-WEIGHT > DISP-GOAL-WGT-TO
85 MOVE OVER-WEIGHT-COMMENT TO WEIGHT-COMMENT
86 MOVE RED-BLACK TO COLOR-CONTROL
87 WHEN OTHER
88 MOVE IN-WEIGHT-COMMENT TO WEIGHT-COMMENT
89 MOVE GREEN-BLACK TO COLOR-CONTROL
90 END-EVALUATE.
91
92 200-UPDATE-SCREEN.
93 STRING DISP-GOAL-WGT-FROM '-' DISP-GOAL-WGT-TO
94 DELIMITED BY SIZE
95 INTO GOAL-WEIGHT-RANGE
96 END-STRING.
97 DISPLAY
98 'Your Goal Weight Range: ' LINE 11 COLUMN 4
99 GOAL-WEIGHT-RANGE LINE 11 COLUMN 28 WITH HIGHLIGHT.

```

*Decide colors to be used*

Figure 16.12 Display Subprogram

```

100 DISPLAY
101 WEIGHT-COMMENT LINE 12 COLUMN 6 WITH BLINK
102 CONTROL IS COLOR-CONTROL. Set foreground-color and
103 DISPLAY background color
104 'Training Heart Rate Range Information (10 Second)'
105 LINE 14 COLUMN 4.
106 DISPLAY
107 'Overall Heart Rate Range: '
108 LINE 15 COLUMN 6
109 DISP-TRAIN-OVERALL-RANGE COLUMN 32 WITH HIGHLIGHT
110 'Adjusted for Fitness Level: ' LINE 16 COLUMN 6
111 DISP-TRAIN-FITNESS-RANGE COLUMN 34 WITH HIGHLIGHT.
112 HIGHLIGHT
113 DISPLAY ' ' LINE 23 COLUMN 1 WITH BLANK LINE.
114 DISPLAY ' ' LINE 24 COLUMN 1 WITH BLANK LINE.
115
116 300-INPUT-ANOTHER-PERSON.
117 DISPLAY 'Another Person? (Y/N): ' LINE 24 COLUMN 10
118 WITH FOREGROUND-COLOR BRIGHT-GREEN
119 BACKGROUND-COLOR MAGENTA.
120 PERFORM WITH TEST AFTER UNTIL VALID-ANOTHER
121 ACCEPT ANOTHER-PERSON-SWITCH LINE 24 COLUMN 33
122 WITH FOREGROUND-COLOR BRIGHT-GREEN
123 BACKGROUND-COLOR MAGENTA
124 IF VALID-ANOTHER
125 DISPLAY ' ' LINE 24 WITH BLANK LINE
126 ELSE
127 DISPLAY ANOTHER-MESSAGE
128 LINE 24 COLUMN 38 WITH HIGHLIGHT BLINK
129 FOREGROUND-COLOR BRIGHT-WHITE
130 BACKGROUND-COLOR RED
131 END-IF
132 END-PERFORM.

```

*Initial perform accepts and sets default values (foreground color) to condition of ACCEPT-UNTIL.*

### Time Program (TIMESUB)

The program to update the displayed time (Figure 16.13) uses the ACCEPT statement to obtain the current time containing hours, minutes, seconds, and hundredths of a second as per the discussion in Chapter 8. Reference modification is used in conjunction with an INSPECT statement to truncate hundredths of a second in the displayed time.

The program is called from two other programs as per the system hierarchy chart in Figure 16.6. This program is different from the other subprograms in that it does not contain any parameters; the program is completely self-contained as it obtains the current time from the system, and then displays the results directly on the monitor.

Figure 16.13 Time Subprogram

```

1 IDENTIFICATION DIVISION.
2 PROGRAM-ID. TIMESUB.
3 AUTHOR. CVV.
4
5 DATA DIVISION.
6 WORKING-STORAGE SECTION.
7 01 FILLER PIC X(37)
8 VALUE 'WS BEGINS HERE FOR SUBPROGRAM TIMESUB'.
9
10 01 TIME-VARIABLES.
11 05 THE-TIME PIC 9(8).
12 05 HH-MM-SS PIC 99B99B99.
13
14 01 FILLER PIC X(35)
15 01 VALUE 'WS ENDS HERE FOR SUBPROGRAM TIMESUB'.
16
17 PROCEDURE DIVISION.
18 000-UPDATE-TIME.
19 ACCEPT THE-TIME FROM TIME.
20 MOVE THE-TIME (1:6) TO HH-MM-SS.
21 INSPECT HH-MM-SS REPLACING ALL ' ' BY ':'.
22 DISPLAY HH-MM-SS LINE 1 COLUMN 60.
23 EXIT PROGRAM.

```

## The Linkage Editor

Beginning COBOL programmers often take the *link program* (or *linkage editor* as it is called on IBM mainframes) for granted, because it functions transparently as the middle step in the compile, link, and execute sequence. Knowledge of the link program assumes greater importance, however, in systems of multiple programs as in the fitness example just presented. Accordingly, we review the compile, link, and execute sequence that was first presented in Chapter 2.

Three distinct programs are associated with the execution of a single COBOL program, a relationship that was shown earlier in Figure 2.3. The COBOL compiler translates a source program into an object (machine language) program; the link program combines the object program with object modules from other COBOL programs and/or vendor-supplied I/O routines to create an executable load module; and finally, the load module accepts the input data and produces the desired results.

Consider now a slightly different scenario in which a system of three COBOL programs (a main program and two subprograms) is to be developed. This time, a total of five steps is required in order to execute the main program:

1. Compile the main program
2. Compile the first subprogram
3. Compile the second subprogram
4. Link the three object programs to produce a load module
5. Execute the load module

It is not necessary, however, to repeat the entire five-step sequence every time the system undergoes additional testing. What if, for example, the subprograms have been successfully debugged, and only the main program is being changed? Can you see that it is inherently wasteful to continually recompile the subprograms if they remain the same? In other words, if only the main program changes, couldn't we just compile the main program (step 1), then link the object program to the existing object programs for the subprograms (step 4), and then execute the resulting load module (step 5)?

Other variations are also possible; for example, if the first subprogram changes but the other two remain the same, the run stream would consist of steps two, four, and five as only the first subprogram would have to be recompiled. Another variation would consist solely of step five, to execute the load module (without recompilation or linking) when all testing has been completed.

Figure 16.14 illustrates the compile, link, and execute sequence for the fitness system developed earlier in the chapter. Figure 16.14a displays the file names of the six programs in the system (as they might appear on a PC); the COB extension indicates a COBOL source program.

Figure 16.14b depicts a conceptual view of the associated run stream. Each of the six programs is compiled separately in steps 1 through 6, the individual object modules are linked together in step 7, and the resulting load module is executed in step 8. Figure 16.14c indicates the presence of the six object modules (extension OBJ) that are produced as a result of the individual compilations.

Figure 16.14d shows the two additional files produced by the link program. FITNESS.MAP contains the descriptive information produced by the link program and is analogous to a COBOL listing produced by the compiler. FITNESS.EXE is the resulting load module that is eventually executed.

### Problems with the Linkage Editor

Students are often frustrated in their attempt to produce a load module with multiple subprograms. Consider, for example, Figure 16.15, which contains—in outline form—a COBOL main (calling) program and two sub (called) programs. Observe, however, that there is an *inconsistency* between the CALL statement of the main program and the PROGRAM-ID paragraph of the first subprogram; that is, the main program is calling SUB1, whereas the PROGRAM-ID paragraph refers to SUBRTN1. This in turn produces the error message in Figure 16.15d.

The exact wording of the error message will vary from system to system; for example, the linkage editor on an IBM mainframe will cite an *unresolved external reference*, whereas the link program on a PC may reference an *undefined symbol*. Regardless of the system, however, the link program will not execute cleanly, despite the fact that all three programs compiled without error.

The reason for the problem becomes apparent when we again consider the functions of the COBOL compiler and the link program. The compiler translates COBOL source statements to machine language, and thus, must accept statements that call other (external) programs—for example, CALL SUB1. The compiler cannot access SUB1 directly, and trusts in the link program to locate the appropriate object module and produce an executable load module. The unresolved external reference detected by the link program means there was a call for a program named SUB1, but that the object module for SUB1 could not be found.

Return to the original COBOL listing of Figure 16.15a and observe once again the inconsistency between the CALL statement in the main program (CALL SUB1) and the PROGRAM-ID paragraph in the subprogram (SUBRTN1). Make the entries consistent (i.e., change SUB1 to SUBRTN1) and the problem is solved.

**Figure 16.14** The Compile, Link, and Execute Sequence

```

DSPLYSUB CBL
FITNESS CBL
INPUTSUB CBL
TIMESUB CBL
WGTCOPY CBL
WGTSUB CBL

```

**(a) Directory before Compilation**

Step 1: Compile fitness program (FITNESS.CBL)  
 Step 2: Compile input program (INPUTSUB.CBL)  
 Step 3: Compile weight goals program (WGTSUB.CBL)  
 Step 4: Compile training program (TRAINSUB.CBL)  
 Step 5: Compile format time program (TIMESUB.CBL)  
 Step 6: Compile final display program (DSPLYSUB.CBL)

Step 7: Link the object programs

Step 8: Execute the load module

**(b) The Run Stream (Conceptual View)**

```

DSPLYSUB CBL DSPLYSUB INT
FITNESS CBL FITNESS INT
INPUTSUB CBL INPUTSUB INT
TIMESUB CBL TIMESUB INT
WGTCOPY CBL TRAINSUB INT
WGTSUB CBL WGTSUB INT

```

**(c) Directory after Compilation****LIMITATIONS OF COBOL-74**

The optional BY REFERENCE and BY CONTENT phrases were not present in COBOL-74. The omission of both phrases defaults to CALLING BY REFERENCE and is the equivalent of the CALL statement in COBOL-74. The INITIAL phrase in the PROGRAM-ID paragraph is also new to COBOL-85. The optional scope terminator, END-CALL, is also new.

Two other minor changes do not add any additional capability per se, but simplify the use of subprograms. These are:

1. EXIT PROGRAM (to return control to the calling program) need not be the only statement in a paragraph, as was required in COBOL-74.
2. An elementary item may appear in the parameter list as opposed to the COBOL-74 restriction to 01- or 77-level entries.

Figure 16.15 Problems with the Linkage Editor

```
IDENTIFICATION DIVISION.
PROGRAM-ID. MAINPROG.
```

```
PROCEDURE DIVISION.
```

```
CALL 'SUB1' USING PARAMETER-1.
CALL 'SUBRTN2' USING PARAMETER-2.
```

*CALL statement inconsistent  
with PROGRAM-ID paragraph  
of first subroutine*

(a) Main Program

```
IDENTIFICATION DIVISION.
PROGRAM-ID. SUBRTN1.
```

```
PROCEDURE DIVISION
 USING PARAMETER-1.
```

```
EXIT PROGRAM.
```

(b) First Subroutine

```
IDENTIFICATION DIVISION.
PROGRAM-ID. SUBRTN2.
```

```
PROCEDURE DIVISION
 USING PARAMETER-2.
```

```
EXIT PROGRAM.
```

(c) Second Subroutine

ERROR - SUB1 IS AN UNRESOLVED EXTERNAL REFERENCE

(d) Error Message



## S U M M A R Y

---

### *Points to Remember*

- ☛ A sub (called) program is a program that is written and compiled independently of other programs but which is executed under the control of a main (calling) program.
- ☛ A hierarchy chart shows the relationship of paragraphs within a COBOL program or programs within a system. The subprograms that comprise a system are developed in stages and tested in top-down fashion just as the paragraphs within a program.
- ☛ The CALL statement in a calling program transfers control to the first executable statement in the called program. The EXIT PROGRAM statement returns control from the called program to the calling program.
- ☛ The argument list is specified in the CALL USING statement of the calling program and in the Procedure Division header of the called program. The data names in the parameter lists can be, but do not have to be, the same.
- ☛ The COPY statement inserts statements into a COBOL program (from a copy library) during compilation, as though the statements had been coded directly in the program itself. A COPY statement may appear anywhere within a program except within another COPY statement.
- ☛ CALLING BY CONTENT prevents the value of a passed parameter modified in the calling program from being changed in the called program; CALLING BY REFERENCE, however, will change the variable in the calling program.
- ☛ The INITIAL phrase in the PROGRAM-ID paragraph restores a program to its initial state each time it is called; that is, all data names are reset to their original values via any VALUE clauses that are present.
- ☛ The linkage editor (link program) combines the object modules produced by compilation of one or more programs with vendor-supplied I/O routines to produce a load module.

### *Key Words and Concepts*

|                               |                               |
|-------------------------------|-------------------------------|
| Argument list                 | Main program                  |
| Called program                | Parameter list                |
| Calling program               | Subprogram                    |
| Linkage editor (link program) | Undefined symbol              |
| Load module                   | Unresolved external reference |

### *COBOL Elements*

|              |                          |
|--------------|--------------------------|
| BY CONTENT   | EXIT PROGRAM             |
| BY REFERENCE | INITIAL                  |
| CALL USING   | LINKAGE SECTION          |
| COPY         | PROCEDURE DIVISION USING |
| END-CALL     |                          |

## FILL - IN

---

1. A called program returns control to its calling program via an \_\_\_\_\_ statement.
2. The LINKAGE SECTION appears in the (calling/called) program, and indicates that space for these data names has already been allocated in the (calling/called) program.
3. The order of arguments in the USING clauses of the called and calling programs (is/is not) important.
4. If program A calls program B, then program A is the main or \_\_\_\_\_ program and program B is the sub or \_\_\_\_\_ program.
5. If program A calls program B and program B calls program C, then program B is (both/neither) a called and a calling program.
6. A COBOL program (may/may not) call multiple subprograms.
7. A \_\_\_\_\_ statement is used to bring in text from a file on disk into a COBOL program.
8. Specification of the (BY CONTENT/BY REFERENCE) phrase ensures that the original values will be restored when control is returned to the calling program.
9. Specification of the (BY CONTENT/BY REFERENCE) phrase does not restore the values and thus functions identically to the COBOL-74 implementation.
10. The \_\_\_\_\_ phrase in the PROGRAM-ID paragraph restores the data names in a called program to their initial values.
11. The PERFORM statement is to a paragraph as the \_\_\_\_\_ statement is to a subprogram.

## TRUE / FALSE

---

1. The COPY clause is permitted only in the Data Division.
2. The Linkage Section appears in the calling program.
3. Data names in CALL . . . USING and PROCEDURE DIVISION USING . . . must be the same.
4. A called program contains only the Data and Procedure Divisions.
5. The COPY statement can be used on an FD only.
6. A COPY statement takes effect during the linking phase of the compile, link, and execution sequence.
7. A program can contain only one CALL statement.
8. The same program can function as both a called and a calling program.
9. The parameter list may contain group items at other than a 01 level.
10. A hierarchy chart can be used to show the relationship of paragraphs in a program or programs in a system.
11. A CALL statement must include either the BY REFERENCE or BY CONTENT phrase.
12. A CALL statement must contain at least one parameter.

## PROBLEMS

1. Answer the following questions with respect to the hierarchy chart in Figure 16.16:
  - a. Which programs are calling programs?
  - b. Which programs are called programs?
  - c. Which programs are both called and calling programs?
  - d. Which programs contain a CALL statement?
  - e. Which programs contain a Linkage Section?
  - f. Which programs might contain a COPY statement?
  - g. Which programs might contain an INITIAL clause?

**Figure 16.16** Hierarchy Chart for Problem 1

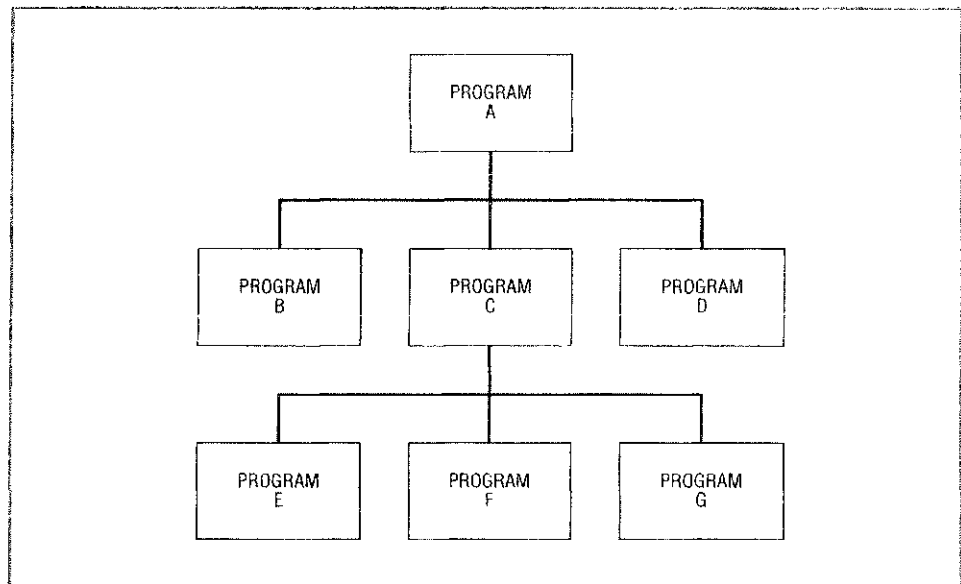

2. Figure 16.17 shows a partial listing of a called and calling program in which the first three Procedure Division statements of the subprogram initialize various counters and switches.
  - a. Are these statements redundant with the existing VALUE clauses; that is, what would be the effect (if any) of removing the MOVE statements from the subprogram?
  - b. What would be the effect (if any) of removing the MOVE ZERO statements, replacing them with VALUE ZERO clauses in the Data Division, and including the INITIAL phrase in the PROGRAM-ID header of the called program?
  - c. Which Procedure Division statement could be substituted for the MOVE ZERO statements with no other changes to the program?

**Figure 16.17** Skeleton Programs for Problem 2

```
IDENTIFICATION DIVISION.
PROGRAM-ID. MAINPROG.
.
.
PROCEDURE DIVISION.
.
 CALL 'SUB1' USING PARAMETER-LIST.
```

**(a) Main Program**

```
IDENTIFICATION DIVISION.
PROGRAM-ID. SUB1.
.
.
WORKING-STORAGE SECTION.
01 SUB-COUNTERS-AND-SWITCHES.
 05 FIRST-COUNTER PIC 9(3) VALUE ZERO.
 05 SECOND-COUNTER PIC 9(3) VALUE ZERO.
 05 TABLE-LOOKUP-SWITCH PIC X(3) VALUE SPACES.
.
PROCEDURE DIVISION
 USING PARAMTER-LIST.
.
.
RESET-DATA-ITEMS.
 MOVE ZEROS TO FIRST-COUNTER.
 MOVE ZEROS TO SECOND-COUNTER.
 MOVE SPACES TO TABLE-LOOKUP-SWITCH.
```

**(b) Subprogram**

3. Answer the following with respect to the COBOL fragment of Figure 16.18.
- What are the ending values for each of the six data names (that is, for A, B, C, D, E, and F)?
  - What is the effect, if any, of removing the BY CONTENT phrase in the CALL statement?
  - What is the effect, if any, of removing the BY REFERENCE phrase in the CALL statement?

Figure 16.18 COBOL Skeleton for Problem 3

```

MOVE ZEROS TO A, B, C.
CALL SUBRTN
 USING A
 BY CONTENT B
 BY REFERENCE C
END-CALL.

```

(a) Calling Program

```

PROGRAM-ID. SUBRTN.

PROCEDURE DIVISION
 USING D, E, F.

 .

 MOVE 10 TO D, E, F
 EXIT PROGRAM.

```

(b) Called Program

4. Answer the following with respect to the COBOL skeleton in Figure 16.19.
  - a. Indicate the necessary steps in a conceptual run stream to compile, link, and execute all three programs.
  - b. Which steps would have to be repeated in the run stream of part (a), given that the subprograms were working perfectly, but that the main program needs modification?
  - c. Which steps would have to be repeated in the run stream of part (a), given that the only change was in the copy member INPUTREC?
  - d. What problems, if any, would arise in connection with the CALL statement for PROGA? In which step (compilation, linking, or execution) would the problem arise (be detected)?
  - e. What problems, if any, would arise in connection with the CALL statement for PROGB? In which step (compilation, linking, or execution) would the problem arise (be detected)?
5. Explain how the concept of top-down testing can be applied to the fitness system as depicted by the hierarchy chart of Figure 16.6.

Figure 16.19 COBOL Programs for Problem 4

```
IDENTIFICATION DIVISION.
PROGRAM-ID. MAINPROG.

WORKING-STORAGE SECTION.
 COPY INPUTREC
01 INPUT-DATA.
 05 INPUT-NAME PIC X(15).
 .
01 PASSED-PARAMETERS.
 05 PARM-A PIC 9(4).
 05 PARM-B PIC XX.

PROCEDURE DIVISION.

 CALL 'PROGA' USING PARM-A, PARM-B, INPUT-DATA.
 CALL 'PROGB' USING PARM-A.
```

(a) Main Program

```
IDENTIFICATION DIVISION.
PROGRAM-ID. PROGA.

LINKAGE SECTION.
 COPY INPUTREC
01 INPUT-DATA.
 05 INPUT-NAME PIC X(15).
 .
01 NEW-DATA-NAMES.
 05 NEW-NAME-A PIC XX.
 05 NEW-NAME-B PIC 9(4).

PROCEDURE DIVISION
 USING NEW-NAME-A, NEW-NAME-B, INPUT-DATA.
```

(b) First Subroutine

```
IDENTIFICATION DIVISION.
PROGRAM-ID. PROG-B.

LINKAGE SECTION.
01 PASSED-PARAMETERS.
 05 PARM-A PIC 9(4).

PROCEDURE DIVISION
 USING PARM-A.
```

(b) Second Subroutine



17

# Sequential File Maintenance

## CHAPTER OUTLINE

---

Overview

**System Concepts**

Sequential versus Nonsequential Processing

Periodic Maintenance

**Data Validation**

Programming Specifications

Designing the Program

The Completed Program

**Sequential File Maintenance**

Programming Specifications

The Balance Line Algorithm

Designing the Hierarchy Chart

**Top-Down Testing**

The Stubs Program

The Completed Program

Summary

Fill-in

True/False

Problems



## OBJECTIVES

---

After reading this chapter you will be able to:

- Describe the file maintenance operation; distinguish between the old master, transaction, and new master files.
- Describe the three transaction types associated with file maintenance.
- Differentiate between sequential and nonsequential file maintenance.
- Describe at least three types of errors that can be detected in a stand-alone edit program; list two errors that cannot be detected in such a program.
- Discuss the balance line algorithm.
- Define top-down testing; explain how a program may be tested before it is completely coded.

## OVERVIEW

---

A large proportion of data-processing activity is devoted to file maintenance. Although printed reports are the more visible result of data processing, all files must be maintained to reflect the changing nature of the physical environment. In every system new records can be added, while existing records can be changed or deleted.

The chapter begins with a discussion of system concepts, emphasizing the importance of data validation in the maintenance process. It continues with coverage of the balance line algorithm, a completely general procedure for sequential file maintenance. The resulting program is implemented in stages through top-down testing. The initial version of the program contains several program stubs and validates the interaction among the higher-level paragraphs in the hierarchy chart. The second, and completed, version fulfills the requirements of the case study.

### System Concepts

In its simplest form, file maintenance implies the existence of three files, an *old master file*, a *transaction file*, and a *new master file*, which is produced as a consequence of processing the first two files with one another. The situation is depicted in Figure 17.1, which contains a system flowchart for the traditional *sequential update*.

Figure 17.2 is an expanded version of Figure 17.1 with hypothetical data included. The old master and transaction files are both in sequence according to the same field (key), in this example, by social security number. The transaction file contains information on how the old master file is to be changed—that is, whether new records are to be *added*, or existing records *changed* or *deleted*. During the update process, every record in the old master file will be copied intact to the new master file, unless the update program detects a transaction for that record. The output produced by the program consists of the new master file and various error messages if problems are encountered.

Figure 17.1 Sequential Update

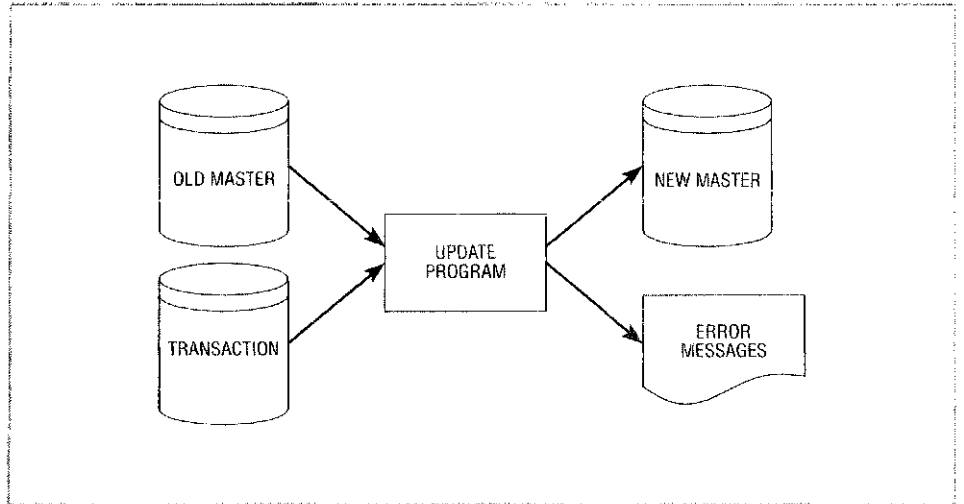
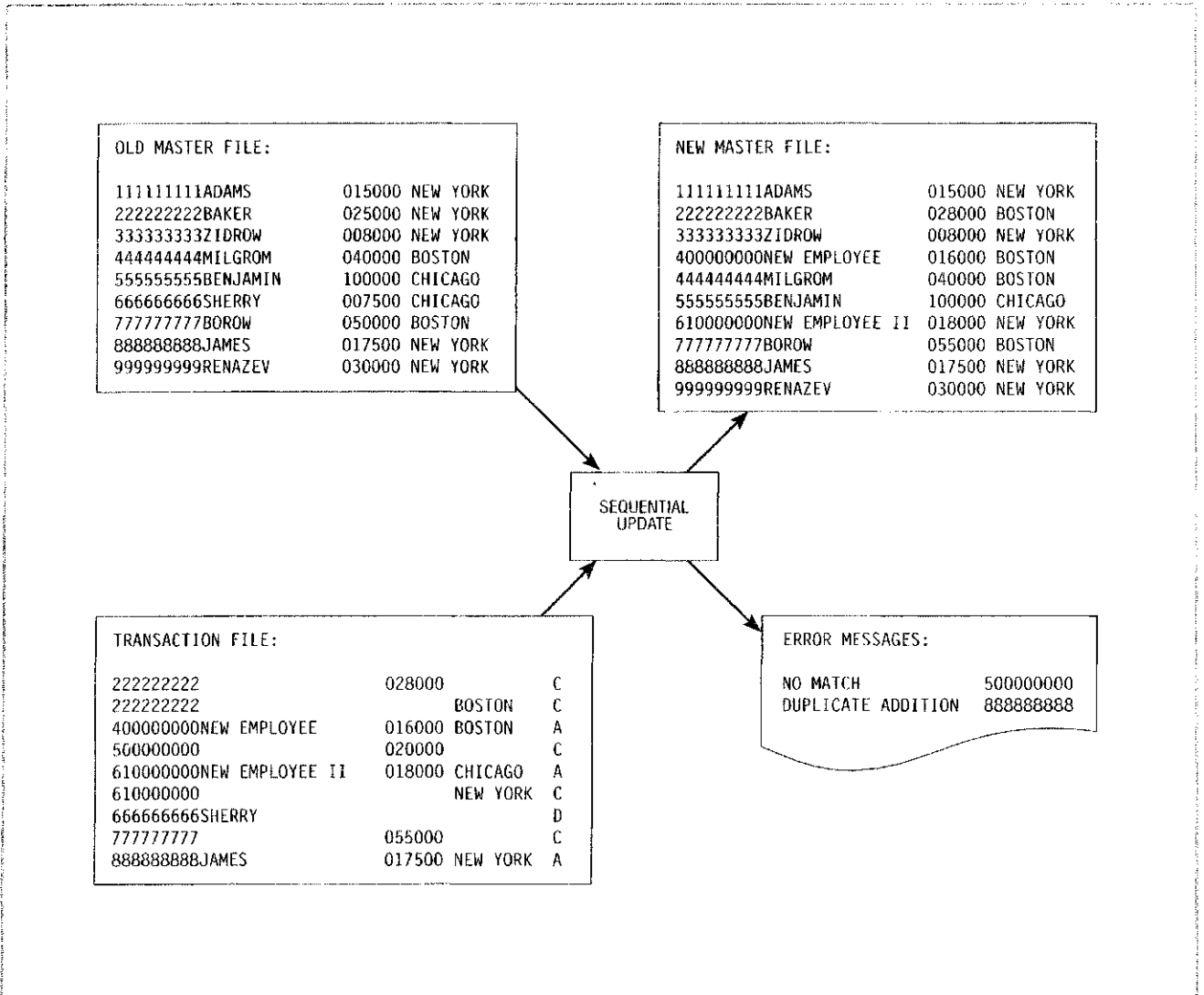

Figure 17.2 Sequential Update with Data Files



Every record in the old master file contains four fields: social security number, name, salary, and location. The records in the old master are in sequence by social security number, the value of which must be *unique* for every record in the file. Records in the transaction file are also in sequence by social security number, and three types of transactions (additions, changes, and deletions) are present. The update procedure must be general enough to accommodate multiple transactions for the same record; for example, employee 22222222 has two records in the transaction file, both of which are corrections.

Records with a transaction type of **A** are to be added to the new master file in their entirety. (Thus, New Employee, with social security number 400000000, does not appear on the old master but has been added to the new master.) Records with a transaction type of **D** are to be deleted. (Hence, Sherry, with social security number 666666666, appears in the old master but not the new master.) Records with a transaction code of **C** indicate a change in the value of a specific field(s) and contain only the social security number and field(s) to be changed. (Accordingly, Baker, with social security number 222222222, has had his salary and location changed to \$28,000 and Boston, respectively.)

Note, too, that in addition to the records for which there is activity, the old master contains several records for which there is no corresponding transaction; for example, there are no transactions for records with social security numbers of 333333333 and 999999999. Such records are simply copied intact to the new master.

All of these illustrations assume that the transaction file is valid in and of itself by virtue of a previously executed *stand-alone edit* program. In other words, the validation of the incoming transaction file has already been accomplished in an earlier program. This enables simplified logic in the maintenance program, as it can assume that all transactions contain a valid code (A, C, or D), that the transactions are in sequence by social security number, that additions contain all necessary fields, and so on. (Data validation was first introduced in Chapter 8.)

There are, however, two types of errors that cannot be detected in the stand-alone edit, and which must be checked in the update program itself. These are the attempted correction or deletion of a nonexistent old master record (a *no match*), and the addition of a new record that is already in the old master file (a *duplicate addition*). The transaction file in Figure 17.2 illustrates both errors (with transactions 500000000 and 888888888, respectively).

### Sequential versus Nonsequential Processing

This chapter is concerned entirely with a *sequential update* whereby every record in the old master is copied to the new master regardless of whether or not it changes. This technique is perfectly adequate when there is substantial activity in the old master file (that is, when many records change), but inefficient if only a few changes are made to the existing master file.

By contrast, a *nonsequential update* uses a single master file, which functions as both the old and new master. The records in the transaction file are processed one at a time, in no particular sequence, and matched against the existing master file. Nonsequential processing works best with low-activity files because unchanged records are left alone; that is, only those master records with a matching transaction record are written (rewritten) in the master file. Nonsequential processing is discussed in Chapter 18.

### Periodic Maintenance

All file maintenance is done *periodically*, with the frequency depending on the application. A file of student transcripts is updated only a few times a year; a bank's checking transactions are updated daily, with other types of systems being updated

Figure 17.3 Two-period Sequential Update

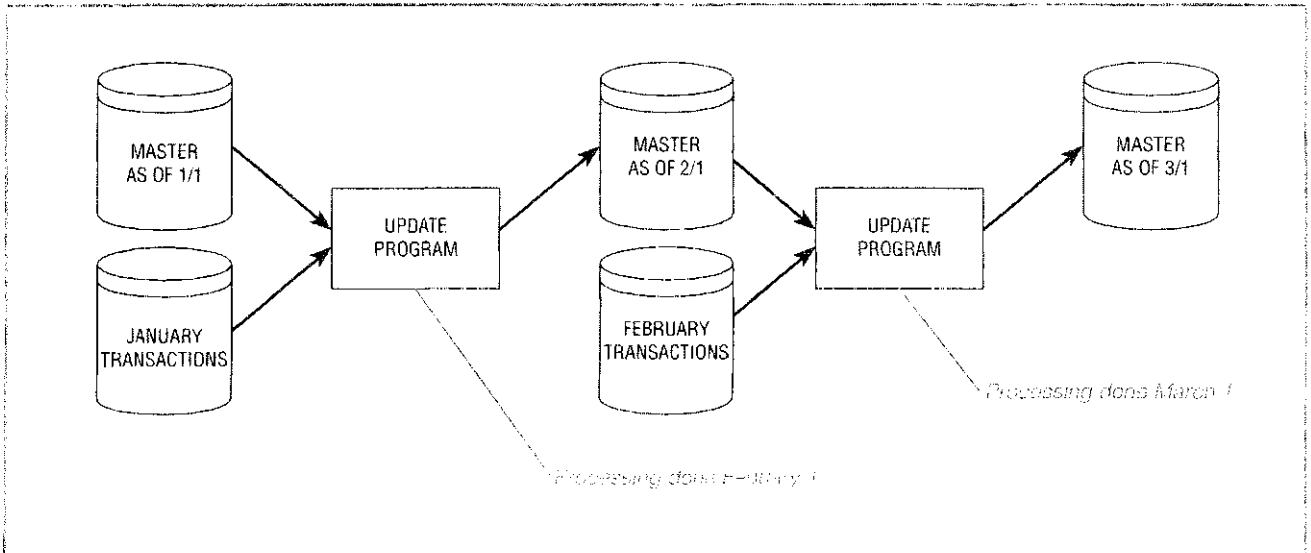

weekly or monthly. (Real-time applications, which process transactions as they occur, are covered in conjunction with nonsequential processing in the next chapter.)

A monthly cycle is depicted in Figure 17.3, beginning with a master file on January 1. Transactions are collected (batched) during the month of January. Then, on February 1, the master file of January 1 (now the old master) is processed with the transactions accrued during January, to produce a new master as of February 1. The process continues from month to month. Transactions are collected during February. On March 1, we use the file created February 1 as the old master, run it against the February transactions, and produce a new master as of March 1. The process continues indefinitely.

Figure 17.3 also serves as a basis for discussion of how *backup procedures* are implemented. Consider, for example, the situation on March 1 after the update has been run. The installation now has three *generations* of the master file; the file just produced (current master), the file produced on February 1st (previous master), and the original master file of January 1st (second previous master).

The availability of previous generations of the master file enables re-creation of the update process, should the need arise. Thus, an installation could rerun the update of March 1st, provided it retained the February master and associated transaction file. It could also go back a generation and recreate the February master, given that it retained the original January master and its associated transaction file. The number of generations that are retained depends on the individual installation, but will seldom be fewer than three. This type of backup is referred to as a *grandfather-father-son* strategy (with apologies to women).

## Data Validation

The need for *data validation* is paramount, regardless of whether processing is done sequentially or nonsequentially, or how many generations of backup are retained. The example in Figure 17.2 simply assumed a valid transaction file, an assumption that is far too unrealistic in practice. Accordingly we introduce concepts of data validation within the basis of a COBOL case study.

Figure 17.4 expands the sequential update of Figure 17.1 to include a separate step for data validation, in which the transaction file is first input to a stand-alone

Figure 17.4 Sequential Update with Data Validation

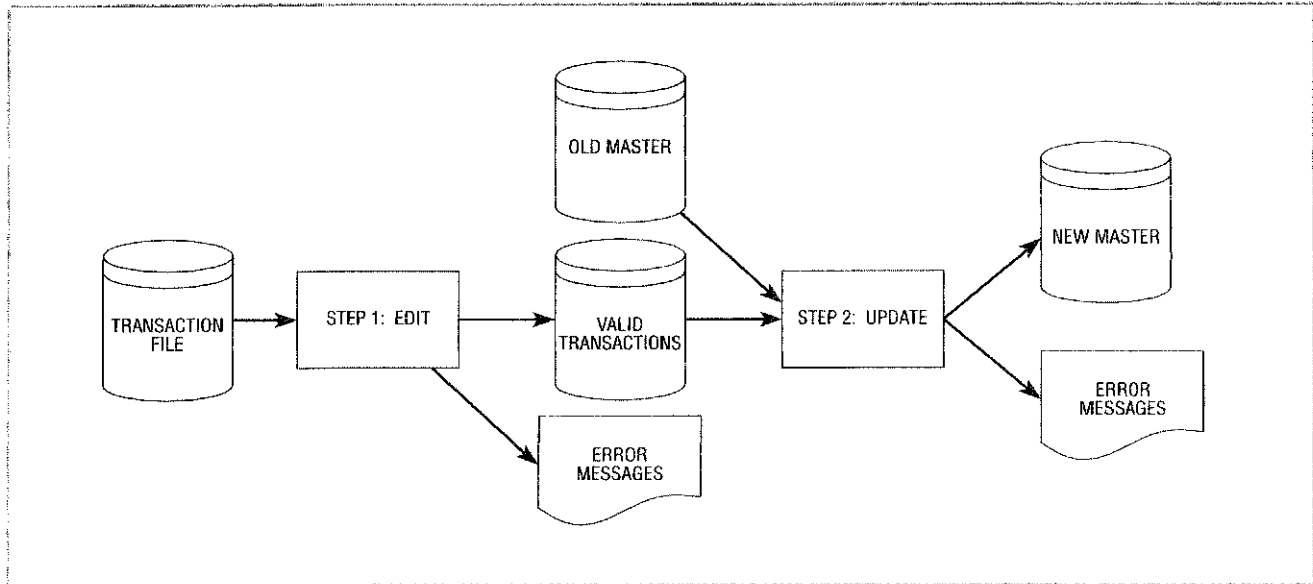

edit program. This program checks transactions for several errors (invalid transaction codes, incomplete additions, and so on), and only those transactions that pass all validity checks will be written to the output (valid) transaction file. The latter is then input to the sequential update.

In effect, Figure 17.4 is a blueprint for the remainder of the chapter. We begin with specifications for the edit program, develop the program completely, present a second set of specifications for the file maintenance (update) program, and develop that program in the second half of the chapter.

## PROGRAMMING SPECIFICATIONS

**Program Name:** Data Validation

**Narrative:** This program illustrates typical types of data validation, which are implemented in a stand-alone edit program.

**Input File(s):** TRANSACTION-FILE

**Input Record Layout:**

|    |                     |            |
|----|---------------------|------------|
| 01 | TRANSACTION-RECORD. |            |
| 05 | TR-SOC-SEC-NUMBER   | PIC X(9).  |
| 05 | TR-NAME.            |            |
| 10 | TR-LAST-NAME        | PIC X(15). |
| 10 | TR-INITIALS         | PIC XX.    |
| 05 | TR-LOCATION-CODE    | PIC X(3).  |
| 05 | TR-COMMISSION-RATE  | PIC 99.    |
| 05 | TR-SALES-AMOUNT     | PIC 9(5).  |
| 05 | TR-TRANSACTION-CODE | PIC X.     |
| 88 | ADDITION            | VALUE 'A'. |
| 88 | CORRECTION          | VALUE 'C'. |
| 88 | DELETION            | VALUE 'D'. |

**Test Data:** See Figure 17.5a.

**Output Files:** VALID-TRANSACTION-FILE

ERROR-FILE

**Output Record Layout:** Identical to the input record layout.

- Processing Requirements:**
1. Process a file of incoming transactions, rejecting any (and all) invalid transactions with an appropriate error message. Each transaction is to be checked for the following:
    - a. Sequence--The transactions are supposed to be in ascending sequence according to social security number by virtue of a previous program. (Multiple transactions with the same social security number are allowed). Accordingly, this program is not to sort the transaction file but to implement logic to ensure that the transactions are in fact in order. (Sorting is time consuming and should not be repeated if the transactions are already in order.)
    - b. Valid transaction code-- Only three types of transaction codes are permitted: A, C, or D, denoting additions, corrections, and deletions, respectively. Any other transaction code (including a blank) is to be rejected.
    - c. Completeness-- Additions are to contain the employee's name and initials, location, and commission rate. All fields are to be checked with individual messages written for any missing field(s). Corrections must contain a value for the sales amount.
    - d. Data types-- TR-COMMISSION-RATE (required for an addition) and TR-SALES-AMOUNT (required for a correction) must be numeric fields. A violation of either condition requires a specific error message
    - e. Valid location code-- Additions are to contain a valid location code—that is, a location code of ATL, BOS, NYC, PHI, or SF (corresponding to the entries in a location codes table to be embedded within the program).
  2. All valid transactions are to be written to a VALID-TRANSACTION-FILE, which will be created as an output file by the program. Invalid transactions may be discarded after the appropriate error message has been printed.

The function of the edit program is best understood by examining Figure 17.5, which contains the input transaction file, associated error messages, and the output (valid) transaction file. Fourteen transactions were input to the edit program (Figure 17.5a), but only eight of these passed all validity checks and thus made it to the output file (Figure 17.5c). You may find it useful to review each of the rejected transactions in conjunction with the associated error message in Figure 17.5b.

Figure 17.5 Valid Transaction File

|                  |         |       |
|------------------|---------|-------|
| 00000000BOROW    | JSATL07 | A     |
| 00000000BOROW    | JS      | 1000C |
| 00000000BOROW    | JS      | 2000C |
| 10000000GRABER   | P       | 3000  |
| 22222222NEW GUY  | RT      | A     |
| 33333333ESMAN    | TNNY 09 | A     |
| 40000000MOLDOF   | BLATL15 | A     |
| 44444444RICHARDS | IM      | 0500C |
| 55555555JORDAN   | BOS07   | A     |
| 70000000MILGROM  | A       | D     |
| 66666666JOHNSON  | M NYC12 | A     |
| 80000000VAZQUEZ  | C       | 5500C |

Figure 17.5 (continued)

```
800000000VILLAR C C
999999999GILLENSON MANYC10 A
```

(a) Transaction File

```
INVALID TRANSACTION CODE 100000000GRABER P 30000
MISSING LOCATION CODE 222222222NEW GUY RT A
MISSING OR NON-NUMERIC COMMISSION RATE 222222222NEW GUY RT A
INVALID LOCATION CODE 333333333ESMAN TNNY 09 A
MISSING NAME OR INITIALS 555555555JORDAN BOS07 A
SOCIAL SECURITY NUMBER OUT OF SEQUENCE 666666666JOHNSON M NYC12 A
MISSING OR NON-NUMERIC SALES AMOUNT 800000000VILLAR C C
```

(b) Error Messages

```
000000000BOROW JSATL07 A
000000000BOROW JS 1000C
000000000BOROW JS 2000C
400000000MOLDOF BLATL15 A
444444444RICHARDS IM 0500C
700000000MILGROM A D
800000000VAZQUEZ C 5500C
999999999GILLENSON MANYC10 A
```

(c) Valid Transaction File

Figure 17.6 Hierarchy Chart for Data Validation Program

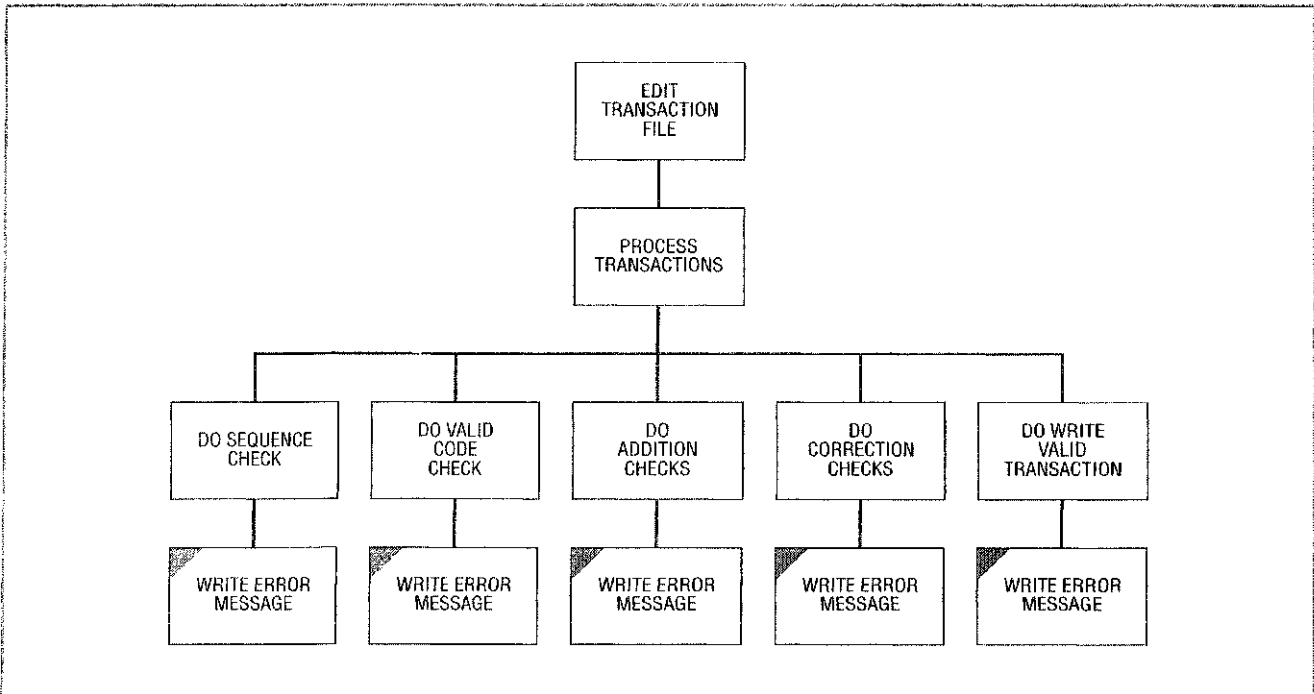

### Designing the Program

The edit program is developed along the same lines as any other program, first by designing a hierarchy chart to include the functions required by the program, and then by developing pseudocode to embrace sequence and decision-making logic.

The hierarchy chart in Figure 17.6 is straightforward and should not present any difficulty. Note, however, that the module WRITE-ERROR-MESSAGE is called from several places in the program because the function is subservient to each of the error-checking modules. We have decided, therefore, to place these statements in a separate routine, rather than repeat the identical code in multiple places throughout the program.

The pseudocode for the data validation program is shown in Figure 17.7. Each incoming transaction is assumed to be valid initially, so that 'YES' is moved to

Figure 17.7 Pseudocode for Data Validation Program

```

Open files
DO while data remains
 READ transaction file
 AT END
 Indicate no more data
 NOT AT END
 Move 'YES' to valid-record-switch
 IF trans-social-security < previous-social-security
 Move 'NO' to valid-record-switch
 Write error message
 ENDIF
 Move trans-social-security to previous-social-security
 IF transaction-code is not valid
 Move 'NO' to valid-record-switch
 Write error message
 ENDIF
 IF addition
 IF transaction fails addition-check(s)
 Move 'NO' to valid-record-switch
 Write error message(s)
 ENDIF
 ELSE
 IF correction
 IF sales-amount not numeric
 Move 'NO' to valid-record-switch
 Write error message
 ENDIF
 ENDIF
 ENDIF
 IF valid-record-switch = 'YES'
 Write valid-transaction-record
 ENDIF
 ENDDO
ENDREAD
Close files
Stop run

```



VALID-RECORD-SWITCH. The transaction is then subjected to the various editing requirements, any one of which could cause VALID-RECORD-SWITCH to be set to 'NO'. Only if the transaction passes all of the individual checks (that is, if VALID-RECORD-SWITCH is still set to 'YES') is it written to the valid record file at the end of the loop.

### The Completed Program

The completed program is shown in Figure 17.8. One technique worthy of special mention is the establishment of a table for the error messages (lines 47 through 64) and the subsequent printing of an error message in the paragraph 400-WRITE-ERROR-MESSAGE (lines 167-172).

Figure 17.8 The Edit Program

```

1 IDENTIFICATION DIVISION.
2 PROGRAM-ID. EDIT.
3 AUTHOR. ROBERT GRAUER.
4
5 ENVIRONMENT DIVISION.
6 INPUT-OUTPUT SECTION.
7 FILE-CONTROL.
8 SELECT TRANSACTION-FILE ASSIGN TO 'A:\CHAPTR17\TRANS.DAT'
9 ORGANIZATION IS LINE SEQUENTIAL.
10 SELECT VALID-TRANSACTION-FILE ASSIGN TO 'A:\CHAPTR17\VALTRANS.DAT'
11 ORGANIZATION IS LINE SEQUENTIAL.
12 SELECT ERROR-FILE ASSIGN TO 'A:\CHAPTR17\ERROR.DAT'
13 ORGANIZATION IS LINE SEQUENTIAL.
14
15 DATA DIVISION.
16 FILE SECTION.
17 FD TRANSACTION-FILE
18 DATA RECORD IS TRANSACTION-RECORD.
19 01 TRANSACTION-RECORD PIC X(37).
20
21 FD VALID-TRANSACTION-FILE
22 DATA RECORD IS VALID-TRANSACTION-RECORD.
23 01 VALID-TRANSACTION-RECORD PIC X(37).
24
25 FD ERROR-FILE
26 DATA RECORD IS ERROR-RECORD.
27 01 ERROR-RECORD PIC X(132).
28
29 WORKING-STORAGE SECTION.
30 01 FILLER PIC X(14)
31 VALUE 'WS BEGINS HERE'.
32
33 01 WS-TRANSACTION-RECORD.
34 05 TR-SOC-SEC-NUMBER PIC X(9).
35 05 TR-NAME.
```

Valid transaction file  
written to separate file

Figure 17.8 (continued)

```

36 10 TR-LAST-NAME PIC X(15).
37 10 TR-INITIALS PIC XX.
38 05 TR-LOCATION-CODE PIC X(3).
39 05 TR-COMMISSION-RATE PIC 99.
40 05 TR-SALES-AMOUNT PIC 9(5).
41 05 TR-TRANSACTION-CODE PIC X.
42 88 ADDITION VALUE 'A'.
43 88 CORRECTION VALUE 'C'.
44 88 DELETION VALUE 'D'.
45 88 VALID-CODES VALUES 'A', 'C', 'D'.
46
47 01 ERROR-VALUES-TABLE.
48 05 ERROR-VALUES.
49 10 FILLER PIC X(40)
50 VALUE 'SOCIAL SECURITY NUMBER OUT OF SEQUENCE'.
51 10 FILLER PIC X(40)
52 VALUE 'INVALID TRANSACTION CODE'.
53 10 FILLER PIC X(40)
54 VALUE 'MISSING NAME OR INITIALS'.
55 10 FILLER PIC X(40)
56 VALUE 'MISSING LOCATION CODE'.
57 10 FILLER PIC X(40)
58 VALUE 'INVALID LOCATION CODE'.
59 10 FILLER PIC X(40)
60 VALUE 'MISSING OR NON-NUMERIC COMMISSION RATE'.
61 10 FILLER PIC X(40)
62 VALUE 'MISSING OR NON-NUMERIC SALES AMOUNT'.
63 05 ERROR-TABLE REDEFINES ERROR-VALUES.
64 10 ERROR-MESSAGE OCCURS 7 TIMES PIC X(40).
65
66 01 LOCATION-VALUES-TABLE.
67 05 LOCATION-VALUES.
68 10 FILLER PIC X(3) VALUE 'ATL'.
69 10 FILLER PIC X(3) VALUE 'BOS'.
70 10 FILLER PIC X(3) VALUE 'NYC'.
71 10 FILLER PIC X(3) VALUE 'PHI'.
72 10 FILLER PIC X(3) VALUE 'SF '.
73 05 LOCATION-TABLE REDEFINES LOCATION-VALUES.
74 10 LOCATION OCCURS 5 TIMES
75 INDEXED BY LOCATION-INDEX PIC X(3).
76
77 01 WS-ERROR-LINE.
78 05 FILLER PIC X(2).
79 05 EL-REASON PIC X(40).
80 05 EL-TRANSACTION PIC X(37).
81 05 FILLER PIC X(54).
82
83 01 WS-SWITCHES-AND-DATANAMES.
84 05 WS-EOF-SWITCH PIC X(3) VALUE 'NO '.
85 05 WS-VALID-RECORD-SWITCH PIC X(3) VALUE SPACES.

```

Figure 17.8 (continued)

```

86 05 WS-PREVIOUS-SOC-SEC-NUMBER PIC X(9) VALUE SPACES.
87 05 WS-ERROR-CODE PIC 99.
88
89 PROCEDURE DIVISION.
90 100-EDIT-TRANSACTION-FILE.
91 OPEN INPUT TRANSACTION-FILE
92 OUTPUT VALID-TRANSACTION-FILE
93 ERROR-FILE.
94 PERFORM UNTIL WS-EOF-SWITCH = 'YES'
95 READ TRANSACTION-FILE INTO WS-TRANSACTION-RECORD
96 AT END
97 MOVE 'YES' TO WS-EOF-SWITCH
98 NOT AT END
99 PERFORM 210-PROCESS-TRANSACTIONS
100 END-READ
101 END-PERFORM.
102 CLOSE TRANSACTION-FILE
103 VALID-TRANSACTION-FILE
104 ERROR-FILE.
105 STOP RUN.
106
107 210-PROCESS-TRANSACTIONS.
108 MOVE 'YES' TO WS-VALID-RECORD-SWITCH.
109 PERFORM 300-DO-SEQUENCE-CHECK.
110 PERFORM 310-DO-VALID-CODE-CHECK.
111 IF ADDITION
112 PERFORM 320-DO-ADDITION-CHECKS
113 ELSE
114 IF CORRECTION
115 PERFORM 330-DO-CORRECTION-CHECKS
116 END-IF
117 END-IF.
118 IF WS-VALID-RECORD-SWITCH = 'YES'
119 PERFORM 340-WRITE-VALID-TRANSACTION
120 END-IF.
121
122 300-DO-SEQUENCE-CHECK.
123 IF TR-SOC-SEC-NUMBER < WS-PREVIOUS-SOC-SEC-NUMBER
124 MOVE 1 TO WS-ERROR-CODE
125 PERFORM 400-WRITE-ERROR-MESSAGE
126 END-IF.
127 MOVE TR-SOC-SEC-NUMBER TO WS-PREVIOUS-SOC-SEC-NUMBER.
128
129 310-DO-VALID-CODE-CHECK.
130 IF NOT VALID-CODES
131 MOVE 2 TO WS-ERROR-CODE
132 PERFORM 400-WRITE-ERROR-MESSAGE
133 END-IF.
134
135 320-DO-ADDITION-CHECKS.

```

*In the perform and 'at end' condition, 'yes' strikes the output.*

*Transaction is assumed valid initially*

*Only valid transactions are written to output file*

*Appropriate subscript is moved to WS-ERROR-CODE*

Figure 17.8 (continued)

```

136 IF TR-LAST-NAME = SPACES OR TR-INITIALS = SPACES
137 MOVE 3 TO WS-ERROR-CODE
138 PERFORM 400-WRITE-ERROR-MESSAGE
139 END-IF.
140 IF TR-LOCATION-CODE = SPACES
141 MOVE 4 TO WS-ERROR-CODE
142 PERFORM 400-WRITE-ERROR-MESSAGE
143 ELSE
144 SET LOCATION-INDEX TO 1
145 SEARCH LOCATION
146 AT END
147 MOVE 5 TO WS-ERROR-CODE
148 PERFORM 400-WRITE-ERROR-MESSAGE
149 WHEN TR-LOCATION-CODE = LOCATION (LOCATION-INDEX)
150 NEXT SENTENCE
151 END-SEARCH
152 END-IF.
153 IF TR-COMMISSION-RATE NOT NUMERIC
154 MOVE 6 TO WS-ERROR-CODE
155 PERFORM 400-WRITE-ERROR-MESSAGE
156 END-IF.
157
158 330-DO-CORRECTION-CHECKS.
159 IF TR-SALES-AMOUNT NOT NUMERIC
160 MOVE 7 TO WS-ERROR-CODE
161 PERFORM 400-WRITE-ERROR-MESSAGE
162 END-IF.
163
164 340-WRITE-VALID-TRANSACTION.
165 WRITE VALID-TRANSACTION-RECORD FROM WS-TRANSACTION-RECORD.
166
167 400-WRITE-ERROR-MESSAGE.
168 MOVE 'NO ' TO WS-VALID-RECORD-SWITCH.
169 MOVE SPACES TO WS-ERROR-LINE.
170 MOVE ERROR-MESSAGE (WS-ERROR-CODE) TO EL-REASON.
171 MOVE WS-TRANSACTION-RECORD TO EL-TRANSACTION.
172 WRITE ERROR-RECORD FROM WS-ERROR-LINE.

```

330-DOH statement has a list of IF statements.

All error messages are produced by a common routine.

The use of an *error message table* enables the programmer to see at a glance all of the errors checked by the program, and further to format those messages in identical fashion. It also facilitates the use of a common routine to display the individual messages, rather than having to duplicate code throughout the program. Observe, therefore, that each error routine moves an appropriate subscript value to WS-ERROR-CODE upon detection of an error, which is then used by 400-WRITE-ERROR-MESSAGE to display the appropriate error.

Is data validation worth the extra time and trouble? Any programmer who has ever been called at two in the morning will answer strongly in the affirmative. Put another way, diligent application of data validation (sometimes known as *defensive programming*) minimizes the need for subsequent debugging. All debugging

techniques, no matter how sophisticated, suffer from the fact that they are applied *after* a problem has occurred. The inclusion of data validation within a system attempts to detect the (inevitable) errors that will occur *before* they produce a problem.

## Sequential File Maintenance

We are now ready to proceed with the main objective of the chapter, the development of a program for sequential file maintenance. Specifications follow in the usual format.

### PROGRAMMING SPECIFICATIONS

**Program Name:** Sequential Update

**Narrative:** This program implements the traditional sequential update via the balance line algorithm.

**Input Files:** TRANSACTION-FILE

OLD-MASTER-FILE

**Input Record Layout:**

|    |                       |            |
|----|-----------------------|------------|
| 01 | TRANSACTION-RECORD.   |            |
| 05 | TR-SOC-SEC-NUMBER     | PIC X(9).  |
| 05 | TR-NAME.              |            |
| 10 | TR-LAST-NAME          | PIC X(15). |
| 10 | TR-INITIALS           | PIC XX.    |
| 05 | TR-LOCATION-CODE      | PIC X(3).  |
| 05 | TR-COMMISSION-RATE    | PIC 99.    |
| 05 | TR-SALES-AMOUNT       | PIC 9(5).  |
| 05 | TR-TRANSACTION-CODE   | PIC X.     |
| 88 | ADDITION              | VALUE 'A'. |
| 88 | CORRECTION            | VALUE 'C'. |
| 88 | DELETION              | VALUE 'D'. |
| 01 | OLD-MASTER-RECORD.    |            |
| 05 | OM-SOC-SEC-NUMBER     | PIC X(9).  |
| 05 | OM-NAME.              |            |
| 10 | OM-LAST-NAME          | PIC X(15). |
| 10 | OM-INITIALS           | PIC XX.    |
| 05 | OM-LOCATION-CODE      | PIC X(3).  |
| 05 | OM-COMMISSION-RATE    | PIC 99.    |
| 05 | OM-YEAR-TO-DATE-SALES | PIC 9(8).  |

**Output File:** NEW-MASTER-FILE

**Output Record Layout:** Identical to old master record.

**Test Data:** See Figure 17.9a (Old Master File) and Figure 17.9b (Valid Transaction File).

- Processing Requirements:**
1. Develop a sequential update program to process an incoming transaction file and the associated old master file to produce a new master file.
  2. The transaction file is assumed to be valid in and of itself by virtue of a stand-alone edit program. Hence, each transaction has a valid transaction code (A, C, or D), numeric

Figure 17.9 Test Data

|                  |                 |
|------------------|-----------------|
| 10000000GRABER   | P ATL150000000  |
| 20000000RUBIN    | MABOS0800020000 |
| 30000000ANDERSON | IRBOS1000113000 |
| 40000000MOLDOF   | BLATL1500000000 |
| 50000000GLASSMAN | JSNYC1000045000 |
| 60000000GRAUER   | RTNYC0800087500 |
| 70000000MILGROM  | A SF 0900120000 |
| 80000000VAZQUEZ  | C ATL1200060000 |
| 90000000CLARK    | E NYC0700002500 |

(a) Old Master

|                   |         |        |
|-------------------|---------|--------|
| 00000000BOROW     | JSATL07 | A      |
| 00000000BOROW     | JS      | 1000C  |
| 00000000BOROW     | JS      | 2000C  |
| 40000000MOLDOF    | BLATL15 | A      |
| 44444444RICHARDS  | IM      | 05000C |
| 70000000MILGROM   | A       | D      |
| 80000000VAZQUEZ   | C       | 55000C |
| 99999999GILLENSON | MANYC10 | A      |

(b) Valid Transaction File (Output of Edit Program)

- fields are numeric, and so on. Nevertheless, the update program must check (and flag) two kinds of errors that could not be detected in the stand-alone edit, as they require interaction with the old master file. These are:
- a. Duplicate additions, in which the social security number of a transaction coded as an addition already exists in the old master,
  - b. No matches, in which the social security number of a transaction coded as either a deletion or a correction, does not exist in the old master.
3. Transactions coded as additions are to be added to the new master file in their entirety, and will contain a value for every field in the transaction record (except for TR-SALES-AMOUNT). The value of YEAR-TO-DATE-SALES in the new master record is to be initialized to zero.
  4. Transactions coded as deletions are to be removed from the master file. These transactions contain only the social security number and transaction code.
  5. Transactions coded as corrections contain only the social security number, name, and the transaction sales amount (TR-SALES-AMOUNT). The value of TR-SALES-AMOUNT on the incoming transaction is to be *added* to the value in the YEAR-TO-DATE-SALES field in the master record.
  6. Any old master record for which there is no corresponding transaction is to be copied intact to the new master.

### The Balance Line Algorithm

Every COBOL book has confronted the problem of a sequential update. Barry Dwyer<sup>1</sup> details a general and elegant solution to the problem known as the *balance line*

1. B. Dwyer, "One More Time—How to Update a Master File," *Communications of the ACM*, vol. 24, no.1 (January 1981).

*algorithm.* To understand this solution, realize that the logic in a sequential update is more difficult than what has been encountered in previous chapters because there are multiple input files. The essence of the problem, then, is to determine whether to read from the old master file, the transaction file, or both. The solution is handled neatly in the balance line algorithm by the concept of an active key.

The *active key* is the smaller of the old master key and transaction key currently being processed. Thus, if the transaction key is less than the old master key, the active key is equal to the transaction key; if the transaction and old master keys are equal, the active key is equal to either; finally, if the old master key is less than the transaction key, the active key is the old master. (Note how easily the technique can be extended to multiple transaction files; the active key is always defined as the smallest value of all keys currently processed.)

The active key determines which records are admitted to the update process, and is illustrated with respect to the data in Figure 17.9. At the start of execution, the initial social security numbers for the old master and transaction records are 100000000 and 000000000, respectively, yielding an active key of 000000000. Thus, only the transaction record is considered for processing, while the old master record is held in abeyance. The algorithm processes this transaction, then reads another record from the transaction file, again with social security number 000000000. The keys are compared and again the transaction key is less than the master key, leaving the active key unchanged. After this transaction is processed, a third transaction is read, also with social security number 000000000, with the same results.

The fourth transaction with social security number 400000000 is read and produces a new active key of 100000000, which is the lesser of the old master (100000000) and transaction (400000000) social security numbers. The old master record is admitted to the update process, while the transaction record is held. The process continues in this fashion until eventually both files are out of data.

The balance line algorithm is expressed in pseudocode in Figure 17.10. The initial records are read from each file, and the first active key is determined. Next the major loop is executed until both the old master and transaction files are out of data. (**HIGH-VALUES** is a COBOL figurative literal and denotes the largest possible value. It is a convenient way of forcing *end-of-file* conditions, as will be seen when test data are examined later in the chapter.)

Within the outer loop, the key of the old master record is compared to the active key. If these values are equal, the old master record is moved (but **not** written) to the new master file, and another record is read from the old master file. We are not, however, finished with the original master record as it must be determined if any transactions exist for that record. Accordingly an inner loop is executed, which processes all transactions whose key is equal to the active key. (The transaction file is read repeatedly in the inner loop after each transaction is processed.) When the transaction key no longer equals the active key, a check is made to see if a deletion was processed, and if not, the new master record is written. The next active key is chosen, and the outer loop continues.

Figure 17.10 does not include the logic to accommodate error processing; that is, although the transaction file is assumed to be valid in and of itself, there are additional errors that come to light only in the actual updating process. Specifically, the update program must reject transactions that attempt to add records that already exist in the old master (duplicate additions), and must also reject transactions that attempt to change or delete records that do not exist (a no match).

The easiest way to accomplish this error processing is through the assignment of an *allocation status* to every value of the active key; that is, the value of the key is either allocated or it is not. If the allocation status is on, the record belongs in the file; if the allocation status is off, the record does not belong. Deletion of an existing record changes the status from on to off, whereas addition of a new record alters the

**Figure 17.10** Balance Line Algorithm

```

Open files
Read transaction-file, at end move high-values to transaction-key
Read old-master-file, at end move high-values to old-master-key
Choose first active-key
DO WHILE active-key not equal high-values
 IF old-master-key = active-key
 Move old-master-record to new-master-record
 Read old-master-file, at end move high-values to old-master-key
 ENDIF
 DO WHILE transaction-key equal active-key
 Apply transaction to new-master-record
 Read transaction-file, at end move high-values to transaction-key
 ENDDO
 IF no deletion was processed
 Write new-master-record
 ENDIF
 Choose next active-key
ENDDO
Close files
Stop run

```

status from off to on. Any attempt to add a record whose status is already on signifies a duplicate addition. In similar fashion, attempting to change or delete a record whose allocation status is off also signifies an error, as the transaction key is not present in the old master.

Figure 17.11 expands the pseudocode of Figure 17.10 to include RECORD-KEY-ALLOCATED-SWITCH to accommodate this discussion. A record is written to the new master file only when RECORD-KEY-ALLOCATED-SWITCH is set to YES. In other words, deletions are accomplished simply by setting the switch to NO and not writing the record.

You should be convinced of the total generality of Figure 17.11 and, further, that multiple transactions for the same key may be presented in any order. For example, if an addition and correction are input in that order, the record will be added and corrected in the same run. However, if the correction precedes the addition, then the correction will be flagged as a no match, and only the addition will take effect. Two additions for the same key will result in adding the first and flagging the second as a duplicate add. An addition, correction, and deletion may be processed in that order for the same transaction. A deletion followed by an addition may also be processed but will produce an error message, indicating an attempt to delete a record that is not in the old master.

### Designing the Hierarchy Chart

Recall that pseudocode and a hierarchy chart depict different things. Pseudocode indicates sequence and decision-making logic, whereas a hierarchy chart depicts function, indicating what has to be done, but not necessarily when. Accordingly, we



Figure 17.11 Expanded Balance Line Algorithm

```

Open files
Read transaction-file, at end move high-values to transaction-key
Read old-master-file, at end move high-values to old-master-key
Choose first active-key
DO WHILE active-key not equal high-values
 IF old-master-key = active-key
 Move 'yes' to record-key-allocated-switch
 Move old-master-record to new-master-record
 Read old-master-file, at end move high-values to old-master-key
 ELSE (active-key is not in old-master-file)
 Move 'no' to record-key-allocated switch
 ENDIF
 DO WHILE transaction-key equal active-key
 DO CASE transaction-code
 CASE addition
 IF record-key-allocated-switch = 'yes'
 Write 'error - duplicate addition'
 ELSE (active-key is not in old-master-file)
 Move transaction-record to new-master-record
 Move 'yes' to record-key-allocated-switch
 ENDIF
 CASE correction
 IF record-key-allocated-switch = 'yes'
 Process correction
 ELSE (active-key is not in old-master-file)
 Write 'error - no matching record'
 ENDIF
 CASE deletion
 IF record-key-allocated-switch = 'yes'
 Move 'no' to record-key-allocated-switch
 ELSE (active-key is not in old-master-file)
 Write 'error - no matching record'
 ENDIF
 END CASE
 Read transaction-file, at end move high-values to transaction-key
 END DO
 IF record-key-allocated-switch = 'yes'
 write new-master-record
 ENDIF
 Choose next active-key
END DO
Close files
Stop run

```

begin by listing the functional modules necessary to accomplish a sequential update using the balance line algorithm:

|                          |                                                                                                                                                                                                                               |
|--------------------------|-------------------------------------------------------------------------------------------------------------------------------------------------------------------------------------------------------------------------------|
| Overall Program Function | UPDATE-MASTER-FILE                                                                                                                                                                                                            |
| Functional Modules       | READ-TRANSACTION-FILE<br>READ-OLD-MASTER-FILE<br>CHOOSE-ACTIVE-KEY<br>PROCESS-ACTIVE-KEY<br>BUILD-NEW-MASTER<br>WRITE-NEW-MASTER<br>APPLY-TRANSACTIONS-TO-MASTER<br>ADD-NEW-RECORD<br>CORRECT-OLD-RECORD<br>DELETE-OLD-RECORD |

The hierarchy chart in Figure 17.12 is developed in top-down fashion, beginning with the overall program function, UPDATE-MASTER-FILE. Development of a hierarchy chart requires explicit specification of the function of each module, which should be apparent from the module name, consisting of a verb, one or two adjectives, and an object. Nevertheless, the module functions are described in depth:

|                    |                                                                                          |
|--------------------|------------------------------------------------------------------------------------------|
| UPDATE-MASTER-FILE | The mainline routine that drives the entire program. It opens the program files, invokes |
|--------------------|------------------------------------------------------------------------------------------|

Figure 17.12 Hierarchy Chart for Sequential Update

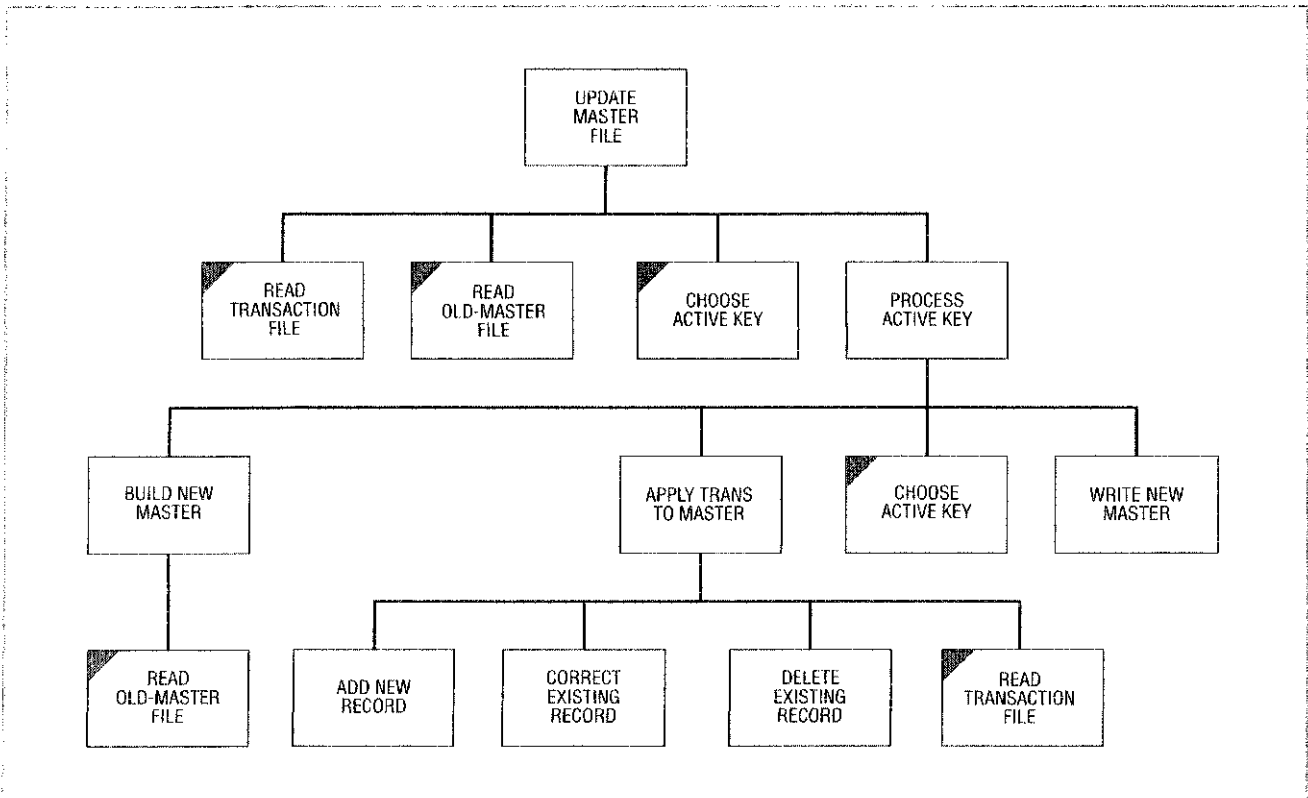

|                       |                                                                                                                                                                                                                                                                                                             |
|-----------------------|-------------------------------------------------------------------------------------------------------------------------------------------------------------------------------------------------------------------------------------------------------------------------------------------------------------|
|                       | subordinate routines to do an initial read from each input file, and determines the first active key. It invokes PROCESS-ACTIVE-KEY until all files are out of data, closes the files, and terminates the run.                                                                                              |
| READ-TRANSACTION-FILE | Reads a record from the transaction file and moves HIGH-VALUES to the transaction key when the file is empty. This module is performed from more than one place in the program as indicated by the shading in the upper left-hand corner.                                                                   |
| READ-OLD-MASTER-FILE  | Reads a record from the old master file and moves HIGH-VALUES to the old master key when the file is empty. This module is performed from more than one place in the program as indicated by the shading in the upper left-hand corner.                                                                     |
| CHOOSE-ACTIVE-KEY     | Determines the active key for the balance line algorithm from the current values of the old master and transaction records. This module is also performed from more than one place.                                                                                                                         |
| PROCESS-ACTIVE-KEY    | Performs up to four subordinates according to the value of active key. All four subordinates are invoked when the keys on the old master and transaction files equal the active key, and no deletions were processed.                                                                                       |
| BUILD-NEW-MASTER      | Moves the current old master record to a corresponding new master record. This module is mandated by the nature of a sequential update, which requires that every record in the old master file be copied to the new master file, regardless of whether the record changes.                                 |
| WRITE-NEW-MASTER      | Writes a new master record, and is performed only after all transactions for that record have been processed.                                                                                                                                                                                               |
| APPLY-TRANS-TO-MASTER | Performs one of three subordinates to add, correct, or delete a record according to the current transaction code. Regardless of the transaction type, the module invokes READ-TRANSACTION-FILE to obtain the next transaction and executes repeatedly as long as the transaction key equals the active key. |
| ADD-NEW-RECORD        | Lowest-level module to add a new record, which will set RECORD-KEY-ALLOCATED-SWITCH to YES.                                                                                                                                                                                                                 |
| CORRECT-OLD-RECORD    | Lowest-level module to update (correct) the year-to-date sales total in an existing master record.                                                                                                                                                                                                          |
| DELETE-OLD-RECORD     | Lowest-level module to delete a record, which will set RECORD-KEY-ALLOCATED-SWITCH to NO.                                                                                                                                                                                                                   |

Top-down testing implies that the highest (most difficult) modules in a hierarchy chart be tested earlier, and more often, than the lower-level (and often trivial) routines. It requires that testing begin as soon as possible, and well before the program is finished. Testing a program before it is completed is accomplished by coding lower-level modules as program stubs, that is, abbreviated versions of completed modules.

The major advantage in this approach is that testing begins sooner in the development cycle. Errors that do exist are found earlier and consequently are easier to correct. Later versions can still contain bugs, but the more difficult problems will already have been resolved in the initial tests.

Figure 17.9 (shown previously) contains sufficient data to adequately test the update program. All transaction types are present with multiple transactions present for the same transaction record (000000000). There is a duplicate addition (400000000) that should be flagged as an error, as well as an attempted correction on a nonexistent social security number (444444444).

It is highly desirable that a person other than the programmer, preferably the user, supply the test data. The latter individual does not know how the program actually works, and thus is in a better position to make up objective data. In addition, the user knows the original specification and is not subject to distortions from the analysis phase. The programmer, on the other hand, is biased, either consciously or subconsciously, and will generate data to accommodate his or her program or interpretation of the specifications. We should also mention that anticipated results are best computed *before* testing begins. Otherwise, it is too easy to assume the program works, because the output "looks right." Indeed, trainees are often so overjoyed merely to get output that they conclude the testing phase upon receiving their first printout.

### The Stubs Program

Figure 17.13 contains the stubs program for a sequential update implemented according to the balance line algorithm. It is *complete* in that it contains a paragraph for every module in the hierarchy chart of Figure 17.12, yet *incomplete* because several of the lower-level modules exist only as *program stubs*, that is, abbreviated paragraphs.

Figure 17.13 uses only two files, the old master and transaction, with record descriptions corresponding to the programming specifications. The new master file is not referenced explicitly in the program; instead, the paragraphs 0060-BUILD-NEW-MASTER and 0080-WRITE-NEW-MASTER contain DISPLAY statements to indicate that they have been executed. Indeed, the program contains many such DISPLAY statements to facilitate testing by indicating program flow.

Consider the test data in Figure 17.9, in conjunction with the program in Figure 17.13 and its associated output (Figure 17.14). The program begins by reading the first record from each file, social security numbers 000000000 and 100000000 for the transaction and old master, respectively. The active key is the smaller of the two, social security number 000000000, and corresponds to the transaction value. The paragraph 0070-APPLY-TRANS-TO-MASTER is entered for the first transaction, after which the lower-level paragraph 0090-ADD-NEW-RECORD is invoked. The second and third transactions also have a social security number of 000000000, so that 0070-APPLY-TRANS-TO-MASTER is executed twice more, each time followed by 0100-CORRECT-EXISTING-RECORD. Finally, when the transaction key no longer

Figure 17.13 Stubs Program

```

1 IDENTIFICATION DIVISION.
2 PROGRAM-ID. SEQSTUB.
3 AUTHOR. ROBERT GRAUER.
4
5 ENVIRONMENT DIVISION.
6 INPUT-OUTPUT SECTION.
7 FILE-CONTROL.
8 SELECT TRANSACTION-FILE ASSIGN TO 'A:\CHAPTR17\VALTRANS.DAT'
9 ORGANIZATION IS LINE SEQUENTIAL.
10 SELECT OLD-MASTER-FILE ASSIGN TO 'A:\CHAPTR17\OLDMAST.DAT'
11 ORGANIZATION IS LINE SEQUENTIAL.
12
13 DATA DIVISION.
14 FILE SECTION.
15 FD TRANSACTION-FILE
16 DATA RECORD IS TRANSACTION-RECORD.
17 01 TRANSACTION-RECORD PIC X(37).
18
19 FD OLD-MASTER-FILE
20 DATA RECORD IS OLD-MAST-RECORD.
21 01 OLD-MAST-RECORD PIC X(39).
22
23 WORKING-STORAGE SECTION.
24 01 FILLER PIC X(14)
25 VALUE 'WS BEGINS HERE'.
26
27 01 WS-TRANS-RECORD.
28 05 TR-SOC-SEC-NUMBER PIC X(9).
29 05 TR-NAME.
30 10 TR-LAST-NAME PIC X(15).
31 10 TR-INITIALS PIC XX.
32 05 TR-LOCATION-CODE PIC X(3).
33 05 TR-COMMISSION-RATE PIC 99.
34 05 TR-SALES-AMOUNT PIC 9(5).
35 05 TR-TRANSACTION-CODE PIC X.
36 88 ADDITION VALUE 'A'.
37 88 CORRECTION VALUE 'C'.
38 88 DELETION VALUE 'D'.
39
40 01 WS-OLD-MAST-RECORD.
41 05 OM-SOC-SEC-NUMBER PIC X(9).
42 05 OM-NAME.
43 10 OM-LAST-NAME PIC X(15).
44 10 OM-INITIALS PIC XX.
45 05 OM-LOCATION-CODE PIC X(3).
46 05 OM-COMMISSION-RATE PIC 99.
47 05 OM-YEAR-TO-DATE-SALES PIC 9(8).
48
49 01 WS-BALANCE-LINE-SWITCHES.
50 05 WS-ACTIVE-KEY PIC X(9).
51 05 WS-RECORD-KEY-ALLOCATED-SWITCH PIC X(3).

```

*Two input files are required*

*Three transaction types are permitted*

Figure 17.16 (continued)

```

52
53 PROCEDURE DIVISION.
54 0010-UPDATE-MASTER-FILE.
55 OPEN INPUT TRANSACTION-FILE
56 OLD-MASTER-FILE.
57 PERFORM 0020-READ-TRANSACTION-FILE.
58 PERFORM 0030-READ-OLD-MASTER-FILE.
59 PERFORM 0040-CHOOSE-ACTIVE-KEY.
60 PERFORM 0050-PROCESS-ACTIVE-KEY
61 UNTIL WS-ACTIVE-KEY = HIGH-VALUES.
62 CLOSE TRANSACTION-FILE
63 OLD-MASTER-FILE.
64 STOP RUN.
65
66 0020-READ-TRANSACTION-FILE.
67 READ TRANSACTION-FILE INTO WS-TRANS-RECORD
68 AT END MOVE HIGH-VALUES TO TR-SOC-SEC-NUMBER
69 END-READ.
70
71 0030-READ-OLD-MASTER-FILE.
72 READ OLD-MASTER-FILE INTO WS-OLD-MAST-RECORD
73 AT END MOVE HIGH-VALUE TO OM-SOC-SEC-NUMBER
74 END-READ.
75
76 0040-CHOOSE-ACTIVE-KEY.
77 IF TR-SOC-SEC-NUMBER LESS THAN OM-SOC-SEC-NUMBER
78 MOVE TR-SOC-SEC-NUMBER TO WS-ACTIVE-KEY
79 ELSE
80 MOVE OM-SOC-SEC-NUMBER TO WS-ACTIVE-KEY
81 END-IF.
82
83 0050-PROCESS-ACTIVE-KEY.
84 DISPLAY ' '.
85 DISPLAY ' '.
86 DISPLAY 'RECORDS BEING PROCESSED'.
87 DISPLAY ' TRANSACTION SOC SEC #: ' TR-SOC-SEC-NUMBER.
88 DISPLAY ' OLD MASTER SOC SEC #: ' OM-SOC-SEC-NUMBER.
89 DISPLAY ' ACTIVE KEY: ' WS-ACTIVE-KEY.
90 DISPLAY ' '.
91
92 IF OM-SOC-SEC-NUMBER = WS-ACTIVE-KEY
93 MOVE 'YES' TO WS-RECORD-KEY-ALLOCATED-SWITCH
94 PERFORM 0060-BUILD-NEW-MASTER
95 ELSE
96 MOVE 'NO' TO WS-RECORD-KEY-ALLOCATED-SWITCH
97 END-IF.
98
99 PERFORM 0070-APPLY-TRANS-TO-MASTER
100 UNTIL WS-ACTIVE-KEY NOT EQUAL TR-SOC-SEC-NUMBER.
101
102 IF WS-RECORD-KEY-ALLOCATED-SWITCH = 'YES'

```

DISPLAY statements  
collated together

Figure 17.13 (continued)

```

103 PERFORM 0080-WRITE-NEW-MASTER
104 END-IF.
105
106 PERFORM 0040-CHOOSE-ACTIVE-KEY.
107
108 0060-BUILD-NEW-MASTER.
109 DISPLAY '0060-BUILD-NEW-MASTER ENTERED'.
110 PERFORM 0030-READ-OLD-MASTER-FILE.
111
112 0070-APPLY-TRANS-TO-MASTER.
113 DISPLAY '0070-APPLY-TRANS-TO-MASTER ENTERED'
114 ' TRANSACTION CODE: ' TR-TRANSACTION-CODE.
115
116 EVALUATE TRUE
117 WHEN ADDITION
118 PERFORM 0090-ADD-NEW-RECORD
119 WHEN CORRECTION
120 PERFORM 0100-CORRECT-EXISTING-RECORD
121 WHEN DELETION
122 PERFORM 0110-DELETE-EXISTING-RECORD
123 WHEN OTHER
124 DISPLAY 'INVALID TRANSACTION CODE'
125 END-EVALUATE.
126
127 PERFORM 0020-READ-TRANSACTION-FILE.
128
129 0080-WRITE-NEW-MASTER.
130 DISPLAY '0080-WRITE-NEW-MASTER ENTERED'.
131
132 0090-ADD-NEW-RECORD.
133 DISPLAY '0090-ADD-NEW-RECORD ENTERED'.
134 IF WS-RECORD-KEY-ALLOCATED-SWITCH = 'YES'
135 DISPLAY ' ERROR-DUPLICATE ADDITION: ' TR-SOC-SEC-NUMBER
136 ELSE
137 MOVE 'YES' TO WS-RECORD-KEY-ALLOCATED-SWITCH
138 END-IF.
139
140 0100-CORRECT-EXISTING-RECORD.
141 DISPLAY '0100-CORRECT-EXISTING-RECORD ENTERED'.
142 IF WS-RECORD-KEY-ALLOCATED-SWITCH = 'YES'
143 NEXT SENTENCE
144 ELSE
145 DISPLAY ' ERROR-NO MATCHING RECORD: ' TR-SOC-SEC-NUMBER
146 END-IF.
147
148 0110-DELETE-EXISTING-RECORD.
149 DISPLAY '0110-DELETE-EXISTING-RECORD ENTERED'.
150 IF WS-RECORD-KEY-ALLOCATED-SWITCH = 'YES'
151 MOVE 'NO' TO WS-RECORD-KEY-ALLOCATED-SWITCH
152 ELSE
153 DISPLAY ' ERROR-NO MATCHING RECORD: ' TR-SOC-SEC-NUMBER
154 END-IF.

```

*DISPLAY statement indicates paragraph has been called*

*Determines which lower level module to execute*

*Partially coded paragraphs*

*RECORD-KEY-ALLOCATED-SWITCH controls deletion*

Figure 17.14 Truncated Output of Stubs Program

```

RECORDS BEING PROCESSED
 TRANSACTION SOC SEC #: 00000000
 OLD MASTER SOC SEC #: 10000000
 ACTIVE KEY: 00000000

0070-APPLY-TRANS-TO-MASTER ENTERED TRANSACTION CODE: A
0090-ADD-NEW-RECORD ENTERED
0070-APPLY-TRANS-TO-MASTER ENTERED TRANSACTION CODE: C
0100-CORRECT-EXISTING-RECORD ENTERED.
0070-APPLY-TRANS-TO-MASTER ENTERED TRANSACTION CODE: C
0100-CORRECT-EXISTING-RECORD ENTERED.
0080-WRITE-NEW-MASTER ENTERED

RECORDS BEING PROCESSED
 TRANSACTION SOC SEC #: 40000000
 OLD MASTER SOC SEC #: 10000000
 ACTIVE KEY: 10000000

0060-BUILD-NEW-MASTER ENTERED
0080-WRITE-NEW-MASTER ENTERED

RECORDS BEING PROCESSED
 TRANSACTION SOC SEC #: 40000000
 OLD MASTER SOC SEC #: 20000000
 ACTIVE KEY: 20000000

0060-BUILD-NEW-MASTER ENTERED
0080-WRITE-NEW-MASTER ENTERED

RECORDS BEING PROCESSED
 TRANSACTION SOC SEC #: 40000000
 OLD MASTER SOC SEC #: 30000000
 ACTIVE KEY: 30000000

0060-BUILD-NEW-MASTER ENTERED
0080-WRITE-NEW-MASTER ENTERED

RECORDS BEING PROCESSED
 TRANSACTION SOC SEC #: 40000000
 OLD MASTER SOC SEC #: 40000000
 ACTIVE KEY: 40000000

0060-BUILD-NEW-MASTER ENTERED
0070-APPLY-TRANS-TO-MASTER ENTERED TRANSACTION CODE: A
0090-ADD-NEW-RECORD ENTERED
 ERROR-DUPLICATE ADDITION: 40000000
0080-WRITE-NEW-MASTER ENTERED

.

RECORDS BEING PROCESSED
 TRANSACTION SOC SEC #: 99999999
 OLD MASTER SOC SEC #:
 ACTIVE KEY: 99999999

0070-APPLY-TRANS-TO-MASTER ENTERED TRANSACTION CODE: A
0090-ADD-NEW-RECORD ENTERED
0080-WRITE-NEW-MASTER ENTERED

```



equals the active key, that is, when the fourth transaction (Moldof, with social security number 400000000) is read, the paragraph 0080-WRITE-NEW-MASTER is executed to write the new (and corrected) record to the new master file.

The next determination of the active key compares the transaction just read (social security number 400000000) to the current old master social record (social security number 100000000), producing an active key of 100000000. The program decides there are no transactions for this old master record and copies it immediately to the new master file, as implied by the paragraphs 0060-BUILD-NEW-MASTER and 0080-WRITE-NEW-MASTER. The next two determinations of the active key (for old master records 200000000 and 300000000) produce a similar result. The fifth determination of the active key finds the same social security number in both files in conjunction with an attempted addition in the transaction file, producing an error message for a duplicate addition.

By now you should be gaining confidence that the program is working correctly, because the paragraphs are executing in proper sequence for the test data. We can say therefore that the initial testing has concluded successfully and move on to developing the completed program.

### The Completed Program

Once the stubs program has been tested and debugged, it is relatively easy to complete the program because the most difficult portion has already been written. We know that the interaction between modules works correctly; that the program will correctly read from the old master, transaction file, or both; that it will apply multiple transactions to the same master record; and that it will properly perform the appropriate lower-level module to add, correct, or delete a record.

Figure 17.15 contains the expanded update program, which defines an additional FD for the NEW-MASTER-FILE as well as completed paragraphs for the addition and correction routines. The DISPLAY statements associated with the testing procedure have also been deleted.

The files associated with the completed program are shown in Figure 17.16. Figures 17.16a and 17.16b repeat the original test data (for convenience), whereas Figures 17.16c and 17.16d contain the actual output. You should take a moment to verify the results to satisfy yourself that the program is working correctly. Observe in particular how multiple transactions were applied to a single old record (Borow), how Borow and Gillenson were successfully added to the new master, and how Milgrom was deleted. The two error messages correctly reflect both errors, an attempted duplicate addition and a nonmatching social security number.

Figure 17.15 Completed Sequential Update

```

1 IDENTIFICATION DIVISION.
2 PROGRAM-ID. SEQPDT.
3 AUTHOR. ROBERT GRAUER.
4
5 ENVIRONMENT DIVISION.
6 INPUT-OUTPUT SECTION.
7 FILE-CONTROL.
8 SELECT TRANSACTION-FILE ASSIGN TO 'A:\CHAPTR17\VALTRANS.DAT'
9 ORGANIZATION IS LINE SEQUENTIAL.
10 SELECT OLD-MASTER-FILE ASSIGN TO 'A:\CHAPTR17\OLDMAST.DAT'
11 ORGANIZATION IS LINE SEQUENTIAL.

```

Figure 17.15 (continued)

```

12 SELECT NEW-MASTER-FILE ASSIGN TO 'A:\CHAPTR17\NEWMAST.DAT'
13 ORGANIZATION IS LINE SEQUENTIAL.
14
15 DATA DIVISION.
16 FILE SECTION.
17 FD TRANSACTION-FILE
18 DATA RECORD IS TRANSACTION-RECORD.
19 01 TRANSACTION-RECORD PIC X(37).
20
21 FD OLD-MASTER-FILE
22 DATA RECORD IS OLD-MAST-RECORD.
23 01 OLD-MAST-RECORD PIC X(39).
24
25 FD NEW-MASTER-FILE
26 DATA RECORD IS NEW-MAST-RECORD.
27 01 NEW-MAST-RECORD PIC X(39).
28
29 WORKING-STORAGE SECTION.
30 01 FILLER PIC X(14)
31 VALUE 'WS BEGINS HERE'.
32
33 01 WS-TRANS-RECORD.
34 05 TR-SOC-SEC-NUMBER PIC X(9).
35 05 TR-NAME.
36 10 TR-LAST-NAME PIC X(15).
37 10 TR-INITIALS PIC XX.
38 05 TR-LOCATION-CODE PIC X(3).
39 05 TR-COMMISSION-RATE PIC 99.
40 05 TR-SALES-AMOUNT PIC 9(5).
41 05 TR-TRANSACTION-CODE PIC X.
42 88 ADDITION VALUE 'A'.
43 88 CORRECTION VALUE 'C'.
44 88 DELETION VALUE 'D'.
45
46 01 WS-OLD-MAST-RECORD.
47 05 OM-SOC-SEC-NUMBER PIC X(9).
48 05 OM-NAME.
49 10 OM-LAST-NAME PIC X(15).
50 10 OM-INITIALS PIC XX.
51 05 OM-LOCATION-CODE PIC X(3).
52 05 OM-COMMISSION-RATE PIC 99.
53 05 OM-YEAR-TO-DATE-SALES PIC 9(8).
54
55 01 WS-NEW-MAST-RECORD.
56 05 NM-SOC-SEC-NUMBER PIC X(9).
57 05 NM-NAME.
58 10 NM-LAST-NAME PIC X(15).
59 10 NM-INITIALS PIC XX.
60 05 NM-LOCATION-CODE PIC X(3).
61 05 NM-COMMISSION-RATE PIC 99.

```

*Output file has been added*

*Three transactions types*

*Record layouts are identical*

Figure 17.15 (continued)

```

62 05 NM-YEAR-TO-DATE-SALES PIC 9(8).
63
64 01 WS-BALANCE-LINE-SWITCHES.
65 05 WS-ACTIVE-KEY PIC X(9).
66 05 WS-RECORD-KEY-ALLOCATED-SWICH PIC X(3).
67
68 PROCEDURE DIVISION.
69 0010-UPDATE-MASTER-FILE.
70 OPEN INPUT TRANSACTION-FILE
71 OLD-MASTER-FILE
72 OUTPUT NEW-MASTER-FILE.
73 PERFORM 0020-READ-TRANSACTION-FILE.
74 PERFORM 0030-READ-OLD-MASTER-FILE.
75 PERFORM 0040-CHOOSE-ACTIVE-KEY.
76 PERFORM 0050-PROCESS-ACTIVE-KEY
77 UNTIL WS-ACTIVE-KEY = HIGH-VALUES.
78 CLOSE TRANSACTION-FILE
79 OLD-MASTER-FILE
80 NEW-MASTER-FILE.
81 STOP RUN.
82
83 0020-READ-TRANSACTION-FILE.
84 READ TRANSACTION-FILE INTO WS-TRANS-RECORD
85 AT END MOVE HIGH-VALUES TO TR-SOC-SEC-NUMBER
86 END-READ.
87
88 0030-READ-OLD-MASTER-FILE.
89 READ OLD-MASTER-FILE INTO WS-OLD-MAST-RECORD
90 AT END MOVE HIGH-VALUE TO OM-SOC-SEC-NUMBER
91 END-READ.
92
93 0040-CHOOSE-ACTIVE-KEY.
94 IF TR-SOC-SEC-NUMBER LESS THAN OM-SOC-SEC-NUMBER
95 MOVE TR-SOC-SEC-NUMBER TO WS-ACTIVE-KEY
96 ELSE
97 MOVE OM-SOC-SEC-NUMBER TO WS-ACTIVE-KEY
98 END-IF.
99
100 0050-PROCESS-ACTIVE-KEY.
101 IF OM-SOC-SEC-NUMBER = WS-ACTIVE-KEY
102 MOVE 'YES' TO WS-RECORD-KEY-ALLOCATED-SWITCH
103 PERFORM 0060-BUILD-NEW-MASTER
104 ELSE
105 MOVE 'NO' TO WS-RECORD-KEY-ALLOCATED-SWITCH
106 END-IF.
107
108 PERFORM 0070-APPLY-TRANS-TO-MASTER
109 UNTIL WS-ACTIVE-KEY NOT EQUAL TR-SOC-SEC-NUMBER.
110
111 IF WS-RECORD-KEY-ALLOCATED-SWITCH = 'YES'
112 PERFORM 0080-WRITE-NEW-MASTER

```

Processing terminates when the active key is HIGH-VALUES. I.e., when both files are empty

Applies multiple transactions to a single master record

Figure 17.15 (continued)

```

113 END-IF.
114
115 PERFORM 0040-CHOOSE-ACTIVE-KEY.
116
117 0060-BUILD-NEW-MASTER.
118 MOVE WS-OLD-MAST-RECORD TO WS-NEW-MAST-RECORD.
119 PERFORM 0030-READ-OLD-MASTER-FILE.
120
121 0070-APPLY-TRANS-TO-MASTER.
122 EVALUATE TRUE
123 WHEN ADDITION
124 PERFORM 0090-ADD-NEW-RECORD
125 WHEN CORRECTION
126 PERFORM 0100-CORRECT-EXISTING-RECORD
127 WHEN DELETION
128 PERFORM 0110-DELETE-EXISTING-RECORD
129 WHEN OTHER
130 DISPLAY 'INVALID TRANSACTION CODE'
131 END-EVALUATE.
132
133 PERFORM 0020-READ-TRANSACTION-FILE.
134
135 0080-WRITE-NEW-MASTER.
136 WRITE NEW-MAST-RECORD FROM WS-NEW-MAST-RECORD.
137
138 0090-ADD-NEW-RECORD.
139 IF WS-RECORD-KEY-ALLOCATED-SWITCH = 'YES'
140 DISPLAY ' ERROR-DUPLICATE ADDITION: ' TR-SOC-SEC-NUMBER
141 ELSE
142 MOVE 'YES' TO WS-RECORD-KEY-ALLOCATED-SWITCH
143 MOVE SPACES TO WS-NEW-MAST-RECORD
144 MOVE TR-SOC-SEC-NUMBER TO NM-SOC-SEC-NUMBER
145 MOVE TR-NAME TO NM-NAME
146 MOVE TR-LOCATION-CODE TO NM-LOCATION-CODE
147 MOVE TR-COMMISSION-RATE TO NM-COMMISSION-RATE
148 MOVE ZEROS TO NM-YEAR-TO-DATE-SALES
149 END-IF.
150
151 0100-CORRECT-EXISTING-RECORD.
152 IF WS-RECORD-KEY-ALLOCATED-SWITCH = 'YES'
153 ADD TR-SALES-AMOUNT TO NM-YEAR-TO-DATE-SALES
154 ELSE
155 DISPLAY ' ERROR-NO MATCHING RECORD: ' TR-SOC-SEC-NUMBER
156 END-IF.
157
158 0110-DELETE-EXISTING-RECORD.
159 IF WS-RECORD-KEY-ALLOCATED-SWITCH = 'YES'
160 MOVE 'NO' TO WS-RECORD-KEY-ALLOCATED-SWITCH
161 ELSE
162 DISPLAY ' ERROR-NO MATCHING RECORD: ' TR-SOC-SEC-NUMBER
163 END-IF.

```

*Expanded from program stub*

*Precludes writing a new master record*

Figure 17.16 Output of the Sequential Update

```

10000000GRABER P ATL150000000
20000000RUBIN MABOS080002000
30000000ANDERSON IRBOS100011300
40000000MOLDOF BLATL150000000
50000000GLASSMAN JSNYC100004500
60000000GRAUER RTNYC080008750
70000000MILGROM A SF 090012000
80000000VAZQUEZ C ATL120006000
90000000CLARK E NYC070000250

```

(a) Old Master

```

00000000BOROW JSATL07 A
00000000BOROW JS 1000C
00000000BOROW JS 2000C
40000000MOLDOF BLATL15 A
44444444RICHARDS IM 0500C
70000000MILGROM A D
80000000VAZQUEZ C 5500C
99999999GILLENSON MANYC10 A

```

(b) Valid Transaction File

```

00000000BOROW JSATL070003000
10000000GRABER P ATL150000000
20000000RUBIN MABOS080002000
30000000ANDERSON IRBOS100011300
40000000MOLDOF BLATL150000000
50000000GLASSMAN JSNYC100004500
60000000GRAUER RTNYC080008750
80000000VAZQUEZ C ATL120011500
90000000CLARK E NYC070000250
99999999GILLENSON MANYC100000000

```

(c) New Master File

```

ERROR-DUPLICATE ADDITION: 40000000
ERROR-NO MATCHING RECORD: 44444444

```

(d) Error Messages

## S U M M A R Y

---

### **Points to Remember**

- ❑ File maintenance is a necessity of every system and enables three types of transactions. New records may be added, while existing records may be changed or deleted.
- ❑ A sequential update copies every record from the old master file to the new master, regardless of whether it changes. By contrast, a nonsequential update uses a single file as both the old and new master. Sequential processing is best when the master file is active and has substantial activity; nonsequential processing is more efficient for inactive files with less activity.
- ❑ Data validation is an essential component of file maintenance. The transaction file is typically run through a stand-alone edit prior to the maintenance program to check for valid codes, complete records, and so on. The update program must still check for duplicate additions and/or no matches (that is, transactions entered as corrections or deletions for records that are not present in the master file).
- ❑ The balance line algorithm is a general approach to sequential file maintenance. The algorithm allows multiple transactions from one or more transaction files, to reference a single master record.
- ❑ Top-down testing was demonstrated through use of a stub program. Early testing ensures that modules are performed in proper sequence and facilitates the correction of any errors detected.

### **Key Words and Concepts**

|                        |                                     |
|------------------------|-------------------------------------|
| Active key             | New master file                     |
| Addition               | No match                            |
| Allocation status      | Nonsequential update                |
| Backup                 | Old master file                     |
| Balance line algorithm | Periodic file maintenance           |
| Correction             | Program stub                        |
| Data validation        | Record-key allocated switch         |
| Defensive programming  | Sequential update                   |
| Deletion               | Stand-alone edit program            |
| Duplicate addition     | Stub program                        |
| End-of-file condition  | Test data                           |
| Error message table    | Top-down testing and implementation |
| Grandfather-father-son | Transaction file                    |
| Hierarchy chart        |                                     |

### **COBOL Element**

HIGH-VALUES

## F I L L - I N

---

1. In a sequential update, \_\_\_\_\_ record in the old master (except those slated for deletion) is copied (rewritten) to the new master, regardless of whether it changes.
2. Incoming transactions to a sequential update have generally been validated in a \_\_\_\_\_ program.
3. The balance line algorithm (does/does not) require every record in the old master file to have a unique key.
4. The balance line algorithm (does/does not) require every record in the transaction file to have a unique key.
5. In general, the three transaction types that are input to a sequential update are \_\_\_\_\_ and \_\_\_\_\_.
6. The RECORD-KEY-ALLOCATED-SWITCH is used in checking for two types of errors: \_\_\_\_\_ additions, and/or \_\_\_\_\_.
7. An incomplete addition (can/can not) be detected in a stand-alone edit program.
8. An invalid transaction code (can/can not) be detected in a stand-alone edit program.
9. An incorrectly entered social security number on an otherwise valid transaction (can/can not) be detected in a stand-alone edit program.
10. Top-down testing requires that the \_\_\_\_\_ levels in a hierarchy chart be tested \_\_\_\_\_ and more often than the lower-level routines.
11. In order to implement top-down testing, a \_\_\_\_\_ program is developed, which contains several one-line paragraphs consisting of \_\_\_\_\_ statements.
12. The grandfather-father-son backup scheme implies that at least \_\_\_\_\_ generations of files are kept.
13. \_\_\_\_\_ is a figurative literal used to force the end-of-file condition.

## T R U E / F A L S E

---

1. The balance line algorithm requires a unique key for every record in the old master file.
2. Transactions to the balance line algorithm must be presented in the following order: additions, changes, deletions.
3. The balance line algorithm permits multiple transactions for the same master record and can be generalized to any number of transaction files.
4. A program must be completely coded before any testing can begin.
5. The high-level modules in a hierarchy chart should be tested first.
6. One can logically assume that input to a maintenance program will be valid.

7. One need not check for duplicate additions if the transaction file has been run through a stand-alone edit program.
8. A module in a hierarchy chart can be performed from more than one place.
9. Pseudocode and hierarchy charts depict the same thing.
10. A program stub may consist of a one-line DISPLAY paragraph.
11. Test data are best designed by the programmer writing the program.
12. Top-down testing can begin before a program is completely finished.
13. The balance line algorithm is restricted to a single transaction file.
14. A hierarchy chart contains decision-making logic.

## PROBLEMS

---

1. The transaction file in Figure 17.9b has both name and initials entered on correction transactions in addition to the social security number. Is this necessary according to the specifications and subsequent COBOL implementation (Figure 17.15)? Describe both an advantage and a disadvantage of entering the name and initials.
2. The specifications of the update program do not discuss how to change (i.e., correct) the social security number of an existing record. With respect to Figure 17.9a, for example, how could the social security number of Sugrue, who already exists in the old master file, be changed to 100000001? Discuss two different approaches, with an advantage and a disadvantage for each.
3. What problems, if any, do you see with each of the following? (Assume no data validation has been done.)
  - a. 

```
IF SEX = 'M'
 ADD 1 TO NUMBER-OF-MEN
ELSE
 ADD 1 TO NUMBER-OF-WOMEN
END-IF.
```
  - b. 

```
SEARCH LOCATION-TABLE
 WHEN INCOMING-LOCATION-CODE = LOCATION (LOC-INDEX)
 MOVE EXPANDED-LOCATION (LOC-INDEX) TO PRINT-LOCATION
END-SEARCH.
```





# Indexed Files

## CHAPTER OUTLINE

---

### Overview

#### **System Concepts**

#### **COBOL Implementation**

#### **Creating an Indexed File**

- Programming Specifications

- Pseudocode

- The Completed Program

#### **Additional COBOL Elements**

- OPEN

- READ

- WRITE

- REWRITE

- DELETE

#### **Maintaining an Indexed File**

- Programming Specifications

- Hierarchy Chart

- Pseudocode

- The Completed Program

#### **Alternate Record Key**

- Programming Specifications

#### **Concatenated Key**

- The START Statement

Limitations of COBOL-74

Summary

Fill-in

True/False

Problems

## OBJECTIVES

---

After reading this chapter you will be able to:

- Describe how an index file enables both sequential and/or nonsequential retrieval of individual records.
- Define the specific terms associated with IBM's VSAM implementation of indexed files.
- Discuss the clauses in the SELECT statement for an indexed file; indicate which clauses are optional and which are required.
- Define file status bytes; state how they may be used to verify the success of an I/O operation.
- Differentiate between the READ statements for sequential and nonsequential access of an indexed file.
- Differentiate between the WRITE, REWRITE, and DELETE statements as they apply to file maintenance of an indexed file.
- Describe the syntax of the START statement and give a reason for its use.
- Distinguish between the primary and alternate keys of an indexed file, and the requirements for each.

## OVERVIEW

---

This chapter covers all major aspects of indexed files, a type of file organization that permits both sequential and nonsequential access to individual records. It begins with a general discussion of how indexed files work, with particular reference to IBM's VSAM implementation. Different vendors use different terminology, but the underlying concepts are the same, namely, a series of indexes that access individual records on a sequential or random basis. More importantly, the COBOL syntax is identical for all vendors who adhere to the ANS 85 standard.

The chapter includes three programs that illustrate all of the COBOL elements associated with this type of file organization. The first shows how to create an indexed file, the second continues with the file maintenance example of the previous chapter, and the last illustrates how individual records may be accessed by multiple keys—for example, name and social security number.

---

### System Concepts

Although different vendors have different physical implementations of indexed files, and consequently different terminology, the principles are the same; namely, a series of *indexes* that allow individual records to be accessed either sequentially or

nonsequentially. This section provides an intuitive discussion of how an indexed file actually works.

In reality, the physical implementation of an indexed file is of little or no concern to the programmer. The operating system establishes and maintains the indexes, and the programmer is concerned primarily with accessing the file through the appropriate COBOL elements. Nevertheless, a conceptual understanding is of benefit in developing a more competent and better-rounded individual. Accordingly, we consider IBM's VSAM implementation.

A VSAM file or data set is divided into *control areas* and *control intervals*. A control interval is a continuous area of auxiliary storage. A control area contains one or more control intervals. A control interval is independent of the physical device on which it resides; that is, a control interval that takes exactly one track of a given direct access device might require more or less than one track if the file were moved to another type of device).

A VSAM file is defined with an index so that individual records may be located on a random basis, with entries in the index known as index records. The lowest-level index is called the *sequence set*. Records in all higher levels are collectively called the *index set*.

An entry in a sequence set contains the highest key in a control interval and a vertical pointer to that interval. An entry in an index set contains the highest key in the index record at the next lower level and a vertical pointer to the sequence set. These concepts are made clearer by examination of Figure 18.1.

Figure 18.1 shows 28 records hypothetically distributed in a VSAM data set. The entire file consists of three control areas; each area in turn contains three control intervals. The shaded areas shown at the end of each control interval contain information required by VSAM. The index set has only one level of indexing. There are three entries in the index set, one for each control area. Each entry in the index

Figure 18.1 Initial VSAM Data Set

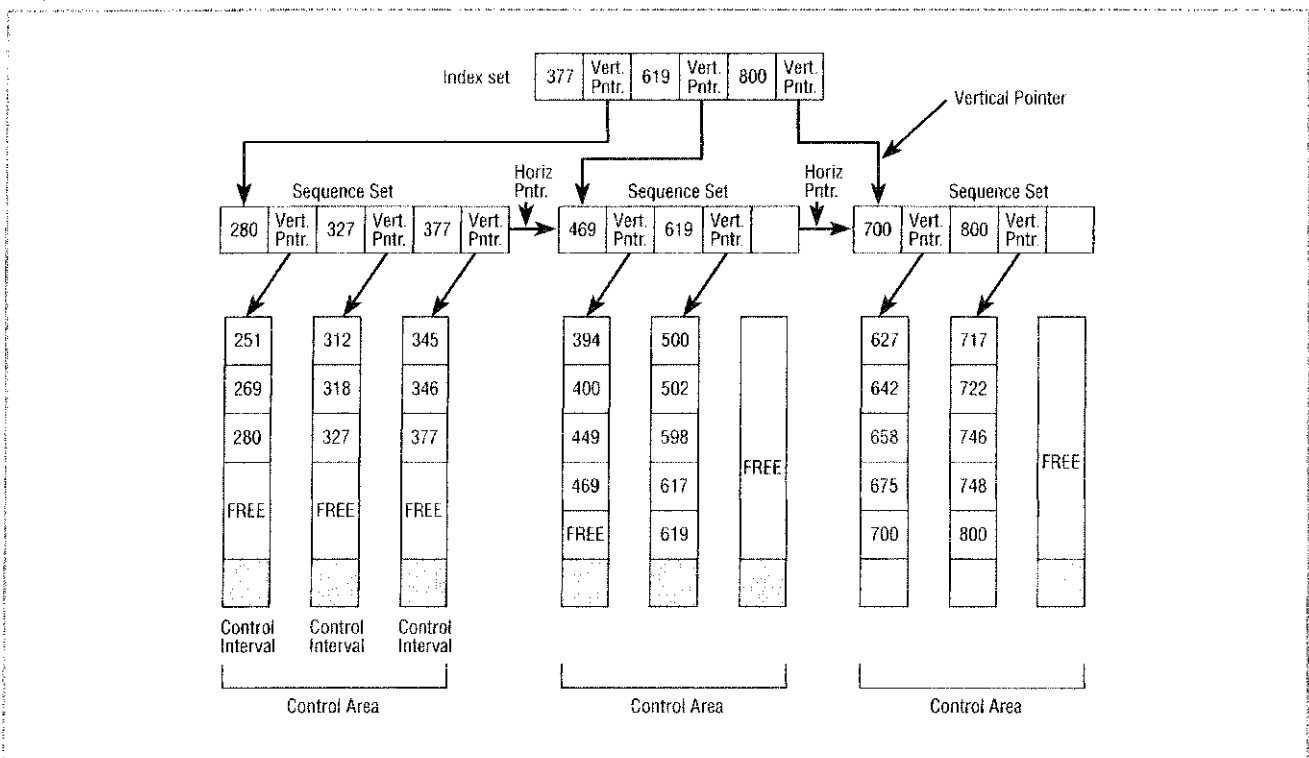

set contains the highest key in the corresponding control area; thus 377, 619, and 800 are the highest keys in the first, second, and third control areas, respectively. Each control area has its own sequence set. The entries in the first sequence set show the highest keys of the control intervals in the first control area to be 280, 327, and 377, respectively. Note that the highest entry in the third control interval, 377, corresponds to the highest entry in the first control area of the index set.

Figure 18.1 illustrates two kinds of pointers, vertical and horizontal. Vertical pointers are used for direct access to an individual record. For example, assume that the record with a key of 449 is to be retrieved. VSAM begins at the highest level of index (that is, at the index set). It concludes that record key 449, if it is present, is in the second control area (377 is the highest key in the first area, whereas 619 is the highest key in the second control area). VSAM follows the vertical pointer to the sequence set for the second control area and draws its final conclusion: record key 449, if it exists, will be in the first control interval of the second control area.

Horizontal pointers are used for sequential access only. In this instance, VSAM begins at the first sequence set and uses the horizontal pointer to get from that sequence set record to the one containing the next highest key. Put another way, the vertical pointer in a sequence set points to data; the horizontal pointer indicates the sequence set containing the next highest record.

Figure 18.1 contains several allocations of *free space*, which are distributed in one of two ways: as free space within a control interval or as a free control interval within a control area. In other words, as VSAM loads a file, empty space is deliberately left throughout the file. This is done to facilitate subsequent insertion of new records.

Figure 18.2 shows the changes brought about by the addition of two new records, with keys of 410 and 730, to the file of Figure 18.1. Addition of the first record, key 410, poses no problem, as free space is available in the control interval

Figure 18.2 Control Interval Split

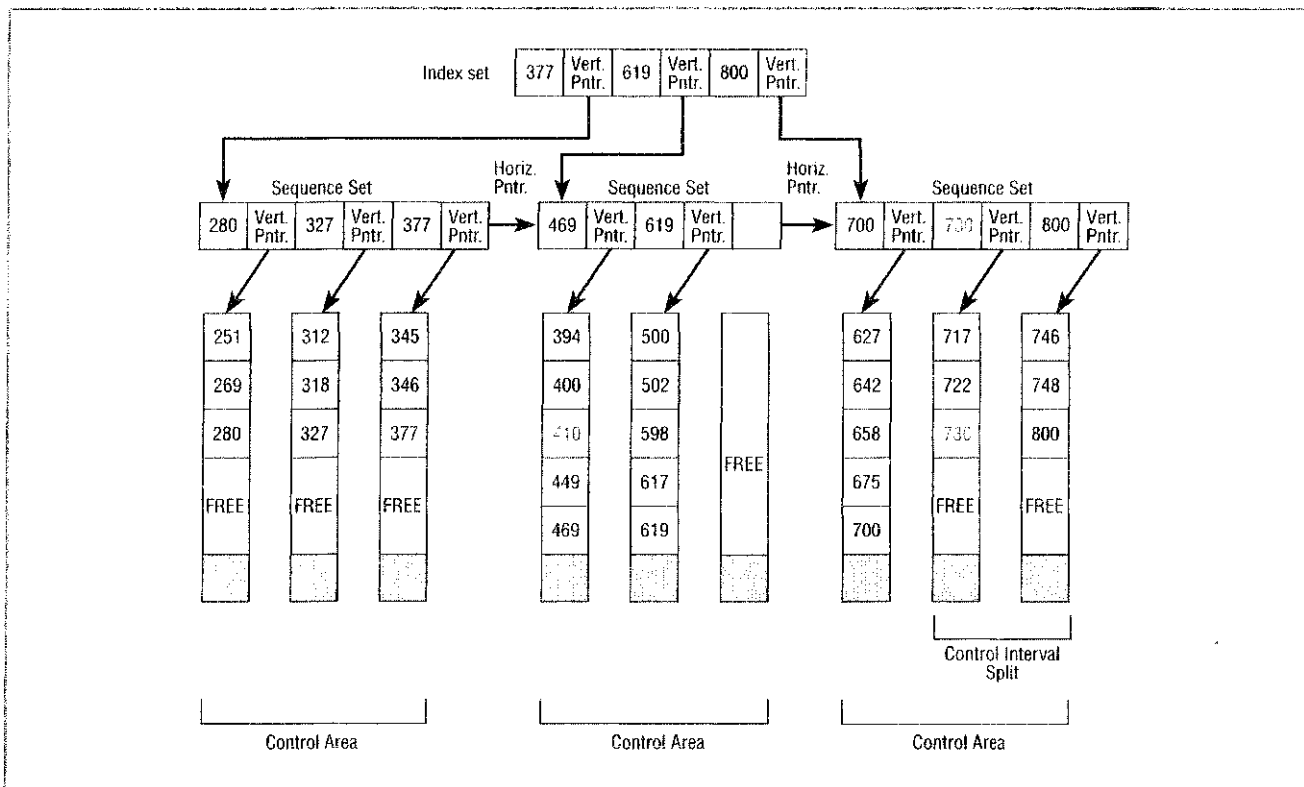

where the record belongs. Record 410 is inserted into its proper place and the other records in that control interval are moved down.

The addition of record key 730 requires different action. The control interval that should contain this record is full in Figure 18.1. Consequently VSAM causes a *control interval split*, in which some of the records in the previously filled control interval are moved to an empty control interval in the same control area. Entries in the sequence set for the third control area will change, as shown in Figure 18.2. This makes considerable sense when we realize that each record in a sequence set contains the key of the highest record in the corresponding control interval. Thus the records in the sequence set must reflect the control interval split. Note that after a control interval split, subsequent additions are facilitated, as free space is again readily available.

Figure 18.3 shows the results of including three additional records, with keys of 316, 618, and 680. Record 316 is inserted into free space in the second control interval of the first control area, with the other records initially in this interval shifted down. Record 618 causes a control interval split in the second control area.

Record 680 also requires a control interval split except that there are no longer any free control intervals in the third control area. Accordingly, a *control area split* is initiated, in which some of the records in the old control area are moved into a new control area at the end of the data set. Both the old and the new control areas will have free control intervals as a result of the split. In addition, the index set has a fourth entry, indicating the presence of a new control area. The sequence set is also expanded to accommodate the fourth control area.

Figure 18.3 Control Area Split

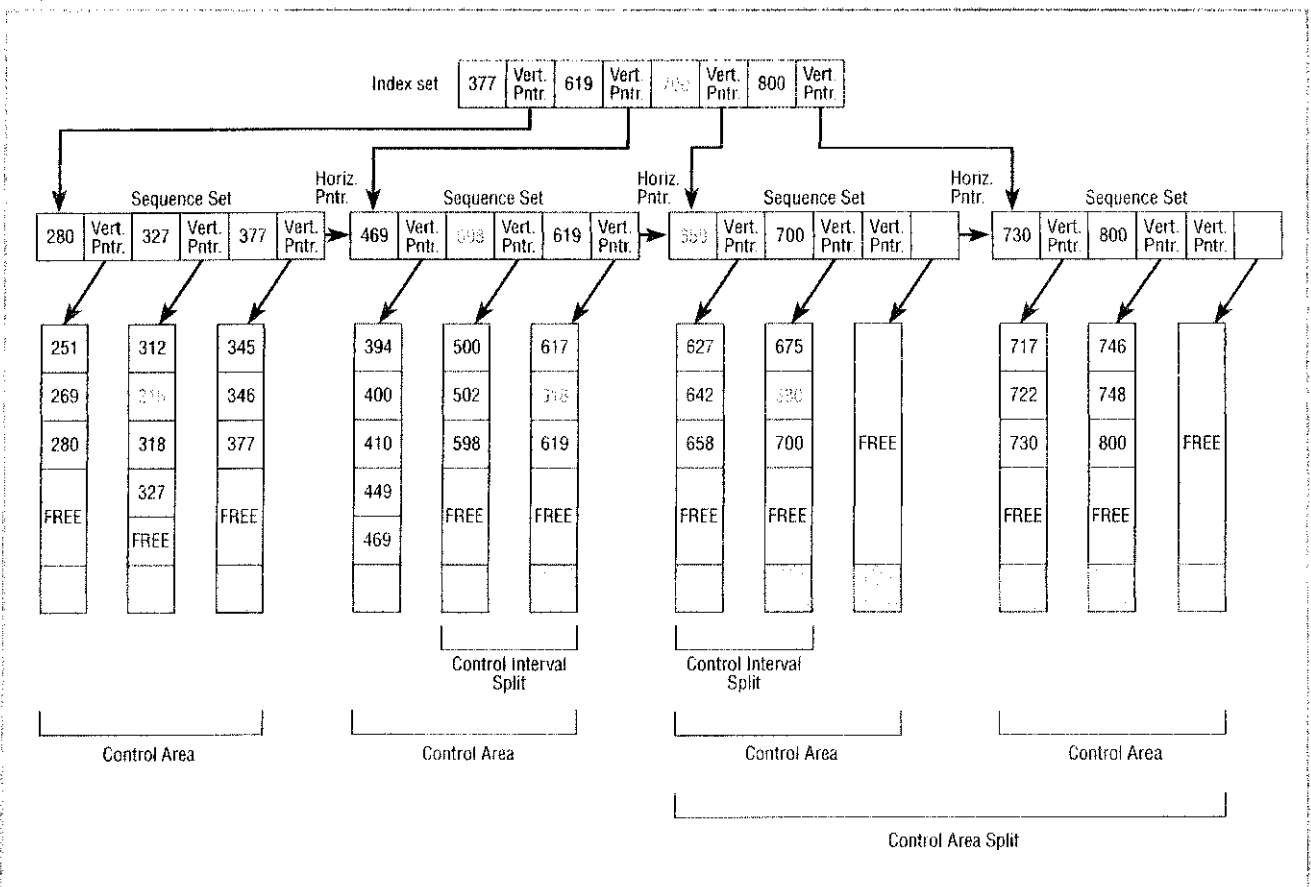

## COBOL Implementation

The COBOL implementation of an indexed file centers on the `SELECT` statement in the Environment Division. Consider:

```

SELECT file-name

 ASSIGN TO {implementor-name-1} . . .
 {literal-1}

 [RESERVE integer-1 [AREA
 AREAS]]

 [ORGANIZATION IS] INDEXED

 [ACCESS MODE IS [SEQUENTIAL]
 [RANDOM]
 [DYNAMIC]]

 RECORD KEY IS data-name-1

 [ALTERNATE RECORD KEY IS data-name-2 [WITH DUPLICATES]] . . .

 [FILE STATUS IS data-name-3]

```

Three clauses are required: `ASSIGN`, `ORGANIZATION IS INDEXED`, and `RECORD KEY`. The function of the `ASSIGN` clause is the same as with a sequential file—to tie a programmer-chosen file name to a system name. The `ORGANIZATION IS INDEXED` clause indicates an indexed file and needs no further explanation.

The `RECORD KEY` clause references a field defined in the `FD` for the indexed record whose value must be unique for each record in the file. The value of the record key is used by the operating system to establish the necessary indexes for the file, which in turn enables the random retrieval of individual records.

The remaining entries—`RESERVE integer AREAS`, `ACCESS MODE`, `ALTERNATE RECORD KEY`, and `FILE STATUS`—are optional. The `RESERVE integer AREAS` clause functions identically as with a sequential file, to increase processing efficiency by allocating alternate I/O areas (or buffers) for the file. If the clause is omitted, the number of alternate areas defaults to the vendor's implementation, which is adequate in most instances. Specification of `RESERVE ZERO AREAS` will slow processing but will save an amount of storage equal to the buffer size. This is generally done only on smaller systems when the amount of main memory is limited.

The meaning of `ACCESS MODE` is apparent when either sequential or random (nonsequential) access is specified. `ACCESS IS DYNAMIC` allows a file to be read both sequentially and nonsequentially in the same program and is illustrated in Figure 18.12 later in the chapter.

`ALTERNATE RECORD KEY` provides a second path for random access. Unlike the record key, which must be unique for every record, the alternate key may contain duplicate values. This capability is extremely powerful and gives COBOL some limited facility for data base management. You could, for example, specify an account number as the record key and a person's name as the alternate key. Realize, however, that while the alternate key is powerful, it is expensive in terms of overhead, in that a second set of indexes must be maintained by the operating system and thus, the feature should not be used indiscriminately. The `ALTERNATE RECORD KEY` clause is illustrated in Figure 18.12 at the end of the chapter.

The **FILE STATUS** clause is available for any type of file organization and allows the programmer to distinguish between the many different types of I/O error conditions. The concept was first introduced in Chapter 6 in connection with debugging (see page 158). The operating system automatically returns a two-position field known as the *I/O status* (or file status bytes) to the data name designated in the **FILE STATUS** clause. The value of the file status bytes may be interrogated by the programmer, who is thus able to more closely monitor the results of any I/O operation.

Table 18.1 lists the various file status codes and their meaning. The use of file status codes is illustrated in the ensuing program to create an indexed file.

**Table 18.1** File Status Codes

|           |                                                                                                                                                                                                                                                                                                                                                                           |
|-----------|---------------------------------------------------------------------------------------------------------------------------------------------------------------------------------------------------------------------------------------------------------------------------------------------------------------------------------------------------------------------------|
| <b>00</b> | A successful input/output operation is performed with no further information available.                                                                                                                                                                                                                                                                                   |
| <b>02</b> | A successful creation of a record with duplicate alternate key value.                                                                                                                                                                                                                                                                                                     |
| <b>04</b> | A READ is successful, but the length of the record being processed does not conform to the fixed file attributes for that file.                                                                                                                                                                                                                                           |
| <b>05</b> | An OPEN is successful, but the referenced optional file is not present at open time.                                                                                                                                                                                                                                                                                      |
| <b>07</b> | An input/output statement is successful; however, for a CLOSE with NO REWIND, REFL/UNIT, or FOR REMOVAL or for an OPEN with NO REWIND the referenced file is on a nonreel/unit medium.                                                                                                                                                                                    |
| <b>10</b> | A sequential READ is attempted and no next logical record exists because (1) the end of file has been reached, or (2) an optional input file is not present.                                                                                                                                                                                                              |
| <b>14</b> | A sequential READ is attempted and the number of significant digits in the record number is larger than the size of the key data item described for the file.                                                                                                                                                                                                             |
| <b>15</b> | A sequential READ statement is attempted for the first time on an optional file that is not present.                                                                                                                                                                                                                                                                      |
| <b>21</b> | A sequence error exists for a sequentially accessed indexed file.                                                                                                                                                                                                                                                                                                         |
| <b>22</b> | An attempt is made to write or rewrite a record that would create a duplicate prime record key or duplicate alternate record key without the DUPLICATES phrase.                                                                                                                                                                                                           |
| <b>23</b> | An attempt is made to randomly access a record that does not exist in the file, or a START or random READ is attempted on an optional input file that is not present.                                                                                                                                                                                                     |
| <b>24</b> | An attempt is made to write beyond the externally defined boundaries.                                                                                                                                                                                                                                                                                                     |
| <b>25</b> | A START statement or a random READ statement has been attempted on an optional file that is not present.                                                                                                                                                                                                                                                                  |
| <b>30</b> | A permanent error exists and no further information is available concerning the input/output operation.                                                                                                                                                                                                                                                                   |
| <b>34</b> | A permanent error exists because of a boundary violation; an attempt is made to write beyond the externally defined boundaries.                                                                                                                                                                                                                                           |
| <b>35</b> | A permanent error exists because an OPEN with the INPUT, I/O, or EXTEND phrase is attempted on a nonoptional file that is not present.                                                                                                                                                                                                                                    |
| <b>37</b> | A permanent error exists because an OPEN is attempted on a file and that file will not support the open mode specified: (1) EXTEND or OUTPUT phrase specified but not supported by the file; (2) I/O phrase is specified, but input and output operations are not supported by the file; or (3) INPUT phrase is specified, but the file will not support READ operations. |
| <b>38</b> | A permanent error exists because an OPEN is attempted on a file previously closed with a lock.                                                                                                                                                                                                                                                                            |
| <b>39</b> | The OPEN is unsuccessful because a conflict has been detected between the fixed file attributes and the ones specified for that file in the program.                                                                                                                                                                                                                      |
| <b>41</b> | An OPEN statement is attempted for a file in the open mode.                                                                                                                                                                                                                                                                                                               |
| <b>42</b> | A CLOSE statement is attempted for a file not in the open mode.                                                                                                                                                                                                                                                                                                           |
| <b>43</b> | In the sequential access mode, the last input/output statement executed for the file prior to the execution of a DELETE or REWRITE statement was not a successfully executed READ statement.                                                                                                                                                                              |
| <b>44</b> | A boundary violation exists because of an attempt to: (1) write or rewrite a record that is larger than the largest or smaller than the smallest record allowed by the RECORD IS VARYING clause of the associated file-name, or (2) rewrite a record and the record is not the same size as the record being replaced.                                                    |
| <b>46</b> | A sequential READ is attempted on a file open in the input or I/O mode and no valid next record has been established because the preceding: (1) START was unsuccessful, (2) READ was unsuccessful but did not cause an at-end condition, or (3) READ caused an at-end condition.                                                                                          |
| <b>47</b> | The execution of a READ or START is attempted on a file not open in the input or I/O mode.                                                                                                                                                                                                                                                                                |
| <b>48</b> | The execution of a WRITE is attempted on a file not open in the I/O, output, or extend mode.                                                                                                                                                                                                                                                                              |
| <b>49</b> | The execution of a DELETE or REWRITE statement is attempted on a file not open in the I/O mode.                                                                                                                                                                                                                                                                           |



## Creating an Indexed File

Our first program creates an indexed file from sequential data, and in so doing, illustrates both the SELECT statement in the Environment Division and the use of the FILE STATUS bytes in the Procedure Division. It is important to realize that unlike sequential files, which can be created (or displayed) with an ordinary text editor or word processor, indexed files require a special procedure to create the associated indexes, and hence the need for this program. The COBOL program is not difficult and serves as a good introduction to indexed files. Specifications follow in the usual format.

### PROGRAMMING SPECIFICATIONS

**Program Name:** Creating an Indexed File

**Narrative:** This program copies the data from an incoming sequential file to an output indexed file. The logic is trivial in nature as the program is intended primarily to illustrate the SELECT statement for indexed files and the use of FILE STATUS bytes.

**Input File(s):** SEQUENTIAL-FILE

**Input Record Layout:**

|    |                    |            |
|----|--------------------|------------|
| 01 | SEQUENTIAL-RECORD. |            |
| 05 | SEQ-SOC-SEC-NUMBER | PIC X(9).  |
| 05 | SEQ-REST-OF-RECORD | PIC X(30). |

**Output File:** INDEXED-FILE

**Output Record Layout:**

|    |                    |            |
|----|--------------------|------------|
| 01 | INDEXED-RECORD.    |            |
| 05 | IND-SOC-SEC-NUMBER | PIC X(9).  |
| 05 | IND-REST-OF-RECORD | PIC X(30). |

**Test Data:**

|                  |   |                |
|------------------|---|----------------|
| 10000000GRABER   | P | ATL150000000   |
| 20000000RUBIN    | M | BOS080002000   |
| 30000000ANDERSON | I | BOS1000113000  |
| 22222222PANZER   | S | NYC060000000   |
| 40000000MOLDOF   | B | LATL150000000  |
| 50000000GLASSMAN | J | SNYC1000045000 |
| 60000000GRAUER   | R | NYC0800087500  |
| 70000000MILGROM  | A | SF 0900120000  |
| 80000000VAZQUEZ  | C | ATL1200060000  |
| 90000000CLARK    | E | NYC0700002500  |

- Processing Requirements:**
1. Copy the records in an incoming sequential file to an equivalent indexed file. The record layouts in both files are the same, with the first nine positions serving as the record key.
  2. Display the FILE STATUS bytes after every I/O operation associated with the indexed file (OPEN, CLOSE, and WRITE).
  3. Verify that the newly created indexed file has its records in sequence, and further, that every record contains a unique value for the record key. Note, for example, that the record for Panzer in the test data is out of sequence and should be flagged accordingly.

### Pseudocode

The logic for this program is simple indeed as indicated in the programming specifications. In essence all we do is read a record from the sequential file, write it to the indexed file, and repeat the loop until the sequential file is out of data. We do not have to concern ourselves with building the indexes per se, as this is done automatically through the appropriate COBOL statements. The logic for the program is depicted in the pseudocode of Figure 18.4.

Figure 18.4 Pseudocode for Creating Indexed File

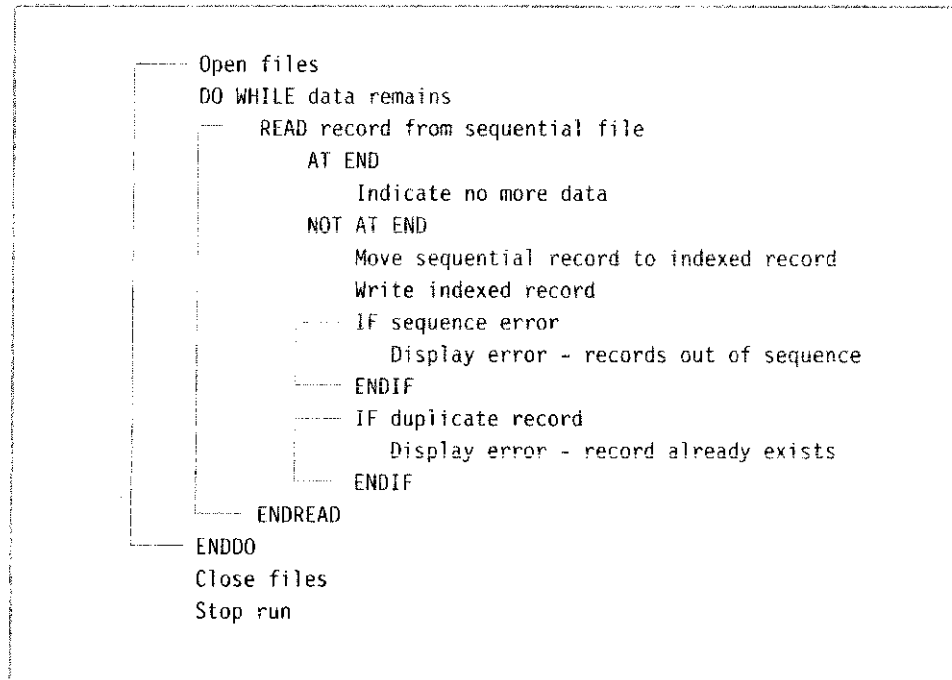

### The Completed Program

Figure 18.5 displays the completed program and contains little that is new in the way of COBOL other than the SELECT statement of lines 10 through 15. As indicated in the previous discussion, the ASSIGN, ORGANIZATION IS INDEXED, and RECORD KEY clauses are required, while the ACCESS IS SEQUENTIAL and FILE STATUS clauses are optional (and included here for purposes of illustration).

The RECORD KEY clause designates a field within the indexed record (IND-SOC-SEC-NUM) that will be used by the operating system to build the necessary indexes. Observe, therefore, that IND-SOC-SEC-NUM is referenced in two places, in the RECORD KEY clause of line 14 and in the FD for the indexed file in line 30.

The optional FILE STATUS clause of line 15 designates a two-position data name, INDEXED-STATUS-BYTES, which in turn is defined in Working-Storage (line 35). The operating system automatically updates the file status bytes after every I/O operation, making the result available to the program via the data name INDEXED-STATUS-BYTES. This, in turn, makes it possible to closely monitor the success (or failure) of various statements within the program.

To illustrate the utility of the file status bytes, return to the test data in the programming specifications, *noting that the record for Panzer is out of sequence*. The logic in the Procedure Division reads a record from the sequential file and

Figure 18.5 Program to Create an Indexed File

```

1 IDENTIFICATION DIVISION.
2 PROGRAM-ID. CREATE.
3 AUTHOR. ROBERT GRAUER.
4
5 ENVIRONMENT DIVISION.
6 INPUT-OUTPUT SECTION.
7 FILE-CONTROL.
8 SELECT SEQUENTIAL-FILE ASSIGN TO 'A:\CHAPTR18\SEQUENCE.DAT'
9 ORGANIZATION IS LINE SEQUENTIAL.
10 SELECT INDEXED-FILE
11 ASSIGN TO 'A:\CHAPTR18\INDMAST.DAT'
12 ORGANIZATION IS INDEXED
13 ACCESS IS SEQUENTIAL
14 RECORD KEY IS IND-SOC-SEC-NUM
15 FILE STATUS IS INDEXED-STATUS-BYTES.
16
17 DATA DIVISION.
18 FILE SECTION.
19 FD SEQUENTIAL-FILE
20 RECORD CONTAINS 39 CHARACTERS
21 DATA RECORD IS SEQUENTIAL-RECORD.
22 01 SEQUENTIAL-RECORD.
23 05 SEQ-SOC-SEC-NUM PIC X(9).
24 05 SEQ-REST-OF-RECORD PIC X(30).
25
26 FD INDEXED-FILE
27 RECORD CONTAINS 39 CHARACTERS
28 DATA RECORD IS INDEXED-RECORD.
29 01 INDEXED-RECORD.
30 05 IND-SOC-SEC-NUM PIC X(9).
31 05 IND-REST-OF-RECORD PIC X(30).
32
33 WORKING-STORAGE SECTION.
34 01 END-OF-FILE-SWITCH PIC X(3) VALUE 'NO'.
35 01 INDEXED-STATUS-BYTES PIC XX.
36
37 PROCEDURE DIVISION.
38 0010-UPDATE-MASTER-FILE.
39 OPEN INPUT SEQUENTIAL-FILE
40 OUTPUT INDEXED-FILE.
41 DISPLAY 'OPEN STATEMENT EXECUTED'.
42 DISPLAY ' FILE STATUS BYTES = ', INDEXED-STATUS-BYTES.
43 DISPLAY ' '.
44 PERFORM UNTIL END-OF-FILE-SWITCH = 'YES'
45 READ SEQUENTIAL-FILE
46 AT END
47 MOVE 'YES' TO END-OF-FILE-SWITCH
48 NOT AT END
49 MOVE SEQ-SOC-SEC-NUM TO IND-SOC-SEC-NUM
50 MOVE SEQ-REST-OF-RECORD TO IND-REST-OF-RECORD
51 WRITE INDEXED-RECORD
52 INVALID KEY PERFORM 0020-EXPLAIN-WRITE-ERROR
53 END-WRITE
54 DISPLAY 'WRITE STATEMENT EXECUTED FOR '
55 SEQUENTIAL-RECORD

```

*SELECT statement includes ORGANIZATION, ACCESS, RECORD KEY and FILE STATUS clauses*

*RECORD KEY is defined within INDEXED-RECORD*

*File status bytes defined in Working-Storage*

*In-line perform and false-condition branch drive program*

Figure 18.5 Program to Create an Indexed File

```

56 DISPLAY ' FILE STATUS BYTES = '
57 INDEXED-STATUS-BYTES
58 DISPLAY ' '
59 END-READ
60 END-PERFORM.
61 CLOSE SEQUENTIAL-FILE
62 INDEXED-FILE.
63 DISPLAY 'CLOSE STATEMENT EXECUTED'.
64 DISPLAY ' FILE STATUS BYTES = ', INDEXED-STATUS-BYTES.
65 DISPLAY ' '.
66 STOP RUN.
67
68 0020-EXPLAIN-WRITE-ERROR.
69 IF INDEXED-STATUS-BYTES = '21'
70 DISPLAY 'ERROR (SEQUENCE) FOR ' SEQUENTIAL-RECORD
71 END-IF.
72 IF INDEXED-STATUS-BYTES = '22'
73 DISPLAY 'ERROR (DUPLICATE KEY) FOR ' SEQUENTIAL-RECORD
74 END-IF.

```

This error message is only displayed if an error is detected.

copies it to the indexed file, repeating the loop until the sequential file is empty. A problem will result, however, because the indexed file requires its records to be in sequence, which is not true in this example. Accordingly it is good technique to include an **INVALID KEY** clause in the **WRITE** statement of lines 51 through 53, which is executed if, and only if, an error is detected. The paragraph performed as a consequence of the error, **0020-EXPLAIN-WRITE-ERROR** (lines 68–74), interrogates the file status bytes to reveal the exact cause of the problem.

Output of the program is shown in Figure 18.6 and consists entirely of display output produced at various points in the program. The first and last lines show the results of the **OPEN** and **CLOSE** statements, respectively; both operations executed successfully as evidenced by file status bytes of 00. Note, too, how file status bytes of 00 are displayed for every *successful* write operation, but that a value of 21, corresponding to an out-of-sequence record, is displayed for Panzer.

## Additional COBOL Elements

Several statements in the Procedure Division are uniquely associated with indexed files or have extended formats for indexed files. These include **OPEN**, **READ**, **WRITE**, **REWRITE**, and **DELETE**. We will discuss each of these statements in isolation, then include them in the illustrative programs that follow.

### OPEN

The **I-O** clause of the **OPEN** statement, **OPEN I-O**, is required when updating indexed files. Consider:

$$\text{OPEN } \left. \begin{array}{l} \boxed{\text{INPUT}} \\ \boxed{\text{OUTPUT}} \\ \boxed{\text{I-O}} \end{array} \right\} \text{file-name}$$

Figure 18.6 Display Output of Create Program

```

OPEN STATEMENT EXECUTED
FILE STATUS BYTES = 00

WRITE STATEMENT EXECUTED FOR 100000000GRABER P ATL150000000
FILE STATUS BYTES = 00

WRITE STATEMENT EXECUTED FOR 200000000RUBIN MABOS0800020000
FILE STATUS BYTES = 00

WRITE STATEMENT EXECUTED FOR 300000000ANDERSON IRBOS1000113000
FILE STATUS BYTES = 00

ERROR (SEQUENCE) FOR 22222222PANZER S NYC0600000000
WRITE STATEMENT EXECUTED FOR 22222222PANZER S NYC0600000000
FILE STATUS BYTES = 21

WRITE STATEMENT EXECUTED FOR 400000000MOLDOF BLATL1500000000
FILE STATUS BYTES = 00

WRITE STATEMENT EXECUTED FOR 500000000GLASSMAN JSNYC1000045000
FILE STATUS BYTES = 00

WRITE STATEMENT EXECUTED FOR 600000000GRAUER RTNYC0800087500
FILE STATUS BYTES = 00

WRITE STATEMENT EXECUTED FOR 700000000MILGROM A SF 0900120000
FILE STATUS BYTES = 00

WRITE STATEMENT EXECUTED FOR 800000000VAZQUEZ C ATL1200060000
FILE STATUS BYTES = 00

WRITE STATEMENT EXECUTED FOR 900000000CLARK E NYC0700002500
FILE STATUS BYTES = 00

CLOSE STATEMENT EXECUTED
FILE STATUS BYTES = 00

```

INPUT and OUTPUT are used when an indexed file is accessed or created. In nonsequential maintenance, however, the *same* indexed file functions as both the old and new master files, and hence is both an input and an output file. The file is opened as an I-O file—for example, OPEN I-O INDEXED-FILE—to enable it to serve both functions in the same program; that is, you may read records from the file (input), as well as write records to the file (output).

**READ**

The READ statement has two distinct formats, for sequential and nonsequential access, respectively. These are:

**Format 1 (Sequential Access)**

```

READ file-name [NEXT] RECORD [INTO identifier-1]
 [AT END imperative-statement-1]
 [NOT AT END imperative-statement-2]
[END-READ]

```

**Format 2 (Nonsequential Access)**

```

READ file-name RECORD [INTO identifier-1]
 [KEY IS data-name-1]
 [INVALID KEY imperative-statement-1]
 [NOT INVALID KEY imperative-statement-2]
[END-READ]

```

The first format, for sequential access, has been used throughout the text and should present no difficulty. (The NEXT phrase is discussed in conjunction with the ACCESS IS DYNAMIC clause of the SELECT statement, and is illustrated in Figure 18.12 toward the end of the chapter.)

The second format, for nonsequential access, *must be preceded by a MOVE statement, in which the key of the desired record is moved to the data name designated as the RECORD KEY in the SELECT statement.* Consider:

```

SELECT INDEXED-FILE
 ASSIGN TO 'A:\CHAPTR18\INDMAST.DAT'
 ORGANIZATION IS INDEXED
 ACCESS IS RANDOM
 RECORD KEY IS IND-SOC-SEC-NUM.
.
.
MOVE 888888888 TO IND-SOC-SEC-NUM.
READ INDEXED-FILE INTO WS-INPUT-AREA
 INVALID KEY
 DISPLAY 'Record 888888888 is not in the indexed file'
 NOT INVALID KEY
.
.
END-READ.

```

*The value of the record key field is moved to the data name designated as the record key.*

*888888888 is the value of the record key field.*

The READ statement accesses the indexed file nonsequentially in an attempt to retrieve the record whose key is 888888888. If the record is in the file, it will be read and made available in WS-INPUT-AREA (as well as in the record area within the FD for INDEXED-FILE). If, however, the record does not exist, the INVALID KEY condition is raised and the indicated error message is displayed.

The KEY IS clause is necessary if multiple keys are specified in the SELECT statement (that is, if ALTERNATE RECORD KEY is included). Consider:

```

SELECT INDEXED-FILE
 ASSIGN TO 'A:\CHAPTR18\INDMAST.DAT'
 ORGANIZATION IS INDEXED
 RECORD KEY IS IND-SOC-SEC-NUM
 ACCESS IS RANDOM
 ALTERNATE RECORD KEY IS IND-NAME WITH DUPLICATES.
.
.
MOVE 'Smith' TO IND-NAME.
READ INDEXED-FILE INTO WS-WORK-AREA
 KEY IS IND-NAME

```

*The value of the record key field is moved to the specified key.*

```

INVALID KEY
 DISPLAY 'Smith is not in the file'
NOT INVALID KEY

```

```

END-READ.

```

As in the case of a single key, the READ statement is preceded by a MOVE statement in which the desired value is moved to the appropriate key field. The file is then searched nonsequentially for the value specified (Smith in the example). The INVALID KEY condition is activated if the record cannot be found.

## WRITE

The WRITE statement also has an optional INVALID KEY clause, as you already know from the COBOL program to create an indexed file (Figure 18.5). Consider:

```

WRITE record-name [FROM identifier-1]
 [INVALID KEY imperative statement-1]
 [NOT INVALID KEY imperative-statement-2]
[END-WRITE]

```

Specification of ACCESS IS SEQUENTIAL (in the SELECT statement) to create the indexed file requires that incoming records be in sequential order, and further, each record is required to have a unique key. The INVALID KEY condition is raised if either of these requirements is violated.

## REWRITE

The REWRITE statement replaces existing records when a file has been opened as an I/O file, as in the case of nonsequential maintenance. Its syntax is similar to that of the WRITE statement:

```

REWRITE record-name [FROM identifier-1]
 [INVALID KEY imperative statement-1]
 [NOT INVALID KEY imperative-statement-2]
[END-REWRITE]

```

The INVALID KEY condition is raised if the record key of the last record read does not match the key of the record to be replaced.

## DELETE

The DELETE statement removes a record from an indexed file. Consider:

```

DELETE file-name RECORD
 [INVALID KEY imperative statement-1]
 [NOT INVALID KEY imperative-statement-2]
[END-DELETE]

```

The DELETE statement is appropriate only for files opened in the I/O mode.

## Maintaining an Indexed File

The distinction between *sequential* and *nonsequential* file maintenance was presented in the previous chapter, but is repeated here for emphasis. A sequential update uses two distinct master files, an old and a new master, with every record in the old master rewritten to the new master regardless of whether it changes. A nonsequential update uses a single master file that functions as both the old and new master, and only the records that change are rewritten. A sequential update is driven by the relationship between the old master and transaction files, whereas a nonsequential update is driven solely by the transaction file; that is, transactions are processed until the transaction file is empty. Finally, a sequential update requires the transaction file to be in sequence, whereas the transactions for a nonsequential update can be in any order.

The sequential update was developed in Chapter 17 through implementation of the balance line algorithm. We continue now with a parallel problem for nonsequential processing.

### PROGRAMMING SPECIFICATIONS

**Program Name:** Nonsequential Update

**Narrative:** This program parallels the update program of Chapter 17 except that the master file is accessed nonsequentially, and thus the transaction file need not be in sequence. In addition, the balance line algorithm does not apply.

**Input File:** TRANSACTION-FILE

**Input Record Layout:**

|    |                     |            |
|----|---------------------|------------|
| 01 | TRANSACTION-RECORD. |            |
| 05 | TR-SOC-SEC-NUMBER   | PIC X(9).  |
| 05 | TR-NAME.            |            |
| 10 | TR-LAST-NAME        | PIC X(15). |
| 10 | TR-INITIALS         | PIC XX.    |
| 05 | TR-LOCATION-CODE    | PIC X(3).  |
| 05 | TR-COMMISSION-RATE  | PIC 99.    |
| 05 | TR-SALES-AMOUNT     | PIC 9(5).  |
| 05 | TR-TRANSACTION-CODE | PIC X.     |
| 88 | ADDITION            | VALUE 'A'. |
| 88 | CORRECTION          | VALUE 'C'. |
| 88 | DELETION            | VALUE 'D'. |

**Input/Output File:** INDEXED-FILE

**Input Record Layout:**

|    |                        |            |
|----|------------------------|------------|
| 01 | IND-MASTER-RECORD.     |            |
| 05 | IND-SOC-SEC-NUMBER     | PIC X(9).  |
| 05 | IND-NAME.              |            |
| 10 | IND-LAST-NAME          | PIC X(15). |
| 10 | IND-INITIALS           | PIC XX.    |
| 05 | IND-LOCATION-CODE      | PIC X(3).  |
| 05 | IND-COMMISSION-RATE    | PIC 99.    |
| 05 | IND-YEAR-TO-DATE-SALES | PIC 9(8).  |

**Test Data:** See Figure 18.7a and 18.7b.



Figure 18.7 Test Data for Nonsequential Update

|                  |                |
|------------------|----------------|
| 10000000GRABER   | P ATL150000000 |
| 20000000RUBIN    | MABOS080002000 |
| 30000000ANDERSON | IRBOS100011300 |
| 40000000MOLDOF   | BLATL150000000 |
| 50000000GLASSMAN | JSNYC100004500 |
| 60000000GRAUER   | RTNYC080008750 |
| 70000000MILGROM  | A SF 090012000 |
| 80000000VAZQUEZ  | C ATL120006000 |
| 90000000CLARK    | E NYC070000250 |

(a) Indexed File (before Update)

|                   |         |        |
|-------------------|---------|--------|
| 44444444RICHARDS  | IM      | 05000C |
| 70000000MILGROM   | A       | D      |
| 00000000BOROW     | JSATL07 | A      |
| 00000000BOROW     | JS      | 10000C |
| 00000000BOROW     | JS      | 20000C |
| 40000000MOLDOF    | BLATL15 | A      |
| 80000000VAZQUEZ   | C       | 55000C |
| 99999999GILLENSON | MANYC10 | A      |

*Transactions are not in sequential order*

(b) Transaction File

|                   |                |
|-------------------|----------------|
| 00000000BOROW     | JSATL070003000 |
| 10000000GRABER    | P ATL150000000 |
| 20000000RUBIN     | MABOS080002000 |
| 30000000ANDERSON  | IRBOS100011300 |
| 40000000MOLDOF    | BLATL150000000 |
| 50000000GLASSMAN  | JSNYC100004500 |
| 60000000GRAUER    | RTNYC080008750 |
| 80000000VAZQUEZ   | C ATL120011500 |
| 90000000CLARK     | E NYC070000250 |
| 99999999GILLENSON | MANYC100000000 |

(c) Indexed File (after Update)

ERROR-NO MATCHING RECORD: 44444444  
 ERROR-DUPLICATE ADDITION: 40000000

(d) Error Messages

- Processing Requirements:**
1. Develop a nonsequential update program to process an incoming transaction file and update the associated indexed file. The processing requirements parallel those of the sequential update program of Chapter 17 with the following changes:
    - a. There is only a single master file (the indexed file), which functions as both the old and new master files.
    - b. The transaction file need not be in sequential order.
    - c. The balance line algorithm does not apply.
  2. The transaction file is assumed to be valid in and of itself by virtue of a stand-alone edit program. Hence, each transaction has a valid transaction code (A, C, or D), numeric fields are numeric, and so on. Nevertheless, the update program must check (and flag) two kinds of errors that could not be detected in the stand-alone edit, as they require interaction with the old master file. These are:
    - a. Duplicate additions, in which the social security number of a transaction coded as an addition already exists in the old master,
    - b. No matches, in which the social security number of a transaction coded as either a deletion or a correction does not exist in the old master.
  3. Transactions coded as additions are to be added to the new master file in their entirety, and will contain a value for every field in the transaction record (except for TR-SALES-AMOUNT). The value of IND-YEAR-TO-DATE-SALES in the new master record is to be initialized to zero.
  4. Transactions coded as deletions are to be removed from the master file. These transactions contain only the social security number and transaction code.
  5. Transactions coded as corrections contain only the social security number, name, and the transaction sales amount (TR-SALES-AMOUNT). The value of TR-SALES-AMOUNT on the incoming transaction is to be *added* to the value in the IND-YEAR-TO-DATE-SALES field in the master record.

Figure 18.7 contains the indexed and transaction files before the update, the indexed file after the update has been run, and the associated error messages (for duplicate additions and no matches). The data parallel the example in Chapter 17 except that the transaction file is no longer in sequence. Nevertheless, the updated indexed file is the same in both examples; that is, Borow and Gillenson have been added, Milgrom has been deleted, and Vazquez has had her record changed. Note, however, that the error messages in Figure 18.7d are reversed (from those in Chapter 17) to match the order in which the transactions were processed.

### Hierarchy Chart

The hierarchy chart of Figure 18.8 is simpler than its counterpart for sequential processing; it also contains four modules that were present in the hierarchy chart of Chapter 17. In other words, regardless of whether the master file is accessed sequentially or nonsequentially, it is still necessary to apply transactions to the master file, to add records to the indexed file, and to correct and/or delete existing records.

Conspicuous by its absence, however, is the module to CHOOSE-ACTIVE-KEY, because the nonsequential update is driven entirely by the transaction file. The program processes the transaction file until there are no more transactions; that is, there is no need for an active key to determine whether the record from the transaction file or the old master file will be admitted to the update process because the balance line algorithm does not apply. (See problem 7.)

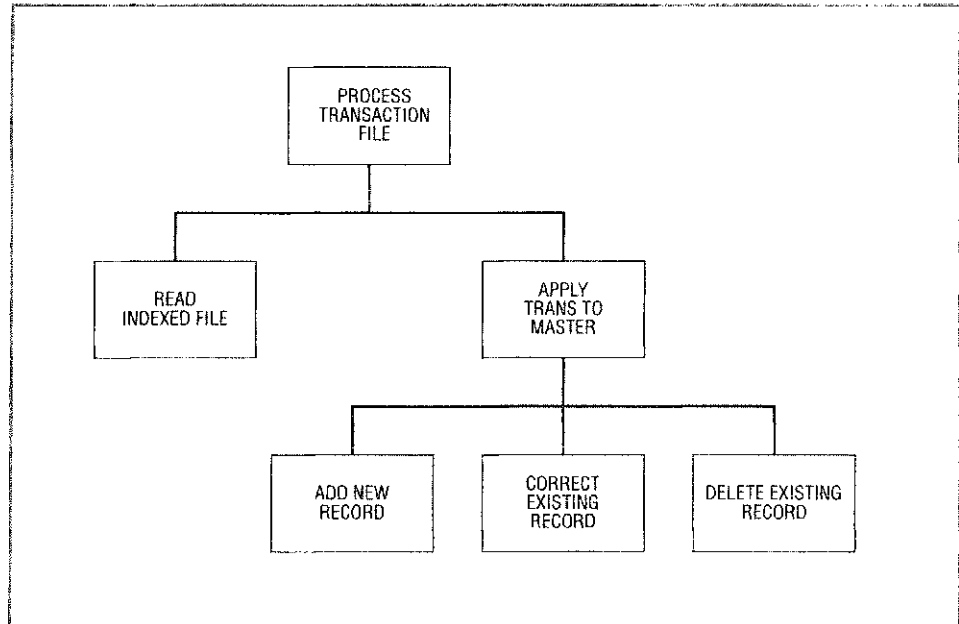
**Figure 18.8** Hierarchy Chart for Nonsequential Update Program**Pseudocode**

The pseudocode for the nonsequential update is driven entirely by the transaction file, which reads a transaction, determines whether or not the corresponding social security number is in the indexed file, then processes the transaction as appropriate. The logic is simpler than that of the balance line algorithm, which had to determine whether the next record was to be read from the transaction file, the old master file, or both.

The pseudocode reads a record from the transaction file and immediately does a random read on the indexed file. The social security number from the transaction file is, or is not, present in the indexed file, which determines the value of the record-key-allocated-switch. The transaction is then processed according to the transaction code (addition, deletion, or correction) and the value of the record-key-allocated-switch. The process continues until the transaction file is exhausted.

**The Completed Program**

The completed program is shown in Figure 18.10. The SELECT statement for the INDEXED-FILE (lines 10–14) contains the required ORGANIZATION IS INDEXED and RECORD KEY clauses, and specifies ACCESS IS RANDOM. INDEXED-FILE is opened as an I/O file in line 63 because it serves as both the old and new master file; that is, it is read from and written to.

The READ statement for the indexed file (lines 79–84) is preceded by a MOVE statement, in which the key of the transaction record is moved to IND-SOC-SEC-NUM, the field defined as the RECORD KEY. The indexed file is read in an attempt to find this record, and the INVALID KEY condition is triggered if the value is not in the file.

The contents of the lowest-level modules, ADD-NEW-RECORD, CORRECT-EXISTING-RECORD and DELETE-EXISTING-RECORD, have been modified slightly (from their counterparts in the sequential update) to include the appropriate I/O statements and contain WRITE, REWRITE, and DELETE statements, respectively.

Figure 10.9 Pseudocode for Nonsequential Update Program

```

Open files
DO WHILE data remains
 READ transaction file
 AT END
 Indicate no more data
 NOT AT END
 Move transaction social security number to record key
 READ INDEXED-FILE
 INVALID KEY
 Move 'NO' TO record-key-allocated-switch
 NOT INVALID KEY
 Move 'YES' TO record-key-allocated-switch
 END-READ
 EVALUATE transaction-code
 WHEN addition
 IF record-key-allocated-switch = 'yes'
 Write 'error - duplicate addition'
 ELSE (transaction is not in indexed file)
 Move transaction-record to new-master-record
 Write indexed record
 ENDIF
 WHEN correction
 IF record-key-allocated-switch = 'yes'
 Process correction
 Rewrite indexed record
 ELSE (transaction is not in indexed file)
 Write 'error - no matching record'
 ENDIF
 WHEN deletion
 IF record-key-allocated-switch = 'yes'
 Delete indexed record
 ELSE (transaction is not in indexed file)
 Write 'error - no matching record'
 ENDIF
 WHEN other
 Write 'error - invalid transaction code'
 END EVALUATE
END READ
END DO
Close files
Stop run

```

Figure 18.10 Nonsequential Update Program

```

1 IDENTIFICATION DIVISION.
2 PROGRAM-ID. NONSEQ.
3 AUTHOR. ROBERT GRAUER.
4
5 ENVIRONMENT DIVISION.
6 INPUT-OUTPUT SECTION.
7 FILE-CONTROL.
8 SELECT TRANSACTION-FILE ASSIGN TO 'A:\CHAPTR18\VALTRANS.DAT'
9 ORGANIZATION IS LINE SEQUENTIAL.
10
11 SELECT INDEXED-FILE
12 ASSIGN TO 'A:\CHAPTR18\INDMAST.DAT'
13 ORGANIZATION IS INDEXED
14 ACCESS IS RANDOM
15 RECORD KEY IS IND-SOC-SEC-NUM.
16
17 DATA DIVISION.
18 FILE SECTION.
19 FD TRANSACTION-FILE
20 RECORD CONTAINS 37 CHARACTERS
21 DATA RECORD IS TRANSACTION-RECORD.
22
23 01 TRANSACTION-RECORD PIC X(37).
24
25 FD INDEXED-FILE
26 RECORD CONTAINS 39 CHARACTERS
27 DATA RECORD IS INDEXED-RECORD.
28
29 01 INDEXED-RECORD.
30 05 IND-SOC-SEC-NUM PIC X(9).
31 05 IND-REST-OF-RECORD PIC X(30).
32
33 WORKING-STORAGE SECTION.
34 01 FILLER PIC X(14)
35 VALUE 'WS BEGINS HERE'.
36
37 01 WS-TRANS-RECORD.
38 05 TR-SOC-SEC-NUMBER PIC X(9).
39 05 TR-NAME.
40 10 TR-LAST-NAME PIC X(15).
41 10 TR-INITIALS PIC XX.
42 05 TR-LOCATION-CODE PIC X(3).
43 05 TR-COMMISSION-RATE PIC 99.
44 05 TR-SALES-AMOUNT PIC 9(5).
45 05 TR-TRANSACTION-CODE PIC X.
46 88 ADDITION VALUE 'A'.
47 88 CORRECTION VALUE 'C'.
48 88 DELETION VALUE 'D'.
49
50 01 WS-MASTER-RECORD.
51 05 MA-SOC-SEC-NUMBER PIC X(9).
52 05 MA-NAME.
53 10 MA-LAST-NAME PIC X(15).

```

*SELECT statement for INDEXED-FILE*

Figure 13.10 (continued)

```

51 10 MA-INITIALS PIC XX.
52 05 MA-LOCATION-CODE PIC X(3).
53 05 MA-COMMISSION-RATE PIC 99.
54 05 MA-YEAR-TO-DATE-SALES PIC 9(8).
55
56 01 PROGRAM-SWITCHES.
57 05 END-OF-FILE-SWITCH PIC X(3) VALUE 'NO '.
58 05 RECORD-KEY-ALLOCATED-SWITCH PIC X(3) VALUE 'NO '.
59
60 PROCEDURE DIVISION.
61 0010-PROCESS-TRANSACTION-FILE.
62 OPEN INPUT TRANSACTION-FILE
63 I-O INDEXED-FILE.
64 PERFORM UNTIL END-OF-FILE-SWITCH = 'YES'
65 READ TRANSACTION-FILE INTO WS-TRANS-RECORD
66 AT END
67 MOVE 'YES' TO END-OF-FILE-SWITCH
68 NOT AT END
69 PERFORM 0020-READ-INDEXED-FILE
70 PERFORM 0030-APPLY-TRANS-TO-MASTER
71 END-READ
72 END-PERFORM.
73 CLOSE TRANSACTION-FILE
74 INDEXED-FILE.
75 STOP RUN.
76
77 0020-READ-INDEXED-FILE.
78 MOVE TR-SOC-SEC-NUMBER TO IND-SOC-SEC-NUM.
79 READ INDEXED-FILE INTO WS-MASTER-RECORD
80 INVALID KEY
81 MOVE 'NO ' TO RECORD-KEY-ALLOCATED-SWITCH
82 NOT INVALID KEY
83 MOVE 'YES' TO RECORD-KEY-ALLOCATED-SWITCH
84 END-READ.
85
86 0030-APPLY-TRANS-TO-MASTER.
87 EVALUATE TRUE
88 WHEN ADDITION
89 PERFORM 0090-ADD-NEW-RECORD
90 WHEN CORRECTION
91 PERFORM 0100-CORRECT-EXISTING-RECORD
92 WHEN DELETION
93 PERFORM 0110-DELETE-EXISTING-RECORD
94 WHEN OTHER
95 DISPLAY 'INVALID TRANSACTION CODE'
96 END-EVALUATE.
97
98 0090-ADD-NEW-RECORD.
99 IF RECORD-KEY-ALLOCATED-SWITCH = 'YES'
100 DISPLAY ' ERROR-DUPLICATE ADDITION: ' TR-SOC-SEC-NUMBER

```

Initial value of end-of-file condition  
set to 'NO' in program

Consequent of READ statement

EVALUATE's default determines  
transaction processing

Figure 18.10 (continued)

```

101 ELSE
102 MOVE SPACES TO WS-MASTER-RECORD
103 MOVE TR-SOC-SEC-NUMBER TO MA-SOC-SEC-NUMBER
104 MOVE TR-NAME TO MA-NAME
105 MOVE TR-LOCATION-CODE TO MA-LOCATION-CODE
106 MOVE TR-COMMISSION-RATE TO MA-COMMISSION-RATE
107 MOVE ZEROS TO MA-YEAR-TO-DATE-SALES
108 WRITE INDEXED-RECORD FROM WS-MASTER-RECORD
109 END-IF.
110
111 0100-CORRECT-EXISTING-RECORD.
112 IF RECORD-KEY-ALLOCATED-SWITCH = 'YES'
113 ADD TR-SALES-AMOUNT TO MA-YEAR-TO-DATE-SALES
114 REWRITE INDEXED-RECORD FROM WS-MASTER-RECORD
115 ELSE
116 DISPLAY ' ERROR-NO MATCHING RECORD: ' TR-SOC-SEC-NUMBER
117 END-IF.
118
119 0110-DELETE-EXISTING-RECORD.
120 IF RECORD-KEY-ALLOCATED-SWITCH = 'YES'
121 DELETE INDEXED-FILE
122 ELSE
123 DISPLAY ' ERROR-NO MATCHING RECORD: ' TR-SOC-SEC-NUMBER
124 END-IF.

```

*Modified to use appropriate I/O statements*

## Alternate Record Key

Our earlier discussion of the SELECT statement included the **ALTERNATE RECORD KEY** phrase to enable a second path for retrieving records from an indexed file. Unlike the record key, which must be unique, the alternate key may contain duplicate values. This capability is illustrated in the third and final program of the chapter, the specifications of which follow in the usual format.

## PROGRAMMING SPECIFICATIONS

**Program Name:** Alternate Indexes

**Narrative:** This program illustrates primary and alternate indexes, as well as nonsequential retrieval on either type of key. It does no useful processing per se, other than to illustrate COBOL syntax

**Input File:** INDEXED-FILE

**Input Record Layout:**

|                       |            |
|-----------------------|------------|
| 01 INDEXED-RECORD.    |            |
| 05 IND-SOC-SEC-NUMBER | PIC X(9).  |
| 05 IND-NAME           | PIC X(15). |
| 05 IND-REST-OF-RECORD | PIC X(16). |

Figure 18.11 Alternate Keys

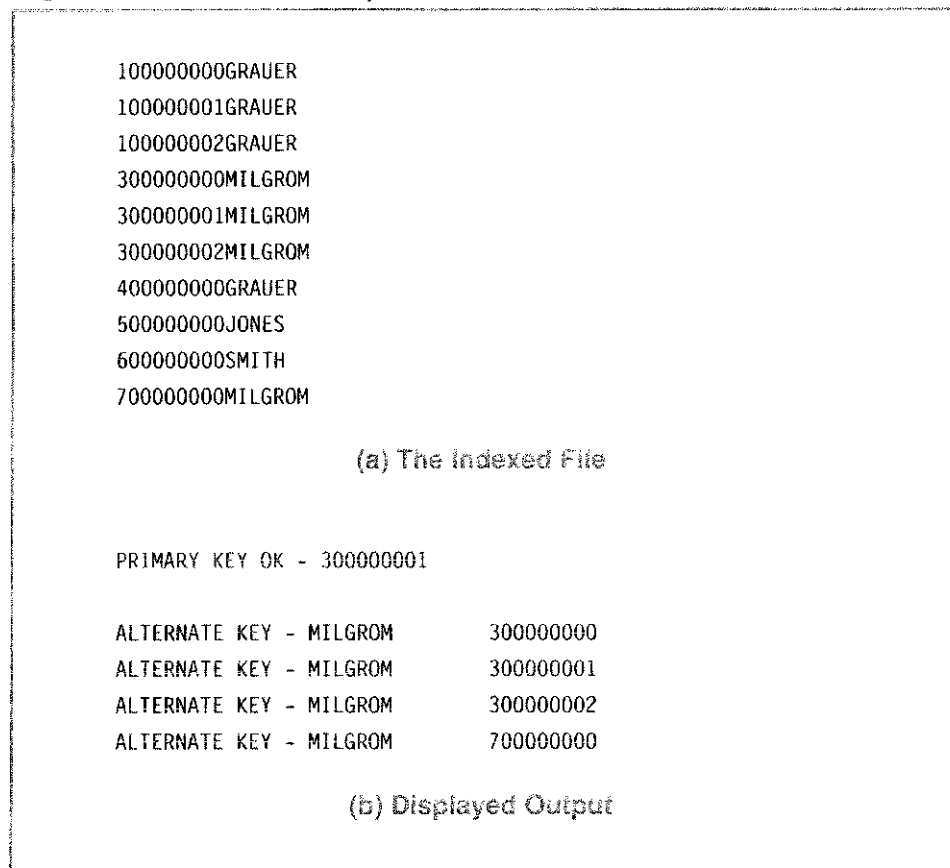

**Test Data:** See Figure 18.11a.

**Report Layout:** There is no formal report produced by this program; instead DISPLAY statements are used to indicate the results as in Figure 18.11b.

- Processing Requirements:**
1. The social security and name fields are designated as the primary and secondary keys, respectively. The value of the social security number is unique, whereas the value of name is not.
  2. Execute a random read for the record whose social security number is 30000001, displaying an appropriate message to indicate whether or not the record was found.
  3. Execute a random read to find the first record whose name is Milgrom, then read sequentially to display all other records with this value in the secondary key.

Figure 18.12 contains the completed program corresponding to these specifications. The SELECT statement in lines 8–13 designates IND-SOC-SEC-NUM and IND-NAME as the primary (record) and alternate key, respectively. The record key is (and must always be) unique, but the alternate key need not be; hence the WITH DUPLICATES phrase is included in the SELECT statement. Both fields are defined within the FD for INDEXED-FILE in lines 21 and 22, respectively. The ACCESS IS DYNAMIC phrase (line 11) indicates both random and sequential retrieval within the same program.



Figure 18.12 Alternate Index Program

```

1 IDENTIFICATION DIVISION.
2 PROGRAM-ID. ALTINDEX.
3 AUTHOR. ROBERT GRAUER.
4
5 ENVIRONMENT DIVISION.
6 INPUT-OUTPUT SECTION.
7 FILE-CONTROL.
8 SELECT INDEXED-FILE
9 ASSIGN TO 'A:\CHAPTR18\ALTINDEX.DAT'
10 ORGANIZATION IS INDEXED
11 ACCESS IS DYNAMIC
12 RECORD KEY IS IND-SOC-SEC-NUM
13 ALTERNATE RECORD KEY IS IND-NAME WITH DUPLICATES.
14
15 DATA DIVISION.
16 FILE SECTION.
17 FD INDEXED-FILE
18 RECORD CONTAINS 40 CHARACTERS
19 DATA RECORD IS INDEXED-RECORD.
20 01 INDEXED-RECORD.
21 05 IND-SOC-SEC-NUM PIC X(9).
22 05 IND-NAME PIC X(15).
23 05 IND-REST-OF-RECORD PIC X(16).
24
25 WORKING-STORAGE SECTION.
26 01 END-OF-FILE-SWITCH PIC X(3) VALUE SPACES.
27
28 PROCEDURE DIVISION.
29 0010-DISPLAY-INDEXED-RECORDS.
30 OPEN INPUT INDEXED-FILE.
31 PERFORM 0020-RETRIEVE-BY-PRIMARY-KEY.
32 PERFORM 0030-RETRIEVE-BY-SECONDARY-KEY.
33 CLOSE INDEXED-FILE.
34 STOP RUN.
35
36 0020-RETRIEVE-BY-PRIMARY-KEY.
37 MOVE '300000001' TO IND-SOC-SEC-NUM.
38 READ INDEXED-FILE
39 INVALID KEY
40 DISPLAY 'RECORD NOT FOUND - 300000001'
41 NOT INVALID KEY
42 DISPLAY 'PRIMARY KEY OK - ', IND-SOC-SEC-NUM
43 END-READ.
44 DISPLAY ' '.
45
46 0030-RETRIEVE-BY-SECONDARY-KEY.
47 MOVE 'MILGROM' TO IND-NAME.
48 READ INDEXED-FILE KEY IS IND-NAME
49 INVALID KEY
50 DISPLAY 'RECORD NOT FOUND - MILGROM'

```

*Indicates path, filename and organization of file*

*Access is dynamic*

*Record key is IND-SOC-SEC-NUM*

*Alternate record key is IND-NAME WITH DUPLICATES*

*Key field is IND-SOC-SEC-NUM*

*Primary key retrieval*

*Secondary key retrieval*

Figure 18.12 (continued)

```

51 NOT INVALID KEY
52 PERFORM 0040-RETRIEVE-DUPLICATES
53 UNTIL IND-NAME NOT EQUAL 'MILGROM'
54 OR END-OF-FILE-SWITCH = 'YES'
55 END-READ.
56
57 0040-RETRIEVE-DUPLICATES.
58 DISPLAY 'ALTERNATE KEY - ' IND-NAME, IND-SOC-SEC-NUM.
59 READ INDEXED-FILE NEXT RECORD
60 AT END
61 MOVE 'YES' TO END-OF-FILE-SWITCH
62 END-READ.

```

*Successful retrieval*

The Procedure Division illustrates the retrieval of records on either field. Lines 36–44 contain the logic for the primary key and have already been covered in the program for a nonsequential update. The READ statement of lines 38–43 is preceded by a MOVE statement in which the key of the desired record (300000001 in the example) is moved to the data name designated as the RECORD KEY in the SELECT statement. If the record is in the file, it will be read into the data name INDEXED-RECORD; and the false-condition branch, NOT INVALID KEY, will indicate the primary key was found. If the record is not in the file, the INVALID KEY condition will be activated to display an appropriate error message.

Lines 46–55 contain a parallel procedure based on the alternate key, but with three important differences:

1. The key value (MILGROM) is moved to the ALTERNATE RECORD KEY (IND-NAME rather than IND-SOC-SEC-NUM).
2. The KEY IS phrase is used to indicate the retrieval is on the alternate rather than the primary key.
3. Successful retrieval causes the execution of 0040-RETRIEVE-DUPLICATES, which retrieves all records for MILGROM. The NEXT RECORD phrase (line 59) in the READ statement indicates sequential retrieval.

The DISPLAY output produced by the program is shown in Figure 18.11b. The first message indicates the successful retrieval based on the primary key (produced by the paragraph 0020-RETRIEVE-BY-PRIMARY-KEY). The second set of messages reflects all records for Milgrom.

## Concatenated Key

The record key in an indexed file may be specified as a group item rather than an elementary item, producing what is known as a *concatenated key*, that is, a key consisting of two (or more) keys strung together to form a single value. Consider, for example, a system for bank loans with a concatenated key defined as follows:

```

05 CUSTOMER-LOAN-NUMBER.
10 CUSTOMER-NUMBER PIC 9(6).
10 LOAN-NUMBER PIC 9(3).

```

In this example CUSTOMER-LOAN-NUMBER is a group item and consists of the elementary items, CUSTOMER-NUMBER and LOAN-NUMBER. Every value of the record key (CUSTOMER-LOAN-NUMBER) must be unique, but there can be several loans for the same customer, with each loan assigned a new loan number. Customer 11111, for example, may have two outstanding loans, with record keys of 11111001 and 11111004, respectively. (Loans 002 and 003 may have been previously paid off.) The problem is to retrieve all loans for a given customer, which leads to a discussion of the START statement.

### The START Statement

The START statement moves nonsequentially (randomly) into an indexed file to the first record whose value is equal to, greater than, or not less than the value contained in the identifier. The INVALID KEY condition is raised if the file does not contain a record meeting the specified criterion. Syntactically, the START statement has the form:

|                 |     |                                                                                                                        |              |
|-----------------|-----|------------------------------------------------------------------------------------------------------------------------|--------------|
| START file-name | KEY | IS EQUAL TO<br>IS =<br>IS GREATER THAN<br>IS ><br>IS NOT LESS THAN<br>IS NOT <<br>IS GREATER THAN OR EQUAL TO<br>IS >= | } identifier |
|-----------------|-----|------------------------------------------------------------------------------------------------------------------------|--------------|

[INVALID KEY imperative-statement-1]

[NOT INVALID KEY imperative-statement-2]

[END-START]

The START statement can be used in conjunction with a concatenated key as shown in Figure 18.13. *Note, however, that START only moves to the designated record, but does not read the record.* In other words, a READ statement is required immediately following START. The subsequent PERFORM statement will then retrieve all loans for the customer in question.

### LIMITATIONS OF COBOL 85

The READ, DELETE, WRITE, REWRITE, and START statements contain both an optional scope terminator and a false-condition branch. As indicated throughout the text, these elements are new to COBOL-85 and were not available in COBOL-74.

Sixteen I/O status codes (i.e., the majority of the entries in Table 18.1) are new to COBOL-85. The new codes (02, 04, 05, 07, 15, 24, 25, 34, 35, 37, 38, 39, 41, 42, 43, 46, and 49) were added to eliminate the need for vendor-specific file status codes that treated the same error condition in different ways.

Figure 18.13 The START Statement

```

SELECT LOAN-FILE
 ASSIGN TO 'A:\CHAPTR18\LOAN.DAT'
 ORGANIZATION IS INDEXED
 ACCESS MODE IS DYNAMIC
 RECORD KEY IS CUSTOMER-LOAN-NUMBER.

```

```

FD LOAN-FILE
 RECORD CONTAINS 120 CHARACTERS
 DATA RECORD IS LOAN-RECORD.

```

```

01 LOAN-RECORD.
 05 CUSTOMER-LOAN-NUMBER.
 10 CUSTOMER-NUMBER PIC 9(6).
 10 LOAN-NUMBER PIC 9(3).

```

*Each record of the file has a concatenated key of customer number and loan number.*

```

PROCEDURE DIVISION.

```

```

 MOVE 33333000 TO CUSTOMER-LOAN-NUMBER.

```

```

 START LOAN-FILE
 KEY IS GREATER THAN CUSTOMER-LOAN-NUMBER
 INVALID KEY DISPLAY 'CUSTOMER 333333 NOT IN FILE'
 END-START.

```

*START statement finds the first loan for customer 333333*

```

 READ LOAN-FILE NEXT RECORD
 AT END
 MOVE 'YES' TO END-OF-FILE-SWITCH
 END-READ.

```

```

 PERFORM UNTIL CUSTOMER-NUMBER NOT EQUAL 333333
 OR END-OF-FILE-SWITCH = 'YES'
 DISPLAY LOAN-RECORD
 READ LOAN-FILE NEXT RECORD
 AT END
 MOVE 'YES' TO END-OF-FILE-SWITCH
 END-READ
END-PERFORM.

```

*PERFORM statement finds all subsequent loans*

## S U M M A R Y

---

### **Points to Remember**

- ☛ Indexed files permit sequential and/or nonsequential access to records within a file. Different vendors have different physical implementations, but the COBOL syntax to access an indexed file is the same for all compilers adhering to the ANS 85 standard. VSAM (Virtual Storage Access Method) is IBM's implementation for indexed files.
- ☛ The SELECT statement for an indexed file has seven clauses: three clauses (ASSIGN, ORGANIZATION IS INDEXED, and RECORD KEY) are required, and the other four (RESERVE AREAS, ACCESS MODE, ALTERNATE RECORD KEY, and FILE STATUS) are optional.
- ☛ The RECORD KEY clause in the SELECT statement specifies a field (defined within the FD of the indexed record) whose value must be unique; the value of the optional alternate record key can contain duplicate values.
- ☛ The Procedure Division has several statements uniquely associated with indexed files, and/or extends the formats of other statements to accommodate indexed files. These include OPEN I-O, READ . . . INVALID KEY, WRITE . . . INVALID KEY, and DELETE.
- ☛ The transaction file does not have to be in sequence when updating an indexed file as the latter can be accessed nonsequentially. The INVALID KEY clause will be activated if the transaction record is not found.
- ☛ The updated indexed file cannot be used as the old master to retest the update program with the same input as previously; you must retain (create) a copy of the original indexed file for repeated testing.
- ☛ A concatenated key consists of two or more fields strung together. Concatenated keys are frequently used in conjunction with the START statement, which moves nonsequentially to the first record satisfying a specified condition.

### **Key Words and Concepts**

|                        |                      |
|------------------------|----------------------|
| Concatenated key       | Indexed file         |
| Control area           | I/O status           |
| Control area split     | Multiple keys        |
| Control interval       | Nonsequential access |
| Control interval split | Scope terminator     |
| False-condition branch | Sequence set         |
| Free space             | Sequential access    |
| Index set              | VSAM organization    |

**COBOL Elements**

|                      |                         |
|----------------------|-------------------------|
| ACCESS IS DYNAMIC    | FILE STATUS             |
| ACCESS IS RANDOM     | INVALID KEY             |
| ACCESS IS SEQUENTIAL | NOT INVALID KEY         |
| ACCESS MODE          | OPEN I-O                |
| ALTERNATE RECORD KEY | ORGANIZATION IS INDEXED |
| DELETE               | RECORD KEY              |
| END-DELETE           | RESERVE AREAS           |
| END-READ             | REWRITE                 |
| END-START            | START                   |
| END-REWRITE          | WITH DUPLICATES         |
| END-WRITE            | WRITE . . . INVALID KEY |

**F I L L - I N**

1. \_\_\_\_\_ files make it possible to retrieve records sequentially and/or nonsequentially.
2. An active file is best updated sequentially, whereas \_\_\_\_\_ processing should be used for inactive files.
3. \_\_\_\_\_ is the IBM specific implementation of COBOL's \_\_\_\_\_ file organization.
4. In IBM's VSAM implementation, a \_\_\_\_\_ contains one or more \_\_\_\_\_.
5. In IBM's VSAM implementation, each entry in a sequence set contains the \_\_\_\_\_ key for the associated control interval.
6. The SELECT statement for indexed files requires three clauses: \_\_\_\_\_, \_\_\_\_\_, and \_\_\_\_\_.
7. An indexed file requires the primary key to be \_\_\_\_\_, but allows \_\_\_\_\_ values for its \_\_\_\_\_ key.
8. Records are added to an indexed file through the \_\_\_\_\_ statement; existing records are changed through \_\_\_\_\_ and removed by the \_\_\_\_\_ statement.
9. The FILE STATUS clause is (optional/required) and requires that a \_\_\_\_\_ byte area be defined in \_\_\_\_\_.
10. FILE STATUS bytes of \_\_\_\_\_ indicate a successful I/O operation, whereas \_\_\_\_\_ indicates an end-of-file condition.
11. The \_\_\_\_\_ statement allows one to enter an indexed file randomly and read sequentially from that point on.
12. A random (nonsequential) READ statement is preceded by a MOVE statement in which the desired key is moved to the field defined as the \_\_\_\_\_.
13. Specification of ACCESS IS \_\_\_\_\_ permits both sequential and nonsequential access of an indexed file in the same program.
14. When a file is open in the \_\_\_\_\_ mode, it may be read from and written to.

## TRUE/FALSE

---

1. ALTERNATE RECORD KEY should always be specified for indexed files to allow for future expansion.
2. The FILE STATUS clause is permitted only for indexed files.
3. A READ statement must contain either the AT END or INVALID KEY clause.
4. Inclusion of the INTO clause in a READ statement is not recommended, as it requires additional storage space.
5. RESERVE 0 AREAS is recommended to speed up processing of an indexed file that is processed sequentially.
6. The value of RECORD KEY must be unique for every record in an indexed file.
7. The value of ALTERNATE RECORD KEY must be unique for every record in an indexed file.
8. The FILE STATUS clause is a mandatory entry in the SELECT statement for an indexed file.
9. An indexed file can be accessed sequentially and nonsequentially in the same program.
10. The first byte of an indexed record should contain either LOW- or HIGH-VALUES.
11. WRITE and REWRITE can be used interchangeably.
12. Records in an indexed file are deleted by moving HIGH-VALUES to the first byte.
13. The COBOL syntax for IBM VSAM files conforms to the ANS 85 standard.
14. Active files are best updated nonsequentially.

## PROBLEMS

---

1. Describe the changes to Figure 18.3 if record keys 401, 723, 724, and 725 were added. What would happen if record keys 502 and 619 were deleted?
2. Assume that record key 289 is to be inserted in the first control area of the VSAM data set in Figure 18.3. Logically, it could be added as the last record in the first control interval or the first record in the second control interval. Is there a preference?  
  
In similar fashion, should record 620 be inserted as the last record in the third interval of the second area or as the first record in the first interval of the third area?  
  
Finally, will record 900 be inserted as the last record in the fourth control area, or will it require creation of a fifth control area? Can you describe in general terms how VSAM adds records at the end of control areas and/or control intervals?
3. Indicate whether each of the following SELECT statements is valid syntactically and logically. (Some of the statements have more than one error.)
  - a. SELECT INDEXED-FILE  
    ASSIGN 'A:\CHAPTR18\INDMAST.DAT'  
    ORGANIZATION INDEXED  
    RECORD IND-SOC-SEC-NUM.

- b. SELECT INDEXED-FILE  
 ASSIGN TO 'A:\CHAPTR18\INDMAST.DAT'  
 RECORD KEY IS IND-SOC-SEC-NUM WITH NO DUPLICATES  
 ALTERNATE KEY IS IND-NAME WITH DUPLICATES.
- c. SELECT INDEXED-FILE  
 ASSIGN 'A:\CHAPTR18\INDMAST.DAT'  
 RESERVE 5 AREAS  
 ORGANIZATION IS INDEXED  
 ACCESS IS SEQUENTIAL  
 RECORD KEY IS IND-SOC-SEC-NUM WITH DUPLICATES  
 ALTERNATE RECORD KEY IS IND-NAME  
 FILE STATUS IS FILE-STATUS-BYTES.
- d. SELECT INDEXED-FILE  
 ASSIGN TO 'A:\CHAPTR18\INDMAST.DAT'  
 ORGANIZATION IS INDEXED  
 ACCESS MODE RANDOM  
 RECORD KEY IS IND-SOC-SEC-NUM, IND-NAME.

4. Given the COBOL definition:

```
05 FILE-STATUS-BYTES PIC 99.
```

What is wrong with the following entries?

- a. IF FILE-STATUS-BYTES EQUAL '10'  
 DISPLAY 'END OF FILE HAS BEEN REACHED'  
 END-IF
- b. IF FILE STATUS-BYTES EQUAL 10  
 DISPLAY 'ERROR - DUPLICATE KEY'  
 END-IF
- c. IF FILE-STATUS-BYTE EQUAL 1  
 DISPLAY 'END OF FILE HAS BEEN REACHED'  
 END-IF
- d. IF FILE STATUS BYTES EQUAL 10  
 DISPLAY 'END OF FILE HAS BEEN REACHED'  
 END-IF
5. Indicate whether each of the following entries is valid syntactically and logically.  
 (Assume INDEXED-FILE and INDEXED-RECORD are valid as a file name and a  
 record name, respectively.)
- a. OPEN INPUT INDEXED-FILE  
 OUTPUT INDEXED-FILE.
- b. READ INDEXED-FILE.
- c. READ INDEXED-FILE  
 AT END MOVE 'YES' TO END-OF-FILE-SWITCH.  
 END-READ.



- d. READ INDEXED-FILE
    - AT END
      - MOVE 'YES' TO END-OF-FILE-SWITCH
    - NOT AT END
      - PERFORM PROCESS-RECORD
 END-READ.
  - e. READ INDEXED-FILE
    - AT END MOVE 21 TO FILE-STATUS-BYTES.
  - f. READ INDEXED-FILE
    - INVALID KEY
      - DISPLAY 'RECORD IS IN FILE'
    - NOT INVALID KEY
      - DISPLAY 'RECORD IS NOT IN FILE'
 END-READ.
  - g. WRITE INDEXED-RECORD.
  - h. WRITE INDEXED-RECORD
    - INVALID KEY
      - DISPLAY 'INVALID KEY'
    - NOT INVALID KEY
      - PERFORM CONTINUE-PROCESSING
 END-WRITE.
  - i. REWRITE INDEXED-RECORD
    - INVALID KEY
      - DISPLAY 'INVALID KEY'
      - PERFORM ERROR-PROCESSING
 END-REWRITE.
  - j. REWRITE INDEXED-FILE.
  - k. DELETE INDEXED-RECORD.
  - l. DELETE INDEXED-FILE.
6. Figure 18.14a contains a slightly modified paragraph from the nonsequential update program of Figure 18.10, which produces the compiler diagnostics in Figure 18.14b. Why do the errors occur?
  7. The balance line algorithm was not used for the nonsequential update program (Figure 18.10) developed in the chapter. The resulting program worked correctly, but it can be made more efficient by changing its logic to include the concept of the active key.
    - a. What are the advantages of including the additional logic and using the balance line algorithm?
    - b. What are the disadvantages to this approach?
    - c. Modify the hierarchy chart and pseudocode of Figures 18.8 and 18.9 to accommodate the algorithm.

**Figure 18.14** Debugging Exercise

```
60 PROCEDURE DIVISION.
61 0010-UPDATE-MASTER-FILE.
62 OPEN INPUT TRANSACTION-FILE
63 I-O INDEXED-FILE.
64 PERFORM UNTIL END-OF-FILE-SWITCH = 'YES'
65 READ TRANSACTION-FILE INTO WS-TRANS-RECORD
66 AT END
67 MOVE 'YES' TO END-OF-FILE-SWITCH
68 NOT AT END
69 PERFORM 0020-READ-INDEXED-FILE
70 PERFORM 0030-APPLY-TRANS-TO-MASTER.
71 END-READ
72 END-PERFORM
```

**(a) Modified Procedure Division**

```
64 W Explicit scope terminator END- 'PERFORM' assumed present
71 E No corresponding active scope for 'END-READ'
72 E No corresponding active scope for 'END-PERFORM'
```

**(b) Error Messages**



# The Year 2000 Problem

---

## CHAPTER OUTLINE

---

Overview

**The Year 2000 Problem**

**Date Arithmetic**

COBOL Intrinsic Calendar Functions

Leap-Year Problem

**Retirement Program Revisited**

Summary

Fill-in

True/False

Problems

For Further Study

## OBJECTIVES

---

After reading this chapter, you will be able to:

- Describe the implications of the Year 2000 problem.
- State the causes of the problem.
- Identify the types of routines that may cause the problem.
- Discuss several types of date arithmetic.
- Use COBOL intrinsic calendar function to do date conversions.

## OVERVIEW

---

This chapter discusses a major information system issue at the end of the twentieth century. This problem is known by several titles such as "the Year 2000 problem," "Millennium 2K," or simply "Y2K." Whatever the name, the problem is one the industry has brought upon itself—threatening the well-being of many companies and governmental organizations. The purpose of this chapter is to define what the problem is, show how it came about, and suggest some ways to deal with it.

The first section of the chapter discusses the nature of the problem by examining a program typical of those written in the 1960s, 1970s, and 1980s. The next section deals with the issues of date arithmetic. The discussion involves the two date formats introduced in Chapter 8: DATE format (YYMMDD) and DAY (YYDDD). The discussion shows how the DAY format can be used in calculating the number of days between two dates. This section of the chapter then looks at the COBOL intrinsic calendar functions to see how they can further simplify date arithmetic.

Leap year processing compounds the Year 2000 problem. The last portion of the chapter looks at this aspect of the problem and presents a Year 2000 compliant version of the original program. For further research on the Year 2000 problem, the section contains a listing of World Wide Web sites dedicated to the problem and its solution.

---

### The Year 2000 Problem

Look at the retirement program listed in Figure 19.1. This program reads an employee file and computes the employee's age, years of service to the company, and the date of retirement. The program then prints a report showing the results of its calculations.

Do you see any problems with this program? First, notice the output format for the retirement date. In line 85, just before DET-RET-YR, the programmer has coded in a value of "/19." As a result, the output report will print the retirement year as "19YY" no matter when the employee is due to retire. Obviously, in the late 1990s, most employees will retire after 1999 and the report format needs to reflect a

retirement year where the first two digits can be 19, 20, or even 21. The report should not state that the retirement date is 1904 when the year actually should be 2004.

This program is a simple example of the Year 2000 problem. When programs like this one were written, programmers assumed that all dates used would be in the twentieth century<sup>1</sup> and that "19" was the valid prefix for all years.

This type of thinking meant that many computer systems incorporated only two digits for representing a year instead of the four digits normally used. As a result, when these systems encounter the year 2000, they act as if the year is 1900. This apparently simple oversight means that when January 1, 2000 comes, many systems will fail entirely or will produce massive amounts of erroneous information. The remedy will not be cheap. Some authorities estimate the cost to fix the problem at \$300 billion to \$600 billion worldwide.<sup>2</sup> The Year 2000 problem is one that will not go away, and the deadline cannot be delayed.

Figure 19-3 Retirement Program, a Year 2000 Problem Example

```

1 IDENTIFICATION DIVISION.
2 PROGRAM-ID. Y2K01.
3 AUTHOR. ARTHUR R. BUSS
4
5 ENVIRONMENT DIVISION.
6 INPUT-OUTPUT SECTION.
7 FILE-CONTROL.
8 SELECT EMPLOYEE-FILE ASSIGN TO 'EMPSERV.DAT'
9 ORGANIZATION IS LINE SEQUENTIAL.
10 SELECT PRINT-FILE ASSIGN TO PRINTER.
11
12 DATA DIVISION.
13 FILE SECTION.
14 FD EMPLOYEE-FILE
15 RECORD CONTAINS 34 CHARACTERS.
16 01 EMPLOYEE-RECORD PIC X(34).
17
18 FD PRINT-FILE
19 RECORD CONTAINS 80 CHARACTERS.
20 01 PRINT-LINE PIC X(80).
21
22 WORKING-STORAGE SECTION.
23 01 EMPLOYEE-DATA.
24 05 EMP-NUM PIC X(05).
25 05 EMP-NAME.
26 10 EMP-LAST PIC X(15).
27 10 EMP-INIT PIC X(02).
28 05 EMP-BIRTHDATE.
29 10 EMP-BIRTH-YR PIC 9(02).
30 10 EMP-BIRTH-MO PIC 9(02).
31 10 EMP-BIRTH-DA PIC 9(02).
32 05 EMP-SERVICE-DATE.
33 10 EMP-SERVICE-YR PIC 9(02).
34 10 EMP-SERVICE-MO PIC 9(02).

```

Figure 19.1 (continued)

|    |    |                    |            |                     |
|----|----|--------------------|------------|---------------------|
| 35 | 10 | EMP-SERVICE-DA     | PIC 9(02). |                     |
| 36 |    |                    |            |                     |
| 37 | 01 | DATA-REMAINS-SW    | PIC X(02). |                     |
| 38 | 88 | NO-DATA-REMAINS    |            | VALUE 'NO'.         |
| 39 |    |                    |            |                     |
| 40 | 01 | INDIVIDUAL-FIELDS. |            |                     |
| 41 | 05 | IND-AGE            | PIC 9(02). |                     |
| 42 | 05 | IND-SERV-YEARS     | PIC 9(02). |                     |
| 43 | 05 | IND-RET-DATE.      |            |                     |
| 44 | 10 | IND-RET-YR         | PIC 9(02). |                     |
| 45 | 10 | IND-RET-MO         | PIC 9(02). |                     |
| 46 | 10 | IND-RET-DA         | PIC 9(02). |                     |
| 47 |    |                    |            |                     |
| 48 | 01 | TODAYS-DATE.       |            |                     |
| 49 | 05 | TODAYS-YR          | PIC 9(02). |                     |
| 50 | 05 | TODAYS-MO          | PIC 9(02). |                     |
| 51 | 05 | TODAYS-DA          | PIC 9(02). |                     |
| 52 |    |                    |            |                     |
| 53 | 01 | CONSTANTS.         |            |                     |
| 54 | 05 | RETIRE-AGE         | PIC 9(02)  | VALUE 65.           |
| 55 |    |                    |            |                     |
| 56 | 01 | HEADING-LINE-1.    |            |                     |
| 57 | 05 |                    | PIC X(05)  | VALUE SPACES.       |
| 58 | 05 |                    | PIC X(10)  | VALUE 'EMPLOYEE'.   |
| 59 | 05 |                    | PIC X(17)  | VALUE SPACES.       |
| 60 | 05 |                    | PIC X(09)  | VALUE 'SERVICE'.    |
| 61 | 05 |                    | PIC X(10)  | VALUE 'RETIREMENT'. |
| 62 |    |                    |            |                     |
| 63 | 01 | HEADING-LINE-2.    |            |                     |
| 64 | 05 |                    | PIC X(07)  | VALUE SPACES.       |
| 65 | 05 |                    | PIC X(14)  | VALUE 'NAME'.       |
| 66 | 05 |                    | PIC X(07)  | VALUE 'INIT'.       |
| 67 | 05 |                    | PIC X(06)  | VALUE 'AGE'.        |
| 68 | 05 |                    | PIC X(08)  | VALUE 'YEARS'.      |
| 69 | 05 |                    | PIC X(10)  | VALUE 'DATE'.       |
| 70 |    |                    |            |                     |
| 71 | 01 | DETAIL-LINE.       |            |                     |
| 72 | 05 |                    | PIC X(05)  | VALUE SPACES.       |
| 73 | 05 | DET-LAST           | PIC X(15). |                     |
| 74 | 05 |                    | PIC X(02)  | VALUE SPACES.       |
| 75 | 05 | DET-INIT           | PIC X(02). |                     |
| 76 | 05 |                    | PIC X(05)  | VALUE SPACES.       |
| 77 | 05 | DET-AGE            | PIC 9(02). |                     |
| 78 | 05 |                    | PIC X(05)  | VALUE SPACES.       |
| 79 | 05 | DET-SERV-YEARS     | PIC 9(02). |                     |
| 80 | 05 |                    | PIC X(02)  | VALUE SPACES.       |
| 81 | 05 | DET-RET-DATE.      |            |                     |
| 82 | 10 | DET-RET-MO         | PIC Z9.    |                     |
| 83 | 10 |                    | PIC X      | VALUE '/'.          |
| 84 | 10 | DET-RET-DA         | PIC Z9.    |                     |
| 85 | 10 |                    | PIC X(03)  | VALUE '/19'.        |
| 86 | 10 | DET-RET-YR         | PIC 9(02). |                     |

Assumes year

Figure 19.1 (continued)

```

87
88 PROCEDURE DIVISION.
89 100-PREPARE-RETIREMENT-REPORT.
90 OPEN INPUT EMPLOYEE-FILE
91 OUTPUT PRINT-FILE
92 PERFORM 210-GET-TODAYS-DATE
93 PERFORM 230-WRITE-HEADERS
94 PERFORM UNTIL NO-DATA-REMAINS
95 READ EMPLOYEE-FILE INTO EMPLOYEE-DATA
96 AT END
97 SET NO-DATA-REMAINS TO TRUE
98 NOT AT END
99 PERFORM 260-PROCESS-DETAIL
100 END-READ
101 END-PERFORM
102 CLOSE EMPLOYEE-FILE
103 PRINT-FILE
104 STOP RUN
105
106
107 210-GET-TODAYS-DATE.
108 ACCEPT TODAYS-DATE FROM DATE
109 * MOVE '000101' TO TODAYS-DATE
110 .
111
112 230-WRITE-HEADERS.
113 WRITE PRINT-LINE FROM HEADING-LINE-1
114 AFTER ADVANCING PAGE
115 WRITE PRINT-LINE FROM HEADING-LINE-2
116 INITIALIZE PRINT-LINE
117 WRITE PRINT-LINE
118 .
119
120 260-PROCESS-DETAIL.
121 PERFORM 310-CALCULATE-EMP-AGE
122 PERFORM 330-CALCULATE-EMP-SERVICE
123 PERFORM 360-CALCULATE-IND-RET-DATE
124 PERFORM 390-WRITE-DETAIL-LINE
125 .
126
127 310-CALCULATE-EMP-AGE.
128 COMPUTE IND-AGE = TODAYS-YR - EMP-BIRTH-YR
129 + (TODAYS-MO - EMP-BIRTH-MO) / 12
130 .
131
132 330-CALCULATE-EMP-SERVICE.
133 COMPUTE IND-SERV-YEARS = TODAYS-YR - EMP-SERVICE-YR
134 + (TODAYS-MO - EMP-SERVICE-MO) / 12
135 .
136
137 360-CALCULATE-IND-RET-DATE.
138 ADD RETIRE-AGE TO EMP-BIRTH-YR GIVING IND-RET-YR

```

100-prepare-retirement-report

109 \* MOVE '000101' TO TODAYS-DATE

310-CALCULATE-EMP-AGE

330-CALCULATE-EMP-SERVICE



Figure 19.1 (continued)

```

139 MOVE EMP-BIRTH-MO TO IND-RET-MO
140 MOVE EMP-BIRTH-DA TO IND-RET-DA
141 .
142
143 390-WRITE-DETAIL-LINE.
144 MOVE EMP-LAST TO DET-LAST
145 MOVE EMP-INIT TO DET-INIT
146 MOVE IND-AGE TO DET-AGE
147 MOVE IND-SERV-YEARS TO DET-SERV-YEARS
148 MOVE IND-RET-MO TO DET-RET-MO
149 MOVE IND-RET-DA TO DET-RET-DA
150 MOVE IND-RET-YR TO DET-RET-YR
151 WRITE PRINT-LINE FROM DETAIL-LINE
152 .

```

At this point, you may think that the case is overstated. Certainly a simple remedy exists for the problem described above. By expanding the DET-RET-YR field size to four positions and eliminating the "19" from the preceding filler field, the program can print either 19YY or 20YY. However, having made the change, the question becomes, "How do I know which lead digits to use, 19 or 20?" It would be just as wrong to assume that all retirement dates will fall after the year 2000 as it was to assume that the dates should come before 2000. A way must be found to determine the appropriate digits.

You can now begin to see the essence of the Year 2000 problem. When there are only two digits to work with, how would the program determine the right century? Should it treat "88" as 1888, 1988, or 2088? Before answering the question, you may want to know how this problem came about in the first place.

From the 1960s through the 1980s, many organizations developed systems containing programs, and, more importantly, files that used only the last two digits of the year whenever a date was required. This practice worked well for a long time and did not seem to cause any particular problems. One exception was when a program had to look far into the future, as in calculating retirement dates. You may still wonder why the system developers did not anticipate the problem and just use four-digit years as a standard practice.

One answer is in the hardware used at the time. Mainframes were the primary computer of the era, and they ran most systems. On these machines, disk storage and primary memory were extremely expensive. Thus, programmers had to use storage economically, and eliminating two "unnecessary" digits was one way to do it. The decision was a conscious one made to save money.<sup>3</sup>

A second answer is in the COBOL compilers. Using the same type of logic in the previous answer, the "ACCEPT...FROM DATE" command returned the system date in YYMMDD format. This date format is the default even in the newer COBOL standards.<sup>4</sup> In order to maintain four-digit years, a programmer would have to deliberately add the extra digits to the year field wherever it was created. From a programming perspective, the course of least resistance was to use just two digits.

A third answer is that most system developers could not envision these programs being around long enough for the problem to matter. They expected that the programs would be replaced long before 2000, and that the new systems would deal with the problem. However, some 20 and even 30 years later, these "legacy" systems are still running, and the problem faces industry now.

Look at the program in Figure 19.1 again.<sup>5</sup> In paragraph 210-GET-TODAYS-DATE (line 107), the ACCEPT statement brings in the current system date and stores it in the TODAYS-DATE group item. Paragraph 310-CALCULATE-EMPLOYEE-AGE, in line 127, uses the system date information to compute the employee's age by using the age calculation introduced in Chapter 8. The code segment below shows the date items and the calculations.

```

01 EMPLOYEE-DATA.
 05 EMP-NUM PIC X(05).
 05 EMP-NAME.
 10 EMP-LAST PIC X(15).
 10 EMP-INIT PIC X(02).
 05 EMP-BIRTHDATE.
 10 EMP-BIRTH-YR PIC 9(02).
 10 EMP-BIRTH-MO PIC 9(02).
 10 EMP-BIRTH-DA PIC 9(02).
 05 EMP-SERVICE-DATE.
 10 EMP-SERVICE-YR PIC 9(02).
 10 EMP-SERVICE-MO PIC 9(02).
 10 EMP-SERVICE-DA PIC 9(02).

01 DATA-REMAINS-SW PIC X(02).
 88 NO-DATA-REMAINS VALUE 'NO'.

01 INDIVIDUAL-FIELDS.
 05 IND-AGE PIC 9(02).
 05 IND-SERV-YEARS PIC 9(02).
 05 IND-RET-DATE.
 10 IND-RET-YR PIC 9(02).
 10 IND-RET-MO PIC 9(02).
 10 IND-RET-DA PIC 9(02).

01 TODAYS-DATE.
 05 TODAYS-YR PIC 9(02).
 05 TODAYS-MO PIC 9(02).
 05 TODAYS-DA PIC 9(02).

310-CALCULATE-EMP-AGE.
 COMPUTE IND-AGE = TODAYS-YR - EMP-BIRTH-YR
 + (TODAYS-MO - EMP-BIRTH-MO) / 12

```

As an example, suppose that an employee was born on January 1, 1970. On January 1, 2000, this employee will be 30 years old. Following the logic of the program, you should find that it will calculate that the employee is 70 years old and overdue for retirement. (Note: If the IND-AGE field were defined as signed, the employee would be -70.) To test this for yourself, remove the asterisk in line 109 and put an asterisk in column 7 of line 108. This change overrides setting TODAYS-DATE from the system date and forces it to be January 1, 2000. Compile the program and check the results.

In the same way, the program has a problem determining how long an employee has worked. Notice paragraph 330-CALCULATE-EMP-SERVICE (line 132). This paragraph uses the same type of logic to compute the employee's time in service. However, if our employee started work on January 1, 1990, the algorithm

will compute the service years as 90. This result is particularly interesting, since the program claims that the employee is only 70 years old.

The question then becomes, "How does one fix the problem?" The answer, in one sense, is quite simple. The programmer must change all of the date fields in the program to incorporate four digits for the year portion of the date. Each task is very simple if there are not too many date fields and they have clearly identified names. However, even in this simple program, you can get a feel for the problem. The programmer must find and change five fields representing years and also correct the print format line. In a larger program, the programmer may easily miss some necessary changes.

The problem becomes more complex because there is more to change than just the program. The input records also contain two-digit year fields. Thus, the file definition must be modified to make sure that all date group items contain four-digit years. In addition to changing the file definition, the data in the files must be changed as well. Thus, some program has to convert the data to the new format. While this process is going on, someone must convert all other associated programs to accept the data in its new format, even if those programs do not use the date fields directly. Coordination of all this effort is critical to ensure that nothing "drops through the cracks." While each change is simple by itself, the implications and volume can be overwhelming.

Some companies have thousands of programs affected by the Year 2000 problem. Many organizations may have 50 million lines of code to inspect and change along with all of the associated files, screens, and reports. Such changes are going to be expensive.<sup>6</sup>

## Date Arithmetic

Another aspect of the problem occurs when a program has to calculate days and not years. Many applications need to determine how many days have occurred between two dates. To accomplish this task, COBOL provides a different type of date structure. The DAY format (YYDDD) describes the sequential number of a date within a given year. In this structure, the YY refers to the years and the DDD refers to the day of the year. December 31 would be 365 in normal years and 366 in leap years. The use of the DAY format makes date arithmetic quite simple as long as the *dates* involved are within the same calendar year.

```

01 TWO-DATES.
 05 FIRST-DATE.
 10 FIRST-YEAR PIC 99.
 10 FIRST-DAY PIC 999.
 05 SECOND-DATE.
 10 SEC-YEAR PIC 99.
 10 SEC-DAY PIC 999.
01 DAYS-DIFFERENCE PIC 999.

 MOVE 97234 TO FIRST-DATE.
 MOVE 97100 TO SECOND-DATE.
 SUBTRACT SEC-DAY FROM FIRST-DAY GIVING DAYS-DIFFERENCE.

```

In the code fragment above, you can see how the DAY format easily provides the number of days between two events as long as both dates are in the same year. The trick is to determine what to do if the two dates span the year boundary. The YY portion of the DAY format does not help much.

Since there are not 1,000 days in a year, simple subtraction would leave a gap of 636 days between December 31, 1997 (97365) and January 1, 1998 (98001), for example. Date calculations crossing the year boundary must take the gap into account. The following code shows one way of handling the problem.

```
MOVE 98030 TO FIRST-DATE.
MOVE 97300 TO SECOND-DATE.
IF FIRST-YEAR > SEC-YEAR
 ADD 365 TO FIRST-DAY
END-IF.
SUBTRACT SEC-DAY FROM FIRST-DAY GIVING DAYS-DIFFERENCE.
```

This code treats the date in the new year as a continuation of the old year and acts as if 98030 were actually 97395. This technique allows the program to compute the difference of 95 days.

You can see what may happen when the millennium changes. If FIRST-YEAR is 00 and SEC-YEAR is 99, the IF condition is false and DAYS-DIFFERENCE would be 270 rather than 95.

Fortunately, the 1989 extensions to COBOL provide a better way to do date arithmetic. These extensions include a number of intrinsic functions that do the kinds of standard operations available in many other languages and in spreadsheet programs. Appendix E, on COBOL 2000, covers the 1989 intrinsic functions as well as the additional functions proposed for the new standard. In the next section, you will see how to use the calendar functions to perform date arithmetic and correct the Year 2000 problem.

### COBOL Intrinsic Calendar Functions

If you have worked with an electronic spreadsheet, you may know that the spreadsheet does not maintain dates YYYYMMDD format. Rather, the spreadsheet maintains a count of the number of days from some arbitrary starting point. In EXCEL, for example, the starting point is January 1, 1900. In other words, EXCEL treats January 1, 1900, as "Day 1." Each day since January 1, 1900 is a consecutively numbered integer. Date arithmetic is simply a matter of adding to or subtracting from these integers. Any date before the defined starting date is invalid.

The intrinsic functions of COBOL allow programmers to use the same type of integer date functions as in a spreadsheet. With COBOL, however, the arbitrary starting point is January 1, 1601. This early date allows consideration of more dates than EXCEL can handle and should be sufficient for most date applications. On the other hand, the early starting date means that the integer values of current dates are quite large. As an example, January 1, 2000 has an integer value of 145732. This means that programs must allow at least six digits for integer date fields.

While integer format dates ease the problem of date calculations, humans have trouble reading dates in this format. Therefore, COBOL has provided functions that convert dates from standard formats to integer and back. The 1989 extension to COBOL provides six intrinsic calendar functions for programmer use.

- CURRENT-DATE—Returns the current system date in YYYYMMDD format.
- WHEN-COMPILED—Returns the compile date in YYYYMMDD format.
- INTEGER-OF-DATE—Converts YYYYMMDD to an integer.
- INTEGER-OF-DAY—Converts YYYYDDD to an integer.

- DATE-OF-INTEGGER—Converts an integer date to YYYYMMDD format.
- DAY-OF-INTEGGER—Converts an integer date to YYYYDDD format.

The syntax for these functions is:

FUNCTION function-name [(argument-1 [, argument-2] . . .)]

The first two functions do not require an argument since they return specific values. The last four functions are the routines that allow COBOL to convert dates to integers and vice versa. These functions work similarly. By reviewing how the DATE-TO-INTEGGER function works, you can easily see how to use the remaining functions.

The program shown in Figure 19.2 uses INTEGER-OF-DATE. You may want to compile and test the program (Y2K02.CBL) for yourself. The program interactively takes the year, month, and day from the user and returns the integer value of the date. Test the program with your birthdate, February 29, 1900, February 29, 2000, and any other date you wish. The program will return zeros for invalid dates.

Looking at the program, you should note several points. In line 6, the integer field has a length of 6. As stated above, six digits are necessary to hold the integer value of current dates. In line 11, DATE-RDF redefines DATE-INPUT because the function INTEGER-OF-DATE requires an elementary item as the input parameter. In line 21 notice that the keyword "FUNCTION" tells COBOL that "INTEGER-OF-DATE" is an intrinsic function and not an identifier.

The syntax is:

FUNCTION INTEGER-OF-DATE (argument-1)

The argument is an elementary item in the format YYYYMMDD, and the function returns a six-digit number.

You may want to rewrite this program to accept DAY values from the user and use the INTEGER-OF-DAY function to convert the value to an integer. You can also write programs to convert an integer to its corresponding DATE or DAY by using the DATE-OF-INTEGGER or DAY-OF-INTEGGER functions. These problems are included in the exercises at the end of the chapter.

Date arithmetic using the intrinsic functions can be quite straightforward. For example:

```
COMPUTE NO-OF-DAYS = FUNCTION INTEGER-OF-DATE (DATE-1)
 - FUNCTION INTEGER-OF-DATE (DATE-2).
```

This statement converts DATE-1 and DATE-2 to integers and subtracts DATE-2 from DATE-1 storing the result in NO-OF-DAYS.

As another exercise, try modifying the program to accept two days and to calculate the difference between them. You may also want to write another program that accepts a date and a number of days from the user. The program then would calculate and return a new date by adding the number of days to the integer of the original date.



One advantage to using the intrinsic calendar functions is that leap-year problems may be avoided or at least minimized.

Figure 19.2 Example of the Integer-of-Date Function

```

1 IDENTIFICATION DIVISION.
2 PROGRAM-ID. Y2K02.
3 DATA DIVISION.
4 WORKING-STORAGE SECTION.
5 01 DATE-DATA.
6 05 DATE-INTEGER PIC 9(06).
7 05 DATE-INPUT.
8 10 DATE-YEAR PIC 9(04).
9 10 DATE-MONTH PIC 9(02).
10 10 DATE-DAY PIC 9(02).
11 05 DATE-RDF REDEFINES DATE-INPUT
12 PIC 9(08).
13 05 LAST-DATE-SW PIC X.
14 88 LAST-DATE VALUE 'N' 'n'.
15
16 PROCEDURE DIVISION.
17 CONVERT-DATE.
18 MOVE 'Y' TO LAST-DATE-SW
19 PERFORM GET-DATE
20 PERFORM UNTIL LAST-DATE
21 COMPUTE DATE-INTEGER = FUNCTION
22 INTEGER-OF-DATE (DATE-RDF)
23 DISPLAY DATE-INTEGER
24 DISPLAY 'DO YOU WISH TO CONTINUE (Y OR N)?'
25 WITH NO ADVANCING
26 ACCEPT LAST-DATE-SW
27 IF NOT LAST-DATE
28 PERFORM GET-DATE
29 END-IF
30 END-PERFORM
31 STOP RUN
32 .
33
34 GET-DATE.
35 DISPLAY 'ENTER YEAR IN "YYYY" FORMAT '
36 WITH NO ADVANCING
37 ACCEPT DATE-YEAR
38 DISPLAY 'ENTER MONTH IN "MM" FORMAT '
39 WITH NO ADVANCING
40 ACCEPT DATE-MONTH
41 DISPLAY 'ENTER DAY IN "DD" FORMAT '
42 WITH NO ADVANCING
43 ACCEPT DATE-DAY
44 .

```

## Leap-Year Problem

A programmer working on the Year 2000 problem and looking at date handling in COBOL programs would encounter special routines written to deal with leap years. Leap years pose special problems, and programs must account for them properly. For example, look again at the program in Figure 19.1 and examine the logic to compute the employee's retirement date (360-CALCULATE-IND-RET-DATE). Notice that the logic assumes that the retirement month and day will be the same as the birth month and day.

```
MOVE EMP-BIRTH-MO TO IND-RET-MO.
MOVE EMP-BIRTH-DA TO IND-RET-DA.
```

In most cases this assumption is valid. However, if an employee was born on February 29, by definition he or she was born in a leap year. A problem occurs because February 29 is invalid for the retirement date 65 years later. For example, a person born on February 29, 1940 would expect to retire in the year 2005. However, 2005 is not a leap year, and February 29 is invalid. In this case, the employee should retire on March 1, 2005. Code must be added to the program to detect the situation and make the adjustment.

Unfortunately, the rules for determining leap years are confusing. Most people know that leap years occur when the year value is equally divisible by four. Many people do not know that years ending in 00 are *not* leap years. There was no February 29 in 1900; yet, some versions of Microsoft's EXCEL will accept February 29 as a valid date for 1900.

Just to make things more difficult, every 400 years February 29 *does* occur in the year ending in 00. So, 1600, 2000, and 2400 are leap years. Consequently, a simple leap year routine that simply divides by 4 often works out better for the year 2000 than a more sophisticated routine that makes adjustments for the century years.

COBOL's intrinsic function INTEGER-OF-DATE manages leap years properly and will return a value of zero when it detects an invalid date. Therefore, the function also provides a way to validate dates. By testing for a zero value, the program can detect when it has encountered an invalid date. Appropriate routines can then be written to deal with the problem.

How can these techniques improve the original program?

## Retirement Program Revisited

Figure 19.3 presents a revision<sup>7</sup> of the original retirement program. This revision eliminates the Year 2000 problems and properly deals with leap years. This new program takes advantage of the 1989 COBOL intrinsic functions and also utilizes a date conversion utility program YEAR-TO-YYYY<sup>8</sup> shown in Figure 19.4. This utility program simulates the COBOL 2000 intrinsic function of the same name. (Note: In order to keep things simple, this version of the program uses the same input file as the original.)

As introduced in the previous section, the CURRENT-DATE intrinsic function returns the system date in YYYYMMDD format and can replace the ACCEPT...FROM DATE statement. Line 119 uses CURRENT-DATE to get the system date. More about CURRENT-DATE can be found in the appendix on COBOL 2000.

Line 120 has been "commented out." This line sets the system date to January 1, 2000. You may test the program to see how it would work in the year 2000, by

deleting the "\*" and recompiling. Be sure to change line 26 of the utility program and recompile that program as well.

In line 140, the program CALLs the utility program YEAR-TO-YYYY<sup>9</sup> using the data group item DATE-CONVERSION-DATA shown beginning in line 44. The utility program takes the value of the first argument "CNV-YY," a two-digit year, and returns "CNV-YEAR," a four-digit year. (Similar CALLs occur in lines 147 and 154.) Because the program needs to determine the proper century, a "window" is necessary. The window is a range of 100 years. The CNV-WINDOW field serves to specify the highest year of the range. YEAR-TO-YYYY adds CNV-WINDOW to the current year determining the latest year the program can return. Thus, if the current year is 2000 and CNV-WINDOW is 15, YEAR-TO-YYYY can return 4 four-digit years from 1916 to 2015. With a current year of 2000 and a WINDOW-MAX set to -15, the utility returns four-digit years from 1886 to 1985.

If years are likely to be equally from the past or the future, the window value should be set at 50. If all of the years to be converted are expected to be less than the current year, the window value should be zero. If all dates will reflect the current and future years only, the window value should be +99.

In the revised program, lines 159 and following manage the retirement-date problem for the employees born on February 29. As explained above, an employee born on this date could not retire on February 29, 65 years later. The program takes advantage of intrinsic function INTEGER-OF-DATES's ability to validate dates. If the function returns a zero, the date proposed is invalid and the program changes the date to March 1. This technique is appropriate only if the source data (i.e., the birthdate) has been previously validated.

Figure 19.3 Revised Retirement Program

```

1 IDENTIFICATION DIVISION.
2 PROGRAM-ID. Y2K03.
3 AUTHOR. ARTHUR R. BUSS
4
5 ENVIRONMENT DIVISION.
6 INPUT-OUTPUT SECTION.
7 FILE-CONTROL.
8 SELECT EMPLOYEE-FILE ASSIGN TO DISK 'EMPSERV.DAT'
9 ORGANIZATION IS LINE SEQUENTIAL.
10 SELECT PRINT-FILE ASSIGN TO PRINTER.
11
12 DATA DIVISION.
13 FILE SECTION.
14 FD EMPLOYEE-FILE
15 RECORD CONTAINS 34 CHARACTERS.
16 01 EMPLOYEE-RECORD PIC X(34).
17
18 FD PRINT-FILE
19 RECORD CONTAINS 80 CHARACTERS.
20 01 PRINT-LINE PIC X(80).
21
22 WORKING-STORAGE SECTION.
23 01 EMPLOYEE-DATA.
24 05 EMP-NUM PIC X(05).
25 05 EMP-NAME.

```



Figure 19.3 (continued)

```

26 10 EMP-LAST PIC X(15).
27 10 EMP-INIT PIC X(02).
28 05 EMP-BIRTHDATE.
29 10 EMP-BIRTH-YR PIC 9(02).
30 10 EMP-BIRTH-MO PIC 9(02).
31 10 EMP-BIRTH-DA PIC 9(02).
32 05 EMP-SERVICE-DATE.
33 10 EMP-SERVICE-YR PIC 9(02).
34 10 EMP-SERVICE-MO PIC 9(02).
35 10 EMP-SERVICE-DA PIC 9(02).
36
37 01 DATA-REMAINS-SW PIC X(02).
38 88 NO-DATA-REMAINS VALUE 'NO'.
39
40 01 CONSTANTS.
41 05 RETIRE-AGE PIC 9(02) VALUE 65.
42 05 YEAR-TO-YYYY PIC X(07) VALUE 'Y2K04'.
43
44 01 DATE-CONVERSION-DATA.
45 05 CNV-YY PIC 9(02).
46 05 CNV-WINDOW PIC S9(02) VALUE ZERO.
47 05 CNV-YEAR PIC 9(04).
48
49 01 INDIVIDUAL-FIELDS.
50 05 IND-AGE PIC 9(02).
51 05 IND-SERV-YEARS PIC 9(02).
52 05 IND-RET-DATE.
53 10 IND-RET-YR PIC 9(04).
54 10 IND-RET-MO PIC 9(02).
55 10 IND-RET-DA PIC 9(02).
56 05 IND-RET-DATE-RDF REDEFINES
57 10 IND-RET-DATE PIC 9(08).
58 05 IND-RET-INT-DATE PIC 9(06).
59
60 01 TODAYS-DATE.
61 05 TODAYS-YR PIC 9(04).
62 05 TODAYS-MO PIC 9(02).
63 05 TODAYS-DA PIC 9(02).
64
65 01 HEADING-LINE-1.
66 05 PIC X(05) VALUE SPACES.
67 05 PIC X(10) VALUE
68 05 'EMPLOYEE'.
69 05 PIC X(07) VALUE SPACES.
70 05 PIC X(10) VALUE SPACES.
71 05 PIC X(09) VALUE 'SERVICE'.
72 05 PIC X(10) VALUE 'RETIREMENT'.
73
74 01 HEADING-LINE-2.
75 05 PIC X(07) VALUE SPACES.
76 05 PIC X(14) VALUE 'NAME'.

```

Value of zero is not  
for conversion  
(Year 2000)

Figure 19.3 (continued)

```

77 05 PIC X(07) VALUE 'INIT'.
78 05 PIC X(06) VALUE 'AGE'.
79 05 PIC X(08) VALUE 'YEARS'.
80 05 PIC X(10) VALUE 'DATE'.
81
82 01 DETAIL-LINE.
83 05 PIC X(05) VALUE SPACES.
84 05 DET-LAST PIC X(15).
85 05 PIC X(02) VALUE SPACES.
86 05 DET-INIT PIC X(02).
87 05 PIC X(05) VALUE SPACES.
88 05 DET-AGE PIC 9(02).
89 05 PIC X(05) VALUE SPACES.
90 05 DET-SERV-YEARS PIC 9(02).
91 05 PIC X(02) VALUE SPACES.
92 05 DET-RET-DATE.
93 10 DET-RET-MO PIC Z9.
94 10 PIC X VALUE '/'.
95 10 DET-RET-DA PIC Z9.
96 10 PIC X VALUE '/'.
97 10 DET-RET-YR PIC 9(04).
98
99 PROCEDURE DIVISION.
100 100-PREPARE-RETIREMENT-REPORT.
101 OPEN INPUT EMPLOYEE-FILE
102 OUTPUT PRINT-FILE
103 PERFORM 210-GET-TODAYS-DATE
104 PERFORM 230-WRITE-HEADERS
105 PERFORM UNTIL NO-DATA-REMAINS
106 READ EMPLOYEE-FILE INTO EMPLOYEE-DATA
107 AT END
108 SET NO-DATA-REMAINS TO TRUE
109 NOT AT END
110 PERFORM 260-PROCESS-DETAIL
111 END-READ
112 END-PERFORM
113 CLOSE EMPLOYEE-FILE
114 PRINT-FILE
115 STOP RUN
116 .
117
118 210-GET-TODAYS-DATE.
119 MOVE FUNCTION CURRENT-DATE TO TODAYS-DATE
120 * MOVE '20000101' TO TODAYS-DATE
121 .
122
123 230-WRITE-HEADERS.
124 WRITE PRINT-LINE FROM HEADING-LINE-1
125 AFTER ADVANCING PAGE
126 WRITE PRINT-LINE FROM HEADING-LINE-2
127 INITIALIZE PRINT-LINE

```

YYYY Format

Test for Year 2000

Figure 19.3 (continued)

```

128 WRITE PRINT-LINE
129 .
130
131 260-PROCESS-DETAIL.
132 PERFORM 310-CALCULATE-EMP-AGE
133 PERFORM 330-CALCULATE-EMP-SERVICE
134 PERFORM 360-CALCULATE-IND-RET-DATE
135 PERFORM 390-WRITE-DETAIL-LINE
136 .
137
138 310-CALCULATE-EMP-AGE.
139 MOVE EMP-BIRTH-YR TO CNV-YY
140 CALL YEAR-TO-YYYY USING DATE-CONVERSION-DATA
141 COMPUTE IND-AGE = TODAYS-YR - CNV-YEAR
142 + (TODAYS-MO - EMP-BIRTH-MO) / 12
143 .
144
145 330-CALCULATE-EMP-SERVICE.
146 MOVE EMP-SERVICE-YR TO CNV-YY
147 CALL YEAR-TO-YYYY USING DATE-CONVERSION-DATA
148 COMPUTE IND-SERV-YEARS = TODAYS-YR - CNV-YEAR
149 + (TODAYS-MO - EMP-SERVICE-MO) / 12
150 .
151
152 360-CALCULATE-IND-RET-DATE.
153 MOVE EMP-BIRTH-YR TO CNV-YY
154 CALL YEAR-TO-YYYY USING DATE-CONVERSION-DATA
155 ADD RETIRE-AGE TO CNV-YEAR GIVING IND-RET-YR
156 MOVE EMP-BIRTH-MO TO IND-RET-MO
157 MOVE EMP-BIRTH-DA TO IND-RET-DA
158 * TEST FOR INVALID FEBRUARY 29 RETIREMENT DATE
159 COMPUTE IND-RET-INT-DATE = FUNCTION INTEGER-OF-DATE
160 (IND-RET-DATE-RDF)
161 * WHEN FOUND, SET DATE TO MARCH 1.
162 IF IND-RET-INT-DATE = ZERO
163 ADD 1 TO IND-RET-MO
164 MOVE 1 TO IND-RET-DA
165 END-IF
166 .
167
168 390-WRITE-DETAIL-LINE.
169 MOVE EMP-LAST TO DET-LAST
170 MOVE EMP-INIT TO DET-INIT
171 MOVE IND-AGE TO DET-AGE
172 MOVE IND-SERV-YEARS TO DET-SERV-YEARS
173 MOVE IND-RET-MO TO DET-RET-MO
174 MOVE IND-RET-DA TO DET-RET-DA
175 MOVE IND-RET-YR TO DET-RET-YR
176 WRITE PRINT-LINE FROM DETAIL-LINE
177 .

```

*Test for Feb 29 Retirement*

*Correction of Retirement Date*

Figure 19.4 Year Conversion Utility Program

```

1 IDENTIFICATION DIVISION.
2 PROGRAM-ID. YEAR-TO-YYYY.
3 AUTHOR. ARTHUR R. BUSS
4
5 ENVIRONMENT DIVISION.
6
7 DATA DIVISION.
8 WORKING-STORAGE SECTION.
9 01 TEMPORARY-DATA.
10 05 WORK-YEAR.
11 10 WORK-HIGH-YY PIC 9(02).
12 10 WORK-LOW-YY PIC 9(02).
13 05 WORK-YYYY REDEFINES WORK-YEAR
14 PIC 9(04).
15
16 LINKAGE SECTION.
17 01 LS-CONVERSION-DATA.
18 05 LS-YY PIC 9(02).
19 05 LS-WIND PIC S9(02).
20 10 LS-HIGH-YY PIC 9(02).
21 10 LS-LOW-YY PIC 9(02).
22
23 PROCEDURE DIVISION USING LS-CONVERSION-DATA.
24
25 MOVE FUNCTION CURRENT-DATE TO WORK-YEAR.
26 * MOVE 2000 TO WORK-YYYY
27 ADD LS-WIND TO WORK-YYYY.
28 MOVE WORK-HIGH-YY TO LS-HIGH-YY
29 MOVE LS-YY TO LS-LOW-YY
30 IF LS-YY > WORK-LOW-YY
31 SUBTRACT 1 FROM LS-HIGH-YY
32 END-IF
33 EXIT PROGRAM
34

```

Without Shifted Out

For Year 2000

## S U M M A R Y

### Points to Remember

- The Year 2000 problem has been known for many years, but has drawn attention only recently. As January 1, 2000 gets nearer, interest and alarm are also growing. This problem will not go away, and the deadline cannot be postponed.
- Making the program corrections is not difficult in itself. The difficulty comes because so many programs and files must be changed and tested.

Information Technology departments must find every occurrence of a date and convert each date to YYYY format.

- Two kinds of date formats are involved: the DATE format (YYYYMMDD) and the DAY format (YYYYDDD). Both types of dates must be corrected.
- The 1989 COBOL extensions to COBOL 85 provide several intrinsic functions that can help in the conversion process. These include CURRENT-DATE, INTEGER-OF-DATE, INTEGER-OF-DAY, DATE-OF-INTEGER, and DAY-OF-INTEGER. COBOL 2000 includes other intrinsic functions, but they may not be available in time.
- The Year 2000 is a leap year. All date routines that accommodate leap years must be checked to assure that 2000 is handled properly.

**Key Words and Concepts**

Y2K  
 Millennium Problem  
 Date Arithmetic  
 Intrinsic Function

**COBOL Elements**

|                 |                 |
|-----------------|-----------------|
| FUNCTION        | INTEGER-OF-DAY  |
| CURRENT-DATE    | DATE-OF-INTEGER |
| INTEGER-OF-DATE | DAY-OF-INTEGER  |

**F I L L - I N**

---

1. The year 2000 problem resulted from a desire to save on \_\_\_\_\_ and \_\_\_\_\_.
2. The correction of the problem (can/cannot) be delayed beyond January 1, 2000.
3. Businesses have (been/not been) quick to recognize and to solve the problem.
4. The 1989 extensions to COBOL 85 have provided new capabilities called \_\_\_\_\_.
5. INTEGER-TO-DATE converts a(n) \_\_\_\_\_ to a \_\_\_\_\_ in \_\_\_\_\_ format.
6. DAY-TO-INTEGER converts a(n) \_\_\_\_\_ in \_\_\_\_\_ format to a(n) \_\_\_\_\_.
7. The year 2000 (is/is not) a leap year.

**T R U E / F A L S E**

---

1. The Year 2000 problem has been known for a number of years.

2. With the Year 2000 problem, finding the changes to make is more difficult than the actual correction.
3. Intrinsic functions were a part of the original COBOL 85 standards.
4. The decision to eliminate the first two positions of the year in dates was a conscious one.
5. INTEGER-TO-DATE and INTEGER-TO-DAY return the same date format.
6. The COBOL statement ACCEPT FROM DATE works the same under the 1985 standards as it will in the 2000 standards.
7. Business, in general, has been slow to recognize the Year 2000 problem and has to scramble to catch up.
8. Even if companies cannot make all date routine changes by December 31, 1999, they should have at least a year before problems show up.

## PROBLEMS

---

1. Write a program that accepts the year and day of the year and displays the integer value of that year and day. Test the program with year 1600 day 365, year 1601 day 1, year 1999 day 365, year 2000 day 1, year 2000 day 366, and any other year and day number. Invalid dates should return a 0 integer value.
2. Write a program that accepts a date and a number of days. The program should add the days to the input date and return the new date. The program should work with negative numbers for the input number of days. Test the program to make sure that it works for dates after January 1, 2000.
3. Accounts Receivable systems need to be able to detect when an invoice is overdue. Write a procedure or a subprogram that calculates the date 90 days prior to the current date and compares an invoice date to see whether or not it is overdue. Use the commenting technique demonstrated in Y2K01 and Y2K02 to test to see how the program would work in the year 2000.
4. Life insurance rates are partially based on the age of the policyholder. Write a procedure that will compute a person's age in years based on their birthdate and the current date. Test the program to see whether it will work in the year 2000.

## FOR FURTHER STUDY

---

This chapter has included Year 2000 problem topics primarily involving COBOL, but the Year 2000 problem has ramifications in other contexts, as well. For example, many personal computers will fail when the system clock changes to January 1, 2000. DOS systems do not recognize dates before January 1, 1980, and when 2000 occurs, many of these systems will assume that 00 must mean that the current year is 1980.

The Year 2000 problem is getting increasing press recognition; interest is likely to grow as 2000 gets nearer. A number of World Wide Web sites address the topic and offer some places to use as starting points for further research.

[http://www.yahoo.com/text/Computers\\_and\\_Internet/Year\\_2000\\_Problem/](http://www.yahoo.com/text/Computers_and_Internet/Year_2000_Problem/)  
<http://www.wa.gov/dis/2000/y2000.htm>  
<http://www.year2000.com/y2klinks.html>  
[http://www.ttuhsc.edu/pages/year2000/y2k\\_bib.htm](http://www.ttuhsc.edu/pages/year2000/y2k_bib.htm)

- 
- <sup>1</sup> The authors recognize that the year 2000 is technically part of the twentieth century, but the problem nonetheless is one that begins on January 1, 2000.
- <sup>2</sup> According to the Gartner Group, quoted in Leon A. Kappelman and James J. Cappel, "A Problem of Rational Origin That Requires a Rational Solution," *Journal of Systems Management* 47, 4 (July-August 1996): 6, 8.
- <sup>3</sup> Kappelman and Cappel contend that the saving in disk space and memory space over the years actually compensates for the conversion costs that are now necessary.
- <sup>4</sup> COBOL 2000 can return the year in either YY or YYYY form. The format "ACCEPT identifier FROM DATE YYYYMMDD" must be used to get four digits. For compatibility's sake, YYMMDD is the default format.
- <sup>5</sup> You may have noticed the period standing alone at the end of each paragraph. Some programmers use this technique to avoid logic errors resulting from misplaced punctuation. The authors have chosen to use introduce this practice here. Scope terminators can replace most uses of the period, as explained in the Programming Tip *Use Scope Terminators* in Chapter 7. The ANS standard requires only a period at the end of a paragraph.
- <sup>6</sup> The Gartner Group has estimated that fixing the problem will cost about \$1 for *each* line of code in the organization. Many companies have 50 million or more lines of code. Quoted in Kappelman and Cappel.
- <sup>7</sup> Y2K03.CBL.
- <sup>8</sup> Y2K04.CBL.
- <sup>9</sup> In this case "YEAR-TO-YYYY" is the name of an identifier (line 44). The identifier contains the file name "y2k04" for the actual program YEAR-TO-YYYY. See Chapter 16, "Subprograms," for further information.

# Object-Oriented COBOL Programming

## CHAPTER OUTLINE

---

Overview

### **The Next Generation of COBOL**

The Development of Structured Programming

Terminology

The Object-Oriented versus Structured Paradigm

The Student-Look-Up System

### **Student-Look-Up Program**

The Registrar Class

Classes and Inheritance

ProcessRequests Method

The StudentDM Class

StudentDM Instance Definition

The Student Class

The Person Class

The StudentUI Class

The StudentPRT Class

### **Conclusion**

Summary

Fill-in

True/False

Problems



## OBJECTIVES

---

After reading this chapter you will be able to:

- Discuss the concept of Object-Oriented programming as compared to structured programming.
- Describe the structure of classes including the class definition as well as the Factory and instance definition.
- Be able to define some major OO concepts including: encapsulation, inheritance, persistence, and polymorphism.
- Describe the similarities and differences between the use of Objects and the use of subroutines.
- Describe the advantages OO programming has over Structured Programming.
- State why OO programming does not invalidate all of the principles of Structured Programming.

## OVERVIEW

---

Object-Orientation (OO) has become an important new way to develop information systems. This technique allows for faster development of systems, reuse of program code, and better management of data. OO is now available for use with COBOL and promises to give additional life to this well-established programming language. The COBOL 2000 standards define Object-Oriented COBOL, but this standard has not been completed and accepted as yet. However, several vendors including Micro Focus have developed their own version of OO COBOL and have tried to make their versions as close as possible to the proposed standards. We use Micro Focus Personal COBOL for Windows in developing the example system in this chapter. Differences in the code presented here and code that matches the official standard should be minimal.

The chapter begins with an introduction to the concepts and reasons for OO COBOL. Next, we review the strengths and weaknesses of structured programming and then make comparisons between the two programming approaches.

The remaining portion of the chapter shows an OO system implementation of the Engineering Senior program developed in Figure 1.6. What was in one program becomes several classes. Each class serves to demonstrate one or more OO concepts. As we present each portion of the system, we attempt to demonstrate the structure of OO classes and methods to show how OO can make system development and maintenance simple.

This chapter by itself is not enough to train you in OO COBOL. You will need further study to become proficient. We have included the names of several new texts of OO COBOL at the end of the chapter. The intent of this chapter is to whet your appetite to learn more about this exciting and challenging new programming technique.

## The Next Generation of COBOL

One of the most exciting new features of the COBOL 2000 Standard is its incorporation of *Object-Orientation* (OO) into the language. Even though the standard will not become official for several years, OO COBOL is available now and offered by several vendors including IBM, Hitachi, and Micro Focus. OO COBOL provides the advantages of object-orientation to the business community without having to train programmers in new languages. In addition, there is no need to worry about making these languages work with critical legacy systems. COBOL, the dominant business language, now has object-orientated capabilities while retaining COBOL's traditional strengths: readability, easy maintenance, powerful file handling, and good reporting.

Previously, OO was limited to such languages as Smalltalk and C++. These languages were designed for highly technical applications and for small, rapidly developed systems. While there is much to commend in these OO languages, they do not have the business orientation that is the trademark of COBOL. For example, these languages do not have the powerful file-handling capabilities of COBOL, nor do their data structures work well with the files created by COBOL legacy systems. The syntax of those languages also tends to be rather abstract and hard to read, making systems developed in these languages difficult to maintain. OO COBOL, on the other hand, maintains and even improves COBOL's traditional readability and maintainability.

Other languages, such as Visual BASIC and Delphi, provide a form of OO and are relatively easy to use. They also provide a way for end users to develop their own business systems. Yet these languages are not necessarily efficient; nor are systems developed in these languages always effective for large applications. In addition, systems developed in Visual BASIC or Delphi are not easily maintained by users other than the developers.

Systems developed in OO COBOL are maintainable and able to interface with the programs and files of traditional COBOL systems. On the other hand, the COBOL 2000 standard provides for the Boolean, integer, and floating-point data types used by other common languages. Thus, the new COBOL can work with systems developed in all computer languages.

The concept of object-orientation may be somewhat threatening to someone who has devoted much time and effort to learning structured COBOL. Students, for example, may be concerned that they have spent much effort learning how to write structured programs only to have this skill made obsolete by object-orientation. These students may wonder, "Why not just learn OO and forget *structured programming* entirely?"

In answer to these concerns, we believe that structured COBOL will not go away soon. Yet OO is coming, and the individual who can "speak" both dialects of COBOL will become a valuable asset to employers. As businesses begin to adopt OO COBOL, they will be seeking out people who can help them make the transition. In the meantime, structured COBOL is the predominant dialect and will continue to be so for many years. The change may be inevitable, but it will be slow. As evidence, even today some legacy systems are still in *pre-structured programming* code.

A second answer is that object-orientation does not eliminate what is good about structured programming. OO promotes and even improves upon the best features of structured programming. Therefore, even though there is much new about OO COBOL, a programmer will not be starting from scratch when learning it.

At this point, many texts attempt to define object-orientation with a series of new terms and potentially confusing terms such as *encapsulation*, *inheritance*, and *polymorphism*. This discussion delays the introduction and definition of these and other terms until they can be demonstrated and defined within the context of a functioning system. It is difficult to define object-orientation in a few sentences or

by simply introducing and explaining the new terms. This entire chapter is, in a sense, a definition. OO represents a new *paradigm* or way of thinking about programming, just as the structured programming was a new way of thinking about programming in its time.

### The Development of Structured Programming

When computers were new and people were still learning how to program them, there were few guidelines as to what constituted a “good” program. Programming was more an art form than a disciplined craft. As a result, the quality of programs varied widely. Programming projects were difficult to estimate and manage because no one could be sure how long a program would take to build. Information systems were difficult to build and, when completed, were usually late and over budget. In many cases, the systems were not completed at all.

Structured programming was developed as a response to this systems development crisis. The structured approach introduced a philosophy of program development and specified “rules” for writing programs. Some of these rules were as follows:

- Break programs into short sections of code called modules. Modules were usually implemented as COBOL paragraphs.
- Build cohesive modules, where each module performs a single task.
- Build loosely coupled modules, where each module is as independent as possible from the other modules.
- Ensure that each module has a single entry and a single exit point.
- Avoid the use of GOTO statements.

The structured techniques brought a new degree of order and discipline into the programming process. As a result, the quality of programs improved and programming projects became more manageable. Structured programming was a great step forward in the evolution of programming.

Unfortunately, the structured paradigm also introduced new problems. Structured programs tend to be cumbersome because the structuring process requires an elaborate hierarchy of operations and control structures. These hierarchies and structures define the operation of a program, but they also mean that there is duplication of effort in developing programs. The higher levels of structured programs tend to follow the same patterns, but must be coded into every program. Elaborate structures also tend to make programs rigid and difficult to change quickly enough to meet new processing requirements. For example, review the Tuition Billing program developed in Chapters 4-7 and shown in Figure 7.4.

Paragraph 100-PREPARE-TUITION-REPORT in line 124 maintains overall control of the program’s process. This paragraph opens and closes files, and performs four other paragraphs. One of those paragraphs, 260-PROCESS-STUDENT-RECORD, does the main processing loop in the program (lines 129 and 130). This paragraph, in lines 148–152, performs four additional paragraphs. Of these paragraphs, 310-COMPUTE-INDIVIDUAL-BILL in lines 166–172, performs four more paragraphs and makes a computation. Thus, out of the twelve paragraphs in the program, three paragraphs are primarily dedicated to controlling the process and do little actual work. For a simple program, a large part of the code is devoted just to control. Figure 3.3 shows the entire hierarchy chart for the program.

Most structured programs spend a similar proportion of code just controlling the process. Unfortunately, these control paragraphs cannot be simply copied from one program to another; each program must have its own set of control paragraphs.

The problems inherent in structured programming are not limited to the Procedure Division. Of the 80 lines in the Data Division, 63 lines specify parts of the report. Only three of the twelve paragraphs actually use those lines. Nevertheless, any paragraph in the program can access those items and every other data item. Structured COBOL provides no way to isolate data items so that only the authorized paragraphs can use them or change their values. Thus, if the structured rules are not followed, code can be inserted in any paragraph to modify data items. Under these circumstances, errors may be introduced to the program, and these errors may be difficult to find.

The Tuition program is a very good structured program. It just reflects the conditions inherent in any structured program. Object-orientation can avoid many of these problems.

Structured programming was a new way of thinking about programming. This new paradigm was far superior to the way people thought about programs before. The superiority of this approach led virtually every company to adopt structured programming as the standard. In the process of change, programmers who had learned to program under the old rules (or lack thereof) had a difficult time making the transition to structured programming. They had to learn a new way to think about programming. In the same way, the transition to object-orientation will be difficult but worthwhile.

The object-orientation approach is not a complete negation of the structured principles. In fact the most important contributions of structured programming are maintained and enhanced. For example, OO programs still incorporate the three basic control structures—sequence, selection, and iteration—discussed in Chapter 3. The principles of cohesiveness and loose coupling mentioned above are actually strengthened in OO programming. OO represents a “paradigm shift” in its approach to the overall design issues, but does not contradict the principles of good programming that have been proved in structured programming.

## Terminology

In order to compare the object-oriented and structured paradigms, some terminology needs to be defined. In learning from a book like this, you should have developed a good idea of what a program is. As defined in Chapter 1, a program is a translation of an algorithm into a form the computer can understand. Usually that algorithm requires the program to input data, process it, and output information.

In working through problems and assignments, you have had to focus on writing individual programs and may have formed the impression that programs are self-sufficient units. You may not have thought about where the input files came from or where the output goes. In “real-world” applications, a program is usually just one part of a system. Systems are collections of software and data units designed to work together to perform an application.

In structured systems, the software units are programs and the data units are files. Generally, one program runs at a time, processing input files and data to create output files and reports. Each program runs to completion before the next program begins. Files provide the link from one program to another and allow the system to function as a whole.

Object-oriented systems consist not of files and programs, but rather of objects. The proposed COBOL 2000 standard defines an object as “an entity that has a unique identity, specific data values, and specific behaviors or program code.” In other words, objects combine the features of files and programs. Objects not only store data, but process it as well. Within an OO system, objects pass data directly and interactively to each other without the use of files. Unlike programs that run

one at a time, many objects may be active at the same time. Objects are linked by sending *messages* to each other.

The messages are requests for the receiving object to perform some action and often to return the results of that action. The messages request the objects to perform a *method*. The COBOL 2000 standard defines a method as “procedural code that defines a specific function... A method may be thought of as a module or subroutine.” Objects can contain many methods, with each method designed to accomplish a particular function. When one object requests (sends a message to) another object to perform a function, the process is called *invoking* a method.

In summary, systems are made up of numerous units that carry out the purposes of the system. In structured systems, these units are programs and files. In OO systems, these units are objects. Objects contain both data and methods. Many objects may be active at one time, and they communicate with each other through messages. Messages are requests for other objects to perform a method.

### The Object-Oriented versus Structured Paradigm

When developing an OO system, the designer tries to identify and represent the *nouns* of the system. The nouns come from the names of entities necessary to accomplish the system’s purpose such as Student, Employee, or Invoice. These entities become candidates for *classes* in the system. In OO terminology, a class is the generic definition of an object. The term *instance* is used to refer to a specific occurrence of an object. Most authors use “instance” and “object” interchangeably. From this point on we use the term “class” to refer to the generic model and “instance” or “object” to refer to a specific example.

As OO designers begin to identify and refine the classes, they specify the types of data belonging to and the behaviors associated with the class. As additional requirements become apparent, additional data items and methods may be added. By looking at the nouns, the OO designer can determine how a class should behave in general without regard to any specific system. Thus, these general class behaviors or methods can be used by many systems. When system-specific requirements dictate the need for additional methods or data items, they can be added to the class without affecting the previously defined data items and methods in the class.

By contrast, the structured approach focuses on the *verbs* of the system. Verbs identify the things a system must do. As each activity of the system is identified, the designer specifies a program or programs to carry it out. These programs are custom designed for their specific system.

OO systems are more flexible than structured systems. By placing procedures in methods contained in classes rather than programs, OO allows common routines to be written just once. Any system that uses the class can use any of its methods. Methods are developed just once, but used in a variety of situations. The need for duplicate coding is reduced and additional functionality can be added to systems with minimum effort.

Methods, once developed and tested, can be reused with confidence and a minimum of testing. In addition, if some change is necessary in the method, the change only has to be made only once in the class. Every system using that class then automatically uses the revised method.

After a class is developed, it becomes a building block available for use in future systems. When the developers of a new system determine the need for a class, they can investigate to see if it is already available. If the new system requires new functionality from a class, new methods can be added to the class without affecting any of the old methods. As a result, classes become more useful and powerful as new functions are defined and implemented as methods. The same cannot be said for structured systems and programs.

Structured systems consist of custom-designed programs. Even when common routines occur, they cannot easily be copied into other programs, nor can other systems just use part of a structured program. As a result, each new program is built from scratch with little use of previously developed routines. Even if the routines can be copied into new programs, it is almost impossible to update all of the copies should some change need to be made.

As an example, suppose that there is a need for a Student Enrollment system. A structured analysis would look at the verbs and might determine that the system needs to:

- ▷ Generate a course schedule.
- ▷ Enroll students.
- ▷ Prepare course rosters.
- ▷ Prepare student schedules.

The structured approach would then design one or more programs to perform each of these activities. Files would be developed to link the processes together so that the system could perform as a whole. Even though preparing course rosters and preparing student schedules are very similar processes, it is unlikely that any of the programs would be reused or that routines would be copied from one program to another.

The OO approach to a Student Enrollment system would focus on the entities who participate in the system. The analysis then might come up with classes such as:

- ▷ Student
- ▷ Advisor
- ▷ Registrar
- ▷ Course

From this analysis, the OO designer would determine the functions and the data that each of these should handle. In producing the actual Course Rosters and the Student Schedules, the system would use methods from both the Student class and the Course class. Some of the same methods could be used in performing each function. In addition, most of these classes developed for Student Enrollment might be used in other systems such as Tuition Billing, Advising, or Grade Reporting. Therefore, these classes are not useful just for the Student Enrollment system, but could be building blocks for other systems as well.

Another difference between OO and structured systems is in how they actually operate. Programs run in a standalone mode with one program operating at a time. Linkages between programs are maintained by passing files. By contrast, many objects may be functioning interactively and linkages are maintained through messages. Objects, unlike programs, are aware of other objects. Since messages, rather than files, provide the linkage between objects, files per se are not necessary in an OO system except to store data while the system is not running.

Objects exist in the memory of the computer only while the system is operating. If there were no way to store the objects, data would be lost when the system shut down. Therefore, OO systems store object data in files until the system starts again. These files provide *persistence* between system runs. An OO system requires special classes called data managers to ensure that the data “persists” from one run of the system to another.

## The Student-Look-Up System

To illustrate the concepts of Object-Oriented COBOL and the differences from structured programming, this chapter uses a OO version of the Engineering Senior program presented in Chapter 2.<sup>1</sup> The design of the system is shown in Figure 20.1. While the original program worked only for Engineering Students with more than 100 credit hours, this version has added functionality, allowing the user to specify a minimum number of credit hours required (rather than 100) and any major, not just engineering. For the purpose of this chapter the OO version is called the Student-Look-Up system.

### PROGRAMMING SPECIFICATIONS

**System Name:** Student-Look-Up system (Object Version of Engineering Senior program)

**Narrative:** This system is an Object-Oriented Enhancement of the Engineering Senior program presented in Chapter 1. The system allows the user to interactively enter a major course of study and a minimum number of credits earned. The system then produces a report listing all students meeting both the major and minimum credit-hours qualifications.

**Input File(s):** STUDENT-FILE

**Input Record Layout:** See Figure 1.3a.

**Test Data:** See Figure 1.3b.

**Report Layout:** See Figure 1.3c.

**Screen Layout:** See Figure 20.8.

- Processing Requirements:**
1. Print a heading line.
  2. Prompt the user for a major.
  3. Prompt the user for the minimum number of credit hours.
  4. Read a file of student records.
  5. For every record, determine whether that student has the major specified in step 2 and has completed more than the number of hours specified in step 3.
  6. Print the name of every student who satisfies the requirements in item 5. Single-space the output.
  7. At the end of the Report, print a line that says " \* \* \* End of Report \* \* \* ."

Look at the design of the Student Look-Up system in Figure 20.1. A system of six classes replaces the original program. The figure does not show a driver program used to initiate the system. Viewing the diagram, you may feel that creating six classes and a driver program has to be more complex than developing just one program. To perform this very simple application, you may be right. However, if you look at the classes as potential building blocks for other systems, you can see that some extra effort here could mean less effort over the long run. The Engineering Senior program can do one function and one function only.

The trick to developing OO systems is not in implementing the classes, but in knowing how to partition out the data and procedures to the various classes. One accomplishes this task through Object-Oriented Analysis and Design. A full discussion of that topic is beyond the scope of this chapter, but it does need to be mentioned briefly.

Figure 20.1 Student-Look-Up System Design

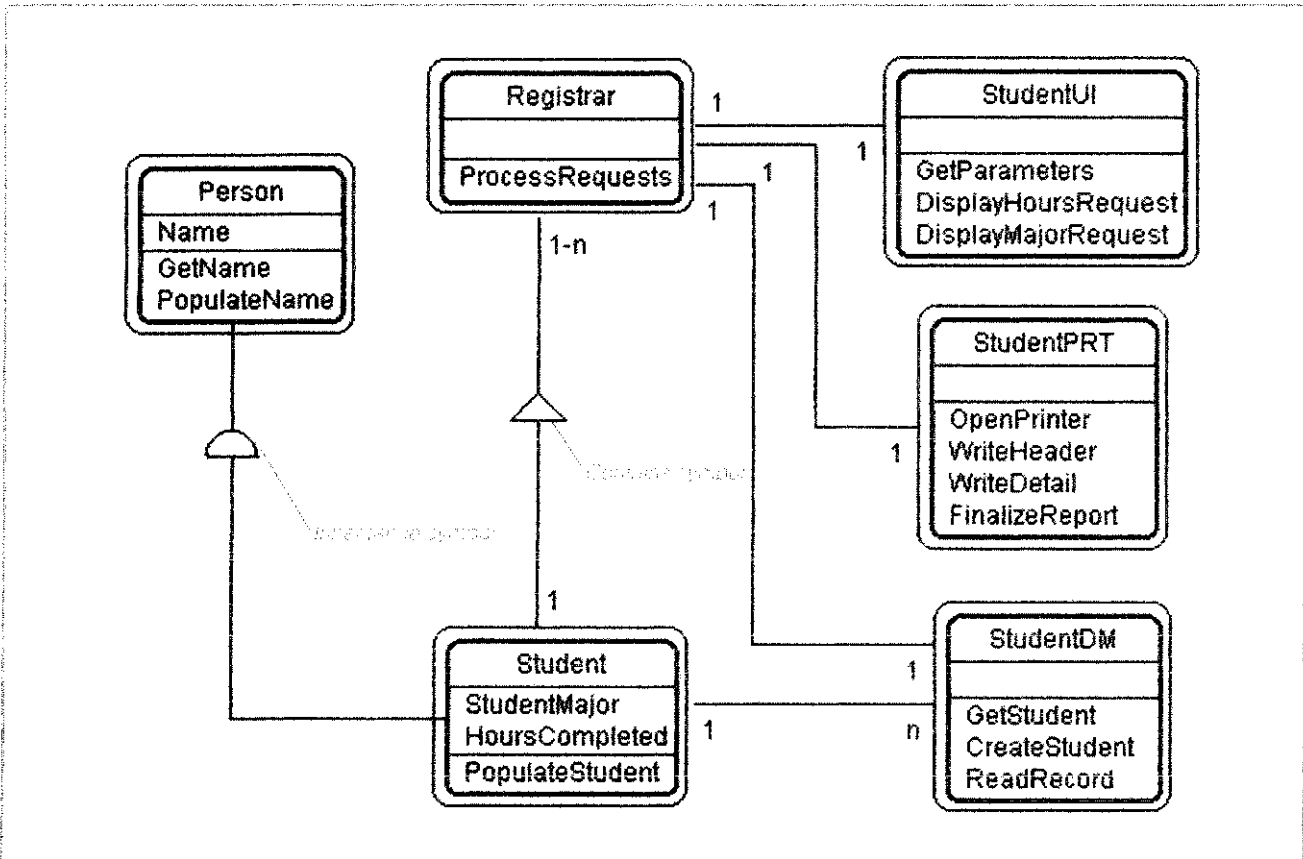

As stated before, OO analysis and design focuses on the nouns used to describe the systems. These nouns often can identify the system classes. For example, in the Student Look-Up system, Registrar and Student are obvious classes.

After identifying the class, the analyst asks three questions about each class:<sup>2</sup>

- What does it know? What data does it own?
- Whom does it know? What other classes are necessary for it to accomplish its work?
- What does it do? What functions does it need to perform?

After answering these questions, the analyst can develop a model of the system such as seen in Figure 20.1. The double boxes with rounded corners represent classes. Each class symbol is divided into three sections. The top section contains the class name. The middle section contains the names for data items owned by the class and the bottom section contains the names of the methods the class can perform. The lines represent the routes messages can take within the system and show the answer to the question, “Whom does it know?” The indicators at either end of the line show how many instances of another class an instance can know at one time. For example, a Student can know only one Registrar object, while the Registrar object can know from 1 to  $n$  instances of Student.

Special relationships between classes are shown by symbols on the connecting lines. The half-circle between Person and Student means that Student *inherits* from Person. We will discuss the concept of inheritance later. The triangle between Registrar and Student means that Student is contained in Registrar. That is, the Registrar is responsible for managing the Student class. This concept is not important to understanding how this system works.



Some of the classes represent the *problem domain* of the system—the purpose of the system. These classes do the primary work of the system. However, just as the functional workers in an office cannot operate efficiently without support and administrative workers such as secretaries, mailroom staff, file clerks, and the like, support classes are needed as well. Some of the support classes include:

- **User Interface Classes.** Classes that handle the interactive screens and windows allowing the users to interact with the system. User interfaces also involve the printing of reports for the user and production of external documents such as invoices and purchase orders.
- **System Interaction Classes.** These classes manage the interfaces to other systems. These other systems may be object-oriented or traditional legacy systems. System Interaction classes would handle files passed between the systems, access to centralized data bases or telecommunications between systems.
- **Data Management Classes.** These classes administer the storage and retrieval of data used by Problem Domain instances. Data Management classes are necessary to maintain the persistence of objects.
- **Drivers.** These programs are not classes at all. They are programs developed to initiate and test objects. Driver programs often are temporary in nature and allow the system developer to see how a class will behave before incorporating it into the system. Most OO systems include a driver program to start the system.

Table 20.1 shows the classes of the Student-Look-Up system, the types of class they are and comments about the functions performed.

The starting point for the system is the Student-Look-Up program. Even though Student-Look-Up is the driver program for the system and not a class, it introduces some of the elements of object-orientation.

### Student-Look-Up Program

Student-Look-Up is the program shown in Figure 20.2 and may be one of the shortest COBOL programs you have ever seen. The program cannot really be called structured because it has only three statements in lines 19–21 of the Procedure Division. There are several other features in this program that may seem strange. The most obvious difference is the use of uppercase and lowercase in the source code. COBOL 85 has always allowed this practice, but acceptance of this practice has been slow. We have used mixed-cases code to symbolize a new age of COBOL.<sup>3</sup> The Programming Tip shows all of the coding conventions we use in this chapter.

**TABLE 20.1** Student-Look-Up System Driver and Classes

|                 |                 |                                                                                                                                                             |
|-----------------|-----------------|-------------------------------------------------------------------------------------------------------------------------------------------------------------|
| Student-Look-Up | Driver          | Initiates the system and creates the Registrar object.                                                                                                      |
| Registrar       | Problem Domain  | Maintains overall control of the system, creates the utility objects: StudentUI, StudentDM, and StudentPRT. Interacts with Student to get the student name. |
| Student         | Problem Domain  | Maintains the Student data. Can produce the student's name, credit hours taken and major.                                                                   |
| Person          | Problem Domain  | Parent Class to Student. Maintains the student name information.                                                                                            |
| StudentDM       | Data Management | Controls the processing of the Student File and creates Student Instances based on requested parameters.                                                    |
| StudentPRT      | User Interface  | Controls the production of the report.                                                                                                                      |
| StudentUI       | User Interface  | Controls the interactive dialog with the user of the system.                                                                                                |

## PROGRAMMING SPECIFICATIONS

**Program Name:** Student-Look-Up

**Narrative:** This program is the primary driver program for the system. The program creates the Registrar object and initiates the system to process a request for a listing of students based on user input specifications.

**Objects Created:** Registrar

**Objects Referenced:** Registrar

- Processing Requirements:**
1. Create Registrar object.
  2. Invoke Registrar method ProcessRequest.

Figure 20.2 Student Look-Up Program

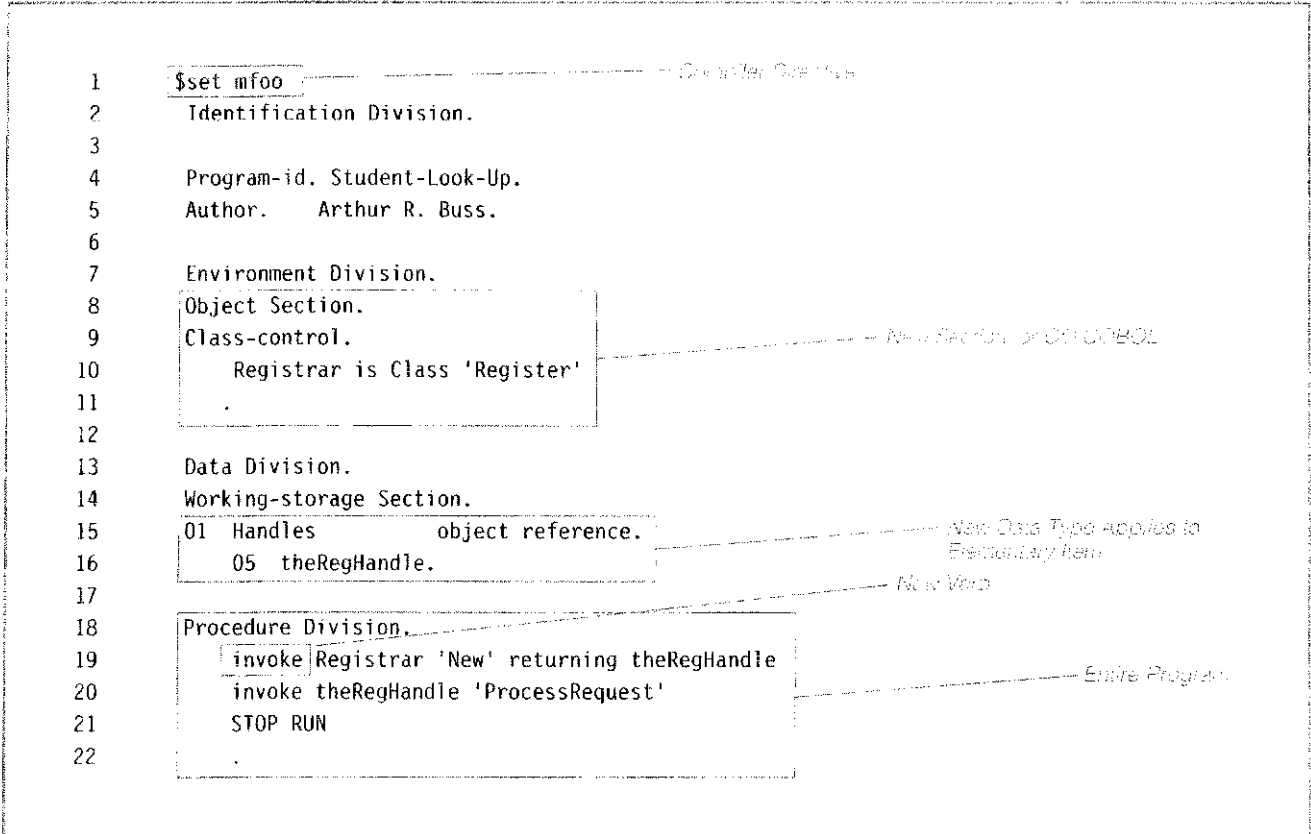

## PROGRAMMING TIP

OO COBOL is so new that there are not well-established ways for coding classes. The following are the conventions for this book.

- ④ Division and section names are capitalized. For example, Procedure Division and Working-storage Section.
- ④ Data item name words are capitalized and separated by hyphens. For example, Student-Name.
- ④ Linkage-storage data names are prefixed by 1s-.
- ④ Method name words are capitalized, but *not* separated by hyphens. For example, ProcessRequests.
- ④ Handle names do not have an initial capital letter, but each succeeding word is capitalized. The words are not separated. For example: theRegHandle.
- ④ COBOL reserved words other than division and section titles are lowercase.
- ④ For visibility purposes, FACTORY, OBJECT, and STOP RUN are uppercase.
- ④ End statements for methods, objects, and classes are capitalized. For example, End Method, End Object, and End Class.
- ④ Division titles are omitted, except where necessary or for clarity. In this system, Student-Look-Up includes all four division titles. Identification Division is not included in any class definition. Environment Division and Data Division are included only in the classes that handle file processing. Procedure Division is included in all classes.
- ④ Within classes, all methods are separated by a blank line.
- ④ To ensure that method names are seen as being part of the method, Method-id statements are *not* separated from the next line.
- ④ When a method Procedure Division has using or returning clauses, each clause is separated onto a separate line and indented. For example:

```

Procedure Division
 using 1s-Stu-Parameters
 returning 1s-theStuHandle.

```

- ④ Procedure Division code is separated from the division title by one line.
- ④ In Procedure Division code, only one period is allowed. The period must be after the last line of code and alone on a line. End scope terminators are always used.

Line 1, starting in column 7, contains the compiler directive: \$set mfoo. This compiler directive tells COBOL that the program is involved in an OO system and allows the program to use several OO reserved words.

**Object Section** in line 8 is new to the Environment Division and is similar in purpose to the Input-Output Section of traditional COBOL. The Object Section defines the interface to classes used in the system.

**Class-control** is the main paragraph within the Object Section and relates each class to a template file for that class. Template files contain class definitions. When the program or class is compiled, these definitions are linked to the program. For example, "Register.cbl" is the template for the Registrar class. When Student-Look-Up is compiled, the definition of Registrar becomes part of the executable code. Whenever the program uses the identifier "Registrar," COBOL refers to that class definition.

The program contains no Input-Output section. Since the classes do all of the file processing, the section is not needed and is omitted.

The Working-Storage Section contains two new features.

1. A new data type, *object reference*.
2. Data type usage specified at the group item level.

OO COBOL uses object reference data as *pointers* to system objects. In OO COBOL, object pointers are generally called *handles*. The 05 level item “theRegHandle,” in line 16, is the handle to the Registrar object.

COBOL 2000 allows the data usage to be established at the group item level. All elementary items assume the data usage of the group item. In line 15, the 01 level item Handles has object reference usage and therefore so does theRegHandle.

The Procedure Division of the Student-Look-Up Driver program has only two statements other than STOP RUN. Both statements use a new COBOL verb *invoke*. Invoke is similar to a CALL in that it addresses programs outside of the current program and turns control over to that procedure. The invoke verb also can pass parameters or arguments to and from the invoked procedure. However, a CALL turns over control to an entire COBOL program while invoke only references a method within an object.

Figure 20.3 Syntax of Invoke

```

INVOKE object-name { literal-1 | data-name-1 }
 [USING {data-name-2}...]
 [RETURNING data-name-3]]

```

Figure 20.3 shows the syntax of the *invoke* verb. The object name specifies the object containing the desired method. *literal-1* or *data-name-1* is the message (name of the method) to be passed to the object. Any data items to be passed to the object are preceded by *using*. The data item to be returned must be preceded by *returning*. Note that multiple data items can be passed to the method but *returning* allows only one data item. The *invoke* verb requires that the named data items be at the 01 level, but entire data groups can be passed by using a 01 level group item. If more than one parameter must be returned, all of the parameters should be elementary items under a single 01 level group item. Arrays can be passed in either direction as long as they are contained within a 01 level group item.

The first *invoke* addresses the Registrar class and passes the message “New.” *New* is a generic message required to create a new instance or occurrence of a class. This process is called *instantiation*. Hence, to instantiate a class means to create a new instance of the class. For example, in the Student Look-Up system, only one Registrar instance is required. Universities only have one Registrar office, and this instance needs to emulate the functions of that office. However, many students attend the university and one would expect the system to instantiate numerous instances of the Student class.

When instantiating a class, the object name in the *invoke* statement is the name of the class. The *New* method instantiates the instance returns its handle. In this case, the handle is called “theRegHandle.”

Look again at Figure 20.2 and line 20. The second *invoke* uses theRegHandle to request the instance method, “ProcessRequest.” The statement invokes theRegHandle instead of Registrar because it points to the instance of the class and its methods are now available. ProcessRequest requires no parameters to be passed. Upon completion, ProcessRequest returns control to the driver program. The driver then stops the run.

After STOP RUN there is a period on a line by itself. A new standard is emerging in COBOL programming to minimize use of the period. Many programmers will use only one period at the end of paragraph and place the period on a separate line for the sake of clarity. End statements replace periods whenever possible. Since COBOL requires that each paragraph end with a period, it is placed on a separate line for visibility.

In examining the driver program, you have encountered several important OO topics without even looking at a class. These topics include Object Section and

Class-control, the Object Reference data type, handles, instantiation, methods, messages, and the Invoke verb. Now, we will look at the Registrar class to see how these and other concepts are used in a class.

### The Registrar Class

Along with the discussion of each class, you will find the programming specifications of that class. Since classes are different from programs, you will notice several new entries. First, we use Class Name rather than Program Name and have a new entry to show what type of class this is. Next, we describe the purpose of the class in the Narrative. The Narrative is followed by the objects created and referenced. We specify objects rather than classes because these are actual instances of classes that are created or referenced. Finally, we specify the methods included in the class. These methods include both *factory* methods and instance methods.

## PROGRAMMING SPECIFICATIONS

**Class Name:** Registrar

**Class Type:** Problem Domain Object

**Narrative:** This object represents the role of a registrar department.

**Objects Created:** StudentDBI  
StudentPRT  
StudentUI

**Objects Referenced:** StudentDBI  
StudentPRT  
StudentUI  
Student

**Factory Methods:** None

**Instance Methods:** ProcessRequests

**Narrative:** This method controls the main processing of the system.

**Processing:**

1. Create the StudentUI objects.
2. Get student requirements from StudentUI.
3. Create the StudentDBI and StudentPRT objects.
4. Get an instance of a Student from StudentDBI that meets the requirements in step 2.
5. Get the student name from Student.
6. Send the Student name to StudentPRT to be printed.
7. Destroy the current Student instance.

The Registrar object contains the attributes and behaviors that are needed to represent the university registrar's role in the Student-Look-Up Billing System. The registrar knows about student data and provides this data on request. The Registrar object, therefore, manages students and can provide data about them.

Figure 20.4 Class Definition of Registrar

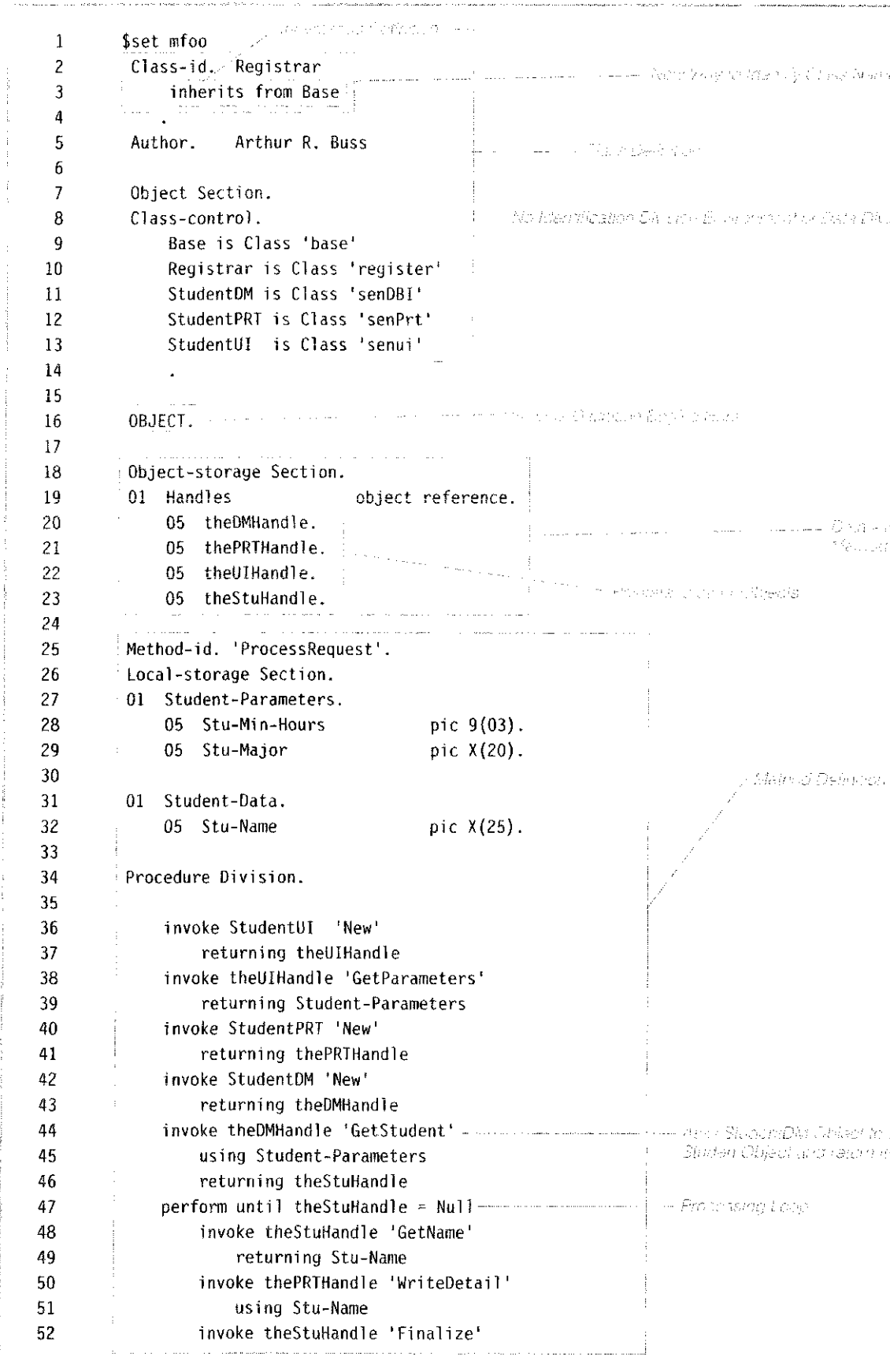
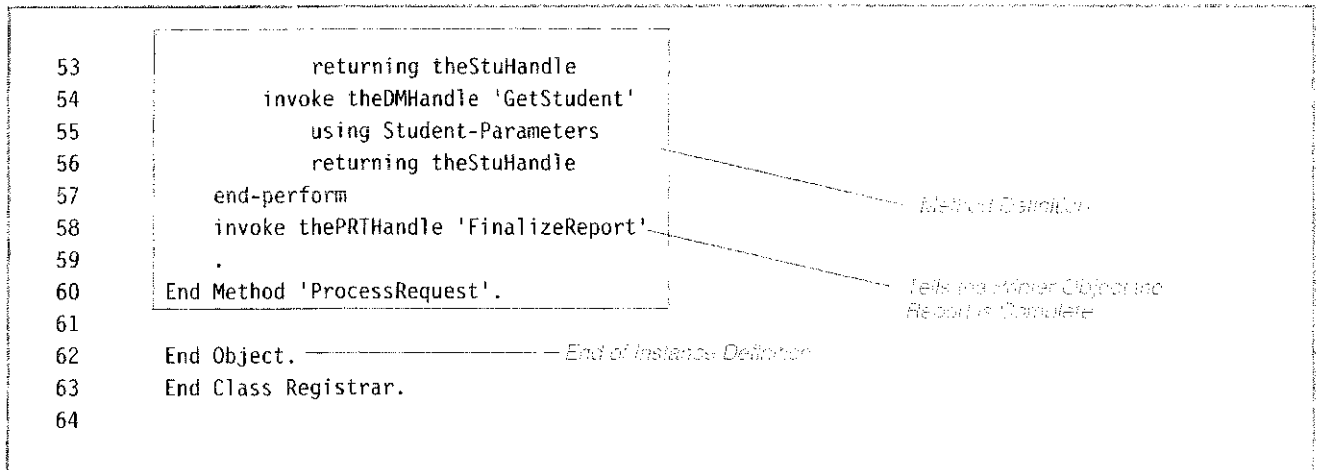

Figure 20.4 (continued)



The class definition can be made up of three parts:

- Class identification area that defines the class name and the linkages of the class definition files for the other classes associated with this one.
- The Factory area. The Factory is a special instance of the class that contains methods and data used for managing all other instances of the class.
- The Object or Instance area. This part of the class definition describes the data formats and methods available to each instance.

You should notice several differences between the class identification area and the start of a traditional program. This example contains no Identification Division statement and no Program-id statement. The Identification Division statement has been left out since it is not required by COBOL 2000. The statement Class-id is the equivalent of the Program-id statement but includes a clause that says "inherits from Base." This clause defines the "inheritance" of the class. The Registrar class is a "child" of Base.

As in the Student-Look-Up program, the class identification area contains an Object Section and Class-control. One of the questions that must be answered for a class is, "Whom does it know?" The Class-control paragraph defines part of the answer. Since Registrar is the key class for this system, it needs to know about and create several other classes. Registrar needs to know about Base because it is the parent class, it needs to know about itself, and, since it instantiates StudentDBI, StudentPRT, and StudentUI, all of these are defined in the Class-control paragraph. Registrar also needs to know Student, but this class does not have to be defined here since Registrar does not instantiate it.

The Factory definition area follows the Class-control section. This area starts with the keyword FACTORY. The Factory is a special instance of the class and contains generic data and methods needed to manage the regular instances. Registrar requires no special data or methods, and therefore Factory does not have to be specified.

The definition of the instance in Figure 20.4 begins with the keyword OBJECT in line 16. As mentioned before, in defining a class the designer needs to ask:

- What does it know?
- Whom does it know?
- What does it do?

To answer the first question, in the Student-Look-Up system the Registrar does not have to have any special knowledge. If the class were to be used with some other system it is likely that some data items would have to be defined and stored in the Object-storage Section in lines 18–23.

The Object-storage Section is similar to the Working-storage Section in a traditional program and contains data available to any instance method. You will see later that methods can own their own data as well. No other program, object, or even the Factory of the current object can use data in the Object-storage Section except through the use of an instance method.

The Object-storage Section also contains a partial answer to the question, “Whom does it know?” The group item `Handles` in lines 19–23 contains the pointers to the objects the Registrar needs to know.

The answer to “What does it do?” is defined by the methods. For Registrar, there is only one method, `ProcessRequests`. This method is discussed below.

### Classes and Inheritance

Look again at the `Class-id` paragraph in lines 2–3. Inheritance is an important OO concept. By stating that Registrar inherits from Base, the clause is saying that Base is the parent class and all of the methods in Base are available to Registrar. Base is a special class provided by Micro Focus as part of the OO COBOL system. The Base class serves as a template for all other classes and has specialized methods for the management of all classes.

For an example of how inheritance works, consider the method `New`. `New` is invoked before an instance exists. `New` also addresses the `Class-id` rather than an instance handle. The Factory contains specialized methods that allow management of the instances. The method `New` creates the instance, and therefore it cannot be contained in an instance. `New` is therefore a *factory method*.

You should notice that the Registrar Class definition in Figure 20.4 does not specify a Factory or its methods. Then where is the method `New`? `New` is a factory method in Base. Whenever a class is instantiated, the parent class is also instantiated and is available to the child class. Because Registrar inherits from Base, Registrar can perform `New` as if it were its own method. Thus, when Student-Look-Up invokes `New`, Registrar receives the message and passes it on to Base. Base then creates the instance of Registrar. The invoking program did not need to know anything about Base, but just asks the Registrar class to create an instance of Registrar. By taking advantage of inheritance, the object programmer does not have to write a method to create an instance for every class. This example is just one way inheritance works to reuse code; other ways are discussed below.

There is one more point to make about factory methods and instance methods. Even though the Factory and instances are parts of the same class, methods belong to either the Factory or the instances. If the Factory needs to invoke an instance method, the invoke must specify the instance handle. Instance methods must use the class name (for example, Registrar) to invoke a Factory method. OO COBOL maintains a strict separation between the two types of methods.

### ProcessRequests Method

The `ProcessRequest` method begins with the `Method-id` paragraph in line 25. Every method begins with a `Method-id` and ends with an `End Method`. These statements provide the method’s boundaries. A method may have its own Data Division and Procedure Division. The Data Division is optional, and, when used, words “Data Division,” do not have to be specified. Data Division entries contain data used only by that method. They are stored in one of three sections.



- \* Working-storage Section—Working storage data are *static*. That is, these data remain from one invocation of the method to the next. Any data that need to be available when the method is invoked and to be available each time the method is invoked should be in the Working-storage Section. Data requiring a value clause must be defined in working storage.
- \* Local-storage Section—Local storage contains data for the method and is re-initialized each time the method is invoked. If value clauses are specified, they are ignored and treated as comments. Local storage data is available only for the current invocation of the method.
- \* Linkage Section—The linkage section works in connection with the method's Procedure Division and passes data to and from the method.

ProcessRequest uses only the Local-Storage Section starting in line 26. The method keeps the minimum number of credit hours and the major for the request. The Local-Storage Section also contains the student name once it is determined.

Not all methods require their own Data Division. Often, methods will use the Object-storage Section defined at the instance level. In this case, with only one method, ProcessRequest could have used either the Object-storage Section for the entire instance or the method's Local-Storage Section. Regardless of where the data are stored, all methods need to have a Procedure Division.

The Procedure Division in line 34 begins by creating the StudentUI object and requesting it to get the parameters necessary to process the system. Then ProcessRequest creates the StudentDM and StudentPRT objects. The next invoke goes to theDMHandle to "getStudent." This invoke passes the parameters received from StudentUI and asks that the StudentDM provide the handle of a Student object matching the requested parameters. Notice that the invoke does not request the StudentDM to get the student name directly.

For StudentDM to provide the name directly would violate the OO principle of encapsulation. This principle requires that only the Student object can manipulate Student data. The StudentDM does not have the authorization to deal with Student data directly. StudentDM can only process files and use the control fields to generate a Student instance. That instance can then manipulate the data.

The concept of encapsulation or *data hiding*, as it is sometimes known, means that data are kept in a "capsule" called an instance. The data is the property of the instance and can be accessed only through one of the instance methods. Other objects must send messages to the instance in order to use any of its data. Encapsulation allows the instance to maintain the data's integrity since there can be no unauthorized changes by other programs or objects.

Compare encapsulation to the way data is treated in programs. In a program, all data are available to every paragraph in the program. Any paragraph could potentially alter any data item in the Data Division. In poorly designed programs or ones that have been hastily modified, logic errors can cause data to be improperly changed and as a result cause unexpected effects. The source of these errors may not be easy to detect since any paragraph could have caused the problem. By restricting all manipulation to an object and its methods, logic errors in methods are much easier to detect and fix.

Returning to ProcessRequests, in line 47 the method begins the main processing loop of the system. The control variable for the loop is theStudentHandle. When the variable becomes "null" the loop stops. Null is a predefined address used by COBOL to indicate that an object does not exist. If for some reason StudentDM cannot create an instance of Student, getStudent returns null in theStudentHandle.

Using a valid Student handle, the first statement requests the Student name from the Student object and then passes that data to StudentPRT for printing. ProcessRequest then "finalizes" the Student object and requests a new Student object.

## PROGRAMMING TIP

### Memory Leakage

One problem in object-oriented systems is called **memory leakage**. Memory leakage occurs when the system generates a new instance of a class and uses the same handle name as the previous instance. OO COBOL will place the new address into the handle overwriting the previous address. The original instance remains in the computer's memory, but since the pointer is gone there is no way to access it. The old instance has become an orphan and the memory assigned to it cannot be used for any other purpose.

As orphans accumulate, the memory available is reduced and the performance of the system degrades.

Some OO systems provide a service called "garbage collection" where the system looks for and removes orphaned instances. The COBOL 2000 standard requires garbage collection but Personal COBOL does not provide it.

In any case, it is a good practice to destroy unneeded instances. The Base method Finalize removes the current instance of an object from memory. The format of this method is:

```
INVOKE identifier-1 'Finalize' RETURNING identifier-1
```

Identifier-1 is the handle of the instance. After processing, identifier-1 is returned as null.

The Registrar object and its method ProcessRequests has served as an introduction to the concept of inheritance and demonstrated how an object interacts with other objects to accomplish a task. This discussion has also included the concept of encapsulation and the need to remove objects from memory when they are no longer necessary.

### The StudentDM Class

Objects exist only in the memory of a computer while a system is running. However, a system that cannot maintain data from one run to another has little practical use. OO systems therefore must provide a way to store and recall data whenever necessary. The OO term for this requirement is Persistence. One method of handling persistence in a system is to have a data management class for each problem domain class. StudentDM is the data manager for the Student class.

The three questions apply here as well.

- StudentDM needs to know the file specifications for the Student persistence file.
- The object needs to know the Student object.
- StudentDM must be able to do all of the file handling to create Student instances.

## PROGRAMMING SPECIFICATIONS

**Class Name:** StudentDM

**Class Type:** Data Management Object

**Narrative:** This object performs all file processing for the Student file. The object opens, closes, and reads records from the file. StudentDM also creates Student instances from the data in the file.

**Objects Created:** Student

**Objects Referenced:** Student

**Factory Methods:** New

**Narrative:** Overrides the Base *New* in order to open the file when the object is created.

**Processing:**

1. Invoke *New* from Base.
2. Open the Student File.

**Instance Method:** GetStudent

**Narrative:** This method controls the process of finding a student record that meets the user's specification.

**Processing:**

1. Set the Student handle to null in case a record cannot be found.
2. Read the Student data file.
3. For every record, determine whether it meets the minimum credit hours required and is in the required major.
4. When a matching record is found, create and populate a Student object. Return the handle for the Student object.

**Instance Method:** ReadRecord

**Narrative:** This is a private method to read Student Records.

**Processing:**

1. Read records from the Student file.
2. At end of file, set an end of file switch and close the file.

**Instance Method:** CreateStudent

**Narrative:** This private method creates an instance of Student and populates it with the values from the current Student Record.

**Processing:**

1. Invoke a new instance of Student.
2. Populate the instance.



Figure 20.7 Class Definition of StudentDM

```

1 $set mfoo
2 Class-id. StudentDM
3 inherits from Base
4 .
5 Author. Arthur R. Buss
6
7 Environment Division.
8 Input-Output Section.
9 File-Control.
10 Select Student-File Assign to 'Student.Dat'
11 Organization is Line Sequential.
12
13 Object section.
14 Class-control.
15 Base is class 'Base'
16 StudentDM is class 'sendbi'
17 Student is class 'sensstu'
18 .
19
20 Data Division.
21 File Section.
22 fd Student-File.
23 01 Student-In.
24 05 Stu-Name pic X(25).
25 05 Stu-Credits pic 9(03).
26 05 Stu-Major pic X(20).
27
28 FACTORY.
29 Object-storage Section.
30 01 Handles object reference.
31 05 theDBIHandle.
32
33 Method-id. 'New'.
34 Linkage Section.
35 01 ls-theDBIHandle object reference.
36
37 Procedure Division
38 returning ls-theDBIHandle.
39
40 invoke super 'New' returning ls-theDBIHandle
41 open input Student-file
42 .
43 End Method 'New'.
44
45 End Factory.
46
47 OBJECT.
48
49 Method-id. 'ReadRecord'.
50 Linkage Section.
51 01 ls-Data-Remains-Switch pic X(03).
52

```

Environment Division

Data Division

Method-id. 'New'

Procedure Division

Linkage Section

Figure 20.5 (continued)

```

53 Procedure Division
54 returning ls-Data-Remains-Switch.
55
56 Move 'YES' to ls-Data-Remains-Switch
57 Read Student-File
58 at end
59 move 'NO' to ls-Data-Remains-Switch
60 close Student-File
61 end-Read
62
63 End Method 'ReadRecord'.
64
65 Method-id. 'GetStudent'.
66 Local-storage Section.
67 01 Data-Remains-Switch pic X(03).
68
69 Linkage Section.
70 01 ls-Stu-Parameters.
71 05 ls-Stu-Credits pic 9(03).
72 05 ls-Stu-Major pic X(20).
73
74 01 ls-theStuHandle object reference.
75
76 Procedure Division
77 using ls-Stu-Parameters
78 returning ls-theStuHandle.
79
80 set ls-theStuHandle to null
81 invoke self.'ReadRecord'
82 returning Data-Remains-Switch
83 perform until Data-Remains-Switch = 'NO' or
84 ls-theStuHandle Not = null
85 evaluate Stu-Credits also Stu-Major
86 when >= ls-Stu-Credits also = ls-Stu-Major
87 invoke self 'CreateStudent'
88 returning ls-theStuHandle
89 when other
90 invoke self 'ReadRecord'
91 returning Data-Remains-Switch
92 end-evaluate
93 end-perform
94
95 End Method 'GetStudent'.
96
97 Method-id. 'CreateStudent'.
98 Linkage Section.
99 01 ls-theStudentHandle object reference.
100
101 Procedure Division
102 returning ls-theStudentHandle.
103
104 invoke Student 'New'

```

*New Clause for Procedure Division*

*Close File when last Record Read*

*Use and Return Data*

*Invoke Method in Same Instance*

*Two Condition Evaluate Statement (See Programming Tip)*

Figure 20.5 (continued)

```

105 returning Is-theStudentHandle
106 invoke Is-theStudentHandle 'PopulateStudent'
107 using Student-In
108 .
109 End Method 'CreateStudent'.
110
111 End Object.
112 End Class StudentDM.
113

```

The class definition for StudentDM in Figure 20.5 looks more like a traditional COBOL program than did Registrar. The Environment Division includes the Input-Output Section with the standard File-Control paragraph. The Data Division also includes a File Section. Object-orientation uses standard file processing.

All of the components of the Class definition should be familiar by now. However, for the first time, Factory is defined and has the factory method *New*. The *New* method has been discussed before as an example of inheritance. Normally Base performs the *New* method. However, there are occasions when some specialized processing is needed at the time an instance is created. For a data manager object, opening files seems to be that type of process. *New*, as defined in Base, cannot open files. Therefore, we have elected to override the *New* procedure in Base and to build our own through a technique called *polymorphism*.

Polymorphism is a Greek term meaning many shapes. In OO programming, polymorphism means that a message may produce different results based on the object it is sent to. Polymorphism is usually achieved by having a method override another, inherited method. Polymorphism can be a powerful tool, and this example is quite simple. A full treatment of the topic is beyond the scope of this chapter.

By defining a Factory method called *New* within StudentDM, the inherited method *New* in the Base method is overridden. When StudentDM or any object receives a message it checks to see whether that method is available. If the method exists within the object, it is executed. If not, the message is passed to the parent object. Therefore, since the Factory method *New* is defined in StudentDM, the local method overrides the inherited method.

Overriding inheritance must be done with caution since the local method must be able to handle all of the processing expected of the inherited method. For example, *New* must be able to create an instance of StudentDM. The local method *New* accomplishes this task through the statement `Invoke super 'New'` returning `Is-theDMHandle` in line 40. The message invokes the parent or super class to do its method *New*. By invoking the parent class, Base instantiates StudentDM and returns its handle. The handle can then in turn be passed on to the original invoking procedure. Having now carried out the primary function of *New*, the local method can go on to open the file as well.

### StudentDM Instance Definition

The Instance Definition of StudentDM is straightforward. To answer the three questions:

- The Instance does not have special data other than that needed to manage the file.
- The only object that it knows is Student.
- What it does is to read records from the file, test to see whether they meet the specifications, and create Student instances containing the Student data.

Of the three methods defined for the instance, only one `GetStudent` is invoked from outside. The other two methods are “private” methods to be used only by other methods in the `StudentDM`.

Beginning at line 65, `GetStudent` maintains a Local-storage Section to hold an end-of-file switch and a Linkage Section to receive the invoking parameters and to pass back the handle for the Student instance.

The Procedure Division has both `using` and `returning` clauses to allow use of the items in the Linkage Section. The algorithm of the method is to initialize the Student handle to null and then invoke the `ReadRecord` method. The `invoke` statement uses the keyword `self`. `Self` refers to the pointer of the current instance. An instance always knows its own memory location and can reference that location by using `self`.

Once the record is read, `GetStudent` evaluates the credit hours against the minimum and the major against the required major. If the test is successful, the routine invokes the `CreateStudent` method, and uses the result to return the Student Handle and to stop the loop. If the test was not successful, the routine invokes `ReadRecord` method to get the next record. When `ReadRecord` runs out of records, it returns “NO” to the Data-Remains-Switch. The loop stops, and because no instance of Student has been created the method returns a null handle to the invoking procedure.

## PROGRAMMING TIP

### Advanced Usage of Evaluate

The COBOL `Evaluate` statement is much more powerful than CASE statements in other languages. In most languages, the CASE statement can test a condition for only one variable at a time. The `Evaluate` statement, however, allows testing of several conditions at once. Consider the `Evaluate` statement in the `GetStudent` method of `StudentDM`.

```

evaluate Stu-Credits also Stu-Major
 when >= Is-Stu-Credits also = Is-Stu-Major
 invoke self 'CreateStudent'
 returning Is-theStuHandle
 when other
 invoke self 'ReadRecord'
 returning
 Data-Remains-Switch
end-evaluate

```

Notice that the `Evaluate` statement tests conditions for `Stu-Credits` but also for `Stu-Major`. `Also` is the keyword that tells the `Evaluate` to test both variables in an AND relationship. The first `When` clause compares the respective variables to `Is-Stu-Credits` and `Is-Stu-Major`. The use of the keyword `Also` makes sure that proper testing occurs.

This test will allow only records that have `Stu-Credits` greater than or equal to `Is-Stu-Credits` AND `Stu-Major` equal to `Is-Stu-Major`.

The `Evaluate` statement can virtually eliminate the need for nested IFs when used properly.

The remaining two methods are easily understood. ReadRecord is a simple read routine that might be found in any traditional COBOL program. The only notable feature is that the routine closes the file when AT END is reached. CreateStudent is also simple. It invokes the New method to create an instance of Student and then invokes the PopulateStudent method to move data from the input file into the instance just created.

In a real system, StudentDM would have more instance methods, such as ones which could add, modify, or delete student records. Students acquainted with indexed files, direct files, or databases are well aware that the use of a sequential file as has been done here, would not be efficient for handling many student records. You should be able to see that if StudentDM were rewritten to use another file organization, Registrar and Student would never know the difference. By encapsulating the file processing in StudentDM, major file changes are invisible to the rest of the system. Polymorphism and encapsulation make system modifications simple.

The StudentDM class serves as an example of how an object can process files and interact with other objects. You have also seen an example of polymorphism and how inherited methods can be overridden.

### The Student Class

## PROGRAMMING SPECIFICATIONS

**Class Name:** Student

**Class Type:** Problem Domain Object

**Narrative:** This class represents the data and behaviors of students in the system. An instance of the class may return the student's major and the number of credit-hours earned.

**Objects Created:** None

**Objects Referenced:** Person (Parent)

**Factory Methods:** None

**Instance Method:** PopulateStudent

**Narrative:** This method moves the data from the linkage section of the method into the Object-storage Section, where the data are available to every method of the instance.

**Processing:**

1. Format and store the Student name.
2. Store the rest of the Student data.

**Instance Method:** GetCreditHours

**Narrative:** Returns the Student credit hours.

**Processing:**

1. Move Credit Hours to linkage section.



**Instance Method:** GetMajor

**Narrative:** Returns the Student major.

**Processing:** 1. Move Major to linkage section.

Figure 20.6 Student Class Definition

```

1 $set mfoo
2 Class-id. Student
3 inherits from Person
4 .
5
6 Object Section.
7 Class-control.
8 Person is Class 'person'
9 Student is Class 'senstu'
10 .
11
12 OBJECT.
13
14 Object-storage Section.
15 01 Student-In.
16 05 Stu-Data.
17 10 Stu-Credits pic 9(03).
18 10 Stu-Major pic X(20).
19
20 Method-id. 'PopulateStudent'.
21 Linkage Section.
22 01 ls-Student-In.
23 05 ls-Stu-Name pic X(25).
24 05 ls-Stu-Data.
25 10 ls-Stu-Credits pic 9(03).
26 10 ls-Stu-Major pic X(20).
27
28 Procedure Division
29 using ls-Student-In.
30 invoke self 'PopulateName'
31 using ls-Stu-Name
32 move ls-Stu-Data to Stu-Data
33 .
34 End Method 'PopulateStudent'.
35
36 Method-id. 'GetCreditHours'.
37 Linkage Section.
38 01 ls-Credit-Hours pic 9(03).
39
40 Procedure Division
41 returning ls-Credit-Hours.
42
43 move Stu-Credits to ls-Credit-Hours
44 .

```

Annotations in the original image:

- A box around line 3 "inherits from Person" has a line pointing to the text "inherits from Person" on the right.
- A box around line 30 "invoke self 'PopulateName'" has a line pointing to the text "Invoke Inherited Method" on the right.

Figure 20.6 (continued)

```

45 End Method 'GetCreditHours'.
46
47 Method-id. 'GetMajor'.
48 Linkage Section.
49 01 ls-Stu-Major pic X(20).
50
51 Procedure Division
52 returning ls-Stu-Major.
53
54 move Stu-Major to ls-Stu-Major
55 .
56 End Method 'GetMajor'.
57
58 End Object.
59 End Class Student.

```

The Student class manages the data for students. Figure 20.6 contains the definition of Student. Notice that that this object does not inherit from Base (line 8). Student inherits from another class, Person. We explain the reason for using inheritance under the discussion for the class Person.

The Student object represents a simple application of how inheritance can work. Student contains three instance methods. Only one, PopulateStudent, is actually used by this system. PopulateStudent stores the data in the Object-storage section after an instance has been created. GetMajor and GetCreditHours are simple methods to show how other applications can retrieve those data items.

PopulateStudent, in line 24, invokes a method called PopulateName. The invoke statement references `self`. However, Student does not have a method called PopulateName. That method is actually in Person.

By referencing `self`, Student looks for a method by the name PopulateName within itself. The Student cannot find the method; it will pass the message to its parent—Person. In a case like this, the programmer may want to reference `super` rather than `self`. Yet there may be some instances where `self` is actually safer. Should PopulateName be added to Student to accommodate some need for polymorphism, using `super` would bypass the local method. Using `self` assures that the proper method is invoked.

Because Student inherits from Person, an instantiation of Student means that Person is instantiated as well. Both Person and Student exist at the same time, but Student does not have to maintain a pointer to Person. The inheritance mechanism handles these relationships.

One other example of inheritance should also be noted. In Figure 20.4, line 54, the ProcessRequest method invokes theStudentHandle with the method GetName. GetName is not defined in the Student object. Student will receive the message and send it on to Person to be performed. Registrar neither knows nor cares that the work is actually done by Person instead of Student.

The Student class is an example of inheritance and of how OO programmers can take advantage of this technique to reuse code in a variety of ways. The Person class gives an example of what a parent class could look like.

## The Person Class

### PROGRAMMING SPECIFICATIONS

- Class Name:** Person
- Class Type:** Problem Domain Object
- Narrative:** This class represents the data and behaviors of persons of any type in the system.
- Objects Created:** None
- Objects Referenced:** None
- Factory Methods:** None
- Instance Method:** PopulateName
- Narrative:** This method moves the formatted name data from the linkage section of the method into the Object-storage Section where the data are available to every method of the instance. The Object-storage Section holds name data in a generalized format and the input name is broken up into its parts.
- Processing:**
1. Find and store the first-name portion of the name and store it in the Object-storage Section.
  2. Find the last-name portion of the name and store it in the Object-storage Section.
- Instance Method:** GetName
- Narrative:** Produces the Name in a formatted form.
- Processing:**
1. Concatenate the first name and last name and move to linkage section.

Many types of people are involved in the operation of a university. Besides students, there are faculty, administration, clerical staff, and facilities staff, to name a few. Each of these roles has its own specialized functions and data. Yet, if one were to ask either a faculty member or a facilities person what their name was, the questioner would expect that either one could respond. Therefore, if the system required a Faculty class or a Staff class in addition to a Student class, each of these classes should be able to respond to a message "GetName."

One way to accomplish this goal would be to code a "GetName" method into each of these classes. However, any change to the method would have to be made in every class using that method. Structured programs often face this problem.

A better approach to meeting the requirement is to take advantage of inheritance. Students, faculty, administration, clerical staff, and facilities staff are all persons. By defining a generic class called Person, all of the common data attributes and associated methods could be placed in Person and every class inheriting from Person could use the methods and access the data.

Some common attributes might be:

- Name
- Address
- Telephone
- Age

By coding these and other attributes into Person, they have to be coded only once, but they are available to any class inheriting from Person. Any changes to the data or the methods is automatically available to the subclasses by making changes only in Person.

Figure 20.7 Person Class Definition

```

1 $set mfoo
2 Class-id. Person
3 inherits from Base
4 .
5
6 Object section.
7 Class-control.
8 Base is Class 'base'
9 Person is Class 'person'
10 .
11 OBJECT.
12
13 Object-storage Section.
14 01 Person-Name.
15 05 Per-Last-Name pic X(20).
16 05 Per-First-Name pic X(20).
17 05 Per-Middle-Name pic X(20).
18
19 01 Counters.
20 05 First-Name-Len pic 9(02).
21 05 Last-Name-Len pic 9(02).
22
23 Method-id. 'PopulateName'.
24 Linkage Section.
25 01 ls-Person-Name pic X(60).
26
27 Procedure Division
28 using ls-Person-Name.
29
30 initialize Counters
31 inspect ls-Person-Name
32 tallying First-Name-Len
33 for characters before initial space
34 inspect ls-Person-Name (First-Name-Len + 2:)
35 tallying Last-Name-Len
36 for characters before initial space
37 move ls-Person-Name (1:First-Name-Len)
38 to Per-First-Name
39 move ls-Person-Name (First-Name-Len + 2 : Last-Name-Len)
40 to Per-Last-Name

```

Three Character  
Group Item

Breaks Full Name to First  
and Last Name

Figure 20.7 (continued)

```

41 .
42 End Method 'PopulateName'.
43
44 Method-id. 'GetName'.
45 Working-storage Section.
46 01 Blank-Char pic X value space.
47
48 Linkage Section.
49 01 ls-Name pic X(25).
50
51 Procedure Division
52 returning ls-Name.
53
54 initialize ls-name
55 string Per-First-Name delimited by space
56 Blank-Char delimited by size
57 Per-Last-Name delimited by space
58 into ls-Name
59 .
60 End Method 'GetName'.
61
62 End Object.
63 End Class Person.
64
65

```

*Reconstructs Full Name*

The Person class, shown in Figure 20.7, looks much like any other class. For example, Person inherits from Base. Note that because Student inherits from Person it also inherits from Base, though indirectly. There may be multiple levels of inheritance defined with lower-level classes inheriting methods and data from grandparent as well as parent classes. You should also note that Person does not have to know what classes inherit from it.

Because Student inherits from Person, any instantiation of Student creates an instantiation of Person as well. OO COBOL then allows Student to access the methods in Person without creating a special handle. Person and Student are attached to each other. However, even though Student knows about Person, Person does not need to know about Student.

The Object-storage Section in lines 14–17 defines how the Name is stored. The format specified here is quite different from that actually stored in the Student file and printed on the output report. The designers of the class wanted to be able to output the name in a variety of formats. Therefore, a more general name format has been specified in the Object-storage Section.

Therefore, PopulateName has to be able to convert a single name field into the three attribute fields. The routine uses the inspect statement to break down the name and to store the results in the proper fields.

GetName reformats the Name into the full-name format and returns the name as a single data item.

The Person class shows how a super class and its methods might be used in an OO system. The class definition shows how objects can input and output data in formats different from the way the class stores them.

## The Credit-Hour Class

### PROGRAMMING SPECIFICATIONS

**Class Name:** StudentUI

**Class Type:** User Interface

**Screen Layout:** See Figure 20.8a.

**Narrative:** This class controls the interface to the user. The class gathers the requested minimum number of credit hours and the name of the desired major.

**Objects Created:** None

**Objects Referenced:** None

**Factory Methods:** None

**Instance Method:** GetParameters

**Narrative:** This method controls the display of requests to the system user and accepts the responses.

**Processing:**

1. Invoke DisplayHoursRequest and store the result in the linkage section.
2. Invoke DisplayMajorRequest and store the result in the linkage section.

**Instance Method:** DisplayHoursRequest

**Narrative:** This is a private method that displays a user prompt for the minimum number of credit hours desired and accepts the response.

**Processing:**

1. Display Prompt.
2. Accept response into the linkage section.

**Instance Method:** DisplayMajorRequest

**Narrative:** This is a private method that displays a user prompt for the desired major and accepts the response.

**Processing:**

1. Display Prompt.
2. Accept response into the linkage section.

Figure 20.8 Screen Sample

```

Enter Minimum Hours: 100
Enter Student Major: Engineering
(a) Display Parameter Prompts

STUDENT NAME

ORVILLE WRIGHT
JOHN ROEBLING

* * * End of Report * * *
(b) Report Sample

```

Figure 20.9 StudentUI Class Definition

```

1 $set mfoo
2 Class-id. StudentUI
3 inherits from Base
4 .
5 Author. Arthur R. Buss
6
7 Object Section.
8 Class-control.
9 Base is Class 'base'
10 StudentUI is Class 'senui'
11 .
12
13 OBJECT.
14
15 Method-id. 'GetParameters'.
16 Linkage Section.
17 01 ls-Student-Parameters.
18 05 ls-Stu-Hours pic 9(03).
19 05 ls-Stu-Major pic X(20).
20
21 Procedure Division
22 returning ls-Student-Parameters.
23
24 invoke self 'DisplayHoursRequest'
25 returning ls-Stu-Hours
26 invoke self 'DisplayMajorRequest'
27 returning ls-Stu-Major
28 .
29 End Method 'GetParameters'.
30
31 Method-id. 'DisplayHoursRequest'.
32 Linkage Section.
33 01 ls-Stu-Hours pic 9(03).
34
35 Procedure Division

```

*Private Methods*

Figure 20.9 (continued)

```
36 returning Is-Stu-Hours.
37
38 display 'Enter Minimum Hours: ' with no advancing
39 accept Is-Stu-Hours
40 .
41 End Method 'DisplayHoursRequest'.
42
43 Method-id. 'DisplayMajorRequest'.
44 Linkage Section.
45 01 Is-Stu-Major pic X(20).
46
47 Procedure Division
48 returning Is-Stu-Major.
49
50 display 'Enter Student Major: ' with no advancing
51 accept Is-Stu-Major
52 move function Upper-Case (Is-Stu-Major) to Is-Stu-Major
53 .
54 End Method 'DisplayMajorRequest'.
55
56 End Object.
57 End Class StudentUI.
```

Figure 20.9 shows the class definition for the StudentUI object. This object controls the user interface to the system. There are no OO techniques that have not been addressed elsewhere.

StudentUI has been kept very simple for instructional purposes, but more elaborate user interfaces could be developed even to the point of using Windows screens without affecting the rest of the system. These more elaborate objects would simply replace StudentUI. OO allows "plug compatibility." When an object needs enhancement, the changes can be made and tested outside of the production system. When ready, the old version of the object can simply be replaced by the new version.

The instance method GetParameters controls the process and uses the private methods DisplayHoursRequest and DisplayMajorRequest to get the user's input.

### The StudentPRT Class

The final class in the system is a print manager, a form of user interface class. This class manages the printing of the report and has been slightly enhanced from the Engineering Senior program in Figure 1.6.



**PROGRAMMING SPECIFICATIONS**

**Class Name:** StudentPRT

**Class Type:** User Interface

**Narrative:** This class controls the printing of the selected student report.

**Report Format:** Figure 20.8b

**Objects Created:** None

**Objects Referenced:** None

**Factory Methods:** New

**Narrative:** Causes the print file to open.

**Processing:** 1. Invoke OpenPrinter.

**Instance Method:** OpenPrinter

**Narrative:** Opens the printer and causes the report headers to be printed.

**Processing:** 1. Open Print File.  
2. Invoke WriteHeader.

**Instance Method:** WriteHeader

**Narrative:** This is a private method that Writes the Report Header.

**Processing:** 1. Write Header Line.  
2. Write Blank Line.

**Instance Method:** WriteDetail

**Narrative:** This is a private method that prints the Detail Line containing a student name.

**Processing:** 1. Move name to Print Line.  
2. Write Print Line.

**Instance Method:** FinalizeReport

**Narrative:** Prints the final report line and closes the print file.

**Processing:** 1. Move End of Report Line to Print Line.  
2. Write the Print Line.  
3. Close the Print File.

Figure 20.10 StudentPRT Class Definition

```

1 $set mfoo
2 Class-id. StudentPRT
3 inherits from Base
4 .
5 Author. Arthur R. Buss
6
7 Environment Division.
8 Input-output Section.
9 File-control.
10 Select PrintFile
11 Assign to printer
12 .
13
14 Object Section.
15 Class-control.
16 Base is Class 'base'
17 StudentPRT is Class 'senprt'
18 .
19
20 Data Division.
21 File Section.
22 fd PrintFile.
23 01 Print-Line pic X(45).
24
25 FACTORY.
26 Object-storage Section.
27 01 thePRTHandle object reference.
28
29 Method-id. 'New'.
30 Linkage Section.
31 01 ls-thePRTHandle object reference.
32
33 Procedure Division
34 returning ls-thePRTHandle.
35
36 invoke super 'New' returning thePRTHandle
37 set ls-thePRTHandle to thePRTHandle
38 invoke thePRTHandle 'OpenPrinter'
39 .
40 End Method 'New'.
41 End Factory.
42
43 OBJECT.
44
45 Method-id. 'OpenPrinter'.
46 Procedure Division.
47
48 open output PrintFile.
49 invoke self 'WriteHeader'
50 .
51 End Method 'OpenPrinter'.
52

```

*Invoke Instance Method*



Figure 20.10 (continued)

```

53 Method-id. 'WriteHeader'.
54 Working-storage Section.
55 01 Heading-Line.
56 05 pic X(10) value Spaces.
57 05 Head-1 pic X(12) value 'STUDENT NAME'.
58 05 pic X(58) value Spaces.
59
60 Procedure Division.
61
62 move Heading-Line to Print-Line
63 write Print-Line after advancing Page
64 move Spaces to Print-Line
65 write Print-Line after advancing 1
66 .
67 End Method 'WriteHeader'.
68
69 Method-id. 'WriteDetail'.
70 Working-storage Section.
71 01 Detail-Line.
72 05 pic X(10) value Spaces.
73 05 Print-Name pic X(25).
74 05 pic X(45) value Spaces.
75
76 Linkage Section.
77 01 ls-Stu-Name pic X(25).
78
79 Procedure Division
80 using ls-Stu-Name.
81
82 move ls-Stu-Name to Print-Name
83 move Detail-Line to Print-Line
84 write Print-Line after advancing 1
85 .
86 End Method 'WriteDetail'.
87
88 Method-id. 'FinalizeReport'.
89 Procedure Division.
90
91 invoke self 'WriteDetail' using ' '
92 invoke self 'WriteDetail' using
93 '* * * End of Report * * *'
94 close PrintFile
95 .
96 End Method 'FinalizeReport'.
97
98 End Object.
99 End Class StudentPRT.

```

Like StudentDM, Student PRT, shown in Figure 20.10, has to manage a file, in this case a print file. Again like StudentDM, the Factory method `New` overrides the Base method in order to open the file. The `New` method does not open the printer directly, but rather invokes the instance method `OpenPrinter`. Notice that `thePRTHandle` is used to invoke the method. The keyword `Self` would not work since it would refer to the Factory and not the instance of the class. Instances and Factories, though related, are independent and can be addressed only through the proper handles.

`OpenPrinter` takes on the responsibility to write out the first report header by invoking the `WriteHeader` method.

StudentPRT, unlike StudentDM, cannot tell when the file should be closed. Only Registrar can tell when all of the records have been processed. Therefore, Registrar has to invoke the method `FinalizeReport`. `FinalizeReport` can print an End of Report line and then close the file.

StudentPRT shows how a report can be produced by an object-oriented system. The only new OO concept is in showing how a Factory method can invoke an instance method within the same class.

---

## Conclusion

In summary, why use object-orientation for COBOL programs instead of structured programming? Object-Oriented allows systems to use:

- Shorter code elements
- Reusable code
- Simpler control structures
- Ways to have better control over data

Object-Oriented does not invalidate the concept of structured programming. OO simply is the next step in providing the capabilities that structured programming claimed to supply.

One might observe that OO COBOL may have advantages for new development, but might question how it would work with the massive amount of COBOL code developed with the traditional methods. The answer is that OO does not have to be "either-or." Traditional programs can invoke objects. We saw that the driver program for the Student-Look-Up system is a traditional program. On the other hand, objects can call traditional programs as well.

An organization can examine its legacy systems and develop a plan to evolve their systems to OO by determining the objects present in the system. Each object can then evolve as common procedures in the traditional programs are converted to methods. The traditional programs can then initially invoke the methods from objects. As the organization develops its OO skills and understanding, the legacy programs can be slowly eliminated. This process can become part of the regular maintenance process and does not have to be overly expensive if good OO analysis and design has been done.

## S U M M A R Y

---

### *Points to Remember*

- ✦ Even though the COBOL 2000 standard has not been adopted yet, OO COBOL compilers are available and can be used to learn this new “dialect.”
- ✦ The emphasis in OO programming is on the development of systems, not just programs. Objects are developed to serve as building blocks for many systems.
- ✦ The structure of methods is similar to that of programs, but methods are simpler and do not need elaborate control structures.
- ✦ Programmers who know both structured and OO COBOL will have an advantage as companies begin to migrate their legacy systems toward object-orientation.
- ✦ Structured systems will not disappear soon, and the migration to OO will be evolutionary rather than revolutionary.

### *Key Words and Concepts*

|                             |                        |
|-----------------------------|------------------------|
| Class                       | System                 |
| Instance                    | Persistence            |
| Factory                     | User Interface Class   |
| Method                      | System Interface Class |
| Message                     | Data Manager Class     |
| Encapsulation               | Problem Domain Class   |
| Polymorphism                | Driver                 |
| Inheritance                 | Pointer                |
| Paradigm                    | Handle                 |
| Structured Programming      | Data Hiding            |
| Object-oriented Programming | Static                 |

### *COBOL Elements*

Invoke  
 Class-id  
 Class Control  
 OBJECT  
 FACTORY  
 Object-storage Section  
 Method-id  
 Local-storage Section  
 Object Reference

TRUE / FALSE

---

1. Object-oriented COBOL (is/is not) part of the COBOL 2000 standard.
2. \_\_\_\_\_ is the COBOL verb for running methods in classes.
3. A(n) \_\_\_\_\_ is the definition of an object; a(n) \_\_\_\_\_ is a specific occurrence of an object.
4. The special instance that allows manipulation of all other instances is called the \_\_\_\_\_.
5. \_\_\_\_\_ is the feature of OO that allows one class to act as if it contained the data and methods of another class.
6. The OO feature that protects the data contained in an object from access by other objects except through methods is called \_\_\_\_\_.
7. \_\_\_\_\_ is a special class and contains methods that are inherited by all other classes.
8. The change to OO represents a \_\_\_\_\_ shift because it represents a new way of thinking about programming.
9. Sometimes, one class overrides a method in a parent class to provide some new capability. This OO feature is called \_\_\_\_\_.
10. A new data type designed for specifying instance handles is called \_\_\_\_\_.

TRUE / FALSE

---

1. Object-Orientation reverses all of the principles of structured programming.
2. The Identification Division does not have to be specified in class definitions.
3. The Procedure Division does not have to be specified in a method.
4. COBOL is the first language to have OO capability.
5. It is not likely that OO COBOL will completely replace structured COBOL in the near future.
6. When developing the specifications for a class, the designer should ask:  
What does it know?  
Whom does it know?  
What does it do?
7. Classes that specifically deal with processing of the application are said to belong to the Problem Domain.
8. OO systems have no need of files.
9. Files provide the links between programs in structured systems.
10. OO systems use files to provide persistence between runs of the system.

## PROBLEMS

---

1. Why is the class name used to invoke a Factory method and a handle to invoke an instance method?
2. How does object-orientation promote the reuse of program code?
3. Write a method for the Person class that would format a name starting with the last name followed by ", " and followed by the first name.
4. Which class should contain a campus phone number if it should be needed by the system?
5. Differentiate between system, program, and class.

## FOR FURTHER STUDY

---

Several texts are now available for learning OO COBOL. These include:

Arranga, E., and Coyle, F. *Object-Oriented COBOL*. SIGS Publications, 1996.

Chapin, N. *Standard Object-Oriented COBOL*. John Wiley & Sons, 1997.

Doke, E. R., and Hardgrave, B. C. *An Introduction to Object COBOL*. John Wiley & Sons, 1998.

Obin, R. *Object-Oriented: An Introduction for COBOL Programmers*. 2nd ed., Micro Focus Publishing, 1995.

Price, W. *Elements of Object-Oriented COBOL*. Object-Z Publishing, 1997.

---

<sup>1</sup>This system can be downloaded from [http://www.prenhall.com/grauer\\_cobol](http://www.prenhall.com/grauer_cobol).

<sup>2</sup>This discussion is an oversimplification of the analysis and design process. For students interested in the OO Analysis and Design process, many books are available. This discussion is based on Peter Coad's book *Object Models: Strategies, Patterns, and Applications*, 2nd ed., Yourdan Press.

<sup>3</sup>COBOL 2000 goes a step beyond and allows free formatting of COBOL programs. This chapter does not show this technique because of the awkward way that the Animator handles free format. Future versions of the compiler should improve in that respect. Students interested in trying free format should place `$set sourceformat "free"` starting in column 7 before the first line of the source code. In free format the comment indicator becomes `"*>"` and can be placed anywhere in a line. All entries to the right of the comment indicator are ignored.

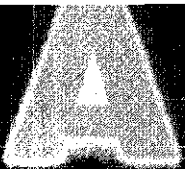

# Micro Focus Personal COBOL for Windows: Users Guide and Tutorial

**Overview:** This appendix describes the use of the Animator portion of Micro Focus's Personal COBOL for Windows. Personal COBOL is a powerful package of development tools offering two source-code editors and a Windows user interfaces generator. The Animator is a version of Micro Focus's professional COBOL editor that is restricted in its capabilities. The personal version contains all of the features necessary to develop programs for use with this text and most elementary and intermediate COBOL courses. Only a few advanced capabilities are eliminated. The student should know that Personal COBOL cannot create a fully executable program file. Instead, Personal COBOL develops an intermediate file executable by the system. As a result, programs using an intermediate file have slightly slower performance than a fully executable program. The Animator's limitations are not serious for educational purposes. Any program developed in the personal version can be recompiled in the professional version to produce fully executable programs.

The second type of editor available with Personal COBOL is the Browser, which is a particularly useful tool for developing object-oriented systems. This chapter does not cover the Browser, but you may want to look at it in connection with Chapter 20, which discusses object oriented COBOL.

The third tool provided by Personal COBOL is the Personal Dialog System (PDS). This tool aids in developing Windows-based user interfaces for COBOL. PDS allows the programmer to design the forms for the system and then to link those forms to the COBOL programs beneath. PDS is an advanced tool, and this chapter does deal with it.

The student is encouraged to read this appendix while sitting at a computer with the Animator program loaded. Most of the examples use the program "hello0.cbl" or "hello0.int," which can be found in the normal default directory c:\PCOBWINSAMPLES. The reader may want to follow along as the material is presented, and duplicate the process.



## Introduction to the Animator

The Animator is a reduced version of Micro Focus's Professional Animator. The most useful features of the professional version are available, and the beginning programmer should find them to be very powerful. For example, the Animator color codes the different types of words used in writing the language after the program has been checked (compiled) once. Typically, all of the COBOL reserved words are in green, all of the variables are in maroon, and text items are in black. This color coding allows the programmer to see whether the compiler recognizes the code being entered as the type of item expected. The wrong color would indicate a misspelling of the item.

The Animator has many debugging tools, extended help screens, and the same user interface as the Professional version. The student new to the Animator may find the tool to be overwhelming, rather than finding it limiting. This appendix presents most of the Animator's capabilities and is designed to serve as a resource for using them.

### Installing the Animator

Consult your *Getting Started* book, page 10, for installing Personal COBOL for Windows. The instructions are for installation in Windows 3.1; however, the software works in Windows95 or Windows NT as well. Windows95 users can simply install the software by using the Run function from the Start menu. Appendix B contains full instructions for installing Personal COBOL in Windows95.

### Learning to Use the Animator

The *Getting Started* booklet generally is too advanced for the beginning COBOL student, and provides only a minimal introduction to the Animator. Most of the book focuses on the Personal Dialog System and Object Oriented COBOL. The beginning student probably should read only the material in Lesson 1. Even in Lesson 1, students should not be concerned about understanding the sample program given there.

### Starting the Animator

Once Personal COBOL has been installed, one can start the Animator from the program group in which it is installed, as shown in Figure A.1. (All figures appear in Windows95 format.) Figure A.2 shows the default icon for the Animator, a picture of a window with the title Personal COBOL. This icon starts the Animator in the default directory established during installation. Usually this directory will be something like C:\PCOBWIN\SAMPLES. Students wishing to store their programs in a different directory should add another icon to the group window. This icon should start the Animator using the executable file "{default directory}\Anim2wg.exe" as the executable file. The working directory should point to the location of the desired files, as shown in Figure A.3. In the Windows 3.1 environment the program groups can be modified using the File menu in the Program Manager. In Windows95, the Settings entry controls the creation of new menu entries. Appendix B contains further instructions for setting up one's own "shortcuts."

Figure A.1 Windows95 Startup Menu

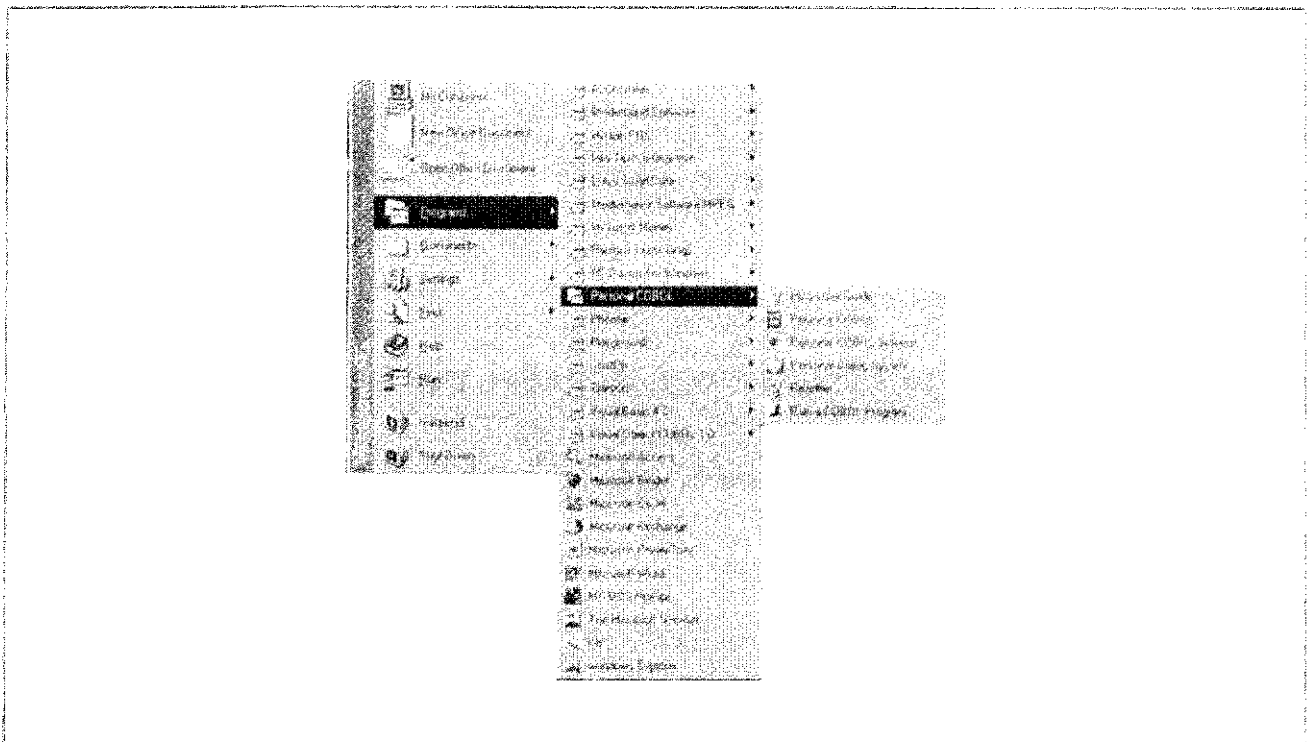

Figure A.2 Starting the Animator

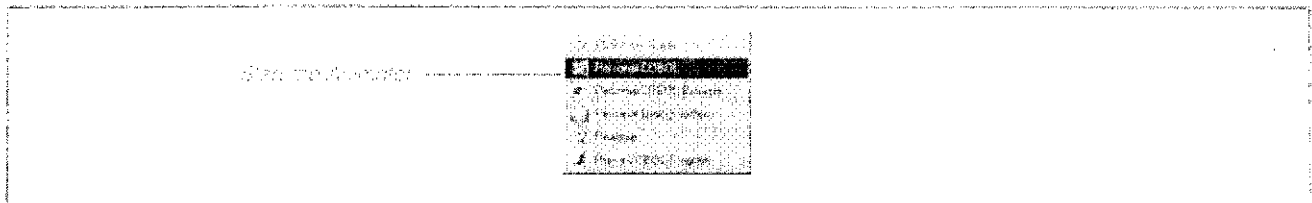
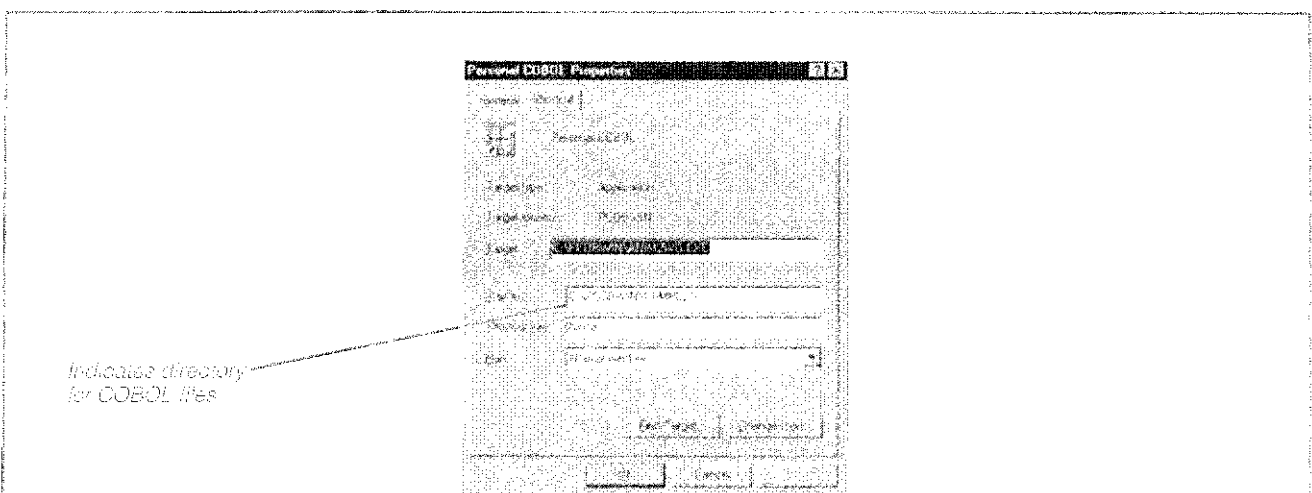

Figure A.3 Properties Window for Personal COBOL Shortcut



## Tour of the Interface

In this section, we look at the main features and the tools of the Animator. One feature of the Animator is the ability to modify the user interface. This feature is addressed at the appropriate point. For sake of clarity, however, the section relates only to the standard interface, as shown in Figure A.4.

Figure A.4 Personal COBOL User Interface

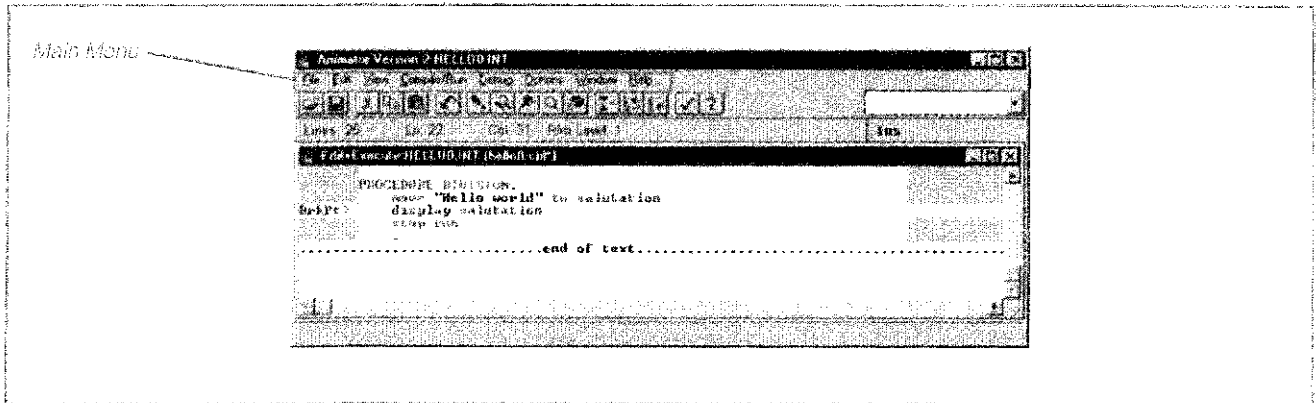

### Main Menu

The Main Menu of the Animator has eight pulldown menu entries, shown in Figure A.5. Some of these entries are familiar to any Windows user, but some are specific to the Animator. Each pulldown menu has several subsections arranged by function. We will look at each menu item separately. Many of the menu operations can also be performed by using shortcut keys. Experienced users often take advantage of these keys to ease the editing process. The shortcut keys are shown in parentheses in the menus and the first time the option is mentioned in the text.

Figure A.5 Animator File Menu

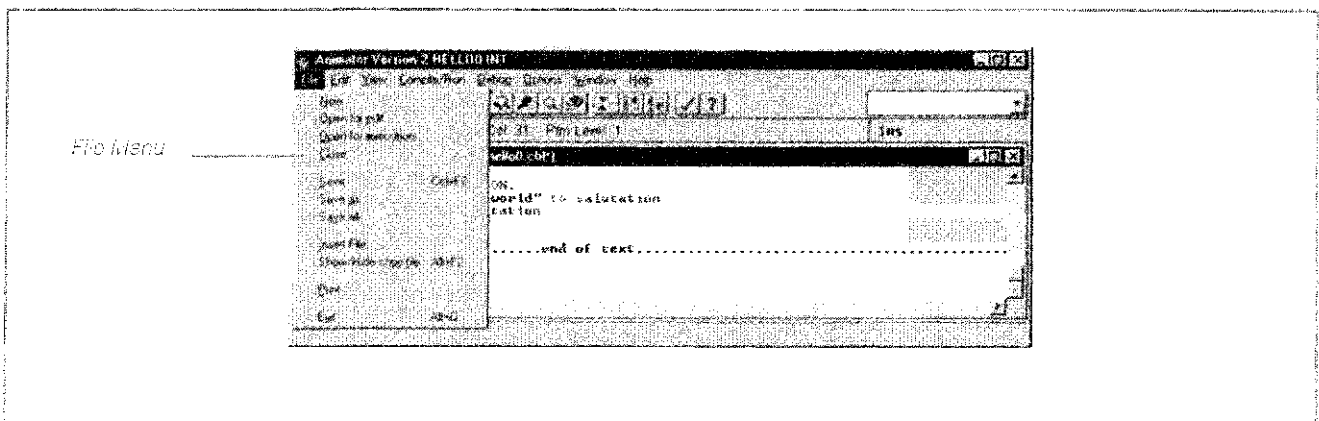

**File:** The File pulldown menu in the Animator has four sections, and is shown in Figure A.5. The first section included has the subcommands *New* and *Close*, which allow the user to create a new file and to close the current file without stopping the Animator. This section has two types of Open instead of one as in many Windows applications. The Animator can open files for Editing Only or for Edit and Execution.

If *Open for edit* is chosen, the Animator looks for COBOL source files with the extension "cbl." Figure A.6 shows the window with the file selection. These files may be edited and checked (compiled), but cannot be run as programs. The edit mode is useful for initially writing programs and checking the syntax for errors. To test program logic, the program must be run in Edit and Execution Mode. Any number of edit windows can be open at the same time.

Figure A.6 Open for Edit Window

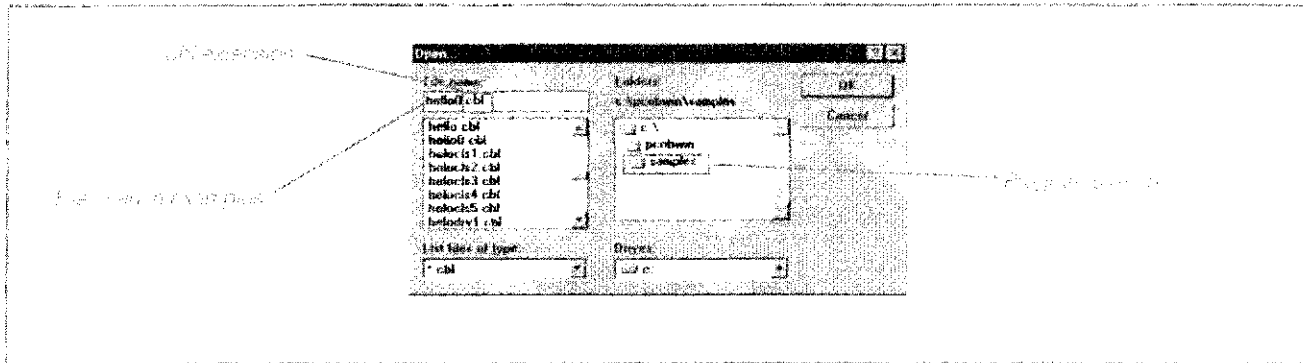

The *Open for execution* mode, shown in Figure A.7, expands the same capability of the edit mode to allow program execution. When selecting a file for the execution window, the Animator looks for "int" files. The "int" extension stands for intermediate file. The distinction is that intermediate files can be executed or run as well as edited. Intermediate files are created whenever a program is "checked." Checking is Micro Focus's term for compiling. Even when a program is checked in an Edit window, an intermediate file is created. However, this file has to be loaded into the Execute window to be run.

Figure A.7 Open for Execution Window

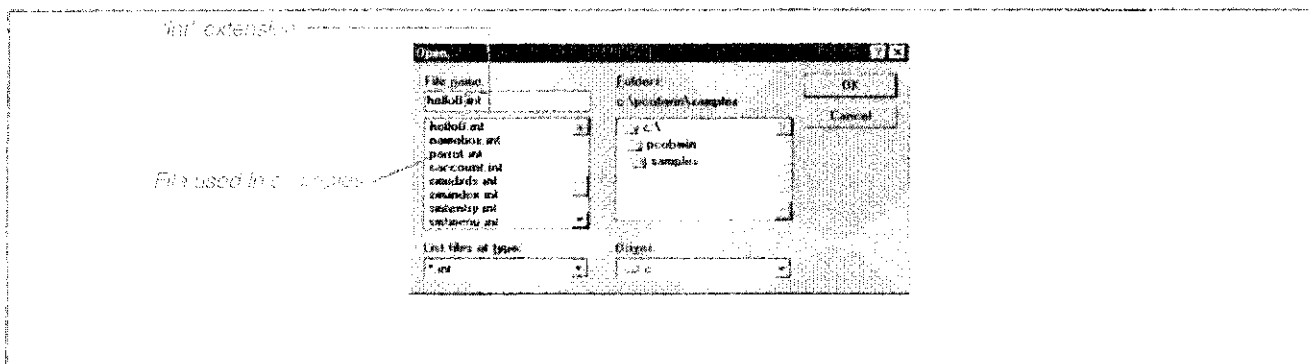

Referring again to Figure A.5, the second section of the File menu contains some standard Windows options: *Save* (Ctrl + F2), *Save As*, and *Save All*. *Save* stores a copy of the current program onto disk. This action can also be accomplished by using the shortcut keys "Ctrl + F2." *Save As* makes a new copy of the current programs and allows the user to change the name or location. Since Animator allows several program windows to be open at the same time, *Save All* simply saves the code and data in all open windows.

The third section of the File menu provides tools for managing the current window. The *Insert File* option allows the user to insert code from another program file into the current program at the cursor location. The second option, *Show/Hide copy file* (Alt + F2), allows the user to determine whether Copy files are expanded in the program or not. Copy files are library files that allow COBOL to use the same code in many programs. See Chapter 16 for a further description. The *Show/Hide* feature allows the programmer to decide whether or not the contents of the Copy file should be seen. In either case the program uses the Copy files in the checking process.

The last two sections of the File menu are *Print* and *Exit* (Alt + Q). *Print* sends the program listing to a printer. *Exit* closes the program, and if any files have not been saved, the Message Box shown in Figure A.8 appears.

Figure A.8 Exit Unsaved File Message Box

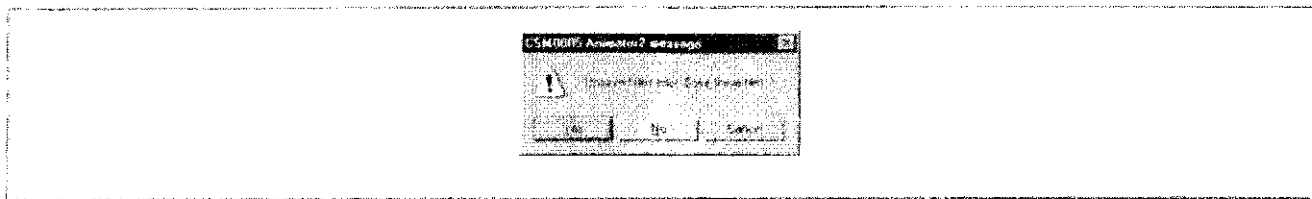
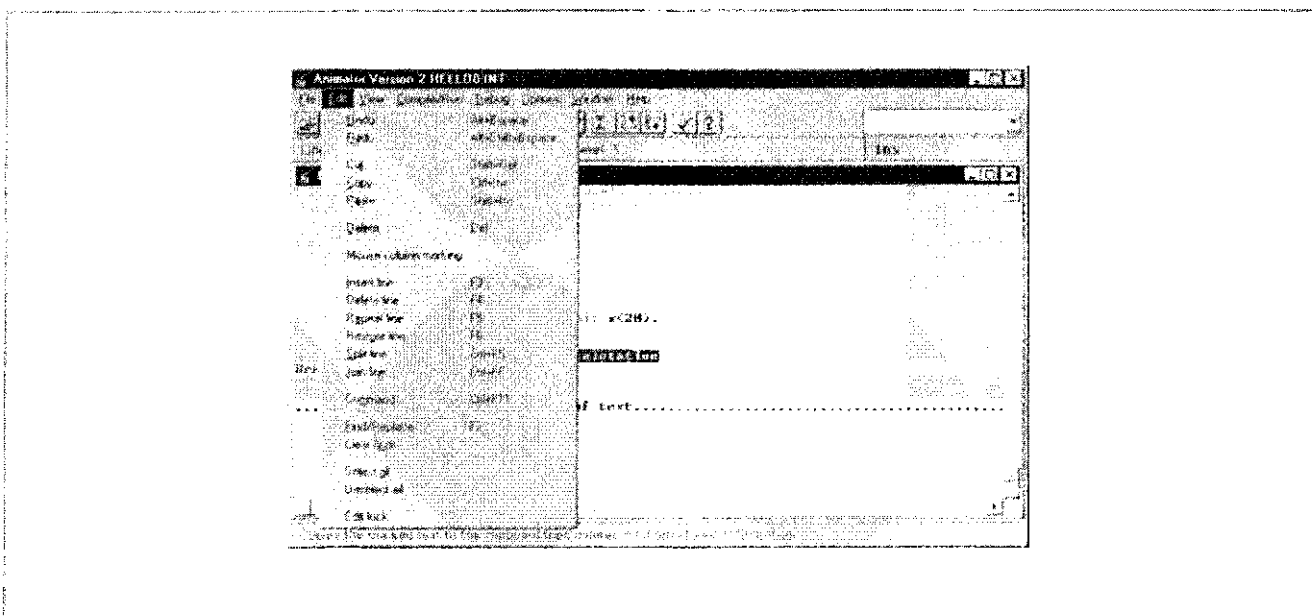

Figure A.9 Edit Menu



**Edit:** Figure A.9 shows the Edit menu. This menu provides useful tools for managing the entry and revision of source code. Entries in the first section of the menu allow the user to manage the changes to code. The first entry, *Undo* (Alt + Bspace),

reverses the last change made to the code during the current session. Up to 100 changes may be undone, but only one action at a time and in reverse order. The *Redo* (Alt + Shift + Bspace) entry restores the change eliminated by the most recent *Undo*.

The next two sections of the Edit menu allow the manipulation of text. These functions are contained in almost all Windows applications: *Cut* (Shift + Del), *Copy* (Ctrl + Ins), *Paste* (Shift + Ins), and *Delete* (Del). *Cut* removes highlighted text from the program and places it in the Windows clipboard. Text in the clipboard may then be placed into another section of the program, another program altogether, or some other type of document. *Copy* places a copy of highlighted text into the Windows clipboard but does not remove the text. *Paste* takes text currently in the clipboard and inserts it into the program where the cursor is currently located. *Delete* removes the highlighted text, but does not place it into the clipboard. Once something is deleted, it can be retrieved only by using the *Undo* command.

The next command, *Mouse Column Marking*, is a toggle command. If the entry is not checked, dragging the mouse highlights entire lines of code no matter where the cursor is located within the line. When the command is checked, dragging the mouse operates to highlight only the columns within the line covered by the mouse. Figure A.10a shows normal highlighting and Figure A.10b shows Column marking. Column marking is similar to using a word processor, but you must be careful about how many lines are marked.

Figure A.10 Animator Highlighting

```

IDENTIFICATION DIVISION.
PROGRAM-ID. Hello.
ENVIRONMENT DIVISION.
DATA DIVISION.
WORKING STORAGE SECTION.
WS calculation.

```

(a) Line Highlighting

```

IDENTIFICATION DIVISION.
PROGRAM-ID. Hello.
ENVIRONMENT DIVISION.
DATA DIVISION.
WORKING STORAGE SECTION.
WS calculation.

```

(b) Column Highlighting

In the fourth section of the Edit menu are six tools for managing lines of text: *Insert line* (F3), *Delete line* (F4), *Repeat line* (F5), *Restore line* (F6), *Split line* (Ctrl + F5), and *Join line* (Ctrl + F6).

These commands are largely self-explanatory.

- *Insert line* allows for a new line.
- *Delete line* eliminates the current line.
- *Repeat line* makes a copy of the current line.
- *Restore line* replaces the most recent deleted line.

- *Split line* breaks the current line at the current cursor location and creates two lines.
- *Join line* combines the current line with the following line. The second line is moved to the end of the first line.

Each command has a shortcut key, and you may find using the shortcut keys to be faster than trying to do the same operations with the mouse or menus.

The next section of Edit menu, *Command* (Ctrl + F11), allows the user to use the Command-prompt editor tool. The Command-prompt editor is the list box (Figure A.11) at the right side of the screen on the same line as the tool bar. This editor allows the user to enter editing commands. There are too many command options to discuss here, but they are all available in the Animator Help system under the entry. A simple example of the command line use would be to enter "goto 10" in the command prompt. The window moves and displays the tenth line of code.

Figure A.11 Command Prompt Editor

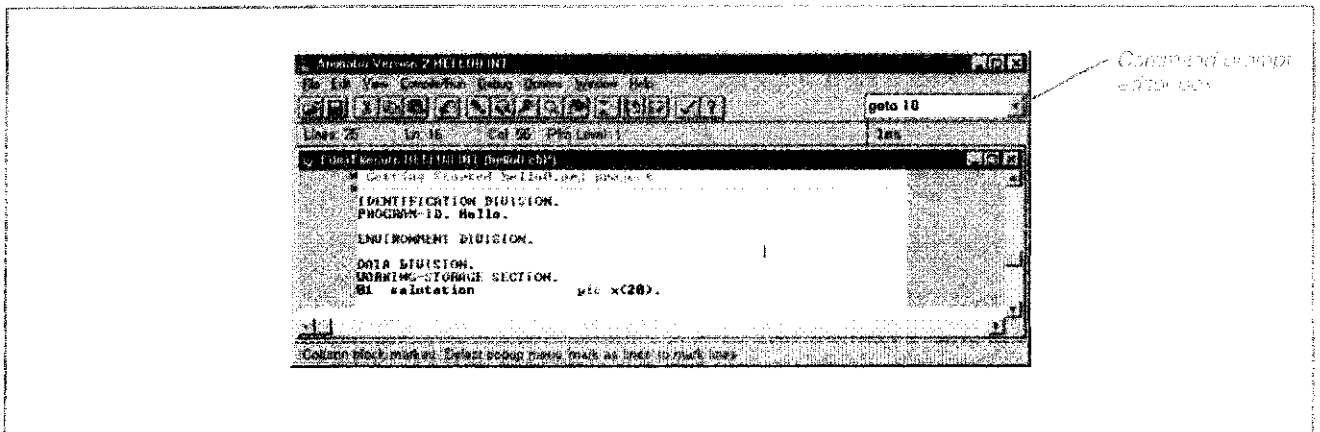

The next section of the Edit menu contains two commands: *Find/Replace* (F2) and *Clear finds*. *Find/Replace* allows two different types of finds: COBOL item information is shown in Figure A.12, and Text is shown in Figure A.15. In the COBOL Item Information mode, the user can enter the name of a data item or a paragraph name. The *Find* operation locates and highlights all occurrences of that data item or paragraph including the definition of the item. The usage of the data item within a line is described in columns 1 to 6. Such messages might include "Defn," "Mod," or "Use."

Figure A.12 Find Window

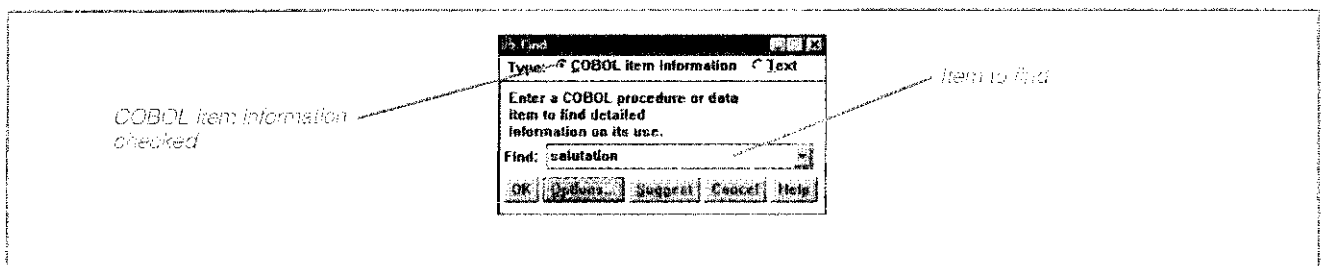

The COBOL item information find window contains a pulldown list of the last several items that have been found, and several buttons:

- *OK* processes the request and brings up a monitor screen, as in Figure A.13, that displays statistics of the item.<sup>1</sup> Also note that a line has been marked with the “Defn” message.
- *Options* brings up a screen that allows changes to the types of entries found in Figure A.51.
- *Suggest* produces a list of data items, such as those shown in Figure A.14, that might also be of interest. This option works only if at least one entry has been made in list box.
- *Cancel* stops the Find process.
- *Help* brings up a Help screen explaining the Find Dialog Box.

Figure A.13 COBOL Item Found

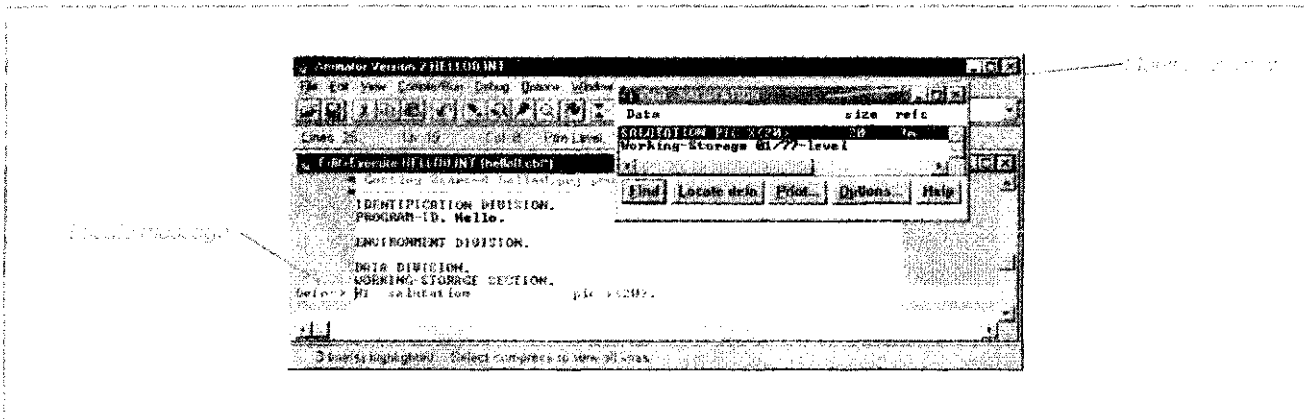
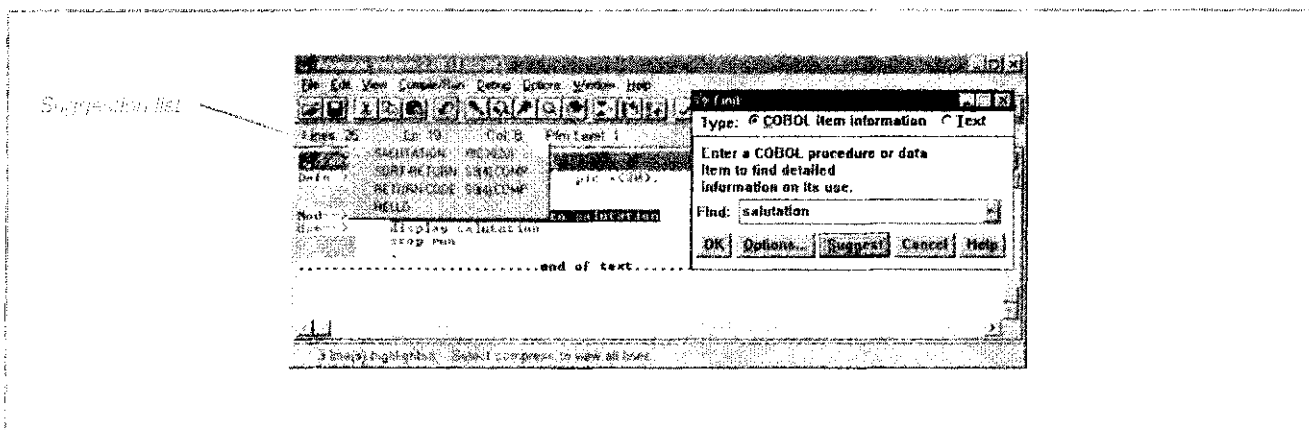

Figure A.14 Find Window With Suggestions



The second type of *Find/Replace* is the more traditional find and replace command shown in Figure A.15. *Find/Replace* allows the user to search for any type of text in the code, both forward and backward, and to view one entry at a time. The user may also replace the selected text with new text.



Figure A.15 Find Window For Text

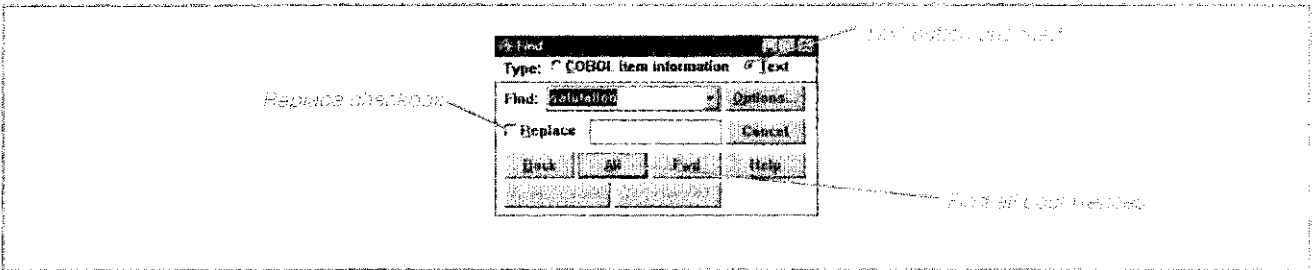

The Text mode finds occurrences even in comment lines. One unique feature of the Text find mode is the ability to “Find All” occurrences of the text. This option works similarly to the Find COBOL Item mode in that it highlights all occurrences of the text. However, the message in columns 1 to 6 is simply FIND.

The *Clear finds* command removes the markings placed by either the Find COBOL Item or Find All.

The last item in the Edit menu is the *Edit lock* Command. When *Edit lock* is on, the Word “EditLock” shows on the Status Bar, as in Figure A.16. Edit locking prevents the user from changing the source code by mistake. The user may want to use this feature when examining code that should not be changed.

**View:** Figure A.17 shows the View menu. View allows the user to move about within the program code. COBOL programs tend to be long and sometimes difficult to maintain on the screen. The tools in the view menu allow users to move easily around the program and to keep track of their work. You may notice that the last entries in the menu are unavailable. They become available only when checking determines that there are syntax errors. Figure A.19 shows the menu when a syntax error has been found.

Figure A.16 Interface with Editing Locked

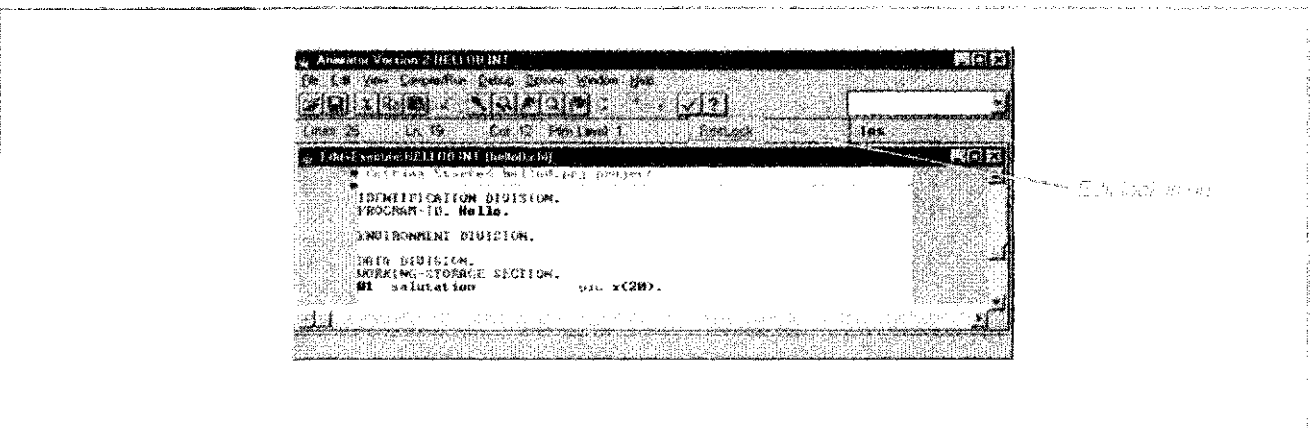
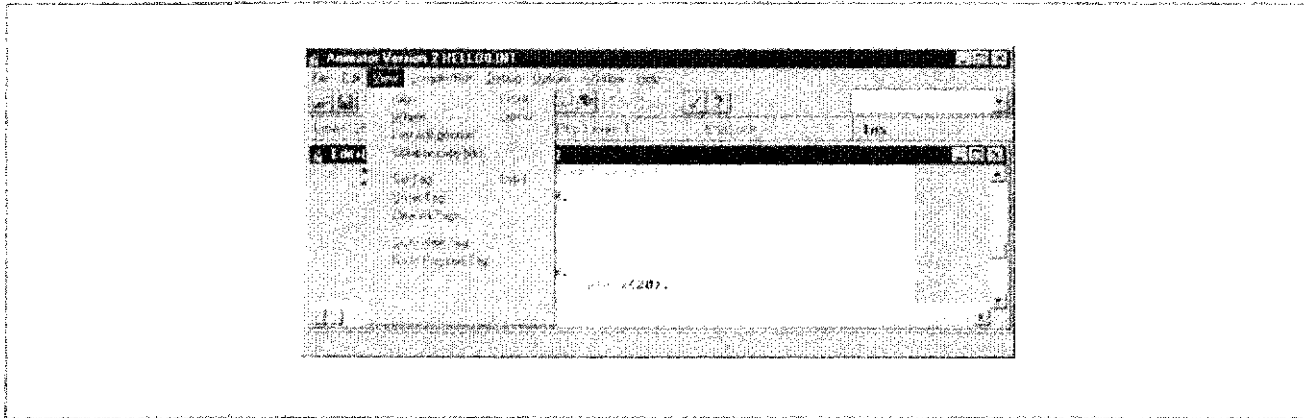

Figure A.17 View Menu



The *Align* (Ctrl + A) command adjusts the entries on the screen so that the current line moves to the third line of the screen.

The *Where* (Ctrl + W) command is available only in Execute mode. When a user is debugging a program and looks at another portion of the program, *Where* allows the user to get back to the current program execution line.

The *Last edit position* command is similar to *Where*, but allows the user to go back to the point where the last program change was made.

*Collapse copy files* is similar to the *Show/Hide copy files* in the File menu. If the copy files are in expanded mode, the user can use this command to reduce them to the single COPY statement.

The next section of the View menu deals with placing and removing Tags. Tags are simply markers the user can place in the source code to save time moving from place to place. The *Set Tag* (Ctrl + T) command marks the current line with a tag, as shown in Figure A.18. The *Unset Tag* command removes the Tag from the current line and *Clear All Tags* removes all of the Tags in the program.

The final section of the View menu allows the user to move quickly through the program. The first two commands, *Go to Next Tag* and *Go to Previous Tag*, control movement to tags set by the user.

The last three commands of the View menu are available only during the checking process if there are syntax errors. Figure A.19 shows the menu with these options available. Notice also that the lines in error are marked. The commands allow the user to *Go to Next Error*, *Go to Previous Error*, and *Go to Current Error*. The last command is useful when the user has moved to some other location in the code trying to determine the nature of the problem and wants to return to the current error.

Figure A.18 Example of a Tag

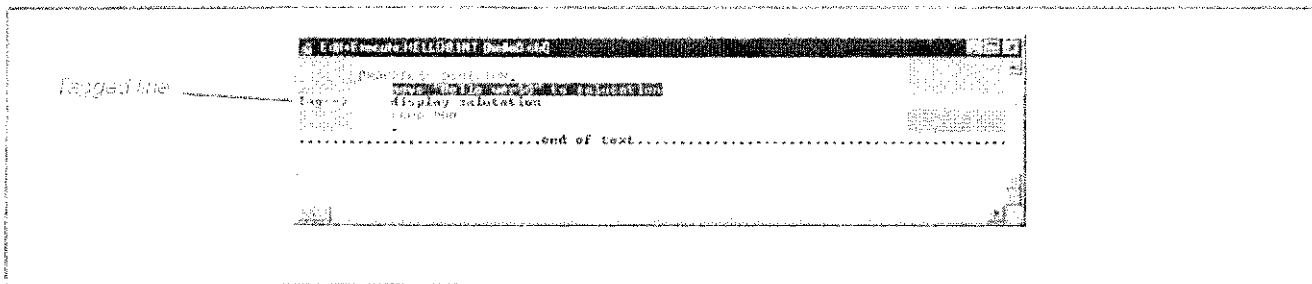
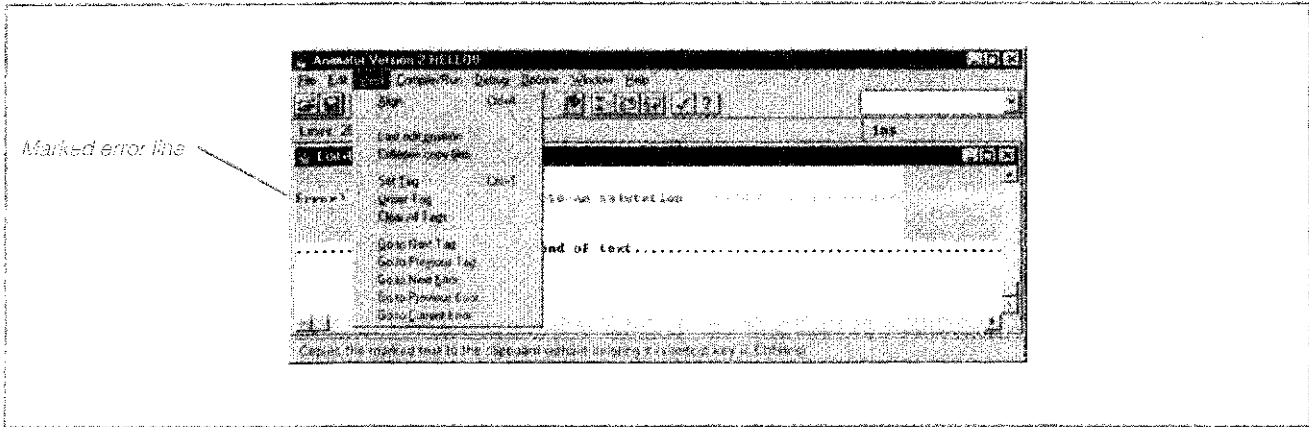

Figure A.19 View Menu when Syntax Errors Exist



**Compile/Run:** The Compile/Run Menu, shown in Figure A.20, provides some powerful tools for checking and debugging of programs. The first entry is simply *Compile Program*. *Compile Program* checks the syntax of the current program for errors. If the window is in Edit mode, *Compile Program* and *Compiler Directives* are the only options available. Figure A.21 shows a compile in process with an error message. Figure A.22 shows the results of the compile with lines containing errors highlighted and a separate window showing the error messages. If the current line is an error line, the information area at the bottom of the screen also shows the error message.

Figure A.20 Compile/Run Menu

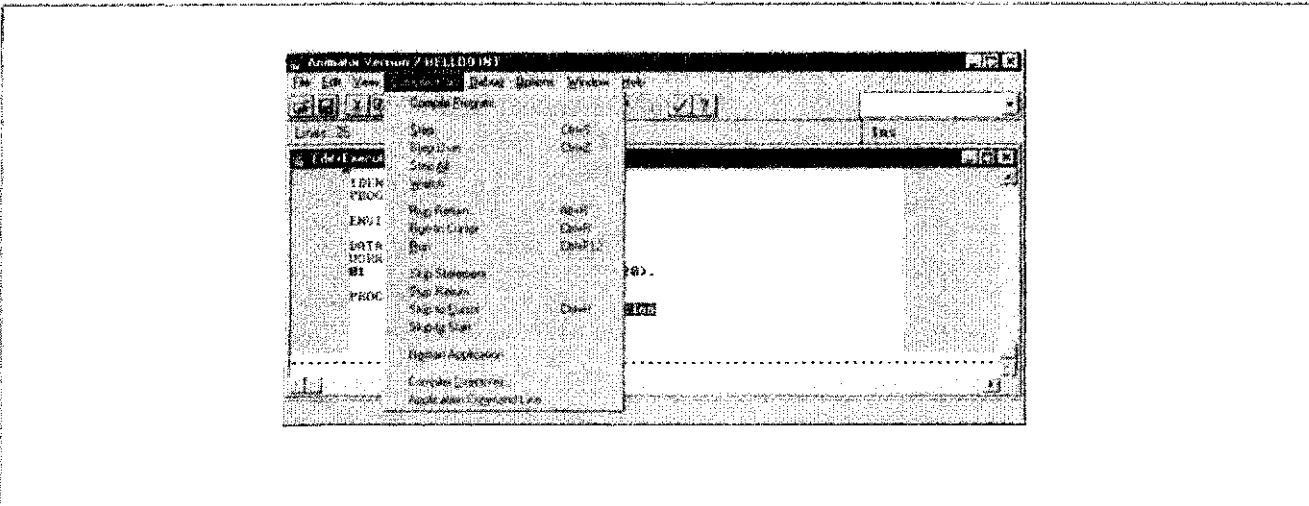

Figure A.21 Compile Processing Windows

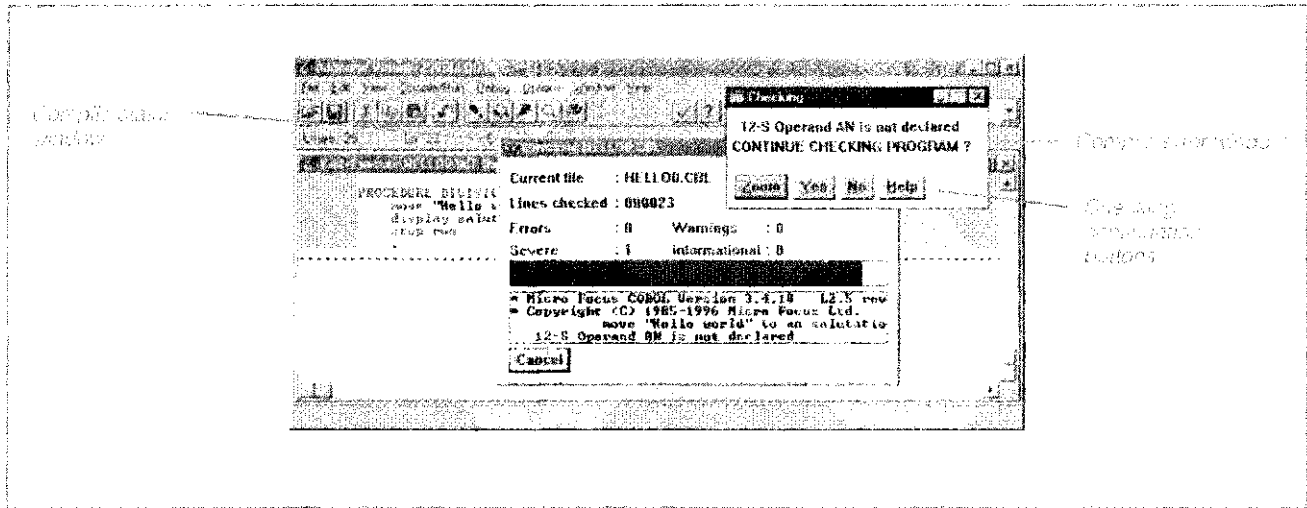
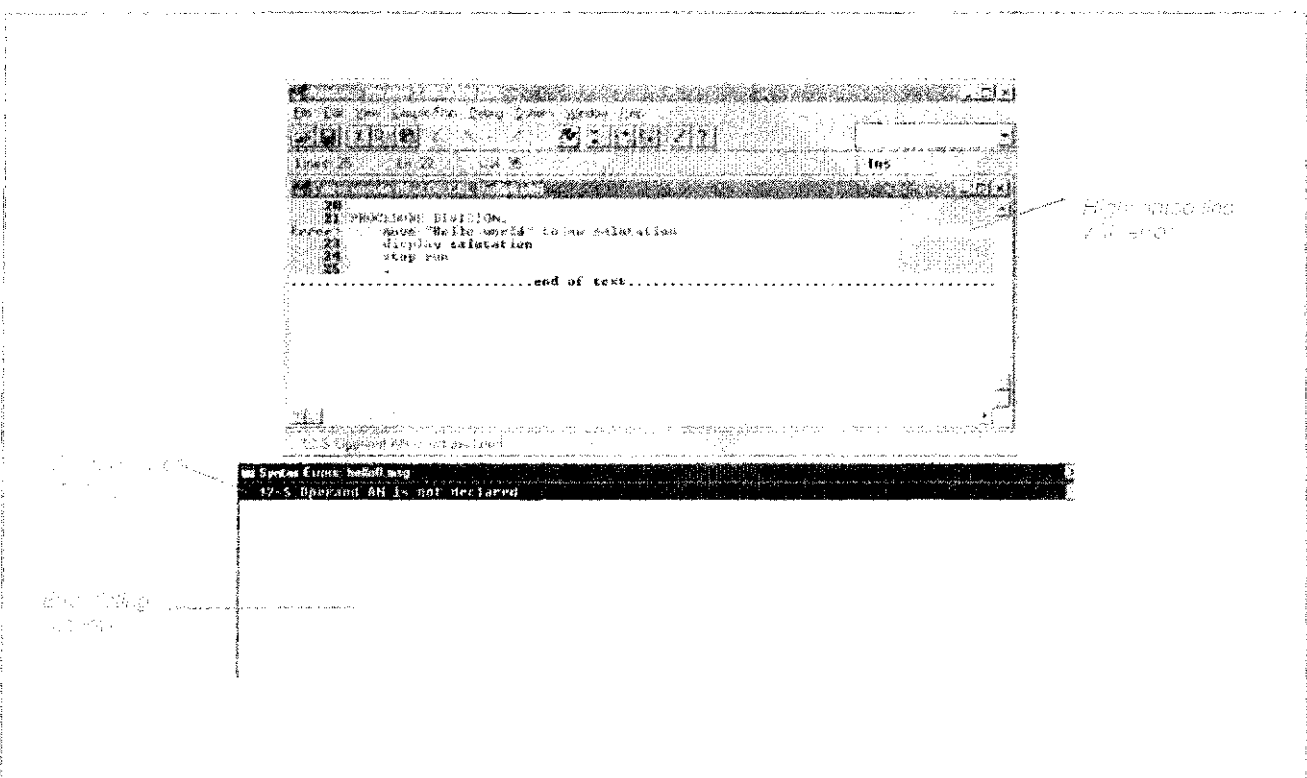

Figure A.22 Results of Compile with Error



The next section of the Compile/Run Menu allows the programmer to run the program on a step-by-step basis. *Step* (Ctrl + S) allows the programmer to execute the program one step at a time. *Step Over* (Ctrl + Z) skips the current line and allow execution at the next line. However, if the current execution point is a PERFORM, *Step Over* executes the perform at full speed and stops on the statement following the PERFORM.

*Step All* runs the entire program at reduced speed. When *Step All* is selected, Animator displays the dialog window in Figure A.23, allowing the user to select the speed of display, to stop the execution, or to run at full speed. The speed of execution may be modified by clicking on the scroll arrows. The slowest speed is 1 and the fastest speed is 6.

Figure A.23 Step All Control Window

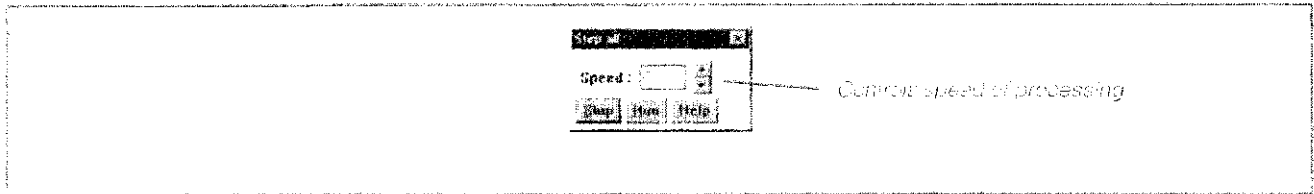

The final option in this section of the Compile/Run Menu is *Watch*. *Watch* acts in the same way as *Step* except that, as each line is executed, the value of the data items for that line are displayed in monitor windows, as in Figure A.24. This option allows the programmer to examine the processing as it occurs.

Figure A.24 Stepping Through Program using Watch Option

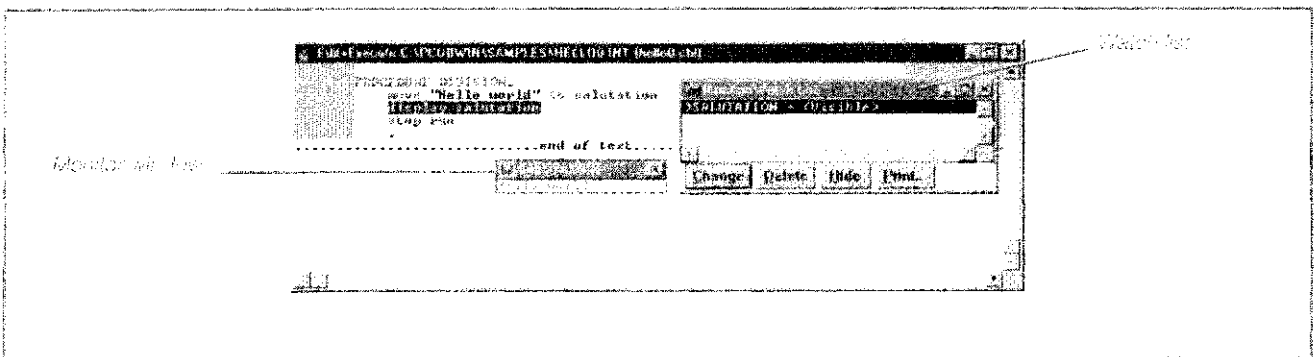

The third section of the Compile/Run menu allows ways for the user to run a program portion or the entire program at full speed. The capability allows the programmer to execute tested portions of code without having to step through each line. The first option is *Run Return*. Use this option when the current execution point is within a Perform. *Run Return* executes the rest of the Perform at full speed and stops at the first statement after the end of the Perform. A common error is to use this command when the program is not in a Perform. As a result, Animator returns an error message box as shown in Figure A.25. The message means that the execution point is not within a Perform and therefore the command cannot be processed.

Figure A.25 Message Indicating Run Return Cannot be Processed

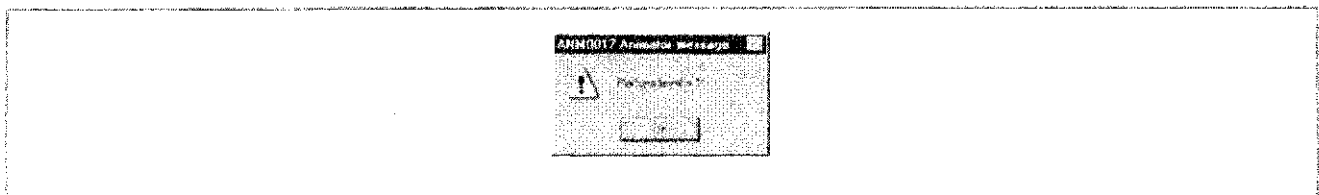

A more general and more useful command is *Run to Cursor* (Ctrl + R). *Run to Cursor* allows the user to position the cursor at some point ahead of the current execution point and then run the program at full speed up to the line where the cursor is located.

The final command in this section is *Run* (Ctrl + F12). This command runs the program until the end.

The next section of the Compile/Run menu involves Skip commands. Programmers should use Skip commands with caution. Skips allow the programmer to avoid executing some lines of code. The danger in doing this is that key actions may not be executed or that key data may not be changed; the results may be unpredictable.

The Skip commands are straightforward. *Skip Statement* means that the current statement is not executed and control moves to the next line of code. *Skip Return* and *Skip to Cursor* (Ctrl + H) are similar to *Run Return* and *Run to Cursor*, but no code is executed. The final Skip command, *Skip to Start*, repositions the execution point at the first line of the program. However, no values are reset and no files are closed. If the programmer wishes to start the program from the beginning, *Restart Application* is more useful.

*Restart Application* is the fifth section of the Compile/Run Menu. This command resets all of the values in the program, closes the files, and resets the execution point to the first line of the procedure division.

The final section of the Compile/Run Menu includes *Compiler Directives* and *Application Command Line*. Compiler directives are commands that dictate how the compiler works with the source code. Since the use of directives is an advanced topic, this chapter does not deal with them. Students should ask their instructor for any compiler directives to be used.

*Application Command Line* brings up the Input box shown in Figure A.26. The user can then enter data for the program to use. The program accesses the information by using the ACCEPT . . . FROM COMMAND-LINE statement in a program. In the example, the statement "accept salutation from command line" places the words "Demo Data" into the data item "salutation." As a result, the output of the program is "Demo Data" rather than "Hello World." This option allows the programmer to have the program get data from outside without having the operator enter it. When the program encounters an ACCEPT . . . FROM COMMAND-LINE statement, the program reads the data placed in the Input Box into the variable specified by the ACCEPT statement.

Figure A.26 Entry of Command Line Data

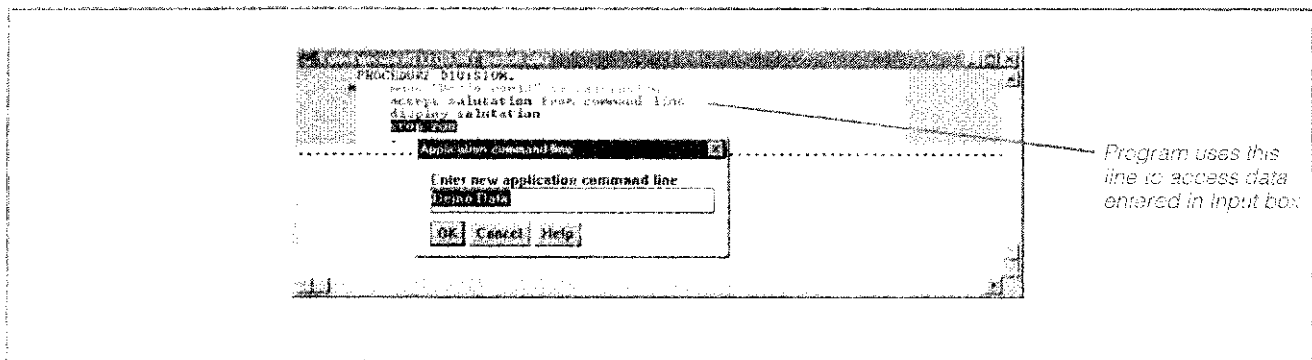

**Debug:** Along with the tools in the Compile/Run menu, the Animator provides another set of tools, shown in Figure A.27, for debugging programs. Breakpoints are major tools for debugging. A simple breakpoint, like that in Figure A.28, marks a line of code in much the same way as a Tag. However, when a program is executing and encounters a breakpoint, the program stops. Tags do not stop execution. A programmer can set a breakpoint at the beginning of a problem area in code. The programmer can then run the program at full speed until it encounters the breakpoint. The program stops and the programmer can then step through the problem area to try to detect the nature of the problem.

Figure A.27 Debug Menu

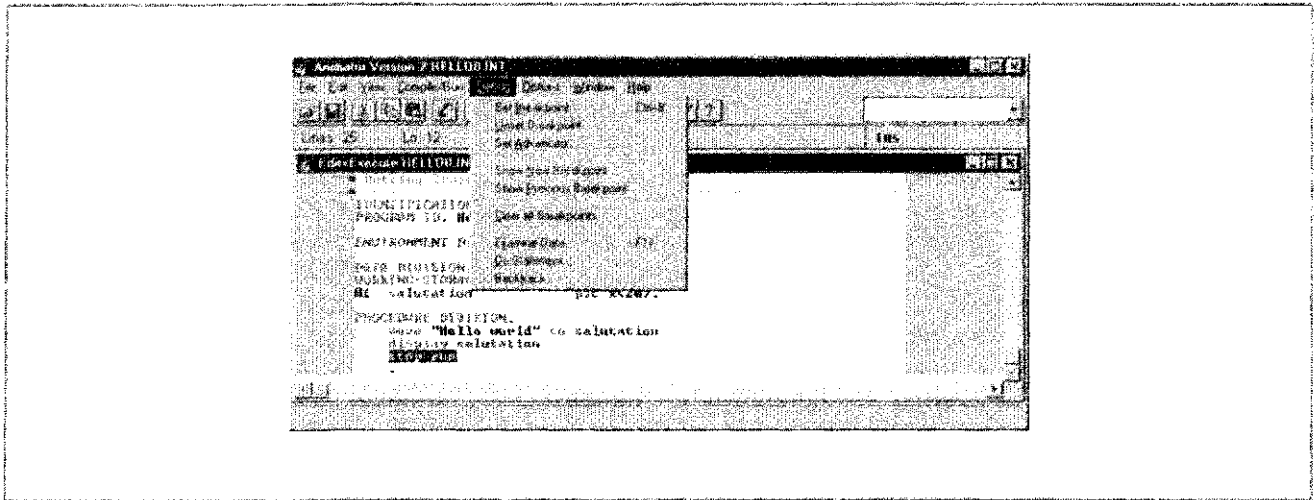
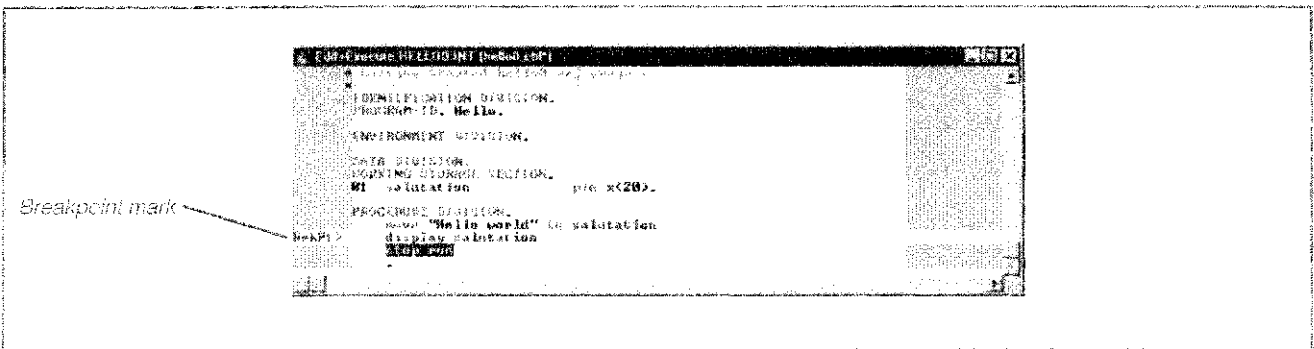
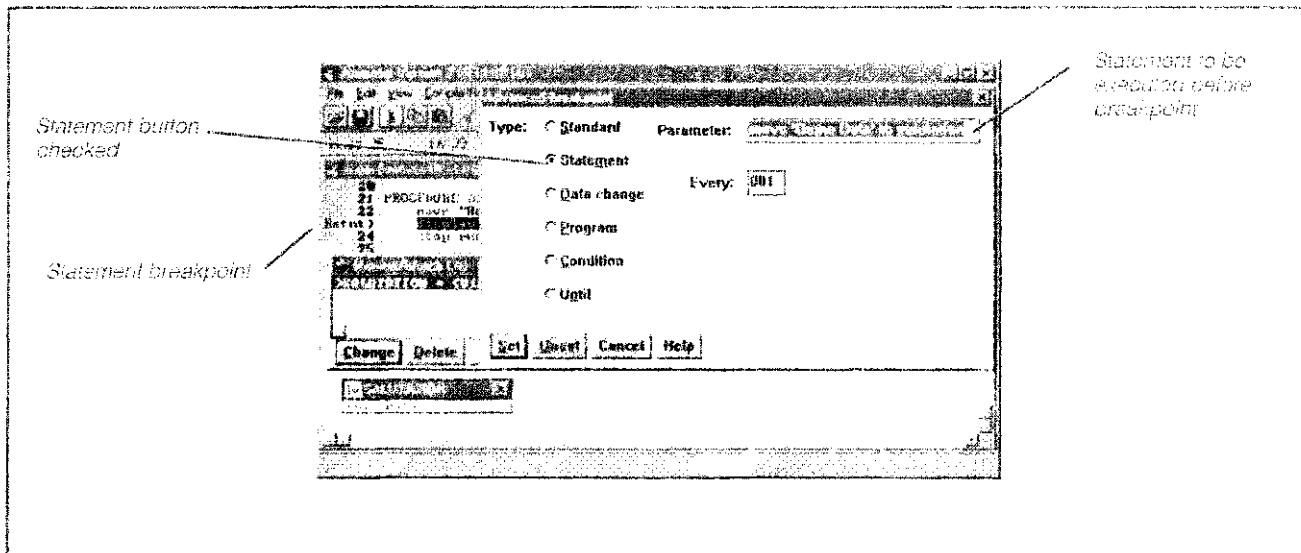

Figure A.28 Setting Breakpoints



While the simple breakpoint is a useful tool, the Animator also provides a set of breakpoints with advanced features. The first section of the menu deals with setting and removing breakpoints. The *Set Breakpoint* (Ctrl + B) command sets a simple breakpoint at the cursor location. *Unset Breakpoint* removes the breakpoint at the cursor location. A breakpoint can also be set by double-clicking on the COBOL verb in the statement. Double-clicking the verb again unsets the breakpoint. *Set Advanced* displays the dialog window shown in Figure A.29 and provides several options for breakpoints.

Figure A.29 Use of Statement Breakpoints



- **Standard**—The normal breakpoint mode as described above.
- **Statement**—Allows the programmer to enter a COBOL statement into the Parameter field to be executed when the program reaches the breakpoint location. This feature allows the programmer to try out a statement without recompiling the program. The execution *does not stop* at the breakpoint, nor does the entered statement replace the breakpoint statement. The temporary statement executes *before* the breakpoint statement. In Figure A.29, the parameter box statement **move "Demo Data" to salutation** is the breakpoint statement. "Demo Data" replaces "Hello World" in the data item "salutation." As a result, "Demo Data" is displayed as in Figure A.30 rather than "Hello World."
- **Data Change**—Allows the programmer to specify a data item in the parameter field to be watched by the program. Figure A.31 shows the data item "salutation" in the Parameter box. Whenever the data changes in Salutation the program halts at the next executable line. This feature is a help to find how data items acquire unexpected values. Only one *Data Change* breakpoint may be specified per program.
- **Program**—Performs a break when the specified program is entered. This feature is useful when the system uses subprograms, or in an Object Oriented system that invokes other objects. Only one *Program* Breakpoint may be specified at a time.
- **Condition**—Stops execution of the program at the breakpoint line only if some specified condition is met. The condition is specified in the Parameter box and cannot be specified in the form of a COBOL statement. In other words, use "salutation = 'Hello world'" rather than "IF SALUTATION IS EQUAL TO 'Hello world.'" Figure A.32 shows the correct specification.
- **Until**—Similar to *Condition*, but tests the condition on every line of code and not just a breakpoint line. Until shows exactly where the condition has been met but slows down the execution of the program, because each line must be tested.



**Figure A.30** Output of Statement Breakpoint

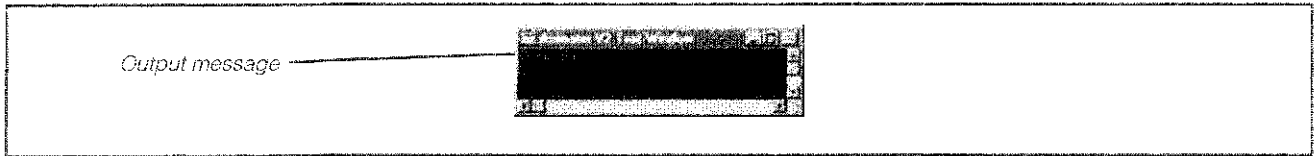

**Figure A.31** Setting a Breakpoint on a Change in Date

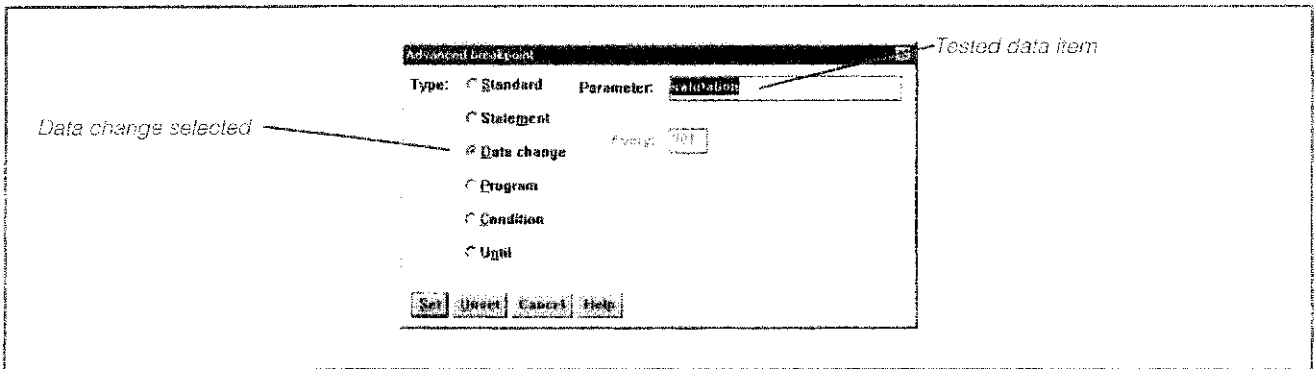

**Figure A.32** Setting a Breakpoint for Meeting a Condition

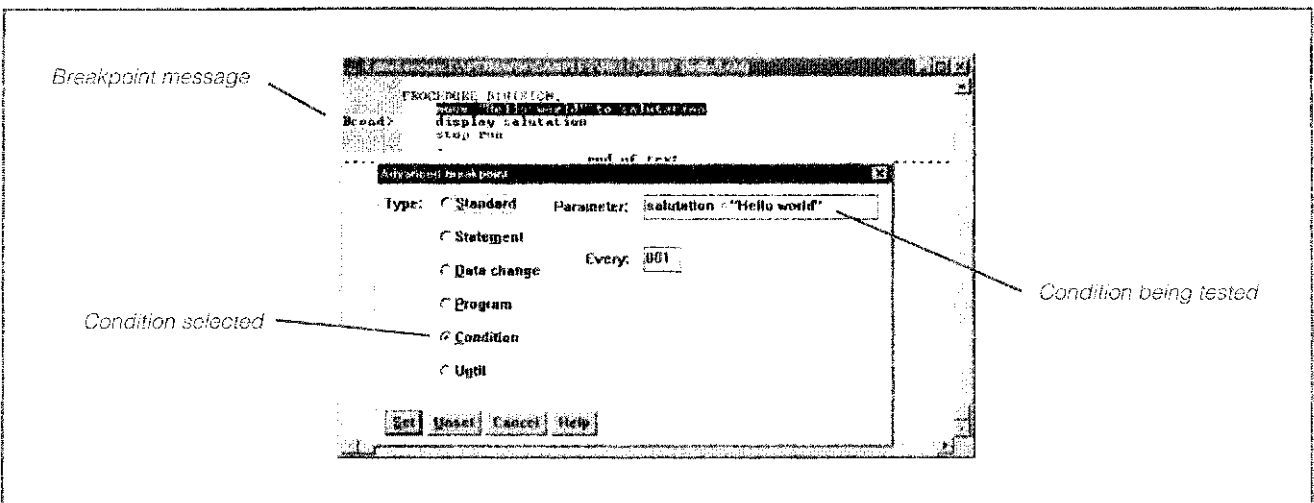

The Advanced dialog box also includes two text boxes—the Parameter box and the "Every" box. The Parameter box allows entry of values for all breakpoint types except Standard. The Every field allows a periodic use of the breakpoint. If the program is in a loop and the programmer wants to execute the breakpoint every other time, 002 should be entered in the field.

The second section of the Debug menu allows movement from one breakpoint to another. *Show Next Breakpoint* moves forward through the code from one breakpoint to the next. *Show Previous Breakpoint* moves backward to the previous breakpoint.

The third section of Debug is the single statement *Clear All Breakpoints*. This command allows removal of the all breakpoints with a single command.

The final section of Debug provides some other debugging tools. *Examine Data* (F11) allows the user to view the contents of a Data item. This command brings up the Examine dialog box as in Figure A.33. The dialog box works similarly to the Find COBOL Data Item box. *OK* displays the value of the chosen value and allows actions to be taken on the data. *Cursor* means that the item currently located by the cursor is to be displayed. *Suggest* presents a list of user defined names and allows the user to choose one. *Cancel* and *Help* allow the user to quit the process or to seek further help from the system.

Figure A.33 Examine Window and Suggested Item List

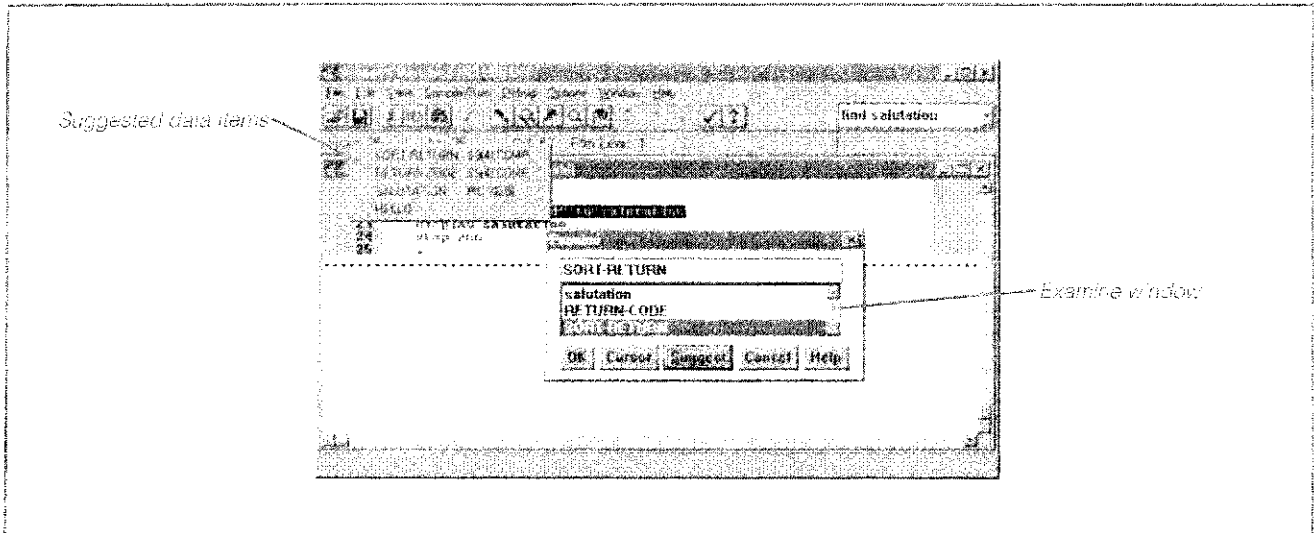

Once an item has been chosen and provided that it is a valid data item, a monitor window opens showing the current value of the item. Figure A.34 shows an example of the window. The window allows the user to see the contents of the window and to change the value. As a result, the user can “fix” the data item if necessary.

Figure A.34 Examine Monitor Window

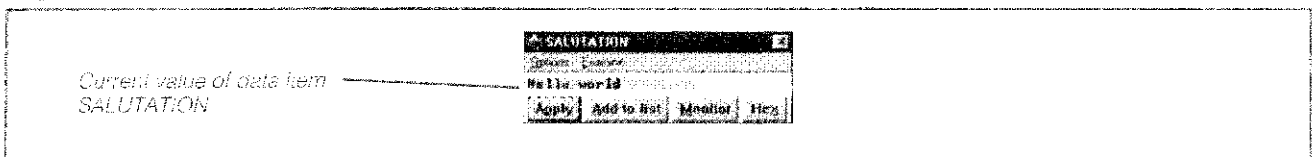

The *Do Statement* command also helps the user to temporarily fix a problem without recompiling and restarting the process. Selecting *Do Statement* brings up an input window as in Figure A.35. The programmer can enter a single COBOL statement and have it executed. The function is similar to a *Statement Breakpoint*, but here the COBOL statement is executed immediately and does not require a breakpoint.

Figure A.35 Use of Do Statement

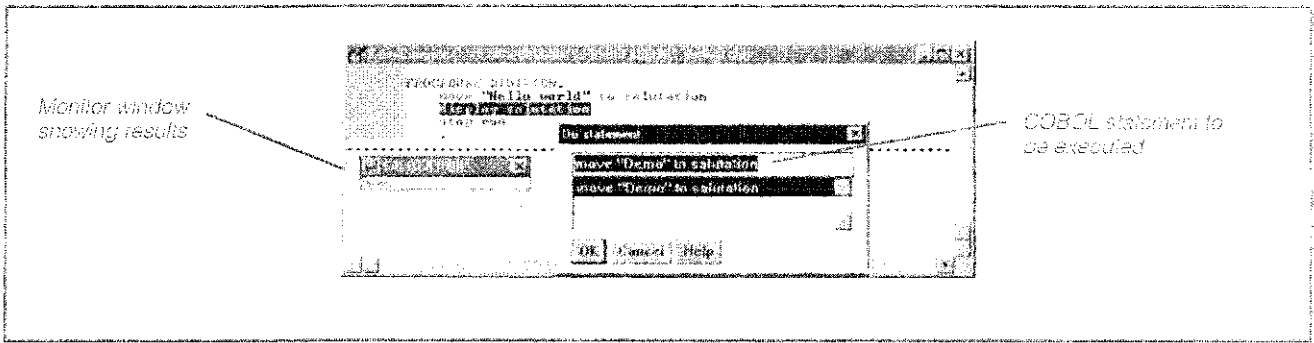

The final option in the Debug menu is *Backtrack*. *Backtrack* allows the user to step backward and forward from the current execution point. For this option to be available, the user must specify the *Backtrack on* option from *Execute options* under the Options Menu.

Figure A.36 Options Menu

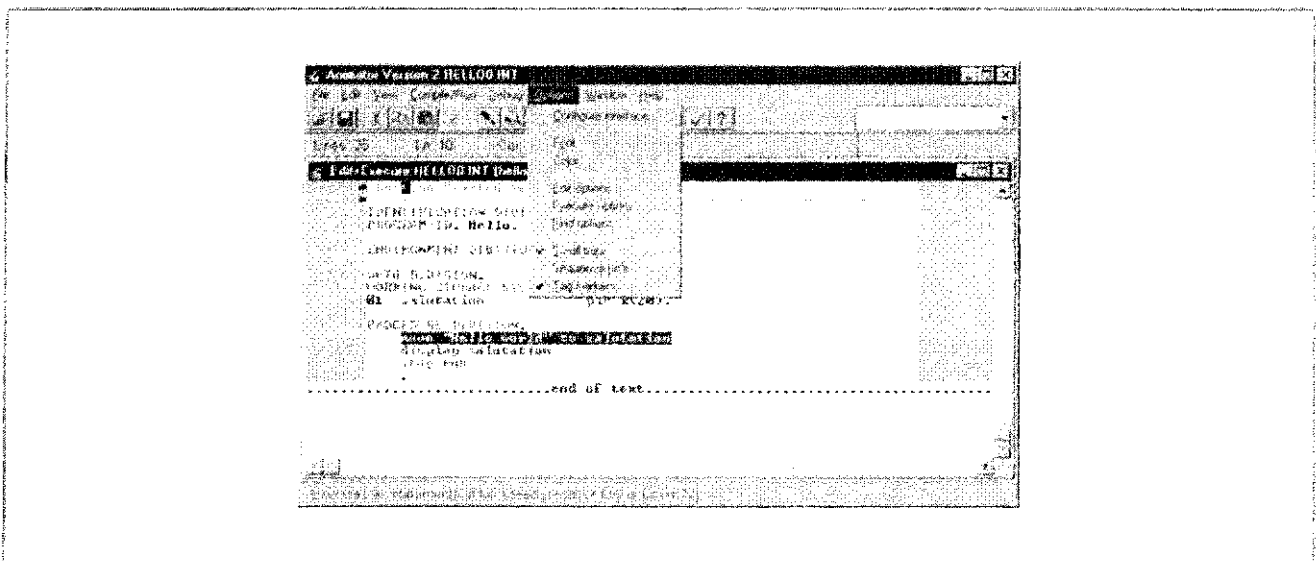

**Options Menu:** The Options Menu, shown in Figure A.36, provides a number of advanced capabilities for the Animater users. This menu manages the user interface and allows each user to individualize the Animater to his or her own taste. The full customization capability for most items is beyond the scope of this chapter, but some features may be appropriate for the student programmer.

The first option of the Options menu is *Configure Interface*. This option provides a selection of five dialog screens:

- *Toolbar*—Allows configuration of the Toolbar options including the position of the toolbar and the buttons contained in the toolbar.
- *Buttonbar*—Manages a bar that has similar functions to the tool bar but uses words instead of icons to show the command. The button bar is not a default configuration, but some users may find it to be useful.

- *Keys*—Allows the user to examine and define special key combinations for executing commands or running macros.
- *Macros*—Allows writing and editing of routines for performing a series of steps with one step. Macros are named and can be assigned to key combinations.
- *General*—Manages the general appearance of the Animator Screen.

The *Toolbar* dialog screen in Figure A.37 controls whether or not the toolbar is visible. The default is visible and positioned at the top. The visible toolbar can be top, bottom left, right, or as a free-floating bar. The user can also add, delete, or move various functions to the tool bar. To make the changes to the current toolbar, the user needs to click on one of the icons in the Current toolbar window. This action sets the focus in the window and activates the buttons at the bottom of the window. Students should not make changes to the toolbar unless directed by the instructor.

Figure A.37 Configure Toolbar Options

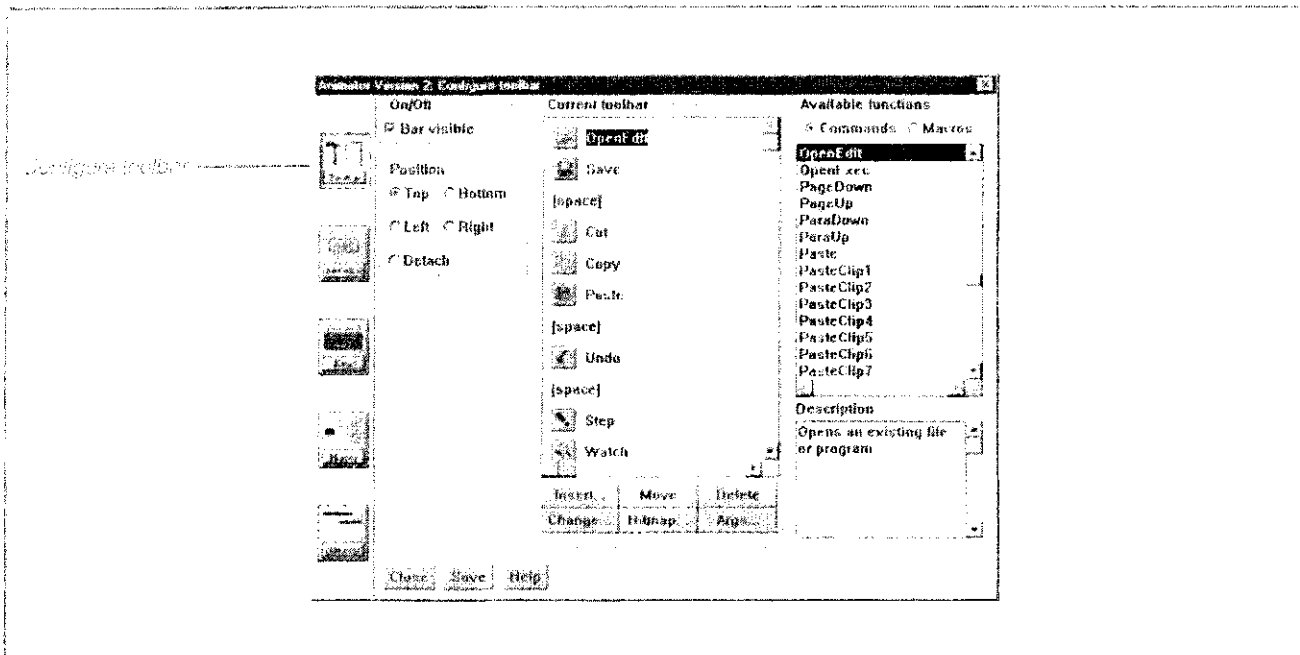

The *Button Bar* option, as shown in Figure A.38, allows the user to have a similar function to the toolbar, but instead of showing icons the buttons use words. The default for the button bar is visibility off. The student may want to turn visibility on since some may find the button bar to be useful. The standard button bar is shown at the bottom of Figure A.39. This discussion does not deal with it further.

Figure A.38 Configure Button Bar Options

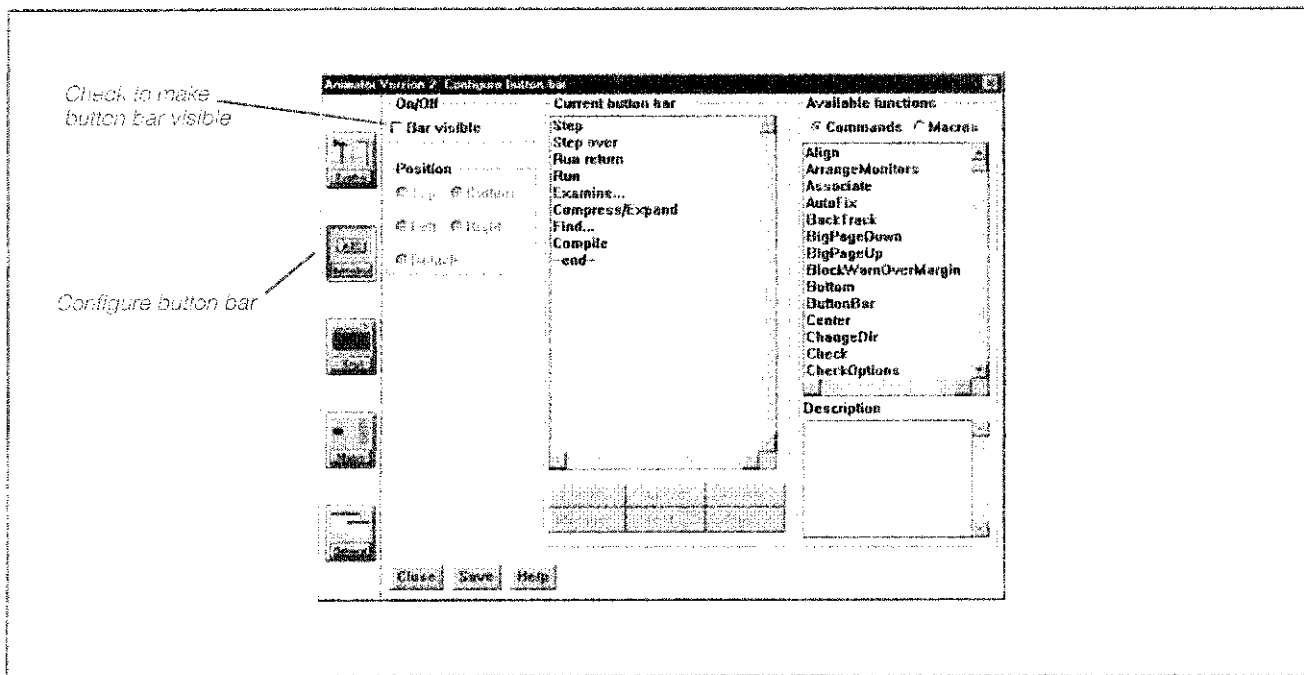
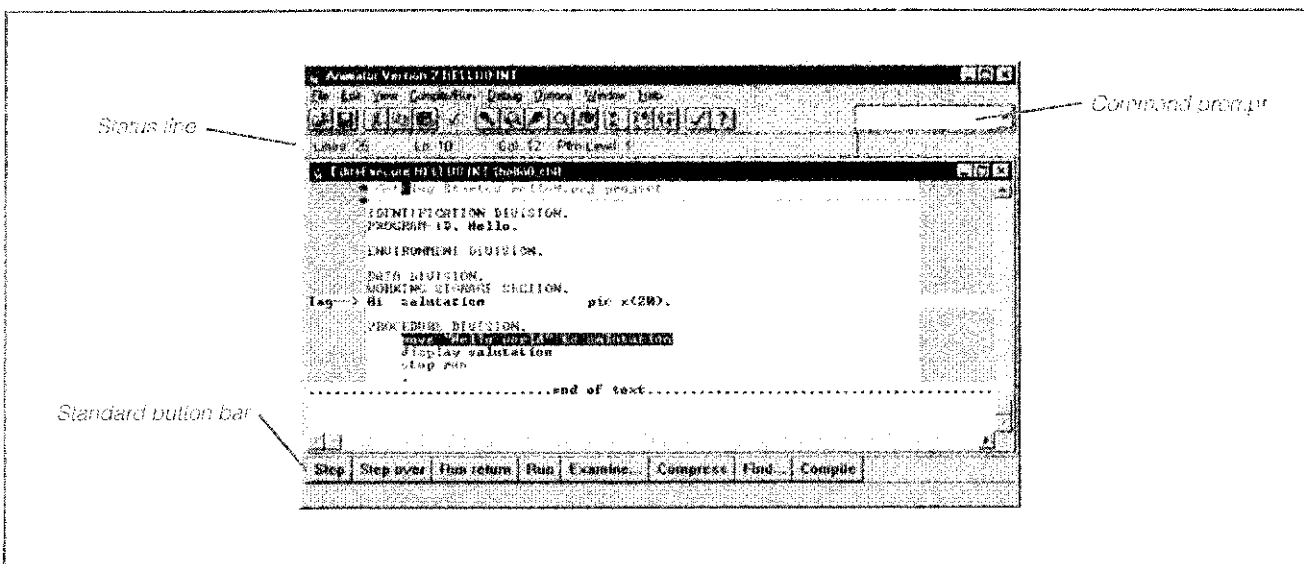
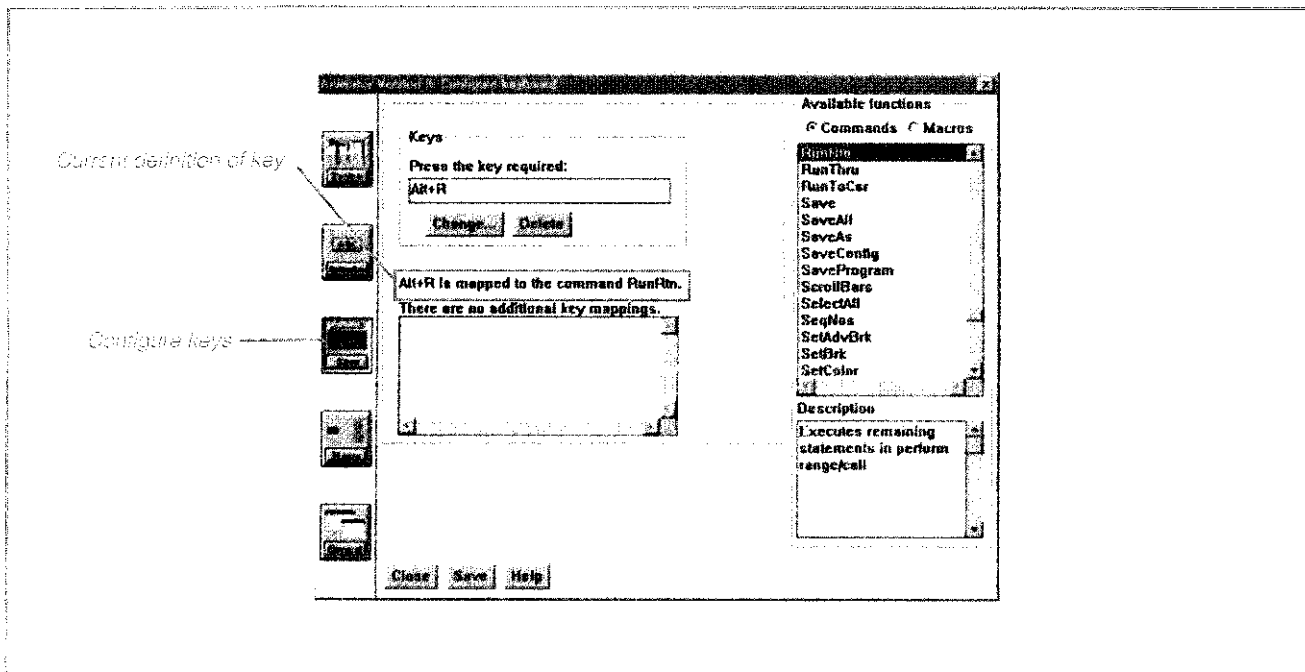

Figure A.39 Interface with Button Bar Visible



The Keys option in Figure A.40 is for users who prefer to use special keys for most functions rather than using the toolbar or menus. The option allows the user to specify the key combinations to be used. Specifying additional special keys should be done with caution until the user understands the Animator Commands thoroughly.

Figure A.40 Configure Special Keys



The *Macros* option should also be used with caution. This option, shown in Figure A.41, allows the user to run a series of commands at one time. A macro is a simple program that executes commands in sequence. Once a macro has been developed, it can be saved for further use, and a key combination can be defined in the key option and used to execute the macro.

The *General* option in Figure A.42 is the last of five interface options. This screen controls three elements of the Animator text editor:

- *Information Line*
- *Status Line*
- *Command Prompt*

In addition, *General* controls the “Hinting” capability. The information line and hinting go together. The *Information Line* defaults are Visible and Bottom, meaning that the line is present at the bottom of the screen. Several of the screen pictures show the information line. In Figure A.36, for example, the Information Line says “Executes all statements at full speed (shortcut key is Ctrl + F12).” If you move the mouse over the tool bar or the button bar, you see a definition of the button in the Information Line. This process is called Hinting. Once you become familiar with the Animator, you may choose to turn the hinting function off.

The *Status Line* is found under the toolbar at the top of the screen, as shown in Figure A.39. This line tells how many lines are in the program, the current line number, the column within the line, and the perform level of the current line. (A perform level greater than one means that the current line is part of one or more Perform statements.) The Status Line should be kept visible.

The Command Prompt, also shown in Figure A.39, should remain on the toolbar rather than being detached. If the Command Prompt is detached, it is not visible unless requested by using *Command* in the Edit menu or Ctrl + F11.

Figure A.41 Configure Macros

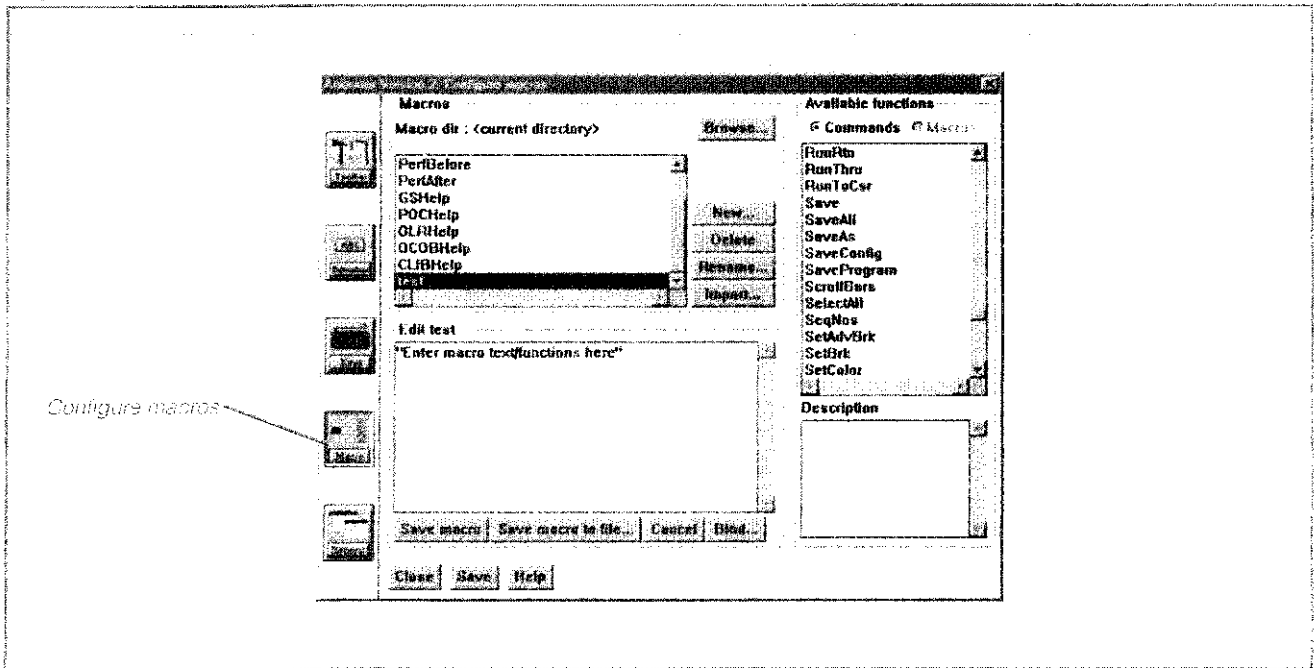
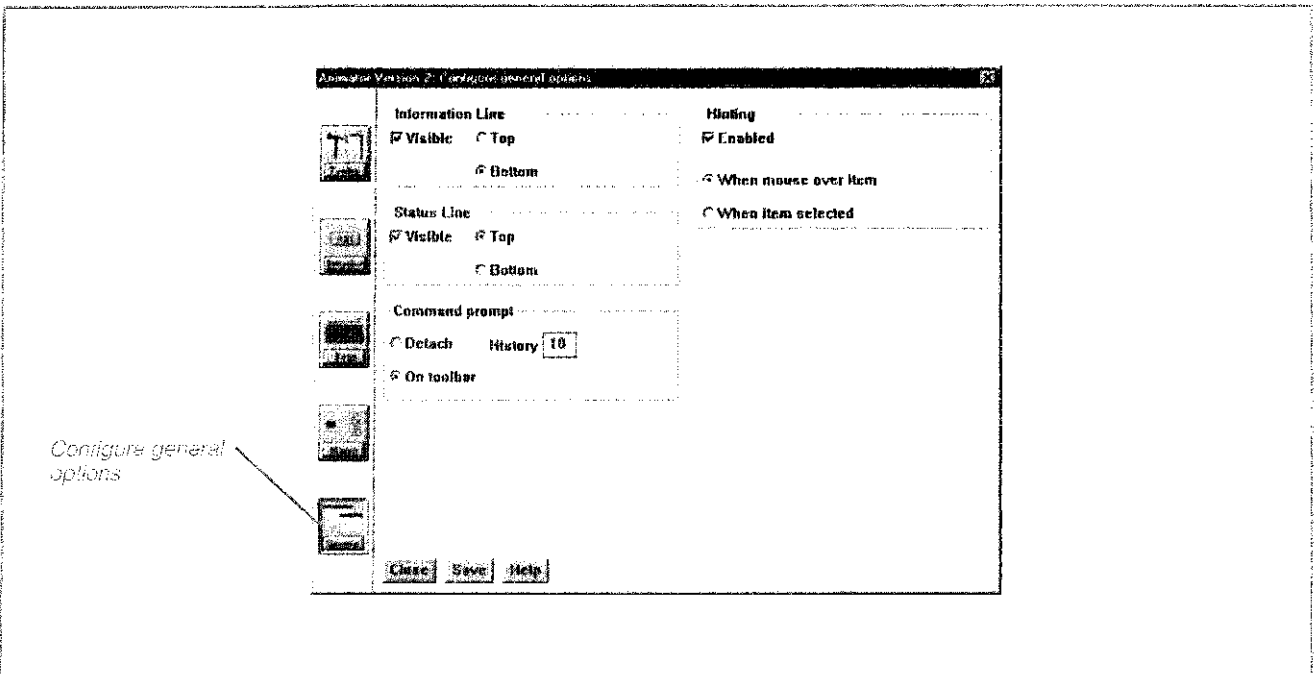
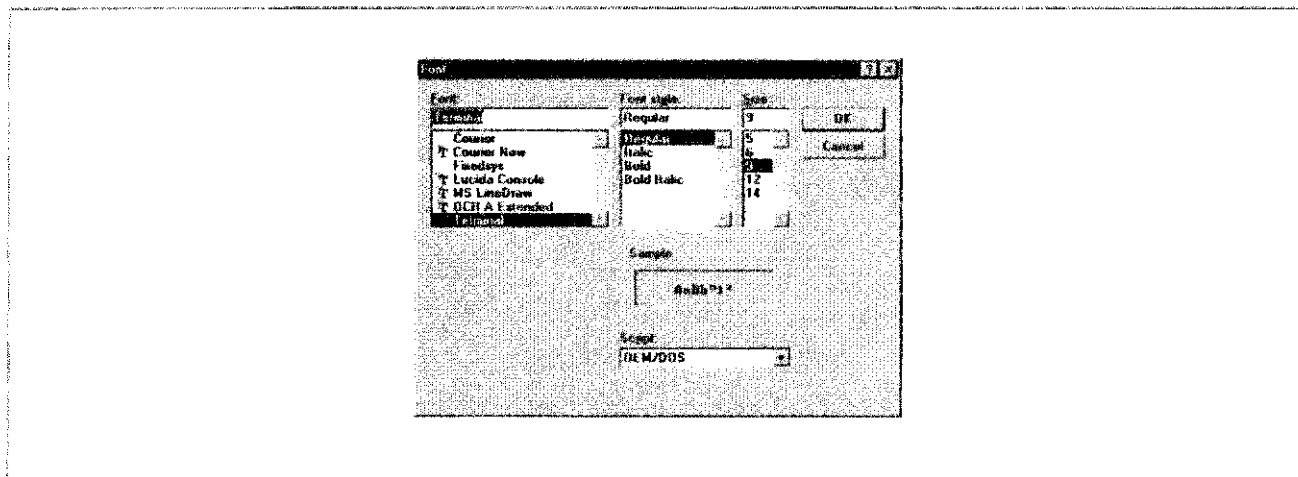

Figure A.42 Configure General Options



The next section of the Options Window deals with the *Font* and the *Color* schemes used in the screen. Figure A.43 shows how the *Font* section allows the user to change the default font type. In addition, the font can be made bold, italic, or both. *Font* also allows the user to make the character size larger or smaller. The *Script* box is for advanced applications beyond the scope of this discussion.

Figure A.43 Font Selection Window



Color allows the user to change the color scheme of the source code. This color coding is very useful in identifying the purpose of various words in the code. Students should look through the default color scheme carefully to learn what the colors mean. There are two sets of colors. The General set shown in Figure A.44 refers to the color schemes for marking lines, margins, and other items. The Syntax set, in Figure A.45, manages the color scheme for verbs, data items, reserved words, and other types of text.

Figure A.44 Configure General Color Scheme Window

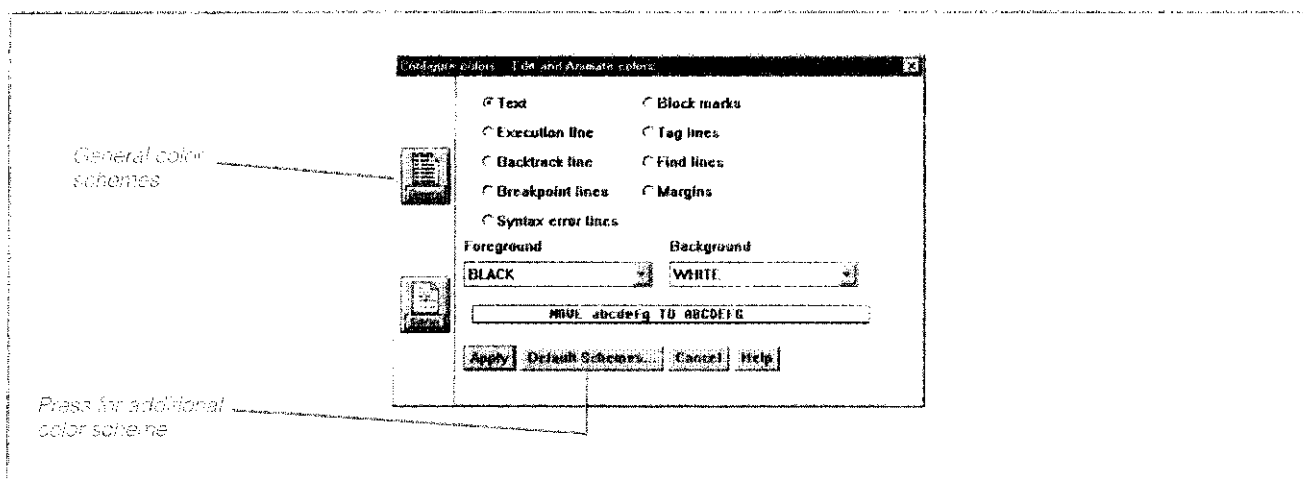

The Animator provides several default color schemes. The color schemes can be altered by clicking on the Default Schemes button in either the General or the Syntax window. The button brings up the list box shown in Figure A.46. Students who work primarily on a monochrome monitor should investigate Plasma Bright or Plasma Powersaver. Other students may want to consider using Preprocessed color scheme rather than the Default. In the Default color scheme the colors for unidentified items are white on magenta. This combination of colors can be annoying. In the Preprocessed color scheme, the unidentified words are black on white.



Figure A.45 Configure Syntax Color Scheme Window

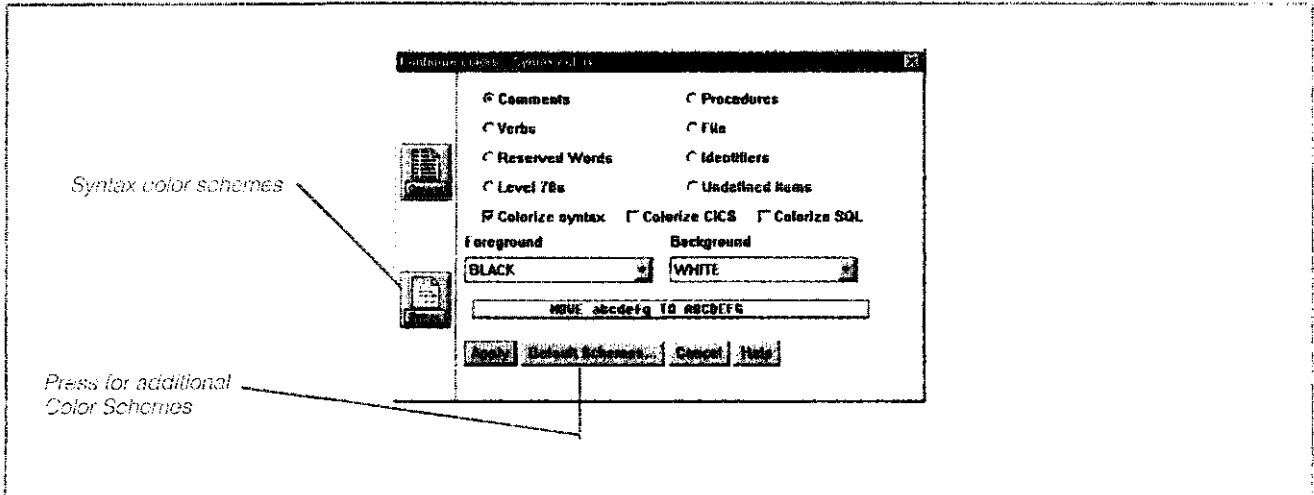
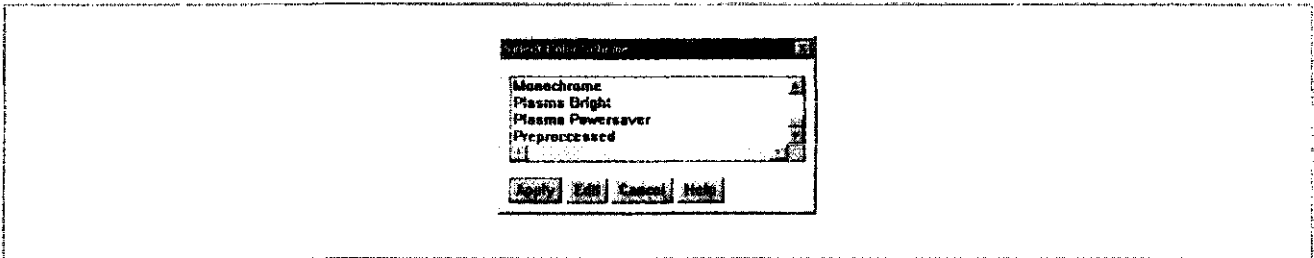

Figure A.46 Alternate Color Scheme List Box



The next section of the Options Menu deals with configuring the interaction with the Animator. Generally the new programmer should not deal with these items until experienced with the Animator. The first option, *Edit options*, has three dialog screens:

- *Profile*—Controls the format of the Animator Source Entry window. The student programmer might want to make one change to the profile. If the instructor requires programs to be written in Upper Case, the Force capitals option could be useful. Figure A.47 shows the Configure Profile window.
- *Global*—The window shown in Figure A.48 controls behavior of the Animator in using external sources to the process. The clipboard used, external files, and typing controls can be modified in this window. The student programmer generally should leave these options alone unless required by the instructor. However, the backup files on saving and warn on loading read only files options could prove to be useful options. Note that automatically backing up files uses additional disk space.
- *Autofix*—Figure A.49 shows the Autofix option that allows the programmer to enter commonly misspelled words and to have the Animator automatically correct them. To add words to the defaults given, click on the Add button.

Figure A.47 Configure Edit Profiles Window

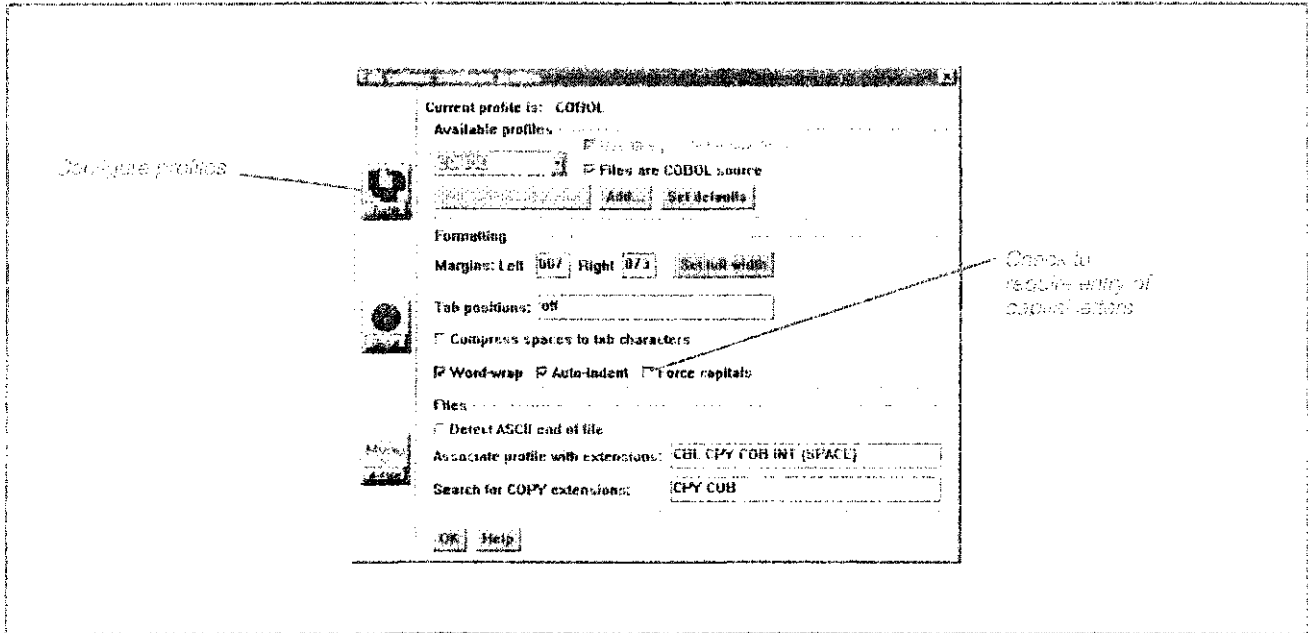
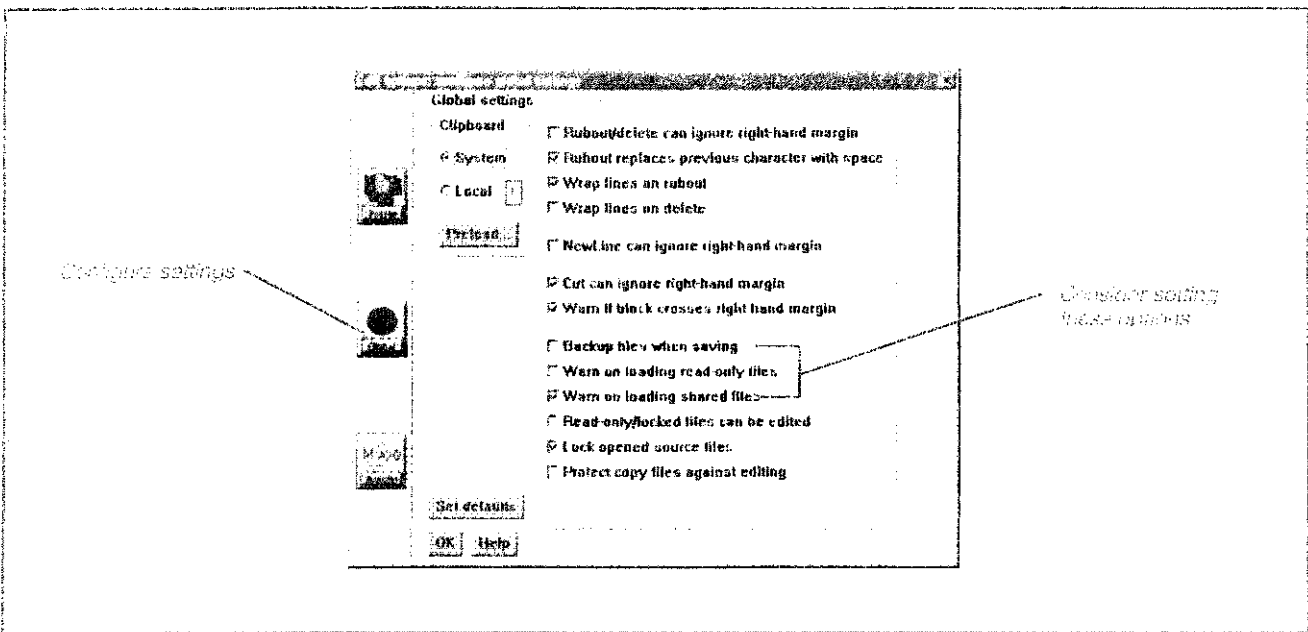

Figure A.48 Configure Global Settings Window



The *Execute Options* of the *Options* menu brings up the dialog box in Figure A.50. The five check options include:

- *Hide on Run*—The default mode that hides the Animator Text when the program is running at full speed.
- *Backtrack on*—Causes Animator to maintain a history of the steps taken in running the program. Is used with the *Backtrack* option of the *Debug* menu.
- *Set Threshold level*— When turned on, tells Animator not to show the actions taken at a level below the current level. In other words, the steps in a perform or a call can be hidden.

- *Analyze*—This function is not available in Personal COBOL.
- *Edit lock on execute*—is option keeps the user from making changes to the program while it is in the execution phase. The function is intended to prevent accidental changes to the program. This is the same function as *Edit lock* in the Edit menu.

Figure A.49 Configure Autofix Words

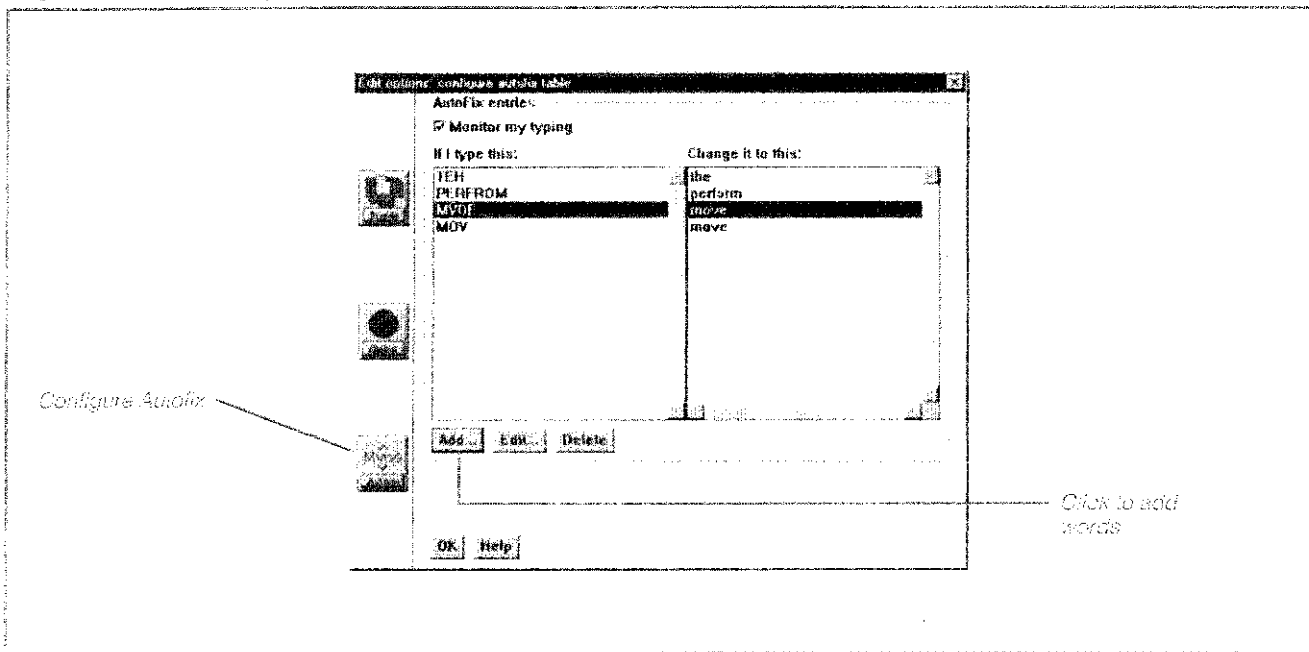

*Find options* is the third option available in this section. Again, *Find options* is generally best left alone by the student programmer. Figure A.51 shows the COBOL data item finds. Once programmers have become experienced in debugging programs, they may want to explore some of the options here.

Figure A.50 Execute Options Window

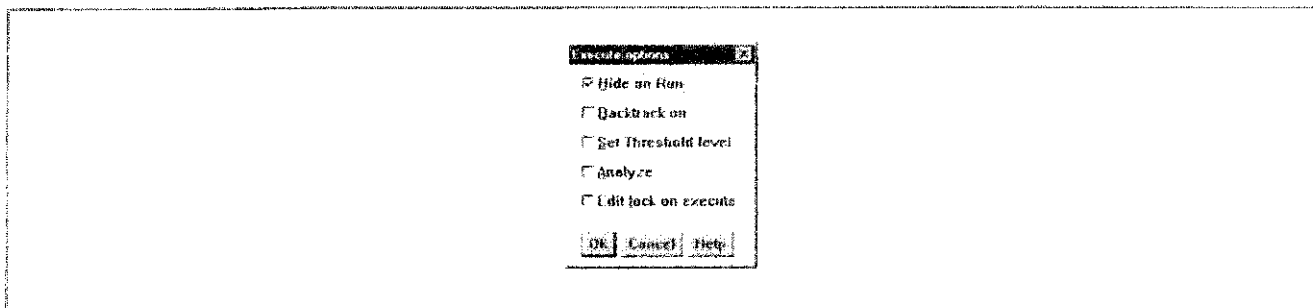
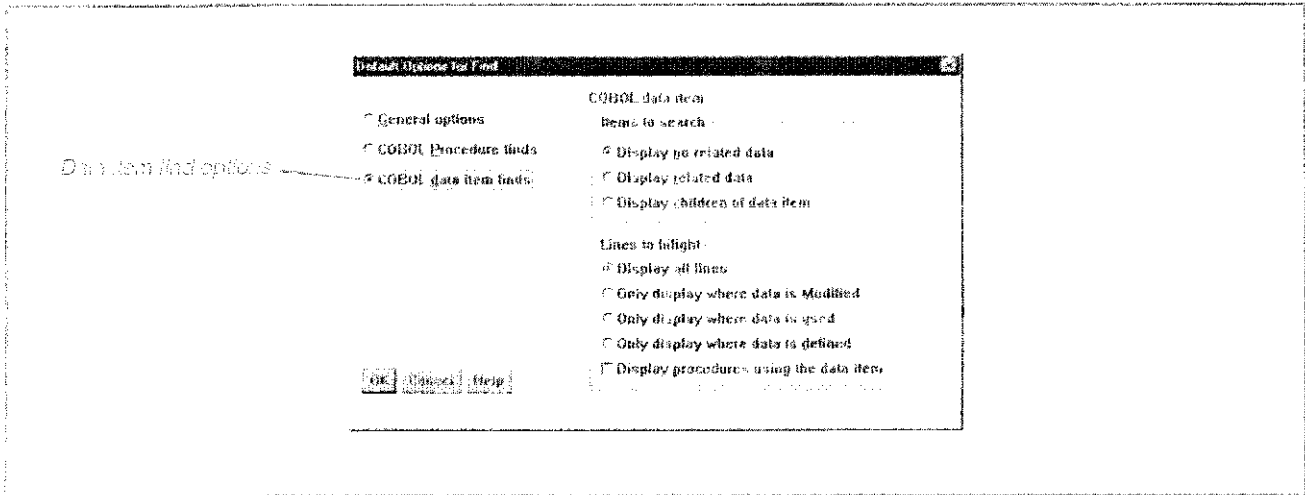

Figure A.51 Configure Options for Find



The final section of the Options Menu contains toggles for turning on or off some of the screen tools. The first option is *Scroll bars*. The scroll bars are the arrows on the right side and bottom of the window. The use of the scroll bars allows rapid movement to portions of the source code not currently visible on the screen. There is probably no need to turn off the Scroll Bars, but if the Scroll Bars are off, the user can still move within the source code by using the arrow keys and by using Tags and Breakpoints as discussed in the View and Debug Menus.

The next option is *Sequence nos.* This option shows or hides the sequence numbers in columns 1 to 6 of the source lines. The default is off, but at times these numbers may be useful particularly if the status line is not visible. Figure A.52 shows a program with sequence numbers.

Figure A.52 User Interface Showing Sequence Numbers

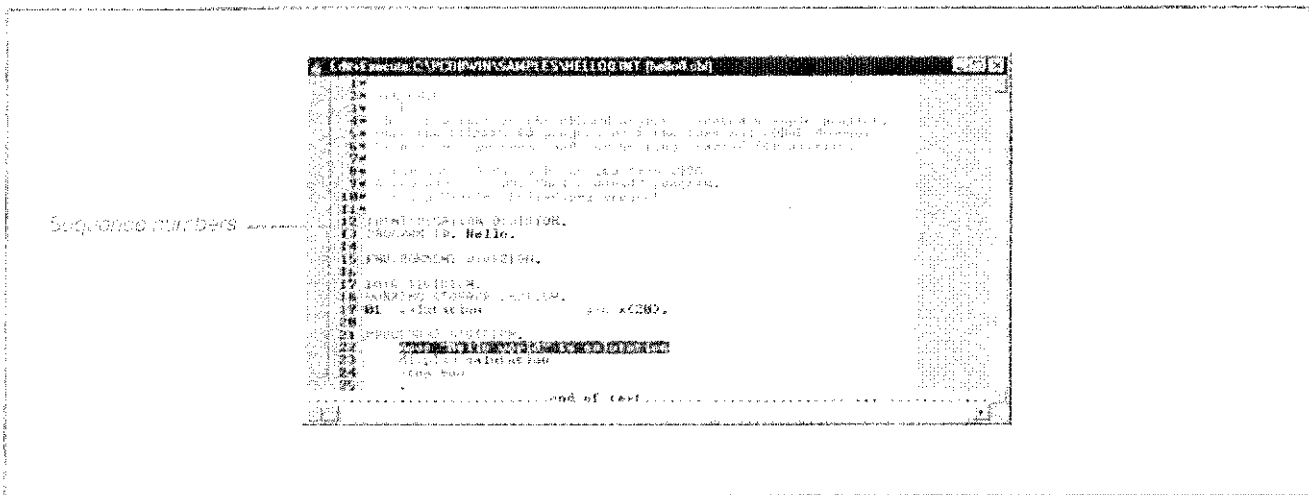

The final option is *Tag markers*. Again, this is a toggle. Tag markers are messages in columns 1 to 6 as in Figure A.53a. If Tag Markers is off, the messages are not shown, but the tagged lines are still highlighted as shown in Figure A.53b. The tagged lines may be Tags, Breakpoints, or Found lines. If both Sequence Nos. and Tag Markers are on, the Tag Marker overrides the line number.

Figure A.53 Tag Marking

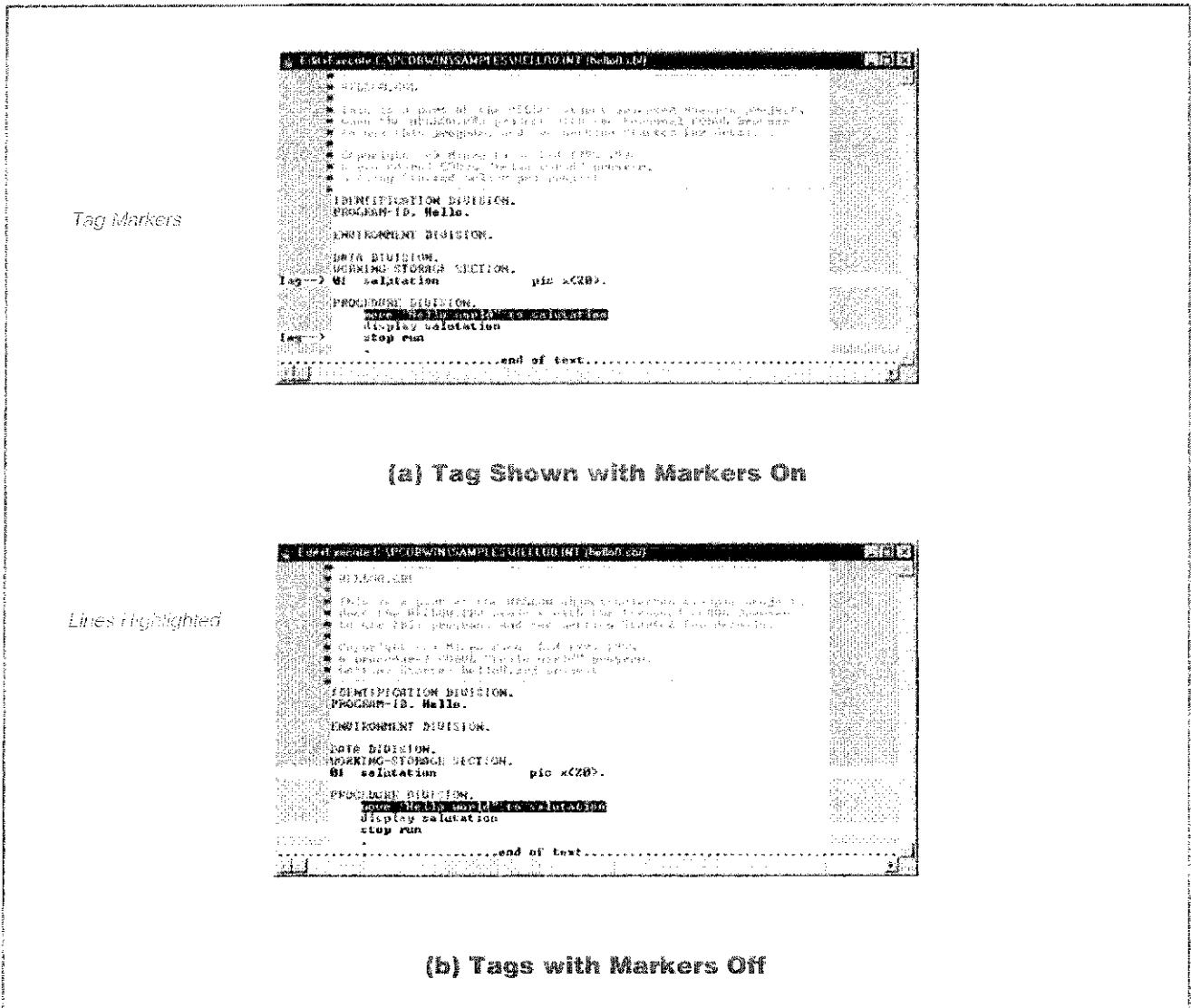

**Window Menu:** Figure A.54 shows the Window menu. This menu is useful when the programmer is working with more than one program at the same time and while debugging programs. Remember that while only one program can be in execute mode, any number of programs can be in edit mode. The first option of the Window menu is Tile. This option allows the programmer to view two or more programs at the same time. Only one program has the focus at one time. This program is shown on top and with the full width of the window. Any other program windows are shown across the bottom. Figure A.55 shows three programs in tile mode. Up to three programs can be shown across the bottom at one time, even though the programmer may be working on more programs.

Clicking on one of the windows will shift the focus to that window, and the programmer may change code in the window. Shifting the focus to one of the windows on the bottom of the screen does not move that program to the top. In order to move this program to the top half of the screen the user must again select Tile. If the user double-clicks on the title bar of a window, that window is expanded to full screen. Double-clicking again on the title bar will return the window to its original size and location.

Figure A.54 Window Menu

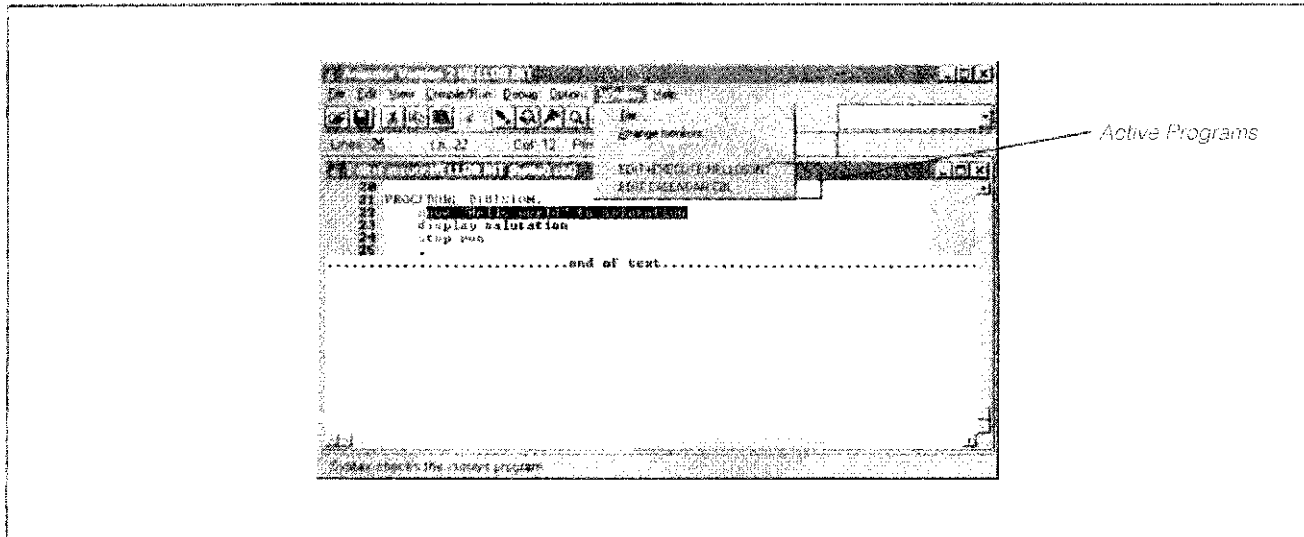
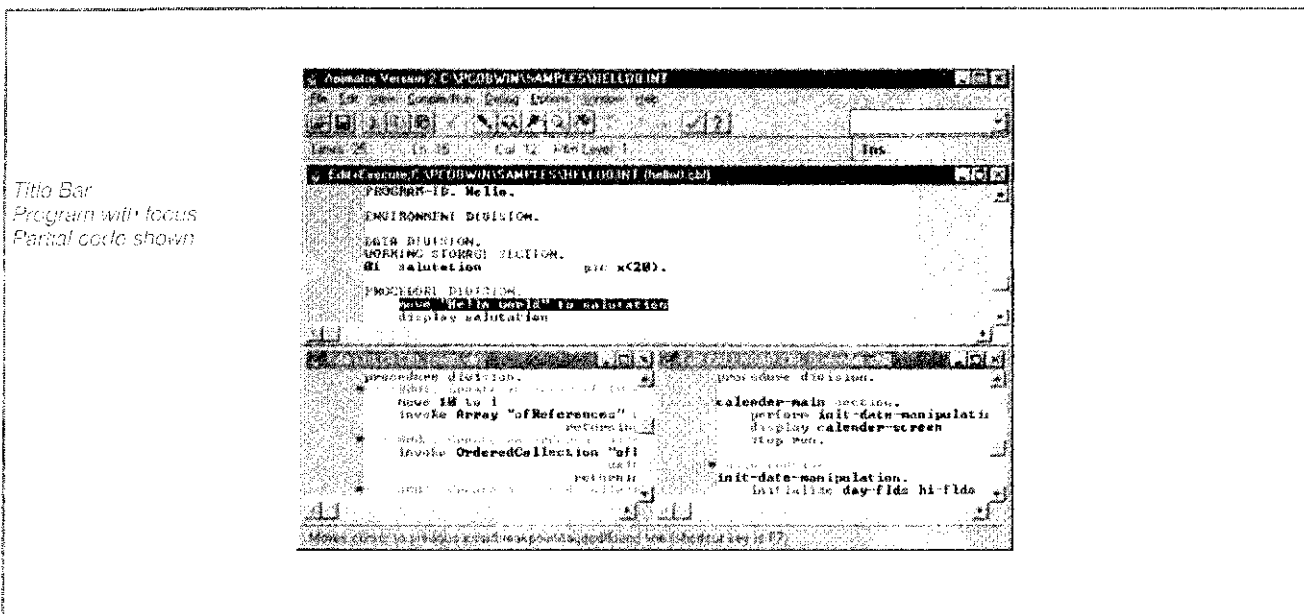

Figure A.55 Three Tiled Programs



When showing multiple programs, the Animator shows only partial lines of code. Using the scroll bars, the user can view the remaining code to the right.<sup>2</sup>

The next option *Arrange Monitors* is available only to a program in Execute mode. Monitors are the small windows that display the value of data items. If there are a number of monitors being used and if the user moves them around, not all of the monitors may be visible. *Arrange Monitors* organizes the monitors along the right-hand side of the window for better visibility. Figure A.56a shows the monitors before alignment, and Figure A.56b shows the monitors after alignment. As can be seen in the figures, the alignment may not impose visibility much. The user can always drag the monitors to where they will be more visible.

Figure A.56 Arranging Monitor Windows

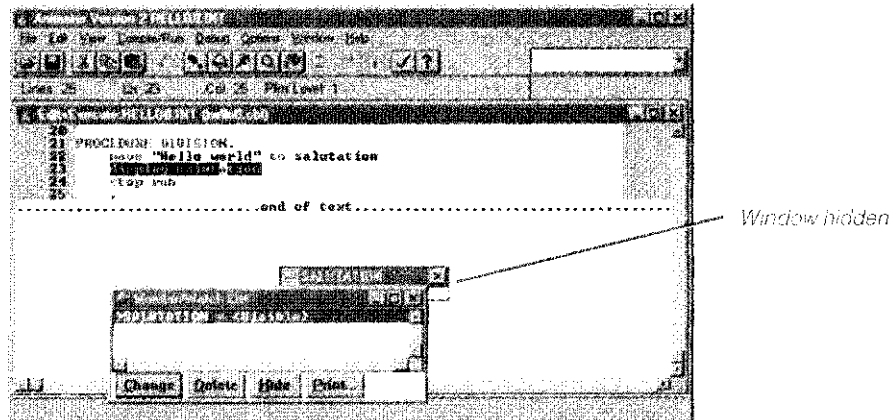

(a) Monitor Windows Before Arrangement

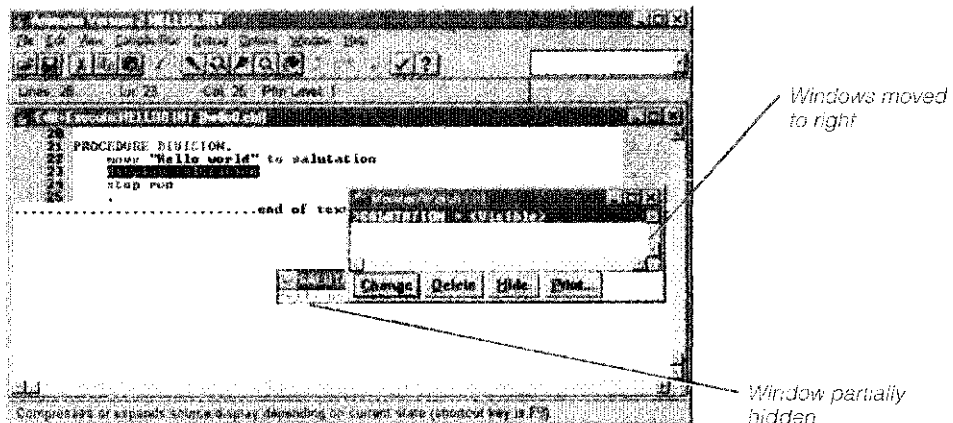

(b) Monitor Windows After Arrangement

The final section of the Window Menu in Figure A.54 shows the name of each program currently being used by the Animator. The user can click on any of the names and make it the current program. The listing also shows the mode of the programs.

**Help Menu:** The Help Menu shown in Figure A.57 contains a number of items that can help the user while in the process of working with the Animator. Several words of caution are necessary, however. Personal COBOL for Windows emphasizes Object-Oriented COBOL. While a student may want to explore this topic in more detail, the chapter on OO COBOL should be reviewed before getting too involved with the tutorials and the use of the browser. Also, the help files were originally developed for other Micro Focus products and in some cases referenced topics have not been included. Attempting to access them produces an error message. Finally, in some cases the references for "hot words" are actually on the same page as the hot word, and clicking on the hot word returns the screen to the top of the page. In this case, the user should scroll down to the point where the topic is discussed.

Figure A.57 Help Menu

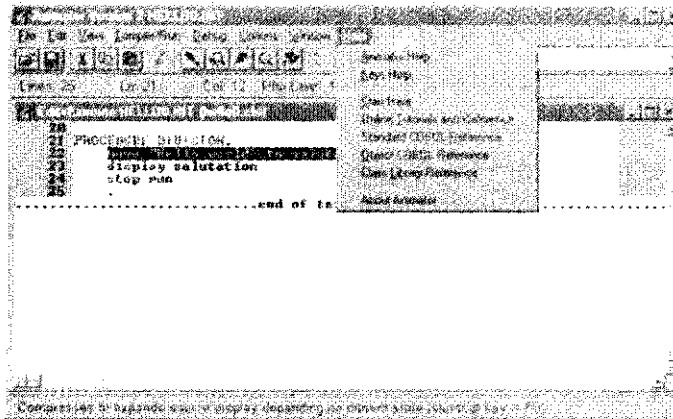

Since the Help process is meant to be self-explanatory, this discussion is limited to brief descriptions of the more useful topics. Explore the Help menu options for yourself.

The first set of topics under the Help menu are *Animator Help* and *Keys Help*. The *Animator Help* should be useful in learning how to use the Animator. Much of the material in this discussion has been based on the Animator Help.

*Keys Help* provides the user with a table of the key combinations used in editing programs in Animator. This table can be a good source for programmers who prefer to use keystrokes rather than the mouse. The student may want to print this screen for further reference.

The second section of the Help Menu contains tutorials and advanced topics options. *Start Here* actually is an introduction to object-oriented programming, and probably is not the best place to start in connection with this book. The student should hold off on this section unless otherwise instructed by the teacher. In the section *On-line Tutorials and Reference*, the beginning programmer should look at the Animator Tutorials and leave the Browser and OO COBOL tutorials for later. In regard to *References*, the most useful section for the beginning programmer is the *System Messages* section. This section provides a point for looking up error message to see what has gone wrong with a program. Those messages take two forms, compiler messages—messages when trying to write the program—and run time messages—messages when trying to test the program. The other reference topics are advanced in nature.

The *Resources* section of the *Online Tutorials and Reference* has some items that may be useful. The most useful resource is the Glossary, which is a dictionary of terms.

*Standard COBOL Reference* is the most useful option for the purposes of this book. Students should review the topics presented, but should not be concerned if they do not understand a lot of the information presented. *COBOL Source Syntax* may be the most useful section for the student. However, the same type of help is available more directly. By moving the cursor to a COBOL verb in the source and pressing Alt+F1, the Animator brings up the help screen for that verb. Figure A.58 is the help screen for the IF statement. In many cases, the Animator Help has more than one screen relating to the topic and it displays a list of options. The option



names in this list are not always helpful. The student should just pick one. If the wrong option is chosen, most help screens have hot words, and the user can usually find the needed information quickly.

Figure A.58 Example of Syntax Help Window

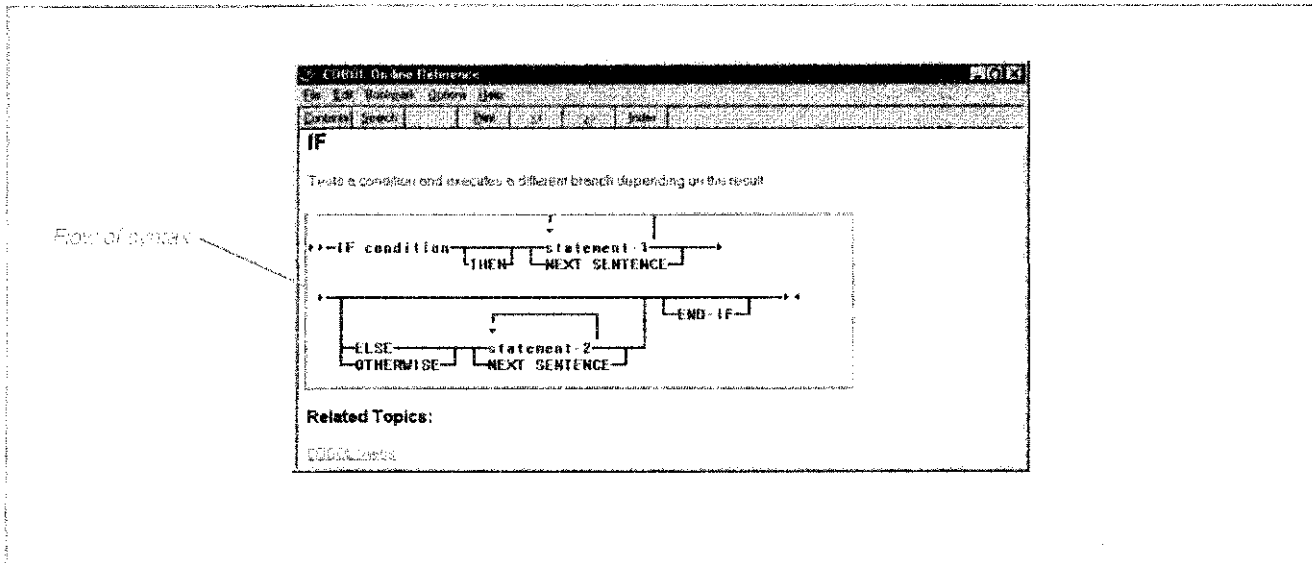

*Object COBOL Reference* and *Class Library Reference* deal with OO COBOL and are probably best left until the programmer is ready to deal with OO topics.

*About Animator* displays an information screen about the version of Animator and current resource statistics.

## Tool Bar

The Toolbar, shown in Figure A.59, is the set of 16 icons displayed below the menu line along with the Command Prompt box. The icons are a quick way to perform a limited set of the menu operations. Command prompt allows direct entry of Animator commands.

Figure A.59 Animator Toolbar



The Toolbar groups the icons by their functions. The first set of icons deals with file handling, the second with editing source code. The third set is a single item to undo changes. The fourth set is for debugging while the fifth set handles breakpoints and tags. The final set allows compiling programs and the help.

Set 1: The first two items:



- \* *Load*, a folder with an arrow, allows the user to load a file for editing (not execution). Clicking on the *Load* icon brings up the Open dialog box which

displays the “cbl” files in the current directory. The user must use the menu to bring in a file for edit and execution.



- *Save*, a diskette, saves the file in its current form to the disk. Saving files regularly is always a good idea.

**Set 2:** This set of icons consists of:



- *Cut*, a pair of scissors, removes highlighted text and places it into the Windows Clipboard.



- *Copy*, two pages, places a copy of the highlighted text into the Windows Clipboard.



- *Paste*, clipboard with a page, copies the current contents of the Clipboard to the current location in the code.

Some words about the Clipboard. Only one item can be placed into the clipboard at a time. Therefore, if something is already in the clipboard and the user cuts or copies a new item, the original item is overwritten. The clipboard is not limited to just the current window. The clipboard makes it easy to cut or copy code from one program and place it in another program in a second window. The clipboard can also be used with another Windows product so that code from a program could be copied into a word processor, for example.

**Set 3:**



- *Undo*, a curved arrow pointing to the left and down, restores the text to the previous state. The icon is active only when some change has been made to the program. *Undo* restores up to 100 changes.<sup>3</sup>

**Set 4:** This set of buttons is available only in the Edit + Execute window. These buttons allow the user to control the process of reviewing code as it runs.



- *Step*, a footprint, allows the user to “step” through the program one line at a time.



- *Watch*, a footprint and a magnifying glass, works in the same way as *Step* but also displays monitors of the data values for items in the current line of code. Examples of a monitor are shown in Figures A.56a and b. *Watch* is particularly useful in debugging code.



- *Run*, a figure “running,” executes the program at full speed.



- *Examine*, a magnifying glass, allows the user to look at the contents of any data item whether or not it is part of the current execution line. This icon represents the same function as “Examine Data” under the Debug menu. Clicking *Examine* brings up the same dialog window shown in Figure A.33.





- *Find*, binoculars and lines of code, brings up the Find dialog window from the Edit menu and shown in Figure A.12. Find allows the user to search for a COBOL item or specific text.

**Set 5:** Set 5 consists of 3 buttons that are active only when the user has set Breakpoints, Tags, or Finds in the code. If more than one type of marking is being used, clicking on any of the buttons will bring up a menu to select the desired type.





- *Toggle Compress*— arrowheads pointing toward the center of the button— causes only the highlighted code lines to be visible. When the code has been compressed, the arrows change to point to the top and bottom. Clicking again expands the code to its original state. Figures A.60a shows an

uncompressed portion of a program. After compression the same code looks like Figure A.60b.

-  • *Previous*—short lines and an arrow going from bottom to top—moves the current location to the previous marked line.
-  • *Next*—short lines and an arrow going from top to bottom—moves the current location to the next marked line.

**Section 6:** The last section of the tool bar contains two buttons.

-  • *Check*—a check mark—compiles the current program. Micro Focus uses the term Check for compile.
-  • *Help*—a question mark—brings up the Help Screen.

**Figure A.60** Example of Expand and Compress

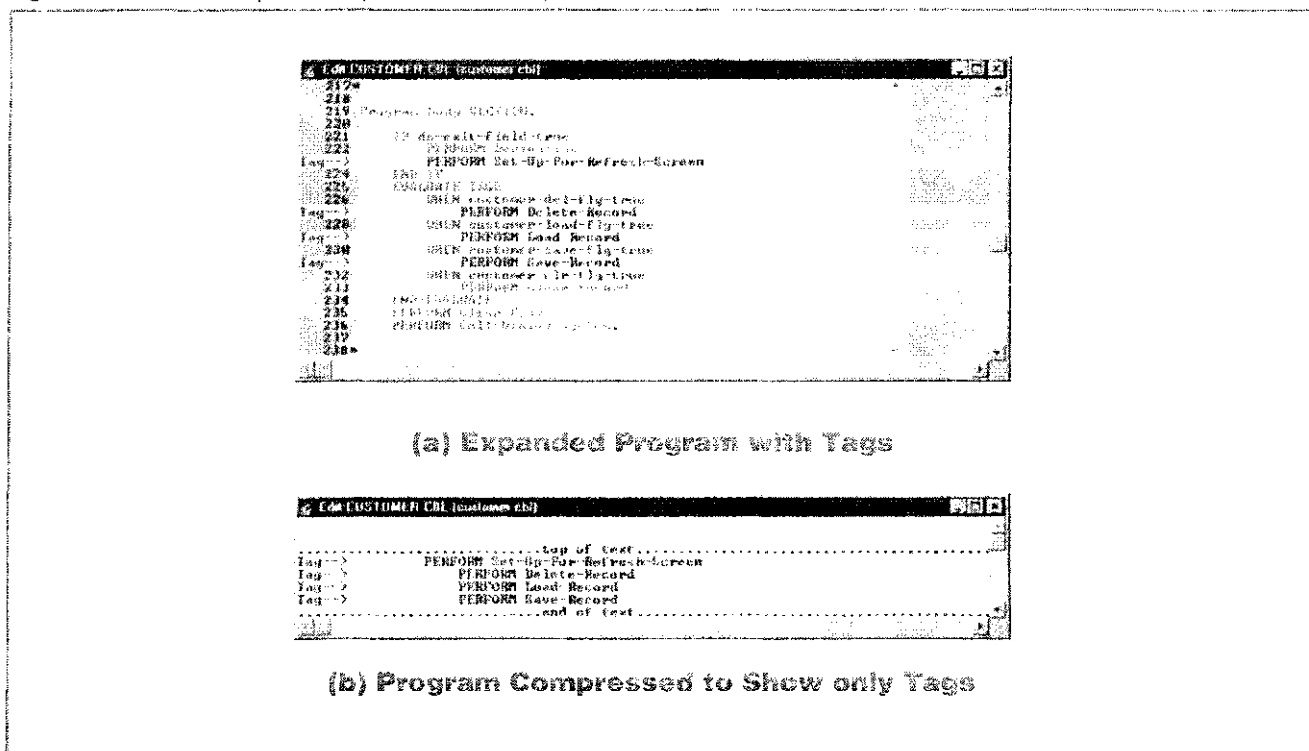

### Command Prompt

This window allows the user to enter Animator commands directly instead of using the menu or the toolbar. The Command Prompt box maintains a history of the last 10 commands entered so that a previously entered command may be reused. Figure A.61 show the Command Prompt with a list of commands.

The Animator commands are available in Animator Help under the topic Command Reference.

Figure A.51 Command Prompt Box with Recent Commands

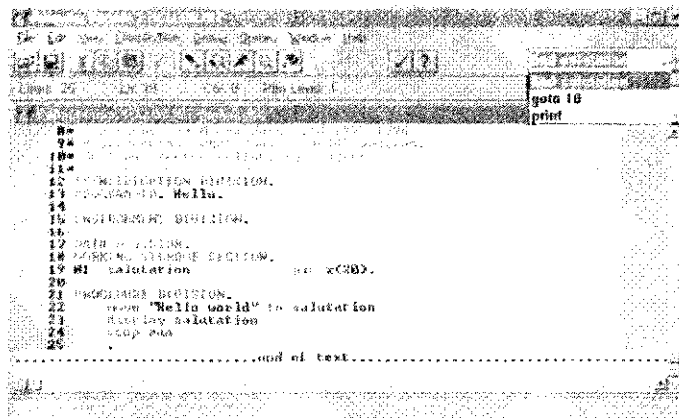

```
Command Prompt
C:\WINDOWS\system32\cmd.exe

goto 18
print
PROGRAMME DEFINITION.
DATA DIVISION.
WORKING-STORAGE SECTION.
FILE SECTION.
PROCEDURE DIVISION.
PROGRAM BEGINNING.
move "Hello world" to calculation
display calculation
stop run
.....end of text.....
```

Command Prompt box

## Editing in Animator

### General Tips

**Highlighting:** When code is highlighted in the Animator, the *entire* line is highlighted. This feature is unlike a standard word processor where highlighting is independent of the lines. This factor can be disconcerting when the user just wants to change one word. However, the developers of the Animator felt that in most cases program code is moved or changed a full line at a time. Thus, highlighting the full line was a better default.

To highlight only a portion of a line, use *Mouse Column Marking* in the Edit menu.

**Mouse Buttons:** Clicking the right mouse button in the source code displays a list of options that can be performed. The options depend on the context, and a typical list is shown in Figure A.62.

**Shortcut Keys:** Programmers should take some effort to learn some of the shortcut keys to facilitate their entry and maintenance of code. Some of the more important keys include:

- F1—Help
- F2—Find
- F3—Insert Line
- F4—Delete Line
- F5—Repeat Line
- F6—Restore Line
- F11—Examine Data
- Ctrl + B—Set Breakpoint
- Ctrl + R—Run to Cursor
- Ctrl + S—Step

Figure 2.62 Options List after Right Click on "Display"

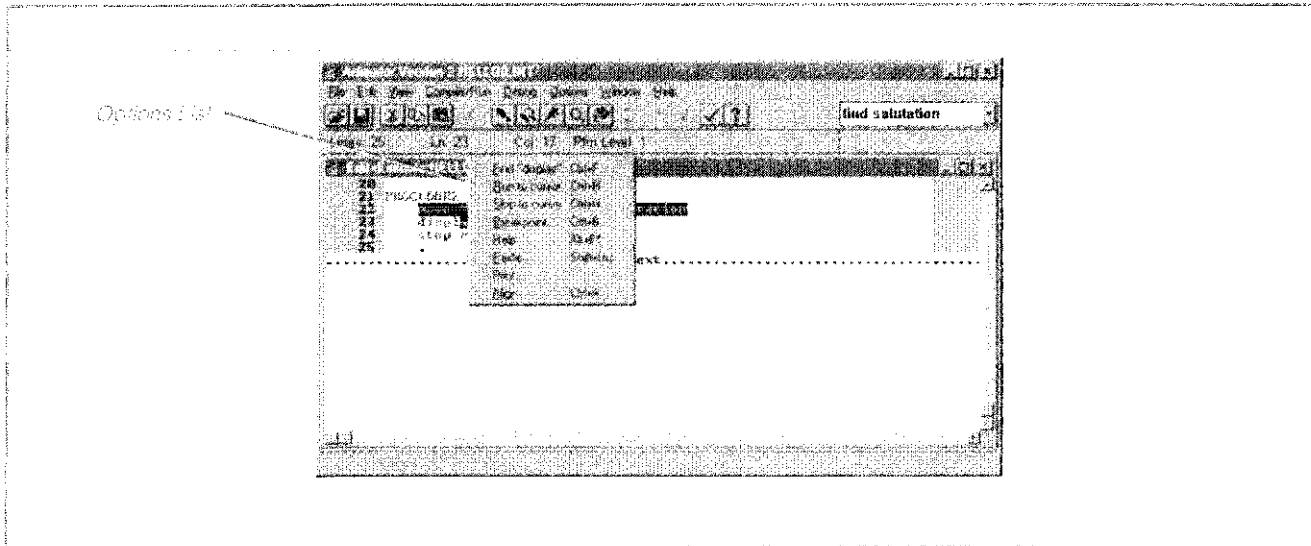

**Loading Errors:** In working with Animator in Windows95, occasionally a load error occurs. Some compatibility problems seem to exist between Windows95 and the Animator, but usually these are resolved by restarting the Animator.

#### Micro Focus File Types

The Animator uses several file types when compiling programs. The user should be careful about deleting files through the operating system. Some of the more common file types include:

- *cbl*—standard file for containing COBOL code. These files are text files and can be edited by any text processor.
- *cpy*—files containing portions of COBOL code. These files are called by the COPY command in a COBOL program.
- *int*—intermediate files. These files contain the object code needed to run and edit a COBOL program. The checking process creates int files.
- *idy*—utility files. These files allow Animator to show the source code while a program is being executed.
- *asv*—autosave files. These files contain a copy of the work in process and may be used to recover programs if there has been some problem.

#### Animator Windows

**Execute Window:** The Edit and Execute window is most generally useful when developing a single program. Only one Execute window can be open at a time. In this window the program can be edited, run, and debugged.

**Edit Window:** Edit windows can be used for writing and changing programs and checking syntax. They cannot be used for running the program. However, as many edit windows as necessary may be opened. This feature is particularly useful when the main program (in the Execute window) calls subprograms. By having the subprograms in Edit windows the programmer can quickly make changes in the subprograms, check them immediately, and then run them from the main program.

## A Brief Animator Tutorial

The purpose of this tutorial is to guide the student through a session with the Animator. At the end of the exercise the student should be able to:

- Start the Animator.
- Enter data.
- Edit and change text.
- Debug and test a program.

You can start the Animator by selecting the Personal COBOL button either in the Personal COBOL window in Windows 3.1 or in the Personal COBOL section of the Start Menu in Windows95. After showing a title screen, the Animator will become active and will look something like Figure A.63. Windows95 was used in preparing these exercises and your screen may look slightly different. You may want to increase the screen to full size by clicking on the appropriate icon in the upper left corner.

Figure A.63 Animator Interface

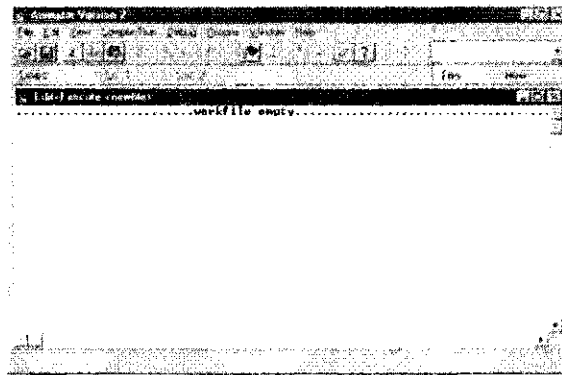

## PROGRAMMING SPECIFICATIONS

**Program Name:** Check Register Program

**Narrative:** This program processes any hours worked by employees file, calculates the gross pay, and prints the results on a report.

**Input File(s):** HOURS-WORKED

**Input Record Layout:** See Figure A.64a

**Test Data:**

|                   |         |
|-------------------|---------|
| 00001TANNER, J    | 2050400 |
| 00002SOLIGO, K    | 1875350 |
| 00003LIGHTFOOT, J | 2575450 |
| 00004SCHLESSER, J | 1500400 |
| 00005WINDSOR, C   | 1250415 |

**Report Layout:** See Figure A.64b

- Processing Requirements:**
1. Print a heading at the beginning of the report.
  2. Read a file of employee hours worked records.
  3. Process each record by:
    - a. Computing gross pay by multiplying pay rate by hours worked.
    - b. Printing a detail line for each record read.

**Figure A.64** Record Layout for Check Register Program

| ID#                                                                                                                                                                                                                                                                                                                                                                                                                                                                                                                                                                                                                                                                                                                                                                                                                                                                                                                                                                                                                                                                                                                                                                                                                                                                                                                                                                          |   |   |   |   | NAME |   |   |   |    |    |    |    |    |    |    |    |    |    |    | PAYRATE |    |    |    |    | HOURS |    |    |   |   |   |   |   |   |   |   |   |    |    |    |    |    |    |    |    |    |    |    |    |    |    |    |    |    |    |    |                |  |  |  |  |  |  |  |  |  |  |  |  |  |  |  |  |  |  |  |  |  |  |  |  |  |  |  |   |   |   |   |   |   |   |   |   |   |   |   |   |   |   |   |   |   |   |   |   |   |   |   |   |   |   |   |   |   |   |   |   |   |   |   |   |   |   |   |   |   |   |   |   |   |   |   |   |   |   |   |   |   |   |   |   |   |   |   |   |   |   |   |   |   |   |   |   |   |   |   |   |   |   |   |   |   |   |   |   |   |   |   |
|------------------------------------------------------------------------------------------------------------------------------------------------------------------------------------------------------------------------------------------------------------------------------------------------------------------------------------------------------------------------------------------------------------------------------------------------------------------------------------------------------------------------------------------------------------------------------------------------------------------------------------------------------------------------------------------------------------------------------------------------------------------------------------------------------------------------------------------------------------------------------------------------------------------------------------------------------------------------------------------------------------------------------------------------------------------------------------------------------------------------------------------------------------------------------------------------------------------------------------------------------------------------------------------------------------------------------------------------------------------------------|---|---|---|---|------|---|---|---|----|----|----|----|----|----|----|----|----|----|----|---------|----|----|----|----|-------|----|----|---|---|---|---|---|---|---|---|---|----|----|----|----|----|----|----|----|----|----|----|----|----|----|----|----|----|----|----|----------------|--|--|--|--|--|--|--|--|--|--|--|--|--|--|--|--|--|--|--|--|--|--|--|--|--|--|--|---|---|---|---|---|---|---|---|---|---|---|---|---|---|---|---|---|---|---|---|---|---|---|---|---|---|---|---|---|---|---|---|---|---|---|---|---|---|---|---|---|---|---|---|---|---|---|---|---|---|---|---|---|---|---|---|---|---|---|---|---|---|---|---|---|---|---|---|---|---|---|---|---|---|---|---|---|---|---|---|---|---|---|---|
| 1                                                                                                                                                                                                                                                                                                                                                                                                                                                                                                                                                                                                                                                                                                                                                                                                                                                                                                                                                                                                                                                                                                                                                                                                                                                                                                                                                                            | 2 | 3 | 4 | 5 | 6    | 7 | 8 | 9 | 10 | 11 | 12 | 13 | 14 | 15 | 16 | 17 | 18 | 19 | 20 | 21      | 22 | 23 | 24 | 25 | 25    | 26 | 27 |   |   |   |   |   |   |   |   |   |    |    |    |    |    |    |    |    |    |    |    |    |    |    |    |    |    |    |    |                |  |  |  |  |  |  |  |  |  |  |  |  |  |  |  |  |  |  |  |  |  |  |  |  |  |  |  |   |   |   |   |   |   |   |   |   |   |   |   |   |   |   |   |   |   |   |   |   |   |   |   |   |   |   |   |   |   |   |   |   |   |   |   |   |   |   |   |   |   |   |   |   |   |   |   |   |   |   |   |   |   |   |   |   |   |   |   |   |   |   |   |   |   |   |   |   |   |   |   |   |   |   |   |   |   |   |   |   |   |   |   |
| (a) Hours Record Layout                                                                                                                                                                                                                                                                                                                                                                                                                                                                                                                                                                                                                                                                                                                                                                                                                                                                                                                                                                                                                                                                                                                                                                                                                                                                                                                                                      |   |   |   |   |      |   |   |   |    |    |    |    |    |    |    |    |    |    |    |         |    |    |    |    |       |    |    |   |   |   |   |   |   |   |   |   |    |    |    |    |    |    |    |    |    |    |    |    |    |    |    |    |    |    |    |                |  |  |  |  |  |  |  |  |  |  |  |  |  |  |  |  |  |  |  |  |  |  |  |  |  |  |  |   |   |   |   |   |   |   |   |   |   |   |   |   |   |   |   |   |   |   |   |   |   |   |   |   |   |   |   |   |   |   |   |   |   |   |   |   |   |   |   |   |   |   |   |   |   |   |   |   |   |   |   |   |   |   |   |   |   |   |   |   |   |   |   |   |   |   |   |   |   |   |   |   |   |   |   |   |   |   |   |   |   |   |   |
| <table border="1"> <thead> <tr> <th>1</th><th>2</th><th>3</th><th>4</th><th>5</th><th>6</th><th>7</th><th>8</th><th>9</th><th>10</th><th>11</th><th>12</th><th>13</th><th>14</th><th>15</th><th>16</th><th>17</th><th>18</th><th>19</th><th>20</th><th>21</th><th>22</th><th>23</th><th>24</th><th>25</th><th>26</th><th>27</th><th>28</th> </tr> </thead> <tbody> <tr> <td colspan="28" style="text-align: center;">CHECK REGISTER</td> </tr> <tr> <td>9</td><td>9</td><td>9</td><td>9</td><td>9</td><td>X</td><td>X</td><td>X</td><td>X</td><td>X</td><td>X</td><td>X</td><td>X</td><td>X</td><td>X</td><td>X</td><td>X</td><td>X</td><td>X</td><td>X</td><td>X</td><td>X</td><td>X</td><td>X</td><td>X</td><td>X</td><td>X</td><td>X</td> </tr> <tr> <td>9</td><td>9</td><td>9</td><td>9</td><td>9</td><td>X</td><td>X</td><td>X</td><td>X</td><td>X</td><td>X</td><td>X</td><td>X</td><td>X</td><td>X</td><td>X</td><td>X</td><td>X</td><td>X</td><td>X</td><td>X</td><td>X</td><td>X</td><td>X</td><td>X</td><td>X</td><td>X</td><td>X</td> </tr> <tr> <td>.</td><td>.</td><td>.</td><td>.</td><td>.</td><td>9</td><td>9</td><td>.</td><td>9</td><td>9</td><td>.</td><td>9</td><td>9</td><td>.</td><td>9</td><td>9</td><td>.</td><td>9</td><td>9</td><td>.</td><td>9</td><td>9</td><td>.</td><td>9</td><td>9</td><td>.</td><td>9</td><td>9</td> </tr> </tbody> </table> |   |   |   |   |      |   |   |   |    |    |    |    |    |    |    |    |    |    |    |         |    |    |    |    |       |    |    | 1 | 2 | 3 | 4 | 5 | 6 | 7 | 8 | 9 | 10 | 11 | 12 | 13 | 14 | 15 | 16 | 17 | 18 | 19 | 20 | 21 | 22 | 23 | 24 | 25 | 26 | 27 | 28 | CHECK REGISTER |  |  |  |  |  |  |  |  |  |  |  |  |  |  |  |  |  |  |  |  |  |  |  |  |  |  |  | 9 | 9 | 9 | 9 | 9 | X | X | X | X | X | X | X | X | X | X | X | X | X | X | X | X | X | X | X | X | X | X | X | 9 | 9 | 9 | 9 | 9 | X | X | X | X | X | X | X | X | X | X | X | X | X | X | X | X | X | X | X | X | X | X | X | . | . | . | . | . | 9 | 9 | . | 9 | 9 | . | 9 | 9 | . | 9 | 9 | . | 9 | 9 | . | 9 | 9 | . | 9 | 9 | . | 9 | 9 |
| 1                                                                                                                                                                                                                                                                                                                                                                                                                                                                                                                                                                                                                                                                                                                                                                                                                                                                                                                                                                                                                                                                                                                                                                                                                                                                                                                                                                            | 2 | 3 | 4 | 5 | 6    | 7 | 8 | 9 | 10 | 11 | 12 | 13 | 14 | 15 | 16 | 17 | 18 | 19 | 20 | 21      | 22 | 23 | 24 | 25 | 26    | 27 | 28 |   |   |   |   |   |   |   |   |   |    |    |    |    |    |    |    |    |    |    |    |    |    |    |    |    |    |    |    |                |  |  |  |  |  |  |  |  |  |  |  |  |  |  |  |  |  |  |  |  |  |  |  |  |  |  |  |   |   |   |   |   |   |   |   |   |   |   |   |   |   |   |   |   |   |   |   |   |   |   |   |   |   |   |   |   |   |   |   |   |   |   |   |   |   |   |   |   |   |   |   |   |   |   |   |   |   |   |   |   |   |   |   |   |   |   |   |   |   |   |   |   |   |   |   |   |   |   |   |   |   |   |   |   |   |   |   |   |   |   |   |
| CHECK REGISTER                                                                                                                                                                                                                                                                                                                                                                                                                                                                                                                                                                                                                                                                                                                                                                                                                                                                                                                                                                                                                                                                                                                                                                                                                                                                                                                                                               |   |   |   |   |      |   |   |   |    |    |    |    |    |    |    |    |    |    |    |         |    |    |    |    |       |    |    |   |   |   |   |   |   |   |   |   |    |    |    |    |    |    |    |    |    |    |    |    |    |    |    |    |    |    |    |                |  |  |  |  |  |  |  |  |  |  |  |  |  |  |  |  |  |  |  |  |  |  |  |  |  |  |  |   |   |   |   |   |   |   |   |   |   |   |   |   |   |   |   |   |   |   |   |   |   |   |   |   |   |   |   |   |   |   |   |   |   |   |   |   |   |   |   |   |   |   |   |   |   |   |   |   |   |   |   |   |   |   |   |   |   |   |   |   |   |   |   |   |   |   |   |   |   |   |   |   |   |   |   |   |   |   |   |   |   |   |   |
| 9                                                                                                                                                                                                                                                                                                                                                                                                                                                                                                                                                                                                                                                                                                                                                                                                                                                                                                                                                                                                                                                                                                                                                                                                                                                                                                                                                                            | 9 | 9 | 9 | 9 | X    | X | X | X | X  | X  | X  | X  | X  | X  | X  | X  | X  | X  | X  | X       | X  | X  | X  | X  | X     | X  | X  |   |   |   |   |   |   |   |   |   |    |    |    |    |    |    |    |    |    |    |    |    |    |    |    |    |    |    |    |                |  |  |  |  |  |  |  |  |  |  |  |  |  |  |  |  |  |  |  |  |  |  |  |  |  |  |  |   |   |   |   |   |   |   |   |   |   |   |   |   |   |   |   |   |   |   |   |   |   |   |   |   |   |   |   |   |   |   |   |   |   |   |   |   |   |   |   |   |   |   |   |   |   |   |   |   |   |   |   |   |   |   |   |   |   |   |   |   |   |   |   |   |   |   |   |   |   |   |   |   |   |   |   |   |   |   |   |   |   |   |   |
| 9                                                                                                                                                                                                                                                                                                                                                                                                                                                                                                                                                                                                                                                                                                                                                                                                                                                                                                                                                                                                                                                                                                                                                                                                                                                                                                                                                                            | 9 | 9 | 9 | 9 | X    | X | X | X | X  | X  | X  | X  | X  | X  | X  | X  | X  | X  | X  | X       | X  | X  | X  | X  | X     | X  | X  |   |   |   |   |   |   |   |   |   |    |    |    |    |    |    |    |    |    |    |    |    |    |    |    |    |    |    |    |                |  |  |  |  |  |  |  |  |  |  |  |  |  |  |  |  |  |  |  |  |  |  |  |  |  |  |  |   |   |   |   |   |   |   |   |   |   |   |   |   |   |   |   |   |   |   |   |   |   |   |   |   |   |   |   |   |   |   |   |   |   |   |   |   |   |   |   |   |   |   |   |   |   |   |   |   |   |   |   |   |   |   |   |   |   |   |   |   |   |   |   |   |   |   |   |   |   |   |   |   |   |   |   |   |   |   |   |   |   |   |   |
| .                                                                                                                                                                                                                                                                                                                                                                                                                                                                                                                                                                                                                                                                                                                                                                                                                                                                                                                                                                                                                                                                                                                                                                                                                                                                                                                                                                            | . | . | . | . | 9    | 9 | . | 9 | 9  | .  | 9  | 9  | .  | 9  | 9  | .  | 9  | 9  | .  | 9       | 9  | .  | 9  | 9  | .     | 9  | 9  |   |   |   |   |   |   |   |   |   |    |    |    |    |    |    |    |    |    |    |    |    |    |    |    |    |    |    |    |                |  |  |  |  |  |  |  |  |  |  |  |  |  |  |  |  |  |  |  |  |  |  |  |  |  |  |  |   |   |   |   |   |   |   |   |   |   |   |   |   |   |   |   |   |   |   |   |   |   |   |   |   |   |   |   |   |   |   |   |   |   |   |   |   |   |   |   |   |   |   |   |   |   |   |   |   |   |   |   |   |   |   |   |   |   |   |   |   |   |   |   |   |   |   |   |   |   |   |   |   |   |   |   |   |   |   |   |   |   |   |   |
| (b) Report Format                                                                                                                                                                                                                                                                                                                                                                                                                                                                                                                                                                                                                                                                                                                                                                                                                                                                                                                                                                                                                                                                                                                                                                                                                                                                                                                                                            |   |   |   |   |      |   |   |   |    |    |    |    |    |    |    |    |    |    |    |         |    |    |    |    |       |    |    |   |   |   |   |   |   |   |   |   |    |    |    |    |    |    |    |    |    |    |    |    |    |    |    |    |    |    |    |                |  |  |  |  |  |  |  |  |  |  |  |  |  |  |  |  |  |  |  |  |  |  |  |  |  |  |  |   |   |   |   |   |   |   |   |   |   |   |   |   |   |   |   |   |   |   |   |   |   |   |   |   |   |   |   |   |   |   |   |   |   |   |   |   |   |   |   |   |   |   |   |   |   |   |   |   |   |   |   |   |   |   |   |   |   |   |   |   |   |   |   |   |   |   |   |   |   |   |   |   |   |   |   |   |   |   |   |   |   |   |   |

Please enter the program shown in Figure A.65 into the Animator. Type the program exactly as it is written. Be careful to start each line in column 8 and to type the periods where they are placed. There are some deliberate errors in the program, but do not correct them yet.

**Figure A.65** Tutorial Program

```

1 IDENTIFICATION DIVISION.
2 PROGRAM-ID. CHECK-REGISTER.
3 AUTHOR. YOUR NAME
4
5 ENVIRONMENT DIVISION.
6 INPUT-OUTPUT SECTION.
7 SELECT WEEKLY-HOUR ASSIGN TO 'HOURS.DAT
8 ORGANIZATION IS LINE SEQUENTIAL.
9 SELECT REPORT-FILE ASSIGN TO 'CON'
10
11 DATA DIVISION.
```

Figure A.65 Continued

```

12 FILE SECTION.
13 FD WEEKLY-HOURS.
14 01 HOURS-RECORD.
15 05 HOURS-ID PIC 9(04).
16 05 HOURS-NAME PIC X(15).
17 05 HOURS-PAYRATE PIC 99V99.
18 05 HOURS-WORKED PIC 99V9.
19
20 FD REPORT-FILE.
21 01 PRINT-LINE PIC X(80).
22
23 WORKING-STORAGE SECTION.
24 01 HEADER-LINE-1.
25 05 PIC X(10) VALUE SPACES.
26 05 PIC X(18)
27 VALUE 'CHECK REGISTER'.
28 05 PIC X(10) VALUE SPACES.
29
30 01 DETAIL-LINE.
31 05 PIC X(05) VALUE SPACES.
32 05 DET-ID PIC 9(05).
33 05 PIC X(01) VALUE SPACES.
34 05 DET-NAME PIC X(15).
35 05 DET-HOURS PIC 99.9.
36 05 PIC X VALUE SPACES.
37 05 DET-PAYRATE PIC 99.99.
38 05 PIC X VALUE SPACES.
39 05 DET-GROSS-PAY PIC 9999.99.
40
41 01 EOF-SWITCH PIC (03) VALUE 'NO '.
42
43 PROCEDURE DIVISION.
44 0000-MAIN-LINE.
45 PERFORM 1000-INITIALIZATION
46 PERFORM 5000-PROCESS-CHECK
47 UNTIL EOF-SWITCH = 'YES'
48 PERFORM 9000-FINALIZE
49 STOP RUN.
50
51 1000-INITIALIZATION.
52 OPEN INPUT WEEKLY-HOURS
53 OUTPUT REPORT-FILE
54 PERFORM 1100-WRITE-HEADER
55 PERFORM 1200-READ-RECORD.
56
57 1100-WRITE-HEADER.
58 WRITE PRINT-LINE FROM HEADER-LINE-1
59 AFTER ADVANCING PAGE.
60
61 1200-READ-RECORD.
62 READ WEEKLY-HOURS
63 AT END MOVE 'NO ' TO EOF-SWITCH

```



Figure A.65 Continued

```

64 END-READ.
65
66 5000-PROCESS-CHECK.
67 MOVE HOURS-ID TO DET-ID
68 MOVE HOURS-NAME TO DET-NAME
69 MOVE HOURS-PAYRATE TO DET-PAYRATE
70 MOVE HOURS-WORKED TO DET-HOURS
71 MULTIPLY HOURS-PAYRATE
72 BY HOURS-WORKED
73 GIVING DET-GROSS-PAY
74 END-MULTIPLY
75 PERFORM 5100-PRINT-DETAIL
76 PERFORM 1200-READ-RECORD.
77
78 5100-PRINT-DETAIL.
79 WRITE PRINT-LINE FROM DETAIL-LINE.
80 AFTER ADVANCING 1
81 END-WRITE.
82
83 9000-FINALIZE.
84 CLOSE WEEKLY-HOURS
85 REPORT-FILE.

```

When you have finished entering the program, check the program by clicking on the Check Mark in the tool bar. The Animator will prompt you to save the program. Save it as Chkreg.cbl.

The Animator then begins to check the program and soon finds an error. You should see message boxes similar to those in Figure A.66. The message boxes in the figure have been moved to make them more visible.

Figure A.66 Compile Error Windows

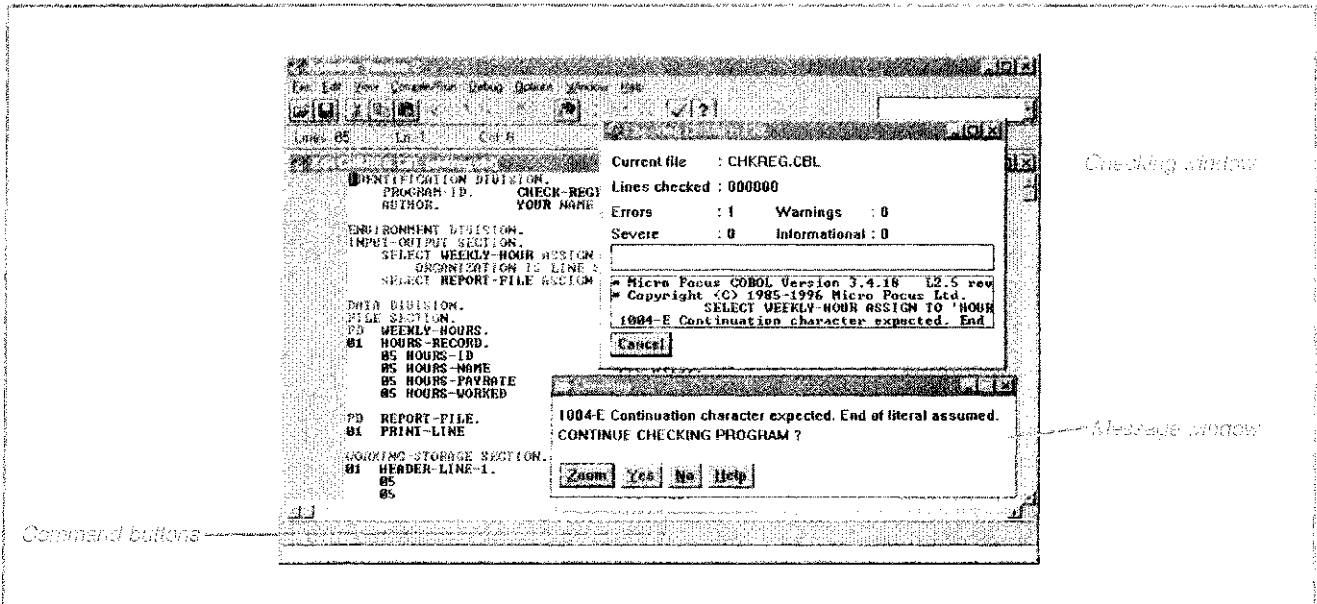

The Checking message window has four buttons:

- Zoom—causes Animator to check the rest of the program without stopping until it is through.
- Yes—has Animator continue to check the program and stop at the next error.
- No—stops checking the rest of the program.
- Help—Brings up a help screen that attempts to explain the error.

You should click on the Zoom button to check the rest of the program.

At the end of the checking process, you should see something like the screen in Figure A.67. Two windows can be seen, but tend to obscure each other. You may want to move one of the windows so that the screen looks like Figure A.67. The first window shows the program source with all error lines marked and highlighted. The information line at the bottom of the window shows the error message for the current error line. The second window contains a list of all the error messages and is called the syntax error window. Do not be surprised at the number of errors found during the first check of a COBOL program. A large number of errors is common when a program is checked the first time. In many cases, one syntax error may cause a number of error messages.

Figure A.67 Results after Syntax Checking

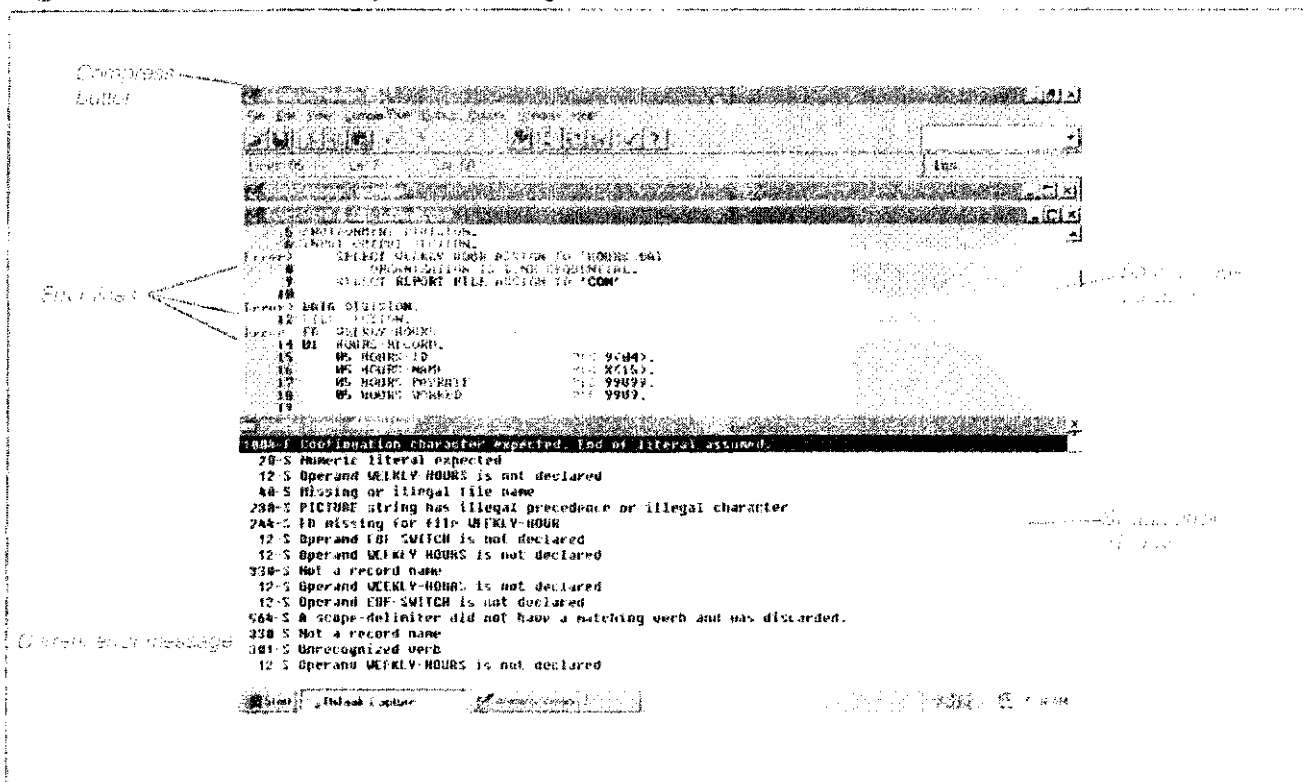

There are several ways of moving around to see the errors. One way is to double-click on a message in the syntax error window. The Animator will move the cursor in the source code window to the appropriate error line. This action associates the messages with the actual lines. Within the source code window you can move

from one error line to the other by clicking the Find Next or Find Previous buttons. As you change from one error to another, the Information Line will contain the error message for the current error line.

You may also want to see the error lines by themselves. To do this, press F9 or click the Compress Button, shown in Figure A.67, to show just the error messages, as in Figure A.68. You may need to expand the size of the window to see all of the messages.

Look at the first error line. The message is "Continuation character expected. End of literal assumed." The problem here is that HOURS.DAT has a quote at the beginning and not at the end. Data file names need to be expressed as alphanumeric literals and enclosed in quotes. To correct this problem, insert a quote after the word DAT.

Move to the next error. Here the error message, "Numeric literal expected," does not help in detecting the problem. The compressed mode also tends to confuse the issue. Expand to the full source code by pressing F9 again or clicking on the Expand key shown in Figure A.68.

Figure A.68 Compressed List of Error Messages

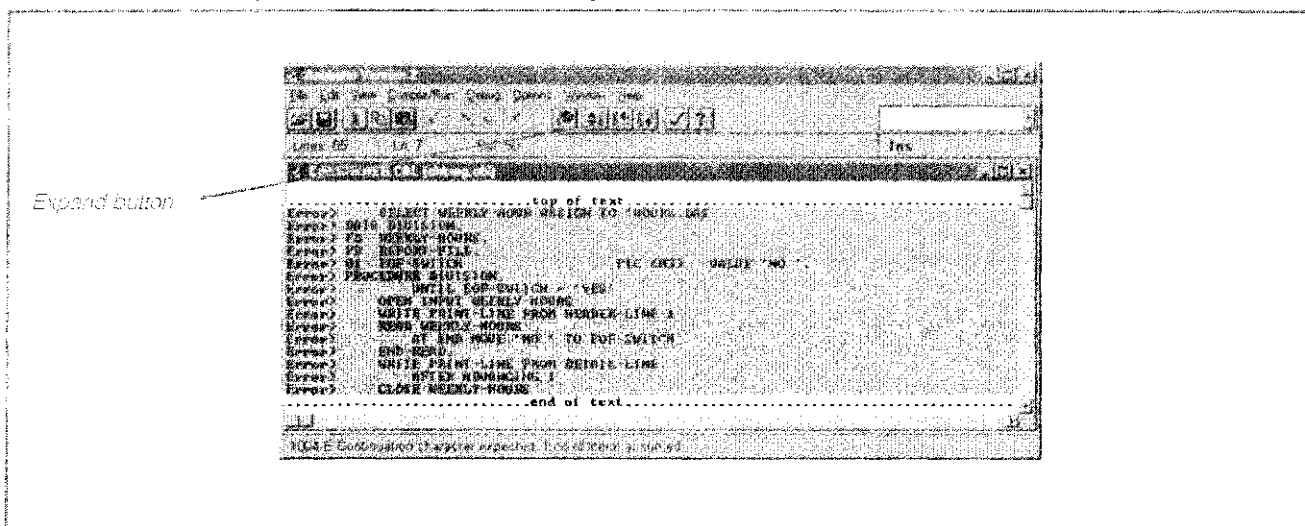

The problem is actually in line 9. SELECT statements must end with a period. Since the period is missing, COBOL attempts to include the DATA DIVISION statement as part of the SELECT STATEMENT. COBOL detects that there is an error, but unfortunately does not give a helpful message. Place a period at the end of line 9 to correct the problem.

This particular error demonstrates several rules of thumb in debugging COBOL programs.

1. Periods are common sources of error because they are often misplaced or omitted.
2. The compiler may not be able to determine that an error has occurred until checking the following line.
3. All error messages should be examined, but sometimes they are misleading.

Use the Find Next and Find Previous buttons shown in Figure A.68 to move through the rest of the errors and notice the messages in the Information Line. Try to understand what COBOL is saying about each error.

Notice the message "WEEKLY-HOURS not declared" in line 13. The problem results from the spelling of "WEEKLY-HOUR" in the SELECT statement in line 7. Incorrect spelling of user defined names are also a major cause of syntax errors. The spelling needs to be changed in the SELECT statement.

Make sure that the WEEKLY-HOURS is spelled correctly, the quote is inserted at the end of line 6, and a period at the end of line 9. Insert a period and the end of line and recheck the program. After checking the program, compress the source to just show the error lines again as in Figure A.69.

Figure A.69 Errors after Second Compile

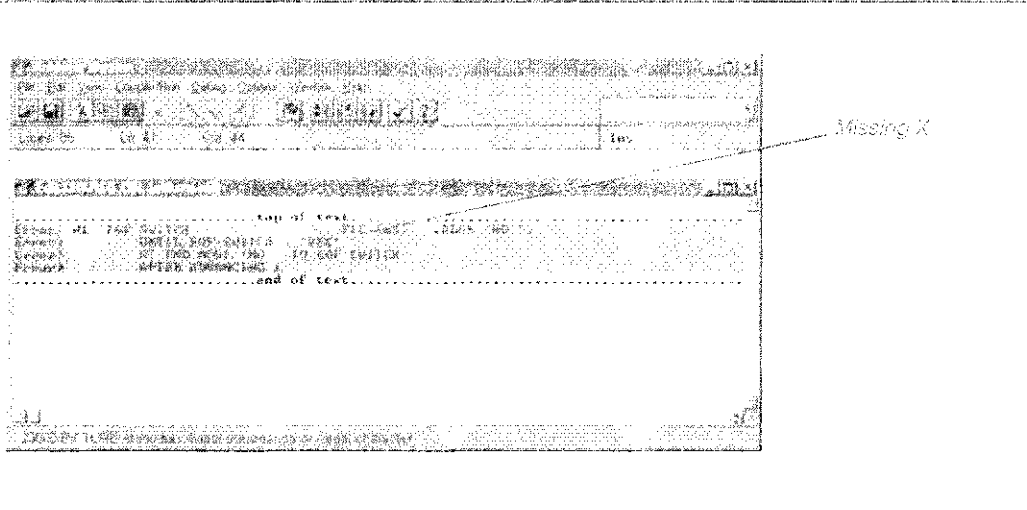

The first error is because the PIC clause does not specify the data type. Correct this line by inserting an "X" before the "(03)" so that the line reads:

```
01 EOF-SWITCH PIC X(03) VALUE 'NO '.
```

This correction will clear up the problems with the next two errors. Since EOF-SWITCH was not valid, any references to it are invalid as well. Correcting the one error will fix the other two as well.

Move to the last line that says "AFTER ADVANCING 1" and expand the source using F9. Figure A.70 shows the result. Using the rules of thumb from above, you should notice that there is a period at the end of line 79. In this case, the period should not be there because AFTER ADVANCING 1 is part of the WRITE statement. Delete the period and recheck the program.

This time the program should compile without errors. If your program still does not compile, you have made other typing errors. Reexamine the code in Figure A.65, make the necessary corrections, and recompile.

Figure A.71 shows the fully compiled program. Note that the buttons allowing testing of the program are now active. If the buttons are not active, you probably are working in an Edit window. If so, close the window by using the File menu. Save the file if necessary. Now, in the File menu, select Open for Execution and select the file Chkreg.int. This action loads the file to the Execute Window, where it can be run and tested.

Figure A.70 Invalid Period Error

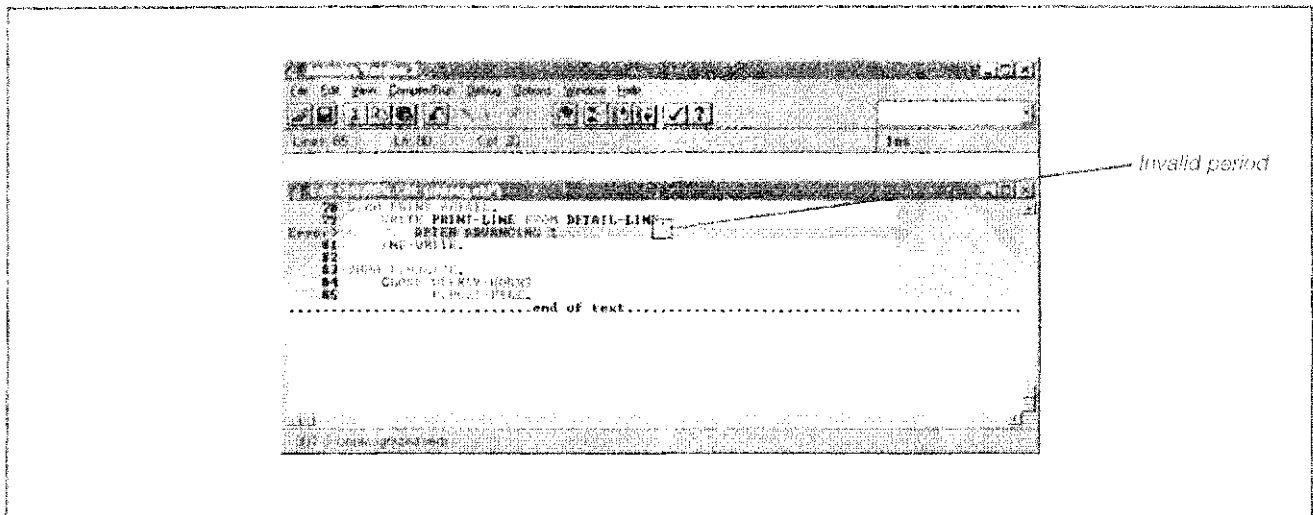
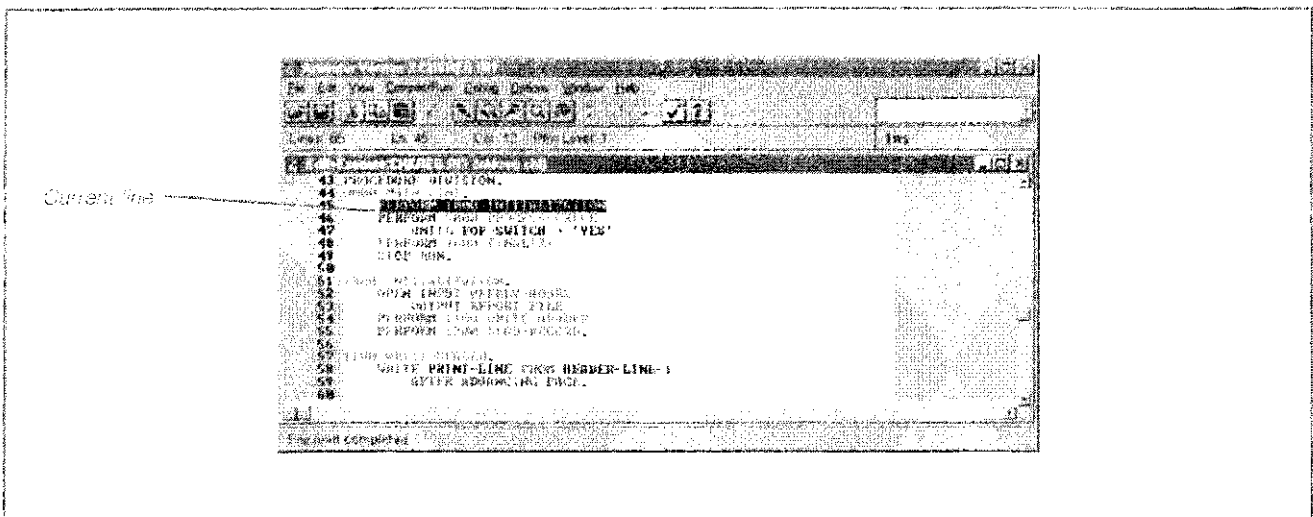

Figure A.71 Compiled Program Ready to Run



At this point, you are ready to test the program, but need data. Click on the file menu and select New. This action opens a new Edit window where you can create data for the input file. However, the Animator thinks that you have opened the file to enter COBOL source code and the cursor is positioned in column 8. To make things easier for entering data, select the Options menu and select Edit options. In the profile screen, select DOCUMENTS from the Profiles list box. As a result, you should see the specifications as in Figure A.72. Click on the Set as Current Profile Button and then Click on the OK button. You will now be able to enter data.

Enter the data shown in Figure A.73 exactly as shown. The numbers begin in column 21. If you wish, you may add some other records to the file. After you have entered the data, select Save As from the File menu. Save the file as HOURS.DAT. Be sure that the file is saved in the same directory as your program. Now return to your Program. Run the program by clicking on the Run Button. If Animator gives a "File Not Found Message," either the file is not in the same directory as the program or the file name has been misspelled. You can correct the

Figure A.72 Configure Profile for Entering Data

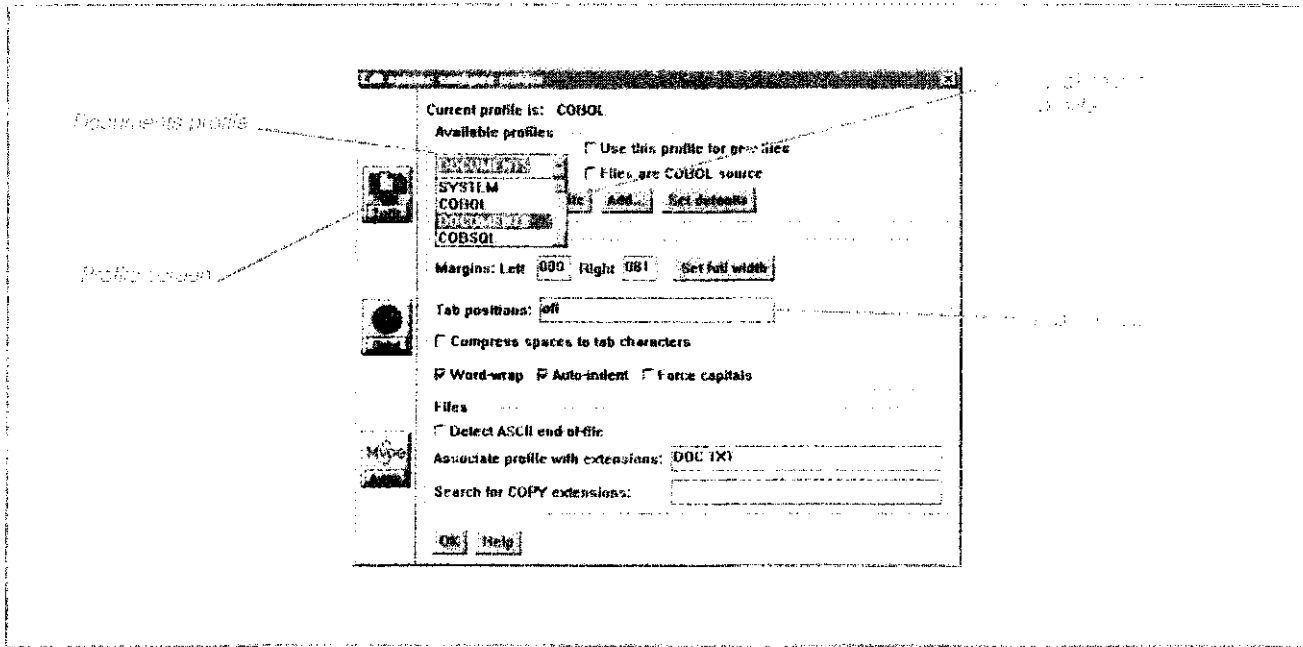
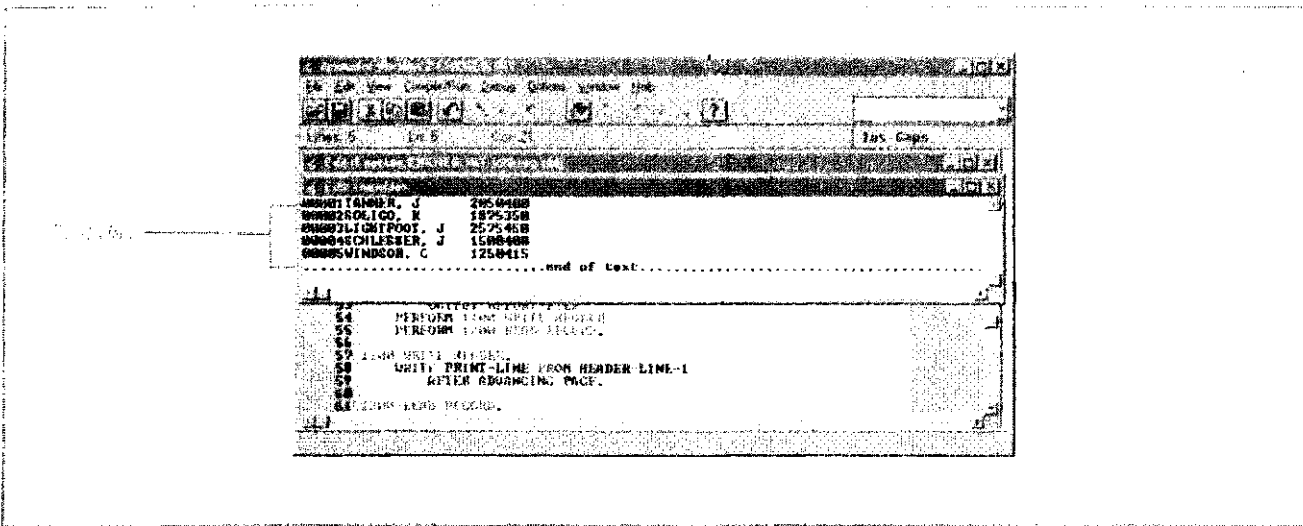

Figure A.73 Create Data File



problem by correctly spelling the file name and using by the full path to the file in its SELECT statement (line 6). Recheck the program and try again.

The program should halt with a message "Illegal character in numeric field (Error 163)." This type of error is very common and usually results because the program file specifications do not match the actual fields in the file. Click on the OK button. Your program is redisplayed, as in Figure A.74, with the line in error highlighted and the error message redisplayed. Click on the OK button again to clear the message box.

Figure A.74 Error Detected

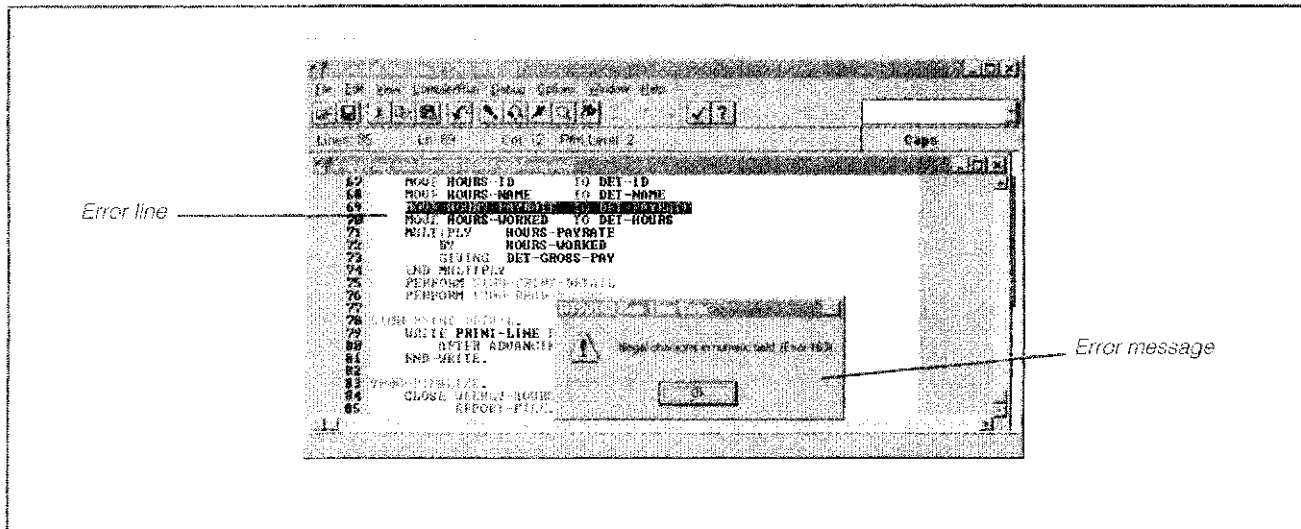

Line 69 should read “MOVE HOURS-PAYRATE TO DET-PAYRATE.” Click on the word HOURS-PAYRATE. Clicking on a Data Name brings up a monitor window, as in Figure A.75. The monitor window presents the data in two forms:

- The left side shows the ASCII values for the field. In this case, “20” is the ASCII value for a space.
- The left side shows the text values for the field. The first character is in fact a space.

Since, spaces cannot be part of a numeric field, the error message was correct. The problem is to determine how the space got there. One way to find out is to “correct” the data item and then step through the program. The cursor should be blinking on the first 2 of ASCII values field. Change the 2 to 3. This converts the character to a zero. Look at the text values to confirm that the change has been made. Now, click on the Apply button. You have now fixed the error so that the program can continue.

Using the Watch Button, step through the program. As you go through the program, notice the monitor windows. You should see that the values seem to be low. Finally, you should come to the Detail-Line monitor box, as shown in Figure A.76. Notice that the name field begins with a “1.” Somehow part of the ID number has gotten into the Name field.

Figure A.75 Monitor Window of HOURS-PAYRATE Field

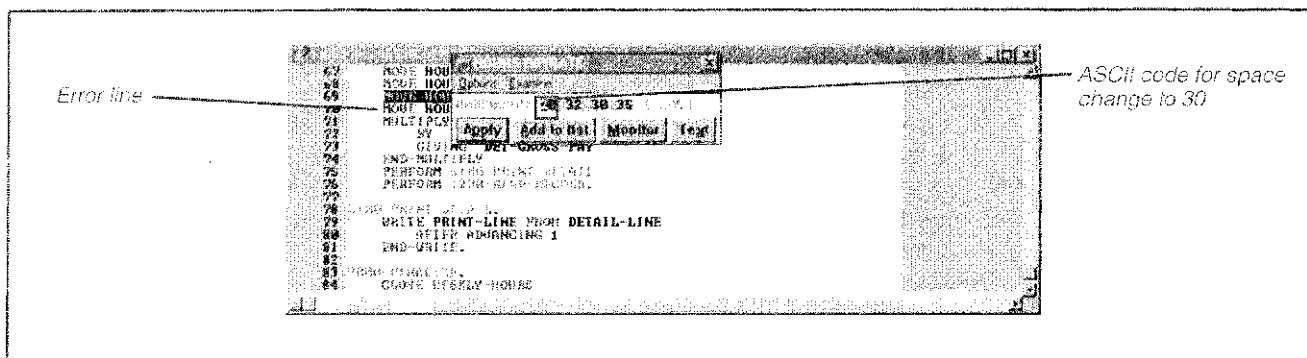

Examine the HOURS.DAT file that you entered. The first 5 characters are the ID number. Now look at your file specification in line 15 of Figure A.65. HOURS-ID is only four characters long. Consequently, every field in the record is off by one character. Go to the proper line in your program and correct the PIC to "X(05)." Recheck the program.

Rerun the program and the same error message "Illegal character in numeric field" appears. However, when you click on OK, the message refers to line 67. Double-click on HOURS-ID and you will see that the field is totally blank, as shown in Figure A.77a. This result does not seem to reflect the same problem as before, but you need more information. Select the Examine Menu in the monitor window and click on Ascend level. By selecting Ascend level, you are asking the Animator to display the group item that contains HOURS-ID. Therefore, the Animator will display HOURS-RECORD, as shown in Figure A.77b. The entire record is filled with spaces. In this case, there may be a blank record or some type of improper read of the record. You will need to investigate further.

Figure A.76 Alignment Error

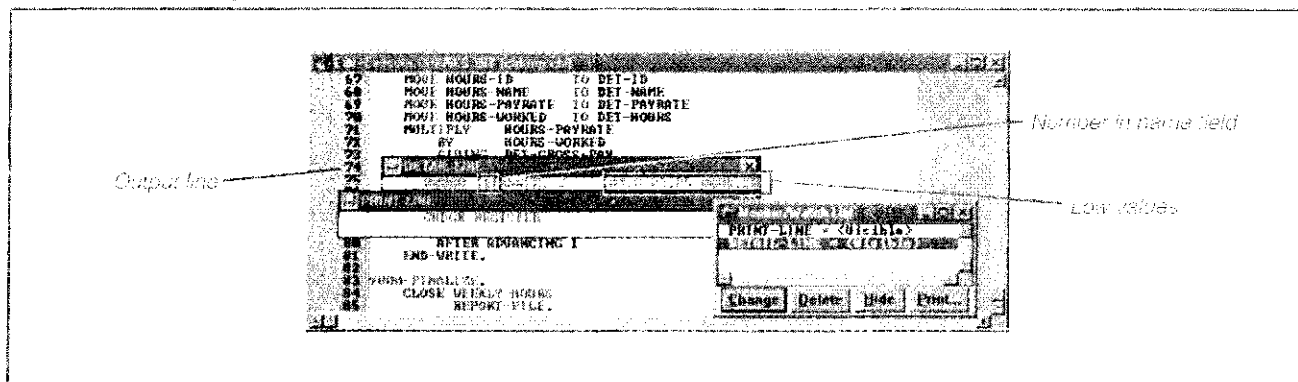

Since the program assigned the print file to "CON" in line 9 of Figure A.65, the Animator directs the output to a window called "Animator V2 Text Window." Open the window if it is not already visible. The results should look like Figure A.78.

You should notice two things about this figure.

1. The words CHECK REGISTER are printed twice. The Animator does not clear out the window between program tests. The first line is left over from the first test of the program. There may be additional lines of output at the top if you have run the program several times.
2. The female symbol at the beginning of the first two lines is the ASCII character for a page break. If the output had gone to the printer, each line would be the start of a new page.

Examining the output in more detail, you should see that all of the input records have been processed. Therefore, something seems to be wrong with the end of file processing.

To test the end of file processing, you will need to rerun the program, but stepping through all of the records becomes very tedious. You will want to see only what happens after the last record is processed.



Figure A.77 End of File Error

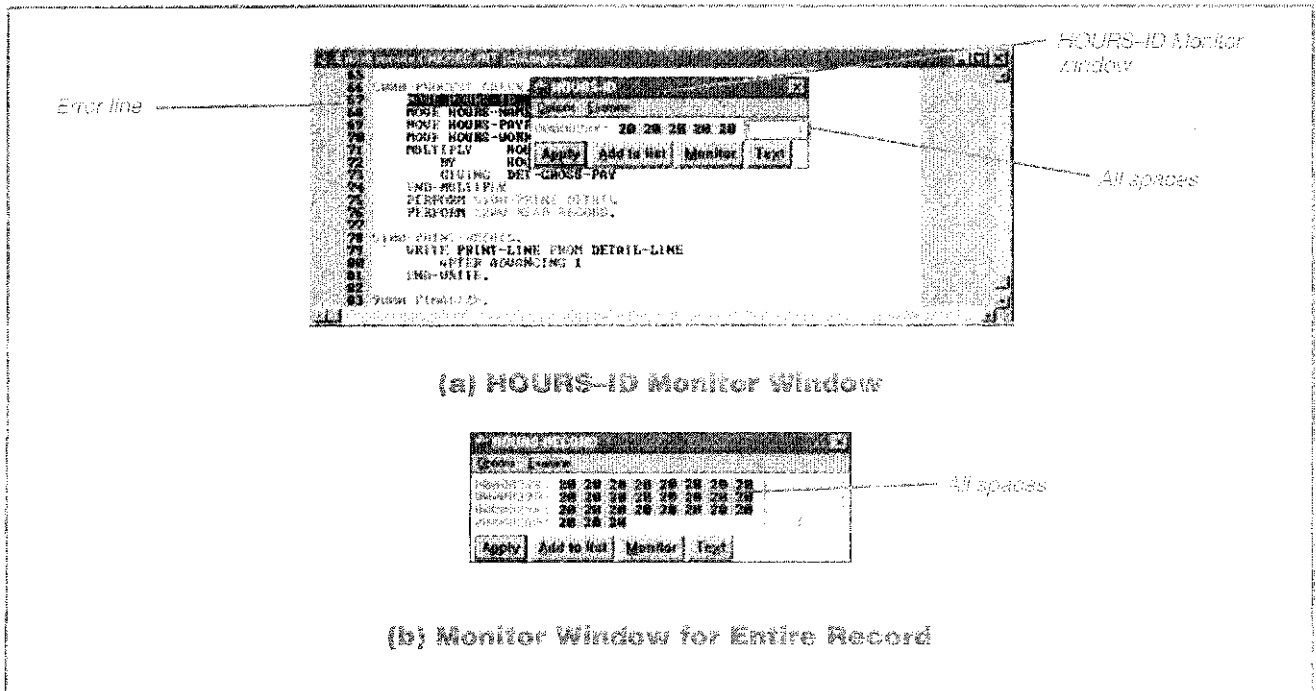

Make sure that line 67 is highlighted. Select "Set advanced" from the Debug menu, as shown in Figure A.79. This action brings up the Advanced breakpoint screen. Click on the Condition radio button and enter the statement "HOURS-ID = 5" into the Parameter box. Your window should look like Figure A.80. This advanced breakpoint will test the HOURS-ID field each time the breakpoint line is reached to see whether it is equal to 5, the ID number for the last record. Click on the Set button and the Animator returns to the Execute screen. The breakpoint line has the message "Bcond" as shown in Figure A.81.

Figure A.78 Screen Output

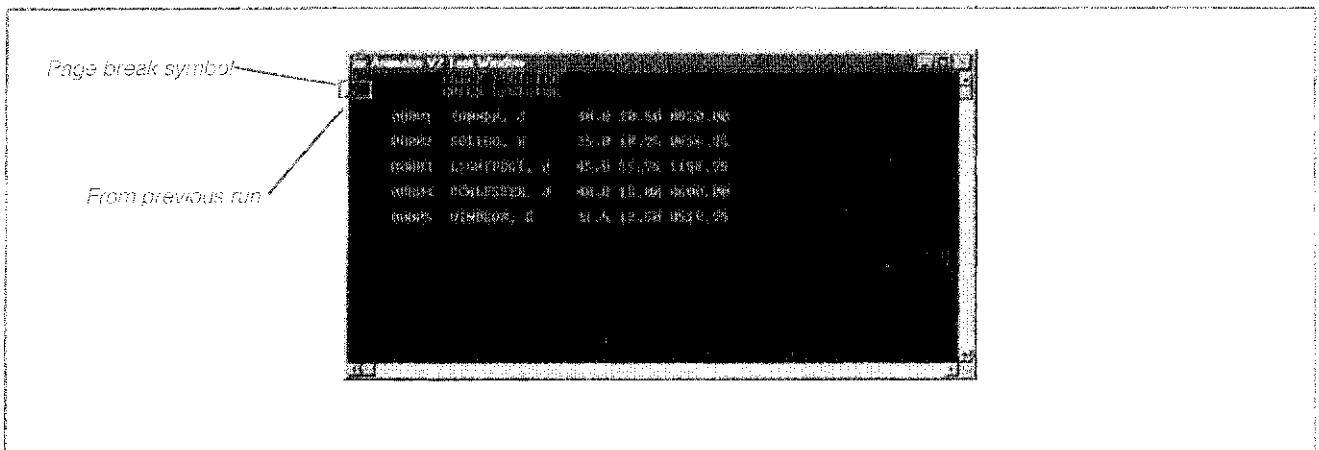

Figure A.79 Set Breakpoint to Find Last Record

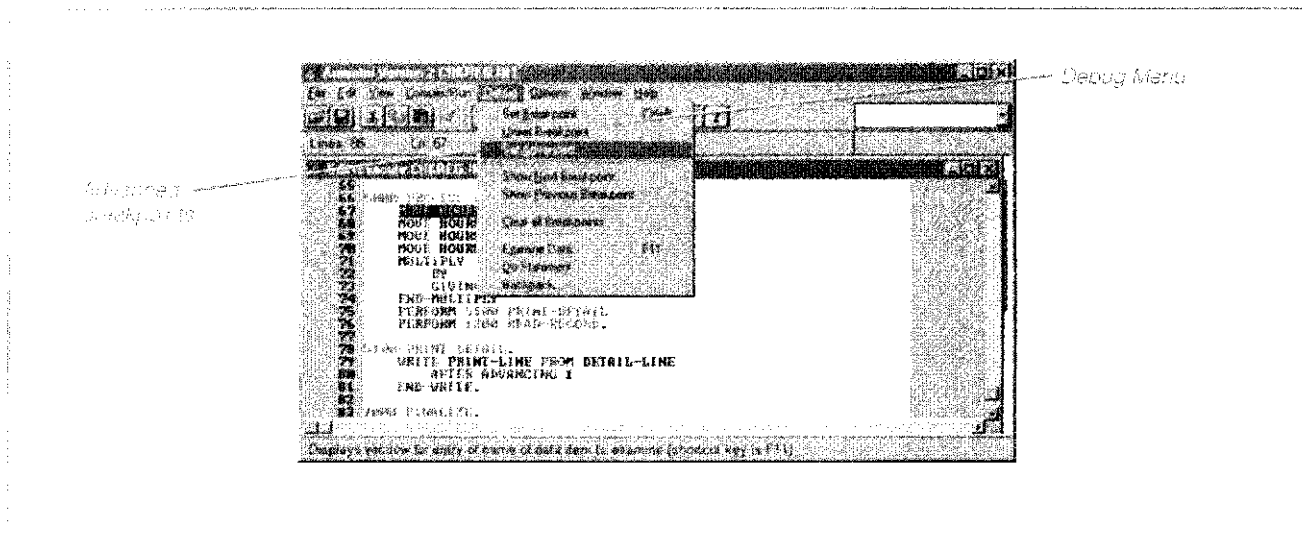
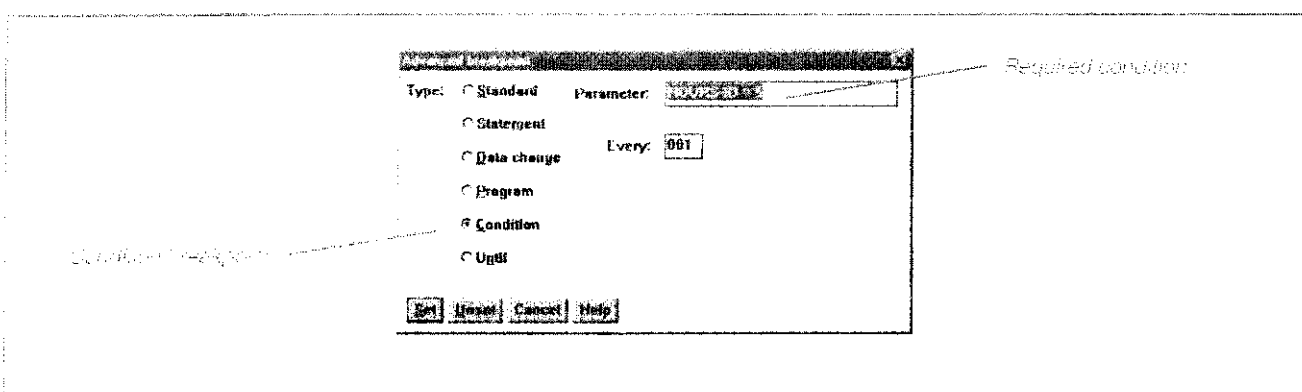

Figure A.80 Set Condition for Last Record



The purpose of this breakpoint is to allow the program to run until the last record is reached. When Animator reaches the breakpoint line and the HOURS-ID field equals 5, you know that the program is now processing the last record.

Use the Compile/Run menu to Restart the program, and rerun it. The program runs until it finds the last record and displays the Run message shown in Figure A.82. Click on the OK button and use the watch button to step through the program until the READ statement occurs. As the highlighting shows in Figure A.83, the program has reached the end of the file and moves "NO" to the EOF-SWITCH. This statement is the problem. In lines 47 and 48, the 5000-PROCESS-CHECK paragraph is performed until EOF-SWITCH is equal to "YES." The AT END conditional statement should read MOVE "YES" TO EOF-SWITCH.

Since the wrong value was sent to the switch, the loop continued on and tried to process a nonexistent record. Reading beyond the end of file is another common error in programming.

Correct the AT END clause, clear the breakpoint and recheck the program. When you rerun the program, it should run to completion and produce the proper output.

This tutorial has attempted to show some of the debugging features of the Animator and how they can assist in the development of programs. Students should

experiment with the various features to find for themselves the features that will make their work easier.

Figure A.61 Condition Breakpoint Set in Program

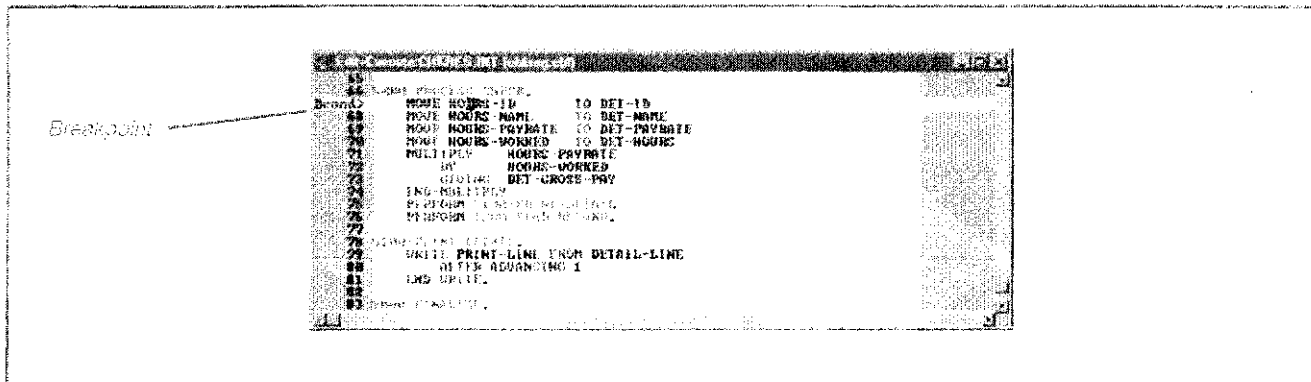

Figure A.62 Breakpoint Encountered Message

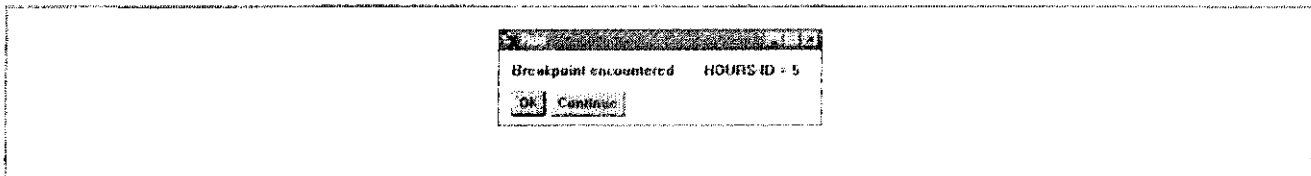
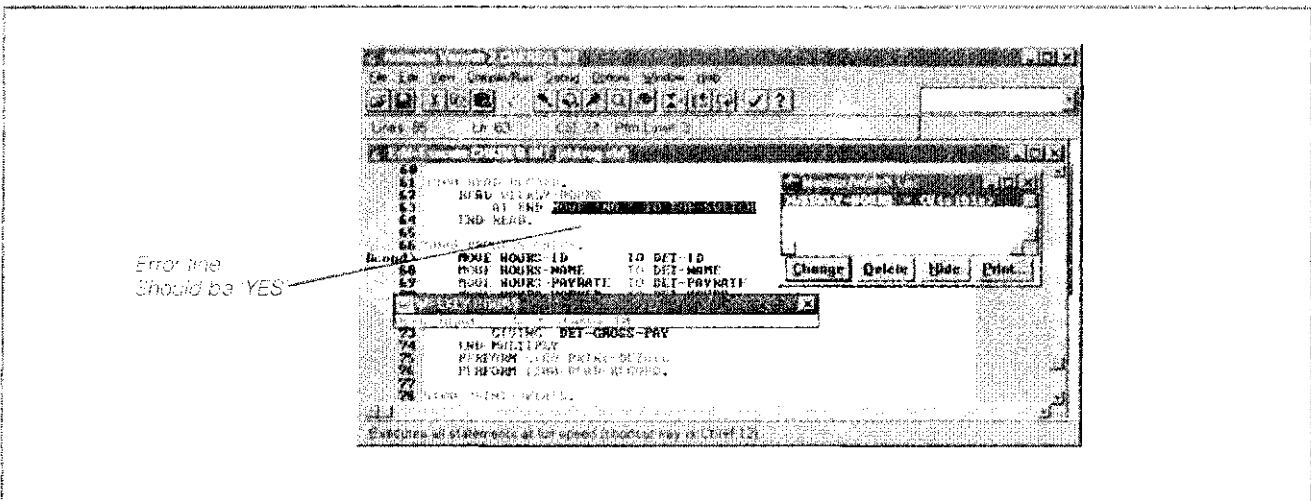

Figure A.83 End of File Logic Error



## Conclusion

Micro Focus has provided students with a powerful tool for learning the COBOL language. The Animator has many features, and this discussion has addressed only the ones that beginning programmers are likely to use. This tool can serve student programmers well because it provides an economical way to learn COBOL and it is not restricted in any significant way. The programs developed through the use of the Animator can be taken to full function compilers, and they can be compiled to be production programs.

We hope that this discussion of the Animator will make the task of learning how to use it easier.

---

<sup>1</sup> The monitor box has several buttons. The Find and Locate defn buttons do not seem to do anything. The cursor is located on the definition of the data item, and pressing either button does not move the cursor. Print produces a report of the data item statistics and Help brings up the Find Report Window help screen.

<sup>2</sup> Note that if the user then moves the program to the top window using the Tile option or expands the window to full screen, the program code is still in the same position relative to the left margin. Sometimes the left arrow on the scroll bar is not active and does not allow moving the screen to the left. If this occurs, click on the right scroll arrow and then the left arrow should become functional.

<sup>3</sup> The Animator does not show a "redo" icon on the tool bar. Redo allows the user to "undo" the most recent "undo." In other words, if the user has undone a change by mistake, redo allows the change to be restored. Redo can be activated by typing the word "redo" in the command window or pressing "Alt + Shift + Backspace."

If the user wants to modify the toolbar to include a button for redo, the toolbar can be changed by using the Configure Interface option of the Options Menu. The toolbar page allows addition of buttons. The redo command has its own icon and can be easily inserted before the space after the undo button.



# Getting Started

**Overview:** This appendix consists of four sections that provide instructions for installing and making use of Personal COBOL.

**Section 1:** Installation

**Section 2:** Creating Shortcuts for the Animator

**Section 3:** Downloading Data and Source Files from the Web

**Section 4:** Printing from COBOL programs with the Animator

## Installation

**Introduction:** The installation procedure for the Micro Focus Personal COBOL Animator is largely self-explanatory and similar to the installation for almost any other Windows software. This section steps you through the process and shows you the windows and messages you can expect to see as you install the software. We recommend that you adopt all of the defaults unless you have the knowledge and need to configure the system differently.

The installation as shown here is done from the CD-ROM in Windows95. The installation process is very similar when using diskettes and when under Windows 3.1 or WindowsNT. These alternative installation modes should not cause any serious differences.

Installation of the Animator performs the following tasks.

1. Create a subdirectory on the computer's hard disk called PCOBWIN. PCOBWIN, in turn, has two additional subdirectories called CLASSLIB and SAMPLES. PCOBWIN contains all of the executable files necessary to run the Animator. CLASSLIB contains special files for Object-Oriented COBOL. SAMPLES contains a number of COBOL source files supplied by Micro Focus. These files demonstrate a number of COBOL concepts and demonstration programs for traditional and Object-Oriented COBOL.
2. Copy files into the appropriate directories.
3. Build a Windows Program Manager Group containing icons to run the Animator.
4. Modify the system environmental variables to allow the Animator to run properly.
5. Reboot the system to allow the new variables to take effect.



## Installation Process

### Step 1: Open the Windows95 Start Menu

Open the Windows95 Start Menu by clicking on the  command button on the task bar or the keyboard Start key.

### Step 2: Select the Run Option and Start the Setup Process

Click on the Run option from the Start Menu shown in Figure B.1a. This action brings up the Window shown in Figure B.1b. In this example, "D:" refers to the CD-ROM drive. On your machine the CD-ROM may have some other letter. If you are installing from diskettes, you probably would use A: instead of D:. "Setup.exe" is the name of the program to install Personal COBOL. Click on the OK button and the Welcome message box shown in Figure B.1c appears. Click on OK again.

Figure B.1 Starting Animator Installation

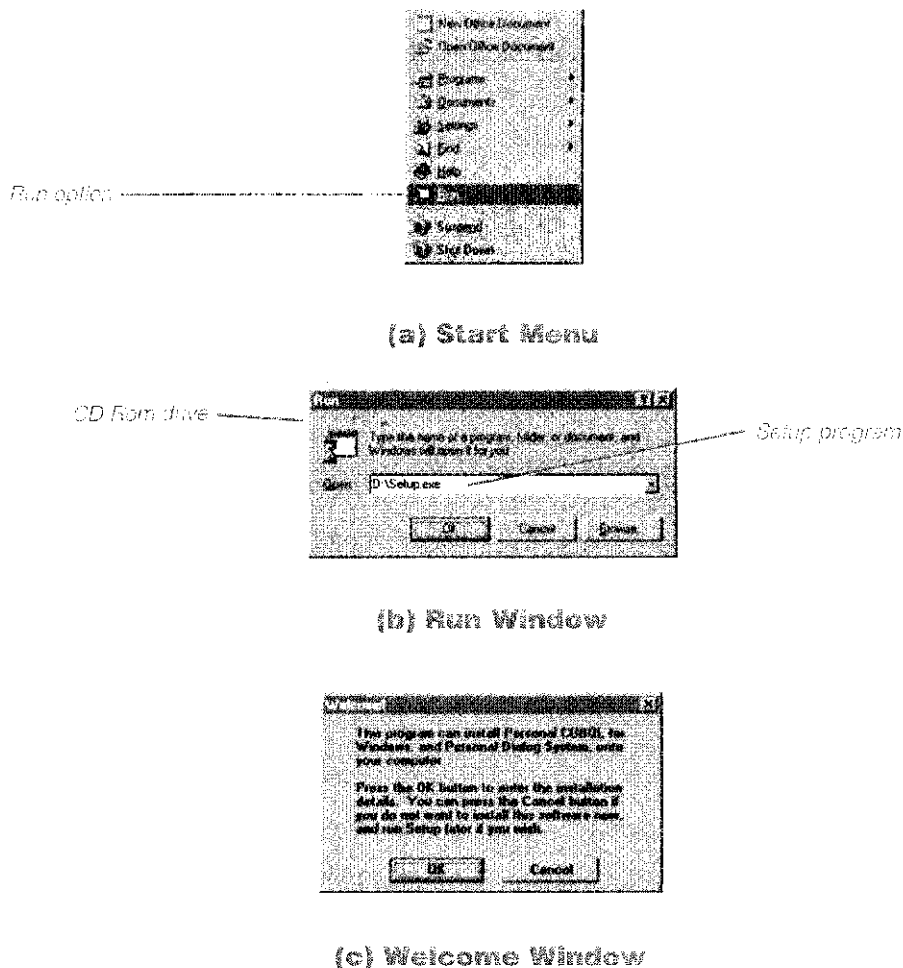

**Step 3: Enter License Registration Information**

Micro Focus wants you to register your copy of the software and requests that you give your name and affiliation information. Figure B.2 shows the License Registration process. Enter your name and college or business into the License Registration Input window in Figure B.2a and click on OK. This action will bring up the License Registration Confirmation Window, as in Figure B.2b. If the information is correct, click on the Yes button and the process continues. If you see some error, click on the No button and the Input window reappears for correction.

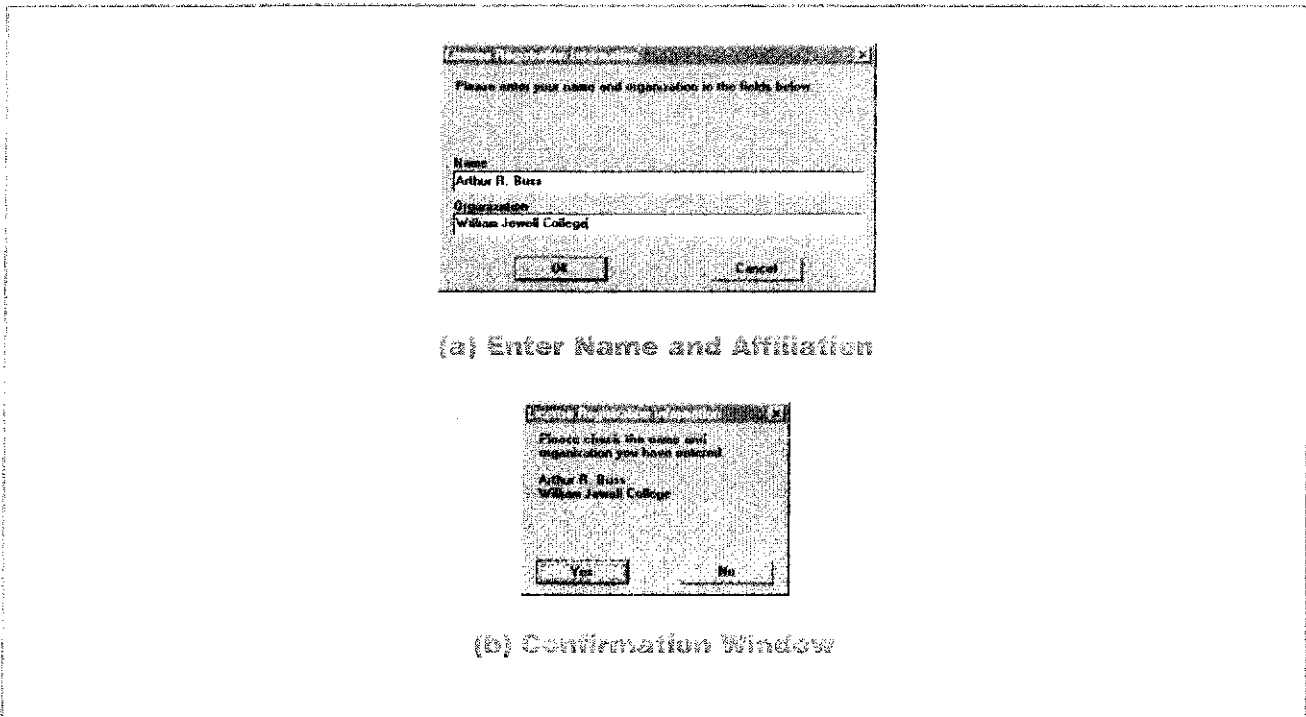
**Figure B.2 License Registration****Step 4: Establish the Configuration**

The next step is to establish how Personal COBOL will run. The setup process requests that you identify the subdirectory to contain the programs, determine the programs to install, and to give a name to the Start Menu Program entry. The window in Figure B.3a suggests that Personal COBOL should reside in C:\PCOBWIN. Unless you need to change the drive or directory for some reason, click on the OK button.

The setup program next allows you to select the programs you will actually install. Figure B.3a shows the Component Installation window. Be sure that you have sufficient hard disk space to install the system and that "Personal COBOL for Windows" is selected. You may choose not to install the Personal Dialog System (PDS) since it requires 4 megabytes of hard disk space and is not discussed in this book. Click on the OK button to continue on in the installation.

The window in Figure B.3c allows you to specify where to find the start icons for the Animator. The default entry is Personal COBOL. You have the option of including the icons in another program group or creating an entirely new group. Click on the OK button when you are ready.



Figure B.3 Establishing Installation Preferences

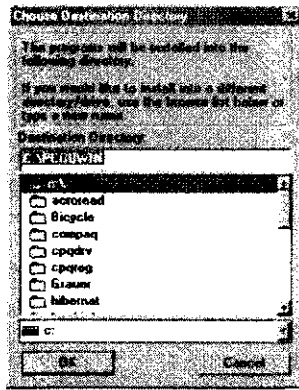

(a) Destination Directory

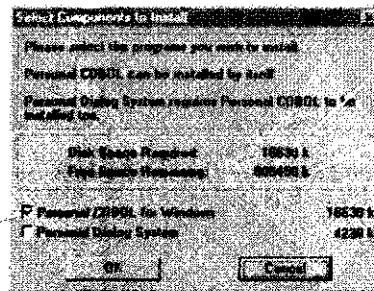

Only Personal COBOL selected

(b) Installation Components

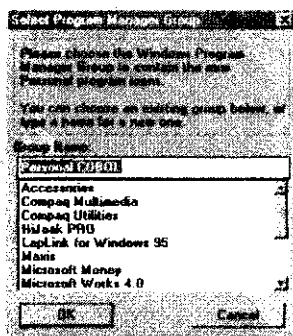

Selected group

(c) Program Manager Group

**Step 9:** Establish Environment Variables

Personal COBOL uses the environmental variables to link together the various programs needed by the system and to assure that the operating system allocates

enough resources to those programs. The window in Figure B.4 explains environmental variables and the changes that will be made. You should normally click on the Modify button to use the default parameters. If you use some other Micro Focus product such as the COBOL Workbench or NetExpress, you may encounter some environmental variable conflicts.

Once you leave this screen, the setup program will begin to copy the files.

Figure B.4 Setting Environment Variables

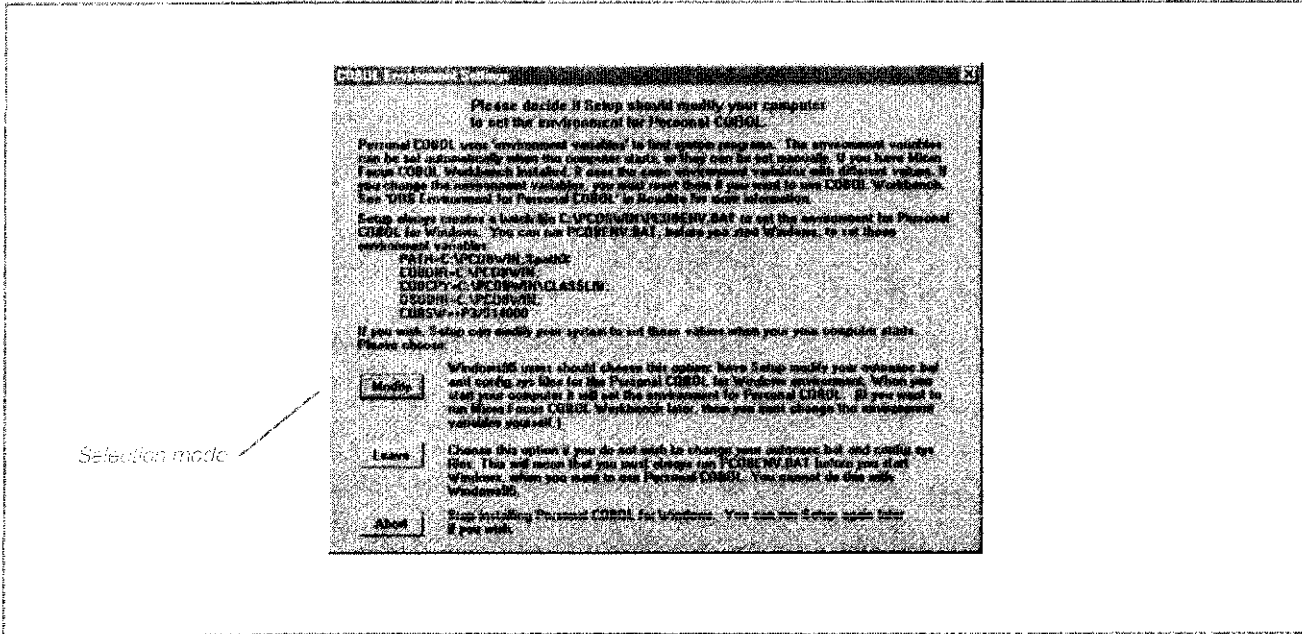

**Step 6:** Copy Files

The setup program now copies the files to the hard disk. The window shown in Figure B.5a keeps track of the progress. Normally you should allow the installation to continue, but it is possible to stop the process by clicking on the Cancel button. If you cancel the process you will need to restart the entire installation process. When copying is complete, you will receive the message box shown in Figure B.5b.

**Step 7:** Review README file

The installation process directs you to the README file. This document, shown in Figure B.6, contains on-line information that was not included in the printed documentation. Take note of the topics presented in this file. You may find them helpful if you are having problems with the Animator. You can also get to the file by using the "Readme" icon in the Start Menu entry.

Figure B.5 Actual Installation

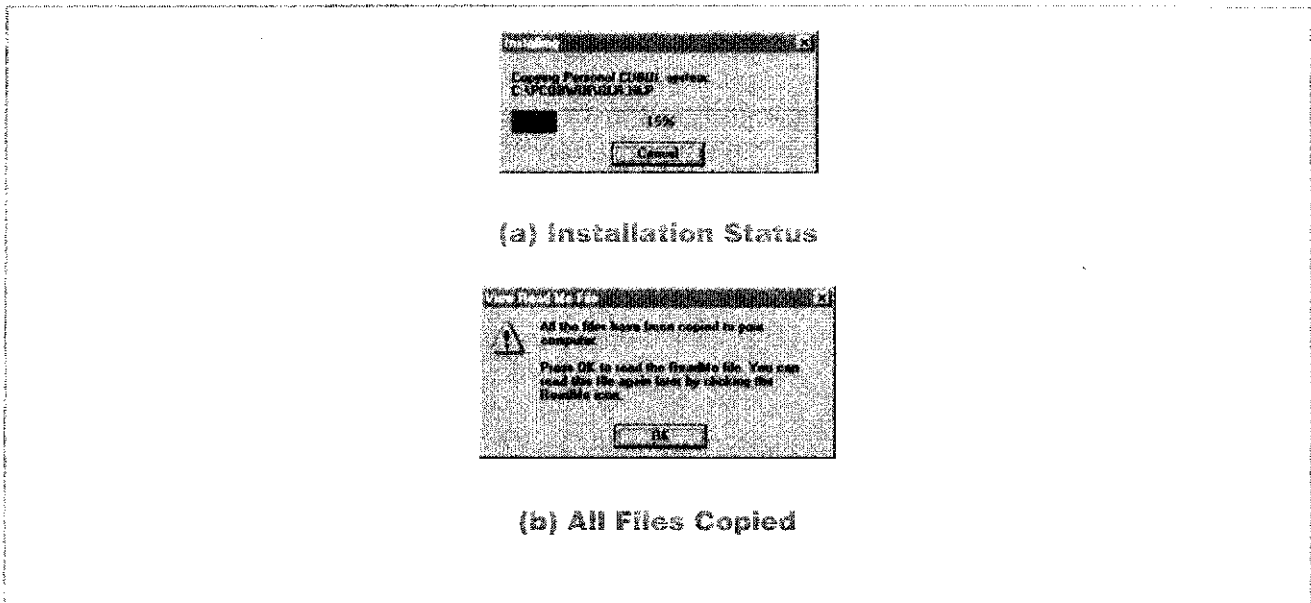
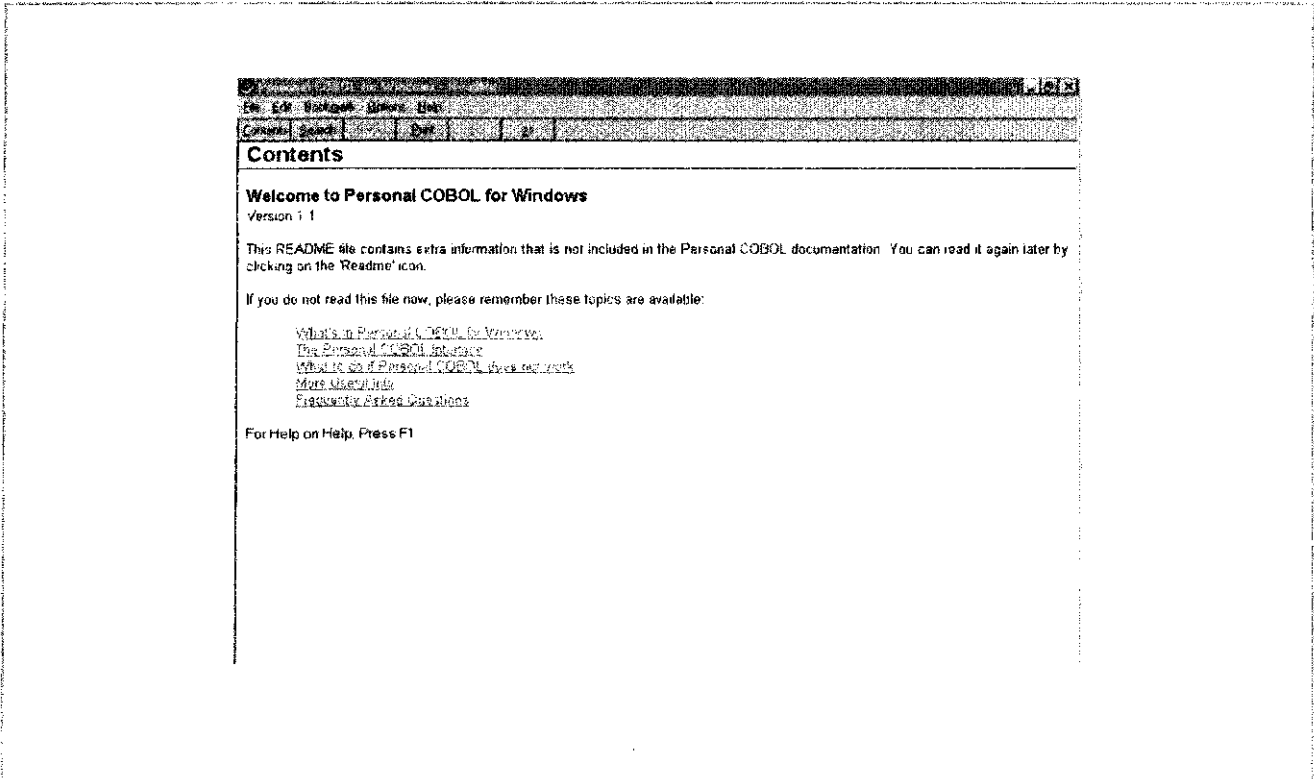

Figure B.6 README File



**Step 8:** Reboot the System

After reviewing the README file, you will see the windows shown in Figure B.7. These windows explain that Personal COBOL will not be functional until the system has been restarted and the new environment variables set. Reboot the system if you plan to use Personal COBOL immediately.

Figure B.7 Request to Restart

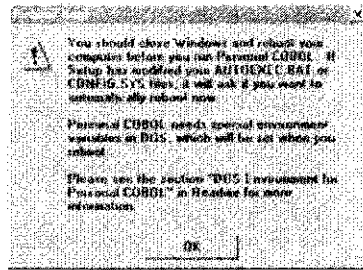

(a) Restart Explanation

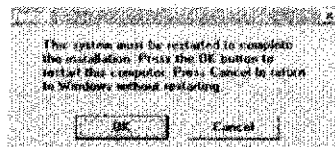

(b) Press OK to Restart

## Creating Shortcuts for the Animator

Windows allows the creation of “shortcuts” or icons that will start various applications. When you installed Personal COBOL, the installation process set up several shortcuts in the Start Menu entry “Personal COBOL.” One of those shortcuts is called Personal COBOL and starts the Animator. When the Animator begins to process, it has a default working directory of C:\PCOBWIN\SAMPLES. However, it is likely that you will want to use some other directory or a floppy disk to store your programs. Therefore, you may want to create one or more new shortcuts to make things easier.

By selecting Taskbar within the Start Menu option Settings, as shown in Figure B.8, you can create your own shortcuts. This option brings up the Taskbar Properties window, as in Figure B.9. Make sure that the “Start Menu Programs” tab is on top. Click on the Add button to create a new short cut. The Add button starts a wizard to help you create a short cut. Figures B.10 through B.12 show the windows the wizard presents and the options we chose to build a shortcut for using COBOL programs on the A drive.

The shortcut is not complete after the wizard has finished. From the Taskbar Properties window shown in Figure B.9, select the Advanced option. A window similar to that shown in Figure B.13 appears. You will probably have to double-click on Programs to show all of the subentries. Click on Personal COBOL to show its contents. Next, select your entry and then click on the file menu. At this point you should see something like Figure B.14. By selecting Properties, you will open the window shown in Figure B.15. Make sure that the Shortcut tab is showing, then enter the directory you wish to use into the “Start in:” text box. Click on the OK button and you will be able to run the Animator using the directory containing your files.

We recommend the use of shortcuts because they help make sure that your programs will find the correct input files.

Figure B.8 Preparing to Create a Shortcut

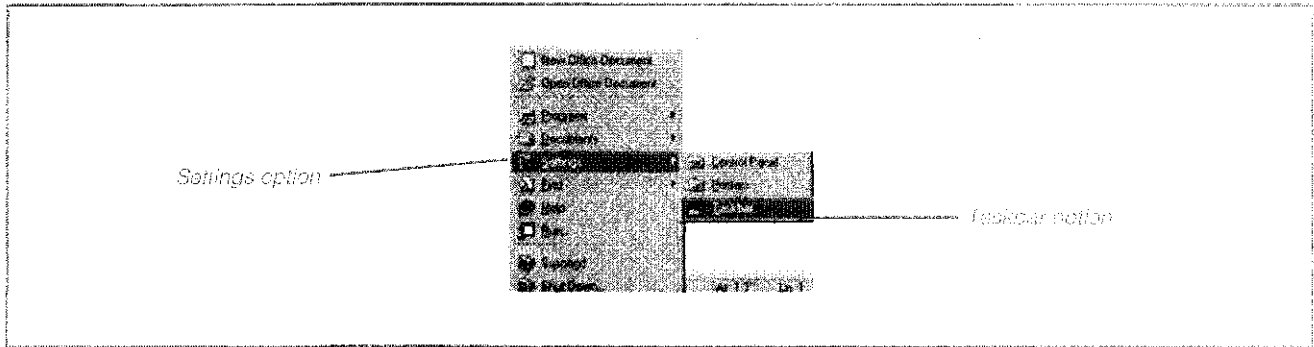

Figure B.9 Taskbar Properties

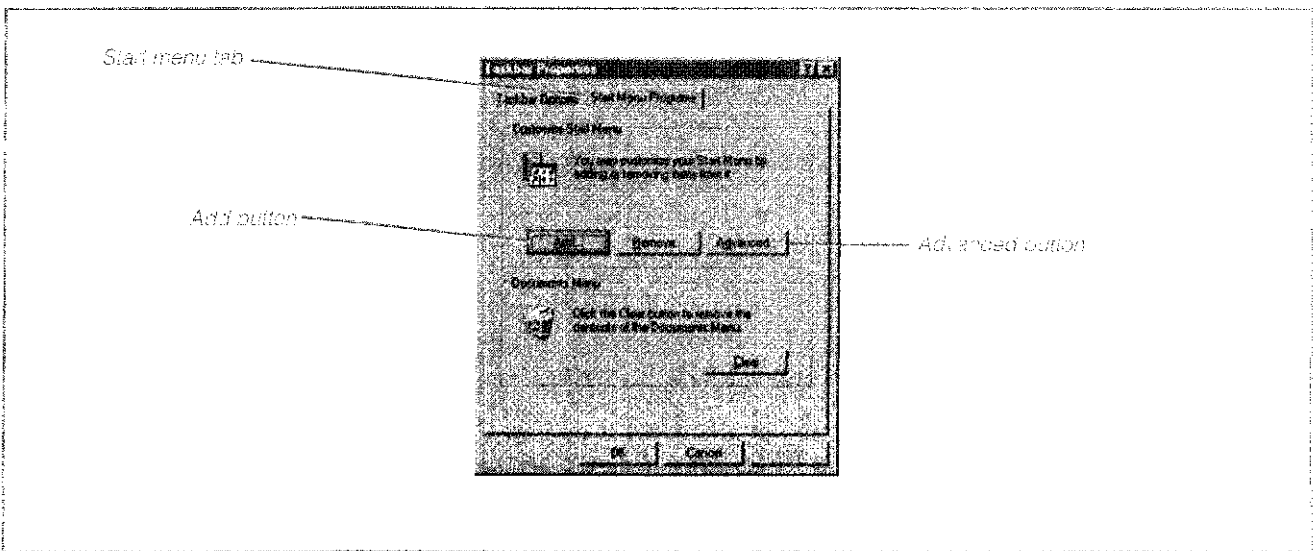

Figure B.10 Establish the Program

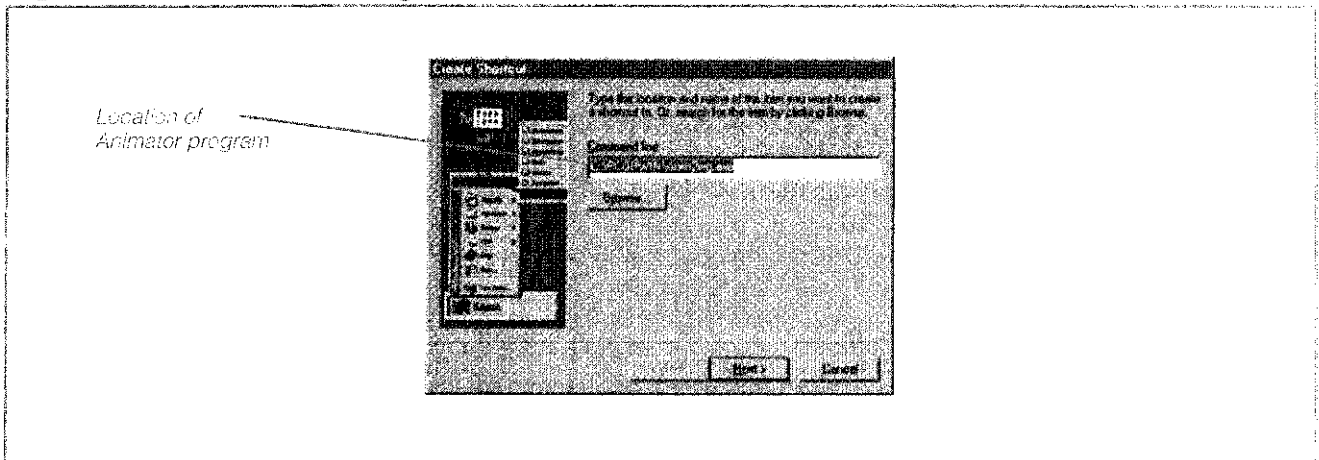

Figure B.11 Set Program Group for Shortcut

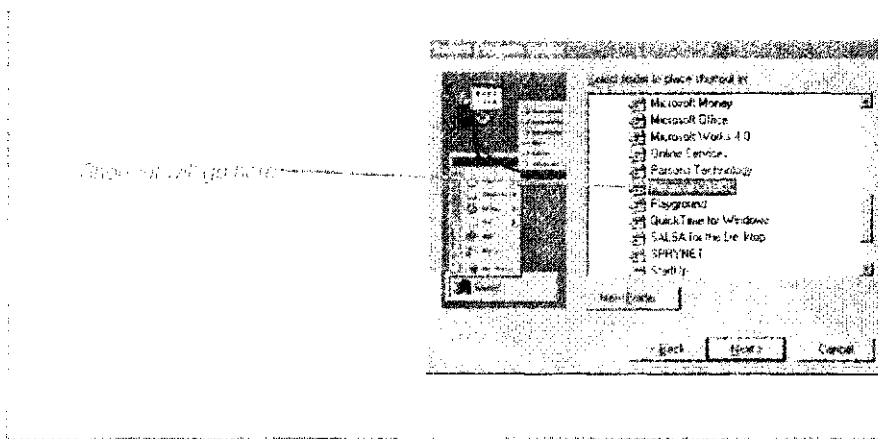

Figure B.12 Establish Name for Shortcut

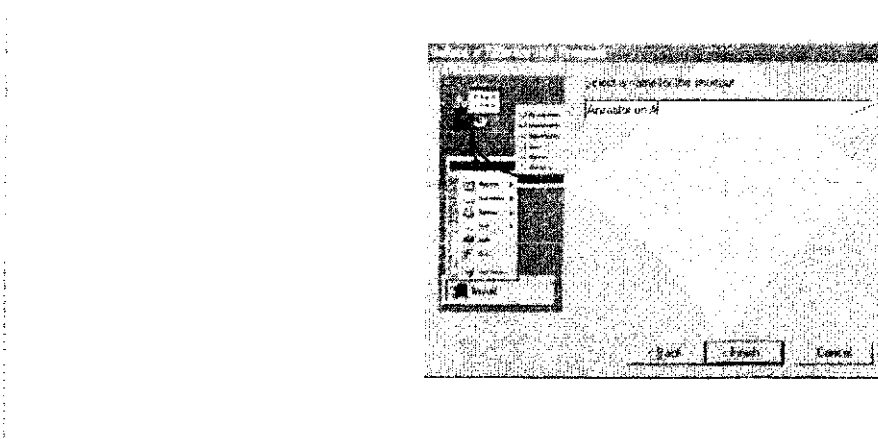

Figure B.13 Expanded List of Folders

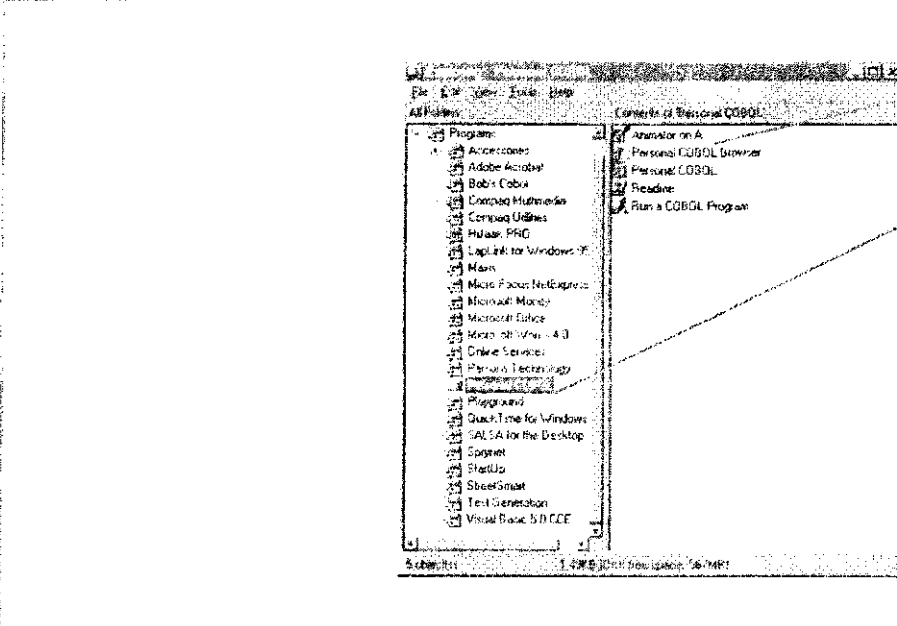

Figure B.14 Change Properties of Shortcut

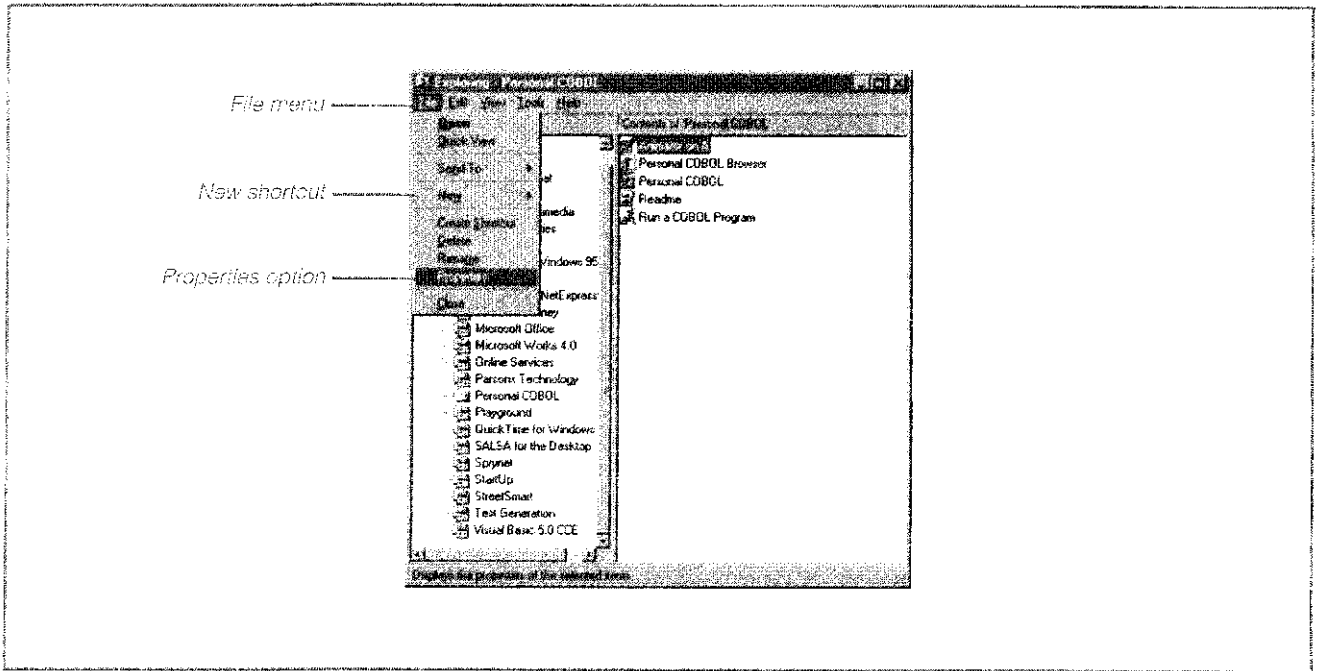
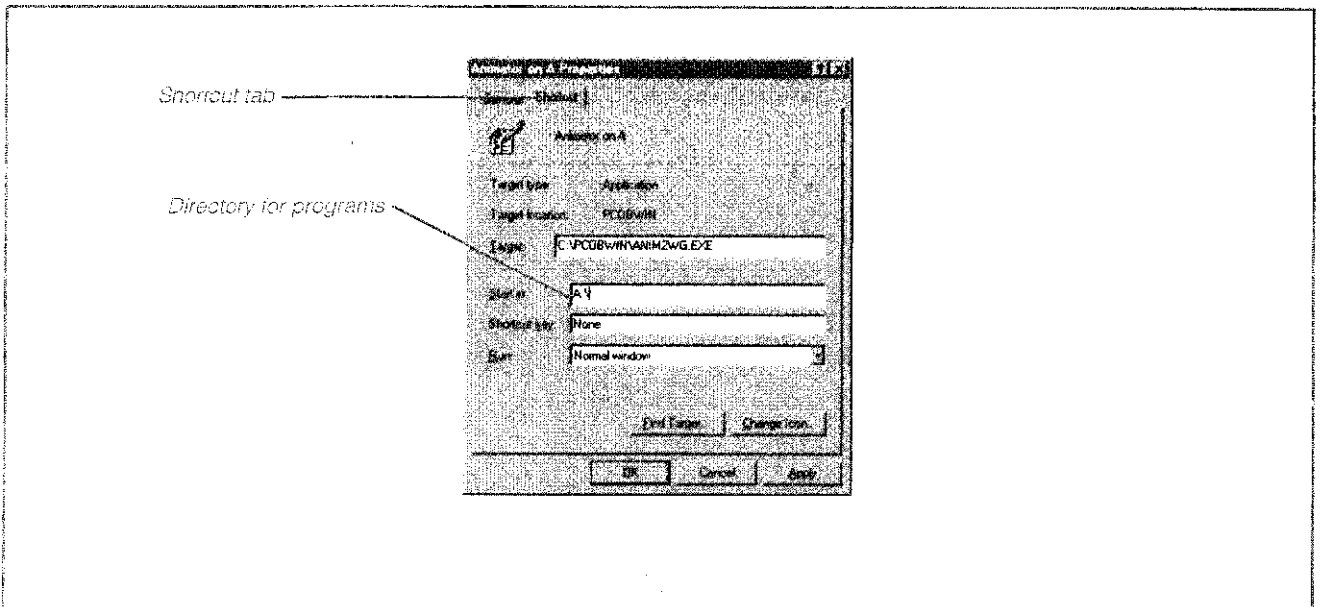

Figure B.15 Change the Default Program Directory



---

## Downloading Data and Source Files from the Web

All of the programs shown in this book and the associated data files are available to you. They can be downloaded from the World Wide Web. You may find the entries under: [www.prenhall.com\grauer\\_cobol](http://www.prenhall.com\grauer_cobol). The process for downloading the files is self-explanatory.

---

## Printing from COBOL Programs with the Animator

As discussed in Chapter 4, the SELECT and ASSIGN statements define external files to the COBOL program. In mainframe applications, the specific printer is established outside the program through the use of Job Control Language (JCL). Hence, in a mainframe COBOL program you might see a statement such as SELECT PRINT-FILE ASSIGN TO UT-S-SYSOUT. UT-S-SYSOUT is a generic name for an output device, and a programmer could write a JCL control statement to direct the data to a specific printer.

COBOL on personal computers works a little differently. Personal computers have output ports that can be directed to various peripheral devices. The most common of these ports is "LPT1:". LPT1 is generally used for the printer directly attached to a PC. In some cases, more than one printer can be attached to a PC, and in other cases the PC may be part of a network and print to a network printer.

### Printing to an Attached Printer

In printing to an attached printer, there are several methods for defining a printer. The simplest method is to say ASSIGN TO PRINTER. The COBOL compiler directs the output to LPT1 as the default system printer. Another way of doing the same thing is to say ASSIGN TO 'LPT1:'. This statement specifically directs the file to the printer. In the same way, the programmer can direct a report to a second attached printer by coding ASSIGN TO 'LPT2:'.

### Printing to the Screen or Data Files

Printed output can also be directed to output devices other than printers. For example, you may not always want to print your report when debugging the program. Instead, you may find it more convenient to view the results on the screen. This process is quicker than printing and can save paper. To print to the screen, simply code ASSIGN TO 'CON'. CON stands for "console" or display device. Once you decide to print a hard copy of the report, change the ASSIGN statement to LPT1 and recompile.

The printed output can also be directed to a file capable of being printed through the use of the Notepad Windows accessory. Again, this is done through the ASSIGN statement. This time make the destination something like "REPORT.TXT". The output of the program goes to a file instead of the printer. To print the file, open it in Notepad and print from this accessory. However, you may want to edit the file before printing.

If you have coded a statement such as:

```
WRITE PRINT-LINE AFTER ADVANCING PAGE.
```



COBOL will insert a control character into the line telling the printer to start at the top of the next page. Notepad does not use this character and you will want to remove it.

### Printing to a Network Printer

Personal COBOL does not utilize the Windows95 or WindowsNT spooling capabilities, and printing to a network printer can be difficult. Even if a network printer is the default printer, ASSIGN TO PRINTER causes COBOL to print to the attached printer. The Windows printer assignments are ignored.

In order to print directly to a network printer, you will need to consult with your instructor or network administrator as to the proper procedure. A beginning place is to use the MS-DOS command "NET USE" to assign a port name to the network printer. The format for this command is:

```
net use lpt3: \\server\printer
```

In this case, "lpt3:" is the printer name to be used in the program. "Server" is the name of the server supporting the printer, and "printer" is the network name for the printer.

### Printing Oversize Pages

In the mainframe environment line printers usually have 132 characters per line. However, most standard PC printers print 80 characters per line. If the report line is longer than 80 characters, most PC printers will "wrap" the print line. That is, the printer prints as 80 characters on the first line and the rest on a second line. As a result, the output is distorted and hard to read.

There are several solutions to the problem. The first is to see whether the printer has some sort of switch or combination of buttons to print in "compressed" mode. Consult your user's manual to see how to accomplish this adjustment.

A second alternative is to print in "landscape" mode. Portrait mode, where the page is taller than it is wide, is the standard way of printing. However, most inkjet and laser printers are also capable of printing the page "sideways" so that the resulting page is wider than it is tall. This mode is called landscape. Again, consult your user's manual to see how this may be accomplished.

A final alternative is to code your program so that it causes the printer to operate in compressed or landscape mode. In the subdirectory C:\PCOBWIN\SAMPLES, Micro Focus has provided an example program for sending control characters directly to the printer. Since many printers use different control characters, this process can be confusing, and you will need to find the proper characters from your user's manual.

# Reserved Words

|                     |                |               |              |
|---------------------|----------------|---------------|--------------|
| ACCEPT              | CLASS          | DEBUG-SUB-1   | END-RETURN   |
| ACCESS              | CLOCK-UNITS    | DEBUG-SUB-2   | END-REWRITE  |
| ADD                 | CLOSE          | DEBUG-SUB-3   | END-SEARCH   |
| ADVANCING           | COBOL          | DEBUGGING     | END-START    |
| AFTER               | CODE           | DECIMAL-POINT | END-STRING   |
| ALL                 | CODE-SET       | DECLARATIVES  | END-SUBTRACT |
| ALPHABET            | COLLATING      | DELETE        | END-UNSTRING |
| ALPHABETIC          | COLUMN         | DELIMITED     | END-WRITE    |
| ALPHABETIC-LOWER    | COMMA          | DELIMITER     | ENTER        |
| ALPHABETIC-UPPER    | COMMON         | DEPENDING     | ENVIRONMENT  |
| ALPHANUMERIC        | COMMUNICATION  | DESCENDING    | EOP          |
| ALPHANUMERIC-EDITED | COMP           | DESTINATION   | EQUAL        |
| ALSO                | COMPUTATIONAL  | DETAIL        | ERROR        |
| ALTER               | COMPUTE        | DISABLE       | ESI          |
| ALTERNATE           | CONFIGURATION  | DISPLAY       | EVALUATE     |
| AND                 | CONTAINS       | DIVIDE        | EVERY        |
| ANY                 | CONTENT        | DIVISION      | EXCEPTION    |
| ARE                 | CONTINUE       | DOWN          | EXIT         |
| AREA                | CONTROL        | DUPLICATES    | EXTEND       |
| AREAS               | CONTROLS       | DYNAMIC       | EXTERNAL     |
| ASCENDING           | CONVERTING     |               |              |
| ASSIGN              | COPY           | EGI           | FALSE        |
| AT                  | CORR           | ELSE          | FD           |
| AUTHOR              | CORRESPONDING  | EMI           | FILE         |
|                     | COUNT          | ENABLE        | FILE-CONTROL |
| BEFORE              | CURRENCY       | END           | FILLER       |
| BINARY              |                | END-ADD       | FINAL        |
| BLANK               | DATA           | END-CALL      | FIRST        |
| BLOCK               | DATE           | END-COMPUTE   | FOOTING      |
| BOTTOM              | DATE-COMPILED  | END-DELETE    | FOR          |
| BY                  | DATE-WRITTEN   | END-DIVIDE    | FROM         |
| CALL                | DAY            | END-EVALUATE  |              |
| CANCEL              | DAY-OF-WEEK    | END-IF        | GENERATE     |
| CD                  | DE             | END-MULTIPLY  | GIVING       |
| CF                  | DEBUG-CONTENTS | END-OF-PAGE   | GLOBAL       |
| CH                  | DEBUG-ITEM     | END-PERFORM   | GO           |
| CHARACTER           | DEBUG-LINE     | END-READ      | GREATER      |
| CHARACTERS          | DEBUG-NAME     | END-RECEIVE   | GROUP        |

|                |                 |                 |                 |
|----------------|-----------------|-----------------|-----------------|
| HEADING        | NO              | REMAINDER       | SYNC            |
| HIGH-VALUE     | NOT             | REMOVAL         | SYNCHRONIZED    |
| HIGH-VALUES    | NUMBER          | RENAMES         |                 |
|                | NUMERIC         | REPLACE         | TABLE           |
| I-O            | NUMERIC-EDITED  | REPLACING       | TALLYING        |
| I-O-CONTROL    |                 | REPORT          | TAPE            |
| IDENTIFICATION | OBJECT-COMPUTER | REPORTING       | TERMINAL        |
| IF             | OCCURS          | REPORTS         | TERMINATE       |
| IN             | OF              | RERUN           | TEST            |
| INDEX          | OFF             | RESERVE         | TEXT            |
| INDEXED        | OMITTED         | RESET           | THAN            |
| INDICATE       | ON              | RETURN          | THEN            |
| INITIAL        | OPEN            | REVERSED        | THROUGH         |
| INITIALIZE     | OPTIONAL        | REWIND          | THRU            |
| INITIATE       | OR              | REWRITE         | TIME            |
| INPUT          | ORDER           | RF              | TIMES           |
| INPUT-OUTPUT   | ORGANIZATION    | RH              | TO              |
| INSPECT        | OTHER           | RIGHT           | TOP             |
| INSTALLATION   | OUTPUT          | ROUNDED         | TRAILING        |
| INTO           | OVERFLOW        | RUN             | TRUE            |
| INVALID        |                 |                 | TYPE            |
| IS             | PACKED-DECIMAL  | SAME            |                 |
|                | PADDING         | SD              | UNIT            |
| JUST           | PAGE            | SEARCH          | UNSTRING        |
| JUSTIFIED      | PAGE-COUNTER    | SECTION         | UNTIL           |
|                | PERFORM         | SECURITY        | UP              |
| KEY            | PF              | SEGMENT         | UPON            |
|                | PH              | SEGMENT-LIMIT   | USAGE           |
| LABEL          | PIC             | SELECT          | USE             |
| LAST           | PICTURE         | SEND            | USING           |
| LEADING        | PLUS            | SENTENCE        |                 |
| LEFT           | POINTER         | SEPARATE        | VALUE           |
| LENGTH         | POSITION        | SEQUENCE        | VALUES          |
| LESS           | POSITIVE        | SEQUENTIAL      | VARYING         |
| LIMIT          | PRINTING        | SET             |                 |
| LIMITS         | PROCEDURE       | SIGN            | WHEN            |
| LINAGE         | PROCEDURES      | SIZE            | WITH            |
| LINAGE-COUNTER | PROCEED         | SORT            | WORDS           |
| LINE           | PROGRAM         | SORT-MERGE      | WORKING-STORAGE |
| LINE-COUNTER   | PROGRAM-ID      | SOURCE          | WRITE           |
| LINES          | PURGE           | SOURCE-COMPUTER |                 |
| LINKAGE        |                 | SPACE           | ZERO            |
| LOCK           | QUEUE           | SPACES          | ZEROES          |
| LOW-VALUE      | QUOTE           | SPECIAL-NAMES   | ZEROS           |
| LOW-VALUES     | QUOTES          | STANDARD        |                 |
|                |                 | STANDARD-1      | +               |
| MEMORY         | RANDOM          | STANDARD-2      | -               |
| MERGE          | RD              | START           | *               |
| MESSAGE        | READ            | STATUS          | /               |
| MODE           | RECEIVE         | STOP            | **              |
| MODULES        | RECORD          | STRING          | >               |
| MOVE           | RECORDS         | SUB-QUEUE-1     | <               |
| MULTIPLE       | REDEFINES       | SUB-QUEUE-2     | =               |
| MULTIPLY       | REEL            | SUB-QUEUE-3     | >=              |
|                | REFERENCE       | SUBTRACT        | <=              |
| NATIVE         | REFERENCES      | SUM             |                 |
| NEGATIVE       | RELATIVE        | SUPPRESS        |                 |
| NEXT           | RELEASE         | SYMBOLIC        |                 |

# COBOL-85 Reference Summary

This appendix contains the composite language skeleton of the revised version of the American National Standard COBOL. It is intended to display complete and syntactically correct formats.

The leftmost margin on pages 710 through 718 is equivalent to margin A in a COBOL source program. The first indentation after the leftmost margin is equivalent to margin B in a COBOL source program.

On pages 719 through 729 the leftmost margin indicates the beginning of the format for a new COBOL verb. The first indentation after the leftmost margin indicates continuation of the format of the COBOL verb. The appearance of the italic letter *S*, *R*, *I*, or *W* to the left of the format for the verbs CLOSE, OPEN, READ, and WRITE indicates the **Sequential** I-O module, **Relative** I-O module, **Indexed** I-O module, or **Report Writer** module in which that general format is used. The following formats are presented:

|                                       |     |
|---------------------------------------|-----|
| Identification Division .....         | 712 |
| Environment Division .....            | 712 |
| File Control Entry .....              | 713 |
| Data Division .....                   | 714 |
| File Description Entry .....          | 715 |
| Data Description Entry .....          | 716 |
| Communication Description Entry ..... | 717 |
| Report Description Entry .....        | 718 |
| Report Group Description Entry .....  | 718 |
| Procedure Division .....              | 719 |
| COBOL Verbs .....                     | 720 |
| COPY and REPLACE Statements .....     | 731 |
| Conditions .....                      | 732 |
| Qualification .....                   | 733 |
| Miscellaneous Formats .....           | 733 |
| Nested Source Programs .....          | 734 |
| A Series of Source Programs .....     | 735 |

## Identification Division

### IDENTIFICATION DIVISION.

PROGRAM-ID. program-name IS { COMMON  
INITIAL } PROGRAM

[AUTHOR. [comment-entry] . . . ]

[INSTALLATION. [comment-entry] . . . ]

[DATE-WRITTEN. [comment-entry] . . . ]

[DATE-COMPILED. [comment-entry] . . . ]

[SECURITY. [comment-entry] . . . ]

## Environment Division

### [ENVIRONMENT DIVISION.

#### [CONFIGURATION SECTION.

[SOURCE-COMPUTER. [computer-name [WITH DEBUGGING MODE] . . . ]

[OBJECT-COMPUTER. [computer-name

[PROGRAM COLLATING SEQUENCE IS alphabet-name-1]

[SEGMENT-LIMIT IS segment-number] . . . ]

[SPECIAL-NAMES. [ [implementor-name-1

{ IS mnemonic-name-1 [ON STATUS IS condition-name-1 [OFF STATUS IS condition-name-2] ]  
IS mnemonic-name-2 [OFF STATUS IS condition-name-2 [ON STATUS IS condition-name-1] ] } . . .  
[ON STATUS IS condition-name-1 [OFF STATUS IS condition-name-2] ]  
[OFF STATUS IS condition-name-2 [ON STATUS IS condition-name-1] ]

[ALPHABET alphabet-name-1 IS

{ STANDARD-1  
STANDARD-2  
NATIVE  
implementor-name-2  
[ literal-1 { THROUGH } literal-2 ]  
[ literal-1 { THRU } literal-2 ]  
[ literal-1 { ALSO } literal-3 ] . . . ] } . . .

[ SYMBOLIC CHARACTERS { { symbolic-character-1 } . . . { IS } { integer-1 } . . . } . . . [ IN alphabet-name-2 ] } . . .

[ CLASS class-name IS { literal-4 { THROUGH } literal-5 } . . . ] . . .

[CURRENCY SIGN IS literal-6]

[DECIMAL-POINT IS COMMA]. . . ]

#### [INPUT-OUTPUT SECTION.

##### FILE-CONTROL.

{file-control-entry} . . .

## Environment Division (continued)

[I-0-CONTROL.

|                                                                                                                                                                                                                                                                                                                                                                                                                                                                                                                                                                                                                                                                                                                                                                                                                                                                                                                                                                                                                                                                                                                                                                                                                                                                                                                                                                                                              |               |                    |                         |               |       |       |                       |          |        |        |                |                |   |                               |               |   |                         |                    |   |     |   |     |                   |  |      |  |  |  |  |  |  |  |  |  |  |  |  |                       |  |  |  |  |  |  |  |  |  |  |  |  |  |  |                  |  |  |  |  |  |  |  |                                                                                                                                                                                                                                                                                                                                                                                                                                                                                                                                                                                                                                                                                                                                                                                                                                                                                                                                               |   |          |   |                      |               |   |     |   |     |   |  |        |  |  |  |  |  |  |  |  |  |        |  |  |  |  |  |  |  |  |  |              |  |  |  |  |  |  |  |  |
|--------------------------------------------------------------------------------------------------------------------------------------------------------------------------------------------------------------------------------------------------------------------------------------------------------------------------------------------------------------------------------------------------------------------------------------------------------------------------------------------------------------------------------------------------------------------------------------------------------------------------------------------------------------------------------------------------------------------------------------------------------------------------------------------------------------------------------------------------------------------------------------------------------------------------------------------------------------------------------------------------------------------------------------------------------------------------------------------------------------------------------------------------------------------------------------------------------------------------------------------------------------------------------------------------------------------------------------------------------------------------------------------------------------|---------------|--------------------|-------------------------|---------------|-------|-------|-----------------------|----------|--------|--------|----------------|----------------|---|-------------------------------|---------------|---|-------------------------|--------------------|---|-----|---|-----|-------------------|--|------|--|--|--|--|--|--|--|--|--|--|--|--|-----------------------|--|--|--|--|--|--|--|--|--|--|--|--|--|--|------------------|--|--|--|--|--|--|--|-----------------------------------------------------------------------------------------------------------------------------------------------------------------------------------------------------------------------------------------------------------------------------------------------------------------------------------------------------------------------------------------------------------------------------------------------------------------------------------------------------------------------------------------------------------------------------------------------------------------------------------------------------------------------------------------------------------------------------------------------------------------------------------------------------------------------------------------------------------------------------------------------------------------------------------------------|---|----------|---|----------------------|---------------|---|-----|---|-----|---|--|--------|--|--|--|--|--|--|--|--|--|--------|--|--|--|--|--|--|--|--|--|--------------|--|--|--|--|--|--|--|--|
| <table style="border-collapse: collapse;"> <tr> <td style="padding: 2px 5px;">RERUN</td> <td style="padding: 2px 5px;">[ ON</td> <td style="padding: 2px 5px;">{ file-name-1</td> <td style="padding: 2px 5px;">}</td> <td style="padding: 2px 5px;">]</td> <td style="padding: 2px 5px;">EVERY</td> <td style="padding: 2px 5px;">{</td> <td style="padding: 2px 5px;">[ END OF</td> <td style="padding: 2px 5px;">]</td> <td style="padding: 2px 5px;">{ REEL</td> <td style="padding: 2px 5px;">}</td> <td style="padding: 2px 5px;">OF file-name-2</td> <td style="padding: 2px 5px;">]</td> <td style="padding: 2px 5px;">}</td> <td style="padding: 2px 5px;">...</td> </tr> <tr> <td></td> <td></td> <td style="padding: 2px 5px;">implementor-name-1</td> <td></td> <td></td> <td></td> <td></td> <td style="padding: 2px 5px;">integer-1 RECORDS</td> <td></td> <td style="padding: 2px 5px;">UNIT</td> <td></td> <td></td> <td></td> <td></td> <td></td> </tr> <tr> <td></td> <td></td> <td></td> <td></td> <td></td> <td></td> <td></td> <td style="padding: 2px 5px;">integer-2 CLOCK-UNITS</td> <td></td> <td></td> <td></td> <td></td> <td></td> <td></td> <td></td> </tr> <tr> <td></td> <td></td> <td></td> <td></td> <td></td> <td></td> <td></td> <td style="padding: 2px 5px;">condition-name-1</td> <td></td> <td></td> <td></td> <td></td> <td></td> <td></td> <td></td> </tr> </table> | RERUN         | [ ON               | { file-name-1           | }             | ]     | EVERY | {                     | [ END OF | ]      | { REEL | }              | OF file-name-2 | ] | }                             | ...           |   |                         | implementor-name-1 |   |     |   |     | integer-1 RECORDS |  | UNIT |  |  |  |  |  |  |  |  |  |  |  |  | integer-2 CLOCK-UNITS |  |  |  |  |  |  |  |  |  |  |  |  |  |  | condition-name-1 |  |  |  |  |  |  |  | <table style="border-collapse: collapse;"> <tr> <td style="padding: 2px 5px;">[</td> <td style="padding: 2px 5px;">[ RECORD</td> <td style="padding: 2px 5px;">]</td> <td style="padding: 2px 5px;">AREA FOR file-name-1</td> <td style="padding: 2px 5px;">{ file-name-2</td> <td style="padding: 2px 5px;">}</td> <td style="padding: 2px 5px;">...</td> <td style="padding: 2px 5px;">]</td> <td style="padding: 2px 5px;">...</td> <td style="padding: 2px 5px;">]</td> </tr> <tr> <td></td> <td style="padding: 2px 5px;">[ SAME</td> <td></td> <td></td> <td></td> <td></td> <td></td> <td></td> <td></td> <td></td> </tr> <tr> <td></td> <td style="padding: 2px 5px;">[ SORT</td> <td></td> <td></td> <td></td> <td></td> <td></td> <td></td> <td></td> <td></td> </tr> <tr> <td></td> <td style="padding: 2px 5px;">[ SORT-MERGE</td> <td></td> <td></td> <td></td> <td></td> <td></td> <td></td> <td></td> <td></td> </tr> </table> | [ | [ RECORD | ] | AREA FOR file-name-1 | { file-name-2 | } | ... | ] | ... | ] |  | [ SAME |  |  |  |  |  |  |  |  |  | [ SORT |  |  |  |  |  |  |  |  |  | [ SORT-MERGE |  |  |  |  |  |  |  |  |
| RERUN                                                                                                                                                                                                                                                                                                                                                                                                                                                                                                                                                                                                                                                                                                                                                                                                                                                                                                                                                                                                                                                                                                                                                                                                                                                                                                                                                                                                        | [ ON          | { file-name-1      | }                       | ]             | EVERY | {     | [ END OF              | ]        | { REEL | }      | OF file-name-2 | ]              | } | ...                           |               |   |                         |                    |   |     |   |     |                   |  |      |  |  |  |  |  |  |  |  |  |  |  |  |                       |  |  |  |  |  |  |  |  |  |  |  |  |  |  |                  |  |  |  |  |  |  |  |                                                                                                                                                                                                                                                                                                                                                                                                                                                                                                                                                                                                                                                                                                                                                                                                                                                                                                                                               |   |          |   |                      |               |   |     |   |     |   |  |        |  |  |  |  |  |  |  |  |  |        |  |  |  |  |  |  |  |  |  |              |  |  |  |  |  |  |  |  |
|                                                                                                                                                                                                                                                                                                                                                                                                                                                                                                                                                                                                                                                                                                                                                                                                                                                                                                                                                                                                                                                                                                                                                                                                                                                                                                                                                                                                              |               | implementor-name-1 |                         |               |       |       | integer-1 RECORDS     |          | UNIT   |        |                |                |   |                               |               |   |                         |                    |   |     |   |     |                   |  |      |  |  |  |  |  |  |  |  |  |  |  |  |                       |  |  |  |  |  |  |  |  |  |  |  |  |  |  |                  |  |  |  |  |  |  |  |                                                                                                                                                                                                                                                                                                                                                                                                                                                                                                                                                                                                                                                                                                                                                                                                                                                                                                                                               |   |          |   |                      |               |   |     |   |     |   |  |        |  |  |  |  |  |  |  |  |  |        |  |  |  |  |  |  |  |  |  |              |  |  |  |  |  |  |  |  |
|                                                                                                                                                                                                                                                                                                                                                                                                                                                                                                                                                                                                                                                                                                                                                                                                                                                                                                                                                                                                                                                                                                                                                                                                                                                                                                                                                                                                              |               |                    |                         |               |       |       | integer-2 CLOCK-UNITS |          |        |        |                |                |   |                               |               |   |                         |                    |   |     |   |     |                   |  |      |  |  |  |  |  |  |  |  |  |  |  |  |                       |  |  |  |  |  |  |  |  |  |  |  |  |  |  |                  |  |  |  |  |  |  |  |                                                                                                                                                                                                                                                                                                                                                                                                                                                                                                                                                                                                                                                                                                                                                                                                                                                                                                                                               |   |          |   |                      |               |   |     |   |     |   |  |        |  |  |  |  |  |  |  |  |  |        |  |  |  |  |  |  |  |  |  |              |  |  |  |  |  |  |  |  |
|                                                                                                                                                                                                                                                                                                                                                                                                                                                                                                                                                                                                                                                                                                                                                                                                                                                                                                                                                                                                                                                                                                                                                                                                                                                                                                                                                                                                              |               |                    |                         |               |       |       | condition-name-1      |          |        |        |                |                |   |                               |               |   |                         |                    |   |     |   |     |                   |  |      |  |  |  |  |  |  |  |  |  |  |  |  |                       |  |  |  |  |  |  |  |  |  |  |  |  |  |  |                  |  |  |  |  |  |  |  |                                                                                                                                                                                                                                                                                                                                                                                                                                                                                                                                                                                                                                                                                                                                                                                                                                                                                                                                               |   |          |   |                      |               |   |     |   |     |   |  |        |  |  |  |  |  |  |  |  |  |        |  |  |  |  |  |  |  |  |  |              |  |  |  |  |  |  |  |  |
| [                                                                                                                                                                                                                                                                                                                                                                                                                                                                                                                                                                                                                                                                                                                                                                                                                                                                                                                                                                                                                                                                                                                                                                                                                                                                                                                                                                                                            | [ RECORD      | ]                  | AREA FOR file-name-1    | { file-name-2 | }     | ...   | ]                     | ...      | ]      |        |                |                |   |                               |               |   |                         |                    |   |     |   |     |                   |  |      |  |  |  |  |  |  |  |  |  |  |  |  |                       |  |  |  |  |  |  |  |  |  |  |  |  |  |  |                  |  |  |  |  |  |  |  |                                                                                                                                                                                                                                                                                                                                                                                                                                                                                                                                                                                                                                                                                                                                                                                                                                                                                                                                               |   |          |   |                      |               |   |     |   |     |   |  |        |  |  |  |  |  |  |  |  |  |        |  |  |  |  |  |  |  |  |  |              |  |  |  |  |  |  |  |  |
|                                                                                                                                                                                                                                                                                                                                                                                                                                                                                                                                                                                                                                                                                                                                                                                                                                                                                                                                                                                                                                                                                                                                                                                                                                                                                                                                                                                                              | [ SAME        |                    |                         |               |       |       |                       |          |        |        |                |                |   |                               |               |   |                         |                    |   |     |   |     |                   |  |      |  |  |  |  |  |  |  |  |  |  |  |  |                       |  |  |  |  |  |  |  |  |  |  |  |  |  |  |                  |  |  |  |  |  |  |  |                                                                                                                                                                                                                                                                                                                                                                                                                                                                                                                                                                                                                                                                                                                                                                                                                                                                                                                                               |   |          |   |                      |               |   |     |   |     |   |  |        |  |  |  |  |  |  |  |  |  |        |  |  |  |  |  |  |  |  |  |              |  |  |  |  |  |  |  |  |
|                                                                                                                                                                                                                                                                                                                                                                                                                                                                                                                                                                                                                                                                                                                                                                                                                                                                                                                                                                                                                                                                                                                                                                                                                                                                                                                                                                                                              | [ SORT        |                    |                         |               |       |       |                       |          |        |        |                |                |   |                               |               |   |                         |                    |   |     |   |     |                   |  |      |  |  |  |  |  |  |  |  |  |  |  |  |                       |  |  |  |  |  |  |  |  |  |  |  |  |  |  |                  |  |  |  |  |  |  |  |                                                                                                                                                                                                                                                                                                                                                                                                                                                                                                                                                                                                                                                                                                                                                                                                                                                                                                                                               |   |          |   |                      |               |   |     |   |     |   |  |        |  |  |  |  |  |  |  |  |  |        |  |  |  |  |  |  |  |  |  |              |  |  |  |  |  |  |  |  |
|                                                                                                                                                                                                                                                                                                                                                                                                                                                                                                                                                                                                                                                                                                                                                                                                                                                                                                                                                                                                                                                                                                                                                                                                                                                                                                                                                                                                              | [ SORT-MERGE  |                    |                         |               |       |       |                       |          |        |        |                |                |   |                               |               |   |                         |                    |   |     |   |     |                   |  |      |  |  |  |  |  |  |  |  |  |  |  |  |                       |  |  |  |  |  |  |  |  |  |  |  |  |  |  |                  |  |  |  |  |  |  |  |                                                                                                                                                                                                                                                                                                                                                                                                                                                                                                                                                                                                                                                                                                                                                                                                                                                                                                                                               |   |          |   |                      |               |   |     |   |     |   |  |        |  |  |  |  |  |  |  |  |  |        |  |  |  |  |  |  |  |  |  |              |  |  |  |  |  |  |  |  |
| <table style="border-collapse: collapse;"> <tr> <td style="padding: 2px 5px;">[ MULTIPLE FILE TAPE CONTAINS</td> <td style="padding: 2px 5px;">{ file-name-3</td> <td style="padding: 2px 5px;">]</td> <td style="padding: 2px 5px;">[ POSITION IS integer-1</td> <td style="padding: 2px 5px;">]</td> <td style="padding: 2px 5px;">}</td> <td style="padding: 2px 5px;">...</td> <td style="padding: 2px 5px;">]</td> <td style="padding: 2px 5px;">...</td> <td style="padding: 2px 5px;">]</td> </tr> </table>                                                                                                                                                                                                                                                                                                                                                                                                                                                                                                                                                                                                                                                                                                                                                                                                                                                                                           |               |                    |                         |               |       |       |                       |          |        |        |                |                |   | [ MULTIPLE FILE TAPE CONTAINS | { file-name-3 | ] | [ POSITION IS integer-1 | ]                  | } | ... | ] | ... | ]                 |  |      |  |  |  |  |  |  |  |  |  |  |  |  |                       |  |  |  |  |  |  |  |  |  |  |  |  |  |  |                  |  |  |  |  |  |  |  |                                                                                                                                                                                                                                                                                                                                                                                                                                                                                                                                                                                                                                                                                                                                                                                                                                                                                                                                               |   |          |   |                      |               |   |     |   |     |   |  |        |  |  |  |  |  |  |  |  |  |        |  |  |  |  |  |  |  |  |  |              |  |  |  |  |  |  |  |  |
| [ MULTIPLE FILE TAPE CONTAINS                                                                                                                                                                                                                                                                                                                                                                                                                                                                                                                                                                                                                                                                                                                                                                                                                                                                                                                                                                                                                                                                                                                                                                                                                                                                                                                                                                                | { file-name-3 | ]                  | [ POSITION IS integer-1 | ]             | }     | ...   | ]                     | ...      | ]      |        |                |                |   |                               |               |   |                         |                    |   |     |   |     |                   |  |      |  |  |  |  |  |  |  |  |  |  |  |  |                       |  |  |  |  |  |  |  |  |  |  |  |  |  |  |                  |  |  |  |  |  |  |  |                                                                                                                                                                                                                                                                                                                                                                                                                                                                                                                                                                                                                                                                                                                                                                                                                                                                                                                                               |   |          |   |                      |               |   |     |   |     |   |  |        |  |  |  |  |  |  |  |  |  |        |  |  |  |  |  |  |  |  |  |              |  |  |  |  |  |  |  |  |

## File Control Entry

**SEQUENTIAL FILE**

SELECT [OPTIONAL] file-name-1

|        |    |                      |   |     |
|--------|----|----------------------|---|-----|
| ASSIGN | TO | { implementor-name-1 | } | ... |
|        |    | literal-1            |   |     |

|           |           |   |        |   |
|-----------|-----------|---|--------|---|
| [ RESERVE | integer-1 | ] | [ AREA | ] |
|           |           |   | AREAS  |   |

[ [ORGANIZATION IS] [LINE]SEQUENTIAL]

|           |           |    |               |   |
|-----------|-----------|----|---------------|---|
| [ PADDING | CHARACTER | IS | { data-name-1 | } |
|           |           |    | literal-2     |   |

|                    |    |                    |   |
|--------------------|----|--------------------|---|
| [ RECORD DELIMITER | IS | { STANDARD-1       | } |
|                    |    | implementor-name-2 |   |

[ACCESS MODE IS SEQUENTIAL]

[FILE STATUS IS data-name-2] .

**RELATIVE FILE**

SELECT [OPTIONAL] file-name-1

|        |    |                      |   |     |
|--------|----|----------------------|---|-----|
| ASSIGN | TO | { implementor-name-1 | } | ... |
|        |    | literal-1            |   |     |

|           |           |   |        |   |
|-----------|-----------|---|--------|---|
| [ RESERVE | integer-1 | ] | [ AREA | ] |
|           |           |   | AREAS  |   |

[ORGANIZATION IS] RELATIVE

|               |    |              |   |                               |                             |
|---------------|----|--------------|---|-------------------------------|-----------------------------|
| [ ACCESS MODE | IS | { SEQUENTIAL | ] | [ RELATIVE KEY IS data-name-1 | ]                           |
|               |    | [ RANDOM     |   | ]                             | RELATIVE KEY IS data-name-1 |
|               |    | [ DYNAMIC    |   | ]                             |                             |

[FILE STATUS IS data-name-2] .

## File Control Entry (continued)

**INDEXED FILE**

```

SELECT [OPTIONAL] file-name-1
 ASSIGN TO {implementor-name-1} . . .
 {literal-1}
 [RESERVE integer-1 [AREA
 AREAS]]
 [ORGANIZATION IS] INDEXED
 [ACCESS MODE IS {SEQUENTIAL
 RANDOM
 DYNAMIC}]
 RECORD KEY IS data-name-1
 [ALTERNATE RECORD KEY IS data-name-2 [WITH DUPLICATES]] . . .
 [FILE STATUS IS data-name-3] .

```

**SORT OR MERGE FILE**

```

SELECT file-name-1 ASSIGN TO {implementor-name-1} . . .
 {literal-1}

```

**Data Division**

[DATA DIVISION.

[FILE SECTION.

[file-description-entry

{record-description-entry} . . . ] . . .

[sort-merge-file-description-entry

{record-description-entry} . . . ] . . .

[report-file-description-entry] . . . ]

[WORKING-STORAGE SECTION.

[77-level-description-entry] . . . ]

[LINKAGE SECTION.

[77-level-description-entry] . . . ]

[COMMUNICATION SECTION.

[communication-description-entry

{record-description-entry} . . . ] . . . ]

[REPORT SECTION.

[report-description-entry

{record-group-description-entry} . . . ] . . . ] ]

## File Description Entry

**SEQUENTIAL FILE**

FD file-name-1

[IS EXTERNAL]

[IS GLOBAL]

$$\left[ \text{BLOCK CONTAINS } [\text{integer-1 TO}] \text{ integer-2 } \left\{ \begin{array}{l} \text{RECORDS} \\ \text{CHARACTERS} \end{array} \right\} \right]$$

$$\left[ \text{RECORD } \left\{ \begin{array}{l} \text{CONTAINS integer-3 CHARACTERS} \\ \text{IS VARYING IN SIZE [ [FROM integer-4] [TO integer-5] CHARACTERS]} \\ \text{[DEPENDING ON data-name-1]} \\ \text{CONTAINS integer-6 TO integer-7 CHARACTERS} \end{array} \right\} \right]$$

$$\left[ \text{LABEL } \left\{ \begin{array}{l} \text{RECORD IS} \\ \text{RECORDS ARE} \end{array} \right\} \left\{ \begin{array}{l} \text{STANDARD} \\ \text{OMITTED} \end{array} \right\} \right]$$

$$\left[ \text{VALUE OF } \left\{ \begin{array}{l} \text{implementor-name-1 IS} \\ \text{literal-1} \end{array} \right\} \dots \right]$$

$$\left[ \text{DATA } \left\{ \begin{array}{l} \text{RECORD IS} \\ \text{RECORDS ARE} \end{array} \right\} \text{ {data-name-3} } \dots \right]$$

$$\left[ \text{LINAGE IS } \left\{ \begin{array}{l} \text{data-name-4} \\ \text{integer-8} \end{array} \right\} \text{ LINES } \left[ \text{WITH FOOTING AT } \left\{ \begin{array}{l} \text{data-name-5} \\ \text{integer-9} \end{array} \right\} \right] \right. \\ \left. \left[ \text{LINES AT TOP } \left\{ \begin{array}{l} \text{data-name-6} \\ \text{integer-10} \end{array} \right\} \right] \left[ \text{LINES AT BOTTOM } \left\{ \begin{array}{l} \text{data-name-7} \\ \text{integer-11} \end{array} \right\} \right] \right]$$

[CODE-SET IS alphabet-name-1] .

**RELATIVE FILE**

FD file-name-1

[IS EXTERNAL]

[IS GLOBAL]

$$\left[ \text{BLOCK CONTAINS } [\text{integer-1 TO}] \text{ integer-2 } \left\{ \begin{array}{l} \text{RECORDS} \\ \text{CHARACTERS} \end{array} \right\} \right]$$

$$\left[ \text{RECORD } \left\{ \begin{array}{l} \text{CONTAINS integer-3 CHARACTERS} \\ \text{IS VARYING IN SIZE [ [FROM integer-4] [TO integer-5] CHARACTERS]} \\ \text{[DEPENDING ON data-name-1]} \\ \text{CONTAINS integer-6 TO integer-7 CHARACTERS} \end{array} \right\} \right]$$

$$\left[ \text{LABEL } \left\{ \begin{array}{l} \text{RECORD IS} \\ \text{RECORDS ARE} \end{array} \right\} \left\{ \begin{array}{l} \text{STANDARD} \\ \text{OMITTED} \end{array} \right\} \right]$$

$$\left[ \text{VALUE OF } \left\{ \begin{array}{l} \text{implementor-name-1 IS} \\ \text{literal-1} \end{array} \right\} \dots \right]$$

$$\left[ \text{DATA } \left\{ \begin{array}{l} \text{RECORD IS} \\ \text{RECORDS ARE} \end{array} \right\} \text{ {data-name-3} } \dots \right]$$



File Description Entry (continued)

**SORT - MERGE FILE**

SD file-name-1

[ RECORD { CONTAINS integer-1 CHARACTERS  
IS VARYING IN SIZE [ [FROM integer-2] [TO integer-3] CHARACTERS]  
[DEPENDING ON data-name-1]  
CONTAINS integer-4 TO integer-5 CHARACTERS } ]

[ DATA { RECORD IS } {data-name-2} . . . ]  
[ RECORDS ARE ]

**REPORT FILE**

FD file-name-1

[IS EXTERNAL]

[IS GLOBAL]

[ BLOCK CONTAINS [integer-1 TO] integer-2 { RECORDS }  
{ CHARACTERS } ]

[ RECORD { CONTAINS integer-3 CHARACTERS  
IS VARYING IN SIZE [ [FROM integer-4] [TO integer-5] CHARACTERS]  
[DEPENDING ON data-name-1]  
CONTAINS integer-6 TO integer-7 CHARACTERS } ]

[ LABEL { RECORD IS } { STANDARD }  
{ RECORDS ARE } { OMITTED } ]

[ VALUE OF { implementor-name-1 IS { data-name-2 }  
{ literal-1 } } . . . ]

[CODE-SET IS alphabet-name-1]

[ REPORT IS ]  
[ REPORTS ARE ] {report-name-1} . . .

**INDEXED FILE**

FD file-name-1

[IS EXTERNAL]

[IS GLOBAL]

[ BLOCK CONTAINS [integer-1 TO] integer-2 { RECORDS }  
{ CHARACTERS } ]

[ RECORD { CONTAINS integer-3 CHARACTERS  
IS VARYING IN SIZE [ [FROM integer-4] [TO integer-5] CHARACTERS]  
[DEPENDING ON data-name-1]  
CONTAINS integer-6 TO integer-7 CHARACTERS } ]

[ LABEL { RECORD IS } { STANDARD }  
{ RECORDS ARE } { OMITTED } ]

[ VALUE OF { implementor-name-1 IS { data-name-2 }  
{ literal-1 } } . . . ]

[ DATA { RECORD IS } {data-name-3} . . . ]  
[ RECORDS ARE ]

## Data Description Entry

### FORMAT 1

```

level-number [data-name-1]
 [FILLER]

[REDEFINES data-name-2]

[IS EXTERNAL]

[IS GLOBAL]

[[PICTURE]
 [PIC]] IS character-string

[[USAGE IS]
 [BINARY]
 [COMPUTATIONAL]
 [COMP]
 [DISPLAY]
 [INDEX]
 [PACKED-DECIMAL]]

[[SIGN IS]
 [LEADING]
 [TRAILING]] [SEPARATE CHARACTER]

[[OCCURS integer-2 TIMES
 [[ASCENDING]
 [DESCENDING]] KEY IS {data-name-3} . . .] . . .
 [INDEXED BY {index-name-1} . . .]
 [OCCURS integer-1 TO integer-2 TIMES DEPENDING ON data-name-4
 [[ASCENDING]
 [DESCENDING]] KEY IS {data-name-3} . . .] . . .
 [INDEXED BY {index-name-1} . . .]]

[[SYNCHRONIZED]
 [SYNC]] [[LEFT]
 [RIGHT]]

[[JUSTIFIED]
 [JUST]] RIGHT

[BLANK WHEN ZERO]

[VALUE IS literal-1] .

```

### FORMAT 2

```

66 data-name-1 RENAMES data-name-2 [[THROUGH]
 [THRU]] data-name-3 .

```

### FORMAT 3

```

88 condition-name-1 { [VALUE IS]
 [VALUES ARE] } [literal-1 [[THROUGH]
 [THRU]] literal-2]

```

## Communication Description Entry

**FORMAT 1**

CD cd-name-1

FOR [INITIAL] INPUT

```
[[SYMBOLIC QUEUE IS data-name-1]
 [SYMBOLIC SUB-QUEUE-1 IS data-name-2]
 [SYMBOLIC SUB-QUEUE-2 IS data-name-3]
 [SYMBOLIC SUB-QUEUE-3 IS data-name-4]
 [MESSAGE DATE IS data-name-5]
 [MESSAGE TIME IS data-name-6]
 [SYMBOLIC SOURCE IS data-name-7]
 [TEXT LENGTH IS data-name-8]
 [END KEY IS data-name-9]
 [STATUS KEY IS data-name-10]
 [MESSAGE COUNT IS data-name-11]]
[data-name-1, data-name-2, data-name-3,
 data-name-4, data-name-5, data-name-6,
 data-name-7, data-name-8, data-name-9,
 data-name-10, data-name-11]
```

**FORMAT 2**

CD cd-name-1 FOR OUTPUT

```
[DESTINATION COUNT IS data-name-1]
[TEXT LENGTH IS data-name-2]
[STATUS KEY IS data-name-3]
[DESTINATION TABLE OCCURS integer-1 TIMES
 [INDEXED BY {index-name-1} . . .]]
[ERROR KEY IS data-name-4]
[SYMBOLIC DESTINATION IS data-name-5] .
```

**FORMAT 3**

CD cd-name-1

FOR [INITIAL] I-O

```
[[MESSAGE DATE IS data-name-1]
 [MESSAGE TIME IS data-name-2]
 [SYMBOLIC TERMINAL IS data-name-3]
 [TEXT LENGTH IS data-name-4]
 [END KEY IS data-name-5]
 [STATUS KEY IS data-name-6]]
[data-name-1, data-name-2, data-name-3,
 data-name-4, data-name-5, data-name-6]
```

## Report Description Entry

```

RD report-name-1
 [IS GLOBAL]
 [CODE literal-1]
 [{ CONTROL IS } {data-name-1} . . . }
 [{ CONTROLS ARE } {FINAL [data-name-1] . . . }]
 [PAGE [LIMIT IS] integer-1 [LINE] [HEADING integer-2]
 [LIMITS ARE] [LINES]
 [FIRST DETAIL integer-3] [LAST DETAIL integer-4]
 [FOOTING integer-5]] .

```

## Report Group Description Entry

### FORMAT 1

```

01 [data-name-1]
 [LINE NUMBER IS { integer-1 [ON NEXT PAGE] }
 [PLUS integer-2 }]
 [NEXT GROUP IS { integer-3
 [PLUS integer-4 }
 [NEXT PAGE] }]
 TYPE IS {
 [REPORT HEADING]
 [RH]
 [PAGE HEADING]
 [PH]
 [CONTROL HEADING] { data-name-2 }
 [CH] [FINAL]
 [DETAIL]
 [DE]
 [CONTROL FOOTING] { data-name-3 }
 [CF] [FINAL]
 [PAGE FOOTING]
 [PF]
 [REPORT FOOTING]
 [RF]
 [[USAGE IS] DISPLAY] .

```

### FORMAT 2

```

level-number [data-name-1]
 [LINE NUMBER IS { integer-1 [ON NEXT PAGE] }
 [PLUS integer-2 }]
 [[USAGE IS] DISPLAY] .

```

## Report Group Description Entry (continued)

**FORMAT 3**

level-number [data-name-1]

|         |                       |
|---------|-----------------------|
| PICTURE | } IS character-string |
| PIC     |                       |

[ [USAGE IS] DISPLAY]

|           |          |                      |
|-----------|----------|----------------------|
| [SIGN IS] | {LEADING | } SEPARATE CHARACTER |
|           | TRAILING |                      |

|             |         |
|-------------|---------|
| [JUSTIFIED] | } RIGHT |
| [JUST       |         |

[BLANK WHEN ZERO]

|                  |                           |   |
|------------------|---------------------------|---|
| [LINE NUMBER IS] | {integer-1 [ON NEXT PAGE] | } |
|                  | PLUS integer-2            |   |

[COLUMN NUMBER IS integer-3]

|                                                             |   |
|-------------------------------------------------------------|---|
| SOURCE IS identifier-1                                      | } |
| VALUE IS literal-1                                          |   |
| {SUM {identifier-2} . . . [UPON {data-name-2} . . . ] . . . |   |
| [RESET ON {data-name-3}]                                    |   |
| [FINAL                                                      |   |

[GROUP INDICATE] .

**Procedure Division****FORMAT 1**

[PROCEDURE DIVISION [USING {data-name-1} . . . ] .

[DECLARATIVES.

{section-name SECTION [segment-number] .

USE statement.

[paragraph-name.

[sentence] . . . ] . . . ) . . .

END DECLARATIVES.]

{section-name SECTION [segment-number] .

[paragraph-name.

[sentence] . . . ] . . . ) . . . ]

**FORMAT 2**

[PROCEDURE DIVISION [USING {data-name-1} . . . ] .

[paragraph-name.

[sentence] . . . ) . . . ]

## COBOL Verbs

ACCEPT identifier-1 [FROM mnemonic-name-1]

ACCEPT identifier-2 FROM  $\left. \begin{array}{l} \text{DATE} \\ \text{DAY} \\ \text{DAY-OF-WEEK} \\ \text{TIME} \end{array} \right\}$

ACCEPT cd-name-1 MESSAGE COUNT

ADD  $\left\{ \begin{array}{l} \text{identifier-1} \\ \text{literal-1} \end{array} \right\} \dots \text{TO} \left\{ \begin{array}{l} \text{identifier-2} \\ \text{literal-2} \end{array} \right\} \dots$   
 [ON SIZE ERROR imperative-statement-1]  
 [NOT ON SIZE ERROR imperative-statement-2]  
 [END-ADD]

ADD  $\left\{ \begin{array}{l} \text{identifier-1} \\ \text{literal-1} \end{array} \right\} \dots \text{TO} \left\{ \begin{array}{l} \text{identifier-2} \\ \text{literal-2} \end{array} \right\} \dots$   
GIVING {identifier-3} [ROUNDED] ...  
 [ON SIZE ERROR imperative-statement-1]  
 [NOT ON SIZE ERROR imperative-statement-2]  
 [END-ADD]

ADD  $\left\{ \begin{array}{l} \text{CORRESPONDING} \\ \text{CORR} \end{array} \right\}$  identifier-1 TO identifier-2 [ROUNDED]  
 [ON SIZE ERROR imperative-statement-1]  
 [NOT ON SIZE ERROR imperative-statement-2]  
 [END-ADD]

ALTER {procedure-name-1} TO [PROCEED TO] procedure-name-2 ...

CALL  $\left\{ \begin{array}{l} \text{identifier-1} \\ \text{literal-1} \end{array} \right\} \left[ \text{USING} \left\{ \begin{array}{l} \text{[BY REFERENCE] identifier-2} \dots \\ \text{BY CONTENT identifier-2} \dots \end{array} \right\} \dots \right]$   
 [ON OVERFLOW imperative-statement-1] [END-CALL]

CALL  $\left\{ \begin{array}{l} \text{identifier-1} \\ \text{literal-1} \end{array} \right\} \left[ \text{USING} \left\{ \begin{array}{l} \text{[BY REFERENCE] identifier-2} \dots \\ \text{BY CONTENT identifier-2} \dots \end{array} \right\} \dots \right]$   
 [ON EXCEPTION imperative-statement-1]  
 [NOT ON EXCEPTION imperative-statement-2]  
 [END-CALL]

## COBOL Verbs (continued)

CANCEL { identifier-1  
literal-1 } . . .

CLOSE { file-name-1 { REEL  
UNIT } [FOR REMOVAL] }  
WITH { NO REWIND  
LOCK } } . . .

CLOSE {file-name-1} [WITH LOCK] } . . .

COMPUTE { identifier-1 [ROUNDED] } . . . = arithmetic-expression-1  
[ON SIZE ERROR imperative-statement-1]  
[NOT ON SIZE ERROR imperative-statement-2]  
[END-COMPUTE]

CONTINUE

DELETE file-name-1 RECORD  
[INVALID KEY imperative-statement-1]  
[NOT INVALID KEY imperative-statement-2]  
[END-DELETE]

DISABLE { INPUT [TERMINAL]  
I-O TERMINAL  
OUTPUT } cd-name-1 [WITH KEY { identifier-1  
literal-1 }]

DISPLAY { identifier-1  
literal-1 } . . . [UPON mnemonic-name-1] [WITH NO ADVANCING]

DIVIDE { identifier-1  
literal-1 } INTO { identifier-2 [ROUNDED] } . . .  
[ON SIZE ERROR imperative-statement-1]  
[NOT ON SIZE ERROR imperative-statement-2]  
[END-DIVIDE]

DIVIDE { identifier-1  
literal-1 } INTO { identifier-2  
literal-2 }  
GIVING { identifier-3 [ROUNDED] } . . .  
[ON SIZE ERROR imperative-statement-1]  
[NOT ON SIZE ERROR imperative-statement-2]  
[END-DIVIDE]

COBOL Verbs (continued)

```

DIVIDE { identifier-1 } BY { identifier-2 }
 { literal-1 } { literal-2 }
 GIVING { identifier-3 } [ROUNDED] } . . .
 [ON SIZE ERROR imperative-statement-1]
 [NOT ON SIZE ERROR imperative-statement-2]
 [END-DIVIDE]

```

```

DIVIDE { identifier-1 } INTO { identifier-2 } GIVING identifier-3 [ROUNDED]
 { literal-1 } { literal-2 }
 REMAINDER identifier-4
 [ON SIZE ERROR imperative-statement-1]
 [NOT ON SIZE ERROR imperative-statement-2]
 [END-DIVIDE]

```

```

DIVIDE { identifier-1 } BY { identifier-2 } GIVING identifier-3 [ROUNDED]
 { literal-1 } { literal-2 }
 REMAINDER identifier-4
 [ON SIZE ERROR imperative-statement-1]
 [NOT ON SIZE ERROR imperative-statement-2]
 [END-DIVIDE]

```

```

ENABLE { INPUT [TERMINAL] }
 { I-O TERMINAL } cd-name-1 [WITH KEY { identifier-1 }]
 { OUTPUT } { literal-1 }

```

```

EVALUATE { identifier-1 } [{ identifier-2 }]
 { literal-1 } [{ literal-2 }]
 { expression-1 } [ALSO { expression-2 }] . . .
 { TRUE } [{ TRUE }]
 { FALSE } [{ FALSE }]

```

```

{ { WHEN
 { ANY
 condition-1
 TRUE
 FALSE
 }
 { [NOT] { { identifier-3 } } [{ THROUGH } { identifier-4 }] }
 { { literal-3 } } [{ THRU } { literal-4 }]
 { { arithmetic-expression-1 } } [{ arithmetic-expression-2 }]
 }
}

```



COBOL Verbs (continued)

```

[ALSO
 [ANY
 condition-2
]
 [TRUE
]
 [FALSE
]
 [NOT] { { identifier-5
 literal-5
 arithmetic-expression-3 }
 [THROUGH] { identifier-6
 literal-6
 arithmetic-expression-4 }
 [THRU]
] } } } ... } ...
imperative-statement-1) . . .
[WHEN OTHER imperative-statement-2]
[END-EVALUATE]

EXIT

EXIT PROGRAM

GENERATE { data-name-1
 report-name-1 }

GO TO [procedure-name-1]

GO TO { procedure-name-1 } . . . DEPENDING ON identifier-1

IF condition-1 THEN { { statement-1 } . . . } { ELSE { statement-2 } . . . [END-IF]
 { NEXT SENTENCE } { ELSE NEXT SENTENCE
 { END-IF } { END-IF }
}

INITIALIZE { identifier-1 } . . .

[REPLACING { { ALPHABETIC
 ALPHANUMERIC
 NUMERIC
 ALPHANUMERIC-EDITED
 NUMERIC-EDITED }
 DATA BY { identifier-2
 literal-1 } } . . .]

INITIATE { report-name-1 } . . .

INSPECT identifier-1 TALLYING
{ identifier-2 FOR { CHARACTERS [{ BEFORE } INITIAL { identifier-4 }
 { AFTER } INITIAL { literal-2 }] . . .
 { ALL
 LEADING } { identifier-3 } [{ BEFORE } INITIAL { identifier-4 }
 { AFTER } INITIAL { literal-2 }] } } } } }

```

COBOL Verbs (continued)

INSPECT identifier-1 REPLACING

$$\left\{ \begin{array}{l} \text{CHARACTERS BY } \left\{ \begin{array}{l} \text{identifier-5} \\ \text{literal-3} \end{array} \right\} \left[ \begin{array}{l} \text{BEFORE} \\ \text{AFTER} \end{array} \right] \text{ INITIAL } \left\{ \begin{array}{l} \text{identifier-4} \\ \text{literal-2} \end{array} \right\} \dots \\ \left\{ \begin{array}{l} \text{ALL} \\ \text{LEADING} \\ \text{FIRST} \end{array} \right\} \left\{ \begin{array}{l} \text{identifier-3} \\ \text{literal-1} \end{array} \right\} \text{ BY } \left\{ \begin{array}{l} \text{identifier-5} \\ \text{literal-3} \end{array} \right\} \left[ \begin{array}{l} \text{BEFORE} \\ \text{AFTER} \end{array} \right] \text{ INITIAL } \left\{ \begin{array}{l} \text{identifier-4} \\ \text{literal-2} \end{array} \right\} \dots \dots \end{array} \right\} \dots$$

INSPECT identifier-1 TALLYING

$$\left\{ \begin{array}{l} \text{identifier-2 FOR } \left\{ \begin{array}{l} \text{CHARACTERS } \left[ \begin{array}{l} \text{BEFORE} \\ \text{AFTER} \end{array} \right] \text{ INITIAL } \left\{ \begin{array}{l} \text{identifier-4} \\ \text{literal-2} \end{array} \right\} \dots \\ \left\{ \begin{array}{l} \text{ALL} \\ \text{LEADING} \end{array} \right\} \left\{ \begin{array}{l} \text{identifier-3} \\ \text{literal-1} \end{array} \right\} \left[ \begin{array}{l} \text{BEFORE} \\ \text{AFTER} \end{array} \right] \text{ INITIAL } \left\{ \begin{array}{l} \text{identifier-4} \\ \text{literal-2} \end{array} \right\} \dots \dots \end{array} \right\} \dots \dots \end{array} \right\} \dots$$

REPLACING

$$\left\{ \begin{array}{l} \text{CHARACTERS BY } \left\{ \begin{array}{l} \text{identifier-5} \\ \text{literal-3} \end{array} \right\} \left[ \begin{array}{l} \text{BEFORE} \\ \text{AFTER} \end{array} \right] \text{ INITIAL } \left\{ \begin{array}{l} \text{identifier-4} \\ \text{literal-2} \end{array} \right\} \dots \\ \left\{ \begin{array}{l} \text{ALL} \\ \text{LEADING} \\ \text{FIRST} \end{array} \right\} \left\{ \begin{array}{l} \text{identifier-3} \\ \text{literal-1} \end{array} \right\} \text{ BY } \left\{ \begin{array}{l} \text{identifier-5} \\ \text{literal-3} \end{array} \right\} \left[ \begin{array}{l} \text{BEFORE} \\ \text{AFTER} \end{array} \right] \text{ INITIAL } \left\{ \begin{array}{l} \text{identifier-4} \\ \text{literal-2} \end{array} \right\} \dots \dots \end{array} \right\} \dots$$

INSPECT identifier-1 CONVERTING  $\left\{ \begin{array}{l} \text{identifier-6} \\ \text{literal-4} \end{array} \right\}$  TO  $\left\{ \begin{array}{l} \text{identifier-7} \\ \text{literal-5} \end{array} \right\}$   
 $\left[ \begin{array}{l} \text{BEFORE} \\ \text{AFTER} \end{array} \right] \text{ INITIAL } \left\{ \begin{array}{l} \text{identifier-4} \\ \text{literal-2} \end{array} \right\} \dots$

MERGE file-name-1  $\left\{ \text{ON } \left\{ \begin{array}{l} \text{ASCENDING} \\ \text{DESCENDING} \end{array} \right\} \text{ KEY } \{ \text{data-name-1} \} \dots \right\} \dots$

[COLLATING SEQUENCE IS alphabet-name-1]

USING file-name-2 {file-name-3} . . .

$$\left\{ \begin{array}{l} \text{OUTPUT PROCEDURE IS procedure-name-1 } \left[ \begin{array}{l} \text{THROUGH} \\ \text{THRU} \end{array} \right] \text{ procedure-name-2 } \\ \text{GIVING } \{ \text{file-name-4} \} \dots \end{array} \right\}$$

MOVE  $\left\{ \begin{array}{l} \text{identifier-1} \\ \text{literal-1} \end{array} \right\}$  TO {identifier-2} . . .

MOVE  $\left\{ \begin{array}{l} \text{CORRESPONDING} \\ \text{CORR} \end{array} \right\}$  identifier-1 TO identifier-2

MULTIPLY  $\left\{ \begin{array}{l} \text{identifier-1} \\ \text{literal-1} \end{array} \right\}$  BY {identifier-2 [ROUNDED]} . . .

[ON SIZE ERROR imperative-statement-1]

[NOT ON SIZE ERROR imperative-statement-2]

[END-MULTIPLY]

COBOL Verbs (continued)

MULTIPLY { identifier-1 } BY { identifier-2 [ROUNDED] } . . .  
 [ON SIZE ERROR imperative-statement-1]  
 [NOT ON SIZE ERROR imperative-statement-2]  
 [END-MULTIPLY]

MULTIPLY { identifier-1 } BY { identifier-2 }  
 { literal-1 } { literal-2 }  
 GIVING { identifier-3 [ROUNDED] } . . .  
 [ON SIZE ERROR imperative-statement-1]  
 [NOT ON SIZE ERROR imperative-statement-2]  
 [END-MULTIPLY]

\$ OPEN { INPUT {file-name-1 [WITH NO REWIND] } . . . }  
 { OUTPUT {file-name-2 [WITH NO REWIND] } . . . } . . .  
 { I-O {file-name-3} . . . }  
 { EXTEND {file-name-4} . . . }

R I OPEN { INPUT {file-name-1} . . . }  
 { OUTPUT {file-name-2} . . . } . . .  
 { I-O {file-name-3} . . . }  
 { EXTEND {file-name-4} . . . }

W OPEN { OUTPUT {file-name-1 [WITH NO REWIND] } . . . }  
 { EXTEND {file-name-2} . . . } . . .

PERFORM [ procedure-name-1 [ { THROUGH }  
 { THRU } procedure-name-2 ] ]  
 [imperative-statement-1 END-PERFORM]

PERFORM [ procedure-name-1 [ { THROUGH }  
 { THRU } procedure-name-2 ] ]  
 { identifier-1 }  
 { integer-1 } TIMES [imperative-statement-1 END-PERFORM]

PERFORM [ procedure-name-1 [ { THROUGH }  
 { THRU } procedure-name-2 ] ]  
 [ WITH TEST { BEFORE }  
 { AFTER } ] UNTIL condition-1  
 [imperative-statement-1 END-PERFORM]

## COBOL Verbs (continued)

```

PERFORM [procedure-name-1 [{ THROUGH } procedure-name-2]]
 [WITH TEST { BEFORE }]
 [WITH TEST { AFTER }]
 VARYING { identifier-2 } FROM { identifier-3 }
 { index-name-1 } { index-name-2 }
 { literal-1 }
 BY { identifier-4 } UNTIL condition-1
 { literal-2 }
 [AFTER { identifier-5 } FROM { identifier-6 }]
 { literal-3 } { index-name-4 }
 { literal-3 } ...
 [BY { identifier-7 } UNTIL condition-2]
 { literal-4 }
[imperative-statement-1 END-PERFORM]

```

```
PURGE cd-name-1
```

```

READ file-name-1 [NEXT] RECORD [INTO identifier-1]
 [AT END imperative-statement-1]
 [NOT AT END imperative-statement-2]
[END-READ]

```

```

READ file-name-1 RECORD [INTO identifier-1]
 [INVALID KEY imperative-statement-3]
 [NOT INVALID KEY imperative-statement-4]
[END-READ]

```

```

READ file-name-1 RECORD [INTO identifier-1]
 [KEY IS data-name-1]
 [INVALID KEY imperative-statement-3]
 [NOT INVALID KEY imperative-statement-4]
[END-READ]

```

```

RECEIVE cd-name-1 { MESSAGE } INTO identifier-1
 { SEGMENT }
 [NO DATA imperative-statement-1]
 [WITH DATA imperative-statement-2]
[END-RECEIVE]

```

```
RELEASE record-name-1 [FROM identifier-1]
```

## COBOL Verbs (continued)

```

RETURN file-name-1 RECORD [INTO identifier-1]
 AT END imperative-statement-1
 [NOT AT END imperative-statement-2]
 [END-RETURN]

```

```

S REWRITE record-name-1 [FROM identifier-1]

```

```

R I REWRITE record-name-1 [FROM identifier-1]
 [INVALID KEY imperative-statement-1]
 [NOT INVALID KEY imperative-statement-2]
 [END-REWRITE]

```

```

SEARCH identifier-1 [VARYING {identifier-2}
 {index-name-2}]
 [AT END imperative-statement-1]
 {WHEN condition-1 {imperative-statement-2}
 {NEXT-SENTENCE}} . . .
 [END-SEARCH]

```

```

SEARCH ALL identifier-1 [AT END imperative-statement-1]
 {WHEN {data-name-1 {IS EQUAL TO} {identifier-3
 {literal-1
 {arithmetic-expression-1}}
 {condition-name-2}
 {AND {data-name-2 {IS EQUAL TO} {identifier-4
 {literal-2
 {arithmetic-expression-2}}
 {condition-name-2}
 {imperative-statement-2}
 {NEXT SENTENCE}
 [END-SEARCH]

```

```

SEND cd-name-1 FROM identifier-1

```

```

SEND cd-name-1 [FROM identifier-1] {WITH identifier-2
 WITH ESI
 WITH EMI
 WITH EGI}
 {BEFORE} ADVANCING {identifier-3} [LINE]
 {AFTER} {integer-1} [LINES]
 {mnemonic-name-1}
 {PAGE}
 [REPLACING LINE]

```

COBOL Verbs (continued)

SET {index-name-1} . . . TO {index-name-2}  
 {identifier-1} {identifier-2}  
 {integer-1}

SET {index-name-3} . . . {UP BY} {identifier-3}  
 {DOWN BY} {integer-2}

SET {mnemonic-name-1} . . . TO {ON}  
 {OFF}

SET {condition-name-1} . . . TO TRUE

SORT file-name-1 {ON {ASCENDING}  
 {DESCENDING} KEY {data-name-1} . . . } . . .

[WITH DUPLICATES IN ORDER]

[COLLATING SEQUENCE IS alphabet-name-1]

{INPUT PROCEDURE IS procedure-name-1 {THROUGH} procedure-name-2}  
 {THRU} USING [file-name-2] . . . }

{OUTPUT PROCEDURE IS procedure-name-3 {THROUGH} procedure-name-4}  
 {THRU} GIVING [file-name-3] . . . }

START file-name-1 KEY {IS EQUAL TO  
 IS =  
 IS GREATER THAN  
 IS >  
 IS NOT LESS THAN  
 IS NOT <  
 IS GREATER THAN OR EQUAL TO  
 IS >=} data-name-1

[INVALID KEY imperative-statement-1]

[NOT INVALID KEY imperative-statement-2]

[END-START]

STOP {RUN  
 {literal-1}}

## COBOL Verbs (continued)

STRING { identifier-1 } . . . DELIMITED BY { identifier-2 }  
 { literal-1 } { literal-2 }  
 { SIZE }

INTO identifier-3

[WITH POINTER identifier-4]

[ON OVERFLOW imperative-statement-1]

[NOT ON OVERFLOW imperative-statement-2]

[END-STRING]

SUBTRACT { identifier-1 } . . . FROM { identifier-3 [ROUNDED] } . . .  
 { literal-1 }

[ON SIZE ERROR imperative-statement-1]

[NOT ON SIZE ERROR imperative-statement-2]

[END-SUBTRACT]

SUBTRACT { identifier-1 } . . . FROM { identifier-2 }  
 { literal-1 } { literal-2 }

GIVING { identifier-3 } [ROUNDED] . . .

[ON SIZE ERROR imperative-statement-1]

[NOT ON SIZE ERROR imperative-statement-2]

[END-SUBTRACT]

SUBTRACT { CORRESPONDING } identifier-1 FROM identifier-2 [ROUNDED]  
 { CORR }

[ON SIZE ERROR imperative-statement-1]

[NOT ON SIZE ERROR imperative-statement-2]

[END-SUBTRACT]

SUPPRESS PRINTING

TERMINATE {report-name-1} . . .

UNSTRING identifier-1

[ DELIMITED BY [ ALL ] { identifier-2 } [ OR [ ALL ] { identifier-3 } ] . . .  
 { literal-1 } { literal-2 }

INTO { identifier-4 [DELIMITER IN identifier-5] [COUNT IN identifier-6] } . . .

[WITH POINTER identifier-7]

[TALLYING IN identifier-8]

[ON OVERFLOW imperative-statement-1]

[NOT ON OVERFLOW imperative-statement-2]

[END-UNSTRING]

COBOL Verbs (continued)

USE [GLOBAL] AFTER STANDARD { EXCEPTION } PROCEDURE ON { {file-name-1} . . . }  
 { ERROR } { INPUT }  
 { OUTPUT }  
 { I-O }  
 { EXTEND }

USE [GLOBAL] BEFORE REPORTING identifier-1

USE FOR DEBUGGING ON { cd-name-1 }  
 { [ALL REFERENCES OF] identifier-1 } . . .  
 { file-name-1 }  
 { procedure-name-1 }  
 { ALL PROCEDURES }

WRITE record-name-1 [FROM identifier-1]

{ BEFORE } ADVANCING { { identifier-2 } [LINE ] }  
 { AFTER } { integer-1 } [LINES ]  
 { mnemonic-name-1 }  
 { PAGE }

[ AT { END-OF-PAGE } imperative-statement-1 ]  
 [ EOP ]

[ NOT AT { END-OF-PAGE } imperative-statement-2 ]  
 [ EOP ]

[END-WRITE]

WRITE record-name-1 [FROM identifier-1]

[INVALID KEY imperative-statement-1]

[NOT INVALID KEY imperative-statement-2]

[END-WRITE]

COPY and REPLACE Statements

COPY text-name-1 { OF } library-name-1  
 { IN }

[ REPLACING { { = pseudo-text-1 = } }  
 { identifier-1 } BY { { = pseudo-text-2 = } }  
 { literal-1 } { identifier-2 }  
 { word-1 } { literal-2 }  
 { word-2 } ] . . . ]

REPLACE { = pseudo-text-1 = } BY { = pseudo-text-2 = } . . .

REPLACE OFF



## Conditions

### RELATION CONDITION

|                                                                                                                                                 |                                                     |                                                                                                                                                 |
|-------------------------------------------------------------------------------------------------------------------------------------------------|-----------------------------------------------------|-------------------------------------------------------------------------------------------------------------------------------------------------|
| $\left. \begin{array}{l} \text{identifier-1} \\ \text{literal-1} \\ \text{arithmetic-expression-1} \\ \text{index-name-1} \end{array} \right\}$ | IS [NOT] <u>G</u> REATER THAN                       | $\left. \begin{array}{l} \text{identifier-2} \\ \text{literal-2} \\ \text{arithmetic-expression-2} \\ \text{index-name-2} \end{array} \right\}$ |
|                                                                                                                                                 | IS [NOT] >                                          |                                                                                                                                                 |
|                                                                                                                                                 | IS [NOT] <u>L</u> ESS THAN                          |                                                                                                                                                 |
|                                                                                                                                                 | IS [NOT] <                                          |                                                                                                                                                 |
|                                                                                                                                                 | IS [NOT] <u>E</u> QUAL TO                           |                                                                                                                                                 |
|                                                                                                                                                 | IS [NOT] =                                          |                                                                                                                                                 |
|                                                                                                                                                 | IS <u>G</u> REATER THAN <u>O</u> R <u>E</u> QUAL TO |                                                                                                                                                 |
|                                                                                                                                                 | IS >=                                               |                                                                                                                                                 |
|                                                                                                                                                 | IS <u>L</u> ESS THAN <u>O</u> R <u>E</u> QUAL TO    |                                                                                                                                                 |
| IS <=                                                                                                                                           |                                                     |                                                                                                                                                 |

### CLASS CONDITION

|                                                                                                                                                                                              |                  |
|----------------------------------------------------------------------------------------------------------------------------------------------------------------------------------------------|------------------|
| $\text{identifier-1 IS [NOT] } \left\{ \begin{array}{l} \text{NUMERIC} \\ \text{ALPHABETIC} \\ \text{ALPHABETIC-LOWER} \\ \text{ALPHABETIC-UPPER} \\ \text{class-name} \end{array} \right\}$ | NUMERIC          |
|                                                                                                                                                                                              | ALPHABETIC       |
|                                                                                                                                                                                              | ALPHABETIC-LOWER |
|                                                                                                                                                                                              | ALPHABETIC-UPPER |
|                                                                                                                                                                                              | class-name       |

### CONDITION-NAME CONDITION

condition-name-1

### SWITCH-STATUS CONDITION

condition-name-1

### SIGN CONDITION

|                                                                                                                                            |          |
|--------------------------------------------------------------------------------------------------------------------------------------------|----------|
| $\text{arithmetic-expression-1 IS [NOT] } \left\{ \begin{array}{l} \text{POSITIVE} \\ \text{NEGATIVE} \\ \text{ZERO} \end{array} \right\}$ | POSITIVE |
|                                                                                                                                            | NEGATIVE |
|                                                                                                                                            | ZERO     |

### NEGATED CONDITION

NOT condition-1

### COMBINED CONDITION

condition-1  $\left\{ \begin{array}{l} \text{AND} \\ \text{OR} \end{array} \right\}$  condition-2 . . .

### ABBREVIATED COMBINED RELATION CONDITION

relation-condition  $\left\{ \begin{array}{l} \text{AND} \\ \text{OR} \end{array} \right\}$  [NOT] [relational-operator] object . . .

## Qualification

### FORMAT 1

$$\left. \begin{array}{l} \text{data-name-1} \\ \text{condition-name} \end{array} \right\} \left\{ \left\{ \begin{array}{l} \text{IN} \\ \text{OF} \end{array} \right\} \text{data-name-2} \right\} \dots \left\{ \begin{array}{l} \text{IN} \\ \text{OF} \end{array} \right\} \left\{ \begin{array}{l} \text{file-name} \\ \text{cd-name} \end{array} \right\} \right\}$$

### FORMAT 2

$$\text{paragraph-name} \left\{ \begin{array}{l} \text{IN} \\ \text{OF} \end{array} \right\} \text{section-name}$$

### FORMAT 3

$$\text{text-name} \left\{ \begin{array}{l} \text{IN} \\ \text{OF} \end{array} \right\} \text{library-name}$$

### FORMAT 4

$$\underline{\text{LINAGE-COUNTER}} \left\{ \begin{array}{l} \text{IN} \\ \text{OF} \end{array} \right\} \text{report-name}$$

### FORMAT 5

$$\left\{ \begin{array}{l} \text{PAGE-COUNTER} \\ \text{LINE-COUNTER} \end{array} \right\} \left\{ \begin{array}{l} \text{IN} \\ \text{OF} \end{array} \right\} \text{report-name}$$

### FORMAT 6

$$\text{data-name-3} \left\{ \begin{array}{l} \text{IN} \\ \text{OF} \end{array} \right\} \left\{ \begin{array}{l} \text{IN} \\ \text{OF} \end{array} \right\} \text{data-name-4} \left\{ \begin{array}{l} \text{IN} \\ \text{OF} \end{array} \right\} \left\{ \begin{array}{l} \text{IN} \\ \text{OF} \end{array} \right\} \text{report-name} \right\}$$

$$\left\{ \begin{array}{l} \text{IN} \\ \text{OF} \end{array} \right\} \text{report-name}$$

## Miscellaneous Formats

### SUBSCRIBING

$$\left\{ \begin{array}{l} \text{condition-name-1} \\ \text{data-name-1} \end{array} \right\} \left( \begin{array}{l} \text{integer-1} \\ \text{data-name-2} \text{ [ } \{\pm\} \text{ integer-2} \} \dots \\ \text{index-name-1} \text{ [ } \{\pm\} \text{ integer-3} \} \end{array} \right)$$

### REFERENCE MODIFICATION

data-name-1 (leftmost-character-position: [length])

### IDENTIFIER

$$\text{data-name-1} \left[ \begin{array}{l} \text{IN} \\ \text{OF} \end{array} \right] \text{data-name-2} \dots \left[ \begin{array}{l} \text{IN} \\ \text{OF} \end{array} \right] \left\{ \begin{array}{l} \text{cd-name} \\ \text{file-name} \\ \text{report-name} \end{array} \right\}$$

[ ( {subscript} . . . ) ] [ (leftmost-character-position: [length] ) ]

## Nested Source Programs

### IDENTIFICATION DIVISION.

PROGRAM-ID. program-name-1 [IS INITIAL PROGRAM ] .

[ENVIRONMENT DIVISION. environment-division-content]

[DATA DIVISION. data-division-content]

[PROCEDURE DIVISION. procedure-division-content]

[ [nested-source-program] . . .

END PROGRAM program-name-1.]

### NESTED-SOURCE-PROGRAM

#### IDENTIFICATION DIVISION.

PROGRAM-ID. program-name-2 [ IS  $\left\{ \begin{array}{l} \text{COMMON} \\ \text{INITIAL} \end{array} \right\}$  PROGRAM ] .

[ENVIRONMENT DIVISION. environment-division-content]

[DATA DIVISION. data-division-content]

[PROCEDURE DIVISION. procedure-division-content]

[nested-source-program] . . .

END PROGRAM program-name-2.

---

## A Series of Source Programs

IDENTIFICATION DIVISION.

PROGRAM-ID. program-name-3 [IS INITIAL PROGRAM ] .

ENVIRONMENT DIVISION. environment-division-content]

DATA DIVISION. data-division-content]

PROCEDURE DIVISION. procedure-division-content]

[nested-source-program] . . .

END PROGRAM program-name-3.) . . .

IDENTIFICATION DIVISION.

PROGRAM-ID. program-name-4 [IS INITIAL PROGRAM ] .

ENVIRONMENT DIVISION. environment-division-content]

DATA DIVISION. data-division-content]

PROCEDURE DIVISION. procedure-division-content]

[ [nested-source-program] . . .

END PROGRAM program-name-4.]



# COBOL 1997, 1998, 1999, 2000, or ...?

*Introduction:* The COBOL language is overdue for its next major revision. Since its origination in 1958, COBOL has had several major revisions reflecting the changing needs of business information systems. Each revision has added to the power and capability of the language, and now perhaps the most sweeping revision is waiting in the wings.

COBOL was originally designed to be as English-like as possible. Even mathematical expressions were to be stated in English. Thus, COBOL has verbs like ADD, SUBTRACT, MULTIPLY, and DIVIDE. Every effort was made to make the language readable, so that even a non-programmer could read it. Eventually, it became apparent that this idealistic approach was too limiting. Programmers found that specifying complex expressions only through the use of ADD, SUBTRACT, MULTIPLY, and DIVIDE verbs was too restrictive. COBOL needed a way to make writing mathematical expressions easy in a way similar to FORTRAN and other languages. The 1964 revision made COBOL more flexible with the addition of the COMPUTE verb and other changes.

By 1974 a new revision was needed. Business applications needed to manipulate character data as well as numbers. Thus, new string operations were added and the INSPECT verb was improved. However, by the 1980s, structured programming had become the standard way to write programs, and COBOL needed to change in order to take advantage of this new technique.

After much discussion in the COBOL community and after the delay of several years, COBOL 1985 was finally released. COBOL 1985 had many new and important features. For the first time, in-line PERFORM statements meant that loops were available directly in the code without having to set up separate paragraphs. Statement terminators such as END-IF and END-READ meant that logic errors caused by the careless placement of the period could be reduced. COBOL 1985 provided a powerful new Case statement, EVALUATE, reducing the programmer's reliance on nested IFs. Another major development in COBOL 1985 was the use of subprograms and new ways of structuring programs. COBOL 1985 was a major step forward in the development of the language. The new COBOL was less English-like, but still maintained its readability, business orientation, and compatibility with previous versions.

In 1989, an enhanced version of the 1985 standard was released. The major change in this version was the introduction of intrinsic functions that were common in other programs but had been neglected in COBOL. Now COBOL programs could use statistical functions such as Average and Standard Deviation as well as business functions such as Present Value and Annuity.

Now, a new COBOL standard is being prepared. Just as the paradigm shift to Structured programming meant a revision to the COBOL standards, the new paradigm shift to object-oriented programming means that COBOL must again be revised. The major addition to the new COBOL is object-orientation, and Chapter 20 deals extensively with those changes. However, there are a number of less dramatic changes in the next version of COBOL that programmers should know about even if they do not use OO COBOL.

That is the good news; the bad news is that the wheels of standardization grind very slowly. The new standards were scheduled to be approved and become official in 1997. However, for a variety of reasons the final approval appears to be delayed until the year 2000. This delay is extremely unfortunate and does not help the cause of the COBOL language.

In spite of this setback, some compiler vendors who have made good faith efforts to begin implementing some of the new language features. The COBOL community should push for a quick adoption of the new standards and ask their language vendors how they are supporting the new standards.

The purpose of this appendix is to describe the enhancements to COBOL that were included in the 1989 revisions and the projected enhancements for COBOL 2000. The appendix does not describe these changes in detail; our aim is intended to provide a summary of the major improvements and their impact.

The major change in the 1989 revision was the addition of intrinsic functions. This appendix includes a section on intrinsic functions that presents:

- The concept of functions.
- The format of the FUNCTION statement.
- Classification of the functions by type.
- Brief descriptions of key functions.
- An introduction to the proposed additions to the functions.
- A discussion of user-defined functions.

The second section of the appendix discusses new data types including Boolean and the operators allowed by the new standards.

Finally, we discuss some of the changes that improve the language, but are difficult to classify.

---

## Intrinsic Functions

Most computer languages provide a set of predefined functions that save programming effort. These functions do standard and well-understood mathematical, business, and statistical operations. COBOL has been slow to adopt this capability, but at last, there was a general recognition that the language had moved beyond being just a specialized business language. Therefore, in 1989 an

enhancement to the 1985 standards defined 42 "intrinsic" functions. Intrinsic means "inherent" or "part of." Thus, these functions are now part of the language.

A function performs an operation and returns a result. Generally functions are used within assignment statements and can be used instead of a variable or literal. Within COBOL the assignment verbs are MOVE and COMPUTE. For example would be:

```
MOVE FUNCTION UPPER CASE ("abcdef") TO DATA-STRING
```

The function-identifier specifies the function as UPPER CASE, and the single argument shown in the parentheses is "abcdef." The UPPER CASE functions converts alphanumeric data to upper case, and as a result DATA-STRING contains the value "ABCDEF" after the MOVE statement has been performed.

An example of a numeric function-identifier would be:

```
COMPUTE NUMERIC-ITEM = FUNCTION SIN(10)
```

The COMPUTE statement calculates the sine of 10 and return the value to NUMERIC-ITEM so that the final value of NUMERIC-ITEM is 0.544. SIN is the function identifier and 10 is the argument.

The format of a function-identifier is as follows:

```
FUNCTION function-name-1 [(argument-1) . . .]
```

Numeric functions must be used with COMPUTE cannot be used with ADD, SUBTRACT, MULTIPLY, or DIVIDE.

### Function Types

The various types of intrinsic functions are shown in the following tables. We have categorized them according to their purpose.

Two business functions are now provided to make the computation of annuities and the value of investments easier.

Table E.1 Business Functions

|               |                          |                             |                                                                     |
|---------------|--------------------------|-----------------------------|---------------------------------------------------------------------|
| ANNUITY       | Interest rate for period | Number of Periods           | The ratio of an annuity paid for an initial investment of \$1.00    |
| PRESENT-VALUE | Discount Rate            | A series of Future Payments | The present value of the Future Payments based on the Discount Rate |

Date functions are based primarily on a starting date of January 1, 1601. This arbitrary date is established to assure accuracy for date arithmetic under virtually all circumstances. All dates are based on the Gregorian calendar. Dates supplied to a date function must be valid calendar dates after December 31, 1600.

Table E.2 Date Functions

|                  |                                             |      |                                                                        |
|------------------|---------------------------------------------|------|------------------------------------------------------------------------|
| CURRENT-DATE     | None                                        | None | Returns the current system date and time in YYYYMMDDHHMMSShh format    |
| DATE-OF-INTEGERS | Number of Days succeeding December 31, 1600 |      | Returns the date in YYYYMMDD format                                    |
| DAY-OF-INTEGERS  | Number of Days succeeding December 31, 1600 |      | Returns the date in YYYYDDD format                                     |
| INTEGER-OF DATE  | Date in YYYYMMDD format                     |      | Returns an integer for the number of days succeeding December 31, 1600 |
| INTEGER OF DAY   | Date in YYYYDDD format                      |      | Returns an integer for the number of days succeeding December 31, 1600 |



There are a number of mathematical functions available as intrinsic functions. All except the Sum function have a single argument. The Sum function can have as many arguments as required, since it adds up a series of numbers.

**Table E.3 Mathematical Functions**

|           |        |                               |                                                |
|-----------|--------|-------------------------------|------------------------------------------------|
| ACOS      | Number | None                          | Returns the Arcosine of the number             |
| ASIN      | Number | None                          | Returns the Arcsine of the number              |
| ATAN      | Number | None                          | Returns the Arctangent of the number           |
| COS       | Number | None                          | Returns the Cosine of the number               |
| FACTORIAL | Number | None                          | Returns the Factorial of the number            |
| LOG       | Number | None                          | Returns the natural Logarithm of the number    |
| LOG10     | Number | None                          | Returns the Logarithm to base 10 of the number |
| SIN       | Number | None                          | Returns the Sine of the number                 |
| SUM       | Number | Number<br>(as many as needed) | Returns the total of all values specified      |
| SQRT      | Number | None                          | Returns the Square Root of the number          |
| TAN       | Number | None                          | Returns the Tangent of the number              |

The intrinsic functions also include a number of statistical functions. Statistical functions work on a series of numbers. The number series can be specified by using one argument for each value. When tables are involved, there is an easier method. Statistical functions can specify ALL for the subscript in the argument, as in the following example:

```
01 TEST-ARRAY.
 05 TEST-RESULT PIC 9(03).
 05 TEST-ITEMS OCCURS 5 TIMES PIC 9(02).

COMPUTE TEST-RESULT = FUNCTION SUM (TEST-ITEMS (ALL)).
```

This statement adds all of the values in the table TEST-ITEMS and stores the results in TEST-RESULT. The SUM function can be considered as a mathematical or statistical function.

**Table E.4 Statistical Functions**

|                    |                          |           |                                                                                                                                        |
|--------------------|--------------------------|-----------|----------------------------------------------------------------------------------------------------------------------------------------|
| MAX                | Number series            | As needed | Returns the value of the highest number in the series                                                                                  |
| MEAN               | Number series            | As needed | Returns the arithmetic average of the series                                                                                           |
| MEDIAN             | Number series            | As needed | Returns the middle value of the series where there are as many values above as below                                                   |
| MIDRANGE           | Number series            | As needed | Returns the average of the maximum argument and the minimum argument                                                                   |
| RANDOM             | Number<br>(not required) | None      | Returns a random number between 0 and 1. If argument-1 is specified, it must be zero or a positive integer and is used as a seed value |
| RANGE              | Number series            | As needed | Returns a value that is equal to the value of the maximum argument minus the value of the minimum argument                             |
| STANDARD-DEVIATION | Number series            | As needed | Returns the standard deviation of the series                                                                                           |
| SUM                | Number series            | As needed | Returns the sum of the number series                                                                                                   |
| VARIANCE           | Number series            | As needed | Returns the variance of the number series                                                                                              |

Another set of functions deals with the use of alphanumeric data and conversion between alphanumeric and numeric data.

**Table E.5** Alphanumeric and Conversion Functions

|            |                                            |                                |                                                                                                         |
|------------|--------------------------------------------|--------------------------------|---------------------------------------------------------------------------------------------------------|
| CHAR       | Integer                                    | None                           | The alphanumeric character corresponding to ordinal position in the collating sequence                  |
| LENGTH     | Alphanumeric string                        | None                           | Returns the number of characters in the string                                                          |
| LOWER-CASE | Alphanumeric string                        | None                           | Converts all alphabetic characters to lower case                                                        |
| NUMVAL     | Edited numeric string                      | None                           | Returns the numeric value of the edited string. Cannot be used with currency symbol                     |
| NUMVAL-C   | Edited numeric string with currency symbol | Symbol used as currency symbol | Returns the numeric value of the edited string. Uses argument-2 to determine the currency symbol        |
| ORD        | Alphanumeric character                     | None                           | Returns the ordinal position number of the alphanumeric character                                       |
| ORD-MAX    | Alphanumeric or numeric series             | None                           | Returns the ordinal position number within the series of the element having the highest collating value |
| ORD-MIN    | Alphanumeric or numeric series             | None                           | Returns the ordinal position number within the series of the element having the lowest collating value  |
| REVERSE    | Alphanumeric string                        | None                           | Returns an alphanumeric string the same length as argument-1 with the characters in reverse order       |
| UPPER-CASE | Alphanumeric string                        | None                           | Converts all alphabetic characters to upper case                                                        |

Finally, a set of miscellaneous functions that are not easily categorized into one of the above tables is provided

**Table E.6** Miscellaneous Functions

|               |               |               |                                                                                                                                     |
|---------------|---------------|---------------|-------------------------------------------------------------------------------------------------------------------------------------|
| INTEGER       | Numeric value |               | Largest Integer not greater than Argument-1. If Argument-1 is +2.3, +2 is returned. If Argument-1 is -2.3, the value returned is -3 |
| INTEGER-PART  | Numeric value | returned      | Integer portion of Argument-1. If Argument-1 is +2.3, +2 is returned. If Argument-1 is -2.3, -2 is returned                         |
| MOD           | Integer       | Integer       | Returns the value of the remainder when Argument-1 is divided by Argument-2. The result is an integer value                         |
| REM           | Numeric value | Numeric value | Same as MOD but can use and return non-integer values.                                                                              |
| WHEN-COMPILED | None          | None          | Returns the compile date and time in YYYYMMDDHHMMDD format                                                                          |

### Intrinsic Functions Added in COBOL 2000

COBOL 2000 adds a number of functions to the 1989 extensions. Several of these functions deal with manipulation of national characters—symbols that are not part of the English language, but are used in other languages. There are also functions that handle special collating sequences in other languages. The following table includes only the new functions that are of more general interest. Other functions may be added or changed before the new standards are adopted.

Table E.7 COBOL 2000 Functions

|                        |                                           |                  |                                                                                                                                                                                                                                   |
|------------------------|-------------------------------------------|------------------|-----------------------------------------------------------------------------------------------------------------------------------------------------------------------------------------------------------------------------------|
| ABS                    | Numeric value                             |                  | Returns the absolute value of Argument-1                                                                                                                                                                                          |
| ALLOCATED- OCCURRENCES | Dynamic Table                             |                  | Returns an integer value for the number of occurrences allocated in the table                                                                                                                                                     |
| BOOLEAN-OF             | Positive Integer                          | Positive Integer | Returns the binary value of Argument-1 in a binary field with Argument-2 number of bits                                                                                                                                           |
| DATE-TO-YYYYMMDD       | Positive Integer                          | Integer          | Converts YYMMDD date format to YYYYMMDD format. Argument-2 allows adjustment to the century range. Argument-2 defines the ending year as a displacement from the current system year. If Argument-2 is omitted, the default is 50 |
| DAY-TO-YYYYDDD         | Positive Integer                          | Integer          | Converts YYDDD date to format to YYYYDDD format. Argument-2 allows adjustment to century range                                                                                                                                    |
| E                      | None                                      | None             | Returns the value of $e$ , the natural logarithm base                                                                                                                                                                             |
| EXP                    | Numeric Item                              |                  | Returns the value of $e$ raised to the Argument-1 power                                                                                                                                                                           |
| EXP10                  | Numeric Item                              |                  | Returns the value of 10 raised to the Argument-1 power                                                                                                                                                                            |
| FRACTION-PART          | Numeric Item                              |                  | Returns the fractional part of Argument-1 eliminating the integer portion                                                                                                                                                         |
| NUMVAL-B               | Boolean Value                             |                  | Returns the decimal equivalent of the Binary value of Argument-1. Function may use the SIGNED keyword following Argument-1 to indicate that Argument-1 is a signed value                                                          |
| NUMVAL-F               | Numeric value specified as floating point |                  | Returns the decimal equivalent of Argument-1                                                                                                                                                                                      |
| PI                     | None                                      |                  | Returns the value of PI up to 31 decimal places                                                                                                                                                                                   |
| YEAR-TO-YYYY           | Positive Integer                          | Integer          | Converts YY to YYYY. Argument-2 specifies a window for candidate dates.                                                                                                                                                           |

In addition to the new intrinsic functions defined above, COBOL 2000 also allows the creation and use of user defined functions.

## New Data Types

The COBOL 2000 standards allow for several new data types that have been available to other languages. These data types include new fixed length BINARY data fields, Floating-Point data types, and new pointer types. These data types can be specified by the USAGE clause of data items within the DATA DIVISION.

COBOL 1985 allowed the BINARY data type. This data type has a variable length dependent upon places specified in the picture clause. The binary options have been expanded to a Boolean data type and several fixed length BINARY data types.

- BIT—this data type is a Boolean Data type used for Boolean Operations. The size of the field is specified by the Picture clause.
- BINARY-CHAR—a binary field using 1 byte for representation.
- BINARY-SHORT—a binary field 2 bytes in length.
- BINARY-LONG—a binary field 4 bytes in length.

- BINARY-DOUBLE—a binary field 8 bytes in length.

COMP(UTATIONAL) usage is left up to the compiler implementers, but is generally the equivalent of BINARY.

Floating point numbers are specified as FLOAT-SHORT or FLOAT-LONG. The size of the fields is dependent on the implementor. Generally, the FLOAT-SHORT will use 2 bytes of storage and FLOAT-LONG uses 4 bytes. In other languages, these data types may be called “Single” or “Double.”

These new data types will make the linking of COBOL programs with programs developed in other languages much easier. COBOL will be able to receive and pass data directly to programs written in other languages. This new compatibility is also enhanced by a new INTEGER data type. This data type accepts Integer data in the format of other languages. The use of INTEGER is limited to use in the LINKAGE SECTION of programs and must be associated with a BY VALUE reference.

In connection with object-oriented COBOL, the 2000 standard provides a new pointer type to specify the pointers for Objects. This USAGE is OBJECT REFERENCE. The pointer type follows the conventions of other pointer and index data types. The SET verb must be used to update these fields.

---

## Miscellaneous New Features

**Free Form Source Code:** In the new COBOL standards, the COBOL programmer is freed from the confines of the 80-column card. The new standards allow source code lines to be from 0 to 255 characters in length, and the code can be placed anywhere in the line. In order to achieve this new freedom, the standards committee has decided to change the comment indicator from a “\*” in column 7 to the characters “\*>” placed anywhere in the source code line. Any characters to the right of the comment indicator are treated as comments. The comment stops at the end of a line. Therefore, if a comment needs to go onto two or lines, each comment line or area must begin with “\*>”. There is no symbol to stop the comment.

The free format also provides new capability in continuing literals from one line to another. The partial literal on the first line should be ended by a “- or ‘-. The second line of the can start anywhere on the second line, but must begin with a “ or ‘. The literal must conclude with a “ or ‘.

The new free format provides new flexibility in writing code and in program documentation.

**Fewer Required Entries:** Another change in the coding of programs is a loosening of the rules for required entries in a program. For example, the Division headers do not have to be specified at all. Section headers are still needed, but only for the sections actually used. One exception to the new rule about Division headers is when the Procedure Division needs a Linkage Section. The Procedure Division header has to specify the use of the Linkage Section. Therefore, the Procedure Division header to define Linkage Section entries.

---

## Conclusion

COBOL 2000 is part of the language’s gradual evolution. While the introduction of object-orientation is the primary new language feature, the addition of new intrinsic functions, the new data types, and the new freedom for coding programs will all make the COBOL programmer’s life easier.



# Answers to Odd-Numbered Exercises

## Chapter 1

### Fill in

1. Input, processing, output
3. Flowchart
5. Decision
7. Programmer-supplied name
9. Relational
11. Fields

### True/False

1. False. Nonnumeric literals may contain numbers, letters, or special characters.
3. False. A dataname may contain hyphens.
5. True.
7. True.
9. False. They must appear in order: IDENTIFICATION, ENVIRONMENT, DATA, and PROCEDURE.
11. True.
13. False. They must be told exactly what to do, and the instructions take the form of a computer program.
15. False. A diamond indicates a decision; a rectangle implies straight forward processing.
17. False. Reserved words are restricted to a preassigned use.
19. False. The rules for pseudocode are at the discretion of the programmer.

## Chapter 2

### Fill in

1. Compiler, source, object (machine)
3. A margin
5. 12, 72
7. Editor (word processor)
9. Debugging
11. Linker
13. Different
15. Execution

### True/False

1. False. A compiler translates a problem-oriented language into a machine oriented language.
3. True.
5. True.
7. False. Division headers may begin anywhere in the A margin (columns 8 to 11), although many people begin them in column 8.
9. False. Paragraph names begin in the A margin.

11. False. A clean compile means only that the program has been translated into machine language; it says nothing about whether the logic of the program is correct.
13. True.
15. False. Each text editor has its own unique commands.
17. False. The compiler produces an object module which is input to the linker, which in turn produces the load module.

## Chapter 3

### Fill-in

1. Sequence, selection, and iteration
3. One, one
5. Hierarchy chart
7. Completeness, functionality, and span of control
9. Pseudocode
11. Span of control
13. Bohm, Jacopini
15. Top down

### True/False

1. False. It may still contain logic errors, but presumably fewer than non-structured code.
3. False. Initialization and termination are too vague and do not follow the verb, adjective, object convention for naming paragraphs.
5. True.
7. False. It is an extension to sequence, selection, and iteration.
9. False. The rules of pseudocode are at the discretion of the programmer, although individual shops may impose standards.
11. False. Testing should begin as soon as possible with the aid of program stubs.
13. False. The name implies that the paragraph is doing three distinct things, as opposed to having a single function.
15. False. Program testing should be ongoing throughout the life of the project.
17. False. The optimal number of modules is a function of the program's design.

## Chapter 4

### Fill-in

1. Identification
3. Braces
5. Programmer supplied
7. SELECT
9. PICTURE
11. FILE, WORKING-STORAGE
13. may not
15. BLOCK CONTAINS, logical, physical

### True/False

1. True.
3. False. Square brackets indicate the entry is optional.
5. False. Some modification, generally in the Environment Division is required.
7. False. It will have a picture clause if it is an elementary item.
9. False. A group item never has a picture clause.
11. False. The determination of whether a data item is a group or elementary item depends on the definition of subordinate data items.
13. True.
15. False. Technically, a program may be written without a File Section, although this is unusual.
17. False. It is optional as indicated by the brackets in the COBOL notation.

## Chapter 5

### Fill-in

1. COMPUTE
3. ROUNDED
5. Before
7. Does not
9. STOP RUN
11.  $N + 1$
13. AFTER ADVANCING PAGE
15. One, left, right
17. Decimal alignment
19. May not
21. SIZE ERROR

### True/False

1. True.
3. False. An ADD statement must contain one word or the other.
5. True.
7. False. The use of BY or INTO determines which operand is the dividend, and which one is the divisor.
9. True.
11. False. If multiplication and division are both present, the order of operations is from left to right.
13. True.
15. True.
17. False. STOP RUN is the last statement executed, but it need not be (and usually isn't) the last physical statement in the program.
19. False. The READ statement specifies a file name.
21. False. They are required whenever a file is present. (Strictly speaking, if a program did not reference any files, then the statements would not be used).
23. True.
25. False. ROUNDED is an optional clause in all the arithmetic statements.
27. False. It is an optional clause.

## Chapter 6

### Fill-in

1. Compilation
3. Execution
5. Compiles
7. Structured walkthrough
9. Detection, correction
11. Run Time Errors

### True/False

1. False. A clean compile means only that the program has been successfully translated into machine language.
3. False. The compiler checks for syntax only and has no way of determining the validity of a program's logic.
5. True.
7. True.
9. False. Spaces are generally required after punctuation symbols, but not before.
11. False. A data name may contain hyphens, letters, or digits only.
13. False. One reads a file and writes a record.
15. False. Walkthroughs should be held for everyone.
17. False. A walkthrough should take a maximum of two hours.

## Chapter 7

### Fill-in

1. Coding standards
3. Floating, fixed
5. V, S
7. Verb, adjective, object
9. Indentation
11. Negative



True/False

- |                                                                                                                                                                                                                                                                                                                                                                                                                                                                                                                                                                                                   |                                                                                                                                                                                                                                                                                                                                                                                                                                                              |
|---------------------------------------------------------------------------------------------------------------------------------------------------------------------------------------------------------------------------------------------------------------------------------------------------------------------------------------------------------------------------------------------------------------------------------------------------------------------------------------------------------------------------------------------------------------------------------------------------|--------------------------------------------------------------------------------------------------------------------------------------------------------------------------------------------------------------------------------------------------------------------------------------------------------------------------------------------------------------------------------------------------------------------------------------------------------------|
| <ul style="list-style-type: none"> <li>1. False. Indentation is used to improve the readability of a program.</li> <li>3. False. Coding standards are a function of the individual shop.</li> <li>5. False. Data names should be meaningful to simplify program maintenance, an activity which takes far more time than initial coding and data entry.</li> <li>7. False. Comments should be used with caution, and always for a specific purpose; a common fault of beginners is to over comment.</li> <li>9. False. The name implies that the paragraph is performing two functions.</li> </ul> | <ul style="list-style-type: none"> <li>11. False. A VALUE clause is used only to assign an initial value; for example for heading lines in Working-Storage. (VALUE clauses are not permitted in the FILE SECTION.)</li> <li>13. False. The assignment of CR and/or DB depends on the accounting system in use.</li> <li>15. False. One or the other should be selected, depending on the accounting system.</li> <li>17. True.</li> <li>19. True.</li> </ul> |
|---------------------------------------------------------------------------------------------------------------------------------------------------------------------------------------------------------------------------------------------------------------------------------------------------------------------------------------------------------------------------------------------------------------------------------------------------------------------------------------------------------------------------------------------------------------------------------------------------|--------------------------------------------------------------------------------------------------------------------------------------------------------------------------------------------------------------------------------------------------------------------------------------------------------------------------------------------------------------------------------------------------------------------------------------------------------------|

Chapter 8

Fill-in

- |                                                                                                                       |                                                                            |
|-----------------------------------------------------------------------------------------------------------------------|----------------------------------------------------------------------------|
| <ul style="list-style-type: none"> <li>1. Validated (checked)</li> <li>3. Numeric</li> <li>5. Completeness</li> </ul> | <ul style="list-style-type: none"> <li>7. 88</li> <li>9. END-IF</li> </ul> |
|-----------------------------------------------------------------------------------------------------------------------|----------------------------------------------------------------------------|

True/False

- |                                                                                                                                                                                                                                                      |                                                                                                                                                                  |
|------------------------------------------------------------------------------------------------------------------------------------------------------------------------------------------------------------------------------------------------------|------------------------------------------------------------------------------------------------------------------------------------------------------------------|
| <ul style="list-style-type: none"> <li>1. False. The output of the edit program is input to the reporting program.</li> <li>3. True.</li> <li>5. False. The alphabetic class test can be applied to only alphabetic or alphanumeric data.</li> </ul> | <ul style="list-style-type: none"> <li>7. True.</li> <li>9. True.</li> <li>11. False. DAY and DATE imply the Julian and calendar dates, respectively.</li> </ul> |
|------------------------------------------------------------------------------------------------------------------------------------------------------------------------------------------------------------------------------------------------------|------------------------------------------------------------------------------------------------------------------------------------------------------------------|

Chapter 9

Fill-in

- |                                                                                                            |                                                                                                                                   |
|------------------------------------------------------------------------------------------------------------|-----------------------------------------------------------------------------------------------------------------------------------|
| <ul style="list-style-type: none"> <li>1. Two</li> <li>3. Section</li> <li>5. Qualified, OF, IN</li> </ul> | <ul style="list-style-type: none"> <li>7. STRING, UNSTRING, and INSPECT</li> <li>9. BEFORE, AFTER</li> <li>11. In-line</li> </ul> |
|------------------------------------------------------------------------------------------------------------|-----------------------------------------------------------------------------------------------------------------------------------|

True/False

- |                                                                                                                                                                                                                                                                                               |                                                                                                                                                 |
|-----------------------------------------------------------------------------------------------------------------------------------------------------------------------------------------------------------------------------------------------------------------------------------------------|-------------------------------------------------------------------------------------------------------------------------------------------------|
| <ul style="list-style-type: none"> <li>1. True.</li> <li>3. False. An in-line perform does not specify a procedure.</li> <li>5. False. CORRESPONDING is always optional.</li> <li>7. False. The CORRESPONDING option has several fine points, but level number is not one of them.</li> </ul> | <ul style="list-style-type: none"> <li>9. False. It is an optional statement which is not favored by the authors.</li> <li>11. True.</li> </ul> |
|-----------------------------------------------------------------------------------------------------------------------------------------------------------------------------------------------------------------------------------------------------------------------------------------------|-------------------------------------------------------------------------------------------------------------------------------------------------|



## Chapter 10

### Fill-in

1. Is not
3. SECURE
5. Last
7. Should not
9. TEST BEFORE
11. Interactive

### True/False

1. False. Both sections may appear in the same program.
3. False. The clauses are optional.
5. True.
7. False. The text would be illegible; i.e., it would blend into the background.
9. True.

## Chapter 11

### Fill-in

1. OCCURS
3. Variable, OCCURS DEPENDING ON
5. May
7. Is
9. Does not change

### True/False

1. False. Tables are established through an OCCURS clause.
3. True.
5. True. However if a subscript does assume a zero value, it would indicate a logic error in the program.
7. False. An index can be used only with the table for which it was defined.
9. False. Variable length records means that records in a file are of different lengths.
11. False. An index is modified by a SET or PERFORM statement.

## Chapter 12

### Fill-in

1. 100, 676, 1296
3. Hard-coded
5. Positional
7. REDEFINES
9. KEY
11. INDEXED BY
13. Compilation
15. Range step

### True/False

1. True.
3. True.
5. True.
7. True.
9. True.
11. False. Examination of the COBOL syntax shows an additional WHEN clause enclosed in brackets.
13. True.
15. True. Good practice however, dictates that a separate subscript be used for every table.

- 17. True.
- 19. True.
- 21. True.
- 23. False. All codes should be unique.
- 25. True.
- 27. False. A range step table occurs when a one-to-one correspondence no longer exists.

## Chapter 13

### Fill-in

- 1. OCCURS
- 3. Seven
- 5. May not, OCCURS, REDEFINES
- 7. 1, 6, 2, 1, 6
- 9. 1, 2, 3

### True/false

- 1. True.
- 3. True in COBOL-85, but not in COBOL-74.
- 5. True.
- 7. False. The program would compile cleanly, but produce problems during execution.
- 9. False. The clauses are all optional

## Chapter 14

### Fill-in

- 1. Key
- 3. EBCDIC, ASCII
- 5. Primary (major), secondary (intermediate), tertiary (minor)
- 7. GIVING, OUTPUT PROCEDURE
- 9. SELECT, SD
- 11. Trailing, embedded
- 13. Identical

### True/false

- 1. False. It can be used on a calculated field if INPUT PROCEDURE is specified.
- 3. False. INPUT PROCEDURE may also be specified with GIVING.
- 5. True.
- 7. False. They are associated with INPUT PROCEDURE and OUTPUT PROCEDURE, respectively.
- 9. True.
- 11. True.
- 13. False. The INPUT PROCEDURE is used if you want to selectively pass records to the sort work file; for example, to increase efficiency by sorting on fewer records.
- 15. True.
- 17. False. INPUT PROCEDURE is not used with the MERGE statement.
- 19. False. The MERGE statement requires that all input files have identical record layouts and appear in the same sequence.

## Chapter 15

### Fill-in

- 1. Change, control break
- 3. Is
- 5. Before
- 7. Pseudocode
- 9. Less
- 11. Rolling

True/False

- 1. False. Control breaks can theoretically extend to any number of levels, although they lose meaning after three or four
- 3. True.
- 5. True.
- 7. True.
- 9. True.

Chapter 16

Fill-in

- 1. EXIT PROGRAM
- 3. Is
- 5. Both
- 7. COPY
- 9. BY REFERENCE
- 11. CALL

True/False

- 1. False. The COPY statement is permitted anywhere except within another COPY.
- 3. False. They can be the same, but there is no COBOL requirement stating they must be the same.
- 5. False. The COPY statement is permitted anywhere except within another COPY.
- 7. False. A program may call several subprograms.
- 9. False. All parameters must be elementary items except for those passed at the 01 level.
- 11. False. Both are optional; omission of both phrases defaults to calling BY REFERENCE which is equivalent to a CALL statement in COBOL-74.

Chapter 17

Fill-in

- 1. Every
- 3. Does
- 5. Additions, changes (corrections), deletions
- 7. Can
- 9. Can not
- 11. Stubs, DISPLAY
- 13. HIGH-VALUES

True/False

- 1. True.
- 3. True.
- 5. True.
- 7. False. Duplicate additions can only be checked against the master file; i.e., during the actual update.
- 9. False. Pseudocode is procedural in nature and indicates sequence and decision making. Hierarchy charts are functional and indicate what has to be done, not necessarily when or if.
- 11. False. The programmer is biased (either consciously or unconsciously), as he or she wrote the program and knows what it does or doesn't do. Ideally test data should be designed by the user, but this is often difficult to achieve.
- 13. False. The balance line algorithm may be used with multiple transaction files (as was done in the chapter).

## Chapter 18

### Fill-in

- |                                             |                                   |
|---------------------------------------------|-----------------------------------|
| 1. Indexed                                  | 9. Optional, two, WORKING-STORAGE |
| 3. VSAM, indexed                            | 11. START                         |
| 5. Highest                                  | 13. DYNAMIC                       |
| 7. Unique, duplicate, alternate (secondary) |                                   |

### True/False

- |                                                                                                                                                                                                                                                                                                             |                                                                                                   |
|-------------------------------------------------------------------------------------------------------------------------------------------------------------------------------------------------------------------------------------------------------------------------------------------------------------|---------------------------------------------------------------------------------------------------|
| 1. False. Specification of ALTERNATE RECORD KEY will require substantial amounts of overhead in retrieving records from an indexed file; it should not be used indiscriminately.                                                                                                                            | 5. False. Specification of zero alternate areas will slow processing.                             |
| 3. False. The COBOL notation places both clauses in brackets to indicate optional entries. Logically however one of the two conditions must pertain, and consequently either clause should be specified. (The authors find these clauses easier to follow than testing the equivalent FILE STATUS entries.) | 7. False. The ALTERNATE RECORD KEY need not be unique, as per the WITH DUPLICATES clause.         |
|                                                                                                                                                                                                                                                                                                             | 9. True.                                                                                          |
|                                                                                                                                                                                                                                                                                                             | 11. False. They have different functions; to enter a new record and to change an existing record. |
|                                                                                                                                                                                                                                                                                                             | 13. True.                                                                                         |

## Chapter 19

### Fill-in

- |                    |                            |
|--------------------|----------------------------|
| 1. storage, memory | 5. integer, date, YYYYMMDD |
| 3. not been        | 7. is                      |

### True/False

- |                                                                               |         |
|-------------------------------------------------------------------------------|---------|
| 1. True                                                                       | 7. True |
| 3. False, they were added in 1989                                             |         |
| 5. False, INTEGER-TO-DATE returns YYYYMMDD and INTEGER-TO-DAY returns YYYYDDD |         |

## Chapter 20

### Fill-in

- |                    |                 |
|--------------------|-----------------|
| 1. is              | 7. Base         |
| 3. class, instance | 9. polymorphism |
| 5. Inheritance     |                 |

### True/False

- |                                                                                          |         |
|------------------------------------------------------------------------------------------|---------|
| 1. False, many of the basic concepts remain.                                             | 7. True |
| 3. False, the Procedure Division is necessary to specify the use of the Linkage Section. | 9. True |
| 5. True                                                                                  |         |

# Projects

## PROGRAMMING SPECIFICATIONS

**Program Name:** Price Break Report

**Narrative:** Write a program to determine whether a customer receives a price break based on quantity ordered.

**Input File:** ORDER-TRANSACTION-FILE

**Input Record Layout:**

| Order Record    |     |   |                  |    |     |             |    |     |    |
|-----------------|-----|---|------------------|----|-----|-------------|----|-----|----|
| Customer Number |     |   | Quantity Ordered |    |     | Item Number |    |     |    |
| 1               | ... | 8 | 9                | 10 | ... | 12          | 13 | ... | 17 |

**Test Data:**

```
51347935000511111
42309847010021222
38901974012532333
21564823050043444
10024567090054555
```

**Report Layout:**

```
XXXXXXXX XXXXX 999 99
Customer Item Qty Discount
Number Number Ordered Percent
```

- Processing Requirements:**
1. Read a file of order records.
  2. For every record read, determine the discount the customer will receive. The discounting of an item is based on the Item Series and Quantity Ordered. Item Series is indicated by the first byte of the Item Number. For example, Item Number 12345 is Item Series 1 because it starts with a 1. The eligibility of discounting is determined as follows.

|                       | Quantity Ordered | Discount Percent |
|-----------------------|------------------|------------------|
| Item Series 1 & 2     | 1-100            | 0%               |
|                       | 101-500          | 10%              |
|                       | 501-999          | 20%              |
| Item Series 3, 4, & 5 | 1-50             | 0%               |
|                       | 51-100           | 15%              |
|                       | 101-500          | 20%              |
|                       | 501-999          | 25%              |

3. Print the Customer Number, Item Number, Quantity Ordered, and Discount Percent allowed for each customer record. Single-space the output.

**Project 2-2**

**Program Name:** Inter-City Piano Program

**Narrative:** Write a program for the Inter-City Piano Company. The program is to process a file of customer records and produce a list of people eligible for a discount in buying a piano.

**Input File:** CUSTOMER-LESSON-FILE

**Input Record Layout:**

| Customer Lesson Record |            |             |    |                    |
|------------------------|------------|-------------|----|--------------------|
| Last Name              | First Name | # of Lesson |    | Purchase Indicator |
| 1 ... 15               | 16 ... 25  | 26 ... 28   | 29 | 30                 |

**Test Data:**

|           |         |     |   |  |
|-----------|---------|-----|---|--|
| CRAWFORD  | SHERRY  | 011 | N |  |
| KARVAZY   | KAREN   | 017 | Y |  |
| MORSE     | KENNETH | 014 | N |  |
| PLUMETREE | MICHELE | 027 | N |  |
| SLY       | MATTHEW | 019 | N |  |
| POWERS    | NANCY   | 024 | Y |  |
| BLAKELY   | KRISTEN | 008 | Y |  |

**Report Layout:**

|            |                    |        |
|------------|--------------------|--------|
| XXXXXXXXXX | XXXXXXXXXXXXXXXXXX | 999    |
| first name | last name          | lesson |

**Processing Requirements:**

1. Read a file of customer records.
2. For every record read, determine whether that person is eligible for a discount to buy a piano. Individuals who have taken 15 or more lessons and have not yet purchased a piano qualify. Do not consider as eligible anyone with a "Y" in position 30 of the input record which indicates that a piano has already been purchased.
3. Print the names of all qualified individuals according to item 2 above. Single-space the output. (Do not print the names of individuals who are not eligible.)

**Project 2-3**

**Program Name:** Delinquent Accounts

**Narrative:** Write a program to process a corporation's account file to select a list of problem accounts. The generated list will then be brought to the attention of the comptroller.

**Input File:** CUSTOMER-ACCOUNT-FILE

**Input Record Layout:**

| Customer Account Record |     |    |    |             |     |    |    |              |     |    |              |    |     |    |
|-------------------------|-----|----|----|-------------|-----|----|----|--------------|-----|----|--------------|----|-----|----|
| Name                    |     |    |    | Account No. |     |    |    | Account Owed |     |    | Days Overdue |    |     |    |
| 1                       | ... | 15 | 16 | 17          | ... | 22 | 23 | 24           | ... | 28 | 29           | 30 | ... | 32 |

**Test Data:**

```

ACME ENTERPRISE 111111 01000 010
BAKER BROTHERS 222222 20000 030
BENJAMIN CO 333333 00500 015
FRANKEL CORP 444444 27500 045
CLARK PROGRESS 555555 32000 005
MARSHAK BOOKS 666666 03500 060
KARLSTROM INC 777777 00100 045
MILGROM THEATRE 888888 15000 014
SPRINGS WATER 999999 20000 007

```

**Report Layout:** Design your own report layout.

**Processing Requirements:**

1. Read a file of customer account records.
2. Determine if the record is a problem account. An account is considered a problem if the amount owed is over 20,000 or the account is more than 30 days overdue.
3. Print the name and associated information (account number, amount owed, and days overdue) of all problem accounts. Space this information reasonably over a print line. Double-space the report.

**Project 2-4**

**Program Name:** Shoe Inventory Program

**Narrative:** Write a program to process a file of shoe inventory records and produce a list of shoes that need reordering.

**Input File:** SHOE-INVENTORY-FILE



**Input Record Layout:**

| Shoe Inventory Record |     |           |    |                  |    |                  |     |    |    |     |    |
|-----------------------|-----|-----------|----|------------------|----|------------------|-----|----|----|-----|----|
| Vendor Name           |     | Style No. |    | Quantity on Hand |    | Reorder Quantity |     |    |    |     |    |
| 1                     | ... | 12        | 13 | ...              | 18 | 19               | ... | 22 | 23 | ... | 26 |

**Test Data:**

|              |                |  |  |  |  |  |  |
|--------------|----------------|--|--|--|--|--|--|
| BASS         | 12121204500300 |  |  |  |  |  |  |
| BRUNO MAGLI  | 23232305000500 |  |  |  |  |  |  |
| KEDS         | 34343407000750 |  |  |  |  |  |  |
| JOAN & DAVID | 45454500500025 |  |  |  |  |  |  |
| LA GEAR      | 56565605000550 |  |  |  |  |  |  |
| FLORSHEIM    | 67676701000075 |  |  |  |  |  |  |
| NIKE         | 78787803000200 |  |  |  |  |  |  |
| REEBOK       | 89898907000800 |  |  |  |  |  |  |

**Report Layout:**

|                |         |      |         |
|----------------|---------|------|---------|
| XXXXXXXXXXXXXX | XXXXXX  | 9999 | 9999    |
| vendor name    | style # | QOH  | Reorder |

**Processing Requirements:**

1. Read a file of shoe inventory records.
2. For each record read, determine whether a particular shoe style should be reordered. Shoes should be reordered when the quantity on hand falls below the reorder quantity.
3. Print the vendor name, style number, quantity on hand, and reorder quantity for only the shoes that should be reordered.

**Project 2-5**

**Program Name:** Mailing List Program

**Narrative:** Write a program to process a file of mailing list records and produce a mailing list.

**Input File:** MAILING-LIST-FILE

**Input Record Layout:**

| Mailing List Record |    |                |    |                |    |     |    |
|---------------------|----|----------------|----|----------------|----|-----|----|
| Name                |    | Street Address |    | City and State |    | Zip |    |
| 1                   | 20 | 21             | 45 | 46             | 63 | 64  | 68 |

**Test Data:**

```

ROBERT T. GRAUER 60 PACIFIC COAST HWY SANTA BARBARA, CA 93101
JANE DOE 123 SOUTH STREET CHARLOTTE, NC 28203
JOHN SMITH 21 JUMP STREET AUSTIN, TX 78701
DEBRA L. FEIT 59 BROADWAY NEW YORK, NY 10006
MEGAN J. ALVORD 9 SOUTH SHORE DRIVE BEVERLY HILLS, CA 90210
GEORGE BERENS 73 WEST FLAGLER MIAMI, FL 33130
GARY FEIN 45 MAIN STREET W CHICAGO, IL 60648
CAROL VAZQUEZ VILAR 9 ROAD TO HANA MAUI, HI 96713

```

**Report Layout:**

```

XXXXXXXXXXXXXXXXXXXX - name
XXXXXXXXXXXXXXXXXXXX - street address
XXXXXXXXXXXXXXXXXXXX XXXXX
 |
 | city & state zip

```

**Processing Requirements:**

1. Read a file of mailing list records.
2. For each record read, create a mailing label. Double-space between each record.

**Project 2-6**

**Program Name:** Church Building Fund Report

**Narrative:** Write a program to print a Church Building Fund Report containing all church members who are behind on their contributions.

**Input File:** CHURCH-BLD-FUND-MSTR-FILE

**Input Record Layout:**

| Church Building Fund Master Record |           |                |           |               |              |
|------------------------------------|-----------|----------------|-----------|---------------|--------------|
| Member Name                        |           | Pledged Amount |           | Member Number | Amount Given |
| 1 ... 15                           | 16 ... 20 | 21 ... 25      | 26 ... 30 | 31 ... 34     | 35 ... 39    |

**Test Data:**

```

JOHN SMITH 00100000T0000100050
ANN LOVING 0020000S00000200025
MARY BROWN 0050000C0A000300500
TOM SAWYER 0007500FG0000400000
JACK CAPPS 0340034000000503400
JILL JACOBS 4000012345000603500
SUSAN CLUB 02000XABCD000702000
MIKE CLOUD 003000FC00000800150

```

**Report Layout:**

|                    |         |         |        |
|--------------------|---------|---------|--------|
| XXXXXXXXXXXXXXXXXX | 99999   | 99999   | 99999  |
| MEMBER             | AMOUNT  | AMOUNT  | GIVEN  |
| NAME               | PLEGDED | TO DATE | AMOUNT |
|                    |         |         | OWED   |

**Processing Requirements:**

1. Read a file of church member building fund master records.
2. For every record read:
  - a. Calculate the AMOUNT OWED = AMOUNT PLEDGED - AMOUNT GIVEN
  - b. Print the church member name, the amount pledged, the amount paid to date, and the amount owed for each church member who owes money to the church. Single-space each line.

**Project 27**

**Program Name:** Telephone Long Distance Carrier Program

**Narrative:** Write a program to process a file of telephone records to produce a report list of customers who are *not* using ET&T as a long distance carrier.

**Input File:** TELEPHONE-FILE

**Input Record Layout:**

| Telephone Record |           |           |                       |
|------------------|-----------|-----------|-----------------------|
| Name             | Area Code | Phone No. | Long Distance Carrier |
| 1 ... 18         | 19 ... 21 | 22 ... 28 | 29 ... 35             |

**Test Data:**

```

MARYANN BARBER 3055557634AT&T
JOEL STUTZ 4076341234ET&T
ROBERT PLANT 3124374962SPRINT
GREGG ELOFSON 2032469368MCI
SARA RUSHINEK 2126662916ET&T
MARK GILLENSON 3163969476TELTEC
DAVID HERTZ 6132463618MCI
JOHN STEWART 8133246846TELTEC

```

**Report Layout:**

|                      |                |               |
|----------------------|----------------|---------------|
| XXXXXXXXXXXXXXXXXXXX | (XXX) XXX-XXXX | XXXXXXX       |
| name                 | area phone #   | long distance |
|                      | code           | carrier       |

- Processing Requirements:**
1. Read a file of telephone records.
  2. For each record read, determine whether the long distance carrier is ET&T or not.
  3. Print the name, complete phone number, and the current long distance carrier of the records that are *not* using ET&T.

**PROGRAMMING SPECIFICATIONS**

**Program Name:** Insurance Policy Holder Report

**Narrative:** Develop a hierarchy chart and either flowchart, pseudocode, or Warnier-Orr diagram for a program to determine which customers have group life insurance policies.

**Input File:** CUSTOMER -INSURANCE-FILE

**Input Record Layout:**

| Customer Insurance Record |   |                              |                                           |                 |
|---------------------------|---|------------------------------|-------------------------------------------|-----------------|
| Customer Number           |   | First Insurance Policy Held  | Effective Date                            | Expiration Date |
| 1 ... 8                   | 9 | 10 ... 11                    | 12 ... 19                                 | 20 ... 27       |
|                           |   | Second Insurance Policy Held | Effective Date                            | Expiration Date |
|                           |   | 28 ... 29                    | 30 ... 37                                 | 38 ... 45       |
|                           |   | Third Insurance Policy Held  | Effective Date                            | Expiration Date |
|                           |   | 46 ... 47                    | 48 ... 55                                 | 56 ... 63       |
|                           |   | First Insurance Policy Rate  | First Insurance Policy Method of Payment  |                 |
|                           |   | 64 ... 68                    | 69                                        |                 |
|                           |   | Second Insurance Policy Rate | Second Insurance Policy Method of Payment |                 |
|                           |   | 70 ... 74                    | 75                                        |                 |
|                           |   | Third Insurance Policy Rate  | Third Insurance Policy Method of Payment  |                 |
|                           |   | 76 ... 80                    | 81                                        |                 |

**Test Data:**

```

513479359GL09101997091019980L0801199608011998HE051519970515199901500A00400Q00025M
423098479SA0428199604281998HE1108199611081997 00010M00300Q
389019749UL0613199706131998GL0101199801012000 00400A00500M
215648239AS0503199605031998XL1210199712102000GL010419970104199900030M00150Q05000A
100245679HE0404199604041998 00500M

```

**Report Layout:**

| USA INSURANCE COMPANY<br>GROUP LIFE POLICY REPORT |                |                 |                |
|---------------------------------------------------|----------------|-----------------|----------------|
| CUSTOMER NUMBER                                   | EFFECTIVE DATE | EXPIRATION DATE | POLICY PREMIUM |
| XXXXXXXX                                          | XX/XX/XXXX     | XX/XX/XXXX      | 9999999        |
| TOTAL GROUP POLICY PREMIUMS                       |                |                 | 99999999       |

- Processing Requirements:**
1. Read a file of customer records.
  2. For every record read:
    - a. Determine whether the customer has a group life insurance policy. Each customer can have as many as three different insurance policies. Check all three policies to determine whether they are group life. A group life insurance policy is indicated with the code 'GL'.
    - b. Calculate the POLICY PREMIUM for each group life insurance policy by checking the METHOD OF PAYMENT field. If the METHOD OF PAYMENT field contains an "M," multiply the rate times 12 (months). If the METHOD OF PAYMENT field contains a "Q," multiply the rate times 4 (quarterly). If the METHOD OF PAYMENT field contains an "A," the rate is the POLICY PREMIUM (annual).
    - c. Accumulate the POLICY PREMIUMS, giving the TOTAL GROUP POLICY PREMIUMS.
    - d. Print the customer number, effective date, expiration date, rate, and policy premium for each customer who has a group life insurance policy. Single-space the output.
  3. After all records have been read, print the total group life policy premiums.

### Project 3-2

**Program Name:** Price Break Report

**Narrative:** This project builds on Project 2-1. Develop the hierarchy chart and either flowchart, pseudocode, or Warnier-Orr diagram to determine whether a customer receives a price break based on quantity ordered, and calculate the unit price and extended price.

**Input file:** ORDER-TRANSACTION-FILE

**Input Record Layout:**

| Order Record  |   |                  |             |    |            |
|---------------|---|------------------|-------------|----|------------|
| Customer Name |   | Quantity Ordered | Item Number |    | Unit Price |
| 1 ... 8       | 9 | 10 ... 12        | 13 ... 17   | 18 | 19 ... 21  |

**Test Data:**

```
513479350005111119105
423098470100212228020
389019740125323337300
215648230500434446340
100245670900545555065
```

**Report Layout:**

|          |        | AUSTIN  | RETAIL | COMPANY  |          |           |
|----------|--------|---------|--------|----------|----------|-----------|
| CUSTOMER | ITEM   | QTY     | UNIT   | EXTENDED | TOTAL    | TOTAL     |
| NUMBER   | NUMBER | ORDERED | PRICE  | PRICE    | QUANTITY | SALES     |
| XXXXXXXX | XXXXX  | 999     | 999    | 999999   | ORDERED  | 999999999 |
|          |        |         |        |          | 999999   |           |

**Processing Requirements:**

1. Read a file of order records.
2. For every record read:
  - a. Determine whether the customer will receive a discount based on the specifications in Project 2-1.
  - b. Calculate the Unit Price by applying the appropriate discount as determined in 2a.
  - c. Calculate the Extended Price by multiplying the Quantity Ordered by the Unit Price.
  - d. Accumulate the Total Quantity Ordered by adding the Quantity Ordered. Accumulate the Total Sales by adding the Extended Price.
  - e. Print the customer number, item number, quantity ordered, unit price (calculated), and extended price for each customer record. Single-space the output.
3. After all records have been read, print the total quantity ordered and the total sales.

**Project 3-3**

**Program Name:** Barcoded Price List

**Narrative:** Develop the hierarchy chart and either flowchart, pseudocode, or Warnier-Orr diagram for a program to create and print a barcoded price list.

**Input File:** ITEM-PRICE-FILE

**Input Record Layout:**

| Item Price Record |                  |            |
|-------------------|------------------|------------|
| Item Number       | Quantity on Hand | Unit Price |
| 1 ... 5           | 6 ... 9          | 10 ... 14  |

**Test Data:**

```

11080105000100
12400120001400
13050001000200
14450020001350
23010010000200
31054100000050
05100006000213
02187090600045
95678002000300
10234001000024

```

**Report Layout:**

| COMPANY ABC BARCODED PRICE LIST |                        |                |               |
|---------------------------------|------------------------|----------------|---------------|
| BARCODED<br>ITEM NUMBER         | BARCODED<br>UNIT PRICE | ITEM<br>NUMBER | UNIT<br>PRICE |
| <99999999>                      | <99999999>             | 99999          | 99999         |
| TOTAL ITEMS:                    | 9999999                |                |               |

**Processing Requirements:**

1. Read a file of price records.
2. For every record read:
  - a. Determine the check digits for the barcoded item number and unit price as follows:

Add each number in the field together and divide by the number of digits being added, then multiply the result by 3.

Place the check digits to the right of the field for 2 positions and place a < to the left of the first digit and > to the right of the last digit.

When the price list prints, a barcode font should be used to cause the appropriate fields to be barcoded (this cannot be done in the lab environment, the fields will just print normal).

For example: ITEM NUMBER = 12345  
check digit =  $1 + 2 + 3 + 4 + 5 = 15$   
 $15/5 = 3$   
 $3 * 3 = 9$   
check digit = 09  
BARCODED ITEM NUMBER = <1234509>

< indicates the beginning of a barcode field and > indicates the end of a barcode field.

Check digits are used to ensure that proper transmission has occurred. The program that uses the data after transmission uses the above algorithm to determine whether the proper data has been sent. If the answer derived does not match the check digits, something was not transmitted properly.
  - b. Increment an accumulator for number of items.
  - c. Print the barcoded item number, barcoded unit price, item number, and unit price.
3. After all records have been read, print the total items.

**Project 3-4**

**Program Name:** Savings Dividends

**Narrative:** Develop the hierarchy chart and either flowchart, pseudocode, or Warnier-Orr diagram for a program to process a file of savings account records and compute and print a dividend report for each account and a total. The Identification, Environment, and Data Divisions for this project can be developed after Chapter 4. Completion of the project requires you to finish Chapter 5 in order to do the Procedure Division.

**Input File:** SAVINGS-FILE

**Input Record Layout:**

| Savings Record |          |          |       |
|----------------|----------|----------|-------|
| Account No.    | Name     | Amount   | Term  |
| 1 ... 8        | 9 ... 24 | 25 .. 31 | 32 33 |

**Test Data:**

|                 |           |
|-----------------|-----------|
| 11000-01MILGROM | 004556018 |
| 23000-05PETERS  | 003067016 |
| 31001-02SMITH   | 002589012 |
| 43045-03JONES   | 006988024 |
| 51005-01VILLAR  | 000455006 |
| 35010-02HANSEN  | 010936036 |

**Report Layout:**

| ACCOUNT NUMBER | NAME               | SAVINGS AMOUNT | DIVIDEND PAID | TOTAL SAVINGS |
|----------------|--------------------|----------------|---------------|---------------|
| XXXXXXXX       | XXXXXXXXXXXXXXXXXX | 9999999        | 9999999       | 99999999      |
| TOTALS         |                    | 99999999       | 99999999      | 999999999     |

**Processing Requirements:**

1. Print a heading at the beginning of the report.
2. Read a file of savings account records.
3. Process each record read by:
  - a. Determining the interest rate as follows:
    - (1) 6% interest on terms of 6 months or less.
    - (2) 7% interest on terms of more than 6 months but less than 12.
    - (3) 8% interest on terms of more than 12 months but less than 18.



- (4) 9% interest on terms of more than 18 months but less than 24.
  - (5) 10% interest on terms of more than 24 months but less than 30.
  - (6) 12% interest on terms of more than 30 months.
- b. Calculating the dividend to be paid by multiplying the amount by the interest rate.
  - c. Calculating the total savings by adding the interest to be paid to the account amount.
  - d. Incrementing savings totals for savings amount, dividend paid, and total savings.
  - e. Printing a detail line for each record read.
4. Print a total line at the end of the report.

### Project 3-5

**Program Name:** Evaluation of Student Curriculum Records

**Narrative:** Develop the hierarchy chart and either flowchart, pseudocode, or Warnier-Orr diagram for a program to evaluate a student's curriculum record and determine the percentage of courses a student has left in order to graduate, the percentage of courses a student has transferred, the percentage of courses for which a student has been awarded proficiency credit, and the percentage of courses a student has completed.

**Input File:** STUDENT-CURRICULUM-FILE

**Input Record Layout:**

| Student Curriculum Record |                 |                 |         |
|---------------------------|-----------------|-----------------|---------|
| Student Id Number         | Course Number 1 | Grade 1         |         |
| 1 ... 5                   | 6 ... 12        | 13              |         |
| Course Number 2           | Grade 2         | Course Number 3 | Grade 3 |
| 14 ... 20                 | 21              | 22 ... 28       | 29      |
| Course Number 4           | Grade 4         | Course Number 5 | Grade 5 |
| 30 ... 36                 | 37              | 38 ... 44       | 45      |
| Course Number 6           | Course Grade 6  | Number 7        | Grade 7 |
| 46 ... 52                 | 53              | 54 ... 60       | 61      |
| Course Number 8           | Course Grade 8  | Number 9        | Grade 9 |
| 62 ... 68                 | 69              | 70 ... 76       | 77      |
| Course Number 10          | Grade 10        |                 |         |
| 78 ... 84                 | 85              |                 |         |

**Test Data:**

```

12345COMP110AENGL110 MATH148KMATH168PCIS150 FCIS230 PSYC105BBUSN110AHUMN410PHUMN420A
34567ENGL110CENGL120 MATH048CMATH210DCI'S150 PCIS230 ACIS330
78921BUSN110 BUSN120 ENGL110AENGL120PMATH048KMATH168BMATH220
34678PSYC105APSYC305 ENGL110AENGL120 ECON210AHUMN410KHUMN420PHUMN430AACCT213AACCT347
47830SPCH275AENGL110 ACCT205AACCT210PACCT347K

```

**Report Layout:**

| UNIVERSITY OF NOWHERE         |           |                       |             |             |
|-------------------------------|-----------|-----------------------|-------------|-------------|
| STUDENT CURRICULUM EVALUATION |           |                       |             |             |
| STUDENT ID                    |           | PERCENTAGE OF COURSES |             |             |
| NUMBER                        | COMPLETED | REMAINING             | TRANSFERRED | PROFICIENCY |
| XXXXX                         | 999       | 999                   | 999         | 999         |

**Processing Requirements:**

1. Read a file of student curriculum records.
2. For every record read:
  - a. Add the total number of courses (course name, not spaces) for each student (a maximum of 10).
  - b. Add the total number of courses where the student was awarded a grade (A, B, C, or D), proficiency (P), or transfer credit (K).
  - c. Add the total number of courses where the student was awarded transfer credit (K).
  - d. Add the total number of courses where the student was awarded proficiency credit (P).
  - e. Determine the percentages of courses left in order to graduate, courses completed, courses transferred, and courses awarded proficiency credit.
  - f. Print student id number and the percentages of courses left in order to graduate, courses completed, courses transferred, and courses awarded proficiency credit.



**Program Name:** Inventory Parts List

**Narrative:** Develop the hierarchy chart and either flowchart, pseudocode, or Warnier-Orr diagram for a program to produce an inventory report. The Identification, Environment, and Data Divisions for this project can be developed after Chapter 4. Completion of the project requires you to finish Chapter 5 in order to do the Procedure Division.

**Input File:** INVENTORY-FILE

**Input Record Layout:**

| Inventory Record |                  |                 |                |            |
|------------------|------------------|-----------------|----------------|------------|
| Part Name        | Quantity on Hand | Amount Received | Amount Shipped | Unit Price |
| 1 ... 20         | 21 ... 23        | 24 ... 26       | 27 ... 29      | 30 ... 33  |

**Test Data:**

```

WIDGETS, SIZE S 1500500960070
WIDGETS, SIZE M 2000750760080
WIDGETS, SIZE L 0005004000090
WHOSIWHATSIS 3501100460100
GIZMOS, TYPE A 2500800360200
GIZMOS, TYPE B 0000500250300
GADGETS, SIZE S 0250180260015
GADGETS, SIZE L 0900280350025

```

**Report Layout:**

| *** INVENTORY REPORT ***     |                      |          |         |                   |               |                |
|------------------------------|----------------------|----------|---------|-------------------|---------------|----------------|
| PART NAME                    | BEGINNING<br>ON HAND | RECEIVED | SHIPPED | ENDING<br>ON HAND | UNIT<br>PRICE | TOTAL<br>VALUE |
| XXXXXXXXXXXXXXXXXX           | 999                  | 999      | 999     | 999               | 9999          | 99999999       |
| TOTAL VALUE OF ALL INVENTORY |                      |          |         |                   |               | 99999999       |

**Processing Requirements:**

1. Read a file of inventory records, and for every record read:
  - a. Determine the quantity on hand at the end of the period. This is equal to the quantity on hand at the start of the period (contained in the input record), plus the amount received, minus the amount shipped.
  - b. Determine the value of the inventory on hand at the end of the period. This is equal to the unit price (contained in the input record) multiplied by the quantity on hand at the end of the period [computed in part a.].
  - c. Print a detail line for every part containing the part name, quantity on hand at the beginning of the period, the amount shipped, the amount received, the quantity on hand at the end of the period, the unit price, and the value of the inventory at the end of the period. Double-space detail lines.
2. When all records have been read, print the total value of all inventory on hand at the end of the period.

**Project 37****Program Name:** Money Changer

**Narrative:** The ACME Widget Corporation has decided to pay its employees in cash rather than by check. Develop the hierarchy chart and either flowchart, pseudocode, or Warnier-Orr diagram for a program to read a file of payroll amounts and determine the required number of bills in each denomination. The Identification, Environment, and Data Divisions for this project can be developed after Chapter 4. Completion of the project requires you to finish Chapter 5 in order to do the Procedure Division.

**Input File:** PAYROLL-FILE

**Input Record Layout:**

| Payroll Record |     |    |             |     |              |
|----------------|-----|----|-------------|-----|--------------|
| Employee Name  |     |    | Soc Sec No. |     | Gross Pay    |
| 1              | ... | 18 | 19          | ... | 27 28 ... 30 |

**Test Data:**

```

JOHN SMITH 123456789350
JESSICA GRAUER 333444555475
CHANDLER LAVOR 987654321178
JEFFRY BOROW 777668888219
MARION MILGROM 999887777341
LYNN FRANKEL 492336789492
KARL KARLSTROM 333228888314
KATHY MARSHAK 245347878368
RHODA HAAS 111111111305
JIM FEGEN 222222222522
MARIO VILLAR 33333333378

```

**Report Layout:**

| EMPLOYEE NAME        |             | \$100 | \$50 | \$20 | \$10 | \$5 | \$1 | PAY |
|----------------------|-------------|-------|------|------|------|-----|-----|-----|
| XXXXXXXXXXXXXXXXXXXX | XXX-XX-XXXX | 9     | 9    | 9    | 9    | 9   | 9   | 999 |
| XXXXXXXXXXXXXXXXXXXX | XXX-XX-XXXX | 9     | 9    | 9    | 9    | 9   | 9   | 999 |
| TOTALS               |             | 99    | 99   | 99   | 99   | 99  | 99  | 999 |

**Processing Requirements:**

1. Read a file of employee pay records.
2. For each record read:
  - a. Determine the number of bills of each denomination required to pay the employee in cash, rather than by check. (Do not include cents in your computation.)
  - b. Use denominations of \$100, \$50, \$20, \$10, \$5, and \$1. Pay employees in the highest denominations possible; e.g., an employee with a gross pay of \$300 should be paid with three \$100 bills rather than six \$50 bills.
  - c. Maintain a running total of the total payroll as well as the number of bills in each denomination for the company as a whole.
  - d. Print a detail line for each employee according to the report format. Double-space detail lines.
3. When all records have been read, print a total line for the company according to specification 2c. above.

**Project 3-3****Program Name:** Real Estate Sales

**Narrative:** Develop the hierarchy chart and either flowchart, pseudocode, or Warnier-Orr diagram for a program to process a file of real estate records and produce a monthly report based on transaction types, commissions paid, and summary. The Identification, Environment, and Data Divisions for this project can be developed after Chapter 4. Completion of the project requires you to finish Chapter 5 in order to do the Procedure Division.

The sales commission on any real estate sale is 6 percent of the total sale and is divided equally between the listing and selling agencies. This produces three possible sales types, which in turn determine the commissions paid to the company and its agents.

1. *The company both sells and lists the property (CO-CO).* The agent who listed the property receives 25 percent of the total (6 percent) commission, and the remaining 75 percent of the commission is divided equally (50 percent each) between the agent who sold the property and the company.
2. *The company sells the property listed by an outside agency (CO-OUT).* The agent who sells the property listed by an outside agency receives 70 percent of the commission due to the company (the commission due to the company is 3 percent of the total sales price, or one half of the total 6 percent commission). The company retains the remaining 30 percent of the 3 percent commission to the selling agency.
3. *An outside agency sells the property that was listed by the company (OUT-CO).* The company receives 50 percent of the sales commission (3 percent of the total price), which is split equally between the company and the listing agent.

**Input File:** REAL-ESTATE-FILE**Input Record Layout:**

| Real Estate Record |       |       |       |           |        |           |        |           |        |
|--------------------|-------|-------|-------|-----------|--------|-----------|--------|-----------|--------|
| Salesperson        | Date  |       |       | CO-CO     |        | CO-OUT    |        | OUT-CO    |        |
|                    | Month | Day   | Year  | Amount    | Status | Amount    | Status | Amount    | Status |
| 1 ... 12           | 13 14 | 15 16 | 17 18 | 19 ... 24 | 25     | 26 ... 31 | 32     | 33 ... 38 | 39     |

**Test Data:**

|         |                             |
|---------|-----------------------------|
| ALVORD  | 080393138500C000000123900K  |
| VILLAR  | 080593215500C130300C234000C |
| VAZQUEZ | 080593345500C123000C273400C |
| GARCIA  | 080893134500K145000C295600C |
| GRAUER  | 081093234000C395000C124400K |
| ALVORD  | 081293000000230000C234000K  |
| VAZQUEZ | 081593138500K234000K0000000 |
| GARCIA  | 081793245000C123000C398400K |
| VILLAR  | 081894345000C000000278400C  |
| GRAUER  | 082193234500C145500K225000C |
| GARCIA  | 082293245500V178000C298600K |
| GRAUER  | 083093263500C000000169600C  |
| ALVORD  | 083193423000C130000K247000C |

**Report Layout:**

| LOTSA HOUSES REALTY COMPANY |              |                             |                                  |                            |
|-----------------------------|--------------|-----------------------------|----------------------------------|----------------------------|
| DATE                        | SALESPERSON  | PROPERTY SOLD<br>CO LISTING | PROPERTY SOLD<br>OUTSIDE LISTING | OUTSIDE SALE<br>CO LISTING |
| MM/DD                       | XXXXXXXXXXXX | 999999                      | 999999                           | 999999                     |
| TOTAL SALES:                |              | 9999999                     | 9999999                          | 9999999                    |
| GROSS TO LOTSA:             |              | 9999999                     | 9999999                          | 9999999                    |
| COMMISSIONS PAID:           |              | 9999999                     | 9999999                          | 9999999                    |
| NET TO LOTSA:               |              | 9999999                     | 9999999                          | 9999999                    |
| MONTHLY SUMMARY             |              |                             |                                  |                            |
| TOTAL SALES:                |              | 9999999                     |                                  |                            |
| COMMISSIONS PAID:           |              | 9999999                     |                                  |                            |
| NET TO LOTSA:               |              | 9999999                     |                                  |                            |

- Processing Requirements:**
1. Print the appropriate report headings as shown in the report layout.
  2. Read a file of real estate records and process each record read by:
    - a. Incrementing each of the three sales type totals with closed sales only. A closed sale is denoted by a "C" in the appropriate STATUS field.
    - b. Printing a detail line of the closed sales for each sales type.
  3. For all three sales types:
    - a. Process the total sales by:
      - (1) Printing the total sales for each of the three types of sale.
    - b. Process the gross commission to the company by:
      - (1) Calculating the gross commissions to the company for each of the three sales types as described in the program narrative.
      - (2) Printing the calculated gross commissions for each sales type.
    - c. Process the commissions paid by:
      - (1) Calculating the commissions paid for each of the three sales types as described in the program narrative.
      - (2) Printing the calculated commissions paid for each sales type.
    - d. Process the net commissions to the company by:
      - (1) Calculating the net commissions to the company for each of the three sales types as described in the program narrative.
      - (2) Printing the calculated net commissions for each sales type.
  4. Process the monthly summary by:
    - a. Printing the total sales for the month.
    - b. Printing the total commission paid for the month.
    - c. Printing the total net commission to the company for the month.

**PROGRAMMING SPECIFICATIONS****Projects 4-1 through 4-8**

**Program Name:** Insurance Policy Holder Report, Price Break Report, Barcoded Price List, Savings Dividends, Evaluation of Student Curriculum Records, Inventory Parts List, Money Changer, and Real Estate Sales

**Narrative:** The specifications for these projects were introduced in Chapter 3, at which time you were to attempt the hierarchy charts, pseudocode, flowcharts, and/or Warnier-Orr diagrams. Now we ask you to develop the Identification, Environment, and Data Divisions, but completion of the projects requires you to finish Chapter 5 in order to do the Procedure Division.

**PROGRAMMING SPECIFICATIONS****Projects 5-1 through 5-8**

**Program Name:** Insurance Policy Holder Report, Price Break Report, Barcoded Price List, Savings Dividends, Evaluation of Student Curriculum Records, Inventory Parts Lists, Money Changer, and Real Estate Sales

**Narrative:** The specifications for these projects were introduced in Chapter 3, at which time you were to attempt the hierarchy charts, pseudocode, flowcharts, and/or Warnier-Orr diagrams. Completion of Chapter 4 enabled you to code the first three COBOL divisions. Now you are expected to develop the Procedure Division and complete the projects.

**PROGRAMMING SPECIFICATIONS****Project 7-1**

**Program Name:** Insurance Policy Holder Report

**Narrative:** The specifications for this project were introduced in Chapter 3. Change the input record to include two decimal places in the policy premium. Use COBOL's editing facility to dress up the reports produced by these changes. Redo the report layout, using any editing features you deem appropriate.

**Input File:** CUSTOMER-INSURANCE-FILE

**Input Record Layout:** Use the record layout from Chapter 3.

**Test Data:** Use the test data from Chapter 3.

**Original Report Layout:** Use the Report Layout from Project 3-1 and modify it to look good, using the editing facility (\$, commas, decimal points, etc.).

| USA INSURANCE COMPANY       |                |                 |                |
|-----------------------------|----------------|-----------------|----------------|
| GROUP LIFE POLICY REPORT    |                |                 |                |
| CUSTOMER NUMBER             | EFFECTIVE DATE | EXPIRATION DATE | POLICY PREMIUM |
| XXXXXXXX                    | XX/XX/XXXX     | XX/XX/XXXX      | 9999999        |
| TOTAL GROUP POLICY PREMIUMS |                |                 | 99999999       |

**Project 7-2**

**Program Name:** Price Break Report

**Narrative:** The specifications for this project were introduced in Chapter 3. The input record and data file have been updated to include two decimal places in the unit price, which requires that the extended price be extended to two decimal places as well. Use COBOL's editing facility to dress up the reports produced by these changes. Redo the report layout, using any editing features you deem appropriate.

**Input File:** ORDER-TRANSACTION-FILE

**Input Record Layout:**

| Order Record    |   |                  |             |    |                    |
|-----------------|---|------------------|-------------|----|--------------------|
| Customer Number |   | Quantity Ordered | Item Number |    | Unit Price         |
| 1 ... 8         | 9 | 10 ... 12        | 13 ... 17   | 18 | 19 (2 decimals) 23 |

**Test Data:**

```

10000001000511111910534
20000002010021222802056
30000003012532333730045
40000004050043444634021
50000005090054555556578
10000001001513456913534
20000002001021234801056
30000003010034321733045
40000004040044324637021
50000005070042456556578
10000001006041111915534
20000002002556622804056
30000003031531133733045
40000004040024214632021
50000005078016455551578

```

**Report Layout:** Use the Report Layout from Project 3-2 and modify it to look good, using the editing facility (\$, commas, decimal points, etc.).



## Project 7-3

**Program Name:** Payroll Program

**Narrative:** Write a program to process a file of employee records, compute and print individual payroll calculations, and compute and print the company totals. The processing specifications are straightforward, but you will have to think about the logic for computing the gross pay and withholding tax. We suggest, therefore, that you begin with pseudocode and a hierarchy chart.

**Input File:** EMPLOYEE-FILE

**Input Record Layout:**

| Employee Record |     |   |      |     |          |    |             |                 |              |                    |  |
|-----------------|-----|---|------|-----|----------|----|-------------|-----------------|--------------|--------------------|--|
| Soc Sec No.     |     |   | Name |     |          |    | Hourly Rate |                 | Hours Worked |                    |  |
|                 |     |   | Last |     | Initials |    |             |                 |              |                    |  |
| 1               | ... | 9 | 10   | ... | 22       | 23 | 24          | 25 (2 decimals) |              | 30 (2 decimals) 33 |  |

**Test Data:**

| 1                                                                 | 2        | 3  | 4         | 5 | 6 |
|-------------------------------------------------------------------|----------|----|-----------|---|---|
| 12345678901234567890123456789012345678901234567890123456789012345 |          |    |           |   |   |
| 111111111                                                         | GRAUER   | RT | 010253550 |   |   |
| 222222222                                                         | JONES    | JJ | 015004075 |   |   |
| 333333333                                                         | MILGROM  | EA | 005754550 |   |   |
| 444444444                                                         | RICHARDS | IM | 011005000 |   |   |
| 555555555                                                         | JEFFRIES | JB | 055503025 |   |   |
| 666666666                                                         | STEVENS  | SS | 007803500 |   |   |
| 777777777                                                         | BROWN    | BB | 080252550 |   |   |
| 888888888                                                         | BAKER    | ED | 025453075 |   |   |
| 999999999                                                         | SUGRUE   | PK | 015352500 |   |   |
| 000000000                                                         | VAZQUEZ  | C  | 040505025 |   |   |

**Report Layout:** Design any suitable report layout that includes one or more heading lines, a detail line for each employee, and a total line at the end of the report. Use editing characters as appropriate.

**Additional Requirements:**

- Print a suitable heading line at the beginning of the report.
- Read a file of employee pay records.
- For every record read,
  - Calculate the gross pay as follows:
 

*Change:*  
*To:*  
Straight time for the first 40 hours  
Time and a half for the next 8 hours (more than 40 and up to 48 hours)  
Double time for anything over 48 hours
  - Calculate federal withholding tax as follows:
    - 18% on first \$200 of gross
    - 20% on amounts between \$200 and less than \$240
    - 22% on amounts between \$240 and less than \$280
    - 24% on amounts over \$280
  - Calculate net pay as gross pay minus federal tax.



- d. Print a detail line for each employee, with suitable editing in all fields. Double-space detail lines.
  - e. Increment company totals for gross pay, federal withholding, and net pay.
4. When all records have been read, print the company totals for all items in part 3e.

**Project 7-4**

**Program Name:** Extended Savings Dividends

**Narrative:** The specifications for this project were introduced in Chapter 3. The input record and data file have been updated to include two decimal places in the amount field, mandating a similar change in the fields for the dividend and total savings. Use COBOL's editing facility to appropriately dress up the reports produced by these changes. Redo the report layout, using any editing features you deem appropriate.

**Input File:** SAVINGS-FILE

**Input Record Layout:**

| Savings Record |     |      |   |    |        |                 |       |
|----------------|-----|------|---|----|--------|-----------------|-------|
| Account No.    |     | Name |   |    | Amount |                 | Term  |
| 1              | ... | 8    | 9 | 25 | 26     | (2 decimals) 34 | 35 36 |

**Test Data:**

|                 |             |
|-----------------|-------------|
| 11000-01MILGROM | 00450000518 |
| 23000-05PETERS  | 00300000016 |
| 31001-02SMITH   | 00258005712 |
| 43045-03JONES   | 00698009024 |
| 51005-01VILLAR  | 00045003906 |
| 35010-02HANSEN  | 01090002936 |

**Report Layout:** Use the Report Layout from Project 3-4 and modify it to look good, using the editing facility (\$, commas, decimal points, etc.). Don't forget to show the calculated average from additional processing requirement two.

**Additional Requirements:** 1. As an aid in maintainability, define the six interest rates in Working-Storage and use these data names in your calculations instead of the raw percentage rates. For example, for a six month or less account term, change the computation

```
Change: COMPUTE IND-DIVIDEND-PAID = SAV-AMOUNT * .06
```

```
To: COMPUTE IND-DIVIDEND-PAID = SAV-AMOUNT * UPTO-6MO-RATE
```

where UPTO-6MO-RATE is defined in Working-Storage with a value of .06.

2. Calculate and print the average savings amount for all savings accounts processed.
3. The savings amount has been extended to two decimal places; extend all other calculated amounts to two decimal places as well.

Update the program and verify your results, then make the following changes. (Hint: You should need to change each rate in only one place in the program.)

- (1) 7% interest on 6 months or less.
- (2) 8% interest on more than 6 months but up to 12.
- (3) 9% interest on more than 12 months but up to 18.
- (4) 10% interest on more than 18 months but up to 24.
- (5) 11% interest on more than 24 months but up to 30.
- (6) 14% interest on more than 30 months.

**Project 7-5**

**Program Name:** Church Building Fund Report

**Narrative:** The specifications for this project were introduced in Project 2-6. The input record and data file have been updated to include two decimal places in the unit price field, mandating a similar extension in the total value. Use COBOL's editing facility to dress up the report. Redo the report layout, using any editing features you deem appropriate. Add total amount pledged, given, and owed. Print all church members, not just those owing money.

**Input File:** CHURCH-BLD-FUND-MSTR-FILE

**Input Record Layout:**

| Church Building Fund Master Record |           |                |           |               |              |
|------------------------------------|-----------|----------------|-----------|---------------|--------------|
| Master Name                        |           | Pledged Amount |           | Member Number | Amount Given |
| 1 ... 15                           | 16 ... 20 | 21 ... 27      | 28 ... 30 | 31 ... 34     | 35 ... 41    |

**Test Data:**

```

JOHN SMITH 00100550T000010005000
ANN LOVING 0020050S0000020002550
MARY BROWN 0050000C0A00030050000
TOM SAWYER 0007500FG000040000000
JACK CAPPS 0340034000000050340034
JILL JACOBS 400001234500060350000
SUSAN CLUB 0200025BCD00070200025
MIKE CLOUD 0030030C0000080015000

```

**Project 7-7**

**Program Name:** Inventory Parts List

**Narrative:** The specifications for this project were introduced in Chapter 3. The input record and data file have been updated to include two decimal places in the unit price field, mandating a similar extension in the total value. Use COBOL's editing facility to dress up the reports produced by these changes. Redo the report layout, using any editing features you deem appropriate.

**Input File:** INVENTORY-FILE

**Input Record Layout:**

| Inventory Record |                  |                 |                |                    |
|------------------|------------------|-----------------|----------------|--------------------|
| Part Name        | Quantity on Hand | Amount Received | Amount Shipped | Unit Price         |
| 1 ... 20         | 21 ... 23        | 24 ... 26       | 27 ... 29      | 30 (2 decimals) 35 |

**Test Data:**

```

WIDGETS, SIZE S 150050096007050
WIDGETS, SIZE M 200075076008075
WIDGETS, SIZE L 000500400009034
WHOSIWHATSIS 350110046010000
GIZMOS, TYPE A 250080036020055
GIZMOS, TYPE B 000050025030087
GADGETS, SIZE S 025018026001599
GADGETS, SIZE L 090028035002565

```

**Project 7-7**

**Program Name:** Money Changer

**Narrative:** The specifications for this project were introduced in Chapter 3. The input record and data file have been updated to include 2 decimal places in the gross pay field; accordingly extend the pay to 2 decimal places. Use COBOL's editing facility to appropriately dress up the reports produced by these changes. Accordingly redo the report layout, using any editing features you deem appropriate.

**Input File:** PAYROLL-FILE

**Input Record Layout:**

| Payroll Record |             |                    |
|----------------|-------------|--------------------|
| Employee Name  | Soc Sec No. | Gross Pay          |
| 1 ... 18       | 19 ... 27   | 28 (2 decimals) 32 |

**Test Data:**

|                |                |
|----------------|----------------|
| JOHN SMITH     | 12345678935050 |
| JESSICA GRAUER | 33344455547577 |
| CHANDLER LAVOR | 98765432117855 |
| JEFFRY BOROW   | 77766888821983 |
| MARION MILGROM | 99988777734122 |
| LYNN FRANKEL   | 49233678949237 |
| KARL KARLSTROM | 33322888831444 |
| KATHY MARSHAK  | 24534787836828 |
| RHODA HAAS     | 11111111130598 |
| JIM FEGEN      | 22222222252244 |
| MARIO VILLAR   | 3333333337869  |

**Processing Requirements:** Extend the calculations to determine the proper number of coins with which to pay the individual. Use quarters, dimes, nickels, and pennies in your computations.

**Project 7-8**

**Program Name:** Extended Real Estate Sales

**Narrative:** The specifications for this project were introduced in Chapter 3. Use COBOL's editing facility to dress up the reports produced by these changes. Redo the report layout, using any editing features you deem appropriate.

**Input File:** REAL-ESTATE-FILE

**Input Record Layout:** Same as project 3-8

**Report Layout:** Use the Report Layout from Project 3-8 and modify it to look good, using the editing facility (\$, commas, decimal points, etc.).

**Processing Requirements:**

1. As an aid in maintainability, define the gross and commission rate for all three sales types in Working-Storage and use these data names in your calculations. For example, change the gross to company

*Change:* COMPUTE TOT-GROSS-CO-CO = TOT-SALES-CO-CO \* .06

*To:* COMPUTE TOT-GROSS-CO-CO = TOT-SALES-CO-CO \*  
GROSS-CO-CO-RATE

where GROSS-CO-CO-RATE is defined in Working-Storage with a value of .06.

2. Print the gross percent to the company for each of the three sales types as shown on the report layout.
3. Print the commission percent paid out for each of the three sales types as shown on the report layout.

Update the program and verify your results, then make the following changes. (Hint: You should need to change each rate in only one place in the program.)

The sales commission on any real estate sale is 8 percent of the total sale and is divided equally between the listing and selling agencies. This produces three possible sales types, which in return determine the commissions paid to the company and its agents.

1. *The company both sells and lists the property (CO-CO).* The agent who listed the property receives 35 percent of the total (8 percent) commission, and the remaining 65 percent of the commission is divided equally (50 percent each) between the agent who sold the property and the company.
2. *The company sells the property listed by an outside agency (CO-OUT).* The agent who sells the property listed by an outside agency receives 60 percent of the commission due to the company (the commission due to the company is 4 percent of the total sales price, or one half of the total 8 percent commission). The company retains the remaining 40 percent of the 4 percent commission to the selling agency.
3. *An outside agency sells the property that was listed by the company (OUT-CO).* The company receives 50 percent of the sales commission (4 percent of the total price), which is split equally between the company and the listing agent.

**Project 7-9**

**Program Name:** Car Sales Program

**Narrative:** Develop the hierarchy chart and either flowchart or pseudocode for a program to process a file of car sales records to produce a commission report.

**Input File:** CAR-SALES-FILE

**Input Record Layout:**

| Car Sales Record |     |                  |   |      |       |     |              |                   |            |    |             |     |    |    |     |    |    |     |    |
|------------------|-----|------------------|---|------|-------|-----|--------------|-------------------|------------|----|-------------|-----|----|----|-----|----|----|-----|----|
| Invoice No.      |     | Type Information |   |      |       |     |              | Sales Information |            |    |             |     |    |    |     |    |    |     |    |
|                  |     | Year             |   | Make | Model |     | Asking Price |                   | Sold Price |    | Salesperson |     |    |    |     |    |    |     |    |
| 1                | ... | 5                | 6 | 7    | 8     | ... | 18           | 19                | ...        | 31 | 32          | ... | 37 | 38 | ... | 43 | 44 | ... | 50 |

**Test Data:**

```

7817592NISSAN PATHFINDER 012996011999WILLCOX
1485190ACURA LEGEND COUPE 015990014567SCHULZ
5747693CHEVROLET CORVETTE ZR1 044988040100MORIN
5868192BMW 535I 027990026200TORRES
8564493LOTUS ESPRIT 073500073250WENDEL
8746588FERRARI TESTAROSSA 105000097500FIXLER
2548991NISSAN 300ZX 009682008714JONES
2554493RANGEROVER 4 DOOR 029775027860MORIN
7246293MERCEDES 560SEC 068900066900CULVER
5684393CADILLAC FLEETWOOD 019988018999TORRES
1574688ROLLS ROYCE CORNICHE 079500070599WILLCOX
1484284FERRARI 308GTB 048500046299FIXLER
2558593JAGUAR XJS CONV 040000035650CULVER
4791491ALFA ROMEO SPYDER 012000011298WENDEL
2853293LEXUS LS400 038988037988SCHULZ
1654190PORSCHE 911 CABRIOLET 037988035988JONES

```

**Report Layout:**

| VERY VERY NICE CARS, INC.<br>COMMISSION REPORT |             |          |              |              |              |             |             |           |               |
|------------------------------------------------|-------------|----------|--------------|--------------|--------------|-------------|-------------|-----------|---------------|
| INVOICE #                                      | SALESPERSON | CAR YEAR | CAR MAKER    | CAR MODEL    | ASKING PRICE | PRICE SOLD  | % OF ASKING | COMM PAID | NET TO DEALER |
| ZZZZ9                                          | XXXXXXX     | 99       | XXXXXXXXXXXX | XXXXXXXXXXXX | 222,229      | 222,229     | 99          | 22,229    | 222,229       |
|                                                |             |          |              |              |              | -----       |             | -----     | -----         |
|                                                |             |          |              |              |              | \$2,222,229 |             | \$222,229 | \$2,222,229   |

**Processing Requirements:**

- Print a heading at the beginning of the report.
- Read a file of Car Sales records.
- For each record read:
  - Calculate the percent of the asking price at which the car was sold. For example, a \$10,000 car which sold for \$9,500, sold for 95% of the asking price. Note: Allow for decimal places in your calculations, but do not print them in your report as shown in the report layout.
  - Calculate the commission paid to the salesperson as follows:
    - For any car sold above 95 percent of the asking price the salesperson receives a 5% commission rate. In addition, the salesperson is paid a bonus equal to 40% of the amount in excess of 95%. For example, a \$10,000 car selling at \$9,800 yields a commission of \$610.00 (\$490.00 + \$120.00).
    - For any car sold between 90 and 95 percent of the asking price the salesperson's 5% commission is reduced by 10% for every percentage point below 95%. For example, a \$10,000 car selling at \$9,400 results in 94% of the asking price and a 4.5% commission rate; therefore the commission paid is \$423.00.
    - For any car sold below 90 percent of the asking price the amount below 90% comes straight out of the salesperson's remaining commission at the 90% level as calculated in paragraph (2)—that is, 2.5% of the asking price is all that's left to play with. For example, a \$10,000 car selling at \$8,900 yields a commission of only \$122.50 (\$222.50 - \$100.00).
  - Calculate the Net to the Dealer, assuming the dealer's markup is 25%—that is, the asking price is the dealer's cost plus 25%. For example, a \$10,000 car selling at \$9,400 yields a net of \$977.00 since the cost to the dealer was \$8000.00.
  - Print a detail line for each record. Double-space all detail lines.
  - Increment appropriate totals as shown on the report layout.
- As an aid in maintainability, define the 5% commission rate, the 40% bonus rate, 95% upper level, 90% lower level, the 10% reduction per percentage point below the lower level, and the 25% markup as constants in Working-Storage. Use the corresponding data names in your calculations instead of the actual values. For example:

```
To: COMPUTE IND-BONUS ROUNDED = BONUS-RATE * CAR-ASKING-
 PRICE * (IND-PERCENT-ASKING - UPPER-LEVEL)

 COMPUTE IND-COMM-PAID ROUNDED = CAR-PRICE-SOLD
 * COMM-RATE + IND-BONUS
```

5. **The Final Challenge!** Once you have verified that your program works with the original rates, determine what effect a 6% commission rate, a 50% bonus, a 15% reduction for every percentage point below the upper level, and a 30% markup would have on the net to the dealer as well as commissions paid by making the appropriate changes in Working-Storage and rerunning the program. Make sure you hand in both reports (.RPT). If this was *your* dealership, which rates would you choose?
6. Print the totals when all records have been processed.

## PROGRAMMING SPECIFICATIONS

**Program Name:** Order Transaction File Validation

**Narrative:** Write a data validation program that will validate an order transaction file.

**Input File:** ORDER-TRANSACTION-FILE

**Input Record Layout:**

|    |                         |                |              |
|----|-------------------------|----------------|--------------|
| 01 | ORDER-ENTRY-TYPE-1-REC. |                |              |
| 05 | REC-TYPE-1              |                | PIC X.       |
| 05 | CUSTOMER-NO-1.          |                |              |
|    | 10                      | REGION-1       | PIC X.       |
|    | 10                      | REST-CUST-NO-1 | PIC X(5).    |
| 05 | PURCH-ORDER-NO-1        |                | PIC X(5).    |
| 05 | PURCHASE-DATE.          |                |              |
|    | 10                      | PURCHASE-MM    | PIC 99.      |
|    | 10                      | PURCHASE-DD    | PIC 99.      |
|    | 10                      | PURCHASE-YYYY  | PIC 9999.    |
| 05 | PARTIAL-SHIP-IND        |                | PIC X.       |
| 05 | TAXABLE-IND             |                | PIC X.       |
| 05 | HOLD-DELIVERY-DATE.     |                |              |
|    | 10                      | HOLD-DEL-MM    | PIC 99.      |
|    | 10                      | HOLD-DEL-DD    | PIC 99.      |
|    | 10                      | HOLD-DEL-YYYY  | PIC 9999.    |
| 01 | ORDER-ENTRY-TYPE-2-REC. |                |              |
| 05 | REC-TYPE-2              |                | PIC X.       |
| 05 | CUSTOMER-NO-2.          |                |              |
|    | 10                      | REGION-2       | PIC X.       |
|    | 10                      | REST-CUST-NO-2 | PIC X(5).    |
| 05 | PURCH-ORDER-NO-2        |                | PIC X(5).    |
| 05 | CUSTOMER-NAME           |                | PIC X(15).   |
| 05 | CUSTOMER-ADDRESS        |                | PIC X(15).   |
| 05 | CUSTOMER-ZIP            |                | PIC 9(5).    |
| 05 | CREDIT-LIMIT            |                | PIC 9.       |
| 05 | BALANCE-DUE             |                | PIC 9(5)V99. |
| 05 | PHONE-NUMBER            |                | PIC X(12).   |
| 01 | ORDER-ENTRY-TYPE-3-REC. |                |              |
| 05 | REC-TYPE-3              |                | PIC X.       |
| 05 | CUSTOMER-NO-3.          |                |              |
|    | 10                      | REGION-3       | PIC X.       |
|    | 10                      | REST-CUST-NO-3 | PIC X(5).    |



|    |                  |                  |              |
|----|------------------|------------------|--------------|
| 05 | PURCH-ORDER-NO-3 |                  | PIC X(5).    |
| 05 | ORDER-ITEM-NO1.  |                  |              |
|    | 10               | ITEM-NUM1        | PIC 9(5).    |
|    | 10               | ITEM1-QUANTITY   | PIC X.       |
|    | 10               | ITEM1-UNIT-PRICE | PIC 9(4)V99. |
| 05 | ORDER-ITEM-NO2.  |                  |              |
|    | 10               | ITEM-NUM2        | PIC 9(5).    |
|    | 10               | ITEM2-QUANTITY   | PIC X.       |
|    | 10               | ITEM2-UNIT-PRICE | PIC 9(4)V99. |
| 05 | ORDER-ITEM-NO3.  |                  |              |
|    | 10               | ITEM-NUM3        | PIC 9(5).    |
|    | 10               | ITEM3-QUANTITY   | PIC X.       |
|    | 10               | ITEM3-UNIT-PRICE | PIC 9(4)V99. |
| 05 | ORDER-ITEM-NO4.  |                  |              |
|    | 10               | ITEM-NUM4        | PIC 9(5).    |
|    | 10               | ITEM4-QUANTITY   | PIC X.       |
|    | 10               | ITEM4-UNIT-PRICE | PIC 9(4)V99. |
| 05 | ORDER-ITEM-NO5.  |                  |              |
|    | 10               | ITEM-NUM5        | PIC 9(5).    |
|    | 10               | ITEM5-QUANTITY   | PIC X.       |
|    | 10               | ITEM5-UNIT-PRICE | PIC 9(4)V99. |

**Test Data:**

```

1004100AA10208051992NY10201992
3004100AA102C1245L001000
3004100AA10244011A025000
3108000AM11172950P015000
1773100A100309021992YN01151993
2773100A1003BIZ SMART 210 FIRST ST. IRVING 7503850002000817-949-8275
3773100A1003906001002000
3143000A3B3333333C008000
1016040BR54902281992NN12161992
3016040BR549586G3C040050
1998100B4D22090192YY013093
2998100B4D22RYX CORP 55512 NOEL DR DALLAS 755229222222214-741-9999
3998100B4D2272600J09000
3998100B4D2233333K000500
1360500CD88808281992YN11021992
2360500CD888ABC CORP 9559 KNOB HILL SAN DIEGO 8650050010000805-744-9889
3360500CD88816789A099900
3360500CD88832600E008800
1999990CL99902291992NY11011992
3999990CL99966666G022000
3999990CL99912345H002200
3999990CL99955555I001050
3999990CL99972600D015050
2350200DB895THE MONEY PIT 10 DOWNTOWN AVEDALLAS 7505220100000214-845-9676
1105105D5M0010101992NN11021992
2105105D5M00CANDY INC. 666 WYLIE LANE HUMBUG 9998830010000717-666-6656
3105105D5M0026666A005000
1025000KM66610101992YN11021992
2025000KM666WIDGET CORP 9995 ABC STREETCARROLLTON7520179000000818-666-9000
3025000KM66637777F025000
1200100KT95509281992NN12121992
3200100KT95533333B001000
3200100KT95555555C000150

```

```

2000100NB456ABC COMPANY N. 123 STREET 7250QQ005000215-626-4153
1631600NN20007301992NN11191992
3631600NN20072600A030000
1143000RT33303311992YY12051992
3143000RT333595XXR040000
3143000RT333X2X005005000
1312000XXX3J04271992BN06011992
3312000XXX3J5555Z1090000
1771600XX20007301992NN11021992
2771600XX200SMITH INDUSTRY N. 333 HAVEN COPPELL 7501630010000214-123-6613
3771600XX20032600A030000
3771600XX20012345E003000
1881600ZZ20007301992NN11021992
3881600ZZ20032600B03000092
3881600ZZ20012345E002000
3881600ZZ20034567K003000
3881600ZZ20045678F001500
3881600ZZ20016789A000100
110100033041 9281992XN11011992

```

**Report Layout:** Develop your own report layout in compliance with the processing requirements. Be sure to give enough detail on the error report for the user to make the appropriate corrections.

**Processing Requirements:** 1. Read a file of order transaction records.

2. The current run date is typically accepted from a file, but for this lab set up a literal in working storage with the run date as November 2, 1992.

3. Validate each input record field for all of the following:

All numeric fields should be validated for numeric values and should be greater than zero.

On the type 1 record, the PARTIAL SHIP and TAXABLE fields should contain either a "Y" or an "N."

The HOLD DELIVERY DATE should be a future date.

The PURCHASE DATE should be the current date or prior to the current date.

On the type 2 record, all fields should contain data.

The quantity field on the type 3 record is a 1-byte alphanumeric field. This is a code that translates as follows:

|         |         |         |
|---------|---------|---------|
| A = 1   | E = 300 | I = 700 |
| B = 10  | F = 400 | J = 800 |
| C = 100 | G = 500 | K = 900 |
| D = 200 | H = 600 |         |

The quantity field should be validated for a valid code.

4. Any record that fails any validity test is to be written to an error file, and an appropriate error message should appear on the error report. It is possible that a record may contain more than one error, and all errors are to be flagged.

5. Valid records are to be written to a valid transaction file. The valid transaction file should be the same format as the input Order Transaction file with the exception that the quantity code on the Type 3 record should be converted to the quantity amount, causing the unit price to be moved to the right two bytes.

## Project 8.2

**Program Name:** Stock Transactions Validation Program

**Narrative:** This project will validate a stock transaction file and produce both a valid stock file and an error report.

**Input File:** STOCK-TRANSACTION-FILE

**Input Record Layout:**

|    |                             |              |
|----|-----------------------------|--------------|
| 01 | STOCK-RECORD.               |              |
| 05 | ST-TRANSACTION-INFORMATION. |              |
| 10 | ST-TRANSACTION-SHARES       | PIC 9(3).    |
| 10 | ST-TRANSACTION-STOCK        | PIC X(14).   |
| 05 | ST-PURCHASE-INFORMATION.    |              |
| 10 | ST-PURCHASE-PRICE           | PIC 9(5)V99. |
| 10 | ST-PURCHASE-DATE.           |              |
| 15 | ST-PURCHASE-YEAR            | PIC 99.      |
| 15 | ST-PURCHASE-MONTH           | PIC 99.      |
| 15 | ST-PURCHASE-DAY             | PIC 99.      |
| 05 | ST-SALE-INFORMATION.        |              |
| 10 | ST-SALE-PRICE               | PIC 9(5)V99. |
| 10 | ST-SALE-DATE.               |              |
| 15 | ST-SALE-YEAR                | PIC 99.      |
| 15 | ST-SALE-MONTH               | PIC 99.      |
| 15 | ST-SALE-DAY                 | PIC 99.      |

**Test Data:**

```

100XYZ CORP 20000009201153000000930103
200ABC CORP 12000009303052200000920305
100ACME WIDGETS 11500009211095000000930331
100BOROW ASSOC 00500009202290000048
300LEE ENTERPRISE 45000009313229000000930422
200NATL GADGET 0100A009205151100000920631
100NATL GISMO 10000009306181200000930606
400AMER WIDGETS 09000009307070800000930906
350MILGROM POWER 10000009004052500000930431
200PARKER INC 0030000920731010000A930428
100SHELLY CO 00300009004310000200
200STEVENS INC 20000009308312200000930922

```

**Report Layout:** Design your own report layout. Be sure to comply with all the processing requirements.

- Processing Requirements:**
1. Read a file of stock records.
  2. Validate each input record for all of the following:
    - a. The month, day, and year of both the purchase and sale date must be numeric.
    - b. The month must be a valid value, that is, between 1 and 12, inclusive.
    - c. The day cannot exceed the maximum days in the corresponding month.
    - d. The date of sale cannot be earlier than the date of purchase.
    - e. The dollar amount of both purchase and sale must be numeric.
  3. Design an appropriate report layout. Invalid transactions are to be displayed with an appropriate error message. If a given transaction contains more than one invalid field,

multiple error messages are required. No further processing is required for invalid transactions.

- Each valid transaction is to be written to a file to be used in Project 9-2.



**Program Name:** Payroll Validation Program

**Narrative:** Develop a program to validate a payroll file and produce both a valid payroll file and an error report.

**Input File:** PAYROLL-FILE

**Input Record Layout:**

```

01 PAYROLL-RECORD.
 05 PAY-SOC-SEC-NUM PIC 9(9).
 05 PAY-NAME.
 10 PAY-LAST PIC X(14).
 10 PAY-FIRST PIC X(12).
 10 PAY-INITIAL PIC X.
 05 PAY-INFO.
 10 PAY-HOURLY-RATE PIC 9(3)V99.
 10 PAY-HOURS-WORKED PIC 9(3)V99.
 10 PAY-SALARY-TYPE PIC X.
 10 PAY-DEPENDENTS PIC 99.
 10 PAY-TAX-STATUS PIC 9.
 10 PAY-INSURANCE PIC X.
 05 PAY-YTD-INFO.
 10 PAY-YTD-EARNINGS PIC 9(6)V99.
 10 PAY-YTD-TAXES PIC 9(5)V99.
 10 PAY-YTD-FICA PIC 9(4)V99.
 10 PAY-YTD-INSURANCE PIC 9(4)V99.

```

**Test Data:**



```

100000000 01000 4000H 3D023150220114340134512050000
111111111BOYER WARD E0150004000S013B0270000000548524202770045000
200000000MERA SASHA X0140004500S045B
222222222DAVERSA NICK A0055004000S014A0099000000148500074349063000
300000000MENEDEZ LOURDES Y0235004000X152C045298220891300025053057500
333333333FRENCH MICHELLE P0650003500H082B117000002671139878670108000
400000000BARBER MARYANN A18000400LH06 AA85927400719262143290900000
444444444GEHLE SHELLY T0157504350H002Z028350000444055212909000000
500000000GRAUER ROBERT T1500 46000 052Z029104050513950214890000000
555555555RICO CHERYL S0074505200H013C013410000201150100709045000
600000000 04000S10AB0099000000137650073436060000
666666666ROWE CANDACE M0300004200S031A0540000001232438040554090000
700000000HEMMERDE CLARKRICHARD 06500 H008Z116000002571143854320000000
777777777SHIM ANNA M0080004800H044C014400000229106108144090000
800000000STUTZ JOEL 005500500H0L11 0991500 075607
888888888VASQUEZ DONNA A0237504000M022C0427500000848813321053058500
900000000PLANT ROBERT 0075005300S0130014410000210050100090045000
999999999VAZQUEZ VILLARCAROL 0180004000M053B032400000699724243324108000

```

**Report Layout:** Design your report layout based on the requirements below.

- Processing Requirements:**
1. Read a file of sales payroll records.
  2. Validate each input record for all of the following:
    - a. The incoming record must contain data for the following fields: social security number, name, hourly rate, hours worked, salary type, number of dependents, tax status, and insurance. If any field is missing, display the message "INCOMING RECORD MISSING DATA" and the input record.
    - b. The incoming fields of hourly rate, hours worked, number of dependents, tax status, ytd earnings, taxes, fica, and insurance must be numeric. If not, display an appropriate error message that contains the entire input record.
    - c. The salary type must be either hourly or salaried (H or S). If it is not, display an appropriate error message, such as "INVALID SALARY TYPE FOR", the social security number, name, and salary type. (Hint: Use a condition name test.)
    - d. *Salaried* employees are not paid overtime; therefore hours worked for salaried employees cannot be over 40 hours. Use the message "NO OVERTIME FOR SALARIED EMPLOYEES", the social security number, name, and hours worked.
    - e. The tax status must be valid (1 through 4). Use the message "INVALID TAX STATUS FOR", the social security number, name, and tax status. (Hint: Use a condition name test.)
    - f. The insurance type must be valid (A, B, C, or Z). Use the message "INVALID INSURANCE FOR", the social security number, name, and insurance type. (Hint: Use a condition name test.)
    - g. A reasonable number of dependents; flag any record where the number of dependents is over 10. (Hint: Use a condition name test.)
  3. Any record that fails any validity test is to be rejected with no further processing, other than displaying the appropriate error message(s). It is possible that a record may contain more than one error (flag all errors). Valid records are to be written to a new file to be used in Projects 9-3 and 16-3.

## Project 8-4

**Program Name:** Car Sales Commissions Validation Program

**Narrative:** This project will validate a file of car sales records and produce both a valid car file and an error report.

**Input File:** CAR-SALES-FILE

| Input Record Layout: | FIELD NAME      | POSITIONS | FIELD TYPE   |
|----------------------|-----------------|-----------|--------------|
|                      | Location        | 1 - 11    | Alphanumeric |
|                      | Branch          | 12 - 15   | Numeric      |
|                      | Salesperson     | 16 - 25   | Alphanumeric |
|                      | Customer Name   | 26 - 35   | Alphanumeric |
|                      | Sale Date       | 36 - 41   | Numeric      |
|                      | Sale Amount     | 42 - 47   | Numeric      |
|                      | Commission Rate | 48 - 50   | Numeric      |
|                      | Car Model       | 51 - 63   | Alphanumeric |
|                      | Car Year        | 64 - 67   | Numeric      |

**Test Data:**

|         |             |         |                 |             |              |      |
|---------|-------------|---------|-----------------|-------------|--------------|------|
| BROWARD | 1234SHIM    | REIMAN  | 131292          | 18725002    | SAAB 900     | 1992 |
| MONROE  | 4528VASQUEZ | HAFEZ   | 101392          | 32875003    | JAGUAR XJS   | 1991 |
| DADE    | 4679DAVERSA |         | 111492030554005 | INFINITI    | Q45          | 1991 |
| BROWARD | 1234SHIM    | PORTO   | 103293025575004 | MB 300E     |              | 1916 |
| MONROE  | 4528BOYER   |         | 063393          | 8125004     | MAZDA 626    | 1991 |
| BROWARD | 1234GEHLE   | LARSH   | 111293020475003 | PEUGOT      | 505GLS       | 1991 |
| DADE    | 9879FRENCH  |         | 092892022750003 | BMW 325iX   |              | 1991 |
| BROWARD | 1234GEHLE   | HOLME   | 93192014700002  | PRELUDE     | SI           | 1992 |
| DADE    | 9879FRENCH  | DEGGS   | 013193013025004 | NISS MAXIMA |              | 1992 |
| BROWARD | 1234GEHLE   | MORENO  | 101293          | 17125       | 5TOY SUPRA   | 1991 |
| DADE    | 0124RICO    | GORMAN  | 103192035500184 | LEXUS       | LS400        | 1992 |
| MONROE  | 4528VASQUEZ | HWANG   | 123192          | 25000       | 4LEGEND C LS | 1990 |
| BROWARD | 4567ROWE    | TOCKMAN | 010491053150006 | BMW 750iL   |              | 1992 |
| DADE    | 0124RICO    | CHUA    | 81593014700004  | TOY CAMRY   | DE           | 1991 |
| DADE    | 9879FRENCH  | SPEARS  | 101693023975001 | NISSAN      | 300Z         | 1992 |
| MONROE  | 4528BOYER   | AUGUSMA | 041093069799002 | MB 500 SL   |              | 1991 |
| DADE    | 4679DAVERSA | RENESCA | 104292004950002 | HYUN EXCEL  | G            | 1991 |
| BROWARD | 4567ROWE    | VIERA   | 11 592010300002 | STERLG      | 825SL        | 1990 |
| MONROE  | 4528BOYER   | LOUIS   | 102992          | 12175104    | MAZ RX7 GXL  | 1991 |
| BROWARD | 4567ROWE    | PINEDA  | 122493016100    | 3AUDI       | QUATTRO      | 1990 |
| DADE    | 0124RICO    | DILEGO  | 112693012800004 | MAZDA       | MIATA        | 1991 |

**Report Layout:** Design your own report layout, subject to the processing requirements.

**Processing Requirements:**

1. Read a file of car sales records.
2. Validate each input record for all of the following:
  - a. The incoming record must contain data for the following fields: location, branch, salesperson, customer, sale amount, commission rate, and model year. If any field is missing, display a single message "INCOMING RECORD MISSING DATA", followed by the input record.
  - b. The incoming fields of branch, sale date, sale amount, and commission rate must be numeric. If not, display an appropriate error message that contains the entire input record.
  - c. Valid dates (sale date): month must be between 1 and 12, inclusive; day should be in conjunction with the month; and year must be the current year or the year before. Display a suitable message "INVALID MONTH", "INVALID DAY", and/or "INVALID YEAR", followed by the input record.
  - d. A reasonable commission rate: flag any record where the rate is not between 0% and 100%. Use the message "INVALID COMMISSION RATE", followed by the input record.
  - e. A reasonable car year: flag any record where the car year is not between 1930 and 1995, inclusive. Use the message "INVALID CAR YEAR", followed by the input record.
3. Any record that fails any validity test is to be rejected with no further processing, other than displaying the appropriate error message(s). It is possible that a record may contain more than one error (all errors are to be flagged).
4. Valid records are to be written to a file to be used in Project 9-4.

**Project 8-5****Program Name:** Invoice Validation Program**Narrative:** Write a data validation program that will validate an invoice file and produce both a valid invoice file and an error report.**Input File:** INVOICE-FILE

**Input Record Layout:**

```

01 INVOICE-RECORD-IN.
 05 INV-INVOICE-NO PIC X(4).
 05 INV-DATE.
 10 INV-MONTH PIC 9(2).
 10 INV-DAY PIC 9(2).
 10 INV-YEAR PIC 9(2).
 05 INV-CUSTOMER-INFO.
 10 INV-CUST-NAME PIC X(10).
 10 INV-CUST-ADDRESS PIC X(10).
 10 INV-CUST-CITY PIC X(10).
 10 INV-CUST-STATE PIC XX.
 10 INV-CUST-ZIP PIC X(5).

```

**Test Data:**

|            |         |            |             |         |
|------------|---------|------------|-------------|---------|
| 2467100493 | Scully  | 20 Main St | Chicago     | IL60666 |
| 38451312   | Minnie  |            | Disney      | TZ      |
| 1578081293 | Schultz | 45 5th St  | Los Angeles | CA90024 |
| 3446123193 | Goofy   | Main St    | Orlando     | FX39575 |
| 0342091093 | Culver  | 1 Sunny Ln | Seattle     | WA98008 |
| 4790111293 | Perez   | 4 Long Dr  | New Orleans | LA79345 |
|            | 09 93   | NoName St  | Somewhere   | 49576   |
| 6836070493 | Fixler  | 3 42nd St  | New York    | NY10020 |
| 2346 3293  | Pluto   | 2 Dog Dr   | Dogville    | PR67453 |
| 4807031893 | Morin   | 9 7th Ave  | Newark      | NJ07632 |
| 0498063093 | Munroe  | 10 Long St | Tulsa       | OK59345 |
| 6234       | Mickey  | Disney St  |             | FL33480 |

**Report Layout:** Develop your own report layout in compliance with the processing requirements.

- Processing Requirements:**
1. Read a file of invoice records.
  2. Validate each input record field for all of the following:
    - a. **Invoice No:**
      - (1) If the invoice number is missing, print an appropriate error message:  
Record missing data in INVOICE NO field for: Smith
      - (2) If the invoice number is not missing, verify that the value is numeric; if not, display an error message:  
Nonnumeric INVOICE NO for: Smith      Invoice No: ABC4
    - b. **Date:**
      - (1) If the invoice date (i.e., Month, Day, or Year) is missing, print an appropriate error message:  
Record missing data in INVOICE DATE field for: Smith

- (2) *If the invoice date is not missing*, verify that the month is valid (i.e., 1 thru 12); error message:

Invalid MONTH for: Smith Invoice No: 1234 Month: 20

(Hint: Use a condition name test for valid months.)

- (3) Verify that the day is valid (i.e., cannot exceed the maximum days in the corresponding month); error message:

Invalid DAY for: Smith Invoice No: 1234 Month: 12 Day: 35

(Hint: Yes, use another condition name test for valid days.)

- (4) Verify that the year is valid; the year must be either the current or previous year; error message:

Invalid YEAR for: Smith Invoice No: 1234 Year: 95

- (5) If the date is valid, then verify the complete date against today's date; error message:

Invalid DATE for: Smith Invoice No: 1234 Month: 12 Day: 31 Year: 95

- c. **Name:** If the name is missing, print an appropriate error message:

Record missing data in NAME field for Invoice No: 1234

- d. **Address:** If the city is missing, print an appropriate error message:

Record missing data in ADDRESS field for: Smith Invoice No: 1234

- e. **City:** If the address is missing, print an appropriate error message:

Record missing data in CITY field for: Smith Invoice No: 1234

- f. **State:**

- (1) If the state is missing, print an appropriate error message:

Record missing data in STATE field for: Smith Invoice No: 1234

- (2) If the state is not missing, then verify that it is a valid state. Valid States are AK, AL, AR, AZ, CA, CO, CT, DC, DE, FL, GA, HI, IA, ID, IL, IN, KS, KY, LA, MA, MD, ME, MI, MN, MO, MS, MT, NC, ND, NE, NH, NJ, NM, NV, NY, OH, OK, OR, PA, RI, SC, SD, TN, TX, UT, VA, VT, WA, WI, WV, and WY; error message:

Invalid STATE for: Smith Invoice No: 1234 State: AT

(Hint: Another condition name test for valid states.)

- g. **Zip:**

- (1) If the zip is missing, print an appropriate error message:

Record missing data in ZIP field for: Smith Invoice No: 1234

- (2) *If the zip is not missing*, verify that the value is numeric; if not, display an error message:

Nonnumeric ZIP for: Smith Invoice No: 1234 Zip: 08307

3. Any record that fails any validity test is to be rejected with no further processing, other than displaying or printing the error message(s). It is possible that a record may contain more than one error (flag all errors except where noted).

4. Valid records are to be written to a new file to be used in Project 9-5.



**Project 8-6**

**Program Name:** Student Record Validation Program

**Narrative:** Write a data validation program that will validate a student file and produce both a valid student file and an error report.

**Input File:** STUDENT-FILE

**Input Record Layout:**

```

01 STUDENT-RECORD.
05 STU-ID PIC X(9).
05 STU-NAME PIC X(16).
05 STU-SCHOOL-INFORMATION.
10 STU-SCHOOL-CODE PIC X(3).
10 STU-MAJOR-CODE PIC X(3).
10 STU-AID-TYPE PIC X.
10 STU-GPA PIC 9V999.
10 STU-CREDIT-HOURS PIC 99.

```

**Test Data:**

| 1         | 2                | 3       | 4       | 5 | 6 |
|-----------|------------------|---------|---------|---|---|
| 235980890 | Kostner, Kevin   | BUSMKT  | S349908 |   |   |
| 293765635 | Roberts, Julia   | COMMKT  | G365710 |   |   |
| 328576407 | Murphy, Eddie    | COMPHYS | 249912  |   |   |
|           | Smith, John      | MDDECOZ | 000003  |   |   |
| 378575600 | Baldwin, Alec    | MUSEEGS | 0G      |   |   |
| 397575906 | Hawn, Goldie     | MEDBIOG | 345015  |   |   |
| 427496794 | Russell, Kurt    | ARTCISG | 369018  |   |   |
| 434562734 | Tweety Bird      | BUSFINS | 387103  |   |   |
| 459797601 | Stallone, Sly    | COMPHYL | 210500  |   |   |
| 470876493 | Gable, Clark     | EMGBIOL | 250L    |   |   |
| 475673723 | Bird, Big        | LAWSTAS | 300509  |   |   |
| 492729475 | Freeman, Morgan  | MUSCISG | 379012  |   |   |
| 524956063 | Newman, Paul     | MEDSTAS | 332101  |   |   |
| 540394065 | Redford, Robert  | ARTACCL | 267510  |   |   |
| 584784755 |                  | ENGSTTL | 310520  |   |   |
| 586432980 | Runner, Road     | COMACCL | 250006  |   |   |
| 593639456 | Davis, Geena     | BUSFINS | 299911  |   |   |
| 635968690 | Sarandon, Susan  | ENGSTAG | 349909  |   |   |
| 658294585 | Douglas, Micheal | BUSMKT  | S300004 |   |   |
| 693764956 | Hitchcock, Al    | MISACCL | 355500  |   |   |
| 732947566 | Mouse, Mickey    | MUSCIS  | S400016 |   |   |
| 740685676 | Bunny, Bugs      | MEDPHYS | 350002  |   |   |
| 753546833 | Duck, Donald     | LAYMKT  | L2499   |   |   |
| 769048304 | Streep, Merril   | ARTFINS | 397002  |   |   |
| 779309498 | Goldberg, Woopi  | LAWMKT  | G289918 |   |   |
| 794784830 | Grant, Cary      | MESEEG  | L2399 G |   |   |
| 816274855 | Crystal, Billy   | COMBIOL | 300105  |   |   |
| 826495896 | Letterman, David | COMCIS  | S300116 |   |   |
| 834858653 | Clark, Dick      | BUSFINS | 379817  |   |   |
| 843020375 | Williams, Robin  | ENGENG  | S276910 |   |   |
| 924649576 | ET               | EEGENG  | Z400112 |   |   |
| 967707888 | Hall, Arsenio    | COMMKT  | G398017 |   |   |

**Report Layout:** Develop your own report layout in compliance with the processing requirements.

**Processing Requirements:**

1. Read a file of student records.
2. Validate each input record field for all of the following:
  - a. **Name:** If the name is missing, print an appropriate error message:  
Record missing data in NAME field for Student ID: 123456789
  - b. **Student ID:**
    - (1) If the student ID is missing, print an appropriate error message:  
Record missing data in STUDENT ID field for: Smith, AB
    - (2) Verify that the value is numeric; if not, display an error message:  
Nonnumeric STUDENT ID for: Smith, AB Student ID: 123456789
  - c. **GPA:**
    - (1) If the GPA is missing, print an appropriate error message:  
Record missing data in GPA field for: Smith, AB Student ID: 123456789
    - (2) *If the GPA is not missing*, verify that the value is numeric; if not, display an error message:  
Nonnumeric GPA for: Smith, AB Student ID: 123456789 GPA: ABCD
    - (3) *If the GPA is numeric*, then verify that the GPA is between 2.5 and 4.0, inclusively (students with a GPA below 2.5 are ineligible for any kind of aid); if not, display an error message:  
GPA out of limits for: Smith, AB Student ID: 123456789 GPA: 5000
  - d. **Credit Hours:**
    - (1) if the credit hours are missing, print an appropriate error message:  
Record missing data in CREDIT HOURS field for: Smith, AB Student ID: 123456789
    - (2) *If the credit hours are not missing*, verify that the value is numeric; if not, display an error message:  
Nonnumeric CREDIT HOURS for: Smith, AB Student ID: 123456789 Credit Hours: AB
    - (3) *If the credit hours are numeric*, then verify that the hours are between 1 and 18, inclusively; if not, display an error message:  
CREDIT HOURS out of limits for: Smith, AB Student ID: 123456789  
Credit Hours: 22
  - e. **Codes:**
    - (1) Valid school codes are ART, BUS, COM, ENG, LAW, MED, and MUS; error message:  
Invalid SCHOOL for: Smith, AB Student ID: 123456789 Major: ABC
    - (2) Valid major codes are ACC, BIO, ECO, ENG, FIN, CIS, MKT, PHY, and STA; error message:  
Invalid MAJOR for: Smith, AB Student ID: 123456789 MAJOR: ABC
    - (3) Valid aid types are S, G, and L; error message:  
Invalid AID TYPE for: Smith, AB Student ID: 123456789 Aid Type: Z
3. Any record that fails any validity test is to be rejected with no further processing, other than displaying or printing the appropriate error message(s). It is possible that a record may contain more than one error (all errors are to be flagged except where noted).
4. Valid records are to be written to a new file, which will be used in Projects 9-6 and 16-2.

**Project 8-7****Program Name:** Salary Report Validation Program**Narrative:** Write a data validation program that will validate a salary file and produce a valid salary file.**Input File:** SALARY-FILE

**Input Record Layout:**

|    |                       |            |
|----|-----------------------|------------|
| 01 | SALARY-RECORD.        |            |
| 05 | SAL-SOC-SEC-NO        | PIC X(9).  |
| 05 | SAL-NAME-AND-INITIALS | PIC X(15). |
| 05 | SAL-BIRTH-DATE.       |            |
| 10 | SAL-BIRTH-MONTH       | PIC 9(2).  |
| 10 | SAL-BIRTH-YEAR        | PIC 9(2).  |
| 05 | SAL-LOCATION-CODE     | PIC X(3).  |
| 05 | SAL-EDUCATION-CODE    | PIC 9.     |
| 05 | SAL-TITLE-DATA.       |            |
| 10 | SAL-TITLE-CODE        | PIC 9(3).  |
| 10 | SAL-TITLE-DATE.       |            |
| 15 | SAL-TITLE-MONTH       | PIC 9(2).  |
| 15 | SAL-TITLE-YEAR        | PIC 9(2).  |
| 05 | SAL-RATING            | PIC 9.     |
| 05 | SAL-SALARY            | PIC 9(6).  |

**Test Data:**

|           |                |                        |
|-----------|----------------|------------------------|
| 125896790 | Beckeles, GG   | 0357MIA404003902054000 |
| 235980890 | Bennett, JA    | 1667LA 406003444046700 |
| 293765635 | Blaney, WC     | 0467CHI504004885078027 |
| 312458697 | Chatani, DH    | 0654NY 605006904123000 |
| 328576407 | Chen, EI       | 0959MIA204002911045999 |
|           | Crumity, TR    | 1663AT 407106915083078 |
| 378575600 | Dailey, TP     | 0566ATL508007842067200 |
| 397575906 | Feuer, D       | 0571CHI309006844090680 |
| 427496794 | Garcia, A      | 0668LA 607002872018050 |
| 459797808 | Gonzalez, L    | 0274NY 309008855030480 |
| 470876493 | Gutierrez, CM  | 0367ATL210001904027090 |
| 492729475 | Jackson, NL    | 0466MIA304003904140980 |
| 524956063 | Largesse, CL   | 0259CHI405011873030856 |
| 540394065 | Levy, MS       | 0560LA 203012891037452 |
| 584784755 |                | 0265ATL015014923350001 |
| 593639456 | Moscatelli, EJ | 0367ATL207012855050120 |
| 635968690 | Murata, Y      | 0670MIA502002894038546 |
| 658294585 | Nilsson, P     | 0175CHI206003915036456 |
| 693764956 | Pauncefort, C  | 0571LA 507002742063740 |
| 732947566 | Raffle, AG     | 0668LA 205007795046589 |
| 740685676 | Robinson, PJ   | 1277NYC507007950       |
| 769048304 | Rodriguez, AM  | 1167MIA503003791028345 |
| 779309498 | Sanchez, MC    | 0759NY 208007904047242 |
| 794784830 | Schand, MI     | 0472LAX709006917 06490 |
| 816274855 | Shinawatra, R  | 0356CHI410007893036478 |
| 826495896 | Tozzi, GA      | 0351ATL408007825192375 |
| 834858653 | Villar, CV     | 0838MIA501002555350000 |
| 843020375 | Wilcoxon, B    | 0457ATL507004874047566 |
| 924649576 | Yadav, S       | 0461MIA209012901037856 |
| 967707888 | Yau, SC        | 0367CHI310003892238745 |

**Report Layout:** Develop your own report layout in compliance with the processing requirements.

**Processing Requirements:**

1. Read a file of salary records.
2. Validate each input record field for all of the following:
  - a. **Name:** If the name is missing, print an appropriate error message:  
Record missing data in NAME field for Soc Sec No: 123456789
  - b. **Soc Sec No:**
    - (1) If the social security number is missing, print an appropriate error message:  
Record missing data in SOC SEC NO field for: Smith, AB
    - (2) If the social security number is not missing, verify that the value is numeric; if not, display an error message:  
Nonnumeric SOC SEC NO for: Smith, AB      Soc Sec No: ABCD6789
  - c. **Salary:**
    - (1) If the salary is missing, print an appropriate error message:  
Record missing data in SALARY field for: Smith, AB      Soc Sec No: 123456789
    - (2) If the salary is not missing, verify that the value is numeric; if not, display an error message:  
Nonnumeric SALARY for: Smith, AB      Soc Sec No: 123456789 Salary: 083078
    - (3) If the salary is numeric, then verify that salary is over \$10,000 and under \$350,000; if not, display an error message:  
SALARY out of limits (under \$010000 or over \$350000) for: Smith, AB  
Soc Sec No: 123456789 Salary: 350001
  - d. **Codes:**
    - (1) Valid location codes are MIA, CHI, LA, NY, and ATL; error message:  
Invalid LOCATION for: Smith, AB      Soc Sec No: 123456789 Location: AT
    - (2) Valid education codes are 1 through 6; error message:  
Invalid EDUCATION for: Smith, AB      Soc Sec No: 123456789 Education: 0
    - (3) Valid title codes are 010, 020, 030, 040, 050, 060, 070, 080, 090, and 100; error message:  
Invalid TITLE for: Smith, AB      Soc Sec No: 123456789 Title: 150
    - (4) Valid ratings are 1 through 5; error message:  
Invalid RATING for: Smith, AB      Soc Sec No: 123456789 Rating: 0
  - e. **Birth Date and Age:**
    - (1) Verify that the values in the birth date are valid; error message:  
Invalid BIRTH MONTH for: Smith, AB Soc Sec No: 123456789  
Birth Month: 16
    - (2) Verify the employee is not under 16 years of age; error message:  
AGE under 16 for: Smith, AB      Soc Sec No: 123456789 Age: 13
  - f. **Title Date:**
    - (1) Verify that the title month is valid; error message:  
Invalid TITLE MONTH for: Smith, AB Soc Sec No: 123456789  
Title Month: 20
    - (2) Verify that the title year is valid; the company was established in 1955; therefore no employee should have had a title before that year; error message:  
TITLE YEAR before 1955 for: Smith, AB Soc Sec No: 123456789  
Title Year: 44

- (3) Verify that the title year is valid; therefore no employee should have had a title year beyond the current year; error message:

TITLE YEAR beyond 1993 for: Smith, AB Soc Sec No: 123456789 Title Year: 95

- (4) If the title year is valid, then verify the complete title date against today's date; error message:

Invalid TITLE DATE for: Smith, AB Soc Sec No: 123456789 Month: 06 Year: 91

3. Any record that fails any validity test is to be rejected with no further processing, other than displaying or printing the appropriate error message(s). It is possible that a record may contain more than one error (all errors are to be flagged except where noted).
4. Valid records are to be written to a new file to be used in Projects 9-7 and 16-3.

## Project 8-8

**Program Name:** Stock Validation Program

**Narrative:** Write a data validation program that will validate a stock file and produce both a valid stock file and an error report.

**Input File:** STOCK-FILE

**Input Record Layout:**

|    |                        |                |
|----|------------------------|----------------|
| 01 | STOCK-RECORD-IN.       |                |
| 05 | STOCK-INFO.            |                |
| 10 | STOCK-NAME             | PIC X(8).      |
| 10 | STOCK-EXCHANGE-CODE    | PIC 9.         |
| 10 | STOCK-INDUSTRY-CODE    | PIC X(3).      |
| 05 | STOCK-CURRENT-INFO.    |                |
| 10 | STOCK-PRICE            | PIC 9(3)V9(3). |
| 10 | STOCK-PE               | PIC 9(3).      |
| 10 | STOCK-DIVIDEND         | PIC 9V99.      |
| 05 | STOCK-PROJECTION-INFO. |                |
| 10 | STOCK-RISK-CODE        | PIC 9.         |
| 10 | STOCK-GROWTH-RATE      | PIC 9V9(4).    |
| 10 | STOCK-SHARES-TO-BUY    | PIC 9(4).      |

**Test Data:**

```

Hhhhhh 0BEE001000999555600100
Aaaaaaa 1BAN012340012220054320000
Anheus 1BEE 527500161123005000015
AT&T 1TEL0421250881324025500100
BellSo 1TEL0477500152764029750065
Chevron 10IL0727500243304009500050
Chrysler 1AUT0200000150602003000025
Compq 1CMP0287500382303015500025
Eeeeeee 1ELL1500000118900000000168
Exxon 10IL0627500142883007000035
Fffffff 1F&L 0102500100010000
Kellogg 1F000583750221123024550010
Kmart 1RET0460000111763005000005

```

```

GenEl 1ELE0775000152203009500050
GnMotr 1AUT0441250153312006750010
IBM 1CMP0903750134843011000050
Marriot 1F&L0180000230283005000020
McDonld 1F&L0465000190404013500010
Norwst 1AIR0377500121002004500015
Reebok 1RET0235000090302007750075
Sears 1RET0425000152003011500050
SwBell 1TEL0603750122923007000030
Upjohn 1DRU0326250111364008000025
USWst 1AIR0356250122121004500025
Wendys 1F&L0120000220244029500050
Bankrs 2BAN0022750080581003200030
Iomega 2ELE0065000090503006750040
Maxwel 2FOO0130000130404007000010
Oracle 2CMP0155000552253012000010
PolkAu 2ELE0062500350752005500025
Seagate 2ELE0171253431303008900045
 3TEL1250000345500045450200
Ccccccc 3BEN0125500120153012340250
CmceBk 3BAN0155000050152004000019
LdmkB 3BAN0000630070101003250500
Dddddddd 4dru0000000204551023000750
Excel 4CMP0117500280244035000075
Ggggggg 4air0100000227500000250100
LilVern 4RET0140000140052006500050
Luria 4RET0071250290952007500025
Metrbk 4BAN0112500090603004000050
Skywst 4AIR0077500200053005000035
Sonesta 4F&L0055000021003008900050
Trustco 4BAN0270000120602004000010
Tyson 4FOO0186250170043005500025
Bbbbbbb 5SD 0013450120751125001500

```

**Report Layout:** Develop your own report layout in compliance with the processing requirements.

- Processing Requirements:**
1. Read a file of stock records.
  2. Validate each input record field for all of the following:
    - a. **Stock Name:** If the name is missing, print an appropriate error message:  
Record missing data in NAME field Industry Code: XXX
    - b. **Exchange Code:**
      - (1) Verify that the value is numeric; if not, display an error message:  
Nonnumeric EXCHANGE CODE for Stock: XXXXXXXX
      - (2) If the **exchange code** is numeric, verify that the code is valid. Valid exchanges are 1 through 4.  
Error message: Invalid EXCHANGE for Stock: XXXXXXXX Exchange: X  
(Hint: Use condition name test for valid exchanges.)
    - c. **Industry Code:** Verify that the industry code is valid. Valid industry codes are: AIR, AUT, BAN, BEE, CMP, DRU, ELE, F&L, FOO, OIL, RET, S&L, and TEL.  
Error message: Invalid INDUSTRY CODE for Stock: XXXXXXXX Industry: XXX  
(Hint: Use condition name test for valid types.)

- d. **PE and Dividend:** Verify that these values are numeric; if not, display the appropriate error message:

Nonnumeric PE for Stock: XXXXXXXX PE: 999

Nonnumeric DIVIDEND for Stock: XXXXXXXX Dividend: 9.99

- e. **Price and Shares to Buy**

- (1) Verify that these values are numeric; if not, display the appropriate error message:

Nonnumeric PRICE for Stock: XXXXXXXX Price: 999.999

Nonnumeric SHARES TO BUY for Stock: XXXXXXXX Shares to Buy: 9999

- (2) Verify that both are not zero; if either is zero, display an error message:

Zero Price and/or Shares to Buy for Stock: XXXXXXXX Price: 999.999 Shares: 9999

- (3) *Finally, when both the **price** and **shares to buy** are numeric and not zero, verify that the potential stock purchase is not over the limit of \$25,000. That is, if the product of the stock price and the shares to buy exceeds \$25,000, the record should be rejected. Display the following error message:*

Total Purchase exceeds limit for Stock: XXXXXXXX Limit: 9999999

- f. **Risk Code and Growth Rate:**

- (1) Verify that the value is numeric; if not, display the appropriate error message:

Nonnumeric RISK CODE for Stock: XXXXXXXX Risk Code: X

Nonnumeric GROWTH RATE for Stock: XXXXXXXX Growth Rate: XXXXX

- (2) *If the **risk code** or **growth rate** is numeric, verify that the codes are valid. Valid risk codes are 1 through 5. Valid growth rates are .01% through 100%. Appropriate error messages are:*

Invalid RISK CODE for Stock: XXXXXXXX Risk Code: X

Invalid GROWTH RATE for Stock: XXXXXXXX Growth Rate: 9.9999

(Hint: Use a condition name test for valid risks and growth rates.)

3. Any record that fails any validity test is to be rejected with no further processing, other than displaying or printing the appropriate error message(s). It is possible that a record may contain more than one error (all errors are to be flagged except where noted).
4. Valid records are to be written to a file to be used in Projects 9-8, 16-4, and 17-6.

## Project 8-9

**Program Name:** Electricity Bill Validation Program

**Narrative:** Write a data validation program that will validate an electric file and produce a valid electric file.

**Input File:** ELECTRIC-FILE

**Input Record Layout:**

|    |                            |           |
|----|----------------------------|-----------|
| 01 | ELECTRIC-RECORD-IN.        |           |
| 05 | EL-ACCOUNT-NO              | PIC X(6). |
| 05 | EL-ACCOUNT-TYPE.           |           |
| 10 | EL-TYPE-CODE               | PIC X.    |
| 10 | EL-CATEGORY-CODE           | PIC XX.   |
| 10 | EL-DEMAND-CODE             | PIC X.    |
| 10 | EL-TIME-OF-USE-CODE        | PIC X.    |
| 05 | EL-METER-INFO.             |           |
| 10 | EL-KW-DEMAND-LEVEL         | PIC 9(4). |
| 10 | EL-SERVICE-USED-FROM-DATE. |           |
| 15 | EL-FROM-YEAR               | PIC 99.   |
| 15 | EL-FROM-MONTH              | PIC 99.   |
| 15 | EL-FROM-DAY                | PIC 99.   |
| 10 | EL-SERVICE-USED-TO-DATE.   |           |
| 15 | EL-TO-YEAR                 | PIC 99.   |
| 15 | EL-TO-MONTH                | PIC 99.   |
| 15 | EL-TO-DAY                  | PIC 99.   |
| 10 | EL-METER-READ-INFO.        |           |
| 15 | EL-CURRENT-READING         | PIC 9(5). |
| 15 | EL-PREVIOUS-READING        | PIC 9(5). |

**Test Data:**

```

342545RRSN100009201239202223574834953
238945CCSX134679202219203223908134576
689353RRSN200009201279202290023401002
466567CGSS100459202259203264024232934
000000CCSL121999203159201100235703465
465758CCSL234569111319112140045602345
763645CGSN100009201249202158349372452
111111RRSN101239202279202260667805678
457686CGSM105129202019203033613335688
487653CGSN200009202239203280038737846
222222CCSM221959614339205305675402466
333333CGSS10550910629911111234457575
349766CGSS204999201229202160034662745
456977CGSL255539203079203150064303245
444444CCSS200259201189214123774275638
945766CCSL121459202219203225545544544
457897CGSM209379202259203220042502145
555555CCSX115909108329206151242547426
460674CGSM107509201209202193423421212
906654RRSN200009201159202140033500856
548645CCSL221009203099203290036404742
666666CGSS100009205309106321242424244
486467RRSN100009112319201314586723745
859734CGSM205009202189203200136409736
146557CGSL123459201189202229721995984
387643CCSM119999201179202106453342345
777777XXXX123459213289412120532506643
984545CGSN1 9109039110049030289734
895098CGSL120009201169202199427483423
567455CGSX142439201069202084932845834
387464CCSM105009202029203035845333845
345456CGSS100309112089201087348773464

```



```

463454CGSL223829203019203270934710374
888888CCSM203119109359208110864636431
436355CCSM218219201149203010863818346
234557RRSN100009202279203251727417234
 CGSL256789205309205291234202345
489753CGSX120009201139202105394739843
487635CCSL120019111129201119475384653
784567CGSX256899103149203310238409549
845543CGSN200009202139203250089503453
387454CCSL220039201179202150189310763
999999CGSS111309202139112313521535218
223456CCSM114569202239203237844673523
348756CCSX121509111119112117864265987
345464RRSN200009201309203220045804975
646757CCSM212349203019203270003002985
758346CGSX221239202029203151038400384
457466CCSX231239112129201230278818236
ZZZZZZCGSN200009602159602163642686637
545465CGSS200509105199106200002300384
346768CCSL143569202179203174598545643
859567CCSX255749107209108200453400454

```

**Report Layout:** Develop your own report layout in compliance with the processing requirements.

- Processing Requirements:**
1. Read a file of electric records.
  2. Validate each input record field for all of the following:
    - a. **Account No:**
      - (1) If the account number is missing, print an appropriate error message:  
Record missing data in ACCOUNT NO field Account Type: RRSN1
      - (2) If the **account number** is not missing, then verify that the value is numeric; if not, display an error message:  
Nonnumeric ACCOUNT NO for Account No: 123456
    - b. **Account Type:** Verify that the account type is a valid account type. Valid account types are RRSN1, RRSN2, CGSN1, CGSN2, CGSS1, CGSS2, CGSM1, CGSM2, CGSL1, CGSL2, CGSX1, CGSX2, CCSM1, CCSM2, CCSL1, CGCL2, CGCX1, CCSX2;  
Error message: Invalid ACCOUNT TYPE for Account: 123456 Type: XXXXX  
(Hint: Use a condition name test for valid types.)
    - c. **KW Demand Level:**
      - (1) Verify that the value is numeric; if not, display an error message:  
Nonnumeric KW DEMAND LEVEL for Account No: 123456
      - (2) If the **kw demand level** is numeric, then verify that the value is consistent with the demand code in the account type as shown below:

| Demand Code | KW Demand Level Range |
|-------------|-----------------------|
| N           | n/a (0)               |
| S           | 21-499                |
| M           | 500-1999              |
| L           | 2000-9999             |
| X           | 2000-9999             |

Error Message:

Inconsistent DEMAND CODE & DEMAND LEVEL for Account No: 123456  
Demand Code: S Demand Level: 545

d. Service Used From and To Dates:

- (1) Verify that the from or to month is valid (i.e., 1 thru 12); error message:  
Invalid FROM MONTH for Account No: 123456 Month: 20  
or Invalid TO MONTH for Account No: 123456 Month: 20
- (2) Verify that the from or to day is valid (i.e., cannot exceed the maximum days in the corresponding month); error message:  
Invalid FROM DAY for Account No: 123456 Month: 12 Day: 35  
or Invalid TO DAY for Account No: 123456 Month: 12 Day: 35  
(Hint: Use a condition name test for valid months and days.)
- (3) Verify that the from or to year is valid; the year must be either the current or previous year; error message:  
Invalid FROM YEAR for Account No: 123456 Year: 95  
or Invalid TO YEAR for Account No: 123456 Year: 95
- (4) If the from or to date is valid, then verify the complete date (year, month, and day) against today's date; error message:  
Invalid FROM DATE for Account No: 123456 Mon: 05 Day: 31 Yr: 95  
or Invalid TO DATE for Account No: 123456 Mon: 05 Day: 31 Yr: 95
- (5) Verify that the from date is prior to the to date; error message:  
FROM DATE is not prior to TO DATE for Account No: 123456  
Current Date: 920325 Previous Date: 920220

- e. Current and Previous Readings: Verify that the value is numeric; if not, display an error message:  
Nonnumeric CURRENT READING for Account No: 123456 Current Reading: 346C4  
or Nonnumeric PREVIOUS READING for Account No: 123456 Previous Reading: 346C4

- 3. Any record that fails any validity test is to be rejected with no further processing, other than displaying or printing the appropriate error message(s). It is possible that a record may contain more than one error (all errors are to be flagged except where noted).
- 4. Valid records are to be written to a file to be used in Projects 9-9, 16-5, and 17-7.

**PROGRAMMING SPECIFICATIONS**

**Project 9-1**

**Program Name:** Doctor Visits Report Program

**Narrative:** This program accepts the valid output file produced by Project 8-1 as input and produces a report as output.

**Input File:** VALID-ORDER-TRANSACTION-FILE

**Input Record Layout:** Identical to the output record of Project 8-1.

**Test Data:** Use the output file of valid records created in Project 8-1 as input.

**Report Layout:** Design your own report layout, subject to the processing requirements.

- Processing Requirements:**
1. Read a file of valid order records.
  2. Write an appropriate heading at the top of each page showing the date the report was run and page number.
  3. Write a detail line for each order showing all of the information in the input record. Print 5 records per page.
  4. Write a total line to print the total number of records.

### Project 9-2

**Program Name:** Stock Transactions Report Program

**Narrative:** This program accepts the valid output file produced by Project 8-2 as input and produces a report as output.

**Input File:** STOCK-TRANSACTION-FILE

**Input Record Layout:** Identical to the output record of Project 8-2.

**Test Data:** Use the output file of valid records created in Project 8-2 as input.

**Report Layout:**

| We Make U Money, Inc.                |        |               |             |              |           |             |              | Page Z9       |
|--------------------------------------|--------|---------------|-------------|--------------|-----------|-------------|--------------|---------------|
| Stock Activity Report as of MM/DD/YY |        |               |             |              |           |             |              |               |
| Stock                                | Shares | Purchase Info |             |              | Sell Info |             |              | Profit / Loss |
|                                      |        | Date          | Price/Share | Total        | Date      | Price/Share | Total        |               |
| XXXXXXXXXXXXXX                       | ZZ9    | MM/DD/YY      | ZZ,ZZ9.99   | ZZZ,ZZ9.99   | MM/DD/YY  | ZZ,ZZ9.99   | ZZZ,ZZZ9.99  | ---,--9.99    |
| .                                    | .      | .             | .           | .            | .         | .           | .            | .             |
| .                                    | .      | .             | .           | .            | .         | .           | .            | .             |
| .                                    | .      | .             | .           | .            | .         | .           | .            | .             |
| Totals                               | Z,ZZ9  |               |             | Z,ZZZ,ZZ9.99 |           |             | Z,ZZZ,ZZ9.99 | -,---,--9.99  |

- Processing Requirements:**
1. Read a file of valid stock records.
  2. Write the appropriate headings showing the date and page number.
  3. For each record read:
    - a. Calculate the
      - (1) total purchase by multiplying the number of shares by the purchase price per share.

- (2) total sale by multiplying the shares by the selling price per share.
  - (3) profit/loss by subtracting the total purchase from the total sale.
  - b. String the record's purchase and sale date into a month, day, and year format.
  - c. Write a detail line for every transaction; print 4 transactions per page.
4. Write totals as shown in the report layout after all records are processed.

**Project 9-3**

**Program Name:** Payroll Report Program

**Narrative:** This program accepts the valid output file produced by Project 8-3 as input and produces a report as output.

**Input File:** PAYROLL-FILE

**Input Record Layout:** Identical to the output record of Project 8-3.

**Test Data:** Use the output file of valid records created in Project 8-3 as input.

**Report Layout:**

| HardWorkers of America as of mm/dd/yy |                   |               |               | Page Z9           |
|---------------------------------------|-------------------|---------------|---------------|-------------------|
| Name                                  | Gross Pay         | Taxes         | Insurance     | Net Pay           |
| <i>last name, first name</i>          | \$\$\$,\$\$9.99   | \$\$\$9.99    | \$\$\$9.99    | \$\$\$,\$\$9.99   |
| .                                     | .                 | .             | .             | .                 |
| .                                     | .                 | .             | .             | .                 |
| .                                     | .                 | .             | .             | .                 |
|                                       | \$\$\$\$,\$\$9.99 | \$\$,\$\$9.99 | \$\$,\$\$9.99 | \$\$\$\$,\$\$9.99 |

- Processing Requirements:**
1. Read a file of valid payroll records.
  2. Write the appropriate headings showing the date and page number.
  3. For each input record read:
    - a. Calculate the gross pay as:
      - (1) Straight time for the first 40 hours worked
      - (2) Time and a half for hours worked over 40

Note: Salaried workers DO NOT get overtime.
    - b. Calculate the deductions:
      - (1) Federal withholding tax is based on the gross pay.
        - (a) 18% on the first \$400
        - (b) 23% on amounts over \$400 and up to \$600, inclusive
        - (c) 25% on amounts over \$600
      - (2) FICA is 6.2% of the gross pay.

(3) Insurance as indicated below depending on the Plan Type.

| Plan | Amount Deducted    |
|------|--------------------|
| A    | \$5                |
| B    | \$8                |
| C    | \$10               |
| Z    | \$0 (no insurance) |

- c. Calculate net pay by subtracting all of the deductions (tax, FICA, and insurance) from the gross pay.
  - d. Write a detail line for each employee. String the name as shown in the report layout. Print only 5 employees per page.
4. Write totals as shown on the report layout after ten records have been processed.

**Project 9-4**

**Program Name:** Car Sales Commissions Report Program

**Narrative:** This program accepts the valid output file produced by Project 8-4 as input and produces a report as output.

**Input File:** CAR-SALES-FILE

**Input Record Layout:** Identical to the output record of Project 8-4.

**Test Data:** Use the output file of valid records created in Project 8-4 as input.

**Report Layout:**

| Very Very Nice Cars, Inc.  |          |                  |         |            | Page Z9   |           |
|----------------------------|----------|------------------|---------|------------|-----------|-----------|
| Commission Report MM/DD/YY |          |                  |         |            |           |           |
| Salesperson                | Date     | Car              | Sale    | Commission | Net       |           |
| XXXXXXXXXX                 | MM/DD/YY | 'YY XXXXXXXXXXXX | ZZZ,ZZ9 | ZZZ,ZZ9    | ZZZ,ZZ9   |           |
| .                          | .        | .                | .       | .          | .         |           |
| .                          | .        | .                | .       | .          | .         |           |
| .                          | .        | .                | .       | .          | .         |           |
|                            |          |                  |         | -----      |           |           |
|                            |          |                  |         | 2,ZZZ,ZZ9  | 2,ZZZ,ZZ9 | 2,ZZZ,ZZ9 |

- Processing Requirements:**
- 1. Read a file of valid car sales records.
  - 2. Write the appropriate headings showing the current date and page.
  - 3. For each record read:
    - a. Calculate the commission paid to the salesperson by multiplying the commission rate by the sale amount.



- b. Calculate the net to the company by subtracting the commission paid from the sale amount.
  - c. Write a detail line, printing 8 sales per page. Use reference modification to show only the last two digits in the car year on the report line.
4. Write totals as shown on the report layout after all the records have been processed.

### Project 9-5

**Program Name:** Invoice Mailing Labels Program

**Narrative:** This program accepts the valid output file produced by Project 8-5 as input and produces a mailing label as output.

**Input File:** INVOICE-FILE

**Input Record Layout:** Identical to the output record of Project 8-5.

**Test Data:** Use the output file of valid records created in Project 8-5 as input.

**Report Layout:**

|                   |                       |
|-------------------|-----------------------|
| Scully            | Schultz               |
| 20 Main St        | 45 5th St             |
| Chicago, IL 60666 | Los Angeles, CA 90024 |

- Processing Requirements:**
1. Read a file of valid invoice records.
  2. For each input record read create a mailing label.
    - a. String the city, state, and zip as shown in the report layout.
    - b. Print the labels in two columns as shown in the report layout.

### Project 9-6

**Program Name:** Student Record Report Program

**Narrative:** This program accepts the valid output file produced by Project 8-6 as input and produces a report as output.

**Input File:** STUDENT-FILE

**Input Record Layout:** Identical to the output record of Project 8-6.

**Test Data:** Use the output file of valid records created in Project 8-6 as input.

**Report Layout:**

| Smart U<br>Student Aid Report 99/99/99 |                  |        |     |              |               |           | Page Z9     |
|----------------------------------------|------------------|--------|-----|--------------|---------------|-----------|-------------|
| StudentID                              | Name             | School | Aid | Credit Hours | Total Tuition | Total Aid | Tuition Due |
| 999999999                              | XXXXXXXXXXXXXXXX | XXX    | X   | Z9           | ZZZ,ZZ9       | ZZZ,ZZ9   | ZZZ,ZZ9     |
| .                                      | .                | .      | .   | .            | .             | .         | .           |
| .                                      | .                | .      | .   | .            | .             | .         | .           |
| .                                      | .                | .      | .   | .            | .             | .         | .           |
|                                        |                  |        |     |              | -----         | -----     | -----       |
|                                        |                  |        |     |              | ZZ9           | Z,ZZZ,ZZ9 | Z,ZZZ,ZZ9   |

**Processing Requirements:**

1. Read a file of valid student records.
2. Write appropriate headings showing the current date and page number.
3. For each input record read:
  - a. Calculate total tuition based on \$300 per credit.
  - b. Calculate total aid based on the GPA as follows:

| GPA        | % Aid |
|------------|-------|
| 2.5 to 3.0 | 60%   |
| 3.1 to 3.5 | 70%   |
| 3.6 to 4.0 | 80%   |

- c. Calculate the tuition due by subtracting the total aid from the total tuition.
  - d. Write a detail line with the information shown on the report layout, printing 10 students per page.
4. Write the totals shown on the report layout after all the records have been processed.

**Project 9-7**

**Program Name:** Salary Report Program

**Narrative:** This program accepts the valid output file produced by Project 8-7 as input and produces a report as output.

**Input File:** SALARY-FILE

**Input Record Layout:** Identical to the output record of Project 8-7.

**Test Data:** Use the output file of valid records created in Project 8-7 as input.

**Report Layout:** Develop your own report layout in compliance with the processing requirements.

- Processing Requirements:**
1. Read a file of valid salary records.
  2. Write an appropriate heading showing the current date and page number.
  3. For each input record read write a detail line showing all of the information in the record. Print 10 employees per page.
  4. Write a total for the salary amounts after all records have been processed.

**Project 9-8**

**Program Name:** Stock Purchases Report Program

**Narrative:** This program accepts the valid output file produced by Project 8-8 as input and produces a report as output.

**Input File:** STOCK-FILE

**Input Record Layout:** Identical to the output record of Project 8-8.

**Test Data:** Use the output file of valid records created in Project 8-8 as input.

**Report Layout:**

| Stock Purchases      |          |        |           | Page Z9      |
|----------------------|----------|--------|-----------|--------------|
| day of Week MM/DD/YY |          |        |           |              |
| Name                 | Exchange | Shares | Price     | Total        |
| XXXXXXXX             | XXX      | Z,ZZ9  | \$ZZ9.999 | \$ZZ,ZZ9.99  |
| .                    | .        | .      | .         | .            |
| .                    | .        | .      | .         | .            |
| .                    | .        | .      | .         | .            |
| -----                |          |        |           | -----        |
| ZZ,ZZ9               |          |        |           | \$ZZZ,ZZ9.99 |

- Processing Requirements:**
1. Read a file of valid stock records.
  2. Write an appropriate heading, showing the page, day of week, and current date.
  3. For each input record read:
    - a. Calculate the total by multiplying the shares to buy by the stock price.
    - b. Write a detail line showing all of the information on the report layout, printing 10 stocks per page.
  4. When all the records are processed, print totals as shown on the report layout.



**Project 9-9**

**Program Name:** Electricity Bill Report Program

**Narrative:** This program accepts the valid output file produced by Project 8-9 as input and produces a report as output.

**Input File:** ELECTRIC-FILE

**Input Record Layout:** Identical to the output record of Project 8-9.

**Test Data:** Use the output file of valid records created in Project 8-9 as input.

**Report Layout:**

| Bright Power & Light<br>Residential Kilowatt Usage |       |              |       |                |         | Page Z9              |           |
|----------------------------------------------------|-------|--------------|-------|----------------|---------|----------------------|-----------|
| Account Info                                       |       | Service Used |       | Meter Readings |         | Total                | Estimated |
| Number                                             | Type  | From         | To    | Previous       | Current | Kilowatt<br>Hrs Used | Bill      |
| 999999                                             | XXXXX | MM/DD        | MM/DD | ZZ,ZZ9         | ZZ,ZZ9  | ZZ,ZZ9               | Z,ZZ9.99  |
| .                                                  | .     | .            | .     | .              | .       | .                    | .         |
| .                                                  | .     | .            | .     | .              | .       | .                    | .         |
| .                                                  | .     | .            | .     | .              | .       | .                    | .         |
|                                                    |       |              |       |                |         | -----                | -----     |
|                                                    |       |              |       |                |         | ZZZ,ZZ9              | ZZ,ZZ9.99 |

- Processing Requirements:**
1. Read a file of valid electric records.
  2. Write an appropriate heading showing the page number.
  3. For each input record read:
    - a. If the account category is residential:
      - (1) Calculate the total kilowatt hours used by subtracting the previous reading from the current reading.
      - (2) Calculate an estimated bill:
 

The first 750 kw hours used will be charged at 3.922¢ per kw hour.

Additional kw hours used will be charged at 4.922¢.
    - b. Print a detail line showing the information in the report layout.
  4. Write the totals shown on the report layout after all records have been processed.

**PROGRAMMING SPECIFICATIONS****Projects 10-1 through 10-9**

**Program Name:** Order Transactions, Stock Transactions, Payroll, Car Sales Commissions, Invoice Mailing Labels, Student Record, Salary, Stock Purchases, and Electricity Bill

**Narrative:** These projects combine the requirements of projects 8-1 through 8-9 and 9-1 through 9-9 as presented earlier in Chapters 8 and 9. The fields in each incoming record transaction are accepted and validated one at a time, after which the necessary computations are done and the report is displayed on the screen.

**Test Data:** Use one or more records from the original data in Chapter 8.

**Screen Layout:** Design your own input and output screen layout (based on the record layout in projects 8-1 through 8-9 and report layout in projects 9-1 through 9-9).

- Processing Requirements:**
1. Display a screen to input and validate a record, repeating the appropriate validations in the corresponding projects in Chapter 8.
  2. Display the calculated information from the corresponding projects in Chapter 9 on the screen.
  3. Optional: write the validated input records to a file after displaying it on the screen.

## PROGRAMMING SPECIFICATIONS

### Project 11-1

**Program Name:** Employee Profiles

**Narrative:** The requirements of this project are typical of compensation reports done in large organizations, which compare individuals with similar skills to one another. (The project is expanded to include material on table lookups in Project 12-1 at the end of the next chapter.)

**Input File:** EMPLOYEE-FILE

**Input Record Layout:**

|    |                                 |            |
|----|---------------------------------|------------|
| 01 | EMPLOYEE-RECORD.                |            |
| 05 | EMP-SOC-SEC-NUMBER              | PIC X(9).  |
| 05 | EMP-NAME-AND-INITIALS           | PIC X(16). |
| 05 | EMP-DATE-OF-BIRTH.              |            |
| 10 | EMP-BIRTH-MONTH                 | PIC 99.    |
| 10 | EMP-BIRTH-YEAR                  | PIC 99.    |
| 05 | EMP-DATE-OF-HIRE.               |            |
| 10 | EMP-HIRE-MONTH                  | PIC 99.    |
| 10 | EMP-HIRE-YEAR                   | PIC 99.    |
| 05 | EMP-SEX                         | PIC X.     |
| 05 | EMP-SALARY-DATA OCCURS 3 TIMES. |            |
| 10 | EMP-SALARY                      | PIC 9(5).  |
| 10 | EMP-SALARY-TYPE                 | PIC X.     |
| 10 | EMP-SALARY-DATE.                |            |
| 15 | EMP-SALARY-MONTH                | PIC 99.    |
| 15 | EMP-SALARY-YEAR                 | PIC 99.    |
| 10 | EMP-SALARY-GRADE                | PIC 9.     |
| 05 | EMP-TITLE-DATA.                 |            |
| 10 | EMP-TITLE-CODE                  | PIC XX.    |
| 10 | EMP-TITLE-DATE.                 |            |
| 15 | EMP-TITLE-MONTH                 | PIC 99.    |
| 15 | EMP-TITLE-YEAR                  | PIC 99.    |
| 05 | EMP-LOCATION-CODE               | PIC 99.    |
| 05 | EMP-EDUCATION-CODE              | PIC 9.     |

**Test Data:**

```

100000000DOE J 12440991M33000M0992331500H09913 350991104
200000000WILCOX PA10581191M29000M1192227500H11912 351191104
400000000LEVINE S 01500890F31000M0892229000M0891228000M02912320890104
500000000SMITHERS M 03500172M48000M0892745500M0891740000M08894280588204
600000000SUPERPROG S 04571091F59000H10916 501091106
700000000LEE B 10530277F40000P0592837500M0291835000M02907400589405
800000000PERSNICKETY P 08550392M25600H03923 500392306
900000000MILGROM MB11550989F32000M1192329000M0591227500M05891321189103

```

**Report Layout:** The report below shows required information and illustrative calculations for A. B. Jones. Print your report according to these general specifications, but do not be concerned about exact line and column positions on a page. (See item 2b in the processing requirements for additional guidelines.)

| PERSONNEL PROFILE |      |            |        |              |       |             |          |            |
|-------------------|------|------------|--------|--------------|-------|-------------|----------|------------|
| NAME:             |      | JONES A.B. |        | SOC-SEC-NO.: |       | 123-45-6789 |          |            |
| AGE:              |      | 21.4 YEARS |        | HIRE DATE:   |       | 1/91        |          |            |
| SALARY            | DATE | TYPE       | % INC. | MBI          | RSI   | GRADE       | MIDPOINT | % MIDPOINT |
| \$24,200          | 7/94 | P          | 10.0   | 6            | 20.0% | 4           | \$28,000 | 86.4       |
| \$22,000          | 1/94 | M          | 10.0   | 12           | 10.0% | 3           | \$21,000 | 104.7      |
| \$20,000          | 1/93 | H          |        |              |       | 3           | \$21,000 | 95.2       |

**Processing Requirements:**

1. Read a file of employee records.
2. For every record read:
  - a. Compute and print the employee's age, using the date of birth and date of execution. (The age calculation will be approximate, as the input birth date contains only the month and year.)
  - b. Print all indicated fields with appropriate editing. Print three employees per page; leave six blank lines between employees.
  - c. Print all associated salary information as described in items 3-6.
3. Each employee has a salary history with 1, 2, or 3 levels of salary data, denoting present, previous, and second previous salary, respectively. Not every employee will have all three salaries indicated, but every employee must have a present salary.
4. Associated with every salary is a salary grade, indicative of the level of responsibility in the company (for example, the janitor and president might have grade levels of 1 and 9, respectively). Each grade has an associated average salary, or midpoint. The salary midpoint is computed by multiplying the grade by \$7,000. The percent of grade midpoint is found by dividing the salary by the grade midpoint and multiplying by 100.
5. Associated with every pair of salaries are three fields: percent salary increase, months between increase (MBI), and annual rate of salary increase (RSI).

- a. Percent salary increase is found by subtracting the old salary from the new salary, dividing by the old salary, and multiplying by 100. For example, new and old salaries of \$22,000 and \$20,000 yield a percent increase of 10%.
  - b. Months between increase (MBI) is simply the number of months between the two salary dates.
  - c. Annual rate of salary increase (RSI) is computed by converting the percent salary increase to a 12-month basis; for example, 10% after 6 months is equivalent to an annual rate of 20%; 10% after 2 years is an annual rate of 5%.
6. Calculate percent salary increase, MBI, and RSI for each pair of salaries as appropriate. Realize, however, that not every employee will have all three salary levels, and hence the calculations cannot be made in every instance. Use an OCCURS clause, subscripts, and a PERFORM VARYING statement to do the calculations. Be sure to include a suitable test to avoid the computation if historical data are not present.

**Project 11-2**

**Program Name:** Benefit Statement

**Narrative:** Most employees do not realize the value of their fringe benefits, which often run to 30% of their annual salaries. Accordingly, benefit statements are often prepared to remind employees how well (their employer thinks) they are being treated. Develop a program to read a file of confidential employee data and to compute and print the fringe benefits for each employee.

**Input File:** EMPLOYEE-FILE

**Input Record Layout:** Use the same record layout as for Project 11-1.

**Test Data:** Use the same test data as for Project 11-1.

**Report Layout:**

```
Employee Benefit Statement
NAME: XXXXXXXXXXXXXXXX BIRTH DATE: 99/99
ANNUAL SALARY: $$$,$$9 HIRE DATE: 99/99
----- Sick Pay Benefit -----
WEEKS AT FULL PAY: Z9 WEEKS AT HALF PAY: Z9
----- Retirement Benefit -----
COMPANY CONTRIBUTES: $$$,$$9 INTEREST RATE: .99 AMT AT AGE 65: $$$,$$$,$$9
----- Life Insurance = $$$,$$9 -----
```

**Processing Requirements:** 1. Read a file of employee records, preparing an individual benefit statement for every record. Each individual statement is to appear on a separate page.

2. For every record read:
- Calculate the retirement benefit based on an annual company contribution for each employee. The contribution is equal to 5% of the first \$15,000 of salary plus 3% on any salary in excess of \$15,000. Hence the company would contribute \$840 annually for an employee earning \$18,000 (5% of 15,000 = 750, plus 3% of 3,000 = 90). The money is invested for the employees and assumed to earn 8% annually. Use the following formula:

$$\text{Amount at age 65} = \frac{\left( (1+i)^n - 1 \right)}{i}$$

where  $i$  = interest rate (for example, .08) and  $n$  = years until age 65 (specify the **ROUNDED** option of any arithmetic statement used in computing  $n$ ).

- Calculate the life insurance benefit as twice an employee's annual salary if the employee earns \$23,000 or less; it is three times the annual salary for those earning more than \$23,000.
- Calculate the amount of sick pay, which is dependent on the individual's length of service. An employee is entitled to one week of full pay and an additional two weeks of half pay, for every year (or fraction thereof) of employment. The maximum benefit, however, is 10 weeks of full salary and 20 of half salary, which is reached after 10 years. (An employee with two years' service, for example, is entitled to two weeks full pay and an additional four weeks of half pay.)
- Use the individual's present salary, EMP-SALARY (1), in all benefit calculations.

### Project 11-3

**Program Name:** Evaluation of Student Curriculum Records

**Narrative:** This project builds on Project 3-5. Write a program using table handling to evaluate a student's curriculum record and determine the percentage of courses a student has left in order to graduate, the percentage of courses a student has transferred, the percentage of courses for which a student has been awarded proficiency credit, and the percentage of courses a student has completed. Print the names of students who are close to graduation and the courses they have left to complete. Project 3-5 limits a student to 10 courses in their curriculum. This project allows for as many courses as needed.

**Input File:** STUDENT-CURRICULUM-FILE

**Input Record Layout:**

| Student Curriculum Record |               |       |
|---------------------------|---------------|-------|
| Student Id Number         | Course Number | Grade |
| 1 ... 5                   | 6 ... 12      | 13    |

**Test Data:**

```
12345COMP110A
12345ENGL110
12345MATH148K
12345MATH168P
12345CIS150 F
12345CIS230
12345PSYC105B
12345BUSN110A
12345HUMN410P
12345HUMN420A
34567ENGL110C
34567ENGL120
34567MATH048C
34567MATH210D
34567CIS230 A
34567CIS330
78921BUSN110
78921BUSN120
78921ENGL110A
78921ENGL120P
78921MATH048K
78921MATH168B
78921MATH220
47830SPCH275A
47830ENGL110
47830ACCT205A
47830ACCT210P
47830ACCT347K
```

**Report Layout:** Use the same report layout as in Project 3-5. Add editing where appropriate. Add the remaining courses to complete for a student who is near graduation (see specifications) using an appropriate format.

- Processing Requirements:**
1. Read a file of student curriculum records.
  2. Dynamically load a table containing all the student curriculum records for one student.
  3. Once all records for one student are loaded into the table:
    - a. Add the total number of courses (course name, not spaces) for each student.
    - b. Add the total number of courses where the student was awarded a grade (A, B, C, or D), proficiency credit (P), or transfer credit (K).
    - c. Add the total number of courses where the student was awarded transfer credit (K).
    - d. Add the total number of courses where the student was awarded proficiency credit (P).
    - e. Determine the percentages of courses left in order to graduate, courses completed, courses transferred, and courses awarded proficiency credit.
    - f. Print student id number and the percentages of courses left to graduate, courses completed, courses transferred, and courses awarded proficiency credit.
    - g. If the student has less than 20% of courses left in order to graduate, print the courses the student has not completed.

**Project 11-4****Program Name:** Computer Status Report**Narrative:** This program will create an individual status report for each record in the file. When all the records have been processed, print a summary report showing totals for each status. (The project is expanded to include material on table lookups in Project 12-4 in the next chapter.)**Input File:** COMPUTER-FILE

**Input Record Layout:**

```

01 COMPUTER-RECORD.
 05 COM-INVOICE-NO PIC 9(5).
 05 COM-CUSTOMER-NAME PIC X(18).
 05 COM-PAYMENT-METHOD PIC XX.
 05 COM-SHIP-INFO.
 10 COM-SHIP-STATUS PIC X.
 10 COM-SHIP-CHARGE PIC 99V99.
 05 COM-COMPONENT-INFO.
 10 COM-NO-COMPONENTS PIC 9.
 10 COM-COMPONENTS OCCURS 1 TO 4 TIMES
 DEPENDING ON COM-NO-COMPONENTS.
 15 COM-COMPONENT PIC X(12).
 15 COM-COST PIC 9(4).

```

**Test Data:**

```

12834Blanco, Erick AM145502486 33MHz 19952400 Modem 0099
79845Casali, Joseph AM375002386 33MHz 1595Laser Printr1399Tape BU 120 0189
59789Davis, Kevin VI165502486 33MHz 2095Laser Pritnr1399
85778Demler, Linda C0380254386 33MHz 2049Dot Matrix 0169Coprocesor 0099Modem/FAX 0119
47597Echavarria, FelipeCK265002486 33MHz 2379Tape BU 250 0250
58684Flemming, Sharon MC145002425 Notebook2395Dot Matrix 0169
48577Gonzalez, Maria VI135003486DX2 50MHz2295Modem/FAX 0119Sound Blstr 0139
56749Katan, Maharan CK245001325 Notebook1895
95877Parmenter, Donita C0335002486 25MHz 1995CD/ROM 0345
38476Pinkwasser, Randi VI389004486DX2 66MHz29959600 Modem 0299Dot Matrix 0169Sound Blstr 0139
37586Stewart, Roberto CK250002386 25MHz 1295FAX 1279

```

**Report Layout:**

| FLY BY NITE COMPUTERS, INC.     |                    |
|---------------------------------|--------------------|
| STATUS REPORT                   |                    |
| INVOICE #: XXXXX                | STATUS: X          |
| CUSTOMER NAME: XXXXXXXXXXXXXXXX | PAYMENT METHOD: XX |
| COMPONENT                       | COST               |
| XXXXXXXXXXXXX                   | \$\$,\$\$9.99      |
| .                               |                    |
| .                               |                    |
| .                               |                    |
|                                 | -----              |
| SUBTOTAL                        | \$\$\$,\$\$9.99    |
| SHIPPING CHARGES                | \$\$\$9.99         |
| TOTAL                           | \$\$\$,\$\$9.99    |

| FLY BY NITE COMPUTERS, INC. |       |                 |                 |
|-----------------------------|-------|-----------------|-----------------|
| SUMMARY BY STATUS           |       |                 |                 |
| STATUS                      | ITEMS | SHIP CHARGES    | COST            |
| 1                           | Z9    | \$\$,\$\$9.99   | \$\$,\$\$9.99   |
| 2                           | Z9    | \$\$,\$\$9.99   | \$\$,\$\$9.99   |
| 3                           | Z9    | \$\$,\$\$9.99   | \$\$,\$\$9.99   |
|                             | ----  | -----           | -----           |
| TOTAL                       | ZZ9   | \$\$\$,\$\$9.99 | \$\$\$,\$\$9.99 |

**Processing Requirements:**

1. Read a file of customer records.
2. For each record read:
  - a. Print the report for each customer on a separate page; print headings as shown on the report layout.
  - b. Process each component ordered by
    - (1) Printing a detail line as shown on the report layout.
    - (2) Incrementing the cost totals for that customer.
  - c. When all items for one customer have been processed:
    - (1) Calculate the customer total by adding the shipping charges to the cost totals.
    - (2) Print the customer total lines as shown in the report layout.
  - d. Increment the appropriate status in the summary table with the above information.
3. After all records have been read, print the a summary table showing totals for each status (as shown on the report layout).



**Project 10**

**Program Name:** Credit Report

**Narrative:** This program produces a credit report for store accounts. The store offers three types of accounts: 20, 40, or 60; a customer may have one of each. The report will show detail lines for each type of account for each customer. The last page is a summary of payments, purchases, interest charged, and current balance by account type.

**Input File:** CREDIT-FILE

**Input Record Layout:**

```

01 CREDIT-RECORD.
 05 CR-ACCOUNT-NO PIC 9(7).
 05 CR-NAME-AND-INITIALS PIC X(18).
 05 CR-NO-OF-ACCOUNTS PIC 9.
 05 CR-TRANSACTIONS OCCURS 1 TO 3 TIMES
 DEPENDING ON CR-NO-OF-ACCOUNTS.
 10 CR-TYPE PIC 99.
 10 CR-BALANCE PIC 9(4)V99.
 10 CR-PAYMENT PIC 9(4)V99.
 10 CR-PURCHASES PIC 9(4)V99.

```

**Test Data:**

```

1234520STUTZ, JD 120058600034300045444
1957620FROST, RD 140045345050000005055
2947660BARBER, MM 3200233900100000095454004753403150003421260233412233412043332
3856740GOLDSMITH, KN 24002343401233403432360342330362330005443
4209540GRAUER, RG 3200342220234221853444006344403000003433260556412034212064523
4908560PLANT, RK 22003430003430002232360043400050000000000
5748920ELOFSON, GS 24008640005640003422360675400375400045334
6847660STEWART, JB 160055600005600164543
7457620GILLENSON, ML 140065513005513035434
8466740RUSHINEK, SF 22004533400500012343460074554084554045334
9436560VAZQUEZ VILLAR, C 3200453450500000344540065666065000004455060054656044656043534

```

**Report Layout:**

| NEEDLESS MARKUP STORES ACCOUNT CREDIT REPORT |                     |           |           |                    |                    |                 | PAGE 29                    |
|----------------------------------------------|---------------------|-----------|-----------|--------------------|--------------------|-----------------|----------------------------|
| ACCOUNT #                                    | 9999999             |           |           |                    |                    |                 | NAME: XXXXXXXXXXXXXXXXXXXX |
| TYPE                                         | PREVIOUS<br>BALANCE | PAYMENT   | PURCHASES | INTEREST<br>CHARGE | CURRENT<br>BALANCE | CREDIT<br>LIMIT | AVAILABLE<br>CREDIT        |
| 99                                           | Z,ZZ9.99            | Z,ZZ9.99  | Z,ZZ9.99  | ZZ9.99             | Z,ZZ9.99CR         | Z,ZZ9.99        | Z,ZZ9.99                   |
| 99                                           | Z,ZZ9.99            | Z,ZZ9.99  | Z,ZZ9.99  | ZZ9.99             | Z,ZZ9.99CR         | Z,ZZ9.99        | Z,ZZ9.99                   |
| 99                                           | Z,ZZ9.99            | Z,ZZ9.99  | Z,ZZ9.99  | ZZ9.99             | Z,ZZ9.99CR         | Z,ZZ9.99        | Z,ZZ9.99                   |
| TOTALS                                       |                     | ZZ,ZZ9.99 | ZZ,ZZ9.99 | Z,ZZ9.99           | ZZ,ZZ9.99CR        |                 |                            |



| NEEDLESS MARKUP STORES ACCOUNT TYPE SUMMARY |           |           |                 |                 |
|---------------------------------------------|-----------|-----------|-----------------|-----------------|
| TYPE                                        | PAYMENT   | PURCHASES | INTEREST CHARGE | CURRENT BALANCE |
| 20                                          | Z,ZZ9.99  | Z,ZZ9.99  | ZZ9.99          | Z,ZZ9.99CR      |
| 40                                          | Z,ZZ9.99  | Z,ZZ9.99  | ZZ9.99          | Z,ZZ9.99CR      |
| 60                                          | Z,ZZ9.99  | Z,ZZ9.99  | ZZ9.99          | Z,ZZ9.99CR      |
| TOTALS                                      | ZZ,ZZ9.99 | ZZ,ZZ9.99 | Z,ZZ9.99        | ZZ,ZZ9.99CR     |

**Processing Requirements:**

1. Read a file of credit records.
2. Develop a page heading routine which prints 5 accounts on every page.
3. For each record read:
  - a. Print the appropriate account headings.
  - b. Process each account type by
    - (1) Calculating the monthly interest charge on the account based on the account balance after the payment has been applied. ( To make life a lot easier, use simple interest and a rate of 18.5%.)
    - (2) Calculating the current balance by adding the interest charge and purchases and subtracting the payment. (Note: a customer could overpay the account, therefore you should remember to make the field signed and display it as such on the report as shown in the report layout or as desired.)
    - (3) Determining the credit limit for each account as follows:
 

| Type | Credit Limit |
|------|--------------|
| 20   | \$1,500      |
| 40   | \$3,500      |
| 60   | \$5,000      |
    - (4) Calculating the available credit on the account by subtracting the current balance from the credit limit determined in (3).
    - (5) Printing a detail line as shown on the report layout.
    - (6) Incrementing the appropriate totals.
  - c. When all accounts for one customer have been processed, print the total lines as shown in the report layout.
  - d. Increment the appropriate account type in the summary table with the above information.
4. After all records have been read, print a summary table showing totals for each account type (as shown on the report layout).

**Project 11-6****Program Name:** Software Cost Analysis**Narrative:** The program will determine the following:

1. The break-even units and revenue for each software product.
2. The break-even units and revenue for each software product if a \$50,000 profit is desired.
3. The break-even units and revenue for each software product if the selling price is reduced by 25%.

**Input File:** SOFTWARE-FILE

**Input Record Layout:**

```

01 SOFTWARE-RECORD.
 05 SOFT-PROGRAM-INFO.
 10 SOFT-PRODUCT-LINE PIC X.
 10 SOFT-PRODUCT-NO PIC 9(4).
 10 SOFT-PROGRAM-NAME PIC X(18).
 05 SOFT-VARIABLE-COSTS.
 10 SOFT-PREP-COSTS.
 15 SOFT-LOADING-PER-DISK PIC 9V99.
 15 SOFT-NO-DISKS-USED PIC 99.
 10 SOFT-MANUAL-PRINTING PIC 99V99.
 10 SOFT-SHIPPING-N-HANDLING PIC 99V99.
 05 SOFT-SELL-PRICE PIC 999V99.
 05 SOFT-FIXED-COST PIC 9(5).

```

**Test Data:**

```

G4695Flight Simulator 15001100003250395025000
B3764WordPerfect 5.1 22511355010252690023000
G1634Leisure Suit Larry10002108502000399520000
U3476Fastback Plus 17501150003501195021000
G6424ChessMaster 05001075005500350018000
B4676Word 2.0 25008555008502997530000
M9775Automap 2.0 07501082502500490018000
G2555Police Quest 07502045504450455505000
D4954PowerPoint 2.0 22510350009502990008000
U7558PROCOMM Plus 2.01 07501105005250690007500
B2154Excel 4.0 26507257510252997528750
E5775Mickey's ABCs 08001035002250290003000
B75841-2-3 3.1 Plus 24508455005553990035800
D2585Harvard Graphics 21505252507253999534500
E6555KidPix 02501054002500350003650
B4954Quattro Pro 4.0 19506450012503195035950
U7588The Norton Desktop10002185007501150027000

```

**Report Layout:**

|                                                                                                     |       |            |
|-----------------------------------------------------------------------------------------------------|-------|------------|
| Nexus Software Inc.<br>Product Cost Analysis as of 99/99/99<br>based on Total Fixed Costs: \$ZZ,ZZ9 |       |            |
| Product Line: X                                                                                     |       |            |
| Product Name: XXXXXXXXXXXXXXXXXXXX                                                                  |       |            |
| Sell Price: ZZ9.99      Total Variable Cost: ZZ9.99                                                 |       |            |
|                                                                                                     | Units | Revenue    |
| Breakeven                                                                                           | Z,ZZ9 | ZZZ,ZZ9.99 |
| Profit: \$\$\$,\$\$9.99                                                                             | Z,ZZ9 | ZZZ,ZZ9.99 |
| Price Decline: Z9%                                                                                  | Z,ZZ9 | ZZZ,ZZ9.99 |

|                                                                                               |                   |                     |                       |
|-----------------------------------------------------------------------------------------------|-------------------|---------------------|-----------------------|
| Nexus Software Inc.<br>Product Cost Analysis<br>Summary Report by Product Line as of 99/99/99 |                   |                     |                       |
| Product<br>Line                                                                               | Breakeven         | Profit:<br>\$ZZ,ZZ9 | Price<br>Decline: Z9% |
| X                                                                                             | \$\$\$,\$\$9      | \$\$\$,\$\$9        | \$\$\$,\$\$9          |
| .                                                                                             | .                 | .                   | .                     |
| .                                                                                             | .                 | .                   | .                     |
| Totals                                                                                        | \$\$,\$\$\$,\$\$9 | \$\$,\$\$\$,\$\$9   | \$\$,\$\$\$,\$\$9     |

**Processing Requirements:**

1. Read a file of software records.
2. For each record read:
  - a. Calculate the total variable costs for each product using the data in each record; include an additional cost of \$1.00 for the disk itself. The software preparation costs will be the loading cost per disk multiplied by the number of disks used; don't forget to add the cost of the blank disk(s) by multiplying the cost of a blank disk by the number of disks used.
  - b. Create a three-item table containing units and revenues. This table should hold break-even units and revenue calculated as described below:
    - (1) Calculate the break-even point and revenue for each product.
    - (2) Calculate the required number of units and associated revenue to yield a \$50,000 profit for each product.
    - (3) Calculate the price decline break-even units and revenue if the selling price is reduced by 25%.
  - c. Print a detail line for each record as shown on the report layout. Design your detail line with a table that mimics the information calculated in item b. above.
  - d. Increment the appropriate revenue totals in your summary table.
3. After all records have been read, print the summary report and totals on a separate page as shown on the report layout. This will require you to create a table to hold all the product lines and revenue information.

## PROGRAMMING SPECIFICATIONS

**Project 12-1**

**Program Name:** Employee Profiles

**Narrative:** This project continues the employee profile program of Project 11-1 by introducing additional material on table lookups.

**Input File:** EMPLOYEE-FILE and TITLE-FILE (see processing requirement 3)

**Input Record Layout:** Use the same record layout as Project 11-1.

**Test Data:** Use the same test data as Project 11-1.

**Report Layout:** Expand the report layout of the earlier project to include space for the various table lookups. You may display the information anywhere you deem appropriate.

**Processing Requirements:** 1. The education table is to be initialized through hard-coding and expanded through a direct lookup according to the following table:

| Code | Description         | Code | Description           |
|------|---------------------|------|-----------------------|
| 1    | Some High School    | 5    | Some Grad School      |
| 2    | High School Diploma | 6    | Master's Degree       |
| 3    | Two Year Degree     | 7    | Ph. D.                |
| 4    | Four Year Degree    | 8    | Other Graduate Degree |

2. The location table is to be initialized through hard-coding and expanded with a sequential search according to the following table:

| Code | Description | Code | Description  |
|------|-------------|------|--------------|
| 05   | Atlanta     | 30   | Los Angeles  |
| 10   | Boston      | 35   | Minneapolis  |
| 15   | Chicago     | 40   | New York     |
| 20   | Detroit     | 45   | Philadelphia |
| 25   | Kansas City |      |              |

3. The title table is to be input loaded and expanded with a binary search according to the following table:

| Code | Title               |
|------|---------------------|
| 15   | Accountant          |
| 18   | Senior Accountant   |
| 30   | Jr. Programmer      |
| 32   | Senior Programmer   |
| 40   | Analyst             |
| 45   | Senior Analyst      |
| 50   | Programming Manager |



**Program Name:** Student Profile Program

**Narrative:** Develop a program to print a set of student profiles, showing detailed information on each student. Among other functions, the program is to convert an incoming set of codes for each student to an expanded, and more readable, format.

**Input File:** STUDENT-FILE and COURSE-FILE (see processing requirement 12)

**Input Record Layout:**

```

01 STUDENT-RECORD-IN.
 05 STU-SOC-SEC-NUMBER PIC 9(9).
 05 STU-NAME-AND-INITIALS.
 10 STU-LAST-NAME PIC X(18).
 10 STU-INITIALS PIC XX.
 05 STU-DATE-OF-BIRTH.
 10 STU-BIRTH-MONTH PIC 99.
 10 STU-BIRTH-YEAR PIC 99.
 05 STU-SEX PIC X.
 05 STU-MAJOR-CODE PIC X(3).
 05 STU-SCHOOL-CODE PIC 9.
 05 STU-CUMULATIVE-CREDITS PIC 999.
 05 STU-CUMULATIVE-POINTS PIC 999.
 05 STU-UNION-MEMBER-CODE PIC X.
 05 STU-SCHOLARSHIP PIC 999.
 05 STU-DATE-OF-ENROLLMENT PIC 9(4).
 05 STU-COURSES-THIS-SEMESTER OCCURS 7 TIMES.
 10 STU-COURSE-NUMBER PIC XXX.
 10 STU-COURSE-CREDITS PIC 9.

```

**Test Data:**

|                  |                                                        |
|------------------|--------------------------------------------------------|
| 100000000ALBERT  | A 0174MSTA1059118Y01509921002200330044004501360026011  |
| 200000000BROWN   | B 0275FSTA1089275N02509921002200330044004              |
| 300000000CHARLES | GG0675MHIS2109286Y100099350135033504350535063          |
| 400000000SMITH   | D 0776FXXX2090269N01009921002200330044194              |
| 500000000BAKER   | EF1074MGEN3032049Y00000994222333334443                 |
| 600000000GULFMAN | SF1173FELE4029059N000009932003333344435553666367527001 |
| 700000000BOROW   | JS1275MIEN3030090Y000009922223                         |
| 800000000MILGROM | MB0376F 5015045Y000009931113138315031603               |
| 900000000MILLER  | K 0174MFRL2015054Y00000993111314031503                 |
| 999919999WAYNE   | N 0473FHIS2090270Y000009945013503350435053             |

**Report Layout:**

| STUDENT PROFILES          |                    | Page Z9                 |
|---------------------------|--------------------|-------------------------|
| *****                     |                    |                         |
| NAME: XXXXXXXXXXXXXXXX XX | AGE: Z9.9          | SOC SEC NO: 999-99-9999 |
| MAJOR: XXXXXXXXXXXXXXXX   | ENROLLED: 99/99    | SCHOOL: XXXXXXXXXXXXX   |
| YEAR IN SCHOOL: XXXXXXXXX | STATUS: XXXXXXXXX  | SEX: XXXXXX GPA: 9.99   |
| COURSES THIS SEMESTER:    | COURSE             | CREDITS                 |
|                           | -----              | -----                   |
|                           | XXXXXXXXXXXXXXXXXX | Z9                      |
|                           | .                  | .                       |
|                           | .                  | .                       |
|                           | .                  | .                       |
|                           | -----              | -----                   |
| TOTAL CREDITS             |                    | Z9                      |

**Processing Requirements:**

1. Process a file of student records, printing a complete student profile for each record.
2. Two students are to appear on each page, with eight blank lines after the last line of the first profile on each page. The page number and literal heading ST U D E N T P R O F I L E S are to appear only before the first profile on each page.
3. The detailed layout for each profile can be seen from the report layout. Additional specifications are given in items 4-11.
4. Student age is to be calculated from date of birth and date of program execution.
5. The social security number requires the insertion of hyphens; accomplish this by defining an output picture containing blanks in appropriate positions and then replace the blanks through the INSPECT verb.
6. The status of the student is either part-time or full-time. Part-time students take fewer than 12 credits per semester.
7. GPA is defined as the cumulative points divided by the cumulative credits and does not include credits taken this semester. Calculate this field to two decimal places.
8. Year in school is a function of cumulative credits and again does not include credits taken this semester. Freshmen have completed fewer than 30; sophomores between 30 and 59, inclusive; juniors between 60 and 89, inclusive; and seniors 90 or more.

9. The incoming STU-SCHOOL-CODE is to be expanded via a direct lookup. Hard-code the following table in your program:

| CODE | SCHOOL       | CODE | SCHOOL      |
|------|--------------|------|-------------|
| 1    | BUSINESS     | 3    | ENGINEERING |
| 2    | LIBERAL ARTS | 4    | EDUCATION   |

10. The incoming STU-MAJOR-CODE is to be expanded via a sequential search. Hard-code the following major table:

| CODE | MAJOR           | CODE | MAJOR           |
|------|-----------------|------|-----------------|
| STA  | STATISTICS      | ECO  | ECONOMICS       |
| FIN  | FINANCE         | FRL  | FOREIGN LANG    |
| MKT  | MARKETING       | EEN  | ELECTRICAL ENG  |
| MAN  | MANAGEMENT      | MEN  | MECHANICAL ENG  |
| EDP  | DATA PROCESSING | CEN  | CHEMICAL ENG    |
| PHY  | PHYSICS         | IEN  | INDUSTRIAL ENG  |
| ENG  | ENGLISH         | ELE  | ELEMENTARY EDUC |
| BIO  | BIOLOGY         | SEE  | SECONDARY EDUC  |
| HIS  | HISTORY         | SPE  | SECONDARY EDUC  |

11. Expand each value of STU-COURSE-NUMBER to an expanded course name using a binary search. An incoming record contains up to seven courses; blanks (that is, spaces) appear in an incoming record with fewer than seven courses.
12. The table of course codes is to be established by reading values from a separate COURSE-FILE, with the following format: course code in positions 1-3 and course name in positions 4-18. The maximum table length is 100 courses, and the table of course codes appears below:

| CODE | COURSE       | CODE | COURSE        |
|------|--------------|------|---------------|
| 100  | ENGLISH I    | 503  | EUR HISTORY   |
| 111  | COMPUTER SCI | 504  | ECONOMICS     |
| 140  | SPANISH I    | 505  | POL SCIENCE   |
| 150  | MUSIC        | 506  | CREATIVE WRIT |
| 160  | ART APPREC   | 555  | EDUC THEORY   |
| 200  | BIOLOGY      | 601  | COBOL         |
| 222  | CHEMISTRY    | 666  | PSYCHOLOGY    |
| 300  | CALCULUS     | 675  | SPECIAL EDUC  |
| 333  | ELECT ENG 1  | 700  | THESIS        |
| 501  | AM HISTORY   |      |               |



## Project 12-3

**Program Name:** Furniture Shipments

**Narrative:** This program takes Project 11-3 and adds table lookups for warehouse and item information.

**Input File:** FURNITURE-FILE and ITEM-FILE (see processing requirement 1a)

**Input Record Layout:**

|    |                               |                                                            |
|----|-------------------------------|------------------------------------------------------------|
| 01 | FURNITURE-RECORD.             |                                                            |
| 05 | FURN-INVOICE-NO               | PIC 9(5).                                                  |
| 05 | FURN-CUSTOMER-NAME-N-INITIALS | PIC X(18).                                                 |
| 05 | FURN-DELIVERY-INFO.           |                                                            |
| 10 | FURN-DELIVERY-WAREHOUSE       | PIC X.                                                     |
| 10 | FURN-DELIVERY-DATE            | PIC 9(6).                                                  |
| 05 | FURN-ORDER-INFO.              |                                                            |
| 10 | FURN-DEPOSIT-PERCENT          | PIC 9V99.                                                  |
| 10 | FURN-NO-ITEMS-ORDERED         | PIC 9.                                                     |
| 10 | FURN-ITEMS-ORDERED            | OCCURS 1 TO 3 TIMES<br>DEPENDING ON FURN-NO-ITEMS-ORDERED. |
| 15 | FURN-ITEM-NO                  | PIC 9(4).                                                  |

**Test Data:**

| 1                       | 2                       | 3 | 4 | 5 | 6 | 7 | 8 |
|-------------------------|-------------------------|---|---|---|---|---|---|
| 23485EDELSTEIN, M       | A061092005213451386     |   |   |   |   |   |   |
| 12834ALIAS, Y           | B072492004217871798     |   |   |   |   |   |   |
| 79845RAHIM, S           | A0927920073230023502375 |   |   |   |   |   |   |
| 59789KELLY, C           | B082492003236093650     |   |   |   |   |   |   |
| 85778WILSON, D          | C0712920123457545904598 |   |   |   |   |   |   |
| 47597GUDAT, G           | A062892008213451397     |   |   |   |   |   |   |
| 58684HYMOWITZ, A        | C10289200912350         |   |   |   |   |   |   |
| 48577BOOZ, B            | C1212920283459936093650 |   |   |   |   |   |   |
| 56749HENNESSY, L        | A09099200415500         |   |   |   |   |   |   |
| 95877MOHD-RAZALLI       | B01129307811345         |   |   |   |   |   |   |
| 38476THOMPSON, J        | A092392009113971399     |   |   |   |   |   |   |
| 48565JACOMINO, R        | A092392010213971345     |   |   |   |   |   |   |
| 67566DESCHELLES, M      | B070492009217871798     |   |   |   |   |   |   |
| 09777SANCHEZ-CARRION, V | C081292002223504599     |   |   |   |   |   |   |
| 48576WENNEMAN, M        | B08169200412300         |   |   |   |   |   |   |
| 45337AL-DAKHIL, A       | A07229200515500         |   |   |   |   |   |   |
| 47567HARDING, J         | C082292002213451397     |   |   |   |   |   |   |

**Report Layout:** Use the same report layout as Project 11-3, but expand the warehouse from the table lookups in both the detail and summary reports. Include the item number in the detail report.

**Processing Requirements:**

1. Follow the same processing requirements as Project 11-3 with the following changes.
  - a. Note that the item description, item cost, and item weight have been replaced in the input record layout by a single item number. Determine the description, cost, and weight via a binary lookup. Initialize the following table by reading values from a separate ITEM-FILE and input-load it:



| Item # | Description | Cost       | Weight | Item # | Description     | Cost       | Weight |
|--------|-------------|------------|--------|--------|-----------------|------------|--------|
| 1345   | 72" Sofa    | \$2,300.00 | 100    | 2375   | Nightstand      | \$300.00   | 45     |
| 1386   | Love Seat   | \$1,300.00 | 80     | 3609   | Desk            | \$450.00   | 98     |
| 1397   | Chair       | \$545.00   | 50     | 3650   | Desk Chair      | \$395.50   | 45     |
| 1399   | Ottoman     | \$350.00   | 40     | 4575   | Dining Table    | \$3,575.50 | 135    |
| 1787   | Soia Table  | \$600.00   | 50     | 4590   | 6 Dining Chairs | \$1,278.00 | 200    |
| 1798   | End Table   | \$545.50   | 35     | 4598   | Console         | \$2,225.50 | 115    |
| 2300   | Dresser     | \$4,300.00 | 95     | 4599   | Credenza        | \$1,235.00 | 250    |
| 2350   | Armoire     | \$5,500.00 | 100    | 5500   | Pool Table      | \$2,300.00 | 250    |

b. The warehouse code is to be expanded via a sequential lookup. Hard-code the following table in your program:

| Warehouse Code | Description |
|----------------|-------------|
| A              | Miami       |
| B              | N. Carolina |
| C              | New York    |



**Program Name:** Computer Status Report

**Narrative:** This program takes Project 11-4 and adds table lookups for payment method, status, and component information.

**Input File:** COMPUTER-FILE and COMPONENT-FILE (see processing requirement 1a)

**Input Record Layout:**

```

01 COMPUTER-RECORD.
 05 COM-INVOICE-NO PIC 9(5).
 05 COM-CUSTOMER-NAME PIC X(18).
 05 COM-PAYMENT-METHOD PIC XX.
 05 COM-SHIP-INFO.
 10 COM-SHIP-STATUS PIC X.
 10 COM-SHIP-CHARGE PIC 99V99.
 05 COM-COMPONENT-INFO.
 10 COM-NO-COMPONENTS PIC 9.
 10 COM-COMPONENTS OCCURS 1 TO 4 TIMES
 DEPENDING ON COM-NO-COMPONENTS.
 15 COM-COMPONENT-NO PIC 9(4).

```

**Test Data:**

```

12834Blanco, Erick AM14550243306250
79845Casali, Joseph AM37500233050008120
59789Davis, Kevin VI16550243305000
85778Demler, Linda C03802543300550092016750
47597Echavarria, FelipeCK26500243308250
58684Flemming, Sharon MC14500245005500
48577Gonzalez, Maria VI135003450067509300
56749Katan, Maharan CK2450013250
95877Parmenter, Donita C033500242509001
38476Pinkwasser, Randi VI3890044660650055009300
37586Stewart, Roberto CK25000232507000

```

**Report Layout:** Use the same report layout as Project 11-4, but expand the status and payment method from the table lookups in both the detail and summary reports. Include the component number in the detail line.

**Processing Requirements:**

1. Follow the same processing requirements as Project 11-4 with the following changes.
  - a. Note that the component description and cost have been replaced in the input record layout by a single component number. Determine the description and cost via a binary lookup for the detail report. Initialize the following table by reading values from a separate COMPONENT-FILE and input-load it:

| Component | Description        | Cost       | Component | Description          | Cost       |
|-----------|--------------------|------------|-----------|----------------------|------------|
| 3250      | 386 25MHz          | \$1,295.00 | 6250      | 2400 BAUD Modem      | \$99.00    |
| 3330      | 386 33MHz          | \$1,595.00 | 6500      | 9600 BAUD Modem      | \$299.00   |
| 3400      | 386 DX40           | \$2,049.00 | 6750      | Modem/FAX Card       | \$119.00   |
| 4250      | 425 Notebook       | \$1,995.00 | 7000      | FAX                  | \$1,279.00 |
| 4330      | 486 33MHz          | \$1,995.00 | 8120      | Tape Backup Unit 120 | \$189.00   |
| 4500      | 486 DX2 50MHz      | \$2,295.00 | 8250      | Tape Backup Unit 250 | \$250.00   |
| 4660      | 486 DX2 66MHz      | \$1,895.00 | 9001      | CD-ROM               | \$345.00   |
| 5000      | Laser Printer      | \$1,399.00 | 9201      | Coprocessor          | \$99.00    |
| 5500      | Dot Matrix Printer | \$169.00   | 9300      | Sound Blaster        | \$139.00   |

b. The status code (printed in both the detail and summary reports) is to be expanded via a binary lookup. Hard-code the following table in your program:

| Status | Description |
|--------|-------------|
| 1      | Assembly    |
| 2      | Packing     |
| 3      | Testing     |

- c. The payment method code is to be expanded via a sequential lookup. Hard-code the following table in your program:

| Payment Code | Method of Payment |
|--------------|-------------------|
| AM           | American Express  |
| MC           | MasterCard        |
| VI           | Visa              |
| CO           | COD               |
| CK           | Check             |

### Project 12-5

**Program Name:** Credit Report

**Narrative:** This program takes Project 11-5 and adds table lookups for the interest rate, credit limit, and account type.

**Input File:** CREDIT-FILE

**Input Record Layout:** Use the same record layout as Project 11-5.

**Test Data:** Use the same test data as Project 11-5.

**Report Layout:** Use the same report layout as Project 11-5, but expand the account type with the appropriate description.

- Processing Requirements:**
1. Follow the same processing requirement as Project 11-5 with the following changes.
    - a. Determine the description, credit limit, and interest rate via a sequential lookup. Hard-code the following table:

| Type | Description | Credit Limit | Interest Rate |
|------|-------------|--------------|---------------|
| 20   | Regular     | \$1,500      | 18.5%         |
| 40   | 3Pay        | \$3,500      | 0%            |
| 60   | Household   | \$5,500      | 17.5%         |

### Project 12-6

**Program Name:** Software Cost Analysis

**Narrative:** This program takes Project 11-6 and adds table lookups for product line description.

**Input File:** SOFTWARE-FILE

**Input Record Layout:** Use the same record layout as Project 11-6.

**Test Data:** Use the same test data as Project 11-6.

**Report Layout:** Use the same report layout as Project 11-6, but expand the product line with the appropriate description.

**Processing Requirements:**

1. Use the processing requirements from Project 11-6 and add the following:
  - a. The product line code should be expanded in the summary report using the following code definitions:

| Code | Product Line          | Code | Product Line     |
|------|-----------------------|------|------------------|
| G    | Games                 | D    | Drawing/Graphics |
| B    | Business Applications | E    | Educational      |
| U    | Utility Applications  | M    | Miscellaneous    |

- b. Today's date is to be printed as shown on the report layout. The current month is to be expanded via a direct lookup. Hard-code the following table in your program:

| Month | Expanded Month | Month | Expanded Month |
|-------|----------------|-------|----------------|
| 1     | January        | 7     | July           |
| 2     | February       | 8     | August         |
| 3     | March          | 9     | September      |
| 4     | April          | 10    | October        |
| 5     | May            | 11    | November       |
| 6     | June           | 12    | December       |

## Project 12-7

**Program Name:** Catalog Orders Program

**Narrative:** Develop a program to calculate the total orders and the total handling charges for the Regal Catalog Company's monthly orders. The order file has been sorted by date.

**Input File:** CATALOG-ORDER-FILE and HANDLING-CLASS-FILE (see processing requirement 7)

**Input Record Layout:**

|    |                       |             |
|----|-----------------------|-------------|
| 01 | CATALOG-ORDER-RECORD. |             |
| 05 | CAT-ITEM-NO           | PIC 9(4).   |
| 05 | CAT-DATE.             |             |
| 10 | CAT-MONTH             | PIC 99.     |
| 10 | CAT-DAY               | PIC 99.     |
| 10 | CAT-YEAR              | PIC 99.     |
| 05 | CAT-QUANTITY          | PIC 9(3).   |
| 05 | CAT-PRICE             | PIC 9(3)99. |
| 05 | CAT-HANDLING-CLASS    | PIC X.      |

**Test Data:**

| 1                   | 2 | 3 | 4 | 5 | 6 |
|---------------------|---|---|---|---|---|
| 441401048901011545A |   |   |   |   |   |
| 177801208901047995G |   |   |   |   |   |
| 313101298904004995E |   |   |   |   |   |
| 118301318901008995D |   |   |   |   |   |
| 476502058902008925F |   |   |   |   |   |
| 599202148901007945C |   |   |   |   |   |
| 518602188901043500F |   |   |   |   |   |
| 347502228902008995E |   |   |   |   |   |
| 834402288901005495B |   |   |   |   |   |

**Report Layout:** Design your own report layout in accordance with the processing specifications.

**Processing Requirements:**

1. Process a file of catalog orders to determine the monthly total for orders and handling charges.
2. Print the month's orders with five blank lines between each month. Print an appropriate heading at the beginning of each new month.
3. The detailed layout can be determined from the report layout. Additional specifications are given in items 4-7.
4. The incoming CAT-MONTH is to be expanded via a direct lookup. Hard-code the following table in your program:

| Month | Expanded Month | Month | Expanded Month |
|-------|----------------|-------|----------------|
| 1     | January        | 7     | July           |
| 2     | February       | 8     | August         |
| 3     | March          | 9     | September      |
| 4     | April          | 10    | October        |
| 5     | May            | 11    | November       |
| 6     | June           | 12    | December       |

5. The incoming CAT-ITEM-NO is to be expanded via a binary search. Input-load the following item table:

| Item No. | Item Description | Item No. | Item Description |
|----------|------------------|----------|------------------|
| 1183     | Portable Phone   | 4414     | Chess Set        |
| 1778     | 20" Television   | 4765     | Table Lamp       |
| 2686     | Coffee Maker     | 5186     | 35mm Camera      |
| 3131     | Ceiling Fan      | 5992     | Tennis Racquet   |
| 3475     | Bedspread        | 8344     | Vase             |

6. Total price is calculated by multiplying the quantity by the price per item.

- 7. The incoming CAT-HANDLING-CLASS is to be expanded via a sequential search. The table for handling classes is to be established by reading values from a separate HANDLING-CLASS-FILE, with the following format: handling class code in position 1 and handling charges in positions 2-5. The maximum table length is 26. The table of class codes is shown:

| Code | Handling Charges |
|------|------------------|
| A    | 6.25             |
| B    | 12.00            |
| C    | 14.25            |
| D    | 16.50            |
| E    | 18.50            |
| F    | 21.25            |
| G    | 25.50            |

### Project 12-8

**Program Name:** Check Register

**Narrative:** The dollar amount of any check is written out in words, in addition to appearing as a number. This project is intended to accomplish that conversion.

**Input File:** CHECKING-ACCOUNT-FILE

**Input Record Layout:**

```

01 CHECKING-RECORD.
 05 CHECK-NUMBER PIC 9(4).
 05 CHECK-AMOUNT PIC 9(5).
```

**Test Data:**

```

111101234
222245000
333345200
444445986
666645906
777700689
888800089
999900008
100001000
200000100
300023000
```

**Report Layout:** The resulting report need not be elaborate. All that is required is a single detail line for each input record, containing the dollar amount and associated conversion.



- Processing Requirements:**
1. Read a file of checking account records.
  2. For each record read:
    - a. Convert the dollar amount to a written amount, with the word "dollars" appended at the end; for example, 234 should be converted to TWO HUNDRED THIRTY-FOUR DOLLARS.
    - b. Cents are not included; that is, all incoming amounts are integer amounts. The maximum dollar amount to be converted is 99,999.
    - c. The report is to contain one line for each record, with the amount expressed in both numbers and words.

**P R O G R A M M I N G   S P E C I F I C A T I O N S**

**Project 13-1**

**Program Name:** Price Break Report

**Narrative:** This project builds on Projects 2-1 and 7-2. Write a program to determine whether a customer receives a price break based on quantity ordered, and calculate the unit price and extended price. Create a report that prints each customer's order, as well as the Total Quantity Ordered and Total Sales for the company.

**Input File:** ORDER-TRANSACTION-FILE

**Input Record Layout:**

| Order Record    |   |                  |             |    |                    |
|-----------------|---|------------------|-------------|----|--------------------|
| Customer Number |   | Quantity Ordered | Item Number |    | Unit Price         |
| 1 ... 8         | 9 | 10 ... 12        | 13 ... 17   | 18 | 19 (2 decimals) 23 |

**Test Data:** Use same test data as in Project 7-2.

**Report Layout:** Use the same layout designed in Project 7-2.

- Processing Requirements:**
1. Read a file of order records.
  2. For every record read:
    - a. Determine whether the customer will receive a discount. The discounting of an item is based on specifications presented in Project 2-1; only 5-item series are included in this exercise, but the program should support up to 100-item series. Because of this additional criterion, utilize a two-dimensional table to determine the discount percent based on the item series and quantity ordered.
    - b. Calculate the unit price by applying the appropriate discount as determined in 2a.
    - c. Calculate the extended price by multiplying the quantity ordered by the unit price.
    - d. Accumulate the customer's and the company's order totals.
  3. Print the customer number, item number, quantity ordered, unit price (calculated), and extended price for each customer record. Single-space the output.
  4. Print the total quantity ordered and the total sales. Double-space the totals.



**Project 13-2**

**Program Name:** Movies

**Narrative:** Develop a program to compute the amount due the hundreds of movie extras who participated in the latest Hollywood extravaganza.

**Input File:** MOVIE-EXTRA-FILE

**Input Record Layout:**

| POSITIONS | FIELD            | PICTURE |
|-----------|------------------|---------|
| 1-9       | SOC-SEC-NUMBER   | 9(9)    |
| 10-27     | NAME             | X(18)   |
| 28-29     | MOVIE-EXPERIENCE | 99      |
| 30        | TYPE-ROLE        | X       |
| 31-34     | HOURS-WORKED     | 999V9   |
| 35-36     | EXPANDED-ROLE    | XX      |

**Test Data:**

| 1         | 2                  | 3         | 4 | 5 | 6 |
|-----------|--------------------|-----------|---|---|---|
| 000000001 | JONES, J.          | 00G0800GN |   |   |   |
| 000000002 | JONES, ROY         | 02F0450FA |   |   |   |
| 000000003 | WILLIAMS, JOHN     | 01E0450EA |   |   |   |
| 000000004 | FOSTER, RAYMOND    | 11B0425BN |   |   |   |
| 000000005 | HIGH, LUCY         | 08A0450AR |   |   |   |
| 000000006 | HARDING, HOWARD    | 04A0450AV |   |   |   |
| 000000007 | ZHE, KEVIN         | 05D0450DN |   |   |   |
| 000000008 | JENNINGS, VIVIAN   | D0200DA   |   |   |   |
| 000000009 | ROOSEVELT, TIMOTHY | 07E0230XX |   |   |   |
| 000000010 | TRUELOVE, BILL     | 09G0450EN |   |   |   |

**Report Layout:**

| HOLLYWOOD EXTRAVAGANZA, INC. |                      |     |      |             |           |             | PAGE Z9       |
|------------------------------|----------------------|-----|------|-------------|-----------|-------------|---------------|
| SOC SEC NO                   | MOVIE EXTRA          | EXP | ROLE | HOURLY-RATE | REG-HOURS | EXTRA-HOURS | PAY           |
| 999-99-9999                  | XXXXXXXXXXXXXXXXXXXX | 99  | X    | \$29.99     | ZZ9.9     | Z9          | \$\$,\$\$9.99 |
| .                            | .                    | .   | .    | .           | .         | .           | .             |
| .                            | .                    | .   | .    | .           | .         | .           | .             |
| .                            | .                    | .   | .    | .           | .         | .           | .             |

**Processing Requirements:**

1. Process a file of pay records for movie extras, to determine the pay owed to each individual.
2. An hourly pay scale is used, with the individual's hourly rate a function of the type of role and his or her experience in previous movies. The following table contains the pay scale and is to be hard-coded in your program:

| Type of Role | Previous experience (number of movies) |       |       |       |       |       |          |
|--------------|----------------------------------------|-------|-------|-------|-------|-------|----------|
|              | 0                                      | 1     | 2     | 3     | 4     | 5-7   | 8 and Up |
| A            | 20.00                                  | 25.00 | 30.00 | 32.00 | 34.00 | 38.00 | 40.00    |
| B            | 14.00                                  | 17.00 | 18.00 | 19.00 | 21.00 | 23.00 | 24.00    |
| C            | 7.00                                   | 7.00  | 7.50  | 8.00  | 8.50  | 8.50  | 9.00     |
| D            | 4.00                                   | 4.00  | 5.00  | 5.50  | 5.50  | 6.00  | 6.00     |
| E            | 3.75                                   | 4.50  | 5.00  | 5.25  | 5.25  | 5.50  | 5.50     |
| F            | 3.50                                   | 3.50  | 3.50  | 3.75  | 3.75  | 3.75  | 4.00     |

The number of previous movies for an individual must be converted into a number from 1 to 7, so that it can be used as a subscript for access into the table.

3. Incoming pay records are to be checked for valid data; specifically:
  - a. Verify that the value in MOVIE-EXPERIENCE is numeric; if not, display an error message and do no further processing for that record.
  - b. Verify that the value in TYPE-ROLE is valid (i.e., A, B, C, D, E, or F); if not, display an error message and do no further processing for that record.
4. Each employee is to receive, as a bonus, a number of extra hours (not appearing on the employee's pay record), for which the employee will be paid at his or her regular hourly rate. The number of extra hours is a function of the EXPANDED-ROLE field in the incoming record as shown in the following table:

| Expanded Role | Extra Hours | Expanded Role | Extra Hours |
|---------------|-------------|---------------|-------------|
| AA            | 01          | DN            | 08          |
| AV            | 01          | DR            | 09          |
| BA            | 03          | EA            | 14          |
| BN            | 05          | EN            | 03          |
| CA            | 05          | ER            | 03          |
| CN            | 04          | FA            | 01          |
| DA            | 08          | FN            | 06          |

5. The bonus table for extra hours is in ascending sequence by the expanded role field. Use a binary search to determine the number of extra hours an individual will receive; that is, if a match is found, take the hours shown in the table and add it to the hours in the incoming record to determine pay. If no match is found, do not add any extra hours. An individual with no extra hours will be paid just for the number of hours on his or her incoming record.
6. The printed report should print no more than four valid records per page. (The employees with invalid data should be displayed in a separate error report.) Double-space between detail lines.

**Project 13-3****Program Name:** Two-level Tables

**Narrative:** This program illustrates two-level tables and PERFORM VARYING in two dimensions. Incoming employee records are checked for one of three locations and one of two performance levels, producing six location-performance combinations. The average salary for each of these six combinations is computed.

**Input File:** EMPLOYEE-FILE

**Input Record Layout:**

```

01 EMPLOYEE-RECORD-IN.
 05 EMP-PERSONAL-INFO.
 10 EMP-SOC-SEC-NUM PIC X(9).
 10 EMP-NAME-AND-INITIALS PIC X(16).
 10 EMP-DATE-OF-BIRTH.
 15 EMP-BIRTH-MONTH PIC 9(2).
 15 EMP-BIRTH-YEAR PIC 9(2).
 05 EMP-COMPANY-INFO.
 10 EMP-DATE-OF-HIRE.
 15 EMP-HIRE-MONTH PIC 9(2).
 15 EMP-HIRE-YEAR PIC 9(2).
 10 EMP-LOCATION-CODE PIC 9(2).
 10 EMP-EDUCATION-CODE PIC 9.
 10 EMP-TITLE-DATA.
 15 EMP-TITLE-CODE PIC 9(3).
 15 EMP-TITLE-DATE PIC 9(4).
 10 EMP-PERFORMANCE PIC 9.
 10 EMP-SALARY PIC 9(5).

```

**Test Data:**

```

354679876KERBEL, NX 075901908025640683115500
264480529CLARK, JS 116007913039990184125300
223340090HUMMER, MR 075202928067340683143980
556667856BENWAY, CX 095911926059990184132554
667893343FITZPATRICK, DT 045706938038780184221550
433556767NORIEGA, LA 116004916024530683218500
455399829VOGEL, VD 036006938032330683124825
688773423BEINHORN, CB 098008923044550683129850
100334234GARCIA, PJ 075901906025640683212000
899843328TOWER, DR 056007903039990184119000
776338380MCDONALD, J 075311908067340683154380

```

**Report Layout:**

| LOCATION/PERFORMANCE AVERAGE SALARY REPORT |                  |                 |
|--------------------------------------------|------------------|-----------------|
| LOCATION                                   | HIGH PERFORMANCE | LOW PERFORMANCE |
| MIAMI                                      | ZZ,ZZ9.99        | ZZ,ZZ9.99       |
| LOS ANGELES                                | ZZ,ZZ9.99        | ZZ,ZZ9.99       |
| NEW YORK                                   | ZZ,ZZ9.99        | ZZ,ZZ9.99       |

**Processing Requirements:**

1. Read a file of employee records.
2. For each record read, determine if the employee is in Miami (code 30), Los Angeles (code 60), or New York (code 80) and has a performance rating of 1 (high performance) or 2 (low performance). Any employee meeting both requirements—that is, an employee with a valid location and performance rating—is a qualified employee. No further processing is necessary for nonqualified employees.
3. Establish a 3-by-2 table to compute salary statistics for the 6 location-performance combinations. Rows 1, 2, and 3 are for Miami, Los Angeles, and New York. Columns 1 and 2 designate high and low performance, respectively.
4. For each qualified employee:
  - a. Determine the appropriate row-column (i.e., location-performance) combination.
  - b. Increment the total of all employee salaries for that row-column combination by this employee's salary.
  - c. Increment the number of employees in that row-column combination by 1.
5. When all employees have been processed, divide the total salaries for each combination by the number of employees in that combination, producing the average salary for that combination. Produce the required report shown in the report layout, showing the six values of average salary.

**Project 13-4**

**Program Name:** Three-level Tables

**Narrative:** This program extends the previous project to illustrate three-level tables and PERFORM VARYING in three dimensions. Incoming employee records are checked for one of three locations, one of six education codes, and one of two performance levels, producing 36 location-education-performance combinations. The average salary for each of these 36 combinations is computed.

**Input File:** EMPLOYEE-FILE

**Input Record Layout:** Same as Project 13-3.

**Test Data:** Same as Project 13-3.

**Report Layout:**

| AVERAGE SALARY REPORT FOR LOCATION: MIAMI |                  |                 |
|-------------------------------------------|------------------|-----------------|
| EDUCATION LEVEL                           | HIGH PERFORMANCE | LOW PERFORMANCE |
| GRADE SCHOOL                              | ZZ,ZZ9.99        | ZZ,ZZ9.99       |
| HIGH SCHOOL                               | ZZ,ZZ9.99        | ZZ,ZZ9.99       |
| ASSOCIATE                                 | ZZ,ZZ9.99        | ZZ,ZZ9.99       |
| BACHELOR                                  | ZZ,ZZ9.99        | ZZ,ZZ9.99       |
| MASTER                                    | ZZ,ZZ9.99        | ZZ,ZZ9.99       |
| DOCTORATE                                 | ZZ,ZZ9.99        | ZZ,ZZ9.99       |

## AVERAGE SALARY REPORT FOR LOCATION: LOS ANGELES

| EDUCATION LEVEL | HIGH PERFORMANCE | LOW PERFORMANCE |
|-----------------|------------------|-----------------|
| GRADE SCHOOL    | ZZ,ZZ9.99        | ZZ,ZZ9.99       |
| HIGH SCHOOL     | ZZ,ZZ9.99        | ZZ,ZZ9.99       |
| ASSOCIATE       | ZZ,ZZ9.99        | ZZ,ZZ9.99       |
| BACHELOR        | ZZ,ZZ9.99        | ZZ,ZZ9.99       |
| MASTER          | ZZ,ZZ9.99        | ZZ,ZZ9.99       |
| DOCTORATE       | ZZ,ZZ9.99        | ZZ,ZZ9.99       |

## AVERAGE SALARY REPORT FOR LOCATION: NEW YORK

| EDUCATION LEVEL | HIGH PERFORMANCE | LOW PERFORMANCE |
|-----------------|------------------|-----------------|
| GRADE SCHOOL    | ZZ,ZZ9.99        | ZZ,ZZ9.99       |
| HIGH SCHOOL     | ZZ,ZZ9.99        | ZZ,ZZ9.99       |
| ASSOCIATE       | ZZ,ZZ9.99        | ZZ,ZZ9.99       |
| BACHELOR        | ZZ,ZZ9.99        | ZZ,ZZ9.99       |
| MASTER          | ZZ,ZZ9.99        | ZZ,ZZ9.99       |
| DOCTORATE       | ZZ,ZZ9.99        | ZZ,ZZ9.99       |

**Processing Requirements:**

1. Read a file of employee records.
2. For each record read, determine if the employee is in Miami, Los Angeles, or New York; has an education code of 1 through 6 for Grade School, High School, Associate, Bachelor, Master, and Doctorate; and has a performance rating of 1 (high performance) or 2 (low performance). Any employee meeting all three requirements—that is, an employee with a valid location, education, and performance rating—is a qualified employee. No further processing is necessary for nonqualified employees.
3. Establish a 3-by-6-by-2 table to compute salary statistics for the 36 location-education-performance combinations. Each location contains rows 1 through 6 for Grade School, High School, Associate, Bachelor, Master, and Doctorate; and columns 1 and 2 designate high and low performance, respectively.
4. For each qualified employee:
  - a. Determine the appropriate row-column (i.e., education-performance) combination for each location.
  - b. Increment the total of all employee salaries for that row-column combination for each location by this employee's salary.
  - c. Increment the number of employees in that row-column combination for that location by 1.
5. When all employees have been processed, divide the total salaries for each combination by the number of employees in that combination, producing the average salary for that combination. Produce the required report shown in the report layout, showing the 36 values of average salary, printing every location on a separate page.

**Project 13-5**

**Program Name:** Payroll Program

**Narrative:** Develop a program to print complete paycheck (including a check stub) and a payroll journal reflecting all checks printed.

**Input File:** PAYROLL-FILE

**Input Record Layout:**

```

01 PAYROLL-RECORD-IN.
 05 PAY-SOC-SEC-NUM PIC 9(9).
 05 PAY-NAME.
 10 PAY-LAST PIC X(14).
 10 PAY-FIRST PIC X(12).
 10 PAY-INITIAL PIC X.
 05 PAY-INFO.
 10 PAY-HOURLY-RATE PIC 9(3)V99.
 10 PAY-HOURS-WORKED PIC 9(3)V99.
 10 PAY-SALARY-TYPE PIC X.
 10 PAY-DEPENDENTS PIC 99.
 10 PAY-TAX-STATUS PIC 9.
 10 PAY-INSURANCE PIC X.
 05 PAY-YTD-INFO.
 10 PAY-YTD-EARNINGS PIC 9(6)V99.
 10 PAY-YTD-TAXES PIC 9(5)V99.
 10 PAY-YTD-FICA PIC 9(4)V99.
 10 PAY-YTD-INSURANCE PIC 9(3)V99.

```

**Test Data:** Use the validated payroll file from Project 8-3.

**Report Layout:**

|                                |                                 | ANDREW INC. |            |           |           | PAGE 29    |
|--------------------------------|---------------------------------|-------------|------------|-----------|-----------|------------|
| PAYROLL JOURNAL AS OF 99/99/99 |                                 |             |            |           |           |            |
|                                |                                 | GROSS       | DEDUCTIONS |           |           |            |
| SOC SEC NO                     | NAME                            | EARNINGS    | TAXES      | FICA      | INSURANCE | NET PAY    |
| 999-99-9999                    | XXXXXXXXXXXXXX, XXXXXXXXXXXX X. | ZZ,ZZ9.99   | Z,ZZ9.99   | Z,ZZ9.99  | Z9.99     | ZZ,ZZ9.99  |
| .                              | .                               | .           | .          | .         | .         | .          |
| .                              | .                               | .           | .          | .         | .         | .          |
| .                              | .                               | .           | .          | .         | .         | .          |
|                                |                                 | -----       | -----      | -----     | -----     | -----      |
|                                |                                 | ZZZ,ZZ9.99  | ZZ,ZZ9.99  | ZZ,ZZ9.99 | ZZ9.99    | ZZZ,ZZ9.99 |

**Processing Requirements:**

1. Read a file of payroll records.
2. For each record read calculate:
  - a. Gross earnings, which is dependent on salary type (salaried or hourly) and can be calculated in one of two ways:
    - (1) Salaried employees are not paid overtime. Gross pay for salaried employees is rate of pay multiplied by the standard 40 hours. If hours exceed 40, place an asterisk (\*) next to the hours worked in the detail line of the payroll journal and calculate the gross earnings using 40 hours.
    - (2) Hourly employees are paid overtime at a rate of time and a half for hours beyond 40 through 48 and double time for hours beyond 48.
  - b. The yearly taxes, which are dependent on two factors: tax status and yearly salary. This amount is divided by 52 to obtain the weekly tax deduction.
    - (1) The tax status is used to determine the proper tax table. Establish a two-level table with the following information to determine the taxes deducted (you may pick the type of initialization and lookup technique):

| <b>Head of Household</b>             |         |             |       |                      |
|--------------------------------------|---------|-------------|-------|----------------------|
| Yearly salary<br>over - but not over |         | The tax is: |       | of the amount over - |
| 0                                    | 24,850  | \$0         | + 15% | \$0                  |
| 24,850                               | 64,200  | \$3,727.50  | + 28% | 24,850               |
| 64,200                               | 128,810 | 14,745.50   | + 33% | 64,200               |

| <b>Married Filing Jointly</b>        |         |             |       |                      |
|--------------------------------------|---------|-------------|-------|----------------------|
| Yearly salary<br>over - but not over |         | The tax is: |       | of the amount over - |
| 0                                    | 30,950  | \$0         | + 15% | \$0                  |
| 30,950                               | 74,800  | \$4,642.50  | + 28% | 30,950               |
| 74,800                               | 128,810 | 16,934.50   | + 33% | 74,800               |

| <b>Single</b>                        |        |             |       |                      |
|--------------------------------------|--------|-------------|-------|----------------------|
| Yearly salary<br>over - but not over |        | The tax is: |       | of the amount over - |
| 0                                    | 18,500 | \$0         | + 15% | \$0                  |
| 18,500                               | 44,900 | \$2,782.50  | + 28% | 18,500               |
| 44,900                               | 93,130 | 10,160.50   | + 33% | 44,900               |

| <b>Married Filing Separately</b>     |         |             |       |                      |
|--------------------------------------|---------|-------------|-------|----------------------|
| Yearly salary<br>over - but not over |         | The tax is: |       | of the amount over - |
| 0                                    | 15,475  | \$0         | + 15% | \$0                  |
| 15,475                               | 37,425  | \$2,321.50  | + 28% | 15,475               |
| 37,425                               | 117,895 | 8,467.50    | + 33% | 37,425               |

- (2) Yearly salary for both salaried and hourly employees is estimated based on a 40-hour week and a 52-week year.
- c. FICA deduction, which is calculated as 7.51% of gross pay for the first \$56,000. After year-to-date earnings reach \$56,000, no FICA will be deducted.
- d. Insurance deducted, which is also determined by the type of insurance plan and number of dependents. Determine the insurance deducted via a table lookup in the following two-level table:

| Number of Dependents | Health Plan |       |        |
|----------------------|-------------|-------|--------|
|                      | Blue Cross  | AvMed | Humana |
| 1                    | 14.00       | 10.00 | 10.00  |
| 2                    | 15.00       | 12.00 | 12.00  |
| 3                    | 20.00       | 15.00 | 15.00  |
| 4                    | 23.00       | 18.00 | 18.00  |
| 5                    | 25.00       | 24.00 | 24.00  |

Note: Beyond 5 dependents the cost of the plan remains the same. Therefore, an employee with 8 dependents pays the 5-dependent rate. No insurance is deducted for those with a Z (NO-INSURANCE).

- e. Net earnings, which is calculated as gross earnings minus deductions (taxes, FICA [if any], and insurance [if any]).
3. Print a payroll journal detail line as shown in the report layout. Use the STRING statement to print the employee name in the following format:
- lastname, firstname initial*
4. Print a heading on top of each new page. Each page is to contain 10 employees. The date of execution should appear on the heading as indicated.
5. When all records have been read, print totals for hours worked, gross pay, all deductions (taxes deducted, FICA deducted, insurance deducted), and net pay.

### Project 13-9

**Program Name:** Extended Student Profile Program

**Narrative:** This program continues the student profile program of Project 12-2 by adding a summary report. The summary report will utilize a three-dimensional table to accumulate totals for each school, major within school, and year in school within major.

**Input File:** STUDENT-FILE and COURSE-FILE from Project 12-2

**Input Record Layout:** Use the same record layout as Project 12-2.

**Test Data:** Use the same test data as Project 12-2.



**Report Layout:**

| STUDENT PROFILES                                       |                       |                  |                    | Page Z9 |
|--------------------------------------------------------|-----------------------|------------------|--------------------|---------|
| Summary Report for School of XXXXXXXXXX as of 99/99/99 |                       |                  |                    |         |
| *****                                                  |                       |                  |                    |         |
| Major: XXXXXXXXXXXXXXXX                                |                       |                  |                    |         |
| Year in School                                         | Number of<br>Students | Total<br>Credits | Average<br>Credits |         |
| Freshman                                               | ZZ9                   | ZZ,ZZ9           | Z,ZZ9              |         |
| Sophomore                                              | .                     | .                | .                  |         |
| Junior                                                 | .                     | .                | .                  |         |
| Senior                                                 | .                     | .                | .                  |         |
| -----                                                  |                       |                  |                    |         |
| Totals                                                 | Z,ZZ9                 | ZZZ,ZZ9          | ZZ,ZZ9             |         |
| *****                                                  |                       |                  |                    |         |
| Major: XXXXXXXXXXXXXXXX                                |                       |                  |                    |         |
| Year in School                                         | Number of<br>Students | Total<br>Credits | Average<br>Credits |         |
| .                                                      | .                     | .                | .                  |         |
| School of XXXXXXXXXX                                   | ZZ,ZZ9                | Z,ZZZ,ZZ9        | ZZZ,ZZ9            |         |

**Processing Requirements:**

1. The following are additional processing requirements to Project 12-2 for the summary report:
  - a. Create a 4 x 18 x 4 (3-dimensional) table to accumulate number of students and total credits for the appropriate school-major-year (in school) combination.
  - b. When all records have been processed, print the summary as shown in the report layout. Each school should begin on a new page.

**PROGRAMMING SPECIFICATIONS**

**Project 14-1**

**Program Name:** Price Break Report

**Narrative:** This project builds on Project 13-1. Write a program to determine whether a customer receives a price break based on quantity ordered and calculate the unit price and extended price. Create a report that prints each customer's order, as well as the total ordered for each customer and a grand total for the company.

**Input File:** ORDER-TRANSACTION-FILE

**Input Record Layout:**

| Customer Order Record |   |                  |             |    |                    |                 |
|-----------------------|---|------------------|-------------|----|--------------------|-----------------|
| Customer Number       |   | Quantity Ordered | Item Number |    | Unit Price         | Salesrep Number |
| 1 ... 8               | 9 | 10 ... 12        | 13 ... 17   | 18 | 19 (2 decimals) 23 | 24 ... 27       |

**Test Data:**

```

10000001000511111910534A100
20000002010021222802056B200
30000003012532333730045A100
40000004050043444634021B202
50000005090054555556578C300
10000001001513456913534A101
20000002001021234801056B202
30000003010034321733045C300
40000004040044324637021A100
50000005070042456556578B202
10000001006041111915534A100
20000002002556622804056B200
30000003031531133733045C300
40000004040024214632021B200
50000005078016455551578B200

```

**Report Layout:** Modify the report designed in Project 7-2, adding salesrep number and region area name.

- Processing Requirements:**
1. Sort the incoming order file by customer number and within customer number by salesrep number.
  2. Read the sorted file of order records.
  3. For every record read:
    - a. Determine whether the customer will receive a discount. The discounting is determined based on the specifications of Project 13-1.
    - b. Calculate the unit price by applying the appropriate discount as determined in 3a.
    - c. Calculate the extended price by multiplying the quantity ordered by the unit price.
    - d. Determine the region a salesrep is assigned to based on the first byte of the salesrep number and utilizing the following table.
 

| Region Code | Region Area Name |
|-------------|------------------|
| A           | Arlington        |
| B           | Bridgeport       |
| C           | Coppell          |
| D           | Dallas           |
| E           | Eules            |
  4. Print the customer number, item number, quantity ordered, unit price (calculated), and extended price for each customer record. Single-space the output.
  5. Print the total quantity ordered and the total sales. Double-space the totals.

**Project 14-2**

**Program Name:** Order Transaction File Validation

**Narrative:** This project builds on Project 8-1, utilizing more advanced programming techniques such as table handling, redefines, internal sort, and control break logic. Write a data validation program that will validate an order transaction file.

**Input File:** ORDER-TRANSACTION-FILE, same as Project 8-1.

**Test Data:** Same as Project 8-1.

**Report Layout:** Same as Project 8-1.

- Processing Requirements:**
1. Read a file of order transaction records.
  2. Sort the order transaction records so that all records for one order can be processed together and so that the record types 1, 2, and 3 are in the appropriate order.
  3. The current run date is typically accepted from a file, but for this lab set up a literal in working storage with the run date as November 2, 1992.
  4. Validate each input record field for all of the following:  
All validations from Project 8-1.  
Change the Quantity Code conversion to Quantity Amount logic in Project 8-1 to utilize a hard coded table containing the Quantity Code and the appropriate Quantity Amount.
  5. Any record that fails any validity test is to be written to an error file, and an appropriate error message should appear on the error report. It is possible that a record may contain more than one error, and all errors are to be flagged.
  6. Valid records are to be written to a valid transaction file. The valid transaction file should be the same format as the input Order Transaction file, with the exception that the quantity code on the Type 3 record should be converted to the quantity amount, causing the unit price to be moved to the right two bytes.

**Project 14-3**

**Program Name:** Sorted Car Sales Program

**Narrative:** Develop a program to process a sales file in order to determine the amount earned by each salesperson.

**Input File:** SALES-FILE

**Input Record Layout:**

```

01 SALES-RECORD-IN.
 05 SA-DEALER PIC X(8).
 05 SA-BRANCH PIC 9(3).
 05 SA-SALESPERSON PIC X(10).
 05 SA-SALES-INFO.
 05 SA-CUSTOMER PIC X(10).
 05 SA-SALE-PRICE PIC 9(6).
 05 SA-COMMISSION-RATE PIC 9V99.
 05 SA-CAR-INFO.
 10 SA-CAR-MAKE PIC X(8).
 10 SA-CAR-MODEL PIC X(8).
 10 SA-CAR-YEAR PIC 9(4).

```

**Test Data:**

```

BROWARD 010GEHLE MORENO 016125005TOYOTA SUPRA 1990
DADE 110DAVERSA RENESCA 004950002HYUNDAI EXCEL G 1990
BROWARD 020ROWE VIERA 014300002STERLING825SL 1989
DADE 100RICO GORMAN 038500004LEXUS 400 LS 1992
BROWARD 010SHIM PORTO 025575004M BENZ 300E 1988
DADE 110FRENCH DEGGS 009025004NISSAN MAXIMA 1988
MONROE 210BOYER PIRES 006125004MAZDA 626 1988
DADE 100RICO CHUA 010700004TOYOTA CAMRY DE 1990
BROWARD 020ROWE PINEDA 009200003AUDI 5000 1988
DADE 110DAVERSA MCDONALD 040000005INFINITI Q45 1992
BROWARD 010GEHLE LARSH 012475003PUEGOT 505GLS 1990
DADE 110FRENCH SPEARS 010975001NISSAN 300Z 1988
BROWARD 020ROWE TOCKMAN 027150006BMW 635 CSI 1988
MONROE 210BOYER AUGUSMA 039799002M BENZ 560 SL 1988
BROWARD 010GEHLE HOLME 9013700002HONDA PRELUDE 1990
MONROE 210BOYER LOUIS 010175004MAZDA RX7 GXL 1990
BROWARD 010SHIM REINMAN 009725002SAAB 900 1988
DADE 100RICO DILEGO 015800004MAZDA MIATA 1992
MONROE 210VASQUEZ HAFEZ 032875003JAGUAR XJ6 1990
DADE 110FRENCH GRAHE 014750003BMW 325 ES 1988
MONROE 210VASQUEZ HWANG 023000004LEGEND COUPE LS 1988

```

**Report Layout:**

| VERY VERY NICE CARS INC.   |             |      |          |          |            |             | PAGE Z9         |                |
|----------------------------|-------------|------|----------|----------|------------|-------------|-----------------|----------------|
| DEALER                     | SALESPERSON | YEAR | MAKE     | MODEL    | CUSTOMER   | PRICE       | COMMISSION PAID | NET TO DEALER  |
| XXXXXXXX                   | XXXXXXXXXX  | 9999 | XXXXXXXX | XXXXXXXX | XXXXXXXXXX | ZZZ,ZZ9     | ZZ,ZZ9.99       | ZZZ,ZZ9.99     |
| .                          | .           | .    | .        | .        | .          | .           | .               | .              |
| .                          | .           | .    | .        | .        | .          | .           | .               | .              |
| .                          | .           | .    | .        | .        | .          | .           | .               | .              |
| VERY VERY NICE CARS TOTALS |             |      |          |          |            | \$Z,ZZZ,ZZ9 | \$ZZZ,ZZ9.99    | \$Z,ZZZ,ZZ9.99 |

- Processing Requirements:**
1. Sort the incoming sales file by dealer, within dealer by salesperson, and within year by car make.
  2. Read the file of sorted sales records, and for each record read:
    - a. Calculate the commission paid to the salesperson by multiplying the sale amount by the commission rate.
    - b. Calculate the net to the dealer by subtracting the commission from the sale amount.
    - c. Print a detail line for each sale.
    - d. Increment the totals as shown on the report layout.
  3. After all records have been read, print Very Very Nice Cars totals. Skip three lines prior to printing the company total.

### Project 14-4

**Program Name:** Sorted Bonus Program

**Narrative:** Write a program to process a bonus file to determine which employees are eligible for a bonus and the bonus amount.

**Input File:** BONUS-FILE

**Input Record Layout:**

|    |                  |            |
|----|------------------|------------|
| 01 | BONUS-RECORD-IN. |            |
| 05 | BO-MANU-PLANT    | PIC XX.    |
| 05 | BO-DEPARTMENT    | PIC X(8).  |
| 05 | BO-EMPLOYEE      | PIC X(15). |
| 05 | BO-MANAGER       | PIC X(10). |
| 05 | BO-SALARY        | PIC 99999. |
| 05 | BO-PERCENTAGE    | PIC 9V99.  |
| 05 | BO-ELIGIBILITY   | PIC X.     |

**Test Data:**

|            |                |          |           |
|------------|----------------|----------|-----------|
| TNInterior | Knowles, CD    | GARCIA   | 30100008Y |
| KYFenders  | Price, MD      | VILLAR   | 24000000N |
| OHTrim     | Inniss, ML     | SPENCER  | 32000012Y |
| KYFenders  | Kanning, DS    | VILLAR   | 28000008Y |
| OHPaint    | Prates, LS     | ALVORD   | 29000015Y |
| KYInterior | Sangastiano, L | LAFEIN   | 32000011Y |
| TNTrim     | Gibbs, GJ      | JONES    | 26000006Y |
| KYFenders  | Barnabas, SJ   | GRAUER   | 30000010Y |
| TNInterior | Davis, JL      | GARCIA   | 31000007Y |
| OHPaint    | Montes, J      | ALVORD   | 27000012Y |
| KYFenders  | Lamania, NC    | GRAUER   | 32000005Y |
| TNTrim     | Romero, CM     | WILLIAMS | 32000018Y |
| OHPaint    | Simonton, DM   | ALVORD   | 25000000N |
| TNTrim     | Wilson, RJ     | JONES    | 24000000N |
| OHPaint    | Keiler, M      | SMITH    | 28000006Y |
| TNInterior | Twinn, SA      | JAMES    | 22000004Y |
| OHPaint    | Chua, CE       | SMITH    | 31000007Y |
| KYInterior | Al-Askar, EK   | BARBER   | 30100009Y |
| OHTrim     | Cardone, J     | FRANK    | 32000008Y |

**Report Layout:**

```

KYInteriorWinter, EK FEIN 22000000N
TNTrim Hess, AM WILLIAMS 36000014Y
OHTrim Boberg, DM FRANK 36000012Y
KYInteriorBehrend, TR BARBER 31000005Y
OHTrim Smith, GM FRANK 26000000N
KYFenders Giberson, CJ GRAUER 34000015Y
TNTrim Clasen, CC JONES 32000010Y
OHTrim Al-Khuwiter, A SPENCER 24000011Y
TNInteriorAlberni, WJ JAMES 32000010Y
KYInteriorChilders, RL BARBER 35000012Y
TNInteriorWarren, AE JAMES 35000011Y

```

| FASSTCARS MANUFACTURERS |          |            |             |           |        | PAGE Z9   |  |
|-------------------------|----------|------------|-------------|-----------|--------|-----------|--|
| PLANT                   | DEPT     | MANAGER    | SOC SEC NO  | SALARY    | BONUS  | TOTAL     |  |
| XX                      | XXXXXXXX | XXXXXXXXXX | 999-99-9999 | ZZ,ZZ9    | Z,ZZ9  | ZZZ,ZZ9   |  |
| .                       | .        | .          | .           | .         | .      | .         |  |
| .                       | .        | .          | .           | .         | .      | .         |  |
| .                       | .        | .          | .           | .         | .      | .         |  |
| FASSTCARS TOTALS        |          |            |             | 2,ZZZ,ZZ9 | ZZ,ZZ9 | 2,ZZZ,ZZ9 |  |

**Processing Requirements:**

- Sort the incoming bonus file by plant, within plant by department, and within department by manager. Sort only the employees that are eligible for a bonus, that is, those that contain a "Y" in the eligibility field.
- Read the file of sorted bonus records, and for each record read:
  - Calculate the bonus amount by multiplying the salary by the bonus percentage.
  - Calculate the total compensation by adding the salary and the bonus.
  - Print a detail line as shown on the report layout.
  - Increment the appropriate totals as shown on the report layout.
- After all records have been read, print totals for Fassstcars.

**Project 14-5**

**Program Name:** Sorted Store Sales Commissions Program

**Narrative:** Develop a program to process sales records for the Needless Markup company. The report is to show sales, commissions paid, and net sales for each transaction.

**Input File:** SALES-FILE

**Input Record Layout:**

```

01 SALES-RECORD.
 05 SAL-PERSON-NAME PIC X(10).
 05 SAL-DATE.
 10 SAL-MONTH PIC 9(2).
 10 SAL-DAY PIC 9(2).
 10 SAL-YEAR PIC 9(2).

```

```

05 SAL-AMOUNT PIC 9(5)V99.
05 SAL-COMMISSION-RATE PIC V99.
05 SAL-STORE-NUMBER PIC 9(2).
05 SAL-DEPARTMENT-NAME PIC X(12).

```

**Test Data:**

```

ADAMS 04229002140000603DESIGNER
HILL 04319000098000501SPORTSWEAR
SMITH 04289000080000502LINGERIE
HARRISON 04239000026000504SPORTSWEAR
HILL 04099000369000401SHOES & BAGS
HARRISON 04189000125500504SPORTSWEAR
HILL 04159000263000401SHOES & BAGS
CLARK 04249000004550504LINGERIE
TURNER 04189000075000302ACCESSORIES
JONES 04259000256000501SPORTSWEAR
ADAMS 04169008396000603DESIGNER
CLARK 04159000478000504SPORTSWEAR
SMITH 04259000155000502LINGERIE
JONES 04309000157990501SPORTSWEAR
JONES 04039000230990401SHOES & BAGS
ADAMS 04089000315000503SPORTSWEAR
LUDLUM 04269006120990603DESIGNER
ADAMS 04059000836000503SPORTSWEAR
SMITH 04129000045250302ACCESSORIES
VANBERGER 04299000055000502LINGERIE
CLARK 04099000237990504SPORTSWEAR
HARRISON 04299000225000504LINGERIE
HARRISON 04309002498250604DESIGNER

```

**Report Layout:**

| NEEDLESS MARKUP        |              |             | 99/99/99 | PAGE 29    |            |            |
|------------------------|--------------|-------------|----------|------------|------------|------------|
| STORE                  | DEPARTMENT   | SALESPERSON | DATE     | SALES      | COMMISSION | NET SALES  |
| XXXXXXXXXXXX           | XXXXXXXXXXXX | XXXXXXXXXX  | 99/99/99 | ZZ,ZZ9.99  | Z,ZZ9.99   | ZZ,ZZ9.99  |
| .                      | .            | .           | .        | .          | .          | .          |
| .                      | .            | .           | .        | .          | .          | .          |
| .                      | .            | .           | .        | .          | .          | .          |
| NEEDLESS MARKUP TOTALS |              |             |          | ZZZ,ZZ9.99 | ZZ,ZZ9.99  | ZZZ,ZZ9.99 |

- Processing Requirements:**
1. Sort the incoming sales file by store, within store by department, and within department by salesperson.
  2. Read the file of sorted sales records, and for each record read:
    - a. Calculate the commission by multiplying the sales amount by the commission rate.
    - b. Calculate the net sales by subtracting the commission from the sale amount.
    - c. Expand the store code via a direct lookup:

| LOCATION CODE | LOCATION NAME |
|---------------|---------------|
| 1             | Bal Harbor    |
| 2             | Dadeland      |
| 3             | The Galleria  |
| 4             | Worth Avenue  |

- d. Print a detail line for each record.
  - e. Increment the totals for sale amount, commission paid, and net sales.
3. Print the totals at the end of the report.

**Project 14-6**

**Program Name:** Sorted Zoo Program

**Narrative:** Write a program to process a zoo's inventory file.

**Input File:** ZOO-FILE

**Input Record Layout:**

```

01 ZOO-RECORD.
 05 ZOO-SPECIES PIC X(8).
 05 ZOO-TYPE PIC X(11).
 05 ZOO-GROUP PIC X(7).
 05 ZOO-SEX PIC X.
 05 ZOO-QUANTITY PIC 99.
 05 ZOO-ACQUISITION-LEVEL PIC 99.
 05 ZOO-SPECIE-VALUE PIC 9(6)V99.

```

**Test Data:**

```

Whale Humpback Mammal F010012509001
Tiger White Mammal F050166008508
Parrot Macaw Bird M050006600005
Tiger White Mammal M070156008505
Parrot Macaw Bird F120007509915
Bear Black Bear Mammal M000102330502
Ray Manta Fish F040004004002
Whale Killer Mammal F020045005002
Ray Manta Fish M020004500504
Whale Killer Mammal M010042005001
Shark Great White Fish F010120120004
Tiger Bengal Mammal M020040209002
Shark Mako Fish F020008990002
Whale Humpback Mammal M000017509001
Bear Grizzly Mammal F030090000002
Shark Mako Fish M060009500508
Bear Black Bear Mammal F030102330503
Parrot Cockatoo Bird F450003050430
Bear Grizzly Mammal M040091010003
Shark Great White Fish M040113000004
Tiger Bengal Mammal F100020508008

```



**Report Layout:**

| Wild Kingdom Zoo Inventory Report 99/99/99 |          |            |     |            |          |              | Page Z9        |
|--------------------------------------------|----------|------------|-----|------------|----------|--------------|----------------|
| Group                                      | Species  | Type       | Sex | Value      | Quantity | Total        | No. to Acquire |
| XXXXXXX                                    | XXXXXXXX | XXXXXXXXXX | X   | ZZZ,ZZ9.99 | Z9       | ZZZ,ZZ9.99   | Z9             |
| .                                          | .        | .          | .   | .          | .        | .            | .              |
| .                                          | .        | .          | .   | .          | .        | .            | .              |
| .                                          | .        | .          | .   | .          | .        | .            | .              |
| Total for Wild Kingdom                     |          |            |     |            | ZZ9      | Z,ZZZ,ZZ9.99 | ZZ9            |

**Processing Requirements:**

1. Sort the incoming animal file by group, within group by species, and within species by type.
2. Read the file of sorted animal records, and for each record read:
  - a. Calculate the value of each animal (quantity times value).
  - b. Determine whether acquisition of addition animals is justified; the zoo should acquire more animals if the acquisition level is below the quantity level.
  - c. Print animal information in that record and calculated values on a detail line.
  - d. Accumulate the animal quantity totals, total values, and acquisition totals.
3. After all records have been read, print totals for Wild Kingdom.

**Project 4-7**

**Program Name:** Sorted PC Software Program

**Narrative:** Write a program to process a PC software file to determine totals for PC software totals.

**Input File:** PC-SOFTWARE-FILE

**Input Record Layout:**

```

01 PC-SOFTWARE-RECORD-IN.
 05 PC-ORDER-INFO.
 10 PC-ORDER-NO PIC 9(5).
 10 PC-ORDER-TYPE PIC X.
 10 PC-CUSTOMER-NAME PIC X(16).
 05 PC-PURCHASE-INFO.
 10 PC-QUANTITY PIC 999.
 10 PC-PRICE PIC 9(3)V99.
 10 PC-DATE PIC 9(6).
 05 PC-PROGRAM-INFO.
 10 PC-PROGRAM-ID.
 15 PC-PROGRAM-NO PIC 9(4).
 15 PC-PLATFORM-CODE PIC X.
 10 PC-PROGRAM-NAME PIC X(16).
 10 PC-VENDOR PIC X(16).

```

## Test Data:

|        |                  |                          |                   |                  |
|--------|------------------|--------------------------|-------------------|------------------|
| 02634P | Zeuqzav-Ralliv   | 015028990203935514W      | Entertainmt Pac   | Microsoft        |
| 79456P | Racal Datacomm   | 003334950201935653D1-2-3 | 2.4               | Lotus            |
| 74523P | American Express | 008019001222923338W      | Money 2.0         | Microsoft        |
| 13473P | Racal Datacomm   | 035084950924923146D      | Norton Anti-Virus | Symantec         |
| 34342R | Neiman Marcus    | 025328950925928000W      | Persuasion 2.1    | Aldus            |
| 63452P | American Express | 010099000116933424W1-2-3 | Upgrade           | Lotus            |
| 53623P | Racal Datacomm   | 035249000130935799W      | AmiPro 3.0        | Lotus            |
| 43646P | Neiman Marcus    | 018325000103939695D      | Borland C++ 3.1   | Borland Int'l    |
| 43623P | Racal Datacomm   | 030099000222933424W1-2-3 | Upgrade           | Lotus            |
| 27345R | Neiman Marcus    | 003139001015926223W      | Gallery Effects   | Aldus            |
| 58424R | American Express | 005334950116935653D1-2-3 | 2.4               | Lotus            |
| 64564P | Neiman Marcus    | 015498950925921332W      | Pagemaker 5.0     | Aldus            |
| 47635P | Zeuqzav-Ralliv   | 015038950203932858D      | Flight Simulator  | Microsoft        |
| 46353P | Racal Datacomm   | 075099991221922359W      | Norton Desktop    | Symantec         |
| 63454P | Zeuqzav-Ralliv   | 015299000203932856W      | Excel 4.0         | Microsoft        |
| 84563R | Racal Datacomm   | 085099991221923784W      | Norton Backup     | Symantec         |
| 45364P | Zeuqzav-Ralliv   | 015299000203937387W      | PowerPoint 3.0    | Microsoft        |
| 44535P | Racal Datacomm   | 055348951223923523W      | Freelance 2.0     | Lotus            |
| 34593P | Zeuqzav-Ralliv   | 015299000203936195W      | Word 2.0          | Microsoft        |
| 74387P | Neiman Marcus    | 018318501007926242D      | Quattro Pro 4.0   | Borland Int'l    |
| 24256P | Racal Datacomm   | 005399000201935417D1-2-3 | 3.1 Plus          | Lotus            |
| 75357R | Neiman Marcus    | 015529951125921514D      | Paradox 4.0       | Borland Int'l    |
| 24246R | American Express | 010399000120935417D1-2-3 | 3.1 Plus          | Lotus            |
| 34534R | Racal Datacomm   | 020335001014922755W1-2-3 |                   | Lotus            |
| 23333P | American Express | 050335000116932755W1-2-3 |                   | Lotus            |
| 32453P | Racal Datacomm   | 125089000215937010W      | Windows 3.1       | Microsoft        |
| 74387P | Neiman Marcus    | 005199001217927540W      | IntelliDraw 1.0   | Aldus            |
| 85634R | American Express | 015348950226933523W      | Freelance 2.0     | Lotus            |
| 43244P | American Express | 020129001120922735W      | Works 2.0         | Microsoft        |
| 49785P | Zeuqzav-Ralliv   | 055023000113931162D      | Mickey&Friends    | Walt Disney Comp |
| 43352P | Racal Datacomm   | 025445951114927388W      | Project 3.0       | Microsoft        |
| 47633P | Zeuqzav-Ralliv   | 015029000113932629D      | Mickey's 123's    | Walt Disney Comp |
| 56352P | Neiman Marcus    | 025089001016921624W      | Visual Basic 2.0  | Microsoft        |
| 46523P | Zeuqzav-Ralliv   | 015032000203938731W      | Dashboard 1.0     | Hewlett-Packard  |
| 43274P | Racal Datacomm   | 090479001214926188D      | FoxPro 2.0        | Microsoft        |
| 26342P | Zeuqzav-Ralliv   | 015029000113932624D      | Mickey's ABC's    | Walt Disney Comp |
| 26437P | Neiman Marcus    | 095059001226921620D      | MMS-DOS 6 Upgrade | Microsoft        |
| 37466P | American Express | 125059001016921620D      | MMS-DOS 6 Upgrade | Microsoft        |
| 47324R | Neiman Marcus    | 045095001114922904D      | Works 2.0         | Microsoft        |
| 26437P | Racal Datacomm   | 045059001016921620D      | MMS-DOS 6 Upgrade | Microsoft        |
| 24364P | Zeuqzav-Ralliv   | 015109000203938101W      | NewWave 4.0       | Hewlett-Packard  |
| 63454P | Neiman Marcus    | 035299000217932856W      | Excel 4.0         | Microsoft        |
| 94534P | Zeuqzav-Ralliv   | 015034000203936649W      | Star Trek:Screen  | Berkeley Systems |
| 48536P | Neiman Marcus    | 055299000217937387W      | PowerPoint 3.0    | Microsoft        |
| 73623P | Racal Datacomm   | 010269001222923804D      | WordPerfect 5.1   | WordPerfect Corp |

**Report Layout:**

| Software R Us, Inc. 99/99/99 |                    |          |                    |          |        | PAGE 29  |
|------------------------------|--------------------|----------|--------------------|----------|--------|----------|
| Customer                     | Vendor             | Platform | Program            | Quantity | Price  | Total    |
| XXXXXXXXXXXXXXXXXX           | XXXXXXXXXXXXXXXXXX | XXXXXXX  | XXXXXXXXXXXXXXXXXX | Z79      | Z79.99 | Z79.99   |
| .                            | .                  | .        | .                  | .        | .      | .        |
| .                            | .                  | .        | .                  | .        | .      | .        |
| .                            | .                  | .        | .                  | .        | .      | .        |
| Total for Software R Us      |                    |          |                    | Z,279    |        | Z,279.99 |

- Processing Requirements:**
- Sort the incoming PC software file by customer, within customer by vendor, and within vendor by platform.
  - Read the file of sorted PC software records, and for each record read:
    - Calculate the total for each program by multiplying the quantity by the price.
    - Determine whether the order is either a purchase (P) or a return (R) by examining the order type field. If the order is a return, then the quantity and total calculated should be negated. Make sure your report will show this (use CR, DB, +, or - editing symbols).
    - Print information in that record and total on a detail line. Expand the platform code as follows: "D" for "DOS", and "W" for "Windows". Print the platform name only for the first detail line.
    - Accumulate totals for quantity and total.
  - After all the records have been read, print company totals for Software R Us.

**Project 14-8**

**Program Name:** Video Program

**Narrative:** Write a program to process a video file to determine totals for video rental and sales revenue.

**Input File:** VIDEO-FILE

**Input Record Layout:**

```

01 VIDEO-RECORD-IN.
 05 VID-TITLE-INFO.
 10 VID-TITLE PIC X(19).
 10 VID-CATEGORY PIC X(11).
 10 VID-RATING PIC X(5).
 05 VID-RENTAL-INFO.
 10 VID-RENTAL-FEE PIC 99V99.
 10 VID-RENTED PIC 9(3).
 05 VID-SELL-INFO.
 10 VID-SELL-PRICE PIC 9(3)V99.
 10 VID-SOLD PIC 9(3).
 10 VID-RETURNED PIC 9(3).
 05 VID-STORE PIC X(10).

```

**Test Data:**

|                     |             |       |                    |            |
|---------------------|-------------|-------|--------------------|------------|
| Rocky Horror        | Drama       | PG-13 | 020040005995101050 | Coco Grove |
| Dirty Harry         | Action      | R     | 017501002000025002 | Miami      |
| Basic Instinct      | New Release | R     | 030020003995099002 | Hialeah    |
| My Girl             | Drama       | PG    | 020007002000060005 | Miami Bch  |
| Cutting Edge        | Drama       | PG-13 | 025010002000035008 | Coco Grove |
| Lethal Weapon III   | Action      | R     | 030015002995103000 | Miami      |
| Candy Man           | New Release | R     | 030020005995105040 | Hialeah    |
| Cape Fear           | Drama       | R     | 020008001995020002 | Miami Bch  |
| Nightmare on Elm St | Horror      | R     | 025006001995006006 | Ft. Laud   |
| ET                  | Childrens   | G     | 015006001995045012 | Hialeah    |
| Caddy Shack         | Comedy      | PG    | 010004501095023005 | Miami      |
| Caddy Shack         | Comedy      | PG    | 010004501095023005 | Coco Grove |
| Final Analysis      | Suspense    | R     | 030012002995076003 | Miami Bch  |
| Dr. Giggles         | New Release | R     | 030030007795092030 | Hialeah    |
| Star Wars II        | Action      | G     | 017505001995050020 | Miami      |
| Wayne's World       | Comedy      | PG    | 030005001595045055 | Miami      |
| Care Bears          | Childrens   | G     | 010007500995035003 | Hialeah    |
| Halloween           | Horror      | PG-13 | 025004001995090095 | Ft. Laud   |
| Dances with Wolves  | Drama       | R     | 030010004995010000 | Coco Grove |
| The Blues Brothers  | Comedy      | PG    | 020001001095015005 | Coco Grove |
| One Flew Over...    | Drama       | R     | 017502501095009000 | Coco Grove |
| The Birds           | Horror      | PG-13 | 015001001495010000 | Ft. Laud   |
| The Fly             | Suspense    | R     | 020007502995065005 | Miami Bch  |
| Pinnocchio          | Childrens   | G     | 010003501495080003 | Hialeah    |
| The Little Mermaid  | Childrens   | G     | 025020001995098003 | Hialeah    |
| To Kill a Mocking.. | Drama       | PG    | 010001000995002001 | Miami Bch  |
| Sneakers            | New Release | R     | 030040007500125000 | Hialeah    |
| The Shining         | Suspense    | R     | 015001501500010004 | Ft. Laud   |
| T2 - Judgement Day  | New Release | R     | 030035003995135001 | Hialeah    |
| Hell Raiser II      | Horror      | R     | 015007701095075080 | Ft. Laud   |
| Wayne's World       | Comedy      | PG    | 030005001595045055 | Coco Grove |
| Star Wars           | Action      | G     | 017505001495030010 | Miami      |
| Beauty & the Beast  | Childrens   | G     | 030020001995200000 | Hialeah    |

**Report Layout:**

| BlokBuzter Monthly Video Rentals & Sales 99/99/99 |        |                      |                    |          |          | PAGE 29          |       |          |
|---------------------------------------------------|--------|----------------------|--------------------|----------|----------|------------------|-------|----------|
| Category                                          | Rating | Movie Title          | Rental Information |          |          | Sell Information |       |          |
|                                                   |        |                      | Fee                | # Rented | Revenue  | Price            | Net   | Revenue  |
| XXXXXXXXXX                                        | XXXXX  | XXXXXXXXXXXXXXXXXXXX | Z9.99              | ZZ9      | ZZ9.99   | ZZ9.99           | ZZ9   | ZZ9.99   |
| .                                                 | .      | .                    | .                  | .        | .        | .                | .     | .        |
| .                                                 | .      | .                    | .                  | .        | .        | .                | .     | .        |
| .                                                 | .      | .                    | .                  | .        | .        | .                | .     | .        |
| Total for BlokBuzter                              |        |                      |                    | Z,ZZ9    | Z,ZZ9.99 |                  | Z,ZZ9 | Z,ZZ9.99 |

**Processing Requirements:**

1. Sort the incoming video file by store, within each store by rating, and within each rating by movie title.
2. Read the file of sorted video records, and for each record read:
  - a. Calculate the rental revenue by multiplying the rental fee by the number of times rented.

- b. Calculate the net sales by subtracting the videos returned from the videos sold. Returns are accepted from other stores so your net could be negative! Make sure your report will show this (use CR, DB, +, or - editing symbols).
  - c. Calculate the sales revenue for each movie by multiplying the selling price by the net sales.
  - d. Print a detail line.
  - e. Accumulate totals as indicated on the report layout.
3. After all the records have been read, print totals for BlokBuzter.

**PROGRAMMING SPECIFICATIONS**

**Project 15-1**

**Program Name:** Price Break Report (Continuation of Project 14-1)

**Narrative:** Write a control break program to determine whether a customer receives a price break based on quantity ordered, and calculate the unit price and extended price. Create a report which prints each customer's order as well as the total ordered for each customer and a grand total for the company.

**Input File:** Order Transaction File

**Input Record Layout:**

| Order Record    |   |                  |             |    |                    |                 |
|-----------------|---|------------------|-------------|----|--------------------|-----------------|
| Customer Number |   | Quantity Ordered | Item Number |    | Unit Price         | Salesrep Number |
| 1 ... 8         | 9 | 10 ... 12        | 13 ... 17   | 18 | 19 (2 decimals) 23 | 24 ... 27       |

**Test Data:** Use the same test data as Project 14-1.

**Report Layout:** You may continue to use the report layout you designed in Project 7-2, or utilize the following specifications.

**Two-Level Report Layout:**

| AUSTIN RETAIL COMPANY |          |              |                           |
|-----------------------|----------|--------------|---------------------------|
| SALESREP:             | XXXX     | REGION AREA: | XXXXXXXXXXXXXXXXXX        |
| CUSTOMER NUMBER:      | XXXXXXXX |              |                           |
| ITEM                  | QUANTITY | UNIT         | EXTENDED                  |
| NUMBER                | ORDERED  | PRICE        | PRICE                     |
| XXXXX                 | ZZ9      | \$\$\$\$.99  | \$\$, \$\$\$, \$\$\$\$.99 |
| XXXXX                 | ZZ9      | \$\$\$\$.99  | \$\$, \$\$\$, \$\$\$\$.99 |
| CUSTOMER TOTAL SALES: |          | \$\$\$\$.99  | \$\$, \$\$\$, \$\$\$\$.99 |

|                          |          |                                   |                           |
|--------------------------|----------|-----------------------------------|---------------------------|
| CUSTOMER NUMBER:         | XXXXXXXX |                                   |                           |
| ITEM                     | QUANTITY | UNIT                              | EXTENDED                  |
| NUMBER                   | ORDERED  | PRICE                             | PRICE                     |
| XXXXX                    | ZZ9      | \$\$\$\$.99                       | \$\$, \$\$\$, \$\$\$\$.99 |
| XXXXX                    | ZZ9      | \$\$\$\$.99                       | \$\$, \$\$\$, \$\$\$\$.99 |
| CUSTOMER TOTAL SALES:    |          | \$\$, \$\$\$, \$\$\$, \$\$\$\$.99 |                           |
| SALESREP TOTAL SALES:    |          | \$\$, \$\$\$, \$\$\$, \$\$\$\$.99 |                           |
| SALESREP:                | XXXX     | REGION AREA:                      | XXXXXXXXXXXXXXXXXX        |
| CUSTOMER NUMBER:         | XXXXXXXX |                                   |                           |
| ITEM                     | QUANTITY | UNIT                              | EXTENDED                  |
| NUMBER                   | ORDERED  | PRICE                             | PRICE                     |
| XXXXX                    | ZZ9      | \$\$\$\$.99                       | \$\$, \$\$\$, \$\$\$\$.99 |
| XXXXX                    | ZZ9      | \$\$\$\$.99                       | \$\$, \$\$\$, \$\$\$\$.99 |
| CUSTOMER TOTAL SALES:    |          | \$\$, \$\$\$, \$\$\$, \$\$\$\$.99 |                           |
| CUSTOMER NUMBER:         | XXXXXXXX |                                   |                           |
| ITEM                     | QUANTITY | UNIT                              | EXTENDED                  |
| NUMBER                   | ORDERED  | PRICE                             | PRICE                     |
| XXXXX                    | ZZ9      | \$\$\$\$.99                       | \$\$, \$\$\$, \$\$\$\$.99 |
| XXXXX                    | ZZ9      | \$\$\$\$.99                       | \$\$, \$\$\$, \$\$\$\$.99 |
| CUSTOMER TOTAL SALES:    |          | \$\$, \$\$\$, \$\$\$, \$\$\$\$.99 |                           |
| SALESREP TOTAL SALES:    |          | \$\$, \$\$\$, \$\$\$, \$\$\$\$.99 |                           |
| TOTAL SALES FOR COMPANY: |          | \$\$, \$\$\$, \$\$\$, \$\$\$\$.99 |                           |

**Three-level Report Layout:**

|                                     |                       |                                   |                           |
|-------------------------------------|-----------------------|-----------------------------------|---------------------------|
|                                     | AUSTIN RETAIL COMPANY |                                   |                           |
| REGION AREA:                        | XXXXXXXXXXXXXXXXXX    |                                   |                           |
| SALESREP:                           | XXXX                  |                                   |                           |
| CUSTOMER NUMBER:                    | XXXXXXXX              |                                   |                           |
| ITEM                                | QUANTITY              | UNIT                              | EXTENDED                  |
| NUMBER                              | ORDERED               | PRICE                             | PRICE                     |
| XXXXX                               | ZZ9                   | \$\$\$\$.99                       | \$\$, \$\$\$, \$\$\$\$.99 |
| XXXXX                               | ZZ9                   | \$\$\$\$.99                       | \$\$, \$\$\$, \$\$\$\$.99 |
| CUSTOMER TOTAL SALES:               |                       | \$\$, \$\$\$, \$\$\$, \$\$\$\$.99 |                           |
| CUSTOMER NUMBER:                    | XXXXXXXX              |                                   |                           |
| ITEM                                | QUANTITY              | UNIT                              | EXTENDED                  |
| NUMBER                              | ORDERED               | PRICE                             | PRICE                     |
| XXXXX                               | ZZ9                   | \$\$\$\$.99                       | \$\$, \$\$\$, \$\$\$\$.99 |
| XXXXX                               | ZZ9                   | \$\$\$\$.99                       | \$\$, \$\$\$, \$\$\$\$.99 |
| CUSTOMER TOTAL SALES:               |                       | \$\$, \$\$\$, \$\$\$, \$\$\$\$.99 |                           |
| SALESREP TOTAL SALES:               |                       | \$\$, \$\$\$, \$\$\$, \$\$\$\$.99 |                           |
| REGION TOTAL SALES:                 |                       | \$\$, \$\$\$, \$\$\$, \$\$\$\$.99 |                           |
| TOTAL NUMBER OF SALESREP IN REGION: | ZZZ9                  |                                   |                           |
| REGION AREA:                        | XXXXXXXXXXXXXXXXXX    |                                   |                           |
| SALESREP:                           | XXXX                  |                                   |                           |
| CUSTOMER NUMBER:                    | XXXXXXXX              |                                   |                           |
| ITEM                                | QUANTITY              | UNIT                              | EXTENDED                  |
| NUMBER                              | ORDERED               | PRICE                             | PRICE                     |
| XXXXX                               | ZZ9                   | \$\$\$\$.99                       | \$\$, \$\$\$, \$\$\$\$.99 |
| XXXXX                               | ZZ9                   | \$\$\$\$.99                       | \$\$, \$\$\$, \$\$\$\$.99 |
| CUSTOMER TOTAL SALES:               |                       | \$\$, \$\$\$, \$\$\$, \$\$\$\$.99 |                           |
| SALESREP TOTAL SALES:               |                       | \$\$, \$\$\$, \$\$\$, \$\$\$\$.99 |                           |
| REGION TOTAL SALES:                 |                       | \$\$, \$\$\$, \$\$\$, \$\$\$\$.99 |                           |
| TOTAL NUMBER OF SALESREP IN REGION: | ZZZ9                  |                                   |                           |
| TOTAL SALES FOR COMPANY:            |                       | \$\$, \$\$\$, \$\$\$, \$\$\$\$.99 |                           |

**Two-level**

- Processing Requirements:**
1. Perform an internal sort on the file of customer records so that the report will break on customer number within salesrep number.
  2. Read the sorted file of order records.
  3. For every record read:
    - a. Determine whether the customer will receive a discount. The discounting of an item is based on specifications in Project 13-1.
    - b. Calculate the unit price by applying the appropriate discount as determined in 2a.
    - c. Calculate the extended price by multiplying the quantity ordered by the unit price.
    - d. Accumulate the customer's and the company's order total.
  4. Print the customer number, item number, quantity ordered, unit price (calculated), and extended price for each customer record. Single-space the output. Use group indication when printing the salesrep number and customer number, only print the salesrep number and customer number when the customer number changes. Print the totals when appropriate. Double-space between headings and totals.

- Three-level Extension:** Extend the report to include a third (higher-level) control break on region as shown in the report format. Begin each region on a new page (expand the region area in the heading) and include multiple salesreps in a region on the same page. Be sure to modify the format of the heading and detail lines, to change the SORT statement to include the extra level control break, and to modify the program to increment totals as necessary.

**Project 15-2**

**Program Name:** Order Transaction File Validation

**Narrative:** This project builds on Project 14-2, utilizing more advanced programming techniques such as table handling, redefines, and control break logic. Write a data validation program that will validate an order transaction file.

**Input File:** ORDER-TRANSACTION-FILE, same as Project 14-2.

**Test Data:** Same as Project 14-2.

**Report Layout:** Same as Project 14-2.

- Processing Requirements:**
1. Read a file of order transaction records.
  2. Sort the order transaction records so that all records for one order can be processed together, and so that the record types 1, 2, and 3 are in the appropriate order.
  3. The current run date is typically accepted from a file, but for this lab set up a literal in working storage with the run date as November 2, 1992.
  4. Validate each input record field for all of the following:
    - All validations from Project 8-1, Project 15-2.
    - Each order must have a type 1 record and cannot have more than 1 type 1 record.
    - Each order must have a type 2 record and cannot have more than 1 type 2 record.
    - Each order must have at least 1 type 3 record and can have up to 5 type 3 records.

(Hint: in order to process the order in its entirety, you will need to process the order using control break logic, and you will need to hold onto all the records for the order in a table until ready to process.)

5. If an error occurs in any part of the order, write the entire order, including all type 1, 2, and 3 records, to an error file. An order may contain more than one error, and all errors are to be flagged.
6. Valid records are to be written to either a Valid Transaction File or a Future/Back-order File. Both files should be the same format as the input Order Transaction file, with the exception that the quantity code on the Type 3 record should be converted to the Quantity Amount, as in Project 14-2.
7. If the hold delivery date is greater than the current run date of November 2, 1992, then write the entire order, including the type 1, 2, and 3 records, to the Future/Back-order Transaction File; otherwise write the order to the new Order Transaction File, assuming that the order passed the validation.

**Project 15-3**

**Program Name:** Car Sales Control Break (Continuation of Project 14-3)

**Narrative:** Develop a control break program to process a sales file in order to determine totals by year, salesperson, and dealer. The choice between a two- or three-level report is between you and your instructor.

**Input File:** SALES-FILE

**Input Record Layout:** Use the same record layout as Project 14-3.

**Test Data:** Use the same test data as Project 14-3.

**Two-level Report Layout:**

| VERY VERY NICE CARS INC.                          |                            |            |             |              | PAGE Z9        |
|---------------------------------------------------|----------------------------|------------|-------------|--------------|----------------|
| salesperson name COMMISSION REPORT AS OF 99/99/99 |                            |            |             |              |                |
| YEAR: 9999                                        |                            |            |             |              |                |
| CAR INFORMATION                                   |                            |            |             | COMMISSION   | NET TO         |
| MAKE                                              | MODEL                      | CUSTOMER   | PRICE       | PAID         | DEALER         |
| XXXXXXXX                                          | XXXXXXXX                   | XXXXXXXXXX | ZZZ,ZZ9     | ZZ,ZZ9.99    | ZZZ,ZZ9.99     |
| .                                                 | .                          | .          | .           | .            | .              |
| .                                                 | .                          | .          | .           | .            | .              |
| .                                                 | .                          | .          | .           | .            | .              |
| **                                                | TOTAL FOR year             |            | \$Z,ZZZ,ZZ9 | \$ZZZ,ZZ9.99 | \$Z,ZZZ,ZZ9.99 |
| *                                                 | TOTAL FOR salesperson name |            | \$Z,ZZZ,ZZ9 | \$ZZZ,ZZ9.99 | \$Z,ZZZ,ZZ9.99 |
|                                                   | VERY VERY NICE CARS TOTALS |            | \$Z,ZZZ,ZZ9 | \$ZZZ,ZZ9.99 | \$Z,ZZZ,ZZ9.99 |



**Three-level  
Report Layout:**

| VERY VERY NICE CARS INC.                     |                            |          |          |             | PAGE 29      |                |
|----------------------------------------------|----------------------------|----------|----------|-------------|--------------|----------------|
| dealer name COMMISSION REPORT AS OF 99/99/99 |                            |          |          |             |              |                |
| SALESPERSON: XXXXXXXXXX                      |                            |          |          |             |              |                |
| CAR INFORMATION                              |                            | CUSTOMER |          | COMMISSION  | NET TO       |                |
| YEAR                                         | MAKE                       | MODEL    | PRICE    | PAID        | DEALER       |                |
| 9999                                         | XXXXXXXX                   | XXXXXXXX | XXXXXXXX | ZZZ,ZZ9     | ZZ,ZZ9.99    | ZZZ,ZZ9.99     |
| .                                            | .                          | .        | .        | .           | .            | .              |
| .                                            | .                          | .        | .        | .           | .            | .              |
| .                                            | .                          | .        | .        | .           | .            | .              |
| ***                                          | TOTAL FOR year             |          |          | \$Z,ZZZ,ZZ9 | \$ZZZ,ZZ9.99 | \$Z,ZZZ,ZZ9.99 |
| **                                           | TOTAL FOR salesperson name |          |          | \$Z,ZZZ,ZZ9 | \$ZZZ,ZZ9.99 | \$Z,ZZZ,ZZ9.99 |
| *                                            | TOTAL FOR dealer name      |          |          | \$Z,ZZZ,ZZ9 | \$ZZZ,ZZ9.99 | \$Z,ZZZ,ZZ9.99 |
| VERY VERY NICE CARS TOTALS                   |                            |          |          | \$Z,ZZZ,ZZ9 | \$ZZZ,ZZ9.99 | \$Z,ZZZ,ZZ9.99 |

**Two-level  
Processing Requirements:**

1. Sort the incoming sales file by salesperson, and within salesperson by year.
2. Read the file of sorted sales records and for each record read:
  - a. Print a detail line as shown in the report layout using the processing requirements for Project 14-3.
  - b. Increment the year, salesperson, and company totals as appropriate.
  - c. Begin every salesperson on a new page with an appropriate heading containing the salesperson name, current date, and page number of the report.
  - d. Print year and salesperson headings whenever the fields change.
  - e. Print year and salesperson totals whenever the fields change.
3. Print the Very Very Nice Cars totals on a separate page at the conclusion of the report.

**Three-level Extension:** Extend the report to include a third (higher-level) control break on dealer as shown in the report format. Begin each dealer on a new page and include multiple salespersons in the same dealer on the same page. Be sure to modify the format of the heading and detail lines, to change the SORT statement to include the extra level control break, and to modify the program to increment all totals as necessary.

**Project 15-4**

**Program Name:** Bonus Control Break Program (Continuation of Project 14-4)

**Narrative:** Write a control break program to process a bonus file to determine bonus totals by manager, department, and plant. The choice between a two- or three-level report is between you and your instructor.

**Input File:** BONUS-FILE

**Input Record Layout:** Use the same record layout as Project 14-4.

**Test Data:** Use the same test data as Project 14-4.

**Two-level Report Layout:**

| FASSTCARS MANUFACTURERS               |                    |           |        | PAGE Z9   |  |
|---------------------------------------|--------------------|-----------|--------|-----------|--|
| BONUS REPORT FOR DEPARTMENT: XXXXXXXX |                    |           |        |           |  |
| MANAGER: XXXXXXXXXX                   |                    |           |        |           |  |
| SOC SEC NO                            | EMPLOYEE           | SALARY    | BONUS  | TOTAL     |  |
| 999-99-9999                           | XXXXXXXXXXXXXXXXXX | ZZ,ZZ9    | Z,ZZ9  | ZZZ,ZZ9   |  |
| .                                     | .                  | .         | .      | .         |  |
| .                                     | .                  | .         | .      | .         |  |
| .                                     | .                  | .         | .      | .         |  |
| ** TOTAL FOR manager name             |                    | Z,ZZZ,ZZ9 | ZZ,ZZ9 | Z,ZZZ,ZZ9 |  |
| *** TOTAL FOR department name         |                    | Z,ZZZ,ZZ9 | ZZ,ZZ9 | Z,ZZZ,ZZ9 |  |
| TOTAL FOR FASSTCARS                   |                    | Z,ZZZ,ZZ9 | ZZ,ZZ9 | Z,ZZZ,ZZ9 |  |

**Three-level Report Layout:**

| FASSTCARS MANUFACTURERS      |             |                    |           | PAGE Z9 |           |
|------------------------------|-------------|--------------------|-----------|---------|-----------|
| BONUS REPORT FOR PLANT: XX   |             |                    |           |         |           |
| DEPARTMENT: XXXXXXXX         |             |                    |           |         |           |
| MANAGER                      | SOC SEC NO  | EMPLOYEE           | SALARY    | BONUS   | TOTAL     |
| XXXXXXXXXXXX                 | 999-99-9999 | XXXXXXXXXXXXXXXXXX | ZZ,ZZ9    | Z,ZZ9   | ZZZ,ZZ9   |
| .                            | .           | .                  | .         | .       | .         |
| .                            | .           | .                  | .         | .       | .         |
| .                            | .           | .                  | .         | .       | .         |
| * TOTAL FOR manager name     |             |                    | Z,ZZZ,ZZ9 | ZZ,ZZ9  | Z,ZZZ,ZZ9 |
| ** TOTAL FOR department name |             |                    | Z,ZZZ,ZZ9 | ZZ,ZZ9  | Z,ZZZ,ZZ9 |
| *** TOTAL FOR plant name     |             |                    | Z,ZZZ,ZZ9 | ZZ,ZZ9  | Z,ZZZ,ZZ9 |
| TOTAL FOR FASSTCARS          |             |                    | Z,ZZZ,ZZ9 | ZZ,ZZ9  | Z,ZZZ,ZZ9 |

**Two-level Processing Requirements:**

1. Sort the incoming bonus file, sorting only the employees that are eligible for a bonus (i.e., those that contain a "Y" in the eligibility field) by department, and within department by manager.
2. Read the file of sorted bonus records and for each record read:
  - a. Print a detail line as shown in the report layout using the processing requirements for Project 14-4.
  - b. Increment the manager, department, and company totals as appropriate.
  - c. Begin every department on a new page with an appropriate heading containing the department name and page number of the report.

- d. Print manager and department headings whenever the fields change.
  - e. Print manager and department totals whenever the fields change.
3. Print the FasstCars Manufacturers totals at the conclusion of the report.

**Three-level Extension:** Extend the report to include a third (higher-level) control break on plant as shown in the report format. Begin each plant on a new page and include multiple departments in the same plant on the same page. Be sure to modify the format of the heading and detail lines, to change the SORT statement to include the extra level control break, and to modify the program to increment all totals as necessary.

**Project 15-5**

**Program Name:** Store Sales Commissions Program (Continuation of Project 14-5)

**Narrative:** Write a control break program to process sales records for Needless Markup to produce totals by salesperson, department, and store. The choice between a two- or three-level report is between you and your instructor.

**Input File:** SALES-FILE

**Input Record Layout:** Use the same record layout as Project 14-5.

**Test Data:** Use the same test data as Project 14-5.

**Two-level Report Layout:**

|                                                |            | NEEDLESS MARKUP INC | 99/99/99   | PAGE 29 |
|------------------------------------------------|------------|---------------------|------------|---------|
| COMMISSION REPORT FOR DEPARTMENT: XXXXXXXXXXXX |            |                     |            |         |
| SALESPERSON: XXXXXXXXXXXX                      |            |                     |            |         |
| DATE                                           | SALES      | COMMISSION          | NET SALES  |         |
| 99/99/99                                       | ZZ,ZZ9.99  | Z,ZZ9.99            | ZZ,ZZ9.99  |         |
| .                                              | .          | .                   | .          |         |
| .                                              | .          | .                   | .          |         |
| .                                              | .          | .                   | .          |         |
| TOTAL FOR salesperson                          | ZZZ,ZZ9.99 | ZZ,ZZ9.99           | ZZZ,ZZ9.99 |         |
| TOTAL FOR department                           | ZZZ,ZZ9.99 | ZZ,ZZ9.99           | ZZZ,ZZ9.99 |         |
| TOTAL FOR NEEDLESS MARKUP                      | ZZZ,ZZ9.99 | ZZ,ZZ9.99           | ZZZ,ZZ9.99 |         |

**Three-level  
Report Layout:**

|                                           |          | NEEDLESS MARKUP INC | 99/99/99   | PAGE Z9    |
|-------------------------------------------|----------|---------------------|------------|------------|
| COMMISSION REPORT FOR STORE: XXXXXXXXXXXX |          |                     |            |            |
| DEPARTMENT: XXXXXXXXXXXX                  |          |                     |            |            |
| SALESPERSON                               | DATE     | SALES               | COMMISSION | NET SALES  |
| XXXXXXXXXX                                | 99/99/99 | ZZ,ZZ9.99           | Z,ZZ9.99   | ZZ,ZZ9.99  |
|                                           | .        | .                   | .          | .          |
|                                           | .        | .                   | .          | .          |
|                                           | .        | .                   | .          | .          |
| TOTAL FOR salesperson                     |          | ZZZ,ZZ9.99          | ZZ,ZZ9.99  | ZZZ,ZZ9.99 |
| TOTAL FOR department name                 |          | ZZZ,ZZ9.99          | ZZ,ZZ9.99  | ZZZ,ZZ9.99 |
| TOTAL FOR store name                      |          | ZZZ,ZZ9.99          | ZZ,ZZ9.99  | ZZZ,ZZ9.99 |
| TOTAL FOR NEEDLESS MARKUP                 |          | ZZZ,ZZ9.99          | ZZ,ZZ9.99  | ZZZ,ZZ9.99 |

**Two-level  
Processing Requirements:**

1. Sort the incoming sales file by department, and within department by salesperson.
2. Read the file of sorted bonus records, and for each record read:
  - a. Print a detail line as shown in the report layout using the processing requirements for Project 14-5.
  - b. Increment the salesperson, department, and company totals as appropriate.
  - c. Begin every department on a new page with an appropriate heading containing the department name, current date, and page number of the report.
  - d. Print salesperson and department headings whenever the fields change.
  - e. Print salesperson and department totals whenever the fields change.
3. Print the Needless Markup total at the conclusion of the report.

**Three-level Extension:**

Extend the report to include a third (higher-level) control break on store as shown in the report format. Begin each store on a new page (expand the store code in the store heading) and include multiple departments in the same store on the same page. Be sure to modify the format of the heading and detail lines, to change the SORT statement to include the extra level control break, and to modify the program to increment all totals as necessary.

**Project 15-6**

**Program Name:** Zoo Control Break Program (Continuation of Project 14-6)

**Narrative:** Write a control break program to process a zoo's inventory animal file to determine totals by group, species, and type of animal. The choice between a two- or three-level report is between you and your instructor.

**Input File:** ZOO-FILE

**Input Record Layout:** Use the same record layout as Project 14-6.

**Test Data:** Use the same test data as Project 14-6.

**Two-level Report Layout:**

| WILD KINGDOM ZOO 99/99/99       |            |          |              | PAGE Z9        |
|---------------------------------|------------|----------|--------------|----------------|
| INVENTORY REPORT - species name |            |          |              |                |
| TYPE: XXXXXXXXXXXX              |            |          |              |                |
| SEX                             | VALUE      | QUANTITY | TOTAL        | NO. TO ACQUIRE |
| F                               | ZZZ,ZZ9.99 | Z9       | ZZZ,ZZ9.99   | Z9             |
| M                               | ZZZ,ZZ9.99 | Z9       | ZZZ,ZZ9.99   | Z9             |
| ** TOTAL FOR type name          |            | ZZ9      | Z,ZZZ,ZZ9.99 | ZZ9            |
| * TOTAL FOR species name        |            | ZZ9      | Z,ZZZ,ZZ9.99 | ZZ9            |
| TOTAL FOR WILD KINGDOM          |            | ZZ9      | Z,ZZZ,ZZ9.99 | ZZ9            |

**Three-level Report Layout:**

| WILD KINGDOM ZOO 99/99/99     |     |            |          | PAGE Z9        |
|-------------------------------|-----|------------|----------|----------------|
| INVENTORY REPORT - group name |     |            |          |                |
| SPECIE: XXXXXXXX              |     |            |          |                |
| TYPE                          | SEX | VALUE      | QUANTITY | NO. TO ACQUIRE |
| XXXXXXXXXXXX                  | F   | ZZZ,ZZ9.99 | Z9       | ZZZ,ZZ9.99     |
|                               | M   | ZZZ,ZZ9.99 | Z9       | ZZZ,ZZ9.99     |
| *** TOTAL FOR type            |     |            | ZZ9      | Z,ZZZ,ZZ9.99   |
| ** TOTAL FOR species name     |     |            | ZZ9      | Z,ZZZ,ZZ9.99   |
| * TOTAL FOR group name        |     |            | ZZ9      | Z,ZZZ,ZZ9.99   |
| TOTAL FOR WILD KINGDOM        |     |            | ZZ9      | Z,ZZZ,ZZ9.99   |

**Two-level Processing Requirements:**

1. Sort the incoming zoo file by species, and within species by type.
2. Read a file of sorted zoo records and for each record read:
  - a. Print a detail line as shown in the report layout using the processing requirements for Project 14-6.
  - b. Increment the type, species, and Wild Kingdom totals as appropriate.
  - c. Begin every species on a new page with an appropriate heading containing the species name, current date, and page number of the report.

- d. Print type and species headings whenever the fields change.
  - e. Print type and species totals whenever the fields change.
3. Print the Wild Kingdom totals at the conclusion of the report.

**Three-level Extension:** Extend the report to include a third (higher-level) control break on group as shown in the report format. Begin each group on a new page and include multiple species in the same group on the same page. Be sure to modify the format of the heading and detail lines, to change the SORT statement to include the extra level control break, and to modify the program to increment all totals as necessary.

**Project 15-7**

**Program Name:** PC Software Control Break Program (Continuation of Project 14-7)

**Narrative:** Write a control break program to process a PC software file to determine totals by customer, vendor, and platform. The choice between a two- or three-level report is between you and your instructor.

**Input File:** PC-SOFTWARE-FILE

**Input Record Layout:** Use the same record layout as Project 14-7.

**Test Data:** Use the same test data as Project 14-7.

**Two-level Report Layout:**

| SOFTWARE R US, INC           |                    | 99/99/99 | PAGE 29  |        |            |
|------------------------------|--------------------|----------|----------|--------|------------|
| SALES REPORT FOR vendor name |                    |          |          |        |            |
| PLATFORM: XXXXXXXX           |                    |          |          |        |            |
| CUSTOMER                     | PROGRAM NAME       | DATE     | QUANTITY | PRICE  | TOTAL      |
| XXXXXXXXXXXXXXXXXX           | XXXXXXXXXXXXXXXXXX | 99/99/99 | ZZ9      | ZZ9.99 | ZZ9.99     |
| .                            | .                  | .        | .        | .      | .          |
| .                            | .                  | .        | .        | .      | .          |
| .                            | .                  | .        | .        | .      | .          |
| TOTAL FOR platform           |                    |          | Z,ZZ9    |        | ZZZ,ZZ9.99 |
| TOTAL FOR vendor name        |                    |          | Z,ZZ9    |        | ZZZ,ZZ9.99 |
| SOFTWARE R US TOTAL          |                    |          | Z,ZZ9    |        | ZZZ,ZZ9.99 |

**Three-level Report Layout:**

| SOFTWARE R US, INC             |                    | 99/99/99 | PAGE 29  |        |            |
|--------------------------------|--------------------|----------|----------|--------|------------|
| SALES REPORT FOR customer name |                    |          |          |        |            |
| VENDOR: XXXXXXXXXXXXXXXX       |                    |          |          |        |            |
| PLATFORM                       | PROGRAM NAME       | DATE     | QUANTITY | PRICE  | TOTAL      |
| XXXXXX                         | XXXXXXXXXXXXXXXXXX | 99/99/99 | ZZ9      | ZZ9.99 | ZZ9.99     |
| .                              | .                  | .        | .        | .      | .          |
| .                              | .                  | .        | .        | .      | .          |
| .                              | .                  | .        | .        | .      | .          |
| TOTAL FOR platform             |                    |          | Z,ZZ9    |        | ZZZ,ZZ9.99 |
| TOTAL FOR vendor name          |                    |          | Z,ZZ9    |        | ZZZ,ZZ9.99 |
| TOTAL FOR customr name         |                    |          | Z,ZZ9    |        | ZZZ,ZZ9.99 |
| SOFTWARE R US TOTAL            |                    |          | Z,ZZ9    |        | ZZZ,ZZ9.99 |

**Two-level**

**Processing Requirements:**

1. Sort the incoming PC software file by vendor, and within vendor by platform.
2. Read the file of sorted PC software records and for each record read:
  - a. Print a detail line as shown in the report layout using the processing requirements for Project 14-7.
  - b. Increment the platform, vendor, and company totals as appropriate.
  - c. Begin every vendor on a new page with an appropriate heading containing the vendor name, current date, and page number of the report.
  - d. Print platform and vendor headings whenever the fields change.
  - e. Print platform and vendor totals whenever the fields change.
3. Print the Software R Us totals at the conclusion of the report.

**Three-level Extension:**

Extend the report to include a third (higher-level) control break on customer as shown in the report format. Begin each customer on a new page and include multiple vendors for the same customer on the same page. Be sure to modify the format of the heading and detail lines, to change the SORT statement to include the extra level control break, and to modify the program to increment all totals as necessary.

**Project 15-8**

**Program Name:** Video Control Break Program (Continuation of Project 14-8)

**Narrative:** Write a control break program to process a video file to determine totals by each store, category, and rating. The choice between a two- or three-level report is between you and your instructor.

**Input File:** VIDEO-FILE

**Input Record Layout:** Use the same record layout as Project 14-8.

**Test Data:** Use the same test data as Project 14-8.

**Two-level Report Layout:**

|                           |       | Blok buzter Video                               |          | 99/99/99 |                  | Page Z9  |   |
|---------------------------|-------|-------------------------------------------------|----------|----------|------------------|----------|---|
|                           |       | MONTHLY VIDEO RENTALS & SALES FOR category name |          |          |                  |          |   |
| RATING: XXXXXXXX          |       | Rental Information                              |          |          | Sell Information |          |   |
| MOVIE TITLE               | FEE   | #RENTED                                         | REVENUE  | PRICE    | NET              | REVENUE  |   |
| XXXXXXXXXXXXXXXXXXXX      | Z9.99 | ZZ9                                             | ZZ9.99   | ZZ9.99   | ZZ9              | ZZ9.99   |   |
| .                         | .     | .                                               | .        | .        | .                | .        | . |
| .                         | .     | .                                               | .        | .        | .                | .        | . |
| .                         | .     | .                                               | .        | .        | .                | .        | . |
| ** TOTAL FOR rating       |       | Z,ZZ9                                           | Z,ZZ9.99 |          | Z,ZZ9            | Z,ZZ9.99 |   |
| * TOTAL FOR category name |       | Z,ZZ9                                           | Z,ZZ9.99 |          | Z,ZZ9            | Z,ZZ9.99 |   |
| TOTAL FOR BLOKBUZTER      |       | Z,ZZ9                                           | Z,ZZ9.99 |          | Z,ZZ9            | Z,ZZ9.99 |   |

**Three-level Report Layout:**

|                            |       | Blok buzter Video                            |          | 99/99/99 |                  | Page Z9  |   |
|----------------------------|-------|----------------------------------------------|----------|----------|------------------|----------|---|
|                            |       | MONTHLY VIDEO RENTALS & SALES FOR store name |          |          |                  |          |   |
| CATEGORY: XXXXXXXXXX       |       | Rental Information                           |          |          | Sell Information |          |   |
| MOVIE TITLE                | FEE   | #RENTED                                      | REVENUE  | PRICE    | NET              | REVENUE  |   |
| XXXXXXXXXXXXXXXXXXXX       | Z9.99 | ZZ9                                          | ZZ9.99   | ZZ9.99   | ZZ9              | ZZ9.99   |   |
| .                          | .     | .                                            | .        | .        | .                | .        | . |
| .                          | .     | .                                            | .        | .        | .                | .        | . |
| .                          | .     | .                                            | .        | .        | .                | .        | . |
| *** TOTAL FOR rating       |       | Z,ZZ9                                        | Z,ZZ9.99 |          | Z,ZZ9            | Z,ZZ9.99 |   |
| ** TOTAL FOR category name |       | Z,ZZ9                                        | Z,ZZ9.99 |          | Z,ZZ9            | Z,ZZ9.99 |   |
| * TOTAL FOR store name     |       | Z,ZZ9                                        | Z,ZZ9.99 |          | Z,ZZ9            | Z,ZZ9.99 |   |
| TOTAL FOR BLOKBUZTER       |       | Z,ZZ9                                        | Z,ZZ9.99 |          | Z,ZZ9            | Z,ZZ9.99 |   |

**Two-level Processing Requirements:**

1. Sort the incoming video file by category, and within category by rating.
2. Read the file of sorted video records and for each record read:
  - a. Print a detail line as shown in the report layout using the processing requirements for Project 14-8.
  - b. Increment the rating, category, and Blok buzter totals as appropriate.



- c. Begin every category on a new page with an appropriate heading containing the category name, current date, and page number of the report.
  - d. Print rating and category headings whenever the fields change.
  - e. Print rating and category totals whenever the fields change.
3. Print the BlokBuzter totals on a separate page at the conclusion of the report.

**Three-level Extension:** Extend the report to include a third (higher-level) control break on store as shown in the report format. Begin each store on a new page and include multiple categories in the same store on the same page. Be sure to modify the format of the heading and detail lines, to change the SORT statement to include the extra level control break, and to modify the program to increment all totals as necessary.

**PROGRAMMING SPECIFICATIONS**

**Project 18-1**

**Program Name:** Invoice Program with Subprogram

**Narrative:** Write a program to produce an invoice for each record in a validated invoice file.

**Input File:** INVOICE-FILE  
STATE-FILE

**Input Record Layout:**

```

01 INVOICE-RECORD-IN.
 05 INV-INVOICE-NO PIC X(4).
 05 INV-DATE.
 10 INV-MONTH PIC 9(2).
 10 INV-DAY PIC 9(2).
 10 INV-YEAR PIC 9(2).
 05 INV-CUSTOMER-INFO.
 10 INV-CUST-NAME PIC X(10).
 10 INV-CUST-ADDRESS PIC X(10).
 10 INV-CUST-CITY PIC X(10).
 10 INV-CUST-STATE PIC XX.
 10 INV-CUST-ZIP PIC X(5).
 05 INV-NO-OF-ITEMS PIC 9.
 05 INV-ITEMS-ORDERED OCCURS 1 TO 4 TIMES
 DEPENDING ON INV-NO-OF-ITEMS.
 10 INV-ITEM-NO PIC 9(4).
 10 INV-QUANTITY PIC 9.

01 STATE-RECORD.
 05 ST-STATE PIC XX.
 05 ST-ZONE PIC 9.

```

**Test Data:**

| Invoice No | Customer Name | Address    | City        | State | Zone                       |
|------------|---------------|------------|-------------|-------|----------------------------|
| 246710049  | Scully        | 20 Main St | Chicago     | IL    | 435353125021100115501      |
| 157808129  | Schultz       | 45 5th St  | Los Angeles | CA    | 5678624500232001           |
| 034209109  | Culver        | 1 Sunny Ln | Seattle     | WA    | 55986190003                |
| 4790111290 | Perez         | 4 Long Dr  | New Orleans | LA    | 7934526800245001           |
| 683607049  | Fixler        | 3 42nd St  | New York    | NY    | 2000121250115503           |
| 480703189  | Morin         | 9 7th Ave  | Newark      | NJ    | 30697432001900031100230002 |
| 049806309  | Munroe        | 10 Long St | Tulsa       | OK    | 59345190005                |

**Report Layout:**

|                      |                              |                               |            |                                    |  |
|----------------------|------------------------------|-------------------------------|------------|------------------------------------|--|
| <b>Date</b> 99/99/99 |                              | <b>Dominoe Catalog Orders</b> |            | <b>Invoice Number</b> 9999         |  |
| <b>Ship To:</b>      | <b>Name</b><br>XXXXXXXXXX    |                               |            | <b>Invoice Order Date</b> 99/99/99 |  |
|                      | <b>Address</b><br>XXXXXXXXXX |                               |            |                                    |  |
|                      | <b>City</b>                  | <b>State</b>                  | <b>Zip</b> |                                    |  |
|                      | XXXXXXXXXX                   | XX                            | XXXXX      |                                    |  |

| Item No.              | Description        | Qty | Price Each | Total Price         | Tot Ship Wt     |
|-----------------------|--------------------|-----|------------|---------------------|-----------------|
| XXXX                  | XXXXXXXXXXXXXXXXXX | 9   | Z,ZZ9.99   | ZZ,ZZ9.99           | ZZ9.99          |
| .                     | .                  | .   | .          | .                   | .               |
| .                     | .                  | .   | .          | .                   | .               |
| .                     | .                  | .   | .          | .                   | .               |
| XXXX                  | XXXXXXXXXXXXXXXXXX | 9   | Z,ZZ9.99   | ZZ,ZZ9.99           | ZZ9.99          |
| <b>Totals</b>         |                    |     |            | <b>\$ZZZ,ZZ9.99</b> | <b>Z,ZZ9.99</b> |
| Total delivery charge |                    |     |            | ZZ9.99              |                 |
| Handling charge       |                    |     |            | 1.50                |                 |
| <b>Total amount</b>   |                    |     |            | <b>\$ZZZ,ZZ9.99</b> |                 |

|                                                |  |  |  |  |  |
|------------------------------------------------|--|--|--|--|--|
| <b>Questions? Call Toll Free 1-800-DOMINOE</b> |  |  |  |  |  |
|------------------------------------------------|--|--|--|--|--|

- Processing Requirements:**
1. Create an invoice, one per page, for each record read.
    - a. Write appropriate invoice headings.
    - b. For each item ordered:
      - (1) The incoming item number is to be used to find the description, price, and shipping weight via a sequential lookup. Hard-code the following table in the program:

| Item Information |                  |              |                |
|------------------|------------------|--------------|----------------|
| Item #           | Item Description | Price (each) | Ship Wt (each) |
| 1100             | Handwoven Rug    | 129.00       | 9.50           |
| 1550             | Crystal Frame    | 39.40        | 3.00           |
| 1250             | Floor Lamp       | 99.00        | 20.30          |
| 3000             | Ceiling Fan      | 299.00       | 50.01          |
| 4500             | Wicker Basket    | 25.00        | 2.00           |
| 6800             | Wall Clock       | 169.00       | 19.30          |
| 3200             | Ceramic Figure   | 39.90        | 10.00          |
| 9000             | Wood Wall Shelf  | 14.90        | 1.00           |

- (2) Compute the total price and total shipping weight.
- (3) Write a detail line for the item.

- (4) Increment appropriate invoice totals.
- c. After all the items ordered in the record have been processed, calculate the total delivery charge and the total invoice amount as follows:
- (1) The total delivery charge should be calculated in a subprogram. There are two steps in obtaining the total delivery charge:
    - (a) You must first determine the appropriate zone. The incoming state is to be used via a binary lookup to determine the appropriate zone (there are three zones in total). Input-load this state/zone table (only once per execution of the program). The state file (16-1STAT.DAT) can be found on the data disk.
    - (b) The total delivery charge is based on the zone and total shipping weight. Once the correct zone has been found, it is to be used in combination with the sum of the total shipping weight as follows:

| Delivery Rates                |                |             |         |         |
|-------------------------------|----------------|-------------|---------|---------|
| Total Ship Wgt Range (in lbs) |                | Zone Number |         |         |
| From                          | To (inclusive) | Zone 1      | Zone 2  | Zone 3  |
| 0                             | 2              | \$4.00      | \$4.25  | \$4.50  |
| 2                             | 4              | \$5.75      | \$6.25  | \$6.75  |
| 4                             | 9              | \$7.75      | \$8.50  | \$9.25  |
| 9                             | 20             | \$10.75     | \$12.00 | \$14.75 |
| 20                            | 30             | \$14.00     | \$15.50 | \$18.25 |
| 30                            | 50             | \$18.25     | \$20.75 | \$25.25 |
| 50                            | 70             | \$21.25     | \$25.00 | \$30.50 |
| 70                            | 999            | \$25.50     | \$29.00 | \$35.00 |

Develop a two-dimensional table to hold the above information and perform a table-lookup to determine the correct charge. Establish this table via a COPY statement. Use a direct lookup for zone dimension.

- (2) The final total amount is calculated by adding the total price, the total delivery charge, and the handling charge. The current handling charge is \$1.50; code this in your program so in the event this charge changes, it can be easily updated.
- d. Print appropriate totals (total price, total delivery charge, handling charge, and total amount) as shown on the layout.
- e. Increment the totals for price, shipping weight, total delivery charge, handling charge, and amount for the Summary Report (see #3).
2. When all records have been processed, write the Summary Report, on a separate page, of all the totals accumulated in e. (Design your summary report.)

## Project 16-2

- Program Name:** Student Aid Report Program with Subprogram
- Narrative:** Write the program to print a detailed student aid report for all validated students and a summary page depicting totals for each school.
- Input File:** STUDENT-FILE  
SCHOOL-FILE (See requirement 1b.)

**Input Record Layout:** Use the same record layout as Project 8-6.

**Test Data:** Use the validated student file from Project 8-6.

**Report Layout:**

**Detailed Student Aid Report:**

| Smart U<br>Student Aid Report |                  |            |             |              |               |           | Page 1<br>99/99/99 |
|-------------------------------|------------------|------------|-------------|--------------|---------------|-----------|--------------------|
| Student ID                    | Name             | School     | Type of Aid | Credit Hours | Total Tuition | Total Aid | Tuition Due        |
| 999999999                     | XXXXXXXXXXXXXXXX | XXXXXXXXXX | XXXXXXXXXX  | 99           | \$ZZZ,ZZ9     | \$ZZZ,ZZ9 | \$ZZZ,ZZ9          |
| .                             | .                | .          | .           | .            | .             | .         | .                  |
| .                             | .                | .          | .           | .            | .             | .         | .                  |
| .                             | .                | .          | .           | .            | .             | .         | .                  |

**Summary Report of Total Aid per School:**

| Smart U<br>Summary Report of Total Aid per School |                        |                        |                        | Page n<br>99/99/99 |
|---------------------------------------------------|------------------------|------------------------|------------------------|--------------------|
| School                                            | Total Tuition          | Total Aid              | Tuition Due            |                    |
| Art                                               | \$ZZ,ZZZ,ZZ9           | \$ZZ,ZZZ,ZZ9           | \$ZZ,ZZZ,ZZ9           |                    |
| .                                                 | .                      | .                      | .                      |                    |
| .                                                 | .                      | .                      | .                      |                    |
| .                                                 | .                      | .                      | .                      |                    |
| University Totals                                 | =====<br>\$ZZZ,ZZZ,ZZ9 | =====<br>\$ZZZ,ZZZ,ZZ9 | =====<br>\$ZZZ,ZZZ,ZZ9 |                    |

- Processing Requirements:**
1. For each valid record read:
    - a. The incoming aid type is to be expanded via a sequential lookup. The table-lookup procedure should be coded in a separate subprogram. Hard-code the following table:

| Aid Type & Expanded Aid Types |                   |
|-------------------------------|-------------------|
| Aid Type                      | Expanded Aid Type |
| S                             | Scholarship       |
| G                             | Grant             |
| L                             | Loan              |

- b. The incoming school code is to be expanded via a binary lookup. The lookup procedure should be coded in a separate subprogram. Use the following table and input-load it in the subprogram (only once per execution of the program).

| School Codes & Expanded Schools |                 |             |                 |
|---------------------------------|-----------------|-------------|-----------------|
| School Code                     | Expanded School | School Code | Expanded School |
| ART                             | Arts & Sciences | LAW         | Law             |
| BUS                             | Business        | MED         | Medicine        |
| COM                             | Communications  | MUS         | Music           |
| ENG                             | Engineering     |             |                 |

- c. Calculate total tuition based on \$300 per credit hour.
- d. Calculate total aid based on the percent of total tuition. This percent is determined by a combination of credit hours and GPA as follows:

| Credit Hours |    | GPA      |      |          |        |            |        |
|--------------|----|----------|------|----------|--------|------------|--------|
| from         | to | from 2.5 | to 3 | from > 3 | to 3.5 | from > 3.5 | to 4.0 |
| 1            | 3  | 30%      |      | 40%      |        | 50%        |        |
| > 3          | 6  | 44%      |      | 52%      |        | 63%        |        |
| > 6          | 9  | 53%      |      | 64%      |        | 72%        |        |
| > 9          | 12 | 62%      |      | 75%      |        | 84%        |        |
| >12          | 15 | 70%      |      | 80%      |        | 92%        |        |
| >15          | 18 | 75%      |      | 88%      |        | 100%       |        |

Develop a two-dimensional table to hold the above information and perform a table-lookup to determine the percent to be used. Establish this table via a COPY statement.

- e. Calculate tuition due by subtracting the total aid from the total tuition.
  - f. Write a detail line with the information shown on the Detailed Student Aid Report, printing ten students per page.
  - g. Increment the school's totals for total tuition, total aid, and total due. (Establish a table to compute the aid statistics for each school that will print at the conclusion of processing, remembering that the number of schools is variable.)
3. When all records have been processed, write the Summary Report of Total Aid per School from the table established in (g).

**Project 16-3**

**Program Name:** Salary Report Program

**Narrative:** Write a program to print a detailed salary report and average salary summary per location for all employees in a validated salary file.

**Input File:** SALARY-FILE  
 LOCATION-FILE (See requirement 2b.)

**Input Record Layout:** Use the same record layout as Project 8-7.

**Test Data:** Use the validated salary file from Project 8-7.

**Report Layout:**

**Detailed Salary Report:**

| Big Bucks, Inc.                     |                    |            |                    |                    |        | Page 1    |
|-------------------------------------|--------------------|------------|--------------------|--------------------|--------|-----------|
| Detailed Salary Report for 99/99/99 |                    |            |                    |                    |        |           |
| Soc Sec No.                         | Name               | Title      | Location           | Education          | Rating | Salary    |
| XXXXXXXXXX                          | XXXXXXXXXXXXXXXXXX | XXXXXXXXXX | XXXXXXXXXXXXXXXXXX | XXXXXXXXXXXXXXXXXX | 9      | \$ZZZ,ZZ9 |
| .                                   | .                  | .          | .                  | .                  | .      | .         |
| .                                   | .                  | .          | .                  | .                  | .      | .         |
| .                                   | .                  | .          | .                  | .                  | .      | .         |

**Summary Report of Average Salaries per Location:**

| Big Bucks, Inc.                                              |               |               |               |               |               | Page n        |
|--------------------------------------------------------------|---------------|---------------|---------------|---------------|---------------|---------------|
| Average Salary Summary - XXXXXXXXXXXXX Location for 99/99/99 |               |               |               |               |               |               |
| Education Level                                              | Rating        |               |               |               | 5             |               |
|                                                              | 1             | 2             | 3             | 4             |               |               |
| Grade School                                                 | \$ZZZ,ZZZ,ZZ9 | \$ZZZ,ZZZ,ZZ9 | \$ZZZ,ZZZ,ZZ9 | \$ZZZ,ZZZ,ZZ9 | \$ZZZ,ZZZ,ZZ9 | \$ZZZ,ZZZ,ZZ9 |
| .                                                            | .             | .             | .             | .             | .             | .             |
| .                                                            | .             | .             | .             | .             | .             | .             |
| Doctorate                                                    | \$ZZZ,ZZZ,ZZ9 | \$ZZZ,ZZZ,ZZ9 | \$ZZZ,ZZZ,ZZ9 | \$ZZZ,ZZZ,ZZ9 | \$ZZZ,ZZZ,ZZ9 | \$ZZZ,ZZZ,ZZ9 |

- Processing Requirements:**
1. Read a file of salary records.
  2. For each record read:
    - a. The incoming title code is to be expanded via a sequential lookup. The table-lookup procedure should be coded in a separate subprogram. Establish the following table via the COPY statement:

| Title Code | Expanded Title | Title Code | Expanded Title |
|------------|----------------|------------|----------------|
| 010        | President      | 060        | DP VP          |
| 020        | Vice Pres      | 070        | DP Mgr         |
| 030        | Mkt VP         | 080        | DP Prog        |
| 040        | Mkt Mgr        | 090        | Clerk          |
| 050        | Mkt Rep        | 100        | Adm Asst       |

- b. The incoming location code is to be expanded via a binary lookup from the following table which is to be input-loaded. Code the lookup and initialization in a subprogram (only once per execution of the program).

| Location Code | Expanded Location | Location Code | Expanded Location |
|---------------|-------------------|---------------|-------------------|
| MIA           | Miami             | NY            | New York          |
| CHI           | Chicago           | ATL           | Atlanta           |
| LA            | Los Angeles       |               |                   |

- c. The incoming education code is to be expanded via a direct lookup from the following table, which is to be hard-coded in your program.

| Education Code | Expanded Education | Education Code | Expanded Education |
|----------------|--------------------|----------------|--------------------|
| 1              | Grade School       | 4              | Bachelors          |
| 2              | High School        | 5              | Masters            |
| 3              | Associates         | 6              | Doctorate          |

- d. Write a detail line with the information shown on the Detailed Salary Report, printing ten employees per page.
- e. Establish a three-dimensional (5 by 6 by 5) table to compute the salary statistics for the 150 location-education-rating combinations.
- (1) Determine the appropriate row-column (i.e., education-rating) combination for each location.
  - (2) Increment the employee salary total for that row-column combination for each location by the employee's salary.
  - (3) Increment the number of employees in that row-column combination for that location by 1.
3. When all employees have been processed, write the Summary Report of Average Salaries per Location. Obtain the average salary by dividing the salary total for each combination by the number of employees in that combination. Print all 150 values of average salaries with every location on a separate page (i.e., 30 education-rating combinations per page).

## Project 16-4

**Program Name:** Stock Program

**Narrative:** Write a program to produce a stock report for each record in a validated stock file.

**Input File:** STOCK-FILE  
INDUSTRY-FILE (See requirement 1b.)

**Input Record Layout:** Use the same record layout as Project 8-8.

**Test Data:** Use the validated stock file from Project 8-8.

**Report Layout:**

| Stock Evaluation Report as of 99/99/99 |          |                  |              |      |                |     |             |         |        | Page Z9        |
|----------------------------------------|----------|------------------|--------------|------|----------------|-----|-------------|---------|--------|----------------|
| Exchange                               | Stock    | Industry         | Market Price | EPS  | Dividend Yield | PE  | Est. Growth | Est. PE | Ind PE | Comments       |
| XXXXXX                                 | XXXXXXXX | XXXXXXXXXXXXXXXX | ZZ9.999      | Z9.9 | ZZ9.99         | ZZ9 | ZZ9.99%     | ZZ9     | Z9     | XXXXXXXXXXXXXX |
| .                                      | .        | .                | .            | .    | .              | .   | .           | .       | .      | .              |
| .                                      | .        | .                | .            | .    | .              | .   | .           | .       | .      | .              |
| .                                      | .        | .                | .            | .    | .              | .   | .           | .       | .      | .              |

| Summary of Stocks to Buy as of 99/99/99 |          |              |               |                |
|-----------------------------------------|----------|--------------|---------------|----------------|
| Exchange                                | Stock    | Market Price | No. of Shares | Total          |
| XXXXXX                                  | XXXXXXXX | ZZ9.99       | Z,ZZ9         | ZZZ,ZZ9.99     |
| .                                       | .        | .            | .             | .              |
| .                                       | .        | .            | .             | .              |
| .                                       | .        | .            | .             | .              |
| Total                                   |          |              | ZZ,ZZ9        | \$Z,ZZZ,ZZ9.99 |

**Processing Requirements:**

1. Read a file of stock records, and for each record read:
  - a. Expand the exchange code, from the incoming record, to the appropriate exchange name as shown below. To determine the exchange name, hard-code the table in your program and implement a direct (positional) table lookup.

| Exchange Code | Exchange Name |
|---------------|---------------|
| 1             | NYSE          |
| 2             | NASDAQ        |
| 3             | OTC           |
| 4             | AMEX          |

- b. Determine the industry description and industry PE. The industry code is to be used to find the description and PE via a binary lookup. Input-load this table (only once per execution of the program).



| Industry Code | Industry Description | Industry PE Range |
|---------------|----------------------|-------------------|
| AIR           | Airline              | 12                |
| AUT           | Automobile           | 7                 |
| BAN           | Bank                 | 7                 |
| BEE           | Beer                 | 9                 |
| CMP           | Computers            | 30                |
| DRU           | Drugs                | 15                |
| ELE           | Electronics          | 25                |
| F&L           | Food & Lodging       | 10                |
| FOO           | Food Products        | 8                 |
| OIL           | Oil                  | 12                |
| RET           | Retail               | 9                 |
| S&L           | Savings & Loan       | 7                 |
| TEL           | Telephone            | 8                 |

- c. Calculate earnings per share (EPS) by dividing the PE into the stock price.
- d. Calculate the dividend yield by dividing the stock price into the dividend.
- e. Determine the estimated annual rate of growth in EPS (Est. Growth) over the next 3–5 years by multiplying the annual growth rate by the risk factor. To determine the risk factor, hard-code the table in your program and implement a direct (positional) table lookup.

| Risk Code | Risk Factor |
|-----------|-------------|
| 1         | .7          |
| 2         | .8          |
| 3         | .95         |
| 4         | 1.1         |
| 5         | 1.3         |

- f. Calculate the estimated price-to-earnings ratio (Est. PE) based on the estimated annual rate of growth in EPS and the current interest rate.
  - (1) The current interest rate should be obtained at execution. Use appropriate DISPLAY/ACCEPT statements to prompt for the interest rate and to enter it. The current interest rate limits are from .5% to 15%. (Remember data validation.)
  - (2) Develop a subprogram to determine the estimated PE. Create a two-dimensional table to hold the information below and perform a table lookup to determine the appropriate PE. Establish this table via a COPY statement in your subprogram.

| Estimated Annual Rate of Growth in EPS |      | Current Interest Rate |            |          |
|----------------------------------------|------|-----------------------|------------|----------|
| from                                   | to   | .5% - 7.9%            | 8% - 10.9% | 11 - 15% |
| .01%                                   | 5%   | 18                    | 9          | 6        |
| 5.01%                                  | 10%  | 20                    | 15         | 8        |
| 10.01%                                 | 15%  | 25                    | 20         | 11       |
| 15.01%                                 | 20%  | 30                    | 21         | 14       |
| 20.01%                                 | 25%  | 40                    | 30         | 18       |
| 25.01%                                 | 30%  | 45                    | 35         | 21       |
| 30.01%                                 | 35%  | 50                    | 40         | 24       |
| 35.01%                                 | 130% | 65                    | 55         | 31       |

- g. Determine the comments by comparing the PE in the record, estimated PE, and the industry PE.
    - (1) Print "BUY NOW" in the comments column when the PE is less than both the estimated PE and the industry PE.
    - (2) Print "Consider" in the comments column when the PE is less than estimated PE.
    - (3) Print "Potential" in the comments column when the PE is less than the industry PE.
  - h. Print a detail line for the record in the file, as shown on the layout. Detail lines are to be double spaced with 10 records per page. Print appropriate headings (and page numbers) on the top of every page in the report.
  - i. Create a summary table to hold the stocks deemed to be bought. This table should contain the exchange, stock name, market price, and shares to purchase.
2. When all records have been processed, create the Summary Report showing all the "BUY NOW" stocks and appropriate investment totals in the headings.

**Project 16-5**

**Program Name:** Electric Program

**Narrative:** Write a program to produce an electric report for each record in a validated electric file.

**Input File:** ELECTRIC-FILE  
TYPE-FILE (See requirement 1a.)

**Input Record Layout:** Use the same record layout as Project 8-9.

**Test Data:** Use the validated electric file from project 8-9.

**Report Layout:**

| Bright Power & Light              |                                |              |        |                |         |                |          |         |                 | Page Z9 |
|-----------------------------------|--------------------------------|--------------|--------|----------------|---------|----------------|----------|---------|-----------------|---------|
| Billing Report as of XXX Z9, 1999 |                                |              |        |                |         |                |          |         |                 |         |
| Account                           |                                | Service Used |        | Meter Readings |         | Kilowatt Hours |          |         | Amount          |         |
| Number                            | Rate Schedule/Class of Service | From         | To     | Previous       | Current | On-Peak        | Off-Peak | Total   | Billed          |         |
| 999999                            | XXXXXXXXXXXXXXXXXXXXXXXXXXXX   | XXX Z9       | XXX Z9 | ZZ,ZZ9         | ZZ,ZZ9  | ZZ,ZZ9         | ZZ,ZZ9   | ZZ,ZZ9  | ZZZ,ZZ9.99      |         |
| .                                 | .                              | .            | .      | .              | .       | .              | .        | .       | .               |         |
| .                                 | .                              | .            | .      | .              | .       | .              | .        | .       | .               |         |
| .                                 | .                              | .            | .      | .              | .       | .              | .        | .       | .               |         |
| TOTALS                            |                                |              |        |                |         | ZZZ,ZZ9        | ZZZ,ZZ9  | ZZZ,ZZ9 | \$ZZ,ZZZ,ZZ9.99 |         |

**Processing Requirements:**

1. Read a file of electric records; for each record read:
  - a. In a subprogram, determine the corresponding description, customer charge, and minimum charge. The incoming account type is to be used to find the description, customer, and minimum charges via a binary lookup. Input-load this table (only once per execution of the program).

| Account Type | Description Type, Category, Demand, Time of Use | Customer Charge | Minimum Charge |
|--------------|-------------------------------------------------|-----------------|----------------|
| CCSL1        | Comm, Curt Svc, 2000+                           | 170.00          | 12,670.00      |
| CCSL2        | Comm, Curt Svc, 2000+, ToU                      | 175.00          | 12,699.00      |
| CCSM1        | Comm, Curt Svc, 500-1999                        | 110.00          | 3,235.00       |
| CCSM2        | Comm, Curt Svc, 500-1999, ToU                   | 120.00          | 3,150.99       |
| CCSX1        | Comm, Curt Svc, 2000+(TV)                       | 400.00          | 13,000.00      |
| CCSX2        | Comm, Curt Svc, 2000+(TV), ToU                  | 410.00          | 12,900.00      |
| CGSL1        | Comm, Gen Svc, 2000+                            | 170.00          | 12,670.00      |
| CGSL2        | Comm, Gen Svc, 2000+, ToU                       | 180.00          | 12,550.00      |
| CGSM1        | Comm, Gen Svc, 500-1999                         | 41.00           | 3,166.00       |
| CGSM2        | Comm, Gen Svc, 500-1999, ToU                    | 55.00           | 3,100.00       |
| CGSN1        | Comm, Gen Svc, non-demand                       | 9.00            | 9.00           |
| CGSN2        | Comm, Gen Svc, non-demand, ToU                  | 12.30           | 12.30          |
| CGSS1        | Comm, Gen Svc, 21-499                           | 35.00           | 166.25         |
| CGSS2        | Comm, Gen Svc, 21-499, ToU                      | 41.50           | 1,365.00       |
| CGSX1        | Comm, Gen Svc, 2000+(TV)                        | 400.00          | 12,500.00      |
| CGSX2        | Comm, Gen Svc, 2000+(TV), ToU                   | 425.00          | 12,900.00      |
| RRSN1        | Res, Residential Svc                            | 5.65            | 5.65           |
| RRSN2        | Res, Residential Svc, ToU                       | 8.95            | 8.95           |



b. The energy charge is determined differently for residential and commercial accounts and whether the account is or is not Time of Use:

(1) Residential Accounts

**Non Time of Use**

The first 750 kw hours used will be charged at 3.922¢ per kw hour.  
 Additional kw hours used will be charged at 4.922¢ per kw hour.  
 (Remember total kw hours used is the current reading minus the previous reading.)

**Time of Use**

The On-Peak kw hours used will be charged at 7.962¢ per kw hour.  
 The Off-Peak kw hours used will be charged at 2.729¢ per kw hour.  
 (Remember total kw hours used is the on-peak kw hours plus the off-peak kw hours.)

(2) Commercial Accounts

**Non Time of Use**

Develop a subprogram to determine the appropriate energy charge. Create a two-dimensional table to hold the information below and perform a table-lookup to determine the appropriate energy rates. Establish this table via a COPY statement in your subprogram. The energy charge is energy rate multiplied by the kw hours used. (Remember the kw hours used is the current reading minus the previous reading.)

| Demand Type | Commercial Account Category |                        |
|-------------|-----------------------------|------------------------|
|             | General Service (GS)        | Curtable Services (CS) |
|             | Energy Rate                 | Energy Rate            |
| N           | 4.564¢                      |                        |
| S           | 1.884¢                      |                        |
| M           | 1.576¢                      | 1.473¢                 |
| L           | 1.573¢                      | 1.373¢                 |
| X           | 1.014¢                      | 0.945¢                 |

**Time of Use**

Develop another subprogram to determine the appropriate energy and fuel rates. Create a two-dimensional table to hold the information below and perform a table-lookup to determine the appropriate energy and fuel rates. Establish this table via a COPY statement in your subprogram. The energy charge is the on-peak rate multiplied by the on-peak kw hours used plus the off-peak rate multiplied by the off-peak kw hours used. (Remember total kw hours used is the on-peak kw hours plus the off-peak kw hours.) This subprogram is almost identical to the other; debug the first before going on to this one.

| Demand Type | Commercial Account Category |          |                        |          |
|-------------|-----------------------------|----------|------------------------|----------|
|             | General Service (GS)        |          | Curtable Services (CS) |          |
|             | On-Peak                     | Off-Peak | On-Peak                | Off-Peak |
| <b>N</b>    | 8.525¢                      | 2.752¢   |                        |          |
| <b>S</b>    | 3.846¢                      | 1.355¢   |                        |          |
| <b>M</b>    | 2.715¢                      | 1.111¢   | 2.615¢                 | 1.102¢   |
| <b>L</b>    | 1.573¢                      | 1.066¢   | 2.733¢                 | 1.046¢   |
| <b>X</b>    | 1.082¢                      | 0.949¢   | 1.062¢                 | 0.939¢   |

- c. The fuel charge is based on the demand code in the following table. Hard-code this table into the program and reference it via a sequential lookup.

| Demand Code | Fuel Rate |
|-------------|-----------|
| <b>N</b>    | 1.824¢    |
| <b>S</b>    | 1.824¢    |
| <b>M</b>    | 1.823¢    |
| <b>L</b>    | 1.816¢    |
| <b>X</b>    | 1.769¢    |

- d. The demand charge is calculated by multiplying the kw demand level by the demand charge. The current demand charge is \$6.25. Note: Residential accounts do not have a demand charge.
- e. Calculate the amount billed, which is the customer charge plus the energy charge plus the fuel charge plus the demand charge (if any). Verify the amount against the minimum charge; if amount calculated is less than the minimum charge, then use the minimum charge as the amount billed.
- f. Use a hard-coded table and a direct lookup to translate the numerical From- and To- month in the record to a 3-character abbreviation (using the first 3 letters of the month) to be printed on the detail line.
- g. Print a detail line for the record in the file, as shown on the layout. Detail lines are to be double spaced with 10 records per page. Print appropriate headings (and page numbers) on the top of every page in the report. Use the table in 1f. to create the format of the date as shown on the layout.
- h. Increment all totals shown in the report layout.
2. When all records have been processed, write the totals accumulated in 1h.

#### Basic Definitions for Account Codes and Types:

**Type Code:** C for Commercial Accounts  
R for Residential Accounts

**Category Code:** RS for Residential Service  
GS for General Service (Commercial)  
CS for Curtable Service (Commercial)

**Demand Code:** Demand is the kw to the nearest whole kw, as determined from the metering equipment for the 30-minute period of the customer's greatest use.

- N for non demand
- S for 21-499 kw demand
- M for 500-1999 kw demand
- L for 2000+ kw demand
- X for 2000+ Transmission Voltage kw demand

**Time of Use:** The energy rate is determined by the time in which the electricity is used, either On-Peak or Off-Peak. Usually the Off-Peak rate is less than the On-Peak rate.

On-Peak Hours are:

from Nov 1-Mar 31, Monday-Friday, 6am-10am & 6pm-10pm  
excluding Thanksgiving, Christmas, and New Year Days  
from Apr 1-Oct 31, Monday-Friday, 12noon-9pm  
excluding Memorial, Independence, and Labor Days

- 1 for non Time of Use
- 2 for Time of Use

(EL-CURRENT-READING contains On-Peak kw hours used and EL-PREVIOUS-READING contains Off-Peak kw hours used.)

## Project 16-6

**Program Name:** Extended Movies Program with Subprograms

**Narrative:** This program extends Project 13-2 to contain two subprograms.

**Input File:** MOVIE-EXTRA-FILE

**Input Record Layout:** Use the same record layout as Project 13-2.

**Test Data:** Use the same test data as Project 13-2.

**Report Layout:** Use the same report layout as Project 13-2.

**Processing Requirements:** Make the following changes to Project 13-2: the table-lookups for pay scale (processing requirement #2) and bonus (processing requirement #4) are to be implemented in a subprogram.

**Project 16-7**

**Program Name:** Extended Payroll Program with Subprogram

**Narrative:** This program extends Project 13-5 to contain subprograms.

**Input File:** PAYROLL-FILE

**Input Record Layout:** Use the same record layout as Project 13-5.

**Test Data:** Use the same test data as Project 13-5.

**Report Layout:** Use the same report layout as Project 13-5.

**Processing Requirements:** Make the following changes to Project 13-5: the table-lookups for taxes (processing requirement #2b) and insurance deduction (processing requirement #2d) are to be implemented in a subprogram.

**PROGRAMMING SPECIFICATIONS****Project 17-1**

**Program Name:** Extended Program Maintenance

**Narrative:** This project deals with program maintenance, in that some of the specifications for the data validation and sequential update programs presented in the chapter, have been changed as indicated below. Implement the changes in whatever program you deem appropriate.

**Input File:** As indicated in the chapter.

**Input Record Layout:** As indicated in the chapter.

**Output File:** NEW-MASTER-FILE

**Output Record Layout:** As indicated in the chapter.

**Test Data:** Use the existing files of Figure 17.5a and 17.9a for the unedited transaction and old master files, respectively.

**Report Layout:** There is no new report other than the indicated error messages.

**Processing Requirements:**

1. Change the stand-alone edit and/or sequential update program (as you deem appropriate) to implement all of the following:
  - a. SORT the valid transaction file (at the end of the edit program or the beginning of the update program). This change also implies that out-of-sequence transactions (which are input to the edit program) are no longer invalid (assuming that is the only error).
  - b. Replace lines 33–45 in the edit program, which describe the transaction file, with a COPY statement; use the same COPY statement in the sequential update program.

- c. Deleted records are to be written to a new file, DELETED-RECORD-FILE, for possible recall at a future date.
  - d. Enable the OM-LASTNAME, OM-INITIALS, OM-LOCATION-CODE, and/or OM-COMMISSION-RATE fields in the old master to be changed if necessary. The change is accomplished by coding any (all) of these fields as a correction in the transaction file; that is, the update program is to check if a value is present in the transaction file, and if so, it will replace the value in the master file with the value in the transaction file.
  - e. The change involved in item d. above implies it is permissible for a correction not to contain a value in the TR-SALES-AMOUNT field. For example, the transaction,
 

80000000VILLAR           C           C

 is now valid and implies a name change for the record in question. (The transaction was previously rejected for not containing a sales amount.)
  - f. The value in the commission field (on both additions and corrections) is to be between 5 and 10 inclusive; any other value is to be rejected with an appropriate error message.
2. Create additional test data (if necessary) so that all of the program modifications can be tested. Rerun both programs with the modified test data.

**Project 17-2**

**Program Name:** Customer Master Sequential File Update

**Narrative:** This project processes output from Project 15-2. Write a program that takes the Valid Order Transaction File created in Project 15-2 and update the Customer Master Sequential File.

**Input File:** VALID-ORDER-TRANSACTION-FILE, created in Project 15-2.

SEQ-CUSTOMER-MSTR.

**Input Record Layout:**

| Sequential Customer Master Record |                        |                       |              |
|-----------------------------------|------------------------|-----------------------|--------------|
| 01                                | SEQ-CUSTOMER-MSTR-REC. |                       |              |
|                                   | 05                     | CUSTOMER-NUMBER       | PIC X(6).    |
|                                   | 05                     | CUSTOMER-NAME         | PIC X(15).   |
|                                   | 05                     | CUSTOMER-ADDRESS      | PIC X(15).   |
|                                   | 05                     | CUSTOMER-CITY         | PIC X(10).   |
|                                   | 05                     | CUSTOMER-ZIP          | PIC 9(5).    |
|                                   | 05                     | CUSTOMER-CREDIT-LIMIT | PIC 9.       |
|                                   | 05                     | DATE-OF-LAST-REV      | PIC 9(8).    |
|                                   | 05                     | BALANCE-DUE           | PIC 9(5)V99. |
|                                   | 05                     | CUSTOMER-PHONE-NUM    | PIC X(12).   |
|                                   | 05                     | FILLER                | PIC X.       |



**Test Data:** VALID-ORDER-TRANSACTION-FILE: Created in Project 15-2

| 1                  | 2               | 3          | 4            | 5          | 6                                  | 7          | 8          |
|--------------------|-----------------|------------|--------------|------------|------------------------------------|------------|------------|
| 1234567890         | 1234567890      | 1234567890 | 1234567890   | 1234567890 | 1234567890                         | 1234567890 | 1234567890 |
| SEQ-CUSTOMER-MSTR: |                 |            |              |            |                                    |            |            |
| 105105             | TARGETWORLD     | 123        | THIS IS IT   | IRVING     | 771233051019920001234214-123-4567  |            |            |
| 661400             | MILLERS OUTLAW  | 999        | W. BELTLINE  | IRVING     | 774303052419920076421214-847-0000  |            |            |
| 771600             | COMPANY 123     | S. 440     | CIRCLE       | DALLAS     | 750163020719920010038385-999-4444  |            |            |
| 795300             | SOUND STUDIO    | 26         | AIRPORT FRWY | IRVING     | 750324112719920235000817-295-4327  |            |            |
| 852300             | PET WORLD       | 210        | N. LION DR.  | FT. WORTH  | 732842120319920029959777-398-3843  |            |            |
| 881600             | GRAND CHICKEN   | 5600       | LUNCH AVE.   | ANYTOWN    | 793051102619920078000915-350-4088  |            |            |
| 900000             | CHRISTMAS, INC. | 100        | SNOW DR.     | NORTH POLE | 000016122519920000000800-010-7252  |            |            |
| 902900             | PARTY'S UNLIMTD | 500        | NEW YR'S AVE | EVERYWHERE | 9999994010119920500000915-295-6859 |            |            |
| 998000             | E-Z CATERING    | 250        | N. MACARTHUR | IRVING     | 730271092019920015270214-695-5432  |            |            |

**Report Layout:** Create a Customer Master Audit Report showing the data before and after the change, as well as the appropriate message indicating the action taken. Create a Customer Master report showing all data on the Customer Master.

- Processing Requirements:**
- Sort the order transaction records by record type, keeping only the type 2 records, and by customer number.
  - Process a file of sorted transactions to accomplish both of the following:
    - Add a new customer (if the customer does not exist on the current customer master file)—enter all information from the transaction record to the new master record.
    - Change (correct) information on a customer (customer master number equals valid order transaction customer number)—transactions to correct will contain all of the information, even if it does not change.
  - All error messages are to appear in one report.
  - The FD's and record descriptions for both the master and transaction files are to be copied into the program. This requires that you establish the necessary COPY members as separate files, and bring them in at compile time.

## Project 17-3

**Program Name:** Inventory Master Sequential File Update

**Narrative:** This project processes output from Project 15-2. Write a program that takes the Valid Order Transaction File created in Project 15-2, and update the Inventory Master Sequential File.

**Input File:** VALID-ORDER-TRANSACTION-FILE, created in Project 15-2.

SEQ-INVENTORY-MSTR.

**Output File:** SHIP-BACKORDER-TRANS-FILE

**Input Record Layout:** Sequential Inventory Master Record

|    |                         |            |
|----|-------------------------|------------|
| 01 | SEQ-INVENTORY-MSTR-REC. |            |
| 05 | INV-ITEM-NUMBER         | PIC 9(5).  |
| 05 | INV-DESCRIPTION         | PIC X(20). |
| 05 | INV-QTY-ON-HAND         | PIC 9(4).  |
| 05 | INV-LOCATION            | PIC X(5).  |

**Test Data:** VALID-ORDER-TRANSACTION-FILE: Created in Project 15-2.

| SEQ-INVENTORY-MSTR: |         |           |
|---------------------|---------|-----------|
| 12345               | ITEM 0  | 0000LOC09 |
| 15555               | ITEM 5  | 0000LOC12 |
| 16789               | ITEM 6  | 0049LOC32 |
| 18633               | ITEM 1  | 0700LOC10 |
| 26666               | ITEM 7  | 0099LOC14 |
| 32600               | ITEM 8  | 0189LOC14 |
| 32950               | ITEM 9  | 0100LOC14 |
| 32966               | ITEM 10 | 0500LOC13 |
| 33333               | ITEM 2  | 1499LOC11 |
| 34567               | ITEM 3  | 0100LOC12 |
| 37777               | ITEM 11 | 0000LOC13 |
| 45678               | ITEM 4  | 1600LOC12 |
| 49880               | ITEM 12 | 0010LOC14 |

**Output Record Layout:** Same as VALID-ORDER-TRANSACTION-FILE, with a ship/back-order indicator alphanumeric field added to the last byte of the record.

**Report Layout:** Create an Inventory Master Audit Report showing the data before and after the change, as well as the appropriate message indicating the action taken. Create an Inventory Master report showing all data on the Inventory Master.

- Processing Requirements:**
1. Sort the order transaction records by order number and record type, keeping only the type 1 and 3 records.
  2. Process a file of sorted transactions to accomplish the following:
    - a. If a type 1 record, hold onto the partial ship indicator and write the entire record to the SHIP-BACKORDER-TRANS-FILE.
    - b. If the item ordered is found on the inventory master file (inventory item number equals valid order transaction item number on type 3 record), determine whether there is enough quantity on hand to ship.
      - If there is enough quantity on hand to ship:
        - \* Update the appropriate inventory master record quantity on hand.
        - \* Create a ship transaction indicating the quantity shipped, placing an 's' in the ship/back-order indicator.
      - If there is not enough quantity on hand to ship, and a partial ship is okay (check the partial ship indicator on the type 1 record):
        - \* Update the appropriate inventory master record quantity on hand to zero.
        - \* Create a ship transaction indicating the quantity shipped, placing an 's' in the ship/back-order indicator.
        - \* Create a back-order transaction indicating the quantity not shipped, placing a 'b' in the ship/back-order indicator.
      - If there is not enough quantity on hand to ship, and a partial ship is not okay (check the partial ship indicator on the type 1 record):
        - \* Create a back-order transaction indicating the entire quantity ordered not shipped, placing a 'b' in the ship/back-order indicator.

- c. If an item is not on the inventory master file, create a back-order transaction for the entire quantity and indicate that an error has occurred with an appropriate error message on the report.
3. All error messages are to appear in one report.
4. The FD's and record descriptions for both the master and the transaction files are to be copied into the program. This requires that you establish the necessary COPY members as separate files, and bring them in at compile time.

## Project 17-4

**Program Name:** Employee Sequential File Update

**Narrative:** This project and the next are more complex applications of the balance line algorithm.

**Input Files:** OLD-MASTER-FILE  
TRANSACTION-FILE

**Input Record Layouts:**

```

01 OLD-MASTER-RECORD.
 05 OLD-SOC-SEC-NUMBER PIC X(9).
 05 OLD-NAME.
 10 OLD-LAST-NAME PIC X(12).
 10 OLD-INITIALS PIC XX.
 05 OLD-DATE-OF-BIRTH.
 10 OLD-BIRTH-MONTH PIC 99.
 10 OLD-BIRTH-YEAR PIC 99.
 05 OLD-DATE-OF-HIRE.
 10 OLD-HIRE-MONTH PIC 99.
 10 OLD-HIRE-YEAR PIC 99.
 05 OLD-LOCATION-CODE PIC X(3).
 05 OLD-PERFORMANCE-CODE PIC X.
 05 OLD-EDUCATION-CODE PIC X.
 05 OLD-TITLE-DATA OCCURS 2 TIMES.
 10 OLD-TITLE-CODE PIC 9(3).
 10 OLD-TITLE-DATE PIC 9(4).
 05 OLD-SALARY-DATA OCCURS 3 TIMES.
 10 OLD-SALARY PIC 9(6).
 10 OLD-SALARY-DATE PIC 9(4).

01 TRANSACTION-RECORD.
 05 TR-SOC-SEC-NUMBER PIC X(9).
 05 TR-NAME.
 10 TR-LAST-NAME PIC X(12).
 10 TR-INITIALS PIC XX.
 05 TR-DATE-OF-BIRTH.

```

```

10 TR-BIRTH-MONTH PIC 99.
10 TR-BIRTH-YEAR PIC 99.
05 TR-DATE-OF-HIRE.
10 TR-HIRE-MONTH PIC 99.
10 TR-HIRE-YEAR PIC 99.
05 TR-LOCATION-CODE PIC X(3).
05 TR-PERFORMANCE-CODE PIC X.
05 TR-EDUCATION-CODE PIC X.
05 TR-TITLE-DATA.
10 TR-TITLE-CODE PIC 9(3).
10 TR-TITLE-DATE PIC 9(4).
05 TR-SALARY-DATA.
10 TR-SALARY PIC 9(6).
10 TR-SALARY-DATE PIC 9(4).
05 TR-TRANSACTION-CODE PIC X.
88 ADDITION VALUE 'A'.
88 CORRECTION VALUE 'C'.
88 DELETION VALUE 'D'.

```

**Output File:** NEW-MASTER-FILE

**Output Record Layout:** Identical to the old master record.

**Test Data: Old Master File:**

```

100000000SUGRUE PK12450888BOSE81000888 800000992 700000891
200000000CRAWFORD MA08430973WASE220005891500585 750001092 700001091 650001090
300000000MILGROM MB
400000000LEE 10741189NYCG4441193 340001192
500000000TATER CR12820550CHIP33311872221185 290001092 280001091 270001090
600000000GRAUER JE11880368WASG3331193 690001191
700000000JONES JJ11860669BOSG89211878911186 320001091 300001090 280001089
800000000SMITH 11860448WASG33311874441186 290001091 260001090 240001089
900000000BAKER ED11780652MIAG32111871231186 680001091 640001090 600001089

```

**Transaction File:**

```

100000000RUBIN J 10701289MIA 50101292 250001292A
000000000RUBIN J X 7774 C
200000000CRAWFORD MA08430973WASE22000592 750001092A
400000000LEE BL C
400000000LEE 1073 C
400000000LEE 1289 C
400000001LEE MIA C
500000000TATER CR D
55555555NEW EMPLOYEE XX C
55555555NEW EMPLOYEE NE09541289WASE22001292 750001292A
55555555NEW EMPLOYEE NE NYC C
700000000JONES A 340001292C
800000000SMITH SS 300 C

```

**Report Layout:** There is no report produced by this program, other than the error messages indicated in the processing requirements. The latter may be produced using DISPLAY statements with programmer discretion as to the precise layout.

- Processing Requirements:**
1. Develop a sequential update program to process an incoming transaction file and the associated old master file to produce a new master file.
  2. Three transaction codes are permitted: A, C, and D, denoting additions, corrections, and deletions, respectively.
  3. The transaction file is assumed to be valid in itself because it has been processed by a stand-alone edit program. Hence each transaction has a valid transaction code (A, C, or D), numeric fields are numeric, and so on. Nevertheless, the update program must check (and flag) two kinds of errors that could not be detected in the stand-alone edit, as they require interaction with the old master file. These are:
    - a. Duplicate additions, in which the social security number of a transaction coded as an addition already exists in the old master.
    - b. No matches, in which the social security number of a transaction coded as either a deletion or a correction, does not exist in the old master.
  4. Transactions coded as additions are added to the new master file in their entirety. These transactions require all fields in the transaction record to be present.
  5. Transactions coded as deletions are removed from the master file. These transactions need contain only the social security number and transaction code.
  6. Transactions coded as corrections contain only the social security number and the corrected value of any field(s) to be changed and are handled on a parameter-by-parameter basis. For example, if birth date and location are to be corrected, the incoming transaction will contain only the social security number and corrected values of birth date and location code in the designated positions on the transaction record.
  7. Any old master record for which there is no corresponding transaction is to be copied intact to the new master.

## Project 17-5

**Program Name:** Extended Employee Sequential File Update

**Narrative:** This program shows the generality of the balance line algorithm by expanding the specifications in the previous project to include a second transaction file. You will find that even though a new input file has been added, there are no additional modules required for the algorithm per se. It will, however, be necessary to change the logic of CHOOSE-ACTIVE-KEY in that the active key is now the smallest of three values.

**Input File:** PROMOTION-FILE

**Input Record Layout:**

```

01 PROMOTION-RECORD.
 05 PR-SOC-SEC-NUMBER PIC X(9).
 05 PR-NAME.
 10 PR-LAST-NAME PIC X(12).
 10 PR-INITIALS PIC XX.
 05 PR-SALARY-DATA.
 10 PR-SALARY PIC 9(6).

```

```

10 PR-SALARY-DATE PIC 9(4).
05 PR-TITLE-DATA.
10 PR-TITLE-CODE PIC 9(3).
10 PR-TITLE-DATE PIC 9(4).
05 PR-PROMOTION-CODE PIC X.
88 SALARY-RAISE VALUE 'R'
88 PROMOTION VALUE 'P'.

```

**Test Data:**

```

100000000SUGRUE PK 900000993 R
100000000SUGRUE PK 9990993P
400000000LEE BL 500001193 R
666666666GLASSMAN C 450001093 R
800000000SMITH SS 750001093 R

```

**Report Layout:** Identical to the previous project.

**Processing Requirements:** Modify the specifications of Project 17-4 to accommodate all of the following:

1. Inclusion of a second transaction (i.e., a promotion) file to accommodate promotions and/or salary increases.
2. Salary increases are to be handled in the following manner: the transaction salary becomes the present salary in the new master, causing the present salary in the old master to become the previous salary in the new master. In similar fashion, the previous salary in the old master becomes the second previous salary in the new master. (The record layout of the master file in the programming specifications allowed three salary levels.)  
Each occurrence of salary is accompanied by a salary date in both the old master and promotion record layouts. Accordingly, the salary dates and the salaries are to be adjusted simultaneously.
3. Promotions (i.e., title changes in the new file) are to be handled in a manner analogous to salary increases. Hence the transaction title, PR-TITLE-CODE, becomes the present title in the new master, causing the present title in the old master to become the previous title in the new master. The associated dates are to be adjusted simultaneously.
4. Deletions (in the original transaction file) are to be written in their entirety to a new file, DELETED-RECORD-FILE, for possible recall at a future date.
5. All error messages are to be expanded to print the entire transaction that is in error.

**Project 17-6**

**Program Name:** Stock Sequential File Update

**Narrative:** Develop a sequential update program to process an incoming transaction file and the associated master stock file to produce a new master stock file.

**Input File:** MASTER-STOCK-FILE  
TRANSACTION-FILE

**Input Record Layout:** Use the record layout in Project 8-8 for the MASTER-STOCK-FILE.

```

01 TRANSACTION-FILE.
 05 TR-INFO.
 10 TR-NAME PIC X(8).
 10 TR-EXCHANGE-CODE PIC 9.
 10 TR-INDUSTRY-CODE PIC X(3).
 05 TR-CURRENT-INFO.
 10 TR-PRICE PIC 9(3)V9(3).
 10 TR-PE PIC 9(3).
 10 TR-DIVIDEND PIC 9V99.
 05 TR-PROJECTION-INFO.
 10 TR-RISK-CODE PIC 9.
 10 TR-GROWTH-RATE PIC 9V9(4).
 10 TR-SHARES-TO-BUY PIC 9(4).
 05 TRANS-CODE PIC X.
 88 ADDITION VALUE 'A'.
 88 CORRECTION VALUE 'C'.
 88 DELETION VALUE 'D'.

```

**Output File:** NEW-MASTER-STOCK-FILE

**Output Record Layout:** Same as master stock file.

**Test Data:** Use the validated stock file from Project 8-8 as the MASTER-STOCK-FILE.

**Transaction File:**

|          | 1             | 2             | 3          | 4          | 5          | 6     |
|----------|---------------|---------------|------------|------------|------------|-------|
|          | 1234567890    | 1234567890    | 1234567890 | 1234567890 | 1234567890 | 12345 |
| Anheus   |               |               | 200550     |            |            | C     |
| Citicorp | 1BAN0262500   | 190002025500  | 123A       |            |            |       |
| Chevron  | 101L0727500   | 2433040095000 | 50A        |            |            |       |
| Compq    |               | 030550032285  |            |            |            | C     |
| GenEl    |               |               |            | 0100C      |            |       |
| GnMotr   |               |               |            |            |            | D     |
| HBO      | 2RET0230000   | 2903020650000 | 75A        |            |            |       |
| Hilton   | 1F&L0497750   | 2212230550000 | 25A        |            |            |       |
| IBM      |               | 383 01000     |            |            |            | C     |
| Kmart    |               |               |            |            |            | D     |
| Marrion  |               | 0155000130143 |            |            |            | C     |
| PolkAu   |               | 005250020     | 4          |            |            | C     |
| Reebok   |               | 007           | 3          | 0055C      |            |       |
| OBrien   | 4RET0048750   | 1500004023001 | 10A        |            |            |       |
| Seagate  | 2ELE017125343 | 13030089000   | 45A        |            |            |       |
| Skywst   |               |               |            |            |            | D     |
| Trustco  |               | 0653          |            |            |            | C     |
| Wendys   | 1F&L0120000   | 2202440295000 | 50A        |            |            |       |

**Report Layout:** There is no output report other than the error messages; use whatever form you deem appropriate.

- Processing Requirements:**
- Sort the master file by stock name.
  - Three transaction codes are permitted: A, C, and D, denoting additions, corrections, and deletions, respectively:
  - The transaction file is assumed to be valid in itself because it has been processed by a stand-alone edit program. Hence each transaction has a valid transaction code (A,



C, or D), numeric fields are numeric, and so on. Nevertheless, the update program must check (and flag) two kinds of errors that could not be detected in the stand-alone edit, as they require interaction with the master file. These are:

- a. Duplicate additions, in which the stock name of a transaction coded as an addition already exists in the master.
  - b. No matches, in which the stock name of a transaction coded as either a deletion or a correction, does not exist in the master.
4. Transactions coded as additions are added to the new master file in their entirety. These transactions require all fields in the transaction record to be present.
  5. Transactions coded as deletions are removed from the master file. These transactions need contain only the stock name and transaction code.
  6. Transactions coded as corrections contain only the stock name and the corrected value of any field(s) to be changed and are handled on a parameter-by-parameter basis. For example, if price and PE are to be corrected, the incoming transaction will contain only the stock name and corrected values of price and PE in the designated positions on the transaction record.
  7. Any master stock record for which there is no corresponding transaction is to be copied intact to the new master.

**Project 17-7**

**Program Name:** Church Building Fund Sequential File Maintenance

**Narrative:** Write a program to update the church members' balance based on their contributions to the church building fund.

**Input File:** CHURCH-BLD-FUND-MSTR-FILE

CHURCH-BLD-FUND-TRAN-FILE

| Church Building Fund Master Record |           |                    |               |                    |           |
|------------------------------------|-----------|--------------------|---------------|--------------------|-----------|
| Member Name                        |           | Pledge Amount      | Member Number | Amount Given       |           |
| 1 ... 15                           | 16 ... 25 | 19 (2 decimals) 27 | 28-32         | 33 (2 decimals) 41 | 42 ... 43 |

| Church Building Fund Master Record |              |            |
|------------------------------------|--------------|------------|
| Member Name                        | Amount Given | Date Given |
| 1 ... 15                           | 16 ... 24    | 25 ... 32  |

**Output File:** NEW-CHURCH-BLD-FUND-MSTR

ERROR-TRANS-FILE

**Output Record Layout:** NEW-CHURCH-BLD-FUND-MSTR: same as Church Member Master Record.

ERROR-TRANS-FILE: same as Church Member Transaction File.



**Test Data:**

Master File:

```

JOHN SMITH 00100000000001000001000XX
ANN LOVING 00200000000002000002000XX
MARY BROWN 00005000000003000003000XX
TOM SAWYER 00075000000004000004000XX
JACK CAPPS 03400000000005000005000XX

```

Transaction File:

```

00002 00003000010021997
00003 00005000008051997
00001 00002000006011997
00001 00000100003021997
00002 00001000002101997
00004 00010010101101997
00001 00500040402021997
00004 00020050603031997
00003 00100020204041997
00003 01000101005051997
00002 15000030206061997

```

**Report Layout:**

| ABC CHURCH MEMBER BUILDING FUND REPORT |                                       |                                       |                                       |
|----------------------------------------|---------------------------------------|---------------------------------------|---------------------------------------|
| MEMBER NAME                            | AMOUNT PLEDGED                        | AMOUNT GIVEN TO DATE                  | AMOUNT OWED                           |
| XXXXXXXXXXXXXXXXXX                     | \$\$, \$\$\$, \$\$\$ .99              | \$\$, \$\$\$, \$\$\$ .99              | \$\$, \$\$\$, \$\$\$ .99              |
| TOTAL                                  | \$\$\$ , \$\$\$ , \$\$\$ , \$\$\$ .99 | \$\$\$ , \$\$\$ , \$\$\$ , \$\$\$ .99 | \$\$\$ , \$\$\$ , \$\$\$ , \$\$\$ .99 |

**Error Report:** Design any report you deem appropriate in conjunction with the processing specifications.

- Processing Requirements:**
1. Read a file of church member building fund transaction records.
  2. Perform an internal sort, sorting the transaction records by church member number.



3. For every record read, accumulate the total amount a church member has given. After all transaction records have been read for a church member:
  - a. Read the sequential church member building fund master record until the church member numbers on the transaction file match the church member numbers on the master file.  
 Make sure that the master records are coming in sorted by church member number by doing a data validation check.
  - b. Calculate the AMOUNT OWED = AMOUNT PLEDGED - AMOUNT GIVEN.
  - c. Update the master record with the new amount given.
  - d. If transaction records exist for a church member who does not have a master record, put this on the error report and keep the transactions on an error file. The Error File should have the same layout of the Transaction File. The error report should contain all the information on the transaction file with an appropriate error message.
  - e. Accumulate the total amount given, the total amount pledged, and the total amount owed by all church members.
  - f. Print the CHURCH MEMBER NAME, the AMOUNT PLEDGED, the AMOUNT PAID TO DATE, and the AMOUNT OWED for each church member. Single-space each line.
4. Print the TOTAL AMOUNT PLEDGED, AMOUNT PAID, and AMOUNT OWED at the end of the report.



**Program Name:** Two-file Merge

**Narrative:** This project merges two sequential files to produce a third file; all three files have different record layouts.

**Input Files:** EMPLOYEE-MASTER-FILE  
SALARY-FILE

**Input Record Layout:**

|    |                         |            |
|----|-------------------------|------------|
| 01 | EMPLOYEE-MASTER-RECORD. |            |
| 05 | EMP-SOC-SEC-NUMBER      | PIC X(9).  |
| 05 | EMP-NAME.               |            |
| 10 | EMP-LAST-NAME           | PIC X(15). |
| 10 | EMP-INITIALS            | PIC XX.    |
| 05 | EMP-BIRTH-DATE          | PIC 9(4).  |
| 05 | EMP-HIRE-DATE           | PIC 9(4).  |
| 05 | EMP-LOC-CODE            | PIC X(3).  |
| 05 | EMP-TITLE-CODE          | PIC 9(3).  |
| 01 | SALARY-RECORD.          |            |
| 05 | SAL-SOC-SEC-NUMBER      | PIC X(9).  |
| 05 | SAL-ANNUAL-SALARY       | PIC 9(6).  |

**Test Data: Employee Master File:**

```

111111111ADAMS JO10521082ATL111
222222222MOLDOLF ML10590484FLA222
333333333FRANKEL LY06560589NJ 111
555555555BOROW JE01430680NY 222
666666666MILGROM IR03480187NY 222
888888888JONES JJ09600684NY 222

```

**Salary File:**

```

111111111050000
222222222100000
444444444075000
555555555040000
777777777043500
888888888035000
999999999042000

```

**Input Files:** MERGED-FILE

**Output Record Layout:**

|    |                     |            |
|----|---------------------|------------|
| 01 | MERGED-DATA-RECORD. |            |
| 05 | MGD-SOC-SEC-NUMBER  | PIC X(9).  |
| 05 | MGD-NAME.           |            |
| 10 | MGD-LAST-NAME       | PIC X(15). |
| 10 | MGD-INITIALS        | PIC XX.    |
| 05 | MGD-BIRTH-DATE      | PIC 9(4).  |
| 05 | MGD-HIRE-DATE       | PIC 9(4).  |
| 05 | MGD-LOC-CODE        | PIC X(3).  |
| 05 | MGD-TITLE-CODE      | PIC 9(3).  |
| 05 | MGD-ANNUAL-SALARY   | PIC 9(6).  |

**Report Layout:** There is no report produced by this program, other than the error messages indicated in the processing requirements. The latter may be produced using DISPLAY statements with programmer discretion as to the precise layout.

- Processing Requirements:**
1. Write a program to merge two input files, each in sequence by social security number, to produce a third file as output.
  2. In order to produce an output record with a given key, that key must be present on both input files. With respect to the test data, for example, records 111111111 and 222222222 should both appear on the merged file. A record is written to the MERGED-FILE by combining fields on the two input records as per the record layouts.
  3. If a key appears on only one input file, that record key is not to appear in the MERGED-FILE. With respect to the test data, for example, record 333333333 should not appear in the MERGED-FILE, as it is not present in the SALARY-FILE. Nor should record key 444444444, as it is not present in the EMPLOYEE-MASTER-FILE.
  4. Any key appearing in only one file should be flagged with an appropriate error message, for example:
 

```

ERROR - RECORD 333333333 NOT IN SALARY-FILE
ERROR - RECORD 444444444 NOT IN EMPLOYEE-MASTER-FILE

```

## PROGRAMMING SPECIFICATIONS

### Project 18-1

**Program Name:** Extended Program Maintenance

**Narrative:** Change the nonsequential update program of Figure 18.10 to accommodate the various changes in specifications listed below.

**Input File:** As indicated in the chapter.

**Input Record Layout:** As indicated in the chapter.

**Test Data:** Use the existing files of Figure 18.7a and 18.7b for the transaction and indexed files, respectively.

**Report Layout:** There is no new report other than the indicated error messages.

- Processing Requirements:**
1. Change the existing program to accommodate all of the following:
    - a. Replace the record descriptions in Working-Storage, (lines 34-45 and 47-54 for the transaction and master files, respectively) with a COPY statement. This in turn requires you to create the necessary copy members.
    - b. Deleted records are to be written to a new file, DELETED-RECORD-FILE, for possible recall at a future date.
    - c. Enable the MA-LAST-NAME, MA-INITIALS, MA-LOCATION-CODE, and/or MA-COMMISSION-RATE fields in the indexed file to be changed if necessary. The change is accomplished by coding any (all) of these fields as a correction in the transaction file; that is, the update program is to check if a value is present in the transaction file, and if so, it will replace the value in the master file with the value in the transaction file.
    - d. The change involved in item c. above implies it is permissible for a correction not to contain a value in the TR-SALES-AMOUNT field. For example, the transaction,
 

```
800000000VILLAR C C
```

 is now valid and implies a name change for the record in question. (The transaction was previously rejected for not containing a sales amount.)
  2. Create additional test data so that all of the program modifications can be tested. Rerun the program with the modified test data.

### Projects 18-2 through 18-7

**Program Name:** Nonsequential File Update

**Narrative:** Implement the programming specifications for Projects 17-2 through 17-7 as a nonsequential (rather than a sequential) update. The file descriptions, test data, and programming specifications given with the sequential program apply here as well, except that the indexed file in this example functions as both the old and new master files in the sequential version.

**Project 18-8**

**Program Name:** Catalog Orders

**Narrative:** Develop an interactive program that will process additions, changes, deletions, and inquiries to an indexed file of catalog orders.

**Input File:** ORDER-FILE

**Input Record Layout:**

```

01 ORDER-RECORD-IN.
 05 ORD-NUMBER PIC 9(6).
 05 ORD-INFO.
 10 ORD-NAME PIC X(10).
 10 ORD-TELEPHONE PIC 9(10).
 05 ORD-ITEMS-ORDERED OCCURS 3 TIMES.
 10 ORD-ITEM-NUMBER PIC 9(4).
 10 ORD-QUANTITY-ORDERED PIC 9.

```

**Test Data:**

```

212467Scully 3052331234125021100115501
561578Schultz 20134715354500232001
036442Culver 401345234790003
479350Perez 30597674566800245001
683736Fixler 20136218231250115503
488907Morin 4137435343320019000311002
043498Munroe 305331485490005

```

**Screen Layouts: Screen A**

Catalog Orders

Order #:

Transaction Types:

- Add
- Change
- Delete
- Inquiry

Enter transaction type:

**Screen B**

| Catalog Orders - trans type |          |        |           |
|-----------------------------|----------|--------|-----------|
| Order #:                    |          | Name:  |           |
| Tel #:                      | ( )      |        |           |
| Item Description            | Quantity | Price  | Total     |
| xxxxxxxxxxxxxxxx            |          | ZZ9.99 | Z,ZZ9.99  |
| xxxxxxxxxxxxxxxx            |          | ZZ9.99 | Z,ZZ9.99  |
| xxxxxxxxxxxxxxxx            |          | ZZ9.99 | Z,ZZ9.99  |
|                             |          |        | -----     |
|                             | Total    |        | ZZ,ZZ9.99 |

- Processing Requirements:**
1. Display Screen A to accept an order # and transaction type (valid transaction types are A, C, D, or I).
  2. Depending on the transaction type, display an appropriate screen using Screen B as a model, and processing the transaction as follows:
    - a. Additions:
      - (1) Accept and validate the order # (don't forget to check for duplicate additions), name, telephone number (numeric), item number (valid item numbers are found in the item table, see requirement #3), and quantity (numeric).
      - (2) For each valid item, look up the price and description from the item table, calculate the total (quantity multiplied by price), and display the item detail line.
      - (3) When all items are entered, display a total for all ordered items.
      - (4) Prompt the user for confirmation and write the record to the indexed file.
    - b. Changes:
      - (1) Display Screen B showing the information found in the order file.
      - (2) For each item, look up and display the price and description from the item table along with the calculated total.
      - (3) Allow modification to the name, telephone, item number, and quantity fields.
      - (4) Validate each item changed against the item table, and for each valid item display the description and price and calculate the total.
      - (5) Prompt the user for confirmation and replace the modified record in the indexed file.
    - c. Deletions:
      - (1) Display Screen B showing the information found in the order file, the corresponding information from the item table for each item, and all totals.
      - (2) Prompt the user for confirmation to delete, and delete the record.
    - d. Inquiries: Display Screen B showing the information found in the order file, the corresponding information from the item table for each item, and all totals.

3. Hard-code the following item table in the program and use a sequential lookup:

| Item Information |                  |              |
|------------------|------------------|--------------|
| Item #           | Item Description | Price (each) |
| 1100             | Handwoven Rug    | 129.00       |
| 1550             | Crystal Frame    | 39.40        |
| 1250             | Floor Lamp       | 99.00        |
| 3000             | Ceiling Fan      | 299.00       |
| 4500             | Wicker Basket    | 25.00        |
| 6800             | Wall Clock       | 169.00       |
| 3200             | Ceramic Figure   | 39.90        |
| 9000             | Wood Wall Shelf  | 14.90        |

4. All error messages are to be displayed on the bottom of the screen and will allow the user to reenter the desired information.

## Project 18-9

**Program Name:** Create Customer Bills

**Narrative:** This project processes output from Projects 17-2 and 17-3. Write a program that takes the Ship/Back-order Transaction File and the VSAM Customer Master file updated in Project 18-2, and create a bill for each customer.

**Input File:** SHIP-BACK-ORDER-TRANS-FILE, created in Project 17-3/Project 18-3.

VSAM-CUSTOMER-MASTER, updated in Project 18-2.

**Input Record Layout:** Ship/back-order transaction record: same as Project 17-3.

VSAM customer master record: same as Project 18-2.

**Test Data:** Ship/back-order transaction record: created in Project 17-3.

VSAM customer master record: updated in Project 18-2.

**Report Layout:** Create a Customer Bill

|                                    |             |                           |                    |
|------------------------------------|-------------|---------------------------|--------------------|
| BILL DATE: XX/XX/XXXX              |             |                           |                    |
| CUSTOMER NAME: XXXXXXXXXXXXXXXX    |             | CUSTOMER NUMBER:          | XXXXXX             |
| CUSTOMER ADDRESS: XXXXXXXXXXXXXXXX |             | XXXXXXXXXXXXXXXXXX        | XXXXX              |
| ORDER NUMBER: XXXXX                |             | PURCHASE DATE: XX/XX/XXXX |                    |
| <hr/>                              |             |                           |                    |
| ITEM NUMBER                        | QUANTITY    | UNIT PRICE                | EXTENDED PRICE     |
| 99999                              | ZZZ         | \$ZZ,ZZZ.99               | \$ZZ,ZZZ,ZZZ.99    |
| 99999                              | ZZZ         | \$ZZ,ZZZ.99               | \$ZZ,ZZZ,ZZZ.99    |
| SUBTOTAL:                          |             |                           | \$ZZZ,ZZZ,ZZZ.99   |
| TAX:                               |             |                           | \$ZZZ,ZZZ.99       |
| TOTAL AMT DUE:                     |             |                           | \$Z,ZZZ,ZZZ,ZZZ.99 |
| <hr/>                              |             |                           |                    |
| ITEMS BACKORDERED:                 |             |                           |                    |
| ITEM NUMBER                        | QUANTITY    |                           |                    |
| XXXXX                              | ZZZ         |                           |                    |
| XXXXX                              | ZZZ         |                           |                    |
| <hr/>                              |             |                           |                    |
| TOTAL ITEMS BACKORDERED            | ZZZ,ZZZ,ZZZ |                           |                    |
| TOTAL ITEMS SHIPPED                | ZZZ,ZZZ,ZZZ |                           |                    |

- Processing Requirements:**
1. Sort the order transaction records by order number, record type, and ship/back-order indicator
  2. Process a file of sorted transactions to create a customer bill.
    - a. The customer number comes from the transaction file and is used to access the customer name and address from the VSAM CUSTOMER MASTER file.
    - b. The order number and purchase date come from the type 1 record on the new transaction file.
    - c. Item number and quantity come from the transaction file.
    - d. Unit price and extended price are calculated based on the item number and quantity as follows:  
 Check the first byte of the item number and then check the quantity to determine the percent of markup on the item. Take the unit cost from the transaction file and use the percent markup to determine the unit price.



| UNIT-PRICE = UNIT-COST * 1. PERCENT MARKUP |            |              |                |                |             |
|--------------------------------------------|------------|--------------|----------------|----------------|-------------|
| EXTENDED PRICE = UNIT-PRICE * QUANTITY     |            |              |                |                |             |
| PERCENT MARKUP                             |            |              |                |                |             |
| FIRST BYTE<br>of ITEM NUMBER               | QTY<br><50 | QTY<br>50-99 | QTY<br>100-199 | QTY<br>200-300 | QTY<br>>300 |
| 1                                          | 30%        | 25%          | 20%            | 15%            | 10%         |
| 2                                          | 25%        | 20%          | 15%            | 10%            | 5%          |
| 3                                          | 35%        | 30%          | 25%            | 20%            | 15%         |
| 4                                          | 40%        | 35%          | 30%            | 25%            | 20%         |

- e. The subtotal is the extended price for each item accumulated per order.
- f. The amount of tax is zero if the taxable item indicator on the type 1 transaction record contains an "N." If the taxable item indicator on the type 1 transaction is a "Y," compute the amount of tax = subtotal \* 8.25%. The total amount due is calculated by adding the subtotal plus tax.
- g. If an item is backordered, a B will exist in the ship/back-order indicator field on the type 3 record of the new Transaction file.
- h. The total items back-ordered is an accumulation of the quantity for each item back-ordered, and the total items shipped is an accumulation of the quantity for each item shipped.

# Index

- 77-level entry, 181
- 88-level entry, 200, 201
- A in PICTURE clause, 17, 79
- A margin, 29
- ACCEPT statement, 206-207, 242-243
  - with screen I-O, 266-268
- ACCESS IS DYNAMIC clause, 554
- ACCESS IS RANDOM clause, 566
- ACCESS IS SEQUENTIAL clause, 562
- ACCESS MODE clause, 554
- Action list, 163
- Active key, 530-531, 537
- Actual decimal point, 172
- ADD statement, 112-113
- ADVANCING clause. *See* WRITE
- AFTER clause. *See* PERFORM VARYING
- ALL literal, 84, 89
- Allocation status, 530-531
- ALPHABETIC clause, 199
- Alphabetic code, 333
- ALPHABETIC-LOWER clause, 221
- Alphabetic test, 197, 199
- ALPHABETIC-UPPER clause, 221
- Alphanumeric code, 333
- Alphanumeric item, 79
- ALTERNATE RECORD KEY clause, 554, 561-562, 570-573
- Alt key, hidden power of, 274
- AND operator, 201
- Animator, 643-695
  - Command Prompt, 678-679
  - Compile/Run Menu, 654-658
  - creating shortcuts for, 703-706
  - Debug Menu, 658-662
  - downloading data/source files from the Web, 707
  - Edit Menu, 648-652
  - editing in, 679-680
  - File Menu, 646-648
  - Help Menu, 674-676
  - highlighting, 649
  - installing, 644, 697-703
  - learning to use, 644
  - Main Menu, 646-676
  - Options Menu, 662-672
  - printing from COBOL programs with, 707-708
  - starting, 644-645
  - Toolbar, 676-678
  - tutorial, 681-694
  - View Menu, 652-655
  - Window Menu, 672-674
  - windows, 680
- Argument list, 477
- Arithmetic symbol, 16
- ASCENDING KEY clause
  - in OCCURS clause, 311, 344, 345
  - in SORT statement, 409
- Ascending sort, 405
- ASCII
  - character set, 273
  - collating sequence, 405-407, 586
- ASSIGN clause. *See* SELECT statement
- Assumed decimal point, 81-82, 117-118
- Asterisk
  - as editing character, 175
  - as multiplication symbol, 111
- AT END clause
  - in READ statement, 99
  - in SEARCH statement, 340, 343
- AUTHOR paragraph, 75
- AUTO clause, 268
- B as insertion character, 175, 237-238
- B margin, 29
- BACKGROUND-COLOR clause, 267, 274, 275
- Backup, 519
- Balance line algorithm, 529-534
- Batch file, 585, 592-593
- Binary table lookup, 335-336
- BLANK WHEN ZERO clause, 177
- BLINK clause, 268
- BLOCK CONTAINS clause, 78-79
- Blocking factor, 78
- Bohm, C., 55
- Braces, 74
- Brackets, 75
- BY CONTENT clause, 480-481, 506
- BY REFERENCE clause, 480-481, 506
- Calculated field (as sort key), 410
- CALL statement, 477-479
- Called program, 477-479
- Calling program, 477-479
- Car Validation and billing program, 278-297
  - completed program, 287-297
  - hierarchy chart, 284
  - programming specifications, 279-280
  - pseudocode, 284-286
  - screen section, 280-284
- Case structure, 56
- Check protection, 175
- Class test, 199
- CLOSE statement, 99
- COBOL
  - evolution of, 38
  - notation, 74-75
  - COBOL revision, 737-743
  - COBOL-74, 38
    - versus COBOL-85, 38
    - limitations of, 90, 221, 258, 325, 357, 398, 428, 506, 574
  - COBOL-85, 38
- COBOL-85 reference
  - summary, 711-736
  - COBOL verbs, 721-731
  - communication description entry, 718
  - conditions, 732
  - COPY and REPLACE statements, 731
  - data description entry, 717
  - data division, 714
  - environment division, 712-713
  - file control entry, 713-714
  - file description entry, 715-716
  - identification division, 712
  - miscellaneous formats, 734
  - nested source programs, 734
  - procedure division, 720
  - qualification, 733
  - report description entry, 719
  - report group description entry, 719-720
  - series of source programs, 735
- COBOL 2000
  - intrinsic functions, 738-742
  - miscellaneous new features, 743
  - new data types, 742-743
- Codes, 332-334
- Coding form, 28
- Coding standards, 179-189
- Collating sequence, 405-408
  - effect on signed numbers, 406-408
- COLLATING SEQUENCE clause, 409
- COLUMN clause, 267
- Comma
  - avoidance of, 181
  - as editing character, 174-175
- Comments, 29
  - limitation of, 184
- Compilation error, 33-35, 140-151
- Compiler, 31
- Compiler option (in Classroom COBOL), 586



- Completeness check, 197  
 Compound test, 200-202  
 COMPUTE statement, 110-111  
   versus arithmetic statements, 116  
 Concatenated key, 573-575  
 Condition name. *See* 88-level entry  
 CONFIGURATION SECTION, 40, 76-77  
 Consistency check, 197  
 Constant  
   avoidance of, 183  
   *See also* Literal  
 Continuation, of nonnumeric literal, 29  
 Control area, 551  
 Control break, 435-471  
 Control field, 437  
 Control interval, 551  
 Control total, 437  
 COPY statement, 479-480  
   with subprograms, 481  
 CR editing character, 176-177  
 Cross reference listing, 159-161  
  
 Data disk, 584, 586-587  
 DATA DIVISION, 11-12, 77-84  
 Data name  
   choice of, 179  
   rules for, 14-15  
 Data validation, 195-221, 519-528  
   in interactive program, 277  
 Date check, 197, 218  
 DATE clause, 206-207  
 DATE-COMPILED paragraph, 75  
 DATE-WRITTEN paragraph, 75  
 DAY clause, 206  
 DAY-OF-WEEK clause, 242-243  
 DB editing character, 176-177  
 Debugging, 139-164  
   compilation errors, 140-151  
   execution errors, 151-158  
   interactive debugging, 161-162  
   tips for, 160-161  
 Decimal alignment (in MOVE statement), 104  
 Defensive programming, 197, 527  
 DELETE statement, 562  
 DESCENDING KEY clause  
   in OCCURS clause, 311, 344  
   in SORT statement, 409  
 Descending sort, 405  
 Desk checking, 162  
  
 Detail line, 48  
 Detail report, 375  
 Direct access to table entries, 344, 345  
 Displacement. *See* Index  
 DISPLAY statement  
   in debugging, 161  
   in top-down testing, 61, 63-64  
 DIVIDE statement, 115-116  
 DO UNTIL structure, 231-232  
   with data validation, 271, 275  
 DO WHILE structure, 231-232, 271  
 Duplicate addition (error condition), 518  
 Duplicate (nonunique) data names, 243-245  
 DUPLICATES IN ORDER clause, 409, 443  
  
 Early error detection. *See* Structured walkthrough  
 EBCDIC, 405-407, 586  
 Edit program. *See* Stand-alone edit  
 Editing, 169-179  
 Editing characters, 171  
 Editor, 28, 30  
 Elementary item, 79  
 ELSE clause, 106  
 Embedded sign, 406-408  
 END-IF terminator, 12, 182  
 End-of-file condition, 6  
 END-PERFORM terminator, 232  
 END-READ terminator, 100  
 END-SEARCH terminator, 398  
 ENVIRONMENT DIVISION, 11  
 Error message table, 214, 215, 220, 525, 527  
 EVALUATE statement, 109, 243  
 Execution error, 35-37, 151-158  
 Existing code check, 197  
 EXIT PROGRAM statement, 477, 478  
 EXIT statement, 233-234  
 Expandable code, 333, 334  
 Exponentiation, 111  
  
 False condition branch. *See* NOT AT END  
 FD. *See* File description  
 Field, 2  
 Figurative constant, 83-84  
 File, 2  
 File description, 77-79  
  
 File maintenance  
   nonsequential, 563-570  
   sequential, 515-544  
 FILE-CONTROL paragraph, 77  
 FILE SECTION, 12, 77-82  
 FILE STATUS clause, 555, 557-560  
 File status codes  
   additions in COBOL-85, 574  
   in debugging, 156-157  
   list of, 555  
 FILLER clause, 82-83  
   optional use of, 83, 180, 357  
 Fixed dollar sign, 174  
 Fixed-length record, 310  
 Floating dollar sign, 174  
 Floating minus sign, 177  
 Floating plus sign, 177  
 Flowchart, 6-8, 57, 58  
 FOREGROUND-COLOR clause, 267, 274, 275  
 Free space, 552  
 Functional paragraph, 54  
  
 GIGO, 37  
 GIVING clause  
   in arithmetic statements, 112, 113, 114, 115  
   in SORT statement, 410, 414-419  
 Grandfather-father-son backup, 519  
 Group item, 79  
 Group move, 105  
  
 Heading line, 48  
 Hierarchy chart, 50-54, 444-446, 451-453, 460-461  
   with subprograms, 479, 485  
 Hierarchy of operations  
   arithmetic, 111  
   logical, 201  
 HIGH-VALUES, 530  
 HIGHLIGHT clause, 268  
 Hopper, Grace Murray, 38  
  
 I-O status. *See* File status codes  
 IDENTIFICATION DIVISION, 11, 75-76  
 IF statement, 106-108  
   class test, 199  
   compound test, 200-202  
   condition name, 200, 201  
   implied condition, 203  
   indentation in, 106-108  
   nested, 203-205  
   NEXT SENTENCE, 205-206  
   relational condition, 198  
   scope terminator, 182, 205  
   sign test, 200  
 Implied decimal point. *See* Assumed decimal point  
 IN qualifier, 245  
 Indentation, 106-108, 183  
 Index, 321-324  
 Index set, 551  
 INDEXED BY clause, 321-322, 343  
 Indexed file, 549-575  
   creation of, 556-559  
   maintenance of, 563-570  
   utility for, 606-608  
 INITIAL clause, 482  
 INITIALIZE statement, 236-237, 486  
 In-line perform. *See* PERFORM statement  
 Input-loaded table, 338-339  
 INPUT-OUTPUT SECTION, 76-77  
 INPUT PROCEDURE, 410, 419-426  
 Insertion characters, 175  
 INSPECT statement, 237-238  
 INSTALLATION paragraph, 75  
 Interactive program, 265-296, 487-504  
 Intrinsic functions, 738-742  
   added in COBOL 2000, 741-742  
   miscellaneous new features, 743  
   new data types, 742-743  
 Iteration structure, 56  
  
 Jacopini, G., 55  
  
 LABEL RECORDS CLAUSE, 40, 79, 99  
 Level numbers, 12, 16, 79-81  
 Limit check, 197  
 LINE CLAUSE, 267  
 LINKAGE SECTION, 477-478  
 Linker (linkage-editor), 31, 504-506, 583, 594  
 Literal, 15-16  
   continuation of, 180  
 Load module, 31  
 Logic errors, 159-160  
 Logical record, 78  
  
 Main program. *See* Calling program  
 Major key, 405  
 MERGE statement, 426-427

- Micro Focus Personal COBOL for Windows, 643-695
- Minor key, 405
- Mnemonic code, 333, 334
- MOVE CORRESPONDING statement, 245
- MOVE statement, 102-105
- MULTIPLY statement, 114-115
  
- Nested IF statement, 203-205
- Nested SEARCH statement, 394, 397
- NEXT SENTENCE clause, 205-206
- No match (error condition), 518
- Nonnumeric literal (continuation of), 15-16, 180
- Nonsequential file maintenance, 563-570
  - versus sequential maintenance, 518
- NOT operator, 201
- NOT AT END clause, 234-235
- Numeric code, 333
- Numeric-edited field, 170
- Numeric field, 79, 172-173
- Numeric item, 79
- Numeric literal, 15-16
- Numeric test, 197-199
  
- OBJECT-COMPUTER paragraph, 40, 76
- Object-oriented (OO) COBOL programming, 603-642
  - classes and inheritance, 619
  - next-generation of COBOL, 605-609
  - object orientation, defined, 604
  - object-oriented vs. structured paradigm, 608-609
  - ProcessRequest method, 619-621
  - Registrar class, 616-619
  - structured programming, development of, 606-607
  - Student class, 627-629
  - Student-Look-Up program, 612-616
  - Student-Look-Up system, 610-639
  - StudentDM class, 621-625
  - StudentDM instance definition, 625-627
  - StudentPRT class, 635-639
  - StudentUI class, 633-635
  - terminology, 607-608
- Object program, 31
- OCCURS clause, 303, 307
  - problems with, 308
- OCCURS DEPENDING ON clause, 310-311, 315
- OF qualifier, 245
- One-level control break, 443-451
- OPEN statement, 98-99
  - I-O clause, 559-560
- Operating system, 31
- OR operator, 201
- ORGANIZATION IS INDEXED clause, 554
- OUTPUT PROCEDURE, 410, 419-426
  
- Page heading routine, 248, 257
- Paragraph, 12
- Paragraph name
  - rules for, 14-15
  - standards in, 181
- Parameter list, 477
- Password protection, 268
- PERFORM statement, 105-106
  - in-line perform, 232
  - sections, 232-233
  - TEST BEFORE/AFTER, 231-232
  - TIMES clause, 322
  - THRU clause, 232-234
  - UNTIL clause, 231
- PERFORM VARYING statement
  - with one-level table, 304-306, 340, 366-367
  - with two-level table, 370-373
  - with three-level table, 382-384
- Personal COBOL for Windows, 643-695
- Physical record, 78
- PICTURE clause, 17, 79
  - standards for, 179
- Positional table, 336
- Precedence. *See* Hierarchy of operations
- Primary key, 405
- Priming (initial) read, 100
  - elimination of, 234-235, 254
  - error in, 157-158
- PROCEDURE DIVISION, 12, 97-130
  - USING clause, 477-478
- Procedure name, 232
- Program specifications, 3-5
- Program stub. *See* Stub program
- PROGRAM-ID paragraph, 76
  - in called program, 477
  - INITIAL clause, 482
- Programmer-supplied-name, 14-15
- Projects, 753-892
- Pseudocode, 8-9, 57-59
- Punctuation symbol, 16
  
- Qualification, 244-245
  
- Range check, 197
- Range-step table, 345-347
  - in two dimensions, 392-394
- READ statement, 99-100
  - false condition branch, 234-235
  - INTO clause, 235-236
  - INVALID KEY clause, 561-562
  - NEXT clause, 561
  - priming read, 100, 157-158
- Readability. *See* Coding standards
- Reasonableness check, 197
- Record, 2
- RECORD CONTAINS clause, 79
- Record description, 12, 79
- RECORD KEY clause, 554
- REDEFINES clause, 336, 338
- Reference modification, 240-242, 504
- Registrar class, 616-619
  - programming specifications, 630
- Relational symbol, 16
- Relative subscripting, 308-309
- RELEASE statement, 410
- RESERVE AREAS clause, 554
- Reserved words, 13-14, 709-710
- RETURN statement, 410-411
- REVERSE-VIDEO clause, 268
- REWRITE statement, 562
- Rolling total, 440-441
- ROUNDED clause, 109-110
- Running total, 440-441
  
- S in PICTURE clause, 176-177
- Scope terminator, 182
- Screen I/O
  - ACCEPT statement, 266-269
  - car validation and billing program, 278-297
  - DISPLAY statement, 269-278
- SCREEN SECTION, 279-283, 288-291, 491-492
- SD statement, 410
- SEARCH statement, 340, 343
  - nested, 397, 398
  - with two-level table, 391, 498
  - VARYING clause, 397, 398, 498
- SEARCH ALL statement, 344-345
- Secondary key, 405
- Section, 232
- SECURE clause, 268
- SECURITY paragraph, 75
- SELECT statement, 76
  - for indexed file, 554-555, 558, 561
- Selection structure, 55-56
- Sequence check, 197
- Sequence numbers, 29
- Sequence set, 551
- Sequence structure, 55
- Sequential file maintenance, 515-544
  - versus nonsequential, 518
- Sequential table lookup, 334-335
- SET statement, 322, 344, 390
- SIGN clause, 408
- Sign test, 200
- Signed numbers, 176-177
  - effect of collating sequence, 406-408
- SIZE ERROR clause, 110
- Slash
  - in arithmetic, 111
  - to begin a page, 183
  - as insertion character, 175
- Sort key, 405
- SORT statement, 409-410
- Sort work file, 410
- Sorting, 404-428
- SOURCE-COMPUTER paragraph, 40, 76
- Source program, 31
- SPACE-FILL clause, 268
- SPACES clause, 83
- Span of control, 54
- Stand-alone edit program, 207-221
- START statement, 574-575
- STOP RUN statement, 102
- String processing, 237-242
- STRING statement, 238-240
- Structured design, 50-54
- Structured programming, 54-56
  - development of, 606-607
- Structured walkthrough, 162-163
- Stub program, 61, 535
- Student class, 627-629
  - programming specification, 630
- Student-Look-Up program, 612-616

- programming specifications, 613
- Student-Look-Up system, 610-639
  - programming specifications, 610
- Student PRT class, 635-639
  - programming specifications, 636
- Subprogram, 475-507
  - execution of, 585
- Subscript
  - versus index, 321-324
  - relative, 308-309
  - rules for, 308
- Subscript check, 197
- SUBTRACT statement, 113-114
- Summary report, 375
- Symbol, 16
  
- Table, 302-305
  - initialization of, 336-339
  - one-level, 366-367, 369
  - two-level, 368-379
  - three-level, 380-390
- Table lookup
  - binary, 335-336
  - direct access, 336
  - sequential, 334-335
  - with two-level table, 390-391
- TEST AFTER clause, 231-232
- TEST BEFORE clause, 231-232
- Test data (generation of), 535
- Three-level control break, 460-470
- Three-level table, 380-390
- TIME clause, 206, 503-504
- Top-down testing, 61-66, 535-540
- Total line, 48
- Transaction file, 516
- Two-level control break, 451-460
- Two-level table, 368-380
  
- Undefined symbol, 505
- UNDERLINE clause, 268
- Unique code, 333
- Unresolved external reference, 505
- UNSTRING statement, 240, 241
- UPDATE clause, 268
- USAGE clause, 309-310
- USING
  - in SORT statement, 410, 414-419
  - in subprogram, 471-478
- Utility sort program, 404
- V in PICTURE clause. *See* Assumed decimal point
- VALUE clause, 83-84
  - with OCCURS clause, 379, 398
- Variable-length record, 310-311
- Variable-length table, 310-311, 316
- VSAM organization, 551-553
  
- Warnier-Orr diagram, 59, 61, 62
- WHEN clause. *See* SEARCH *and* SEARCH ALL
- WORKING-STORAGE SECTION, 12, 82-84
- WRITE statement, 100-101
  - FROM clause, 236
  - INVALID KEY clause, 562
- WS BEGINS HERE, 236
  
- X in PICTURE clause, 79
  
- Year 2000 program, 583-602
  - COBOL intrinsic calendar functions, 591-593
  - date arithmetic, 590-593
  - leap-year problem, 594
  - leap-year processing, 584
  - problem description, 584-590
  - retirement program, 594-599
- ZERO FILL clause, 268
- Zero suppression, 172, 174
- ZEROS clause, 83