

# Mathematical Foundations of Automata Theory

Jean-Éric Pin

Version of August 23, 2013



# Preface

These notes form the core of a future book on the algebraic foundations of automata theory. This book is still incomplete, but the first eleven chapters now form a relatively coherent material, covering roughly the topics described below.

## The early years of automata theory

Kleene's theorem [46] is usually considered as the starting point of automata theory. It shows that the class of recognisable languages (that is, recognised by finite automata), coincides with the class of rational languages, which are given by rational expressions. Rational expressions can be thought of as a generalisation of polynomials involving three operations: union (which plays the role of addition), product and the star operation. It was quickly observed that these essentially combinatorial definitions can be interpreted in a very rich way in algebraic and logical terms. Automata over infinite words were introduced by Büchi in the early 1960s to solve decidability questions in the first-order and monadic second-order logic of one successor. Investigating the two-successor logic, Rabin was led to the concept of tree automata, which soon became a standard tool for studying logical definability.

## The algebraic approach

The definition of the *syntactic monoid*, a monoid canonically attached to each language, first appeared in a paper of Rabin and Scott [89], where the notion is credited to Myhill. It was shown in particular that a language is recognisable if and only if its syntactic monoid is finite. However, the first classification results on recognisable language were rather stated in terms of automata [60] and the first nontrivial use of the syntactic monoid is due to Schützenberger [94]. Schützenberger's theorem (1965) states that a rational language is star-free if and only if its syntactic monoid is finite and aperiodic. This elegant result is considered, right after Kleene's theorem, as the most important result of the algebraic theory of automata. Schützenberger's theorem was supplemented a few years later by a result of McNaughton [56], which establishes a link between star-free languages and first order logic of the order relation.

Both results had a considerable influence on the theory. Two other important algebraic characterisations date back to the early seventies: Simon [96] proved that a rational language is piecewise testable if and only if its syntactic monoid is  $\mathcal{J}$ -trivial and Brzozowski-Simon [12] and independently, McNaughton [55] characterised the locally testable languages. The logical counterpart of the first

result was obtained by Thomas [116]. These successes settled the power of the algebraic approach, which was axiomatized by Eilenberg in 1976 [27].

### Eilenberg's variety theory

A variety of finite monoids is a class of monoids closed under taking submonoids, quotients and finite direct products. Eilenberg's theorem states that varieties of finite monoids are in one to one correspondence with certain classes of recognisable languages, the varieties of languages. For instance, the rational languages are associated with the variety of all finite monoids, the star-free languages with the variety of finite aperiodic monoids, and the piecewise testable languages with the variety of finite  $\mathcal{J}$ -trivial monoids. Numerous similar results have been established over the past thirty years and, for this reason, the theory of finite automata is now intimately related to the theory of finite monoids.

Several attempts were made to extend Eilenberg's variety theory to a larger scope. For instance, partial order on syntactic semigroups were introduced in [69], leading to the notion of ordered syntactic semigroups. The resulting extension of Eilenberg's variety theory permits one to treat classes of languages that are not necessarily closed under complement, contrary to the original theory. Other extensions were developed independently by Straubing [112] and Ésik and Ito [29].

### The topological point of view

Due allowance being made, the introduction of topology in automata theory can be compared to the use of  $p$ -adic analysis in number theory.

The notion of a variety of finite monoids was coined after a similar notion, introduced much earlier by Birkhoff for infinite monoids: a *Birkhoff variety of monoids* is a class of monoids closed under taking submonoids, quotient monoids and direct products. Birkhoff proved in [8] that his varieties can be defined by a set of identities: for instance the identity  $xy = yx$  characterises the variety of commutative monoids. Almost fifty years later, Reiterman [91] extended Birkhoff's theorem to varieties of finite monoids: any variety of finite monoids can be characterised by a set of *profinite identities*. A profinite identity is an identity between two profinite words. Profinite words can be viewed as limits of sequences of words for a certain metric, the profinite metric. For instance, one can show that the sequence  $x^{n!}$  converges to a profinite word denoted by  $x^\omega$  and the variety of finite aperiodic monoids can be defined by the identity  $x^\omega = x^{\omega+1}$ .

The profinite approach is not only a powerful tool for studying varieties but it also led to unexpected developments, which are at the heart of the current research in this domain. In particular, Gehrke, Grigorieff and the author [31] proved that any lattice of recognisable languages can be defined by a set of profinite equations, a result that subsumes Eilenberg's variety theorem.

### The logical approach

We already mentioned Büchi, Rabin and McNaughton remarkable results on the connexion between logic and finite automata. Büchi's *sequential calculus* is a logical language to express combinatorial properties of words in a natural way.

For instance, properties like “a word contains two consecutive occurrences of  $a$ ” or “a word of even length” can be expressed in this logic. However, several parameters can be adjusted. Different fragments of logic can be considered: first order, monadic second order,  $\Sigma_n$ -formulas and a large variety of logical and nonlogical symbols can be employed.

There is a remarkable connexion between first order logic and the concatenation product. The polynomial closure of a class of languages  $\mathcal{L}$  is the set of languages that are sums of marked products of languages of  $\mathcal{L}$ . By alternating *Boolean closure* and *polynomial closure*, one obtains a natural hierarchy of languages. The level 0 is the Boolean algebra  $\{\emptyset, A^*\}$ . Next, for each  $n \geq 0$ , the level  $2n + 1$  is the polynomial closure of the level  $2n$  and the level  $2n + 2$  is the Boolean closure of the level  $2n + 1$ . A very nice result of Thomas [116] shows that a recognisable language is of level  $2n + 1$  in this hierarchy if and only if it is definable by a  $\Sigma_{n+1}$ -sentence of first order logic in the signature  $\{<, (\mathbf{a})_{a \in A}\}$ , where  $\mathbf{a}$  is a predicate giving the positions of the letter  $a$ .

There are known algebraic characterisations for the three first levels of this hierarchy. In particular, the second level is the class of piecewise testable languages characterised by Simon [95].

### Contents of these notes

The algebraic approach to automata theory relies mostly on semigroup theory, a branch of algebra which is usually not part of the standard background of a student in mathematics or in computer science. For this reason, an important part of these notes is devoted to an introduction to semigroup theory. Chapter II gives the basic definitions and Chapter V presents the structure theory of finite semigroups. Chapters XIII and XV introduce some more advanced tools, the relational morphisms and the semidirect and wreath products.

Chapter III gives a brief overview on finite automata and recognisable languages. It contains in particular a complete proof of Kleene’s theorem which relies on Glushkov’s algorithm in one direction and on linear equations in the opposite direction. For a comprehensive presentation of this theory I recommend the books of my colleague Jacques Sakarovitch [92]. The recent book of Olivier Carton [14] also contains a nice presentation of the basic properties of finite automata. Recognizable and rational subsets of a monoid are presented in Chapter IV. The notion of a syntactic monoid is the key notion of this chapter, where we also discuss the ordered case. The profinite topology is introduced in Chapter VI. We start with a short synopsis on general topology and metric spaces and then discuss the relationship between profinite topology and recognisable languages. Chapter VII is devoted to varieties of finite monoids and to Reiterman’s theorem. It also contains a large collection of examples. Chapter VIII presents the equational characterisation of lattices of languages and Eilenberg’s variety theorem. Examples of application of these two results are gathered in Chapter IX. Chapters X and XI present two major results, at the core of the algebraic approach to automata theory: Schützenberger’s and Simon’s theorem. The last five chapters are still under construction. Chapter XII is about polynomial closure, Chapter XIV presents another deep result of Schützenberger about unambiguous star-free languages and its logical counterpart. Chapter XVI gives a brief introduction to sequential functions and the wreath product principle. Chapter XVII presents some logical descriptions of

languages and their algebraic characterisations.

### Notation and terminology

The term *regular set* is frequently used in the literature but there is some confusion on its interpretation. In Ginzburg [35] and in Hopcroft, Motwani and Ullman [41], a regular set is a set of words accepted by a finite automaton. In Salomaa [93], it is a set of words defined by a regular grammar and in Carroll and Long [13], it is a set defined by a regular expression. This is no real problem for languages, since, by Kleene's theorem, these three definitions are equivalent. This is more problematic for monoids in which Kleene's theorem does not hold. Another source of confusion is that the term *regular* has a well-established meaning in semigroup theory. For these reasons, I prefer to use the terms *recognisable* and *rational*.

I tried to keep some homogeneity in notation. Most of the time, I use Greek letters for functions, lower case letters for elements, capital letters for sets and cursive letters for sets of sets. Thus I write: "let  $s$  be an element of a semigroup  $S$  and let  $\mathcal{P}(S)$  be the set of subsets of  $S$ ". I write functions on the left and transformations and actions on the right. In particular, I denote the action of a word  $u$  on a state  $q$  by  $q \cdot u$ . Why so many computer scientists prefer the awful notation  $\delta(q, u)$  is still a mystery. It leads to heavy formulas, like  $\delta(\delta(q, u), v) = \delta(q, uv)$ , to be compared to the simple and intuitive  $(q \cdot u) \cdot v = q \cdot uv$ , for absolutely no benefit.

I followed Eilenberg's tradition to denote varieties of semigroups by boldface letters, like  $\mathbf{V}$ , and varieties of languages by calligraphic letters, like  $\mathcal{V}$ . However, I have adopted Almeida's suggestion to have a different notation for operators on varieties, like  $\mathbf{EV}$ ,  $\mathbf{LV}$  or  $\mathbf{PV}$ .

I use the term *morphism* for *homomorphism*. Semigroups are usually denoted by  $S$  or  $T$ , monoids by  $M$  or  $N$ , alphabets are  $A$  or  $B$  and letters by  $a$ ,  $b$ ,  $c$ , ... but this notation is not frozen: I may also use  $A$  for semigroup and  $S$  for alphabet if needed! Following a tradition in combinatorics,  $|E|$  denotes the number of elements of a finite set. The notation  $|u|$  is also used for the length of a word  $u$ , but in practice, there is no risk of confusion between the two.

To avoid repetitions, I frequently use brackets as an equivalent to "respectively", like in the following sentence : a semigroup [monoid, group]  $S$  is commutative if, for all  $x, y \in S$ ,  $xy = yx$ .

Lemmas, propositions, theorems and corollaries share the same counter and are numbered by section. Examples have a separate counter, but are also numbered by section. References are given according to the following example: Theorem 1.6, Corollary 1.5 and Section 1.2 refer to statements or sections of the same chapter. Proposition VI.3.12 refers to a proposition which is external to the current chapter.

### Acknowledgements

Several books on semigroups helped me in preparing these notes. Clifford and Preston's treatise [17, 18] remains the classical reference. My favourite source for the structure theory is Grillet's remarkable presentation [38]. I also borrowed a lot from the books by Almeida [2], Eilenberg [27], Higgins [40], Lallement [50] and Lothaire [52] and also of course from my own books [66, 62]. Another source

of inspiration (not yet fully explored!) are the research articles by my colleagues Jorge Almeida, Karl Auinger, Jean-Camille Birget, Olivier Carton, Victor Guba, Rostislav Horčík, John McCammond, Stuart W. Margolis, Dominique Perrin, Mark Sapir, Imre Simon, Ben Steinberg, Howard Straubing, Pascal Tesson, Denis Thérien, Misha Volkov, Pascal Weil and Marc Zeitoun.

I would like to thank my Ph.D. student Yann Pequignot, my colleagues at LIAFA and LaBRI and the students of the Master Parisien de Recherches en Informatique (notably Aiswarya Cyriac, Nathanaël Fijalkow, Arthur Milchior, Jill-Jénn Vie and Furcy) for pointing out many misprints and corrections on earlier versions of this document. I would like to acknowledge the assistance and the encouragements of my colleagues of the Picasso project, Adolfo Ballester-Bolinches, Antonio Cano Gómez, Ramon Esteban-Romero, Xaro Soler-Escrivà, Maria Belén Soler Monreal, Jorge Palanca and of the Pessoa project, Jorge Almeida, Mário J. J. Branco, Vítor Hugo Fernandes, Gracinda M. S. Gomes and Pedro V. Silva. Other careful readers include Anne Schilling. Special thanks are due to Jean Berstel and to Paul Gastin for providing me with their providential  $\text{\LaTeX}$  packages.

Paris, September 2012

Jean-Éric Pin





# Contents

<b>I</b>	<b>Algebraic preliminaries</b>	1
1	Subsets, relations and functions	1
1.1	Sets	1
1.2	Relations	1
1.3	Functions	2
1.4	Injective and surjective relations	4
1.5	Relations and set operations	7
2	Ordered sets	8
3	Exercises	9
<b>II</b>	<b>Semigroups and beyond</b>	11
1	Semigroups, monoids and groups	11
1.1	Semigroups, monoids	11
1.2	Special elements	12
1.3	Groups	13
1.4	Ordered semigroups and monoids	14
1.5	Semirings	14
2	Examples	15
2.1	Examples of semigroups	15
2.2	Examples of monoids	16
2.3	Examples of groups	16
2.4	Examples of ordered monoids	16
2.5	Examples of semirings	16
3	Basic algebraic structures	17
3.1	Morphisms	17
3.2	Subsemigroups	18
3.3	Quotients and divisions	19
3.4	Products	20
3.5	Ideals	20
3.6	Simple and 0-simple semigroups	22
3.7	Semigroup congruences	22
4	Transformation semigroups	25
4.1	Definitions	25
4.2	Full transformation semigroup and symmetric group	26
4.3	Product and division	26
5	Generators	27
5.1	$A$ -generated semigroups	27

5.2	Cayley graphs . . . . .	27
5.3	Free semigroups . . . . .	28
5.4	Universal property . . . . .	29
5.5	Presentations and rewriting systems . . . . .	29
6	Idempotents in finite semigroups . . . . .	30
7	Exercises . . . . .	33
<b>III</b>	<b>Languages and automata . . . . .</b>	<b>35</b>
1	Words and languages . . . . .	35
1.1	Words . . . . .	35
1.2	Orders on words . . . . .	36
1.3	Languages . . . . .	36
2	Rational languages . . . . .	39
3	Automata . . . . .	40
3.1	Finite automata and recognisable languages . . . . .	40
3.2	Deterministic automata . . . . .	43
3.3	Complete automata and trim automata . . . . .	45
4	Operations on recognisable languages . . . . .	46
4.1	Boolean operations . . . . .	47
4.2	Product . . . . .	49
4.3	Star . . . . .	50
4.4	Quotients . . . . .	52
4.5	Inverses of morphisms . . . . .	53
4.6	Minimal automata . . . . .	53
5	Rational versus recognisable . . . . .	56
5.1	Local languages . . . . .	56
5.2	Glushkov's algorithm . . . . .	59
5.3	Linear equations . . . . .	62
5.4	Extended automata . . . . .	65
5.5	Kleene's theorem . . . . .	67
6	Exercises . . . . .	68
<b>IV</b>	<b>Recognizable and rational sets . . . . .</b>	<b>73</b>
1	Rational subsets of a monoid . . . . .	73
2	Recognizable subsets of a monoid . . . . .	75
2.1	Recognition by monoid morphisms . . . . .	75
2.2	Operations on sets . . . . .	77
2.3	Recognizable sets . . . . .	78
3	Connexion with automata . . . . .	81
3.1	Transition monoid of a deterministic automaton . . . . .	81
3.2	Transition monoid of a nondeterministic automaton . . . . .	83
3.3	Monoids versus automata . . . . .	84
4	Syntactic monoid . . . . .	86
4.1	Definitions . . . . .	86
4.2	Syntactic monoid of a language . . . . .	87
4.3	Computation of the syntactic monoid of a language . . . . .	88
5	Recognition by ordered structures . . . . .	89
5.1	Ordered automata . . . . .	89
5.2	Recognition by ordered monoids . . . . .	90

5.3	Syntactic order . . . . .	90
5.4	Computation of the syntactic ordered monoid . . . . .	91
6	Exercises . . . . .	93
<b>V</b>	<b>Green's relations and local theory . . . . .</b>	<b>95</b>
1	Green's relations . . . . .	95
2	Inverses, weak inverses and regular elements . . . . .	103
2.1	Inverses and weak inverses . . . . .	103
2.2	Regular elements . . . . .	105
3	Rees matrix semigroups . . . . .	107
4	Structure of regular $\mathcal{D}$ -classes . . . . .	112
4.1	Structure of the minimal ideal . . . . .	113
5	Green's relations in subsemigroups and quotients . . . . .	114
5.1	Green's relations in subsemigroups . . . . .	114
5.2	Green's relations in quotient semigroups . . . . .	115
6	Green's relations and transformations . . . . .	118
7	Summary: a complete example . . . . .	121
8	Exercises . . . . .	123
<b>VI</b>	<b>Profinite words . . . . .</b>	<b>125</b>
1	Topology . . . . .	125
1.1	General topology . . . . .	125
1.2	Metric spaces . . . . .	126
1.3	Compact spaces . . . . .	127
1.4	Topological semigroups . . . . .	128
2	Profinite topology . . . . .	128
2.1	The free profinite monoid . . . . .	128
2.2	Universal property of the free profinite monoid . . . . .	131
2.3	$\omega$ -terms . . . . .	132
3	Recognizable languages and clopen sets . . . . .	134
<b>VII</b>	<b>Varieties . . . . .</b>	<b>137</b>
1	Varieties . . . . .	137
2	Free pro- <b>V</b> monoids . . . . .	138
3	Identities . . . . .	141
3.1	What is an identity? . . . . .	141
3.2	Properties of identities . . . . .	142
3.3	Reiterman's theorem . . . . .	143
4	Examples of varieties . . . . .	144
4.1	Varieties of semigroups . . . . .	144
4.2	Varieties of monoids . . . . .	148
4.3	Varieties of ordered monoids . . . . .	153
4.4	Summary . . . . .	153
5	Exercises . . . . .	154

<b>VIII</b>	<b>Equations and languages</b> . . . . .	157
1	Equations . . . . .	157
2	Equational characterisation of lattices . . . . .	157
3	Lattices of languages closed under quotients . . . . .	160
4	Streams of languages . . . . .	161
5	$\mathcal{C}$ -streams . . . . .	162
6	Varieties of languages . . . . .	163
7	The variety theorem . . . . .	164
8	Summary . . . . .	167
<b>IX</b>	<b>Algebraic characterisations</b> . . . . .	169
1	Varieties of languages . . . . .	169
1.1	Locally finite varieties of languages . . . . .	169
1.2	Commutative languages . . . . .	172
1.3	$\mathcal{R}$ -trivial and $\mathcal{L}$ -trivial languages . . . . .	174
1.4	Some examples of $+$ -varieties . . . . .	176
2	Lattices of languages . . . . .	178
2.1	The role of the zero . . . . .	178
2.2	Languages defined by density . . . . .	181
2.3	Cyclic and strongly cyclic languages . . . . .	187
3	Exercises . . . . .	192
4	Notes . . . . .	193
<b>X</b>	<b>Star-free languages</b> . . . . .	195
1	Star-free languages . . . . .	195
2	Schützenberger's theorem . . . . .	196
<b>XI</b>	<b>Piecewise testable languages</b> . . . . .	201
1	Subword ordering . . . . .	201
2	Simple languages and shuffle ideals . . . . .	205
3	Piecewise testable languages and Simon's theorem . . . . .	206
4	Some consequences of Simon's theorem . . . . .	208
5	Exercises . . . . .	210
<b>XII</b>	<b>Polynomial closure</b> . . . . .	211
1	Polynomial closure of a lattice of languages . . . . .	211
2	A case study . . . . .	216
<b>XIII</b>	<b>Relational morphisms</b> . . . . .	217
1	Relational morphisms . . . . .	217
2	Injective relational morphisms . . . . .	219
3	Relational $\mathbf{V}$ -morphisms . . . . .	220
3.1	Aperiodic relational morphisms . . . . .	222
3.2	Locally trivial relational morphisms . . . . .	222
3.3	Relational $\llbracket ese \leq e \rrbracket$ -morphisms . . . . .	223
4	Four examples of $\mathbf{V}$ -morphisms . . . . .	224
5	Three examples of relational morphisms . . . . .	224
5.1	Concatenation product . . . . .	224

5.2	Pure languages . . . . .	227
5.3	Flower automata . . . . .	228
<b>XIV</b>	<b>Unambiguous star-free languages . . . . .</b>	<b>231</b>
1	Unambiguous star-free languages . . . . .	231
<b>XV</b>	<b>Wreath product . . . . .</b>	<b>233</b>
1	Semidirect product . . . . .	233
2	Wreath product . . . . .	233
3	Basic decomposition results . . . . .	235
4	Exercises . . . . .	240
<b>XVI</b>	<b>Sequential functions . . . . .</b>	<b>241</b>
1	Definitions . . . . .	241
1.1	Pure sequential transducers . . . . .	241
1.2	Sequential transducers . . . . .	244
2	Composition of sequential functions . . . . .	245
3	Sequential functions and wreath product . . . . .	249
4	The wreath product principle and its consequences . . . . .	250
4.1	The wreath product principle . . . . .	250
5	Applications of the wreath product principle . . . . .	251
5.1	The operations $T \mapsto U_1 \circ T$ and $L \mapsto LaA^*$ . . . . .	251
5.2	The operations $T \mapsto \bar{2} \circ T$ and $L \mapsto La$ . . . . .	253
5.3	The operation $T \mapsto U_2 \circ T$ and star-free expressions . . . . .	254
<b>XVII</b>	<b>An excursion into logic . . . . .</b>	<b>257</b>
1	Introduction . . . . .	257
2	The formalism of logic . . . . .	257
2.1	Syntax . . . . .	257
2.2	Semantics . . . . .	260
2.3	Logic on words . . . . .	263
3	Monadic second-order logic on words . . . . .	265
4	First-order logic of the linear order . . . . .	269
4.1	First order and star-free sets . . . . .	269
4.2	Logical hierarchy . . . . .	271
	<b>Annex . . . . .</b>	<b>277</b>
<b>A</b>	<b>A transformation semigroup . . . . .</b>	<b>279</b>
	<b>References . . . . .</b>	<b>283</b>
	<b>Index . . . . .</b>	<b>292</b>



# Chapter I

## Algebraic preliminaries

### 1 Subsets, relations and functions

#### 1.1 Sets

The set of subsets of a set  $E$  is denoted by  $\mathcal{P}(E)$  (or sometimes  $2^E$ ). The *positive Boolean operations* on  $\mathcal{P}(E)$  comprise *union* and *intersection*. The *Boolean operations* also include *complementation*. The complement of a subset  $X$  of  $E$  is denoted by  $X^c$ . Thus, for all subsets  $X$  and  $Y$  of  $E$ , the following relations hold

$$(X^c)^c = X \quad (X \cup Y)^c = X^c \cap Y^c \quad (X \cap Y)^c = X^c \cup Y^c$$

We denote by  $|E|$  the number of elements of a finite set  $E$ , also called the *size* of  $E$ . A *singleton* is a set of size 1. We shall frequently identify a singleton  $\{s\}$  with its unique element  $s$ .

Given two sets  $E$  and  $F$ , the set of ordered pairs  $(x, y)$  such that  $x \in E$  and  $y \in F$  is written  $E \times F$  and called the *product* of  $E$  and  $F$ .

#### 1.2 Relations

Let  $E$  and  $F$  be two sets. A *relation* on  $E$  and  $F$  is a subset of  $E \times F$ . If  $E = F$ , it is simply called a *relation on  $E$* . A relation can also be viewed as a function<sup>1</sup> from  $E$  into  $\mathcal{P}(F)$  by setting, for each  $x \in E$ ,

$$\tau(x) = \{y \in F \mid (x, y) \in \tau\}$$

By abuse of language, we say that  $\tau$  is a relation from  $E$  into  $F$ .

The *inverse of a relation*  $\tau \subseteq E \times F$  is the relation  $\tau^{-1} \subseteq F \times E$  defined by

$$\tau^{-1} = \{(y, x) \in F \times E \mid (x, y) \in \tau\}$$

Note that if  $\tau$  is a relation from  $E$  in  $F$ , the relation  $\tau^{-1}$  can be also viewed as a function from  $F$  into  $\mathcal{P}(E)$  defined by

$$\tau^{-1}(y) = \{x \in E \mid y \in \tau(x)\}$$

---

<sup>1</sup>Functions are formally defined in the next section, but we assume the reader is already familiar with this notion.

A relation from  $E$  into  $F$  can be extended to a function from  $\mathcal{P}(E)$  into  $\mathcal{P}(F)$  by setting, for each subset  $X$  of  $E$ ,

$$\tau(X) = \bigcup_{x \in X} \tau(x) = \{y \in F \mid \text{for some } x \in X, (x, y) \in \tau\}$$

If  $Y$  is a subset of  $F$ , we then have

$$\begin{aligned} \tau^{-1}(Y) &= \bigcup_{y \in Y} \tau^{-1}(y) = \{x \in E \mid \text{there exists } y \in Y \text{ such that } y \in \tau(x)\} \\ &= \{x \in E \mid \tau(x) \cap Y \neq \emptyset\} \end{aligned}$$

**Example 1.1** Let  $\tau$  be the relation from  $E = \{1, 2, 3\}$  into  $F = \{1, 2, 3, 4\}$  defined by  $\tau = \{(1, 1), (1, 2), (2, 1), (2, 3), (2, 4)\}$ .

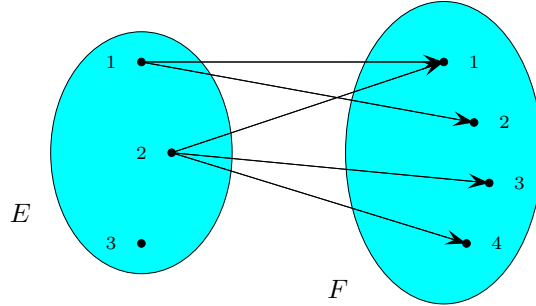

**Figure 1.1.** The relation  $\tau$ .

Then  $\tau(1) = \{1, 2\}$ ,  $\tau(2) = \{1, 3, 4\}$ ,  $\tau(3) = \emptyset$ ,  $\tau^{-1}(1) = \{1, 2\}$ ,  $\tau^{-1}(2) = \{1\}$ ,  $\tau^{-1}(3) = \{2\}$ ,  $\tau^{-1}(4) = \{2\}$ .

Given two relations  $\tau_1 : E \rightarrow F$  and  $\tau_2 : F \rightarrow G$ , we denote by  $\tau_1\tau_2$  or by  $\tau_2 \circ \tau_1$  the *composition* of  $\tau_1$  and  $\tau_2$ , which is the relation from  $E$  into  $G$  defined by

$$\tau_2 \circ \tau_1(x) = \{z \in G \mid \text{there exists } y \in F \text{ such that } y \in \tau_1(x) \text{ and } z \in \tau_2(y)\}$$

### 1.3 Functions

A (partial) *function*  $\varphi : E \rightarrow F$  is a relation on  $E$  and  $F$  such that for every  $x \in E$ , there exists one and only one (in the case of a partial function, at most one) element  $y \in F$  such that  $(x, y) \in \varphi$ . When this  $y$  exists, it is denoted by  $\varphi(x)$ . The set

$$\text{Dom}(\varphi) = \{x \in E \mid \text{there exists } y \in F \text{ such that } (x, y) \in \varphi\}$$

is called the *domain* of  $\varphi$ . A function of domain  $E$  is sometimes called a *total function* or a *mapping* from  $E$  into  $F$ . The set

$$\text{Im}(\varphi) = \{y \in F \mid \text{there exists } x \in E \text{ such that } (x, y) \in \varphi\}$$



is called the *range* or the *image* of  $\varphi$ . Given a set  $E$ , the identity mapping on  $E$  is the mapping  $Id_E : E \rightarrow E$  defined by  $Id_E(x) = x$  for all  $x \in E$ .

A mapping  $\varphi : E \rightarrow F$  is called *injective* if, for every  $u, v \in E$ ,  $\varphi(u) = \varphi(v)$  implies  $u = v$ . It is *surjective* if, for every  $v \in F$ , there exists  $u \in E$  such that  $v \in \varphi(u)$ . It is *bijective* if it is simultaneously injective and surjective. For instance, the identity mapping  $Id_E(x)$  is bijective.

**Proposition 1.1** *Let  $\varphi : E \rightarrow F$  be a mapping. Then  $\varphi$  is surjective if and only if there exists a mapping  $\psi : F \rightarrow E$  such that  $\varphi \circ \psi = Id_F$ .*

**Proof.** If there exists a mapping  $\psi$  with these properties, we have  $\varphi(\psi(y)) = y$  for all  $y \in F$  and thus  $\varphi$  is surjective. Conversely, suppose that  $\varphi$  is surjective. For each element  $y \in F$ , select an element  $\psi(y)$  in the nonempty set  $\varphi^{-1}(y)$ . This defines a mapping  $\psi : F \rightarrow E$  such that  $\varphi \circ \psi(y) = y$  for all  $y \in F$ .  $\square$

A consequence of Proposition 1.1 is that surjective maps are *right cancellative* (the definition of a right cancellative map is transparent, but if needed, a formal definition is given in Section 1.2).<sup>2</sup>

**Corollary 1.2** *Let  $\varphi : E \rightarrow F$  be a surjective mapping and let  $\alpha$  and  $\beta$  be two mappings from  $F$  into  $G$ . If  $\alpha \circ \varphi = \beta \circ \varphi$ , then  $\alpha = \beta$ .*

**Proof.** By Proposition 1.1, there exists a mapping  $\psi : F \rightarrow E$  such that  $\varphi \circ \psi = Id_F$ . Therefore  $\alpha \circ \varphi = \beta \circ \varphi$  implies  $\alpha \circ \varphi \circ \psi = \beta \circ \varphi \circ \psi$ , whence  $\alpha = \beta$ .  $\square$

**Proposition 1.3** *Let  $\varphi : E \rightarrow F$  be a mapping. Then  $\varphi$  is injective if and only if there exists a mapping  $\psi : \text{Im}(\varphi) \rightarrow E$  such that  $\psi \circ \varphi = Id_E$ .*

**Proof.** Suppose there exists a mapping  $\psi$  with these properties. Then  $\varphi$  is injective since the condition  $\varphi(x) = \varphi(y)$  implies  $\psi \circ \varphi(x) = \psi \circ \varphi(y)$ , that is,  $x = y$ . Conversely, suppose that  $\varphi$  is injective. Define a mapping  $\psi : \text{Im}(\varphi) \rightarrow E$  by setting  $\psi(y) = x$ , where  $x$  is the unique element of  $E$  such that  $\varphi(x) = y$ . Then  $\psi \circ \varphi = Id_E$  by construction.  $\square$

It follows that injective maps are *left cancellative*.

**Corollary 1.4** *Let  $\varphi : F \rightarrow G$  be an injective mapping and let  $\alpha$  and  $\beta$  be two mappings from  $E$  into  $F$ . If  $\varphi \circ \alpha = \varphi \circ \beta$ , then  $\alpha = \beta$ .*

**Proof.** By Proposition 1.3, there exists a mapping  $\psi : \text{Im}(\varphi) \rightarrow F$  such that  $\psi \circ \varphi = Id_F$ . Therefore  $\varphi \circ \alpha = \varphi \circ \beta$  implies  $\psi \circ \varphi \circ \alpha = \psi \circ \varphi \circ \beta$ , whence  $\alpha = \beta$ .  $\square$

We come to a standard property of bijective maps.

**Proposition 1.5** *If  $\varphi : E \rightarrow F$  is a bijective mapping, there exists a unique bijective mapping from  $F$  to  $E$ , denoted by  $\varphi^{-1}$ , such that  $\varphi \circ \varphi^{-1} = Id_F$  and  $\varphi^{-1} \circ \varphi = Id_E$ .*

---

<sup>2</sup>For the mathematically oriented reader only: Proposition 1.1 and Corollary 1.2 are actually both equivalent to the axiom of choice.

**Proof.** Since  $\varphi$  is bijective, for each  $y \in F$  there exists a unique  $x \in E$  such that  $\varphi(x) = y$ . Thus the condition  $\varphi^{-1} \circ \varphi = Id_E$  requires that  $x = \varphi^{-1}(\varphi(x)) = \varphi^{-1}(y)$ . This ensures the uniqueness of the solution. Now, the mapping  $\varphi^{-1} : F \rightarrow E$  defined by  $\varphi^{-1}(y) = x$ , where  $x$  is the unique element such that  $\varphi(x) = y$ , clearly satisfies the two conditions  $\varphi \circ \varphi^{-1} = Id_F$  and  $\varphi^{-1} \circ \varphi = Id_E$ .  $\square$

The mapping  $\varphi^{-1}$  is called the *inverse* of  $\varphi$ .

It is clear that the composition of two injective [surjective] mappings is injective [surjective]. A partial converse to this result is given in the next proposition.

**Proposition 1.6** *Let  $\alpha : E \rightarrow F$  and  $\beta : F \rightarrow G$  be two mappings and let  $\gamma = \beta \circ \alpha$  be their composition.*

- (1) *If  $\gamma$  is injective, then  $\alpha$  is injective. If furthermore  $\alpha$  is surjective, then  $\beta$  is injective.*
- (2) *If  $\gamma$  is surjective, then  $\beta$  is surjective. If furthermore  $\beta$  is injective, then  $\alpha$  is surjective.*

**Proof.** (1) Suppose that  $\gamma$  is injective. If  $\alpha(x) = \alpha(y)$ , then  $\beta(\alpha(x)) = \beta(\alpha(y))$ , whence  $\gamma(x) = \gamma(y)$  and  $x = y$  since  $\gamma$  is injective. Thus  $\alpha$  is injective. If, furthermore,  $\alpha$  is surjective, then it is bijective and, by Proposition 1.5,  $\gamma \circ \alpha^{-1} = \beta \circ \alpha \circ \alpha^{-1} = \beta$ . It follows that  $\beta$  is the composition of the two injective maps  $\gamma$  and  $\alpha^{-1}$  and hence is injective.

(2) Suppose that  $\gamma$  is surjective. Then for each  $z \in G$ , there exists  $x \in E$  such that  $\gamma(x) = z$ . It follows that  $z = \beta(\alpha(x))$  and thus  $\beta$  is surjective. If, furthermore,  $\beta$  is injective, then it is bijective and, by Proposition 1.5,  $\beta^{-1} \circ \gamma = \beta^{-1} \circ \beta \circ \alpha = \alpha$ . It follows that  $\alpha$  is the composition of the two surjective maps  $\beta^{-1}$  and  $\gamma$  and hence is surjective.  $\square$

The next result is extremely useful.

**Proposition 1.7** *Let  $E$  and  $F$  be two finite sets such that  $|E| = |F|$  and let  $\varphi : E \rightarrow F$  be a function. The following conditions are equivalent:*

- (1)  *$\varphi$  is injective,*
- (2)  *$\varphi$  is surjective,*
- (3)  *$\varphi$  is bijective.*

**Proof.** Clearly it suffices to show that (1) and (2) are equivalent. If  $\varphi$  is injective, then  $\varphi$  induces a bijection from  $E$  onto  $\varphi(E)$ . Thus  $|E| = |\varphi(E)| \leq |F| = |E|$ , whence  $|\varphi(E)| = |F|$  and  $\varphi(E) = F$  since  $F$  is finite.

Conversely, suppose that  $\varphi$  is surjective. By Proposition 1.1, there exists a mapping  $\psi : F \rightarrow E$  such that  $\varphi \circ \psi = Id_F$ . Since  $\psi$  is injective by Proposition 1.6, and since we have already proved that (1) implies (2),  $\psi$  is surjective. It follows by Proposition 1.6 that  $\varphi$  is injective.  $\square$

## 1.4 Injective and surjective relations

The notions of surjective and injective functions can be extended to relations as follows. A relation  $\tau : E \rightarrow F$  is *surjective* if, for every  $v \in F$ , there exists  $u \in E$  such that  $v \in \tau(u)$ . It is called *injective* if, for every  $u, v \in E$ ,  $\tau(u) \cap \tau(v) \neq \emptyset$  implies  $u = v$ . The next three propositions provide equivalent definitions.

**Proposition 1.8** *A relation is injective if and only if it is the inverse of a partial function.*

**Proof.** Let  $\tau : E \rightarrow F$  be a relation. Suppose that  $\tau$  is injective. If  $y_1, y_2 \in \tau^{-1}(x)$ , then  $x \in \tau(y_1) \cap \tau(y_2)$  and thus  $y_1 = y_2$  since  $\tau$  is injective. Thus  $\tau^{-1}$  is a partial function.

Suppose now that  $\tau^{-1}$  is a partial function. If  $\tau(x) \cap \tau(y) \neq \emptyset$ , there exists some element  $c$  in  $\tau(x) \cap \tau(y)$ . It follows that  $x, y \in \tau^{-1}(c)$  and thus  $x = y$  since  $\tau^{-1}$  is a partial function.  $\square$

**Proposition 1.9** *Let  $\tau : E \rightarrow F$  be a relation. Then  $\tau$  is injective if and only if, for every  $X, Y \subseteq E$ ,  $X \cap Y = \emptyset$  implies  $\tau(X) \cap \tau(Y) = \emptyset$ .*

**Proof.** Suppose that  $\tau$  is injective and let  $X$  and  $Y$  be two disjoint subsets of  $E$ . If  $\tau(X) \cap \tau(Y) \neq \emptyset$ , then  $\tau(x) \cap \tau(y) \neq \emptyset$  for some  $x \in X$  and  $y \in Y$ . Since  $\tau$  is injective, it follows  $x = y$  and hence  $X \cap Y \neq \emptyset$ , a contradiction. Thus  $X \cap Y = \emptyset$ .

If the condition of the statement holds, then it can be applied in particular when  $X$  and  $Y$  are singletons, say  $X = \{x\}$  and  $Y = \{y\}$ . Then the condition becomes  $x \neq y$  implies  $\tau(x) \cap \tau(y) = \emptyset$ , that is,  $\tau$  is injective.  $\square$

**Proposition 1.10** *Let  $\tau : E \rightarrow F$  be a relation. The following conditions are equivalent:*

- (1)  $\tau$  is injective,
- (2)  $\tau^{-1} \circ \tau = Id_{\text{Dom}(\tau)}$ ,
- (3)  $\tau^{-1} \circ \tau \subseteq Id_E$ .

**Proof.** (1) implies (2). Suppose that  $\tau$  is injective and let  $y \in \tau^{-1} \circ \tau(x)$ . By definition, there exists  $z \in \tau(x)$  such that  $y \in \tau^{-1}(z)$ . Thus  $x \in \text{Dom}(\tau)$  and  $z \in \tau(y)$ . Now,  $\tau(x) \cap \tau(y) \neq \emptyset$  and since  $\tau$  is injective,  $x = y$ . Therefore  $\tau^{-1} \circ \tau \subseteq Id_{\text{Dom}(\tau)}$ . But if  $x \in Id_{\text{Dom}(\tau)}$ , there exists by definition  $y \in \tau(x)$  and thus  $x \in \tau^{-1} \circ \tau(x)$ . Thus  $\tau^{-1} \circ \tau = Id_{\text{Dom}(\tau)}$ .

(2) implies (3) is trivial.

(3) implies (1). Suppose that  $\tau^{-1} \circ \tau \subseteq Id_E$  and let  $x, y \in E$ . If  $\tau(x) \cap \tau(y)$  contains an element  $z$ , then  $z \in \tau(x)$ ,  $z \in \tau(y)$  and  $y \in \tau^{-1}(z)$ , whence  $y \in \tau^{-1} \circ \tau(x)$ . Since  $\tau^{-1} \circ \tau \subseteq Id_E$ , it follows that  $y = x$  and thus  $\tau$  is injective.  $\square$

Proposition 1.10 has two useful consequences.

**Corollary 1.11** *Let  $\tau : E \rightarrow F$  be a relation. The following conditions are equivalent:*

- (1)  $\tau$  is a partial function,
- (2)  $\tau \circ \tau^{-1} = Id_{\text{Im}(\tau)}$ ,
- (3)  $\tau \circ \tau^{-1} \subseteq Id_F$ .

**Proof.** The result follows from Proposition 1.10 since, by Proposition 1.8,  $\tau$  is a partial function if and only if  $\tau^{-1}$  is injective.  $\square$

**Corollary 1.12** *Let  $\tau : E \rightarrow F$  be a relation. Then  $\tau$  is a surjective partial function if and only if  $\tau \circ \tau^{-1} = Id_F$ .*

**Proof.** Suppose that  $\tau$  is a surjective partial function. Then by Corollary 1.11,  $\tau \circ \tau^{-1} = Id_F$ .

Conversely, if  $\tau \circ \tau^{-1} = Id_F$ , then  $\tau$  is a partial function by Corollary 1.11 and  $\tau \circ \tau^{-1} = Id_{\text{Im}(\tau)}$ . Therefore  $\text{Im}(\tau) = F$  and  $\tau$  is surjective.  $\square$

Corollary 1.12 is often used under the following form.

**Corollary 1.13** *Let  $\alpha : F \rightarrow G$  and  $\beta : E \rightarrow F$  be two functions and let  $\gamma = \alpha \circ \beta$ . If  $\beta$  is surjective, the relation  $\gamma \circ \beta^{-1}$  is equal to  $\alpha$ .*

**Proof.** Indeed,  $\gamma = \alpha \circ \beta$  implies  $\gamma \circ \beta^{-1} = \alpha \circ \beta \circ \beta^{-1}$ . Now, by Corollary 1.12,  $\beta \circ \beta^{-1} = Id_F$ . Thus  $\gamma \circ \beta^{-1} = \alpha$ .  $\square$

It is clear that the composition of two injective [surjective] relations is injective [surjective]. Proposition 1.6 can be also partially adapted to relations.

**Proposition 1.14** *Let  $\alpha : E \rightarrow F$  and  $\beta : F \rightarrow G$  be two relations and let  $\gamma = \beta \circ \alpha$  be their composition.*

- (1) *If  $\gamma$  is injective and  $\beta^{-1}$  is surjective, then  $\alpha$  is injective. If furthermore  $\alpha$  is a surjective partial function, then  $\beta$  is injective.*
- (2) *If  $\gamma$  is surjective, then  $\beta$  is surjective. If furthermore  $\beta$  is injective of domain  $F$ , then  $\alpha$  is surjective.*

**Proof.** (1) Suppose that  $\gamma$  is injective. If  $\alpha(x) \cap \alpha(y) \neq \emptyset$ , there exists an element  $z \in \alpha(x) \cap \alpha(y)$ . Since  $\beta^{-1}$  is surjective, there is a  $t$  such that  $z \in \beta^{-1}(t)$  or, equivalently,  $t \in \beta(z)$ . Then  $t \in \beta(\alpha(x)) \cap \beta(\alpha(y))$ , whence  $\gamma(x) = \gamma(y)$  and  $x = y$  since  $\gamma$  is injective. Thus  $\alpha$  is injective.

If furthermore  $\alpha$  is a surjective partial function, then by Proposition 1.8,  $\alpha^{-1}$  is an injective relation and by Corollary 1.12,  $\alpha \circ \alpha^{-1} = Id_F$ . It follows that  $\gamma \circ \alpha^{-1} = \beta \circ \alpha \circ \alpha^{-1} = \beta$ . Thus  $\beta$  is the composition of the two injective relations  $\gamma$  and  $\alpha^{-1}$  and hence is injective.

(2) Suppose that  $\gamma$  is surjective. Then for each  $z \in G$ , there exists  $x \in E$  such that  $z \in \gamma(x)$ . Thus there exists  $y \in \alpha(x)$  such that  $z \in \beta(y)$ , which shows that  $\beta$  is surjective.

Suppose that  $\beta$  is injective of domain  $F$  or, equivalently, that  $\beta^{-1}$  is a surjective partial map. Then by Proposition 1.10,  $\beta^{-1} \circ \beta = Id_F$ . It follows that  $\beta^{-1} \circ \gamma = \beta^{-1} \circ \beta \circ \alpha = \alpha$ . Therefore  $\alpha$  is the composition of the two surjective relations  $\beta^{-1}$  and  $\gamma$  and hence is surjective.  $\square$

**Proposition 1.15** *Let  $E, F, G$  be three sets and  $\alpha : G \rightarrow E$  and  $\beta : G \rightarrow F$  be two functions. Suppose that  $\alpha$  is surjective and that, for every  $s, t \in G$ ,  $\alpha(s) = \alpha(t)$  implies  $\beta(s) = \beta(t)$ . Then the relation  $\beta \circ \alpha^{-1} : E \rightarrow F$  is a function.*

**Proof.** Let  $x \in E$ . Since  $\alpha$  is surjective, there exists  $y \in G$  such that  $\alpha(y) = x$ . Setting  $z = \beta(y)$ , one has  $z \in \beta \circ \alpha^{-1}(x)$ .

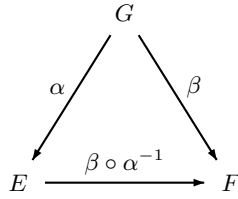

Let  $z' \in \beta \circ \alpha^{-1}(x)$ . Then  $z' = \beta(y')$  for some  $y' \in \alpha^{-1}(x)$ . Thus  $\alpha(y') = x$  and since  $\alpha(y) = \alpha(y')$ , the condition of the statement implies that  $\beta(y) = \beta(y')$ . Thus  $z = z'$ , which shows that  $\beta \circ \alpha^{-1}$  is a function.  $\square$

### 1.5 Relations and set operations

We gather in this section three elementary properties of relations. The first two propositions can be summarized by saying that “union commutes with relations”, “Boolean operations commute with inverses of functions”, “union, intersection and set difference commute with injective relations”. The last one is a more subtle property of surjective partial functions.

**Proposition 1.16** *Let  $\tau : E \rightarrow F$  be a relation. Then for every  $X, Y \subseteq E$ , the relation  $\tau(X \cup Y) = \tau(X) \cup \tau(Y)$  holds.*

**Proof.** It follows immediately from the definition:

$$\tau(X \cup Y) = \bigcup_{z \in X \cup Y} \tau(x) = \left( \bigcup_{z \in X} \tau(x) \right) \cup \left( \bigcup_{z \in Y} \tau(x) \right) = \tau(X) \cup \tau(Y). \quad \square$$

**Proposition 1.17** *Let  $\tau : E \rightarrow F$  be an injective relation. Then, for every  $X, Y \subseteq E$ , the following relations hold:*

$$\tau(X \cup Y) = \tau(X) \cup \tau(Y) \quad \tau(X \cap Y) = \tau(X) \cap \tau(Y) \quad \tau(X - Y) = \tau(X) - \tau(Y).$$

**Proof.** The first formula follows from Proposition 1.16.

It follows from the inclusion  $X \cap Y \subseteq X$  that  $\tau(X \cap Y) \subseteq \tau(X)$  and similarly  $\tau(X \cap Y) \subseteq \tau(Y)$ . Thus  $\tau(X \cap Y) \subseteq \tau(X) \cap \tau(Y)$ . Now, if  $z \in \tau(X) \cap \tau(Y)$ , then  $z \in \tau(x) \cap \tau(y)$  for some  $x \in X$  and  $y \in Y$ . But since  $\tau$  is injective, it follows  $x = y$  and thus  $z \in \tau(X \cap Y)$ . Thus  $\tau(X) \cap \tau(Y) \subseteq \tau(X \cap Y)$ , which proves the second relation.

The first relation gives  $\tau(X - Y) \cup \tau(Y) = \tau(X \cup Y)$ . Thus

$$\tau(X) - \tau(Y) \subseteq \tau(X \cup Y) - \tau(Y) \subseteq \tau(X - Y)$$

Furthermore,  $\tau(X - Y) \subseteq \tau(X)$  and since  $\tau$  is injective,  $\tau(X - Y) \cap \tau(Y) = \emptyset$  by Proposition 1.9. Thus  $\tau(X - Y) \subseteq \tau(X) - \tau(Y)$  and finally  $\tau(X - Y) = \tau(X) - \tau(Y)$ , which proves the third relation.  $\square$

More precise results hold for inverse of functions on the one hand, and for surjective partial functions on the other hand.

**Proposition 1.18** *Let  $\varphi : E \rightarrow F$  be a function. Then, for every  $X, Y \subseteq F$ , the following relations hold:*

$$\begin{aligned}\varphi^{-1}(X \cup Y) &= \varphi^{-1}(X) \cup \varphi^{-1}(Y) \\ \varphi^{-1}(X \cap Y) &= \varphi^{-1}(X) \cap \varphi^{-1}(Y) \\ \varphi^{-1}(X^c) &= (\varphi^{-1}(X))^c.\end{aligned}$$

**Proof.** By Proposition 1.8, the relation  $\varphi^{-1}$  is injective and thus Proposition 1.17 gives the first two formulas. The third one relies on the fact that  $\varphi^{-1}(F) = E$ . Indeed, the third property of Proposition 1.17 gives  $\varphi^{-1}(X^c) = \varphi^{-1}(F - X) = \varphi^{-1}(F) - \varphi^{-1}(X) = E - \varphi^{-1}(X) = (\varphi^{-1}(X))^c$ .  $\square$

**Proposition 1.19** *Let  $\varphi : E \rightarrow F$  be a surjective partial function. Then for every  $X \subseteq E$  and  $Y \subseteq F$ , the following relations hold:*

$$\varphi(X) \cap Y = \varphi(X) \cap \varphi(\varphi^{-1}(Y)) = \varphi(X \cap \varphi^{-1}(Y))$$

**Proof.** By Corollary 1.12,  $\varphi \circ \varphi^{-1} = Id_F$ . It follows that  $\varphi(X) \cap Y = \varphi(X) \cap \varphi(\varphi^{-1}(Y))$ . Furthermore,  $\varphi(X \cap \varphi^{-1}(Y)) \subseteq \varphi(X) \cap \varphi(\varphi^{-1}(Y))$ . Finally, if  $y \in \varphi(X) \cap Y$ , then  $y = \varphi(x)$  for some  $x \in X$  and since  $y \in Y$ ,  $x \in \varphi^{-1}(Y)$ . It follows that  $\varphi(X) \cap Y \subseteq \varphi(X \cap \varphi^{-1}(Y))$ , which concludes the proof.  $\square$

## 2 Ordered sets

If  $\mathcal{R}$  is a relation on  $E$ , two elements  $x$  and  $y$  of  $E$  are said to be *related by  $\mathcal{R}$*  if  $(x, y) \in \mathcal{R}$ , which is also denoted by  $x \mathcal{R} y$ .

A relation  $\mathcal{R}$  is *reflexive* if, for each  $x \in E$ ,  $x \mathcal{R} x$ , *symmetric* if, for each  $x, y \in E$ ,  $x \mathcal{R} y$  implies  $y \mathcal{R} x$ , *antisymmetric* if, for each  $x, y \in E$ ,  $x \mathcal{R} y$  and  $y \mathcal{R} x$  imply  $x = y$  and *transitive* if, for each  $x, y, z \in E$ ,  $x \mathcal{R} y$  and  $y \mathcal{R} z$  implies  $x \mathcal{R} z$ .

A relation is a *preorder* if it is reflexive and transitive, an *order* (or *partial order*) if it is reflexive, transitive and antisymmetric and an *equivalence relation* (or an *equivalence*) if it is reflexive, transitive and symmetric. If  $\mathcal{R}$  is a preorder, the relation  $\sim$  defined by  $x \sim y$  if and only if  $x \mathcal{R} y$  and  $y \mathcal{R} x$  is an equivalence relation, called the *equivalence relation associated with  $\mathcal{R}$* .

Relations are ordered by inclusion. More precisely, if  $\mathcal{R}_1$  and  $\mathcal{R}_2$  are two relations on a set  $S$ ,  $\mathcal{R}_1$  *refines*  $\mathcal{R}_2$  (or  $\mathcal{R}_1$  is *thinner* than  $\mathcal{R}_2$ , or  $\mathcal{R}_2$  is *coarser* than  $\mathcal{R}_1$ ) if and only if, for each  $s, t \in S$ ,  $s \mathcal{R}_1 t$  implies  $s \mathcal{R}_2 t$ . Equality is thus the thinnest equivalence relation and the *universal* relation, in which all elements are related, is the coarsest. The following property is obvious.

**Proposition 2.20** *Any intersection of preorders is a preorder. Any intersection of equivalence relations is an equivalence relation.*

It follows that, given a set  $R$  of relations on a set  $E$ , there is a smallest preorder [equivalence relation] containing all the relations of  $E$ . This relation is called the *preorder* [equivalence relation] *generated by  $R$* .

**Proposition 2.21** *Let  $\mathcal{R}_1$  and  $\mathcal{R}_2$  be two preorders [equivalence relations] on a set  $E$ . If they commute, the preorder [equivalence relation] generated by  $\mathcal{R}_1$  and  $\mathcal{R}_2$  is equal to  $\mathcal{R}_1 \circ \mathcal{R}_2$ .*

**Proof.** Suppose that  $\mathcal{R}_1$  and  $\mathcal{R}_2$  commute and let  $\mathcal{R} = \mathcal{R}_1 \circ \mathcal{R}_2$ . Then  $\mathcal{R}$  is clearly reflexive but it is also transitive. Indeed, if  $x_1 \mathcal{R} x_2$  and  $x_2 \mathcal{R} x_3$ , there exist  $y_1, y_2 \in E$  such that  $x_1 \mathcal{R}_1 y_1$ ,  $y_1 \mathcal{R}_2 x_2$ ,  $x_2 \mathcal{R}_1 y_2$  and  $y_2 \mathcal{R}_2 x_3$ . Since  $\mathcal{R} = \mathcal{R}_2 \circ \mathcal{R}_1$ , one gets  $y_1 \mathcal{R} y_2$  and since  $\mathcal{R}_1$  and  $\mathcal{R}_2$  commute, there exists  $y$  such that  $y_1 \mathcal{R}_1 y$  and  $y \mathcal{R}_2 y_2$ . It follows that  $x_1 \mathcal{R}_1 y$  and  $y \mathcal{R}_2 x_3$  and thus  $x_1 \mathcal{R} x_3$ .  $\square$

An *upper set* of an ordered set  $(E, \leq)$  is a subset  $F$  of  $E$  such that, if  $x \leq y$  and  $x \in F$ , then  $y \in F$ . The upper set generated by an element  $x$  is the set  $\uparrow x$  of all  $y \in E$  such that  $x \leq y$ . The intersection [union] of any family of upper sets is also an upper set.

### 3 Exercises

**1.** Let  $\varphi_1 : E_1 \rightarrow E_2$ ,  $\varphi_2 : E_2 \rightarrow E_3$  and  $\varphi_3 : E_3 \rightarrow E_1$  be three functions. Show that if, among the mappings  $\varphi_3 \circ \varphi_2 \circ \varphi_1$ ,  $\varphi_2 \circ \varphi_1 \circ \varphi_3$ , and  $\varphi_1 \circ \varphi_3 \circ \varphi_2$ , two are surjective and the third is injective, or two are injective and the third is surjective, then the three functions  $\varphi_1$ ,  $\varphi_2$  and  $\varphi_3$  are bijective.

**2.** This exercise is due to J. Almeida [2, Lemma 8.2.5].

Let  $X$  and  $Y$  be finite sets and let  $P$  be a partially ordered set. Let  $\varphi : X \rightarrow Y$ ,  $\gamma : Y \rightarrow X$ ,  $\pi : X \rightarrow P$  and  $\theta : Y \rightarrow P$  be functions such that:

- (1) for any  $x \in X$ ,  $\pi(x) \leq \theta(\varphi(x))$ ,
- (2) for any  $y \in Y$ ,  $\theta(y) \leq \pi(\gamma(y))$ ,
- (3) if  $x_1, x_2 \in X$ ,  $\varphi(x_1) = \varphi(x_2)$  and  $\pi(x_1) = \theta(\varphi(x_1))$ , then  $x_1 = x_2$ ,
- (4) if  $y_1, y_2 \in Y$ ,  $\gamma(y_1) = \gamma(y_2)$  and  $\theta(y_1) = \pi(\gamma(y_1))$ , then  $y_1 = y_2$ .

Then  $\varphi$  and  $\gamma$  are mutually inverse functions,  $\pi = \theta \circ \varphi$  and  $\theta = \pi \circ \gamma$ .





# Chapter II

## Semigroups and beyond

The purpose of this chapter is to introduce the basic algebraic definitions that will be used in this book: semigroups, monoids, groups and semirings, morphisms, substructures and quotients for these structures, transformation semigroups and free semigroups. We also devote a short section to idempotents, a central notion in finite semigroup theory.

### 1 Semigroups, monoids and groups

#### 1.1 Semigroups, monoids

Let  $S$  be a set. A *binary operation* on  $S$  is a mapping from  $S \times S$  into  $S$ . The image of  $(x, y)$  under this mapping is often denoted by  $xy$  and is called the *product* of  $x$  and  $y$ . In this case, it is convenient to call *multiplication* the binary operation. Sometimes, the additive notation  $x + y$  is adopted, the operation is called *addition* and  $x + y$  denotes the *sum* of  $x$  and  $y$ .

An operation on  $S$  is *associative* if, for every  $x, y, z$  in  $S$ ,  $(xy)z = x(yz)$ . It is *commutative*, if, for every  $x, y$  in  $S$ ,  $xy = yx$ .

An element  $1$  of  $S$  is called an *identity element* or simply *identity* or *unit* for the operation if, for all  $x \in S$ ,  $x1 = x = 1x$ . It is easy to see there can be at most one identity, which is then called *the identity*. Indeed if  $1$  and  $1'$  are two identities, one has simultaneously  $11' = 1'$ , since  $1$  is an identity, and  $11' = 1$ , since  $1'$  is an identity, whence  $1 = 1'$ . In additive notation, the identity is denoted by  $0$  to get the intuitive formula  $0 + x = x = x + 0$ .

A *semigroup* is a pair consisting of a set  $S$  and an associative binary operation on  $S$ . A semigroup is a pair, but we shall usually say “ $S$  is a semigroup” and assume the binary operation is known. A *monoid* is a triple consisting of a set  $M$ , an associative binary operation on  $M$  and an identity for this operation. The number of elements of a semigroup is often called its *order*<sup>1</sup>. Thus a semigroup of order 4 is a semigroup with 4 elements.

The *dual semigroup* of a semigroup  $S$ , denoted by  $\tilde{S}$ , is the semigroup defined on the set  $S$  by the operation  $*$  given by  $s * t = ts$ .

A semigroup [monoid, group] is said to be *commutative* if its operation is commutative.

---

<sup>1</sup>This well-established terminology has of course nothing to do with the order relations.

If  $S$  is a semigroup,  $S^1$  denotes the monoid equal to  $S$  if  $S$  is a monoid, and to  $S \cup \{1\}$  if  $S$  is not a monoid. In the latter case, the operation of  $S$  is completed by the rules

$$1s = s1 = s$$

for each  $s \in S^1$ .

## 1.2 Special elements

Being idempotent, zero and cancellable are the three important properties of an element of a semigroup defined in this section. We also define the notion of semigroup inverse of an element. Regular elements, which form another important category of elements, will be introduced in Section 2.2.

### Idempotents

Let  $S$  be a semigroup. An element  $e$  of  $S$  is an *idempotent* if  $e = e^2$ . The set of idempotents of  $S$  is denoted by  $E(S)$ . We shall see later that idempotents play a fundamental role in the study of finite semigroups.

An element  $e$  of  $S$  is a *right identity* [*left identity*] of  $S$  if, for all  $s \in S$ ,  $se = s$  [ $es = s$ ]. Observe that  $e$  is an identity if and only if it is simultaneously a right and a left identity. Furthermore, a right [left] identity is necessarily idempotent. The following elementary result illustrates these notions.

**Proposition 1.1 (Simplification lemma)** *Let  $S$  be a semigroup. Let  $s \in S$  and  $e, f$  be idempotents of  $S^1$ . If  $s = esf$ , then  $es = s = sf$ .*

**Proof.** If  $s = esf$ , then  $es = eesf = esf = s$  and  $sf = esff = esf = s$ .  $\square$

### Zeros

An element  $e$  is said to be a *zero* [*right zero*, *left zero*] if, for all  $s \in S$ ,  $es = e = se$  [ $se = e$ ,  $es = e$ ].

**Proposition 1.2** *A semigroup has at most one zero element.*

**Proof.** Assume that  $e$  and  $e'$  are zero elements of a semigroup  $S$ . Then by definition,  $e = ee' = e'$  and thus  $e = e'$ .  $\square$

If  $S$  is a semigroup, we denote by  $S^0$  the semigroup obtained from  $S$  by addition of a zero: the support of  $S^0$  is the disjoint union of  $S$  and the singleton<sup>2</sup>  $0$  and the multiplication (here denoted  $*$ ) is defined by

$$s * t = \begin{cases} st & \text{if } s, t \in S \\ 0 & \text{if } s = 0 \text{ or } t = 0. \end{cases}$$

A semigroup is called *null* if it has a zero and if the product of two elements is always zero.

---

<sup>2</sup>A singleton  $\{s\}$  will also be denoted by  $s$ .

### Cancellative elements

An element  $s$  of a semigroup  $S$  is said to be *right cancellative* [*left cancellative*] if, for every  $x, y \in S$ , the condition  $xs = ys$  [ $sx = sy$ ] implies  $x = y$ . It is *cancellative* if it is simultaneously right and left cancellative.

A semigroup  $S$  is *right cancellative* [*left cancellative, cancellative*] if all its elements are right cancellative [*left cancellative, cancellative*].

### Inverses

We have to face a slight terminology problem with the notion of an inverse. Indeed, semigroup theorists have coined a notion of inverse that differs from the standard notion used in group theory and elsewhere in mathematics. Usually, the context should permit to clarify which definition is understood. But to avoid any ambiguity, we shall use the terms *group inverse* and *semigroup inverse* when we need to distinguish the two notions.

Let  $M$  be a monoid. A *right group inverse* [*left group inverse*] of an element  $x$  of  $M$  is an element  $x'$  such that  $xx' = 1$  [ $x'x = 1$ ]. A *group inverse* of  $x$  is an element  $x'$  which is simultaneously a right and left group inverse of  $x$ , so that  $xx' = x'x = 1$ .

We now come to the notion introduced by semigroup theorists. Given an element  $x$  of a semigroup  $S$ , an element  $x'$  is a *semigroup inverse* or simply *inverse* of  $x$  if  $xx'x = x$  and  $x'xx' = x'$ .

It is clear that any group inverse is a semigroup inverse but the converse is not true. A thorough study of semigroup inverses will be given in Section 2, but let us warn the reader immediately of some counterintuitive facts about inverses. An element of an infinite monoid may have several right group inverses and several left group inverses. The situation is radically different for a finite monoid: each element has at most one left [right] group inverse and if these elements exist, they are equal. However, an element of a semigroup (finite or infinite) may have several semigroup inverses, or no semigroup inverse at all.

## 1.3 Groups

A monoid is a *group* if each of its elements has a group inverse. A slightly weaker condition can be given.

**Proposition 1.3** *A monoid is a group if and only if each of its elements has a right group inverse and a left group inverse.*

**Proof.** In a group, every element has a right group inverse and a left group inverse. Conversely, let  $G$  be a monoid in which every element has a right group inverse and a left group inverse. Let  $g \in G$ , let  $g'$  [ $g''$ ] be a right [left] inverse of  $g$ . Thus, by definition,  $gg' = 1$  and  $g''g = 1$ . It follows that  $g'' = g''(gg') = (g''g)g' = g'$ . Thus  $g' = g''$  is an inverse of  $g$ . Thus  $G$  is a group.  $\square$

For finite monoids, this result can be further strengthened as follows:

**Proposition 1.4** *A finite monoid  $G$  is a group if and only if every element of  $G$  has a left group inverse.*

Of course, the dual statement for right group inverses hold.

**Proof.** Let  $G$  be a finite monoid in which every element has a left group inverse. Given an element  $g \in G$ , consider the map  $\varphi : G \rightarrow G$  defined by  $\varphi(x) = gx$ . We claim that  $\varphi$  is injective. Suppose that  $gx = gy$  for some  $x, y \in G$  and let  $g'$  be the left group inverse of  $g$ . Then  $g'gx = g'gy$ , that is  $x = y$ , proving the claim. Since  $G$  is finite, Proposition I.1.7 shows that  $\varphi$  is also surjective. In particular, there exists an element  $g'' \in G$  such that  $1 = gg''$ . Thus every element of  $G$  has a right group inverse and by Proposition 1.3,  $G$  is a group.  $\square$

**Proposition 1.5** *A group is a cancellative monoid. In a group, every element has a unique group inverse.*

**Proof.** Let  $G$  be a group. Let  $g, x, y \in G$  and let  $g'$  be a group inverse of  $g$ . If  $gx = gy$ , then  $g'gx = g'gy$ , that is  $x = y$ . Similarly,  $xg = yg$  implies  $x = y$  and thus  $G$  is cancellative. In particular, if  $g'$  and  $g''$  are two group inverses of  $g$ ,  $gg' = gg''$  and thus  $g' = g''$ . Thus every element has a unique inverse.  $\square$

In a group, the unique group inverse of an element  $x$  is denoted by  $x^{-1}$  and is called the *inverse* of  $x$ . Thus  $xx^{-1} = x^{-1}x = 1$ . It follows that the equation  $gx = h$  [ $xg = h$ ] has a unique solution:  $x = g^{-1}h$  [ $x = hg^{-1}$ ].

## 1.4 Ordered semigroups and monoids

An *ordered semigroup* is a semigroup  $S$  equipped with an order relation  $\leq$  on  $S$  which is compatible with the product: for every  $x, y \in S$ , for every  $u, v \in S^1$   $x \leq y$  implies  $uxv \leq uyv$ .

The notation  $(S, \leq)$  will sometimes be used to emphasize the role of the order relation, but most of the time the order will be implicit and the notation  $S$  will be used for semigroups as well as for ordered semigroups. If  $(S, \leq)$  is an ordered semigroup, then  $(S, \geq)$  is also an ordered semigroup, called the *dual* of  $S$ . *Ordered monoids* are defined analogously.

## 1.5 Semirings

A *semiring* is a quintuple consisting of a set  $k$ , two binary operations on  $k$ , denoted additively and multiplicatively, and two elements 0 and 1, satisfying the following conditions:

- (1)  $k$  is a commutative monoid for the addition with identity 0,
- (2)  $k$  is a monoid for the multiplication with identity 1,
- (3) Multiplication is distributive over addition: for all  $s, t_1, t_2 \in k$ ,  $s(t_1 + t_2) = st_1 + st_2$  and  $(t_1 + t_2)s = t_1s + t_2s$ ,
- (4) for all  $s \in k$ ,  $0s = s0 = 0$ .

A *ring* is a semiring in which the monoid  $(k, +, 0)$  is a group. A semiring is *commutative* if its multiplication is commutative.

## 2 Examples

We give successively some examples of semigroups, monoids, groups, ordered monoids and semirings.

### 2.1 Examples of semigroups

- (1) The set  $\mathbb{N}_+$  of positive integers is a commutative semigroup for the usual addition of integers. It is also a commutative semigroup for the usual multiplication of integers.
- (2) Let  $I$  and  $J$  be two nonempty sets. Define an operation on  $I \times J$  by setting, for every  $(i, j), (i', j') \in I \times J$ ,

$$(i, j)(i', j') = (i, j')$$

This defines a semigroup, usually denoted by  $B(I, J)$ .

- (3) Let  $n$  be a positive integer. Let  $B_n$  be the set of all matrices of size  $n \times n$  with zero-one entries and at most one nonzero entry. Equipped with the usual multiplication of matrices,  $B_n$  is a semigroup. For instance,

$$B_2 = \left\{ \begin{pmatrix} 1 & 0 \\ 0 & 0 \end{pmatrix}, \begin{pmatrix} 0 & 1 \\ 0 & 0 \end{pmatrix}, \begin{pmatrix} 0 & 0 \\ 1 & 0 \end{pmatrix}, \begin{pmatrix} 0 & 0 \\ 0 & 1 \end{pmatrix}, \begin{pmatrix} 0 & 0 \\ 0 & 0 \end{pmatrix} \right\}$$

This semigroup is nicknamed the *universal counterexample* because it provides many counterexamples in semigroup theory. Setting  $a = \begin{pmatrix} 0 & 1 \\ 0 & 0 \end{pmatrix}$  and  $b = \begin{pmatrix} 0 & 0 \\ 1 & 0 \end{pmatrix}$ , one gets  $ab = \begin{pmatrix} 1 & 0 \\ 0 & 0 \end{pmatrix}$ ,  $ba = \begin{pmatrix} 0 & 0 \\ 0 & 1 \end{pmatrix}$  and  $0 = \begin{pmatrix} 0 & 0 \\ 0 & 0 \end{pmatrix}$ . Thus  $B_2 = \{a, b, ab, ba, 0\}$ . Furthermore, the relations  $aa = bb = 0$ ,  $aba = a$  and  $bab = b$  suffice to recover completely the multiplication in  $B_2$ .

- (4) Let  $S$  be a set. Define an operation on  $S$  by setting  $st = s$  for every  $s, t \in S$ . Then every element of  $S$  is a left zero, and  $S$  forms a *left zero semigroup*.
- (5) Let  $S$  be the semigroup of matrices of the form

$$\begin{pmatrix} a & 0 \\ b & 1 \end{pmatrix}$$

where  $a$  and  $b$  are positive rational numbers, under matrix multiplication. We claim that  $S$  is a cancellative semigroup without identity. Indeed, since

$$\begin{pmatrix} a & 0 \\ b & 1 \end{pmatrix} \begin{pmatrix} x & 0 \\ y & 1 \end{pmatrix} = \begin{pmatrix} ax & 0 \\ bx + y & 1 \end{pmatrix}$$

it follows that if

$$\begin{pmatrix} a & 0 \\ b & 1 \end{pmatrix} \begin{pmatrix} x_1 & 0 \\ y_1 & 1 \end{pmatrix} = \begin{pmatrix} a & 0 \\ b & 1 \end{pmatrix} \begin{pmatrix} x_2 & 0 \\ y_2 & 1 \end{pmatrix}$$

then  $ax_1 = ax_2$  and  $bx_1 + y_1 = bx_2 + y_2$ , whence  $x_1 = x_2$  and  $y_1 = y_2$ , which proves that  $S$  is left cancellative. The proof that  $S$  is right cancellative is dual.

- (6) If  $S$  is a semigroup, the set  $\mathcal{P}(S)$  of subsets of  $S$  is also a semigroup, for the multiplication defined, for every  $X, Y \in \mathcal{P}(S)$ , by

$$XY = \{xy \mid x \in X, y \in Y\}$$

## 2.2 Examples of monoids

- (1) The trivial monoid, denoted by  $1$ , consists of a single element, the identity.
- (2) The set  $\mathbb{N}$  of nonnegative integers is a commutative monoid for the addition, whose identity is  $0$ . It is also a commutative monoid for the max operation, whose identity is also  $0$  and for the multiplication, whose identity is  $1$ .
- (3) The monoid  $U_1 = \{1, 0\}$  defined by its multiplication table  $1 * 1 = 1$  and  $0 * 1 = 0 * 0 = 1 * 0 = 0$ .
- (4) More generally, for each nonnegative integer  $n$ , the monoid  $U_n$  is defined on the set  $\{1, a_1, \dots, a_n\}$  by the operation  $a_i a_j = a_j$  for each  $i, j \in \{1, \dots, n\}$  and  $1 a_i = a_i 1 = a_i$  for  $1 \leq i \leq n$ .
- (5) The monoid  $\tilde{U}_n$  has the same underlying set as  $U_n$ , but the multiplication is defined in the opposite way:  $a_i a_j = a_i$  for each  $i, j \in \{1, \dots, n\}$  and  $1 a_i = a_i 1 = a_i$  for  $1 \leq i \leq n$ .
- (6) The monoid  $B_2^1$  is obtained from the semigroup  $B_2$  by adding an identity. Thus  $B_2^1 = \{1, a, b, ab, ba, 0\}$  where  $aba = a$ ,  $bab = b$  and  $aa = bb = 0$ .
- (7) The *bicyclic monoid* is the monoid  $M = \{(i, j) \mid (i, j) \in \mathbb{N}^2\}$  under the operation

$$(i, j)(i', j') = (i + i' - \min(j, i'), j + j' - \min(j, i'))$$

## 2.3 Examples of groups

- (1) The set  $\mathbb{Z}$  of integers is a commutative group for the addition, whose identity is  $0$ .
- (2) The set  $\mathbb{Z}/n\mathbb{Z}$  of integers modulo  $n$ , under addition is also a commutative group.
- (3) The set of  $2 \times 2$  matrices with entries in  $\mathbb{Z}$  and determinant  $\pm 1$  is a group under the usual multiplication of matrices. This group is denoted by  $GL_2(\mathbb{Z})$ .

## 2.4 Examples of ordered monoids

- (1) Every monoid can be equipped with the equality order, which is compatible with the product. It is actually often convenient to consider a monoid  $M$  as the ordered monoid  $(M, =)$ .
- (2) The natural order on nonnegative integers is compatible with addition and with the max operation. Thus  $(\mathbb{N}, +, \leq)$  and  $(\mathbb{N}, \max, \leq)$  are both ordered monoids.
- (3) We denote by  $U_1^+ [U_1^-]$  the monoid  $U_1 = \{1, 0\}$  ordered by  $0 < 1$  [ $1 < 0$ ].

## 2.5 Examples of semirings

- (1) Rings are the first examples of semirings that come to mind. In particular, we denote by  $\mathbb{Z}$ ,  $\mathbb{Q}$  and  $\mathbb{R}$ , respectively, the rings of integers, rational and real numbers.

- (2) The simplest example of a semiring which is not a ring is the *Boolean semiring*  $\mathbb{B} = \{0, 1\}$  whose operations are defined by the following tables

+	0	1
0	0	1
1	1	1

×	0	1
0	0	0
1	0	1

- (3) If  $M$  is a monoid, then the set  $\mathcal{P}(M)$  of subsets of  $M$  is a semiring with union as addition and multiplication given by

$$XY = \{xy \mid x \in X \text{ and } y \in Y\}$$

The empty set is the zero and the unit is the singleton  $\{1\}$ .

- (4) Other examples include the semiring of nonnegative integers  $\mathbb{N} = (\mathbb{N}, +, \times)$  and its completion  $\mathcal{N} = (\mathbb{N} \cup \{\infty\}, +, \times)$ , where addition and multiplication are extended in the natural way

$$\begin{aligned} \text{for all } x \in \mathcal{N}, \quad x + \infty &= \infty + x = \infty \\ \text{for all } x \in \mathcal{N} - \{0\}, \quad x \times \infty &= \infty \times x = \infty \\ \infty \times 0 &= 0 \times \infty = 0 \end{aligned}$$

- (5) The Min-Plus semiring is  $\mathcal{M} = (\mathbb{N} \cup \{\infty\}, \min, +)$ . This means that in this semiring the sum is defined as the minimum and the product as the usual addition. Note that  $\infty$  is the zero of this semiring and 0 is its unit.

### 3 Basic algebraic structures

#### 3.1 Morphisms

On a general level, a morphism between two algebraic structures is a map preserving the operations. Therefore a *semigroup morphism* is a map  $\varphi$  from a semigroup  $S$  into a semigroup  $T$  such that, for every  $s_1, s_2 \in S$ ,

$$(1) \quad \varphi(s_1 s_2) = \varphi(s_1) \varphi(s_2).$$

Similarly, a *monoid morphism* is a map  $\varphi$  from a monoid  $S$  into a monoid  $T$  satisfying (1) and

$$(2) \quad \varphi(1) = 1.$$

A *morphism of ordered monoids* is a map  $\varphi$  from an ordered monoid  $(S, \leq)$  into a monoid  $(T, \leq)$  satisfying (1), (2) and, for every  $s_1, s_2 \in S$  such that  $s_1 \leq s_2$ ,

$$(3) \quad \varphi(s_1) \leq \varphi(s_2).$$

Formally, a *group morphism* between two groups  $G$  and  $G'$  is a monoid morphism  $\varphi$  satisfying, for every  $s \in G$ ,  $\varphi(s^{-1}) = \varphi(s)^{-1}$ . In fact, this condition can be relaxed.

**Proposition 3.6** *Let  $G$  and  $G'$  be groups. Then any semigroup morphism from  $G$  to  $G'$  is a group morphism.*

**Proof.** Let  $\varphi : G \rightarrow G'$  be a semigroup morphism. Then by (1),  $\varphi(1) = \varphi(1)\varphi(1)$  and thus  $\varphi(1) = 1$  since 1 is the unique idempotent of  $G'$ . Thus  $\varphi$  is a monoid morphism. Further,  $\varphi(s^{-1})\varphi(s) = \varphi(s^{-1}s) = \varphi(1) = 1$  and similarly  $\varphi(s)\varphi(s^{-1}) = \varphi(ss^{-1}) = \varphi(1) = 1$ .  $\square$

A *semiring morphism* between two semirings  $k$  and  $k'$  is a map  $\varphi : k \rightarrow k'$  which is a monoid morphism for the additive structure and for the multiplicative structure.

The semigroups [monoids, groups, ordered monoids, semirings], together with the morphisms defined above, form a category. We shall encounter in Chapter XIII another interesting category whose objects are semigroups and whose morphisms are called *relational morphisms*.

A morphism  $\varphi : S \rightarrow T$  is an *isomorphism* if there exists a morphism  $\psi : T \rightarrow S$  such that  $\varphi \circ \psi = Id_T$  and  $\psi \circ \varphi = Id_S$ .

**Proposition 3.7** *In the category of semigroups [monoids, groups, semirings], a morphism is an isomorphism if and only if it is bijective.*

**Proof.** If  $\varphi : S \rightarrow T$  an isomorphism, then  $\varphi$  is bijective since there exists a morphism  $\psi : T \rightarrow S$  such that  $\varphi \circ \psi = Id_T$  and  $\psi \circ \varphi = Id_S$ .

Suppose now that  $\varphi : S \rightarrow T$  is a bijective morphism. Then  $\varphi^{-1}$  is a morphism from  $T$  into  $S$ , since, for each  $x, y \in T$ ,

$$\varphi(\varphi^{-1}(x)\varphi^{-1}(y)) = \varphi(\varphi^{-1}(x))\varphi(\varphi^{-1}(y)) = xy$$

Thus  $\varphi$  is an isomorphism.  $\square$

Proposition 3.7 does not hold for morphisms of ordered monoids. In particular, if  $(M, \leq)$  is an ordered monoid, the identity induces a bijective morphism from  $(M, =)$  onto  $(M, \leq)$  which is not in general an isomorphism. In fact, a morphism of ordered monoids  $\varphi : M \rightarrow N$  is an isomorphism if and only if  $\varphi$  is a bijective monoid morphism and, for every  $x, y \in M$ ,  $x \leq y$  is equivalent with  $\varphi(x) \leq \varphi(y)$ .

Two semigroups [monoids, ordered monoids] are *isomorphic* if there exists an isomorphism from one to the other. As a general rule, we shall identify two isomorphic semigroups.

### 3.2 Subsemigroups

A *subsemigroup* of a semigroup  $S$  is a subset  $T$  of  $S$  such that  $s_1 \in T$  and  $s_2 \in T$  imply  $s_1s_2 \in T$ . A *submonoid* of a monoid is a subsemigroup containing the identity. A *subgroup* of a group is a submonoid containing the inverse of each of its elements.

A subsemigroup  $G$  of a semigroup  $S$  is said to be a *group in  $S$*  if there is an idempotent  $e \in G$  such that  $G$ , under the operation of  $S$ , is a group with identity  $e$ .

**Proposition 3.8** *Let  $\varphi : S \rightarrow T$  be a semigroup morphism. If  $S'$  is a subsemigroup of  $S$ , then  $\varphi(S')$  is a subsemigroup of  $T$ . If  $T'$  is a subsemigroup of  $T$ , then  $\varphi^{-1}(T')$  is a subsemigroup of  $S$ .*

**Proof.** Let  $t_1, t_2 \in \varphi(S')$ . Then  $t_1 = \varphi(s_1)$  and  $t_2 = \varphi(s_2)$  for some  $s_1, s_2 \in S'$ . Since  $S'$  is a subsemigroup of  $S$ ,  $s_1s_2 \in S'$  and thus  $\varphi(s_1s_2) \in \varphi(S')$ . Now since  $\varphi$  is a morphism,  $\varphi(s_1s_2) = \varphi(s_1)\varphi(s_2) = t_1t_2$ . Thus  $t_1t_2 \in \varphi(S')$  and  $\varphi(S')$  is a subsemigroup of  $T$ .



Let  $s_1, s_2 \in \varphi^{-1}(T')$ . Then  $\varphi(s_1), \varphi(s_2) \in T'$  and since  $T'$  is a subsemigroup of  $T$ ,  $\varphi(s_1)\varphi(s_2) \in T'$ . Since  $\varphi$  is a morphism,  $\varphi(s_1)\varphi(s_2) = \varphi(s_1s_2)$  and thus  $s_1s_2 \in \varphi^{-1}(T')$ . Therefore  $\varphi^{-1}(T')$  is a subsemigroup of  $S$ .  $\square$

Proposition 3.8 can be summarized as follows: *substructures are preserved by morphisms and by inverses of morphisms*. A similar statement holds for monoid morphisms and for group morphisms.

### 3.3 Quotients and divisions

Let  $S$  and  $T$  be two semigroups [monoids, groups, ordered monoids]. Then  $T$  is a *quotient* of  $S$  if there exists a surjective morphism from  $S$  onto  $T$ .

Note that any ordered monoid  $(M, \leq)$  is a quotient of the ordered monoid  $(M, =)$ , since the identity on  $M$  is a morphism of ordered monoid from  $(M, =)$  onto  $(M, \leq)$ .

Finally, a semigroup  $T$  *divides* a semigroup  $S$  (notation  $T \preceq S$ ) if  $T$  is a quotient of a subsemigroup of  $S$ .

**Proposition 3.9** *The division relation is transitive.*

**Proof.** Suppose that  $S_1 \preceq S_2 \preceq S_3$ . Then there exists a subsemigroup  $T_1$  of  $S_2$ , a subsemigroup  $T_2$  of  $S_3$  and surjective morphisms  $\pi_1 : T_1 \rightarrow S_1$  and  $\pi_2 : T_2 \rightarrow S_2$ . Put  $T = \pi_2^{-1}(T_1)$ . Then  $T$  is a subsemigroup of  $S_3$  and  $S_1$  is a quotient of  $T$  since  $\pi_1(\pi_2(T)) = \pi_1(T_1) = S_1$ . Thus  $S_1$  divides  $S_3$ .  $\square$

The next proposition shows that division is a partial order on finite semigroups, up to isomorphism.

**Proposition 3.10** *Two finite semigroups that divide each other are isomorphic.*

**Proof.** We keep the notation of the proof of Proposition 3.9, with  $S_3 = S_1$ . Since  $T_1$  is a subsemigroup of  $S_2$  and  $T_2$  is a subsemigroup of  $S_1$ , one has  $|T_1| \leq |S_2|$  and  $|T_2| \leq |S_1|$ . Furthermore, since  $\pi_1$  and  $\pi_2$  are surjective,  $|S_1| \leq |T_1|$  and  $|S_2| \leq |T_2|$ . It follows that  $|S_1| = |T_1| = |S_2| = |T_2|$ , whence  $T_1 = S_2$  and  $T_2 = S_1$ . Furthermore,  $\pi_1$  and  $\pi_2$  are bijections and thus  $S_1$  and  $S_2$  are isomorphic.  $\square$

The term *division* stems from a property of finite groups, usually known as Lagrange's theorem. The proof is omitted but is not very difficult and can be found in any textbook on finite groups.

**Proposition 3.11 (Lagrange)** *Let  $G$  and  $H$  be finite groups. If  $G$  divides  $H$ , then  $|G|$  divides  $|H|$ .*

The use of the term *division* in semigroup theory is much more questionable since Lagrange's theorem does not extend to finite semigroups. However, this terminology is universally accepted and we shall stick to it.

Let us mention a few useful consequences of Lagrange's theorem.

**Proposition 3.12** *Let  $G$  be a finite group. Then, for each  $g \in G$ ,  $g^{|G|} = 1$ .*

**Proof.** Consider the set  $H$  of all powers of  $g$ . Since  $G$  is finite, two powers, say  $g^p$  and  $g^q$  with  $q > p$ , are equal. Since  $G$  is a group, it follows that  $g^{q-p} = 1$ . Let  $r$  be the smallest positive integer such that  $g^r = 1$ . Then  $H = \{1, g, \dots, g^{r-1}\}$  is a cyclic group and by Lagrange's theorem,  $|G| = rs$  for some positive integer  $s$ . It follows that  $g^{|G|} = (g^r)^s = 1^s = 1$ .  $\square$

**Proposition 3.13** *A nonempty subsemigroup of a finite group is a subgroup.*

**Proof.** Let  $G$  be a finite group and let  $S$  be a nonempty subsemigroup of  $G$ . Let  $s \in S$ . By Proposition 3.12,  $s^{|G|} = 1$ . Thus  $1 \in S$ . Consider now the map  $\varphi : S \rightarrow S$  defined by  $\varphi(x) = xs$ . It is injective, for  $G$  is right cancellative, and hence bijective by Proposition I.1.7. Consequently, there exists an element  $s'$  such that  $s's = 1$ . Thus every element has a left inverse and by Proposition 1.4,  $S$  is a group.  $\square$

### 3.4 Products

Given a family  $(S_i)_{i \in I}$  of semigroups [monoids, groups], the *product*  $\prod_{i \in I} S_i$  is the semigroup [monoid, group] defined on the cartesian product of the sets  $S_i$  by the operation

$$(s_i)_{i \in I} (s'_i)_{i \in I} = (s_i s'_i)_{i \in I}$$

Note that the semigroup  $1$  is the identity for the product of semigroups [monoids, groups]. Following a usual convention, which can also be justified in the framework of category theory, we put  $\prod_{i \in \emptyset} S_i = 1$ .

Given a family  $(M_i)_{i \in I}$  of ordered monoids, the product  $\prod_{i \in I} M_i$  is naturally equipped with the order

$$(s_i)_{i \in I} \leq (s'_i)_{i \in I} \text{ if and only if, for all } i \in I, s_i \leq s'_i.$$

The resulting ordered monoid is the product of the ordered monoids  $(M_i)_{i \in I}$ .

The next proposition, whose proof is obvious, shows that product preserves substructures, quotients and division. We state it for semigroups, but it can be readily extended to monoids and to ordered semigroups or monoids.

**Proposition 3.14** *Let  $(S_i)_{i \in I}$  and  $(T_i)_{i \in I}$  be two families of semigroups such that, for each  $i \in I$ ,  $S_i$  is a subsemigroup [quotient, divisor] of  $T_i$ . Then  $\prod_{i \in I} S_i$  is a subsemigroup of [quotient, divisor] of  $\prod_{i \in I} T_i$ .*

### 3.5 Ideals

Let  $S$  be a semigroup. A *right ideal* of  $S$  is a subset  $R$  of  $S$  such that  $RS \subseteq R$ . Thus  $R$  is a right ideal if, for each  $r \in R$  and  $s \in S$ ,  $rs \in R$ . Symmetrically, a *left ideal* is a subset  $L$  of  $S$  such that  $SL \subseteq L$ . An *ideal* is a subset of  $S$  which is simultaneously a right and a left ideal.

Observe that a subset  $I$  of  $S$  is an ideal if and only if, for every  $s \in I$  and  $x, y \in S^1$ ,  $xsy \in I$ . Here, the use of  $S^1$  instead of  $S$  allows to include the cases  $x = 1$  and  $y = 1$ , which are necessary to recover the conditions  $SI \subseteq S$  and  $IS \subseteq I$ . Slight variations on the definition are therefore possible:

- (1)  $R$  is a right ideal if and only if  $RS^1 \subseteq R$  or, equivalently,  $RS^1 = R$ ,
- (2)  $L$  is a left ideal if and only if  $S^1L \subseteq L$  or, equivalently,  $S^1L = L$ ,

(3)  $I$  is an ideal if and only if  $S^1IS^1 \subseteq I$  or, equivalently,  $S^1IS^1 = I$ .

Note that any intersection of ideals [right ideals, left ideals] of  $S$  is again an ideal [right ideal, left ideal].

Let  $R$  be a subset of a semigroup  $S$ . The ideal [right ideal, left ideal] *generated* by  $R$  is the set  $S^1RS^1$  [ $RS^1$ ,  $S^1R$ ]. It is the smallest ideal [right ideal, left ideal] containing  $R$ . An ideal [right ideal, left ideal] is called *principal* if it is generated by a single element. Note that the ideal [right ideal, left ideal] generated by an idempotent  $e$  is equal to  $SeS$  [ $eS$ ,  $Se$ ]. Indeed, the equality  $S^1eS^1 = SeS$  follows from the fact that  $e = eee$ .

Ideals are stable under surjective morphisms and inverse of morphisms.

**Proposition 3.15** *Let  $\varphi : S \rightarrow T$  be a semigroup morphism. If  $J$  is an ideal of  $T$ , then  $\varphi^{-1}(J)$  is a ideal of  $S$ . Furthermore, if  $\varphi$  is surjective and  $I$  is an ideal of  $S$ , then  $\varphi(I)$  is an ideal of  $T$ . Similar results apply to right and left ideals.*

**Proof.** If  $J$  is an ideal of  $T$ , then

$$S^1\varphi^{-1}(J)S^1 \subseteq \varphi^{-1}(T^1)\varphi^{-1}(J)\varphi^{-1}(T^1) \subseteq \varphi^{-1}(T^1JT^1) \subseteq \varphi^{-1}(J)$$

Thus  $\varphi^{-1}(J)$  is an ideal of  $S$ .

Suppose that  $\varphi$  is surjective. If  $I$  is an ideal of  $S$ , then

$$T^1\varphi(I)T^1 = \varphi(S^1)\varphi(I)\varphi(S^1) = \varphi(S^1IS^1) = \varphi(I)$$

Thus  $\varphi(I)$  is an ideal of  $T$ .  $\square$

Let, for  $1 \leq k \leq n$ ,  $I_k$  be an ideal of a semigroup  $S$ . The set

$$I_1I_2 \cdots I_n = \{s_1s_2 \cdots s_n \mid s_1 \in I_1, s_2 \in I_2, \dots, s_n \in I_n\}$$

is the *product* of the ideals  $I_1, \dots, I_n$ .

**Proposition 3.16** *The product of the ideals  $I_1, \dots, I_n$  is an ideal contained in their intersection.*

**Proof.** Since  $I_1$  and  $I_n$  are ideals,  $S^1I_1 = I_1$  and  $I_nS^1 = I_n$ . Therefore

$$S^1(I_1I_2 \cdots I_n)S^1 = (S^1I_1)I_2 \cdots (I_nS^1) = I_1I_2 \cdots I_n$$

and thus  $I_1I_2 \cdots I_n$  is an ideal. Furthermore, for  $1 \leq k \leq n$ ,  $I_1I_2 \cdots I_n \subseteq S^1I_kS^1 = I_k$ . Thus  $I_1I_2 \cdots I_n$  is contained in  $\bigcap_{1 \leq k \leq n} I_k$ .  $\square$

A nonempty ideal  $I$  of a semigroup  $S$  is called *minimal* if, for every nonempty ideal  $J$  of  $S$ ,  $J \subseteq I$  implies  $J = I$ .

**Proposition 3.17** *A semigroup has at most one minimal ideal.*

**Proof.** Let  $I_1$  and  $I_2$  be two minimal ideals of a semigroup  $S$ . Then by Proposition 3.16,  $I_1I_2$  is a nonempty ideal of  $S$  contained in  $I_1 \cap I_2$ . Now since  $I_1$  and  $I_2$  are minimal ideals,  $I_1I_2 = I_1 = I_2$ .  $\square$

The existence of a minimal ideal is assured in two important cases, namely if  $S$  is finite or if  $S$  possesses a zero. In the latter case,  $0$  is the minimal ideal. A nonempty ideal  $I \neq 0$  such that, for every nonempty ideal  $J$  of  $S$ ,  $J \subseteq I$  implies  $J = 0$  or  $J = I$  is called a *0-minimal ideal*. It should be noted that a semigroup may have several 0-minimal ideals as shown in the next example.

**Example 3.1** Let  $S = \{s, t, 0\}$  be the semigroup defined by  $xy = 0$  for every  $x, y \in S$ . Then  $0$  is the minimal ideal of  $S$  and  $\{s, 0\}$  and  $\{t, 0\}$  are two  $0$ -minimal ideals.

### 3.6 Simple and $0$ -simple semigroups

A semigroup  $S$  is called *simple* if its only ideals are  $\emptyset$  and  $S$ . It is called  *$0$ -simple* if it has a zero, denoted by  $0$ , if  $S^2 \neq \{0\}$  and if  $\emptyset, 0$  and  $S$  are its only ideals. The notions of *right simple*, *right  $0$ -simple*, *left simple* and *left  $0$ -simple* semigroups are defined analogously.

**Lemma 3.18** *Let  $S$  be a  $0$ -simple semigroup. Then  $S^2 = S$ .*

**Proof.** Since  $S^2$  is a nonempty, nonzero ideal, one has  $S^2 = S$ .  $\square$

#### Proposition 3.19

- (1) *A semigroup  $S$  is simple if and only if  $SsS = S$  for every  $s \in S$ .*
- (2) *A semigroup  $S$  is  $0$ -simple if and only if  $S \neq \emptyset$  and  $SsS = S$  for every  $s \in S - 0$ .*

**Proof.** We shall prove only (2), but the proof of (1) is similar.

Let  $S$  be a  $0$ -simple semigroup. Then  $S^2 = S$  by Lemma 3.18 and hence  $S^3 = S$ .

Let  $I$  be set of the elements  $s$  of  $S$  such that  $SsS = 0$ . This set is an ideal of  $S$  containing  $0$  but not equal to  $S$ , since  $\bigcup_{s \in S} SsS = S^3 = S$ . Therefore  $I = 0$ . In particular, if  $s \neq 0$ , then  $SsS \neq 0$ , and since  $SsS$  is an ideal of  $S$ , it follows that  $SsS = S$ .

Conversely, if  $S \neq \emptyset$  and  $SsS = S$  for every  $s \in S - 0$ , we have  $S = SsS \subseteq S^2$  and therefore  $S^2 \neq 0$ . Furthermore, if  $J$  is a nonzero ideal of  $S$ , it contains an element  $s \neq 0$ . We then have  $S = SsS \subseteq SJS = J$ , whence  $S = J$ . Therefore  $S$  is  $0$ -simple.  $\square$

The structure of simple semigroups will be detailed in Section 3.

### 3.7 Semigroup congruences

A *semigroup congruence* is a stable equivalence relation. Thus an equivalence relation  $\sim$  on a semigroup  $S$  is a congruence if, for each  $s, t \in S$  and  $u, v \in S^1$ , we have

$$s \sim t \text{ implies } usv \sim utv.$$

The set  $S/\sim$  of equivalence classes of the elements of  $S$  is naturally equipped with a structure of semigroup, and the function which maps every element onto its equivalence class is a semigroup morphism from  $S$  onto  $S/\sim$ . Four particular cases of congruences are extensively used.

#### (a) Rees congruence

Let  $I$  be an ideal of a semigroup  $S$  and let  $\equiv_I$  be the equivalence relation identifying all the elements of  $I$  and separating the other elements. Formally,  $s \equiv_I t$  if and only if  $s = t$  or  $s, t \in I$ . Then  $\equiv_I$  is a congruence called the *Rees congruence of  $I$* . The quotient of  $S$  by  $\equiv_I$  is usually denoted by  $S/I$ . The

support of this semigroup is the set  $(S - I) \cup 0$  and the multiplication (here denoted  $*$ ) is defined by

$$s * t = \begin{cases} st & \text{if } s, t \in S - I \\ 0 & \text{if } s = 0 \text{ or } t = 0. \end{cases}$$

Let us mention a useful decomposition result:

(b) *Syntactic congruence*

Let  $P$  be a subset of a semigroup  $S$ . The *syntactic congruence* of  $P$  is the congruence  $\sim_P$  over  $S$  defined by  $s \sim_P t$  if and only if, for every  $x, y \in S^1$ ,

$$xsy \in P \iff xty \in P$$

The quotient semigroup  $S/\sim_P$  is called the *syntactic semigroup* of  $P$  in  $S$ . The syntactic semigroup is particularly important in the theory of formal languages.

(c) *Congruence generated by a relation*

Let  $R$  be a relation on  $S$ , that is, a subset of  $S \times S$ . The set of all congruences containing  $R$  is nonempty since it contains the universal relation on  $S$ . Further, it is closed under intersection. It follows that the intersection of all congruences containing  $R$  is a congruence, called the *congruence generated by  $R$* . Let us give a more constructive definition.

**Proposition 3.20** *The congruence generated by a relation  $R$  on a semigroup  $S$  is the reflexive-transitive closure of the relation*

$$\{(xry, xsy) \mid (r, s) \in R \text{ and } x, y \in S^1\}$$

**Proof.** If a congruence contains  $R$ , it certainly contains the relation

$$\bar{R} = \{(xry, xsy) \mid (r, s) \in R \text{ and } x, y \in S^1\}$$

and hence its reflexive-transitive closure  $\bar{R}^*$ . Therefore, it suffices to show that  $\bar{R}^*$  is a congruence. Let  $(u, v) \in \bar{R}^*$ . By definition, there exists a finite sequence  $u = u_0, u_1, \dots, u_n = v$  such that, for  $0 \leq i \leq n - 1$

$$(u_0, u_1) \in \bar{R}, (u_1, u_2) \in \bar{R}, \dots, (u_{n-1}, u_n) \in \bar{R}$$

Therefore, one has, for some  $x_i, y_i, r_i, s_i \in S$  such that  $(r_i, s_i) \in R$ ,

$$\begin{aligned} (u_0, u_1) &= (x_0 r_0 y_0, x_0 s_0 y_0), (u_1, u_2) = (x_1 r_1 y_1, x_1 s_1 y_1), \dots, \\ (u_{n-1}, u_n) &= (x_{n-1} r_{n-1} y_{n-1}, x_{n-1} s_{n-1} y_{n-1}) \end{aligned}$$

Let now  $x, y \in S^1$ . Now, the relations

$$(x u_i y, x u_{i+1} y) = (x x_i r_i y_i y, x x_i s_i y_i y) \in \bar{R} \quad (0 \leq i \leq n - 1)$$

show that  $(x u y, x v y) \in \bar{R}^*$ . Thus  $\bar{R}^*$  is a congruence.  $\square$

(d) *Nuclear congruence*

For each semigroup morphism  $\varphi : S \rightarrow T$ , the equivalence  $\sim_\varphi$  defined on  $S$  by

$$x \sim_\varphi y \text{ if and only if } \varphi(x) = \varphi(y)$$

is a congruence. This congruence, called the *nuclear congruence* of  $\varphi$ , has the following standard property.

**Proposition 3.21 (First isomorphism theorem)** *Let  $\varphi : S \rightarrow T$  be a morphism of semigroups and let  $\pi : S \rightarrow S/\sim_\varphi$  be the quotient morphism. Then there exists a unique semigroup morphism  $\tilde{\varphi} : S/\sim_\varphi \rightarrow T$  such that  $\varphi = \tilde{\varphi} \circ \pi$ . Moreover,  $\tilde{\varphi}$  is an isomorphism from  $S/\sim_\varphi$  onto  $\varphi(S)$ .*

**Proof.** The situation is summed up in the following diagram:

$$\begin{array}{ccc} & S & \\ \pi \swarrow & & \searrow \varphi \\ S/\sim_\varphi & \xrightarrow{\tilde{\varphi}} & T \end{array}$$

Unicity is clear: if  $s$  is the  $\sim_\varphi$ -class of some element  $x$ , then necessarily

$$\tilde{\varphi}(s) = \varphi(x) \tag{3.1}$$

Furthermore, if  $x$  and  $y$  are arbitrary elements of  $s$ , then  $\varphi(x) = \varphi(y)$ . Therefore, there is a well-defined function  $\tilde{\varphi}$  defined by Formula (3.1). Moreover, if  $\pi(x_1) = s_1$  and  $\pi(x_2) = s_2$ , then  $\pi(x_1x_2) = s_1s_2$ , whence

$$\tilde{\varphi}(s_1)\tilde{\varphi}(s_2) = \varphi(x_1)\varphi(x_2) = \varphi(x_1x_2) = \tilde{\varphi}(s_1s_2)$$

Therefore  $\tilde{\varphi}$  is a morphism. We claim that  $\tilde{\varphi}$  is injective. Indeed, suppose that  $\tilde{\varphi}(s_1) = \tilde{\varphi}(s_2)$ , and let  $x_1 \in \pi^{-1}(s_1)$  and  $x_2 \in \pi^{-1}(s_2)$ . Then  $\varphi(x_1) = \varphi(x_2)$  and thus  $x_1 \sim_\varphi x_2$ . It follows that  $\pi(x_1) = \pi(x_2)$ , that is,  $s_1 = s_2$ . Thus  $\tilde{\varphi}$  induces an isomorphism from  $S/\sim_\varphi$  onto  $\varphi(S)$ .  $\square$

When two congruences are comparable, the quotient structures associated with them can also be compared.

**Proposition 3.22 (Second isomorphism theorem)** *Let  $\sim_1$  and  $\sim_2$  be two congruences on a semigroup  $S$  and  $\pi_1$  [ $\pi_2$ ] the canonical morphism from  $S$  onto  $S/\sim_1$  [ $S/\sim_2$ ]. If  $\sim_2$  is coarser than  $\sim_1$ , there exists a unique surjective morphism  $\pi : S/\sim_1 \rightarrow S/\sim_2$  such that  $\pi \circ \pi_1 = \pi_2$ .*

**Proof.** Since  $\pi \circ \pi_1 = \pi_2$ , Corollary I.1.13 shows that  $\pi$  is necessarily equal to the relation  $\pi_2 \circ \pi_1^{-1}$ . Furthermore, Proposition I.1.15 shows that this relation is actually a function.

Since  $\pi_1$  and  $\pi_2$  are morphisms,

$$\pi(\pi_1(s)\pi_1(t)) = \pi(\pi_1(st)) = \pi_2(st) = \pi_2(s)\pi_2(t) = \pi(\pi_1(s))\pi(\pi_1(t))$$

and thus  $\pi$  is a morphism.  $\square$

**Proposition 3.23** *Let  $S$  be a semigroup,  $(\sim_i)_{i \in I}$  be a family of congruences on  $S$  and  $\sim$  be the intersection of these congruences. Then the semigroup  $S/\sim$  is isomorphic to a subsemigroup of the product  $\prod_{i \in I} S/\sim_i$ .*

**Proof.** Denote by  $\pi_i : S \rightarrow S/\sim_i$  the projections and by  $\pi : S \rightarrow \prod_{i \in I} S/\sim_i$  the morphism defined by  $\pi(s) = (\pi_i(s))_{i \in I}$  for every  $s \in S$ . The nuclear congruence of  $\pi$  is equal to  $\sim$ , and thus, by Proposition 3.21,  $S/\sim$  is isomorphic to  $\pi(S)$ .  $\square$

**Corollary 3.24** *Let  $S$  be a finite semigroup with zero having (at least) two distinct 0-minimal ideals  $I_1$  and  $I_2$ . Then  $S$  is isomorphic to a subsemigroup of  $S/I_1 \times S/I_2$ .*

**Proof.** Under these assumptions, the intersection of  $I_1$  and  $I_2$  is 0 and thus the intersection of the Rees congruences  $\equiv_{I_1}$  and  $\equiv_{I_2}$  is the identity. It remains to apply Proposition 3.23 to conclude.  $\square$

(e) *Congruences of ordered semigroups*

Let  $(M, \leq)$  be an ordered monoid. A *congruence of ordered semigroup* on  $M$  is a stable preorder coarser than  $\leq$ . If  $\preceq$  is a congruence of ordered monoid, the equivalence  $\sim$  associated with  $\preceq$  is a semigroup congruence and the preorder  $\preceq$  induces a stable order relation on the quotient monoid  $S/\sim$ , that will also be denoted by  $\leq$ . Finally, the function which maps each element onto its equivalence class is a morphism of ordered monoids from  $M$  onto  $(M/\sim, \leq)$ .

## 4 Transformation semigroups

### 4.1 Definitions

A [partial] *transformation* on a set  $P$  is a [partial] function from  $P$  into itself. A *permutation* is a bijective transformation. For instance, if  $P = \{1, 2, 3\}$  and  $f$ ,  $g$  and  $h$  are defined in the table below, then  $f$  is a transformation,  $g$  is a partial transformation and  $h$  is permutation.

	1	2	3
$f$	2	1	2
$g$	-	2	3
$h$	1	2	3

Let  $P$  be a set and  $S$  be a semigroup. A *right action* from  $S$  on  $P$  is a map  $P \times S \rightarrow P$ , denoted  $(p, s) \mapsto p \cdot s$ , such that, for each  $s, t \in S$  and  $p \in P$ ,

$$(p \cdot s) \cdot t = p \cdot (st)$$

This condition implies that one may use the notation  $p \cdot st$  in the place of  $(p \cdot s) \cdot t$  or  $p \cdot (st)$  without any ambiguity. We will follow this convention in the sequel.

An action is *faithful* if the condition

$$\text{for all } p \in P, p \cdot s = p \cdot t$$

implies  $s = t$ . A *transformation semigroup* on  $P$  is a semigroup  $S$  equipped with a faithful action of  $S$  on  $P$ .

Given an action of  $S$  on  $P$ , the relation  $\sim$  defined on  $S$  by  $s \sim t$  if and only if

$$\text{for all } p \in P, p \cdot s = p \cdot t$$

is a congruence on  $S$  and the action of  $S$  on  $P$  induces a faithful action of  $S/\sim$  on  $P$ . The resulting transformation semigroup  $(P, S/\sim)$  is called the transformation semigroup induced by the action of  $S$  on  $P$ .

**Example 4.1** Each semigroup  $S$  defines a transformation semigroup  $(S^1, S)$ , given by the faithful action  $q \cdot s = qs$ .

**Example 4.2** Let  $R$  be a right-zero semigroup. By definition, the operation on  $R$  is defined by  $st = t$  for every  $s, t \in R$ . One can associate to  $R$  a transformation semigroup  $(R, R)$  defined by the action  $r \cdot s = s$  for every  $r, s \in R$ . In particular, if  $R = \{1, \dots, n\}$ , this transformation semigroup is usually denoted by  $\bar{\mathbf{n}}$ .

A transformation semigroup  $(P, S)$  is said to be *fixpoint-free* if, for every  $p \in P$  and every  $s \in S$ ,

$$p \cdot s = p \quad \text{implies} \quad s = s^2.$$

For instance, translations of the plane form a fixpoint-free transformation semigroup.

## 4.2 Full transformation semigroup and symmetric group

The *full transformation semigroup* on a set  $P$  is the semigroup  $\mathcal{T}(P)$  of all transformations on  $P$ . If  $P = \{1, \dots, n\}$ , the notation  $\mathcal{T}_n$  is also used. According to the definition of a transformation semigroup, the product of two transformations  $\alpha$  and  $\beta$  is the transformation  $\alpha\beta$  defined by  $p \cdot (\alpha\beta) = (p \cdot \alpha) \cdot \beta$ . At this stage, the reader should be warned that the product  $\alpha\beta$  is not equal to  $\alpha \circ \beta$ , but to  $\beta \circ \alpha$ . In other words, the operation on  $\mathcal{T}(P)$  is reverse composition.

The set of all partial transformations on  $P$  is also a semigroup, denoted by  $\mathcal{F}(P)$ . Finally, the *symmetric group* on a set  $P$  is the group  $\mathcal{S}(P)$  of all permutations on  $P$ . If  $P = \{1, \dots, n\}$ , the notations  $\mathcal{F}_n$  and  $\mathcal{S}_n$  are also used.

The importance of these examples stems from the following embedding results.

**Proposition 4.25** *Every semigroup  $S$  is isomorphic to a subsemigroup of the monoid  $\mathcal{T}(S^1)$ . In particular, every finite semigroup is isomorphic to a subsemigroup of  $\mathcal{T}_n$  for some  $n$ .*

**Proof.** Let  $S$  be a semigroup. We associate with each element  $s$  of  $S$  the transformation on  $S^1$ , also denoted by  $s$ , and defined, for each  $q \in S^1$ , by  $q \cdot s = qs$ . This defines an injective morphism from  $S$  into  $\mathcal{T}(S^1)$  and thus  $S$  is isomorphic to a subsemigroup of  $\mathcal{T}(S^1)$ .  $\square$

A similar proof leads to the following result, known as Cayley theorem.

**Theorem 4.26 (Cayley theorem)** *Every group  $G$  is isomorphic to a subgroup of  $\mathcal{S}(G)$ . In particular, every finite group is isomorphic to a subgroup of  $\mathcal{S}_n$  for some  $n$ .*

## 4.3 Product and division

Let  $(P_i, S_i)_{i \in I}$  be a family of transformation semigroups. The *product* of this family is the transformation semigroup  $(\prod_{i \in I} P_i, \prod_{i \in I} S_i)$ . The action is defined componentwise:

$$(p_i)_{i \in I} \cdot (s_i)_{i \in I} = (p_i \cdot s_i)_{i \in I}.$$



A transformation semigroup  $(P, S)$  *divides* a transformation semigroup  $(Q, T)$  if there exists a surjective partial function  $\pi: Q \rightarrow P$  and, for every  $s \in S$ , an element  $\hat{s} \in T$ , called a *cover* of  $s$ , such that, for each  $q \in \text{Dom}(\pi)$ ,  $\pi(q) \cdot s = \pi(q \cdot \hat{s})$ . The chosen terminology is justified by the following result.

**Proposition 4.27** *If  $(P, S)$  divides  $(Q, T)$ , then  $S$  divides  $T$ . If  $S$  divides  $T$ , then  $(S^1, S)$  divides  $(T^1, T)$ .*

**Proof.** If  $(P, S)$  divides  $(Q, T)$ , there exists a surjective partial function  $\pi: Q \rightarrow P$  such that every element  $s \in S$  has at least one cover. Furthermore, if  $\hat{s}_1$  is a cover of  $s_1$  and  $\hat{s}_2$  is a cover of  $s_2$ , then  $\hat{s}_1 \hat{s}_2$  is a cover of  $s_1 s_2$ , since, for each  $q \in \text{Dom}(\pi)$ ,

$$\pi(q) \cdot s_1 s_2 = \pi(q \cdot \hat{s}_1) \cdot s_2 = \pi((q \cdot \hat{s}_1) \cdot \hat{s}_2) = \pi(q \cdot \hat{s}_1 \hat{s}_2).$$

Therefore, the set of all covers of elements of  $S$  form a subsemigroup  $R$  of  $T$ . Furthermore, if two elements  $s_1$  and  $s_2$  have the same cover  $\hat{s}$ , then, for each  $q \in \text{Dom}(\pi)$ ,

$$\pi(q) \cdot s_1 = \pi(q \cdot \hat{s}) = \pi(q) \cdot s_2$$

Since  $\pi$  is surjective and the action of  $S$  is faithful, it follows  $s_1 = s_2$ . Therefore, there is a well-defined map  $\hat{s} \rightarrow s$  from  $R$  onto  $S$  and this map is a morphism.

Suppose now that  $S$  divides  $T$ . Then there exists a subsemigroup  $R$  of  $T$  and a surjective morphism  $\pi$  from  $R$  onto  $S$ , which can be extended to a surjective partial function from  $T^1$  onto  $S^1$ , by setting  $\pi(1) = 1$  if  $R$  is not a monoid. For each  $s \in S$ , choose an element  $\hat{s} \in \pi^{-1}(s)$ . Then, for every  $q \in R^1$ ,  $\pi(q \cdot \hat{s}) = \pi(q)s$  and thus  $(S^1, S)$  divides  $(T^1, T)$ .  $\square$

## 5 Generators

### 5.1 $A$ -generated semigroups

Given a subset  $A$  of a semigroup  $S$ , the subsemigroup of  $S$  *generated* by  $A$  is the smallest subsemigroup of  $S$  containing  $A$ . It is denoted by  $\langle A \rangle$  and consists of all products  $a_1 \cdots a_n$  of elements of  $A$ .

If  $S$  is a monoid, the *submonoid generated* by  $A$  is defined in a similar way, but it always contains the identity of  $S$ . Finally, if  $S$  is a group, the *subgroup generated* by  $A$  is the smallest subgroup of  $S$  containing  $A$ . It consists of all products of the form  $a_1 \cdots a_n$ , where each  $a_i$  is either an element of  $A$  or the inverse of an element of  $A$ .

A semigroup [monoid, group] generated by  $A$  is also called  *$A$ -generated*. For instance, the semigroup  $B_2$  is  $A$ -generated, with  $A = \{a, b\}$  and  $a = \begin{pmatrix} 0 & 1 \\ 0 & 0 \end{pmatrix}$  and  $b = \begin{pmatrix} 0 & 0 \\ 1 & 0 \end{pmatrix}$ .

A semigroup [monoid, group] is called *monogenic* if it is generated by a single element.

### 5.2 Cayley graphs

Given an  $A$ -generated monoid  $M$ , the *right Cayley graph* of  $M$  has  $M$  as set of vertices and the triples of the form  $(m, a, ma)$ , with  $m \in M$  and  $a \in A$ , as edges. The *left Cayley graph* of  $M$  has the same set of vertices, but the edges

are the triples of the form  $(m, a, am)$ , with  $m \in M$  and  $a \in A$ . Therefore the notion of Cayley graph depends on the given set of generators. However, it is a common practice to speak of the Cayley graph of a monoid when the set of generators is understood.

The right and left Cayley graphs of  $B_2^1$  are represented in Figure 5.1.

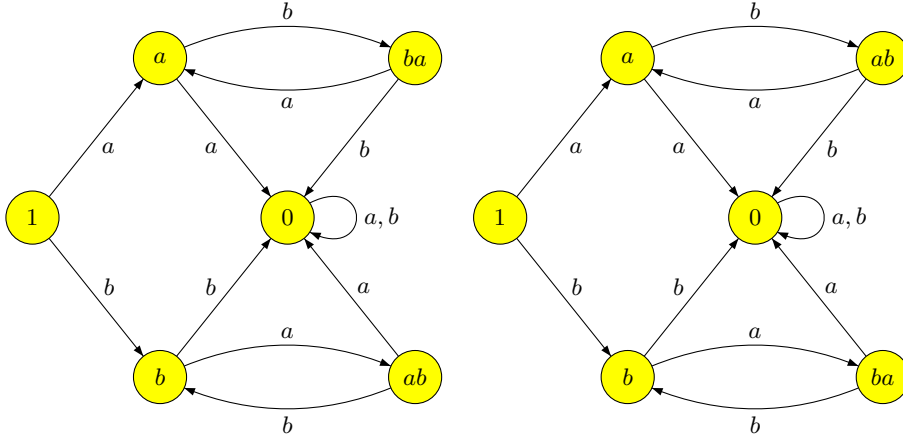

Figure 5.1. The left (on the left) and right (on the right) Cayley graph of  $B_2^1$ .

### 5.3 Free semigroups

Let  $A$  be a set called an *alphabet*, whose elements are called *letters*. A finite sequence of elements of  $A$  is called a *finite word* on  $A$ , or just a *word*. We denote by mere juxtaposition

$$a_0 a_1 \cdots a_n$$

the sequence  $(a_0, a_1, \dots, a_n)$ . The set of words is endowed with the operation of *concatenation product* also called *product*, which associates with two words  $x = a_0 a_1 \cdots a_p$  and  $y = b_0 b_1 \cdots b_q$  the word  $xy = a_0 a_1 \cdots a_p b_0 b_1 \cdots b_q$ . This operation is associative. It has an identity, the *empty word*, denoted by  $1$  or  $\varepsilon$ , which is the empty sequence.

We denote by  $A^*$  the set of words on  $A$  and by  $A^+$  the set of nonempty words. The set  $A^*$  [ $A^+$ ], equipped with the concatenation product is thus a monoid with identity  $1$  [a semigroup]. The set  $A^*$  is called the *free monoid* on  $A$  and  $A^+$  the *free semigroup* on  $A$ .

Let  $u = a_0 a_1 \cdots a_p$  be a word in  $A^*$  and let  $a$  be a letter of  $A$ . A nonnegative integer  $i$  is said to be an *occurrence* of the letter  $a$  in  $u$  if  $a_i = a$ . We denote by  $|u|_a$  the number of occurrences of  $a$  in  $u$ . Thus, if  $A = \{a, b\}$  and  $u = abaab$ , one has  $|u|_a = 3$  and  $|u|_b = 2$ . The sum

$$|u| = \sum_{a \in A} |u|_a$$

is the *length* of the word  $u$ . Thus  $|abaab| = 5$ .

## 5.4 Universal property

Free structures are defined in category theory by a so-called universal property. The next proposition, which shows that  $A^+ [A^*]$  satisfies this universal property, justifies our terminology.

**Proposition 5.28** *If  $\varphi$  is a function from  $A$  into a semigroup [monoid]  $S$ , there exists a unique semigroup [monoid] morphism  $\bar{\varphi} : A^+ \rightarrow S$  [ $A^* \rightarrow S$ ] such that, for each  $a \in A$ ,  $\bar{\varphi}(a) = \varphi(a)$ . Moreover,  $\bar{\varphi}$  is surjective if and only if the set  $\varphi(A)$  generates  $S$ .*

**Proof.** Define a mapping  $\bar{\varphi} : A^+ \rightarrow S$  by setting, for each word  $a_0 a_1 \cdots a_n$ ,

$$\bar{\varphi}(a_0 a_1 \cdots a_n) = \varphi(a_0) \varphi(a_1) \cdots \varphi(a_n)$$

One can easily verify that  $\bar{\varphi}$  is the required morphism. On the other hand, any morphism  $\bar{\varphi}$  such that  $\bar{\varphi}(a) = \varphi(a)$  for each  $a \in A$  must satisfy these two equalities, which shows it is unique.

By construction, the set  $\varphi(A)$  generates  $\bar{\varphi}(A)$ . Consequently, the morphism  $\bar{\varphi}$  is surjective if and only if the set  $\varphi(A)$  generates  $S$ .  $\square$

This result has several frequently used corollaries.

**Corollary 5.29** *Let  $S$  be a semigroup and let  $A$  be a subset of  $S$  generating  $S$ . The identity map from  $A$  into  $S$  induces a morphism of semigroups from  $A^+$  onto  $S$ .*

This morphism is called the *natural* morphism from  $A^+$  onto  $S$ .

**Corollary 5.30** *Let  $\eta : A^+ \rightarrow S$  be a morphism and  $\beta : T \rightarrow S$  be a surjective morphism. Then there exists a morphism  $\varphi : A^+ \rightarrow T$  such that  $\eta = \beta \circ \varphi$ .*

$$\begin{array}{ccc} A^+ & \xrightarrow{\varphi} & T \\ & \searrow \eta & \swarrow \beta \\ & & S \end{array}$$

**Proof.** Let us associate with each letter  $a \in A$  an element  $\varphi(a)$  of  $\beta^{-1}(\eta(a))$ . We thus define a function  $\varphi : A \rightarrow T$ , which, by Proposition 5.28, can be extended to a morphism  $\varphi : A^+ \rightarrow T$  such that  $\eta = \beta \circ \varphi$ .  $\square$

## 5.5 Presentations and rewriting systems

A *semigroup presentation* is a pair  $\langle A \mid R \rangle$ , where  $A$  is an alphabet and  $R$  a subset of  $A^+ \times A^+$ . The elements of  $A$  are called *generators* and the ones of  $R$ , *relations*. The semigroup *presented by*  $\langle A \mid R \rangle$  is the quotient of the free semigroup  $A^+$  by the congruence  $\sim_R$  generated by  $R$ . In other words, it is the semigroup generated by the set  $A$  submitted to the relations  $R$ . This intuitive meaning is suggested by the notation. Indeed  $\langle X \rangle$  traditionally denotes the

semigroup generated by a set  $X$  and the vertical bar used as a separator can be interpreted as “such that”, as in a definition like  $\{n \in \mathbb{N} \mid n \text{ is prime}\}$ .

By extension, a semigroup is said to be *defined by a presentation*  $\langle A \mid R \rangle$  if it is isomorphic to the semigroup presented by  $\langle A \mid R \rangle$ . Usually, we write  $u = v$  instead of  $(u, v) \in R$ .

*Monoid presentations* are defined analogously by replacing the free semigroup by the free monoid. In particular, relations of the form  $u = 1$  are allowed.

**Example 5.1** The monoid presented by  $\langle \{a, b\} \mid ab = ba \rangle$  is isomorphic to the additive monoid  $\mathbb{N}^2$ .

**Example 5.2** The monoid presented by  $\langle \{a, b\} \mid ab = 1 \rangle$  is the bicyclic monoid defined in Section 2.2.

## 6 Idempotents in finite semigroups

If  $S$  is a monogenic semigroup, generated by a single element  $x$ , the set  $S$  consists of the successive powers of  $x$ . If  $S$  is infinite, it is isomorphic to the additive semigroup of positive integers. If  $S$  is finite, there exist integers  $i, p > 0$  such that

$$x^{i+p} = x^i.$$

The minimal  $i$  and  $p$  with this property are called respectively the *index* and the *period* of  $x$ . The semigroup  $S$  then has  $i + p - 1$  elements and its multiplicative structure is represented in Figure 6.2.

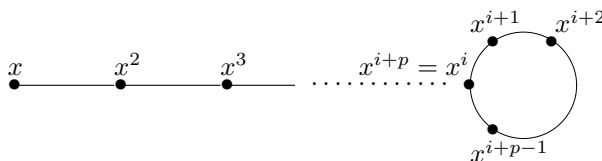

**Figure 6.2.** The semigroup generated by  $x$ .

The next result is a key property of finite semigroups.

**Proposition 6.31** *Each element of a finite semigroup has an idempotent power.*

**Proof.** Let  $i$  and  $p$  be the index and the period of an element  $x$ . Observe that, for  $k \geq i$ ,  $x^k = x^{k+p}$ . In particular, if  $k$  is a multiple of  $p$ , say  $k = qp$ , one has

$$(x^k)^2 = x^{2k} = x^{k+qp} = x^k$$

and thus  $x^k$  is idempotent. In fact, it is easy to see that the subsemigroup  $\{x^i, \dots, x^{i+p-1}\}$  is isomorphic to the additive group  $\mathbb{Z}/p\mathbb{Z}$ .  $\square$

Proposition 6.31 has two important consequences.

**Corollary 6.32** *Every nonempty finite semigroup contains at least one idempotent.*

**Proposition 6.33** *For each finite semigroup  $S$ , there exists an integer  $\omega$  such that, for each  $s \in S$ ,  $s^\omega$  is idempotent.*

**Proof.** By Proposition 6.31, every element  $s$  of  $S$  has an idempotent power  $s^{n_s}$ . Let  $n$  be the least common multiple of the  $n_s$ , for  $s \in S$ . Then  $s^n$  is idempotent for each  $s \in S$ .  $\square$

The least integer  $\omega$  satisfying the property stated in Proposition 6.33 is called the *exponent* of  $S$ .

Here is another elementary property connected with idempotents.

**Proposition 6.34** *Let  $S$  be a finite semigroup and let  $n = |S|$ . For every sequence  $s_1, \dots, s_n$  of  $n$  elements of  $S$ , there exists an index  $i \in \{1, \dots, n\}$  and an idempotent  $e \in S$  such that  $s_1 \cdots s_i e = s_1 \cdots s_i$ .*

**Proof.** Consider the sequence  $s_1, s_1 s_2, \dots, s_1 \cdots s_n$ . If these elements are all distinct, the sequence exhausts the elements of  $S$  and one of them, say  $s_1 \cdots s_i$ , is idempotent. The result is thus clear in this case. Otherwise, two elements of the sequence are equal, say  $s_1 \cdots s_i$  and  $s_1 \cdots s_j$  with  $i < j$ . Then we have

$$s_1 \cdots s_i = s_1 \cdots s_i (s_{i+1} \cdots s_j) = s_1 \cdots s_i (s_{i+1} \cdots s_j)^\omega$$

where  $\omega$  is the exponent of  $S$ . The proposition follows, since  $(s_{i+1} \cdots s_j)^\omega$  is idempotent.  $\square$

If  $S$  is a semigroup and  $n$  is a positive integer, we set

$$S^n = \{s_1 \cdots s_n \mid s_i \in S \text{ for } 1 \leq i \leq n\}$$

**Corollary 6.35** *Let  $S$  be a finite semigroup and let  $E(S)$  be the set of idempotents of  $S$ . Then for every  $n \geq |S|$ ,  $S^n = SE(S)S$ .*

Corollary 6.35 states that every sufficiently long sequence of elements of a finite semigroup contains a subsequence of consecutive elements whose product is idempotent. The proof of this result is elementary and relies mainly on the pigeon-hole principle. We shall now present a more difficult result whose proof rests on a celebrated combinatorial theorem, due to Ramsey, which we shall admit without proof.

An  $m$ -colouring of a set  $E$  is a function from  $E$  into  $\{1, \dots, m\}$ . An  $r$ -subset of  $E$  is a subset with  $r$  elements.

**Theorem 6.36 (Ramsey)** *Let  $r, k, m$  be integers satisfying  $k \geq r$ ,  $m > 0$ . Then there exists an integer  $N = R(r, k, m)$  such that for every finite set  $E$  having at least  $N$  elements and for every  $m$ -colouring of the set of the  $r$ -subsets of  $E$ , there exists a  $k$ -subset of  $E$  of which all  $r$ -subsets have the same colour.*

The next result clearly generalises Proposition 6.34.

**Theorem 6.37** *For each finite semigroup  $S$ , for each  $k > 0$ , there exists an integer  $N > 0$  such that, for every alphabet  $A$ , for every morphism  $\varphi : A^+ \rightarrow S$  and for every word  $w$  of  $A^+$  of length greater than or equal to  $N$ , there exists an idempotent  $e \in S$  and a factorisation  $w = xu_1 \cdots u_k y$  with  $x, y \in A^*$ ,  $u_1, \dots, u_k \in A^+$  and  $\varphi(u_1) = \dots = \varphi(u_k) = e$ .*

**Proof.** It suffices to prove the result for  $k \geq 2$ . Put  $N = R(2, k + 1, |S|)$  and let  $w$  be a word of length greater than or equal to  $N$ . Let  $w = a_1 \cdots a_N w'$ , where  $a_1, \dots, a_N$  are letters. We define a colouring into  $|S|$  colours of pairs of elements of  $\{1, \dots, N\}$  in the following way: the colour of  $\{i, j\}$ , where  $i < j$ , is the element  $\varphi(a_i \cdots a_{j-1})$  of  $S$ . According to Ramsey's theorem, one can find  $k + 1$  indices  $i_0 < i_1 < \cdots < i_k$  such that all the pairs of elements of  $\{i_0, \dots, i_k\}$  have the same colour  $e$ . Since we assume  $k \geq 2$ , one has in particular

$$\varphi(a_{i_0}) \cdots \varphi(a_{i_1-1}) = \varphi(a_{i_1}) \cdots \varphi(a_{i_2-1}) = \varphi(a_{i_0}) \cdots \varphi(a_{i_2-1})$$

whereby  $ee = e$ . Thus  $e$  is idempotent and we obtain the required factorisation by taking  $x = a_1 \cdots a_{i_0-1}$ ,  $u_j = a_{i_{j-1}} \cdots a_{i_j-1}$  for  $1 \leq j \leq k$  and  $y = a_{i_k} \cdots a_N w'$ .  $\square$

There are many quantifiers in the statement of Theorem 6.37, but their order is important. In particular, the integer  $N$  does not depend on the size of  $A$ , which can even be infinite.

**Proposition 6.38** *Let  $M$  be a finite monoid and let  $\pi : A^* \rightarrow M$  be a surjective morphism. For any  $n \geq 0$ , there exists  $N > 0$  and an idempotent  $e$  in  $M$  such that, for any  $u_0, u_1, \dots, u_N \in A^*$  there exists a sequence  $0 \leq i_0 < i_1 < \dots < i_n \leq N$  such that  $\pi(u_{i_0} u_{i_0+1} \cdots u_{i_1-1}) = \pi(u_{i_1} u_{i_1+1} \cdots u_{i_2-1}) = \dots = \pi(u_{i_{n-1}} \cdots u_{i_n-1}) = e$ .*

**Proof.** Let  $N = R(2, n + 1, |M|)$  and let  $u_0, u_1, \dots, u_N$  be words of  $A^*$ . Let  $E = \{1, \dots, N\}$ . We define a colouring into  $|M|$  colours of the 2-subsets of  $E$  in the following way: the colour of the 2-subset  $\{i, j\}$  (with  $i < j$ ) is the element  $\pi(u_i u_{i+1} \cdots u_{j-1})$  of  $M$ . According to Ramsey's theorem, one can find  $k + 1$  indices  $i_0 < i_1 < \cdots < i_k$  such that all the 2-subsets of  $\{i_0, \dots, i_k\}$  have the same colour. In particular, since  $k \geq 2$ , one gets

$$\begin{aligned} \pi(u_{i_0} u_{i_0+1} \cdots u_{i_1-1}) &= \pi(u_{i_1} u_{i_1+1} \cdots u_{i_2-1}) = \dots = \pi(u_{i_{n-1}} \cdots u_{i_n-1}) \\ &= \pi(u_{i_0} u_{i_0+1} \cdots u_{i_2-1}) \end{aligned}$$

Let  $e$  be the common value of these elements. It follows from the equalities  $\pi(u_{i_0} u_{i_0+1} \cdots u_{i_1-1}) = \pi(u_{i_1} u_{i_1+1} \cdots u_{i_2-1}) = \pi(u_{i_0} u_{i_0+1} \cdots u_{i_2-1})$  that  $ee = e$  and thus  $e$  is idempotent.  $\square$

There is also a uniform version of Theorem 6.37, which is more difficult to establish.

**Theorem 6.39** *For each finite semigroup  $S$ , for each  $k > 0$ , there exists an integer  $N > 0$  such that, for every alphabet  $A$ , for every morphism  $\varphi : A^+ \rightarrow S$  and for every word  $w$  of  $A^+$  of length greater than or equal to  $N$ , there exists an idempotent  $e \in S$  and a factorisation  $w = x u_1 \cdots u_k y$  with  $x, y \in A^*$ ,  $|u_1| = \dots = |u_k|$  and  $\varphi(u_1) = \dots = \varphi(u_k) = e$ .*

Let us conclude this section with an important combinatorial result of Imre Simon. A *factorisation forest* is a function  $F$  that associates with every word  $x$  of  $A^2 A^*$  a factorisation  $F(x) = (x_1, \dots, x_n)$  of  $x$  such that  $n \geq 2$  and  $x_1, \dots, x_n \in A^+$ . The integer  $n$  is the *degree* of the factorisation  $F(x)$ . Given a factorisation

forest  $F$ , the *height function* of  $F$  is the function  $h : A^* \rightarrow \mathbb{N}$  defined recursively by

$$h(x) = \begin{cases} 0 & \text{if } |x| \leq 1 \\ 1 + \max \{h(x_i) \mid 1 \leq i \leq n\} & \text{if } F(x) = (x_1, \dots, x_n) \end{cases}$$

The *height* of  $F$  is the least upper bound of the heights of the words of  $A^*$ .

Let  $M$  be a finite monoid and let  $\varphi : A^* \rightarrow M$  be a morphism. A factorisation forest  $F$  is *Ramseyan modulo*  $\varphi$  if, for every word  $x$  of  $A^2A^*$ ,  $F(x)$  is either of degree 2 or there exists an idempotent  $e$  of  $M$  such that  $F(x) = (x_1, \dots, x_n)$  and  $\varphi(x_1) = \varphi(x_2) = \dots = \varphi(x_n) = e$  for  $1 \leq i \leq n$ . The factorisation forest theorem was first proved by I. Simon in [98, 99, 100] and later improved in [16, 21, 22, 48]:

**Theorem 6.40** *Let  $\varphi$  be a morphism from  $A^*$  into a finite monoid  $M$ . There exists a factorisation forest of height  $\leq 3|M| - 1$  which is Ramseyan modulo  $\varphi$ .*

**Proof.** TO DO.  $\square$

## 7 Exercises

### Section 2

1. Show that, up to isomorphism, there are 5 semigroups of order 2. There are also 14 semigroups of order 3 and the number of semigroups of order  $\leq 8$  is known to be 1843120128...

### Section 3

2. Let  $I$  and  $J$  be ideals of a semigroup  $S$  such that  $I \subseteq J$ . Show that  $I$  is an ideal of  $J$ ,  $J/I$  is an ideal of  $S/I$  and  $(S/I)/(J/I) = S/J$ .

3. Let  $T$  be a semigroup and let  $R$  and  $S$  be subsemigroups of  $T$ .

- (1) Show that  $R \cup S$  is a subsemigroup of  $T$  if and only if  $RS \cup SR$  is a subset of  $R \cup S$ .
- (2) Show that this condition is satisfied if  $R$  and  $S$  are both left ideals or both right ideals, or if either  $R$  or  $S$  is an ideal.
- (3) Show that if  $R$  is an ideal of  $T$ , then  $S \cap R$  is an ideal of  $S$  and  $(S \cup R)/R = S/(S \cap R)$ .

4. (**Hickey**) Let  $M$  be a monoid and let  $m$  be an element of  $M$ .

- (1) Show that the operation  $\circ$  defined on the set  $mM \cap Mm$  by

$$xm \circ my = xmy$$

is well defined.

- (2) Show that  $(mM \cap Mm, \circ)$  is a monoid with identity  $m$  which divides  $M$ .

### Section 4

5. Show that, if  $n \geq 2$ ,  $\mathcal{T}_n$  is generated by the three functions  $a$ ,  $b$ , and  $c$  of the table below

1	1	2	3	...	$n-1$	$n$
$a$	2	3	4	...	$n$	1
$b$	2	1	3	...	$n-1$	$n$
$c$	1	2	3	...	$n-1$	1

An element  $s$  of  $\mathcal{T}_n$  is a function from  $\{1, \dots, n\}$  into itself. We define the *rank*  $r(s)$  of  $s$  to be  $|\text{Im}(s)|$  and the *defect* of  $s$  to be  $n - r(s)$ . For instance,  $a$  and  $b$  have rank  $n$  and defect 0 and  $c$  has rank  $n - 1$  and defect 1.

Show that if  $s$  is an element of  $\mathcal{T}_n$  of defect 1, then  $a$ ,  $b$  and  $s$  generate  $\mathcal{T}_n$ .

**6.** Let  $(P, S)$  be a transformation semigroup. Show that  $(P, S)$  divides  $(P, 1_P) \times (S^1, S)$ .

### Section 5

**7.** Show that the number of words of length  $n$  on a  $k$ -letter alphabet is  $k^n$ . Show that, if  $k \geq 2$ , the number of words of length  $\leq n$  is  $\frac{k^{n+1}-1}{k-1}$ .

**8.** Describe the semigroups  $\langle \{a, b\} \mid a^2 = a, b^2 = b, ab = ba \rangle$  and  $\langle \{a, b\} \mid a^2 = a, b^2 = b \rangle$ .

**9.** Show that the monoid presented by  $\langle \{a, b\} \mid ab = ba = 1 \rangle$  is the group  $(\mathbb{Z}, +)$ .

### Section 6

**10.** Let  $S$  be a semigroup. Show that for each idempotent  $e$  of  $S$ , the sets

$$eS = \{es \mid s \in S\}, \quad Se = \{se \mid s \in S\} \quad \text{and} \quad eSe = \{ese \mid s \in S\}$$

are subsemigroups of  $S$ . The semigroup  $eSe$  [ $eS$ ,  $Se$ ] is called the [*left*, *right*] local *semigroup* associated with  $e$ . Show that  $eSe$  is a monoid with identity  $e$ . Prove that an element  $s$  of  $S$  belongs to  $eSe$  [ $eS$ ,  $Se$ ] if and only if  $es = s = se$  [ $es = s$ ,  $se = s$ ]. Show that  $eSe = eS \cap Se$ . What is the connexion with Exercise 4?



## Chapter III

# Languages and automata

This chapter offers a brief overview of the theory of finite automata and formal languages. For a complete introduction to this theory, the reader is referred to specialized books [14, 42, 92].

There are different manners to describe a set of words, or *language*. The *constructive approach* consists in giving a collection of basic languages and a set of construction rules to build new languages from previously defined ones. The definition of rational languages is of this type. In the *descriptive approach*, the words of a language are characterised by a property: the language of words of even length, the set of binary representations of prime numbers are examples of this approach. The *automata approach* is a special case of the descriptive approach: an automaton reads a word as input and decides whether the word is accepted or not. The set of words accepted by the automaton defines a language. Another variant of the descriptive approach consists in defining languages by logical formulas, a point of view further studied in Chapter XVII.

The first three sections of this chapter review standard definitions on words, rational languages and finite automata. The minimal automaton of a language is defined in terms of morphisms of automata, which is more precise than just requiring that the number of states be minimal.

Section 4 gives an overview of standard constructions on automata related to various operations on languages: Boolean operations, product, star, quotients, inverse of morphisms.

The main result of Section 5 is Kleene's theorem, which states that a language is recognisable if and only if it is rational. Kleene's theorem is obtained in two steps. First, we present Glushkov's algorithm to pass from rational expressions to finite automata. Next, we use linear equations to pass from finite automata to rational expressions.

## 1 Words and languages

### 1.1 Words

Let  $u = a_0a_1 \cdots a_n$  be a word of  $A^*$ . The *reversal* of  $u$  is the word  $\tilde{u} = a_n a_{n-1} \cdots a_0$  obtained by reading  $u$  from right to left.

A word  $x \in A^*$  is a *factor* of  $u$  if  $x = a_r a_{r+1} \cdots a_s$  for some  $r$  and  $s$  such that  $0 \leq r \leq s \leq n$ . This amounts to saying that there exist two words  $v, w \in A^*$

such that  $u = vxw$ . Similarly,  $x$  is a *left factor*, or *prefix*, of  $u$ , if there exists a word  $w \in A^*$  such that  $u = xw$  and  $x$  is a *right factor* or *suffix* of  $u$ , if there exists a word  $v$  of  $A^*$  such that  $u = vx$ .

**Example 1.1** If  $u = abaabba$ ,  $aba$  is a prefix,  $ba$  is a suffix and  $abaa$ ,  $baab$  are factors of  $u$ . One has  $|u|_a = 4$  and  $|u|_b = 3$ , since  $u$  contains four occurrences of  $a$  and three of  $b$ .

## 1.2 Orders on words

The relation “being a prefix of” is an order relation on  $A^*$ , called the *prefix order*, which is partial if  $A$  contains at least two letters. There are other interesting orders on the free monoid. We describe two of them, the lexicographic order and the shortlex order.

Let  $A$  be an alphabet and let  $\leq$  be a total order on  $A$ . The *lexicographic order* induced by  $\leq$  is the total order on  $A^*$  used in a dictionary. Formally, it is the order  $\leq_{lex}$  on  $A^*$  defined by  $u \leq_{lex} v$  if and only if  $u$  is a prefix of  $v$  or  $u = pau'$  and  $v = pbv'$  for some  $p \in A^*$ ,  $a, b \in A$  with  $a < b$ . In the *shortlex order*, words are ordered by length and words of equal length are ordered according to the lexicographic order. Formally, it is the order  $\leq$  on  $A^*$  defined by  $u \leq v$  if and only if  $|u| < |v|$  or  $|u| = |v|$  and  $u \leq_{lex} v$ .

For instance, if  $A = \{a, b\}$  with  $a < b$ , then  $ababb <_{lex} abba$  but  $abba < ababb$ . The next proposition summarizes elementary properties of the shortlex order. The proof is straightforward and omitted.

**Proposition 1.1** *Let  $u, v \in A^*$  and let  $a, b \in A$ .*

- (1) *If  $u < v$ , then  $au < av$  and  $ua < va$ .*
- (2) *If  $ua \leq vb$ , then  $u \leq v$ .*

An important consequence of Proposition 1.1 is that the shortlex order is *stable*: if  $u \leq v$ , then  $xuy \leq xvy$  for all  $x, y \in A^*$ .

## 1.3 Languages

Let  $A$  be a finite alphabet. The subsets of the free monoid  $A^*$  are called *languages*. For instance, if  $A = \{a, b\}$ , the sets  $\{aba, babaa, bb\}$  and  $\{a^n ba^n \mid n \geq 0\}$  are languages.

Several operations can be defined on languages. The *Boolean operations* comprise union, complement (with respect to the set  $A^*$  of all words), intersection and difference. Thus, if  $L$  and  $L'$  are languages of  $A^*$ , one has:

$$\begin{aligned} L \cup L' &= \{u \in A^* \mid u \in L \text{ or } u \in L'\} \\ L \cap L' &= \{u \in A^* \mid u \in L \text{ and } u \in L'\} \\ L^c &= A^* - L = \{u \in A^* \mid u \notin L\} \\ L - L' &= L \cap L'^c = \{u \in A^* \mid u \in L \text{ and } u \notin L'\} \end{aligned}$$

One can also mention the symmetric difference, defined as follows

$$L \Delta L' = (L - L') \cup (L' - L) = (L \cup L') - (L \cap L')$$

The *concatenation product* or simply *product* of two languages  $L$  and  $L'$  is the language

$$LL' = \{uu' \mid u \in L \text{ and } u' \in L'\}.$$

The product is an associative operation on the set of languages, which admits the language<sup>1</sup>  $\{1\}$  as an identity, since the formula  $\{1\}L = L\{1\} = L$  holds for each language  $L$ . The product is distributive over union, which means that, for all languages  $L$ ,  $L_1$  and  $L_2$ , one has

$$L(L_1 \cup L_2) = LL_1 \cup LL_2 \quad \text{and} \quad (L_1 \cup L_2)L = L_1L \cup L_2L \quad (1.1)$$

Therefore the languages over  $A^*$  form a semiring with union as addition and concatenation product as multiplication. For this reason, it is convenient to replace the symbol  $\cup$  by  $+$  and to denote the empty language by  $0$  and the language  $\{1\}$  by  $1$ . For instance, (1.1) can be rewritten as  $L(L_1 + L_2) = LL_1 + LL_2$  and  $(L_1 + L_2)L = L_1L + L_2L$ . Another convenient notation is to denote simply by  $u$  the language  $\{u\}$ . We shall use freely these conventions without any further warning.

Note that the product is not commutative if the alphabet contains at least two letters. Further, it is not distributive over intersection. For instance

$$(b \cap ba)\{a, aa\} = 0\{a, aa\} = 0 \quad \text{but} \\ b\{a, aa\} \cap ba\{a, aa\} = \{ba, baa\} \cap \{baa, baaa\} = baa$$

The powers of a language can be defined like in any monoid, by setting  $L^0 = 1$ ,  $L^1 = L$  and by induction,  $L^n = L^{n-1}L$  for all  $n > 0$ . The *star* of a language  $L$ , denoted by  $L^*$ , is the sum (union) of all the powers of  $L$ :

$$L^* = \sum_{n \geq 0} L^n.$$

The operator  $L^+$  is a variant of the star operator, obtained by considering the sum of all nonzero powers of a language:

$$L^+ = \sum_{n > 0} L^n.$$

**Example 1.2** If  $L = \{a, ba\}$  the words of  $L^+$ , ordered by increasing length, are  $a, aa, ba, aaa, abaa, baaa, aaaaa, aabaa, abaaa, ababa, baaaa, baaba, babaa$ , etc.

Note that the notation  $A^*$  [ $A^+$ ] is compatible with the definition of the operations  $L^*$  and  $L^+$ . Also note the following formula

$$0^* = 1, \quad 0^+ = 0 \quad \text{and} \quad 1^* = 1 = 1^+.$$

Let  $L$  be a language of  $A^*$  and let  $u$  be a word of  $A^*$ . The *left* [*right*] *quotient*  $u^{-1}L$  [ $Lu^{-1}$ ] of  $L$  by  $u$  is defined as follows:

$$u^{-1}L = \{v \in A^* \mid uv \in L\} \quad \text{and} \quad Lu^{-1} = \{v \in A^* \mid vu \in L\}$$

<sup>1</sup> The language  $\{1\}$ , which consists of only one word, the empty word, should not be confused with the empty language.

It is easy to verify that the formula  $v^{-1}(u^{-1}L) = (uv)^{-1}L$  and  $u^{-1}(Lv^{-1}) = (u^{-1}L)v^{-1}$  hold for all words  $u$  and  $v$  of  $A^*$ . We also let as an exercise to the reader the following formulas, where  $a$  is a letter:

$$\begin{aligned} u^{-1}(L_1 + L_2) &= u^{-1}L_1 + u^{-1}L_2 \\ u^{-1}(L_1 - L_2) &= u^{-1}L_1 - u^{-1}L_2 \\ u^{-1}(L_1 \cap L_2) &= u^{-1}L_1 \cap u^{-1}L_2 \\ a^{-1}(L_1L_2) &= \begin{cases} (a^{-1}L_1)L_2 & \text{if } 1 \notin L_1, \\ (a^{-1}L_1)L_2 + a^{-1}L_2 & \text{if } 1 \in L_1 \end{cases} \\ a^{-1}L^* &= (a^{-1}L)L^* \end{aligned}$$

**Example 1.3** Let  $A = \{a, b\}$  and  $L = A^*abaA^*$ . Then

$$\begin{aligned} 1^{-1}L &= L & a^{-1}L &= A^*abaA^* + baA^* \\ b^{-1}L &= L & (ab)^{-1}L &= A^*abaA^* + aA^*, \text{ etc.} \end{aligned}$$

More generally, for any subset  $X$  of  $M$ , the left [right] quotient  $X^{-1}L$  [ $LX^{-1}$ ] of  $L$  by  $X$  is

$$\begin{aligned} X^{-1}L &= \bigcup_{u \in X} u^{-1}L = \{v \in A^* \mid \text{there exists } u \in X \text{ such that } uv \in L\} \\ LX^{-1} &= \bigcup_{u \in X} Lu^{-1} = \{v \in A^* \mid \text{there exists } u \in X \text{ such that } vu \in L\} \end{aligned}$$

One has, for all languages  $X, Y$  and  $L$  (new exercises...)

$$\begin{aligned} (X + Y)^{-1}L &= X^{-1}L + Y^{-1}L \\ (XY)^{-1}L &= Y^{-1}(X^{-1}L) \\ (X^*)^{-1}L &= L + (X^*)^{-1}(X^{-1}L) \end{aligned}$$

To avoid too much parentheses, it is convenient to define precedence orders for operators on languages, summarized in Table 1.1.

Operator	Priority
$L^*, L^c,$	1
$L_1L_2, X^{-1}L, LX^{-1}$	2
$L_1 + L_2, L_1 \cap L_2$	3

**Table 1.1.** Operation precedence table.

The unary operators  $L^*$  and  $L^c$  have higher priority. The product and the quotients have higher priority than union and intersection.

## 2 Rational languages

The set of *rational* (or *regular*) languages on  $A^*$  is the smallest set of languages  $\mathcal{F}$  satisfying the following conditions:

- (a)  $\mathcal{F}$  contains the languages 0 and  $a$  for each letter  $a \in A$ ,
- (b)  $\mathcal{F}$  is closed under finite union, product and star (i.e., if  $L$  and  $L'$  are languages of  $\mathcal{F}$ , then the languages  $L + L'$ ,  $LL'$  and  $L^*$  are also in  $\mathcal{F}$ ).

The set of rational languages of  $A^*$  is denoted by  $\text{Rat}(A^*)$ .

This definition calls for a short comment. Indeed, there is a small subtlety in the definition, since one needs to ensure the existence of a “smallest set” satisfying the preceding conditions. For this, first observe that the set of all languages of  $A^*$  satisfies Conditions (a) and (b). Further, the intersection of all the sets  $\mathcal{F}$  satisfying Conditions (a) and (b) again satisfies these conditions: the resulting set is by construction the smallest set satisfying (a) and (b).

To obtain a more constructive definition, one can think of the rational languages as a kind of LEGO<sup>TM</sup> box. The basic LEGO bricks are the empty language and the languages reduced to a single letter and three operators can be used to build more complex languages: finite union, product and star. For instance, it is easy to obtain a language consisting of a single word. If this word is the empty word, one makes use of the formula  $0^* = 1$ . For a word  $a_1 a_2 \cdots a_n$  of positive length, one observes that

$$\{a_1 a_2 \cdots a_n\} = \{a_1\}\{a_2\} \cdots \{a_n\}.$$

Finite languages can be expressed as a finite union of singletons. For instance,

$$\{abaaba, ba, baa\} = abaaba + ba + baa$$

Consequently, finite languages are rational and the above definition is equivalent with the following more constructive version:

**Proposition 2.2** *Let  $\mathcal{F}_0$  be the set of finite languages of  $A^*$  and, for all  $n > 0$ , let  $\mathcal{F}_{n+1}$  be the set of languages that can be written as  $K + K'$ ,  $KK'$  or  $K^*$ , where  $K$  and  $K'$  are languages from  $\mathcal{F}_n$ . Then*

$$\mathcal{F}_0 \subseteq \mathcal{F}_1 \subseteq \mathcal{F}_2 \cdots$$

*and the union of all the sets  $\mathcal{F}_n$  is the set of rational languages.*

**Example 2.1** If  $A = \{a, b\}$ , the language  $(a + ab + ba)^*$  is a rational language.

**Example 2.2** The set  $L$  of all words containing a given factor  $u$  is rational, since  $L = A^*uA^*$ . Similarly, the set  $P$  of all words having the word  $p$  as a prefix is rational since  $P = pA^*$ .

**Example 2.3** The set of words of even [odd] length is rational. Indeed, this language can be written as  $(A^2)^*$  [ $(A^2)^*A$ ].

A variant of the previous description consists in using *rational expressions* to represent rational languages. Rational expressions are formal expressions (like polynomials in algebra or terms in logic) defined recursively as follows:

- (1) 0 and 1 are rational expressions,

- (2) for each letter  $a \in A$ ,  $a$  is a rational expression,  
 (3) if  $e$  and  $e'$  are rational expressions, then  $(e + e')$ ,  $(ee')$  and  $e^*$  are rational expressions.

In practice, unnecessary parentheses can be wiped out by applying the precedence rules given in Table 1.1. For instance,  $((0^*a)(ba)^* + (bb^*))^*$  is a rational expression that should formally be written as  $((0^*a)(ba)^* + (bb^*))^*$ .

The *value* of a rational expression  $e$ , denoted by  $v(e)$ , is the language represented by  $e$ . The symbol 0 represents the empty language, the symbol 1 the language reduced to the empty word, and each symbol  $a$  the language  $\{a\}$ . Finally, the operators union, product and star have their natural interpretation. Formally, one has

$$\begin{aligned} v(0) &= 0 \\ v(1) &= 1 \\ v(a) &= a \text{ for each letter } a \in A \\ v((e + e')) &= v(e) + v(e') \\ v((ee')) &= v(e)v(e') \\ v(e^*) &= (v(e))^* \end{aligned}$$

Beware not to confuse the notions of rational expression and of rational language. In particular, two rational expressions can represent the same language. For instance, the following expressions all represent the set of all words on the alphabet  $\{a, b\}$ .

$$e_1 = (a + b)^*, \quad e_2 = (a^*b)^*a^*, \quad e_3 = 1 + (a + b)(a + b)^*$$

The difficulty raised by this example is deeper than it seems. Even if a rational language can be represented by infinitely many different rational expressions, one could expect to have a unique reduced expression, up to a set of simple identities like  $0 + L = L = L + 0$ ,  $1L = L = L1$ ,  $(L^*)^* = L^*$ ,  $L + K = K + L$  or  $L(K + K') = LK + LK'$ . In fact, one can show there is no finite basis of identities for the rational expressions: there exist no finite set of identities permitting to deduce all identities between rational expressions. Finding a complete infinite set of identities is already a difficult problem that leads to unexpected developments involving finite simple groups [23, 47].

We conclude this section by a standard result: rational languages are closed under morphisms. An extension of this result will be given in Proposition IV.1.1. The proof of this proposition can be found on page 74.

**Proposition 2.3** *Let  $\varphi : A^* \rightarrow B^*$  be a morphism. If  $L$  is a rational language of  $A^*$ , then  $\varphi(L)$  is a rational language of  $B^*$ .*

## 3 Automata

### 3.1 Finite automata and recognisable languages

A finite *automaton* is a 5-tuple  $\mathcal{A} = (Q, A, E, I, F)$ , where  $Q$  is a finite set called the set of *states*,  $A$  is an alphabet,  $E$  is a subset of  $Q \times A \times Q$ , called the set of *transitions* and  $I$  and  $F$  are subsets of  $Q$ , called respectively the set of *initial states* and the set of *final states*.

It is convenient to represent an automaton by a labelled graph whose vertices are the states of the automaton and the edges represent the transitions. The initial [final] states are pictured by incoming [outgoing] arrows.

**Example 3.1** Let  $\mathcal{A} = (Q, A, E, I, F)$  where  $Q = \{1, 2\}$ ,  $I = \{1, 2\}$ ,  $F = \{2\}$ ,  $A = \{a, b\}$  and  $E = \{(1, a, 1), (2, b, 1), (1, a, 2), (2, b, 2)\}$ . This automaton is represented in Figure 3.1.

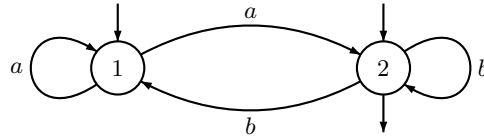

**Figure 3.1.** An automaton.

Two transitions  $(p, a, q)$  and  $(p', a', q')$  are *consecutive* if  $q = p'$ . A *path* in the automaton  $\mathcal{A}$  is a finite sequence of consecutive transitions

$$c = (q_0, a_1, q_1), (q_1, a_2, q_2), \dots, (q_{n-1}, a_n, q_n)$$

also denoted by

$$c : q_0 \xrightarrow{a_1} q_1 \cdots q_{n-1} \xrightarrow{a_n} q_n \quad \text{or} \quad q_0 \xrightarrow{a_1 \cdots a_n} q_n.$$

The state  $q_0$  is its *origin*, the state  $q_n$  its *end*, the word  $a_1 \cdots a_n$  is its *label* and the integer  $n$  is its *length*. It is also convenient to consider that for each state  $q \in Q$ , there is an empty path  $q \xrightarrow{1} q$  from  $q$  to  $q$  labelled by the empty word.

A path in  $\mathcal{A}$  is called *initial* if its origin is an initial state and *final* if its end is a final state. It is *successful* (or *accepting*) if it is initial and final.

**Example 3.2** Consider the automaton represented in Figure 3.1. The path

$$c : 1 \xrightarrow{a} 1 \xrightarrow{a} 2 \xrightarrow{b} 2 \xrightarrow{b} 1 \xrightarrow{a} 2 \xrightarrow{b} 2$$

is successful, since its end is a final state. However the path

$$c : 1 \xrightarrow{a} 1 \xrightarrow{a} 2 \xrightarrow{b} 2 \xrightarrow{b} 1 \xrightarrow{a} 2 \xrightarrow{b} 1$$

has the same label, but is not successful, since its end is 1, a nonfinal state.

A word is *accepted* by the automaton  $\mathcal{A}$  if it is the label of at least one successful path (beware that it can be simultaneously the label of a nonsuccessful path). The *language recognised* (or *accepted*) by the automaton  $\mathcal{A}$  is the set, denoted by  $L(\mathcal{A})$ , of all the words accepted by  $\mathcal{A}$ . Two automata are *equivalent* if they recognise the same language.

A language  $L \subseteq A^*$  is *recognisable* if it is recognised by a finite automaton, that is, if there is a finite automaton  $\mathcal{A}$  such that  $L = L(\mathcal{A})$ .

**Example 3.3** Consider the automaton represented in Figure 3.2.

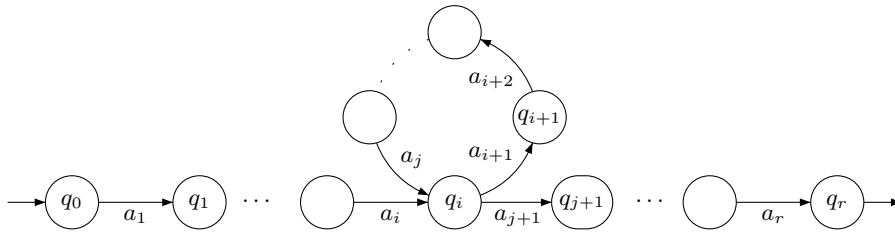

**Figure 3.3.** Illustration of the pumping lemma.

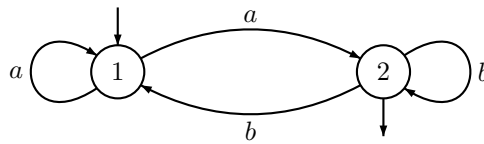

**Figure 3.2.** The automaton  $\mathcal{A}$ .

We let the reader verify that the language accepted by  $\mathcal{A}$  is  $aA^*$ , the set of all words whose first letter is  $a$ .

Example 3.3 is elementary but it already raises some difficulties. In general, deciding whether a given word is accepted or not might be laborious, since a word might be the label of several paths. The notion of deterministic automaton introduced in Section 3.2 permits one to avoid these problems.

We shall see in the Section 4 that the class of recognisable languages owns many convenient closure properties. We shall also see that the recognisable languages are exactly the rational languages. Before studying these results in more detail, it is good to realise that there are some nonrecognisable languages. One can establish this result by a simple, but nonconstructive argument (cf. Exercice 15). To get an explicit example, we shall establish a property of the recognisable languages known as the *pumping lemma*. Although this statement is formally true for any recognisable language, it is only interesting for the infinite ones.

**Proposition 3.4 (Pumping lemma)** *Let  $L$  be a recognisable language. Then there is an integer  $n > 0$  such that every word  $u$  of  $L$  of length greater than or equal to  $n$  can be factorised as  $u = xyz$  with  $x, y, z \in A^*$ ,  $|xy| \leq n$ ,  $y \neq 1$  and, for all  $k \geq 0$ ,  $xy^kz \in L$ .*

**Proof.** Let  $\mathcal{A} = (Q, A, E, I, F)$  be an  $n$ -state automaton recognising  $L$  and let  $u = a_1 \cdots a_r$  be a word of  $L$  of length  $r \geq n$ . Let  $q_0 \xrightarrow{a_1} q_1 \cdots q_{r-1} \xrightarrow{a_r} q_r$  be a successful path labelled by  $u$ . As  $r \geq n$ , there are two integers  $i$  and  $j$ , with  $i < j \leq n$ , such that  $q_i = q_j$ . Therefore, the word  $a_{i+1} \cdots a_j$  is the label of a loop around  $q_i$ , represented in Figure 3.3. Let  $x = a_1 \cdots a_i$ ,  $y = a_{i+1} \cdots a_j$  and  $z = a_{j+1} \cdots a_r$ . Then  $|xy| \leq n$  and for all  $k \geq 0$ , one gets  $xy^kz \in L$ , since the word  $xy^kz$  is the label of a successful path.  $\square$

Unfortunately, the pumping lemma does not characterise the recognisable languages. In other words, there exist some nonrecognisable languages which



satisfy the pumping lemma (see Exercice 8). However, in some cases, the pumping lemma remains a convenient criterion to show that a language is not recognisable. Here is a standard example.

**Corollary 3.5** *The language  $\{a^n b^n \mid n \geq 0\}$  is not recognisable.*

**Proof.** Let  $L = \{a^n b^n \mid n \geq 0\}$ . Suppose that  $L$  is recognisable. By the pumping lemma, there is an integer  $n > 0$  such that the word  $a^n b^n$  can be written as  $a^n b^n = xyz$  with  $x, y, z \in A^*$ ,  $|xy| \leq n$ ,  $y \neq 1$  and  $xy^2z \in L$  (as one can see, we only use a very weak form of the pumping lemma). As  $|xy| \leq n$ , the word  $xy$  is prefix of  $a^n$  and thus  $x = a^r$ ,  $y = a^s$  and  $z = a^t b^n$ , with  $r + s + t = n$  and  $s \neq 0$ .

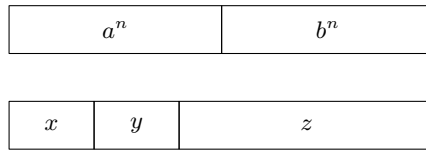

Then  $xy^2z = a^r a^{2s} a^t b^n$  and since  $s \neq 0$ , one has  $r + 2s + t \neq n$ . It follows that  $xy^2z$  is not in  $L$ , a contradiction. Therefore  $L$  is not recognisable.  $\square$

### 3.2 Deterministic automata

An automaton  $\mathcal{A} = (Q, A, E, I, F)$  is *deterministic* if  $I$  contains exactly one initial state and if, for every state  $q \in Q$  and for every letter  $a \in A$ , there exists *at most* one state  $q'$  such that  $q \xrightarrow{a} q'$  is a transition of  $E$ . If  $q_-$  is the unique initial state, we adopt the notation  $(Q, A, E, q_-, F)$  instead of  $(Q, A, E, \{q_-\}, F)$ .

**Example 3.4** The automaton represented in Figure 3.4 is deterministic.

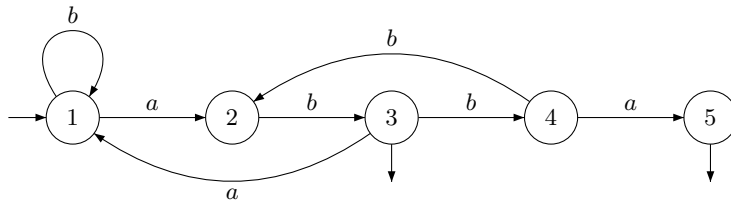

**Figure 3.4.** A deterministic automaton.

The following result is one of the cornerstones of automata theory. Its proof is based on the so-called *subset construction*.

**Proposition 3.6** *Every finite automaton is equivalent to a deterministic one.*

**Proof.** Let  $\mathcal{A} = (Q, A, E, I, F)$  be an automaton. Consider the deterministic automaton  $D(\mathcal{A}) = (\mathcal{P}(Q), A, \cdot, I, \mathcal{F})$  where  $\mathcal{F} = \{P \subseteq Q \mid P \cap F \neq \emptyset\}$  and, for each subset  $P$  of  $Q$  and for each letter  $a \in A$ ,

$$P \cdot a = \{q \in Q \mid \text{there exists } p \in P \text{ such that } (p, a, q) \in E\}$$

We claim that  $D(\mathcal{A})$  is equivalent to  $\mathcal{A}$ .

If  $u = a_1 \cdots a_n$  is accepted by  $\mathcal{A}$ , there is a successful path

$$c : q_0 \xrightarrow{a_1} q_1 \cdots q_{n-1} \xrightarrow{a_n} q_n$$

The word  $u$  also defines a path

$$I = P_0 \xrightarrow{a_1} P_1 \cdots P_{n-1} \xrightarrow{a_n} P_n \quad (3.2)$$

in  $D(\mathcal{A})$ . Let us show by induction on  $i$  that, for  $0 \leq i \leq n$ ,  $q_i \in P_i$ . Since  $c$  is a successful path, one has  $q_0 \in I = P_0$ . Suppose that  $q_{i-1} \in P_{i-1}$ . Then since  $q_{i-1} \xrightarrow{a_i} q_i$  is a transition, one gets  $q_i \in P_{i-1} \cdot a_i = P_i$ . For  $i = n$ , we get  $q_n \in P_n$  and since  $c$  is a successful path,  $q_n \in F$ . It follows that  $P_n$  meets  $F$  and hence  $P_n \in \mathcal{F}$ . Therefore  $u$  is accepted by  $D(\mathcal{A})$ .

Conversely, let  $u = a_1 \cdots a_n$  be a word accepted by  $D(\mathcal{A})$  and let (3.2) the successful path defined by  $u$ . Since  $P_n$  is a final state, one can choose an element  $q_n$  in  $P_n \cap F$ . We can now select, for  $i = n, n-1, \dots, 1$ , an element  $q_{i-1}$  of  $P_{i-1}$  such that  $q_{i-1} \xrightarrow{a_i} q_i$  is a transition in  $\mathcal{A}$ . Since  $q_0 \in I$  and  $q_n \in F$ , the path  $q_0 \xrightarrow{a_1} q_1 \cdots q_{n-1} \xrightarrow{a_n} q_n$  is successful, and thus  $u$  is accepted by  $\mathcal{A}$ . This proves the claim and the proposition.  $\square$

The subset construction converts a nondeterministic  $n$ -state automaton into a deterministic automaton with at most  $2^n$  states. One can show that this bound is tight (see Exercise 10).

**Example 3.5** Let  $A = \{a, b\}$ . Starting from the automaton  $\mathcal{A}$  represented in Figure 3.5, we get the automaton  $D(\mathcal{A})$  drawn in Figure 3.6. In practice, it suffices to compute the accessible states of  $D(\mathcal{A})$ , which gives the deterministic automaton shown in Figure 3.7.

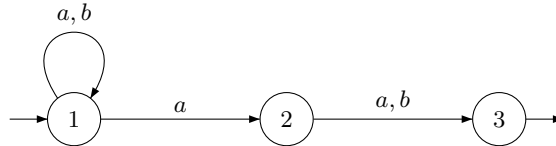

Figure 3.5. A nondeterministic automaton.

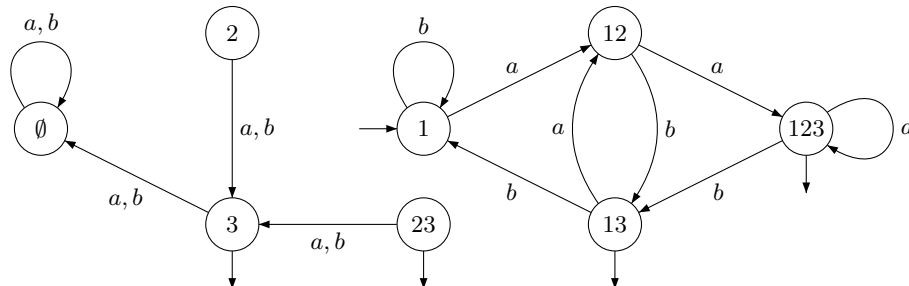

Figure 3.6. After determinisation...

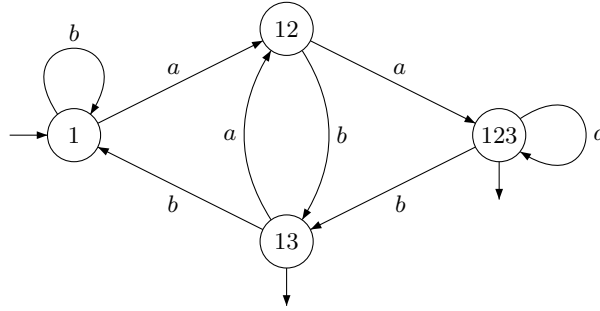

Figure 3.7. ... and trimming.

We shall give in Theorem IV.3.20 a purely algebraic proof of this result.

### 3.3 Complete automata and trim automata

#### Complete automata

An automaton  $\mathcal{A} = (Q, A, \cdot, q_-, F)$  is *complete* if, for each state  $q \in Q$  and for each letter  $a \in A$ , there is *at least* one state  $q'$  such that  $q \xrightarrow{a} q'$  is a transition.

**Example 3.6** The automaton represented in Figure 3.8 is neither complete, nor deterministic. It is not deterministic, since the transitions  $(1, a, 1)$  and  $(1, a, 2)$  have the same label and the same origin. It is not complete, since there is no transition of the form  $2 \xrightarrow{a} q$ .

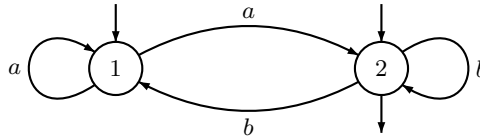

Figure 3.8. An incomplete, nondeterministic automaton.

On the other hand, the automaton represented in Figure 3.9 is complete and deterministic.

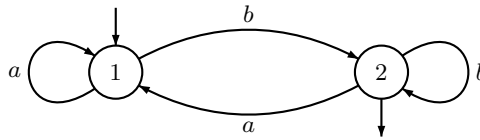

Figure 3.9. A complete and deterministic automaton.

#### Trim automata

In a finite automaton, states which cannot be reached from the initial state or from which one cannot reach any final state are clearly useless. This leads

to the following definition. A deterministic automaton  $\mathcal{A} = (Q, A, E, q_-, F)$  is *trim* if, for every state  $q \in Q$ , there exist two words  $u$  and  $v$  such that  $q_- \cdot u = q$  and  $q \cdot v \in F$ . It is not difficult to see that every deterministic automaton is equivalent to a trim one.

### Standard automata

The construction described in this section might look somewhat artificial, but it will be used in the study of the product and of the star operation.

A deterministic automaton is *standard* if there is no transition ending in the initial state.

**Proposition 3.7** *Every deterministic automaton is equivalent to a deterministic standard automaton.*

**Proof.** Let  $\mathcal{A} = (Q, A, E, q_-, F)$  be a deterministic automaton. If  $\mathcal{A}$  is not standard, let  $p$  be a new state and  $\mathcal{A}' = (Q \cup \{p\}, A, E', p, F')$  be the standard automaton defined by  $E' = E \cup \{(p, a, q) \mid (q_-, a, q) \in E\}$  and

$$F' = \begin{cases} F & \text{if } q_- \notin F \\ F \cup \{p\} & \text{if } q_- \in F \end{cases}$$

Then the path  $q_- \xrightarrow{a_0} q_1 \xrightarrow{a_1} q_2 \cdots q_{n-1} \xrightarrow{a_{n-1}} q_n$  is successful in  $\mathcal{A}$  if and only if the path  $p \xrightarrow{a_0} q_1 \xrightarrow{a_1} q_2 \cdots q_{n-1} \xrightarrow{a_{n-1}} q_n$  is successful in  $\mathcal{A}'$ . Consequently,  $\mathcal{A}$  and  $\mathcal{A}'$  are equivalent.  $\square$

**Example 3.7** Standardization is illustrated in Figure 3.10.

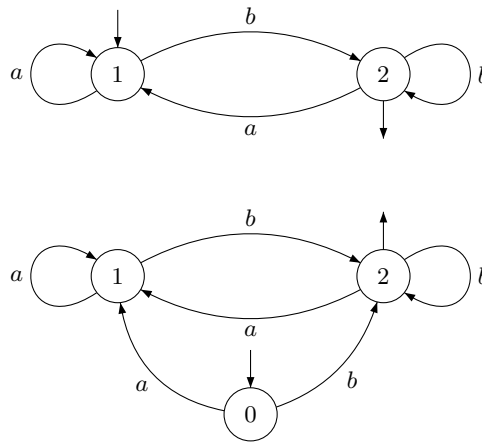

**Figure 3.10.** An automaton and its standardized version.

## 4 Operations on recognisable languages

We review in this section some classical results on finite automaton. We give explicit constructions for the following operations: Boolean operations, product, star, quotients and inverses of morphisms.

### 4.1 Boolean operations

We give in this section the well known constructions for union, intersection and complement. Complementation is trivial, but requires a deterministic automaton.

**Proposition 4.8** *The union of two recognisable languages is recognisable.*

**Proof.** Let  $L [L']$  be a recognisable language of  $A^*$  recognised by the automaton  $\mathcal{A} = (Q, A, E, I, F)$  [ $\mathcal{A}' = (Q', A, E', I', F')$ ]. We suppose that  $Q$  and  $Q'$  are disjoint sets and thus one can identify  $E$  and  $E'$  with subsets of  $(Q \cup Q') \times A \times (Q \cup Q')$ . Then  $L + L'$  is recognised by the automaton  $(Q \cup Q', A, E \cup E', I \cup I', F \cup F')$ .  $\square$

**Example 4.1** If  $L [L']$  is recognised by the automaton  $\mathcal{A} [\mathcal{A}']$  represented in Figure 4.11, then  $L + L'$  is recognised by the automaton represented in Figure 4.12.

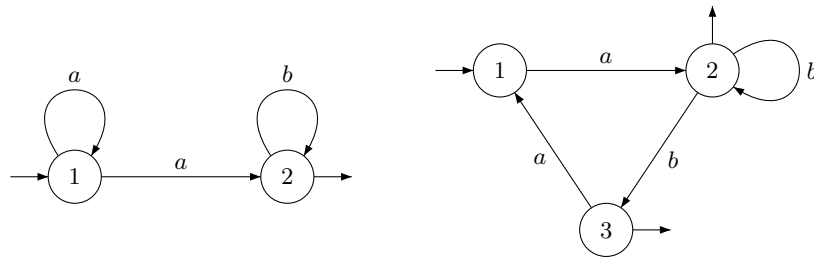

Figure 4.11. The automata  $\mathcal{A}$  and  $\mathcal{A}'$ .

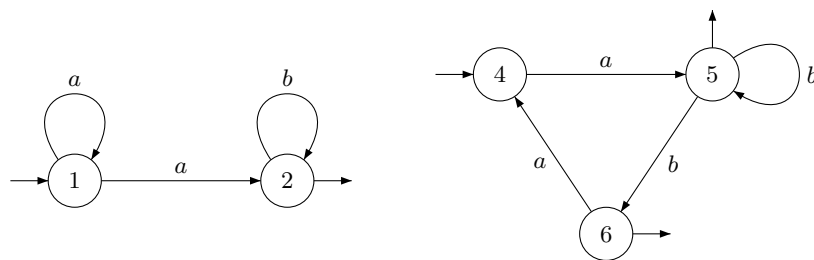

Figure 4.12. An automaton recognising  $L + L'$ .

**Corollary 4.9** *Every finite language is recognisable.*

**Proof.** Since recognisable languages are closed under union, it suffices to verify that the singletons are recognisable. But it is clear that the language  $a_1 a_2 \cdots a_n$  is recognised by the automaton represented in Figure 4.13.  $\square$

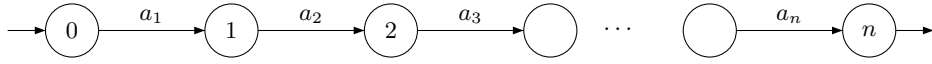

Figure 4.13. An automaton recognising  $a_1 \cdots a_n$ .

**Proposition 4.10** *The intersection of two recognisable languages is recognisable.*

**Proof.** Let  $L [L']$  be a recognisable language of  $A^*$  recognised by the automaton  $\mathcal{A} = (Q, A, E, I, F)$  [ $\mathcal{A}' = (Q', A, E', I', F')$ ]. Consider the automaton  $\mathcal{B} = (Q \times Q', A, T, I \times I', F \times F')$  where

$$T = \left\{ ((q_1, q'_1), a, (q_2, q'_2)) \mid (q_1, a, q_2) \in E \text{ and } (q'_1, a, q'_2) \in E' \right\}.$$

A word  $u = a_1 a_2 \cdots a_n$  is the label of a successful path in  $\mathcal{B}$

$$(q_0, q'_0) \xrightarrow{a_1} (q_1, q'_1) \xrightarrow{a_2} (q_2, q'_2) \cdots (q_{n-1}, q'_{n-1}) \xrightarrow{a_n} (q_n, q'_n)$$

if and only if the paths

$$\begin{aligned} q_0 &\xrightarrow{a_1} q_1 \xrightarrow{a_2} q_2 \cdots q_{n-1} \xrightarrow{a_n} q_n \text{ and} \\ q'_0 &\xrightarrow{a_1} q'_1 \xrightarrow{a_2} q'_2 \cdots q'_{n-1} \xrightarrow{a_n} q_n \end{aligned}$$

are successful paths of  $\mathcal{A}$  and  $\mathcal{A}'$  respectively. Therefore,  $\mathcal{B}$  recognises  $L \cap L'$ .  $\square$

In practice, one just computes the trim part of  $\mathcal{B}$ .

**Example 4.2** If  $L [L']$  is recognised by the automaton  $\mathcal{A} [\mathcal{A}']$  represented in Figure 4.11, then  $L \cap L'$  is recognised by the trim automaton represented in Figure 4.14.

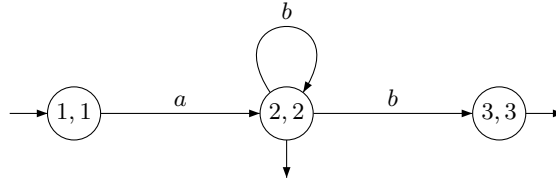
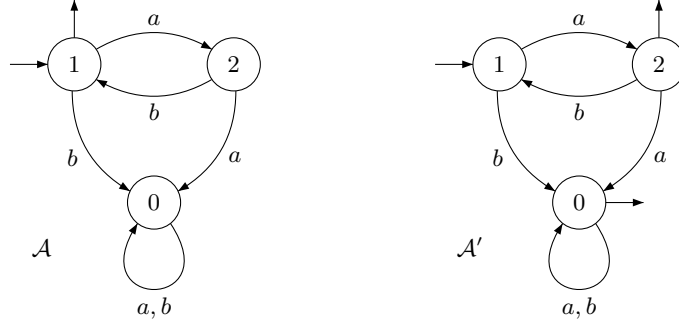

Figure 4.14. A trim automaton recognising  $L \cap L'$ .

**Proposition 4.11** *The complement of a recognisable language is recognisable.*

**Proof.** Let  $L$  be a recognisable language of  $A^*$  and let  $\mathcal{A} = (Q, A, \cdot, q_-, F)$  be a complete deterministic automaton recognising  $L$ . Then the automaton  $\mathcal{A}' = (Q, A, \cdot, q_-, Q - F)$  recognises  $L^c$ . Indeed, since  $\mathcal{A}$  and  $\mathcal{A}'$  are both deterministic and complete, every word  $u$  of  $A^*$  is the label of exactly one path starting in  $q_-$ . Let  $q$  be the end of this path. Then  $u$  belongs to  $L$  if and only if  $q$  belongs to  $F$  and  $u$  belongs to  $L^c$  if and only if  $q$  belongs to  $Q - F$ .  $\square$

**Example 4.3** If  $L$  is recognised by the complete deterministic automaton  $\mathcal{A}$ , then  $L^c$  is recognised by the automaton  $\mathcal{A}'$  represented in Figure 4.15.



**Figure 4.15.** Complementation of a deterministic automaton.

## 4.2 Product

**Proposition 4.12** *The product of two recognisable languages is recognisable.*

**Proof.** Let  $L_1$  and  $L_2$  be two recognisable languages of  $A^*$ , recognised by the automata  $\mathcal{A}_1 = (Q_1, A, E_1, I_1, F_1)$  and  $\mathcal{A}_2 = (Q_2, A, E_2, I_2, F_2)$ , respectively. One may assume, by Propositions 3.6 and 3.7 that  $\mathcal{A}_2$  is a standard deterministic automaton and thus in particular that  $I_2 = \{i\}$ . One can also suppose that  $Q_1$  and  $Q_2$  are disjoint. Let now  $\mathcal{A} = (Q, A, E, I, F)$ , where

$$\begin{aligned} Q &= (Q_1 \cup Q_2) - \{i\}, \\ E &= E_1 \cup \{(q, a, q') \in E_2 \mid q \neq i\} \cup \{(q_1, a, q') \mid q_1 \in F_1 \text{ and } (i, a, q') \in E_2\}, \\ I &= I_1, \text{ and} \\ F &= \begin{cases} F_2 & \text{if } i \notin F_2, \\ F_1 \cup (F_2 - \{i\}) & \text{if } i \in F_2 \text{ (i.e. if } 1 \in L_2). \end{cases} \end{aligned}$$

We claim that  $\mathcal{A}$  recognises  $L_1L_2$ . If  $u$  is a word of  $L_1L_2$ , then  $u = u_1u_2$  for some  $u_1 \in L_1$  and  $u_2 \in L_2$ . Therefore, there is a successful path  $c_1 : i_1 \xrightarrow{u_1} q_1$  in  $\mathcal{A}_1$  (with  $i_1 \in I_1$  and  $q_1 \in F_1$ ) and a successful path  $c_2 : i \xrightarrow{u_2} q_2$  in  $\mathcal{A}_2$ , with  $q_2 \in F_2$ . If  $u_2 = 1$ , then  $L_2$  contains the empty word, the path  $c_1$  is a successful path of  $\mathcal{A}$  and  $u$  is accepted by  $\mathcal{A}$ . If  $u_2$  is not the empty word, let  $a$  be the first letter of  $u_2$  and let  $i \xrightarrow{a} q$  be the first transition of  $c_2$ . Since  $q_1 \in F_1$ ,  $q_1 \xrightarrow{a} q$  is by definition a transition of  $E$ . Further, if  $q' \xrightarrow{b} q''$  is a transition of  $c_2$  different from the first transition, then  $q'$  is the end of a transition of  $\mathcal{A}_2$ . Since  $\mathcal{A}_2$  is standard, this implies  $q' \neq i$  and it follows from the definition of  $E$  that the transition  $q' \xrightarrow{b} q''$  is also a transition of  $\mathcal{A}$ . Let  $c'_2$  be the path of  $\mathcal{A}$  obtained by replacing in  $c_2$  the first transition  $i \xrightarrow{a} q$  by  $q_1 \xrightarrow{a} q$ . The resulting path  $c_1c'_2$  is a successful path of  $\mathcal{A}$  of label  $u$  and hence  $u$  is accepted by  $\mathcal{A}$ .

Conversely, let  $u$  be a word accepted by  $\mathcal{A}$ . Then  $u$  is the label of a successful path  $c : i_1 \xrightarrow{u} f$  of  $\mathcal{A}$ . Since the initial states of  $\mathcal{A}$  are contained in  $Q_1$ , and since there is no transition of  $\mathcal{A}$  starting in  $Q_2$  and ending in  $Q_1$ ,  $c$  visits first

some states of  $Q_1$  and then possibly some states of  $Q_2$ . If all the states visited by  $c$  are in  $Q_1$ , one has in particular  $f \in Q_1$ . But this is only possible if  $1 \in L_2$ , and in this case,  $c$  is also a successful path of  $\mathcal{A}_1$ , and hence  $u \in L_1 \subseteq L_1L_2$ . If  $c$  visits some states of  $Q_2$ , then  $c$  contains a unique transition of the form  $e = (q_1, a, q_2)$  with  $q_1 \in F_1$  and  $q_2 \in Q_2$ . Therefore  $c = c_1ec_2$ , where  $c_1$  is a path in  $\mathcal{A}_1$  and  $c_2$  is a path in  $\mathcal{A}_2$ . Denoting by  $u_1$  [ $u_2$ ] the label of  $c_1$  [ $c_2$ ], we get  $u = u_1au_2$ . Since  $c_1$  is a successful path in  $\mathcal{A}_1$ , one has  $u_1 \in L_1$ . Further, by definition of  $E$ ,  $e' = (i, a, q_2)$  is a transition of  $\mathcal{A}_2$ . Therefore the path  $e'c_2$  is a successful path in  $\mathcal{A}_2$  of label  $au_2$ . It follows that  $au_2 \in L_2$  and thus  $u \in L_1L_2$ , proving the claim and the proposition.  $\square$

**Example 4.4** If  $L_1$  [ $L_2$ ] is recognised by the automaton  $\mathcal{A}_1$  [ $\mathcal{A}_2$ ] represented in Figure 4.16, then  $L_1L_2$  is recognised by the automaton represented in Figure 4.17.

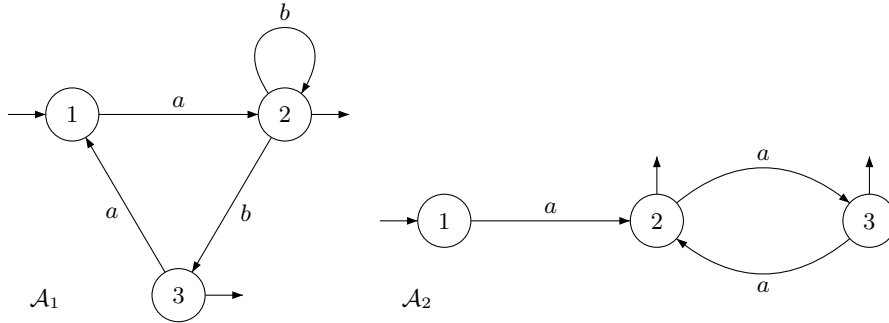

Figure 4.16. The automata  $\mathcal{A}_1$  and  $\mathcal{A}_2$ .

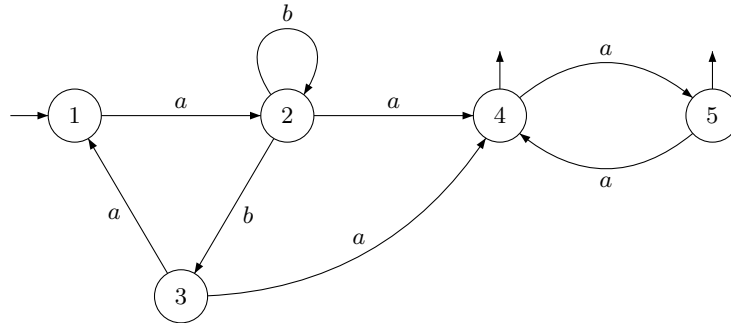

Figure 4.17. An automaton recognising  $L_1L_2$ .

### 4.3 Star

**Proposition 4.13** *The star of a recognisable language is recognisable.*

**Proof.** Let  $L$  be a recognisable language of  $A^*$ , recognised by the deterministic standard automaton  $\mathcal{A} = (Q, A, E, q_-, F)$ . Let  $\mathcal{A}' = (Q, A, E', \{q_-\}, F \cup \{q_-\})$  be the nondeterministic automaton defined by

$$E' = E \cup \{(q, a, q') \mid q \in F \text{ and } (q_-, a, q') \in E\}.$$



Let us show that  $\mathcal{A}'$  recognises  $L^*$ . If  $u$  is a word of  $L^*$ , then either  $u$  is the empty word, which is accepted by  $\mathcal{A}'$  since  $q_-$  is a final state, or  $u = u_1u_2 \cdots u_n$  with  $u_1, \dots, u_n \in L - 1$ . Each  $u_i$  is the label of a successful path of  $\mathcal{A}$ , say  $c_i : q_- \xrightarrow{u_i} q_i$  with  $q_i \in F$ . Let  $a_i$  be the first letter of  $u_i$  and let  $q_- \xrightarrow{a_i} p_i$  be the first transition of  $c_i$ . Let  $i \in \{2, \dots, n\}$ . As  $q_{i-1} \in F$ , the definition of  $E'$  shows that  $q_{i-1} \xrightarrow{a_i} p_i$  is a transition of  $\mathcal{A}'$ . Denote by  $c'_i$  the path obtained by replacing in  $c_i$  the first transition  $q_- \xrightarrow{a_i} p_i$  by  $q_{i-1} \xrightarrow{a_i} p_i$ . This defines, for  $2 \leq i \leq n$ , a path  $c'_i : q_{i-1} \xrightarrow{u_i} q_i$  in  $\mathcal{A}'$ . Therefore, the path  $c_1c'_2 \cdots c'_n$  is a successful path of label  $u$  in  $\mathcal{A}'$  and hence  $u$  is accepted by  $\mathcal{A}'$ .

Conversely, let  $u$  be a word accepted by  $\mathcal{A}'$ . If  $u = 1$ , one has  $u \in L^*$ . Otherwise,  $u$  is the label of a nonempty successful path  $c$  of  $\mathcal{A}'$ . This path can be factorised as

$$c = q_- \xrightarrow{u_0} q_1 \xrightarrow{a_1} q'_1 \xrightarrow{u_1} q_2 \xrightarrow{a_2} q'_2 \cdots q_n \xrightarrow{a_n} q'_n \xrightarrow{u_n} q_{n+1}$$

where the transitions  $e_1 = q_1 \xrightarrow{a_1} q'_1$ ,  $e_2 = q_2 \xrightarrow{a_2} q'_2$ ,  $\dots$ ,  $e_n = q_n \xrightarrow{a_n} q'_n$  are exactly the transitions of  $E' - E$  occurring in  $c$ . Thus by definition of  $E'$ , one gets, for  $1 \leq i \leq n$ ,  $q_i \in F$  and  $e'_i = (q_-, a_i, q'_i) \in E$ . Furthermore,  $q_{n+1} \in F \cup \{q_-\}$  since  $c$  is a successful path. Consequently, the paths

$$q_- \xrightarrow{a_i} q'_i \xrightarrow{u_i} q_{i+1}$$

are paths of  $\mathcal{A}$ . For  $1 \leq i \leq n - 1$ , these paths are successful, since  $q_i \in F$ . Moreover, since  $\mathcal{A}$  is standard<sup>2</sup>,  $q_{n+1}$  is different from  $q_-$  and hence  $q_{n+1} \in F$ . Consequently  $a_iu_i \in L$  for  $1 \leq i \leq n$ . Since  $q_- \xrightarrow{u_0} q_1$  is also a successful path of  $\mathcal{A}$ , one also has  $u_0 \in L$ , and hence  $u \in L^*$ .  $\square$

**Example 4.5** If  $L$  is recognised by the standard deterministic automaton represented in Figure 4.18, then  $L^*$  is recognised by the nondeterministic automaton represented in Figure 4.19.

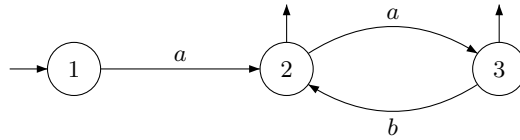

Figure 4.18. A standard automaton recognising  $L$ .

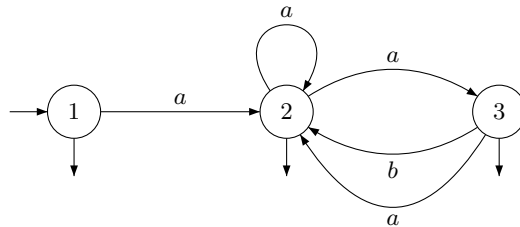

Figure 4.19. An automaton recognising  $L^*$ .

<sup>2</sup>This is the only place where this property is used

**Example 4.6** This example shows that the algorithm above does not work if one does not start with a standard automaton. Indeed, consider the automaton  $\mathcal{A}$  represented in Figure 4.20, which recognises the language  $L = (ab)^*a$ . Then the nondeterministic automaton  $\mathcal{A}' = (Q, A, E', \{q_-\}, F \cup \{q_-\})$ , where

$$E' = E \cup \{(q, a, q') \mid q \in F \text{ and } (q_-, a, q') \in E\}.$$

does not recognise  $L^*$ . Indeed, the word  $ab$  is accepted by  $\mathcal{A}'$  but is not a word of  $L^*$ .

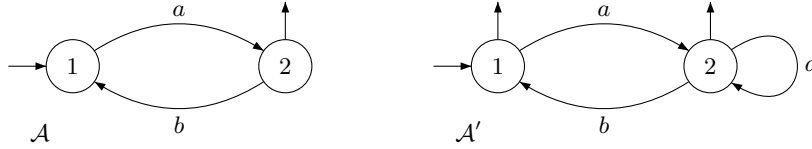

Figure 4.20. A nonstandard automaton  $\mathcal{A}$  and the automaton  $\mathcal{A}'$ .

#### 4.4 Quotients

We first treat the left quotient by a word and then the general case.

**Proposition 4.14** *Let  $\mathcal{A} = (Q, A, \cdot, q_-, F)$  be a deterministic automaton recognising a language  $L$  of  $A^*$ . Then, for each word  $u$  of  $A^*$ , the language  $u^{-1}L$  is recognised by the automaton  $\mathcal{A}_u = (Q, A, \cdot, q_- \cdot u, F)$ , obtained from  $\mathcal{A}$  by changing the initial state. In particular  $u^{-1}L$  is recognisable.*

**Proof.** First the following formulas hold:

$$\begin{aligned} u^{-1}L &= \{v \in A^* \mid uv \in L\} \\ &= \{v \in A^* \mid q_- \cdot (uv) \in F\} \\ &= \{v \in A^* \mid (q_- \cdot u) \cdot v \in F\}. \end{aligned}$$

Therefore  $u^{-1}L$  is accepted by  $\mathcal{A}_u$ .  $\square$

**Proposition 4.15** *Any quotient of a recognisable language is recognisable.*

**Proof.** Let  $\mathcal{A} = (Q, A, E, I, F)$  be an automaton recognising a language  $L$  of  $A^*$  and let  $K$  be a language of  $A^*$ . We do not assume that  $K$  is recognisable. Setting

$$I' = \{q \in Q \mid q \text{ is the end of an initial path whose label belongs to } K\}$$

we claim that the automaton  $\mathcal{B} = (Q, A, E, I', F)$  recognises  $K^{-1}L$ . Indeed, if  $u \in K^{-1}L$ , there exists a word  $x \in K$  such that  $xu \in L$ . Therefore, there is a successful path of label  $xu$ , say  $p \xrightarrow{x} q \xrightarrow{u} r$ . By construction,  $p$  is an initial state,  $r$  is a final state and  $q$  belongs to  $I'$ . It follows that  $u$  is accepted by  $\mathcal{B}$ .

Conversely, if a word  $u$  is accepted by  $\mathcal{B}$ , it is the label of a final path starting in a state  $q$  of  $I'$ . By definition of  $I'$ , there is a word  $x \in K$  which is the label of an initial path ending in  $q$ . Consequently, the word  $xu$  is accepted by  $\mathcal{A}$  and hence belongs to  $L$ . It follows that  $u \in K^{-1}L$ , which proves the claim.

For the language  $LK^{-1}$ , a similar proof works by considering the automaton  $(Q, A, E, I, F')$ , where

$$F' = \{q \in Q \mid q \text{ is the origin of a final path whose label belongs to } K.\} \quad \square$$

### 4.5 Inverses of morphisms

We now show that recognisable languages are closed under inverses of morphisms. A concise proof of an extension of this result will be given in Proposition IV.2.10.

**Proposition 4.16** *Let  $\varphi : A^* \rightarrow B^*$  be a morphism. If  $L$  is a recognisable language of  $B^*$ , then  $\varphi^{-1}(L)$  is a recognisable language of  $A^*$ .*

**Proof.** Let  $\mathcal{B} = (Q, B, E, I, F)$  be an automaton recognising  $L$ . Let  $\mathcal{A} = (Q, A, T, I, F)$ , where

$$T = \{(p, a, q) \mid \text{there is a path labelled by } \varphi(a) \text{ from } p \text{ to } q \text{ in } \mathcal{B}\}$$

We claim that  $\mathcal{A}$  recognises  $\varphi^{-1}(L)$ . First, if  $u$  is accepted by  $\mathcal{A}$ , there is a successful path of  $\mathcal{A}$  labelled by  $u$ . Consequently, there is a successful path of  $\mathcal{B}$  labelled by  $\varphi(u)$ . Thus  $\varphi(u)$  is accepted by  $\mathcal{B}$  and  $u \in \varphi^{-1}(L)$ .

Let now  $u = a_1 \cdots a_n$  be a word of  $\varphi^{-1}(L)$ . Since the word  $\varphi(u)$  is accepted by  $L$ , there is a successful path in  $\mathcal{B}$  labelled by  $\varphi(u)$ . Let us factorise this path as

$$q_0 \xrightarrow{\varphi(a_1)} q_1 \cdots q_{n-1} \xrightarrow{\varphi(a_n)} q_n$$

These paths define in turn a successful path in  $\mathcal{A}$  labelled by  $u$ :

$$q_0 \xrightarrow{a_1} q_1 \cdots q_{n-1} \xrightarrow{a_n} q_n$$

which shows that  $u$  is accepted by  $\mathcal{A}$ .  $\square$

### 4.6 Minimal automata

Let  $L$  be a language of  $A^*$ . The *Nerode automaton* of  $L$  is the deterministic automaton  $\mathcal{A}(L) = (Q, A, \cdot, L, F)$  where  $Q = \{u^{-1}L \mid u \in A^*\}$ ,  $F = \{u^{-1}L \mid u \in L\}$  and the transition function is defined, for each  $a \in A$ , by the formula

$$(u^{-1}L) \cdot a = a^{-1}(u^{-1}L) = (ua)^{-1}L$$

Beware of this rather abstract definition. Each state of  $\mathcal{A}(L)$  is a left quotient of  $L$  by a word, and hence is a language of  $A^*$ . The initial state is the language  $L$ , and the set of final states is the set of all left quotients of  $L$  by a word of  $L$ .

**Proposition 4.17** *A language  $L$  is recognisable if and only if the set  $\{u^{-1}L \mid u \in A^*\}$  is finite. In this case,  $L$  is recognised by its Nerode automaton.*

**Proof.** Let  $L$  be a recognisable language, accepted by the deterministic automaton  $\mathcal{A} = (Q, A, \cdot, q_-, F)$ . By Proposition 4.14, the language  $u^{-1}L$  is accepted by the automaton  $\mathcal{A}_u = (Q, A, \cdot, q_- \cdot u, F)$ . If  $n$  is the number of states of  $\mathcal{A}$ , there are at most  $n$  automata of the form  $\mathcal{A}_u$  and hence at most  $n$  distinct languages of the form  $u^{-1}L$ .

Conversely, if the set  $\{u^{-1}L \mid u \in A^*\}$  is finite, the Nerode automaton of  $L$  is finite and recognises  $L$ . Indeed, a word  $u$  is accepted by  $\mathcal{A}(L)$  if and only if  $L \cdot u = u^{-1}L$  is a final state, that is if  $u \in L$ . It follows that  $L$  is recognisable.  $\square$

Let us define a partial order on deterministic automata as follows. Let  $\mathcal{A} = (Q, A, E, q_-, F)$  and  $\mathcal{A}' = (Q', A, E', q'_-, F')$  be two deterministic automata. Then  $\mathcal{A}' \leq \mathcal{A}$  if there is a surjective function  $\varphi : Q \rightarrow Q'$  such that  $\varphi(q_-) = q'_-$ ,  $\varphi^{-1}(F') = F$  and, for every  $u \in A^*$  and  $q \in Q$ ,  $\varphi(q.u) = \varphi(q).u$ .

Let  $L$  be a recognisable language. The next proposition shows that, amongst the trim and complete deterministic automata recognising  $L$ , the Nerode automaton of  $L$  is minimal for this partial order. For this reason it is called the *minimal complete automaton* of  $L$ .

**Proposition 4.18** *Let  $\mathcal{A} = (Q, A, \cdot, q_-, F)$  be a trim and complete deterministic automaton accepting  $L$ . For each state  $q$  of  $Q$ , let  $L_q$  be the language recognised by  $(Q, A, \cdot, q, F)$ . Then  $\mathcal{A}(L) = (\{L_q \mid q \in Q\}, A, \cdot, L_{q_-}, \{L_q \mid q \in F\})$ , where, for all  $a \in A$  and for all  $q \in Q$ ,  $L_q \cdot a = L_{q \cdot a}$ . Further, the map  $q \mapsto L_q$  defines a morphism from  $\mathcal{A}$  onto  $\mathcal{A}(L)$ .*

**Proof.** Let  $q$  be a state of  $Q$ . Since  $q$  is accessible, there is a word  $u$  of  $A^*$  such that  $q_- \cdot u = q$ , and by Proposition 4.14, one has  $L_q = u^{-1}L$ . Conversely, if  $u$  is a word, one has  $u^{-1}L = L_q$  with  $q = q_- \cdot u$ . Therefore

$$\{L_q \mid q \in Q\} = \{u^{-1}L \mid u \in A^*\} \quad \text{and} \quad \{L_q \mid q \in F\} = \{u^{-1}L \mid u \in L\}$$

which proves the first part of the statement.

Further, for all  $a \in A$ , one has

$$\varphi(q \cdot a) = L_{q \cdot a} = L_q \cdot a = \varphi(q) \cdot a \tag{4.3}$$

which shows that the map  $\varphi : q \mapsto L_q$  is a morphism from  $\mathcal{A}$  onto  $\mathcal{A}(L)$ .  $\square$

The direct computation of the Nerode automaton is probably the most efficient method for a computation by hand, because it gives directly the minimal automaton. In practice, one starts with the quotient  $L = 1^{-1}L$  and one maintains a table of quotients of  $L$ . For each quotient  $R$ , it suffices to compute the quotients  $a^{-1}R$  for each letter  $a$ . These quotients are compared to the existing list of quotients and possibly added to this list. But there is a hidden difficulty: the comparison of two rational expressions is not always easy since a given language might be represented by two very different rational expressions.

**Example 4.7** For  $L = (a(ab)^*)^* \cup (ba)^*$ , we get successively:

$$\begin{aligned}
1^{-1}L &= L = L_1 \\
a^{-1}L_1 &= (ab)^*(a(ab)^*)^* = L_2 \\
b^{-1}L_1 &= a(ba)^* = L_3 \\
a^{-1}L_2 &= b(ab)^*(a(ab)^*)^* \cup (ab)^*(a(ab)^*)^* = bL_2 \cup L_2 = L_4 \\
b^{-1}L_2 &= \emptyset \\
a^{-1}L_3 &= (ba)^* = L_5 \\
b^{-1}L_3 &= \emptyset \\
a^{-1}L_4 &= a^{-1}(bL_2 \cup L_2) = a^{-1}L_2 = L_4 \\
b^{-1}L_4 &= b^{-1}(bL_2 \cup L_2) = L_2 \cup b^{-1}L_2 = L_2 \\
a^{-1}L_5 &= \emptyset \\
b^{-1}L_5 &= a(ba)^* = L_3
\end{aligned}$$

which gives the minimal automaton represented in Figure 4.21.

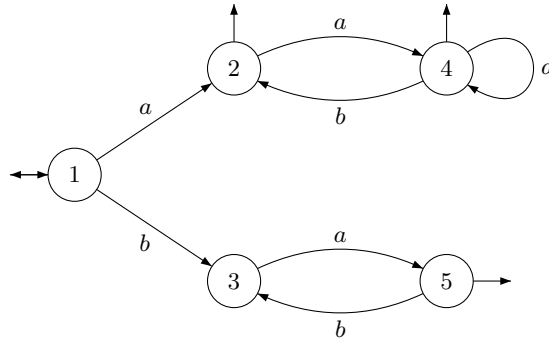

**Figure 4.21.** The minimal automaton of  $L$ .

There are standard algorithms for minimizing a given trim deterministic automaton [42] based on the computation of the *Nerode equivalence*. Let  $\mathcal{A} = (Q, A, E, q_-, F)$  be a trim deterministic automaton. The Nerode equivalence  $\sim$  on  $Q$  is defined by  $p \sim q$  if and only if, for every word  $u \in A^*$ ,

$$p \cdot u \in F \iff q \cdot u \in F$$

One can show that  $\sim$  is actually a congruence, in the sense that  $F$  is saturated by  $\sim$  and that  $p \sim q$  implies  $p \cdot x \sim q \cdot x$  for all  $x \in A^*$ . It follows that there is a well-defined quotient automaton  $\mathcal{A}/\sim = (Q/\sim, A, E, \tilde{q}_-, F/\sim)$ , where  $\tilde{q}_-$  is the equivalence class of  $q_-$ .

**Proposition 4.19** *Let  $\mathcal{A}$  be a trim [and complete] deterministic automaton. Then  $\mathcal{A}/\sim$  is the minimal [complete] automaton of  $\mathcal{A}$ .*

We shall in particular use the following consequence.

**Corollary 4.20** *A trim deterministic automaton is minimal if and only if its Nerode equivalence is the identity.*

One can show that the operations of completion and of minimization commute. In other words, if  $\mathcal{A}$  is a trim automaton and if  $\bar{\mathcal{A}}$  is its completion, then the minimal automaton of  $\bar{\mathcal{A}}$  is the completion of the minimal automaton of  $\mathcal{A}$ .

**Example 4.8** The minimal and minimal complete automata of  $(ab)^*$  are given in Figure 4.22.

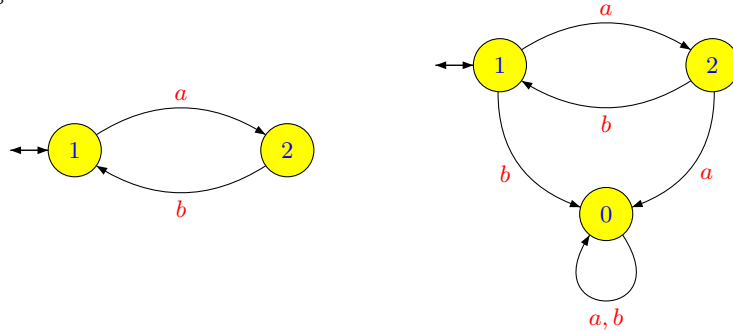

**Figure 4.22.** The minimal and minimal complete automata of  $(ab)^*$ .

**Example 4.9** The minimal and minimal complete automata of  $aA^*b$  are given in Figure 4.23.

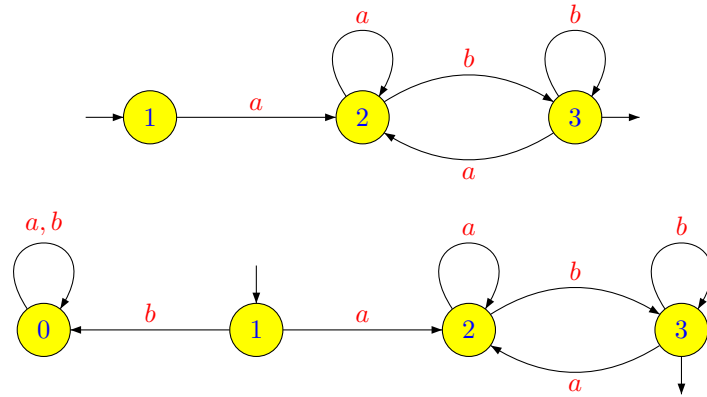

**Figure 4.23.** The minimal and minimal complete automata of  $aA^*b$ .

## 5 Rational versus recognisable

### 5.1 Local languages

A language  $L$  of  $A^*$  is said to be *local* if there exist two subsets  $P$  and  $S$  of  $A$  and a subset  $N$  of  $A^2$  such that <sup>3</sup>

$$L - 1 = (PA^* \cap A^*S) - A^*NA^*.$$

<sup>3</sup> $P$  stands for prefix,  $S$  for suffix and  $N$  for non-factor.

For instance, if  $A = \{a, b, c\}$ , the language

$$(abc)^* = 1 \cup [(aA^* \cap A^*c) - A^*\{aa, ac, ba, bb, cb, cc\}A^*]$$

is local. The terminology can be explained as follows: in order to check whether a nonempty word belongs to  $L$ , it suffices to verify that its first letter is in  $P$ , its last letter is in  $S$  and its factors of length 2 are not in  $N$ : all these conditions are local. Conversely, if a language  $L$  is local, it is easy to recover the parameters  $P$ ,  $S$  and  $N$ . Indeed,  $P$  [ $S$ ] is the set of first [last] letters of the words of  $L$ , and  $N$  is the set of words of length 2 that are factors of no word of  $L$ .

It is easy to compute a deterministic automaton recognising a local language, given the parameters  $P$ ,  $S$  and  $N$ .

**Proposition 5.21** *Let  $L = (PA^* \cap A^*S) - A^*NA^*$  be a local language. Then  $L$  is recognised by the automaton  $\mathcal{A}$  in which the set of states is  $A \cup \{1\}$ , the initial state is 1, the set of final states is  $S$ , and the transitions are given by the rules  $1 \cdot a = a$  if  $a \in P$  and  $a \cdot b = b$  if  $ab \notin N$ .*

**Proof.** Let  $u = a_1 \cdots a_n$  be a word accepted by  $\mathcal{A}$  and let

$$1 \xrightarrow{a_1} a_1 \xrightarrow{a_2} a_2 \cdots a_{n-1} \xrightarrow{a_n} a_n$$

be a successful path of label  $u$ . Then the state  $a_n$  is final and hence  $a_n \in S$ . Similarly, since  $1 \xrightarrow{a_1} a_1$  is a transition, one has necessarily  $a_1 \in P$ . Finally, since for  $1 \leq i \leq n-1$ ,  $a_i \xrightarrow{a_{i+1}} a_{i+1}$  is a transition, the word  $a_i a_{i+1}$  is not in  $N$ . Consequently,  $u$  belongs to  $L$ .

Conversely, if  $u = a_1 \cdots a_n \in L$ , one has  $a_1 \in P$ ,  $a_n \in S$  and, for  $1 \leq i \leq n$ ,  $a_i a_{i+1} \notin N$ . Thus  $1 \xrightarrow{a_1} a_1 \xrightarrow{a_2} a_2 \cdots a_{n-1} \xrightarrow{a_n} a_n$  is a successful path of  $\mathcal{A}$  and  $\mathcal{A}$  accepts  $u$ . Therefore, the language accepted by  $\mathcal{A}$  is  $L$ .  $\square$

For a local language containing the empty word, the previous construction can be easily modified by taking  $S \cup \{1\}$  as the set of final states.

**Example 5.1** Let  $A = \{a, b, c\}$ ,  $P = \{a, b\}$ ,  $S = \{a, c\}$  and  $N = \{ab, bc, ca\}$ . Then the automaton in Figure 5.24 recognises the language  $L = (PA^* \cap A^*S) - A^*NA^*$ .

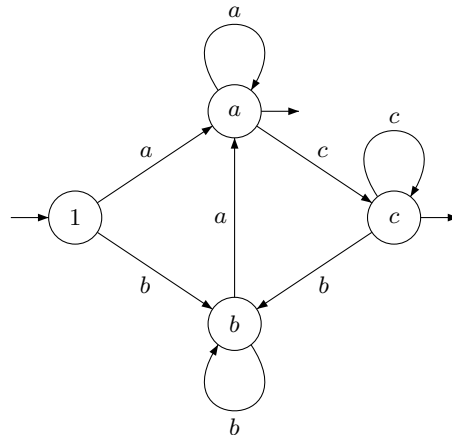

**Figure 5.24.** An automaton recognising a local language.

Note also that the automaton  $\mathcal{A}$  described in Proposition 5.21 has a special property: all the transitions of label  $a$  have the same end, namely the state  $a$ . More generally, we shall say that a deterministic automaton (not necessarily complete)  $\mathcal{A} = (Q, A, \cdot)$  is *local* if, for each letter  $a$ , the set  $\{q \cdot a \mid q \in Q\}$  contains at most one element. Local languages have the following characterisation:

**Proposition 5.22** *A rational language is local if and only if it is recognised by a local automaton.*

**Proof.** One direction follows from Proposition 5.21. To prove the opposite direction, consider a local automaton  $\mathcal{A} = (Q, A, \cdot, q_0, F)$  recognising a language  $L$  and let

$$\begin{aligned} P &= \{a \in A \mid q_0 \cdot a \text{ is defined}\}, \\ S &= \{a \in A \mid \text{there exists } q \in Q \text{ such that } q \cdot a \in F\}, \\ N &= \{x \in A^2 \mid x \text{ is the label of no path in } \mathcal{A}\}, \\ K &= (PA^* \cap A^*S) - A^*NA^*. \end{aligned}$$

Let  $u = a_1 \cdots a_n$  be a nonempty word of  $L$  and let  $q_0 \xrightarrow{a_1} q_1 \cdots q_{n-1} \xrightarrow{a_n} q_n$  be a successful path of label  $u$ . Necessarily,  $a_1 \in P$ ,  $a_n \in S$  and, for  $1 \leq i \leq n-1$ ,  $a_i a_{i+1} \notin N$ . Consequently,  $u \in K$ , which shows that  $L - 1$  is contained in  $K$ .

Let now  $u = a_1 \cdots a_n$  be a nonempty word of  $K$ . Then  $a_1 \in P$ ,  $a_n \in S$ , and, for  $1 \leq i \leq n-1$ ,  $a_i a_{i+1} \notin N$ . Since  $a_1 \in P$ , the state  $q_1 = q_0 \cdot a_1$  is well defined. Further, since  $a_1 a_2 \notin N$ ,  $a_1 a_2$  is the label of some path  $p_0 \xrightarrow{a_1} p_1 \xrightarrow{a_2} p_2$  in  $\mathcal{A}$ . But since  $\mathcal{A}$  is a local automaton,  $q_0 \cdot a_1 = p_0 \cdot a_1$ . It follows that the word  $a_1 a_2$  is also the label of the path  $q_0 \xrightarrow{a_1} p_1 \xrightarrow{a_2} p_2$ . One can show in the same way by induction that there exists a sequence of states  $p_i$  ( $0 \leq i \leq n$ ) such that  $a_i a_{i+1}$  is the label of a path  $p_{i-1} \xrightarrow{a_i} p_i \xrightarrow{a_{i+1}} p_{i+1}$  of  $\mathcal{A}$ . Finally, since  $a_n \in S$ , there is a state  $q$  such that  $q \cdot a_n \in F$ . But since  $\mathcal{A}$  is a local automaton, one has  $q \cdot a_n = p_{n-1} \cdot a_n = p_n$ , whence  $p_n \in F$ . Therefore  $q_0 \xrightarrow{a_1} p_1 \cdots p_{n-1} \xrightarrow{a_n} p_n$  is a successful path in  $\mathcal{A}$  and its label  $u$  is accepted by  $\mathcal{A}$ . Thus  $K = L - 1$ .  $\square$

Local languages are stable under various operations:

**Proposition 5.23** *Let  $A_1$  and  $A_2$  be two disjoint subsets of the alphabet  $A$  and let  $L_1 \subseteq A_1^*$  and  $L_2 \subseteq A_2^*$  be two local languages. Then the languages  $L_1 + L_2$  and  $L_1 L_2$  are local languages.*

**Proof.** Let  $\mathcal{A}_1$  [ $\mathcal{A}_2$ ] be a local automaton recognising  $L_1$  [ $L_2$ ]. The proofs of Propositions 4.8 and 4.12 give an automaton recognising  $L_1 + L_2$  and  $L_1 L_2$ . A simple verification shows that these constructions produce a local automaton when  $\mathcal{A}_1$  and  $\mathcal{A}_2$  are local.  $\square$

**Proposition 5.24** *Let  $L$  be a local language. Then the language  $L^*$  is a local language.*

**Proof.** Let  $\mathcal{A}$  be a local automaton recognising  $L$ . The proof of Proposition 4.13 gives an automaton recognising  $L^*$ . A simple verification shows that this construction produces a local automaton when  $\mathcal{A}$  is local.  $\square$



### 5.2 Glushkov's algorithm

Glushkov's algorithm is an efficient way to convert a rational expression into a nondeterministic automaton.

A rational expression is said to be *linear* if each letter has at most one occurrence in the expression. For instance, the expression

$$[a_1 a_2 (a_3 a_4)^* + (a_5 a_6)^* a_7]^* \tag{5.4}$$

is linear. One can linearize a rational expression by replacing each occurrence of a letter by a distinct symbol. For instance, the expression (5.4) is a linearization of the expression  $e = [ab(ba)^* + (ac)^*b]^*$ . Now, given an automaton for  $e'$ , the linearization of  $e$ , it is easy to obtain an automaton for  $e$ , simply by replacing the letters of  $e'$  by the corresponding letters in  $e$ . For instance, starting from the automaton  $\mathcal{A}$  which recognises  $[(a_1 a_2)^* a_3]^*$ , one gets a nondeterministic automaton  $\mathcal{A}'$  which recognises  $[(ab)^* a]^*$  by replacing  $a_1$  and  $a_3$  by  $a$  and  $a_2$  by  $b$ , as shown in Figure 5.25.

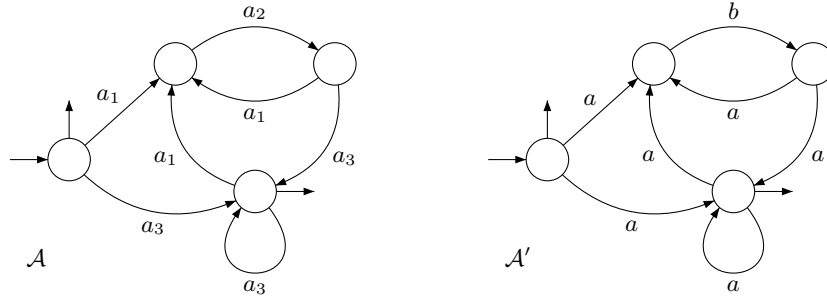

Figure 5.25. Construction of an automaton recognising  $[(ab)^*a]^*$ .

It remains to find an algorithm to compute the automaton of a linear expression.

**Proposition 5.25** *Every linear expression represents a local language.*

**Proof.** The proof works by induction on the formation rules of a linear expression. First, the languages represented by 0, 1 and  $a$ , for  $a \in A$ , are local languages. Next, by Proposition 5.24, if  $e$  represents a local language, then so does  $e^*$ . Let now  $e$  and  $e'$  be two linear expressions and suppose that the expression  $(e + e')$  is still linear. Let  $B$  [ $B'$ ] be the set of letters occurring in  $e$  [ $e'$ ]. Since  $(e + e')$  is linear, the letters of  $B$  [ $B'$ ] do not occur in  $e'$  [ $e$ ]. In other words,  $B$  and  $B'$  are disjoint and the local language represented by  $e$  [ $e'$ ] is contained in  $B^*$  [ $B'^*$ ]. By Proposition 5.23, the language represented by  $(e + e')$  is also a local language. A similar argument applies for the language represented by  $ee'$ .  $\square$

Proposition 5.21 allows one to compute a deterministic automaton recognising a local language. It suffices to test whether the empty word belongs to  $L$  and to compute the sets

$$\begin{aligned} P(L) &= \{a \in A \mid aA^* \cap L \neq \emptyset\}, \\ S(L) &= \{a \in A \mid A^*a \cap L \neq \emptyset\}, \\ F(L) &= \{x \in A^2 \mid A^*xA^* \cap L \neq \emptyset\}. \end{aligned}$$

This can be done by recursion, given a linear rational expression representing the language. We first compute the procedure

EmptyWord( $e$ : linear expression): **boolean**;  
which tells whether the empty word belongs to the language represented by  $e$ .

```

EmptyWord(0) = false;
EmptyWord(1) = true;
EmptyWord( $a$ ) = false for all  $a \in A$ ;
EmptyWord( $e + e'$ ) = EmptyWord( $e$ ) or EmptyWord( $e'$ );
EmptyWord( $e \cdot e'$ ) = EmptyWord( $e$ ) and EmptyWord( $e'$ );
EmptyWord( $e^*$ ) = true;

```

Now  $P$ ,  $S$  and  $F$  are computed by the following recursive procedures:

<pre> P(0) = <math>\emptyset</math>; P(1) = <math>\emptyset</math>; P(<math>a</math>) = <math>\{a\}</math> for all <math>a \in A</math>; P(<math>e + e'</math>) = <math>P(e) \cup P(e')</math>; <b>if</b> EmptyWord(<math>e</math>)   <b>then</b> <math>P(e \cdot e') = P(e) \cup P(e')</math>   <b>else</b> <math>P(e \cdot e') = P(e)</math>; P(<math>e^*</math>) = <math>P(e)</math>; </pre>	<pre> S(0) = <math>\emptyset</math>; S(1) = <math>\emptyset</math>; S(<math>a</math>) = <math>\{a\}</math> for all <math>a \in A</math>; S(<math>e + e'</math>) = <math>S(e) \cup S(e')</math>; <b>if</b> EmptyWord(<math>e'</math>)   <b>then</b> <math>S(e \cdot e') = S(e) \cup S(e')</math>   <b>else</b> <math>S(e \cdot e') = S(e')</math>; S(<math>e^*</math>) = <math>S(e)</math>; </pre>
---	---

```

F(0) =  $\emptyset$ ;
F(1) =  $\emptyset$ ;
F( $a$ ) =  $\emptyset$  for all  $a \in A$ ;
F( $e + e'$ ) =  $F(e) \cup F(e')$ ;
F( $e \cdot e'$ ) =  $F(e) \cup F(e') \cup S(e)P(e')$ ;
F( $e^*$ ) =  $F(e) \cup S(e)P(e)$ ;

```

In summary, Glushkov's algorithm to convert a rational expression  $e$  into a nondeterministic automaton works as follows:

- (1) Linearize  $e$  into  $e'$  and memorize the coding of the letters.
- (2) Compute recursively the sets  $P(e')$ ,  $S(e')$  and  $F(e')$ . Then compute a deterministic automaton  $\mathcal{A}'$  recognising  $e'$ .
- (3) Convert  $\mathcal{A}'$  into a nondeterministic automaton  $\mathcal{A}$  recognising  $e$ .

**Example 5.2** Consider the rational expression  $e = (a(ab)^*)^* + (ba)^*$ . We first linearize  $e$  into  $e' = (a_1(a_2a_3)^*)^* + (a_4a_5)^*$ . Let  $L = L(e)$  and  $L' = L(e')$ . To compute the sets  $P$ ,  $S$  and  $F$ , one can either use the above-mentioned recursive procedures, or proceed to a direct computation (this method is usually preferred in a computation by hand...). Recall that  $P$  [ $S$ ] is the set of first [last] letters of the words of  $L'$ . We get

$$P = \{a_1, a_4\} \quad \text{and} \quad S = \{a_1, a_3, a_5\}$$

Note that  $a_1$  belongs to  $S$  since  $a_1$  is a word of  $L'$ .

Next we compute the set  $F$  of all words of length 2 that are factors of some word of  $L'$ . We get  $F = \{a_1a_2, a_1a_1, a_2a_3, a_3a_1, a_3a_2, a_4a_5, a_5a_4\}$ . For instance,  $a_3a_1$  is a factor of  $a_1a_2a_3a_1$  and  $a_3a_2$  is a factor of  $a_1a_2a_3a_2a_3$ . Since the empty word belongs to  $L'$ , the state 1 is final and we finally obtain the automaton represented in Figure 5.26. Since this automaton is local, there is actually no

need to write the labels on the transitions. We now convert this automaton into a nondeterministic automaton recognising  $L$ , represented in Figure 5.27.

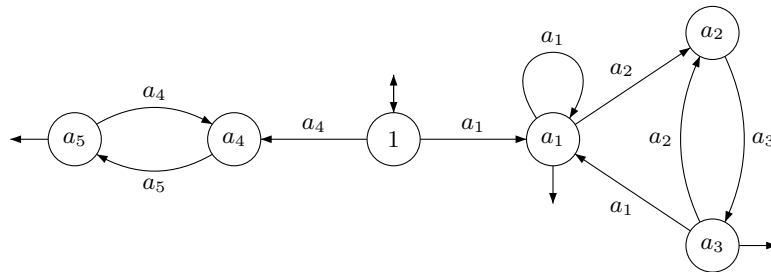

Figure 5.26. A local automaton recognising  $L'$ .

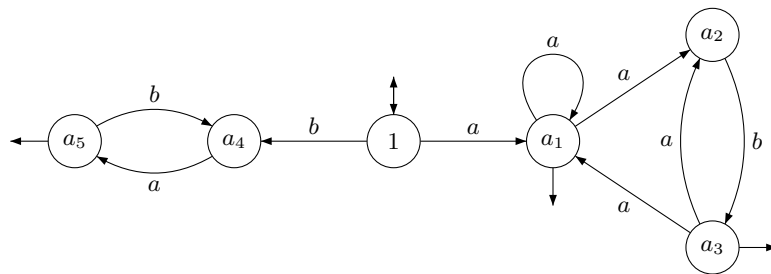

Figure 5.27. A nondeterministic automaton recognising  $L$ .

To get a deterministic automaton, it remains to apply the algorithm described in Section 3.2, which leads to the automaton represented in Figure 5.28.

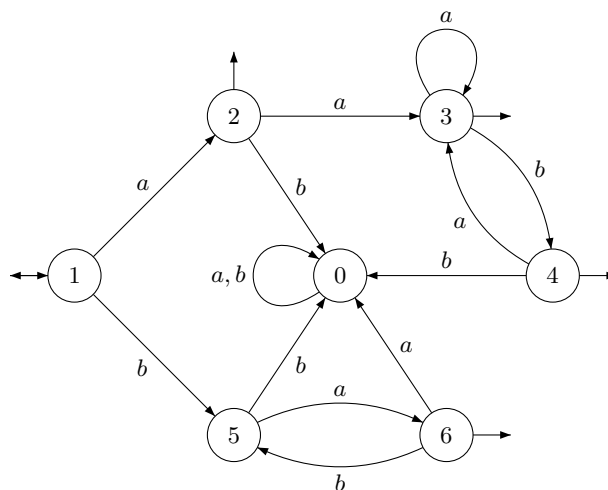

Figure 5.28. A deterministic automaton recognising  $L$ .

### 5.3 Linear equations

In this section, we give an algorithm to convert an automaton into a rational expression. The algorithm amounts to solving a system of linear equations on languages. We first consider an equation of the form

$$X = KX + L, \quad (5.5)$$

where  $K$  and  $L$  are languages and  $X$  is the unknown. When  $K$  does not contain the empty word, the equation admits a unique solution.

**Proposition 5.26 (Arden's Lemma)** *If  $K$  does not contain the empty word, then  $X = K^*L$  is the unique solution of the equation  $X = KX + L$ .*

**Proof.** Replacing  $X$  by  $K^*L$  in the expression  $KX + L$ , one gets

$$K(K^*L) + L = K^+L + L = (K^+ + 1)L = K^*L,$$

and hence  $X = K^*L$  is a solution of (5.5). To prove uniqueness, consider two solutions  $X_1$  and  $X_2$  of (5.5). By symmetry, it suffices to show that each word  $u$  of  $X_1$  also belongs to  $X_2$ . Let us prove this result by induction on the length of  $u$ .

If  $|u| = 0$ ,  $u$  is the empty word and if  $u \in X_1 = KX_1 + L$ , then necessarily  $u \in L$  since  $1 \notin K$ . But in this case,  $u \in KX_2 + L = X_2$ . For the induction step, consider a word  $u$  of  $X_1$  of length  $n + 1$ . Since  $X_1 = KX_1 + L$ ,  $u$  belongs either to  $L$  or to  $KX_1$ . If  $u \in L$ , then  $u \in KX_2 + L = X_2$ . If  $u \in KX_1$  then  $u = kx$  for some  $k \in K$  and  $x \in X_1$ . Since  $k$  is not the empty word, one has necessarily  $|x| \leq n$  and hence by induction  $x \in X_2$ . It follows that  $u \in KX_2$  and finally  $u \in X_2$ . This concludes the induction and the proof of the proposition.  $\square$

If  $K$  contains the empty word, uniqueness is lost.

**Proposition 5.27** *If  $K$  contains the empty word, the solutions of (5.5) are the languages of the form  $K^*M$  with  $L \subseteq M$ .*

**Proof.** Since  $K$  contains the empty word, one has  $K^+ = K^*$ . If  $L \subseteq M$ , one has  $L \subseteq M \subseteq K^*M$ . It follows that the language  $K^*M$  is solution of (5.5) since

$$K(K^*M) + L = K^+M + L = K^*M + L = K^*M$$

Conversely, let  $X$  be a solution of (5.5). Then  $L \subseteq X$  and  $KX \subseteq X$ . Consequently,  $K^2X \subseteq KX \subseteq X$  and by induction,  $K^nX \subseteq X$  for all  $n$ . It follows that  $K^*X = \sum_{n \geq 0} K^nX \subseteq X$ . The language  $X$  can thus be written as  $K^*M$  with  $L \subseteq M$ : it suffices to take  $M = X$ .  $\square$

In particular, if  $K$  contains the empty word, then  $A^*$  is the maximal solution of (5.5) and the minimal solution is  $K^*L$ .

Consider now a system of the form

$$\begin{aligned} X_1 &= K_{1,1}X_1 + K_{1,2}X_2 + \cdots + K_{1,n}X_n + L_1 \\ X_2 &= K_{2,1}X_1 + K_{2,2}X_2 + \cdots + K_{2,n}X_n + L_2 \\ &\vdots \\ X_n &= K_{n,1}X_1 + K_{n,2}X_2 + \cdots + K_{n,n}X_n + L_n \end{aligned} \quad (5.6)$$

We shall only consider the case when the system admits a unique solution.

**Proposition 5.28** *If, for  $1 \leq i, j \leq n$ , the languages  $K_{i,j}$  do not contain the empty word, the system (5.6) admits a unique solution. If further the  $K_{i,j}$  and the  $L_i$  are rational languages, then the solutions  $X_i$  of (5.6) are rational languages.*

**Proof.** The case  $n = 1$  is handled by Proposition 5.26. Suppose that  $n > 1$ . Consider the last equation of the system (5.6), which can be written

$$X_n = K_{n,n}X_n + (K_{n,1}X_1 + \cdots + K_{n,n-1}X_{n-1} + L_n)$$

According to Proposition 5.26, the unique solution of this equation is

$$X_n = K_{n,n}^*(K_{n,1}X_1 + \cdots + K_{n,n-1}X_{n-1} + L_n)$$

Replacing  $X_n$  by this expression in the  $n - 1$  first equations, we obtain a system of  $n - 1$  equations with  $n - 1$  unknowns and one can conclude by induction.  $\square$

We shall now associate a system of linear equations with every finite automaton  $\mathcal{A} = (Q, A, E, I, F)$ . Let us set, for  $p, q \in Q$ ,

$$K_{p,q} = \{a \in A \mid (p, a, q) \in E\}$$

$$L_q = \begin{cases} 1 & \text{if } q \in F \\ 0 & \text{if } q \notin F \end{cases}$$

The solutions of the system defined by these parameters are the languages recognised by the automata

$$\mathcal{A}_q = (Q, A, E, \{q\}, F)$$

More precisely, we get the following result:

**Proposition 5.29** *The system (5.6) admits a unique solution  $(R_q)_{q \in Q}$ , given by the formula*

$$R_q = \{u \in A^* \mid \text{there is a path of label } u \text{ from } q \text{ to } F\}$$

Further, the language recognised by  $\mathcal{A}$  is  $\sum_{q \in I} R_q$ .

**Proof.** Since the languages  $K_{p,q}$  do not contain the empty word, Proposition 5.28 shows that the system (5.6) admits a unique solution. It remains to verify that the family  $(R_q)_{q \in Q}$  is solution of the system, that is, satisfies for all  $q \in Q$  the formula

$$R_q = K_{q,1}R_1 + K_{q,2}R_2 + \cdots + K_{q,n}R_n + L_q \quad (5.7)$$

Let us denote by  $S_q$  the right hand side of (5.7). If  $u \in R_q$ , then  $u$  is by definition the label of a path from  $q$  to a final state  $f$ . If  $u$  is the empty word, one has necessarily  $q = f$  and hence  $L_q = 1$ . Thus  $u \in S_q$  in this case. Otherwise, let  $(q, a, q')$  be the first transition of the path. One has  $u = au'$ , where  $u'$  is the label of a path from  $q'$  to  $f$ . Then one has  $a \in K_{q,q'}$ ,  $u' \in R_{q'}$  and finally  $u \in S_q$ .

Conversely, let  $u \in S_q$ . If  $u = 1$ , one has necessarily  $u \in L_q$ , whence  $q \in F$  and  $u \in R_q$ . Otherwise there is a state  $q'$  such that  $u \in K_{q,q'}R_{q'}$ . Therefore,  $u = au'$  for some  $a \in K_{q,q'}$  and  $u' \in R_{q'}$ . On the one hand,  $(q, a, q')$  is a

transition of  $\mathcal{A}$  by definition of  $K_{q,q'}$  and on the other hand  $u'$  is the label of a final path starting in  $q'$ . The composition of these paths gives a final path of label  $u$  starting in  $q$ . Therefore  $u \in R_q$  and thus  $R_q = S_q$ .  $\square$

For example, if  $\mathcal{A}$  is the automaton represented in Figure 5.29,

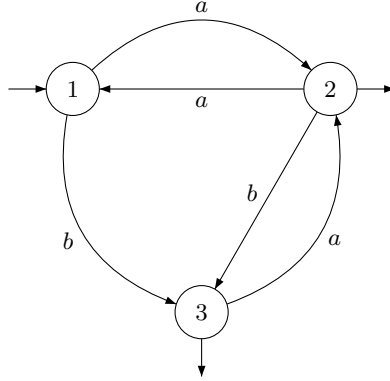

Figure 5.29. An automaton.

The system can be written

$$\begin{aligned} X_1 &= aX_2 + bX_3 \\ X_2 &= aX_1 + bX_3 + 1 \\ X_3 &= aX_2 + 1 \end{aligned}$$

Substituting  $aX_2 + 1$  for  $X_3$ , one gets the equivalent system

$$\begin{aligned} X_1 &= aX_2 + b(aX_2 + 1) = (a + ba)X_2 + b \\ X_2 &= aX_1 + b(aX_2 + 1) + 1 = aX_1 + baX_2 + (b + 1) \\ X_3 &= aX_2 + 1 \end{aligned}$$

Substituting  $(a + ba)X_2 + b$  for  $X_1$ , one gets a third equivalent system

$$\begin{aligned} X_1 &= (a + ba)X_2 + b \\ X_2 &= a((a + ba)X_2 + b) + baX_2 + (b + 1) = (aa + aba + ba)X_2 + (ab + b + 1) \\ X_3 &= aX_2 + 1 \end{aligned}$$

The solution of the second equation is

$$X_2 = (aa + aba + ba)^*(ab + b + 1)$$

Replacing  $X_2$  by its value in the two other equations, we obtain

$$X_1 = (a + ba)(aa + aba + ba)^*(ab + b + 1) + b \text{ and } X_3 = a(aa + aba + ba)^*(ab + b + 1) + 1$$

Finally, the language recognised by the automaton is

$$X_1 = (a + ba)(aa + aba + ba)^*(ab + b + 1) + b$$

since 1 is the unique initial state.

### 5.4 Extended automata

The use of equations is not limited to deterministic automata. The same technique applies to nondeterministic automata and to more powerful automata, in which the transition labels are not letters, but rational languages.

An *extended automaton* is a quintuple  $\mathcal{A} = (Q, A, E, I, F)$ , where  $Q$  is a set of states,  $A$  is an alphabet,  $E$  is a subset of  $Q \times \text{Rat}(A^*) \times Q$ , called the set of transitions,  $I$  [ $F$ ] is the set of initial [final] states. The label of a path

$$c = (q_0, L_1, q_1), (q_1, L_2, q_2), \dots, (q_{n-1}, L_n, q_n)$$

is the rational language  $L_1 L_2 \cdots L_n$ . The definition of a successful path is unchanged. A word is accepted by  $\mathcal{A}$  if *it belongs to* the label of a successful path.

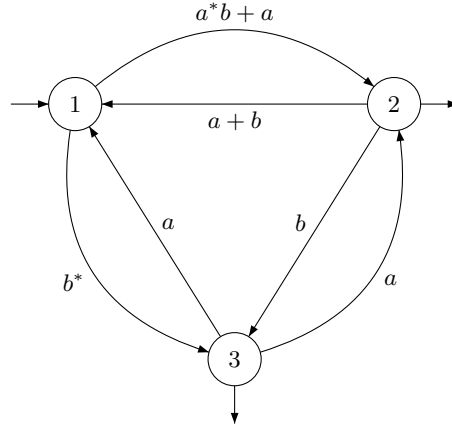

Figure 5.30. An extended automaton.

In the example represented in Figure 5.30, the set of transitions is

$$\{(1, a^*b + a, 2), (1, b^*, 3), (2, a + b, 1), (2, b, 3), (3, a, 1), (3, a, 2)\}$$

Let  $\mathcal{A} = (Q, A, E, I, F)$  be an extended automaton. For all  $p, q \in Q$ , we denote by  $K_{p,q}$  the label of the transition from  $p$  to  $q$ . Notice that  $K_{p,q}$  might possibly be the empty language. We also put

$$L_q = \begin{cases} 1 & \text{if there is a path labelled by } u \text{ from } q \text{ to } F \\ 0 & \text{otherwise} \end{cases}$$

Yet the associated system does not necessarily fulfil the condition  $1 \notin K_{i,j}$  and Proposition 5.29 needs to be modified as follows:

**Proposition 5.30** *The system (5.6) has a minimal solution  $(R_q)_{q \in Q}$ , given by the formula*

$$R_q = \{u \in A^* \mid \text{there is a path labelled by } u \text{ from } q \text{ to } F\}$$

*In particular the language recognised by  $\mathcal{A}$  is  $\sum_{q \in I} R_q$ .*

**Proof.** Let us first verify that the family  $(R_q)_{q \in Q}$  is indeed a solution of (5.6), i.e. satisfies, for all  $q \in Q$ :

$$R_q = K_{q,1}R_1 + K_{q,2}R_2 + \cdots + K_{q,n}R_n + L_q \quad (5.8)$$

Denote by  $S_q$  the right hand side of (5.8). If  $u \in R_q$ , then  $u$  is by definition the label of a path from  $q$  to  $F$ . If  $u = 1$ , one has  $L_q = 1$  and thus  $u \in S_q$ . Otherwise, let  $(q, u_1, q')$  be the first transition of the path. One has  $u = u_1u'$ , where  $u'$  is the label of a path from  $q'$  to  $F$ . Therefore  $u_1 \in K_{q,q'}$ ,  $u' \in R_{q'}$  and finally  $u \in S_q$ .

Conversely, let  $u \in S_q$ . If  $u = 1$ , one has necessarily  $u \in L_q$ , whence  $q \in F$  and  $u \in R_q$ . Otherwise, there is a state  $q'$  such that  $u \in K_{q,q'}R_{q'}$ . Thus  $u = u_1u'$  for some  $u_1 \in K_{q,q'}$  and  $u' \in R_{q'}$ . On the one hand,  $(q, u_1, q')$  is a transition of  $\mathcal{A}$  by the definition of  $K_{q,q'}$  and on the other hand,  $u'$  is the label of a path from  $q'$  to  $F$ . Therefore  $u = u_1u'$  is the label of a path from  $q$  to  $F$  and  $u \in R_q$ . Consequently  $R_q = S_q$ .

It remains to verify that if  $(X_q)_{q \in Q}$  is a solution of the system, then  $R_q \subseteq X_q$  for all  $q \in Q$ . If  $u \in R_q$ , there exists a path labelled by  $u$  from  $q$  to  $F$ :

$$(q_0, u_1, q_1)(q_1, u_2, q_2) \cdots (q_{r-1}, u_r, q_r)$$

with  $q_0 = q$ ,  $q_r \in F$ ,  $u_i \in K_{q_{i-1}, q_i}$  and  $u_1u_2 \cdots u_r = u$ . Let us show by induction on  $r - i$  that  $u_{i+1} \cdots u_r$  belongs to  $X_{q_i}$ . By hypothesis, the  $X_q$  are solutions of

$$X_q = K_{q,1}X_1 + K_{q,2}X_2 + \cdots + K_{q,n}X_n + L_q$$

In particular, since  $q_r \in F$ , one has  $1 \in L_{q_r}$  and hence  $1 \in X_{q_r}$ , which gives the result for  $r - i = 0$ . Further, if  $u_{i+1} \cdots u_r$  is an element of  $X_{q_i}$ , the inclusion  $K_{q_{i-1}, q_i}X_{q_i} \subseteq X_{q_{i-1}}$  shows that  $u_iu_{i+1} \cdots u_r$  is an element of  $X_{q_{i-1}}$ , which concludes the induction. In particular,  $u = u_1 \cdots u_r \in X_q$ .  $\square$

**Example 5.3** For the extended automaton represented in Figure 5.30, the system can be written

$$\begin{aligned} X_1 &= (a^*b + a)X_2 + b^*X_3 \\ X_2 &= (a + b)X_1 + bX_3 + 1 \\ X_3 &= aX_1 + aX_2 + 1 \end{aligned}$$

Replacing  $X_3$  by  $aX_1 + aX_2 + 1$ , and observing that  $a + b^*a = b^*a$ , we obtain the equivalent system

$$\begin{aligned} X_1 &= (a^*b + a)X_2 + b^*(aX_1 + aX_2 + 1) = b^*aX_1 + (a^*b + b^*a)X_2 + b^* \\ X_2 &= (a + b)X_1 + b(aX_1 + aX_2 + 1) + 1 = (a + b + ba)X_1 + baX_2 + b + 1 \\ X_3 &= aX_1 + aX_2 + 1 \end{aligned}$$

We deduce from the second equation

$$X_2 = (ba)^*((a + b + ba)X_1 + b + 1)$$

and replacing  $X_2$  by its value in the first equation, we obtain

$$\begin{aligned} X_1 &= b^*aX_1 + (a^*b + b^*a)(ba)^*((a + b + ba)X_1 + b + 1) + b^* \\ &= (b^*a + (a^*b + b^*a)(ba)^*(a + b + ba))X_1 + (a^*b + b^*a)(ba)^*(b + 1) + b^* \end{aligned}$$



Finally, the language recognised by the automaton is

$$X_1 = (b^*a + (a^*b + b^*a)(ba)^*(a + b + ba))^*[(a^*b + b^*a)(ba)^*(b + 1) + b^*]$$

since 1 is the unique initial state.

### 5.5 Kleene's theorem

We are now ready to state the most important result of automata theory.

**Theorem 5.31 (Kleene)** *A language is rational if and only if it is recognisable.*

**Proof.** It follows from Proposition 5.29 that every recognisable language is rational. Corollary 4.9 states that every finite language is recognisable. Further, Propositions 4.8, 4.12 and 4.13 show that recognisable languages are closed under union, product and star. Thus every rational language is recognisable.  $\square$

The following corollary is now a consequence of Propositions 2.3, 4.8, 4.10, 4.11, 4.12, 4.13, 4.15 and 4.16.

**Corollary 5.32** *Recognizable [rational] languages are closed under Boolean operations, product, star, quotients, morphisms and inverses of morphisms.*

We conclude this section by proving some elementary decidability results on recognisable languages. Recall that a property is *decidable* if there is an algorithm to check whether this property holds or not. We shall also often use the expressions “given a recognisable language  $L$ ” or “given a rational language  $L$ ”. As long as only decidability is concerned, it makes no difference to give a language by a nondeterministic automaton, a deterministic automaton or a regular expression, since there are algorithms to convert one of the forms into the other. However, the chosen representation is important for complexity issues, which will not be discussed here.

**Theorem 5.33** *Given a recognisable language  $L$ , the following properties are decidable:*

- (1) *whether a given word belongs to  $L$ ,*
- (2) *whether  $L$  is empty,*
- (3) *whether  $L$  is finite,*
- (4) *whether  $L$  is infinite,*

**Proof.** We may assume that  $L$  is given by a trim deterministic automaton  $\mathcal{A} = (Q, A, \cdot, q_-, F)$ .

(1) To test whether  $u \in L$ , it suffices to compute  $q_- \cdot u$ . If  $q_- \cdot u \in F$ , then  $u \in L$ ; if  $q_- \cdot u \notin F$ , or if  $q_- \cdot u$  is undefined, then  $u \notin L$ .

(2) Let us show that  $L$  is empty if and only if  $F = \emptyset$ . The condition  $F = \emptyset$  is clearly sufficient. Since  $\mathcal{A}$  is trim, every state of  $\mathcal{A}$  is accessible. Now, if  $\mathcal{A}$  has at least one final state  $q$ , there is a word  $u$  such that  $q_- \cdot u = q$ . Therefore  $u \in L$  and  $L$  is nonempty.

(3) and (4). Let us show that  $L$  is finite if and only if  $\mathcal{A}$  does not contain any loop. If  $\mathcal{A}$  contains a loop  $q \xrightarrow{u} q$ , then  $L$  is infinite: indeed, since  $\mathcal{A}$

is trim, there exist paths  $q_- \xrightarrow{x} q$  and  $q \xrightarrow{y} f$ , where  $f$  is a final state and thus  $L$  contains all the words  $xu^ny$ . Conversely, if  $L$  is infinite, the proof of the pumping lemma shows that  $\mathcal{A}$  contains a loop. Now, checking whether an automaton contains a loop is easy. Consider the directed graph  $G$  obtained from  $\mathcal{A}$  by removing all the labels. Then  $\mathcal{A}$  is loop-free if and only if  $G$  is acyclic, a property that can be checked by standard algorithms. One can for instance compute the transitive closure  $G'$  of  $G$  and check whether  $G'$  contains an edge of the form  $(q, q)$ .  $\square$

We leave as an exercise to the reader to prove that the inclusion problem and the equality problem are decidable for two given recognisable languages.

## 6 Exercises

### Section 1

- Let us say that two words  $x$  and  $y$  are *power of the same word* if there exists a word  $z$  and two nonnegative integers  $n$  and  $m$  such that  $x = z^n$  and  $y = z^m$ . Show that two words commute if and only if they are power of the same word.
- Two words  $x$  and  $y$  are *conjugate* if there exist two words  $u$  and  $v$  such that  $x = uv$  and  $y = vu$ .
  - Show that two words are conjugate if and only if there exists a word  $z$  such that  $xz = zy$ .
  - Conclude that the conjugacy relation is an equivalence relation.
- A word  $u$  is a *subword* of  $v$  if  $v$  can be written as

$$v = v_0u_1v_1u_2v_2 \cdots u_kv_k$$

where  $u_i$  and  $v_i$  are words (possibly empty) such that  $u_1u_2 \cdots u_k = u$ . For instance, the words *baba* and *acab* are subwords of *abcacbab*.

- Show that the subword relation is a partial ordering on  $A^*$ .
- (Difficult) Prove that if  $A$  is finite, any infinite set of words contains two words, one of which is a subword of the other.

### Section 2

- Simplify the following rational expressions
  - $((abb)^*)^*$ ,
  - $a^*b + a^*ba^*$
  - $0^*ab1^*$ ,
  - $(a^*b)^*a^*$ .
- Let  $e, e_1, e_2, e_3$  be four rational expressions. Verify that the following pairs of rational expressions represent the same language:
  - $e_1 + e_2$  and  $e_2 + e_1$ ,
  - $((e_1 + e_2) + e_3)$  and  $(e_1 + (e_2 + e_3))$ ,
  - $((e_1e_2)e_3)$  and  $(e_1(e_2e_3))$ ,

- (4)  $(e_1(e_2 + e_3))$  and  $((e_1e_2) + (e_1e_3))$ ,
- (5)  $((e_1 + e_2)e_3)$  and  $((e_1e_3) + (e_2e_3))$ ,
- (6)  $e^{**}$  and  $e^*$ ,
- (7)  $0 + e$  and  $e$ ,
- (8)  $1e$  and  $e$ ,
- (9)  $0^*$  and  $1$ ,
- (10)  $(e_1 + e_2)^*$  and  $(e_1^*e_2)^*e_1^*$ .

### Section 3

**6.** A well-parenthesised word is a word on the alphabet  $\{(,)\}$  containing as many left parentheses as right parentheses and such that each of its prefixes contains at least as many left parentheses than right parentheses. For instance,  $((()()))$  is a well-parenthesised word, but  $((()()))()$  is not.

Prove that the language of all well parenthesised words is not recognisable.

**7.** Prove that the following languages are not recognisable:

- (1)  $\{u \in \{a, b\}^* \mid |u|_a = |u|_b\}$ ,
- (2)  $\{a^n b^m \mid n, m \geq 0 \text{ and } n = 2m\}$ ,
- (3)  $\{u \in A^* \mid u = \tilde{u}\}$
- (4)  $\{v\tilde{v}w \mid v, w \in \{a, b\}^+\}$
- (5)  $\{u \in a^* \mid |u| \text{ is a prime number}\}$

**8.** Let  $A = \{a, b, c\}$ . Show that the language

$$L = \{(ab)^n c^n \mid n > 0\} + A^* b b A^* + A^* a a A^*$$

is not recognisable, but satisfies the pumping lemma: there is an integer  $n > 0$  such that every word  $u$  of  $L$  of length greater than or equal to  $n$  can be factorised as  $u = xyz$  with  $x, y, z \in A^*$ ,  $|xy| \leq n$ ,  $y \neq \epsilon$  and, for all  $k \geq 0$ ,  $xy^k z \in L$ .

**9.** Prove that, for each  $n > 0$ , the language

$$L_n = \{u \in \{a, b\}^* \mid |u|_a \equiv |u|_b \pmod{n}\}$$

is recognisable, and compute its minimal automaton.

**10.** Let  $\mathcal{A}_n = (\{0, 1, \dots, n-1\}, \{a, b\}, E_n, \{0\}, \{0\})$  be the nondeterministic automaton defined by

$$E_n = \{(i, a, i+1) \mid 0 \leq i \leq n-1\} \cup \{(n-1, a, 0)\} \cup \\ \{(i, b, i) \mid 1 \leq i \leq n-1\} \cup \{(i, b, 0) \mid 1 \leq i \leq n-1\}$$

and represented in Figure 6.31. Show that any deterministic automaton equivalent to  $\mathcal{A}_n$  has at least  $2^n$  states.

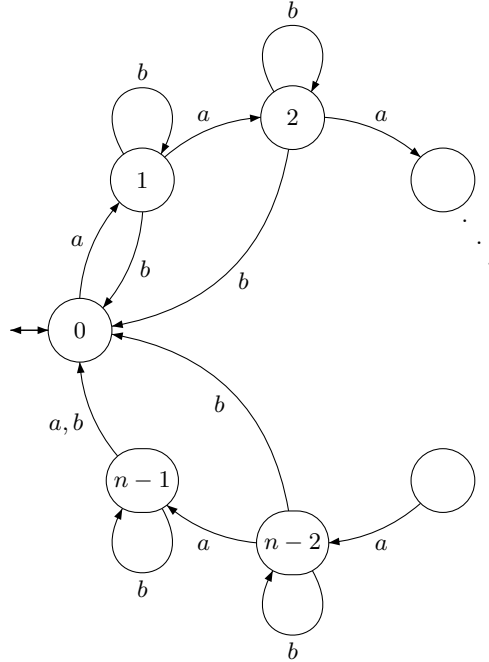

Figure 6.31. The automaton  $\mathcal{A}_n$ .

#### Section 4

11. The *shuffle* of two words  $u$  and  $v$  is the language  $u \sqcup v$  consisting of all words

$$u_1 v_1 u_2 v_2 \cdots u_k v_k$$

where  $k \geq 0$ , the  $u_i$  and  $v_i$  are words of  $A^*$ , such that  $u_1 u_2 \cdots u_k = u$  and  $v_1 v_2 \cdots v_k = v$ . For instance,

$$ab \sqcup ba = \{abab, abba, baba, baab\}.$$

By extension, the shuffle of two languages  $K$  and  $L$  is the language

$$K \sqcup L = \bigcup_{u \in K, v \in L} u \sqcup v$$

Prove that the shuffle is a commutative and associative operation, which distributes over union. Show that if  $K$  and  $L$  are recognisable, then  $K \sqcup L$  is recognisable.

12. Compute the minimal automaton of the language  $(a(ab)^*b)^*$ .

13. Consider the sequence of languages  $D_n$  defined by  $D_0 = \{1\}$  and  $D_{n+1} = (aD_n b)^*$ . Compute the minimal automaton of  $D_0$ ,  $D_1$  and  $D_2$ . Guess from these examples the minimal automaton of  $D_n$  and prove that your guess is correct.

Let, for  $u \in A^*$ ,  $\|u\| = |u|_a - |u|_b$ . Show that, for all  $n \geq 0$ , the following conditions are equivalent:

- (1)  $u \in D_n$ ,

(2)  $\|u\| = 0$  and for all prefixes  $v$  of  $u$ ,  $0 \leq \|v\| \leq n$ .

Conclude that, for all  $p, q \geq 0$ ,  $D_p \sqcup D_q = D_{p+q}$ .

Let  $D = \bigcup_{n \geq 0} D_n$ . Show that that  $D$  is not recognisable.

### Section 5

**14.** For each of these languages on the alphabet  $\{a, b\}$ , compute their minimal automaton, the transition monoid of this minimal automaton and a rational expression representing them:

- (1) The language  $a(a + b)^*a$ .
- (2) The set of words containing two consecutive  $a$ .
- (3) The set of words with an even number of  $b$  and an odd number of  $a$ .
- (4) The set of words not containing the factor  $abab$ .

**15.** This exercise relies on the notion of a *countable set*. Let  $A$  be a finite nonempty alphabet. Prove that  $A^*$  and the set of recognisable languages of  $A^*$  are countable. (Hint: one can enumerate the finite automata on the alphabet  $A$ ). Arguing on the fact that the set of subsets of an infinite set is uncountable, deduce that there exist some nonrecognisable languages on  $A^*$ .

Use a similar argument to prove that there are some nonrational languages on  $A^*$ .



## Chapter IV

# Recognizable and rational sets

The notions of rational and recognisable sets are usually defined for finitely generated free monoids, under the common name of regular sets. Following Eilenberg [27], one can extend these notions to arbitrary monoids. The price to pay is that Kleene's theorem does not extend to arbitrary monoids. Although the classes of rational and recognisable sets coincide in finitely generated free monoids, they form in general incomparable classes.

### 1 Rational subsets of a monoid

Let  $M$  be a monoid. We have already seen that the set  $\mathcal{P}(M)$  of subsets of  $M$  is a semiring with union as addition and product defined by the formula

$$XY = \{xy \mid x \in X \text{ and } y \in Y\}$$

For this reason, we shall adopt the notation we already introduced for languages. Union is denoted by  $+$ , the empty set by  $0$  and the singleton  $\{m\}$ , for  $m \in M$  by  $m$ . This notation has the advantage that the identity of  $\mathcal{P}(M)$  is denoted by  $1$ .

The powers of a subset  $X$  of  $M$  are defined by induction by setting  $X^0 = 1$ ,  $X^1 = X$  and  $X^n = X^{n-1}X$  for all  $n > 1$ . The *star* and *plus* operations are defined as follows:

$$X^* = \sum_{n \geq 0} X^n = 1 + X + X^2 + X^3 + \dots$$
$$X^+ = \sum_{n > 0} X^n = X + X^2 + X^3 + \dots$$

Note that  $X^*$  [ $X^+$ ] is the submonoid [subsemigroup] of  $M$  generated by  $X$ . The set of rational subsets of a monoid  $M$  is the smallest set  $\mathcal{F}$  of subsets of  $M$  satisfying the following conditions:

- (1)  $\mathcal{F}$  contains  $0$  and the singletons of  $\mathcal{P}(M)$ ,
- (2)  $\mathcal{F}$  is closed under union, product and star (in other words, if  $X, Y \in \mathcal{F}$ , then  $X + Y \in \mathcal{F}$ ,  $XY \in \mathcal{F}$  and  $X^* \in \mathcal{F}$ ).

**Example 1.1** In a finite monoid, all subsets are rational.

**Example 1.2** The rational subsets of  $\mathbb{N}^k$  are the *semilinear* sets, which are finite unions of subsets of the form

$$\{v_0 + n_1v_1 + \cdots + n_rv_r \mid n_1, \dots, n_r \in \mathbb{N}\}$$

where  $v_0, v_1, \dots, v_r$  are vectors of  $\mathbb{N}^k$ .

The rational subsets are by construction closed under union, product and star. They are also stable under morphisms.

**Proposition 1.1** *Let  $\varphi : M \rightarrow N$  be a monoid morphism. If  $R$  is a rational subset of  $M$ , then  $\varphi(R)$  is a rational subset of  $N$ . If further  $\varphi$  is surjective, then for each rational subset  $S$  of  $N$ , there exists a rational subset  $R$  of  $M$  such that  $\varphi(R) = S$ .*

**Proof.** Denote by  $\mathcal{F}$  the set of subsets  $K$  of  $M$  such that  $\varphi(K)$  is a rational subset of  $N$ . The set  $\mathcal{F}$  contains the finite sets, since, if  $K$  is finite,  $\varphi(K)$  is also finite and hence rational. Furthermore,  $\mathcal{F}$  is stable under union: if  $K$  and  $K'$  are in  $\mathcal{F}$ , that is, if  $\varphi(K)$  and  $\varphi(K')$  are rational, then  $\varphi(K) + \varphi(K') = \varphi(K + K')$  is rational, and hence  $K + K'$  is in  $\mathcal{F}$ . The proof that  $KK'$  and  $K^*$  are in  $\mathcal{F}$  is similar but rests on the formulas

$$\varphi(KK') = \varphi(K)\varphi(K') \text{ and } \varphi(K^*) = (\varphi(K))^*.$$

It follows that  $\mathcal{F}$  contains the rational subsets of  $M$ . By the definition of  $\mathcal{F}$ , this means that if  $L$  is rational, so is  $\varphi(L)$ .

For the second part of the statement, assume that  $\varphi$  is surjective and consider the set  $\mathcal{S}$  of subsets  $S$  of  $N$  such that  $S = \varphi(R)$  for some rational subset  $R$  of  $M$ . First observe that  $\emptyset \in \mathcal{S}$  since  $\varphi(\emptyset) = \emptyset$ . Since  $\varphi$  is surjective, every element  $n$  of  $N$  can be written as  $\varphi(m)$  for some  $m \in M$ . Thus  $\mathcal{S}$  contains the singletons. Further, the formula

$$\varphi(R)\varphi(R') = \varphi(RR') \quad \varphi(R + R') = \varphi(R) + \varphi(R') \quad \varphi(R^*) = (\varphi(R))^*$$

show that  $\mathcal{S}$  is closed under union, product and star. Consequently,  $\mathcal{S}$  contains the rational subsets of  $N$ , which concludes the proof.  $\square$

However, the rational subsets of a monoid are not necessarily closed under intersection, as shown by the following counterexample:

**Example 1.3** Let  $M = a^* \times \{b, c\}^*$ . Consider the rational subsets

$$\begin{aligned} R &= (a, b)^*(1, c)^* = \{(a^n, b^n c^m) \mid n, m \geq 0\} \\ S &= (1, b)^*(a, c)^* = \{(a^n, b^m c^n) \mid n, m \geq 0\} \end{aligned}$$

Their intersection is

$$R \cap S = \{(a^n, b^n c^n) \mid n \geq 0\}$$

Let  $\pi$  be the projection from  $M$  onto  $\{b, c\}^*$ . If  $R \cap S$  was rational, the language  $\pi(R \cap S) = \{b^n c^n \mid n \geq 0\}$  would also be rational by Proposition 1.1. But Corollary III.3.5 shows that this language is not rational.



It follows also that the complement of a rational subset is not necessarily rational. Otherwise, the rational subsets of a monoid would be closed under union and complement and hence under intersection.

Rational subsets are closed under direct products, in the following sense:

**Theorem 1.2** *Let  $R_1$  [ $R_2$ ] be a rational subset of a monoid  $M_1$  [ $M_2$ ]. Then  $R_1 \times R_2$  is a rational subset of  $M_1 \times M_2$ .*

**Proof.** Let  $\pi_1 : M_1 \rightarrow M_1 \times M_2$  and  $\pi_2 : M_2 \rightarrow M_1 \times M_2$  be the morphisms defined by  $\pi_1(m) = (m, 1)$  and  $\pi_2(m) = (1, m)$ . Then we have

$$R_1 \times R_2 = (R_1 \times \{1\})(\{1\} \times R_2) = \pi_1(R_1)\pi_2(R_2)$$

which shows, by Proposition 1.1, that  $R_1 \times R_2$  is rational.  $\square$

Recall that a monoid is *finitely generated* if it admits a finite set of generators.

**Proposition 1.3** *Each rational subset of a monoid  $M$  is a rational subset of a finitely generated submonoid of  $M$ .*

**Proof.** Consider the set  $\mathcal{R}$  of subsets  $R$  of  $M$  that are rational subsets of a finitely generated submonoid of  $M$ . It is clear that  $\mathcal{R}$  contains the empty set and the singletons, since  $\{m\}$  is a rational subset of  $m^*$ . If  $R$  and  $S$  are in  $\mathcal{R}$ , there exist some finite subsets  $F$  and  $G$  of  $M$  such that  $R$  is a rational subset of  $F^*$  and  $S$  is a rational subset of  $G^*$ . It follows that  $R + S$  and  $RS$  are rational subsets of  $(F + G)^*$ , and  $R^*$  is a rational subset of  $F^*$ . Consequently,  $R + S$ ,  $RS$  and  $R^*$  are also in  $\mathcal{R}$ , proving that  $\mathcal{R}$  contains the rational subsets of  $M$ .  $\square$

## 2 Recognizable subsets of a monoid

Recognizable languages are usually defined in terms of automata. This is the best definition from an algorithmic point of view, but it is an asymmetric notion. It turns out that to handle the fine structure of recognisable languages, it is more appropriate to use a more abstract definition, using monoids in place of automata, due to Rabin and Scott [89]. Although these definitions will be mainly used in the context of free monoids, it is as simple to give them in a more general setting.

### 2.1 Recognition by monoid morphisms

Let  $\varphi : M \rightarrow N$  be a monoid morphism. A subset  $L$  of  $M$  is *recognised* by  $\varphi$  if there exists a subset  $P$  of  $N$  such that

$$L = \varphi^{-1}(P).$$

If  $\varphi$  is surjective, we say that  $\varphi$  *fully recognises*  $L$ . Note that in this case, the condition  $L = \varphi^{-1}(P)$  implies  $P = \varphi(L)$ .

**Proposition 2.4** *If  $\varphi : M \rightarrow N$  recognises  $L$ , then the morphism from  $M$  onto  $\varphi(M)$  induced by  $\varphi$  fully recognises  $L$ .*

**Proof.** Since  $\varphi$  recognises  $L$ , there exists a subset  $P$  of  $N$  such that  $L = \varphi^{-1}(P)$ . It follows that  $L = \varphi^{-1}(P \cap \varphi(M))$  which proves the result.  $\square$

Let us say that a congruence  $\sim$  on  $M$  *saturates* a subset  $L$  of  $M$  if the conditions  $u \in L$  and  $u \sim v$  imply  $v \in L$ . Let us start by an elementary, but useful observation:

**Proposition 2.5** *Let  $\varphi : M \rightarrow N$  be a monoid morphism and let  $L$  be a subset of  $M$ . The following conditions are equivalent:*

- (1)  $L$  is recognised by  $\varphi$ ,
- (2)  $L$  is saturated by  $\sim_\varphi$ ,
- (3)  $\varphi^{-1}(\varphi(L)) = L$ .

**Proof.** (1) implies (2). If  $L$  is recognised by  $\varphi$ , then  $L = \varphi^{-1}(P)$  for some subset  $P$  of  $N$ . Thus if  $x \in L$  and  $x \sim_\varphi y$ , one has  $\varphi(x) \in P$  and since  $\varphi(x) = \varphi(y)$ ,  $y \in \varphi^{-1}(P) = L$ . Therefore  $L$  is saturated by  $\sim_\varphi$ .

(2) implies (3). Suppose that  $L$  is saturated by  $\sim_\varphi$ . If  $x \in \varphi^{-1}(\varphi(L))$ , there exists  $y \in L$  such that  $\varphi(x) = \varphi(y)$ , that is,  $x \sim_\varphi y$ . It follows that  $x \in L$ , which proves the inclusion  $\varphi^{-1}(\varphi(L)) \subseteq L$ . The opposite inclusion is trivial.

(3) implies (1). Setting  $P = \varphi(L)$ , one has  $\varphi^{-1}(P) = L$ . Thus  $L$  is recognised by  $\varphi$ .  $\square$

By extension, one also says that a monoid  $N$  [fully] *recognises* a subset  $L$  of a monoid  $M$  if there exists a [surjective] monoid morphism  $\varphi : M \rightarrow N$  that recognises  $L$ .

**Example 2.1** Let  $(T, \oplus)$  be the commutative monoid defined on  $\{0, 1, 2\}$  by

$$x \oplus y = \min\{x + y, 2\}$$

and let  $\varphi$  be the surjective morphism from  $(\mathbb{N}, +)$  onto  $T$  defined by  $\varphi(0) = 0$ ,  $\varphi(1) = 1$  and  $\varphi(n) = 2$  for all  $n \geq 2$ . The subsets of  $\mathbb{N}$  recognised by  $\varphi$  are  $\varphi^{-1}(\emptyset) = \emptyset$ ,  $\varphi^{-1}(0) = \{0\}$ ,  $\varphi^{-1}(1) = \{1\}$ ,  $\varphi^{-1}(2) = \{2, 3, \dots\}$ ,  $\varphi^{-1}(\{0, 1\}) = \{0, 1\}$ ,  $\varphi^{-1}(\{0, 2\}) = \{0, 2, 3, 4, \dots\}$ ,  $\varphi^{-1}(\{1, 2\}) = \{1, 2, 3, 4, \dots\}$  and  $\varphi^{-1}(\{0, 1, 2\}) = \mathbb{N}$ .

**Example 2.2** Let  $M = B_2^1 = \{1, a, b, ab, ba, 0\}$  be the multiplicative monoid defined by the relations  $aba = a$ ,  $bab = b$ ,  $aa = bb = 0$ . Let  $A = \{a, b\}$  and let  $\varphi : A^* \rightarrow M$  be the morphism defined by  $\varphi(a) = a$  and  $\varphi(b) = b$ . One has  $\varphi^{-1}(1) = \{1\}$ ,  $\varphi^{-1}(a) = (ab)^*a$ ,  $\varphi^{-1}(b) = (ba)^*b$ ,  $\varphi^{-1}(ab) = (ab)^+$ ,  $\varphi^{-1}(ba) = (ba)^+$  and  $\varphi^{-1}(0) = A^*aaA^* + A^*bbA^*$ .

**Example 2.3** Recall that  $U_2$  denotes the monoid  $\{1, a_1, a_2\}$  defined by  $a_1a_1 = a_2a_1 = a_1$  and  $a_1a_2 = a_2a_2 = a_2$ . Let  $\pi : A^* \rightarrow U_2$  be a morphism and let  $A_1 = \{a \in A \mid \pi(a) = a_1\}$ ,  $A_2 = \{a \in A \mid \pi(a) = a_2\}$  and  $B = \{a \in A \mid \pi(a) = 1\}$ . Then  $\pi^{-1}(1) = B^*$ ,  $\pi^{-1}(a_1) = A^*A_1B^*$  and  $\pi^{-1}(a_2) = A^*A_2B^*$ .

We conclude this section by a very useful property of a morphism recognising a subset of a monoid.

**Proposition 2.6** *Let  $M$  be a monoid,  $P$  a subset of  $M$  and  $\varphi : M \rightarrow N$  be a morphism recognising  $P$ . Then for each subset  $R$  of  $M$ , one has*

- (1)  $\varphi(R \cap P) = \varphi(R) \cap \varphi(P)$ ,
- (2)  $\varphi(R \cup P) = \varphi(R) \cup \varphi(P)$ ,
- (3)  $\varphi(R - P) = \varphi(R) - \varphi(P)$ .

**Proof.** (1) The inclusion  $\varphi(P \cap R) \subseteq \varphi(P) \cap \varphi(R)$  is clear. To prove the opposite inclusion, consider an element  $s$  of  $\varphi(P) \cap \varphi(R)$ . Then one has  $s = \varphi(r)$  for some  $r \in R$ . It follows that  $r \in \varphi^{-1}(s)$ , wherefore  $r \in \varphi^{-1}(\varphi(P))$  and finally  $r \in P$ . Thus  $r \in P \cap R$  and  $s \in \varphi(P \cap R)$ , which proves (1).

(2) is trivial.

(3) Let  $r \in R - P$ . Then  $\varphi(r) \in \varphi(R)$ . Further, if  $\varphi(r) \in \varphi(P)$ , then  $r \in P$  since  $\varphi$  recognises  $P$ . Therefore  $\varphi(R - P) \subseteq \varphi(R) - \varphi(P)$ .

To establish the opposite inclusion, consider an element  $x$  of  $M$  such that  $\varphi(x) \in \varphi(R) - \varphi(P)$ . Then  $\varphi(x) \in \varphi(R)$  and thus  $\varphi(x) = \varphi(r)$  for some  $r \in R$ . If  $r \in P$ , then  $\varphi(x) \in \varphi(P)$ , a contradiction. Therefore  $r \in R - P$  and  $\varphi(x) \in \varphi(R - P)$ .  $\square$

**Corollary 2.7** *Let  $M$  be a monoid,  $P$  a subset of  $M$  and  $\varphi : M \rightarrow N$  be a morphism recognising  $P$ . If  $P = X_1 - X_2$  with  $X_2 \subseteq X_1$ , then  $\varphi(P) = \varphi(X_1) - \varphi(X_2)$ .*

**Proof.** When  $X_2$  is a subset of  $X_1$ , the conditions  $P = X_1 - X_2$  and  $X_2 = X_1 - P$  are equivalent. Proposition 2.6 now shows that  $\varphi(X_2) = \varphi(X_1) - \varphi(P)$ , which in turn gives  $\varphi(P) = \varphi(X_1) - \varphi(X_2)$ .  $\square$

## 2.2 Operations on sets

Simple operations on sets have a natural algebraic counterpart. We now study in this order complement, intersection, union, inverses of morphisms and left and right quotients.

**Proposition 2.8** *Let  $L$  be a subset of the monoid  $M$ . If  $L$  is recognised by  $\varphi : M \rightarrow N$ , then  $M - L$  is also recognised by  $\varphi$ .*

**Proof.** If  $L = \varphi^{-1}(P)$  then, by Proposition I.1.18,  $M - L = \varphi^{-1}(N - P)$ .  $\square$

For  $1 \leq i \leq n$ , let  $\varphi_i : M \rightarrow M_i$  be a surjective monoid morphism. The product of these morphisms is the surjective morphism

$$\varphi : M \rightarrow \text{Im}(\varphi) \subseteq M_1 \times \cdots \times M_n$$

defined by  $\varphi(x) = (\varphi_1(x), \dots, \varphi_n(x))$ .

**Proposition 2.9** *Let  $L_1, \dots, L_n$  be subsets of  $M$ . If each  $L_i$  is recognised by  $\varphi_i$ , then the sets  $\bigcap_{1 \leq i \leq n} L_i$  and  $\bigcup_{1 \leq i \leq n} L_i$  are recognised by  $\varphi$ .*

**Proof.** Suppose that  $L_i = \varphi_i^{-1}(P_i)$  for some subset  $P_i$  of  $M_i$ . The result follows immediately from the two formulas

$$\bigcap_{1 \leq i \leq n} L_i = \varphi^{-1}(P_1 \times \cdots \times P_n)$$

$$\bigcup_{1 \leq i \leq n} L_i = \varphi^{-1}\left(\bigcup_{1 \leq i \leq n} M_1 \times \cdots \times M_{i-1} \times P_i \times M_{i+1} \times \cdots \times M_n\right)$$

$\square$

**Proposition 2.10** *Let  $\eta : R \rightarrow M$  and  $\varphi : M \rightarrow N$  be two morphisms of monoids. If  $\varphi$  recognises a subset  $L$  of  $M$ , then  $\varphi \circ \eta$  recognises  $\eta^{-1}(L)$ .*

**Proof.** Suppose that  $L = \varphi^{-1}(P)$  for some subset  $P$  of  $N$ . Then  $\eta^{-1}(L) = \eta^{-1}(\varphi^{-1}(P)) = (\varphi \circ \eta)^{-1}(P)$ . Thus  $\varphi \circ \eta$  recognises  $\eta^{-1}(L)$ .  $\square$

Recall that, for each subset  $X$  of  $M$  and for each element  $s$  of  $M$ , the *left* [*right*] quotient  $s^{-1}X$  [ $Xs^{-1}$ ] of  $X$  by  $s$  is defined as follows:

$$s^{-1}X = \{t \in M \mid st \in X\} \quad \text{and} \quad Xs^{-1} = \{t \in S \mid ts \in X\}$$

More generally, for any subset  $K$  of  $M$ , the left [*right*] quotient  $K^{-1}X$  [ $XK^{-1}$ ] of  $X$  by  $K$  is

$$K^{-1}X = \bigcup_{s \in K} s^{-1}X = \{t \in M \mid \text{there exists } s \in K \text{ such that } st \in X\}$$

$$XK^{-1} = \bigcup_{s \in K} Xs^{-1} = \{t \in M \mid \text{there exists } s \in K \text{ such that } ts \in X\}$$

**Proposition 2.11** *Let  $\varphi : M \rightarrow N$  be a morphism of monoids. If  $\varphi$  recognises a subset  $L$  of  $M$ , it also recognises  $K^{-1}L$  and  $LK^{-1}$  for every subset  $K$  of  $M$ .*

**Proof.** Suppose that  $L = \varphi^{-1}(P)$  for some subset  $P$  of  $N$ , and let  $R = \varphi(K)$ . We claim that  $\varphi^{-1}(R^{-1}P) = K^{-1}L$ . Indeed, one has the following sequence of equivalent statements:

$$\begin{aligned} m \in \varphi^{-1}(R^{-1}P) &\iff \varphi(m) \in R^{-1}P \\ &\iff \text{there exists } r \in R \text{ such that } r\varphi(m) \in P \\ &\iff \text{there exists } k \in K \text{ such that } \varphi(k)\varphi(m) \in P \\ &\iff \text{there exists } k \in K \text{ such that } km \in \varphi^{-1}(P) \\ &\iff \text{there exists } k \in K \text{ such that } km \in L \\ &\iff m \in K^{-1}L \end{aligned}$$

Thus  $\varphi$  recognises  $K^{-1}L$ . A similar proof works for  $LK^{-1}$ .  $\square$

### 2.3 Recognizable sets

A subset of a monoid is *recognizable* if it is recognised by a finite monoid. We denote by  $\text{Rec}(M)$  the set of recognisable subsets of  $M$ . We shall see shortly in Section 3 that if  $M = A^*$ , then  $\text{Rec}(A^*)$  is the set of recognisable languages, as defined in Section 3.1. Thus our new definition is consistent with the old one.

Notice that Propositions 2.8, 2.9, 2.10 and 2.11 subsume Propositions III.4.8, III.4.10, III.4.11, III.4.12, III.4.13, III.4.15, III.4.16 with a shorter proof. One can summarize these results in the following statement:

**Corollary 2.12** *For any monoid  $M$ ,  $\text{Rec}(M)$  is closed under Boolean operations and left and right quotients. Further, if  $\varphi : N \rightarrow M$  is a morphism,  $L \in \text{Rec}(M)$  implies  $\varphi^{-1}(L) \in \text{Rec}(N)$ .*

Although Kleene's theorem does not extend to arbitrary monoids, a weaker property holds for finitely generated monoids.

**Theorem 2.13 (McKnight)** *Let  $M$  be a monoid. The following conditions are equivalent:*

- (1)  $M$  is finitely generated,
- (2) every recognisable subset of  $M$  is rational,
- (3) the set  $M$  is a rational subset of  $M$ .

**Proof.** (1) implies (2). Let  $M$  be a finitely generated monoid. Then there exists a finite alphabet  $A$  and a surjective morphism  $\pi$  from  $A^*$  onto  $M$ . Let  $R$  be a recognisable subset of  $M$ . By Corollary 2.12, the set  $\pi^{-1}(R)$  is recognisable in  $A^*$  and hence is rational by Kleene's theorem. Now, since  $R = \pi(\pi^{-1}(R))$ , Proposition 1.1 shows that  $R$  is rational.

- (2) implies (3) is clear, since  $M$  is a recognisable subset of  $M$ .  
 (3) implies (1) follows immediately from Proposition 1.3.  $\square$

Let us come back to arbitrary monoids. We have seen that the intersection of two rational subsets is not necessarily rational, but that the intersection of two recognisable sets is recognisable. What about the intersection of a rational subset and a recognisable subset?

**Proposition 2.14** *The intersection of a rational subset and of a recognisable subset of a monoid is rational.*

**Proof.** Let  $R$  be a rational subset of a monoid  $M$ . By Proposition 1.3,  $R$  is a rational subset of a finitely generated submonoid  $N$  of  $M$ . Let us denote by  $\iota$  the identity mapping from  $N$  into  $M$ . Since  $N$  is finitely generated, there exist a finite alphabet  $A$  and a surjective morphism  $\pi : A^* \rightarrow N$ . By the second part of Proposition 1.1, there exists a rational language  $K$  of  $A^*$  such that  $\iota(\pi(K)) = R$ . If  $S$  is a recognisable subset of  $M$ , then  $S \cap N$ , which is equal to  $\iota^{-1}(S)$ , is a recognisable subset of  $N$  by Proposition 2.10 and, for the same reason,  $\pi^{-1}(S \cap N)$  is a recognisable subset of  $A^*$ . By Kleene's theorem, the language  $K' = K \cap \pi^{-1}(S \cap N)$  is also rational. It follows by Proposition 1.1 that  $\iota(\pi(K'))$  is a rational subset of  $M$ . Now, since  $\pi$  is surjective, Proposition I.1.19 gives the relations

$$\pi(K') = \pi(K \cap \pi^{-1}(S \cap N)) = \pi(K) \cap (S \cap N)$$

and since  $\iota$  is injective, one has by Proposition I.1.17:

$$\iota(\pi(K')) = \iota(\pi(K) \cap (S \cap N)) = \iota(\pi(K)) \cap \iota(S \cap N) = R \cap S$$

It follows that  $R \cap S$  is a rational subset of  $M$ .  $\square$

The next theorem gives a description of the recognisable subsets of a finite product of monoids. Note that this result does not extend to finite products of semigroups.

**Theorem 2.15 (Mezei)** *Let  $M_1, \dots, M_n$  be monoids and let  $M = M_1 \times \dots \times M_n$ . A subset of  $M$  is recognisable if and only if it is a finite union of subsets of the form  $R_1 \times \dots \times R_n$ , where each  $R_i$  is a recognisable subset of  $M_i$ .*

**Proof.** Since  $R_i$  is recognisable, there exists a morphism  $\alpha_i$  from  $M_i$  onto some finite monoid  $F_i$  such that  $\alpha_i^{-1}(\alpha_i(R_i)) = R_i$ . Let  $\alpha : M \rightarrow F_1 \times \cdots \times F_n$  be the product morphism defined by  $\alpha(m_1, \dots, m_n) = (\alpha_1(m_1), \dots, \alpha_n(m_n))$ . The relations

$$\begin{aligned} \alpha^{-1}(\alpha(R_1 \times \cdots \times R_n)) &= \alpha_1^{-1}(\alpha_1(R_1)) \times \cdots \times \alpha_n^{-1}(\alpha_n(R_n)) \\ &= R_1 \times \cdots \times R_n \end{aligned}$$

show that  $R_1 \times \cdots \times R_n$  is recognisable. Further, Corollary 2.12 shows that any finite union of subsets of this form is recognisable.

Consider now a recognisable subset  $R$  of  $M$ . Then there exist a morphism  $\alpha$  from  $M$  onto a finite monoid  $F$  such that  $R = \alpha^{-1}(\alpha(R))$ . For  $1 \leq i \leq n$ , let us define a morphism  $\beta_i : M_i \rightarrow F$  by setting  $\beta_i(m_i) = \alpha(1, \dots, 1, m_i, 1, \dots, 1)$ . We also define a morphism  $\beta : M \rightarrow F^n$  by setting

$$\beta(m_1, \dots, m_n) = (\beta_1(m_1), \dots, \beta_n(m_n)).$$

Setting

$$Q = \{(x_1, \dots, x_n) \in F^n \mid x_1 \cdots x_n \in \alpha(R)\}$$

and observing that  $\beta_1(m_1) \cdots \beta_n(m_n) = \alpha(m_1, \dots, m_n)$ , one gets

$$\begin{aligned} \beta^{-1}(Q) &= \{(m_1, \dots, m_n) \in M \mid \beta_1(m_1) \cdots \beta_n(m_n) \in \alpha(R)\} \\ &= \{(m_1, \dots, m_n) \in M \mid \alpha(m_1, \dots, m_n) \in \alpha(R)\} \\ &= \alpha^{-1}\alpha(R) = R \end{aligned}$$

Further,  $\beta^{-1}(x_1, \dots, x_n) = \beta_1^{-1}(x_1) \times \cdots \times \beta_n^{-1}(x_n)$  and therefore

$$R = \beta^{-1}(Q) = \bigcup_{(x_1, \dots, x_n) \in Q} \beta_1^{-1}(x_1) \times \cdots \times \beta_n^{-1}(x_n)$$

Since the sets  $\beta_i^{-1}(x_i)$  are by construction recognisable subsets of  $M_i$ , the desired decomposition is obtained.  $\square$

One of the most important applications of Theorem 2.15 is the fact that the product of two recognisable relations over finitely generated free monoids is recognisable. Let  $A_1, \dots, A_n$  be finite alphabets. Then the monoid  $A_1^* \times \cdots \times A_n^*$  is finitely generated, since it is generated by the finite set

$$\{(1, \dots, 1, a_i, 1, \dots, 1) \mid a_i \in A_i, 1 \leq i \leq n\}$$

**Proposition 2.16** *Let  $A_1, \dots, A_n$  be finite alphabets. The product of two recognisable subsets of  $A_1^* \times \cdots \times A_n^*$  is recognisable.*

**Proof.** Let  $M = A_1^* \times \cdots \times A_n^*$  and let  $X$  and  $Y$  be two recognisable subsets of  $M$ . By Theorem 2.15,  $X$  is a finite union of subsets of the form  $R_1 \times \cdots \times R_n$ , where  $R_i$  is a recognisable subset of  $A_i^*$  and  $Y$  is a finite union of subsets of the form  $S_1 \times \cdots \times S_n$ , where  $S_i$  is a recognisable subset of  $A_i^*$ . It follows that  $XY$  is a finite union of subsets of the form  $R_1 S_1 \times \cdots \times R_n S_n$ . Since  $A_i^*$  is a free monoid, the sets  $R_i$  and  $S_i$  are rational by Kleene's theorem. It follows that  $R_i S_i$  is rational and hence recognisable. Finally, Theorem 2.15 shows that  $XY$  is recognisable.  $\square$

### 3 Connexion with automata

The case of the free monoid is of course the most important. There is a natural way to associate a finite monoid with a finite automaton. We start by explaining this construction for deterministic automata, which is a bit easier than the general case.

#### 3.1 Transition monoid of a deterministic automaton

Let  $\mathcal{A} = (Q, A, E)$  be a deterministic automaton. Each letter  $a \in A$  defines a partial transformation  $q \rightarrow q \cdot a$  on  $Q$ , which maps each state  $q$  onto the unique state  $q \cdot a$  (when it exists) such that  $(q, a, q \cdot a) \in E$ . If there is no such state,  $q \cdot a$  is undefined.

More generally, each word  $u$  defines a partial transformation  $q \rightarrow q \cdot u$  on  $Q$ , which maps each state  $q$  onto the end state of the unique path of label  $u$  and origin  $q$  (when it exists). One can also define  $q \cdot u$  by induction on the length of  $u$ . First, the empty word defines the identity transformation: for each state  $q$ ,  $q \cdot 1 = q$ . Next, for every word  $u \in A^+$  and for every letter  $a \in A$ , one sets  $q \cdot (ua) = (q \cdot u) \cdot a$  if  $(q \cdot u)$  and  $(q \cdot u) \cdot a$  are defined.

**Example 3.1** Let  $\mathcal{A}$  be the automaton of Figure III.3.4. One has  $1 \cdot ba = 2$ ,  $2 \cdot ba = 1$  and  $3 \cdot ba = 5$  and for  $q = 4, 5$ , the value of  $q \cdot ba$  is undefined. Similarly, the partial transformation associated to  $babbb$  is defined on its domain  $\{1, 2\}$  by  $1 \cdot babbb = 2$  and  $2 \cdot babbb = 1$ .

The partial function  $(q, a) \rightarrow q \cdot a$  from  $Q \times A$  into  $Q$  is called the *transition function* of  $\mathcal{A}$ . If  $\mathcal{A}$  is complete, it is a total function. Note that the set  $E$  of transitions completely determines the transition function and can also be recovered from it. For this reason, a deterministic automaton is often given as a triple  $(Q, A, \cdot)$ , where “ $\cdot$ ” denotes the transition function.

It follows from the definitions that the function which maps a word  $u$  onto the partial transformation  $q \rightarrow q \cdot u$  defines a morphism from  $A^*$  into the monoid  $\mathcal{F}(Q)$  of partial transformations on  $Q$ . The range of this map is a monoid, called the transformation monoid of  $\mathcal{A}$ .

We now present an algorithm to compute a presentation of the transition monoid of a finite automaton. Rather than giving a formal description of the algorithm, we shall explain it step by step on an example. Consider the finite deterministic automaton represented in Figure 3.1.

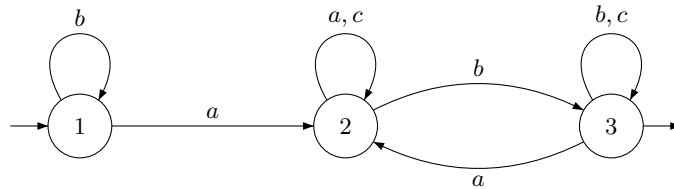

**Figure 3.1.** A deterministic automaton.

We start our computation by giving the generators of its transition monoid.

1	1	2	3
<i>a</i>	2	2	2
<i>b</i>	1	3	3
<i>c</i>	-	2	3

Thus  $a$  maps all states onto state 2 and  $c$  defines a partial identity: it maps states 2 and 3 onto themselves and is undefined on state 1.

The transition monoid is equal to the transformation monoid generated by these generators. In order to compute it, we proceed as follows. We first fix a total order on the alphabet, for instance  $a < b < c$ , but any total order would do. We also denote by  $<$  the shortlex order induced by this total order (see Section 1.2 for the definition). We maintain simultaneously a list of elements, in increasing order for  $<$ , and a list of rewriting rules of the form  $u \rightarrow v$ , where  $v < u$ .

We compute the elements of the transition monoid by induction on the rank of the words in the shortlex order. The partial transformation associated with the empty word is the identity and the partial transformations associated with the letters are the three generators.

The general principle is now the following. Each time we consider a new word  $w$ , we first try to use an existing rewriting rule to reduce  $w$ . If this is possible, we simply consider the next word in the shortlex order. If this is not possible, we compute the partial transformation associated with  $w$  and check whether this partial transformation already appeared or not in our list of partial transformations. If it already appeared as  $u$ , we add  $w \rightarrow u$  to the list of the rewriting rules, otherwise, we add  $w$  to the list of elements. Let us also mention a convenient trick to compute the partial transformation associated with  $w$  when  $w$  is irreducible. Suppose that  $w = px$ , where  $x$  is a letter. Since  $w$  is irreducible, so is  $p$  and hence  $p$  is certainly in the list of elements. Therefore we already know the partial transformation associated with  $p$  and it suffices to compose it with  $x$  to get the partial transformation associated with  $w$ .

Let us go back to our example. Since we already considered the words of length  $\leq 1$ , we now consider the first word of length 2, namely  $aa$ . The partial transformation associated with  $aa$  can be computed directly by following the transition on Figure 3.1, or by using the table below. One can see that  $aa$  defines the same partial transformation as  $a$  and thus we add the rewriting rule  $aa \rightarrow a$  to our list. Next, we compute  $ab$ . This transformation maps all states to 3 and is a new partial transformation. We then proceed by computing  $ac$ , which defines the same partial transformation as  $a$ , and then,  $ba$ ,  $bb$  (which give the new rewriting rules  $ba \rightarrow a$  and  $bb \rightarrow b$ ),  $bc$  and  $ca$  (which define new partial transformations) and  $cb$  and  $cc$  (which give the new rewriting rules  $cb \rightarrow bc$  and  $cc \rightarrow c$ ). At this stage our two lists look like this:

1	1	2	3	
<i>a</i>	2	2	2	<b>Rewriting rules</b>
<i>b</i>	1	3	3	$aa \rightarrow a$
<i>c</i>	-	2	3	$bb \rightarrow b$
<i>ab</i>	3	3	3	$ac \rightarrow a$
<i>bc</i>	-	3	3	$cb \rightarrow bc$
<i>ca</i>	-	2	2	$ba \rightarrow a$
				$cc \rightarrow c$



The next step is to compute the partial transformations corresponding to the words of length 3, but it suffices to consider the words starting with  $ab$ ,  $bc$  or  $ca$ , since the other words can be reduced using the rewriting rules we have already produced. Now  $aba$  can be reduced by using  $ba \rightarrow a$ ,  $abb$  can be reduced by using  $bb \rightarrow b$ . The word  $abc$  defines the same partial transformation as  $ab$ , which gives the new rule  $abc \rightarrow ab$ . Similarly,  $bca$  defines the same partial transformation as  $ca$ , giving the rule  $bca \rightarrow ca$ . Further,  $bc b$ ,  $bcc$  and  $caa$  can be reduced using  $cb \rightarrow bc$ ,  $cc \rightarrow c$  and  $aa \rightarrow a$  respectively. Finally,  $cab$  defines the same partial transformation as  $bc$ , which gives the new rule  $abc \rightarrow bc$  and  $cac$  can be reduced by using the rule  $ac \rightarrow a$ .

No word of length 3 defines a new partial transformation and thus the algorithm terminates. A presentation of the transition monoid of  $\mathcal{A}$  is given in the following table:

1	1	2	3			
a	2	2	2	<b>Rewriting rules</b>		
b	1	3	3			
c	-	2	3			
ab	3	3	3			
bc	-	3	3			
ca	-	2	2			
				$aa \rightarrow a$	$bb \rightarrow b$	$abc \rightarrow ab$
				$ac \rightarrow a$	$cb \rightarrow bc$	$bca \rightarrow ca$
				$ba \rightarrow a$	$cc \rightarrow c$	$cab \rightarrow bc$

One can show that the rewriting system obtained at the end of the algorithm is converging, which means that every word has a unique reduced form. In particular, the order in which the reduction rules are applied does not matter. The rewriting system can be used to compute the product of two elements. For instance  $abbc \rightarrow abc \rightarrow ab$  and thus  $(ab)(bc) = ab$ .

A presentation of the transition monoid is obtained by replacing the symbol  $\rightarrow$  by  $=$ . In our example, the presentation would be  $\langle \{a, b, c\} \mid aa = a, bb = b, abc = ab, ac = a, cb = bc, bca = ca, ba = a, cc = c, cab = bc \rangle$ .

### 3.2 Transition monoid of a nondeterministic automaton

Let now  $\mathcal{A} = (Q, A, E, I, F)$  be a nondeterministic finite automaton. To each word  $u \in A^*$ , there corresponds a relation on  $Q$ , denoted by  $\mu(u)$ , and defined by  $(p, q) \in \mu(u)$  if there exists a path from  $p$  to  $q$  with label  $u$ .

**Proposition 3.17** *The function  $\mu$  is a morphism from  $A^*$  into the monoid of relations on  $Q$ .*

**Proof.** Clearly,  $\mu(1)$  is the identity relation. Let now  $u$  and  $v$  be two words of  $A^*$ . Then one has  $(p, r) \in \mu(u)\mu(v)$  if and only if there is a state  $q$  such that  $(p, q) \in \mu(u)$  and  $(q, r) \in \mu(v)$ . By definition of  $\mu$ , this means there is a path from  $p$  to  $q$  with label  $u$  and path from  $q$  to  $r$  with label  $v$ . Therefore, there is a path from  $p$  to  $r$  with label  $uv$  and  $(p, r) \in \mu(uv)$ .

Conversely, suppose that  $(p, r) \in \mu(uv)$ . Then there is a path from  $p$  to  $r$  with label  $uv$ . Let  $q$  the state reached on this path after reading  $u$ :

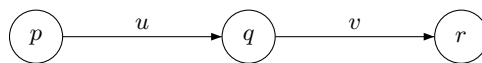

Then  $(p, q) \in \mu(u)$  and  $(q, r) \in \mu(v)$  and hence  $(p, r) \in \mu(u)\mu(v)$ .  $\square$

The monoid  $\mu(A^*)$  is called the *transition monoid* of  $\mathcal{A}$  and denoted by  $M(\mathcal{A})$ . For practical computation, it can be conveniently represented as a monoid of Boolean matrices of order  $|Q| \times |Q|$ . In this case,  $\mu(u)$  can be identified with the matrix defined by

$$\mu(u)_{p,q} = \begin{cases} 1 & \text{if there exists a path from } p \text{ to } q \text{ with label } u \\ 0 & \text{otherwise} \end{cases}$$

**Example 3.2** If  $\mathcal{A}$  is the automaton below, one gets

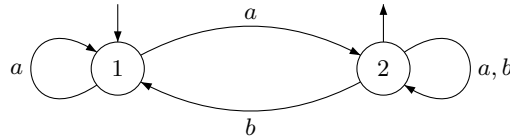

$$\begin{aligned} \mu(a) &= \begin{pmatrix} 1 & 1 \\ 0 & 1 \end{pmatrix} & \mu(b) &= \begin{pmatrix} 0 & 0 \\ 1 & 1 \end{pmatrix} & \mu(aa) &= \mu(a) \\ \mu(ab) &= \begin{pmatrix} 1 & 1 \\ 1 & 1 \end{pmatrix} & \mu(ba) &= \mu(bb) = \mu(b) \end{aligned}$$

Thus the transition monoid of  $\mathcal{A}$  is the monoid of Boolean matrices

$$\mu(A^*) = \left\{ \begin{pmatrix} 1 & 0 \\ 0 & 1 \end{pmatrix}, \begin{pmatrix} 0 & 0 \\ 1 & 1 \end{pmatrix}, \begin{pmatrix} 1 & 1 \\ 0 & 1 \end{pmatrix}, \begin{pmatrix} 1 & 1 \\ 1 & 1 \end{pmatrix} \right\}.$$

### 3.3 Monoids versus automata

We now show that our definition of recognisable sets is equivalent with the standard definition using automata.

**Proposition 3.18** *If a finite automaton recognises a language  $L$ , then its transition monoid recognises  $L$ .*

**Proof.** Let  $\mathcal{A}$  be a finite automaton recognising  $L$  and let  $\mu : A^* \rightarrow M(\mathcal{A})$  be the natural morphism from  $A^*$  onto the transition monoid of  $\mathcal{A}$ . Observe now that a word  $u$  is recognised by  $\mathcal{A}$  if and only if  $(p, q) \in \mu(u)$  for some initial state  $p$  and some final state  $q$ . It follows that  $L = \mu^{-1}(P)$  where

$$P = \{m \in M(\mathcal{A}) \mid m_{p,q} = 1 \text{ for some initial state } p \text{ and some final state } q\}$$

It follows that  $\mu$  recognises  $L$ .  $\square$

**Example 3.3** Let  $A = \{a, b\}$  and let  $\mathcal{A}$  be the (incomplete) deterministic automaton represented below.

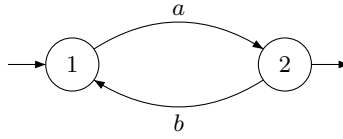

**Figure 3.2.** A deterministic automaton.

It is easy to see that  $\mathcal{A}$  recognises the language  $(ab)^*a$ . The transition monoid  $M$  of  $\mathcal{A}$  contains six elements which correspond to the words  $1, a, b, ab, ba$  and  $aa$ . Furthermore  $aa$  is a zero of  $S$  and thus can be denoted  $0$ . The other relations defining  $M$  are  $aba = a, bab = b$  and  $bb = 0$ .

1	a	b	aa	ab	ba
1	2	–	–	1	–
2	–	1	–	–	2

One recognises the monoid  $B_2^1$  defined on page 16.

Converting a monoid into an automaton is also very easy.

**Proposition 3.19** *If a language is recognised by a finite monoid, then it is also recognised by a finite deterministic automaton.*

**Proof.** Let  $L$  be a language recognised by a finite monoid  $M$ . Then there is a morphism  $\varphi : A^* \rightarrow M$  and a subset  $P$  of  $M$  such that  $L = \varphi^{-1}(P)$ . Take the right representation of  $A$  on  $M$  defined by  $s \cdot a = s\varphi(a)$ . This defines a deterministic automaton  $\mathcal{A} = (M, A, \cdot, 1, P)$ . Now, a word  $u$  is accepted by  $\mathcal{A}$  if and only if  $1 \cdot u \in P$ . Since  $1 \cdot u = \varphi(u)$ , this condition means  $\varphi(u) \in P$  or  $u \in \varphi^{-1}(P)$ . Since  $L = \varphi^{-1}(P)$ , we conclude that  $\mathcal{A}$  recognises  $L$ .  $\square$

**Example 3.4** Let  $\varphi : \{a, b\}^* \rightarrow B_2^1 = \{1, a, b, ab, ba, 0\}$  be the morphism defined by  $\varphi(a) = a$  and  $\varphi(b) = b$ . By applying the algorithm described above, one gets the automaton pictured in Figure 3.3, which also recognises  $(ab)^*$ .

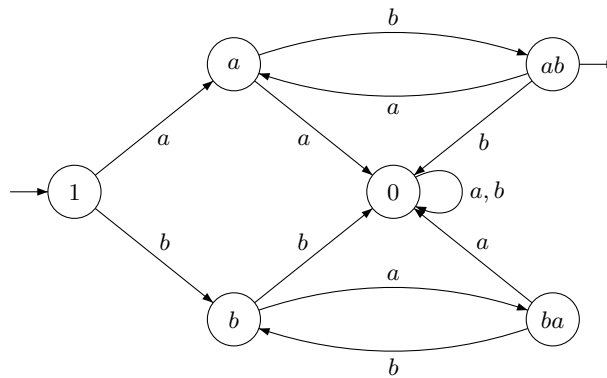

**Figure 3.3.** The automaton associated with  $\varphi$ .

We can now summarize the results of this section.

**Theorem 3.20** *Let  $L$  be a language. The following conditions are equivalent*

- (1)  $L$  is recognised by a finite deterministic automaton,
- (2)  $L$  is recognised by a finite automaton,
- (3)  $L$  is recognised by a finite monoid.

**Proof.** (1) implies (2) is clear and (2) implies (3) follows from Proposition 3.18. Finally, (3) implies (1) follows from Proposition 3.19.  $\square$

This result implies that any finite automaton is equivalent to a deterministic one, a good illustration of the power of the algebraic approach. Indeed, the usual proof requires the subset construction, but the proof is straightforward with monoids.

## 4 Syntactic monoid

The syntactic congruence is one of the key notions of this chapter. Roughly speaking, it is the monoid analog of the notion of minimal automaton, but it can be defined for any subset of a monoid.

### 4.1 Definitions

The main definition was already given in Section 3.7. Given a subset  $L$  of  $M$  the *syntactic congruence* of  $L$  in  $M$  is the relation  $\sim_L$  defined on  $M$  by  $u \sim_L v$  if and only if, for all  $x, y \in M$ ,

$$xuy \in L \iff xvy \in L \quad (4.1)$$

The quotient  $M/\sim_L$  is the *syntactic monoid* of  $L$  and the natural morphism  $\eta_L : M \rightarrow M/\sim_L$  is the *syntactic morphism* of  $L$ . Finally, the set  $\eta_L(L)$  is called the *syntactic image* of  $L$ . The syntactic monoid of a language  $L$  is often denoted  $M(L)$  and we shall use freely this notation.

The syntactic congruence is characterised by the following property.

**Proposition 4.21** *The syntactic congruence of  $L$  is the coarsest congruence that saturates  $L$ . Furthermore, a congruence  $\sim$  saturates  $L$  if and only if  $\sim_L$  is coarser than  $\sim$ .*

**Proof.** We first need to show that  $\sim_L$  saturates  $L$ . Suppose that  $u \in L$  and  $u \sim_L v$ . Then, one has, by taking  $x = y = 1$  in (4.1),

$$u \in L \iff v \in L$$

and thus  $v \in L$ . It follows that  $\eta_L$  recognises  $L$ .

Suppose now that a congruence  $\sim$  saturates  $L$  and that  $u \sim v$ . Since  $\sim$  is a congruence, we also have  $xuy \sim xvy$  for every  $x, y \in M$ . Since  $\sim$  saturates  $L$ , it follows that  $xuy \in L$  if and only if  $xvy \in L$  and hence  $u \sim_L v$ . Therefore,  $\sim_L$  is coarser than  $\sim$ .

Finally, if  $\sim_L$  is coarser than  $\sim$ , the condition  $u \sim v$  implies  $u \sim_L v$ . Therefore, if  $u \in L$ , then  $v \in L$  and  $\sim$  saturates  $L$ .  $\square$

It is sometimes convenient to state this result in terms of morphisms:

**Corollary 4.22** *Let  $\varphi : M \rightarrow N$  be a surjective morphism of monoids, let  $L$  be a subset of  $M$  and let  $\eta_L : M \rightarrow M(L)$  be the syntactic morphism of  $L$ . Then  $\varphi$  recognises  $L$  if and only if there is a surjective morphism  $\pi : N \rightarrow M(L)$  such that  $\eta_L = \pi \circ \varphi$ .*

$$\begin{array}{ccc}
 M & \xrightarrow{\varphi} & N \\
 \eta_L \searrow & & \swarrow \pi \\
 & & M(L)
 \end{array}$$

One says that  $\eta_L$  factorises through  $\varphi$ .

Corollary 4.22 is often used in the following simpler form, which implies that the syntactic monoid of a subset is the smallest monoid recognising this subset.

**Corollary 4.23** *Let  $L$  be a subset of a monoid  $M$ . A monoid  $N$  fully recognises  $L$  if and only if the syntactic monoid of  $L$  is a quotient of  $N$ .*

Let us state another useful result:

**Proposition 4.24** *Let  $\varphi : M \rightarrow N$  be a surjective morphism and let  $L$  be a subset of  $N$ . Then the syntactic monoid of  $L$  in  $N$  is equal to the syntactic monoid of  $\varphi^{-1}(L)$  in  $M$ .*

**Proof.** Let  $u, v \in M$ . We claim that  $u \sim_{\varphi^{-1}(L)} v$  if and only if  $\varphi(u) \sim_L \varphi(v)$ . Indeed, the condition  $u \sim_{\varphi^{-1}(L)} v$  means that, for all  $x, y \in M$ ,

$$xuy \in \varphi^{-1}(L) \iff xvy \in \varphi^{-1}(L)$$

or, equivalently

$$\varphi(xuy) \in L \iff \varphi(xvy) \in L$$

Since  $\varphi$  is surjective, this latter condition exactly means that  $\varphi(u) \sim_L \varphi(v)$ , proving the claim. It follows that  $M/\sim_{\varphi^{-1}(L)}$  is isomorphic to  $N/\sim_L$ , which gives the result.  $\square$

## 4.2 Syntactic monoid of a language

Corollary 4.22 applies in particular when  $M$  is a free monoid  $A^*$ . In this case, one can characterise the syntactic monoid in terms of division.

**Proposition 4.25** *Let  $L$  be a language of  $A^*$  and let  $M(L)$  be the syntactic monoid of  $L$ .*

- (1) *A monoid  $M$  recognises  $L$  if and only if  $M(L)$  divides  $M$ .*
- (2) *If  $M$  recognises  $L$  and if  $M$  divides  $N$ , then  $N$  recognises  $L$ .*

**Proof.** (1) Let  $\varphi : A^* \rightarrow M$  be a morphism recognising  $L$ . Then the morphism  $\varphi : A^* \rightarrow \varphi(A^*)$  also recognises  $L$  and by Corollary 4.22,  $M(L)$  is a quotient of  $\varphi(A^*)$  and thus divides  $N$ .

Let  $\eta : A^* \rightarrow M(L)$  be the syntactic morphism of  $L$ . If  $M(L)$  divides  $M$ , there is a submonoid  $N$  of  $M$  and a surjective morphism  $\beta : N \rightarrow M(L)$ . According to Corollary II.5.30, there exists a morphism  $\varphi : A^* \rightarrow M$  such that  $\eta = \beta \circ \varphi$ . Let  $P = \beta^{-1}(\eta(L))$ .

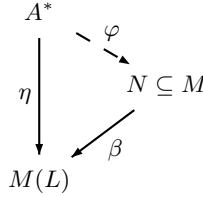

Then

$$L = \eta^{-1}\eta(L) = \varphi^{-1}(\beta^{-1}(\eta(L))) = \varphi^{-1}(P)$$

and hence  $M$  recognises  $L$ .

(2) If  $M$  recognises  $L$ , then by (1),  $M(L)$  divides  $M$ . Thus if  $M$  divides  $N$ ,  $M(L)$  also divides  $N$  and by (1) again,  $N$  recognises  $L$ .  $\square$

It is interesting to translate the results of Section 2.2 in terms of syntactic monoids. In the next proposition, we denote by  $M(L)$  the syntactic monoid of a language  $L$ .

**Proposition 4.26** *Let  $L, L_1, L_2$  and  $K$  be languages of  $A^*$ . Then the following properties hold:*

- (1)  $M(L^c) = M(L)$ ,
- (2)  $M(L_1 \cap L_2)$  divides  $M(L_1) \times M(L_2)$ ,
- (3)  $M(L_1 + L_2)$  divides  $M(L_1) \times M(L_2)$ ,
- (4)  $M(LK^{-1})$  and  $M(K^{-1}L)$  divide  $M(L)$ ,
- (5) If  $\varphi : B^* \rightarrow A^*$  is a morphism, then  $M(\varphi^{-1}(L))$  divides  $M(L)$ .

**Proof.** This is an immediate consequence of Propositions 2.8, 2.9, 2.10, 2.11 and 4.21.  $\square$

Note that the proof of these results is notably shorter than their automata theoretic counterpart.

### 4.3 Computation of the syntactic monoid of a language

The easiest way to compute the syntactic monoid of a recognisable language  $L$  is to first compute its minimal (deterministic) automaton and then to apply the following result.

**Proposition 4.27** *The syntactic monoid of a recognisable language is equal to the transition monoid of its minimal automaton.*

**Proof.** Let  $\mathcal{A} = (Q, A, \cdot, q_-, F)$  be the minimal automaton of a recognisable language  $L$  of  $A^*$  and let  $M$  be its transition monoid. It suffices to verify that two words  $u, v \in A^*$  satisfy  $u \sim_L v$  if and only if they define the same transition in  $M$ .

Suppose that  $u \sim_L v$  and let  $p \in Q$ . Since  $\mathcal{A}$  is trim, there exists a word  $x \in A^*$  such that  $q_- \cdot x = p$ . Now since  $u \sim_L v$ , one has, for all  $y \in A^*$ ,

$$xuy \in L \iff xvy \in L$$

that is,

$$q_- \cdot xuy \in F \iff q_- \cdot xvy \in F$$

or yet

$$(p \cdot u) \cdot y \in F \iff (p \cdot v) \cdot y \in F.$$

Therefore, the states  $p \cdot u$  and  $p \cdot v$  are Nerode equivalent and hence equal by Corollary III.4.20. Thus  $u$  and  $v$  define the same transition in  $M$ .

Suppose now that  $u$  and  $v$  define the same transition in  $M$ . Then if  $xuy \in L$ , then  $q_- \cdot xuy \in F$ . Since  $xuy$  and  $xvy$  define the same transition in  $M$ , one also gets  $q_- \cdot xvy \in F$ , and hence  $xvy \in L$ .  $\square$

## 5 Recognition by ordered structures

We have seen that a subset of a monoid and its complement have the same syntactic monoid. Similarly, a language and its complement have the same complete minimal automaton. Although this property is usually very convenient, there are cases where it is desirable to distinguish between a subset and its complement. Introducing a partial order on monoids solves this problem in an elegant way.

### 5.1 Ordered automata

An *ordered automaton* is a deterministic automaton  $\mathcal{A} = (Q, A, \cdot)$  equipped with a partial order  $\leq$  on  $Q$  such that, for all  $p, q \in Q$  and  $a \in A$ ,  $p \leq q$  implies  $p \cdot a \leq q \cdot a$ . This implies in particular that, for all  $u \in A^*$ ,  $p \cdot u \leq q \cdot u$ .

There is a natural way to define a preorder on the set of states of any deterministic automaton. Let  $\mathcal{A} = (Q, A, \cdot, q_-, F)$  be a deterministic automaton. Define a relation  $\leq$  on  $Q$  by setting  $p \leq q$  if and only if, for all  $u \in A^*$ ,  $p \cdot u \in F$  implies  $q \cdot u \in F$ . This preorder turns out to be an order if  $\mathcal{A}$  is minimal and complete.

**Proposition 5.28** *If  $\mathcal{A}$  is a minimal complete deterministic automaton, the relation  $\leq$  is a partial order on  $Q$ .*

**Proof.** The relation  $\leq$  is clearly reflexive and transitive. Suppose that  $p \leq q$  and  $q \leq p$ . Then, for all  $u \in A^*$ ,  $p \cdot u \in F \iff q \cdot u \in F$ . Since  $\mathcal{A}$  is minimal, this implies  $p = q$ . Thus  $\leq$  is an order.

Further, if  $p \leq q$ , then for all  $a \in A$ ,  $p \cdot a \leq q \cdot a$  since, for all  $u \in A^*$ ,  $p \cdot au \in F$  implies  $q \cdot au \in F$ .  $\square$

**Example 5.1** Consider the minimal complete automaton of  $(ab)^*$ , represented in Figure III.4.22. The order on the set of states is  $0 < 1$  and  $0 < 2$ . Indeed, one has  $0 \cdot u = 0$  for all  $u \in A^*$  and thus, the formal implication

$$q \cdot u \in F \Rightarrow 0 \cdot u \in F$$

holds for any  $q \in Q$ . One can verify that there is no other relations among the states of  $Q$ . For instance, 1 and 2 are incomparable since  $1 \cdot ab = 1 \in F$  but  $2 \cdot aba = 0 \notin F$  and  $1 \cdot b = 0 \notin F$  but  $2 \cdot b = 1 \in F$ .

**Example 5.2** Consider the minimal complete automaton of  $aA^*b$ , represented in Figure III.4.23. The order on the set of states is  $0 < 1 < 2 < 3$ .

## 5.2 Recognition by ordered monoids

A *congruence on an ordered monoid*  $(M, \leq)$  is a stable preorder which is coarser than  $\leq$ . In particular, the order relation  $\leq$  is itself a congruence. If  $\preceq$  is a congruence on  $M$ , then the equivalence relation  $\sim$  associated with  $\preceq$  is a congruence on  $M$ . Furthermore, there is a well-defined stable order on the quotient set  $M/\sim$ , given by

$$[s] \leq [t] \quad \text{if and only if } s \preceq t$$

Thus  $(M/\sim, \leq)$  is an ordered monoid, also denoted  $M/\preceq$ .

Let  $\varphi : M \rightarrow N$  be a surjective morphism of ordered monoids. A subset  $Q$  of  $M$  is *recognised* by  $\varphi$  if there exists an upper set  $P$  of  $N$  such that

$$Q = \varphi^{-1}(P)$$

This condition implies that  $Q$  is an upper set of  $M$  and that

$$\varphi(Q) = \varphi(\varphi^{-1}(P)) = P$$

By extension, a subset  $Q$  of  $M$  is said to be *recognised* by an ordered monoid  $N$  if there exists a surjective morphism of ordered monoids from  $M$  onto  $N$  that recognises  $Q$ .

It is sometimes convenient to formulate this definition in terms of congruences. Let  $M$  be an ordered monoid and let  $\preceq$  a congruence on  $M$ . A subset  $Q$  of  $M$  is said to be *recognised* by  $\preceq$  if, for every  $q \in Q$ ,  $q \preceq p$  implies  $p \in Q$ . It is easy to see that a surjective morphism of ordered monoids  $\varphi$  recognises  $Q$  if and only if the nuclear congruence  $\preceq_\varphi$  recognises  $Q$ .

How does this definition relate to the standard definition using monoids? Simply by considering a monoid as an ordered monoid, with the equality relation as an order relation.

**Example 5.3** Consider the monoid  $B_2^1 = \{1, a, b, ab, ba, 0\}$  and let  $\pi : \{a, b\}^* \rightarrow M$  be the morphism defined by  $\pi(a) = a$  and  $\pi(b) = b$ . Let us define an order on  $B_2^1$  by setting  $ab \leq 1$ ,  $ba \leq 1$ , and  $0 \leq x$  for all  $x \in B_2^1$ . Then the set  $I = \{1, ab\}$  is an upper set and  $\pi^{-1}(I) = (ab)^*$ . Thus the language  $(ab)^*$  is recognised by the ordered monoid  $(B_2^1, \leq)$ .

It suffices to reverse the order to recognise the complement of a language.

**Proposition 5.29** *Let  $L$  be a language of  $A^*$ . If  $L$  is recognised by an ordered monoid  $(M, \leq)$ , then  $L^c$  is recognised by the ordered monoid  $(M, \geq)$ .*

**Proof.** Let  $\varphi : A^* \rightarrow M$  be a morphism and let  $P$  be an upper set of  $(M, \leq)$  such that  $\varphi^{-1}(P) = L$ . Then  $\varphi^{-1}(P^c) = L^c$  and it suffices to show that  $P^c$  is a  $\geq$ -upper set. Suppose that  $x \in P^c$  and  $x \geq y$ . If  $y \in P$ , then  $x \in P$ , since  $P$  is a  $\leq$ -upper set. Thus  $y \in P^c$ , which concludes the proof.  $\square$

## 5.3 Syntactic order

First note that, if  $(M, \leq)$  is an ordered monoid, the congruence  $\leq$  recognises every upper set of  $M$ . The syntactic congruence of an upper set  $Q$  of  $M$  is the coarsest congruence among the congruences on  $M$  that recognise  $Q$ .



Let  $M$  be an ordered monoid and let  $P$  be an upper set of  $M$ . Define a relation  $\preceq_P$  on  $M$  by setting  $u \preceq_P v$  if and only if, for every  $x, y \in M$ ,

$$xuy \in P \Rightarrow xvy \in P$$

One can show that the relation  $\preceq_P$  is a congruence of ordered monoids on  $M$  that recognises  $P$ . This congruence is called the *syntactic congruence* of  $P$  in  $M$ .

The ordered monoid  $(M(P), \leq) = M/\preceq_P$  is the *syntactic ordered monoid* of  $P$ , the order relation on  $M(P)$  the *syntactic order* of  $P$  and the quotient morphism  $\eta_P$  from  $M$  onto  $M(P)$  the *syntactic morphism* of  $P$ .

The syntactic congruence is characterised by the following property.

**Proposition 5.30** *The syntactic congruence of  $P$  is the coarsest congruence that recognises  $P$ . Furthermore, a congruence  $\preceq$  recognises  $P$  if and only if  $\preceq_P$  is coarser than  $\preceq$ .*

It is sometimes convenient to state this result in terms of morphisms:

**Corollary 5.31** *Let  $\varphi : M \rightarrow N$  be a surjective morphism of ordered monoids and let  $P$  be an upper set of  $M$ . The following properties hold:*

- (1) *The morphism  $\varphi$  recognises  $P$  if and only if  $\eta_P$  factorises through it.*
- (2) *Let  $\pi : N \rightarrow R$  be a surjective morphism of ordered monoids. If  $\pi \circ \varphi$  recognises  $P$ , then  $\varphi$  recognises  $P$ .*

## 5.4 Computation of the syntactic ordered monoid

We already know that the syntactic monoid of a language is equal to the transition monoid of its minimal automaton. Its syntactic order can be computed in two different ways: either directly on the syntactic monoid or by using the order on the complete minimal automaton.

Let  $L$  be a language, let  $\eta : A^* \rightarrow M$  be its syntactic monoid and let  $P = \eta(L)$ . The syntactic order  $\leq_P$  is the partial order on  $M$  defined as follows :  $u \leq_P v$  if and only if, for every  $s, t \in M$ ,

$$sut \in P \Rightarrow svt \in P$$

Let  $\mathcal{A} = (Q, A, \cdot, q_-, F)$  be the minimal automaton of  $L$  and let  $\leq$  be the natural order on  $Q$ . The next proposition gives the relations between  $\leq_L$ ,  $\leq_P$  and  $\leq$ .

**Proposition 5.32** *Let  $u$  and  $v$  be two words of  $A^*$ . The following conditions are equivalent:*

- (1)  $u \leq_L v$ ,
- (2)  $\eta(u) \leq_P \eta(v)$ ,
- (3) for all  $q \in Q$ ,  $q \cdot u \leq q \cdot v$ .

**Proof.** (1) implies (2). Suppose that  $u \leq_L v$  and let  $s, t \in M$  be such that  $s\eta(u)t \in P$ . Since  $\eta$  is surjective, there exist some words  $x, y$  such that  $\eta(x) = s$  and  $\eta(y) = t$ . Observing that  $s\eta(u)t = \eta(x)\eta(u)\eta(y) = \eta(xuy)$ , one gets  $\eta(xuy) \in P$  and hence  $xuy \in L$  as  $\eta$  recognises  $L$ . Condition (1) implies that  $xvy \in L$ , or equivalently,  $\eta(xvy) \in P$ . By a similar argument, we get  $\eta(xvy) = s\eta(v)t$  and thus  $s\eta(v)t \in P$ , which proves (2).

(2) implies (1). Suppose that  $\eta(u) \leq_P \eta(v)$  and let  $x, y \in A^*$  be such that  $xuv \in L$ . Then  $\eta(xuv) \in P$  and since  $\eta(xuv) = \eta(x)\eta(u)\eta(y)$ , one gets by (2)  $\eta(x)\eta(v)\eta(y) \in P$ . Observing again that  $\eta(x)\eta(v)\eta(y) = \eta(xvy)$ , one concludes that  $\eta(xvy) \in P$  and finally  $xvy \in L$ . Thus  $u \leq_L v$ .

(1) implies (3). Suppose that  $u \leq_L v$  and let  $q$  be a state of  $Q$ . Since  $\mathcal{A}$  is trim, there is a word  $x$  such that  $q \cdot x = q$ . Let  $y$  be a word such that  $(q \cdot u) \cdot y \in F$ . Then  $q \cdot xuy \in F$  and thus  $xuy \in L$ . Since  $u \leq_L v$ , one has  $xvy \in L$  and hence  $(q \cdot v) \cdot y \in F$ . Thus  $q \cdot u \leq q \cdot v$ .

(3) implies (1). Assume that, for every  $q \in Q$ ,  $q \cdot u \leq q \cdot v$ . Let  $x, y \in A^*$ . If  $xuy \in L$ , then  $q \cdot xuy \in F$  and since  $q \cdot xu \leq q \cdot xv$ , one gets  $q \cdot xvy \in F$  and finally  $xvy \in L$ . Thus  $u \leq_L v$ .  $\square$

**Corollary 5.33** *The syntactic ordered monoid of a recognisable language is equal to the transition monoid of its ordered minimal automaton.*

**Example 5.4** Let  $\mathcal{A}$  be the deterministic automaton of  $(ab)^*$  (Example 5.1). Its transition monoid was calculated in Example 3.3. Its syntactic monoid and its syntactic order are represented below (an arrow from  $u$  to  $v$  means that  $u < v$ ).

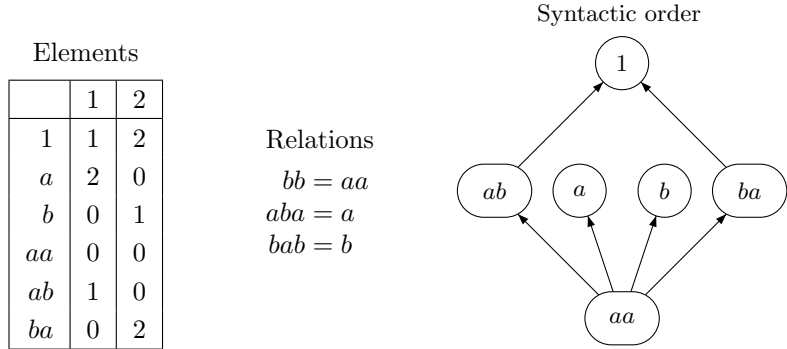

**Example 5.5** The ordered minimal automaton of the language  $aA^*b$  was computed in Example 5.2. This automaton is represented again below, but the sink state 0 is omitted. The order on the states is  $0 < 1 < 2 < 3$ . The elements of the syntactic monoid, the relations defining it and the syntactic order are also presented in the tables below.

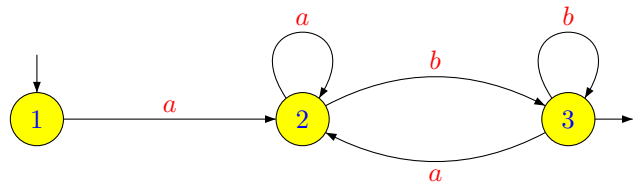

Elements

	1	2	3
1	1	2	3
$a$	2	2	2
$b$	0	3	3
$ab$	3	3	3
$ba$	0	2	2

Relations

$$aa = a$$

$$bb = b$$

$$aba = a$$

$$bab = b$$

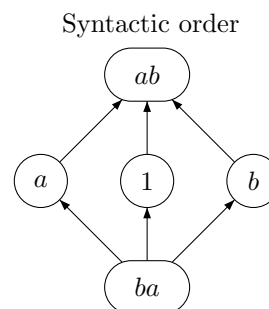

## 6 Exercises

### Section 1

- (Difficult). Show that the rational subsets of a finitely generated commutative monoid form a Boolean algebra.
- (Difficult). Show that the rational subsets of a finitely generated free group form a Boolean algebra.

### Section 2

- Show that the set  $\{0\}$  is a rational subset of the additive group  $\mathbb{Z}$  but is not recognisable.
- Describe the rational [recognisable] subsets of the additive monoids  $\mathbb{N}$  and  $\mathbb{Z}$ .
- (Difficult). Let  $G$  be a group and let  $H$  be a subgroup of  $G$ .
  - Show that  $H$  is a recognisable subset of  $G$  if and only if  $H$  has finite index in  $G$ .
  - Show that  $H$  is a rational subset of  $G$  if and only if  $H$  is finitely generated.

### Section 3

- Let  $\mathcal{A}$  be a complete  $n$ -state deterministic automaton. Show that the transition monoid of  $\mathcal{A}$  has at most  $n^n$  elements. Can this bound be reached?

Suppose now that  $\mathcal{A}$  is an  $n$ -state nondeterministic automaton. Show that the transition monoid of  $\mathcal{A}$  has at most  $2^{n^2}$  elements. Can this bound be reached?

### Section 4

- Compute the syntactic monoid of the following languages on the alphabet  $\{a, b\}^*$ :
  - $\{u \mid |u| \text{ is odd}\}$
  - $a^*$
  - $\{aba, b\}$

- (4)  $(ab)^*$
- (5)  $(aba)^*$
- (6)  $A^*aA^*aA^*bA^*$
- (7)  $A^*aaA^*$
- (8)  $A^*abA^*$
- (9)  $A^*abaA^*$
- (10)  $(a(ab)^*b)^*$
- (11)  $(aa + bb)^*$
- (12)  $(ab + ba)^*$
- (13)  $(a + bab)^*$
- (14)  $(a + bb + aba)^*$

**Section 5**

**8.** Compute the minimal ordered automaton and the ordered syntactic monoid of the languages of Exercise 7.

# Chapter V

## Green's relations and local theory

Green's relations were introduced and studied by Green in 1951 [37]. These relations can be considered as a noncommutative generalisation to semigroups of the standard notion of being a multiple among integers or polynomials. They also have a natural interpretation in the Cayley graph of an  $A$ -generated monoid. They are essential for understanding the structure of semigroups.

### 1 Green's relations

Let  $S$  be a semigroup. We define on  $S$  four preorder relations  $\leq_{\mathcal{R}}$ ,  $\leq_{\mathcal{L}}$ ,  $\leq_{\mathcal{J}}$  and  $\leq_{\mathcal{H}}$  as follows

$$\begin{aligned} s \leq_{\mathcal{R}} t & \text{ if and only if } s = tu \text{ for some } u \in S^1 \\ s \leq_{\mathcal{L}} t & \text{ if and only if } s = ut \text{ for some } u \in S^1 \\ s \leq_{\mathcal{J}} t & \text{ if and only if } s = utv \text{ for some } u, v \in S^1 \\ s \leq_{\mathcal{H}} t & \text{ if and only if } s \leq_{\mathcal{R}} t \text{ and } s \leq_{\mathcal{L}} t \end{aligned}$$

These relations can be considered as a noncommutative generalisation of the notion of multiple over the integers. For instance  $s \leq_{\mathcal{R}} t$  if  $s$  is a *right multiple* of  $t$ , in the sense that one can pass from  $t$  to  $s$  by right multiplication by some element of  $S^1$ . These definitions can be reformulated in terms of ideals as follows

$$\begin{aligned} s \leq_{\mathcal{R}} t & \iff sS^1 \subseteq tS^1 \\ s \leq_{\mathcal{L}} t & \iff S^1s \subseteq S^1t \\ s \leq_{\mathcal{J}} t & \iff S^1sS^1 \subseteq S^1tS^1 \\ s \leq_{\mathcal{H}} t & \iff s \leq_{\mathcal{R}} t \text{ and } s \leq_{\mathcal{L}} t \end{aligned}$$

Thus  $s \leq_{\mathcal{J}} t$  [ $s \leq_{\mathcal{R}} t$ ,  $s \leq_{\mathcal{L}} t$ ] if the ideal [right ideal, left ideal] generated by  $s$  is contained in the ideal [right ideal, left ideal] generated by  $t$ . The following diagram summarises the connexions between these four preorders.

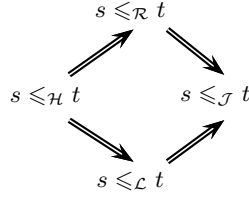

The equivalences associated with these four preorder relations are denoted by  $\mathcal{R}$ ,  $\mathcal{L}$ ,  $\mathcal{J}$  and  $\mathcal{H}$ , respectively. Therefore

$$\begin{aligned}
 s \mathcal{R} t &\iff sS^1 = tS^1 \\
 s \mathcal{L} t &\iff S^1s = S^1t \\
 s \mathcal{J} t &\iff S^1sS^1 = S^1tS^1 \\
 s \mathcal{H} t &\iff s \mathcal{R} t \text{ and } s \mathcal{L} t
 \end{aligned}$$

Thus two elements  $s$  and  $t$  are  $\mathcal{R}$ -equivalent if they generate the same right ideal, or, equivalently, if there exist  $p, q \in S^1$  such that  $s = tp$  and  $t = sq$ . The equivalence classes of the relation  $\mathcal{R}$  are the  $\mathcal{R}$ -classes of  $S$ . The  $\mathcal{L}$ -classes,  $\mathcal{J}$ -classes and  $\mathcal{H}$ -classes are defined in a similar way. If  $s$  is an element of  $S$ , its  $\mathcal{R}$ -class [ $\mathcal{L}$ -class,  $\mathcal{J}$ -class,  $\mathcal{H}$ -class] is denoted by  $R(s)$  [ $L(s)$ ,  $J(s)$ ,  $H(s)$ ]. If  $\mathcal{K}$  is one of the Green's relations, we shall use the notation  $s <_{\mathcal{K}} t$  if  $s \leq_{\mathcal{K}} t$  but  $s \not\sim_{\mathcal{K}} t$ .

If  $M$  is an  $A$ -generated monoid, the relations  $\mathcal{R}$  and  $\leq_{\mathcal{R}}$  [ $\mathcal{L}$  and  $\leq_{\mathcal{L}}$ ] have a natural interpretation on the right [left] Cayley graph of  $M$ .

**Proposition 1.1** *Let  $M$  be an  $A$ -generated monoid and let  $s, t \in M$ . Then  $s \leq_{\mathcal{R}} t$  [ $s \leq_{\mathcal{L}} t$ ] if and only if there is a path from  $t$  to  $s$  in the right [left] Cayley graph of  $M$ . Further  $s \mathcal{R} t$  [ $s \mathcal{L} t$ ] if and only if  $s$  and  $t$  are in the same strongly connected component of the right [left] Cayley graph of  $M$ .*

**Proof.** Suppose that  $s \leq_{\mathcal{R}} t$ . Then  $tp = s$  for some  $p \in M$ . Since  $M$  is  $A$ -generated,  $p$  can be written as a product of elements of  $A$ , say  $p = a_1 \cdots a_n$ . Therefore there is a path

$$s \xrightarrow{a_1} sa_1 \xrightarrow{a_2} \cdots s(a_1 \cdots a_{n-1}) \xrightarrow{a_n} s(a_1 \cdots a_n) = t$$

The other cases are similar.  $\square$

It follows in particular that the  $\mathcal{R}$ -classes [ $\mathcal{L}$ -classes] of  $M$  correspond to the strongly connected components of the right [left] Cayley graph.

**Example 1.1** Let us consider the monoid  $M$  considered in Section 3.1.

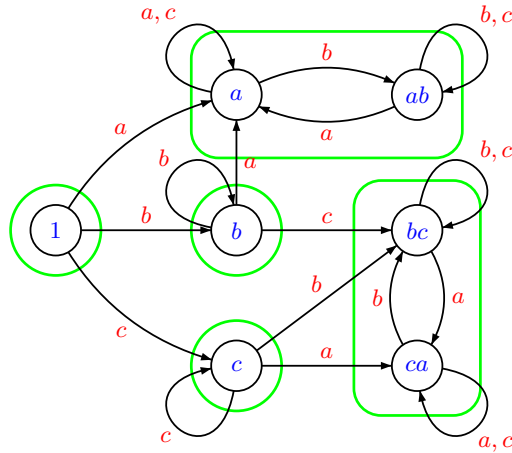

Figure 1.1. The right Cayley graph of  $M$ .

The right Cayley graph of  $M$  is represented in Figure 1.1. The strongly connected components of this graph are the  $\mathcal{R}$ -classes of  $M$ :  $\{1\}$ ,  $\{b\}$ ,  $\{c\}$ ,  $\{a, ab\}$  and  $\{bc, ca\}$ .

The next propositions summarize some useful properties of Green's relations.

**Proposition 1.2** *In each semigroup  $S$ , the relations  $\leq_{\mathcal{R}}$  and  $\mathcal{R}$  are stable on the left and the relations  $\leq_{\mathcal{L}}$  and  $\mathcal{L}$  are stable on the right.*

**Proof.** Indeed, if  $s \leq_{\mathcal{R}} t$ , then  $sS^1 \subseteq tS^1$  and thus  $usS^1 \subseteq utS^1$ . It follows that  $us \leq_{\mathcal{R}} ut$ . The other cases are analogous.  $\square$

**Proposition 1.3** *Let  $S$  be a semigroup.*

- (1) *Let  $e$  be an idempotent of  $S$ . Then  $s \leq_{\mathcal{R}} e$  if and only if  $es = s$  and  $s \leq_{\mathcal{L}} e$  if and only if  $se = s$ .*
- (2) *If  $s \leq_{\mathcal{R}} sxy$ , then  $s \mathcal{R} sx \mathcal{R} sxy$ . If  $s \leq_{\mathcal{L}} yxs$ , then  $s \mathcal{L} xs \mathcal{L} yxs$ .*

**Proof.** We shall prove only the first part of each statement, since the other part is dual.

(1) If  $s \leq_{\mathcal{R}} e$ , then  $s = eu$  for some  $u \in S^1$ . It follows that  $es = e(eu) = (ee)u = eu = s$ . Conversely, if  $es = s$ , then  $s \leq_{\mathcal{R}} e$  by definition.

(2) If  $s \leq_{\mathcal{R}} sxy$ , then  $s \leq_{\mathcal{R}} sxy \leq_{\mathcal{R}} sx \leq_{\mathcal{R}} s$ , whence  $s \mathcal{R} sx \mathcal{R} sxy$ .  $\square$

The first part of Proposition 1.3 can be extended to the preorder  $\leq_{\mathcal{H}}$ .

**Proposition 1.4** *Let  $S$  be a semigroup. Let  $s \in S$  and  $e$  be an idempotent of  $S$ . Then  $s \leq_{\mathcal{H}} e$  if and only if  $es = s = se$ .*

**Proof.** It follows from Proposition 1.3.  $\square$

The restriction of the preorder  $\leq_{\mathcal{H}}$  to  $E(S)$  is actually an order, called the *natural order* on  $E(S)$  and denoted by  $\leq$ .

**Corollary 1.5** *Let  $S$  be a semigroup and let  $e$  and  $f$  be idempotents of  $S$ . The following conditions are equivalent:*

- (1)  $e \leq f$ ,
- (2)  $ef = e = fe$ ,
- (3)  $fef = e$ .

**Proof.** The equivalence of (1) and (2) follows from Proposition 1.4 and that of (2) and (3) from the Simplification lemma.  $\square$

Despite its elementary nature, the next proposition is one of the cornerstones of semigroup theory.

**Proposition 1.6** *In each semigroup  $S$ , the relations  $\leq_{\mathcal{R}}$  and  $\leq_{\mathcal{L}}$  [ $\mathcal{R}$  and  $\mathcal{L}$ ] commute.*

**Proof.** Suppose that  $s \leq_{\mathcal{R}} r$  and  $r \leq_{\mathcal{L}} t$ . Then  $s = rv$  and  $r = ut$  for some  $u, v \in S^1$ . It follows that  $s = utv \leq_{\mathcal{L}} tv \leq_{\mathcal{R}} t$ . Thus  $\leq_{\mathcal{L}} \circ \leq_{\mathcal{R}} \subseteq \leq_{\mathcal{R}} \circ \leq_{\mathcal{L}}$ . The opposite inclusion holds by duality and hence  $\leq_{\mathcal{R}}$  and  $\leq_{\mathcal{L}}$  commute. The proof for  $\mathcal{R}$  and  $\mathcal{L}$  is similar.  $\square$

Here is a first consequence of Proposition 1.6.

**Proposition 1.7** *The relation  $\leq_{\mathcal{J}}$  is equal to  $\leq_{\mathcal{L}} \circ \leq_{\mathcal{R}}$  and to  $\leq_{\mathcal{R}} \circ \leq_{\mathcal{L}}$ . It is also the preorder generated by  $\leq_{\mathcal{R}}$  and  $\leq_{\mathcal{L}}$ .*

**Proof.** It follows directly from Proposition I.2.21.  $\square$

We now introduce the fifth Green's relation  $\mathcal{D}$ , which is the preorder generated by  $\mathcal{R}$  and  $\mathcal{L}$ . Propositions 1.6 and I.2.21 immediately leads to an easier definition.

**Proposition 1.8** *The relation  $\mathcal{D}$  is equal to  $\mathcal{L} \circ \mathcal{R}$  and to  $\mathcal{R} \circ \mathcal{L}$ .*

One can therefore give the following definition of  $\mathcal{D}$ :

$$\begin{aligned} s \mathcal{D} t &\iff \text{there exists } u \in S \text{ such that } s \mathcal{R} u \text{ and } u \mathcal{L} t \\ &\iff \text{there exists } v \in S \text{ such that } s \mathcal{L} v \text{ and } v \mathcal{R} t. \end{aligned}$$

The equivalence classes of  $\mathcal{D}$  are called the  $\mathcal{D}$ -classes of  $S$ , and the  $\mathcal{D}$ -class of an element  $s$  is denoted by  $D(s)$ .

It is easy to see that  $s \mathcal{D} t$  implies  $s \mathcal{J} t$ . Indeed, if  $s \mathcal{D} t$ , there exists  $u \in S$  such that  $s \mathcal{R} u$  and  $u \mathcal{L} t$ . It follows that  $sS^1 = uS^1$  and  $S^1u = S^1t$ , whence  $S^1sS^1 = S^1tS^1$ . The following diagram summarises the connexions between the five Green's relations.

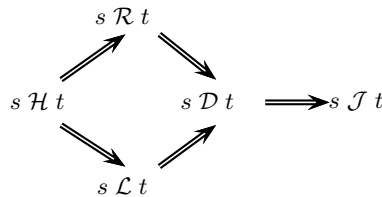



The equality  $\mathcal{D} = \mathcal{J}$  does not hold in arbitrary semigroups (see Example 1.2 below) but it holds for finite semigroups.

**Theorem 1.9** *In a finite semigroup, the Green's relations  $\mathcal{J}$  and  $\mathcal{D}$  are equal. Furthermore, the following properties hold:*

- (1) *If  $s \leq_{\mathcal{J}} sx$  (in particular if  $s \mathcal{J} sx$ ), then  $s \mathcal{R} sx$ ;*
- (2) *If  $s \leq_{\mathcal{J}} xs$  (in particular if  $s \mathcal{J} xs$ ), then  $s \mathcal{L} xs$ .*
- (3) *If  $s \mathcal{J} t$  and  $s \leq_{\mathcal{R}} t$ , then  $s \mathcal{R} t$ ;*
- (4) *If  $s \mathcal{J} t$  and  $s \leq_{\mathcal{L}} t$ , then  $s \mathcal{L} t$ ;*
- (5) *if  $s = usv$  for some  $u, v \in S^1$ , then  $us \mathcal{H} s \mathcal{H} sv$ .*

**Proof.** If  $x \mathcal{D} y$ , there exist  $z \in S$  such that  $x \mathcal{R} z$  and  $z \mathcal{L} y$ . It follows that  $x \mathcal{J} z$  and  $z \mathcal{J} y$ , whence  $x \mathcal{J} y$ .

Conversely, suppose that  $x \mathcal{J} y$ . Then there exist  $s, t, u, v \in S^1$  such that  $y = txu$  and  $x = syv$ , whence  $x = stxuv$ . By multiplying on the left by  $st$  and on the right by  $uv$ , we obtain by induction the relation  $(st)^n x (uv)^n = x$  for all  $n > 0$ . By Proposition II.6.33, one can choose  $n$  such that both  $(st)^n$  and  $(uv)^n$  are idempotent. It follows that  $(st)^n x = (st)^n (st)^n x (uv)^n = (st)^n x (uv)^n = x$  and similarly  $x = x (uv)^n$ . Therefore  $tx \mathcal{L} x$  and  $xu \mathcal{R} x$ . The first relation implies  $y = txu \mathcal{L} xu$  and finally  $y \mathcal{D} x$ .

(1) If  $s \leq_{\mathcal{J}} sx$ , there exist  $u, v \in S^1$  such that  $usxv = s$ . By multiplying on the left by  $u$  and on the right by  $xv$ , we obtain by induction the relation  $u^n s (xv)^n = s$  for all  $n > 0$ . By Proposition II.6.33, one can choose  $n$  such that  $u^n$  is idempotent. It follows that  $s = u^n s (xv)^n = u^n u^n s (xv)^n = u^n s$ , whence  $s(xv)^n = s$ . It follows that  $s \mathcal{R} sx$ , since  $(sx)(v(xv)^{n-1}) = s$ .

(2) is dual from (1).

(3) If  $s \leq_{\mathcal{R}} t$ , there exist  $u \in S^1$  such that  $s = tu$ . If further  $s \mathcal{J} t$ , then  $t \mathcal{J} tu$  and  $t \mathcal{R} tu$  by (1). Thus  $s \mathcal{R} t$ .

(4) is dual from (3).

(5) If  $s = usv$  then  $s \leq_{\mathcal{J}} us$ . It follows by (1) that  $s \mathcal{R} sv$  and a dual argument shows that  $s \mathcal{L} us$ . Since the relation  $\mathcal{R}$  is stable on the left, one has  $us \mathcal{R} usv = s$  and dually,  $sv \mathcal{L} s$ . Thus  $us \mathcal{H} s \mathcal{H} sv$ .  $\square$

**Example 1.2** Let  $S$  be the infinite semigroup of matrices of the form

$$\begin{pmatrix} a & 0 \\ b & 1 \end{pmatrix}$$

where  $a$  and  $b$  are strictly positive rational numbers, equipped with the usual multiplication of matrices. Then the four relations  $\mathcal{R}$ ,  $\mathcal{L}$ ,  $\mathcal{H}$  and  $\mathcal{D}$  coincide with the equality, but  $S$  has a single  $\mathcal{J}$ -class.

Proposition 1.8 shows that for two elements  $s$  and  $t$ , the three conditions  $s \mathcal{D} t$ ,  $R(s) \cap L(t) \neq \emptyset$  and  $L(s) \cap R(t) \neq \emptyset$  are equivalent. It is therefore possible to represent  $\mathcal{D}$ -classes by an "egg-box picture", as in Figure 1.2.

*					*
		*			
				*	
	*		*		

**Figure 1.2.** A  $\mathcal{D}$ -class containing some idempotents.

Each row represents an  $\mathcal{R}$ -class, each column an  $\mathcal{L}$ -class and each cell an  $\mathcal{H}$ -class. The possible presence of an idempotent within an  $\mathcal{H}$ -class is indicated by a star. We shall see later (Proposition 1.13) that these  $\mathcal{H}$ -classes containing an idempotent are groups, and that all such groups occurring within a given  $\mathcal{D}$ -class are isomorphic. The next proposition describes the structure of a  $\mathcal{D}$ -class.

**Proposition 1.10 (Green's lemma)** *Let  $s$  and  $t$  be two  $\mathcal{R}$ -equivalent elements of  $S$ . If  $s = tp$  and  $t = sq$  for some  $p, q \in S^1$ , then the map  $x \rightarrow xp$  is a bijection from  $L(t)$  onto  $L(s)$ , the map  $x \rightarrow xq$  is a bijection from  $L(s)$  and  $L(t)$ . Further, these bijections preserve the  $\mathcal{H}$ -classes and are inverse one from the other.*

**Proof.** Let  $n \in L(s)$  (see Figure 1.3). Since  $\mathcal{L}$  is stable on the right,  $nq \in L(sq)$ . Furthermore, there exist  $u \in S^1$  such that  $n = us$ , whence  $nqp = usqp = utp = us = n$ . Similarly, if  $m \in L(t)$ , then  $mpq = m$  and thus the maps  $x \rightarrow xp$  and  $x \rightarrow xq$  define inverse bijections between  $L(s)$  and  $L(t)$ . Moreover, Proposition 1.2 shows that the maps  $x \rightarrow xp$  and  $x \rightarrow xq$  preserve the  $\mathcal{H}$ -classes.  $\square$

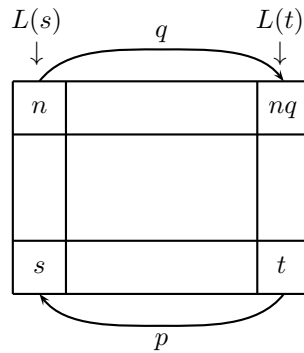

**Figure 1.3.** An illustration of Green's lemma.

There is of course a dual version of Green's lemma for  $\mathcal{L}$ -equivalent elements. Green's lemma has several important consequences. First, the "Location theorem" of Clifford and Miller:

**Theorem 1.11 (Location theorem)** *Let  $D$  be a  $\mathcal{D}$ -class of a semigroup  $S$ , and let  $s$  and  $t$  be elements of  $D$ . The following conditions are equivalent:*

- (1)  $st \in R(s) \cap L(t)$ ,
- (2)  $R(t) \cap L(s)$  contains an idempotent,
- (3)  $\bar{s}st = t$  and  $st\bar{t} = s$  for some inverse  $\bar{s}$  of  $s$  and some inverse  $\bar{t}$  of  $t$ .

If  $S$  is finite, then these conditions are equivalent to

- (4)  $st \in D$ .

**Proof.** (1) implies (2). If  $st \in R(s) \cap L(t)$ , the multiplication on the right by  $t$  is, by Green's lemma, a bijection from  $L(s)$  onto  $L(t)$  preserving the  $\mathcal{H}$ -classes. In particular, there exists an element  $e \in R(t) \cap L(s)$  such that  $et = t$ . Since  $e \mathcal{R} t$ , one has  $e = tv$  for some  $v \in S^1$  and  $ee = etv = tv = e$ . Thus  $e$  is idempotent.

	$L(s)$	$L(t)$
$R(s)$	$s$	$st$
$R(t)$	$*e$	$t$

(2) implies (3). Let  $e$  be an idempotent of  $R(t) \cap L(s)$ . First, one gets  $et = t$  and  $se = s$  by Proposition 1.3. Since  $t \mathcal{R} e$ ,  $e = tt'$  for some  $t' \in S^1$ . Setting  $\bar{t} = t'e$ , we get  $t\bar{t}t = tt'et = eet = t$  and  $\bar{t}t\bar{t} = t'ett'e = t'e = \bar{t}$ . Thus  $\bar{t}$  is an inverse of  $t$ . Furthermore,  $st\bar{t} = stt'e = se = s$ . The proof of the existence of  $\bar{s}$  is dual.

(3) implies (1) is clear.

Finally, if  $S$  is finite, Conditions (1) and (4) are equivalent By Theorem 1.9.  $\square$

**Proposition 1.12** *Let  $D$  be a  $\mathcal{D}$ -class of a semigroup  $S$ . If  $D$  contains an idempotent, it contains at least one idempotent in each  $\mathcal{R}$ -class and in each  $\mathcal{L}$ -class.*

**Proof.** Suppose that  $D$  contains an idempotent  $e$  and let  $s \in D$ . Then  $e \mathcal{R} r$  and  $r \mathcal{L} s$  for some  $r \in D$ . Thus  $er = r$  by Proposition 1.3 and  $ru = e$  for some  $u \in S^1$ . It follows that  $ur$  is idempotent, since  $urur = u(ru)r = uer = ur$ . Furthermore  $r(ur) = er = r$ . Consequently  $r \mathcal{L} ur$ ,  $L(s) = L(r) = L(ur)$  and thus the  $\mathcal{L}$ -class of  $s$  contains an idempotent.  $\square$

Here is a useful consequence of the Location theorem.

**Proposition 1.13** *Let  $H$  be an  $\mathcal{H}$ -class of a semigroup  $S$ . The following conditions are equivalent:*

- (1)  $H$  contains an idempotent,
- (2) there exist  $s, t \in H$  such that  $st \in H$ ,
- (3)  $H$  is a group.

Further, every group of  $S$  is contained in an  $\mathcal{H}$ -class.

**Proof.** The equivalence of (1) and (2) follows from Theorem 1.11. Furthermore, it is clear that (3) implies (1). Let us show that (1) implies (3).

Let  $H$  be a  $\mathcal{H}$ -class containing an idempotent  $e$ . Then  $H$  is a semigroup: indeed, if  $s, t \in H$ , we have  $st \in R(s) \cap L(t) = H$ . Moreover, if  $s \in H$ , we have  $s \mathcal{R} e$  and hence  $es = s$  by Proposition 1.3. Further, by Green's lemma, the map  $x \rightarrow xs$  is a permutation on  $H$ . In particular, there exists  $t \in H$  such that  $ts = e$ , and thus  $H$  is a group with identity  $e$ .

Finally, if  $H$  is a group with identity  $e$ , then  $H$  is contained in the  $\mathcal{H}$ -class of  $e$ . Indeed, if  $t$  is the inverse of an element  $s$  of  $H$ , then  $st = ts = e$  and  $se = es = s$ , which proves that  $s \mathcal{H} e$ .  $\square$

The following is another remarkable consequence of Green's lemma.

**Proposition 1.14** *Two maximal subgroups of a  $\mathcal{D}$ -class are isomorphic.*

**Proof.** From Proposition 1.13, the two groups are of the form  $H(e)$  and  $H(f)$  for some idempotent  $e, f$  of the same  $\mathcal{D}$ -class  $D$ . Since  $e \mathcal{D} f$ , there exists  $s \in R(e) \cap L(f)$ . Thus  $es = s, sf = s$  and  $ts = f$  for some  $t \in S^1$ . By Green's lemma, the function  $\varphi$  defined by  $\varphi(x) = txs$  is a bijection from  $H(e)$  onto  $H(f)$ , which maps  $e$  to  $f$  since  $tes = ts = f$ .

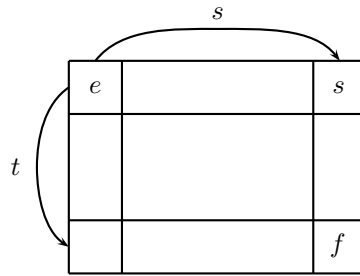

**Figure 1.4.** The  $\mathcal{D}$ -class  $D$ .

We claim that  $\varphi$  is a morphism. First observe that  $st$  is idempotent, since  $stst = sft = st$ . Furthermore,  $st \mathcal{R} s$  since  $sts = sf = s$ . If  $y \in H(e)$ , then  $y \mathcal{R} e \mathcal{R} s \mathcal{R} st$  and by Proposition 1.3,  $(st)y = y$ . It follows that for all  $x, y \in H(e)$ ,

$$\varphi(xy) = txys = tx(sty)s = (txs)(tys) = \varphi(x)\varphi(y)$$

proving the claim. Thus  $H(e)$  and  $H(f)$  are isomorphic.  $\square$

For finite semigroups, some other properties hold.

**Corollary 1.15** *Let  $S$  be a finite semigroup and let  $s, t \in S$  be two  $\mathcal{J}$ -related elements of  $S$ . If  $st \mathcal{L} s$  or  $ts \mathcal{R} s$ , then  $H(t)$  is a group. If  $st = s$  or  $ts = s$ , then  $t$  is idempotent.*

**Proof.** Suppose that  $st \mathcal{L} s$  (the other case is dual) and let  $J$  be the common  $\mathcal{J}$ -class of  $s, t$  and  $st$ . Since  $st \leq_{\mathcal{L}} t$ , Theorem 1.9 shows that  $t \mathcal{L} st$ , whence  $s \mathcal{L} t$  since  $st \mathcal{L} s$ . Thus  $L(s) = L(t)$  and  $R(t) \cap L(s) = H(t)$ . Since  $st \in J$ ,

Theorem 1.11 shows that  $H(t)$  contains an idempotent. Thus by Proposition 1.13,  $H(t)$  is a group.

Suppose that  $st = s$  and let  $e$  be the idempotent of  $H(t)$ . By Green's lemma, the left multiplication by  $s$  induces a bijection from  $H(t)$  onto  $H(st)$ . But since  $e \mathcal{L} s$ ,  $se = s$  by Proposition 1.3. Thus  $se = s = st$ , whence  $e = t$ .  $\square$

The case  $t = s$  is worth a separate statement, that should be compared with Proposition 1.13.

**Corollary 1.16** *Let  $S$  be a finite semigroup and let  $s \in S$ . If  $s \mathcal{J} s^2$ , then  $H(s)$  is a group.*

We conclude this section by two results on the maximal  $\mathcal{J}$ -classes of a finite semigroup.

**Proposition 1.17** *In a finite monoid, the  $\mathcal{J}$ -class of the identity is a group.*

**Proof.** Let  $J$  be the  $\mathcal{J}$ -class of 1. If  $e$  is an idempotent of  $J$ , then  $e \leq 1$  by Corollary 1.5 whence  $e = 1$  by Theorem 1.9. It follows that  $J$  contains a unique idempotent and by Proposition 1.12, a unique  $\mathcal{R}$ -class and a unique  $\mathcal{L}$ -class. Thus  $J$  is an  $\mathcal{H}$ -class and thus a group.  $\square$

**Proposition 1.18** *Let  $J$  be a  $\leq_{\mathcal{J}}$ -maximal  $\mathcal{J}$ -class of a semigroup  $S$ . If  $J$  is finite, it is either regular or reduced to a single null element.*

**Proof.** Let  $J$  be a maximal  $\mathcal{J}$ -class. Suppose that  $J$  is not regular and contains two distinct elements  $s$  and  $t$ . Then  $s = utv$  and  $t = xsy$  for some  $x, y, u, v \in S^1$ . Thus  $s = uxsyv$  and since  $s \neq t$ , we may assume that  $(u, v) \neq (1, 1)$  whence  $u \in S$  or  $v \in S$ . Suppose that  $u \in S$ , the other case being dual. Then  $ux \in S$  and since  $s \leq_{\mathcal{J}} ux$ , it follows that  $s \mathcal{J} ux$  since  $J$  is maximal. Similarly,  $s \leq_{\mathcal{J}} svy$ , whence  $svy \in J$ . Thus  $J$  contains  $ux$ ,  $svy$  and their product. Therefore it is regular by Corollary 2.25.  $\square$

## 2 Inverses, weak inverses and regular elements

In this section, we study in more detail the notion of semigroup inverse introduced in Chapter II.

### 2.1 Inverses and weak inverses

An element  $\bar{s}$  of a semigroup  $S$  is a *weak inverse* of an element  $s$  if  $\bar{s}s\bar{s} = \bar{s}$ . It is an *inverse* (or a *semigroup inverse*) of  $s$  if, furthermore,  $s\bar{s}s = s$ . Note that any idempotent is its own inverse.

We denote the set of all weak inverses [inverses] of the element  $s$  by  $W(s)$  [ $V(s)$ ].

**Proposition 2.19** *If  $\bar{s}$  is a weak inverse of  $s$ , then  $\bar{s}s$  and  $s\bar{s}$  are idempotents and  $s\bar{s}s$  is an inverse of  $\bar{s}$ . Furthermore, the relations  $s\bar{s} \mathcal{L} \bar{s} \mathcal{R} \bar{s}s$  and  $\bar{s}s \mathcal{L} s\bar{s} \mathcal{R} s\bar{s}$  hold.*

**Proof.** If  $\bar{s}$  is a weak inverse of  $s$ , then  $\bar{s}s\bar{s} = \bar{s}$ . Thus  $s\bar{s}s\bar{s} = s\bar{s}$  and  $\bar{s}s\bar{s}s = \bar{s}s$ . Furthermore, since  $\bar{s}(s\bar{s}s)\bar{s} = \bar{s}s\bar{s}$  and  $(s\bar{s}s)\bar{s}(s\bar{s}s) = s\bar{s}s$ ,  $s\bar{s}s$  is an inverse of  $\bar{s}$ . The relations of the statement follow immediately.  $\square$

**Corollary 2.20** *If  $\bar{s}$  is an inverse of  $s$ , then  $\bar{s}s$  and  $s\bar{s}$  are idempotents. Furthermore,  $s$  and  $\bar{s}$  are in the same  $\mathcal{D}$ -class and the relations  $s\bar{s} \mathcal{L} \bar{s} \mathcal{R} \bar{s}s \mathcal{L} s \mathcal{R} s\bar{s}$  hold.*

**Proof.** If  $\bar{s}$  is an inverse of  $s$ , then  $s\bar{s}s = s$  and the result follows from Proposition 2.19.  $\square$

The case where  $\bar{s}$  is a weak inverse [an inverse] of  $s$  is depicted in Figure 2.5. However, it may happen that some of the elements represented in different  $\mathcal{H}$ -classes are actually in the same  $\mathcal{H}$ -class. In particular, if  $s = \bar{s}$ , the  $\mathcal{H}$ -class of  $s$  is a group  $H$  whose identity is the idempotent  $e = s\bar{s} = \bar{s}s$ . Furthermore,  $s$ ,  $\bar{s}$  and  $e$  are all in  $H$  and  $\bar{s}$  is the group inverse of  $s$  in  $H$ .



**Figure 2.5.** Two egg-box pictures. On the left,  $\bar{s}$  is a weak inverse of  $s$ . On the right,  $\bar{s}$  is an inverse of  $s$ .

In general, an element may have several inverses. However, it has at most one inverse in a given  $\mathcal{H}$ -class.

**Proposition 2.21** *An  $\mathcal{H}$ -class  $H$  contains an inverse  $\bar{s}$  of an element  $s$  if and only if  $R(H) \cap L(s)$  and  $R(s) \cap L(H)$  contain an idempotent. In this case,  $H$  contains a unique inverse of  $s$ .*

**Proof.** Suppose that  $H$  contains an inverse  $\bar{s}$  of  $s$ . Then by Corollary 2.20, the idempotent  $\bar{s}s$  belongs to  $R(\bar{s}) \cap L(s)$  and the idempotent  $s\bar{s}$  to  $R(s) \cap L(\bar{s})$ . Conversely, suppose that  $R(s) \cap L(H)$  contains an idempotent  $e$  and  $R(H) \cap L(s)$  an idempotent  $f$ . Then  $e \mathcal{R} s$  and thus  $es = s$  by Proposition 1.3. Now, by Green's lemma, there exists a unique element  $\bar{s} \in H$  such that  $\bar{s}s = f$ . Since  $s \mathcal{L} f$ ,  $sf = s$  and hence  $s\bar{s}s = s$ . Similarly,  $f \mathcal{R} \bar{s}$ , whence  $f\bar{s} = \bar{s}$  and  $\bar{s}s\bar{s} = \bar{s}$ . Thus  $\bar{s}$  is an inverse of  $s$ .

Finally, suppose that  $H$  contains two inverses  $\bar{s}_1$  and  $\bar{s}_2$  of  $s$ . Then Corollary 2.20 shows that  $s\bar{s}_1$  and  $s\bar{s}_2$  are idempotents of the same  $\mathcal{H}$ -class and hence are equal. Similarly,  $\bar{s}_1s$  and  $\bar{s}_2s$  are equal. It follows that  $\bar{s}_1s\bar{s}_1 = \bar{s}_2s\bar{s}_1 = \bar{s}_2s\bar{s}_2$ , that is,  $\bar{s}_1 = \bar{s}_2$ .  $\square$

Two elements  $s$  and  $t$  of a semigroup  $S$  are said to be *conjugate* if there exist  $u, v \in S^1$  such that  $s = uv$  and  $t = vu$ . Conjugate idempotents can be characterised as follows:

**Proposition 2.22** *Let  $e$  and  $f$  be two idempotents of a semigroup  $S$ . The following conditions are equivalent:*

- (1)  $e$  and  $f$  are conjugate,
- (2) there exist two elements  $u, v \in S$  such that  $u \mathcal{D} v \mathcal{D} e \mathcal{D} f$ ,  $uv = e$  and  $vu = f$ ,
- (3)  $e$  and  $f$  are  $\mathcal{D}$ -equivalent.

**Proof.** It is clear that (2) implies (1) and (3).

(1) implies (3). Suppose first that  $e = uv$  and  $f = vu$  for some  $u, v \in S^1$ . Then  $uvuv = uv$  and  $vuvv = vu$ , whence  $uv \mathcal{R} uvu$  and  $uvu \mathcal{L} vu$ . Thus  $e = uv \mathcal{D} vu = f$ .

(3) implies (2). Suppose that  $e \mathcal{D} f$ . Then there exists  $s \in S$  such that  $e \mathcal{R} s$  and  $s \mathcal{L} f$ . By Green's lemma, there exists an element  $\bar{s} \in L(e) \cap R(f)$  such that  $\bar{s}s = f$ . Thus  $s\bar{s}s = sf = s$  and  $\bar{s}s\bar{s} = f\bar{s} = \bar{s}$ . It follows that  $\bar{s}$  is an inverse of  $s$ . By Corollary 2.20,  $\bar{s}s$  is an idempotent of the same  $\mathcal{H}$ -class as  $e$  and thus is equal to  $e$ .  $\square$

We conclude this section by an elementary result on idempotents.

**Proposition 2.23** *Let  $e$  be an idempotent of a semigroup  $S$ . If  $e = xy$  for some  $x, y \in S$ , then  $ex$  and  $ye$  are mutually inverse elements.*

**Proof.** Indeed,  $(ex)(ye)(ex) = exyex = ex$  and  $(ye)(ex)(ye) = yexye = ye$ .  $\square$

## 2.2 Regular elements

An element is *regular* if it has at least one inverse. A semigroup is called *regular* if all its elements are regular. Similarly, a  $\mathcal{D}$ -class [ $\mathcal{L}$ -class,  $\mathcal{R}$ -class,  $\mathcal{J}$ -class] is called *regular* if all its elements are regular. A nonregular  $\mathcal{D}$ -class is also called a *null  $\mathcal{D}$ -class*.

The set of regular elements of a semigroup  $S$  is denoted by  $\text{Reg}(S)$ . Since an idempotent is its own inverse,  $E(S)$  is a subset of  $\text{Reg}(S)$ .

The next proposition gives various characterisations of regular elements.

**Proposition 2.24** *Let  $s$  be an element of a semigroup  $S$ . The following conditions are equivalent:*

- (1)  $s$  is regular,
- (2)  $s\bar{s}s = s$  for some  $\bar{s} \in S$ ,
- (3)  $D(s)$  contains an idempotent,
- (4)  $R(s)$  contains an idempotent,
- (5)  $L(s)$  contains an idempotent,

**Proof.** (1) implies (2) by definition. Condition (2) states that  $s$  is a weak inverse of  $\bar{s}$ . Thus Proposition 2.19 shows that (2) implies (1), (3), (4) and (5). The equivalence of (3), (4) and (5) follows from Proposition 1.12.

(4) implies (1). Let  $e$  be an idempotent such that  $s \mathcal{R} e$ . Then  $es = s$  and  $st = e$  for some  $t \in S^1$ . We claim that  $\bar{s} = tst$  is an inverse of  $s$ . Indeed  $s\bar{s}s = ststs = ees = es = s$  and  $\bar{s}s\bar{s} = tstst = \bar{s}$ . Thus  $s$  is regular.  $\square$

It is useful to restate Proposition 2.24 in terms of  $\mathcal{D}$ -classes.

**Corollary 2.25** *Let  $\mathcal{D}$  be a  $\mathcal{D}$ -class of a finite semigroup. The following conditions are equivalent:*

- (1)  $\mathcal{D}$  is regular,
- (2)  $\mathcal{D}$  contains a regular element,
- (3)  $\mathcal{D}$  contains an idempotent,
- (4) each  $\mathcal{R}$ -class of  $\mathcal{D}$  contains an idempotent,
- (5) each  $\mathcal{L}$ -class of  $\mathcal{D}$  contains an idempotent,
- (6) there exist two elements of  $\mathcal{D}$  whose product belongs to  $\mathcal{D}$ .

Corollary 2.25 shows that a regular  $\mathcal{D}$ -class contains at least one idempotent in each  $\mathcal{R}$ -class and in each  $\mathcal{L}$ -class. It follows that all the  $\mathcal{R}$ -classes and  $\mathcal{L}$ -classes contained in a regular  $\mathcal{D}$ -class are regular.

Let  $\mathcal{K}$  be one of the Green's relations  $\mathcal{R}$ ,  $\mathcal{L}$ ,  $\mathcal{J}$  or  $\mathcal{H}$ . A semigroup is  $\mathcal{K}$ -trivial if and only if  $a \mathcal{K} b$  implies  $a = b$ .

**Proposition 2.26** *Let  $S$  be a finite semigroup and let  $\mathcal{K}$  be one of the Green's relations  $\mathcal{R}$ ,  $\mathcal{L}$ ,  $\mathcal{H}$  or  $\mathcal{J}$ . Then  $S$  is  $\mathcal{K}$ -trivial if and only if its regular  $\mathcal{K}$ -classes are trivial.*

**Proof.** Let  $n$  be the exponent of  $S$ .

(a)  $\mathcal{K} = \mathcal{R}$ . Suppose  $x \mathcal{R} y$ . Then there exist  $c, d \in S^1$  such that  $xc = y$ ,  $yd = x$ , whence  $xcd = x$ . One has  $(cd)^n \mathcal{R} (cd)^n c$  and since the restriction of  $\mathcal{R}$  to the regular  $\mathcal{R}$ -class is trivial, one gets  $(cd)^n = (cd)^n c$ . It follows that  $x = x(cd)^n = x(cd)^n c = xc = y$  and therefore  $S$  is  $\mathcal{R}$ -trivial.

(b)  $\mathcal{K} = \mathcal{L}$ . The proof is dual.

(c)  $\mathcal{K} = \mathcal{J}$ . By (a) and (b),  $S$  is  $\mathcal{R}$ -trivial and  $\mathcal{L}$ -trivial. Since  $\mathcal{J} = \mathcal{D} = \mathcal{R} \circ \mathcal{L}$ ,  $S$  is  $\mathcal{J}$ -trivial.

(d)  $\mathcal{K} = \mathcal{H}$ . Suppose that  $x \mathcal{H} y$ . Then there exist  $a, b, c, d \in S^1$  such that  $ax = y$ ,  $by = x$ ,  $xc = y$  and  $yd = x$ . It follows that  $x = axd$  and therefore  $a^n x d^n = x$ . Since  $a^n$  is idempotent and since  $a^{n+1} \mathcal{H} a^n$ , one gets  $a^{n+1} = a^n$  since the  $\mathcal{H}$ -class of  $a^n$  is regular. It follows that  $x = a^n x d^n = a^{n+1} x d^n = a(a^n x d^n) = ax = y$ . Therefore  $S$  is  $\mathcal{H}$ -trivial.  $\square$

A finite  $\mathcal{H}$ -trivial semigroup is also called aperiodic. See Proposition VII.4.22 for more details. We conclude this section by another property of finite semigroups.

**Proposition 2.27** *Let  $S$  be a finite semigroup and let  $T$  be a subsemigroup of  $S$ . Let  $s \in T$  and let  $e$  be an idempotent of  $S$ . Suppose that, for some  $u, v \in T^1$ ,  $e \mathcal{R}_S us$ ,  $us \mathcal{L}_S s$ ,  $s \mathcal{R}_S sv$  and  $sv \mathcal{L}_S e$ . Then  $e \in T$  and  $e \mathcal{R}_T us \mathcal{L}_T s \mathcal{R}_T sv \mathcal{L}_T e$ .*

$*e$		$us$
$sv$		$s$



**Proof.** Since  $R_S(us) \cap L_S(sv)$  contains an idempotent, Green's lemma shows that  $svus$  belongs to  $R_S(sv) \cap L_S(us)$ , which is equal to  $H_S(s)$ . It follows that the right translation  $\rho_{vus}$  is a permutation on  $H_S(s)$ . Since  $T$  is finite, some power of  $vus$ , say  $(vus)^n$  is an idempotent  $f$  of  $T$ . Since  $\rho_{vus}$  is a permutation on  $H_S(s)$ ,  $\rho_f$  is also a permutation on  $H_S(s)$  and since  $f^2 = f$ , this permutation is the identity. In particular,  $sf = s$ , that is,  $s(vus)^n = s$ . It follows that  $s \mathcal{R}_T sv \mathcal{R}_T svus$  and a dual argument shows that  $s \mathcal{L}_T us \mathcal{L}_T svus$ . Thus  $svus \in R_T(sv) \cap L_T(us)$  and by Green's lemma again,  $R_T(us) \cap L_T(sv)$  contains an idempotent. This idempotent belongs to the  $\mathcal{H}$ -class  $R_S(us) \cap L_S(sv)$ , thereby it is equal to  $e$ . Thus  $e \in T$ .  $\square$

### 3 Rees matrix semigroups

The Location Theorem indicates the product of two elements  $s$  and  $t$  of the same  $\mathcal{D}$ -class  $D$  either falls out of  $D$  or belongs to the intersection of the  $\mathcal{R}$ -class of  $s$  and of the  $\mathcal{L}$ -class of  $t$ . In the latter case, the location of  $st$  in the egg-box picture is precisely known and the intersection of the  $\mathcal{R}$ -class of  $t$  and of the  $\mathcal{L}$ -class of  $s$  is a group. This suggests that the structure of a regular  $\mathcal{D}$ -class depends primarily on the coordinates of its elements in the egg-box picture and on its maximal groups. This motivates the following definition.

Let  $I$  and  $J$  be two nonempty sets,  $G$  be a group and  $P = (p_{j,i})_{j \in J, i \in I}$  be a  $J \times I$ -matrix with entries in  $G$ . The *Rees matrix semigroup* with  $G$  as *structure group*,  $P$  as *sandwich matrix* and  $I$  and  $J$  as indexing sets, is the semigroup  $M(G, I, J, P)$  defined on the set  $I \times G \times J$  by the operation

$$(i, g, j)(i', g', j') = (i, gp_{j,i'}g', j') \quad (3.1)$$

More generally, if  $P = (p_{j,i})_{j \in J, i \in I}$  is a  $J \times I$ -matrix with entries in  $G^0$ , we denote by  $M^0(G, I, J, P)$  the semigroup, called a *Rees matrix semigroup with zero*, defined on the set  $(I \times G \times J) \cup 0$  by the operation

$$(i, g, j)(i', g', j') = \begin{cases} (i, gp_{j,i'}g', j') & \text{if } p_{j,i'} \neq 0 \\ 0 & \text{otherwise} \end{cases}$$

As suggested by the terminology, Rees matrix semigroups can be equivalently defined as semigroups of matrices. We first equip  $G^0$  with a semiring structure as follows. We define an addition on  $G^0$  by setting  $g + 0 = 0 + g = g$  for all  $g \in G^0$  and  $g + g' = 0$  for all  $g, g' \in G$ . This addition is associative and the multiplication on  $G^0$  distributes over this addition and thus  $G^0$  is a semiring. We now identify each element of  $M^0(G, I, J, P)$  with an  $I \times J$ -matrix with entries in  $G^0$ :  $0$  is identified with the null matrix and  $(i, g, j)$  with the matrix whose sole nonzero entry is  $g$  in row  $i$  and column  $j$ . The product of two matrices  $X$  and  $Y$  in  $M^0(G, I, J, P)$  is  $XPY$ . Note that all products can be calculated using only trivial sums  $0 + g = g + 0 = g$ .

**Example 3.1** A *Brandt semigroup* is a Rees matrix semigroup in which  $I = J$  and  $P$  is the identity matrix. Therefore, the product is defined by

$$(i, g, j)(i', g', j') = \begin{cases} (i, gg', j') & \text{if } j = i', \\ 0 & \text{otherwise.} \end{cases}$$

A *Brandt aperiodic semigroup* is a Brandt semigroup whose structure group is trivial. If  $I = \{1, \dots, n\}$ , this semigroup is denoted by  $B_n$ . For instance,  $B_2$  is the semigroup of  $2 \times 2$  Boolean matrices

$$B_2 = \left\{ \begin{pmatrix} 1 & 0 \\ 0 & 0 \end{pmatrix}, \begin{pmatrix} 0 & 1 \\ 0 & 0 \end{pmatrix}, \begin{pmatrix} 0 & 0 \\ 1 & 0 \end{pmatrix}, \begin{pmatrix} 0 & 0 \\ 0 & 1 \end{pmatrix}, \begin{pmatrix} 0 & 0 \\ 0 & 0 \end{pmatrix} \right\}$$

under multiplication. This semigroup is studied in more detail in Section 2.1.

The regularity of a Rees matrix semigroups depends only on its sandwich matrix.

**Proposition 3.28** *A Rees matrix semigroup with zero is regular if and only if every row and every column of its sandwich matrix has a nonzero entry.*

**Proof.** Let  $S = M^0(G, I, J, P)$  be a regular Rees matrix semigroup with zero and let  $s = (i, g, j)$  be a nonzero element of  $S$ . Since  $s$  is regular, there exists a nonzero element  $\bar{s} = (i', g', j')$  such that  $s\bar{s}s = s$ . It follows that  $p_{j,i'} \neq 0$  and  $p_{j',i} \neq 0$ . Consequently, every row and every column of  $P$  has a nonzero entry.

Conversely, assume that in  $P$ , every row  $j$  contains a nonzero entry  $p_{j,i_j}$  and every column  $i$  contains a nonzero entry  $p_{j_i,i}$ . Then each nonzero element  $s = (i, g, j)$  admits as an inverse the element  $\bar{s} = (i_j, p_{j,i_j}^{-1}g^{-1}p_{j_i,i}^{-1}, j_i)$  since

$$\begin{aligned} s\bar{s}s &= (i, gp_{j,i_j}p_{j,i_j}^{-1}g^{-1}p_{j_i,i}^{-1}p_{j_i,i}g, j) = s \text{ and} \\ \bar{s}s\bar{s} &= (i_j, p_{j,i_j}^{-1}g^{-1}p_{j_i,i}^{-1}p_{j_i,i}gp_{j,i_j}p_{j,i_j}^{-1}g^{-1}p_{j_i,i}^{-1}, j_i) = \bar{s} \end{aligned}$$

Thus  $S$  is regular.  $\square$

Green's relations in a regular Rees matrix semigroup with zero are easy to describe.

**Proposition 3.29** *Let  $S = M^0(G, I, J, P)$  be a regular Rees matrix semigroup with zero. Then  $S$  is 0-simple. In particular,  $\mathcal{D} = \mathcal{J}$  in  $S$  and all the elements of  $S - 0$  are in the same  $\mathcal{D}$ -class. Furthermore, if  $s = (i, g, j)$  and  $s' = (i', g', j')$  are two elements of  $S - 0$ , then*

$$s \leq_{\mathcal{R}} s' \iff s \mathcal{R} s' \iff i = i', \quad (3.2)$$

$$s \leq_{\mathcal{L}} s' \iff s \mathcal{L} s' \iff j = j', \quad (3.3)$$

$$s \leq_{\mathcal{H}} s' \iff s \mathcal{H} s' \iff i = i' \text{ and } j = j'. \quad (3.4)$$

**Proof.** Proposition 3.28 implies that in  $P$ , every row  $j$  contains a nonzero entry  $p_{j,i_j}$  and every column  $i$  contains a nonzero entry  $p_{j_i,i}$ .

Formula 3.1 shows that if  $s \leq_{\mathcal{R}} s'$ , then  $i = i'$ . The converse is true, since

$$(i, g, j)(i_j, p_{j,i_j}^{-1}g^{-1}g', j') = (i, gp_{j,i_j}p_{j,i_j}^{-1}g^{-1}g', j') = (i, g', j')$$

This proves (3.2). Property (3.3) is dual and (3.7) is the conjunction of (3.2) and (3.6).

Setting  $t = (i, 1, j')$ , it follows in particular that  $s \mathcal{R} t \mathcal{L} s'$ , whence  $s \mathcal{D} s'$ . Thus the relations  $\mathcal{D}$  and hence  $\mathcal{J}$  are universal on  $S - 0$ . Finally, if  $e$  and  $f$  are nonzero idempotents such that  $e \leq f$ ,  $e \mathcal{H} f$  by (3), and hence  $e = f$  by

Proposition 1.13. Thus every nonzero idempotent of  $S$  is 0-minimal and  $S$  is 0-simple.  $\square$

	$j$	$j'$
$i$	$(i, g, j)$	$(i, gp_{j,i'}g', j')$
$i'$	*	$(i', g', j')$

**Figure 3.6.** The product of two elements when  $p_{j,i'} \neq 0$ .

A slightly more precise result holds for Rees matrix semigroups.

**Proposition 3.30** *Let  $S = M(G, I, J, P)$  be a Rees matrix semigroup. Then  $S$  is simple. In particular,  $\mathcal{D}$  and  $\mathcal{J}$  are both the universal relation and every  $\mathcal{H}$ -class is a group. Furthermore, if  $s = (i, g, j)$  and  $s' = (i', g', j')$  are two elements of  $S$ , then*

$$s \leq_{\mathcal{R}} s' \iff s \mathcal{R} s' \iff i = i', \tag{3.5}$$

$$s \leq_{\mathcal{L}} s' \iff s \mathcal{L} s' \iff j = j', \tag{3.6}$$

$$s \leq_{\mathcal{H}} s' \iff s \mathcal{H} s' \iff i = i' \text{ and } j = j'. \tag{3.7}$$

**Proof.** The proposition mostly follows from Proposition 3.29 by considering  $S^0$ . A complementary property is that  $s \mathcal{R} ss' \mathcal{L} s'$ , which shows that the relations  $\mathcal{D}$  and  $\mathcal{J}$  are universal on  $S$ . It follows that  $S$  is simple. Taking  $s = s'$ , we get  $s \mathcal{H} s^2$  and thus by Proposition 1.13,  $H(s)$  is a group. Consequently, each  $\mathcal{H}$ -class is a group.  $\square$

We remind the reader that a semigroup  $S$  is simple if its only ideals are  $\emptyset$  and  $S$ . It is 0-simple if it has a zero, denoted by 0, if  $S^2 \neq 0$  and if  $\emptyset, 0$  and  $S$  are its only ideals. By Proposition II.3.19, a simple semigroup has a single  $\mathcal{J}$ -class, and a 0-simple semigroup has a single nonzero  $\mathcal{J}$ -class.

**Proposition 3.31** *A 0-simple semigroup contains a single nonzero  $\mathcal{D}$ -class and this  $\mathcal{D}$ -class is regular.*

**Proof.** Let  $S^0$  be a simple semigroup. By Proposition II.3.19,  $S$  is a regular  $\mathcal{D}$ -class of  $S^0$ . Furthermore, if  $s \in S$ , then  $s^2 \in S$  and Corollary 1.16 shows that  $s \mathcal{H} s^2$ . It follows by Proposition 1.13 that  $H(s)$  is a group.  $\square$

A similar result holds for simple semigroups.

**Proposition 3.32** *A simple semigroup contains a single  $\mathcal{D}$ -class. This  $\mathcal{D}$ -class is regular and each of its  $\mathcal{H}$ -classes is a group.*

We can now state the main theorem of this section.

**Theorem 3.33 (Rees-Sushkevich theorem)**

- (1) A semigroup is simple if and only if it is isomorphic to some Rees matrix semigroup.
- (2) A semigroup is 0-simple if and only if it is isomorphic to some regular Rees matrix semigroup with zero.

**Proof.** By Proposition 3.29, every regular Rees matrix semigroup with zero is 0-simple. Similarly by Proposition 3.30, every Rees matrix semigroup is simple.

Let  $S$  be a 0-simple semigroup. Let  $(R_i)_{i \in I} [(L_j)_{j \in J}]$  be the set of  $\mathcal{R}$ -classes [ $\mathcal{L}$ -classes] of  $S$  and let  $e$  be an idempotent of  $S$ . We denote by  $H_{i,j}$  the  $\mathcal{H}$ -class  $R_i \cap L_j$ . By Propositions 1.13 and 3.31, the  $\mathcal{H}$ -class of  $e$  is a group  $G$ . Let us choose for each  $i \in I$  an element  $s_i \in L(e) \cap R_i$  and for each  $j \in J$  an element  $r_j \in R(e) \cap L_j$ . By Proposition 1.3,  $er_j = r_j$  and  $s_i e = s_i$ . Consequently, by Green's lemma the map  $g \rightarrow s_i g r_j$  from  $G$  into  $H_{i,j}$  is a bijection. It follows that each element of  $S - 0$  admits a unique representation of the form  $s_i g r_j$  with  $i \in I, j \in J$  and  $g \in G$ .

Let  $P = (p_{j,i})_{j \in J, i \in I}$  be the  $J \times I$  matrix with entries in  $G^0$  defined by  $p_{j,i} = r_j s_i$ . By Theorem 1.11,  $r_j s_i \in G$  if  $H_{i,j}$  contains an idempotent and  $r_j s_i = 0$  otherwise. Define a map  $\varphi : S \rightarrow M^0(G, I, J, P)$  by setting

$$\varphi(s) = \begin{cases} (i, g, j) & \text{if } s = s_i g r_j \\ 0 & \text{if } s = 0 \end{cases}$$

Clearly  $\varphi(s)\varphi(0) = \varphi(0)\varphi(s) = 0 = \varphi(0)$ . Let now  $s$  and  $s'$  be nonzero elements. Setting  $\varphi(s) = (i, g, j)$  and  $\varphi(s') = (i', g', j')$ , we have

$$\varphi(s)\varphi(s') = (i, g, j)(i', g', j') = \begin{cases} (i, g r_j s_i g', j) & \text{if } H_{i',j} \text{ contains an idempotent} \\ 0 & \text{otherwise} \end{cases}$$

Since  $s \in H_{i,j}$  and  $s' \in H_{i',j'}$ , Theorem 1.11 shows that  $ss' \neq 0$  if and only if  $H_{i',j}$  contains an idempotent and in this case,  $ss' = s_i g r_j s_i g' r_j = s_i (g r_j s_i g') r_j$ . Therefore  $\varphi$  is a morphism, bijective by construction and hence is an isomorphism.

The case of simple semigroups can be handled in a similar way.  $\square$

**Example 3.2** Let  $S$  be the semigroup generated by the following transformations:

	1	2	3	4	5	6
* $a$	1	1	1	4	4	4
* $b$	2	2	2	5	5	5
* $c$	3	3	3	6	6	6
* $d$	1	4	0	4	1	0

The elements of  $S$  and a set of relations defining  $S$  are given below

	1	2	3	4	5	6
* $a$	1	1	1	4	4	4
* $b$	2	2	2	5	5	5
* $c$	3	3	3	6	6	6
* $d$	1	4	0	4	1	0
$bd$	4	4	4	1	1	1
* $cd$	0	0	0	0	0	0
$db$	2	5	0	5	2	0
$dc$	3	6	0	6	3	0
$bdb$	5	5	5	2	2	2
$bdc$	6	6	6	3	3	3
$dbd$	4	1	0	1	4	0
* $dbdb$	5	2	0	2	5	0
$dbdc$	6	3	0	3	6	0

Relations:

$$\begin{array}{lllll}
 aa = a & ab = b & ac = c & ad = a & ba = a \\
 bb = b & bc = c & ca = a & cb = b & cc = c \\
 da = d & dd = d & cd = 0 & dcd = 0 & bdbd = a
 \end{array}$$

Finally, its  $D$ -class structure is the following:

* $a$ $bd$	* $b$ $bdb$	* $c$ $bdc$
* $d$ $dbd$	* $dbdb$ $db$	$dc$ $dbdc$

$$\boxed{* 0}$$

It follows that  $S$  is a 0-simple semigroup, isomorphic to the Rees matrix semigroup  $M(\mathbb{Z}/2\mathbb{Z}, 2, 3, P)$ , where  $\mathbb{Z}/2\mathbb{Z}$  is the multiplicative group  $\{1, -1\}$  and

$$P = \begin{pmatrix} 1 & 1 \\ 1 & -1 \\ 1 & 0 \end{pmatrix}$$

The isomorphism is given by  $a = (1, 1, 1)$ ,  $b = (1, 1, 2)$ ,  $c = (1, 1, 3)$  and  $d = (2, 1, 1)$ .

The Rees-Sushkevich theorem has some particular cases of interest. If  $G$  is trivial and  $P_{i,j} = 1$  for all  $i \in I$  and  $j \in J$ , then  $M(I, J, G, P)$  is isomorphic to a rectangular band  $B(I, J)$ , which is the set  $I \times J$  with the multiplication

$$(i, j)(k, \ell) = (i, \ell)$$

If  $I = \{1, \dots, n\}$  and  $J = \{1, \dots, m\}$ , the notation  $B(n, m)$  is also used.

**Corollary 3.34** *Let  $S$  be a nonempty finite aperiodic semigroup. The following conditions are equivalent:*

- (1)  $S$  is simple,
- (2)  $S$  is idempotent and for all  $e, f, s \in S$ ,  $esf = ef$ ,
- (3)  $S$  is isomorphic to a rectangular band.

**Proof.** The equivalence of (1) and (3) follows directly from the Rees-Sushkevich theorem.

(3) implies (2) since in  $B(I, J)$ ,  $(i, j)(k, \ell)(\ell, m) = (i, m) = (i, j)(\ell, m)$ .

(2) implies (1). Let  $I$  be a nonempty ideal of  $S$  and let  $s \in I$  and  $e \in S$ . Since  $I$  is an ideal,  $ese \in I$ . Further, one has by (2),  $ese = ee = e$ . It follows that  $e \in I$  and hence  $I = S$ . Therefore  $S$  is simple.  $\square$

*	*	*	*	*	*
*	*	*	*	*	*
*	*	*	*	*	*
*	*	*	*	*	*

**Figure 3.7.** An aperiodic simple semigroup: the rectangular band  $B(4, 6)$ .

Furthermore, if  $I [J]$  is a singleton and then  $M(I, J, G, P)$  is a right [left] zero semigroup. Conversely, any right [left] zero semigroup is isomorphic to such a Rees matrix semigroup.

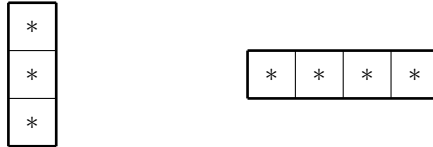

**Figure 3.8.** A left zero semigroup and a right zero semigroup.

### 4 Structure of regular $\mathcal{D}$ -classes

Let  $D$  be a regular  $\mathcal{D}$ -class of a semigroup  $S$ . We define a semigroup  $D^0$  whose support is  $D \cup 0$  and multiplication (denoted by  $*$ ) is given by

$$s * t = \begin{cases} st & \text{if } st \in D, \\ 0 & \text{otherwise} \end{cases}$$

We then have the following proposition.

**Proposition 4.35** *If  $D$  is a regular  $\mathcal{D}$ -class of a semigroup,  $D^0$  is a regular 0-simple semigroup.*

**Proof.** We first verify that all elements of  $D$  are  $\mathcal{D}$ -equivalent in  $D^0$ . Let  $s, t \in D$  and let  $r \in D$  be such that  $s \mathcal{R} r \mathcal{L} t$ . Let  $u$  and  $v$  be elements of  $S^1$  such that  $r = su$  and  $s = rv$ . Since  $D$  is regular,  $L(s)$  [ $L(r)$ ] contains an idempotent  $e$  [ $f$ ]. Thus  $se = s$  and  $rf = r$  by Proposition 1.3. It follows that  $r = s(eu)$  and  $s = r(fv)$ . Furthermore,  $eu \mathcal{L} su$  since  $e \mathcal{L} s$  and thus  $eu \in D$ . Similarly,  $fv \in D$  and hence  $s \mathcal{R} r$  in  $D^0$ . Dually,  $r \mathcal{L} t$  in  $D^0$  and finally,  $s \mathcal{D} t$  in  $D^0$ .

It follows that  $0$  and  $D^0$  are the only ideals of  $D^0$ . Thus  $D^0$  is 0-simple. Since  $D$  is regular,  $D^0$  is also regular.  $\square$

An important particular case occurs when  $D$  is itself a semigroup. We say in this case that is a *full  $\mathcal{D}$ -class* of  $S$ .

**Proposition 4.36** *Let  $D$  be a regular  $\mathcal{D}$ -class of a semigroup. The following conditions are equivalent:*

- (1)  $D$  is full,
- (2)  $D$  is a simple semigroup,
- (3) every  $\mathcal{H}$ -class of  $D$  contains an idempotent,
- (4) the product of any two idempotents of  $D$  is also in  $D$ ,
- (5)  $D$  is isomorphic to some Rees matrix semigroup.

**Proof.** The equivalence of (1) and (2) is trivial and that of (2) and (5) follows from Theorem 3.33.

(1) implies (4) is trivial.

(4) implies (3). Let  $H$  be an  $\mathcal{H}$ -class of  $D$  and let  $x \in H$ . Since  $D$  is regular, there exist by Proposition 1.12 an idempotent  $e$  in  $R(x)$  and an idempotent  $f$  in  $L(x)$ . By (4),  $fe$  belongs to  $D$  and thus, by the Location theorem (Theorem 1.11),  $R(e) \cap L(f)$  contains an idempotent. But  $R(e) \cap L(f)$  is equal to  $H$ , which proves (3).

(3) implies (1) also follows from the Location theorem.  $\square$

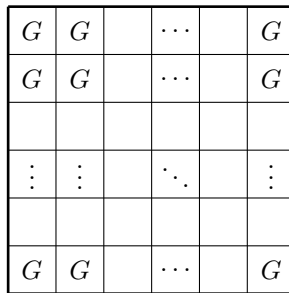

**Figure 4.9.** A completely regular  $\mathcal{D}$ -class.

### 4.1 Structure of the minimal ideal

**Proposition 4.37** *Let  $S$  be a finite semigroup. Then  $S$  has a unique minimal ideal. This ideal is a regular simple semigroup.*

**Proof.** The set of all ideals has a  $\leq_{\mathcal{J}}$ -minimal element  $I$ , which is the unique minimal ideal of  $S$ . By construction,  $I$  is simple. Let  $s \in S$ . The descending sequence  $s \geq_{\mathcal{J}} s^2 \geq_{\mathcal{J}} s^3 \dots$  is stationary. In particular, there exists an integer  $n$  such that  $s^n \mathcal{J} s^{2n}$  and hence  $s^n \mathcal{H} s^{2n}$ . It follows by Proposition 1.13 that  $H(s^n)$  contains an idempotent. Thus  $E(S)$  is nonempty and contains a  $\leq_{\mathcal{J}}$ -minimal element  $e$ . This minimal idempotent belongs to  $I$  and thus  $I$  is simple.  $\square$

It follows that the minimal ideal of a finite semigroup has the following structure. Every  $\mathcal{H}$ -class is a group and all these groups are isomorphic.

$* \ G$	*	*	*	*	*
*	*	*	*	*	*
*	*	*	*	*	*
*	*	*	*	*	*

Figure 4.10. The minimal ideal of a finite semigroup.

## 5 Green's relations in subsemigroups and quotients

Let us start with a trivial observation: Green's relations are stable under morphisms.

**Proposition 5.38** *Let  $\varphi : S \rightarrow T$  be a morphism and let  $\mathcal{K}$  be one of the relations  $\leq_{\mathcal{R}}, \leq_{\mathcal{L}}, \leq_{\mathcal{H}}, \leq_{\mathcal{J}}, \mathcal{R}, \mathcal{L}, \mathcal{H}, \mathcal{D}$  or  $\mathcal{J}$ . If  $s \mathcal{K} t$ , then  $\varphi(s) \mathcal{K} \varphi(t)$ .*

Let now  $T$  be a subsemigroup [a quotient] of a semigroup  $S$ . It is often useful to compare Green's relations defined in  $S$  and  $T$ . For this purpose, if  $\mathcal{K}$  is any one of Green's relations or preorders, we denote by  $\mathcal{K}_S$  [ $\mathcal{K}_T$ ] the Green's relation or preorder defined in the semigroup  $S$  [ $T$ ].

### 5.1 Green's relations in subsemigroups

We first consider the case of subsemigroups.

**Proposition 5.39** *Let  $T$  be a subsemigroup of a finite semigroup  $S$  and let  $s, t \in T$  with  $t$  regular in  $T$ . Let  $\mathcal{K}$  be one of the relations  $\leq_{\mathcal{R}}, \leq_{\mathcal{L}}, \leq_{\mathcal{H}}, \mathcal{R}, \mathcal{L}$  or  $\mathcal{H}$ . If  $s \mathcal{K}_S t$ , then  $s \mathcal{K}_T t$ .*

**Proof.** Suppose that  $s \leq_{\mathcal{R}_S} t$ . If  $\bar{t}$  is an inverse of  $t$  in  $T$ , then  $t \mathcal{R}_T t\bar{t}$  and thus  $s \leq_{\mathcal{R}_S} t\bar{t}$ . Since  $t\bar{t}$  is idempotent, it follows from Proposition 1.3 that  $t\bar{t}s = s$ . Thus  $s \leq_{\mathcal{R}_T} t\bar{t}$  and finally  $s \leq_{\mathcal{R}_T} t$ . The proof for the other relations is similar.  $\square$



Proposition 5.39 does not extend to  $\leq_{\mathcal{J}}$ ,  $\mathcal{D}$  nor  $\mathcal{J}$ . Let  $S$  be, unsurprisingly, the universal counterexample  $B_2 = \{a, b, ab, ba, 0\}$ , with  $aba = a$ ,  $bab = b$  and  $a^2 = b^2 = 0$ . Let  $T = E(S) = \{ab, ba, 0\}$ . Then  $ab \mathcal{J}_S ba$ , but  $ab \not\leq_{\mathcal{J}_T} ba$ .

However, if  $T$  is an ideal of  $S$ , the following property holds:

**Proposition 5.40** *Let  $T$  be an ideal of a finite semigroup  $S$  and let  $s, t \in T$  with  $s$  or  $t$  regular in  $T$ . Let  $\mathcal{K}$  be one of the relations  $\leq_{\mathcal{R}}$ ,  $\leq_{\mathcal{L}}$ ,  $\leq_{\mathcal{H}}$ ,  $\leq_{\mathcal{J}}$ ,  $\mathcal{R}$ ,  $\mathcal{L}$ ,  $\mathcal{H}$  or  $\mathcal{J}$ . If  $s \mathcal{K}_S t$ , then  $s \mathcal{K}_T t$ .*

**Proof.** Suppose that  $s \leq_{\mathcal{J}_S} t$ . Then  $s = utv$  for some  $u, v \in S^1$ . If  $s$  is regular, let  $\bar{s}$  be an inverse of  $s$  in  $T$ . Then  $s = s\bar{s}s\bar{s}s = s\bar{s}utv\bar{s}s$ . Since  $T$  is an ideal,  $s\bar{s}u$  and  $v\bar{s}s$  are elements of  $T$ . Thus  $s \leq_{\mathcal{J}_T} t$ . If  $t$  is regular, let  $\bar{t}$  be an inverse of  $t$  in  $T$ . Then  $s = utv = ut\bar{t}\bar{t}t\bar{t}v$ . Since  $T$  is an ideal,  $ut\bar{t}$  and  $\bar{t}t\bar{t}v$  are elements of  $T$ . Thus  $s \leq_{\mathcal{J}_T} t$ . The proof for the other relations is similar.  $\square$

If  $T$  is a local subsemigroup of  $S$  (see Exercise II.10), a similar result holds without any regularity assumption.

**Proposition 5.41** *Let  $e$  be an idempotent of a finite semigroup  $S$  and let  $T = eSe$ . Let  $\mathcal{K}$  be one of the relations  $\leq_{\mathcal{R}}$ ,  $\leq_{\mathcal{L}}$ ,  $\leq_{\mathcal{H}}$ ,  $\leq_{\mathcal{J}}$ ,  $\mathcal{R}$ ,  $\mathcal{L}$ ,  $\mathcal{H}$  or  $\mathcal{J}$ . If two elements  $s$  and  $t$  of  $T$  satisfy  $s \mathcal{K}_S t$ , then  $s \mathcal{K}_T t$ .*

**Proof.** Suppose that  $s \leq_{\mathcal{R}_S} t$ . Then  $s = tu$  for some  $u \in S^1$ . Since  $s = ese$  and  $t = ete$ ,  $s = ese = eteu = eteeue$ . Thus  $s \leq_{\mathcal{R}_T} t$ . The proof for the other relations is similar.  $\square$

A useful consequence of Proposition 5.39 is the following corollary:

**Corollary 5.42** *Let  $T$  be a subsemigroup of a finite semigroup  $S$  and let  $D$  be a regular  $\mathcal{D}_T$ -class of  $T$ . Then the restrictions to  $D$  of the Green's relations in  $S$  and  $T$  coincide.*

**Proof.** Since  $D$  is a  $\mathcal{D}_T$ -class of  $T$ , the relations  $\mathcal{D}_T$ ,  $\mathcal{D}_S$ ,  $\mathcal{J}_T$  and  $\mathcal{J}_S$  are universal on  $D$  and hence equal. The rest of the corollary follows directly from Proposition 5.39.  $\square$

## 5.2 Green's relations in quotient semigroups

In this subsection,  $\varphi$  will denote a surjective morphism from a semigroup  $S$  onto a semigroup  $T$ . Little can be said in the general case.

**Proposition 5.43** *Let  $\mathcal{K}$  be one of the relations  $\mathcal{R}$ ,  $\mathcal{L}$ ,  $\mathcal{H}$ ,  $\mathcal{D}$  or  $\mathcal{J}$  and let  $K$  be a  $\mathcal{K}_T$ -class of  $T$ . Then  $\varphi^{-1}(K)$  is a union of  $\mathcal{K}_S$ -classes.*

**Proof.** The result follows immediately from Proposition 5.38.  $\square$

More precise results hold for finite semigroups.

**Proposition 5.44** *Suppose that  $S$  is finite. Let  $J$  be a  $\mathcal{J}$ -class of  $T$  and let  $I$  be a  $\leq_{\mathcal{J}}$ -minimal  $\mathcal{J}$ -class of  $S$  contained in  $\varphi^{-1}(J)$ . Then*

- (1)  $\varphi(I) = J$  and  $\varphi$  induces a surjective morphism from  $I^0$  onto  $J^0$ ,

- (2) each  $\mathcal{R}$ -class [ $\mathcal{L}$ -class] of  $S$  contained in  $I$  maps under  $\varphi$  onto an  $\mathcal{R}$ -class [ $\mathcal{L}$ -class] of  $T$  contained in  $J$ ,
- (3)  $I$  is regular if and only if  $J$  is regular. In this case,  $I$  is the unique minimal  $\mathcal{J}$ -class of  $\varphi^{-1}(J)$ .
- (4) If  $J$  is null, then every  $\mathcal{J}$ -class in  $\varphi^{-1}(J)$  is null.

**Proof.** (1) First, by Proposition 5.43,  $\varphi^{-1}(J)$  is a union of  $\mathcal{J}$ -classes of  $S$ . Since  $S$  is finite, there exists a  $\leq_{\mathcal{J}}$ -minimal  $\mathcal{J}$ -class  $I$  of  $S$  contained in  $\varphi^{-1}(J)$ .

Let  $s \in I$  and  $t \in J$ . Since  $\varphi(s) \mathcal{J} t$  and  $\varphi$  is surjective, one has  $t = \varphi(u)\varphi(s)\varphi(v)$  for some  $u, v \in S^1$ . Therefore  $\varphi(usb) = t$  and  $usb \in \varphi^{-1}(J)$ . Since  $s \in I$  and  $I$  is a minimal  $\mathcal{J}$ -class in  $\varphi^{-1}(J)$ , it follows that  $usb \in I$ . Therefore  $\varphi(I) = J$ .

Let  $s, t \in I$ . If  $st \in I$ , then  $\varphi(st) \in J$ . If  $st \notin I$ , then  $st <_{\mathcal{J}} s$  and hence  $\varphi(st) \notin J$ : otherwise,  $I$  would not be a minimal  $\mathcal{J}$ -class in  $\varphi^{-1}(J)$ . Therefore,  $\varphi$  induces a well-defined surjective morphism from  $I^0$  onto  $J^0$ .

(2) Let  $R$  be an  $\mathcal{R}$ -class of  $I$ . Let  $r \in R$  and let  $t$  be an element of  $J$   $\mathcal{R}$ -equivalent to  $\varphi(r)$ . Then  $t = \varphi(r)x$  for some  $x \in T^1$  and since  $\varphi$  is surjective,  $\varphi(u) = x$  for some  $u \in S^1$ . It follows that  $\varphi(ru) = \varphi(r)\varphi(u) = \varphi(r)x = t$  and therefore  $ru \in \varphi^{-1}(J)$ . Since  $ru \leq_{\mathcal{R}} r$  and  $I$  is a minimal  $\mathcal{J}$ -class of  $\varphi^{-1}(J)$  containing  $ru$ , one gets  $ru \in I$ . It follows by Theorem 1.9 that  $ru \in R$  and thus  $t \in \varphi(R)$ . Consequently,  $\varphi$  maps  $R$  onto an  $\mathcal{R}$ -class of  $T$  containing in  $J$ . The proof is dual for the  $\mathcal{L}$ -classes.

(3) If  $I$  is regular, it contains an idempotent  $e$ . Therefore  $\varphi(e)$  is an idempotent of  $J$ , and  $J$  is regular. Suppose now that  $J$  is regular and let  $e$  be an idempotent of  $J$ . By (1), there is an element  $x \in I$  such that  $\varphi(x) = e$ . It follows that  $\varphi(x^\omega) = e$  and since  $x^\omega \leq x$  and  $I$  is a  $\leq_{\mathcal{J}}$ -minimal  $\mathcal{J}$ -class, one gets  $x^\omega \in I$ . Thus  $I$  is regular.

Let  $I_1$  and  $I_2$  be two  $\leq_{\mathcal{J}}$ -minimal  $\mathcal{J}$ -classes of  $\varphi^{-1}(J)$ . The previous argument shows that there exist two idempotents  $e_1 \in I_1$  and  $e_2 \in I_2$  such that  $\varphi(e_1) = \varphi(e_2) = e$ . It follows that  $\varphi(e_1e_2) = e$  and thus  $e_1e_2 \in \varphi^{-1}(J)$ . But since  $e_1e_2 \leq_{\mathcal{J}} e_1$  and  $e_1e_2 \leq_{\mathcal{J}} e_2$ , one gets  $e_1e_2 \in I_1 \cap I_2$ , a contradiction.

(4) is a consequence of (3) since a  $\mathcal{J}$ -class is null if and only if it is not regular.  $\square$

One says that an element  $y$  of  $T$  is *lifted* to an element  $x$  of  $S$  if  $\varphi(x) = y$ . Similarly, a subset  $Y$  of  $T$  is lifted to a subset  $X$  of  $S$  if  $\varphi(X) = Y$ .

**Theorem 5.45 (Lifting lemma)** *If  $\varphi$  is a morphism from a finite semigroup onto a finite semigroup, then*

- (1) every idempotent lifts to an idempotent,
- (2) every  $\mathcal{J}$ -class lifts to a  $\mathcal{J}$ -class,
- (3) every regular  $\mathcal{R}$ -class [ $\mathcal{L}$ -class,  $\mathcal{H}$ -class] lifts to a regular  $\mathcal{R}$ -class [ $\mathcal{L}$ -class,  $\mathcal{H}$ -class],
- (4) every group lifts to a group.

**Proof.** (1) has been proved several times, but we repeat the argument. If  $e$  is an idempotent of  $T$ , and  $x$  is an element of  $S$  such that  $\varphi(x) = e$ , then  $\varphi(x^\omega) = e$ .

(2) follows from Proposition 5.44.

(3) Let  $R$  be a regular  $\mathcal{R}$ -class of  $T$  and let  $r \in R$ . Let  $J$  be the regular  $\mathcal{J}$ -class of  $T$  containing  $R$ . By Proposition 5.44, there is a unique  $\leq_{\mathcal{J}}$ -minimal  $\mathcal{J}$ -class  $I$  of  $S$  contained in  $\varphi^{-1}(J)$ . Choose  $s \in I$  such that  $\varphi(s) = r$ . By Proposition 5.44 again, the  $\mathcal{R}$ -class of  $s$  maps onto an  $\mathcal{R}$ -class of  $J$ , which is necessarily  $R$ . Similarly, the  $\mathcal{L}$ -class of  $s$  maps onto the  $\mathcal{L}$ -class of  $r$  and hence, the  $\mathcal{H}$ -class of  $s$  maps onto the  $\mathcal{H}$ -class of  $r$ .

(4) If  $H$  is a group of  $T$ , it is contained into a maximal group  $G$  of  $T$  which is also an  $\mathcal{H}$ -class. Then we may use the argument of (3) with  $r$  idempotent and we may choose by (1)  $s$  to be also idempotent. Then  $G$  lifts to an  $\mathcal{H}$ -class containing an idempotent, which is therefore a group  $K$ . In particular,  $\varphi$  induces a group morphism from  $K$  onto  $G$  and the group  $\varphi^{-1}(H)$  is mapped onto  $H$ . This proves that  $H$  lifts to a group.  $\square$

The following example shows that Property (2) in Proposition 5.44 does not extend to  $\mathcal{H}$ -classes.

**Example 5.1** The minimal automata of the languages

$$K = \{a^i b a^j \mid i \equiv 0 \pmod 2 \text{ and } j \equiv 0 \pmod 2\}$$

$$L = \{a^i b a^j \mid i + j \equiv 0 \pmod 2\}$$

are represented in Figure 5.11:

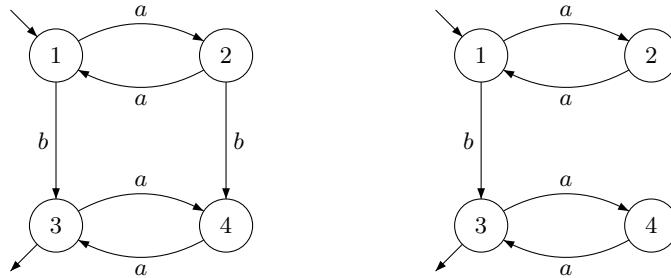

**Figure 5.11.** The minimal automata of  $K$  and  $L$ .

Their syntactic monoids  $M$  (on the left) and  $N$  (on the right) are respectively

1	1	2	3	4
$a$	2	1	4	3
$b$	3	0	0	0
$ab$	0	3	0	0
$ba$	4	0	0	0
$bb$	0	0	0	0
$aba$	0	4	0	0

1	1	2	3	4
$a$	2	1	4	3
$b$	3	4	0	0
$ab$	4	3	0	0
$bb$	0	0	0	0

The monoid  $M = \{1, a, b, ab, ba, bab, 0\}$  is presented on  $\{a, b\}$  by the relations  $aa = 1$ ,  $bab = 0$  and  $bb = 0$ . The monoid  $N = \{1, a, b, ab, 0\}$  is presented on  $\{a, b\}$  by the relations  $aa = 1$ ,  $ba = ab$  and  $bb = 0$ .

The  $\mathcal{J}$ -class structure of  $M$  and  $N$  is represented below:

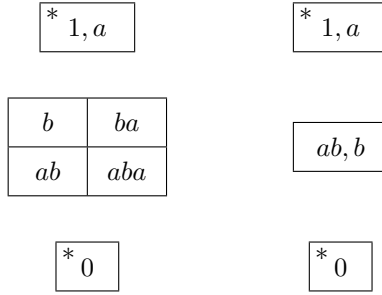

Let  $\varphi : M \rightarrow N$  be the surjective morphism defined by  $\varphi(1) = 1$ ,  $\varphi(a) = a$ ,  $\varphi(b) = b$ ,  $\varphi(ab) = ab$ ,  $\varphi(ba) = ab$  and  $\varphi(aba) = b$ . Then  $J = \{ab, b\}$  is both a  $\mathcal{J}$ -class and an  $\mathcal{H}$ -class of  $N$  and  $I = \{b, ab, ba, aba\} = \varphi^{-1}(J)$  is a  $\mathcal{J}$ -class of  $M$ . However no  $\mathcal{H}$ -class of  $I$  is mapped onto  $J$ .

## 6 Green's relations and transformations

Semigroups are often given as transformation semigroups. We shall therefore examine the Green's relations in such semigroups.

Given an element  $a \in \mathcal{T}(E)$ , we denote by  $\text{Im}(a)$  the range of  $a$  and by  $\text{Ker}(a)$  the partition on  $E$  induced by the equivalence relation  $\sim_a$  defined by

$$p \sim_a q \iff p \cdot a = q \cdot a$$

Finally, we set  $\text{rank}(a) = |\text{Im}(a)| = |\text{Ker}(a)|$ . For example, if

$$a = \begin{pmatrix} 1 & 2 & 3 & 4 & 5 & 6 & 7 \\ 1 & 4 & 5 & 5 & 5 & 4 & 1 \end{pmatrix}$$

we have  $\text{Im}(a) = \{1, 4, 5\}$ ,  $\text{Ker}(a) = 17/26/345$  and  $\text{rank}(a) = 3$ .

We first mention an elementary property of the rank.

**Lemma 6.46** *Let  $a, b \in \mathcal{T}(E)$ . Then  $\text{rank}(ab) \leq \max\{\text{rank}(a), \text{rank}(b)\}$ .*

**Proof.** This follows from the two relations  $\text{Im}(ab) \subseteq \text{Im}(b)$  and  $\text{Ker}(ab) \subseteq \text{Ker}(a)$ .  $\square$

One can now describe the Green's relations in the semigroup  $\mathcal{T}(E)$ .

**Proposition 6.47** *Let  $a, b$  be elements of  $\mathcal{T}(E)$ . Then*

- (1)  $a \leq_{\mathcal{R}} b$  if and only if  $\text{Ker}(a)$  is a partition coarser than  $\text{Ker}(b)$  and  $a \mathcal{R} b$  if and only if  $\text{Ker}(a) = \text{Ker}(b)$ ,
- (2)  $a \leq_{\mathcal{L}} b$  if and only if  $\text{Im}(a) \subseteq \text{Im}(b)$  and  $a \mathcal{L} b$  if and only if  $\text{Im}(a) = \text{Im}(b)$ ,
- (3)  $a \leq_{\mathcal{J}} b$  if and only if  $\text{rank}(a) \leq \text{rank}(b)$  and  $a \mathcal{J} b$  if and only if  $\text{rank}(a) = \text{rank}(b)$ .

**Proof.** (1) If  $a \leq_{\mathcal{R}} b$ , there exists  $u \in \mathcal{T}(E)$ , such that  $a = bu$  and therefore  $\text{Ker}(a)$  is coarser than  $\text{Ker}(b)$ . Conversely, if this condition is satisfied, the relation  $u = a \circ b^{-1}$  is a function such that  $bu = a$ . Therefore  $a \leq_{\mathcal{R}} b$ . The result for  $\mathcal{R}$  follows immediately.

(2) If  $a \leq_{\mathcal{L}} b$ , there exists  $u \in \mathcal{T}(E)$ , such that  $au = b$  and therefore  $\text{Im}(a) \subseteq \text{Im}(b)$ . Conversely, if  $\text{Im}(a) \subseteq \text{Im}(b)$ , there exists for each  $q \in E$  an element  $q'$  such that  $q' \cdot b = q \cdot a$ . The function  $q \rightarrow q'$  defines a transformation  $u$  such that  $ub = a$  and thus  $a \leq_{\mathcal{L}} b$ . The result for  $\mathcal{L}$  follows immediately.

(3) If  $a \leq_{\mathcal{J}} b$ , there exist  $u, v \in \mathcal{T}(E)$  such that  $a = ubv$  and therefore  $\text{rank}(a) \leq \text{rank}(b)$ . Conversely, suppose that  $\text{rank}(a) \leq \text{rank}(b)$ . We construct a transformation  $u$  by sending each class of  $\text{Ker}(a)$  onto an element of  $\text{Im}(b)$  and two distinct classes onto two distinct elements; this is possible since  $|\text{Im}(a)| = |\text{Ker}(a)| \leq |\text{Im}(b)|$ . Then  $\text{Ker}(u) = \text{Ker}(a)$  and  $\text{Im}(u) \subseteq \text{Im}(b)$  by construction. Therefore  $a \mathcal{R} u$  by (1),  $u \leq_{\mathcal{L}} b$  by (2) and finally  $a \leq_{\mathcal{J}} u \leq_{\mathcal{J}} b$ . The result for  $\mathcal{J}$  follows immediately.  $\square$

We can now pass to the general study of transformation semigroups. Given a set  $E$  and a partition  $\mathcal{E} = \{E_1, \dots, E_n\}$  of  $E$ , we say that a subset  $F$  of  $E$  is a *transversal* of  $\mathcal{E}$  if, for  $1 \leq i \leq n$ ,  $|E_i \cap F| = 1$ .

**Proposition 6.48** *Let  $S$  be a subsemigroup of  $\mathcal{T}(E)$ . An element  $a$  belongs to a group of  $S$  if and only if  $\text{Im}(a)$  is a transversal of  $\text{Ker}(a)$ .*

**Proof.** If  $a$  belongs to a group, then  $a^n = a$  for a certain  $n \geq 2$  and therefore  $a$  induces a bijection on  $\text{Im}(a)$ . Let  $K$  be a class of  $\text{Ker}(a)$ . If  $|K \cap \text{Im}(a)| \geq 2$ , two elements of  $\text{Im}(a)$  have the same image under  $a$ , which contradicts the above property. Therefore  $|K \cap \text{Im}(a)| \leq 1$  for every  $K \in \text{Ker}(a)$ . Furthermore, if  $K \cap \text{Im}(a) = \emptyset$  for a class  $K$  of  $\text{Ker}(a)$ , it follows that

$$|\text{Im}(a)| = \sum_{K \in \text{Ker}(a)} |K \cap \text{Im}(a)| < |\text{Ker}(a)|$$

a contradiction. Therefore  $\text{Im}(a)$  is a transversal of  $\text{Ker}(a)$ .

Conversely, if this condition is satisfied,  $a$  induces a bijection on its image and therefore  $a^n = a$  for some  $n \geq 2$ . It follows by Proposition 1.13 that  $a$  belongs to a group of  $S$ .  $\square$

Part of Proposition 6.47 extends to all transformation semigroups.

**Proposition 6.49** *Let  $S$  be a subsemigroup of  $\mathcal{T}(E)$ . Then*

- (1) *if  $a \leq_{\mathcal{R}} b$ , then  $\text{Ker}(a)$  is a coarser partition than  $\text{Ker}(b)$  and if  $a \mathcal{R} b$ , then  $\text{Ker}(a) = \text{Ker}(b)$ ,*
- (2) *if  $a \leq_{\mathcal{L}} b$ , then  $\text{Im}(a) \subseteq \text{Im}(b)$  and if  $a \mathcal{L} b$ , then  $\text{Im}(a) = \text{Im}(b)$ ,*
- (3) *if  $a \leq_{\mathcal{J}} b$ , then  $\text{rank}(a) \leq \text{rank}(b)$  and if  $a \mathcal{J} b$ , then  $\text{rank}(a) = \text{rank}(b)$ .*

**Proof.** See the proof of Proposition 6.47.  $\square$

Note that the equivalences stated in Proposition 6.47 for  $\mathcal{T}(E)$  **do not hold** for all transformation semigroups. For instance, in the semigroup  $S$  represented in Figure A.2, the elements  $acb$  and  $acbc$  have the same image but are not  $\mathcal{L}$ -equivalent. Similarly,  $\text{rank}(acac) = \text{rank}(cbcb)$ , but these two idempotents are not  $\mathcal{J}$ -equivalent.

However, Proposition 6.48 enables us to locate very easily the elements of a group in  $S$ . One can then reconstruct completely the regular  $\mathcal{D}$ -class of such an element  $x$  by the following algorithm:

- (1) Calculate all the sets of the form  $\text{Im}(xr)$  (where  $r \in S^1$ ) such that  $|\text{Im}(xr)| = |\text{Im}(x)|$ . For each such set  $I$ , remember an element  $r$  such that  $I = \text{Im}(xr)$ .
- (2) In parallel to (1), calculate all the transformations  $xr$  ( $r \in S^1$ ) such that  $\text{Im}(xr) = \text{Im}(x)$ . One obtains the  $\mathcal{H}$ -class of  $x$ .
- (3) Calculate all the partitions of the form  $\text{Ker}(sx)$  (where  $s \in S^1$ ) such that  $|\text{Ker}(sx)| = |\text{Ker}(x)|$ . For each such partition  $K$ , remember an element  $s$  such that  $K = \text{Ker}(sx)$ .
- (4) Among the sets calculated in (1), retain only those which are transversals of one of the partitions calculated in (3): one obtains a set  $\mathcal{I} = \{\text{Im}(xr_1), \dots, \text{Im}(xr_n)\}$ , where  $r_1 = 1$ . Similarly, among the partitions calculated in (3), retain only those which admits as a transversal one of the sets calculated in (1). We obtain a set  $\mathcal{K} = \{\text{Ker}(s_1x), \dots, \text{Ker}(s_mx)\}$ , where  $s_1 = 1$ .
- (5) The results are summarized in the double-entry table below, representing the egg-box picture of the  $\mathcal{D}$ -class of  $x$ . If  $H_{i,j} = R_{s_ix} \cap L_{xr_j}$ , one has  $H_{i,j} = s_i H r_j$ , which enables us to calculate the  $\mathcal{D}$ -class completely. Finally, the  $\mathcal{H}$ -class  $H_{i,j}$  is a group if and only if  $\text{Im}(xr_j)$  is a transversal of  $\text{Ker}(s_ix)$ .

	Im( $xr_1$ )	Im( $xr_j$ )	Im( $xr_n$ )
	$H$	$xr_j$	
Ker( $x$ ) = Ker( $s_1x$ )	$s_ix$	$H_{i,j}$	
Ker( $s_mx$ )	$s_mx$		

**Justification of the algorithm.**

Recall that  $x$  is an element of a group in  $S$ . Suppose that  $rx \mathcal{R} x$  and let  $e \in E(S)$  and  $s \in S^1$  are such that  $x \mathcal{R} xr$ ,  $xr \mathcal{L} e$ ,  $e \mathcal{R} sx$  and  $sx \mathcal{L} x$ .

$x$		$xr$
$sx$		$e$

then by Proposition 6.48  $\text{Im}(e)$  is a transversal of  $\text{Ker}(e)$  and by Proposition 6.49,  $\text{Im}(e) = \text{Im}(xr)$  and  $\text{Ker}(sx) = \text{Ker}(e)$ , so that  $\text{Im}(xr)$  is a transversal of  $\text{Ker}(sx)$ . Conversely, suppose that  $\text{Im}(xr)$  is a transversal of a certain  $\text{Ker}(sx)$ , where  $|\text{Im}(xr)| = |\text{Im}(x)|$  and  $|\text{Ker}(sx)| = |\text{Ker}(x)|$ . Let  $e\mathcal{T}(E)$  be a transformation with range  $\text{Im}(xr)$  and with kernel  $\text{Ker}(sx)$ . Then by Proposition 6.47

one has in  $\mathcal{T}(E)$ ,  $x \mathcal{D} xr \mathcal{D} sx$ ,  $xr \mathcal{L} e$  and  $e \mathcal{L} sx$ . It follows that  $x \mathcal{R} xr$ ,  $xr \mathcal{L} e$ ,  $e \mathcal{R} sx$  and  $sx \mathcal{L} x$ . Now,  $x$ ,  $xr$  and  $sx$  belong to  $S$  and by Proposition 2.27, one has  $e \in S$  and  $x$ ,  $xr$ ,  $sx$  and  $e$  are in the same  $\mathcal{D}$ -class of  $S$ .

This proves that the algorithm computes the  $\mathcal{R}$ -class of  $x$ .  $\square$

In practice, this algorithm is only useful for computing regular  $\mathcal{D}$ -classes.

## 7 Summary: a complete example

We compute in this section the minimal ordered automaton and the ordered syntactic monoid of the language  $L = (a + bab)^*(1 + bb)$ . We invite the reader to verify this computation by hand. It is the best possible exercise to master the notions introduced in the first chapters.

The minimal automaton of  $L$  is represented in Figure 7.12.

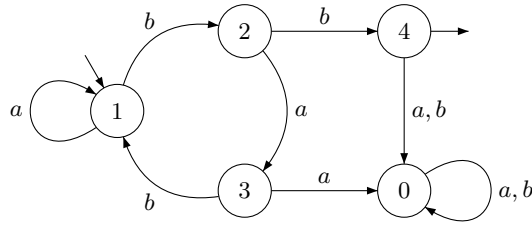

Figure 7.12. The minimal automaton of  $L$ .

The order on the set of states is  $2 < 4$  and  $0 < q$  for each state  $q \neq 0$ . The syntactic monoid of  $L$  has 27 elements including a zero:  $b^2a^2 = 0$ .

	1	2	3	4
* 1	1	2	3	4
a	1	3	0	0
b	2	4	1	0
* a <sup>2</sup>	1	0	0	0
ab	2	1	0	0
ba	3	0	1	0
b <sup>2</sup>	4	0	2	0
a <sup>2</sup> b	2	0	0	0
aba	3	1	0	0
ab <sup>2</sup>	4	2	0	0
ba <sup>2</sup>	0	0	1	0
bab	1	0	2	0
* b <sup>2</sup> a	0	0	3	0
b <sup>3</sup>	0	0	4	0

	1	2	3	4
a <sup>2</sup> ba	3	0	0	0
a <sup>2</sup> b <sup>2</sup>	4	0	0	0
aba <sup>2</sup>	0	1	0	0
* abab	1	2	0	0
ab <sup>2</sup> a	0	3	0	0
ab <sup>3</sup>	0	4	0	0
ba <sup>2</sup> b	0	0	2	0
* baba	1	0	3	0
bab <sup>2</sup>	2	0	4	0
* b <sup>2</sup> a <sup>2</sup>	0	0	0	0
* aba <sup>2</sup> b	0	2	0	0
abab <sup>2</sup>	2	4	0	0
babab	2	0	1	0

It is defined by the following set of relations:

$$\begin{array}{llllll}
 a^2a = a^2 & b^2ab = ba^2 & b^3a = 0 & b^4 = 0 & a^2ba^2 = 0 & \\
 a^2bab = a^2 & a^2b^2a = 0 & a^2b^3 = 0 & ababa = a & ab^2a^2 = 0 & \\
 ba^2ba = b^2a & ba^2b^2 = b^3 & baba^2 = a^2 & bab^2a = a^2ba & bab^3 = a^2b^2 & \\
 b^2a^2 = 0 & babab^2 = b^2 & & & & 
 \end{array}$$

It contains 7  $\mathcal{D}$ -classes, 15  $\mathcal{R}$ -classes, 10  $\mathcal{L}$ -classes and 23  $\mathcal{H}$ -classes. The minimal ideal reduces to the zero, but there is a unique regular 0-minimal ideal. Its  $\mathcal{D}$ -class structure is represented below:

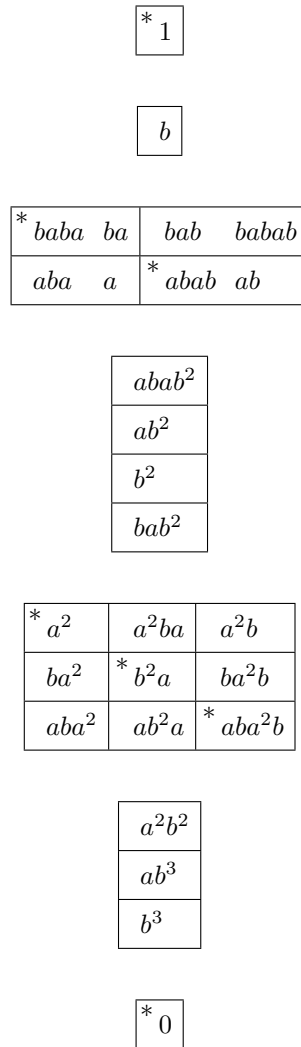

The syntactic preorder satisfies  $0 < x$  for all  $x \neq 0$ . The other relations are represented below, with our usual convention: an arrow from  $u$  to  $v$  means that  $u < v$ .



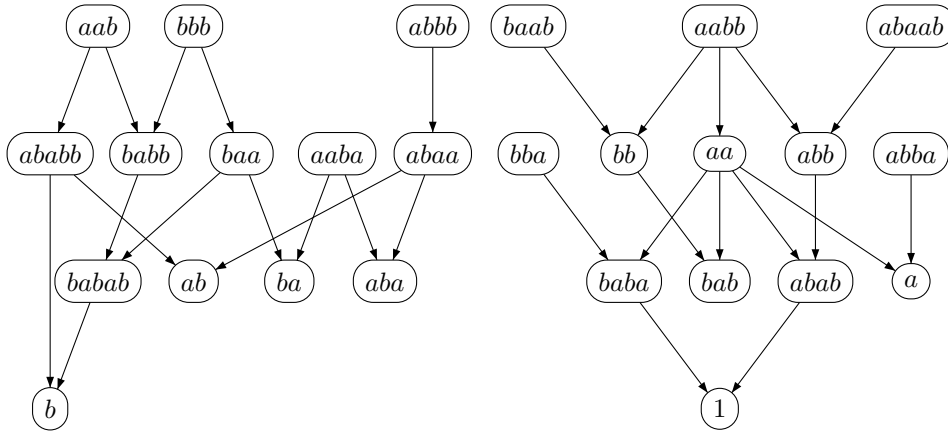

## 8 Exercises

1. Describe Green's relations in the syntactic monoids of Exercise IV.7.
2. Describe Green's relations in the following monoids:
  - (1) the monoid of all functions from  $\{1, 2, 3\}$  into itself,
  - (2) the monoid of all order-preserving functions from  $\{1, 2, 3\}$  into itself (a function  $f$  is *order-preserving* if  $i \leq j$  implies  $f(i) \leq f(j)$ ),
  - (3) the monoid of all partial functions from  $\{1, 2, 3\}$  into itself,
  - (4) the monoid of all relations on  $\{1, 2, 3\}$ ,
  - (5) the monoid of all reflexive relations on  $\{1, 2, 3\}$ ,
  - (6) the monoid of all upper-triangular Boolean matrices of size  $3 \times 3$ ,
  - (7) the monoid of all unitriangular Boolean matrices of size  $3 \times 3$  (a matrix is unitriangular if it is upper-triangular and if its diagonal entries are all equal to 1).
3. Let  $M$  be a finite monoid. Let  $\mathcal{P}(M)$  be the set of subsets of  $M$ .
  - (1) Show that  $\mathcal{P}(M)$  is a monoid for the following product: given two subsets  $X$  and  $Y$ ,  $XY = \{xy \mid x \in X, y \in Y\}$ .
  - (2) Show that the set  $\mathcal{P}_1(M)$  of subsets of  $M$  containing 1 is a submonoid of  $\mathcal{P}(M)$ . Show that this monoid is  $\mathcal{J}$ -trivial.
4. Let  $s$  and  $t$  be regular elements of a semigroup  $S$ . Show that the following conditions are equivalent:
  - (1)  $s \mathcal{R} t$ ,
  - (2) there exists  $\bar{s} \in V(s)$  and  $\bar{t} \in V(t)$  such that  $s\bar{s} = t\bar{t}$ ,
  - (3) for all  $\bar{s} \in V(s)$ , there exists  $\bar{t} \in V(t)$  such that  $s\bar{s} = t\bar{t}$ .

A dual result holds for  $\mathcal{L}$ . Finally, show that the following conditions are equivalent:

  - (1)  $s \mathcal{H} t$ ,
  - (2) there exists  $\bar{s} \in V(s)$  and  $\bar{t} \in V(t)$  such that  $s\bar{s} = t\bar{t}$  and  $\bar{s}s = \bar{t}t$ ,

(3) for all  $\bar{s} \in V(s)$ , there exists  $\bar{t} \in V(t)$  such that  $s\bar{s} = t\bar{t}$  and  $\bar{s}s = \bar{t}t$ .

**5.** Let  $S$  be a finite semigroup. Show that the number of inverses of an element  $s$  of  $S$  is equal to the product of the number of idempotents of the  $\mathcal{R}$ -class of  $s$  by the number of idempotents of the  $\mathcal{L}$ -class of  $s$ .

**6.** Let  $S$  be a regular semigroup. Show that the following conditions are equivalent:

- (1)  $S$  is simple,
- (2) for all  $s \in S$ , every weak inverse of  $s$  is also an inverse of  $s$ ,
- (3) for all  $s, t$  in  $S$ , if  $us = ut$  and  $sv = tv$  for some  $u, v \in S$ , then  $s = t$ .

**7.** A *right group* is a semigroup that is right simple and left cancellative. Prove that if  $G$  is a group and  $S$  is a right zero semigroup, the  $G \times S$  is a right group.

Show that the following conditions are equivalent:

- (1)  $S$  is a right group,
- (2)  $S$  is right simple and contains at least one idempotent,
- (3) for each  $s, t \in S$ , the equation  $ax = b$  has a unique solution in  $S$ ,
- (4)  $S$  is isomorphic with a Rees matrix semigroup  $M(G, I, J, P)$ , where  $|I| = 1$  and  $P$  is the  $J \times I$  column matrix whose entries are all equal to the identity of  $G$ .

**8.** A monoid  $M$  is an *inverse monoid* if every element of  $M$  has a unique inverse. Show that a finite monoid is inverse if and only if  $M$  is regular (that is, every element of  $M$  is regular) and the idempotents commute in  $M$ .

**9.** Let  $Q$  be a finite set and let  $\mathcal{I}(Q)$  be the monoid of partial injective functions from  $Q$  to  $Q$  under composition. Show that  $\mathcal{I}(Q)$  is an inverse monoid and that if  $M$  is a finite inverse monoid, then  $M$  is isomorphic to a submonoid of  $\mathcal{I}(M)$ .

# Chapter VI

## Profinite words

The results presented in this chapter are a good illustration of the following quotation of Marshall Stone [103]: *A cardinal principle of modern mathematical research may be stated as a maxim: “One must always topologize”*. Indeed, a much deeper insight into the structure of recognisable languages is made possible by the introduction of topological concepts.

### 1 Topology

We start with a brief reminder of the elements of topology used in the sequel: open and closed sets, continuous functions, metric spaces, compact spaces, etc. This section is by no means a first course in topology but is simply thought as a remainder.

#### 1.1 General topology

Recall that a *topology* on a set  $E$  is a set  $\mathcal{T}$  of subsets of  $E$  satisfying the following conditions:

- (1) The empty set and  $E$  are in  $\mathcal{T}$ ,
- (2) The union of arbitrary many elements of  $\mathcal{T}$  is an element of  $\mathcal{T}$ ,
- (3) The intersection of finitely many elements of  $\mathcal{T}$  is an element of  $\mathcal{T}$ .

The elements of  $\mathcal{T}$  are called the *open sets*. The complement of an open set is called a *closed set*. A set is *clopen* if it is both open and closed.

The *closure* of a subset  $X$  of  $E$ , denoted by  $\overline{X}$ , is the intersection of the closed sets containing  $X$ . A subset of  $E$  is *dense* if its closure is equal to  $E$ .

A *topological space* is a set  $E$  together with a topology on  $E$ . A topology  $\mathcal{T}_1$  on a set is a *refinement* of a topology  $\mathcal{T}_2$  on the same set, if each open set for  $\mathcal{T}_1$  is also an open set for  $\mathcal{T}_2$ . One also says that  $\mathcal{T}_1$  is *coarser* than  $\mathcal{T}_2$  or that  $\mathcal{T}_2$  is *stronger* than  $\mathcal{T}_1$ .

The coarsest topology on  $E$  is the *trivial* topology, which reduces to the empty set and  $E$ . The strongest topology is the *discrete* topology defined by  $\mathcal{T} = \mathcal{P}(E)$ .

If  $F$  is a subset of a topological space  $(E, \mathcal{T})$ , then the traces  $F \cap X$  for  $X \in \mathcal{T}$ , define a topology on  $F$ , called the *relative topology*.

It is sometimes convenient to give a *basis* for a topology on  $E$ . This is a collection  $\mathcal{B}$  of subsets of  $E$  such that every open set is the union of elements of  $\mathcal{B}$ . An equivalent condition is that  $\mathcal{B}$  satisfies the two following conditions:

- (i)  $E$  is the union of all the elements of  $\mathcal{B}$ ,
- (ii) every finite intersection of elements of  $\mathcal{B}$  is a union of elements of  $\mathcal{B}$ .

The open sets of the topology generated by  $\mathcal{B}$  are by definition the arbitrary unions of elements of  $\mathcal{B}$ .

A map from a topological space into another one is *continuous* if the inverse image of each open set is an open set. It is a *homeomorphism* if it is a continuous bijection and the inverse bijection is also continuous. Two topological spaces are *homeomorphic* if there is a homeomorphism between them.

Let  $(E_i, \mathcal{T}_i)_{i \in I}$  be a family of topological spaces, and let  $E = \prod_{i \in I} E_i$  be the cartesian product of the  $E_i$ 's. Denote by  $\pi_i$  the natural projection from  $E$  onto  $E_i$ , defined by  $\pi_i((e_j)_{j \in I}) = e_i$ . The *product topology* on  $E$  is the topology generated by the basis consisting of the finite intersections of sets of the form  $\pi_i^{-1}(X_i)$  where  $X_i$  is an open set of  $E_i$ . These sets are nothing else than the products  $\prod_{i \in I} X_i$  where the  $X_i$ 's are open sets of  $E_i$  and where  $X_i = E_i$  except for a finite number of indices. The natural projections  $\pi_i : E \rightarrow E_i$  are then continuous and a mapping  $\varphi : F \rightarrow E$  is continuous if and only if the mappings  $\pi_i \circ \varphi : F \rightarrow E_i$ , for  $i \in I$ , are all continuous.

A topological space  $(E, \mathcal{T})$  is *Hausdorff* if for each  $u, v \in E$  with  $u \neq v$ , there exist *disjoint* open sets  $U$  and  $V$  such that  $u \in U$  and  $v \in V$ . If  $f$  is a continuous map from a topological space  $X$  into an Hausdorff space  $Y$ , then the graph of  $f$  is closed in  $X \times Y$ .

## 1.2 Metric spaces

A *metric*  $d$  on a set  $E$  is a map  $d : E \rightarrow \mathbb{R}_+$  from  $E$  into the set of nonnegative real numbers satisfying the three following conditions, for every  $x, y, z \in E$ :

- (1)  $d(x, y) = 0$  if and only if  $x = y$ ,
- (2)  $d(y, x) = d(x, y)$ ,
- (3)  $d(x, z) \leq d(x, y) + d(y, z)$

A *metric space* is a set  $E$  together with a metric  $d$  on  $E$ .

The topology defined by  $d$  is obtained by taking as a basis the *open  $\varepsilon$ -balls* defined for  $x \in E$  and  $\varepsilon > 0$  by

$$B(x, \varepsilon) = \{y \in E \mid d(x, y) < \varepsilon\}$$

Every metric space is Hausdorff. Indeed, given two distinct elements  $x$  and  $y$ , the open balls  $B(x, \varepsilon)$  and  $B(y, \varepsilon)$  are disjoint if  $\varepsilon$  is set to be half the distance between  $x$  and  $y$ .

A sequence  $(x_n)_{n \geq 0}$  of elements of a metric space  $(E, d)$  is converging to a *limit*  $x$  if, for each  $\varepsilon > 0$ , there exists an integer  $k$  such that for each  $n \geq k$ ,  $d(x_n, x) < \varepsilon$ . A sequence is said to be *converging* if it admits a limit.

Limits are convenient to characterise other topological properties of metric spaces. For instance, a subset  $F$  of  $E$  is closed if and only if, for every sequence  $(x_n)_{n \geq 0}$  of elements of  $F$  converging to a limit  $x$ ,  $x$  itself belongs to  $F$ . A map  $\varphi : (E, d) \rightarrow (E', d')$  between two metric spaces is continuous if and only if, for

every sequence  $(x_n)_{n \geq 0}$  of elements of  $E$  converging to a limit  $x$ , the sequence  $(\varphi(x_n))_{n \geq 0}$  converges to  $\varphi(x)$ .

A *Cauchy sequence* in a metric space  $(E, d)$  is a sequence  $(x_n)_{n \geq 0}$  of elements of  $E$  such that for each  $\varepsilon > 0$ , there exists an integer  $k$  such that for each  $n \geq k$  and  $m \geq k$ ,  $d(x_n, x_m) < \varepsilon$ . Every converging sequence is a Cauchy sequence, but the converse does not hold in general. A metric space in which each Cauchy sequence is convergent is said to be *complete*. Every closed subset of a complete space is complete.

Let  $(E_i, d_i)_{1 \leq i \leq n}$  be a finite family of metric spaces. Then  $(E_1 \times \cdots \times E_n, d)$  is a metric space, where  $d$ , defined by

$$d((x_1, \dots, x_n), (y_1, \dots, y_n)) = \max\{d(x_1, y_1), \dots, d(x_n, y_n)\}$$

is a metric that defines the product topology.

Let  $(E, d)$  and  $(E', d')$  be two metric spaces. A function  $\varphi$  from  $E$  into  $E'$  is said to be *uniformly continuous* if for each  $\varepsilon > 0$ , there exists  $\delta > 0$  such that the relation  $d(x, y) < \delta$  implies  $d'(\varphi(x), \varphi(y)) < \varepsilon$ . If  $\varphi$  is uniformly continuous, the image under  $\varphi$  of a Cauchy sequence of  $E$  is a Cauchy sequence of  $E'$ . We say that  $\varphi$  is a *uniform homeomorphism* if it is a uniformly continuous bijection and  $\varphi^{-1}$  is also uniformly continuous. Two metric spaces are *uniformly homeomorphic* if there is a uniform homeomorphism between them.

We say that  $\varphi$  is an *isometry* if it is a bijection from  $E$  onto  $E'$  such that, for each  $x, y \in E$ ,

$$d(x, y) = d'(\varphi(x), \varphi(y))$$

The *completion* of a metric space  $E$  is a complete metric space  $\widehat{E}$  together with an isometric embedding of  $E$  as a dense subspace of  $\widehat{E}$ . One can prove that every metric space admits a completion, which is unique up to isometric equivalence: if  $\widehat{E}_1$  and  $\widehat{E}_2$  are two completions of  $E$ , there exists an isometry of  $\widehat{E}_1$  onto  $\widehat{E}_2$ , whose restriction to  $E$  is the identity.

The completion of  $E$  can be constructed as follows. Let  $C(E)$  be the set of Cauchy sequences in  $E$ . Define an equivalence relation  $\sim$  on  $C(E)$  as follows. Two Cauchy sequences  $x = (x_n)_{n \geq 0}$  and  $y = (y_n)_{n \geq 0}$  are equivalent if the interleaved sequence  $x_0, y_0, x_1, y_1, \dots$  is also a Cauchy sequence. The completion of  $E$  is defined to be the set  $\widehat{E}$  of equivalence classes of  $C(E)$ . The metric  $d$  on  $E$  extends to a metric on  $\widehat{E}$  defined by

$$d(x, y) = \lim_{n \rightarrow \infty} d(x_n, y_n)$$

where  $x$  and  $y$  are representative Cauchy sequences of elements in  $\widehat{E}$ . The definition of the equivalence ensures that the above definition does not depend on the choice of  $x$  and  $y$  in their equivalence class and the fact that  $\mathbb{R}$  is complete ensures that the limit exists.

### 1.3 Compact spaces

An important notion is that of *compact* space. A family of open sets  $(U_i)_{i \in I}$  is said to *cover* a topological space  $(E, \mathcal{T})$  if  $E = \bigcup_{i \in I} U_i$ . A topological space  $(E, \mathcal{T})$  is said to be *compact* if it is Hausdorff and if, for each family of open sets covering  $E$ , there exists a finite subfamily that still covers  $E$ .

Compact metric spaces admit two important characterisations. First, a metric space is compact if and only if every sequence has a convergent subsequence. Second, a metric space is compact if and only if it is complete and *precompact*, which means that, for every  $n > 0$ , the space can be covered by a finite number of open balls of radius  $< 2^{-n}$ .

If  $X$  is a closed set of a compact space  $E$ , then  $X$ , equipped with the relative topology, is also a compact space. We shall use freely the well-known result that every product of compact spaces is compact (Tychonov's theorem).

One can show that if  $\varphi : E \rightarrow F$  is a continuous map from a topological space  $E$  into a topological Hausdorff space  $F$ , the image of a compact under  $\varphi$  is still compact. Further if  $E$  is a compact metric space and  $F$  is a metric space, then every continuous function from  $E$  to  $F$  is uniformly continuous.

We conclude this section with a useful extension result that is worth to be stated separately.

**Proposition 1.1** *Let  $E$  and  $F$  be metric spaces. Any uniformly continuous function  $\varphi : E \rightarrow F$  admits a unique uniformly continuous extension  $\widehat{\varphi} : \widehat{E} \rightarrow \widehat{F}$ . Further, if  $\widehat{E}$  is compact and if  $\varphi$  is surjective, then  $\widehat{\varphi}$  is surjective.*

In particular, if  $F$  is complete, any uniformly continuous function from  $E$  to  $F$  admits a unique uniformly continuous extension from  $\widehat{E}$  to  $F$ .

## 1.4 Topological semigroups

A *topological semigroup* is a semigroup  $S$  equipped with a topology for which the semigroup operation is continuous. This means that the function from  $S \times S$  into  $S$  which maps  $(x, y)$  onto  $xy$  is continuous. A *compact semigroup* is a topological semigroup which is compact as a topological space.

## 2 Profinite topology

### 2.1 The free profinite monoid

Let  $A$  be a finite alphabet. A morphism  $\varphi : A^* \rightarrow M$  *separates* two words  $u$  and  $v$  of  $A^*$  if  $\varphi(u) \neq \varphi(v)$ . By extension, we say that a monoid  $M$  *separates* two words if there is a morphism from  $A^*$  onto  $M$  that separates them.

#### Example 2.1

- (1) The words *ababa* and *abaa* can be separated by a group of order 2. Indeed, let  $\pi : A^* \rightarrow \mathbb{Z}/2\mathbb{Z}$  be the morphism defined by  $\pi(x) = |x| \pmod{2}$ . Then  $\pi(ababa) = 1$  and  $\pi(abaa) = 0$  and hence  $\pi$  separates  $u$  and  $v$ .
- (2) More generally, two words  $u$  and  $v$  of unequal length can be separated by a finite cyclic group. Indeed, suppose that  $|u| < |v|$  and let  $n = |v|$ . Let  $\pi : A^* \rightarrow \mathbb{Z}/n\mathbb{Z}$  be the morphism defined by  $\pi(x) = |x| \pmod{n}$ . Then  $\pi(v) = 0$  but  $\pi(u) \neq 0$ . Note that  $u$  and  $v$  can also be separated by a finite monoid of size  $|u| + 2$ . Define an addition  $\oplus$  on  $M = \{0, 1, \dots, |u| + 1\}$  by  $s \oplus t = \min\{s + t, |u| + 1\}$  and let  $\varphi : A^* \rightarrow M$  be the morphism defined by  $\varphi(x) = \min\{|x|, |u| + 1\}$ . Then  $\varphi(u) = |u|$  and  $\varphi(v) = |u| + 1$ .
- (3) A similar idea can be applied if the number of occurrences of some letter  $a$  is not the same in  $u$  and  $v$ . Assume for instance that  $|u|_a < |v|_a$  and let

$n = |v|_a$ . Then the morphism  $\pi : A^* \rightarrow \mathbb{Z}/n\mathbb{Z}$  defined by  $\pi(a) = 1$  and  $\pi(c) = 0$  for  $c \neq a$  separates  $u$  and  $v$ .

- (4) Recall (see Section 2.2) that the monoid  $U_2$  is defined on the set  $\{1, a, b\}$  by the operation  $aa = ba = a$ ,  $bb = ab = b$  and  $1x = x1 = x$  for all  $x \in \{1, a, b\}$ . Let  $u$  and  $v$  be words of  $\{a, b\}^*$ . Then the words  $ua$  and  $vb$  can be separated by the morphism  $\pi : A^* \rightarrow U_2$  defined by  $\pi(a) = a$  and  $\pi(b) = b$  since  $\pi(ua) = a$  and  $\pi(vb) = b$ .

These examples are a particular case of a general result.

**Proposition 2.2** *Any pair of distinct words of  $A^*$  can be separated by a finite monoid.*

**Proof.** Let  $u$  and  $v$  be two distinct words of  $A^*$ . Since the language  $\{u\}$  is recognisable, there exists a morphism  $\varphi$  from  $A^*$  onto a finite monoid  $M$  which recognises it, that is, such that  $\varphi^{-1}(\varphi(u)) = \{u\}$ . It follows that  $\varphi(v) \neq \varphi(u)$  and thus  $\varphi$  separates  $u$  and  $v$ .  $\square$

We now define a metric on  $A^*$  with the following intuitive idea in mind: two words are close for this metric if a large monoid is required to separate them. Let us now give the formal definition. Given two words  $u, v \in A^*$ , we set

$$r(u, v) = \min \{|M| \mid M \text{ is a monoid that separates } u \text{ and } v\}$$

$$d(u, v) = 2^{-r(u, v)}$$

with the usual conventions  $\min \emptyset = +\infty$  and  $2^{-\infty} = 0$ . The following proposition establishes the main properties of  $d$ .

**Proposition 2.3** *The function  $d$  is an ultrametric, that is, satisfies the following properties, for all  $u, v, w \in A^*$ ,*

- (1)  $d(u, v) = 0$  if and only if  $u = v$ ,
- (2)  $d(u, v) = d(v, u)$ ,
- (3)  $d(u, w) \leq \max\{d(u, v), d(v, w)\}$ .

*It also satisfies the property*

- (4)  $d(uw, vw) \leq d(u, v)$  and  $d(wu, wv) \leq d(u, v)$ .

**Proof.** (1) follows from Proposition 2.2.

(2) is trivial.

(3) Let  $M$  be a finite monoid separating  $u$  and  $w$ . Then  $M$  separates either  $u$  and  $v$ , or  $v$  and  $w$ . It follows that  $\min(r(u, v), r(v, w)) \leq r(u, w)$  and hence  $d(u, w) \leq \max\{d(u, v), d(v, w)\}$ .

(4) A finite monoid separating  $uw$  and  $vw$  certainly separates  $u$  and  $v$ . Therefore  $d(uw, vw) \leq d(u, v)$  and, dually,  $d(wu, wv) \leq d(u, v)$ .  $\square$

Thus  $(A^*, d)$  is a metric space, but it is not very interesting as a topological space.

**Proposition 2.4** *The topology defined on  $A^*$  by  $d$  is discrete: every subset is clopen.*

**Proof.** Let  $u$  be a word of  $A^*$  and let  $n$  be the size of the syntactic monoid  $M$  of the language  $\{u\}$ . Then if  $d(u, v) < 2^{-n}$ ,  $r(u, v) > n$  and in particular,  $M$  does not separate  $u$  and  $v$ . It follows that  $u = v$ . Therefore the open ball  $B(u, 2^{-n})$  is equal to  $\{u\}$ . It follows that every singleton is open. Now if  $U$  is a language of  $A^*$ , one has  $U = \bigcup_{u \in U} \{u\}$  and hence  $U$  is open. For the same reason,  $U^c$  is open and thus every subset of  $A^*$  is clopen.  $\square$

The completion of  $(A^*, d)$ , denoted by  $\widehat{A^*}$ , is much more interesting. Its elements are called the *profinite words* on the alphabet  $A$ .

**Theorem 2.5** *The set of profinite words  $\widehat{A^*}$  is compact if and only if  $A$  is finite.*

**Proof.** Suppose that  $A$  is finite. Since  $\widehat{A^*}$  is complete, it suffices to verify that, for every  $n > 0$ ,  $A^*$  is covered by a finite number of open balls of radius  $< 2^{-n}$ . Consider the congruence  $\sim_n$  defined on  $A^*$  by

$$u \sim_n v \text{ if and only if } \varphi(u) = \varphi(v) \text{ for every morphism } \varphi \\ \text{from } A^* \text{ onto a monoid of size } \leq n.$$

Since  $A$  is finite, there are only finitely many morphisms from  $A^*$  onto a monoid of size  $\leq n$ , and thus  $\sim_n$  is a congruence of finite index. Furthermore,  $d(u, v) < 2^{-n}$  if and only if  $u$  and  $v$  cannot be separated by a monoid of size  $\leq n$ , i.e. are  $\sim_n$ -equivalent. It follows that the  $\sim_n$ -classes are open balls of radius  $< 2^{-n}$  and cover  $A^*$ .

If  $A$  is infinite, let  $(a_n)_{n \geq 0}$  be an infinite sequence of letters of  $A$ . Then, for all  $i, j \geq 0$  with  $i \neq j$ ,  $d(a_i, a_j) = 2^{-2}$  since the morphism  $\varphi : A^* \rightarrow U_1$  defined by  $\varphi(a_i) = 1$  and  $\varphi(a_k) = 0$  for  $k \neq i$  separates  $a_i$  and  $a_j$ . It follows that the sequence  $(a_n)_{n \geq 0}$  has no convergent subsequence and thus  $\widehat{A^*}$  is not compact.  $\square$

The density of  $A^*$  in  $\widehat{A^*}$  has several useful consequences, which are summarized in the next propositions.

**Proposition 2.6** *The function  $(u, v) \rightarrow uv$  from  $A^* \times A^*$  to  $A^*$  is uniformly continuous.*

**Proof.** By Proposition 2.3, one has for all  $u, u', v, v' \in A^*$ ,

$$d(uv, u'v') \leq \max\{d(uv, uv'), d(uv', u'v')\} \leq \max\{d(v, v'), d(u, u')\}$$

which proves the result.  $\square$

It follows from Proposition 1.1 that the product on  $A^*$  can be extended in a unique way, by continuity, to  $\widehat{A^*}$ . Since the formulas  $(xy)z = x(yz)$  and  $1x = x = x1$  are preserved by passage to the limit, this extended product is also associative and admits the empty word as identity element. The product on  $\widehat{A^*}$  is also uniformly continuous and makes  $\widehat{A^*}$  a topological monoid. It is called the *free profinite monoid* because it satisfies a universal property comparable to that of  $A^*$ . Before stating this universal property precisely, let us state another useful consequence of the density of  $A^*$ .



**Proposition 2.7** *Every morphism  $\varphi$  from  $A^*$  into a discrete finite monoid  $M$  is uniformly continuous and can be extended (in a unique way) to a uniformly continuous morphism  $\widehat{\varphi}$  from  $\widehat{A^*}$  into  $M$ .*

**Proof.** If  $d(u, v) < 2^{-|M|}$ , then  $\varphi$  does not separate  $u$  and  $v$  and hence  $\varphi(u) = \varphi(v)$ . It follows that  $\varphi$  is a uniformly continuous function from  $A^*$  into the discrete metric space  $M$ . Therefore  $\varphi$  has a unique uniformly continuous extension  $\widehat{\varphi}$  from  $\widehat{A^*}$  into  $M$ . It remains to prove that  $\widehat{\varphi}$  is a morphism. Let

$$D = \{(u, v) \in \widehat{A^*} \times \widehat{A^*} \mid \widehat{\varphi}(uv) = \widehat{\varphi}(u)\widehat{\varphi}(v)\}$$

We claim that  $D = \widehat{A^*} \times \widehat{A^*}$ , which exactly says that  $\widehat{\varphi}$  is a morphism. We already have  $\widehat{\varphi}(uv) = \widehat{\varphi}(u)\widehat{\varphi}(v)$  for  $u, v \in A^*$  since  $\varphi$  is a morphism, and thus  $D$  contains  $A^* \times A^*$ . Since  $A^* \times A^*$  is dense in  $\widehat{A^*} \times \widehat{A^*}$ , it suffices to prove that  $D$  is closed, which essentially follows from the uniform continuity of the product. In more details, let  $\pi : A^* \times A^* \rightarrow A^*$  be the map defined by  $\pi(u, v) = uv$ . Proposition 2.6 shows that  $\pi$  is uniformly continuous and has a unique continuous extension  $\widehat{\pi}$  from  $\widehat{A^*} \times \widehat{A^*}$  to  $\widehat{A^*}$  (the product on  $\widehat{A^*}$ ). With this notation in hand, we get

$$\widehat{\varphi}(uv) = (\widehat{\varphi} \circ \widehat{\pi})(u, v) \quad \text{and} \quad \widehat{\varphi}(u)\widehat{\varphi}(v) = (u, v) \text{ARevoir}$$

It follows that

$$D = \bigcup_{m \in M} (\widehat{\varphi} \circ \widehat{\pi})^{-1}(m) \cap (\widehat{\pi} \circ (\widehat{\varphi} \times \widehat{\varphi}))^{-1}(m)$$

Since  $\widehat{\varphi} \circ \widehat{\pi}$  and  $\widehat{\pi} \circ (\widehat{\varphi} \times \widehat{\varphi})$  are both continuous and  $\{m\}$  is a closed subset of  $M$ , it follows that  $D$  is closed, which concludes the proof.  $\square$

However, there are some noncontinuous morphisms from  $\widehat{A^*}$  onto a finite monoid. For instance, the morphism  $\varphi : \widehat{A^*} \rightarrow U_1$  defined by

$$\varphi(u) = \begin{cases} 1 & \text{if } u \in A^* \\ 0 & \text{otherwise} \end{cases}$$

is not continuous since  $\varphi^{-1}(1) = A^*$  is not closed. Now, the restriction of  $\varphi$  to  $A^*$ , which is continuous, has a continuous extension to  $\widehat{A^*}$ . But this extension maps every profinite word to 1 and is therefore not equal to  $\varphi$ .

## 2.2 Universal property of the free profinite monoid

We are ready to state the universal property of  $\widehat{A^*}$ .

**Proposition 2.8** *If  $\varphi$  is a function from  $A$  into a finite monoid  $M$ , there exists a unique (uniformly) continuous monoid morphism  $\widehat{\varphi} : \widehat{A^*} \rightarrow M$  such that, for each  $a \in A$ ,  $\widehat{\varphi}(a) = \varphi(a)$ . Moreover,  $\widehat{\varphi}$  is surjective if and only if the set  $\varphi(A)$  generates  $M$ .*

**Proof.** First, there exists by Proposition II.5.28 a unique morphism from  $A^*$  into  $M$  which extends  $\varphi$  and by Proposition 2.7, a unique uniformly continuous morphism  $\widehat{\varphi}$  from  $\widehat{A^*}$  into  $M$  that extends  $\varphi$ .

One has  $\widehat{\varphi}(\widehat{A^*}) \subseteq \overline{\varphi(A^*)}$ . Since  $M$  is discrete, it follows that  $\widehat{\varphi}$  is surjective if and only if  $\varphi(A)$  generates  $M$ .  $\square$

One can also use Proposition 2.7 to define directly the metric on  $\widehat{A^*}$ . Let us say that a morphism  $\varphi$  from  $A^*$  onto a finite monoid  $M$  *separates* two profinite words  $u$  and  $v$  of  $\widehat{A^*}$  if  $\widehat{\varphi}(u) \neq \widehat{\varphi}(v)$ .

Given two profinite words  $u, v \in \widehat{A^*}$ , we set

$$\begin{aligned} r(u, v) &= \min \{|M| \mid M \text{ is a finite monoid that separates } u \text{ and } v\} \\ d(u, v) &= 2^{-r(u, v)} \end{aligned}$$

with the usual conventions  $\min \emptyset = +\infty$  and  $2^{-\infty} = 0$ .

The term *profinite* is justified by the following property, which often serves as a definition in the literature.

**Proposition 2.9** *The profinite topology on  $\widehat{A^*}$  is the least topology which makes continuous every morphism from  $A^*$  onto a finite discrete monoid.*

**Proof.** Proposition 2.7 shows that every morphism from  $A^*$  onto a finite discrete monoid is continuous for the topology defined by  $d$ .

Suppose now that  $\widehat{A^*}$  is equipped with a topology  $\mathcal{T}$  such that every morphism from  $A^*$  onto a finite discrete monoid is continuous. We claim that for all  $\varepsilon > 0$  and for all  $x \in \widehat{A^*}$ , the ball

$$B(x, \varepsilon) = \{y \in \widehat{A^*} \mid d(x, y) < \varepsilon\}$$

is open in  $\mathcal{T}$ . First observe that  $d(x, y) < \varepsilon$  if and only if  $x$  and  $y$  cannot be separated by a monoid of size  $< n$ , where  $n$  is the smallest positive integer such that  $2^{-n} < \varepsilon$ . It follows that  $B(x, \varepsilon)$  is the intersection of the sets  $\varphi^{-1}(\varphi(x))$ , where  $\varphi$  runs over the set of all morphisms from  $A^*$  onto a monoid of size  $< n$ . By the property of  $\mathcal{T}$ , each set of the form  $\varphi^{-1}(\varphi(x))$  is open and since  $A$  is finite, there are finitely many morphisms from  $A^*$  onto a monoid of size  $< n$ . This proves the claim and the proposition.  $\square$

What about sequences? First, every profinite word is the limit of a Cauchy sequence of words. Next, a sequence of profinite words  $(u_n)_{n \geq 0}$  is converging to a profinite word  $u$  if and only if, for every morphism  $\varphi$  from  $A^*$  onto a finite monoid,  $\widehat{\varphi}(u_n)$  is ultimately equal to  $\widehat{\varphi}(u)$ .

### 2.3 $\omega$ -terms

It is relatively difficult to give “concrete” examples of profinite words which are not words. One such example is the profinite word  $x^\omega$ , associated with every profinite word  $x$ . The formal definition is

$$x^\omega = \lim_{n \rightarrow \infty} x^{n!}$$

and is justified by the following result, which shows that the sequence  $x^{n!}$  has indeed a limit in  $\widehat{A^*}$ .

**Proposition 2.10** *For each  $x \in \widehat{A^*}$ , the sequence  $(x^{n!})_{n \geq 0}$  is a Cauchy sequence. It converges to an idempotent element of  $\widehat{A^*}$ .*

**Proof.** For the first part of the statement, it suffices to show that for  $p, q \geq n$ ,  $x^{p!}$  and  $x^{q!}$  cannot be separated by a monoid of size  $\leq n$ . Let indeed  $\varphi : \widehat{A^*} \rightarrow M$  be a monoid morphism, with  $|M| \leq n$ , and put  $s = \varphi(x)$ . Since  $M$  is finite,  $s$  has an idempotent power  $e = s^r$ , with  $r \leq n$ . By the choice of  $p$  and  $q$ , the integer  $r$  divides simultaneously  $p!$  and  $q!$ . Consequently,  $s^{p!} = s^{q!} = e$ , which shows that  $M$  cannot separate  $x^{p!}$  and  $x^{q!}$ .

For  $n$  large enough, we also have  $\varphi(x^{n!})\varphi(x^{n!}) = ee = e = \varphi(x^{n!})$ . It follows that the limit of the sequence  $(x^{n!})_{n \geq 0}$  is idempotent.  $\square$

Note that  $x^\omega$  is simply a notation and one should resist the temptation to interpret it as an infinite word. The right intuition is to interpret  $\omega$  as the exponent of a finite semigroup. To see this, let us compute the image of  $x^\omega$  under a morphism to a finite monoid.

Let  $M$  be a finite monoid of exponent  $\omega$ , let  $\varphi : A^* \rightarrow M$  a morphism and let  $s = \varphi(x)$ . Then the sequence  $s^{n!}$  is ultimately equal to the unique idempotent  $s^\omega$  of the subsemigroup of  $M$  generated by  $s$ . Consequently, we obtain the formula

$$\widehat{\varphi}(x^\omega) = \varphi(x)^\omega$$

which justifies the notation  $x^\omega$ . Note also that  $x^\omega x^\omega = x^\omega$  and  $(x^\omega)^\omega = x^\omega$ .

Two related examples are the profinite words  $x^{\omega+1}$  and  $x^{\omega-1}$ , which are defined in a natural way by the formulas

$$x^{\omega+1} = \lim_{n \rightarrow \infty} x^{n!+1} \quad \text{and} \quad x^{\omega-1} = \lim_{n \rightarrow \infty} x^{n!-1}$$

It follows immediately from the definition that  $xx^\omega = x^{\omega+1} = x^\omega x$  and that  $xx^{\omega-1} = x^\omega = x^{\omega-1}x$ . With the notation of the previous paragraph, one also gets  $\varphi(x^{\omega+1}) = s^{\omega+1}$  but the interpretation of  $x^{\omega-1}$  is a little bit more subtle. Let us first recall the structure of the subsemigroup generated by  $s$ : its minimal ideal is a group  $G$  whose identity is  $s^\omega$ . It is tempting to write  $\varphi(x^{\omega-1}) = s^{\omega-1}$ , but it may happen that  $s^{\omega-1}$  is not in  $G$ . Worse, if  $M$  is idempotent, its exponent is 1 and  $s^{\omega-1}$  is not even defined. In fact, in  $M$  one has  $\lim_{n \rightarrow \infty} s^{n!-1} = s^{2\omega-1}$  and thus the right formula is  $\varphi(x^{\omega-1}) = s^{2\omega-1}$ .

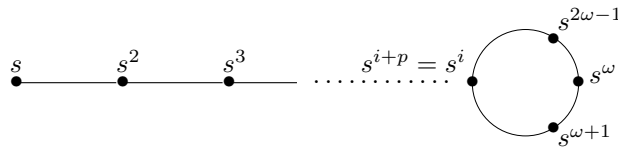

**Figure 2.1.** The semigroup generated by  $s$ .

Note that  $s^{2\omega-1}$  is the inverse of  $s^{\omega+1}$  in  $G$  and this is the right interpretation. Indeed, one can show that in the free profinite monoid,  $x$  generates a compact semigroup whose minimal ideal is a monogenic compact group with identity  $x^\omega$ . Then  $x^{\omega-1}$  is the inverse of  $x^{\omega+1}$  in this group.

The  $\omega$ -terms on  $A$  form the smallest submonoid of  $\widehat{A}^*$  containing  $A^*$  and closed under the operations  $x \rightarrow x^\omega$ ,  $x \rightarrow x^{\omega+1}$  and  $x \rightarrow x^{\omega-1}$ . For instance, if  $A = \{a, b, c\}$ ,  $abc$ ,  $a^\omega$  and  $((ab^\omega c)^{\omega-1} ab)^\omega$  are examples of  $\omega$ -terms. These  $\omega$ -terms represent the most intuitive examples of profinite words, but unfortunately, they are way more profinite words than  $\omega$ -terms. To be precise, the free profinite monoid  $\widehat{A}^*$  is uncountable (even on a one letter alphabet!) while the set of  $\omega$ -terms is countable.

### 3 Recognizable languages and clopen sets

There is a strong connexion between recognisable and clopen subsets. We start by considering the recognisable subsets of  $\widehat{A}^*$ .

**Proposition 3.11** *Let  $P$  be a subset of  $\widehat{A}^*$  and let  $M$  be its syntactic monoid. The following conditions are equivalent:*

- (1)  $P$  is clopen,
- (2) the syntactic congruence of  $P$  is a clopen subset of  $\widehat{A}^* \times \widehat{A}^*$ ,
- (3)  $P$  is recognisable and its syntactic morphism is a continuous map from  $\widehat{A}^*$  onto the discrete finite space  $M$ .

**Proof.** Let us denote by  $\sim_P$  the syntactic congruence of  $P$  and by  $\widehat{\eta} : \widehat{A}^* \rightarrow M$  its syntactic morphism. Recall that  $s \sim_P t$  if, for all  $u, v \in \widehat{A}^*$ , the conditions  $usv \in P$  and  $utv \in P$  are equivalent.

(1) implies (2). It follows from the definition of  $\sim_P$  that

$$\sim_P = \bigcap_{u, v \in \widehat{A}^*} ((u^{-1}Pv^{-1} \times u^{-1}Pv^{-1}) \cup (u^{-1}P^c v^{-1} \times u^{-1}P^c v^{-1})) \quad (3.1)$$

If  $P$  is clopen, each set  $u^{-1}Pv^{-1}$  is also clopen. Indeed,  $u^{-1}Pv^{-1}$  is the inverse image of the clopen set  $P$  under the continuous function  $x \mapsto uxy$ . Now, Formula (3.1) shows that  $\sim_P$  is closed.

In order to show that the complement of  $\sim_P$  is closed, consider a sequence  $(s_n, t_n)$  of elements of  $(\sim_P)^c$ , converging to a limit  $(s, t)$ . Since  $s_n \not\sim_P t_n$ , there exist some profinite words  $u_n, v_n$  such that  $u_n s_n v_n \in P$  and  $u_n t_n v_n \notin P$ . Since  $\widehat{A}^* \times \widehat{A}^*$  is compact, the sequence  $(u_n, v_n)$  has a convergent subsequence. Let  $(u, v)$  be its limit. Since both  $P$  and  $P^c$  are closed and since the multiplication in  $\widehat{A}^*$  is continuous, one gets  $usv \in P$  and  $utv \notin P$ . Therefore,  $s \not\sim_P t$ , which shows that  $(\sim_P)^c$  is closed. Thus  $\sim_P$  is clopen.

(2) implies (3). If  $\sim_P$  is clopen, then for each  $s \in \widehat{A}^*$ , there exists an open neighborhood  $U$  of  $s$  such that  $U \times U \subseteq \sim_P$ . Therefore  $U$  is contained in the  $\sim_P$ -class of  $s$ . This proves that the  $\sim_P$ -classes form an open partition of  $\widehat{A}^*$ . By compactness, this partition is finite and thus  $P$  is recognisable. Further, since each  $\sim_P$ -class is open, the syntactic morphism of  $P$  is continuous.

(3) implies (1). Let  $\pi : \widehat{A}^* \rightarrow M$  be the syntactic morphism of  $P$ . Since  $P$  is recognisable,  $M$  is finite. One has  $P = \pi^{-1}(\pi(P))$  and since  $M$  is finite,  $\pi(P)$  is clopen in  $M$ . Finally, since  $\pi$  is continuous,  $P$  is clopen in  $\widehat{A}^*$ .  $\square$

We now turn to languages of  $A^*$ .

**Proposition 3.12** *If  $L$  is a language of  $A^*$ , then  $L = \overline{L} \cap A^*$ . Further, the following conditions are equivalent:*

- (1)  $L$  is recognisable,
- (2)  $L = K \cap A^*$  for some clopen subset  $K$  of  $\widehat{A^*}$ ,
- (3)  $\overline{L}$  is clopen in  $\widehat{A^*}$ ,
- (4)  $\overline{L}$  is recognisable in  $\widehat{A^*}$ .

**Proof.** The inclusion  $L \subseteq \overline{L} \cap A^*$  is obvious. Let  $u \in \overline{L} \cap A^*$  and let  $M$  be the syntactic monoid of  $\{u\}$ . Since  $M$  separates  $u$  from any word  $v$  different from  $u$ , one gets  $r(u, v) \leq |M|$  if  $u \neq v$ . Let  $(u_n)_{n \in \mathbb{N}}$  be a sequence of words of  $L$  converging to  $u$ . If  $d(u_n, u) < 2^{-|M|}$ , one has necessarily  $u = u_n$  and thus  $u \in L$ .

(1) implies (2). If  $L$  is recognisable, there is a morphism  $\varphi$  from  $A^*$  onto a finite monoid  $M$  such that  $L = \varphi^{-1}(\varphi(L))$ . Let  $K = \widehat{\varphi}^{-1}(\varphi(L))$ . Since  $M$  is discrete,  $\varphi(L)$  is a clopen subset of  $M$  and since  $\widehat{\varphi}$  is continuous,  $K$  is also clopen. Further,  $\varphi$  and  $\widehat{\varphi}$  coincide on  $A^*$  and thus  $L = \widehat{\varphi}^{-1}(\varphi(L)) \cap A^* = K \cap A^*$ .

(2) implies (3). Suppose that  $L = K \cap A^*$  with  $K$  clopen. Since  $K$  is open and  $A^*$  is dense in  $\widehat{A^*}$ ,  $K \cap A^*$  is dense in  $K$ . Thus  $\overline{L} = \overline{K \cap A^*} = K$ . Thus  $\overline{L}$  is clopen in  $\widehat{A^*}$ .

(3) implies (4) follows from Proposition 3.11.

(4) implies (1). Let  $\widehat{\eta} : \widehat{A^*} \rightarrow F$  be the syntactic morphism of  $\overline{L}$  and let  $P = \widehat{\eta}(\overline{L})$ . Let  $\eta$  be the restriction of  $\widehat{\eta}$  to  $A^*$ . Then we have  $L = \overline{L} \cap A^* = \widehat{\eta}^{-1}(P) \cap A^* = \eta^{-1}(P)$ . Thus  $L$  is recognisable.  $\square$

We now describe the closure in  $\widehat{A^*}$  of a recognisable language of  $A^*$ .

**Proposition 3.13** *Let  $L$  be a recognisable language of  $A^*$  and let  $u \in \widehat{A^*}$ . The following conditions are equivalent:*

- (1)  $u \in \overline{L}$ ,
- (2)  $\widehat{\varphi}(u) \in \varphi(L)$ , for all morphisms  $\varphi$  from  $A^*$  onto a finite monoid,
- (3)  $\widehat{\varphi}(u) \in \varphi(L)$ , for some morphism  $\varphi$  from  $A^*$  onto a finite monoid that recognises  $L$ ,
- (4)  $\widehat{\eta}(u) \in \eta(L)$ , where  $\eta$  is the syntactic morphism of  $L$ .

**Proof.** (1) implies (2). Let  $\varphi$  be a morphism from  $A^*$  onto a finite monoid  $F$  and let  $\widehat{\varphi}$  be its continuous extension to  $\widehat{A^*}$ . Then  $\widehat{\varphi}(\overline{L}) \subset \overline{\widehat{\varphi}(L)}$  since  $\widehat{\varphi}$  is continuous, and  $\overline{\widehat{\varphi}(L)} = \widehat{\varphi}(L) = \varphi(L)$  since  $F$  is discrete. Thus if  $u \in \overline{L}$ , then  $\widehat{\varphi}(u) \in \varphi(L)$ .

(2) implies (4) and (4) implies (3) are trivial.

(3) implies (1). Let  $\varphi$  be a morphism from  $A^*$  onto a finite monoid  $F$ . Let  $u_n$  be a sequence of words of  $A^*$  converging to  $u$ . Since  $\widehat{\varphi}$  is continuous,  $\widehat{\varphi}(u_n)$  converges to  $\widehat{\varphi}(u)$ . But since  $F$  is discrete,  $\widehat{\varphi}(u_n)$  is actually ultimately equal to  $\widehat{\varphi}(u)$ . Thus for  $n$  large enough, one has  $\widehat{\varphi}(u_n) = \widehat{\varphi}(u)$ . It follows by (3) that  $\varphi(u_n) = \widehat{\varphi}(u_n) \in \varphi(L)$  and since  $\varphi$  recognises  $L$ , we finally get  $u_n \in \varphi^{-1}(\varphi(L)) = L$ . Therefore  $u \in \overline{L}$ .  $\square$

Let us denote by  $\text{Clopen}(\widehat{A^*})$  the Boolean algebra of all clopen sets of  $\widehat{A^*}$ .

**Theorem 3.14** *The maps  $L \mapsto \overline{L}$  and  $K \mapsto K \cap A^*$  define mutually inverse isomorphisms between the Boolean algebras  $\text{Rec}(A^*)$  and  $\text{Clopen}(\widehat{A^*})$ . In particular, the following formulas hold, for all  $L, L_1, L_2 \in \text{Rec}(A^*)$ :*

- (1)  $\overline{L^c} = (\overline{L})^c$ ,
- (2)  $\overline{L_1 \cup L_2} = \overline{L_1} \cup \overline{L_2}$ ,
- (3)  $\overline{L_1 \cap L_2} = \overline{L_1} \cap \overline{L_2}$ .

**Proof.** Property (1) follows from Proposition 3.13. Indeed, let  $\eta$  be the syntactic morphism of  $L$ . Then since  $L = \eta^{-1}(\eta(L))$  and  $L^c = \eta^{-1}(\eta(L)^c)$ , one has  $\eta(L^c) = \eta(L)^c$ . Therefore, one gets the following sequence of equalities:

$$\overline{L^c} = \widehat{\eta}^{-1}(\eta(L^c)) = \widehat{\eta}^{-1}(\eta(L)^c) = [\widehat{\eta}^{-1}(\eta(L))]^c = (\overline{L})^c$$

Property (2) is a general result of topology and (3) is a consequence of (1) and (2).  $\square$

Theorem 3.14 shows that the closure operator behaves nicely with respect to Boolean operations. It also behaves nicely for the left and right quotients and for inverse of morphisms.

**Proposition 3.15** *Let  $L$  be a recognisable language of  $A^*$  and let  $x, y \in A^*$ . Then  $x^{-1}Ly^{-1} = x^{-1}\overline{L}y^{-1}$ .*

**Proof.** Let  $\eta$  be the syntactic morphism of  $L$ . Since  $\eta$  also recognises  $x^{-1}Ly^{-1}$ , Proposition 3.13 can be used twice to get

$$\begin{aligned} u \in \overline{x^{-1}Ly^{-1}} &\iff \widehat{\eta}(u) \in \eta(x^{-1}Ly^{-1}) \iff \eta(x)\widehat{\eta}(u)\eta(y) \in \eta(L) \\ &\iff \widehat{\eta}(xuy) \in \eta(L) \iff xuy \in \overline{L} \iff u \in x^{-1}\overline{L}y^{-1} \end{aligned}$$

which gives the result.  $\square$

**Proposition 3.16** *Let  $\varphi : A^* \rightarrow B^*$  be a morphism of monoids and  $L$  be a recognisable language of  $B^*$ . Then  $\widehat{\varphi}^{-1}(\overline{L}) = \overline{\varphi^{-1}(L)}$ .*

**Proof.** Let  $\eta$  be the syntactic morphism of  $L$  and let  $N = \eta \circ \varphi(A^*)$ . Then  $N$  is a submonoid of  $M$  and the surjective morphism  $\eta \circ \varphi : A^* \rightarrow N$  recognises  $\varphi^{-1}(L)$ . Using Proposition 3.13 and observing that  $\widehat{\eta \circ \varphi} = \widehat{\eta} \circ \widehat{\varphi}$ , we have on the one hand

$$u \in \widehat{\varphi}^{-1}(\overline{L}) \iff \widehat{\varphi}(u) \in \overline{L} \iff \widehat{\eta}(\widehat{\varphi}(u)) \in \eta(L) \cap N \iff \widehat{\eta \circ \varphi}(u) \in \eta(L) \cap N$$

Using again Proposition 3.13, and observing that  $\varphi(\varphi^{-1}(L)) = L \cap \varphi(A^*)$  we get on the other hand

$$u \in \overline{\varphi^{-1}(L)} \iff \widehat{\eta \circ \varphi}(u) \in \eta(\varphi(\varphi^{-1}(L))) \iff \widehat{\eta \circ \varphi}(u) \in \eta(L \cap \varphi(A^*))$$

Now, by Proposition IV.2.6,  $\eta(L \cap \varphi(A^*)) = \eta(L) \cap \eta(\varphi(A^*)) = \eta(L) \cap N$ . Thus the two conditions  $u \in \widehat{\varphi}^{-1}(\overline{L})$  and  $u \in \overline{\varphi^{-1}(L)}$  are equivalent, which concludes the proof.  $\square$

# Chapter VII

## Varieties

The definition of a variety of finite monoids is due to Eilenberg [27]. It is inspired by the definition of a Birkhoff variety of monoids (see Exercise 1) which applies to infinite monoids, while Eilenberg's definition is restricted to finite monoids. The word "variety" was coined after the term used in algebraic geometry to designate the solutions of a set of algebraic equations. This is no coincidence: a theorem of Birkhoff states that a Birkhoff variety can be described by a set of identities (see Exercise 2). The counterpart of Birkhoff's theorem for varieties of finite monoids was obtained by Reiterman [91]. The statement is exactly the same: *any variety of finite monoids can be described by a set of identities*, but the definition of an identity is now different! For Birkhoff, an identity is a formal equality between words, but for Reiterman, it is a formal equality between profinite words. One must always topologize...

**Warning.** Since we are mostly interested in finite semigroups, the semigroups and monoids considered in this chapter are either finite or free, except in Exercises 1 and 2.

### 1 Varieties

A *variety of semigroups* is a class of semigroups  $\mathbf{V}$  such that:

- (1) if  $S \in \mathbf{V}$  and if  $T$  is a subsemigroup of  $S$ , then  $T \in \mathbf{V}$ ,
- (2) if  $S \in \mathbf{V}$  and if  $T$  is a quotient of  $S$ , then  $T \in \mathbf{V}$ ,
- (3) if  $(S_i)_{i \in I}$  is a finite family of semigroups of  $\mathbf{V}$ , then  $\prod_{i \in I} S_i$  is also in  $\mathbf{V}$ .

Conditions (1) and (2) can be replaced by a single condition: if  $S \in \mathbf{V}$  and if  $T$  divides  $S$ , then  $T \in \mathbf{V}$ . Therefore, a variety of semigroups can be defined as a class of semigroups closed under division and finite products.

A more subtle point: condition (3) can be replaced by the conjunction of conditions (4) and (5):

- (4) the trivial semigroup  $1$  belongs to  $\mathbf{V}$ ,
- (5) if  $S_1$  and  $S_2$  are semigroups of  $\mathbf{V}$ , then  $S_1 \times S_2$  is also in  $\mathbf{V}$ .

Indeed, condition (4) is obtained by taking  $I = \emptyset$  in (3).

#### Example 1.1

- (1) The class  $\mathbf{S}$  of all semigroups forms a variety of semigroups.
- (2) The smallest variety of semigroups is the trivial variety, consisting of the empty semigroup and of the semigroup with one element 1. This variety is denoted by  $\mathbf{1}$ .

Varieties of monoids, varieties of ordered semigroups and varieties of ordered monoids are defined in the same way: it suffices to replace every occurrence of *semigroup* by *monoid* [*ordered semigroup*, *ordered monoid*] in the definition.

We shall sometimes use the term “variety” as a shorthand for variety of semigroups [monoids, etc.]. Examples of varieties are deferred to Section 4.

Let  $\mathcal{C}$  be a class of monoids [semigroups, ordered monoids, ordered semigroups]. The intersection of all varieties containing  $\mathcal{C}$  is a variety, called the *variety generated by  $\mathcal{C}$*  and denoted by  $\langle \mathcal{C} \rangle$ . The next proposition provides a more explicit description.

**Proposition 1.1** *A monoid belongs to  $\langle \mathcal{C} \rangle$  if and only if it divides a finite product of monoids of  $\mathcal{C}$ .*

**Proof.** Let  $\mathbf{V}$  be the class of all monoids dividing a finite product of monoids of  $\mathcal{C}$ . Since a variety is closed under division and finite product, every monoid of  $\mathbf{V}$  belongs to  $\langle \mathcal{C} \rangle$ . Therefore, it suffices to prove that  $\mathbf{V}$  is a variety. Proposition II.3.14 shows that  $\mathbf{V}$  is closed under product and Proposition II.3.9 shows that  $\mathbf{V}$  is closed under division. Thus  $\mathbf{V}$  is a variety.  $\square$

The *supremum* of two varieties  $\mathbf{V}_1$  and  $\mathbf{V}_2$  is the variety generated by  $\mathbf{V}_1$  and  $\mathbf{V}_2$ . It is denoted by  $\mathbf{V}_1 \vee \mathbf{V}_2$ . A direct application of Proposition 1.1 gives the following characterisation.

**Corollary 1.2** *A monoid belongs to  $\mathbf{V}_1 \vee \mathbf{V}_2$  if and only if it divides a monoid of the form  $M_1 \times M_2$ , with  $M_1 \in \mathbf{V}_1$  and  $M_2 \in \mathbf{V}_2$ .*

## 2 Free pro- $\mathbf{V}$ monoids

We introduced the free profinite monoid  $\widehat{A^*}$  in Section 2. A similar notion, the free pro- $\mathbf{V}$  monoid, can be defined for each variety of monoids [semigroups]  $\mathbf{V}$ .

A monoid  $M$  *separates* two words  $u$  and  $v$  of the free monoid  $A^*$  if there exists a morphism  $\varphi$  from  $A^*$  onto  $M$  such that  $\varphi(u) \neq \varphi(v)$ . Let  $\mathbf{V}$  be a variety of monoids. We set

$$r_{\mathbf{V}}(u, v) = \min\{\text{Card}(M) \mid M \text{ is a monoid of } \mathbf{V} \text{ that separates } u \text{ and } v\}$$

and  $d_{\mathbf{V}}(u, v) = 2^{-r_{\mathbf{V}}(u, v)}$ , with the usual conventions  $\min \emptyset = +\infty$  and  $2^{-\infty} = 0$ . We first establish some general properties of  $d_{\mathbf{V}}$ .

**Proposition 2.3** *The following properties hold for every  $u, v, w \in A^*$*

- (1)  $d_{\mathbf{V}}(u, v) = d_{\mathbf{V}}(v, u)$
- (2)  $d_{\mathbf{V}}(uw, vw) \leq d_{\mathbf{V}}(u, v)$  and  $d_{\mathbf{V}}(wu, wv) \leq d_{\mathbf{V}}(u, v)$
- (3)  $d_{\mathbf{V}}(u, w) \leq \max\{d_{\mathbf{V}}(u, v), d_{\mathbf{V}}(v, w)\}$



**Proof.** The first assertion is trivial. A monoid of  $\mathbf{V}$  separating  $uw$  and  $vw$  certainly separates  $u$  and  $v$ . Therefore  $d_{\mathbf{V}}(uw, vw) \leq d_{\mathbf{V}}(u, v)$ , and dually,  $d_{\mathbf{V}}(wu, wv) \leq d_{\mathbf{V}}(u, v)$ .

Let  $M$  be a monoid of  $\mathbf{V}$  separating  $u$  and  $w$ . Then  $M$  separates either  $u$  and  $v$ , or  $v$  and  $w$ . It follows that  $\min(r_{\mathbf{V}}(u, v), r_{\mathbf{V}}(v, w)) \leq r_{\mathbf{V}}(u, w)$  and hence  $d_{\mathbf{V}}(u, w) \leq \max\{d_{\mathbf{V}}(u, v), d_{\mathbf{V}}(v, w)\}$ .  $\square$

In the general case,  $d_{\mathbf{V}}$  is not always a metric, because one may have  $d_{\mathbf{V}}(u, v) = 0$  even if  $u \neq v$ . For instance, if  $\mathbf{V}$  is the variety of commutative monoids,  $d_{\mathbf{V}}(ab, ba) = 0$ , since there is no way to separate  $ab$  and  $ba$  by a commutative monoid. To work around this difficulty, we first observe that, by Proposition 2.3, the relation  $\sim_{\mathbf{V}}$  defined by

$$u \sim_{\mathbf{V}} v \text{ if and only if } d_{\mathbf{V}}(u, v) = 0$$

is a congruence on  $A^*$ . Then Proposition VI.2.6 can be generalised as follows.

**Proposition 2.4**

- (1) *The function  $d_{\mathbf{V}}$  is an ultrametric on  $A^*/\sim_{\mathbf{V}}$ .*
- (2) *The product on  $A^*/\sim_{\mathbf{V}}$  is uniformly continuous for this metric.*

**Proof.** (1) follows directly from Proposition 2.3, since  $d_{\mathbf{V}}(u, v) = 0$  implies  $u \sim_{\mathbf{V}} v$  by definition. We use the same proposition to obtain the relation

$$d_{\mathbf{V}}(uv, u'v') \leq \max\{d_{\mathbf{V}}(uv, uv'), d_{\mathbf{V}}(uv', u'v')\} \leq \max\{d_{\mathbf{V}}(v, v'), d_{\mathbf{V}}(u, u')\}$$

which proves (2).  $\square$

The completion of the metric space  $(A^*/\sim_{\mathbf{V}}, d_{\mathbf{V}})$  is denoted by  $\widehat{F}_{\mathbf{V}}(A)$  and called the *free pro- $\mathbf{V}$  monoid* on  $A$ . Its main properties are presented in the next three propositions:

**Proposition 2.5** *The following properties hold for each finite alphabet  $A$ :*

- (1) *The monoid  $\widehat{F}_{\mathbf{V}}(A)$  is compact.*
- (2) *There is a surjective uniformly continuous morphism  $\pi_{\mathbf{V}}$  from  $\widehat{A}^*$  onto  $\widehat{F}_{\mathbf{V}}(A)$ .*

**Proof.** (1) Since  $\widehat{F}_{\mathbf{V}}(A)$  is complete, it suffices to verify that, for every  $n > 0$ ,  $A^*$  is covered by a finite number of open balls of radius  $< 2^{-n}$ . Consider the congruence  $\sim_n$  defined on  $A^*$  by

$$u \sim_n v \text{ if and only if } \varphi(u) = \varphi(v) \text{ for every morphism } \varphi \text{ from } A^* \text{ onto a monoid of size } \leq n \text{ of } \mathbf{V}.$$

Since  $A$  is finite, there are only finitely many morphisms from  $A^*$  onto a monoid of size  $\leq n$ , and thus  $\sim_n$  is a congruence of finite index. Furthermore,  $d_{\mathbf{V}}(u, v) < 2^{-n}$  if and only if  $u$  and  $v$  cannot be separated by a monoid of  $\mathbf{V}$  of size  $\leq n$ , i.e. are  $\sim_n$ -equivalent. It follows that the  $\sim_n$ -classes are open balls of radius  $< 2^{-n}$  and cover  $A^*$ .

(2) Let  $\pi_{\mathbf{V}}$  be the natural morphism from  $A^*$  onto  $A^*/\sim_{\mathbf{V}}$ . Since  $d_{\mathbf{V}}(u, v) \leq d(u, v)$ ,  $\pi_{\mathbf{V}}$  is uniformly continuous, and since  $\widehat{A}^*$  is compact, Proposition VI.1.1

shows that it can be extended to a uniformly continuous morphism from  $\widehat{A^*}$  onto  $\widehat{F_{\mathbf{V}}}(A)$ .  $\square$

The monoid  $\widehat{F_{\mathbf{V}}}(A)$  has the following universal property:

**Proposition 2.6** *For each mapping  $\varphi$  from  $A$  into a monoid  $M$  of  $\mathbf{V}$ , there is a unique uniformly continuous morphism  $\widehat{\varphi} : \widehat{F_{\mathbf{V}}}(A) \rightarrow M$  such that, for all  $a \in A$ ,  $\varphi(a) = \widehat{\varphi}(\pi_{\mathbf{V}}(a))$ .*

**Proof.** Let  $\varphi$  be a continuous morphism from  $\widehat{A^*}$  into a monoid  $M$  of  $\mathbf{V}$ . Up to replacing  $M$  by  $\varphi(A^*)$ , we may assume that  $\varphi$  is onto. Since  $A^*$  is dense in  $\widehat{A^*}$ , and  $M$  is discrete, the restriction of  $\varphi$  to  $A^*$  is also surjective. Furthermore, since  $u \sim_{\mathbf{V}} v$  implies  $\varphi(u) = \varphi(v)$ , Proposition II.3.22 shows that there is a surjective morphism  $\pi$  from  $A^*/\sim_{\mathbf{V}}$  onto  $M$  such that  $\varphi = \pi \circ \pi_{\mathbf{V}}$ . We claim that this morphism is uniformly continuous. Indeed if  $d_{\mathbf{V}}(u, v) < 2^{-|M|}$ , then  $u$  and  $v$  cannot be separated by  $M$ , and hence  $\varphi(u) = \varphi(v)$ . Since  $A^*/\sim_{\mathbf{V}}$  is dense in  $\widehat{F_{\mathbf{V}}}(A)$ ,  $\pi$  can be extended by continuity to a surjective morphism from  $\widehat{F_{\mathbf{V}}}(A)$  onto  $M$ . Thus  $M$  is a quotient of  $\widehat{F_{\mathbf{V}}}(A)$ .  $\square$

**Proposition 2.7** *A finite  $A$ -generated monoid belongs to  $\mathbf{V}$  if and only if it is a continuous quotient of  $\widehat{F_{\mathbf{V}}}(A)$ .*

**Proof.** If  $M$  is an  $A$ -generated monoid of  $\mathbf{V}$ , there exists a surjective morphism  $\varphi$  from  $A^*$  onto  $M$ . Following the argument used in the proof of Proposition 2.6, if  $d_{\mathbf{V}}(u, v) < 2^{-|M|}$ , then  $\varphi(u) = \varphi(v)$ , and thus  $\varphi$  is uniformly continuous with respect to  $d_{\mathbf{V}}$ . By Proposition VI.1.1,  $\varphi$  can be extended to a uniformly continuous morphism from  $\widehat{F_{\mathbf{V}}}(A)$  onto  $M$ .

Conversely, assume that  $M$  is a finite quotient of  $\widehat{F_{\mathbf{V}}}(A)$  and let  $\pi : \widehat{F_{\mathbf{V}}}(A) \rightarrow M$  be a surjective morphism. The set

$$D = \{(u, v) \in \widehat{F_{\mathbf{V}}}(A) \times \widehat{F_{\mathbf{V}}}(A) \mid \pi(u) = \pi(v)\}$$

is the inverse image under  $\pi$  of the diagonal of  $M \times M$ , and since  $M$  is discrete and  $\pi$  is continuous, it is a clopen subset of  $\widehat{F_{\mathbf{V}}}(A) \times \widehat{F_{\mathbf{V}}}(A)$ . Let  $\mathcal{F}$  be the class of all morphisms from  $\widehat{F_{\mathbf{V}}}(A)$  onto a monoid of  $\mathbf{V}$ . For each  $\varphi \in \mathcal{F}$ , let

$$C_{\varphi} = \{(u, v) \in \widehat{F_{\mathbf{V}}}(A) \times \widehat{F_{\mathbf{V}}}(A) \mid \varphi(u) \neq \varphi(v)\}$$

Each  $C_{\varphi}$  is open by continuity of  $\varphi$ . Furthermore, if  $(u, v)$  does not belong to any  $C_{\varphi}$ , then  $u$  and  $v$  cannot be separated by any monoid of  $\mathbf{V}$  and hence  $d_{\mathbf{V}}(u, v) = 0$ , which gives  $u = v$  and  $\pi(u) = \pi(v)$ . It follows that the family  $D \cup (C_{\varphi})_{\varphi \in \mathcal{F}}$  is a covering of  $\widehat{F_{\mathbf{V}}}(A) \times \widehat{F_{\mathbf{V}}}(A)$  by open sets, and since  $\widehat{F_{\mathbf{V}}}(A)$  is compact, it admits a finite subcovering, say  $D \cup (C_{\varphi})_{\varphi \in \mathcal{F}}$ . Therefore, if  $\varphi(u) = \varphi(v)$  for each  $\varphi \in \mathcal{F}$ , then  $\pi(u) = \pi(v)$ . Consequently  $M$  is a quotient of a submonoid of the finite monoid  $\prod_{\varphi \in \mathcal{F}} \varphi(\widehat{F_{\mathbf{V}}}(A))$  and thus belongs to  $\mathbf{V}$ .  $\square$

Given a variety  $\mathbf{V}$ , it is in general a hard problem to describe the structure of  $\widehat{F_{\mathbf{V}}}(A)$ . However, if  $\mathbf{V}$  is generated by a single monoid  $M$ , then  $\widehat{F_{\mathbf{V}}}(A)$  has a simple structure. Let  $M^A$  be the set of all functions from  $A$  to  $M$ . Each

function  $\varphi : A \rightarrow M$  extends in a unique way to a monoid morphism from  $A^*$  into  $M$ , also denoted by  $\varphi$ . Denote by  $M^{M^A}$  the monoid of all functions from  $M^A$  to  $M$  under pointwise multiplication.

For each letter  $a \in A$ , let  $\tilde{a}$  be the function from  $M^A$  to  $M$  defined by  $\tilde{a}(\varphi) = \varphi(a)$ . This defines a function  $a \mapsto \tilde{a}$  from  $A$  into  $M^{M^A}$ , which can be extended to a morphism  $u \mapsto \tilde{u}$  from  $A^*$  into  $M^{M^A}$ . We claim that, for any function  $\varphi : A \rightarrow M$ , one has  $\tilde{u}(\varphi) = \varphi(u)$  for each word  $u \in A^*$ . Indeed, if  $u = a_1 \cdots a_n$ , one gets by definition

$$\tilde{u}(\varphi) = \tilde{a}_1(\varphi) \cdots \tilde{a}_n(\varphi) = \varphi(a_1) \cdots \varphi(a_n) = \varphi(u)$$

The image of  $A^*$  under the map  $u \mapsto \tilde{u}$  is a submonoid  $F$  of  $M^{M^A}$ .

**Proposition 2.8** *If  $\mathbf{V}$  is generated by a single monoid  $M$ , then  $\widehat{F}_{\mathbf{V}}(A)$  is equal to  $F$ . In particular,  $\widehat{F}_{\mathbf{V}}(A)$  is a submonoid of  $M^{M^A}$  and hence is finite.*

**Proof.** It suffices to prove that  $u \sim_{\mathbf{V}} v$  is equivalent to  $\tilde{u} = \tilde{v}$ . Recall that  $u \sim_{\mathbf{V}} v$  if and only if, for each morphism  $\varphi : A^* \rightarrow N$ , where  $N \in \mathbf{V}$ , one has  $\varphi(u) = \varphi(v)$ .

Suppose that  $u \sim_{\mathbf{V}} v$  and let  $\varphi : A \rightarrow M$  be a function, which extends to a morphism from  $A^*$  to  $M$ . Since  $M \in \mathbf{V}$ , one has  $\varphi(u) = \varphi(v)$  and thus  $\tilde{u}(\varphi) = \tilde{v}(\varphi)$ . It follows that  $\tilde{u} = \tilde{v}$ .

Suppose now that  $\tilde{u} = \tilde{v}$ . Since  $\mathbf{V}$  is generated by  $M$ , every monoid  $N$  of  $\mathbf{V}$  divides a power of  $M$ . Therefore there exist a positive integer  $n$ , a submonoid  $T$  of  $M^n$  and a surjective morphism  $\pi : T \rightarrow N$ . By Corollary II.5.30, there exists a morphism  $\alpha : A^* \rightarrow T$  such that  $\varphi = \pi \circ \alpha$ . It follows that  $u \sim_{\mathbf{V}} v$  if and only if, for each  $n$  and for each morphism  $\alpha : A^* \rightarrow M^n$ , one has  $\alpha(u) = \alpha(v)$ . Denoting by  $\pi_i$  the  $i$ -th projection from  $M^n$  onto  $M$  and setting  $\alpha_i = \pi_i \circ \alpha$ , we get  $\alpha(u) = (\alpha_1(u), \dots, \alpha_n(u))$ . Now since  $\alpha_i$  is a morphism from  $A^*$  to  $M$ , one has  $\alpha_i(u) = \tilde{u}(\alpha_i)$ . It follows immediately that if  $\tilde{u} = \tilde{v}$ , then  $\alpha(u) = \alpha(v)$ . Therefore  $u \sim_{\mathbf{V}} v$ , which concludes the proof.  $\square$

A variety such that  $\widehat{F}_{\mathbf{V}}(A)$  is finite for each alphabet  $A$  is called *locally finite*. It is tempting to guess, in view of Proposition 2.8, that every locally finite variety is generated by a single monoid. However, this is not the case: one can show that the variety of idempotent monoids is locally finite but not finitely generated.

## 3 Identities

### 3.1 What is an identity?

Let  $A$  be a finite alphabet and let  $u$  and  $v$  be two profinite words of  $\widehat{A}^*$ . A monoid  $M$  satisfies the *profinite identity*  $u = v$  if, for each monoid morphism  $\varphi : A^* \rightarrow M$ , one has  $\widehat{\varphi}(u) = \widehat{\varphi}(v)$ . Similarly, an ordered monoid  $(M, \leq)$  satisfies the *profinite identity*  $u \leq v$  if, for each monoid morphism  $\varphi : A^* \rightarrow M$ , one has  $\widehat{\varphi}(u) \leq \widehat{\varphi}(v)$ . An identity  $u = v$  [ $u \leq v$ ] where  $u$  and  $v$  are words is sometimes called an *explicit identity*.

One can give similar definitions for [ordered] semigroups, by taking two nonempty profinite words  $u$  and  $v$ . A semigroup  $S$  satisfies the *identity*  $u = v$  if,

for each semigroup morphism  $\varphi : A^+ \rightarrow S$ , one has  $\widehat{\varphi}(u) = \widehat{\varphi}(v)$  [ $\widehat{\varphi}(u) \leq \widehat{\varphi}(v)$ ]. The context is usually sufficient to know which kind of identities is considered. In case of ambiguity, one can utilise the more precise terms [ordered] *monoid identity* or [ordered] *semigroup identity*.

Formally, a profinite identity is a pair of profinite words. But in practice, one often think directly in terms of elements of a monoid. Consider for instance the explicit identity  $xy^3z = yxyzzy$ . A monoid  $M$  satisfies this identity if, for each morphism  $\gamma : \{x, y, z\}^* \rightarrow M$ , one has  $\gamma(xy^3z) = \gamma(yxyzzy)$ . Setting  $\gamma(x) = s$ ,  $\gamma(y) = t$  and  $\gamma(z) = u$ , this can be written as  $st^3u = tstut$ . Since this equality should hold for **any** morphism  $\gamma$ , it is equivalent to require that, for **all**  $s, t, u \in M$ , one has  $st^3u = tstut$ . Now, the change of variables is unnecessary, and one can write directly that  $M$  satisfies the identity  $xy^3z = yxyzzy$  if and only if, for all  $x, y, z \in M$ , one has  $xy^3z = yxyzzy$ . Similarly, a monoid is commutative if it satisfies the identity  $xy = yx$ .

It is also possible to interpret directly any  $\omega$ -term in a finite semigroup [monoid]  $S$ . As it was already mentioned, the key idea is to think of  $\omega$  as the exponent of  $S$ . For instance, an identity like  $x^\omega y^\omega = y^\omega x^\omega$  can be readily interpreted by saying that idempotents commute in  $S$ . The identity  $x^\omega y x^\omega = x^\omega$  means that, for every  $e \in E(S)$  and for every  $s \in S$ ,  $ese = e$ . Propositions 4.23 and 4.27 provide other enlighting examples.

### 3.2 Properties of identities

Let us now state some elementary but important properties of identities. We consider identities of ordered monoids, but the result can be readily adapted to the other types of identities.

**Proposition 3.9** *Let  $u$  and  $v$  be profinite words on the alphabet  $A$  and let  $M$  be an ordered monoid satisfying the identity  $u \leq v$ . Then for all  $x, y \in \widehat{A}^*$ ,  $M$  satisfies the identity  $xuy \leq xvy$ . Further, for each morphism  $\gamma : A^* \rightarrow B^*$ ,  $M$  satisfies the identity  $\widehat{\gamma}(u) \leq \widehat{\gamma}(v)$ .*

**Proof.** Let  $\varphi : A^* \rightarrow M$  be a monoid morphism. Since  $M$  satisfies the identity  $u \leq v$ , one has  $\widehat{\varphi}(u) \leq \widehat{\varphi}(v)$ . Since  $\widehat{\varphi}$  is a morphism, it follows that  $\widehat{\varphi}(xuy) \leq \widehat{\varphi}(xvy)$  for all  $x, y \in \widehat{A}^*$ . Therefore,  $M$  satisfies the identity  $xuy \leq xvy$ .

Let  $\gamma : A^* \rightarrow B^*$  and  $\alpha : B^* \rightarrow M$  be morphisms. Then  $\alpha \circ \gamma$  is a morphism from  $A^*$  into  $M$ . Since  $M$  satisfies the identity  $u \leq v$  and since  $\widehat{\alpha \circ \gamma} = \widehat{\alpha} \circ \widehat{\gamma}$ , one has  $\widehat{\alpha}(\widehat{\gamma}(u)) \leq \widehat{\alpha}(\widehat{\gamma}(v))$ . Therefore  $M$  satisfies the identity  $\widehat{\gamma}(u) \leq \widehat{\gamma}(v)$ .  $\square$

It is a common practice to use implicitly the second part of Proposition 3.9 without giving the morphism  $\gamma$  explicitly, but simply by substituting a profinite word for a letter. For instance, one can prove that the monoid identity

$$xyx = x \tag{3.1}$$

implies the identity  $x^2 = x$  by taking  $y = 1$  in (3.1). Similarly, the identity  $x^\omega y x^\omega = x^\omega$  implies the identity  $x^{\omega+1} = x^\omega$  by taking  $y = x$ , since  $x^\omega x x^\omega = x^\omega x^\omega x = x^\omega x$ .

### 3.3 Reiterman's theorem

Given a set  $E$  of profinite identities, the class of monoids [semigroups, ordered monoids, ordered semigroups] defined by  $E$  is the class of all monoids [semigroups, ordered monoids, ordered semigroups] satisfying all the identities of  $E$  and is denoted by  $\llbracket E \rrbracket$ .

The main result of this section, Reiterman's theorem 3.13, states that varieties can be characterised by profinite identities. We first establish the easy part of this result.

**Proposition 3.10** *Let  $E$  be a set of identities. Then  $\llbracket E \rrbracket$  is a variety of monoids [semigroups, ordered monoids, ordered semigroups].*

**Proof.** We treat only the case of ordered monoids, but the other cases are similar. Since varieties are closed under intersection, it suffices to prove the result when  $E$  consists of a single identity, say  $u \leq v$ . Let  $M$  be an ordered monoid satisfying this identity. Clearly, every submonoid of  $M$  satisfies the same identity.

Let  $N$  be a quotient of  $M$  and let  $\pi : M \rightarrow N$  be a surjective morphism. We claim that  $N$  also satisfies  $u \leq v$ . Indeed, if  $\varphi : A^* \rightarrow N$  is a morphism, there exists by Corollary II.5.30 a morphism  $\psi : A^* \rightarrow M$  such that  $\varphi = \pi \circ \psi$ . Since  $M$  satisfies the identity  $u \leq v$ , one gets  $\widehat{\psi}(u) \leq \widehat{\psi}(v)$  and thus  $\pi(\widehat{\psi}(u)) \leq \pi(\widehat{\psi}(v))$ . Finally, since  $\widehat{\varphi} = \pi \circ \widehat{\psi}$ , one obtains  $\widehat{\varphi}(u) \leq \widehat{\varphi}(v)$ , which proves the claim.

Finally, let  $(M_i)_{i \in I}$  be a finite family of ordered monoids satisfying the identity  $u \leq v$ . We claim that their product  $M = \prod_{i \in I} M_i$  also satisfies this identity. Indeed, let  $\pi_i$  denotes the projection from  $M$  onto  $M_i$  and let  $\varphi$  be a morphism from  $A^*$  into  $M$ . Since  $\pi_i \circ \varphi$  is a morphism from  $A^*$  into  $M_i$  and since  $\widehat{\pi_i \circ \varphi} = \pi_i \circ \widehat{\varphi}$ , one has  $\pi_i \circ \widehat{\varphi}(u) \leq \pi_i \circ \widehat{\varphi}(v)$ . As this holds for each  $i$ , one has  $\widehat{\varphi}(u) \leq \widehat{\varphi}(v)$ . This proves the claim and concludes the proof.  $\square$

A variety  $\mathbf{V}$  satisfies a given identity if every monoid of  $\mathbf{V}$  satisfies this identity. We also say in this case that the given identity is an identity of  $\mathbf{V}$ . Identities of  $\mathbf{V}$  are closely related to free pro- $\mathbf{V}$  monoids.

**Proposition 3.11** *Let  $A$  be a finite alphabet. Given two profinite words  $u$  and  $v$  of  $\widehat{A^*}$ ,  $u = v$  is an identity of  $\mathbf{V}$  if and only if  $\pi_{\mathbf{V}}(u) = \pi_{\mathbf{V}}(v)$ .*

**Proof.** If  $u = v$  is an identity of  $\mathbf{V}$ , then  $u$  and  $v$  cannot be separated by any monoid of  $\mathbf{V}$ . Thus  $d_{\mathbf{V}}(u, v) = 0$ ,  $u \sim_{\mathbf{V}} v$  and  $\pi_{\mathbf{V}}(u) = \pi_{\mathbf{V}}(v)$ . Conversely if  $\pi_{\mathbf{V}}(u) = \pi_{\mathbf{V}}(v)$ , then by Proposition 2.5,  $\varphi(u) = \varphi(v)$  for every continuous morphism  $\varphi$  from  $\widehat{A^*}$  into a monoid of  $\mathbf{V}$ , and thus  $u = v$  is an identity of  $\mathbf{V}$ .  $\square$

**Corollary 3.12** *Let  $\mathbf{V}$  and  $\mathbf{W}$  be two varieties of monoids satisfying the same identities on the alphabet  $A$ . Then  $\widehat{F}_{\mathbf{V}}(A)$  and  $\widehat{F}_{\mathbf{W}}(A)$  are isomorphic.*

In particular, an identity of a monoid of  $\mathbf{V}$  can be given as a pair  $(u, v)$  of elements of  $\widehat{F}_{\mathbf{V}}(A)$ . Given a set  $E$  of identities, we denote by  $\llbracket E \rrbracket$  the class of monoids satisfying all the identities of  $E$ . Reiterman's theorem states these classes are exactly the varieties of monoids [semigroups, ordered monoids, ordered semigroups].

**Theorem 3.13 (Reiterman)** *A class of [ordered] monoids [semigroups] is a variety if and only if it can be defined by a set of profinite identities.*

**Proof.** The first part of the theorem follows from Proposition 3.10. Let now  $\mathbf{V}$  be a variety of monoids. Let  $E$  be the class of all identities which are satisfied by every monoid of  $\mathbf{V}$  and let  $\mathbf{W} = \llbracket E \rrbracket$ . Clearly  $\mathbf{V} \subseteq \mathbf{W}$ . Let  $M \in \mathbf{W}$ . Since  $M$  is finite, there exists a finite alphabet  $A$  and a surjective morphism  $\varphi : A^* \rightarrow M$  which can be extended to a uniformly continuous morphism from  $\hat{A}^*$  onto  $M$ . Let  $\pi : \hat{A}^* \rightarrow \hat{F}_{\mathbf{V}}(A)$  be the natural morphism and let  $u, v \in \hat{A}^*$ . By Proposition 3.11, if  $\pi(u) = \pi(v)$ , then  $u = v$  is an identity of  $\mathbf{V}$  and thus, is satisfied by  $M$ . In particular,  $\pi(u) = \pi(v)$  implies  $\varphi(u) = \varphi(v)$  and by Proposition II.3.22,  $\varphi$  factors through  $\pi$ . Therefore  $M$  is a quotient of  $\hat{F}_{\mathbf{V}}(A)$  and by Proposition 2.5,  $M$  is in  $\mathbf{V}$ . Thus  $\mathbf{V} = \mathbf{W}$ .  $\square$

## 4 Examples of varieties

We now illustrate Reiterman's theorem by giving identities defining various varieties.

### 4.1 Varieties of semigroups

#### Nilpotent semigroups

A semigroup  $S$  is *nilpotent* if it has a zero and  $S^n = 0$  for some positive integer  $n$ . Recall that  $S^n$  denotes the set of all products of the form  $s_1 \cdots s_n$ , with  $s_1, \dots, s_n \in S$ . Equivalent definitions are given below.

**Proposition 4.14** *Let  $S$  be a nonempty semigroup. The following conditions are equivalent:*

- (1)  $S$  is nilpotent,
- (2)  $S$  satisfies the identity  $x_1 \cdots x_n = y_1 \cdots y_n$ , where  $n = |S|$ ,
- (3) for every  $e \in E(S)$  and every  $s \in S$ , one has  $es = e = se$ ,
- (4)  $S$  has a zero which is the only idempotent of  $S$ .

**Proof.** (1) implies (2). This follows immediately from the definition.

(2) implies (3). Let  $s \in S$  and  $e \in E(S)$ . Taking  $x_1 = s$  and  $x_2 = \dots = x_n = y_1 = \dots = y_n = e$ , one gets  $s = e$  if  $n = 1$  and  $se = e$  if  $n > 1$ . Therefore  $se = e$  in all cases. Similarly  $es = e$ , which proves (3).

(3) implies (4). Since  $S$  is a nonempty semigroup, it contains an idempotent by Corollary II.6.32. Further, by (3), every idempotent of  $S$  is a zero of  $S$ , but Proposition II.1.2 shows that a semigroup has at most one zero.

(4) implies (1). Denote by  $0$  the zero of  $S$ . Then by Corollary II.6.35,  $S^n = SE(S)S = S\{0\}S = 0$ .  $\square$

Nilpotent semigroups form a variety, denoted by  $\mathbf{N}$ , and defined by the identities  $x^\omega y = x^\omega = yx^\omega$ .

### Lefty and righty trivial semigroups

A semigroup is called *lefty [righty] trivial* if, for every idempotent  $e$  of  $S$ , the semigroup  $eS [Se]$  is trivial. Equivalently,  $e$  is a left [right] zero of  $S$ , that is, for every  $s \in S$ , one has  $es = e [se = e]$ . Equivalent definitions are possible:

**Proposition 4.15** *Let  $S$  be a nonempty semigroup and let  $I$  be its minimal ideal. Let  $n = |S|$ . The following conditions are equivalent:*

- (1)  $S$  is lefty trivial,
- (2)  $I$  is a left zero semigroup and is equal to  $E(S)$ ,
- (3)  $I$  is a left zero semigroup and  $S^n = I$ ,
- (4)  $S$  satisfies the identity  $x_1 \cdots x_n x = x_1 \cdots x_n$ .

**Proof.** (1) implies (2). Let  $s \in I$ . Then for every  $e \in E(S)$ , one has  $e = es \in I$  since  $I$  is an ideal and therefore  $E(S) \subseteq I$ . Moreover if  $e \in E(S)$  and  $s, t \in S^1$ ,  $(set)(set) = se(tset) = se = set$  since  $e$  is a left zero of  $S$ . It follows that  $E(S)$  is a nonempty ideal of  $S$  contained in  $I$  and hence  $E(S) = I$  since  $I$  is minimal. Further, since every idempotent of  $S$  is a left zero,  $I$  is a left zero semigroup.

(2) implies (3). By Corollary II.6.35,  $S^n = SE(S)S$ . If  $I = E(S)$ , this gives  $S^n = SIS = I$ .

(3) implies (4). Suppose that (3) holds and let  $x, x_1, \dots, x_n \in S$ . Then  $x_1 \cdots x_n \in I$  and since  $I$  is an ideal,  $x_1 \cdots x_n x \in I$ . Now since  $I$  is a left zero semigroup,

$$x_1 \cdots x_n = (x_1 \cdots x_n)(x_1 \cdots x_n x) = (x_1 \cdots x_n)(x_1 \cdots x_n)x = (x_1 \cdots x_n)x$$

which proves (4).

(4) implies (1). Let  $s \in S$  and  $e \in E(S)$ . Taking  $x = s$  and  $x_1 = \dots = x_n = e$ , one gets  $es = e$  and hence  $S$  is lefty trivial.  $\square$

Note that, in a lefty trivial semigroup, all regular elements are in the minimal ideal. Further, all nonregular  $\mathcal{D}$ -classes are trivial. Let us state the dual result for the righty trivial semigroups.

**Proposition 4.16** *Let  $S$  be a nonempty semigroup and let  $I$  be its minimal ideal. Let  $n = |S|$ . The following conditions are equivalent:*

- (1)  $S$  is righty trivial,
- (2)  $I$  is a right zero semigroup and is equal to  $E(S)$ ,
- (3)  $I$  is a right zero semigroup and  $S^n = I$ ,
- (4)  $S$  satisfies an identity of the form  $xx_1 \cdots x_n = x_1 \cdots x_n$ .

The lefty [righty] trivial semigroups form a variety of finite semigroups, denoted by  $\ell\mathbf{1}$  [ $r\mathbf{1}$ ], and defined by the identity  $x^\omega y = x^\omega [yx^\omega = x^\omega]$ . For historical reasons, a different notation is often used in the literature. The variety  $\ell\mathbf{1}$  is denoted by  $\mathbf{K}$  and the variety  $r\mathbf{1}$  by  $\mathbf{D}$ .

### Locally trivial semigroups

A semigroup is called *locally trivial* if for every  $s \in S$  and  $e \in E(S)$ ,  $ese = e$ . Equivalent definitions are given below.

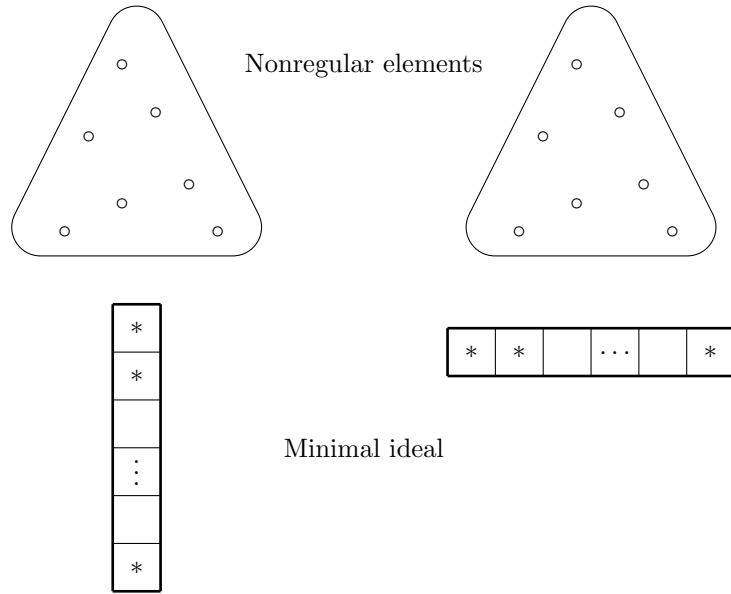

**Figure 4.1.** A lefty trivial semigroup (on the left) and a righty trivial semigroup (on the right).

**Proposition 4.17** *Let  $S$  be a nonempty semigroup and let  $n = |S|$ . The following conditions are equivalent:*

- (1)  $S$  is locally trivial,
- (2) the minimal ideal of  $S$  is equal to  $E(S)$ ,
- (3) for every  $e, f \in E(S)$  and every  $s \in S$ , one has  $esf = ef$ ,
- (4)  $S$  satisfies an identity of the form  $x_1 \cdots x_n x x_1 \cdots x_n = x_1 \cdots x_n$ .

**Proof.** (1) implies (2). Let  $s \in I$ . Then for every  $e \in E(S)$ , one has  $e = ese \in I$  since  $I$  is an ideal and therefore  $E(S) \subseteq I$ . Moreover if  $e \in E(S)$  and  $s, t \in S^1$ ,  $(set)(set) = se(tset) = set$  and thus  $set$  is idempotent. It follows that  $E(S)$  is a nonempty ideal of  $S$  contained in  $I$  and hence  $E(S) = I$ .

(2) implies (3). Suppose that  $I = E(S)$ . Then  $I$  is an aperiodic semigroup, which is also simple by Proposition V.4.37. Let  $s \in S$  and let  $e, f \in E(S)$ . Then  $e, f, esf \in I$  since  $I$  is an ideal. It follows by Corollary V.3.34 that  $esf = eesff = e(esf)f = ef$ .

(3) implies (4). By Corollary II.6.35,  $S^n = SE(S)S$ . Let  $x, x_1, \dots, x_n \in S$ . Then  $x_1 \cdots x_n \in S^n$  and hence  $x_1 \cdots x_n = set$  for some  $s, t \in S$  and  $e \in E(S)$ . It follows by (3)

$$x_1 \cdots x_n x x_1 \cdots x_n = (set)x(set) = s(etxse)t = set = x_1 \cdots x_n$$

which gives (4).

(4) implies (1). Let  $s \in S$  and  $e \in E(S)$ . Taking  $x = s$  and  $x_1 = \dots = x_n = e$ , one gets  $ese = e$  and hence  $S$  is locally trivial.  $\square$



Thus the locally trivial semigroups form a variety of finite semigroups, denoted by  $\mathbb{L}\mathbf{1}$ , and defined by the identity  $x^\omega y x^\omega = x^\omega$ .

### Locally groups

A semigroup is *locally a group* if for every  $e \in E(S)$ , the semigroup  $eSe$  is a group. Equivalent definitions are given below.

**Proposition 4.18** *Let  $S$  be a nonempty semigroup. The following conditions are equivalent:*

- (1)  $S$  is locally a group,
- (2) every idempotent of  $S$  belongs to the minimal ideal of  $S$ ,
- (3)  $S$  satisfies the identity  $(x^\omega y x^\omega)^\omega = x^\omega$ ,

**Proof.** Let  $I$  be the minimal ideal of  $S$  and let  $n$  be the exponent of  $S$ .

(1) implies (2). Let  $s \in I$  and let  $e \in E(S)$ . Since  $eSe$  is a group whose identity is  $e$ , one has  $(ese)^n = e$ . Now,  $I$  is an ideal and thus  $e \in I$ . It follows that  $E(S)$  is a subset of  $I$ .

(2) implies (3). Suppose that  $E(S) \subseteq I$ . By Proposition V.4.37,  $I$  is a simple semigroup. Let  $s \in S$  and let  $e \in E(S)$ . Since  $I$  is an ideal, one has  $e, ese \in I$  and thus  $e \mathcal{J} ese$ . Since  $ese \leq_{\mathcal{R}} e$  and  $ese \leq_{\mathcal{L}} e$ , Theorem V.1.9 shows that  $ese \mathcal{H} e$ . Therefore  $(ese)^n = e$  and  $S$  satisfies the identity  $(x^\omega y x^\omega)^\omega = x^\omega$ .

(3) implies (1). Let  $s \in S$  and  $e \in E(S)$ . Taking  $x = e$  and  $y = s$ , one gets  $(ese)^\omega = e$ , which shows that  $S$  is locally a group.  $\square$

Semigroups which are locally a group form a variety of finite semigroups, denoted by  $\mathbb{L}\mathbf{G}$  and defined by the identity  $(x^\omega y x^\omega)^\omega = x^\omega$ .

### Simple semigroups

**Proposition 4.19** *A semigroup is simple if and only if it satisfies the identities  $x^{\omega+1} = x$  and  $(xyx)^\omega = x^\omega$ .*

**Proof.** Let  $S$  be a simple semigroup. By Proposition V.3.32,  $S$  has a single  $\mathcal{D}$ -class, which is a union of groups. Let  $x, y \in S$ . One has  $x^{\omega+1} \leq_{\mathcal{H}} x$  and  $(xyx)^\omega \leq_{\mathcal{H}} x$  and hence by Theorem V.1.9 (3) and (4),  $x^{\omega+1} \mathcal{H} x$  and  $(xyx)^\omega \mathcal{H} x^\omega$ . It follows immediately that  $(xyx)^\omega = x^\omega$  since an  $\mathcal{H}$ -class contains a unique idempotent and  $x^{\omega+1} = x$  since  $x^\omega$  is the identity of the  $\mathcal{H}$ -class containing  $x$  and  $x^{\omega+1}$ .

Conversely, suppose that  $S$  satisfies the two identities

$$x^{\omega+1} = x \text{ and } (xyx)^\omega = x^\omega$$

The first identity shows that every element  $x$  is  $\mathcal{H}$ -equivalent to  $x^\omega$  and to  $x^{\omega+1}$  and hence belongs to the maximal group whose identity is  $x^\omega$ . In particular, all the elements of  $S$  are regular. Further, if  $x, y \in S$ , one has  $y \leq_{\mathcal{J}} xyx \leq_{\mathcal{J}} (xyx)^\omega = x^\omega \mathcal{J} x$ . It follows that  $y \leq_{\mathcal{J}} x$  and by duality  $x \leq_{\mathcal{J}} y$ . It follows that all elements of  $S$  are  $\mathcal{J}$ -equivalent.  $\square$

Simple semigroups form a variety of semigroups, usually denoted by  $\mathbf{CS}$ .

## 4.2 Varieties of monoids

### Groups

The next proposition shows that groups form a variety of monoids, denoted by  $\mathbf{G}$ .

**Proposition 4.20** *The class of all groups is a variety of monoids, defined by the identity  $x^\omega = 1$ .*

**Proof.** Finite groups are closed under quotients and finite direct products and it follows from Proposition II.3.13 that a submonoid of a group is a group.

Since a monoid is a group if and only if its unique idempotent is 1, the identity  $x^\omega = 1$  characterises the variety of finite groups.  $\square$

Subvarieties of  $\mathbf{G}$  include the variety  $\mathbf{Gcom}$  of commutative groups and, for each prime number  $p$ , the variety  $\mathbf{G}_p$  of  $p$ -groups. Recall that a group is a  $p$ -group if its order is a power of  $p$ .

### Commutative monoids

A monoid is commutative if and only if it satisfies the identity  $xy = yx$ . Therefore, the commutative monoids form a variety of monoids, denoted by  $\mathbf{Com}$ .

**Proposition 4.21** *Every commutative monoid divides the product of its monogenic submonoids.*

**Proof.** Let  $M$  be a commutative monoid and let  $N$  be the product of its monogenic submonoids. Let  $\varphi : N \rightarrow M$  be the morphism which transforms each element on  $N$  into the product of its coordinates. Then  $\varphi$  is clearly surjective and thus  $M$  is a quotient of  $N$ .  $\square$

### Aperiodic monoids

A monoid  $M$  is *aperiodic* if there is an integer  $n > 0$  such that, for all  $x \in M$ ,  $x^n = x^{n+1}$ . Since we assume finiteness, quantifiers can be inverted in the definition:  $M$  is aperiodic if for each  $x \in M$ , there is an integer  $n > 0$  such that  $x^n = x^{n+1}$ . Other characterisations of aperiodic monoids are given in Proposition 4.22 (see also Proposition V.2.26).

**Proposition 4.22** *Let  $M$  be a finite monoid. The following conditions are equivalent:*

- (1)  $M$  is aperiodic,
- (2)  $M$  is  $\mathcal{H}$ -trivial,
- (3) the groups in  $M$  are trivial.

**Proof.** Let  $n$  be the exponent of  $M$ .

(1) implies (3). Let  $G$  be a group in  $M$  with identity  $e$  and let  $x \in G$ . Then the elements  $x^n = e$  and  $x^{n+1} = ex$  are also in  $G$ . By (1), one gets  $x^n = x^{n+1}$  and thus  $ex = e$ . It follows that  $x = e$  since a group is cancellative. Thus  $G$  is trivial.

(1) implies (2). Suppose  $a \mathcal{H} b$ . Then there exist  $u, v, x, y \in S^1$  such that  $ua = b$ ,  $vb = a$ ,  $ax = b$  and  $by = a$ , whence  $uay = a$  and therefore  $u^n ay^n = a$ . Since  $u^n \mathcal{H} u^{n+1}$ ,  $u^n = u^{n+1}$  and thus  $a = u^n ay^n = u^{n+1} ay^n = u(u^n ay^n) = ua = b$ . Therefore  $M$  is  $\mathcal{H}$ -trivial.

(3) implies (2) follows from the fact that each group in  $M$  is contained in an  $\mathcal{H}$ -class.

(2) implies (1). Let  $x \in M$ . Then the  $\mathcal{H}$ -class of the idempotent  $x^n$  is a group  $G$ , which is trivial by (3). Since  $x^n$  and  $x^{n+1}$  belong to  $G$ , one gets  $x^n = x^{n+1}$ .  $\square$

We denote by  $\mathbf{A}$  the variety of aperiodic monoids. A monoid is *aperiodic* if and only if it satisfies the identity  $x^\omega = x^\omega x$ , which can also be written, by abuse of notation,  $x^\omega = x^{\omega+1}$ .

### $\mathcal{J}$ -trivial, $\mathcal{R}$ -trivial and $\mathcal{L}$ -trivial monoids

We denote by  $\mathbf{J} [\mathbf{R}, \mathbf{L}]$ , the variety of  $\mathcal{J}$ -trivial [ $\mathcal{R}$ -trivial,  $\mathcal{L}$ -trivial] monoids. The identities defining these varieties are given in the next proposition.

**Proposition 4.23** *The following equalities hold*

$$\mathbf{R} = \llbracket (xy)^\omega x = (xy)^\omega \rrbracket$$

$$\mathbf{L} = \llbracket y(xy)^\omega = (xy)^\omega \rrbracket$$

$$\mathbf{J} = \llbracket y(xy)^\omega = (xy)^\omega = (xy)^\omega x \rrbracket = \llbracket x^{\omega+1} = x^\omega, (xy)^\omega = (yx)^\omega \rrbracket$$

Moreover, the identities  $(x^\omega y^\omega)^\omega = (x^\omega y)^\omega = (xy^\omega)^\omega = (xy)^\omega$  are satisfied by  $\mathbf{J}$ .

**Proof.** (1) Let  $M$  be a monoid and let  $x, y \in M$ . If  $\omega$  is interpreted as the exponent of  $M$ , we observe that  $(xy)^\omega x \mathcal{R} (xy)^\omega$  since  $((xy)^\omega x)(y(xy)^\omega)^{\omega-1} = (xy)^{2\omega} = (xy)^\omega$ . Thus if  $M$  is  $\mathcal{R}$ -trivial, the identity  $(xy)^\omega x = (xy)^\omega$  holds in  $M$ .

Conversely, assume that  $M$  satisfies the identity  $(xy)^\omega x = (xy)^\omega$  and let  $u$  and  $v$  be two  $\mathcal{R}$ -equivalent elements of  $M$ . Then, there exist  $x, y \in M$  such that  $ux = v$  and  $vy = u$ . It follows that  $u = uxy = u(xy)^\omega$  and thus  $v = ux = u(xy)^\omega x$ . Now, since  $(xy)^\omega x = (xy)^\omega$ ,  $u = v$  and  $M$  is  $\mathcal{R}$ -trivial.

(2) The proof is dual for the variety  $\mathbf{L}$ .

(3) Since  $\mathbf{J} = \mathbf{R} \cap \mathbf{L}$ , it follows from (1) and (2) that  $\mathbf{J}$  is defined by the identities  $y(xy)^\omega = (xy)^\omega = (xy)^\omega x$ . Taking  $y = 1$ , we obtain  $x^\omega = x^\omega x$  and also  $(xy)^\omega = y(xy)^\omega = (yx)^\omega y = (yx)^\omega$ . Conversely, suppose that a monoid satisfies the identities  $x^{\omega+1} = x^\omega$  and  $(xy)^\omega = (yx)^\omega$ . Then we have  $(xy)^\omega = (yx)^\omega = (yx)^{\omega+1} = y(xy)^\omega x$ , whence  $(xy)^\omega = y^\omega (xy)^\omega x^\omega = y^{\omega+1} (xy)^\omega x^\omega = y(xy)^\omega$  and likewise  $(xy)^\omega = (xy)^\omega x$ .  $\square$

Note that the following inclusions hold:  $\mathbf{J} \subset \mathbf{R} \subset \mathbf{A}$  and  $\mathbf{J} \subset \mathbf{L} \subset \mathbf{A}$ .

### Semilattices

A *semilattice* is an idempotent and commutative monoid. Semilattices form a variety, denoted by  $\mathbf{J}_1$  and defined by the identities  $x^2 = x$  and  $xy = yx$ .

**Proposition 4.24** *The variety  $\mathbf{J}_1$  is generated by the monoid  $U_1$ .*

**Proof.** Proposition 4.21 shows that the variety  $\mathbf{J}_1$  is generated by its monogenic monoids. Now, there are only two monogenic idempotent monoids: the trivial monoid and the monoid  $U_1$  considered in Section 2.2. It follows that  $U_1$  generates  $\mathbf{J}_1$ .  $\square$

Let us also mention a useful property

**Proposition 4.25** *A  $\mathcal{J}$ -trivial idempotent monoid is a semilattice.*

**Proof.** Let  $M$  be a  $\mathcal{J}$ -trivial idempotent monoid. Proposition 4.23 show that  $M$  satisfies the identity  $(xy)^\omega = (yx)^\omega$ . Since  $M$  is idempotent, this identity becomes  $xy = yx$  and thus  $M$  is comutative. Therefore  $M$  is a semilattice.  $\square$

### Idempotent and $\mathcal{R}$ -trivial [ $\mathcal{L}$ -trivial] monoids

Idempotent and  $\mathcal{R}$ -trivial [ $\mathcal{L}$ -trivial] monoids form a variety of monoids, denoted by  $\mathbf{R}_1$  [ $\mathbf{L}_1$ ].

**Proposition 4.26** *The variety  $\mathbf{R}_1$  [ $\mathbf{L}_1$ ] is defined by the identity  $xyx = xy$  [ $xyx = yx$ ].*

**Proof.** We give only the proof for  $\mathbf{R}_1$ , since the case of  $\mathbf{L}_1$  is symmetric.

Let  $M$  be an idempotent and  $\mathcal{R}$ -trivial monoid. Let  $x, y \in M$ . Since  $M$  is idempotent, one gets  $xy = xyxy$  and thus  $xy \mathcal{R} xyx$ . But  $M$  is  $\mathcal{R}$ -trivial and thus  $xy = xyx$ . It follows that  $\mathbf{R}_1$  satisfies the identity  $xy = xyx$ .

Conversely, let  $M$  be a monoid satisfying the identity  $xyx = xy$ . Taking  $y = 1$  gives  $x^2 = x$  and thus  $M$  is idempotent. It follows also that  $M$  satisfies the identity  $(xy)^\omega x = (xy)^\omega$  and hence is  $\mathcal{R}$ -trivial by Proposition 4.23.  $\square$

We shall see later (Proposition IX.1.6) that the variety  $\mathbf{R}_1$  [ $\mathbf{L}_1$ ] is generated by the monoid  $U_2$  [ $\tilde{U}_2$ ].

### The variety $\mathbb{D}\mathbf{S}$

A monoid belongs to the variety  $\mathbb{D}\mathbf{S}$  if each of its regular  $\mathcal{D}$ -class is a semigroup. In this case, every regular  $\mathcal{D}$ -class is completely regular (See Figure V.4.9).

The next proposition gathers various characterisations of  $\mathbb{D}\mathbf{S}$  and shows in particular that  $\mathbb{D}\mathbf{S} = \llbracket ((xy)^\omega (yx)^\omega (xy)^\omega)^\omega = (xy)^\omega \rrbracket$ .

**Proposition 4.27** *Let  $M$  be a monoid. The following conditions are equivalent:*

- (1)  $M$  belongs to  $\mathbb{D}\mathbf{S}$ ,
- (2)  $M$  satisfies the identity  $((xy)^\omega (yx)^\omega (xy)^\omega)^\omega = (xy)^\omega$ ,
- (3) every regular  $\mathcal{H}$ -class of  $M$  is a group,
- (4) if  $s, t \in M$ ,  $s$  is regular and  $s \leq_{\mathcal{J}} t$ , then  $s \mathcal{R} st$  and  $s \mathcal{L} ts$ ,
- (5) for each idempotent  $e \in M$ , the set

$$M_e = \{s \in M \mid e \leq_{\mathcal{J}} s\}$$

is a subsemigroup of  $M$ .

**Proof.** (1) implies (2). Let  $x, y \in M$ . By Proposition V.2.22,  $(xy)^\omega$  and  $(yx)^\omega$  are conjugate idempotents. In particular, they belong to the same  $\mathcal{D}$ -class  $D$ . Since  $M \in \mathbb{DS}$ ,  $D$  is a simple semigroup and by Proposition 4.19, it satisfies the identity  $(xyx)^\omega = x^\omega$ . Therefore, condition (2) is satisfied.

(2) implies (3). Let  $x$  be regular element, let  $D$  be its  $\mathcal{D}$ -class and let  $y$  be an inverse of  $x$ . Then  $e = xy$  and  $f = yx$  are two idempotents of  $D$ . The  $\mathcal{H}$ -class  $H$  of  $x$  is equal to  $R(e) \cap L(f)$ . Further, condition (2) gives  $(efe)^\omega = e$ . It follows that  $ef \mathcal{J} e \mathcal{J} fe$  and hence  $ef$  and  $fe$  also belong to  $D$ . Thus by Theorem V.1.11,  $R(e) \cap L(f)$  contains an idempotent and Proposition V.1.13 shows that  $H$  is a group, which proves (3).

(3) implies (1). Let  $D$  be a regular  $\mathcal{D}$ -class. If each regular  $\mathcal{H}$ -class of  $D$  is a group, then each regular  $\mathcal{H}$ -class contains an idempotent and  $D$  is a semigroup by Theorem V.1.11.

Thus (1), (2) and (3) are equivalent. We now show that (1)–(3) implies (4). Let  $s$  be a regular element of  $M$ . By (3),  $s \mathcal{H} s^\omega$ . If  $s \leq_{\mathcal{J}} t$ , then  $s = xty$  for some  $x, y \in M$ . Now  $(xty)^\omega = ((xty)^\omega(yxt)^\omega(xty)^\omega)^\omega$  and hence  $(xty)^\omega \mathcal{J} t(xty)^\omega$ . It follows that

$$s \mathcal{J} s^\omega = (xty)^\omega \mathcal{J} t(xty)^\omega = ts^\omega \leq_{\mathcal{J}} ts \leq_{\mathcal{J}} s$$

and hence  $s \mathcal{J} ts$ . It follows from Theorem V.1.9 that  $s \mathcal{L} ts$ . Similarly,  $s \mathcal{R} st$ .

(4) implies (3). Condition (4) applied with  $s = t$  shows that, if  $s$  is regular, then  $s \mathcal{R} s^2$  and  $s \mathcal{L} s^2$ . Therefore  $s \mathcal{H} s^2$  and by Proposition V.1.13, the  $\mathcal{H}$ -class of  $s$  is a group, which establishes (3). Thus conditions (1)–(4) are equivalent.

(1)–(4) implies (5). Let  $e$  be an idempotent and let  $s, t \in M_e$ . Then  $e \leq_{\mathcal{J}} s$ ,  $e \leq_{\mathcal{J}} t$  and by (4),  $te \mathcal{L} e$  and  $e \mathcal{R} es$ . Since  $M \in \mathbb{DS}$ , the  $\mathcal{D}$ -class  $D$  of  $e$  is a semigroup. Since  $es, te \in D$ , one gets  $este \in D$  and hence  $e \mathcal{J} este \leq_{\mathcal{J}} st$ . Thus  $st \in M_e$ . This proves (5).

(5) implies (1). Let  $D$  be a regular  $\mathcal{D}$ -class of  $M$  and let  $e$  be an idempotent of  $D$ . If  $s, t \in D$ , then  $s, t \in M_e$  and by (5),  $st \in M_e$ , that is  $e \leq_{\mathcal{J}} st$ . Since  $st \leq_{\mathcal{J}} s \mathcal{J} e$ , one has  $e \mathcal{J} st$  and hence  $st \in D$ .  $\square$

It is also useful to characterise the monoids that are not in  $\mathbb{DS}$ .

**Proposition 4.28** *Let  $M$  be a monoid. The following conditions are equivalent:*

- (1)  $M$  does not belong to  $\mathbb{DS}$ ,
- (2) there exist two idempotents  $e, f \in M$  such that  $e \mathcal{J} f$  but  $ef \not\mathcal{J} e$ ,
- (3)  $B_2^1$  divides  $M \times M$ .

**Proof.** (1) implies (2). If  $M$  does not belong to  $\mathbb{DS}$ ,  $M$  contains a regular  $\mathcal{D}$ -class  $D$  which is not a semigroup. By Proposition V.4.36, one can find two idempotent  $e, f \in D$  such that  $ef \notin D$ .

(2) implies (3). Let  $D$  be the  $\mathcal{D}$ -class of  $e$ . Since  $e \mathcal{J} f$ , Proposition V.2.22 shows that there exist two elements  $s, \bar{s} \in D$  such that  $s\bar{s} = e$  and  $\bar{s}s = f$ . Since  $ef \notin D$ , Theorem V.1.11 shows that  $L(e) \cap R(f)$  contains no idempotent and thus  $\bar{s}^2 \notin D$ . Let  $N$  be the submonoid of  $M \times M$  generated by the elements  $a = (s, \bar{s})$  and  $\bar{a} = (\bar{s}, s)$ . Then  $a$  and  $\bar{a}$  are mutually inverse in  $N$  and the element  $a\bar{a} = (e, f)$  and  $\bar{a}a = (f, e)$  are idempotent. Therefore, the four elements  $a, \bar{a}, a\bar{a}$  and  $\bar{a}a$  form a regular  $\mathcal{D}$ -class  $C$ .

$a$	${}^*a\bar{a}$
${}^*\bar{a}a$	$\bar{a}$

Further,  $aa = (ss, \bar{s}\bar{s})$  and  $bb = (\bar{s}\bar{s}, ss)$ . Since  $\bar{s}^2 \notin D$ , it follows that  $aa$  and  $bb$  are not in  $C$  and in fact  $N - (C \cup \{1\})$  is the ideal of  $N$  consisting of all elements  $x$  such that  $x <_{\mathcal{J}} a$ . It follows that  $N/J$  is isomorphic to  $B_2^1$ , which proves (2).

(3) implies (1). Suppose that  $M \in \mathbb{DS}$ . Since  $\mathbb{DS}$  is a variety of monoids,  $M \times M \in \mathbb{DS}$  and since  $B_1^2$  divides  $M \times M$ ,  $B_1^2$  also belongs to  $\mathbb{DS}$ , a contradiction.  $\square$

**The variety  $\mathbb{DA}$**

A monoid  $M$  belongs to the variety  $\mathbb{DA}$  if each regular  $\mathcal{D}$ -class of  $M$  is an aperiodic semigroup. It is equivalent to require that every regular  $\mathcal{D}$ -class is a rectangular band.

*	*		...		*
*	*		...		*
⋮	⋮		⋮		⋮
*	*		...		*

**Figure 4.2.** A regular  $\mathcal{D}$ -class in a monoid of  $\mathbb{DA}$ .

The next proposition gathers various characterisations of  $\mathbb{DA}$  and shows in particular that  $\mathbb{DA} = \mathbb{DS} \cap \mathbf{A} = \llbracket (xy)^\omega (yx)^\omega (xy)^\omega = (xy)^\omega, x^{\omega+1} = x^\omega \rrbracket$ .

**Proposition 4.29** *Let  $M$  be a monoid. The following conditions are equivalent:*

- (1)  $M$  belongs to  $\mathbb{DA}$ ,
- (2)  $M$  is aperiodic and belongs to  $\mathbb{DS}$ ,
- (3)  $M$  satisfies the identities  $(xy)^\omega (yx)^\omega (xy)^\omega = (xy)^\omega$  and  $x^{\omega+1} = x^\omega$ ,
- (4) for each  $e \in E(M)$  and each  $s \in M$ ,  $e \leq_{\mathcal{J}} s$  implies  $ese = e$ ,
- (5)  $M$  is aperiodic and for each  $e, f \in E(M)$ ,  $e \mathcal{J} f$  implies  $efe = e$ .

**Proof.** We prove (3)  $\Rightarrow$  (2)  $\Rightarrow$  (1)  $\Rightarrow$  (4)  $\Rightarrow$  (5)  $\Rightarrow$  (3) in this order.

(3) implies (2) follows from Proposition 4.27.

(2) implies (1). If  $M \in \mathbb{DS}$ , each regular  $\mathcal{D}$ -class is completely regular and hence is a simple semigroup. Further, if  $M$  is aperiodic, each regular  $\mathcal{D}$ -class is a simple aperiodic semigroup and hence is idempotent by Corollary V.3.34.

(1) implies (4). Let  $M \in \mathbb{DA}$ . Let  $e \in E(M)$  and  $s \in M$  be such that  $e \leq_{\mathcal{J}} s$ . Since  $M \in \mathbb{DS}$ , Proposition 4.27 (4) shows the set  $M_e = \{x \in M \mid e \leq_{\mathcal{J}} x\}$  is a subsemigroup of  $M$ . Since  $s$  and  $e$  belong to  $M_e$ , one also has  $ese \in M_e$ , and hence  $e \leq_{\mathcal{J}} ese$ . Since  $ese \leq_{\mathcal{J}} e$  one gets finally  $ese \mathcal{J} e$ . But each regular  $\mathcal{D}$ -class of  $M$  is a rectangular band, and thus  $ese = e$ .

(4) implies (5). For each  $x \in M$ , one has  $x^\omega \leq_{\mathcal{J}} x$ , and thus by (4),  $x^{\omega+1} = x^\omega$ . Therefore  $M$  is aperiodic. Further if  $e$  and  $f$  are two  $\mathcal{J}$ -equivalent idempotents of  $M$ , then  $e \leq_{\mathcal{J}} f$  and by (4),  $efe = e$ .

(5) implies (3). Suppose that  $M$  satisfies (5). Then  $M$  is aperiodic and satisfies the identity  $x^{\omega+1} = x^\omega$ . Further if  $x, y \in M$ , the elements  $(xy)^\omega$  and  $(yx)^\omega$  are two conjugate idempotents, which are  $\mathcal{J}$ -equivalent by Proposition V.2.22. It follows that  $(xy)^\omega(yx)^\omega(xy)^\omega = (xy)^\omega$ .  $\square$

### 4.3 Varieties of ordered monoids

A nilpotent ordered semigroup is *positive* [*negative*] if it satisfies the identity  $x^\omega \leq y$  [ $y \leq x^\omega$ ]. Positive [negative] nilpotent ordered semigroups form a variety, denoted by  $\mathbf{N}^+$  [ $\mathbf{N}^-$ ], and defined by the identities  $yx^\omega = x^\omega = x^\omega y$  and  $x^\omega \leq y$  [ $yx^\omega = x^\omega = x^\omega y$  and  $y \leq x^\omega$ ].

We denote by  $\mathbf{J}_1^+$  [ $\mathbf{J}_1^-$ ] the variety of ordered monoids defined by the identities  $x^2 = x$ ,  $xy = yx$  and  $x \leq 1$  [ $1 \leq x$ ]. Proposition 4.24 can be readily adapted to the ordered case.

**Proposition 4.30** *The variety  $\mathbf{J}_1^+$  [ $\mathbf{J}_1^-$ ] is generated by the monoid  $U_1^+$  [ $U_1^-$ ].*

We denote by  $\mathbf{J}^+$  [ $\mathbf{J}^-$ ] the variety of ordered monoids defined by the identity  $x \leq 1$  [ $1 \leq x$ ]. The notation is justified by the following result.

**Proposition 4.31** *An ordered monoid satisfying the identity  $x \leq 1$  [ $1 \leq x$ ] is  $\mathcal{J}$ -trivial.*

**Proof.** Recall that the profinite word  $x^\omega$  is defined as the limit of the sequence  $x^{n!}$ . Similarly, the profinite word  $x^{\omega-1}$  is defined as the limit of the sequence  $x^{n!-1}$ . It follows that  $(xy)^\omega = (xy)^\omega(xy)^\omega = (xy)^\omega x(yx)^{\omega-1}y$ .

Let  $M$  be an ordered monoid satisfying the identity  $x \leq 1$ . This identity gives  $(yx)^{\omega-1}y \leq 1$  and thus  $(xy)^\omega = (xy)^\omega x(yx)^{\omega-1}y \leq (xy)^\omega x \leq (xy)^\omega$ . Therefore,  $M$  satisfies the identities  $(xy)^\omega x = (xy)^\omega$  and, by a dual argument,  $y(xy)^\omega = (xy)^\omega$ . It follows by Proposition 4.23 that  $M$  is  $\mathcal{J}$ -trivial.  $\square$

A locally positive  $\mathcal{J}$ -trivial is an ordered semigroup  $S$  such that, for each idempotent  $e \in S$ , the ordered semigroup  $eSe$  is positive  $\mathcal{J}$ -trivial. Locally positive  $\mathcal{J}$ -trivial semigroups form a variety of ordered semigroups, denoted by  $\mathbb{L}\mathbf{J}^+$  and defined by the identity  $\llbracket x^\omega y x^\omega \leq x^\omega \rrbracket$ . This variety plays a crucial role in the study of the polynomial closure (see Chapter XII).

### 4.4 Summary

We summarize in the next table the varieties defined so far.

<b>G</b>	Groups	$\llbracket x^\omega = 1 \rrbracket$
<b>Com</b>	Commutative monoids	$\llbracket xy = yx \rrbracket$
<b>J</b>	$\mathcal{J}$ -trivial monoids	$\llbracket y(xy)^\omega = (xy)^\omega = (xy)^\omega x \rrbracket$
<b>R</b>	$\mathcal{R}$ -trivial monoids	$\llbracket (xy)^\omega x = (xy)^\omega \rrbracket$
<b>L</b>	$\mathcal{L}$ -trivial monoids	$\llbracket y(xy)^\omega = (xy)^\omega \rrbracket$
<b>J<sub>1</sub></b>	Semilattices	$\llbracket x^2 = x, xy = yx \rrbracket$
<b>R<sub>1</sub></b>	Idempotent and $\mathcal{R}$ -trivial	$\llbracket xyx = xy \rrbracket$
<b>L<sub>1</sub></b>	Idempotent and $\mathcal{L}$ -trivial	$\llbracket xyx = yx \rrbracket$
<b>A</b>	Aperiodic monoids	$\llbracket x^{\omega+1} = x^\omega \rrbracket$
<b>DA</b>	Regular $\mathcal{D}$ -classes are aperiodic semigroups	$\llbracket (xy)^\omega (yx)^\omega (xy)^\omega = (xy)^\omega, x^{\omega+1} = x^\omega \rrbracket$
<b>DS</b>	Regular $\mathcal{D}$ -classes are semigroups	$\llbracket ((xy)^\omega (yx)^\omega (xy)^\omega)^\omega = (xy)^\omega \rrbracket$

Notation	Name	Profinite identities
<b>N</b>	Nilpotent semigroups	$\llbracket yx^\omega = x^\omega = x^\omega y \rrbracket$
<b>ℓ1 or K</b>	Lefty trivial semigroups	$\llbracket x^\omega y = x^\omega \rrbracket$
<b>r1 or D</b>	Righty trivial semigroups	$\llbracket yx^\omega = x^\omega \rrbracket$
<b>L1</b>	Locally trivial semigroups	$\llbracket x^\omega yx^\omega = x^\omega \rrbracket$
<b>LG</b>	Locally groups	$\llbracket (x^\omega yx^\omega)^\omega = x^\omega \rrbracket$
<b>CS</b>	Simple semigroups	$\llbracket x^{\omega+1} = x, (xyx)^\omega = x^\omega \rrbracket$
<b>N<sup>+</sup></b>	Positive nilpotent	$\llbracket yx^\omega = x^\omega = x^\omega y, x^\omega \leq y \rrbracket$
<b>N<sup>-</sup></b>	Negative nilpotent	$\llbracket yx^\omega = x^\omega = x^\omega y, y \leq x^\omega \rrbracket$
<b>J<sub>1</sub><sup>+</sup></b>	Positive semilattices	$\llbracket x^2 = x, xy = yx, x \leq 1 \rrbracket$
<b>J<sub>1</sub><sup>-</sup></b>	Negative semilattices	$\llbracket x^2 = x, xy = yx, 1 \leq x \rrbracket$
<b>J<sup>+</sup></b>	Positive $\mathcal{J}$ -trivial	$\llbracket x \leq 1 \rrbracket$
<b>J<sup>-</sup></b>	Negative $\mathcal{J}$ -trivial	$\llbracket 1 \leq x \rrbracket$
<b>LJ<sup>+</sup></b>	Locally positive $\mathcal{J}$ -trivial	$\llbracket x^\omega yx^\omega \leq x^\omega \rrbracket$

## 5 Exercises

In Exercises 1 and 2, we exceptionally consider infinite monoids.

**1.** A *Birkhoff variety* of monoids is a class  $\mathbf{V}$  of (possibly infinite) monoids such that:

- (1) if  $S \in \mathbf{V}$  and if  $T$  is a submonoid of  $S$ , then  $S \in \mathbf{V}$ ,
- (2) if  $S \in \mathbf{V}$  and if  $T$  is a quotient of  $S$ , then  $S \in \mathbf{V}$ ,



- (3) if  $(S_i)_{i \in I}$  is a (possibly infinite) family of monoids of  $\mathbf{V}$ , the product  $\prod_{i \in I} S_i$  is also in  $\mathbf{V}$ .

Show that the class of all commutative monoids forms a Birkhoff variety, but that the class of all groups does not (consider the submonoid  $\mathbb{N}$  of  $\mathbb{Z}$ ).

- 2.** Let  $A$  be an alphabet and let  $u, v \in A^*$ . A monoid  $M$  satisfies the identity  $u = v$  if and only if, for each monoid morphism  $\varphi : A^* \rightarrow M$ ,  $\varphi(u) = \varphi(v)$ .

Show that a class of monoids is a Birkhoff variety if and only if it can be defined by a set of identities (Birkhoff's theorem). Birkhoff's theorem can be extended to any variety of algebras, including semigroups, ordered semigroups and ordered monoids.

We are now back with the usual convention of this chapter: semigroups are either finite or free.

- 3.** Let  $\mathbf{G}_S$  be the variety of *semigroups* generated by all groups. Show that  $\mathbf{G}_S = \llbracket x^\omega y = yx^\omega = y \rrbracket$ .

- 4.** Show that the variety  $\mathbf{N}$  is defined by the identity  $yx^\omega z = x^\omega$ . Show that the group  $\mathbb{Z}/2\mathbb{Z}$  satisfies the semigroup identity  $yx^\omega y = x^\omega$ . Conclude that this identity does not define  $\mathbf{N}$ .

- 5.** Let  $\mathbf{V}$  be a variety of [ordered] monoids. A semigroup  $S$  is *locally*  $\mathbf{V}$  if, for every idempotent  $e$  of  $S$ , the [ordered] semigroup  $eSe$  belongs to  $\mathbf{V}$ . Show that the locally  $\mathbf{V}$  [ordered] semigroups form a variety of [ordered] semigroups, denoted by  $\mathbb{L}\mathbf{V}$ .

- 6.** Let  $\mathbf{V}$  be the variety of monoids. Given a monoid  $M$ , denote by  $\langle E(M) \rangle$  the submonoid of  $M$  generated by the idempotents of  $M$ . Show that the monoids  $M$  such that  $\langle E(M) \rangle$  belongs to  $\mathbf{V}$  form a variety of monoids, denoted by  $\mathbb{E}\mathbf{V}$ .



# Chapter VIII

## Equations and languages

In this chapter, we show how profinite words can be used to give algebraic descriptions of certain classes of regular languages. Examples are deferred to the next chapter.

### 1 Equations

Formally, a *profinite equation* is a pair  $(u, v)$  of profinite words of  $\widehat{A^*}$ . We also use the term *explicit equation* when both  $u$  and  $v$  are words of  $A^*$ . We say that a recognisable language  $L$  of  $A^*$  *satisfies the profinite equation*  $u \rightarrow v$  (or  $v \leftarrow u$ ) if the condition  $u \in \bar{L}$  implies  $v \in \bar{L}$ .

Proposition VI.3.13 gives immediately some equivalent definitions:

**Corollary 1.1** *Let  $L$  be a recognisable language of  $A^*$ , let  $\eta$  be its syntactic morphism and let  $\varphi$  be any morphism onto a finite monoid recognising  $L$ . The following conditions are equivalent:*

- (1)  $L$  satisfies the equation  $u \rightarrow v$ ,
- (2)  $\widehat{\eta}(u) \in \eta(L)$  implies  $\widehat{\eta}(v) \in \eta(L)$ ,
- (3)  $\widehat{\varphi}(u) \in \varphi(L)$  implies  $\widehat{\varphi}(v) \in \varphi(L)$ .

### 2 Equational characterisation of lattices

Given a set  $E$  of equations of the form  $u \rightarrow v$ , the subset of  $\text{Rec}(A^*)$  defined by  $E$  is the set of all recognisable languages of  $A^*$  satisfying all the equations of  $E$ .

A *lattice of languages* of  $A^*$  is a set of recognisable languages of  $A^*$  containing the empty language  $\emptyset$ , the full language  $A^*$  and which is closed under finite union and finite intersection.

**Proposition 2.2** *The set of recognisable languages of  $A^*$  defined by a set of equations form a lattice of languages.*

**Proof.** Let  $E$  be a set of equations and let  $\mathcal{L}$  be the class of languages of  $A^*$  defined by  $E$ . We claim that  $\mathcal{L}$  is a lattice. First, it is clear that the empty language and the full language  $A^*$  satisfy any equation of the form  $u \rightarrow v$ . Therefore, these two languages are in  $\mathcal{L}$ .

Let now  $L_1$  and  $L_2$  be languages of  $\mathcal{L}$  and let  $u \rightarrow v$  be an equation of  $E$ . Then, for  $i = 1, 2$ , the condition  $u \in \overline{L}_i$  implies  $v \in \overline{L}_i$ . Recall that, by Theorem VI.3.14, one has  $\overline{L_1 \cup L_2} = \overline{L_1} \cup \overline{L_2}$  and  $\overline{L_1 \cap L_2} = \overline{L_1} \cap \overline{L_2}$ . Suppose that  $u \in \overline{L_1 \cup L_2}$ . Then either  $u \in \overline{L_1}$  or  $u \in \overline{L_2}$  and thus either  $v \in \overline{L_1}$  or  $v \in \overline{L_2}$  and finally  $v \in \overline{L_1 \cup L_2}$ . Similarly, if  $u \in \overline{L_1 \cap L_2}$ , then  $u \in \overline{L_1}$  and  $u \in \overline{L_2}$ , whence  $v \in \overline{L_1}$  and  $v \in \overline{L_2}$  and finally  $v \in \overline{L_1 \cap L_2}$ .

It follows that  $L_1 \cap L_2$  and  $L_1 \cup L_2$  satisfy all the equations of  $E$  and thus  $\mathcal{L}$  is a lattice of languages.  $\square$

Our aim is now to show that the converse of Proposition 2.2 also holds. We start with a result on languages interesting on its own right. Note in particular that there is no assumption on the languages in this proposition.

**Proposition 2.3** *Let  $L, L_1, \dots, L_n$  be languages. If  $L$  satisfies all the explicit equations satisfied by  $L_1, \dots, L_n$ , then  $L$  belongs to the lattice of languages generated by  $L_1, \dots, L_n$ .*

**Proof.** We claim that

$$L = \bigcup_{I \in \mathcal{I}} \bigcap_{i \in I} L_i \quad (2.1)$$

where  $\mathcal{I}$  is the set of all subsets  $I$  of  $\{1, \dots, n\}$  for which there exists a word  $v \in L$  such that  $v \in L_i$  if and only if  $i \in I$ .

Let  $R$  be the right member of (2.1). If  $u \in L$ , let  $I = \{i \mid u \in L_i\}$ . By construction,  $I \in \mathcal{I}$  and  $u \in \bigcap_{i \in I} L_i$ . Thus  $u \in R$ . This proves the inclusion  $L \subseteq R$ .

To prove the opposite direction, consider a word  $u \in R$ . By definition, there exists a set  $I \in \mathcal{I}$  such that  $u \in \bigcap_{i \in I} L_i$  and a word  $v \in L$  such that  $v \in L_i$  if and only if  $i \in I$ . We claim that the equation  $v \rightarrow u$  is satisfied by each language  $L_i$ . Indeed, if  $i \in I$ , then  $u \in L_i$  by definition. If  $i \notin I$ , then  $v \notin L_i$  by definition of  $I$ , which proves the claim. It follows that  $v \rightarrow u$  is also satisfied by  $L$ . Since  $v \in L$ , it follows that  $u \in L$ . This concludes the proof of (2.1) and shows that  $L$  belongs to the lattice of languages generated by  $L_1, \dots, L_n$ .  $\square$

An important consequence of Proposition 2.3 is that finite lattices of languages can be defined by explicit equations.

**Corollary 2.4** *A finite set of languages of  $A^*$  is a lattice of languages if and only if it can be defined by a set of explicit equations of the form  $u \rightarrow v$ , where  $u, v \in A^*$ .*

**Proof.** Proposition 2.2 shows that a set of recognisable languages defined by a set of equations form a lattice of languages.

To prove the opposite direction, consider a finite lattice  $\mathcal{L}$  of languages and let  $E$  be the set of explicit equations satisfied by all the languages of  $\mathcal{L}$ . Proposition 2.3 shows that any language  $L$  that satisfies the equations of  $E$  belongs to  $\mathcal{L}$ . Thus  $\mathcal{L}$  is defined by  $E$ .  $\square$

We now are now ready for the main result.

**Theorem 2.5** *A set of recognisable languages of  $A^*$  is a lattice of languages if and only if it can be defined by a set of equations of the form  $u \rightarrow v$ , where  $u, v \in \widehat{A^*}$ .*

**Proof.** For each recognisable language  $L$ , set

$$E_L = \{(u, v) \in \widehat{A^*} \times \widehat{A^*} \mid L \text{ satisfies } u \rightarrow v\}$$

**Lemma 2.6** *For each recognisable language  $L$ ,  $E_L$  is a clopen subset of  $\widehat{A^*} \times \widehat{A^*}$ .*

**Proof.** One has

$$\begin{aligned} E_L &= \{(u, v) \in \widehat{A^*} \times \widehat{A^*} \mid L \text{ satisfies } u \rightarrow v\} \\ &= \{(u, v) \in \widehat{A^*} \times \widehat{A^*} \mid u \in \overline{L} \text{ implies } v \in \overline{L}\} \\ &= \{(u, v) \in \widehat{A^*} \times \widehat{A^*} \mid v \in \overline{L} \text{ or } u \notin \overline{L}\} \\ &= (\overline{L}^c \times \widehat{A^*}) \cup (\widehat{A^*} \times \overline{L}) \end{aligned}$$

The result follows since, by Proposition VI.3.12,  $\overline{L}$  is clopen.  $\square$

Let  $\mathcal{L}$  be a lattice of languages and let  $E$  be the set of profinite equations satisfied by all languages of  $\mathcal{L}$ . We claim that  $E$  defines  $\mathcal{L}$ . First, by definition, every language of  $\mathcal{L}$  satisfies the equations of  $E$ . It just remains to prove that if a language  $L$  satisfies the equations of  $E$ , then  $L$  belongs to  $\mathcal{L}$ .

First observe that the set

$$\{E_L\} \cup \{E_K^c \mid K \in \mathcal{L}\}$$

is a covering of  $\widehat{A^*} \times \widehat{A^*}$ . Indeed, if  $(u, v) \notin \cup_{K \in \mathcal{L}} E_K^c$ , then  $(u, v) \in \cap_{K \in \mathcal{L}} E_K$ , which means that  $u \rightarrow v$  is an equation satisfied by all languages of  $\mathcal{L}$ . It follows that  $L$  also satisfies this equation, and thus  $(u, v) \in E_L$ . Further, Lemma 2.6 shows that the elements of this covering are open sets. Since  $\widehat{A^*} \times \widehat{A^*}$  is compact, it admits a finite subcovering, and we may assume that this covering contains  $E_L$  and is equal to

$$\{E_L\} \cup \{E_{L_1}^c, \dots, E_{L_n}^c\}$$

for some languages  $L_1, \dots, L_n$  of  $\mathcal{L}$ . By the same argument as above, it follows that if an equation  $u \rightarrow v$  is satisfied by  $L_1, \dots, L_n$ , then it is satisfied by  $L$ . By Proposition 2.3,  $L$  belongs to the lattice of languages generated by  $L_1, \dots, L_n$  and hence belongs to  $\mathcal{L}$ .  $\square$

Writing  $u \leftrightarrow v$  for  $(u \rightarrow v \text{ and } v \rightarrow u)$ , we get an equational description of the Boolean algebras of languages.

**Corollary 2.7** *A set of recognisable languages of  $A^*$  is a Boolean algebra of languages if and only if it can be defined by a set of equations of the form  $u \leftrightarrow v$ , where  $u, v \in \widehat{A^*}$ .*

We now specialize Theorem 2.5 and Corollary 2.7 to interesting subcases. We consider lattices of languages closed under quotient in Section 3, streams of languages in Section 4,  $\mathcal{C}$ -streams in Section 5 and varieties of languages in Section 6.

### 3 Lattices of languages closed under quotients

We say that a class  $\mathcal{L}$  of recognisable languages is a *lattice of languages closed under quotients* if for every  $L \in \mathcal{L}$  and  $u \in A^*$ ,  $u^{-1}L$  and  $Lu^{-1}$  are also in  $\mathcal{L}$ .

Let  $u$  and  $v$  be two profinite words of  $\widehat{A^*}$ . We say that  $L$  *satisfies the equation*  $u \leq v$  if, for all  $x, y \in \widehat{A^*}$ , it satisfies the equation  $xuy \rightarrow xvy$ . Since  $A^*$  is dense in  $\widehat{A^*}$ , it is equivalent to state that  $L$  satisfies these equations only for all  $x, y \in A^*$ . But there is a much more convenient characterisation using the syntactic ordered monoid of  $L$ .

**Proposition 3.8** *Let  $L$  be a recognisable language of  $A^*$ , let  $(M, \leq_L)$  be its syntactic ordered monoid and let  $\eta : A^* \rightarrow M$  be its syntactic morphism. Then  $L$  satisfies the equation  $u \leq v$  if and only if  $\widehat{\eta}(u) \leq_L \widehat{\eta}(v)$ .*

**Proof.** Corollary 1.1 shows that  $L$  satisfies the equation  $u \leq v$  if and only if, for every  $x, y \in A^*$ ,  $\widehat{\eta}(xvy) \in \eta(L)$  implies  $\widehat{\eta}(xvy) \in \eta(L)$ . Since  $\widehat{\eta}(xuy) = \widehat{\eta}(x)\widehat{\eta}(u)\widehat{\eta}(y) = \eta(x)\widehat{\eta}(u)\eta(y)$  and since  $\eta$  is surjective, this is equivalent to saying that, for all  $s, t \in M$ ,  $s\widehat{\eta}(u)t \in \eta(L)$  implies  $s\widehat{\eta}(v)t \in \eta(L)$ , which exactly means that  $\widehat{\eta}(u) \leq_L \widehat{\eta}(v)$ .  $\square$

We can now state the equational characterisation of lattices of languages closed under quotients.

**Theorem 3.9** *A set of recognisable languages of  $A^*$  is a lattice of languages closed under quotients if and only if it can be defined by a set of equations of the form  $u \leq v$ , where  $u, v \in \widehat{A^*}$ .*

**Proof.** Let  $L$  be a recognisable language satisfying the equation  $u \leq v$  and let  $x, y \in A^*$ . Since  $L$  satisfies the equation  $xuy \rightarrow xvy$ , the condition  $xuy \in \overline{L}$  implies  $xvy \in \overline{L}$  and hence  $u \in x^{-1}\overline{L}y^{-1}$  implies  $v \in x^{-1}\overline{L}y^{-1}$ . Since  $x^{-1}\overline{L}y^{-1} = x^{-1}Ly^{-1}$  by Proposition VI.3.15, the language  $x^{-1}Ly^{-1}$  satisfies the equation  $u \leq v$ . It follows that the set of recognisable languages defined by a set of equations of the form  $u \leq v$  is a lattice of languages closed under quotients.

In the opposite direction, let  $\mathcal{L}$  be a lattice of languages of  $A^*$  closed under quotients. By Theorem 2.5,  $\mathcal{L}$  can be defined by a set  $E$  of equations of the form  $u \rightarrow v$ , where  $u, v \in \widehat{A^*}$ . Let now  $u \rightarrow v$  be an equation of  $E$ ,  $L$  a language of  $\mathcal{L}$  and  $x, y$  two words of  $A^*$ . Since  $\mathcal{L}$  is closed under quotient,  $x^{-1}Ly^{-1}$  belongs to  $\mathcal{L}$  and thus satisfies also the equation  $u \rightarrow v$ . It follows that  $L$  satisfies the equation  $xuy \rightarrow xvy$  and hence  $L$  satisfies the equation  $u \leq v$ . It follows that  $\mathcal{L}$  is defined by the equations of the form  $u \leq v$  where  $u \rightarrow v$  is an equation of  $E$ .  $\square$

Theorem 3.9 can be readily extended to Boolean algebras. Let  $u$  and  $v$  be two profinite words. We say that a recognisable language  $L$  *satisfies the equation*  $u = v$  if it satisfies the equations  $u \leq v$  and  $v \leq u$ . Proposition 3.8 now gives immediately:

**Proposition 3.10** *Let  $L$  be a recognisable language of  $A^*$  and let  $\eta$  be its syntactic morphism. Then  $L$  satisfies the equation  $u = v$  if and only if  $\widehat{\eta}(u) = \widehat{\eta}(v)$ .*

This leads to the following equational description of Boolean algebras of languages closed under quotients.

**Corollary 3.11** *A set of recognisable languages of  $A^*$  is a Boolean algebra of languages closed under quotients if and only if it can be defined by a set of equations of the form  $u = v$ , where  $u, v \in \widehat{A}^*$ .*

## 4 Streams of languages

A *class of recognisable languages* is a correspondence  $\mathcal{F}$  which associates with each alphabet  $A$  a set  $\mathcal{F}(A^*)$  of recognisable languages of  $A^*$  in such a way that, if  $\sigma : A \rightarrow B$  is a bijection, a language  $L$  belongs to  $\mathcal{F}(A^*)$  if and only if  $\sigma(L)$  belongs to  $\mathcal{F}(B^*)$ . It follows that, if we fix for each nonnegative integer  $n$  an alphabet  $A_n = \{a_1, \dots, a_n\}$ , the class  $\mathcal{F}$  is completely determined by the family  $(\mathcal{F}(A_n^*))_{n \in \mathbb{N}}$ .

We use here the terms *class* and *correspondence* instead of *set* and *function* to avoid any paradox of set theory, since it is known, for instance, that the finite sets do not form a set. However, we shall use the term “bijection” instead of “one-to-one and onto correspondence”.

A *positive stream of languages* is a class of recognisable languages  $\mathcal{V}$  such that

- (1) for each alphabet  $A$ ,  $\mathcal{V}(A^*)$  is a lattice of languages,
- (2) for each morphism of monoid  $\varphi : A^* \rightarrow B^*$ ,  $X \in \mathcal{V}(B^*)$  implies  $\varphi^{-1}(X) \in \mathcal{V}(A^*)$ ,

A *stream of languages* is a positive stream of languages closed under complementation. This amounts replacing (1) by (1') in the previous definition

- (1') for each alphabet  $A$ ,  $\mathcal{V}(A^*)$  is a Boolean algebra.

In the sequel, we fix for each nonnegative integer  $n$  an alphabet  $A_n = \{a_1, \dots, a_n\}$ . Let  $u$  and  $v$  be two profinite words of  $\widehat{A}_n^*$  and let  $L$  be a recognisable language of  $A^*$ . One says that  $L$  *satisfies the profinite identity*  $u \rightarrow v$  [ $u \leftrightarrow v$ ] if, for each morphism  $\gamma : A_n^* \rightarrow A^*$ ,  $L$  satisfies the equation  $\widehat{\gamma}(u) \rightarrow \widehat{\gamma}(v)$  [ $\widehat{\gamma}(u) \leftrightarrow \widehat{\gamma}(v)$ ]. The next proposition gives an alternative definition.

**Proposition 4.12** *Let  $L$  be a recognisable language of  $A^*$  and let  $\varphi : A^* \rightarrow M$  be any surjective morphism onto a finite monoid recognising  $L$ . Then  $L$  satisfies the profinite identity  $u \rightarrow v$ , where  $u, v \in \widehat{A}_n^*$ , if and only if, for every morphism  $\alpha : A_n^* \rightarrow M$ ,  $\widehat{\alpha}(u) \in \varphi(L)$  implies  $\widehat{\alpha}(v) \in \varphi(L)$ .*

**Proof.** Suppose that, for every morphism  $\alpha : A_n^* \rightarrow M$ ,  $\widehat{\alpha}(u) \in \varphi(L)$  implies  $\widehat{\alpha}(v) \in \varphi(L)$ . If  $\gamma : A_n^* \rightarrow A^*$  is a morphism, then  $\widehat{\varphi}(\widehat{\gamma}(u)) \in \varphi(L)$  implies  $\widehat{\varphi}(\widehat{\gamma}(v)) \in \varphi(L)$  and thus  $L$  satisfies the equation  $\widehat{\gamma}(u) \rightarrow \widehat{\gamma}(v)$ .

In the opposite direction, suppose that  $L$  satisfies the profinite identity  $u \rightarrow v$  and let  $\alpha : A_n^* \rightarrow M$  be a morphism. By Corollary II.5.30, there is a morphism  $\gamma : A_n^* \rightarrow A^*$  such that  $\varphi \circ \gamma = \alpha$ . Now  $L$  satisfies the equation  $\widehat{\gamma}(u) \rightarrow \widehat{\gamma}(v)$  and thus, by Corollary 1.1,  $\widehat{\varphi}(\widehat{\gamma}(u)) \in \varphi(L)$  implies  $\widehat{\varphi}(\widehat{\gamma}(v)) \in \varphi(L)$ . Since  $\widehat{\varphi} \circ \widehat{\gamma} = \widehat{\alpha}$ , one gets  $\widehat{\alpha}(u) \in \varphi(L)$  implies  $\widehat{\alpha}(v) \in \varphi(L)$ .  $\square$

**Theorem 4.13** *A class of recognisable languages of  $A^*$  is a positive stream of languages if and only if it can be defined by a set of profinite identities of the form  $u \rightarrow v$ . It is a stream of languages if and only if it can be defined by a set of profinite identities of the form  $u \leftrightarrow v$ .*

Before proving this theorem, let us clarify one point: the identities defining a stream are not necessarily on the same alphabet.

**Proof.** Let  $\mathcal{V}$  be a class of languages defined by a set  $E$  of profinite identities of the form  $u \rightarrow v$ . For each  $n$ , let  $E_n$  be the set of all identities  $u \rightarrow v$  of  $E$  such that  $u, v \in \widehat{A}_n^*$ . By definition,  $\mathcal{V}(A^*)$  is the set of languages satisfying all the equations of the form  $\gamma(u) \rightarrow \gamma(v)$ , where  $(u, v) \in E_n$  for some  $n$  and  $\gamma : A_n^* \rightarrow A^*$  is a morphism. In particular, Theorem 3.9 shows that  $\mathcal{V}(A^*)$  is a lattice of languages.

To prove that  $\mathcal{V}$  is a positive stream of languages, it remains proving that it is closed under inverse of morphisms. Let  $\varphi : A^* \rightarrow B^*$  be a morphism and let  $L \in \mathcal{V}(B^*)$ . We claim that  $\varphi^{-1}(L)$  satisfies all the identities of  $E$ . Indeed, let  $(u, v) \in E_n$  and let  $\gamma : A_n^* \rightarrow B^*$  be a morphism. We want to show that  $\varphi^{-1}(L)$  satisfies the equation  $\widehat{\gamma}(u) \rightarrow \widehat{\gamma}(v)$ . Suppose that  $\widehat{\gamma}(u) \in \overline{\varphi^{-1}(L)}$ . Since Proposition VI.3.16 states that  $\overline{\varphi^{-1}(L)} = \widehat{\varphi^{-1}(L)}$ , one gets  $\widehat{\varphi}(\widehat{\gamma}(u)) \in \overline{L}$ . Since  $\widehat{\varphi} \circ \widehat{\gamma} = \widehat{\varphi \circ \gamma}$ , we finally get  $\widehat{\varphi \circ \gamma}(u) \in \overline{L}$ . Now, as  $L$  satisfies the identity  $u \rightarrow v$ , one obtains  $\widehat{\varphi \circ \gamma}(v) \in \overline{L}$ , which, by the same argument in reverse order, implies that  $\widehat{\gamma}(v) \in \overline{\varphi^{-1}(L)}$ . This proves that  $\varphi^{-1}(L)$  satisfies the equation  $\widehat{\gamma}(u) \rightarrow \widehat{\gamma}(v)$  and thereby the identity  $u \rightarrow v$ . This validates the claim and confirms that  $\varphi^{-1}(L)$  belongs to  $\mathcal{V}(A^*)$ . Therefore  $\mathcal{V}$  is a positive stream of languages.

Let now  $\mathcal{V}$  be a positive stream of languages. Then, for each  $n$ , the set  $\mathcal{V}(A_n^*)$  is a lattice of languages and by Theorem 2.5, it is defined by a set  $E_n$  of profinite equations of the form  $u \rightarrow v$ , with  $u, v \in \widehat{A}_n^*$ . We claim that these equations are actually identities satisfied by  $\mathcal{V}$ . Let  $\gamma : A_n^* \rightarrow A^*$  be a morphism and let  $u \rightarrow v$  be an equation of  $E_n$ . If  $L \in \mathcal{V}(A^*)$ , then  $\gamma^{-1}(L) \in \mathcal{V}(A_n^*)$  and thus  $\gamma^{-1}(L)$  satisfies the equation  $u \rightarrow v$ . Thus  $u \in \gamma^{-1}(L)$  implies  $v \in \gamma^{-1}(L)$ . Now, Proposition VI.3.16 shows that  $\overline{\gamma^{-1}(L)} = \widehat{\gamma^{-1}(L)}$  and thereby, the conditions  $x \in \overline{\gamma^{-1}(L)}$  and  $\widehat{\gamma}(x) \in \overline{L}$  are equivalent. Thus  $\widehat{\gamma}(u) \in \overline{L}$  implies  $\widehat{\gamma}(v) \in \overline{L}$ , which means that  $L$  satisfies the equation  $\widehat{\gamma}(u) \rightarrow \widehat{\gamma}(v)$ . Therefore  $u \rightarrow v$  is an identity of  $\mathcal{V}$ . It follows that  $\mathcal{V}$  is defined by a set of identities of the form  $u \rightarrow v$ .  $\square$

## 5 $\mathcal{C}$ -streams

Let  $\mathcal{C}$  be a class of morphisms between finitely generated free monoids that satisfies the following properties :

- (1)  $\mathcal{C}$  is closed under composition. That is, if  $A, B$  and  $C$  are finite alphabets, and  $f : A^* \rightarrow B^*$  and  $g : B^* \rightarrow C^*$  are elements of  $\mathcal{C}$ , then  $g \circ f$  belongs to  $\mathcal{C}$ .
- (2)  $\mathcal{C}$  contains all length-preserving morphisms.

Examples include the classes of all *length-preserving* morphisms (morphisms for which the image of each letter is a letter), of all *length-multiplying* morphisms (morphisms such that, for some integer  $k$ , the length of the image of a word is  $k$  times the length of the word), all *non-erasing* morphisms (morphisms for which the image of each letter is a nonempty word), all *length-decreasing* morphisms (morphisms for which the image of each letter is either a letter of the empty word) and all morphisms.

A *positive  $\mathcal{C}$ -stream of languages* is a class of recognisable languages  $\mathcal{V}$  such that :



- (1) for every alphabet  $A$ ,  $\mathcal{V}(A^*)$  is a lattice of languages,
- (2) if  $\varphi: A^* \rightarrow B^*$  is a morphism of  $\mathcal{C}$ ,  $L \in \mathcal{V}(B^*)$  implies  $\varphi^{-1}(L) \in \mathcal{V}(A^*)$ ,

A  $\mathcal{C}$ -stream of languages is a positive  $\mathcal{C}$ -stream of languages closed under complement.

Let  $u$  and  $v$  be two profinite words of  $\widehat{A}_n^*$  and let  $L$  be a recognisable language of  $A^*$ . One says that  $L$  satisfies the profinite  $\mathcal{C}$ -identity  $u \rightarrow v$  [ $u \leftrightarrow v$ ] if, for each  $\mathcal{C}$ -morphism  $\gamma: A_n^* \rightarrow A^*$ ,  $L$  satisfies the equation  $\hat{\gamma}(u) \rightarrow \hat{\gamma}(v)$  [ $\hat{\gamma}(u) \leftrightarrow \hat{\gamma}(v)$ ].

**Theorem 5.14** *A class of recognisable languages of  $A^*$  is a positive  $\mathcal{C}$ -stream of languages if and only if it can be defined by a set of profinite  $\mathcal{C}$ -identities of the form  $u \rightarrow v$ . It is a stream of languages if and only if it can be defined by a set of profinite  $\mathcal{C}$ -identities of the form  $u \leftrightarrow v$ .*

**Proof.** The proof of Theorem 4.13 carries over by changing every occurrence of “morphism” by “ $\mathcal{C}$ -morphism”. Note however that the closure of  $\mathcal{C}$  under composition is needed to show that  $\gamma \circ \varphi$  belongs to  $\mathcal{C}$ .  $\square$

The notion of  $\mathcal{C}$ -identity can be sometimes confusing. Let us illustrate it by a few examples.

**Example 5.1** **TO DO.**

## 6 Varieties of languages

A *positive variety of languages* is a class of recognisable languages such that

- (1) for each alphabet  $A$ ,  $\mathcal{V}(A^*)$  is a lattice of languages,
- (2) for each morphism of monoid  $\varphi: A^* \rightarrow B^*$ ,  $X \in \mathcal{V}(B^*)$  implies  $\varphi^{-1}(X) \in \mathcal{V}(A^*)$ ,
- (3) If  $X \in \mathcal{V}(A^*)$  and  $u \in A^*$ ,  $u^{-1}X \in \mathcal{V}(A^*)$  and  $Xu^{-1} \in \mathcal{V}(A^*)$ .

A *variety of languages* is a positive variety of languages closed under complementation. This amounts replacing (1) by (1') in the previous definition

- (1') for each alphabet  $A$ ,  $\mathcal{V}(A^*)$  is a Boolean algebra.

Let  $u$  and  $v$  be two profinite words of  $\widehat{A}_n^*$  and let  $L$  be a recognisable language of  $A^*$ . One says that  $L$  satisfies the profinite identity  $u \leq v$  [ $u = v$ ] if, for all morphisms  $\gamma: A_n^* \rightarrow A^*$ ,  $L$  satisfies the equation  $\hat{\gamma}(u) \leq \hat{\gamma}(v)$  [ $\hat{\gamma}(u) = \hat{\gamma}(v)$ ].

**Theorem 6.15** *A class of recognisable languages of  $A^*$  is a positive variety of languages if and only if it can be defined by a set of profinite identities of the form  $u \leq v$ . It is a variety of languages if and only if it can be defined by a set of profinite identities of the form  $u = v$ .*

**Proof.** The proof, which combines the arguments of Theorems 3.9 and 4.13 is left as an exercise to the reader.  $\square$

A *positive  $\mathcal{C}$ -variety of languages* is a class of recognisable languages  $\mathcal{V}$  such that

- (1) for every alphabet  $A$ ,  $\mathcal{V}(A^*)$  is a lattice of languages,
- (2) if  $\varphi: A^* \rightarrow B^*$  is a morphism of  $\mathcal{C}$ ,  $L \in \mathcal{V}(B^*)$  implies  $\varphi^{-1}(L) \in \mathcal{V}(A^*)$ ,
- (3) if  $L \in \mathcal{V}(A^*)$  and if  $a \in A$ , then  $a^{-1}L$  and  $La^{-1}$  are in  $\mathcal{V}(A^*)$ .

A  $\mathcal{C}$ -variety of languages is a positive  $\mathcal{C}$ -variety of languages closed under complement.

Let  $u$  and  $v$  be two profinite words of  $\widehat{A}_n^*$  and let  $L$  be a recognisable language of  $A^*$ . One says that  $L$  satisfies the profinite  $\mathcal{C}$ -identity  $u \leq v$  [ $u = v$ ] if, for all  $\mathcal{C}$ -morphisms  $\gamma : A_n^* \rightarrow A^*$ ,  $L$  satisfies the equation  $\hat{\gamma}(u) \leq \hat{\gamma}(v)$  [ $\hat{\gamma}(u) = \hat{\gamma}(v)$ ].

**Theorem 6.16** *A class of recognisable languages of  $A^*$  is a positive  $\mathcal{C}$ -variety of languages if and only if it can be defined by a set of profinite identities of the form  $u \leq v$ . It is a  $\mathcal{C}$ -variety of languages if and only if it can be defined by a set of profinite identities of the form  $u = v$ .*

**Proof.** The proof, which combines the arguments of Theorems 3.9 and 5.14 is left as an exercise to the reader.  $\square$

When  $\mathcal{C}$  is the class of all morphisms, we recover the definition of a variety of languages. When  $\mathcal{C}$  is the class of length-preserving [length-multiplying, non-erasing, length-decreasing] morphisms, we use the term  $lp$ -variety [ $lm$ -variety,  $ne$ -variety,  $ld$ -variety] of languages.

## 7 The variety theorem

In this section, we present a slightly different algebraic point of view to characterise varieties of languages, proposed by Eilenberg [27].

If  $\mathbf{V}$  is a variety of finite monoids, denote by  $\mathcal{V}(A^*)$  the set of recognisable languages of  $A^*$  whose syntactic monoid belongs to  $\mathbf{V}$ . The following is an equivalent definition:

**Proposition 7.17**  *$\mathcal{V}(A^*)$  is the set of languages of  $A^*$  recognised by a monoid of  $\mathbf{V}$ .*

**Proof.** If  $L \in \mathcal{V}(A^*)$ , then the syntactic monoid of  $L$ , which recognises  $L$ , belongs to  $\mathbf{V}$ . Conversely, if  $L$  is recognised by a monoid  $M$  of  $\mathbf{V}$ , then by Proposition IV.4.25, the syntactic monoid of  $L$  divides  $M$  and thus belongs also to  $\mathbf{V}$ .  $\square$

The correspondence  $\mathbf{V} \rightarrow \mathcal{V}$  associates with each variety of finite monoids a class of recognisable languages. We shall see later (Proposition 7.20) that  $\mathcal{V}$  is a variety of languages. For now, we show that this correspondence is one to one.

**Theorem 7.18** *Let  $\mathbf{V}$  and  $\mathbf{W}$  be two varieties of finite monoids. Suppose that  $\mathbf{V} \rightarrow \mathcal{V}$  and  $\mathbf{W} \rightarrow \mathcal{W}$ . Then  $\mathbf{V} \subseteq \mathbf{W}$  if and only if, for every finite alphabet  $A$ ,  $\mathcal{V}(A^*) \subseteq \mathcal{W}(A^*)$ . In particular,  $\mathbf{V} = \mathbf{W}$  if and only if  $\mathcal{V} = \mathcal{W}$ .*

**Proof.** If  $\mathbf{V} \subseteq \mathbf{W}$ , it follows immediately from the definitions that  $\mathcal{V}(A^*) \subseteq \mathcal{W}(A^*)$ . The proof of the opposite inclusion is based on the following proposition.

**Proposition 7.19** *Let  $\mathbf{V}$  be a variety of monoids and let  $M \in \mathbf{V}$ . Then there exist a finite alphabet  $A$  and languages  $L_1, \dots, L_k \in \mathcal{V}(A^*)$  such that  $M$  is isomorphic with a submonoid of  $M(L_1) \times \dots \times M(L_k)$ .*

**Proof.** Since  $M$  is finite, there exists a finite alphabet  $A$  and a surjective monoid morphism  $\varphi : A^* \rightarrow M$ . For each  $s \in M$ , put  $L_s = \varphi^{-1}(s)$ . Then  $L_s$  is recognised by  $M$  and thus  $L_s \in \mathcal{V}(A^*)$ . Let  $M_s$  be the syntactic monoid of  $L_s$ . By Proposition IV.4.24, it is also the syntactic monoid of the singleton  $\{s\}$  in  $M$ . We denote by  $\pi_s : M \rightarrow M_s$  the projection and by  $\pi : M \rightarrow \prod_{s \in M} M_s$  the morphism of monoids defined by  $\pi(x) = (\pi_s(x))_{s \in M}$ . We claim that  $\pi$  is injective. If  $\pi(x) = \pi(y)$ , then in particular,  $\pi_y(x) = \pi_y(y)$ . This means that, for every  $s, t \in M$ ,  $syt = y$  if and only if  $sxt = y$ . Applying this result with  $s = t = 1$ , one gets  $x = y$ . This proves the claim and shows that  $M$  is isomorphic with a submonoid of  $\prod_{s \in M} M_s$ .  $\square$

We can now complete the proof of Theorem 7.18. Suppose that  $\mathcal{V}(A^*) \subseteq \mathcal{W}(A^*)$  for every finite alphabet  $A$  and let  $M \in \mathbf{V}$ . Then by Proposition 7.19,  $M$  is isomorphic with a submonoid of the form  $M(L_1) \times \cdots \times M(L_k)$ , where  $L_1, \dots, L_k \in \mathcal{V}(A^*)$ . It follows that  $L_1, \dots, L_k \in \mathcal{W}(A^*)$  and hence  $M(L_1), \dots, M(L_k) \in \mathbf{W}$ . Therefore  $M \in \mathbf{W}$ .  $\square$

We now characterise the classes of languages which can be associated with a variety of monoids.

**Proposition 7.20** *Let  $\mathbf{V}$  be a variety of finite monoids. If  $\mathbf{V} \rightarrow \mathcal{V}$ , then  $\mathcal{V}$  is a variety of languages.*

**Proof.** Let  $L, L_1, L_2 \in \mathcal{V}(A^*)$  and let  $a \in A$ . Then by definition  $M(L), M(L_1), M(L_2)$  are in  $\mathbf{V}$ . By Proposition IV.2.9, the languages  $L_1 \cup L_2$  and  $L_1 \cap L_2$  are recognised by a submonoid  $T$  of  $M(L_1) \times M(L_2)$ . Now since  $\mathbf{V}$  is a variety of monoids,  $T \in \mathbf{V}$  and thus  $L_1 \cup L_2$  and  $L_1 \cap L_2$  belong to  $\mathcal{V}(A^*)$ . Since  $\emptyset$  and  $A^*$  are recognised by the trivial monoid, which is certainly in  $\mathbf{V}$ ,  $\mathcal{V}(A^*)$  is a Boolean algebra of languages. Similarly, Proposition IV.2.11 shows that the languages  $a^{-1}L$  and  $La^{-1}$  are recognised by  $M(L)$  and Proposition IV.2.10 shows that, if  $\varphi : B^* \rightarrow A^*$  is a monoid morphism, then  $\varphi^{-1}(L)$  is recognised by  $M(L)$ . Thus  $\mathcal{V}$  is a variety of languages.  $\square$

To each variety of languages  $\mathcal{V}$ , we associate the variety of monoids  $\mathbf{V}$  generated by the monoids of the form  $M(L)$  where  $L \in \mathcal{V}(A^*)$  for a certain alphabet  $A$ . This defines a correspondence  $\mathcal{V} \rightarrow \mathbf{V}$ . We are now ready to state Eilenberg's variety theorem.

**Theorem 7.21** *The correspondences  $\mathbf{V} \rightarrow \mathcal{V}$  and  $\mathcal{V} \rightarrow \mathbf{V}$  define mutually inverse bijective correspondences between varieties of finite monoids and varieties of languages.*

**Proof.** Let  $\mathcal{V}$  be a variety of languages and suppose that  $\mathcal{V} \rightarrow \mathbf{V}$  and  $\mathbf{V} \rightarrow \mathcal{W}$ . We claim that  $\mathcal{V} = \mathcal{W}$ . First, if  $L \in \mathcal{V}(A^*)$ , one has  $M(L) \in \mathbf{V}$  by definition and therefore  $L \in \mathcal{W}(A^*)$ , still by definition. Therefore, for every alphabet  $A$ ,  $\mathcal{V}(A^*) \subseteq \mathcal{W}(A^*)$ .

The inclusion  $\mathcal{W}(A^*) \subseteq \mathcal{V}(A^*)$  is more difficult to prove. Let  $L \in \mathcal{W}(A^*)$ . Then  $M(L) \in \mathbf{V}$  and since  $\mathbf{V}$  is the variety generated by the monoids of the form  $M(L)$  where  $L$  is a language of  $\mathcal{V}$ , there exist an integer  $n > 0$  and, for  $1 \leq i \leq n$ , alphabets  $A_i$  and languages  $L_i \in \mathcal{V}_i(A_i^*)$  such that  $M(L)$  divides  $M(L_1) \times \cdots \times M(L_k)$ . Denote by  $M$  this product of monoids. Since  $M(L)$  divides

$M$ , it is a quotient of a submonoid  $T$  of  $M$ . By Corollary IV.4.22,  $T$  recognises  $L$ . Therefore there exists a surjective morphism of monoids  $\varphi : A^* \rightarrow T$  and a subset  $P$  of  $T$  such that  $L = \varphi^{-1}(P)$ . Let  $\pi_i : M \rightarrow M(L_i)$  be the  $i$ -th projection defined by  $\pi_i(s_1, \dots, s_n) = s_i$ . Put  $\varphi_i = \pi_i \circ \varphi$  and let  $\eta_i : A^* \rightarrow M(L_i)$  be the syntactic morphism of  $L_i$ . Since  $\eta_i$  is onto, there exists by Corollary II.5.30 a morphism of monoids  $\psi_i : A^* \rightarrow A_i^*$  such that  $\varphi_i = \eta_i \circ \psi_i$ . We can summarize the situation in a diagram:

$$\begin{array}{ccc}
 A^* & \xrightarrow{\psi_i} & A_i^* \\
 \varphi \downarrow & \searrow \varphi_i & \downarrow \eta_i \\
 T \subseteq M & \xrightarrow{\pi_i} & M(L_i)
 \end{array}$$

We recall that we are seeking to prove that  $L \in \mathcal{V}(A^*)$ , which is finally obtained by a succession of reductions of the problem. First, one has

$$L = \varphi^{-1}(P) = \bigcup_{s \in P} \varphi^{-1}(s)$$

Since  $\mathcal{V}(A^*)$  is closed under union, it suffices to establish that for every  $s \in P$ , one has  $\varphi^{-1}(s)$  belongs to  $\mathcal{V}(A^*)$ . Setting  $s = (s_1, \dots, s_n)$ , one gets  $\{s\} = \bigcap_{1 \leq i \leq n} \pi_i^{-1}(s_i)$ . Consequently

$$\varphi^{-1}(s) = \bigcap_{1 \leq i \leq n} \varphi^{-1}(\pi_i^{-1}(s_i)) = \bigcap_{1 \leq i \leq n} \varphi_i^{-1}(s_i)$$

As  $\mathcal{V}(A^*)$  is a lattice, it suffices to establish that, for  $1 \leq i \leq n$ ,  $\varphi_i^{-1}(s_i) \in \mathcal{V}(A^*)$ .

Since  $\varphi_i = \eta_i \circ \psi_i$ , one has  $\varphi_i^{-1}(s_i) = \psi_i^{-1}(\eta_i^{-1}(s_i))$ . Now since  $\mathcal{V}$  is a variety of languages, it suffices to prove that  $\eta_i^{-1}(s_i) \in \mathcal{V}(A_i^*)$ , which results from the following lemma.

**Lemma 7.22** *Let  $\mathcal{V}$  be a variety of languages and let  $\eta : A^* \rightarrow M$  be the syntactic morphism of a language  $L$  of  $\mathcal{V}(A^*)$ . Then for every  $x \in M$ ,  $\eta^{-1}(x)$  belongs to  $\mathcal{V}(A^*)$ .*

**Proof.** Let  $P = \eta(L)$ . Then  $L = \eta^{-1}(P)$ . Setting  $E = \{(s, t) \in M^2 \mid sxt \in P\}$ , we claim that

$$\{x\} = \left( \bigcap_{(s,t) \in E} s^{-1}Pt^{-1} \right) - \left( \bigcup_{(s,t) \in E^c} s^{-1}Pt^{-1} \right) \quad (7.2)$$

Let  $R$  be the right hand side of (7.2). It is clear that  $x$  belongs to  $R$ . Conversely, let  $u$  be an element of  $R$ . If  $sxt \in P$ , then  $u \in s^{-1}Pt^{-1}$ , that is,  $sut \in P$ . And if  $sxt \notin P$ , then  $u \notin s^{-1}Pt^{-1}$ . It follows that  $u \sim_L x$  and thus  $u = x$ , which proves the claim. Since  $\eta^{-1}$  commutes with Boolean operations and quotients,  $\eta^{-1}(x)$  is a Boolean combination of quotients of  $L$  and hence belongs to  $\mathcal{V}(A^*)$ .  $\square$

There is an analogous theorem for varieties of ordered monoids.

**Theorem 7.23** *The correspondences  $\mathbf{V} \rightarrow \mathcal{V}$  and  $\mathcal{V} \rightarrow \mathbf{V}$  define mutually inverse bijective correspondences between varieties of finite ordered monoids and positive varieties of languages.*

### Eilenberg's +-varieties

In his original presentation, Eilenberg introduced a variant of his variety theorem. We shall briefly review this version and discuss its connexion with the point of view presented in this chapter.

The first difference is that languages are now subsets of a free semigroup, instead of a free monoid in the usual case. In this setting, it is natural to use semigroups instead of monoids and in particular, there is a notion of syntactic semigroup. A *+ -variety of languages* is a class of recognisable languages such that

- (1) for each alphabet  $A$ ,  $\mathcal{V}(A^+)$  is a Boolean algebra,
- (2) for each semigroup morphism  $\varphi : A^+ \rightarrow B^+$ , if  $X \in \mathcal{V}(B^+)$  then  $\varphi^{-1}(X) \in \mathcal{V}(A^+)$ ,
- (3) If  $X \in \mathcal{V}(A^+)$  and  $u \in A^*$ ,  $u^{-1}X \in \mathcal{V}(A^+)$  and  $Xu^{-1} \in \mathcal{V}(A^+)$ .

*Positive + -varieties* of languages can be defined in the same way. The second Eilenberg's

**Theorem 7.24** *The correspondences  $\mathbf{V} \rightarrow \mathcal{V}$  and  $\mathcal{V} \rightarrow \mathbf{V}$  define mutually inverse bijective correspondences between varieties of finite semigroups and + -varieties of languages.*

There is an analogous theorem for varieties of ordered semigroups.

**Theorem 7.25** *The correspondences  $\mathbf{V} \rightarrow \mathcal{V}$  and  $\mathcal{V} \rightarrow \mathbf{V}$  define mutually inverse bijective correspondences between varieties of finite ordered semigroups and positive + -varieties of languages.*

To interpret this result in the context of this chapter, let us introduce a notation: if  $S$  is a semigroup, denote by  $S^I$  the monoid  $S \cup \{I\}$ , where  $I$  is a new identity.

Let  $\mathbf{V}$  be a variety of finite semigroups and let  $\mathcal{V}$  be the corresponding variety of languages. We define another class of languages  $\mathcal{V}'$  as follows. For each alphabet  $A$ ,  $\mathcal{V}'(A^*)$  consists of all languages of  $A^*$  recognised by a morphism  $\varphi : A^* \rightarrow S^I$  such that the semigroup  $\varphi(A^+)$  is in  $\mathbf{V}$ . This is the case in particular if  $S \in \mathbf{V}$  and  $\varphi : A^+ \rightarrow S$  is a surjective morphism. Then one can show that  $\mathcal{V}$  is a *ne*-variety of languages. Further, every language of  $\mathcal{V}(A^+)$  is a language of  $\mathcal{V}'(A^*)$ . Conversely, if  $L$  is a language of  $\mathcal{V}'(A^*)$ , then  $L \cap A^+$  is a language of  $\mathcal{V}(A^+)$ .

## 8 Summary

We summarize on a table the various types of equations we have used so far.

<b>Closed under</b>	<b>Equations</b>	<b>Definition</b>
$\cup, \cap$	$u \rightarrow v$	$\widehat{\eta}(u) \in \widehat{\eta}(L) \Rightarrow \widehat{\eta}(v) \in \widehat{\eta}(L)$
quotient	$u \leq v$	$xuy \rightarrow xvy$
complement	$u \leftrightarrow v$	$u \rightarrow v$ and $v \rightarrow u$
quotient and complement	$u = v$	$xuy \leftrightarrow xvy$
<b>Closed under inverse of morphisms</b>		<b>Interpretation of variables</b>
all morphisms		words
nonerasing morphisms		nonempty words
length multiplying morphisms		words of equal length
length preserving morphisms		letters

# Chapter IX

## Algebraic characterisations

In this chapter, we give explicit examples of the algebraic characterisations described in Chapter VI.

### 1 Varieties of languages

The two simplest examples of varieties of languages are the variety  $\mathcal{I}$  corresponding to the trivial variety of monoids  $\mathbf{1}$  and the variety  $\mathcal{Rat}$  of rational languages corresponding to the variety of all monoids. For each alphabet  $A$ ,  $\mathcal{I}(A^*)$  consists of the empty and the full language  $A^*$  and  $\mathcal{Rat}(A^*)$  is the set of all rational languages on the alphabet  $A$ .

We provide the reader with many more examples in this section. Other important examples are the topic of Chapters X, XI and XIV.

#### 1.1 Locally finite varieties of languages

Let  $\mathcal{V}$  be a [positive] variety of languages. One says that  $\mathcal{V}$  is *locally finite* if the corresponding variety of [ordered] monoids is locally finite. Here is a more combinatorial characterisation.

**Proposition 1.1** *A [positive] variety of languages  $\mathcal{V}$  is locally finite if and only if, for each alphabet  $A$ ,  $\mathcal{V}(A^*)$  is a finite set.*

**Proof.** Let  $\mathbf{V}$  be the variety of [ordered] monoids corresponding to  $\mathcal{V}$ . If  $\mathbf{V}$  is locally finite, then, for each alphabet  $A$ ,  $\widehat{F}_{\mathbf{V}}(A)$  is a finite monoid which recognises all the languages of  $\mathcal{V}(A^*)$ . It follows that  $\mathcal{V}(A^*)$  is a finite set.

Conversely, suppose that for each alphabet  $A$ ,  $\mathcal{V}(A^*)$  is a finite set. Define an equivalence  $\equiv_{\mathbf{V}}$  on  $A^*$  by  $u \equiv_{\mathbf{V}} v$  if and only if, for all  $L \in \mathcal{V}(A^*)$ , the conditions  $u \in L$  and  $v \in L$  are equivalent. Since  $\mathcal{V}(A^*)$  is finite, this equivalence has finite index. We claim that  $u \equiv_{\mathbf{V}} v$  implies  $u \sim_{\mathbf{V}} v$ . Indeed, let  $\varphi$  be a morphism from  $A^*$  onto a monoid  $M$  of  $\mathbf{V}$  and suppose that  $u \equiv_{\mathbf{V}} v$ . Then the language  $L = \varphi^{-1}(\varphi(u))$  belongs to  $\mathcal{V}(A^*)$  and since  $u \in L$ , one gets  $v \in L$ , that is  $\varphi(v) = \varphi(u)$ , which proves the claim. It follows that  $\sim_{\mathbf{V}}$  has finite index and thus  $\widehat{F}_{\mathbf{V}}(A)$  is a finite monoid.  $\square$

**A combinatorial description**

Proposition VII.2.8 shows that if  $\mathbf{V}$  is generated by a single [ordered] monoid, then  $\mathcal{V}$  is locally finite. In this case, one can give a more precise description of  $\mathcal{V}$ .

**Proposition 1.2** *Let  $\mathbf{V}$  be a variety of ordered monoids generated by a single ordered monoid  $M$  and let  $\mathcal{V}$  be the corresponding positive variety. Then, for each alphabet  $A$ ,  $\mathcal{V}(A^*)$  is the lattice generated by the sets of the form  $\varphi^{-1}(\uparrow m)$ , where  $\varphi : A^* \rightarrow M$  is an arbitrary morphism and  $m \in M$ .*

**Proof.** It is clear that  $\varphi^{-1}(\uparrow m) \in \mathcal{V}(A^*)$  and thus  $\mathcal{V}(A^*)$  also contains the lattice generated by these sets. Conversely, let  $L \in \mathcal{V}(A^*)$ . Then there exists an integer  $n \geq 0$ , a morphism  $\varphi : A^* \rightarrow M^n$  and an upper set  $I$  of  $M$  such that  $L = \varphi^{-1}(I)$ . Since  $\varphi^{-1}(I) = \bigcup_{m \in P} \varphi^{-1}(\uparrow m)$ , it is sufficient to establish the result when  $L = \varphi^{-1}(\uparrow m)$  where  $m \in M^n$ . Denote by  $\pi_i$  the  $i$ -th projection from  $M^n$  onto  $M$ . Setting  $m = (m_1, \dots, m_n)$ , we have  $m = \bigcap_{1 \leq i \leq n} \pi_i^{-1}(m_i)$ , whence

$$\varphi^{-1}(\uparrow m) = \bigcap_{1 \leq i \leq n} (\pi_i \circ \varphi)^{-1}(\uparrow m_i)$$

Since  $m_i \in M$  and  $\pi_i \circ \varphi$  is a morphism from  $A^*$  into  $M$ , the result follows.  $\square$

There is of course a similar result for the varieties of monoids, the proof of which is similar.

**Proposition 1.3** *Let  $\mathbf{V}$  be a variety of monoids generated by a single monoid  $M$  and let  $\mathcal{V}$  be the corresponding variety of languages. Then, for every alphabet  $A$ ,  $\mathcal{V}(A^*)$  is the Boolean algebra generated by the sets of the form  $\varphi^{-1}(m)$ , where  $\varphi : A^* \rightarrow M$  is an arbitrary morphism and  $m \in M$ .*

**Languages corresponding to  $\mathbf{J}_1$ ,  $\mathbf{J}_1^+$  and  $\mathbf{J}_1^-$** 

Let us denote by  $\mathcal{J}_1$  [ $\mathcal{J}_1^+$ ,  $\mathcal{J}_1^-$ ] the [positive] variety of languages corresponding to  $\mathbf{J}_1$  [ $\mathbf{J}_1^+$ ,  $\mathbf{J}_1^-$ ].

**Proposition 1.4** *For each alphabet  $A$ ,  $\mathcal{J}_1(A^*)$  is the Boolean algebra generated by the languages of the form  $A^*aA^*$  where  $a$  is a letter. Equivalently,  $\mathcal{J}_1(A^*)$  is the Boolean algebra generated by the languages of the form  $B^*$  where  $B$  is a subset of  $A$ .*

**Proof.** The equality of the two Boolean algebras considered in the statement results from the formulas

$$B^* = A^* - \bigcup_{a \in A-B} A^*aA^* \quad \text{and} \quad A^*aA^* = A^* - (A - \{a\})^*$$

Since  $\mathbf{J}_1$  is generated by  $U_1$ , one can use Proposition 1.3 to describe  $\mathcal{J}_1$ . Let  $\varphi : A^* \rightarrow U_1$  be a morphism, and let  $B = \{a \in A \mid \varphi(a) = 1\}$ . Then  $\varphi^{-1}(1) = B^*$  and  $\varphi^{-1}(0) = A^* - B^*$ , which establishes the proposition.  $\square$



If  $B$  is a subset of  $A$ , denote by  $F(B)$  the set of words of  $A^*$  containing at least one occurrence of each letter of  $B$ . Thus

$$F(B) = \bigcap_{a \in B} A^* a A^*$$

The next proposition is thus a variant of Proposition 1.4 and its proof is left as an exercise to the reader.

**Proposition 1.5** *For each alphabet  $A$ ,  $\mathcal{J}_1^-(A^*)$  is the set of finite unions of languages of the form  $F(B)$  where  $B \subseteq A$ . Similarly,  $\mathcal{J}_1^+(A^*)$  is the set of finite unions of languages of the form  $B^*$  where  $B \subseteq A$ .*

### Languages corresponding to $\mathbf{R}_1$ and $\mathbf{L}_1$

Another interesting example of locally finite variety is the variety  $\mathbf{R}_1$  of idempotent and  $\mathcal{R}$ -trivial monoids.

**Proposition 1.6** *Let  $L$  be a recognisable subset of  $A^*$  and let  $M$  be its syntactic monoid. The following conditions are equivalent:*

- (1)  $M$  divides  $\tilde{U}_2^n$  for some  $n > 0$ ,
- (2)  $M$  belongs to  $\mathbf{R}_1$ ,
- (3)  $M$  satisfies the identity  $xyx = xy$ ,
- (4)  $L$  is a disjoint union of sets of the form

$$a_1 \{a_1\}^* a_2 \{a_1, a_2\}^* a_3 \{a_1, a_2, a_3\}^* \cdots a_n \{a_1, a_2, \dots, a_n\}^*$$

where the  $a_i$ 's are distinct letters of  $A$ ,

- (5)  $L$  is a Boolean combination of sets of the form  $B^* a A^*$ , where  $a \in A$  and  $B \subseteq A$ .

**Proof.** (1) implies (2) since  $\tilde{U}_2 \in \mathbf{R}_1$ .

(2) implies (3). Let  $x, y \in M$ . Since  $M$  is idempotent,  $xy = xyxy$  and thus  $xy \mathcal{R} xyx$ . But  $M$  is  $\mathcal{R}$ -trivial and therefore  $xy = xyx$ .

(3) implies (4). Let  $\rho : A^* \rightarrow A^*$  be the function which associates with any word  $u$  the sequence of all distinct letters of  $u$  in the order in which they first appear when  $u$  is read from left to right. For example, if  $u = caabacb$ , then  $\rho(u) = cab$ . In fact  $\rho$  is sequential function, realised by the sequential transducer  $\mathcal{T} = (\mathcal{P}(A), A, \emptyset, \cdot, *)$ , where the transition and the output functions are defined by

$$\begin{aligned} B \cdot a &= B \cup \{a\} \\ B * a &= \begin{cases} 1 & \text{if } a \in B \\ 0 & \text{otherwise} \end{cases} \end{aligned}$$

Define an equivalence  $\sim$  on  $A^*$  by setting  $u \sim v$  if  $\rho(u) = \rho(v)$ . It is easy to see that the equivalence classes of  $\sim$  are the disjoint sets

$$L_{(a_1, \dots, a_n)} = a_1 \{a_1\}^* a_2 \{a_1, a_2\}^* a_3 \{a_1, a_2, a_3\}^* \cdots a_n \{a_1, a_2, \dots, a_n\}^*$$

where  $(a_1, \dots, a_n)$  is a sequence of distinct letters of  $A$ . We claim that  $\sim$  is a congruence. If  $u \sim v$ , then  $u$  and  $v$  belong to some set  $L_{(a_1, \dots, a_n)}$ . Let

$a$  be a letter. If  $a = a_i$  for some  $i$ , then  $ua, va \in L_{(a_1, \dots, a_n)}$ , and  $au, av \in L_{(a, a_1, \dots, a_{i-1}, a_{i+1}, \dots, a_n)}$ . Thus  $ua \sim va$  and  $au \sim av$ . If  $a \notin \{a_1, \dots, a_n\}$ , then  $ua, va \in L_{(a_1, \dots, a_n, a)}$  and  $au, av \in L_{(a, a_1, \dots, a_n)}$  and thus again  $ua \sim va$  and  $au \sim av$ , which proves the claim.

Let  $\eta : A^* \rightarrow M$  be the syntactic morphism of  $L$ . If  $u \in L_{(a_1, \dots, a_n)}$ , then  $u = a_1 u_1 a_2 u_2 \cdots a_n u_n$  where  $u_i \in \{a_1, \dots, a_i\}^*$  for  $1 \leq i \leq n$  and thus by (3),  $\eta(u) = \eta(a_1 \cdots a_n)$ . It follows that  $u \sim v$  implies  $\eta(u) = \eta(v)$  and therefore  $L$  is a disjoint union of equivalence classes of  $\sim$ , that is of sets of the form  $L_{(a_1, \dots, a_n)}$ . (4) implies (5). First observe that

$$L_{(a_1, \dots, a_n)} = A_n^* \cap \bigcap_{1 \leq i \leq n} A_{i-1}^* a_i A_i^* \text{ where } A_i = \{a_1, \dots, a_i\} \text{ and } A_0 = \emptyset$$

Condition (5) is now a consequence of the following equalities:

$$A_i^* = A^* - \bigcup_{a \notin A_i} A^* a A^* \quad A_{i-1}^* a_i A_i^* = A_{i-1}^* a_i A^* \cap A_i^*$$

(5) implies (1). By the variety theorem (Theorem VIII.7.18), it is sufficient to show that, for  $B \subseteq A$  and  $a \in A$ ,  $B^* a A^*$  is recognised by  $\tilde{U}_2$ . Let  $\tilde{U}_2 = \{1, a_1, a_2\}$  and let  $\varphi : A^* \rightarrow \tilde{U}_2$  be the morphism defined by

$$\begin{aligned} \varphi(a) &= a_1 \\ \varphi(b) &= \begin{cases} 1 & \text{if } b \in B - \{a\} \\ a_2 & \text{for } b \in A - (B \cup \{a\}) \end{cases} \end{aligned}$$

Then  $\varphi^{-1}(a_1) = B^* a A^*$ , which concludes the proof.  $\square$

There is of course a dual version for the variety  $\mathbf{L}_1$  of idempotent and  $\mathcal{R}$ -trivial monoids.

**Proposition 1.7** *Let  $L$  be a recognisable subset of  $A^*$  and let  $M$  be its syntactic monoid. The following conditions are equivalent:*

- (1)  $M$  divides  $U_2^n$  for some  $n > 0$ ,
- (2)  $M$  belongs to  $\mathbf{L}_1$ ,
- (3)  $M$  satisfies the identity  $xyx = yx$ ,
- (4)  $L$  is a disjoint union of sets of the form

$$\{a_1, a_2, \dots, a_n\}^* a_n \{a_1, a_2, \dots, a_{n-1}\} \cdots \{a_1, a_2\}^* a_2 \{a_1\}^* a_1$$

where the  $a_i$ 's are distinct letters of  $A$ ,

- (5)  $L$  is a Boolean combination of sets of the form  $A^* a B^*$ , where  $a \in A$  and  $B \subseteq A$ .

## 1.2 Commutative languages

We now come to the study of commutative languages. We study successively the languages corresponding to aperiodic and commutative monoids (variety  $\mathbf{Acom}$ ), to commutative groups and to arbitrary commutative monoids.

**Languages recognised by aperiodic commutative monoids**

If  $a$  is a letter of an alphabet  $A$ , let us denote by  $L(a, k)$  the set of words of  $A^*$  which contain exactly  $k$  occurrences of  $a$

$$L(a, k) = \{u \in A^+ \mid |u|_a = k\}$$

Then the following result holds.

**Proposition 1.8** *For each alphabet  $A$ ,  $\mathcal{Acom}(A^*)$  is the Boolean algebra generated by the sets of the form  $L(a, k)$  where  $a \in A$  and  $k \geq 0$ .*

**Proof.** First, every set of the form  $L(a, k)$  is recognised by an aperiodic commutative monoid. Indeed, let  $N = \{1, x, x^2, \dots, x^k, x^{k+1}\}$  be the cyclic monoid defined by the relation  $x^{k+2} = x^{k+1}$ , and let  $\varphi : A^* \rightarrow N$  be the morphism defined by  $\varphi(a) = x$  and  $\varphi(b) = 1$  if  $b \neq a$ . Then clearly  $L(a, k) = \varphi^{-1}(x^k)$ .

By Proposition VII.4.21,  $\mathbf{Acom}$  is generated by its cyclic monoids, and Proposition 1.3 can be used to describe  $\mathcal{Acom}$ . Let  $M = \{1, x, x^2, \dots, x^n\}$  be a cyclic monoid, defined by the relation  $x^{n+1} = x^n$ , and let  $\varphi : A^* \rightarrow M$  be a morphism. Then for each  $a \in A$  there exists an integer  $n_a$  such that  $\varphi(a) = x^{n_a}$ . Let  $k$  be an integer such that  $0 \leq k < n$ . Then

$$\begin{aligned} \varphi^{-1}(x^k) &= \{u \in A^* \mid \sum_{a \in A} n_a |u|_a = k\} \\ &= \bigcup_{a \in A} \bigcap_{a \in A} L(a, k_a) \end{aligned}$$

where the union is taken over the set of families  $(k_a)_{a \in A}$  such that  $\sum_{a \in A} n_a k_a = k$ . Finally, for  $k = n$ , we have

$$\varphi^{-1}(x^n) = A^* - \bigcup_{0 \leq k < n} \varphi^{-1}(x^k)$$

which concludes the proof.  $\square$

**Languages recognised by commutative groups**

For each positive integer  $n$ , let  $\mathbf{Ab}(n)$  be the variety of all abelian groups of exponent dividing  $n$ . This variety is known to be generated by the cyclic groups of order  $n$ . Let us call  $n$ -commutative a language recognised by a group in  $\mathbf{Ab}(n)$ . A description of these languages was given in [27].

**Proposition 1.9** *For each alphabet  $A$ , the  $n$ -commutative languages of  $A^*$  form the Boolean algebra generated by the languages of the form*

$$F(a, k, n) = \{u \in A^* \mid |u|_a \equiv k \pmod{n}\} = ((B^* a)^n)^* (B^* a)^k B^*,$$

where  $a \in A$ ,  $B = A - \{a\}$  and  $0 \leq k < n$ .

We shall present an improved version of this result, which avoids using complementation. Let  $A = \{a_1, \dots, a_s\}$  be an alphabet. Let us call  $n$ -elementary commutative a language of the form

$$F(r_1, \dots, r_s, n) = \{u \in A^* \mid |u|_{a_1} \equiv r_1 \pmod{n}, \dots, |u|_{a_s} \equiv r_s \pmod{n}\}$$

where  $r_1, \dots, r_s \in \{0, \dots, n-1\}$ . Thus, with the notation of Proposition 1.9,

$$F(r_1, \dots, r_s, n) = F(a_1, r_1, n) \cap \dots \cap F(a_s, r_s, n)$$

**Proposition 1.10** *A language is  $n$ -commutative if and only if it is a disjoint union of  $n$ -elementary commutative languages.*

**Proof.** Let  $A = \{a_1, \dots, a_s\}$ , let  $G$  be a group in  $\mathbf{Ab}(n)$  and let  $\varphi : A^* \rightarrow G$  be a morphism. If  $L$  is recognised by  $\varphi$ , then  $L = \varphi^{-1}(P)$  for some subset  $P$  of  $G$ . Put  $\varphi(a_1) = g_1, \dots, \varphi(a_s) = g_s$ . Let  $u \in A^*$  and, for  $1 \leq i \leq s$ , let  $|u|_{a_i} \equiv r_i \pmod n$ . Adopting an additive notation for  $G$ , we get

$$\varphi(u) = \sum_{1 \leq i \leq s} |u|_{a_i} g_i = \sum_{1 \leq i \leq s} r_i g_i$$

Therefore  $u \in L$  if and only if  $\sum_{1 \leq i \leq s} r_i g_i \in P$  and hence

$$L = \bigcup_{(r_1, \dots, r_s) \in E} F(r_1, \dots, r_s, n)$$

where  $E = \{(r_1, \dots, r_s) \mid \sum_{1 \leq i \leq s} r_i g_i \in P\}$ . This concludes the proof, since the languages  $F(r_1, \dots, r_s, n)$  are clearly pairwise disjoint.  $\square$

### Languages recognised by commutative monoids

Let  $\mathit{Com}$  be the variety of languages corresponding to the variety of commutative monoids. The following result is now a consequence of Propositions 1.8 and 1.10.

**Proposition 1.11** *For each alphabet  $A$ ,  $\mathit{Com}(A^*)$  is the Boolean algebra generated by the languages of the form  $L(a, k)$ , where  $a \in A$  and  $k > 0$ , and  $F(a, k, n)$ , where  $a \in A$  and  $0 \leq k < n$ .*

### 1.3 $\mathcal{R}$ -trivial and $\mathcal{L}$ -trivial languages

We study in this section the languages whose syntactic monoids are  $\mathcal{R}$ -trivial or  $\mathcal{L}$ -trivial. Surprisingly, the corresponding results for  $\mathcal{J}$ -trivial and  $\mathcal{H}$ -trivial monoids are noticeably more difficult and will be treated in separate chapters (Chapters X and XI).

Let  $\mathcal{A} = (Q, A, \cdot)$  be a complete deterministic automaton. We say that  $\mathcal{A}$  is *extensive* if there is a partial ordering  $\leq$  on  $Q$  such that for every  $q \in Q$  and for every  $a \in A$ , one has  $q \leq q \cdot a$ . It is important to note that although  $Q$  is equipped with a partial order, we do not require  $\mathcal{A}$  to be an ordered automaton. In other words, we do not assume that the action of each letter is order preserving.

**Proposition 1.12** *The transition monoid of an extensive automaton is  $\mathcal{R}$ -trivial.*

**Proof.** Let  $\mathcal{A} = (Q, A, \cdot)$  be an extensive automaton and let  $u, v, x, y$  be words of  $A^*$ . Suppose that  $ux$  and  $v$  on the one hand, and  $vy$  and  $u$  on the other hand, have the same action on  $Q$ . It then follows, for every  $q \in Q$ , that  $q \cdot u \leq q \cdot ux = q \cdot v$  and  $q \cdot v \leq q \cdot vy = q \cdot u$ , whence  $q \cdot u = q \cdot v$  and therefore  $u$  and  $v$

have the same action on  $Q$ . It follows from this that the transition monoid of  $\mathcal{A}$  is  $\mathcal{R}$ -trivial.  $\square$

One can deduce from Proposition 1.13 a first characterisation of languages recognised by an  $\mathcal{R}$ -trivial monoid.

**Proposition 1.13** *A language is recognised by an  $\mathcal{R}$ -trivial monoid if and only if it is recognised by an extensive automaton.*

**Proof.** If a language is recognised by an extensive automaton, it is recognised by the transition monoid of this automaton by Proposition IV.3.18. Now this monoid is  $\mathcal{R}$ -trivial by Proposition 1.12.

Conversely, let  $L$  be a language of  $A^*$  recognised by an  $\mathcal{R}$ -trivial monoid. Then there exist a morphism  $\eta : A^* \rightarrow M$  and a subset  $P$  of  $M$  such that  $\eta^{-1}(P) = L$ . We have seen in Section 3 that the automaton  $\mathcal{A} = (M, A, \cdot)$ , defined by  $m \cdot a = m\eta(a)$ , recognises  $L$ . Since  $m \geq_{\mathcal{R}} m\eta(a)$ , the order  $\geq_{\mathcal{R}}$  makes  $\mathcal{A}$  an extensive automaton. Thus  $L$  is recognised by an extensive automaton.  $\square$

We now describe the variety of languages  $\mathcal{R}$  corresponding to  $\mathbf{R}$ .

**Theorem 1.14** *For each alphabet  $A$ ,  $\mathcal{R}(A^*)$  consists of the languages which are disjoint unions of languages of the form  $A_0^*a_1A_1^*a_2 \cdots a_kA_k^*$ , where  $k \geq 0$ ,  $a_1, \dots, a_k \in A$ ,  $A_k \subseteq A$  and, for  $0 \leq i \leq k - 1$ ,  $A_i$  is a subset of  $A - \{a_{i+1}\}$ .*

**Proof.** Let  $L = A_0^*a_1A_1^*a_2 \cdots a_kA_k^*$ , with  $k \geq 0$ ,  $a_1, \dots, a_k \in A$ ,  $A_k \subseteq A$  and, for  $0 \leq i \leq k - 1$ ,  $A_i$  is a subset of  $A - \{a_{i+1}\}$ . Let us set, for  $0 \leq i \leq k$ ,  $A'_i = A - (A_i \cup \{a_{i+1}\})$ . Then the automaton represented in Figure 1.1 recognises  $L$ .

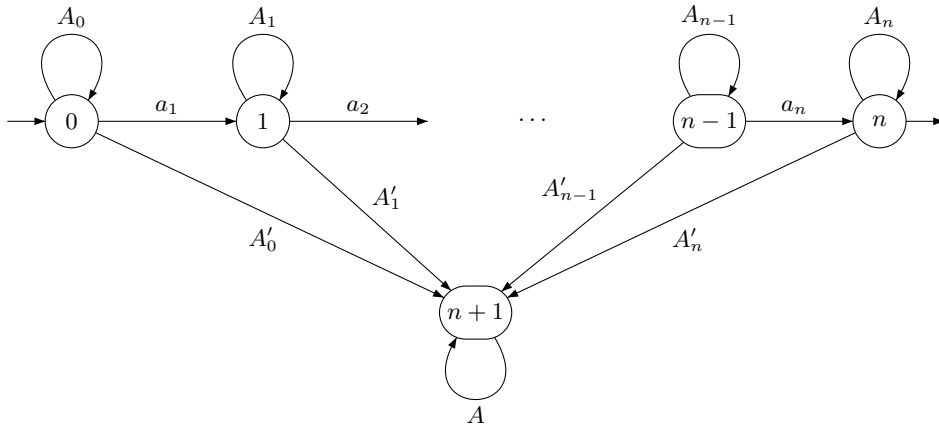

Figure 1.1. An automaton recognising  $L$ .

Since this automaton is extensive for the natural order on the integers, it follows by Proposition 1.13 that  $L$  belongs to  $\mathcal{L}(A^*)$ .

Conversely, let  $L \in \mathcal{L}(A^*)$ . By Proposition 1.13,  $L$  is recognised by an extensive automaton  $\mathcal{A} = (Q, A, \cdot, q_-, F)$ . Let  $S$  be the set of sequences of the

form  $(q_0, a_1, \dots, a_k, q_k)$  such that  $q_0 = q_-, q_0 \cdot a_1 = q_1, \dots, q_{k-1} \cdot a_k = q_k$  and  $q_k \in F$ . Setting, for  $q \in Q$ ,  $A_q = \{a \in A \mid q \cdot a = q\}$ , we claim that

$$L = \bigcup_{(q_0, a_1, \dots, a_k, q_k) \in S} A_{q_0}^* a_1 A_{q_1}^* \cdots A_{q_{k-1}}^* a_k A_{q_k}^* \quad (1.1)$$

Note also that this union is disjoint since  $\mathcal{A}$  is deterministic. Let  $K$  be the right hand side of (1.1). If  $u \in K$ , there is a sequence  $(q_0, a_1, \dots, a_k, q_k) \in S$  and a factorisation  $u = u_0 a_1 u_1 \cdots a_k u_k$  such that  $u_0 \in A_{q_0}^*, \dots, u_k \in A_{q_k}^*$ . It follows that  $q_0 \cdot u_0 = q_0, q_0 \cdot a_1 = q_1, \dots, q_{k-1} \cdot a_k = q_k$  and  $q_k \cdot u_k = q_k$ . Therefore,  $q_0 \cdot u = q_k$  and thus  $u \in L$  since  $q_0 = q_-$  and  $q_k \in F$ .

Conversely, let  $u \in L$ . Since  $\mathcal{A}$  is extensive, the successful path of label  $u$  visits successively an increasing sequence of states  $q_- = q_0 < q_1 < \dots < q_k \in F$ . This gives a factorisation  $u = u_0 a_1 u_1 \cdots a_k u_k$ , such that  $q_0 \cdot u_0 = q_0, q_0 \cdot a_1 = q_1, \dots, q_{k-1} \cdot a_k = q_k$  and  $q_k \cdot u_k = q_k$ . Consequently,  $u$  belongs to  $K$ . This proves the claim and the theorem.  $\square$

A dual result holds for the variety of languages  $\mathcal{L}$  corresponding to  $\mathbf{L}$ .

**Theorem 1.15** *For each alphabet  $A$ ,  $\mathcal{L}(A^*)$  consists of the languages which are disjoint unions of languages of the form  $A_0^* a_1 A_1^* a_2 \cdots a_k A_k^*$ , where  $k \geq 0$ ,  $a_1, \dots, a_k \in A$ ,  $A_0 \subseteq A$  and, for  $1 \leq i \leq k$ ,  $A_i$  is a subset of  $A - \{a_i\}$ .*

We conclude this section with a representation theorem for  $\mathcal{R}$ -trivial monoids. Let us denote by  $\mathcal{E}_n$  the submonoid of  $\mathcal{T}_n$  consisting of all extensive functions from  $\{1, \dots, n\}$  into itself.

**Proposition 1.16** *For every  $n > 0$ , the monoid  $\mathcal{E}_n$  is  $\mathcal{R}$ -trivial.*

**Proof.** Let  $f, g \in \mathcal{E}_n$  such that  $f \mathcal{R} g$ . There exist  $a, b \in \mathcal{E}_n$  such that  $fa = g$  and  $gb = f$ . Let  $q \in \{1, \dots, n\}$ . Since  $a$  is extensive one has  $q \cdot f \leq q \cdot fa = q \cdot g$  and likewise  $q \cdot g \leq q \cdot gb = q \cdot f$ . It follows that  $f = g$  and thus  $\mathcal{E}_n$  is  $\mathcal{R}$ -trivial.  $\square$

**Theorem 1.17** *A finite monoid is  $\mathcal{R}$ -trivial if and only if it is a submonoid of  $\mathcal{E}_n$  for some  $n > 0$ .*

**Proof.** If  $M$  is  $\mathcal{R}$ -trivial, the relation  $\geq_{\mathcal{R}}$  is a partial ordering. It follows that, for every  $m \in M$ , the right translation  $\rho_m : M \rightarrow M$  defined by  $\rho_m(x) = xm$  is extensive for this order. We have seen in Proposition II.4.25 that the function  $m \mapsto \rho_m$  is an injective morphism from  $M$  into  $\mathcal{T}(M)$ . Therefore,  $M$  is a submonoid of  $\mathcal{E}_n$  with  $n = |M|$ .

Conversely, suppose that  $M$  is a submonoid of  $\mathcal{E}_n$ . Then  $\mathcal{E}_n$  is  $\mathcal{R}$ -trivial by Proposition 1.16 and  $M$  is also  $\mathcal{R}$ -trivial since the  $\mathcal{R}$ -trivial monoids form a variety of monoids.  $\square$

## 1.4 Some examples of +-varieties

### Varieties corresponding to $\mathbf{N}$ , $\mathbf{N}^+$ and $\mathbf{N}^-$

Let us denote by  $\mathcal{N} [\mathcal{N}^+, \mathcal{N}^-]$  the +-variety corresponding to  $\mathbf{N} [\mathbf{N}^+, \mathbf{N}^-]$ . Recall that a subset  $F$  of a set  $E$  is *cofinite* if the complement of  $F$  in  $E$  is finite.

**Proposition 1.18** For each alphabet  $A$ ,

- (1)  $\mathcal{N}^-(A^+)$  consists of the empty subset and of the cofinite languages of  $A^+$ ,
- (2)  $\mathcal{N}^+(A^+)$  consists of  $A^+$  and of the finite languages of  $A^+$ ,
- (3)  $\mathcal{N}(A^+)$  is the set of finite or cofinite languages of  $A^+$ .

**Proof.** (1). Denote by  $\varphi : A^+ \rightarrow S$  the syntactic morphism of  $L$ . If  $L$  is empty,  $S$  is trivial, and thus belongs to  $\mathbf{tN}^-$ . If  $L$  is a cofinite subset of  $A^+$ , there exists an integer  $n$  such that  $L$  contains all the words of length  $\geq n$ . If  $u$  is such a word, we have  $xuy \in L$  for each  $x, y \in A^*$ , thereby showing that all the words of  $A^+$  of length  $\geq n$  are syntactically equivalent and have the same image  $e$  under  $\varphi$ . By Proposition VII.4.14,  $S$  is thus nilpotent. There remains to prove that  $s \leq e$  for every  $s \in S$ . Let  $v \in \varphi^{-1}(s)$ . Then the formal implication

$$(xvy \in L \Rightarrow xuy \in L)$$

shows that  $v \leq_L u$ , whence  $s \leq e$  in  $S$ . Therefore  $S \in \mathbf{N}^-$ .

Conversely, let  $(S, \leq) \in \mathbf{N}^-$ ,  $I$  be an upper set of  $S$  and let  $\varphi : A^+ \rightarrow S$  be a morphism of semigroups. If  $I$  is empty,  $\varphi^{-1}(I)$  is empty also. Otherwise,  $I$  contains necessarily  $0$ , since  $0$  is maximal for  $\leq$ . Let  $u$  be a word of length greater than or equal to  $|S|$ . By Proposition VII.4.14,  $\varphi(u) = 0$  and hence  $\varphi(u) \in I$ . Therefore  $\varphi^{-1}(I)$  is cofinite.

(2) follows from (1) by taking the complement.

(3) What precedes shows that the syntactic semigroup of a finite or cofinite subset is a nilpotent semigroup. To prove the converse, consider a nilpotent nonempty semigroup  $S$ . Let  $P$  be a subset of  $S$  and let  $\varphi : A^+ \rightarrow S$  be a morphism of semigroups. Then  $0$  belongs either to  $P$ , or to  $S - P$  and the argument above shows that  $\varphi^{-1}(P)$  is either finite or cofinite.  $\square$

### Varieties corresponding to $\ell\mathbf{1}$ , $r\mathbf{1}$ and $\mathbb{L}\mathbf{1}$

Let us denote by  $\mathcal{LI}$  [ $\ell\mathcal{I}$ ,  $r\mathcal{I}$ ] the  $+$ -variety corresponding to  $\mathbb{L}\mathbf{1}$  [ $\ell\mathbf{1}$ ,  $r\mathbf{1}$ ].

**Proposition 1.19** For each alphabet  $A$ ,  $\ell\mathcal{I}(A^+)$  [ $r\mathcal{I}(A^+)$ ] is the set of languages of the form  $FA^* \cup G$  [ $A^*F \cup G$ ] where  $F$  and  $G$  are finite languages of  $A^+$ . It is also the Boolean algebra generated by the languages of the form  $uA^*$  or  $\{u\}$ , where  $u \in A^+$ .

**Proof.** Let  $L$  be a language of the form  $FA^* \cup G$ , where  $F$  and  $G$  are finite languages of  $A^+$ . We claim that the syntactic semigroup of  $L$  belongs to  $\ell\mathbf{1}$ . Since the syntactic semigroup of  $G$  is nilpotent by Proposition 1.18, it suffices to consider the syntactic semigroup  $S$  of the language  $FA^*$ . Let  $n$  be the maximum length of the words of  $F$  and let  $u$  be a word of length greater than or equal to  $n$ . Then for every word  $v \in A^*$ , one has  $uv \sim_{FA^*} u$ , since the three conditions  $xvuy \in FA^*$ ,  $xu \in FA^*$  and  $xuy \in FA^*$  are clearly equivalent. It follows that  $ts = t$  for every  $t \in S^n$  and by Proposition VII.4.15,  $S$  belongs to  $\ell\mathbf{1}$ .

Conversely, let  $L$  be a language recognised by a semigroup  $S \in \ell\mathbf{1}$  and let  $n = |S|$ . Then there exists a morphism  $\varphi : A^+ \rightarrow S$  such that  $L = \varphi^{-1}(\varphi(L))$ . Let  $u$  be a word of  $L$  of length greater than or equal to  $n$ . Let us write  $u = vs$  with  $|v| = n$  and  $s \in A^*$ . By Proposition VII.4.15 (4), one has  $\varphi(u) = \varphi(v)\varphi(s) = \varphi(vs)$ . It follows that  $L = FA^* \cup G$ , where  $F$  is the set of words of  $L$  of length  $n$  and  $G$  is the set of words of  $L$  of length less than  $n$ .

The second part of the statement is easy to prove. First, we know that  $\mathcal{LI}(A^+)$  is a Boolean algebra and by the first part of the statement, it contains the languages of the form  $uA^*$  or  $\{u\}$ , where  $u \in A^+$ . Further, the Boolean algebra generated by the languages of the form  $uA^*$  or  $\{u\}$  contains the languages of the form  $FA^* \cup G$ , with  $F$  and  $G$  finite.  $\square$

**Proposition 1.20** *For each alphabet  $A$ ,  $\mathcal{LI}(A^+)$  is the set of languages of the form  $FA^*G \cup H$  where  $F$ ,  $G$  and  $H$  are finite languages of  $A^+$ . It is also the Boolean algebra generated by the languages of the form  $uA^*$  or  $A^*u$ , where  $u \in A^+$ .*

**Proof.** Let  $L$  be a language of the form  $FA^*G \cup H$ , where  $F$ ,  $G$  and  $H$  are finite languages of  $A^+$ . We claim that the syntactic semigroup of  $L$  belongs to  $\mathbb{L1}$ . Since the syntactic semigroup of  $H$  is nilpotent by Proposition 1.18, it suffices to consider the syntactic semigroup  $S$  of the language  $FA^*G$ . Let  $n$  be the maximum length of the words of  $F$  and  $G$  let  $u$  be a word of length greater than or equal to  $n$ . Then for every word  $v \in A^*$ , one has  $uvu \sim_{FA^*G} u$ , since the conditions  $xvuy \in FA^*G$  and  $xuy \in FA^*G$  are clearly equivalent. It follows that  $tst = t$  for every  $t \in S^n$  and by Proposition VII.4.17,  $S$  belongs to  $\mathbb{L1}$ .

Conversely, let  $L$  be a language recognised by a semigroup  $S \in \mathbb{L1}$  and let  $n = |S|$ . Then there exists a morphism  $\varphi : A^+ \rightarrow S$  such that  $L = \varphi^{-1}(\varphi(L))$ . Let  $u$  be a word of  $L$  of length greater than or equal to  $2n$ . Let us write  $u = pvs$  with  $|p| = |s| = n$ . By Proposition VII.4.17, one has  $\varphi(u) = \varphi(ps) = \varphi(pA^*s)$  and hence  $pA^*s \subseteq L$ . It follows that  $L$  is a finite union of languages of the form  $pA^*s$ , with  $|p| = |s| = n$  and of a set of words of length less than  $2n$ .

The second part of the statement is easy to prove. First, we know that  $\mathcal{LI}(A^+)$  is a Boolean algebra and by the first part of the statement, it contains the languages of the form  $uA^*$ ,  $A^*u$  or  $\{u\}$ , where  $u \in A^+$ . Further, the Boolean algebra generated by these languages contains the languages of the form  $FA^*G \cup H$ , with  $F$ ,  $G$  and  $H$  finite.  $\square$

## 2 Lattices of languages

We first give a number of examples of lattices of languages. We start by revisiting some classical examples studied between 1960 and 1980. Then we consider some more recent examples.

### 2.1 The role of the zero

An element  $0$  of a monoid  $M$  is a *zero* if, for all  $m \in M$ ,  $0m = 0 = 0m$ . It is easy to see that a monoid has at most one zero element. This allows one to use the notation  $0$  for the zero without ambiguity. Observe that the trivial monoid has a zero, but this is the only case for which  $1 = 0$ . Also note that the minimal ideal of a monoid with zero reduces to  $\{0\}$ . A quotient of a monoid with zero also has a zero, but this is not the case for a submonoid.



### Languages with zero

A *language with zero* is a language whose syntactic monoid has a zero, or equivalently, a language fully recognised by a monoid with zero.

**Proposition 2.21** *The class of recognisable languages with zero is closed under Boolean operations and under quotients. It is not closed under inverses of morphisms, even for length-preserving morphisms.*

**Proof.** Let  $\mathcal{C}$  be the class of recognisable languages with zero. The empty language and the full language belong to  $\mathcal{C}$ , since their syntactic monoid is trivial. Proposition IV.2.8 shows that  $\mathcal{C}$  is closed under complement. Let  $L_1$  and  $L_2$  be two languages of  $\mathcal{C}$  and let  $\varphi_1 : A^* \rightarrow M_1$  and  $\varphi_2 : A^* \rightarrow M_2$  be their respective syntactic morphisms. By Proposition IV.2.9,  $L_1 \cap L_2$  is recognised by the morphism  $\varphi : A^* \rightarrow \text{Im}(\varphi) \subseteq M_1 \times M_2$  defined by  $\varphi(u) = (\varphi_1(u_1), \varphi_2(u_2))$ . We claim that the monoid  $M = \text{Im}(\varphi)$  has a zero. Indeed, let  $u_1$  and  $u_2$  be words such that  $\varphi_1(u_1) = 0$  and  $\varphi_2(u_2) = 0$ . Then the element  $\varphi(u_1u_2)$  is a zero of  $M$ . Indeed, if  $\varphi(u)$  is an element of  $M$ , then  $\varphi(u)\varphi(u_1u_2) = \varphi(uu_1u_2) = (\varphi_1(uu_1u_2), \varphi_2(uu_1u_2)) = (0, 0) = \varphi(u_1u_2)$  and similarly,  $\varphi(u)\varphi(u_1u_2) = \varphi(u_1u_2)$ . This proves the claim and shows that  $L_1 \cap L_2$  is a language with zero. Thus  $\mathcal{C}$  is closed under Boolean operations.

Let  $L$  be a recognisable language with zero and let  $M$  be its syntactic monoid. Let  $u$  be a word of  $A^*$ . It follows from Proposition IV.2.11 that the languages  $u^{-1}L$  and  $Lu^{-1}$  are also recognised by  $M$ . It follows that the syntactic monoid of these languages is a quotient of  $M$  and hence has a zero. Thus  $\mathcal{C}$  is closed under quotients.

Finally let  $A = \{a, b\}$  and let  $\varphi : A^* \rightarrow A^*$  be the length-preserving morphism defined by  $\varphi(a) = \varphi(b) = a$ . If  $L = (a^2)^*$ , then  $\varphi^{-1}(L) = (A^2)^*$ . Now  $L$  has a zero, but the syntactic monoid of  $(A^2)^*$  is the cyclic group of order 2, which has no zero.  $\square$

According to Corollary VIII.3.11, the class of recognisable languages with zero has an equational definition, but finding one explicitly requires a little bit of work.

Let us fix a total order on the alphabet  $A$ . Let  $u_0, u_1, \dots$  be the ordered sequence of all words of  $A^+$  in the induced shortlex order. For instance, if  $A = \{a, b\}$  with  $a < b$ , the first elements of this sequence would be

$$1, a, b, aa, ab, ba, bb, aaa, aab, aba, abb, baa, bab, bba, bbb, aaaa, \dots$$

It is proved in [90, 4] that the sequence of words  $(v_n)_{n \geq 0}$  defined by

$$v_0 = u_0, v_{n+1} = (v_n u_{n+1} v_n)^{(n+1)!}$$

converges to an idempotent  $\rho_A$  of the minimal ideal of the free profinite monoid on  $A$ . This profinite element can be used to give an equational characterisation of the recognisable languages with zero.

**Proposition 2.22** *A recognisable language has a zero if and only if it satisfies the equation  $x\rho_A = \rho_A = \rho_A x$  for all  $x \in A^*$ .*

**Proof.** Let  $L$  be a recognisable language and let  $\eta : A^* \rightarrow M$  be its syntactic monoid. Since  $\rho_A$  belongs to the minimal ideal of  $A^*$ ,  $\eta(\rho_A)$  is an element of the minimal ideal of  $M$ . In particular, if  $M$  has a zero,  $\eta(\rho_A) = 0$  and  $L$  satisfies the equations  $x\rho_A = \rho_A = \rho_A x$  for all  $x \in A^*$ .

Conversely, assume that  $L$  satisfies these equations. Let  $m \in M$  and let  $x \in A^*$  be such that  $\eta(x) = m$ . Then the equations  $\eta(x\rho_A) = \eta(\rho_A) = \eta(\rho_A x)$  give  $m\eta(\rho_A) = \eta(\rho_A) = \eta(\rho_A)m$ , showing that  $\eta(\rho_A)$  is a zero of  $M$ . Thus  $L$  has a zero.  $\square$

In the sequel, we shall use freely the symbol  $0$  in equations to mean that a monoid has a zero. For instance the equation  $x \leq 0$  of Theorem 2.25 below should be formally replaced by the two equations  $x\rho_A = \rho_A = \rho_A x$  and  $x \leq \rho_A$ .

### Nondense languages

A language  $L$  of  $A^*$  is *dense* if, for every word  $u \in A^*$ ,  $L \cap A^*uA^* \neq \emptyset$ , or, equivalently, if  $(A^*)^{-1}L(A^*)^{-1} = A^*$ . Note that dense languages are not closed under intersection:  $(A^2)^*$  and  $(A^2)^*A \cup \{1\}$  are dense, but their intersection is not dense.

**Proposition 2.23** *Nondense or full languages are closed under finite union, finite intersection and left and right quotients.*

**Proof.** Let  $L_1$  and  $L_2$  be two nondense languages of  $A^*$ . Then there exist two words  $u_1, u_2 \in A^*$  such that  $L_1 \cap A^*u_1A^* = \emptyset$  and  $L_2 \cap A^*u_2A^* = \emptyset$ . It follows that  $(L_1 \cap L_2) \cap A^*u_1A^* = \emptyset$  and  $(L_1 \cup L_2) \cap A^*u_1u_2A^* = \emptyset$ . Thus  $L_1 \cap L_2$  and  $L_1 \cup L_2$  are nondense. If  $L_1 = A^*$ , then  $L_1 \cap L_2 = L_2$  and  $L_1 \cup L_2 = A^*$ . Thus nondense or full languages are closed under finite union and finite intersection.

Let  $L$  be a nondense language. Then there exists a word  $u \in A^*$  such that  $L \cap A^*uA^* = \emptyset$ . Let  $x, y \in A^*$ . We claim that  $x^{-1}Ly^{-1} \cap A^*uA^* = \emptyset$ . Otherwise, there exist two words  $s, t$  such that  $sut \in x^{-1}Ly^{-1}$ . It follows that  $xsuty \in L$ , a contradiction, since  $L \cap A^*uA^* = \emptyset$ . Thus  $x^{-1}Ly^{-1}$  is nondense. If  $L = A^*$ , then  $x^{-1}Ly^{-1} = A^*$  for all words  $x, y \in A^*$ . Therefore nondense or full languages are closed under left and right quotients.  $\square$

**Proposition 2.24** *Nondense or full languages are not closed under inverse of morphisms, even for length-preserving morphisms.*

**Proof.** Let  $\varphi : \{a, b\}^* \rightarrow \{a, b\}^*$  be the morphism defined by  $\varphi(a) = \varphi(b) = a$ . Then  $a^+$  is nondense in  $\{a, b\}^*$ , but  $\varphi^{-1}(a^+) = \{a, b\}^+$  is dense and not full.  $\square$

We now give an equational description of nondense or full languages of the form foretold by Theorem VIII.3.9.

**Theorem 2.25** *A language of  $A^*$  is nondense or full if and only if it satisfies the identity  $0 \leq x$ .*

**Proof.** Let  $L$  be a recognisable language of  $A^*$ , let  $\eta : A^* \rightarrow M$  be its syntactic monoid and  $P$  its syntactic image. First observe that the identity  $0 \leq x$  means

that if  $0 \in P$ , then  $P = M$  and hence  $M = \{0\}$  since  $M$  is the syntactic monoid of  $P$ .

Suppose that  $L$  is nondense. Then there exists a word  $u \in A^*$  such that  $L \cap A^*uA^* = \emptyset$ . It follows that for all  $x \in A^*$ ,  $xu \sim_L u \sim_L ux$  and hence  $\eta(u)$  is a zero in  $M$ . Further  $0 \notin P$ . If now  $L$  is full, then  $M$  is the trivial monoid which has a zero. Thus the identity is satisfied in both cases.

Conversely, assume that  $M$  satisfies the identity  $0 \leq x$ . Then  $M$  has a zero. If  $0 \in P$ , then  $M$  is the trivial monoid and  $L$  is full. Otherwise,  $0 \notin P$ . Let  $u$  be a word such that  $\eta(u) = 0$ . Then  $\eta(A^*uA^*) = 0$  and hence  $L \cap A^*uA^* = \emptyset$ . Thus  $L$  is nondense.  $\square$

## 2.2 Languages defined by density

The *density* of a language  $L \subseteq A^*$  is the function which counts the number of words of length  $n$  in  $L$ . More formally, it is the function  $d_L : \mathbb{N} \rightarrow \mathbb{N}$  defined by

$$d_L(n) = |L \cap A^n|$$

where  $|E|$  denotes the cardinality of a set  $E$ . We first state some elementary properties of this function.

**Proposition 2.26** *Let  $L_1$  and  $L_2$  be two languages. Then, for all  $n$ ,*

- (1)  $d_{L_1 \cup L_2}(n) \leq d_{L_1}(n) + d_{L_2}(n)$ ,
- (2)  $d_{L_1 \cap L_2}(n) \leq \min\{d_{L_1}(n), d_{L_2}(n)\}$ ,
- (3)  $d_{L_1 L_2}(n) \leq \sum_{0 \leq k \leq n} d_{L_1}(k) d_{L_2}(n - k)$ .

**Proof.** The double relation

$$(L_1 \cap L_2) \cap A^n \subseteq (L_1 \cup L_2) \cap A^n = (L_1 \cap A^n) \cup (L_2 \cap A^n)$$

gives immediately (1) and (2). Relation (3) follows from the fact that  $L_1 L_2 \cap A^n$  is the union of the languages  $(L_1 \cap A^k)(L_2 \cap A^{n-k})$ , for  $0 \leq k \leq n$ .  $\square$

If  $d_L(n) = O(1)$ , then  $L$  is called a *slender language*. A language that has at most one word of each length is called a *thin language*. Finally, a language is *sparse* if it has a polynomial density, that is, if  $d_L(n) = O(n^k)$  for some  $k > 0$ . See [122] for a general reference.

### Slender languages

Not that if  $|A| \leq 1$ , all recognisable languages are slender. This is trivial if the alphabet is empty. If  $A = \{a\}$ , every recognisable language of  $A^*$  is a finite union of languages of the form  $a^k = a^k 1^* 1$ , and  $a^k a^* = a^k a^* 1$ .

Recognizable slender languages have a simple description (see [122, Theorem 3.6]).

**Theorem 2.27** *A recognisable language is slender if and only if it is a finite union of languages of the form  $xu^*y$ , where  $x, u, y \in A^*$ .*

Since we only consider lattices of recognisable languages, we are interested in the class of recognisable languages which are either slender or full. We first study their closure properties.

**Proposition 2.28** *Recognizable slender languages are closed under finite union, finite intersection, quotients and morphisms.*

**Proof.** Since any language contained in a slender language is also slender, recognisable slender languages are closed under finite intersection. Closure under finite union is a direct consequence of Theorem 2.27. Closure under morphisms is trivial.

Let  $a$  be a letter of  $A$  and let  $x, u, y$  be words of  $A^*$ . Then

$$a^{-1}(xu^*y) = \begin{cases} (a^{-1}x)u^*y & \text{if } x \neq 1, \\ (a^{-1}u)u^*y & \text{if } x = 1 \text{ and } u \neq 1, \\ a^{-1}y & \text{if } x = 1 \text{ and } u = 1. \end{cases}$$

Therefore  $a^{-1}(xu^*y)$  is a recognisable slender language in all cases. It follows now from Theorem 2.27 that recognisable slender languages are closed under left quotient by letters, and, by induction, by any word. The proof for right quotients is similar.  $\square$

**Proposition 2.29** *Recognizable slender languages are not closed under inverse of morphisms, even for length-preserving morphisms.*

**Proof.** We use the same example as for Proposition 2.24. Let  $\varphi : \{a, b\}^* \rightarrow \{a, b\}^*$  be the morphism defined by  $\varphi(a) = \varphi(b) = a$ . Then  $a^+$  is slender in  $\{a, b\}^*$ , but  $\varphi^{-1}(a^+) = \{a, b\}^+$  is not slender nor full.  $\square$

Recall that a *cycle* in a directed graph is a path such that the start vertex and end vertex are the same. A *simple cycle* is a closed directed path, with no repeated vertices other than the starting and ending vertices. The following result is folklore, but we give a self-contained proof for the convenience of the reader.

**Theorem 2.30** *Let  $L$  be a recognisable language and let  $\mathcal{A}$  be its minimal deterministic trim automaton. The following conditions are equivalent:*

- (1)  $L$  is slender,
- (2)  $\mathcal{A}$  does not contain any connected pair of cycles,
- (3)  $\mathcal{A}$  does not contain any connected pair of simple cycles.

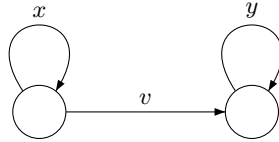

**Figure 2.2.** Two connected cycles, where  $x, y \in A^+$  and  $v \in A^*$ .

**Proof.** (1) implies (2). If  $\mathcal{A}$  contains a connected pair of cycles, then  $L$  contains a language of the form  $ux^*vy^*w$  where  $u, v, w \in A^*$  and  $x, y \in A^+$ . In particular, it contains the words  $ux^{i|y|}vy^{(n-i)|x|}w$  for  $0 \leq i \leq n$ . Therefore  $d_L(|uvw| + n|xy|) \geq n$  and thus  $L$  is not slender.

(2) implies (3) is clear.

(3) implies (1). Let  $n$  be the number of states of  $\mathcal{A}$  and let  $w$  be a word of  $L$  of length  $\geq n$ . Consider a successful path  $p$  for  $w$ . Since  $|w| \geq n$ , this path has a loop, which by (3), is necessarily an iteration of a unique simple cycle, as pictured in Figure 2.3.

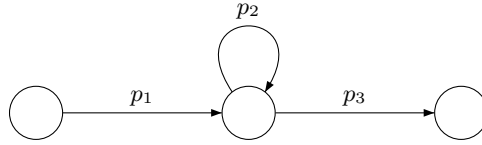

Figure 2.3. The path  $p$ .

In other words, one can write  $p = p_1 p_2^k p_3$  for some  $k > 0$ . It follows that  $L$  is a subset of  $\bigcup_{|u|, |x|, |v| \leq n} ux^*v$  and hence is slender.  $\square$

We now state the equational characterisation of slender or full languages. We denote by  $i(u)$  the first letter (or *initial*) of a word  $u$ .

**Theorem 2.31** *Suppose that  $|A| \geq 2$ . A recognisable language of  $A^*$  is slender or full if and only if it is nondense or full and satisfies the equations  $x^\omega u y^\omega = 0$  for each  $x, y \in A^+$ ,  $u \in A^*$  such that  $i(uy) \neq i(x)$ .*

**Proof.** Let  $L$  be a recognisable language of  $A^*$ . If  $L$  is slender, it is sparse and we shall see independently in Corollary 2.35 that, since  $|A| \geq 2$ , this implies that  $L$  is nondense. Therefore, by Theorem 2.25,  $L$  has a zero and satisfies the equations  $0 \leq x$  for all  $x \in A^*$ . It suffices now to prove that if  $i(uy) \neq i(x)$ , then  $x^\omega u y^\omega \leq 0$ . This formally means that, for every  $v, w \in A^*$ ,

$$\hat{\eta}(vx^\omega u y^\omega w) \in \eta(L) \Rightarrow \eta(v)0\eta(w) \in \eta(L) \tag{2.2}$$

But  $\eta(v)0\eta(w) = 0$  and  $0 \notin \eta(L)$  since  $L$  is a nondense language. It follows that (2.2) holds if and only if  $\hat{\eta}(vx^\omega u y^\omega w) \notin \eta(L)$ . Let  $\mathcal{A} = (Q, A, \cdot, i, F)$  be the minimal trim automaton of  $L$ . If  $\hat{\eta}(vx^\omega u y^\omega w) \in \eta(L)$ , then the state  $i \cdot vx^\omega u y^\omega w$  is a final state. Setting  $p = i \cdot vx^\omega$  and  $q = p \cdot u y^\omega$ , we have  $p \cdot x^\omega = p$  and  $q \cdot y^\omega = q$ . Further, the condition  $i(uy) \neq i(x)$  ensures that the paths defined by  $x^\omega$  and by  $u y^\omega$  are distinct. It follows that  $\mathcal{A}$  contains a connected pair of cycles, a contradiction with Theorem 2.30.

Suppose now that  $L$  is not slender nor full and let  $\mathcal{A}$  be the minimal automaton of  $L$ . By Theorem 2.30,  $\mathcal{A}$  contains a connected pair of simple cycles. Therefore, there exist some words  $x, y \in A^+$ ,  $u_0, u_1, u_2 \in A^*$  such that  $i(u_1 y) \neq i(x)$  and  $u_0 x^* u_1 y^* u_2 \subseteq L$ . It follows that  $\hat{\eta}(u_0 x^\omega u_1 y^\omega u_2) \in \eta(L)$  and thus  $L$  does not satisfy the equation  $x^\omega u_1 y^\omega \leq 0$ .  $\square$

Let us add two comments to this result. First, on a one letter alphabet, every recognisable language is slender, but not necessarily nondense or full: on the alphabet  $\{a\}$ , the language  $a^+$  is slender, dense, but not full. Second, it looks a little bit suspicious to characterise a class of languages which is not closed under complement by equations of the form  $u = v$  and not by equations of the form  $u \leq v$ , as Theorem VIII.3.9 would suggest. The explanation lies in

the first condition, “nondense or full”, which, by Theorem 2.25, can be defined by equations of the form  $x \leq 0$ .

We now consider the Boolean closure of slender languages. A language is called *coslender* if its complement is slender.

**Proposition 2.32** *Recognizable slender or coslender languages are closed under Boolean operations. They are also closed under quotients but not under inverse of morphisms, even for length-preserving morphisms.*

**Proof.** Let  $\mathcal{C}$  be the class of recognisable slender or coslender languages. It is clearly closed under complement. Let  $L_1, L_2 \in \mathcal{C}$ . If  $L_1$  and  $L_2$  are both slenders, then  $L_1 \cap L_2$  is also slender by Proposition 2.28. Suppose now that  $L_1$  and  $L_2$  are coslender. Then  $L_1^c$  and  $L_2^c$  are slender and so is their union by Theorem 2.27. Since  $(L_1 \cap L_2)^c = L_1^c \cup L_2^c$ , it follows that  $L_1 \cap L_2$  is coslender. Thus  $\mathcal{C}$  is closed under finite intersection and hence under Boolean operations.

Since slender languages are closed under quotients and since quotients commute with complement (in the sense that  $u^{-1}L^c = (u^{-1}L)^c$ )  $\mathcal{C}$  is closed under quotients.

Finally, let  $\varphi : \{a, b, c\}^* \rightarrow \{a, b, c\}^*$  be the morphism defined by  $\varphi(a) = \varphi(b) = a$  and  $\varphi(c) = c$ . Then  $a^+$  is slender in  $\{a, b\}^*$ , but  $\varphi^{-1}(a^+) = \{a, b\}^+$  is nor slender nor coslender.  $\square$

We now come to the equational characterisation.

**Theorem 2.33** *Suppose that  $|A| \geq 2$ . A recognisable language of  $A^*$  is slender or coslender if and only if its syntactic monoid has a zero and satisfies the equations  $x^\omega uy^\omega = 0$  for each  $x, y \in A^+$ ,  $u \in A^*$  such that  $i(uy) \neq i(x)$ .*

**Proof.** This is an immediate consequence of Theorem 2.31.  $\square$

Note that if  $A = \{a\}$ , the language  $(a^2)^*$  is slender but its syntactic monoid, the cyclic group of order 2, has no zero. Therefore the condition  $|A| \geq 2$  in Theorem 2.33 is mandatory.

### Sparse languages

The closure properties of sparse languages are similar to that of slender languages. See [122, Theorem 3.8].

**Proposition 2.34** *Sparse languages are closed under finite union, finite intersection, product and quotients. They are not closed under inverses of morphisms, even for length-preserving morphisms.*

**Proof.** Proposition 2.26 implies immediately that sparse languages are closed under finite union, finite intersection and product.

Closure under quotients can be proved exactly in the same way as for slender languages and we omit the details. Finally, the example used in the proof of Proposition 2.29 also shows that recognisable slender languages are not closed under inverse of length-preserving morphisms.  $\square$

**Corollary 2.35** *Suppose that  $|A| \geq 2$ . Then any recognisable sparse language of  $A^*$  is nondense.*

**Proof.** Let  $L$  be a recognisable sparse language. Then by Proposition 2.28, the language  $(A^*)^{-1}L(A^*)^{-1}$  is also slender. Therefore this language has a polynomial density and since  $|A| \geq 2$ , it can not be equal to  $A^*$ . Therefore  $L$  is nondense.  $\square$

Recognizable sparse languages have been characterised in [33, 115, 59]. See also [122, Theorem 3.6]. We gather these results in a slightly different form.

**Theorem 2.36** *Let  $L$  be a recognisable language. The following conditions are equivalent:*

- (1)  $L$  is sparse,
- (2)  $L$  is a finite union of languages of the form  $u_0v_1^*u_1 \cdots v_k^*u_k$ , where  $u_0, v_1, \dots, v_k, u_k$  are words.
- (3) the minimal deterministic trim automaton of  $L$  does not contain any pattern of the form

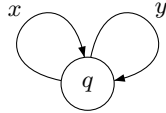

**Figure 2.4.** The forbidden pattern.

where  $x$  and  $y$  are nonempty words such that  $i(x) \neq i(y)$ .

**Proof.** (2) implies (1). Since recognisable sparse languages are closed under finite union, it suffices to verify that each language  $L$  of the form  $u_0v_1^*u_1 \cdots v_k^*u_k$  is sparse. Considering a typical word  $u_0v_1^{r_1}u_1 \cdots v_k^{r_k}u_k$  of  $L$ , one gets

$$\begin{aligned} d_L(n) &= \text{Card}(\{(r_1, \dots, r_k) \mid |u_0 \cdots u_k| + r_1|v_1| + \dots + r_k|v_k| = n\}) \\ &\leq \text{Card}(\{(n_0, \dots, n_k) \mid n_0 + n_1 + \dots + n_k = n\}) \\ &= \binom{n+k}{k} \end{aligned}$$

Since  $\binom{n+k}{k} = O(n^k)$ , the language  $L$  is sparse.

(1) implies (3). Let  $\mathcal{A} = (Q, A, \cdot, q_0, F)$  be the minimal deterministic trim automaton of  $L$ . Suppose that the forbidden pattern occurs in  $\mathcal{A}$ . Since  $\mathcal{A}$  is trim, the state  $q$  is accessible and co-accessible and there exist two words  $u$  and  $v$  such that  $q_0 \cdot u = q$  and  $q \cdot v \in F$ . It follows that  $L$  contains the language  $u\{x, y\}^*v$  and a fortiori the language  $K = u\{x^{|y|}, y^{|x|}\}^*v$ . Setting  $r = |x||y|$  and  $s = |uv|$ , we get  $d_K(s + rn) = 2^n$  and thus  $L$  is not sparse.

(3) implies (2). If (3) is satisfied, every path of  $\mathcal{A}$  contains only elementary loops. It follows that each word of  $L$  belongs to some language  $u_0v_1^*u_1 \cdots v_k^*u_k$  contained in  $L$ , where  $k$  and the length of the words  $u_i$  and  $v_i$  is bounded by the number of states of  $\mathcal{A}$ . There are only finitely many languages of this form and their union is  $L$ . Therefore  $L$  is sparse.  $\square$

It follows that a minimal deterministic automaton recognises a sparse language if and only if it does not contain two cycles reachable from one another.

**Corollary 2.37** *Recognizable sparse languages are closed under morphisms.*

**Proof.** This follows immediately from Condition (2) in the previous theorem.  $\square$

Note that the condition *recognisable* in Corollary 2.37 is mandatory. Indeed, consider a bijection  $f$  from  $\{a, b\}^*$  onto  $\mathbb{N}$  such that  $f(u) \geq |u|$  for all  $u \in \{a, b\}^*$ . One can construct such a bijection by taking  $f(u)$  to be the rank of  $u$  in the shortlex order:  $1, a, b, aa, ab, ba, bb, aaa, aab, aba, \dots$ . Now, let

$$L = \{uc^{f(|u|)-|u|} \mid u \in \{a, b\}^*\}$$

The property of  $f$  implies that  $L$  is a thin language. Let now  $\pi$  be the projection morphism from  $\{a, b, c\}^*$  onto  $\{a, b\}^*$  defined by  $\pi(a) = a$ ,  $\pi(b) = b$  and  $\pi(c) = 1$ . Then  $\pi(L) = \{a, b\}^*$  and this language is not sparse.

**Theorem 2.38** *Suppose that  $|A| \geq 2$ . A recognisable language of  $A^*$  is sparse or full if and only if it is nondense or full and satisfies the equations  $(x^\omega y^\omega)^\omega = 0$  for each  $x, y \in A^+$  such that  $i(x) \neq i(y)$ .*

**Proof.** The proof is similar to that of Theorem 2.31. Let  $L$  be a recognisable language of  $A^*$ .

If  $L$  is sparse, then it is nondense by Corollary 2.35. Therefore, by Theorem 2.25,  $L$  has a zero and satisfies the equations  $0 \leq x$  for all  $x \in A^*$ . It suffices now to prove the relation  $(x^\omega y^\omega)^\omega \leq 0$  when  $i(x) \neq i(y)$ , which formally means that, for every  $v, w \in A^*$ ,

$$\hat{\eta}(v(x^\omega y^\omega)^\omega w) \in \eta(L) \Rightarrow 0 \in \eta(L) \quad (2.3)$$

But  $0 \notin \eta(L)$  since  $L$  is a nondense language and thus (2.3) holds if and only if  $\hat{\eta}(v(x^\omega y^\omega)^\omega w) \notin \eta(L)$ . Let  $\mathcal{A} = (Q, A, \cdot, i, F)$  be the minimal trim automaton of  $L$ . If  $\hat{\eta}(v(x^\omega y^\omega)^\omega w) \in \eta(L)$ , then the state  $i \cdot v(x^\omega y^\omega)^\omega w$  is a final state. Setting  $p = i \cdot v(x^\omega y^\omega)^\omega x^\omega$ , we get  $p \cdot x^\omega = p$  and  $p \cdot y^\omega (x^\omega y^\omega)^{\omega-1} = p$  and thus  $\mathcal{A}$  contains the pattern of Figure 2.4. This contradicts Theorem 2.36.

If  $L$  is not sparse, then its minimal deterministic trim automaton contains the pattern represented in Figure 2.4. Consequently, there exist some words  $u, v \in A^*$  and  $x, y \in A^+$  such that  $i(x) \neq i(y)$  and  $u\{x, y\}^*v \subseteq L$ . It follows that  $\hat{\eta}(u(x^\omega y^\omega)^\omega v) \in \eta(L)$  and thus  $L$  does not satisfy the equation  $u(x^\omega y^\omega)^\omega v \leq 0$ .  $\square$

Pursuing the analogy with slender languages, we consider now the Boolean closure of sparse languages. A language is called *cosparse* if its complement is sparse.

**Theorem 2.39** *Suppose that  $|A| \geq 2$ . A recognisable language of  $A^*$  is sparse or cosparse if and only if its syntactic monoid has a zero and satisfies the equations  $(x^\omega y^\omega)^\omega = 0$  for each  $x, y \in A^+$  such that  $i(x) \neq i(y)$ .*

**Proof.** This is an immediate consequence of Theorem 2.38.  $\square$



### 2.3 Cyclic and strongly cyclic languages

#### Cyclic languages

A language is *cyclic* if it is closed under conjugation, power and root. Thus  $L$  is cyclic if and only if, for all  $u, v \in A^*$  and  $n > 0$ ,

- (1)  $u^n \in L$  if and only if  $u \in L$ ,
- (2)  $uv \in L$  if and only if  $vu \in L$ .

Let  $L \in \text{Rec}(A^*)$ , let  $\varphi : A^* \rightarrow M$  be a surjective morphism fully recognising  $L$  and let  $P = \eta(L)$ . A direct translation of the definition shows that a recognisable language is cyclic if and only if it satisfies, for all  $x, y \in M$  and  $n > 0$ ,

$$(xy \in P \iff yx \in P) \quad \text{and} \quad (x^n \in P \iff x \in P)$$

With the notation of Section 1, we get:

**Proposition 2.40** *A recognisable language is cyclic if and only if it satisfies the identities  $xy \leftrightarrow yx$  and  $x^\omega \leftrightarrow x$ .*

The closure properties of cyclic languages are summarized as follows.

**Proposition 2.41** *Recognizable cyclic languages are closed under inverse of morphisms and under Boolean operations but not under quotients.*

**Proof.** The first part of the statement follows from Theorem VIII.4.13 and Proposition 2.40. Further, the language  $L = \{abc, bca, cab\}$  is cyclic, but its quotient  $a^{-1}L = \{bc\}$  is not cyclic.  $\square$

Here is a useful property of the groups of a monoid fully recognising a cyclic language. This property holds of course for the syntactic monoid but we shall need this slightly more general result in the proof of Theorem 2.51.

**Proposition 2.42** *Let  $M$  be a monoid fully recognising a recognisable cyclic language  $L$  and let  $H$  be a group of  $M$ . Let also  $P$  be the image of  $L$  in  $M$ . Then either  $H$  and  $P$  are disjoint or  $H$  is a subset of  $P$ . In the latter case, all the groups of the  $\mathcal{D}$ -class of  $H$  are also contained in  $P$ .*

**Proof.** Suppose that  $P \cap H$  contains some element  $x$ . Then  $x^\omega$  is the identity of  $H$  and it belongs to  $P$  by Condition (1) of the definition of a cyclic language. Now, for any element  $h \in H$ , we get  $h^\omega = x^\omega$  and thus  $h \in P$  by (1). Therefore  $H$  is contained in  $P$ .

Suppose now that  $P$  contains  $H$  and let  $H'$  be another group of the same  $\mathcal{D}$ -class. Let  $e$  and  $e'$  be the idempotents of  $H$  and  $H'$ , respectively. By Proposition V.2.22,  $e$  and  $e'$  are conjugate and it follows from Condition (2) that  $e'$  is in  $P$ . Now, by the first part of the proposition,  $H'$  is contained in  $P$ .  $\square$

**Corollary 2.43** *The syntactic monoid of a recognisable cyclic language has a zero.*

**Proof.** Let  $I$  be the minimal ideal of  $M$ . By Proposition V.4.37,  $I$  is a regular simple semigroup and by Proposition 2.42, one has either  $I \subseteq P$  or  $I \cap P = \emptyset$ . It follows that any two elements  $s$  and  $t$  of  $I$  satisfy  $s \sim_P t$ . Indeed, for all  $x, y \in M$ , one gets  $xsy, xty \in I$  and thus the conditions  $xsy \in P$  and  $xty \in P$

are equivalent. Since  $M$  is the syntactic monoid of  $P$ , one has  $s = t$ , which means that  $I$  has a unique element and this element is necessarily a zero of  $M$ .  $\square$

**Example 2.1** Consider the language  $L = b(b + ab)^*(1 + a) + ab(b + ab)^*$ . The minimal automaton of this language is represented in Figure 2.5.

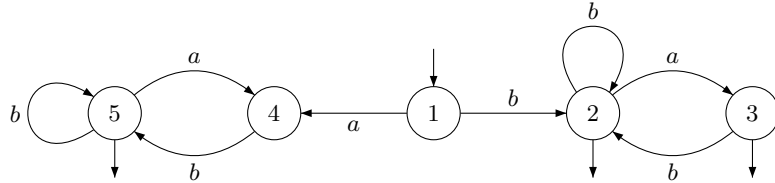

Figure 2.5. The minimal automaton of  $L$ .

The syntactic monoid of  $L$  is the monoid with zero presented by the relations

$$b^2 = b \quad a^2 = 0 \quad aba = a \quad bab = b$$

Its transition table and its  $\mathcal{J}$ -class structure are represented below. The syntactic image of  $L$  is  $\{b, ab, ba\}$ . It follows that  $L$  is cyclic, a property that is not so easy to see from the regular expression representing  $L$ .

$$\boxed{* 1}$$

$a$	$* ab$
$* ba$	$* b$

$$\boxed{* a^2}$$

**Strongly cyclic languages**

Let  $\mathcal{A} = (Q, A, \cdot)$  be a finite (possibly incomplete) deterministic automaton. A word  $u$  stabilizes a subset  $P$  of  $Q$  if  $P \cdot u = P$ . Given a subset  $P$  of  $Q$ , we denote by  $\text{Stab}(P)$  the set of all words that stabilize  $P$ . We also denote by  $\text{Stab}(\mathcal{A})$  the set of words which stabilize at least one nonempty subset  $P$  of  $Q$ : it is by definition the language that stabilizes  $\mathcal{A}$ .

**Proposition 2.44** *The language  $\text{Stab}(\mathcal{A})$  is the set of words  $u$  such that, for some state  $q$  of  $\mathcal{A}$ ,  $q \cdot u^n$  is defined for all  $n > 0$ .*

**Proof.** If  $u \in \text{Stab}(\mathcal{A})$ , then  $u$  stabilizes some nonempty subset  $P$  of  $Q$ . Therefore for each state  $q \in P$ ,  $q \cdot u^n$  is defined for all  $n > 0$ .

Conversely, suppose that for some state  $q$  of  $\mathcal{A}$ ,  $q \cdot u^n$  is defined for all  $n > 0$ . Then there exist two integers  $k < m$  such that  $q \cdot u^k = q \cdot u^m$ . It follows that  $u$  stabilizes the set  $\{q \cdot u^i \mid k \leq i \leq m\}$ .  $\square$

**Example 2.2** If  $\mathcal{A}$  is the automaton represented in Figure 2.6, then

$$\text{Stab}(\{1\}) = (b + aa)^*, \text{Stab}(\{2\}) = (ab^*a)^*, \text{Stab}(\{1, 2\}) = a^*$$

and  $\text{Stab}(\mathcal{A}) = (b + aa)^* + (ab^*a)^* + a^*$ .

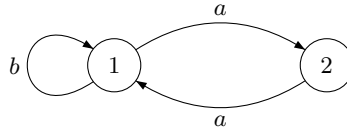

**Figure 2.6.** The automaton  $\mathcal{A}$ .

A language is *strongly cyclic* if it stabilizes some finite deterministic automaton.

**Proposition 2.45** *Let  $L$  be a nonfull recognisable language. The following conditions are equivalent:*

- (1)  $L$  is strongly cyclic,
- (2) there is a morphism  $\varphi$  from  $A^*$  onto a finite monoid  $T$  with zero such that  $L = \varphi^{-1}(\{t \in T \mid t^\omega \neq 0\})$ ,
- (3) the syntactic monoid  $M$  of  $L$  has a zero and its syntactic image is the set of all elements  $s \in M$  such that  $s^\omega \neq 0$ .

**Proof.** (1) implies (2). If  $L$  is strongly cyclic, it stabilizes a trim automaton  $\mathcal{A}$ . Let  $T$  be the transition monoid of  $\mathcal{A}$ , let  $k$  be the exponent of  $T$  and let  $\varphi : A^* \rightarrow T$  be the natural morphism. Let  $u \in A^*$  and let  $t = \varphi(u)$ . If  $u \notin L$  then by Proposition 2.44, there exists for each state  $q$  an integer  $n_q$  such that  $q \cdot u^{n_q}$  is undefined. Consequently, if  $n$  is larger than all the  $n_q$ , then  $q \cdot u^n$  is undefined for every  $q$ . Therefore  $t^n = t^\omega$  and this element is a zero of  $T$ . If now  $u \in L$ , then for some state  $q$  of  $\mathcal{A}$ ,  $q \cdot u^n$  is defined for all  $n > 0$  and thus  $t^\omega$  is not a zero of  $T$ . This proves (2).

(2) implies (3). Suppose that (2) holds and let  $R = \{t \in T \mid t^\omega \neq 0\}$ . Let  $\eta : A^* \rightarrow M$  be the syntactic morphism of  $L$  and let  $P$  be its syntactic image. By Proposition IV.4.24, there is a surjective morphism  $\pi : T \rightarrow M$  such that  $\eta = \pi \circ \varphi$  and  $R = \pi^{-1}(P)$ . It follows that  $M$  has a zero. Further, this zero is not in  $P$ , otherwise  $R$  would contain the zero of  $T$ . Let now  $u$  be a word of  $A^*$ . Let  $t = \varphi(u)$  and  $s = \pi(t)$ . If  $t^\omega = 0$ , then  $s^\omega = 0$ . If  $t^\omega \neq 0$ , then  $t^\omega \in R$ . It follows that  $s^\omega \in P$  and thus  $s^\omega \neq 0$ . Consequently, the conditions  $t^\omega \neq 0$  and  $s^\omega \neq 0$  are equivalent, which proves (3).

(3) implies (1). Suppose now that  $M$  has a zero and that  $P$  is the set of all elements  $s \in M$  such that  $s^\omega \neq 0$ . We modify the construction given in the proof of Proposition IV.3.19. We take  $\mathcal{A} = (M - 0, A, \cdot, 1, P)$  where the action is defined as follows

$$s \cdot a = \begin{cases} s\eta(a) & \text{if } s\eta(a) \neq 0 \\ \text{undefined} & \text{otherwise} \end{cases}$$

We claim that  $L$  stabilizes  $\mathcal{A}$ . Let  $u \in A^*$  and  $s = \eta(u)$ . If  $u \in L$ , then  $s \cdot u^n = s^{n+1}$ . This element is nonzero, for otherwise one would have  $(s^{n+1})^\omega = s^\omega = 0$  which is not possible by the definition of  $P$ . If now  $u \notin L$ , then there is an

integer  $n$  such that  $s^n = 0$  and thus the transition  $q \cdot u^n$  is undefined for all  $q \in M - 0$  which proves the claim.  $\square$

**Example 2.3** Let  $L = (b + aa)^* + (ab^*a)^* + a^*$  be the strongly cyclic language considered in Example 2.2. The syntactic monoid of  $L$  is the monoid with zero presented by the relations  $aa = 1$ ,  $bb = b$ ,  $abab = 0$  and  $bab = 0$ . Its transition table and its  $\mathcal{J}$ -class structure are represented below. The syntactic image of  $L$  is  $\{1, a, b, aba\}$ .

	1	2	3	4	5	6	
*	1	1	2	3	4	5	6
	$a$	3	5	1	6	2	4
*	$b$	4	2	2	4	0	0
	$ab$	2	0	4	0	2	4
	$ba$	6	5	5	6	0	0
*	$aba$	5	0	6	0	5	6
*	$bab$	0	0	0	0	0	0

*	1	$a$
---	---	-----

*	$aba$	$ab$
$ba$	*	$b$

*	0
---	---

It remains to give the equational description of strongly cyclic languages.

**Proposition 2.46** *A recognisable language is strongly cyclic if and only if it satisfies the identities  $ux^\omega v \rightarrow x^\omega$  and  $x^\omega \leftrightarrow x$ .*

Let us first prove a technical lemma.

**Lemma 2.47** *A language which satisfies the identities  $ux^\omega v \rightarrow x^\omega$  and  $x^\omega \leftrightarrow x$  also satisfies the identities  $xy \leftrightarrow yx$  and  $0 \leq x$ .*

**Proof.** Let  $L$  be a language which satisfies the identities  $ux^\omega v \rightarrow x^\omega$  and  $x^\omega \leftrightarrow x$ . The main trick to get the identity  $xy \leftrightarrow yx$  is hidden in the fact that  $(xy)^\omega$  and  $(yx)^\omega$  are conjugate. More precisely, the derivation

$$\begin{aligned}
 xy \leftrightarrow (xy)^\omega &= (xy)^\omega (xy)^\omega = (xy)^{\omega-1} xy (xy)^{\omega-1} xy \\
 &= ((xy)^{\omega-1} x) (yx)^\omega y \rightarrow (yx)^\omega \leftrightarrow yx
 \end{aligned}$$

shows that  $xy \rightarrow yx$  and the opposite identity  $yx \rightarrow xy$  follows by symmetry.

Theorem 2.25 shows that  $L$  satisfies the identity  $0 \leq x$  if and only if it is nondense or full. Let  $n$  be the exponent of  $L$ . Suppose that  $L$  is not full and let us prove that it is nondense. Let  $x \notin L$ . We claim that for all  $u, v \in A^*$ ,  $ux^n v \notin L$ . Indeed, if  $ux^n v \in L$ , the identity  $ux^\omega v \rightarrow x^\omega$  gives  $x^n \in L$  and the identity  $x^\omega \leftrightarrow x$  gives  $x \in L$ , a contradiction. This proves the claim and the lemma.  $\square$

Let us now come back to the proof of Proposition 2.46.

**Proof.** Let  $L$  be a recognisable strongly cyclic language, let  $M$  be its syntactic monoid and let  $P$  be its syntactic image. Lemma 2.47 shows that  $L$  has a zero. Observing that  $x^\omega = (x^\omega)^\omega$ , one gets

$$x \in P \iff x^\omega \neq 0 \iff (x^\omega)^\omega \neq 0 \iff x^\omega \in P$$

which proves that  $L$  satisfies the identity  $x^\omega \leftrightarrow x$ . Finally, if  $ux^\omega v \in P$ , then  $(ux^\omega v)^\omega \neq 0$ . Therefore  $x^\omega \neq 0$ , whence  $x \in P$  and finally  $x^\omega \in P$  since  $x^\omega \leftrightarrow x$ . Thus  $L$  satisfies the identity  $ux^\omega v \rightarrow x^\omega$ .

Conversely, suppose that  $L$  satisfies the two identities of the statement. By Lemma 2.47,  $M$  has a zero and  $0 \notin P$ . By Proposition 2.45, it suffices to prove that  $x \in P$  if and only if  $x^\omega \neq 0$ . First, if  $x \in P$ , then  $x^\omega \in P$  and since  $0 \notin P$ , one has  $x^\omega \neq 0$ . Now, if  $x^\omega \neq 0$ , then  $ux^\omega v \in P$  for some  $u, v \in M$  (since  $x^\omega$  is not equivalent to 0 in the syntactic equivalence of  $P$ ). It follows  $x^\omega \in P$  by the first identity and  $x \in P$  by the second one.  $\square$

The next corollaries allows a precise comparison between cyclic and strongly cyclic languages.

**Corollary 2.48** *Any recognisable strongly cyclic language is cyclic.*

**Proof.** It suffices to prove that a recognisable strongly cyclic language also satisfies the identity  $xy \leftrightarrow yx$ . Indeed, for each  $x, y \in M$ ,  $(xy)^\omega$  and  $(yx)^\omega$  are two conjugate idempotents. It follows that  $(xy)^\omega \neq 0$  if and only if  $(yx)^\omega \neq 0$ .  $\square$

**Corollary 2.49** *Let  $L$  be a recognisable cyclic language. Let  $M$  be its syntactic monoid and let  $P$  be its syntactic image. Then  $L$  is strongly cyclic if and only if for all idempotent  $e, f$  of  $M$ , the conditions  $e \in P$  and  $e \leq_{\mathcal{J}} f$  imply  $f \in P$ .*

The proof is again a typical exercise on identities.

**Proof.** Let  $\varphi : A^* \rightarrow M$  be the syntactic morphism of  $L$ . Suppose that  $L$  is strongly cyclic and let  $e, f$  be two idempotents of  $M$  such that  $e \leq_{\mathcal{J}} f$ . Also let  $s, t \in M$  be such that  $e = sft$ . Lifting up to  $A^*$ , one can find words  $x, y, u, v$  such that  $\varphi(x) = e$ ,  $\varphi(y) = f$ ,  $\varphi(u) = s$  and  $\varphi(v) = t$ . By Proposition 2.46,  $L$  satisfies the identities (a)  $ux^\omega v \rightarrow x^\omega$  and (b)  $x^\omega \leftrightarrow x$ . Now  $\widehat{\varphi}(uy^\omega v)^\omega = sft = e \in P$ , and thus by (b)  $\widehat{\varphi}(uy^\omega v) \in P$ . Since  $\widehat{\varphi}(uy^\omega v) = \widehat{\varphi}(u)\widehat{\varphi}(y)^\omega\widehat{\varphi}(v)$ , it follows by (a) that  $\widehat{\varphi}(y)^\omega \in P$  and thus  $f \in P$ .

In the opposite direction, suppose that for all idempotent  $e, f$  of  $M$ , the conditions  $e \in P$  and  $e \leq_{\mathcal{J}} f$  imply  $f \in P$ . Since  $L$  is cyclic it satisfies the identity  $x^\omega \leftrightarrow x$  by Proposition 2.40. We claim that it also satisfies the identity  $ux^\omega v \rightarrow x^\omega$ . First,  $\widehat{\varphi}(ux^\omega v) \in P$  implies  $\widehat{\varphi}(ux^\omega v)^\omega \in P$  since  $x^\omega \leftrightarrow x$ . Further, since  $\widehat{\varphi}(ux^\omega v)^\omega \leq_{\mathcal{J}} \widehat{\varphi}(x^\omega)$ , one also has  $\widehat{\varphi}(x^\omega) \in P$ , which finally gives  $\widehat{\varphi}(x) \in P$  since  $x^\omega \leftrightarrow x$ .  $\square$

**Proposition 2.50** *Recognizable strongly cyclic languages are closed under inverse of morphisms, finite intersection and finite union but not under quotients.*

**Proof.** Theorem VIII.4.13 and Proposition 2.46 show that strongly cyclic languages form a positive stream of languages. It remains to show that there are not closed under quotients. The language  $L = (b + aa)^* + (ab^*a)^* + a^*$  of Example 2.3 is strongly cyclic. However, its quotient  $b^{-1}L = (b + aa)^*$  is not strongly cyclic, since  $aa \in (b + aa)^*$  but  $a \notin (b + aa)^*$ .  $\square$

We now give the connexion between cyclic and strongly cyclic languages.

**Theorem 2.51** *A recognisable language is cyclic if and only if it is a Boolean combination of recognisable strongly cyclic languages.*

**Proof.** Propositions 2.40 and 2.46 and the remark preceding Proposition 2.50 show that a Boolean combination of recognisable strongly cyclic language is cyclic.

We now show that any cyclic language  $L$  is a Boolean combination of recognisable strongly cyclic languages. The proof is by induction on the size of a monoid with zero fully recognising  $L$ . Such a monoid always exists, since by Corollary 2.43, the syntactic monoid of  $L$  has a zero.

Let  $T$  be a monoid with zero, let  $\varphi : A^* \rightarrow T$  be a surjective morphism recognising  $L$  and let  $P = \varphi(L)$ . We may also assume that  $0 \notin P$ . Otherwise, observing that  $0 \notin P^c$ , it suffices to prove the result for  $L^c$ , which is also cyclic and fully recognised by  $\varphi$ .

If  $T$  is trivial, then  $1 = 0$  and  $P$  is empty. Thus  $L$  is necessarily the empty language, which is strongly cyclic since it stabilizes the empty automaton. Suppose now that  $T$  is nontrivial. Let us set

$$R = \{t \in T \mid t^\omega \neq 0\}, \quad S = R - P, \quad U = \varphi^{-1}(R) \text{ and } V = U - L$$

Proposition 2.45 shows that  $U$  is strongly cyclic. Further  $P$  is a subset of  $R$  and thus  $L$  is contained in  $U$ . Also note that  $V = \varphi^{-1}(S)$ . Let  $D$  be a 0-minimal  $\mathcal{J}$ -class of  $T$  and let  $s \in D$ . Then  $s$  is a nonzero element such that  $t \leq_{\mathcal{J}} s$  implies  $t \mathcal{J} s$  or  $t = 0$ .

Suppose first that  $P \cap D = \emptyset$ . We claim that  $s \sim_P 0$ . Indeed, let  $x, y \in T$ . Since  $x0y = 0$  and  $0 \notin P$ , it suffices to prove that  $xsy \notin P$ . But this is clear, since  $xsy$  belongs to  $D \cup \{0\}$ , which is disjoint from  $P$ . Therefore  $L$  is fully recognised by  $T/\sim_P$ , a strict quotient of  $T$ , and the induction hypothesis gives the result.

Suppose now that  $P \cap D \neq \emptyset$  and let  $t \in P \cap D$ . Then  $t^\omega \in P$  since  $L$  is cyclic. In particular  $t^\omega \neq 0$  and thus  $t^\omega \in P \cap D$ . We claim that  $t \sim_S 0$ . Again, as  $0 \notin S$ , it suffices to prove that for all  $x, y \in T$ ,  $xyt \notin S$ . We consider two cases. If  $(xyt)^\omega = 0$ , then  $xyt \notin R$  by the definition of  $R$ . Now, if  $(xyt)^\omega \neq 0$ , then  $(xyt)^\omega \mathcal{J} t^\omega$  since  $D$  is a 0-minimal  $\mathcal{J}$ -class. But since  $t^\omega \in P$ , we also have  $(xyt)^\omega \in P$  by Proposition 2.42.

It follows that the language  $V$  is fully recognised by  $T/\sim_S$ , a strict quotient of  $T$ . Since  $V$  is a cyclic language, the induction hypothesis tells us that  $V$  is a Boolean combination of recognisable strongly cyclic languages and so is  $L = U - V$ .  $\square$

### 3 Exercises

1. Consider the variety of semigroups  $\mathbf{N}_k = \llbracket x_1 \cdots x_k = y_1 \cdots y_k \rrbracket$  and let  $\mathcal{N}_k$  be the corresponding  $+$ -variety of languages.

- (1) Show that a nonempty semigroup  $S$  is in  $\mathbf{N}_k$  if and only if it has a zero and satisfies  $S^k = 0$ .
- (2) Show that, for every alphabet  $A$ ,  $\mathcal{N}_k(A^+)$  is the Boolean algebra generated by the languages of the form  $\{u\}$  where  $|u| < k$ .

2. Consider the variety of semigroups  $\ell\mathbf{1}_k = \llbracket x_1 \cdots x_k y = x_1 \cdots x_k \rrbracket$  and let  $\ell\mathcal{I}_k$  be the corresponding  $+$ -variety of languages. Show that, for every alphabet  $A$ ,  $\ell\mathcal{I}_k(A^+)$  is the set of all languages of the form  $FA^* \cup G$ , where  $F$  and  $G$  are

subsets of  $A^+$  formed of words of length equal to or less than  $k$  and less than  $k$  respectively.

**3.** Consider the variety of semigroups  $\mathbb{L}\mathbf{1}_k = \llbracket x_1 \cdots x_k y x_1 \cdots x_k = x_1 \cdots x_k \rrbracket$  and let  $\mathcal{L}\mathcal{I}_k$  be the corresponding  $+$ -variety of languages. Show that, for every alphabet  $A$ ,  $\mathcal{L}\mathcal{I}_k(A^+)$  is the Boolean algebra generated by the languages of the form  $uA^*$  and  $A^*u$ , where  $|u| \leq k$ .

## 4 Notes

The results of Section 2.3 are adapted from [6].





# Chapter X

## Star-free languages

The characterisation of star-free languages, obtained by Schützenberger in 1965, is the second most important result of the theory of finite automata, right after Kleene's theorem.

### 1 Star-free languages

Let  $A$  be a finite alphabet. The set of *star-free* languages of  $A^*$  is the smallest set  $\mathcal{R}$  of languages of  $A^*$  such that

- (a)  $\mathcal{R}$  contains the empty set, the set  $\{1\}$  and, for each  $a \in A$ , the singleton  $\{a\}$ .
- (b)  $\mathcal{R}$  is closed under finite union, finite product and complement.

Thus the definition of the star-free languages follows the same definition scheme as the one of rational languages, with the difference that the star operation is replaced by the complement. Since the rational languages are closed under complement, every star-free subset is rational, but we shall see later on that the converse is not true. It follows also immediately from the definition that every finite set is star-free.

We shall follow the notation of Chapter IV. Union will be denoted additively, the empty set will be denoted by 0, the singleton  $\{u\}$  will be simply denoted by  $u$ , the product will be denoted by simple juxtaposition and  $L^c$  will denote the complement of a subset  $L$  of  $A^*$ . The star-free sets are thus described by expressions using the letters of the alphabet  $A$ , the constants 0 and 1 and the three operators union, product and complement. It is not always easy to find such an expression, as is shown in the examples below.

#### Example 1.1

- (1)  $A^*$  is a set star-free, since  $A^* = 0^c$
- (2) If  $B$  is a subset of  $A$ ,  $A^*BA^*$  is star-free by (1). It follows that  $B^*$  is star-free, since

$$B^* = A^* - \sum_{a \in A-B} A^*aA^* = \left( \sum_{a \in A-B} 0^c a 0^c \right)^c$$

- (3) If  $A = \{a, b\}$ , the set  $(ab)^*$  is star-free. Indeed

$$(ab)^* = (b0^c + 0^c a + 0^c a a 0^c + 0^c b b 0^c)^c$$

## 2 Schützenberger's theorem

Recall that a finite monoid  $M$  is aperiodic if there exists an integer  $n$  such that, for all  $x \in M$ ,  $x^n = x^{n+1}$ .

**Proposition 2.1** *Aperiodic monoids form a variety of finite monoids.*

We also prove a useful property of aperiodic monoids.

**Proposition 2.2** *A finite ordered monoid  $M$  is aperiodic if and only if it satisfies the identity  $x^{n+1} \leq x^n$  for some  $n > 0$ .*

**Proof.** If  $M$  is aperiodic, it satisfies by definition an identity of the form  $x^{n+1} = x^n$  and the identity  $x^{n+1} \leq x^n$  is trivially satisfied. Conversely, suppose that  $M$  satisfies the identity  $x^{n+1} \leq x^n$  for some  $n > 0$ . Let  $\omega$  be a multiple of the exponent of  $M$  such that  $\omega \geq n$ . Then

$$x^\omega = x^{2\omega} \leq x^{2\omega-1} \leq x^{2\omega-2} \leq \dots \leq x^{\omega+1} \leq x^\omega$$

whence  $x^\omega = x^{\omega+1}$  for all  $x \in M$ . Thus  $M$  is aperiodic.  $\square$

We are now ready to state Schützenberger's theorem.

**Theorem 2.3 (Schützenberger)** *A language is star-free if and only if its syntactic monoid is aperiodic.*

**Proof.** The easiest part of the proof relies on a syntactic property of the concatenation product<sup>1</sup>. Let  $L_0$  and  $L_1$  be two recognisable languages of  $A^*$  and let  $L = L_0L_1$ . Let  $M_0$ ,  $M_1$  and  $M$  be the ordered syntactic monoids of  $L_0$ ,  $L_1$  and  $L$ .

**Lemma 2.4** *If  $M_0$  and  $M_1$  are aperiodic, so is  $M$ .*

**Proof.** Let  $n_0$ ,  $n_1$  and  $m$  be the respective exponents of  $M_0$ ,  $M_1$  and  $M$  and let  $n = n_0 + n_1 + 1$ . We claim that, for all  $x \in M$ ,  $x^{n+1} \leq x^n$ . By Proposition 2.2, this property will suffice to show that  $M$  is aperiodic.

By the definition of the syntactic order, the claim is equivalent to proving that, for each  $x, u, v \in A^*$ ,  $ux^n v \in L$  implies  $ux^{n+1} v \in L$ . One can of course suppose that  $x \neq 1$ . If  $ux^n v \in L$ , there exists a factorisation  $ux^n v = x_0 x_1$  with  $x_0 \in L_0$  and  $x_1 \in L_1$ . Two cases are possible. Either  $x_0 = ux^{n_0} r$  with  $rx_1 = x^{n-n_0} v$ , or  $x_1 = sx^{n_1} v$  with  $x_0 s = ux^{n-n_1}$ . Let us consider the first case, since the second case is symmetric. Since  $M_0$  is aperiodic and since  $ux^{n_0} r \in L_0$ , we have  $ux^{n_0+1} r \in L_0$  and hence  $ux^{n+1} v \in L$ .  $\square$

Let us fix an alphabet  $A$  and let  $\mathcal{A}(A^*)$  be the set of recognisable languages of  $A^*$  whose syntactic monoid is aperiodic. An elementary computation shows that the syntactic monoid of the languages  $\{1\}$  and  $a$ , for  $a \in A$ , is aperiodic. Therefore, the set  $\mathcal{A}(A^*)$  contains the languages of this type. Further, by Proposition IV.2.8, a language and its complement have the same syntactic monoid,  $\mathcal{A}(A^*)$  is closed under complement. It is also closed under finite union by Proposition IV.2.9 and hence under Boolean operations. Lemma 2.4 shows

<sup>1</sup>an improved version of this result is given in Theorem XIII.5.19

that  $\mathcal{A}(A^*)$  is also closed under product. Consequently,  $\mathcal{A}(A^*)$  contains the star-free sets.

To establish the converse<sup>2</sup>, we need two elementary properties of aperiodic monoids. The first property is a simple reformulation of Theorem V.1.9 (5) in the case of aperiodic monoids.

**Lemma 2.5 (Simplification Lemma)** *Let  $M$  an aperiodic monoid and let  $p, q, r \in M$ . If  $pqr = q$ , then  $pq = q = qr$ .*

**Proof.** Let  $n$  the exponent of  $M$ . Since  $pqr = q$ , we also have  $p^n q r^n = q$ . Since  $M$  is aperiodic, we have  $p^n = p^{n+1}$  and hence  $pq = pp^n q r^n = p^n q r^n = q$  and, in the same way,  $qr = q$ .  $\square$

The second property leads to a decomposition of each subset of an aperiodic monoid as a Boolean combination of right ideals, left ideals, or ideals.

**Lemma 2.6** *Let  $M$  be an aperiodic monoid and let  $m \in M$ . Then  $\{m\} = (mM \cap Mm) - J_m$ , with  $J_m = \{s \in M \mid m \notin MsM\}$ .*

**Proof.** It is clear that  $m \in (mM \cap Mm) - J_m$ . Conversely, if  $s \in (mM \cap Mm) - J_m$ , there exist  $p, r \in M$  such that  $s = pm = mr$ . Moreover, as  $s \notin J_m$ ,  $m \in MsM$ . It follows by Theorem V.1.9 that  $m \mathcal{H} s$  and by Proposition VII.4.22 that  $m = s$  since  $M$  is aperiodic.  $\square$

We now need proving that if  $\varphi : A^* \rightarrow M$  is a morphism from  $A^*$  into an aperiodic monoid  $M$ , the set  $\varphi^{-1}(P)$  is star-free for every subset  $P$  of  $M$ . The formula

$$\varphi^{-1}(P) = \sum_{m \in P} \varphi^{-1}(m)$$

allows one to assume that  $P = \{m\}$ . We shall show that  $\varphi^{-1}(m)$  is star-free by induction on the integer  $r(m) = |M - MmM|$ . The initial step is treated in the next lemma.

**Lemma 2.7** *If  $r(m) = 0$ , then  $m = 1$  and  $\varphi^{-1}(m)$  is star-free*

**Proof.** If  $r(m) = 0$ , then  $M = MmM$  and there exist  $u, v \in M$  such that  $umv = 1$ . Further, the Simplification Lemma applied to  $(um)1(v) = 1$  and to  $(u)1(mv) = 1$  gives  $u = v = 1$  and hence also  $m = 1$ . Let us show that  $\varphi^{-1}(1) = B^*$ , where  $B = \{a \in A \mid \varphi(a) = 1\}$ . If  $u \in B^*$ , we have of course  $\varphi(u) = 1$ . Conversely, if  $\varphi(u) = 1$ , the Simplification Lemma shows that  $\varphi(a) = 1$  for each letter  $a$  of  $u$ , and hence  $u \in B^*$ . Now, as was shown in example 1.1, (2),  $B^*$  is a star-free set.  $\square$

Assume now that  $r(m) > 0$  and that the property has been established for each element  $s$  such that  $r(s) < r(m)$ . We shall now prove the formula

$$\varphi^{-1}(m) = (UA^* \cap A^*V) - (A^*CA^* \cup A^*WA^*) \quad (2.1)$$

<sup>2</sup>Another proof is given on page 255.

where

$$\begin{aligned} U &= \sum_{(n,a) \in E} \varphi^{-1}(n)a & V &= \sum_{(a,n) \in F} a\varphi^{-1}(n) \\ C &= \{a \in A \mid m \notin M\varphi(a)M\} & W &= \sum_{(a,n,b) \in G} a\varphi^{-1}(n)b \end{aligned}$$

with

$$\begin{aligned} E &= \{(n, a) \in M \times A \mid n\varphi(a) \mathcal{R} m \text{ but } n \notin mM\} \\ F &= \{(a, n) \in A \times M \mid \varphi(a)n \mathcal{L} m \text{ but } n \notin Mm\} \\ G &= \{(a, n, b) \in A \times M \times A \mid \\ &\quad m \in (M\varphi(a)nM \cap Mn\varphi(b)M) - M\varphi(a)n\varphi(b)M\} \end{aligned}$$

Denote by  $L$  the right hand side of (2.1). We first prove the inclusion  $\varphi^{-1}(m) \subseteq L$ . Let  $u \in \varphi^{-1}(m)$  and let  $p$  be the shortest prefix of  $u$  such that  $\varphi(p) \mathcal{R} m$ . The word  $p$  cannot be empty, since otherwise  $m \mathcal{R} 1$ , whence  $m = 1$  by the Simplification Lemma. Put  $p = ra$  with  $r \in A^*$  and  $a \in A$  and let  $n = \varphi(r)$ . By construction,  $(n, a) \in E$  since

- (a)  $n\varphi(a) = \varphi(r)\varphi(a) = \varphi(p) \mathcal{R} m$ ,
- (b) since  $m \leq_{\mathcal{R}} \varphi(p) = n\varphi(a) \leq_{\mathcal{R}} n$ , one has  $n \notin mM$ , for otherwise we would have  $n \mathcal{R} m$ .

It follows that  $p \in \varphi^{-1}(n)a$  and  $u \in UA^*$ . A symmetric argument would show that  $u \in A^*V$ . If  $u \in A^*CA^*$ , there exists a letter  $a$  of  $C$  such that  $m = \varphi(u) \in M\varphi(a)M$ , a contradiction with the definition of  $C$ . Similarly, if  $u \in A^*WA^*$ , there exist  $(a, n, b) \in G$  such that  $m \in M\varphi(a)n\varphi(b)M$ , a contradiction this time with the definition of  $G$ . Therefore  $u \in L$ .

Conversely, let  $u \in L$  and let  $s = \varphi(u)$ . Since  $u \in UA^*$ , we have  $u \in \varphi^{-1}(n)aA^*$  for some  $(n, a) \in E$  and hence  $s = \varphi(u) \in n\varphi(a)M$ . Now, since  $(n, a) \in E$ ,  $n\varphi(a)M = mM$  and thus  $s \in mM$ . A dual argument shows that  $u \in VA^*$  implies  $s \in Mm$ . By Lemma 2.6, in order to prove that  $s = m$ , and hence that  $u \in \varphi^{-1}(m)$ , it suffices to prove that  $s \notin J_m$ , that is,  $m \in MsM$ . Supposing the contrary, consider a factor  $f$  of  $u$  of minimal length such that  $m \notin M\varphi(f)M$ . The word  $f$  is necessarily nonempty. If  $f$  is a letter, this letter is in  $C$  and  $u \in A^*CA^*$ , which is impossible. We may thus set  $f = agb$ , with  $a, b \in A$ . Set  $n = \varphi(g)$ . Since  $f$  is of minimal length, we have  $m \in M\varphi(a)nM$  and  $m \in Mn\varphi(b)M$ . Consequently  $(a, n, b) \in G$  and  $f \in W$ , which is impossible again.

Formula (2.1) is thus established and it suffices now to show that  $U$ ,  $V$  and  $W$  are star-free, since we have already seen in Example 1.1 that  $A^*CA^*$  is star-free. Let  $(n, a) \in E$ . Since  $n\varphi(a)M = mM$ , we have  $MmM \subseteq MnM$  and hence  $r(n) \leq r(m)$ . Moreover, as  $m \leq_{\mathcal{R}} n$ , Theorem V.1.9 shows that if  $MmM = MnM$ , we have  $n \mathcal{R} m$ , which is not possible since  $n \notin mM$ . Therefore  $r(n) < r(m)$  and  $U$  is star-free by the induction hypothesis.

A symmetric argument would work for  $V$ . There remains to treat the case  $W$ . Let  $(a, n, b) \in G$ . One has  $r(n) \leq r(m)$  since  $m \in MnM$ . Suppose that  $MmM = MnM$ . Then in particular  $n \in MmM$  and as  $m \in M\varphi(a)nM$  and  $m \in Mn\varphi(b)M$ , it follows  $n \in M\varphi(a)nM$  and  $n \in Mn\varphi(b)M$ , whence  $n \mathcal{L} \varphi(a)n$  and  $n \mathcal{R} n\varphi(b)$ . By Proposition V.1.10,  $n\varphi(b) \mathcal{L} \varphi(a)n\varphi(b)$ , and

hence  $m \mathcal{J} \varphi(a)n\varphi(b)$ , a contradiction with the definition of  $G$ . Consequently  $r(n) < r(m)$  and  $W$  is star-free by the induction hypothesis.  $\square$

**Example 2.1** Let  $A = \{a, b\}$  and let  $L = (ab)^*$ . The minimal automaton of  $L$  is represented in Figure 2.1.

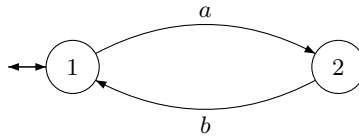
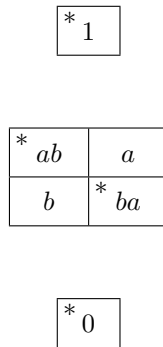

**Figure 2.1.** The minimal automaton of  $(ab)^*$ .

The syntactic monoid  $M$  of  $L$  is the monoid consisting of the six matrices

$$\begin{aligned}
 I &= \begin{pmatrix} 1 & 0 \\ 0 & 1 \end{pmatrix} & a &= \begin{pmatrix} 0 & 1 \\ 0 & 0 \end{pmatrix} & b &= \begin{pmatrix} 0 & 0 \\ 1 & 0 \end{pmatrix} \\
 aa &= \begin{pmatrix} 0 & 0 \\ 0 & 0 \end{pmatrix} & ab &= \begin{pmatrix} 1 & 0 \\ 0 & 0 \end{pmatrix} & ba &= \begin{pmatrix} 0 & 0 \\ 0 & 1 \end{pmatrix}
 \end{aligned}$$

and it is defined by the relations  $a^2 = b^2 = 0$ ,  $aba = a$  and  $bab = b$ . Its  $\mathcal{D}$ -class structure is given in Figure 2.2:



**Figure 2.2.** The  $\mathcal{D}$ -class structure of  $M$ .

This monoid is aperiodic, since  $x^2 = x^3$  for each  $x \in M$ , and hence  $L$  is star-free.

**Example 2.2** Let  $A = \{a, b\}$  and let  $L' = (aa)^*$ . The minimal automaton of  $L'$  is represented in Figure 2.3:

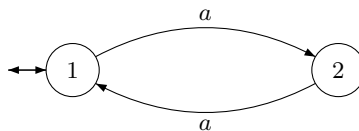

**Figure 2.3.** The minimal automaton of  $(aa)^*$ .

The syntactic monoid  $M'$  of  $L'$  is the monoid consisting of the three matrices

$$I = \begin{pmatrix} 1 & 0 \\ 0 & 1 \end{pmatrix} \quad a = \begin{pmatrix} 0 & 1 \\ 1 & 0 \end{pmatrix} \quad b = \begin{pmatrix} 0 & 0 \\ 0 & 0 \end{pmatrix}$$

and it is defined by the relations  $a^2 = 1$  and  $b = 0$ . Its  $\mathcal{D}$ -class structure is given in Figure 2.4:

$$\boxed{*1, a}$$

$$\boxed{*0}$$

**Figure 2.4.** The  $\mathcal{D}$ -class structure of  $M'$ .

This monoid is not aperiodic, since, for each  $n > 0$ ,  $a^n \neq a^{n+1}$  and hence  $L'$  is not star-free.

# Chapter XI

## Piecewise testable languages

Simon's theorem shows that the languages recognised by  $\mathcal{J}$ -trivial monoids are exactly the shuffle ideals. This result has far reaching consequences, both in semigroup theory and in automata theory. We shall present two of the seven published proofs of Simon's theorem: the first one, due to Imre Simon, is based on a careful analysis of the subword ordering and has a strong combinatorial flavour. The second one, due to Straubing and Thérien, is more algebraic in nature.

As a preliminary step, we shall explore the properties of the subword ordering and give an algebraic characterisation of the shuffle ideals.

### 1 Subword ordering

Let  $A$  be a finite alphabet. Recall that a word  $u = a_1 \dots a_k \in A^*$  (where  $a_1, \dots, a_k$  are letters) is a *subword* of a word  $v \in A^*$  if there exist words  $v_0, v_1, \dots, v_k \in A^*$  such that  $v = v_0 a_1 v_1 \dots a_k v_k$ . One also says that  $v$  is a *superword* of  $u$ . For instance, *ardab* is a subword of *abracadabra*.

The subword ordering is a partial ordering on  $A^*$ , which is compatible with the concatenation product. Here is another important property of the subword ordering, due to Higman:

**Theorem 1.1** *A set of words of  $A^*$  that are pairwise incomparable for the subword ordering is necessarily finite.*

**Proof.** A sequence of words  $(u_n)_{n \geq 0}$  is said to be *subword-free* if, for all  $i < j$ ,  $u_i$  is not a subword of  $u_j$ . We claim there exist no infinite subword-free sequence. Otherwise, one would be able to find an "earliest" subword-free sequence, in the following sense:

- (1)  $u_0$  is a shortest word beginning a subword-free sequence of words,
- (2)  $u_1$  is a shortest word such that  $u_0, u_1$  is the beginning a subword-free sequence of words,
- (3)  $u_2$  is a shortest word such that  $u_0, u_1, u_2$  is the beginning a subword-free sequence of words, and so on.

Since  $A$  is finite, there exist infinitely many  $u_i$  that begin with the same letter  $a$ , say  $u_{i_0} = av_{i_0}$ ,  $u_{i_1} = av_{i_1}$ ,  $\dots$ , with  $i_0 < i_1 < \dots$ . Let us show that the sequence

$$u_0, u_1, \dots, u_{i_0-1}, v_{i_0}, v_{i_1}, \dots \quad (1.1)$$

is subword-free. First of all, the sequence  $u_0, u_1, \dots, u_{i_0-1}$  is subword-free. Next, the sequence  $v_{i_0}, v_{i_1}, \dots$  is subword-free: if  $i_r < i_s$ , then  $u_{i_r}$  is not a subword of  $u_{i_s}$  and hence  $v_{i_r}$  is not a subword of  $v_{i_s}$ . Finally, if  $0 \leq k < i_0$  and  $r \geq 0$ , then  $u_k$  is not a subword of  $v_{i_r}$ , for otherwise it would be a subword of  $u_{i_r}$ . Now, since  $v_{i_0}$  is shorter  $u_{i_0}$ , the sequence (1.1) is “earlier” than our original sequence, a contradiction. This proves the claim and the theorem follows.  $\square$

For each  $n \geq 0$ , we define an equivalence relation  $\sim_n$  on  $A^*$  by  $u \sim_n v$  if and only if  $u$  and  $v$  have the same subword of length  $\leq n$ . For instance,  $abbac \sim_1 cab$ , since these two words have the same letters  $a$ ,  $b$  and  $c$ , and  $ababab \sim_3 bababa$  since any word of length  $\leq 3$  is a subword of both words.

**Proposition 1.2** *The relation  $\sim_n$  is a congruence of finite index on  $A^*$ .*

**Proof.** Suppose that  $u \sim_n v$  and let  $x, y$  be two words of  $A^*$ . Let  $w$  be a subword of  $xuy$  of length less  $\leq n$ . The word  $w$  can be factorised as  $w_0w_1w_2$  where  $w_0, w_1$  and  $w_2$  are subwords of  $x, u$  and  $y$ , respectively. Since  $w_1$  is shorter than  $w$ ,  $|w_1| \leq n$  and thus  $w_1$  is also a subword of  $v$ . It follows that  $w_0w_1w_2$  is a subword of  $xvy$ . Dually, every subword of  $xvy$  of length  $\leq n$  is a subword of  $xuy$ . Thus  $xuy \sim_n xvy$ , showing that  $\sim_n$  is a congruence.

The  $\sim_n$ -class of  $u$  is entirely determined by the set of subwords of  $u$  of length  $\leq n$ . Since there are finitely many such words, the congruence  $\sim_n$  has finite index.  $\square$

We shall now establish some useful properties of this congruence.

**Proposition 1.3** *Let  $u, v \in A^*$  and  $a \in A$ . If  $uav \sim_{2n-1} uv$ , then either  $ua \sim_n u$  or  $av \sim_n v$ .*

**Proof.** Suppose that  $ua \not\sim_n u$  and  $av \not\sim_n v$ . Then there exists a word  $x$  of length  $\leq n$  which is a subword of  $ua$  but not of  $u$ . Likewise there exists a word  $y$  of length  $\leq n$  which is a subword of  $av$  but not of  $v$ . Necessarily one has  $x = x'a$  and  $y = ay'$  and  $x'ay'$  is a word of length  $\leq 2n - 1$  which is a subword of  $uav$  but not of  $uv$ . Therefore  $uav \not\sim_{2n-1} uv$ .  $\square$

If  $u$  is a word, we denote by  $c(u)$  the *content* of  $u$ , that is, the set of letters of  $A$  occurring in  $u$ . For instance,  $c(babaa) = \{a, b\}$ .

**Proposition 1.4** *Let  $u, v \in A^*$  and let  $n > 0$ . Then  $u \sim_n vu$  if and only if there exist  $u_1, \dots, u_n \in A^*$  such that  $u = u_1 \cdots u_n$  and  $c(v) \subseteq c(u_1) \subseteq \dots \subseteq c(u_n)$ .*

**Proof.** First of all, the result is trivial if  $u = 1$ . We shall suppose from now on that  $u$  is nonempty.

Let us show that the condition is necessary by induction on  $n$ . If  $n = 1$ ,  $u \sim_1 vu$  implies that  $u$  and  $vu$  have the same content and hence  $c(v) \subseteq c(u)$ . Suppose that  $u \sim_{n+1} vu$  and let  $u_{n+1}$  be the shortest suffix of  $u$  such that



$c(u_{n+1}) = c(u)$ . Since  $u$  is nonempty, so is  $u_{n+1}$ . Put  $u_{n+1} = au'$  with  $a \in A$ . By definition of  $u_{n+1}$ ,  $c(u')$  is strictly contained in  $c(u)$  and thus  $a$  is not a letter of  $u'$ . We claim that  $w \sim_n vw$ , where  $w$  is the prefix of  $u$  such that  $u = wau'$ . Let  $x$  be a subword of  $vw$  of length  $\leq n$ . Then  $xa$  is a subword of length  $\leq n+1$  of  $vwa$  and therefore of  $vu$ . Since  $u \sim_{n+1} vu$ ,  $xa$  is a subword of  $u = wau'$  and, since  $a$  is not a letter of  $u'$ ,  $xa$  is a subword of  $wa$ . Therefore  $x$  is a subword of  $w$ . Conversely, it is clear that every subword of  $w$  is a subword of  $vw$ , which proves the claim. By the induction hypothesis, there exist  $u_1, \dots, u_n \in A^*$  such that  $w = u_1 \cdots u_n$  and  $c(v) \subseteq c(u_1) \subseteq \dots \subseteq c(u_n)$ . Now  $u = wu_{n+1}$  and  $c(u_n) \subseteq c(u) = c(u_{n+1})$ , which concludes the induction step.

We now show that the condition is sufficient, again by induction on  $n$ . For  $n = 1$ ,  $u_1 = u$  and  $c(v) \subseteq c(u)$  implies  $c(u) = c(vu)$ , that is,  $u \sim_1 vu$ . Suppose that  $u = u_1 \cdots u_{n+1}$  with  $c(v) \subseteq c(u_1) \subseteq \dots \subseteq c(u_{n+1})$ . Then  $c(vu) = c(u) = c(u_{n+1})$  and  $u_1 \cdots u_n \sim_n vu_1 \cdots u_n$  by the induction hypothesis. Let  $x$  be a nonempty subword of length  $\leq n+1$  of  $vu$ . Let  $x'$  be the longest suffix of  $x$  such that  $x'$  is a subword of  $u_{n+1}$  and put  $x = x''x'$ .

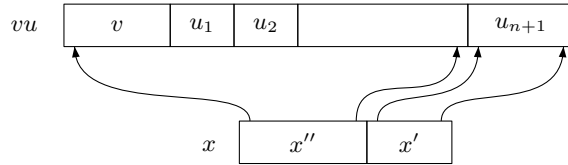

Since  $c(vu) = c(u_{n+1})$ , the factor  $u_{n+1}$  contains each letter of  $vu$ , and hence of  $x$ , at least once. In particular,  $x'$  is nonempty. Further, by the definition of  $x'$ ,  $x''$  is a subword of length  $\leq n$  of  $vu_1 \cdots u_n$ . Since  $u_1 \cdots u_n \sim_n vu_1 \cdots u_n$ ,  $x''$  is a subword of  $u_1 \cdots u_n$  and therefore  $x$  is a subword of  $u$ . Consequently, every subword of  $u$  is a subword of  $vu$  and therefore  $u \sim_{n+1} vu$ , which completes the proof.  $\square$

**Corollary 1.5** For every  $u, v \in A^*$ , one has  $(uv)^n u \sim_n (uv)^n \sim_n v(uv)^n$ .

**Proof.** The formula  $(uv)^n \sim_n v(uv)^n$  follows from Proposition 1.4. The other part of the formula is dual.  $\square$

We conclude this section with a remarkable combinatorial property of the congruence  $\sim_n$ .

**Proposition 1.6** If  $f \sim_n g$ , there exists  $h$  such that  $f$  and  $g$  are subwords of  $h$  and  $f \sim_n h \sim_n g$ .

**Proof.** The proof is achieved by induction on  $k = |f| + |g| - 2|f \wedge g|$  where  $f \wedge g$  is the largest common prefix of  $f$  and  $g$ . If  $k = 0$ , then  $f = g$  and it suffices to take  $h = f = g$ . The result is also trivial if  $f$  is a subword of  $g$  (or  $g$  is a subword of  $f$ ). These cases are excluded from now on. Thus one has  $f = uav$ ,  $g = ubw$  with  $a, b \in A$  and  $a \neq b$ . We claim that either  $ubw \sim_n ubav$  or  $uav \sim_n uabw$ . Suppose that none of these assertions is true. Since  $ubw = g \sim_n f$  and  $f$  is a subword of  $ubav$ , there exists a word  $r$  of length  $\leq n$  which is a subword of  $ubav$  but not of  $ubw$ . Likewise, there exists a word  $s$  of length  $\leq n$  which is a subword of  $uabw$  but not of  $uav$ .

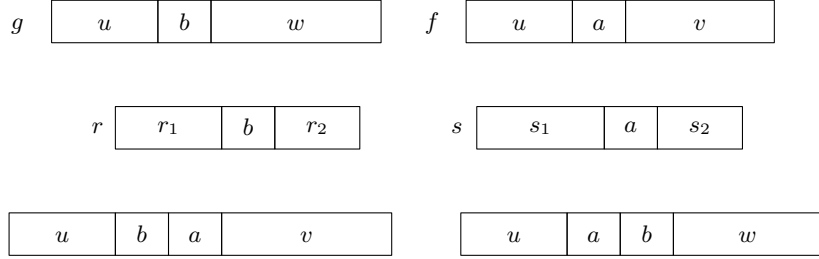

Necessarily  $r = r_1br_2$  where  $r_1$  is a subword of  $u$  and  $r_2$  is a subword of  $av$ , and  $s = s_1as_2$  where  $s_1$  is a subword of  $u$  and  $s_2$  is a subword of  $bw$ . It follows that  $r_1b$  is not a subword of  $u$  (for otherwise  $r = r_1br_2$  would be a subword of  $uav = f$  and therefore of  $g$ ). Likewise  $s_1a$  is not a subword of  $u$ .

Since  $r_2$  is a subword of  $av$ , one has  $r_2 = r'_2r''_2$  where  $r''_2 = 1$  or  $a$  and  $r'_2$  is a subword of  $v$ . Likewise, since  $s_2$  is a subword of  $bw$ ; one has  $s_2 = s''_2s'_2$  where  $s''_2 = 1$  or  $b$  and  $s'_2$  is a subword of  $w$ . Finally

$$|r_1bs'_2| + |s_1ar'_2| \leq |r_1as_2| + |s_1br_2| \leq |r| + |s| \leq 2n$$

and therefore one of the words  $r_1bs'_2$  or  $s_1ar'_2$  is of length  $\leq n$ . Suppose for example that this is  $r_1bs'_2$ . Then  $r_1bs'_2$  is a subword of  $ubw = g$  and therefore also of  $f = uav$ . However,  $r_1b$  is not a subword of  $u$ . Thus  $bs'_2$  is a subword of  $v$ , and a fortiori  $s_2$  is a subword of  $v$ .

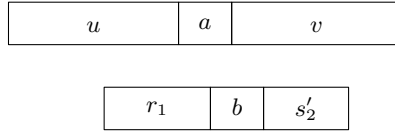

Thus  $s = s_1as_2$  is a subword of  $uav = f$ , a contradiction. This proves the claim. Suppose, for example, that  $f = uav \sim_n uabw$ . Then

$$\begin{aligned} |uav| + |uabw| - 2|uav \wedge uabw| &\leq |f| + |g| + 1 - 2|ua| \\ &\leq |f| + |g| + 1 - (2|f \wedge g| + 2) \\ &< k \end{aligned}$$

By the induction hypothesis, there exists  $h$  such that  $f = uav$  is a subword of  $h$ ,  $uabw$  is a subword of  $h$  and  $f \sim_n h \sim_n uabw$ . The proposition follows from this, since  $g$  is a subword of  $uabw$ .  $\square$

**Example 1.1** Let  $f = a^3b^3a^3b^3$  and  $g = a^2b^4a^4b^2$ . We have  $f \sim_4 g$  since all words of length 4 except  $baba$  are subwords of  $f$  and  $g$ . Applying the algorithm described in the proof of Proposition 1.6, we obtain successively

$$f = (aa)a(b^3a^3b^3) \sim_4 (aa)b(b^3a^4b^2) = g$$

whence

$$(aa)a(b^3a^3b^3) \sim_4 (aa)ab(b^3a^4b^2) \quad \text{or} \quad (aa)b(b^3a^4b^2) \sim_4 (aa)ba(b^3a^3b^3)$$

The second possibility can be ruled out, for  $baba$  is a subword of  $a^2bab^3a^3b^3$ . Therefore

$$(a^3b^3)a(a^2b^3) \sim_4 (a^3b^3)b(a^4b^2)$$

and consequently

$$(a^3b^3)a(a^2b^3) \sim_4 (a^3b^3)ab(a^4b^2) \quad \text{or} \quad (a^3b^3)b(a^4b^2) \sim_4 (a^3b^3)ba(a^2b^3)$$

The first possibility can be ruled out, for  $baba$  is a subword of  $a^3b^3aba^4b^2$ . Then

$$(a^3b^4a^3)a(b^2) \sim_4 (a^3b^4a^3)b(b^2)$$

and consequently

$$(a^3b^4a^3)a(b^2) \sim_4 (a^3b^4a^3)ab(b^2) \quad \text{or} \quad (a^3b^4a^3)b(b^2) \sim_4 (a^3b^4a^3)ba(b^2)$$

The second possibility can be ruled out, for  $baba$  is a subword of  $a^3b^4a^3bab^2$ . Therefore

$$a^3b^4a^4b^2 \sim_4 a^3b^4a^4b^3$$

It follows from this that  $f$  and  $g$  are subwords of  $h = a^3b^4a^4b^3$  and that  $f \sim_4 h \sim_4 g$ .

## 2 Simple languages and shuffle ideals

The *shuffle* of two languages  $L_1$  and  $L_2$  of  $A^*$  is the language  $L_1 \sqcup L_2$  of  $A^*$  defined by:

$$L_1 \sqcup L_2 = \{w \in A^* \mid w = u_1v_1 \cdots u_nv_n \text{ for some } n \geq 0 \text{ such that} \\ u_1 \cdots u_n \in L_1, v_1 \cdots v_n \in L_2\}$$

In particular, if  $L$  is a language of  $A^*$ , a language of the form  $L \sqcup A^*$  is called a *shuffle ideal*. Thus a language  $L$  of  $A^*$  is a shuffle ideal if every superword of a word of  $L$  is also in  $L$ .

A *simple language* is a shuffle ideal of the form

$$A^* \sqcup a_1 \cdots a_k = A^*a_1A^*a_2A^* \cdots A^*a_kA^*$$

where  $a_1, \dots, a_k \in A$ . Thus  $A^*a_1A^*a_2A^* \cdots A^*a_kA^*$  is the set of superwords of the word  $a_1 \cdots a_k$ . We can now state our first characterisation of shuffle ideals:

**Theorem 2.7** *A language is a shuffle ideal if and only if it is a finite union of simple languages.*

**Proof.** Clearly, every finite union of simple languages is a shuffle ideal. Conversely, let  $L$  be a shuffle ideal and let  $F$  be the set of all minimal words of  $L$  for the subword ordering. Thus  $L$  is the set of all superwords of  $F$ , that is  $L = F \sqcup A^*$ . Furthermore, since the elements of  $F$  are pairwise incomparable for the subword ordering, Higman's theorem (Theorem 1.1) shows that  $F$  is finite. Therefore  $L$  is the finite union of the simple languages  $A^* \sqcup u$ , where the union runs over all words  $u \in F$ .  $\square$

One can give a constructive proof which does not rely on Higman's theorem.

**Proposition 2.8** *Let  $L$  be recognisable language such that  $L \sqcup A^* = L$ . Then one can effectively find a finite language  $F$  such that  $L = F \sqcup A^*$ .*

**Proof.** Let  $n$  be the number of states of the minimal automaton  $\mathcal{A}$  of  $L$ . Set

$$F = \{u \in L \mid |u| \leq n\} \text{ and } K = F \sqcup A^*$$

We claim that  $L = K$ . Since  $F \subseteq L$ , one has  $F \sqcup A^* \subseteq L \sqcup A^* = L$  and hence  $K \subseteq L$ . If the inclusion is strict, consider a word  $u$  of minimal length in  $L - K$ . Necessarily,  $|u| > n$ , for otherwise  $u \in F$ . Let  $u = a_1 \cdots a_r$  and let  $q_0 \xrightarrow{a_1} q_1 \cdots q_{r-1} \xrightarrow{a_r} q_r$  be a successful path of label  $u$  in  $\mathcal{A}$ . As  $r > n$ , there exist two indices  $i < j$  such that  $q_i = q_j$ . Thus the word  $v = a_1 \cdots a_i a_{j+1} \cdots a_r$  is also accepted by  $\mathcal{A}$  and therefore belongs to  $L$ . Furthermore, since  $v$  is shorter than  $u$ ,  $v$  belongs to  $K$  and  $u$  belongs to  $K \sqcup A^*$ . Now, since

$$K \sqcup A^* = (F \sqcup A^*) \sqcup A^* = F \sqcup (A^* \sqcup A^*) = F \sqcup A^* = K$$

one has  $u \in K$ , a contradiction. This proves the claim and the proposition.  $\square$

**Corollary 2.9** *Every shuffle ideal is a recognisable language.*

We now come to the algebraic characterisation of shuffle ideals.

**Theorem 2.10** *A language is a shuffle ideal if and only if its ordered syntactic monoid satisfies the identity  $1 \leq x$ .*

**Proof.** Let  $L$  be a language and let  $\eta : A^* \rightarrow (M, \leq)$  be its ordered syntactic morphism. Suppose that  $L$  is a shuffle ideal. If  $uv \in L$ , then  $uxv \in L$  for each  $x \in A^*$ . Therefore  $1 \leq_L x$  and thus  $M$  satisfies the identity  $1 \leq x$ .

Conversely, if  $M$  satisfies the identity  $x \leq 1$ , then, for every  $x \in A^*$ ,  $1 \leq_L x$ , that is, the condition  $uv \in L$  implies  $uxv \in L$ . Therefore  $L$  is a shuffle ideal.  $\square$

### 3 Piecewise testable languages and Simon's theorem

A language is called *piecewise testable* if and only if it is a union of  $\sim_n$ -classes for some positive integer  $n$ .

The terminology chosen can be explained as follows: a language  $L$  is piecewise testable if there exists an integer  $n > 0$  such that one can test whether or not a word belongs to  $L$  by simple inspection of its subwords of length  $\leq n$ . Here is a first description of these languages.

**Proposition 3.11** *A language of  $A^*$  is piecewise testable if and only if it belongs to the Boolean algebra generated by the simple languages on  $A^*$ .*

**Proof.** Let  $L = A^*a_1A^* \cdots a_nA^*$  be a simple language of  $A^*$ . If  $u \in L$ , then  $a_1 \cdots a_n$  is a subword of  $u$ . Therefore, if  $u \sim_n v$ ,  $a_1 \cdots a_n$  is also a subword of  $v$  and  $v \in L$ . This shows that  $L$  is saturated by  $\sim_n$  and therefore is a finite union of  $\sim_n$ -classes.

Let  $u$  be a word of  $A^*$ . A moment's reflexion should suffice to verify the following formula:

$$\{v \in A^* \mid v \sim_n u\} = \left( \bigcap_{a_1 \cdots a_k \in E} A^* a_1 A^* \cdots a_k A^* \right) - \left( \bigcup_{a_1 \cdots a_k \in F} A^* a_1 A^* \cdots a_k A^* \right)$$

where  $E$  is the set of subwords of  $u$  of length  $\leq n$  and  $F$  is the set of words of length  $\leq n$  which are not subwords of  $u$ . It follows from this formula that if  $L$  is a union of  $\sim_n$ -classes for some positive integer  $n$ , then  $L$  belongs to the Boolean algebra generated by the simple languages on  $A^*$ .  $\square$

The syntactic characterisation of piecewise testable languages is the main result of this chapter. It relies on two results of semigroup theory of independent interest.

**Proposition 3.12** *Any finite ordered monoid satisfying the identity  $x \leq 1$  is  $\mathcal{J}$ -trivial.*

**Proof.** Let  $x$  and  $y$  be two elements of  $M$  such that  $x \mathcal{J} y$ . Then  $x = rys$  and  $y = uxv$  for some  $r, s, u, v \in M$ . Since  $r \leq 1$  and  $s \leq 1$ , it follows that  $x = rys \leq y$  and similarly,  $y \leq x$ . Thus  $x = y$ .  $\square$

**Theorem 3.13 (Simon)** *Let  $M$  be a finite  $\mathcal{J}$ -trivial monoid and let  $n$  be the maximal length of strict  $<_{\mathcal{J}}$ -chains in  $M$ . If  $\varphi : A^* \rightarrow M$  is a surjective morphism, then  $M$  is a quotient of the monoid  $A^*/\sim_{2n-1}$ .*

**Proof.** By Proposition II.3.22, it suffices to show that if  $f \sim_{2n-1} g$ , then  $\varphi(f) = \varphi(g)$ . By Proposition 1.6, we may assume that  $f$  is a subword of  $g$ . We note furthermore that if  $f$  is a subword of  $h$  and  $h$  is a subword of  $g$ , then we also have  $f \sim_{2n-1} h$ . This enables us to assume that  $f = uv$  and  $g = uav$  for some  $a \in A$ . In this case, Proposition 1.3 shows that either  $ua \sim_n u$  or  $av \sim_n v$ . Assuming the latter, there exists by Proposition 1.4 a factorisation  $v = v_1 v_2 \cdots v_n$  such that  $\{a\} \subseteq c(v_1) \subseteq \cdots \subseteq c(v_n)$ . Consider the  $\leq_{\mathcal{J}}$ -chain of length  $n+1$

$$\varphi(v_1 \cdots v_n) \leq_{\mathcal{J}} \varphi(v_2 \cdots v_n) \leq_{\mathcal{J}} \cdots \leq_{\mathcal{J}} \varphi(v_n) \leq_{\mathcal{J}} 1$$

By the choice of  $n$ , this chain is not strict and there exists an index  $i$  such that  $\varphi(v_i \cdots v_n) \mathcal{J} \varphi(v_{i+1} \cdots v_n)$ . Since  $M$  is  $\mathcal{J}$ -trivial, one has  $\varphi(v_i \cdots v_n) = \varphi(v_{i+1} \cdots v_n) = s$ . Let  $b \in c(v_i)$ . Then  $v_i = v'_i b v''_i$  for some  $v'_i, v''_i \in A^*$  and thus  $s = \varphi(v_i \cdots v_n) \leq_{\mathcal{J}} \varphi(b v''_i v_{i+1} \cdots v_n) \leq_{\mathcal{J}} \varphi(v''_i v_{i+1} \cdots v_n) \leq_{\mathcal{J}} \varphi(v_{i+1} \cdots v_n) = s$ . Since  $M$  is  $\mathcal{J}$ -trivial, we get

$$s = \varphi(v_i \cdots v_n) = \varphi(b v''_i v_{i+1} \cdots v_n) = \varphi(v''_i v_{i+1} \cdots v_n) = \varphi(v_{i+1} \cdots v_n).$$

Consequently, one has  $\varphi(b)s = s$  for each  $b \in c(v_i)$  and hence also for  $b \in c(v_{i-1}), \dots, b \in c(v_0)$  and  $b = a$ . Therefore  $\varphi(v) = \varphi(v_1 \cdots v_n) = s = \varphi(a)s = \varphi(av)$ . It follows that  $\varphi(f) = \varphi(uav) = \varphi(uv) = \varphi(g)$ , which concludes the proof.  $\square$

We now return to the announced characterisation of piecewise testable languages.

**Theorem 3.14 (Simon)** *A language is piecewise testable if and only if its syntactic monoid is finite and  $\mathcal{J}$ -trivial.*

**Proof.** Let  $L$  be a simple language. Then by Theorem 2.10, the ordered syntactic monoid of  $L$  satisfies the identity  $x \leq 1$ . By Proposition 3.12, this monoid is  $\mathcal{J}$ -trivial. Now if  $L$  is piecewise testable, it is by Proposition 3.11 a Boolean combination of simple languages, its syntactic monoid divides a product of finite  $\mathcal{J}$ -trivial monoids and hence is itself finite and  $\mathcal{J}$ -trivial.

Conversely, if the syntactic monoid of  $L$  is finite and  $\mathcal{J}$ -trivial, then by Theorem 3.13,  $L$  is a union of  $\sim_{2n-1}$ -classes, where  $n$  is the maximal length of strict  $<_{\mathcal{J}}$ -chains in  $M$ . Thus  $L$  is piecewise testable.  $\square$

## 4 Some consequences of Simon's theorem

Simon's theorem has unexpected consequences in semigroup theory. We start by defining, for each integer  $n > 0$ , three monoids  $\mathcal{C}_n$ ,  $\mathcal{R}_n$  and  $\mathcal{U}_n$  which will serve us as examples of  $\mathcal{J}$ -trivial monoids.

The monoid  $\mathcal{C}_n$  is the submonoid of  $\mathcal{T}_n$  consisting of all order preserving and extensive functions from  $\{1, \dots, n\}$  into itself. Recall that a transformation  $a$  on  $\{1, \dots, n\}$  is *order preserving* if  $p \leq q$  implies  $p \cdot a \leq q \cdot a$  and *extensive* if for all  $p$ ,  $p \leq p \cdot a$ .

The monoid  $\mathcal{R}_n$  is the monoid of all reflexive relations on  $\{1, \dots, n\}$ . It is convenient to consider  $\mathcal{R}_n$  as the monoid of Boolean matrices of size  $n \times n$  having only one entries on the diagonal. For example

$$\mathcal{R}_2 = \left\{ \begin{pmatrix} 1 & 0 \\ 0 & 1 \end{pmatrix}, \begin{pmatrix} 1 & 1 \\ 0 & 1 \end{pmatrix}, \begin{pmatrix} 1 & 0 \\ 1 & 1 \end{pmatrix}, \begin{pmatrix} 1 & 1 \\ 1 & 1 \end{pmatrix} \right\}$$

Finally,  $\mathcal{U}_n$  is the submonoid of  $\mathcal{R}_n$  consisting of the upper triangular matrices of  $\mathcal{C}_n$ . The matrices of  $\mathcal{U}_n$  are called *unitriangular*. For example,

$$\mathcal{U}_3 = \left\{ \begin{pmatrix} 1 & \varepsilon_1 & \varepsilon_2 \\ 0 & 1 & \varepsilon_3 \\ 0 & 0 & 1 \end{pmatrix} \mid \varepsilon_1, \varepsilon_2, \varepsilon_3 \in \{0, 1\} \right\}$$

**Proposition 4.15** *For each  $n > 0$ , the monoids  $\mathcal{C}_n$ ,  $\mathcal{R}_n$  and  $\mathcal{U}_n$  are  $\mathcal{J}$ -trivial.*

**Proof.** Let us show that  $\mathcal{C}_n$  is  $\mathcal{J}$ -trivial. If  $f, g \in \mathcal{C}_n$  and  $f \mathcal{J} g$ , then  $g = afb$  and  $f = cgd$  for some  $a, b, c, d \in \mathcal{C}_n$ . Let  $p \in \{1, \dots, n\}$ . Since  $a$  is extensive, one has  $p \leq p \cdot a$  and since  $f$  is order-preserving, one has  $p \cdot f \leq p \cdot a f$ . It follows, since  $b$  is extensive, that  $p \cdot a f \leq p \cdot a f b$  and finally  $p \cdot f \leq p \cdot a f b = p \cdot g$ . Similar reasoning would show that  $p \cdot g \leq p \cdot f$ . It follows that  $f = g$  and thus  $\mathcal{C}_n$  is  $\mathcal{J}$ -trivial.

Since  $\mathcal{U}_n$  is a submonoid of  $\mathcal{R}_n$ , it is sufficient to establish that  $\mathcal{R}_n$  is  $\mathcal{J}$ -trivial. But  $\mathcal{R}_n$  is naturally ordered by the order defined by  $m \leq n$  if and only if, for all  $i, j$ ,  $m_{i,j} \leq n_{i,j}$  and this order is stable under product. Since all entries on the diagonal are equal to 1, the identity  $1 \leq x$  holds in  $\mathcal{R}_n$  and thus  $\mathcal{R}_n$  is  $\mathcal{J}$ -trivial by Proposition 3.12.  $\square$

The next proposition gives another property of the monoids  $\mathcal{C}_n$ ,  $\mathcal{R}_n$  and  $\mathcal{U}_n$ .

**Proposition 4.16** *For each  $n, m > 0$ , the monoid  $\mathcal{C}_n \times \mathcal{C}_m$ ,  $[\mathcal{R}_n \times \mathcal{R}_m, \mathcal{U}_n \times \mathcal{U}_m]$  is isomorphic to a submonoid of  $\mathcal{C}_{n+m}$   $[\mathcal{R}_{n+m}, \mathcal{U}_{n+m}]$ .*

**Proof.** Let  $\varphi : \mathcal{C}_n \times \mathcal{C}_m \rightarrow \mathcal{C}_{n+m}$  be the function defined by  $\varphi(f, g) = h$  where

$$p \cdot h = \begin{cases} p \cdot f & \text{if } 1 \leq p \leq n, \\ (p - n) \cdot g + n & \text{if } n + 1 \leq p \leq n + m \end{cases}$$

Then  $\varphi$  is clearly an injective morphism and therefore  $\mathcal{C}_n \times \mathcal{C}_m$  is isomorphic to a submonoid of  $\mathcal{C}_{n+m}$ .

Let now  $\psi : \mathcal{R}_n \times \mathcal{R}_m \rightarrow \mathcal{R}_{n+m}$  be the function defined by  $\psi(R, S) = T$  where  $T$  is the relation defined by  $(i, j) \in T$  if and only if  $(i, j) \in R$  or  $(i - n, j - n) \in S$ . Then  $\psi$  is an injective morphism and therefore  $\mathcal{R}_n \times \mathcal{R}_m$  is isomorphic to a submonoid of  $\mathcal{R}_{n+m}$ . The proof is similar for  $\mathcal{U}_n$ .  $\square$

The next result shows that the monoids  $\mathcal{C}_n$ ,  $\mathcal{R}_n$  and  $\mathcal{U}_n$  generate the variety of  $\mathcal{J}$ -trivial monoids.

**Theorem 4.17** *Let  $M$  be a finite monoid. the following conditions are equivalent:*

- (1)  $M$  is  $\mathcal{J}$ -trivial,
- (2) there exists an integer  $n > 0$  such that  $M$  divides  $\mathcal{C}_n$ ,
- (3) there exists an integer  $n > 0$  such that  $M$  divides  $\mathcal{R}_n$ ,
- (4) there exists an integer  $n > 0$  such that  $M$  divides  $\mathcal{U}_n$ .

**Proof.** By Proposition 4.15, the monoids  $\mathcal{C}_n$ ,  $\mathcal{R}_n$  and  $\mathcal{U}_n$  are  $\mathcal{J}$ -trivial. Therefore each of the conditions (2), (3) or (4) implies (1). Moreover (4) implies (3) since  $\mathcal{U}_n$  is a submonoid of  $\mathcal{R}_n$ . It remains to prove that (1) implies (2) and (4).

Let  $M$  be a  $\mathcal{J}$ -trivial monoid. By Proposition VIII.7.19, there exist a finite alphabet  $A$  and languages  $L_1, \dots, L_k \in \mathcal{J}(A^*)$  such that  $M$  is isomorphic with a submonoid of  $M(L_1) \times \dots \times M(L_k)$ . Now by Theorem 3.14 and by Proposition 3.11, each  $L_i$  is a Boolean combination of simple languages. It follows now from Proposition IV.4.26 that  $M$  divides a product of syntactic monoids of simple languages. Therefore, by Proposition 4.16, it suffices to establish (2) and (4) when  $M$  is the syntactic monoid of a simple language  $L = A^*a_1A^* \dots a_nA^*$ . The minimal automaton  $\mathcal{A}$  of  $L$  is pictured in Figure 4.1:

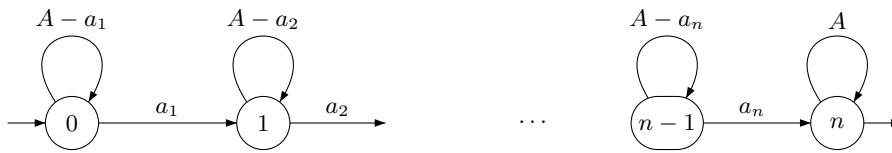

**Figure 4.1.** An automaton recognising  $L$ .

Since the transitions of  $\mathcal{A}$  are increasing and extensive functions, the transition monoid of  $\mathcal{A}$ , which is also the syntactic monoid of  $L$ , is a submonoid of  $\mathcal{C}_{n+1}$ , which proves that (1) implies (2).

Further,  $L$  is also recognised by the nondeterministic automaton  $\mathcal{B}$  represented in Figure 4.2:

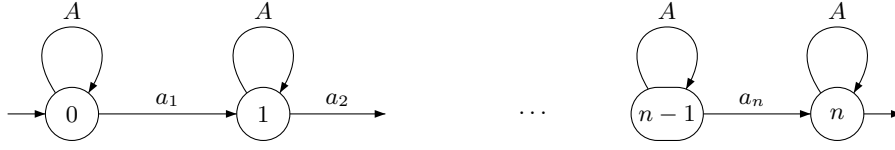

**Figure 4.2.** A nondeterministic automaton recognising  $L$ .

The transition monoid of  $\mathcal{B}$  is a monoid of unitriangular Boolean matrices, that is, a submonoid of  $\mathcal{U}_{n+1}$ . It follows that  $M$  divides  $\mathcal{U}_{n+1}$ .  $\square$

Theorem 3.13 has another very important consequence.

**Theorem 4.18** *Every finite  $\mathcal{J}$ -trivial monoid is a quotient of a finite ordered monoid satisfying the identity  $1 \leq x$ .*

**Proof.** Let  $M$  be a  $\mathcal{J}$ -trivial monoid. By Theorem 3.13,  $M$  is a quotient of the monoid of the form  $A^*/\sim_k$ . Now, the subword ordering induces a stable partial order on  $A^*/\sim_k$ . Furthermore, since the empty word is a subword of every word, the identity  $1 \leq x$  holds in this ordered monoid.  $\square$

## 5 Exercises

1. Let  $L = A_0^*a_1A_1^*\cdots a_nA_n^*$ , where  $a_1, \dots, a_n \in A$ ,  $A_0, \dots, A_n \subseteq A$  and  $a_1 \notin A_0 \cup A_1$ ,  $a_2 \notin A_1 \cup A_2$ ,  $\dots$ ,  $a_n \notin A_{n-1} \cup A_n$ . Show that  $L$  is piecewise testable. Use this result to show that the language  $abab^*ca^*b$  is piecewise testable.

2. Let  $L$  be a language. Prove that the following conditions are equivalent:

- (1)  $L$  is the complement of a shuffle ideal,
- (2)  $L$  is a finite union of languages of the form  $A_0^*(1 + a_1)A_1^*\cdots(1 + a_n)A_n^*$ , where  $a_1, \dots, a_n \in A$  and  $A_0, \dots, A_n \subseteq A$ ,
- (3)  $L$  satisfies the identity  $x \leq 1$ .



## Chapter XII

# Polynomial closure

The *polynomial closure*  $\text{Pol}(\mathcal{L})$  of a class of languages  $\mathcal{L}$  of  $A^*$  is the set of languages that are finite unions of marked products of the form  $L_0 a_1 L_1 \cdots a_n L_n$ , where the  $a_i$  are letters and the  $L_i$  are elements of  $\mathcal{L}$ .

The main result of this chapter gives an equational description of  $\text{Pol}(\mathcal{L})$ , given an equational description of  $\mathcal{L}$ , when  $\mathcal{L}$  is a lattice of languages closed under quotient. It can be formally stated as follows:

*If  $\mathcal{L}$  is a lattice of languages closed under quotients, then  $\text{Pol}(\mathcal{L})$  is defined by the set of equations of the form  $x^\omega \leq x^\omega y x^\omega$ , where  $x, y$  are profinite words such that the equations  $x = x^2$  and  $x \leq y$  are satisfied by  $\mathcal{L}$ .*

### 1 Polynomial closure of a lattice of languages

Let  $\mathcal{L}$  be a set of languages of  $A^*$ . An  $\mathcal{L}$ -*monomial of degree  $n$*  is a language of the form  $L_0 a_1 L_1 \cdots a_n L_n$ , where each  $a_i$  is a letter of  $A$  and each  $L_i$  is a language of  $\mathcal{L}$ . An  $\mathcal{L}$ -*polynomial* is a finite union of  $\mathcal{L}$ -monomials. Its *degree* is the maximum of the degrees of its monomials. The *polynomial closure* of  $\mathcal{L}$ , denoted by  $\text{Pol}(\mathcal{L})$ , is the set of all  $\mathcal{L}$ -polynomials.

Our main result gives an equational description of  $\text{Pol}(\mathcal{L})$ , given an equational description of  $\mathcal{L}$ , when  $\mathcal{L}$  is a lattice of languages closed under quotients. To state this result in a concise way, let us introduce a convenient notation. Given a set  $\mathcal{R}$  of recognisable languages, denote by  $\Sigma(\mathcal{R})$  the set of equations of the form  $x^\omega \leq x^\omega y x^\omega$ , where  $x, y$  are profinite words of  $\widehat{A^*}$  such that the equations  $x = x^2$  and  $x \leq y$  are satisfied by  $\mathcal{R}$ . Note that the function mapping  $\mathcal{R}$  to the class of languages satisfying  $\Sigma(\mathcal{R})$  is monotonic for the inclusion. We can now state our main result:

**Theorem 1.1** *If  $\mathcal{L}$  is a lattice of languages closed under quotients, then  $\text{Pol}(\mathcal{L})$  is defined by the set of equations  $\Sigma(\mathcal{L})$ .*

The proof is divided into several parts. We first prove in Proposition 1.2 that  $\text{Pol}(\mathcal{L})$  satisfies the equations of  $\Sigma(\mathcal{L})$ . To establish the converse of this property, we consider a language  $K$  satisfying all the equations of  $\Sigma(\mathcal{L})$ . We convert this property into a topological property (Proposition 1.3) and then use a compactness argument to show that  $K$  satisfies the equations of  $\Sigma(\mathcal{F})$ ,

where  $\mathcal{F}$  is a finite sublattice of  $\mathcal{L}$  (Proposition 1.4). The final part of the proof consists in proving that  $K$  belongs to  $\text{Pol}(\mathcal{F})$ . This is where the factorisation forest theorem arises, but a series of lemmas (Lemmas 1.5 to 1.10) are still necessary to find explicitly a polynomial expression for  $K$ .

**Proposition 1.2** *If  $\mathcal{L}$  is a lattice of languages, then  $\text{Pol}(\mathcal{L})$  satisfies the equations of  $\Sigma(\mathcal{L})$ .*

**Proof.** Since, by Theorem VIII.2.5, the set of languages satisfying  $\Sigma(\mathcal{L})$  is a lattice of languages, it suffices to prove the result for any  $\mathcal{L}$ -monomial. Let  $L = L_0 a_1 L_1 \cdots a_n L_n$  be an  $\mathcal{L}$ -monomial and let  $\eta: A^* \rightarrow M$  be its syntactic morphism. Let, for  $0 \leq i \leq n$ ,  $\eta_i: A^* \rightarrow M_i$  be the syntactic morphism of  $L_i$ . Let  $x$  and  $y$  be two profinite words such that each  $L_i$  satisfies the two equations  $x = x^2$  and  $x \leq y$ .

Since  $A^*$  is dense in  $\widehat{A^*}$ , one can find a word  $x' \in A^*$  such that  $r(x', x) > \max\{|M_0|, \dots, |M_n|, |M|\}$ . It follows that  $\eta(x') = \widehat{\eta}(x)$  and, for  $0 \leq i \leq n$ ,  $\eta_i(x') = \widehat{\eta}_i(x)$ . Similarly, one can associate with  $y$  a word  $y' \in A^*$  such that  $\eta(y') = \widehat{\eta}(y)$  and, for  $0 \leq i \leq n$ ,  $\eta_i(y') = \widehat{\eta}_i(y)$ . It follows that each  $L_i$  satisfies the equations  $x' = x'^2$  and  $y' \leq x'$  and that  $L$  satisfies the equation  $x^\omega \leq x^\omega y x^\omega$  if and only if it satisfies the equations  $x'^\omega \leq x'^\omega y' x'^\omega$ . In other terms, it suffices to prove the result when  $x$  and  $y$  are words.

We need to establish the relation

$$\widehat{\eta}(x^\omega) \leq \widehat{\eta}(x^\omega y x^\omega) \quad (1.1)$$

Let  $k$  be an integer such that  $k > n$  and  $\widehat{\eta}(x^\omega) = \eta(x^k)$ . Since  $\widehat{\eta}(x^\omega y x^\omega) = \eta(x^k y x^k)$ , proving (1.1) amounts to showing that  $x^k \leq_L x^k y x^k$ . Let  $u, v \in A^*$  and suppose that  $u x^k v \in L$ . Thus  $u x^k v = u_0 a_1 u_1 \cdots a_n u_n$ , where, for  $0 \leq i \leq n$ ,  $u_i \in L_i$ . Since  $k > n$ , one can find  $h \in \{0, \dots, n\}$ ,  $j \in \{1, \dots, k\}$  and  $u'_h, u''_h \in A^*$  such that  $u_h = u'_h x u''_h$ ,  $u x^{j-1} = u_0 a_1 u_1 \cdots a_h u''_h$  and  $x^{k-j} v = u''_h a_{h+1} u_{h+1} \cdots a_n u_n$ . Since  $u_h \in L_h$  and  $L_h$  satisfies the equations  $x = x^2$  and  $x \leq y$ , one has  $u'_h x^{k-j+1} y x^j u''_h \in L_h$ , and since

$$u x^k y x^k v = u_0 a_1 u_1 \cdots a_h (u'_h x^{k-j+1} y x^j u''_h) a_{h+1} u_{h+1} \cdots a_n u_n$$

one gets  $u x^k y x^k v \in L$ . Thus  $x^k \leq_L x^k y x^k$ , which completes the proof.  $\square$

The rest of this section is devoted to showing the converse implication in Theorem 1.1. Let us introduce, for each recognisable language  $L$  of  $A^*$ , the sets

$$E_L = \left\{ (x, y) \in \widehat{A^*} \times \widehat{A^*} \mid L \text{ satisfies } x = x^2 \text{ and } x \leq y \right\}$$

$$F_L = \left\{ (x, y) \in \widehat{A^*} \times \widehat{A^*} \mid L \text{ satisfies } x^\omega \leq x^\omega y x^\omega \right\}.$$

Lemma VIII.2.6 shows that the set  $E_L$  is clopen in  $\widehat{A^*} \times \widehat{A^*}$ . A similar argument, using the continuous map  $\beta: \widehat{A^*} \times \widehat{A^*} \rightarrow M^2$  defined by

$$\beta(x, y) = (\widehat{\eta}(x^\omega y x^\omega), \widehat{\eta}(x^\omega))$$

would show that  $F_L$  is clopen.

We now convert our equational conditions into a topological property. Recall that a *cover* [open cover] of a topological space  $X$  is a collection of subsets [open subsets] of  $X$  whose union is  $X$ .

**Proposition 1.3** *Let  $\mathcal{F}$  be a set of recognisable languages of  $A^*$  and let  $K$  be a recognisable language of  $A^*$ . The following conditions are equivalent:*

- (1)  $K$  satisfies the profinite equations of  $\Sigma(\mathcal{F})$ ,
- (2) the set  $\{F_K\} \cup \{E_L^c \mid L \in \mathcal{F}\}$  is an open cover of  $\widehat{A^*} \times \widehat{A^*}$ .

**Proof.** Indeed  $\mathcal{F}$  satisfies the two profinite equations  $x = x^2$  and  $x \leq y$  if and only if  $(x, y) \in \bigcap_{L \in \mathcal{F}} E_L$  or, equivalently,  $(x, y) \notin \bigcup_{L \in \mathcal{F}} E_L^c$ . Similarly,  $K$  satisfies the equation  $x^\omega \leq x^\omega y x^\omega$  if and only if  $(x, y) \in F_K$ . Now, condition (1) is equivalent to saying that  $(x, y) \notin \bigcup_{L \in \mathcal{F}} E_L^c$  implies  $(x, y) \in F_K$ , which is another way to say that  $\{F_K\} \cup \{E_L^c \mid L \in \mathcal{F}\}$  is a cover of  $\widehat{A^*} \times \widehat{A^*}$ . Since  $F_K$  and  $E_L$  are clopen, it is an open cover.  $\square$

**Proposition 1.4** *If  $K$  satisfies the equations of  $\Sigma(\mathcal{L})$ , there is a finite subset  $\mathcal{F}$  of  $\mathcal{L}$  such that  $K$  satisfies the equations of  $\Sigma(\mathcal{F})$ .*

**Proof.** Proposition 1.3 shows that  $\{F_K\} \cup \{E_L^c \mid L \in \mathcal{L}\}$  is a cover of  $\widehat{A^*} \times \widehat{A^*}$ . Since  $\widehat{A^*}$  is compact, one can extract from this cover a finite cover, say  $\{F_K\} \cup \{E_L^c \mid L \in \mathcal{F}\}$ . By Proposition 1.3 again,  $K$  satisfies the profinite equations of the form  $x^\omega \leq x^\omega y x^\omega$  such that all the languages of  $\mathcal{F}$  satisfy the equations  $x = x^2$  and  $x \leq y$ .  $\square$

Let  $K$  be a recognisable language satisfying all the equations of  $\Sigma(\mathcal{L})$  and let  $\eta : A^* \rightarrow M$  be its syntactic morphism. Let also  $\mathcal{F} = \{L_1, \dots, L_n\}$  be a finite subset of  $\mathcal{L}$  as given by Proposition 1.4. For  $1 \leq i \leq n$ , let  $\eta_i : A^* \rightarrow M_i$  be the syntactic morphism of  $L_i$ . Let  $\mu : A^* \rightarrow M_1 \times \dots \times M_n$  be the morphism defined by  $\mu(u) = (\eta_1(u), \dots, \eta_n(u))$ . Finally, let  $V = \mu(A^*)$  and, for  $1 \leq i \leq n$ , let  $\pi_i : V \rightarrow M_i$  be the natural projection. We set  $S = \{(\eta(u), \mu(u)) \mid u \in A^*\}$ . Then  $S$  is a submonoid of  $M \times V$  and the two morphisms  $\alpha : S \rightarrow M$  and  $\beta : S \rightarrow V$  defined by  $\alpha(m, v) = m$  and  $\beta(m, v) = v$  are surjective. Further, the morphism  $\delta : A^* \rightarrow S$  defined by  $\delta(u) = (\eta(u), \mu(u))$  satisfies  $\eta = \alpha \circ \delta$  and  $\mu = \beta \circ \delta$ . The situation is summarized in the following diagram:

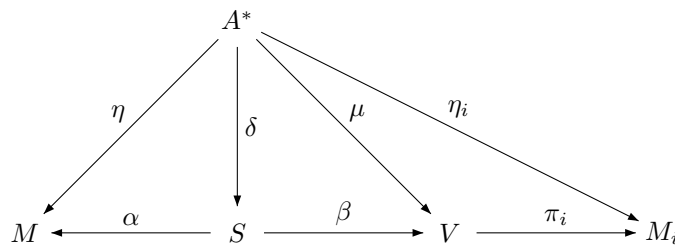

We now arrive at the last step of the proof of Theorem 1.1, which consists in proving that  $K$  belongs to  $\text{Pol}(\mathcal{F})$ .

We start with three auxiliary lemmas. The first one states that every downward closed language recognised by  $\mu$  belongs to  $\mathcal{L}$  and relies on the fact that  $\mathcal{L}$  is a lattice of languages closed under quotients. The second one gives a key property of  $S$  and this is the only place in the proof where we use the equations of  $\Sigma(\mathcal{L})$ . The third one is an elementary, but useful, observation.

**Lemma 1.5** *Let  $t \in V$ . Then the language  $\mu^{-1}(\uparrow t)$  belongs to  $\mathcal{L}$ .*

**Proof.** Let  $t = (t_1, \dots, t_n)$  and let  $z$  be a word such that  $\mu(z) = t$ . Then  $t_i = \eta_i(z)$  and  $\mu^{-1}(\uparrow t) = \bigcap_{1 \leq i \leq n} \eta_i^{-1}(\uparrow t_i)$ . Moreover, one gets for each  $i \in \{1, \dots, n\}$ ,

$$\eta_i^{-1}(\uparrow t_i) = \{x \in A^* \mid \eta_i(z) \leq \eta_i(x)\} = \{x \in A^* \mid z \leq_{L_i} x\} = \bigcap_{(u,v) \in E_i} u^{-1}L_i v^{-1}$$

where  $E_i = \{(u, v) \in A^* \times A^* \mid uzv \in L_i\}$ . Since  $L_i$  is recognisable, there are only finitely many quotients of the form  $u^{-1}L_i v^{-1}$  and hence the intersection is finite. The result follows, since  $\mathcal{L}$  is a lattice of languages closed under quotients.  $\square$

**Lemma 1.6** *For every idempotent  $(e, f) \in S$  and for every  $(s, t) \in S$  such that  $f \leq t$ , one has  $e \leq ese$ .*

**Proof.** Let  $x$  and  $y$  be two words such that  $\delta(x) = (e, f)$  and  $\delta(y) = (s, t)$ . Then  $\eta(x) = e$ ,  $\mu(x) = f$ ,  $\eta(y) = s$  and  $\mu(y) = t$  and since  $f$  is idempotent and  $f \leq t$ ,  $\mathcal{F}$  satisfies the equations  $x = x^2$  and  $x \leq y$ . Therefore  $K$  satisfies the equation  $x^\omega \leq x^\omega y x^\omega$ . It follows that  $\hat{\eta}(x^\omega) \leq \hat{\eta}(x^\omega y x^\omega)$ , that is  $e \leq ese$ .  $\square$

Before we continue, let us point out a subtlety in the proof of Lemma 1.6. It looks like we have used words instead of profinite words in this proof and the reader may wonder whether one could change “profinite” to “finite” in the statement of our main result. The answer is negative for the following reason: if  $\mathcal{F}$  satisfies the equations  $x = x^2$  and  $x \leq y$ , it does not necessarily imply that  $\mathcal{L}$  satisfies the same equations. In fact, the choice of  $\mathcal{F}$  comes from the extraction of the finite cover and hence is bound to  $K$ .

We now set, for each idempotent  $f$  of  $V$ ,  $L(f) = \mu^{-1}(\uparrow f)$ .

**Lemma 1.7** *For each idempotent  $f$  of  $V$ , one has  $L(1)L(f)L(1) = L(f)$ .*

**Proof.** Since  $1 \in L(1)$ , one gets the inclusion  $L(f) = 1L(f)1 \subseteq L(1)L(f)L(1)$ . Let now  $s, t \in L(1)$  and  $x \in L(f)$ . Then by definition,  $1 \leq \mu(s)$ ,  $f \leq \mu(x)$  and  $1 \leq \mu(t)$ . It follows that  $f = 1f1 \leq \mu(s)\mu(x)\mu(t) = \mu(sxt)$ , whence  $sxt \in L(f)$ . This gives the opposite inclusion  $L(1)L(f)L(1) \subseteq L(f)$ .  $\square$

We now come to the combinatorial argument of the proof. By Theorem II.6.40, there exists a factorisation forest  $F$  of height  $\leq 3|S| - 1$  which is Ramseyan modulo  $\delta$ . We use this fact to associate with each word  $x$  a certain language  $R(x)$ , defined recursively as follows:

$$R(x) = \begin{cases} L(1)xL(1) & \text{if } |x| \leq 1 \\ R(x_1)R(x_2) & \text{if } F(x) = (x_1, x_2) \\ R(x_1)L(f)R(x_k) & \text{if } F(x) = (x_1, \dots, x_k), \text{ with } k \geq 3 \text{ and} \\ & \delta(x_1) = \dots = \delta(x_k) = (e, f) \end{cases}$$

In particular  $R(1) = L(1)$ , since  $L(1)$  is a submonoid of  $A^*$ .

Denote by  $\mathcal{E}$  the finite set of languages of the form  $L(f)$ , where  $f$  is an idempotent of  $V$ . We know by Lemma 1.5 that  $\mathcal{E}$  is a subset of  $\mathcal{L}$ . Let us say that an  $\mathcal{E}$ -monomial is in *normal form* if it is of the form  $L(1)a_0L(f_1)a_1 \cdots L(f_k)a_kL(1)$  where  $f_1, \dots, f_k$  are idempotents of  $V$ .

**Lemma 1.8** *For each  $x \in A^*$ ,  $R(x)$  is equal to an  $\mathcal{E}$ -monomial in normal form of degree  $\leq 2^{h(x)}$ .*

**Proof.** We prove the result by induction on the length of  $x$ . The result is true if  $|x| \leq 1$ . Suppose that  $|x| \geq 2$ . If  $F(x) = (x_1, x_2)$ , then  $R(x) = R(x_1)R(x_2)$  otherwise  $R(x) = R(x_1)L(f)R(x_k)$ . We treat only the latter case, since the first one is similar. By the induction hypothesis,  $R(x_1)$  and  $R(x_k)$  are equal to  $\mathcal{E}$ -monomials in normal form. It follows by Lemma 1.7 that  $R(x)$  is equal to an  $\mathcal{E}$ -monomial in normal form, whose degree is lesser than or equal to the sum of the degrees of  $R(x_1)$  and  $R(x_k)$ . The result now follows from the induction hypothesis, since  $2^{h(x_1)} + 2^{h(x_k)} \leq 2^{1+\max\{h(x_1), \dots, h(x_k)\}} \leq 2^{h(x)}$ .  $\square$

**Lemma 1.9** *For each  $x \in A^*$ , one has  $x \in R(x)$ .*

**Proof.** We prove the result by induction on the length of  $x$ . The result is trivial if  $|x| \leq 1$ . Suppose that  $|x| \geq 2$ . If  $F(x) = (x_1, x_2)$ , one has  $x_1 \in R(x_1)$  and  $x_2 \in R(x_2)$  by the induction hypothesis and hence  $x \in R(x)$  since  $R(x) = R(x_1)R(x_2)$ . Suppose now that  $F(x) = (x_1, \dots, x_k)$  with  $k \geq 3$  and  $\delta(x_1) = \dots = \delta(x_k) = (e, f)$ . Then  $R(x) = R(x_1)L(f)R(x_k)$ . Since  $x_1 \in R(x_1)$  and  $x_k \in R(x_k)$  by the induction hypothesis and  $\mu(x_2 \cdots x_{k-1}) = f$ , one gets  $x_2 \cdots x_{k-1} \in L(f)$  and finally  $x \in R(x_1)L(f)R(x_k)$ , that is,  $x \in R(x)$ .  $\square$

If  $R$  is a language, let us write  $\eta(x) \leq \eta(R)$  if, for each  $u \in R$ ,  $\eta(x) \leq \eta(u)$ .

**Lemma 1.10** *For each  $x \in A^*$ , one has  $\eta(x) \leq \eta(R(x))$ .*

**Proof.** We prove the result by induction on the length of  $x$ . First, applying Lemma 1.6 with  $e = f = 1$  shows that if  $(s, t) \in S$  and  $1 \leq t$ , then  $1 \leq s$ . It follows that  $1 \leq \eta(\mu^{-1}(\uparrow 1)) = \eta(L(1)) = \eta(R(1))$ .

If  $|x| \leq 1$ , one gets  $R(x) = L(1)xL(1)$  and  $\eta(x) \leq \eta(L(1))\eta(x)\eta(L(1)) = \eta(R(x))$  since  $1 \leq \eta(L(1))$ . Suppose now that  $|x| \geq 2$ . If  $F(x) = (x_1, x_2)$ , then  $R(x) = R(x_1)R(x_2)$  and by the induction hypothesis,  $\eta(x_1) \leq \eta(R(x_1))$  and  $\eta(x_2) \leq \eta(R(x_2))$ . Therefore,  $\eta(x) = \eta(x_1)\eta(x_2) \leq \eta(R(x_1))\eta(R(x_2)) = \eta(R(x))$ . Finally, suppose that  $F(x) = (x_1, \dots, x_k)$  with  $k \geq 3$  and  $\delta(x_1) = \dots = \delta(x_k) = (e, f)$ . Then  $R(x) = R(x_1)L(f)R(x_k)$ . By the induction hypothesis,  $e \leq \eta(R(x_1))$  and  $e \leq \eta(R(x_k))$ . Now, if  $u \in L(f)$ , one gets  $f \leq \mu(u)$ . Since  $(\eta(u), \mu(u)) \in S$ , it follows from Lemma 1.6 that the relation  $e \leq e\eta(u)e$  holds in  $M$ . Finally, we get  $\eta(x) = e \leq e\eta(L(f))e \leq \eta(R(x_1))\eta(L(f))\eta(R(x_k)) = \eta(R(x))$ .  $\square$

We can now conclude the proof of Theorem 1.1. We claim that  $K = \bigcup_{x \in K} R(x)$ . The inclusion  $K \subseteq \bigcup_{x \in K} R(x)$  is an immediate consequence of Lemma 1.9. To prove the opposite inclusion, consider a word  $u \in R(x)$  for some  $x \in K$ . It follows from Lemma 1.10 that  $\eta(x) \leq \eta(u)$ . Since  $\eta(x) \in \eta(K)$ , one gets  $\eta(u) \in \eta(K)$  and finally  $u \in K$ . Now, by Lemma 1.8, each language  $R(x)$  is an  $\mathcal{E}$ -monomial of degree  $\leq 2^{h(x)}$ . Since  $h(x) \leq 3|S| - 1$  for all  $x$ , and since  $\mathcal{E}$  is finite, there are only finitely many such monomials. Therefore  $K$  is equal to an  $\mathcal{E}$ -polynomial. Finally, Lemma 1.5 shows that each  $\mathcal{E}$ -polynomial belongs to  $\text{Pol}(\mathcal{L})$ , and thus  $K \in \text{Pol}(\mathcal{L})$ .  $\square$

## 2 A case study

As an application of this result, we establish a set of profinite equations defining the class of languages of the form  $L_0 a_1 L_1 \cdots a_n L_n$ , where each language  $L_i$  is either of the form  $u^*$  (where  $u$  is a word) or  $A^*$  (where  $A$  is the alphabet) and we prove that this class is decidable.

We have seen that the recognisable languages that are either slender or full form a lattice of languages closed under quotients, denoted by  $\mathcal{S}$  in the sequel. One can show that the languages of  $\text{Pol}(\mathcal{S})$  are finite unions of languages of the form  $L_0 a_1 L_1 \cdots a_n L_n$ , where the  $a_i$  are letters and the  $L_i$  are languages of the form  $A^*$  or  $u^*$  for some word  $u$ . In particular,  $\text{Pol}(\mathcal{S})$  contains all recognisable sparse languages but it also contains the nonsparse language  $A^*$  if  $|A| \geq 2$ .

An equational description of  $\text{Pol}(\mathcal{S})$  was given in [9]. Let us denote by  $\Sigma'(\mathcal{S})$  the set of equations of the form

$$(x^\omega y^\omega)^\omega \leq (x^\omega y^\omega)^\omega z (x^\omega y^\omega)^\omega$$

where  $z \in A^*$  and  $x, y \in A^+$  and  $i(x) \neq i(y)$ .

**Theorem 2.11** *A recognisable language of  $A^*$  belongs to  $\text{Pol}(\mathcal{S})$  if and only if it satisfies the equations of  $\Sigma'(\mathcal{S})$ .*

# Chapter XIII

## Relational morphisms

Relational morphisms form a powerful tool in semigroup theory. Although the study of relational morphisms can be reduced in theory to the study of morphisms, their systematic use leads to concise proofs of nontrivial results. Furthermore, they provide a natural definition of the Mal'cev product and its variants, an important tool for decomposing semigroups into simpler pieces.

### 1 Relational morphisms

A *relational morphism* between two semigroups  $S$  and  $T$  is a relation  $\tau : S \rightarrow T$  which satisfies

- (1) for every  $s \in S$ ,  $\tau(s) \neq \emptyset$ ,
- (2) for every  $s_1, s_2 \in S$ ,  $\tau(s_1)\tau(s_2) \subseteq \tau(s_1s_2)$

For a relational morphism between two monoids  $S$  and  $T$ , a third condition is required

- (3)  $1 \in \tau(1)$

The *graph* of a relational morphism  $\tau$  is the subset  $R$  of  $S \times T$  defined by

$$R = \{(s, t) \in S \times T \mid t \in \tau(s)\}$$

The following result is an immediate consequence of the definition of a relational morphism.

**Proposition 1.1** *The graph of a relational morphism between two semigroups [monoids]  $S$  and  $T$  is a subsemigroup [submonoid] of  $S \times T$ .*

Let us also mention another immediate result.

**Proposition 1.2** *The composition of two relational morphisms is a relational morphism.*

Examples of relational morphisms include two standard classes:

- (1) morphisms,
- (2) inverses of surjective morphisms.

Indeed if  $\alpha : S \rightarrow T$  is a surjective morphism, then the relation  $\alpha^{-1} : T \rightarrow S$  is a relational morphism. These two classes generate all relational morphisms. More precisely, every relational morphism is the composition of a morphism and the inverse of a surjective morphism.

**Proposition 1.3** *Let  $\tau : S \rightarrow T$  be a relational morphism and let  $R$  be its graph. Then the projections from  $S \times T$  onto  $S$  and  $T$  induce morphisms  $\alpha : R \rightarrow S$  and  $\beta : R \rightarrow T$  such that  $\alpha$  is surjective and  $\tau = \beta \circ \alpha^{-1}$ .*

**Proof.** The factorisation of  $\tau$  as  $\beta \circ \alpha^{-1}$  is an immediate consequence of the definition. The surjectivity of  $\alpha$  stems from the fact that, for all  $s \in S$ ,  $\tau(s)$  is nonempty.  $\square$

The factorisation  $\tau = \beta \circ \alpha^{-1}$ , pictured in Figure 1.1 is called the *canonical factorisation* of  $\tau$ .

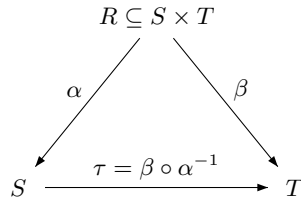

**Figure 1.1.** The canonical factorisation of a relational morphism.

We shall see that in most cases the properties of  $\tau$  are bounded to that of  $\beta$  (see in particular Propositions 2.5 and 3.11).

The next result extends Proposition II.3.8 to relational morphisms. We remind the reader that if  $\tau$  is a relation from  $S$  into  $T$  and  $T'$  is a subset of  $T$ , then  $\tau^{-1}(T') = \{s \in S \mid \tau(s) \cap T' \neq \emptyset\}$ .

**Proposition 1.4** *Let  $\tau : S \rightarrow T$  be a relational morphism. If  $S'$  is a subsemigroup of  $S$ , then  $\tau(S')$  is a subsemigroup of  $T$ . If  $T'$  is a subsemigroup of  $T$ , then  $\tau^{-1}(T')$  is a subsemigroup of  $S$ .*

**Proof.** Let  $t_1, t_2 \in \tau(S')$ . Then  $t_1 \in \tau(s_1)$  and  $t_2 \in \tau(s_2)$  for some  $s_1, s_2 \in S'$ . It follows that  $t_1 t_2 \in \tau(s_1)\tau(s_2) \subseteq \tau(s_1 s_2) \subseteq \tau(S')$  and therefore  $\tau(S')$  is a subsemigroup of  $T$ .

Let  $s_1, s_2 \in \tau^{-1}(T')$ . Then by definition there exist  $t_1, t_2 \in T'$  such that  $t_1 \in \tau(s_1)$  and  $t_2 \in \tau(s_2)$ . Thus  $t_1 t_2 \in \tau(s_1)\tau(s_2) \subseteq \tau(s_1 s_2)$ , whence  $s_1 s_2 \in \tau^{-1}(t_1 t_2)$ . Therefore  $s_1 s_2 \in \tau^{-1}(T')$  and hence  $\tau^{-1}(T')$  is a subsemigroup of  $S$ .  $\square$

**Example 1.1** Let  $E$  be the set of all injective partial functions from  $\{1, 2, 3, 4\}$  into itself and let  $F$  be the set of all bijections on  $\{1, 2, 3, 4\}$ . Let  $\tau$  be the relation that associates to each injective function  $f$  the set of all possible bijective extensions of  $f$ . For instance, if  $f$  is the partial function defined by  $f(1) = 3$



and  $f(3) = 2$ , then  $\tau(f) = \{h_1, h_2\}$  where  $h_1$  and  $h_2$  are the bijections given in the following table

	<b>1</b>	<b>2</b>	<b>3</b>	<b>4</b>
$h_1$	3	1	2	4
$h_2$	3	4	2	1

Let  $Id$  be the identity map on  $\{1, 2, 3, 4\}$ . Then  $\tau^{-1}(Id)$  is the set of *partial identities* on  $E$ , listed in the table below:

<b>1</b>	<b>2</b>	<b>3</b>	<b>4</b>
-	-	-	-
-	-	-	4
-	-	3	-
-	-	3	4
-	2	-	-
-	2	-	4
-	2	3	-
-	2	3	4

<b>1</b>	<b>2</b>	<b>3</b>	<b>4</b>
1	-	-	-
1	-	-	4
1	-	3	-
1	-	3	4
1	2	-	-
1	2	-	4
1	2	3	-
1	2	3	4

## 2 Injective relational morphisms

According to the definition of an injective relation given in Chapter I, a relational morphism  $\tau : S \rightarrow T$  is *injective* if, for every  $s_1, s_2 \in S$ , the condition  $s_1 \neq s_2$  implies that  $\tau(s_1)$  and  $\tau(s_2)$  are disjoint, or equivalently, if  $\tau(s_1) \cap \tau(s_2) \neq \emptyset$  implies  $s_1 = s_2$ . Note in particular that if  $\alpha : R \rightarrow T$  is a surjective morphism, then  $\alpha^{-1} : T \rightarrow R$  is an injective relational morphism.

**Proposition 2.5** *Let  $S \xrightarrow{\alpha^{-1}} R \xrightarrow{\beta} T$  be the canonical factorisation of a relational morphism  $\tau : S \rightarrow T$ . Then  $\tau$  is injective [surjective] if and only if  $\beta$  is injective [surjective].*

**Proof.** By Proposition I.1.8,  $\alpha^{-1}$  is an injective relational morphism. It is also surjective, since  $(s, t) \in \alpha^{-1}(s)$  for every  $(s, t) \in R$ . Thus if  $\beta$  is injective [surjective], then  $\tau = \beta \circ \alpha^{-1}$  is also injective [surjective].

Suppose now that  $\tau$  is injective. Let  $r_1$  and  $r_2$  be two elements of  $R$  such that  $\beta(r_1) = \beta(r_2) = t$ . Since  $\alpha$  is surjective,  $r_1 \in \alpha^{-1}(\alpha(r_1))$  and  $r_2 \in \alpha^{-1}(\alpha(r_2))$ . It follows that  $t \in \beta(\alpha^{-1}(\alpha(r_1))) \cap \beta(\alpha^{-1}(\alpha(r_2))) = \tau(\alpha(r_1)) \cap \tau(\alpha(r_2))$ , whence  $\alpha(r_1) = \alpha(r_2)$  since  $\tau$  is injective. Therefore  $r_1 = (\alpha(r_1), \beta(r_1))$  is equal to  $r_2 = (\alpha(r_2), \beta(r_2))$ .

Finally, if  $\tau$  is surjective, then  $\beta$  is surjective by Proposition I.1.14.  $\square$

Proposition 2.5 has two interesting consequences.

**Corollary 2.6** *A semigroup  $S$  divides a semigroup  $T$  if and only if there exists an injective relational morphism from  $S$  into  $T$ .*

**Proof.** If  $S$  divides  $T$ , there exists a semigroup  $R$ , a surjective morphism  $\alpha : R \rightarrow S$  and an injective morphism  $\beta : R \rightarrow T$ . Then  $\alpha^{-1}$  is an injective

relational morphism and thus  $\tau = \beta \circ \alpha^{-1}$  is an injective relational morphism from  $S$  into  $T$ .

Conversely, if  $\tau$  is an injective relational morphism from  $S$  into  $T$  and if  $S \xrightarrow{\alpha^{-1}} R \xrightarrow{\beta} T$  is the canonical factorisation of  $\tau$ . Proposition 2.5 shows that  $\beta$  is injective. Since  $\alpha$  is surjective,  $S$  divides  $T$ .  $\square$

**Corollary 2.7** *Let  $\tau : S \rightarrow T$  be an injective relational morphism. Then for any subsemigroup  $T'$  of  $T$ ,  $\tau^{-1}(T')$  divides  $T'$ . Furthermore  $\tau^{-1}(E(T)) \subseteq E(S)$ .*

**Proof.** Let  $S \xrightarrow{\alpha^{-1}} R \xrightarrow{\beta} T$  be the canonical factorisation of  $\tau$ . Then  $\beta$  is injective by Proposition 2.5 and thus  $\beta^{-1}(T')$  is isomorphic to a subsemigroup of  $T'$ . Finally,  $\tau^{-1}(T')$  is equal to  $\alpha(\beta^{-1}(T'))$  and thus divides  $T'$ .

Let  $s \in \tau^{-1}(E(T))$ . Then  $\tau(s)$  contains some idempotent  $f$  of  $T$ . As  $\tau(s)\tau(s) \subseteq \tau(s^2)$ ,  $\tau(s^2)$  also contains  $f$ . Thus  $f \in \tau(s) \cap \tau(s^2)$  whence  $s = s^2$  since  $\tau$  is injective. Thus  $s$  is idempotent and  $\tau^{-1}(E(T)) \subseteq E(S)$ .  $\square$

If  $T$  is finite, Corollary 2.7 can be improved as follows.

**Proposition 2.8** *Let  $T$  be a finite semigroup and let  $\tau : S \rightarrow T$  be an injective relational morphism. Then  $\tau^{-1}(E(T)) = E(S)$ .*

**Proof.** Let  $e \in E(S)$ . By Proposition 1.4,  $\tau(e)$  is a subsemigroup of  $T$ , which, by Corollary II.6.32, contains an idempotent. Thus  $e \in \tau^{-1}(E(T))$ , showing that  $E(S) \subseteq \tau^{-1}(E(T))$ . The opposite inclusion follows from Corollary 2.7.  $\square$

### 3 Relational $\mathbf{V}$ -morphisms

Let  $\mathbf{V}$  be a variety of finite semigroups. A [relational] morphism  $\tau : S \rightarrow T$  is said to be a [relational]  $\mathbf{V}$ -morphism if, for every subsemigroup  $T'$  of  $T$  which belongs to  $\mathbf{V}$ , the semigroup  $\tau^{-1}(T')$  also belongs to  $\mathbf{V}$ .

The definition can be readily adapted to the case of varieties of ordered semigroups. Let  $\mathbf{V}$  be a variety of finite ordered semigroups and let  $S$  and  $T$  be two ordered semigroups. Then a [relational] morphism  $\tau : S \rightarrow T$  is said to be a [relational]  $\mathbf{V}$ -morphism if, for every ordered subsemigroup  $T'$  of  $T$  which belongs to  $\mathbf{V}$ , the ordered semigroup  $\tau^{-1}(T')$  also belongs to  $\mathbf{V}$ .

In practice,  $\mathbf{V}$  is often one of the following varieties:

- (1)  $\mathbf{A}$ , the variety of aperiodic semigroups,
- (2)  $\mathbf{N}$ , the variety of nilpotent semigroups,
- (3)  $\mathbf{L1} = \llbracket ese = e \rrbracket$ , the variety of locally trivial semigroups,
- (4)  $\mathbf{LJ}^- = \llbracket e \leq ese \rrbracket$ , the variety of ordered semigroups  $S$ , such that, for all  $e \in E(S)$ , the ordered submonoid  $eSe$  satisfies the identity  $1 \leq x$ .

A relational  $\mathbf{A}$ -morphism is also called an *aperiodic relational morphism* and a relational  $\mathbf{L1}$ -morphism is also called a *locally trivial relational morphism*.

The definition of relational  $\mathbf{V}$ -morphism is formally reminiscent of that of a continuous function. This analogy is confirmed by the following proposition, whose proof is immediate.

**Proposition 3.9** *Relational  $\mathbf{V}$ -morphisms are closed under composition.*

Let us mention another elementary result.

**Proposition 3.10** *Injective relational morphisms are relational  $\mathbf{V}$ -morphisms for every variety  $\mathbf{V}$ .*

**Proof.** This follows directly from Corollary 2.7.  $\square$

Note that the converse to Proposition 3.10 does not hold. Let  $N_2 = \{0, a\}$  and  $N_3 = \{0, a, b\}$  be the nilpotent semigroups with two and three elements, respectively and let  $\varphi : N_3 \rightarrow N_2$  be the morphism defined by  $\varphi(a) = \varphi(b) = a$  and  $\varphi(0) = 0$ . Then the only subsemigroups of  $N_2$  are 0 and  $N_2$ . It follows that  $\varphi$  is a relational  $\mathbf{V}$ -morphism for every variety  $\mathbf{V}$  since  $\varphi^{-1}(0) = 0$  and  $\varphi^{-1}(N_2) = N_3$ , which divides  $N_2 \times N_2$ . However,  $\varphi$  is not injective.

We can now state our announced result on canonical factorisations.

**Proposition 3.11** *Let  $S \xrightarrow{\alpha^{-1}} R \xrightarrow{\beta} T$  be the canonical factorisation of a relational morphism  $\tau : S \rightarrow T$ . Then  $\tau$  is a relational  $\mathbf{V}$ -morphism if and only if  $\beta$  is a  $\mathbf{V}$ -morphism.*

**Proof.** First,  $\alpha^{-1}$  is an injective relational morphism and thus a relational  $\mathbf{V}$ -morphism by Proposition 3.10. Thus if  $\beta$  is a relational  $\mathbf{V}$ -morphism, then  $\tau$  is a relational  $\mathbf{V}$ -morphism by Proposition 3.9.

Conversely, suppose that  $\tau$  is a relational  $\mathbf{V}$ -morphism. Let  $\gamma : S \times T \rightarrow T \times T$  be the relational morphism defined by  $\gamma(s, t) = \tau(s) \times \{t\}$ . Let  $T'$  be a subsemigroup of  $T$  belonging to  $\mathbf{V}$ . Setting  $D = \{(t, t) \mid t \in T'\}$ , one gets

$$\gamma^{-1}(D) = \{(s, t) \in S \times T \mid t \in \tau(s) \cap T'\} = \beta^{-1}(T')$$

It follows that  $\beta^{-1}(T')$  is a subsemigroup of  $\tau^{-1}(T') \times T'$  and thus is in  $\mathbf{V}$ . Thus  $\beta$  is a relational  $\mathbf{V}$ -morphism.  $\square$

Relational morphisms can be restricted to subsemigroups.

**Proposition 3.12** *Let  $\tau : S \rightarrow T$  be a relational morphism and let  $T'$  be a subsemigroup of  $T$ . Then the relation  $\hat{\tau} : \tau^{-1}(T') \rightarrow T'$ , defined by  $\hat{\tau}(s) = \tau(s) \cap T'$ , is a relational morphism. Furthermore, if  $\tau$  is injective [a relational  $\mathbf{V}$ -morphism], so is  $\hat{\tau}$ .*

**Proof.** Let  $s \in \tau^{-1}(T')$ . Then by definition  $\tau(s) \cap T' \neq \emptyset$  and thus  $\hat{\tau}(s) \neq \emptyset$ . Let  $s_1, s_2 \in \tau^{-1}(T')$ . One gets

$$\begin{aligned} \hat{\tau}(s_1)\hat{\tau}(s_2) &= (\tau(s_1) \cap T')(\tau(s_2) \cap T') \\ &\subseteq \tau(s_1)\tau(s_2) \cap T' \subseteq \tau(s_1s_2) \cap T' \subseteq \hat{\tau}(s_1s_2) \end{aligned}$$

and thus  $\hat{\tau}$  is a relational morphism. The second part of the statement is obvious.  $\square$

We now turn to more specific properties of relational  $\mathbf{V}$ -morphisms.

### 3.1 Aperiodic relational morphisms

**Theorem 3.13** Let  $S \xrightarrow{\alpha^{-1}} R \xrightarrow{\beta} T$  be the canonical factorisation of a relational morphism  $\tau : S \rightarrow T$ . The following conditions are equivalent:

- (1)  $\tau$  is aperiodic,
- (2) for every idempotent  $e \in T$ ,  $\tau^{-1}(e)$  is aperiodic,
- (3) the restriction of  $\tau$  to each group in  $S$  is injective,
- (4) the restriction of  $\tau$  to each  $\mathcal{H}$ -class in a regular  $\mathcal{D}$ -class of  $S$  is injective.

Moreover, one obtains four equivalent conditions (1')–(4') by replacing  $\tau$  by  $\beta$  and  $S$  by  $R$  in (1)–(4).

**Proof.** The equivalence of (1) and (1') follows from Proposition 3.11. Furthermore, (1) implies (2) and (4) implies (3) are obvious.

(3) implies (1). Let  $T'$  be an aperiodic subsemigroup of  $T$ ,  $S' = \tau^{-1}(T')$  and let  $H$  be a group in  $S'$ . Since  $S$ ,  $T$  and  $R$  are finite, there exists by Theorem V.5.45 a group  $H'$  in  $R$  such that  $\alpha(H') = H$ . Now  $\beta(H')$  is a group in  $T'$ , but since  $T'$  is aperiodic, this group is a singleton  $\{e\}$ . Let  $h_1, h_2 \in H$  and  $h'_1, h'_2 \in H'$  be such that  $\alpha(h_1) = h'_1$  and  $\alpha(h'_2) = h_2$ . Then  $e = \beta(h'_1) = \beta(h'_2) \in \tau(h_1) \cap \tau(h_2)$ . It follows from Condition (3) that  $h_1 = h_2$ , which shows that  $H$  is trivial. Therefore  $S'$  is aperiodic.

(2) implies (4). Given a regular  $\mathcal{H}$ -class  $H$ , there exists an element  $a \in S$  such that the function  $h \rightarrow ha$  is a bijection from  $H$  onto a group  $G$  of the same  $\mathcal{D}$ -class. Let  $e$  be the identity of  $G$  and let  $h_1$  and  $h_2$  be elements of  $H$  such that  $\tau(h_1) \cap \tau(h_2) \neq \emptyset$ . Then we have

$$\emptyset \neq (\tau(h_1) \cap \tau(h_2))\tau(a) \subseteq \tau(h_1)\tau(a) \cap \tau(h_2)\tau(a) \subseteq \tau(h_1a) \cap \tau(h_2a)$$

Setting  $g_1 = h_1a$ ,  $g_2 = h_2a$  and  $g = g_2g_1^{-1}$ , we obtain in the same way

$$\emptyset \neq (\tau(g_1) \cap \tau(g_2))\tau(g_1^{-1}) \subseteq \tau(e) \cap \tau(g)$$

Furthermore, we have

$$\begin{aligned} (\tau(e) \cap \tau(g))(\tau(e) \cap \tau(g)) &\subseteq (\tau(e) \cap \tau(g))\tau(e) \\ &\subseteq \tau(e)\tau(e) \cap \tau(g)\tau(e) \subseteq \tau(ee) \cap \tau(ge) = \tau(e) \cap \tau(g) \end{aligned}$$

which proves that  $\tau(e) \cap \tau(g)$  is a nonempty semigroup. Let  $f$  be an idempotent of this semigroup. Then  $e, g \in \tau^{-1}(f)$ , whence  $e = g$  since  $\tau^{-1}(f)$  is aperiodic. It follows that  $g_1 = g_2$  and hence  $h_1 = h_2$ , which proves (4).

The equivalence of the statements (1)–(4) results from this. Applying this first theorem to  $\beta$  gives the equivalence of (1')–(4').  $\square$

### 3.2 Locally trivial relational morphisms

**Theorem 3.14** Let  $S \xrightarrow{\alpha^{-1}} R \xrightarrow{\beta} T$  be the canonical factorisation of a relational morphism  $\tau : S \rightarrow T$ . The following conditions are equivalent:

- (1)  $\tau$  is locally trivial,
- (2) for every idempotent  $e \in T$ ,  $\tau^{-1}(e)$  is locally trivial,

Moreover, one obtains two equivalent conditions (1')–(2') by replacing  $\tau$  by  $\beta$  and  $S$  by  $R$  in (1)–(2).

**Proof.** The equivalence of (1) and (1') follows from Proposition 3.11. Furthermore, (1) implies (2) is obvious.

(2) implies (1). Up to replacing  $\tau$  by the relational morphism  $\hat{\tau} : S \rightarrow \tau(S)$  defined in Proposition 3.12, we may assume that  $\tau$  is surjective. Further, it follows from Theorem 3.13 that  $\tau$  is an aperiodic relational morphism.

Let  $T'$  be a locally trivial subsemigroup of  $T$  and let  $S' = \tau^{-1}(T')$ . Since  $T'$  is an aperiodic semigroup and  $\tau$  is an aperiodic relational morphism,  $S'$  is aperiodic. Let  $e, f$  be idempotents of  $S'$ . Since  $\tau(e)$  and  $\tau(f)$  are nonempty subsemigroups of  $T'$ , there exist idempotents  $e', f' \in T'$  such that  $e' \in \tau(e)$  and  $f' \in \tau(f)$ . Now since  $T'$  is locally trivial,  $e' \mathcal{J} f'$  and thus  $e' = a'f'b'$  for some  $a', b' \in T'$ . Choose  $a, b \in S'$  such that  $a' \in \tau^{-1}(a)$  and  $b' \in \tau^{-1}(b)$ . Then we have

$$e' = a'f'b' \in \tau(a)\tau(f)\tau(b) \subseteq \tau(afb)$$

and therefore  $e, afb \in \tau^{-1}(e')$ . Since  $\tau^{-1}(e')$  is locally trivial by (2),  $e$  is in the minimal ideal of  $\tau^{-1}(e')$  and hence  $e \leq_{\mathcal{J}} afb \leq_{\mathcal{J}} f$ . A dual argument would show that  $f \leq_{\mathcal{J}} e$  and hence  $e \mathcal{J} f$ . Thus all the idempotents of  $S'$  belong to its minimal ideal and  $S'$  is aperiodic. These two properties show that  $S'$  is locally trivial.

The equivalence of the statements (1)–(2) results from this. Applying this first theorem to  $\beta$  gives the equivalence of (1')–(2').  $\square$

**Proposition 3.15** *Let  $\pi : S \rightarrow T$  a surjective, locally trivial, morphism. Then  $S$  and  $T$  have the same number of regular  $\mathcal{J}$ -classes.*

**Proof.** It suffices to show that if  $x, y$  are two regular elements of  $S$ ,  $x \mathcal{J} y$  if and only if  $\pi(x) \mathcal{J} \pi(y)$ . One direction is easy, since  $\pi$  maps a regular  $\mathcal{D}$ -class onto a regular  $\mathcal{J}$ -class.

Suppose now that  $\pi(x) \mathcal{J} \pi(y)$  and let  $e$  and  $f$  respectively be idempotents of the  $\mathcal{D}$ -classes of  $x$  and  $y$ . Since  $e \mathcal{J} x$  and  $f \mathcal{J} y$ , we also have

$$\pi(e) \mathcal{J} \pi(x) \mathcal{J} \pi(y) \mathcal{J} \pi(f)$$

In particular,  $\pi(f) = x\pi(e)y$  for some  $x, y \in T$ . Since  $\pi$  is surjective, one has  $x = \pi(c)$  and  $y = \pi(d)$  for some  $c, d \in S$ . It follows that  $\pi(f) = \pi(cfd)$ . Now since  $\pi(e)$  is idempotent, the semigroup  $\pi^{-1}(\pi(e))$  is locally trivial and since  $e, cfd$  are both in it, one has  $ecfde = e$ . Thus  $e \leq_{\mathcal{J}} f$  and a similar reasoning would show that  $f \leq_{\mathcal{J}} e$ . Therefore  $e \mathcal{J} f$ , which shows that  $x \mathcal{J} y$ .  $\square$

### 3.3 Relational $[[ese \leq e]]$ -morphisms

Recall that if  $S$  is an ordered semigroup, the upper set generated by an element  $x \in S$  is the set  $\uparrow x$  of all  $y \in E$  such that  $x \leq y$ .

**Proposition 3.16** *Let  $S$  be an ordered semigroup and let  $e \in E(S)$ . Then the ordered semigroup  $e(\uparrow e)e$  belongs to the variety  $[[e \leq ese]]$ .*

**Proof.** Let  $R = e(\uparrow e)e$ . Let  $r \in R$  and  $f \in E(R)$ . Then  $f = ege$  with  $e \leq g$  and  $r = ese$  with  $e \leq s$ . It follows  $ef = f = fe$  and  $f = fef \leq fsf = fese = frf$ . Thus  $R \in \llbracket e \leq ese \rrbracket$ .  $\square$

**Proposition 3.17** *Let  $\tau : S \rightarrow T$  be a relational morphism. The following conditions are equivalent:*

- (1)  $\tau$  is a relational  $\llbracket e \leq ese \rrbracket$ -morphism,
- (2) for any  $e \in E(T)$ ,  $\tau^{-1}(e(\uparrow e)e)$  is an ordered semigroup of  $\llbracket e \leq ese \rrbracket$ ,
- (3) for any  $e \in E(T)$ ,  $f \in E(\tau^{-1}(e))$  and  $s \in \tau^{-1}(e(\uparrow e)e)$ ,  $f \leq fsf$ .

**Proof.** Proposition 3.16 shows that (1) implies (2) and (2) implies (3) is trivial. Let us show that (3) implies (1). Assuming (3), let  $R$  be an ordered subsemigroup of  $T$  such that  $R \in \llbracket e \leq ese \rrbracket$ . Let  $U = \tau^{-1}(R)$ ,  $s \in U$ ,  $r \in \tau(s) \cap R$  and  $f \in E(U)$ . Since  $\tau(f) \cap R$  is a non empty subsemigroup of  $T$ , it contains an idempotent  $e$ . Now  $e \leq ere$  since  $R \in \llbracket e \leq ese \rrbracket$  and thus  $e, ere \in e(\uparrow e)e$ . Furthermore  $f \in \tau^{-1}(e)$ , and since  $ere \in \tau(f)\tau(s)\tau(f) \subseteq \tau(fsfs)$ ,  $fsf \in \tau^{-1}(ere)$ . It follows by (3) that  $f \leq fsf$  and thus  $U \in \llbracket e \leq ese \rrbracket$ . Therefore,  $\tau$  is a relational  $\llbracket e \leq ese \rrbracket$ -morphism.  $\square$

## 4 Four examples of V-morphisms

Let  $M$  is a monoid and let  $E$  be the set of its idempotents. Let us denote by  $2^E$  the monoid of subsets of  $E$  under intersection.

**Theorem 4.18** *Let  $M$  be a monoid.*

- (1) *If  $M$  is  $\mathcal{R}$ -trivial, the map  $\pi : M \rightarrow 2^E$  defined by  $\pi(s) = \{e \in E \mid es = e\}$  is a surjective  $\mathbf{K}$ -morphism.*
- (2) *If  $M$  is  $\mathcal{L}$ -trivial, the map  $\pi : M \rightarrow 2^E$  defined by  $\pi(s) = \{e \in E \mid se = e\}$  is a surjective  $\mathbf{D}$ -morphism.*
- (3) *If  $M$  is  $\mathcal{J}$ -trivial, the map  $\pi : M \rightarrow 2^E$  defined by  $\pi(s) = \{e \in E \mid es = e = se\}$  is a surjective  $\mathbf{N}$ -morphism.*
- (4) *If  $M$  belongs to  $\mathbb{DA}$ , the map  $\pi : M \rightarrow 2^E$  defined by  $\pi(s) = \{e \in E \mid ese = e\}$  is a surjective  $\mathbb{L1}$ -morphism.*

## 5 Three examples of relational morphisms

In this section, we give three examples of relational morphisms stemming from the theory of automata and recognisable languages. Our first example describes an important property of the concatenation product. The second one deals with purity, a property of the star of a language. The third one gives a nice syntactic property of the flower automata.

### 5.1 Concatenation product

Let, for  $0 \leq i \leq n$ , let  $L_i$  be a recognisable language of  $A^*$ , let  $\eta_i : A^* \rightarrow M(L_i)$  be its syntactic morphism and let

$$\eta : A^* \rightarrow M(L_0) \times M(L_1) \times \cdots \times M(L_n)$$

be the morphism defined by

$$\eta(u) = (\eta_0(u), \eta_1(u), \dots, \eta_n(u))$$

Let  $a_1, a_2, \dots, a_n$  be letters of  $A$  and let  $L = L_0 a_1 L_1 \cdots a_n L_n$ . Let  $\mu : A^* \rightarrow M(L)$  be the syntactic morphism of  $L$ . The properties of the relational morphism

$$\tau = \eta \circ \mu^{-1} : M(L) \rightarrow M(L_0) \times M(L_1) \times \cdots \times M(L_n)$$

were first studied by Straubing [107] and later in [67, 83, 73].

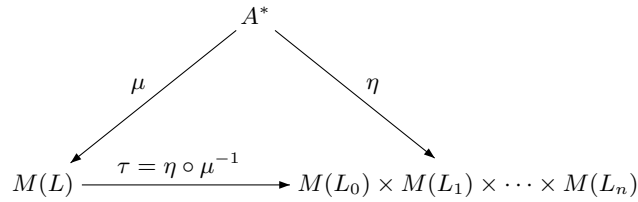

**Theorem 5.19** *The relational morphism  $\tau : M(L) \rightarrow M(L_0) \times M(L_1) \times \cdots \times M(L_n)$  is a relational  $\llbracket e \leq ese \rrbracket$ -morphism.*

**Proof.** Let  $R$  be an ordered subsemigroup of  $M(L_0) \times M(L_1) \times \cdots \times M(L_n)$  satisfying the identity  $x^\omega \leq x^\omega y x^\omega$ , and let  $x, y \in \eta^{-1}(R)$ . Let  $k$  be an integer such that  $\mu(x^k)$  and  $\eta(x^k)$  are idempotent. It suffices to show that for every  $u, v \in A^*$ ,  $ux^k v \in L$  implies  $ux^k y x^k v \in L$ . Let  $r = 2n + 1$ . Then  $\eta(x^{rk}) = \eta(x^k)$ , and since  $ux^k v \in L$ ,  $ux^{rk} v \in L$ . Consequently, there is a factorisation of the form  $ux^{rk} v = u_0 a_1 \cdots a_n u_n$ , where  $u_i \in L_i$  for  $0 \leq i \leq n$ . The next step is a lemma of independent interest.

**Lemma 5.20** *Suppose that  $uf^r v = u_0 a_1 \cdots a_n u_n$ , with  $r > n$ . Then one of the words  $u_i$  contains  $f$  as a factor.*

**Proof.** Otherwise each factor  $f$  should contain at least one letter  $a_i$ .

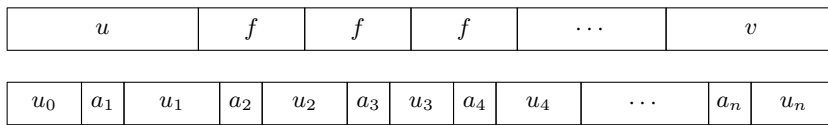

Since  $r > n$ , this would give a contradiction.  $\square$

By Lemma 5.20 applied to  $f = x^k$ , there exist  $1 \leq h \leq n$  and  $0 \leq j \leq r - 1$  such that  $u_h = u'_h x^{2k} u''_h$  for some  $u'_h, u''_h \in A^*$ ,  $ux^{jk} = u_0 a_1 \cdots a_{h-1} u'_h$  and  $x^{(r-j-1)k} v = u''_h a_h \cdots a_n u_n$ . Now since  $\eta(x)$  and  $\eta(y)$  belong to  $R$ ,

$$\eta(x^k) \leq \eta(x^k) \eta(y) \eta(x^k)$$

and by projection onto  $M(L_h)$ ,  $\eta_h(x^k) \leq \eta_h(x^k) \eta_h(y) \eta_h(x^k)$ . In particular, the condition  $u'_h x^k u''_h \in L_h$  implies  $u'_h x^k y x^k u''_h \in L_h$ . Thus  $ux^{(j+1)k} y x^{(r-j)k} v \in L$  and hence  $ux^k y x^k v \in L$ , which concludes the proof.  $\square$

Theorem 5.19 is often used in the following weaker form.

**Corollary 5.21** *The relational morphism  $\tau : M(L) \rightarrow M(L_0) \times M(L_1) \times \cdots \times M(L_n)$  is an aperiodic relational morphism.*

**Proof.** By Theorem 5.19,  $\tau$  is a relational  $\llbracket e \leq ese \rrbracket$ -morphism. In particular, for each idempotent  $e$ ,  $\tau^{-1}(e)$  is a semigroup satisfying the identity  $e \leq ese$ . In particular, it satisfies the identity  $x^\omega \leq x^\omega x x^\omega$ , that is  $x^\omega \leq x^{\omega+1}$  and is aperiodic by Proposition X.2.2. Thus  $\tau$  is aperiodic.  $\square$

Let  $L_0, L_1, \dots, L_n$  be languages of  $A^*$  and let  $a_1, \dots, a_n$  be letters of  $A$ . The (marked) product

$$L = L_0 a_1 L_1 \cdots a_n L_n$$

is said to be *unambiguous* if every word of  $L$  admits a unique decomposition of the form  $u = u_0 a_1 u_1 \cdots a_n u_n$  with  $u_0 \in L_0, \dots, u_n \in L_n$ .

**Example 5.1** Let  $A = \{a, b, c\}$ . The marked product  $\{a, c\}^* a \{1\} b \{b, c\}^*$  is unambiguous.

**Theorem 5.22** *If the product  $L_0 a_1 L_1 \cdots a_n L_n$  is unambiguous, the relational morphism  $\tau : M(L) \rightarrow M(L_0) \times M(L_1) \times \cdots \times M(L_n)$  is a locally trivial relational morphism.*

**Proof.** By Theorem 3.14, it suffices to show that if  $e$  is an idempotent of  $M(L_0) \times M(L_1) \times \cdots \times M(L_n)$ , then the semigroup  $\tau^{-1}(e)$  is locally trivial. It follows from Theorem 5.19 that  $\tau^{-1}(e)$  satisfies the identity  $x^\omega \leq x^\omega y x^\omega$  and it just remains to prove the opposite identity  $x^\omega y x^\omega \leq x^\omega$ . Let  $x, y \in \tau^{-1}(e)$ , let  $k$  be an integer such that  $\mu(x^k)$  is idempotent and let  $h = x^k$ . It suffices to show that  $u h y h v \in L$  implies  $u h v \in L$ . Let  $r = n + 2$ . Then  $\eta(h^r) = \eta(h)$ , and if  $u h y h v \in L$ , then  $u h^r y h^r v \in L$ . Consequently, there is a factorisation of the form  $u h^r y h^r v = u_0 a_1 \cdots a_n u_n$ , where  $u_i \in L_i$  for  $0 \leq i \leq n$ .

$u h^r y h^r v$							
$u_0$	$a_1$	$u_1$	$a_2$	$u_2$	$\cdots$	$a_n$	$u_n$

First assume that one of the words  $u_i$  contains  $h y h$  as a factor, that is,  $u_i = u'_i h y h u''_i$  with  $u_0 a_1 \cdots a_i u'_i = u h^{r-1}$  and  $u''_i a_{i+1} \cdots a_n u_n = h^{r-1} v$ . Since  $\eta(x) = \eta(y) = e$ , one has  $\eta_i(h y h) = \eta_i(h)$  and hence,  $u'_i h y h u''_i \in L_i$  implies  $u'_i h u''_i \in L_i$ . Consequently, one has

$$u h^{2r-1} v = u h^{r-1} h h^{r-1} v = u_0 a_1 \cdots a_i (u'_i h u''_i) a_{i+1} \cdots a_n u_n$$

which shows that  $u h^{2r-1} v$  belongs to  $L$ . Since  $\eta(h^{2r-1}) = \eta(h)$ , it follows that  $u h v$  is also in  $L$ , as required.

Suppose now that none of the words  $u_i$  contains  $h y h$  as a factor. Then there are factorisations of the form

$$u h^{r-1} = u_0 a_1 \cdots a_i u'_i \quad h y h = u''_i a_{i+1} \cdots a_j u'_j \quad h^{r-1} v = u''_j a_{j+1} \cdots a_n u_n$$

with  $u_i = u'_i u''_i$  and  $u_j = u'_j u''_j$ . By Lemma 5.20 applied to the word  $u_0 a_1 \cdots a_i u'_i$ , one of the words  $u_0, \dots, u_{i-1}, u'_i$  contains  $h$  as a factor. Similarly, one of the



words  $u_j'', u_{j+1}, \dots, u_n$  contains  $h$  as a factor. Therefore one gets factorisations

$$\begin{aligned} uh^{r-1} &= u_0 a_1 \cdots a_\ell u'_\ell h u''_\ell a_{\ell+1} \cdots u'_i \\ h^{r-1} v &= u_j'' a_{j+1} \cdots a_m u'_m h u''_m a_{m+1} \cdots a_n u_n \end{aligned}$$

with

$$u_0 a_1 \cdots a_\ell u'_\ell = u h^p \quad u'_\ell h u''_\ell = u_\ell \quad u''_\ell \cdots u'_i = h^{r-p-1}$$

and

$$u_j'' a_{j+1} \cdots a_m = h^q \quad u'_m h u''_m = u_m \quad u''_m \cdots a_n u_n = h^{r-q-1} v$$

Since  $h \sim_{L_\ell} h^{r-p} y h^p$  and  $u'_\ell h u''_\ell \in L_\ell$ , one also has  $u'_\ell h^{r-p} y h^p u''_\ell \in L_\ell$ . By a similar argument, one gets  $u'_m h^{r-q-1} y h^{q+1} u''_m \in L_m$ . Finally, the word  $u h^r y h^r y h^r v$  can be factorised either as

$$u_0 a_1 \cdots u_{\ell-1} a_\ell (u'_\ell h^{r-p} y h^p u''_\ell) a_{\ell+1} \cdots a_n u_n$$

or as

$$u_0 a_1 \cdots a_m (u'_m h^{r-q-1} y h^{q+1} u''_m) a_{m+1} \cdots a_n u_n$$

a contradiction, since this product should be unambiguous.  $\square$

## 5.2 Pure languages

A submonoid  $L^*$  of  $A^*$  is *pure* if for all  $u \in A^*$  and  $n > 0$ , the condition  $u^n \in L^*$  implies  $u \in L^*$ .

Let  $\eta : A^* \rightarrow M(L)$  be the syntactic morphism of  $L$  and  $\mu : A^* \rightarrow M(L^*)$  be the syntactic morphism of  $L^*$ . Then  $\tau = \eta \circ \mu^{-1}$  is a relational morphism from  $M(L^*)$  to  $M(L)$ .

$$\begin{array}{ccc} & A^* & \\ \mu \swarrow & & \searrow \eta \\ M(L^*) & \xrightarrow{\tau = \eta \circ \mu^{-1}} & M(L) \end{array}$$

The following result is due to Straubing [107].

**Theorem 5.23** *If  $L$  is pure, the relational morphism  $\tau : M(L^*) \rightarrow M(L)$  is aperiodic.*

**Proof.** Let  $e$  be an idempotent of  $M(L)$  and let  $x \in \eta^{-1}(e)$ . Let  $k$  be an integer such that  $k > |x|$  and  $\mu(x^k)$  is idempotent. By Proposition X.2.2, it suffices to show that for every  $u, v \in A^*$ ,

$$u x^k v \in L^* \text{ implies } u x^{k+1} v \in L^* \quad (5.1)$$

Suppose that  $u x^k v \in L^*$ . Then  $u x^k v = u_1 \cdots u_n$ , where each  $u_i$  belongs to  $L - \{1\}$ . Let us say that the  $r$ -th occurrence of  $x$  is *cut* if, for some  $j$ ,  $u x^{r-1}$  is a prefix of  $u_1 \cdots u_j$  and  $u_1 \cdots u_j$  is a proper prefix of  $u x^r$ .

$$\begin{array}{|c|c|c|} \hline ux^{r-1} & x & x^{k-r}v \\ \hline \end{array}$$

$$\begin{array}{|c|c|} \hline u_1 \cdots u_j & u_{j+1} \cdots u_n \\ \hline \end{array}$$

There are two cases to consider. First assume that one of the occurrences of  $x$  is not cut. Then for some  $j \in \{1, \dots, n\}$ , the word  $u_j$  contains  $x$  as a factor, that is,  $ux^{r-1} = u_1 \cdots u_{j-1}f$ ,  $u_j = fx^t g$  and  $x^q v = gu_{j+1} \cdots u_n$  for some  $f, g \in A^*$  and  $t > 0$  such that  $r + t + q - 1 = k$ .

$$\begin{array}{|c|c|c|} \hline ux^{r-1} & x^t & x^q v \\ \hline \end{array}$$

$$\begin{array}{|c|c|c|c|c|} \hline u_1 \cdots u_{j-1} & \underbrace{f \quad x^t \quad g}_{u_j} & u_{j+1} \cdots u_n \\ \hline \end{array}$$

Since  $x \sim_L x^2$  and since  $t > 0$ , one gets  $fx^t g \sim_L fx^{t+1} g$  and thus  $fx^{t+1} g \in L$ . It follows that  $ux^{k+1}v = u_1 \cdots u_{j-1}fx^{t+1}gu_{j+1} \cdots u_n \in L^*$ , proving (5.1) in this case.

Suppose now that every occurrence of  $x$  is cut. Then for  $1 \leq r \leq k$ , there exists  $j_r \in \{1, \dots, n\}$  and  $f_r \in A^*$ ,  $g_r \in A^+$  such that

$$ux^{r-1}f_r = u_1 \cdots u_{j_r}, \quad x = f_r g_r \quad \text{and} \quad g_r x^{k-r}v = u_{j_r+1} \cdots u_n$$

Since there are  $|x|$  factorisations of  $x$  of the form  $fg$ , and since  $|x| < k$ , there exist two indices  $r \neq r'$  such that  $f_r = f_{r'}$  and  $g_r = g_{r'}$ . Thus, for some indices  $i < j$  and some factorisation  $x = fg$ , one has  $ux^{r-1}f = u_1 \cdots u_i$ ,  $gx^s f = u_{i+1} \cdots u_j$  and  $gx^t v = u_{j+1} \cdots u_n$ . It follows that  $gx^s f = g(fg)^s f = (gf)^{s+1}$ . Since  $gx^s f \in L^*$  and since  $L$  is pure,  $gf \in L^*$ . Therefore,  $ux^{k+1}v = ux^{r-1}xx^s xxx^t v = (u^{r-1}f)(gx^s f)(gf)(gx^t v) \in L^*$ , proving (5.1) in this case as well.  $\square$

**Corollary 5.24** *If  $L$  is star-free and pure, then  $L^*$  is star-free.*

**Proof.** By Theorem X.2.3,  $L$  is star-free if and only if  $M(L)$  is aperiodic. Now, if  $L$  is pure, the relational morphism  $\tau$  is aperiodic and hence  $M(L^*)$  is aperiodic. It follows that  $L^*$  is star-free.  $\square$

### 5.3 Flower automata

Let  $L$  be a finite language if  $A^*$ . The *flower automaton* of  $L^*$  is the finite nondeterministic automaton  $\mathcal{A} = (Q, A, E, I, F)$ , where  $Q = \{1, 1\} \cup \{(u, v) \in A^+ \times A^+ \mid uv \in L\}$ ,  $I = F = \{(1, 1)\}$ . There are four types of transitions:

$$\begin{aligned} & \{((u, av) \xrightarrow{a} (ua, v) \mid uav \in L, (u, v) \neq (1, 1)\} \\ & \{((u, a) \xrightarrow{a} (1, 1) \mid ua \in L, u \neq 1\} \\ & \{((1, 1) \xrightarrow{a} (a, v) \mid av \in L, v \neq 1\} \\ & \{((1, 1) \xrightarrow{a} (1, 1) \mid a \in L\} \end{aligned}$$

It is easy to see that this automaton recognises  $L^*$ .

**Example 5.2** Let  $A = \{a, b\}$  and  $L = \{a, ba, aab, aba\}$ .

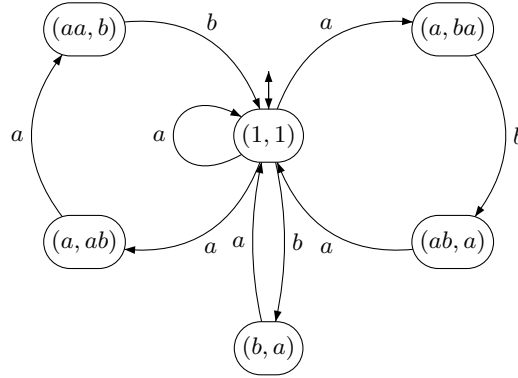

**Figure 5.2.** A flower automaton.

The transition monoid of the flower automaton of  $L^*$  is called the flower monoid of  $L^*$ . Since it recognises  $L^*$ , the syntactic monoid of  $L^*$  is a quotient of it.

Recall that a subset  $X$  of the free monoid  $A^*$  is a code over  $A$  if for all  $n, m > 0$  and  $x_1, \dots, x_n, x'_1, \dots, x'_m \in X$ , the condition

$$x_0 x_1 \cdots x_n = x'_1 x'_2 \cdots x'_m$$

implies  $n = m$  and  $x_i = x'_i$  for  $1 \leq i \leq n$ . In other words, a set  $X$  is a code if any word in  $X^+$  can be written uniquely as a product of words in  $X$ .

**Theorem 5.25** *Let  $X$  be a finite code. The natural morphism from the flower semigroup of  $X^+$  onto its syntactic semigroup is a locally trivial morphism.*

**Proof.** TO DO  $\square$



## Chapter XIV

# Unambiguous star-free languages

Recall that  $\mathbb{DA}$  denotes the class of finite semigroups in which every regular  $\mathcal{D}$ -class is an aperiodic semigroup (or idempotent semigroup, which is equivalent in this case). Several characterisations of  $\mathbb{DA}$  were given in Proposition VII.4.29.

### 1 Unambiguous star-free languages

Let  $A$  be a finite alphabet. The set of *unambiguous star-free* languages of  $A^*$  is the smallest set of languages of  $A^*$  containing the languages of the form  $B^*$ , for  $B \subseteq A$ , which is closed under finite union and unambiguous marked product.

Let us start by an elementary observation.

**Proposition 1.1** *Every finite language is unambiguous star-free.*

**Proof.** If  $a_1, \dots, a_k$  are letters of  $A$ , the marked product  $\{1\}a_1\{1\}a_2 \cdots a_k\{1\}$  is unambiguous. It follows that for any word  $u$ , the language  $\{u\}$  is unambiguous star-free. Further, any finite language is the disjoint union of the languages  $\{u\}$ , for  $u \in F$ . Thus every finite language is unambiguous star-free.  $\square$

**Example 1.1** The language  $\{a, c\}^* a \{1\} b \{b, c\}^*$  is unambiguous star-free (see Example XIII.5.1).

The aim of this section is to prove the following theorem

**Theorem 1.2** *A language is unambiguous star-free if and only if its syntactic monoid is finite and belongs to  $\mathbb{DA}$ .*

**Proof.** The easiest part of the proof relies on Theorem XIII.5.22. Let

$$L = L_0 a_1 L_1 \cdots a_n L_n$$

be an unambiguous marked product. Let  $M_0, \dots, M_n$  and  $M$  be the respective syntactic monoids of  $L_0, \dots, L_n$  and  $L$ .

**Lemma 1.3** *If  $M_0, \dots, M_n$  belong to  $\mathbb{DA}$ , so is  $M$ .*

**Proof.** Since the monoids  $M_0, \dots, M_n$  are all in  $\mathbb{DA}$ , so is their product  $N$ . Further, by Theorem XIII.5.22, there is a locally trivial relational morphism  $\tau$  from  $M$  into  $N$ . Let  $M \xrightarrow{\alpha^{-1}} R \xrightarrow{\beta} N$  be the canonical factorisation of  $\tau$ . Since  $M$  is a quotient of  $R$ , it suffices to prove that  $R$  belongs to  $\mathbb{DA}$ . By Theorem XIII.3.14,  $\beta$  is a locally trivial morphism. Let  $D$  be a regular  $\mathcal{D}$ -class of  $R$ . Then  $\beta(D)$  is a regular  $\mathcal{D}$ -class of  $N$  and since  $N$  belongs to  $\mathbb{DA}$ , this  $\mathcal{D}$ -class is an aperiodic simple semigroup. In particular,  $\beta(D)$  is in  $\mathbb{L1}$  and since  $\beta$  is a locally trivial morphism, the semigroup  $\beta^{-1}(\beta(D))$  also belongs to  $\mathbb{L1}$ . It follows in particular that  $D$  is an aperiodic simple semigroup and thus  $R$  belongs to  $\mathbb{DA}$ .  $\square$

# Chapter XV

## Wreath product

In this chapter, we introduce two important notions: the semidirect product of semigroups and the wreath product of transformation semigroups. We also prove some basic decomposition results.

### 1 Semidirect product

Let  $S$  and  $T$  be semigroups. We write the product in  $S$  additively to provide a more transparent notation, but it is not meant to suggest that  $S$  is commutative. A *left action* of  $T$  on  $S$  is a map  $(t, s) \mapsto t \cdot s$  from  $T^1 \times S$  into  $S$  such that, for all  $s, s_1, s_2 \in S$  and  $t, t_1, t_2 \in T$ ,

- (1)  $t_1 \cdot (t_2 \cdot s) = (t_1 t_2) \cdot s$
- (2)  $t \cdot (s_1 + s_2) = t \cdot s_1 + t \cdot s_2$
- (3)  $1 \cdot s = s$

If  $S$  is a monoid with identity  $0$ , the action is *unitary* if it satisfies, for all  $t \in T$ ,

- (4)  $t \cdot 0 = 0$

The *semidirect product* of  $S$  and  $T$  (with respect to the given action) is the semigroup  $S * T$  defined on  $S \times T$  by the multiplication

$$(s, t)(s', t') = (s + t \cdot s', tt')$$

### 2 Wreath product

Let  $X = (P, S)$  and  $Y = (Q, T)$  be two transformation semigroups. To make the notation more readable, we shall denote the semigroup  $S$  and its action on  $P$  additively and the semigroup  $T$  and its action on  $Q$  multiplicatively. The *wreath product* of  $X$  and  $Y$ , denoted  $X \circ Y$ , is the transformation semigroup  $(P \times Q, W)$  where  $W$  consists of all pairs  $(f, t)$ , with  $f$  is a function from  $Q$  into  $S$  and  $t \in T$ . Since we are thinking of  $f$  as acting on the right on  $Q$ , we will use the more suitable notation  $q \cdot f$  in place of  $f(q)$ . The action of  $W$  on  $P \times Q$  is given by

$$(p, q) \cdot (f, t) = (p + q \cdot f, q \cdot t) \tag{2.1}$$

We claim that this action is faithful. Indeed, if  $(p, q) \cdot (f, t) = (p, q) \cdot (f', t')$  for all  $(p, q) \in P \times Q$ , then  $q \cdot t = q \cdot t'$  for all  $q \in Q$  and thus  $t = t'$  since  $T$  acts faithfully

on  $Q$ . On the other hand,  $p + q \cdot f = p + q \cdot f'$  for all  $p \in P$  and thus  $q \cdot f = q \cdot f'$  since  $S$  acts faithfully on  $P$ . Thus  $f = f'$ , proving the claim. In particular  $W$  can be considered as a subset of the semigroup of all transformations on  $P \times Q$ . We leave it to the reader to verify that  $W$  is closed under composition and that the product on  $W$  is defined by

$$(f, t)(f', t') = (g, tt')$$

where  $g$  is defined, for each  $q \in Q$  by

$$q \cdot g = q \cdot f + (q \cdot t) \cdot f'$$

Let us now verify that Formula (2.1) really defines an action of  $W$  on  $P \times Q$ . If  $(p, q) \in P \times Q$  and  $(f, t), (f', t') \in W$ , we have

$$\begin{aligned} ((p, q) \cdot (f, t)) \cdot (f', t') &= (p + q \cdot f, q \cdot t) \cdot (f', t') = (p + q \cdot f + (q \cdot t) \cdot f', q \cdot tt') \\ &= (p, q) \cdot ((f, t)(f', t')) \end{aligned}$$

Given two semigroups  $S$  and  $T$ , consider the wreath product  $(S^1, S) \circ (T^1, T) = (S^1 \times T^1, W)$ . The semigroup  $W$  is called the *wreath product* of  $S$  and  $T$  and is denoted  $S \circ T$ . The connexions with the semidirect product and the product are given in the next propositions.

**Proposition 2.1** *Let  $S$  and  $T$  be semigroups. Then every semidirect product of  $S$  and  $T$  is a subsemigroup of  $S \circ T$ . Furthermore,  $S \circ T$  is a semidirect product of  $S^{T^1}$  and  $T$ .*

**Proof.** Let  $S * T$  be a semidirect product of  $S$  and  $T$ . Let  $\varphi: S * T \rightarrow S \circ T$  be the function defined by  $\varphi(s, t) = (f, t)$  where  $f: T^1 \rightarrow S$  is given by  $t \cdot f = t \cdot s$  for every  $t \in T^1$ . It is easy to verify that  $\varphi$  is a semigroup morphism.

For the second part of the statement, define a left action  $(t, f) \mapsto t \cdot f$  of  $T$  on  $S^{T^1}$  as follows:  $t \cdot f$  is the function from  $T^1$  into  $S$  defined by  $t' \cdot (t \cdot f) = (t't) \cdot f$ . Then the semidirect product defined by this action is isomorphic to  $S \circ T$ .  $\square$

**Proposition 2.2** *Let  $X$  and  $Y$  be transformation semigroups. Then  $X \times Y$  divides  $X \circ Y$ .*

**Proof.** Let  $X = (P, S)$  and  $Y = (Q, T)$ . Since the transformation semigroups  $X \times Y$  and  $X \circ Y$  have the same set of states,  $P \times Q$ , it suffices to show that  $S \times T$  can be embedded into  $S^Q \times T$ . With each pair  $(s, t)$ , associate the pair  $(f, t)$ , where  $f$  is the constant map onto  $s$ . Then, for every pair  $(p, q) \in P \times Q$ ,  $(p, q) \cdot (s, t) = (p + s, q \cdot t) = (p + q \cdot f, q \cdot t) = (p, q) \cdot (f, t)$ , which concludes the proof.  $\square$

A routine computation shows that the wreath product on transformation semigroups is associative. The wreath product also preserves division.

**Proposition 2.3** *If  $(P_1, S_1)$  divides  $(Q_1, T_1)$  and  $(P_2, S_2)$  divides  $(Q_2, T_2)$ , then  $(P_1, S_1) \circ (P_2, S_2)$  divides  $(Q_1, T_1) \circ (Q_2, T_2)$ .*



**Proof.** Let  $\pi_1: Q_1 \rightarrow P_1$  and  $\pi_2: Q_2 \rightarrow P_2$  be the surjective mappings defining the divisions. Let  $\pi = \pi_1 \times \pi_2: Q_1 \times Q_2 \rightarrow P_1 \times P_2$ . For  $(f, s_2) \in (P_1, S_1) \circ (P_2, S_2)$ , define  $\widehat{(f, s_2)} = (g, \hat{s}_2)$  by choosing a cover  $\hat{s}_2$  of  $s_2$  and, for each  $q_2 \in Q_2$ , a cover  $g(q_2)$  of  $f(\pi_2(q_2))$ . Now, for each  $(q_1, q_2) \in Q_1 \times Q_2$ ,

$$\begin{aligned} \pi(q_1, q_2) \cdot (f, s_2) &= (\pi_1(q_1), \pi_2(q_2)) \cdot (f, s_2) = (\pi_1(q_1) \cdot f(\pi_2(q_2)), \pi_2(q_2) \cdot s_2) \\ &= (\pi_1(q_1 \cdot g(q_2)), \pi_2(q_2 \cdot \hat{s}_2)) = \pi(q_1 \cdot g(q_2), q_2 \cdot \hat{s}_2) \\ &= \pi((q_1, q_2) \cdot (g, \hat{s}_2)) \end{aligned}$$

and this computation concludes the proof.  $\square$

In view of Proposition 2.3, we have the following corollary.

**Corollary 2.4** *If  $S_1$  divides  $T_1$  and  $S_2$  divides  $T_2$ , then  $S_1 \circ S_2$  divides  $T_1 \circ T_2$ .*

If  $X = (P, S)$  is a transformation semigroup, then  $X^1$  denotes the transformation semigroup obtained by adjoining to  $S$  the identity map  $1_P$  on  $P$ . If  $p$  is a state, we denote by  $c_p$  the constant map defined, for all  $q \in P$ , by  $c_p(q) = p$ . The transformation semigroup obtained by adjoining to  $S$  all the constant maps  $c_p$  is denoted by  $\overline{X}$ .

**Proposition 2.5** *Let  $X$  and  $Y$  be transformation semigroups. Then  $(X \circ Y)^1$  divides  $X^1 \circ Y^1$  and  $\overline{X \circ Y}$  divides  $\overline{X} \circ \overline{Y}$ .*

**Proof.** Let  $X = (P, S)$  and  $Y = (Q, T)$ . First note that the four transformation semigroups  $\overline{X \circ Y}$ ,  $\overline{X} \circ \overline{Y}$ ,  $(X \circ Y)^1$  and  $X^1 \circ Y^1$  have the same set of states,  $P \times Q$ . Next,  $1_{P \times Q}$  has the same action as  $(f, 1_Q) \in (S^1)^Q \times T$ , where  $f(q) = 1_P$  for all  $q \in Q$ . Thus  $(X \circ Y)^1$  embeds into  $X^1 \circ Y^1$ .

Finally, if  $(p, q) \in P \times Q$ , the constant map  $c_{(p,q)}$  has exactly the same action as the pair  $(g, c_q) \in \overline{S}^Q \times \overline{T}$  where  $g(x) = c_p$  for all  $x \in Q$ . Thus  $\overline{X \circ Y}$  embeds into  $\overline{X} \circ \overline{Y}$ .  $\square$

### 3 Basic decomposition results

In this section, we give some useful decomposition results. Let us first remind Proposition VII.4.21, which gives a useful decomposition result for commutative monoids and Proposition 3.6, which gives a decomposition involving  $\tilde{U}_n$  and  $U_n$ .

**Proposition 3.6** *For every  $n > 0$ ,  $U_n$  divides  $U_2^n$  and  $\tilde{U}_n$  divides  $\tilde{U}_2^n$ .*

**Proof.** Arguing by induction on  $n$ , it suffices to verify that  $U_n$  divides  $U_{n-1} \times U_2$ . But a simple computation shows that  $U_n$  is isomorphic to the submonoid  $N$  of  $U_{n-1} \times U_2$  defined as follows:

$$N = \{(1, 1)\} \cup \{(a_i, a_1) \mid 1 \leq i \leq n-1\} \cup \{(a_1, a_2)\}$$

A dual proof works for  $\tilde{U}_n$ .  $\square$

A more precise result follows from Proposition IX.1.6: a monoid is idempotent and  $\mathcal{R}$ -trivial if and only if it divides  $\tilde{U}_2^n$  for some  $n > 0$ . Dually, a monoid is idempotent and  $\mathcal{L}$ -trivial if and only if it divides  $U_2^n$  for some  $n > 0$ .

**Proposition 3.7** For every  $n > 0$ ,  $\tilde{U}_n$  divides  $U_n \circ U_2$ .

**Proof.** Let  $\pi : U_n \times U_2 \rightarrow \tilde{U}_n$  be the surjective partial map defined by  $\pi(1, a_1) = 1$  and, for  $1 \leq i \leq n$ ,  $\pi(a_i, a_2) = a_i$ .

For  $1 \leq j \leq n$ , we set  $\hat{a}_j = (f_j, a_2)$  where  $f_j : U_2 \rightarrow U_n$  is defined by  $1 \cdot f_j = a_2 \cdot f_j = 1$  and  $a_1 \cdot f_j = a_j$ . We also set  $\hat{1} = (f, 1)$  where  $f : U_2 \rightarrow U_n$  is defined by  $1 \cdot f = a_1 \cdot f = a_2 \cdot f = 1$ . Now a simple verification shows that  $\pi$  is indeed a cover:

$$\begin{aligned} \pi(a_i, a_2) \cdot 1 &= \pi(a_i, a_2) = \pi(a_i + a_2 \cdot f, a_2 \cdot 1) = \pi((a_i, a_2) \cdot \hat{1}) \\ \pi(1, a_1) \cdot 1 &= \pi(1, a_1) = \pi(1 + a_1 \cdot f, a_1 \cdot 1) = \pi((1, a_1)(f, 1)) = \pi((1, a_1) \cdot \hat{1}) \\ \pi(a_i, a_2) \cdot a_j &= a_i = \pi(a_i, a_2) = \pi(a_i + a_2 \cdot f_j, a_2 \cdot a_2) = \pi((a_i, a_2) \cdot \hat{a}_j) \\ \pi(1, a_1) \cdot a_j &= a_j = \pi(a_j, a_2) = \pi(1 + a_1 \cdot f_j, a_1 \cdot a_2) = \pi((1, a_1) \cdot \hat{a}_j) \end{aligned}$$

Thus  $\tilde{U}_n$  divides  $U_n \circ U_2$ .  $\square$

It follows now immediately from Propositions 3.7 and 3.6:

**Corollary 3.8** For every  $n > 0$ ,  $\tilde{U}_n$  divides  $\underbrace{U_2 \circ \cdots \circ U_2}_{n+1 \text{ times}}$ .

For each  $n > 0$ , let  $\mathbf{D}_n$  be the class of finite semigroups  $S$  such that, for all  $s_0, s_1, \dots, s_n$  in  $S$ ,  $s_0 s_1 \cdots s_n = s_1 \cdots s_n$ . In such a semigroup, a product of more than  $n$  elements is determined by the last  $n$  elements. By Proposition VII.4.15, these semigroups are lefty trivial. We shall now give a decomposition result for the semigroups in  $\mathbf{D}_n$ . As a first step, we decompose  $\bar{\mathbf{n}}$  as a product of copies of  $\bar{\mathbf{2}}$ .

**Lemma 3.9** If  $2^k > n$ , then  $\bar{\mathbf{n}}$  divides  $\bar{\mathbf{2}}^k$ .

**Proof.** The result is trivial, since if  $T$  is any subset of size  $n$  of  $\bar{\mathbf{2}}^k$ ,  $(T, T)$  is a sub-transformation semigroup of  $\bar{\mathbf{2}}^k$  isomorphic to  $\bar{\mathbf{n}}$ .  $\square$

We now decompose the semigroups of  $\mathbf{D}_n$  as an iterated wreath product of transformation semigroups of the form  $(T, T)$ .

**Proposition 3.10** Let  $S$  be a semigroup of  $\mathbf{D}_n$  and let  $T = S \cup \{t\}$ , where  $t$  is a new element. Then  $(S^1, S)$  divides  $\underbrace{(T, T) \circ \cdots \circ (T, T)}_{n \text{ times}}$ .

**Proof.** Let  $\varphi : T^n \rightarrow S^1$  be the partial function defined on sequences of the form  $(t, \dots, t, x_i, \dots, x_1)$ , where  $x_1, \dots, x_i \in S$ , by

$$\varphi(t, \dots, t, x_i, \dots, x_1) = \begin{cases} x_i \cdots x_1 & \text{if } i > 0 \\ 1 & \text{if } i = 0 \end{cases}$$

Clearly  $\varphi$  is surjective. If  $s \in S$ , we set  $\hat{s} = (f_{n-1}, \dots, f_1, s)$ , where, for  $1 \leq i \leq n-1$ ,  $f_i : T^i \rightarrow T$  is defined by  $(t_i, \dots, t_1) \cdot f_i = t_i$ . Thus

$$(t_n, \dots, t_1) \hat{s} = (t_{n-1}, \dots, t_1, s)$$

It follows that if  $p = (t, \dots, t, x_i, \dots, x_1)$  is in the domain of  $\varphi$ , then  $p \cdot \hat{s}$  is also in the domain of  $\varphi$  and  $\varphi(p \cdot \hat{s}) = \varphi(p) \cdot s$ . This proves the proposition.  $\square$

Proposition 3.10 and Lemma 3.9 now give immediately.

**Corollary 3.11** *Every semigroup of  $\mathbf{D}_n$  divides a wreath product of copies of  $\bar{2}$ .*

The  $\mathcal{R}$ -trivial monoids admit also a simple decomposition.

**Theorem 3.12** *A monoid is  $\mathcal{R}$ -trivial if and only if it divides a wreath product of the form  $U_1 \circ \dots \circ U_1$ .*

**Proof.** We first show that every monoid of the form  $U_1 \circ \dots \circ U_1$  is  $\mathcal{R}$ -trivial. Since  $U_1$  itself is  $\mathcal{R}$ -trivial, and since, by Proposition 2.1, a wreath product is a special case of semidirect product, it suffices to show that the semidirect product  $S * T$  of two  $\mathcal{R}$ -trivial monoids  $S$  and  $T$  is again  $\mathcal{R}$ -trivial. Indeed, consider two  $\mathcal{R}$  equivalent elements  $(s, t)$  and  $(s', t')$  of  $S * T$ . Then,  $(s, t)(x, y) = (s', t')$  and  $(s', t')(x, y) = (s, t)$  for some elements  $(x, y)$  and  $(x', y')$  of  $S * T$ . Therefore, on one hand  $s + tx = s'$  and  $s' + t'x = s$  and on the other hand,  $ty = t'$  and  $t'y' = t$ . It follows that  $s \mathcal{R} s'$  and  $t \mathcal{R} t'$ . Therefore  $s = s'$  and  $t = t'$ , and  $S * T$  is  $\mathcal{R}$ -trivial.

Let  $M = \{s_1, \dots, s_n\}$  be an  $\mathcal{R}$ -trivial monoid of size  $n$ . We may assume that  $s_i \leq_{\mathcal{R}} s_j$  implies  $j \leq i$ . Let us identify the elements of  $U_1^n$  with words of length  $n$  on the alphabet  $\{0, 1\}$ . Let  $\varphi : U_1 \times \dots \times U_1 \rightarrow M$  be the onto partial function defined by

$$\varphi(1^{n-j}0^j) = s_j \quad (0 \leq j \leq n)$$

Thus  $\varphi(u)$  is not defined if  $u \notin 1^*0^*$ . For each  $s \in M$ , let

$$\hat{s} = (f_{n-1}, \dots, f_2, a_1)$$

with

$$a_1 = \begin{cases} 1 & \text{if } s = 1 \\ 0 & \text{if } s \neq 1 \end{cases}$$

where  $f_{i+1} : \underbrace{U_1 \times \dots \times U_1}_{i \text{ times}} \rightarrow U_1$  is defined by

$$f_{i+1}(1^{i-j}0^j) = \begin{cases} 1 & \text{if } s_j s = s_k \text{ and } k \leq i \\ 0 & \text{if } s_j s = s_k \text{ and } k > i \end{cases}$$

If  $u \notin 1^*0^*$ , the value of  $f_{i+1}(u)$  can be chosen arbitrarily.

Let  $p = 1^{n-j}0^j$  and  $s \in M$ . Let  $k$  be such that  $s_k = s_j s$ . Since  $s_k \leq_{\mathcal{R}} s_j$ ,  $k \geq j$ . Then

$$\begin{aligned} p\hat{s} &= (f_{n-1}, \dots, f_2, a_1)(1^{n-j}0^j) \\ &= 1^{n-k}0^k \end{aligned}$$

whence  $\varphi(p\hat{s}) = s_k = s_j s = \varphi(p)s$ . Therefore,  $M$  divides  $U_1 \circ \dots \circ U_1$ .  $\square$

As a preparation to the next theorem, we prove another decomposition result, which is important in its own right.

**Proposition 3.13** *Let  $M$  be a finite aperiodic monoid and let  $\pi : A^* \rightarrow M$  be a surjective morphism. Then one of the following cases occur:*

- (1)  $M$  is a monogenic monoid,
- (2)  $M$  is isomorphic to  $\tilde{U}_n$  for some  $n > 0$ ,
- (3) there is a proper partition  $A = B \cup C$  such that  $\pi((B^*C)^*)$  and  $\pi(B^*)$  are proper submonoids of  $M$ .

**Proof.** Let  $S = M - \{1\}$ . Since  $M$  is aperiodic,  $S$  is a subsemigroup of  $M$ . Let  $L$  be an  $\mathcal{L}$ -class of  $S$ , maximal for the order  $\leq_{\mathcal{J}}$ . First assume that  $S$  is the semigroup generated by  $L$ . If  $|L| = 1$ ,  $S$  is monogenic and so is  $M$ . Otherwise,  $|L| > 1$  and by Proposition V.1.18,  $L$  is regular and thus consists of  $\mathcal{L}$ -equivalent idempotents. Now, Proposition V.1.3 shows that if  $e$  and  $f$  are  $\mathcal{L}$ -equivalent idempotents, then  $ef = e$  and  $fe = f$ . It follows that  $L$  is a semigroup and hence  $S = L$ . In particular, we are in the second case.

Now assume that the semigroup generated by  $L$  is strictly contained in  $S$  and put

$$B = \{a \in A \mid \pi(a) \in L\} \quad \text{and} \quad C = A - B$$

As  $\pi(A)$  generates  $S$  and  $\pi(B)$  does not,  $B$  is a strict subset of  $A$ , so that  $C$  is nonempty. We claim that  $\pi(B^+)$  and  $\pi(B^*C)^+$  are proper subsemigroups of  $S$ . For the first part of the claim, we observe that  $\pi(B)$  is contained in  $L$  and thus  $\pi(B^+)$  is contained in the subsemigroup of  $S$  generated by  $L$ , which is a proper subsemigroup of  $S$ . For the second part, we observe that every element of  $\pi(B^*C)^+$  is  $<_{\mathcal{J}}$ -below  $L$  and thus  $\pi(B^*C)^+$  is contained in  $S - L$ . It follows now from the claim that we are in the third case of the proposition.  $\square$

**Proposition 3.14** *Let  $M$  be a monoid. Suppose that  $M = L \cup N$  where  $L$  is a left ideal and  $N$  is a submonoid of  $M$ . Then  $M$  divides  $L^1 \circ \bar{N}$ .*

**Proof.** Let  $\varphi : L^1 \times N \rightarrow M$  be the map defined by  $\varphi(l, n) = ln$ . Since  $M = L \cup N$  and  $L \cup N \subseteq L^1N$ ,  $M = L^1N$ , and  $\varphi$  is onto.

Let  $m \in M$ . If  $m \in L$ , we set  $\hat{m} = (g, c_1)$ , where  $g : N \rightarrow L^1$  is defined by  $g(n) = nm$  for all  $n \in N$ . Otherwise, if  $m \notin L$ , we set  $\hat{m} = (f, m)$ , where  $f(n) = 1$  for all  $n \in N$ .

Let  $(l, n) \in L^1 \times N$ . Then

$$\varphi(l, n) \cdot m = (ln) \cdot m = lnm$$

Now, if  $m \in L$ ,

$$(l, n) \cdot \hat{m} = (l, n)(g, c_1) = (l \cdot g(n), 1) = (lnm, 1)$$

and since  $L$  is a left ideal,  $lnm \in L$ . On the other hand, if  $m \in N$ ,

$$(l, n) \cdot \hat{m} = (l, n)(f, m) = (l \cdot f(n), nm) = (l, nm)$$

and since  $N$  is a monoid,  $nm \in N$ . In both cases,  $\varphi((l, n) \cdot \hat{m}) = lnm$ . It follows that  $\varphi$  is a covering and thus  $M$  divides  $L^1 \circ \bar{N}$ .  $\square$

**Theorem 3.15** *A monoid is aperiodic if and only if it divides a wreath product of the form  $U_2 \circ \cdots \circ U_2$ .*

**Proof.** Let  $M$  be an aperiodic monoid. Consider the three cases given by Proposition 3.13. If  $M$  is monogenic, then it is  $\mathcal{R}$ -trivial, and the result follows from Theorem 3.12. If  $M$  is isomorphic to  $\tilde{U}_n$  for some  $n > 0$ , the result follows from Corollary 3.8. Finally, suppose there is a proper partition  $A = B \cup C$  such that  $L = \pi((B^*C)^*)$  and  $M = \pi(B^*)$  are proper submonoids of  $M$ . Then  $L$  is a left ideal of  $M$ , and since  $A^* = (B^*C)^* \cup B^*$ ,  $M = L \cup N$ . Thus by Proposition 3.14,  $M$  divides  $L^1 \circ \bar{N}$ . Arguing by induction on  $|M|$ , we may assume that  $L$  and  $N$  divide wreath products of copies of  $U_2$ . It follows, by Proposition 2.5, that  $L^1$  and  $\bar{N}$  also divide wreath products of copies of  $U_2$ , since  $U_2 = U_2^1 = \bar{U}_2$ . Finally,  $M$  itself divides a wreath product of copies of  $U_2$ .  $\square$

**Proposition 3.16** *Let  $X = (P, S)$  be a transformation semigroup such that  $P \cdot S = P$ . Then  $\bar{\mathbf{2}} \circ X$  divides  $X \circ (R, R)$ , where  $R$  is the set  $\{1, 2\}^P \times S$ .*

**Proof.** Define  $\varphi : P \times R \rightarrow \{1, 2\} \times P$  by setting  $\varphi(p, f, s) = (p \cdot f, p \cdot s)$  for each  $p \in P$ ,  $f \in \{1, 2\}^P$  and  $s \in S$ . Given a transformation  $v = (g, t)$  of  $\bar{\mathbf{2}} \circ X$ , with  $g \in \{1, 2\}^P$  and  $t \in S$ , define the transformation  $\hat{v}$  of  $X \circ (R, R)$  by setting

$$(p, f, s) \cdot \hat{v} = (p \cdot s, g, t)$$

then we have

$$\begin{aligned} \varphi(p, f, s) \cdot v &= (p \cdot f, p \cdot s)(g, t) = (p \cdot f + (p \cdot s) \cdot g, p \cdot st) \\ &((p \cdot s) \cdot g, p \cdot st) = \varphi(p \cdot s, g, t) = \varphi((p, f, s) \cdot \hat{v}) \end{aligned}$$

Thus  $\bar{\mathbf{2}} \circ X$  divides  $X \circ (R, R)$ .  $\square$

Given a property  $\mathcal{P}$ , we say that a semigroup  $S$  is *locally* in a variety  $\mathbf{V}$  if the local semigroup of each idempotent is in  $\mathbf{V}$ . For instance, a semigroup  $S$  is *locally trivial* if, for each  $s \in S$  and  $e \in E(S)$ ,  $ese = e$ .

We shall admit without proof our last decomposition result (see the Notes section).

**Proposition 3.17** *A semigroup is locally  $\mathcal{R}$ -trivial if and only if it divides a wreath product of the form  $U_1 \circ \dots \circ U_1 \circ \bar{\mathbf{2}} \circ \dots \circ \bar{\mathbf{2}}$ .*

**Proof.** TO DO.  $\square$

We now turn to groups.

**Proposition 3.18** *Let  $\pi : G \rightarrow H$  be a surjective morphism and let  $K = \pi^{-1}(1)$ . Then  $G$  is isomorphic to a subgroup of  $K \circ H$ .*

**Proof.** For each  $h \in H$ , select an element  $p_h$  of  $G$  such that  $\pi(p_h) = h$ . For each  $g \in G$ , define a map  $\hat{g} : H \rightarrow K$  by setting  $\hat{g}(h) = p_h g p_h^{-1}$ . Finally, let  $\varphi : G \rightarrow K \circ H$  be the map defined by

$$\varphi(g) = (\hat{g}, \pi(g))$$

Let us show that  $\varphi$  is a group morphism. By Proposition II.3.6, it suffices to prove that  $\varphi$  is a semigroup morphism. Let  $g_1, g_2 \in G$  and let  $s_1 = \pi(g_1)$  and  $s_2 = \pi(g_2)$ . One gets

$$\varphi(g_1)\varphi(g_2) = (\hat{g}_1, s_1)(\hat{g}_2, s_2) = (\hat{g}_1 + s_1\hat{g}_2, s_1s_2)$$

with, for each  $h \in H$ ,

$$(\hat{g}_1 + s_1 \hat{g}_2)(h) = \hat{g}_1(h) \hat{g}_2(hs_1) = p_h g_1 p_{hs_1}^{-1} p_{hs_1} g_2 p_{hs_1 s_2}^{-1} = p_h g_1 g_2 p_{hs_1 s_2}^{-1} = \widehat{g_1 g_2}(h)$$

and thus  $\varphi(g_1)\varphi(g_2) = \varphi(g_1 g_2)$ .

Finally, we prove that  $\varphi$  is injective. If  $\varphi(g_1) = \varphi(g_2)$ , then  $\pi(g_1) = \pi(g_2) = s$  and  $\hat{g}_1(1) = \hat{g}_2(1)$ , that is,  $p_1 g_1 p_s^{-1} = p_1 g_2 p_s^{-1}$ , whence  $g_1 = g_2$ . It follows that  $G$  is isomorphic to a subgroup of  $K \circ H$ .  $\square$

A subgroup  $H$  of a group  $G$  is *normal* if, for each  $h$  in  $H$  and each  $g$  in  $G$ , the element  $hgh^{-1}$  is still in  $H$ . A group  $G$  is *soluble* if there is an ascending chain of subgroups  $1 = G_0 \subseteq G_1 \subseteq \dots \subseteq G_n = G$  such that, for  $1 \leq i \leq n$ ,  $G_{i-1}$  is normal in  $G_i$  and  $G_i/G_{i-1}$  is a commutative group.

**Proposition 3.19** *A group is soluble if and only if it divides a wreath product of cyclic groups.*

**Proof.** TO DO.  $\square$

**Theorem 3.20 (Krohn-Rhodes)** *Let  $M$  be a monoid. Then there exists a sequence  $G_1, \dots, G_n$  of groups dividing  $M$  and a sequence  $M_0, \dots, M_n$  of aperiodic monoids such that  $M$  divides  $M_0 \circ G_1 \circ M_1 \cdots \circ G_n \circ M_n$ .*

**Proof.** TO DO.  $\square$

## 4 Exercises

### Section 3

1. Show that any finite inverse monoid divides a semidirect product of the form  $S * G$ , where  $S$  an idempotent and commutative monoid and  $G$  is a finite group. Actually, a stronger result holds: a finite monoid divides the semidirect product of an idempotent and commutative monoid by a group if and only if its idempotents commute.

# Chapter XVI

## Sequential functions

So far, we have only used automata to define languages but more powerful models allow one to define functions or even relations between words. These automata not only read an input word but they also produce an output. These devices are also called transducers. In the deterministic case, which forms the topic of this chapter, they define the so called sequential functions. The composition of two sequential functions is also sequential.

Straubing's "wreath product principle" [105, 110] provides a description of the languages recognised by the wreath product of two monoids. It has numerous applications, including Schützenberger's theorem on star-free languages [20, 57], the characterisation of languages recognised by solvable groups [105] or the expressive power of fragments of temporal logic [19, 121].

### 1 Definitions

#### 1.1 Pure sequential transducers

A *pure sequential transducer* is an 6-tuple  $\mathcal{T} = (Q, A, R, q_0, \cdot, *)$ , where  $Q$  is a finite set of *states*,  $A$  is a finite alphabet called the *input alphabet*,  $R$  is a semigroup (possibly infinite) called the *output semigroup*,  $q_0 \in Q$  is the *initial state*,  $(q, a) \mapsto q \cdot a \in Q$  and  $(q, a) \mapsto q * a \in R$  are partial functions with the same domain contained in  $Q \times A$ , called respectively the *transition function* and the *output function*. Both functions are conveniently represented in Figure 1.1, in which the vertical slash is a separator.

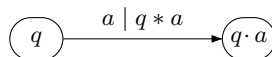

**Figure 1.1.** A transition and its output function.

The transition and the output functions can be extended to partial functions

$Q \times A^* \rightarrow Q$  (resp.  $Q \times A^* \rightarrow R^1$ ) by setting, for each  $u \in A^*$  and each  $a \in A$ :

$$\begin{aligned} q \cdot 1 &= q & q * 1 &= 1 \\ q \cdot (ua) &= (q \cdot u) \cdot a & \text{if } q \cdot u \text{ and } (q \cdot u) \cdot a \text{ are defined} \\ q * (ua) &= (q * u)((q \cdot u) * a) & \text{if } q * u, q \cdot u \text{ and } (q \cdot u) * a \text{ are defined} \end{aligned}$$

To decongest this type of formulas, it is convenient to fix some priority rules on the operators. Our choice is to give highest priority to concatenation, then to dot and then to star. For instance, we write  $q \cdot ua$  for  $q \cdot (ua)$ ,  $q * ua$  for  $q * (ua)$  and  $q \cdot u * a$  for  $(q \cdot u) * a$ .

**Proposition 1.1** *Let  $\mathcal{T} = (Q, A, R, q_0, \cdot, *)$  be a pure sequential transducer. Then the following formulas hold for all  $q \in Q$  and for all  $u, v \in A^*$ :*

- (1)  $q \cdot uv = (q \cdot u) \cdot v$
- (2)  $q * uv = (q * u)(q \cdot u * v)$

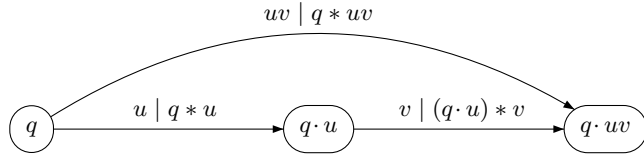

**Proof.** The first formula is a standard property of deterministic automata. The second one can be proved by induction on the length of  $v$ . If  $v = 1$ , it is obvious. If  $v = wa$ , where  $a$  is a letter, one gets successively

$$\begin{aligned} q * uv &= q * uwa = (q * uw)(q \cdot uw * a) \\ &= (q * u)(q \cdot u * w)((q \cdot u) \cdot w * a) \\ &= (q * u)(q \cdot u * wa) = (q * u)(q \cdot u * v) \end{aligned}$$

which gives the result.  $\square$

The function *realised* by the pure sequential transducer  $\mathcal{T}$  is the partial function  $\varphi: A^* \rightarrow R^1$  defined by

$$\varphi(u) = q_0 * u$$

A *pure sequential function* is a partial function that can be realised by a pure sequential transducer. Pure sequential functions preserve prefixes: if  $u$  is a prefix of  $v$ , and if  $\varphi(v)$  is defined, then  $\varphi(u)$  is defined and is a prefix of  $\varphi(v)$ .

**Example 1.1** The transducer pictured in Figure 1.2 converts text from uppercase to lowercase.

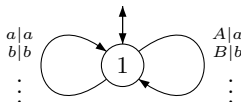

**Figure 1.2.** Conversion from uppercase to lowercase.



**Example 1.2** Consider the prefix code  $P = \{0000, 0001, 001, 010, 011, 10, 11\}$  represented by the tree pictured in Figure 1.3.

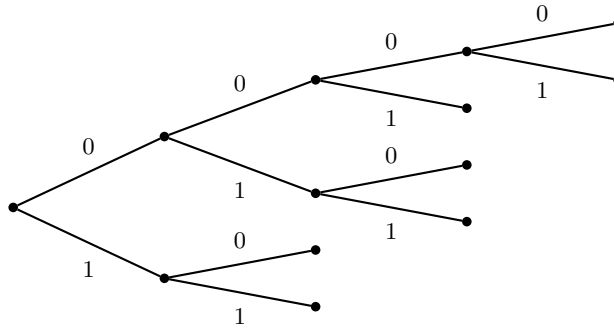
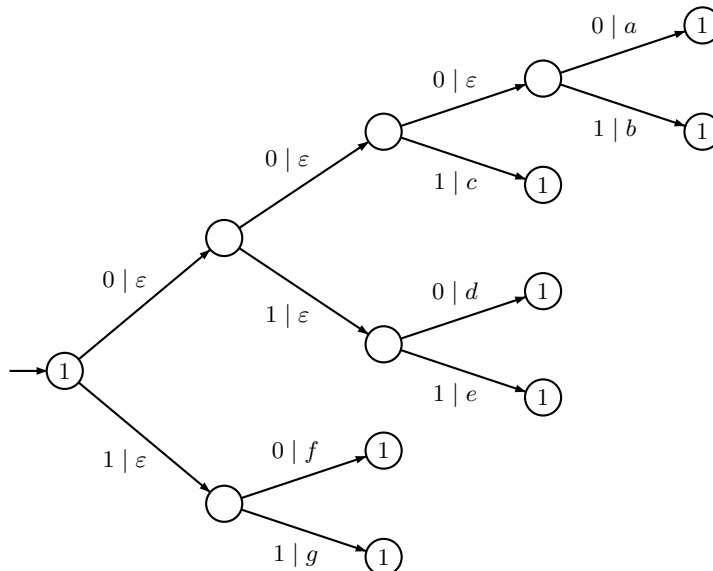

**Figure 1.3.** A prefix code.

Since  $P$  is a prefix code, the coding function  $\varphi : \{a, b, c, d, e, f\}^* \rightarrow \{0, 1\}^*$  defined by

$$\begin{array}{llll} \varphi(a) = 0000 & \varphi(b) = 0001 & \varphi(c) = 001 & \varphi(d) = 010 \\ \varphi(e) = 011 & \varphi(f) = 10 & \varphi(g) = 11 & \end{array}$$

is injective. The corresponding decoding function from  $\{0, 1\}^*$  to  $\{a, b, c, d, e, f\}^*$  can be realised by the pure sequential transducer pictured in Figures 1.4 and 1.5.



**Figure 1.4.** A pure sequential transducer for the decoding function.

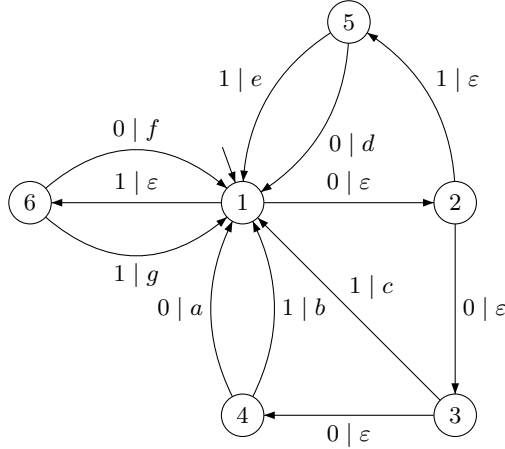

Figure 1.5. The same pure sequential transducer, folded up.

**Example 1.3** Let  $\varphi : \{a, b\}^* \rightarrow (\mathbb{N}, +)$  be the function which counts the number of occurrences of the factor  $aba$  in a word. It is a pure sequential function, realised by the transducer represented in Figure 1.6.

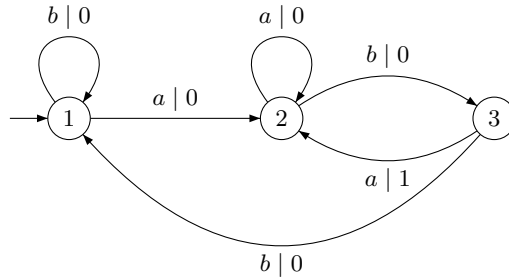

Figure 1.6. A function computing the number of occurrences of  $aba$ .

### 1.2 Sequential transducers

Let  $a$  and  $b$  be two distinct letters. A function as simple as the function  $u \rightarrow ua$  is not pure sequential since  $b$  is a prefix of  $bb$ , but  $ba$  is not a prefix of  $bba$ . However, it is easy to realise this function by a machine which reproduces its input as its output and concatenates an  $a$  at the end of the final output. Such a machine is an example of a sequential transducer. Here is the formal definition.

A *sequential transducer* is an 8-tuple  $\mathcal{T} = (Q, A, R, q_0, \cdot, *, m, \rho)$ , where  $(Q, A, R, q_0, \cdot, *)$  is a pure sequential transducer,  $m \in R^1$  is the *initial prefix* and  $\rho : Q \rightarrow R^1$  is a partial function, called the *terminal function*.

The function *realised* by the sequential transducer  $\mathcal{T}$  is the partial function  $\varphi : A^* \rightarrow R^1$  defined by

$$\varphi(u) = m(q_0 * u)\rho(q_0 \cdot u)$$

A *sequential function* is a partial function that can be realised by a sequential transducer.

**Example 1.4** Let  $u, v \in A^*$ . The map  $\varphi : A^* \rightarrow A^*$  defined by  $\varphi(x) = uxv$  is realised by the sequential transducer represented in Figure 1.7. Its initial prefix is  $u$  and its terminal function  $\rho$  is defined by  $\rho(1) = v$ .

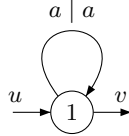

**Figure 1.7.** A sequential transducer realising the function  $x \rightarrow uxv$ .

**Example 1.5** The function  $\varphi : A^* \rightarrow A^*$  defined by  $\varphi(x) = x(ab)^{-1}$  is realised by the sequential transducer represented in Figure 1.8.

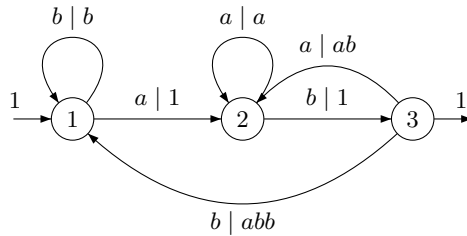

**Figure 1.8.** A sequential transducer realising the function  $x \rightarrow x(ab)^{-1}$ .

**Example 1.6** In the *reverse binary representation*, a binary word  $a_0a_1 \cdots a_n$  represents the number  $\sum_{0 \leq i \leq n} a_i 2^i$ . For instance, the word 1011 represents  $1 + 4 + 8 = 13$ . Multiplication by 3 can then be performed by the following sequential transducer.

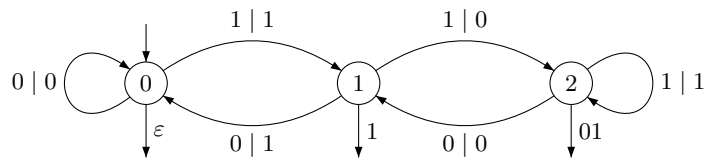

**Figure 1.9.** A sequential transducer realising the multiplication by 3.

For instance, on the input 1011, which represents 13, the output would be 111001, which represents  $1 + 2 + 4 + 32 = 39$ .

## 2 Composition of sequential functions

The goal of this section is to establish that the composition of two [pure] sequential functions is also a [pure] sequential function.

Let  $\varphi : A^* \rightarrow B^*$  and  $\theta : B^* \rightarrow C^*$  be two pure sequential functions, realised respectively by the pure sequential transducers

$$\mathcal{A} = (Q, A, B, q_0, \cdot, *) \text{ and } \mathcal{B} = (P, B, C, p_0, \cdot, *)$$

The composition of these two functions can be realised by feeding  $\mathcal{B}$  with the output of  $\mathcal{A}$ . This observation leads to the following definition. The *wreath product* of  $\mathcal{B}$  by  $\mathcal{A}$  is the pure sequential transducer

$$\mathcal{B} \circ \mathcal{A} = (P \times Q, A, C, (p_0, q_0), \cdot, *)$$

defined by

$$(p, q) \cdot a = (p \cdot (q * a), q \cdot a) \text{ and } (p, q) * a = p * (q * a)$$

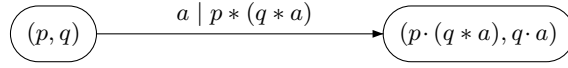

**Figure 2.10.** A transition and its output in  $\mathcal{B} \circ \mathcal{A}$ .

Intuitively, the second component of  $(p, q)$  is used to simulate  $\mathcal{A}$ . The first component and the output function are obtained by using the output of a transition in  $\mathcal{A}$  as input in  $\mathcal{B}$ .

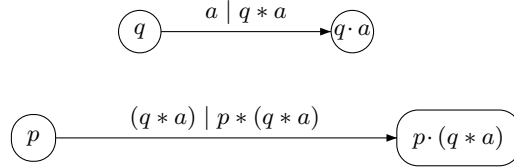

**Figure 2.11.** The output of  $\mathcal{A}$  as input of  $\mathcal{B}$ .

This definition can be extended to sequential transducers as follows. Let

$$\mathcal{A} = (Q, A, B, q_0, \cdot, *, n, \rho) \text{ and } \mathcal{B} = (P, B, C, p_0, \cdot, *, m, \sigma)$$

be two sequential transducers. The *wreath product* of  $\mathcal{B}$  by  $\mathcal{A}$  is the sequential transducer

$$\mathcal{B} \circ \mathcal{A} = (P \times Q, A, C, (p_0 \cdot n, q_0), \cdot, *, m(p_0 * n), \omega)$$

defined by

$$\begin{aligned} (p, q) \cdot a &= (p \cdot (q * a), q \cdot a) \\ (p, q) * a &= p * (q * a) \\ \omega(p, q) &= (p * \rho(q)) \sigma(p \cdot \rho(q)) \end{aligned}$$

The computation of the initial prefix and of the terminal function are illustrated in Figure 2.12.

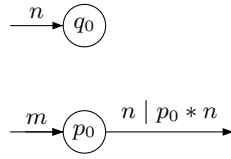

Figure 2.12. The initial prefix.

The next proposition describes the behaviour of  $\mathcal{B} \circ \mathcal{A}$ .

**Proposition 2.2** *The following formulas hold for all states  $(p, q)$  of  $\mathcal{B} \circ \mathcal{A}$  and for all  $u \in A^*$ :*

$$(p, q) \cdot u = (p \cdot (q * u), q \cdot u)$$

$$(p, q) * u = p * (q * u)$$

**Proof.** We prove the result by induction on the length of  $u$ . If  $u = 1$ , one gets on the one hand  $(p, q) \cdot 1 = (p, q)$  and on the other hand  $q * 1 = 1$  and  $q \cdot 1 = q$ , whence  $(p \cdot (q * 1), q \cdot 1) = (p \cdot 1, q) = (p, q)$ , which proves the first formula. The second one is trivial since by definition  $(p, q) * 1 = 1 = p * (q * 1)$ .

Suppose by induction that the formulas are true for a word  $u$  of length  $n$  and let  $a$  be a letter. Setting  $v = ua$ ,  $w = q * u$  and  $w' = (q \cdot u) * a$ , one gets  $q * v = q * (ua) = (q * u)((q \cdot u) * a) = ww'$  and

$$(p, q) \cdot v = (p \cdot (q * u), q \cdot u) \cdot a = (p \cdot w, q \cdot u) \cdot a$$

$$= (p \cdot w \cdot (q \cdot u * a), (q \cdot u) \cdot a) = (p \cdot ww', q \cdot v) = (p \cdot (q * v), q \cdot v)$$

which proves the first formula. Further

$$(p, q) * v = ((p, q) * u)((p, q) \cdot u * a) = (p * (q * u))((p \cdot (q * u), q \cdot u) * a)$$

$$= (p * w)((p \cdot w, q \cdot u) * a) = (p * w)((p \cdot w) * (q \cdot u * a))$$

$$= (p * w)((p \cdot w) * w') = p * (ww') = p * (q * v)$$

which gives the second one.  $\square$

**Example 2.1** Let  $A = \{a, b\}$ ,  $B = \{a, b\}$  and  $C = \{a, b, c\}$  and let  $\mathcal{A}$  and  $\mathcal{B}$  be the pure sequential transducers represented in Figure 2.13.

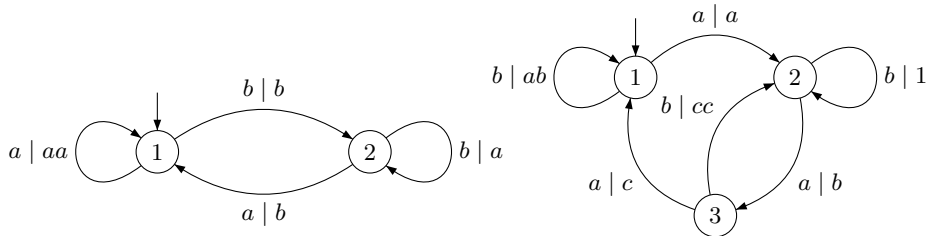
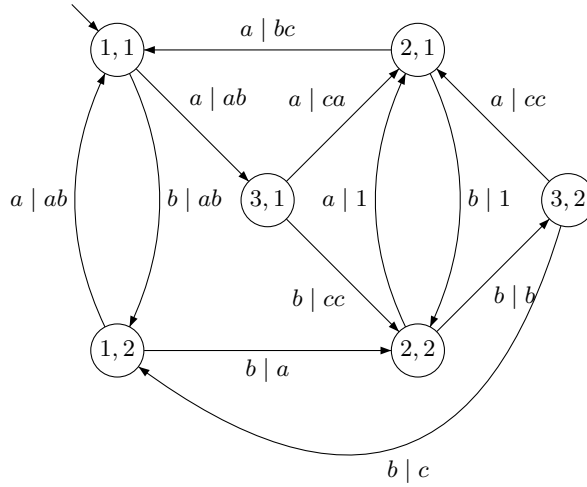

Figure 2.13. The transducers  $\mathcal{A}$  (on the left) and  $\mathcal{B}$  (on the right).

The wreath product  $\mathcal{B} \circ \mathcal{A}$  is defined by the formula

$$\begin{array}{llll}
 (1,1) \cdot a = (3,1) & (1,1) * a = ab & (1,1) \cdot b = (1,2) & (1,1) * b = ab \\
 (1,2) \cdot a = (1,1) & (1,2) * a = ab & (1,2) \cdot b = (2,2) & (1,2) * b = a \\
 (2,1) \cdot a = (1,1) & (2,1) * a = bc & (2,1) \cdot b = (2,2) & (2,1) * b = 1 \\
 (2,2) \cdot a = (2,1) & (2,2) * a = 1 & (2,2) \cdot b = (3,2) & (2,2) * b = b \\
 (3,1) \cdot a = (2,1) & (3,1) * a = ca & (3,1) \cdot b = (2,2) & (3,1) * b = cc \\
 (3,2) \cdot a = (2,1) & (3,2) * a = cc & (3,2) \cdot b = (1,2) & (3,2) * b = c
 \end{array}$$

and is represented in Figure 2.14.



**Figure 2.14.** The wreath product  $\mathcal{B} \circ \mathcal{A}$ .

**Theorem 2.3** Let  $\mathcal{A}$  and  $\mathcal{B}$  be two [pure] sequential transducers realising the functions  $\varphi : A^* \rightarrow B^*$  and  $\theta : B^* \rightarrow C^*$ . Then  $\mathcal{B} \circ \mathcal{A}$  realises the function  $\theta \circ \varphi$ .

**Proof.** Let  $\mathcal{A} = (Q, A, B, q_0, \cdot, *, n, \rho)$  and  $\mathcal{B} = (P, B, C, p_0, \cdot, *, m, \sigma)$  be two sequential transducers realising the functions  $\varphi : A^* \rightarrow B^*$  and  $\theta : B^* \rightarrow C^*$ , respectively. Let  $\eta$  be the function realised by  $\mathcal{B} \circ \mathcal{A}$  and let  $u \in A^*$ . Setting  $p = p_0 \cdot n$ ,  $q = q_0 \cdot u$  and  $v = q_0 * u$ , one gets  $\varphi(u) = n(q_0 * u)\rho(q_0 \cdot u) = nv\rho(q)$ . The computation of  $\eta(u)$  gives

$$\begin{aligned}
 \eta(u) &= m(p_0 * n)((p, q_0) * u)\omega((p, q_0) \cdot u) \\
 &= m(p_0 * n)(p * (q_0 * u))\omega(p \cdot (q_0 * u), q_0 \cdot u) \\
 &= m(p_0 * n)(p * v)\omega(p \cdot v, q)
 \end{aligned}$$

Further, one has

$$\begin{aligned}
 \omega(p \cdot v, q) &= (p \cdot v * \rho(q))\sigma((p \cdot v) \cdot \rho(q)) \\
 &= (p \cdot v * \rho(q))\sigma(p \cdot v\rho(q)) \\
 &= (p \cdot v * \rho(q))\sigma(p_0 \cdot nv\rho(q)) \\
 &= (p \cdot v * \rho(q))\sigma(p_0 \cdot \varphi(u))
 \end{aligned}$$

Coming back to the computation of  $\eta(u)$ , we get:

$$\begin{aligned}
\eta(u) &= m(p_0 * n)(p * v)\omega(p \cdot v, q) \\
&= m(p_0 * n)(p * v)(p \cdot v * \rho(q))\sigma(p_0 \cdot \varphi(u)) \\
&= m(p_0 * n)(p_0 \cdot n * v)(p_0 \cdot nv * \rho(q))\sigma(p_0 \cdot \varphi(u)) \\
&= m(p_0 * nv\rho(q))\sigma(p_0 \cdot \varphi(u)) \\
&= m(p_0 * \varphi(u))\sigma(p_0 \cdot \varphi(u)) \\
&= \theta(\varphi(u))
\end{aligned}$$

which proves that  $\eta = \theta \circ \varphi$ .  $\square$

**Corollary 2.4** *The composition of two [pure] sequential functions is a [pure] sequential function.*

### 3 Sequential functions and wreath product

Since the wreath product is better defined in terms of transformation semigroups, we need to adapt two standard definitions to this setting.

First, the *transformation semigroup of a sequential transducer* is the transformation semigroup of its underlying automaton. Next, a subset  $L$  of a semigroup  $R$  is *recognised by a transformation semigroup*  $(P, S)$  if there exist a surjective morphism  $\varphi: R \rightarrow S$ , a state  $p_0 \in P$  and a subset  $F \subseteq P$  such that  $L = \{u \in R \mid p_0 \cdot \varphi(u) \in F\}$ .

**Theorem 3.5** *Let  $\sigma: A^+ \rightarrow R$  be a sequential function realised by a sequential transducer  $\mathcal{T}$ , and let  $(Q, T)$  be the transformation semigroup of  $\mathcal{T}$ . If  $L$  is a subset of  $R$  recognised by a transformation semigroup  $(P, S)$ , then  $\sigma^{-1}(L)$  is recognised by  $(P, S) \circ (Q, T)$ .*

**Proof.** Let  $\mathcal{T} = (Q, A, R, q_0, \cdot, *, m, \rho)$ . Since  $L$  is recognised by  $(P, S)$ , there is a surjective morphism  $\varphi: R \rightarrow S$ , a state  $p_0 \in P$  and a subset  $F \subseteq P$  such that  $L = \{u \in R \mid p_0 \cdot \varphi(u) \in F\}$ . Let  $(P, S) \circ (Q, T) = (P \times Q, W)$  and define a morphism  $\psi: A^+ \rightarrow W$  by setting

$$(p, q) \cdot \psi(u) = (p \cdot \varphi(q * u), q \cdot u)$$

By hypothesis, the map  $q \mapsto \varphi(q * u)$  is a function from  $Q$  into  $S$  and thus  $\psi$  is well defined. Let

$$I = \{(p, q) \in P \times \text{Dom}(\rho) \mid p \cdot \varphi(\rho(q)) \in F\}$$

Now, since

$$(p_0 \cdot \varphi(m), q_0) \cdot \psi(u) = (p_0 \cdot \varphi(m)\varphi(q_0 * u), q_0 \cdot u)$$

one has

$$\begin{aligned}
\sigma^{-1}(L) &= \{u \in A^+ \mid \sigma(u) \in L\} = \{u \in A^+ \mid p_0 \cdot \varphi(\sigma(u)) \in F\} \\
&= \{u \in A^+ \mid p_0 \cdot \varphi(m(q_0 * u)\rho(q_0 \cdot u)) \in F\} \\
&= \{u \in A^+ \mid p_0 \cdot \varphi(m)\varphi(q_0 * u)\varphi(\rho(q_0 \cdot u)) \in F\} \\
&= \{u \in A^+ \mid (p_0 \cdot \varphi(m), q_0) \cdot \psi(u) \in I\}
\end{aligned}$$

Therefore,  $\sigma^{-1}(L)$  is recognised by  $(P \times Q, W)$ .  $\square$

## 4 The wreath product principle and its consequences

The aim of this section is to characterise the languages recognised by the wreath product of two transformation semigroups.

### 4.1 The wreath product principle

Let  $X = (P, S)$  and  $Y = (Q, T)$  be two transformation semigroups, let  $Z = X \circ Y = (P \times Q, W)$ , and let  $L$  be a language of  $A^+$  recognised by  $Z$ . Then there exist a state  $(p_0, q_0)$ , a subset  $F$  of  $P \times Q$  and a morphism  $\eta: A^+ \rightarrow W$  such that  $L = \{u \in A^+ \mid (p_0, q_0) \cdot \eta(u) \in F\}$ . Denote by  $\pi$  the natural projection from  $W$  onto  $T$ , defined by  $\pi(f, t) = t$  and let  $\varphi = \pi \circ \eta: A^+ \rightarrow T$ .

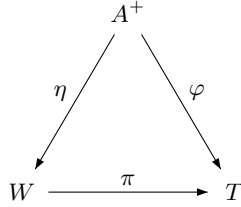

Let  $B = Q \times A$ . Define a function  $\sigma: A^+ \rightarrow B^+$  by

$$\sigma(a_1 a_2 \cdots a_n) = (q_0, a_1)(q_0 \cdot \varphi(a_1), a_2) \cdots ((q_0 \cdot \varphi(a_1 \cdots a_{n-1})), a_n)$$

Note that  $\sigma$  is a sequential function, realised by the transducer  $(Q, A, B^+, q_0, \cdot, *)$  where  $q \cdot a = q \cdot \varphi(a)$  and  $q * a = (q, a)$ .

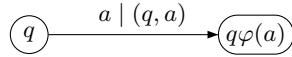

**Figure 4.15.** A pure sequential transducer realising  $\sigma$ .

We are now ready to state the wreath product principle.

**Theorem 4.6 (Wreath product principle)** *Each language of  $A^+$  recognised by  $Z$  is a finite union of languages of the form  $U \cap \sigma^{-1}(V)$ , where  $U \subseteq A^+$  is recognised by  $Y$  and  $V \subseteq B^+$  is recognised by  $X$ .*

**Proof.** First, we may assume that  $F = (p, q)$  for some  $(p, q) \in P \times Q$ . This is a consequence of the formula

$$L = \bigcup_{(p,q) \in F} \{u \in A^+ \mid (p_0, q_0) \cdot u \in (p, q)\}$$

For each letter  $a$ , set  $\eta(a) = (f_a, t_a)$ . Note that  $\varphi(a) = t_a$ . Define a function  $\alpha: B \rightarrow S$  by setting  $\alpha(q, a) = q \cdot f_a$  and extend it into a morphism  $\alpha: B^+ \rightarrow S$ .



Let  $u = a_1 a_2 \cdots a_n$  be a word. Then

$$\begin{aligned} (p_0, q_0) \cdot u &= (p_0, q_0) \cdot (f_{a_1}, t_{a_1})(f_{a_2}, t_{a_2}) \cdots (f_{a_n}, t_{a_n}) \\ &= (p_0 + q_0 \cdot f_{a_1} + \cdots + (q_0 \cdot t_{a_1} \cdots t_{a_{n-1}}) f_{a_n}, q_0 \cdot t_{a_1} \cdots t_{a_n}) \\ &= (p_0 + \alpha(q_0, a_1) + \cdots + \alpha(q_0 \cdot \varphi(a_1 \cdots a_{n-1}), a_n), q_0 \cdot \varphi(u)) \\ &= (p_0 + \alpha(\sigma(u)), q_0 \cdot \varphi(u)) \end{aligned}$$

It follows that  $(p_0, q_0) \cdot u \in F$  if and only if the following two conditions are satisfied:

- (1)  $p_0 + \alpha(\sigma(u)) = p$ ,
- (2)  $q_0 \cdot \varphi(u) = q$ .

Setting  $U = \{u \in A^+ \mid q_0 \cdot \varphi(u) = q\}$  and  $V = \{v \in B^+ \mid p_0 + \alpha(v) = p\}$ , condition (1) can be reformulated as  $u \in \sigma^{-1}(V)$ , and condition (2) as  $u \in U$ . Thus

$$L = U \cap \sigma^{-1}(V)$$

Now,  $U$  is recognised by  $Y$  and  $V$  is recognised by  $X$ , which concludes the proof.  $\square$

We now derive a variety version of Theorem 4.6. It is stated in the case where both  $\mathbf{V}$  and  $\mathbf{W}$  are varieties of monoids, but similar statements hold if  $\mathbf{V}$  or  $\mathbf{W}$  is a variety of semigroups. Let us define the variety  $\mathbf{V} * \mathbf{W}$  as the class of all divisors of wreath products of the form  $S \circ T$  with  $S \in \mathbf{V}$  and  $T \in \mathbf{W}$ .

**Corollary 4.7** *Let  $\mathbf{V}$  and  $\mathbf{W}$  be two varieties of monoids and let  $\mathcal{U}$  be the variety of languages associated with  $\mathbf{V} * \mathbf{W}$ . Then, for every alphabet  $A$ ,  $\mathcal{U}(A^*)$  is the smallest lattice containing  $\mathcal{W}(A^*)$  and the languages of the form  $\sigma_\varphi^{-1}(V)$ , where  $\sigma_\varphi$  is the sequential function associated with a morphism  $\varphi : A^* \rightarrow T$ , with  $T \in \mathbf{W}$ , and  $V \in \mathcal{V}((A \times T)^*)$ .*

**Proof.** Since  $\mathbf{W}$  is contained in  $\mathbf{V} * \mathbf{W}$ ,  $\mathcal{W}(A^*)$  is contained in  $\mathcal{U}(A^*)$ . Furthermore, if  $V$  and  $\sigma_\varphi$  are given as in the statement, then  $\sigma_\varphi^{-1}(V) \in \mathcal{U}(A^*)$  by Theorem 3.5.

It follows from the definition of  $\mathbf{V} * \mathbf{W}$  and from Proposition IV.4.25 that every language of  $\mathcal{U}(A^*)$  is recognised by a wreath product of the form  $S \circ T$ , with  $S \in \mathbf{V}$  and  $T \in \mathbf{W}$ . Theorem 4.6 now suffices to conclude.  $\square$

## 5 Applications of the wreath product principle

In this section, we give several applications of the wreath product principle. We study the operations  $L \mapsto LaA^*$  and  $L \mapsto La$ , where  $a$  is a letter of  $A$ . Then we give a description of the languages corresponding to  $\mathbf{J}_1 * \mathbf{V}$ ,  $\llbracket yx = x \rrbracket * \mathbf{V}$  and  $\mathbf{r1} * \mathbf{V}$ , where  $\mathbf{V}$  is a variety of monoids (resp. semigroups). Recall that the variety  $\mathbf{r1}$  is defined by the identity  $yx^\omega = x^\omega$ .

### 5.1 The operations $T \mapsto U_1 \circ T$ and $L \mapsto LaA^*$

The study of this operation is based on the following proposition.

**Proposition 5.8** *Let  $A$  be an alphabet, let  $a \in A$  and let  $L$  be a language of  $A^*$  recognised by a monoid  $T$ . Then  $LaA^*$  is recognised by the wreath product  $U_1 \circ T$ .*

**Proof.** Let  $\varphi: A^* \rightarrow T$  be a morphism recognising  $L$ , let  $B = T \times A$  and let  $\sigma_\varphi: A^* \rightarrow B^*$  be the sequential function associated with  $\varphi$ . Let  $P = \varphi(L)$  and  $C = \{(p, a) \mid p \in P\}$ . Then we have

$$\begin{aligned} \sigma_\varphi^{-1}(B^*CB^*) &= \{a_1a_2 \cdots a_n \in A^* \mid \sigma_\varphi(a_1a_2 \cdots a_n) \in B^*CB^*\} \\ &= \{a_1a_2 \cdots a_n \in A^* \mid \text{there exists an } i \text{ such that} \\ &\quad (\varphi(a_1a_2 \cdots a_{i-1}), a_i) \in C\} \\ &= \{a_1a_2 \cdots a_n \in A^* \mid \text{there exists an } i \text{ such that} \\ &\quad a_i = a \text{ and } a_1a_2 \cdots a_{i-1} \in \varphi^{-1}(P)\} \\ &= LaA^* \end{aligned}$$

Since  $B^*CB^*$  is recognised by  $U_1$ , the proposition follows from Theorem 3.5.  $\square$

Proposition 5.8 leads to the following result on varieties.

**Theorem 5.9** *Let  $\mathbf{V}$  be a variety of monoids and let  $\mathcal{V}$  be the corresponding variety. Then the variety  $\mathcal{W}$  which corresponds to  $\mathbf{J}_1 * \mathbf{V}$  is defined as follows. For each alphabet  $A$ ,  $\mathcal{W}(A^*)$  is the Boolean algebra generated by the languages  $L$  and  $LaA^*$ , where  $a \in A$  and  $L \in \mathcal{V}(A^*)$ .*

**Proof.** For each alphabet  $A$ , denote by  $\mathcal{V}'(A^*)$  the Boolean algebra generated by the languages  $L$  and  $LaA^*$ , where  $a \in A$  and  $L \in \mathcal{V}(A^*)$ .

We first show that  $\mathcal{V}'(A^*) \subseteq \mathcal{W}(A^*)$ . Since  $\mathbf{J}_1 * \mathbf{V}$  contains  $\mathbf{V}$ ,  $\mathcal{W}(A^*)$  contains  $\mathcal{V}(A^*)$ . Let  $L \in \mathcal{V}(A^*)$  and  $a \in A$ . Then  $L$  is recognised by some monoid  $T$  of  $\mathbf{V}$  and, by Proposition 5.8,  $LaA^*$  is recognised by  $U_1 \circ T$ . This monoid belongs to  $\mathbf{J}_1 * \mathbf{V}$  and hence  $LaA^* \in \mathcal{W}(A^*)$ .

To establish the opposite inclusion, it suffices now, by Corollary 4.7, to verify that  $L \in \mathcal{V}'(A^*)$  for every language  $L$  of the form  $\sigma_\varphi^{-1}(V)$ , where  $\sigma_\varphi$  is the sequential function associated with a morphism of monoids  $\varphi: A^* \rightarrow T$ , with  $T \in \mathbf{V}$ , and  $V$  is a subset of  $(T \times A)^*$  recognised by a monoid of  $\mathbf{J}_1$ . Let  $B = T \times A$ . By Proposition IX.1.4,  $V$  is a Boolean combination of languages of the form  $B^*CB^*$ , for some subset  $C$  of  $T \times A$ . Let Since Boolean operations commute with  $\sigma_\varphi^{-1}$ , we may assume that  $V = B^*CB^*$ , where  $C = (t, a)$  for some  $(t, a) \in B$ . In this case

$$\begin{aligned} L &= \{u \in A^* \mid \sigma_\varphi(u) \in B^*CB^*\} \\ &= \{a_1a_2 \cdots a_n \in A^* \mid (\varphi(a_1 \cdots a_{i-1}), a_i) = (t, a) \text{ for some } i\} \\ &= \varphi^{-1}(t)aA^* \end{aligned} \tag{5.1}$$

Now,  $\varphi^{-1}(t)$  is recognised by  $T$  and thus  $\varphi^{-1}(t) \in \mathcal{V}(A^*)$ . It follows that  $\varphi^{-1}(t)aA^* \in \mathcal{V}'(A^*)$  and thus  $L \in \mathcal{V}'(A^*)$ . Therefore  $\mathcal{W}(A^*) \subseteq \mathcal{V}'(A^*)$ .  $\square$

**5.2 The operations  $T \mapsto \bar{\mathbf{2}} \circ T$  and  $L \mapsto La$**

Recall that  $\bar{\mathbf{2}}$  denotes the transformation semigroup  $\{\{1, 2\}, \{1, 2\}\}$  with the action defined by  $r \cdot s = s$ . The results are quite similar to those presented in Section 5.1, but the monoid  $U_1$  is now replaced by  $\bar{\mathbf{2}}$ .

**Proposition 5.10** *Let  $A$  be an alphabet, let  $a \in A$  and let  $L$  be a language of  $A^*$  recognised by a monoid  $T$ . Then  $La$  is recognised by the wreath product  $\bar{\mathbf{2}} \circ T$ .*

**Proof.** Let  $\varphi : A^* \rightarrow T$  be a morphism recognising  $L$ , let  $B = T \times A$  and let  $\sigma_\varphi : A^* \rightarrow B^*$  be the sequential function associated with  $\varphi$ . Let  $P = \varphi(L)$  and  $C = \{(p, a) \mid p \in P\}$ . Then we have

$$\begin{aligned} \sigma_\varphi^{-1}(B^*C) &= \{u \in A^* \mid \sigma_\varphi(u) \in B^*C\} \\ &= \{a_1 a_2 \cdots a_n \in A^+ \mid (\varphi(a_1 a_2 \cdots a_{n-1}), a_n) \in C\} \\ &= \{a_1 a_2 \cdots a_n \in A^+ \mid a_n = a \text{ and } a_1 a_2 \cdots a_{n-1} \in \varphi^{-1}(P)\} \\ &= La \end{aligned}$$

Since the language  $B^*C$  is recognised by  $\bar{\mathbf{2}}$ , the proposition now follows from Theorem 3.5.  $\square$

A result similar to Proposition 5.10 holds if  $T$  is a semigroup which is not a monoid. The proof is left as an exercise to the reader.

**Proposition 5.11** *Let  $A$  be an alphabet, let  $a \in A$  and let  $L$  be a language of  $A^+$  recognised by an semigroup  $T$  such that  $T \neq T^1$ . Then the languages  $La$  and  $\{a\}$  are recognised by the wreath product  $\bar{\mathbf{2}} \circ (T^1, T)$ .*

We now turn to varieties. Observe that the semigroup  $\bar{\mathbf{2}}$  generates the variety  $\llbracket yx = x \rrbracket$ .

**Theorem 5.12** *Let  $\mathbf{V}$  be a variety of monoids and let  $\mathcal{V}$  be the corresponding variety. Let  $\mathcal{W}$  be the variety corresponding to  $\llbracket yx = x \rrbracket * \mathbf{V}$ . Then, for each alphabet  $A$ ,  $\mathcal{W}(A^+)$  is the lattice generated by the languages  $L$  (contained in  $A^+$ ) or  $La$ , where  $a \in A$  and  $L \in \mathcal{V}(A^*)$ .*

**Proof.** For each alphabet  $A$ , let  $\mathcal{V}'(A^+)$  be the lattice generated by the languages  $L$  (contained in  $A^+$ ) or  $La$ , where  $a \in A$  and  $L \in \mathcal{V}(A^*)$ .

We first show that  $\mathcal{V}'(A^+) \subseteq \mathcal{W}(A^+)$ . Since  $\llbracket yx = x \rrbracket * \mathbf{V}$  contains  $\mathbf{V}$ , every language of  $\mathcal{V}(A^*)$  contained in  $A^+$  is also in  $\mathcal{W}(A^+)$ . Let  $L \in \mathcal{V}(A^*)$  and  $a \in A$ . Then  $L$  is recognised by some monoid  $T$  of  $\mathbf{V}$  and, by Proposition 5.10,  $La$  is recognised by  $\bar{\mathbf{2}} \circ T$ . Now this semigroup belongs to  $\llbracket yx = x \rrbracket * \mathbf{V}$  and thus  $La \in \mathcal{W}(A^+)$ .

To establish the opposite inclusion, it suffices now, by Corollary 4.7, to verify that  $L \in \mathcal{V}'(A^+)$  for every language  $L$  of the form  $\sigma_\varphi^{-1}(V)$ , where  $\sigma_\varphi$  is the sequential function associated with a morphism of monoids  $\varphi : A^* \rightarrow T$ , with  $T \in \mathbf{V}$ , and  $V$  is a language of  $(T \times A)^+$  recognised by a transformation semigroup of  $\llbracket yx = x \rrbracket$ . Let  $B = T \times A$ . Then  $V$  is a finite union of languages of the form  $B^*c$ , for some letter  $c \in B$ . Since union commutes with  $\sigma_\varphi^{-1}$ , we may assume that  $V = B^*c$ , where  $c = (t, a)$  for some  $(t, a) \in B$ . In this case

$$\begin{aligned} L &= \{u \in A^+ \mid \sigma_\varphi(u) \in B^*c\} \\ &= \{a_1 a_2 \cdots a_n \in A^+ \mid (\varphi(a_1 \cdots a_{n-1}), a_n) = (t, a)\} \\ &= \varphi^{-1}(t)a \end{aligned}$$

Now,  $\varphi^{-1}(t)$  is recognised by  $T$  and thus  $\varphi^{-1}(t) \in \mathcal{V}(A^*)$ . It follows that  $\varphi^{-1}(t)a \in \mathcal{V}'(A^+)$  for each letter  $a$  and thus  $L \in \mathcal{V}'(A^+)$ . Therefore  $\mathcal{W}(A^+) \subseteq \mathcal{V}'(A^+)$ .  $\square$

The semigroup version of Theorem 5.12 can be obtained by using Proposition 5.11 instead of Proposition 5.10.

**Theorem 5.13** *Let  $\mathbf{V}$  be a variety of semigroups which is not a variety of groups, and let  $\mathcal{V}$  be the corresponding variety. Let  $\mathcal{W}$  be the variety corresponding to  $\llbracket yx = x \rrbracket * \mathbf{V}$ . Then, for each alphabet  $A$ ,  $\mathcal{W}(A^+)$  is the Boolean algebra generated by the languages  $L$ ,  $\{a\}$  or  $La$ , where  $a \in A$  and  $L \in \mathcal{V}(A^+)$ .*

The smallest variety of semigroups containing  $B(1, 2)$  and closed under semidirect product is known to be the variety  $\mathbf{r1}$  [27]. Therefore, Theorems 5.12 and 5.13 lead to a language interpretation of the operation  $\mathbf{V} \rightarrow \mathbf{r1} * \mathbf{V}$ .

**Corollary 5.14** *Let  $\mathbf{V}$  be a variety of monoids and let  $\mathcal{V}$  be the corresponding positive variety. Let  $\mathcal{W}$  be the positive variety corresponding to  $\mathbf{r1} * \mathbf{V}$ . Then, for each alphabet  $A$ ,  $\mathcal{W}(A^+)$  is the smallest lattice containing  $\mathcal{V}(A^+)$  and closed under the operation  $L \mapsto Lu$ , for each  $u \in A^*$ .*

**Corollary 5.15** *Let  $\mathbf{V}$  be a variety of ordered semigroups which is not a variety of groups and let  $\mathcal{V}$  be the corresponding positive variety. Let  $\mathcal{W}$  be the positive variety corresponding to  $\mathbf{r1} * \mathbf{V}$ . Then, for each alphabet  $A$ ,  $\mathcal{W}(A^+)$  is the smallest lattice containing  $\mathcal{V}(A^+)$  and the languages  $\{a\}$ , for each  $a \in A$ , and closed under the operation  $L \mapsto Lu$ , for each  $u \in A^*$ .*

### 5.3 The operation $T \mapsto U_2 \circ T$ and star-free expressions

Recall that  $U_2$  denotes the monoid  $\{1, a_1, a_2\}$  defined by  $a_1a_1 = a_2a_1 = a_1$  and  $a_1a_2 = a_2a_2 = a_2$ .

**Proposition 5.16** *Let  $A$  be an alphabet and let  $T$  be a monoid. Then every language of  $A^*$  recognised by  $U_2 \circ T$  is a Boolean combination of languages of the form  $K$  or  $Ka(LbA^*)^c$  where  $a, b \in A$  and  $K$  and  $L$  are recognised by  $T$ .*

**Proof.** Let  $L$  be a language of  $A^*$  recognised by  $U_2 \circ T$  and let  $B = T \times A$ . The wreath product principle tells us that  $L$  is a finite union of languages of the form  $U \cap \sigma^{-1}(V)$ , where  $U \subseteq A^*$  is recognised by  $T$  and  $V \subseteq B^*$  is recognised by  $U_2$ . By Proposition IX.1.7, every language of  $B^*$  recognised by  $U_2$  is a Boolean combination of languages of the form  $B^*bC^*$ , where  $b \in B$  and  $C \subseteq B$ . Therefore, it suffices to prove that a language of the form  $\sigma^{-1}(V)$  has the right form. We claim that

$$\sigma^{-1}(B^*bC^*) = \varphi^{-1}(m)a \left( \bigcup_{(n,c) \notin C} \varphi^{-1}((m\varphi(a))^{-1}n)cA^* \right)^c \quad (5.2)$$

Indeed, let  $b = (t, a)$  and let  $u = a_1a_2 \cdots a_n$  be a word of  $A^*$ . Then  $\sigma(u)$  belongs to  $B^*bC^*$  if and only if there exists an  $i$  such that  $\varphi(a_1a_2 \cdots a_{i-1}) = m$ ,  $a_i = a$  and, for  $i \leq j \leq n-1$ ,  $(\varphi(a_1 \cdots a_j), a_{j+1}) \in C$ . The negation of the latter condition can be stated as follows: there is a  $j$  such that  $(\varphi(a_1 \cdots a_j), a_{j+1}) \notin C$ . In other words,  $\varphi(a_1 \cdots a_j) = m$  and  $a_{j+1} = c$  for

some  $(n, c) \notin C$ . Now, if  $\varphi(a_1 a_2 \cdots a_{i-1}) = m$ ,  $a_i = a$  and  $\varphi(a_1 \cdots a_j) = n$ , then  $m\varphi(a)\varphi(a_{i+1} \cdots a_j) = n$  and therefore  $\varphi(a_{i+1} \cdots a_j) \in (m\varphi(a))^{-1}n$  and  $a_{i+1} \cdots a_n \in \varphi^{-1}\left((m\varphi(a))^{-1}n\right)cA^*$ . This justifies 5.2.

Now, each language  $\varphi^{-1}(m)$  and  $\varphi^{-1}\left((m\varphi(a))^{-1}n\right)$  is recognised by  $T$ , which concludes the proof.  $\square$

Proposition 5.16 leads to a new proof of the fact that a language recognised by an aperiodic monoid is star-free, the difficult part of Theorem X.2.3. Proposition 5.16 shows that if all the languages recognised by  $T$  are star-free, then  $U_2 \circ T$  has the same property. Now Theorem XV.3.15 shows that every aperiodic monoid divides a wreath product of copies of  $U_2$  and it suffices to proceed by induction to conclude.



# Chapter XVII

## An excursion into logic

### 1 Introduction

### 2 The formalism of logic

In this section, we review some basic definitions of logic: first-order logic, second-order, monadic second-order and weak monadic second-order logic.

#### 2.1 Syntax

Let us start by defining the syntax of *first-order logic*.

The basic ingredients are the *logical symbols* which encompass the logical connectives:  $\wedge$  (and),  $\vee$  (or),  $\neg$  (not),  $\rightarrow$  (implies), the equality symbol  $=$ , the *quantifiers*  $\exists$  (there exists) and  $\forall$  (for all), an infinite set of variables (most often denoted by  $x, y, z$ , or  $x_0, x_1, x_2, \dots$ ) and parenthesis (to ensure legibility of the formulas).

In addition to these logical symbols, we make use of a set  $\mathcal{L}$  of nonlogical symbols. These auxiliary symbols can be of three types: relation symbols (for instance  $<$ ), function symbols (for instance  $\min$ ), or constant symbols (for instance  $0, 1$ ). Expressions are built from the symbols of  $\mathcal{L}$  by obeying the usual rules of the syntax, then first-order formulas are built by using the logical symbols, and are denoted by  $\mathbf{FO}[\mathcal{L}]$ . We now give a detailed description of the syntactic rules to obtain the logical formulas in three steps, passing successively, following the standard terminology, from terms to atomic formulas and subsequently to formulas.

We first define the set of  $\mathcal{L}$ -terms. It is the least set of expressions containing the variables, the constant symbols of  $\mathcal{L}$  (if there are some) which is closed under the following formation rule: if  $t_1, t_2, \dots, t_n$  are terms and if  $f$  is a function symbol with  $n$  arguments, then the expression  $f(t_1, t_2, \dots, t_n)$  is a term. In particular, if  $\mathcal{L}$  does not contain any function symbol, the only terms are the variables and the constant symbols.

**Example 2.1** Let us take as set of nonlogical symbols

$$\mathcal{L} = \{ <, g, 0 \}$$

where  $<$  is a binary relation symbol,  $g$  is a two-variable function symbol and  $0$  is a constant. Then the following expressions are terms:

$$x_0 \quad g(0, 0) \quad g(x_1, g(0, x_2)) \quad g(g(x_0, x_1), g(x_1, x_2))$$

The *atomic formulas* are formulas either of the form

$$(t_1 = t_2)$$

where  $t_1$  and  $t_2$  are terms, or of the form

$$R(t_1, \dots, t_n)$$

where  $t_1, \dots, t_n$  are terms and  $R$  is a  $n$ -ary relation symbol of  $\mathcal{L}$ .

**Example 2.2** Continuing Example 2.1, the following expressions are atomic formulas:

$$(g(x_1, g(0, x_2)) = x_1) \quad (g(0, 0) < 0) \\ (g(g(x_0, x_1), g(x_1, x_2)) < g(x_3, x_1))$$

Notice that, in order to improve legibility, we did not apply literally the definition of atomic formulas: indeed, since  $<$  is a symbol of binary relation, one should write  $<(t_1, t_2)$  instead of  $t_1 < t_2$ .

Finally, the *first-order formulas* on  $\mathcal{L}$  form the least set of expressions containing the empty formula and the atomic formulas and closed under the following formation rules:

- (i) If  $(\varphi_i)_{i \in I}$  is a finite family of first-order formulas, so are the expressions

$$\left(\bigwedge_{i \in I} \varphi_i\right) \quad \text{and} \quad \left(\bigvee_{i \in I} \varphi_i\right)$$

- (ii) If  $\varphi$  and  $\psi$  are first-order formulas, so are the expressions

$$\neg\varphi \quad \text{and} \quad (\varphi \rightarrow \psi)$$

- (iii) If  $\varphi$  is a first-order formula and if  $x$  is a variable, then the expressions

$$(\exists x\varphi) \quad \text{and} \quad (\forall x\varphi)$$

are first-order formulas.

To make notations easier, we set

$$\mathbf{true} = \bigwedge_{i \in \emptyset} \varphi_i \quad \text{and} \quad \mathbf{false} = \bigvee_{i \in \emptyset} \varphi_i$$

**Example 2.3** The following expressions are first-order formulas of our example language:

$$(\exists x (\forall y ((y < g(z, 0)) \wedge (x < 0)))) \quad (\forall x (y = x))$$

Again, it is convenient to simplify notation by suppressing some of the parenthesis and we shall write the previous formulas under the form

$$\exists x \forall y (y < g(x, 0)) \wedge (z < 0) \quad \forall x y = x$$



In a first-order formula, some variables occur after a quantifier (existential or universal): the occurrences of these variables are said to be *bounded* and the other occurrences are said to be *free*. For example, in the formula

$$\exists x (\underline{y} < h(x, 0)) \wedge \forall y (\underline{z} < \underline{y})$$

the simply underlined occurrences of  $x$  and  $y$  are bounded and the occurrences of  $z$  and  $y$  doubly underlined are free. A variable is free if at least one of its occurrences is free. The set  $FV(\varphi)$  of free variables of a formula  $\varphi$  can be defined inductively as follows:

- (1) If  $\varphi$  is an atomic formula,  $FV(\varphi)$  is the set of variables occurring in  $\varphi$ ,
- (2)  $FV(\neg\varphi) = FV(\varphi)$
- (3)  $FV(\bigwedge_{i \in I} \varphi_i) = FV(\bigvee_{i \in I} \varphi_i) = \bigcup_{i \in I} FV(\varphi_i)$
- (4)  $FV(\varphi \rightarrow \psi) = FV(\varphi) \cup FV(\psi)$
- (5)  $FV(\exists x\varphi) = FV(\forall x\varphi) = FV(\varphi) - \{x\}$

A *sentence* is a formula in which all occurrences of variables are bounded. For example, the formula

$$\exists x \forall y (y < f(x, 0))$$

is a sentence.

We shall denote by  $\varphi(x_1, x_2, \dots, x_n)$  a formula  $\varphi$  in which the set of free variables is contained in  $\{x_1, \dots, x_n\}$  (but is not necessarily equal to  $\{x_1, \dots, x_n\}$ ).

The variables used in first-order logic, or *first-order variables*, are interpreted, as we shall see, as the elements of a set. In *second-order logic*, one makes use of another type of variables, called *second-order variables*, which represent relations. These variables are denoted traditionally by capital letters:  $X_0, X_1$ , etc.. One builds in this way the set of second-order formulas on  $\mathcal{L}$ , denoted by  $F_2(\mathcal{L})$ . The set of terms is the same as for first-order. The *atomic formulas* are either of the form

$$(t_1 = t_2)$$

where  $t_1$  and  $t_2$  are terms, or of the form

$$R(t_1, \dots, t_n) \quad \text{or} \quad X(t_1, \dots, t_n)$$

where  $t_1, \dots, t_n$  are terms,  $R$  is a  $n$ -ary relation symbol of  $\mathcal{L}$  and  $X$  is a variable representing a  $n$ -ary relation.

Finally, *second-order formulas* on  $\mathcal{L}$  form the least set of expressions containing the atomic formulas and closed under the following formation rules:

- (i) If  $\varphi$  and  $\psi$  are second-order formulas, then so are

$$\neg\varphi, \quad (\varphi \wedge \psi), \quad (\varphi \vee \psi), \quad (\varphi \rightarrow \psi)$$

- (ii) If  $\varphi$  is a second-order formula, if  $x$  is a variable and if  $X$  is a variable of relation, then the expressions

$$(\exists x\varphi) \quad (\forall x\varphi) \quad (\exists X\varphi) \quad (\forall X\varphi)$$

are second-order formulas.

We call *monadic second-order logic* the fragment of second-order logic in which the only relation variables are unary relation variables, in other words, variables representing subsets of the domain. By convenience, they are called *set variables*. We denote by  $\mathbf{MSO}(\mathcal{L})$  the set of monadic second-order logic on  $\mathcal{L}$ . We shall also use the notation  $x \in X$  instead of  $X(x)$ .

## 2.2 Semantics

We have adopted so far a syntactic point of view to define formulas with no reference to semantics. But of course, formulas would be uninteresting if they were meaningless. Giving a precise meaning to formulas requires to specify the domain on which we want to interpret each of the symbols of the language  $\mathcal{L}$ . Formally, a *structure*  $\mathcal{S}$  on  $\mathcal{L}$  is given by a nonempty set  $D$ , called *domain* and by a map defined on  $\mathcal{L}$ , called an *assignment* which associates

- (1) with each  $n$ -ary relation symbol of  $\mathcal{L}$ , a  $n$ -ary relation defined on  $D$ ,
- (2) with each  $n$ -ary function symbol  $f$  of  $\mathcal{L}$ , a  $n$ -ary function defined on  $D$ ,
- (3) with each constant symbol  $c$  of  $\mathcal{L}$ , an element of  $D$ .

To improve notations, we shall use the same notation for the relation [function, constant] symbols and for the relations [functions, constants] represented by these symbols. The context will allow us to determine easily what the notation stands for. For example, we shall always employ the symbol  $<$  to designate the usual order relation on a set of integers, independently of the domain ( $\mathbb{N}$ ,  $\mathbb{Z}$ , or a subset of  $\mathbb{N}$ ).

We still have to interpret variables. Let us start by first-order variables. Given a fixed structure  $\mathcal{S}$  on  $\mathcal{L}$ , with domain  $D$ , a *valuation* on  $\mathcal{S}$  is a map  $\nu$  from the set of variables into the set  $D$ . It is then easy to extend  $\nu$  to a function of the set of terms of  $\mathcal{L}$  into  $D$ , by induction on the formation rules of terms:

- (1) If  $c$  is a constant symbol, we put  $\nu(c) = c$ ,
- (2) if  $f$  is a  $n$ -ary function symbol and if  $t_1, \dots, t_n$  are terms,

$$\nu(f(t_1, \dots, t_n)) = f(\nu(t_1) \dots \nu(t_n))$$

If  $\nu$  is a valuation and  $a$  an element of  $D$ , we denote by  $\nu \binom{a}{x}$  the valuation  $\nu'$  defined by

$$\nu'(y) = \begin{cases} \nu(y) & \text{if } y \neq x \\ a & \text{if } y = x \end{cases}$$

The notion of interpretation can be now easily formalized. Define, for each first-order formula  $\varphi$  and for each valuation  $\nu$ , the expressions “the valuation  $\nu$  satisfies  $\varphi$  in  $\mathcal{S}$ ”, or “ $\mathcal{S}$  satisfies  $\varphi[\nu]$ ”, denoted by  $\mathcal{S} \models \varphi[\nu]$ , as follows:

- (1)  $\mathcal{S} \models (t_1 = t_2)[\nu]$  if and only if  $\nu(t_1) = \nu(t_2)$
- (2)  $\mathcal{S} \models R(t_1, \dots, t_n)[\nu]$  if and only if  $(\nu(t_1), \dots, \nu(t_n)) \in R$
- (3)  $\mathcal{S} \models \neg\varphi[\nu]$  if and only if not  $\mathcal{S} \models \varphi[\nu]$
- (4)  $\mathcal{S} \models (\bigwedge_{i \in I} \varphi)[\nu]$  if and only if for each  $i \in I$ ,  $\mathcal{S} \models \varphi_i[\nu]$
- (5)  $\mathcal{S} \models (\bigvee_{i \in I} \varphi)[\nu]$  if and only if there exists  $i \in I$ ,  $\mathcal{S} \models \varphi_i[\nu]$
- (6)  $\mathcal{S} \models (\varphi \rightarrow \psi)[\nu]$  if and only if  $\mathcal{S} \not\models \varphi[\nu]$  or  $\mathcal{S} \models \psi[\nu]$
- (7)  $\mathcal{S} \models (\exists x\varphi)[\nu]$  if and only if  $\mathcal{S} \models \varphi[\nu \binom{a}{x}]$  for some  $a \in D$
- (8)  $\mathcal{S} \models (\forall x\varphi)[\nu]$  if and only if  $\mathcal{S} \models \varphi[\nu \binom{a}{x}]$  for each  $a \in D$

Note that, actually, the truth of the expression “the valuation  $\nu$  satisfies  $\varphi$  in  $\mathcal{S}$ ” only depends on the values taken by the free variables of  $\varphi$ . In particular,

if  $\varphi$  is a sentence, the choice of the valuation is irrelevant. Therefore, if  $\varphi$  is a sentence, one says that  $\varphi$  is satisfied by  $\mathcal{S}$  (or that  $\mathcal{S}$  satisfies  $\varphi$ ), and denote by  $\mathcal{S} \models \varphi$ , if, for each valuation  $\nu$ ,  $\mathcal{S} \models \varphi[\nu]$ .

Next we move to the interpretation of second-order formulas. Given a structure  $\mathcal{S}$  on  $\mathcal{L}$ , with domain  $D$ , a *second-order valuation* on  $\mathcal{S}$  is a map  $\nu$  which associates with each first-order variable an element of  $D$  and to each  $n$ -ary relation variable a subset of  $D^n$  (i.e. a  $n$ -ary relation on  $D$ ).

If  $\nu$  is a valuation and  $R$  a subset of  $D^n$ ,  $\nu \binom{R}{X}$  denotes the valuation  $\nu'$  defined by

$$\begin{aligned} \nu'(x) &= \nu(x) \text{ if } x \text{ is a first-order variable} \\ \nu'(Y) &= \begin{cases} \nu(Y) & \text{if } Y \neq X \\ R & \text{if } Y = X \end{cases} \end{aligned}$$

The notion of interpretation, already defined for first order, is supplemented by the following rules:

- (9)  $\mathcal{S} \models (X(t_1, \dots, t_n))[\nu]$  if and only if  $(\nu(t_1), \dots, \nu(t_n)) \in \nu(X)$
- (10)  $\mathcal{S} \models (\exists X\varphi)[\nu]$  if and only if there exists  $R \subseteq D^n$ ,  $\mathcal{S} \models \varphi[\nu \binom{R}{X}]$
- (11)  $\mathcal{S} \models (\forall X\varphi)[\nu]$  if and only if for each  $R \subseteq D^n$ ,  $\mathcal{S} \models \varphi[\nu \binom{R}{X}]$

*Weak monadic second-order logic* is composed with the same formulas than monadic second-order logic, but the interpretation is even more restricted: are only considered valuations which associate with set variables *finite* subsets of the domain  $D$ .

Two formulas  $\varphi$  and  $\psi$  are said to be *logically equivalent* if, for each structure  $\mathcal{S}$  on  $\mathcal{L}$ , we have  $\mathcal{S} \models \varphi$  if and only if  $\mathcal{S} \models \psi$ .

It is easy to see that the following formulas are logically equivalent:

- (1)  $\varphi \wedge \psi$  and  $\neg(\neg\varphi \vee \neg\psi)$
- (2)  $\varphi \rightarrow \psi$  and  $\neg\varphi \vee \psi$
- (3)  $\forall x\varphi$  and  $\neg(\exists x \neg\varphi)$
- (4)  $\varphi \vee \psi$  and  $\psi \vee \varphi$
- (5)  $\varphi \wedge \psi$  and  $\psi \wedge \varphi$
- (6)  $\varphi \wedge \text{false}$  and  $\text{false}$
- (7)  $\varphi \vee \text{false}$  and  $\varphi$

Consequently, up to logical equivalence, we may assume that the formulas are built without the symbols  $\wedge$ ,  $\rightarrow$  and  $\forall$ .

Logical equivalence also permits one to give a more structured form to formulas. A formula is said to be under *disjunctive normal form* if it can be written as disjunction of conjunctions of atomic formulas or of negations of atomic formulas, in other words under the form

$$\bigvee_{i \in I} \bigwedge_{j \in J_i} (\varphi_{ij} \vee \neg\psi_{ij})$$

where  $I$  and the  $J_i$  are finite sets, and where the  $\varphi_{ij}$  and the  $\psi_{ij}$  are atomic formulas. The next result is standard and easily proved.

**Proposition 2.1** *Every quantifier free formula is logically equivalent to a quantifier free formula in disjunctive normal form.*

One can set up a hierarchy inside first-order formulas as follows. Let  $\Sigma_0 = \Pi_0$  be the set of quantifier-free formulas. Next, for each  $n \geq 0$ , denote by  $\Sigma_{n+1}$  the least set  $\Delta$  of formulas such that

- (1)  $\Delta$  contains the Boolean combinations of formulas of  $\Sigma_n$ ,
- (2)  $\Delta$  is closed under finite disjunctions and conjunctions,
- (3) if  $\varphi \in \Delta$  and if  $x$  is a variable,  $\exists x\varphi \in \Delta$ .

Similarly, denote by  $\Pi_{n+1}$  the least set  $\Gamma$  of formulas such that

- (1)  $\Gamma$  contains the Boolean combinations of formulas of  $\Pi_n$ ,
- (2)  $\Gamma$  is closed under finite disjunctions and conjunctions,
- (3) if  $\varphi \in \Gamma$  and if  $x$  is a variable,  $\forall x\varphi \in \Gamma$ .

In particular,  $\Sigma_1$  is the set of *existential* formulas — that is of the form

$$\exists x_1 \exists x_2 \dots \exists x_k \varphi$$

where  $\varphi$  is quantifier-free.

Finally, we denote by  $\mathcal{B}\Sigma_n$  the set of Boolean combinations of formulas of  $\Sigma_n$ . A first-order formula is said to be in *prenex normal form* if it is of the form

$$\psi = Q_1x_1 Q_2x_2 \dots Q_nx_n \varphi$$

where the  $Q_i$  are existential or universal quantifiers ( $\exists$  or  $\forall$ ) and  $\varphi$  is quantifier-free. The sequence  $Q_1x_1 Q_2x_2 \dots Q_nx_n$ , which can be considered as a word on the alphabet

$$\{ \exists x_1, \exists x_2, \dots, \forall x_1, \forall x_2, \dots \},$$

is called the quantification prefix of  $\psi$ . The interest of these formulas in prenex normal form comes from the following result.

**Proposition 2.2** *Every first order-formula is logically equivalent to a formula in prenex normal form.*

**Proof.** It suffices to verify that if the variable  $x$  does not occur in the formula  $\psi$  then

$$\begin{aligned} \exists x(\varphi \wedge \psi) &\equiv (\exists x\varphi) \wedge \psi \\ \exists x(\varphi \vee \psi) &\equiv (\exists x\varphi) \vee \psi \end{aligned}$$

and the same formulas hold for the quantifier  $\forall$ . Hence it is possible, by renaming the variables, to throw back the quantifiers to the outside.  $\square$

Proposition 2.2 can be improved to take into account the level of the formula in the  $\Sigma_n$  hierarchy.

**Proposition 2.3** *For each integer  $n \geq 0$ ,*

- (1) *Every formula of  $\Sigma_n$  is logically equivalent to a formula in prenex normal form in which the quantification prefix is a sequence of  $n$  (possibly empty) alternating blocks of existential and universal quantifiers, starting with a block of existential quantifiers.*

- (2) Every formula of  $\Pi_n$  is logically equivalent to a formula in prenex normal form in which the quantification prefix is a sequence of  $n$  (possibly empty) alternating blocks of existential and universal quantifiers, starting with a block of universal quantifiers.

For example, the formula

$$\underbrace{\exists x_1 \exists x_2 \exists x_3}_{\text{block 1}} \underbrace{\forall x_4 \forall x_5}_{\text{block 2}} \underbrace{\exists x_6 \exists x_7}_{\text{block 3}} \varphi(x_1, \dots, x_6)$$

belongs to  $\Sigma_3$  (and also to all  $\Sigma_n$ 's such that  $n \geq 3$ ). Similarly the formula

$$\underbrace{\phantom{\exists x_1 \exists x_2 \exists x_3}}_{\text{block 1}} \underbrace{\forall x_4 \forall x_5}_{\text{block 2}} \underbrace{\exists x_6 \exists x_7}_{\text{block 3}} \varphi(x_1, \dots, x_7)$$

belongs to  $\Sigma_3$  and to  $\Pi_2$ , but not to  $\Sigma_2$ , since the counting of blocks of a  $\Sigma_n$ -formula should always begin by a possibly empty block of existential quantifiers.

One can also introduce normal forms and a hierarchy for monadic second-order formulas. Thus, one can show that every monadic second-order formula is logically equivalent to a formula of the form

$$\psi = Q_1 X_1 Q_2 X_2 \dots Q_n X_n \varphi$$

where the  $Q_i$  are existential or universal quantifiers and  $\varphi$  is a first-order formula.

### 2.3 Logic on words

The logical language that we shall use now was introduced by Büchi under the name of "sequential calculus". To interpret formulas on words, one considers each word as a map associating a letter with each index. Let  $u = a_0 a_1 \dots a_{n-1}$ , where  $a_0, \dots, a_{n-1}$  are letters, be a nonempty word on the alphabet  $A$ . The *domain* of  $u$ , denoted by  $\text{Dom}(u)$  is the set

$$\text{Dom}(u) = \{0, \dots, |u| - 1\}$$

Define for each letter  $a \in A$  a unary relation  $\mathbf{a}$  on the domain of  $u$  by

$$\mathbf{a} = \{i \in \text{Dom}(u) \mid a_i = a\}.$$

Finally, let us associate with each word  $u$  the structure

$$\mathcal{M}_u = (\text{Dom}(u), (\mathbf{a})_{a \in A}),$$

For example, if  $u = abbaab$ , then  $\text{Dom}(u) = \{0, 1, \dots, 5\}$ ,  $\mathbf{a} = \{0, 3, 4\}$  and  $\mathbf{b} = \{1, 2, 5\}$ . We shall also consider various other nonlogical symbols, notably  $<$ ,  $S$ ,  $\min$  and  $\max$ , that will be interpreted respectively as follows:

- (1) the symbol  $<$  will represent the usual order;
- (2) the symbol  $S$  will represent the successor relation on  $\text{Dom}(u)$ , defined by  $S(x, y)$  if and only if  $y = x + 1$ .
- (3) the symbols  $\min$  and  $\max$  will represent the minimum and the maximum of the domain:  $0$  and  $|u| - 1$ .

From now on, we shall interpret logical formulas on words, that is, on a structure of the form  $\mathcal{M}_u$  as explained above. Let  $\varphi$  be a sentence. A nonempty word  $u$  satisfies  $\varphi$  if the structure  $\mathcal{M}_u$  satisfies  $\varphi$ . This is denoted by  $u \models \varphi$ . We also say that  $u$  is a *model* of  $\varphi$ . The language defined by  $\varphi$  is the set

$$L(\varphi) = \{u \in A^+ \mid u \text{ satisfies } \varphi\}$$

From now on, all the variables will be interpreted as natural integers. Therefore, we shall use logical equivalence restricted to interpretations of domain  $\mathcal{N}$ .

In the sequel, we shall mainly consider two logical languages: the language

$$\mathcal{L}_{<} = \{<\} \cup \{\mathbf{a} \mid a \in A\}$$

will be called the *language of the linear order* and the language

$$\mathcal{L}_S = \{S\} \cup \{\mathbf{a} \mid a \in A\}$$

will be called the *language of the successor*. The atomic formulas of the language of the linear order are of the form

$$\mathbf{a}(x), \quad x = y, \quad x < y$$

and those of the language of the successor are of the form

$$\mathbf{a}(x), \quad x = y, \quad S(x, y).$$

We shall denote respectively by  $\mathbf{FO}[<]$  and  $\mathbf{MSO}[<]$  the set of first-order and monadic second-order formulas of signature  $\{<, (\mathbf{a})_{a \in A}\}$ . Similarly, we denote by  $\mathbf{FO}[S]$  and  $\mathbf{MSO}[S]$  the same sets of formulas of signature  $\{S, (\mathbf{a})_{a \in A}\}$ . Inside first order, the  $\Sigma_n[<]$  (resp.  $\Sigma_n[S]$ ) hierarchy is based on the number of quantifier alternations.

We shall now start the comparison between the various logical languages we have introduced. First of all, the distinction between the signatures  $S$  and  $<$  is only relevant for first order in view of the following proposition. A relation  $R(x_1, \dots, x_n)$  on the integers is said to be *defined* by a formula  $\varphi(x_1, \dots, x_n)$  if, for each  $i_1, \dots, i_n \in \text{Dom}(u)$ , one has  $R(i_1, \dots, i_n)$  if and only if  $\varphi(i_1, \dots, i_n)$  is true.

**Proposition 2.4** *The successor relation can be defined in  $\mathbf{FO}[<]$ , and the order relation on integers can be defined in  $\mathbf{MSO}[S]$ .*

**Proof.** The successor relation can be defined by the formula

$$(i < j) \wedge \forall k \left( (i < k) \rightarrow ((j = k) \vee (j < k)) \right)$$

which states that  $j = i + 1$  if  $i$  is smaller than  $j$  and there exist no element between  $i$  and  $j$ . The formula  $i < j$  can be expressed in  $\mathbf{MSO}[S]$  as follows:

$$\exists X \left[ \forall x \forall y \left( ((x \in X) \wedge S(x, y)) \rightarrow (y \in X) \right) \right] \wedge (j \in X) \wedge (i \notin X)$$

which intuitively means that there exists an interval of  $\text{Dom}(u)$  of the form  $[k, |u| - 1]$  containing  $j$  but not  $i$ .  $\square$

If  $x$  is a variable, it is convenient to write  $x + 1$  [ $x - 1$ ] to replace a variable  $y$  submitted to the condition  $S(x, y)$  [ $S(y, x)$ ]. However, the reader should be aware of the fact that  $x + y$  is not definable in  $\mathbf{MSO}[<]$ .

We shall also use the symbols  $\leq$  and  $\neq$  with their usual interpretations:  $x \leq y$  stands for  $(x < y) \vee (x = y)$  and  $x \neq y$  for  $\neg(x = y)$ .

The symbols  $\min$ ,  $\max$  can also be defined in  $\mathbf{FO}[S]$  with two alternations of quantifiers:

$$\begin{aligned} \min : & \exists \min \forall x \neg S(x, \min) \\ \max : & \exists \max \forall x \neg S(\max, x) \end{aligned}$$

We shall sometimes need a parametrized, or relative, notion of satisfaction for a formula. Let indeed  $\varphi(x, y)$  be a formula with only two free variables  $x$  and  $y$ . Let  $u = a_0 \cdots a_{n-1}$  be a nonempty word and let  $i, j \in \text{Dom}(u)$ . Then  $u$  is said to satisfy the formula  $\varphi$  between  $i$  and  $j$  if  $a_i \dots a_{j-1} \models \varphi$ .

**Proposition 2.5** *For each sentence  $\varphi$ , there exists a formula  $\varphi(x, y)$  with the same signature, the same order (and, in the case of a first-order formula, the same level in the hierarchy  $\Sigma_n$ ), having  $x$  and  $y$  as unique free variables and which satisfies the following property: for each word  $u$  and for each  $s, t \in \text{Dom}(u)$ ,  $u \models \varphi(s, t)$  if and only if  $u$  satisfies  $\varphi$  between  $s$  and  $t$ .*

**Proof.** The formulas  $\varphi(x, y)$  are built by induction on the formation rules as follows: if  $\varphi$  is an atomic formula, we set  $\varphi(x, y) = \varphi$ . Otherwise, we set

$$\begin{aligned} (\neg\varphi)(x, y) &= \neg\varphi(x, y) \\ (\varphi \vee \psi)(x, y) &= \varphi(x, y) \vee \psi(x, y) \\ (\exists z\varphi)(x, y) &= \exists z ((x \leq z) \wedge (z < y) \wedge \varphi(x, y)) \\ (\exists X\varphi)(x, y) &= \exists X ((\forall z (X(z) \rightarrow (x \leq z) \wedge (z < y))) \wedge \varphi(x, y)) \end{aligned}$$

It is easy to verify that the formulas  $\varphi(x, y)$  built in this way have the required properties.  $\square$

### 3 Monadic second-order logic on words

This section is devoted to the proof of a result of Büchi stating that the subsets of  $A^*$  definable in monadic second-order logic are exactly the rational sets.

**Theorem 3.6** *A language is definable by a formula of  $\mathbf{MSO}[S]$  if and only if it is recognisable.*

The proof of this result can be decomposed into two parts: passing from words to formulas, and from formulas to words. To pass from words to formulas, we simulate the behaviour of an automaton by a formula.

**Proposition 3.7** *For each automaton  $\mathcal{A} = (Q, A, E, I, F)$ , there exists a formula  $\varphi$  of  $\mathbf{MSO}[<]$  such that  $L(\varphi) = L^+(\mathcal{A})$ .*

**Proof.** Suppose that  $Q = \{1, \dots, n\}$ . We first write a formula  $\psi$  expressing the existence of a path of label  $u$ . To this purpose, we associate with each state  $q$  a

set variable  $X_q$  which encodes the set of positions in which a given path visits the state  $q$ . The formula states that the  $X_q$ 's are pairwise disjoint and that if a path is in state  $q$  in position  $x$ , in state  $q'$  in position  $x + 1$  and if the  $x$ -th letter is an  $a$ , then  $(q, a, q') \in E$ . This gives

$$\psi = \left( \bigwedge_{q \neq q'} \neg \exists x (X_q(x) \wedge X_{q'}(x)) \right) \wedge \left( \forall x \forall y S(x, y) \rightarrow \bigvee_{(q, a, q') \in E} (X_q(x) \wedge \mathbf{a}(x) \wedge X_{q'}(y)) \right)$$

There remains to state that the path is successful. It suffices to know that 0 belongs to one of the  $X_q$ 's such that  $q \in I$  and that max belongs to one of the  $X_q$ 's such that  $q \in F$ . Therefore, we set

$$\psi_+ = \psi \wedge \left( \bigvee_{q \in I} X_q(0) \right) \wedge \left( \bigvee_{q \in F} X_q(\max) \right)$$

The formula

$$\varphi = \exists X_1 \exists X_2 \cdots \exists X_n \psi_+$$

now entirely encodes the automaton.  $\square$

To pass from sentences to sets of words, a natural idea is to argue by induction on the formation rules of formulas. The problem is that the set  $L(\varphi)$  is only defined when  $\varphi$  is a sentence. The traditional solution in this case consists of adding constants to interpret free variables to the structure in which the formulas are interpreted. For the sake of homogeneity, we proceed in a slightly different way, so that these structures remain words.

The idea is to use an extended alphabet of the form

$$B_{p,q} = A \times \{0, 1\}^p \times \{0, 1\}^q$$

such that  $p$  [ $q$ ] is greater than or equal to the number of first-order [second-order] variables of  $\varphi$ . A word on the alphabet  $B_{p,q}$  can be identified with the sequence

$$(u_0, u_1, \dots, u_p, u_{p+1}, \dots, u_{p+q})$$

where  $u_0 \in A^*$  and  $u_1, \dots, u_p, u_{p+1}, \dots, u_{p+q} \in \{0, 1\}^*$ . We are actually interested in the set  $K_{p,q}$  of words of  $B_{p,q}^*$  in which each of the components  $u_1, \dots, u_p$  contains exactly one occurrence of 1. If the context permits, we shall note  $B$  instead of  $B_{p,q}$  and  $K$  instead of  $K_{p,q}$ . We also set

$$K = K \cap B^*$$

For example, if  $A = \{a, b\}$ , a word of  $B_{3,2}^*$  is represented in Figure 3.1.



$u_0$	$a$	$b$	$a$	$a$	$b$	$a$	$b$
$u_1$	0	1	0	0	0	0	0
$u_2$	0	0	0	0	1	0	0
$u_3$	1	0	0	0	0	0	0
$u_4$	0	1	1	0	0	1	1
$u_5$	1	1	0	1	0	1	0

Figure 3.1. A word of  $B_{3,2}^*$ .

The elements of  $K$  are called *marked words* on  $A$ . This terminology expresses the fact that the elements of  $K$  are (finite or infinite) words in which labels marking certain positions have been added. Each of the  $p$  first rows only marks one position and the last  $q$  ones an arbitrary number of positions.

We first prove the following property.

**Proposition 3.8** *For each  $p, q \geq 0$ , the set  $K_{p,q}$  is a star-free language of  $B_{p,q}^*$ .*

**Proof.** Set, for  $1 \leq i \leq p$ ,

$$C_i = \{ (b_0, b_1, \dots, b_{p+q}) \in B \mid b_i = 1 \}$$

Then  $K$  is the language of  $B^*$  containing exactly one letter of each  $C_i$ , for  $1 \leq i \leq p$ . Now the formula

$$K = \bigcap_{1 \leq i \leq p} B^* C_i B^* - \bigcup_{1 \leq i \leq p} B^* C_i B^* C_i B^*.$$

shows that  $K$  is a star-free subset of  $B^*$ .  $\square$

The interpretation of formulas on the words of  $B_{p,q}^*$  follows the main lines of the interpretation described in Section 2.3 although the interpretation of  $\mathbf{a}$  is slightly modified. Let  $u_0 = a_0 a_1 \dots a_{n-1}$ , where  $a_0, \dots, a_{n-1}$  are letters. Then

$$\mathbf{a} = \{ i \in \text{Dom}(u_0) \mid a_i = a \}.$$

Let  $\varphi(x_1, \dots, x_r, X_1, \dots, X_s)$  be a formula in which the first-order [second-order] free variables are  $x_1, \dots, x_r$  [ $X_1, \dots, X_s$ ], with  $r \leq p$  and  $s \leq q$ . Let  $u = (u_0, u_1, \dots, u_{p+q})$  be a word of  $K_{p,q}$  and, for  $1 \leq i \leq p$ , denote by  $n_i$  the position of the unique 1 of the word  $u_i$ . In the example above, one would have  $n_1 = 1$ ,  $n_2 = 4$  and  $n_3 = 0$ . A word  $u$  is said to satisfy  $\varphi$  if  $u_0$  satisfies  $\varphi[\nu]$ , where  $\nu$  is the valuation defined by

$$\begin{aligned} \nu(x_j) &= n_j & (1 \leq j \leq r) \\ \nu(X_j) &= \{ i \in \text{Dom}(u_0) \mid u_{p+j,i} = 1 \} & (1 \leq j \leq s) \end{aligned}$$

In other words, each  $X_j$  is interpreted as the set of positions of 1's in  $u_{p+j}$ , and each  $x_j$  as the unique position of 1 in  $u_j$ . Note that for  $p = q = 0$ , we recover the customary interpretation of sentences.

Set

$$S_{p,q}(\varphi) = \{ u \in K_{p,q} \mid u \text{ satisfies } \varphi(x_1, \dots, x_p, X_1, \dots, X_q) \}$$

Again, we shall sometimes simply use the notation  $L(\varphi)$  instead of  $S_{p,q}(\varphi)$ . Conjunctions and disjunctions are easily converted into Boolean operations.

**Proposition 3.9** For each finite family of formulas  $(\varphi_i)_{i \in I}$ , the following equalities hold:

- (1)  $L(\bigvee_{i \in I} \varphi_i) = \bigcup_{i \in I} L(\varphi_i)$ ,
- (2)  $L(\bigwedge_{i \in I} \varphi_i) = \bigcap_{i \in I} L(\varphi_i)$ ,
- (3)  $L(\neg \varphi) = K_{p,q} - L(\varphi)$

**Proof.** This is an immediate consequence of the definitions.  $\square$

To conclude the proof of Theorem 3.6, it remains to prove by induction on the formation rules of formulas that the sets  $L(\varphi)$  are rational. Let us start with the atomic formulas. As for the set  $K$ , we prove a slightly more precise result that will be used later on in this chapter.

**Proposition 3.10** For each variable  $x, y$ , for each set variable  $X$  and for each letter  $a \in A$ , the sets of the form  $L(\mathbf{a}(x))$ ,  $L(x = y)$ ,  $L(x < y)$  and  $L(X(x))$  are star-free, and hence rational, subsets of  $B^*$ .

**Proof.** Set, for  $i, j \in \{1, \dots, p+q\}$

$$\begin{aligned} C_{j,a} &= \{b \in B_{p,q} \mid b_j = 1 \text{ and } b_0 = a\} \\ C_{i,j} &= \{b \in B_{p,q} \mid b_i = b_j = 1\} \\ C_i &= \{b \in B_{p,q} \mid b_i = 1\} \end{aligned}$$

Then we have, by setting  $B = B_{p,q}$

$$\begin{aligned} L(\mathbf{a}(x_i)) &= K \cap B^* C_{i,a} B^* \\ L(x_i = x_j) &= K \cap B^* C_{i,j} B^* \\ L(x_i < x_j) &= K \cap B^* C_i B^* C_j B^* \\ L(X_i(x_j)) &= K \cap B^* C_{i+p,j} B^* \end{aligned}$$

which establishes the proposition.  $\square$

Proposition 3.9 allows one to treat logical connectives. There remains to treat the case of the formulas of the form  $\exists x \varphi$  and  $\exists X \varphi$ . Denote by  $\pi_i$  the function that erases the  $i$ -th component, defined by

$$\pi_i(b_0, b_1, \dots, b_{p+q}) = (b_0, b_1, \dots, b_{i-1}, b_{i+1}, \dots, b_{p+q})$$

Thus  $\pi_i$  should be considered as a function from  $B_{p,q}$  into  $B_{p-1,q}$  if  $i \leq p$  and into  $B_{p,q-1}$  if  $p < i \leq p+q$ .

**Proposition 3.11** For each formula  $\varphi$ , the following formulas hold

- (1)  $S_{p-1,q}(\exists x_p \varphi) = \pi_p(S_{p,q}(\varphi))$
- (2)  $S_{p,q-1}(\exists X_q \varphi) = \pi_{p+q}(S_{p,q}(\varphi))$

**Proof.** This follows from the definition of existential quantifiers.  $\square$

We are now ready to show that if  $L(\varphi)$  is rational, then so are  $L(\exists x \varphi)$  and  $L(\exists X \varphi)$ . We may assume that  $x = x_p$  and  $X = X_q$ . Then, by Proposition 3.11, we have  $L(\exists x_p \varphi) = \pi_p(L(\varphi))$  and  $L(\exists X_q \varphi) = \pi_{p+q}(L(\varphi))$ . Since morphisms preserve rationality, the result follows.

This concludes the proof of Büchi's theorem. Note that the proof of Proposition 3.7 shows that the hierarchy on formulas of  $\mathbf{MSO}[\langle]$  based on the number of alternations of second-order quantifiers collapses to the first level. We have indeed the following result.

**Proposition 3.12** *Every formula of  $\mathbf{MSO}[\langle]$  is equivalent to a formula of the form*

$$\exists X_1 \dots \exists X_k \varphi(X_1, \dots, X_k)$$

where  $\varphi$  is a first-order formula.

In fact, one can even show that every formula of  $\mathbf{MSO}[\langle]$  is equivalent to a formula of the form  $\exists X \varphi(X)$  where  $\varphi$  is a first-order formula.

## 4 First-order logic of the linear order

We now study the language  $\mathbf{FO}[\langle]$  of the first-order logic of the linear order. We shall, in a first step, characterise the sets of words definable in this logic, which happen to be the star-free sets. Next, we shall see in Section 4.2 how this result can be refined to establish a correspondence between the levels the  $\Sigma_n$ -hierarchy of first-order logic and the concatenation hierarchy of star-free sets.

### 4.1 First order and star-free sets

We shall prove the following key result.

**Theorem 4.13** *A language is star-free if and only if it is definable by a formula of  $\mathbf{FO}[\langle]$ .*

The first part of the proof consists in converting languages into formulas. To start with, the equalities

$$L(\mathbf{true}) = A^* \quad L(\mathbf{false}) = \emptyset$$

show that the basic star-free sets are definable by a formula of  $\mathbf{FO}[\langle]$ . The Boolean operations are easily converted into connectives as in Proposition 3.9.

We now treat the marked product. We shall use Proposition 2.5 to replace each formula  $\varphi \in \mathbf{FO}[\langle]$  by a formula  $\varphi(x, y) \in \mathbf{FO}[\langle]$  such that for each word  $u = a_0 \dots a_{n-1}$  and each  $s, t \in \text{Dom}(u)$ , we have  $u \models \varphi(s, t)$  if and only if  $a_s a_{s+1} \dots a_t \models \varphi$ . The next result, whose proof is immediate, shows that if  $X_1 \subset A^*$  and  $X_2 \subset A^*$  are definable in  $\mathbf{FO}[\langle]$ , then so is the marked product  $X_1 a X_2$  for each  $a \in A$ .

**Proposition 4.14** *Let  $X_1 \subset A^*$  and  $X_2 \subset A^*$ . If  $X_1 = L(\varphi_1)$  and  $X_2 = L(\varphi_2)$ , then  $X_1 a X_2 = L(\varphi)$  with  $\varphi = \exists y \varphi_1(0, y - 1) \wedge \mathbf{a}(y) \wedge \varphi_2(y, \max)$ .*

For the opposite implication, from formulas to words, we show by induction on the formation rules of formulas that  $L(\varphi)$  is star-free for every formula  $\varphi \in \mathbf{FO}[\langle]$ . In order to treat formulas with free variables, we shall work with the extended alphabets  $B_{p,q}$  introduced in Section 3. But since there is no set variables any more, we may assume that  $q = 0$ , which permits one to eliminate the  $q$  indices in the notation. Therefore, we simply set  $B_p = A \times \{0, 1\}^p$  and

we denote by  $K_p$  (or simply  $K$ ) the set of the words  $u$  of  $B_p^*$  in which the components  $u_1, \dots, u_p$  contain exactly one occurrence of 1. Note that  $K_0 = A^*$ , but that  $K_p$  does not contain the empty word for  $p > 0$ .

We also set, for each formula  $\varphi = \varphi(x_1, \dots, x_p)$ ,

$$S_p(\varphi) = \{u \in K_p \mid u \models \varphi\}$$

By Proposition 3.10, the sets  $L(\mathbf{a}(x))$ ,  $L(x = y)$  and  $L(x < y)$  are star-free. By Proposition 3.8, the set  $K$  is also star-free. The Boolean operations are translated in the usual way by connectives. There remains to treat the case of quantifiers. We shall use the following result.

**Proposition 4.15** *Let  $B$  be an alphabet and let  $B = C \cup D$  be a partition of  $B$ . Let  $X$  be a star-free language of  $B^*$  such that every word of  $X$  has exactly one letter in  $C$ . Then  $X$  can be written under the form*

$$X = \bigcup_{1 \leq i \leq n} Y_i b_i Z_i$$

with  $n \geq 0$ ,  $b_i \in C$ , and where the  $Y_i \subset D^*$  and  $Z_i \subset D^*$  are star-free sets.

**Proof.** Let  $\mu : B^* \rightarrow M$  be the syntactic morphism of  $X$ . Since  $X$  is star-free, Theorem X.2.3 shows that  $M$  is aperiodic. Then

$$X = \bigcup \mu^{-1}(s) b \mu^{-1}(u)$$

where the union runs over all the triples  $(s, b, u)$  such that  $s \in M$ ,  $b \in C$ ,  $u \in M$  and  $s\mu(b)u \in \mu(X)$ . Since  $M$  is an aperiodic monoid, the sets  $\mu^{-1}(s)$  and  $\mu^{-1}(u)$  are star-free by Theorem X.2.3.  $\square$

We now treat the case of the existential quantifiers. Suppose that  $X = L(\varphi)$  is star-free. Denote by  $\pi : B_p \rightarrow B_{p-1}$  the projection which erases the component corresponding to  $x_p$  (we may assume  $x = x_p$ ). Let us apply Proposition 4.15 with  $X = L(\varphi)$ ,  $B = B_p$ ,  $C = \{b \in B_p \mid b_p = 1\}$  and  $D = \{b \in B_p \mid b_p = 0\}$ . The fact that each word of  $X$  contains exactly one occurrence in  $C$  follows from the inclusion  $X \subset K$ . Therefore

$$\pi(X) = \bigcup_{1 \leq i \leq n} \pi(Y_i) \pi(b_i) \pi(Z_i)$$

Since the restriction of  $\pi$  to  $D^*$  is an isomorphism, the sets  $\pi(Y_i)$  and  $\pi(Z_i)$  are all star-free. Therefore  $L(\exists x \varphi) = \pi(X)$  is a star-free subset. This concludes the proof of Theorem 4.13.  $\square$

The proof of Theorem 4.13 given above makes use of the syntactic characterisation of star-free sets. One can also show directly that  $L(\varphi)$  is aperiodic for  $\varphi \in \mathbf{FO}[\langle \cdot \rangle]$ .

We can now prove the result announced before.

**Corollary 4.16** *One has  $\mathbf{FO}[\langle \cdot \rangle] < \mathbf{MSO}[\langle \cdot \rangle]$ .*

**Proof.** We have already seen that  $\mathbf{FO}[\langle \cdot \rangle] \leq \mathbf{MSO}[\langle \cdot \rangle]$ . Let  $\varphi$  be a formula of  $\mathbf{MSO}[\langle \cdot \rangle]$  such that  $L(\varphi)$  is not a star-free set. Then, by Theorem 4.13, there are no formula of  $\mathbf{FO}[\langle \cdot \rangle]$  equivalent to  $\varphi$ .  $\square$

**Example 4.1** Let  $\varphi$  be the formula

$$\varphi = \exists X (X(\min) \wedge \forall x (X(x) \leftrightarrow \neg X(x+1)) \wedge \neg X(\max))$$

where  $\leftrightarrow$  is the connective designating logical equivalence.

A finite word  $u$  satisfies  $\varphi$  if and only if  $|u|$  is even. Thus  $X = L(\varphi)$  is not star-free and hence  $\varphi$  cannot be equivalent to any formula of  $\mathbf{FO}[<]$  or, equivalently,  $X$  is not definable in  $\mathbf{FO}[<]$ .

## 4.2 Logical hierarchy

We shall see in this section how to refine the characterisation of the first-order definable sets of the logic of the linear order (Theorem 4.13). We shall actually establish a bijection between the concatenation hierarchy of star-free sets defined in Chapter VII and the logical hierarchy  $\Sigma_n(<)$ . Since the concatenation hierarchy is infinite, it will show that the hierarchy defined on formulas by quantifier alternation is also infinite.

Let us recall the notation introduced in Section 2: we denote by  $\Sigma_n(<)$  the set of formulas of the language  $\mathbf{FO}[<]$  with at most  $n$  alternating blocks of quantifiers and by  $\mathcal{B}\Sigma_n(<)$  the set of Boolean combinations of formulas of  $\Sigma_n(<)$ .

**Theorem 4.17** *For each integer  $n \geq 0$ ,*

- (1) *A language is definable by a formula of  $\mathcal{B}\Sigma_n(<)$  if and only if it is a star-free set of level  $n$ .*
- (2) *A language is definable by a formula of  $\Sigma_{n+1}(<)$  if and only if it is a star-free set of level  $n + 1/2$ .*

**Proof.** The first part of the proof consists in converting sets of words to formulas. To start with, the equalities

$$L(\mathbf{true}) = A^* \quad L(\mathbf{false}) = \emptyset$$

show that each star-free subset of level 0 is definable by a formula of  $\mathcal{B}\Sigma_0$ .

By induction, suppose that the star-free sets of level  $n + 1/2$  are definable by a formula of  $\Sigma_{n+1}(<)$ . Proposition 3.9 shows now that the star-free sets of level  $n + 1$  are definable by a formula of  $\mathcal{B}\Sigma_{n+1}(<)$ .

Suppose now that the star-free sets of level  $n$  are definable by a formula of  $\mathcal{B}\Sigma_n(<)$ . If  $X$  is a star-free subset of  $A^*$  of level  $n + 1/2$ ,  $X$  can be written as a finite union of subsets of the form

$$X_0 a_1 X_1 a_2 \cdots a_k X_k$$

where  $k \geq 0$ ,  $X_0, X_1, \dots, X_k$  are star-free sets of level  $n$  of  $A^*$  and  $a_1, \dots, a_k$  are letters.

We now use again the “relativised” version of the first-order formula given by Proposition 2.5. If  $X_0 = L(\varphi_0)$ ,  $X_1 = L(\varphi_1)$ ,  $\dots$ ,  $X_k = L(\varphi_k)$ , we have  $X_0 a_1 X_1 \cdots a_k X_k = L(\varphi)$ , where  $\varphi$  is the formula

$$\begin{aligned} \exists x_1 \cdots \exists x_k \bigwedge_{1 \leq i \leq k-1} (x_i < x_{i+1}) \bigwedge_{1 \leq i \leq k} \mathbf{a}_i(x_i) \wedge \varphi_1(0, x_1 - 1) \\ \bigwedge_{1 \leq i \leq k-1} \varphi(x_i + 1, x_{i+1} - 1) \wedge \varphi(x_k, \max) \end{aligned}$$

showing that  $X_0 a_1 X_1 \cdots a_k X_k$  is definable by a formula of  $\Sigma_{n+1}$ . It follows, by Proposition 3.9, that if the star-free subsets of level  $n$  are definable by a formula of  $\mathcal{B}\Sigma_n(<)$ , the star-free subsets of level  $n + 1/2$  are definable by a formula of  $\Sigma_{n+1}(<)$ .

We now arrive at the second part of the proof, the conversion from formulas to star-free sets. We recall the scheme of the proof of Theorem 4.13, which consists in arguing by induction on the formation rules of formulas. For this purpose, we build, for each alphabet  $B$ , a hierarchy of star-free subsets of  $B^*$  which differs from the usual hierarchy, in particular at level 0.

The induction that follows forces very precise requirements on the subsets of  $B^*$  of level 0. In particular, they have to contain the subsets of the form  $L(\mathbf{a}(x_i))$ ,  $L(x_i = x_j)$  and  $L(x_i < x_j)$  and to be closed under quotient. This leads us to the following definition, which will be subsequently justified by the lemmas 4.19 and 4.20. For each  $\varepsilon = (\varepsilon_1, \dots, \varepsilon_p) \in \{0, 1\}^p$ , we set

$$K(\varepsilon) = \{u \in B_p^* \mid \text{for } 1 \leq i \leq p, u_i \text{ contains exactly } \varepsilon_i \text{ occurrences of } 1\}$$

Note that  $K_p = K(1, \dots, 1)$ . For  $a \in A$ ,  $i \in \{1, \dots, p\}$  and  $\varepsilon \in \{0, 1\}^p$ , we set

$$K(a, i, \varepsilon) = \{u \in K(\varepsilon) \mid \text{if } u_{i, n_i} = 1, \text{ then } u_{0, n_i} = a\}$$

This definition is interesting only if  $\varepsilon_i = 1$ . In this case,  $K(a, i, \varepsilon)$  is the set of the words of  $K(\varepsilon)$  such that, if  $n_i$  is the unique position of 1 in  $u_i$ , the letter of  $u_0$  in position  $n_i$  is an  $a$ . Finally, if  $i, j \in \{1, \dots, p\}$ , we set

$$\begin{aligned} K_=(i, j, \varepsilon) &= \{u \in K(\varepsilon) \mid u_{i, n} = 1 \text{ if and only if } u_{j, n} = 1\} \\ K_<(i, j, \varepsilon) &= \{u \in K(\varepsilon) \mid \text{if } u_{i, n_i} = 1 \text{ and } u_{j, n_j} = 1, \text{ then } n_i < n_j\} \end{aligned}$$

Again, these definitions are only interesting if  $\varepsilon_i = \varepsilon_j = 1$ . In this case,  $K_=(i, j, \varepsilon)$  [ $K_<(i, j, \varepsilon)$ ] is the set of the words of  $K(\varepsilon)$  such that the unique position of 1 in  $u_i$  is equal to [precedes] the unique position of 1 in  $u_j$ .

The languages of  $B_p^*$  of level 0 form the least set of subsets closed under finite intersection and finite union and containing the subsets of the form  $K(\varepsilon)$ ,  $K(a, i, \varepsilon)$ ,  $K_=(i, j, \varepsilon)$  and  $K_<(i, j, \varepsilon)$  for each  $\varepsilon \in \{0, 1\}^p$ ,  $a \in A$  and  $i, j \in \{1, \dots, p\}$ .

Next, level  $n + 1/2$  is the least set of subsets closed under finite intersection and finite union and containing the subsets of the form

$$L_0 b_1 L_1 b_2 \cdots b_k L_k$$

where  $k \geq 0$ ,  $b_1, \dots, b_k \in B_p$  and  $L_0, L_1, \dots, L_k$  are subsets of level  $n$  of  $B_p^*$ . The level  $n + 1$  is the closure of level  $n + 1/2$  under finite union, finite intersection and the operations  $X \rightarrow Y - X$  where  $Y$  is a subset of level 0.

For  $p = 0$ , we recover the usual hierarchy.

**Lemma 4.18** *The hierarchy of subsets of  $B_0^*$  coincides with the concatenation hierarchy.*

**Proof.** We have  $B_0 = A$  and the only subsets of level 0 are  $\emptyset$  and  $A^*$ . It follows that the two hierarchies coincide.  $\square$

The subsets of level  $n$  [ $n + 1/2$ ] are closed under quotient.

**Lemma 4.19** *Let  $n \geq 0$  and let  $X$  be a language of  $B_p^*$  of level  $n$  [ $n + 1/2$ ]. For each  $u, v \in B_p^*$ , the languages  $u^{-1}X$  and  $Xv^{-1}$  are of level  $n$  [ $n + 1/2$ ].*

**Proof.** Arguing by induction on the length of  $u$ , it suffices to treat the case where  $u = b$ , with  $b \in B_p$ . we treat only the case of a right quotient, the other case being dual.

We already know that the quotients commute with Boolean operations: if  $X_1$  and  $X_2$  are languages of  $B_p^*$ , then

$$\begin{aligned}(X_1 \cup X_2)b^{-1} &= X_1b^{-1} \cup X_2b^{-1} \\ (X_1 \cap X_2)b^{-1} &= X_1b^{-1} \cap X_2b^{-1} \\ (X_1 - X_2)b^{-1} &= X_1b^{-1} - X_2b^{-1}\end{aligned}$$

Moreover, if  $b_1, \dots, b_k$  are letters of  $B_p$ ,  $L_0, L_1, \dots, L_k$  are languages of  $B_p^*$ , one has the formula

$$\begin{aligned}(L_0b_1L_1b_2 \cdots b_kL_k)b^{-1} &= \\ \begin{cases} L_0b_1L_1b_2 \cdots b_k(L_kb^{-1}) \cup L_0b_1L_1b_2 \cdots b_{k-1}L_{k-1} & \text{if } 1 \in L_k \text{ and } b = b_k \\ L_0b_1L_1b_2 \cdots b_k(L_kb^{-1}) & \text{otherwise} \end{cases}\end{aligned}\tag{4.1}$$

We now conclude the proof by induction. The subsets of level 0 are closed under quotient. Let indeed  $K'$  be one of the subsets  $K'(\varepsilon)$ ,  $K'(a, i, \varepsilon)$ ,  $K'_=(i, j, \varepsilon)$  or  $K'_<(i, j, \varepsilon)$ . If  $u$  is not a suffix of any word of  $K'$ , then of course  $K'u^{-1} = \emptyset$ . Otherwise, we have in particular, denoting by  $\varepsilon'_i$  the number of occurrences of 1 in  $u_i$ ,  $\varepsilon'_i \leq \varepsilon_i$  and

$$\begin{aligned}K'(\varepsilon)u^{-1} &= K'(\varepsilon - \varepsilon') \\ K'(a, i, \varepsilon)u^{-1} &= K'(a, i, \varepsilon - \varepsilon') \\ K'_=(i, j, \varepsilon)u^{-1} &= K'_=(i, j, \varepsilon - \varepsilon') \\ K'_<(i, j, \varepsilon)u^{-1} &= K'_<(i, j, \varepsilon - \varepsilon')\end{aligned}$$

If the subsets of level  $n$  are closed under quotient, the formula 4.1 shows that every quotients of a marked product of such subsets is of level  $n + 1/2$ . It follows that the subsets of level  $n + 1/2$  are closed under quotient since quotients commute with Boolean operations. Next, the same argument shows that the subsets of level  $n + 1$  are closed under quotient, completing the induction.  $\square$

We come back to the conversion of formulas into star-free sets. The induction starts by the formulas of  $\mathcal{B}\Sigma_0$ .

**Lemma 4.20** *If  $\varphi \in \mathcal{B}\Sigma_0$ ,  $L_p(\varphi)$  is a subset of level 0 of  $B_p^*$ .*

**Proof.** We may assume that  $\varphi$  is in disjunctive normal form. Then we get rid of the negations of atomic formulas by replacing

$$\begin{aligned}\neg(x = y) &\text{ by } (x < y) \vee (y < x) \\ \neg(x < y) &\text{ by } (x = y) \vee (y < x) \\ \neg\mathbf{a}(x) &\text{ by } \bigvee_{b \neq a} \mathbf{b}(x)\end{aligned}$$

Thus  $\varphi$  is now a disjunction of conjunctions of atomic formulas, and by Proposition 3.9, we are left with the case of atomic formulas. Finally, the formulas

$$\begin{aligned} L_p(\mathbf{a}(x_i)) &= K(a, i, 1, \dots, 1) \\ L_p(x_i = x_j) &= K_{=} (i, j, 1, \dots, 1) \\ L_p(x_i < x_j) &= K_{<} (i, j, 1, \dots, 1) \end{aligned}$$

conclude the proof since these subsets are of level 0 by definition.  $\square$

The key step of the induction consists to convert existential quantifiers into concatenation products.

**Lemma 4.21** *Let  $\varphi$  be a formula of  $\Sigma_n$  and  $x_{i_1}, \dots, x_{i_k}$  be free variables of  $\varphi$ . If  $L_p(\varphi)$  is a subset of level  $n$  of  $B_p^*$ , then  $L_{p-k}(\exists x_{i_1} \dots \exists x_{i_k} \varphi)$  is a subset of level  $n + 1/2$  of  $B_p^*$ .*

**Proof.** Up to a permutation of the free variables, we may assume that  $x_{i_1} = x_1, \dots, x_{i_k} = x_k$ . We first establish the formula

$$L_{p-k}(\exists x_{i_1} \dots \exists x_{i_k} \varphi) = \pi(L_p(\varphi)) \tag{4.2}$$

where  $\pi : B_p \rightarrow B_{p-k}$  is the function erasing the components of index 1 to  $k$ , defined by:

$$\pi_i(b_0, b_1, \dots, b_p) = (b_0, b_{k+1}, \dots, b_p)$$

Indeed, if  $u = (u_0, u_1, \dots, u_p) \in L_p(\varphi)$ , we have in particular  $u \in K_p$ . For  $1 \leq i \leq p$ , denote by  $n_i$  the position of the unique 1 of the word  $u_i$ . Then we have  $u_0 \models \varphi[\nu]$ , where  $\nu$  is the valuation defined by  $\nu(x_i) = n_i$  for  $1 \leq i \leq p$ . Now  $\nu = \nu'[\binom{n_1}{x_1} \dots \binom{n_k}{x_k}]$ , where  $\nu'$  is the valuation defined by  $\nu'(x_i) = n_i$  for  $k + 1 \leq i \leq p$ . It follows  $u_0 \models (\exists x_1 \dots \exists x_k \varphi)[\nu']$  and as  $\pi(u)_0 = u_0$ , it follows  $\pi(u) \in L_{p-k}(\exists x_1 \dots \exists x_k \varphi)$ .

Conversely, if  $v \in L_{p-k}(\exists x_1 \dots \exists x_k \varphi)$ , there exist positions  $n_1, \dots, n_k$  such that

$$v_0 \models \varphi[\nu'(\binom{n_1}{x_1} \dots \binom{n_k}{x_k})].$$

Let  $u$  be the unique word of  $K_p$  such that  $\pi(u) = v$  and such that, for  $1 \leq i \leq k$ , the position of the unique 1 of  $u_i$  is  $n_i$ . Then  $u_0 = v_0$ , and as  $\nu = \nu'[\binom{n_1}{x_1} \dots \binom{n_k}{x_k}]$ , we have  $u_0 \models \varphi[\nu]$ , whence  $u \in L_p(\varphi)$ , proving Formula 4.2.

We shall now express  $L_p(\varphi)$  as a finite union of marked products of subsets of level  $n$ . Set  $L = S_p(\varphi)$ ,  $D = \{ b \in B_p \mid \text{for } 1 \leq i \leq k, b_i = 0 \}$  and, for  $I \subseteq \{1, \dots, p\}$ ,

$$C_I = \{ b \in B_p \mid \text{for each } i \in I \ b_i = 1 \}$$

If  $u \in L$ , there exists, for  $1 \leq i \leq k$ , a unique position  $n_i$  such that  $u_{i, n_i} = 1$ . Then there exists an ordered partition  $P = (I_1, \dots, I_r)$  of  $\{1, \dots, k\}$  such that  $u$  is uniquely factorised as  $u = u_0 b_1 u_1 b_2 \dots b_r u_r$ , where  $b_j \in C_{I_j}$ ,  $u_0, \dots, u_r \in D^*$ .

		$a_1$			$a_2$				$a_3$		$\dots$
0	0	1	0	0	0	0	0	0	0	0	$\dots$
0	0	0	0	0	0	0	0	0	1	0	$\dots$
0	0	0	0	0	1	0	0	0	0	0	$\dots$
0	0	1	0	0	0	0	0	0	0	0	$\dots$
					$\vdots$						$\dots$



Next we obtain the formula below, in which  $Q(x) = \{u \in B_p^* \mid u^{-1}L = x^{-1}L\}$  and  $\mathcal{P}$  denotes the set of ordered partitions of  $\{1, \dots, k\}$ :

$$L = \bigcup_{P \in \mathcal{P}} \bigcup_{(x_0, b_1, x_1, \dots, b_r, x_r) \in E_P} [Q(x_0)] b_1 [(x_0 b_1)^{-1} Q(x_0 b_1 x_1)] b_2 \cdots \cdots b_r [(x_0 b_1 x_1 \cdots b_r)^{-1} Q(x_0 b_1 x_1 \cdots b_r x_r)] \tag{4.3}$$

in which if  $P = (I_1, \dots, I_r)$  is an ordered partition,  $E_P$  is the set of

$$(x_0, b_1, x_1, \dots, b_r, x_r)$$

such that  $x_0 b_1 x_1 \cdots b_r x_r \in L$ , with  $x_0, x_1, \dots, x_p \in B_p^*$  and, for  $1 \leq j \leq r$ ,  $b_j \in C_{I_j}$ .

Let  $L'$  be the right hand side of the formula 4.3. First of all, if  $u \in L$ , there exists an ordered partition  $(I_1, \dots, I_r)$  of  $\{1, \dots, k\}$  and a factorisation  $u = u_0 b_1 u_1 \cdots b_r u_r$ , with, for  $1 \leq j \leq r$ ,  $b_j \in C_{I_j}$ . Now, by construction,  $x \in Q(x)$  for each  $x$ , and hence

$$u_0 \in Q(u_0), u_1 \in (u_0 b_1)^{-1} Q(u_0 b_1 u_1), \dots, u_r \in (u_0 b_1 \cdots u_{r-1} b_r)^{-1} Q(u_0 b_1 \cdots u_{r-1} b_r u_r)$$

thereby establishing the inclusion  $L \subseteq L'$ . Conversely, if there exists an ordered partition  $P$  of  $\{1, \dots, k\}$  and if

$$u \in [Q(x_0)] b_1 [(x_0 b_1)^{-1} Q(x_0 b_1 x_1)] b_2 \cdots b_k [(x_0 b_1 x_1 \cdots b_r)^{-1} Q(x_0 b_1 x_1 \cdots b_r x_r)]$$

for some  $(x_0, b_1, x_1, \dots, b_k, x_r) \in E_P$ , we have  $u = u_0 b_1 u_1 \cdots b_r u_r$ , with  $b_j \in C_{I_j}$  and

$$u_0 \in Q(x_0), u_1 \in (x_0 b_1)^{-1} Q(x_0 b_1 x_1), \dots, u_r \in (x_0 b_1 x_1 \cdots b_r)^{-1} Q(x_0 b_1 x_1 \cdots b_r x_r)$$

Therefore, for  $0 \leq i \leq r$ ,  $x_0 b_1 x_1 \cdots b_i u_i \in Q(x_0 b_1 x_1 \cdots b_i x_i)$ , whence

$$(x_0 b_1 x_1 \cdots b_i u_i)^{-1} L = (x_0 b_1 x_1 \cdots b_i x_i)^{-1} L$$

Next we show that  $x_0 b_1 x_1 \cdots b_i x_i b_{i+1} u_{i+1} \cdots b_r u_r \in L$  by induction on  $r-i$ . For  $i = r$ , the result follows from the fact that  $(x_0, b_1, x_1, \dots, b_r, x_r) \in E_P$ . Next, if

$$x_0 b_1 x_1 \cdots b_i x_i b_{i+1} u_{i+1} \cdots b_r u_r \in L$$

we have  $b_{i+1} u_{i+1} \cdots b_r u_r \in (x_0 b_1 x_1 \cdots b_i x_i)^{-1} L$  and hence

$$b_{i+1} u_{i+1} \cdots b_r u_r \in (x_0 b_1 x_1 \cdots b_i u_i)^{-1} L$$

whence  $x_0 b_1 x_1 \cdots b_{i-1} x_{i-1} b_i u_i \cdots b_r u_r \in L$ , allowing the induction. Consequently

$$u = u_0 b_1 u_1 \cdots b_r u_r \in L$$

and the inclusion  $L' \subseteq L$  is proved.

A second formula gives an expression of  $Q(x)$  in terms of the quotients of  $L$ .

$$Q(x) = \left( \bigcap_{y \in x^{-1}L} Ly^{-1} \right) - \left( \bigcup_{y \notin x^{-1}L} Ly^{-1} \right) \quad (4.4)$$

Let indeed  $Q'(x)$  be the right hand side of (4.4). If  $u \in Q(x)$ , then  $u^{-1}L = x^{-1}L$ . Therefore the following sequence of equivalences hold

$$y \in x^{-1}L \iff y \in u^{-1}L \iff uy \in L \iff u \in Ly^{-1}$$

showing that  $Q(x) \subseteq Q'(x)$ . Let now  $u \in Q'(x)$ . If  $y \in x^{-1}L$ , then  $u \in Ly^{-1}$  and hence  $uy \in L$  and  $y \in u^{-1}L$ . Similarly, if  $y \notin x^{-1}L$ , then  $y \notin u^{-1}L$ . Therefore  $u^{-1}L = x^{-1}L$  and  $u \in Q(x)$ , proving (4.4).

Since  $L$  is recognisable, Proposition III.4.17 shows that  $L$  has only finitely many quotients on the right and on the left. It follows that only finitely many unions and intersections occur in Formulas (4.3) and (4.4). Besides, Lemma 4.19 shows that all the quotients of  $L$  are of level  $n$ . Consequently, the subsets of the form  $Q(x)$  and their quotients are of level  $n$ . Formula 4.3 now gives an expression of  $L_p(\varphi)$  as a finite union of products of the form  $X_0b_1X_1 \cdots b_rX_r$  where  $b_j \in C_{I_j}$  and the  $X_0, \dots, X_{r-1}$  [ $X_r$ ] are level  $n$  subsets of  $D^*$ . By Formula 4.2,  $L_{p-r}(\exists x_{i_1} \cdots \exists x_{i_r} \varphi)$  is thus a finite union of subsets of the form  $\pi(X_0b_1X_1b_2 \cdots b_rX_r)$ . Therefore, proving that  $L_{p-r}(\exists x_{i_1} \cdots \exists x_{i_k} \varphi)$  is of level  $n + 1/2$ , amounts to proving that if  $X$  is a subset of  $B_p^*$  of level  $n$  contained in  $D^*$ , then  $\pi(X)$  is a subset of  $B_{p-k}^*$  of level  $n$ .

Let  $\delta : B_{p-k} \rightarrow B_p$  be the function defined by

$$\delta(b_0, \dots, b_{p-k}) = (b_0, 0, \dots, 0, b_1, \dots, b_{p-k})$$

Then we have, for each subset  $X$  of  $D^*$ ,

$$\pi(X) = \delta^{-1}(X)$$

Thus, it suffices to verify by induction that the subsets of level  $n$  [ $n + 1/2$ ] are stable under  $\delta^{-1}$ . For level 0, this follows from the formulas

$$\begin{aligned} \delta^{-1}(K(\varepsilon_1, \dots, \varepsilon_{p-k})) &= K(0, \dots, 0, \varepsilon_{k+1}, \dots, \varepsilon_p) \\ \delta^{-1}(K(a, i, \varepsilon_1, \dots, \varepsilon_{p-k})) &= K(a, k+i, 0, \dots, 0, \varepsilon_{k+1}, \dots, \varepsilon_p) \\ \delta^{-1}(K_{=}(i, j, \varepsilon_1, \dots, \varepsilon_{p-k})) &= K_{=}(k+i, k+j, 0, \dots, 0, \varepsilon_{k+1}, \dots, \varepsilon_p) \\ \delta^{-1}(K_{<}(i, j, \varepsilon_1, \dots, \varepsilon_{p-k})) &= K_{<}(k+i, k+j, 0, \dots, 0, \varepsilon_{k+1}, \dots, \varepsilon_p) \end{aligned}$$

and from the fact that  $\delta^{-1}$  commutes with the Boolean operations. This latter property also permits one to pass from level  $n+1/2$  to level  $n+1$  in the induction step. Passing from level  $n$  to level  $n + 1/2$ , requires the formula

$$\delta^{-1}(X_0b_1X_1 \cdots b_kX_k) = \bigcup_{c_1 \in \delta^{-1}(b_1)} \delta^{-1}(X_0)c_1\delta^{-1}(X_1) \cdots c_k\delta^{-1}(X_k) \\ \vdots \\ c_k \in \delta^{-1}(b_k)$$

which follows from the fact that  $\delta$  is length preserving.  $\square$

We can now conclude the second part of the proof of Theorem 4.17. Since the only variable-free formulas of  $\mathcal{B}\Sigma_0$  are **true** and **false**, the only subsets of  $A^*$  definable by a formula of  $\mathcal{B}\Sigma_0(<)$  are  $\emptyset$  and  $A^*$ , which are indeed of level 0.

By Lemma 4.20, for each formula  $\varphi$  of  $\mathcal{B}\Sigma_0(<)$ ,  $L_p(\varphi)$  is a subset of  $B_p^*$  of level 0. Suppose by induction that, for each formula  $\varphi$  of  $\mathcal{B}\Sigma_n(<)$ ,  $L_p(\varphi)$  is a subset of  $B_p^*$  of level  $n$ . Consider the set  $\Delta$  of formulas  $\varphi$  such that, for each  $p \geq 0$ ,  $L_p(\varphi)$  is a subset of  $B_p^*$  of level  $n + 1/2$ . The set  $\Delta$  contains  $\mathcal{B}\Sigma_n(<)$  by the induction hypothesis and, by Proposition 3.9, it is closed under finite disjunction and finite conjunction. Finally, Lemma 4.21 shows that if  $\varphi \in \Delta$  and if  $x_1, \dots, x_k$  are free variables of  $\varphi$ , then  $\exists x_1 \cdots \exists x_k \varphi \in \Delta$ . Therefore  $\Delta$  contains  $\Sigma_{n+1}(<)$  and each formula of  $\Sigma_{n+1}(<)$  defines a subset  $B_p^*$  of level  $n + 1/2$ .

To conclude, suppose by induction that for each formula  $\varphi$  of  $\Sigma_{n+1}(<)$ ,  $L_p(\varphi)$  is a subset of  $B_p^*$  of level  $n + 1/2$ . The proof of Proposition 3.8 shows that  $K_p$  is of level 1 and thus Proposition 3.9 shows that for each formula  $\varphi$  of  $\mathcal{B}\Sigma_{n+1}(<)$ ,  $L_p(\varphi)$  is a subset of  $B_p^*$  of level  $n + 1$ .  $\square$



# Annex A

## A transformation semigroup

We compute in this section the structure of a 4-generator transformation semigroup  $S$ . We compute successively the list of its elements, a presentation for it, its right and left Cayley graphs, its  $\mathcal{D}$ -class structure and the lattice of its idempotents.

* 1	1	2	3	4
$a$	2	3	4	0
$b$	3	1	4	0
$c$	2	1	4	3
$a^2$	3	4	0	0
$ab$	1	4	0	0
$ac$	1	4	3	0
$ba$	4	2	0	0
$b^2$	4	3	0	0
$bc$	4	2	3	0
$ca$	3	2	0	4
$cb$	1	3	0	4
$a^3$	4	0	0	0
$aba$	2	0	0	0
$ab^2$	3	0	0	0
$abc$	2	3	0	0
$aca$	2	0	4	0
$acb$	3	0	4	0
$ba^2$	0	3	0	0
$bab$	0	1	0	0
$bac$	3	1	0	0
$b^2a$	0	4	0	0
$bca$	0	3	4	0
$acb$	0	1	4	0
$cab$	4	1	0	0

	1	2	3	4
$cac$	4	1	0	3
$cba$	2	4	0	0
$cbc$	2	4	0	3
* $a^4$	0	0	0	0
* $bab$	1	0	0	0
* $cac$	1	0	3	0
$acbc$	4	0	3	0
* $baba$	0	2	0	0
$bcac$	0	4	3	0
* $bcbe$	0	2	3	0
$cabc$	3	2	0	0
* $caca$	0	2	0	4
$cacb$	0	3	0	4
$cbac$	1	3	0	0
$cbca$	3	0	0	4
* $cbcb$	1	0	0	4
$acbca$	0	0	4	0
$cacac$	0	1	0	3
$cacbc$	0	4	0	3
$cbcac$	4	0	0	3
$cbcbc$	2	0	0	3
* $acbcac$	0	0	3	0
* $cacbca$	0	0	0	4
$cacbca$	0	0	0	3

Relations :

$c^2 = 1$	$a^2b = a^3$	$a^2c = b^2$	$b^3 = b^2a$
$b^2c = a^2$	$ca^2 = b^2$	$cb^2 = a^2$	$a^4 = 0$
$aba^2 = ab^2$	$abac = abab$	$ab^2a = a^3$	$abca = a^2$
$abcb = ab$	$acab = abab$	$acba = a^3$	$ba^3 = b^2a$
$bab^2 = ba^2$	$babc = baba$	$baca = ba$	$bacb = b^2$
$b^2a^2 = 0$	$b^2ab = 0$	$b^2ac = ba^2$	$bcab = b^2a$
$bcba = baba$	$caba = baba$	$cab^2 = ba^2$	$cba^2 = ab^2$
$cbab = abab$	$ababa = aba$	$acaca = aca$	$acacb = acb$
$acbcb = acbca$	$babab = bab$	$bcaca = acbca$	$bcacb = acbca$
$bcbca = bca$	$bcacb = bcb$		

The idempotents of  $S$  are  $1, a^4 = 0$  and

$e_1 = acac$	$e_2 = cbc b$	$e_3 = caca$	$e_4 = bcbc$
$e_5 = abab$	$e_6 = cacbca$	$e_7 = baba$	$e_8 = acbcac$

Recall that the natural order on idempotents is defined as follows:  $e \leq f$  if and only if  $ef = e = fe$  (or, equivalently, if  $fef = e$ ).

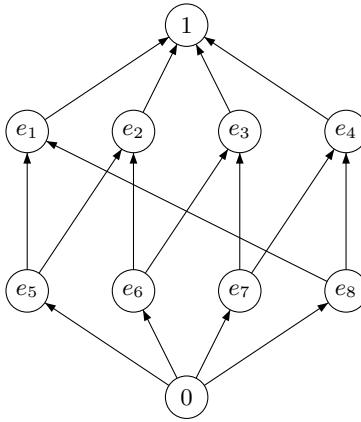
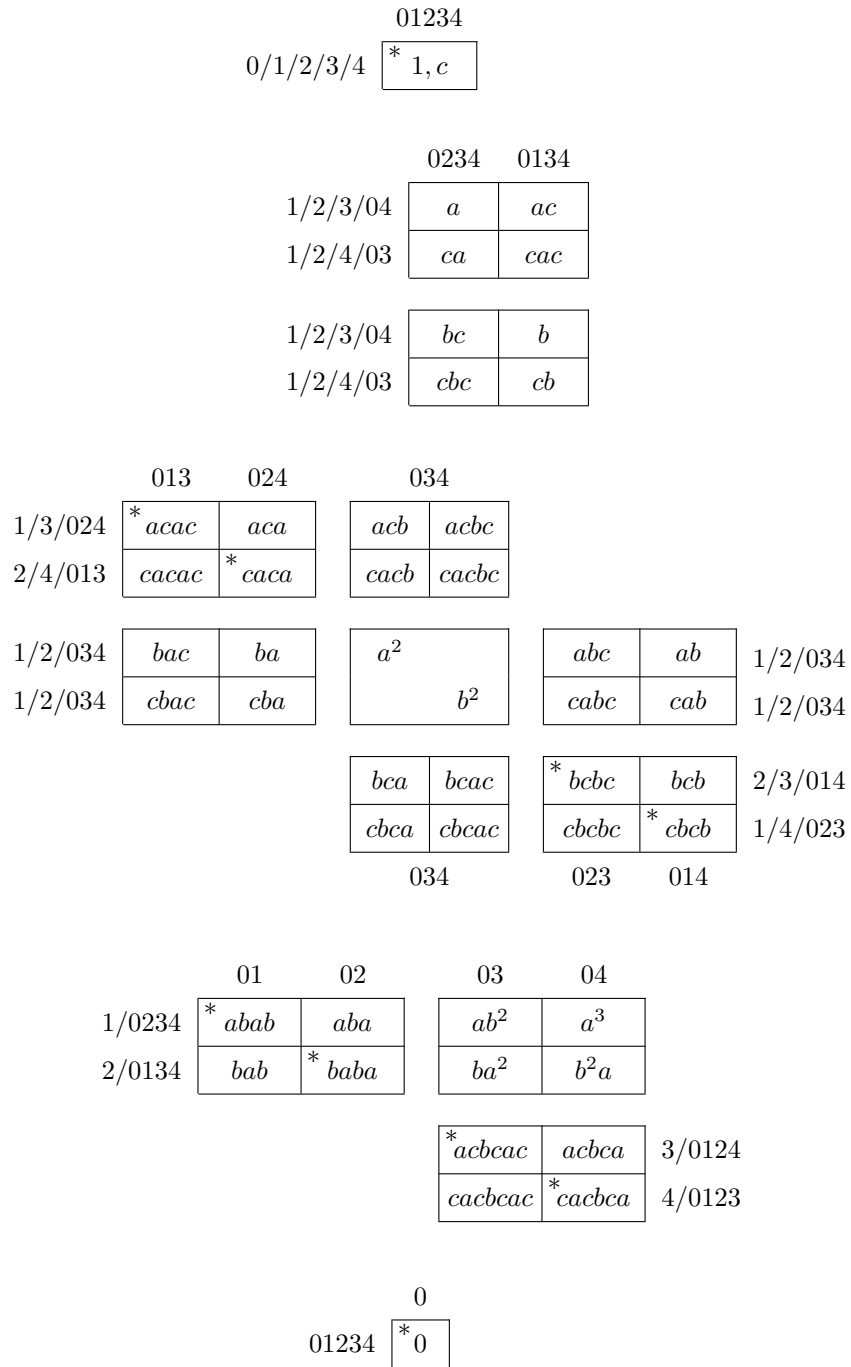

Figure A.1. The lattice of idempotents.

The  $\mathcal{D}$ -class structure of  $S$  is represented in Figure A.2. Note that the nonregular elements  $bac$  and  $cbac$  have the same kernel and the same range but are not  $\mathcal{H}$ -equivalent.



**Figure A.2.** The  $\mathcal{D}$ -class structure of  $S$ .





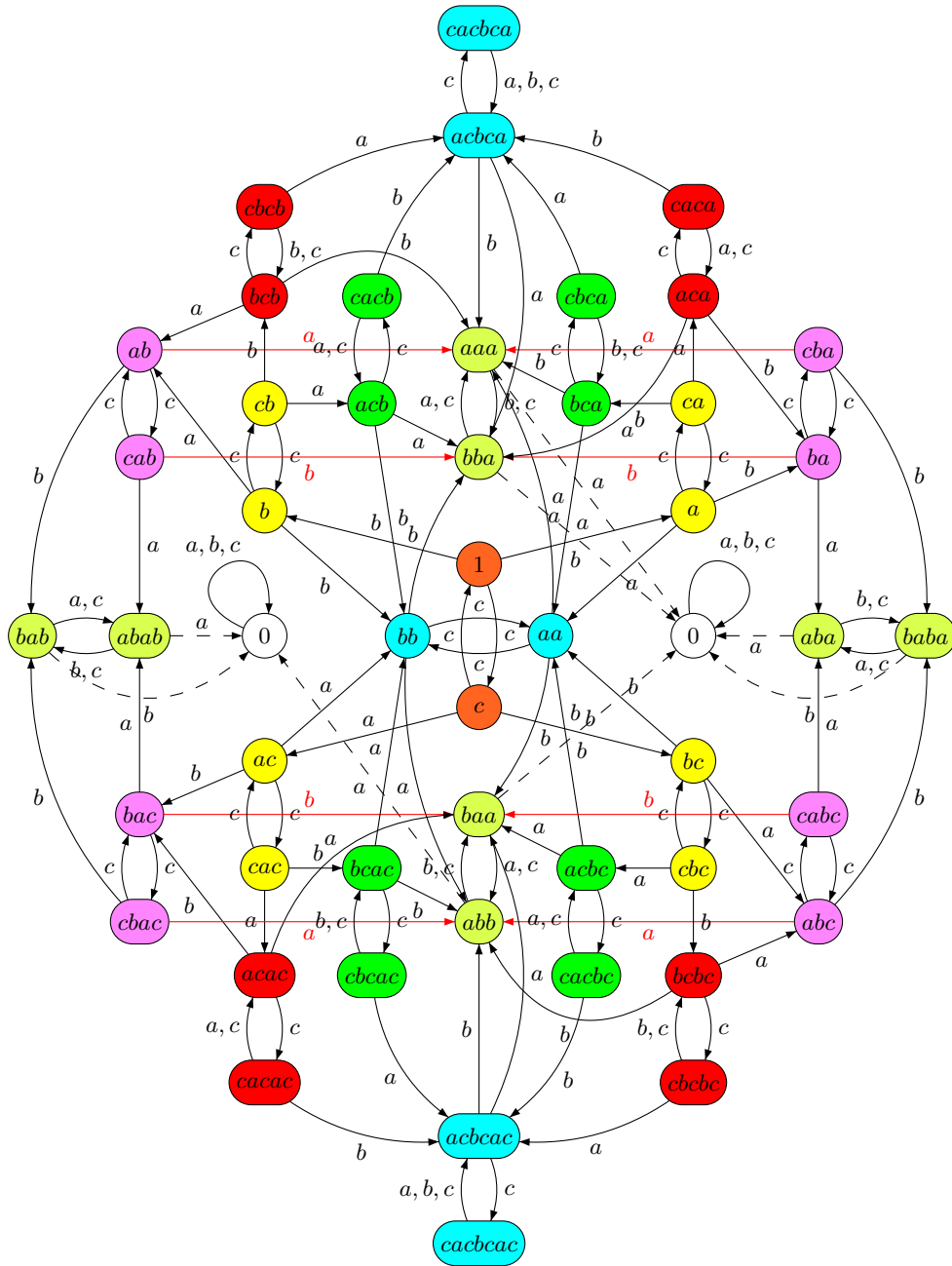

**Figure A.4.** The left Cayley graph of  $S$ . To avoid unesthetic crossing lines, the zero is represented twice in this diagram.



# Bibliography

- [1] J. ALMEIDA, Residually finite congruences and quasi-regular subsets in uniform algebras, *Portugal. Math.* **46**,3 (1989), 313–328.
- [2] J. ALMEIDA, *Finite semigroups and universal algebra*, World Scientific Publishing Co. Inc., River Edge, NJ, 1994. Translated from the 1992 Portuguese original and revised by the author.
- [3] J. ALMEIDA, Profinite semigroups and applications, in *Structural theory of automata, semigroups, and universal algebra*, pp. 1–45, *NATO Sci. Ser. II Math. Phys. Chem.* vol. 207, Springer, Dordrecht, 2005. Notes taken by Alfredo Costa.
- [4] J. ALMEIDA AND M. V. VOLKOV, Profinite identities for finite semigroups whose subgroups belong to a given pseudovariety, *J. Algebra Appl.* **2**,2 (2003), 137–163.
- [5] J. ALMEIDA AND P. WEIL, Relatively free profinite monoids: an introduction and examples, in *NATO Advanced Study Institute Semigroups, Formal Languages and Groups*, J. Fountain (ed.), vol. 466, pp. 73–117, Kluwer Academic Publishers, 1995.
- [6] M.-P. BÉAL, O. CARTON AND C. REUTENAUER, Cyclic languages and strongly cyclic languages, in *STACS 96 (Grenoble, 1996)*, pp. 49–59, *Lect. Notes Comp. Sci.* vol. 1046, Springer, Berlin, 1996.
- [7] J. BERSTEL, *Transductions and context-free languages*, Teubner, 1979.
- [8] G. BIRKHOFF, On the structure of abstract algebras, *Proc. Cambridge Phil. Soc.* **31** (1935), 433–454.
- [9] M. J. BRANCO AND J.-E. PIN, Equations for the polynomial closure, in *ICALP 2009, Part II*, S. Albers and W. Thomas (eds.), pp. 115–126, *Lect. Notes Comp. Sci.* vol. 5556, Springer, Berlin, 2009.
- [10] J. BRZOZOWSKI, K. CULIK AND A. GABRIELAN, Classification of non-counting events, *J. Comput. Syst. Sci.* **5** (1971), 41–53.
- [11] J. A. BRZOZOWSKI AND F. E. FICH, Languages of R-Trivial Monoids, *J. Comput. Syst. Sci.* **20**,1 (1980), 32–49.
- [12] J. A. BRZOZOWSKI AND I. SIMON, Characterizations of locally testable events, *Discrete Math.* **4** (1973), 243–271.

- [13] J. CARROLL AND D. LONG, *Theory of finite automata with an introduction to formal languages*, Prentice-Hall, Inc., Upper Saddle River, NJ, USA, 1989.
- [14] O. CARTON, *Langages formels, calculabilité et complexité*, Vuibert, 2008.
- [15] O. CARTON, J.-E. PIN AND X. SOLER-ESCRIVÀ, Languages Recognized by Finite Supersoluble Groups, *Journal of Automata, Languages and Combinatorics* **14**,2 (2009), 149–161.
- [16] J. CHALOPIN AND H. LEUNG, On factorization forests of finite height, *Theoret. Comput. Sci.* **310**,1-3 (2004), 489–499.
- [17] A. H. CLIFFORD AND G. B. PRESTON, *The Algebraic Theory of Semigroups*, vol. 1, Amer. Math. Soc., 1961.
- [18] A. H. CLIFFORD AND G. B. PRESTON, *The Algebraic Theory of Semigroups*, vol. 2, Amer. Math. Soc., 1967.
- [19] J. COHEN, D. PERRIN AND J.-E. PIN, On the expressive power of temporal logic, *J. Comput. System Sci.* **46**,3 (1993), 271–294.
- [20] R. S. COHEN AND J. A. BRZOZOWSKI, On star-free events, in *Proc. Hawaii Int. Conf. on System Science*, B. K. Kinariwala and F. F. Kuo (eds.), pp. 1–4, University of Hawaii Press, Honolulu, HI, 1968.
- [21] T. COLCOMBET, A combinatorial theorem for trees: applications to monadic logic and infinite structures, in *Automata, languages and programming*, pp. 901–912, *Lect. Notes Comp. Sci.* vol. 4596, Springer, Berlin, 2007.
- [22] T. COLCOMBET, Factorisation Forests for Infinite Words, in *Fundamentals of Computation Theory, 16th International Symposium, FCT 2007, Budapest, Hungary, August 27-30, 2007, Proceedings*, E. Csuhaj-Varjú and Z. Ésik (eds.), pp. 226–237, *Lect. Notes Comp. Sci.* vol. 4639, Springer, Berlin, 2007.
- [23] J. H. CONWAY, *Regular Algebra and Finite Machines*, Chapman and Hall, London, 1971.
- [24] A. DE LUCA AND S. VARRICCHIO, *Finiteness and Regularity in Semigroups and Formal Languages*, Springer-Verlag, 1999.
- [25] V. DIEKERT AND P. GASTIN, Pure future local temporal logics are expressively complete for Mazurkiewicz traces, *Inform. and Comput.* **204**,11 (2006), 1597–1619. Conference version in LATIN 2004, LNCS 2976, 170–182, 2004.
- [26] S. EILENBERG, *Automata, languages, and machines. Vol. A*, Academic Press [A subsidiary of Harcourt Brace Jovanovich, Publishers], New York, 1974. Pure and Applied Mathematics, Vol. 58.
- [27] S. EILENBERG, *Automata, languages, and machines. Vol. B*, Academic Press [Harcourt Brace Jovanovich Publishers], New York, 1976. With two chapters (“Depth decomposition theorem” and “Complexity of semigroups and morphisms”) by Bret Tilson, Pure and Applied Mathematics, Vol. 59.

- [28] Z. ÉSIK, Extended temporal logic on finite words and wreath products of monoids with distinguished generators, in *DLT 2002, Kyoto, Japan*, Ito, Masami et al. (ed.), Berlin, 2002, pp. 43–58, *Lect. Notes Comp. Sci.* n° 2450, Springer.
- [29] Z. ÉSIK AND M. ITO, Temporal logic with cyclic counting and the degree of aperiodicity of finite automata, *Acta Cybernetica* **16** (2003), 1–28.
- [30] Z. ÉSIK AND K. G. LARSEN, Regular languages definable by Lindström quantifiers, *Theoret. Informatics Appl.* **37** (2003), 179–241.
- [31] M. GEHRKE, S. GRIGORIEFF AND J.-E. PIN, Duality and equational theory of regular languages, in *ICALP 2008, Part II*, L. A. et al. (ed.), Berlin, 2008, pp. 246–257, *Lect. Notes Comp. Sci.* vol. 5126, Springer.
- [32] S. GINSBURG AND E. H. SPANIER, Bounded ALGOL-like languages, *Trans. Amer. Math. Soc.* **113** (1964), 333–368.
- [33] S. GINSBURG AND E. H. SPANIER, Bounded regular sets, *Proc. Amer. Math. Soc.* **17** (1966), 1043–1049.
- [34] S. GINSBURG AND E. H. SPANIER, Semigroups, Presburger formulas, and languages, *Pacific J. Math.* **16** (1966), 285–296.
- [35] A. GINZBURG, *Algebraic theory of automata*, Academic Press, New York, 1968.
- [36] R. GRAHAM, On finite 0-simple semigroups and graph theory, *Math. Syst. Theory* **2** (1968), 325–339.
- [37] J. A. GREEN, On the structure of semigroups, *Ann. of Math. (2)* **54** (1951), 163–172.
- [38] P. A. GRILLET, *Semigroups, An Introduction to the Structure Theory*, Marcel Dekker, Inc., New York, 1995.
- [39] J. B. HICKEY, Semigroups under a sandwich operation, *Proc. Edinburgh Math. Soc. (2)* **26,3** (1983), 371–382.
- [40] HIGGINS, *Techniques of Semigroup Theory*, World Scientific, 1999.
- [41] J. HOPCROFT, R. MOTWANI AND J. D. ULLMAN, *Introduction to automata theory, languages, and computation*, Addison-Wesley, Boston, ed. 2nd, 2001.
- [42] J. HOPCROFT AND J. D. ULLMAN, *Introduction to Automata Theory, Languages and Computation*, Addison Wesley, 1979.
- [43] J. M. HOWIE, *An Introduction to Semigroup Theory*, Academic Press, 1976.
- [44] J. M. HOWIE, *Automata and Languages*, Clarendon Press, 1991.
- [45] J. M. HOWIE, *Fundamentals of semigroup theory*, *London Mathematical Society Monographs. New Series* vol. 12, The Clarendon Press Oxford University Press, New York, 1995. Oxford Science Publications.

- [46] S. C. KLEENE, Representation of events in nerve nets and finite automata, in *Automata studies*, pp. 3–41, Princeton University Press, Princeton, N. J., 1956. *Annals of mathematics studies*, no. 34.
- [47] D. KROB, Complete sets of  $B$ -rational identities, *Theoret. Comp. Sci.* **89** (1991), 207–343.
- [48] M. KUFLEITNER, The Height of Factorization Forests, in *Mathematical Foundations of Computer Science 2008, 33rd International Symposium, MFCS 2008, Torun, Poland, August 25-29, 2008, Proceedings*, E. Ochmanski and J. Tyszkiewicz (eds.), pp. 443–454, *Lect. Notes Comp. Sci.* vol. 5162, Springer, Berlin, 2008.
- [49] M. KUNC, Equational description of pseudovarieties of homomorphisms, *Theoretical Informatics and Applications* **37** (2003), 243–254.
- [50] G. LALLEMENT, *Semigroups and Combinatorial Applications*, Wiley and Sons, 1979.
- [51] M. V. LAWSON, *Finite Automata*, CRC Press, 2003.
- [52] M. LOTHAIRE, *Combinatorics on Words, Encyclopedia of Mathematics and its Applications* vol. 17, Cambridge University Press, 1983.
- [53] M. LOTHAIRE, *Combinatorics on words, Cambridge Mathematical Library*, Cambridge University Press, Cambridge, 1997. With a foreword by Roger Lyndon and a preface by Dominique Perrin, Corrected reprint of the 1983 original, with a new preface by Perrin.
- [54] MASCLE, Torsion Matrix Semigroups and Recognizable Transductions, in *Automata, Languages and Programming*, Kott (ed.), Berlin, 1986, pp. 244–253, *Lect. Notes Comp. Sci.*, Springer.
- [55] R. MCNAUGHTON, Algebraic decision procedures for local testability, *Math. Systems Theory* **8**,1 (1974), 60–76.
- [56] R. MCNAUGHTON AND S. PAPERT, *Counter-free automata*, The M.I.T. Press, Cambridge, Mass.-London, 1971. With an appendix by William Henneman, M.I.T. Research Monograph, No. 65.
- [57] A. R. MEYER, A note on star-free events, *J. Assoc. Comput. Mach.* **16** (1969), 220–225.
- [58] M. MORSE AND G. A. HEDLUND, Unending chess, symbolic dynamics and a problem in semigroups, *Duke Math. J.* **11** (1944), 1–7.
- [59] G. PĂUN AND A. SALOMAA, Thin and slender languages, *Discrete Appl. Math.* **61**,3 (1995), 257–270.
- [60] M. PERLES, M. RABIN AND E. SHAMIR, The theory of definite automata, *IEEE Trans. Electron. Comput.* **12** (1963), 233–243.
- [61] D. PERRIN, Finite automata, in *Handbook of theoretical computer science, Vol. B*, pp. 1–57, Elsevier, Amsterdam, 1990.

- [62] D. PERRIN AND J.-E. PIN, *Infinite Words, Pure and Applied Mathematics* vol. 141, Elsevier, 2004. ISBN 0-12-532111-2.
- [63] M. PETRICH, *Inverse Semigroups*, Wiley and Sons, 1984.
- [64] J.-É. PIN, Propriétés syntactiques du produit non ambigu, in *7th ICALP*, Berlin, 1980, pp. 483–499, *Lect. Notes Comp. Sci.* n° 85, Springer.
- [65] J.-E. PIN, Hiérarchies de concaténation, *RAIRO Inform. Théor.* **18**,1 (1984), 23–46.
- [66] J.-E. PIN, *Varieties of formal languages*, Plenum Publishing Corp., New York, 1986. With a preface by M.-P. Schützenberger, Translated from the French by A. Howie.
- [67] J.-E. PIN, A property of the Schützenberger product, *Semigroup Forum* **35** (1987), 53–62.
- [68] J.-E. PIN, Finite semigroups and recognizable languages: an introduction, in *Semigroups, formal languages and groups (York, 1993)*, pp. 1–32, Kluwer Acad. Publ., Dordrecht, 1995.
- [69] J.-E. PIN, A variety theorem without complementation, *Russian Mathematics (Iz. VUZ)* **39** (1995), 80–90.
- [70] J.-E. PIN, The expressive power of existential first order sentences of Büchi’s sequential calculus, in *Automata, languages and programming (Paderborn, 1996)*, pp. 300–311, *Lecture Notes in Comput. Sci.* vol. 1099, Springer, Berlin, 1996.
- [71] J.-É. PIN, Bridges for concatenation hierarchies, in *25th ICALP*, Berlin, 1998, pp. 431–442, *Lect. Notes Comp. Sci.* n° 1443, Springer.
- [72] J.-É. PIN, Logic On Words, in *Current Trends in Theoretical Computer Science, Entering the 21st Century*, G. R. G. Păun and A. Salomaa (eds.), pp. 254–273, Word Scientific, 2001.
- [73] J.-E. PIN, Algebraic tools for the concatenation product, *Theoret. Comput. Sci.* **292** (2003), 317–342.
- [74] J.-E. PIN, The expressive power of existential first order sentences of Büchi’s sequential calculus, *Discrete Mathematics* **291** (2005), 155–174.
- [75] J.-E. PIN, Profinite methods in automata theory, in *26th International Symposium on Theoretical Aspects of Computer Science (STACS 2009)*, S. Albers (ed.), pp. 31–50, Internationales Begegnungs- Und Forschungszentrum für Informatik (IBFI), Schloss Dagstuhl, Germany, Dagstuhl, Germany, 2009.
- [76] J.-É. PIN, A. PINGUET AND P. WEIL, Ordered categories and ordered semigroups, *Communications in Algebra* **30** (2002), 5651–5675.
- [77] J.-E. PIN AND H. STRAUBING, Monoids of upper triangular matrices, in *Semigroups (Szeged, 1981)*, pp. 259–272, *Colloq. Math. Soc. János Bolyai* vol. 39, North-Holland, Amsterdam, 1985.

- [78] J.-É. PIN AND H. STRAUBING, Some results on  $\mathcal{C}$ -varieties, *Theoret. Informatics Appl.* **39** (2005), 239–262.
- [79] J.-É. PIN, H. STRAUBING AND D. THÉRIEN, Some results on the generalized star-height problem, *Information and Computation* **101** (1992), 219–250.
- [80] J.-É. PIN AND P. WEIL, Polynomial closure and unambiguous product, in *22th ICALP*, Berlin, 1995, pp. 348–359, *Lect. Notes Comp. Sci.* n° 944, Springer.
- [81] J.-É. PIN AND P. WEIL, Profinite semigroups, Mal'cev products and identities, *J. of Algebra* **182** (1996), 604–626.
- [82] J.-É. PIN AND P. WEIL, A Reiterman theorem for pseudovarieties of finite first-order structures, *Algebra Universalis* **35** (1996), 577–595.
- [83] J.-E. PIN AND P. WEIL, Polynomial closure and unambiguous product, *Theory Comput. Systems* **30** (1997), 1–39.
- [84] J.-É. PIN AND P. WEIL, A conjecture on the concatenation product, *ITA* **35** (2001), 597–618.
- [85] J.-É. PIN AND P. WEIL, Semidirect products of ordered semigroups, *Communications in Algebra* **30** (2002), 149–169.
- [86] J.-É. PIN AND P. WEIL, The wreath product principle for ordered semigroups, *Communications in Algebra* **30** (2002), 5677–5713.
- [87] N. PIPPENGER, Regular languages and Stone duality, *Theory Comput. Syst.* **30**,2 (1997), 121–134.
- [88] L. POLÁK, Syntactic semiring of a language, in *MFCS 2001*, pp. 611–620, *Lect. Notes Comp. Sci.* vol. 2136, Springer, Berlin, 2001.
- [89] M. O. RABIN AND D. SCOTT, Finite automata and their decision problems, *Rap. Tech.*, IBM J. Res. and Develop., 1959. "Reprinted in *Sequential Machines*, E. F. Moore (ed.), Addison-Wesley, Reading, Massachusetts, (1964), 63–91."
- [90] N. R. REILLY AND S. ZHANG, Decomposition of the lattice of pseudovarieties of finite semigroups induced by bands, *Algebra Universalis* **44**,3-4 (2000), 217–239.
- [91] J. REITERMAN, The Birkhoff theorem for finite algebras, *Algebra Universalis* **14**,1 (1982), 1–10.
- [92] J. SAKAROVITCH, *Éléments de théorie des automates*, Vuibert, 2003.
- [93] A. SALOMAA, *Computation and automata*, *Encyclopedia of Mathematics and its Applications* vol. 25, Cambridge University Press, Cambridge, 1985. With a foreword by Grzegorz Rozenberg.
- [94] M.-P. SCHÜTZENBERGER, On finite monoids having only trivial subgroups, *Information and Control* **8** (1965), 190–194.



- [95] I. SIMON, *Hierarchies of Events with Dot-Depth One*, PhD thesis, University of Waterloo, Waterloo, Ontario, Canada, 1972.
- [96] I. SIMON, Piecewise testable events, in *Proc. 2nd GI Conf.*, H. Brackage (ed.), pp. 214–222, *Lecture Notes in Comp. Sci.* vol. 33, Springer Verlag, Berlin, Heidelberg, New York, 1975.
- [97] I. SIMON, Limited Subsets of a Free Monoid, in *Proc. 19th Annual Symposium on Foundations of Computer Science*, Piscataway, N.J., 1978, pp. 143–150, IEEE.
- [98] I. SIMON, Properties of factorization forests, in *Formal properties of finite automata and applications, Ramatuelle, France, May 23-27, 1988, Proceedings*, pp. 65–72, *Lect. Notes Comp. Sci.* vol. 386, Springer, Berlin, 1989.
- [99] I. SIMON, Factorization forests of finite height, *Theoret. Comput. Sci.* **72**,1 (1990), 65–94.
- [100] I. SIMON, A short proof of the factorization forest theorem, in *Tree automata and languages (Le Touquet, 1990)*, pp. 433–438, *Stud. Comput. Sci. Artificial Intelligence* vol. 10, North-Holland, Amsterdam, 1992.
- [101] M. STONE, The theory of representations for Boolean algebras, *Trans. Amer. Math. Soc.* **40** (1936), 37–111.
- [102] M. H. STONE, Applications of the theory of Boolean rings to general topology, *Trans. Amer. Math. Soc.* **41**,3 (1937), 375–481.
- [103] M. H. STONE, The representation of Boolean algebras, *Bull. Amer. Math. Soc.* **44**,12 (1938), 807–816.
- [104] H. STRAUBING, Aperiodic homomorphisms and the concatenation product of recognizable sets, *J. Pure Appl. Algebra* **15**,3 (1979), 319–327.
- [105] H. STRAUBING, Families of recognizable sets corresponding to certain varieties of finite monoids, *J. Pure Appl. Algebra* **15**,3 (1979), 305–318.
- [106] H. STRAUBING, A generalization of the Schützenberger product of finite monoids, *Theoret. Comput. Sci.* **13**,2 (1981), 137–150.
- [107] H. STRAUBING, Relational morphisms and operations on recognizable sets, *RAIRO Inf. Theor.* **15** (1981), 149–159.
- [108] H. STRAUBING, Finite semigroup varieties of the form  $V * D$ , *J. Pure Appl. Algebra* **36**,1 (1985), 53–94.
- [109] H. STRAUBING, Semigroups and languages of dot-depth two, *Theoret. Comput. Sci.* **58**,1-3 (1988), 361–378. Thirteenth International Colloquium on Automata, Languages and Programming (Rennes, 1986).
- [110] H. STRAUBING, The wreath product and its applications, in *Formal properties of finite automata and applications (Ramatuelle, 1988)*, pp. 15–24, *Lecture Notes in Comput. Sci.* vol. 386, Springer, Berlin, 1989.

- [111] H. STRAUBING, *Finite automata, formal logic, and circuit complexity*, Birkhäuser Boston Inc., Boston, MA, 1994.
- [112] H. STRAUBING, On logical descriptions of regular languages, in *LATIN 2002*, Berlin, 2002, pp. 528–538, *Lect. Notes Comp. Sci.* n° 2286, Springer.
- [113] H. STRAUBING AND D. THÉRIEN, Partially ordered finite monoids and a theorem of I. Simon, *J. Algebra* **119**,2 (1988), 393–399.
- [114] H. STRAUBING AND P. WEIL, On a conjecture concerning dot-depth two languages, *Theoret. Comput. Sci.* **104**,2 (1992), 161–183.
- [115] A. SZILARD, S. YU, K. ZHANG AND J. SHALLIT, Characterizing regular languages with polynomial densities, in *Mathematical foundations of computer science 1992 (Prague, 1992)*, pp. 494–503, *Lect. Notes Comp. Sci.* vol. 629, Springer, Berlin, 1992.
- [116] W. THOMAS, Classifying regular events in symbolic logic, *J. Comput. System Sci.* **25**,3 (1982), 360–376.
- [117] A. THUE, Über unendliche Zeichenreihen, *Norske Vid. Selsk. Skr. I Math-Nat. Kl.* **7** (1906), 1–22.
- [118] A. THUE, Über die gegenseitige Loge gleicher Teile gewisser Zeichenreihen, *Norske Vid. Selsk. Skr. I Math-Nat. Kl. Chris.* **1** (1912), 1–67.
- [119] B. TILSON, On the complexity of finite semigroups, *J. Pure Appl. Algebra* **5** (1974), 187–208.
- [120] P. WEIL, Profinite methods in semigroup theory, *Int. J. Alg. Comput.* **12** (2002), 137–178.
- [121] TH. WILKE, Classifying discrete Temporal Properties, in *STACS'99*, C. Meinel (ed.), Trier, Germany, 1999, pp. 32–46, *Lecture Notes in Comput. Sci.* vol. 1563, Springer.
- [122] S. YU, Regular languages, in *Handbook of language theory*, G. Rozenberg and A. Salomaa (eds.), vol. 1, ch. 2, pp. 679–746, Springer, 1997.

# Index of Notation

$2^E$ , 1	$r\mathbf{1}$ , 145
$B_2^1$ , 16	$\tilde{U}_n$ , 16
$E$ , 12	$\mathbf{1}$ , 169
$X^c$ , 1	
$\mathbf{A}$ , 149	
$\mathbf{D}$ , 145	
$\mathbb{D}\mathbf{A}$ , 152	
$\mathbb{D}\mathbf{S}$ , 150	
$\mathbf{G}$ , 148	
$\mathbf{Gcom}$ , 148	
$\mathbf{G}_p$ , 148	
$\mathbf{K}$ , 145	
$\mathbb{L}\mathbf{G}$ , 147	
$\mathbb{L}\mathbf{1}$ , 147	
$\mathbf{L}_1$ , 150	
$\mathbf{N}$ , 144	
$\mathbf{N}^-$ , 153	
$\mathbf{N}^+$ , 153	
$\mathbf{R}_1$ , 150	
$\mathbf{J}$ , 149	
$\mathbf{J}^-$ , 153	
$\mathbf{J}^+$ , 153	
$\mathbf{J}_1$ , 149	
$\mathbf{J}_1^-$ , 153	
$\mathbf{J}_1^+$ , 153	
$\mathbf{L}$ , 149	
$\mathbf{R}$ , 149	
$\bar{n}$ , 26	
$\mathcal{D}$ , 98	
$\mathcal{H}$ , 96	
$\mathcal{J}$ , 96	
$\mathcal{L}$ , 96	
$\mathcal{P}(E)$ , 1	
$\mathcal{P}(M)$ , 17	
$\mathcal{R}$ , 96	
$\widehat{A^*}$ , 130	
$\ell\mathbf{1}$ , 145	
$\leq_{\mathcal{J}}$ , 95	
$\leq_{\mathcal{L}}$ , 95	
$\leq_{\mathcal{R}}$ , 95	

# Index

- action, 25
  - faithful, 25
- addition, 11
- alphabet, 28
- aperiodic, 148, 149
- assignment, 260
- associative, 11
- automata
  - equivalent, 41
- automaton, 40
  - complete, 45
  - deterministic, 43
  - extended, 65
  - extensive, 174
  - flower, 228
  - local, 58
  - minimal, 54
  - minimal complete, 54
  - Nerode, 53
  - standard, 46
- $B_2^1$ , 16
- band
  - rectangular, 111
- basis for a topology, 126
- Boolean operations, 1, 36
  - positive, 1
- bounded occurrence, 259
- cancellative, 13
  - semigroup, 13
- Cauchy sequence, 127
- Cayley graph, 27
- class
  - of recognisable languages, 161
- closure, 125
- cofinite, 176
- colouring, 31
- commutative, 11
- compact, 127
- completion, 127
- composition, 2
- concatenation, 28
- congruence, 90
  - generated by, 23
  - nuclear, 23
  - ordered monoid, 25
  - Rees, 22
  - semigroup, 22
  - syntactic, 23, 86, 91
- conjugate, 104
- content, 202
- continuous, 126
- cover, 27
- $\mathcal{D}$ -class, 98
  - full, 113
- decidable, 67
- dense, 125
- disjunctive normal form, 261
- division, 19
  - of transformation semigroups, 27
- domain, 2, 260, 263
- existential, 262
- exponent, 31
- extensive, 208
- factor, 35
  - left, 36
  - right, 36
- factorisation
  - canonical, 218
- factorisation forest, 32
- finitely generated, 75
- fixpoint-free, 26
- formula
  - atomic, 258
  - second-order, 259

- first-order, 258
  - logically equivalent, 261
  - second-order, 259
- free
  - monoid, 28
  - occurrence, 259
  - profinite monoid, 130
  - semigroup, 28
- fully recognising, 75
- function, 2
  - bijective, 3
  - injective, 3
  - inverse, 4
  - surjective, 3
  - total, 2
- graph
  - of a relational morphism, 217
- Green's lemma, 100
- group, 13
  - generated by, 27
  - in a semigroup, 18
  - right, 124
  - structure, 107
  - symmetric, 26
- $\mathcal{H}$ -class, 96
- Hausdorff, 126
- hierarchy
  - logical, 271
- homeomorphism, 126
  - uniform, 127
- ideal, 20
  - 0-minimal, 21
  - generated by, 21
  - left, 20
  - minimal, 21
  - principal, 21
  - right, 20
  - shuffle, 205
- idempotent, 12
- identity, 11, 155
  - element, 11
  - explicit, 141
  - left, 12
  - partial, 219
  - right, 12
- image, 3
- index, 30
- injective
  - relational morphism, 219
- inverse, 13, 14, 103
  - group, 13
  - of a relation, 1
  - semigroup, 13
  - weak, 103
- isometry, 127
- isomorphic, 18
- isomorphism, 18
- $\mathcal{J}$ -class, 96
- $\mathcal{J}$ -trivial, 106
- $\mathcal{L}$ -class, 96
- $\mathcal{L}$ -trivial, 106
- label, 41
- language, 35, 36
  - local, 56
  - of the linear order, 264
  - of the successor, 264
  - piecewise testable, 206
  - recognisable, 41
  - recognised, 41
  - simple, 205
- lattice of languages
  - closed under quotients, 160
- length, 28
- letters, 28
- lifted, 116
- limit, 126
- linear
  - expression, 59
- local
  - automaton, 58
  - language, 56
- locally, 239
  - group, 147
  - trivial, 145, 239
- locally  $\mathbf{V}$ , 155
- locally finite
  - variety, 141, 169
- logic
  - first-order, 257
  - monadic
    - second-order, 259
    - weak, 261
  - second-order, 259
- logical symbol, 257
- mapping, 2

- metric, 126
- model, 264
- monogenic, 27
- monoid, 11
  - bicyclic, 16
  - free, 28
  - free pro- $\mathbf{V}$ , 139
  - generated by, 27
  - inverse, 124
  - separates, 138
  - syntactic, 86, 91
  - transition, 84
- morphism
  - fully recognising, 75
  - group, 17
  - length-decreasing, 162
  - length-multiplying, 162
  - length-preserving, 162
  - monoid, 17
  - non-erasing, 162
  - of ordered monoids, 17
  - recognising, 75
  - semigroup, 17
  - semiring, 18
- multiplication, 11
  
- Nerode equivalence, 55
- normal, 240
- null
  - $\mathcal{D}$ -class, 105
  - semigroup, 12
  
- occurrence, 28
- $\omega$ -term, 134
- open
  - $\varepsilon$ -ball, 126
- operation
  - binary, 11
- order, 8
  - natural, 97
  - partial, 8
  - prefix, 36
  - shortlex, 36
- order preserving, 208
- ordered automaton, 89
- Ordered monoids, 14
  
- path, 41
  - accepting, 41
  - end, 41
  - final, 41
  - initial, 41
  - length, 41
  - origin, 41
  - successful, 41
- period, 30
- permutation, 25
- plus, 73
- positive
  - stream, 161
  - variety, 163
- positive +-variety, 167
- precompact, 128
- prefix, 36
- prenex normal form, 262
- preorder
  - generated by a set, 8
- presentation, 29
- product, 1, 11, 20, 28, 37
  - of ideals, 21
  - of transformation semigroups, 26
  - unambiguous, 226
- profinite
  - identity, 141
  - monoid, 130
- profinite  $\mathcal{C}$ -identity, 163
- profinite identity, 161, 163, 164
- pumping lemma, 42
- pure, 227
  
- quantifier, 257
- quotient, 19
  - left, 37, 78
  
- $\mathcal{R}$ -class, 96
- $\mathcal{R}$ -trivial, 106
- range, 3
- rank, 34, 118
- rational, 39
- rational expression, 39
  - linear, 59
  - value, 40
- recognisable, 78
- refinement, 125
- regular, 39, 105
  - $\mathcal{D}$ -class, 105
  - semigroup, 105
- relation, 1
  - antisymmetric, 8

- coarser, 8
- equivalence, 8
- injective, 4
- preorder, 8
- reflexive, 8
- surjective, 4
- symmetric, 8
- thinner, 8
- transitive, 8
- universal, 8
- relational morphism, 217
  - aperiodic, 220
  - locally trivial, 220
- reversal, 35
- ring, 14
- sandwich matrix, 107
- saturate, 76
- semigroup, 11
  - 0-simple, 22
  - $A$ -generated, 27
  - Brandt, 107
    - aperiodic, 108
  - commutative, 11
  - compact, 128
  - dual, 11, 14
  - free, 28
  - generated by, 27
  - left 0-simple, 22
  - left simple, 22
  - left zero, 15
  - local, 34
  - $\bar{n}$ , 26
  - negative nilpotent, 153
  - nilpotent, 144
  - order, 11
  - ordered, 14
  - positive nilpotent, 153
  - Rees
    - with zero, 107
  - Rees matrix, 107
  - right 0-simple, 22
  - right simple, 22
  - simple, 22
  - syntactic, 23
  - topological, 128
  - transformation, 25
- semilattice, 149
- semilinear, 74
- semiring, 14
  - Boolean, 17
- sentence, 259
- set
  - closed, 125
  - open, 125
- shuffle, 70
- Simplification lemma, 12
- singleton, 1
- size, 1
- soluble, 240
- space
  - complete, 127
  - metric, 126
  - topological, 125
- star, 37, 73
- star-free, 195
- state
  - final, 40
  - initial, 40
- states, 40
- stream, 161
- structure, 260
- subgroup, 18
- submonoid, 18
- subsemigroup, 18
- subword, 68, 201
- suffix, 36
- sum, 11
- superword, 201
- supremum, 138
- syntactic
  - congruence, 86
  - image, 86
  - monoid, 86
  - morphism, 86
- syntactic order, 91
- term, 257
- topology, 125
  - coarser, 125
  - discrete, 125
  - product, 126
  - relative, 125
  - stronger, 125
  - trivial, 125
- transformation, 25
  - partial, 25
- transformation semigroup
  - fixpoint-free, 26
  - full, 26

- sequential transducer, 249
- transition
  - function, 81
- transitions, 40
  - consecutive, 41
- transversal, 119
- trim, 46
- trivial
  - lefty (righty), 145
- $U_1$ , 16
- $U_1^+$ , 16
- $U_1^-$ , 16
- $U_n$ , 16
- $\tilde{U}_n$ , 16
- unambiguous star-free, 231
- uniformly continuous, 127
- unit, 11
- unitriangular, 208
- universal counterexample, 15
- upper set, 9
- V**-morphism
  - relational, 220
- valuation, 260
  - second-order, 261
- variable
  - first-order, 259
  - second-order, 259
  - set, 259
- variety, 163
  - +variety, 167
  - Birkhoff, 154
  - generated, 138
  - locally finite, 141, 169
  - of semigroups, 137
  - positive, 163
- word, 28
  - accepted, 41
  - conjugate, 68
  - empty, 28
  - marked, 267
- zero, 12
  - left, 12
  - right, 12