

Making Everything Easier!™

2nd Edition

Music Theory

FOR
DUMMIES®

Learn to:

- Compose, deconstruct, and comprehend music
- Play with musical forms and genres

Michael Pilhofer, MM

Masters of Music in Music Education

Holly Day

Internationally published music writer



Get More and Do More at Dummies.com®



Start with **FREE** Cheat Sheets

Cheat Sheets include

- Checklists
- Charts
- Common Instructions
- And Other Good Stuff!

To access the Cheat Sheet created specifically for this book, go to
www.dummies.com/cheatsheet/musictheory

Get Smart at Dummies.com

Dummies.com makes your life easier with 1,000s of answers on everything from removing wallpaper to using the latest version of Windows.

Check out our

- Videos
- Illustrated Articles
- Step-by-Step Instructions

Plus, each month you can win valuable prizes by entering our Dummies.com sweepstakes.*

Want a weekly dose of Dummies? Sign up for Newsletters on

- Digital Photography
- Microsoft Windows & Office
- Personal Finance & Investing
- Health & Wellness
- Computing, iPods & Cell Phones
- eBay
- Internet
- Food, Home & Garden

Find out "HOW" at Dummies.com

*Sweepstakes not currently available in all countries; visit Dummies.com for official rules.



Music Theory

FOR

DUMMIES®

2ND EDITION

Music Theory

FOR

DUMMIES®

2ND EDITION

by Michael Pilhofer and Holly Day



WILEY

John Wiley & Sons, Inc.

Music Theory For Dummies® 2nd Edition

Published by
John Wiley & Sons, Inc.
111 River St.
Hoboken, NJ 07030-5774
www.wiley.com

Copyright © 2012 by John Wiley & Sons, Inc., Hoboken, New Jersey

Published simultaneously in Canada

No part of this publication may be reproduced, stored in a retrieval system or transmitted in any form or by any means, electronic, mechanical, photocopying, recording, scanning or otherwise, except as permitted under Sections 107 or 108 of the 1976 United States Copyright Act, without the prior written permission of the Publisher. Requests to the Publisher for permission should be addressed to the Permissions Department, John Wiley & Sons, Inc., 111 River Street, Hoboken, NJ 07030, (201) 748-6011, fax (201) 748-6008, or online at <http://www.wiley.com/go/permissions>.

Trademarks: Wiley, the Wiley logo, For Dummies, the Dummies Man logo, A Reference for the Rest of Us!, The Dummies Way, Dummies Daily, The Fun and Easy Way, Dummies.com, Making Everything Easier, and related trade dress are trademarks or registered trademarks of John Wiley & Sons, Inc., and/or its affiliates in the United States and other countries, and may not be used without written permission. All other trademarks are the property of their respective owners. John Wiley & Sons, Inc., is not associated with any product or vendor mentioned in this book.

LIMIT OF LIABILITY/DISCLAIMER OF WARRANTY: THE PUBLISHER AND THE AUTHOR MAKE NO REPRESENTATIONS OR WARRANTIES WITH RESPECT TO THE ACCURACY OR COMPLETENESS OF THE CONTENTS OF THIS WORK AND SPECIFICALLY DISCLAIM ALL WARRANTIES, INCLUDING WITHOUT LIMITATION WARRANTIES OF FITNESS FOR A PARTICULAR PURPOSE. NO WARRANTY MAY BE CREATED OR EXTENDED BY SALES OR PROMOTIONAL MATERIALS. THE ADVICE AND STRATEGIES CONTAINED HEREIN MAY NOT BE SUITABLE FOR EVERY SITUATION. THIS WORK IS SOLD WITH THE UNDERSTANDING THAT THE PUBLISHER IS NOT ENGAGED IN RENDERING LEGAL, ACCOUNTING, OR OTHER PROFESSIONAL SERVICES. IF PROFESSIONAL ASSISTANCE IS REQUIRED, THE SERVICES OF A COMPETENT PROFESSIONAL PERSON SHOULD BE SOUGHT. NEITHER THE PUBLISHER NOR THE AUTHOR SHALL BE LIABLE FOR DAMAGES ARISING HEREFROM. THE FACT THAT AN ORGANIZATION OR WEBSITE IS REFERRED TO IN THIS WORK AS A CITATION AND/OR A POTENTIAL SOURCE OF FURTHER INFORMATION DOES NOT MEAN THAT THE AUTHOR OR THE PUBLISHER ENDORSES THE INFORMATION THE ORGANIZATION OR WEBSITE MAY PROVIDE OR RECOMMENDATIONS IT MAY MAKE. FURTHER, READERS SHOULD BE AWARE THAT INTERNET WEBSITES LISTED IN THIS WORK MAY HAVE CHANGED OR DISAPPEARED BETWEEN WHEN THIS WORK WAS WRITTEN AND WHEN IT IS READ.

For general information on our other products and services, please contact our Customer Care Department within the U.S. at 877-762-2974, outside the U.S. at 317-572-3993, or fax 317-572-4002.

For technical support, please visit www.wiley.com/techsupport.

Wiley publishes in a variety of print and electronic formats and by print-on-demand. Some material included with standard print versions of this book may not be included in e-books or in print-on-demand. If this book refers to media such as a CD or DVD that is not included in the version you purchased, you may download this material at <http://booksupport.wiley.com>. For more information about Wiley products, visit www.wiley.com.

Library of Congress Control Number: 2011937913

ISBN 978-1-118-09550-8 (pbk); ISBN 978-1-118-16926-1 (ebk); ISBN 978-1-118-16927-8 (ebk); ISBN 978-1-118-16928-5 (ebk)

Manufactured in the United States of America

10 9 8 7 6 5 4 3 2 1



About the Authors

Michael Pilhofer teaches music theory and percussions at McNally Smith College of Music in St. Paul, Minnesota. He has worked as a professional musician for more that 20 years and has toured and recorded with Joe Lovano, Marian McPartland, Kenny Wheeler, Dave Holland, Bill Holman, Wycliffe Gordon, Peter Erskine, and Gene Bertoncini.

Holly Day is a writing instructor at the Open Book Writing Collective in Minneapolis. She has written about music for numerous publications, including *Guitar One*, *Music Alive!*, *Computer Music Journal*, *The Oxford American*, and *Mixdown* magazine. Her previous books include *Music Composition For Dummies*, *Shakira*, *The Insider's Guide to the Twin Cities*, and *Walking Twin Cities*.

Dedication

To Wolfgang and Astrid, with much love.

Authors' Acknowledgments

Special acknowledgement goes to all the musicians and composers who took the time out of their very busy schedules to share their thoughts on writing music with us: Steve Reich, Philip Glass, Irmin Schmidt, Barry Adamson, Jonathan Segel, John Hughes III, Nick Currie, Andrew Bird, Rachel Grimes, Christian Frederickson, Pan Sonic, Mark Mallman, and the late Dr. Robert Moog. A huge thanks to each one of you.

A big thank you also goes to the staff at Wiley: Corbin Collins, our project editor for the first edition, Elizabeth Rea, our project editor for the second edition, acquisitions editor Stacy Kennedy, copy editor Jessica Smith, and technical reviewers Karen Ladd and Kyle Adams. We thank our agent, Matt Wagner, as well.

Special thanks goes to Tom Day for mastering and producing the CD for the book and to rock poster artist Emek for continuing to inspire through his works.

Publisher's Acknowledgments

We're proud of this book; please send us your comments at <http://dummies.custhelp.com>. For other comments, please contact our Customer Care Department within the U.S. at 877-762-2974, outside the U.S. at 317-572-3993, or fax 317-572-4002.

Some of the people who helped bring this book to market include the following:

Acquisitions, Editorial, and Vertical Websites

Project Editor: Elizabeth Rea
(*Previous Edition: Corbin Collins*)

Acquisitions Editor: Stacy Kennedy

Copy Editor: Jessica Smith

Assistant Editor: David Lutton

Editorial Program Coordinator: Joe Niesen

Technical Editors: Kyle Adams, Ph.D.,
Karen Ladd, Ph.D.

Vertical Websites: Rich Graves, Doug Kuhn

Editorial Manager: Michelle Hacker

Editorial Assistant: Alexa Koschier

Cover Photos: © iStockphoto.com/Rubén Hidalgo

Cartoons: Rich Tennant
(www.the5thwave.com)

Composition Services

Project Coordinator: Nikki Gee

Layout and Graphics: Carl Byers

Proofreader: Susan Hobbs

Indexer: Christine Karpeles

Publishing and Editorial for Consumer Dummies

Kathleen Nebenhaus, Vice President and Executive Publisher

Kristin Ferguson-Wagstaffe, Product Development Director

Ensley Eikenburg, Associate Publisher, Travel

Kelly Regan, Editorial Director, Travel

Publishing for Technology Dummies

Andy Cummings, Vice President and Publisher

Composition Services

Debbie Stailey, Director of Composition Services

Contents at a Glance

<i>Introduction</i>	1
<i>Part I: Getting Started with Music Theory</i>	7
Chapter 1: What Is Music Theory, Anyway?.....	9
Chapter 2: Determining What Notes Are Worth	15
Chapter 3: Giving It a Rest	29
Chapter 4: Introducing Time Signatures.....	37
Chapter 5: Playing with Beat	51
<i>Part II: Putting Notes Together</i>	59
Chapter 6: Music Notes (And Where to Find Them).....	61
Chapter 7: Mastering the Major and Minor Scales	79
Chapter 8: Key Signatures and the Circle of Fifths.....	93
Chapter 9: Intervals: The Distance between Pitches.....	109
Chapter 10: Chord Building	133
Chapter 11: Chord Progressions.....	157
<i>Part III: Musical Expression through Form, Tempo, Dynamics, and More</i>	175
Chapter 12: The Building Blocks of Music: Rhythm, Melody, Harmony, and Song Form.....	177
Chapter 13: Relying on Classical Forms.....	189
Chapter 14: Tapping Into Popular Genres and Forms.....	199
Chapter 15: Creating Varied Sound through Tempo and Dynamics	207
Chapter 16: Instrument Tone Color and Acoustics	219
<i>Part IV: The Part of Tens</i>	225
Chapter 17: Ten Frequently Asked Questions about Music Theory	227
Chapter 18: Ten Valuable Music Resources	233
Chapter 19: Ten Music Theorists You Should Know About.....	239
<i>Part V: Appendixes</i>	247
Appendix A: On the CD	249
Appendix B: Chord Chart.....	255
Appendix C: Glossary.....	293
<i>Index</i>	297

Table of Contents

Introduction 1

About This Book	1
Conventions Used in This Book.....	2
What You're Not to Read.....	2
Foolish Assumptions.....	2
How This Book Is Organized	3
Part I: Getting Started with Music Theory	3
Part II: Putting Notes Together	4
Part III: Musical Expression through Form, Tempo, Dynamics, and More	4
Part IV: The Part of Tens.....	4
Part V: Appendixes	4
Icons Used in This Book	5
Where to Go from Here.....	5

Part 1: Getting Started with Music Theory 7

Chapter 1: What Is Music Theory, Anyway? 9

Unearthing the Birth of Music and Theory	10
Putting the Spotlight on Music Theory Fundamentals	11
Understanding the foundation: Notes, rests, and beats	11
Manipulating and combining notes	11
Studying musical form and compositions	12
Seeing How Theory Can Help Your Music.....	13

Chapter 2: Determining What Notes Are Worth 15

Meeting the Beat.....	16
Recognizing Notes and Note Values.....	17
Examining the notes and their components	17
Looking at note values	19
Whole (Semibreve) Notes.....	20
Half (Minim) Notes	21
Quarter (Crotchet) Notes	22
Eighth (Quaver) Notes and Beyond	23
Extending Notes with Dots and Ties	25
Using dots to increase a note's value.....	26
Adding notes together with ties.....	26
Mixing All the Note Values Together	27

Chapter 3: Giving It a Rest	29
Getting to Know the Rests	30
Whole (semibreve) rests	30
Half (minim) rests	31
Quarter (crotchet) rests	32
Eighth (quaver) rests and beyond	33
Extending the Break with Dotted Rests	34
Practicing Beats with Notes and Rests	35
Chapter 4: Introducing Time Signatures	37
Decoding the Time Signature and Measures	37
Keeping It Simple with Simple Time Signatures	39
Using measures to count in simple time	40
Practicing counting beats in simple time	43
Working with Compound Time Signatures	44
Using measures to count in compound time	45
Practicing counting beats in compound time	46
Feeling the Pulse of Asymmetrical Time Signatures	47
Chapter 5: Playing with Beat	51
Creating Stress Patterns and Syncopation	51
Studying the general rule of placing stress	52
Syncopation: Hitting the off-beat	52
Getting a Jump on Pick-Up Notes	54
Irregular Rhythms: Triplets and Duplets	56
Adding interest with triplets	56
Working with duplets	57
Part II: Putting Notes Together	59
Chapter 6: Music Notes (And Where to Find Them)	61
Meeting the Staff, Clefs, and Notes	62
The treble clef	62
The bass clef	63
The grand staff and middle C	64
C clefs: Alto and tenor	65
Identifying Half Steps, Whole Steps, and Accidentals on the Staff	66
Working with half steps	66
Taking whole steps	68
Changing pitch with accidentals	70
Finding the Notes on the Piano and Guitar	73
Looking for notes on the piano	74
Picking out notes on the guitar	74
Using Mnemonics to Help Remember Notes	76

Chapter 7: Mastering the Major and Minor Scales	79
Following Major Scale Patterns	79
Working with major scales on piano and guitar	81
Listening to the major scales	84
Discovering All Minor Scale Patterns Have to Offer	84
Playing natural minor scales on piano and guitar	85
Having fun with harmonic minor scales on piano and guitar	87
Making great music with melodic minor scales on piano and guitar	89
Listening to the minor scales	90
Chapter 8: Key Signatures and the Circle of Fifths	93
Understanding the Circle of Fifths	93
Sharps: Father Charles Goes Down and Ends Battle	95
Flats: Battle Ends And Down Goes Charles's Father	96
Recognizing Major Key Signatures	96
Finding Minor Key Signatures and Relative Minors	98
Reviewing the Key Signatures	98
C major and A natural minor	99
G major and E natural minor	99
D major and B natural minor	100
A major and F sharp natural minor	101
E major and C sharp natural minor	101
B/C flat major and G sharp/A flat natural minor	102
F sharp/G flat major and D sharp/E flat natural minor	103
C sharp major/D flat and A sharp/B flat natural minor	104
A flat major and F natural minor	105
E flat major and C natural minor	106
B flat major and G natural minor	106
F major and D natural minor	107
Chapter 9: Intervals: The Distance between Pitches	109
Breaking Down Harmonic and Melodic Intervals	109
Quantity: Counting lines and spaces	110
Quality: Considering half steps	113
Naming intervals	114
Looking at Unisons, Octaves, Fourths, and Fifths	114
Perfect unisons	114
Augmented unisons	115
Octaves	115
Fourths	116
Fifths	118
Recognizing Seconds, Thirds, Sixths, and Sevenths	119
Seconds	120
Thirds	123
Sixths and sevenths	126

Building Intervals.....	126
Determining quantity	127
Determining quality	127
Showing Major and Perfect Intervals in the C Major Scale	130
Chapter 10: Chord Building.....	133
Creating Triads with Three Pitches	134
Roots, thirds, and fifths.....	134
Major triads	136
Minor triads	138
Augmented triads	139
Diminished triads.....	141
Expanding to Seventh Chords.....	142
Major sevenths.....	143
Minor sevenths.....	144
Dominant sevenths	145
Minor 7 flat 5 chords	145
Diminished sevenths	146
Minor-major sevenths	147
Looking at All the Triads and Sevenths	148
A.....	148
A flat.....	148
B	149
B flat.....	149
C	149
C flat.....	150
C sharp	150
D.....	150
D flat.....	151
E	151
E flat	152
F.....	152
F sharp.....	152
G	153
G flat.....	153
Manipulating Triads through Voicing and Inversion.....	153
Taking a look at open and close voicing.....	153
Identifying inverted chords	154
Chapter 11: Chord Progressions	157
Reviewing Diatonic Chords, Chromatic Chords, and Minor Scale Modes	158
Identifying and Naming Chord Progressions	159
Assigning chord names and numbers.....	159
Looking at chord progressions in major keys.....	160
Checking out chord progressions in minor keys.....	162
Adding a Seventh Chord to a Triad.....	163

Seeing (And Hearing) Chord Progressions in Action..... 165
 Applying Chord Knowledge to Fake Books and Tabs 167
 Modulating to a New Key..... 168
 Reaching a Musical Cadence through Chord Progressions 169
 Authentic cadences 170
 Plagal cadences 171
 Deceptive cadences 173
 Half-cadence 173

Part III: Musical Expression through Form, Tempo, Dynamics, and More..... 175

Chapter 12: The Building Blocks of Music: Rhythm, Melody, Harmony, and Song Form.....177

Establishing Rhythm 178
 Shaping the Melody..... 179
 Complementing the Melody with Harmony 181
 Working with Musical Phrases and Periods..... 182
 Linking Musical Parts to Create Forms..... 184
 One-part form (A) 185
 Binary form (AB)..... 185
 Three-part form..... 186
 Arch form (ABCBA) 187

Chapter 13: Relying on Classical Forms.....189

Counterpoint as a Classical Revelation 189
 Sussing Out the Sonata 190
 Starting with the exposition 190
 Moving on to something new: Development 192
 Taking a rest with recapitulation..... 192
 Rounding Up the Rondo..... 193
 Figuring Out the Fugue..... 194
 Combining Forms into a Symphony 195
 Observing Other Classical Forms 196
 Concerto..... 197
 Duet 197
 Etude..... 197
 Fantasia 197

Chapter 14: Tapping Into Popular Genres and Forms199

Feeling the Blues..... 199
 12-bar blues 200
 8-bar blues 201
 16-bar blues 201
 24-bar blues 202
 32-bar blues ballads and country 202

Having Fun with Rock and Pop	203
Improvising with Jazz.....	205
Chapter 15: Creating Varied Sound through Tempo and Dynamics. . .	207
Taking the Tempo of Music.....	207
Establishing a universal tempo: The minim	208
Keeping steady time with a metronome	209
Translating tempo notation.....	209
Speeding up and slowing down: Changing the tempo	211
Dealing with Dynamics: Loud and Soft	211
Modifying phrases	212
Checking out other dynamic markings	214
Examining the piano pedal dynamics	215
Looking at the articulation markings for other instruments.....	216
Chapter 16: Instrument Tone Color and Acoustics.	219
Delving Into Tone Color	220
Attack: Checking out the beginning sound of a note.....	220
Timbre: Hearing the body of a note	221
Decay: Listening for the final sound of a note.....	222
Building the Band: An Acoustics Lesson	223
 Part IV: The Part of Tens.....	 225
 Chapter 17: Ten Frequently Asked Questions about Music Theory	 227
Why Is Music Theory Important?	227
If I Can Already Play Some Music Without Knowing Music Theory, Why Bother Learning It?	228
Why Is So Much Music Theory Centered on the Piano Keyboard?.....	228
Is There a Quick and Easy Way to Learn to Read Music?	229
How Do I Identify a Key Based on the Key Signature?	229
Can I Transpose a Piece of Music into Another Key?	230
Will Learning Music Theory Hinder My Ability to Improvise?	230
Do I Need to Know Theory if I Just Play Drums?	230
Where Do the 12 Musical Notes Come From?.....	231
How Does Knowing Theory Help Me Memorize a Piece of Music?	231
 Chapter 18: Ten Valuable Music Resources	 233
Dolmetsch Online	233
Open Directory Project.....	234
ClassicalWorks.com	234
Smithsonian Folkways Series	234

The Rough Guide to Classical Music.....	235
The Virgin Directory of World Music.....	235
American Mavericks.....	236
Parallels and Paradoxes: Explorations in Music and Society	236
The Art of Practicing: A Guide to Making Music from the Heart.....	236
The Guitar Chord Bible.....	237
Chapter 19: Ten Music Theorists You Should Know About	239
Pythagoras (582–507 BC).....	239
Boethius (480–524 AD).....	240
Gerbert d’Aurillac/Pope Sylvester II (950–1003)	241
Guido D’Arezzo (990–1040)	242
Nicola Vicentino (1511–1576).....	242
Christiaan Huygens (1629–1695)	243
Arnold Schoenberg (1874–1951).....	243
Harry Partch (1901–1974).....	244
Karlheinz Stockhausen (1928–2007)	244
Robert Moog (1934–2005).....	245
<i>Part V: Appendixes</i>	247
Appendix A: On the CD	249
Track Listing.....	249
Customer Care	253
Appendix B: Chord Chart.	255
Appendix C: Glossary	293
<i>Index</i>.....	297

Introduction

What do you think of when you hear the phrase *music theory*? Does the image of your elementary school music teacher eyeing you from behind the piano pop into your head? Or perhaps you have flashbacks to a later image of fellow college students in theory classes determinedly trying to notate theremin whistles? If either of these ideas is anything close to your own perception of what music theory is, hopefully this book will be a pleasant surprise.

For a lot of self-taught musicians, the idea of theory seems daunting and even a little self-defeating. After all, if you can already read guitar tabs and play some scales, why would you want to muddle what you already know with theory?

Even the most basic music theory training gives you the information you need to expand your range and abilities as a musician. A decent amount of note-reading ability enables you to play a particular type of music, whereas some basic knowledge about chord progressions can help you write your own music.

About This Book

Music Theory For Dummies, 2nd Edition, is designed to teach you everything you need to know to become fluent at knocking out a solid beat, reading musical scores, and learning to anticipate where a song should go, whether you're reading someone else's music or writing your own.

Each chapter is as self-contained as possible. In other words, you don't have to read every single chapter to understand what the next one is talking about. Reading the chapters consecutively does help, though, because knowledge of music builds from simple concepts to complex ones.

We cover a lot of territory in this book, from discovering the basics of note values and time signatures to dissecting lead lines and adding harmony to a melody to studying the standard forms that much of popular and classical music follow. So if you're new to the world of music theory, pace yourself while reading this book. Read it while you're sitting at your piano or with your guitar or whatever instrument you're working with next to you, and stop every couple of pages to practice the information you read. If you were taking a music class, this book would cover several years' worth of information, so if you don't learn everything in one or two months, you should refrain from self-flagellation.

Conventions Used in This Book

For organizational purposes, the following conventions have been used throughout this book:

- ✓ When we introduce you to a new musical term, we put it in *italics*.
- ✓ Keywords or key parts of lists appear in **boldface**.
- ✓ Websites are in `monofont` to help them stand out. Note that some web addresses may break across two lines of text. In such cases, no hyphens were inserted to indicate a break. So if you type exactly what you see — pretending that the line break doesn't exist — you can get to your web destination.

What You're Not to Read

The historical information and musician quotes contained in the sidebars or preceded by the Technical Stuff icon all make for interesting reading; however, if you never learn why the piano is the preferred tool of most composers or who invented the term *minim*, you can still understand everything else in this book. Unless you're being tested on this information — and we promise we won't show up at your door to administer a test — this information is included for entertainment purposes only.

Foolish Assumptions

We assume that if you're reading this book, you love music, you want desperately to understand music and everything about it, and you're a nut for the complicated dance of perfect timing and arrangement of tones. At the very least, we assume that you have a couple of books of sheet music lying around that have been frustrating you, or you have an old piano in the corner of your house that you'd like to mess around with.

This book is written for the following types of musicians (which, frankly, covers the gamut):

- ✓ **The absolute beginner:** We wrote this book with the intent that it would accompany the beginning musician from his very first steps into note reading and tapping out rhythms all the way into his first real attempts at composing music by using the principles of music theory. Beginning musicians should start with Part I at the beginning of the book and just

keep reading until reaching the back cover. The book is organized to follow the lesson plan that college music theory classes offer.

- ✔ **The music student who drifted away:** This book can also be helpful for the musician who took instrument lessons as a child and still remembers how to read sheet music but who was never exposed to the principles of building scales, following basic improvisation, or jamming with other musicians. A lot of folks fall into this camp, and, luckily, if you do, this book is designed to gently ease you back into the joy of playing music. It shows you how to work outside the constraints of playing from a piece of music and truly begin to improvise and even write your own music.
- ✔ **The experienced performer:** This book is also intended for the seasoned musician who already knows how to play music but never got around to working out how to read sheet music beyond the basic fake-book or lead sheet. If this description sounds like you, start with Part I, because it specifically discusses the note values used in sheet music. If you're already familiar with the concepts of eighth notes, quarter notes, and so on, Part II may be a good starting point. In that part of the book, we lay out the entire music staff and match it to both the piano keyboard and the guitar neck for easy reference.

How This Book Is Organized

Music Theory For Dummies, 2nd Edition, is organized into five parts. The first three are each based on a particular aspect of music, and the fourth, the Part of Tens, contains information about fun aspects of music theory that have little or nothing to do with actually playing or writing it. The fifth part provides three appendixes, including a guide on how to listen to the audio tracks, a rundown of chord charts, and a glossary. This organization makes it easy for you to find what you need to know quickly. This is, after all, a reference book, and nobody wants to spend all day thumbing through pages to find one simple technique. You can read about each part in the following sections.

Part I: Getting Started with Music Theory

Without rhythm, music would be one long, unbroken, unwavering note, and dancing to it would be awfully tricky. This part introduces you to music theory beginning with rhythm, the most basic component of any type of music. Being able to keep proper rhythm can make or break a performer or performance. In this part, we discuss the various values of notes and rests

used in written music as well as more advanced concepts like time signatures and beat, including syncopation.

Part II: Putting Notes Together

In this part, we cover basic note reading and some silly mnemonics to help you remember the order of the notes on the grand staff. We go over major and minor scales, key signatures and the use of the all-important Circle of Fifths, interval basics, chord building, and basic chord progressions and musical cadences. We also include tons of audio examples, performed on both piano and guitar.

Part III: Musical Expression through Form, Tempo, Dynamics, and More

In this part, we show you how to put everything you know together in order to start writing your own music. We first show you the basics of musical form, and then we discuss and dissect the structure of various types of classical forms — including fugues and sonatas — and forms used in popular genres of music like the 12-bar blues, 32-bar blues ballads, and forms in rock and pop. We also cover tempo and dynamics as well as tone.

Part IV: The Part of Tens

In this part of the book, we jazz it up a bit and focus on theory outside of playing music. We answer some of the most common questions people have about music theory. We also help you further your musical exploits by listing additional music theory and history books as well as Internet resources. We round off the part by profiling some fascinating music theorists without whom this book, or any other book like it, wouldn't be possible.

Part V: Appendixes

You can find a lot of useful information in the appendixes of this book. Appendix A tells you how to listen to each audio track in the book. Appendix B shows you how to play all the chords from Chapter 10 on both the piano and guitar. Appendix C is a glossary of some common musical terms.

Icons Used in This Book

Icons are handy little graphic images meant to point out particular types of information. You can find the following icons in this book; they're conveniently located along the left-hand margins.



This icon highlights time-saving advice and information that can help you understand key concepts.



When we discuss something that may be problematic or confusing, we use this icon.



This icon flags information that's, well, technical; you can go ahead and skip it if you want to.



When we make a point or offer some information that we feel you should keep with you forever, we toss in this icon.



This icon points out audio tracks that relate to the topic currently being discussed in the book.

Where to Go from Here

If you're a beginning music student or want to start again fresh, plow through Part I. If you're already familiar with the basics of rhythm and want to simply find out how to read notes, head to Part II. If you're a trained musician who wants to know how to improvise and begin to write music, Part III covers the basics of chord progressions, scales, and cadences. You can also check out Part IV, which discusses a variety of musical forms you can start plugging your own musical ideas into.

Relax and have fun with your quest into music theory. Listening to, playing, and writing music are some of the most enjoyable experiences you'll ever have. *Music Theory For Dummies*, 2nd Edition, may have been written by teachers, but we promise, no clock-watching tyrants will show up at your door to see how fast you're making your way through this book! We hope you enjoy reading this book as much as we did writing it. Sit back, read, and then start your own musical adventure.

Part I

Getting Started with Music Theory

The 5th Wave

By Rich Tennant



"Going up the scale."

In this part . . .

This part starts you down the road of understanding what music theory is and how it helps you comprehend music, whether you're playing it, writing it, or just analyzing it. We start by explaining what different notes and rests are worth and then help you read time signatures. The part wraps up with coverage of beat patterns and of how different notes help create varied rhythms in music.

Chapter 1

What Is Music Theory, Anyway?

In This Chapter

- ▶ Checking out a bit of music history
 - ▶ Getting to know the basics of music theory
 - ▶ Finding out how theory can affect your playing
-

One of the most important things to remember about music theory is that music came first. Music existed for thousands of years before theory came along to explain what people were trying to accomplish when pounding on their drums. So don't ever think that you can't be a good musician just because you've never taken a theory class. In fact, if you *are* a good musician, you likely already know a lot of theory. You simply may not know the terminology or technicalities.

The concepts and rules that make up music theory are much like the grammatical rules that govern written language (which also came along after people had successfully discovered how to talk to one another). Just as being able to transcribe language made it possible for people far away to “hear” conversations and stories the way the author intended, being able to transcribe music allows musicians to read and play compositions exactly as the composer intended. Learning to read music is a lot like learning a new language, to the point where a fluent person can “hear” a musical “conversation” when reading a piece of sheet music.

Plenty of people in the world can't read or write, but they can still communicate their thoughts and feelings verbally just fine. In the same way, plenty of intuitive, self-taught musicians have never learned to read or write music and find the whole idea of learning music theory tedious and unnecessary. However, just like the educational leaps that can come with learning to read and write, music theory can help musicians master new techniques, perform unfamiliar styles of music, and develop the confidence they need to try new things.

Unearthing the Birth of Music and Theory

From what historians can tell, by the time the ancient world was beginning to establish itself — approximately 7000 B.C. — musical instruments had already achieved a complexity in design that would be carried all the way into the present. For example, some of the bone flutes found from this time period are still playable, and short performances have been recorded on them for modern listeners to hear.

Similarly, pictographs and funerary ornaments have shown that by 3500 B.C., Egyptians were using harps as well as double-reed clarinets, lyres, and their own version of the flute. By 1500 B.C., the Hittites of northern Syria had modified the traditional Egyptian lute/harp design and invented the first two-stringed guitar, with a long, fretted neck, tuning pegs at the top of the neck, and a hollow soundboard to amplify the sound of the strings being plucked.

A lot of unanswered questions remain about ancient music, such as why so many different cultures came up with so many of the same tonal qualities in their music completely independent of one another. Many theorists have concluded that certain patterns of notes just sound right to listeners, and certain other patterns don't. Music theory, then, very simply, could be defined as a search for how and why music sounds right or wrong. In other words, the purpose of music theory is to explain *why* something sounded the way it did and *how* that sound can be made again.

Many people consider ancient Greece to be the actual birthplace of music theory, because the ancient Greeks started entire schools of philosophy and science built around dissecting every aspect of music that was known then. Even Pythagoras (the triangle guy) got into the act by creating the 12-pitch octave scale similar to the one that musicians and composers still use today (see Chapter 7). He did this via the first Circle of Fifths (see Chapter 8), a device still religiously used by musicians from all walks of life.

Another famous Greek scientist and philosopher, Aristotle, is responsible for many books about music theory. He began a rudimentary form of music notation that remained in use in Greece and subsequent cultures for nearly a thousand years after his death.

In fact, so much music theory groundwork was laid in ancient Greece that substantial changes didn't seem necessary until the European Renaissance nearly 2,000 years later. Neighbors and conquerors of Greece were all more than happy to incorporate Greek math, science, philosophy, art, literature, and music into their own cultures.

Putting the Spotlight on Music Theory Fundamentals

While it would be nice to be one of those people who can sit at any instrument and play beautiful music without any training whatsoever, most folks need some sort of structured instruction, whether from a teacher or from reading a book. In the following sections, we go over the basic information you need to start learning how to read music, play scales, understand key signatures, and build chords.

Understanding the foundation: Notes, rests, and beats

Learning how to read music is essential to a musician, especially one who wants to share his music with other musicians or discover what other musicians are playing. By studying the basic elements, such as time values of each type of written note, musical rests, time signatures, and rhythm, you put yourself on the path to mastering music. All these elements come together to establish a foundation that allows you to read, play, and study music.

Manipulating and combining notes

Reading musical notes on both the treble and bass clef staves as well as finding notes on the piano and guitar — the two most common instruments on which people teach themselves to play — are crucial to making and studying music.

When you can read notes on the staves, you can determine a musical piece's *key signature*, which is a group of symbols that tells you what key that song is written in. You can use the Circle of Fifths to help train yourself to read key signatures on sight by counting the sharps or flats in a time signature. You can read more about key signatures and the Circle of Fifths in Chapter 8.

After you've become familiar with key signatures, you're ready to move on to intervals, chords, and chord progressions, which create the complexity of musical sound — from pleasing and soothing to tense and in need of resolution. As we discuss in Chapter 9, you build scales and chords using one of two types of intervals: melodic and harmonic. Chapters 10 and 11 show you everything you need to know about building chords and chord progression.

Linking the keyboard to music notation

Prior to the Renaissance period, few truly innovative changes occurred in music technology. Stringed instruments, woodwinds, horns, and percussion instruments had been around for thousands of years, and although they had experienced many improvements in design and playing technique, they were essentially the same instruments used by the people of ancient cultures. It wasn't until the 1300s that a brand new musical interface appeared: the keyboard.

With the invention of the keyboard came the beginning of modern musical *notation* — written music. The keyboard-notation link was fostered because of the ease of composing for full orchestras on the keyboard. Also, most newly commissioned work was created for keyboard instruments because of the public's perception of the keyboard as a superior instrument.

Fifteenth-century French composers began adding as many lines as they needed to their

musical staves (see Chapter 9 to find out about the musical staff). They also wrote music with multiple staves to be played simultaneously by different instruments. Because the keyboard has so many notes available, separate staves for left- and right-handed playing began to be used. These staves are the bass clef and the treble clef.

As noted in Chapter 11, keyboards also had the advantage of being incredibly easy to build chords on. By the 17th century, the five-lined staff was considered standard for most musical instrumentation — probably because it was easier and cheaper to print just one kind of sheet music for musicians to compose on. The system hasn't changed much over the past four centuries, and it probably won't change again until a new, more appealing instrument interface enters the scene.

Studying musical form and compositions

Most popular and classical music is composed using specific forms. A *form* is a structural blueprint used to create a certain type of music. The building blocks of form include musical phrases and periods (which we cover in Chapter 12), and rhythm, melody, and harmony enter the picture to create the *genre*, or style, of a piece of music.

When sitting down to write music, you have to choose what form you're going to follow; for example, classical and popular. You can choose from many different classical and popular forms, including sonatas, concertos, 16-bar blues, and verse-chorus form (Chapters 13 and 14 provide plenty of information on the forms you may encounter). You can create varied sound in whatever form you choose by playing with tempo, dynamics, and instrument tone color (see Chapters 15 and 16 for more).

Seeing How Theory Can Help Your Music

If you didn't know better, you may think that music was something that could start on any note, go wherever it wanted, and stop whenever the performer felt like getting up for a glass of iced tea. Although it's true that many folks have been to musical performances that actually do follow this style of "composition," for the most part these performances are confusing and annoyingly self-indulgent and feel a little pointless.

The only people who can pull off a spontaneous jam *well* are those who know music thoroughly enough to stack chords and notes next to one another so they make sense to listeners. And, because music is inherently a form of communication, connecting with your listeners is the goal.

Learning about music theory is also incredibly inspiring. Nothing can describe the feeling you get when the light bulb goes off in your head and you suddenly realize you can put a 12-bar blues progression together and build a really good song out of it. Or when you can look at a piece of classical music and find yourself looking forward to playing through it for the first time. Or the first time you sit down to jam with your friends and find you have the confidence to take the lead.



However, the inescapable fact is this: What you get out of music is what you put into it. If you want to be able to play classical music, you must know how to sight-read and know how to keep a steady beat. If you plan to become a rock guitarist, knowing what notes you need to play in a given key is especially important. Learning to play music takes a lot of personal discipline, but in the end, it's worth all the hard work. Plus, of course, playing music is fun, and knowing how to play music well is incredibly fun. Everybody loves a rock star/jazz man/Mozart.

Chapter 2

Determining What Notes Are Worth

In This Chapter

- ▶ Understanding rhythm, beat, and tempo
 - ▶ Reviewing notes and note values
 - ▶ Counting (and clapping) out different notes
 - ▶ Getting to know ties and dotted notes
 - ▶ Combining note values and counting them out
-

Just about everyone has taken some sort of music lessons, either formal paid lessons from a local piano teacher or at the very least the state-mandated rudimentary music classes offered in public school. Either way, we're sure you've been asked at some point to knock out a beat, if only by clapping your hands.

Maybe the music lesson seemed pretty pointless at the time or served only as a great excuse to bop your grade-school neighbor on the head. However, counting out a beat is exactly where you have to start with music. Without a discernible beat, you have nothing to dance or nod your head to. Although all the other parts of music (pitch, melody, harmony, and so on) are pretty darned important, without beat, you don't really have a song.



Everything around you has a rhythm to it, including you. In music, the *rhythm* is the pattern of regular or irregular pulses. The most basic thing you're striving to find in songs is the rhythm. Luckily, written music makes it easy to interpret other composers' works and produce the kind of rhythm they had in mind for their songs.

In this chapter, we provide you with a solid introduction to the basics of counting notes and discovering a song's rhythm, beat, and tempo.

Note: You may notice in this chapter that we've given two different names for the notes mentioned — for example, quarter (crotchet) note. The first name (quarter) is the common U.S. name for the note, and the second name (crotchet) is the common U.K. name for the same note. The U.K. names are also used in medieval music and in some classical circles. After Chapter 3, we only use the U.S. common names for the notes, because the U.S. usage is more universally standard.

Meeting the Beat

A *beat* is a pulsation that divides time into equal lengths. A ticking clock is a good example. Every minute, the second hand ticks 60 times, and each one of those ticks is a beat. If you speed up or slow down the second hand, you're changing the *tempo* of the beat. *Notes* in music tell you what to play during each of those ticks. In other words, the notes tell you how long and how often to play a certain musical *pitch* — the low or high sound a specific note makes — within the beat.

When you think of the word *note* as associated with music, you may think of a sound. However, in music, one of the main uses for notes is to explain exactly how long a specific pitch should be held by the voice or an instrument. The *note value*, indicated by the size and shape of the note, determines this length. Together with the preceding three features, the note value determines what kind of rhythm the resulting piece of music will have. It determines whether the song will run along very quickly and cheerfully, will crawl along slowly and somberly, or will progress in some other way.

When figuring out how to follow the beat, *rhythm sticks* (fat, cylindrical hard wood instruments) come in real handy. So do drum sticks. If you've got a pair, grab 'em. If you don't, clapping or smacking your hand against bongos or your desktop works just as well.



Eventually “hearing” a beat in your head (or “feeling” a beat in your body) is absolutely fundamental while you play music, whether you're reading a piece of sheet music or jamming with other musicians. The only way you can master this basic task is *practice, practice, practice*. Following along with the beat is something you need to pick up if you want progress in music.



Perhaps the easiest way to practice working with a steady beat is to buy a metronome. They're pretty cheap, and even a crummy one should last you for years. The beauty of a metronome is that you can set it to a wide range of tempos, from very, very slow to hummingbird fast. If you're using a metronome to practice — especially if you're reading from a piece of sheet music — you can set the beat to whatever speed you're comfortable with and gradually speed it up to the composer's intended speed when you've figured out the pacing of the song.

Recognizing Notes and Note Values

If you think of music as a language, then notes are like letters of the alphabet — they're that basic to the construction of a piece of music. Studying how note values fit against each other in a piece of sheet music is as important as knowing musical pitches because if you change the note values, you end up with completely different music. In fact, when musicians talk about performing a piece of music "in the style of" Bach, Beethoven, or Philip Glass, they're talking as much about using the rhythm structure and pace characteristics of that particular composer's music as much as any particular chord progressions or melodic choices.

Examining the notes and their components

Notes are made up of up to three specific components: note head, stem, and flag (see Figure 2-1).

- ✔ **Head:** The *head* is the round part of a note. Every note has one.
- ✔ **Stem:** The *stem* is the vertical line attached to the note head. Eighth (quaver) notes, quarter (crotchet) notes, and half (minim) notes all have stems.
- ✔ **Flag:** The *flag* is the little line that comes off the top or bottom of the note stem. Eighth (quaver) notes and shorter notes have flags.

Figure 2-1:
The whole (semibreve) note has a head; the quarter (crotchet) note has a head and stem; and the eighth (quaver) note has a head, stem, and flag.





Stems can point either up or down, depending where on the *staff* they appear (you find out all about staves in Chapters 4 and 6). Whether the stem points up or down makes no difference in the value of the note.

Instead of each note getting a flag, notes with flags can also be connected to each other with a *beam*, which is just a cleaner-looking incarnation of the flag. For example, Figure 2-2 shows how two eighth (quaver) notes can be written as each having a flag, or as connected by a beam.

Figure 2-2:

You can write eighth (quaver) notes with individual flags, or you can connect them with a beam.

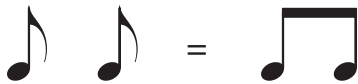

Figure 2-3 shows four sixteenth (semiquaver) notes with flags grouped three separate ways: individually, in two pairs connected by a double beam, and all connected by one double beam. It doesn't matter which way you write them; they sound the same when played.

Figure 2-3:

These three groups of sixteenth (semi-quaver) notes, written in three different ways, all sound alike when played.



Likewise, you can write eight thirty-second (demisemi-quaver) notes in either of the ways shown in Figure 2-4. Notice that these notes get *three* flags (or three beams). Using beams instead of individual flags on notes is simply a case of trying to clean up an otherwise messy-looking piece of musical notation.

Beams help musical performers by allowing them to see where the larger beats are. Instead of seeing sixteen disconnected sixteenth (semiquaver) notes, it's helpful for a performer to see four groups of four sixteenths (semiquavers) connected by a beam.

Figure 2-4:

Like eighth (quaver) notes and sixteenth (semiquaver) notes, you can write thirty-second (demisemi-quaver) notes separately or "beamed" together.



Looking at note values

As you may remember from school or music lessons, each note has its own note *value*. Before we go into detail on each kind of note, have a look at Figure 2-5, which shows most of the kinds of notes you'll encounter in music arranged so their values add up the same in each row. At the top is the whole (semibreve) note, below that half (minim) notes, then quarter (crotchet) notes, eighth (quaver) notes, and finally sixteenth (semiquaver) notes on the bottom. Each level of the "tree of notes" is equal to the others. The value of a half (minim) note, for example, is half of a whole (semibreve) note, and the value of a quarter (crotchet) note is a quarter of a whole (semibreve) note.



Another way to think of notes is to imagine a whole (semibreve) note as a pie, which is easy because it's round. To divvy up the pie into quarter (crotchet) notes, cut it in quarters. Cutting the pie into eight pieces gives you eighth (quaver) notes, and so on.

Depending on the time signature of the piece of music (see Chapter 4), the note value that's equal to one beat changes. In the most common time signature, 4/4 time, also called *common time*, a whole (semibreve) note is held for four beats, a half (minim) note is held for two, and a quarter (crotchet) note lasts one beat. An eighth (quaver) note lasts half a beat, and a sixteenth (semiquaver) note lasts just a quarter of a beat in 4/4 time.

Figure 2-5:
Each level
of this tree
of notes
lasts as
many beats
as every
other level.

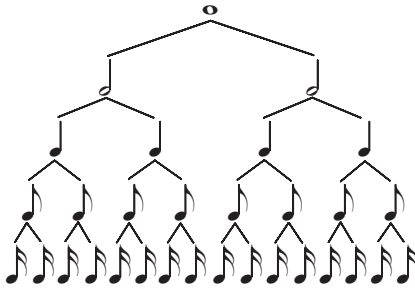

Often, the quarter (crotchet) note equals one beat. If you sing, “MA-RY HAD A LIT-TLE LA-MB,” each syllable is one beat (you can clap along with it), and each beat gets one quarter (crotchet) note if the song is notated in 4/4 time. We talk more about time signatures and counting beats accordingly in Chapter 4.

Whole (Semibreve) Notes

The whole note (called a *semibreve* note in the U.K.) lasts the longest of all the notes. Figure 2-6 shows what it looks like.

Figure 2-6:
A whole
(semibreve)
note is a
hollow oval.



In 4/4 time, a whole (semibreve) note lasts for an entire four beats (see Chapter 4 for more on time signatures). For four whole beats (semibreves), you don’t have to do anything with that one note except play and hold it. That’s it.

Usually, when you count note values, you clap or tap on the note and say aloud the remaining beats. You count the beats of whole (semibreve) notes like the ones shown in Figure 2-7, like this:

CLAP two three four CLAP two three four CLAP two three four

“CLAP” means you clap your hands, and “two three four” is what you say out loud as the note is held for four beats.

Figure 2-7:

When you see three whole (semibreve) notes in a row, each one gets its own “four-count.”



Even better for the worn-out musician is coming across a double whole (breve) note. You don't see them a whole heck of a lot, but when you do, they look like Figure 2-8, and they're generally used in slow-moving processional music or in medieval music. When you see a double whole (breve) note, you have to hold the note for an entire eight counts, like so:

CLAP two three four five six seven eight

Figure 2-8:

Hold a double whole (breve) note for eight counts.



You can also show a note that lasts for eight counts by tying together two whole (semibreve) notes. We discuss *ties* later in this chapter.

Half (Minim) Notes

It's simple logic what comes after whole (semibreve) notes in value — a half (minim) note, of course. You hold a half (minim) note for half as long as you would a whole (semibreve) note. Half (minim) notes look like the notes in Figure 2-9. When you count out the half (minim) notes in Figure 2-9, it sounds like this:

CLAP two CLAP two CLAP two

Because the highest-valued note in Figure 2-9 is a half (minim) note, you only count up to the number two.



Figure 2-9:

Hold a half
(minim)
note for
half as long
as a whole
(semibreve)
note.



You could have a whole (semibreve) note followed by two half (minim) notes, as shown in Figure 2-10. In that case, you count out the three notes as follows:

CLAP two three four CLAP two CLAP two

Figure 2-10:

A whole
(semibreve)
note
followed
by two half
(minim)
notes.



Quarter (Crotchet) Notes

Divide a whole (semibreve) note, which is worth four beats, by four, and you get a quarter (crotchet) note with a note value of one beat. Quarter (crotchet) notes look like half (minim) notes except that the note head is completely filled in, as shown in Figure 2-11. Four quarter (crotchet) notes are counted out like this:

CLAP CLAP CLAP CLAP



Because the highest-valued note is a quarter (crotchet) note, you only count up to one. Four quarter (crotchet) notes together last as long as one whole (semibreve) note.

Figure 2-11:

These four quarter (crotchet) notes get one beat apiece.



Suppose you replace one of the quarter (crotchet) notes with a whole (semibreve) note and one with a half (minim) note, as shown in Figure 2-12. In that case, you count out the notes like this:

CLAP two three four CLAP CLAP CLAP two

Figure 2-12:

A mixture of whole (semibreve), half (minim), and quarter (crotchet) notes is getting closer to what you find in music.



Eighth (Quaver) Notes and Beyond

When sheet music includes eighth (quaver) notes and beyond, it really starts to look a little intimidating. Usually, just one or two clusters of eighth (quaver) notes in a piece of musical notation isn't enough to frighten the average beginning student, but when that same student opens to a page that's littered with eighth (quaver) notes, sixteenth (semiquaver) notes, or thirty-second (semidemi-quaver) notes, she just knows she has some work ahead of her. Why? Because usually these notes are *fast*.

An eighth (quaver) note, shown in Figure 2-13, has a value of half of a quarter (crotchet) note. Eight eighth (quaver) notes last as long as one whole (semibreve) note, which means an eighth (quaver) note lasts half a beat (in 4/4, or common, time).

Figure 2-13:

You hold an eighth (quaver) note for one-eighth as long as a whole (semibreve) note.



How can you have half a beat? Easy. Tap your toe for the beat and clap your hands twice for every toe tap.

CLAP-CLAP CLAP-CLAP CLAP-CLAP CLAP-CLAP

Or you can count it out as follows:

ONE-and TWO-and THREE-and FOUR-and

The numbers represent four beats, and the “ands” are the half beats.

Just think of each tick of a metronome as an eighth (quaver) note instead of a quarter (crotchet) note. That means a quarter (quaver) note is now two ticks, a half (minim) note is four ticks, and a whole (semibreve) note lasts eight ticks.

Similarly, if you have a piece of sheet music with sixteenth (semiquaver) notes, each sixteenth (semiquaver) note can equal one metronome tick, an eighth (quaver) note two ticks, a quarter (crotchet) note four ticks, a half (minim) note eight ticks, and a whole (semibreve) note can equal sixteen ticks.

A sixteenth (semiquaver) note has a note value of one quarter of a quarter (crotchet) note, which means it lasts one-sixteenth as long as a whole (semibreve) note. A sixteenth (semiquaver) note looks like the note in Figure 2-14.

Figure 2-14:

You hold a sixteenth (semi-quaver) note for half as long as an eighth (quaver) note.



If you have a piece of sheet music with thirty-second (demisemi-quaver) notes, as shown in Figure 2-15, remember that a thirty-second (demisemi-quaver) note equals one metronome tick, a sixteenth (semi-quaver) note equals two, an eighth (quaver) note equals four, a quarter (crotchet) note equals eight, a half (minim) note equals sixteen, and a whole (semibreve) note equals thirty-two ticks.

Figure 2-15:

You hold a thirty-second (demisemi-quaver) note for half as long as a sixteenth (semi-quaver) note.



You'll be glad to hear that you won't run into thirty-second (demisemi-quaver) notes very often.

Extending Notes with Dots and Ties

Sometimes you want to add to the value of a note. You have two main ways to extend a note's value in written music: *dots* and *ties*. I explain each in the following sections.

Using dots to increase a note's value

Occasionally, you'll come across a note followed by a small dot, called an *augmentation dot*. This dot indicates that the note's value is increased by one half of its original value. The most common use of the dotted note is when a half (minim) note is made to last three quarter (crotchet) note beats instead of two, as shown in Figure 2-16. Another way to think about dots is that they make a note equal to *three* of the next shorter value instead of two.

Figure 2-16:

You hold a dotted half (dotted minim) note for an additional one-half as long as a regular half (minim) note.

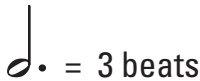

Less common, but still applicable here, is the dotted whole (dotted semi-breve) note. This dotted note means the whole (semibreve) note's value is increased from four beats to six beats.



If you see two dots behind the note — called a *double-dotted note* — increase the time value of the note by another quarter of the original note, on top of the half increase indicated by the first dot. A half (minim) note with two dots behind it is worth two beats plus one beat plus one-half a beat, or three and a half beats. You rarely see this type of notation in modern music. Composer Richard Wagner was very fond of the triple-dotted note in the 1800s.

Adding notes together with ties

Another way to increase the value of a note is by *tying* it to another note, as Figure 2-17 shows. Ties connect notes of the same pitch together to create one sustained note instead of two separate ones. When you see a tie, simply add the notes together. For example, a quarter (crotchet) note tied to another quarter (crotchet) note equals one note held for two beats:

CLAP-two!

Figure 2-17:

Two quarter (crotchet) notes tied together equal a half (minim) note.



Don't confuse ties with *slurs*. A slur looks kind of like a tie, except that it connects two notes of *different* pitches. (You find out more about slurs in Chapter 15.)

Mixing All the Note Values Together

You won't encounter many pieces of music that are composed entirely of one kind of note, so you need to practice working with a variety of note values.

The four exercises shown in Figures 2-18 through 2-21 can help make a beat stick in your head and make each kind of note automatically register its value in your brain. Each exercise contains five groups (or *measures*) of four beats each. The measures are notated with vertical lines, called *barlines*, that are explained more in Chapter 4.

In these exercises, you clap on the CLAPs and say the numbers aloud. Where you see a hyphenated CLAP-CLAP, do two claps per beat (in other words, two claps in the space of one normal clap).



Start out counting and then dive in after you count four.

Exercise 1

CLAP CLAP CLAP CLAP | CLAP two three CLAP | CLAP two three four |
CLAP two three four | CLAP CLAP CLAP four

Figure 2-18:
Exercise 1.

Exercise 2

CLAP two three four | CLAP two three four | CLAP CLAP three CLAP |
 CLAP two CLAP four | CLAP two three four

Figure 2-19:
 Exercise 2.



Exercise 3

CLAP CLAP-CLAP CLAP four | CLAP two three four | CLAP two three
 CLAP | CLAP-CLAP CLAP three four | CLAP two CLAP four

Figure 2-20:
 Exercise 3.



Exercise 4

CLAP two CLAP four | CLAP two three CLAP | CLAP two three four | one
 CLAP three four | CLAP two three four

Figure 2-21:
 Exercise 4.



Chapter 3

Giving It a Rest

In This Chapter

- ▶ Counting out the values of rests
 - ▶ Dotting rests to lengthen their breaks
 - ▶ Mixing up notes and rests
-

Sometimes the most important aspects of a conversation are the things that aren't said. Likewise, many times the notes you *don't* play make all the difference in a piece of music.

These silent “notes” are called, quite fittingly, *rests*. When you see a rest in a piece of music, you don't have to do anything but continue counting out the beats during it. Rests are especially important when writing down your music for other people to read — and in reading other composers' music — because rests make the rhythm of that piece of music even more precise than musical notes alone would.

Rests work particularly well with music for multiple instruments. Rests make it easy for a performer to count out the beats and keep time with the rest of the ensemble, even if the performer's instrument doesn't come into play until later in the performance. Likewise, in piano music, rests tell the left or right hand — or both — to stop playing in a piece.



Don't let the name fool you. A rest in a piece of music is anything but nap time. If you don't continue to steadily count through the rests, just as you do when you're playing notes, your timing will be off and eventually the piece will fall apart.

Note: You may notice in this chapter that we've given two different names for the notes or rests mentioned — for example, quarter (crotchet) rest. The first name (quarter) is the common U.S. name for the rest, and the second name (crotchet) is the common U.K. name for the same rest. The U.K. names are also used in medieval music and in some classical circles. After this chapter, we only use the U.S. names for notes and rests, because the U.S. usage is more globally recognized.

Getting to Know the Rests

Think of rests as the spaces between words in a written sentence. If those spaces weren't there, you'd just be stringing one long word together into gobbledygook.



Musical rests don't get claps (or notes from instruments or voices). You just count them out in your head. Just remember to stop playing your instrument while you're counting.

Figure 3-1 shows the relative values of rests, ranging from a whole (semibreve) rest at the top to the sixteenth (semiquaver) rests at the bottom. At the top is the whole (semibreve) rest, below it half (minim) rests, then quarter (crotchet) rests, eighth (quaver) rests, and sixteenth (semiquaver) rests. We discuss each of these rests in the following sections.

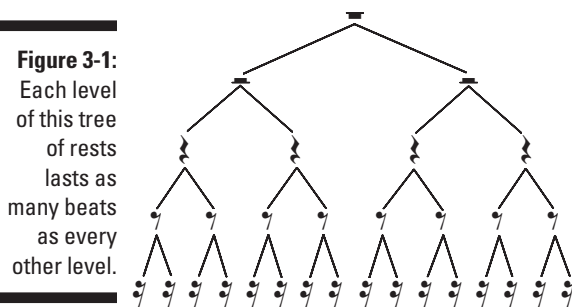

Whole (semibreve) rests

Just like a whole (semibreve) note, a whole (semibreve) rest is worth four beats (in the most common time signature, 4/4; see Chapter 4 for all you need to know about time signatures). Look at Figure 3-2 for an example of a whole (semibreve) rest.



The whole (semibreve) rest looks like an upside-down hat. You can remember what this rest looks like by imagining it's a hat that has been taken off and set down on a table, because this rest is a long one.

Figure 3-2:
A whole
(semibreve)
rest looks
like an
upside-
down hat.

Even better than a double whole (breve) note for the worn-out musician is the very rare double whole (breve) rest, which you can see in Figure 3-3. When you come across one of these, usually in 4/2 music, you don't have to play anything for eight beats.

Figure 3-3:
You'll rarely
encounter
the double
whole
(breve) rest.

Half (minim) rests

If a whole (semibreve) rest is held for four beats, then a half (minim) rest is held for two beats. Half (minim) rests look like the one in Figure 3-4.



As do whole (semibreve) rests, half (minim) rests also look like hats. However, the half (minim) rest is right side up because the wearer didn't have time to lay it down on a table.

Figure 3-4:
The half
(minim) rest
lasts half
as long as
the whole
(semibreve)
rest.

Take a look at the notes and rest in Figure 3-5. If you were to count out this music in 4/4 time, it would sound like this:

CLAP two three four CLAP two REST two

Figure 3-5:

A whole (semibreve) note, half (minim) note, and half (minim) rest.



Quarter (crotchet) rests

Divide a whole (semibreve) rest by four or a half (minim) rest by two, and you get a quarter (crotchet) rest. A quarter (crotchet) rest, shown in Figure 3-6, lasts one-quarter as long as a whole (semibreve) rest.

Figure 3-6:

A quarter (crotchet) rest, written like a kind of squiggle, is like a silent quarter (crotchet) note.



Figure 3-7 shows a whole (semibreve) note and a half (minim) note separated by two quarter (crotchet) rests. You would clap out the music in Figure 3-7 as follows:

CLAP two three four REST REST CLAP two

Figure 3-7:
Two quarter
(crotchet)
rests tucked
between
notes.



Eighth (quaver) rests and beyond

Eighth (quaver) rests, sixteenth (semiquaver) rests, and thirty-second (demisemiquaver) rests are easy to recognize because they all have little curlicue flags, a little bit like their note counterparts, as we explain in Chapter 2. Here's the lowdown on the different numbers of flags each note and rest has:

- ✓ **One flag:** Eighth (quaver) note and eighth (quaver) rest; see Figure 3-8
- ✓ **Two flags:** Sixteenth (semiquaver) note and sixteenth (semiquaver) rest; see Figure 3-9
- ✓ **Three flags:** Thirty-second (demisemiquaver) note and thirty-second (demisemiquaver) rest; see Figure 3-10

Figure 3-8:
An eighth
(quaver)
rest has a
stem and
one curly
flag.



As you may imagine, eighth (quaver) rests can be as tricky to count out as their note equivalents (see Chapter 2 for more on counting notes). An eighth (quaver) rest lasts half as long as a quarter (crotchet) rest, which usually means less than a whole beat. (Chapter 4 addresses time signatures, which affect just how many beats are in a note or rest.) Eight eighth (quaver) rests make up a whole (semibreve) rest.



Using a metronome to count out notes and rests may help you figure out a piece of music. You can assign the ticks of the metronome to be any portion of the beat that you want. Having a quarter (crotchet) note equal one beat may

seem natural much of the time, but instead of trying to think about half beats, you can also assign an eighth (quaver) note to equal one tick. Then a quarter (crotchet) note would equal two ticks, a half (minim) note four, and a whole (semibreve) note eight ticks. The relation among the different notes and rests always stays the same no matter how many metronome ticks in a whole (semibreve) note.

A sixteenth (semiquaver) rest looks like the one in Figure 3-9. It has a note value of one-sixteenth of a whole (semibreve) rest. In other words, sixteen sixteenth (semiquaver) rests make up a whole (semibreve) rest.

Figure 3-9:

A sixteenth
(semi-
quaver) rest
has two
curly flags.



You probably won't ever encounter one, but you still need to be able to recognize a thirty-second (demisemi-quaver) rest. A thirty-second (demisemi-quaver) rest, which is shown in Figure 3-10, has a value of one thirty-second of a whole (semibreve) rest. So thirty-two thirty-second (demisemi-quaver) rests make up a whole (semibreve) rest.

Figure 3-10:

A thirty-
second
(demisemi-
quaver) rest
is very rare
and has
three curly
flags.



Extending the Break with Dotted Rests

Unlike notes, rests are never tied together to make them longer. Rests are, however, sometimes dotted when the value of the rest needs to be extended. Just like with notes, when you see a rest followed by an *augmentation dot*, the rest's value is increased by one half of its original value.

Figure 3-11 shows a dotted half (minim) rest, which you hold for a half (minim) rest plus one half of a half (minim) rest. A dotted quarter (crotchet) rest is extended by another half of a quarter (crotchet) rest.

Figure 3-11:

Hold a dotted half (minim) rest for a half (minim) rest plus one half of a half (minim) rest, making it worth three quarter (crotchet) rests.



Practicing Beats with Notes and Rests

The best way to really hear the way rests affect a piece of music is to mix them up with notes. To avoid adding to the confusion, we use only quarter (crotchet) notes in the following exercises.

The five exercises shown in Figures 3-12 through 3-16 are exactly what you need to practice making a beat stick in your head and making each kind of note and rest automatically register its value in your brain. Each exercise contains three groups of four beats each.



In these exercises, with four beats in every measure (4/4 time), you clap on the notes and count the rests aloud. Start out counting and then dive in after you count four.

Exercise 1

CLAP CLAP CLAP CLAP | One two three four | CLAP two three CLAP

Figure 3-12:
Exercise 1.



Exercise 2

One two three four | CLAP two CLAP four | CLAP two three CLAP

Figure 3-13:
Exercise 2.



Exercise 3

One CLAP three CLAP | One two three four | CLAP two three CLAP

Figure 3-14:
Exercise 3.

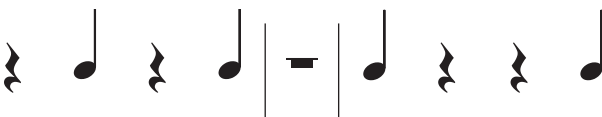

Exercise 4

One two CLAP CLAP | One two three four | CLAP CLAP CLAP four

Figure 3-15:
Exercise 4.



Exercise 5

One two three four | CLAP two three CLAP | One two CLAP CLAP

Figure 3-16:
Exercise 5.



Chapter 4

Introducing Time Signatures

In This Chapter

- ▶ Introducing measures and time signatures
- ▶ Knowing the difference between simple and compound time signatures
- ▶ Finding out about asymmetrical time signatures

If you're worried about how you're supposed to keep track of where you are in a long piece of music, never fear. The geniuses who came up with music notation figured out a way to make order of the onslaught of notes and rests. You just have to become familiar with time signatures and the structure of the musical staff, including the concept of measures (or bars). This chapter explains everything you need to know.

Decoding the Time Signature and Measures

In printed music, right after the clef and the key signature (see Chapter 8 for more about key signatures) at the beginning of the staff, you see a pair of numbers, one written over the other.

The pair of numbers is called the *time signature*, which, incidentally, is the main topic of this chapter. The time signature tells you two things:

- ✓ **The number of beats in each measure:** The top number in the time signature tells you the number of beats to be counted off in each measure. If the top number is three, each measure contains three beats.
- ✓ **Which note gets one beat:** The bottom number in the time signature tells you which type of note value equals one beat — most often, eighth notes and quarter notes. If the bottom number is four, a quarter note is one beat. If it's an eight, an eighth note carries the beat.

Figure 4-1 shows three common time signatures.

Figure 4-1:

Three typical time signatures, which you read as “three-four time,” “four-four time,” and “six-eight time.”

$\frac{3}{4}$ $\frac{4}{4}$ $\frac{6}{8}$



Written music contains the following two main types of time signatures, which we cover later in this chapter:

- ✓ **Simple:** With simple time signatures, the beat of a piece of music can be broken down into two-part rhythms.
- ✓ **Compound:** In compound time signatures, the beat is broken down into three-part rhythms.

A *measure* (sometimes called a *bar*) is a segment of written music contained within two vertical lines. Each measure in a piece of music has as many beats as is allowed by the time signature. For instance, if you’re working with a 4/4 time signature, each measure in that piece of music will contain exactly four beats (as stated by the top number of the time signature) carried by notes or rests. If the time signature is 3/4, each measure will have three beats in it, as shown in Figure 4-2. The one exception to this rule is when the measure uses pick-up notes (see Chapter 5 for more about pick-up notes). With these notes, you put a strong accent on the first beat of each measure, the “1” beat. Musicians call this the *downbeat*.

Figure 4-2:

Given the 3/4 time signature, each measure contains three beats, and the quarter note equals one beat.

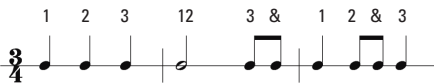



Practicing counting through measures is a great way to make sure you're playing the piece of music in front of you according to the beat chosen by the composer. As we make clear in Chapters 2 and 3, continuously counting beats in your head while you're playing is incredibly important to the resulting sound. Timing is everything in music. You must become so comfortable with the inherent beat of whatever you're playing that you don't even know you're counting beats anymore. (Head to Chapter 2 for more information on beats.)

Keeping It Simple with Simple Time Signatures

Simple time signatures are the easiest to count, because a one-two pulse in a piece of music feels the most natural to a listener and a performer. The following four requirements indicate that a time signature is a simple one:

- ✓ **Each beat is divided into two equal components.** If a single beat has more than one note, those notes are always grouped together to equal one beat. This characteristic is most obvious when it's applied to eighth and smaller notes. In simple time, two eighth notes are always connected together with a bar called a *beam*, as are four sixteenth notes, or eight thirty-second notes. (If you have two sixteenth notes and one eighth note, those three notes, which equal one beat, are also beamed together.) Figure 4-3 shows the progression of how notes are beamed together in simple time.

Figure 4-3:
Each level
of this tree
equals
every other
layer, and
multiple
notes within
a beat are
always
grouped
together to
equal one
beat.



- ✔ **The note that gets one beat has to be an undotted note.** When you're counting a song out in your head, you're only going to be counting undotted notes that are divisible by two. Usually this means you'll be counting quarter notes, but you also may be counting half notes, whole notes, or, sometimes, eighth notes.

In 4/4 time, for example, in your head you'll be counting, "One-two-three-four" over and over again. In 3/4 time, it'll be "one-two-three" over and over again; in 2/4 time, "one-two."

- ✔ **The top number isn't divisible by 3 except when it is 3.** For example, 3/4 and 3/8 are considered simple time signatures, whereas 6/4, 6/8, and 9/16 aren't (because they are divisible by 3; these are compound time signatures).
- ✔ **The number of beats is the same in every measure.** Every measure, or bar, of music in a simple time signature has the same number of beats throughout the song. After you get into the groove of counting out the time, you don't have to worry about doing anything but making sure the notes in the song follow that beat all the way through.

Using measures to count in simple time

Measures (or bars) help performers keep track of where they are in a piece of music and help them play the appropriate beat. In simple time, the measure is where the true rhythm of a piece of music can be felt, even if you're just reading a piece of sheet music without playing it. And keep in mind that in simple time, a slightly stronger accent is placed on the first beat of each measure.

Here are some common examples of simple time signatures:

- ✔ **4/4:** Used in popular, classical, rock, jazz, country, bluegrass, hip-hop, and house music
- ✔ **3/4:** Used for waltzes and country and western ballads
- ✔ **2/4:** Used in polkas and marches
- ✔ **3/8:** Used in waltzes, minuets, and country and western ballads
- ✔ **2/2:** Used in marches and slow-moving processions

Counting 4/4 time

When you see a line of music that has a 4/4 time signature like the one in Figure 4-4, the beat is counted off like this:

ONE two three four ONE two three four ONE two three four

Figure 4-4:

A time signature of 4/4 satisfies the requirements of simple time.

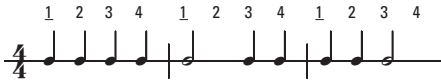

The bottom number 4 in the time signature in Figure 4-4 tells you that the quarter note gets the beat, and the top number 4 tells you that each measure contains four beats, or four quarter notes.



Because 4/4 time is so often used in popular types of music, it's frequently referred to as *common time*. In fact, instead of writing "4/4" for the time signature, some composers just write a large "C" instead.

Counting 3/4 time

If the time signature of a line of music is 3/4, as in Figure 4-5, the beat is counted like this:

ONE two three ONE two three ONE two three

Figure 4-5:

A time signature of 3/4 satisfies the requirements of simple time.

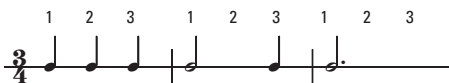

Counting 3/8 time

If the time signature is 3/8, the first note — whatever it may be — gets the beat. In Figure 4-6, that first note is an eighth note.

Figure 4-6:

A time signature of $3/8$ satisfies the requirements of simple time.

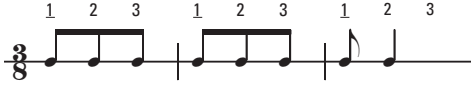

You count out the beat of the music shown in Figure 4-6 like this:

ONE two three ONE two three ONE two three



The time signatures $3/8$ and $3/4$ have almost exactly the same rhythm structure in the way the beat is counted off. However, because $3/8$ uses eighth notes instead of quarter notes, the eighth notes get the beat.

Counting $2/2$ time

If the time signature of a line is $2/2$, also called *cut time*, the half note gets the beat. And because the top number determines that the measure contains two beats, you know that each measure has two half notes, as shown in Figure 4-7.

Figure 4-7:

In $2/2$ time, the half note gets the beat, and each measure contains two beats.

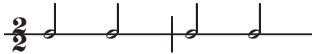

You count the music in Figure 4-7 like this:

ONE two ONE two



Time signatures with a 2 as the lower number were widely used in medieval and pre-medieval music. Music from this period used a rhythm structure, called a *tactus* — later called a *minim* — that was based on the rhythm pattern of a human heartbeat.

Practicing counting beats in simple time

Using the information from earlier in the chapter, practice counting out the *beats* (not the notes) shown in Figures 4-8 through 4-12. When counting these beats out loud, remember to give the first beat a slight stress. For a challenge, try tapping out the notes while you count the beats out loud.

Exercise 1

ONE two three four | ONE two three four | ONE two three four

Figure 4-8:
Exercise 1.



Exercise 2

ONE two three | ONE two three | ONE two three

Figure 4-9:
Exercise 2.

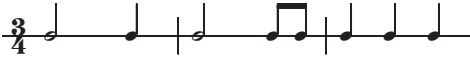

Exercise 3

ONE two three | ONE two three | ONE two three

Figure 4-10:
Exercise 3.

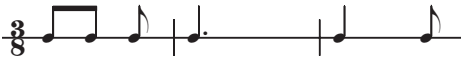

Exercise 4

ONE two three | ONE two three | ONE two three

Figure 4-11:
Exercise 4.

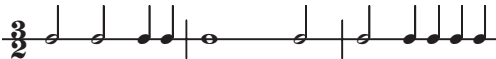

Exercise 5

ONE two | ONE two | ONE two

Figure 4-12:
Exercise 5.



Working with Compound Time Signatures

Just a wee bit trickier than simple time signatures are *compound time signatures*. Here's a short list of rules that help you immediately tell when you're dealing with a compound time signature:

- ✓ **The top number is evenly divisible by 3, with the exception of time signatures where the top number is 3.** Any time signature with a top number of 6, 9, 12, 15, and so on according to the multiples of 3 is a compound time signature. However, 3/4 and 3/8 aren't compound time signatures because the top number is 3 (they're simple time signatures, which I discuss earlier). The most common compound time signatures are 6/8, 9/8, and 12/8. See Figure 4-13 for an example.

Figure 4-13:

A time signature of 6/8 is a compound time signature.



- ✓ **Each beat is divided into three components.** *Three* eighth notes are beamed together, as are *six* sixteenth notes. Figure 4-14 shows the “three-based” grouping of beamed notes used in compound time.

Figure 4-14:

Compound time divides notes into groups of three.

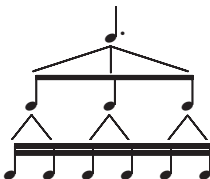

Using measures to count in compound time

One big difference between music in a simple time signature and music in compound time signature is that they *feel* different, both to listen to and to play.



In compound time, an accent is not only placed on the first beat of each measure (as in simple time), but a slightly softer accent is also placed on each successive beat. Therefore, there are two distinctly accented beats in each measure of music with a 6/8 time, three accents in a piece of 9/8 music, and four accents in a piece of music with a 12/8 time signature.

Some examples of compound time signatures are

- ✓ 6/8: Used in mariachi music
- ✓ 12/8: Found in 12-bar blues and doo-wop music
- ✓ 9/4: Used in jazz and progressive rock



To determine the number of accents per measure under a compound time signature, divide the top number by three. Doing so helps you find the pulse in the music you're playing and, therefore, where to put the accents. In a piece of 6/8 music, for example, you would put the accent at the beginning of each measure, but you also would put a slight accent at the beginning of the second group of eighth notes in a measure.

Counting 6/8 time

The beat accents in Figure 4-15 would go like this:

ONE two three FOUR five six ONE two three FOUR five six

Figure 4-15:

In this compound 6/8 time signature, you accent the first and the second sets of three eighth notes.



Counting 9/4 time

If the time signature is something scary, like 9/4, an example of which is shown in Figure 4-16, you would count off the beat like so:

ONE two three FOUR five six SEVEN eight nine

Figure 4-16:

A time signature of 9/4 is a compound time signature.



Practicing counting beats in compound time

Using the information from earlier in this chapter, practice counting out the beats in Figures 4-17 through 4-19. When counting these beats out loud, remember to give the first beat a slight stress and put an additional stress at the pulse points of the measure, which are generally located after every third beat. (The *ands* in the beat patterns are meant to capture the lilt of some of the notes within the beat. We admit this isn't a scientific method, but it should give you a general idea of how to count out beats in different time signatures.)

Exercise 1

ONE two three FOUR-and five six | ONE two three FOUR five six | ONE two three FOUR five six

Figure 4-17:
Exercise 1.



Exercise 2

ONE two three FOUR-and-five-and-six-and | ONE two three FOUR five six | ONE two three FOUR-and-five-and-six-and

Figure 4-18:
Exercise 2.



Exercise 3

ONE two three FOUR five six SEVEN eight nine | ONE two three FOUR-
and-five-and-six-and | SEVEN eight nine

Figure 4-19:
Exercise 3.



Feeling the Pulse of Asymmetrical Time Signatures

Asymmetrical time signatures (also sometimes called *complex* or *irregular* time signatures) generally contain five or seven beats, compared to the traditional two-, three-, and four-beat measure groupings introduced earlier in this chapter. Asymmetrical time signatures are common in traditional music from around the world, including in European folk music and in Eastern (particularly Indian) popular and folk music.



When you play or hear a piece of music with an asymmetrical time signature, you notice that the pulse of the song feels and sounds quite a bit different from music written under simple or compound time signatures (which I discuss earlier in this chapter). Music with 5/4, 5/8, and 5/16 time signatures is usually divided into two pulses — either two beats plus three beats, or vice versa. The stress pattern doesn't have to repeat itself from measure to measure; the only constant is that each measure still contains five beats.

For example, in Figure 4-20, the pulse is defined by the placements of the half notes in each grouping, making the stresses fall on the third beat in the first measure and on the fourth beat in the second measure.

ONE two THREE four five | ONE two three FOUR five

Figure 4-20:

In this example of 5/4 time, the stress is on beats one, three, one, and four.

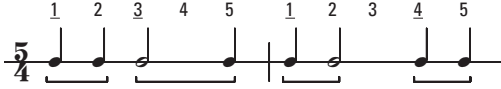

In Figure 4-21, the beaming of the eighth notes shows where the stresses are to occur — on the first eighth note of each set of beamed notes.

ONE two THREE four five | ONE two three FOUR five

Figure 4-21:

In this example of 5/8 time, the stress is on beats one, three, one, and four.

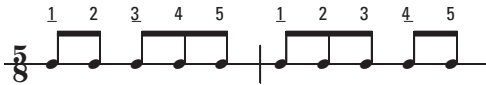

Music with 7/4, 7/8, and 7/16 time signatures looks like the music in Figures 4-22 and 4-23. Again, the stress patterns don't have to stay the same from one measure to the next.

If the time signature were 7/4, as shown in Figure 4-22, you would count off the beat like this:

ONE two three FOUR five six seven | ONE two three four FIVE six seven

Figure 4-22:

In this example of 7/4 time, the stress is on beats one, four, one, and five.

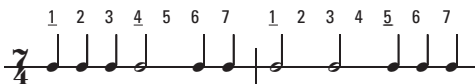

Here's how you count off a time signature of 7/8, as shown in Figure 4-23:

ONE two three FOUR five SIX seven | ONE two THREE four FIVE six seven

Figure 4-23:

In this example of 7/8 time, the stress is on beats one, four, six, one, three, and five.



Asymmetrical time signatures are only considered “complex” from a Western point of view. These irregular time signatures have been used regularly throughout history and around the world, including in ancient Greece and Persia. They also can still be heard in Bulgarian folk music. Modern Western composers and ensembles as diverse as Steve Albini, Beck, Dave Brubeck, June of 44, Andrew Lloyd Webber, Frank Zappa, Pink Floyd, Yo-Yo Ma, Bobby McFerrin, and Stereolab have all used asymmetrical time signatures in their music. A whole genre of rock, called *math rock*, is based on using complex time signatures, such as 7/8, 11/8, 13/8, and so on, in order to break away from the 4/4 time that’s the standard in rock.

Chapter 5

Playing with Beat

In This Chapter

- ▶ Understanding why music sometimes strays from the beat
 - ▶ Making up the difference with pick-up notes
 - ▶ Mixing things up with triplets and duplets
-

The rules of notes and rests may seem strict, but even the most casual listener can recognize that music isn't a force controlled by robotic percussionists and gigantic clicking metronomes. If the world itself were a perfectly ordered organism, with every living thing on it moving along in perfect time, all music might sound similar. However, even the healthiest human heart skips a beat now and then, and so does music.

The trick for composers and music theorists alike has been to translate these skipped beats into written notation, making such deviations fit naturally into the score. This chapter explains everything you need to know about working with a beat.

Creating Stress Patterns and Syncopation

The underlying rhythmic pulse of music is called the *beat*. In some ways, the beat is everything. It determines how people dance to music or even how they feel when they hear it. The beat influences whether people feel excited, agitated, mellow, or relaxed by music. When you're writing a piece of music down on paper, the way you group your notes together in a *measure* (the music contained within two *bar lines*) reflects the kind of beat the music will have. As a musician, you can feel this natural pulse when you play music and count off the beats.

Studying the general rule of placing stress

Generally, the first beat of a measure receives the strongest stress. If more than three beats are in a measure, usually a secondary strong beat comes halfway through the measure. Lots of theories exist about why the brain seems to demand that music be broken up into units of two and three beats (not the least being that the beat of music tends to be similar to the beat of the human heart). But no one has come to a consensus on why music should be broken up into units of two or three beats.

In a piece of music with four beats in each measure, such as a piece in 4/4 time, the first beat in the measure has a strong accent, and the third beat has a slightly less strong accent. The beats would be counted as follows:

ONE two THREE four

A piece of music written in 6/8 time, which has six beats in each measure, is counted as follows:

ONE two three FOUR five six

See Chapter 4 for more on time signatures.

Syncopation: Hitting the off-beat

Syncopation is, very simply, a deliberate disruption of the two- or three-beat stress pattern. Musicians most often create syncopation by stressing an *off-beat*, or a note that isn't on the beat.

In 4/4 time, the general stress pattern is that the first and the third beats are strong, and the second and fourth are weak. Another way to say this is that *downbeats*, or accented beats, such as those at the beginning or halfway through a measure, are strong, and *upbeats*, or unaccented beats, are generally weak.

So if you had a piece of music that looked like the music in Figure 5-1, the quarter rest where the natural downbeat is located is considered the point of syncopation in the music. The fourth beat of the measure is accented instead of the third beat, which is normally accented, creating a different-sounding rhythm than you would normally have in 4/4 time music. The measure would be counted off as ONE-two-three-FOUR.

Figure 5-1:

A measure with syncopation.

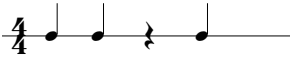

In the figure, the natural stress of the meter has been disrupted. The count ONE-two-(three)-FOUR is weird to your ear because you want to hear that nonexistent quarter note that would carry the downbeat in the middle of the measure.



If you do anything that disrupts the natural beat with either an accent or an upbeat with no subsequent downbeat being played, you have created syncopation.

People often mistake syncopation as being comprised of cool, complex rhythms with lots of sixteenth notes and eighth notes, as often heard in jazz music, but that isn't necessarily true. For example, Figure 5-2 shows a bunch of eighth notes and then a bunch of sixteenth and thirty-second notes.

Figure 5-2:

These measures may look complicated, but they don't show syncopation.



Just because Figure 5-2 shows a dense rhythm doesn't necessarily mean those rhythms are syncopated. As you can see from the accent marks, the downbeat is still on the "one" and "four" count in both measures, which is the normal downbeat.

Even if a piece of music contains an entire measure of eighth notes, it doesn't necessarily have syncopation. Every eighth note has a subsequent *rhythmic resolution*. In other words, the downbeats still occur in the measure where they're supposed to be, on the accented notes shown in the figure. The same is true of a bunch of sixteenth notes in a row. They aren't syncopated because, again, even though you have some interesting notes that aren't on

the downbeat, everything ends up always resolving to the beat of ONE two THREE four, or ONE two three FOUR five six.

Now take a look at the rhythm in Figure 5-3. Inside each box is a point of syncopation in the measures, giving you a rhythm of ONE two three FOUR one TWO three FOUR. The natural stresses have been shifted over in both measures, resulting in a purposefully disjointed-sounding beat.

Figure 5-3:
This music shows two places where the note placement creates syncopation.

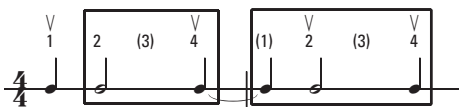

So does syncopation involve a carefully placed rest or an accented note? The answer is both. If your perspective of where the downbeat occurs is moved, a point of syncopation results because it's shifting where the strong and the weak accents are built.



Try counting out the beats while listening to the Rolling Stones' "Satisfaction," and you'll hear some great examples of syncopation.

Getting a Jump on Pick-Up Notes

Up until now, you've had to follow the rule that says 4/4 meter has four beats to every measure. Think of every measure like a jug of water that you have to fill right to the top without spilling over — you can't end up short and you can't spill any over. That's the rule.

But like every good rule, this one has an exception. It's called a *pick-up measure*, which is an odd measure at the beginning of a piece of music, as shown in Figure 5-4. This measure contains *pick-up notes*.

Figure 5-4:
The quarter note standing alone in the first measure is a pick-up note.



The pick-up measure shown in Figure 5-4 has only one beat where three should be (given that the piece is in 3/4 time). From that point on, the song follows the rules set forth by the 3/4 time signature all the way to the very end, where you suddenly come across a measure that looks like the one in Figure 5-5.

Figure 5-5:
The last measure of the song “picked up” the remaining two notes from the first incomplete pick-up measure.



The final measure is the second part of the pick-up measure: The final two beats are considered the remainder part of the first measure. In other words, the last measure “fixes” what looked wrong with that first measure, and therefore you have a piece of music written according to all the rules of music theory.

Like a lot of cases when dealing with music theory, the matter of using pick-up notes is mostly notational. In Figure 5-5, the listener doesn’t necessarily know that the last bar is incomplete unless he or she is listening really carefully. Usually, it’s only the composer that has to worry about the whole business of balancing out the end with the pick-up measure.



In contemporary music, especially rock music, you can still have the first pick-up measure, but you don't necessarily have to adhere to the perfect rule of finishing it in the final measure. Often musicians start a song with a pick-up measure, but their last measure is a complete one.

Irregular Rhythms: Triplets and Duplets

Another way you can add rhythmic interest and variety to music is through the use of irregular rhythms (also called *irrational rhythm* or *artificial division*). An irregular rhythm is any rhythm that involves dividing the beat differently from what's allowed by the time signature. The most common of these divisions is called a *triplet*, which is three notes joined together that equal the beat of a single note. The second most common type of irregular rhythm is a *duplet*, which is two bracketed notes with a note value of three of the same notes.



Irregular note divisions, such as triplets and duplets, allow for more complex rhythms than “regular” notation time normally allows.

Adding interest with triplets

Say you want to put a quick little sequence of three notes where you'd normally play one quarter note. In 4/4 time, if you want to play an even number of notes in your sequence, you can use a couple of eighth notes, or four sixteenth notes, or eight thirty-second notes. But what if you want to play an odd number of notes, and you absolutely want that odd number of notes to equal one beat?

The answer is to play a *triplet*, which is what you get when you have a note that's usually divisible by two equal parts divided into three equal parts. You can see what a quarter note divided into triplets looks like in Figure 5-6.



A good way to count out the beats while playing triplets is to say the number of the beat followed by the word *triplet* (with two syllables), making sure to divide the triplet played into three equal parts.

Figure 5-6:

When a quarter note in 4/4 time is divided into three equal notes, the result is a triplet.

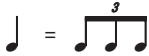

For example, the measures in Figure 5-7 would be counted off like this:

ONE two THREE-trip-let four ONE-trip-let two THREE-trip-let four

Figure 5-7:

A piece of music using both quarter notes and triplets.



You can show the triplet notation in two ways: with the number 3 written over the group of three notes or with a bracket as well as the number. Read triplet notation as meaning “three notes in the time of two.”

Working with duplets

Duplets work like triplets, except in reverse. Composers use duplets when they want to put two notes in a space where they should put three.

An example would be dividing a dotted quarter note into two eighth notes instead of three eighth notes as you would in a measure of music under a compound time signature (see Chapter 4 for more on compound time signatures). A good way to count duplets is to count the second note in each pair

as *and* instead of assigning it a number value as you would any other beat in compound meter.

You count the measures shown in Figure 5-8 like this:

ONE two three FOUR-and ONE-and FOUR five six

Figure 5-8:
Each duplet
gets the
same time
value as the
dotted note
it replaces.



Part II

Putting Notes Together

The 5th Wave

By Rich Tennant



"Nice arrangement, Chelsea, but please stop dotting your half notes with hearts."

In this part . . .

In this part, you begin to read music. You're presented with the grand staff, the treble and bass clefs, and all the note names. You take the plunge into half steps and whole steps, which are the first steps of musical intervals, and you also get to know scales and the building blocks of chords. We guide you through key signatures and the Circle of Fifths, which shows the relationship among the different keys and chords in music. After discussing intervals in detail, this part closes with instruction in identifying and creating chords and chord progressions.

Chapter 6

Music Notes (And Where to Find Them)

In This Chapter

- ▶ Getting to know the staff, clefs, and their notes
 - ▶ Understanding half steps, whole steps, and accidentals
 - ▶ Applying knowledge of the staves to the piano and guitar
 - ▶ Memorizing notes with mnemonics
-

Johannes Gutenberg's invention of the European printing press in 1450 is considered by many to be the official end of the Dark Ages for Europe. Eventually, his invention would make it possible for ordinary people to own books, and along the way, sheet music also began being printed for ordinary musicians to own. Soon, people with a little musical know-how could teach themselves all the principles of music theory previously unavailable to those outside the institutions of religion or higher learning.

As the proficiency of the “common” musician increased, the need for more new sheet music increased as well. After composers learned they could turn a decent profit by selling multiple, machine-printed copies of their music — instead of one laboriously hand-drawn copy at a time — they began flooding the market with new compositions.

This evolution eventually led to the standardization of sheet music. For years, composers were free to use as many or as few staff lines as they wanted to express notation, but by the 1500s, the five-line staff that musicians use today was gradually becoming universally accepted, at least in Europe.

This chapter discusses the musical staves and where to find notes on them as well as the concept of intervals. Mastering these concepts allows you to both navigate your way through a piece of sheet music and even begin to learn how to improvise.

Meeting the Staff, Clefs, and Notes

Notes and rests in music are written on what musicians call a *musical staff* (or staves, if you're talking about two). A staff is made of five parallel horizontal lines, containing four spaces between them, as shown in Figure 6-1.

Notes and rests are written on the lines and spaces of the staff. The particular musical notes that are meant by each line and space depend on which *clef* is written at the beginning of the staff. You may run across any of the following clefs (though the first two are the most common):

- ✓ Treble clef
- ✓ Bass clef
- ✓ C clefs, including alto and tenor



Think of each clef as a graph of *itches*, or *tones*, shown as notes plotted over time on five lines and four spaces. Each pitch or tone is named after one of the first seven letters of the alphabet: A, B, C, D, E, F, G, A, B, C . . . and it keeps on going that way indefinitely, repeating the note names as the pitches repeat in *octaves*. The pitches ascend as you go from A to G, with every eighth note — where you return to your starting letter — signifying the beginning of a new octave.

Figure 6-1:

The two primary staves: the treble clef staff (left) and the bass clef staff (right).

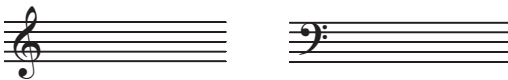

The treble clef

The *treble clef* is for higher-pitched notes. It contains the notes above middle C on the piano, which means all the notes you play with your right hand. On the guitar, the treble clef is usually the only clef you ever read. Most woodwind instruments, high brass instruments, and violins stick solely to the treble clef. Any instrument that makes *upper-register*, or high, sounds has its music written in the treble clef.

The treble clef is also sometimes called the *G clef*. Note that the shape of the treble clef itself resembles a stylized G. The loop on the treble clef also circles the second line on the staff, which is the note G, as shown in Figure 6-2.

The notes are located in the treble clef on lines and spaces, in order of ascending pitch, as shown in Figure 6-3.

Figure 6-2:

The treble clef always tells you that G is on the second staff line.

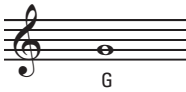

Figure 6-3:

The notes of the treble clef.



The bass clef

On the piano, the *bass clef* contains lower-pitched notes, the ones below middle C, including all the notes you play with your left hand. Music is generally written in the bass clef for lower wind instruments like the bassoon, the lower brass instruments like the tuba, and the lower stringed instruments like the bass guitar.

Another name for the bass clef is the *F clef*. The curly top of the clef partly encircles where the F note is on the staff, and it has two dots that surround the F note, as shown in Figure 6-4. (It also looks a bit like a cursive letter F, if you use your imagination.)

Figure 6-4:

The two dots of the bass clef surround the F note on the staff.

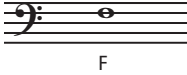

The notes on the bass clef are arranged in ascending order, as shown in Figure 6-5.

Figure 6-5:

The notes of the bass clef.

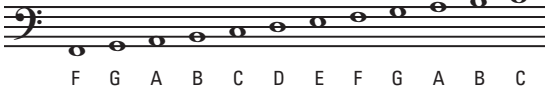

The grand staff and middle C

Put the treble and bass clefs together and you get the *grand staff*, as shown in Figure 6-6.

Figure 6-6:

The grand staff contains both the treble and bass clefs, connected by ledger lines and middle C.

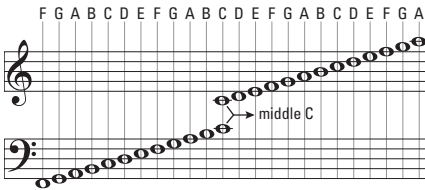



Middle C is located one line below the treble clef and one line above the bass clef. But it's not *in* either clef. Instead it's written on a ledger line. *Ledger lines* are lines written above the bass clef and below the treble clef that are necessary to connect the two clefs. Put it all together, and the notes flow smoothly from one clef to the other with no interruptions.

C clefs: Alto and tenor

Occasionally, you may come across an animal known as the *C* clef. The *C* clef is a moveable clef that you can place on any line of the staff. The line that runs through the center of the *C* clef, no matter which line that is, is considered middle C, as you can see in Figure 6-7.

C clefs are preferred in classical notation for instrumental ranges that hover right above or right below middle C. Instead of having to constantly switch between reading treble and bass clefs, a musician just has one musical staff to read.

C clefs were more commonly used before sheet music was standardized and able to easily accommodate a wide range of tones. Today, the only *C* clefs in common use are

- ✓ **The alto clef:** Puts middle C on the third staff line; most commonly used for writing viola music
- ✓ **The tenor clef:** Puts middle C on the next-to-the-top line of the staff; most commonly used for writing cello, trombone, and bassoon music

Figure 6-7: Notice how moving the position of middle C changes the position of the letter names on the staff.

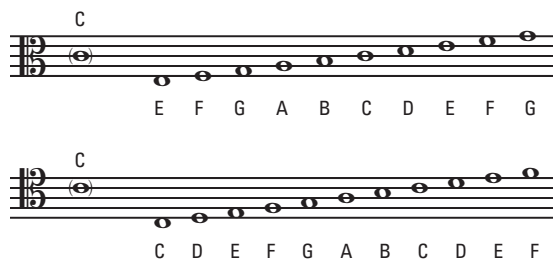

Identifying Half Steps, Whole Steps, and Accidentals on the Staff

In Western music, an octave is broken up into 12 tones called *half steps*, or *semitones*. But a musical *scale* contains seven notes, meaning that some of the distance between notes in a scale spans one semitone and some spans at least two semitones. In other words, some half steps are skipped when building scales. (Check out Chapter 7 for much more on scales.)

When musicians talk about the notes A, B, C, D, E, F, and G, they mean the *natural* notes — specifically, the notes that correspond to the white keys on a keyboard. The white keys of the keyboard were assigned the natural letter notes, which turn out to be the notes of the C major scale, beginning with C. However, because you're dealing with a musical vocabulary made up of 12 semitones, the keyboard also has five black keys, repeated over and over, which represent the semitones that are skipped in the C scale. The black keys were added much later than the original white keys in order to help build more perfect musical scales on the piano.

Moving a whole step on the piano or guitar means you move two half steps from your starting position. Half steps and whole steps are *intervals*, which we discuss in Chapter 9. Knowing the difference between whole steps and half steps is important when working with the patterns used to build scales and chords (covered in Chapters 7 and 10, respectively).

You also employ half steps when you come across an *accidental*, a notation used to raise or lower a natural note pitch. So when a note is *sharped*, you add a half step to the note; when a note is *flatted*, you remove a half step from the note.

Working with half steps

In Western musical notation, the smallest difference between two pitches is the half step, or semitone. Using the piano keyboard as a reference, if you pick a key, play it, and then play the key that's right next to it (on the left or right) whether that key is black or white, you've moved one half step in pitch. See Figure 6-8 for an illustration of this principle.



Strictly speaking, musical pitch is a continuous spectrum, because it's determined by the frequency of vibration (see Chapter 16). Therefore, many other *microtonal* sounds actually exist between consecutive half steps. Western musical notation only recognizes the division of pitch into half steps. In contrast, many Eastern instruments, particularly sitars and fretless stringed instruments, use *quarter tones*. Quarter tones are pitches located halfway between each half step.

As you can see in Figure 6-8, if you start out playing an E on the piano, a half step to the left brings you to E flat/D sharp. A half step to the right lands you on E sharp/F natural.

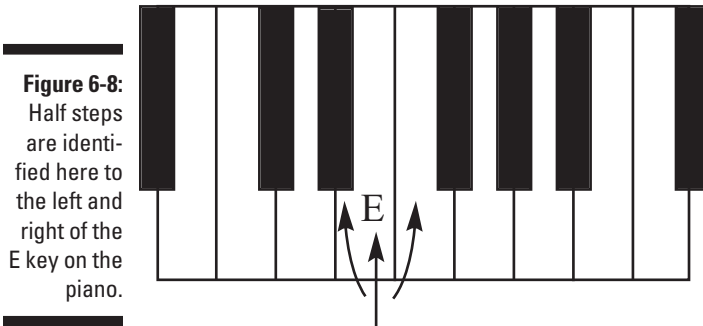

Half steps are even easier and more straightforward on the guitar: Each fret is a half step. You just move one fret up or one fret down from your starting point, and that move of one fret equals one half step. Moving down the neck (toward the headstock of the guitar) flats the note (Figure 6-9), while moving up the neck (toward the body) sharps it (Figure 6-10).

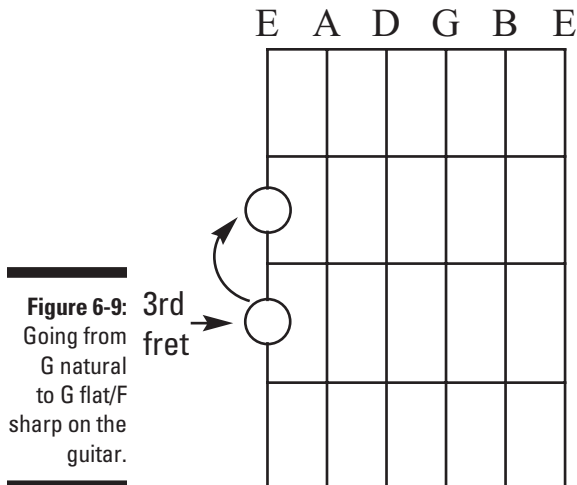

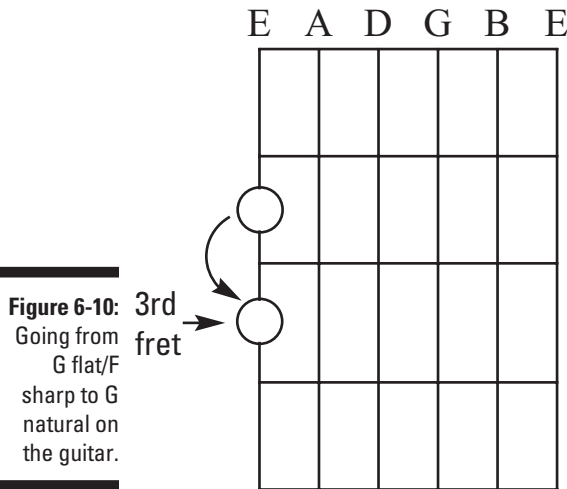

When a musician refers to a note being *flatted*, you know you need to move one half step to the left of that natural note; if it's being *sharped*, you know to move one half step to the right. Every black key on a piano has two names: It can be referred to as the flat of the white key on its right or the sharp of the white key on its left. It doesn't matter which way it's named. For example, while E flat and D sharp are written as different notes, they have the same pitch, or sound. Notes with the same pitch are referred to as *enharmonic*.

Taking whole steps

Following the logic that a half step on the piano or guitar is one key or fret away from the starting point, it only makes sense that a whole step would be two keys or frets away from the starting point.

Say, for example, that you start on E on the keyboard. One whole step to the left of E would be D, as shown in Figure 6-11.

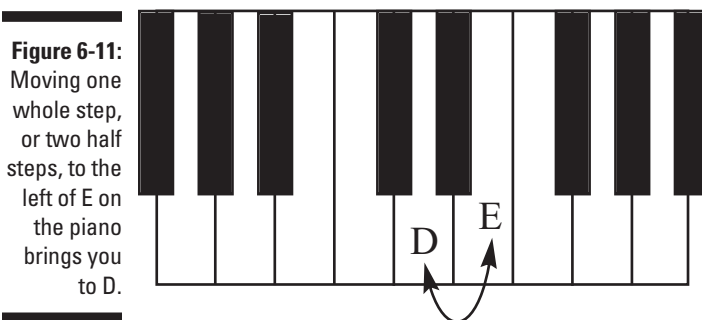

Dr. Robert Moog, inventor, on keyboard alternatives

I think sound generation is a mature technology. Between analog and digital technology, you can make just about any sound you can imagine cheaply and easily. What we don't have cheap and easily yet are really good, new player interfaces — we're still working with the same old electronic organ principle. The same keyboards that were put into electronic organs 60 years ago are being used today, and there is very little difference. They feel the same, and, in fact, the organ keyboards that were developed in 1935 feel better than most keyboards that are designed today. A keyboard is just the starting point, especially if you think of all the ways that people like to move and push and touch when they're playing music. I think the field is wide open for developing really sophisticated, really human-oriented control devices.

But the problem for instrument designers is that people don't want to give up their keyboards.

Millions of people know how to play the piano. It's what there is when you're learning how to play music. If somebody were to start off at the age of 30 or 40 or 50 and learn a new control device, they'd have to practice as much as they did when they were learning how to play the piano when they were kids. It's similar to the Dvorak keyboard, where you can type 20 or 30 percent faster than on a regular Qwerty keyboard. Anybody can do it, but very few people do it because it takes a certain amount of learning when you're an adult. Your mother's not going to teach you how to type on a Dvorak keyboard. Most adults already have plenty to do, and they're not going to relearn how to type. So new alternate controllers are like that, too. Designing them is going to be half the job — the other half is going to be musicians developing technique on those new interfaces. It's going to take decades.

Meanwhile, one whole step to the *right* of E would be F sharp, as shown in Figure 6-12.

Figure 6-12: Moving one whole step, or two half steps, to the right of E on the piano brings you to F sharp.

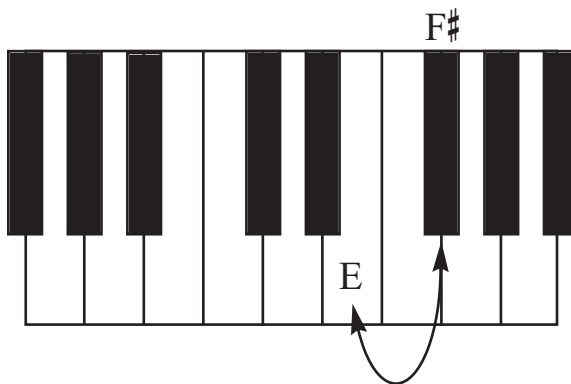

On the guitar, a whole step is represented by a move of two frets up or down the neck.



The distance between the consecutive white piano keys E and F, and B and C, equal a half step, whereas the distance between the remaining white keys (G-A, A-B, C-D, D-E, F-G) is a whole step. That's because the piano is designed around the *C scale*.

Changing pitch with accidentals

Accidentals are notations used to raise or lower a natural note pitch on the staff by a half step. They apply to the note throughout a measure until you see another accidental. You can use these different types of accidentals:

- ✓ Sharps
- ✓ Flats
- ✓ Double sharps
- ✓ Double flats
- ✓ Naturals

Raising pitch with sharps

A *sharp* is shown in Figure 6-13.

Figure 6-13:

A sharp
looks like
a pound,
or number,
sign.



A sharp is placed before a note to indicate that the note is a half step higher, as shown in Figure 6-14.

Figure 6-15 shows a sharped E (the enharmonic of F natural). E sharp is one half step up in pitch from E.

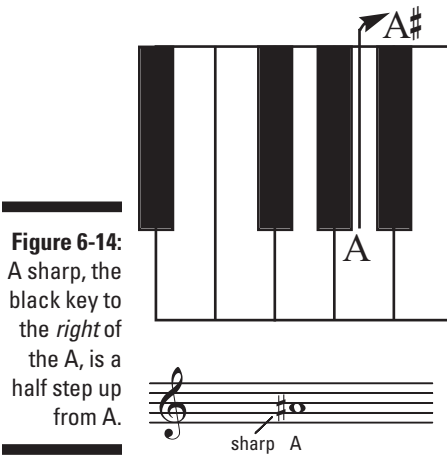

Figure 6-15: E to E sharp.



Using flats to lower pitch

You can see what a *flat* looks like in Figure 6-16.

Figure 6-16: A flat looks a bit like a lowercase *b*.

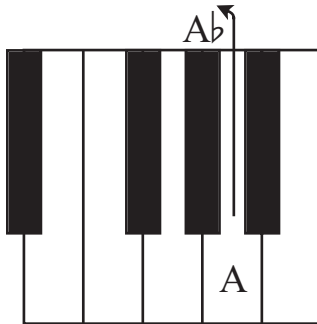

A flat does just the opposite of a sharp: It lowers the note by a half step, as shown in Figure 6-17.

**Figure 6-17:**

A flat, the black key to the *left* of the A, is a half step down from A.



Figure 6-18 shows a flatted E. E flat is one half step down in pitch from E.

Figure 6-18:
E to E flat.

Doubling pitch with double sharps and flats

Every once in a while, you'll run into a *double sharp* or a *double flat*, which are shown in Figure 6-19.

Figure 6-19:

A double sharp looks kind of like an X, whereas a double flat is just two flats in a row.



The notation on the left in Figure 6-19 is a double sharp, and the one on the right is a double flat. The double sharp raises the natural note two half steps — or one whole step — whereas the double flat lowers the note two half steps, or one whole step.

Canceling sharps and flats with naturals

Last but not least is the *natural*, which you can see in Figure 6-20.

Figure 6-20:

A natural cancels out an already established sharp or flat.

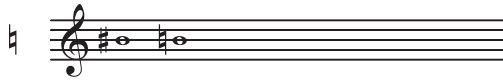

When you see a natural sign next to a note, it means that any sharp or flat that's already in effect (either given in the key signature or in the same measure; see Chapter 8 for information on key signatures) is cancelled for the rest of the measure. In other words, you're supposed to play the "natural" version of the note instead of whatever sharp or flat was in effect, even if it was a double sharp or double flat.

Finding the Notes on the Piano and Guitar

Sometimes you just can't remember which note is which when you're playing a musical instrument, especially when you're a beginner. But don't worry. The figures in this section can be used as a handy reference when you can't quite remember. We focus on the notes on the piano and guitar because those are the two most common instruments musicians pick up on their own when first learning to play music.

Looking for notes on the piano

Figure 6-21 shows a little more than three octaves' worth of the piano keyboard. The corresponding natural notes on the grand staff are labeled on the keyboard. (We discuss the grand staff in more detail earlier in the chapter.)

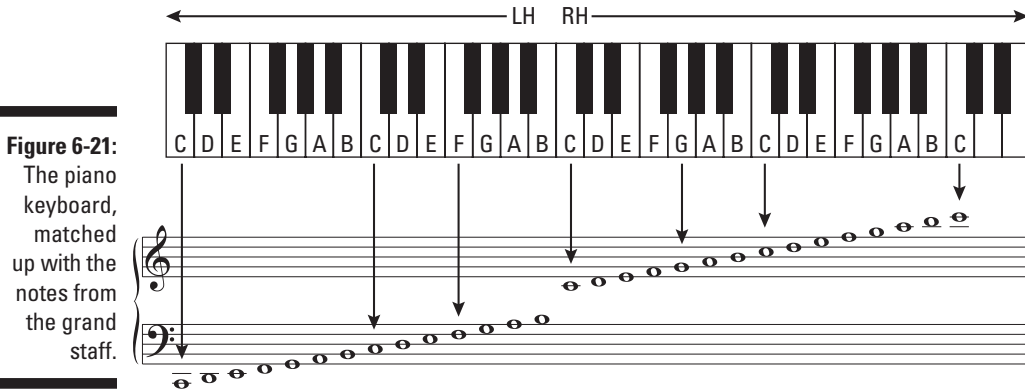

Picking out notes on the guitar

The trouble with laying out the neck of a guitar against musical notation is that notes repeat themselves all along the neck, and it can get confusing with so many options for playing notes in different ways. So we've broken the guitar neck into three nonrepeating sections to correspond along the natural notes on the staff, stopping at the 12th fret (which usually has two dots on it). The 12th fret is also known as the *octave mark*, meaning it's the same note as the string played open, except one octave higher.

Figures 6-22 through 6-24 show the notes of the first three frets of the guitar, then the next five, and then the next four.



Figure 6-22:

The first string position is called *open*, meaning no fret is depressed. The notes of the first three frets of the guitar neck are shown here.

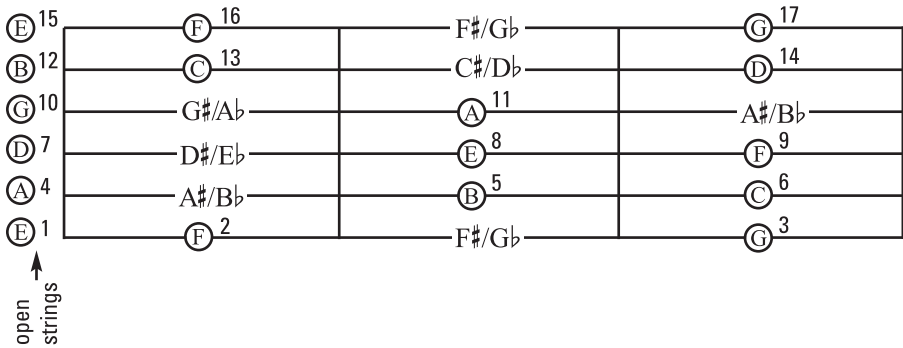
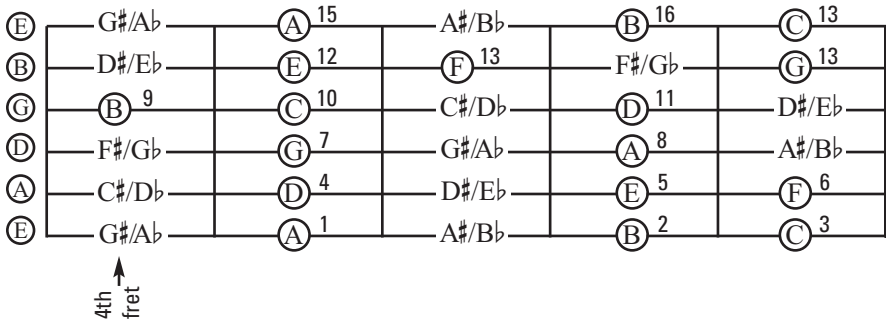

Figure 6-23:

The notes of the 4th through 8th frets.



The figure consists of two parts. At the top is a musical staff in treble clef with a key signature of one sharp (F#). The notes are placed on the staff lines and spaces, corresponding to frets 9 through 16. Below the staff is a fretboard diagram with six strings labeled E, B, G, D, A, E from top to bottom. The frets are numbered 1 through 16. The notes are as follows:

E	C#/D \flat	D	15	D#/E \flat	E	16
B	G#/A \flat	A	12	A#/B \flat	B	13
G	E	F	10	F#/G \flat	G	11
D	B	C	7	C#/D \flat	D	8
A	F#/G \flat	G	4	G#/A \flat	A	5
E	C#/D \flat	D	1	D#/E \flat	E	2

An arrow labeled "9th fret" points to the 9th fret on the D string.

Figure 6-24:
The notes
of the 9th
through 12th
frets.

Using Mnemonics to Help Remember Notes

A zillion silly ways exist to remember the order of the notes along the musical staff. In fact, we probably have enough to build an entire book around. In this section, we provide just a few to get you going. Feel free to come up with your own *mnemonics* (memory helpers) to help keep things straight.

Here are some easy ways to remember the order of the notes of the treble clef staff lines, starting at the first line, on E, and heading up through G, B, D, and F on the top line of the staff:

- ✓ Every Good Boy Deserves Favor
- ✓ Every Good Boy Deserves Fudge
- ✓ Every Good Boy Does Fine
- ✓ Every Good Bird Does Fly

The notes in the spaces between the treble clef staff lines are easy to remember. They spell the word FACE, starting at the first space note, F, and heading up to the E in the top space on the staff. Everybody uses this one, and there's really no reason to try to come up with a complicated phrase when FACE is right there, staring you in the . . .

Here are some mnemonics for the notes on the bass clef staff lines, starting at the bottom note, G, and heading up to the A at the top:

- ✓ **Go Buy Donuts For Al**
- ✓ **Good Boys Do Fine Always**
- ✓ **Great Big Dreams For America**

For the space notes between the bass clef staff lines, just remember any one of the following:

- ✓ **All Cows Eat Grass**
- ✓ **All Cars Eat Gas**
- ✓ **Alley Cats Eat Garbage**

Chapter 7

Mastering the Major and Minor Scales

In This Chapter

- ▶ Understanding major and minor scale patterns
 - ▶ Playing the scales on piano and guitar
 - ▶ Listening to all the major and minor scales
-

To put it simply, a *scale* is any group of consecutive notes that provides the material for part or all of a piece of music. We could write an entire encyclopedia on the different types of scales used in music from around the world, but because this book is primarily concerned with the Western tradition of music, we confine our discussion to the two most frequently used scales: the major and the minor.



It's impossible to overemphasize just how important knowing your scales is to playing music. And it isn't enough to be able to play the scales back and forth and up and down, either. In order to successfully improvise or compose, you need to know how to jump around on your instrument and still land on all the right notes within the scale.

Say you're jamming with a group of musicians. If you know what key the rest of the band is playing in, and you know all the notes that are within that key (scales are determined by keys — you can read a lot more about keys and key signatures in Chapter 8), it's impossible to mess up so long as you stick to those notes. In fact, you can noodle all day in the proper key and sound like a regular Carlos Santana or Louis Armstrong.

Following Major Scale Patterns

Even though every major scale contains a different set of notes, each scale is put together exactly the same way. The specific major-scale pattern of intervals is what makes them *major scales*.



Major scales follow the interval pattern of WWHWWWH, which means **Whole step Whole step Half step Whole step Whole step Half step**. We discuss half steps and whole steps at length in Chapter 6, but here's a quick refresher:

- ✓ **Half step:** Moving one piano key to the left or the right, or one guitar fret up or down.
- ✓ **Whole step:** Moving two piano keys to the left or the right, or two guitar frets up or down.

Pitchwise, a half-step is exactly 1/12 of an octave, or 1 semitone. A whole step is exactly 1/6 of an octave, or 2 semitones.

Each of the eight notes in a major scale is assigned a *scale degree* according to the order it appears in the scale:

- ✓ **1st note:** Tonic
- ✓ **2nd note:** Supertonic
- ✓ **3rd note:** Mediant
- ✓ **4th note:** Subdominant
- ✓ **5th note:** Dominant
- ✓ **6th note:** Submediant
- ✓ **7th note:** Leading tone (or leading note)
- ✓ **8th note:** Tonic

The 1st and 8th notes, the *tonics*, determine the name of the scale. (Scales that share the same starting notes are called *parallel scales*. For example, C major and C minor are parallel scales, because they both start on the same note: C.) Relative to the tonic note, the rest of the notes in the scale are usually attached to the numbers 2 through 7 (because 1 and 8 are already taken by the tonic). Each of these numbers represents a scale degree, and their pattern of whole steps and half steps determine the key of the scale.



The 1st and the 8th notes have the same name here because they're the exact same note — at the 8th note, the scale repeats itself. You won't hear a musician talk about the 8th degree of a scale — instead, she'll refer to the 1st note as the tonic.

So, for example, if you're playing a piece of music in the key of C major, which sequentially has the notes C, D, E, F, G, A, B, and C in it, and someone asks you to play the 4th and 2nd notes in the scales, you play an F and a D. And you do the same thing if that person asks you to play the subdominant and the supertonic.



Mastering scales is all about recognizing patterns on an instrument. If you look at a piano keyboard or the neck of a guitar, can you see where the 1, 2, 3, 4, 5, 6, 7, and 8 of each scale go? If you're given a scale and asked to play the sequence 5-3-2-1-6-4-5-8, do you know what notes you would play? Eventually, you want to be able to answer yes to these questions for all 12 major scales. Here's how:

- ✓ Picture each scale in your head and where it's located on your instrument.
- ✓ Know the letter name and number of each note in each scale.
- ✓ Be able to play sequences of notes when given the key and number.

Only when you can do all three things for the 12 major scales can you stop practicing your scales.



The *major scale*, or the *diatonic scale*, is the most popular scale and the one that's the easiest to recognize when played. Songs like “Happy Birthday” and “Mary Had a Little Lamb” are composed in the major/diatonic scale.

Working with major scales on piano and guitar

If someone were to ask you to play the scale for C major on the piano, you would put it together like the one in Figure 7-1.

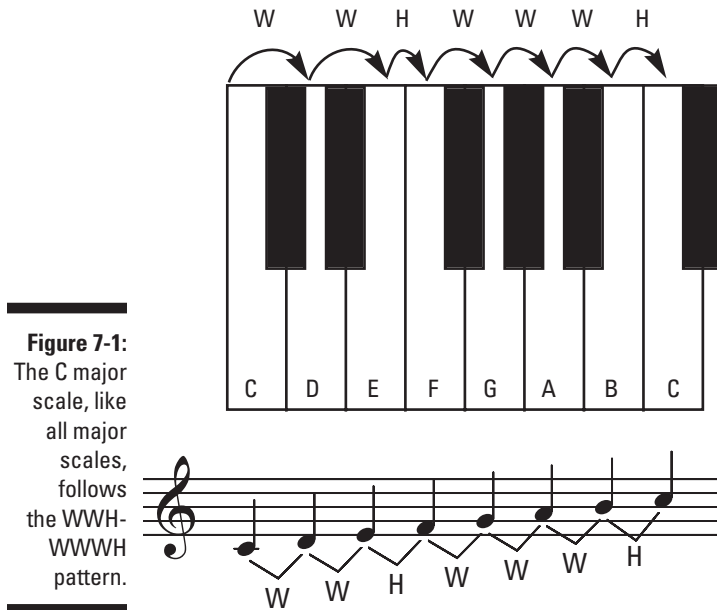

Notice the arrow pointing to the steps in the figure — every single major scale you work with follows this pattern, using different combinations of black and white keys on the piano, depending on the scale.

To play each major scale on the piano, begin with the piano key that is the name of the scale. For the A major scale, for example, you begin with the A. (If you haven't memorized the notes of the piano keyboard, refer to Chapter 6.) Then play the major scale pattern: WWHWWH. The scale ends on the same note it began with, only an octave higher.



To see the major scale for every key, refer to Chapter 8, which illustrates key signatures by showing the scale on the staff for each key. To hear all the major scales, listen to the tracks listed in the upcoming section “Listening to the major scales.”

Playing scales on the guitar is even simpler than playing them on the piano. Guitarists think of the guitar neck as being broken up into blocks of four frets, and, depending on what key you want to play in, your hand is positioned over that block of four frets. Each four-fret block contains two octaves' worth of every pitch within that scale.

Major scales on the guitar follow the pattern shown in Figure 7-2, playing the notes in the number order they appear. **Remember:** The 8th note (tonic) of the first octave serves as the 1st note (tonic) of the second octave.

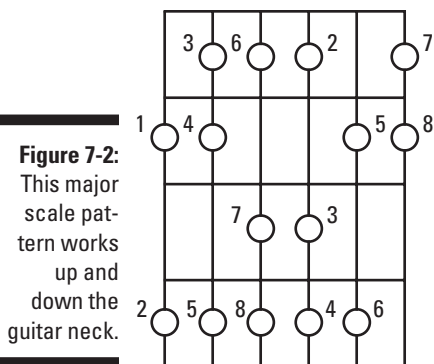

To play each scale on the guitar, begin with the correct fret on the first string (the top string as you hold the guitar, the low E string) to play the E major scale:

- ✓ **Open string:** E
- ✓ **1st fret:** F
- ✓ **2nd fret:** F[#]/G^b
- ✓ **3rd fret:** G
- ✓ **4th fret:** G[#]/A^b
- ✓ **5th fret:** A
- ✓ **6th fret:** A[#]/B^b
- ✓ **7th fret:** B
- ✓ **8th fret:** C
- ✓ **9th fret:** C[#]/D^b
- ✓ **10th fret:** D
- ✓ **11th fret:** D[#]/E^b
- ✓ **12th fret:** E
- ✓ **13th fret:** F

To play major scales on the guitar, you just move that pattern along the neck to build whatever major scale you'd like. You determine the key by the first and last notes of the scale, so if someone asks you to play a C major scale, you simply start the scale on the 8th fret. No black keys or white keys to fool with here — just the same pattern repeated along the neck, over and over. (To see the notes on the frets of a guitar, check out Chapter 6.)



The *actual* pitch of the guitar is one octave (12 half steps) lower than the *written* pitch. This discrepancy occurs simply because most sheet music is written for piano, so the notes would fall below the staff if they were accurately written for guitar. On the piano, the middle octave is the most frequently used and is therefore centered on the grand staff. If composers had to write guitar parts at their actual sounding pitch, they would have to use too many ledger lines and the part would be confusing.

Listening to the major scales



Listen to Tracks 1 through 15 to hear each of the major scales played on the piano and guitar. Note that F sharp and G flat, D flat and C sharp, and B and C flat are all enharmonic scales.

Track	Scale
1	A major
2	A flat major
3	B major
4	B flat major
5	C major
6	C flat major
7	C sharp major
8	D major
9	D flat major
10	E major
11	E flat major
12	F major
13	F sharp major
14	G major
15	G flat major

Discovering All Minor Scale Patterns Have to Offer

When you hear the term *minor scales*, you may be led to believe that this set of scales is much less important than the grand collection of major scales. Or you may think the minor scales are only for sad, sappy songs. But the truth is that the arrangements and tones (or note sounds) available in the minor scales — divided, according to composition, into the natural, harmonic, and melodic minor scales — can be much more flexible for a composer to use than the major scales alone.



Even though every type of minor scale contains a different set of notes, each type of scale is put together in a specific way. These specific patterns of intervals are what put the minor scales into their little niche. The scale degrees in minor all have the same names as the ones in major, except 7, which is called the *subtonic*.

Each of the eight notes in a minor scale has a name:

- ✓ **1st note:** Tonic
- ✓ **2nd note:** Supertonic
- ✓ **3rd note:** Mediant
- ✓ **4th note:** Subdominant
- ✓ **5th note:** Dominant
- ✓ **6th note:** Submediant
- ✓ **7th note:** Subtonic
- ✓ **8th note:** Tonic



In the harmonic and melodic minor scales, the 7th degree is called the *leading tone*. In the melodic minor scale, the 6th degree is called the *submediant*. (You can read more about degrees earlier in the chapter.)

In the following sections, we discuss the natural, harmonic, and melodic minor scales and how to play them on the piano and guitar.

Playing natural minor scales on piano and guitar



Natural minor scales follow the interval pattern of WHWWHWW, which translates into **Whole step Half step Whole step Whole step Half step Whole step Whole step**. The first note (and last) in the scale determines the scale name.

A natural minor scale is taken from the major scale of the same name, but with the 3rd, 6th, and 7th degrees lowered by one half step. So, for instance, if someone asks you to play the scale for A natural minor on the piano, you put it together as shown in Figure 7-3.

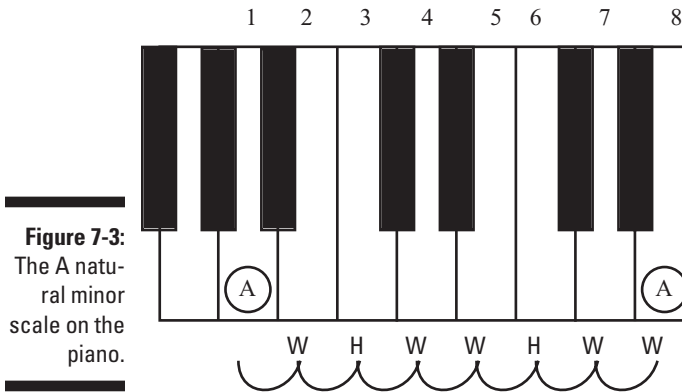

Figure 7-3:
The A natural minor scale on the piano.

The same pattern also applies for each note up and down the guitar neck. Natural minor scales on the guitar follow the pattern shown in Figure 7-4. Play the notes in the number order shown in the figure. Your first note is indicated by the 1 shown on the first E string.

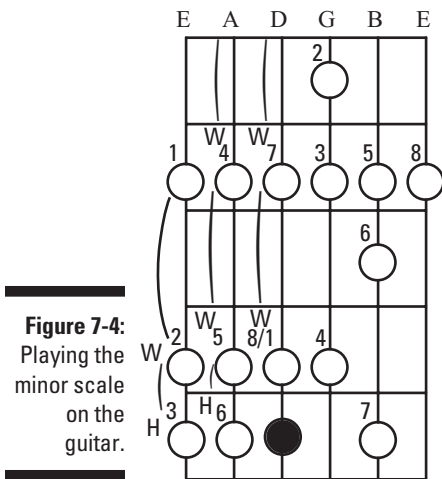

Figure 7-4:
Playing the minor scale on the guitar.

Just as with major scales, to play natural minor scales on the guitar, you simply move the Figure 7-4 pattern along the neck of the guitar to build whatever minor scale you'd like. Whatever note you start with on the top (low E) string is the tonic and therefore names the scale. If someone asks you to play an A minor scale on the guitar, for example, you play the pattern shown in Figure 7-5.

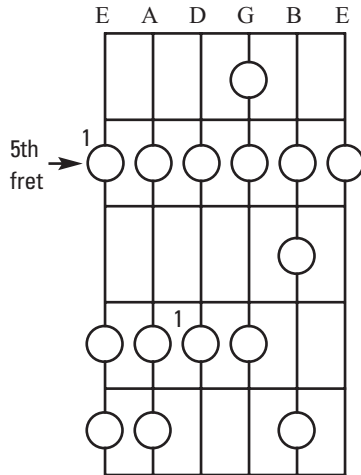

Figure 7-5:
The A natural
minor
scale on the
guitar.

Having fun with harmonic minor scales on piano and guitar

The *harmonic minor scale* is a variation of the natural minor scale (which we discuss in the preceding section). It occurs when the 7th note of the natural minor scale is raised by a half step. The step is *not* raised in the key signature; instead, it's raised through the use of accidentals (sharps, double sharps, or naturals). You can read about accidentals in Chapter 6. This sometimes means that you will mix sharps and flats in the same scale, which is okay.

To play the scale for A harmonic minor on the piano, you put the scale together as shown in Figure 7-6.

Figure 7-6:

Notice how the piano scale changes when you add a half step to the 7th scale degree.

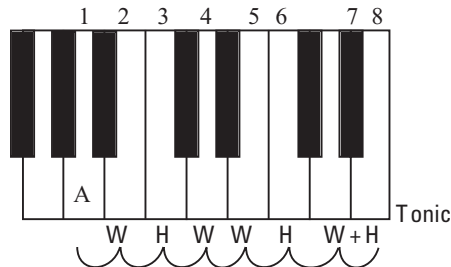



When you're writing music and you want to use a harmonic scale, write it out using the natural minor key first, and then go back and add the accidental that raises the 7th degree up a half step.

Playing harmonic minor scales on the guitar is simple. You just position the pattern shown in Figure 7-7 over the root (tonic) position that you want to play in. Move it around to a different root to play the scale for that note.

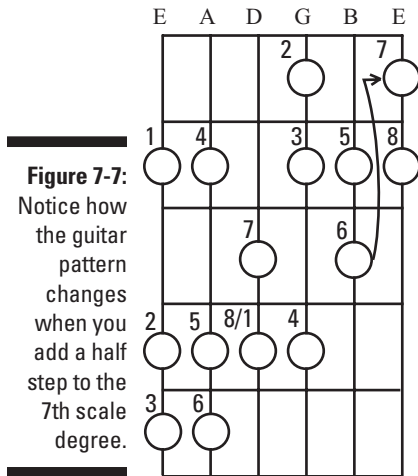

As always, the key is determined by the first and last notes of the scale, so if someone asks you to play an A harmonic minor scale on the guitar, you play what's shown in Figure 7-8.

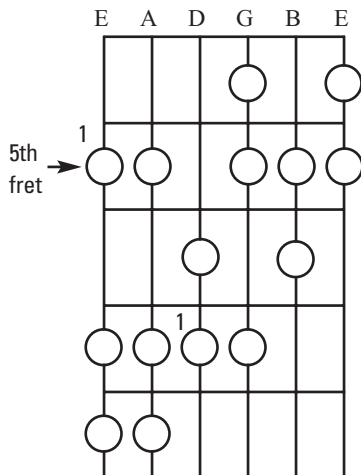

Making great music with melodic minor scales on piano and guitar

The *melodic minor scale* is derived from the natural minor scale (see the earlier section “Playing natural minor scales on piano and guitar” for details). In the melodic minor scale, the 6th and 7th notes of the natural minor scale are each raised by one half step when going up the scale. However, keep in mind that they return to the natural minor when going down the scale.



This scale is a tricky one, so we’re going to reiterate: While you’re going up in pitch when playing a piece, you raise the 6th and 7th degrees of the natural minor scale a half step, but during parts of the same piece where the pitch goes down, you play the notes according to the natural minor scale. Scales in which the 6th and 7th degrees are flat in natural minor will require naturals to raise those two degrees.

To play an A melodic minor scale ascending (going up) the piano, you play what’s shown in Figure 7-9.

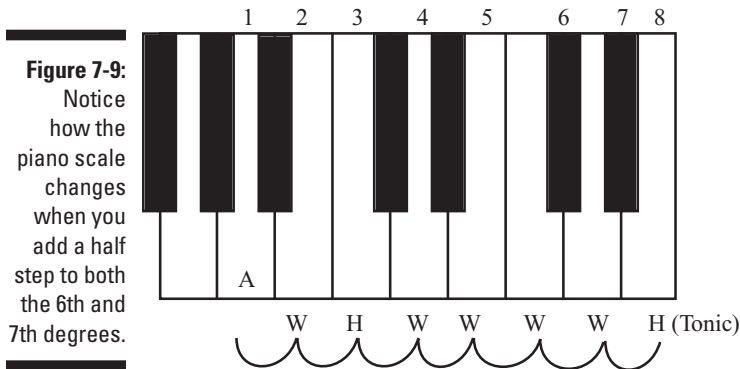

When writing music in the melodic minor scale, composers write out the song using the natural minor pattern, and then they add the accidentals that modify any ascending 6th and 7th notes afterward.

The wonderful thing about the guitar is that you only have to memorize one pattern for each type of scale and you’re set. To play the ascending A melodic minor scale on guitar, play the pattern as shown in Figure 7-10. To play an A melodic minor scale ascending on the guitar, you play it as shown in Figure 7-11.

And, of course, for the descending notes on both the piano and guitar you revert to A natural minor.

Figure 7-10:
Notice how the piano pattern changes when you add a half step to the 6th and 7th degrees of the scale.

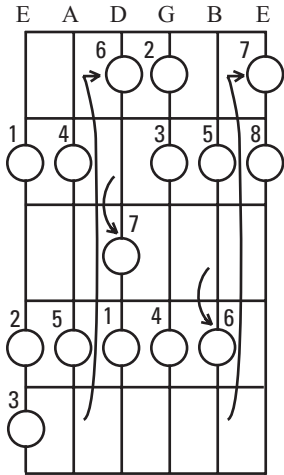
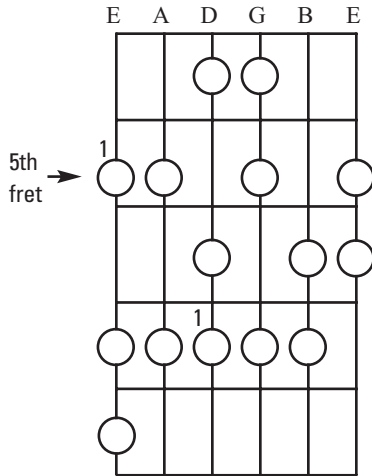

Figure 7-11:
An A melodic minor ascending scale on the guitar.



Listening to the minor scales



Listen to Tracks 16 through 60 to hear each of the minor scales played on piano and guitar.

<i>Track</i>	<i>Scale</i>
16	A natural minor
17	A harmonic minor
18	A melodic minor
19	A flat natural minor
20	A flat harmonic minor
21	A flat melodic minor
22	A sharp natural minor
23	A sharp harmonic minor
24	A sharp melodic minor
25	B natural minor
26	B harmonic minor
27	B melodic minor
28	B flat natural minor
29	B flat harmonic minor
30	B flat melodic minor
31	C natural minor
32	C harmonic minor
33	C melodic minor
34	C sharp natural minor
35	C sharp harmonic minor
36	C sharp melodic minor
37	D natural minor
38	D harmonic minor
39	D melodic minor
40	D sharp natural minor
41	D sharp harmonic minor
42	D sharp melodic minor
43	E natural minor
44	E harmonic minor
45	E melodic minor
46	E flat natural minor
47	E flat harmonic minor
48	E flat melodic minor
49	F natural minor
50	F harmonic minor
51	F melodic minor
52	F sharp natural minor
53	F sharp harmonic minor

<i>Track</i>	<i>Scale</i>
54	F sharp melodic minor
55	G natural minor
56	G harmonic minor
57	G melodic minor
58	G sharp natural minor
59	G sharp harmonic minor
60	G sharp melodic minor

Chapter 8

Key Signatures and the Circle of Fifths

In This Chapter

- ▶ Studying the Circle of Fifths
 - ▶ Exploring the major and minor key signatures
 - ▶ Examining the major and minor keys
-

At the beginning of most pieces of written music, you'll find a group of sharps or flats located directly to the right of the time signature. This group of symbols is called the *key signature*, and it tells you what key the song is written in.

When you know a song's *key*, or the scale that the set of notes used to compose the song you're playing comes from, you may find reading the music easier. You can anticipate the notes on the sheet music based on your knowledge of the scales and the notes in those keys. Also, in a situation where you're playing with other musicians, if you know the key you're playing in and can anticipate the chords, you can guess where the melody of the song is going. It's almost like knowing what word is going to come next — or at least what limited selection of words could come next — to fit into a sentence.

In this chapter, you find out all about key signatures and how to recognize them on sight. You also read about Pythagoras's Circle of Fifths and how to use it to read key signatures. Finally, we round out the chapter with a discussion about major and minor key signatures and their relative minors and majors.

Understanding the Circle of Fifths

In the sixth century B.C., the Greek scholar and philosopher Pythagoras decided to try and make things easier for everyone by standardizing, or at least dissecting, musical tuning. He had already discovered the relationship

between pitch frequencies and lengths of string and had defined what an octave was, so he figured standardizing tuning was the next logical step.

He divided a circle into 12 equal sections, like a clock. The result of his experimentation eventually became known as the Circle of Fifths, which is still used today. Each of the 12 points around the circle was assigned a pitch value, which roughly corresponds to the present system of an octave with 12 half steps. Western music theorists have since updated Pythagoras's Circle of Fifths to what you see in Figure 8-1. We discuss this circle further in the next section.

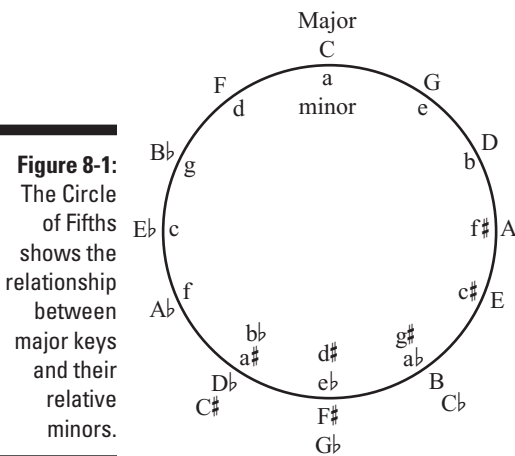

In mathematical terms, the unit of measure used in the Circle is *cents*, with 1,200 cents equal to one octave. Each half step, then, is broken up into 100 cents.

The creation and use of the Circle of Fifths is the very foundation of modern Western music theory, which is why we talk about it so much in this book. Figure 8-2 shows a slightly different version of the Circle of Fifths than is shown in Figure 8-1. The former figure can be used to help you learn to read key signatures on sight by counting the sharps or flats in a time signature.

The Circle of Fifths helps you figure out which sharps and flats occur in the different keys. The name of the key being played is the letter on the outside of the circle. To figure out how many sharps are in each key, count *clockwise* from C at the top of the circle.

Figure 8-2:
The Circle of Fifths tells you how many sharps and flats are in the key signatures and scales of each key.

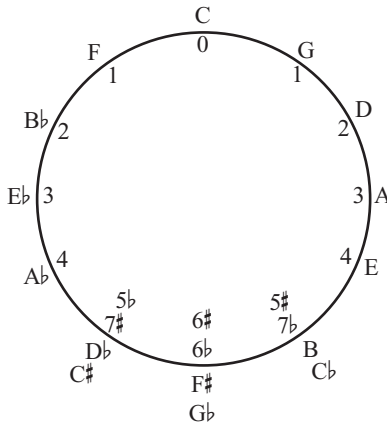

C major has a number value of 0, so it has no sharps. G has a value of 1, so it has one sharp. When you play the G major scale on the piano, you play only white keys until you come to the seventh interval and land on that one sharp: F sharp, in this case. D has two sharps, A has three, and so on around the circle. The number value by each letter on the right-hand side of the circle represents how many sharps are in that key, which is determined by that key's scale.

Along with all the technical things the Circle of Fifths predicts, it's also your best friend for deciphering key signatures on sight. It's just as essential in writing music, because its clever design is helpful in composing and harmonizing melodies, building chords, and moving to different keys within a composition.



Each of the circle's 12 stops is actually the fifth pitch in the scale of the preceding stop, which is why it's called the Circle of Fifths. For example, the fifth pitch, or the *dominant* note, of the C scale is G. If you look at the Circle of Fifths in Figure 8-2, you can see that G is the next letter to the right of C. If you keep going clockwise, you see that the dominant note of the G scale, D, is the next stop, and so on around the circle. (You can find full coverage of scales in Chapter 7.)

Sharps: Father Charles Goes Down and Ends Battle



The sharps always appear in a specific order in every key: F, C, G, D, A, E, B. You can easily remember this pattern of sharps by using the mnemonic *Father Charles Goes Down And Ends Battle*.

For example, if you're playing a song in the key of B major, you know from the Circle of Fifths that B major has five sharps. And you know from the *Father Charles* mnemonic that those sharps are F sharp, C sharp, G sharp, D sharp, and A sharp, because the sharps are always in that order. If you're playing the key of D major, which has two sharps, you know those sharps are F sharp and C sharp because *Father Charles*. . . . If you have a better mnemonic than the one we suggest, feel free to use it.

Flats: Battle Ends And Down Goes Charles's Father

For the major scales and keys with flats, you move counterclockwise around the Circle of Fifths (refer to Figure 8-2), starting at C, which still has a number value of 0. Therefore, the key of F major has one flat, the key of B flat major has two flats, and so on.



Like the sharps, the flats appear in a specific order in every key: B, E, A, D, G, C, F. The mnemonic we suggest here is *Battle Ends And Down Goes Charles's Father*, which is, you'll notice, the exact reverse of the order of sharps in the circle.

So, G flat, for example, which is six steps away from C major on the circle, has six flats in its scale, and they are B flat, E flat, A flat, D flat, G flat, and C flat. The key of B flat, which is two steps away from C at the top of the circle, has B flat and E flat in its key. Notice that the orders of sharps and flats given in the mnemonics are exactly the order in which they are written in key signatures.



We can't emphasize enough how useful knowing the Circle of Fifths is. It's useful as a composer, as a performer, and as a student of music theory. All we can do is say it over and over and over: The Circle of Fifths — memorize it and use it.

Recognizing Major Key Signatures

To figure out how many sharps are in each key signature, count clockwise on the Circle of Fifths (see Figure 8-2) from C major. The number of sharps in each successive key goes up by one in that key's key signature. At G, one "stop" from C major, there's one sharp in the key signature. At D, two stops from C, there are two sharps in the key signature. See Figure 8-3 to see the sharps going "up."

Figure 8-3:

The sharps are arranged in the key signature going “up.”



Therefore, if you’re playing a song in the key of B major, which is located five stops from the C major on the circle, you know that key has five sharps. But also, if you know the mnemonic *Father Charles Goes Down And Ends Battle*, you know that those five sharps in B major are F sharp, C sharp, G sharp, D sharp, and A sharp. If you’re playing in the key of D major, which has two sharps, you know those sharps are F sharp and C sharp.

For major scales that have flats, you go counterclockwise around the Circle of Fifths. The flats appear in a specific order in every key as you go from C around the circle counterclockwise: B flat, E flat, A flat, D flat, G flat, C flat, and F flat. (You know this if you remember the mnemonic *Battle Ends And Down Goes Charles’s Father*.) Going counterclockwise, F, which is one stop from C major, has one flat in the key signature; B flat, which is two stops from C major, has two flats in the key signature (and so on around the circle). Figure 8-4 shows the flats going “down.”

Figure 8-4:

The flats are arranged in the key signature going “down.”



It’s easy to remember that the first flat is always B flat because the flat sign itself looks kind of like a lowercase *b*, which is actually what it originally was.

So, for example, G flat, which is six steps away from C major on the circle, has six flats in its key signature. And because you know the mnemonic *Battle Ends And Down Goes Charles’s Father*, you know that those flats are B flat, E flat, A flat, D flat, G flat, and C flat. B flat, which is two steps away, has two flats, and now you know those flats have to be B flat and E flat.

Finding Minor Key Signatures and Relative Minors

The Circle of Fifths works the same way for *minor* keys as it does for major keys. The minor keys are represented by the lowercase letters *inside* the Circle of Fifths shown in Figure 8-1.



The minor keys on the inside of the circle are the *relative minors* of the major keys on the outside of the circle. The relative minor and its major key have the same key signature. The only difference is that the relative minor's scale starts on a different tonic, or first note. The tonic, or starting point, of a relative minor is a minor third — or three half steps — lower than its relative major key.

For example, C major's relative minor is A minor (refer to Figure 8-1, the Circle of Fifths where C is on the outside and A is on the inside of the circle). A minor's tonic note is A, which is three half steps to the left of C on the piano or three frets toward the head of the neck on the guitar.

Even the *Father Charles . . .* and *Battle Ends . . .* mnemonics stay the same when you're dealing with minor keys. That's because no difference exists in the key signature between a major key and its relative minor.

On sheet music, the relative minor is the note one full line or space below the major key note. C is in the third space on the treble clef, and A, its relative minor, is in the second space, below it.



On the piano or guitar, a major chord and its relative minor go together like bread and butter. Many, many songs use this chord progression because it just sounds good. (You can find more about chords and chord progressions in Chapters 10 and 11.)

Reviewing the Key Signatures

In the following sections, we provide a rundown of the major and natural minor key signatures and a couple of octaves' worth of notes in those keys, arranged in a scale. Because this chapter focuses on the Circle of Fifths, we order the key signatures following the circle, as opposed to alphabetical order.



Don't be thrown by the word *natural* when we use it to describe minor key signatures in this section. As we explain in Chapter 7, more than one kind of minor exists.

C major and A natural minor

Figure 8-5 shows the C major key signature, and Figure 8-6 shows the A natural minor key signature, C's relative natural minor.

Figure 8-5:
The C major
key signa-
ture and
scale.

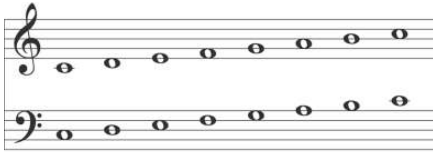
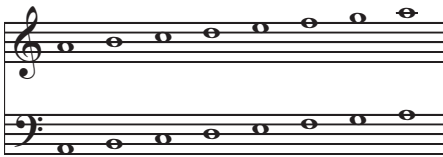

Figure 8-6:
The A natu-
ral minor
key signa-
ture and
scale.



As you can see, the C major and the A natural minor have the same key signature (that is, no sharps and no flats) and the same notes in the scale because A is the relative natural minor of C. The only difference is that the C major scale starts on C, whereas the A natural minor scale starts on A.

G major and E natural minor

Figure 8-7 shows the G major key signature, and Figure 8-8 shows the E natural minor key signature, G's relative natural minor.

Figure 8-7:
The G major
key signa-
ture and
scale.

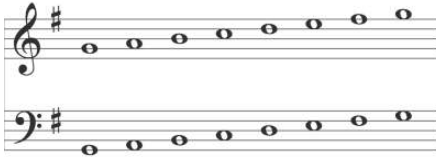
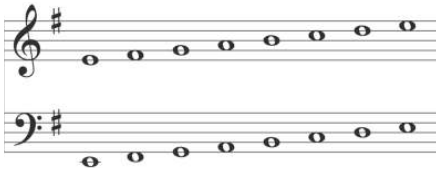

Figure 8-8:
The E natu-
ral minor
key signa-
ture and
scale.



You've now added one sharp (F) to the key signature. The next stop (D) has two (F and C, because *Father Charles*. . .), and you keep adding one more sharp until you get to the bottom of the Circle of Fifths.

D major and B natural minor

Figure 8-9 shows the D major key signature, and Figure 8-10 shows the B natural minor key signature, D's relative natural minor.

Figure 8-9:
The D major
key signa-
ture and
scale.

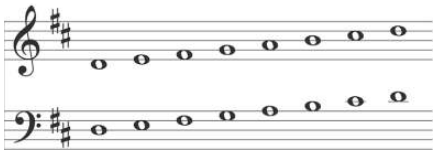
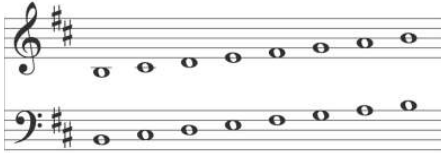

Figure 8-10:
The B natural minor key signature and scale.



A major and F sharp natural minor

Figure 8-11 shows the A major key signature, and Figure 8-12 shows the F sharp natural minor key signature, A's relative natural minor.

Figure 8-11:
The A major key signature and scale.

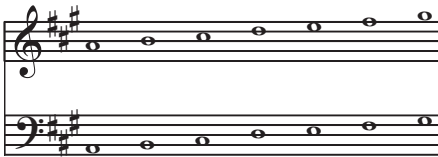
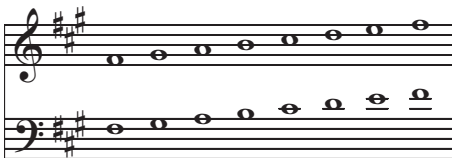

Figure 8-12:
The F sharp natural minor key signature and scale.



E major and C sharp natural minor

Figure 8-13 shows the E major key signature, and Figure 8-14 shows the C sharp natural minor key signature, E's relative natural minor.

Figure 8-13:
The E major
key signa-
ture and
scale.

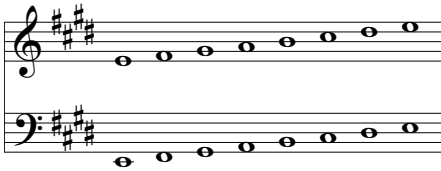
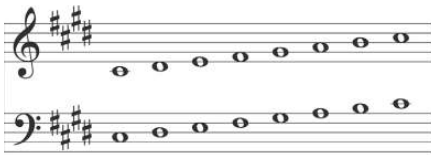

Figure 8-14:
The C sharp
natural
minor key
signature
and scale.



B/C flat major and G sharp/A flat natural minor

Figure 8-15 shows the B major key signature and C flat major key signature. Figure 8-16 shows the G sharp natural minor key signature and the A flat natural minor key signature.

Figure 8-15:
The B major
and C flat
major key
signatures
and scales.



Figure 8-16:
The G sharp
natural
minor and A
flat natural
minor key
signatures
and scales.

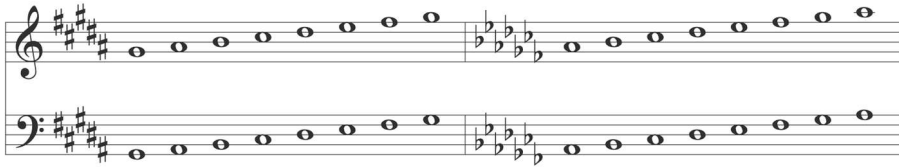

Confused by the double naming here? Take a look at a keyboard, and you see that a black key doesn't exist for C flat. Instead, you see a white key: B. C flat and B are *enharmonic equivalents* of one another, meaning they're the same but with different names. All the notes in the key of B major and the key of C flat major sound exactly the same — they just use different musical notation. The same goes for G sharp natural minor and A flat natural minor — same notes, just different notation.



As the number of sharps has been going up by one at each stop on the Circle of Fifths, from this point on, the number of flats will be going down by one until returning to the 12 o'clock (C major/A natural minor) position.

F sharp/G flat major and D sharp/E flat natural minor

Figure 8-17 shows the F sharp major key signature and the G flat major key signature. Figure 8-18 shows the D sharp natural minor key signature and the E flat natural minor key signature. More enharmonic equivalents!

Figure 8-17:
The F sharp major and G flat major key signatures and scales.



Figure 8-18:
The D sharp natural minor and E flat natural minor key signatures and scales.



C sharp major/D flat and A sharp/B flat natural minor

Figure 8-19 shows the C sharp major key signature and the D flat major key signature. Figure 8-20 shows the A sharp natural minor key signature and the B flat natural minor key signature.

Figure 8-19:
The C sharp major and D flat major key signatures and scales.

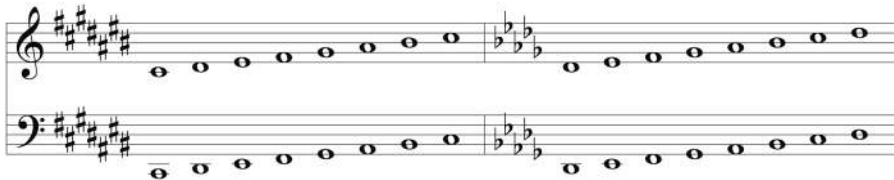

Figure 8-20:

The A sharp natural minor and B flat natural minor key signatures and scales.



These are the last of the enharmonic equivalent key signatures you have to remember. We promise. Also, these are the last of the keys with sharps in their signatures. From this point on, you're working with flats alone as you continue going up the left side of the Circle of Fifths.

A flat major and F natural minor

Figure 8-21 shows the A flat major key signature and the F natural minor key signature, which is A flat's relative natural minor.

Figure 8-21:

The A flat major and F natural minor key signatures and scales.

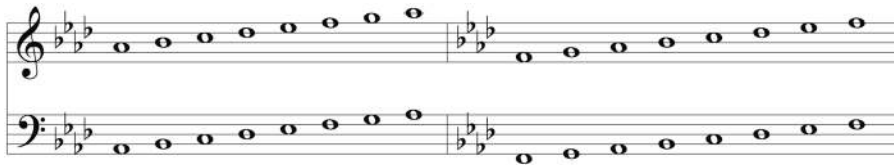

E flat major and C natural minor

Figure 8-22 shows the E flat major key signature and the C natural minor key signature, which is E flat's relative natural minor.

Figure 8-22:

The E flat major and C natural minor key signatures and scales.



B flat major and G natural minor

Figure 8-23 shows the B flat major key signature and the G natural minor key signature, which is B flat's relative natural minor.

Figure 8-23:

The B flat major and G natural minor key signatures and scales.



F major and D natural minor

Figure 8-24 shows the F major key signature and the D natural minor key signature, which is F major's relative natural minor.

Figure 8-24:
The F major
and D natu-
ral minor
key signa-
tures and
scales.

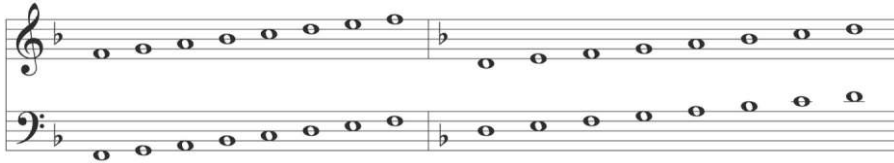

Chapter 9

Intervals: The Distance between Pitches

In This Chapter

- ▶ Understanding the different kinds of intervals
 - ▶ Checking out unisons, octaves, fourths, and fifths
 - ▶ Figuring out seconds, thirds, sixths, and sevenths
 - ▶ Creating your own intervals
 - ▶ Seeing how intervals relate to the major scale
-

The distance between two musical pitches is called an *interval*. Even if you've never heard the word *interval* used in relation to music before, if you've listened to music, you've heard how intervals work with one another. If you've ever played music, or even just accidentally set a coffee cup down on a piano keyboard hard enough to make a couple of jangly notes sound out, you've worked with intervals. Scales and chords are both built from intervals. Music gets its richness from intervals. This chapter reviews the types of intervals most commonly used in music and discusses how intervals are used in building scales and chords.

Breaking Down Harmonic and Melodic Intervals

The following two types of intervals exist:

- ✓ A *harmonic interval* is what you get when you play two notes at the same time, as shown in Figure 9-1.
- ✓ A *melodic interval* is what you get when you play two notes separately in time, one after the other, as shown in Figure 9-2.

Figure 9-1:

A harmonic interval is two notes played simultaneously.

**Figure 9-2:**

A melodic interval is two notes played one after the other.



The *identity* of an interval, and this goes for both harmonic and melodic intervals, is determined by two things:

- ✓ Quantity
- ✓ Quality

We explain what we mean by each of these in the following sections.

Quantity: Counting lines and spaces

The first step in naming an interval is finding the distance between the notes as they're written on the staff. The *quantity*, or *number size*, of an interval is based on the number of lines and spaces contained by the interval on the music staff. Musicians and composers use different names to indicate the quantity of intervals:

- ✓ Unison (or prime)
- ✓ Second
- ✓ Third
- ✓ Fourth

- ✓ Fifth
- ✓ Sixth
- ✓ Seventh
- ✓ Octave



You determine an interval's quantity by simply adding up the lines and spaces included in the interval. You must count every line and every space between the notes as well as the lines or spaces that the notes are on. Accidentals don't matter when counting interval quantity.

Take a look at Figure 9-3 for an example of how easy it is to determine an interval's quantity. If you start on either the top or bottom note and count all the lines and spaces contained in the interval in the figure, including the lines or spaces that contain both notes, you end up with the number five. Therefore, the interval in Figure 9-3 has the quantity, or number size, of five, or a fifth. Because the notes are written together to be played at the same time, it's a *harmonic fifth*.

Figure 9-3:

The five lines and spaces in this interval's total quantity indicate this interval is a fifth.



Figure 9-4 shows a melodic second. Note that the sharp *accidental* (the #) on the F does absolutely nothing to the quantity of the interval. Interval quantity is only a matter of counting the lines and spaces. (You can read about accidentals in Chapter 6.)

Figure 9-4:

The fact that the first note is F sharp doesn't affect the quantity of the interval.



Figure 9-5 shows interval quantities from unison (the two notes are the same) to octave (the two notes are exactly an octave apart) and all the intervals in between. Sharps and flats are thrown in for fun, but remember, they don't matter when it comes to interval quantity.

Figure 9-5:

Melodic intervals in order from left to right: unison, second, third, fourth, fifth, sixth, seventh, and octave.



What if an interval spans more than one octave? In that case, it's called a *compound interval*. As with all interval quantities, you just count the lines and spaces for a compound interval. The example shown in Figure 9-6 has the quantity of ten and is therefore called a *tenth*.

Figure 9-6:
A compound
interval
with a total
quantity of
ten, which
is called a
tenth.



Quality: Considering half steps

Interval *quality* is based on the number of half steps from one note to another. Unlike in interval quantity, accidentals (sharps and flats), which raise or lower a pitch by a half step, do matter in interval quality. (See Chapter 6 for details on accidentals.) Interval quality gives an interval its distinct sound.

Each of the intervals shown in Figure 9-7 have exactly the same quantity, but they sound different because each one has a different quality.

Figure 9-7:
All these
intervals are
fifths, but
the various
qualities of
the fifths
make them
sound
different.



PLAY THIS!



Play Track 61 to hear the differences between the intervals that have the same quantity (fifth) but different qualities.

The terms used to describe quality, and their abbreviations, are as follows:

- ✓ **Major (M):** Contains two half steps between notes
- ✓ **Minor (m):** Contains a half step less than a major interval, or one half step between notes

- ✓ **Perfect (P):** Refers to the harmonic quality of unisons, octaves, fourths, and fifths
- ✓ **Diminished (dim):** Contains a half step less than a minor or perfect interval
- ✓ **Augmented (aug):** Contains a half step more than a major or perfect interval

Naming intervals



Every interval gets its full name from the combination of both the quantity and the quality of the interval. For example, you may encounter a *major third* or a *perfect fifth*. (You can read more about interval quantity and quality in the previous sections.)

Here are the possible combinations that you use when describing intervals:

- ✓ Perfect (P) can only be used with unisons, fourths, fifths, and octaves.
- ✓ Major (M) and minor (m) can only be used with seconds, thirds, sixths, and sevenths.
- ✓ Diminished (dim) can be used with any interval, with the exception of unisons.
- ✓ Augmented (aug) can be used with any interval.

Looking at Unisons, Octaves, Fourth, and Fifths

Unisons, octaves, fourths, and fifths share the same characteristics in that they all use the terms perfect, augmented, or diminished to identify their quality. (See the earlier section “Quality: Considering half steps” for more information.)

Perfect unisons

A *perfect melodic unison* is possibly the easiest move you can make on an instrument (except for a rest, of course). You just press a key, pluck, or blow the same note twice. You can play unisons on most stringed instruments because the same note occurs more than once on these instruments, such as on the guitar (the 5th fret on the low E string is the same as the open A string, for example).

In music written for multiple instruments, a perfect harmonic unison occurs when two (or more) people play exactly the same note, in the exact same manner, on two different instruments.

Augmented unisons

To make a perfect unison augmented, you add one half step between the notes. You can alter either of the notes in the pair to increase the distance between the notes by a half step.

The interval from B flat to B is called an *augmented unison* (or *augmented prime*) — *unison* because the note names are the same (both Bs) and *augmented* because the interval is one half step greater than a perfect unison.



A diminished unison doesn't exist, because no matter how you change the unisons with accidentals, you're still adding half steps to the total interval.

Octaves

When you have two notes with an interval quantity of eight lines and spaces, you have an *octave*. A *perfect octave* is a lot like a perfect unison in that the same note (on a piano, it would be the same white or black key on the keyboard) is being played. The only difference is that the two notes are separated by 12 half steps, including the starting note, either above or below the starting point.

The perfect melodic octave in Figure 9-8 has 12 half steps between the notes.

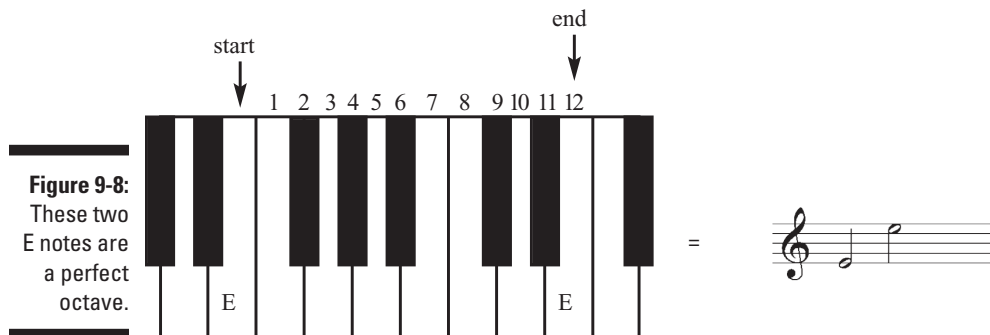
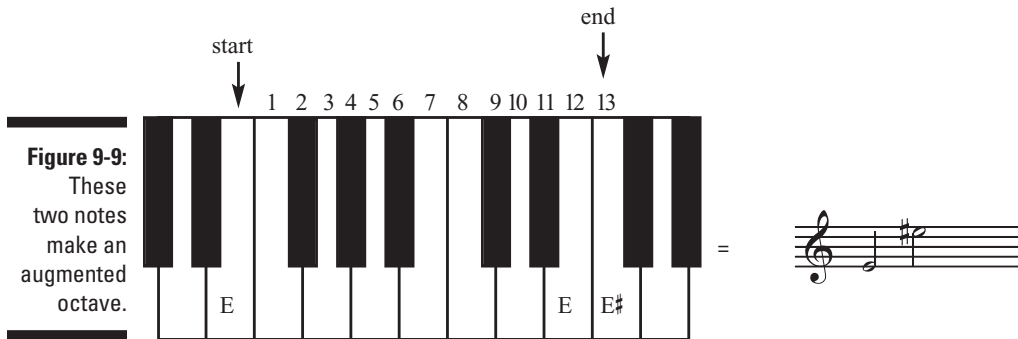
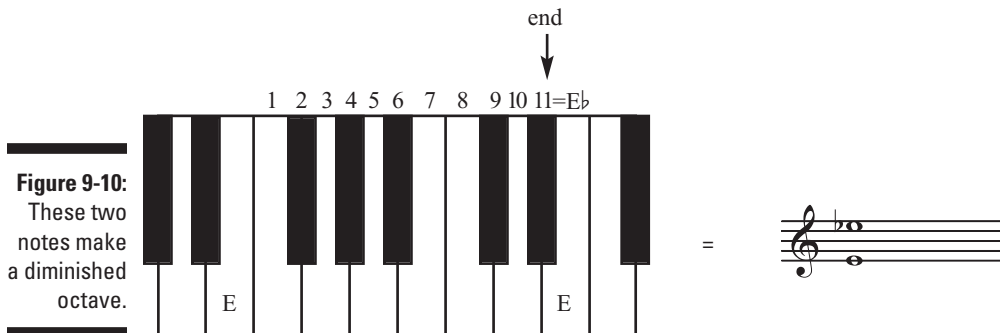

Figure 9-8:
These two
E notes are
a perfect
octave.

To make a perfect octave augmented, you increase the distance between the notes by one more half step. Figure 9-9 shows an augmented octave from E to E sharp. It was augmented by raising the top note a half step so that 13 half steps come between the first note and the last. You could also make an augmented octave by lowering the bottom E note a half step to E flat.



To make the same octave diminished, you *decrease* the distance between the notes by one half step. For example, Figure 9-10 illustrates lowering the top note a half step so that only 11 half steps come between the first note and the last. You could also raise the bottom note by a half step to make another diminished octave.



Fourths

Fourths are pairs of notes separated by four lines and spaces. All fourths are perfect in quality, containing five half steps between notes — except for the fourth from F natural to B natural, which contains *six* half steps (making it an *augmented fourth*). Compare the note pairs in Figure 9-11 on the keyboard to see what we mean.

Figure 9-11:

Fourths as seen on the staff with the special (augmented) case of the F natural and the B natural circled.



Figure 9-12 shows the connection between each fourth on a keyboard. Note that unlike the rest, the F natural and B natural require six half steps.

Figure 9-12:

On the keyboard, every natural fourth is a perfect fourth (except for the interval between F natural and B natural).

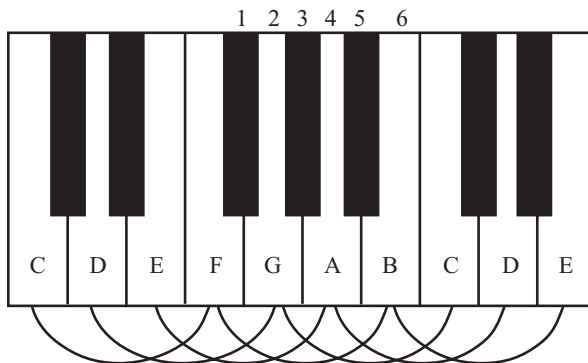

Because augmented fourths are a half step larger than perfect fourths, you can create a perfect fourth between the notes F natural and B natural by either raising the bottom note to F sharp or lowering the top note to B flat.

If the natural fourth is perfect, adding the same accidental (either a sharp or a flat) to both notes doesn't change the interval's quality. It stays a perfect fourth. The same number of half steps (five) occurs between D natural and G natural that occurs between D sharp and G sharp, or D flat and G flat, as shown in Figures 9-13 and 9-14. If one note changes but the other doesn't, the quality of the interval does change.

Figure 9-13:

Adding accidentals to both notes in a perfect fourth interval doesn't change it from being a perfect fourth.

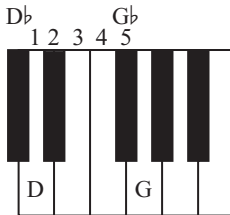
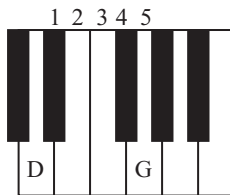
**Figure 9-14:**

You can see on a keyboard the same principle shown in Figure 9-13.

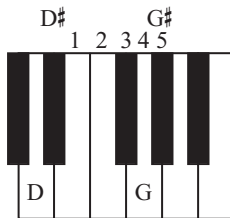

Fifths

Fifths are pairs of notes separated by five lines and spaces (as shown in Figure 9-15). Fifths are pretty easy to recognize in notation, because they're two notes that are exactly two lines or two spaces apart.

Figure 9-15:

Fifths have an interval quantity of five lines and spaces.



All fifths are *perfect* fifths, meaning that the interval contains seven half steps. However, as you may have guessed, the interval between B to F is a *diminished fifth*, which turns out to have the same sound as an augmented fourth. Only six half steps occur between those two notes whether you're going from F natural to B natural or B natural to F natural.

You can create a perfect fifth between F natural and B natural by adding one more half step — either by turning the B natural to a B flat or by raising the F natural to an F sharp. This time, because the notes are flipped around from the order they appeared in the interval of fourths, both changes *increase* the size of the interval.

Again, just as in a perfect fourth, if a fifth is perfect (every case except F natural and B natural), adding the same accidentals to both notes in the interval doesn't change its quality. And, as with fourths, if only one of the notes is altered with an accidental, the quality does change.

Recognizing Seconds, Thirds, Sixths, and Sevenths

Seconds, thirds, sixths, and sevenths all share the characteristic of using the terms *major, minor, augmented, and diminished* to identify their quality. (Check out the earlier section “Quality: Considering half steps” for more information.)



A major interval made *smaller* by one half step becomes minor, whereas a major interval made *larger* by one half step becomes augmented. A minor interval made *larger* by one half step becomes major, and a minor interval made *smaller* by one half step becomes diminished.

Clear as mud, right? Well, don't worry. We tell you everything you need to know in the following sections. Also, Table 9-1 summarizes the intervals from unison to octave. Notice in the table that the identity of the interval itself depends on the quantity of the interval number — that is, how many lines and spaces are included in the total interval.

Table 9-1 Intervals from Unison to Octave	
<i>Half Steps between Notes</i>	<i>Interval Name</i>
0	Perfect unison/diminished second
1	Augmented unison/minor second
2	Major second/diminished third
3	Augmented second/minor third
4	Major third/diminished fourth
5	Perfect fourth/augmented third
6	Augmented fourth/diminished fifth
7	Perfect fifth/diminished sixth
8	Augmented fifth/minor sixth
9	Major sixth/diminished seventh
10	Augmented sixth/minor seventh
11	Major seventh/diminished octave
12	Augmented seventh/perfect octave
13	Augmented octave

Seconds

When you have two notes with an interval quantity of two lines and spaces, you have a *second*, as you can see in Figure 9-16. Seconds are pretty easy to recognize — they're the two notes perched right next to each other, one on a line and one in a space.

Figure 9-16:
These three sets of notes are all seconds.



If one half step (one piano key or one guitar fret) exists between seconds, the interval is a *minor second* (m2). If two half steps (one whole step, or two adjacent piano keys or guitar frets) exist between seconds, the interval is a *major second* (M2).

For example, the interval between E natural and F natural is a minor second, because one half step occurs between those two notes (see Figure 9-17).

Figure 9-17:

The interval between E and F is a minor second, because it only contains one half step.

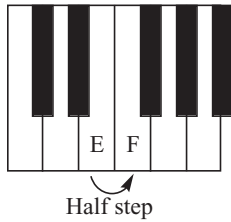

Meanwhile, the interval between F and G is a major second, because two half steps (one whole step) exist between those two notes, as illustrated in Figure 9-18.

Figure 9-18:

The interval between F and G is a major second, because it contains two half steps.

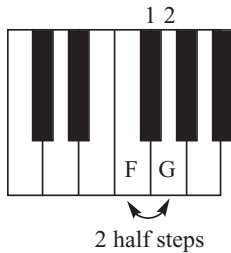

A major second is made minor by decreasing its quantity by one half step. You can decrease its quantity either by lowering the top note a half step or raising the bottom note a half step. Both moves reduce the distance between the notes to one half step (one piano key or one guitar fret), as Figure 9-19 shows.

Figure 9-19:

Turning a major second into a minor second.



A minor second can be turned into a major second by increasing the interval size by one half step. You can increase the interval size either by raising the top note a half step or by lowering the bottom note a half step. Both moves make the distance between the notes two half steps (two piano keys or three guitar frets).



The only place that half steps occur between white-key seconds is from E natural to F natural and B natural to C natural — the two spots on the keyboard where there are no black keys between the two white keys.

Adding the same accidental to both notes of a natural second doesn't change its quality. All the seconds shown in Figure 9-20 are major seconds.

Figure 9-20:

Major seconds.



All the seconds shown in Figure 9-21 are minor seconds.

Figure 9-21:

Minor seconds.



An augmented second is one half step larger than a major second. In other words, three half steps exist between each note. You turn a major second into an augmented second either by raising the top note or lowering the bottom note one half step, as shown in Figures 9-22 and 9-23.

Figure 9-22:
Turning a major second interval into an augmented second.



Figure 9-23:
Turning a major second interval into an augmented second on the piano: F to G sharp, and F flat to G.

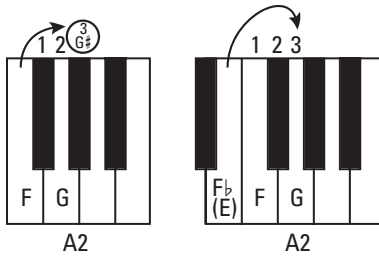

A diminished second is one half step smaller than a minor second — meaning no steps occur between each note. They're the same note. A diminished second is an *enharmonic* equivalent of a perfect unison. You're playing the same two notes, but the notation for the pair is different.

Thirds

Thirds occur when you have an interval that contains three lines and spaces as Figure 9-24 does.

Figure 9-24:

Thirds are located on adjacent lines or spaces.



If a third contains four half steps, it's called a *major third* (M3). Major thirds occur from C to E, F to A, and G to B. If a third contains three half steps, it's called a *minor third* (m3). Minor thirds occur from D to F, E to G, A to C, and B to D.

Figure 9-25 shows major and minor thirds on the musical staff.

Figure 9-25:

Major and minor thirds on the staff.

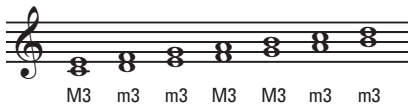

A major third can be turned into a minor third if you decrease its interval size by one half step, making the total three half steps between notes. You can decrease its interval size either by lowering the top note a half step or raising the bottom note a half step (see Figure 9-26).

Figure 9-26:

Turning a major third into a minor third.



A minor third can be turned into a major third by adding one more half step to the interval, either by — you guessed it — raising the top note a half step or by lowering the bottom note a half step, as shown in Figure 9-27.

Figure 9-27:
Turning a
minor third
into a major
third.



As with seconds, fourths, and fifths, the same accidental added to both notes of a third (both major and minor) doesn't change its quality; and adding an accidental to just one of the notes of a third does change its quality.

An augmented third is a half step larger than a major third, with five half steps between notes. Starting from a major third, raise the upper note a half step or lower the bottom note a half step. Figure 9-28 shows augmented thirds. An augmented third is also the enharmonic equivalent of a perfect fourth — they're the same note, but the notation is different.

Figure 9-28:
Turning a
major third
into an
augmented
third.



A diminished third is a half step smaller than a minor third. Beginning with a minor third, either raise the bottom note a half step or lower the upper note a half step, making for an interval of two half steps (see Figure 9-29).

Figure 9-29:

Turning a minor third into a diminished third.



Sixths and sevenths

When you have two notes with an interval quantity of six lines and spaces, as in Figure 9-30, you have a *sixth*. The notes in a sixth are always separated by two lines and a space or two spaces and a line.

Figure 9-30:

Harmonic sixth intervals.



When you have two notes with an interval quantity of seven lines and spaces, as in Figure 9-31, you have a *seventh*. Sevenths always consist of a pair of notes that are both on lines or spaces. They're separated by three lines or three spaces.

Figure 9-31:

Harmonic seventh intervals.

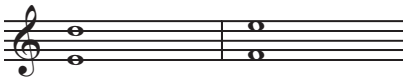

Building Intervals

The first step in building any interval when creating a piece of music is to create the desired quantity, or number size, above or below a given note. Then you determine the quality. We detail each of these steps in the following sections.

Determining quantity

Determining quantity is easy, especially on paper. For, say, a unison interval, just pick a note. Then, right next to the first note, put another one exactly like it.

Want to make your interval an octave? Put the second note exactly seven lines and spaces above or below the first, making for a total interval quantity of eight lines and spaces, as shown in Figure 9-32.

Figure 9-32:
Octaves of
the note G
(spanning
the two
clefs, with
middle C
indicated).

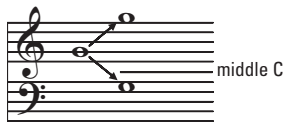

How about a fourth? Put the second note three spaces and lines above or below the first note, making for a total interval quantity of four lines and spaces. And a fifth? Put the second note four spaces and lines above or below the first note, making for a total interval quantity of five lines and spaces.

Determining quality

The second step to building an interval is to decide what the quality of the interval will be. Say, for example, your starting note is an A flat. And suppose you want your interval to be a perfect fifth above A flat. First, you count out the *quantity* needed for the fifth interval, meaning you count an additional four spaces above the starting note, making for a total quantity of five lines and spaces, as shown in Figure 9-33.

Figure 9-33:

Figuring out the quantity needed to build a perfect fifth above A flat.



Next, you have to alter the second note in order to make it a perfect fifth. Because all fifths are perfect so long as both notes have the same accidental (except for darned B and F), in order to make this pair a perfect fifth, you have to flat the second note so it matches the first, as shown in Figure 9-34.

Figure 9-34:

Flattening the second note to match the first makes a perfect fifth.



If you want to make the second note an augmented fifth (aug5, or sometimes A5) *below* A, you count *down* an additional four lines and spaces from A to make a total quality of five lines and spaces, and then you write the note, which is D. See Figure 9-35.

Figure 9-35:

Building an augmented fifth below A starts with finding the quantity.



Now you alter your added note to make the interval augmented. As you now know, a fifth is an augmented fifth when an additional half step is added to the interval ($7 + 1 = 8$ half steps), so you would lower the bottom note to a D flat, as shown in Figure 9-36.

Figure 9-36:

Adding the accidental makes the interval augmented.



To make the second note a diminished fifth (dim5, or sometimes D5) *above* A, you count *up* an additional four lines and spaces, to make a total quality of five lines and spaces, and then write the note, which is E.

Finally, you alter your added note to make the interval diminished. A fifth is a diminished fifth when a half step is removed from the perfect fifth ($7 - 1 = 6$ half steps), so you would lower the top note to an E flat, as shown in Figure 9-37.

Figure 9-37:

Adding the accidental makes the fifth diminished.



Note that a diminished fifth is the same as an augmented fourth — both intervals are made up of six half steps.

Showing Major and Perfect Intervals in the C Major Scale

A *scale* is really nothing more than a specific succession of intervals, starting from the first note of the scale, or the *tonic* note. Getting comfortable with intervals and their qualities is the first step to mastering scales and chords. (See Chapters 11 and 12 for much more on major and minor scales.)

Table 9-2, using the C major scale as an example, illustrates the relationship between the first note and every interval used in a major scale.

<i>Note</i>	<i>Interval from Tonic</i>	<i>Note Name</i>
First note (tonic)	Perfect unison	C
Second note	Major 2nd (M2)	D
Third note	Major 3rd (M3)	E
Fourth note	Perfect 4th (P4)	F
Fifth note	Perfect 5th (P5)	G
Sixth note	Major 6th (M6)	A
Seventh note	Major 7th (M7)	B
Eighth note	Perfect octave (P8)	C

Figure 9-38 shows the intervals from Table 9-2 on the musical scale. These intervals are found in the same order in any major scale. In the major scale, only major and perfect intervals occur above the tonic note. Knowing this can make identifying the qualities of intervals much easier. If the top note of an interval is in the major scale of the bottom note, it must be major (if it's a second, third, sixth, or seventh) or perfect (if it's a unison, fourth, fifth, or octave).

Figure 9-38:
Simple
intervals in
the C major
scale.



PLAY THIS!



Listen to Track 62 to hear simple intervals in the C major scale.

Chapter 10

Chord Building

In This Chapter

- ▶ Getting a grip on major, minor, augmented, and diminished triads
 - ▶ Looking at all the different kinds of seventh chords
 - ▶ Reviewing the triads and sevenths
 - ▶ Inverting and changing voicing for triads and sevenths
-

A *chord* is, quite simply, three or more notes played together or, in the case of arpeggiated chords, one after another. By this simple definition, banging a coffee cup or your elbow on top of three or more piano keys at the same time makes a chord — it probably doesn't sound particularly musical, but it's still technically a chord.

To the uninitiated and experienced performer alike, chord construction can sometimes seem like magic. There's something absolutely beautiful and amazing about the way the individual notes in a chord work to enhance one another. Most people don't appreciate a properly played chord until they hear the way “wrong” notes sound against each other — for example, your coffee cup pushing onto the piano keyboard in a poorly constructed chord.

In most Western music, chords are constructed from *consecutive intervals of a third* — that is, each note in a chord is a third apart from the one before and/or after it (see Chapter 9 if you need a refresher on your intervals). Figure 10-1 illustrates two stacks of thirds to show you what we mean.

Figure 10-1:
Two stacks
of thirds,
one on the
lines and
the other in
the spaces.





With chords based on intervals of a third, all the notes are either going to be line notes or space notes, resting one on top of another like the examples in Figure 10-1.

Creating Triads with Three Pitches

Triads, which consist of any three pitches from the same scale, are the most common type of chord used in music. Here are the different types of triads you'll likely work with:

- ✓ Major
- ✓ Minor
- ✓ Augmented
- ✓ Diminished

In the following sections, we provide information on these triads, but first we introduce what triads are and what they're made of.

Roots, thirds, and fifths

The term *triad* refers to chords that contain three different pitches and are built of thirds. The bottom note of a triad is called the *root*; many beginning music students are taught to think of a triad as being a tree, with the root of a triad being its, well, root. Chords carry the letter name of the root note, as in the root of a *C chord*, shown in Figure 10-2.

Figure 10-2:
The root of
a C chord
(either C
could be the
root).

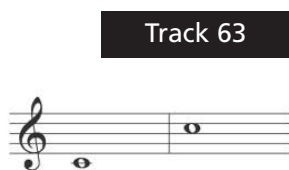

Play Track 63 to hear the root of a C chord.

The second note of a triad is the *third* (see Chapter 9 for more information about intervals). The third of a chord is referred to as such because it's a third interval away from the root of the chord. Figure 10-3 shows the root and major third of a C chord.

Figure 10-3:
The root and
major third
of a C major
chord.



Track 64

PLAY THIS!



Play Track 64 to hear the root and major third of a C chord.

The third of a chord is especially important in constructing chords, because it's the *quality* of the third that determines whether you're dealing with a major or minor chord. (We discuss quality more in Chapter 9.)

The last note of a triad is the *fifth*. This note is referred to as a fifth because it's a fifth from the root, as shown in Figure 10-4.

Figure 10-4:
The root and
fifth of a C
major chord.

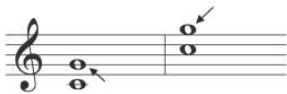

Track 65

PLAY THIS!



Play Track 65 to hear the root and fifth of a C major chord.

Combine the root, third, and fifth, and you have a triad, such as those shown in Figure 10-5.

Figure 10-5:
C major
triads.



Track 66

PLAY THIS!



Play Track 66 to hear a C major triad.

The following sections walk you through building a variety of different triads: major, minor, augmented, and diminished. Table 10-1 has a handy chart to help you keep the formulas straight.

Table 10-1 Building Triads	
<i>Building Triads by Counting Half Steps</i>	
Major =	Root position + 4 half steps + 3 half steps (7 half steps above root)
Minor =	Root position + 3 half steps + 4 half steps (7 half steps above root)
Augmented =	Root position + 4 half steps + 4 half steps (8 half steps above root)
Diminished =	Root position + 3 half steps + 3 half steps (6 half steps above root)
<i>Building Triads with Major Scale Degrees</i>	
Major =	1, 3, 5
Minor =	1, \flat 3, 5
Augmented =	1, 3, \sharp 5
Diminished =	1, \flat 3, \flat 5

Major triads

Because they're made of intervals, triads are affected by interval *quality* (see Chapter 9 for a refresher on quantity and quality). The quantities of the notes that make up the triad are intervals of root, third, and fifth, but it's the interval quality of each note that changes the voicing of the triad.

A major triad contains a root, a major third above the root, and a perfect fifth above the root. You can build major triads in two ways. We describe each method in the following sections.

Half-step counting method

You can count out the half steps between notes to build a major triad using this formula:

Root position + 4 half steps + 3 half steps (or 7 half steps above root)

Figure 10-6 shows C major on the piano keyboard. The pattern stays the same no matter the root, but it looks trickier when you move away from C. Notice the pattern of half steps between the root, the third, and the fifth.

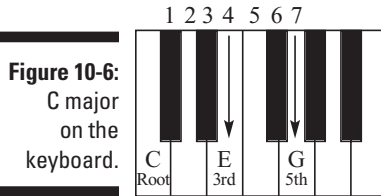

First, major third, and fifth method

The second way to construct major triads is to simply take the first, third, and fifth notes from a major scale.

For example, if someone asks you to write down an F major chord, you first write out the key signature for F major, as shown in Figure 10-7. (Review Chapter 8 for more on key signatures.)



Then you write your triad on the staff, using F as your root, as seen in Figure 10-8.



If you were to build an A flat major chord, you would first write down the key signature for A flat major and then build the triad, as shown in Figure 10-9.



Minor triads

A minor triad is made up of a root, a minor third above the root, and a perfect fifth above the root. As with major triads, you can build minor triads two different ways, as noted in the following sections.

Half-step counting method

As with major triads, you can count out the half steps between notes to build a minor chord using this formula:

Root position + 3 half steps + 4 half steps (7 half steps above root)

Figure 10-10 shows C minor on the piano keyboard, and Figure 10-11 shows it on the staff. In Figure 10-10, notice the pattern of half steps between the root, the third, and the fifth.

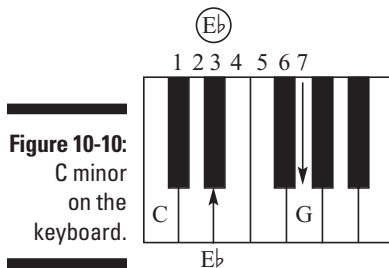

First, minor third, and fifth method

The second way to construct minor triads is to just take the first, the minor or *flat third* (which means you lower the third degree of the major third one half step), and fifth intervals from a major scale.

For example, for an F minor chord, you write down the key signature for F major and then build the triad, as in Figure 10-12.

Figure 10-12:

The F minor triad lowers the third one half step.

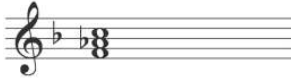

If you were to build an A flat minor chord, you would write the A flat key signature and add the notes, flattening the third, as shown in Figure 10-13.

Figure 10-13:

The A flat minor triad lowers the third one half step.



Augmented triads

Augmented triads are major triads that have had the fifth *raised* a half step, creating a slightly dissonant sound.



An augmented triad is a stack of major thirds with four half steps between each interval.

You can build a C augmented triad (written as *Caug*) by counting out the half steps between intervals, like this:

Root position + 4 half steps + 4 half steps (8 half steps above root)

C augmented is shown in Figures 10-14 and 10-15.

Figure 10-14:
C augmented on the keyboard.

Figure 10-15:
C augmented
on the staff.



Using the method of starting with the major key signature first and then building the chord, the formula you want to remember for building augmented chords is

Augmented triad = 1 + 3 + sharp 5

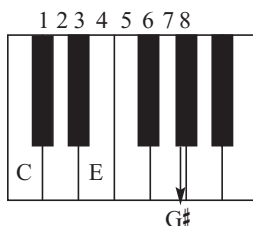
So the first major scale degree and third major scale degree stay the same in the chord, but the fifth major scale degree is raised a half step.



It's important to note here that *sharp 5* doesn't mean that the note will necessarily be a sharp. Instead, it means that the fifth note occurring in the scale degree is raised, or sharped, a half step.

Therefore, if someone asks you to write down an augmented F triad, you first write the key signature for F and then write your triad on the staff, using F as your root and raising the fifth position one half step, as shown in Figure 10-16.

Figure 10-16:
The F augmented triad.



If you were to build an A flat augmented triad, you would go through the same process and come up with a triad that looks like the one in Figure 10-17. Note that the perfect fifth of A flat major is an E flat. Given A flat's key signature, you have to "natural" the fifth to get to that E natural.

Figure 10-17:
The A flat augmented triad.



Diminished triads



Diminished triads are minor triads that have had the fifth *lowered* a half step.

Diminished triads are stacks of minor thirds with three half steps between each interval.

You can build a C diminished triad (written as *Cdim*) by counting out the half steps between intervals, like this:

Root position + 3 half steps + 3 half steps (6 half steps above root)

C diminished is shown in Figures 10-18 and 10-19.

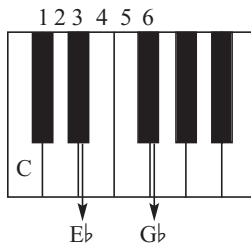

Figure 10-18:
C diminished
on the
keyboard.



Figure 10-19:
C diminished
on the staff.



Using the method of starting with the major key signature first and then building the chord, the formula you want to remember for building diminished chords is

Diminished triad = 1 + flat 3 + flat 5

So the first major scale degree stays the same, but the third major scale degree and the fifth major scale degree are both lowered one half step.



It's important to note here that the terms *flat 3* and *flat 5* don't mean these notes will necessarily *be flats*. These notes are only the third and fifth notes occurring in the scale degree lowered a half step.

Therefore, if someone asks you to write down an F diminished triad, you first write the key signature for F, and then you write your triad on the staff, using F as your root and lowering the third and fifth intervals one half step, as shown in Figure 10-20.

Figure 10-20:
The F diminished triad.

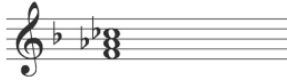

If you were to build an A flat diminished triad, you would go through the same process and come up with a triad that looks like the one in Figure 10-21.

Figure 10-21:
The A flat diminished triad.



Note that the perfect fifth of A flat major is an E flat — flattening the fifth makes it a double flat.

Expanding to Seventh Chords

When you add another third above the fifth of a triad, you've gone beyond the land of triads. You now have a *seventh chord*. Seventh chords got their name because the last third interval is a seventh interval above the root.

Several kinds of seventh chords exist. The six most commonly used seventh chords are as follows:

- ✓ Major sevenths
- ✓ Minor sevenths
- ✓ Dominant sevenths
- ✓ Minor 7 flat 5 chords (also sometimes called *half-diminished*)
- ✓ Diminished sevenths
- ✓ Minor-major sevenths



The easiest way to understand how sevenths are built is to think of each as a triad with a seventh tacked onto it. Looking at sevenths this way, you can see that seventh chords are really just variations on the four triads discussed earlier in this chapter. The names of the chords tell you how to put the seventh together with the triad.

The following sections walk you through building a variety of different sevenths: major, minor, dominant, diminished, and more. Table 10-2 gathers all this info on how to build sevenths.

Table 10-2 Building Sevenths

<i>Building Sevenths by Counting Half Steps</i>	
Major =	Root + 4 half steps + 3 half steps + 4 half steps (11 half steps above root)
Minor =	Root + 3 half steps + 4 half steps + 3 half steps (10 half steps above root)
Dominant =	Root + 4 half steps + 3 half steps + 3 half steps (10 half steps above root)
Minor 7 flat 5 =	Root + 3 half steps + 3 half steps + 4 half steps (10 half steps above root)
Diminished =	Root + 3 half steps + 3 half steps + 3 half steps (9 half steps above root)
Minor-major =	Root + 3 half steps + 4 half steps + 4 half steps (11 half steps above root)
<i>Building Sevenths with Major Scale Degrees</i>	
Major =	1, 3, 5, 7
Minor =	1, \flat 3, 5, \flat 7
Dominant =	1, 3, 5, \flat 7
Minor 7 flat 5 =	1, \flat 3, \flat 5, \flat 7
Diminished =	1, \flat 3, \flat 5, $\flat\flat$ 7
Minor-major =	1, \flat 3, 5, 7

Major sevenths

A major seventh chord consists of a major triad with a major seventh added above the root. Figure 10-22 shows how to first build a major triad using the C major example from earlier in the chapter.

Figure 10-22:
C major triad.



Now add a major seventh to the top of the pile, as is done in Figure 10-23. The result is

C major seventh = C major triad + major seventh interval

Figure 10-23:
C major seventh (CM7 or Cmaj7).



B natural is a major seventh from the root of the triad. Notice that it's also a major third (four half steps) away from the fifth of the triad.

Minor sevenths

A minor seventh chord consists of a minor triad with a minor seventh added above the root. Using the C minor example from earlier in the chapter, you first build a minor triad like the one in Figure 10-24.

Figure 10-24:
C minor triad (Cm or Cmi).



Now add a minor seventh to the top of the pile, as is done in Figure 10-25. The result is

C minor seventh = C minor triad + minor seventh

Figure 10-25:
C minor seventh (Cm7).



B flat is a minor seventh (ten half steps) from the root of the triad. It's also a minor third (three half steps) away from the fifth of the triad.

To build a minor seventh using major scale degrees, you pick the first, flatted third, fifth, and flatted seventh degrees from the scale.

Dominant sevenths

A dominant seventh chord, sometimes called a *major-minor* seventh chord, consists of a major triad with a minor seventh added above the root, as shown in Figure 10-26. The formula for this seventh is

C dominant seventh = C major triad + minor seventh

Figure 10-26:
C dominant
seventh (C7).

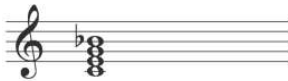

Ten half steps fall between the root and the minor seventh, and three half steps fall between the fifth of the triad and the minor seventh.



The dominant seventh is the only seventh chord that doesn't truly give away the relationship between the triad and the seventh in its name. You just have to remember it. And don't confuse major seventh and dominant seventh chords. The major seventh is always written as M7, whereas the dominant seventh is written simply as 7 (occasionally, dom7). For example, G major seventh is written GM7, and the dominant is written G7.

To build a dominant seventh using major scale degrees, you pick the first, third, fifth, and flatted seventh degrees from the scale.

Minor 7 flat 5 chords

A *minor 7 flat 5 chord* (or *half-diminished seventh*) is a diminished triad with a minor seventh added above the root. Its name, minor 7 flat 5, tells you everything you need to know about how this chord is supposed to be put together.

Minor 7 refers to the seventh being a minor seventh, or ten half steps, from the root, as shown in Figure 10-27.

Figure 10-27:

The root and minor seventh of a C minor 7 flat 5 chord.



Flat 5 refers to the diminished triad, which shares a flatted third with a minor chord but also has a flatted fifth, as shown in Figure 10-28.

Figure 10-28:

C diminished triad.



Put the two together, and you have the C minor 7 flat 5 (half-diminished) chord, as shown in Figure 10-29.

Figure 10-29:

C minor 7 flat 5 chord.

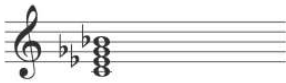

To build a minor 7 flat 5 (half-diminished) chord using major scale degrees, you pick the first, flatted third, flatted fifth, and flatted seventh degrees from the scale.

Diminished sevenths

The *diminished seventh* chord is a stack of three consecutive minor thirds. The name is also a dead giveaway on how the chord is to be built. Just as with the major seventh, which is a major triad with a major seventh, and the minor seventh, which is a minor triad with a minor seventh, a diminished seventh is a diminished triad with a diminished seventh from the root tacked onto it. You can see a diminished seventh in Figure 10-30. The formula for the diminished seventh is as follows:

C diminished seventh = C diminished triad + diminished seventh

Figure 10-30:
C diminished
seventh
(Cdim7).

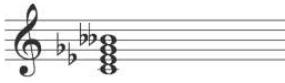

Note that the seventh in a diminished seventh is *double-flatted* from the major seventh, so the diminished seventh of Cdim7 is a double-flatted B. Just as with intervals, though, spelling counts — no matter what accidentals appear, a C seventh chord has to have some form of C, E, G, and B.

To build a diminished seventh using major scale degrees, you pick the first, flatted third, flatted fifth, and double-flatted seventh degrees from the scale.

Minor-major sevenths

The name *minor-major sevenths* isn't supposed to be confusing. The first part of the name tells you that the first part of the chord, the triad, is a minor chord, and the second part of the name tells you that the second part of the chord, the seventh, is a major seventh above the root.

Therefore, to build a minor-major seventh chord, start with your minor chord, as shown in Figure 10-31.

Figure 10-31:
C minor
triad.



Then add your major seventh, as in Figure 10-32. The formula is as follows:

C minor-major seventh = C minor + major seventh interval

Figure 10-32:
C minor-
major
seventh
(Cm/M7).



To build a minor-major seventh using major scale degrees, you pick the first, flatted third, fifth, and seventh degrees from the scale.

Looking at All the Triads and Sevenths

This section lays out all the types of triads and sevenths we discuss in this chapter in order of appearance and for every key. Figures 10-33 through 10-47 illustrate the triads and sevenths.

A

PLAY THIS!



Play Track 67 to hear the triads and sevenths of A: A major, A minor, A augmented, A diminished, A major seventh, A minor seventh, A dominant seventh, A minor 7 flat 5, A diminished seventh, and A minor-major seventh.

Track 67

Figure 10-33:
A triads and
sevenths.



A flat

PLAY THIS!



Play Track 68 to hear the triads and sevenths of A flat: A flat major, A flat minor, A flat augmented, A flat diminished, A flat major seventh, A flat minor seventh, A flat dominant seventh, A flat minor 7 flat 5, A flat diminished seventh, and A flat minor-major seventh.

Track 68

Figure 10-34:
A flat
triads and
sevenths.

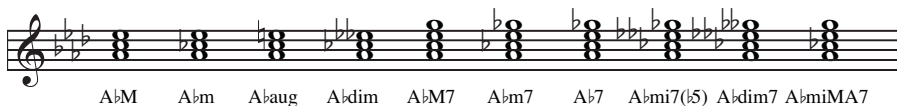

B



Play Track 69 to hear the triads and sevenths of B: B major, B minor, B augmented, B diminished, B major seventh, B minor seventh, B dominant seventh, B minor 7 flat 5, B diminished seventh, and B minor-major seventh.

Track 69

Figure 10-35:
B triads and
sevenths.

BM Bm Baug Bdim BM7 Bm7 B7 Bmi7(b5) Bdim7 BmiMA7

B flat



Play Track 70 to hear the triads and sevenths of B flat: B flat major, B flat minor, B flat augmented, B flat diminished, B flat major seventh, B flat minor seventh, B flat dominant seventh, B flat minor 7 flat 5, B flat diminished seventh, and B flat minor-major seventh.

Track 70

Figure 10-36:
B flat
triads and
sevenths.

B♭M B♭m B♭aug B♭dim B♭M7 B♭m7 B♭7 B♭mi7(b5) B♭dim7 B♭miMA7

C



Play Track 71 to hear the triads and sevenths of C: C major, C minor, C augmented, C diminished, C major seventh, C minor seventh, C dominant seventh, C minor 7 flat 5, C diminished seventh, and C minor-major seventh.

Track 71

Figure 10-37:
C triads and
sevenths.

CM Cm Caug Cdim CM7 Cm7 C7 Cmi7(b5) Cdim7 CmiMA7

C flat

PLAY THIS!



Play Track 72 to hear the triads and sevenths of C flat: C flat major, C flat minor, C flat augmented, C flat diminished, C flat major seventh, C flat minor seventh, C flat dominant seventh, C flat minor 7 flat 5, C flat diminished seventh, and C flat minor-major seventh.

Note: C flat is an enharmonic equivalent of B. The chords here sound exactly like the B chords, but in the interest of being complete, we include C flat as well.

Track 72

Figure 10-38:
C flat
triads and
sevenths.

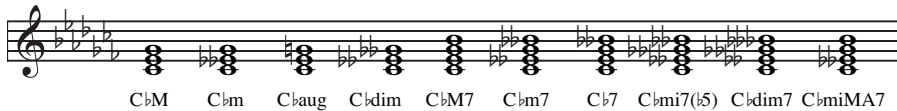

C sharp

PLAY THIS!



Play Track 73 to hear the triads and sevenths of C sharp: C sharp major, C sharp minor, C sharp augmented, C sharp diminished, C sharp major seventh, C sharp minor seventh, C sharp dominant seventh, C sharp minor 7 flat 5, C sharp diminished seventh, and C sharp minor-major seventh.

Track 73

Figure 10-39:
C sharp
triads and
sevenths.

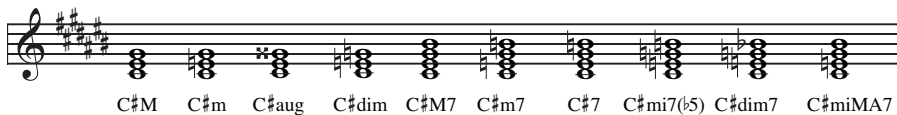

D

PLAY THIS!



Play Track 74 to hear the triads and sevenths of D: D major, D minor, D augmented, D diminished, D major seventh, D minor seventh, D dominant seventh, D minor 7 flat 5, D diminished seventh, and D minor-major seventh.

Track 74

Figure 10-40:
D triads and
sevenths.

DM Dm Daug Ddim DM7 Dm7 D7 Dmi7(b5) Ddim7 DmiMA7

D flat

PLAY THIS!



Play Track 75 to hear the triads and sevenths of D flat: D flat major, D flat minor, D flat augmented, D flat diminished, D flat major seventh, D flat minor seventh, D flat dominant seventh, D flat minor 7 flat 5, D flat diminished seventh, and D flat minor-major seventh.

Track 75

Figure 10-41:
D flat
triads and
sevenths.

D^bM D^bm D^baug D^bdim D^bM7 D^bm7 D^b7 D^bmi7(b5) D^bdim7 D^bmiMA7

E

PLAY THIS!



Play Track 76 to hear the triads and sevenths of E: E major, E minor, E augmented, E diminished, E major seventh, E minor seventh, E dominant seventh, E minor 7 flat 5, E diminished seventh, and E minor-major seventh.

Track 76

Figure 10-42:
E triads and
sevenths.

EM Em Eaug Edim EM7 Em7 E7 Emi7(b5) Edim7 EmiMA7

E flat

PLAY THIS!



Play Track 77 to hear the triads and sevenths of E flat: E flat major, E flat minor, E flat augmented, E flat diminished, E flat major seventh, E flat minor seventh, E flat dominant seventh, E flat minor 7 flat 5, E flat diminished seventh, and E flat minor-major seventh.

Track 77

Figure 10-43:
E flat
triads and
sevenths.

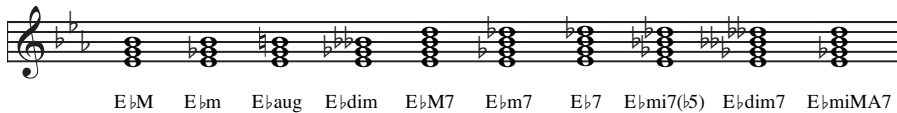

F

PLAY THIS!



Play Track 78 to hear the triads and sevenths of F: F major, F minor, F augmented, F diminished, F major seventh, F minor seventh, F dominant seventh, F minor 7 flat 5, F diminished seventh, and F minor-major seventh.

Track 78

Figure 10-44:
F triads and
sevenths.



F sharp

PLAY THIS!



Play Track 79 to hear the triads and sevenths of F sharp: F sharp major, F sharp minor, F sharp augmented, F sharp diminished, F sharp major seventh, F sharp minor seventh, F sharp dominant seventh, F sharp minor 7 flat 5, F sharp diminished seventh, and F sharp minor-major seventh.

Track 79

Figure 10-45:
F sharp
triads and
sevenths.



G

Play Track 80 to hear the triads and sevenths of G: G major, G minor, G augmented, G diminished, G major seventh, G minor seventh, G dominant seventh, G minor 7 flat 5, G diminished seventh, and G minor-major seventh.

Track 80

Figure 10-46:
G triads and
sevenths.

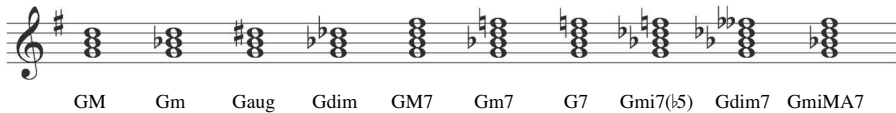
**G flat**

Play Track 81 to hear the triads and sevenths of G flat: G flat major, G flat minor, G flat augmented, G flat diminished, G flat major seventh, G flat minor seventh, G flat dominant seventh, G flat minor 7 flat 5, G flat diminished seventh, and G flat minor-major seventh.

Track 81

Figure 10-47:
G flat
triads and
sevenths.

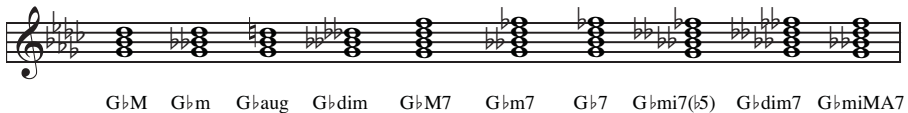

Manipulating Triads through Voicing and Inversion

Here's a riddle: When is a triad not a perfect little stack of thirds built on top of a root? Answer: when its *voicing* is *open*, or when it's *inverted*. *Voicing*, or *spacing* as it's referred to in some classical circles, simply refers to the way a chord is arranged.

Taking a look at open and close voicing

Sometimes, the notes of a triad are spread out over two or more octaves, with the different parts rearranged so that, for example, the root may carry

the highest-sounding note, or the third, or the fifth can carry the lowest-sounding note. The notes are still the same (C, E, G, for example) — they're just located an octave or even octaves above or below where you would expect them in a normal triad. When all the notes of a chord are in the same octave, the chord is considered to be in a *close voicing*.

Figure 10-48 shows a C major chord with close voicing.

Figure 10-48:

C major
chord with
close
voicing.



The chord in Figure 10-49, however, is also a C major chord, but with *open voicing*, meaning that the notes in the chord aren't all located in the same octave.

Figure 10-49:

C major
chord with
open
voicing.



Both chords in Figures 10-48 and 10-49 have the same notes contained in the triad, but in the latter case the third has been raised a full octave from its close position. Both chords are still considered to be in the *root position*, because the root note, C, is still the lowest note of the triad.

Identifying inverted chords

If the lowest-sounding pitch of a chord is *not* the root, the chord is considered to be *inverted*. Here are the possible inversions of a triad:

- ✓ **First inversion:** If the third of a chord is the lowest-sounding note, the chord is in *first inversion*. Figure 10-50 shows the C major chord in first inversion, with close (same octave) and open (different octaves) voicing.

- ✓ **Second inversion:** When the fifth of a chord is the lowest-sounding note, the chord is in *second inversion*. Figure 10-51 shows the C major chord in second inversion.
- ✓ **Third inversion:** When the seventh of a chord is the lowest-sounding note, that chord is in *third inversion*. Figure 10-52 shows the C major 7 chord in third inversion.

Figure 10-50:
C major
chord in first
inversion,
close and
open
voicing.

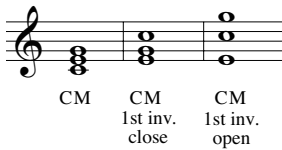

Figure 10-51:
C major
chord in
second
inversion,
close and
open
voicing.

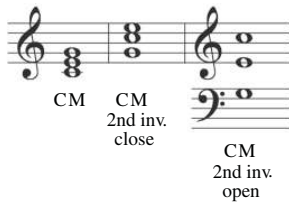
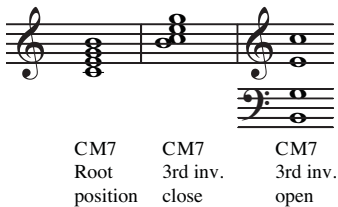

Figure 10-52:
C major 7
chord in
third inver-
sion, close
and open
voicing.



So how do you identify inverted chords? Simple: They aren't arranged in stacks of thirds. To find out which chord it is, you have to rearrange the

chord into thirds again. Only one way exists to rearrange a chord into thirds, so you don't have to guess on the order of the notes. You may need a little patience, though.

Look at, for instance, the three inverted chords shown in Figure 10-53.

Figure 10-53:
Inverted
chords.



If you try moving the notes up or down octaves (in order to rearrange them so they're all in stacks of thirds), they end up being an F sharp major triad, a G diminished seventh, and a D major triad (see Figure 10-54).

Figure 10-54:
Rearranging
the inverted
chords into
stacks of
thirds.



From rearranging the chords, you can tell that the first example was an F sharp major in second inversion, because the fifth was the lowest-sounding note in the chord. The second example was a G diminished seventh, also in second inversion, because the fifth of the chord was at the bottom of the stack. The third example was a D major triad in first inversion, because the third of the chord was the lowest-sounding note.

Having double the fun

Besides the methods we preview in this chapter, you also can build a chord through *doubling*, which simply means you have multiple versions of the root, third, fifth, or even seventh in a chord. A C major triad is still a C major triad

with two C's in it, for example, so long as it has at least one E and G. It's also still a C major triad if it has multiple E's or G's; however, doubling the root note is the most common use of doubling.

Chapter 11

Chord Progressions

In This Chapter

- ▶ Progressing with diatonic and chromatic chords and minor scale modes
 - ▶ Getting a handle on chord progressions and their notation
 - ▶ Taking advantage of seventh chords
 - ▶ Understanding fake books and tabs
 - ▶ Having a quick peek at modulation
 - ▶ Using chord progressions to produce cadences
-

As you may have guessed, constructing music is about as far from randomly throwing notes together as writing a book is from randomly pulling letters out of a Scrabble bag. There are about as many rules to putting a song together as there are to putting a sentence together, and in this chapter we show you a few more.

When you analyze the bulk of Western harmonic music, you start to see certain patterns emerge in the ways chord progressions are built. It's possible for any one chord to progress to any one of the other chords in a key; however, certain chord progressions are used more frequently than others. Why? Because they simply sound better. These progressions obviously are natural patterns that are pleasing to listeners and composers alike, because the same patterns continuously appear in popular music, classical, rock, jazz, and so on.

Music theorists have taken note of these patterns and have come up with a set of rules concerning chord progressions. These rules, which we discuss throughout this chapter, are immensely helpful in songwriting.

Reviewing Diatonic Chords, Chromatic Chords, and Minor Scale Modes

The key signature of a piece of Western music tells you which notes can be used in that piece. Therefore, if you have a song written in C major, the only seven notes that can appear (in any order) in the song are C, D, E, F, G, A, and B (with the odd sharp or flat thrown in as rare exceptions allowed by accidentals). If your song is written in A major, the only notes appearing in that song will be A, B, C sharp, D, E, F sharp, and G sharp (again, with possible accidentals). The chords will also be made of some combination of these seven notes for each key.



Chords built on the seven notes of a major key signature are called *diatonic chords*. Chords that are built on notes *outside* of the key signature are called *chromatic chords*.

Minor keys get a little trickier because nine notes can potentially fit under a single minor key signature when you consider the melodic and harmonic minor scales (review Chapter 7 if you're unclear on these kinds of minor scales).

Because the natural, melodic, and harmonic scales are taught as separate scales, musicians often have the misconception that you must stick to only one of these types of minor scales when composing music. Alas, for those folks who like nice, simple rules to build music against, this just isn't so.



The easiest way to think about chords built on minor keys is to recognize that each key signature has just one minor scale. One facet of minor keys is the flexible nature of the 6th and 7th degrees of the scale.

The 6th and 7th degrees can be in the scale in two different ways depending on what sounds better in the context of the music. Often the two different versions of those degrees, or *modes*, will appear in the same piece of music. The minor scale therefore has potentially nine notes in it, as shown in Figure 11-1.

Figure 11-1:
The A minor scale, including harmonic and melodic mode steps.

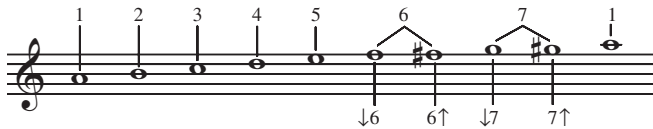

Notice how the use of arrows indicates where the 6th and 7th degrees are either raised (up arrow) or unaltered (down arrow).

Identifying and Naming Chord Progressions

Triads strung together to form a succession of chords are called *progressions*. Chord progressions make up pretty much all of Western harmonic music. (You can read more about triads in Chapter 10.)



When breaking down a piece of music based on chord progressions, roman numerals represent the different scale degrees. Capitalized roman numerals represent the chords with a major third, and lowercased roman numerals represent the minor chords. Other special characters indicate whether the chord is diminished ($^{\circ}$) or augmented ($+$), as you can see in Table 11-1.

<i>Chord Type</i>	<i>Roman Numeral Format</i>	<i>Example</i>
Major	Uppercase	V
Minor	Lowercase	ii
Diminished	Lowercase with $^{\circ}$	vii $^{\circ}$
Augmented	Uppercase with +	III+

Assigning chord names and numbers

Because the name of a chord comes from its root note, it's only natural that the root of each chord located within a scale would also carry the scale degree with its name. In other words, a chord's name tells you what the chord is, based on the root note, whereas a chord's *number* tells you what the chord does, based on key.

For example, consider the C major scale. Each note of the C major scale is assigned a scale degree number and name, like so:

<i>Scale Degree Number and Name</i>	<i>Note</i>
1 Tonic	C
2 Supertonic	D
3 Mediant	E
4 Subdominant	F
5 Dominant	G
6 Submediant	A
7 Leading tone	B
8/1 Tonic	C

When you build triads within the C major scale, each triad is assigned the scale degree of the root in its name, as shown in Figure 11-2.

Figure 11-2:
Tonic triads
in the C
major scale.

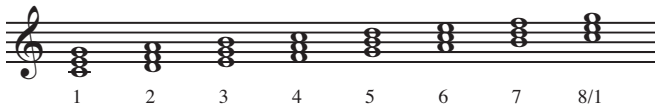

Looking at chord progressions in major keys

The chart for chord progressions in the C major scale looks like this:

<i>Scale Degree Number/Name</i>	<i>Note</i>
I Tonic	C
ii Supertonic	D
iii Mediant	E
IV Subdominant	F
V Dominant	G
vi Submediant	A
vii [°] Leading tone	B
(I) Tonic	C

Because the leading tone is a diminished triad, it has the [°] symbol next to its roman numeral.

Figure 11-3 takes another look at the C major scale, this time with the chords' names according to the root of each triad written underneath them (and their shorthand names, such as CM or Dm, written above them). The capital *M* in the chord's shorthand name (such as in CM) stands for major, and the lower-case *m* (such as in Em) stands for minor.

Figure 11-3:
Triads contained within the key of C major.

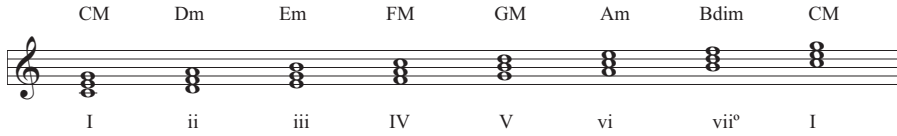

As you can see in Figure 11-3, the chord progression naturally follows the pattern of ascending the scale starting with the tonic note, in this case C. Figure 11-4 shows the triads contained within the key of E flat major. The eight notes that make up the key of E flat major are used to produce the eight chords shown in Figure 11-4.

Figure 11-4:
Triads contained within the key of E flat major.

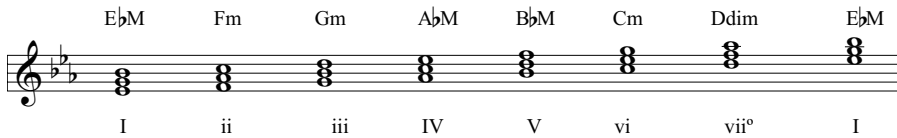

Notice that the pattern of major and minor chords is the same for C major and E flat major. In fact, it's the same for every major key. So if you say a chord is a ii chord, other musicians will automatically know that it's minor.

Table 11-2 shows common chord progressions for major keys. Any of the triads in the table with an added seventh chord are also acceptable in that triad's numbered place as well. (You can read more about seventh chords in the later section "Adding a Seventh Chord to a Triad.")



Major key signatures can contain minor chords.

Table 11-2 Common Major Key Chord Progressions	
Chord	Leads To
I	Can appear anywhere and lead anywhere
ii	I, V, or vii° chords
iii	I, IV, or vi chords
IV	I, ii, V, or vii° chords
V	I or vi chords
vi	I, ii, iii, IV, or V chords
vii°	I chord

Checking out chord progressions in minor keys

When dealing with minor keys, the construction of triads is unfortunately a lot more involved than it is with the major keys. The 6th and 7th degrees of the scale are variable, depending on whether the music uses notes from the natural minor, harmonic minor, or melodic minor. So for nearly all minor triads, more possibilities for building chords exist in the 6th and 7th degrees than they do in the major scale. Therefore, if you're looking at a piece of music written in C minor, the possible chords within that key are the ones in Figure 11-5.

Figure 11-5:
Possible triads within the key of C minor.

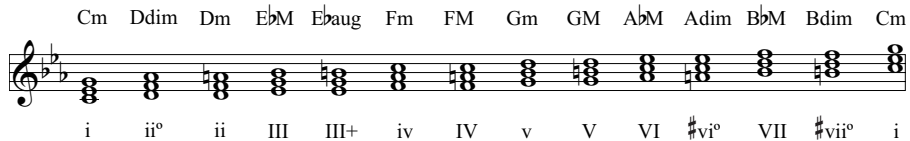

Although any of the chords from Figure 11-5 are possible, the most common choices made by traditional composers are those shown in Figure 11-6.

Figure 11-6:
Possible scale degrees used in C minor.

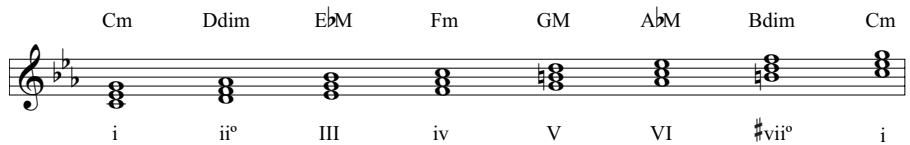

Notice in Figure 11-6 that the supertonic and the leading tone triads are diminished, resulting in a combination of the natural, harmonic, and melodic scales in coming up with this set of chords. Neither chord uses scale degree 6, so these two chords result from the natural and harmonic minor scales only.



You may find it helpful to remember that, with the raised 7th degree, the 5th (V) and 7th (vii°) degrees of both major and minor scales of the same letter name are identical.

Table 11-3 shows common chord progressions for minor chords. Any of the triads in Table 11-3 with added seventh chords are also acceptable in that triad's



numbered place as well. The parenthetical chords are the less-commonly used, but still acceptable, chords that would work in the progression.

Minor key signatures can contain major chords.

Table 11-3 Common Minor Key Chord Progressions

<i>Chord</i>	<i>Leads To</i>
i chords	Can appear anywhere and lead anywhere
ii° (ii) chords	i, V (v), or vii° (VII) chords
III (III+) chords	i, iv (IV), VI (#vi°), or vii° (VI) chords
iv (IV) chords	i, V (v), or vii° (VII) chords
V (v) chords	I or VI (#vi°) chords
VI (#vi°) chords	i, III (III+), iv (IV), V (v), or vii° (VII) chords
vii° (VII) chords	i chord

Adding a Seventh Chord to a Triad

Of course, we can't forget the seventh chords (you may want to peek at Chapter 10 for a refresher on these chords). When you add the additional seventh above the regular triad, you end up with a combination of the triad's chord symbols and the seventh's symbol.

When dealing with progressions that use seventh chords, you'll see symbols like the one in Figure 11-7. This symbol indicates a *minor 7 flat 5 chord*, also sometimes called a *half-diminished seventh*.

Figure 11-7:

This symbol means the chord is a minor 7 flat 5 chord (half-diminished seventh).



Table 11-4 shows the roman numerals that composers use to describe seventh chords.

Table 11-4 Seventh Chord Labels		
<i>Seventh Chord Type</i>	<i>Roman Numeral</i>	<i>Example</i>
Major 7th	Uppercase with M7	IM7
Major minor 7th	Uppercase with a 7	V7
Minor 7th	Lowercase with a 7	iii7
Minor 7 flat 5	Lowercase with \emptyset 7	ii \emptyset 7
Diminished 7th	Lowercase with $^\circ$	vii $^\circ$

Be aware that the “M7” by the I and IV chords is common to popular music — classical musicians tend to just use a “7” for these chords. Figure 11-8 shows the seventh chords based on C major.

Figure 11-8: Sevenths in C major.

CM7 Dm7 Em7 FM7 G7 Am7 Bm7(b5) CM7

I^{M7} ii⁷ iii⁷ IV^{M7} V⁷ vi⁷ vii^{o7} I^{M7}

When taking into consideration the natural, harmonic, and melodic scales, 16 seventh chords can occur in a minor key. The seventh chords shown in Figure 11-9 are the most commonly used.

Figure 11-9: Seventh chords in C minor.

Cm7 Dm7(b5) EbM7 Fm7 G7 AbM7 Bdim7 Cm7

i⁷ ii^{o7} III^{M7} iv⁷ V⁷ VI^{M7} #vii^{o7} i⁷

Table 11-5 collects, in one place, the major, minor, and seventh chord symbols.

<i>Major Scale Triads</i>	<i>Minor Scale Triads</i>	<i>Rare Chords Based on Minor Scales</i>	<i>7th Chords Based on Major Scales</i>	<i>7th Chords Based on Minor Scales</i>
I	I		IM7	i7
ii	ii°	ii	ii7	iiø7
iii	III	III+	iii7	IIIIM7
IV	Iv	IV	IVM7	iv7
V	V	v	V7	V7
vi	VI	#vi°	vi7	VIM7
vii°	#vii°	VII	viiø7	#vii°7

Seeing (And Hearing) Chord Progressions in Action

In this section, we show you some musical examples so you can see the rules of chord progression in practice. (You can read about these rules in the earlier section “Identifying and Naming Chord Progressions.”) Note that when we talk about *chords*, we’re not only talking about the stacked triads and sevenths, but we’re talking about the individual notes that make up the chords as well.

Take a look at the traditional song “London Bridge,” a portion of which is shown in Figure 11-10.

Figure 11-10: First seven measures of “London Bridge.”

The musical score for the first seven measures of "London Bridge" is shown in 4/4 time. The melody line (treble clef) and bass line (bass clef) are presented. The lyrics are: "Lon- don bridge is fall- ing down, fall- ing down, fall- ing down, Lon- don bridge is fall- ing down, My fair". Above the melody line, the chords are labeled: C, G7, C, C, G7, C, G7. Below the bass line, the chords are labeled: I, V7, I, V7.

Notice that the first two measures of the song use the notes found in the C major triad (C, E, and G), making C major the I chord. In the third measure, the first chord is a G7 chord (G, B, D, and F). The fourth measure goes back to the C/I chord, and returns to the G7/V chord in the seventh measure.

Judging from the common chord progression in Table 11-2, the next chord would have to be a I or vi chord. See Figure 11-11 to find out what happens next.

Figure 11-11:
As you can see, the song returns to the I chord.

I

The example shown in Figure 11-12 is a lead sheet for the traditional English folk song “Scarborough Fair.” (We explain lead sheets in the next section.) Less traditional versions of some of the chords in the minor scale are used here: the III, IV, and VII chords. The pattern of progression still holds, though: The i chord leads to the VII chord, the III to the IV, and then another III to the VII chord. The I/i chord can appear anywhere in a piece of music — and, in this one, it certainly does.



TIP

Like everything in music and art in general, you’re the creator of your work, and you can decide whether you want to follow the rules or try something completely different. However, Tables 11-2 and 11-3 earlier in the chapter do make a good launch pad for familiarizing yourself on how chords fit against one another. Just for fun, try playing, or just listening to, the following chord progressions to get a feel of how easy it can be to build a great song — or at least a halfway decent pop song.

PLAY THIS!



Play Track 82 to hear the I-V-I (GM-DM-GM) chord progression in G major. Play Track 83 to hear the I-ii-V-I-iii-V-vii°-I (CM-Dm-GM-CM-Em-GM-Bdim-CM) chord progression in C major. Play Track 84 to hear the i-iv-V-VI-iv-vii°-i (Fm-Bflatm-CM-Dflatm-Bflatm-Edim-Fm) chord progression in F minor.

Figure 11-12 is a lead sheet for the song "Scarborough Fair." It consists of four staves of music in 3/4 time. Each staff shows a melody line with corresponding chord diagrams and Roman numeral labels below. The chords are: Dm (i), C (VII), Dm (-i), F (III), Dm (i), G (IV), A (V), Dm (i), F (III), C (VII), Dm (i), C (VII), and Dm (i). The melody is written in treble clef.

Figure 11-12:
Lead sheet
for "Scar-
borough
Fair."



Play Track 85 to hear the i-III-VI-III-VII-i-v7-i (Am-CM-FM-CM-GM-Am-Em7-Am) chord progression in A minor.

Applying Chord Knowledge to Fake Books and Tabs

If you've ever picked up a *fake book* (thousands and thousands of these are available), you've seen lead sheets. *Lead sheets* provide just enough information for a performer to play a song competently by providing the lead melody line and noting the basic chords beneath the melody lines or above the staff to fill out the harmony, either with a straight chord or with improvisation. Figure 11-13 shows a short example.

Figure 11-13:
A sample of
a lead sheet.

Figure 11-13 shows a sample of a lead sheet. It features a single staff of music in treble clef with a key signature of one sharp (F#). The melody consists of four measures. Below the staff, the chords are labeled: EM, Em, Edim, and EM7.

Fake books are great for working on note reading and for improvising within a key. Often, for guitar fake books, the lead sheets go so far as to draw the chords for you with *tablature*, or *tabs*. You've been looking at guitar tabs in this book already. Figure 11-14 shows the guitar tab for an E major chord.

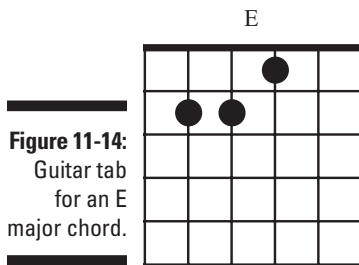

When reading guitar tabs, you just put your fingers on the guitar fret board where the little black dots are, and presto — you've got your chord. The lines in the figure represent the guitar strings, with the low E string on the far left. Guitar tabs in lead sheets also have the name of the chord written right next to the tab, making it even easier to either improvise or anticipate the notes that may logically be in the melody line.

Modulating to a New Key

Sometimes a piece of music temporarily moves into a new key. This move is called *modulation*. Modulation is common in traditional classical music, and long symphony and concerto movements almost always spend at least some time in a different key, usually a closely related key such as the relative minor or relative major of the original key. The key signature of these pieces of music remain the same, of course, but the qualities of and Roman numerals assigned to the chords are completely different, leading to a completely different set of chord progressions.



If you find that a piece of music suddenly contains chord progressions that you wouldn't expect in that key, it may be that the piece has modulated. Lots of accidentals in a piece or a new key signature stuck in the middle of a piece are clues that the music has modulated.

A favorite way for modulating current pop music is to simply move the key up one whole step, for example, from F major to G major (a lot of music theorists call this a “truck driver” modulation, since it feels like shifting into a higher gear). As long as you remember to keep your key signatures straight, dealing with modulation within a piece usually isn't a problem.

Reaching a Musical Cadence through Chord Progressions

A *cadence* is any place in a piece of music that has the feel of an ending. Cadence can refer to a strong, definite stopping point, like at the end of a song or even a movement or section, but it can also refer to a short pause that comes at the end of an individual musical phrase.

A piece of music can come to an end by simply stopping, of course, but if that stopping position doesn't "make sense" to the listeners, they're not going to be happy with it. Ending a song on the wrong note or notes is like ending a conversation mid-sentence, and most listeners react with dissatisfaction at a song simply stopping instead of ending properly.



A universally satisfying ending provides clues in the music, through chord progressions, that tell the listener the end of the song is near. Like the ending of a story (or a sentence, paragraph, chapter, or book), an ending in music "makes sense" if it follows certain constraints or rules. As with the customs for storytelling, these expectations can be different in different musical genres or traditions.

Of course, if you're writing music, you don't *have* to follow any of the rules of cadence, including the rules designed to provide a certain level of comfort and satisfaction for your listeners. But if you don't, be prepared for angry, torch-wielding mobs to follow you home after your performances. Don't say we didn't warn you.

The basic foundation of most music is a *harmonic goal*, where a phrase starts at a I chord and follows a series of chord progressions to end at a IV or V chord, depending on the genre (popular music tends to use the IV-I more often, and classical music uses the V-I) and the type of cadence used in the song (see Chapter 10 for more on the different types of chords). A song can have two chords or a hundred chords, and it can be a 3-second song or a 45-minute song, but, no matter what, eventually it *will* reach that harmonic goal of the IV or V chord before going back to the I chord.



A continuum of tension and release moves through music, with the I chord being the point of rest or release and every chord leading up to the return to the I chord being points of tension. The two-chord progression between the IV or V chord and the I chord is the cadence.

When you really think about it, the entire history of Western music can be summed up by I-V-I or I-IV-I. From Baroque-period music to rock 'n' roll, this formula holds darned true. What's really amazing is that this simple formula has resulted in so many songs that sound so different from one another. This

variation is possible because the notes and chords in a key signature can be arranged in so many different ways.

Here are the four types of cadences commonly used in Western harmonic music:

- ✓ Authentic cadence
- ✓ Plagal cadence
- ✓ Deceptive cadence
- ✓ Half-cadence

We discuss each of these cadences in the following sections.

Authentic cadences

Authentic cadences are the most obvious-sounding cadences and are therefore considered the strongest. In an authentic cadence, the harmonic goal of the musical phrase that starts with a I/i chord and ends with a cadence is the V chord; the cadence occurs when you move from that V/v chord to an I/i chord. The phrase involved in the authentic cadence essentially ends at the V/v chord, and the song either ends completely there or starts a new phrase with the I/i chord.



Listen to Track 86 for an example of an authentic cadence.

Two types of authentic cadences are used in music:

- ✓ Perfect authentic cadence (PAC)
- ✓ Imperfect authentic cadence (IAC)

In the following sections, we provide information on each.

Perfect authentic cadence

In a *perfect authentic cadence*, or PAC as it's often called by acronym-loving music theorists, the two chords that make up the cadence are both in their root positions, meaning (as we discuss in Chapter 13) that the note on the bottom of the stack is the *root* (the note the chord is named after).

The strongest PAC occurs when the second chord, the I/i chord, has the root of the chord on both the bottom *and* the top of the stack of notes. This PAC makes for a high-impact end to a song.

Note in Figure 11-15 how the top note on the I chord is the same as the bottom note, making the root of the chord both the highest and lowest-pitched note of the chord.

Figure 11-15:
A perfect
authentic
cadence
(PAC).

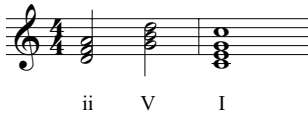

Listen to Track 87 for an example of a perfect authentic cadence.

Imperfect authentic cadence

A V-I chord progression made with inverted chords — chords where the root, third, and fifth aren't in a perfect stack — is called an *imperfect authentic cadence* (IAC).

The difference between a PAC and an IAC is illustrated in Figure 11-16. Note how the PAC ends with the root of the chord in the root position, whereas the IAC ends with an inverted chord.

Figure 11-16:
Difference
between a
PAC and
an IAC.

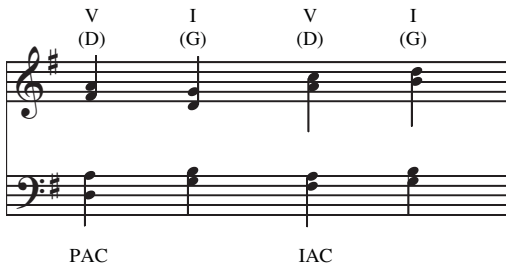

Listen to Track 88 to hear the difference between a perfect authentic cadence and an imperfect authentic cadence.

Plagal cadences

The harmonic goal of a *plagal cadence* is ultimately the four (IV/iv) chord, with the cadence occurring when that chord moves to the 1 (I/i) chord. Possible plagal cadences include IV-I, iv-i, iv-I, and IV-i.

This structure originated with medieval church music, mostly vocal music, and is therefore often referred to as the *Amen cadence*. If you're familiar with Gregorian chants or even many modern hymns, you've heard the Amen cadence in action. The cadence usually happens, not surprisingly, at the point where the chanters sing the two-chord "A-men."

“Amazing Grace,” whose music is shown in Figure 11-17, contains a great example of a plagal cadence. Where would *American Idol* be without this classic gem?

Figure 11-17:
A plagal cadence in “Amazing Grace.”

A - maz - ing - grace! how sweet the sound! That
'Twas grace that - taught my heart to fear. And
Thro' man - y - dan - gers, toils, and snares I
When we've been - there ten thou - sand years. Bright

G D7 Em C G

IV I

PLAY THIS!



Listen to Track 89 to hear an example of a plagal cadence.

Plagal cadences are usually used within a song to end a phrase, instead of at the very end of a song, because they're not as decisive-sounding as perfect cadences are.

Figure 11-18 shows two more examples of plagal cadences.

Figure 11-18:
Two more examples of plagal cadences.

IV (F) I (C) IV (F) I (C)

PLAY THIS!



Listen to Track 90 to hear two more examples of plagal cadences.

Deceptive cadences

A *deceptive cadence* (sometimes called an *interrupted cadence*) reaches an ultimate point of tension on a V/v chord, just like the authentic cadence, but then it resolves to something other than the tonic (I/i) chord. Hence the name *deceptive cadence*. You think you're about to return to the I chord, but then you don't.

A deceptive cadence leads from the V/v chord to any chord *other* than the I/i chord. Deceptive cadences are considered one of the weakest cadences because they invoke a feeling of incompleteness.

The most common deceptive cadence, used 99 times out 100, is when you have a V/v chord that moves up to a vi/VI chord. The phrase looks and feels like it's about to end and close with the I chord, but instead it moves up to the vi instead, as shown in Figure 11-19. The VI or vi is the most common second chord used in deceptive cadences because it shares two notes with the I chord and thus heightens the "deception" when a listener expects to hear I.

Figure 11-19:
Deceptive cadence.

The figure shows a musical score for a deceptive cadence in 4/4 time. The treble clef staff contains two chords: a V chord (G4, B4, D5) and a vi chord (F4, A4, C5). The bass clef staff contains the corresponding bass notes: B2, D3, F3 for the V chord, and F3, A2, C3 for the vi chord. The chords are labeled 'V' and 'vi' below the bass staff.



Listen to Track 91 to hear an example of a deceptive cadence.

Half-cadence

With a *half-cadence*, the musical phrase ends *at* the point of tension, the V/v chord itself. It basically plays to a V chord and stops, resulting in a musical phrase that feels unfinished. This cadence received its name because it just doesn't feel like it's done yet.

The most common form of half-cadence occurs when the V chord is preceded by the I chord in second inversion (when the fifth of a chord is the lowest-sounding note; see Chapter 10). This pattern produces two chords with the same bass note, as you can see in Figure 11-20. The first measure of the figure shows keyboard spacing, and the second measure shows vocal spacing.

Figure 11-20:
Half-
cadences
don't quite
sound
finished.

The figure shows two musical staves. The top staff is in treble clef and contains two measures of music. The first measure has a chord of G4, B4, and D5. The second measure has a chord of A4, C5, and E5. The bottom staff is in bass clef and contains two measures of music. The first measure has a chord of G2, B2, and D3. The second measure has a chord of A2, C3, and E3. Below the bottom staff, the first measure is labeled 'I V' and 'Keyboard spacing', and the second measure is labeled 'I V' and 'Vocal spacing'.



Listen to Track 92 to hear an example of a half-cadence.

Part III

Musical Expression through Form, Tempo, Dynamics, and More

The 5th Wave

By Rich Tennant



"My compositions always follow the same progression: fear, denial, and acceptance."

In this part . . .

In this part, you discover how different kinds of music are structured. From the smallest phrases of music through whole symphonies, structure is important. In the big picture, from classical to rock, blues, and jazz, music comes in numerous distinct forms and genres, and this part helps get you acquainted with them. This part also touches on varied sound in the form of tempo, dynamics, and instrument tone.

Chapter 12

The Building Blocks of Music: Rhythm, Melody, Harmony, and Song Form

In This Chapter

- ▶ Reviewing rhythm, melody, and harmony
 - ▶ Understanding musical phrases and periods
 - ▶ Picking out and labeling the parts of a song
-

When we talk about musical *form*, we mean the structural blueprint used to create a specific type of music. For example, if you want to write a sonata, you follow a specific song structure. Although style elements like the basic melody, theme, and key signature would be entirely up to you, the way the sonata as a whole fits together — the beginning, middle, and ending — is set right from the beginning by the constraints of the sonata form itself.



In many ways, knowing how form works makes composing music extremely easy. After all, the pattern's already there — you just have to fill in the blanks. The real challenge is making your particular sonata, fugue, or concerto stand out from every other piece of music written in that form.

A lot of crossover exists between the definitions of form and genre, but they are two different concepts. *Genre* is more about how music sounds, regardless of its structure; examples are jazz, pop, country, and classical (although there are also certain forms unique to classical music).

The problem with identifying forms in modern music is that new music is still evolving. Students of music form in the 21st century may soon be studying

anti-4/4 math-rock pioneers like Steve Albini alongside the composers Philip Glass and Beethoven.

In this chapter, we explain exactly what we mean when we refer to “musical form,” and we discuss some of the more common musical forms you’ll encounter.

Establishing Rhythm

We can’t talk about form and genre without talking about rhythm, which is the most basic element of music. You can write a piece of music without a melody line or without harmonic accompaniment, but you just can’t write a piece of music without rhythm — unless, of course, your “music” is one single, sustained note with no variations in pitch.

Often, the rhythm differentiates one genre from another — such as the difference between alternative rock and punk rock, for example. Put a faster tempo to any Son Volt or Wilco song, and you can file the result in the same section of the record store as the Ramones and the Sex Pistols. Change the inherent rhythm patterns of a song, even a Sex Pistols song, and you can change it to anything from a tango to a waltz. Rhythm is *that* important to genre.

Rhythm moves through music as a generative force in several different ways. It creates the basic pulse of a song, as discussed in Part I of this book. Rhythm is the part of the song your toes tap along to and your head nods to. Meter (determined by the individual measures in a piece of music; see Chapter 4 for more about measures) helps organize notes into groups using a time signature and defines the repetitive pattern of strong and weak beats that noticeably move a song along. This pulse creates a feeling of familiarity and expectation for the listener so that, theoretically, you can throw a pile of unexpected, jangly notes and chords at the listener and still retain a feeling of connection with your audience by holding on to them with the same, steady beat.

The actual rhythm that you hear when you listen to a song is usually referred to as the *surface rhythm*. For example, often when people say they like the *beat* of a pop song, they mean they enjoy the surface rhythm, which may simply be a rhythmic pattern on the drums. Sometimes the surface rhythm matches the underlying pulse of a song (the beat as determined by the time signature that governs the entire piece of music), especially in pop music, where the drums and the bass lines usually follow the basic beat. But sometimes, because of *syncopation* (which emphasizes the “off” beats), the surface rhythm and the pulse don’t match up.

Tempo comes into play when you discuss the speed of the rhythm of a piece. Is it going to move along quickly and lively or somberly and slowly? The speed at which a piece of music is played determines the overall feeling of the music for the audience. Rarely do you have a super-happy song played slowly and quietly, nor do you hear a super-sad song played at “Flight of the Bumblebee” speeds (see Chapter 15 for more about tempo).

Shaping the Melody

Most often, the melody is the part of the song you can’t get out of your head. The *melody* is the lead line of a song — the part that the harmony is built around, and the part that gives as much glimpse into the emotion of a piece as the rhythm does. (Refer to the later section on harmony for more information.)

Much of melody’s expressive power comes from the upward or downward flow of pitch. The pitch of a song goes up, and it can make the song sound like it’s getting either more tense or more lively; the pitch of a song goes down, and it can give that part of the song an increased melancholic or dark feel. The shape of the pitch’s travels is called its *contour*.

Here are the four common *melodic contours*:

- ✓ Arch
- ✓ Wave
- ✓ Inverted arch
- ✓ Pivotal

Contour simply means that the melody is shaped a certain way; the shape of a melody is especially easy to pick out when you have the sheet music right in front of you. The possibilities for building melodic phrases (that is, starting at the I chord, going up to the IV or V chord, and ending at the I chord; see Chapter 11 for more information about chord progressions) with just four basic contours are virtually infinite. For more information about composing music, *Music Composition For Dummies* by Holly Day and Scott Jarrett (John Wiley & Sons, Inc.) is a good place to start.

Figure 12-1 shows a stretch of music that has an *arch contour*. Note how the melody line in the treble clef first goes up in pitch from a low point to a high point and how it then goes back down again, creating the arch. When music goes up in pitch gradually like this, it results in an increase in tension in that section of the composition. The lower the pitch gets in such a gradual arch, the more the level of tension decreases.

Figure 12-1:

In the arch contour, the pitch of notes goes up and then down.

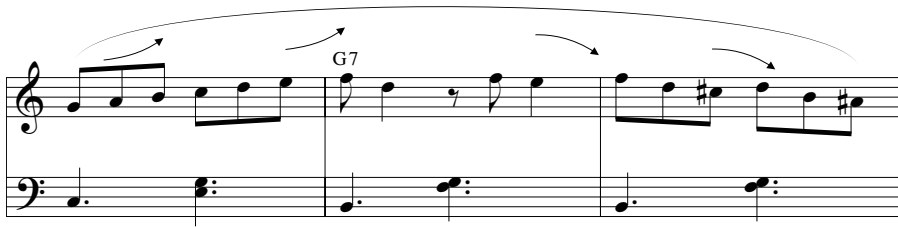

Figure 12-2 shows music with a *wave contour*. Note how the melody line goes up, and down, and up again, and down again — just like a series of waves.

Figure 12-2:

In the wave contour, pitch goes up and down and up and down, like waves on the sea.



Figure 12-3 shows music with an *inverted arch contour*. You may have noticed that the music in Figure 12-3 looks a lot like that in Figure 12-1. The only difference is that the melody line in Figure 12-3 goes down in pitch and then up to the end of the phrase. Therefore, the phrase starts out sounding relaxed and calm but contains an increase in tension as the arch rises toward the end of the phrase.

Figure 12-3:

In the inverted arch contour, the pitch starts out high, goes down, and then heads up again.



Figure 12-4 shows an example of music with a *pivotal contour*. A pivotal melody line essentially pivots around the central note of the piece — in the case of the music in Figure 12-4, the E. A pivotal contour is a lot like a wave contour, except that the movement above and below the central note is minimal and continuously returns to that central note. Traditional folk music uses this melodic pattern a lot.

Figure 12-4:
The pivotal contour revolves around a certain pitch.



Any melody line in a piece of music generally falls into one of the preceding categories of contour. Try randomly picking up a piece of sheet music and tracing out the melody pattern yourself to see what we mean.



The *range* of a melody is determined by the interval between the highest and lowest pitches of the song. The rise and fall of tension is often proportional to its range. Melodies with a narrow pitch range tend to have only a slight amount of musical tension in them, whereas melodies with a wide range of pitches are more likely to have a greater level of tension. As the range of pitches in a song is widened, the potential for greater levels of tension increases.

Complementing the Melody with Harmony

Harmony is the part of the song that fills out the musical ideas expressed in the melody (see the preceding section for more on melody). Often, when you build a harmony based on a melodic line, you're essentially filling in the missing notes of the chord progressions used in the song. For example, take a look at the simple melody line shown in Figure 12-5.

Figure 12-5:

A simple melody line in the key of C.



You can fill out the harmony in Figure 12-5 by simply grabbing the notes of the I and V chords and placing them in the bass line, as shown in Figure 12-6.

Figure 12-6:

Harmony for a melody line in the key of C.

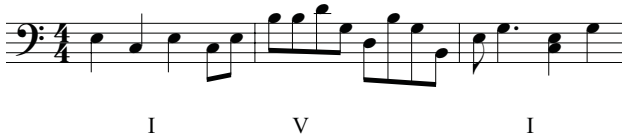

To put it really simply, harmony is all about the building of *chords*, which are tones coming from the scale in which the music is composed. (You can read more about chords in Chapter 10.) Harmony also stems from the order of the chord progressions themselves, and also how a phrase resolves itself through the V-I or IV-I cadence (see Chapter 11 for coverage of cadences).



Consonant harmonies are those that sound stable and pleasing to the ear, such as the I chord at the end of a phrase. *Dissonant* harmonies sound unstable and unpleasant to the ear; they may sound wrong or seem to clash until they're resolved into consonant harmonies. Tension can be created in a song through harmony by creating dissonance, often by adding extra third intervals on top of a triad to build sevenths, ninths, and so on. (Check out Chapter 9 for coverage of intervals.) Many seventh chords are dissonant harmonies. Composers also use the tension between consonance and dissonance to establish a sense of a beginning and ending in a song.

Working with Musical Phrases and Periods

Two of the building blocks of musical form are phrases and periods. A *musical phrase* is the smallest unit of music with a defined beginning and end. Most musical phrases consist of a beginning I chord progressing to a IV or a

V chord and ending again on the I chord. Theoretically, thousands of chord progressions may exist between that first I chord and the IV or V chord. However, you may lose your audience in that time.

Musical phrases are like sentences in a paragraph — just as most readers don't want to wade through a thousand lines of text to find out the point of a sentence, most music audiences are listening for the musical idea expressed in a phrase and get bored if it sounds like you're just meandering between chords and not coming to a resolution.

So how long should a musical phrase be? It's really up to the composer, but generally, a phrase is usually two to four measures long. Within that space, a phrase begins, works through one or more chord progressions, and resolves itself back to the I chord. (Check out Chapter 11 for the scoop on chord progressions.)

When a composer really wants you to understand that a group of measures are to be linked together in a phrase and played as an important unit — kind of like a topic sentence in an essay — he or she links the phrase together with a curved line called a *phrase line*, as shown in Figure 12-7. Notice how the phrase both begins and ends on the I chord, or the G major chord. (The numbers above the Roman numerals are fingering markings for the pianist; you don't need to worry about them.)

Figure 12-7:
Note the phrase line in the bass clef.



Don't confuse phrase lines with ties and slurs. A phrase line ties an entire musical phrase together, whereas slurs and ties only tie together a small part of a phrase. (If you want to read about ties, head to Chapter 2. We discuss slurs in Chapter 15.)

The phrase represents the smallest unit ending with a cadence in a piece of music. The next larger unit used in musical form is the period. Musical *periods* are created when two or three musical phrases are linked together. In the case of musical periods, the first musical phrase is one that ends in a half-cadence (ending *at* the V/v chord), and the second phrase ends with an authentic cadence (ending with the V/v chord resolving to the I/i chord). We cover cadences in Chapter 11.



The half-cadence comes across like a comma in a sentence, with the authentic cadence, or consequent, ending the linked phrases like a period.

Figure 12-8 shows an example of a musical period.

Figure 12-8:
A musical period is made of linked phrases.

Linking Musical Parts to Create Forms

The division of music into *parts* occurs when you link two or more periods that sound like they belong together. (See the preceding section for a discussion of periods.) They share major harmonic focal points, similar melody lines, and similar rhythm structure. They may have other resemblances, too. Parts can be further linked together to create musical *forms*.

Composers conventionally give alphabetic labels to the musical parts within a composition: A, B, C, and so forth. If a part is repeated in a song, its letter also is repeated. For example, ABA is a familiar layout in classical music, where the opening *theme*, or the main musical idea that runs through a song (labeled A), after vanishing during part B, is repeated at the end of the song.

As the *contrast form*, where you have different musical sections that can differ widely from one another, AB forms come in a boundless array of possibilities. You may see recurring sections, unique ones, or any combination of both. For example, a *rondo* — a popular form in classical music — alternates between a recurring section and others that occur one time each. A rondo, then, would be labeled ABACADA . . . (and so on).

You may even encounter an *ongoing form*, which has no recurrence whatsoever: ABCDE. . . This form creates what's known as a *through-composed* piece of music.

In the following sections, we describe some of the most common forms you may encounter in music.

Rachel Grimes, composer, on the limits of form

In school, there's the tendency to get didactic about theory, so you get into this mind-set that only certain chord progressions are allowed, and all the rest aren't. Pop music is very didactic that way. There are certain expected standards, like you're not allowed to go to a VI chord after resolving to a IV or a V — you're just expected to

go to the I, and there really isn't much deviation from that pattern. I think the biggest challenge for students and users of music theory is to accept that certain groundwork has been laid out for them, so far as what sounds "right" in Western music, but that deviations from that groundwork and those patterns are still allowed.

One-part form (A)

The *one-part form*, also known as *A form* or *unbroken form*, is the most primitive song structure and is also sometimes referred to as the *air form* or *ballad form*. In a one-part form, a simple melody is repeated with slight changes to accommodate different words, as in a *strophic* song like "Old McDonald Had a Farm." This song repeats the same musical line but changes the words with each verse.

The one-part form is mostly found in folk songs, carols, or other songs that are short and have a limited theme and movement. A forms come only in a single variety. They may be long or short, but they're always described as A (or AA, or even AAA).

Binary form (AB)

Binary form consists of two contrasting sections that function as statement and counterstatement. The pattern may be a simple AB, as in "My Country, 'Tis of Thee," or in simple minuets, where the form is usually AABB, with the second A and second B being variations of the first A and B.



In the binary form used in the Baroque period, the pattern can involve a change of key, usually to the key of the fifth of the original key if the piece is in a major key. Part A begins in one key and ends in the key of the fifth, while part B begins in the new key and ends in the original key. Each part is repeated, giving the pattern AABB.

Musicians reflect on knowing when a song is done

Steve Reich (composer): When I start out, I always have a rough idea of how much time I have to work with a piece of music, whether it's going to be a long piece or a short piece of music. And that's often dependent on whoever's commissioning the piece. Exactly how long it is, how many minutes it ends up being — that's worked out by musical intuition, which is the rock-bottom foundation of composing music for me, and, I think, for most composers. In other words, you sketch out the number of movements you're going to have, and the basic harmonies you're going to be using to get through the movements, and the rest is worked out in detail largely by intuition, by listening to the music itself.

Barry Adamson (Nick Cave and the Bad Seeds): I guess there's a point where all the criteria are satisfied, and also, sometimes there's an immediate feeling that you didn't write the song, that it's something perfect and separate from yourself, because now you're hearing the finished thing and you can't remember how it was put together.

Momus (a.k.a. Nick Currie): I work very quickly. Concept, lyrical notes, chord structure, bass

line, percussion, more arrangement, vocal, mix. It's usually all done in one ultra-concentrated session of perhaps eight hours. A day's work. It's finished when you get the mix you like, simple as that. It's important to me not to leave things open. I like to make quick decisions, and bring things to a conclusion. This is probably one reason I'm so prolific.

John Hughes III (soundtrack composer): With me? I don't know. I think that's the biggest problem for me. I know, with other musicians, too, it's just sort of not knowing when to stop. So, usually, I usually feel my best stuff is the stuff I don't feel like I have to keep working on. Usually, if there's something that I keep on adding stuff to, and changing it over and over, it's probably already dead, and the core of it just isn't right. Usually, my favorite stuff, I'll get done really quick, and the longer I dwell on it — I don't know if it's just because I get sick of it or what — but you just kind of know when something's done.

Mika Vainio (Pan Sonic): When we feel that the song is bearable.

Three-part form (ABA)

Songs frequently take the form ABA, known as *three-part form* or *ternary/tertiary form*. This simple form is produced by varying and repeating the melody. For example, "Twinkle, Twinkle, Little Star" states a tune, varies it, and then restates it (which makes it ABA form). The B part here may be called the *bridge*, or the link, between the two A parts.

Here's how the three-part song form works:

- ✓ The first part, A, may be played once or repeated immediately.
- ✓ The middle part, B, is a contrasting section, meaning it's different than the first section.
- ✓ The last part is the same or very similar to the first part, A.

Three-part ABA form extends the idea of statement and departure by bringing back the first section. Both contrast and repetition are used in this form. Pop music is frequently a variation on ABA, called AABA, while blues is often AAB. AABA form is used in songs like “Over the Rainbow.”

Arch form (ABCBA)

Music written in *arch form* is made up of three parts: A, B, and C. In arch form, the A, B, and C are played sequentially, and then part B is played a second time, directly following the C, and the song ends with the replaying of the A part.

Chapter 13

Relying on Classical Forms

In This Chapter

- ▶ Understanding counterpoint and how it began
 - ▶ Reviewing the many classical and enduring forms
-

During the Golden Age of classical music, from the late 1700s to the mid-1800s, composers were competing viciously with one another to create new and more vibrant types of music. With the adoption of the piano by classical artists, existing ways of playing music could be further developed, including counterpoint, which uses both hands to create melody and harmony. In this chapter, we explain the development of counterpoint and its use in a variety of classical forms and genres, from sonatas and rondos to fugues, symphonies, and more.

Counterpoint as a Classical Revelation

The most famous development in the Golden Age of classical music was the emergence of counterpoint as a popular musical technique. Composers of the period began writing music for the left hand that was just as complicated as the music written for the right. The left-hand music they created often mirrored closely what the right hand had been playing.

Prior to the Classical period, the bass line in most music was limited to simple melodic accompaniment. This limited use of the bass line was a carry-over from the music of the Catholic Church, where the organ provided simple bass lines (figured bass) to accompany vocalists.

The invention of counterpoint not only enhanced the melody of musical arrangements, but it also blurred exactly where the melody ended and the harmony began. Almost every classical composer, using all the forms discussed in this chapter, has used counterpoint in his or her own music — even the right-handed ones. Figure 13-1 shows an example of counterpoint.

Figure 13-1:
Example of counterpoint from J.S. Bach's "Aus meines Herzens Grunde" ("From the Depths of My Heart").



Sussing Out the Sonata

The *sonata* was the most popular form used by instrumental composers from the mid-18th century until the beginning of the 20th century. This form is considered by many to be the first true break from the liturgical music that had made such an impact on Western music from the Medieval period on through the Baroque period.

Sonatas are based on the song (ternary) form, ABA, which means they have three defined parts: exposition, development, and recapitulation. (For more on the song form and other common forms, check out Chapter 12.) The true genius of the sonata is that not only does its structure allow many of the rules of basic music theory to be broken, but it also *encourages* such defiance. With a sonata, it's perfectly allowable to switch to a new key and time signature in the middle of the song. In the following sections, we explain the three parts of a sonata.

Starting with the exposition

The first part of a sonata, called the *exposition*, presents the basic thematic material of the *movement*, or each self-contained part of a piece of music. This part is also often broken up into two thematic parts:

- ✓ **First part:** Generally, the first part of the exposition presents the main theme of the song, or the musical “thread” that ties the piece together. This first part usually is the line that sticks the most in your head.
- ✓ **Second part:** The second part of the exposition is a “reflection” of the first part, in that it sounds a lot like the first part but is slightly changed.

Put on Beethoven’s Sonata in C Minor, Opus 13 to get a good example of these two defined parts, or look at the excerpts shown in Figures 13-2 and 13-3 from the same sonata.

Figure 13-2:
Excerpt
from the
opening
theme, first
part, of
Beethoven’s
Sonata in
C Minor,
Opus 13.



Figure 13-3:
Excerpt
from the
second part
of Sonata
in C Minor,
Opus 13,
which is a
reflective
theme of
the first.



Moving on to something new: Development

The second part of the sonata form, called the *development*, often sounds like it belongs to a completely different piece of music altogether. In this part, you can move through different key signatures and explore musical ideas that are completely different from the original theme.

Often this part of the sonata is the most exciting. Here you can include your big chords and increase tension with the use of stronger rhythm and greater *interval content* (number of interval steps between each note).

Figure 13-4 shows an excerpt from the development of Sonata in C Minor, Opus 13.

Figure 13-4:
Excerpt
from the
second part,
or develop-
ment, of
Beethoven's
Sonata in
C Minor,
Opus 13.

Taking a rest with recapitulation

After the excitement of a sonata's development, it feels natural to come to rest where you began. The third and final part of a sonata is the *recapitulation*, where the composition returns to the original key and the musical theme expressed in the first section and brings it all to a close. Figure 13-5 shows an excerpt of the final movement of Beethoven's Sonata No. 8. Sonata in C Minor, Opus 13.

The musical score consists of three systems of piano music. Each system is written for a grand staff (treble and bass clefs) in C minor (three flats) and 4/4 time. The first system contains four measures. The second system begins at measure 5 and contains five measures, with a slur encompassing measures 6 and 7. The third system begins at measure 10 and contains five measures.

Figure 13-5:
Excerpt
from the
third part of
Beethoven's
Sonata No.
8, Sonata
in C Minor,
Opus 13.

Rounding Up the Rondo

Rondos expand on the freedom of expression inherent in the sonata form (see the earlier section “Sussing Out the Sonata”) by allowing even more disparate sections of music to be joined together by a common musical section. The formula for a rondo is ABACA Technically, with a rondo you can indefinitely continue adding brand new sections — featuring different keys or time signatures — to a particular piece so long as you keep linking them together with the opening (A) theme. The A section of Mozart’s *Rondo Alla Turca* ties more than six different musical ideas together using this form. See Figure 13-6 for an excerpt.

The musical score for Figure 13-6 is presented in four systems. Each system consists of a treble clef staff and a bass clef staff. The time signature is 3/4. The first system (measures 1-6) features a melodic line in the treble clef and a rhythmic accompaniment in the bass clef. The second system (measures 7-14) includes a repeat sign and a first ending. The third system (measures 15-20) continues the melodic and rhythmic patterns. The fourth system (measures 21-26) concludes the excerpt with a final cadence.

Figure 13-6:

Excerpt
from the A
section of
Mozart's
*Rondo Alla
Turca*.

Figuring Out the Fugue

Another major musical form to come out of the Classical period was the *fugue*, the form fully developed by Bach, although it had been around for a century or so prior. A fugue is a highly evolved form of imitative counterpoint, in which two (or more) musical lines use the same theme, either at the same pitch or transposed. Fugues are defined by the way the notes in the treble clef and the notes in the bass clef switch off carrying the main theme and driving the rhythm of the piece, resulting in a call-and-response feel.

Note, for example, in Figure 13-7 how the eighth notes and sixteenth notes appear first in one clef and then in the other, making both clefs alternately

responsible for carrying the harmony (eighth notes) and melody (sixteenth notes) of the music.

Figure 13-7:
Excerpt
from Bach's
Fugue in C
Major.

Combining Forms into a Symphony

Literally, a *symphony* is a harmonious melding of elements. In music, a symphony is a piece of music that combines several different musical forms and is usually performed by an orchestra.

Traditionally, a symphony consists of four movements (self-contained sections inside a single musical piece):

- ✓ Sonata allegro, or fast sonata
- ✓ Slow movement (free choice)
- ✓ Minuet (a short, stately piece of dance music set in 3/4 time)
- ✓ Combination of sonata and rondo



The idea of a symphony is that it combines a multitude of musical forms harmoniously, so the aforementioned pattern is absolutely not set in stone.

The symphony form leaves the field for musical experimentation wide open. Some pieces that have come from this form are the most enduring and recognizable classical music pieces ever recorded. The most famous one, of course, is Beethoven's Symphony No. 5 (Opus 67), whose opening line, "Bu-bu-bu-BUM," is possibly the most universally known opening theme of any type of music. Figure 13-8 shows you the music for this legendary theme.

Allegro con brio

Figure 13-8:
Bu-bu-bu-
BUM....

Observing Other Classical Forms

The classical forms in the following sections are enduring and important. They're more determined by how many performers are involved in the

performance than the official structure of the music performed or the role of the performers themselves.

Concerto

A *concerto* is a composition written for a solo instrument backed by an orchestra. The concerto often creates superstars of classical music, such as pianist Lang Lang and violinist Itzhak Perlman. The soloists often carry as much weight as the long-dead composers themselves do.

Duet

Anybody who's ever sat through a piano lesson has probably played a *duet*, which is a piece of music written for two people. A duet generally consists of two pianists or a pianist and a vocalist. When other instrumentation is used, such as a bass and a violin, or some other combination, the term *duo* is most commonly applied.

Piano duets are most often used as teaching devices, with the student handling the basic melody line and the more advanced pianist handling the trickier accompaniment.

Etude

An *etude* is a brief musical composition based on a particular technical aspect of music, such as building scales, designed to help instruct the performer through musical exercise.

Fantasia

Fantasias are freeform and try to convey the impression of being completely improvised and divinely inspired, and are most often written for a solo instrument or a small ensemble. The modern equivalent of the fantasia is free jazz.

Chapter 14

Tapping Into Popular Genres and Forms

In This Chapter

- ▶ Dealing with the blues
 - ▶ Topping the charts with rock and pop
 - ▶ Kicking back with jazz
-

Discussing *form* when talking about popular music is tricky because the term is often misused. Think of form as being the specific way a piece of music is constructed, with governing rules to that type of music's construction (such as the classical forms discussed in Chapter 13). *Genre*, on the other hand, refers to a song's style, such as the instrumentation used, overall tone of the music, and so on.

However, some popular modern genres of music have been around long enough that specific patterns can be seen in their overall construction. These genres are:

- ✓ Blues
- ✓ Folk/rock/pop
- ✓ Pop
- ✓ Jazz

Feeling the Blues

The blues is the first truly American folk music (aside from the unique music that the Native Americans had before the European invasion). The structure of the blues is the common ancestor of pretty much all other constructions of American popular music and has been influential around the world. Around the turn of the 20th century, field holler, church music, and African percussion had all melded into what is now known as the blues. By 1910, the word *blues* to describe this music was in widespread use.

Blues music uses *song*, or *ternary*, form in three parts that follows an AABA pattern of I, IV, and V chords in a given scale. (You can read about song form in Chapter 12.) The B section is the *bridge*, a contrasting section that prepares the listener or performer for the return of the original A section. (Plenty of people complain that rock music only uses three chords: the I, IV, and V chords. Well, that all started with the blues!)



The blues is almost always played in 4/4 time, with the rhythm beat out either in regular quarter notes or in eighth notes and with strong accents given on both the first and third beats of each measure.

The most common types of blues songs are the 12-bar blues, the 8-bar blues, the 16-bar blues, the 24-bar blues, and the 32-bar blues. The “bar” refers to how many measures are used in each style of blues (see Chapter 4 for more about measures).

12-bar blues

The name is pretty self-explanatory: In *12-bar blues*, you have 12 bars, or measures, of music to work with. In each verse of the 12-bar blues (you can have as many verses as you want, but usually a 12-bar blues composition has three or four), the third 4-bar segment works to resolve the previous 4 bars. The resolution, or conclusion, to the I chord at the end of the verse may signal the end of the song. Or, if the 12th bar is a V chord, the resolution to the I chord signals that you go back to the beginning of the song to repeat the progression for another verse. If the song continues on to a new verse, the V chord at the end of the song is called the *turnaround*.



The most commonly used pattern — read from left to right, starting at the top and working down — for the 12-bar blues looks like this:

I	I	I	I
IV	IV	I	I
V	IV	I	V/I (turnaround)

So if you were playing a 12-bar blues song in the key of C, you would play it like this:

C	C	C	C
F	F	C	C
G	F	C	G/C (turnaround)

If you can hit those chords in that order, you have the bare bones for Muddy Waters’s classic “You Can’t Lose What You Ain’t Never Had.” Change the



tonic (I) chord to an A (AAAA DDAA EDAA/A), and you have Robert Johnson's "Crossroads Blues."

If you're playing the 12-bar blues in a *minor* key, here's the common pattern to use:

i	iv	i	i
iv	iv	i	i
ii	V	i	v/i (turnaround)

Count Basie's famous and much-loved variation on the 12-bar blues took elements of both the major and minor keys, as shown here:

I	IV	I	v
IV	IV	I	VI
ii	V	I	v/I (turnaround)

8-bar blues

8-bar blues is similar to 12-bar blues — it just has shorter verses in it and a slightly different common use of chord progressions. Here's the standard pattern used for 8-bar blues:

I	IV	I	VI
ii	V	I	V/I (turnaround)

16-bar blues

Another variation on the basic 12-bar blues is the 16-bar blues. Where the 8-bar blues is four bars shorter than the 12-bar blues, the 16-bar blues, as you can probably guess, is that much longer.

The 16-bar blues uses the same basic chord pattern structure as the 12-bar blues, with the 9th and 10th measures stated twice, like so:

I	I	I	I
IV	IV	I	I
V	IV	V	IV
V	IV	I	V/I

24-bar blues

The 24-bar blues progression is similar to a 12-bar traditional blues progression except that each chord progression is doubled in duration, like so:

I	I	I	I
I	I	I	I
IV	IV	IV	IV
I	I	I	I
V	V	IV	IV
I	I	I	V/I (turnaround)

32-bar blues ballads and country

The 32-bar blues pattern is where you see the true roots of rock and jazz music. This extended version of the 12-bar blues pattern has the AABA structure, also called *song form*, that was adopted by rock bands in the 1960s. The pattern is also referred to as the SRDC Model: Statement (A1), Restatement (A2), Departure (B), and Conclusion (A3).

A typical 32-bar blues layout can look something like this:

(A1)	I	I	VI	VI
	ii	V	IV	V
(A2)	I	I	VI	VI
	ii	V	IV	I
(B)	I	I	I	I
	IV	IV	IV	IV
(A3)	I	I	VI	VI
	ii	V	IV	V/I

When it was first created, 32-bar blues wasn't nearly as popular with "true" blues performers as the 12-bar structure was, partly because it didn't work as well with the short call-and-response form of lyricism that earmarked the blues. It did work well for the country music genre, though, and Hank Williams (Sr.) used this construction in songs like "Your Cheating Heart" and "I'm So Lonesome (I Could Cry)." Freddy Fender used this structure in his hits "Wasted Days and Wasted Nights" and "Before the Next Teardrop Falls."

However, when this particular blues structure was picked up by people like Irving Berlin and George Gershwin, a lot — perhaps all — of the true heart of blues disappeared from the resulting music. The 32-bar blues transitioned into popular songs like “Frosty the Snowman” and “I Got Rhythm.”

The 32-bar blues also was significantly altered by the intervention of other classically trained composers, who mixed the ideas of the sonata and the rondo (see Chapter 13) with the traditional American blues. The result was the eventual creation of non-bluesy-sounding songs that used such aspects of classical music as the ability to change keys during the bridge section of a song.

Having Fun with Rock and Pop

Most early rock and pop songs follow the structure of either the 12-bar blues or the 32-bar blues (see those sections earlier in this chapter). Chuck Berry’s “Johnny B. Goode” is one variation of the 12-bar blues structure used in rock, as is the Rolling Stones’s “19th Nervous Breakdown.” The Beach Boys were masters of the 32-bar structure, using it in such songs as “Good Vibrations” and “Surfer Girl.” The Beatles also used this structure in many of their songs, including “From Me to You” and “Hey Jude.” Jerry Lee Lewis’s “Great Balls of Fire,” The Righteous Brothers’s “You’ve Lost That Loving Feeling,” and Led Zeppelin’s “Whole Lotta Love” all also use the AABA 32-bar.

In 32-bar pop music, the music is broken into four 8-bar sections. Songs like Fats Waller’s “Ain’t Misbehavin’” and Duke Ellington’s “It Don’t Mean a Thing” follow the AABA 32-bar structure, whereas Charlie Parker took the rondo approach (ABAC) to the 32-bar variation in songs like “Ornithology” and “Donna Lee.”

Fender opens up the world of rock

The real break between blues and rock came when the first electric guitars hit the market in the late 1940s. Leo Fender built his first solid-body electric guitar, the precursor to the Telecaster, out of his garage in Orange County, California, around the same time that Les Paul was working on a similar design in New York. Both designs were loosely based on Adolph

Rickenbacher’s solid-body prototypes that had been making the rounds in the music industry since the 1930s. The electric guitar provided the opportunity to use such musical devices as *sustain* and *distortion*, which were previously unavailable to your average bluesman with an acoustic guitar.

Compound AABA form really should be called AABAB2 form (but it isn't), because in this form, after you play the first 32 bars, you move into a second bridge section (B2) that sends you right back to the beginning of the song to repeat the original 32 bars of the song. The Beatles's "I Want to Hold Your Hand," The Police's "Every Breath You Take," Boston's "More Than a Feeling," and Tom Petty and the Heartbreakers's "Refugee" all follow this pattern.

The *verse-chorus* structure (also called ABAB form) is the most widely used form in rock and pop music today. Verse-chorus form follows the structure of the lyrics attached to it. You can, of course, write an instrumental piece that follows the same pattern as a verse-chorus rock or pop song, but the structure itself gets its name from the way the words in a song fit together.



Verse-chorus songs are laid out like this:

- ✓ **Introduction (I):** The introduction sets the mood and is usually instrumental, although sometimes it may include a spoken recitation, like in Prince's "Let's Go Crazy."
- ✓ **Verse (V):** The verse begins the story of the song.
- ✓ **Chorus (C):** The chorus is the most memorable lyrical points of the song — the song's *hook*.
- ✓ **Verse (V):** Another verse continues the story.
- ✓ **Chorus (C):** The second chorus reinforces the hook.
- ✓ **Bridge (B):** The bridge, which may be instrumental or lyrical, usually occurs only once in the song and forms a contrast with the repetition of verses and choruses.
- ✓ **Chorus (C):** The final chorus repeats the original chorus to fade, or it just stops at the I chord.

The typical rock/pop song structure, as we describe it here, is IVCVCBC. And just as in the 12-bar blues structure, the chords of choice are the I, IV, and V chords.

Thousands, perhaps even millions, of popular songs follow this structure. The Beatles's "Ob-La-Di, Ob-La-Da," Tom Jones's "Sex Bomb," Kenny Rogers's "The Gambler," Lady Gaga's "Poker Face," and Eminem's "Lose Yourself" are all examples of this structure used in contemporary pop music. The really amazing thing is how different from one another, either by virtue of lyrics or the music itself, one song can sound from the next.

Mark Mallman, musician, on the rules

Don't let theory bring you down. Theory is the tool that you use to get where you want to go. Just remember, you're the boss of your music. But at the same time, theory is a language that will enable you to communicate more decisively and more easily with other musicians. Sometimes, I'll find the need to bring in an extra bassist, and I'll get these guys whose technique is great, and they know all these tunes, but they have no theory training. I'll yell out, "Let's go up to the 5!" during the course of a

song, and it takes them forever to figure out what we're doing, and I can't use someone like that. Every musician should know the basics of music theory, like scales, and how rhythm works, the really simple stuff that you can learn in a week. Knowing this stuff is like having all the secrets to making it through Super Mario Brothers. There's this magic that happens in a band setting when everyone knows where the other person is going with a song, and you can't have that magic without knowing theory.

Improvising with Jazz

The true spirit of jazz has always been improvisation, which makes identifying the actual construction of jazz most difficult. The goal in jazz is to create a new interpretation of an established piece (called a *standard*), or to build on an established piece of music by changing the melody, harmonies, or even the time signature. It's almost like the point of jazz is to break *away* from form.

The closest way to define how jazz is constructed is to take the basic idea behind blues vocalizations — the *call-and-response vocals* — and replace the voices with the various instruments that make up the jazz sound: brass, bass, percussive (including piano), and wind instruments, along with the more recent inclusion, the electric guitar. In Dixieland jazz, for example, musicians take turns playing the lead melody on their instruments while the others improvise *countermelodies*, or contrasting secondary melodies, that follow along in the background.



The one predictable element of music in the jazz genre — excluding *free jazz*, where no real discernible rules exist but jazz instrumentation is used — is the rhythm. All jazz music, with the exception of free jazz, uses clear, regular meter and strongly pulsed rhythms that can be heard throughout the music.

Chapter 15

Creating Varied Sound through Tempo and Dynamics

In This Chapter

- ▶ Keeping time with tempo
 - ▶ Controlling loudness with dynamics
-

Everybody knows that making good music is about more than just stringing a collection of notes together. Music is just as much about communication as it is about making sounds. And in order to really communicate to your audience, you need to grab their attention, inspire them, and wring some sort of emotional response out of them.

Tempo (speed) and *dynamics* (volume) are two tools you can use to turn those carefully metered notes on sheet music into the elegant promenade of Liszt's Hungarian Rhapsody No. 2, the sweeping exuberance of Chopin's études, or, in a more modern context, the slow creepiness of Nick Cave's "Red Right Hand."

Tempo and dynamics are the markings in a musical sentence that tell you whether you're supposed to feel angry or happy or sad when you play a piece of music. These markings help a performer tell the composer's story to the audience. In this chapter, we help you get familiar with both concepts and their accompanying notation.

Taking the Tempo of Music

Tempo means "time," and when you hear people talk about the tempo of a musical piece, they're referring to the speed at which the music progresses.

The point of tempo isn't necessarily how quickly or slowly you can play a musical piece, however. Tempo sets the basic mood of a piece of music. Music that's played very, very slowly, or *grave*, can impart a feeling of extreme somberness, whereas music played very, very quickly, or *prestissimo*, can seem maniacally happy and bright. (We explain these Italian terms, along with others, later in this section.)



The importance of tempo can truly be appreciated when you consider that the original purpose of much music was to accompany people dancing. Often the movement of the dancers' feet and body positions worked to set the tempo of the music, and the musicians followed the dancers.

Prior to the 17th century, composers had no real control over how their transcribed music would be performed by others, especially by those who had never heard the pieces performed by their creator. It was only in the 1600s that composers started using tempo (and dynamic) markings in sheet music. The following sections explain how tempo got its start and how it's used in music today.

Establishing a universal tempo: The minim

The first person to write a serious book about tempo and timing in music was the French philosopher and mathematician Marin Mersenne. From an early age, Mersenne was obsessed with the mathematics and rhythms that governed daily life — such as the heartbeats of mammals, the hoof beats of horses, and the wing flaps of various species of birds. This obsession led to his interest in the field of music theory, which was still in its infancy at the time. With the 1636 release of his book, *Harmonie universelle*, Mersenne introduced the concept of a universal music tempo, called the *minim* (named after his religious order), which was equal to the beat of the human heart, around 70 to 75 beats per minute (bpm). Furthermore, Mersenne introduced the idea of splitting his minim into smaller units so that composers could begin adding more detail to their written music.

Mersenne's minim was greeted with open arms by the musical community. Since the introduction of written music a few hundred years before, composers had been trying to find some way to accurately reproduce the timing needed for other musicians to properly perform their written works. Musicians loved the concept because having a common beat unit to practice with made it easier for individual musicians to play the growing canon of musical standards with complete strangers.

Keeping steady time with a metronome

Despite what you may have gathered from horror movies such as Dario Argento's *Two Evil Eyes* and a number of Alfred Hitchcock's films, that pyramid-shaped ticking box does have a purpose besides turning human beings into mindless zombies.



Practicing with a metronome is the best possible way to learn how to keep a steady pace throughout a song, and it's one of the easiest ways to match the tempo of the piece you're playing to the tempo conceived by the person who wrote the piece.

The metronome was first invented in 1696 by the French musician and inventor Étienne Loulié. His first prototype consisted of a simple weighted pendulum and was called a *cronomètre*. The problem with Loulié's invention, though, was that in order to work with beats as slow as 40 to 60 bpm, the device had to be at least 6 feet tall.

It wasn't until more than 100 years later that two German tinkerers, Dietrich Nikolaus Winkel and Johann Nepomuk Maelzel, worked independently to produce the spring-loaded design that's the basis for analog (non-electronic) metronomes today. Maelzel was the first to slap a patent on the finished product, and as a result, his initial is attached to the standard tempo sign, *MM=120*. *MM* is short for *Maelzel's metronome*, and the *120* means that 120 bpm, or 120 quarter notes, should be played in the piece.

Like the concept of the minim (refer to the previous section), the metronome was warmly received by musicians and composers alike. From then on, when composers wrote a piece of music, they could give musicians an exact number of beats per minute to be played. The metronomic markings were written over the staff so that musicians would know what to calibrate their metronomes to. For example, *quarter note=96*, or *MM=96*, means that 96 quarter notes should be played per minute in a given song. These markings are still used today for setting mostly electronic metronomes, particularly for classical and avant-garde compositions that require precise timing.

Translating tempo notation

Although the metronome was the perfect invention for control freaks like Beethoven, most composers were happy to instead use the growing vocabulary of tempo notation to generally describe the pace of a song. Even

today, composers still use the same Italian words to describe tempo and pace in music. These words are in Italian simply because when these phrases came into use (1600–1750), the bulk of European music came from Italian composers.

Table 15-1 lists some of the most standard tempo notations in Western music, usually found written above the time signature at the beginning of a piece of music, as shown in Figure 15-1.

Notation	Description
<i>Grave</i>	The slowest pace; very formal and very, very slow
<i>Largo</i>	Funeral march slow; very serious and somber
<i>Larghetto</i>	Slow, but not as slow as <i>largo</i>
<i>Lento</i>	Slow
<i>Adagio</i>	Leisurely; think graduation and wedding marches
<i>Andante</i>	Walking pace; close to the original minim
<i>Andantino</i>	Slightly faster than <i>andante</i> ; think Patsy Cline’s “Walking After Midnight,” or any other lonely cowboy ballad you can think of
<i>Moderato</i>	Right smack in the middle; not fast or slow, just moderate
<i>Allegretto</i>	Moderately fast
<i>Allegro</i>	Quick, brisk, merry
<i>Vivace</i>	Lively, fast
<i>Presto</i>	Very fast
<i>Prestissimo</i>	Maniacally fast; think “Flight of the Bumblebee”

Figure 15-1:

Allegro means the music would be played at a brisk pace.



Just to make things a little more precise, modifying adverbs such as *molto* (very), *meno* (less), *poco* (a little), and *non troppo* (not too much) are sometimes used in conjunction with the tempo notation terms listed in Table 15-1. For example, if a piece of music says that the tempo is *poco allegro*, it means that the piece is to be played “a little fast,” whereas *poco largo* would mean “a little slow.”



If you have a metronome, try setting it to different speeds to get a feel of how different pieces of music may be played to each different setting.



Play Track 93 to hear examples of 80 (slow), 100 (moderate), and 120 (fast) beats per minute.

Speeding up and slowing down: Changing the tempo

Sometimes a different tempo is attached to a specific musical phrase within a song to set it apart from the rest. The following are a few tempo changes you're likely to encounter in written music:

- ✓ **Accelerando (*accel.*):** Gradually play faster and faster.
- ✓ **Stringendo:** Quickly play faster.
- ✓ **Doppio movimento:** Play phrase twice as fast.
- ✓ **Ritardando (*rit.*, *ritard.*, *rallentando*, or *rall.*):** Gradually play slower and slower.
- ✓ **Calando:** Play slower and softer.

At the end of musical phrases in which the tempo has been changed, you may see *a tempo*, which indicates a return to the original tempo of the piece.

Dealing with Dynamics: Loud and Soft

Dynamic markings tell you how loudly or softly to play a piece of music. Composers use dynamics to communicate how they want a piece of music to “feel” to an audience, whether it’s quiet, loud, or aggressive, for example.

The most common dynamic markings, from softest to loudest, are shown in Table 15-2.

<i>Notation</i>	<i>Abbreviation</i>	<i>Description</i>
<i>Pianissimo</i>	<i>pp</i>	Play very softly
<i>Piano</i>	<i>p</i>	Play softly
<i>Mezzo piano</i>	<i>mp</i>	Play moderately softly
<i>Mezzo forte</i>	<i>mf</i>	Play moderately loudly
<i>Forte</i>	<i>f</i>	Play loudly
<i>Fortissimo</i>	<i>ff</i>	Play very loudly



Dynamic markings can be placed at the beginning or anywhere else within a piece of music. For example, in the music shown in Figure 15-2, *pianissimo* (*pp*) means that the piece is to be played very softly until you reach the next dynamic marking. *Fortissimo* (*ff*) means that the rest of the selection is to be played very loudly.

Figure 15-2:

The dynamic markings here mean you would play the first bar very softly, *pianissimo*, and the second bar very loudly, *fortissimo*.



Modifying phrases

Sometimes when reading a piece of music, you may find one of the markings in Table 15-3 attached to a musical phrase or a section of music generally four to eight measures long.

<i>Notation</i>	<i>Abbreviation</i>	<i>Description</i>
<i>Crescendo</i>	<i>cresc.</i> <	Play gradually louder
<i>Diminuendo</i>	<i>dim.</i> > or <i>decrecendo</i> <i>decr.</i> >	Play gradually softer

In Figure 15-3, the long <, called a *hairpin*, means to play the selection gradually louder and louder until you reach the end of the *crescendo*.

Figure 15-3:

The *crescendo* here means play gradually louder and louder until the end of the hairpin.



In Figure 15-4, the > hairpin beneath the phrase means to play the selection gradually softer and softer until you reach the end of the *diminuendo*.

Figure 15-4:

The *diminuendo*, or *decrecendo*, here means play gradually softer and softer until the end of the hairpin.

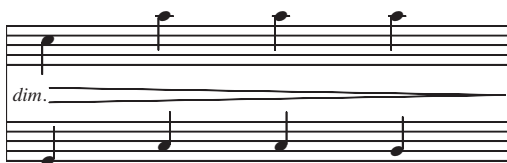

Another common marking you'll probably come across in written music is a *slur*, which you can see in Figure 15-5. Just like when your speech is slurred and the words stick together, a musical slur is to be played with all the notes “slurring” into one another. Slurs look like curves that connect the notes.

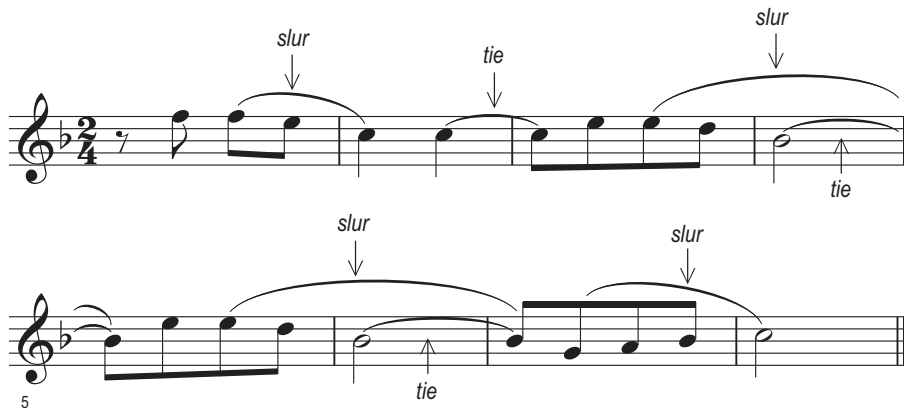

Figure 15-5:
Slurs over
groups of
notes.

Checking out other dynamic markings

You probably won't see any of the following notations in a beginning-to-intermediate piece of music, but for more advanced pieces, you may find one or two (listed alphabetically):

- ✓ ***Agitato***: Excitedly, agitated
- ✓ ***Animato***: With spirit
- ✓ ***Appassionato***: Impassioned
- ✓ ***Con forza***: Forcefully, with strength
- ✓ ***Dolce***: Sweetly
- ✓ ***Dolente***: Sadly, with great sorrow
- ✓ ***Grandioso***: Grandly
- ✓ ***Legato***: Smoothly, with the notes flowing from one to the next
- ✓ ***Sotto voce***: Barely audible

The piano: A composer's universal tool

Since its creation, the piano has been the universal tool of choice for composing music, because almost every note you would ever want to work with is present right there in front of you on the keyboard. Most pianos have at least seven octaves to work with, and a few concert pianos have eight.

You want to compose music for a bassoon? The lower registers of the piano work quite nicely. Pieces written for strings can be easily hammered out in the middle and upper registers. And unlike most other instruments, you can

play chords and multiple notes simultaneously on a piano, which works well for trying to figure out how that multi-instrument orchestral piece you're writing will eventually sound.

You can blame the fact that the piano was invented by an Italian, Bartolomeo Cristofori, for the bulk of tempo and dynamic markings being Italian words. From the first day of the piano's release to the initially Italian market, composers were finding new ways to write music on this spectacularly flexible instrument.

Examining the piano pedal dynamics

Additional dynamic markings relate to the use of the three foot pedals located at the base of the piano (some pianos have only two pedals). The standard modern piano pedal setup is, from left to right:

✓ **Soft pedal (or *una corda* pedal):** On most modern upright pianos, the soft pedal moves the resting hammers inside the piano closer to their corresponding strings. Because the hammers have less distance to travel to reach the string, the speed at which they hit the strings is reduced, and the volume of the resulting notes is therefore much quieter and has less sustain.

Most modern grand pianos have three strings per note, so when you press a key, the hammer strikes all three simultaneously. The soft pedal is called *una corda* (“one string”) because it moves all the hammers to the right so that they only strike one of the strings. This effectively cuts the volume of the sound by two-thirds.

✓ **Middle pedal:** If it's present (many modern pianos have only the two outer pedals to work with), the middle pedal has a variety of roles, depending on the piano. On some American pianos, this pedal gives the notes a tinny, honky-tonk piano sound when depressed. Some other

pianos have a bass sustain pedal as their middle pedal. It works like a sustain pedal but only for the bass half of the piano keyboard. Still other pianos — specifically many concert pianos — have a *sostenuto* pedal for their middle pedal, which works to sustain one or more notes indefinitely, while allowing successive notes to be played without sustain.

- ✓ **Damper pedal (or sustaining or loud pedal):** The damper pedal does exactly the opposite of what the name would imply — when this pedal is pressed, the damper inside the piano *lifts off* the strings and allows the notes being played to die out naturally. This creates a ringing, echoey effect for single notes and chords (which can be heard, for example, at the very end of The Beatles’s “A Day in the Life”). The damper pedal can also make for a really muddled sound if too much of a musical phrase is played with the pedal held down.



In sheet music notation, the entire musical phrase to be altered by use of pedals is horizontally bracketed, with the name of the pedal to be used listed beside or beneath it. If no pedal number is given, the damper pedal is to be automatically used for the selection.

For example, in Figure 15-6, the “Ped.” signifies that the damper pedal (usually the foot pedal farthest to your right) is to be depressed during the selection. The breaks in the brackets (shown with ^) mean that in these places, you briefly lift your foot off the pedal.

Figure 15-6:

Pedal dynamics show you which pedal to use and how long to hold it down.

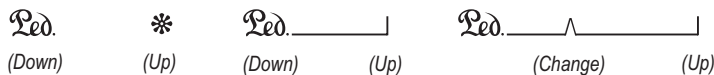

Looking at the articulation markings for other instruments

Although most articulation markings are considered universal instructions — that is, applicable to all instruments — some are aimed specifically at certain musical instruments. Table 15-4 lists some of these markings and their respective instruments.

From harpsichord to piano

The concept of using dynamic markings in sheet music came about around the same time as the piano — and for good reason. Before the invention of the piano by Bartolomeo Cristofori in 1709, most composers were confined to writing most of their pieces for the harpsichord, an instrument without the capability to play both soft and loud sounds easily.

Here's why varying the sounds is difficult: The basic internal design of the harpsichord follows the design of a stringed instrument. However, instead of having one's fingers in direct contact with the string (as with a guitar or fiddle), harpsichords are fitted with a plucking mechanism inside the instrument itself. When a certain key is pressed, the corresponding internal string is plucked by the mechanism. No matter how

hard or soft you press the instrument's keys, the resulting volume is pretty much the same.

Although the piano looks a lot like a harpsichord, it's really very different. The piano incorporates a hammer-and-lever mechanism that strikes each string with the same force as the human finger on the piano key did; the fact that a hammer hits a string every time you press a key is why the piano is considered a percussive instrument. The piano made both quiet and loud sounds possible on the same instrument, and, therefore, in the same musical piece. This flexibility is why the piano was originally named the *gravicembalo col pian e forte*, or "harpsichord with soft and loud." The name was later shortened to pianoforte and, finally, to simply piano.

Table 15-4 **Articulation Markings for Specific Instruments**

Notation	What It Means
Stringed instruments	
<i>Martellato</i>	A short, hammered stroke played with very short bow strokes
<i>Pizzicato</i>	To pluck the string or strings with your fingers
<i>Spiccato</i>	With a light, bouncing motion of the bow
<i>Tremolo</i>	Quickly playing the same sequence of notes on a stringed instrument
<i>Vibrato</i>	Slight change of pitch on the same note, producing a vibrating, trembling sound
Horns	
<i>Chiuso</i>	With the horn bell stopped up (to produce a flatter, muted effect)
Vocals	
<i>A capella</i>	Without any musical accompaniment
<i>Choro</i>	The chorus of the song
<i>Parlando or parlante</i>	Singing in a speaking, oratory style
<i>Tessitura</i>	The average range used in a piece of vocal music

Chapter 16

Instrument Tone Color and Acoustics

In This Chapter

- ▶ Mixing up tone color
 - ▶ Getting acquainted with acoustics
-

Have you ever wondered why more songs don't use a tuba or a bassoon for the lead instrument, or why so many great parts for instruments have been taken by pianos and guitars? Okay, maybe you haven't thought that much about it, but if you're considering writing music, you probably should.

The simple explanation for why some instruments are used for lead lines in music and others aren't is that the human ear reacts more favorably to higher-pitched sounds than to lower-pitched ones. Notice that it is the higher-pitched range that babies and small children babble in, that birds sing in, and that pretty much all the happy little things make noise in. People can't get away from enjoying these sounds — it's part of the human wiring.

High-pitched notes also convey a greater sense of immediacy. You can bow the cello until your arm falls off, but it's not going to sound as urgent and lively as it would if the same passage were played at the same speed on a violin. Similarly, when you're trying to get an idea across in conversation, especially an important idea, your voice tone tends to drift up toward the higher registers, not down into the lower ones. This is why lead instruments are sometimes called *talking* instruments.

In this chapter, we examine what constitutes instrument tone and what makes each instrument sound just the way it does. We also discuss basic acoustics and instrument harmonics, and explain why small ensembles and orchestras are put together the way they are.

Delving Into Tone Color

The *tone color*, or character, of an instrument is made up of three basic components:

- ✓ Attack
- ✓ Timbre (or harmonic content)
- ✓ Decay

These three factors are what make every instrument sound different. Even if you're hearing the instrument through your car radio speakers, you can immediately tell, just by listening, what instrument is being played. We discuss each of these factors in the following sections.

Attack: Checking out the beginning sound of a note

The *attack* is the very first sound you notice when you hear a note, and it's possibly the most distinguishing aspect of a note played by an instrument. The violin, piano, and guitar all have their own distinctive attacks. Here's a brief rundown of each:

- ✓ **Violin:** When you hear the first microsecond of a violin being played, you instantly know it's a violin because of that quick, raw sound of a bow being drawn across the familiar-sounding string. It's beautiful, immediate, and unmistakable. You don't even know you're hearing the first tiny point of contact, but it's there. If you were to slow down a recording of any virtuoso's violin solo, you would find that gorgeous, familiar rasp at the beginning of every bow stroke.
- ✓ **Piano:** Each time you hit the key of a piano, a tiny hammer strikes three metal strings simultaneously, producing a beautiful, ringing attack. It's even more amazing to open up a piano and listen to how each note sounds when the frontpiece or lid isn't muffling the sound.
- ✓ **Guitar:** The guitar's distinctive attack is a sharp little twang when the metal strings are first plucked. However, the sound is definitely less pronounced when the guitar has nylon strings. The different types of strings are partly responsible for the variety of guitar-playing styles by musicians. Rock, pop, and country-and-western songs are usually played with metal-strung guitars because the metal strings provide a nice, crisp, aggressive-sounding twang. Classical, flamenco, and much of folk music use nylon-strung guitars because the attack is much softer-sounding, making for mellower music.



The speed of an instrument's attack can play just as big a role in the sound of an instrument: The plucking of a string on a harpsichord is quick and sharp, which is much different from the languorous drawing of a bow across the strings of a double bass.

Timbre: Hearing the body of a note

The *timbre* (pronounced *tam-ber*), or harmonic content, of an instrument is what determines the middle part, or body, of each played note. When you remove the attack and the decay of some instruments' sounds with digital equipment, you find a lot of surprising similarities between instruments. (You can read about decay in the next section.)

For example, the timbre and pitch range of a flute and violin are almost identical, but because one is blown and one is bowed, the initial attack of each separate note is completely different and identifies these instruments by their very first split-second sounds.

However, the *harmonics* — or sound waves — between some instruments are radically different, simply because of their construction. For example, the harmonic content between a note on a guitar and the same note on a piano is completely different, because one note on a guitar is one string being plucked, but one note on a piano is actually three strings being hit with a hammer.



Any sound, no matter the source, is caused by something vibrating. Without vibration, sound doesn't exist. These vibrations cause the air particles next to the source to vibrate as well, and those air particles, in turn, cause the particles next to them to vibrate, and so on and so on, creating a sound wave. Just like a wave in water, the farther out the sound wave moves, the weaker it gets, until it completely dissipates. If the original vibration creates a strong enough wave, though, it eventually reaches your ears and registers as a sound.

You hear sounds because air vibrates against your eardrums, causing them to vibrate. These vibrations are then analyzed by your brain and registered as music, traffic, birds singing — whatever. Because sound waves are picked up by each unique eardrum and dissected by each unique brain, chances are that nobody hears the same sound exactly the same as anybody else.

Each complete vibration of a sound wave is called a *cycle*. The number of cycles completed in one second is called the *frequency* of the vibration. One of the most noticeable differences between two sounds is the difference in pitch; the frequency of a sound determines its pitch. Frequency is measured in *hertz*, with one hertz (Hz) being one cycle per second. One thousand hertz is called a *kilohertz* and is written as 1 kHz. A high-frequency vibration produces a high-pitched note; a low-frequency vibration gives a low-pitched note.



Reproducing “natural” sounds with synthesizers

When the first synthesizers were developed, the designers were attempting to reproduce “natural” instruments instead of just synthetic sounds (like the flat, artificial sound of a 1970s synthesizer, for example). The developers of the synthesizer discovered that the biggest challenge in making it sound natural wasn’t in reproducing another instrument’s timbre —

which is what the engineers had primarily focused on from the onset — but in reproducing the attack and decay of each instrument. Eventually, they had to record samples of the instruments themselves into the synthesizers in order to make sounds distinguishable from one another.



The human hearing range (audible range) is about 16Hz to 16kHz. The frequencies of notes that can be played on a piano range from 27.5 Hz to just over 4kHz.

Instruments get their specific sounds because their sounds come from many different tones all sounding together at different frequencies. A single note played on a piano, for example, actually consists of several tones all sounding together at slightly different frequencies, or multiples of the frequency base. The musical note produced by a tuning fork is called a *pure tone* because it consists of one tone sounding at just one frequency.

Decay: Listening for the final sound of a note

Decay is the final part of an instrument’s played note. Here are the two types of instrument decay:

- ✓ **Impulsive:** An *impulsive* decay belongs to instruments that need to be played continuously, or in pulses, in order to continue sounding. Tones are produced and immediately begin to decay until the next note played starts the process again. Common examples of instruments with an impulsive decay are those produced by plucking or striking, such as the guitar, most percussion instruments, and the piano.
- ✓ **Sustained:** A *sustained* decay is one for which the vibrating column of an instrument, such as the body of a flute, clarinet, or other column-shaped instrument, is excited continuously so that the sound continues in a more or less steady state as long as the note is being played. Instruments producing sustained tones are those that are bowed or blown, such as violins and other bowed stringed instruments, woodwinds, free-reed instruments such as the accordion, and brass instruments.

Building the Band: An Acoustics Lesson

Next time you go out to see an orchestra or a big band play, or even when you watch one of those late-night show bands perform on TV, take a look at where the performers are sitting in relation to each other. Pay particular attention to which instrument is the “lead” instrument.

As you study an orchestra or band, you’ll likely notice these two things:

- ✓ **Especially in an orchestral setting, all the performers playing the same instruments are sitting together.** This setup isn’t because they all have to share the same piece of sheet music — it’s because when you stick two violins or flutes or clarinets together they sound louder and fuller. If you stick *ten* of them together, you’ve got a wall of sound coming at you from that area of the orchestra.

Incidentally, this setup is one reason instruments are so challenging to play. They’re not particularly tricky to play well in themselves, but you often have to play them in exact synchronization with other performers.

- ✓ **The lead instruments are in front of all the other instruments, especially in acoustic performances.** This setup is beneficial because of volume and perception: The sound waves from the instruments in the front of the ensemble will be heard a microsecond before the rest of the band and will, therefore, be perceived as being louder because you hear them a split second before the other instruments.

This principle applies to a regular four-piece electric band setting, too. If you want your singer to be heard above the guitars, make sure the amplifier carrying his or her voice is placed closer to the audience than the guitar and bass amp.



The best place to sit at an orchestral performance is directly behind the conductor but far enough back to be at the same height level as him. Conductors build each orchestra for each performance around where they stand so they can hear exactly what’s being played. Similarly, this situation makes it pretty easy for a seasoned audio engineer to record an orchestral performance. Put the microphones right where the conductor’s standing, and you’ll record the piece of music exactly as the conductor intended for it to be heard.

Part IV

The Part of Tens

The 5th Wave

By Rich Tennant



"Does anyone else feel the flute and cello part is a bit too appassionato?"

In this part . . .

This quick part provides short chapters about several different topics. You can get answers to frequently asked questions you may have found yourself wondering about. You also can check out the wide variety of other music resources available and get the back story of some of history's most important contributors to music theory.

Chapter 17

Ten Frequently Asked Questions about Music Theory

In This Chapter

- ▶ Knowing what music theory can do for you
 - ▶ Reviewing some of the top queries about music theory
-

You may have skipped to this chapter just to see whether your top ten questions match the ones listed here. Without the benefit of a write-in campaign, we can't possibly know exactly what's ticking away in all those musically minded heads out there, but we gave it a shot. With this chapter, we aim to answer ten questions we're most frequently asked about music theory, including why it's important to musical studies and what it can help you accomplish.

Why Is Music Theory Important?

Music theory helps people better understand music. The more you know about music theory, the better your comprehension of music, and the better you will play and compose (if that's your cup of tea). It's like learning to read and write: These skills can help you communicate better. Are they absolutely necessary? No. Are they tremendously helpful? Yes.

Here's just one example: By knowing music theory, you can know exactly what a composer wanted you to hear in the piece of music he or she wrote down, no matter how many years separate the two of you.

If I Can Already Play Some Music Without Knowing Music Theory, Why Bother Learning It?

Plenty of people in the world can't read or write, yet they can still communicate their thoughts and feelings verbally. And, similarly, many intuitive, self-taught musicians have never learned to read or write music. Many of them find the whole idea of music theory tedious and unnecessary.

However, the issue is educational. Leaps and bounds come from learning to read and write. In the same way, music theory can help musicians learn new techniques and new styles that they would never stumble upon on their own. It gives them confidence to try new things. In short, learning music theory makes you a smarter musician, whether you're playing, studying, or composing.

Why Is So Much Music Theory Centered on the Piano Keyboard?

A keyboard instrument, such as the piano, has several advantages over other instruments — so far as composing goes, anyway. Here they are:

- ✔ **Everything you need is right there.** The main advantage of a keyboard instrument is that the tuning of the keyboard is such that the ascending and descending notes are laid out right in front of you in a no-nonsense straight line. Plus, early on when the piano was first created, the notes matched the pitch notations already being used in sheet music. So in order to go up a half step, you simply had to go over one key from where you started. This simple clarity was, and still is, extremely helpful in the composition process.
- ✔ **From the first try at playing, anyone can make musical noise on a keyboard.** With a keyboard there's no practicing with a bow, no learning how to properly blow over or into a mouthpiece, and no fingertip calluses that need to be built up.
- ✔ **A keyboard has a huge range.** No limit exists to how many octaves you can pile on a keyboard. The three to four octaves of the piano's predecessor, the harpsichord, were adequate to cover the range of music being performed in the 16th century. As the harpsichord quickly inspired instruments like the virginal, the spinet, the clavichord, and eventually the piano, more octaves were added to the basic form, until it became the eight-octave, concert-ready monster used today.

Is There a Quick and Easy Way to Learn to Read Music?

Does anything help make learning to read music any easier? Of course. All first-year music students are given a couple of cheesy mnemonics to help them memorize the lines and spaces of the treble and bass clefs.

Here are just a few mnemonics to consider (and if coming up with your own phrases works better, go for it!):

Treble clef (from bottom to top of staff)

Notes on the lines: **Every Good Boy Deserves Fudge** (EGBDF).

Notes on the spaces: **FACE**. That's it — everyone uses this one.

Bass clef (from bottom to top of staff)

Notes on the lines: **Go Buy Donuts For Alan** (GBDFA).

Notes on the spaces: **All Cows Eat Grass** (ACEG).

How Do I Identify a Key Based on the Key Signature?

Determining the key of a piece of music is a real doozie, especially for musicians who aren't comfortable following a piece of sheet music note for note but who want to *sound* like they know what they're doing right out of the gate — as opposed to noodling around until they figure out what the other musicians are playing.

If you know whether a piece of music is written in a major or minor key, you're on your way to determining the key. With a little practice, you can usually figure out whether a piece is in major or minor after hearing just one or two measures of a song. Here are some quick rules:

- ✓ If the key signature has no sharps or flats, the piece is in C major (or A minor).
- ✓ If the key signature has one flat, the piece is in F major (or D minor).
- ✓ If the key signature has more than one flat, the piece is written in the key of the next-to-last flat in the key signature.

- ✓ If the key signature has sharps, take the note of the last sharp and go up one note (changing the letter name). If the last sharp is D sharp, the key is E. If it's F sharp, the key is G.
- ✓ The relative minor of a key is a minor third down from the major. So when you move three adjacent keys, black or white, to the left — or three frets up the guitar neck (toward the tuning pegs) — you land on the relative minor.

Can I Transpose a Piece of Music into Another Key?

To transpose a piece of music into another key, you can simply move every note in the piece up or down by the same interval. For example, to transpose a song that you already know in the key of G into the key of C, you need to move everything up a perfect fourth or down a perfect fifth.

Another way to transpose a song is to learn the scale degrees of the original piece of music, and then play those same scale degrees in the new key. *Music Composition For Dummies*, published by John Wiley & Sons, Inc. and written by Scott Jarrett and Holly Day, goes into transposing music in greater depth.

Will Learning Music Theory Hinder My Ability to Improvise?

Learning music theory will absolutely not thwart your improv skills! Learning proper grammar didn't keep you from using slang or swearing, did it? Seriously, though, understanding the basics of music theory, especially chord progressions and scale degrees, will make playing with other musicians and improvising that much easier.

Do I Need to Know Theory if I Just Play Drums?

A lot of drummers, especially early on, take their role of being drummer to mean that they determine and keep the beat and that everyone else is following their lead. A really good drummer, however, realizes that he's also a part of the band. He acknowledges that in order to play with everyone else, he needs to know how time signatures and note values work and how to use

tempo and dynamics to best fit each individual song just as much as everyone else in the band. A drummer who plays loud and fast or soft and slow all night for every single song gets boring. The guy who can mix it up and can play loud and soft *and* fast and slow adds contrast and makes the music that much more interesting.

Where Do the 12 Musical Notes Come From?

Many theories have been bandied about regarding the origin of the 12 notes used in music today. Some people think their origin is in math. The number 12 is easily divisible by the numbers 2, 3, and 4, which makes for an easy division of the tones between an octave.

Other theorists say that Pythagoras, a Greek from the island of Samos, had a cultural reverence for the number 12 and, therefore, made his version of the Circle of Fifths with 12 points on it.

If composers had strictly used the solfège model (see Chapter 19 for more on solfège) and abandoned Pythagoras's Circle of Fifths, today's model would have nine points on it instead. The best answer to the question of the notes' origin, however, is from Schoenberg, who said a scale had 12 notes simply because 1 plus 2 equals 3. Many non-Western cultures have more or fewer pitches in their musical systems of scales and octaves.

How Does Knowing Theory Help Me Memorize a Piece of Music?

If you know scales, chords, and intervals, you can apply all this information to whatever piece of music you're learning to play. When you understand the form and compositional techniques used in a piece, it simplifies what you need to memorize for performances, both solo and in a group. Knowing how a musical piece is constructed makes it easier to anticipate what needs to come next in a piece.



Another good way to learn a piece of music is to divide the piece into smaller parts, and then play each of those small parts until you can play them from memory. As we discuss in Chapters 13 and 14, many pieces of music are composed of sections of music used again and again with only slight variations.

Chapter 18

Ten Valuable Music Resources

In This Chapter

- ▶ Poking around some helpful websites
 - ▶ Checking out other music books
-

Music theory is about more than just learning how to read notes and keep a steady beat — it's also about exploring the relationship between man and music, discovering why some things sound really cool and others sound really bad, and finding new ways to communicate with the language of music. This chapter gives you a taste of just a few websites and books to get you started down the path of total music theory immersion. After you get started, you may never come back.

Dolmetsch Online

The Dolmetsch site (www.dolmetsch.com) — named after performer, composer, and music historian Arnold Dolmetsch — is a detailed music theory, instruction, and history site. Just about every musical term and concept you can think of is defined and discussed on this site. Plus you can also find classical composers' biographies and a rundown of the evolution of classical music. On the site, you can read essays, both speculative and factual, on the effect the invention of the piano and the guitar has had on music theory. You also can review chord charts for guitars, fingering charts for woodwinds, and a breakdown of the evolution of music notation from the ancient Greeks to the present.

If you're a visual or auditory learner, you're in luck. The site has dozens of music and video files to go along with the notation charts (the files are playable with a free download of the browser plug-in Scorch). It's not exactly like having a music teacher at your desk, but it does work well as a supplement to the novice-to-intermediate musician trying to learn more about an instrument.

Open Directory Project

If there's a Heaven specially made for die-hard music theorists, the Open Directory Project Music Theory site (www.dmoz.org/Arts/Music/Theory) is a glimpse of it. The Open Directory Project Music Theory site, or ODP, is a catalog of editor-monitored links about every subject imaginable.

The ODP links range from basic music tutorial sites to incredibly wild and speculative sites concerning the effect of music on the brain and the very origins of music itself. You can peruse discussion groups full of vigorous arguments on why musicians and composers should toss out the five-lined music staff and rework music notation to fit a six-lined staff instead. You can also visit sites dedicated to composers' takes on atonal tunings and samples of some of their compositions. Because it's a catalog of music theory-related links, the list changes on a fairly regular basis. In fact, it's worth dropping by every few weeks just to see what new sites have joined the list.

ClassicalWorks.com

The ClassicalWorks.com site (www.classicalworks.com) has an excellent global history of music in timetable form, spanning nearly 4,000 years of music history (click the History of Music link to view this info). The entries are pretty short and sweet, but all the dates, events, and names you need are right there on one site. A fair amount of historic artwork accompanies specific groups of entries as well. For example, you can see pictures of Gregorian chants drawn on illuminated manuscripts and excerpts from Egyptian murals commemorating some of the oldest known musical ensembles. The site's Google search engine allows you to easily find an event or name you specifically need to look up.

Smithsonian Folkways Series

The Smithsonian Folkways music series (www.folkways.si.edu) is an amazing project run by the Smithsonian Institute. Folkways Recordings was founded in 1948 in New York City by Moses Asch and Marian Distler, who sought to record and document the entire world of sound. During the 40 years that Asch owned the label, Folkways' tiny staff released 2,168 albums, which included traditional, ethnic, and contemporary music from around the world; poetry, spoken word, and instructional recordings in numerous languages; and documentary recordings of individuals, communities,

current events, and natural sounds. After Asch's death in 1987, the Smithsonian Institution Center for Folklife and Cultural Heritage in Washington, D.C., acquired Folkways Recordings.

As a condition of the acquisition, the Smithsonian agreed that virtually all of Asch's 2,168 titles would remain in print forever. Whether the Smithsonian sells 8,000 copies each year or only one copy every five years, every Folkways title ever released will forever remain available for purchase. Folkways has also released 300 new titles since the Smithsonian's acquisition of the label, adding rock, hip-hop, and electronic music recordings. Considering how much music and culture have changed all over the world in the past 60 years, this amazing collection has more significance today than ever.

The Rough Guide to Classical Music

The Rough Guide to Classical Music, edited by Joe Staines and Jonathan Buckley (Rough Guides/Penguin), is a wonderful guide to classical music. Not only does it profile more than 160 classical composers with full biographical sketches, but it also provides coherent and believable reviews of the best (and worst) recordings of those composers' works. Each entry discusses the types of music the composer delved into, notes where his influence is most felt in later composers' works, and explains the political pressures that made the composer write the types of music that he did.

This book is fun to read straight through and to jump around in as a reference. It's an indispensable guide for anyone who wants to learn more about classical music.

The Virgin Directory of World Music

The Virgin Directory of World Music by Philip Sweeney (Owl Books/Henry Holt & Company) is a well-organized summary of traditional music from around the globe. It's divided into regions of the world: Africa (North, West, Central, South, and East), Europe (North, South, and East), the Middle East and India, and so on. Each division is then broken down into the states and countries of those regions, with descriptions of their traditional music. Each division even has detailed mention of notable performers who have recorded and released albums of the music of their region, from South Africa's Ladysmith Black Mambazo to Jamaica's The Jolly Boys.

American Mavericks

American Mavericks, edited by Susan Key and Larry Roethe (University of California Press), is gorgeous enough to be a coffee table book. If you're as obsessed with music as we are *and* you have a coffee table, you really should pick up a copy. It's loaded with fantastic photographs of unique American composers and their equally unique choices of instruments. It features in-depth profiles of composers as varied and dissimilar as John Cage, Aaron Copland, Steve Mackey, and Carl Ruggles. The book also comes with a CD containing 18 tracks of music — one for every composer — many from albums that are just about impossible to find in your local record store.

Parallels and Paradoxes: Explorations in Music and Society

Parallels and Paradoxes: Explorations in Music and Society by Daniel Barenboim and Edward W. Said (Pantheon Books) is a collection of conversation transcripts between Daniel Barenboim, Music Director of the Chicago Symphony Orchestra and the Deutsche Staatsoper Berlin, and Edward W. Said, literary critic, political analyst, and all-over expert on Middle Eastern culture.

In these conversations, Barenboim and Said discuss the effect of music on global and national politics (and vice versa) in incredibly minute detail, from the difficulties of conducting Wagner in post-Hitler Germany to the comparisons between Jane Austen and Verdi. The book is full of the type of really brilliant and deep conversations musicians and music lovers dream about having with their peers.

The Art of Practicing: A Guide to Making Music from the Heart

The Art of Practicing: A Guide to Making Music from the Heart by Madeline Bruser (Bell Tower/Crown Books) isn't your average music book. This book's strength is that it covers something that's not usually talked about in music instruction books: training your body to learn how to play music.

It's really not enough to know how to read notes and tap out a rhythm. Learning to endure the many hours of training necessary to truly master an instrument is also important. The book covers all sorts of info related to this topic. It includes breathing exercises to help you relax before practicing, ergonomically correct hand and body positions for playing instruments for an extended period of time, and a variety of stretching exercises for working out all the kinks and knots that form during practice.

The Guitar Chord Bible

The great thing about playing the guitar is that you can put the same chord together in so many different ways. *The Guitar Chord Bible*, by Phil Capone (Chartwell Books, Inc.), shows you not only all the chords you can find on the neck of a guitar, but at least three different ways you can play each one. The book is further broken up into musical styles, so if you want to know specifically what chords are popularly used in rock, blues, soul, and funk, you can look those sections up for even quicker reference.

Chapter 19

Ten Music Theorists You Should Know About

In This Chapter

- ▶ Seeing who had the most impact on music theory
 - ▶ Considering music theory's evolution
-

The evolution of music theory and notation is almost as amazing as the evolution of human writing. Modern music notation is sort of like Esperanto that lots of people can understand. People all over the Western world, and much of the Eastern world as well, know how to communicate with each other effectively through sheet music, chord theory, and the Circle of Fifths. In this chapter, we introduce ten music theorists who have helped define how we look at music or have changed our view of music entirely.

Pythagoras (582–507 BC)

Anyone who's ever taken a geometry class has heard of Pythagoras. He was obsessed with the idea that everything in the world could be broken down into a mathematical formula and that numbers themselves were the ultimate reality. As a result, Pythagoras came up with all sorts of equations for calculating things. He's particularly well known for his Pythagorean theorem.

The beautiful thing about ancient Greek culture is that the study of science, art, music, and philosophy were considered one great big pursuit. So it wasn't that strange for someone like Pythagoras to turn his attention to music and try to come up with mathematical theories to define it.

Because the lyre was the most popular instrument of the day, it's only natural that Pythagoras used it and other stringed instruments to create his working model for what would eventually be called the Pythagorean Circle, which then eventually evolved into the Circle of Fifths.

According to legend, Pythagoras took a piece of string from a lyre, plucked it, measured its tone and vibration rate, and then cut that string in half and made a new set of measurements. He named the difference between the rate of vibration of the first length of string and the second an *octave*, and then he went to work breaking the octave up into 12 evenly divided units. Every point around the circle was assigned a pitch value, and each pitch value was exactly $\frac{1}{12}$ octave higher or lower than the note next to it.

The problem with Pythagoras's Circle was that he wasn't a musician. Even though the Circle was mathematically sound and an amazing conceptual leap, some of the "tunings" he proposed weren't particularly pleasing to the ear. Also, due to variations in the size of sound waves that he (and everyone else who lived 2,500 years ago) wasn't privy to, his octaves quickly fell out of tune the farther you went from the starting point. For example, a high C, tuned to his perfect fifths, was definitely not in tune with a low C, because in his system you moved just a bit out of pitch with each new octave in between.

For the next 2,000 years, musicians and theorists alike concentrated on tempering this Circle, with its 12 spots and shape left intact, but they retuned some of his "perfect" fifths using *Pythagorean commas* to create a Circle that was much more musician- and audience-friendly.

Boethius (480–524 AD)

If it hadn't been for the Roman statesman and philosopher Anicius Manlius Severinus Boethius, the Greek contribution to music theory may have been completely lost, along with much of Europe's own musical history. Boethius was a remarkable man who dedicated his short life to studying Greek mathematics, philosophy, history, and music theory. He was the first scholar after Pythagoras to try to connect the pitch of a note with the vibration of sound waves.

Not content to sit at home writing books, Boethius's most ambitious project was also one of his most enduring. He began venturing out into the western European countryside with music scribes who transcribed the folk music of the different groups of people that made up the landscape. Because of this work, you can still hear today what sort of music rural people were playing and singing during this time period.



Formal music traditionally didn't have lyrics; music with lyrics was considered lowbrow and aesthetically in bad taste. Ironically, his study of common music led to Boethius's exploration of writing songs with lyrics that told a story — an idea that would one day lead to a highbrow genre of music: the opera.

Sadly, before Boethius could write his own fully formed opera, or translate the entire works of Plato and Aristotle, or come up with a unifying theory to explain Greek philosophy (all three were lifetime goals of his), he was thrown in prison under charges of practicing magic, sacrilege, and treason.

Despite facing a death sentence, Boethius continued to write in prison. His last work was the *De consolazione philosophia* (*The Consolation of Philosophy*), a novella-sized treatise about how the greatest joys in life came from treating other people decently and from learning as much as possible about the world while living. Well into the 12th century, Boethius's many texts were standard reading in religious and educational institutions all over Europe.

Gerbert d'Aurillac/Pope Sylvester II (950–1003)

Gerbert of Aurillac, later known as Pope Sylvester II, was born in Aquitaine. He entered the Benedictine monastery of St. Gerald in Aurillac when he was a child and received his early education there. Highly intelligent and a voracious reader, Gerbert rose up among the ranks of the monastery so quickly that rumors began that he had received his genius from the Devil.

From 972 to 989, Gerbert was the abbot at the royal Abbey of St. Remi in Reims, France, and at the Italian monastery at Bobbio (Italy). At St. Remi, he taught mathematics, geometry, astronomy, and music, incorporating Boethius's method of teaching all four at once in a system called the *quadriivium*. At the time, the laws of music were considered to be divine and objective, and learning the relationships among the musical movement of the celestial spheres, the functions of the body, and the sounds of the voice and musical instruments was important.

Gerbert resurrected an instrument from ancient Greece called a *monochord* for his students, from which it was possible to calculate musical vibrations. He was the first European after the fall of Rome to come up with a standard notation of notes in tones and semitones (half steps). He wrote extensively about the measurement of organ pipes and eventually designed and built the first hydraulically powered musical organ (as opposed to the hydraulically powered siren of the Roman arenas). It exceeded the performance of any other previously constructed church organ.

Guido D'Arezzo (990–1040)

Guido D'Arezzo was a Benedictine monk who spent the first part of his religious training at the monastery of Pomposa, Italy. While there, he recognized the difficulty singers had in remembering the pitches to be sung in Gregorian chants and decided to do something about it. He reworked the *neumatic notation* (early music markings) used in Gregorian chant and designed his own musical staff for teaching Gregorian chants much faster. He attracted positive attention from his supervisors because of his work. However, he also attracted animosity from the other monks in his own abbey and soon left the monastic life for the town of Arezzo, which had no official religious order but did have a lot of decent singers who desperately needed training.

While in Arezzo, he improved his musical staff. He added a time signature at the beginning to make it easier for performers to keep up with one another. He also devised *solfège*, a vocal scale system that used six tones, as opposed to the four tones used by the Greeks — *ut* (later changed to *do*), *re*, *mi*, *fa*, *so*, and *la* — to be placed in specific spots on the staff. Later, when the diatonic scale was combined with the “Guidonian Scale,” as it’s sometimes called, the *ti* sound finished the octave (later making *The Sound of Music* possible). The *Micrologus*, written at the cathedral at Arezzo, contains Guido’s teaching method and his notes regarding musical notation.

Nicola Vicentino (1511–1576)

Nicola Vicentino was an Italian music theorist of the Renaissance period whose experiments with keyboard design and equal-temperament tuning rival those of many 20th century theorists. Around 1530, he moved from Venice to Ferrara, a hotbed of experimental music. He served briefly as a music tutor for the Duke of Este to support himself while writing treatises on the relevance of ancient Greek music theory in contemporary music and on why, in his opinion, the whole Pythagorean system should be thrown out the window. He was both adored and reviled by contemporaries for his disdain for the 12-tone system and was invited to speak at international music conferences on his beliefs.

Vicentino amazed the music world even more when, to further prove the inadequacies of the diatonic scale, he designed and built his own microtonal keyboard that matched a music scale of his own devising, called the *archicembalo*. On the *archicembalo*, each octave contained 31 tones, making it possible to play acoustically satisfactory intervals in every key — predating the well-tempered *meantone* keyboard in use today by nearly 200 years. Unfortunately, he only built a few of the instruments, and before his work could catch on, he died of the plague.

Christiaan Huygens (1629–1695)

Christiaan Huygens did as much for science and the scientific revolution of the 17th century as Pythagoras did for mathematics. Huygens was a mathematician, astronomer, physicist, and music theorist. His discoveries and scientific contributions are staggering and well known.

In his later years, he turned his immense brain to the problem of meantone temperament in the musical scale and devised his own 31-tone scale, which he introduced in his books *Lettre Touchant le Cycle Harmonique* and *Novus cyclus harmonicus*.

In these books, he developed a simple method for calculating string lengths for any regular tuning system, worked out the use of logarithms in the calculation of string lengths and interval sizes, and demonstrated the close relationship between meantone tuning and 31-tone equal temperament.

As much as people in the scientific community applauded Huygens's genius, people in the musical world weren't yet ready (and still aren't) to give up their Pythagorean 12-tone scale. So aside from a few experimental instruments built on his calculations, the main principle adopted from his theories was to rebuild and retune instruments so that 12 tones could finally build a true octave.

Arnold Schoenberg (1874–1951)

Arnold Schoenberg was an Austrian-born composer who immigrated to the U.S. in 1934 to escape Nazi persecution. He's primarily known for his explorations of atonalism and 12-tone musical systems (or, serialism), but Schoenberg was also an accomplished expressionist painter and poet.

Schoenberg's compositions weren't well-received in his home country. The press there declared him "insane" after hearing a performance of "String Quartet #2, op. 10." His piece "Pierre Lunaire," which featured a woman alternately singing and rambling about witchcraft against a backdrop of seemingly competing instruments, was dubbed "creepy and maddening" by his critics in Berlin. His music, along with American jazz, was eventually labeled "degenerate art" by the Nazi Party.

Throughout his career, Schoenberg's work featured many firsts. His symphonic poem, "Pelleas and Melisande," featured the first known recorded trombone glissando. His opera, "Moses und Aron," was the first one to draw on both his experiments with the 12-tone series and on atonality. His most massive composition, "Gurrelieder," combined orchestra, vocals, and a narrator — over 400 performers were required for the original performance of the piece. Even today, his vibrant compositions feel disturbing, chaotic, beautiful, and amazingly contemporary.

Harry Partch (1901–1974)

At age 29, Harry Partch gathered up 14 years of music he had written, based on what he called the “tyranny of the piano” and the 12-tone scale, and burned it all in a big iron stove. For the next 45 years, Partch devoted his entire life to producing sounds found only in microtonal scales — the tones found between the notes used on the piano keys.

Partch devised complex theories of intonation and performances to accompany them, including a 43-tone scale, with which he created most of his compositions. Because there were no available instruments upon which to perform his 43-tone scale, Partch built approximately 30 instruments.

Some of his remarkable instruments include the Kitharas I & II, lyre-like instruments made of glass rods that produced gliding tones on four of the chords; two Chromelodeons, reed pump organs tuned to the complete 43-tone octave with total ranges of more than five acoustic octaves; the Surrogate Kithara, with two banks of eight strings and sliding glass rods under the strings as dampeners; and two Adapted Guitars that used a sliding plastic bar above the strings, with one string tuned to a six-string 1/1 unison and the other tuned to a ten-string chord whose higher three notes are a few microtonal vibrations apart.

Partch’s orchestras also incorporated unusual percussive instruments, such as the sub-bass Marimba Eroica, which used tones that vibrate at such a low frequency that the listener can “feel” the notes more than hear them; the Mazda Marimba, made up of tuned light bulbs severed at the socket; the Zymo-Xyl, which created loud, piercing shrieks by vibrating suspended liquor bottles, auto hubcaps, and oar bars; and the Spoils of War, which consisted of artillery shell casings, Pyrex chemical solution jars, a high wood block, a low marimba bar, spring steel flexitones (Whang Guns), and a gourd.

Karlheinz Stockhausen (1928–2007)

Stockhausen’s greatest influence as a theorist can best be felt in the genres of music that came directly out of his teachings. During the 1950s, he helped develop the genres of *minimalism* and *serialism*. Much of the 1970s “krautrock” scene was created by his former students at the National Conservatory of Cologne, Germany. His teachings and compositions also greatly influenced the musical renaissance of 1970s West Berlin (notable characters included David Bowie and Brian Eno).

In the long run, Stockhausen can be seen as the father of *ambient music*, and the concept of *variable form*, in which the performance space and the instrumentalists themselves are considered a part of a composition and changing even one element of a performance changes the entire performance.

He's also responsible for *polyvalent form* in music, in which a piece of music can be read upside-down, from left-to-right, or from right-to-left. Or, if multiple pages are incorporated in a composition in this form, the pages can be played in any order the performer wishes. As former student and composer Irmin Schmidt said, "Stockhausen taught me that the music I played was *mine*, and that the compositions I wrote were for the *musicians* who were to play it."

Robert Moog (1934–2005)

Although no one knows for sure who built the first fretted guitar or who truly designed the first real keyboard, music historians do know who created the first pitch-proper, commercially available synthesizer: Robert Moog. He's widely recognized as the father of the synthesizer keyboard, and his instrument revolutionized the sound of pop and classical music from the day the instrument hit the streets in 1966.

He specially designed keyboards for everyone from Wendy Carlos to Sun Ra to the Beach Boys, and he even worked with groundbreaking composers like Max Brand. Unfortunately, Moog wasn't the greatest businessman — or perhaps he was just very generous with his ideas — and so the only synthesizer-related patent he ever filed was for something called a *low-pass filter*.

When he first began building synthesizers, his goal was to create a musical instrument that played sounds that were different from any instrument that came before. However, as people began to use synthesizers to re-create "real" instrument sounds, he became disillusioned with the instrument and decided that the only way to get people to work with "new" sounds was to break away from the antiquated keyboard interface altogether. So his North Carolina-based company, Big Briar, began working on Leon Theremin's theremin design to create a MIDI theremin, which was designed to eliminate the interval steps between each note but still keep the tonal color of each individual instrument's MIDI patch.

Outside of building instruments, Moog also wrote hundreds of articles speculating on the future of music and music technology for a variety of publications, including *Computer Music Journal*, *Electronic Musician*, and *Popular Mechanics*. His ideas were way ahead of their time, and many of his predictions, such as those from his 1976 article in *The Music Journalist* that predicted the advent of MIDI instruments and touch-sensitive keyboards, have already come true.

Part V

Appendixes

The 5th Wave

By Rich Tennant

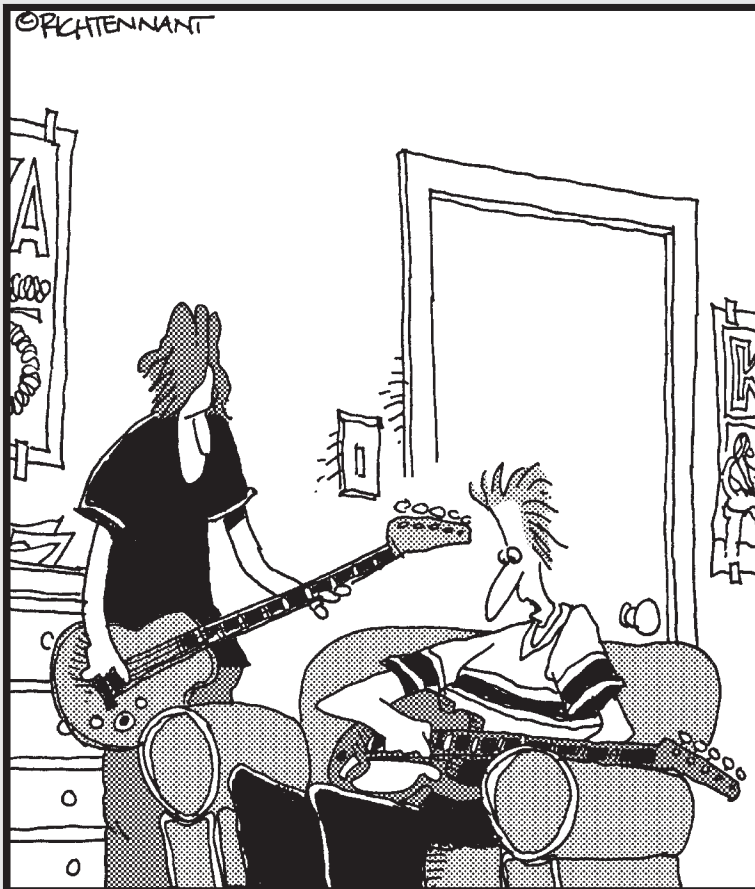

“First you play a G7 diminished, followed by an augmented 9th, then a perverted 32nd chord ending with a mangled 11th with a recovering 3rd.”

In this part . . .

This part contains three helpful appendixes, including the audio track listing as well as a handy chord chart detailing how to play all the chords discussed in this book, both on piano and on the guitar. You also get a glossary with definitions of key terms in music and music theory.

Appendix A

On the CD

Track Listing

The following is a list of the tracks that appear on this book's audio CD. Note that the accompanying CD is an audio-only CD that will play in any standard CD player or in your computer's CD-ROM drive.

<i>Track</i>	<i>Figure</i>	<i>Chapter</i>	<i>Description</i>
1		7	A major scale, piano and guitar
2		7	A flat major scale, piano and guitar
3		7	B major scale, piano and guitar
4		7	B flat major scale, piano and guitar
5		7	C major scale, piano and guitar
6		7	C flat major scale, piano and guitar
7		7	C sharp major scale, piano and guitar
8		7	D major scale, piano and guitar
9		7	D flat major scale, piano and guitar
10		7	E major scale, piano and guitar
11		7	E flat major scale, piano and guitar
12		7	F major scale, piano and guitar
13		7	F sharp major scale, piano and guitar
14		7	G major scale, piano and guitar
15		7	G flat major scale, piano and guitar
16		7	A natural minor scale, piano and guitar

(continued)

Table A-1 (continued)

<i>Track</i>	<i>Figure</i>	<i>Chapter</i>	<i>Description</i>
17		7	A harmonic minor scale, piano and guitar
18		7	A melodic minor scale, piano and guitar
19		7	A flat natural minor scale, piano and guitar
20		7	A flat harmonic minor scale, piano and guitar
21		7	A flat melodic minor scale, piano and guitar
22		7	A sharp natural minor scale, piano and guitar
23		7	A sharp harmonic minor scale, piano and guitar
24		7	A sharp melodic minor scale, piano and guitar
25		7	B natural minor scale, piano and guitar
26		7	B harmonic minor scale, piano and guitar
27		7	B melodic minor scale, piano and guitar
28		7	B flat natural minor scale, piano and guitar
29		7	B flat harmonic minor scale, piano and guitar
30		7	B flat melodic minor scale, piano and guitar
31		7	C natural minor scale, piano and guitar
32		7	C harmonic minor scale, piano and guitar
33		7	C melodic minor scale, piano and guitar
34		7	C sharp natural minor scale, piano and guitar
35		7	C sharp harmonic minor scale, piano and guitar
36		7	C sharp melodic minor scale, piano and guitar
37		7	D natural minor scale, piano and guitar
38		7	D harmonic minor scale, piano and guitar
39		7	D melodic minor scale, piano and guitar
40		7	D sharp natural minor scale, piano and guitar
41		7	D sharp harmonic minor scale, piano and guitar
42		7	D sharp melodic minor scale, piano and guitar
43		7	E natural minor scale, piano and guitar
44		7	E harmonic minor scale, piano and guitar

<i>Track</i>	<i>Figure</i>	<i>Chapter</i>	<i>Description</i>
45		7	E melodic minor scale, piano and guitar
46		7	E flat natural minor scale, piano and guitar
47		7	E flat harmonic minor scale, piano and guitar
48		7	E flat melodic minor scale, piano and guitar
49		7	F natural minor scale, piano and guitar
50		7	F harmonic minor scale, piano and guitar
51		7	F melodic minor scale, piano and guitar
52		7	F sharp natural minor scale, piano and guitar
53		7	F sharp harmonic minor scale, piano and guitar
54		7	F sharp melodic minor scale, piano and guitar
55		7	G natural minor scale, piano and guitar
56		7	G harmonic minor scale, piano and guitar
57		7	G melodic minor scale, piano and guitar
58		7	G sharp natural minor scale, piano and guitar
59		7	G sharp harmonic minor scale, piano and guitar
60		7	G sharp melodic minor scale, piano and guitar
61		9	Intervals with a quality of fifths
62		9	Simple intervals in the C major scale
63		10	The root of a C major chord
64		10	The root and the first third of a C major chord
65		10	The root and fifth of a C major chord
66		10	C major triad
67	Figure 10-33	10	AM, Am, Aaug, Adim, AM7, Am7, A7, Am7(♭5), Adim7, AmiMA7 on piano
68	Figure 10-34	10	A♭M, A♭m, A♭aug, A♭dim, A♭M7, A♭m7, A♭7, A♭m7(♭5), A♭dim7, A♭miMA7 on piano
69	Figure 10-35	10	BM, Bm, Baug, Bdim, BM7, Bm7, B7, Bm7(♭5), Bdim7, BmiMA7 on piano
70	Figure 10-36	10	B♭M, B♭m, B♭aug, B♭dim, B♭M7, B♭m7, B♭7, B♭m7(♭5), B♭dim7, B♭miMA7 on piano

(continued)

Table A-1 (continued)			
Track	Figure	Chapter	Description
71	Figure 10-37	10	CM, Cm, Caug, Cdim, CM7, Cm7, C7, Cm7(b5), Cdim7, CmiMA7 on piano
72	Figure 10-38	10	CbM, Cbm, Cbaug, Cbdim, CbM7, Cbm7, Cb7, Cbm7(b5), Cbdim7, CbmiMA7 on piano
73	Figure 10-39	10	C#M, C#m, C#aug, C#dim, C#M7, C#m7, C#7, C#m7(b5), C#dim7, C#miMA7 on piano
74	Figure 10-40	10	DM, Dm, Daug, Ddim, DM7, Dm7, D7, Dm7(b5), Ddim7, DmiMA7 on piano
75	Figure 10-41	10	DbM, Dbm, Dbaug, Dbdim, DbM7, Dbm7, Db7, Dbm7(b5), Dbdim7, DbmiMA7 on piano
76	Figure 10-42	10	EM, Em, Eaug, Edim, EM7, Em7, E7, Em7(b5), Edim7, EmiMA7 on piano
77	Figure 10-43	10	EbM, Ebm, Ebaug, Ebdim, EbM7, Ebm7, Eb7, Ebm7(b5), Ebdim7, EbmiMA7 on piano
78	Figure 10-44	10	FM, Fm, Faug, Fdim, FM7, Fm7, F7, Fm7(b5), Fdim7, FmiMA7 on piano
79	Figure 10-45	10	F#M, F#m, F#aug, F#dim, F#M7, F#m7, F#7, F#m7(b5), F#dim7, F#miMA7 on piano
80	Figure 10-46	10	GM, Gm, Gaug, Gdim, GM7, Gm7, G7, Gm7(b5), Gdim7, GmiMA7 on piano
81	Figure 10-47	10	GbM, Gbm, Gbaug, Gbdim, GbM7, Gbm7, Gb7, Gbm7(b5), Gbdim7, GbmiMA7 on piano
82		11	Key of G major chord progressions
83		11	Key of C major chord progressions
84		11	Key of F minor chord progressions
85		11	Key of A minor chord progressions
86		11	Authentic cadence
87		11	Perfect authentic cadence
88		11	Difference between a perfect authentic cadence and an imperfect authentic cadence
89		11	Plagal cadence
90		11	Two more plagal cadences
91		11	Deceptive cadence
92		11	Half-cadence
93		15	80 beats per minute (00:00) 100 beats per minute (00:12) 120 beats per minute (00:20)

Customer Care

If you have trouble with the CD, please call Wiley Product Technical Support at 877-762-2974. Outside the United States, call 317-572-3993. You can also contact Wiley Product Technical Support at support.wiley.com. Wiley will provide technical support only for installation and other general quality control items.

To place additional orders or to request information about other Wiley products, please call 877-762-2974.

Appendix B

Chord Chart

This appendix functions as a quick reference to the chords on the piano and guitar. It covers all the keys and shows each key's chords to the 7th degree. We list the piano chords followed by the guitar chords.



The tricky thing about diagramming guitar chords is that the same chord can be built in many ways, in many different places on the neck. To make things easier, we only include chords that don't go beyond the upper seven frets of the guitar neck.

For piano, the keys to be played in the chord are shown in gray. For the guitar, black dots show you where to put your fingers on the frets. An "X" above a string means you don't play that string. An "O" above a string stands for "open," meaning you play the string but don't fret it. Also, for each guitar chord diagram, the pitches for each open (non-fretted) string are, from left to right, (low) E, A, D, G, B, (high) E.

A



Am



Aaug



Adim



AM7



Am7



A7



Am7(b5)



Adim7



AmiMA7



AbM



Abm



Abaug



Abdim



$A\flat M7$  $A\flat m7$  $A\flat 7$  $A\flat mi7(b5)$  $A\flat dim7$  $A\flat miMA7$ 

BM

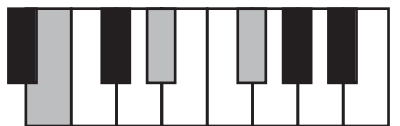

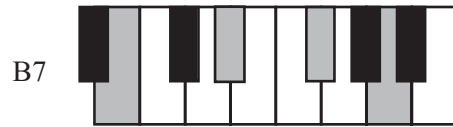

Bdim7



BmiMA7



BbM



Bbm



Bbaug



Bbdim



BbM7



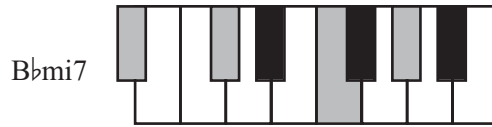

Caug



Cdim



CM7



Cm7



C7



Cmi7(b5)



Cdim7



CmiMA7



CbM

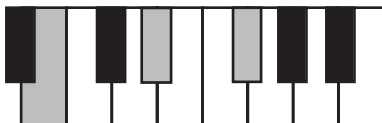

Cbm



Cbaug



Cbdim



CbM7

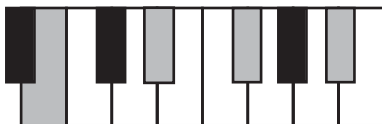

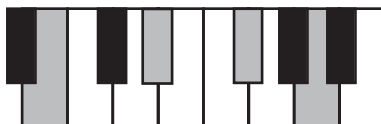
C \flat m7C \flat 7C \flat mi7(b5)C \flat dim7C \flat miMA7

C#M



C#m



C#aug



C#dim



C#M7



C#m7



C#7



C#m7(b5)



C#dim7



C#miMA7



DM



Dm



Daug





$D^{\flat}M$  $D^{\flat}m$  $D^{\flat}aug$  $D^{\flat}dim$  $D^{\flat}M7$  $D^{\flat}m7$  $D^{\flat}7$ 

D \flat m7(b5)



D \flat dim7



D \flat miMA7



EM



Em



Eaug



Edim



EM7



Em7



E7



Em7(b5)



Edim7



EmiMA7



EbM



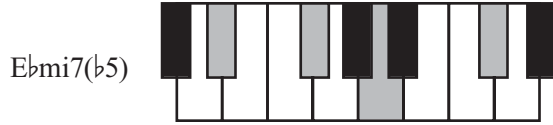

E \flat dim7E \flat miMA7

FM



Fm



Faug



Fdim



FM7



Fm7



F7



Fmi7(b5)



Fdim7



FmiMA7



F#M

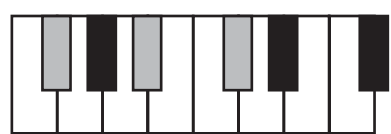

F#m



F#aug



F#dim



F#M7

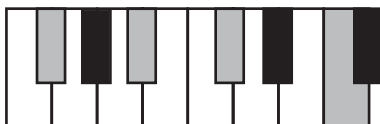

F#m7



F#7

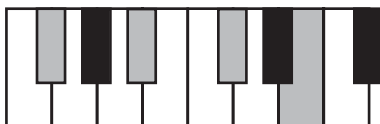

F#mi7(b5)



F#dim7



F#miMA7



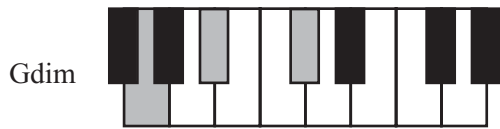

Gm7(b5)



Gdim7



GmiMA7



GbM



Gbm



Gbaug



Gbdim



GbM7



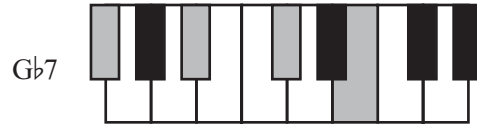

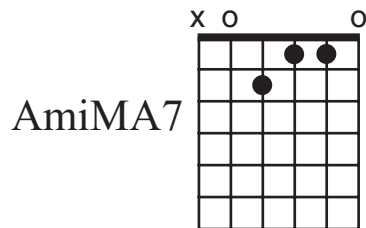
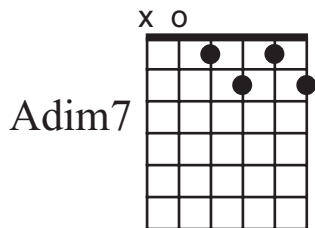
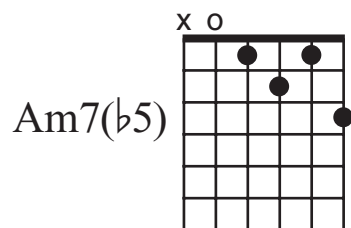
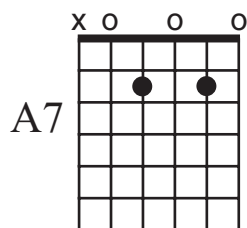
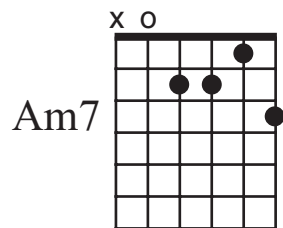
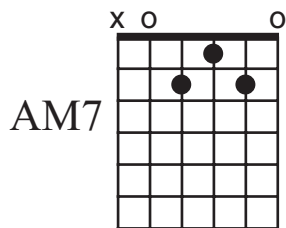
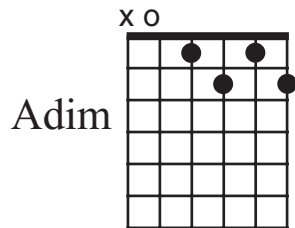
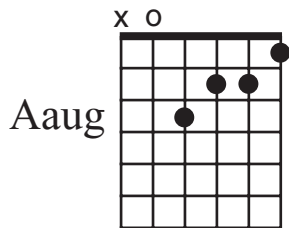
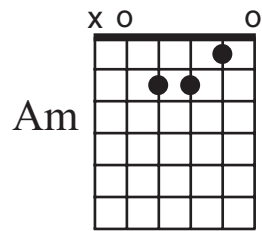
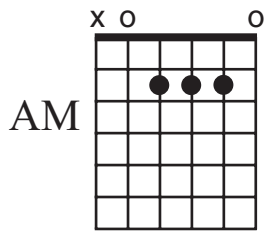

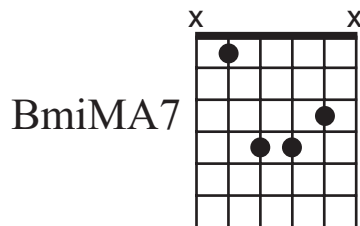
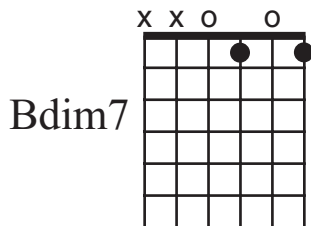
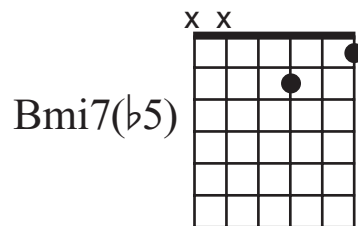
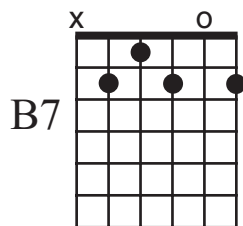
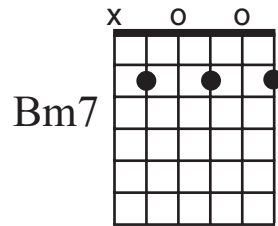
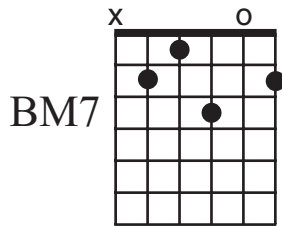
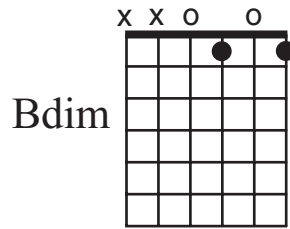
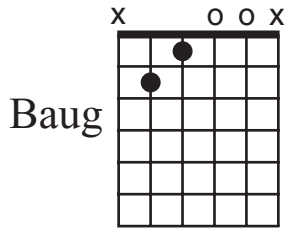
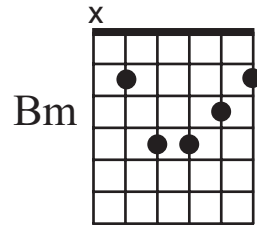
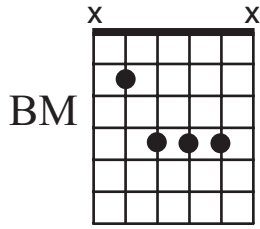

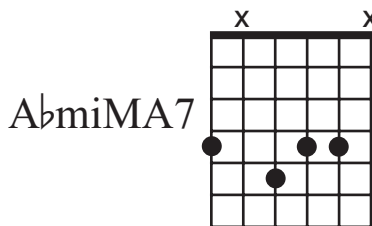
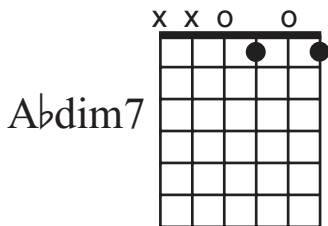
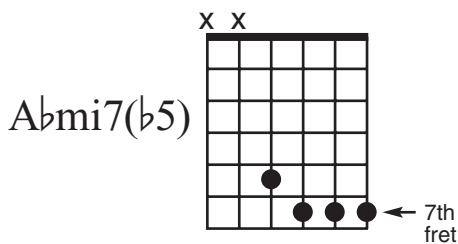
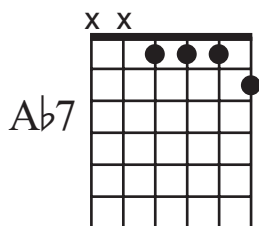
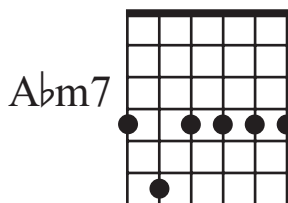
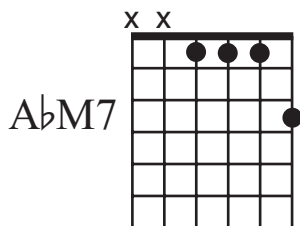
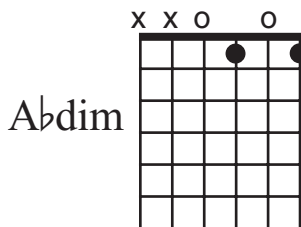
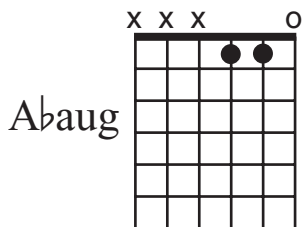
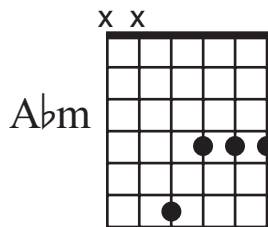
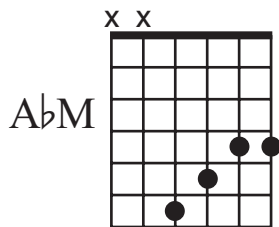

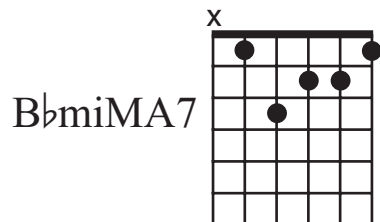
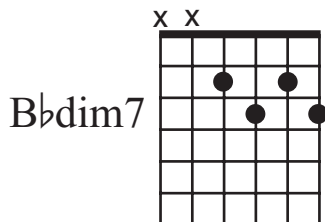
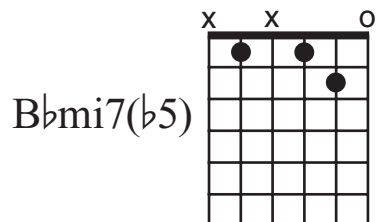
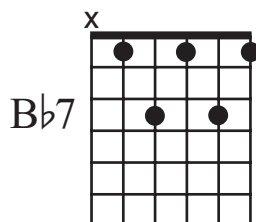
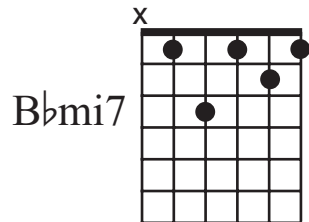
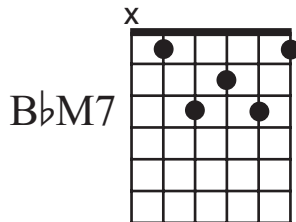
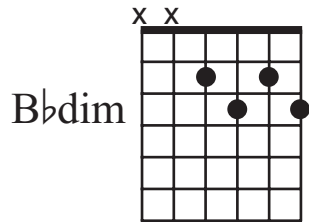
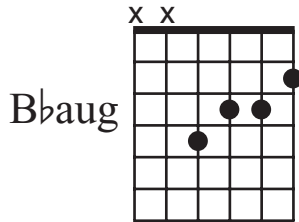
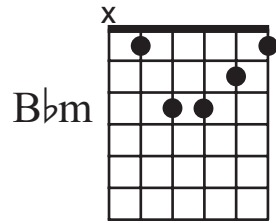
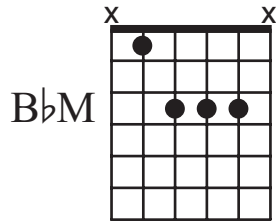

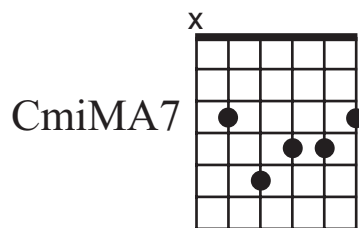
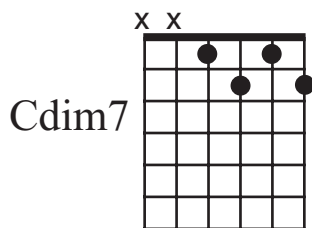
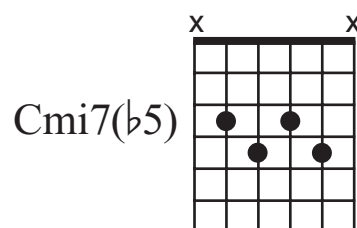
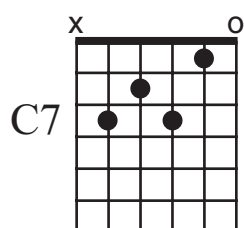
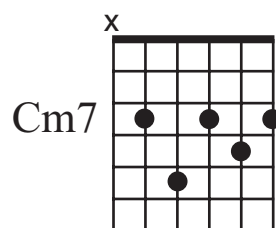
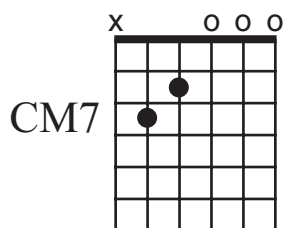
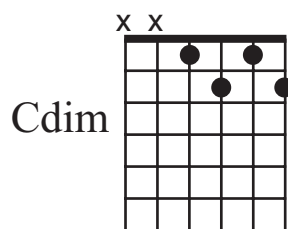
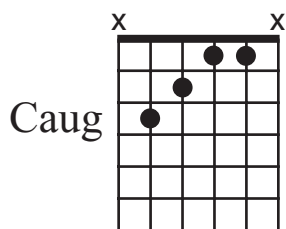
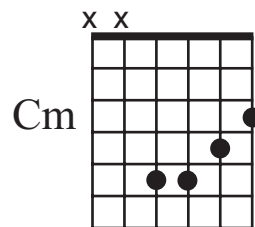
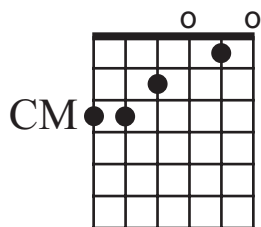

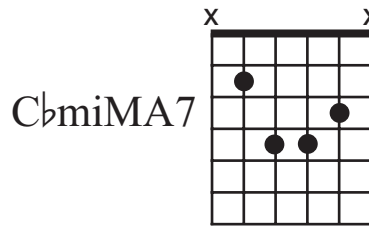
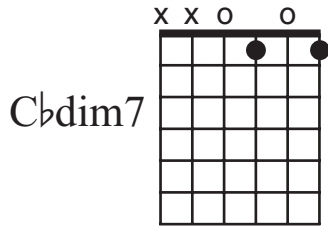
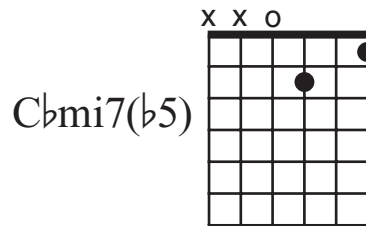
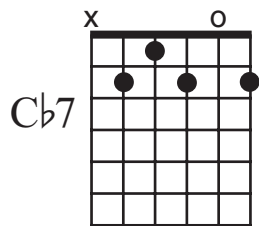
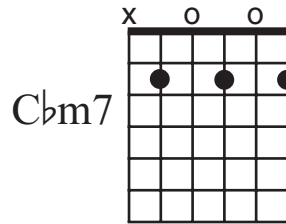
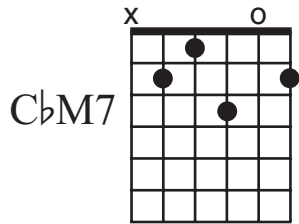
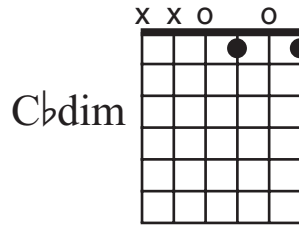
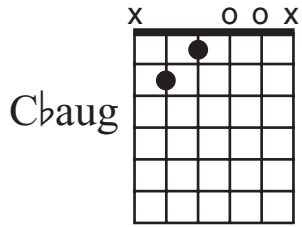
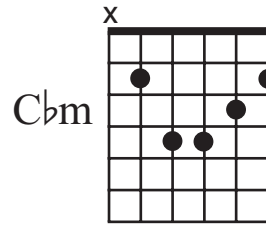
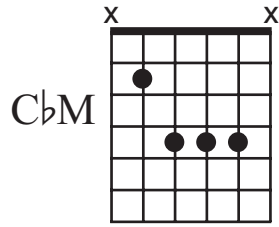

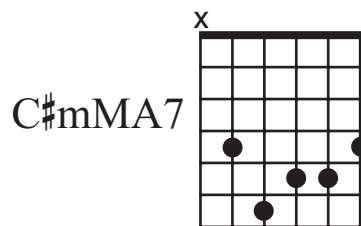
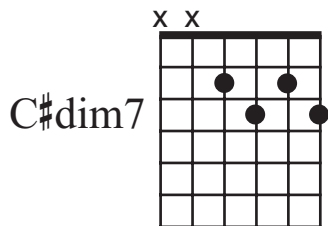
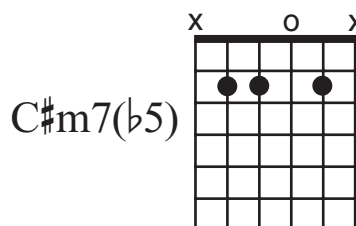
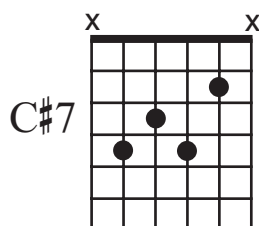
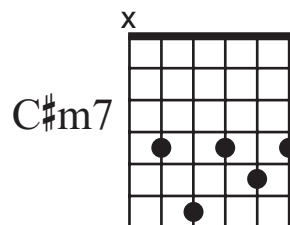
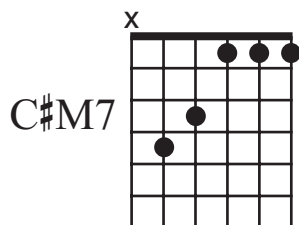
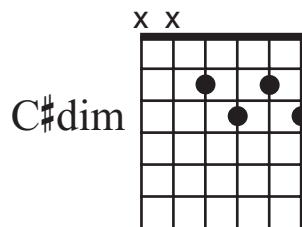
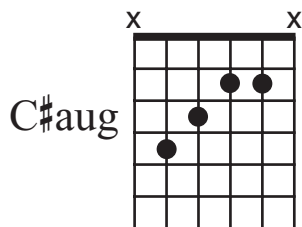
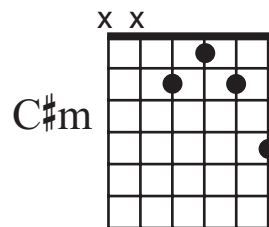
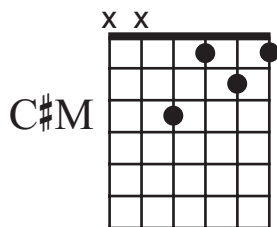

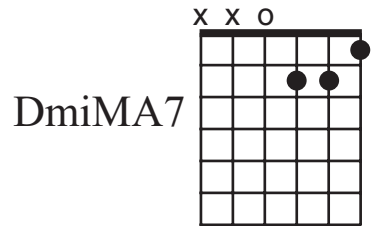
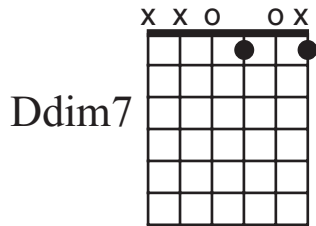
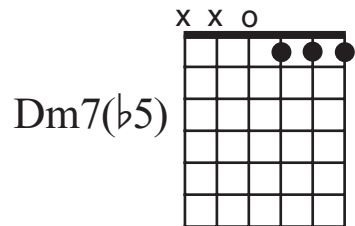
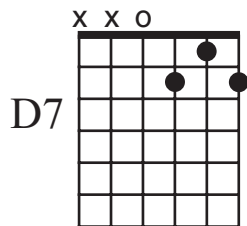
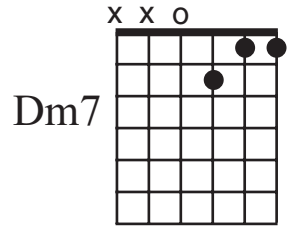
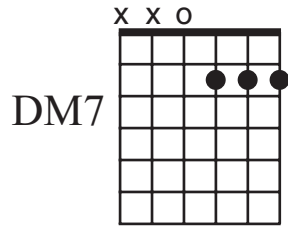
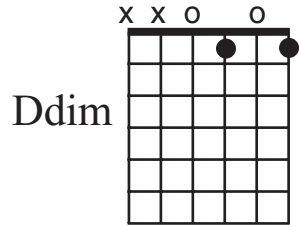
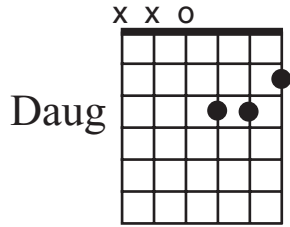
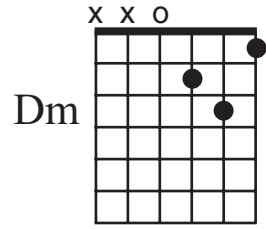
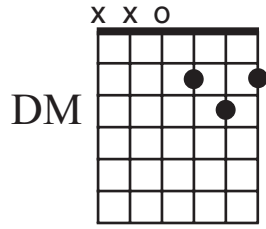

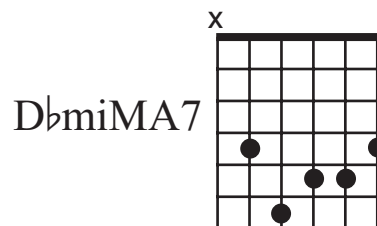
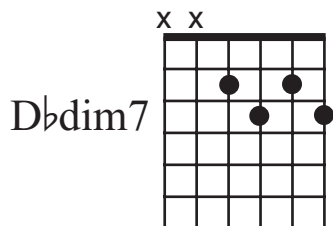
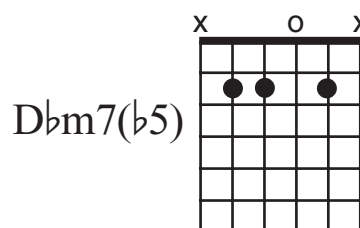
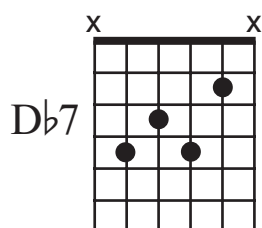
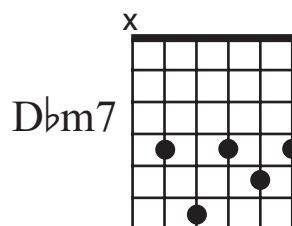
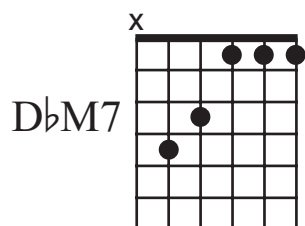
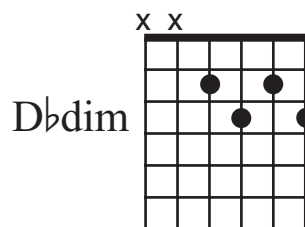
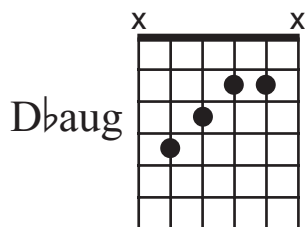
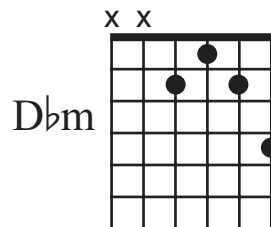
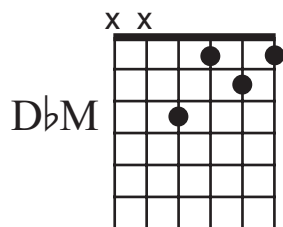

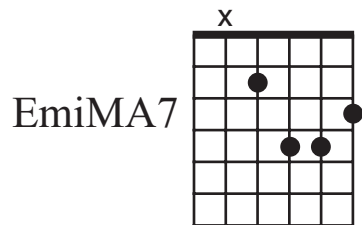
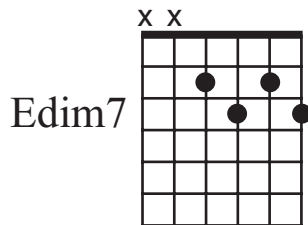
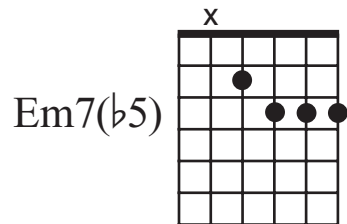
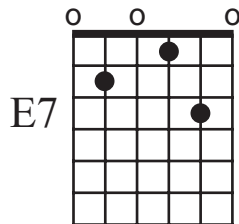
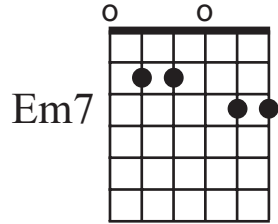
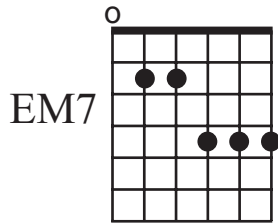
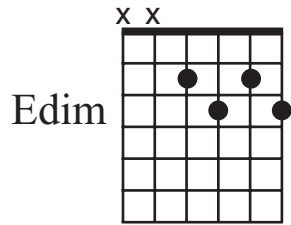
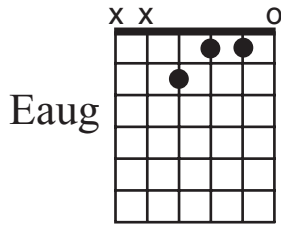
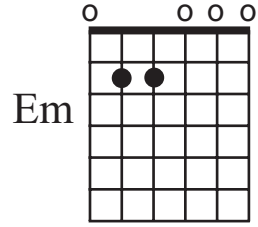
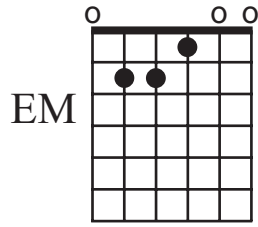

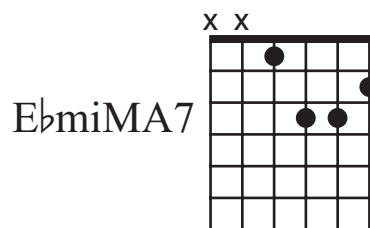
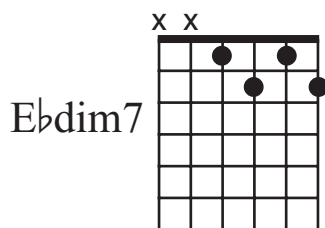
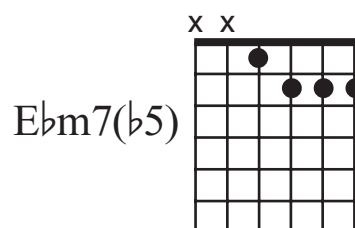
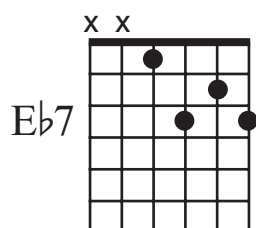
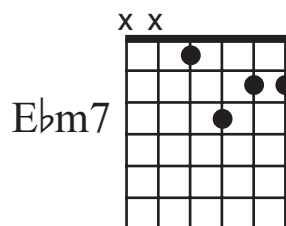
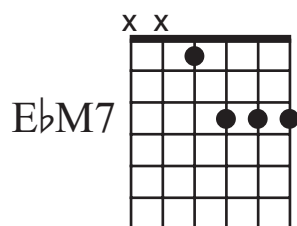
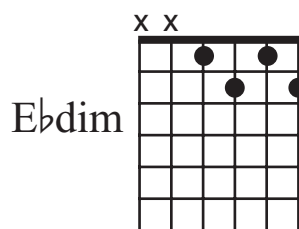
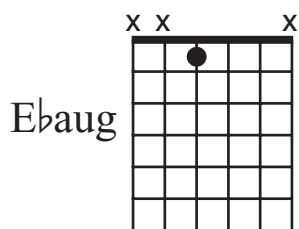
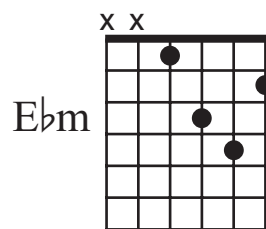
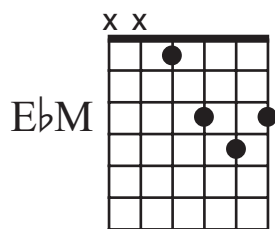

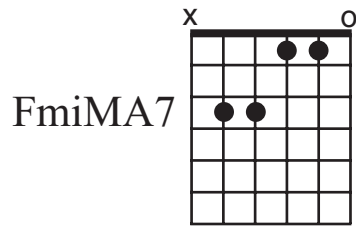
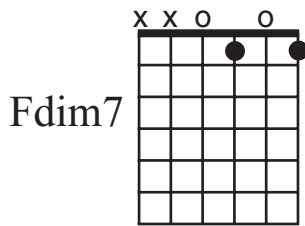
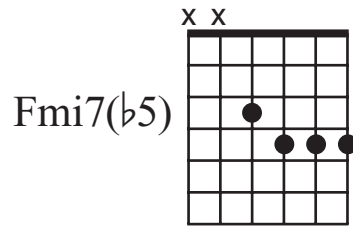
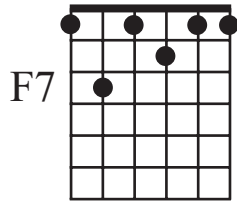
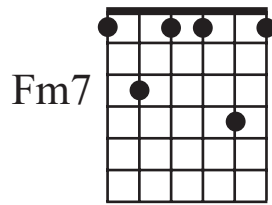
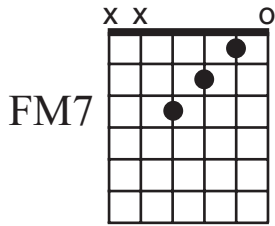
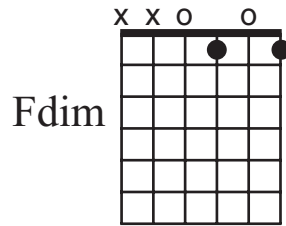
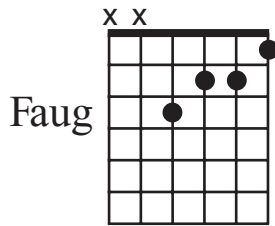
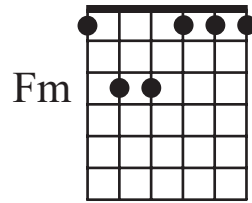
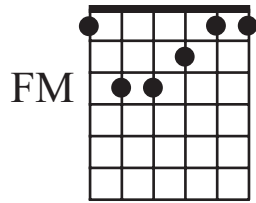

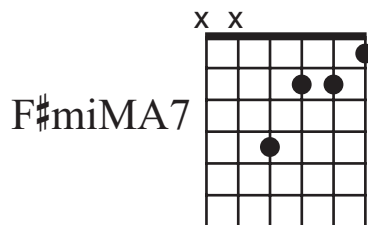
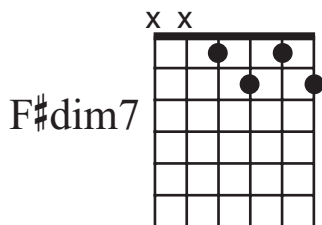
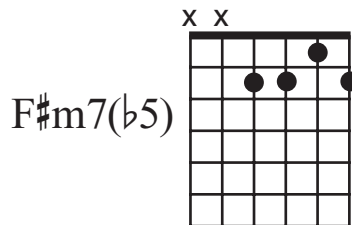
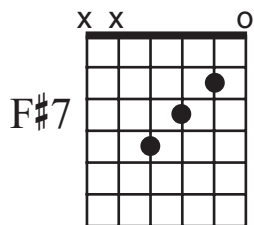
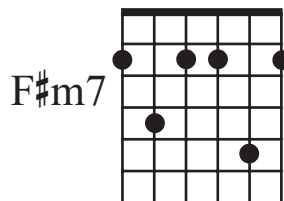
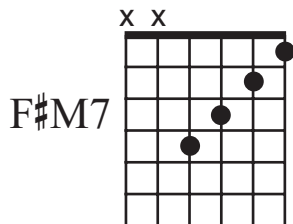
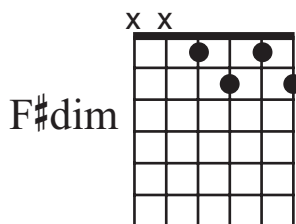
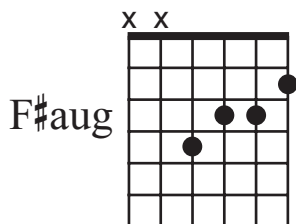
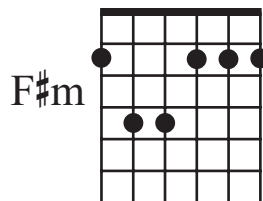
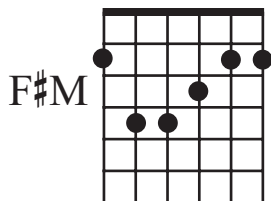

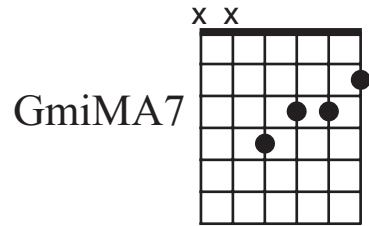
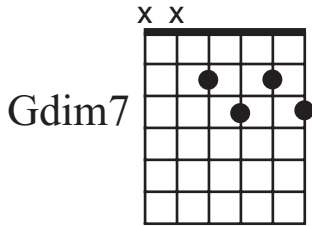
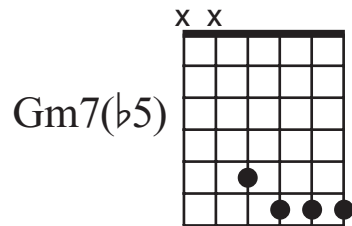
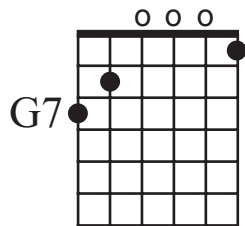
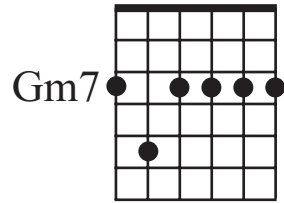
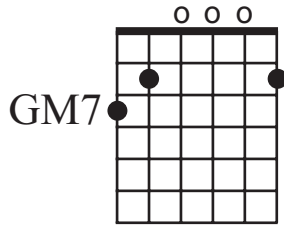
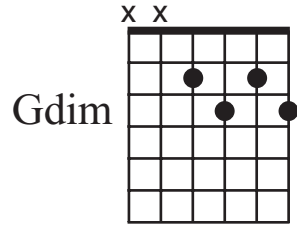
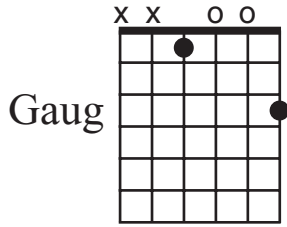
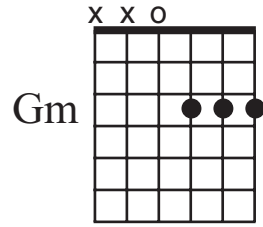
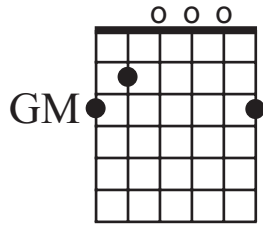

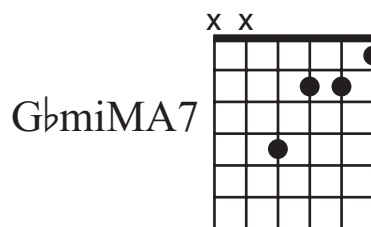
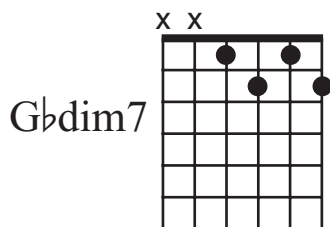
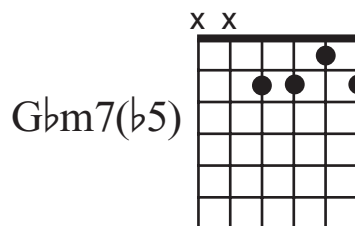
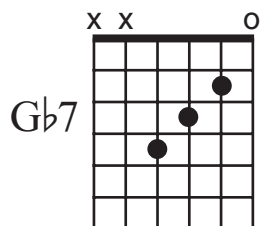
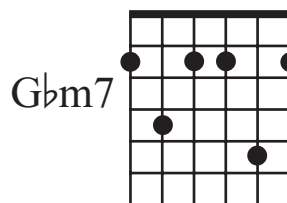
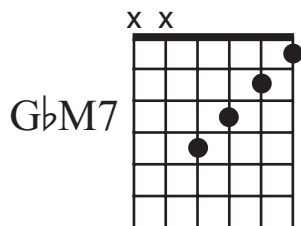
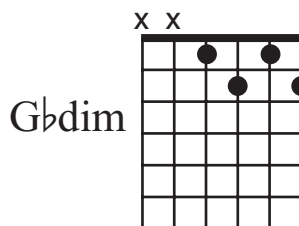
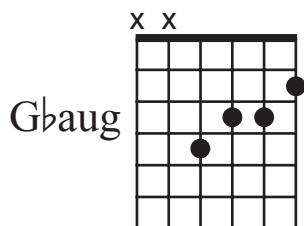
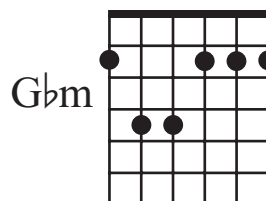
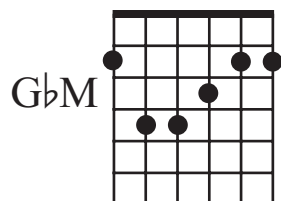

Appendix C

Glossary



accompaniment: The use of additional music to support a lead melodic line.

atonal: Music that is not in a key and not organized diatonically.

augmentation dot: A dot placed after a note or rest that extends its value by half of the original value. See *dotted note* and *dotted rest*.

bar lines: Vertical lines in written music that separate notes into different groups of notes and rests, depending on the time signature used.

bass clef: The lower staff in the grand staff. The bass clef establishes the pitch of the notes on the lines and spaces of the staff below middle C.

beam: A bar used (instead of a flag) to connect the stems of eighth notes and smaller notes.

beat: One of a series of repeating, consistent pulsations of time in music. Each pulsation is also called a beat.

bridge: The contrasting musical section between two similar sections of music. Also sometimes called the B section.

cadence: The ending of a musical phrase containing points of repose or release of tension.

call and response: When a soloist is answered by another musician or group of musicians.

chord: The simultaneous sounding of at least two pitches or notes.

chord progression: Moving from one chord to another, usually in established patterns.

chromatic: A musical scale with 12 pitches, each one semitone apart. See *diatonic*.

compound time: A meter whose beat count can be equally divided into thirds (6/8, 9/4, and so on) with the exception of any time signature that has a 3 as the top number of its time signature (as in 3/4 or 3/8 time).

cut time: Another name for 2/2 time.

diatonic: Conforming to the notes found in a given key. In a piece written in C major, for example, the C, D, E, F, G, A, and B are all diatonic pitches, and any other notes used in the piece are non-diatonic, or chromatic. See *chromatic*.

dotted note: A note followed by an augmentation dot means the note is worth one and a half times its normal value.

dotted rest: A rest followed by an augmentation dot means the rest is worth one and a half times its normal value.

downbeat: The first beat of a measure of music.

duplet: A pair of joined notes used in compound time to divide a beat that should contain three equal parts into two equal parts.

flag: A curved line added to the stem of a note to indicate a reduced rhythmic value. Flags are equivalent to beams. See *beam*.

form: The overall shape, organization, or structure of a musical composition.

genre: A style or manner of music.

grand staff: The combination of the bass clef staff and the treble clef staff. See *bass clef* and *treble clef*.

half step: The smallest interval in Western music, represented on the piano by moving one adjacent key, black or white, to the left or right from a starting point, or on the guitar by moving one fret up or down from a starting point.

harmony: Pitches heard simultaneously in ways that produce chords and chord progressions.

homophony: Layers of musical activity, such as melody and accompaniment.

improvisation: Spontaneous musical creation.

interval: The distance between the pitches of two notes.

key (signature): The scale degree of a piece of music, which is normally defined by the beginning and ending chord of a song and by the order of

whole steps and half steps between tonic scale degrees. (The key of C, for example, would be represented by the first C of the scale and the C an octave above the first.)

lead sheet: A scaled-down, notated melody with chord symbols, usually for rock or jazz music, which a musical performance is based on.

measure: A segment of written music, contained within two vertical bars, that includes as many beats as the top number of the key signature indicates. A measure is also called a bar.

melody: A succession of musical tones, usually of varying pitch and rhythm, that together have an identifiable shape and meaning.

meter: The organization of rhythmic patterns in a composition in such a way that a regular, repeating pulse of beats continues throughout the composition.

middle C: The C note located one ledger line below the treble staff or one line above the bass staff. See *staff* and *grand staff*.

notation: The use of written or printed symbols to represent musical sounds.

note: A symbol used to represent the duration of a sound and, when placed on a music staff, the pitch of the sound.

octave: Two tones that span eight different diatonic pitches that have the same pitch quality and the same pitch names in Western music.

pick-up notes: Introductory notes placed before the first measure in a piece of music.

pitch: The highness or lowness of a tone produced by a single frequency.

polyphony: Layers of different melodic and rhythmic activity within a single piece of music.

rest: A symbol used to notate a period of silence.

rhythm: A pattern of regular or irregular pulses in music.

scale: A series of notes in ascending or descending order that presents the pitches of a key, beginning and ending on the tonic of that key.

score: A printed version of a piece of music.

simple time: A time signature in which the accented beats of each measure are divisible by two, as in 4/4 time.

staff: Five horizontal, parallel lines, containing four spaces between them, on which notes and rests are written.

syncopation: A deliberate disruption of the two- or three-beat stress pattern, most often by stressing an off-beat, or a note that isn't on the beat.

tempo: The rate or speed of the beat in a piece of music.

timbre: The unique quality of sound made by an instrument.

time signature: A notation made at the beginning of a piece of music, in the form of two numbers such as 3/4, that indicates the number of beats in each measure or bar and shows which note value constitutes one beat. The top (or first) number tells how many beats are in a measure, and the bottom (or second) number tells which kind of note receives the count of one beat.

tonal: A song or section of music that's organized by key or scale.

tonic: The first scale degree of a diatonic scale.

treble clef: A symbol written at the beginning of the upper musical staff in the grand staff. The treble clef establishes the pitch of the notes on the lines and spaces of the staff existing above middle C.

trill: When a player rapidly alternates between two notes a whole step or half step apart.

triplet: Used in simple time to divide a beat that should contain two equal parts into three equal parts.

turnaround: A chord progression leading back to the beginning of the song.

whole step: An interval consisting of two half steps, represented on the piano by moving two adjacent keys, black or white, to the left or right from a starting point, or on the guitar by moving two frets up or down the neck from a starting point.

Index

• Symbols & Numerics •

< (hairpin), 213
(sharp), 70–71
8-bar blues music, 201
4/4 time signatures (common time), 19–20, 40–41
9/4 time signatures, 46
“19th Nervous Breakdown” (Rolling Stones), 203
6/8 time signatures, 45
16-bar blues music, 201
32-bar blues music, 202–203
3/4 time signatures, 41
3/8 time signatures, 41–42
12-bar blues music, 200–201
24-bar blues music, 202
2/2 time signatures, 42

• A •

A (musical note), 148
A (one-part) form, 185
a capella, 217
A flat (musical note), 148
A flat major key signature, 105
A flat natural minor key signature, 102–103
A major key signature, 101
A natural minor key signature, 99
A sharp natural minor, 104–105
AB (binary) forms, 185
ABA (three-part) forms, 185–187
ABCBA (arch) forms, 187
accelerando, 211
accidentals
described, 66, 70
double flats, 72–73
double sharps, 72–73
flats, 71–72

naturals, 73
sharps, 70–71
accompaniment, 293
acoustics, 223
adagio, 210
Adamson, Barry (musician), 186
agitato, 214
“Ain’t Misbehavin’” (Waller), 203
air forms, 185
Albini, Steve (math-rock pioneer), 178
allegretto, 210
allegro, 210
alto clef, 65
“Amazing Grace,” 172
Amen cadence, 171–172
American Mavericks (Key & Roethe), 236
andante, 210
andantino, 210
animato, 214
appassionato, 214
arch contours, 179–180
arch (ABCBA) forms, 187
archicembalo, 242
Aristotle (philosopher), 10
articulation markings, 217
artificial division, 56–58
The Art of Practicing: A Guide to Making Music from the Heart (Bruser), 236–237
Asch, Moses (Folkways Recordings), 234–235
asymmetrical time signatures, 47–49
atonal, 293
attack, 220–221
audible range, 222
audio examples
chord progressions, 166–167
intervals, 131
major scales, 84
minor scales, 90–92
seventh chords, 148–153
triads, 148–153

augmentation dot

defined, 293

notes, 26

rests, 34–35

augmented notes

described, 26

fourths, 116–117

quality, 114

second, 123

third, 125

unisons, 115

augmented triads, 139–140

authentic cadence, 170–171

• B •

B (musical note), 149

B flat (musical note), 149

B flat major key signature, 106

B flat natural minor key signature, 104–105

B major key signature, 102

B natural minor key signature, 100–101

Bach, Johann Sebastian (composer)

“From the Depths of My Heart,” 190

Fugue in C Major, 195

ballad forms, 185

bar lines, 293

Barenboim, Daniel

Parallels and Paradoxes: Explorations in Music and Society, 236

bass clef

defined, 293

mnemonics for, 229

overview, 63–64

The Beach Boys

“Good Vibrations,” 203

“Surfer Girl,” 203

beam, 18–19, 39, 293

beat

defined, 293

duplets, 57–58

eighth (quaver) notes, 23–25

half (minim) notes, 21–22

irregular rhythms, 56–58

overview, 16

pick-up measure, 54–56

quarter (crotchet) notes, 22–23

sixteenth (semiquaver) notes, 23–25

stress, 52

syncopation, 52–54, 178, 296

thirty-second (semidemi-quaver) notes,
23, 25

triplets, 56–57

whole (semibreve) notes, 20–21

beat counting

compound time signatures, 46–47

simple time signatures, 43–44

The Beatles

“From Me to You,” 203

“Hey Jude,” 203

“I Want to Hold Your Hand,” 204

“Ob-La-Di, Ob-La-Da,” 204

Beethoven, Ludwig Van (composer)

Sonata in C Minor, Opus 13, 191–193

Symphony No. 5 (Opus 67), 196

“Before the Next Teardrop Falls” (Fender),
202

Berlin, Irving (musician), 203

Berry, Chuck

“Johnny B. Goode,” 203

binary (AB) forms, 185

blues music

8-bar, 201

overview, 199–200

16-bar, 201

32-bar, 202–203

turnaround, 200

12-bar, 200–201

24-bar, 202

Boethius, Anicius Manlius Severinus
(philosopher), 240–241

Boston

“More Than a Feeling,” 204

Brahms, Johannes

“Lullaby,” 165–166

bridge, 186, 293

Bruser, Madeline

The Art of Practicing: A Guide to Making Music from the Heart, 236–237

Buckley, Jonathan

The Rough Guide to Classical Music, 235

• C •

C (musical note), 149

C clef, 65

C flat (musical note), 150

C flat major key signature, 102

- C major key signature, 99
- C major scale, 130–131
- C natural minor key signature, 106
- C sharp (musical note), 150
- C sharp major key signature, 104
- C sharp natural minor key signature, 101–102
- cadence
 - authentic, 170–171
 - deceptive, 173
 - defined, 293
 - half-cadence, 173–174
 - imperfect authentic, 171
 - overview, 169–170
 - perfect authentic, 170–171
 - plagal, 171–172
- calando, 211
- call and response
 - defined, 293
 - described, 205
- Capone, Phil
 - The Guitar Chord Bible*, 237
- CD
 - customer care, 253
 - technical support, 253
 - track listings, 249–252
- chart, chord
 - for guitar, 278–292
 - overview, 255
 - for piano, 256–277
- chiuso, 217
- chord
 - defined, 293
 - inverted
 - first inversion, 154
 - identifying, 155–156
 - overview, 154–156
 - second inversion, 155
 - third inversion, 155
 - overview, 133, 158–159
- chord building
 - doubling, 156
 - overview, 133–134
 - seventh chords
 - audio examples, 148–153
 - diminished sevenths, 146–147
 - dominant sevenths, 145
 - major sevenths, 143–144
 - minor 7 flat 5 chord, 145–146
 - minor sevenths, 144–145
 - minor-major sevenths, 147–148
 - overview, 142–143
- triads
 - audio examples, 148–153
 - augmented, 139–140
 - building, 136
 - diminished, 141–142
 - fifth, 135
 - inversions, 154–156
 - major, 136–137
 - minor, 138–139
 - overview, 134
 - root, 134
 - third, 134–135
 - voicing, 153–154
- chord chart
 - for guitar, 278–292
 - overview, 255
 - for piano, 256–277
- chord progression
 - audio examples, 166–167
 - cadence
 - authentic, 170–171
 - deceptive, 173
 - half-cadence, 173–174
 - imperfect authentic, 171
 - overview, 169–170
 - perfect authentic, 170–171
 - plagal, 171–172
 - chromatic chords, 158
 - defined, 293
 - diatonic chords, 158
 - examples, 165–167
 - fake books, 167–168
 - lead sheets, 167
 - in major keys, 160–161
 - in minor keys, 162–163
 - minor scale modes, 158–159
 - modulation, 168
 - naming, 159–160
 - overview, 159
 - scale degree numbers, 159–160
 - seventh chords, 163–165
 - tabs, 168

- choro, 217
 - chromatic, 293
 - chromatic chords, 158
 - Circle of Fifths
 - flats mnemonic, 96
 - overview, 93–95
 - sharps mnemonic, 95–96
 - clarinets, 10
 - classical forms
 - concerto, 197
 - counterpoint, 189–190
 - duet, 197
 - etude, 197
 - fantasia, 197
 - fugue, 194–195
 - rondo, 193–194
 - sonata
 - development, 192
 - exposition, 190–191
 - first part, 191
 - overview, 190
 - recapitulation, 192–193
 - second part, 191
 - symphony, 195–196
 - ClassicalWorks.com, 234
 - classification (musical)
 - blues
 - 8-bar, 201
 - overview, 199–200
 - 16-bar, 201
 - 32-bar, 202–203
 - turnaround, 200
 - 12-bar, 200–201
 - 24-bar, 202
 - country music, 202–203
 - defined, 294
 - described, 12, 177, 199
 - jazz, 205
 - pop music, 202–204
 - rock music, 202–204
 - clef
 - alto, 65
 - bass (F), 63–64
 - C, 65
 - overview, 62
 - tenor, 65
 - treble (G), 62–63
 - close voicing, 154
 - common time, 19–20, 40–41
 - complex time signatures, 47–49
 - compound intervals, 112–113
 - compound time
 - beat counting, 46–47
 - defined, 294
 - measures used to count in, 45–46
 - 9/4 time, 46
 - overview, 44
 - requirements for, 44
 - 6/8 time, 45
 - con forza, 214
 - concerto, 197
 - consonant harmonies, 182
 - contours
 - arch, 179–180
 - inverted arch, 180
 - overview, 179
 - pivotal, 181
 - wave, 180
 - contrast forms, 184
 - countermelodies, 205
 - counterpoint, 189–190
 - counting beats
 - compound time signatures, 46–47
 - simple time signatures, 43–44
 - country music, 202–203
 - crescendo, 213
 - Crisofori, Bartolomeo (inventor), 215, 217
 - chronométré, 209
 - “Crossroads Blues” (Johnson), 201
 - crotchet (quarter) notes
 - beat, 22–23
 - components, 17
 - overview, 22–23
 - crotchet (quarter) rests, 32–33
 - Currie, Nick (musician), 186
 - cut time, 294
 - cycle, 221
- **D** •
- D (musical note), 150–151
 - D flat (musical note), 151
 - D flat major key signature, 104
 - D major key signature, 100
 - D natural minor key signature, 107

D sharp natural minor key signature, 103–104
 damper pedal (piano), 216
 D'Arezzo, Guido (music theorist), 242
 d'Aurillac, Gerbert/Pope Sylvester II (music theorist), 241
 Day, Holly
 Music Composition For Dummies, 179, 230
 decay, 222
 deceptive cadence, 173
 development, 192
 diatonic
 chords, 158
 defined, 294
 diminished notes
 fifth, 119
 quality, 114
 sevenths, 146–147
 third, 125–126
 diminished triads, 141–142
 diminuendo, 213
 Distler, Marian (Folkways Recordings), 234
 Dixieland jazz, 205
 dolce, 214
 dolente, 214
 Dolmetsch, Arnold (music historian), 233
 Dolmetsch Online, 233
 dominant notes, 80, 85
 dominant sevenths, 145
 “Donna Lee” (Parker), 203
 doppio movimento, 211
 dot, augmentation
 defined, 293
 notes, 26
 rests, 34–35
 dotted note, 294
 dotted rest, 34–35, 294
 double flats, 72–73
 double sharps, 72–73
 double-dotted note, 26
 doubling, 156
 downbeat, 38, 294
 drummers, music theory for, 230–231
 duet, 197
 duplet
 defined, 294
 overview, 57–58

dynamics
 instrument markings, 216–217
 notations, 212–214
 overview, 211–212
 phrase modification, 212–214
 piano pedal, 215–216

● E ●

E (musical note), 151
 E flat (musical note), 152
 E flat major key signature, 106
 E flat natural minor key signature, 103–104
 E major key signature, 101–102
 E natural minor key signature, 99–100
 8-bar blues music, 201
 eighth (quaver) notes
 beat, 23–25
 components, 17
 overview, 23–25
 eighth (quaver) rests, 33–34
 electric guitars, 203
 Ellington, Duke
 “*It Don't Mean a Thing*,” 203
 Eminem
 “*Lose Yourself*,” 204
 enharmonic equivalents, 103
 enharmonic notes, 68
 etude, 197
 “*Every Breath You Take*” (The Police), 204
 examples
 audio
 chord progressions, 166–167
 intervals, 131
 major scales, 84
 minor scales, 90–92
 seventh chords, 148–153
 triads, 148–153
 chord progressions, 165–167
 exposition, 190–191

● F ●

F (bass) clef
 defined, 293
 mnemonics for, 229
 overview, 63–64
 F (musical note), 152

- F major key signature, 107
 - F natural minor key signature, 105
 - F sharp (musical note), 152
 - F sharp major key signature, 103–104
 - F sharp natural minor key signature, 101
 - fake books, 167–168
 - fantasia, 197
 - Fender, Freddy
 - “Before the Next Teardrop Falls,” 202
 - “Wasted Days and Wasted Nights,” 202
 - Fender, Leo (inventor), 203
 - fifths
 - overview, 118–119
 - triads, 135
 - flag
 - defined, 294
 - described, 17, 18
 - rests, 33
 - flats
 - Circle of Fifths, 96
 - double, 72–73
 - overview, 71–72
 - flatted note, 66, 68
 - flutes, 10
 - Folkways Recordings, 234–235
 - form
 - air, 185
 - arch (ABCBA), 187
 - ballad, 185
 - binary (AB), 185
 - classical
 - concerto, 197
 - counterpoint, 189–190
 - duet, 197
 - etude, 197
 - fantasia, 197
 - fugue, 194–195
 - rondo, 193–194
 - sonata, 190–193
 - symphony, 195–196
 - contrast, 184
 - creating, 184–187
 - defined, 294
 - described, 12, 177–178
 - genre compared, 199
 - limits of, 185
 - one-part (A), 185
 - song, 200, 202
 - three-part (ABA), 185–187
 - unbroken, 185
 - forte, 212
 - fortissimo, 212
 - 4/4 time signatures (common time),
 - 19–20, 40–41
 - fourths, 116–118
 - free jazz, 205
 - frequency, 221
 - “From Me to You” (The Beatles), 203
 - “From the Depths of My Heart” (Bach), 190
 - “Frosty the Snowman,” 203
 - fugue, 194–195
- **G** ●
- G (musical note), 153
 - G flat (musical note), 153
 - G flat major key signature, 103–104
 - G major key signature, 99–100
 - G natural minor key signature, 106
 - G sharp natural minor key signature,
 - 102–103
 - “The Gambler” (Rogers), 204
 - genre
 - blues
 - 8-bar, 201
 - overview, 199–200
 - 16-bar, 201
 - 32-bar, 202–203
 - turnaround, 200
 - 12-bar, 200–201
 - 24-bar, 202
 - country music, 202–203
 - defined, 294
 - described, 12, 177, 199
 - jazz, 205
 - pop music, 202–204
 - rock music, 202–204
 - Gershwin, George (musician),
 - “I Got Rhythm,” 203
 - “Good Vibrations” (The Beach Boys), 203
 - grand staff
 - defined, 294
 - described, 64

grandioso, 214
grave speed, 208, 210
“Great Balls of Fire” (Lewis), 203
Grimes, Rachel (composer), 185
Guidonian Scale, 242
guitar
 actual pitch versus written pitch, 84
 attack, 220
 electric, 203
 half steps, 67–68
 history, 10
 major scales, 82–84
 minor scales
 harmonic, 88
 melodic, 89–90
 natural, 86–87
 note illustration, 74–76
 whole steps, 70
The Guitar Chord Bible (Capone), 237
Gutenberg, Johannes (inventor), 61

• H •

< (hairpin), 213
half (minim) notes
 beat, 21–22
 components, 17
 overview, 21–22
half (minim) rests, 31–32
half step (semitone)
 defined, 294
 on guitar, 67–68
 overview, 66–68
 on piano, 67
half-cadence, 173–174
half-diminished seventh, 145, 163
harmonic fifth, 111
harmonic goal, 169
harmonic intervals, 109–110
harmonic minor scales, 87–88
harmonics, 221
harmony
 defined, 294
 overview, 181–182
harps, 10
harpsichord, 217

head (note), 17
hertz (Hz), 221
“Hey Jude” (The Beatles), 203
homophony, 294
hook, 204
Hughes, John III (soundtrack composer), 186
Huygens, Christiaan (music theorist), 243

• I •

“I Got Rhythm,” (Gershwin), 203
“I Want to Hold Your Hand” (The Beatles), 204
identifying key based on key signature, 229–230
“I’m So Lonesome (I Could Cry)” (Williams), 202
imperfect authentic cadence, 171
importance of music theory, 227
improvisation
 defined, 294
 music theory and improvisation skills, 230
impulsive decay, 222
instrument markings, 216–217
internal design of piano, 217
interval
 audio examples, 131
 building, 126–129
 in C major scale, 130–131
 compound, 112–113
 defined, 294
 harmonic, 109–110
 identity, 110
 melodic, 109–110
 naming, 114
 overview, 109–110
 quality
 determining, 127–129
 fifths, 118–119
 fourths, 116–118
 octaves, 115–116
 overview, 113–114, 119–120
 seconds, 120–123
 sevenths, 126

interval (*continued*)
 sixths, 126
 thirds, 123–126
 unisons, 114–115
 quantity
 determining, 127
 overview, 110–113
 inverted arch contours, 180
 inverted chords
 first inversion, 154
 identifying, 155–156
 overview, 154–156
 second inversion, 155
 third inversion, 155
 irrational rhythms, 56–58
 irregular rhythms, 56–58
 irregular time signatures, 47–49
 “It Don’t Mean a Thing” (Ellington), 203

• J •

Jarrett, Scott
 Music Composition For Dummies,
 179, 230
 jazz, 205
 “Johnny B. Goode” (Berry), 203
 Johnson, Robert
 “Crossroads Blues,” 201
 Jones, Tom
 “Sex Bomb,” 204

• K •

key
 described, 93
 major
 chord progressions in, 160–161
 key signature, identifying key based on,
 229–230
 minor
 chord progressions in, 162–163
 key signature, identifying key based on,
 229–230
 transposing music into another, 230
 Key, Susan
 American Mavericks, 236
 key signature
 A flat major, 105
 A flat natural minor, 102–103

A major, 101
 A natural minor, 99
 A sharp natural minor, 104–105
 B flat major, 106
 B flat natural minor, 104–105
 B major, 102
 B natural minor, 100–101
 C flat major, 102
 C major, 99
 C natural minor, 106
 C sharp major, 104
 C sharp natural minor, 101–102
 D flat major, 104
 D major, 100
 D natural minor, 107
 D sharp natural minor, 103–104
 defined, 294–295
 described, 11, 93
 E flat major, 106
 E flat natural minor, 103–104
 E major, 101–102
 E natural minor, 99–100
 F major, 107
 F natural minor, 105
 F sharp major, 103–104
 F sharp natural minor, 101
 G flat major, 103–104
 G major, 99–100
 G natural minor, 106
 G sharp natural minor, 102–103
 G sharp/A flat natural minor, 102–103
 identifying key based on, 229–230
 major, 96–97
 minor, 98
 keyboard. *See also* piano
 alternatives, 69
 history, 12
 kilohertz (kHz), 221

• L •

Lady Gaga
 “Poker Face,” 204
 largetto, 210
 largo, 210
 lead instruments, 222
 lead sheet, 167, 295

leading note, 80
 leading tone, 85
 Led Zeppelin
 "Whole Lotta Love," 203
 ledger lines, 65
 legato, 214
 lento, 210
 Lewis, Jerry Lee
 "Great Balls of Fire," 203
 "Lose Yourself" (Eminem), 204
 loud pedal, 216
 Loulié, Étienne (musician/inventor), 209
 "Lullaby" (Brahms), 165–166
 lute/harp, 10
 lyres, 10

• *M* •

Maelzel, Johann Nepomuk (inventor), 209
 Maelzel's metronome (MM), 209
 major key
 chord progressions in, 160–161
 key signature, identifying key based on,
 229–230
 major key signatures, 96–97
 major (M) quality, 113
 major scales
 audio examples, 84
 on guitar, 82–84
 overview, 79–81
 patterns, 79–81
 on piano, 81–82
 major second, 120–123
 major sevenths, 143–144
 major third, 124–125
 major triads, 136–137
 major-minor seventh chord, 145
 Mallman, Mark (musician), 205
 martellato, 217
 math rock, 49
 measure
 compound time signatures, measures
 used to count in, 45–46
 defined, 295
 overview, 38–39
 simple time signatures, measures used to
 count in, 40–42
 mediant notes, 80, 85

melodic intervals, 109–110
 melodic minor scales, 89–90
 melody
 contours
 arch, 179–180
 inverted arch, 180
 overview, 179
 pivotal, 181
 wave, 180
 defined, 295
 overview, 179–181
 range, 181
 memorizing music, 231
 Mersenne, Marin (philosopher/
 mathematician), 208
 meter, 295
 metronome, 16, 209
 mezzo forte, 212
 mezzo piano, 212
 middle C, 64–65, 295
 middle pedal (piano), 215–216
 minim, 42
 minim (half) notes
 beat, 21–22
 components, 17
 overview, 21–22
 tempo, 208
 minim (half) rests, 31–32
 minor 7 flat 5 chord, 145–146, 163
 minor key
 chord progressions in, 162–163
 key signature, identifying key based on,
 229–230
 minor key signatures, 98
 minor (m) quality, 113
 minor scales
 audio examples, 90–92
 chord progressions, 158–159
 on guitar, 86–90
 harmonic, 87–88
 melodic, 89–90
 natural, 85–87
 overview, 84–85
 on piano, 85–86, 87, 89
 minor second, 120–123
 minor sevenths, 144–145

- minor third, 124–126
- minor triads, 138–139
- minor-major sevenths, 147–148
- MM (Maelzel's metronome), 209
- mnemonics
 - for bass clef, 229
 - for learning to read music, 229
 - to remember notes, 76–77
- moderato, 210
- modulation, 168
- Momus (musician), 186
- monochord, 241
- Moog, Robert (inventor), 69, 245
- “More Than a Feeling” (Boston), 204
- Mozart
 - Rondo Alla Turca*, 193–194
- Music Composition For Dummies* (Day & Jarrett), 179, 230
- music composition on piano, 215, 217
- music history, 10
- music theorists
 - Anicius Manlius Severinus Boethius, 240–241
 - Arnold Schoenberg, 243
 - Christiaan Huygens, 243
 - Gerbert d'Aurillac/Pope Sylvester II, 241
 - Guido D'Arezzo, 242
 - Harry Partch, 244
 - Karlheinz Stockhausen, 244–245
 - Nicola Vicentino, 242
 - Pythagoras, 239–240
 - Robert Moog, 245
- music theory
 - advantages of, 13
 - for drummers, 230–231
 - fundamentals, 11–12
 - history of, 10
 - importance of, 205, 227
 - improvisation skills and, 230
 - memorizing music and, 231
 - piano as center of, 228
 - reason for learning, 228
- musical note. *See also specific notes*
 - augmented
 - described, 26
 - fourths, 116–117
 - quality, 114
 - second, 123
 - third, 125
 - unisons, 115
 - components of, 17–19
 - defined, 295
 - described, 16
 - diminished
 - fifth, 119
 - quality, 114
 - sevenths, 146–147
 - third, 125–126
 - flag, 17, 18
 - head, 17
 - minim (half)
 - beat, 21–22
 - components, 17
 - overview, 21–22
 - tempo, 208
 - mnemonics used to remember, 76–77
 - origin of, 231
 - overview, 17
 - stem, 17, 18
 - values
 - combination of note values, practicing with, 27–28
 - of common notes, 20–25
 - described, 16
 - extending, 25–27
 - overview, 17, 19–20
 - whole (semibreve)
 - beat, 20–21
 - components, 17
 - overview, 20–21
- musical parts, 184
- musical period, 183–184
- musical phrases, 182–184
- musical staff
 - defined, 296
 - described, 62
 - grand
 - defined, 294
 - described, 64
 - history, 12

• N •

naming
 chord progressions, 159–160
 intervals, 114
 natural minor scales, 85–87
 natural notes, 66
 naturals, 73
 neumatic notation, 242
 9/4 time signatures, 46
 “19th Nervous Breakdown” (Rolling Stones), 203
 notation
 defined, 295
 history, 12
 overview, 212–214
 tempo, 209–211
 note. *See also specific notes*
 augmented
 described, 26
 fourths, 116–117
 quality, 114
 second, 123
 third, 125
 unisons, 115
 components of, 17–19
 defined, 295
 described, 16
 diminished
 fifth, 119
 quality, 114
 sevenths, 146–147
 third, 125–126
 flag, 17, 18
 head, 17
 minim (half)
 beat, 21–22
 components, 17
 overview, 21–22
 tempo, 208
 mnemonics used to remember, 76–77
 origin of, 231
 overview, 17
 stem, 17, 18

values
 combination of note values, practicing with, 27–28
 of common notes, 20–25
 described, 16
 extending, 25–27
 overview, 17, 19–20
 whole (semibreve)
 beat, 20–21
 components, 17
 overview, 20–21

• O •

“Ob-La-Di, Ob-La-Da” (The Beatles), 204
 octave
 defined, 295
 overview, 115–116
 octave mark, 74
 one-part (A) form, 185
 Open Directory Project, 234
 open voicing, 154
 orchestra, 222
 “Ornithology” (Parker), 203

• P •

parallel scales, 80
Parallels and Paradoxes: Explorations in Music and Society (Barenboim & Said), 236
 Parker, Charlie (musician)
 “Donna Lee,” 203
 “Ornithology,” 203
 parlando, 217
 parlante, 217
 Partch, Harry (music theorist), 244
 patterns (major scales), 79–81
 Paul, Les (inventor), 203
 perfect authentic cadence, 170–171
 perfect fifth, 119
 perfect fourth, 116–117
 perfect octave, 115–116
 perfect (P) quality, 114
 perfect unisons, 114–115

- phrase line, 183
- phrase modification, 212–214
- pianissimo, 212
- piano
 - attack, 220
 - as center of music theory, 228
 - damper pedal, 216
 - half steps, 67
 - internal design, 217
 - major scales, 81–82
 - middle pedal, 215–216
 - minor scales
 - harmonic, 87
 - melodic, 89
 - natural, 85–86
 - music composition on, 215, 217
 - note illustration, 74
 - soft pedal, 215
 - whole steps, 68–70
- piano (dynamic notation), 212
- piano pedal, 215–216
- pick-up measure, 54–56
- pick-up notes, 54–55, 295
- pitch
 - accidentals used to change, 70–73
 - defined, 295
 - described, 16
 - guitar actual pitch versus written pitch, 84
- pivotal contours, 181
- pizzicato, 217
- plagal cadence, 171–172
- “Poker Face” (Lady Gaga), 204
- The Police
 - “Every Breath You Take,” 204
- polyphony, 295
- polyvalent form, 245
- pop music, 202–204
- Pope Sylvester II (music theorist), 241
- prestissimo, 208, 210
- presto, 210
- progression, chord
 - audio examples, 166–167
 - cadence
 - authentic, 170–171
 - deceptive, 173
 - half-cadence, 173–174
 - imperfect authentic, 171
 - overview, 169–170
 - perfect authentic, 170–171
 - plagal, 171–172
 - chromatic chords, 158
 - defined, 293
 - diatonic chords, 158
 - examples, 165–167
 - fake books, 167–168
 - lead sheets, 167
 - in major keys, 160–161
 - in minor keys, 162–163
 - minor scale modes, 158–159
 - modulation, 168
 - naming, 159–160
 - overview, 159
 - scale degree numbers, 159–160
 - seventh chords, 163–165
 - tabs, 168
- pure tone, 222
- Pythagoras (scholar/philosopher), 10, 93, 231, 239–240
- Pythagorean commas, 240



- quality (intervals)
 - determining, 127–129
 - fifths, 118–119
 - fourths, 116–118
 - octaves, 115–116
 - overview, 113–114, 119–120
 - seconds, 120–123
 - sevenths, 126
 - sixths, 126
 - thirds, 123–126
 - unisons
 - augmented, 115
 - perfect, 114–115
- quantity (intervals)
 - determining, 127
 - overview, 110–113
- quarter (crotchet) notes
 - beat, 22–23
 - components, 17
 - overview, 22–23
- quarter (crotchet) rests, 32–33
- quarter tones, 66

quaver (eighth) notes
 beat, 23–25
 components, 17
 overview, 23–25
 quaver (eighth) rests, 33–34

• R •

range, 181
 read music, mnemonics for learning to, 229
 reason for learning music theory, 228
 recapitulation, 192–193
 “Refugee” (Tom Petty and the Heartbreakers), 204
 Reich, Steve (composer), 186
 resources
American Mavericks (Key & Roethe), 236
The Art of Practicing: A Guide to Making Music from the Heart (Bruser), 236–237
 ClassicalWorks.com, 234
 Dolmetsch Online, 233
The Guitar Chord Bible (Capone), 237
 Open Directory Project, 234
Parallels and Paradoxes: Explorations in Music and Society (Barenboim & Said), 236
The Rough Guide to Classical Music (Staines & Buckley), 235
 Smithsonian Folkways Series, 234–235
The Virgin Directory of World Music (Sweeney), 235
 rest
 defined, 295
 dotted, 34–35
 eighth (quaver), 33–34
 flags, 33
 half (minim), 31–32
 overview, 29–30
 practice exercises, 35–36
 quarter (crotchet), 32–33
 sixteenth (semiquaver), 34
 thirty-second (demisemiquaver), 34
 whole (semibreve), 30–31
 rhythm
 defined, 295
 irrational, 56–58
 irregular, 56–58
 overview, 15, 178–179
 surface, 178

syncopation, 178
 tempo, 179
 rhythm sticks, 16
 Rickenbacher, Adolph (inventor), 203
 The Righteous Brothers
 “You’ve Lost That Loving Feeling,” 203
 ritardando, 211
 rock music, 202–204
 Roethe, Larry
American Mavericks, 236
 Rogers, Kenny
 “The Gambler,” 204
 Rolling Stones
 “19th Nervous Breakdown,” 203
 rondo, 184, 193–194
Rondo Alla Turca (Mozart), 193–194
 root
 open/closed voicing, 154
 triads, 134
The Rough Guide to Classical Music (Staines & Buckley), 235

• S •

Said, Edward W.
Parallels and Paradoxes: Explorations in Music and Society, 236
 scale
 defined, 295
 major
 audio examples, 84
 on guitar, 82–84
 overview, 79–81
 patterns, 79–81
 on piano, 81–82
 minor
 audio examples, 90–92
 on guitar, 86–90
 harmonic, 87–88
 melodic, 89–90
 natural, 85–87
 overview, 84–85
 on piano, 85–86, 87, 89
 overview, 79
 parallel, 80
 scale degree, 80
 scale degree numbers, 159–160
 Schoenberg, Arnold (composer), 243
 score, 295

- seconds, 120–123
- semibreve (whole) notes
 - beat, 20–21
 - components, 17
 - overview, 20–21
- semibreve (whole) rests, 30–31
- semitone (half step)
 - defined, 294
 - on guitar, 67–68
 - overview, 66–68
 - on piano, 67
- seventh chords
 - audio examples, 148–153
 - diminished sevenths, 146–147
 - dominant sevenths, 145
 - major sevenths, 143–144
 - minor 7 flat 5 chord, 145–146
 - minor sevenths, 144–145
 - minor-major sevenths, 147–148
 - overview, 142–143
- sevenths, 126
- “Sex Bomb” (Jones), 204
- sharp
 - Circle of Fifths, 95–96
 - overview/symbol (#), 70–71
- sharped note, 66, 68
- simple time signature
 - beat counting, 43–44
 - defined, 296
 - 4/4 time, 40–41
 - measures used to count in, 40–42
 - overview, 39–40
 - requirements for, 39–40
 - 3/4 time, 41
 - 3/8 time, 41–42
 - 2/2 time, 42
- 6/8 time signatures, 45
- 16-bar blues music, 201
- sixteenth (semiquaver) notes
 - beat, 23–25
 - illustrated, 18
- sixteenth (semiquaver) rests, 34
- sixths, 126
- slur, 27, 214
- Smithsonian Folkways Series, 234–235
- soft pedal (piano), 215
- sonata
 - development, 192
 - exposition, 190–191
 - first part, 191
 - overview, 190
 - recapitulation, 192–193
 - second part, 191
- Sonata in C Minor, Opus 13 (Beethoven), 191–193
- sotto voce, 214
- spacing, 153–154
- spiccato, 217
- staff
 - defined, 296
 - described, 62
 - grand
 - defined, 294
 - described, 64
 - history, 12
- Staines, Joe
 - The Rough Guide to Classical Music*, 235
- standard, 205
- stem (note), 17, 18
- Stockhausen, Karlheinz (music theorist), 244–245
- stress, 52
- stringendo, 211
- subdominant notes, 80, 85
- submediant notes, 80, 85
- supertonic notes, 80, 85
- surface rhythm, 178
- “Surfer Girl” (The Beach Boys), 203
- sustained decay, 222
- sustaining pedal, 216
- Sweeney, Philip
 - The Virgin Directory of World Music*, 235
- symphony, 195–196
- Symphony No. 5 (Opus 67) [Beethoven], 196
- syncopation, 52–54, 178, 296
- synthesizers
 - origin of, 245
 - reproducing natural sounds with, 222

• T •

- tabs, 168
tactus, 42
tempo
 accelerando, 211
 adagio, 210
 agitato, 214
 allegretto, 210
 allegro, 210
 andante, 210
 andantino, 210
 animato, 214
 appassionato, 214
 calando, 211
 changing, 211
 con forza, 214
 defined, 296
 dolce, 214
 dolente, 214
 doppio movimento, 211
 grandioso, 214
 grave, 208
 grave speed, 210
 larghetto, 210
 largo, 210
 legato, 214
 lento, 210
 metronome used to keep a steady pace,
 209
 minim, 208
 moderato, 210
 notation, 209–211
 overview, 16, 207–208
 prestissimo, 208, 210
 presto, 210
 ritardando, 211
 sotto voce, 214
 stringendo, 211
 universal, 208
 vivace, 210
tenor clef, 65
tessitura, 217
theme, 184

third
 overview, 123–126
 triads, 134–135
32-bar blues music, 202–203
thirty-second note, 19, 23, 25
thirty-second rest, 34
3/4 time signatures, 41
3/8 time signatures, 41–42
three-part (ABA) forms, 185–187
ties, 26–27
timbre, 221–222, 296
time signature. *See also specific time signatures*
 asymmetrical, 47–49
 compound, 38, 44–47
 defined, 296
 overview, 37–38
 simple
 beat counting, 43–44
 defined, 296
 4/4 time, 40–41
 measures used to count in, 40–42
 overview, 39–40
 requirements for, 39–40
 3/4 time, 41
 3/8 time, 41–42
 2/2 time, 42
Tom Petty and the Heartbreakers
 (“Refugee”), 204
tonal, 296
tone color
 attack, 220–221
 decay, 222
 overview, 220
 timbre, 221–222
tonic, 296
tonic notes, 80, 85
transposing music into another key, 230
treble (G) clef
 defined, 296
 mnemonics for, 229
 overview, 62–63
tremolo, 217
triads
 audio examples, 148–153
 augmented, 139–140

triads (*continued*)

- building, 136
- diminished, 141–142
- fifth, 135
- inversions, 154–156
- major, 136–137
- minor, 138–139
- overview, 134
- root, 134
- third, 134–135
- voicing, 153–154

trill, 296

triple

- defined, 296
- overview, 56–57

tuning fork, 222

turnaround, 200, 296

12-bar blues music, 200–201

24-bar blues music, 202

2/2 time signatures, 42

• U •

una corda pedal, 215

unbroken forms, 185

unisons, 114–115

universal tempo, 208

• V •

Vainio, Mika (musician), 186

verse-chorus songs, 204

vibrato, 217

Vicentino, Nicola (music theorist), 242

violin, 220

The Virgin Directory of World Music
(Sweeney), 235

vivace, 210

voicing, 153–154

• W •

Waller, Fats

“Ain’t Misbehavin,’” 203

“Wasted Days and Wasted Nights”
(Fender), 202

Waters, Muddy

“You Can’t Lose What You Ain’t
Never Had,” 200

wave contours, 180

“Whole Lotta Love” (Led Zeppelin), 203

whole (semibreve) notes

beat, 20–21

components, 17

overview, 20–21

whole (semibreve) rests, 30–31

whole step

defined, 296

on guitar, 70

overview, 66

on piano, 68–70

Williams, Hank, Sr. (musician)

“I’m So Lonesome (I Could Cry),” 202

“Your Cheating Heart,” 202

Winkel, Dietrich Nikolaus (inventor), 209

• Y •

“You Can’t Lose What You Ain’t Never
Had” (Waters), 200

“Your Cheating Heart” (Williams), 202

“You’ve Lost That Loving Feeling” (The
Righteous Brothers), 203

John Wiley & Sons, Inc.

End-User License Agreement

READ THIS. You should carefully read these terms and conditions before opening the software packet(s) included with this book “Book”. This is a license agreement “Agreement” between you and John Wiley & Sons, Inc. “WILEY”. By opening the accompanying software packet(s), you acknowledge that you have read and accept the following terms and conditions. If you do not agree and do not want to be bound by such terms and conditions, promptly return the Book and the unopened software packet(s) to the place you obtained them for a full refund.

- 1. License Grant.** WILEY grants to you (either an individual or entity) a nonexclusive license to use one copy of the enclosed software program(s) (collectively, the “Software”) solely for your own personal or business purposes on a single computer (whether a standard computer or a workstation component of a multi-user network). The Software is in use on a computer when it is loaded into temporary memory (RAM) or installed into permanent memory (hard disk, CD-ROM, or other storage device). WILEY reserves all rights not expressly granted herein.
- 2. Ownership.** WILEY is the owner of all right, title, and interest, including copyright, in and to the compilation of the Software recorded on the physical packet included with this Book “Software Media”. Copyright to the individual programs recorded on the Software Media is owned by the author or other authorized copyright owner of each program. Ownership of the Software and all proprietary rights relating thereto remain with WILEY and its licensors.
- 3. Restrictions on Use and Transfer.**
 - (a)** You may only (i) make one copy of the Software for backup or archival purposes, or (ii) transfer the Software to a single hard disk, provided that you keep the original for backup or archival purposes. You may not (i) rent or lease the Software, (ii) copy or reproduce the Software through a LAN or other network system or through any computer subscriber system or bulletin-board system, or (iii) modify, adapt, or create derivative works based on the Software.
 - (b)** You may not reverse engineer, decompile, or disassemble the Software. You may transfer the Software and user documentation on a permanent basis, provided that the transferee agrees to accept the terms and conditions of this Agreement and you retain no copies. If the Software is an update or has been updated, any transfer must include the most recent update and all prior versions.
- 4. Restrictions on Use of Individual Programs.** You must follow the individual requirements and restrictions detailed for each individual program in the “About the CD” appendix of this Book or on the Software Media. These limitations are also contained in the individual license agreements recorded on the Software Media. These limitations may include a requirement that after using the program for a specified period of time, the user must pay a registration fee or discontinue use. By opening the Software packet(s), you agree to abide by the licenses and restrictions for these individual programs that are detailed in the “About the CD” appendix and/or on the Software Media. None of the material on this Software Media or listed in this Book may ever be redistributed, in original or modified form, for commercial purposes.

5. Limited Warranty.

- (a) WILEY warrants that the Software and Software Media are free from defects in materials and workmanship under normal use for a period of sixty (60) days from the date of purchase of this Book. If WILEY receives notification within the warranty period of defects in materials or workmanship, WILEY will replace the defective Software Media.
- (b) WILEY AND THE AUTHOR(S) OF THE BOOK DISCLAIM ALL OTHER WARRANTIES, EXPRESS OR IMPLIED, INCLUDING WITHOUT LIMITATION IMPLIED WARRANTIES OF MERCHANTABILITY AND FITNESS FOR A PARTICULAR PURPOSE, WITH RESPECT TO THE SOFTWARE, THE PROGRAMS, THE SOURCE CODE CONTAINED THEREIN, AND/OR THE TECHNIQUES DESCRIBED IN THIS BOOK. WILEY DOES NOT WARRANT THAT THE FUNCTIONS CONTAINED IN THE SOFTWARE WILL MEET YOUR REQUIREMENTS OR THAT THE OPERATION OF THE SOFTWARE WILL BE ERROR FREE.
- (c) This limited warranty gives you specific legal rights, and you may have other rights that vary from jurisdiction to jurisdiction.

6. Remedies.

- (a) WILEY's entire liability and your exclusive remedy for defects in materials and workmanship shall be limited to replacement of the Software Media, which may be returned to WILEY with a copy of your receipt at the following address: Software Media Fulfillment Department, Attn.: Music Theory For Dummies, 2nd Edition, John Wiley & Sons, Inc., 10475 Crosspoint Blvd., Indianapolis, IN 46256, or call 1-800-762-2974. Please allow four to six weeks for delivery. This Limited Warranty is void if failure of the Software Media has resulted from accident, abuse, or misapplication. Any replacement Software Media will be warranted for the remainder of the original warranty period or thirty (30) days, whichever is longer.
- (b) In no event shall WILEY or the author be liable for any damages whatsoever (including without limitation damages for loss of business profits, business interruption, loss of business information, or any other pecuniary loss) arising from the use of or inability to use the Book or the Software, even if WILEY has been advised of the possibility of such damages.
- (c) Because some jurisdictions do not allow the exclusion or limitation of liability for consequential or incidental damages, the above limitation or exclusion may not apply to you.

7. U.S. Government Restricted Rights. Use, duplication, or disclosure of the Software for or on behalf of the United States of America, its agencies and/or instrumentalities "U.S. Government" is subject to restrictions as stated in paragraph (c)(1)(ii) of the Rights in Technical Data and Computer Software clause of DFARS 252.227-7013, or subparagraphs (c) (1) and (2) of the Commercial Computer Software - Restricted Rights clause at FAR 52.227-19, and in similar clauses in the NASA FAR supplement, as applicable.

8. General. This Agreement constitutes the entire understanding of the parties and revokes and supersedes all prior agreements, oral or written, between them and may not be modified or amended except in a writing signed by both parties hereto that specifically refers to this Agreement. This Agreement shall take precedence over any other documents that may be in conflict herewith. If any one or more provisions contained in this Agreement are held by any court or tribunal to be invalid, illegal, or otherwise unenforceable, each and every other provision shall remain in full force and effect.

Apple & Macs

iPad For Dummies
978-0-470-58027-1

iPhone For Dummies,
4th Edition
978-0-470-87870-5

MacBook For Dummies, 3rd
Edition
978-0-470-76918-8

Mac OS X Snow Leopard For
Dummies
978-0-470-43543-4

Business

Bookkeeping For Dummies
978-0-7645-9848-7

Job Interviews
For Dummies,
3rd Edition
978-0-470-17748-8

Resumes For Dummies,
5th Edition
978-0-470-08037-5

Starting an
Online Business
For Dummies,
6th Edition
978-0-470-60210-2

Stock Investing
For Dummies,
3rd Edition
978-0-470-40114-9

Successful
Time Management
For Dummies
978-0-470-29034-7

Computer Hardware

BlackBerry
For Dummies,
4th Edition
978-0-470-60700-8

Computers For Seniors
For Dummies,
2nd Edition
978-0-470-53483-0

PCs For Dummies,
Windows
7 Edition
978-0-470-46542-4

Laptops For Dummies,
4th Edition
978-0-470-57829-2

Cooking & Entertaining

Cooking Basics
For Dummies,
3rd Edition
978-0-7645-7206-7

Wine For Dummies,
4th Edition
978-0-470-04579-4

Diet & Nutrition

DiETING For Dummies,
2nd Edition
978-0-7645-4149-0

Nutrition For Dummies,
4th Edition
978-0-471-79868-2

Weight Training
For Dummies,
3rd Edition
978-0-471-76845-6

Digital Photography

Digital SLR Cameras &
Photography For Dummies,
3rd Edition
978-0-470-46606-3

Photoshop Elements 8
For Dummies
978-0-470-52967-6

Gardening

Gardening Basics
For Dummies
978-0-470-03749-2

Organic Gardening
For Dummies,
2nd Edition
978-0-470-43067-5

Green/Sustainable

Raising Chickens
For Dummies
978-0-470-46544-8

Green Cleaning
For Dummies
978-0-470-39106-8

Health

Diabetes For Dummies,
3rd Edition
978-0-470-27086-8

Food Allergies
For Dummies
978-0-470-09584-3

Living Gluten-Free
For Dummies,
2nd Edition
978-0-470-58589-4

Hobbies/General

Chess For Dummies,
2nd Edition
978-0-7645-8404-6

Drawing
Cartoons & Comics
For Dummies
978-0-470-42683-8

Knitting For Dummies,
2nd Edition
978-0-470-28747-7

Organizing
For Dummies
978-0-7645-5300-4

Su Doku For Dummies
978-0-470-01892-7

Home Improvement

Home Maintenance
For Dummies,
2nd Edition
978-0-470-43063-7

Home Theater
For Dummies,
3rd Edition
978-0-470-41189-6

Living the
Country Lifestyle
All-in-One
For Dummies
978-0-470-43061-3

Solar Power Your Home
For Dummies,
2nd Edition
978-0-470-59678-4

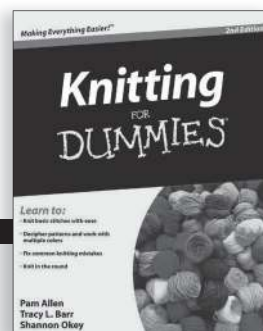
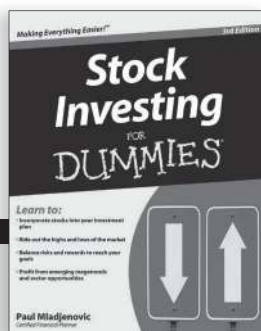
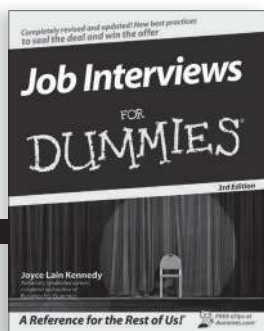
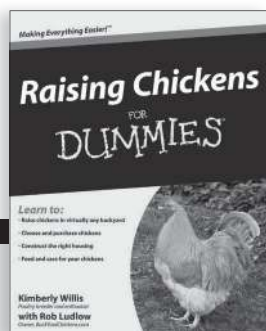

Internet

Blogging For Dummies,
3rd Edition
978-0-470-61996-4

eBay For Dummies,
6th Edition
978-0-470-49741-8

Facebook For Dummies,
3rd Edition
978-0-470-87804-0

Web Marketing
For Dummies,
2nd Edition
978-0-470-37181-7

WordPress
For Dummies,
3rd Edition
978-0-470-59274-8

Language & Foreign Language

French For Dummies
978-0-7645-5193-2

Italian Phrases
For Dummies
978-0-7645-7203-6

Spanish For Dummies,
2nd Edition
978-0-470-87855-2

Spanish
For Dummies,
Audio Set
978-0-470-09585-0

Math & Science

Algebra I
For Dummies,
2nd Edition
978-0-470-55964-2

Biology For Dummies,
2nd Edition
978-0-470-59875-7

Calculus For Dummies
978-0-7645-2498-1

Chemistry For Dummies
978-0-7645-5430-8

Microsoft Office

Excel 2010 For Dummies
978-0-470-48953-6

Office 2010 All-in-One
For Dummies
978-0-470-49748-7

Office 2010 For Dummies,
Book + DVD Bundle
978-0-470-62698-6

Word 2010 For Dummies
978-0-470-48772-3

Music

Guitar For Dummies,
2nd Edition
978-0-7645-9904-0

iPod & iTunes For
Dummies, 8th Edition
978-0-470-87871-2

Piano Exercises
For Dummies
978-0-470-38765-8

Parenting & Education

Parenting For Dummies,
2nd Edition
978-0-7645-5418-6

Type 1 Diabetes
For Dummies
978-0-470-17811-9

Pets

Cats For Dummies,
2nd Edition
978-0-7645-5275-5

Dog Training For Dummies,
3rd Edition
978-0-470-60029-0

Puppies For Dummies,
2nd Edition
978-0-470-03717-1

Religion & Inspiration

The Bible For Dummies
978-0-7645-5296-0

Catholicism For Dummies
978-0-7645-5391-2

Women in the Bible
For Dummies
978-0-7645-8475-6

Self-Help & Relationship

Anger Management
For Dummies
978-0-470-03715-7

Overcoming Anxiety
For Dummies,
2nd Edition
978-0-470-57441-6

Sports

Baseball
For Dummies,
3rd Edition
978-0-7645-7537-2

Basketball
For Dummies,
2nd Edition
978-0-7645-5248-9

Golf For Dummies,
3rd Edition
978-0-471-76871-5

Web Development

Web Design
All-in-One
For Dummies
978-0-470-41796-6

Web Sites
Do-It-Yourself
For Dummies,
2nd Edition
978-0-470-56520-9

Windows 7

Windows 7
For Dummies
978-0-470-49743-2

Windows 7
For Dummies,
Book + DVD Bundle
978-0-470-52398-8

Windows 7 All-in-One
For Dummies
978-0-470-48763-1

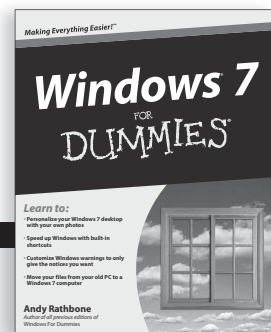
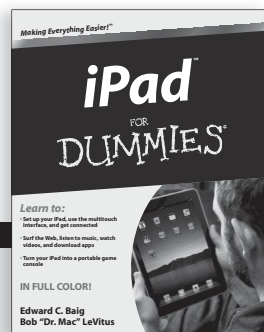
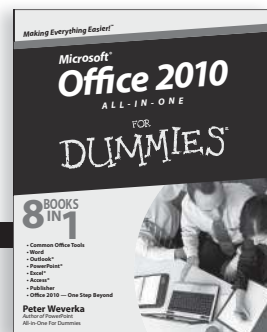
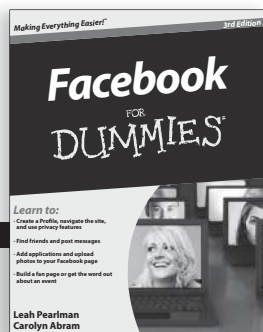

DUMMIES.COM[®]

Wherever you are
in life, Dummies
makes it easier.

The screenshot shows the Dummies.com homepage with the following elements:

- Header:** "DUMMIES.COM[®] Making Everything Easier[™]" with "Store" and "Help" links.
- Navigation:** "Start Exploring" button, a search bar, and a grid of category links including Business & Careers, Health & Fitness, Photography & Video, Computers & Software, Home & Garden, Relationships & Family, Consumer Electronics, Internet, Religion & Spirituality, Crafts & Hobbies, Music & Creative Arts, Sports & Outdoors, Education & Languages, Personal Finance, Games, Food & Drink, Pets, and Travel.
- Main Content:**
 - How-to Videos:** "How to Customize the Windows 7 Desktop" article with a "Watch Video" button.
 - How-to Step-by-Steps:** "How to Replace a Fiberglass Screen on a Screen Door" article with three numbered steps (Step 1, Step 2, Step 3) and a "See More" link.
- Right Side Promotions:**
 - "WHAT WILL YOU DO FIRST WITH THE FIRST 4G PHONE?" featuring a HTC Evo 4G phone.
 - "Back-to-School Giveaway" with an "Enter Now" button.
 - "Bestselling Titles in Education" featuring "ASVAB For Dummies, 2nd Edition" for \$19.99 and "Algebra Workbook For Dummies, 2nd Edition" for \$19.99.



From fashion to Facebook[®],
wine to Windows[®], and everything in between,
Dummies makes it easier.

Visit us at Dummies.com



Dummies products make life easier!

DIY • Consumer Electronics •
 Crafts • Software • Cookware •
 Hobbies • Videos • Music •
 Games • and More!

For more information, go to
Dummies.com® and search
 the store by category.

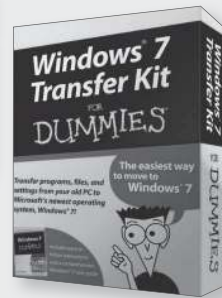
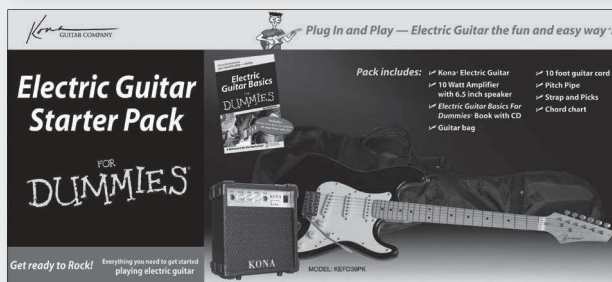
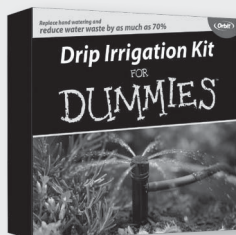
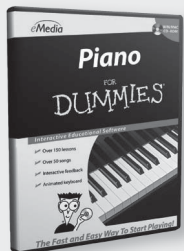

FOR
DUMMIES®
 Making everything easier!™

Mobile Apps FOR DUMMIES®

There's a Dummies App for This and That

With more than 200 million books in print and over 1,600 unique titles, Dummies is a global leader in how-to information. Now you can get the same great Dummies information in an App. With topics such as Wine, Spanish, Digital Photography, Certification, and more, you'll have instant access to the topics you need to know in a format you can trust.

To get information on all our Dummies apps, visit the following:

www.Dummies.com/go/mobile from your computer.

www.Dummies.com/go/iphone/apps from your phone.

