



•• DEFENSE SYSTEMS ••

U.S. ORDNANCE

••• MANUFACTURING •••

OPERATOR'S MANUAL



MACHINE GUN, 7.62 MM, MK 43 MOD 0

SAFETY INFORMATION

Warnings

Keep Weapon Pointed at target - down range/impact area.

Never stand in front of weapon or expose body or hands to breech, ejection port, or muzzle.

Keep Safety on S until you're ready to fire.

Always check the chamber/bore after clearing the weapon.

Check barrel bore and chamber before firing.

Change hot barrels by holding onto carrying handle.
(Refer to pages 61 and 84 for procedures.)

Be sure barrel lock lever is locked down before charging and firing the gun.

Before starting inspection, be sure to clear weapon (p 26).

If cover is opened on hot cartridge (hot barrel), an open cover cook-off could occur and result in serious injury or death. Evacuate area for 15 minutes and then do Immediate Action (p 32).

Never reload a runaway gun until it has been repaired.

Be sure machine gun is cleared before moving it.

When removing a stuck unfired cartridge, stay clear of the muzzle. Do not allow cartridge to contact any hard surface. Cartridge may fire on contact. Remove a stuck unfired cartridge using the same procedures for removing a stuck or ruptured cartridge case.

The climate temperature in different regions will make a difference as to what constitutes a hot gun. A hot, sunny day can cause a cookoff within 50 rounds, with weapon and ammunition in sun.

Before field stripping, clear and check that the bolt is in forward position.

Bolt assembly is under spring tension. It can twist and injure your hand.

Barrels issued for a specific gun should not be changed from gun to gun. Each barrel and bolt assembly should remain together as initially issued.

Only use authorized ammunition in machine gun.

Be sure Blank Firing Adaptor (BFA) is removed before firing live ammunition.

Do not fire blank ammunition towards personnel within 20 feet of muzzle. Fragments of a closure wad or particles of unburned propellant might inflict injury within that range.

Cautions

Do not use tip of driving spring guide assembly as a tool.

Insert reamer carefully to prevent damage.

Do not get lubricant in gas system.

Contents

SAFETY INFORMATION iii

CHAPTER 1

INTRODUCTION 1

Section I. General Information 1

Scope

Section II. Equipment Description 2

Equipment Characteristics, Capabilities and Features 2

Location and Description of Major Components 2

MK43 MOD 0 Machine Gun 2

CHAPTER 2

OPERATING INSTRUCTIONS 10

Section I. Description and Use of Operator's Controls and Indicators^{1 0}

MK43 MOD 0 Machine Gun 10

Front Sight Adjustment 14

Trigger Guard 15

Section II. Preventive Maintenance Checks and Services(PMCS) 16

Section III. Operation Under Usual Conditions 21

Assembly and Preparation for Use 21

Loading Ammunition in the MK43 MOD 0 21

Clearing and Unloading the MK43 MOD 0 26

Initial Adjustments, Daily Checks, and Self-Test 30

Field Zeroing 30

Operating Procedures Immediate Action 32

Runaway Machine Gun 32

Misfire 34

Remedial Action (Steps to take if immediate action-misfire does not work) . . . 36

Removing Stuck or Ruptured Cartridge Case (When round fires

but cartridge case does not extract) 38

Section IV. Operation Under Unusual Conditions 42

In Extremely Cold Climate 42

In Hot, Wet Climate	43
In Hot, and Sandy Areas	43
After Exposure to Water	43
CHAPTER 3	
MAINTENANCE INSTRUCTIONS	44
Section I. Lubrication Guide and Instructions	44
Recommended Lubrication Areas	46
Section II. Troubleshooting Procedures	47
Introduction	47
Section III. Field-Stripping Machine Gun Procedures	53
Shoulder Buttstock and Buffer Assembly	53
Bolt Assembly and Operating Rod Assembly	56
Cover and Cartridge Feed Tray Assembly	59
Barrel and Handle Assembly	61
Trigger Mechanism Grip Assembly	62
Forearm Grip, Sling Swivel and Bipod Assembly	65

Section IV. Cleaning and Inspection	67
Bolt Assembly and Operating Rod Assembly	67
Cover Assembly and Cartridge Feed Tray Assembly	70
Barrel and Handle Assembly	72
Trigger Mechanism Grip Assembly	77
Receiver	79
Section V. Reassembling Machine Gun	80
Forearm Grip, Sling Swivel and Bipod Assembly	80
Trigger Mechanism Grip Assembly	82
Barrel and Handle Assembly	84
Cover and Cartridge Feed Tray Assembly	85
Bolt Assembly and Operating Rod Assembly	87
Shoulder Buttstock and Buffer Assembly	90
Assembly of Buttstock to Receiver	91
Section VI. Maintenance Checklist	93
Section VII. Machine Gun Check Out Procedure	94

CHAPTER 4	
AMMUNITION	96
APPENDIX A	
REFERENCES	98
APPENDIX B	
COMPONENTS OF END ITEM AND BASIC ISSUE ITEMS LISTS	100
Section I. Introduction	100
Section II. Components of End Item	103
Section III. Basic Issue Items	104
APPENDIX C	
ADDITIONAL AUTHORIZED LIST	108
Section I. Introduction	108
APPENDIX D	
EXPENDABLE/DURABLE SUPPLIES AND MATERIALS LIST	110
Section I. Introduction	110
Section II. Expendable/Durable Supplies and Materials List	112

CHAPTER 1-INTRODUCTION

SECTION I. GENERAL INFORMATION



Scope

Type of Manual: Operator's Manual.

Model Number and Equipment Name: MK43 MOD 0 7.62-mm Machine Gun.

Purpose of Equipment: The MK43 MOD 0 7.62-mm Machine Gun is a light weight general purpose weapon for assault use. The weapon is intended for hand held or blpod supported firing. The weapon is also capable of being fired from standard mounts.

Equipment Characteristics, Capabilities and Features.

The MK43 MOD 0 is air-cooled and has fixed headspace allowing quick barrel changes for cooling and maintenance when required. Two barrel assemblies are issued with each gun. Barrels issued for a specific gun should not be changed from gun to gun. Each barrel and bolt assembly should remain together as initially received. The machine gun is gas operated and fires from the open bolt position.

Location and Description of Major Components.**MK43 MOD 0 Machine Gun**

Cover Assembly. Positions and holds cartridge in place for stripping, feeding link belt and chambering rounds.

Cocking Handle Assembly. Provides a means to manually move the bolt assembly to the rear.

Trigger Mechanism and Grip Assembly. Controls the firing of the machine gun.

Barrel/Assembly. The barrel assembly houses cartridges for firing.

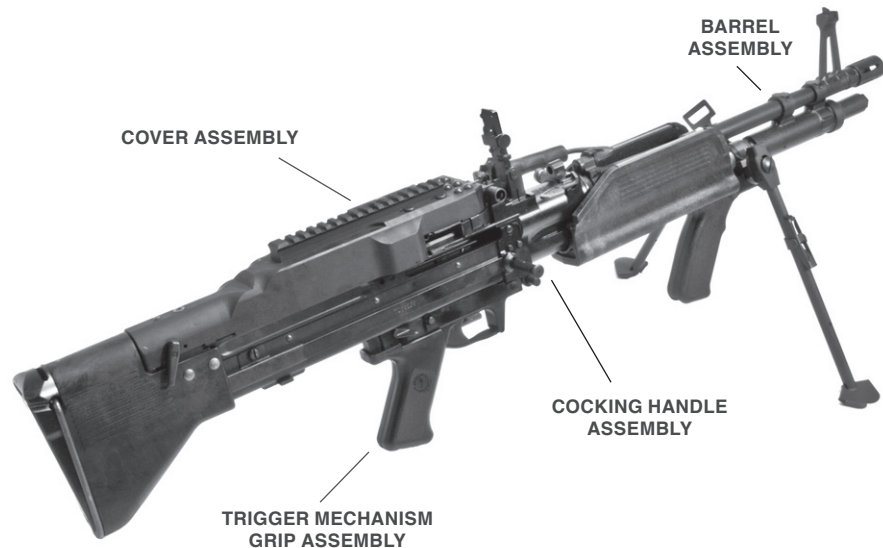

Carrying Handle Assembly. Provides a means to carry the machine gun and change barrels with one hand. The carrying handle assembly folds left when the rear sight is used and the machine gun is fired.

Receiver Assembly. Supports all major components. Houses internal parts and, through a series of cam ways, controls operation of weapon.

Shoulder Buttstock. Provides a suitable surface to stabilize the weapon against the shoulder while firing the machine gun from any position except from the hip.

Bipod Assembly. Provides a semi-stable platform when the machine gun is fired from the prone position.

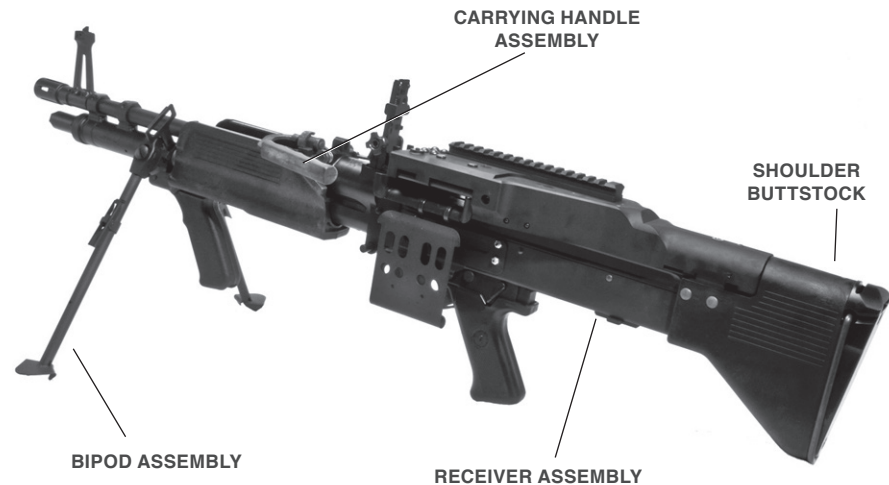

Cartridge Feed Tray Assembly. Guides cartridges for positioning and feeding.

Bandoleer Bracket Assembly. This assembly supports the ammunition bandoleer.

Rear Sight Assembly. Provides a means to aim the machine gun at the target with accuracy. The sight adjusts horizontally as well as vertically.

Forearm Grip Assembly. Provides a hand hold when firing from the hip or from the standing or kneeling position.

Front Mounting Pin. Provides a means to attach gun to a pintle assembly.

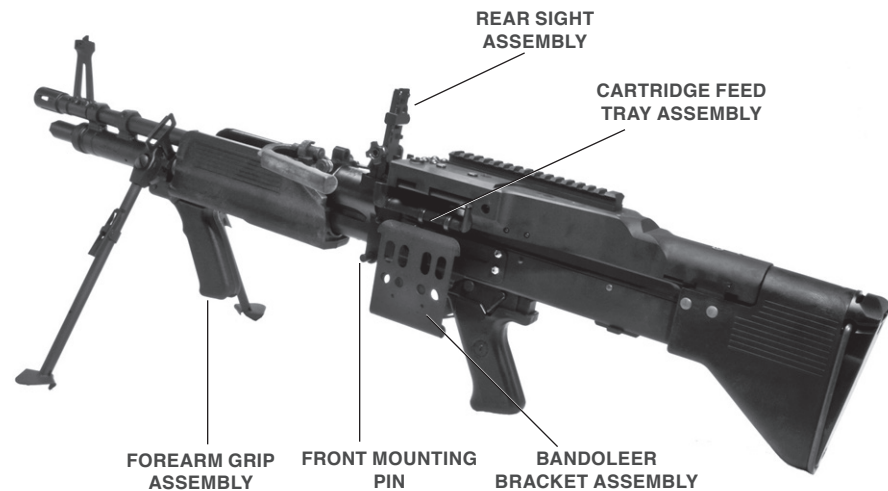

**Equipment Data.
MK43 MOD 0 Machine Gun**

Weight 20.8 lb. (9.4 kg)
Length:
 Short Barrel 37.7 in. overall (958 mm overall)
 Long Barrel 42.2 in. overall (1071 mm overall)
Maximum Effective Range 1100 meters
Maximum Range 3725 meters
Tracer Burn Out 900 meters or more
Rates of fire:
 Sustained 100 rd per min (4 to 6 seconds between bursts)
 Recommend barrel change every 6 min
 Rapid 200 rd per min (2 to 3 seconds between bursts)
 Recommend barrel change every 2 min
 Cyclic 500-650 rounds per minute
 Recommend barrel change every min
Muzzle velocity 2800 fps (853 m/sec)
Capacity of bandoleer 100 rds

Rifling:

Number of lands 4
Right hand twist..... One turn in 12 in. (304.8mm)

Trigger pull:

Maximum 11.5 lb (5.2 kg)
Minimum 8.0 lb (2.7 kg)



CHAPTER 2- OPERATING INSTRUCTIONS

SECTION I. DESCRIPTION & USE OF OPERATOR'S CONTROLS & INDICATORS

MK 43 MOD 0 Machine Gun

Cocking Handle. Pull back to move bolt rearward.

Cover Latch Lever. Holds cover closed. Pull back on lower end of latch to open.

Barrel Lock Lever. Locks barrel in place. To unlock barrel, push in on barrel lock lever from left side of weapon and raise lever.

Bipod Leg Lock. Depress to extend or retract bipod foot.

Trigger. Pull rearward to fire weapon. Release to stop firing.

Safety Move safety up to F (fire) and down to S (safe).



Rear Sight

Range Scale - use to judge target distance.

Scale Retaining/Adjusting Screw - locks range scale in place.

Elevating Knob - use for minor (fine) adjustments in range.

Windage Scale - indicates left or right windage.

Windage Knob -adjusts windage scale left or right.

Rear Sight Aperture - lines up with front sight for long range targets.

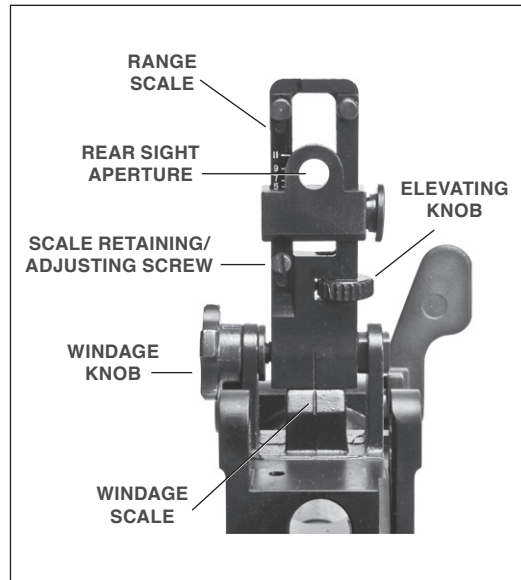
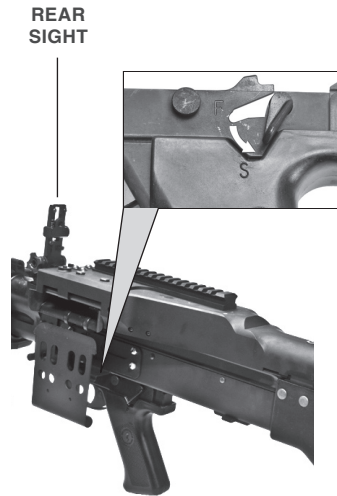

Front Sight Adjustment

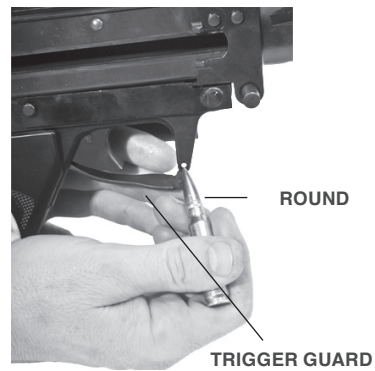
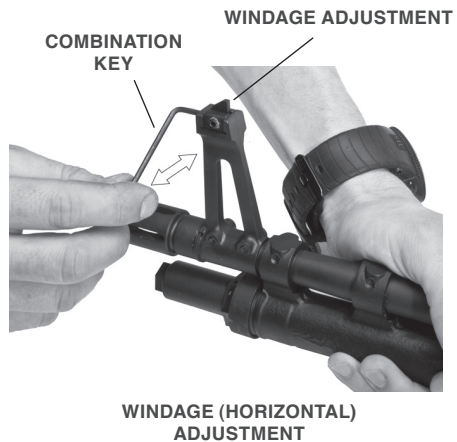
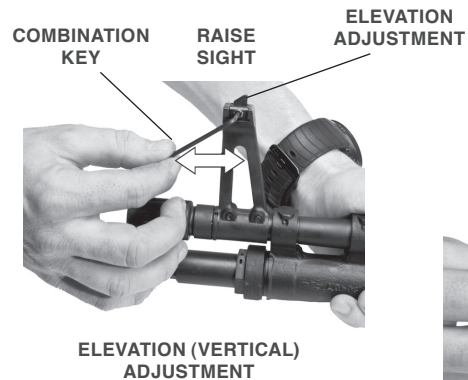

Open Trigger Guard

1. Depress spring detent with a round or any other pointed object.
2. Pull trigger guard down.



SECTION II. PREVENTATIVE MAINTENANCE CHECKS AND SERVICES (PMCS)

General

Always keep in mind the Cautions and Warnings when performing your before (B) or during (D) PMCS. After you operate, perform your after (A) PMCS.

Perform before (B) PMCS if: (1) you are the assigned operator and the machine gun has been stored and not used for a period of 90 days or (2) you have been issued the machine gun for the first time.

Operator/Crew PMCS B - Before D - During A - After

Item No.	Interval			Item to be inspected and procedure
	B	D	A	
1	•			<p>WARNING: Before starting inspection, be sure to clear weapon (p 26)</p> <p>MK43 MOD 0 Machine Gun Tools and Equipment. Visually check for missing or damaged tools and equipment.</p>
2	•			<p>Barrel Assembly. Open cover, pull bolt to rear, push cocking handle forward and lock. Close cover, place on safe (S). Tilt weapon end to end to make sure gas piston slides freely (a clicking sound will be heard as the piston slides in the cylinder). Run a dry swab through the bore to remove excess lubricant or obstructions.</p> <p>Equipment is NOT ready/available if: Gas piston will not slide. Obstruction in barrel.</p>

Operator/Crew PMCS
B - Before D - During A - After

Item No.	Interval			Item to be inspected and procedure
	B	D	A	
3	•			<p>Trigger Mechanism Grip Assembly.</p> <ol style="list-style-type: none"> 1. Make sure that flat spring is in place (p 62). 2. Check that Safety is in F position. 3. Pull bolt to the rear. 4. Move safety to S 5. Push charging handle forward and lock. 6. Pull the trigger. <p>Equipment is NOT ready/available if: Weapon functions with safety at S.</p>
4	•			<p>Cover Assembly. Lightly lubricate all moving parts before using.</p>

Operator/Crew PMCS
B - Before D - During A - After

Item No.	Interval			Item to be inspected and procedure
	B	D	A	
5	•			<p>Gun Receiver Assembly. Check for free movement of cocking handle. Check barrel lock lever. Make sure it locks barrel in place.</p> <p>Equipment is NOT ready/available if: Cocking handle binds or barrel is loose.</p>
6		•		<p>MK43 MOD 0 Machine Gun. Erratic or sluggish firing may indicate carbon build-up. Switch barrels (p 61). If firing is still erratic or sluggish, field-strip the weapon and perform the necessary maintenance (p 53) to complete the fire mission.</p> <p>Equipment is NOT ready/available if: Weapon ceases to operate.</p>

Operator/Crew PMCS
B - Before D - During A - After

Item No.	Interval			Item to be inspected and procedure
	B	D	A	
7				<ul style="list-style-type: none"> MK43 MOD 0 Machine Gun. Field-strip (p 53) clean, inspect and lubricate entire weapon (p 44).
8				<ul style="list-style-type: none"> MK43 MOD 0 Machine Gun (Inspection). Inspect operating rod assembly and barrel assembly for burrs, cracks and chips. Make sure the gas piston slides back and forth freely. Inspect components of trigger assembly for wear. Check safety in S position, sear should move slightly and in F position, sear should move freely. Inspect breech bolt assembly for defects - e.g., cracks or chips. Reassemble weapon and check for proper functioning. <p>Equipment is NOT ready/available if: Weapon fails to function properly or has damaged or missing parts.</p>

SECTION III. OPERATION UNDER UNUSUAL CONDITIONS



Assembly and Preparation for Use

Loading Ammunition in the MK43 MOD0



1. Point weapon down range.
2. Move safety to F.

3. Pull cocking handle rearward to the charged position, then push it forward until it locks.
4. Move safety to S.

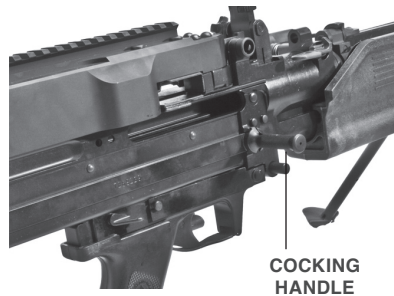

5. Turn latch lever and open cover.
6. Raise cartridge feed tray and check chamber for ammunition.

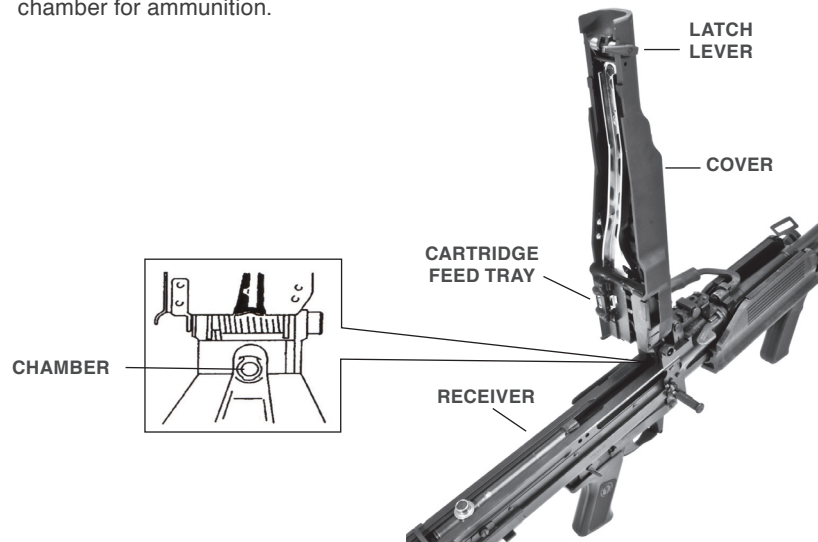

7. Lower cartridge feed tray. Place bandoleer on bandoleer bracket.
8. Place ammunition on feed tray with open side of links down and with first round in the feed groove. (Make sure cartridge retainer pawl holds ammunition link on feed tray).
9. Close cover.

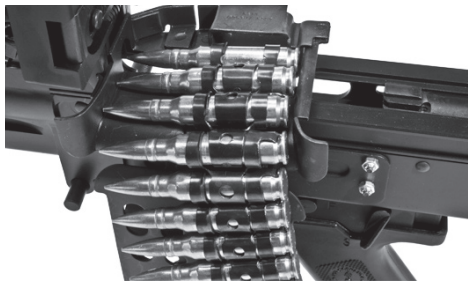

10. Move safety to F.
11. The gun is ready to fire.



Clearing and Unloading the MK43 MOD 0:

1. Point weapon down range.
2. Move safety to "F"
3. Pull cocking handle rearward to the charged position then push it forward until it locks.

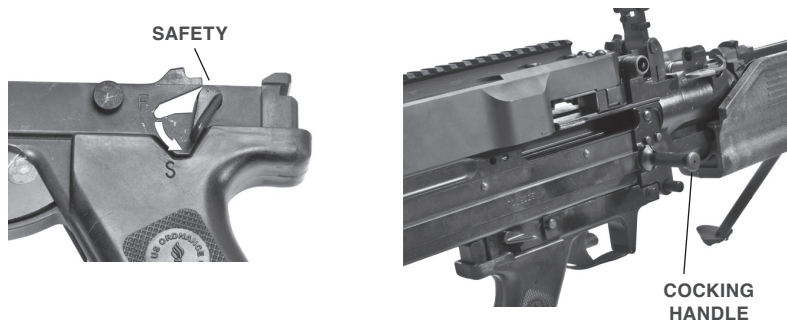

4. Move safety to S.

WARNING: If cover is opened on hot cartridge (hot barrel), an open cover cook-off could occur and result in serious injury or death. Evacuate area for 15 minutes and then do Immediate Action, (p 30).

5. Turn latch lever and open cover.



6. Remove ammunition and link belt and raise feed tray.
7. Inspect chamber. If empty, go to step 8. If a round is chambered, see page 38 for stuck or ruptured cartridge case and page 47 for trouble-shooting.

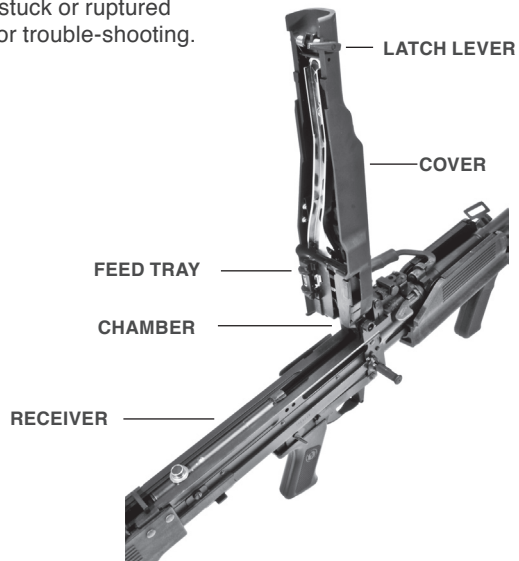

8. Lower feed tray.
9. Close cover. Cover latch should catch and hold cover closed.
10. Move safety to F. Pull cocking handle rearward and hold it. Pull trigger and allow cocking handle to move forward slowly.

Initial Adjustments, Daily Checks, and Self-Test

Field Zeroing

1. Choose a target between 300 and 700 meters.
2. Set range scale on rear sight to 500 meters.
3. Zero windage scale with index line.
4. Aim at six o'clock on bottom of target.
5. Fire burst of 6 to 9 rounds and observe impact of burst.
6. Correct for left or right wind by adjusting windage knob. Then correct range by adjusting elevating knob. Adjust until a burst of 6-9 rounds is on target.
7. Loosen scale retaining/adjusting screw and adjust range scale so 500 meter mark is on top of slide.

Note

One mil is equal to one meter at 1000 meters.

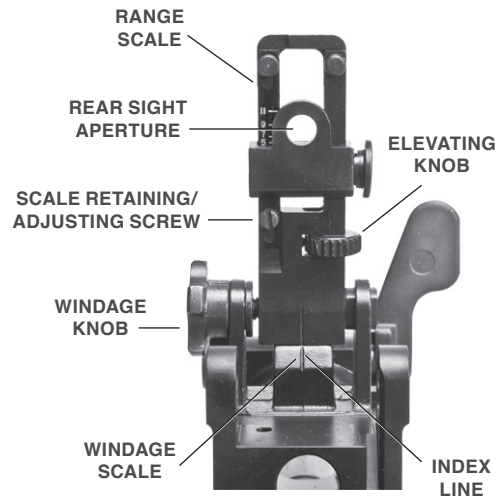

Operating Procedures Immediate Action

Runaway Machine Gun



WARNING: Always keep machine gun pointed down range.

1. If runaway occurs (machine gun won't stop firing), take the following actions to correct it quickly.
2. Break link belt (grasp belt and twist firmly) or let machine gun fire if near end of link belt.

3. Pull cocking handle all the way back and hold it. Place safety to S and remove link belt.
4. Clear machine gun (pg 26).
5. Notify organizational maintenance for repairs.

WARNING: Never reload runaway gun until it has been repaired. Be sure machine gun is cleared before moving it.

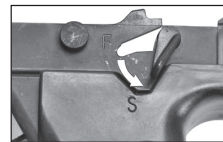

MOVE SAFETY TO S



Misfire

If weapon stops firing before you complete your mission, take immediate action within 10 seconds.

1. Pull cocking handle rearward.
2. Check ejection port.
3. If a round or cartridge case is ejected, push cocking handle forward and fire again.



WARNING: If cover is opened on a hot cartridge (hot barrel), and open cover cook-off could occur and result in serious injury or death. Close cover and evacuate area for 15 minutes.

4. If nothing is ejected and the barrel is hot enough to cause a cookoff (200 rounds fired within 2 minutes), wait at least 15 minutes (make sure bolt is locked rearward). Repeat steps for Immediate Action.
5. If Immediate Action fails to remove cartridge case, take Remedial Action (pg 36).

Remedial Action (Steps to Take if Immediate Action Misfire Fails)

WARNING: If cover is opened on a hot cartridge (hot barrel), and open cover cook-off could occur and result in serious injury or death. Close cover and evacuate area for 15 minutes.



1. Keep weapon on target (down range/impact area). Clear weapon when barrel is cool (after 15 minutes wait) using the following steps.
2. Pull cocking handle rearward, to the charged position.
3. If a round is not ejected, move safety to S.
4. Open cover, remove ammunition link belt and raise feed tray.
5. Inspect receiver, chamber, extractor, and ammunition.
6. If a round is in chamber, lower feed tray and close cover.
7. Push cocking handle forward.
8. Move safety to F.
9. Attempt to fire.
10. If a round is fired and ejected, reload and continue to fire.
11. If a weapon does not fire or eject, clear and unload weapon, and notify organizational maintenance for repair.

Removing Stuck or Ruptured Cartridge Case (When Round Fires but Cartridge Case Does Not Extract)

WARNING: When removing a stuck unfired cartridge, stay clear of the muzzle. Do not allow cartridge to contact any hard surface. Cartridge may fire on contact. Remove a stuck unfired cartridge using the same procedures for removing a stuck or ruptured cartridge case.

1. Pull cocking handle rearward to the charged position, and move safety to S.
2. Remove barrel. See page 53, Field Stripping.
3. Stuck cartridge case/unfired cartridge-Insert cleaning rod in muzzle and tap out case/cartridge.

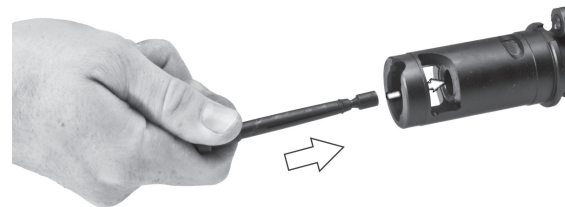

4. Ruptured cartridge case-
 - a. Push ruptured cartridge extractor inside ruptured case in chamber until it seats.

- b. Lightly tap out ruptured cartridge with cleaning rod.
- c. Remove extractor from cartridge case.
- d. Unscrew extractor tool and remove cartridge case. Reassemble tool.

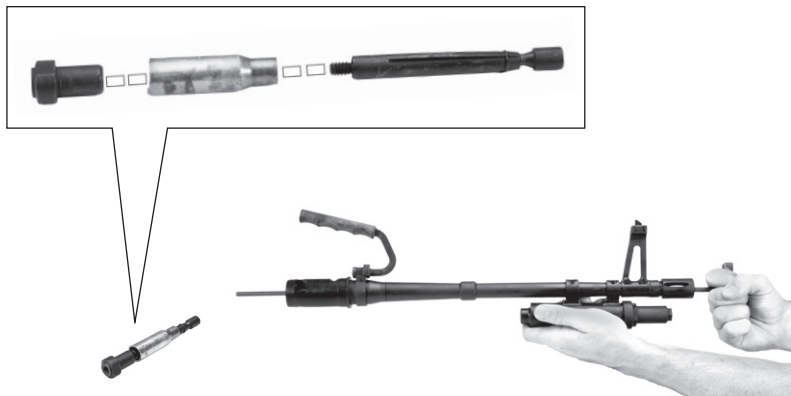

5. Install barrel. See Reassembly on page 84.
6. Close cover.
7. Hold cocking handle rearward.
8. Move safety to F.
9. Pull trigger and ease cocking handle forward.
10. Once weapon is cleared, do not move safety to S when bolt is forward.
Leave safety at F.



SECTION IV. OPERATION UNDER UNUSUAL CONDITIONS

WARNING: The climate temperature in different regions will make a difference as to what constitutes a hot gun. A hot, sunny day can cause a cookoff within 60 rounds, if the weapon and ammunition are left in the direct sun.



In Extremely Cold Climate:

Lubricate according to Lube Guide (pg 44). Keep weapon free of moisture.

In Hot, Wet Climate:

Lubricate and inspect more frequently. Use a light coating of lubricant and keep weapon dry.

In Hot, and Sandy Areas:

Inspect daily and clean frequently. Wipe lubricant from exposed surfaces and keep sand out of parts. Cover weapon as much as possible.

After Exposure to Water:

First make sure weapon is dry before lubricating. Then disassemble, clean, lubricate, and reassemble as soon as possible.



CHAPTER 3-MAINTENANCE INSTRUCTIONS

SECTION I. LUBRICATION GUIDE AND INSTRUCTION

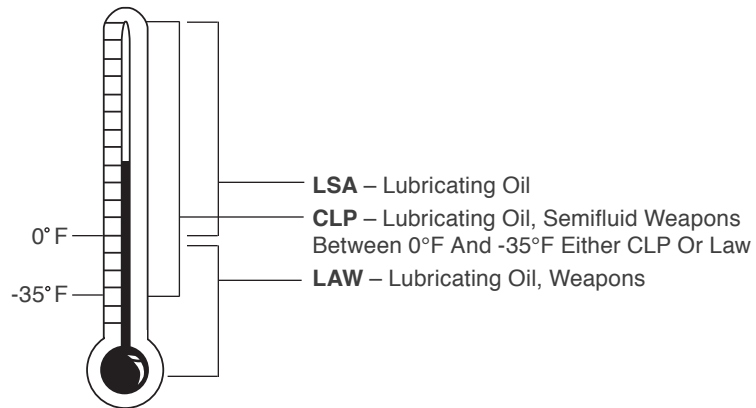

1. Under all but the coldest arctic conditions, LSA or CLP can be used on your machine gun. Remember to remove excessive oil from the bore before firing.
2. Lightly Lube-A film of oil barely visible to the eye.
3. Generously Lube-Heavy enough so that It can be spread with the finger.
4. External Surfaces. Put lubricant (item 1, 2 or 3, a p D) on a clean swab (item 5, app D) and generously lubricate all shaded areas. Lightly lubricate all other areas except rubber-coated parts.

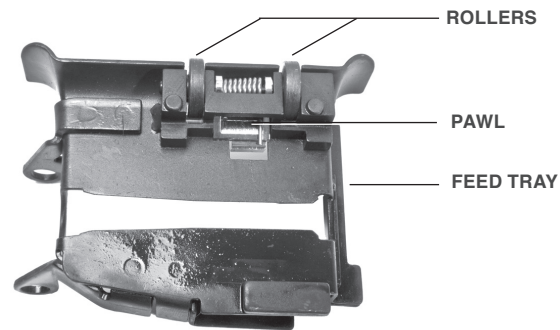

Recommended Lubrication Areas

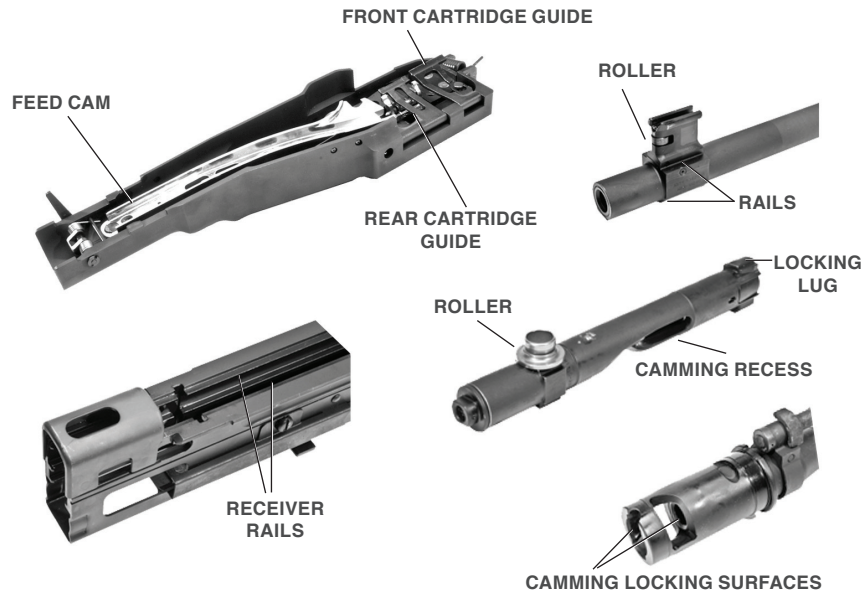

SECTION II. TROUBLESHOOTING PROCEDURES



Introduction

The table lists the common malfunctions which you may find during the operation or maintenance of the machine gun or its components. You should perform the test/inspections and corrective actions in the order listed.

This manual cannot list all malfunctions that may occur nor all tests or inspections and corrective actions. If a malfunction is not listed or is not corrected by listed corrective actions, notify your supervisor.

WARNING: Keep weapon pointed at target impact area. Never stand in front of weapon or expose body or hands to breach, ejection port, or muzzle.

Malfunction	Test or Inspection	Corrective Action
Cook Off*	Hot Barrel- If you have fired 200 or more rounds within 2 minutes (rapid rate of fire), barrel will be hot enough to cause cook off.	Cool weapon for 15 minutes
Failure to Fire	Check ammunition.	Replace faulty ammunition.
	Check for broken or damaged firing pin.	Notify organizational maintenance.
	Check for weak or broken firing pin spring, guide assembly, or compression spring.	

*COOKOFF - A misfire of a chambered round caused by the weapon overheating.

Malfunction	Test or Inspection	Corrective Action
Failure to Extract	Broken extractor or spring.	Notify organizational maintenance.
	Short recoil.	Clean gas port, piston, gas cylinder, operating rod, and chamber (73-76, 79).
	Dirty ammunition or chamber.	Clean chamber and/or use new ammunition.
Sluggish Operation	Friction from dirt, carbon, burrs, or lack of lubrication.	Clean/lubricate or notify organizational maintenance.
Wadding and Unburned Powder	Manually charge weapon (if firing blanks).	Clean/lubricate or notify organizational maintenance.

Malfunction	Test or Inspection	Corrective Action
Failure to Chamber	Ruptured cartridge case.	Remove (pg 38).
	Carbon build-up in gas cylinder.	Remove carbon.
	Carbon build-up in receiver assembly.	Remove carbon.
	Damaged round.	*Remove round and recharge weapon.
	Dirty chamber.	Clean or replace barrel.

* Dispose of damaged round according to range SOP.

Malfunction	Test or Inspection	Corrective Action
Failure to Eject	Frozen or damaged ejector spring.	Notify organizational maintenance.
	Short recoil.	Clean gas port, piston, gas cylinder, chamber, and operating rod tube (pg 73-76 & 79).
Failure to Cock or Runaway Gun	Operating rod sear notch or sear worn.	Notify organizational maintenance.
	Sear plunger or spring broken or missing.	Notify organizational maintenance.

Malfunction	Test or Inspection	Corrective Action
Failure to Feed	Insufficient gas pressure (short recoil).	Clean gas system, barrel, chamber and socket (p 73-76).
	Improper lubrication.	Lubricate as necessary (44-46).
	Defective ammunition or links.	Use new ammunition belt.
	Ammunition belt installed wrong.	Install with open side of link down (p 24).
	Damaged or weak operating parts.	Notify organizational maintenance.
	Obstruction in receiver assembly.	Remove.

SECTION III. FIELD-STRIPPING MACHINE GUN PROCEDURES



Shoulder Buttstock and Buffer Assembly

WARNING: Before field stripping, clear and verify that the bolt is in the forward position.

1. Clear the weapon.
2. Close cover.
3. Hold cocking handle rearward.
4. Move safety to F.
5. Pull trigger and ease cocking handle forward slowly. The breech bolt should now be in the forward position.
6. Open cover.
7. Push the buttstock forward in the direction shown and remove the yoke.

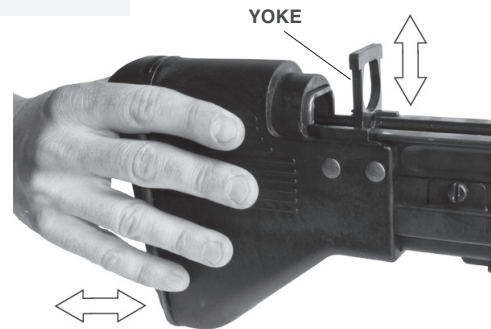

WARNING: Drive spring and drive spring guide are under spring tension. These parts may eject when the buttstock is being removed from the receiver. Avoid exposing your body to ejection parts.

8. Slide the buttstock off the end of the receiver.

9. Remove the drive spring and drive spring guide from the receiver.

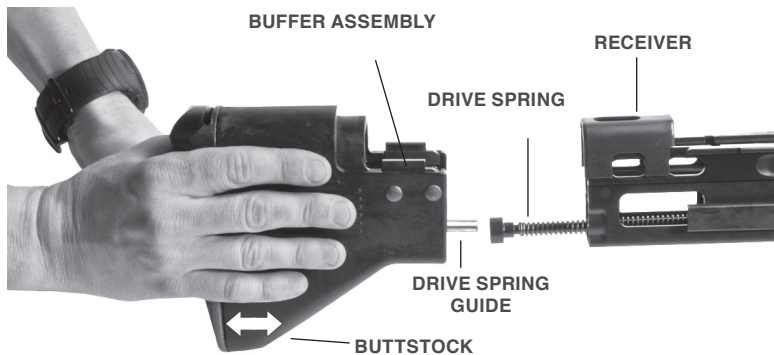

10. Remove the buffer assembly from the buttstock as shown.

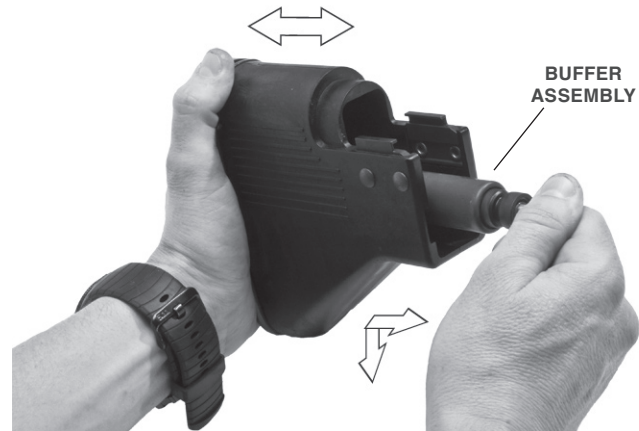

Bolt Assembly and Operating Rod Assembly

1. Move safety to F.
2. Pull trigger and hold it while pulling cocking handle rearward.



3. Remove bolt assembly and operating rod assembly as a unit.

WARNING: Bolt assembly is under spring tension. It can twist and injure your hand.

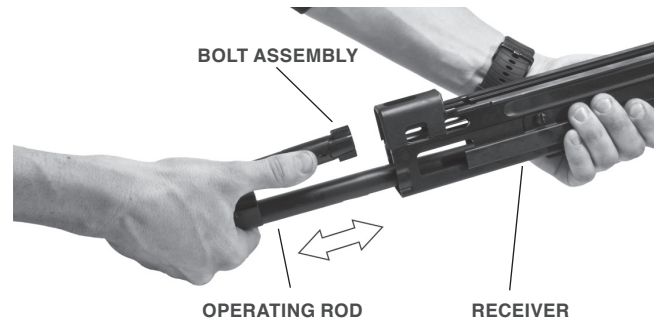

4. Push operating rod assembly toward rear of slot in bolt assembly.
5. Separate operating rod assembly from bolt assembly.

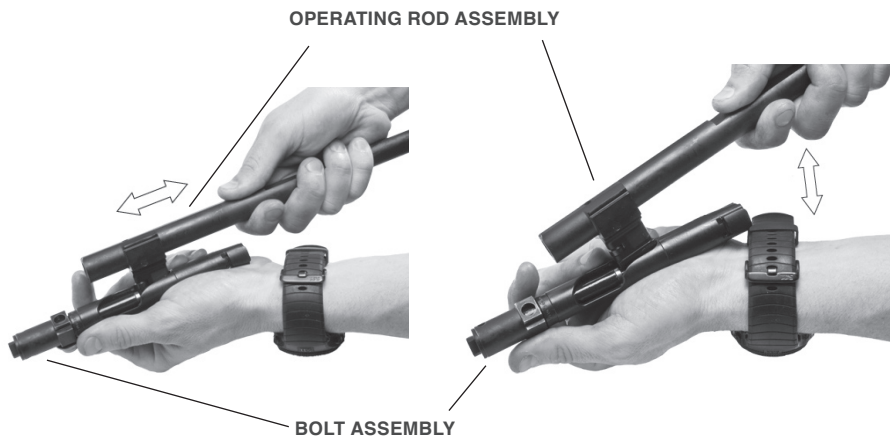

Cover and Cartridge Feed Tray Assembly

CAUTION: Do not use tip of driving spring guide assembly as a tool.

1. Use a round (cleaning rod) or similar item to unlatch hook of hinge pin latch. Remove hinge pin latch and cover hinge pin.

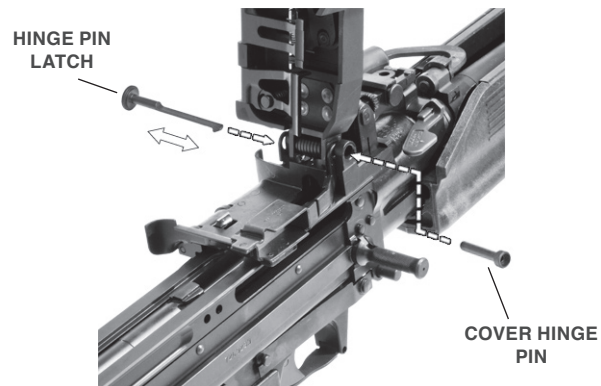

2. Remove cover assembly, torsion spring and cartridge feed tray assembly.

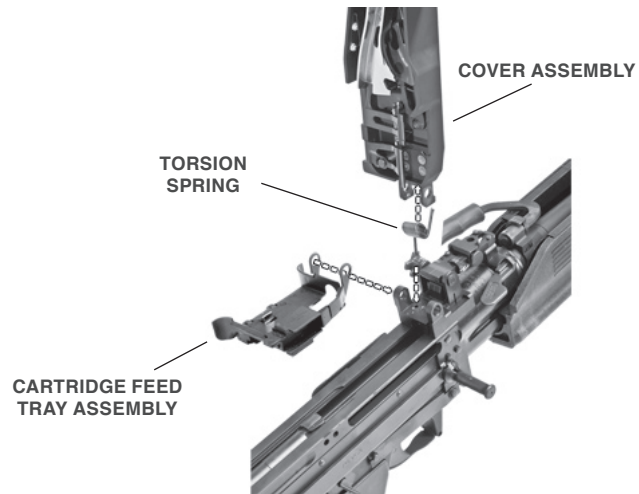

Barrel and Handle Assembly

1. Push in spring detent and raise barrel lock lever.
2. Slide out barrel and handle assembly to remove.

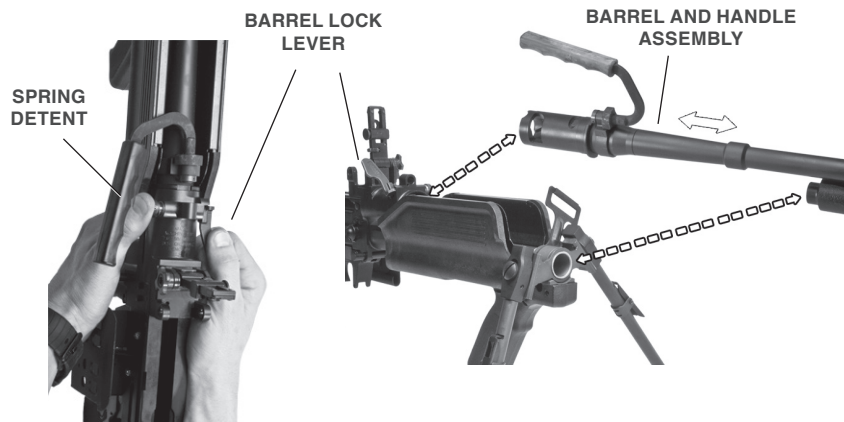

Trigger Mechanism Grip Assembly

1. Use cleaning rod or similar item to push the latch in the head of the front pin to disengage it.

CAUTION: Do not use tip of driving spring guide assembly as a tool.



2. Grasp the flat spring on the right side of the grip assembly and pull the latch from the front pin.
3. Slide the slotted end of the spring from the grooved pin.

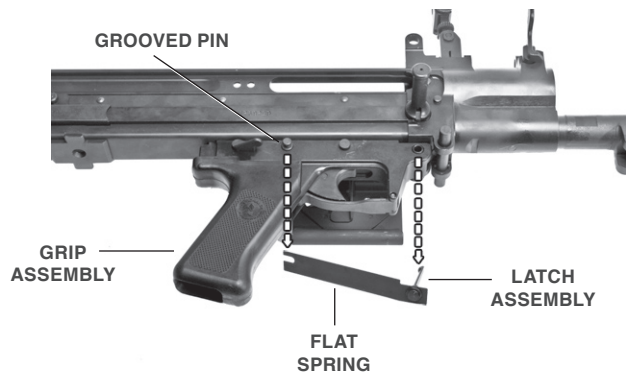

4. Push out front pin.
5. Slide trigger mechanism grip assembly forward and pull out.

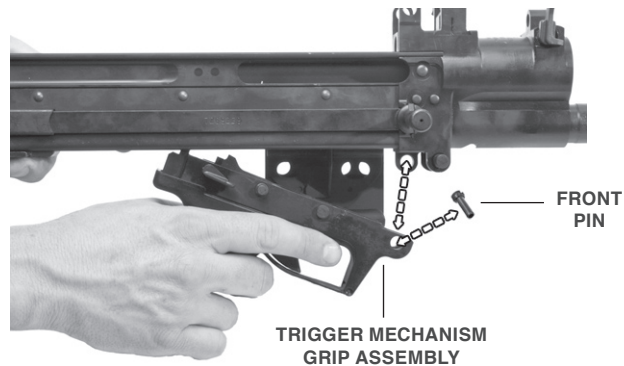

Forearm Grip, Sling Swivel, and Bipod Assembly

1. Insert the end of the punch in the grip access hole and push down on the spring detent.
2. Slide the forearm grip, sling swivel and bipod assembly forward.

CAUTION: Do not use tip of driving spring guide assembly as a tool.

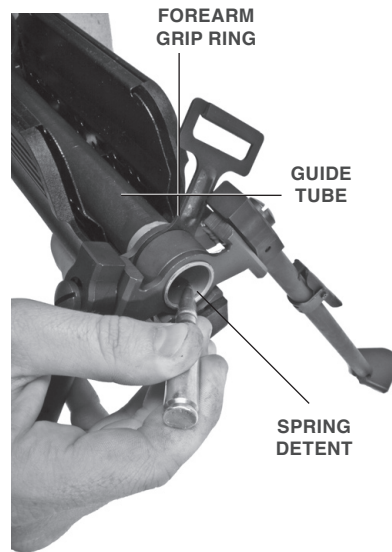

3. Remove forearm grip assembly, sling swivel and bipod assembly from the guide tube.
4. Separate sling swivel and bipod assembly from the forward grip ring of the forearm grip assembly.



SECTION IV. CLEANING AND INSPECTION

Bolt Assembly and Operating Rod Assembly

Inspect and Clean Bolt Assembly

1. Inspect bolt assembly for burrs and cracks.
2. Make sure roller operates freely and is not cracked.

NOTE: Rotate cam actuator assembly so holes line up with headless straight pin. Use reamer of combination wrench to remove or replace headless straight pin.

3. Remove headless straight pin and unscrew bolt plug assembly. Remove cam actuator assembly from breech bolt. Separate spring, guide, and firing pin.
4. Make sure spring is not kinked.
5. Inspect threads on bolt plug assembly and in breech bolt for damage.
6. Clean powder fouling, corrosion, and dirt from all parts.

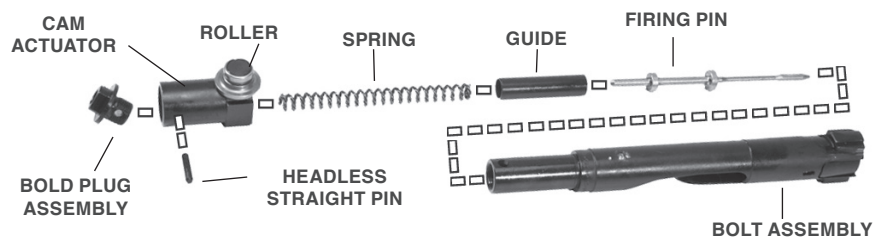

7. Drop firing pin into breech bolt. Assemble and drop spring and guide into breech bolt.
8. Assemble cam actuator assembly on breech bolt with roller to front. Screw in bolt plug assembly and align three holes. Insert headless straight pin. Make sure cam actuator assembly rotates freely when headless straight pin is fully seated.

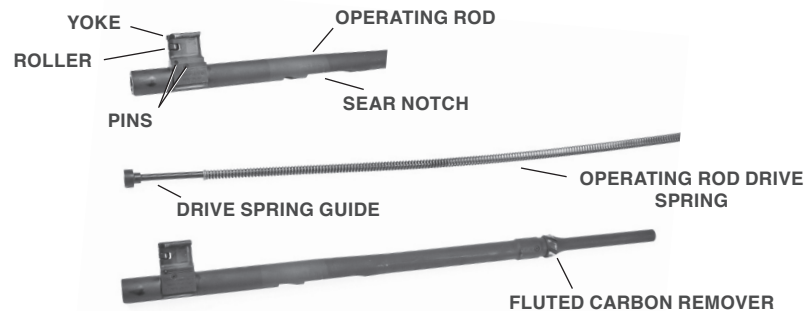

NOTE: Use fluted carbon remover to clean inside of receiver (p 81).

Inspect and Clean Operating Rod Assembly

1. Inspect operating rod, yoke, sear notch, pins, and drive spring guide for burrs, cracks and chips.
2. Inspect operating rod drive spring for tension, kinks, breaks and wear.
3. Make sure roller operates freely.
4. Clean power fouling, corrosion, and dirt from all parts.

Cover Assembly and Cartridge Feed Tray Assembly

Inspect and Clean Cover Assembly

1. Inspect cover assembly for bent, burred, cracked, loose, or missing parts.
2. Check spring action of front and rear guides, feed pawls (beneath the cartridge guides), and feed cam assembly.
3. Make sure feed cam assembly is secure and operates freely.
4. Clean powder fouling corrosion, and dirt from all areas.

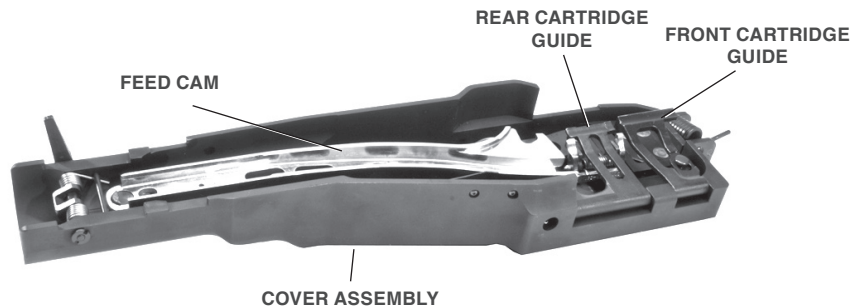

Inspect and Clean Cartridge Feed Tray Assembly

1. Inspect for burred, cracked, missing, or loose parts.
2. Check that feed tray fits on receiver and that feed pawl works properly and rollers turn freely.
3. Clean corrosion and dirt from all areas.
4. Remove lubricant from top surfaces of feed tray if gun is to be fired.

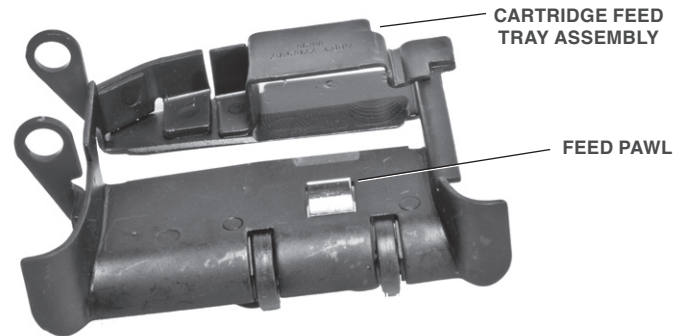

Barrel and Handle Assembly

Inspect Barrel

1. Check for burrs, cracks and wear especially in the barrel socket area.
2. Make sure sight and flash suppressor are tight.
3. Make sure handle is secure but turns freely.

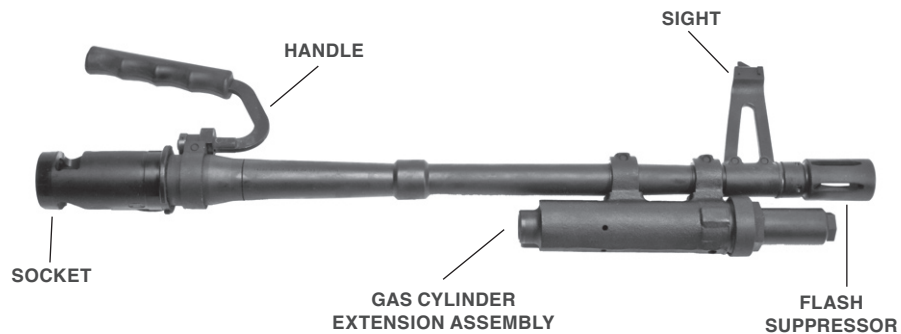

WARNING: Barrels issued for a specific gun should not be changed from gun to gun. Each barrel and bolt assembly should remain together as Initially issued.

4. To clean barrel, keep barrel and handle assembly upside down to keep gas system dry.
5. Run a clean rod with swab (item 5, app D) saturated with lubricant through bore. Leave bore wet.



Inspect and Clean Gas System

NOTE: Gas piston clicks when barrel is tilted. Take gas system (gas cylinder) apart only when you don't hear a click.

1. Use combination wrench and clean swab item 5, app D) to clean powder fouling, corrosion, and dirt from all parts.

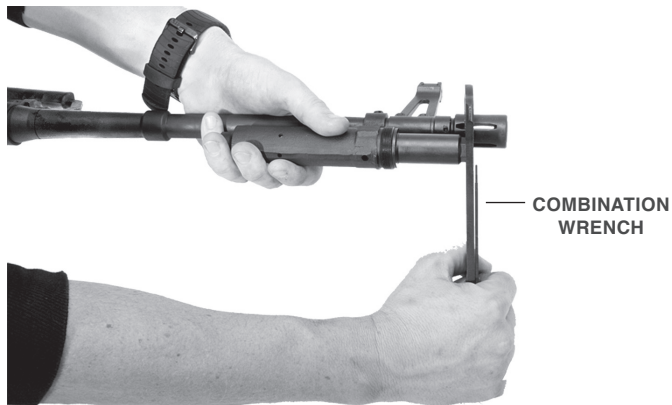

2. Disassemble gas cylinder extension assembly with combination wrench. If gas cylinder extension assembly is difficult to move, add a drop of lubricant where the two protrusions contact the serrated lock nut and try again.
3. Clean extension vent hole with safety wire.



CAUTION: Insert reamer carefully to prevent damage.

4. Clean gas port, gas piston holes, and gas cylinder vent hole with reamer portion of wrench.
5. Bottom the reamer in the gas port to make sure you have removed all carbon. Run small arms cleaning brush (bore) through bore to remove carbon deposits.

CAUTION: Do not get lubricant in gas system.

6. Reassemble gas system (gas cylinder).
7. Tighten gas cylinder extension assembly with wrench. Do not over-tighten. Then loosen the gas cylinder extension assembly 2 or 3 clicks.

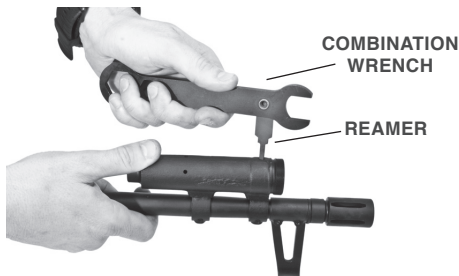

Trigger Mechanism Grip Assembly

Inspect and Clean Trigger Mechanism Grip Assembly

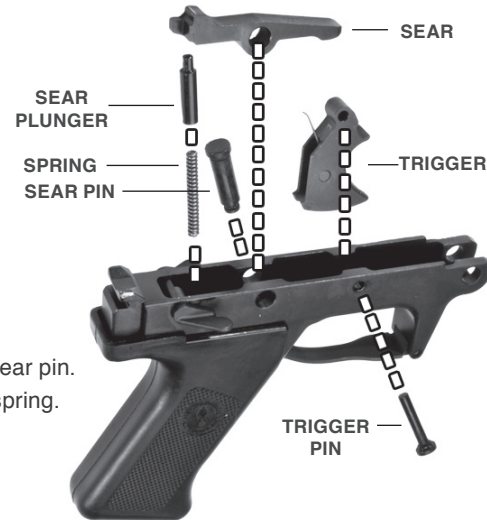

1. Hold down on sear and remove sear pin.
2. Remove sear, sear plunger and spring.
3. Remove trigger pin and trigger.
4. Clean powder fouling, corrosion, and dirt from all areas.

5. Inspect sear for chips, cracks, and signs of wear.
6. Inspect sear plunger and spring for signs of wear.
7. Position trigger in grip. Align holes and insert trigger pin through the right side of grip and secure trigger.
8. Insert spring and sear plunger into hole. Position sear and apply slight pressure to align holes. Insert sear pin through left side of grip and secure sear.
9. Check safety:
 - F-Sear moves freely.
 - S-Sear moves slightly.

Receiver

Inspect and Clean Receiver

1. Clean powder fouling, corrosion, and dirt from all areas.
2. When weapon is disassembled, use fluted end of operating rod assembly to remove carbon from (operating rod) guide tube.
3. Check receiver rails for burrs and wear.
4. Check that cocking handle moves freely.

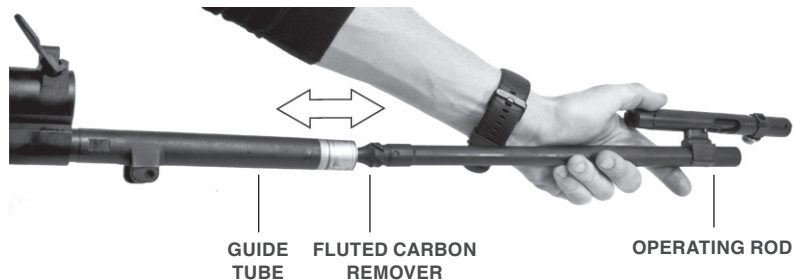

Forearm Grip, Sling Swivel and Bipod Assembly

1. Position forearm grip under the guide tube of assembly. Push assembly upwards over the guide tube and slide the assembly rearward until the forearm tabs engage the receiver grooves.
2. Position sling swivel and bipod assembly in line with forward grip ring.
3. Slide forearm grip assembly, sling swivel and bipod assembly onto guide tube end.

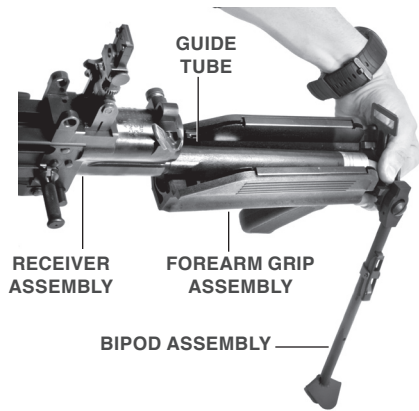

4. Depress spring detent with punch or suitable tool.
5. Slide forearm grip ring onto guide tube until spring detent aligns/engages with hole in guide tube. Verify that all components are secured.

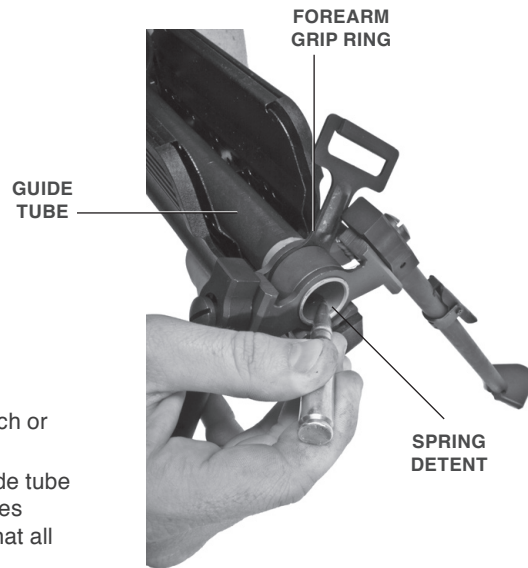

Trigger Mechanism Grip Assembly

1. Position trigger mechanism grip assembly in bottom slot of receiver.
2. Align holes and install front pin. Position the flat on the head of the pin parallel with the gun receiver so it fully enters the hole.

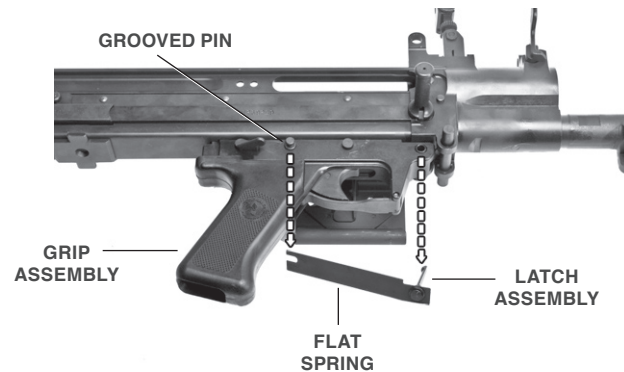

3. Hold latch assembly with latch pointed towards the front of the grip assembly. Slide slotted end of flat spring onto grooved pin in the grip assembly.
4. Align latch pin with the hollow front pin and push it into the pin until the hook snaps into position.
5. Verify that the latch is secured.

Barrel and Handle Assembly

1. Make sure barrel lock lever is up (unlocked).
2. Install barrel and handle assembly.
3. Push barrel lock down (locked).

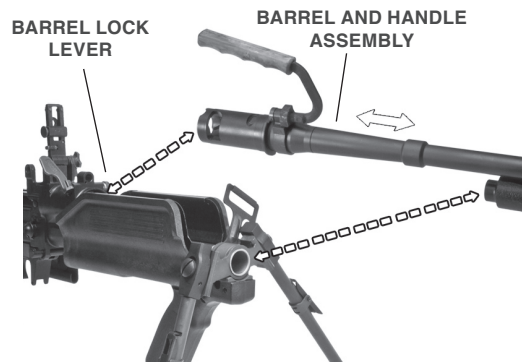

Cover and Cartridge Feed Tray Assembly

1. Position cartridge feed tray assembly on receiver assembly.
2. Install torsion spring in cover. Make sure that ends of torsion spring are inserted in holes of cover and receiver.

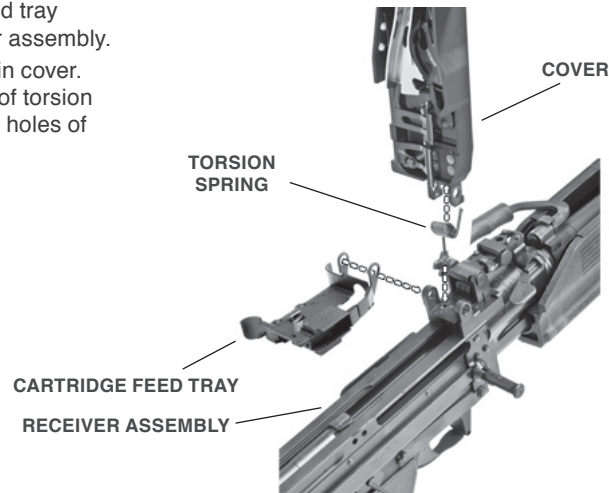

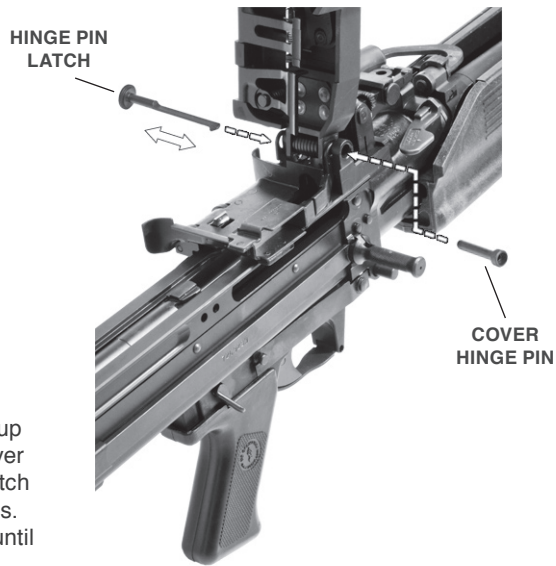

3. Apply slight pressure to line up torsion .spring and insert cover hinge pin. Install hinge pin latch through hinge pin until it locks. Keep cover assembly open until machine gun is reassembled.

Bolt Assembly and Operating Rod Assembly

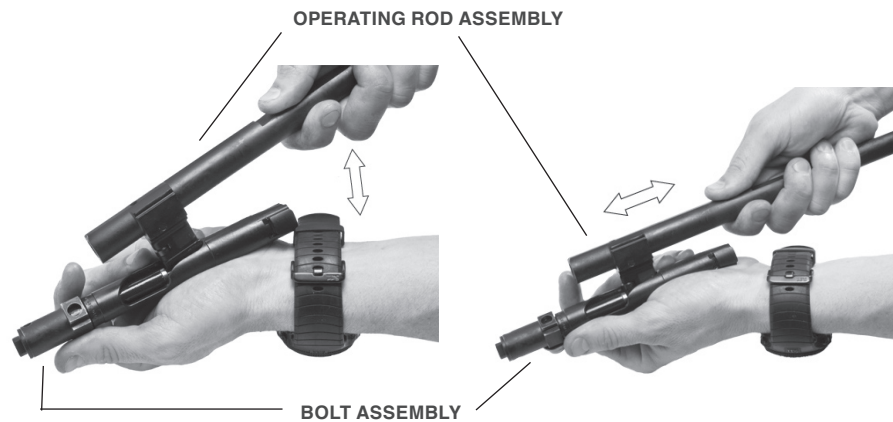

1. Place tower of operating assembly against spool of firing pin in slot of bolt assembly and push spool forward.
2. Seat tower between spools of firing pin. Let tower slide back in bolt assembly.

3. Start operating rod assembly with bolt assembly into weapon. Turn bolt assembly so that stripping lugs line up with upper rails. Push in until stripping lugs engage rails.

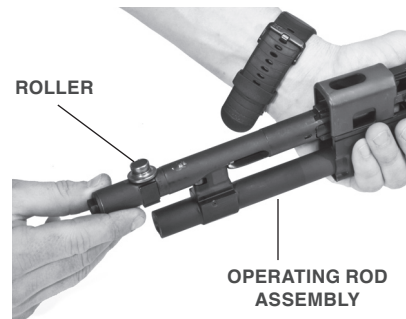
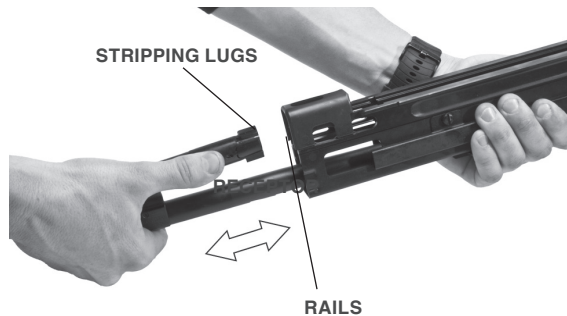

4. Turn roller straight up and push bolt assembly and operating rod assembly as a unit into weapon.
5. Move safety to F. Pull back on trigger and hold. Push breech bolt into receiver until it locks in place.

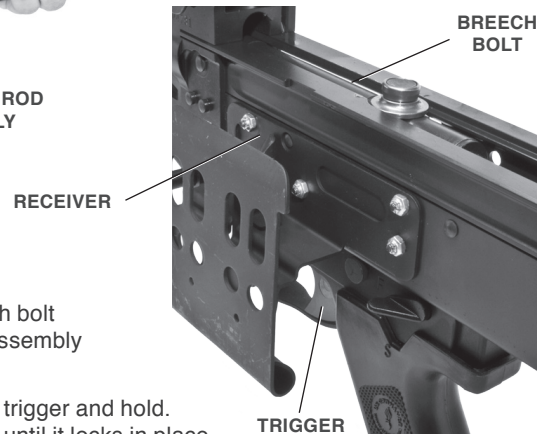

Shoulder Buttstock and Buffer Assembly

1. Install the buffer assembly into the buttstock as shown.

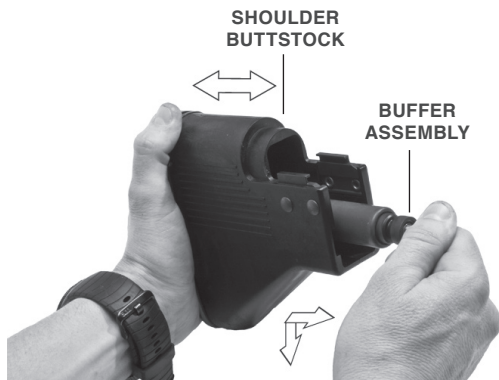

Assembly of Buttstock to Receiver

1. Install the drive spring and the drive spring guide into the receiver.
2. Align the drive spring guide with the buffer assembly.
3. Slide the buttstock onto the end of the receiver.

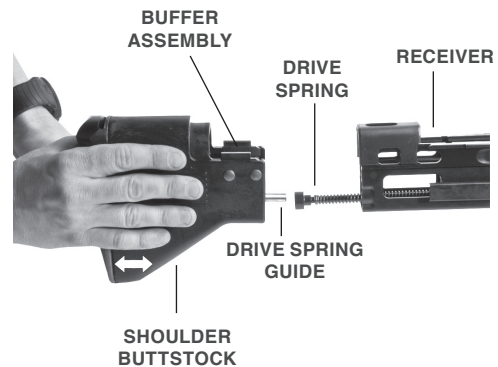

4. Push the buttstock forward as shown and install the yoke.
5. Close cover.
6. Manually cycle weapon system to ensure proper function.

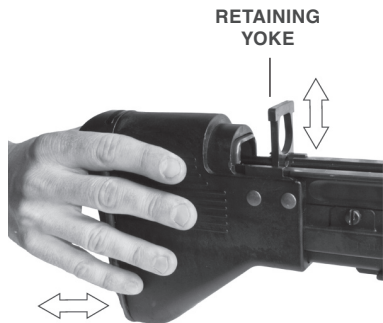

SECTION VI. MAINTENANCE CHECKLIST



Check the cleanliness and overall condition of the following:

1. Barrel assemblies. Chamber, bore and flash suppressor, gas cylinder, gas port, and gas piston.
2. Receiver assembly. Operating rod guide, rails, and rear bridge rivets.
3. Bolt assembly.
4. Front and rear sights.
5. Shoulder buttstock.
6. Bipod assembly.
7. Trigger mechanism grip assembly.
8. Cocking handle assembly.
9. Cover assembly and cartridge feed tray assembly.
10. Blank firing attachment (BFA). Clean after firing 500 rounds or after each day's firing, whichever comes first. Remember BFA causes carbon fouling.

SECTION VII. MACHINE GUN CHECK OUT PROCEDURE

Bolt Assembly Rearward? Good. **Safety in S?** Good.

1. Point weapon down range.
2. Load machine gun with dummy ammunition (p 24).
3. Squeeze trigger. Nothing should happen.
4. Move safe to F.
5. Squeeze trigger. Bolt assembly should move forward, strip and chamber a dummy round, and lock.
6. Pull cocking handle back. Dummy round should eject, and bolt assembly should lock to rear.

WARNING: After unloading dummyround, be sure the barrel is cleared.

7. Move safety to S.
8. Unload dummy ammunition and clear weapon (p 26).
9. Verify that the projectile stayed with the dummy cartridge case.
10. Close cover and latch.
11. Move safety to F. Pull cocking handle, squeeze trigger and ease bolt assembly forward.



CHAPTER 4 - AMMUNITION

WARNING: This is the only ammunition authorized for use in your machine gun. If it is not shown, it is not authorized.

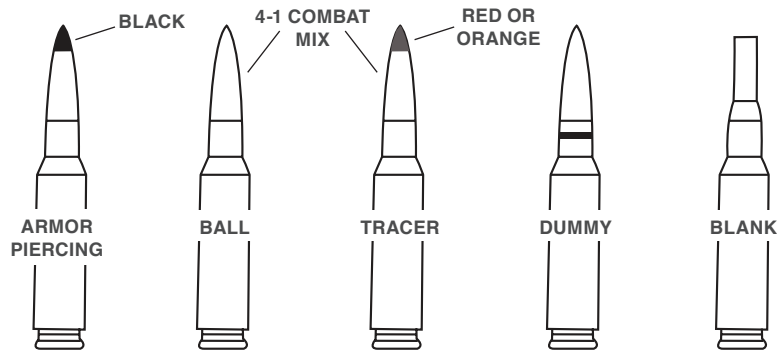

Care, Handling, and Preservation.

- Do not open ammunition containers until the ammunition is to be used. Ammunition removed from the airtight containers, particularly in damp climates, is likely to corrode.
- Protect ammunition from mud, dirt and water. If the ammunition gets wet or dirty, wipe it off prior to use. Wipe off light corrosion as soon as it is discovered. Heavily corroded cartridges or cartridges which have dented cases or loose projectiles should not be fired.
- Do not expose ammunition to the direct rays of the sun. If the powder is hot, excessive pressure may be developed when the gun is fired.
- Do not oil or grease ammunition. Dust and other abrasives collecting on oiled or greased ammunition will damage the operating parts of the gun.

Ammunition Which Fails To Fire.

Dispose of any ammunition, which fails to fire, according to authorized procedures.

APPENDIX A

★ REFERENCES

Scope.

This appendix lists some manuals referenced in this manual, and some other sources of information about M60 machine guns and ancillary equipment.

Field Manuals.

Machine gun 7.62-MM, M60 -- FM 23-67

Firing Table.

FT 7.62-A-2

Machine Gun, 7.62-mm; M60 on Mount, Machine Gun: 7.62-mm, M122 and Machine Gun, 7.62-mm: M73 on Tank, Combat, Full-Track: 105-mm Gun, M60 Series and Rifle, 7.62mm: M14; Firing Cartridge, 7.62mm, Ball, NATO, M59; Cartridge, 7.62mm, Ball, NATO, M80; Cartridge, 7.62mm: AP, NATO, M61 and Cartridge, 7.62mm: Tracer, NATO, M62.

Forms

DA Form 2028 -Recommended Changes to Publications and Blank Forms SF 368 - Quality Deficiency Report

Technical Manuals.

TM 02705E-IO/I- Operators Manual for Machine Gun, 7.62 MM, M60E3 and Mount, Tripod, Machine Gun, 7.62MM, M122.

TM 3-220 - Chemical, Biological and Radiological (CBR) Decontamination

TM 11-5855-213-10 -Operators Manual for Night Vision Sight, Individual Served Weapon, AN/PVS4

APPENDIX B

SECTION I. INTRODUCTION

Scope.

This appendix lists components of end item and basic issue items for the MK43 MOD 0 machine gun to help you inventory items required for safe and efficient operation.

General.

The Components of End Item and Basic Issue Items Lists are divided into the following sections:

- a. Section II. Components of End Item. This listing is for informational purposes only and is not authority to requisition replacements. These items are part of the end item but are removed and separately packaged for transportation or shipment. As part of the end item, these items must be with the end item whenever it is issued or transferred between property accounts. Illustrations are furnished to assist you identifying the items.
- b. Section III. Basic Issue Items. These are the minimum essential items required to place the MK43MOD0 machine gun in operation, to operate it, and to perform emergency repairs.

Although shipped separately packaged, BII must be with the MK43 Mod0 machine gun during operation and whenever it is transferred between property accounts. The illustrations will assist you with hard-to-identify items. This manual is your authority to request/requisition replacement BII, based on approved allowance for the end item.

Explanation of Columns

The following provides an explanation of columns found in the tabular listings:

- a. Column (1) - Illustration Number. This column indicates the number of the illustration in which the item is shown.
- b. Column (2) - National Stock Number. Indicates the National stock number assigned to the item and will be used for requisitioning purposes.
- c. Column (3) - Description. Indicates the Federal item name and, if required, a minimum description to identify and locate the item. The last line for each item indicates the Contractor and Government Entity Code (CAGEC) (in parentheses) followed by the part number.
- d. Column (4) - Unit of Measure (U/M). Indicates the measure used in performing the actual operational/maintenance function. This measure is expressed by a two-character alphabetical abbreviation (e.e., ea., in., pr.).
- e. Column (5) - Quantity required. Indicates the quantity of the item authorized to be used with/on the equipment.

SECTION II. COMPONENTS OF END ITEM



This page intentionally left blank



(1) Illustration Number	(2) National Stock Number	(3) Description CAGEC & Part Number	(4) U/M	(5) Quantity Required
1	1005-00-312-7177	Sling, Small Arm (19204) 12002983	EA	1

★ SECTION III. BASIC ISSUE ITEMS



(1) Illustration Number	(2) National Stock Number	(3) Description CAGEC & Part Number	(4) U/M	(5) Quantity Required
1	1005-01-184-6362	Barrel and carrying handle assembly (26978) MD3521	EA	1
2	1005-01-791-5420	Carrying case for barrel assembly and equipment (19205) 7791009	EA	1
3	4933-00-652-9950	Extractor for ruptured cartridge case (19205) 7790352	EA	1
4	5120-00-461-1075	Wrench, screwdriver, and reamer (combination) (19204) 8448458	EA	1
5	0640-LP-544-4800	TM, Operators Manual SW-370-AJ-OP11-010/ M43 MOD 0	EA	1

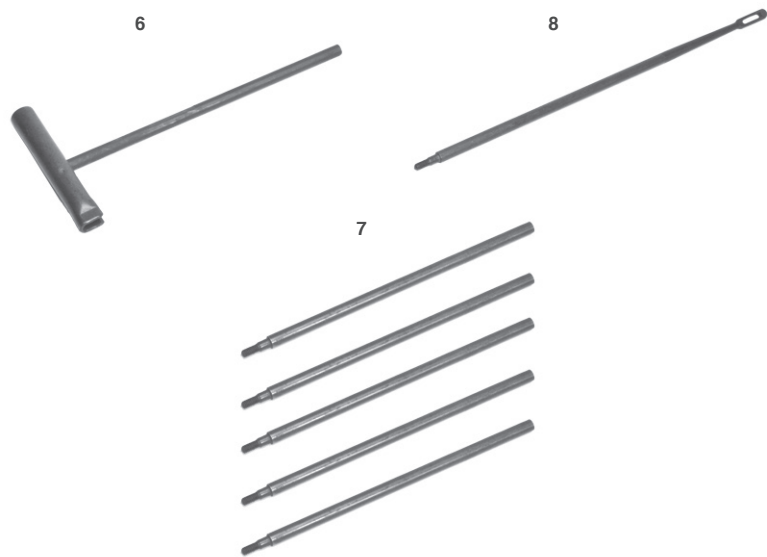

(1) Illustration Number	(2) National Stock Number	(3) Description CAGEC & Part Number	(4) U/M	(5) Quantity Required
6	5340-01-285-2683	Handle assembly: Cleaning rod (19204) 7266115	EA	1
7	1005-00-726-6109	Rod sections, cleaning, small arms (19204) 7266109	EA	5
8	1005-00-726-6110	Swab holder section, small arms cleaning rod (19204) 7266110	EA	1

APPENDIX C - ADDITIONAL AUTHORIZED LIST

SECTION I. INTRODUCTION

Scope.

The appendix lists additional items you are authorized for the support of the MK43 MOD0 Machine Gun.

General.

This list identifies items that do not have to accompany the MK43 MOD 0 Machine Gun and that do not have to be turned in with it.

Explanation of Listing.

National stock numbers, descriptions, and quantities are provided to help you identify and request the additional items you require to support this equipment.

SECTION II. ADDITIONAL AUTHORIZED LIST

(1) National Stock Number	(2) Description FSCM & Part Number	(3) U/M	(4) Quantity Required
1005-00-140-3515	Firing attachment, blank: (19204) 12002981	EA	1
1005-00-556-4174	Brush, cleaning, small arms: (bore) (19204) 5564174	EA	2
1005-00-690-3115	Brush, cleaning, small arms: (chamber) (19204) 7790452	EA	1
1005-00-350-4100	Brush, cleaning, small arms: (receiver) (19204) 8448466	EA	1

BORE
BRUSH

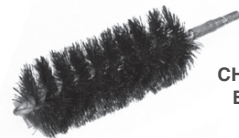

CHAMBER
BRUSH



RECEIVER
BRUSH



APPENDIX D - EXPENDABLE SUPPLIES

SECTION I. INTRODUCTION

Scope.

This appendix lists expendable supplies and materials you will need to operate and maintain the MK43 M 8 D 0 Machine Gun.

Explanation of Columns.

- a. Column (1) - Item Number (Item Number). This number is assigned to the entry in the listing and is referenced in the narrative instructions to identify the material (e.g., "Use wiping rag, item 4, app D).
- b. Column (2) - Level. This column identifies the lowest level of maintenance that requires the listed item.

c. Column (3) - National Stock Number. This is the National stock number assigned to the item; use to request or requisition the item.

d. Column (4) - Description. Indicates the Federal item name and, if required, a description to identify item. The last line for each item indicates the Contractor and Government Entity Code (CAGEC) in parentheses followed by the part number.

e. Column (5) - Unit of Measure (U/M). Indicates the measure used in performing the actual maintenance function. This measure is expressed by a two-character alphabetical abbreviation (e.g., ea., in., pr.). If the unit of measure differs from the unit of issue, requisition the lowest unit of issue that will satisfy your requirements.

**SECTION II. EXPENDABLE/DURABLE SUPPLIES AND MATERIALS LIST**

(1) Item Number	(2) Level	(3) National Stock Number	(4) Description CAGEC & Part Number	(5) U/M
1	C	9150-01-102-1473	Cleaner, lubricant and preservative (CLP) 1/2 oz. bottle (81349) MIL-L-63460	OZ
2	C	9150-00-753-4686	Lubricating Oil (LSA)	QT
3	C	9150-00-292-9689	Lubricating Oil (LAW)	QT
4	C	7920-00-205-1711	RAG WIPING: (cotton) 50lb. bdl. (81348) a-a-531	LB
5	C	1005-00-288-3565	Swab, small arms cleaning (cotton) 2 1/2 in. sq. (1000 per pkg.) (19204) 5019316	PG

USORD.COM



Ph:775.343.1320

ISO 9001:2008

Fax:775.343.1331