

SIGARMS Training



SIGARMS

SIGARMS, INC. Corporate Park Exeter, NH 03833

P230 Pocket Pistol

Armorer's Manual

P230

ARMORERS MANUAL

The SIGARMS Armorers Manual is intended as a Reference Source to be used in conjunction with the formal training received in the SIGARMS ACADEMY Armorers School.

SIG-Sauer Pistols are accompanied by an Owners Manual which explains and illustrates user responsibilities and safety precautions. It is recommended that this information be read and adhered to at all times. Information provided in either manual may change without notification.

This publication is copyrighted, is solely for the use of the registered owner, and may not be reproduced, copied or distributed in any form without the express written consent of SIGARMS.

TABLE OF CONTENTS

	page #
1.0 INTRODUCTION	1-1
1.1 General	1-1
1.2 Technical Specifications of the SIG-Sauer P230	1-1
2.0 DESIGN AND COMPONENTS	2-1
2.1 Weapon	2-1
2.1.1 General	2-1
2.1.2 The Slide	2-2
2.1.3 The Frame	2-3
2.1.4 The Magazine	2-4
3.0 HANDLING	3-1
3.1 Loading	3-1
3.2 Reloading	3-1
3.3 Unloading	3-1
3.4 Firing the Pistol	3-2
3.5 Cycle of Operation	3-2
4.0 GENERAL DISASSEMBLY AND ASSEMBLY	4-1
4.1 Disassembly	4-1
4.2 Assembly	4-2
5.0 MAGAZINE - DISASSEMBLY AND ASSEMBLY	5-1
5.1 Disassembly	5-1
5.2 Assembly	5-1

TABLE OF CONTENTS continued

	page #
6.0 WEAPON INSPECTION	6-1
6.1 General	6-1
6.2 Function Inspection	6-1
6.2.1 Unload and Make the Weapon Safe	6-1
6.2.2 Trigger and Hammer Mechanism	6-1
6.2.3 Recoil Spring	6-2
6.2.4 Magazine	6-2
6.2.5 Slide Catch Lever	6-3
6.2.6 External Condition of the Weapon	6-3
6.2.7 Inspection of the Serial Numbered Parts	6-3
6.3 Parts Inspection	6-3
6.3.1 General	6-3
6.3.2 Areas of Inspection	6-3
7.0 CLEANING	7-1
7.1 Cleaning the Pistol	7-1
7.1.1 General	7-1
7.1.2 Cleaning Procedures	7-1
7.1.3 Lubrication Specifications	7-2
8.0 WEAPON FUNCTIONS	8-1
8.1 Function of the Trigger Assembly	8-1
8.1.1 Double Action/Single Action Function	8-1
8.1.2 Disconnecter Operation	8-2
8.1.3 Decocking Lever and Safety Intercept Notch	8-3
8.1.4 Firing Pin Safety Lock	8-4

TABLE OF CONTENTS continued

	page #
8.0 WEAPON FUNCTIONS continued...	
8.2 Straight Blowback Operation	8-5
8.3 Arresting Mechanism (Slide Catch Lever)	8-5
9.0 THE SLIDE - DISASSEMBLY AND ASSEMBLY	9-1
9.1 Removal of the Extractor Assembly	9-2
9.2 Installation of the Extractor Assembly	9-3
9.3 Removal of the Firing Pin Assembly	9-4
9.4 Installation of the Firing Pin Assembly	9-5
10.0 THE FRAME - DISASSEMBLY AND ASSEMBLY	10-1
10.1 Takedown Lever Assembly	10-3
10.1.1 Disassembly	10-3
10.1.2 Assembly	10-3
10.2 Slide Catch Lever	10-3
10.2.1 Removal	10-3
10.2.2 Installation	10-3
10.2.3 Removal and Installation of the Slide Catch Lever Spring	10-4
10.3 Grip Plates, Left and Right	10-5
10.3.1 Removal	10-5
10.3.2 Installation	10-5
10.4 Trigger Assembly	10-6
10.4.1 Disassembly	10-6
10.4.2 Assembly	10-7

	page #
10.0 THE FRAME - DISASSEMBLY AND ASSEMBLY continued...	
10.5 Hammer Strut/Magazine Catch Assembly	10-8
10.5.1 Disassembly	10-8
10.5.2 Assembly	10-8
10.6 Hammer Assembly	10-9
10.6.1 Disassembly	10-10
10.6.2 Assembly	10-11
11.0 SIGHT ADJUSTMENT	11-1
11.1 Zeroing the P230 Pistol	11-1
11.2 Sight Specifications	11-2
11.3 Using the Combination Sight Pusher	11-3
11.3.1 Placement of the Pistol in the Sight Pusher	11-4
11.3.2 Moving the Sights	11-4
11.3.3 Changing the Sights	11-4
11.3.4 Centering the Sights	11-4
12.0 TROUBLESHOOTING	12-1
12.1 General	12-1
12.2 Stoppages, Malfunctions and their Corrections	12-1
12.2.1 Feeding	12-1
12.2.2 Extraction and Ejection	12-2
12.2.3 Other	12-3
13.0 PARTS DIAGRAM	13-0
Parts Diagram	13-0
Parts List	13-1
14.0 TOOLS	14-1
14.1 Tools Necessary for Weapon Disassembly	14-1

1.1 General

The SIG-SAUER P230 semi automatic pistol was developed in the mid 1970s specifically for Law Enforcement Agencies throughout the world. Its compact design and light weight makes it a particularly suitable pistol for concealed carrying. The P230 may be carried with confidence and safety through its use of multiple passive safety features and double action/single action trigger mechanism. This pistol is self-loading and may be fired by simply pulling the trigger. The slide is automatically locked open by the magazine after the last shot is fired. The P230 is available in both blued and stainless steel models.

1.2 Technical Specifications of the SIG-Sauer P230

Caliber:	.380 ACP (9mm short)
System of Operation:	Straight blowback
Safety System:	1) Patented automatic firing pin lock 2) Decocking lever 3) Hammer safety intercept notch

Dimensions and Weights:

Length, overall	6.61 in.
Height, overall	4.68 in.
Width, overall	1.22 in.
Barrel Length	3.62 in.
Rifling Lead	9.84 in.
Number of Rifling Grooves	6
Sight Base	4.72 in.
Weight, excluding magazine	16.2 oz. (20.8 oz.*)
Weight of empty magazine	1.4 oz. (1.6 oz.*)
Trigger Pull Weight	DA 9.9 lbs/SA 3.75 lbs.
Magazine Capacity/Rounds	7

*Stainless Model

NOTE: *Above subject to change without notice. Parts are interchangeable. Broken parts must be replaced, do not repair broken or damaged parts.*



The SIG-SAUER P230 With Magazine Inserted

- | | | | |
|-----|-----------------|-----|----------------|
| 1. | Slide | 29. | Hammer |
| 11. | Barrel | 35. | Magazine catch |
| 18. | Trigger | 38. | Frame |
| 20. | Take-down lever | 43. | Magazine |
| 24. | Decocking lever | | |

NOTE: *The reference numbers identifying individual parts throughout this manual are identical with the numbers in the parts list section.*

2.1 Weapon

2.1.1 General

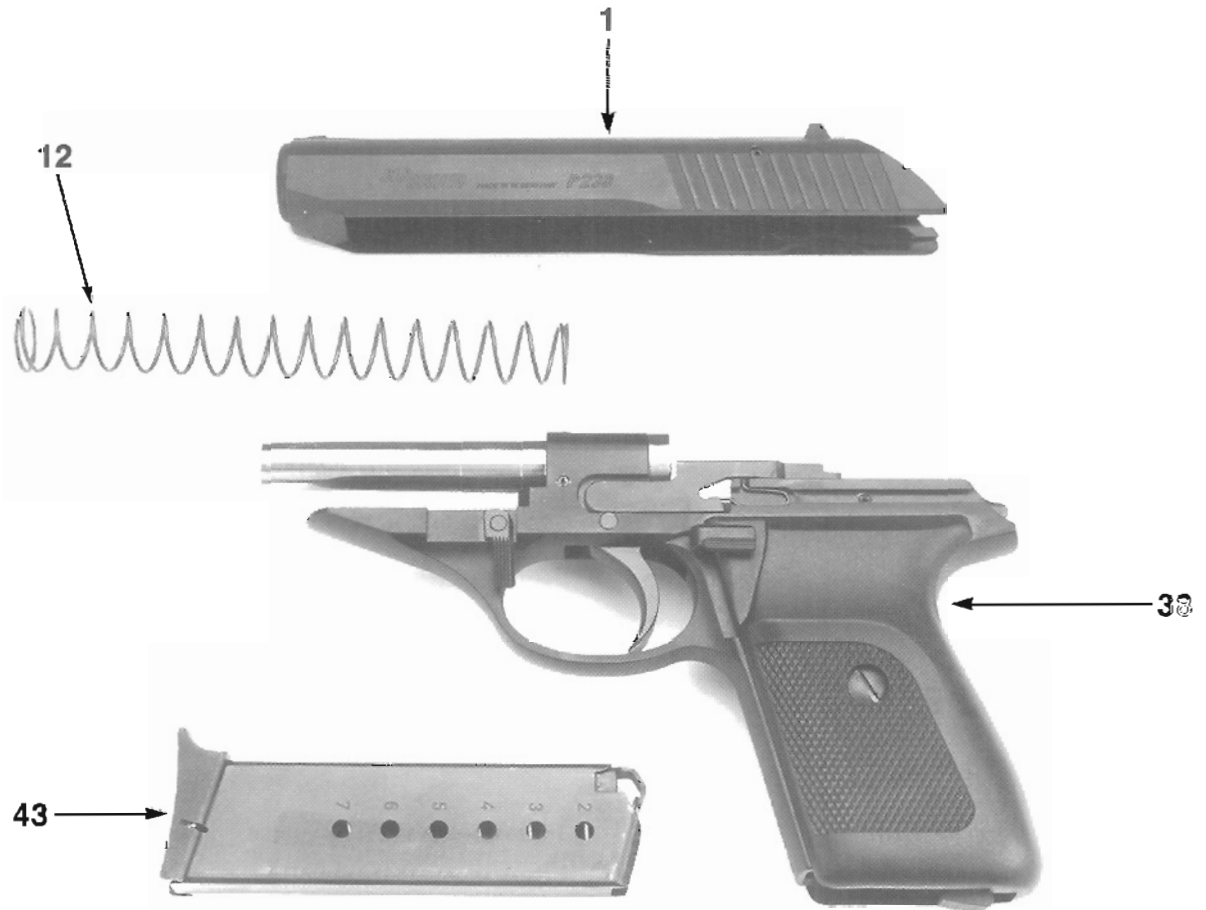

The Main Components of the SIG-SAUER P230 Pistol

- 1. The Slide
- 12. The Recoil Spring
- 38. The Frame
- 43. The Magazine

2.0 DESIGN AND COMPONENTS

2.1 Weapon

2.1.2 The Slide

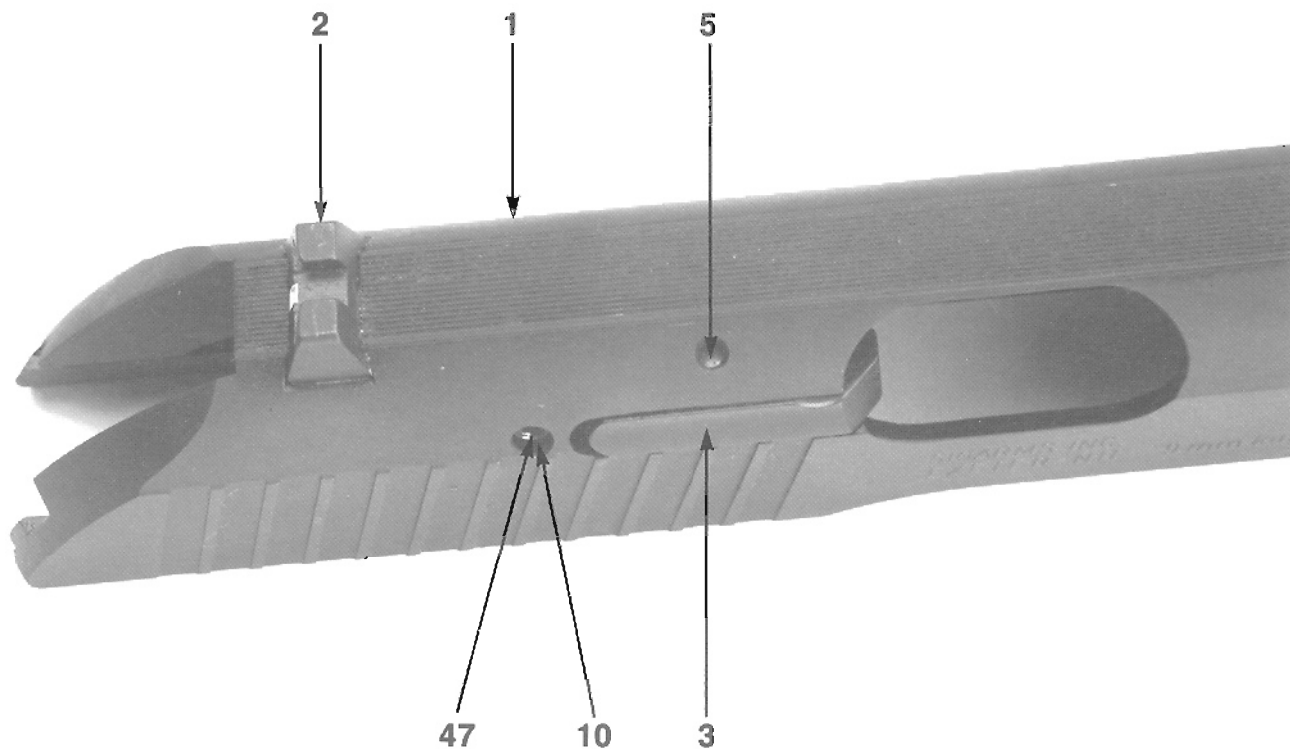

The Slide

1. Slide
2. Rear sight
3. Extractor
5. Extractor pin
10. Outer pin H.D.
47. Inner pin H.D.

2.1 Weapon

2.1.3 The Frame

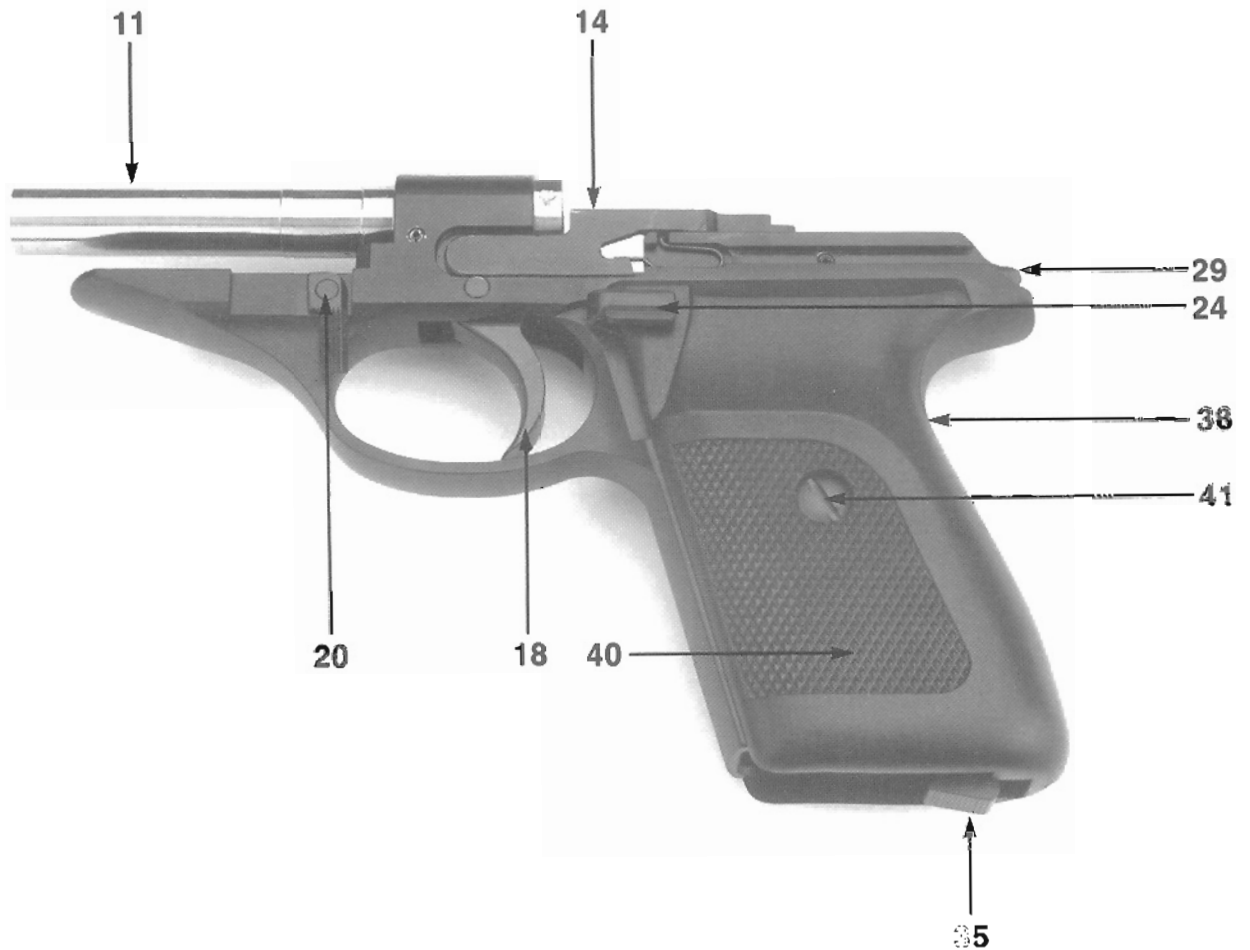

The Frame

- | | | | |
|-----|-------------------|-----|------------------|
| 11. | Barrel | 29. | Hammer |
| 14. | Slide catch lever | 35. | Magazine catch |
| 18. | Trigger | 38. | Frame |
| 20. | Takedown lever | 40. | Left grip plate |
| 24. | Decocking lever | 41. | Grip plate screw |

2.0 DESIGN AND COMPONENTS

2.1 Weapon

2.1.4 The Magazine

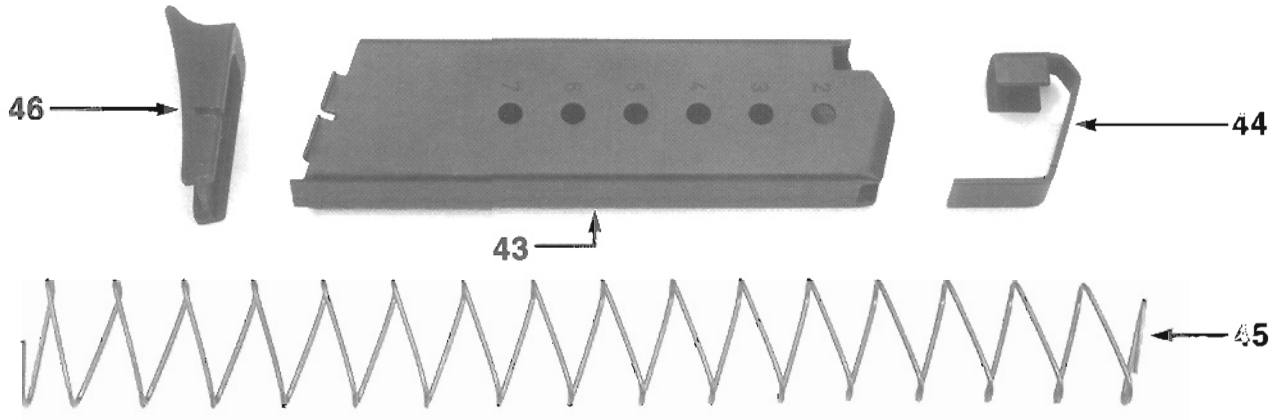

The Magazine

- 43. Magazine tube
- 44. Magazine follower
- 45. Magazine spring
- 46. Magazine floorplate

NOTES:

NOTE: *The operations described hereafter (loading, reloading, and unloading) are always to be carried out with the finger off of the trigger and the muzzle pointing in a safe direction. In addition, descriptions of the pistol will be made as if the operator were pointing it directly away from him, as in firing.*

3.1 Loading - Sequence of Operations

1. Trigger finger off of the trigger and muzzle pointing in a safe direction.
2. Insert a full magazine and ensure that it has engaged the magazine catch (**check**).
3. Pull the slide completely to the rear and release it to chamber the first round from the magazine.
4. You may either fire the pistol or thumb down the decocking lever (to safely lower the hammer) and place it in the holster.

3.2 Reloading - Sequence of Operations

1. Trigger finger off of the trigger and muzzle pointing in a safe direction.
2. Depress the magazine catch to remove the empty magazine.
3. Insert a fresh magazine and ensure that it has engaged the magazine catch (**check**).
4. If the slide is locked back pull it to the rear and allow it to spring forward.
5. You may either fire the pistol or thumb down the decocking lever (to safely lower the hammer) and place it in the holster.

3.3 Unloading - Sequence of Operations

1. Trigger finger off of the trigger and muzzle pointing in a safe direction.
2. Remove the magazine.
3. Pull the slide to the rear to eject the chambered round, inspect both the chamber and the magazine well to make sure the pistol is unloaded. **Check a second time.**
4. Let the slide go forward and thumb down the decocking lever.

3.0 HANDLING

3.4 Firing the Pistol - Sequence of Operations

1. Remove the pistol from its holster and assume a shooting position.
2. Pull the trigger to fire (no external safety lever has to be operated).
3. When through firing, remove the trigger finger from the trigger, thumb down the decocking lever, reload, unload, or place the pistol back in its holster.

3.5 Cycle of Operation

In order to understand the functioning of the P230 semiautomatic pistol, the cycle of operation must be understood.

1. **Feeding:** Placing a cartridge in the path of the slide.
2. **Chambering:** Moving the cartridge from the magazine to the chamber.
3. **Closing:** Sealing the chamber by the breech face of the slide resting against the cartridge case.
4. **Firing:** Ignition of the primer and firing the cartridge.
5. **Opening:** Unsealing the chamber by the rearward pressure of the fired cartridge against the breech face.
6. **Extracting:** "Pulling" the spent cartridge from the chamber.
7. **Ejecting:** "Pushing" the spent cartridge out the ejection port.
8. **Cocking:** Returning the firing mechanism to the cocked position, ready to fire another round.

NOTE: *With blowback operated pistols such as the SIG-Sauer P230, no mechanical locking of the barrel and slide takes place. The weight of the slide and resistance of the recoil spring seals the chamber during firing.*

4.1 Disassembly - Sequence of Operations

1. Remove the magazine. Unload and check the chamber both visually and physically. **Check again!**
2. Thumb down the take-down lever to the vertical position.



3. Pull the slide to the rear, lift the rear of the slide away from the frame and gradually allow it to move forward off of the barrel while releasing the tension of the recoil spring.



4. Remove the recoil spring from the barrel.

5.1 Disassembly - Sequence of Operations

1. Invert the magazine.
2. Depress the magazine spring with a suitable tool through the opening in the side of the floorplate.
3. Slide the floorplate off the magazine tube, ensuring the magazine spring tension is gradually released.

NOTE: *The magazine spring is under great pressure - keep work operation away from the face.*

4. Remove the magazine spring and magazine follower from the magazine tube.

5.2 Assembly - Sequence of Operations

1. Place the magazine follower on the magazine spring (raised end of spring under the front of the magazine follower).
2. Hold magazine tube vertically and insert the magazine follower and magazine spring.
3. Invert the magazine, compress the magazine spring completely into the magazine tube and install the floorplate.

NOTE: *Be sure that the magazine spring locks into the floorplate opening, securing it to the magazine tube.*

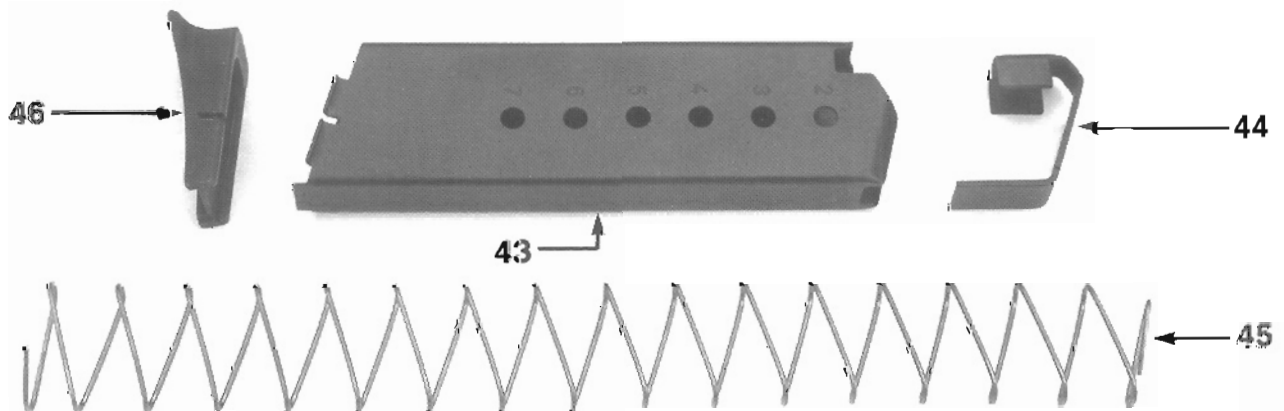

Magazine Disassembled

- | | |
|-----------------------|-------------------------|
| 43. Magazine tube | 45. Magazine spring |
| 44. Magazine follower | 46. Magazine floorplate |

6.1 General

The armorer should carry out the following inspections:

1. Function inspection
2. Parts inspection

6.2 Function Inspection

A function inspection is to be carried out on the assembled weapon:

1. To determine causes of malfunction
2. After repair work
3. Following cleaning and during weapon inspections, as well as after parts inspection and lubrication

6.2.1 Unload and Make the Weapon Safe

Remove the magazine, pull the slide to the rear to eject the chambered round, inspect both the chamber and magazine well to be sure the pistol is unloaded. **Check a second time.** (See Section 3.3 - **Unloading Procedures.**)

6.2.2 Trigger and Hammer Mechanisms

A. Decocking lever

1. Clear the pistol.
2. Cock the hammer.
3. Place moderate pressure on the back of the hammer to ensure positive sear engagement with the hammer.
4. Thumb down the decocking lever and check that the trigger returns to the double action position.
5. Check that the hammer has come to rest in the safety intercept notch before reaching the extreme dropped position.

B. Double action function

1. With hammer decocked, pull the trigger.
2. Check that the hammer is cocked and drops forcefully, striking the firing pin.

6.2 Function Inspection (cont'd)

6.2.2 Trigger and Hammer Mechanisms (cont'd)

C. Disconnecter operation

1. With hammer forward and the trigger retained to the rear, pull the slide to the rear and release it.
2. Check that the hammer is retained in the cocked position (trigger remains pulled).

D. Single-action function

1. Release the trigger.
2. Check that the trigger bar engages the safety lever once more, and that upon pulling the trigger again, the hammer is released.

6.2.3 Recoil Spring

Check the force of the recoil spring and smooth cycling of the slide. Pull the slide to the rear and check that the slide springs forward smartly. Repeat once.

6.2.4 Magazine

1. Check the condition of the magazine tube, the lips and the floorplate.
2. Check for correct interlocking of the floorplate and the magazine tube.
3. Check for smooth movement and springing of the magazine follower.
4. Check for ease of insertion of the magazine into the frame and positive locking by the magazine catch.
5. Check for free movement of the magazine catch.
6. With an empty magazine in place, pull the slide to the rear and release it. The slide must be arrested in the rear position by the slide catch lever.

6.2 Function Inspection (cont'd)

6.2.5 Slide Catch Lever

1. Remove the empty magazine used to lock the slide open. Retract the slide slightly to disengage the internal slide catch lever. Release the slide, allowing it to move forward to the closed position.
2. Thumb down the decocking lever.

6.2.6 External Condition of the Weapon

Inspect condition of front and rear sights, grip plates and takedown lever, as well as tight seating of the sights and grip plates.

6.2.7 Inspection of the Serial Numbered Parts

Ensure agreement of the serial numbers on the slide and frame.

6.3 Parts Inspection

6.3.1 General

This inspection includes a close check of individual parts for damage such as cracks, unacceptable deformation, smoothness and condition of all sliding and bearing surfaces, as well as function and condition of all springs. This inspection should be carried out as a normal part of preventive maintenance each time the pistol is disassembled.

Parts inspection is to be performed with the weapon unloaded, disassembled and cleaned.

6.3.2 Areas of Inspection

A. Barrel

1. Bore and chamber
2. Feed ramp
3. Muzzle

B. Recoil spring

C. Slide

1. Ejection port
2. Extractor/loaded chamber indicator

6.3 Parts Inspection (cont'd)

6.3.2 Areas of Inspection (cont'd)

C. Slide (cont'd)

3. Firing pin and firing pin spring
4. Projection of the firing pin through the breech face
5. Arresting surface for slide catch lever
6. Pins H.D. of the slide
7. Safety lock and safety lock spring
8. Front and rear sights, contrast markings, tightness of fit
9. Finish

D. Frame

1. Take-down lever
2. Trigger, trigger pivot pin, trigger bar, and trigger bar spring
3. Decocking lever and spring
4. Slide catch lever and slide catch lever spring
5. Sear, sear spring and safety lever
6. Hammer
7. Hammer strut assembly/magazine catch
8. Grip plates, grip plate screws and washers
9. Finish

E. Magazine

1. Magazine tube and lips
2. Magazine floorplate
3. Magazine spring
4. Magazine follower

7.1 Cleaning the Pistol

7.1.1 General

Pistol must be stored in a dry location. Humidity and rapid temperature changes are detrimental and encourage corrosion. If a pistol is not to be used for some time, lubricate it well, particularly the bore of the barrel and the exterior surfaces. Clean the pistol immediately after each use (applicable to both blued and stainless steel guns.)

7.1.2 Cleaning Procedures

1. Disassemble the pistol after assuring it is UNLOADED.
2. Clean all areas with a cloth treated with a small amount of cleaning solvent.

CAUTION: *Some cleaning solvents and treated cloths may be detrimental to the finish of your weapon. Please read the manufacturers' warning labels before using.*

3. Cleaning the barrel

CAUTION: *Use of a steel brush may be harmful to the smooth barrel surface.*

- A. To remove all traces of powder residue and bullet fouling from the barrel, push a borebrush of the appropriate diameter treated with cleaning solvent through the bore at least ten times, from the chamber end. Give special attention to the forward edge of the chamber.
 - B. Dry the barrel using a jag or slotted tip cleaning rod and cloth patches.
 - C. Continue until the patches inserted into the bore return clean.
4. Reassemble the pistol.
 5. Carry out function checks (6.2).
 6. See lubrication specification (7.1.3).

7.0 CLEANING

7.1 Cleaning the Pistol (cont'd)

7.1.3 Lubrication Specifications

1. **DO NOT FIRE THE PISTOL WITHOUT LUBRICATION.** For user level lubrication, place several small drops of oil on the left and right frame rails. Lightly lubricate the interior and exterior of the barrel and recoil spring. If the weapon has been further disassembled, lightly lubricate all moving parts before reassembly. Assemble the pistol and cycle the slide back and forth several times to disburse the lubricant evenly. The blued surfaces of the slide should be lightly treated with a lubricant/preservative to maintain the integrity of the finish. Wipe off any excess lubrication on the pistol's exterior.
2. Do not over-lubricate the weapon.

8.1 Function of the Trigger Assembly

8.1.1 Double Action/Single Action Function

With the weapon loaded and the hammer decocked, the first shot can be fired double-action by pulling the trigger.

By pulling the trigger, the trigger bar is drawn forward and moves the hammer rearward. The trigger bar also operates the safety lever to lift the safety lock. The safety lever draws the sear out of engagement with the hammer while the safety lock is raised and frees the firing pin. Continued movement of the trigger causes the trigger bar to release the hammer which strikes the firing pin and fires the cartridge.

With the weapon loaded and the hammer cocked, the first shot can be fired single-action by pulling the trigger.

When pulling the trigger in the single-action mode, the trigger bar is drawn forward, pivoting the safety lever which lifts the safety lock to free the firing pin, and moves the sear to release the hammer.

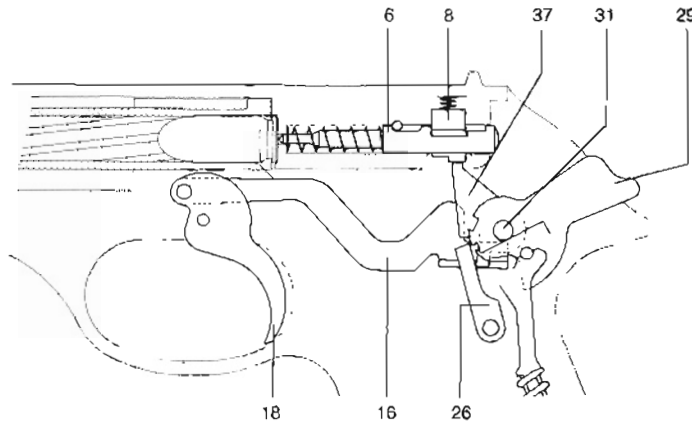

Function of the Trigger Assembly

6.	Firing pin	26.	Sear
8.	Safety lock	29.	Hammer
16.	Trigger bar	31.	Hammer pivot pin
18.	Trigger	37.	Safety lever

8.1 Function of the Trigger Assembly

8.1.2 Disconnecter Operation (Automatic Interruption of Trigger Function)

1. Upon firing - the blowback reaction thrusts the slide rearward. The slide disconnects the trigger bar from the safety lever, which allows the firing pin and firing pin safety lock to reset to the locked position, as well as releasing the sear. The sear, under pressure of the sear spring, returns to its initial position and arrests the hammer as the slide goes forward. In order to fire the next shot, the trigger must be released to allow the trigger bar and safety lever to engage.
2. Incomplete locking - if the slide does not fully return into battery due to a weapon, magazine or ammunition malfunction, the connection between the firing pin safety lock and safety lever is not made. Therefore, the safety lock remains engaged, blocking the firing pin. In this disconnected state, the slide also cams down the trigger bar and effectively interrupts subsequent trigger functions.

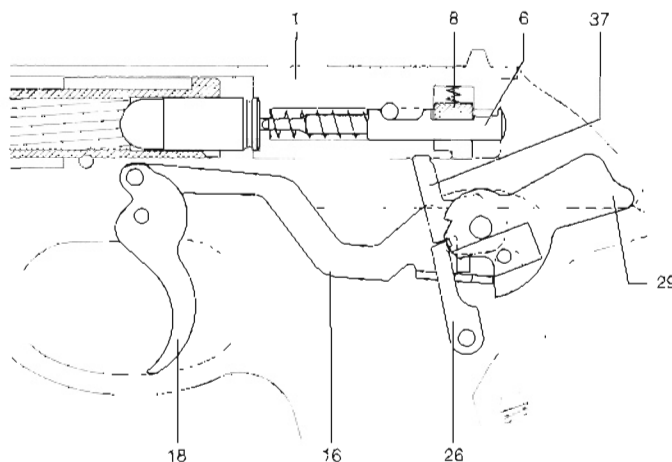

Trigger Assembly, Disconnecter Operated

1.	Slide	18.	Trigger
6.	Firing pin	26.	Sear
8.	Safety lock	29.	Hammer
16.	Trigger bar	37.	Safety lever

8.1 Function of the Trigger Assembly (cont'd)

8.1.3 Decocking Lever and Safety Intercept Notch

The decocking lever allows the cocked hammer to be safely lowered into the safety intercept notch. In this condition, the weapon can be carried with a cartridge in the chamber, ready for immediate use. The safety intercept notch is the rest position of the hammer or the double-action position. It also becomes effective if the hammer should slip while someone tries to thumbcock or drops the weapon. Thumbing down the decocking lever moves the sear out of engagement with the hammer's single action notch. The hammer then drops forward, and the decocking lever returns to its original position. The hammer is arrested by the sear engaging in the safety intercept notch. During this operation, the safety lever remains in its rest position and does not lift the safety lock. Hence, during and after decocking, the firing pin remains constantly locked. This ensures that decocking the weapon as instructed cannot cause an unintentional discharge of a cartridge.

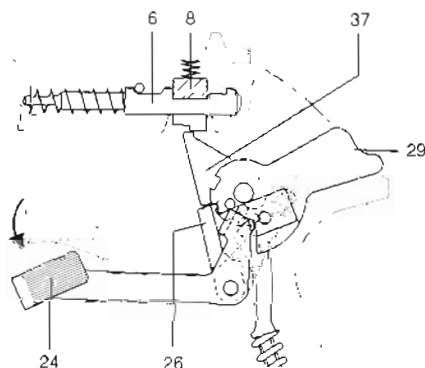

Function of the Decocking Lever and Safety Intercept Notch

6.	Firing pin	26.	Sear
8.	Safety lock	29.	Hammer
24.	Decocking lever	37.	Safety lever

8.0 WEAPON FUNCTIONS

8.1 Function of the Trigger Assembly (cont'd)

8.1.4 Firing Pin Safety Lock

In order to achieve optimum safety, the firing pin is locked in the slide by the safety lock. When the trigger is pulled, the trigger bar pivots the safety lever to raise the safety lock (thus freeing the firing pin) immediately prior to releasing the hammer.

After each shot, the firing pin spring retracts the firing pin; allowing engagement of the safety lock during each cycle of operation. The combination of the automatically locked firing pin and the positive engagement of the hammer in the safety intercept notch effectively prevents unintentional firing of the pistol whether cocked or decocked.

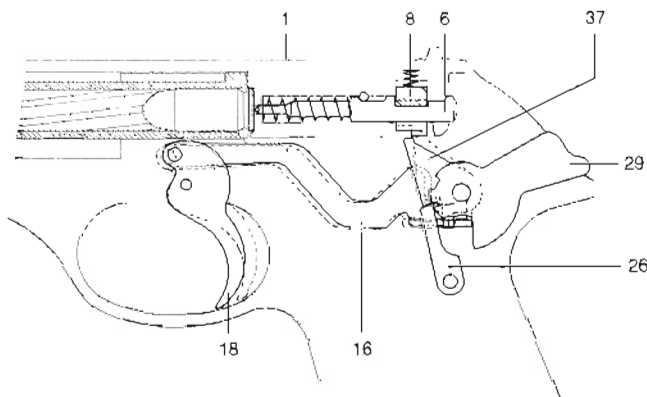

Function of the Firing Pin Safety Lock

1.	Slide	18.	Trigger
6.	Firing pin	26.	Sear
8.	Safety lock	29.	Hammer
16.	Trigger bar	37.	Safety lever

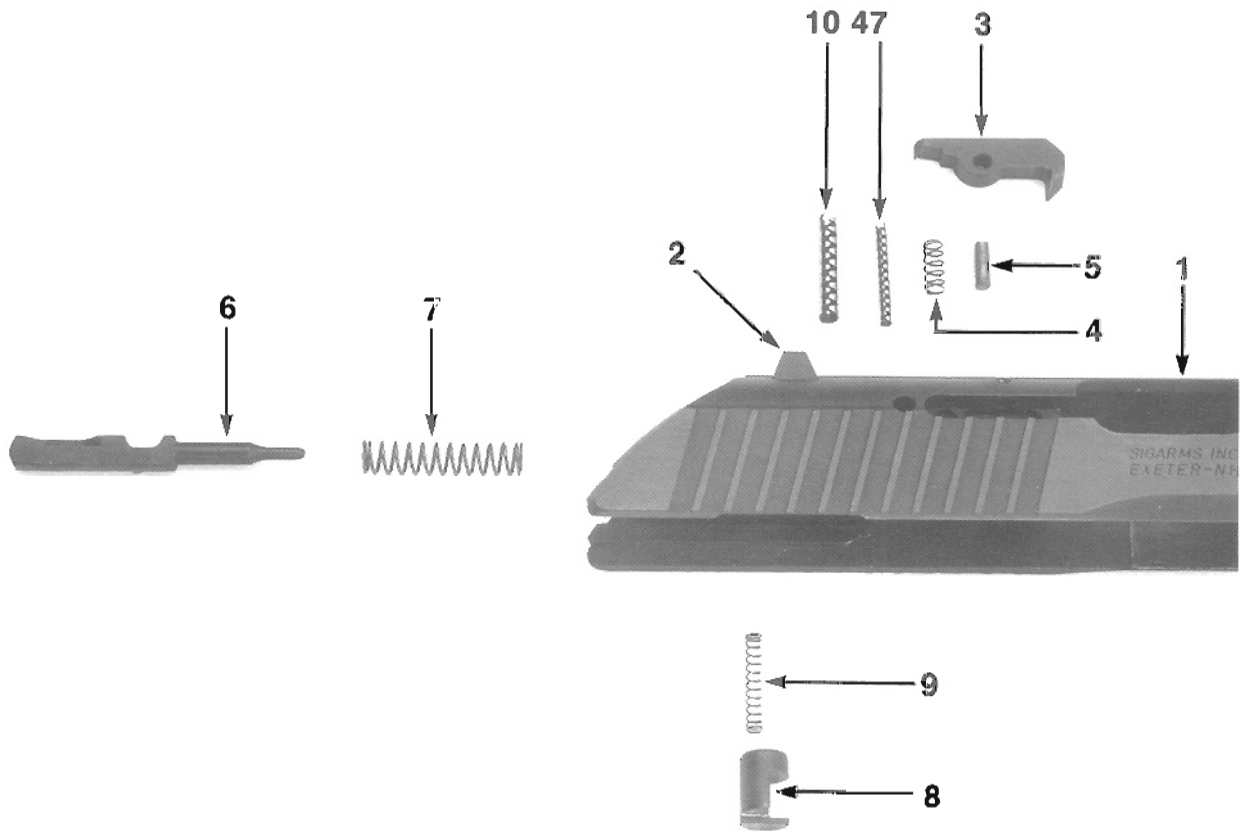

Slide Disassembled

- | | | | |
|----|------------------|-----|-------------------------------|
| 1. | Slide | 7. | Firing pin spring |
| 2. | Rear sight | 8. | Firing pin safety lock |
| 3. | Extractor | 9. | Firing pin safety lock spring |
| 4. | Extractor spring | 10. | Outer pin H.D. |
| 5. | Extractor pin | 47. | inner pin H.D. |
| 6. | Firing pin | | |

9.1 Removal of the Extractor Assembly

Sequence of Operations

1. Clear the pistol and remove the slide from the frame.
2. Place the slide in an upright position on a suitable flat surface.
3. Using a 1/16" punch, drive out the extractor pin (top to bottom) through the opening in the slide exterior. The extractor pin should be removed from the bottom inside of the slide.



4. Remove the extractor and extractor spring from their positions in the slide.

9.2 Installation of the Extractor Assembly

1. Start the extractor pin into the bottom of the slide.

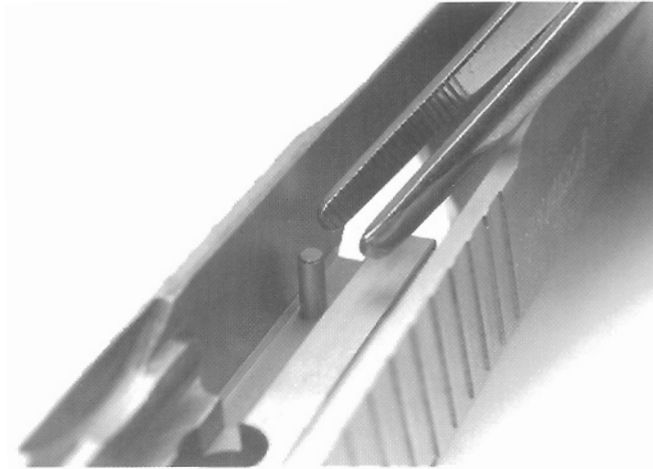

2. Install the extractor spring and extractor into the slide.
3. While exerting inward pressure on the extractor, seat the extractor pin completely.
4. Check that the extractor moves freely in its recess.

9.0 THE SLIDE - DISASSEMBLY AND ASSEMBLY

9.3 Removal of the Firing Pin Assembly

1. Place the slide on either side over any suitable surface.
2. Remove the inner and outer pins H.D., using a 3/32" roll pin punch.
3. Fully depress the firing pin safety lock to release the firing pin.
4. Remove the firing pin from the firing pin well.



5. Remove the firing pin safety lock and safety lock spring from the safety lock well in the bottom of the slide.

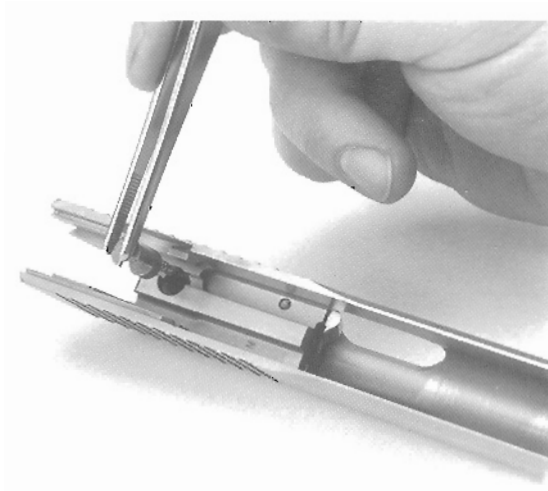

9.3 Removal of the Firing Pin Assembly (cont'd)

6. Separate the safety lock spring from the safety lock.
7. Place the slide in the vertical position, muzzle elevated, and remove the firing pin spring.

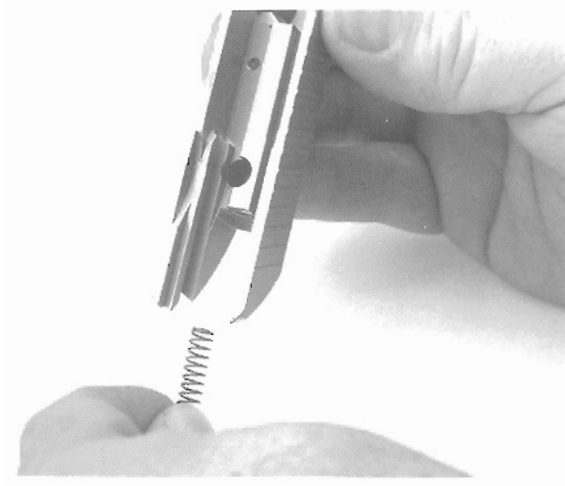

9.4 Installation of the Firing Pin Assembly

1. Start the outer pin H.D. into the slide approximately 1/16" with the groove at 12 o'clock.
2. Elevate the rear of the slide to the vertical and fully seat the firing pin spring (either end) in the firing pin well.



9.0 THE SLIDE - DISASSEMBLY AND ASSEMBLY

9.4 Installation of the Firing Pin Assembly (cont'd)

3. Install the safety lock spring in the safety lock.
4. Position the safety lock and spring in the safety lock well.
5. Depress the safety lock to allow passage of the firing pin.

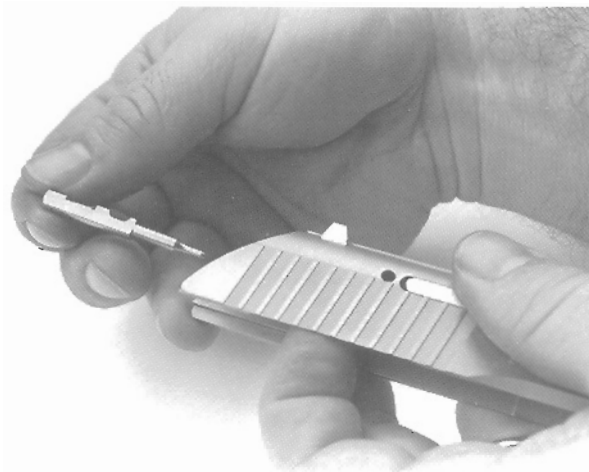

6. Insert the firing pin fully into the firing pin well, positioning the retaining notch to the vertical.
7. Drive the outer pin H.D. through until it passes through the firing pin retaining notch.
8. Center the inner pin H.D. with the groove at 6 o'clock in the outer roll pin.
9. Center the inner and outer pins H.D. in the slide.
10. Check that the firing pin and safety lock move freely within the slide.

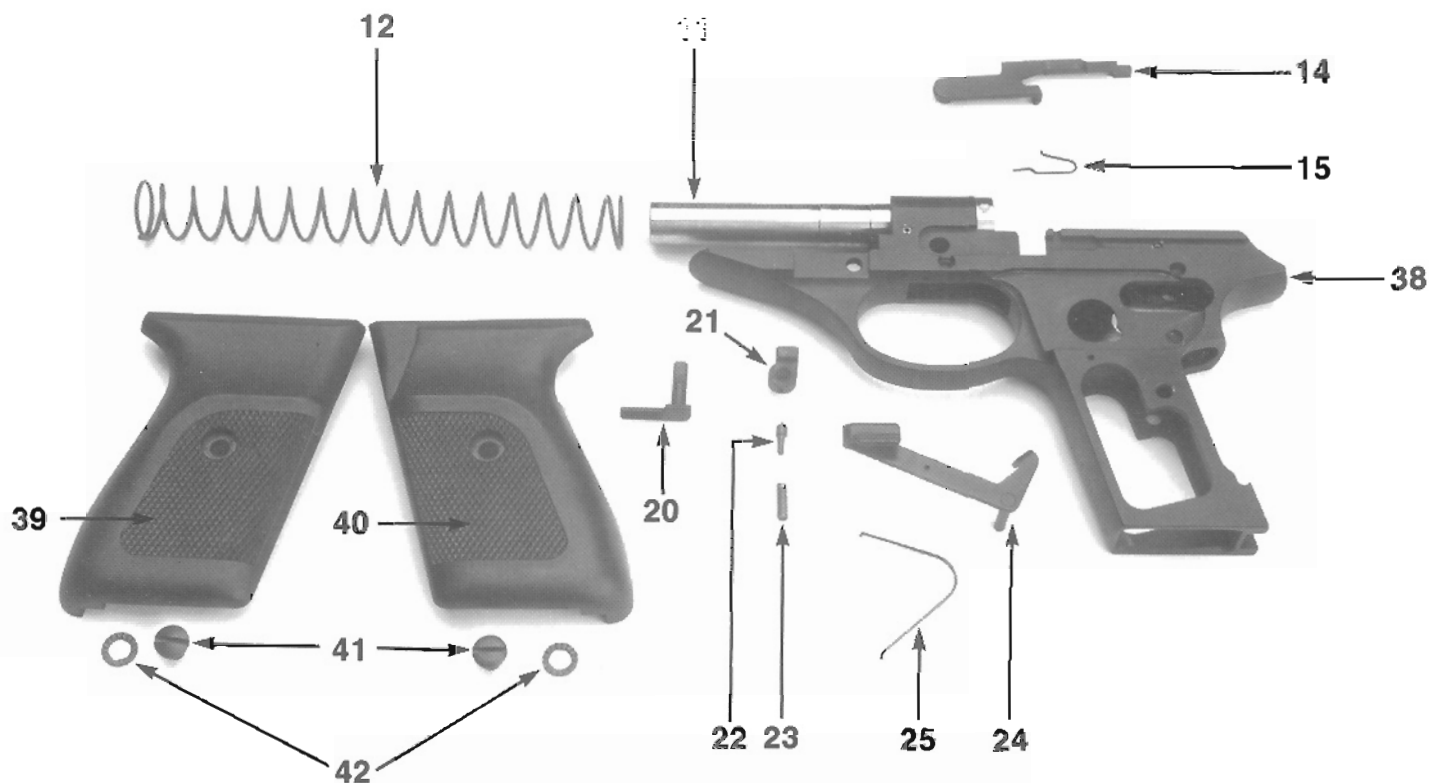

Left Side P230, Disassembled

- | | | | |
|-----|--------------------|-----|------------------------|
| 11. | Barrel | 24. | Decocking lever |
| 12. | Recoil spring | 25. | Decocking lever spring |
| 14. | Slide catch lever | 38. | Frame |
| 15. | Slide catch spring | 39. | Right grip plate |
| 20. | Takedown lever | 40. | Left grip plate |
| 21. | Slide stop | 41. | Grip plate screw |
| 22. | Slide stop pin | 42. | Grip plate washer |
| 23. | Slide stop spring | | |

10.0 THE FRAME - DISASSEMBLY AND ASSEMBLY

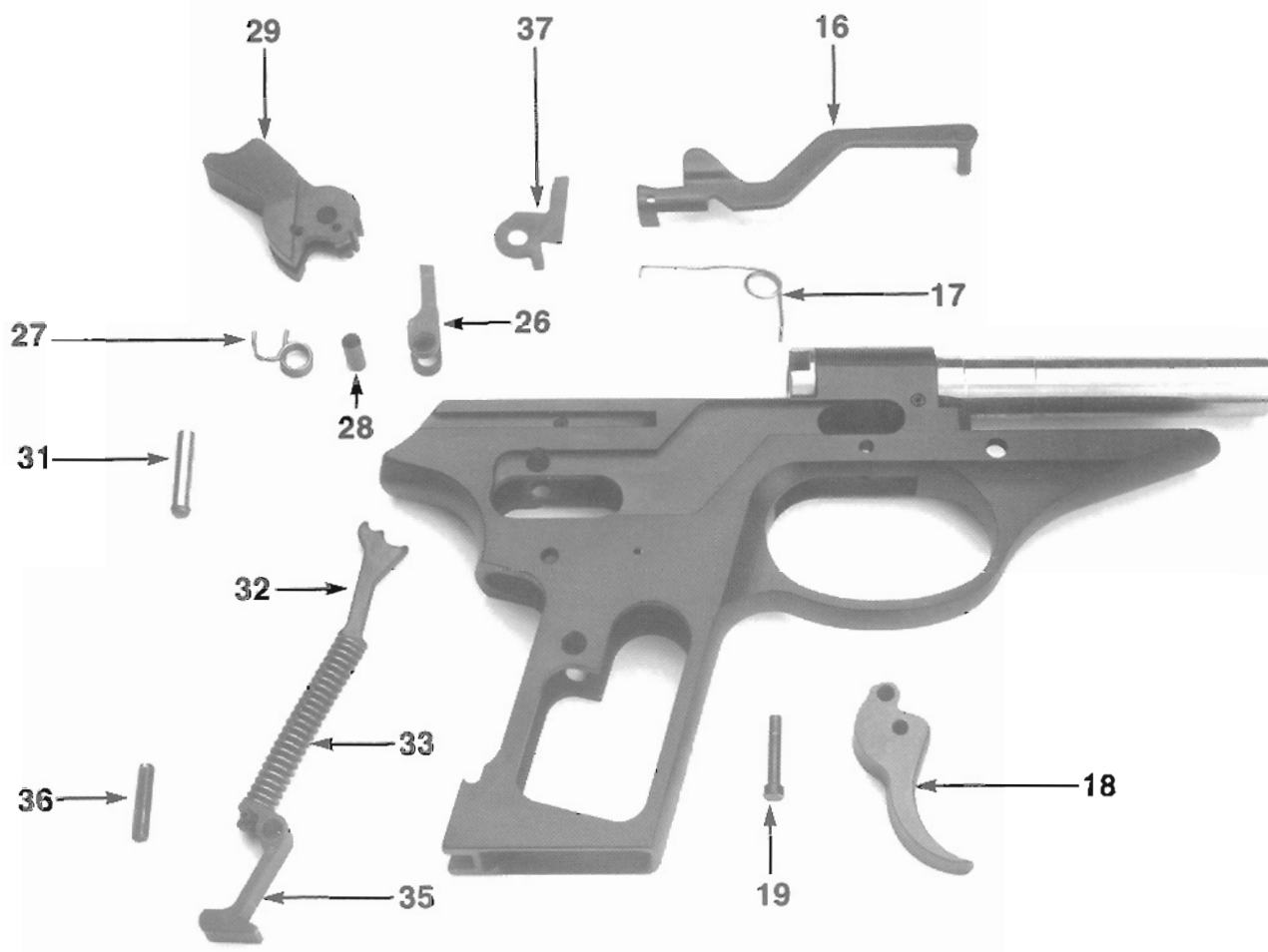

Right Side P230, Disassembled

- | | | | |
|-----|--------------------|-----|--------------------|
| 16. | Trigger bar | 29. | Hammer |
| 17. | Trigger bar spring | 31. | Hammer pivot pin |
| 18. | Trigger | 32. | Hammer strut |
| 19. | Trigger pivot pin | 33. | Mainspring |
| 26. | Sear | 35. | Magazine catch |
| 27. | Sear spring | 36. | Magazine catch pin |
| 28. | Sear shaft | 37. | Safety lever |

10.1 Takedown Lever Assembly

10.1.1 Disassembly

Sequence of Operations:

1. Ensure the takedown lever is turned down to the vertical position.
2. By simultaneously pressing in on the takedown lever shaft on the right side of the frame and lifting the takedown lever handle away from the left side of the frame, the takedown lever can be removed from the frame.
3. The slide stop, slide stop pin, and slide stop spring are released as the takedown lever is removed and may be lifted from the frame individually.

10.1.2 Assembly

1. Insert the slide stop pin and slide stop spring into the stop pin well in the frame.
2. Install the slide stop in the forward position over the slide stop pin.
3. Fully seat the slide stop in the frame and install the takedown lever in the vertical position, ensuring the takedown lever handle is flush within its recess.

10.2 Slide Catch Lever

10.2.1 Removal

1. Pivot the slide catch lever diagonal to the frame until it disengages from the slide catch lever spring.
2. The slide catch lever may be lifted vertically away from the frame.

10.2.2 Installation

1. Place the slide catch lever into the slide catch lever notch, diagonal to the frame.
2. Pivot the slide catch lever into the frame recess while engaging the slide catch lever spring.

NOTE: *The rear of the slide catch lever also functions as the ejector in the P230 pistol.*

10.2 Slide Catch Lever (cont'd)

10.2.3 Removal and Installation of the Slide Catch Lever Spring

1. The slide catch lever spring may be removed from its position by lifting the engaging (long) end vertically and away from the frame.

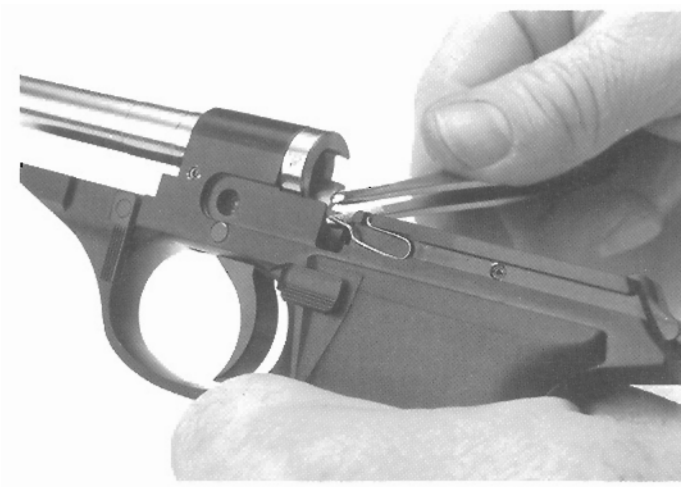

2. The slide catch lever spring may be installed by starting the short end into the upper frame rail and then compressing the spring until it seats in its recess.



10.3 Grip Plates, Left and Right

10.3.1 Removal

Sequence of Operations:

1. Using a proper fitting screwdriver, remove the grip plate screws.
2. Carefully remove the right grip plate and the left grip plate.

10.3.2 Installation

To install, reverse the order used for removal.

NOTE: *Ensure the grip plate washers are in place during reinstallation of the grip plates.*

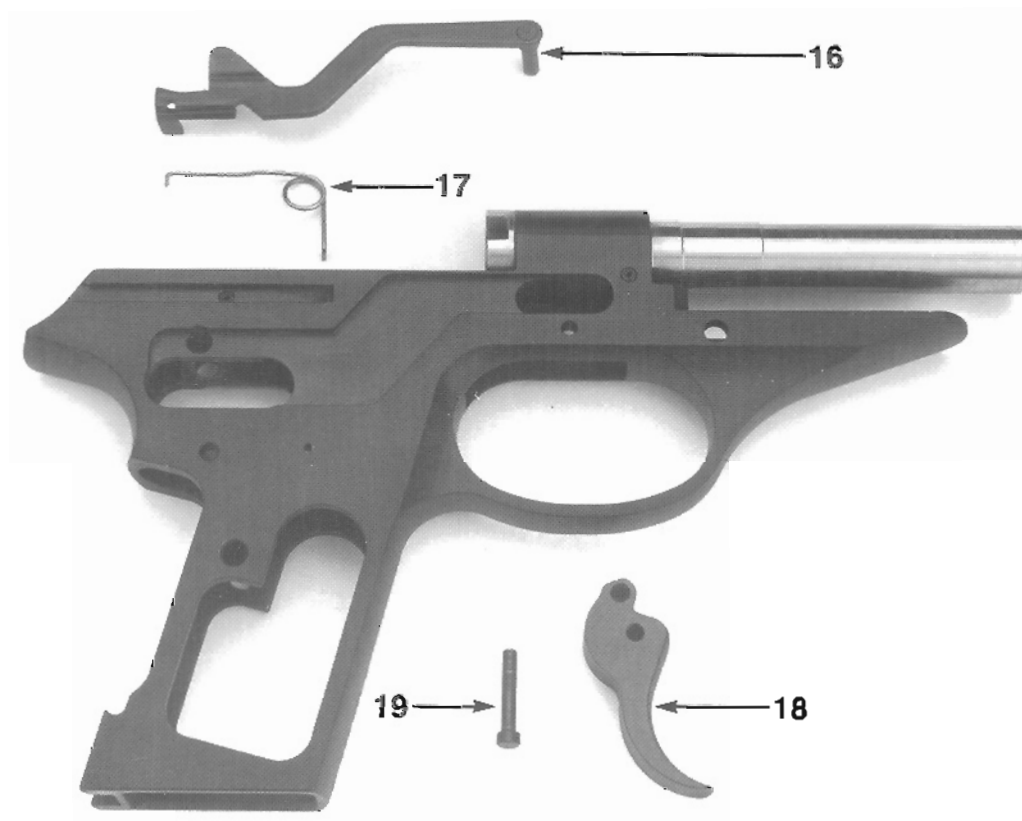

Trigger Assembly

- | | | | |
|-----|--------------------|-----|-------------------|
| 16. | Trigger bar | 18. | Trigger |
| 17. | Trigger bar spring | 19. | Trigger pivot pin |

10.4 Trigger Assembly

10.4.1 Disassembly

Sequence of Operations:

1. Remove the right grip plate and the left grip plate.
2. Unhook the trigger bar spring and remove it.
3. Lift the trigger bar from its recess in the frame.

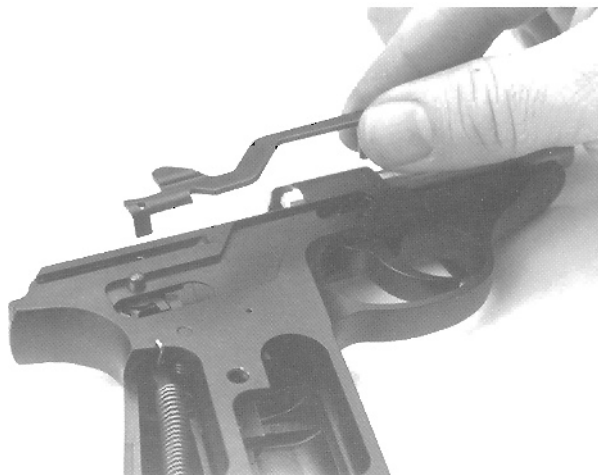

4. Push out the trigger pivot pin from the right side of the frame.
5. Remove the trigger from the frame by rotating it to the front and downward.



10.4 Trigger Assembly (cont'd)

10.4.2 Assembly

Sequence of Operations:

1. Position the trigger in the frame.
2. Insert the trigger pivot pin from the left side, ensuring that it is fully seated.
3. Place the trigger bar in its frame recess, connecting it with the trigger.

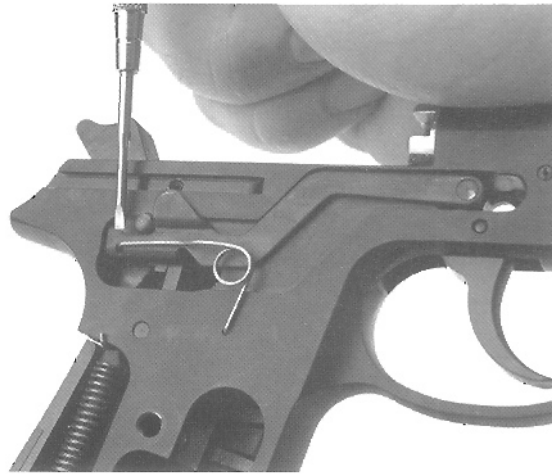

4. Reinstall the trigger bar spring, making sure that it is properly positioned.
5. Install the right grip plate, the left grip plate and the grip plate screws.

10.5 Hammer Strut/Magazine Catch Assembly

10.5.1 Disassembly

Sequence of Operations:

1. Remove the right grip plate and the left grip plate.
2. Ensure the hammer is completely forward.
3. Press up on the magazine catch, compressing the main spring until the assembly is free from its mounting in the frame.
4. Remove the hammer strut/magazine catch assembly from the frame.
5. Remove the mainspring pin from the hammer strut.

NOTE: *When relaxing any tensioned spring, wear adequate eye protection and use caution!*

6. Separate the magazine catch, mainspring and hammer strut.

10.5.2 Assembly

1. Compress the mainspring on the hammer strut with the magazine catch and install the mainspring pin.
2. Insert the hammer strut/magazine catch assembly through its opening in the frame.
3. Seat the strut into the hammer and mount the magazine catch in the frame.
4. Install the grip plates.

NOTE: *All roll pins must be replaced once removed from the initial installation.*

10.5 Hammer Strut/Magazine Catch Assembly (cont'd)

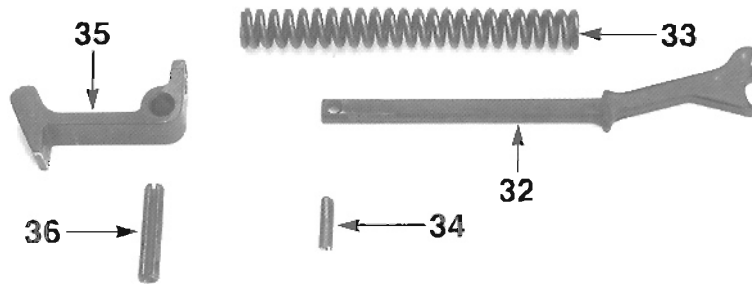

Hammer Strut/Magazine Catch Assembly

- | | | | |
|-----|--------------|-----|--------------------|
| 32. | Hammer strut | 34. | Mainspring pin |
| 33. | Mainspring | 35. | Magazine catch |
| | | 36. | Magazine catch pin |

10.6 Hammer Assembly

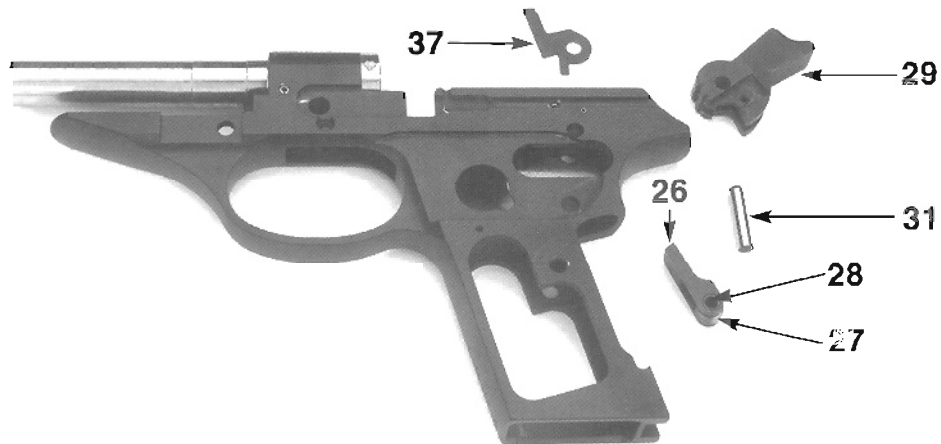

Hammer Assembly

- | | | | |
|-----|-------------|-----|------------------|
| 26. | Sear | 29. | Hammer |
| 27. | Sear spring | 31. | Hammer pivot pin |
| 28. | Sear shaft | 37. | Safety lever |

10.6 Hammer Assembly (cont'd)

10.6.1 Disassembly

Sequence of Operations:

1. Remove the right and left grip plate, trigger assembly and hammer strut/magazine catch assembly.
2. Remove the decocking lever spring.
3. Fully depress the decocking lever to disengage the sear and hammer.

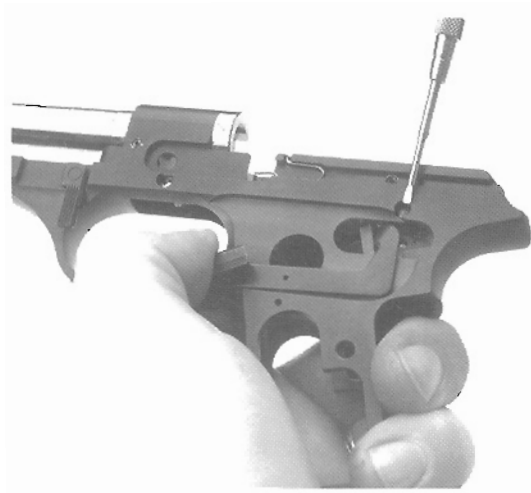

4. Push out the hammer pivot pin.
5. Remove the hammer.
6. Remove the safety lever.
7. Lift the decocking lever from its recess in the frame.
8. Remove the sear, sear spring and sear shaft from the opening in the rear of the frame.
9. Remove the sear shaft and spring from the sear.

10.6 Hammer Assembly (cont'd)

10.6.2 Assembly

Sequence of Operations:

1. Assemble the sear, sear spring and sear shaft.
2. Position the sear through the opening at the rear of the frame.



3. Install the decocking lever, ensuring its position is maintained by sear spring tension.



10.6 Hammer Assembly (cont'd)

10.6.2 Assembly

Sequence of Operations:

4. Depress the decocking lever, moving the sear fully forward in the frame.
5. Install the safety lever.



6. Install the hammer and hammer pivot pin.
7. Release the decocking lever, allowing the sear to rest against the hammer.
8. Install the decocking lever spring.
9. Reinstall the hammer strut assembly, the trigger assembly, the grip plates and the recoil spring.

11.1 Zeroing the P230 Pistol

General Note - No windage or elevation correction should be made until the shooter has become familiar with the firing characteristics of the weapon.

When zeroing, the target should be at 25 yards and the pistol should be fired from a rested position using the single-action mode. Sighting should be "point of aim, point of impact."

1. Windage - A change in windage is accomplished by moving the rear sight either to the left or right in its dovetail. When doing this, follow the rear sight rule: Move the rear sight in the direction the group is to go. Moving the rear sight 0.020 inches in the dovetail alters the point of impact by approximately 4 inches at 25 yards.
2. Elevation - A change in elevation is accomplished by changing the rear sight. There are 5 sight heights available for elevation adjustment in increments of 0.012 inches each. Each increment available will move bullet placement on the target approximately 2.5 inches at 25 yards. The sights are coded according to their height. (See accompanying sight reference chart.)

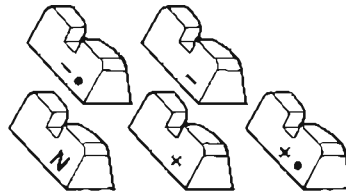

11.0 SIGHT ADJUSTMENT

11.2 Sight Specifications

P220 Fixed front sight		P220 Adjustable front sight		P225		P226		P228		P230	
REAR	SIGHT	REAR	FRONT	REAR	FRONT	REAR	FRONT	REAR	FRONT	REAR	SIGHT
SIGHTS TO RAISE THE STRIKE OF THE BULLET											
— • •	10	9	10	9	10	9	10	9	10	9	— •
— •	9	8	9	8	9	8	9	8	9	8	—
—		7	8	7	8	7	8	7	8	7	—
N —											
STANDARD SIGHTS											
N	8	6	7	8	8	8	8	8	8	8	N
N+											
SIGHTS TO LOWER THE STRIKE OF THE BULLET											
+	7	5	6	7	7	7	7	7	7	7	+
+ •	6		5	6	6	6	6	6	6	6	+ •
	5			5	5	5	5	5	5	5	

NOTE:

1. P220 & P226 dovetailed front sights are the same.
2. At 25 yards each rear sight change will move the strike of the bullet approximately 2", and each front sight change approximately 1" on the P220, P225, P226, P228 and P229. On the P230, each rear sight increment will move the strike of the bullet approximately 2.5" at 25 yards.
3. All sight adjustments should be made on the rear sight first.
4. When zeroing, the weapon should be rested using single action. Sighting should be point of aim, point of impact.
5. Sight rule: Numbers up, groups up; numbers down, groups down; this is true for both front and rear sights.

11.3 Using the Sight Pusher

The sight pusher is a tool designed to move or change the rear sight on the P230 pistol. When moving or changing sights, the slide can either remain on the pistol or be removed. **MAKE SURE THAT THE PISTOL IS UNLOADED BEFORE WORKING WITH IT.**

The sight pusher has an open and closed side to ensure correct fit of the gun; insert the slide into the “open side.”

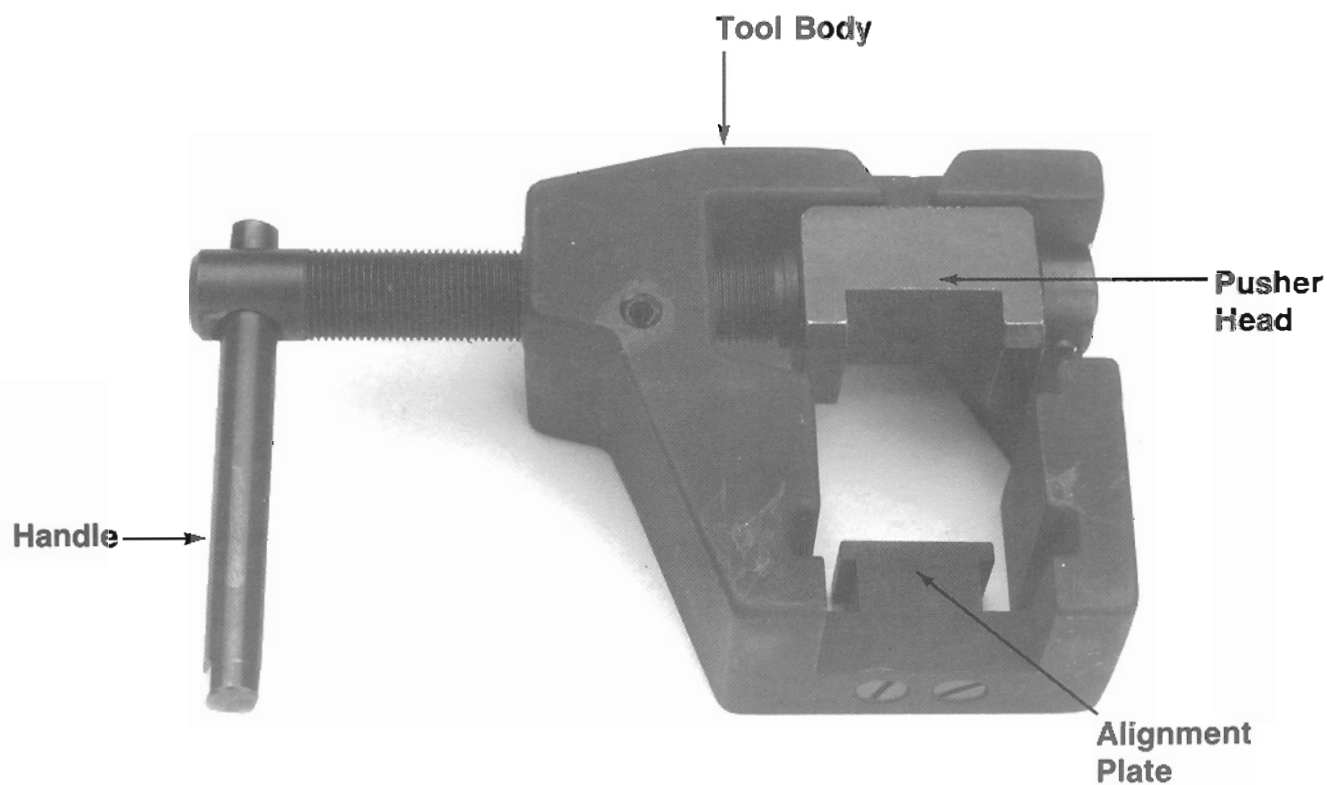

NOTE: *There are several generations of sight pushers in the field. Some may vary somewhat to the example shown.*

11.0 SIGHT ADJUSTMENT

11.3 Using the Combination Sight Pusher

11.3.1 Placement of the Pistol in the Sight Pusher

Place the sight pusher on the rear of the slide by sliding the alignment plate into the slide rails and centering the pusher head over the rear sight.

11.3.2 Moving the Sights

To move the sight, rotate the pusher's handle until the pusher head is seated against the sight; further turning will move the sight for windage adjustments.

11.3.3 Changing the Sights

To change the sights, rotate the pusher's handle to push the sight to the outside of the pusher (the opposite side from the handle) and off the slide, remove the slide from the tool and insert the new sight, aligning it in the dovetail, then put the slide back into the pusher and push the new sight into place.

NOTE: *Install and remove SIG sights from the left side of the slide, due to a chamfered edge machined on the right corners of the sight base to aid in sight installation.*

11.3.4 Centering the Sights

When changing sights, a pencil can be used to mark the original location of the sights in the dovetail. After removing the sights to be replaced, push the new sights on the slide and align to the mark.

NOTE: *Rough alignment can be achieved by centering the rear sight in its dovetail.*

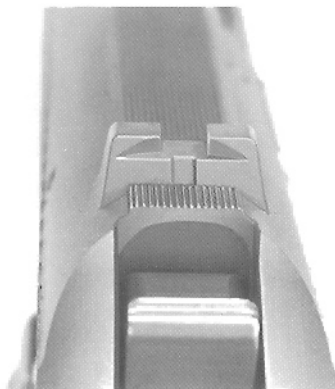

THE PISTOL MUST BE ZEROED - After sights have been moved or changed.

12.1 General

In a well kept and properly maintained weapon, malfunctions or stoppages rarely occur.

12.2 Stoppages, Malfunctions and Their Correction

12.2.1 Feeding

<u>Problem</u>	<u>Cause</u>	<u>Correction</u>
No cartridge fed into chamber	1) Magazine not seated properly	Insert magazine properly
	2) Magazine dirty or deformed	Insert fresh magazine, clean or replace the removed magazine
	3) Weak magazine spring	Replace magazine spring
	4) Corroded, dirty or damaged ammunition	Change ammunition
Cartridge does not chamber	1) Cartridge incorrectly fed	Check or change magazine
	2) Low quality ammunition	Change ammunition
Slide does not close completely	1) Shooter error	Keep wrists locked and maintain a firm grip when firing the pistol
	2) Out of spec or defective ammunition	Replace ammunition
	3) Weapon dirty	Field strip, clean and lubricate per specification
	4) Chamber dirty	Clean the chamber and bore
	5) Recoil spring weak or broken	Replace recoil spring and guide

12.0 TROUBLESHOOTING

12.2 Stoppages, Malfunctions and Their Correction (cont'd)

<u>Problem</u>	<u>Cause</u>	<u>Correction</u>
Slide does not close completely	6) Weapon too heavily lubricated	Clean and lubricate as per specification
	7) Binding in the frame rails	Check to ensure no Pins are protruding in the frame rails
Double feed	1) Low quality ammunition	Replace ammunition
	2) Dirty extractor	Clean breech face
	3) Broken extractor	Replace extractor
	4) Damaged magazine	Replace magazine
	5) Ruptured case in chamber	Clear, clean and inspect the weapon, replace the ammunition

12.2.2 Extraction and Ejection

<u>Problem</u>	<u>Cause</u>	<u>Correction</u>
Slide has sprung forward but spent case sticks in the chamber	1) Underpowered ammunition	Replace ammunition
	2) Too little rearward movement due to dirt or lack of lubrication	Clean and lubricate the weapon then perform a function check
	3) Damaged or broken extractor	Replace extractor
	4) Ruptured case in chamber	Clear, clean and inspect the weapon, replace the ammunition
Inconsistent ejection to include trapping brass in the ejection port	1) Low quality ammunition	Replace ammunition
	2) Shooter error	Lock wrists when firing
	3) Extractor damaged	Replace extractor
	4) Ejector damaged	Replace ejector/slide catch lever

12.2 Stoppages, Malfunctions and Their Correction (cont'd)

12.2.2 Extraction and ejection (cont'd)

<u>Problem</u>	<u>Cause</u>	<u>Correction</u>
Inconsistent ejection to include trapping brass in the ejection port	5) Dirty gun, insufficient recoil to cycle the action	Clean and lubricate the weapon per specifications

12.2.3 Other

After being pulled, the trigger remains in the rearward position and is no longer under pressure	1) Trigger bar spring broken or incorrectly installed	Replace or correctly mount the trigger bar spring
The cocked hammer cannot be released by the trigger	1) Trigger bar spring broken or positioned improperly on the trigger bar	Check trigger bar spring position or replace trigger bar spring
	2) Broken sear	Replace sear AND hammer
	3) Broken safety lever	Replace safety lever
	4) Damaged trigger bar	Replace trigger bar
Slide is arrested before the last round is fired	1) Slide catch spring weak or broken	Replace the slide catch spring
Slide is not arrested after the last round is fired	1) Shooter error	Lock wrist when firing pistol
	2) Underpowered ammunition	Replace ammunition
	3) Improperly lubricated	Lubricate weapon per specifications
	4) Magazine follower jammed in upper part of the magazine	Repair or replace magazine
	5) Slide catch lever is damaged or broken	Replace the slide catch lever

12.0 TROUBLESHOOTING

12.2 Stoppages, Malfunctions and Their Correction (cont'd)

12.2.3 Other (cont'd)

<u>Problem</u>	<u>Cause</u>	<u>Correction</u>
Decocking lever does not spring back	1) Decocking lever spring is out of position or broken	Replace or correctly mount the decocking lever spring
Hammer does not stay cocked when the slide is pulled to the rear and released	1) Arm of the sear spring is not secured or is broken	Install the sear spring correctly or replace it
	2) Hammer or sear defective	Replace the hammer AND the sear

13.0 PARTS DIAGRAM

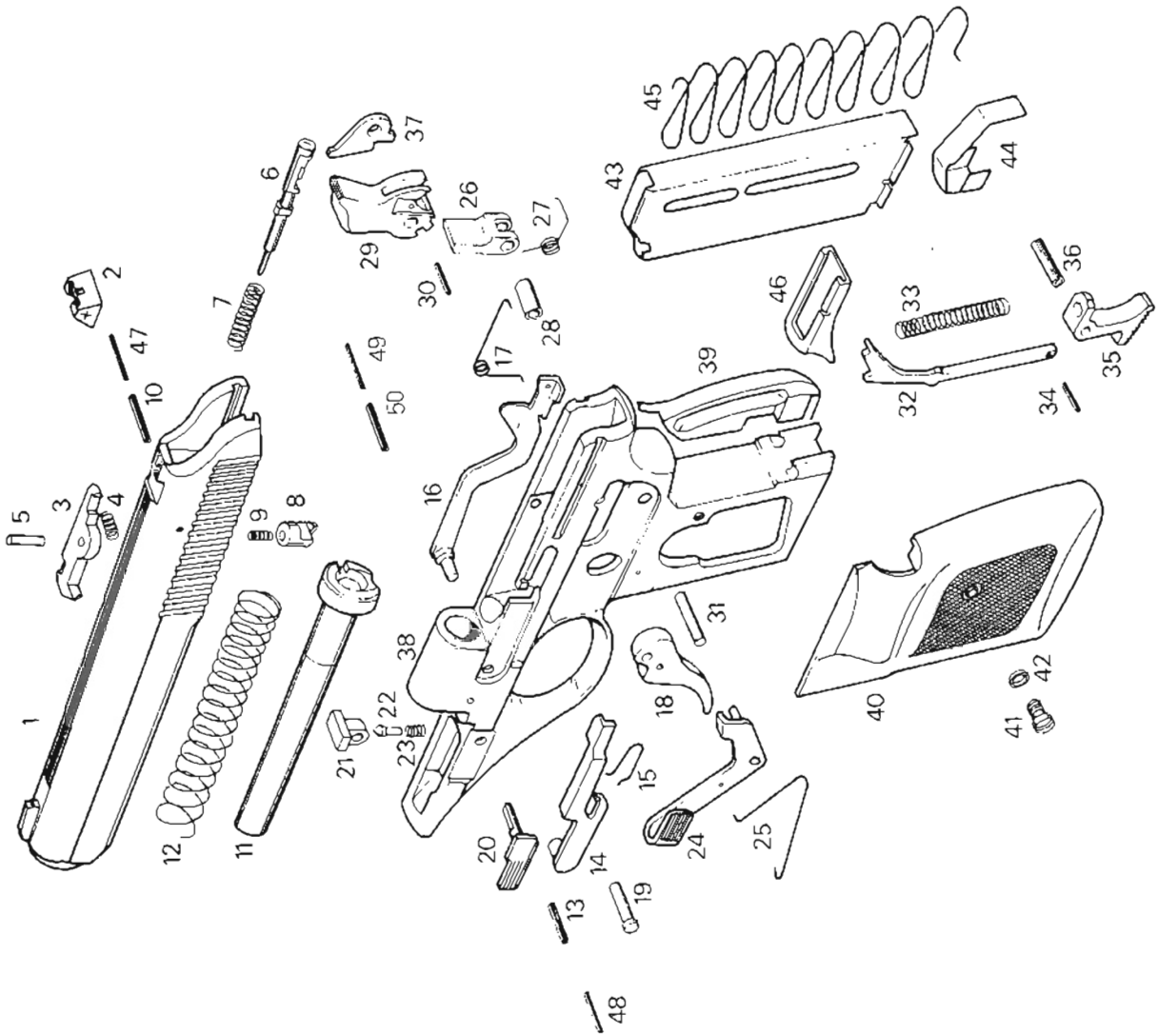

13.0 PARTS DIAGRAM

#	Designation	#	Designation	#	Designation
1.	Slide	18.	Trigger	35.	Magazine catch
2.	Rear sight	19.	Trigger pivot pin	36.	Magazine catch pin
3.	Extractor	20.	Take-down lever	37.	Safety lever
4.	Extractor spring	21.	Slide stop	38.	Frame
5.	Extractor pin	22.	Slide stop pin	39.	Right grip plate
6.	Firing pin	23.	Slide stop spring	40.	Left grip plate
7.	Firing pin spring	24.	Decocking lever	41.	Grip plate screw
8.	Safety lock	25.	Decocking lever spring	42.	Grip plate washer
9.	Safety lock spring	26.	Sear	43.	Magazine tube
10.	Outer pin H.D.	27.	Sear spring	44.	Follower
11.	Barrel	28.	Sear shaft	45.	Magazine spring
12.	Recoil spring	29.	Hammer	46.	Magazine floorplate
13.	Outer pin H.D.	30.	Hammer strut pin	47.	Inner pin H.D.
14.	Slide catch lever	31.	Hammer pivot pin	48.	Inner pin H.D.
15.	Slide catch spring	32.	Hammer strut	49.	Inner hammer stop pin H.D.
16.	Trigger bar	33.	Mainspring	50.	Outer hammer stop pin H.D.
17.	Trigger bar spring	34.	Mainspring pin		

14.1 Tools Necessary for Weapon Disassembly

- (1) Straight Blade Screwdriver suitable for grip plate screw removal
- (1) 1/8" Straight Blade Screwdriver
- (1) 1/8" Punch
- (1) 3/32" Roll Pin Punch
- (1) 1/16" Punch
- (1) 4 - 8 oz. Hammer

For further assistance after consulting the manual, contact:

SIGARMS, INC.
Corporate Park
Exeter, NH 03833
(603) 772-2302

NOTES
