

M&P Series Armorer's Manual



Smith & Wesson®

This manual contains privileged information. It is limited to instructions for field maintenance and repair of Smith & Wesson pistols, and it is to be used only by fully trained and qualified armorers.

The use of the material published herein is restricted to those individuals who have satisfactorily completed the S&W Armorer's course and who have maintained certification through required updates.

Individuals who have not completed this Smith & Wesson factory training must refrain from using this manual. Any misunderstanding or misinterpretation of the contents can cause damage to the pistol and serious injury to any person who is using or is near the weapon.

When Smith & Wesson pistols are correctly used and carefully maintained by qualified armorers employing the instructions contained in this manual, the optimum in weapon performance will be sustained.

The instructions are devoted solely to maintenance of the Smith & Wesson pistols in service. Smith & Wesson does not disclose herein, and will not disclose, company manufacturing techniques, which are fully proprietary.

To assure reliable functioning, you must use only authorized Smith & Wesson parts and magazines specifically manufactured for your particular model of pistol. The use or installation of parts in a Smith & Wesson pistol that are not authorized by the Company jeopardizes the correct function of that weapon and may cause serious injury or death.

Smith & Wesson cannot be responsible for the consequences of careless handling or use, the use of defective or improper ammunition, unauthorized adjustments, the use of unauthorized or modified parts, corrosion, neglect or unreasonable use of the pistol.

This manual is not intended to replace the Safety & Instruction Manual provided with the firearm. Please refer to the manual for questions concerning the safe use and handling of this firearm.



WARNING: WEAR SAFETY GLASSES EVERY TIME YOU PERFORM MAINTENANCE ON A FIREARM.

This information contained herein may be subject to foreign export control laws.



M&P9, M&P40, M&P357, M&P45 WITHOUT MANUAL SAFETY

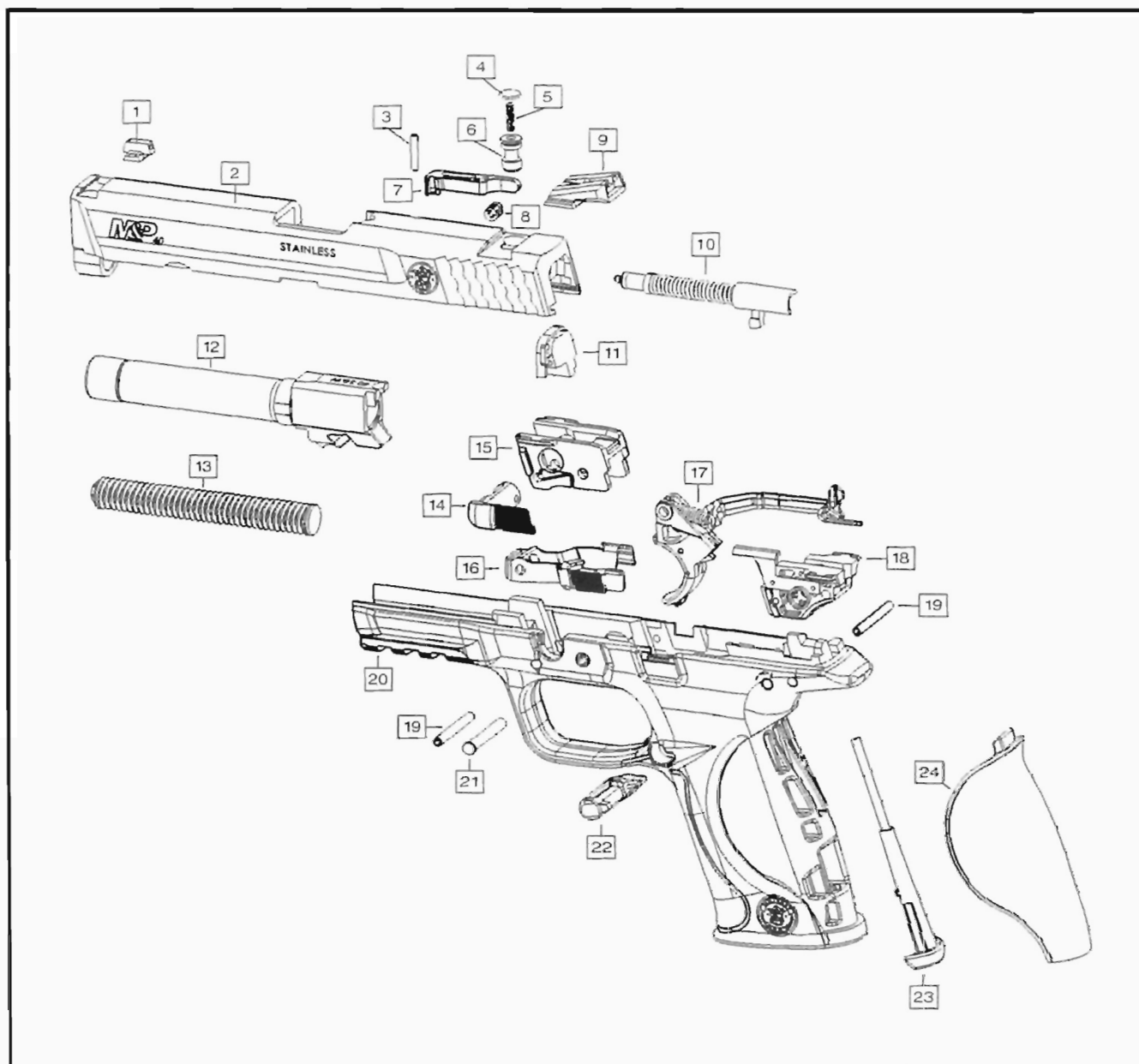

- | | | | | | |
|----|-----------------------|----|------------------------------|----|-------------------------|
| 1 | Sight, Front | 11 | Assembly, End Cap | 19 | Coil Pin, Locking Block |
| 2 | Slide | 12 | Barrel | 20 | Frame |
| 3 | Pin, Extractor | 13 | Assembly, Recoil | 21 | Headed Pin, Trigger |
| 4 | F/P Plunger Spacer | 14 | Guide Rod | 22 | Assembly, Magazine |
| 5 | Spring, Striker Block | 15 | Takedown Lever | 23 | Catch |
| 6 | Striker Block | 16 | Locking Block | 24 | Assembly, Frame Tool |
| 7 | Extractor | 17 | Assembly, Slide Stop | | |
| 8 | Spring, Extractor | 18 | Assembly, Trigger Bar | | |
| 9 | Sight, Rear | | Assembly, Sear Housing Block | | |
| 10 | Assembly, Striker | | | | |

Table of Contents

Section 1	Page	Section 8	Page
Technical Specifications	4	Frame Reassembly	
This manual contains privileged information.		A) Install Magazine Catch	24
		B) Install Sear Housing Assembly	25
		C) Install Trigger Assembly	26-27
		D) Install Slide	28-29
		E) Sear Housing Block Disassembly	30
		F) Sear Housing Block Reassembly	31-32
Section 2		Section 8	
Field Strip		Frame Reassembly	
A) Clear Firearm	7	A) Replacing Grip Insert	33
B) Remove Slide	8		
C) Recoil Guide Spring	9	Section 9	
D) Barrel Removal	9	Safety Features	
E) Magazine Disassembly	10	A) Trigger Safety	34
F) Magazine Reassembly	10	B) Striker Safety	35
Pistol Field Stripped	11	C) Slide - In Battery/Out of Battery	35
		D) Magazine Safety	36
		E) Manual Safety	36
		F) Internal Lock	37
Section 3		Section 10	
Slide Disassembly		Maintenance	38
Slide Components	12		
A) Remove Striker Assembly	13	Section 11	
B) Remove Rear Sight	14	Lubrication	39
C) Sight Installation	14		
D) Remove Front Sight	14	Section 12	
E) Sight Installation	14	Storing Pistols	40
Section 4		Section 13	
Slide Reassembly		Troubleshooting	41
A) Striker Installation	15		
Section 5			
Striker			
A) Striker Disassembly	16		
B) Striker Reassembly	17		
Section 6			
Extractor Replacement			
A) Extractor Replacement	18		
B) Check Extractor Hook Location	18		
Section 7			
Frame Disassembly			
Frame Components	19		
A) Remove Trigger Assembly	20-21		
B) Remove Sear Housing Assembly	22		
C) Remove Magazine Catch	23		

THIS PAGE INTENTIONALLY LEFT BLANK

A) Clear Firearm

Keep the firearm pointed in a safe direction at all times.

1. Remove magazine by depressing magazine release and removing magazine downward.
2. Rack slide to rear and lock rearward by lifting slide stop.
3. Inspect chamber and clear.

NOTES:

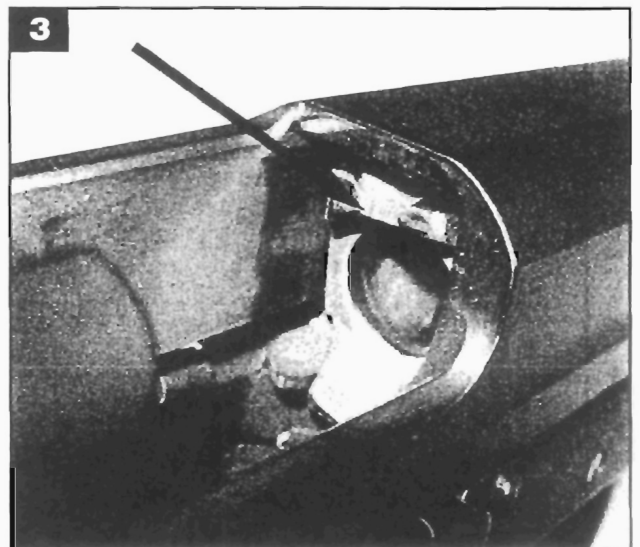
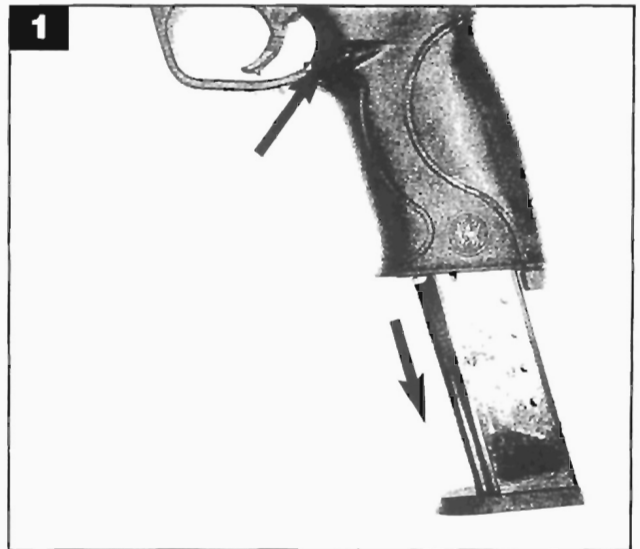

B) Remove Slide

1. Push sear deactivation lever down in frame.
2. Push takedown latch clockwise 90°
3. Hold slide, push down slide stop. Pull slide slightly rearward then forward off frame.

NOTES:

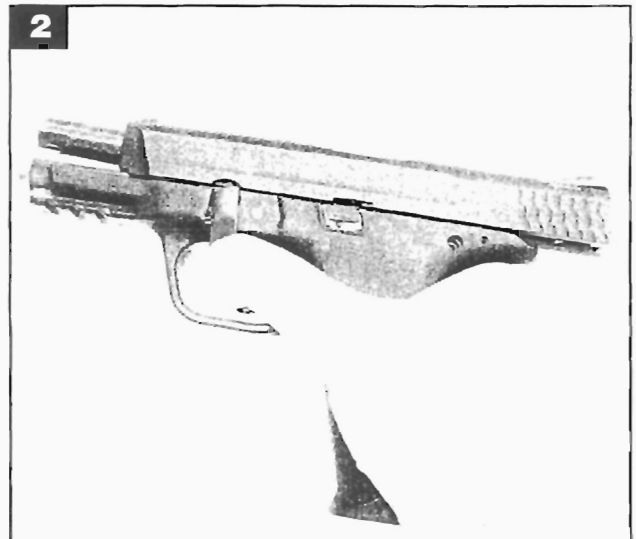
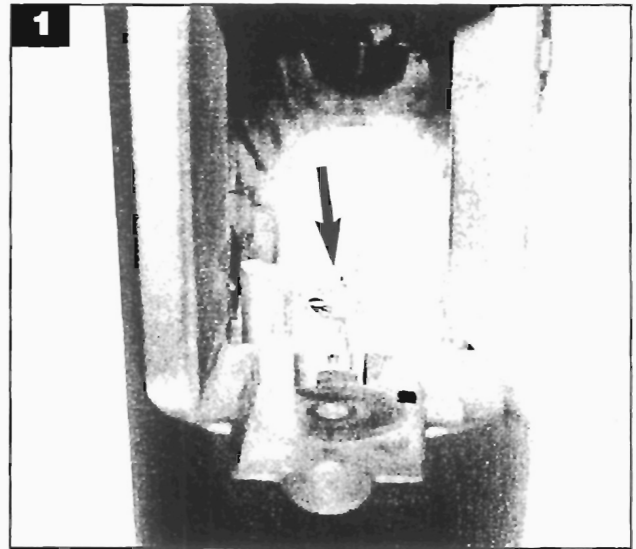

C) Recoil Guide Spring

- 1. Push recoil spring assembly slightly forward, lift up and out.

D) Barrel Removal

- 1. Lift the barrel up.
- 2. Slide rearward and out.

NOTES:

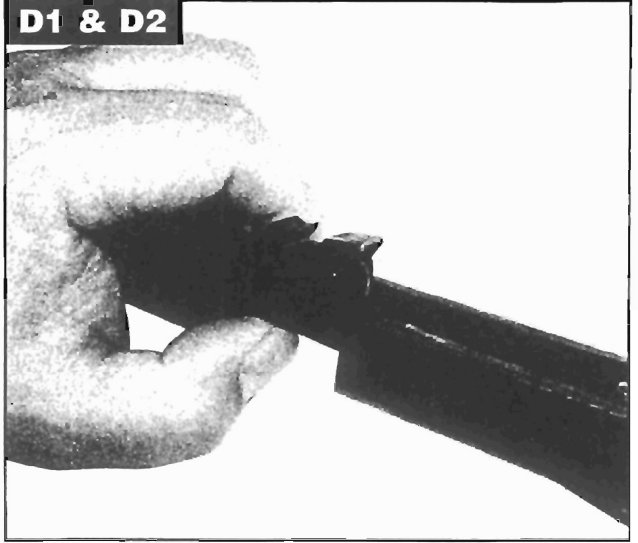
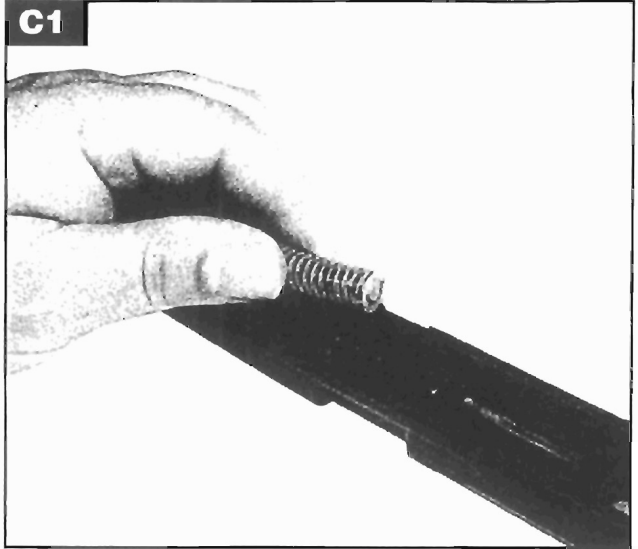

Ensure magazine is unloaded before disassembly!

E) Magazine Disassembly

1. Depress button on bottom of butt plate and slide butt plate off magazine tube.
2. Remove butt plate catch, magazine spring, and follower (Do not remove follower from spring).

F) Magazine Reassembly

1. Install follower, magazine spring, and butt plate catch into magazine tube.
2. Install butt plate onto magazine tube and lock butt plate catch tab into butt plate.

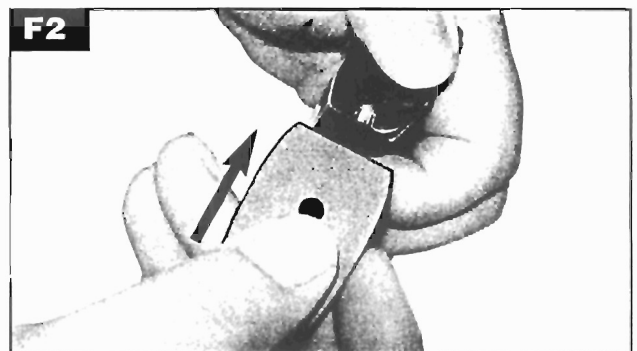
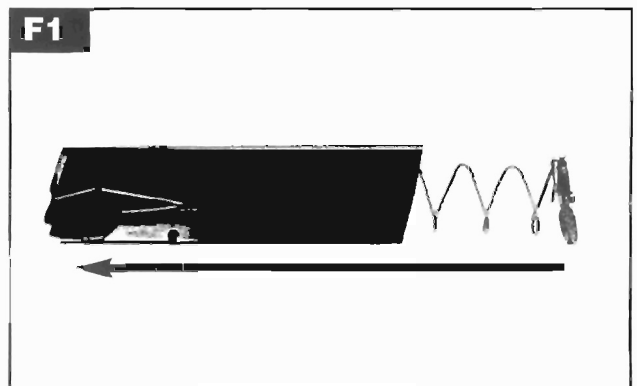
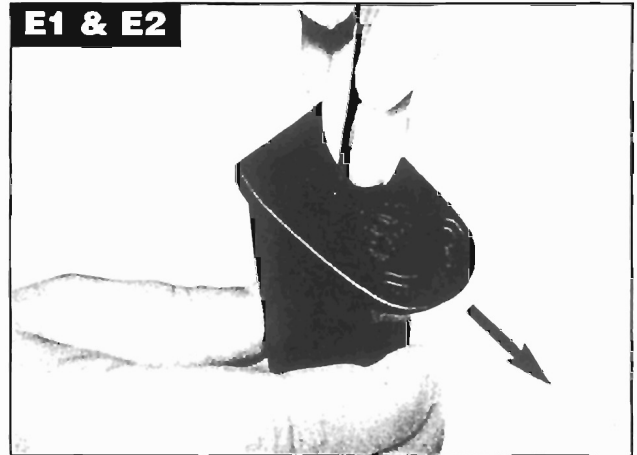

.45 ACP MODELS ONLY

Note Spring Direction - Orange Up (to bottom of follower) End of orange wire facing rearward and spring seated firmly on follower.

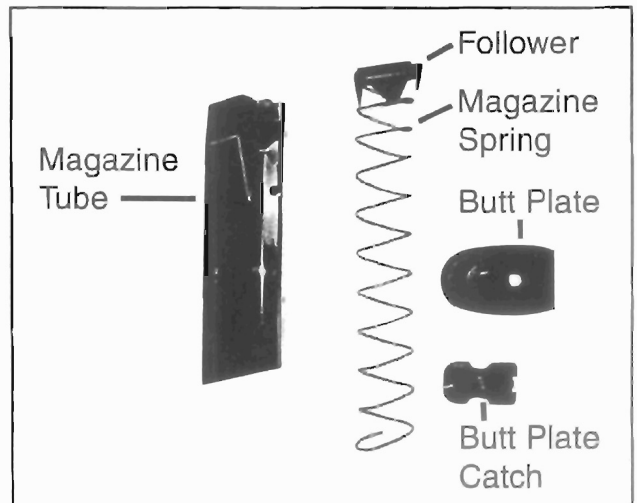
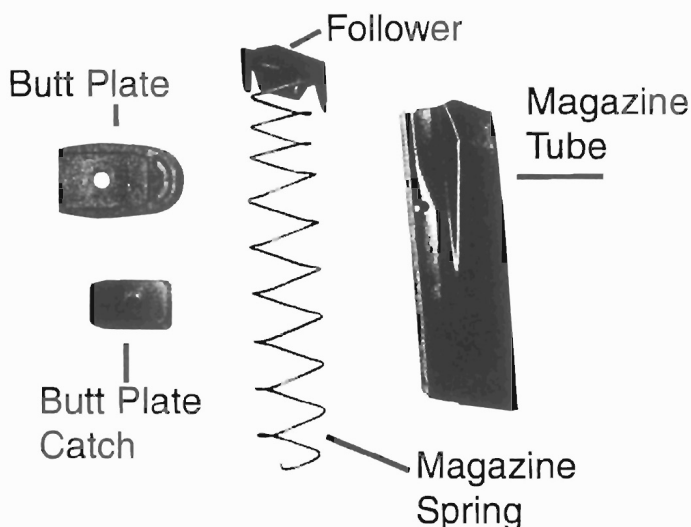

NOTE:

Field stripping the pistol allows easy access for cleaning.

Only factory trained Smith & Wesson Armorsers should perform any further disassembly and maintenance as described in this manual.

NOTES:



Slide Disassembly

SLIDE COMPONENTS

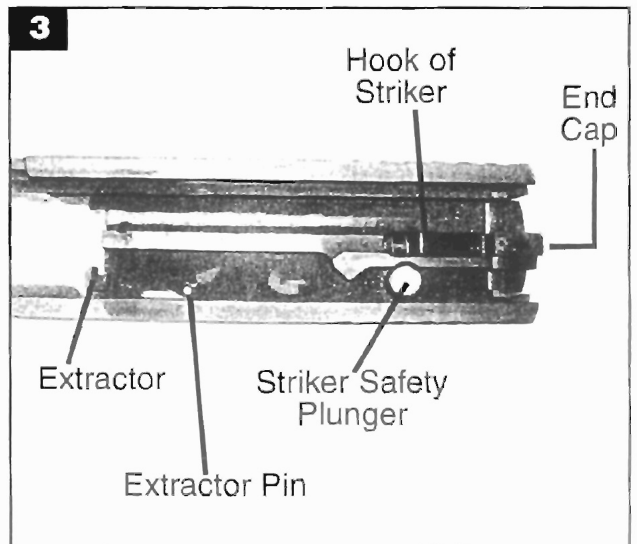
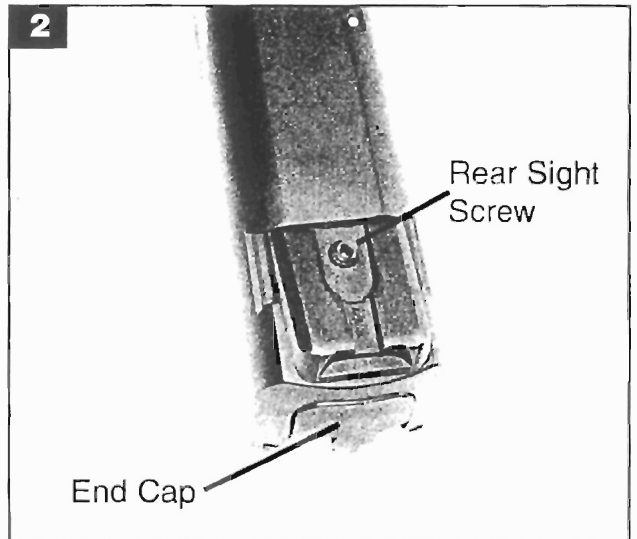
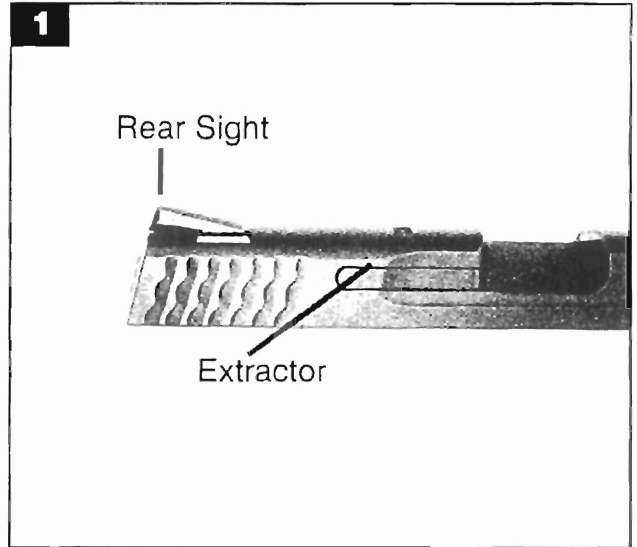

NOTES:

A) Remove Striker Assembly

1. Using small drift, push down on striker guide.
2. Remove end cap downward.
3. Push down striker safety plunger. Remove striker assembly rearward.

NOTES:

NOTES:

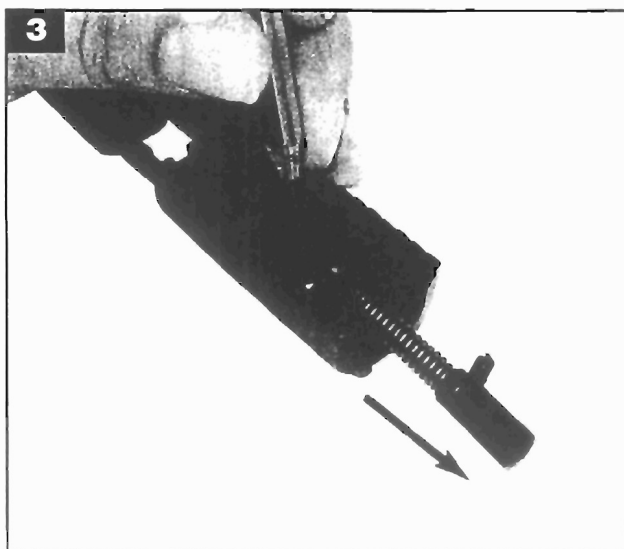
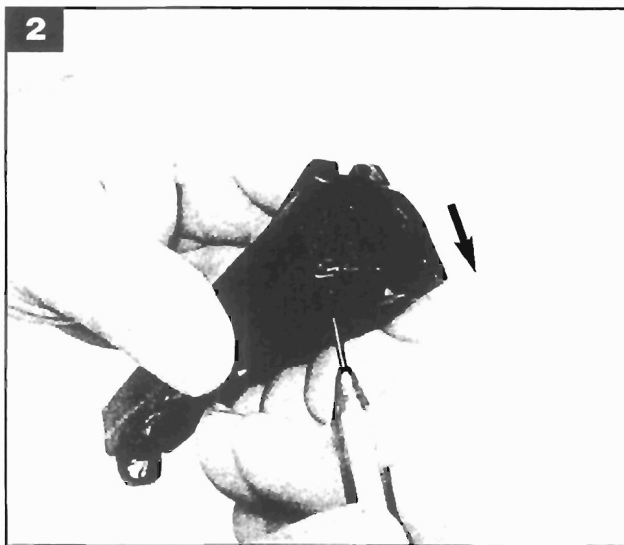
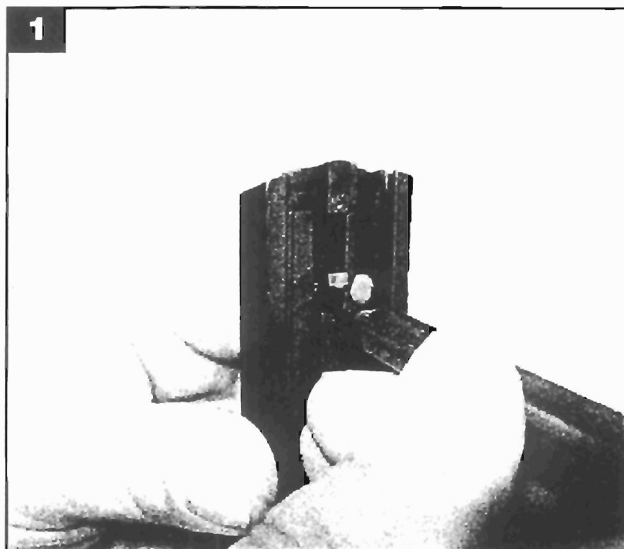

B) Remove Rear Sight

1. Loosen allen screw with 1/16" allen wrench - 2 rotations.
2. Remove sight left to right.

NOTE: While removing sight, place finger on spring plate and slowly release so that critical parts are not lost.

C) Sight Installation

1. Install striker safety plunger and spring.
2. Install spring plate by placing plate on top of slide and in front of dovetail. With your finger partially covering spring plate, slide plate to rear, centering over spring and compress spring down.
3. Install sight right to left so that spring plate is covered. Inspect striker safety plunger for free movement before fully seating sight.
4. Fully seat sight. Tighten sight screw.

Note: Every time the striker safety plunger or rear sight are removed and/or replaced, you must verify striker safety is functioning safely - follow instructions on page 35.

D) Remove Front Sight

1. Remove sight left to right.

E) Sight Installation

1. Install sight right to left.

Note: Whenever sight is removed or adjusted, pistol must be test fired to verify accuracy.

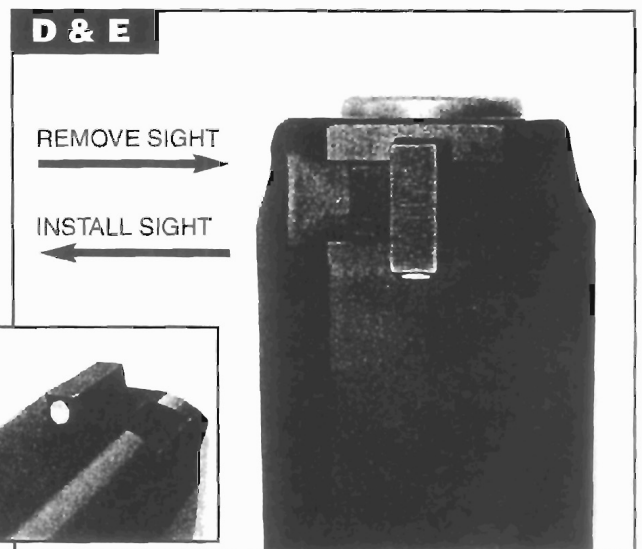
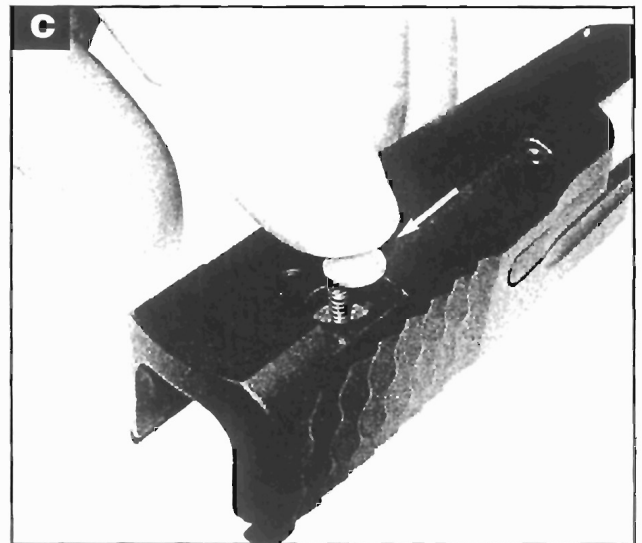
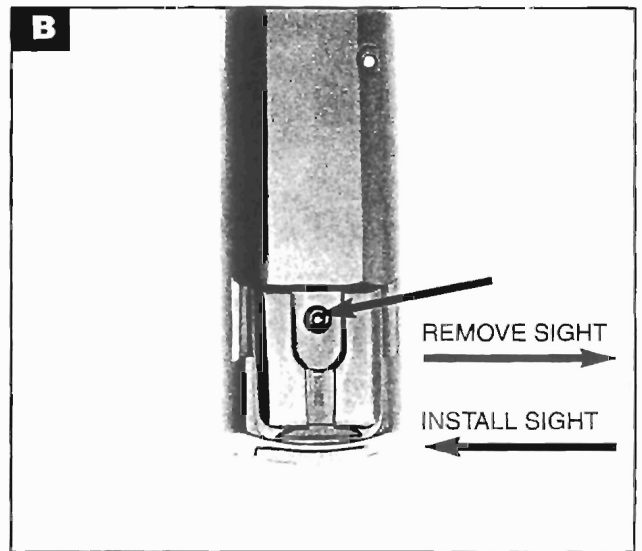

A) Striker Installation

1. Push down striker safety plunger and hold.
2. Install striker assembly into rear of slide.
3. Depress striker guide into slide. Hold guide to rear with #4 drift. Install endcap.

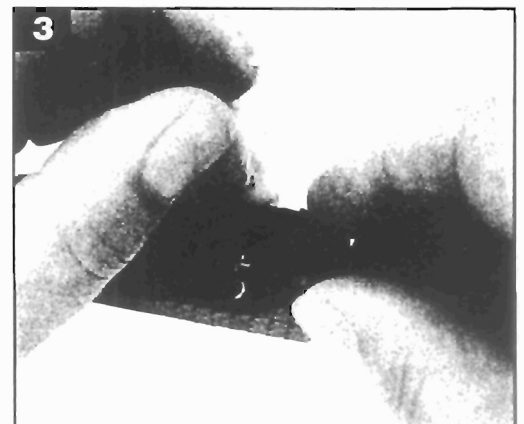
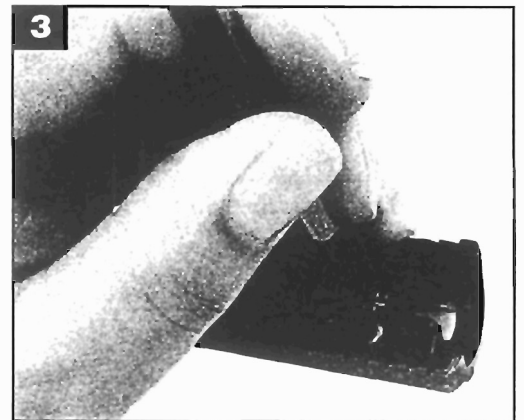
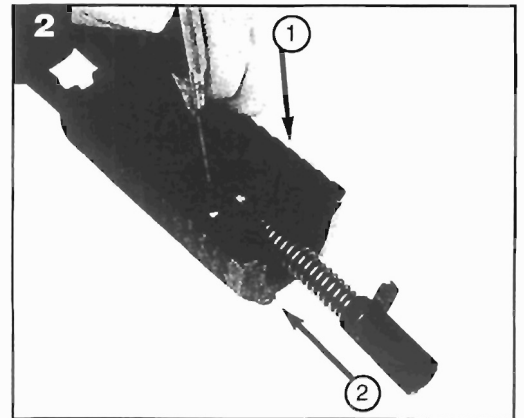
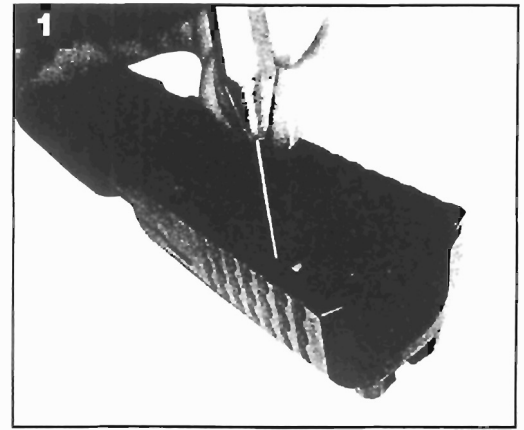

NOTES:

A) Striker Disassembly

1. Place rear of striker into rear of slide with striker hook supported by interior of slide.
2. Compress striker spring and remove striker spring keepers (2).
3. Remove striker spring.
4. Remove striker guide and striker return spring from striker.

NOTES:

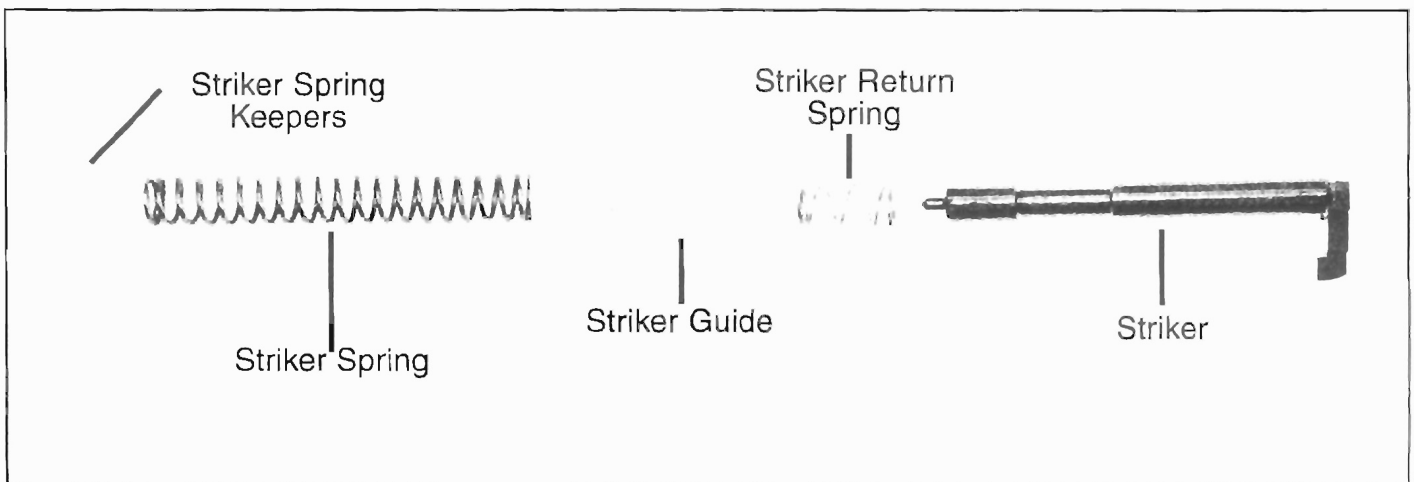
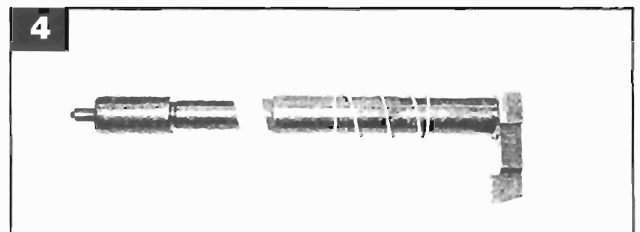
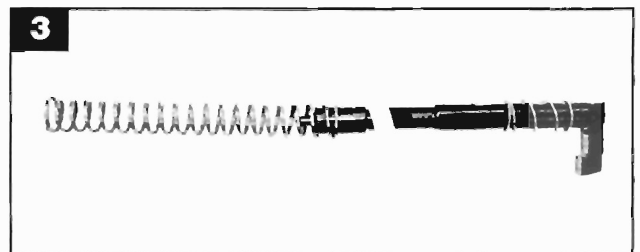
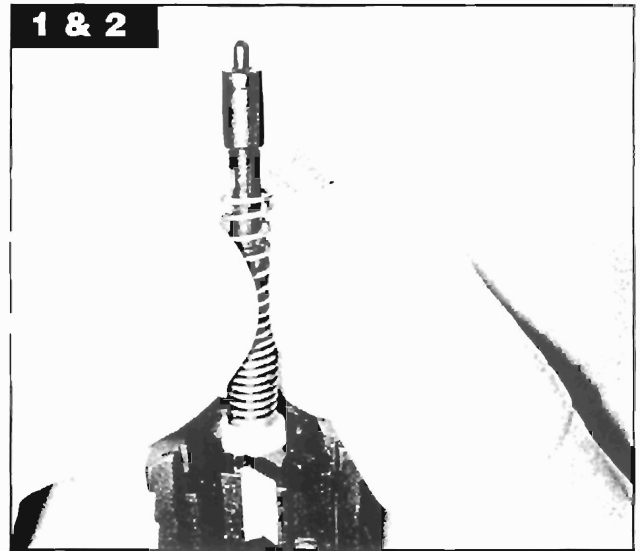

B) Striker Reassembly

1. Install striker return spring onto striker.
2. Install striker guide onto striker.
3. Install striker spring onto striker.
4. Place rear of striker into rear of slide with striker hook supported by interior of slide.
5. Compress striker spring and install striker spring keepers (narrow ends inside spring).

NOTES:

NOTES:

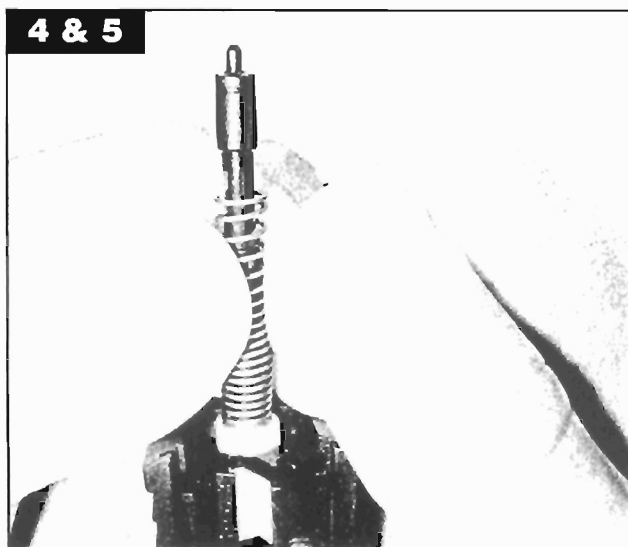
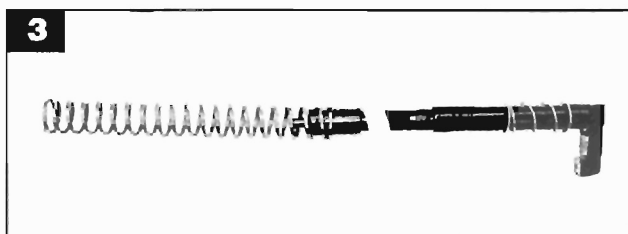
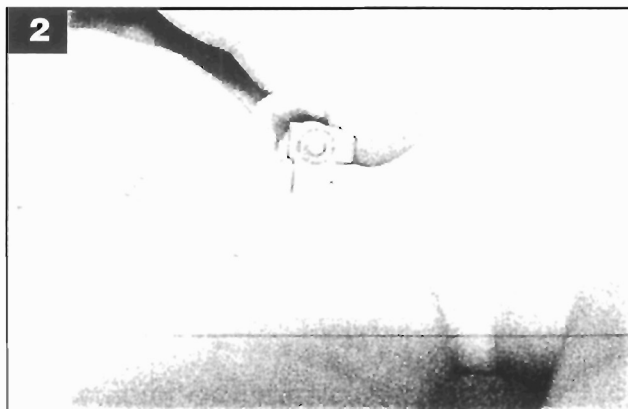
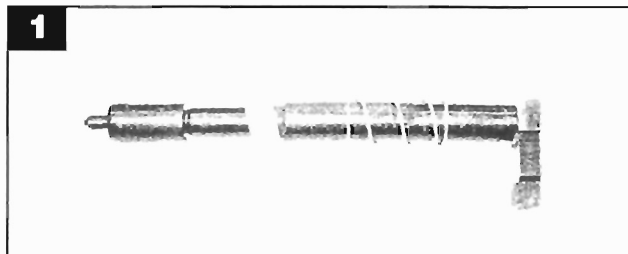

Extractor Replacement

A) Extractor Replacement

1. Remove extractor pin from top of slide to bottom.
2. Remove extractor and extractor spring.
3. Install new extractor and extractor spring.
4. Install extractor pin from bottom of slide.

B) Check Extractor Hook Location

Use the bar gauge to measure distance from extractor hook to opposite side of bolt.

1. Insert "NO GO" side of gauge into extractor area from underside of slide. (Refer to Photo B) "NO GO" side should not fit between extractor hook and opposite side of slide. If "NO GO" side fits between extractor hook and opposite side of slide, remove extractor and file adjustment pad. Reinstall and check gauge again.
2. Insert "GO" side of gauge into extractor area. "GO" side should fit between hook of extractor and opposite side of slide. Do not compress Extractor Spring. If "GO" side does not fit, extractor has been over filed and should be replaced. Repeat step 1.

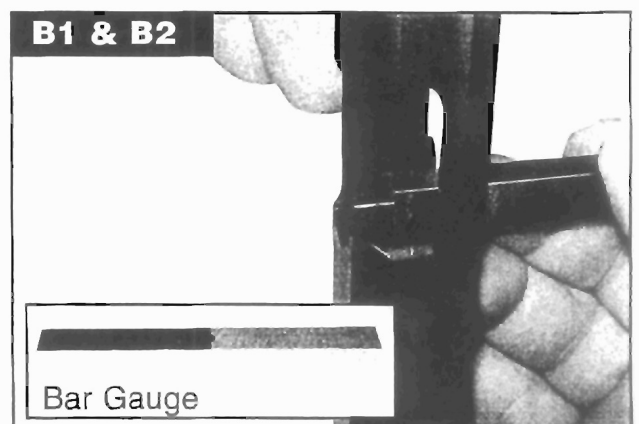
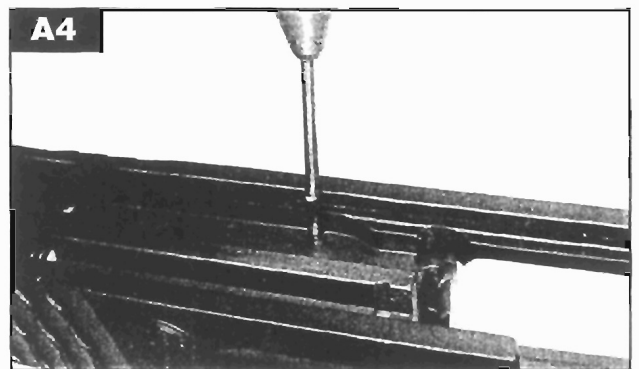
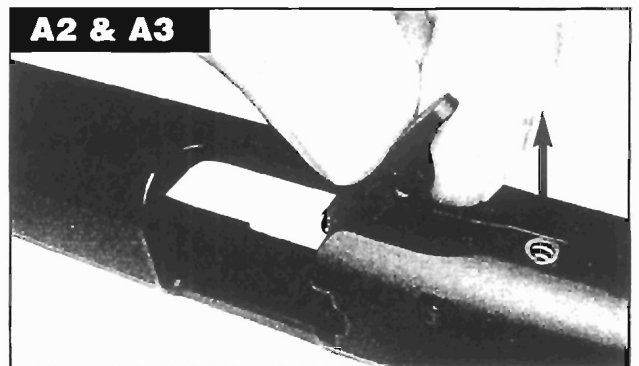
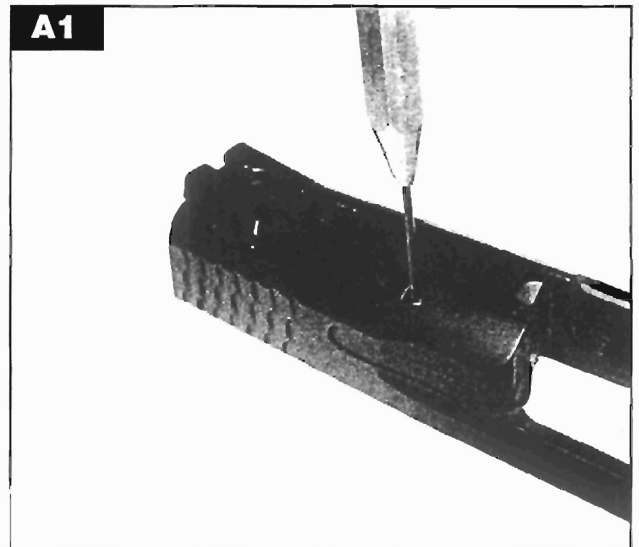
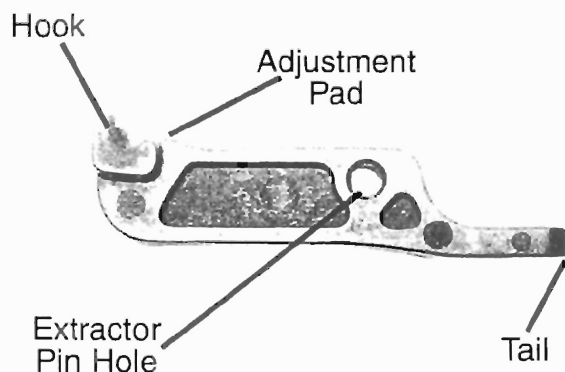

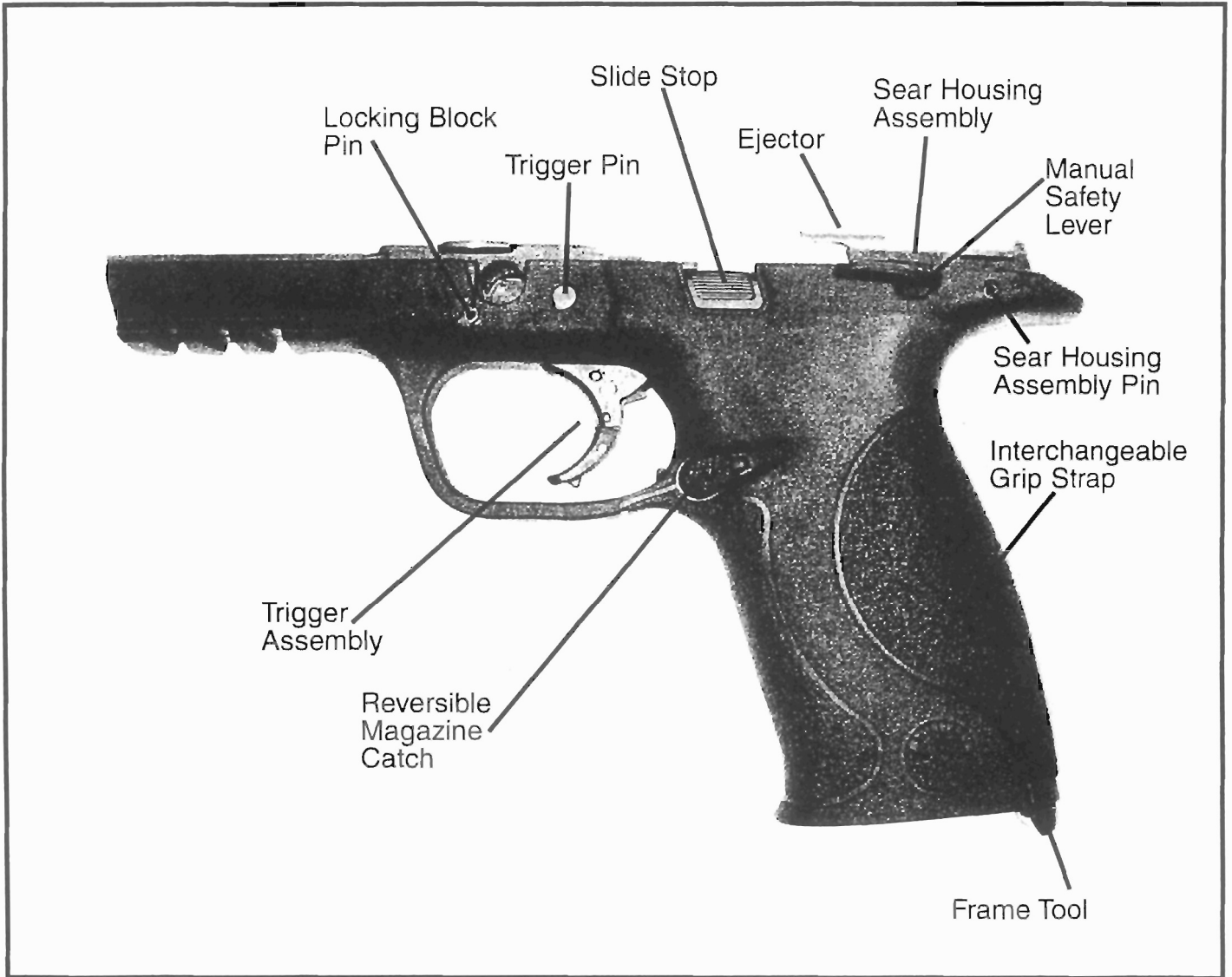

Frame Disassembly

A) Remove Trigger Assembly

1. Rotate takedown lever counter-clockwise until it stops. Lift takedown lever out of frame.
2. Remove locking block pin in frame, right to left with 1/8 roll pin punch.
3. Remove trigger pin right to left with No. 4 drift.



1/8" Roll Pin Punch

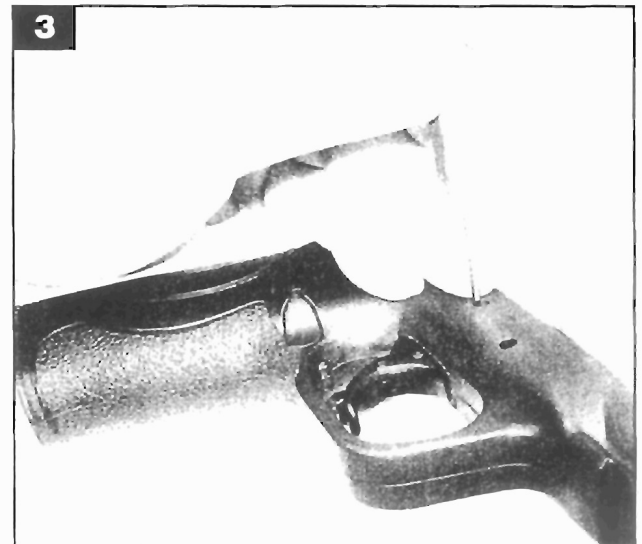
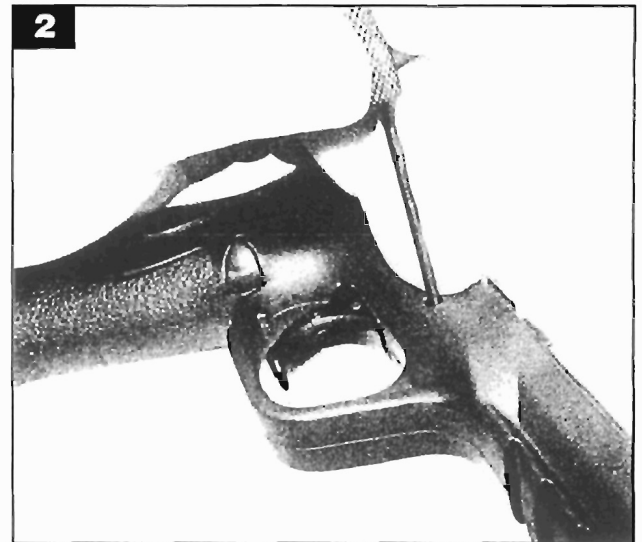
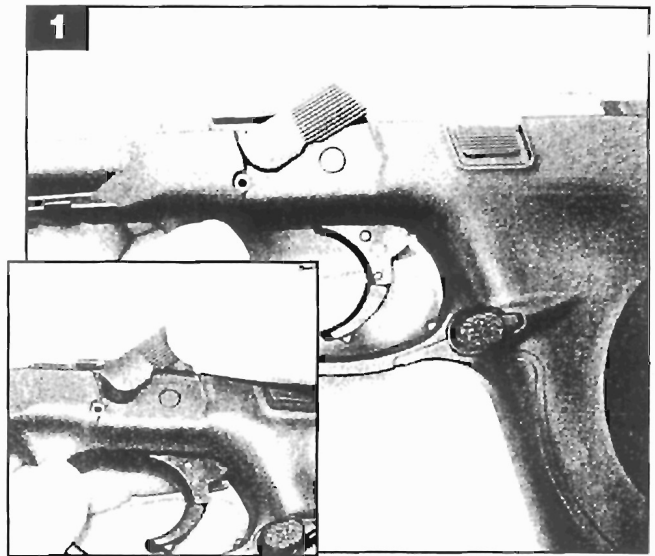

NOTES:

NOTE: Be sure not to lose takedown lever retaining wire (see arrow) when removing locking block.

A) Remove Trigger Assembly

4. Lift locking block out of frame.
5. Remove slide stop and trigger assembly from frame.

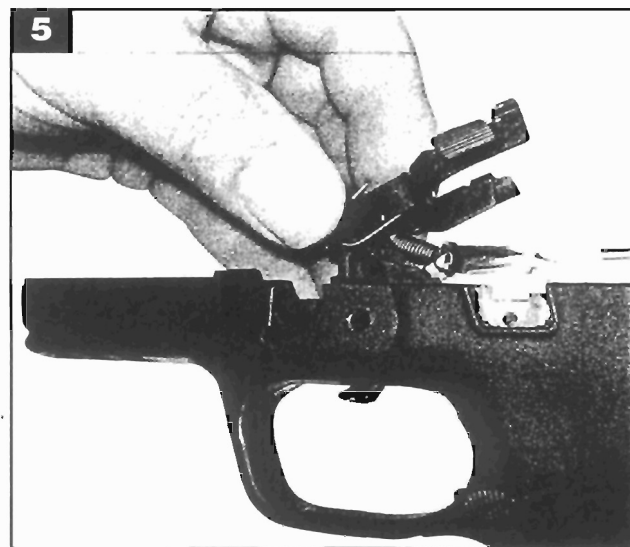
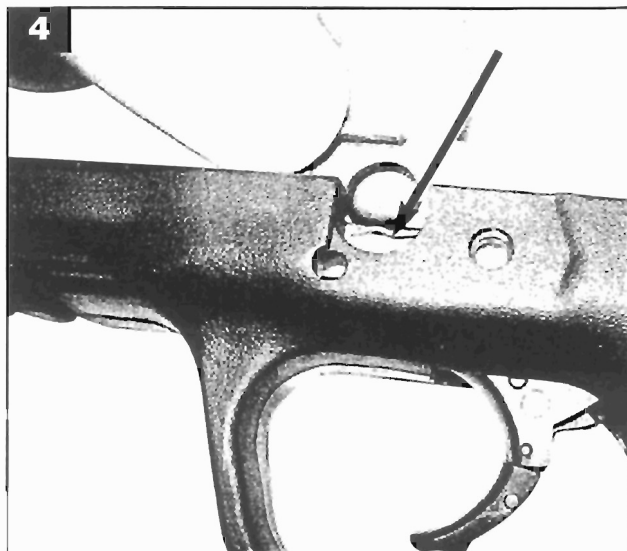

NOTES:

B) Remove Sear Housing Assembly

1. Remove sear housing assembly pin, right to left with 1/8" roll pin punch.
2. Lift sear housing assembly out of frame with punch.
3. Remove ejector from sear housing block.

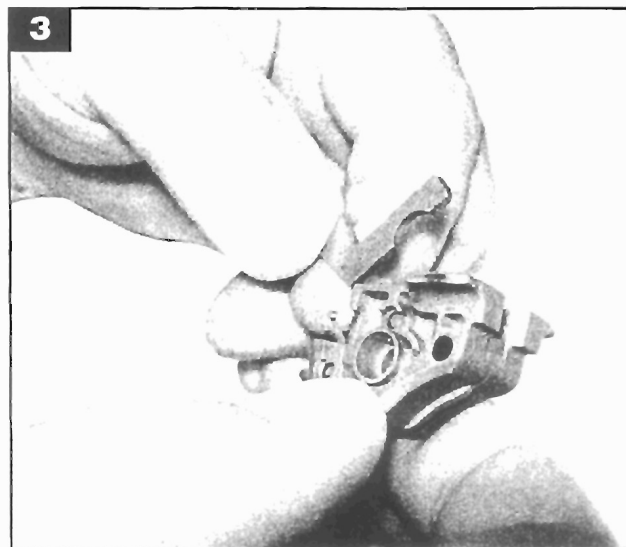
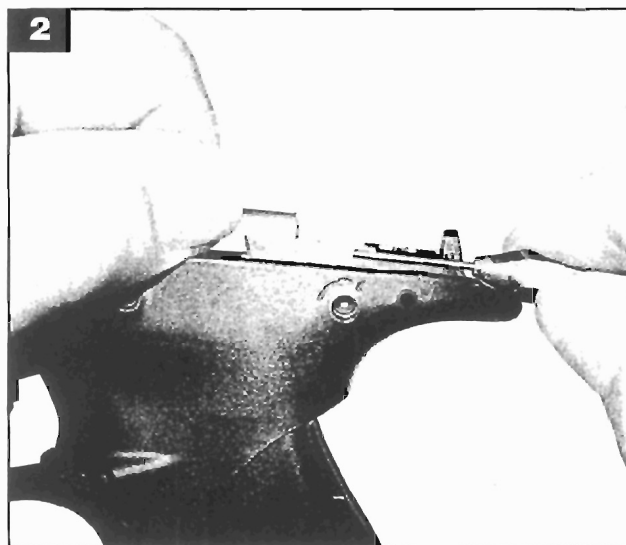
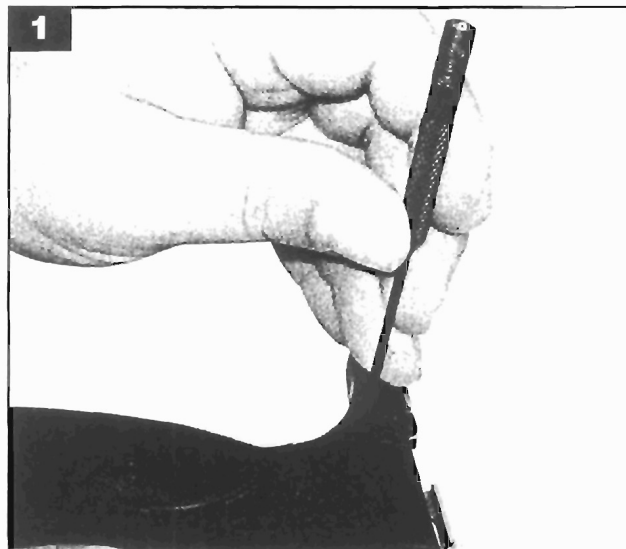

NOTES:

NOTE: The magazine catch spring is an integral part of the frame and is not removable. Be careful not to bend spring.

C) Remove Magazine Catch

1. Move the magazine catch spring from the magazine catch recess.
2. Slide the magazine catch half-way out of the frame.
3. Hold magazine catch while moving the magazine catch spring around the end of the magazine catch.
4. Slide the magazine catch all the way out of the frame.

NOTES:

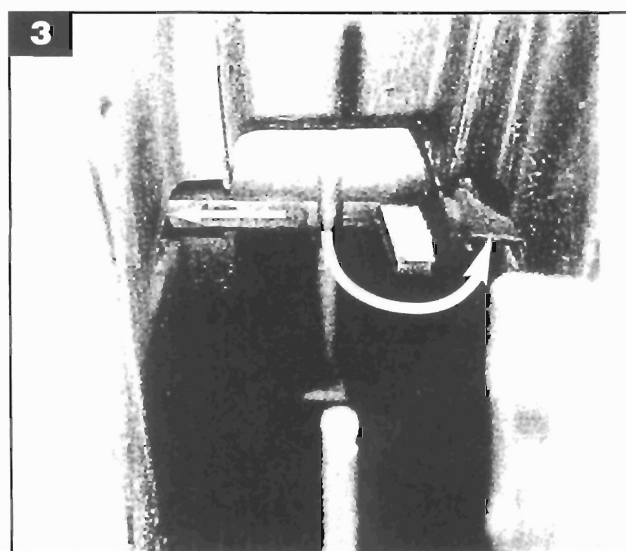
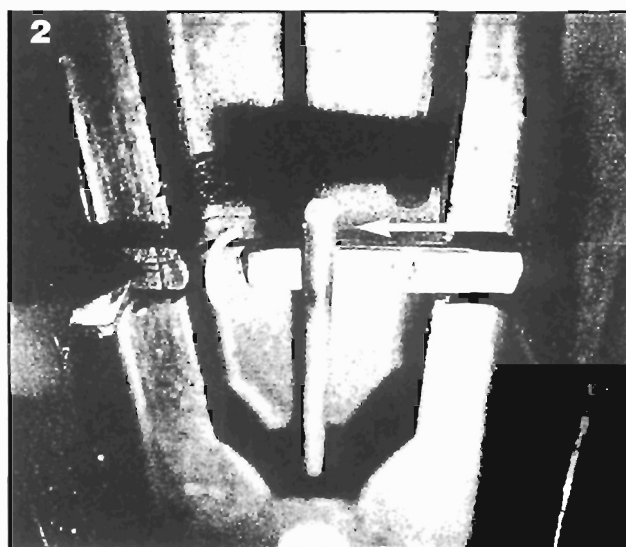
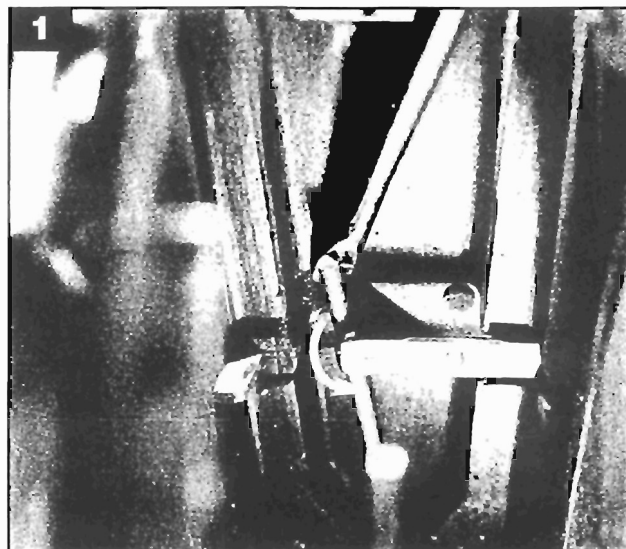

Frame Reassembly

A) Install Magazine Catch

1. Start magazine catch in frame from the right/left side according to preference.
2. Lift magazine catch spring with screwdriver. Push magazine catch completely in frame.
3. Reach in through top of frame with a screwdriver and push spring until it snaps into recess of catch.

NOTES:

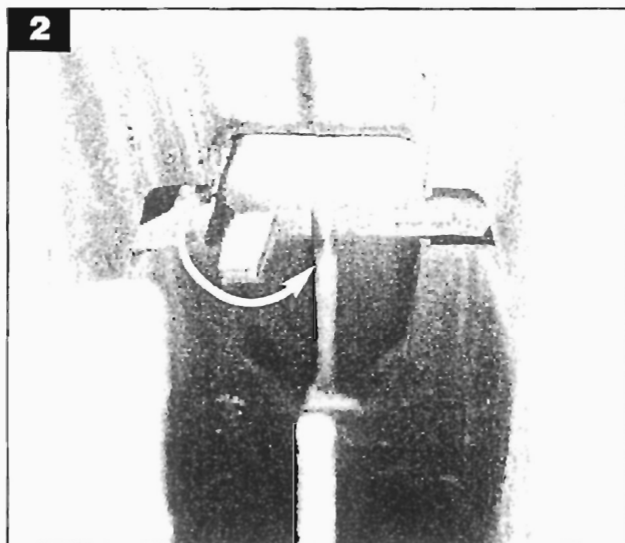

B) Install Sear Housing Assembly

1. No-Lock Models: Install cap into frame where internal locking mechanism would be.
2. Install ejector in sear housing block then lower sear housing block assembly into frame.
3. For Manual Safety Models Only: Install manual safety lever onto rear of sear housing block and into the lowered (ready to fire) position then lower sear housing block assembly into frame.
4. Push sear housing block assembly completely in frame.
5. Install sear housing block assembly pin in frame left to right with 1/8" roll pin punch.

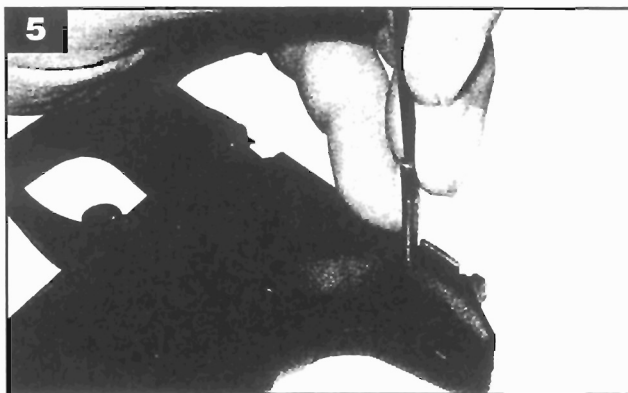
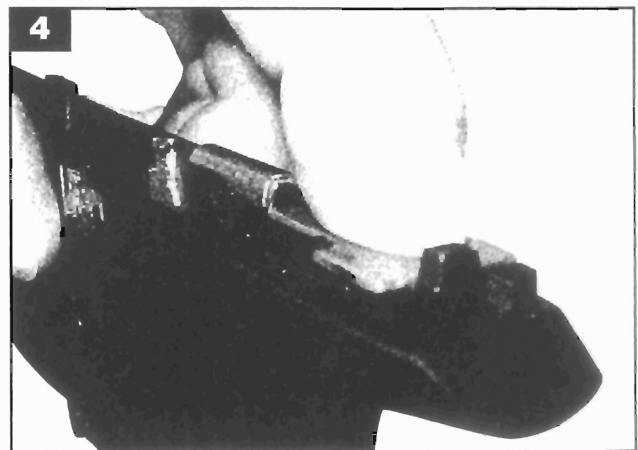
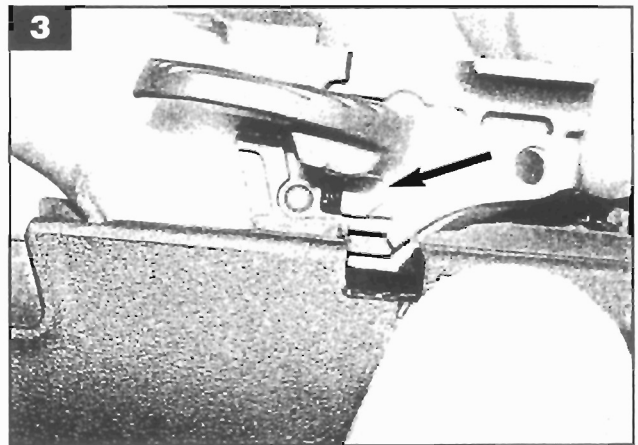
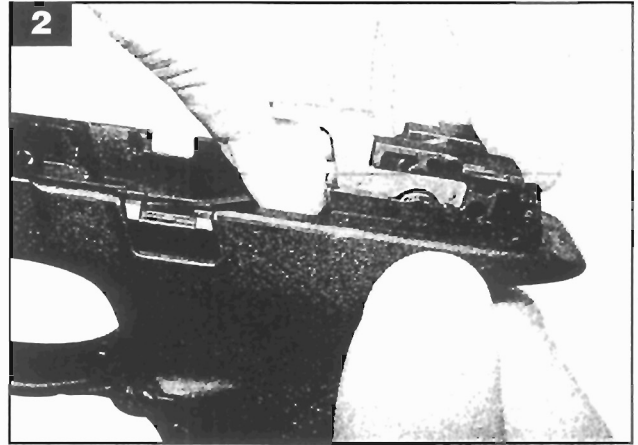
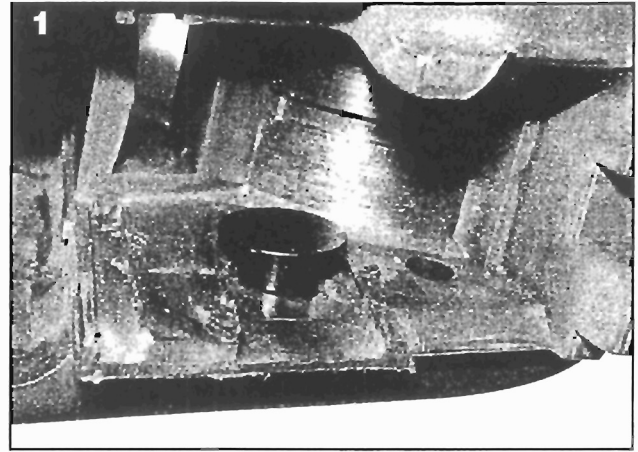

C) Install Trigger Assembly

1. Install trigger return spring with open coil up when assembled.
2. Insert trigger assembly with slide stop.
3. Install trigger and slide stop into frame by guiding tail of trigger bar into sear housing block assembly, then lower trigger and slide stop into frame.

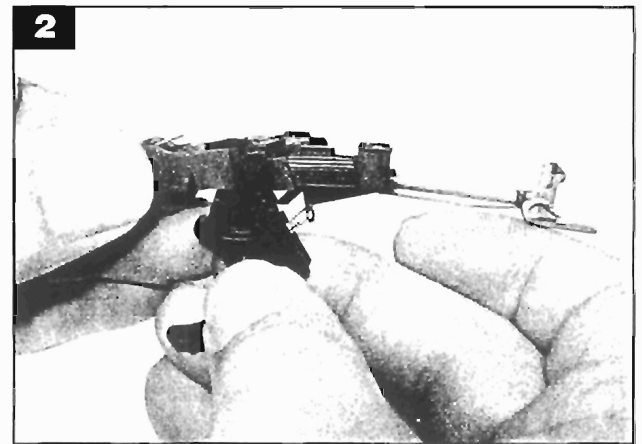
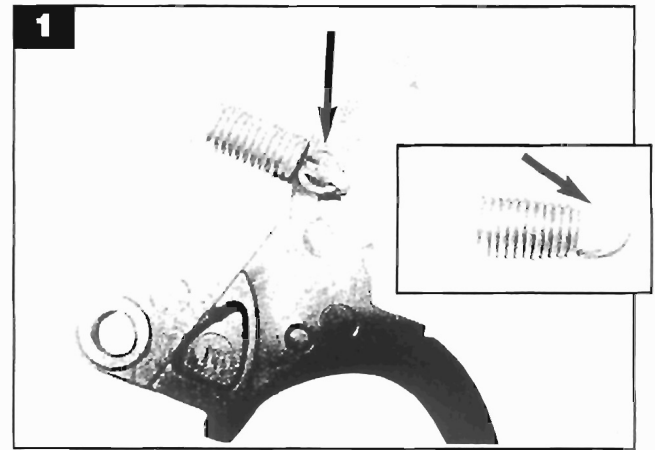

NOTES:

C) Install Trigger Assembly

4. Install takedown lever retaining wire (see arrow) in locking block assembly.
5. Install locking block assembly including takedown lever retaining wire into frame.
6. Install trigger pin left to right through locking block, slide stop assembly trigger assembly, capturing trigger return spring. Seat with drift.
7. Install locking block pin left to right with 1/8" roll pin punch.

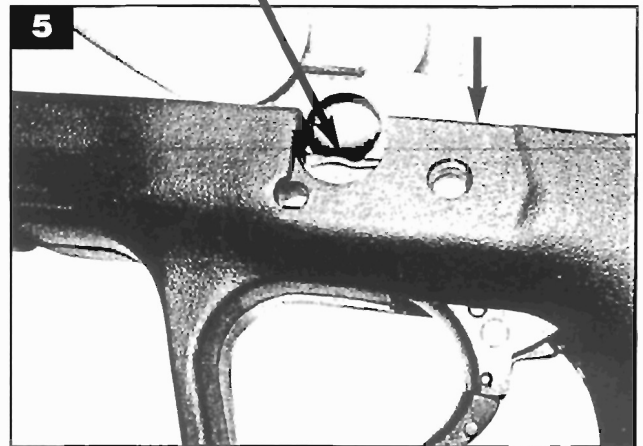
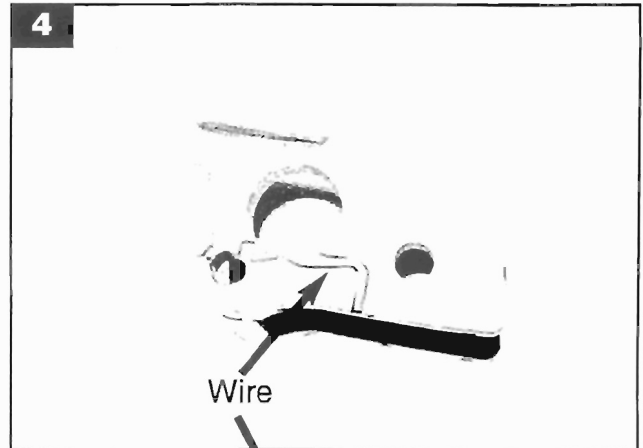

NOTES:

D) Install slide

1. Insert takedown lever. Rotate down.
2. Insert barrel.
3. Insert guide rod, small end forward.
4. Ensure that yellow sear deactivation lever is in the downward position.

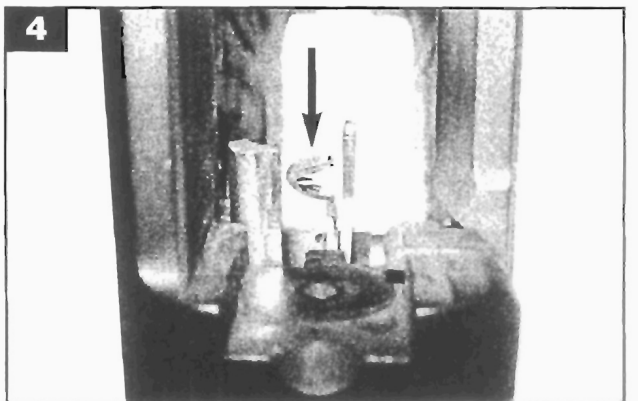
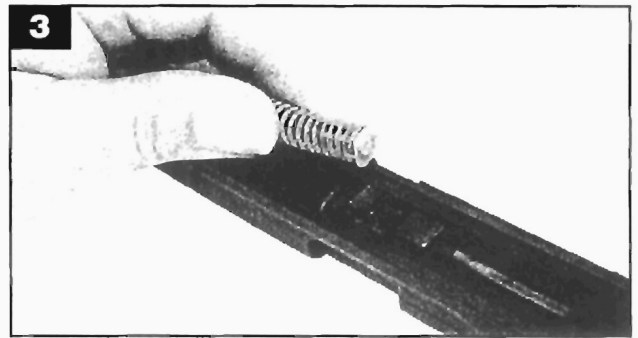
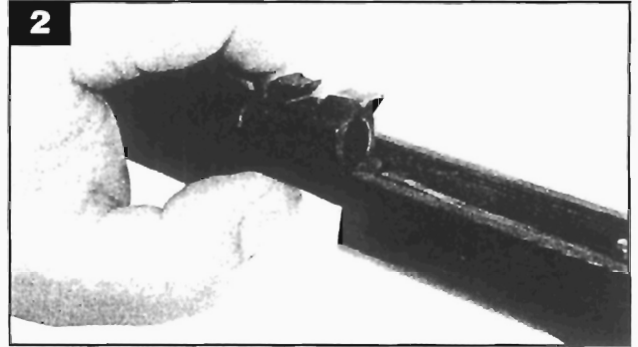
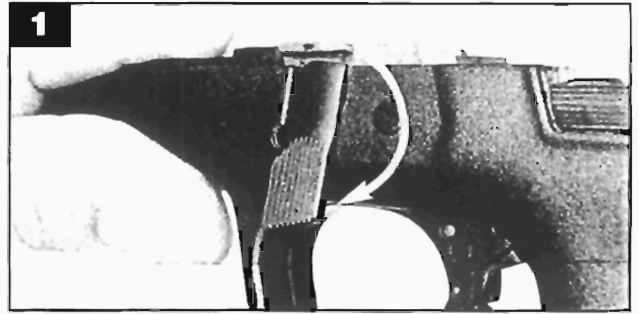
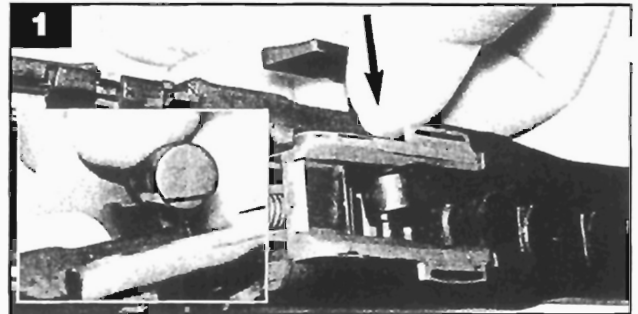

NOTES:

D) Install slide

5. Align rails of frame with rail grooves of slide and rack slide rearward.
6. Lock back with slidestop lever.
7. Push takedown lever up. Move slide forward slowly.

NOTES:

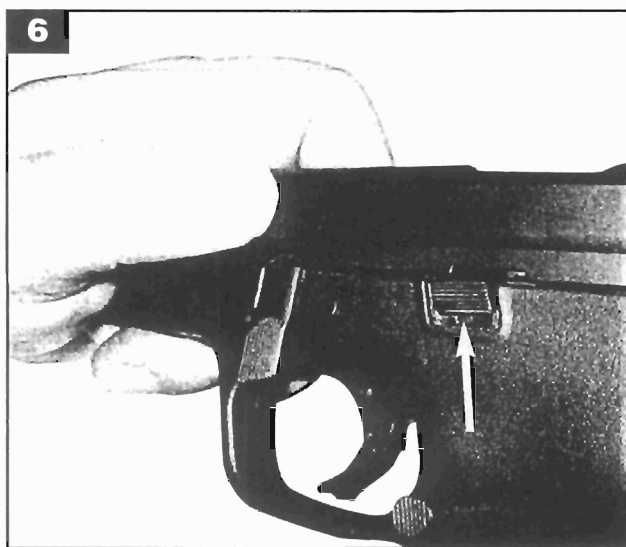
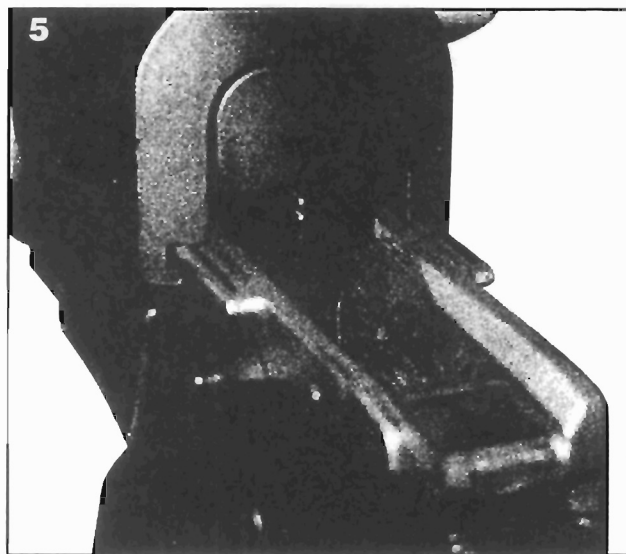

Sear Housing Block Disassembly

It Is Not Normally Necessary to Disassemble Sear Housing Block for Regular Cleaning!!

In the event that the handgun is extremely dirty or has been submerged and disassembly is necessary, follow these instructions:

E) Sear Housing Block Disassembly

1. Place finger on top of sear. Push out sear pin with drift.
2. Remove sear, sear plunger and sear spring.
3. For .45 ACP Models - Slide ejector forward, out of sear housing. For manual safety models, carefully lift manual safety detent out of sear housing relaxing spring slowly.
4. Place finger on levers in sear housing block. Push out sear deactivation lever pin.
5. Remove sear deactivation lever, magazine safety lever and magazine safety lever spring.

Manual safety sear housing block.

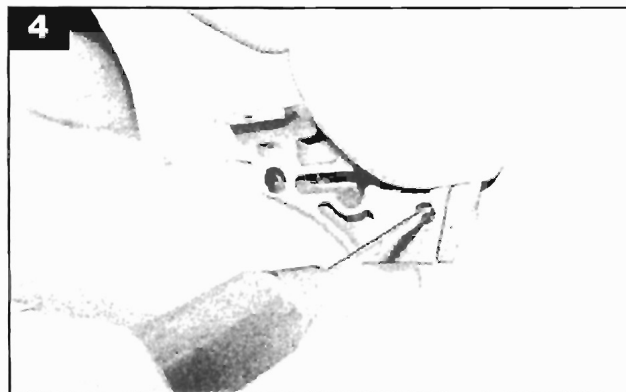
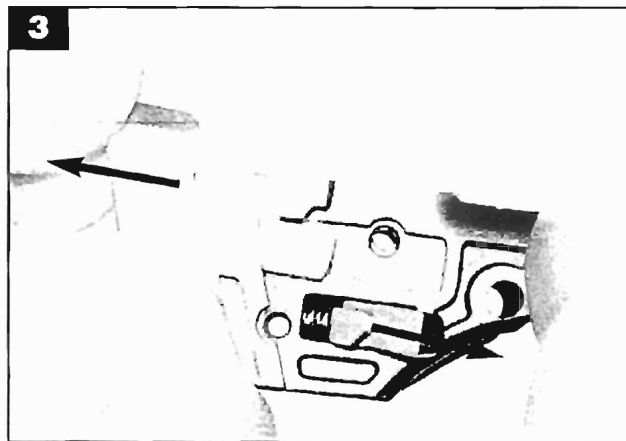
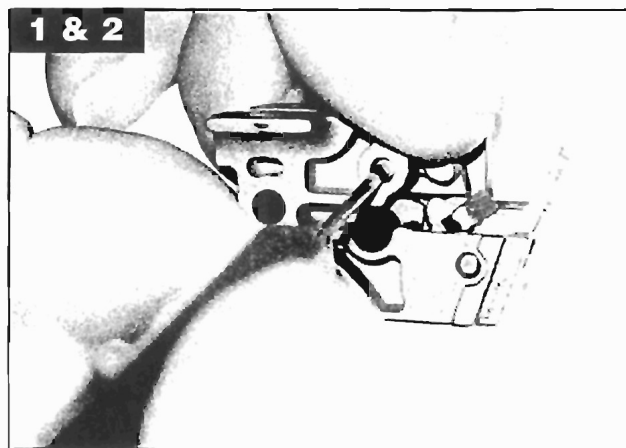

Fully disassembled sear housing block.

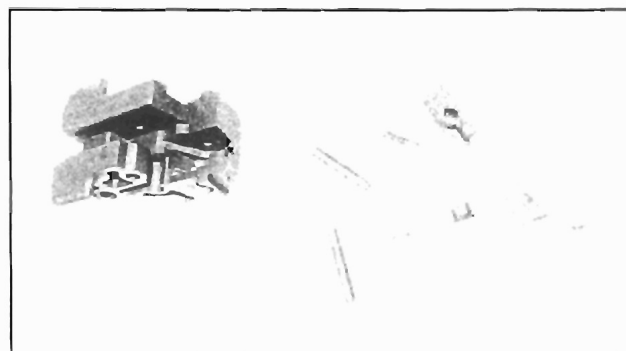

F) Sear Housing Block Reassembly

1. Insert sear deactivation lever into sear housing block.
2. Place magazine safety lever spring on magazine safety lever with bent leg of spring in loop of lever.
3. Insert spring and lever in sear housing block. Align levers and spring. Install sear deactivation lever pin (Longer Pin).

FOR MODELS WITHOUT MAGAZINE SAFETY

4. For NON-magazine safety models only: Insert retaining spring into sear housing block.
5. For NON-magazine safety models only: Install the sear deactivation lever pin. (Shorter Pin)

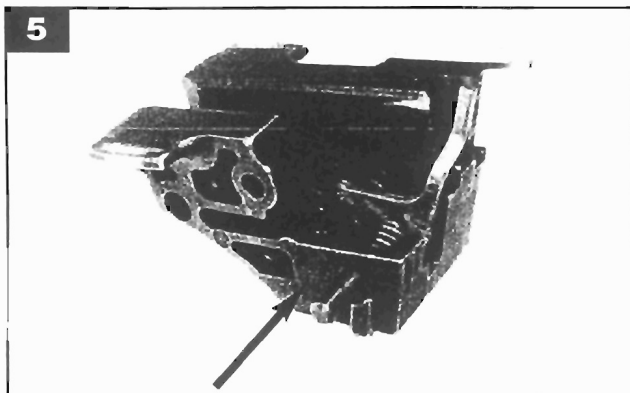
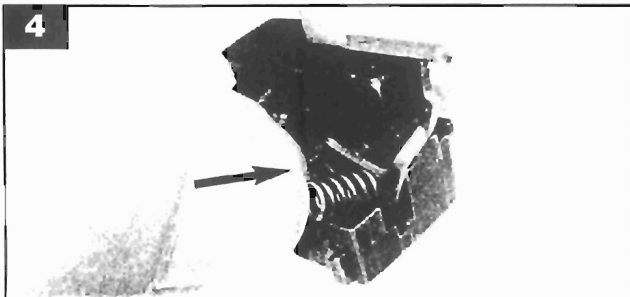
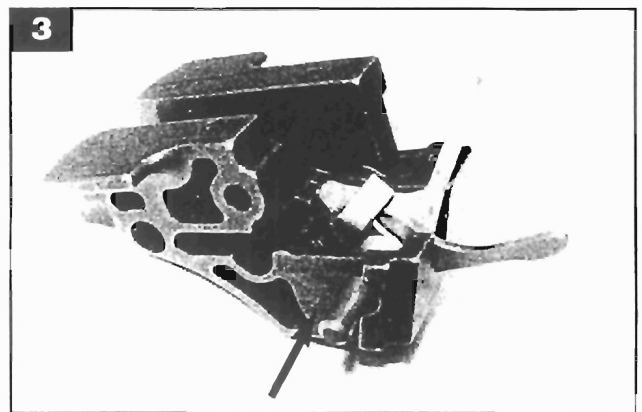
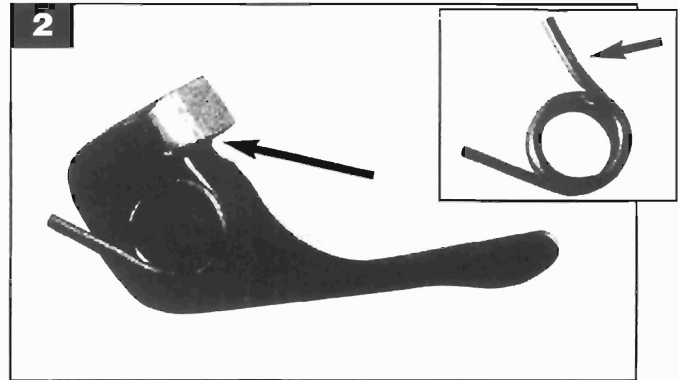
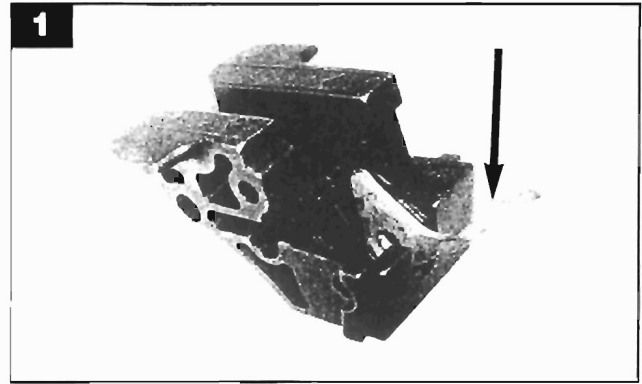

Sear Housing Block Reassembly

F) Sear Housing Block Reassembly Cont.

6. Insert sear spring and sear plunger into sear housing block.

7. Place sear on top of plunger and spring. Compress plunger and spring with sear, align sear in sear housing block. Install sear pin (shorter pin).

Manual Safety Models: sear pin has a head.

8. Manual Safety Models - Install ejector and then install sear pin left to right. (Longer Pin)

9. Manual Safety Models - Install manual safety detent and detent spring by compressing spring into sear housing with detent, lowering both into sear housing.

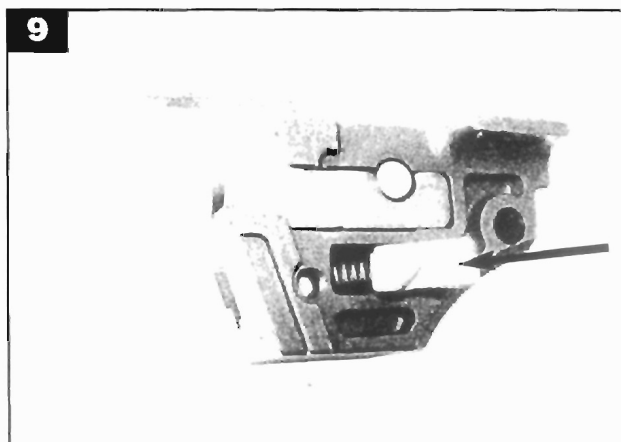
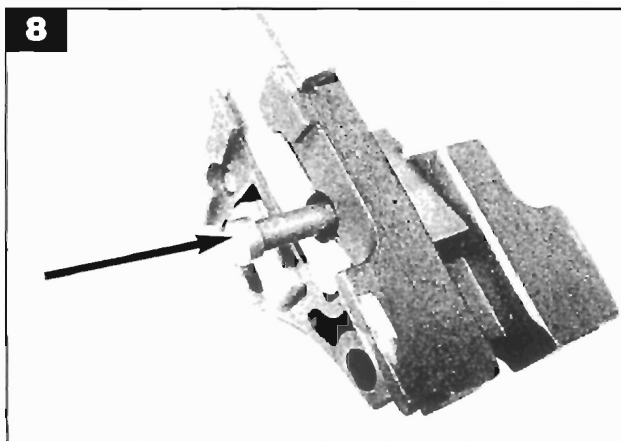
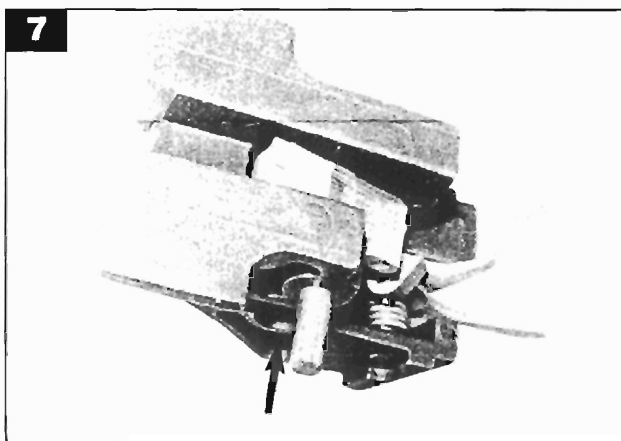
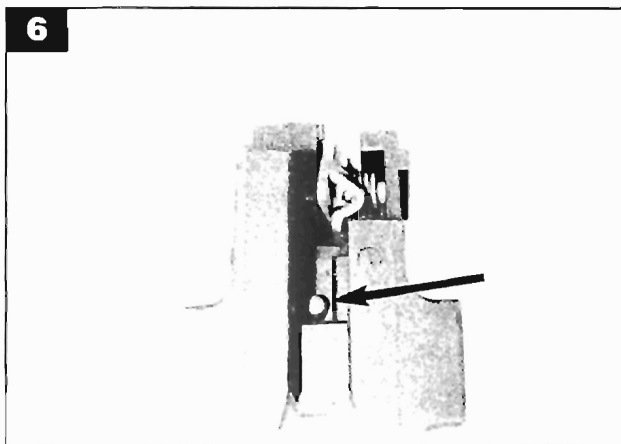

A) Replacing Grip Insert

1. Twist frame tool 90° and pull out of the frame.
2. Lift back strap off rear of frame. Backstrap can be changed to different sizes.
3. Repeat in opposite direction for new grip insert.

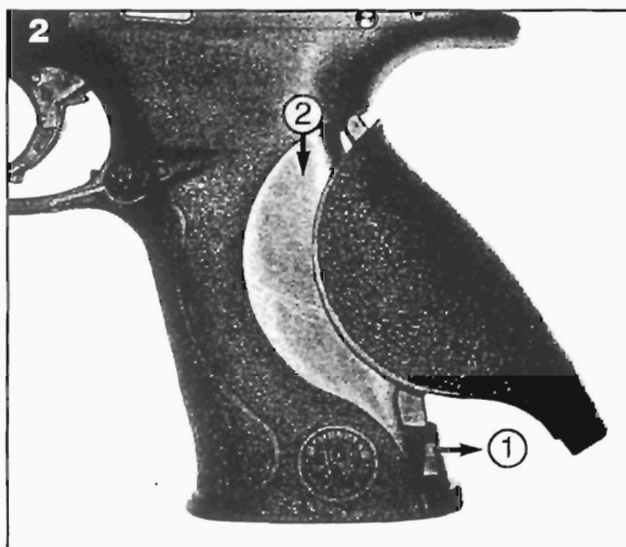
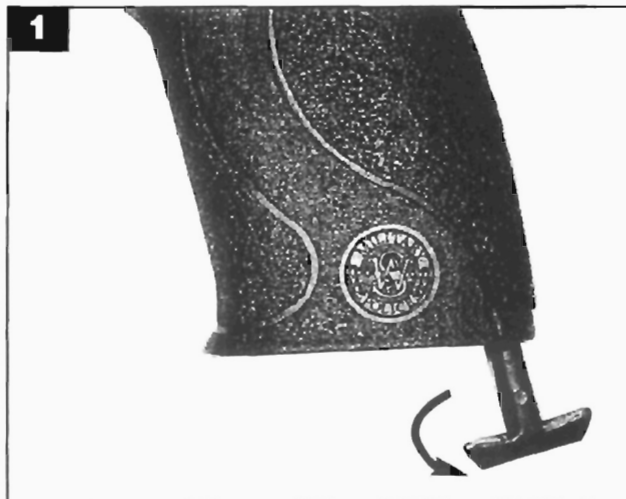

NOTES:

All Safety Features Should Be Function Tested After Performing Any Maintenance Procedures.

A) Trigger Safety

TO VERIFY TRIGGER SAFETY IS FUNCTIONING PROPERLY:

1. Push on upper half of trigger. Trigger should remain blocked and not move into the fire position. If the trigger does move into the fire position, replace the trigger assembly.
2. Push on lower section of trigger. Trigger should move into the fire position. When released, trigger should return to the blocked position. If trigger does not return on it's own, replace the trigger assembly.

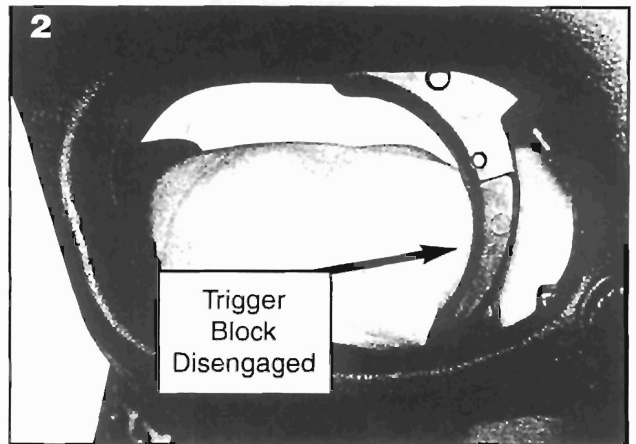
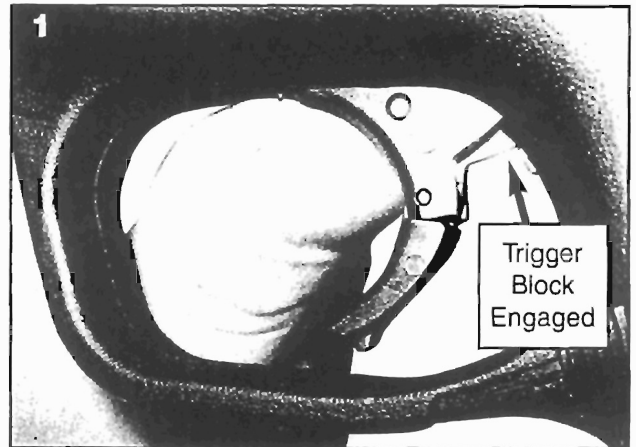

All Safety Features Should Be Function Tested After Performing Any Maintenance Procedures.

B) Striker Safety

The striker safety plunger is designed to block the striker from moving forward until the trigger is pulled.

TO VERIFY STRIKER SAFETY IS FUNCTIONING PROPERLY:

1. With slide removed from frame, reset striker safety by pulling striker fully to the rear position and then slowly let striker move forward.
2. With slide off, push striker forward. Striker should not move forward and protrude from the breech face. If it does, replace the striker. Reinspect.
3. With slide removed from frame, push and hold the striker safety plunger down. Push Striker forward. Striker should move forward and protrude from the breech face.

C) Slide Fully in Battery

1. Barrel locked with slide.
Firearm will fire when slide is in battery.

Note: Magazine safety version must have magazine inserted in the frame.

Slide Out of Battery

2. Barrel unlocked from slide.
Firearm will not fire when slide is out of battery 1/4" or more.
(Note space in figure B).

Note: Magazine safety version must have magazine inserted in the frame.

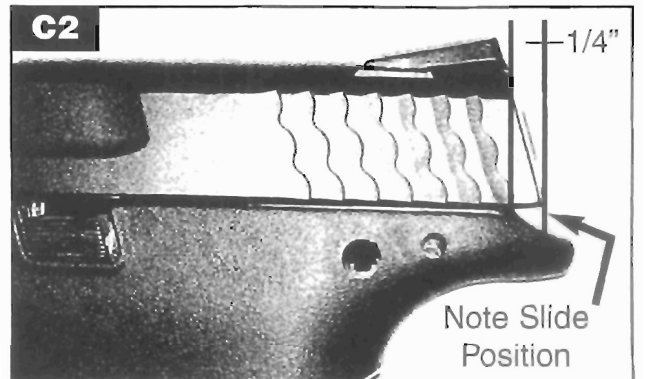
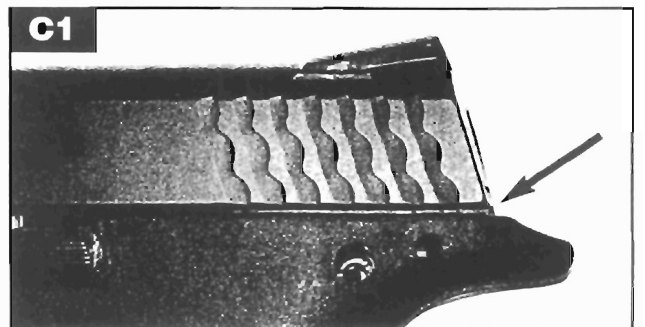
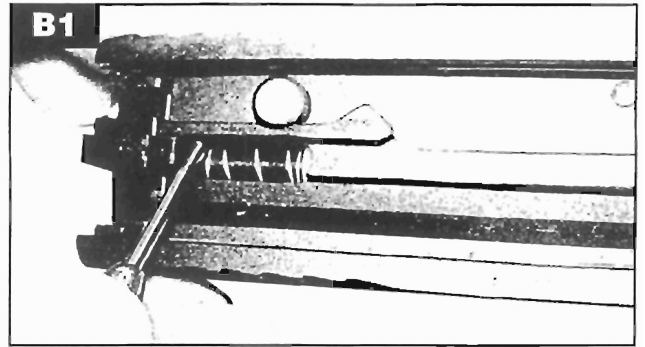

Safety Features

All Safety Features Should Be Function Tested After Performing Any Maintenance Procedures.

D) Magazine Safety

1. Magazine Removed
With magazine removed, the magazine safety lever is down and pushes the trigger bar to the right and off center with the sear. If trigger is pulled, the trigger bar will not engage sear and the pistol must not fire.
2. Magazine Installed
With magazine fully seated (engaged with the magazine catch), the magazine safety lever is up and allows the trigger bar to move left and on center with the sear. If trigger is pulled, the trigger bar will engage sear and the pistol must fire.

E) Manual Safety

1. Manual Safety Engaged
When engaged (upward position), the manual safety is designed to block the trigger bar from contacting the sear. When the trigger is pulled the pistol must not fire.
2. Manual Safety Disengaged
When disengaged (downward position) the manual safety allows the trigger bar to contact sear when the trigger is pulled. Pistol must fire.

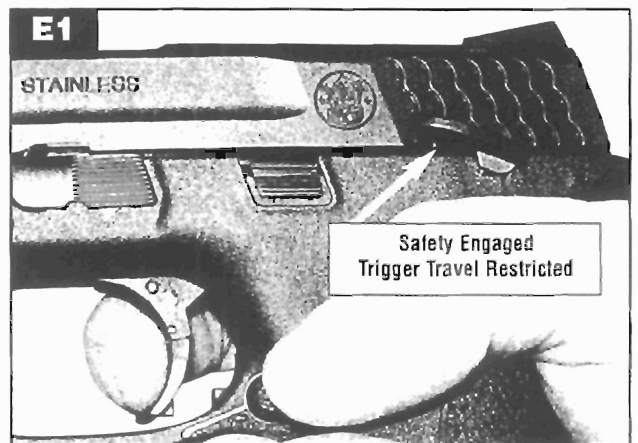
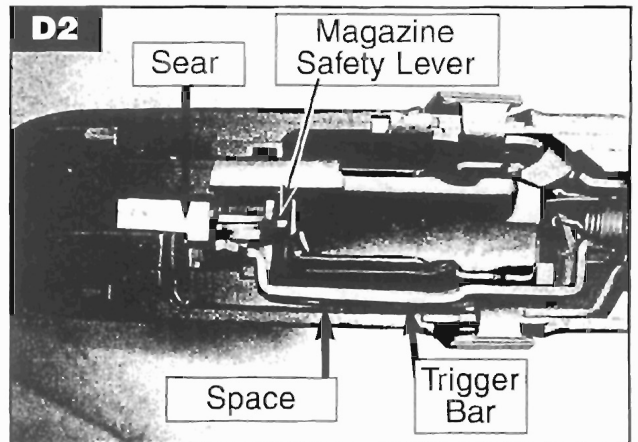
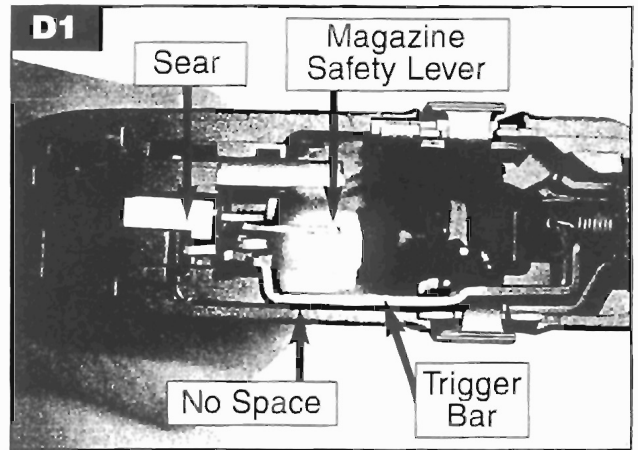

All Safety Features Should Be Function Tested After Performing Any Maintenance Procedures.

F) Internal Lock

For models with a magazine safety, this check must be done with the magazine installed.

1. With internal lock in the unlocked position, pull and hold the trigger to the rear. Engage lock with supplied key and turn clockwise to lock.

NOTE: Trigger bar moves to the right side of the sear, disengaging from the sear. Ensure the lock remains in that position.

2. Release trigger, then pull to the rear to ensure trigger bar does not engage sear.
3. To unlock - engage lock with supplied key and turn counter-clockwise.

Note: Trigger bar moves to left and on center with sear. Trigger bar can engage sear if the trigger is pulled. Ensure the lock remains in that position.

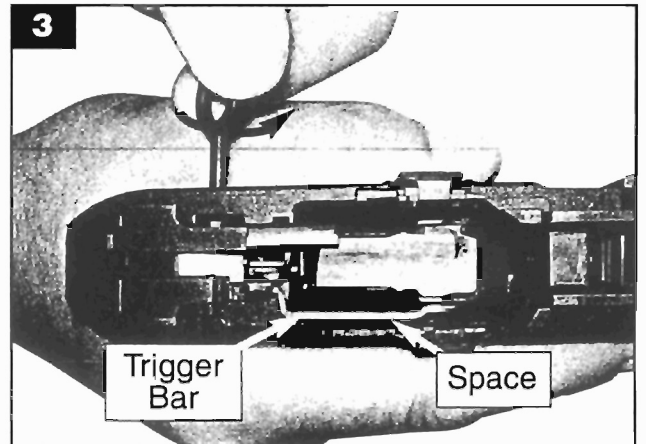
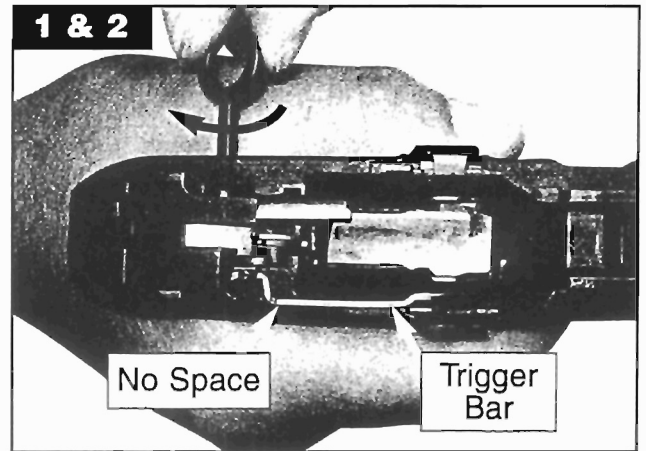

The following maintenance program is suggested to assist the police armorer in planning his own program depending on frequency of firing, climate, etc. Note: Use only brass, copper or nylon brushes for the following maintenance procedures.

At least every six (6) months or after firing, a pistol should be cleaned with special attention given to the following areas:

1) BARREL

- a. Clean with a wire brush using reciprocating strokes only.
- b. The breech face and the locking lug should be cleaned as well. This can be best accomplished with a wire type tooth brush.
- c. The feed ramp should be cleaned.
- d. When the barrel is cleaned, a lightly oiled patch should be passed through the barrel and chamber.

2) SLIDE

- a. The slide should be cleaned with a wire brush with special attention given to the breech face.
- b. The extractor should be cleaned in the hook area and inspected for freedom and movement and a damaged hook.
- c. Recoil Guide and Spring - wipe with a lightly oiled patch.
- d. Plunger - depress striker safety to ensure freedom of movement.

3) FRAME

- a. Clean the frame with a brush.
- b. Wipe out any residue with a cloth.
- c. Inspect levers to ensure freedom of movement.

4) MAGAZINES

- a. The magazines should be disassembled and the parts wiped clean.
- b. Reassemble the magazine and check for freedom of follower.

5) When the pistol is fully assembled, make all safety and functioning checks.

6) One (1) drop of oil should be placed in the following areas - refer to Page 39.

Once a year, the pistol should be completely disassembled by a qualified armorer. (Note: Sear Housing Assembly Block should never be disassembled for Regular Cleaning)

The frame, slide and all component parts should be cleaned with a good solvent. "READ THE LABEL". Do not use a solvent that could be hazardous to your health or detrimental to the frame polymer material.

Inspect the parts for wear, unauthorized polishing, filing, or spring damage.

As the pistol is reassembled, wipe the parts with a lightly oiled patch. When the pistol is completely assembled, one (1) drop of oil should be applied to the following areas - refer to Page 39.

When the pistol is fully assembled, make all of the safety and functioning checks. Pistol should be test-fired before returning to service.

NOTE: Carburetor, engine or brake cleaner are not recommended for cleaning Smith & Wesson firearms.

To ensure proper functioning, the magazine spring assembly, recoil spring assembly and trigger return spring should be replaced every 5 years or after every 5,000 rounds -- whichever comes first.

After cleaning the frame, slide and barrel, use a soft cloth and apply a light coating of a premium grade lubricant to all external metal surfaces and wipe clean.

- 1) One (1) drop on each rail insert in the frame (4 drops).**
- 2) One (1) drop on the muzzle of the barrel.**
- 3) One (1) drop on the top front corners of the barrel hood.**
- 4) One (1) drop on the tail of the trigger bar.**

This will assure proper lubrication of the pistol. Care should be taken not to over-lubricate your pistol. Excess lubricant can collect large quantities of unburnt powder and carbon residue, which could interfere with the proper functioning of the pistol.

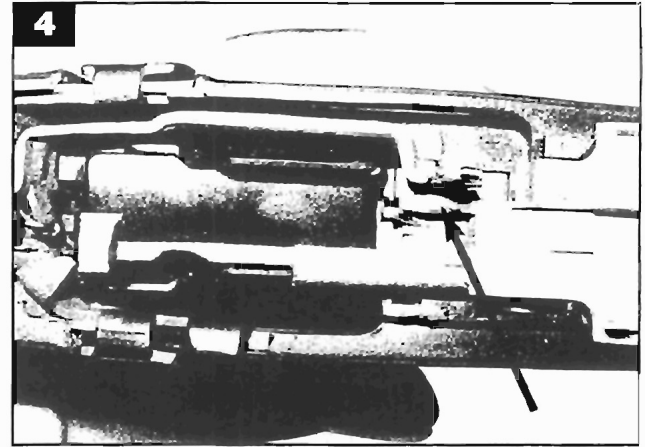

Two areas that MUST remain clean and dry:

#1 - Striker Channel in Slide

#2 - Magazine Tube

Storing Pistols

Pistols should be stored in a locked, unloaded condition.

Do not store pistols with a plug in the barrel, other than the plug that was supplied, as it could contribute to sweating.

Maintenance or storage rooms should be kept at a constant temperature with minimum humidity. Guns should not be stored in any encasement which will attract or hold moisture, such as leather or vinyl holsters. If pistols are to be stored over a long period of time, the internal mechanism of the lockwork should be lightly oiled with an acid-free lubricating oil. The exterior of the guns, as well as the bore of the barrel and the chamber, should be lightly coated with an anti-rust oil. It is an established fact that moisture is the greatest enemy of metallic objects, particularly in climates where temperature and humidity are high and salt air is present.

Extreme care should be exercised that all metallic surfaces should be kept clean and oiled.

Refer to the Maintenance Section when returning the weapon to service.

Magazines should be carefully wiped down and very lightly oiled and inspected before storage.

Malfunction	Probable Cause	Corrective Action
1. Failure to Feed	magazine not properly seated into the frame	seat (tap) magazine
	sticky magazine follower	clean and inspect
	bent magazine lips	replace magazine
	underpowered ammunition (light)	replace ammunition
	weak recoil spring	replace
	tight extractor	replace extractor
2. Failure to Chamber	dirty chamber	clean and inspect
	defective cartridge case	replace
	weak recoil spring	replace
3. Failure to Close (Lock)	dirty slide and barrel	inspect and clean
	dirty chamber mouth	clean
	weak recoil spring	replace
4. Failure to Fire	ammunition failure	replace
	ammunition failure (hard primer)	replace
	dirt or obstruction in striker channel in slide	inspect and clean
	broken striker	replace striker
5. Failure to Extract	overpowered (hot) ammunition	replace ammunition
	underpowered (light) ammunition	replace ammunition
	broken extractor	replace extractor
	dirty chamber	clean chamber
	shooter induced (limp wrist)	evaluate and correct
6. Failure to Eject (including Stove Pipes)	broken ejector	replace ejector
	underpowered ammunition	replace ammunition
	damaged extractor	replace extractor
	shooter induced	evaluate and correct
	dirty pistol	inspect and clean
7. Failure to Stay Open Last Round (Lock Back)	damaged magazine	replace magazine
	damaged magazine follower	replace
	dirty magazine	inspect and clean
	damaged slide stop assembly	replace slide stop assembly
	shooter induced (limp wrist)	evaluate and correct
	underpowered ammunition	replace
	shooter induced (improper hand placement)	evaluate and correct
	shooter induced (improper hand placement)	evaluate and correct
8. Slide Stop Early	improperly installed slide stop assembly	reinstall or replace
	overpowered ammunition	replace
	broken slide stop spring	replace slide stop assembly