

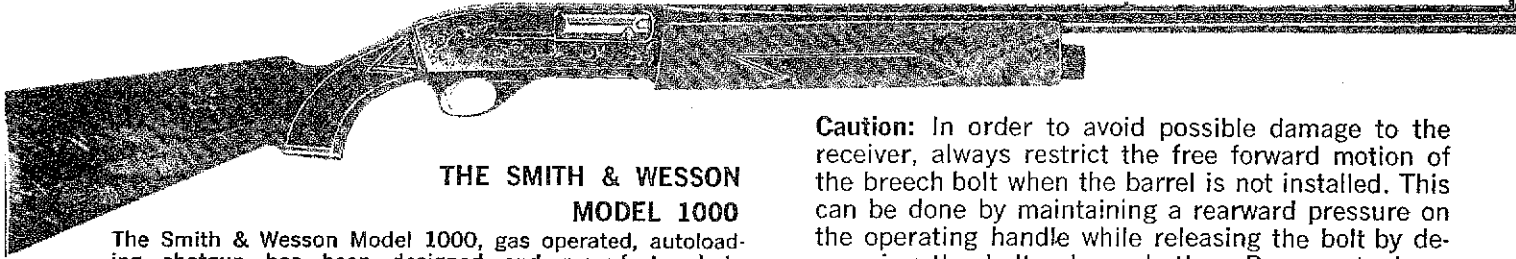

Smith & Wesson

Model 1000

GAS OPERATED 20 GA. AUTOLOADING SHOTGUN OPERATION AND MAINTENANCE MANUAL



THE SMITH & WESSON MODEL 1000

The Smith & Wesson Model 1000, gas operated, autoloading shotgun has been designed and manufactured to provide many years of outstanding performance. This Manual has been prepared so that any owner of a S & W Model 1000 will be able to have a better understanding of the proper care and routine maintenance of his new Smith & Wesson and as a result, enjoy the total satisfaction of his purchase. If there are any questions concerning material in this Manual, please contact the source from whom the S & W Model 1000 was purchased or any qualified gunsmith.

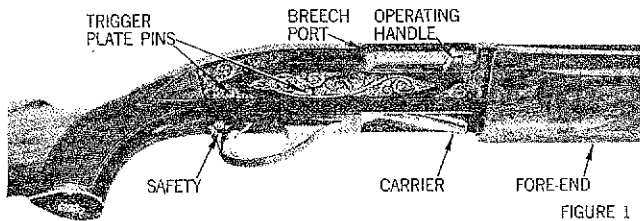

FIGURE 1

ASSEMBLY — (FIG. 1)

The S & W Model 1000 is carefully prepared for shipment in a polystyrol bed which has been inletted to receive the barrel and the action (together with stock and fore-end) as two separate components. In order to assemble:

1. Remove the action group from the box, push safety button #69 to "on" position, (red indicator not showing) and unscrew the fore-end cap (#110) by turning counter-clockwise.
2. With the butt plate (#118) placed on a non-skid surface, carefully slide the fore-end (#102) upward and off the magazine tube (#21). Pull the operating handle (#66) to the rear until the breech bolt (#35) locks in the open (most rearward) position.
3. After removing the barrel (#2) from the box and with the butt placed on a non-skid surface, position the barrel guide ring (#7) over the magazine tube.
4. Then carefully slide the barrel guide ring over the magazine tube while aligning the barrel breech with the barrel slot in the receiver (#9). When properly aligned, the barrel should insert easily into receiver. If a bind is noted, remove the barrel and repeat the above with more careful attention to the alignment of barrel to the barrel slot in the receiver.
5. Slide the fore-end over the magazine tube until the diagonal end of the fore-end is securely positioned against the receiver. Approximately $\frac{5}{8}$ " of the threaded portion of the magazine tube will then be exposed beyond the front end of the fore-end.
6. Firmly thread on the fore-end cap (clockwise) until it is snug against the fore-end. There should be no looseness in the fore-end.

Caution: In order to avoid possible damage to the receiver, always restrict the free forward motion of the breech bolt when the barrel is not installed. This can be done by maintaining a rearward pressure on the operating handle while releasing the bolt by depressing the bolt release button. Be sure to keep fingers away from the ejection port.

DISASSEMBLY

1. Pull the operating handle to the rear until the breech bolt locks in the open position.
2. Check to see that the chamber and magazine tube are empty.
3. Remove the fore-end cap by twisting counter-clockwise.
4. While holding the barrel firmly into the receiver, slide the fore-end off the magazine tube.
5. While comfortably gripping the stock or pistol grip, carefully withdraw barrel breech from the receiver and slide the barrel guide ring off the magazine tube.

LOADING — (FIG. 1)

1. With the Model 1000 fully assembled, push the Safety button (#69) from the left side (for right-handed shooters) which will place the gun in a "Safe" condition. (See Safety section page 5).
2. While pointing the gun in a safe direction, pull the operating handle to the rear until the breech bolt locks in the open position.
3. Load the first shotshell through the open ejection port. This can be done directly into the chamber or by laying the shell on the carrier (#88).
4. If you have physically chambered the first round, merely depress the breech bolt release button to close the breech bolt, being careful to keep your fingers away from the ejection port. If the first round is resting on the carrier, depress the breech bolt release button with the left hand and the first round will be chambered by the forward motion of the breech bolt.
5. To load the next shell, turn the gun so that the trigger guard is facing up. Depress the breech bolt release button and simultaneously depress the carrier with the front end of the shell and push the shell fully into the spring loaded magazine tube until the shell stopper plate (#17) is perfectly latched.
6. Two additional shells can be loaded in the same manner as described in (5) above. However, if the magazine capacity reducing pin (#28) is utilized, the magazine capacity is restricted to two rounds.

Caution: The Model 1000 should be loaded only in the hunting field or on the range. When it is removed from its carrying case, the operating handle should be locked in the open position until the gun is to be loaded.

MODEL 1000 PARTS LIST

Subject to change without notice F.O.B. Springfield, Ma.

When ordering part, please include Model No., Serial No., Part No. and Description.

View No.	Part No.	Description	View No.	Part No.	Description
2	*	Barrel Assembly (Includes Vent Rib and Sights)	62	12365	Plunger Stopper Pin
3		Barrel (Not Illustrated)	63	12248	Link (R)
4		Ventilated Rib (Not Illustrated)	64	12249	Link (L)
5	12215	Front Sight for Ventilated Rib	65	12250	Link Pin
7	12216	Barrel Ring Guide	66	12251	Operating Handle
8	12217	Receiver Assembly (Includes Views No. 9 thru 19)	67	12252	Trigger Plate Assembly (Includes Views No. 68 thru 99)
9	12218	Receiver	68	12253	Trigger Plate
10	12219	Ejector (Not Illustrated)	69	12369	Safety Button
11	12220	Carrier Latch Assembly	70	12371	Safety Button Spring Sleeve
12		Carrier Latch (Not Illustrated)	71	12370	Safety Button Spring
13		Latch Button (Not Illustrated)	72	12372	Safety Button Spring Stopper Pin
14	12221	Latch Spring	73	12373	Sear
15	12376	Latch Pin	74	12374	Sear Pin
16	12342	Latch Pin Stopper Spring	75	12375	Sear Spring
17	12350	Magazine Shell Stopper Plate	76	12392	Trigger Assembly (Includes Views No. 77 thru 79)
18	12377	Shell Stopper Plate Spring	77	12391	Trigger
19	12376	Shell Stopper Plate Pin	78	12393	Trigger Connector Plate
20	12222	Magazine Tube Assembly (Includes Views No. 21 thru 28)	79	12394	Trigger Connector Plate Pin
21	12223	Magazine Tube	80	12395	Trigger Pin
22	12224	Magazine Tube Nut	81	12400	Trigger Pin Bushing (Large)
23	12225	Magazine Follower	82	12402	Trigger Plate Stopper Spring (Large)
24	12226	Magazine Spring	83	12339	Hammer Spring
25	12227	Magazine Spring Retainer Washer	84	12340	Hammer Spring Sleeve
27	12228	Piston Shock Absorber	85	12254	Hammer
28	12229	Capacity Reducing Pin	86	12255	Hammer Pin
29	12230	Action Spring Tube	87	12256	Carrier Assembly (Includes Views No. 88 thru 91)
30	12306	Action Spring Tube Nut	88	12257	Carrier (Not Illustrated)
31	12304	Action Spring Guide	89	12258	Carrier Dog (Not Illustrated)
32	12303	Action Spring	91	12259	Carrier Dog Pin (Not Illustrated)
33	12307	Action Spring Retainer Screw	92	12324	Carrier Spring Guide Pin
34	12231	Breech Bolt Assembly (Includes Views No. 35 thru 42)	93	12323	Carrier Spring
35	12232	Breech Bolt	94	12325	Carrier Spring Sleeve
36	12233	Extractor	95	12401	Trigger Plate Pin Bushing (Small)
37	12329	Extractor Spring	96	12403	Trigger Plate Pin Stopper Spring (Small)
38	12330	Extractor Spring Plunger	97	12308	Auto Safety
40	12234	Firing Pin	98	12309	Auto Safety Spring
41	12332	Firing Pin Spring	99	12310	Auto Safety Stopper Pin
42	12235	Firing Pin Stopper Pin	100	12260	Trigger Plate Pin (Large)
43	12236	Locking Block	101	12261	Trigger Plate Pin (Small)
44	12237	Pressure Compensator Valve Assembly	102	12262	Fore-end Assembly (Includes Views No. 103 thru 109)
45		Pressure Compensator Cap (Not Illustrated)	103		Fore-end (Not Illustrated)
46		Pressure Compensator Stern (Not Illustrated)	104	12263	Fore-end Ratchet Spring (Not Illustrated)
47		Pressure Compensator Synthetic Rubber (Not Illustrated)	105	12264	Fore-end Ratchet Pin (Not Illustrated)
48		Pressure Compensator Valve (Not Illustrated)	106	12265	(Fore-end Ratchet Screw (Not Illustrated)
49	12238	Piston	107		Fore-end Guide (R) (Not Illustrated)
50	12239	Piston Pin	108		Fore-end Guide (L) (Not Illustrated)
51	12240	Piston Connector Ring	109		FRP Liner (Not Illustrated)
52	12241	Piston Connector Ring Spring	110	12266	Fore-end Cap
53	12242	Action Bar Sleeve Assembly	112	12267	Stock Assembly (Includes Butt Plate Stock)
54		Action Bar Sleeve (Not Illustrated)	113		Stock (Not Illustrated)
55		Action Bar Holder (Not Illustrated)	114	12380	Stock Grip Cap Spacer (Not Illustrated)
56	12243	Action Bar (R)	115	12381	Stock Grip Cap (Not Illustrated)
57	12244	Action Bar (L)	116	12382	Stock Grip Cap Screw (Not Illustrated)
58	12245	Breech Bolt Base Assembly (Includes Views No. 59 thru 66)	117	12383	Stock Grip Cap Inlay (Not Illustrated)
59	12246	Breech Bolt Base	118	12384	Stock Butt Plate
60	12364	Plunger Spring	119	12385	Stock Butt Plate Spacer
61	12247	Plunger	120	12386	Stock Butt Plate Screw
			121	12389	Stock Retainer Washer
			122	12388	Stock Retainer Spring Washer
			123	12387	Stock Retainer Bolt

* See Barrel Chart

SMITH & WESSON MODEL 1000 BARREL CHART

MODEL TYPE	20 GAUGE ORDER NUMBER	BARREL LENGTH	TYPE OF CHOKE
MODEL 1000	12009	26"	Skeet
VENTILATED	12210	26"	Improved Cylinder
RIB (EXTRA	12211	28"	Modified
BARRELS ONLY)	12212	28"	Full

For inquiries,
send to:

Smith & Wesson
2100 Roosevelt Ave.
Springfield, Ma. 01101



MODEL 1000 E

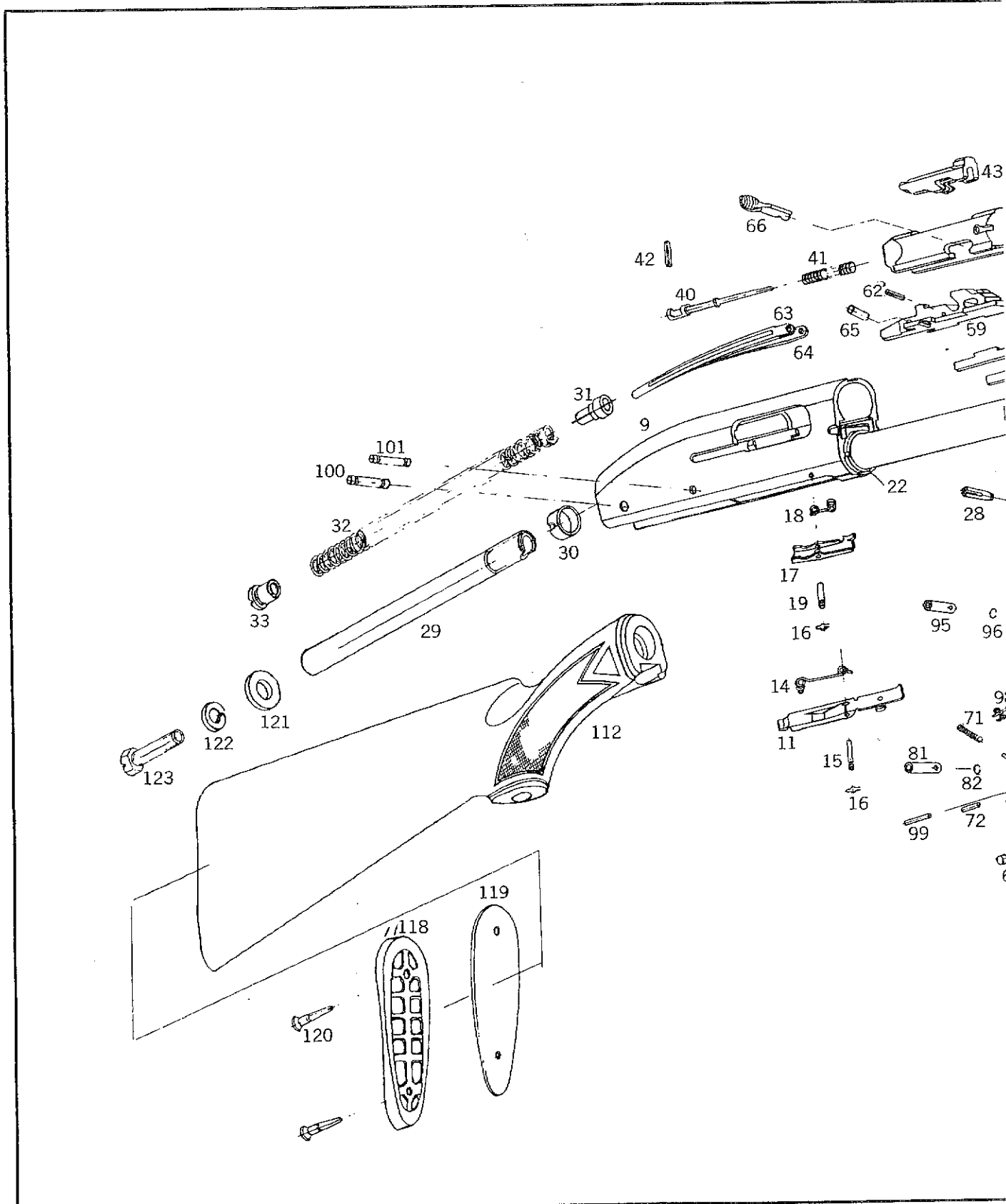

Wesson

For service or parts,
send to:

Smith & Wesson

2095 Roosevelt Ave.

Springfield, Ma. 01101

Attn. Service Dept.

LOADED VIEW

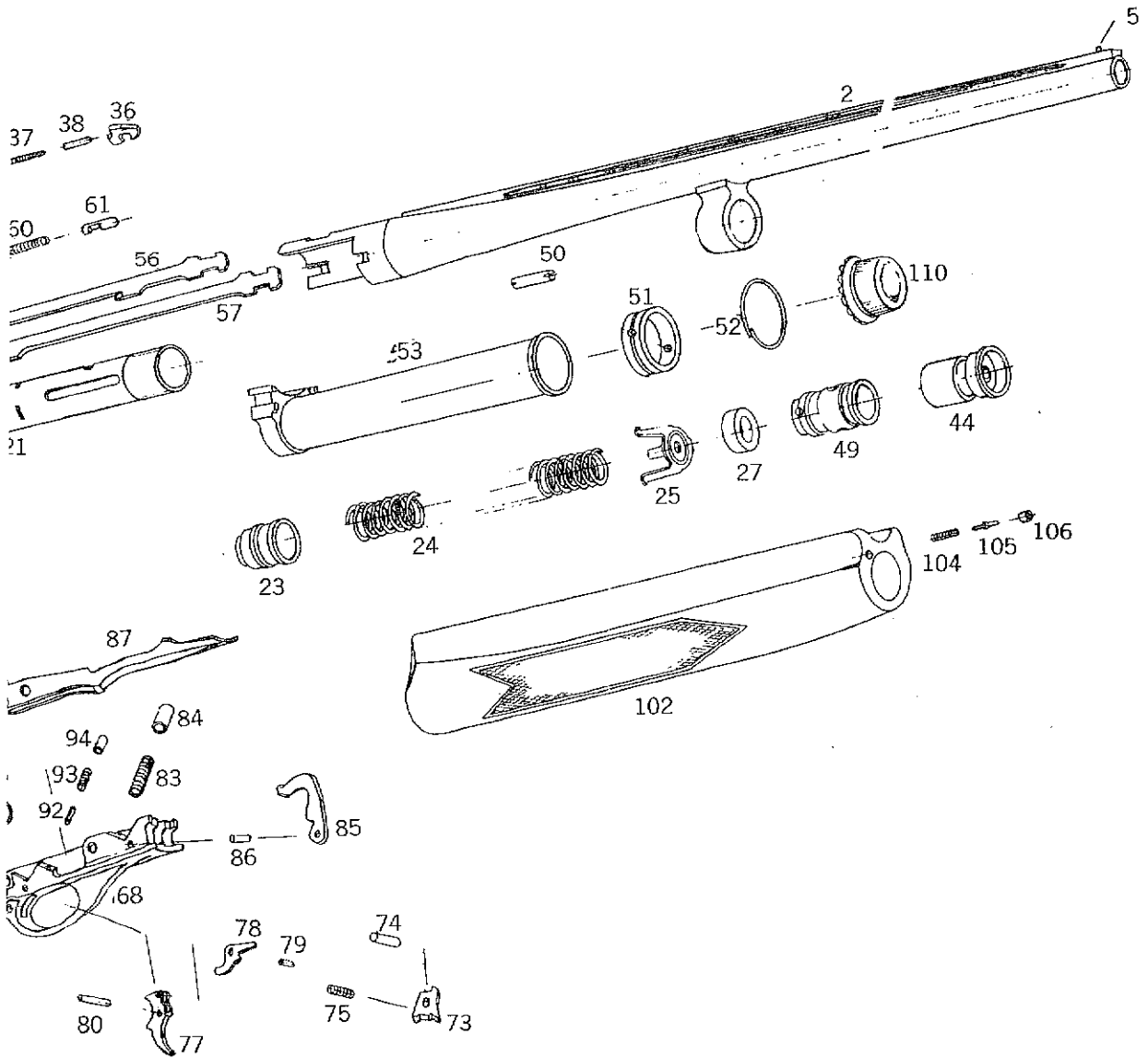

UNLOADING

1. The Safety button should be on "Safe". (See Safety Section Page 5).
2. Pull the operating handle to the rear and in so doing, one shell will be ejected through the ejection port. Allowing the bolt to close will place another shell in position to be extracted.
3. The gun will be emptied by repeating the above operation until the operating handle locks in the rearward position.
4. Be doubly safe and at this time, check both the chamber and the magazine tube for any remaining shells.

SAFETY

1. The Safety button is located to the rear of the trigger (#77) so that the shooter can quickly recognize by sight or feel, whether the "Safety" is on or off.
2. For the right handed shooter, the Safety button is set in the "on" or "safe" position by pushing the button from the left side so that it protrudes on the right side.
3. When pushed from the right side, the Safety button is set in the "off" or "fire" position and protrudes on the left side and shows a red stripe.

NOTE: Even when not in use, it is a good safety practice to have the Safety button set in the "safe" position.

TO CONVERT SAFETY FROM RIGHT HAND TO LEFT HAND OPERATION:

1. Follow instructions to remove Trigger Plate Assembly, (Cleaning of Trigger Plate Assembly Page 5).
2. **CAUTION:** Remove Safety button spring stop pin (#72). The Safety button spring may eject when the drift punch is removed from the Safety button pin hole.
3. Remove Safety button spring (#71) and Spring Sleeve (#70).
4. Remove Safety button (#69) and turn end-for-end (red indicator now should be on right side of receiver) and replace with the double machine cut facing the Safety button spring sleeve hole.
5. Replace Safety button spring sleeve with open end up, spring and spring stop pin.
6. Replace trigger plate assembly.

NOTE: When replacing Trigger Plate Assembly, be sure Bolt Release Button is depressed.

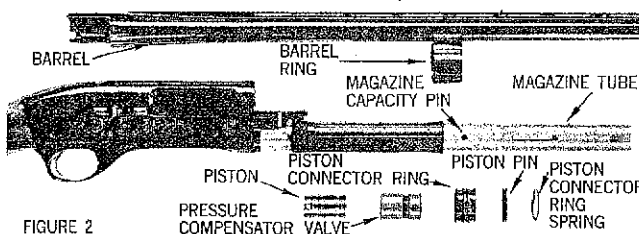

FIGURE 2

CHANGING MAGAZINE CAPACITY — (FIG. 2)

Each S & W Model 1000 is assembled with a magazine capacity of 2 rounds. Magazine capacity may be increased to 3 rounds as follows:

1. Open Breech Bolt, Remove Fore-End Cap, Fore-End and Barrel.
2. Drive out the Magazine Capacity Reducing Pin (#28) with force applied from the solid end of the pin. This will allow the Magazine Spring (#24) and Magazine Follower (#23) to work its full length.
3. To reduce the magazine capacity to 2 rounds again, merely return the Magazine Reducing Pin, this time, driving it from the split end

CLEANING OF THE GAS CYLINDER — (FIG. 2)

The routine cleaning of the gas cylinder will insure the smoothness of its motion and maintain the maximum operational performance of the Model 1000.

1. Move the Operating Handle to the open and locked position.
 2. Remove Fore-End Cap, Fore-End and Barrel.
 3. Remove the Piston Connector Ring Spring (#52) from its slot in the Piston Connector Ring (#51). Either remove the ring spring completely or relocate the ring spring to either of the adjacent, larger slots. Later production guns have no external piston connector ring spring. The piston pin is retained by a spring within the piston.
- SPECIAL NOTE:** Release of the bolt, after the piston connector ring has been removed may allow the bolt and carrier assembly to move forward, partially out of the receiver and in doing so, disconnect the links from the action spring guide.
4. Push out and remove the Piston Pin (#50). A ball point pen point or any small diameter blunt object will suffice as the pusher "tool".
 5. Slide the Piston Connector Ring from the Magazine Tube.
 6. Withdraw the Pressure Compensator Valve Assembly (#44) and the Piston (#49) from the Cylinder (Magazine Tube). The removal of these parts may be assisted by applying pressure through any one of the 3 vent slots in the side of the Magazine Tube.
 7. Clean the inside of the Cylinder with a brass cleaning brush and any commercial gun solvent. Complete the cleaning operation with a dry patch.
 8. Clean both the Compensator Valve and Piston as in (6) above.
 9. Insert the piston into the cylinder (Magazine Tube) with the end having the piston pin holes to the rear and with the gas port at the top (barrel side) of the tube.
 10. Insert the pressure compensator valve into the cylinder with the solid end face down.
 11. Make sure piston holes are clearly visible through vent slots.
 12. Slide Piston Connector Ring over the Magazine Tube.
 13. Align piston holes and piston connector ring holes and insert Piston Pin.
 14. Align piston pin slot with piston connector ring slots and reposition ring spring into center piston connector ring slot.

FIELD CLEANING OF THE GAS CYLINDER

If unusually dirty conditions prevail or an unusual amount of shooting has been done since the last cleaning and the Model 1000 becomes sluggish operationally or ejection patterns become erratic, the following field cleaning should suffice until the cleaning procedure noted previously is convenient:

1. Move the Operating Handle to the open and locked position.
2. Remove Fore-End Cap, Fore-End and Barrel.
3. Grip the Piston Connector Ring and reciprocate the piston through its full stroke until the movement is smooth which indicates that cylinder contamination has been cleaned by the piston's edge.

CLEANING OF TRIGGER PLATE ASSEMBLY

1. Push out Trigger Plate Pins (#100, #101) with Drift Punch. (FIG. 1)
2. Remove Trigger Plate Assembly (#67).
3. Trigger (#77), Safety Button (#69), Hammer

- (#85), Carrier Assembly (#87) and Sear (#73) are assembled in Trigger Plate (#68).
4. Clean the Trigger Plate Assembly with cleaning oil and dry thoroughly.
 5. Lubricate with gun oil.
 6. When replacing Trigger Plate into Receiver, be sure Bolt Release Button is depressed and

Trigger Plate Pin Bushings are centered. If binding occurs, it is also helpful to have cocked the hammer (#85). If proper alignment of Trigger Plate Pin Holes is difficult to achieve, a slight movement of the Breech Bolt will be of help.

7. Replace Trigger Plate Pins.

GUNSMITH ONLY

Disassembly and Cleaning of Breech Bolt Assembly:

1. Remove Fore-End Cap, Fore-End, and Barrel.
2. Remove Trigger Plate Assembly (#67).
3. Remove Piston Connector Ring (#51) as previously mentioned as well as Pressure Compensator Valve Assembly (#44) and Piston (#49).
4. Remove Operating Handle from Breech Bolt (#35) after aligning its position with the middle notch in the breech bolt way.
5. While depressing the Bolt Release Button, hold Action Bar Sleeve Assembly (#53) and push forward. The entire breech bolt group will then be pushed out of the receiver.
6. Clean each part with cleaning oil, wipe dry and lubricate with gun oil and reassemble Breech Bolt Assembly in the following sequence.

- a. Breech Bolt (#35)
- b. Locking Block (#43)
- c. Links (#63 and #64)
- d. Link Pin (#65) and insert Assembly partially into Receiver.
- e. Breech Bolt Base (#59).
- f. Attach Action Bars (#56 and #57) to Action Bar Sleeve (#54) and slide over Magazine Tube.
- g. Mate Action bars to Breech Bolt Base (#59) and continue to insert into the Receiver.

NOTE: Be sure that mated ends of the links are inserted into the Action Spring Guide (#31).

7. Replace Bolt handle, into the Breech Bolt.
8. Replace Trigger Assembly.
9. Reassemble gas system.

INSTRUCTIONS FOR ORDERING PARTS

When ordering parts, please give the following information:

1. Model number of the firearm.
2. Serial number of the firearm.
3. Gauge and choke of the firearm.
4. Part name and number of the part required.

Please order parts separately from factory repair service as delivery may be delayed.

Send your order to:

Smith & Wesson
 2100 Roosevelt Ave.
 Springfield, MA 01101
 Attn: Parts Department

INSTRUCTIONS FOR FACTORY SERVICE

Should your Smith & Wesson long gun require adjustment, repair, or refinishing, we recommend most sincerely that the weapon be returned to the factory. There is no other way to insure that the work will be done in a properly equipped and staffed shop.

Charges are very reasonable, being based on the cost of parts replaced plus a labor charge for the time expended on the job. A labor charge for one hour is usually sufficient to cover all but very extensive overhaul jobs.

Long guns returned to the factory should be **MARKED FOR THE ATTENTION OF THE SERVICE DEPARTMENT**. A letter of instructions should be enclosed with the gun, and shipment by individuals must be Prepaid. Adherence to these suggestions will prevent loss of time in handling at the factory.

When your Long gun arrives for service, it will be very carefully inspected, together with your letter of instructions. Next, a quotation covering total cost of work to be performed will be sent to you. No actual work will be connected before receiving your approval of our quotation unless you specifically authorize us to do so.

THE SMITH & WESSON SPORTING GOODS GROUP PRODUCTS

- SMITH & WESSON AMMUNITION
- COMPONENTS
- PUMP SHOTGUNS
- HANDGUNS
- AUTOMATIC SHOTGUNS
- LEATHER GOODS
- PELLET GUNS
- BB GUNS
- MARINE DISTRESS SIGNALS AND FLARES



Smith & Wesson

a BANGOR PUNTA Company

Springfield, Ma. 01101