

INSTRUCTION MANUAL INSERT FOR

RUGER® 10/22® TAKEDOWN RIFLE

The **RUGER® 10/22® TAKEDOWN RIFLE** has an adjustable lock-up mechanism. The following directions describe the adjustment necessary to ensure proper lockup the first time the barrel is installed. After the first adjustment, the barrel may be installed by following steps 1 and 3 **only**, and the barrel may be removed by following steps 1 and 5 **only**.

1. Remove the magazine, lock the bolt open (see Instruction Manual page 12), and verify the rifle is unloaded by visually inspecting the chamber.
2. Loosen the adjustment knob by turning it **clockwise** as far as possible with finger pressure. (See Figures below.)

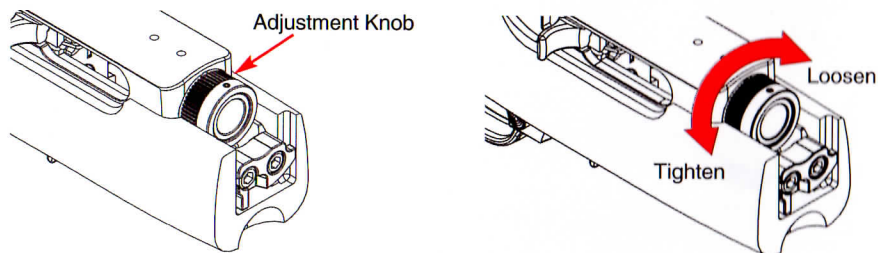

3. Install the barrel assembly by ① inserting it into the receiver and ② rotating it **clockwise** until it locks into place. (See Figures below.)

INSTALLING THE BARREL ASSEMBLY

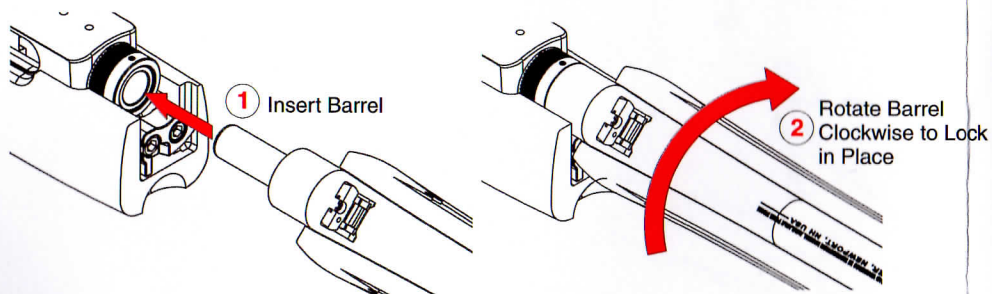

4. Tighten the adjustment knob by turning it **counterclockwise** as far as possible with finger pressure.
5. To remove the barrel assembly, ① lock the bolt back and ② push the locking lever towards the muzzle. Next, ③ rotate the barrel assembly **counterclockwise** and ④ pull the barrel assembly out of the receiver. (See Figures below.)

REMOVING THE BARREL ASSEMBLY

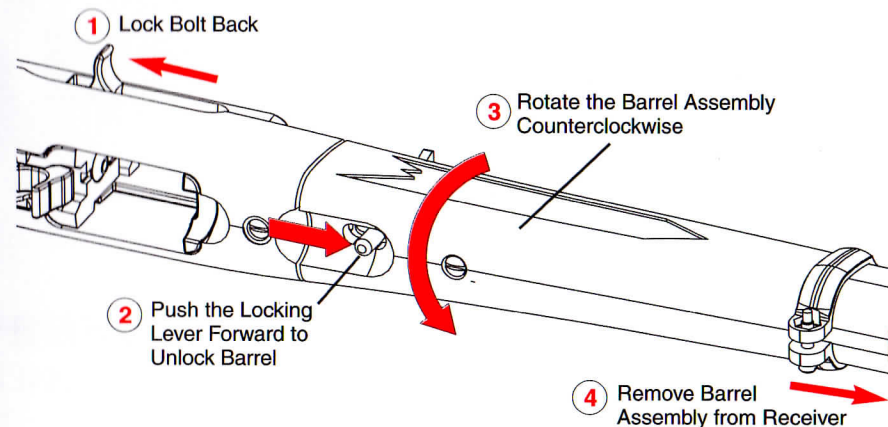

6. Tighten the adjustment knob by rotating it counterclockwise one or two (1 - 2) more clicks.
7. Reinstall the barrel assembly. You should feel some resistance when turning the barrel assembly, but it should not be difficult. If further adjustment is needed, remove the barrel assembly and "tighten" or "loosen" the adjustment knob accordingly.

NOTE: Following barrel installation, best fired shot accuracy will be achieved if the action is dry cycled prior to actually firing ammunition in the rifle: Remove the magazine from the rifle and be certain the chamber is empty. Keeping the rifle pointed in a safe direction, pull the bolt handle fully to the rear while holding the bolt lock up, then release the bolt handle, letting it "slingshot" (freely fly forward) into the ready-to-fire position. Repeat 2 - 3 times. This will properly "seat" the barrel assembly.

SUPPLEMENTAL PARTS LIST

Please See Pages 33 - 39 of the Enclosed Instruction Manual For All Other Parts Lists and Exploded View Drawings

Key	Part Name	Part No.	Model
1	Buttstock Assembly	B30470	10/22-TD
* 2	Receiver - Takedown	B00117	10/22-TD
** 3	Insert	KB00080	10/22-TD
4	Detent Spring	B00087	10/22-TD
5	Safety Detent Plunger	B-53	10/22-TD
6	Adjusting Knob	KB00088	10/22-TD
7	Spacer	KB00082	10/22-TD
8	Spacer Pin	KB00090	10/22-TD
9	Clamp	KB00089	10/22-TD
10	Barrel Retainer Screw	B-67	10/22-TD

Key	Part Name	Part No.	Model
11	Takedown Screw	B-65	10/22-TD
12	Locking Plunger	KB00085	10/22-TD
13	Locking Plunger Detent	KB00083	10/22-TD
14	Locking Plunger Spring	B00086	10/22-TD
15	Mounting Screw	B00091	10/22-TD
16	Locking Lever	KB00081	10/22-TD
17	Block	B00084	10/22-TD
18	Stock - Forend	B00471	10/22-TD
19	Barrel	K0B8021	10/22-TD

* Because the receiver of the **10/22® TAKEDOWN RIFLE** is a serial numbered component, it is defined as a “firearm” by Federal law and is not sold as a separate component.

** PARTS SO MARKED MUST BE FACTORY INSTALLED

RUGER® 10/22® TAKEDOWN RIFLE SUPPLEMENTAL PARTS EXPLODED VIEW

