

MP 5

— MP5K / MP5KA1 —

BRIEF DESCRIPTION
OF THE

MP 5
SUBMACHINE GUN

- MP5K/MP5KA1 -

GENERAL

The MP5 Submachine Gun, for 9 mm x 19 (Luger) ammunition, is an automatic small arm produced in accordance with the most advanced manufacturing methods. It permits either single shots or bursts to be fired from all positions.

The submachine gun is recoil-operated, with stationary barrel and delayed roller locked bolt system.

Its high accuracy in the single-fire mode results from the fact that the submachine gun fires from closed bolt position, in conjunction with the recoil operated delayed roller locked bolt system.

This delayed roller locked bolt system also allows the weapon to be held more easily when firing bursts.

The MP5 offers absolute safety because it fires from the closed bolt position.

The ammunition is fed from a 15- or 30-round magazine.

Models:

1. MP5A2 with fixed butt stock (Fig.1)
2. MP5A3 with retractable butt stock (Fig. 2)
3. MP5K and MP5KA1 (page 50).



Fig. 1 MP5A2 with fixed butt stock



Fig. 2 MP5A3 with retractable butt stock

ASSEMBLIES

1. Receiver with barrel, cocking mechanism and sights
 2. Bolt assembly
 3. Pistol grip with trigger mechanism
 4. Fixed butt stock; retractable butt stock
 5. Handguard
 6. Magazine
- Accessories (page 18)

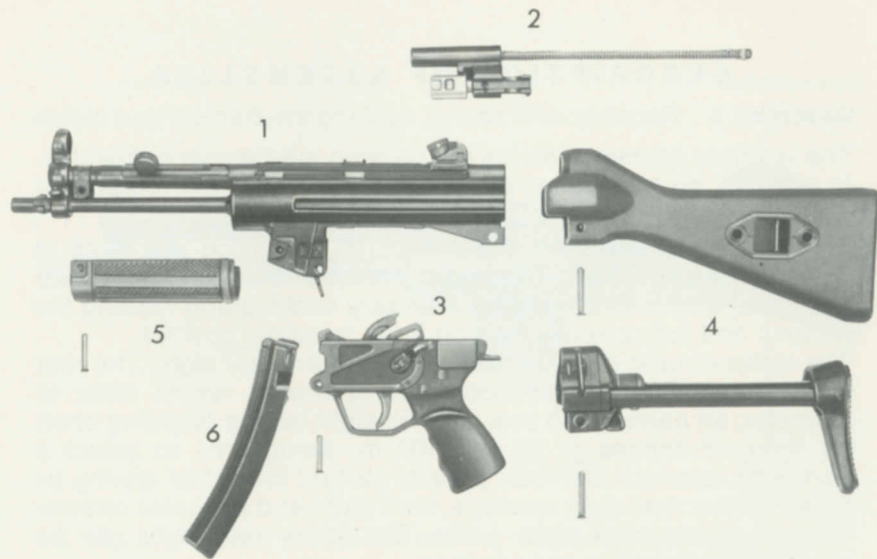

Fig. 3 Assemblies

DESCRIPTION OF ASSEMBLIES

Assembly 1 Receiver with barrel, cocking mechanism and sights

The receiver connects the barrel, cocking mechanism and sights. In addition, all assemblies are either contained in the receiver or attached to it (Fig. 4).

The barrel is press-fitted into the barrel extension and fixed in place by means of pins. The cocking mechanism is located above the barrel and is employed for manually cocking and loading the weapon and for securing the bolt in its rearmost position.

The sights consist of the front sight and rotary rear sight. The rear sight has 4 aperture positions; the apertures, which differ in diameter, all correspond to a uniform sight setting (sighting shot) for firing at ranges of 25 and 100 m. Being able to select a particular aperture diameter permits perfect individual aiming by means of the rear sight aperture, front sight and the outer circumference of the front sight cover. The rotary rear sight can be adjusted for elevation and windage.

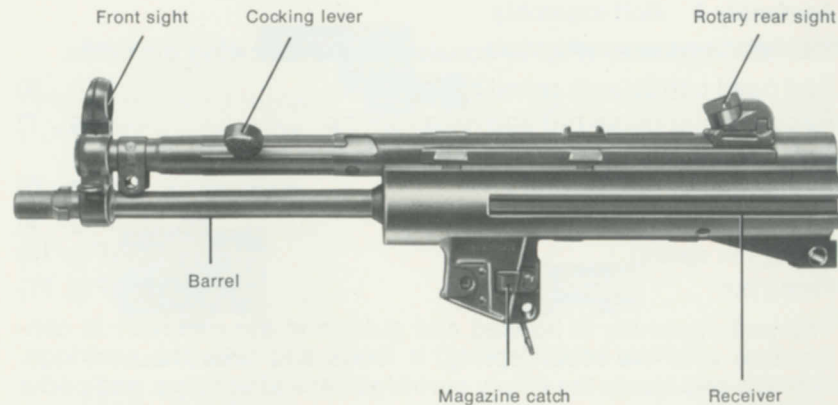

Fig. 4 Receiver with barrel, cocking mechanism and sights

Assembly 2 Bolt assembly

The bolt assembly (Fig. 5) consists of the following elements:

Bolt head carrier with recoil spring tube (Fig. 6)

Recoil spring guide rod and recoil spring (Fig. 7)

Bolt head with locking rollers, extractor and extractor spring (Fig. 8)

Locking piece (Fig. 9)

Firing pin spring (Fig. 10)

Firing pin (Fig. 11)

The bolt assembly is housed and guided in the receiver; in conjunction with the recoil spring, it feeds and fires the cartridge, extracts and ejects the empty cartridge case after firing, and cocks the hammer.

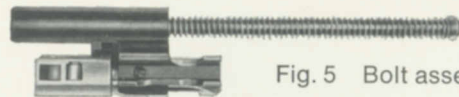

Fig. 5 Bolt assembly



Recoil spring tube

Fig. 6 Bolt head carrier with recoil spring tube



Fig. 7 Recoil spring guide rod with recoil spring

Extractor with extractor spring

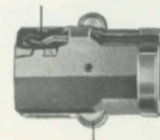

Locking roller

Fig. 8 Bolt head

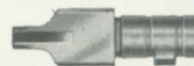

Fig. 9 Locking piece



Fig. 10 Firing pin spring



Fig. 11 Firing pin

Assembly 3 Pistol grip with trigger mechanism

The pistol grip (Fig. 12) is hinged to the receiver and can be swung down and removed from it; it contains the trigger housing (Fig. 13), with components of the trigger and safety mechanism. The safety axle connects the trigger housing to the pistol grip.



Fig. 12 Pistol grip with trigger mechanism

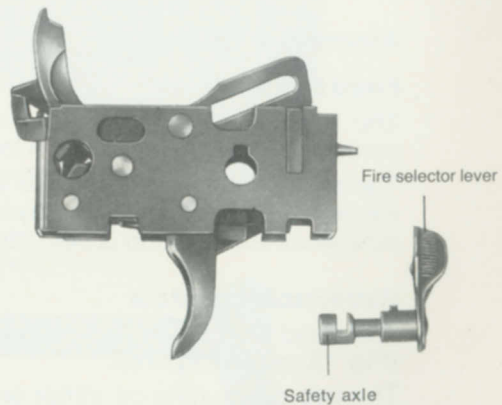

Fig. 13 Trigger housing with trigger mechanism and safety components

Assembly 4 Butt stock

Fixed butt stock

The fixed butt stock (Fig. 14) closes the rear of the receiver. It is connected to the receiver by a locking pin.

The sling holder is attached to the butt stock by means of tubular rivets, which are also employed for safekeeping of the locking pins when the weapon is field stripped.

Retractable butt stock

The fixed butt stock can be replaced by a retractable butt stock (Fig. 15) when required.

The two guide rails on either side of the butt stock are guided in grooves on the receiver. They are secured by a locking catch in both the retracted and extended positions.

A sling holder is attached to the back plate.

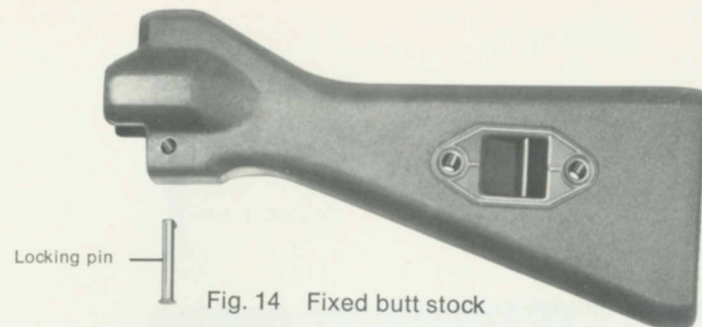

Fig. 14 Fixed butt stock

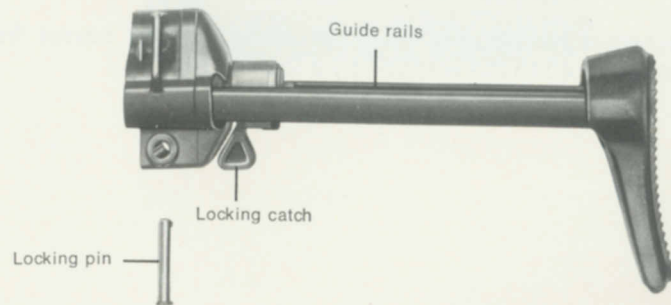

Fig. 15 Retractable butt stock

Assembly 5 Handguard

The detachable handguard (Fig. 16) encircles the barrel from below. It is attached to the weapon by a locking pin.



Fig. 16 Handguard

Assembly 6 Magazine

The magazine holds 15 or 30 rounds and is employed for feeding the cartridges to the submachine gun.

The magazine consists of:

Magazine housing (Fig. 17)

Floor plate (Fig. 18)

Follower with follower spring and locking plate (Fig. 19)



Fig. 17 Magazine housing



Fig. 18 Floor plate



Fig. 19 Follower, with follower spring and locking plate

ACCESSORIES

Multi-purpose carrying sling

The multi-purpose carrying sling (Fig. 20) is employed for carrying the submachine gun, while permitting the shooter to fire immediately from all positions (see pages 44–47).

Blank attachment

The blank attachment (Fig. 21) permits blank ammunition to be fired. For better identification, it is prominently marked with a coloured ring.

Powder residues can be removed by soaking the blank attachment in kerosene.

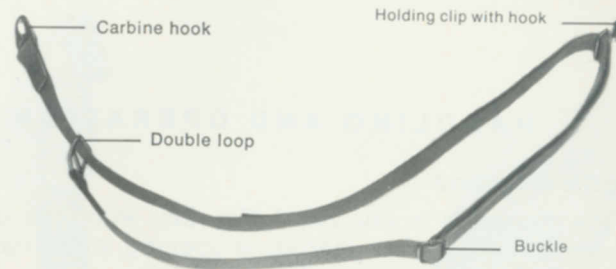

Fig. 20 Multi-purpose carrying sling

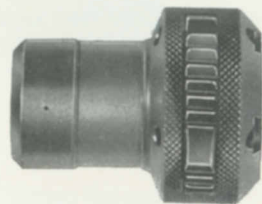

Fig. 21 Blank attachment

HANDLING AND OPERATION

Filling the magazine

Hold the magazine in one hand (Fig. 22); with your other hand, place the cartridge in the magazine opening, pressing the uppermost cartridge under the lip with your thumb.

Emptying the magazine

Hold the magazine in one hand, with the bullet end of the cartridges pointing toward your other hand (Fig. 23). Using your thumb, push the cartridges to the right, into your open hand.

Note: A magazine filler and emptier is available for both operations.



Fig. 22 Filling the magazine



Fig. 23 Emptying the magazine

Safety

The fire selector lever is situated on the left side of the pistol grip. It can be rotated to three positions:

S = Safe, E = Single fire, F = Burst (Fig. 24).

In order to permit the selected mode to be recognized on both sides of the weapon, the letters S, E and F are also marked on the right hand side of the pistol grip. An indicator mark located on the face of the safety axle indicates the position to which the fire selector lever has been set (Fig. 25).

Setting the safety!

Set fire selector lever to -S-. It is now impossible to pull the trigger. Cocking and loading can be performed with the safety engaged.

Firing:

Single fire: Set fire selector lever to -E- Single fire.

Bursts: Set fire selector lever to -F- Burst.

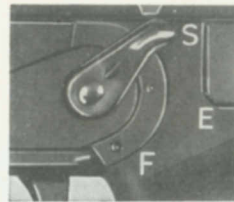

Safe

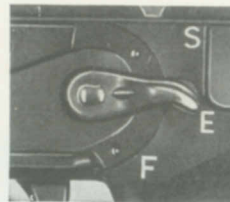
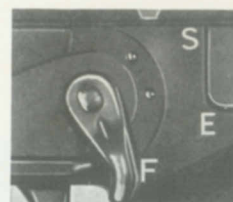
Single fire
Fig. 24

Burst



Safe

Single fire
Fig. 25

Burst

Inserting and removing the magazine

Engage the safety!

Insert magazine into the magazine well (Fig. 26) until you hear the magazine catch engage.

To remove the magazine, push the magazine release lever (Fig. 27).



Fig. 26 Inserting
the magazine



Fig. 27 Removing
the magazine

Loading the submachine gun

Engage the safety!

Retract the cocking lever with your left hand and engage it in the recess in the receiver (Fig. 28).

Insert a loaded magazine into the magazine well until you hear the magazine catch engage (Fig. 26).

Disengage the cocking lever and let it snap forward.

The weapon is now loaded and on "Safe".

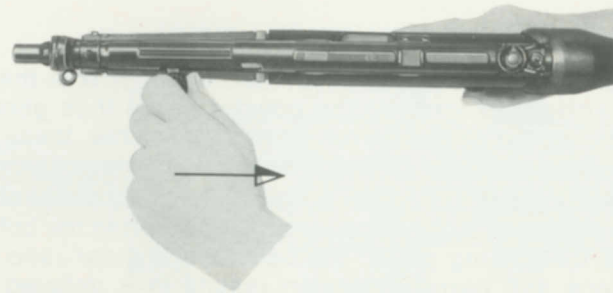

Fig. 28 Retracting the cocking lever

OPERATING PRINCIPLE

The weapon is loaded and cocked, with the safety off.

Pulling the trigger releases the hammer, which strikes the firing pin. The cartridge is ignited. The powder gases thus generated drive the bullet out of the barrel. At the same time, these gases also exert pressure on the cartridge case.

This causes forces to act on the bolt head face; a portion of these forces is transmitted to the receiver and a portion to the bolt head carrier, via the locking piece; the balanced angular ratio of the locking piece and barrel extension results in a delayed recoil movement of the bolt head.

This guarantees that the bolt keeps the barrel locked until the bullet has left the muzzle.

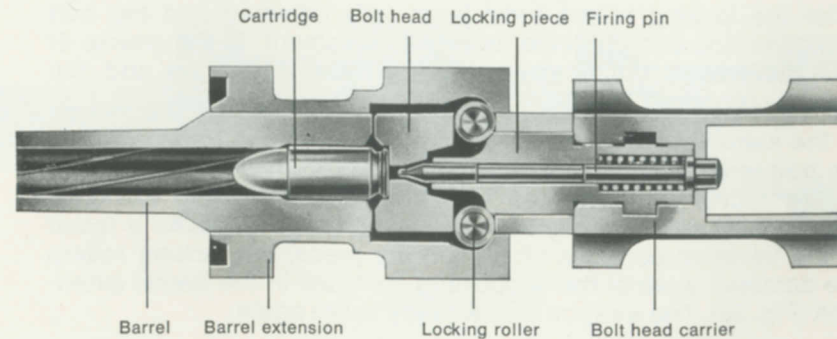

Fig. 29 Bolt in locked position

After the locking rollers have been fully cammed into the bolt head, the bolt can continue its recoil movement. In the course of this movement, the empty cartridge case is ejected and the hammer recocks.

At the same time, the recoil spring is compressed, which returns the bolt to its forward position. During the course of this process, a new round is chambered from the magazine. The extractor engages the extracting groove in the cartridge case. As a result of the bevelled surfaces of the locking piece, the locking rollers are cammed against the supporting surfaces in the barrel extension (Fig. 30). The weapon is now ready to fire again.

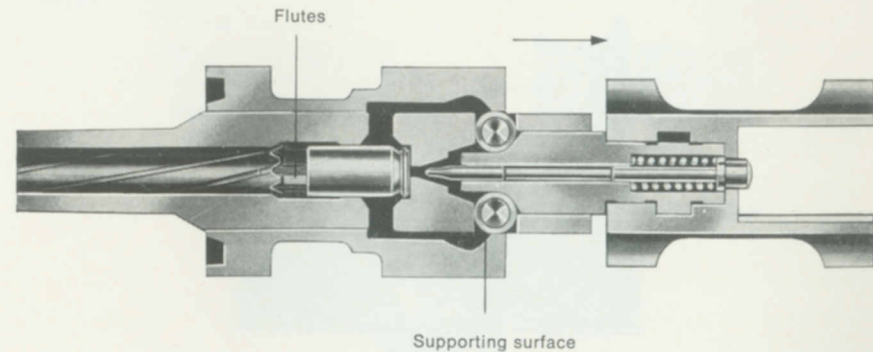

Fig. 30 Bolt in unlocked position

In the **single fire mode** (Fig. 31) the hammer must be released again by the trigger every time a shot is fired.

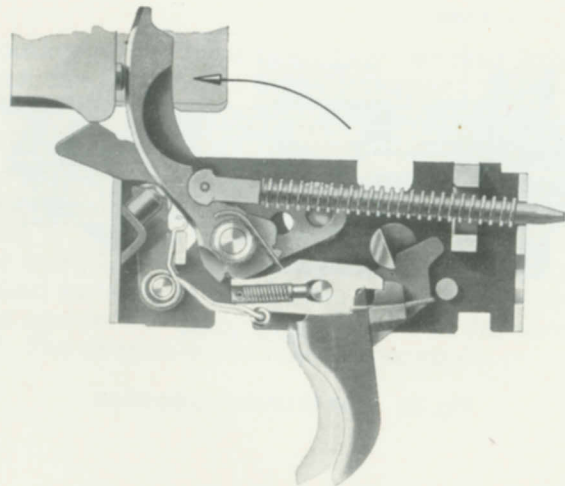

Fig. 31 Single fire

In the **burst mode** (Fig. 32) the sear is moved out of reach of the catch notch in the hammer. The hammer is now held only by the catch and is repeatedly released by the bolt, acting on the release lever.

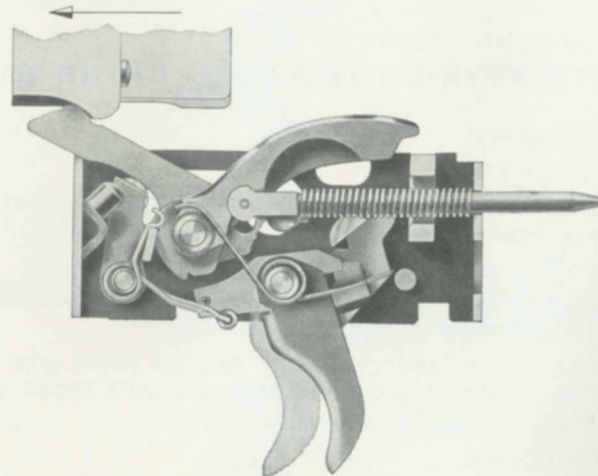

Fig. 32 Burst

STRIPPING THE SUBMACHINE GUN

Engage the safety!

Remove magazine.

Unload chamber; retract cocking lever and make sure that the chamber is clear. Then let cocking lever snap forward.

Unhook multi-purpose sling from front sight holder.

Remove butt stock locking pin and place it in the tubular rivet in the fixed butt stock (Fig. 33).

Slide off butt stock; swing down or remove pistol grip. Using the cocking lever, retract bolt head assembly with recoil spring and remove them from the receiver (Fig. 34).

Detach handguard.

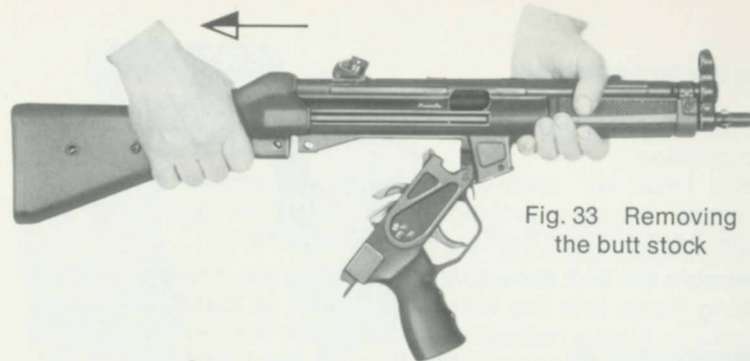

Fig. 33 Removing the butt stock



Fig. 34 Removing the bolt assembly

Stripping the bolt assembly

Remove recoil spring from recoil spring tube by edging it off in the rearmost position.

Rotate bolt head 90° toward your body and detach it from the locking piece. Remove locking piece, firing pin and firing pin spring from the bolt head carrier (Figs. 35 and 36).

To reassemble the bolt assembly, insert firing pin, firing pin spring and locking piece into the bolt head. Insert all parts in the bolt head carrier in such a manner that the lug on the locking piece is guided through the recess in the bore of the bolt head carrier. Rotate bolt head until you hear it engage.

Press recoil spring into the recoil spring tube.

Stripping the pistol grip with trigger mechanism

Uncock hammer (spring).

Rotate selective fire lever until it is in a vertical position, then pull out.

Remove trigger assembly housing.

Note: Further stripping of the trigger assembly housing may only be performed by ordnance personnel. If the trigger assembly housing is severely fouled, it can be washed out in a cleaning solvent.

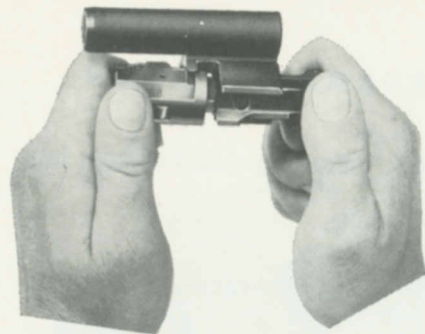

Fig. 35 Removing the bolt assembly components

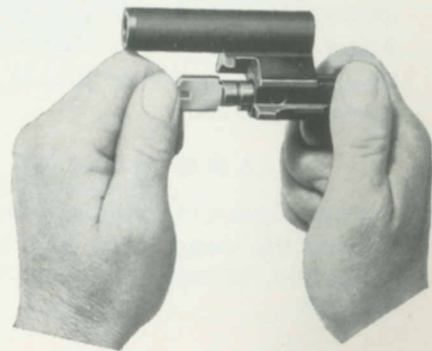

Fig. 36 Stripping the bolt assembly

ASSEMBLING THE SUBMACHINE GUN

Attach handguard.

Insert the assembled bolt assembly, including recoil spring, into the receiver.

Attach pistol grip and swing it into position.
(Set fire selector lever on pistol grip to "S".)

Push the fixed or retractable butt stock onto the receiver and press locking pin into place (Fig. 37).

Attach the multi-purpose carrying sling.

Check the weapon for proper assembly by performing several cocking motions.

JAMMING AND MALFUNCTIONS

Always! Cock and continue firing.

Should the weapon fail to fire, engage the safety, remove the magazine, unload the weapon and determine the source of trouble.



Fig. 37 Assembling the submachine gun

ADJUSTING THE ROTARY REAR SIGHT

Any corrections which may be required when sighting-in the weapon may only be performed by adjusting the rear sight for elevation or windage.

Elevation adjustment:

Insert elevation adjustment tool into the rear sight cylinder (Fig. 38) in such a manner that the wedges of the tool engage the two splines in the cylinder, which contain the catch bolts. Press Phillips-head screwdriver downward into the adjustment tool and hold firmly.

Rotate rear sight cylinder manually in the desired direction (rotating clockwise lowers the strike 1.4 cm (0.55 in.) per click at a range of 25 m, rotating counterclockwise raises it correspondingly).

After performing the correction, withdraw Phillips-head screwdriver and remove elevation adjustment tool. The catch bolts will then reengage in the splines.

After performing the **elevation adjustment**, set the desired aperture again.



Fig. 38 Elevation adjustment

Windage adjustment:

Correction of left-hand deviation: Loosen clamping screw (Fig. 39). Turn adjusting screw (Fig. 40) counterclockwise, in accordance with the required correction. Then retighten clamping screw.

Correction of right-hand deviation: Loosen clamping screw (Fig. 39). Turn adjusting screw (Fig. 40) clockwise until the required correction is obtained. Then retighten clamping screw.

Note: Each revolution of the adjusting screw moves the mean strike 5.5 cm (2.16 in) to the left or right at a range of 25 m.

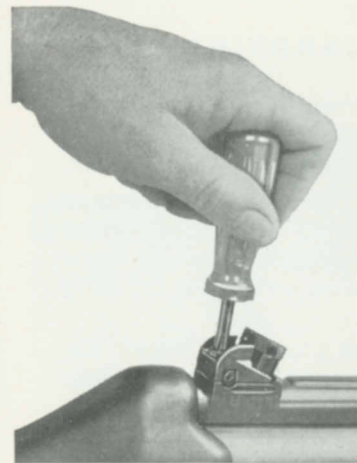

Fig. 39
Loosening the clamping screw

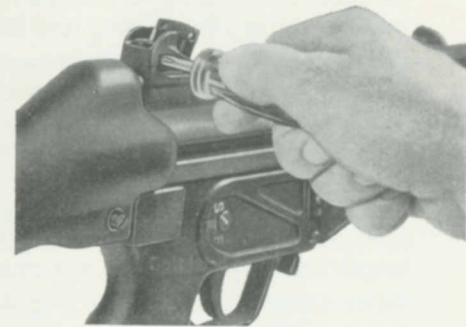

Fig. 40
Rotating the adjusting screw

USING THE MULTI-PURPOSE CARRYING SLING

The multi-purpose carrying sling is attached to the front of the weapon by inserting its carbine hook into the eye on the front sight holder; at the rear, its loop and hook are attached to the butt stock.

When employed as a normal carrying sling, the double loop hangs from the carbine hook. To convert the sling to the "ready" carrying mode (Fig. 43), pull the double loop over the carbine hook (Fig. 41) and attach to the receiver, depending upon how the sling is worn.

Set the multi-purpose carrying sling to the proper length for the individual shooter by readjusting the sliding buckle. The correct sling length can be checked by assuming the desired firing position.

When slinging the weapon (Fig. 42), one half of the sling (1) should extend over the shooter's back, with the other half (2) resting across his chest.

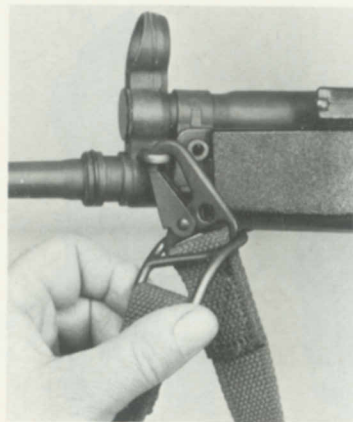

Fig. 41 Pulling the double loop over the carbine hook

— Shown here on the HK 33 Rifle —



Fig. 42 How to wear the multi-purpose carrying sling

Carrying and slinging modes

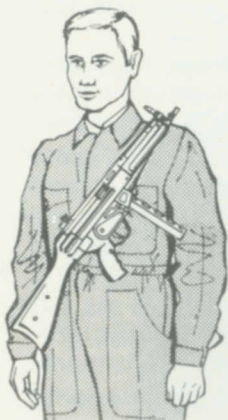

Fig. 43

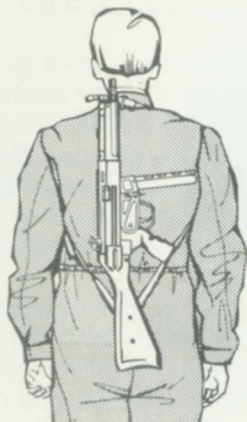

Fig. 44



Fig. 45

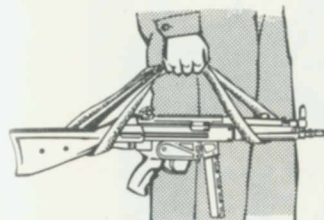

Fig. 46

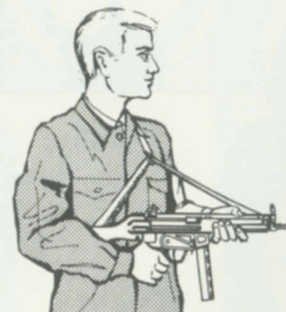

Fig. 47

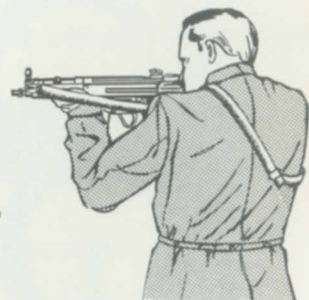
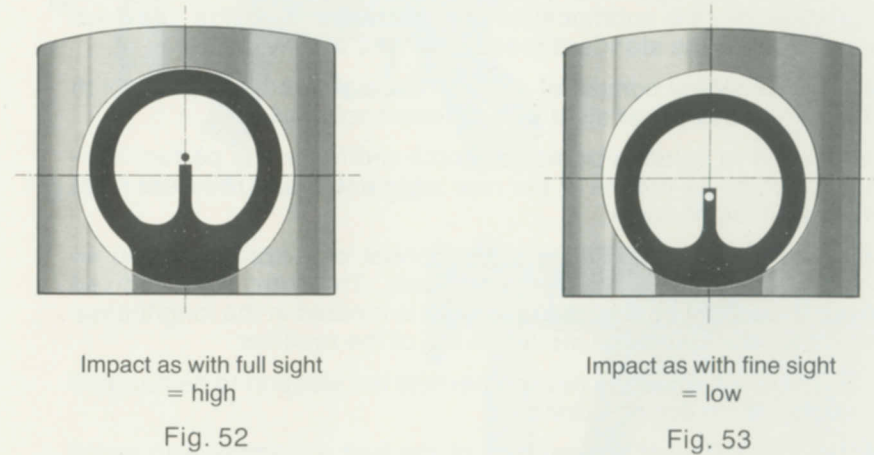
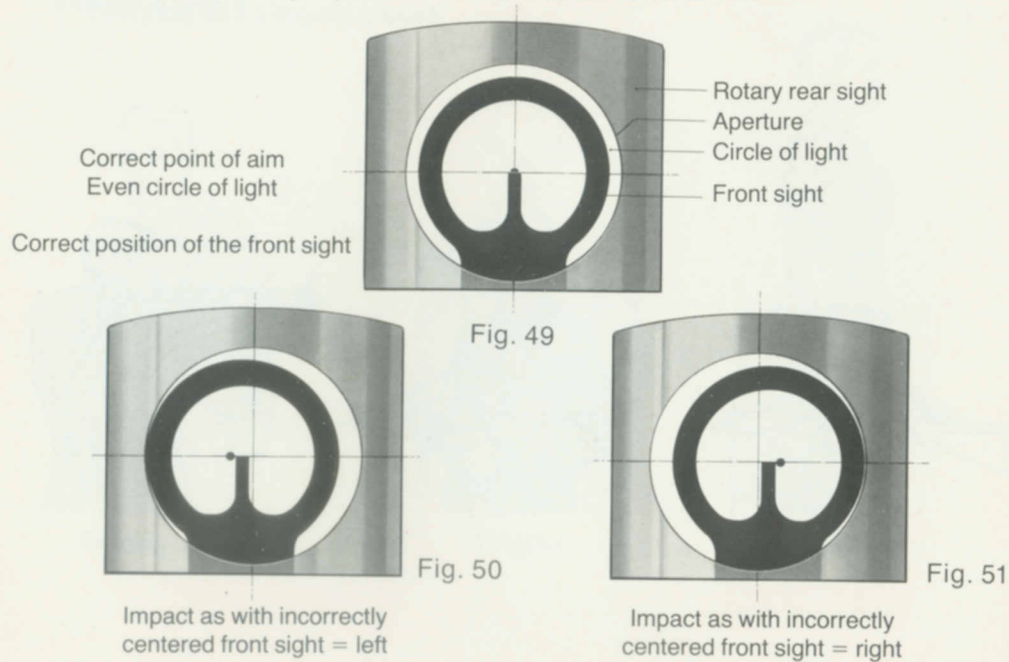

Fig. 48

Firing positions

Sight pictures for MP5 Submachine Gun



MP5K AND MP5KA1 SUBMACHINE GUNS

The action and operation principle, as well as the handling and operation of this submachine gun correspond to the previous description of the standard models MP5A2 and MP5A3.

MP5K The sights consist of a rigid front sight and an open-notch adjustable rotary rear sight with different notch widths.

Being able to select a particular notch width permits perfect individual aiming by means of the rear sight notch and the front sight in the front sight cover.

MP5KA1 The non-adjustable sights consist of a front sight and an open rear sight with rectangular notch. The front sight is fixed to the front sight holder; the rear sight is located in the longitudinal fixture for the HK scope mount on top of the receiver.

The grip just behind the muzzle permits the weapon to be handled securely, even during bursts.

Note: The different dimensions of the bolt assembly with recoil spring dot **not** permit it to be employed in the MP5A2, MP5A3 and MP5SD Submachine guns.

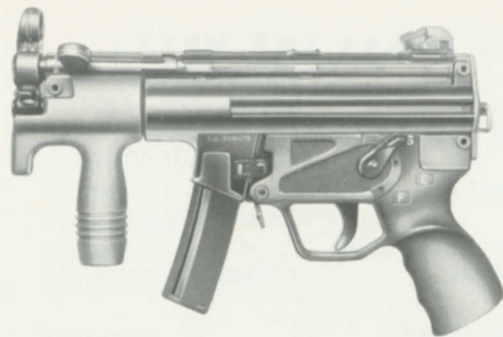

Fig. 54 MP5K Submachine gun



Fig. 55 MP5KA1 Submachine gun

SPECIFICATIONS, MP5A2 AND MP5A3

Rate of fire	approx. 800 r. p. m.
Muzzle velocity - V_0 -	approx. 1312 f.p.s. (400 m/sec)
Muzzle energy - E_0 -	470 ft.lbs (650 J)
6 grooves with constant right-hand twist	
Sighting shot	25 and 100 m
Maximum height of trajectory above the line of sight at a range of 50 to 60 m	4.33 in. (11 cm)
Weights	
Weight of weapon with fixed butt stock, without magazine	5.59 lbs (2.54 kg)
Weight of weapon with retractable butt stock, without magazine	6.34 lbs (2.88 kg)
Steel magazine for 30 rounds, empty	6.0 oz. (0.17 kg)
Cartridge	185 gr. (12 g)
Lengths	
Length of weapon with fixed butt stock	26.77 in. (680 mm)
Length of weapon with retractable butt stock	25.98 in. (660 mm)
Length of weapon with butt stock retracted	19.29 in. (490 mm)
Line of sight	13.39 in. (340 mm)
Barrel	8.85 in. (225 mm)
Cartridge case	0.74 in. (19 mm)

SPECIFICATIONS MP5K AND MP5KA1

Modes of fire	Single fire and bursts
Rate of fire	approx. 900 r.p.m.
Muzzle velocity - V_0 -	approx. 1230 f.p.s. (375 m/sec)
Muzzle energy - E_0 -	420 ft.lbs (570 J)

Weights

Weight of weapon, without magazine	4.4 lbs (2.00 kg)
Steel magazine for 15 rounds, empty	4.23 oz. (0.12 kg)

Lengths

Length of weapon	12.80 in. (325 mm)
Line of sight	10.25 in/7.48 in (260/190 mm)
Barrel	4.53 in. (115 mm)
Width/height of weapon	1.96/8.26 in. (50/210 mm)

TABLE OF CONTENTS

	Page
General	2
Assemblies	4
Description of assemblies	6
Handling and operation	20
Operating principle	28
Stripping the submachine gun	34
Assembling the submachine gun	38
Jamming and malfunctions	38
Adjusting the rotary rear sight	40
Using the multi-purpose carrying sling	44
Sight pictures for submachine gun MP5	48
MP5K and MP5KA1 Submachine Guns	50
Specifications MP5A2 and MP5A3	52
Specifications MP5K and MP5KA1	53
