

U.S. MARINE CORPS TECHNICAL MANUAL

ORGANIZATIONAL AND INTERMEDIATE MAINTENANCE MANUAL INCLUDING REPAIR PARTS LIST

PISTOL, CALIBER .45, MEU(SOC)

(1005-01-370-7353)



THIS PUBLICATION IS REQUIRED FOR OFFICIAL USE OR FOR ADMINISTRATIVE OR OPERATIONAL PURPOSES. DISTRIBUTION IS LIMITED TO U.S. GOVERNMENT AGENCIES ONLY. OTHER REQUESTS FOR THIS DOCUMENT MUST BE REFERRED TO: COMMANDANT OF THE MARINE CORPS (AREB), WASHINGTON, D.C. 20380-0001.

DESTRUCTION NOTICE: FOR UNCLASSIFIED, LIMITED DOCUMENTS, DESTROY BY ANY METHOD THAT WILL PREVENT DISCLOSURE OF THE CONTENTS OR RECONSTRUCTION OF THE DOCUMENT.

FOR OFFICIAL USE ONLY

AUGUST 1994
184 005261 00

DEPARTMENT OF THE NAVY
Headquarters, U.S. Marine Corps
Washington, D.C. 20380-0001

31 August 1994

1. This Manual, TM 00526A-24&P/2, is effective upon receipt and contains organizational and intermediate maintenance instructions for the Caliber .45, MEU (SOC) Pistol.

2. Notice of discrepancies or suggested changes should be forwarded on NAVMC 10772 to: Commander, Marine Corps Logistics Bases (Code 850), Albany, Georgia 31704-5000. In addition, notice of discrepancies should also be forwarded via Naval message or copy of submitted NAVMC 10772 to: Commander, MARCORSSYSCOM (Code CBGI), Quantico, Virginia 22134-5080.

BY DIRECTION OF THE COMMANDANT OF THE MARINE CORPS

OFFICIAL:



D. R. BLOOMER
Colonel, USMC
Director, Program Support
Marine Corps Systems Command

Distribution: 18400526100

TABLE OF CONTENTS

	<u>Page</u>
LIST OF ILLUSTRATIONS	v
LIST OF TABLES	vii
SAFETY SUMMARY	viii
CHAPTER 1 INTRODUCTION	1-1
Section I. GENERAL INFORMATION	1-1
1-1. SCOPE	1-1
1-2. FORMS, RECORDS AND REPORTS	1-1
1-3. ISSUE AND RECOVERY OF INDIVIDUAL PISTOLS	1-2
1-4. REPORTING EQUIPMENT IMPROVEMENT RECOMMENDATIONS (EAR)	1-2
1-5. CORROSION PREVENTION AND CONTROL (CPC)	1-2
1-6. FOURTH AND SPECIAL FIFTH ECHELON MAINTENANCE	1-2
Section II. EQUIPMENT DESCRIPTION AND DATA	1-3
1-7. GENERAL DESCRIPTION	1-3
1-8. EQUIPMENT DATA	1-3
CHAPTER 2 FUNCTIONAL DESCRIPTION	2-1
2-1. GENERAL DESCRIPTION	2-1
2-2. NOMENCLATURE	2-1
2-3. DESCRIPTION OF MAJOR COMPONENTS	2-2
2-4. SERIAL NUMBER LOCATIONS	2-3
2-5. ASSOCIATED EQUIPMENT	2-4
CHAPTER 3 OPERATION	3-1
Section I. INTRODUCTION.	3-1
3-1. CLEARING THE WEAPON	3-1
3-2. FIELD STRIPPING THE WEAPON.	3-3
3-3. REASSEMBLING THE WEAPON	3-7
Section II. OPERATING PROCEDURES	3-9
3-4. LOADING THE WEAPON	3-9
3-5. UNLOADING THE WEAPON	3-9
3-6. IMMEDIATE ACTION	3-10

	<u>Page</u>
CHAPTER 4 SCHEDULED MAINTENANCE	4-1
Section I. INTRODUCTION	4-1
4-1. INSPECTING THE WEAPON	4-1
4-2. OPERATIONAL CHECK	4-1
Section II. ORGANIZATIONAL PREVENTIVE MAINTENANCE	4-2
4-3. GENERAL	4-2
4-4. ORGANIZATIONAL TOOLS AND EQUIPMENT	4-3
4-5. PREVENTIVE MAINTENANCE PROCEDURES	4-3
4-6. CLEANING THE WEAPON	4-5
4-7. LUBRICATING THE WEAPON	4-6
Section III. INTERMEDIATE LEVEL MAINTENANCE.	4-6
4-8. GENERAL	4-6
Section IV. CARE AND PREPARATION FOR STORAGE AND SHIPMENT	4-6
4-9. STORAGE PROCEDURES	4-6
4-10. SHIPPING PROCEDURES	4-7
CHAPTER 5 TROUBLESHOOTING PROCEDURES	5-1
5-1. TROUBLESHOOTING	5-1
CHAPTER 6 CORRECTIVE MAINTENANCE	6-1
Section I. INTRODUCTION.	6-1
6-1. GENERAL	6-1
Section II. ORGANIZATIONAL MAINTENANCE	6-2
6-2. FIRING PIN GROUP	6-2
6-3. RECOIL GROUP	6-4
6-4. COMBAT PISTOL GRIP	6-6
6-5. MAGAZINE CATCH GROUP	6-7
6-6. PLUNGER TUBE GROUP	6-9
6-7. MAINSPRING HOUSING GROUP	6-12
6-8. MAGAZINE ASSEMBLY	6-16

Page

Section III. INTERMEDIATE MAINTENANCE 6-17

6-9. THIRD ECHELON MAINTENANCE 6-17

6-10. EXTRACTOR 6-17

6-11. EJECTOR AND EJECTOR PIN. 6-18

6-12. FOURTH ECHELON MAINTENANCE 6-21

6-13. MAINTENANCE OF THE SLIDE ASSEMBLY 6-21

6-14. MAINTENANCE OF THE RECEIVER ASSEMBLY 6-26

6-15. GRIP SCREW BUSHING 6-34

6-16. PLUNGER TUBE 6-37

6-17. TRIGGER PULL TEST 6-39

Section IV. SAFETY CHECK 6-41

6-18. SAFETY CHECK 6-41

CHAPTER 7 REPAIR PARTS AND SPECIAL TOOLS LIST 7-1

Section I. INTRODUCTION 7-1

7-1. SCOPE 7-1

7-2. GENERAL 7-1

7-3. EXPLANATION OF COLUMNS (SECTIONS II AND III) 7-1

7-4. EXPLANATION OF INDEX FORMAT AND COLUMNS
(SECTION IV) 7-7

7-5. HOW TO LOCATE REPAIR PARTS 7-8

Section II. REPAIR PARTS LIST 7-9

Fig. No.

WEAPON SYSTEM 7-1 7-9

FIRING PIN GROUP 7-2 7-10

SLIDE ASSEMBLY WITH SLIDE STOP 7-3 7-11

MAGAZINE CATCH, PLUNGER TUBE AND
EJECTOR GROUPS 7-4 7-12

MAINSRING HOUSING GROUP 7-5 7-13

RECEIVER ASSEMBLY 7-6 7-14

COMBAT PISTOL GRIP GROUP.... 7-7 7-16

MAGAZINE ASSEMBLY 7-8 7-17

	<u>Page</u>
Section III. SPECIAL TOOLS LIST..	7-18
	<u>Fig. No.</u>
SPECIAL TOOLS LIST	7-9 7-18
Section IV. CROSS REFERENCE INDEXES	7-19
NATIONAL STOCK NUMBER INDEX	7-19
PART NUMBER INDEX	7-20
CONTRACTOR AND GOVERNMENT ENTITY CODE INDEX	7-21
APPENDIX A REFERENCESA-1
APPENDIX B COMPONENTS LIST..B-1
APPENDIX C FABRICATION INSTRUCTIONS	C-1

LIST OF ILLUSTRATIONS

<u>Figure</u>	<u>Title</u>	<u>Page</u>
1-1.	Weapon Record Book, MCCDC 22741.	1-3
2-1.	MEU(SOC) .45 Caliber Pistol-Left Side	2-1
2-2.	MEU(SOC) .45 Caliber Pistol-Right Side	2-2
2-3.	MEU(SOC) .45 Caliber Pistol - Major Components	2-3
2-4.	Serial Number Locations	2-3
2-5.	The MEU(SOC) .45 Caliber Pistol Weapon System	2-4
3-1.	Clearing The Weapon	3-2
3-2.	Checking The Weapon	3-2
3-3.	Field Stripping The Weapon	3-3
3-4.	Aligning The Disassembly Notch	3-4
3-5.	Removing The Slide Stop	3-4
3-6.	Separating The Slide Assembly From The Receiver Assembly	3-5
3-7.	Removing The Recoil Spring And Recoil Spring Guide	3-5
3-8.	Removing The Recoil Spring Plug....	3-6
3-9.	Removing The Barrel Bushing	3-6
3-10.	Removing The Barrel	3-7
3-11.	Reassembling The Slide And Receiver Assemblies	3-8
6-1.	Firing Pin Group	6-2
6-2.	Recoil Group	6-4
6-3.	Removing Combat Pistol Grip....	6-6
6-4.	Magazine Catch Lock	6-7
6-5.	Magazine Catch Group	6-8
6-6.	Removing Ambidextrous Thumb Safety.	6-10
6-7.	Removing Plunger Tube Group	6-11
6-8.	Plunger Tube Group	6-11
6-9.	Removing Mainspring Housing Pin.	6-13
6-10.	Removing Mainspring Housing	6-13

<u>Figure</u>	<u>Title</u>	<u>Page</u>
6-11.	Removing Mainspring Retaining Pin	6-14
6-12.	Removing Mainspring Group	6-14
6-13.	Firing Pin Group	6-17
6-14.	Removing Ejector Pin.	6-19
6-15.	Removing Ejector	6-19
6-16.	Installing Ejector And Ejector Pin	6-20
6-17.	Firing Pin Group	6-22
6-18.	Recoil Group	6-23
6-19.	Removing And Installing Front Sight	6-23
6-20.	Checking HeadSpace	6-25
6-21.	Removing Ambidextrous Thumb Safety	6-26
6-22.	Removing Mainspring Housing Pin	6-27
6-23.	Removing Mainspring Housing..	6-27
6-24.	Removing Beavertail Grip Safety	6-28
6-25.	Removing Sear Spring	6-28
6-26.	Removing Hammer Pin.....	6-29
6-27.	Removing Hammer Group	6-29
6-28.	Removing Sear Pin	6-30
6-29.	Removing Trigger	6-31
6-30.	Removing Hammer Strut And Hammer Strut Pin	6-31
6-31.	Removing Grip Screw Bushing	6-35
6-32.	Installing Grip Screw Bushing.	6-36
6-33.	Removing And Installing The Plunger Tube	6-37
6-34.	Staking The Plunger Tube	6-38
6-35.	Test Fixture	6-39
6-36.	Trigger Pull Test	6-40
6-37.	Ambidextrous Thumb Safety Test....	6-42
6-38.	Beavertail Grip Safety Test....	6-43
6-39.	Half-Cock Position Test	6-43
6-40.	Disconnecter Test	6-44

LIST OF TABLES

<u>Number</u>	<u>Title</u>	<u>Page</u>
1-1.	Specifications and Capabilities	1-3
4-1.	Organizational Tools and Equipment.	4-3
4-2.	Preventive Maintenance Checks and Services (PMCS) Quarterly Schedule	4-4
5-1.	Organizational Troubleshooting Chart.	5-1
5-2.	Intermediate Troubleshooting Chart..	5-4
6-1.	Intermediate Maintenance Special Tools and Test Equipment	6-21

SAFETY SUMMARY

The following WARNINGS and CAUTIONS appear on the page referenced and are listed here for emphasis.

WARNING

Make certain fingers are outside of the trigger guard and the pistol is pointed in a safe direction at all times. (Page 3-1/3-9)

WARNING

After the pistol is unloaded, and with the slide assembly to the rear, always physically check the chamber for a cartridge to preclude injury from a negligent discharge. (Page 3-1/3-10)

WARNING

Make certain the weapon is cleared. (Page 3-3)

WARNING

Recoil spring guide is under spring tension. Use care to prevent recoil spring from flying free or causing injury. (Page 3-5 /6-4/6-21)

WARNING

Recoil spring is under tension and could fly free. (Page 3-8)

WARNING

If your pistol stops firing with a live round in a hot barrel (misfire), manually cock the hammer without opening the chamber and make one additional attempt to fire. If the pistol still fails to free, wait approximately 10 seconds, ensure that during this time you keep the muzzle pointed in a safe direction. (Page 3-10)

WARNING

Keep your face away from the ejection port while clearing a hot chamber. (Page 3-10)

WARNING

The MEU(SOC) .45 Caliber Pistol is built individually. Its major groups and components are hand-fitted to function on the assigned pistol and are not interchangeable. The use of lights or any such devices are not authorized. (Page 4-1)

WARNING

**Before starting an inspection or repairs, be sure to clear the pistol. Do not actuate the trigger until the pistol has been cleared. Remove the magazine and inspect the chamber, to ensure that it is empty. Do not have live ammunition in the vicinity of the work area.
(Page 4-2/6-1/6-42)**

WARNING

**Make the pistol safe before cleaning. Ensure that the pistol is not loaded.
(Page 4-5)**

WARNING

Ensure there is no live ammunition stored in the pistol or in the magazines. (Page 4-6)

WARNING

**Under no circumstances should the pistol be shipped while it still contains live ammunition, either in the shipping box or in the pistol itself.
(Page 4-7)**

WARNING

Firing pin is under spring tension. Use care to prevent firing pin spring from flying free or causing injury. (Page 6-2 / 6-17 / 6-21)

WARNING

Magazine catch lock is under spring tension. Use care to prevent magazine catch lock from flying free or causing injury. (Page 6-7/6-30)

WARNING

Mainspring housing components are under spring tension. Use care to prevent components from flying free or causing injury. (Page 6-12)

WARNING

Magazine assembly is under spring tension, care must be taken when removing the magazine base. (Page 6-16)

WARNING

Place the Insert Tool inside of the plunger tube to prevent deforming and damaging the plunger tube during staking procedures. (Page 6-38)

WARNING

Insure that an empty magazine is installed when checking the trigger pull. (Page 6-39)

WARNING

While stoning, critical dimensions should *not* be altered. If so, weapon failure may result. (Page 6-41)

Do not leave rounds in the magazine for extended periods of time since this will cause the spring to lose tension and may cause a malfunction. (Page 3-1/3-10)

CAUTION

Use only authorized lubrication. Do not mix lubricants. (Page 4-6)

CHAPTER 1

INTRODUCTION

Section I. GENERAL INFORMATION

1-1. SCOPE

a. Type of Manual. Organizational and Intermediate Maintenance procedures (Second through Fourth Echelons) for the Marine Expeditionary Unit (Special Operating Capabilities) (MEU(SOC)) .45 Caliber Pistol. This Manual includes a Repair Parts List. Basic operator's procedures are outlined in TM 00526A-10/1, Operator's Manual.

b. Equipment Name and Model Number. This weapon is the Pistol, Caliber .45, Automatic, Model M1911A1, modified by the Rifle Team Equipment Shop, Weapons Training Battalion, Marine Corps Combat Development Center, 27211 Garand Road, Quantico, Virginia 22134-5036, to support MEU(SOC) missions.

1-2. FORMS, RECORDS, AND REPORTS

a. Forms and Records. The Marine Corps forms and procedures used for equipment maintenance will be those prescribed by the current edition of TM 4700-15/1 (Equipment Record Procedures). Appendix A (References) lists those specific forms to be used with the pistol, but is not to be considered all-inclusive. Responsibility for the proper execution of forms and records rests with the using unit. In order to ensure that accurate records are maintained, it is imperative that the following instructions be followed:

(1) NAVMC 1018. Inspection Tag. This form will be attached to each MEU(SOC) .45 Caliber Pistol that is evacuated to higher echelon for repair. The instructions for completing this form are contained in TM 4700-15/1.

(2) NAVMC 11003. Ordnance Serialized Items/Rounds Fired Data Card. The instructions for completing this form are contained in TM 4700-15/1.

(3) Weapon Record Book

(a) In order to keep an accurate count, you must maintain the Weapon Record Book, MCCDC 22741. It is the responsibility of the shooter to record entries of rounds fired, by type and number, on the day that firing occurs. All inspections, repairs, and part replacements will be recorded in Weapon Record Book. The *shok-buff is* to be checked every 1000 rounds. See Figure 1-1 for an example of annotations of the Weapon Record Book.

1-2. FORMS, RECORDS, AND REPORTS (Continued)

(b) In the event a weapon record book must be reconstructed, a Limited Technical Inspection at the Intermediate Maintenance Activity must be performed. Assistance in recovering data should be requested from the Commanding Officer, Weapons Training Battalion, Marine Corps Combat Development Center, 27211 Garand Road, Quantico, Virginia 22134-5036.

b. Accidents and Malfunctions Reports. Accidents involving injury to personnel or damage to the MEU(SOC) .45 Caliber Pistol will be reported in accordance with the current edition of MCO 5101.8 (Ground Mishap Report). Explosive and ammunition malfunctions will be reported in accordance with MCO 8025.1 (Class V (W) Malfunctions and Deficiencies).

1-3. ISSUE AND RECOVERY OF INDIVIDUAL PISTOLS. Individual pistols will be issued and recovered in the same manner as other individual weapons. NAVMC 10576 (Memorandum Receipt for Individual Weapons and Accessories) will be used as the issue document. NAVMC 10520 (Weapons Custody Receipt Card) will be used when the MEU(SOC) .45 Caliber Pistol is drawn from the armory for use. Detailed instructions for using these forms are contained in TM 4700-15/1.

1-4. REPORTING EQUIPMENT IMPROVEMENT RECOMMENDATIONS (EIR). Personnel recognizing a way of improving this weapon should submit SF 368 (Product Quality Deficiency Report (PQDR)) in accordance with MCO 4855.10 (Product Quality Deficiency Report (PQDR)) to: Commander, Marine Corps Logistics Base (Code 856), 814 Radford Blvd, Albany, Georgia 31704-1128. A reply will be provided.

1-5. CORROSION PREVENTION AND CONTROL (CPC). The prevention of corrosion on any equipment is important, and it is critically important for the safe functioning of a weapon system such as this pistol. Corrosion prevention is carried out in accordance with TM 3080-12 (Corrosion Prevention and Control for Marine Corps Ground Equipment). If a recurrent corrosion problem is identified, it should be reported on SF 368 (PQDR) in accordance with guidance contained in MCO 4855.10 (PQDR).

14. FOURTH AND SPECIAL FIFTH ECHELON MAINTENANCE. All fourth echelon and special fifth echelon maintenance requires a qualified Rifle Team Equipment (RTE) repairman (MOS 2112) to perform repairs. All special fifth echelon maintenance will be accomplished by Weapons Training Battalion, Quantico, Virginia, through the Marine Corps Logistics Base, Albany, Georgia. When special fifth echelon maintenance is required, ship the pistol as per the instructions contained in para 4-10 of this Manual.

DATE	NUMBER OF ROUNDS FIRED	CUMULATIVE TOTAL OF ROUNDS FIRED	USERS NAME AND RANK	REMARKS
<i>Jan 10, 93</i>	<i>40</i>	<i>40</i>	<i>Cpl A. Jones</i>	
<i>Feb 20, 93</i>	<i>25</i>	<i>65</i>	<i>L/Cpl Mitchell</i>	
<i>Mar 21, 93</i>	<i>35</i>	<i>100</i>	<i>Capt Johnson</i>	
<i>Jun 22, 93</i>	<i>28</i>	<i>128</i>	<i>Cpl A. Jones</i>	<i>Firing pin replaced</i>
<i>Sep 19, 93</i>	<i>44</i>	<i>172</i>	<i>Cpl A. Jones</i>	

Figure 1-1. Weapon Record Book

Section II. EQUIPMENT DESCRIPTION AND DATA

1-7. GENERAL DESCRIPTION. The MEU(SOC) .45 Caliber Pistol is an air-cooled, magazine-fed, recoil-operated, automatic-loading defensive hand weapon. A detailed description is provided in Chapter 2 of this Manual.

1-8. EQUIPMENT DATA. Pistol specifications and capabilities are contained in Table 1-1.

Table 1-1. Specifications and Capabilities

SPECIFICATIONS

Caliber:	.45 Caliber NATO
Weight:	
Pistol w/empty magazine	2.5 pounds
Pistol w/loaded magazine	3.0 pounds

Table 1-1. Specifications and Capabilities- Continued

SPECIFICATIONS - Continued

Length:	
Overall length	8.37 inches
Barrel length	5.03 inches
Magazine capacity:	7 rounds
Safety:	Ambidextrous thumb safety
Rifling:	1 turn in 16 inches, left-hand spiral
Sight radius:	6.48 inches
Trigger pull:	4.5 to 5.0 pounds

CAPABILITIES

Maximum Range:	1,500 meters
Maximum Effective Range:	50 meters
Muzzle velocity:	830 feet per second

CHAPTER 2

FUNCTIONAL DESCRIPTION

2-1. GENERAL DESCRIPTION. The MEU(SOC) .45 Caliber Pistol is an air-cooled, magazine-fed, recoil-operated, automatic-loading, defensive hand weapon. It is fed from a seven-round stainless steel magazine and is a semi-automatic weapon, firing one round each time the trigger is squeezed. The weapon can be carried in either a hip or shoulder holster and may be securely connected to the shooter by the pistol lanyard. The MEU(SOC) .45 Caliber Pistol Weapon System components are listed in Appendix B.

2-2. NOMENCLATURE

a. The left side of the pistol, Figure 2-1, reveals front sight (1), slide (2), rear sight (3), ambidextrous thumb safety (4), combat pistol grip (5), magazine catch (6), and slide stop (7).

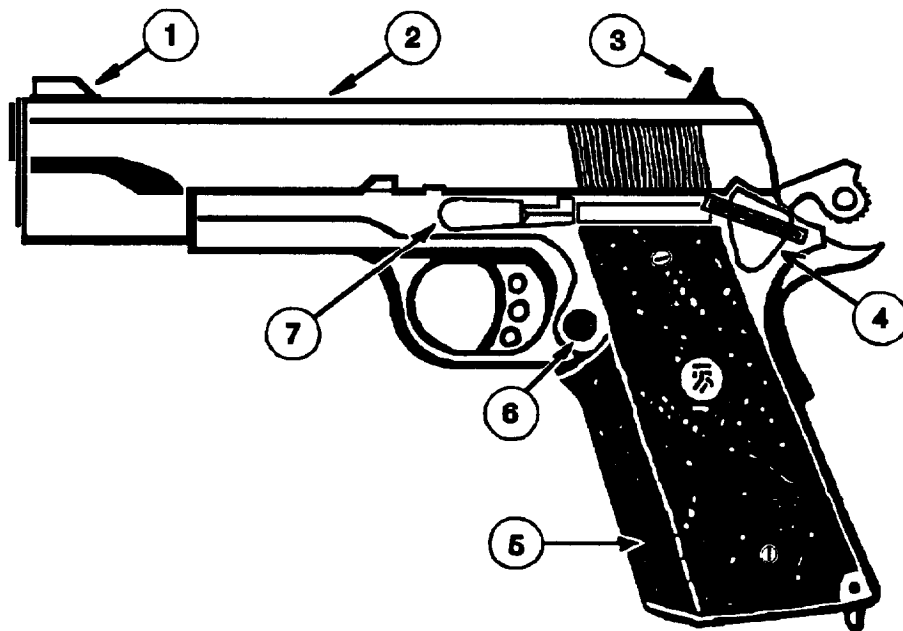

Figure 2-1. MEU(SOC) .45 Caliber Pistol - Left Side

2-2. NOMENCLATURE (Continued)

b. The right side of the Pistol, Figure 2-2, reveals hammer (1), trigger (2), magazine well (3), lanyard loop (4), and beavertail grip safety (5).

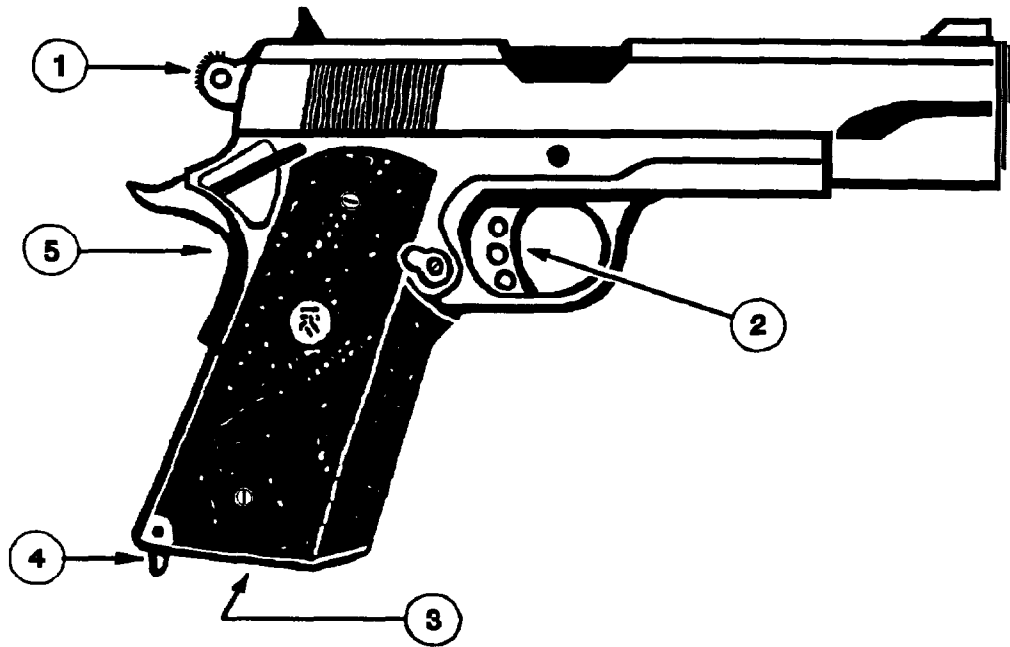

Figure 2-2. MEU(SOC) .45 Caliber Pistol - Right Side

2-3. DESCRIPTION OF MAJOR COMPONENTS (Refer to Figure 2-3)

(1) **SLIDE ASSEMBLY.** The slide assembly houses the barrel, the firing pin, and the extractor. The slide assembly holds and fires the cartridge, extracts and ejects the empty cartridge case after firing, and cocks the hammer.

(2) **RECEIVER ASSEMBLY.** The receiver assembly houses the trigger, hammer, sear, magazine catch, ambidextrous thumb safety, and beavertail grip safety. The receiver assembly also accepts and locks the magazine assembly into place.

(3) **SLIDE STOP.** The receiver assembly is connected to the slide assembly, through the barrel link, by the slide stop.

(4) **MAGAZINE ASSEMBLY.** The magazine assembly is held in the receiver assembly by the magazine catch. The magazine assembly holds the cartridges and presents the cartridge for cambering by the forward motion of the slide assembly.

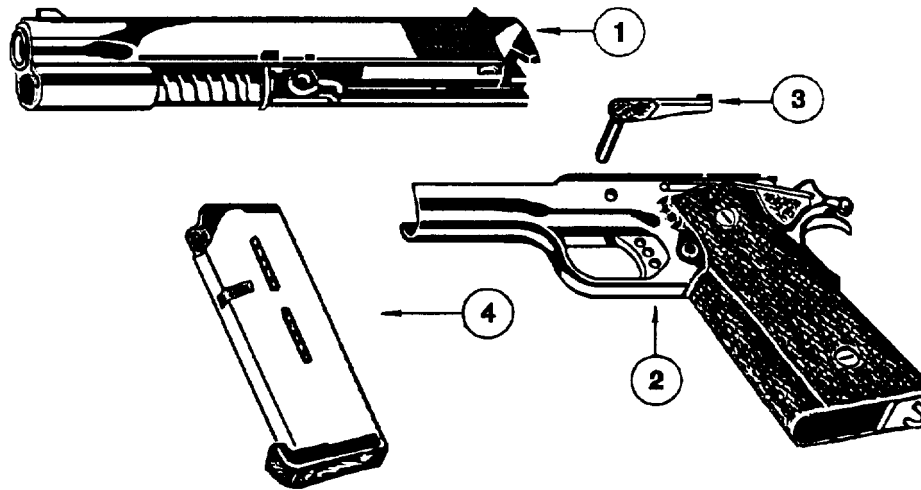

Figure 2-3. MEU(SOC) .45 Caliber Pistol - Major Components
 Numbers are keyed to the text on page 2-2

2-4. SERIAL NUMBER LOCATIONS. The MEU(SOC) .45 Caliber Pistol components are hand fitted and are not interchangeable. The last four digits of the weapon serial number (1), Figure 2-4, are stamped on the top of the barrel (2), on the right-side of slide assembly (3), inside of the beavertail grip safety (4), on each of the ambidextrous thumb safety (5), and on the inside face of the mainspring housing group (6).

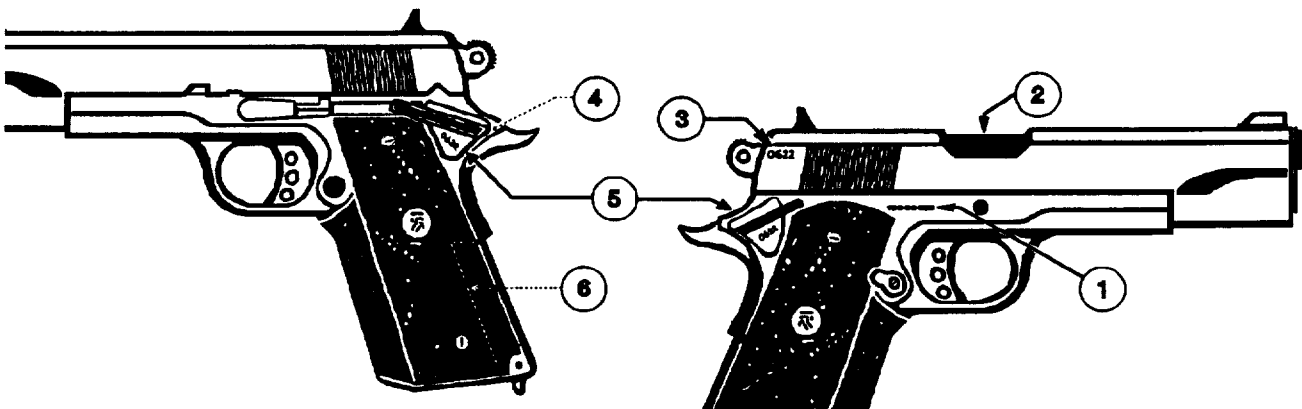

Figure 2-4. Serial Number Locations

2-5. ASSOCIATED EQUIPMENT. The MEU(SOC) .45 Caliber Pistol Weapon System, Figure 2-5, is comprised of the one pistol (1), one weapon record book (2), five shok-buffs (3), and seven magazines (4).

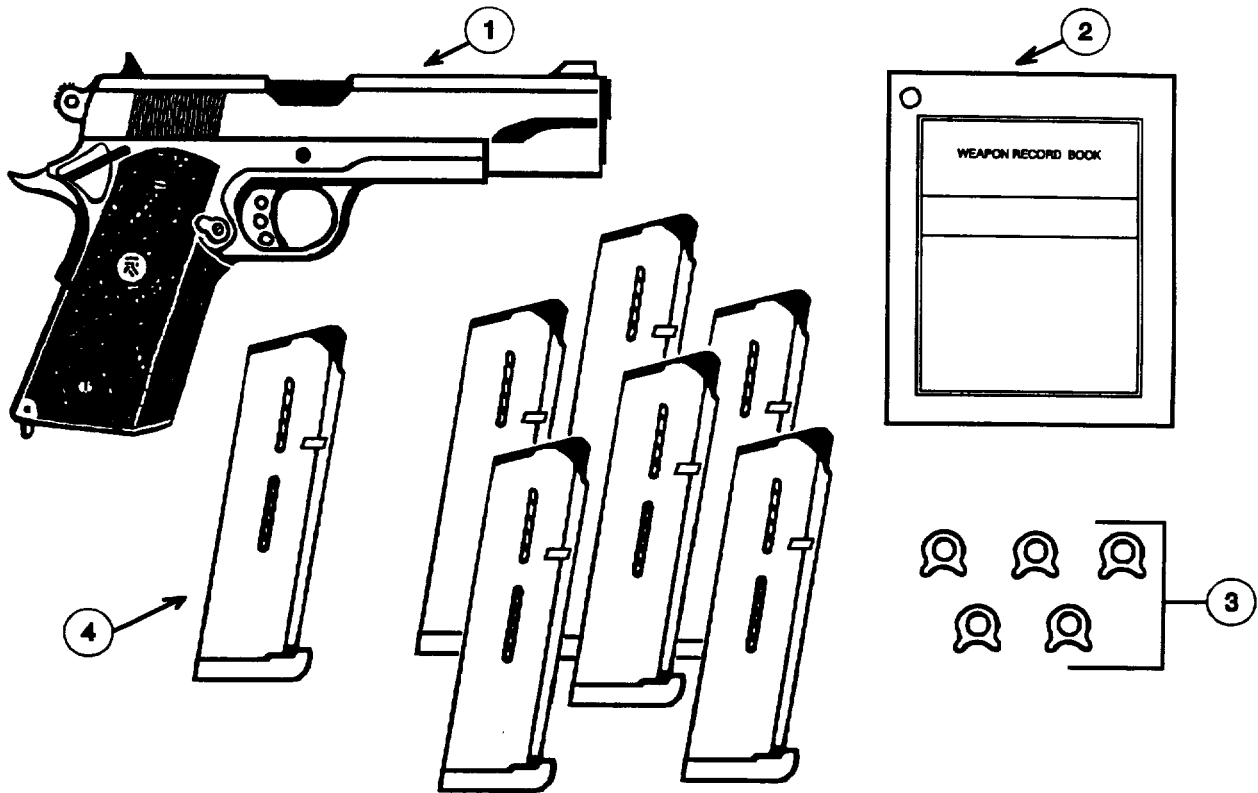

Figure 2-5. The MEU(SOC) .45 Caliber Pistol Weapon System

CHAPTER 3

OPERATION

Section I. INTRODUCTION

3-1. CLEARING THE WEAPON. Always assume every weapon to be loaded until you have personally determined it to be safe. Procedures for clearing/unloading the weapon are outlined in TM 00526A-10/1, Operator's Manual, and are summarized below.

WARNING

Make certain fingers are outside of the trigger guard and the pistol is pointed in a safe direction at all times.

a. Remove Magazine. With the right thumb, depress the magazine catch (1), Figure 3-1, inward until the magazine drops from the pistol. Catch the magazine in the left hand.

b. Open Chamber. With the right thumb pushing up on the slide stop (2), use the left hand to pull the slide assembly rearward. Engage the slide stop into the slide stop notch (3). Watch for live round or empty cartridge to be ejected.

WARNING

After the pistol is unloaded, and with the slide assembly to the rear, always physically check the chamber for a cartridge to preclude injury from a negligent discharge.

CAUTION

Do not leave rounds in the magazine for extended periods of time since this will cause the spring to lose tension and may cause a malfunction.

3-1. CLEARING THE WEAPON (Continued)

c. Inspect Chamber. Tilt the pistol and inspect the chamber (4) for the presence of live round or empty cartridge. Visually view and physically insert finger to check the chamber. Remove any live round or empty cartridge from the chamber. Do not leave rounds in magazine for extended periods of time.

d. On Safe. With the right thumb, push down on the slide stop to allow the slide assembly to return to the forward position. Pull the trigger (1), Figure 3-2, on a cleared pistol. The ambidextrous thumb safety (2) can be moved to the SAFE position only when the hammer is *cocked*.

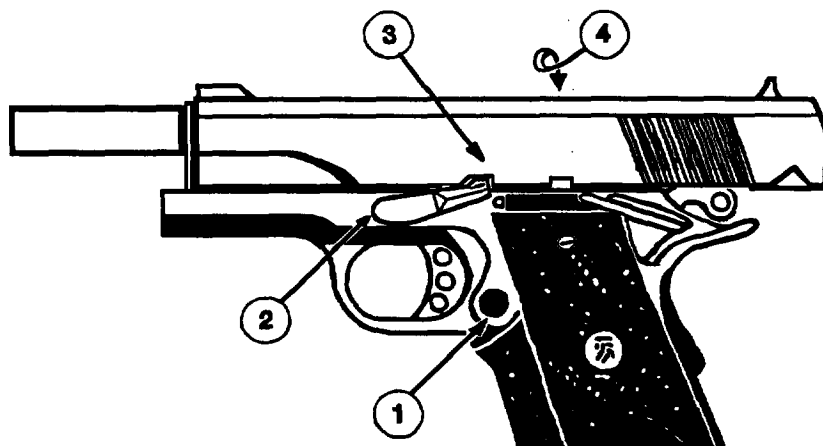

Figure 3-1. Clearing The Weapon

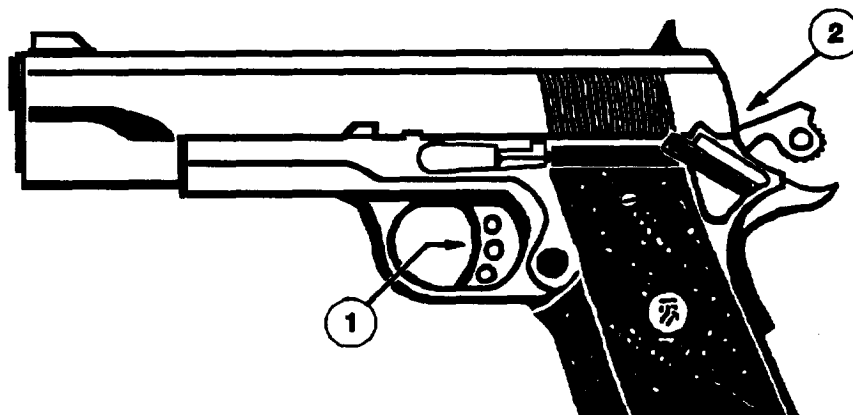

Figure 3-2. Checking The Weapon

3-2. FIELD STRIPPING THE WEAPON. The weapon may be field stripped into four major groups, Figure 3-3, to clean, inspect, and/or repair. They are: Slide Assembly (1), Receiver Assembly (2), Slide Stop (3), and Magazine Assembly (4). Procedures for field stripping the weapon are outlined in TM 00526A-10/1, Operator's Manual, and are summarized below.

WARNING

Make certain the weapon is cleared.

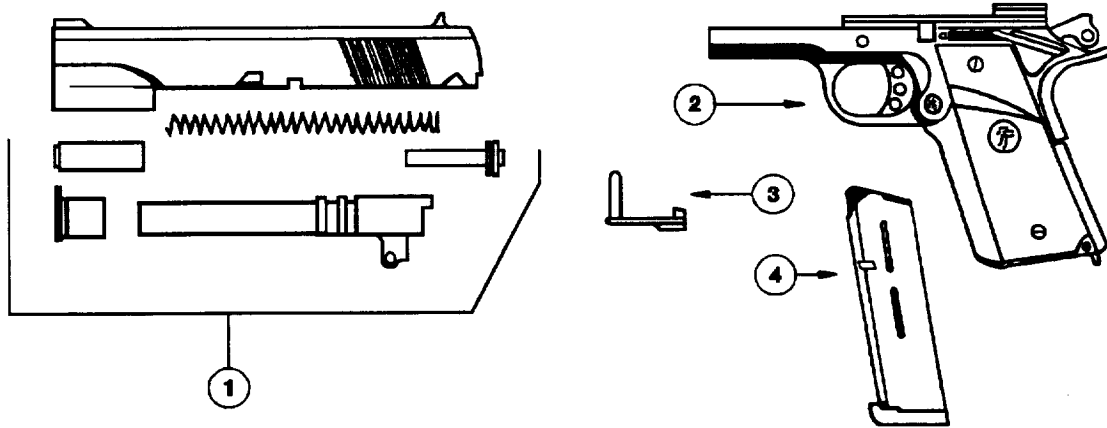

Figure 3-3. Field Stripping The Weapon

- a. In a designated SAFE area, remove the magazine and lock the slide assembly to the rear. Visually and physically check the chamber for any LIVE rounds.
- b. Return the slide assembly to the forward position.
- c. Pull the trigger.
- d. Move the disassembly notch (1), Figure 3-4, in the slide assembly to a position above the slide stop (2) on the receiver assembly.

3-2. FIELD STRIPPING THE WEAPON (Continued)

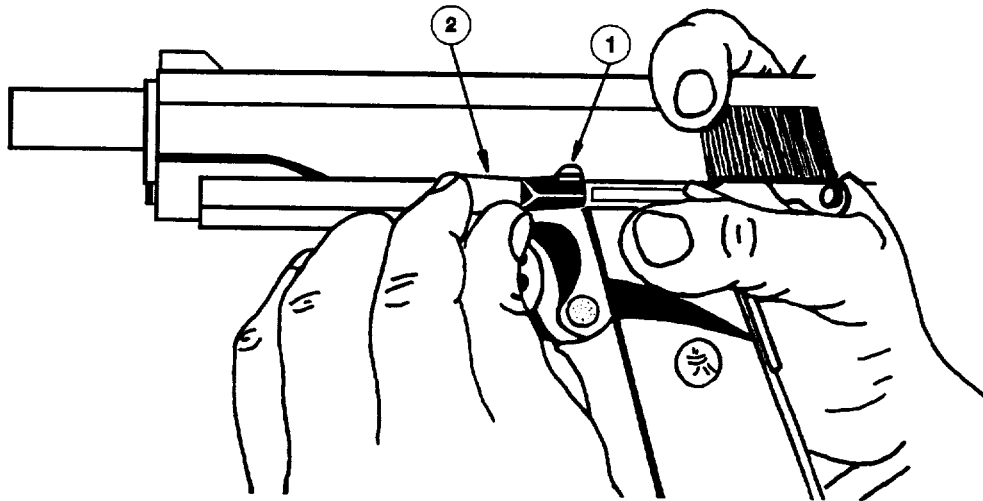

Figure 3-4. Aligning The Disassembly Notch

e. Remove the slide stop (1), Figure 3-5, from the disassembly notch (2) by pushing from right to left.

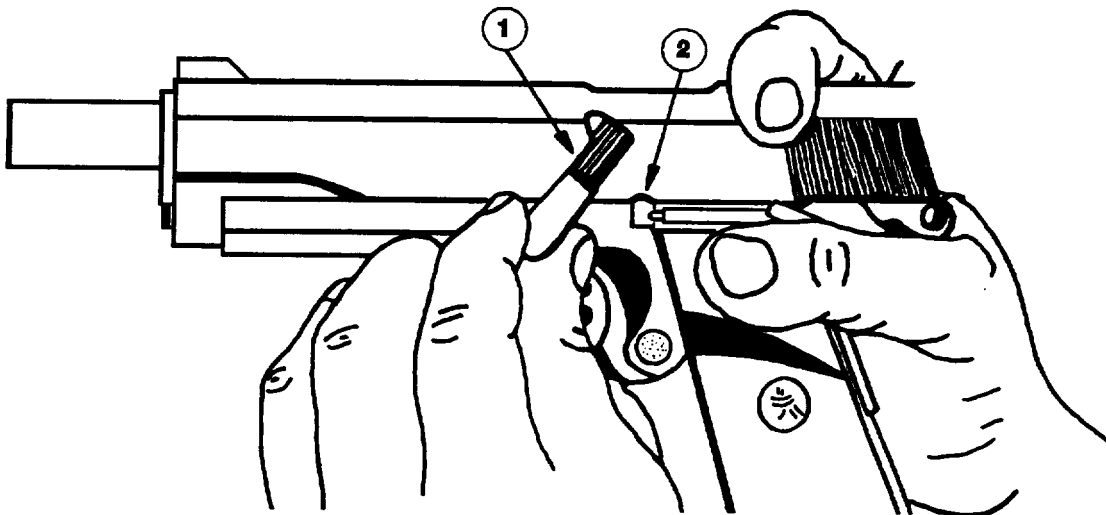

Figure 3-5. Removing The Slide Stop

WARNING

Recoil spring guide is under spring tension. Use care to prevent recoil spring from flying free or causing injury.

f. Separate the slide assembly (1), Figure 3-6, from the receiver assembly (2),

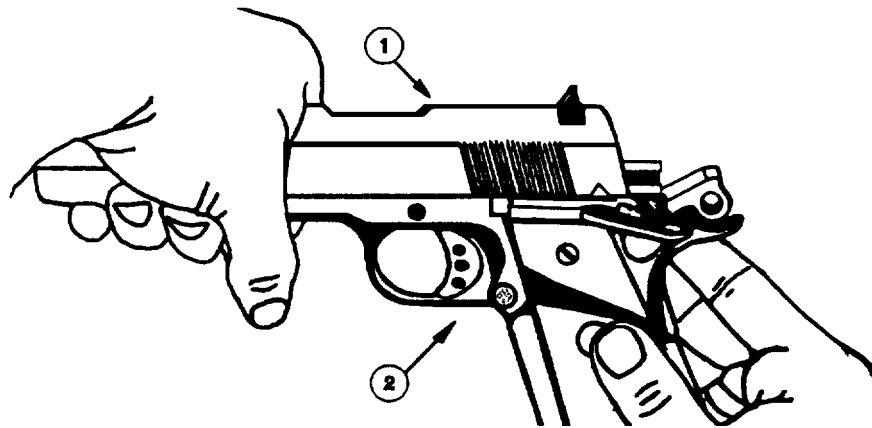

Figure 3-6. Separating The Slide Assembly From The Receiver Assembly

g. Lift the recoil spring guide (1), Figure 3-7, and twist the recoil spring (2) out of the recoil spring plug (3). Separate the shock-buff (4) from the recoil spring guide (1).

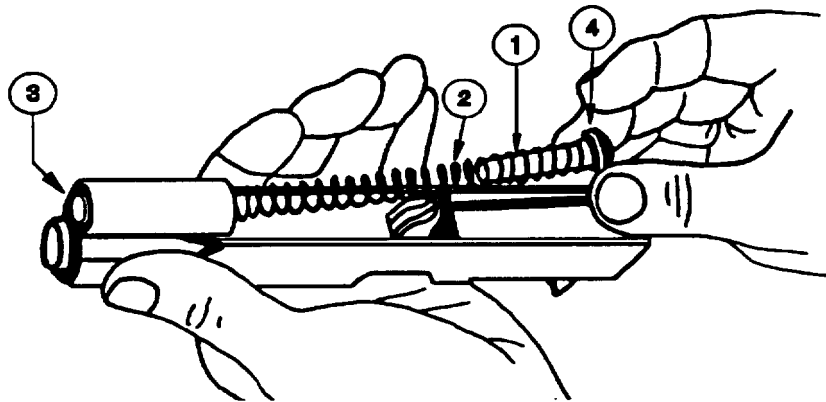

Figure 3-7. Removing The Recoil Spring And Recoil Spring Guide

3-2. FIELD STRIPPING THE WEAPON (Continued)

h. Rotate the barrel bushing (1), Figure 3-8, clockwise and remove the recoil spring plug (2) by inverting the slide assembly (3).

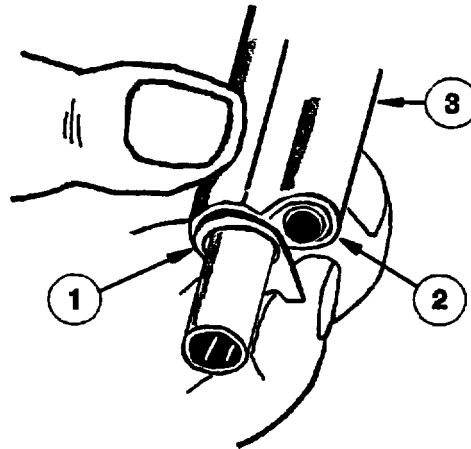

Figure 3-8. Removing The Recoil Spring Plug

i. Rotate the barrel bushing (1), Figure 3-9, counter-clockwise until the bearing lug (2) aligns with the opening in the slide assembly (3). Lift and remove the barrel bushing.

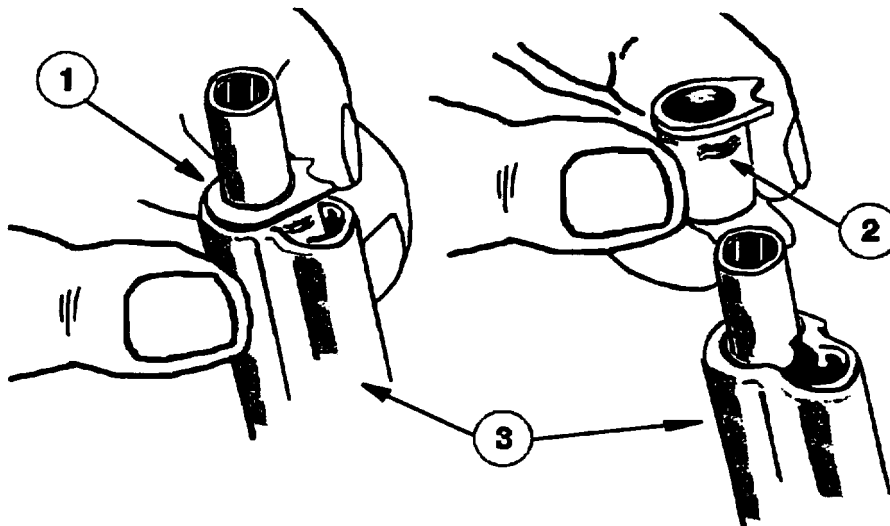

Figure 3-9. Removing The Barrel Bushing

j. Place barrel link (1), Figure 3-10, in the forward position. Remove barrel (2) from slide assembly (3) by sliding it up over the locking recesses and out of the slide.

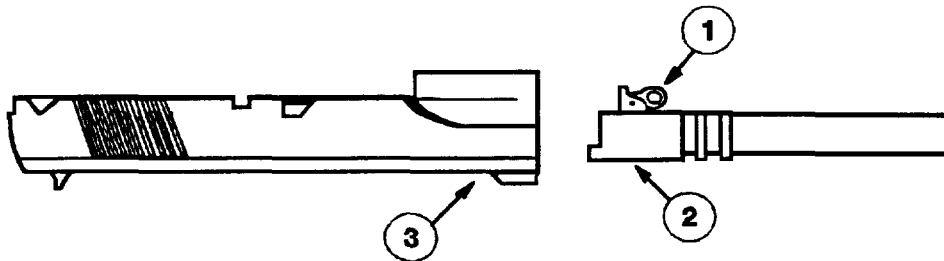

Figure 3-10. Removing The Barrel

3-3. REASSEMBLING THE WEAPON

a. Slide Assembly

NOTE

Place the barrel link in the forward position for installation.

(1) Install the barrel (2), Figure 3-10, into the slide assembly (3). Move the barrel all the way into the locking recesses.

(2) Place the barrel bushing (1), Figure 3-9, over the barrel and rotate clockwise.

(3) Insert recoil spring (2), Figure 3-7, into slide assembly. Twist recoil spring plug (3) onto the recoil spring.

(4) Rotate barrel bushing (1), Figure 3-8, counter-clockwise over recoil spring plug (2) .

(5) Install a shok-buff (4), Figure 3-7, onto recoil spring guide (1). Insert recoil spring guide (1) into recoil spring (2).

3-3. REASSEMBLING THE WEAPON (Continued)

b. Receiver Assembly

(1) Cock the hammer.

(2) Align the rails on the receiver assembly (1), Figure 3-11, with the groove in the slide assembly (2) and push forward stopping at the barrel link (1), Figure 3-10.

WARNING

Recoil spring is under tension and could fly free.

(3) With one hand, compress and hold the recoil spring and guide along the barrel, just forward of the barrel link, while pushing the receiver assembly (1), Figure 3-11, completely forward.

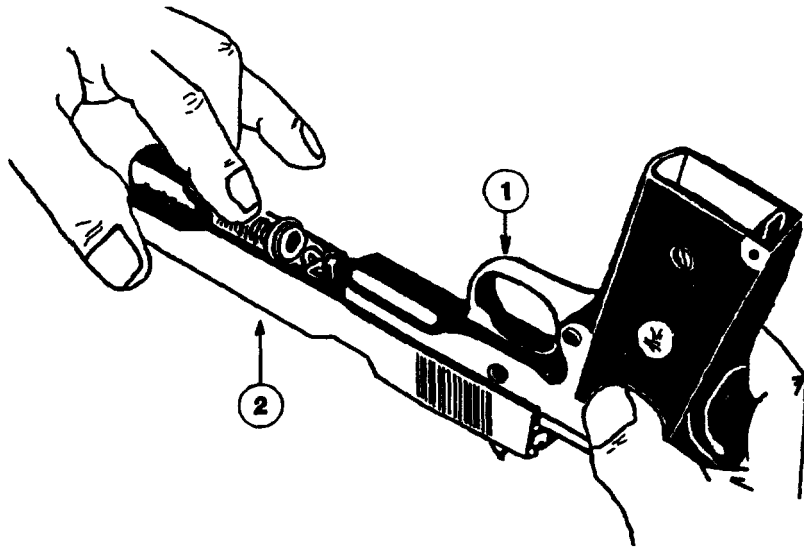

Figure 3-11. Reassembling The Slide And Receiver Assemblies

(4) Insert the slide stop (1), Figure 3-5, through the hole in the receiver assembly and through the barrel link (1), Figure 3-10, in the slide assembly at the disassembly notch.

(5) Cycle the slide assembly to the rear and release. Squeeze the trigger.

(6) Perform the Safety Check procedures outlined in para 6-18 on page 6-41.

Section II. OPERATING PROCEDURES

3-4. LOADING THE WEAPON. The procedures for loading the weapon are outlined in TM 00526A-10/1, Operator's Manual, and are summarized below.

a. To fill the magazine:

(1) Place one cartridge on the follower and push downward against the cartridge with the thumb to seat the cartridge under the lip of the magazine.

(2) While pushing the cartridge down, push the cartridge against the rear of the follower, otherwise the cartridge may not seat properly into the magazine.

(3) Fill no more than 7 rounds.



Make certain fingers are outside of the trigger guard and the pistol is pointed in a safe direction at all times.

b. To load the pistol:

(1) Draw pistol from the holster.

(2) Insert a magazine into the magazine well.

(3) Pull the slide assembly to the rear and release, putting a round in the chamber.

(4) Push the ambidextrous safety lever to the SAFE position.

3-5. UNLOADING THE WEAPON

a. Depress the magazine catch and the magazine will fall free.

b. If the slide assembly is in the forward position, pull the slide assembly to the rear while pushing up on the slide stop. This will lock the slide assembly to the rear.

3-5. UNLOADING THE WEAPON (Continued)

WARNING

After the pistol is unloaded, and with the slide assembly to the rear, always physically check the chamber for a cartridge to preclude injury from a negligent discharge.

- c. Physically check the chamber for the presence of a cartridge.
- d. Push down on the slide stop allowing the slide assembly to go forward.
- e. Squeeze the trigger.
- f. Return pistol to the holster.

CAUTION

Do not leave rounds in the magazine for extended periods of time since this will cause the spring to lose tension and may cause a malfunction.

- g. Do not store cartridges in the magazine for extended periods of time.

3-6. IMMEDIATE ACTION. Immediate action is the action performed promptly by the shooter any time there is an unscheduled or unanticipated interruption in firing the pistol.

WARNING

If your pistol stops firing with a live round in a hot barrel (misfire), manually cock the hammer without opening the chamber and make one additional attempt to fire. If the pistol still fails to free, wait approximately 10 seconds, ensure that during this time you keep the muzzle pointed in a safe direction.

Keep your face away from the ejection port while clearing a hot chamber.

a. Stoppage. Most stoppages may be quickly remedied by:

(1) Tapping the bottom of magazine to ensure that it is fully seated in the weapon.

(2) Pulling the slide rearward rapidly, to its full extent. Rotate the pistol to the right allowing the unfired round to drop out. Observe, through the open ejection port, the condition of the chamber, the receiver, and the next round in the magazine.

(3) Releasing the slide and allowing it to return to the forward position, cambering a new cartridge.

(4) Aiming and attempting to fire the pistol again. If pistol fails to fire, see Troubleshooting Chart in Chapter 5 of this Manual.

b. Jammed Cartridges. Cartridges which are not fully seated to the rear of the magazine may become crossed and cause a jam to occur.

(1) Remove the magazine.

(2) Pull the slide assembly to the rear and lock it with the slide stop.

(3) Inspect the chamber. Remove any obstructions.

(4) Insert another loaded magazine into the pistol. Release the slide assembly

(5) Aim and attempt to fire the pistol again.

CHAPTER 4

SCHEDULED MAINTENANCE

Section I. INTRODUCTION

4-1. INSPECTING THE WEAPON

a. Inspections reveal the need for repairs, cleaning or lubrication. The periodic Limited Technical Inspection (LTI) is required to ensure that only safe, serviceable MEU(SOC) .45 Caliber Pistols are in the hands of Marines. Unsafe conditions can develop from metal fatigue in pistol components. This can be caused by stress fractures (cracks) which result from the direct metal-to-metal contact during pistol recoil and counter-recoil. All MEU(SOC) .45 Caliber Pistols will receive periodic inspections.

(1) An inspection must be performed by the unit's armorer (21 11) before initial issue, before issue for marksmanship training (pre-fire inspection), and before initial issue for a security duty assignment.

(2) Quarterly Preventive Maintenance Checks and Services (PMCS) will be conducted every ninety days at the intermediate maintenance activity (IMA).

b. A weapon in use and subject to the elements, however, requires no inspection for cleanliness since its use and exposure is sufficient evidence that it requires repeated cleaning and lubrication. The user will combine daily cleaning with a program of inspection by the unit armorer for damage detection.

c. The MEU(SOC) .45 Caliber Pistol will be field stripped as outlined in TM 00526A-10/1, Operator's Manual. Inspect for obvious damage and repair or evacuate to higher echelon for maintenance.

4-2. OPERATIONAL CHECK

WARNING

The MEU(SOC) .45 Caliber Pistol is built individually. Its major groups and components are hand-fitted to function on the assigned pistol and are not interchangeable. The use of lights or any such devices are not authorized.

4-2. OPERATIONAL CHECK (Continued)

WARNING

Before starting an inspection or repairs, be sure to clear the pistol. Do not actuate the trigger until the pistol has been cleared. Remove the magazine and inspect the chamber, to ensure that it is empty. Do not have live ammunition in the vicinity of the work area.

a. Before Firing. Always clean and inspect your pistol prior to firing. Firing a weapon with a dirty bore or chamber will multiply and speed the process of any corrosive action which may have begun. Apply a light coat of Cleaner, Lubricant and Preservative (CLP) on all moving parts.

b. After Firing. The MEU(SOC) .45 Caliber Pistol must be cleaned after it has been fired because firing produces deposits of primer fouling, powder ashes, carbon and metal fouling. After firing, clean for three consecutive days using the items listed in Appendix B. Cleaning procedures are contained in para 4-6. Following the three consecutive days of cleaning, check the pistol the next several days for fouling by running a clean swab through the bore. Use cotton tip applicators to clean hard to reach areas.

c. Daily Service. As part of daily service, inspect the bore and chamber, and clean component parts of the pistol. Wipe entire pistol thoroughly, dry, and re-lubricate in accordance with para 4-7 of this Manual or TM 00526A-10/1, Operator's Manual .

d. Extended Periods. A pistol sheltered in garrison and infrequently used must be inspected often to detect dirt, moisture and signs of corrosion and must be cleaned accordingly. For weapons used infrequently, for periods greater than 90 days, consider placing them in storage. See storage procedures contained in para 4-9 of this Manual.

Section II. ORGANIZATIONAL PREVENTIVE MAINTENANCE

4-3. GENERAL. Organizational preventive maintenance is the responsibility of the using unit. Its phases consist of inspecting, servicing, and lubricating the weapon. There are two maintenance echelons within organizational maintenance--first and second echelons. First echelon refers to the maintenance that the shooter or operator performs. Second echelon is performed by the unit's armorer (2111) who is specially trained for that purpose.

4-4. ORGANIZATIONAL TOOLS AND EQUIPMENT. The tools and equipment listed in Table 4-1 are authorized at the organizational maintenance level for the proper care and cleaning of the MEU(SOC) .45 Caliber Pistol.

Table 4-1. Organizational Tools and Equipment

ITEM	CAGE	NSN/PN	ITEM IDENTIFICATION	U/I	QTY
1	81348	6515-00-303-8250	Applicator, Cotton Tip	PK	1
2	19204	1005-00-242-5687	Bottle Assembly, Cylindrical	EA	1
3	19205	1005-00-550-4036	Brush, Cleaning Bore .45 cal	EA	1
4	19204	1005-00-494-6602	Brush, Cleaning Small Arms	EA	1
5	81349	9150-01-102-1473	Cleaner, Lubricant and Preservative, (CLP) 1/2 oz. bottle	OZ	1
6	81349	6850-00-224-6657	Cleaning Compound, Rifle Bore, 6 oz can	OZ	1
7	81349	9150-00-292-9689	Lubricating Oil, LAW	QT	1
8	81349	9150-00-935-6597	Lubricating Oil, LSA	OZ	1
9	81349	9150-00-949-0323	Lubricating Oil, LSA-T	OZ	1
10	58536	7920-00-205-1711	Rag, Wiping	LB	1
11	19204	1005-00-556-4102	Rod, Cleaning, Small Arms	EA	1
12	19204	1005-00-288-3565	Swabs, Cleaning, Small Arms	PK	1
13	58536	7510-00-266-6712	Tape, Masking, 1" wide	RO	1

4-5. PREVENTIVE MAINTENANCE PROCEDURES

a. Perform Organizational Preventive Maintenance Checks and Services (PMCS), Table 4-2, every 90 days to keep the weapon ready for use. If the weapon has not been used in 90 days, consider placing it in storage as per instructions in para 4-9 of this Manual. If you see rust on a weapon, the PMCS must be done immediately.

b. Field strip the weapon (see para 3-2 or TM 00526A-10/1). Inspect all assemblies for missing, broken, or loose parts. Inspect parts for cracks, dents, burrs, excessive wear, rust, or corrosion. Make sure all items are cleaned and lubricated (see TM 00526A-10/1). Evacuate the weapon to intermediate maintenance if repairs are not authorized at organizational maintenance (see SMR codes in Chapter 7).

**Table 4-2. Preventive Maintenance Checks and Services (PMCS)
Quarterly Schedule**

ITEM INSPECTED	PROCEDURE/CONDITION
Slide Assembly:	
Slide	Front and rear sights must be securely attached. Rear sight must be square and front sight post must not be burred. Special attention should be paid to cleaning the face of the slide. Must not have powder residue or fouling. Check firing-pin hole for erosion or pitting.
Barrel	Check barrel and bore for cracks and erosion. Check locking recesses for wear. The barrel link must move freely.
Barrel Bushing	Check the bearing lug on the barrel bushing for serviceability.
Recoil Spring Plug	Check recoil spring plug for serviceability. Must not have powder residue or fouling inside the plug.
Recoil Guide and Recoil Spring	Check recoil guide for serviceability (shok-buff is checked every 1000 rounds). Check recoil spring for wear, tension, and shape.
Receiver Assembly:	
Hammer	Hammer must move freely and provide a safe pistol in the <i>half cocked</i> position.
Ambidextrous Thumb Safety	Must move freely and provide a positive no fire when in the SAFE position.
Beavertail Grip Safety	Must move freely and provide a positive no fire unless fully depressed.
Magazine Catch	Check for wear. Must hold the magazine securely in place.

**Table 4-2. Preventive Maintenance Checks and Services (PMCS)
Quarterly Schedule - Continued**

ITEM INSPECTED	PROCEDURE / CONDITION
Receiver Assembly (Continued):	
Trigger	Check for dents and wear. Must move freely within receiver assembly.
Ejector	Check for wear and serviceability.
Slide Stop	Check for wear; must hold slide assembly to the rear. Must be kept clean.
Magazine Assembly:	Check for dents and serviceability. Check for correct loading of cartridges in the magazine. Special attention should be paid to cleaning the magazine. Must be free of powder residue and fouling.
Safety Check:	Reassemble the pistol and ensure parts are installed correctly. Perform the Safety Check outlined in para 6-18 on page 6-41. If the pistol does not function properly and the cause cannot be determined by using Table 5-1, Organizational Troubleshooting Chart, evacuate to intermediate maintenance for repairs.

4-6. CLEANING THE WEAPON. Cleaning is a vital part of organizational preventive maintenance. The MEU(SOC) .45 Caliber Pistol should be cleaned as soon as possible after firing, and each time it is exposed to field conditions, using the procedures outlined in TM 00526A-10/1, operator's Manual.



Make the pistol safe before cleaning. Ensure that the pistol is not loaded.

4-7. LUBRICATING THE WEAPON. The MEU(SOC) .45 Caliber Pistol is to be lubricated in accordance with TM 00526A-10/1, Operator's Manual, and TM 9150-15/1, Military Use of Cleaner, Lubricant, Preservative (CLP) for Weapons and Support Equipment.

CAUTION

Use only authorized lubrication. Do not mix lubricants.

A small amount of CLP may be stored in the cylindrical bottle assembly. Do not mix lubricants together.

Section III. INTERMEDIATE LEVEL MAINTENANCE

4-8. GENERAL. Quarterly PMCS will be conducted every 90 days at the IMA. Corrective maintenance procedures are outlined in Chapter 6 of this Manual.

Section IV. CARE AND PREPARATION FOR STORAGE AND SHIPMENT

4-9. STORAGE PROCEDURES. When the weapon is to be stored for an extended period of time, greater than 90 days, follow the procedures outlined in MCO P4450.7. Ensure that the weapon is thoroughly clean as outlined in TM 00526A-10/1, Operator's Manual. Inspect the bore and chamber and leave a medium coat of CLP in the bore. On all other surfaces of the weapon apply a medium coat of CLP to provide extra lubrication and corrosion protection.

WARNING

Ensure there is no live ammunition stored in the pistol or in the magazines.

- a. Ensure that no ammunition is stored in the pistol by following the procedures for clearing the weapon found in para 3-1 on page 3-1 or TM 00526A-10/1, Operator's Manual.
- b. Place the slide assembly in the forward position.
- c. Pull the trigger to release spring tension on the sear spring.

4-10. SHIPPING PROCEDURES. Pistols requiring special fifth echelon maintenance will be shipped in accordance with the disposition and auto-retrograde message.

WARNING

Under no circumstances should the pistol be shipped while it still contains live ammunition, either in the shipping box or in the pistol itself.

a. Ensure that no ammunition is shipped in the pistol by following the procedures for clearing the pistol found in para 3-1 on page 3-1 or TM 00526A-10/1, Operator's Manual.

b. Complete NAVMC 1018 in accordance with TM 4700-15/1, and detail the required maintenance action as thoroughly as possible.

c. Clean the pistol by following the procedures outlined in TM 00526A-10/1, Operator's Manual.

d. Place the pistol in a shipping box. Fill shipping box with a cushioning material. Close the box and seal all seams and joints with tape.

e. Mark the box in accordance with MIL-STD- 129.

f. Ship in accordance with MCO P4610. 19 and MCO 8020.1. Shipment must be accomplished through the use of U.S. Registered Mail, Return Receipt Requested. The shipment must be addressed to :

Commanding Officer (Code 468-4)
Weapons Training Battalion
Marine Corps Combat Development Center
27211 Garand Road
Quantico, Virginia 22134-5036

Mark for: DMISA WTBN 93 01AMPA

g. After the repair is completed, the pistol is returned to MCLB Albany, GA, or MCLB Barstow, CA, to be placed in stock.

CHAPTER 5

TROUBLESHOOTING PROCEDURES

5-1. TROUBLESHOOTING. This Manual cannot list all of the possible malfunctions that may occur, nor all causes and corrective actions. The malfunctions listed in the Symptom Index are discussed on the page indicated. Table 5-1 is the Organizational Troubleshooting Chart. Table 5-2 is the Intermediate Troubleshooting Chart. If a malfunction is not listed (except when the malfunction and cause are obvious), or it is not corrected by the listed action, evacuate the pistol to the next higher maintenance activity.

SYMPTOM INDEX

Troubleshooting Sequence	Organizational Troubleshooting Page	Intermediate Troubleshooting Page
a. Failure to Feed	5-1	N/A
b. Failure to Chamber	5-2	N/A
c. Failure to Lock	5-2	5-5
d. Failure to Fire	5-3	5-5
e. Failure to Unlock	5-3	5-5
f. Failure to Extract	5-3	5-5
g. Failure to Eject	5-4	5-5
h. Failure to Cock	5-4	5-6

Table 5-1. Organizational Troubleshooting Chart

MALFUNCTION	PROBABLE CAUSE	CORRECTIVE ACTION
--------------------	-----------------------	--------------------------

a. FAILURE TO FEED (cartridge fails to properly move from the magazine)

Step 1. Dirty magazine.
Clean and lubricate (TM 00526A-10/1).

Step 2. Weak/broken magazine spring.
Replace spring or replace entire magazine (TM 00526A-10/1).

Table 5-1. Organizational Troubleshooting Chart - Continued

MALFUNCTION

PROBABLE CAUSE

CORRECTIVE ACTION

a. FAILURE TO FEED (Continued)

Step 3. Worn or broken magazine catch.
Replace magazine catch (para 6-5).

Step 4. Magazine spring assembled backward.
Assemble properly (TM 00526A-10/1).

Step 5. Bent magazine follower.
Replace follower or replace entire magazine (TM 00526A-10/1).

b. FAILURE TO CHAMBER (cartridge fails to properly move into the chamber)

Step 1. Dirty or obstructed chamber.
Remove obstruction, clean and lubricate (TM 00526A-10/1).

Step 2. Weak or broken recoil spring.
Replace recoil spring (para 6-3).

Step 3. Lack of lubrication.
Lubricate properly (TM 00526A-10/1).

c. FAILURE TO LOCK (barrel locking recesses do not engage the recesses in slide)

Step 1. Lack of lubrication on operating parts and/or dirty barrel locking recesses.
Clean and lubricate appropriate parts (TM 00526A-10/1).

Step 2. Burred locking recesses on the barrel or in the slide assembly.
Evacuate pistol to intermediate maintenance.

Step 3. Weak or broken recoil spring.
Replace recoil spring (para 6-3).

Step 4. Broken barrel link and/or barrel link pin.
Evacuate pistol to intermediate maintenance.

Table 5-1. Organizational Troubleshooting Chart - Continued

MALFUNCTION**PROBABLE CAUSE****CORRECTIVE ACTION**

d. FAILURE TO FIRE (hammer falls but the primer of the cartridge does not ignite)*Step 2.* Faulty ammunition.

Replace ammunition and report lot number.

Step 2. Broken/frozen firing pin and/or firing pin spring.

Replace firing pin and/or firing pin spring (para 6-2).

Step 3. Bent or broken hammer strut and/or hammer strut pin.

Evacuate pistol to intermediate maintenance.

Step 4. Weak mainspring.

Replace mainspring (para 6-7).

e. FAILURE TO UNLOCK (barrel locking recesses do not disengage from slide recesses)*Step 1.* Broken barrel link and/or barrel link pin.

Evacuate pistol to intermediate maintenance.

Step 2. Broken barrel lugs.

Evacuate pistol to intermediate maintenance.

f. FAILURE TO EXTRACT (cartridge case is riot removed from the chamber)*Step 1.* Broken or worn extractor.

Evacuate pistol to intermediate maintenance.

Step 2. Dirty chamber.

Clean and lubricate (TM 00526A-10/1).

Step 3. Pitted chamber.

Evacuate pistol to intermediate maintenance.

Table 5-1. Organizational Troubleshooting Chart - Continued

MALFUNCTION
PROBABLE CAUSE
CORRECTIVE ACTION
g. FAILURE TO EJECT (cartridge case is not ejected from the pistol)
<i>Step 1.</i> Faulty extractor. Evacuate pistol to intermediate maintenance.
<i>Step 2.</i> Broken or bent ejector. Evacuate pistol to intermediate maintenance.
h. FAILURE TO COCK (hammer fails to retract and/or remain in fully cocked position)
<i>Step 1.</i> Worn full cock notch on hammer. Evacuate pistol to intermediate maintenance.
<i>Step 2.</i> Worn sear. Evacuate pistol to intermediate maintenance.
<i>Step 3.</i> Defective sear spring. Evacuate pistol to intermediate maintenance.
<i>Step 4.</i> Broken or worn disconnecter. Evacuate pistol to intermediate maintenance.
<i>Step 5.</i> Broken hammer strut. Evacuate pistol to intermediate maintenance.

Table 5-2. Intermediate Troubleshooting Chart

MALFUNCTION
PROBABLE CAUSE
CORRECTIVE ACTION
a. FAILURE TO FEED - <i>Not applicable</i>
b. FAILURE TO CHAMBER - <i>Not applicable</i>

Table 5-2. Intermediate Troubleshooting Chart - Continued

MALFUNCTION**PROBABLE CAUSE****CORRECTIVE ACTION**

c. FAILURE TO LOCK

Broken barrel link.
Replace barrel link (para 6-13).

d. FAILURE TO FIRE

Bent or broken hammer strut and/or hammer strut pin.
Replace hammer strut and/or hammer strut pin (para 6-14).

e. FAILURE TO UNLOCK

Step 1. Broken barrel link and/or barrel link pin.
Replace barrel link and/or barrel link pin (para 6-13).

Step 2. Broken barrel lugs.
Evacuate pistol to special fifth echelon maintenance for barrel replacement.

f. FAILURE TO EXTRACT

Step 1. Broken or worn extractor.
Replace extractor (para 6-10).

Step 2. Pitted chamber.
Evacuate pistol to special fifth echelon maintenance for barrel replacement.

g. FAILURE TO EJECT

Step 1. Faulty extractor.
Replace extractor (para 6-10).

Step 2. Broken or bent ejector.
Replace ejector (para 6-11).

Table 5-2. Intermediate Troubleshooting Chart - Continued

MALFUNCTION

PROBABLE CAUSE

CORRECTIVE ACTION

h. FAILURE TO COCK

Step 1. Worn full cock notch on hammer.
Replace hammer (para 6-14).

Step 2. Worn sear.
Replace sear (para 6-14).

Step 3. Defective sear spring.
Replace sear spring (para 6-14).

Step 4. Broken or worn disconnecter.
Replace disconnecter (para 6-14).

CHAPTER 6

CORRECTIVE MAINTENANCE

Section I. INTRODUCTION

6-1. GENERAL

a. This chapter contains inspection, disassembly, and reassembly procedures required for corrective maintenance on the MEU(SOC) .45 Caliber Pistol.

WARNING

Before starting an inspection or repairs, be sure to clear the pistol. Do not actuate the trigger until the pistol has been cleared. Remove the magazine and inspect the chamber, to ensure that it is empty. Do not have live ammunition in the vicinity of the work area.

b. Organizational maintenance will be performed by the 2111 armorer who is authorized to repair/replace those items beginning in para 6-2 on page 6-2. For all other repairs, the pistol will be evacuated to the intermediate maintenance activity (IMA).

c. Inspections to determine the weapon's serviceability will be performed in accordance with the appropriate inspection procedures of this Manual and with TI 00526-24/3C (Periodic Technical Inspection, Pistol, Caliber .45, 1911A1)

d. Third echelon maintenance will be performed by a 2111 at the IMA. This involves the replacement of the extractor, the ejector, and the ejector pin. Maintenance procedures for these items begin in para 6-9 on page 6-17.

e. Fourth echelon maintenance will be accomplished by a qualified Rifle Team Equipment (RTE) technician, 2112, at the IMA. The special tools and test equipment in Table 6-1 are required as a part of the inventory of the small arms technician's tool box. The 2112 is authorized to repair/replace those items beginning in para 6-12 on page 6-21.

f. Special fifth echelon maintenance will be accomplished by Weapons Training Battalion, Quantico, Virginia which will function as the pistol's rebuild facility. They are responsible for the *total rebuild* and/or *total replacement* of the pistol, which includes rear sight, slide assembly, receiver assembly, rebarreling, and refinishing of the pistol.

Section II. ORGANIZATIONAL MAINTENANCE

6-2. FIRING PIN GROUP (Figure 6-1)

NOTE

While the SMR codes indicate that the firing pin stop and the extractor are intermediate maintenance parts, they can be removed at organizational maintenance for the purpose of inspection and for gaining access to the firing pin and firing pin spring.

a. Disassembly

(1) Field strip the pistol following the procedures outlined in para 3-2 of this Manual or in TM 00526A-10/1, Operator's Manual.

WARNING

Firing pin is under spring tension. Use care to prevent firing pin spring from flying free or causing injury.

(2) Using a 3/32" punch, depress the head of the firing pin (1) and slide the firing pin stop (2) out of the slide assembly (3).

(3) Remove firing pin (1), firing pin spring (4), and extractor (5).

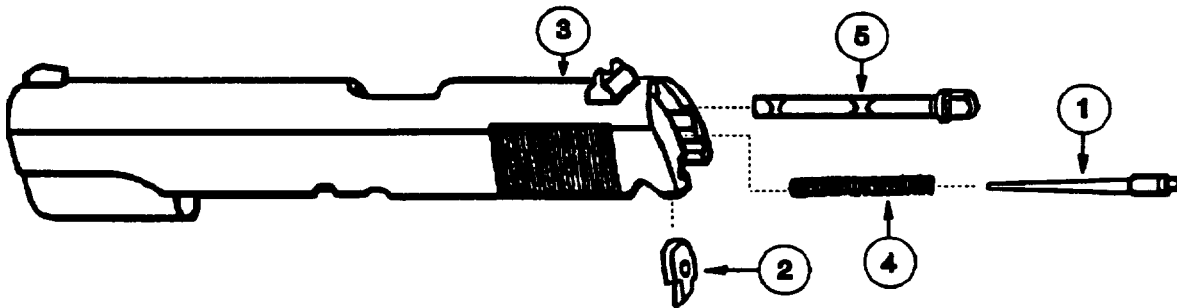

Figure 6-1. Firing Pin Group

b. Inspection

(1) Inspect the firing pin (1) to make sure it is straight and has a smooth, round tip. Check that the firing pin is free of burrs and cracks and the head is not mushroomed. If mushroomed, try to redress with a medium stone. If burred or cracked, replace firing pin.

(2) Check the firing pin stop (2) for cracks, chips or burrs. If unserviceable, evacuate to intermediate maintenance for repairs.

(3) Inspect the firing pin spring (4) to make sure it is not bent or compressed. Check that it does not hang in the firing pin hole when the pistol is fired or during cleaning. Ensure that it has a minimum of three coils from the tip of the firing pin. If unserviceable, replace firing pin spring.

(4) Check the extractor (5) for wear, weakness, broken lip or deformation. If unserviceable, evacuate to intermediate maintenance for repairs.

(5) Inspect the face of the slide (3) for cracks, chips, or gouges. If unserviceable, evacuate to intermediate maintenance for a technical inspection.

c. Reassembly**NOTE****Align the slot in the extractor with the firing pin stop slot.**

(1) Insert the extractor (5) into the slide assembly.

(2) Slide the tapered end of the firing pin spring (4) onto the firing pin (1) first. Insert them into the slide assembly (3)

(3) Slide the firing pin stop (2) into the firing pin stop slot located in the slide assembly (3). Use a 3/32" punch to depress the head of the firing pin (1) while continuing to slide the firing pin stop (2) forward. The head of the firing pin (1) will protrude through the hole in the firing pin stop (2).

(4) Reassemble slide assembly to receiver assembly by following the procedures outlined in para 3-3 of this Manual or in TM 00526A-10/1, Operator's Manual.

(5) Once the pistol is completely reassembled, perform the safety checks outlined in para 6-18 of this Manual.

6-3. RECOIL GROUP (Figure 6-2)

a. Disassemble

NOTE

While the SMR codes indicate that some recoil group components are intermediate maintenance parts, they can be removed at organizational maintenance for the purpose of inspection and for gaining access to the shok-buff, recoil spring and spring plug.

(1) Field strip the pistol following the procedures outlined in para 3-2 of this Manual or in TM 00526A- 10/1, Operator's Manual.

WARNING

Recoil spring guide is under spring tension. Use care to prevent recoil spring from flying free or causing injury.

(2) Remove recoil spring guide (1) and recoil spring (2) from the rear of slide assembly. Separate recoil spring guide (1) from recoil spring (2).

(3) Separate the shok-buff (3) from the recoil spring guide (1).

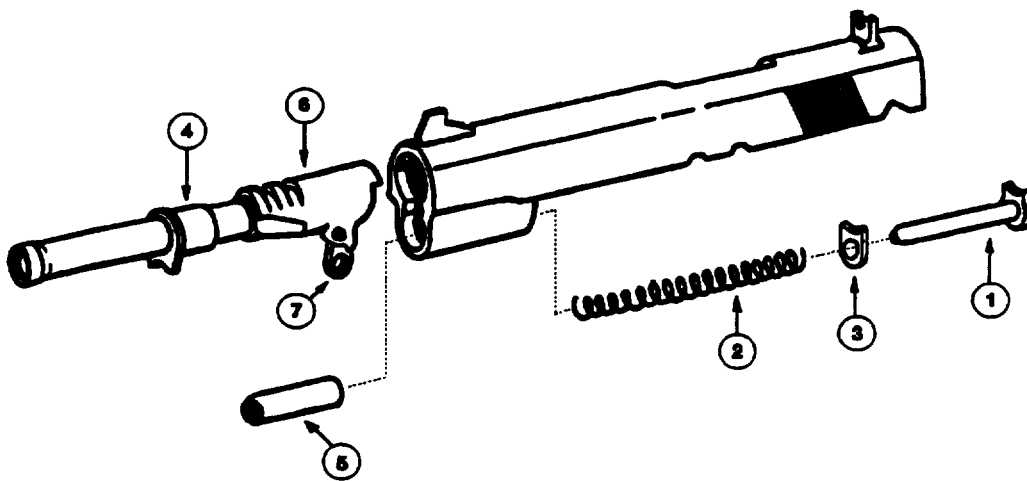

Figure 6-2. Recoil Group

(4) Rotate barrel bushing (4) clockwise and remove the recoil spring plug (5). Rotate barrel bushing (4) counter-clockwise and remove from barrel (6).

(5) Place barrel link (7) in the forward position. Remove barrel (6) from slide assembly by sliding it up over the locking recesses and out of the slide.

b. Inspection

(1) Inspect recoil spring guide (1) for burrs and distortions. If unserviceable, evacuate to intermediate maintenance for replacement of the recoil spring guide.

(2) Inspect recoil spring (2) to make sure it is not bent or compressed. Small bends that do not interrupt the recoil of the pistol are acceptable. The minimum acceptable length is six inches. If unserviceable, replace recoil spring.

(3) Check shok-buff (3) for wear or deformation. Replace shok-buff every 1000 rounds or if unserviceable.

(4) Inspect barrel bushing (4) for cracks, burrs and elongation. If cracked, burred or elongated, evacuate to intermediate maintenance for repairs.

(5) Inspect recoil spring plug (5) for cracks, burrs and distortions. If cracked, burred or distorted, replace recoil plug.

(6) Inspect barrel (6) for cracks, burrs, pits, bulges or distortions. If any of these conditions exist, evacuate to intermediate maintenance.

(7) Inspect barrel link (7) for cracks, burrs and distortions. If unserviceable, evacuate to intermediate maintenance for repairs.

c. Reassembly

(1) Place the barrel link (7) in the forward position and insert barrel (6) into slide assembly.

(2) Rotate barrel bushing (4) counter-clockwise to install recoil spring plug (5). Rotate barrel bushing (4) clockwise and lock atop the recoil spring plug (5).

(3) Install shok-buff (3) onto recoil spring guide (1).

6-3. RECOIL GROUP (Continued)

c. Reassembly (Continued)

(4) Place recoil spring guide (1) into recoil spring (2). Install recoil spring guide (1) and recoil spring (2) through the rear of the slide assembly,

(5) Reassemble slide assembly to receiver assembly by following the procedures outlined in para 3-3 of this Manual or in TM 00526A-10/1, Operator's Manual.

(6) Once the pistol is completely reassembled, perform the safety checks outlined in para 6-18 of this Manual.

6-4. COMBAT PISTOL GRIP (Figure 6-3)

a. Disassembly

(1) Using a small flat-tip screwdriver, remove the four grip screws (1),
Figure 6-3.

(2) Remove the one piece combat pistol grip (2).

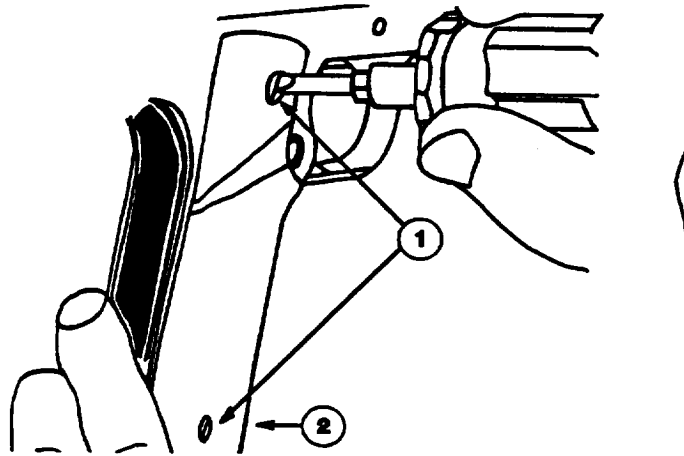

Figure 6-4. Magazine Catch Lock

b. Inspection. Inspect the one piece combat pistol grip (2), Figure 6-3, for wear and tear. If worn or torn, replace combat pistol grip. Check that all grip screws (1) are present. Replace, if missing or burred.

c. Reassemble

(1) Install the one piece combat pistol grip (2), Figure 6-3, and align the holes for the grip screw (1).

(2) Use a small flat-tip screwdriver to tighten the four grip screws (1), Figure 6-3 (two per side).

6-5. MAGAZINE CATCH GROUP (Figures 6-4 and 6-5)

a. Disassembly

(1) Field strip the pistol following the procedures outlined in para 3-2 of this Manual or in TM 00526A-10/1, Operator's Manual.

WARNING

Magazine catch lock is under spring tension. Use care to prevent magazine catch lock from flying free or causing injury.

(2) Using a small flat-tip screwdriver, turn the magazine catch lock (1), Figure 6-4, counter-clockwise 90 degrees to unlock *while* depressing the left side magazine catch.

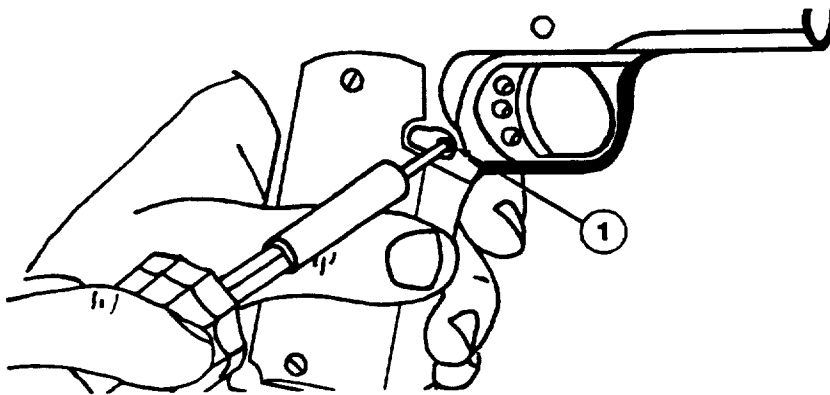

Figure 6-4. Magazine Catch Lock

6-5. MAGAZINE CATCH GROUP (Continued)

a. Disassembly (Continued)

(3) Remove the magazine catch group, Figure 6-5, out the right side of the pistol as a group.

(4) Remove magazine catch lock (1), Figure 6-5, and magazine catch spring (2) out of the magazine catch (3).

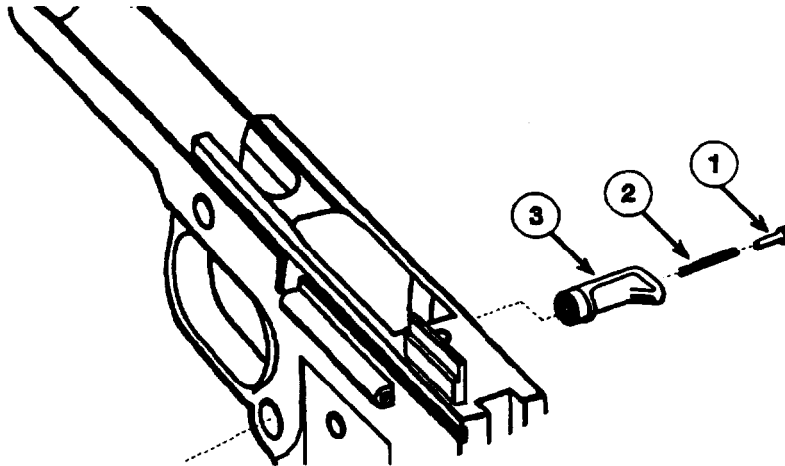

Figure 6-5. Magazine Catch Group

b. Inspection

(1) Inspect that the magazine catch lock (1), Figure 6-5, lays flat along the surface of the receiver assembly. Check for burrs and cracks. If burred or cracked, replace magazine catch lock.

(2) Inspect that the magazine catch group moves freely within the receiver assembly. Check for worn magazine catch spring (2), Figure 6-5. If worn, replace magazine catch spring.

(3) Inspect that the magazine catch group holds the magazine assembly securely inside the magazine well. Check the magazine catch (3), Figure 6-5, for burrs and cracks. If burred or cracked, replace magazine catch.

c. Reassembly

(1) Install the magazine catch lock (1), Figure 6-5, and magazine catch spring (2) into the magazine catch (3).

(2) Insert the magazine catch group, Figure 6-5, into the right side of the pistol.

(3) Use a small flat-tip screwdriver to turn the magazine catch lock (1), Figure 6-5, clockwise 90 degrees to secure in place while depressing the left side of the magazine catch.

(4) Reassemble slide assembly to receiver assembly by following the procedures outlined in para 3-3 of this Manual or in TM 00526A-10/1, Operator's Manual.

(5) Once the pistol is completely reassembled, perform the safety checks outlined in para 6-18 of this Manual.

6-4. PLUNGER TUBE GROUP (Figures 6-6 thru 6-8)

a. Disassembly

NOTE

While the SMR codes indicate that the majority of receiver assembly components are intermediate maintenance parts, they can be removed at organizational maintenance for the purpose of inspection and for gaining access to the plunger tube group.

(1) Field strip the pistol following the procedures outlined in para 3-2 of this Manual or in TM 00526A-10/1, Operator's Manual.

(2) Cock the hammer.

(3) Lift, wiggle and remove the *left side* ambidextrous thumb safety (1), Figure 6-6, from the pistol.

(4) Rotate the right side ambidextrous thumb safety (2), Figure 6-6, *down* to clear the hammer pin. Remove the ambidextrous thumb safety from the pistol.

(5) Place the receiver assembly on a bench block.

(6) Using a 1/16" punch, push components out of the plunger tube from the slide stop side of the plunger tube (1), Figure 6-7.

(7) Catch safety detent plunger (1), Figure 6-8, plunger spring (2), and slide stop plunger (3) as they emerge from the safety side of the plunger tube (4).

6-6. PLUNGER TUBE GROUP (Continued)

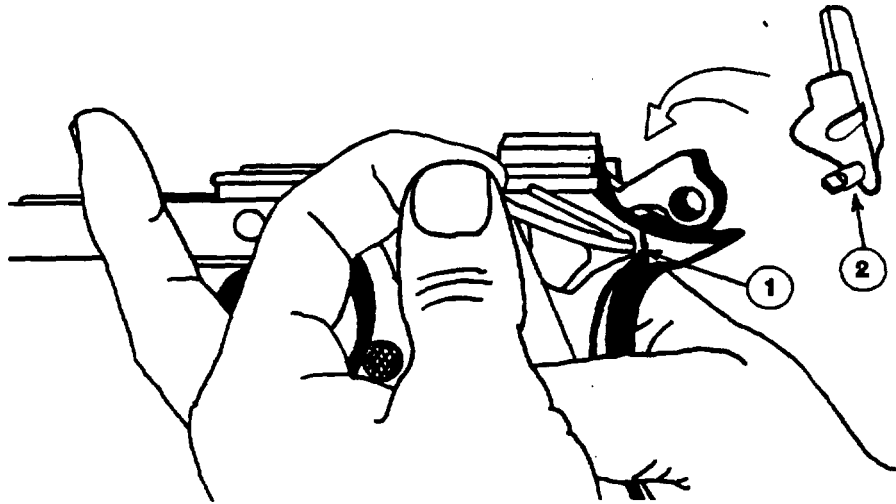

Figure 6-6. Removing Ambidextrous Thumb Safety

b. Inspection

(1) Inspect the safety detent plunger (1), Figure 6-8, for wear and burrs. If worn or burred, replace safety plunger.

(2) Inspect the plunger spring (2), Figure 6-8, to make sure it is not bent or compressed. If bent or compressed, replace plunger spring.

(3) Inspect the slide stop plunger (3), Figure 6-8, for wear and burrs. If worn or burred, replace slide stop plunger.

(4) Inspect plunger tube (4), Figure 6-8, for burrs and deformation. If burred or deformed, evacuate to intermediate maintenance for repairs.

c. Reassembly

(1) Use a 1/16" punch to insert slide stop plunger (3), Figure 6-8, plunger spring (2) and safety plunger (1) through the safety side of the plunger tube (4).

(2) Cock the hammer.

(3) Install the right side ambidextrous thumb safety (2), Figure 6-6, and rotate it *up* to engage the hammer pin.

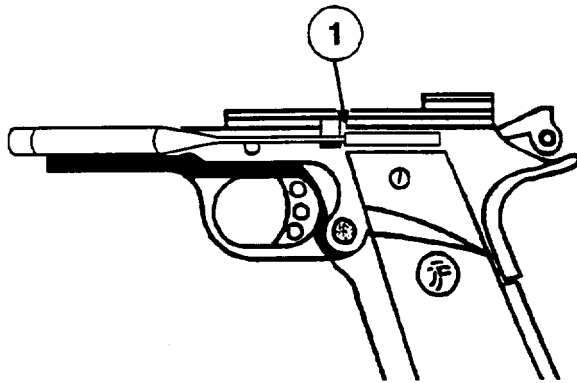

Figure 6-7. Removing Plunger Tube Group

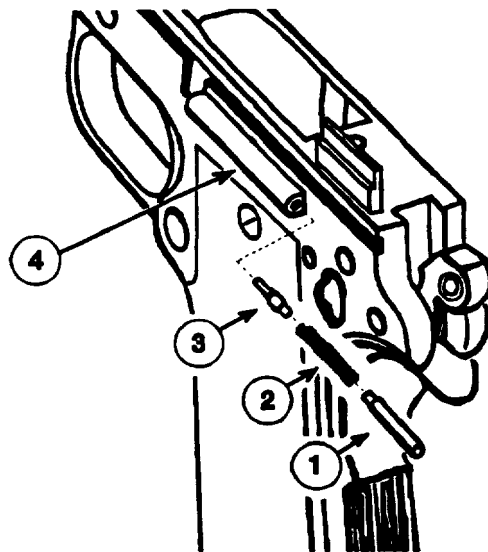

Figure 6-8. Plunger Tube Group

(4) Install the *left side* ambidextrous thumb safety (1), Figure 6-6. Push it in and rotate it *down so as to* engage the right side ambidextrous thumb safety.

(5) Reassemble slide assembly to receiver assembly by following the procedures outlined in para 3-3 of this Manual or in TM 00526A-10/1, Operator's Manual.

(6) Once the pistol is completely reassembled, perform the safety checks outlined in para 6-18 of this Manual.

6-7. MAINSPRING HOUSING GROUP (Figures 6-9 thru 6-12)

a. Disassembly

NOTE

While the SMR codes indicate that the majority of receiver assembly components are intermediate maintenance parts, they can be removed at organizational maintenance for the purpose of inspection and for gaining access to the mainspring housing group.

(1) Field strip the pistol following the procedures outlined in para 3-2 of this Manual or in TM 00526A-10/1, Operator's Manual.

(2) Cock the hammer.

(3) Lift, wiggle and remove the *left side* ambidextrous thumb safety (1), Figure 6-6, from the pistol.

(4) Rotate the *right side* ambidextrous thumb safety (2), Figure 6-6, *down* to clear the hammer pin. Remove the ambidextrous thumb safety from the pistol.

(5) Release the hammer.

(6) Place the receiver assembly on a bench block.

(7) Using a 5/32" punch and 4 oz hammer, drive out mainspring housing pin (1), Figure 6-9, from the receiver assembly (2).

(8) Separate mainspring housing group (1), Figure 6-10, from the receiver assembly (2).

WARNING

Mainspring housing components are under spring tension. Use care to prevent components from flying free or causing injury.

(9) Using a 5/32" punch positioned in the bench block, push in on mainspring cap (1), Figure 6-11, to relieve pressure on mainspring retaining pin (2).

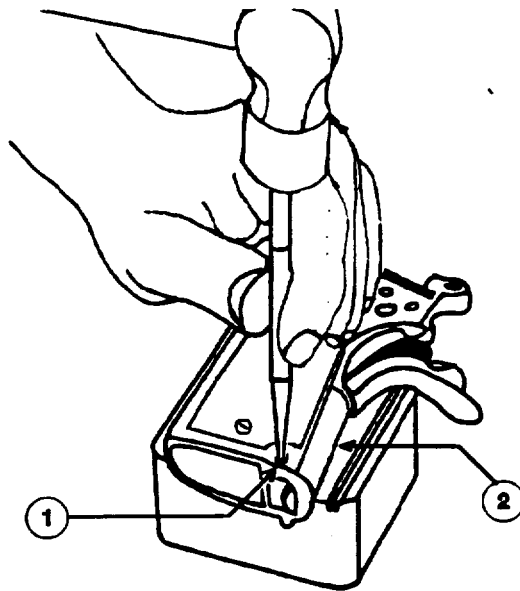

Figure 6-9. Removing Mainspring Housing Pin

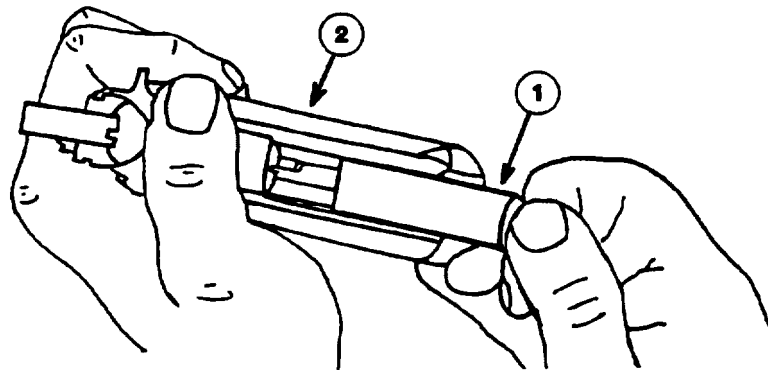

Figure 6-10. Removing Mainspring Housing

(10) Using a 1/16" punch, remove mainspring retaining pin (2), Figure 6-11.

(11) After removing mainspring retaining pin (1), Figure 6-12, from mainspring housing (2), separate mainspring cap (3), mainspring (4), detent plunger (5) .

(12) Using a 1/16" punch and 4 oz hammer, drive out the tubular spring pin (6), Figure 6-12, from mainspring housing (2) and remove lanyard loop (7).

6-7. MAINSPRING HOUSING GROUP (Continued)

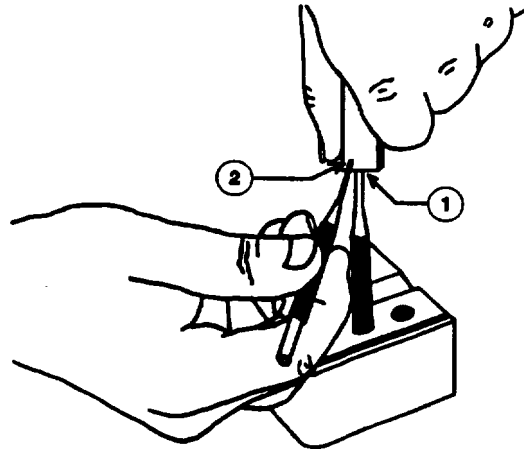
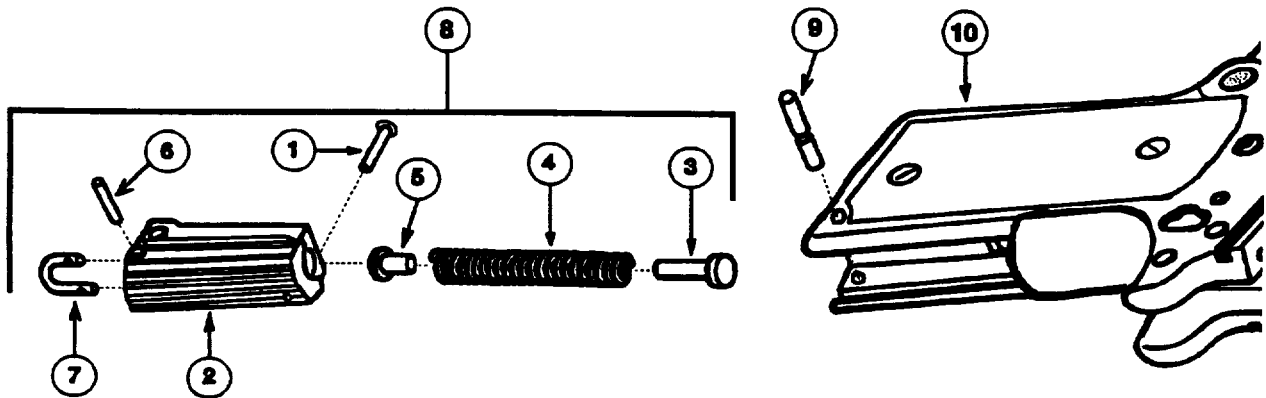

Figure 6-11. Removing Mainspring Retaining Pin

NOTE

The mainspring housing group (8) is held by the mainspring housing pin (9) within the receiver assembly (10).



6-12. Mainspring Housing Group

b. Inspection

(1) Inspect mainspring retaining pin (1), Figure 6-122 tubular spring pin (6), and mainspring housing pin (9) for wear and burrs. If worn or burred, replace as required.

(2) Inspect mainspring cap (3), Figure 6-12, and detent plunger (5) for wear and burrs. If worn or burred, replace as required.

(3) Inspect mainspring (4), Figure 6-12, to make sure it is not bent or compressed. Check mainspring length: 2“ minimum and 2-5/16” maximum. If bent, compressed or the wrong length, replace mainspring.

(4) Inspect lanyard loop (7), Figure 6-12, for bends and wear. If bent or worn, replace lanyard loop.

(5) Inspect mainspring housing (2), Figure 6-12, for burrs on mating surfaces and wear. If worn or burred, replace mainspring housing group (8).

c. Reassembly

(1) Use a 1/16” punch and 4 oz hammer to install tubular spring pin (6), Figure 6-12, into mainspring housing (2) to secure lanyard loop (7).

(2) Install detent plunger (5), Figure 6-12, mainspring (4), and mainspring cap (3) into mainspring housing (2).

(3) Use a 5/32” punch positioned in the bench block to push in on mainspring cap (1), Figure 6-11, while using a 1/16” punch to install mainspring retaining pin (2).

(4) Slide mainspring housing group (1), Figure 6-10, onto the receiver assembly (2).

(5) Use a 5/32” punch and 4 oz hammer to install mainspring housing pin (1), Figure 6-9.

(6) Cock the hammer.

(7) Install the *right side* ambidextrous thumb safety (2), Figure 6-6, and rotate it *up* to engage the hammer pin.

(8) Install the *left side* ambidextrous thumb safety (1), Figure 6-6. Push it in and rotate it *down so as to* engage the right side ambidextrous thumb safety.

6-7. MAINSPRING HOUSING GROUP (Continued)

c. Reassembly (Continued)

(9) Release the hammer.

(10) Reassemble slide assembly to receiver assembly by following the procedures outlined in para 3-3 of this Manual or in TM 00526A-10/1, Operator's Manual

(11) Once the pistol is completely reassembled, perform the safety checks outlined in para 6-18 of this Manual.

6-8. MAGAZINE ASSEMBLY

a. Disassembly. Procedures are outlined in TM 00526A-10/1, Operator's Manual.

b. Inspection

(1) Inspect magazine follower for deformation and cracks. If deformed or cracked, replace the magazine follower.

(2) Inspect magazine spring for spring tension by pushing down on the follower by hand. If magazine follower is not under spring tension, replace magazine spring.

(3) Inspect magazine bumper, base, and housing for deformation, cracks pitting. If unserviceable, replace magazine assembly.

WARNING

Magazine assembly is under spring tension, care must be taken when removing the magazine base.

c. Reassemble. Procedures are outlined in TM 00526A-10/1, Operator's Manual

Section III. INTERMEDIATE MAINTENANCE

6-9. THIRD ECHELON MAINTENANCE. Third echelon maintenance will be performed by a 2111, who is authorized to replace the extractor, the ejector, and the ejector pin. Maintenance will be performed using a 5 oz dead blow hammer.

6-10. EXTRACTOR (Figure 6-13)

a. Disassembly

NOTE

While the SMR code indicates that the firing pin stop is a fourth echelon maintenance part, it can be removed at third echelon for the purpose of inspection and for gaining access to the extractor.

(1) Field strip the pistol and disassemble the firing pin group following the procedures outlined in para 3-2 of this Manual.

WARNING

Firing pin is under spring tension. Use care to prevent firing pin Spring from flying free or causing injury.

(2) Using a 3/32" punch, depress the head of the firing pin and remove the firing pin stop (1) from the slide assembly (2).

(3) Remove firing pin, firing pin spring, and the extractor (3).

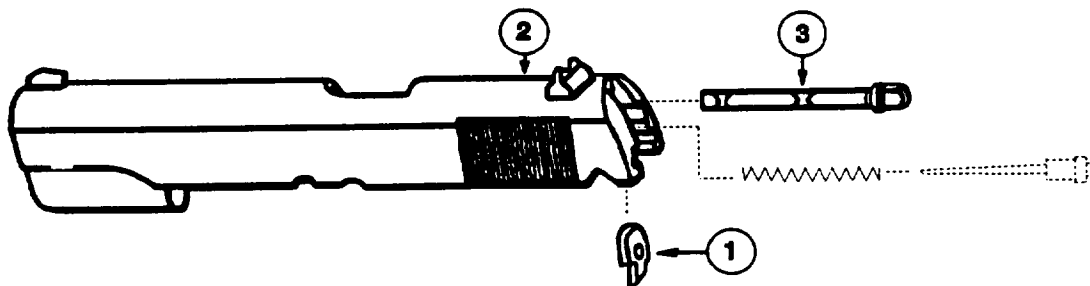

Figure 6-13. Firing Pin Group

6-10. EXTRACTOR (Continued)

b. Inspection

(1) Inspect extractor (3) for wear, weakness, broken lip or deformation. If unserviceable, replace extractor.

(2) Inspect firing pin stop (1) for cracks, chips or burrs. If unserviceable, evacuate to fourth echelon maintenance for repairs.

c. Reassembly

(1) Install firing pin spring, firing pin, and extractor (3) into slide assembly (2).

(2) Position firing pin stop (1) into the slot within the slide assembly (2).

(3) Use a 3/32" punch to depress the head of the firing pin while sliding firing pin stop (1) over the head of the firing pin and into position.

(4) Reassemble slide assembly to receiver assembly by following the procedures outlined in para 3-3 of this Manual or in TM 00526A- 10/1, Operator's Manual.

(5) Once the pistol is completely reassembled, perform the safety checks outlined in Para 6-18 of this Manual.

6-11. EJECTOR AND EJECTOR PIN (Figures 6-14 thru 6-16)

a. Disassembly

(1) Field strip the pistol following the procedures outlined in para 3-2 of this Manual or in TM 00526A-10/1, Operator's Manual.

NOTE

The ejector pin is driven out from the left side of the pistol.

(2) Using a 1/16" punch and 4 oz hammer, drive the ejector pin (1), Figure 6-14, from the left side of the pistol out through the right side of the pistol.

(3) Tighten ejector (1), Figure 6-15, in a vise (2). Hit the receiver assembly with a 5 oz dead blow hammer (3) to disconnect from ejector.

b. Inspection

(1) Inspect ejector (1), Figure 6-15, for wear and burrs. If worn or burred, replace ejector.

(2) Inspect ejector pin (1), Figure 6-14, for wear and burrs. If worn or burred, replace ejector pin.

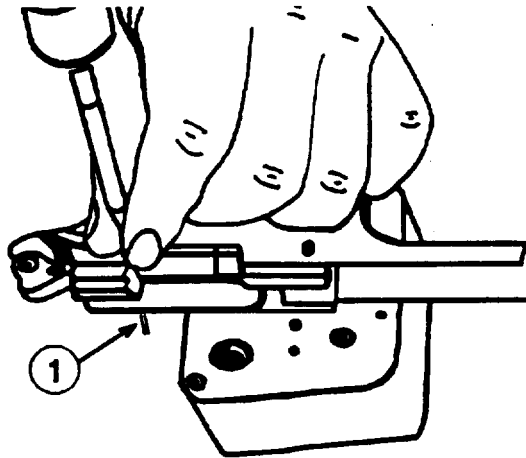

Figure 6-14. Removing Ejector Pin

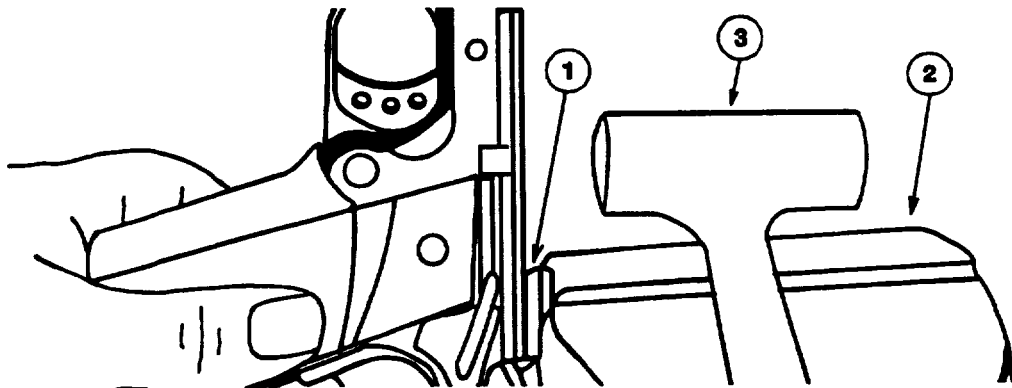

Figure 6-15. Removing Ejector

6-11. EJECTOR AND EJECTOR PIN (Continued)

c. Reassemble

(1) Align ejector (1), Figure 6-16, with the appropriate holes in receiver assembly (2). Use a 5 oz dead blow hammer to hit and seat ejector (1) within receiver assembly (2).

NOTE

The ejector pin is installed through the right side of the pistol.

(2) Use a 1/16" punch and 4 oz hammer to install ejector pin (3), Figure 6-16, through the right side of the pistol.

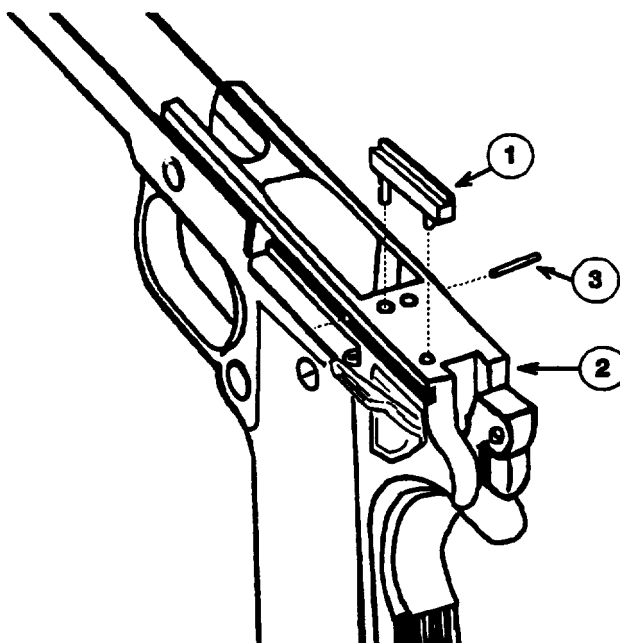

6-16. Installing Ejector And Ejector Pin

(3) Reassemble slide assembly to receiver assembly by following the procedures outlined in para 3-3 of this Manual or in TM 00526A-10/1, Operator's Manual.

(4) Once the pistol is completely reassembled, perform the safety checks outlined in para 6-18 of this Manual.

6-12. FOURTH ECHELON MAINTENANCE. Fourth echelon maintenance will be performed by a 2112 using the special tools and test equipment in Table 6-1.

Table 6-1. Intermediate Maintenance Special Tool and Test Equipment

ITEM	CAGE	NSN/PN	ITEM IDENTIFICATION	U/I	QTY
1	12238	257-990-100	Carbide burr	EA	1
2	81348	5120-00-221-1999	Gage, Feeler	EA	1
3	12238	184-100450	Gage, HeadSpace	EA	1
4	5H988	Locally fabricated	Insert Tool, plunger tube	EA	1
5	80009	3439-00-596-1718	Solder, Silver	RL	1
6	5H988	Locally fabricated	Staking Tool, plunger tube	EA	1
7	12238	080-644-000	Staking Tool, stock screw bushing	EA	1
8	19204	4933-00-647-3696	Trigger Pull, measuring fixture	EA	1
9	81348	5120-00-198-5401	Wrench, hex head (.050)	EA	1

6-13. MAINTENANCE OF THE SLIDE ASSEMBLY (Figures 6-17 thru 6-20)

a. Disassembly

(1) Field strip the pistol and disassemble the firing pin group following the procedures outlined in para 3-2 of this Manual.



Firing pin is under spring tension. Use care to prevent firing pin spring from flying free or causing injury.

Recoil spring guide is under spring tension. Use care to prevent recoil spring from flying free or causing injury.

(2) Using a 3/32” punch, depress the head of the firing pin and remove the firing pin stop (1), Figure 6-17, from the slide assembly (2).

(3) Disassemble the recoil group following the procedures outlined in para 6-3 of this Manual.

6-13. MAINTENANCE OF THE SLIDE ASSEMBLY (Continued)

a. Disassembly (Continued)

(4) Using a 5/32" punch and 4 oz hammer, drive out barrel link pin (1), Figure 6-18.

(5) Separate barrel link (2), Figure 6-18, from barrel (3).

(6) Separate barrel bushing (4), Figure 6-18, from barrel (3).

NOTE

Do not remove the front sight unless it is unserviceable and requires replacement. Do not attempt to remove the rear sight.

(7) Using a 5/32" punch and 4 oz hammer, remove front sight (5), Figure 6-18, only if damaged. Refer to Figure 6-19 for illustrated removal of front sight (1).

(8) Using a .050 hex head wrench, remove rear sight set screw (6), Figure 6-18, only if damaged.

(9) Separate recoil spring guide (7), Figure 6-18, from recoil spring.

(10) The slide stop (8), Figure 6-18, would have been removed from the pistol during initial field stripping procedures.

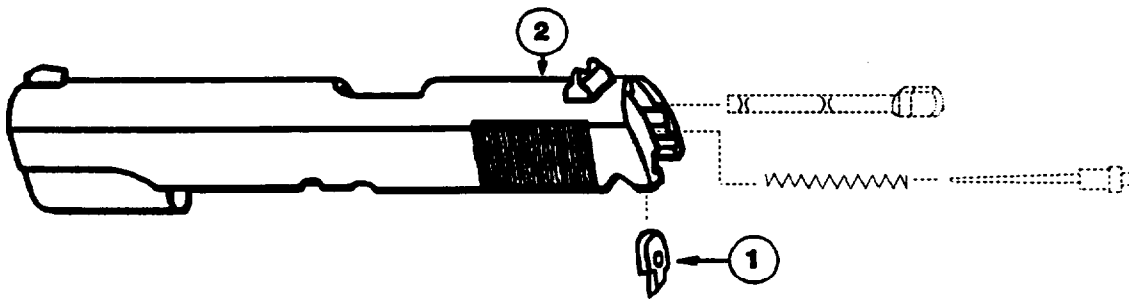

Figure 6-17. Firing Pin Group

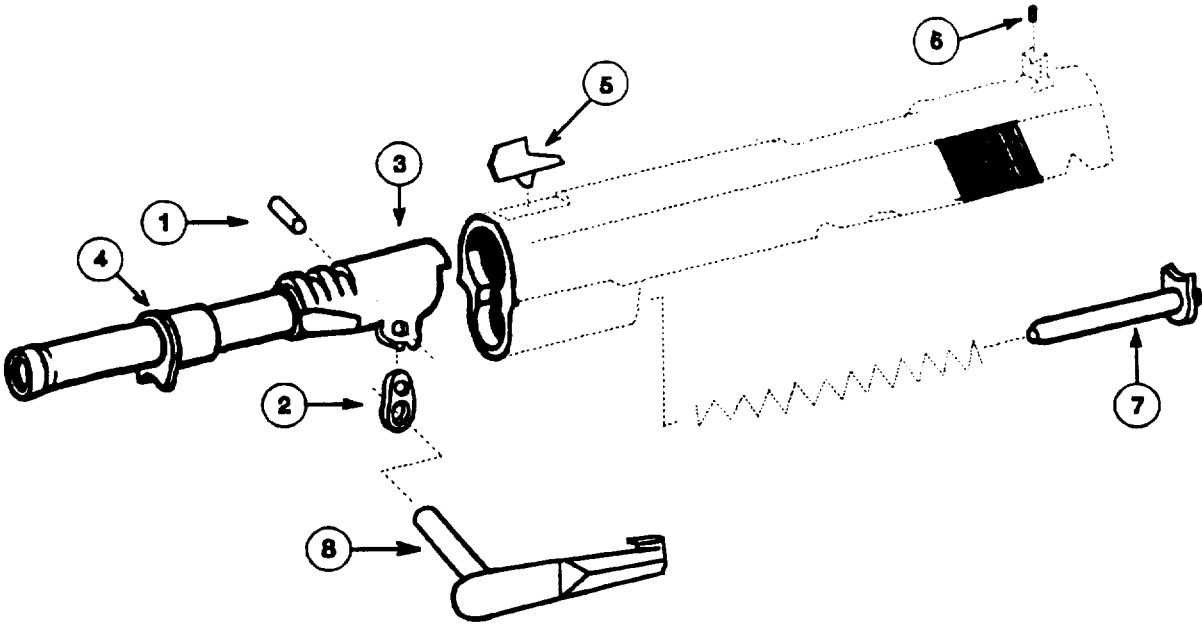

Figure 6-18. Recoil Group

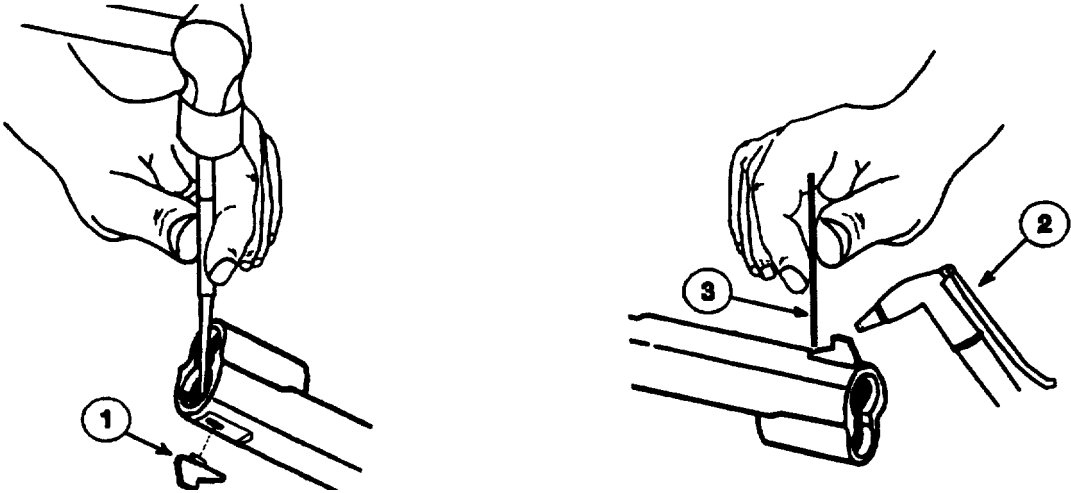

Figure 6-19. Removing And Installing Front Sight

6-13. MAINTENANCE OF THE SLIDE ASSEMBLY (Continued)

b. Inspection

(1) Using a flashlight and jeweler's eyepiece, perform a technical inspection the slide (2), Figure 6-17, and on the barrel (3), Figure 6-18. Check for burrs, pits, bulges or distortions. Check for the sharpness of the lands and crown. Inspect the face of the slide for cracks, chips or gouges. If any of these conditions "can not be corrected, evacuate the pistol to special fifth echelon maintenance for replacement of the slide or slide assembly. Shipping procedures are outlined in para 4-10 of this Manual.

(2) The headspace gage (1), Figure 6-20, indicates the wear on the shoulder of the chamber (2) by measuring the distance between the rear of the headspace gage and the face of the slide (3). The headspace distance will also indicate wear on the locking recesses (not shown). Insert feeler gage (4) between headspace gage (1) and face of slide (3). The headspace distance is correct if the GO-NO GO distance is between .903 minimum and .925 maximum. If headspace distance is too much or not enough, evacuate the pistol to special fifth echelon maintenance for replacement of the slide and/or slide assembly.

(3) Inspect firing pin stop (1), Figure 6-17, for cracks, chips or burrs. If unserviceable, replace firing pin stop.

(4) Inspect barrel link pin (1), Figure 6-18, and barrel link (2) for burrs and distortions. If unserviceable, replace barrel link or barrel link pin.

(5) Inspect barrel bushing (4), Figure 6-18, for burrs and distortions. If unserviceable, replace barrel bushing.

(6) Inspect front sight (5), Figure 6-18, for burrs and distortions. Check that front sight is securely attached to slide assembly. If unserviceable, replace front sight. If loose, clean area thoroughly and reapply silver solder.

(7) Check that the set screw (6), Figure 6-18, securing the rear sight is tight. If loose, tighten with .050 hex head wrench. If rear sight is unserviceable, evacuate the pistol to special fifth echelon maintenance for replacement of the rear sight.

(8) Inspect recoil spring guide (7), Figure 6-18, for burrs and distortions. If unserviceable, replace recoil spring guide.

NOTE

Although not a component of the slide assembly, the slide stop is included here for inspection criteria and replacement procedures. ,

(9) Inspect slide stop (8), Figure 6-18, for burrs and distortions. If unserviceable, replace slide stop.

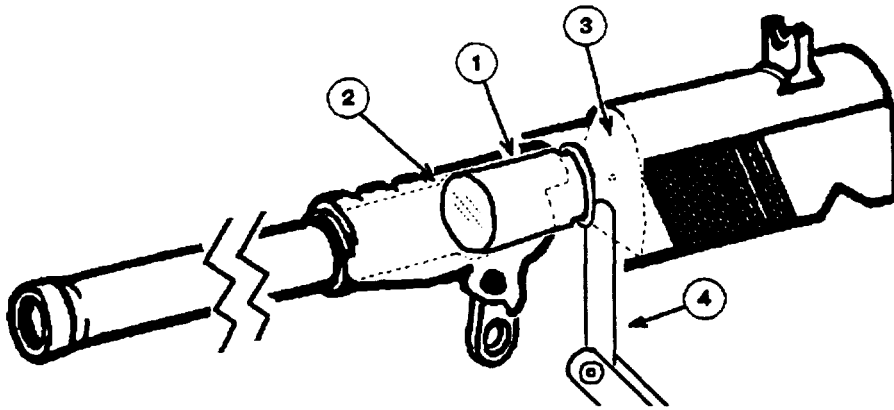

Figure 6-20. Checking Headspace

c. Reassembly

(1) Use a 5/32" punch and 4 oz hammer to install barrel link pin (1), Figure 6-18, through barrel link (2) and barrel (3).

(2) If the front sight was removed, use a welding torch (2), Figure 6-19, to sweat silver solder (3) around front sight (1) to secure it to the slide assembly.

(3) If this is a new firing pin stop (1), Figure 6-17, use a power grinder with the carbide burr to cut a radius on the lower right corner sufficient to clear the receiver assembly. Position firing pin stop into the slot within the slide assembly (2).

(4) Reassemble the recoil group into the slide assembly by following the procedures outlined in para 6-3 of this Manual.

(5) Reassemble slide assembly to receiver assembly by following the procedures outlined in para 3-3 of this Manual or in TM 00526A-10/1, Operator's Manual.

(6) Once the pistol is completely reassembled, perform the safety checks outlined in para 6-18 of this Manual.

6-14. MAINTENANCE OF THE RECEIVER ASSEMBLY (Figures 6-21 thru 6-30)

a. Disassembly

(1) Field strip the pistol following the procedures outlined in para 3-2 of this Manual or in TM 00526A- 10/1, Operator's Manual.

(2) Remove the combat pistol grip by following the procedures outlined in para 6-4 of this Manual.

(3) Cock the hammer.

(4) Lift, wiggle and remove the *left side* ambidextrous thumb safety (1), Figure 6-21, from the pistol.

(5) Rotate the *right side* ambidextrous thumb safety (2), Figure 6-21, *down* to clear the hammer pin. Remove the ambidextrous thumb safety from the pistol.

(6) Release the hammer.



Figure 6-21. Removing Ambidextrous Thumb Safety

(7) Using a 5/32" punch and 4 oz hammer, drive out mainspring housing pin (1), Figure 6-22, from the receiver assembly (2).

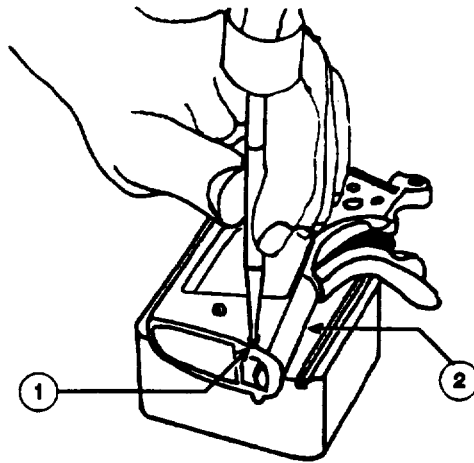

Figure 6-22. Removing Mainspring Housing Pin

(8) Separate mainspring housing group (1), Figure 6-23, from the receiver assembly (2).

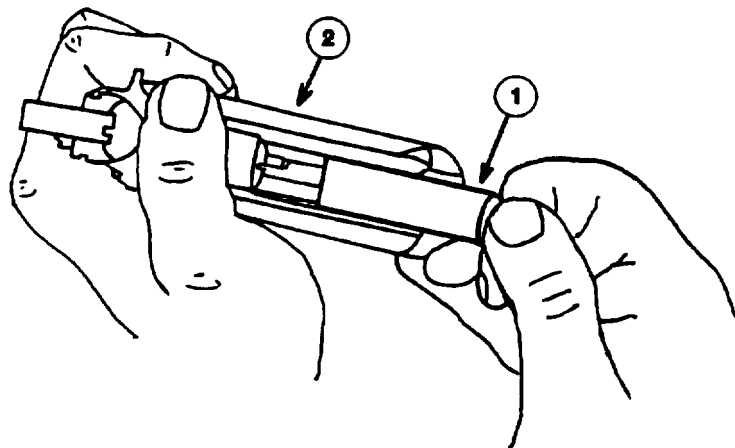

Figure 6-23. Removing Mainspring Housing

6-14. MAINTENANCE OF THE RECEIVER ASSEMBLY (Continued)

a. Disassembly (Continued)

(9) Remove beavertail grip safety (1), Figure 6-24.

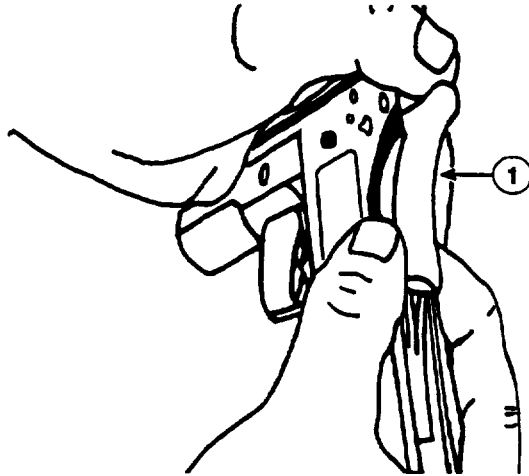

Figure 6-24. Removing Beavertail Grip Safety

(10) Lift hammer strut (1), Figure 6-25, and remove sear spring (2).

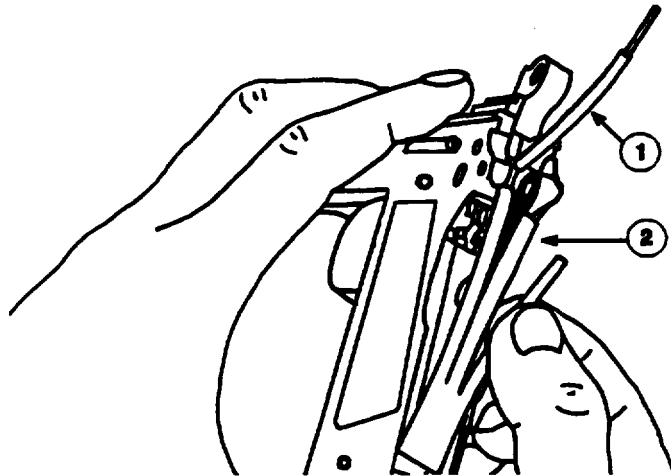

Figure 6-25. Removing Sear Spring

(11) Using a 3/32" punch, push hammer pin (1), Figure 6-26, out of the left side of the pistol.

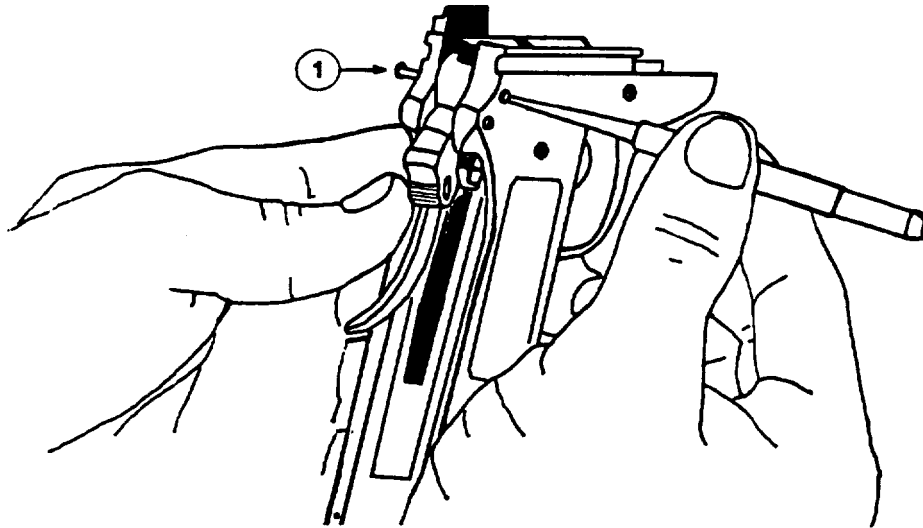

Figure 6-26. Removing Hammer Pin

(12) Lift and remove hammer group (1), Figure 6-27, from receiver assembly.

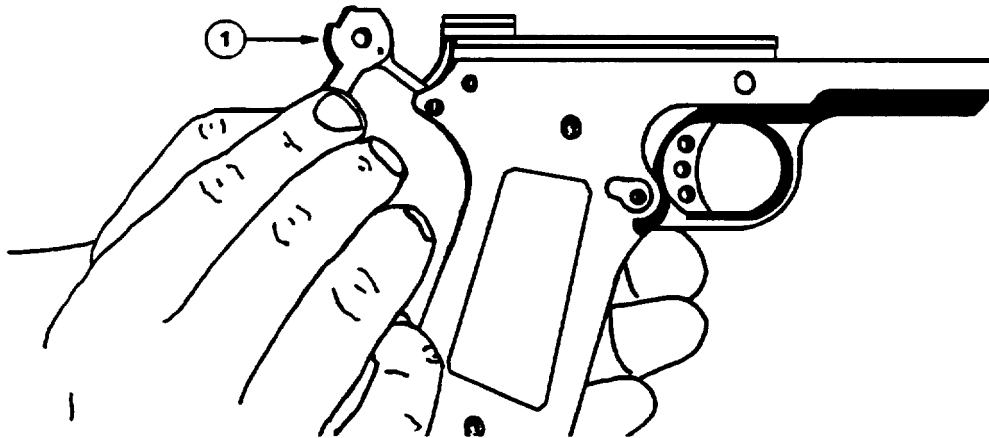

Figure 6-27. Removing Hammer Group

6-14. MAINTENANCE OF THE RECEIVER ASSEMBLY (Continued)

a. Disassembly (Continued)

(13) Using a 3/32" punch, push sear pin (1), Figure 6-28, out of the left side of the pistol.

(14) Lift and remove the disconnecter (2), Figure 6-28, and sear (3) as a group from the receiver assembly (4).

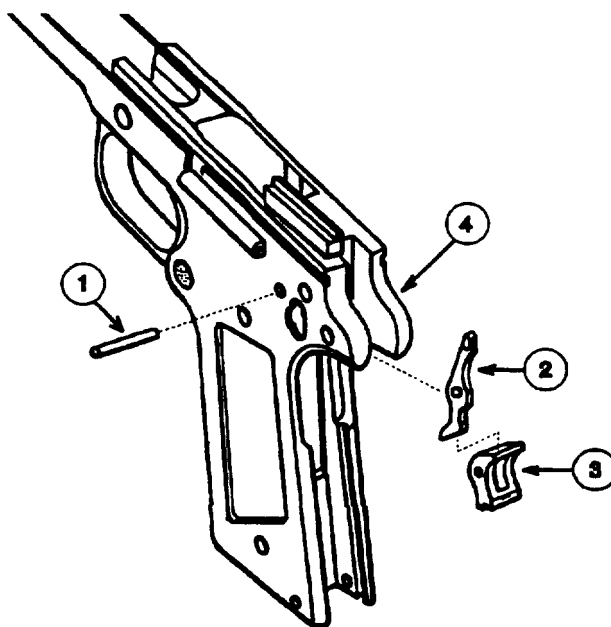

Figure 6-28. Removing Sear Pin



Magazine catch lock is under spring tension. Use care to prevent magazine catch lock from flying free or causing injury.

(15) Remove magazine catch group by following the procedures outlined in para 6-5 of this Manual.

(16) Remove trigger (1), Figure 6-29, from receiver assembly (2).

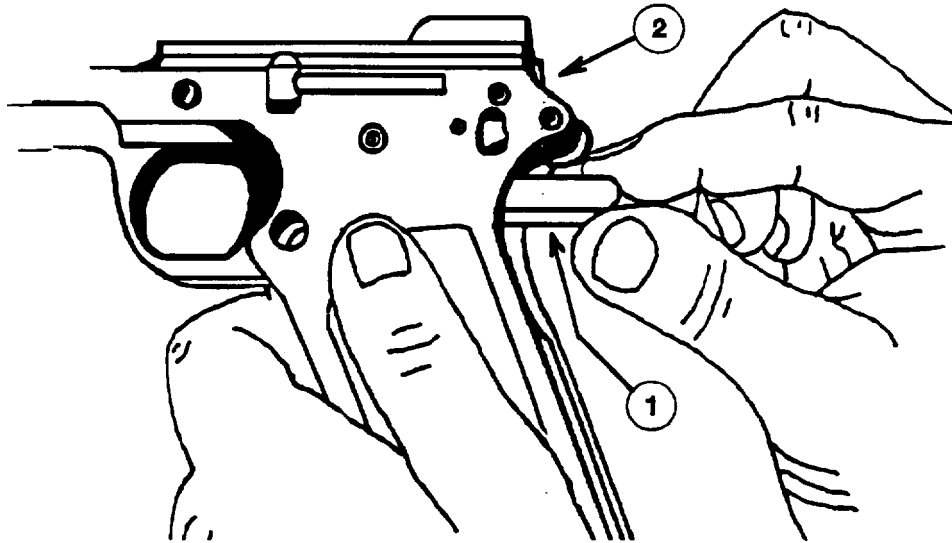

Figure 6-29. Removing Trigger

(17) Place the hammer group on a bench block.

(18) Using a 3/32" punch and 4 oz hammer, drive out hammer strut pin (1), Figure 6-30. Separate hammer strut (2) from hammer (3).

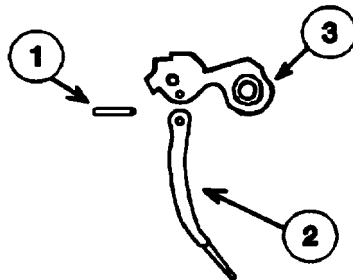

Figure 6-30. Removing Hammer Strut And Hammer Strut Pin

6-14. MAINTENANCE OF THE RECEIVER ASSEMBLY (Continued)

b. Inspection

(1) Using a flashlight and jeweler's eyepiece, perform a technical inspection on the receiver housing (2), Figure 6-29. Check for wear or burrs in the slide mating grooves. Inspect for deformation, pits, bulges or distortions. Check slide stop notch for oversize or wear. If any of these conditions can not be corrected, evacuate the pistol to special fifth echelon maintenance for replacement of the receiver housing. Shipping procedures are outlined in para 4-10 of this Manual.

(2) Inspect the one piece combat pistol grip (2), Figure 6-3, for wear and tear. If unserviceable, replace combat pistol grip.

(3) Inspect the pin portion and lug of ambidextrous thumb safeties (1) and (2), Figure 6-21, for burrs, wear and cracks. If unserviceable, replace the ambidextrous thumb safety as a set.

(4) Inspect mainspring housing (1), Figure 6-23, for burrs on mating surfaces, spring tension, and wear. If unserviceable, replace mainspring housing group.

(5) Inspect beavertail grip safety (1), Figure 6-24, for burrs, wear and cracks on the tip which engages the trigger. If unserviceable, replace beavertail grip safety.

(6) Inspect sear spring (2), Figure 6-25, for broken leaves, cracks and tension. If unserviceable, replace sear spring.

(7) Inspect hammer pin (1), Figure 6-26, for wear and burrs. If unserviceable, replace hammer pin.

(8) Inspect hammer strut pin (1), Figure 6-30, and hammer strut (2) for burrs or wear. If unserviceable, replace hammer strut or hammer strut pin.

(9) Inspect half-cock notch and full-cock notch positions of the hammer (3), Figure 6-30, for cracks, wear or chips. If unserviceable, replace hammer.

(10) Inspect sear pin (1), Figure 6-28, for wear and burrs. If unserviceable, replace sear pin.

(11) Inspect disconnecter (2), Figure 6-28, for burrs or wear. If unserviceable, replace disconnecter.

(12) Inspect sear (3), Figure 6-28, for worn or chipped tips or worn lugs. If unserviceable, replace sear.

(13) Inspect that the magazine catch group moves freely within the receiver assembly and holds the magazine assembly securely inside the magazine well. If unserviceable, replace magazine catch spring (2), Figure 6-5. Check magazine lock (1) and magazine catch (3) for burrs and cracks. If burred or cracked, replace magazine lock and/or magazine catch.

(14) Inspect trigger (1), Figure 6-29, for burrs or wear. If unserviceable, replace trigger.

c. Reassemble

(1) Align the hammer strut (2), Figure 6-30, with the hammer (3).

(2) Use a 3/32" punch and 4 oz hammer to install hammer strut pin (1), Figure 6-30.

(3) Place trigger (1), Figure 6-29, inside receiver assembly (2).

(4) Install the magazine catch group by following the procedures outlined in para 6-5 of this Manual.

(5) Place disconnecter (2), Figure 6-28, inside the sear (3) and install them both as a group into the receiver assembly (4).

NOTE

When installing the sear pin and the hammer pin, the head of the pin should be on the left side of the pistol.

(6) Use your hand to push the sear pin (1), Figure 6-28, from the left side of the pistol to the right.

(7) Install hammer group (1), Figure 6-27, inside receiver assembly.

(8) Use your hand to push the hammer pin (1), Figure 6-26, from the left side of the pistol to the right.

(9) Lift hammer strut (1), Figure 6-25, and install sear spring (2) inside receiver assembly.

(10) Partially install mainspring housing group (1), Figure 6-23, to hold sear spring in position.

6-14. MAINTENANCE OF THE RECEIVER ASSEMBLY (Continued)

c. Reassembly (Continued)

(11) Drop hammer strut (1), Figure 6-25, and install beavertail grip safety (1), Figure 6-24.

(12) Cock the hammer.

(13) Install the *right side* ambidextrous thumb safety (2), Figure 6-21, and rotate it *up* to engage the hammer pin (1), Figure 6-26.

(14) Install the *left side* ambidextrous thumb safety (1), Figure 6-21. Push it in and rotate it *down so as* to engage the right side ambidextrous thumb safety.

(15) Release the hammer.

(16) Fully install mainspring housing group. Use a 5/32" punch and 4 oz hammer to install mainspring housing pin (1), Figure 6-22, into the receiver assembly (2).

(17) Install the one piece combat pistol grip by following the procedures outlined in para 6-4 of this Manual.

(18) Reassemble slide assembly to receiver assembly by following the procedures outlined in para 3-3 of this Manual or in TM 00526A-10/1, Operator's Manual.

(19) Once the pistol is completely reassembled, perform the safety checks outlined in para 6-18 Of this Manual.

6-15. GRIP SCREW BUSHING (Figures 6-31 and 6-32)

a. Disassembly

(1) Field strip the pistol following the procedures outlined in para 3-2 of this Manual or in TM 00526A-10/1, Operator's Manual.

(2) Using a small flat-tip screwdriver, remove the four grip screws (1), Figure 6-31. Remove the one piece combat pistol grip (2).

(3) Disassemble the receiver assembly by following the procedures outlined in para 6-14 of this Manual.

NOTE

Do not remove the grip screw bushings unless they are unserviceable and require replacement.

(4) Using an appropriately sized flat-tip screwdriver, remove the unserviceable grip screw bushing (3), Figure 6-31. If the grip screw bushing is stripped, use a pair of pliers to lift and twist the grip screw bushing out of the receiver assembly (4).

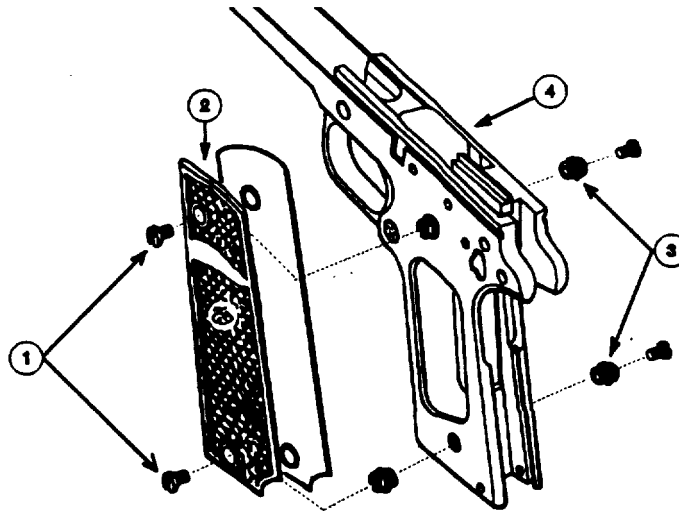

6-31. Removing Grip Screw Bushing

b. Inspection

(1) Check that grip screws (1), Figure 6-31, have not stripped the threads in the grip screw bushings (3). If stripped, use the appropriately sized tap to redress the threads in the grip screw bushing.

(2) Check that grip screw bushings (3), Figure 6-31, are tight and are held securely within the receiver assembly (4). If loose, tighten using an appropriately sized flat-tip screwdriver. Check that grip screw bushings (3) have not stripped the threads in the receiver assembly (4). If stripped, use the appropriately sized tap to *redress the threads in the* receiver assembly.

c. Reassembly

(1) Place the receiver on a bench block. Use an appropriately sized flat-tip screwdriver to install the grip screw bushing (3), Figure 6-31.

(2) If replacement is required, use a 1/8" punch, a 4 oz hammer, and the Stock Screw Bushing Staking Tool (3), Figure 6-32, for staking (*flaring*) the underside of the grip screw bushing (1).

6-15. GRIP SCREW BUSHING (Continued)

a. Reassembly (Continued)

(3) Reassemble the receiver assembly by following the procedures outlined in para 6-14 of this Manual.

(4) Install the one piece combat pistol grip (2), Figure 6-31, and align the holes for the grip screws (1).

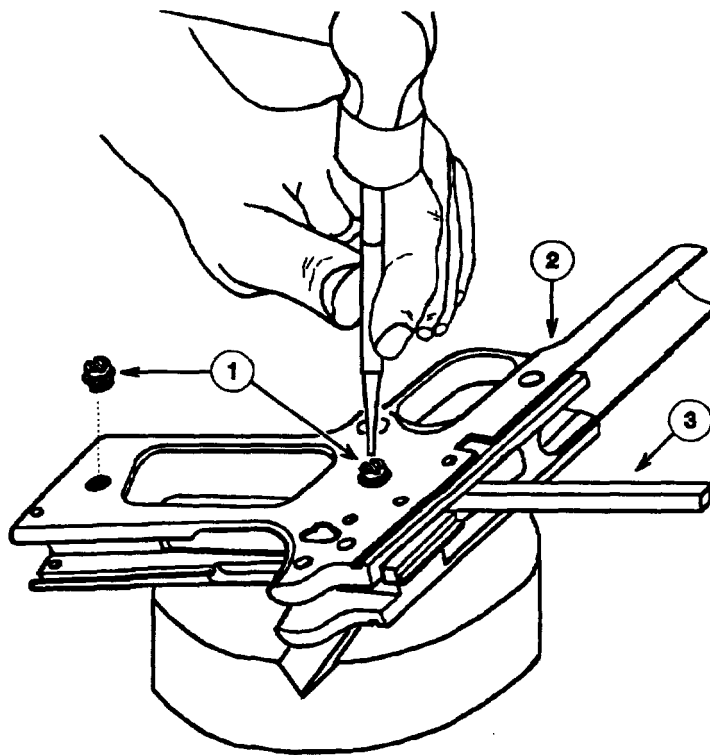

6-32. Installing Grip Screw Bushing

(5) Use a small flat-tip screwdriver to tighten the four grip screws (1), Figure 6-31.

(6) Reassemble slide assembly to receiver assembly by following the procedures outlined in para 3-3 of this Manual or in TM 00526A-10/1, Operator's Manual.

(7) Once the pistol is completely reassembled, perform the safety checks outlined in para 6-18 of this Manual.

6-16. PLUNGER TUBE (Figures 6-33 and 6-34)a. Disassembly

(1) Field strip the pistol following the procedures outlined in para 3-2 of this Manual or in TM 00526A-10/1, Operator's Manual.

NOTE

Detail strip the receiver assembly only enough to gain access to the plunger tube group.

(2) Disassemble the receiver assembly by following the procedures outlined in para 6-6 of this Manual.

(3) Place the receiver assembly on a bench block.

(4) Using a 1/16" punch, remove plunger tube components.

NOTE

Do not remove the plunger tube unless it is unserviceable and requires replacement.

(5) Using a pair of parallel-jaw pliers, clamp hold of plunger tube (1), Figure 6-33, and wiggle it off receiver assembly (2).

b. Inspection. Inspect plunger tube (1), Figure 6-33, for burrs and deformation. If burred or deformed, replace plunger tube.

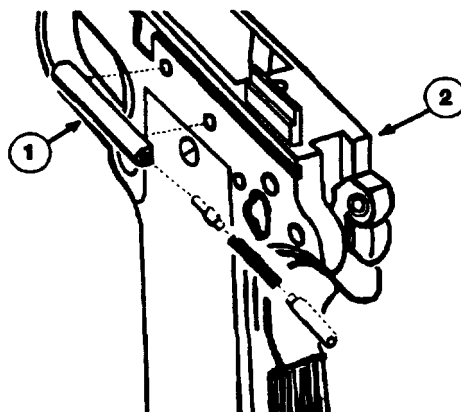

Figure 6-33. Removing And Installing The Plunger Tube

6-16. PLUNGER TUBE (Continued)

c. Reassemble

(1) If replacement is required, align the tabs on plunger tube with the holes in the receiver assembly, refer to Figure 6-33.



Place the Insert Tool inside of the plunger tube to prevent deforming and damaging the plunger tube during staking procedures.

(2) Use a 4 oz hammer, the Plunger Tube Staking Tool (1), Figure 6-34, and the Insert Tool (2) for staking (*flaring*) the underside of the plunger tube.

(3) Reassemble the receiver assembly by following the procedures outlined in para 6-6 of this Manual.

(4) Reassemble slide assembly to receiver assembly by following the procedures outlined in para 3-3 of this Manual or in TM 00526A-10/1, Operator's Manual.

(5) Once the pistol is completely reassembled, perform the safety checks outlined in para 6-18 of this Manual.

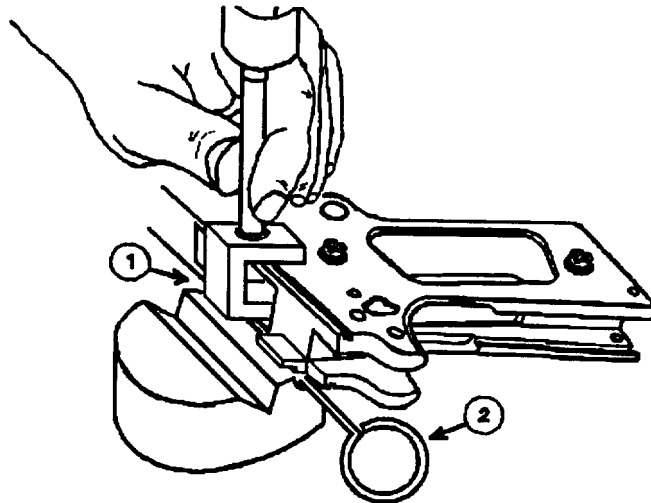

Figure 6-34. Staking The Plunger Tube

6-17. TRIGGER PULL TEST (Figures 6-35 and 6-36)a. Testing Trigger Pull

(1) Check the feel of the trigger pull. The trigger pull should have a clean, crisp break, and have only slight over-travel. Correct trigger pull is between 4.5 and 5.0 pounds.



Insure that an empty magazine is installed when checking the trigger pull.

NOTE

Make certain the test fixture does not contact or rub any portion of the pistol and that test fixture and barrel are parallel.

(2) Place the test fixture (1), Figure 6-35, on the work bench and add test weights (2) until minimum load of 4.5 pounds is reached. A *scale-type* measuring device may also be used for the trigger pull test.

(3) With the ambidextrous thumb safety (1), Figure 6-36, in the FIRE position and the hammer (2) cocked, hook the notched portion of the test fixture rod over the center portion of the trigger (3).

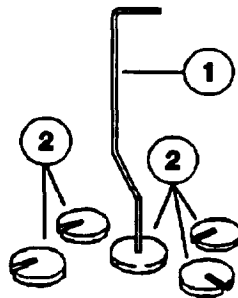

Figure 6-35. Test Fixture

6-17. TRIGGER PULL TEST (Continued)

a. Testing Trigger Pull (Continued)

NOTE

A slow and steady lift must be utilized to assure a true and accurate check.

(4) Depress the beavertail grip safety (4), Figure 6-36, and carefully raise the weight from the bench. Hold the weapon in a vertical position. Using the 4.5 pound weight (minimum), the trigger should *not* release the hammer.

(5) Remove test fixture and add weights until maximum load of 5.0 pounds is reached. Repeat the procedures in para (4) above. The trigger should release the hammer.

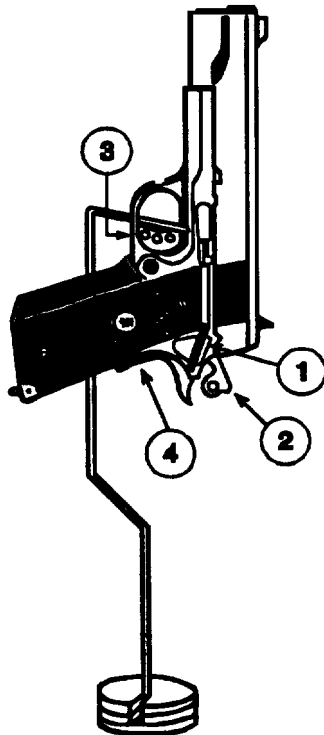

Figure 6-36. Trigger Pull Test

b. Correcting Trigger Pull**WARNING**

While stoning, critical dimensions should *not* be altered. If so, weapon failure may result.

(1) Trigger Pull Too Light. *This is* evidence of a worn cocking notch on the hammer, worn or damaged sear, or a weak compression of the mainspring within the mainspring housing group. Examine the components for wear or damage. If trigger pull cannot be corrected by stoning, replace with new components, as required.

(2) Trigger Pull Excess. *This is* evidence of burrs or surface irregularities on the hammer full-cock notch or sear. A mainspring that is damaged or too strong and/or interferes or binds between the mating surfaces of the pertinent parts within the receiver assembly are other probable causes. If the trigger pull cannot be corrected by stoning or changing magazine assemblies, replace with new components, as required.

(3) Creep in Trigger. Creep is defined as a perceptible movement of the trigger after the slack has been taken up and before the hammer is released. It is caused by rough or uneven mating surfaces of the sear, hammer, and disconnecter and also by unserviceable sear or hammer pin. If the creep cannot be corrected by stoning, replace with new components, as required.

Section IV. SAFETY CHECK

6-18. SAFETY CHECK (Figures 6-37 thru 6-40)

a. General. Whenever the pistol is disassembled beyond the normal field stripping, a Safety Check should be performed when the pistol is reassembled. This quick check indicates whether or not the pistol has been properly assembled and/or assembled with all components. By following the procedures outlined in TM 00526A-10/1, Operator's Manual, a properly executed Safety Check can also reveal many of the more obvious malfunctions that could occur between the interactive components of the pistol.

6-17. SAFETY CHECK (Continued)

WARNING

Before starting an inspection or repairs, be sure to clear the pistol. Do not actuate the trigger until the pistol has been cleared. Remove the magazine and inspect the chamber, to ensure that it is empty. Do not have live ammunition in the vicinity of the work area.

b. Ambidextrous Thumb Safety Test. With the pistol unloaded, cock the hammer (1), Figure 6-37, and push the ambidextrous thumb safety (2) up to the SAFE position. Grasp the pistol so that the beavertail grip safety (3) is depressed. Squeeze the trigger (4) three or four times. If the hammer (1) falls, replace the ambidextrous thumb safety and/or the beavertail grip safety.

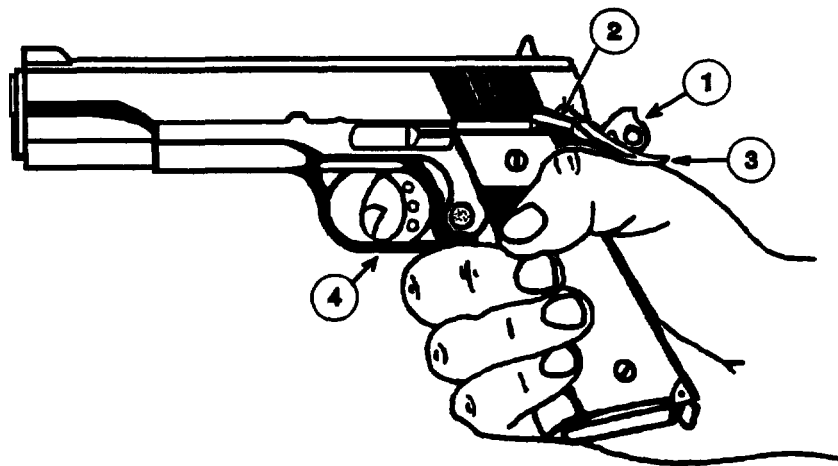

Figure 6-37. Ambidextrous Thumb Safety Test

c. Beavertail Grip Safety Test. With the pistol unloaded, cock the hammer (1), Figure 6-38, and pull the ambidextrous thumb safety (2) down to the FIRE position. Grasp the pistol *without* depressing the beavertail grip safety (3) and squeeze the trigger (4) three or four times. If the hammer (1) falls, replace the beavertail grip safety, the sear and/or the sear spring.

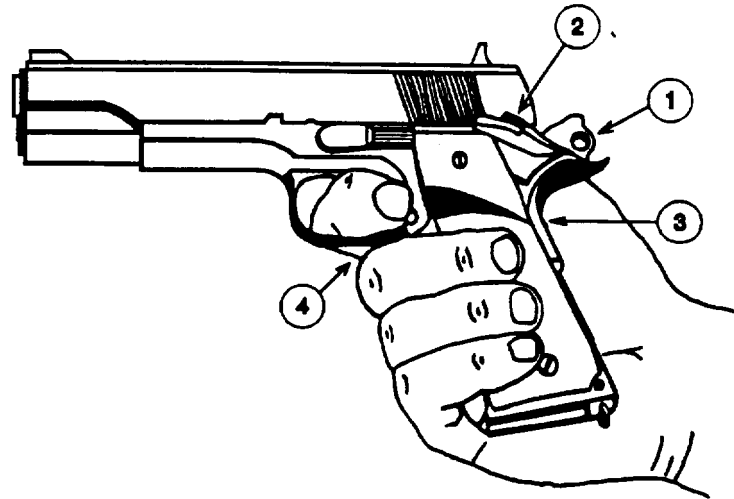

Figure 6-38. Beavertail Grip Safety Test

d. Half-Cock Position Test. With the pistol unloaded, draw back the hammer until the sear engages the half-cock position notch (1), Figure 6-39, then squeeze the trigger (2). If the hammer falls, replace the sear and/or hammer. Draw the hammer back *nearly* to full cock position (3) and let thumb slip off the hammer. The hammer should fall only to the half-cock notch position. If the hammer falls, replace the sear and/or hammer.

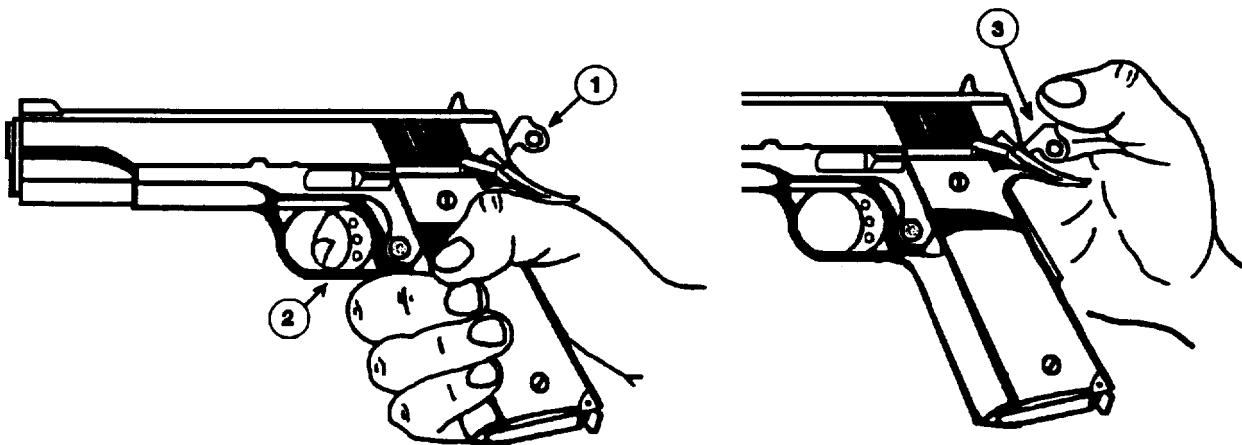

Figure 6-39. Half-Cock Position Test

6-17. SAFETY CHECK (Continued)

e. Disconnecter Test

(1) With the pistol unloaded, cock the hammer, push the slide assembly (1), Figure 6-40, 1/8 to 1/4 inch to the rear and hold in that position while squeezing the trigger (2). Let the slide assembly go forward, maintaining pressure on the trigger. If the hammer falls, replace the disconnector.

(2) Pull the slide assembly rearward and engage the slide stop. Squeeze the trigger and release the slide assembly simultaneously. The hammer should not fall; if it does, replace the disconnector.

(3) Release the pressure on the trigger and then squeeze it. The hammer should then fall; if it does not fall, replace the sear and/or trigger. Also, check for a faulty disconnector which would prevent the hammer from falling. The disconnector should prevent the release of the hammer unless the slide assembly is in a forward position and locked into battery. This also prevents the firing of more than one shot with each squeeze of the trigger.

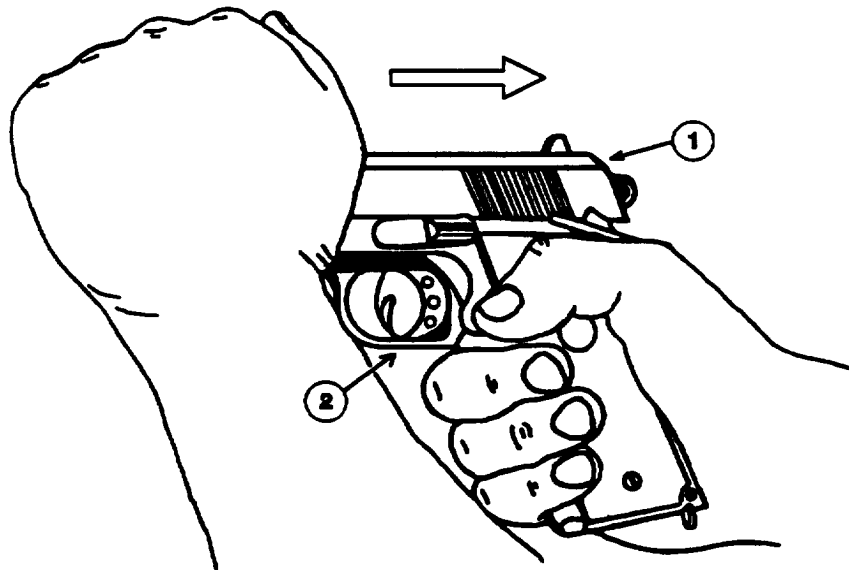

Figure 6-40. Disconnecter Test

CHAPTER 7

REPAIR PARTS AND SPECIAL TOOLS LIST

Section I. INTRODUCTION

7-1. SCOPE. This Repair Parts and Special Tools List (RPSTL) lists and authorizes spares and repair parts; special tools; and other special support equipment required for performance of organizational and intermediate maintenance of the MEU(SOC) .45 Caliber Pistol. It authorizes the requisitioning, issue and disposition of spares, repair parts and special tools indicated by the Source, Maintenance, and Recoverability (SMR) codes.

7-2. GENERAL. In addition to Section 1, Introduction, this Repair Parts and Special Tools List is divided into the following sections:

a. Section II. Repair Parts List. A list of spares and repair parts authorized by this RPSTL for use in the performance of maintenance. The list also includes parts which must be removed for replacement of the authorized parts. Parts lists are composed of parts in each group listed in ascending figure and item number sequence.

b. Section III. Special Tools List. A list of special tools and other special support equipment authorized by this RPSTL for the performance of maintenance.

c. Section IV. Cross Reference Indexes. There are two cross-reference indexes in this RPSTL: The National Stock Number Index and the Part Number Index. Both indexes refer you to the figure and item number.

7-3. EXPLANATION OF COLUMNS (SECTIONS II AND III)

a. ITEM NO. (Column (1)). Indicates the number used to identify items called out in the illustration.

b. SMR CODE (Column (2)). The Source, Maintenance, and Recoverability (SMR) code is a five-position code containing supply/requisitioning information, maintenance level authorization criteria, and disposition instructions as shown in the following manner:

7-3. EXPLANATION OF COLUMNS (SECTIONS II AND III) (Continued)

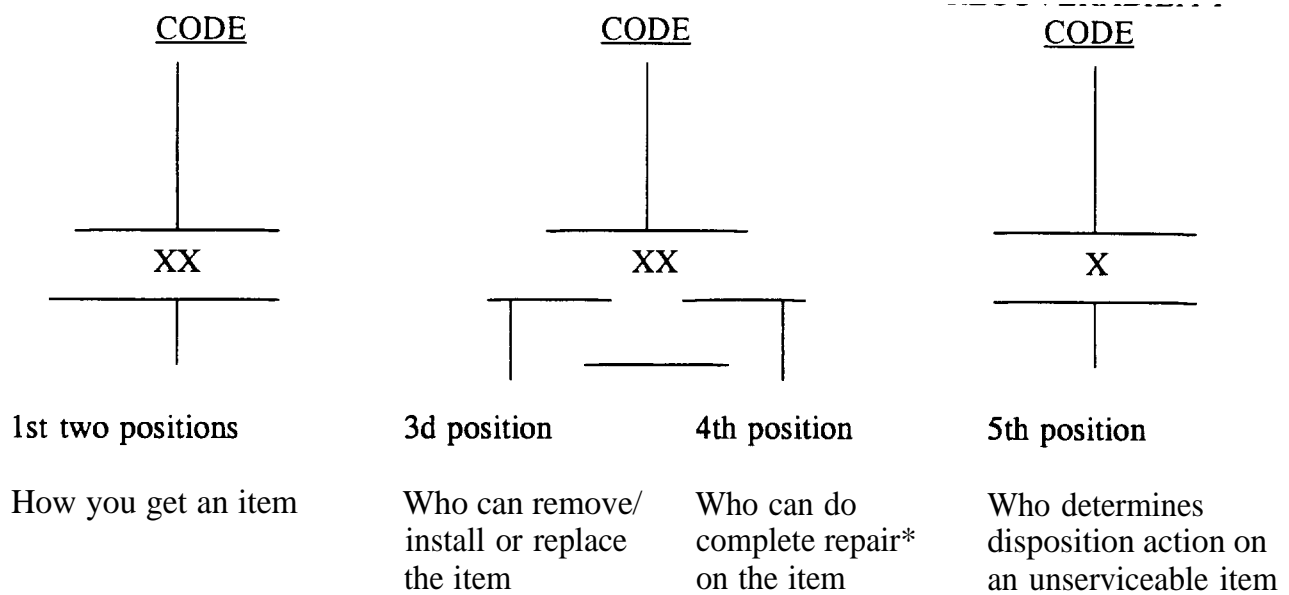

NOTE

*** Complete Repair Maintenance capacity, capability, and authority to perform all corrective maintenance tasks of the repair function in a use/user environment in order to restore serviceability to a failed item.**

(1) Source Code. The source code tells you how to get an item needed for maintenance, repair, or overhaul of an end item/equipment. Explanation of source codes follows:

Source Code

Application/Explanation

PA	Stocked items; use the applicable NSN to request/requisition items with these source codes. They are authorized to the level indicated by the code entered in the 3d position of the SMR code.
PB	
PC	
PD	
PE	
PF	
PG	

NOTE

Items coded PC are subject to deterioration.

<u>Source Code</u>	<u>Application / Explanation</u>
KD KF KB	Items with these codes are not to be requested/requisitioned individually. They are part of a kit which is authorized to the maintenance level indicated in the 3d position of the SMR code. The complete kit must be requisitioned and applied.

<u>Source Code</u>	<u>Echelon</u>	<u>Application / Explanation</u>
MO -	Made at Org Level	Items with these codes are not to be requested/requisitioned individually. They must be made from the bulk material identified in the fabrication instruction.
MF -	Made at 3rd Echelon	
MH -	Made at 4th Echelon	
ML -	Made at Specialized Repair Activity	
MD -	Made at Depot	

<u>Source Code</u>	<u>Echelon</u>	<u>Application / Explanation</u>
AO -	Assembled at Org Level	Items with these codes are not to be requested/requisitioned individually. The parts that make up the assembled item must be requisitioned or fabricated or assembled at the level of maintenance indicated by the source code. If the 3rd position code of the SMR code authorizes you to replace the item, but the source code indicates the item is assembled at a higher level, order the item from the higher level of maintenance.
AF -	Assembled by 3rd Echelon	
AH -	Assembled by 4th Echelon	
AL -	Assembled by SRA	
A D -	Assembled by Depot	

7-3. **EXPLANATION OF COLUMNS (SECTIONS II AND III)** (Continued)

<u>Source Code</u>	<u>Application/Explanation</u>
XA -	Do not requisition an XA-coded item. Order its next higher assembly. (Also refer to NOTE below.)
XB -	If an XB-coded item is not available from salvage, order it using the CAGE and part number given.
XC -	Installation drawing, diagram, instruction sheet, field service drawing, that is identified by manufacturer's part number.
XD -	Items not stocked. Order an XD-coded item through normal supply channels using the CAGE and part number given, if no NSN is available.

NOTE

Cannibalization or controlled exchange, when authorized, may be used as a source of supply for items with the above source codes, except for those coded XA.

(2) Maintenance Code. Maintenance codes tell you the level(s) of maintenance authorized to *replace* and *repair* support items. The maintenance codes are entered in the third and fourth positions of the SMR code as follows:

(a) The maintenance code entered in the third position tells you the lowest maintenance level authorized to *replace an* item. The maintenance code will indicate one of the following levels of maintenance:

<u>Maintenance Code</u>	<u>Application / Explanation</u>
C -	Crew or operator maintenance done within unit maintenance.
O -	organizational level can remove and replace.
F -	Third echelon can remove and replace.
H -	Fourth echelon can remove and replace.
L -	Specialized repair activity can remove and replace.
D -	Depot level can remove and replace.

(b) The maintenance code entered in the fourth position tells you whether or not the item is to be *repaired* and identifies the lowest maintenance level with the capability to do complete repair (i. e., perform all authorized repair functions)'.

NOTE

Some limited repair may be done on the item at a lower level of maintenance, if authorized by the SMR codes.

This position will contain one of the following maintenance codes:

Maintenance Code

Application / Explanation

- O - Organizational is the lowest level that can do complete repair of the item.
- F - Intermediate Third Echelon is the lowest level that can do complete repair of the item.
- H - Intermediate Fourth Echelon is the lowest level that can do complete repair of the item.
- L - Specialized repair activity (designate the specialized repair activity) is the lowest level that can do complete repair of the item.
- D - Depot is the lowest level that can do complete repair of the item.
- Z - Non-reparable. No repair is authorized.
- B - No repair is authorized. No parts or special tools are authorized for the maintenance of a B-coded item. However, the item may be reconditioned by adjusting, lubricating, etc., at the user level.

(3) Recoverability Code. Recoverability codes are assigned to items to indicate the disposition action on unserviceable items. The recoverability code is entered in the fifth position of the SMR code as follows:

7-3. EXPLANATION OF COLUMNS (SECTIONS II AND III) (Continued)

<u>Recoverability Code</u>	<u>Application/Explanation</u>
Z -	Non-reparable item. When unserviceable, condemn and dispose of the item at the level of maintenance shown in the third position of the SMR code.
O -	Reparable item. When uneconomically repairable, condemn and dispose of the item at the organizational level.
F -	Reparable item. When uneconomically repairable, condemn and dispose of the item at the Third Echelon level.
H -	Reparable item. When uneconomically repairable, condemn and dispose of the item at the Fourth Echelon level.
D -	Reparable item. When beyond lower level repair capability, return to depot. Condemnation/disposal of item not authorized below depot level.
L -	Reparable item. Condemnation and disposal not authorized below specialized repair activity (SRA).
A -	Item requires special handling or condemnation procedures because of specific reasons (e.g., precious metal content, high dollar value, critical material, or hazardous material). Refer to appropriate manuals/directives for specific instructions.

c. NSN (Column (3)). The national stock number for the item is listed in this column.

d. CAGE CODE (Column (4)). The Commercial and Government Entity Code is a five-digit numeric code which is used to identify the manufacturer, distributor, or Government agency, etc., that supplies the item.

e. PART NUMBER (Column (5)). Indicates the primary number used by the manufacturer (individual, company, firm, corporation, or Government activity), which controls the design and characteristics of the item by means of its engineering drawings, specifications, standards, and inspection requirements to identify an item or range of items.

NOTE

When you use an NSN to requisition an item, the item you receive may have a different part number from the part ordered.

f. DESCRIPTION (Column (6)). This column includes the following information:

(1) The Federal item name and, when required, a minimum description to identify the item.

(2) The statement *END OF FIGURE* appears just below the last item description in the Description column in both Section II and III.

g. QTY (Column (7)). The QTY (Quantity per figure column) indicates the quantity of the item used in the breakout shown on the illustration figure, which is prepared for a functional group, sub-functional group, or an assembly. A V appearing in this column in lieu of a quantity indicates that the quantity is variable and the quantity may vary from application to application.

7-4. EXPLANATION OF INDEX FORMAT AND COLUMNS (SECTION IV)

a. National Stock Number (NSN) Index

(1) STOCK NUMBER Column. This column lists the NSN in national item identification number (NIIN) sequence. The NIIN consists of the last nine digits of the NSN.

_____	<u>NSN</u>	
NSN (i.e., 1005-01-360-7146)	_____	When using this column to locate an item, ignore the
NIIN	_____	first four digits of the NSN. Use the complete NSN
	_____	(13 digits) when requisitioning items by stock number.

(2) FIG. Column. This column lists the number of the figure where the item is identified/located in Section 11, The figures are in numerical order in Section II.

(3) ITEM Column. The item number identifies the item associated with the figure listed in the adjacent FIG. column. This item is also identified by the NSN listed on the same line.

b. Part Number Index. Part numbers in this index are listed by part number in ascending alphanumeric sequence (vertical arrangement of letters and number combination which places the first letter or digit of each group in order A through Z, followed by the numbers O through 9 and each following letter or digit in like order).

7-4. EXPLANATION OF INDEX FORMAT AND COLUMNS (SECTION IV)

(Continued)

- (1) PART NUMBER Column. Indicates the part number assigned to the item.
- (2) FIG. Column. This column lists the number of the figure where the item is identified/located in Section II.
- (3) ITEM Column. The item number is the number assigned to the item as it appears in the figure referenced in the adjacent figure number column.

7-5. HOW TO LOCATE REPAIR PARTS

a. When National Stock Numbers or Part Numbers are Not Known

- (1) First. Using the table of contents, determine the assembly group or subassembly group to which the item belongs. This is necessary since figures are prepared for assembly groups and subassembly groups, and listings are divided into the same groups.
- (2) Second. Find the figure covering the assembly group or subassembly group to which the item belongs.
- (3) Third. Look in the repair parts list for the figure and item numbers. The NSNs and part numbers are on the same line as the associated item numbers.

b. When National Stock Number or Part Number is Known

- (1) First. If you have the national stock number, look in the STOCK NUMBER column of the National Stock Number Index. The NSN is arranged in national item identification number (NIIN) sequence. Note the figure and item number next to the NSN.
- (2) Second. Turn to the figure and locate the item number. Verify that the item is the one you are looking for.

NOTE

If you have the part number, look in the PART NUMBER column of the part index. Identify the figure and item number, look up the item on the figure in Section II.

Section II. REPAIR PARTS LIST

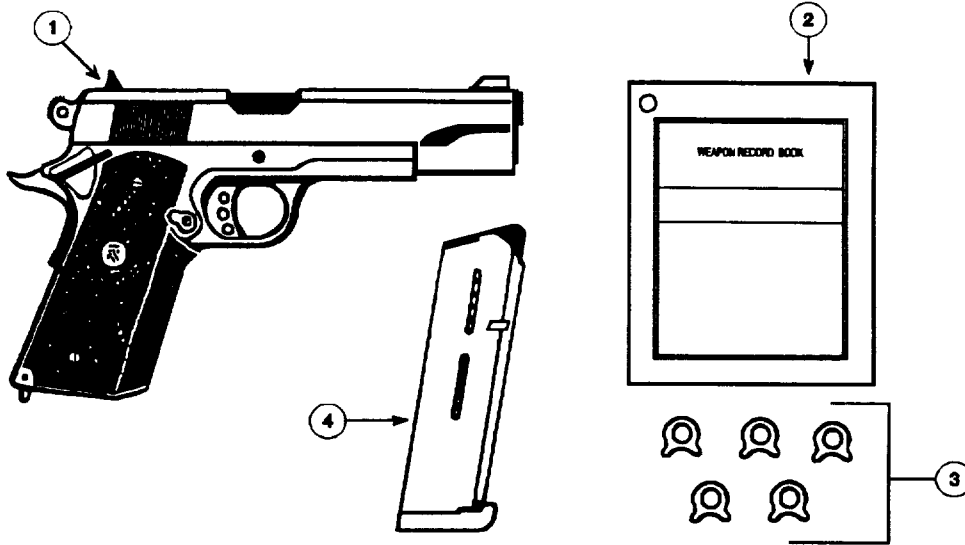

Figure 7-1. Weapon System

(1) Item No.	(2) SMR Code	(3) NSN	(4) CAGEC	(5) Part Number	(6) Description	(7) Qty
1	PACOL	1005-01-370-7353	01365	93001A0009	Pistol, MEU(SOC) .45 cal	1
2	XDCZZ		5H988	MCCDC 22741	Weapon Record Book	1
3	PACZZ	1005-01-373-7868	12238	965-002-100	Shok-buff	5
4	PACUZ	1005-01-373-2774	12238	965-047-470	Magazine Cartridge, stainless steel	7

END OF FIGURE 7-1

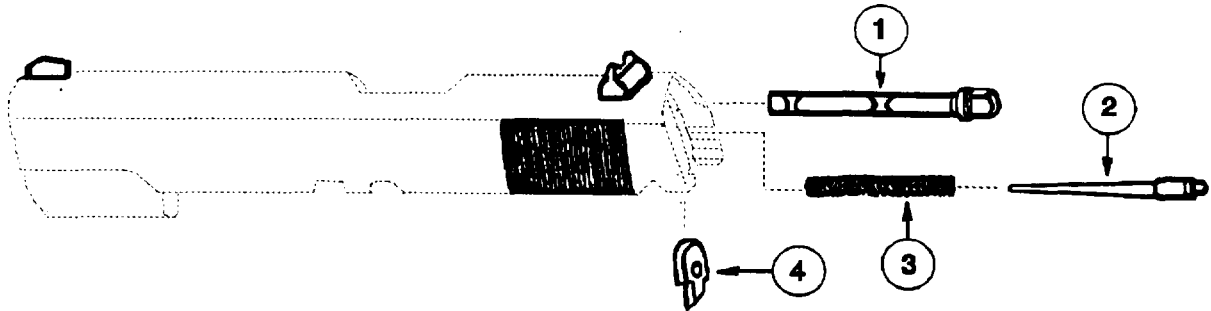

Figure 7-2. Firing Pin Group

(1) Item No.	(2) SMR Code	(3) NSN	(4) CAGEC	(5) Part Number	(6) Description	(7) Qty
1	PAFZZ	1005-00-600-8598	19204	6008598	Extractor	1
2	PAOZZ	1005-00-600-8599	19204	6008599	Firing pin	1
3	PAOZZ	5360-01-373-6955	0WBAA0	SSF45	Spring, firing pin	1
4	PAHZZ	1005-00-501-3205	19204	5013205	Stop, firing pin	1

END OF FIGURE 7-2

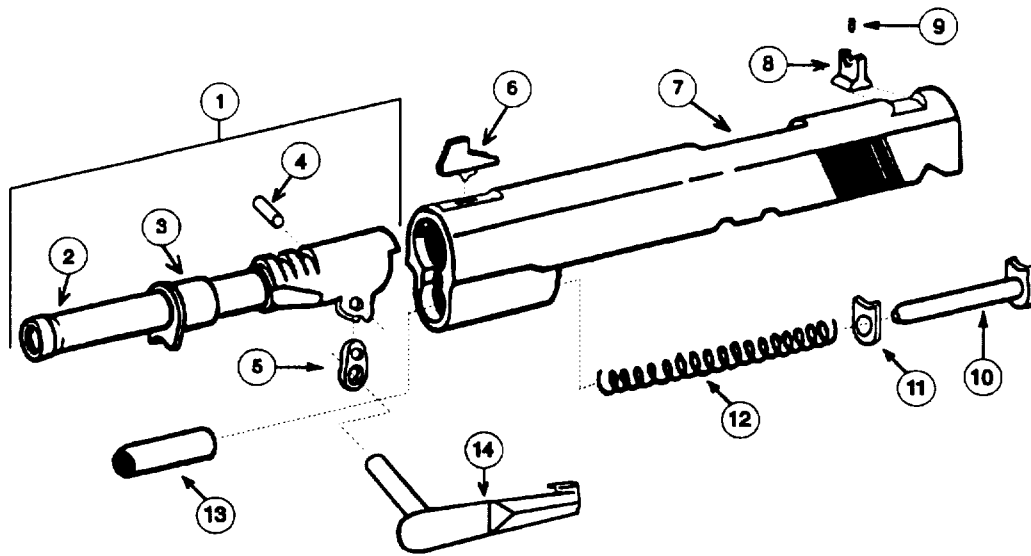

Figure 7-3. Slide Assembly With Slide Stop

(1) Item No.	(2) SMR Code	(3) NSN	(4) CAGEC	(5) Part Number	(6) Description	(7) Qty
1	PAHLZ	1005-01-373-3209	0WBA0	DBBL&P45	Barrel Kit	1
2	XAHHL		0WBA0	DB45	Barrel	1
3	PAHZZ	3120-01-373-6986	0WBA0	BB545	Barrel bushing	1
4	PAHZZ	5315-00-501-3199	19204	5013199	Pin, barrel link	1
5	PAHZZ	3040-00-501-3198	19204	5013198	Barrel link	1
6	PAHZZ	1005-01-373-1556	12238	601-402-224	Sight, front	1
7	XDHHL		19205	P14546	Slide	1
8	MLLLZ		5H988	MEUSOC-RS	Sight, rear	1
9	PAHZZ	5305-00-899-5142	96906	MS51038-26	Set Screw, rear sight	1
10	PAHZZ	1005-00-600-8597	19204	6008597	Guide, recoil spring	1
11	PACZZ	1005-01-373-7868	12238	965-002-100	Shok-buff	1
12	PAOZZ	5360-01-373-6954	0WBA0	SSR45	Spring, recoil	1
13	PAOZZ	5340-00-501-3201	19204	5013201	Plug, recoil spring	1
14	PAHZZ	5340-00-600-8595	19204	6008595	Slide stop	1

END OF FIGURE 7-3

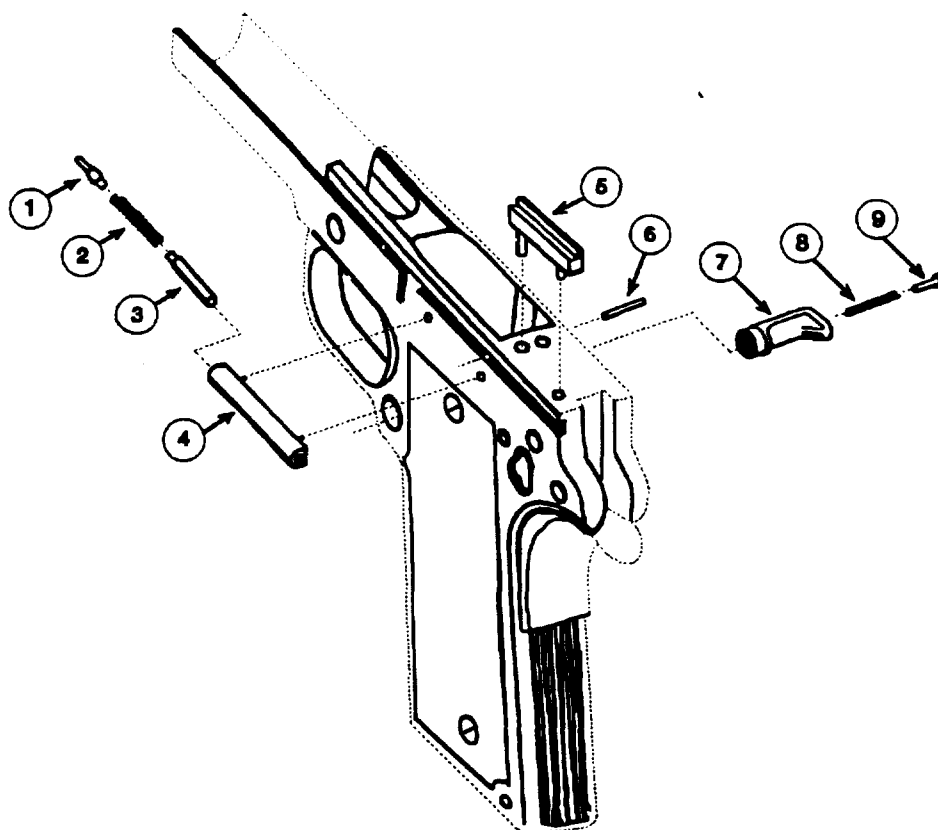

Figure 7-4. Magazine Catch, Plunger Tube And Ejector Groups

(1) Item No.	(2) SMR Code	(3) NSN	(4) CAGEC	(5) Part Number	(6) Description	(7) Qty
1	PAOZZ	5340-00-501-3193	19204	5013193	Plunger, slide stop	1
2	PAOZZ	5360-01-373-6956	0WBA0	SSP45	Spring, plunger	1
3	PAOZZ	5340-00-501-3195	19204	5013195	Plunger, safety detent	1
4	PAHZZ	5340-00-600-8594	19204	6008594	Plunger tube	1
5	PAFZZ	1005-00-903-8192	19204	11010485	Ejector	1
6	PAFZZ	5315-00-501-3203	19204	5013203	Pin, ejector	1
7	PAOZZ	1005-00-600-8609	19204	6008609	Catch, magazine	1
8	PAOZZ	5360-01-373-6958	0WBA0	SSMR45	Spring, magazine catch	1
9	PAOZZ	1005-00-501-3218	19204	5013218	Lock, magazine catch	1

END OF FIGURE 7-4

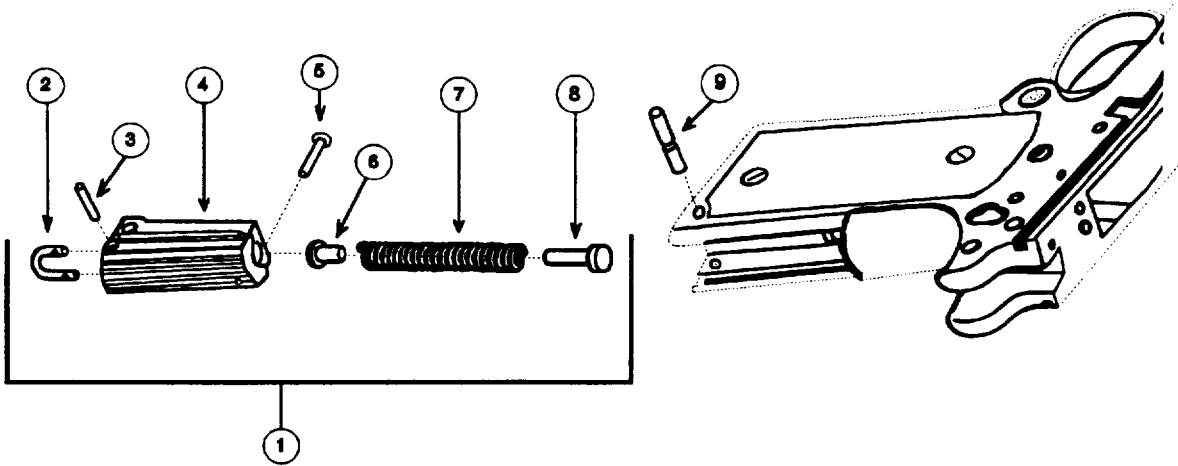

Figure 7-5. Mainspring Housing Group

(1) Item No.	(2) SMR Code	(3) NSN	(4) CAGEC	(5) Part Number	(6) Description	(7) Qty
1	PAOZZ	1005-00-556-4058	19204	5564058	Mainspring Housing Group	1
2	PAOZZ	1005-00-501-3214	19204	5013214	Loop, lanyard	1
3	PAOZZ	5315-00-844-4790	96906	MS16562-25	Pin, spring: tubular	1
4	XAOZZ		19204	5503841	Housing, mainspring	1
5	PAOZZ	5315-00-501-3210	19204	5013210	Pin, mainspring retaining	1
6	PAOZZ	5340-00-501-3213	19204	5013213	Plunger, detent	1
7	PAOZZ	5360-01-374-0284	0WBAA0	SSM45	Mainspring	1
8	PAOZZ	5315-00-501-3209	19204	5013209	Cap, mainspring	1
9	PAOZZ	5315-00-501-3212	19204	5013212	Pin, mainspring housing	1

END OF FIGURE 7-5

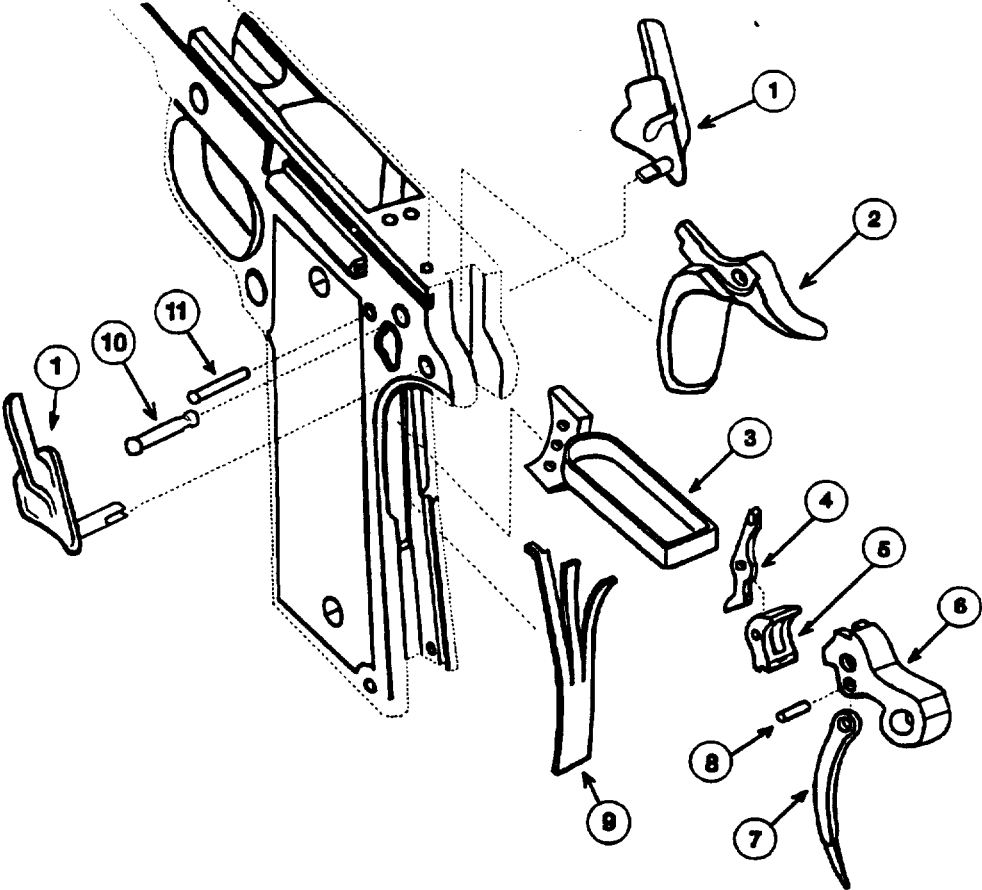

Figure 7-6. Receiver Assembly

(1) Item No.	(2) SMR Code	(3) NSN	(4) CAGEC	(5) Part Number	(6) Description	(7) Qty
1	XDHZZ		OKING	201A BLUE SAFETY	Safety, ambidextrous thumb, SET	1
2	PAHZZ	1005-01-373-2775	12238	181-115-180	Safety, beavertail grip	1
3	PAHZZ	1005-01-373-2848	12238	205-005-000	Trigger	1
4	PAHZZ	1005-00-600-8603	19204	6008603	Disconnecter	1
5	PAHZZ	1005-01-373-1555	12238	584-300-452	Sear	1
6	PAHZZ	1005-01-373-1557	12238	583-300-451	Hammer	1
7	PAHZZ	1005-00-600-8600	19204	6008600	Hammer strut	1
8	PAHZZ	5315-00-501-3207	19204	5013207	Pin, hammer strut	1
9	PAHZZ	5360-01-373-6959	0WBA0	SSS45	Spring, sear	1
10	XDHZZ		OKING	201A HAMMER PIN	Pin, hammer	1
11	PAHZZ	5315-00-501-3211	19204	5013211	Pin, sear	1

END OF FIGURE 7-6

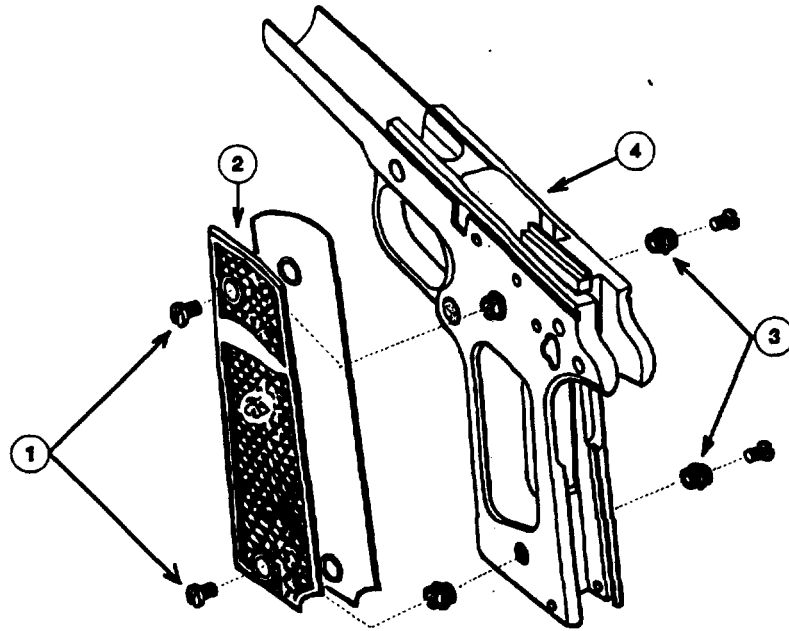

Figure 7-7. Combat Pistol Grip Group

(1) Item No.	(2) SMR Code	(3) NSN	(4) CAGEC	(5) Part Number	(6) Description	(7) Qty
1	PAOZZ	5305-00-601-9023	19204	6019023	Screw, grip, pistol	4
2	PAOZZ	1005-01-373-2849	12238	692-545-245	Pistol Grip, combat	1
3	PAHZZ	3120-00-601-9022	19204	6019022	Bushing, grip screw	4
4	XDFHL		19204	6535359	Receiver Housing	1

END OF FIGURE 7-7

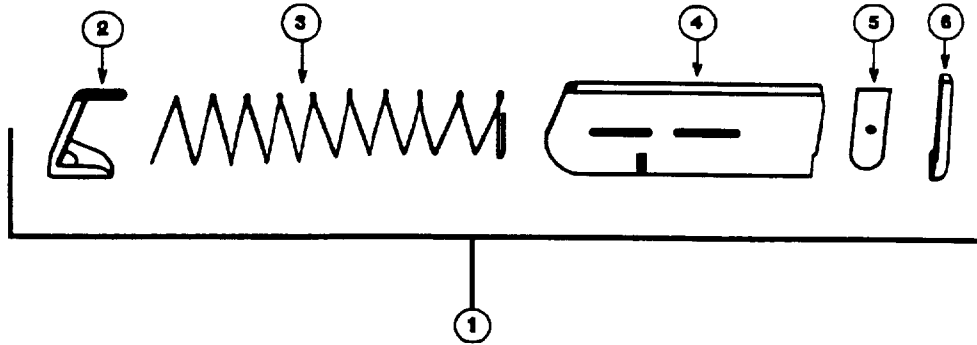

Figure 7-8. Magazine Assembly

(1) Item NO.	(2) SMR Code	(3) NSN	(4) CAGEC	(5) Part Number	(6) Description	(7) Qty
1	PAC0Z	1005-01-373-2774	12238	965-047-470	Magazine Assembly	1
2	XBOZZ		0WILS	P47F7	Follower, magazine	1
3	XBOZZ		0WILS	P47S7	Spring, magazine	1
4	XBOZZ		0WILS	P47T7	Housing, magazine	1
5	XBOZZ		0WILS	P47R	Floorplate, magazine	1
6	XBOZZ		0WILS	P47B	Pad, magazine	1

END OF FIGURE 7-8

Section III. SPECIAL TOOLS LIST

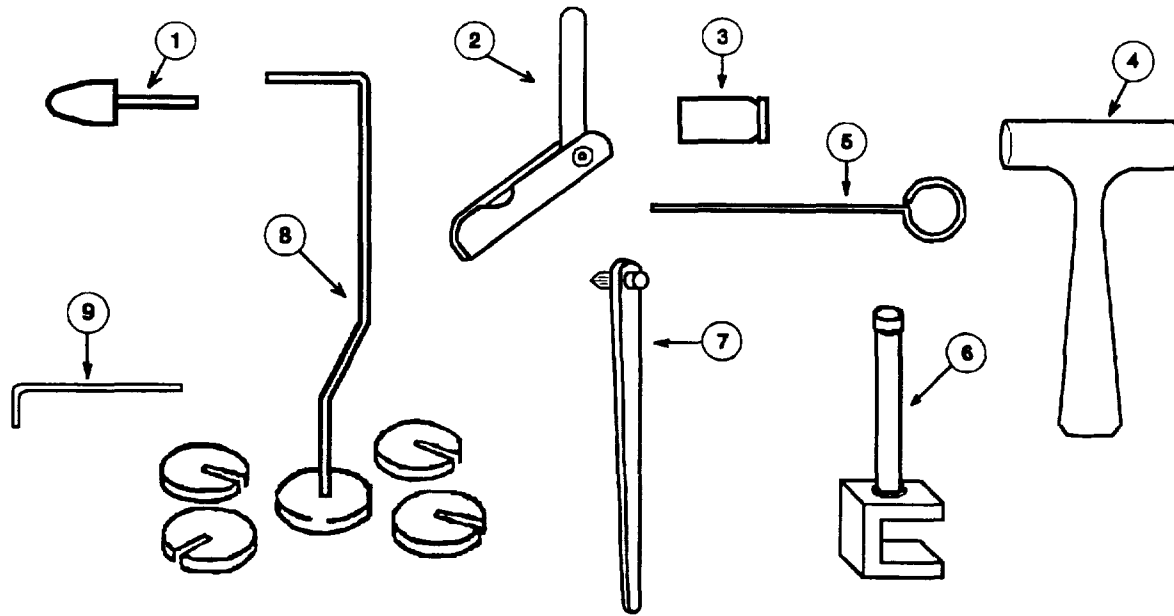

Figure 7-9. Special Tools List

(1) Item No.	(2) SMR Code	(3) NSN	(4) CAGEC	(5) Part Number	(6) Description	(7) Qty
1	XDHZZ		12238	257-990-100	Carbide burr	1
2	PAHZZ	5120-00-221-1999	81348	GGG-G-17	Gage, feeler	1
3	XDHZZ		12238	184-100-450	Gage, headspace	1
4	PAFZZ	5120-01-072-7987	61711	57-540	Hammer, dead blow, 5 oz	1
5	MHHZZ	Fabricate Locally	5H988		Insert Tool, plunger tube	1
6	MHHZZ	Fabricate Locally	5H988		Staking Tool, plunger tube	1
7	XDHZZ		12238	080-644-000	Staking Tool, stock screw bushing	1
8	PAHZZ	4933-00-647-3696	19204	7274758	Trigger Pull, measuring fixture	1
9	PAHZZ	5120-00-198-5401	81348	GGG-K-275	Wrench, hex head, .050	1

END OF FIGURE 7-9

Section IV. CROSS REFERENCE INDEXES**NATIONAL STOCK NUMBER INDEX**

STOCK NUMBER	FIG.	ITEM	STOCK NUMBER	FIG.	ITEM
5340-00-501-3193	7-4	1	3120-00-601-9022	7-7	3
5340-00-501-3195	7-4	3	5305-00-601-9023	7-7	1
3040-00-501-3198	7-3	5	5315-00-844-4790	7-5	3
5315-00-501-3199	7-3	4	5305-00-899-5142	7-3	9
5340-00-501-3201	7-3	13	1005-00-903-8192	7-4	5
5315-00-501-3203	7-4	6	1005-01-370-7353	7-1	1
1005-00-501-3205	7-2	4	1005-01-373-1555	7-6	5
5315-00-501-3207	7-6	8	1005-01-373-1557	7-6	6
5315-00-501-3209	7-5	8	1005-01-373-2848	7-6	3
5315-00-501-3210	7-5	5	1005-01-373-2849	7-7	2
5315-00-501-3211	7-6	11	1005-01-373-1556	7-3	6
5315-00-501-3212	7-5	9	1005-01-373-2774	7-1	4
5340-00-501-3213	7-5	6	1005-01-373-2774	7-8	1
1005-00-501-3214	7-5	2	1005-01-373-2775	7-6	2
1005-00-501-3218	7-4	9	1005-01-373-3209	7-3	1
1005-00-556-4058	7-5	1	5360-01-373-6954	7-3	12
5340-00-600-8594	7-4	4	5360-01-373-6955	7-2	3
5340-00-600-8595	7-3	14	5360-01-373-6956	7-4	2
1005-00-600-8597	7-3	10	5360-01-373-6958	7-4	8
1005-00-600-8598	7-2	1	5360-01-373-6959	7-6	9
1005-00-600-8599	7-2	2	3120-01-373-6986	7-3	3
1005-00-600-8600	7-6	7	1005-01-373-7868	7-1	3
1005-00-600-8603	7-6	4	1005-01-373-7868	7-3	11
1005-00-600-8609	7-4	7	5360-01-374-0284	7-5	7

PART NUMBER INDEX

PART NUMBER	FIG.	ITEM	PART NUMBER	FIG.	ITEM
BB545	7-3	3	5013207	7-6	8
DB45	7-3	2	5013209	7-5	8
DBBL&P45	7-3	1	5013210	7-5	5
MCCDC 22741	7-1	2	5013211	7-6	11
MEUSOC-RS	7-3	8	5013212	7-5	9
MS16562-25	7-5	3	5013213	7-5	6
MS51038-26	7-3	9	5013214	7-5	2
P14546	7-3	7	5013218	7-4	9
P47B	7-8	6	5503841	7-5	4
P47F7	7-8	2	5564058	7-5	1
P47R	7-8	5	583-300-451	7-6	6
P47S7	7-8	3	584-300-452	7-6	5
P47T7	7-8	4	6008594	7-4	4
SSF45	7-2	3	6008595	7-3	14
SSM45	7-5	7	6008597	7-3	10
SSMR45	7-4	8	6008598	7-2	1
SSP45	7-4	2	6008599	7-2	2
SSR45	7-3	12	6008600	7-6	7
SSS45	7-6	9	6008603	7-6	4
11010485	7-4	5	6008609	7-4	7
181-115-180	7-6	2	601-402-224	7-3	6
201A BLUE SAFETY--			6019022	7-7	3
	7-6	1	6019023	7-7	1
201A HAMMER PIN--			6535359	7-7	4
	7-6	10			
			692-545-245	7-7	2
205-005-000	7-6	3	93001A0009	7-1	1
5013193	7-4	1	965-002-100	7-1	3
5013195	7-4	3	965-002-100	7-3	11
5013198	7-3	5			
			965-047-470	7-1	4
5013199	7-3	4	965-047-470	7-8	1
5013201	7-3	13			
5013203	7-4	6			
5013205	7-2	4			

CONTRACTOR AND GOVERNMENT ENTITY CODE INDEX

<u>Code</u>	<u>Manufacturer</u>	<u>Code</u>	<u>Manufacturer</u>
0KING	King's Gun Works 1837 W. Glen Oaks Blvd Glendale, CA 91201	58536	Federal Commercial item promulgated by General Services Administration Washington, DC
0WBA0	Bar-Sto Precision Machine 73377 Sullivan Road PO Box 1838 Twentynine Palms, CA 92277	61711	Stanley Works 10640 East 59th Street Indianapolis, IN 46236-9701
0WILS	Wilson Gun Shop, Inc Route 3, Box 578 Berryville, AR 72616	80009	Tektronix, Inc 14150 SW Karl Braun Dr Beaverton, OR 97077
01365	Marine Corps Logistics Base Albany, GA 31704	81348	Federal Specifications item promulgated by General Services Administration, Washington, DC
12238	Brownells, Inc Route 2, Box 1 Montezuma, IA 50171-9804	81349	Military Specifications item promulgated by military/agencies under authority of Defense Standardization Manual 4120 3-M
19204	Rock Island Arsenal Rock Island, IL 61201	%906	Military Standards items promulgated by Military Departments under authority of Defense Standardization Manual 4120 3-M
19205	Springfield Armory Springfield, MA 01101		
5H988	Weapons Training Battalion 27211 Garand Road Marine Corps Combat Development Center, Quantico, VA 22134-5036		

APPENDIX A

REFERENCES

A-1. SCOPE. This appendix lists all orders, technical manuals, forms, and miscellaneous publications referenced in this Manual.

A-2. MARINE CORPS ORDERS

MCO P4450.7	Preparation for Storage
MCO P4610.19	Report of Transportation Discrepancies in Shipment
MCO 4855.10	Product Quality Deficiency Report (PQDR)
MCO 5101.8	Ground Mishap Report
MCO 8020.1	Handling, Transportation, and Storage
MCO 8025.1	Class V (W) Malfunctions and Deficiencies

A-3. TECHNICAL MANUALS

TM 00526A-10/1	Operator's Manual, Pistol, Caliber .45, MEU(SOC)
TM 3080-12	Corrosion Prevention and Control for Marine Corps Ground Equipment
TM 4700-15/1	Equipment Record Procedures
TM 9150-15/1	Military Use of Cleaner, Lubricant, Preservative (CLP) MIL-L-63460 for Weapons and Support Equipment

A-4. FORMS

MCCDC 22741	Weapon Record Book
NAVMC 1018	Inspection Tag
NAVMC 10520	Weapon Custody Receipt Card
NAVMC 10576	Memorandum Receipt for Individual Weapons and Accessories
NAVMC 11003	Ordnance Serialized Items/Rounds Fired Data Card
SF 368	Product Quality Deficiency Report (PQDR)

A-5. OTHERS

MIL-STD-129	Military Standard, Marking for Shipment and Storage
TI 00526-24/3C	Periodic Technical Inspection, Pistol, Caliber .45, 1911A1



APPENDIX B
COMPONENTS LIST
LIST OF COMPONENTS

ITEM	CAGE	NSN/PN	ITEM IDENTIFICATION	U/I	QTY
SUPPLY SYSTEM RESPONSIBILITY					
1	01365	1005-01-370-7353	MEU(SOC) .45 Caliber Pistol Consists of:	EA	1
2	12238	1005-01-373-2774	Magazine, Cartridge, Stainless Steel, 7-round capacity	EA	7
3	12238	1005-01-373-7868	Shok-Buffs	EA	5
4	01365	184 005260 00	TM 00526A-10/1	EA	1
5	5H988	MCCDC 22741	Weapon Record Book	EA	1
COLLATERAL MATERIAL					
6	19204	1005-00-242-5687	Bottle Assembly, Cylindrical	EA	1
7	19205	1005-00-550-4036	Brush, Cleaning Bore .45 cal	EA	1
8	19204	1005-00-494-6602	Brush, Cleaning Small Arms	EA	1
9	19204	1095-00-592-6491	Holster, Hip, M1916	EA	1
	19205	1095-00-973-2353	Holster, Shoulder, M7	EA	1
10	81349	8465-00-965-1705	Lanyard, Pistol, Nylon	EA	1
11	19204	1005-00-556-4102	Rod, Cleaning, Small Arms	EA	

LIST OF COMPONENTS - Continued

ITEM	CAGE	NSN/PN	ITEM IDENTIFICATION	U/I	QTY
USING UNIT RESPONSIBILITY					
12	81348	6515-00-303-8250	Applicator, Cotton Tip	PK	1
13	81349	9150-01-102-1473	Cleaner, Lubricant and Preservative, (CLP) 1/2 oz. bottle	OZ	1
14	81349	6850-00-224-6657	Cleaning Compound, Rifle Bore, 6 oz can	OZ	1
15	81349	9150-00-292-9689	Lubricating Oil, LAW	QT	1
16	81349	9150-00-935-6597	Lubricating Oil, LSA	OZ	1
17	81349	9150-00-949-0323	Lubricating Oil, LSA-T	OZ	1
18	58536	7920-00-205-1711	Rag, Wiping	LB	1
19	80009	3439-00-596-1718	Solder, Silver	RL	1
20	19204	1005-00-288-3565	Swabs, Cleaning, Small Arms	PK	1
21	58536	7510-00-266-6712	Tape, Masking, 1" wide	RO	1

APPENDIX C

FABRICATION INSTRUCTIONS

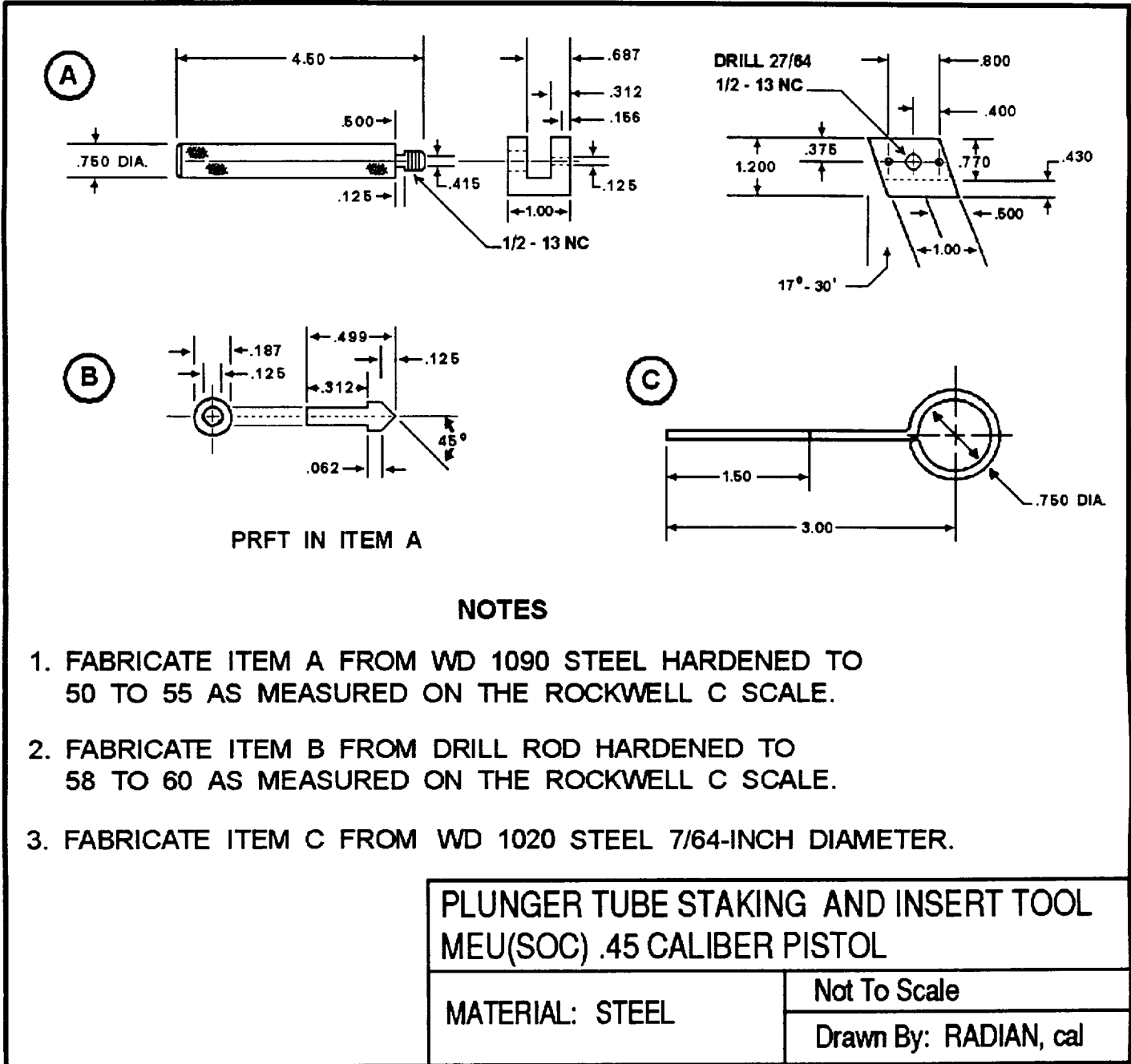

Plunger Tube Staking And Insert Tools

