

© MAGTECH®

PUMP ACTION SHOTGUN



MODEL 586.2

**12 Gauge
3" Chamber**

© MAGTECH®

**Companhia Brasileira
de Cartuchos**

Rua Buarque de Macedo, 3133
95780-000 Montenegro RS
CNPJ/MF 57.494.031/0010-54
www.cbc.com.br

Printed in Brazil

Instruction Folder and Parts List

**IMPORTANT: Read this instruction folder carefully
before you handle the gun**

1. SAFETY INSTRUCTION

WARNING: Do not load the gun before you have carefully read this folder.

- **Read these basic safety instructions.** Learn how to handle your gun safely. Failure to obey these instructions can result in serious personal injury. Only you can prevent accidents.
- **Get to know your gun.** To use it correctly and safely, follow the instructions in this folder.
- **Handle every gun as if it were loaded.** Do not fully rely on the safety catch. Use it as shown in this folder.
- **Never make adjustments.** Do not make changes or alterations to any part of a gun. Use only MAGTECH parts. Never adjust the trigger, nor change the shape or size of the sear, sear notch, or other parts.
- **Make yourself safe.** Protect your eyes by using safety glasses or sunglasses when shooting. Use ear plugs or muffs when target shooting. Never drink alcoholic beverages before or during shooting.
- **Take care of your gun.** Maintain the barrel clean and free from obstructions. Clean the gun often, to ensure proper functioning of the mechanism. Worn, damaged, or missing parts may be dangerous.
- **Watch the muzzle of your gun.** Always keep the gun pointed in a safe direction.
- **Never use the wrong ammunition.** Use only shotshells of the gauge marked on your gun. Hand-loaded shells can be dangerous. MAGTECH is not responsible for accidents or damage caused by shells badly loaded by hand.
- **Load your gun safety.** Never load your gun before you are in a place where it is safe to shoot. Load only when you are ready to shoot.
- **Know your target.** Before you pull the trigger, make sure you can see the target clearly, and the path of the bullet, slug, or shot charge beyond the target. Never shoot at water, rocks, or any hard surface. Bullets may glance off such surfaces and cause injuries.
- **Know the range of your gun.** Remember that shotgun pellets can travel 400 meters and shotguns slugs have a range of more than 800 meters. Rimfire bullets can travel more than 2.5km. Centerfire bullets can travel more than 8km.
- **If your gun miss fires.** Keep the gun pointed in a safe direction, then unload carefully, avoiding exposure to breech. If the gun fires but the report or recoil seems weak, unload and then make sure the barrel is not obstructed.
- **Unload your gun whenever you are not shooting.** Never carry or store a loaded gun in a building or vehicle. Unload your gun before climbing up a tree, fence, or slippery surface.
- **Store your gun safety.** Keep guns and ammunition away from children. Lock unloaded guns and shells securely in separate places.

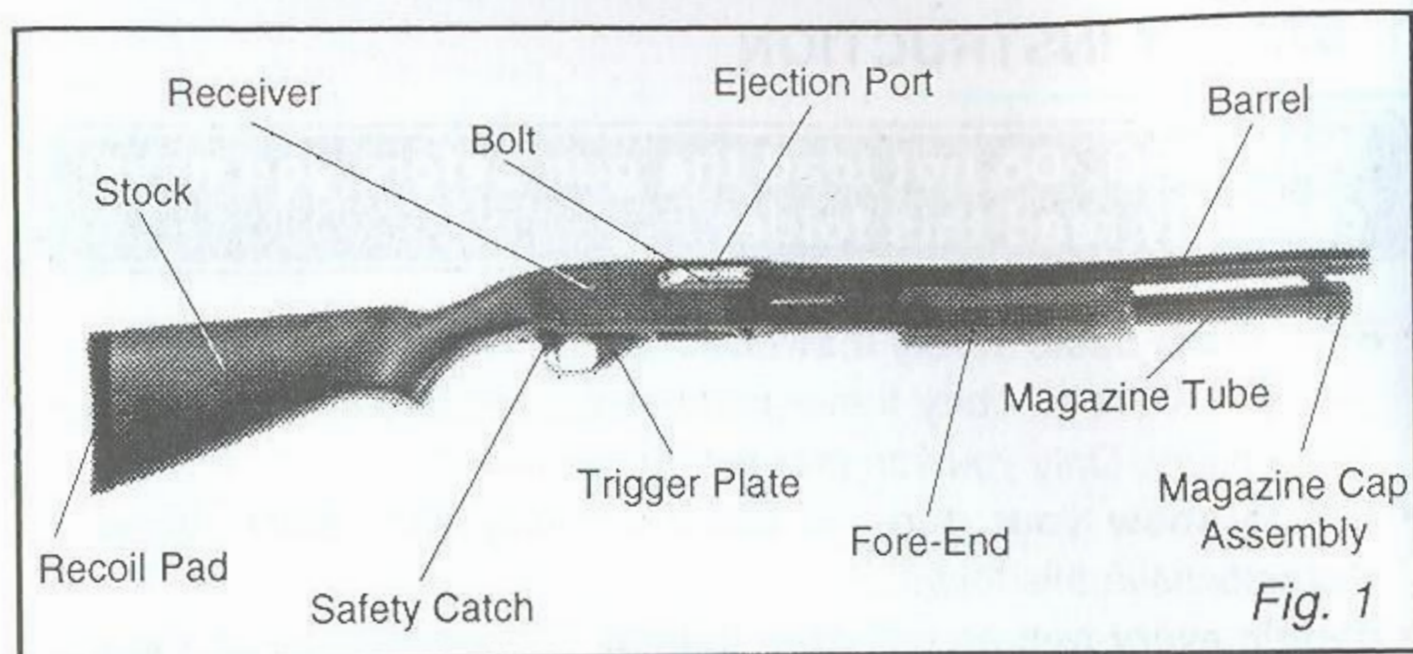

2. IMPORTANT PARTS OF THE GUN

Read carefully.

These instructions should be read carefully before using the gun, to ensure that the shooter knows the correct and safe way to handle it. Any carelessness in following these safety instructions may result in injury to the shooter and/or damage to the gun itself.

Figs.1 and 2 show the main parts of **MODEL 586.2** Pump Action Shotguns. These figures will help you to understand this folder.

• SAFETY CATCH

The safety catch is a button conveniently located behind the trigger (see Fig.2).

This safety catch, when properly engaged, provides protection against accidental or unintentional firing under normal conditions of use.

To lock the trigger, push the safety catch from left to right, so that the red band cannot be seen. The safety catch should be maintained in this position during the loading and unloading of the gun, and until the shooter is ready to fire the gun.

The safety catch has been carefully adjusted by the manufacturer of this gun.

If part of the firing action is changed, the safety catch will have to be adjusted again. This adjustment should be carried out by the manufacturer, or by a qualified gunsmith.

WARNING: Do not touch the trigger whilst the safety catch is being engaged. Never keep pressure on the trigger whilst closing the gun, even if the safety catch is engaged.

• TRIGGER

The gun will fire when the red band is visible and the trigger is pulled (see Fig. 2).

The trigger pull has been adjusted at the factory, in accordance with international safety rules. Any adjustment in the parts of the safety mechanism trigger assembly or disconnect, should be made by the factory, or by a

competent gunsmith, in order to ensure the safety of the gun. Never put your finger on the trigger if you are not ready to fire at the target.

• ACTION BAR LOCK LEVER

This part is located on the left side of the trigger plate, in front of the trigger (see Fig. 2).

The gun can be opened by pressing this part, even if the safety catch is engaged. If there is a shell in the chamber, it will be expelled through the ejection port.

• STOCK AND FORE-END

The stock and fore-end are made of good quality hardwood, dried in the open-air and conditioned in kilns.

The shooter uses the fore-end to support the gun with his hand, and also to pull the bolt backwards. To open the action, press the action bar lock upward and pull the fore-end backwards. This will make the two action bars push the bolt backwards.

When the fore-end has been pushed back as much as possible and then pushed forward again, the top shell in the magazine tube will be transported forward by the carrier. It will be fully lodged in the chamber when the bolt has been completely closed and locked against the barrel.

• RECEIVER AND TRIGGER PLATE

The receiver and trigger plate are made of high quality steel, machined with special equipment, and finely finished.

• BARREL

The barrel is made of special high-grade alloyed steel, hot forged and finished on special machines. The letters "PN" stamped on the gun barrel certify that the gun has been tested with overload shells charged with smokeless powder and that it has developed pressures within international standards.

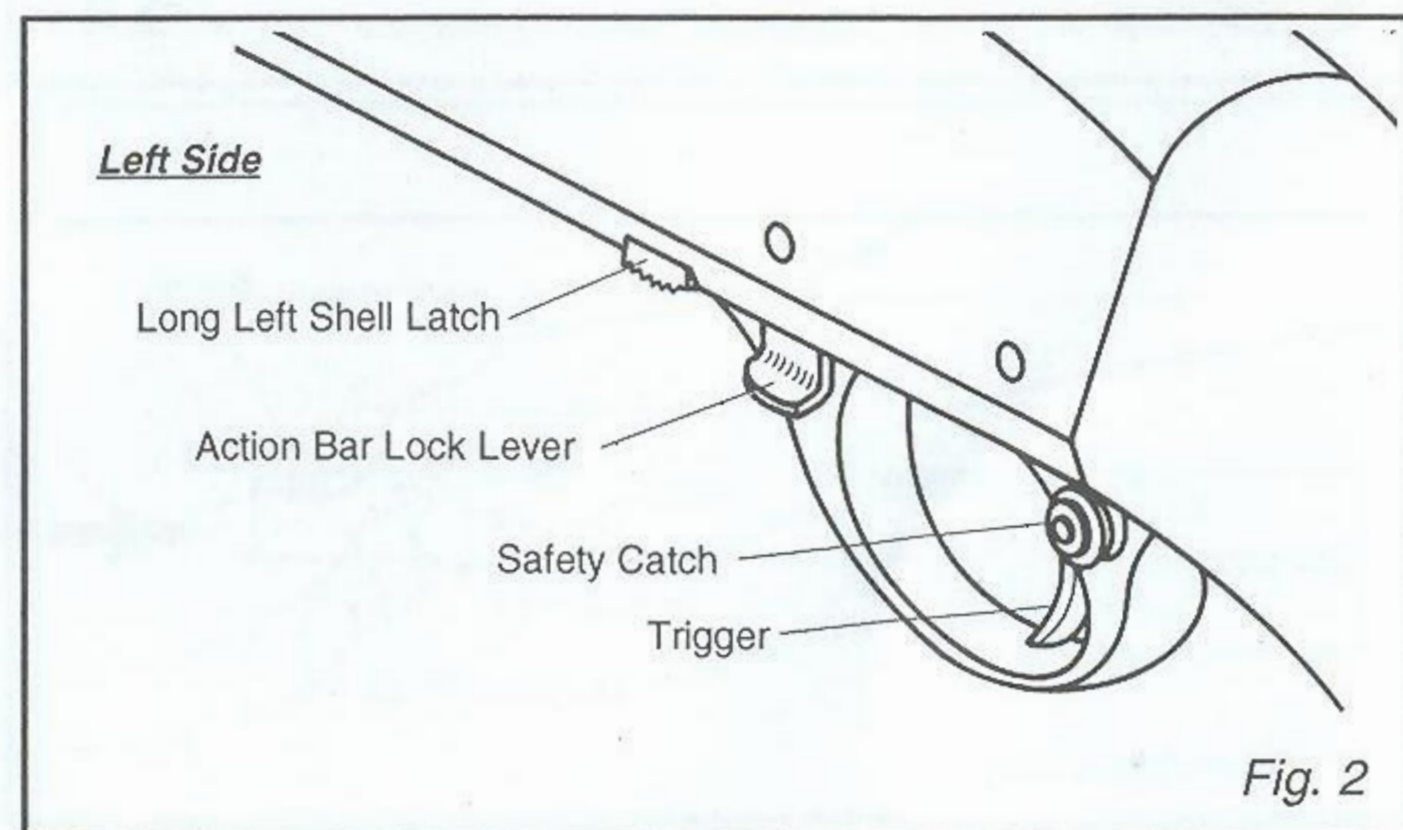

• BOLT ASSEMBLY

To ensure perfect locking of the gun, the total height of the bolt assembly and sliding bars has a tight tolerance, and has been carefully controlled during manufacture and assembly. A change of the bolt assembly, or part of the assembly should be carried out by the manufacturer or by a qualified gunsmith.

• LONG LEFT SHELL LATCH (see Fig. 2)

This part is used for unloading the shells in the magazine, without pumping the action.

3. TO ASSEMBLE THE GUN

Model 586.2 Pump Action Shotguns are packed with the barrel assemblies separated from the receivers.

WARNING: Do not pump the action repeatedly and abruptly when the barrel is not assembled. Do not pull the trigger repeatedly when the bolt is not in the receiver, nor when the trigger-plate assembly is un-mounted. The pulling of the trigger when the gun is not fully assembled may damage some of the parts.

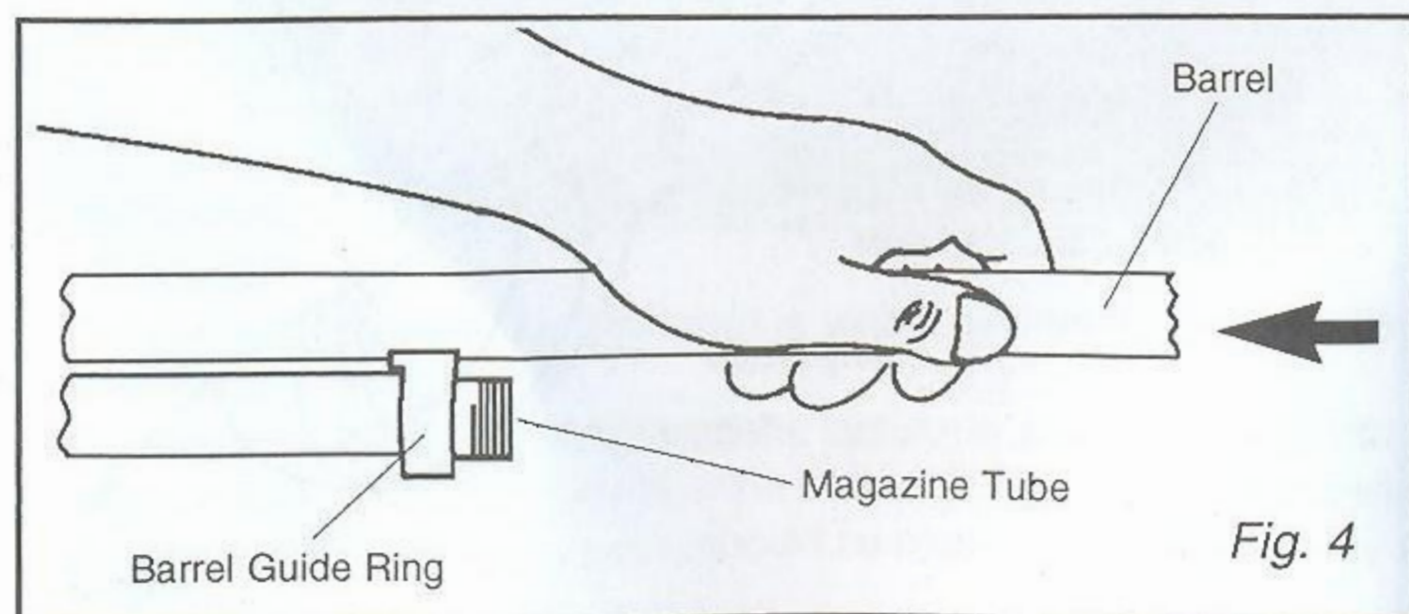
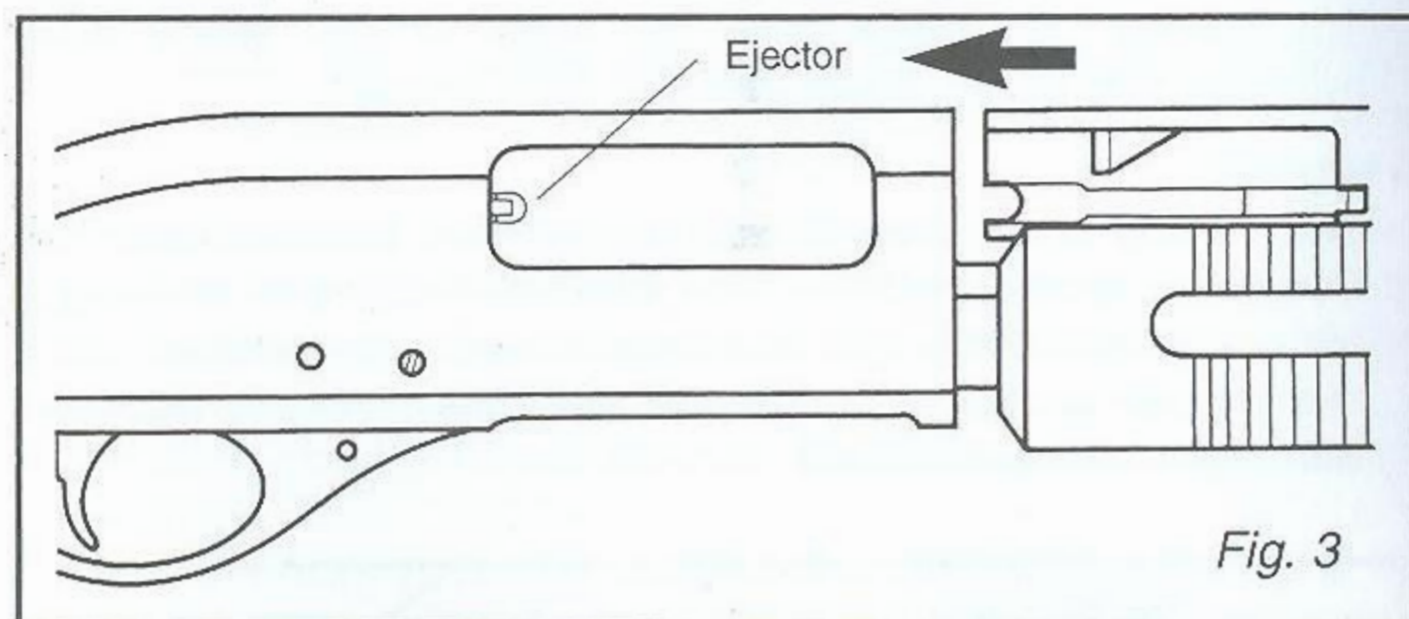

- Before assembling, clean the barrel as instructed under "CLEANING AND LUBRICATION".
- Unscrew and remove the magazine cap assembly.
- Press the action bar lock upwards. Fig 2. Pull the fore-end about half-way backwards.
- Hold the barrel in front of the receiver. See Fig. 3.
- Insert the rear end of the barrel into the receiver, slide the barrel guide ring over the magazine tube. See Fig. 4.
- Align the ejector cut at the rear of the barrel with the ejector in the receiver. See Fig. 3.
- Replace and tighten the magazine cap assembly.

4. TO LOAD AND UNLOAD THE GUN

4.1 TO LOAD ONLY ONE SHELL

1. Point the gun in a safe direction.
2. Engage the safety catch. The red band will not be visible.
3. Push the action bar lock upwards.
4. Pull the fore-end full backwards to open the action.
5. Put one shell through the ejection port. See Fig.5.
6. Push the fore-end forward to close the action.

WARNING: The gun is now loaded

7. To fire the gun, first disengage the safety catch. The red band will be visible.

WARNING: The gun is ready to fire

8. Pull the trigger to fire the gun.
9. Pull the fore-end fully backwards to eject the empty shell.

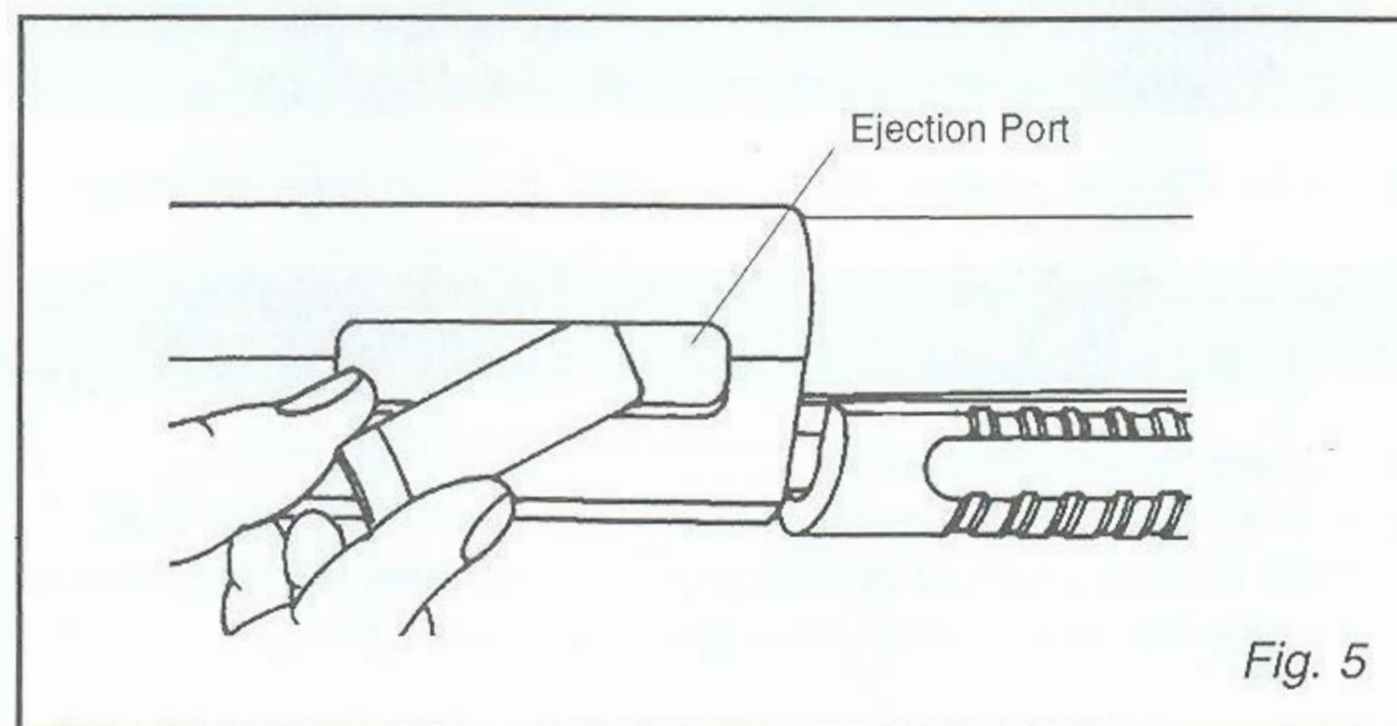

4.2 TO LOAD THE CHAMBER AND THE MAGAZINE

1. Repeat Operations 1 to 6 given under Item 4.1.

WARNING: The gun is now loaded

2. To fill the magazine, press the shell against the carrier. See Fig. 6.
3. Push the shells, one at a time, to fill the magazine up to its capacity. Make sure that the rim of each shell snaps past the shell latch to prevent it from sliding back.

Note: If the shell slides back over the carrier:

- Maintain the gun pointed in a safe direction.
- Do not pull the trigger. Try to open the action.
- If the gun cannot be opened, re-insert the cartridge into the magazine tube, by pushing it with a screwdriver or similar tool, through the slot in the carrier, taking care not to press the cartridge primer.
- Alternatively, remove the trigger plate assembly as shown in Fig. 10.

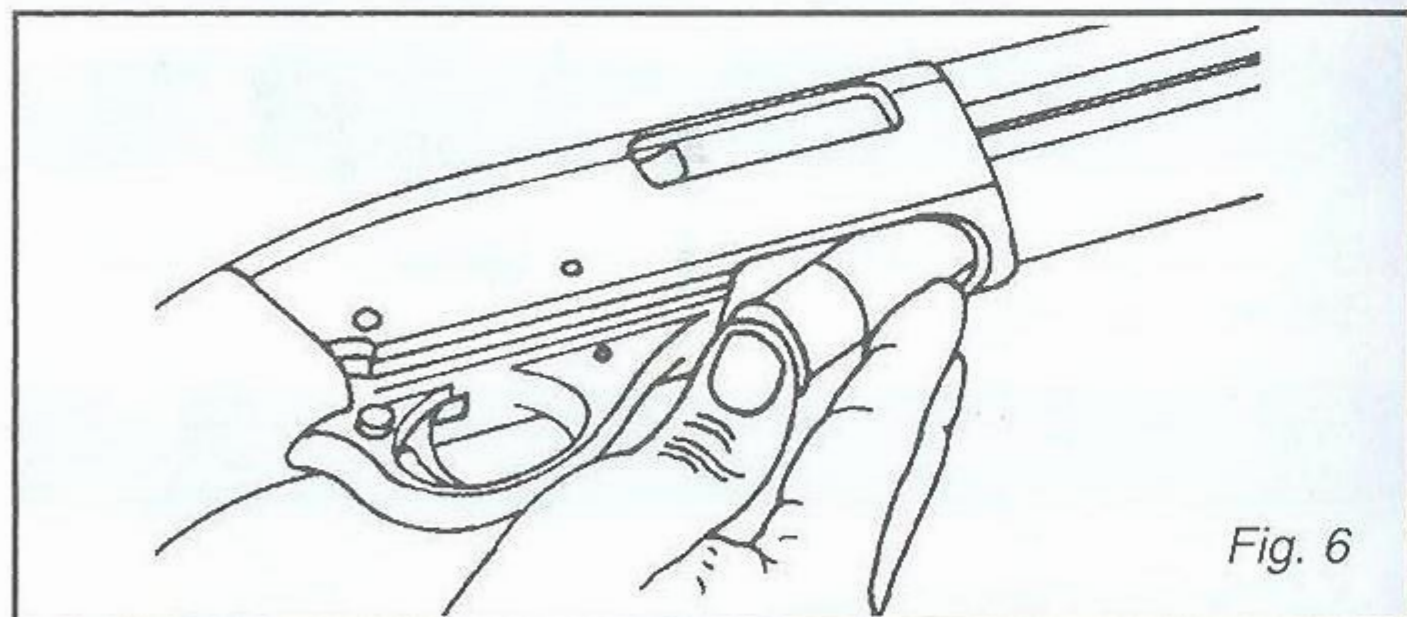

WARNING: The chamber and magazine are now fully loaded

4. To fire the gun, release the safety catch. The red band will show.

WARNING: The gun is now ready to fire

5. Pull the trigger to fire the gun.
6. Pull the fore-end completely backwards to eject the empty shell.
7. Slide the fore-end fully forward to put the next shell into the chamber.
8. Engage the safety catch when you have finished firing.

4.3 TO UNLOAD THE GUN WITHOUT FIRING IT, AND WITHOUT THE HELP OF THE LONG LEFT SHELL LATCH.

There are two procedures for unloading the gun.

1st Procedure: While inserting and extracting cartridges by operating the action.

1. Point the gun in a safe direction.
2. Engage the safety catch, the red band should not be visible.
3. Press the action bar lock, and keep it pressed.
4. Pull and push the fore-end backwards and forwards successively, to operate the action thus extracting a cartridge from the chamber, ejecting it through the ejection port, and inserting a new cartridge into the chamber. Repeat these operations of extracting and inserting until all the cartridges have been extracted from the gun. Check that no cartridge has remained in the chamber or in the magazine.

Note: As the ejected cartridges are propelled to a considerable distance, the ejecting port should be pointed to a place where the ejected cartridges can be easily collected.

2nd Procedure: Without inserting cartridges into the chamber.

1. Point the gun in a safe direction.
2. Engage the safety catch. The red band should not be visible.
3. Press the action bar lock, and keep it pressed.
4. If there is a cartridge in the chamber, extract it by fully pulling back the fore-end; keeping the fore-end pushed back, tilt the gun to the side of the ejection port, thus allowing the next cartridge to fall out of the gun.
5. Repeat the operations described above until all the cartridges have been emptied through the ejection port check that no cartridge has remained in the chamber or in the magazine.

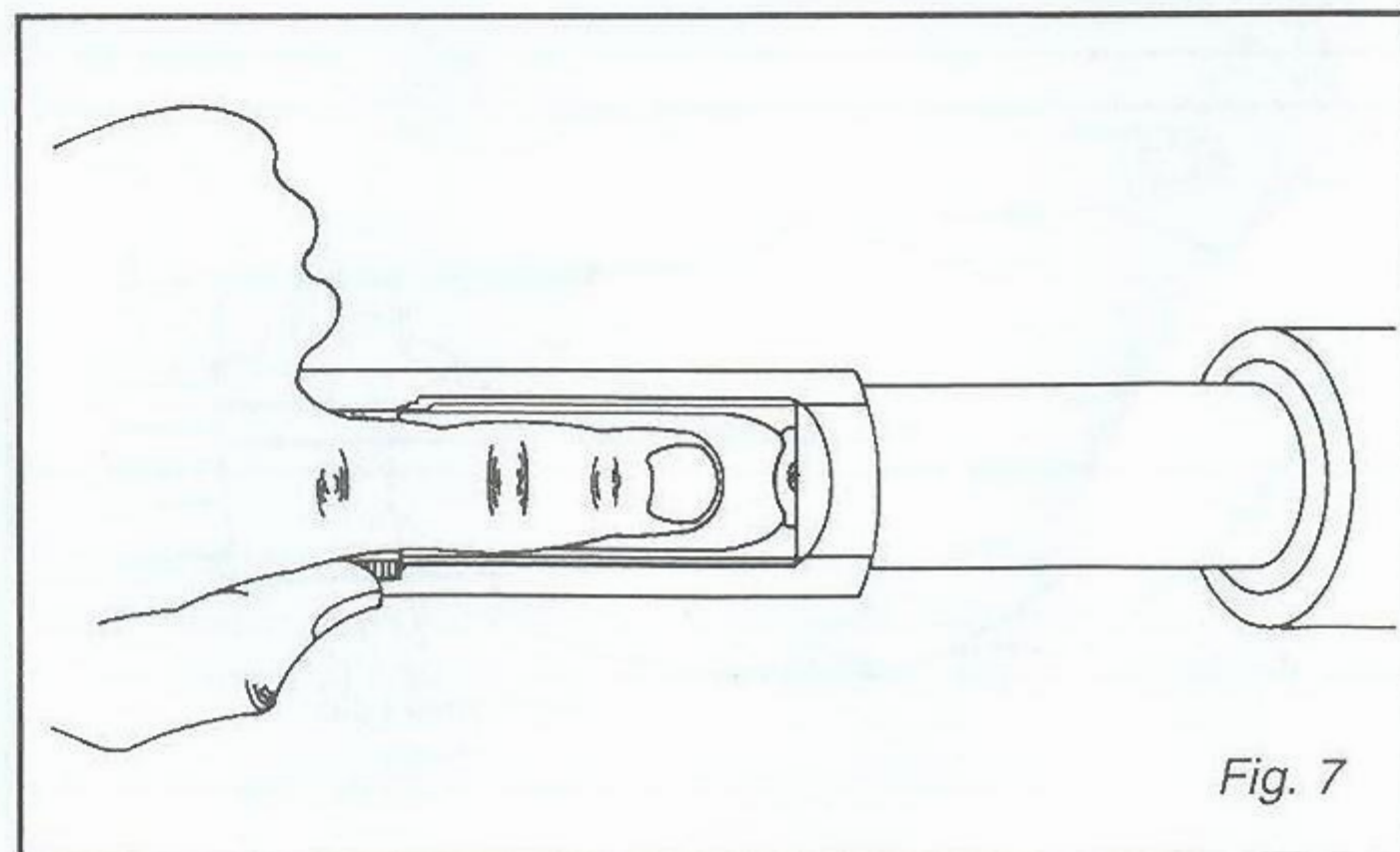

4.4 TO UNLOAD THE GUN WITH THE HELP OF THE LONG LEFT SHELL LATCH

1. Point the gun in a safe direction.
2. Engage the safety catch. The red band should not be visible.
3. Repeat operations 3 and 4 of the 2nd procedure, in order extract the cartridge from the chamber (if any), and to remove the next cartridge from the magazine.
4. Keeping the fore-end fully pulled back, press the carrier until it is retained near the chamber (see Fig.7).
5. Then press the button of long left shell latch, so that two cartridges are released from the magazine. Repeat these operations until all the cartridges have been extracted. Check that no cartridge has remained in the chamber or in the magazine.

5. TO DISASSEMBLE THE GUN

- Engage the safety catch. The red band will not be visible.
- Remove the front and rear pins of the trigger plate. See Fig. 10.
- Lift the rear part of the trigger plate assembly, slide it backwards, and remove it from the receiver.

Note: Do not pull the trigger to allow the hammer to snap forward when the trigger plate assembly is being removed. This can be assured by always keeping the safety catch engaged. The red band will not be visible.

- Pull the fore-end backwards to open the action.

Note: Look into the ejection port and check the chamber and magazine to ensure that there are no shells in the gun.

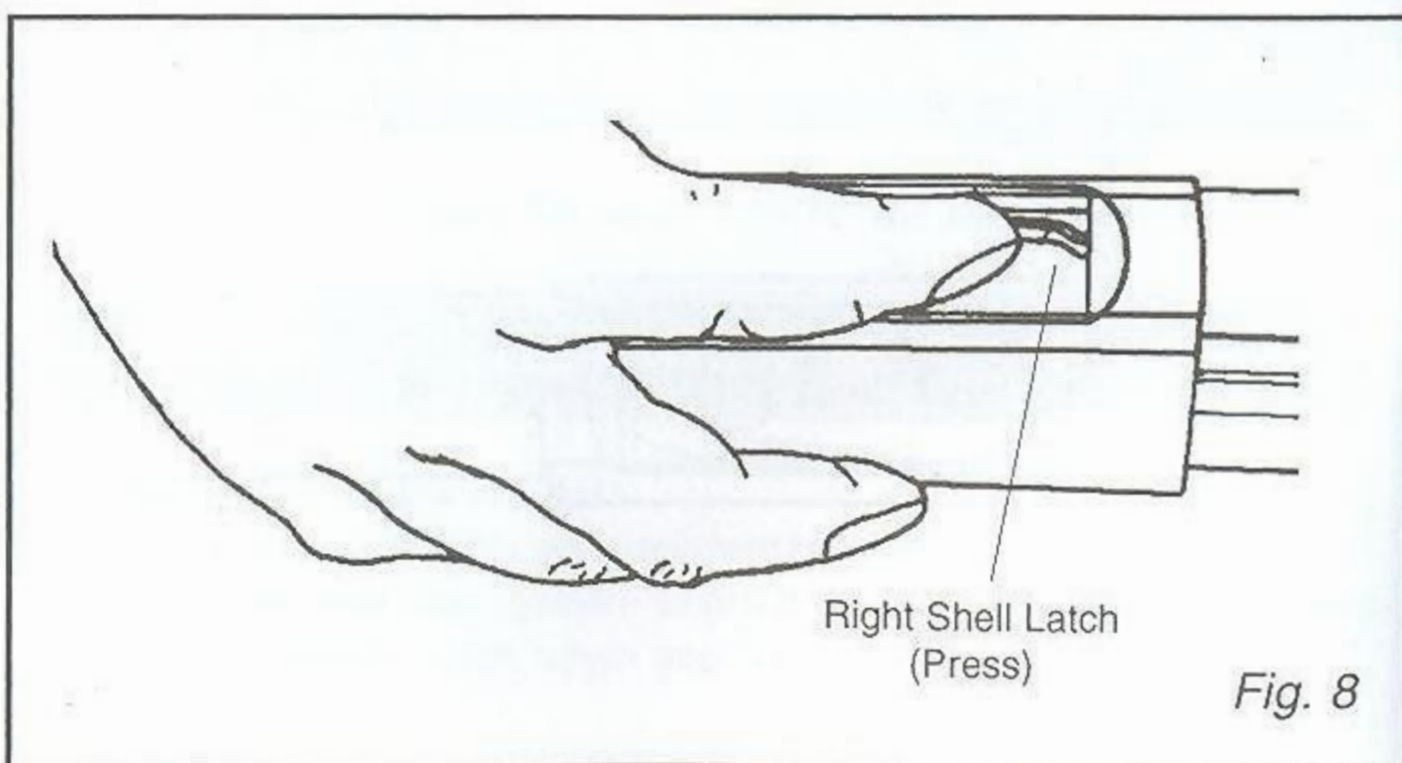

- Unscrew and remove the magazine cap assembly.
- Hold the barrel in front of the magazine tube, and pull the barrel from the receiver.
- Put your finger into the bottom of the receiver, and press down the right shell latch. See Fig. 8.
- Slide the fore-end forward, and remove from the magazine tube. See Fig. 9.

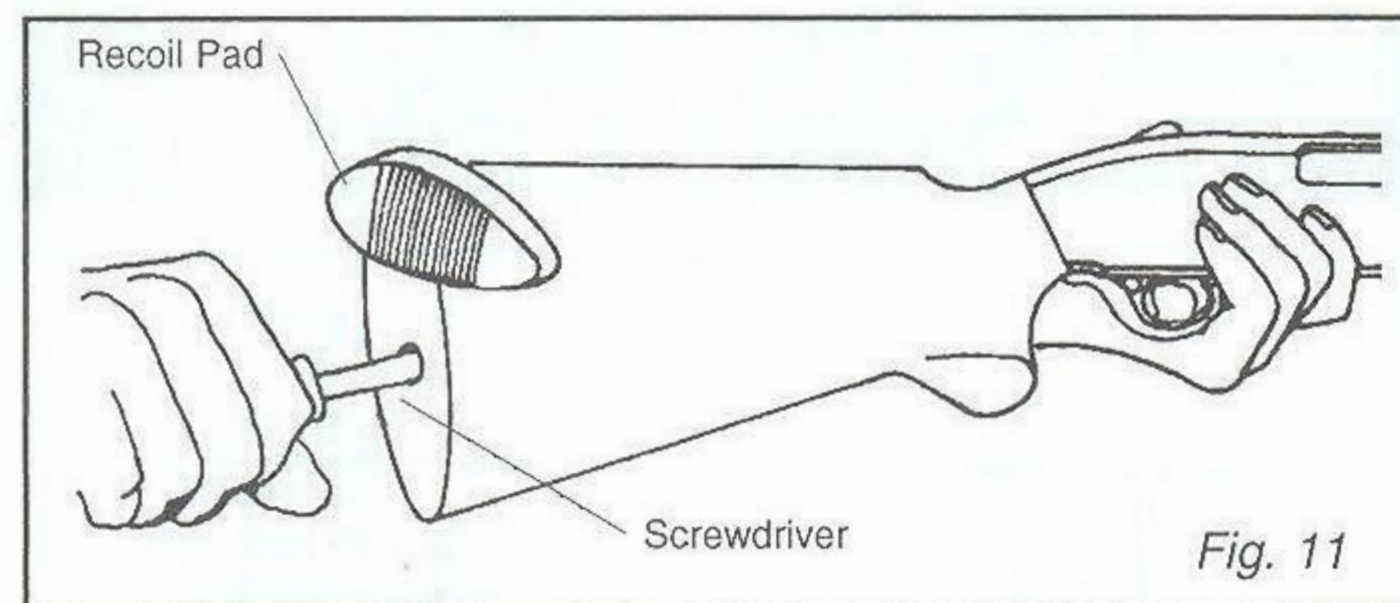
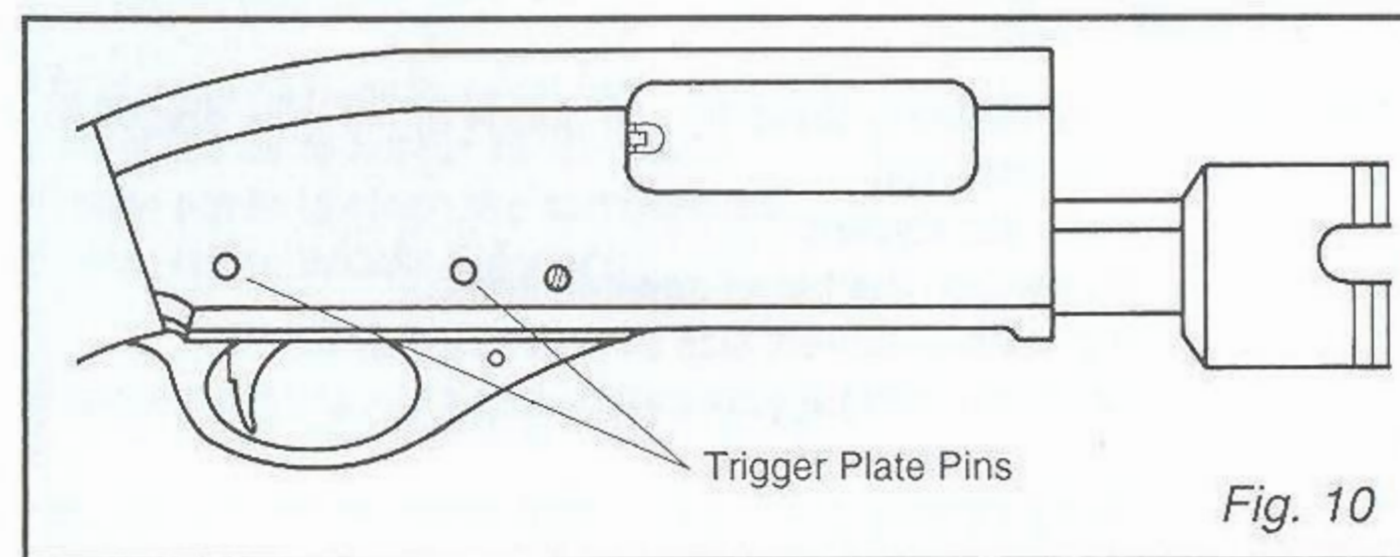
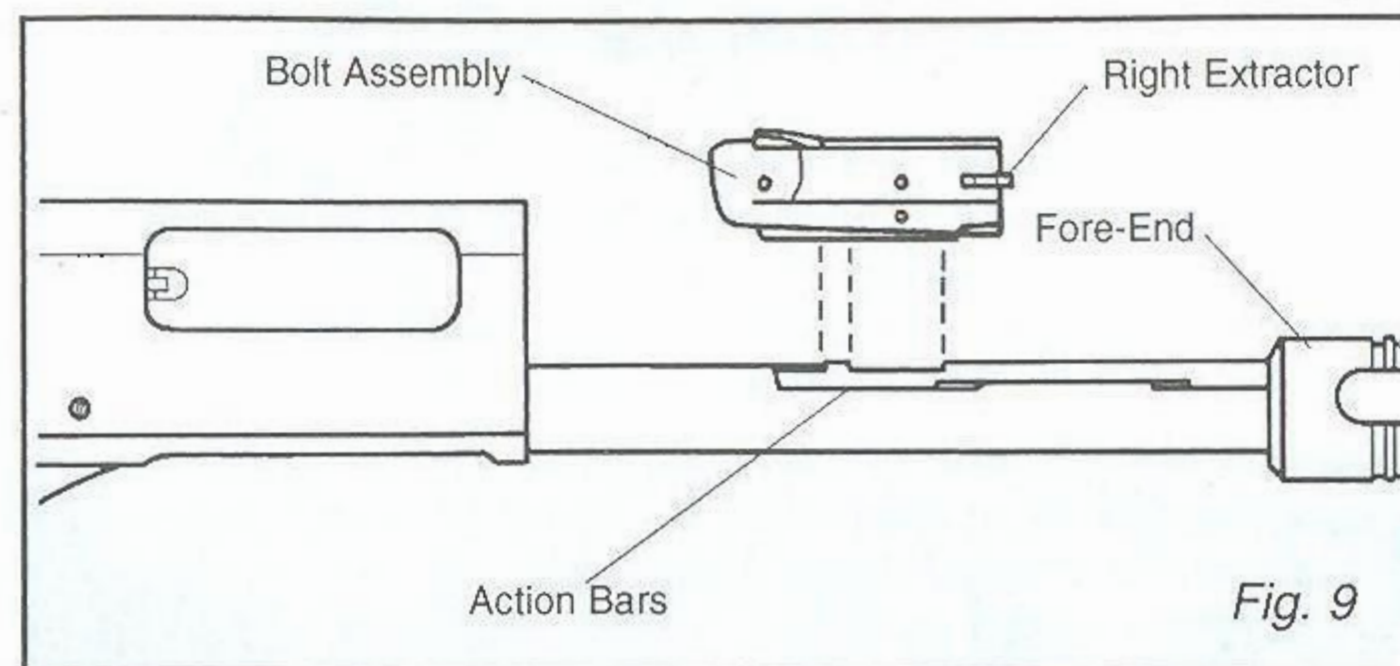

5.1 TO REMOVE THE STOCK

- Fully loosen one of the screws of the recoil pad. See Fig. 11.
- Turn the recoil pad to one side, to uncover the seating of the stock screw.
- Fully loosen the stock screw, and remove the stock.

5.2 TO ASSEMBLE THE STOCK

- Place the stock in the receiver.
- Tighten the stock screw well, so that there is no play. This will avoid cracking or breakage of the stock.
- Turn the recoil pad to its correct position, and tighten the screw.

6. CLEANING AND LUBRICATION

- Clean the gun only with fine mineral oil.
- Always avoid excessive lubrication. A thin coat of oil is all that is needed to prevent the possibility of rusting.
- Before storing a gun, it should be carefully cleaned and oiled. Outside surfaces should be wiped with a light coat of oil.

WARNING: Over-lubrication is not recommended because it can cause serious problems, and may even result in the accidental firing of the gun.

6.1 THE BARREL

- Select the correct cleaning brush for the gauge of the gun, and fix the brush on the cleaning rod.
- Put the brush into the solvent.
- Push the brush through the barrel several times.
- Push a cleaning cloth of correct size through the barrel.
- Repeat several times, using a new patch each time, until the barrel is clean.
- Remove the firing residue from the locking notch in the barrel. See Fig. 12.

WARNING: After cleaning, make sure that there is no obstruction in the barrel. Never try to remove obstructions in the barrel by another shot.

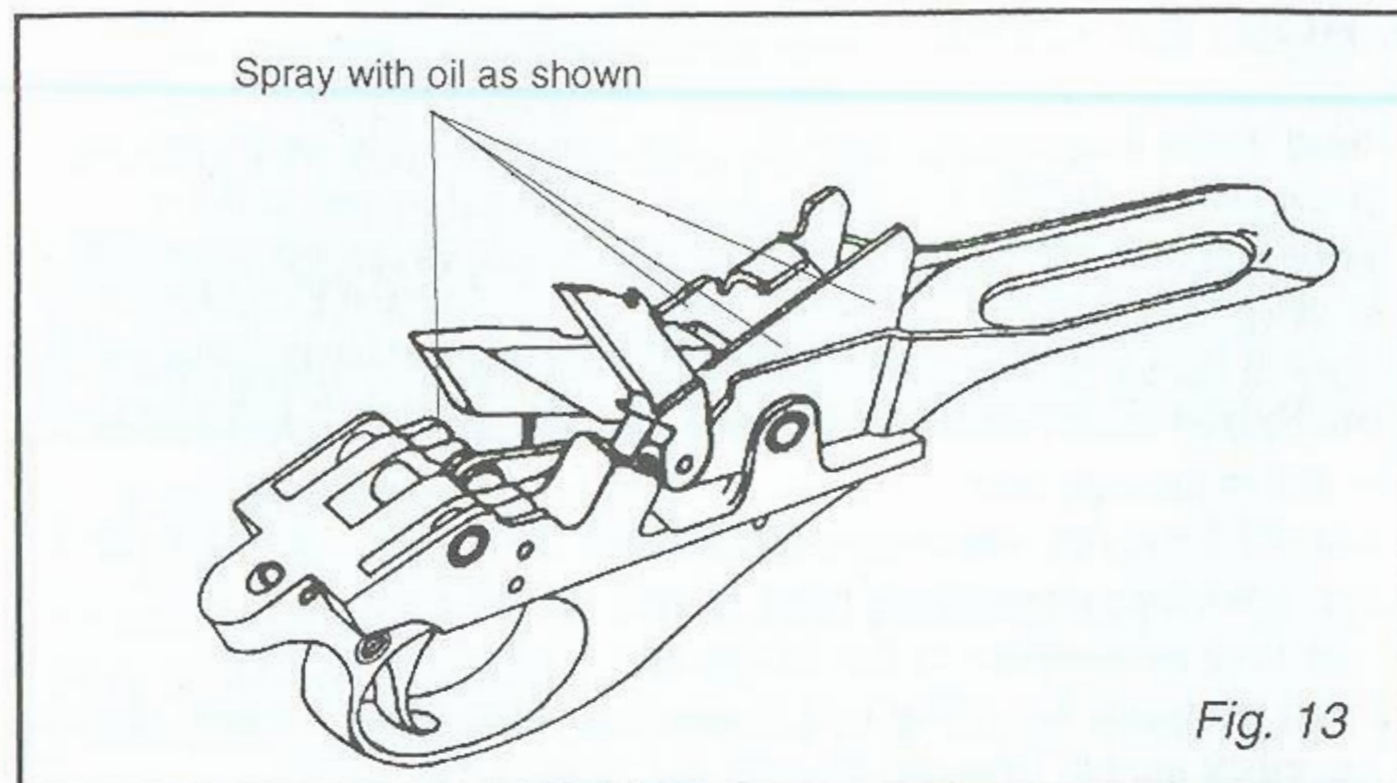
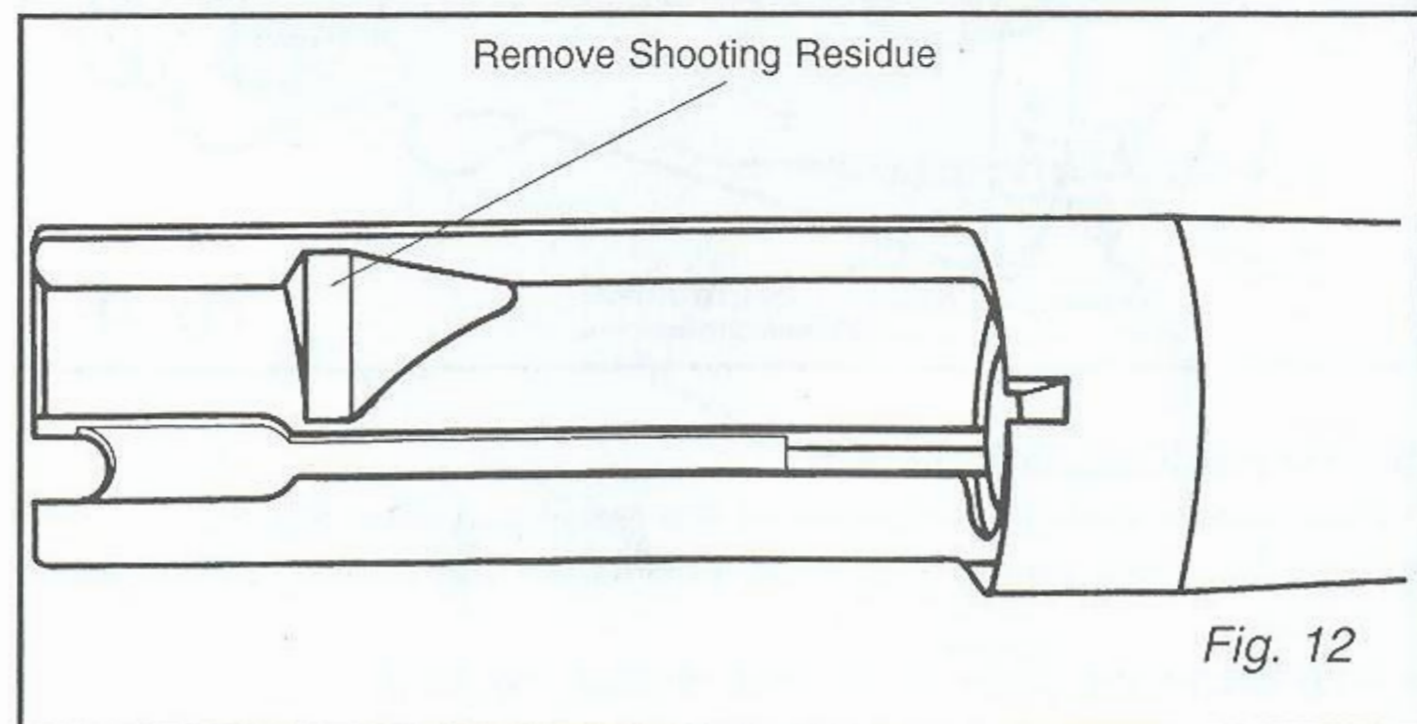

6.2 THE BOLT

- Brush the bolt with a cleaning solvent.
- Dry with a clean cloth.

6.3 THE TRIGGER PLATE

- Spray the oil over the assembly. See Fig. 13.
- Allow the oil to act for 15 minutes.
- Spray again to clean the components.
- Remove the excess lubricant.

7. TO REASSEMBLE THE GUN

- Place the fore-end assembly on the magazine tube. See Fig. 9.
- Place the bolt assembly on the action bars.
- Guide the action bars into the receiver.
- Slide the actions until stopped by the right shell latch.
- Press the right shell latch. See Fig. 8.
- Slide the action bars until stopped by the left shell latch.
- **Press the button of the long left shell latch. See Fig. 2.**
- Slide the fore-end assembly fully backwards.
- Hold the gun in front of the receiver. See Fig. 3.
- Slide the barrel guide ring over the magazine tube. See Fig. 4.
- Align the ejector cut at the rear of the barrel with the ejector in the receiver. See Fig. 3.
- Seat the barrel carefully in the receiver. Do not force the barrel against the receiver.
- Place and tighten the magazine cap assembly.
- Slide the fore-end forward until the actions is closed.
- Carefully put the trigger plate assembly (carrier first) into the receiver.
- Position and align the holes, and tap in the front and rear trigger plate pins. See Fig. 10.

9. ROUTINE CARE

- Read these instructions carefully. Only use your gun when you really know how to handle it and are aware of the safety precautions.
- Make sure that the barrel bore is free from grease, cotton waste, mud, or other obstructions.
Even a partial obstruction can result in a bulged or burst barrel.
- The use of shells loaded with black powder or with corrosive primers is not recommended.
- MAGTECH is not responsible for damage or injuries caused by shells that have been incorrectly hand loaded or reloaded.
Use only ammunition of the gauge stamped on the barrel.
- If play between the barrel and its seating in the stock is noted, tighten the stock screw. This will prevent cracking of the wood.
- When the gun is to be stored, it is recommended that it should be uncocked, to avoid unnecessary compression of the striker spring.

8. ACCESSORIES

8.1 INTERCHANGEABLE CHOKES (see Fig. 14)

Supplied free of charge only for guns with that have barrels with ventilated ribs.

The choke is installed by screwing it into the barrel muzzle. The following three types of chokes are available:

“Cylinder Choke” - That does not constrict the barrel muzzle.

“Modified Choke” - That results in a medium constriction of the barrel muzzle.

“Full Choke”- That results in the maximum constriction of the barrel muzzle.

The choke should first be screwed into the gun muzzle by hand as much as possible, and then tightened by using the multi-functional tool supplied with the gun. The tool should be fitted into the appropriate slots in the choke, and turned until the rear face of the choke rests firmly against its seating in the barrel. The final tightening should be done by turning the tool by hand only. Do not use any mechanical leverage on the tool to make the final tightening. (see fig. 15). To remove the choke proceed in the inverse manner.

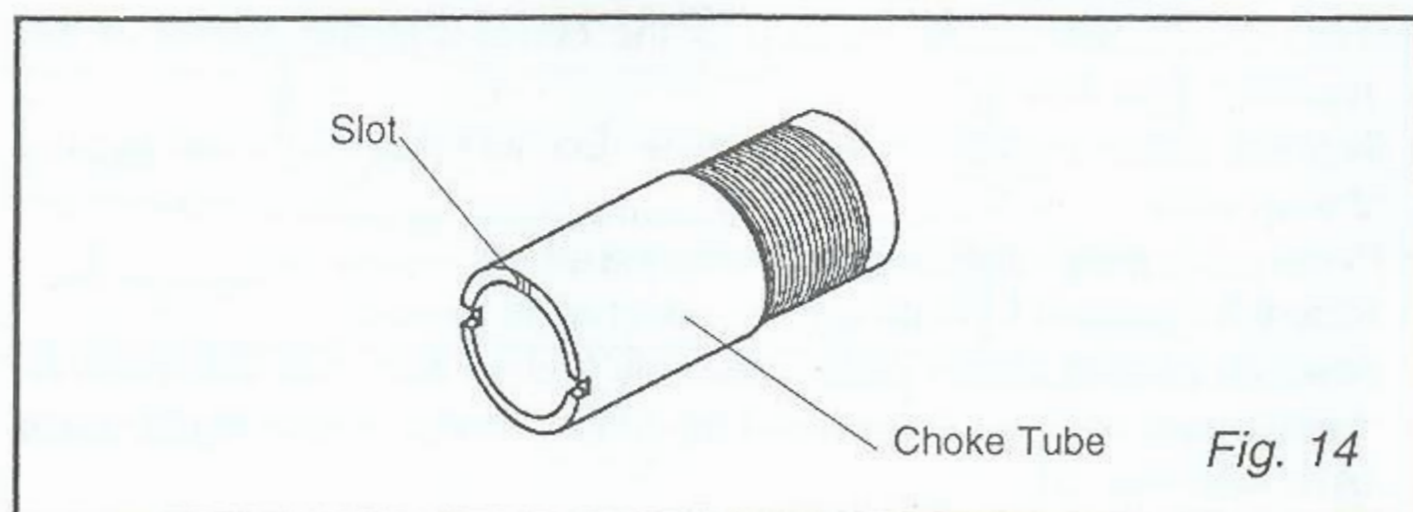

The types of chokes are identified by small notches on the mouths of the chokes: 1 notch identifies a full choke, 3 notches identifies a modified choke, cylinder chokes do not have any notches.

WARNING: To avoid damage to a gun fitted with an interchangeable choke, before firing make sure that the choke is in good condition and that it has been properly screwed in.

8.2 MULTI-FUNCTIONAL TOOL

This small light tool (see Fig 15) has been specially designed for pump 586.2, for the following uses:

- ① As a tool to tighten or loosen a choke in its seating in the barrel.
- ② As screwdriver for mounting accessory butt stock-mounted shell carrier.
- ③ As a screwdriver for screws in the gun.
- ④ As a tool to take out the magazine spring retainer.
 - Insert the side of the tool as indicated by ④ in fig 15, into the slots of the magazine spring retainer.
 - Rotate the tool 1/8 of a turn, and pull out the retainer.
- ⑤ Auxiliary Holes

Note: If the retainer is difficult to pull out, use a metal rod (such as a screwdriver), by inserting the same through the hole in the tool ⑤ to help pull it out.

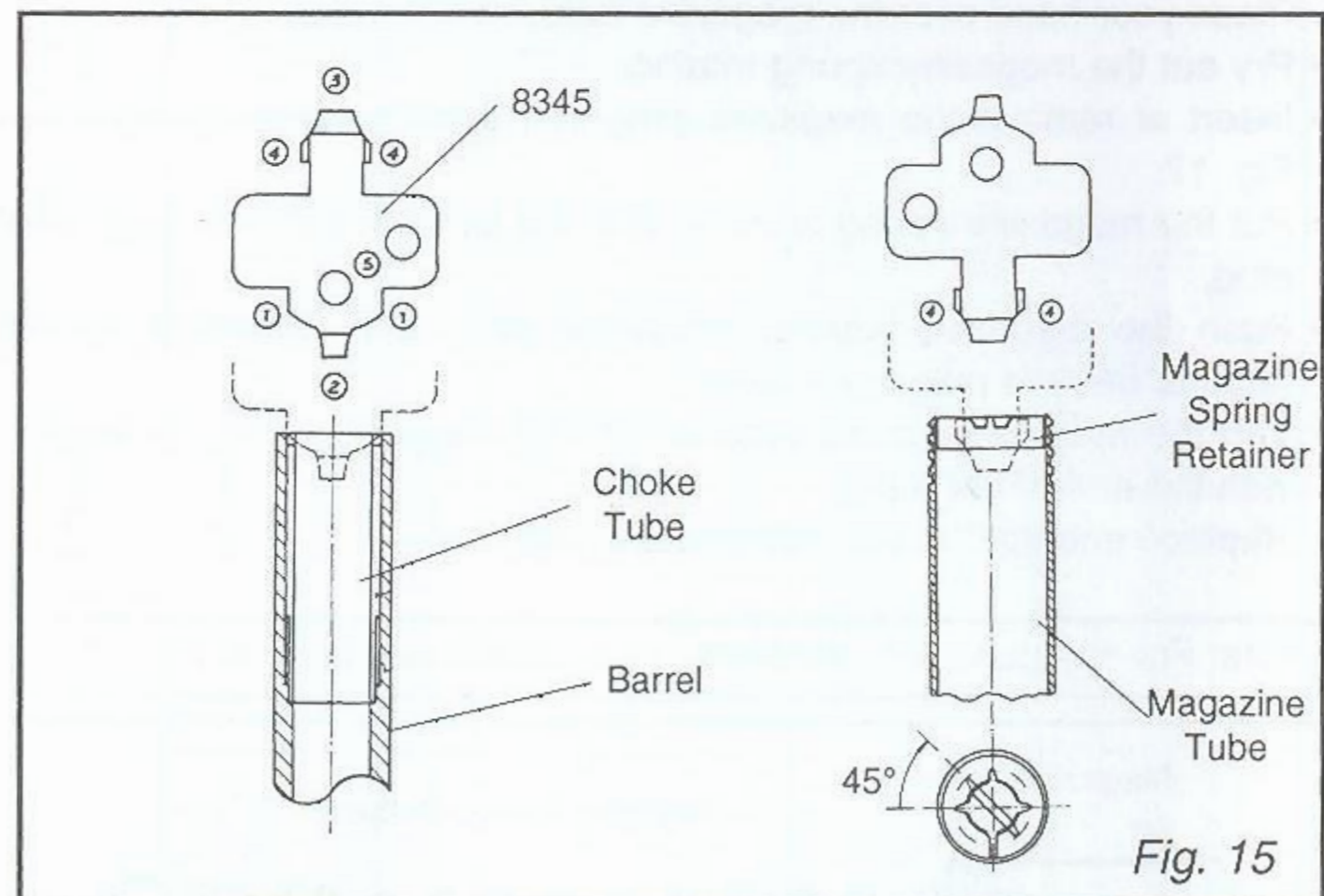

Note: The multi-functional tool supplied with shotguns models with ventilated ribs, is for use in putting on or changing interchangeable chokes, and can also be used to remove the magazine spring retainer.

8.3 TO INSTALL OR REMOVE THE MAGAZINE PLUG

(for specially made guns)

- Engage the safety catch. The red band will not be visible.
- Make sure that there are no shells in the chamber or in the magazine tube.
- Unscrew and remove the magazine cap assembly.
- Put a screwdriver in the open end of the magazine tube and insert the tip under the rim of the magazine spring retainer. See Fig. 16.

WARNING: Be very carefull when removing the magazine spring retainer, because the retainer is under pressure of the magazine spring.

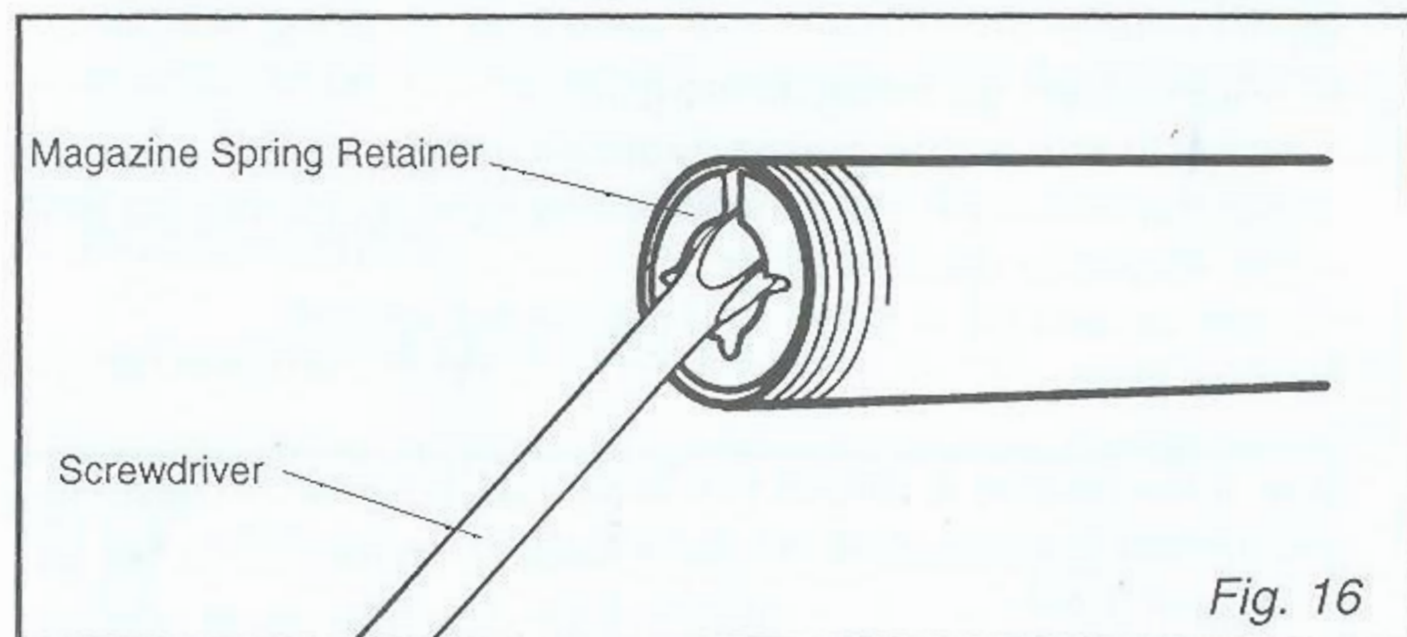

- Place your hand over the magazine tube.
- Pry out the magazine spring retainer.
- Insert or remove the magazine plug into the magazine spring. See Fig. 17.
- Put the magazine spring retainer over the large end of the magazine plug.
- Push the magazine spring, magazine plug, and magazine spring retainer into the magazine tube.
- Tap the magazine spring retainer into the magazine tube, to level it with the end of the tube.
- Replace and tighten the magazine cap assembly.

Note: For shotguns with ventilated ribs, please see Note of Fig. 15.

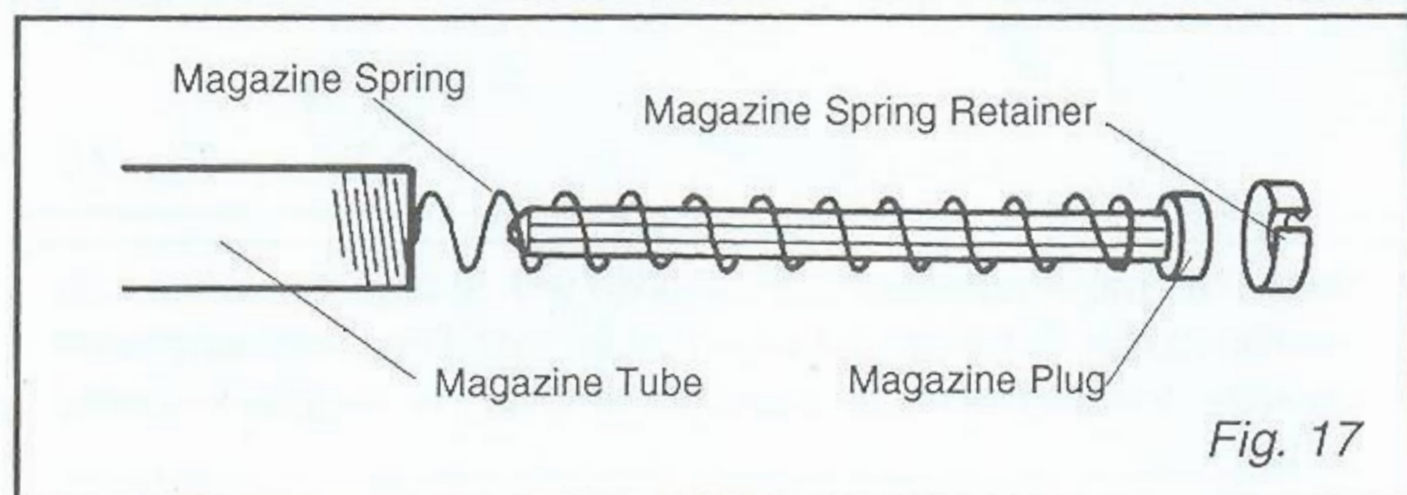

9. SPECIFICATIONS

MODEL	STOCK	MAGAZINE CAPACITY	BARREL LENGHT	TYPE	CHOKE	TOTAL LENGHT (mm)	TOTAL WEIGHT (kg)
586.2	WOOD	4	24"	PLAIN BARREL	MODIFIED (M)	1130	3,26
586.2	WOOD	4	26"	PLAIN BARREL	MODIFIED (M)	1175	3,29
586.2	WOOD	4	28"	PLAIN BARREL	MODIFIED (M)	1225	3,32
586.2	WOOD	4	30"	PLAIN BARREL	FULL (F)	1275	3,35
586.2	WOOD	4	24"	PLAIN BARREL	CYLINDER (CYL)	1130	3,26
586.2 P	WOOD	7	19"	PLAIN BARREL	CYLINDER (CYL)	1000	3,25
586.2 P	EPOXI BLACK PAINTED	7	19"	PLAIN BARREL	CYLINDER (CYL)	1000	3,25
586.2 P	PISTOL GRIP	7	19"	PLAIN BARREL	CYLINDER (CYL)	750	3,20
586.2 VR DE LUXE	WOOD HIGH GLOSS	4	26"	VENTILATED RIB	INCLUDES 3 CHOKES (IC) F, M, CYL	1175	3,48
586.2 VR DE LUXE	WOOD HIGH GLOSS	4	28"	VENTILATED RIB	INCLUDES 3 CHOKES (IC) F, M, CYL	1225	3,52
586.2 S	WOOD	4	24"	RIFLE SIGHTS	CYLINDER (CYL)	1130	3,30

10. PARTS LIST

STOCK ASSEMBLY

7682		Stock Assembly (Std)
8288		Stock Assembly (Std- Black Grained)
8389		Stock Assembly (Monte Carlo)
8665		Stock Assembly (High Gloss - De Luxe Models)
8314		Short Stock Assembly
	* 6639	Stock (Std)
	* 8287	Stock (Std - Black Grained)
	* 8359	Stock (Monte Carlo)
	* 8664	Stock (High Gloss - De Luxe Models)
	* 8313	Short Stock
	8666	Recoil Pad (Std)
	8629	Recoil Pad (De Luxe Models)
	* 8640	Grip Cap (De Luxe Models)
	* 8330	Recoil Pad for Short Stock
	1985	Recoil Pad Screw (2 pieces)
	7924	Stock Bold
	0148	Stock Bold Spring Whasher
	0149	Stock Bold Whasher
7994		Pistol Grip
	8418	Pistol Grip Screw

FORE-END ASSEMBLY

7702		Fore-End Assembly (Std)
8286		Fore-End Assembly (Std - Black Grained)
8419		Fore-End Assembly (Beaver Tail)
8668		Fore-End Assembly (Beaver Tail - High Gloss)
	7707	Fore-End (Std)
	8285	Fore-End (Std - Black Grained)
	8336	Fore-End (Beaver Tail)
	8667	Fore-End (Beaver Tail - High Gloss)
	8335	Action Bar Assembl
	7708	Fore-End Nut

BREECH BOLT ASSEMBLY

8654		Breech Bolt Assembly (Std)
8655		Breech Bolt Assembly (Chrome Plated)
	8624	Breech Bolt (Std)
	8639	Breech Bolt (Chrome Plated)
	7711	Breech Bolt Leader
	7717	Bolt Link (2 pieces)
	7718	Bolt Link Pin, Lower
	7719	Bolt Link Pin, Upper
	7720	Breech Bolt Pin
	7715	Firing Pin
	7716	Firing Pin Retractor Spring
	3127	Firing Pin Retaining Pin
	7712	Extractor Spring, Right
	7713	Extractor Plunger, Right
	7714	Right Extractor
	8645	Extractor Spring, Left
	8646	Extractor Pin, Left
	8642	Left Extractor

TRIGGER PLATE ASSEMBLY

7722		Trigger Plate Assembly (Std)
8669		Trigger Plate Assembly (Polished)
	7683	Trigger Plate (Std)
	8670	Trigger Plate (Polished)
	7793	Carrier Dog Spring
	7742	Carrier Dog Follower
	7735	Carrier Assembly
	7736	Carrier
	7737	Carrier Dog
	7738	Carrier Dog Pin
	7726	Disconnecter Assembly
	8671	Disconnecter Assembly (De Luxe Models)
	7728	Trigger (Std)
	8638	Trigger (Chrome Plated)
	7727	Disconnecter
	7729	Disconnecter Pin
	7730	Disconnecter Plunger
	7731	Disconnecter Plunger Pin
	7732	Sear
	7657	Disconnecter Plunger Spring
	6088-2	Disconnecter Plunger Retainer
	7955	Action Bar Lock Lever
	7740	Action Bar Lock Lever Pin
	7743	Action Bar Lock
	7746	Hammer Spring
	7745	Hammer
	7744	Action Bar Lock Spring
	7723	Safety Catch
	7724	Safety Catch Detent Ball
	2559	Safety Switch Spring
	7725	Safety Catch Spring Retaining Pin
	7733	Trigger Pin
	7734	Sear Pin
	7747	Hammer Pin (2 pieces)
	7748	Trigger Plate Pin Detent Spring (2 pieces)
	7753	Trigger Plate Pin (2 pieces)

RECEIVER ASSEMBLY

**8552		Receiver 586.2 STD
**8553		Receiver 586.2 S (Sand Blasted)
**8554		Receiver 586.2 VR (Polished)
	7691	Shell Latch, Right
	3681	Shell Latch Screw, Right
	8617	Long Left Shell Latch
	7909	Shell Latch Spring, Left
	8637	Ejector
	6874	Ejector Screw
	8620	Magazine Tube, for 4 cartridges
	8619	Magazine Tube, for 6 cartridges
	7694	Magazine Follower
	7938	Magazine Spring
	7696	Magazine Spring Retainer
	8653	Magazine Cap Assembly

— BARREL ASSEMBLY —

8598		Barrel Assembly - 24" Modified Choke - 4 cartridges
8599		Barrel Assembly - 26" Modified Choke - 4 cartridges
8600		Barrel Assembly - 28" Modified Choke - 4 cartridges
8595		Barrel Assembly - 30" Full Choke - 4 cartridges
8586		Barrel Assembly - 24" Cylinder Choke - 4 cartridges
8565		Barrel Assembly - 19" Cylinder Choke - 6 cartridges
8605		Barrel Assembly - 24" Cylinder Choke - 4 cartridges
		Rifle Sights (Sand Blasted)
8602		Barrel Assembly - 26" Interchangeable Chokes Ventilated Rib (Polished)
8603		Barrel Assembly - 28" Interchangeable Chokes Ventiladed Rib (Polished)
	7659	Magazine Cap Detent
	2559	Magazine Cap Detent Spring
	7163	Magazine Cap Detent Retainer
	0132	Front Sight
	7171	Rear Sight
	7172	Rear Sight Elevator
	0338	Rear Sight Screw (2 pieces)
	6863	Front Sight
	8636	Front-Bead Sight (White Plastic - De Luxe Models)
	8628	Mid-Bead Sight (De Luxe Models)

— ACESSORIES —

8647		Choke Tube; Full Choke
8648		Choke Tube; Modified Choke
8649		Choke Tube; Cylinder Choke
8345		Multi-Functional Tool
8561		Magazine Plug
8644		Rear and Front Swivel Assembly
	*0935	Rear Swivel Bushing (2 pieces)
	*1260	Swivel (2 pieces)
	*1984	Rear Swivel Screw
	*8325	Front Swivel Screw
	*8326	Nut of the Front Swivel Screw

(*) This Part is not sold separately

(**) This Part is sold only on an exchange basis

PUMP ACTION SHOTGUN

MODEL 586.2

12 Gauge
3" Chamber

-When ordering parts, always give the following information as shown in this list

1. Part Number
2. Part Name
3. Model Number
4. Serial Number

