

KEL-TEC PMR-30

SAFETY, INSTRUCTION, AND PARTS MANUAL



MADE IN USA

Table of Contents:

Safety Instructions and Warnings.....	2-3
Description, Ammunition, and Controls.....	4-5
Malfunctioning.....	6-7
Magazine Loading.....	7
Exploded View and Parts List.....	8-9
Firing.....	10
Unloading	11
Dry-firing.....	11
Disassembly.....	11-13
Assembly.....	13-14
Maintenance, Cleaning, and Lubrication.....	14-15
Service and Warranty.....	15-16

KEL-TEC PMR-30 Pistol

SAFETY, INSTRUCTION & PARTS MANUAL

STATEMENT OF LIABILITY

This firearm may be classified as a dangerous weapon and is surrendered by KEL-TEC CNC INDUSTRIES INC. with the understanding that the purchaser assumes all liability resulting from unsafe handling or any action that constitutes a violation of any applicable laws or regulations. Firearms can cause serious injury and death. **Safety must be the prime consideration of anyone who handles firearms. Always treat a firearm as though it were loaded. Always keep the muzzle pointed in a safe direction.** In owning a firearm, you are responsible for the firearm's safety and security. Always secure firearms from children.



READ THESE INSTRUCTIONS AND WARNINGS CAREFULLY, BE SURE YOU UNDERSTAND THESE INSTRUCTIONS AND WARNINGS BEFORE USING THIS FIREARM.

This SAFETY, INSTRUCTION & PARTS MANUAL should always accompany this firearm and be transferred with it upon change of ownership or when the firearm is loaned or presented to another person. A copy of the SAFETY, INSTRUCTION & PARTS MANUAL is available FREE upon request and can also be downloaded from the internet at: <http://www.kel-tec-cnc.com>.

READ AND CAREFULLY FOLLOW THESE WARNINGS AND INSTRUCTIONS

These warnings and instructions are provided to assure the safe functioning of the firearm. Failure to heed these instructions may result in improper functioning and serious injury.

Kel-Tec firearms are designed to function reliably with proper care and knowledgeable use. Do not use your firearm unless you fully understand these instructions, and the safe operation of your firearm.

Only safe gun-handling habits will ensure the safe use of your firearm. This is your responsibility. Accidents are the result of violating the rules of safe gun handling noted below and common sense.

Before handling a firearm, understand its operation.

Never accept or pick up a firearm without checking the magazine and the chamber to assure the weapon is empty. Do not trust the extractor to clear the chamber, always look and feel.

Always make sure the **muzzle is pointed in a safe direction at all times.** Never point a firearm at anyone or anything you do not intend to shoot.

Make sure your "audience" is at least 5 feet behind you, not next to you when firing.

Keep your firearm unloaded when not in use. Never keep a loaded firearm in the home or vehicle. Never store a firearm with a cartridge in the chamber.

Never store firearms and ammunition together, keep them locked up and away from children.

Never touch the trigger when working the action.

Never alter any components of your firearm.

Never take medications, drugs, or alcohol when handling firearms.

Never load or unload a firearm without assuring the muzzle is pointed in a safe direction.

Never load a firearm except immediately before shooting.

SAFE GUN HANDLING IS YOUR RESPONSIBILITY



Discharging firearms in poorly ventilated areas, cleaning firearms, or handling ammunition may result in exposure to lead and other substances known to cause birth defects, reproductive harm, and other serious physical injury. Have adequate ventilation at all times. Wash hands thoroughly after exposure.

Never discharge a firearm without proper shooting glasses and ear protection. Never shoot at any water surface or any surface where a ricochet can occur.

Never shoot until you are sure of your backstop and what lies beyond it.

If the gun does not discharge after pulling the trigger, do not change its direction for at least 30 seconds, you could be having a "hang fire", and the cartridge could go off when you do not expect it. After waiting 30 seconds, remove the magazine and remove the unfired case, while keeping the firearm pointed in a safe direction

Always be aware of other people so that they cannot accidentally walk into the line of fire. When firing on a target range, be alert and follow the range officer's commands. Never cross obstacles such as fences or streams with a loaded firearm.

Do not allow a firearm to be used by individuals who do not understand its safe operation and the rules of safe gun handling.



CAUTION: After firing several rounds the exterior metal parts of the firearm get VERY hot and can cause severe burns if touched.

Be sure all accessories are compatible with the firearm and that the accessories do not interfere with safe operation of the firearm.

When transporting your firearm, be sure your firearm is unloaded and on SAFE.

If you do not understand how to operate any of our products or have any questions about their safe handling, please write, call, or email us.

KEL-TEC CNC INDUSTRIES INC

1475 Cox Road

Cocoa FL 32926

Telephone Number: 321-631-0068

Toll free: 1-800-515-9983

Hours: M-F 8am-4pm EST (excluding holidays)

Website: <http://www.kel-tec-cnc.com/>

Email: ktcustserv2@kel-tec-cnc.com

INTRODUCTION

The PMR-30 pistol is an auto-loading firearm chambered for the .22WMR cartridge. Only standard, commercially manufactured, brass-cased ammunition should be used. It accepts a proprietary magazine that holds up to 30 rounds, unless limited by law. Where limited by law, magazine capacity may be reduced, and may be noted on the magazine.

AMMUNITION NOTE:

The PMR-30 pistol is designed and chambered for the .22WMR cartridge. The type of ammunition is also marked on the barrel of the pistol. Do not use any other ammunition.

Only use US made, SAAMI spec, commercially manufactured ammunition, clean, dry, and in good condition. Never use non-standard, reloaded or damaged cartridges. Use only brass-cased ammunition. Any other ammunition is considered non-standard and use of it may void the warranty on this firearm.

Never use ammunition where the pressure levels exceed industry standards. Kel-Tec firearms are manufactured from high quality materials. They will provide extended service life. However, all warranties, expressed or implied, are voided and Kel-Tec will not be liable for property damage or personal injury and consequential damages, if faulty, non-standard, or reloaded ammunition is used in any Kel-Tec firearm.

The PMR-30 pistol functions best with high power ammo, often with bullet weights of 40gr and up. This includes, but is not limited to, the following:

- CCI Maxi Mag 40gr
- Winchester Super-X 40gr
- Remington Premier Magnum 33gr

Low power ammo and/or light-weight bullets may cause failure to feed problems due to the lack of energy to cycle the slide all the way back. The following are currently low power, and may not function reliably in the PMR-30 pistol, especially if the grip is not held firmly:

- Winchester Dynampoint 45gr
- Winchester Supreme 30gr

Please take the ammo type into account before sending your pistol in for repair work. All testing at the factory will be done with high-power ammo.

CONSTRUCTION

The grip assembly, magazine, and slide cover, are made of an impact-resistant, glass-reinforced Nylon. The rear portion of the grip houses an aluminum receiver (sometimes called frame) which houses the firing mechanism, guides the slide, supports the magazine, ties the grip halves together, and has the serial number engraved into it, which is visible from the rear of the pistol. A picatinny accessory rail is integrated just forward of the trigger guard, under the barrel, to allow for the attachment of accessories such as a bi-pod, flashlight, or laser. **Check with federal and local laws before attaching ANY type of extra grip to this rail.**

The firing mechanism is hammer fired and of conventional single action type. There is an ambidextrous safety lever on both sides located at the rear of the grip. Down is FIRE mode and red coloring should be visible, up is SAFE mode and the lever should fully cover any red coloring. The Safety disconnects the trigger mechanism and fully blocks the sear so the hammer cannot drop. The sear is also balanced so it cannot be activated by dropping the pistol.

The magazine is a unique double-stack double-feed style polymer magazine. The magazine body and follower are impregnated with molybdenum disulfide dry lubricant for enhanced reliability. The magazine release is on the heel of the grip (bottom rear) and must be pressed in to be able to remove the magazine. The PMR-30 will automatically lock back the slide when the magazine is emptied during normal firing. There is also a manual slide lock lever accessible on the left side of the pistol, just in front of the safety lever. **This is not meant as a slide release.**

The slide, barrel, and barrel block are made of hardened steel. The rear of the slide is covered with an injection molded nylon cover that also houses the rear fiber-optic sights. Dual extractors and the firing-pin are housed under the slide cover. The front sight is also fiber-optic and housed in aluminum, which is dovetailed into the steel slide and is drift adjustable for windage. The recoil springs and steel guide rod are captive and hold the polyurethane buffer in place. A steel cross-pin holds the upper assembly which includes the slide, barrel, barrel block, recoil springs and buffer to the grip assembly.

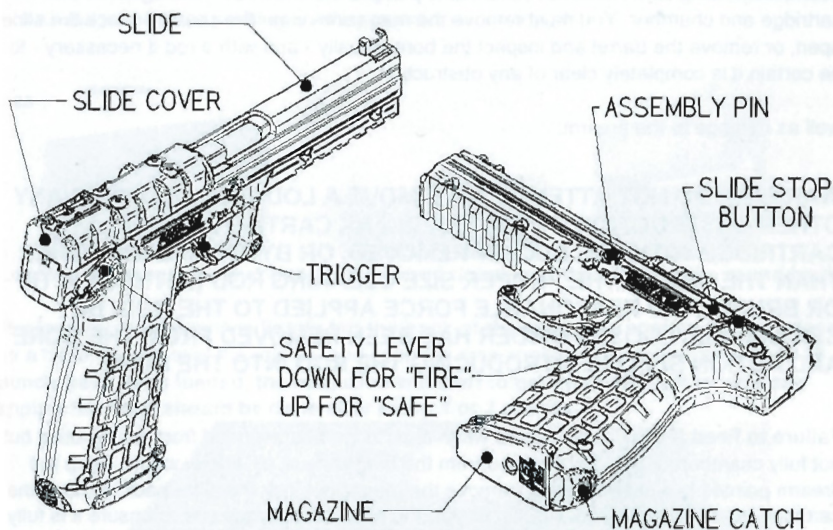

PMR-30 Operating Controls

INSTRUCTIONS FOR USE

Safety

To achieve operator safety, combined with ease of handling, the PMR-30 pistol's manual safety, when applied, disconnects the trigger from activating the sear, and positively blocks the sear from rotating, which blocks the hammer from falling. The safety can only be applied when the hammer is fully cocked. If the safety will not activate, the hammer is already dropped, or only partially cocked. Fully cycle the slide to fully cock the hammer,

and then the safety can be engaged. Only when the red color near the safety lever is fully obscured is the safety engaged, and the gun considered "on safe". Obviously the safest condition of the pistol is magazine removed, with the slide locked back. Other modes of storing or carrying will gradually improve readiness at the cost of safety. Always take steps to avoid unauthorized users, like children, from gaining access to a firearm.

MALFUNCTIONING

Proper function of your firearm is directly related to proper maintenance and care, and to the quality of ammunition you use. Your pistol should be cleaned and LIGHTLY lubricated with a light gun oil or dry-film lubricant after each use to insure proper functioning.

Excessive lubrication will likely combine with powder residue and gum-up the operation of the firearm and cause many of the malfunctions listed below. Some of the more common types of malfunctions which may occur are as follows:

Failure to Fire (FTFR): A failure to fire or an unusual sound upon firing is always a signal to cease firing and examine the misfired cartridge and possibly the bore of the firearm, before continuing to fire. It is not sufficient to just pull the slide back and examine the cartridge and chamber. You must remove the magazine, clear the chamber, lock the slide open, or remove the barrel and inspect the bore visually - and with a rod if necessary - to be certain it is completely clear of any obstruction. **Failure to detect and remove a bore obstruction can result in serious injury or death to the shooter and bystanders**, as well as damage to the firearm.

WARNING: DO NOT ATTEMPT TO REMOVE A LODGED BULLET OR ANY OTHER OBSTRUCTION BY USING A BLANK CARTRIDGE, OR A CARTRIDGE WITH THE BULLET REMOVED, OR BY ANY MEANS OTHER THAN THE USE OF THE PROPER SIZE CLEANING ROD (WITHOUT A TIP OR BRUSH) AND REASONABLE FORCE APPLIED TO THE ROD. BE CERTAIN ALL LOOSE POWDER HAS BEEN REMOVED FROM THE BORE AND ACTION BEFORE INTRODUCING THE ROD INTO THE BORE.

Failure to Feed (FTFD): This occurs when a cartridge has been fed from a magazine but not fully chambered, or is not stripped from the magazine at all. If this occurs, keep the firearm pointed in a safe direction, remove the magazine, lock the slide back, remove the cartridge, re-insert the magazine, firmly slap the base of the magazine to ensure it is fully seated, release the slide and continue shooting. If the problem continues, change the magazine or ammunition type and clean the firearm and magazine. The most common causes are improperly loaded or damaged magazines, dirt or foreign objects in the magazine impeding the cartridges or magazine follower, faulty or underpowered ammunition, or a dirty chamber or slide.

Failure to Extract (FTEX): A fired case is not fully extracted from the chamber of the firearm. Keep the firearm pointed in a safe direction, remove the magazine, clear the firearm by operating the slide and locking it back, remove the case, and continue firing as usual. If the problem continues, change the magazine and ammunition type. The most common causes are damaged or dirty extractors, dirty chamber, or faulty ammunition. Improperly loaded or sized cartridges can also cause this. If any of the above problems are not solved by cleaning the firearm, including brushing the bore and chamber, or by use of other brands of ammunition, stop firing, unload and un-chamber, and contact the Kel-Tec CNC service department for possible repair or replacement of the firearm.

Failure to Eject (FTEJ): A fired case is extracted from the chamber, but not correctly ejected from the firearm. This is also commonly called a "stove-pipe jam" as the empty case is often pointing out of the ejection opening and resembles an old-time stove pipe. Keep the firearm pointed in a safe direction, remove the magazine, clear the firearm by operating the slide and locking it back, remove the case, and continue firing as usual. If the problem continues, change the magazine and ammunition type. The most common causes are damaged or dirty extractors, damaged ejector, dirty or faulty chamber, or faulty ammunition. Improperly loaded or sized cartridges can also cause this. If any of the above problems are not solved by cleaning the firearm, including brushing the bore and chamber, or by use of other brands of ammunition, stop firing, unload and un-chamber, and contact the Kel-Tec CNC service department for possible repair or replacement of the firearm.

LOADING THE MAGAZINE

Loading the PMR-30's double stack magazine is very different from loading most other magazines. Failure to load the magazine properly can result in rim-lock which will lead to a FTFD malfunction. To load, fill the magazine by pressing a cartridge downward in the center of the magazine, with the rim situated within the rim window. Then slide the round back all the way before pushing another round down on top of it.



Loading the magazine by pushing the round down, and then sliding the round back

After loading about 5 rounds lightly tap the back of the magazine against a flat surface, like a table, to help seat the rounds, and keep the rims arranged correctly. Once 15 to 20 rounds have been loaded, the magazine will start to get more difficult to load and tapping the back should be done after every 1 or 2 rounds.



Tapping the back of the magazine on a flat surface to seat rounds and ease loading

Do not load more than 30 rounds in the magazine. The last round should be on the left side of the magazine when 30 rounds are loaded. The view ports on the side of the magazine are spaced for every 5 rounds, but only if the round is fully seen in the view port, not just partially seen.

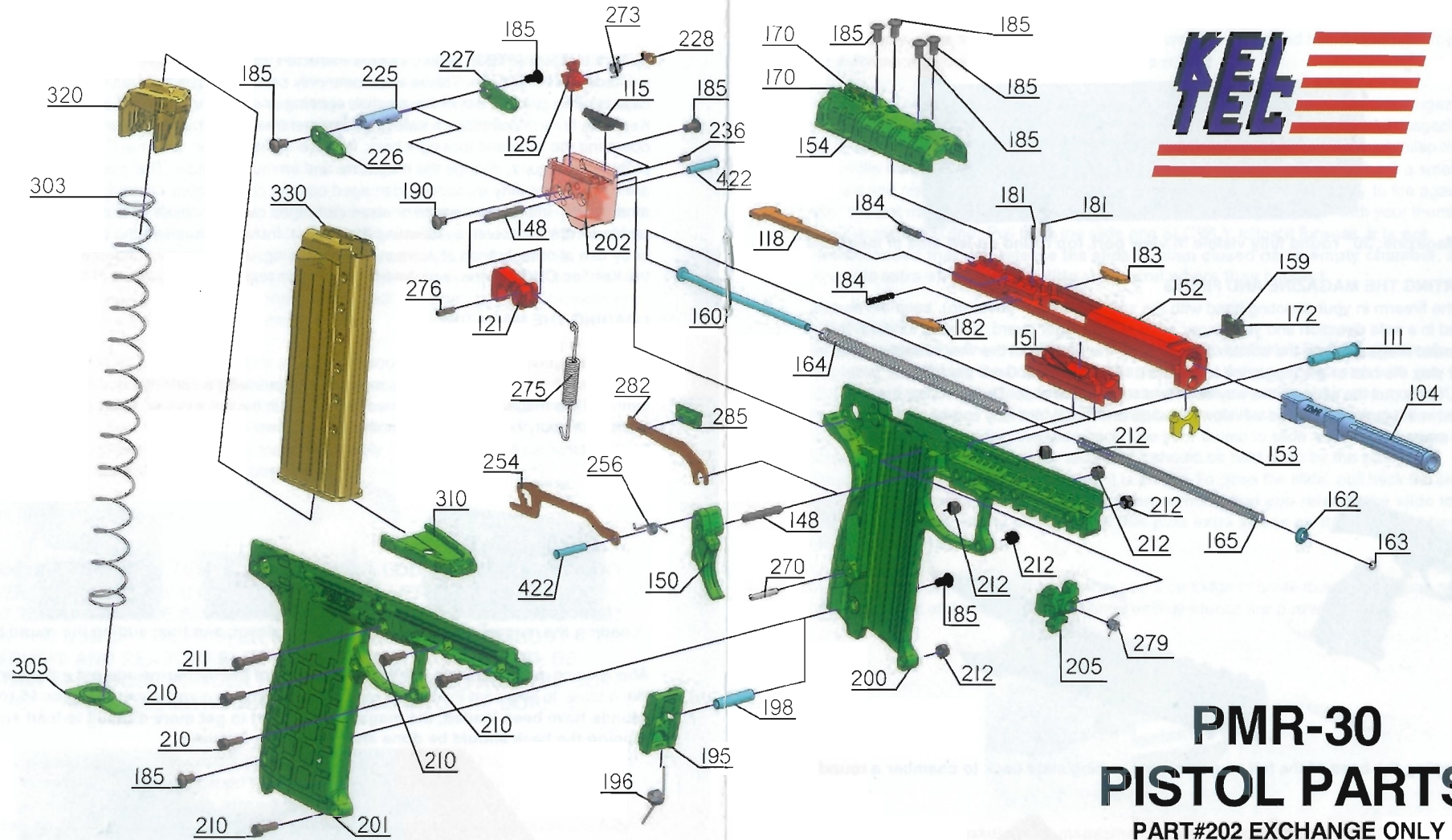

PMR-30 PISTOL PARTS

PART#202 EXCHANGE ONLY

- | | | | | |
|------------------|-----------------------------------|-----------------------|-------------------------|---------------------------|
| 104 BARREL 4.3 | 159 FIBER FRONT SIGHT | 185 SLIDE COVER SCREW | 225 SAFETY | 282 SLIDE STOP BRAZEMENT |
| 111 ASSEMBLY PIN | 160 RECOIL SPRING GUIDE | 190 RECEIVER SCREW | 226 SAFETY LEVER RIGHT | 285 SLIDE STOP BUTTON |
| 115 EJECTOR | 162 RECOIL SPRING CATCH | 195 MAG CATCH | 227 SAFETY LEVER LEFT | 303 MAGAZINE SPRING |
| 118 FIRING PIN | 163 RECOIL SPRING GUIDE LOCK RING | 196 MAG CATCH SPRING | 228 SAFETY SNAP | 305 MAGAZINE SPRING PLATE |
| 121 HAMMER | 164 OUTER RECOIL SPRING | 198 MAG CATCH AXIS | 236 EJECTOR PIN | 310 MAGAZINE BOTTOM PLATE |
| 125 SEAR | 165 INNER RECOIL SPRING | 200 GRIP LEFT | 254 TRIGGER BAR | 320 MAGAZINE FOLLOWER |
| 148 TRIGGER AXIS | 170 REAR SIGHT FIBER | 201 GRIP RIGHT | 256 TRIGGER SPRING | 330 MAGAZINE BODY |
| 150 TRIGGER | 172 FRONT SIGHT FIBER | 202 RECEIVER | 270 HAMMER SPRING CATCH | 422 SEAR AXIS |
| 151 BARREL BLOCK | 181 EXTRACTOR AXIS | 205 FEEDRAMP | 273 SEAR SPRING | |
| 152 SLIDE | 182 EXTRACTOR RIGHT | 210 M3-10 SOCKET HEAD | 275 HAMMER SPRING | |
| 153 BUFFER | 183 EXTRACTOR LEFT | 211 M3-16 SOCKET HEAD | 276 HAMMER SPRING PIN | |
| 154 SLIDE COVER | 184 EXTRACTOR SPRING | 212 M3 NUT | 279 SLIDE STOP SPRING | |



Full Magazine: 30th round fully visible in view port, top round on left side of magazine

INSERTING THE MAGAZINE AND FIRING

Hold the firearm in your shooting hand with the safety on "safe" (lever up), keep the muzzle pointed in a safe direction and your finger outside the trigger guard, pointing forward. Insert the loaded magazine into the bottom of the grip of the firearm all the way in until it clicks in. Firmly slap the butt of the magazine to ensure it is fully seated. Grab the polymer slide cover, firmly pull the slide all the way back and release the slide. Do not follow the slide forward with your hand as this will slow the slide and it may not fully chamber the first round in the magazine.



Slapping the base of the full magazine and pulling slide back to chamber a round



Sweeping the safety lever down for fire, or up for safe

Take aim at a safe target, disengage the safety by sweeping the safety lever down with your thumb. Slowly squeeze the trigger until a round is fired. Release the trigger and you are ready to fire another round. Upon firing, the slide moves rearward extracting and ejecting the fired round and returns to the forward position feeding another round

automatically. This sequence can be repeated until the last round has been fired. The slide will automatically lock back after the last round is fired.

Remove the empty magazine by grabbing the bottom of the magazine and the magazine catch with your thumb and pointer finger. Squeeze the mag catch and pull the magazine out in one motion. If you wish to continue firing, insert a loaded magazine, and slap the bult of the magazine to ensure it is fully seated. Then simply pull the slide back a small amount and release it to chamber the first round. The firearm is now ready to fire again. After the last magazine is emptied, sweep the safety lever up to "safe" with your thumb. Remove the magazine. Pull back the slide and SLOWLY follow it forward. It is not recommended that you release the slide to slam closed on an empty chamber, as this puts extra stress on the slide and barrel where they contact.

UNLOADING

To safely unload the firearm, sweep the safety lever up for "safe". Remove the empty magazine by grabbing the bottom of the magazine and the magazine catch with your thumb and pointer finger. Squeeze the mag catch and pull the magazine out in one motion. Grab the slide cover and pull and hold it all the way back in one fast motion to eject the round in the chamber. While holding the slide back, use your thumb to slide and hold the slide stop button up. Now slowly release the slide and it should be held open by the slide stop. Visually inspect the chamber to be sure it is empty. To close the slide, pull back the slide and SLOWLY follow it forward. It is not recommended that you release the slide to slam closed on an empty chamber, as this puts extra stress on the slide and barrel where they contact.

To unload a full or partially full magazine, use a cartridge or small tool to push each round forward and out of the magazine. Continue until all rounds are pushed out.



Unloading the magazine by pushing rounds forward

DRY-FIRING

Dry-firing is pulling the trigger and dropping the hammer when the chamber is empty. Excessive dry-firing is not recommended, but it can be done occasionally without worry of damaging the firearm. Remove the magazine and unload your firearm as discussed in section entitled "Unloading" above. Before dry-firing, always be 100% sure that the chamber is empty, the magazine is removed, and always point the firearm in a safe direction.

DISASSEMBLY

NOTE: Basic disassembly, also called field stripping, can be performed with only a small pointed tool, or a cartridge. None of the screws on the firearm should ever need to be removed for general maintenance.

Remove the magazine and unload your firearm as discussed in the section entitled "Unloading" above. Manually cycle the slide to be sure that there is no round in the chamber. Make sure the safety is engaged. With the tip of a cartridge or other pointed object, push out and remove the assembly pin. Grab the slide and guide the upper assembly forward off of the lower grip assembly.

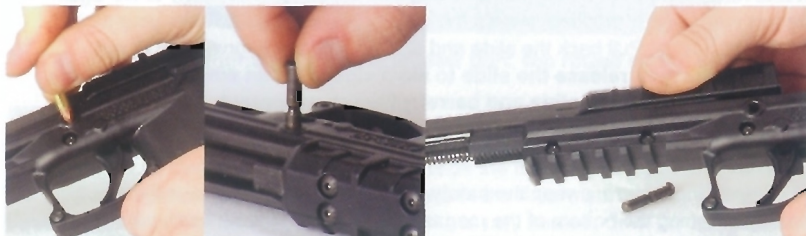

Removing the assembly pin and sliding the upper assembly forward and off the grip

Flip the slide assembly upside down so you can access the captive recoil springs. Grab the springs near the barrel block and compress the springs until the guide rod is free of the barrel block. Slowly lift the spring assembly up and carefully release the tension on the springs. The captive recoil spring assembly can now be set aside. Remove the buffer from the front of the slide and set it aside. Slide the barrel block fully forward and lift it out of the slide. Tip the slide over and the barrel should fall out of the slide easily. The firearm is now fully field stripped and ready for cleaning. Always use polymer safe cleaners designed for firearms. **NEVER DROP THE HAMMER WITH THE SLIDE ASSEMBLY REMOVED FROM THE GRIP ASSEMBLY.** This can damage the receiver.

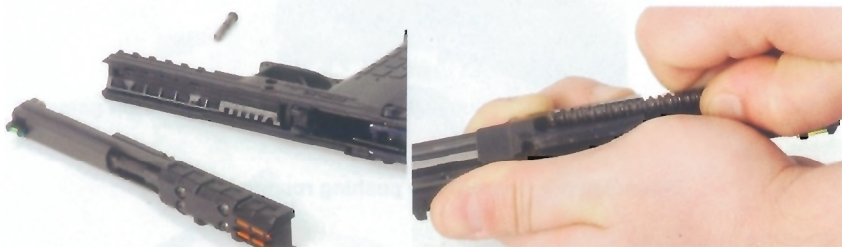

Slide assembly removed from grip assembly and compressing the recoil springs



Removing the recoil spring assembly and the buffer

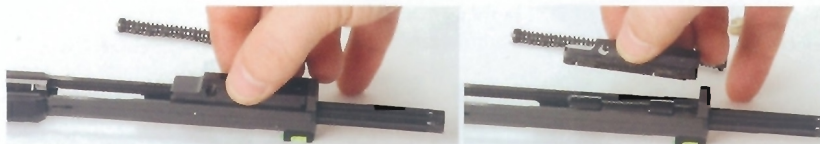

Sliding the barrel block forward and lifting it out

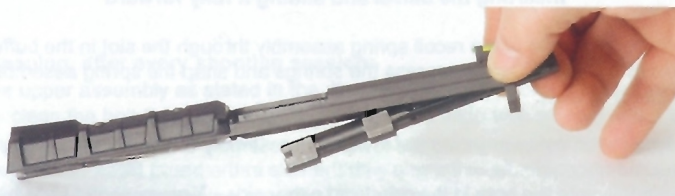

Barrel now can be removed from the slide



Fully Field Stripped

ASSEMBLY

Insert the barrel into the slide. Be sure the large end of the barrel tabs are oriented out of the slide, or the barrel will not sit level. Slide the barrel all the way forward, so the muzzle sticks out of the front of the slide. Place the barrel block into the slide rails through the cutouts at the front of the slide. The recoil spring slot should be oriented forward, it will not go in backwards. You may have to jiggle the barrel slightly to allow the barrel block to drop fully into the slide rails. Now push the barrel block all the way back towards the extractors. Insert the buffer into the two slots for it at the front of the slide. The buffer should be oriented so the rounded edges point to the front of the slide, it will not fit correctly if put in backwards. **DO NOT FORGET THE BUFFER, NEVER FIRE THE PMR-30 WITHOUT A BUFFER INSTALLED.**

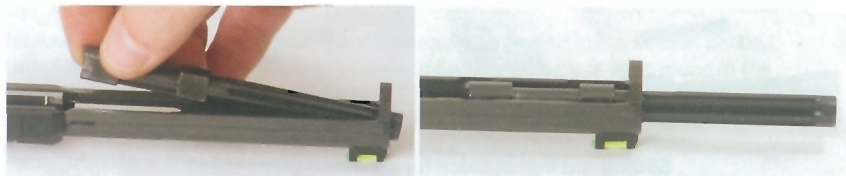

Inserting the barrel and sliding it fully forward

Slide the squared off end of the recoil spring assembly through the slot in the buffer, and into the hole in the slide. Then compress the springs and snap the spring assembly into the slot in the barrel block.

Slide the upper slide assembly onto the lower grip assembly and pull it all the way back to line up the assembly pin hole in the grip with the hole in the barrel block. Push the assembly pin fully into the hole in the grip from either side. Now cycle the slide by hand to be sure it moves smoothly.

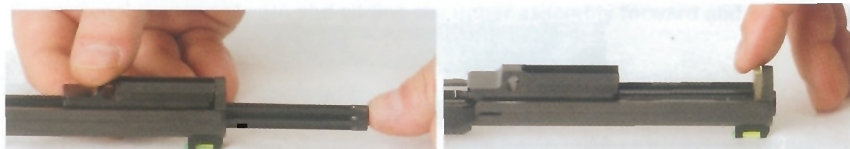

Dropping the barrel block in, sliding it back, and inserting the buffer



Snapping the captive recoil springs in place



Sliding the upper assembly back on the grip and inserting the assembly pin

SIGHT ADJUSTMENT

The PMR-30 pistol's rear sight is not adjustable, but the front sight is drift adjustable for windage. However this adjustment requires special tools and techniques in order to not damage the front sight or the firearm's finish. Please consult with a local gunsmith before attempting front sight adjustment.

MAINTENANCE

Your firearm is a precision instrument and to ensure reliable function, it is necessary to follow a routine maintenance procedure. After firing your pistol, be sure to unload it following the procedure outlined in the section entitled "Unloading" before any cleaning or maintenance procedure.

CLEANING SOLVENT WARNING:

Never use automotive brake cleaner, or any solvent not designed for polymer firearms on the polymer parts of the firearm including, but not limited to the buffer and front and rear sight tubes. Doing so will damage or destroy the parts and this abuse will not be covered by any warranty. Always use polymer-safe solvents designed for firearms when cleaning polymer firearm parts.

Routine cleaning, after every shooting session:

Remove the upper assembly as stated in the disassembly section of this manual. Thoroughly clean the bolt face and all interior sides of the slide with solvent and a brush. Brush the barrel bore and chamber with a good powder removing solvent and bore brush. Wipe the areas clean with patches or a swab. Using a small brush dipped in solvent, remove all deposits from around the breech of the barrel and slide, as well as the insides of the slide and barrel block (including the rails, chamber, and adjacent areas) which have been subjected to powder or primer residue. Remove any residue on the receiver with light brushing and a polymer safe solvent. After cleaning the entire gun, use a cloth to apply a light coating of high quality gun oil to all external and internal surfaces and wipe clean. There should only be a light film of oil on the slide and barrel. Reinstall the upper assembly and firearm as stated in the assembly section of this manual. **DO NOT FORGET TO REINSTALL THE BUFFER.** Manually cycle the bolt back and forth to check the function of the firearm. If any parts are damaged or badly worn or the firearm does not work correctly the firearm should not be fired and should be returned to Kel-Tec for servicing immediately.

LUBRICATION WARNING:

Firing a firearm with oil, grease, or any other material even partially obstructing the bore may damage the firearm and injure the shooter and those nearby.

Do not spray or apply lubricants directly on ammunition. If the powder charge of a cartridge is affected by the lubricant, it may not be ignited, but the energy from the primer may be sufficient to push the bullet into the bore where it may become lodged. Firing a subsequent bullet into the obstructed bore will damage the firearm and may injure the shooter and bystanders. Use lubricants properly. You are responsible for the proper care and maintenance of your firearm.

WARNING:

It is not recommended that you disassemble the grip; the hammer spring is constantly under tension and can easily injure you or others. If the need arises to lubricate the trigger assembly do so through the top of the receiver.

SERVICE

Should your firearm require adjustment, or repair, it should be returned unloaded to the factory. Always remove any non-factory accessories including scopes and muzzle devices before sending in for repairs. **Kel-Tec CNC IND INC cannot be held responsible for lost or damaged accessories sent in with the firearm.** In shipping the firearm, be sure to adhere to the following rules:

Individuals who wish to return the firearm for service can do so by shipping via UPS prepaid. No return authorization number is required.

Include a letter of instruction, full name, address, phone number, email, and the gun's serial number. Retain a copy of the serial number for your records to use in tracking your repair. This will insure prompt service and handling once your firearm has been received. You will receive a quotation for anything other than warranty work. You will be notified of full charges and no work will commence before receiving your approval of our quotation if non-warranty work is necessary. Please see the warranty page at the end of this manual or contact Kel-Tec directly for more details. All quotations are payable by C.O.D., VISA, M.C. or money orders only. No personal checks accepted.

WARRANTY

This warranty is granted by Kel-Tec CNC Industries, Inc. P.O. Box 236009, Cocoa, FL 32923. This lifetime warranty is effective from the date of purchase and applies to the original owner of a Kel-Tec firearm.

Kel-Tec firearms are warranted to be free from defects in material and workmanship. Any such defects of which Kel-Tec receives written notice by the original owner, will be remedied by Kel-Tec without charge within a reasonable time after such notification and delivery of the product as provided below.

Warranty claims (in writing) and the gun concerned should be delivered (transportation charges pre-paid) to:

Kel-Tec CNC, Inc
Service Department
1475 Cox Road
Cocoa, FL 32926.

No return authorization number is required. In addition, a copy of a bill of sale in the owner's name, or a copy of ATF Form 4473, indicating date of purchase must be included.

In order to expedite service, warranty claims should state the model and serial number of the gun concerned and a description of the difficulty experienced. It is recommended that shipments be insured by the owner, since Kel-Tec will accept no responsibility for loss or damage in transit.

Transportation and insurance charges for return to owner will be paid by Kel-Tec if the claim is covered by the warranty.

Under no circumstances shall Kel-Tec be responsible for incidental or consequential damages with respect to economic loss or injury or property damage, whether as a result of breach of express or implied warranty, negligence or otherwise. Some states do not allow the exclusion or limitation of incidental or consequential damages, so the above limitation or exclusion may not apply to you.

Kel-Tec will not be responsible for defects resulting from careless handling, unauthorized or unsafe adjustments or modifications, non-standard, defective, or improper ammunition, corrosion, neglect, fire damage, water damage, theft, abuse, ordinary wear and tear, or unreasonable use.

KEL-TEC CNC INDUSTRIES INC.
1475 COX ROAD
COCOA FL 32926
321-631-0068
www.kel-tec-cnc.com

"THE USE OF A LOCKING DEVICE OR SAFETY LOCK IS ONLY ONE ASPECT OF RESPONSIBLE FIREARM STORAGE. FIREARMS SHOULD BE STORED UNLOADED AND LOCKED IN A LOCATION THAT IS BOTH SEPARATE FROM THEIR AMMUNITION AND INACCESSIBLE TO CHILDREN AND OTHER UNAUTHORIZED PERSONS."



OWNED



MADE



PARTS ©