



# Operator's Manual



Semiautomatic Rifle

**SL8-5**

Caliber .223 Rem.

## Table of contents

Safety notes	2
Description	3
Subassemblies	6
Notes on use	14
Handling and operation	15
Filling of magazine	15
Emptying of magazine	15
Loading of SL8-5	16
Reloading of SL8-5	18
Firing	19
Faults and stoppages, causes, remedies	20
Principle of operation	22
Disassembly of SL8-5	24
Reassembly of SL8-5	26
Adaptation of buttstock	29
Sight adjustment	32
Sight pictures	34
Optical sight adjustment	38
Care	40
Accessories	41
Special purpose accessories	42
Specifications	43
Parts list	44

# Operator's Manual

## Semiautomatic Rifle **SL8-5**

Caliber .223 Rem.

## Safety notes

### The following safety notes are to be heeded on principle:

- When handling rifles special caution is necessary as position and direction of the rifle can be changed easily.
- Carefully read this operation manual before handling the rifle. Only use the rifle after you have understood these instructions.
- Observe all notes on handling and operation. Failure to do so may result in danger to life and limb.
- Do not use the rifle if you have previously taken alcohol, drugs or medicine or if you feel physically unwell.
- Before handling, in case of stoppages and before cleaning it has to be checked whether
  - the rifle is unloaded (cartridge chamber free)
  - the barrel is free of obstructions and
  - the magazine is empty.
- When giving or taking the rifle, the rifle always has to be unloaded and the bolt must always be open.
- Always treat the rifle as if it were loaded and ready to fire.
- Never point the rifle at anyone during handling and practice. Always point the rifle into a safe direction.
- Keep your finger off the trigger when loading, unloading or otherwise handling the rifle. Always place the trigger finger against the trigger guard. The trigger may only be pulled if your sights are aimed at the target.
- Disassemble the rifle only as far as described in this manual.
- Always wear protective goggles when using the rifle. When firing, your eyes are endangered by ejected cartridge cases or cartridge cases bounced off walls.
- Always wear hearing protection when using the rifle.
- Be sure that also bystanders wear ear protection equipment.
- Only use factory-loaded and undamaged cartridges of the correct caliber.
- During firing, always hold the rifle so that your hands are not within the bolt path to avoid injuries.
- **Caution:** Always mind that the muzzle area is free during firing.
- Store the weapon and ammunition in separate places.
- The mature design of the SL8-5 rifle offers maximum safety during handling.
- Heckler & Koch do not assume any liability for events due to disregarding this manual, wrong handling, negligence, improper treatment, unauthorised part exchange and other manipulations in, with or at the rifle.
- This operator's manual is included in the scope of supply of the rifle and always has to be passed on along with the rifle.

## Description

The HK SL8-5 semiautomatic rifle of cal.223 Remington is the civilian target version of the G36 Assault Rifle of the Federal German Armed Forces.

The SL8-5 is a semiautomatic gas-operated weapon with rotating bolt head. Its receiver, buttstock and handguard consist of fiber-reinforced plastics.

The continuous sight rail carries a mechanical aperture sight

The sight rail enables any of a wide variety of sighting systems to be used.

The longitudinally-adjustable buttstock fitted with exchangeable cheek rest may be individually adapted to the shooter.

The heavy barrel, cold-forged together with the cartridge chamber is hard-chrome plated and screwed to the barrel extension.

The cocking lever arranged on top of the bolt and capable of being swivelled to the right or left allows the rifle to be operated easily by both right and left handed shooters.

The transparent magazine has a capacity of 10 cartridges. Optionally a 2-round magazine is available.

The automatic bolt catch allows the magazine to be replaced quickly after it has been emptied.



Fig. 1 SL8-5, left view



Fig. 2 SL8-5, right view



Fig. 3 SL8-5 with optical sight on short sight rail (special purpose accessory)



Fig. 4 SL8-5 on bipod, carrying handle with integrated optical sight and reflex sight (special purpose accessory)

## Subassemblies

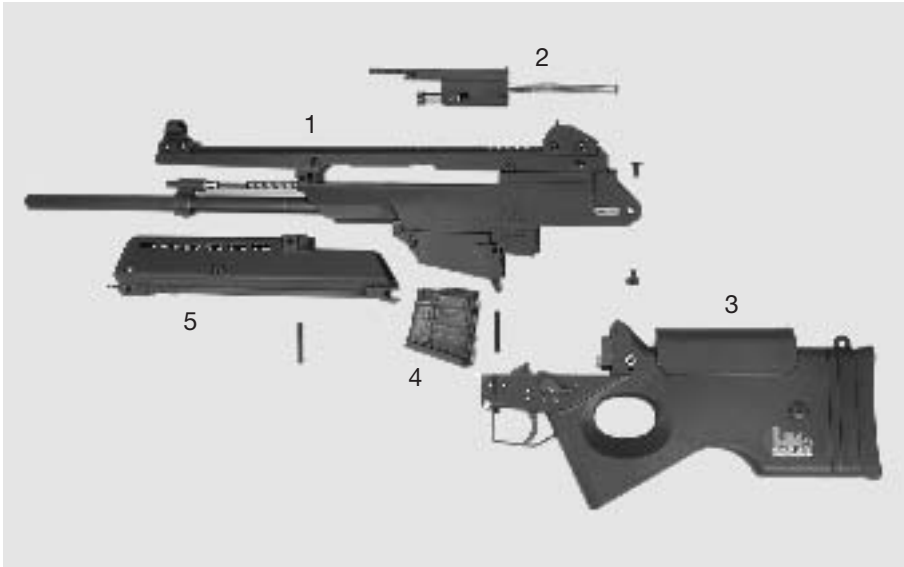

Fig. 5 Subassemblies

- 1 Receiver with barrel, gas drive unit, sight rail with sight unit
- 2 Bolt assembly with recoil spring
- 3 Buttstock, compl,
- 4 Magazine, compl.
- 5 Handguard



### Receiver with barrel, gas drive unit, sight rail with sighting attachment

The receiver consists of fiber-reinforced plastics and houses the other subassemblies.

The barrel is inserted into the barrel extension in the receiver and screwed up with a nut. The gas tap-off unit is fastened on top of the barrel. The gas piston and the push rod have been inserted into the gas tap-off unit.

The sight rail is screwed to the receiver with 3 screws. The front and rear sights are fastened on the sight rail with 2 screws, each.

The lower part of the receiver carries the supports for the handguard and the magazine well.

The right side of the receiver carries the ejection opening with the cartridge case deflector.

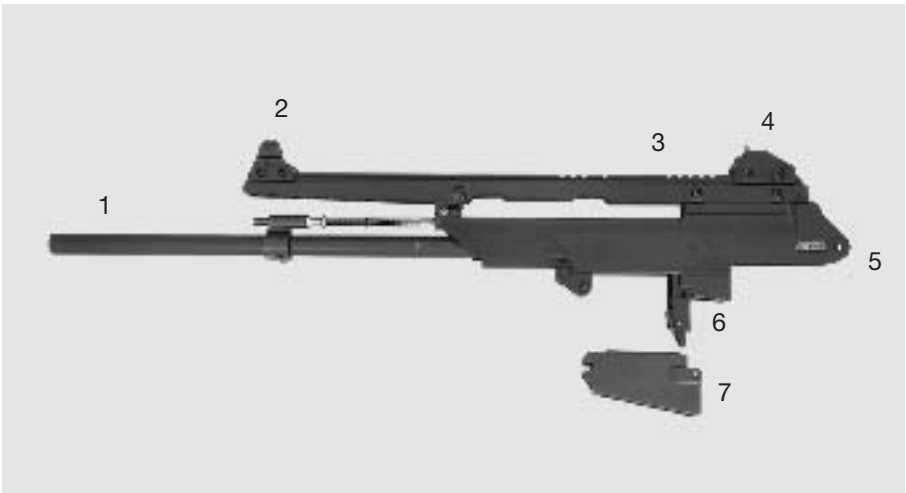

Fig. 6 Receiver with barrel, gas drive unit, sight rail with sighting attachment

- 1 Barrel
- 2 Front sight
- 3 Sight rail
- 4 Rear sight
- 5 Receiver
- 6 Magazine catch
- 7 Magazine well

### **Gas drive unit**

The gas tap-off unit is pinned to the barrel. After the bullet has passed the gas bore in the barrel, part of the propellant gases is led onto the gas piston guided in the gas tap-off unit.

The gas piston drives the bolt via the push rod. The recoil spring takes the push rod and the gas piston back to the starting position.



Fig. 6 Gas drive unit

### **Magazine well**

The magazine well is supported on support tenons in the forward part of the receiver. After having been swivelled upwards, it is supported by a locking pin together with the buttstock. When the locking pin has been removed, the magazine well is supported by the magazine catch.

### Bolt assembly with recoil spring

The bolt assembly guided in the receiver is driven by the gas piston via the push rod and in connection with the recoil spring serves for feeding and ignition of the cartridge, for extraction and ejection of the spent case after the shot. The hammer will be cocked during the rearward movement of the bolt assembly.

The bolt head is guided in the bolt head carrier and is held by the control bolt.

The forward part of the bolt head carries the locking lugs. The spring-loaded extractor is located in the recess between the locking lugs. The spring-loaded ejector is located in the bolt face opposite the extractor (fig. 10).

The firing pin is held by the locking pin.

The forward part of the bolt head carrier houses the cocking lever. It can be swivelled out both to the right and left.



Fig. 8 Bolt assembly with recoil spring

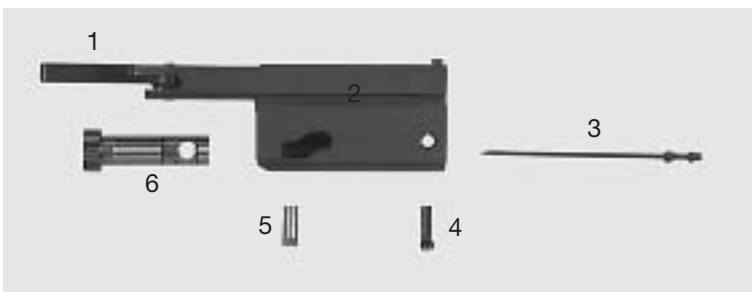

Fig. 9 Bolt components

- |                     |                 |
|---------------------|-----------------|
| 1 Cocking lever     | 4 Retaining pin |
| 2 Bolt head carrier | 5 Control bolt  |
| 3 Firing pin        | 6 Bolt head     |

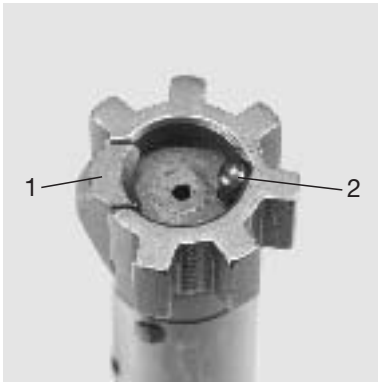

Fig. 10 Bolt head

- 1 Extractor
- 2 Ejector

### **Buttstock, complete**

The buttstock is screwed to the receiver with 2 cheesehead screws.

For individual adaptation to shooter requirements the buttstock can be adjusted longitudinally and the cheek rest in height through the use of exchangeable inserts.

The forward part of the buttstock carries the trigger and safety mechanisms.



Fig. 11 Buttstock, compl.



Fig. 12 Cheek rest, cheek



Fig. 13 Butt plate with exchangeable spacer

## Trigger mechanism

The SL8-5 has a letoff-point trigger with a trigger pull of approx. 18 N.

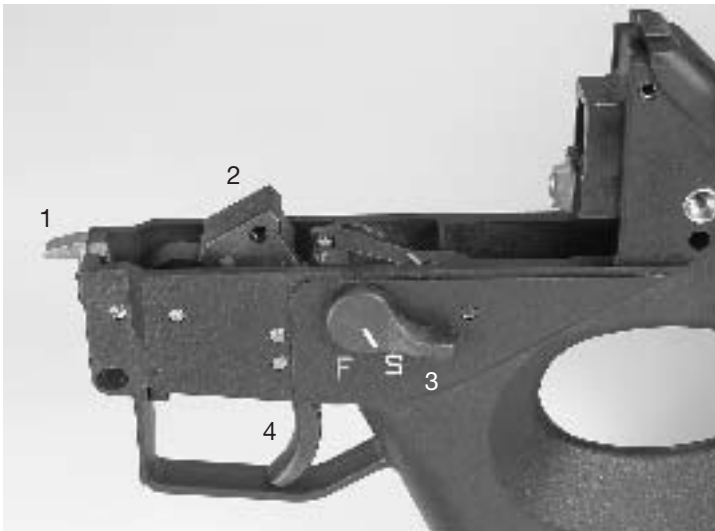

Fig. 14 Trigger mechanism

- 1 Catch
- 2 Hammer
- 3 Safety
- 4 Trigger

## Use of the safety

The safety of the trigger mechanism is ambidextrous and has two positions, "S" = Safe and "F" Fire.

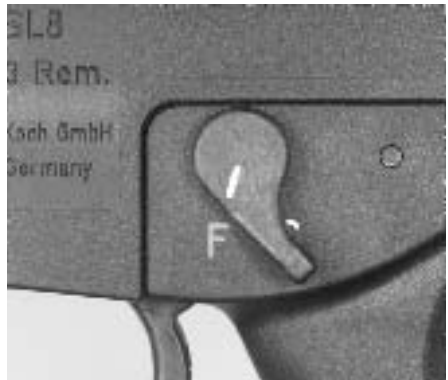
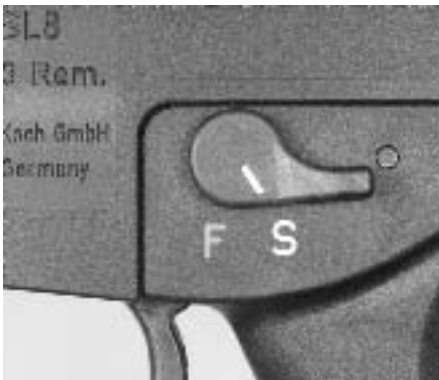

Fig. 15 Positions of the safety lever "S" = Safe and "F" Fire

## Handguard

The removable handguard surrounds the barrel and the gas drive unit. It is supported against the receiver and fastened with a locking pin. The eyebolt also serves as an axle for the bipod (special purpose accessory).



Fig. 16 Handguard with eyebolt

## Magazine

The transparent plastic magazine has a capacity of 10 cartridges. The contents of the magazine can be recognized from the outside.



Fig. 17 Magazine

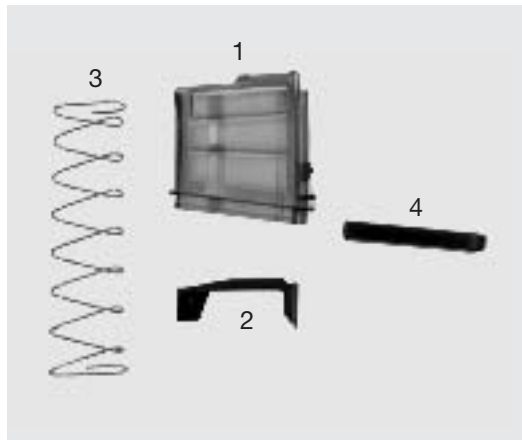

Fig. 18 Magazine, disassembled

- 1 Magazine housing
- 2 Follower
- 3 Follower spring
- 4 Magazine floor plate

## Notes on use:

### Ammunition and accuracy

HK guarantees a good accuracy with the use of suitable ammunition according to product information HK number 160/98.

Reloaded ammunition may not exceed the permissible max. gas pressures acc. to C.I.P. and official bulletin.

Reloading data of the propellant and bullet manufacturers are to be taken into consideration.

### Sight rail

The sight rail may not be used as a carrying handle.

Except for loading and unloading, no fingers may be in the opening between the sight rail and the receiver.

With the bolt locked open and the magazine removed, a blow against the buttstock might close the bolt and catch the fingers.

### Handling safety

Compared to the basic military version, the SL8-5 trigger pull has been essentially reduced. When handling the weapon in loaded condition, improper use, such as extreme blows against or drops of the weapon, thus have to be avoided.

**Attention!** For all selfloading weapons, the rule applies that the grip is to be held tightly during firing so the trigger finger can follow the weapon movement. If the trigger finger does not follow the weapon movement, the weapon movement might cause another shot to be fired.

Due to design reasons, a slight tapping of the primer is possible when a round is loaded into the chamber. This, however, will not cause cartridge ignition even if the same cartridge is loaded into the chamber repeatedly.

Multiple feeding of one and the same cartridge should be omitted as there is the danger of the bullet being loosened from the cartridge case.



## Handling and operation

### Filling of magazine

- Tightly grasp magazine
- slide individual cartridges one by one below the magazine lips.

**Note:** The magazine has a capacity of 10 cartridges. As indicated by the figure 10 and a cartridge symbol on the top right of the magazine, with the magazine filled the uppermost cartridge in the magazine has to be on the right.



Fig. 19 Filling of magazine



Fig. 20 Magazine filled

### Emptying of magazine

- Tightly grasp magazine
- slide cartridges out of magazine and catch them.

## Loading of the SL8-5

Starting situation: There is no magazine in the weapon, the bolt is closed (locked).

- Put the rifle on "SAFE"!
- Insert a filled magazine into the magazine well until the magazine catch audibly clicks into place.

The rifle is now partially loaded with the safety on.

- Swivel cocking lever outwards, pull back bolt as far as it will go and let it snap forward (do not lead bolt forward by hand)



Fig. 21 Retract bolt

Alternatively:

- swing out cocking lever, retract bolt as far as it will go and hold it there
- push catch upwards



Fig. 22 Push catch upwards

- insert filled magazine into magazine well as far as it will go
  - swivel cocking lever outwards, pull back bolt as far as it will go and let it snap forward (do not lead bolt forward by hand).
- The rifle is now loaded and with the safety on.

## Reloading the SL8-5

Starting situation:

- The magazine has been emptied
- the bolt is held by the catch
- put the rifle on "SAFE"
- push magazine catch forwards and remove empty magazine



Fig. 23 Push magazine catch forwards

- insert filled magazine into magazine well as far as it will go
- swivel cocking lever outwards, pull back bolt as far as it will go and let it snap forward (do not lead bolt forward by hand).

The rifle is now loaded and with the safety on.

## **Bolt closing aid**

If required, the cocking lever can also be used as a bolt closing aid.

To do so:

- Swivel cocking lever outwards and push cocking lever against receiver (cocking lever will remain in the swivelled out position)
- use cocking lever to push bolt forwards until it is completely locked
- then pull cocking lever outwards and allow it to snap back into starting position (direction of fire).



Fig. 24 Push cocking lever inwards (closing aid)

## **Firing**

- Set the safety of the rifle to "FIRE"
- pull trigger.

On interruption or cessation of fire, immediately put the safety of the rifle to "SAFE".

## **Faults and stoppages, causes, remedies**

In the event of stoppages on the rifle, it is to be considered as loaded until the condition of the weapon has been checked and determined and the fault has been eliminated.

During the elimination of stoppages, safety guidelines are to be taken into account.

With stoppages such as failure of round to ignite, incomplete locking of bolt, or failure to eject the spent case, first of all the following steps are to be taken:

1. Put the rifle on "SAFE"
2. Remove magazine
3. Unload rifle
4. Ensure that barrel, cartridge chamber and receiver are free
5. Then determine and eliminate the cause of the stoppage.

The items listed in the following do not cover all stoppages theoretically possible.

The causes indicated do not apply exclusively.

<b>Stoppage/Fault</b>	<b>Cause</b>	<b>Remedy</b>
Cartridge not ignited	Ammunition fault (dud round ) Firing pin damaged or broken Hammer spring damaged or broken	Recock  Replace firing pin  Take rifle to maintenance shop
Bolt did not open after the shot	Cartridge case stuck in chamber because it is deformed or the cartridge chamber is dirty	Unload. Retract bolt to eject spent case. Clean if fouled Should it be impossible to extract round, lock bolt open by catch and eject case from chamber via cleaning rod and ejection adapter
Gas drive unit fouled or defective		Clean gas piston if required replace gas piston
Cartridge case not extracted or ejected	Cartridge chamber dirty ejector or extractor broken	Clean cartridge chamber Take rifle to maintenance shop
Ejector or extractor spring damaged		Take rifle to maintenance shop
Insufficient bolt recoil		Unload Retract bolt via cocking lever to eject Spent case Check for smooth running and check cartridge chamber for fouling. Clean if required.
No cartridge fed by bolt	Magazine not inserted properly Magazine loose  Magazine lips damaged Magazine well damaged Follower spring lame	Insert magazine properly  Check magazine catch and notches on magazine If required, replace Replace magazine Replace magazine well Replace follower spring
Bolt not fully closed	Cartridge chamber dirty Barrel extension fouled	Clean cartridge chamber Clean barrel extension
Cartridge not fully fed	Cartridge damaged Recoil spring lame Improperly cocked	Recock Replace recoil spring Allow cocking lever to snap forward. On releasing cocking lever do not lead It in its forward movement
Bolt does not open after the last shot	Magazine spring lame  Catch damaged	Replace magazine, follower stay Take damaged one to maintenance shop Take rifle to maintenance shop
Trigger cannot be pulled with the hammer cocked	Sear broken or compression spring lame	Take rifle to maintenance shop
Magazine stuck in magazine well	Magazine damaged Magazine catch defective	Replace magazine Take rifle to maintenance shop

## Principle of operation

### Bolt assembly locked

Via the barrel nut, the barrel is permanently screwed to the barrel extension in the receiver. The bolt head carrier houses the bolt head. In the bolt head carrier, the bolt head is supported so that it can rotate and move longitudinally.

In the locked condition, the bolt head carrier is in its forwardmost position. In the barrel extension, the bolt head is turned in such a way that its locking lugs are behind the locking projections of the barrel extension.

Starting situation: The rifle is fully loaded and with the safety off.

Upon operation of the trigger, the hammer is released. It hits the firing pin which ignites the cartridge.

The propellant gases accelerate the bullet. After the bullet has passed the gas tap-off bore, part of the propellant gases flows into the gas tap-off system.

Via the gas piston and the push rod, the propellant gases push the bolt head carrier to the rear. In the process, the control bolt and control cam rotate and unlock the bolt head in the bolt head carrier.

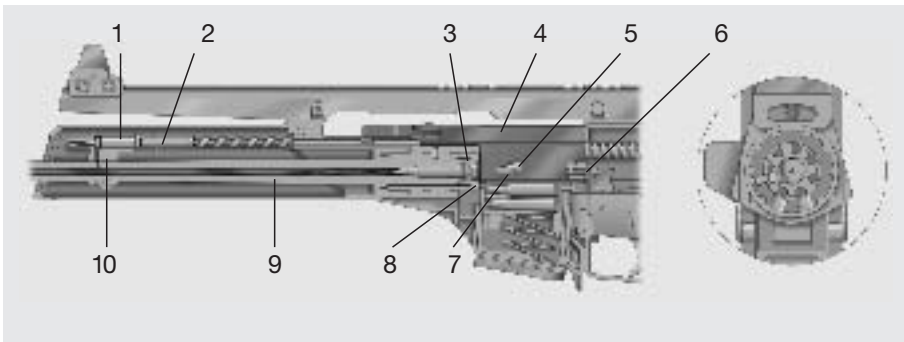

Fig. 25 Bolt assembly locked

- |                     |                       |
|---------------------|-----------------------|
| 1 Gas piston        | 6 Firing pin          |
| 2 Push rod          | 7 Control cam         |
| 3 Bolt head         | 8 Barrel extension    |
| 4 Bolt head carrier | 9 Barrel              |
| 5 Control bolt      | 10 Gas tap off system |



### Bolt assembly unlocked

The locking lugs are released. The bolt head unlocks and can withdraw from the barrel extension. The bolt head and bolt head carrier travel to the rear together.

The extractor in the bolt head extracts the spent case from the cartridge chamber. On passing the ejection opening the spring loaded ejector ejects the spent case to the right.

During bolt recoil, the hammer is cocked and the recoil spring compressed. The bolt hits the buffer in the backplate and is decelerated.

The recoil spring force moves the bolt forwards again. During the forward movement of the bolt, the bolt head pushes the next cartridge out of the magazine into the cartridge chamber.

The bolt head moves towards the barrel whereas the bolt head carrier continues its forward movement. In the process the bolt head is rotated and locked via the control bolt and the control cam in the bolt head carrier.

Only after the bolt has been fully locked can the tip of the firing pin project from the bolt head and ignite the cartridge.

The rifle is again ready to fire.

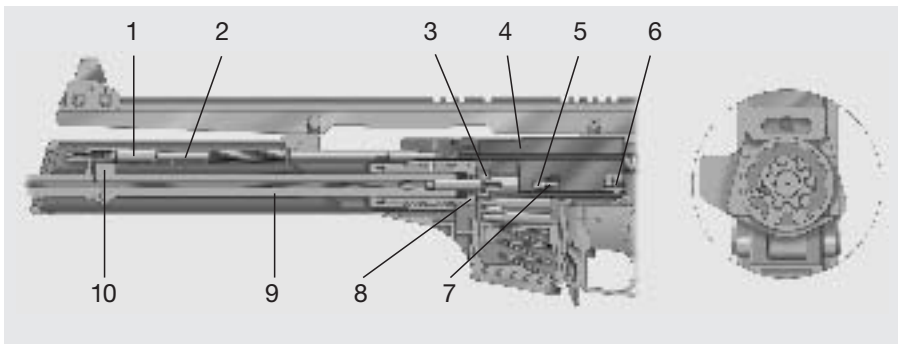

Fig. 26 Bolt assembly unlocked

- |                     |                       |
|---------------------|-----------------------|
| 1 Gas piston        | 6 Firing pin          |
| 2 Push rod          | 7 Control cam         |
| 3 Bolt head         | 8 Barrel extension    |
| 4 Bolt head carrier | 9 Barrel              |
| 5 Control bolt      | 10 Gas tap off system |

## Disassembly of the SL8-5

### Safety check

- Put the rifle on "SAFE"
- remove the magazine
- use cocking lever to retract bolt as far as it will go.
- push catch upwards. The bolt will thus be locked in the open condition
- check whether the cartridge chamber is free
- use cocking lever to retract bolt somewhat to release catch and return bolt to its forward position.

### Disassembly into subassemblies

- Use 5 mm angular screwdriver of assembly tool to undo cheesehead screws on the right and left of the receiver
- pull locking pin from the receiver
- withdraw buttstock from the receiver to the rear
- pull cocking lever backwards and remove bolt with recoil spring from the receiver
- withdraw handguard locking pin and pull handguard forwards off the receiver
- push magazine catch forwards, swivel magazine well downwards and remove.

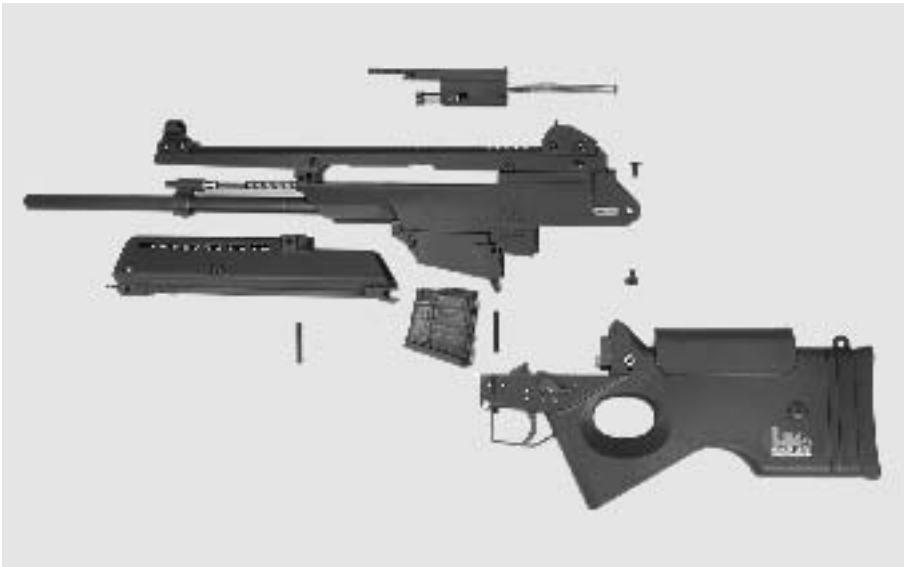

Fig. 27 SL8-5 disassembled into subassemblies

### Disassembly of push rod and of gas piston

- Pull push rod out of the gas piston to the rear against spring pressure
- swivel push rods sideways and detach forwards
- remove gas piston.



Fig. 28 Pull out push rod



Fig. 29 Removal of gas piston

### Disassembly of bolt assembly

- Push out locking pin to the left (for example using gas piston)
- remove firing pin to the rear
- pull out control bolt to the left
- remove bolt head forwards.

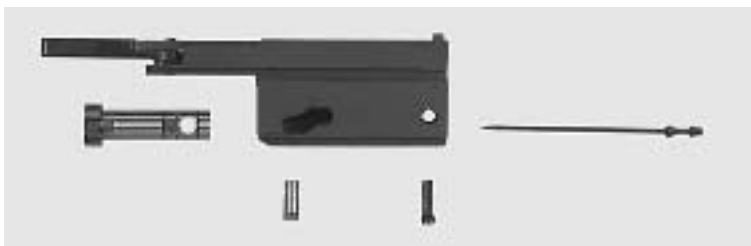

Fig. 30 Bolt assembly disassembled

## Reassembly of SL8-5

### Assembly of bolt assembly

- From the front, insert bolt head, extractor to the right, into bolt head carrier
- insert control bolt into bolt head carrier from the left, ensuring that the flat surfaces are parallel to the direction of fire. Insert bolt head
- introduce firing pin into the bolt head carrier and bolt head from the rear
- introduce firing pin retaining pin into the bolt head carrier.

**CAUTION:** It is to be ensured that above all during reassembly of the bolt **all** components are completely and correctly assembled.

### Assembly of push rod and of gas piston

- Insert gas piston into gas tap-off unit
- insert push rod into receiver from the front, pull backwards against spring pressure and insert into support in the gas piston.

### Assembly of subassemblies

- From the front, slide handguard onto receiver over the barrel
- insert locking pin into handguard
- insert forward part of magazine well into support tenon and swivel upwards until magazine catch clicks into place
- insert bolt assembly with recoil spring into the receiver from the rear
- mount buttstock onto receiver from the rear, (hammer cocked) and insert locking pin into receiver
- screw buttstock onto receiver right and left, using cheesehead screws
- put the rifle on SAFE!
- Carry out a check of functioning (cock, check catch function, put safety on FIRE, pull trigger, put safety on SAFE)
- insert magazine.

### Disassembly of magazine

- Compress lower part of magazine housing until the forward catch is free
- slide magazine floor plate to the rear
- compress lower part of magazine housing until the rear catch is free
- slide off magazine floor plate to the rear
- **Caution:** Magazine floor plate is under spring tension, therefore protect magazine floor plate against springing out with your thumb.
- Remove follower spring and follower from the magazine housing.



Fig. 31 Compress magazine housing



Fig. 32 Remove magazine floor plate

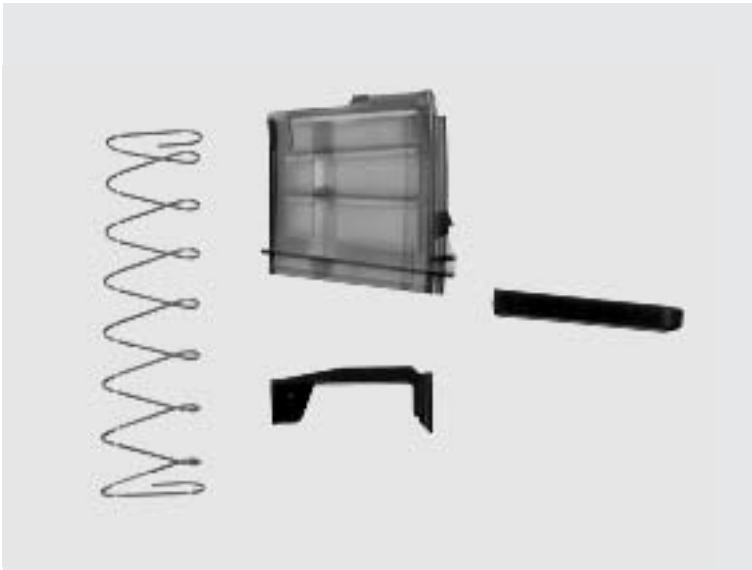

Fig. 33 Magazine disassembled

**Assembly of magazine**

- Insert follower and follower spring into the magazine housing from below
- slide magazine floor plate onto magazine housing from the rear
- slide magazine floor plate forwards over both catches as far as it will go.

## Adaptation of buttstock

The cheek rest and buttstock may be individually adapted to the shooter by the use of spacers.

### Length adjustment of the buttstock

- Using 5 mm angular screwdriver of assembly tool, unscrew cheesehead screws left and right from buttstock
- remove butt plate with spacers from the buttstock to the rear



Fig. 34 Removal of butt plate with spacer

- according to individual requirements, place the required number of spacers onto the butt plate (1 spacer = 10 mm. a maximum of 50 mm possible)
- insert butt plate with spacers into buttstock



Fig. 35 Insertion of butt plate into buttstock

- screw butt plate onto buttstock with cheesehead screws right and left.



### **Cheek rest**

- Unscrew lenshead countersunk screw of cheek rest and cheek from buttstock using Phillips head screwdriver of assembly tool
- depending on individual requirement either place only the cheek rest or cheek rest with up to 2 additional cheeks onto buttstock.
- tightly screw cheek rest and cheek(s) onto buttstock with lenshead countersunk screws.



Fig. 36 Adapt cheek rest and screw up tightly

## Sight adjustment

If the point of impact has to be corrected, this will be done by adjustment of the rear sight.

The diopter sight will be zeroed in to hit the point of aim at 100 meters.

For purposes of the adjustment set flip-type rear sight to 100 meters.

## Height adjustment

- If the weapon's point of impact is too high, turn the upper adjusting screw clockwise with 2.5 mm angular screwdriver
- if the weapon's point of impact is too low, turn the upper adjusting screw to the left.

1 clockwise revolution of the height adjustment screw raises /counterclockwise revolution lowers the point of impact by approximately 11 cm at a zeroing-in range of 100 m.



Fig. 37 Height adjustment

### Lateral adjustment

- If the weapon's point of impact is too far right, turn the side adjusting screw counterclockwise to the left with 2 mm angular screwdriver
- if the weapon's point of impact is too far left, turn the side adjusting screw clockwise to the right.

1 click of the windage adjustment screw changes the point of impact by approx. 3.3 cm at a zeroing-in range of 100 m.



Fig. 38 Height adjustment

# Sight pictures

## Aiming with the aperture sight

Before aiming, the sight is to be adjusted to the corresponding target distance. The target is aimed at via the aperture bore and via the front sight.

It is to be noted that the target should appear to be resting in the middle of the upper edge of the front sight post.

At the same time, the inner circle of the aperture bore and the outer circle of the front sight holder have to form a clearly visible light gap.

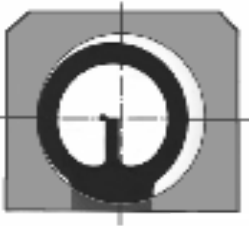
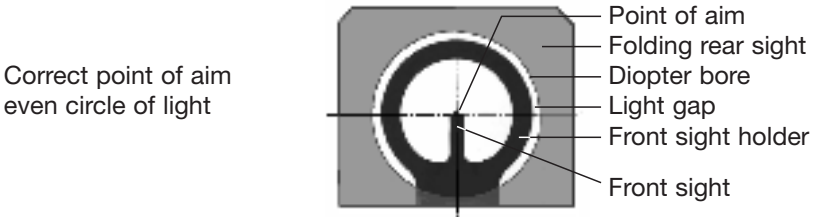

Impact as with incorrectly centered front sight = left



Impact as with incorrectly centered front sight = right

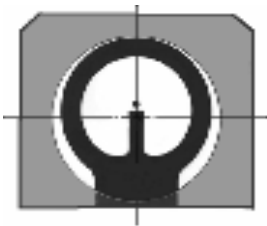

Impact as with full sight = high

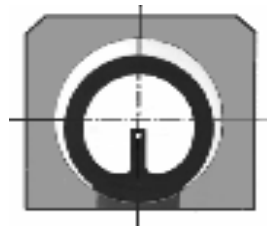

Impact as with fine sight = low

Fig. 39 Sight pictures

## Special purpose accessories

### Optical sighting units



Fig. 40 Optical sighting units

- 1 Carrying handle with integrated 3 power optical sight and reflex sight with red dot
- 2 Carrying handle with integrated 3 power optical sight
- 3 3 power optical sight

### Special purpose accessories

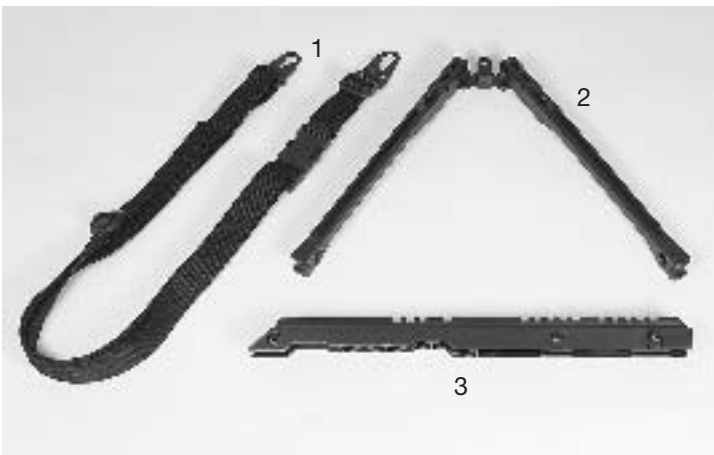

Fig. 41 Special purpose accessories

- 1 Carrying sling
- 2 Bipod
- 3 Sight rail, short

### Optical sight

Instead of the mechanical aperture sight, also the 3 power optical sight may be assembled onto the sight rail.

The optical sight is equipped with range marks from 200 to 800 meters in 200 meter steps.

### Carrying handle with optical sight

3 power optical sight integrated into carrying handle. The carrying handle is assembled onto the weapon's receiver instead of the sight rail.



- 1 Height adjustment screw
- 2 Windage adjustment screw

Fig. 42  
Optical sight assembled onto sight rail



- 1 Height adjustment screw
- 2 Windage adjustment screw

Fig. 43  
Carrying handle with optical sight assembled onto weapon receiver

### Carrying handle with optical sight and reflex sight

The 3 power Optical sight is integrated into the carrying handle.

A red dot reflex sight is assembled above the optical sight. During daylight hours, the luminous dot is activated by opening the slide of the light collector. During dusk or darkness, the slide of the light collector is to be closed and the rotary switch for the then battery powered luminous dot is to be turned to the left to the "I" position. With the illumination turned on, the luminous intensity of the luminous dot may be increased for approx. 30 seconds by pressing the rotary switch. The reflex sight serves as a snapshot sight for ranges of up to approx. 150 meters.

Replacement of battery of the reflex sight

– turn battery compartment to the left.

The battery compartment is under spring tension and is pressed out towards the rear

– withdraw battery compartment all the way

– remove Lithium battery and replace by a new one. Check correct polarity.

Battery type

– Battery "Sonnenschein" Lithium 3.6 V

SL760/S (Ø 14.5 x 50 mm)

or

– Battery "Saft" Lithium 3.4 V

VG 96945 T 1605.

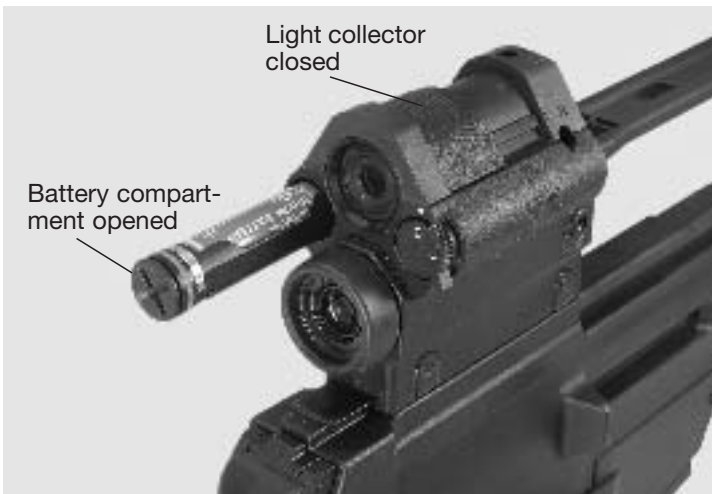

Fig. 44 Carrying handle with optical sight and reflex sight

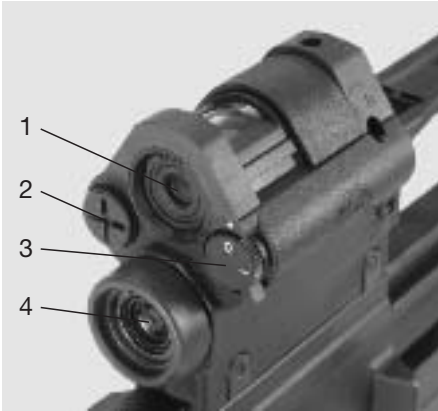

Fig. 45 Adjustment of optical sight – height correction

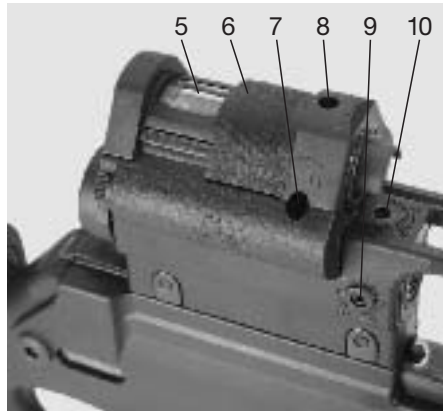

Fig. 46 Adjustment of optical sight – windage correction

- |                                 |  |
|---------------------------------|--|
| 1 Reflex sight (non magnifying) | 6 Slide                                    |
| 2 Battery compartment           | 7 Windage adjustment screw (reflex sight)  |
| 3 Rotary switch                 | 8 Height adjustment screw (reflex sight)   |
| 4 Optical sight (3 power)       | 9 Windage adjustment screw (optical sight) |
| 5 Light collector               | 10 Height adjustment screw (optical sight) |

## Optical sight adjustment

If the point of impact has to be corrected, this will be done by adjustment of the optical sight.

The optical sight will be zeroed in to hit the point of aim at 200 meters.

With a sighting-in distance of 100 meters, the point of impact will be approx. 4 cm high, at 300 meters it will be approx. 8 cm low.

### Height adjustment

- If the weapon's point of impact is too high, turn the adjusting screw counter-clockwise with 2.5 mm angular screwdriver (direction "T")
- if the weapon's point of impact is too low, turn the adjusting screw to the right (direction "H").

### Adjustment of the reflex sight

For adjustment of the reflex sight, the red dot is to be adjusted with respect to the 100 m aiming mark of the sighting-in target for the optical sight.

**Note:** One quarter turn of the adjustment screws will shift the point of impact by approx. 20 cm at 100 meters.



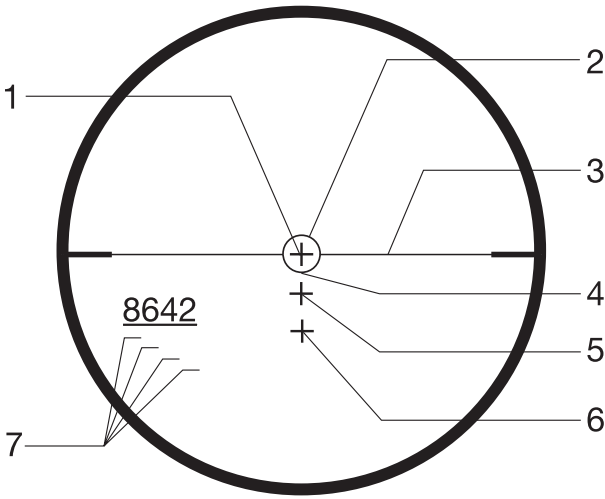

Fig. 47 Reticle of optical sight

- 1 200 meter lead mark\*
- 2 Aiming circle  $\varnothing$  1.75 m at 400 meters distance
- 3 Horizontal line to find out whether weapon is canted
- 4 Sight mark approx. 400 meters
- 5 Sight mark 600 meters
- 6 Sight mark 800 meters
- 7 Man size, height 1.75 meters at range "X"

\*If zeroed - in at 200 meters = point of impact 4 cm high at 100 meters distance  
 = point of impact 8 cm low at 300 meters distance

## Care

### Cleaning agents and equipment

The following will be used for cleaning and care of the rifle.

- HK Cleaning kit or commercially available cal. 223 cleaning kit
- pull-throughs and cleaning cloths
- chloride and acid-free cleaning or preserving agent.

Do not clean with:

- Metallic objects
- Synthetic materials, such as nylon, perlon or similar as long as the weapon is hot
- Water.

### Care

Regular cleaning and care as well as inspection will preserve the functional reliability of the weapon and increase its longevity.

### Normal cleaning

Normal cleaning is to be carried out after each firing.

- Put the rifle on "SAFE" and check whether the cartridge chamber is free
- clean fouled components and surfaces with cleaning brush and cleaning cloth
- lock the bolt open and pull oil-soaked cleaning brush through the barrel several times,  
then pull clean pull-through through the barrel and lightly oil barrel bore
- after cleaning check rifle for smooth running and proper functioning of components
- put weapon on SAFE.

### Main cleaning

The main cleaning should be carried out in intervals of approximately 1000 rounds, once a year or if the weapon is heavily fouled:

- Put the weapon on "SAFE" and check whether the cartridge chamber is free
- disassemble the SL8 into its main components
- carry out a normal cleaning

in addition:

- Clean cartridge chamber with cleaning brush
- disassemble and clean bolt assembly
- remove, clean and lubricate gas piston
- disassemble and clean magazine
- clean and oil metal components, all movable components and guideways
- reassemble components and check for functioning and smooth running
- put weapon on SAFE.

## Accessories

### HK Combination tool

The tools required for disassembly/assembly as well as for diopter/optical sight adjustment have been combined in one unit.

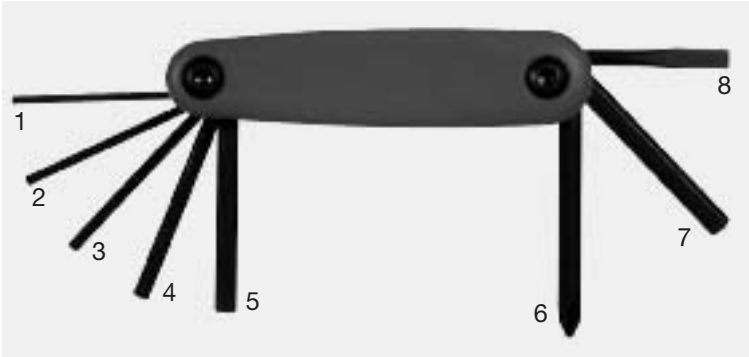

Fig. 48 HK Combination tool

- 1 Angular screwdriver 2 mm (diopter sight lateral adjustment)
- 2 Angular screwdriver 2.5 mm (diopter sight height adjustment) and adjustment of optical sight
- 3 Angular screwdriver 3 mm
- 4 Angular screwdriver 4 mm
- 5 Angular screwdriver 5 mm (assembly and longitudinal adjustment of buttstock)
- 6 Phillips screwdriver (adjustment of cheek rest)
- 7 Angular screwdriver 6 mm
- 8 Screwdriver 5 mm

## Special purpose accessories

### Bipod

The bipod is fastened to the eyebolt in the forward part of the handguard. The eyebolt has an additional catch position to hold the bipod.

After the locking levers on both bipod legs have been depressed, the bipod can be folded to lie along the handguard.



Fig. 49 Depressing the catch levers



Fig. 50 Bipod folded up

## Specifications

Principle of operation

Gas-operated weapon with rotating bolt head

### Dimensions

Caliber	.223 Remington
Overall length (adjustable)	970–1020 mm
Barrel length	500 mm
Twist of rifling	178 mm, righthand
Sight radius	447 mm
Overall height (mech. sight)	243 mm
Overall width	58 mm

### Weights

SL8-5 without magazine	Approx. 4 kg
Magazine, empty	Approx. 0.07 kg
Optical sight (special purpose accessory)	Approx. 0.14 kg
Carrying handle with optical sight	Approx. 0.22 kg
Carrying handle with optical sight and reflex sight	Approx. 0.43 kg
Bipod	Approx. 0.25 kg

### Other data

Trigger pull	Approx. 18 N
Magazine capacity	10 cartridges
Bore profile	Lands/grooves, hard chrome plated
Number of grooves	6
Sight	Diopter sight 100 m/300 m
Optical sight (special purpose accessory)	3 power optical sight
	Carrying handle with 3 power optical sight
	Carrying handle with 3 power optical sight and non magnifying reflex sight (luminous dot)

## Parts list

Item	Designation	Ident No.	Item	Designation	Ident No.
—	Semiautomatic rifle SL8-5 compl.	207 737	52	Buffer	205 452
1	Receiver	218 443	53	Elbow spring	205 428
—	Barrel, compl. (2–5)	217 906	54	Hammer	217 936
2	Barrel	217 907	55	Elbow spring	205 429
3	Nut	205 378	56	Catch disc	217 614
4	Gas tap-off unit	217 919	57	Catch piece	205 419
5	Clamping sleeve	927 605	58	Compression spring	205 418
6	Piston, compl.	205 381	59	Sear	205 439
7	Rod, compl.	205 384	60	Compression spring	217 917
8	Rail	217 947	61	Elbow spring	217 918
9	Cheesehead screw (3x)	986 785	62	Trigger	217 934
10	Washer (3x)	214 112	63	Elbow spring	205 466
11	Threaded washer (3 x)	214 113	64	Catch	214 879
—	Front sight, compl. (12–14)	217 933	—	Locking lever, compl. (65–68)	219 094
12	Front sight	217 796	65	Elbow spring	214 616
13	Front sight holder	217 795	66	Catch	219 095
14	Clamping sleeve	928 747	67	Bolt	214 615
15	Cheesehead screw (4x)	988 428	68	Locking lever	214 613
—	Rear sight, compl. (16–24)	217 925	69	Slide	219 411
16	Clamping sleeve	987 695	70	Elbow spring	205 201
17	Rear sight housing	217 991	71	Safety lever	205 437
18	Compression spring	217 504	72	Safety lever axle	217 945
19	Rear sight support	217 992	73	Axle	205 202
20	Rear sight	217 997	74	Clamping sleeve	988 371
21	Compression spring	217 518	75	Axle (3x)	205 469
22	Leaf spring	217 515	76	Axle	205 424
23	Screw	217 505	77	Elbow spring	205 369
24	Screw	217 517	78	Magazine catch	205 368
—	Bolt assembly (25–42)	217 908	79	Axle	205 469
—	Bolt head, compl. (25–32)	205 404	80	Magazine well	205 471
25	Bolt head	205 405	81	Locking pin (2x)	214 125
26	Cylindrical pin	214 644	82	Eyebolt spring	205 363
27	Extractor	205 406	83	Eyebolt	205 362
28	Compression spring	205 407	84	Handguard	218 445
29	Rubber bolt	214 662	—	Magazine, compl. (85–88) (10 cartridges)	217 929
30	Clamping sleeve	928 389	85	Magazine housing	217 930
31	Ejector bolt	205 408	86	Follower	217 931
32	Compression spring	205 411	87	Follower spring	217 932
—	Bolt head carrier (33–38)	217 909	88	Magazine floor plate	205 478
33	Compression spring	205 393			
34	Fork	205 394			
35	Bush	205 473			
36	Cocking lever	205 395			
37	Rivet	205 210			
38	Bolt head carrier	217 910			
39	Control bolt	205 390			
—	Bolt, compl. (40–41)	205 412			
40	O-ring	983 411			
41	Bolt	205 413			
42	Firing pin	205 391			
43	Recoil spring, compl.	205 445			
—	Buttstock, compl.	217 914			
44	Lenshead countersunk screw	988 372			
45	Cheek rest	217 948			
46	Cheek	217 916			
47	Buttstock	218 449			
48	Spacer piece	218 448			
49	Butt plate, compl.	218 450			
50	Cheesehead screw	217 903			
51	Backplate	218 447			

### Option

—	Magazine, compl., 2-round	219 415
—	Follower spring	219 417
—	Locking plate	219 410

### Accessory

—	HK Assembly tool	988 496
---	------------------	---------

### Special purpose accessory

—	Optical sight 3 x 4°	217 964
—	Carrying handle with optical sight 3 x 4°	217 723
—	Carrying handle with optical sight 3 x 4° and reflex sight (luminous sight)	205 458
—	Aluminium sight rail, short	209 074
—	Bipod, compl.	214 636
—	Carrying sling, compl.	214 085

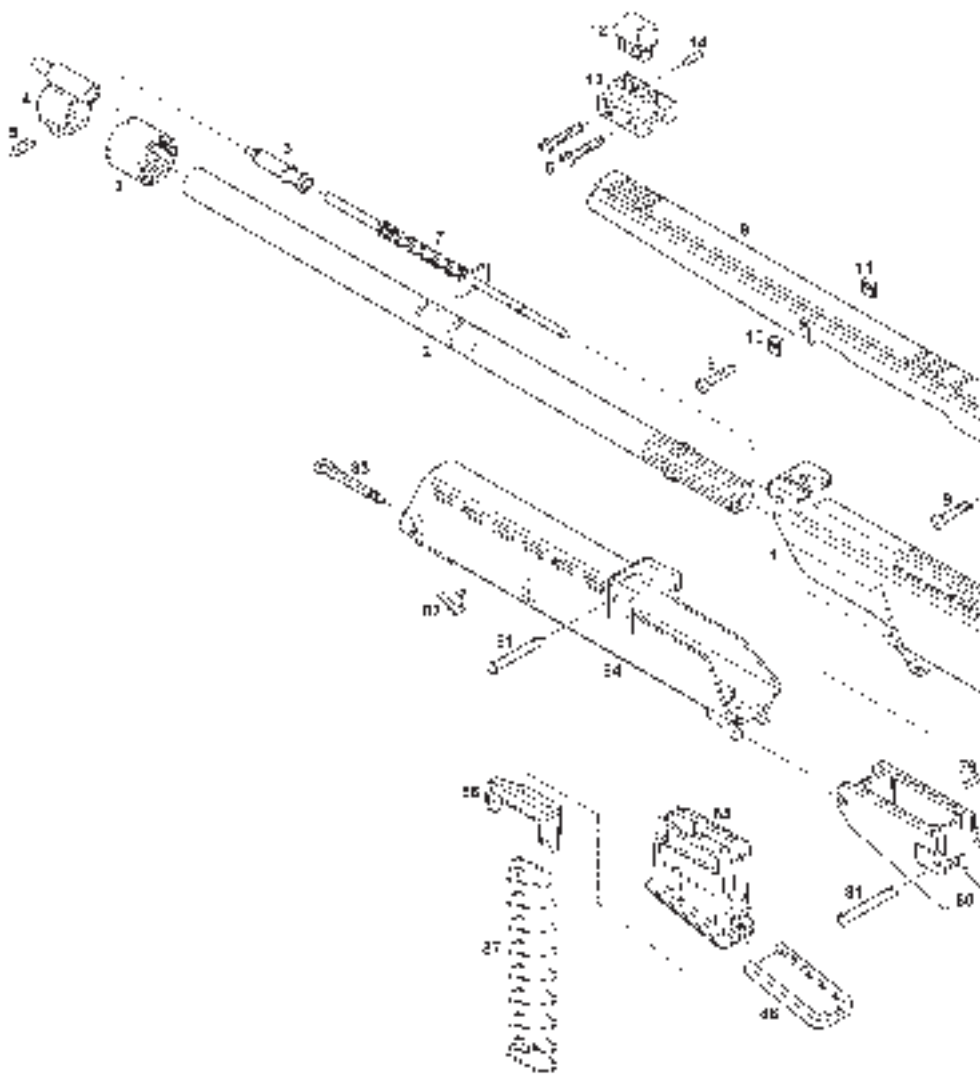

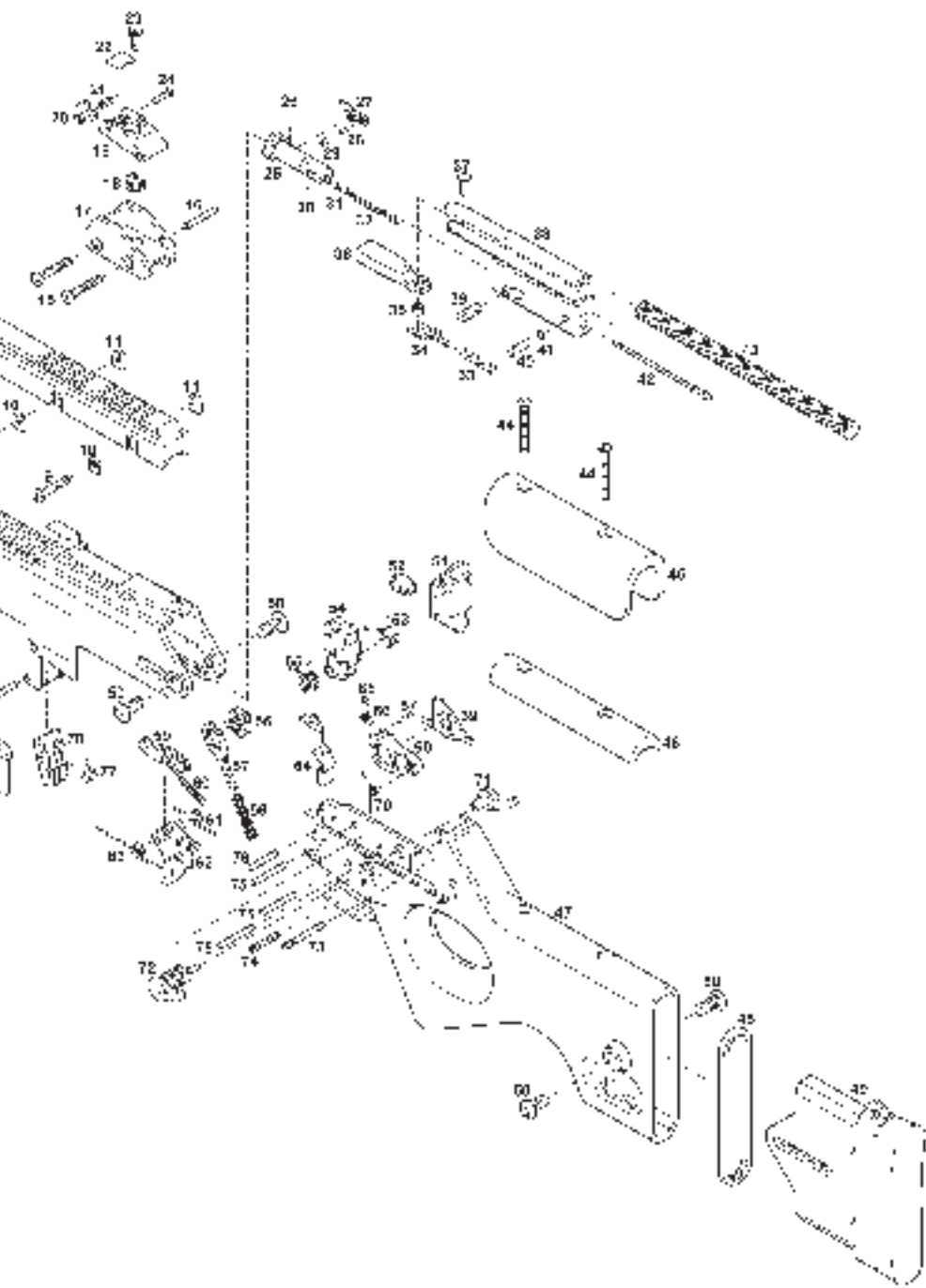







**Heckler & Koch**  
**Jagd- und Sportwaffen GmbH**  
**Postfach 1329**  
**D-78722 Oberndorf/N.**

Telephone: +49 (0) 74 23/79-0

Telefax: +49 (0) 74 23/79 22 80

E-mail: [hkinfoboard@heckler-koch.de](mailto:hkinfoboard@heckler-koch.de)

<http://www.heckler-koch.de>

© Copyright 2004

Subject to modifications

Ident-Nr. 984 431

HK 1a - 0305 / RAL

Printed in the Federal Republic of Germany

OD 0405