

Owner's Manual



Harrington &
Richardson®
Shotguns

New England
Firearms Shotguns



IMPORTANT

This manual contains operating, care and maintenance instructions. To assure safe operation, any user of this firearm must read this manual carefully. Failure to follow the instructions and warnings in this manual can cause accidents resulting in injury or death. This manual should always accompany this firearm, and be transferred with it upon change of ownership.

WARNING: KEEP THIS FIREARM OUT OF THE REACH OF CHILDREN, UNAUTHORIZED INDIVIDUALS, AND OTHERS UNFAMILIAR WITH THE SAFE HANDLING OF FIREARMS.

This firearm was manufactured by H&R 1871, LLC, and has been tested using proof and service ammunition that meets Sporting Arms & Ammunition Manufacturers Institute (SAAMI) & American National Standards Institute (ANSI) performance standards.

H&R 1871, LLC assumes no liability or responsibility for injury or damages resulting from misuse, neglect, alterations, the use of parts not of our manufacture or the use of ammunition that is faulty, handloaded, reloaded or not made to the above standards.

SERIAL NUMBER NOTICE: To assist in keeping all custom-fit barrels paired up with their respective receivers, we have etched the last three digits of the serial number on the left side of the barrel lug. If this firearm is a "combo", each additional barrel also has the last three digits of the serial number etched on the left side of the lug.

Do not attempt to mount a barrel on this firearm without ensuring the last three digits of the serial number match. Serious injury or damage to the firearm could result.

Before You Use This Firearm

It is very important that you read and understand this manual before using this firearm. Warnings should be read and heeded carefully. Also follow "The Guide to Firearm Safety", in this manual.

•**WARNING:** Your gun is shipped completely assembled and should not be used or disassembled without fully reading and understanding the instructions in this Owner's Manual.

•**WARNING:** It is a violation of federal law to alter or deface the serial number of any firearm.

Refer to the drawing below for location of the components named in this manual. This firearm has been treated with protective oils before leaving the factory and must be thoroughly cleaned before use. With the firearm pointed in a safe direction, press the release lever and, while holding it down, apply downward force on the barrel in the area of the forend to open the action (See A). Make sure the firearm is not loaded, and wipe all exterior surfaces with a clean soft cloth to remove excess oil.

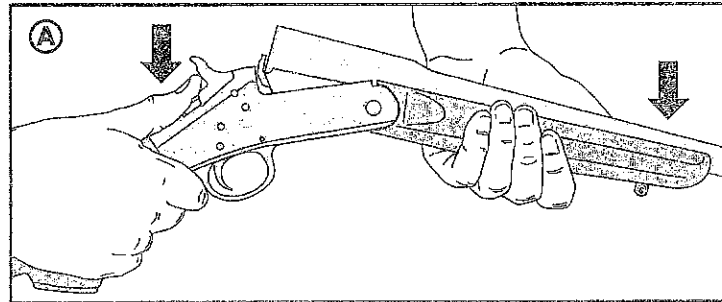
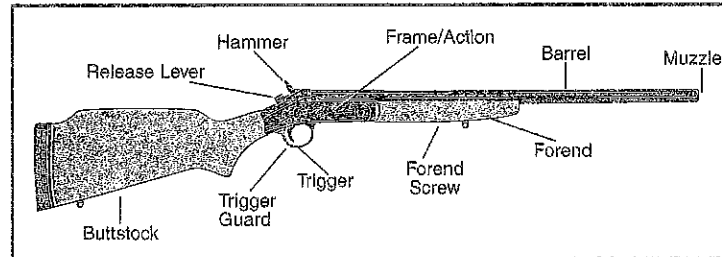

Opening the action

Using a cleaning rod and patches of the proper size for your firearm, push the patches through the bore, starting at the chamber end, until the patches come out clean. If the firearm is to be stored prior to use, lightly oil the interior and exterior metal parts. Be sure to clean again before using.

How the Firing Mechanism Operates

All shotguns and rifles manufactured by H&R 1871, LLC have a built-in "transfer bar" type mechanism. When the hammer is in the fully forward (un-cocked) position and the trigger is fully forward, there is no contact between the hammer and the firing pin (See B). **This is the normal carrying position.**

When the hammer is manually pulled back fully into the cocked position, the transfer bar moves upward to form a bridge between the hammer and the firing pin (See C). When the hammer is in the cocked position and the trigger is pulled and held, the hammer falls, striking the transfer bar, transferring the hammer blow to the firing pin (See D). As soon as the trigger is released, the transfer bar is pulled down, creating a void between the hammer and the firing pin (See B).

Loading and Firing

•**WARNING:** Use only ammunition of the correct gauge as stamped on the barrel. Never use shotshells that are longer than designated on the barrel, as this would create a serious safety hazard. Shotshells of the correct gauge that are shorter than the stamped chamber length designation are safe to use.

•**WARNING:** Wear impact-protective glasses when shooting, disassembling or cleaning firearms.

Make sure the hammer is forward (un-cocked). Open the action (See A). Look through the bore to be sure that there are no obstructions.

Place the proper shell in the chamber and close the action with enough force to assure it is securely locked in place, and cannot be opened without pressing the release lever. (You will hear a distinct "click" when the action locks closed.) Insure that the action is closed and

locked before proceeding. While avoiding contact with the trigger, raise the firearm and place the buttstock securely against your shoulder. Pull the hammer fully to the rear to the cocked position. Take careful aim and pull the trigger to fire.

NOTICE: This firearm should never be dry fired, as damage could occur to the barrel and/or firing pin.

Should you decide not to fire after cocking the hammer, carefully lower the firearm from your shoulder and keep the muzzle pointed in a safe direction. Carefully hold the hammer back securely with your thumb and pull the trigger (See E). Slowly let the hammer move forward approximately 1/4", then release the trigger (See F). Continue to guide the hammer down until it is fully forward (See B). Practice this procedure with an empty firearm until you are thoroughly familiar with it.

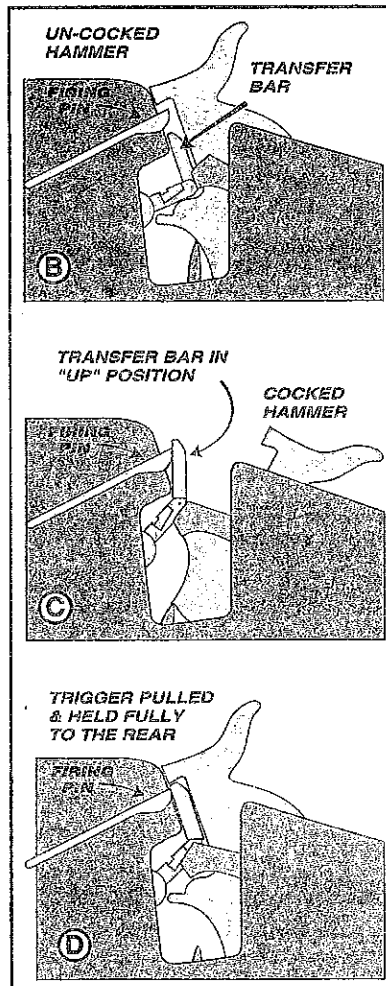

Transfer Bar System

How to Unload Your Firearm

Changing hammer position—cocked to un-cocked

This firearm has an "automatic ejection" feature which ejects both fired and unfired shells when the action is opened.

To eject a fired casing or an unfired round of ammunition from the firearm, first point the muzzle in a safe direction and ensure no one is in the ejection path. Press the release lever and open the firearm fully (See A). The empty casing or unfired round will automatically be ejected from the firearm. Using extreme care, fired or unfired cartridges can be caught as they are

ejected from the chamber. (Always handle live ammunition carefully to avoid accidental discharge.)

•WARNING: In case of a misfire, keep the firearm pointed in a safe direction and wait one minute before opening firearm.

Combination Guns with Additional Barrel(s)

To change the barrel, you need a Phillips head screwdriver. First, make sure the firearm is unloaded and pointed in a safe direction, and the action is closed. Remove the forend screw and pull the forend down and off the barrel. Holding the barrel with one hand, push down on the release lever and open the action. Remove the barrel from the frame by pushing rearward and upward on the barrel. To install a barrel, reverse the procedure above. Replace the forend and be sure the forend screw is securely fastened.

•WARNING: Do not attempt to interchange barrels from one H&R or NEF frame to another. Doing so could result in injury or death. Interchangeable barrels are available for some models, but they must be factory-fitted. Call our Service Department for details 866-776-9292

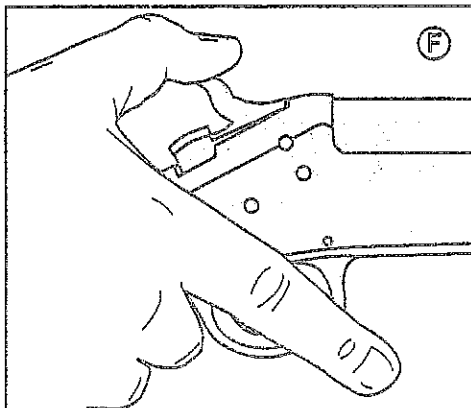
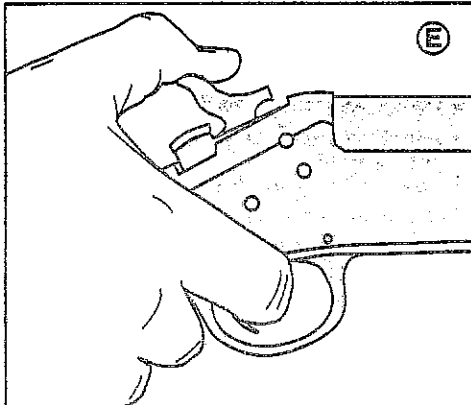

LIMITED WARRANTY

H&R 1871, LLC

TWO YEAR LIMITED WARRANTY AGAINST DEFECTS IN MATERIAL & WORKMANSHIP

This firearm warranty is good only to the ORIGINAL OWNER who has registered his ownership with H&R 1871, LLC at 60 Industrial Rowe, Gardner, MA.

WARRANTY and CERTIFICATE OF OWNERSHIP card must be completed and mailed to H&R 1871® at the above address WITHIN TEN (10) DAYS of purchase to insure the protection of the warranty. NOTICE of defect in materials and/or workmanship must be received by the company WITHIN TWO (2) YEARS from the date of purchase.

Normal wear, or damage resulting from neglect, abuse, alteration, or repairs not made or authorized by H&R 1871® or use of non-H&R parts are not covered by the warranty.

THIS WARRANTY GIVES YOU SPECIFIC LEGAL RIGHTS, AND YOU MAY ALSO HAVE OTHER RIGHTS WHICH VARY FROM STATE TO STATE.

H&R 1871, LLC'S PERFORMANCE UNDER THE ABOVE WARRANTY

1. After notice of defect in material and/or workmanship is received by H&R 1871, LLC, H&R shall send instructions for shipment of the firearm; and repairs will be made and the firearm returned within a reasonable time after the firearm is received. Cost of shipping, insurance charges, etc. involved in returning the firearm to the company shall be prepaid by the original owner.
2. Cost of parts and labor performed shall be provided without charge by H&R 1871®.
3. If H&R 1871®, after receipt of the firearm, determines that the defects in material and/or workmanship were the result of abuse and/or neglect, or otherwise not covered by the warranty set forth above, H&R shall notify such owner to that effect and give an estimate for repair. In such cases, repair, return shipping and insurance charges, etc. shall be paid by such owner.
4. In the event that H&R 1871® is unable to make warranty repairs to the firearm, it shall, within a reasonable time after its receipt, notify the owner to that effect and give him the option either to receive a replacement of the same model, if then available in its inventory, or to receive a refund, either of which, if feasible, will be made through the store of purchase.

H&R 1871, LLC • 60 Industrial Rowe • Gardner, MA 01440 U.S.A. • www.hr1871.com

WARNING

Children are attracted to and can operate firearms that can cause severe injuries or death.

Prevent child access by always keeping guns locked away and unloaded when not in use. If you keep a loaded firearm where a child obtains and improperly uses it, you may be fined or sent to prison.

ADVERTENCIA

A los niños los atraen las armas de fuego y las pueden hacer funcionar. Ellos pueden causarse lesiones graves y la muerte.

Evite que los niños tengan acceso a las armas de fuego guardándolas siempre con llave y descargadas cuando no las esté utilizando. Si usted tiene un arma de fuego cargada en un lugar en que un niño tiene acceso a ella y la usa indebidamente, le pueden dar una multa o enviarlo a la cárcel.

H&R 1871 • P.O. Box 1871 • Madison, NC 27025
Phone 866-776-9292 • www.hr1871.com

Guide to Firearm Safety

1. Read and understand the owner's manual before using a firearm.
2. If you are unfamiliar with firearms, attend a firearms safety class taught by a certified instructor.
3. Handle every firearm as if it were loaded and ready to fire.
4. Control the muzzle, and never point a firearm at anything you don't want to shoot.
5. Keep the safety on SAFE until you are ready to shoot.
6. Unless you are hunting, carry your firearm empty, with the action open.
7. Before shooting, be sure you have an adequate backstop. All ammunition is dangerous beyond your line of sight.
8. Avoid ricochets by never shooting at water or any hard, flat surface.
9. Do not run, climb, or jump over an obstacle with a loaded firearm.
10. Do not climb into or out of a tree or tree stand with a loaded firearm. Do not allow others to pass loaded firearms to you while in a tree stand.
11. Do not enter or ride in a motor vehicle with loaded firearms.
12. Do not lean a loaded firearm against anything.
13. Do not bump, drop or jar a loaded firearm.
14. Do not pull a firearm toward you by the muzzle.
15. Wear hearing protectors when shooting.
16. Wear impact-protective glasses when shooting, disassembling or cleaning firearms.
17. Avoid alcoholic beverages and drugs before and during shooting.
18. Use only ammunition of the correct gauge, caliber, size and bullet shape for your firearm.
19. Do not use damaged, dirty, modified, or improperly handloaded ammunition.
20. Keep the barrel and mechanism of the firearm free of obstructions.
21. Do not use a firearm that fails to function properly. Do not try to force a jammed action.
22. Be sure no one is in the path of ejecting shells or cartridges.
23. Do not interchange parts between firearms, and be sure disassembly and reassembly are correct and complete.
24. Before cleaning, be sure the chamber, action and magazine are completely unloaded.
25. Unload firearms before storing, transporting, or leaving unattended.
26. Store firearms and ammunition separately, locked and out of the reach of children.

Failure to follow these rules, or other instructions in this manual, can result in personal injury or death.

Health Warning: Discharging of firearms in poorly ventilated areas and handling ammunition may cause exposure to lead and/or lead compounds. Exposure may cause cancer, birth defects or damage to the kidney, nervous, blood forming and reproductive systems. Have adequate ventilation at all times, especially in confined areas. Wash hands thoroughly after shooting, handling ammunition, or cleaning a firearm. Do not eat or smoke during these activities.

Safety Warning: We strongly recommend that you take a hunter safety course, taught by a certified instructor, before you use this firearm. Your State Fish & Game Department or a local gun shop can suggest courses in your area.

Safety Warning: Keep this firearm out of the reach of children, unauthorized individuals, and others unfamiliar with the safe handling of firearms.



Harrington & Richardson

Topper® Shotgun

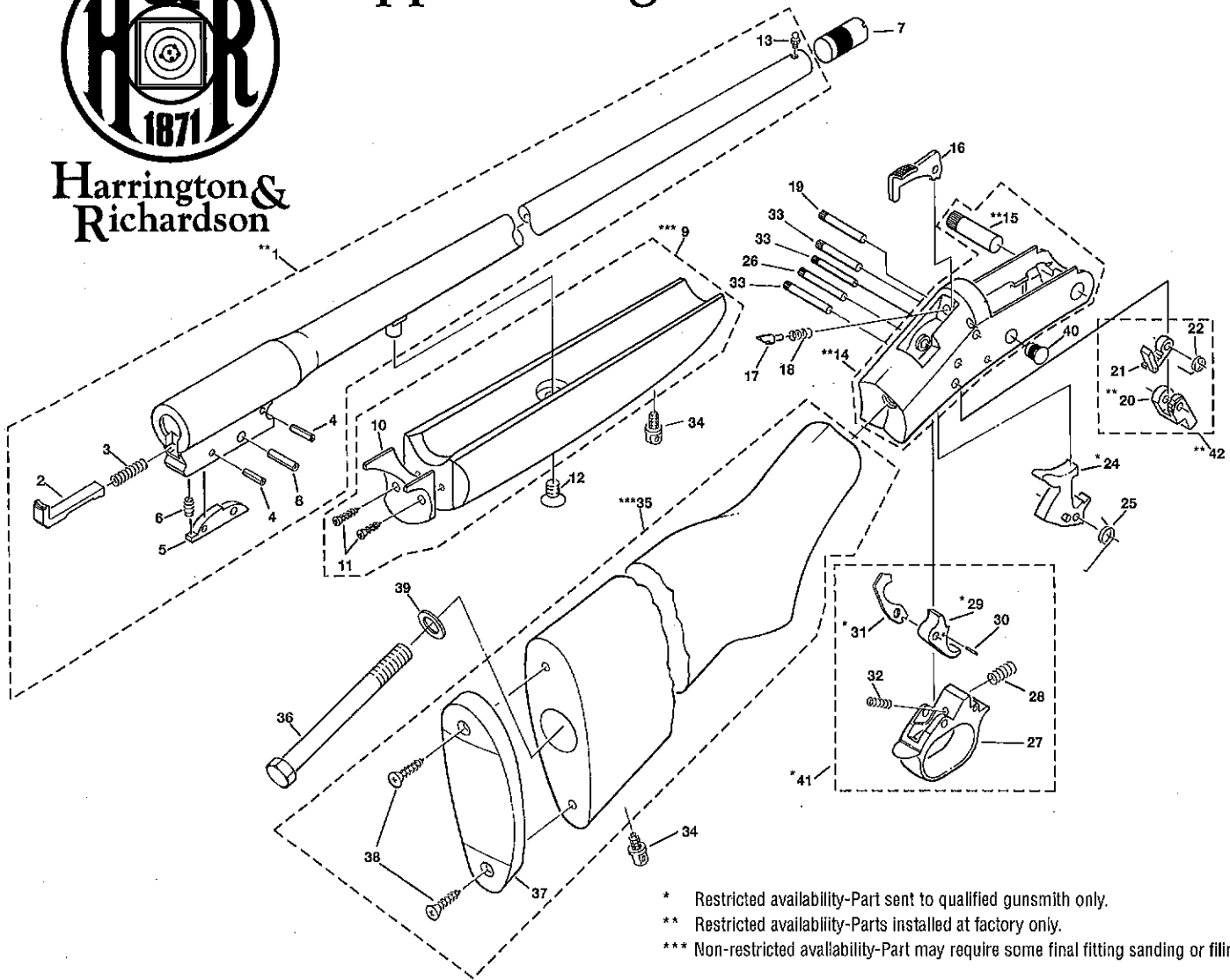

- * Restricted availability-Part sent to qualified gunsmith only.
- ** Restricted availability-Parts installed at factory only.
- *** Non-restricted availability-Part may require some final fitting sanding or filing.

ILL. NO.	PART NAME
**1	.BARREL
2	.EJECTOR
3	.EJECTOR SPRING
4	.PIN EJECTOR LATCH
5	.EJECTOR LATCH
6	.SPRING EJECTOR LATCH
7	.CHOKE
8	.EJECTOR STOP PIN
***9	.FOREND
10	.SPACER-FOREND
11	.SCREW-FOREND SPCR.
12	.SCREW-FRD.-SHORT
13	.SIGHT-FRONT
**14	.FRAME
**15	.JOINT PIN
16	.RELEASE LEVER
17	.FIRING PIN
18	.SPRING-FIRING PIN
19	.RELEASE LEVER PIN
**20	.BARREL CATCH
21	.STRIKER
22	.LIFTER SPRING

ILL. NO.	PART NAME
23	.N/A
*24	.HAMMER
25	.HAMMER SPRING
26	.TRIGGER GRD. PIN
27	.TRIGGER GRD.
28	.BARREL CATCH SPRING
*29	.TRIGGER
30	.TRIG. EXTEN PIN
*31	.TRIG EXTENSION
32	.SPRING TRIGGER
33	.HMR., TRIG, & CATCH PIN
34	.N/A
***35	.STOCK
36	.SCREW TANG
37	.BUTT PLATE
38	.RECOIL PAD
39	.SCREW BUTT PLATE
40	.WASHER TANG SCREW
41	.VIEW HOLE PIN
*41	.TRIGGER GUARD ASS'Y.
**42	.BRL. CATCH STRIKER ASS'Y.

ILL. NO.	PART NAME	TOPPER SB1-498 410 Bore	TOPPER JUNIOR SB1-258 20 GAUGE	TOPPER JUNIOR SB1-458 410 Bore	TOPPER JUNIOR CLASSIC SB1-288 20 GAUGE	TOPPER JUNIOR CLASSIC SB1-488 410 Bore
**1	BARREL	S00956	S00981	S00969	S00976	S00978
2	EJECTOR	S02705	S02703	S02705	S02703	S02705
3	EJECTOR SPRING	S01695	S01695	S01695	S01695	S01695
4	PIN EJECTOR LATCH	S01676	S01676	S01676	S01676	S01676
5	EJECTOR LATCH	S01208	S01208	S01208	S01208	S01208
6	SPRING EJECTOR LATCH	S01696	S01696	S01696	S01696	S01696
7	CHOKE	N/A	N/A	N/A	N/A	N/A
8	EJECTOR STOP PIN	S01677	S01677	S01677	S01677	S01677
***9	FOREND	S00921	S00921	S00921	S02121	S02121
10	SPACER-FOREND	S01201	S01201	S01201	S01201	S01201
11	SCREW-FOREND SPCR.	S00146	S00146	S00146	S00146	S00146
12	SCREW FRD.-SHORT	S01279	S01279	S01279	S01279	S01279
13	SIGHT-FRONT	S03432	S03432	S03433	S03432	S03433
**14	FRAME	S00698	S00698	S00698	S00695	S00695
**15	JOINT PIN	S01207	S01207	S01207	S01207	S01207
16	RELEASE LEVER	S01203	S01203	S01203	S01203	S01203
17	FIRING PIN	S01671	S01671	S01671	S01671	S01671
18	SPRING-FIRING PIN	S01697	S01697	S01697	S01697	S01697
19	RELEASE LEVER PIN	S02161	S02161	S02161	S02161	S02161
**20	BARREL CATCH	S03643	S03643	S03643	S03643	S03643
21	STRIKER	S02043	S02043	S02043	S02043	S02043
22	LIFTER SPRING	S01693	S01693	S01693	S01693	S01693
23	N/A	N/A	N/A	N/A	N/A	N/A
*24	HAMMER	S01202	S01202	S01202	S01202	S01202
25	HAMMER SPRING	S01691	S01691	S01691	S01691	S01691
26	TRIGGER GRD. PIN	S01670	S01670	S01670	S01670	S01670
27	TRIGGER GRD.	S01204	S01204	S01204	S01204	S01204
28	BARREL CATCH SPRING	S04006	S04006	S04006	S04006	S04006
*29	TRIGGER	S01205	S01205	S01205	S01205	S01205
30	TRIG. EXTEN PIN	S01191	S01191	S01191	S01191	S01191
*31	TRIG EXTENSION	S01221	S01221	S01221	S01221	S01221
32	SPRING TRIGGER	S04005	S04005	S04005	S04005	S04005
33	HMR., TRIG, & CATCH PIN	S02160	S02160	S02160	S02160	S02160
34	N/A	N/A	N/A	N/A	N/A	N/A
***35	STOCK	S00892	S00923	S00923	S00979	S00979
36	SCREW TANG	S01723	S01723	S01723	S01723	S01723
37	BUTT PLATE	S01994	N/A	N/A	N/A	N/A
37	RECOIL PAD	N/A	S00423	S00423	S00423	S00423
38	SCREW BUTT PLATE	S01722	S01722	S01722	S01722	S01722
39	WASHER TANG SCREW	S01755	S01755	S01755	S01755	S01755
40	VIEW HOLE PIN	S03636	S03636	S03636	S03636	S03636
*41	TRIGGER GUARD ASS'Y.	S02197	S02197	S02197	S02197	S02197
**42	BRL. CATCH STRIKER ASS'Y.	S02042	S02042	S02042	S02042	S02042