

This manual provides basic service and information for Certified GLOCK Armorer's and is not intended for use otherwise.

Certification can only be granted by GLOCK after attending a GLOCK armorer's school.

GLOCK cannot be held responsible for any misinterpretation of the instructions in this manual that can lead to improper functioning of the pistol.

For additional information and service guidelines, please contact GLOCK, Inc. for your nearest certified field representative.

GLOCK, Inc.

**6000 Highlands Parkway
Smyrna, GA 30082
Tel. (770) 432-1202
Fax. (770) 433-8719**

www.glock.com
www.glocktraining.com
www.gssfonline.com
www.teamglock.com

Information and specifications contained within this manual may change without notification.

This Armorer's Manual may be supplemented by Technical Bulletins.

Table of Contents

I.	Course Information.....	6
II.	Introduction.....	7
III.	Safety.....	8
IV.	Technical Specifications.....	9
	Special GLOCK Models.....	12
V.	Component Parts of GLOCK Pistols.....	13
VI.	“Safe Action” System.....	14
	Trigger Safety.....	14
	Firing Pin Safety.....	15
	Drop Safety.....	15
VII.	Pistol Nomenclature.....	16
VIII.	Unloading Procedure & Safety Check.....	17
IX.	Field Stripping.....	19
	Slide Removal.....	20
	Nomenclature of Field Stripped Pistol.....	24
	Reassembly.....	25
X.	Detail Slide Strip/Disassembly (only by a certified GLOCK armorer).....	26
	Slide Disassembly.....	26
	Removal of Firing Pin Assembly.....	27
	Extractor Depressor Plunger Assembly Removal.....	28
	Extractor Removal.....	29
	Firing Pin Safety Removal.....	29
	Slide Detail Stripped.....	30

	Further Slide Disassembly	31
	Firing Pin Disassembly.....	32
XI.	Slide Reassembly	34
	Firing Pin Safety	34
	Extractor	34
	Different Extractors for Different Calibers	35
	Extractor Depressor Plunger.....	35
	Firing Pin Assembly	36
XII.	Receiver Disassembly	37
	Locking Block Pin Removal.....	38
	Trigger Mechanism Housing Pin Removal.....	38
	Trigger Pin Removal	39
	Comparison of the Three Pins.....	40
	Slide Stop Lever Removal	40
	Locking Block Removal.....	41
	Trigger Assembly Removal.....	41
	Trigger Assembly Disassembly	42
	Connector Options	44
	Trigger Springs	44
	Trigger Pull Weight Chart	45
	Slide Lock Removal	46
	Magazine Catch Removal	47
	Ambidextrous Magazine Catch Removal.....	48
XIII.	Receiver Reassembly Procedures.....	49
	Standard Magazine Catch Replacement.....	49
	Ambidextrous Magazine Release Replacement.....	49
	Different Slide Lock Springs.....	50
	Slide Lock Spring Replacement	50
	Slide Lock Replacement.....	51
	Different Trigger Mechanism Housings with Ejector	52
	Connector Replacement.....	53
	Coiled Trigger Spring Replacement.....	53
	New York Trigger Spring.....	54
	Trigger Bar Replacement.....	54

	Trigger Assembly Replacement.....	54
	Different Locking Blocks	55
	Locking Block Replacement.....	55
	Locking Block Pin Replacement.....	55
	Trigger Mechanism Housing Pin Replacement.....	56
	Slide Stop Lever Replacement.....	56
	Trigger Pin Replacement	57
XIV.	Magazines.....	58
	Magazine Disassembly	60
XV.	Field Inspection	63
	Fully Assembled Pistol	63
	Engagement	65
	Field Inspections While Field Stripped	66
XVI.	Sight Adjustments, Removal and Installation.....	67
	Sight Mounting Tools.....	67
	Rear Sights	68
	Rear Sight Mounting Tools	69
	Rear Sight Height Chart.....	71
	Front Sight Mounting Tools	72
	Front Sight Removal and Installation	73
XVII.	Ambidextrous Controls and Operation.....	75
XVIII.	Maintenance	76
	Field Stripping	76
	Cleaning Supplies.....	76
	Lubrication	78
XIX.	Scheduled Replacement Parts	80

XX.	Loading	81
XXI.	Ammunition	82
XXII.	Service Procedures and Diagnostics	83
	Gauges	85
XXIII.	Parts Overview	87
	Optional Parts	87
	Original vs. New Parts	90
	Three Generations of GLOCK Magazines	93
	GLOCK "Safe Action" Firing Pin Marking	94

Addendum (only available for the US Version of the GLOCK Armorer's Manual)

I Course Information

All students must be citizens of the United States or have an Export License granted through the US State Department. Applicants must also be current law enforcement officers, members of the US military, or employees of a GLOCK Stocking Dealer and must furnish a written letter on agency or company letterhead stating their eligibility in accordance with GLOCK, Inc. corporate policy. Honorably retired law enforcement or military personnel may be accepted. Occasionally, others may be approved.

Please contact the Training Division if there are questions regarding any exceptions to this requirement.

Course Outline

- Safety Rules
- History
- Models/ Calibers
- Basic Operation
- Field Stripping (Disassembly and Reassembly)
- Detail Strip – Slide (Disassembly and Reassembly)
- Detail Strip – Receiver (Disassembly and Reassembly)
- Cleaning and Maintenance
- Troubleshooting
- Written Test

Course Objectives

Upon successful completion of this training, the student should have the ability to serve as an armorer for GLOCK pistols. They should be able to successfully detail disassemble and reassemble all models. Students should have all the information necessary, be able to understand all facets of the GLOCK Safe Action System and demonstrate the knowledge and ability to maintain, troubleshoot and service GLOCK handguns.

GLOCK pistols are the product of advanced technology and incorporate numerous innovative design features which result in ease of operation, extreme reliability, simple function, minimal maintenance, durability and light weight. GLOCK was the first company to successfully produce a polymer handgun receiver and marry it to a strong steel slide and barrel. The GLOCK pistol incorporates the "Safe Action" system which features three safeties and is similar to a constant double action only system.

The GLOCK "Safe Action" Trigger System offers several advantages over conventional double action pistol designs. GLOCK handguns do not need external levers to make them in either "safe" or "ready to fire" condition. The action is never set (or fully cocked) except when the trigger is pulled completely to the rear. Every GLOCK pistol has three automatic safeties and they work sequentially



off the movement of the trigger. The first safety is the **Trigger Safety**. This safety was designed to block any unwanted rearward movement of the trigger due to inertia or lateral pressure. The **Firing Pin Safety** blocks any unwanted forward movement of the firing pin that might have happened due to inertia or premature separation of the firing pin and trigger bar. The **Drop Safety** also prevents any premature disengagement of the trigger bar and the firing pin by not allowing the back of the trigger bar to move downwards unless the trigger is pressed. As the trigger is intentionally moved rearwards, the

safeties are released one by one until the pistol fires and as the trigger is released forwards, the safeties re-engage fully in sequence.

GLOCK pistols combine the safety and simplicity of revolver-like operation with a manageable constant double action only trigger pull, high magazine capacity, rapid recovery and the reduced recoil of a modern, semiautomatic pistol. The major metal components of GLOCK handguns are treated with GLOCK's special hardening surface process called "tenifer" that leaves them nearly as hard as a diamond, seals out moisture and helps prevent corrosion.

This surface hardening process penetrates the surface of the slide, barrel and GLOCK brand metal sights. The matte black finish is a final process applied to the surface making the pistol extremely resistant to abrasions and scratches. Should this black finish wear off after heavy and

extensive use, the surface still retains its corrosion protection and durability.

This manual provides maintenance and technical information for certified GLOCK armorers. It contains numerous pictures, each showing exactly how a specific procedure is to be carried out. This makes maintenance extremely simple and straightforward. A unique feature of the GLOCK pistol is that all parts are generally interchangeable within the same model. No hand fitting, filing or polishing is required or advised.

III Safety

This section in the manual is devoted to safety with all firearms and especially GLOCK pistols. Please read and be familiar with this information prior to using any firearm or performing any maintenance on GLOCK handguns. Always wear eye protection while performing maintenance and eye and ear protection while shooting.

Primary Firearm Safety Rules

1. Handle all firearms as if they were loaded.
2. Always keep the muzzle pointed in a safe direction.
3. Keep your finger off the trigger and out of the trigger guard until the sights are aligned on the target and you have made the decision to fire.
4. Be certain of your target and verify the surrounding area is safe before firing.

Additional Safety Concerns

5. When storing a firearm, it should be unloaded and secured away from minors, untrained and unauthorized persons.
6. Quality ear and eye protection should always be worn by all present when firing.
7. Use only the ammunition recommended by the manufacturer, make sure it's in good condition and is the proper caliber.
8. Make sure the firearm is in good condition and the barrel free of obstructions.
9. Thoroughly read and understand the user's manual that is supplied with your firearm and never use any firearm unless you completely understand its operation and safety features.
10. The safe and rational use of a firearm depends on common sense and proper training.
11. Never allow anyone to use firearms while under the influence of drugs, alcohol or medication.

Special Warning

If any safety proves to be ineffective, unload and do not use again until a GLOCK certified armorer has inspected and properly repaired the firearm.

Technical Specifications

IV

	U.S.	Metric	U.S.	Metric	U.S.	Metric
	G17/G17C		G17L		G19/G19C	
Action	Safe Action (constant double action mode)		Safe Action (constant double action mode)		Safe Action (constant double action mode)	
Caliber	9x19		9x19		9x19	
Overall length (slide)	7.32 in.	186 mm	8.85 in.	225 mm	6.85 in.	174 mm
Height incl. magazine	5.43 in.	138 mm	5.43 in.	138 mm	5.00 in.	127 mm
Width	1.18 in.	30 mm	1.18 in.	30 mm	1.18 in.	30 mm
Length between sights	6.49/6.73 in.	165/171 mm	8.07 in.	205 mm	6.02/6.26 in.	153/159 mm
Barrel length	4.49 in.	114 mm	6.02 in.	153 mm	4.02 in.	102 mm
Barrel rifling	Hexagonal profile with right hand twist					
Length of twist	9.84 in.	250 mm	9.84 in.	250 mm	9.84 in.	250 mm
Magazine capacity	17		17		15	
Mass (weight):						
Empty without magazine	22.04/21.87 oz.	625/620 g	23.63 oz.	670 g	20.99/20.67 oz.	595/586 g
Empty magazine	2.75 oz.	78 g	2.75 oz.	78 g	2.46 oz.	70 g
Full magazine	~9.87 oz.	~280 g	~9.87 oz.	~280 g	~8.99 lbs.	~255 g
Trigger pull (standard)	~5.5 lbs.	~2.5 kg	~4.5 lbs.	~2.0 kg	~5.5 lbs.	~2.5 kg
Trigger travel for discharge	0.5 in.	12.5 mm	0.5 in.	12.5 mm	0.5 in.	12.5 mm
Number of safeties	3		3		3	
	G20/G20C		G21/G21C			
Action	Safe Action (constant double action mode)		Safe Action (constant double action mode)			
Caliber	10 mm Auto		.45 Auto			
Overall length (slide)	7.59 in.	193 mm	7.59 in.	193 mm		
Height incl. magazine	5.47 in.	139 mm	5.47 in.	139 mm		
Width	1.27 in.	32.5 mm	1.27 in.	32.5 mm		
Length between sights	6.77/7.00 in.	172/178 mm	6.77/7.00 in.	172/178 mm		
Barrel length	4.60 in.	117 mm	4.60 in.	117 mm		
Barrel rifling	Hexagonal profile with right hand twist		Octagonal profile with right hand twist			
Length of twist	9.84 in.	250 mm	15.75 in.	400 mm		
Magazine capacity	15		13			
Mass (weight):						
Empty without magazine	27.68/27.34 oz.	785/775 g	26.28/25.93 oz.	745/735 g		
Empty magazine	2.64 oz.	75 g	3.1 oz.	88 g		
Full magazine	~11.46 oz.	~325 g	~12.0 oz.	~340 g		
Trigger pull (standard)	~5.5 lbs.	~2.5 kg	~5.5 lbs.	~2.5 kg		
Trigger travel for discharge	0.5 in.	12.5 mm	0.5 in.	12.5 mm		
Number of safeties	3		3			
	G22/G22C		G23/G23C		G24/G24C	
Action	Safe Action (constant double action mode)		Safe Action (constant double action mode)		Safe Action (constant double action mode)	
Caliber	.40		.40		.40	
Overall length (slide)	7.32 in.	186 mm	6.85 in.	174 mm	8.85 in.	225 mm
Height incl. magazine	5.43 in.	138 mm	5.00 in.	127 mm	5.43 in.	138 mm
Width	1.18 in.	30 mm	1.18 in.	30 mm	1.18 in.	30 mm
Length between sights	6.49/6.73 in.	165/171 mm	6.02/6.26 in.	153/159 mm	8.07 in.	205 mm
Barrel length	4.49 in.	114 mm	4.02 in.	102 mm	6.02 in.	153 mm
Barrel rifling	Hexagonal profile with right hand twist					
Length of twist	9.84 in.	250 mm	9.84 in.	250 mm	9.84 in.	250 mm
Magazine capacity	15		13		15	
Mass (weight):						
Empty without magazine	22.92/22.54 oz.	650/639 g	21.16/20.92 oz.	600/593 g	26.70 oz.	757 g
Empty magazine	2.75 oz.	78 g	2.46 oz.	70 g	2.75 oz.	78 g
Full magazine	~11.46 oz.	~325 g	~9.87 oz.	~280 g	~11.46 oz.	~325 g
Trigger pull (standard)	~5.5 lbs.	~2.5 kg	~5.5 lbs.	~2.5 kg	~4.5 lbs.	~2.0 kg
Trigger travel for discharge	0.5 in.	12.5 mm	0.5 in.	12.5 mm	0.5 in.	12.5 mm
Number of safeties	3		3		3	

	U.S.	Metric	U.S.	Metric	U.S.	Metric
	G25		G26		G27	
Action	Safe Action (constant double action mode)		Safe Action (constant double action mode)		Safe Action (constant double action mode)	
Caliber	.380 AUTO		9x19		.40	
Overall length (slide)	6.85 in.	174 mm	6.29 in.	160 mm	6.29 in.	160 mm
Height incl. magazine	5.00 in.	127 mm	4.17 in.	106 mm	4.17 in.	106 mm
Width	1.18 in.	30 mm	1.18 in.	30 mm	1.18 in.	30 mm
Length between sights	6.02 in.	153 mm	5.67 in.	144 mm	5.67 in.	144 mm
Barrel length	4.02 in.	102 mm	3.46 in.	88 mm	3.46 in.	88 mm
Barrel rifling	Hexagonal profile with right hand twist					
Length of twist	9.84 in.	250 mm	9.84 in.	250 mm	9.84 in.	250 mm
Magazine capacity	13		10		9	
Mass (weight):						
Empty without magazine	20.11 oz.	570 g	19.75 oz.	560 g	19.75 oz.	560 g
Empty magazine	2.40 oz.	68 g	1.98 oz.	56 g	2.12 oz.	60 g
Full magazine	~7.20 oz.	~204 g	~6.35 oz.	~180 g	~7.23 lbs.	~205 g
Trigger pull (standard)	~5.5 lbs.	~2.5 kg	~5.5 lbs.	~2.5 kg	~5.5 lbs.	~2.5 kg
Trigger travel for discharge	0.5 in.	12.5 mm	0.5 in.	12.5 mm	0.5 in.	12.5 mm
Number of safeties	3		3		3	
	G28		G29		G30	
Action	Safe Action (constant double action mode)		Safe Action (constant double action mode)		Safe Action (constant double action mode)	
Caliber	.380 AUTO		10 mm Auto		.45 Auto	
Overall length (slide)	6.29 in.	160 mm	6.77 in.	172 mm	6.77 in.	172 mm
Height incl. magazine	4.17 in.	106 mm	4.45 in.	113 mm	4.76 in.	121 mm
Width	1.18 in.	30 mm	1.27 in.	32.5 mm	1.27 in.	32.5 mm
Length between sights	5.67 in.	144 mm	5.95 in.	151 mm	5.95 in.	151 mm
Barrel length	3.46 in.	88 mm	3.78 in.	96 mm	3.78 in.	96 mm
Barrel rifling	Hexagonal profile with right hand twist		Hexagonal profile with right hand twist		Octagonal profile with right hand twist	
Length of twist	9.84 in.	250 mm	9.84 in.	250 mm	15.75 in.	400 mm
Magazine capacity	10		10		10	
Mass (weight):						
Empty without magazine	18.66 oz.	529 g	24.69 oz.	700 g	23.99 oz.	680 g
Empty magazine	1.98 oz.	56 g	2.40 oz.	68 g	2.50 oz.	71 g
Full magazine	~5.11 oz.	~145 g	~8.29 oz.	~235 g	~9.87 oz.	~280 g
Trigger pull (standard)	~5.5 lbs.	~2.5 kg	~5.5 lbs.	~2.5 kg	~5.5 lbs.	~2.5 kg
Trigger travel for discharge	0.5 in.	12.5 mm	0.5 in.	12.5 mm	0.5 in.	12.5 mm
Number of safeties	3		3		3	
	G31/G31C		G32/G32C		G33	
Action	Safe Action (constant double action mode)		Safe Action (constant double action mode)		Safe Action (constant double action mode)	
Caliber	.357		.357		.357	
Overall length (slide)	7.32 in.	186 mm	6.85 in.	174 mm	6.29 in.	160 mm
Height incl. magazine	5.43 in.	138 mm	5.00 in.	127 mm	4.17 in.	106 mm
Width	1.18 in.	30 mm	1.18 in.	30 mm	1.18 in.	30 mm
Length between sights	6.49/6.73 in.	165/171 mm	6.02/6.26 in.	153/159 mm	5.67 in.	144 mm
Barrel length	4.49 in.	114 mm	4.02 in.	102 mm	3.46 in.	88 mm
Barrel rifling	Hexagonal profile with right hand twist					
Length of twist	15.98 in.	406 mm	15.98 in.	406 mm	15.98 in.	406 mm
Magazine capacity	15		13		9	
Mass (weight):						
Empty without magazine	23.28/23.10 oz.	660/655 g	21.52/21.34 oz.	610/605 g	19.75 oz.	560 g
Empty magazine	2.75 oz.	78 g	2.46 oz.	70 g	2.12 oz.	60 g
Full magazine	~9.87 oz.	~280 g	~8.64 oz.	~245 g	~6.88 oz.	~195 g
Trigger pull (standard)	~5.5 lbs.	~2.5 kg	~5.5 lbs.	~2.5 kg	~5.5 lbs.	~2.5 kg
Trigger travel for discharge	0.5 in.	12.5 mm	0.5 in.	12.5 mm	0.5 in.	12.5 mm
Number of safeties	3		3		3	

	U.S.	Metric	U.S.	Metric	U.S.	Metric
	G34		G35		G36	
Action	Safe Action (constant double action mode)		Safe Action (constant double action mode)		Safe Action (constant double action mode)	
Caliber	9x19		.40		.45 AUTO	
Overall length (slide)	8.15 in.	207 mm	8.15 in.	207 mm	6.77 in.	172 mm
Height incl. magazine	5.43 in.	138 mm	5.43 in.	138 mm	4.76 in.	121 mm
Width	1.18 in.	30 mm	1.18 in.	30 mm	1.13 in.	28.5 mm
Length between sights	7.56 in.	192 mm	7.56 in.	192 mm	6.18 in.	157 mm
Barrel length	5.32 in.	135 mm	5.32 in.	135 mm	3.78 in.	96 mm
Barrel rifling	Hexagonal profile with right hand twist				Octagonal profile with right hand twist	
Length of twist	9.84 in.	250 mm	9.84 in.	250 mm	15.75 in.	400 mm
Magazine capacity	17		15		6	
Mass (weight):						
Empty without magazine	22.92 oz.	650 g	24.52 oz.	695 g	20.11 oz.	570 g
Empty magazine	2.75 oz.	78 g	2.75 oz.	78 g	2.40 oz.	68 g
Full magazine	~9.87 oz.	~280 g	~11.46 oz.	~325 g	~6.88 lbs.	~195 g
Trigger pull (standard)	~4.5 lbs.	~2.0 kg	~4.5 lbs.	~2.0 kg	~5.5 lbs.	~2.5 kg
Trigger travel for discharge	0.5 in.	12.5 mm	0.5 in.	12.5 mm	0.5 in.	12.5 mm
Number of safeties	3		3		3	
	G37		G38		G39	
Action	Safe Action (constant double action mode)		Safe Action (constant double action mode)		Safe Action (constant double action mode)	
Caliber	.45 G.A.P.		.45 G.A.P.		.45 G.A.P.	
Overall length (slide)	7.32 in.	186 mm	6.85 in.	174 mm	6.30 in.	160 mm
Height incl. magazine	5.51 in.	140 mm	5.00 in.	127 mm	4.17 in.	106 mm
Width	1.18 in.	30 mm	1.18 in.	30 mm	1.18 in.	30 mm
Length between sights	6.49 in.	165 mm	6.02 in.	153 mm	5.67 in.	144 mm
Barrel length	4.49 in.	114 mm	4.02 in.	102 mm	3.46 in.	88 mm
Barrel rifling	Octagonal profile with right hand twist					
Length of twist	15.75 in.	400 mm	15.75 in.	400 mm	15.75 in.	400 mm
Magazine capacity	10		8		6	
Mass (weight):						
Empty without magazine	25.95 oz.	735 g	24.16 oz.	685 g	19.33 oz.	548 g
Empty magazine	2.68 oz.	76 g	2.33 oz.	66 g	1.94 oz.	55 g
Full magazine	~9.53 oz.	~270 g	~7.76 oz.	~220 g	~6.00 oz.	~170 g
Trigger pull (standard)	~5.5 lbs.	~2.5 kg	~5.5 lbs.	~2.5 kg	~5.5 lbs.	~2.5 kg
Trigger travel for discharge	0.5 in.	12.5 mm	0.5 in.	12.5 mm	0.5 in.	12.5 mm
Number of safeties	3		3		3	

Special GLOCK Models

Compensated Pistols



“Compensated” Pistols are offered in Full-Size and Compact models of both the Standard Frame (full-size and compact) and Large Frame (full-size only) designs.

The Barrel/Slide porting helps to re-direct gases and keep the muzzle down in rapid-fire shooting.

Restricted Law Enforcement Agency Purchase Only

The following GLOCK pistols are restricted to LE agency purchase only. There can be no sales of these models to individuals: G17T FX, G17T UTM, G19T FX, G26T FX (Blue), G17P, G17R, G22P, G19P, G19R, G23P, 26P (Red), G18 (Select Fire), G25 & G28 (.380) (US Law Enforcement only). (Fig. 5)

5 Sizes	NO Live Fire	FX Marking Cartridges UTM Marking Cartridges
Standard	17 P 22 P 17 R	17 T FX 17 T UTM
Compact	19 P 23 P 19 R	19 T FX 19 T UTM
Subcompact	26 P	26 T FX



Training Models



Practice Models
Reset Models

Exploded Drawing GLOCK 17

6

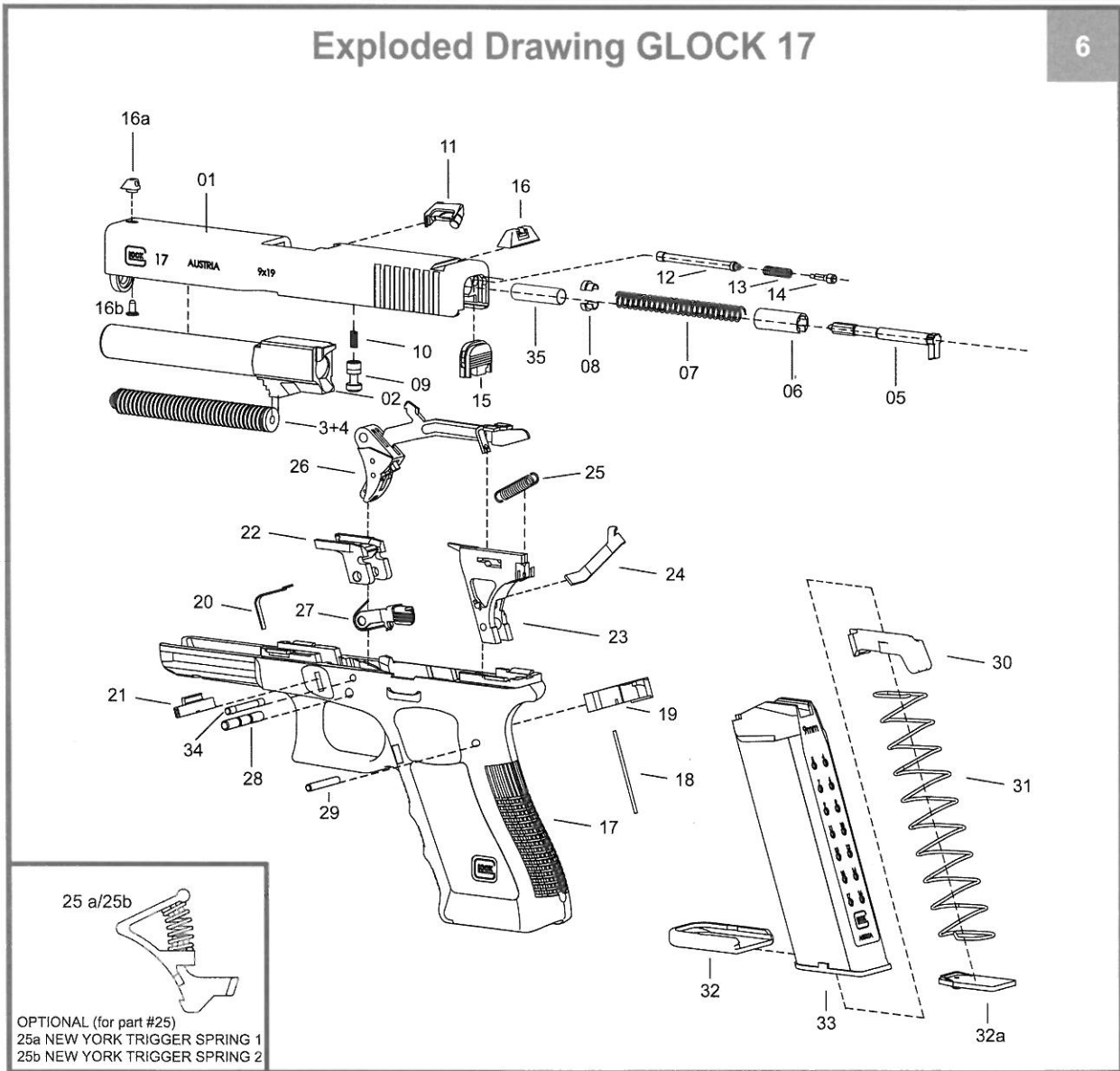

- | | | | |
|------------------------------|--|--|------------------------------|
| 1. Slide | 12. Extractor depressor plunger | 20. Slide lock spring | 26. Trigger with trigger bar |
| 2. Barrel | 13. Extractor depressor plunger spring | 21. Slide lock | 27. Slide stop lever |
| 3. } Recoil spring assembly | 14. Spring-loaded bearing | 22. Locking block | 28. Trigger pin |
| 4. } | 15. Slide cover plate | 23. Trigger mechanism housing with ejector | 29. Trigger housing pin |
| 5. Firing pin | 16. Rear sight | 24. Connector | 30. Follower |
| 6. Spacer sleeve | 16a/b. Front sight / screw | 25. Trigger spring | 31. Magazine spring |
| 7. Firing pin spring | 17. Receiver | 25a. New York Trigger Spring 1 | 32. Magazine floor plate |
| 8. Spring cups | 18. Magazine catch spring | 25b. New York Trigger Spring 2 | 32a. Magazine insert |
| 9. Firing pin safety | 19. Magazine catch | | 33. Magazine tube |
| 10. Firing pin safety spring | | | 34. Locking block pin |
| 11. Extractor | | | 35. Channel liner |

VI “Safe Action” System

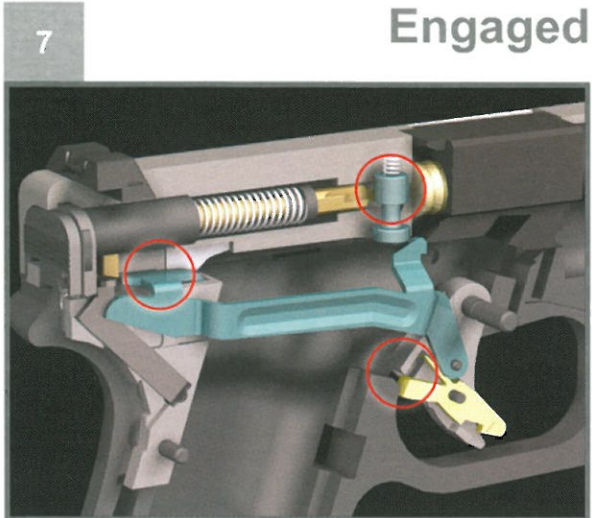

GLOCK pistols do not feature a conventional manual safety lever; however, they are equipped with the revolutionary, fully automatic safety system consisting of three passive, independent, mechanical safety devices that collectively form the “Safe Action” system. (Fig. 7)

Trigger Safety

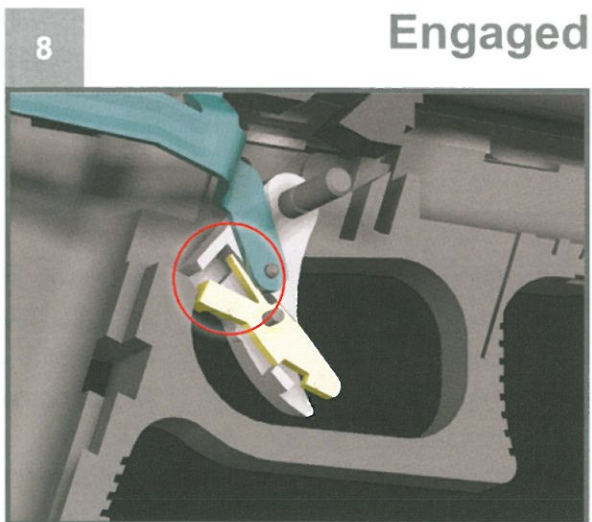

The trigger safety is incorporated into the trigger in the form of a lever and when in the forward position, blocks the trigger from moving rearward. To fire the pistol, the trigger safety and the trigger itself, must be deliberately depressed at the same time. If the trigger safety is not depressed, the trigger will not move rearwards and allow the pistol to fire. The trigger safety is designed to prevent unintentional firing when the pistol is dropped, falls or is subjected to forces such as inertia or lateral pressures. (Fig. 8)

Firing Pin Safety

The spring-loaded firing pin safety projects into the firing pin channel and mechanically blocks the firing pin from moving forward. When the trigger is being moved rearwards, a vertical extension of the trigger bar pushes the firing pin safety upwards, clearing the firing pin channel. During the slide cycling process, the firing pin safety automatically engages with an assist from the firing pin safety spring. The firing pin safety was designed to avoid unintentional firing due to inertia or should extreme forces cause a separation of slide and receiver. (Fig. 9)

Engaged

9

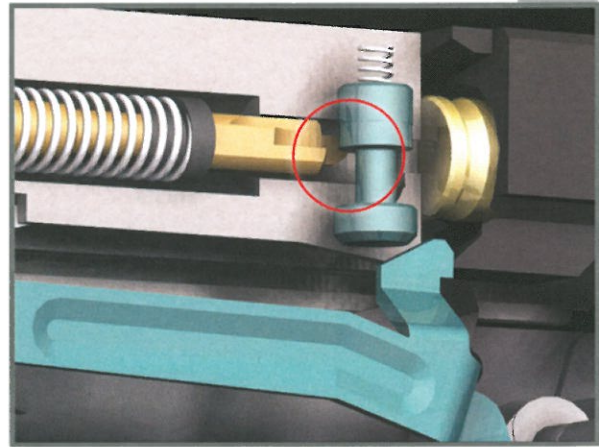

Drop Safety

The rear part of the trigger bar, which has a cruciform shape, rests with both arms on the drop safety shelf located in the trigger mechanism housing. When the trigger is pulled to the rear, the trigger bar begins to move off the safety shelf as the trigger bar is forced downwards and rearwards by the connector until finally separating from the firing pin lug. During the slide cycling process, the connector is pushed inward by a cam in the slide releasing the trigger bar which is then lifted with help from the trigger spring and caught by the firing pin lug. The trigger bar is engaged by the firing pin lug and both arms are pushed onto the drop safety shelf again. (Fig. 10)

Engaged

10

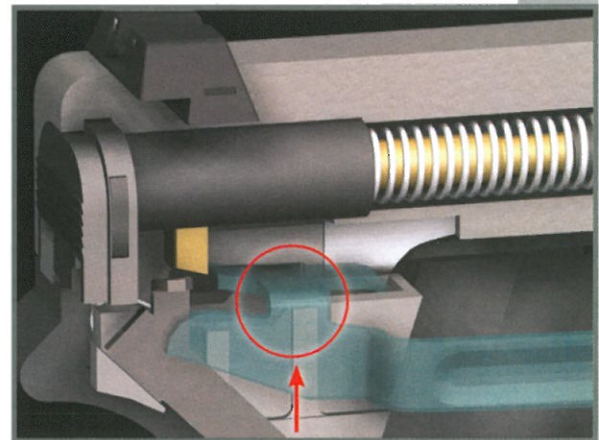

VII Pistol Nomenclature

11



16

Unloading Procedure & Safety Check

VIII

- Point the pistol in a safe direction
- With fingers outside the trigger guard, press inward on the magazine catch and remove the magazine. (Fig. 12)



- Using the overhand method, pull the slide to the rear ejecting any chambered ammunition. (Fig. 13)



Caution

For safety reasons you may repeat this step several times.

- While pulling the slide to the rear, push upwards on the slide stop to lock the slide to the rear. (Fig. 14)



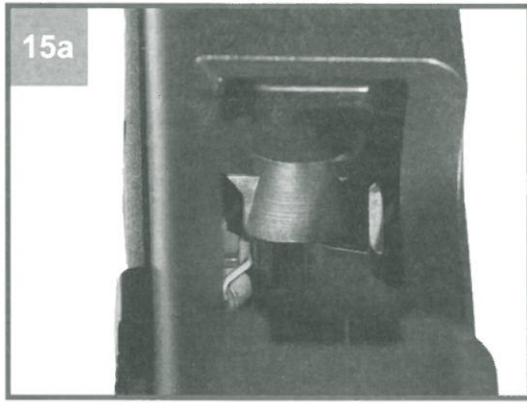

- Visually check both the chamber and magazine well to ensure all ammunition has been removed from the pistol. (Fig. 15a)



- Physically (with your finger) check both the chamber and magazine well to ensure all ammunition has been removed from the pistol. (Fig 15b /15c)

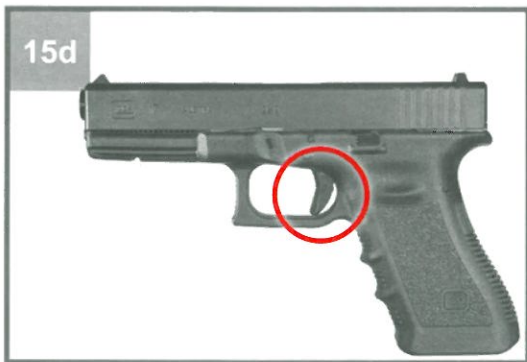

- Release Slide
Point Pistol in a safe direction
Pull trigger

“Field Strip” is the term often used to describe the basic break-down of the weapon at the general user level to facilitate normal maintenance such as cleaning and lubrication. This can be done very quickly with no tools and leaves the basic pistol in 4 parts.

Note: Safety and eye protection reminder

- Be certain that the handgun is **NOT LOADED** and there is **NO AMMUNITION** in the immediate area.
- Always wear **EYE PROTECTION**

Field Strip (Fig. 16)



Slide Removal

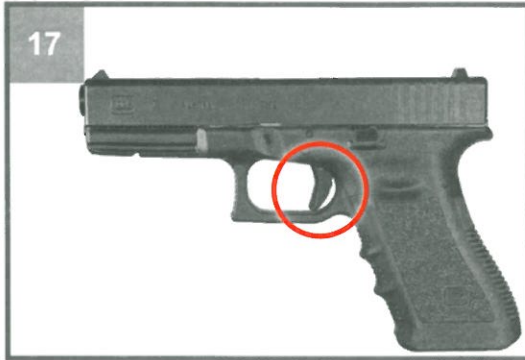

Verify again that the pistol is **NOT LOADED**. (Conduct weapons safety check).

- The trigger should then be in the rearward position and the engagement between the firing pin and the trigger bar will have been released. (Fig. 17)

If you are certain that there is **NO AMMUNITION** in the handgun or **IMMEDIATE AREA**, you may begin.

If you are not certain that the handgun is unloaded always perform an unloading procedure and safety check. (Ref. VIII)

Disassembly Grip

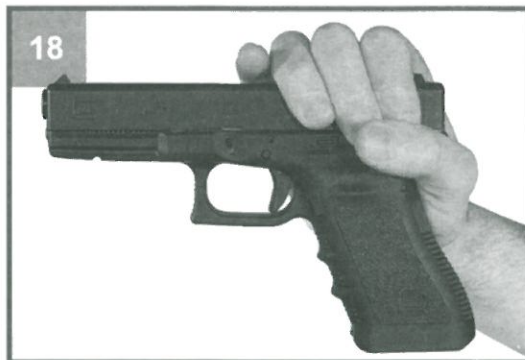

Grasp the pistol as shown. (Fig. 18)

- Clenching your hand will cause the slide and barrel to move rearwards about 1/8 in. (3 mm). This will allow the slide lock to disengage from the barrel and now the slide lock can be pulled downwards.

- With the slide slightly retracted and both sides of the slide lock pulled downwards, you can now push the slide assembly forward and remove it from the receiver. (Fig. 19 / 20).



Caution
If you move the slide further than 1/8 in. (3 mm) to the rear, you may cause the action to re-set and the trigger to move forward again. This will not allow the slide to be removed from the receiver unless the trigger is again pressed rearwards releasing the firing pin/trigger bar engagement.

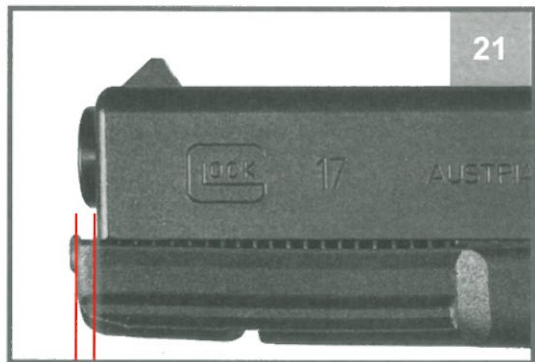

1/8 in. (3 mm)

Recoil Spring/Rod Removal



- With thumb and forefinger, grasp the recoil spring assembly near the end that is against the barrel lug. The spring is “captured” on the rod and compressing the spring about 1/4 in. (6 mm) will allow it to be removed. (Fig. 22a / 22b)

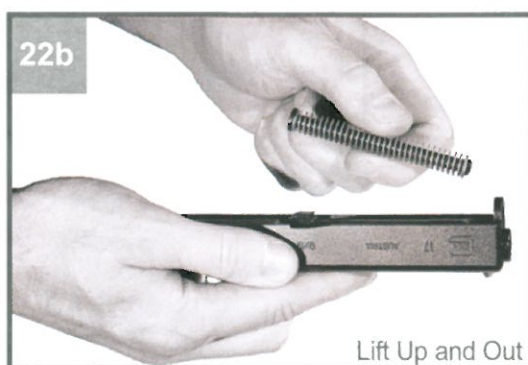

Barrel Removal

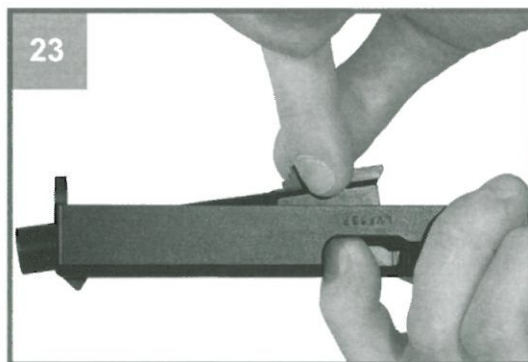

- Grasp the barrel by the bottom lug and lift it clear of the slide. (Fig. 23)

Note:

GLOCK barrels are “hammer forged” and utilize “hexagonal” and “octagonal” rifling. Advantages are increased accuracy, higher velocities, ease of cleaning, better bullet fit and the tenifer protection. The chamber and rifling are formed at the same time. (Fig. 24)

Rifling

Conventional

- Sharp lands that cut bullet jacket
- Grooves that allow gas to escape
- Areas for powder residue to collect
- Harder to clean

Hexagonal or Octagonal

- Better bullet to barrel fit
- Better gas seal
- Higher, more uniform velocities
- Increased accuracy

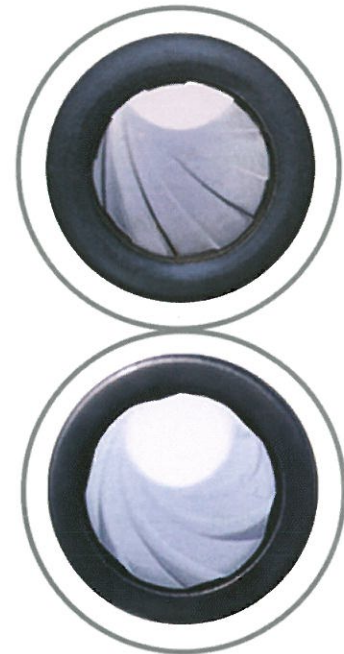

Caution
When field stripping, guard against dropping the slide assembly and damaging the guide ring or the rear of the slide rails. Check for cracks and/or bent rails.
(Fig. 25a / 25b)

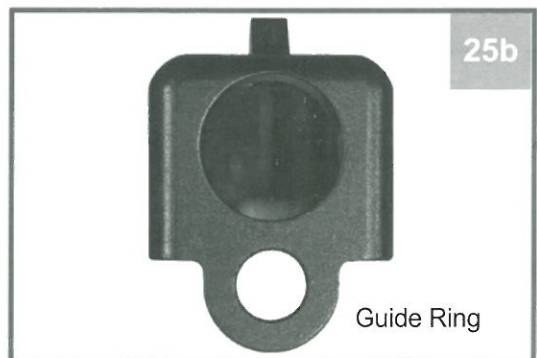
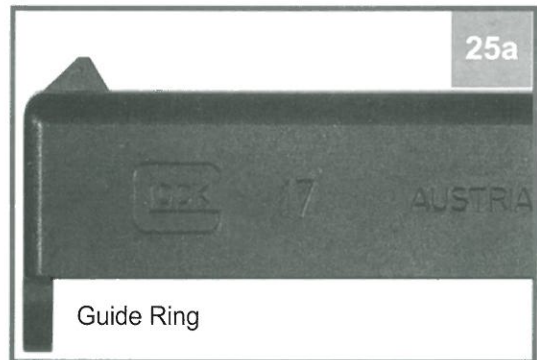

Nomenclature of Field Stripped Pistol

26

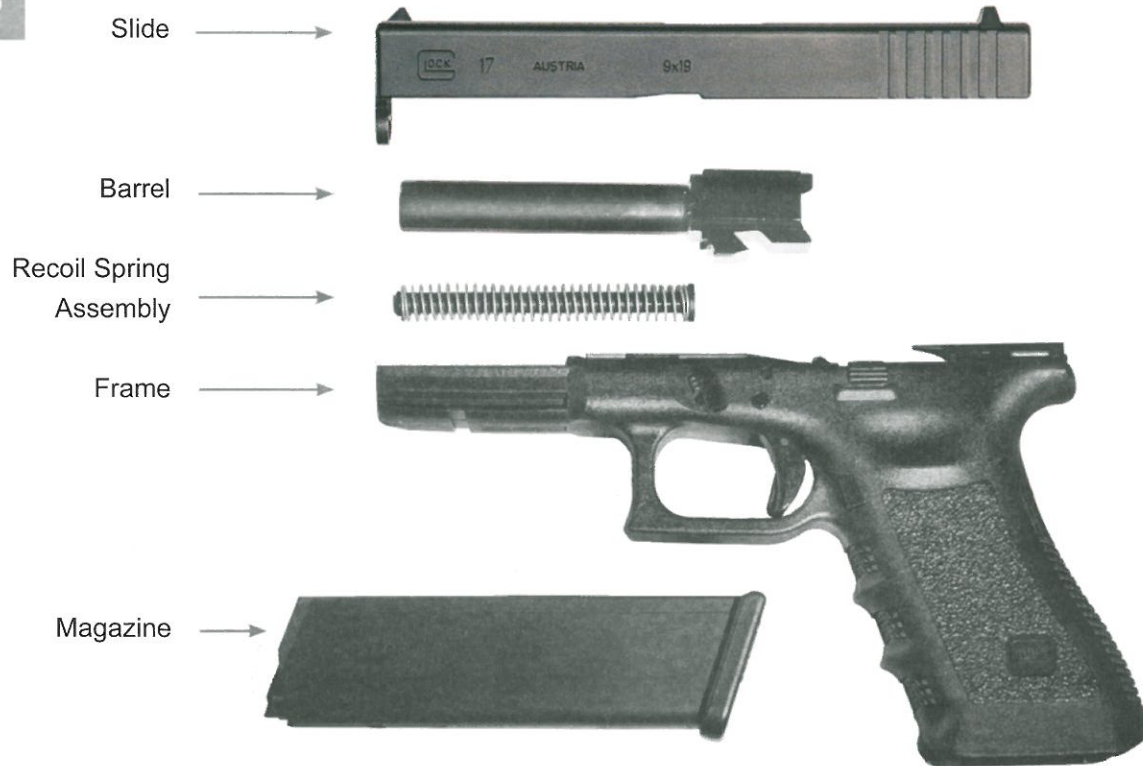

Basic Field Strip

All GLOCK pistols can be "field stripped" in seconds without any tools.

Notes:

Reassembly

- Grasp the barrel by the bottom lug and place it back into the slide. (Fig. 27)
- Pick up the recoil spring/guide rod assembly and place it back into the proper position. Ensure the smaller, beveled end goes into position inside the end of the guide ring. The larger end seats against the bottom barrel lug.

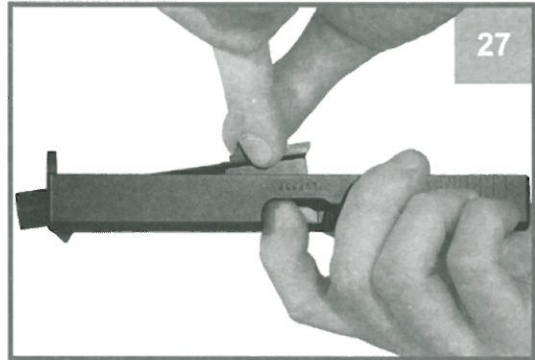

The rim of the back end of the rod seats into a semi-circular "half-moon" cut on the barrel lug. (Fig. 28)

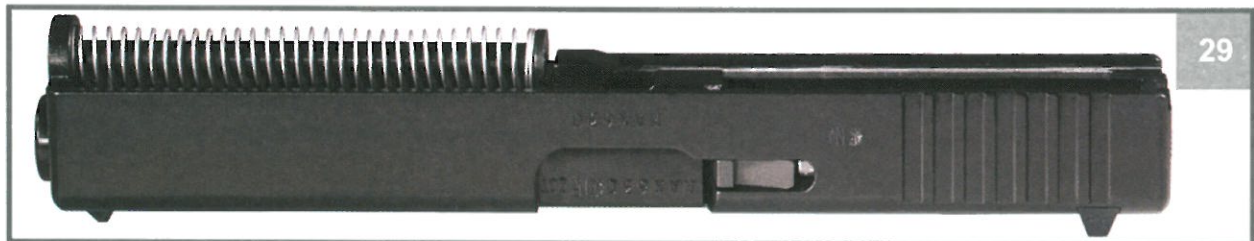
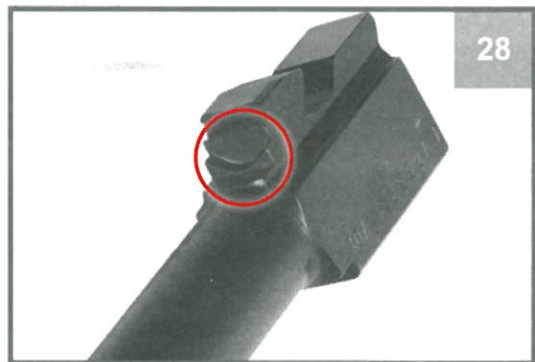

Caution

Make certain the rod rim seats fully into the cut. The rod should be centered and parallel with the barrel. (Fig. 29)

- Line up the slide grooves with the frame rails and push the slide onto the receiver. If you encounter resistance, check again to see if the rod is completely seated, centered and parallel. (Fig. 30)



X Detail Slide Strip/Disassembly (only by a certified GLOCK armorer)

Tools

Complete detail disassembly and reassembly of the GLOCK pistol can be accomplished with only 3 tools.

1. A straight pin punch of 3/32 in. (2.5 mm).



2. A screwdriver with a 1/8 in. (3 mm) blade 3 in. (76 mm) long (or more).
(Only for removal/replacement of magazine catch.)
3. Needle nose pliers (any common type long nose pliers).
(Only for removal/replacement of magazine catch.)



Notes:

Removal of Firing Pin Assembly

- Insert the pin punch under the firing pin lug and on top of the firing pin spacer sleeve (black polymer visible just under the firing pin lug). (Fig. 32)

Caution

Spacer sleeve is under spring tension.

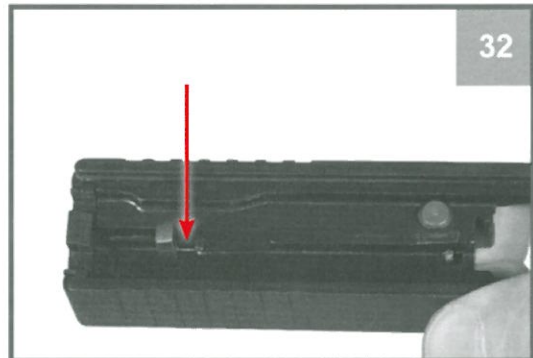

- Place your thumb over the slide cover plate as you push downwards (toward the muzzle end) on the spacer sleeve. (Fig. 33a / 33b)

Caution

Parts located under the slide cover plate are under spring tension and can escape if your thumb is not over the plate.

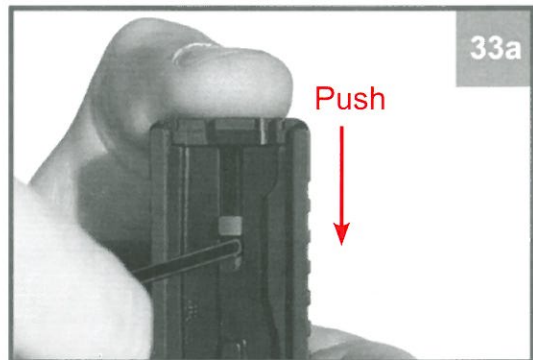

- While pressing downward (toward muzzle) on the firing pin spacer sleeve, slide the cover plate down and off.

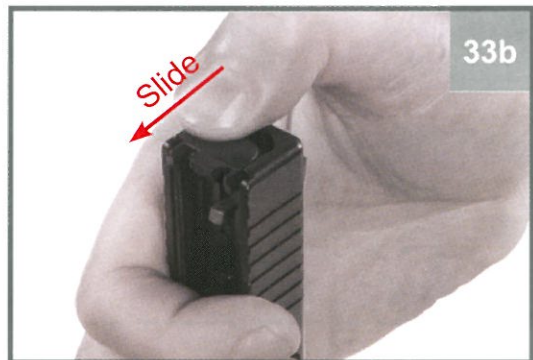

Note:

It is possible the slide cover plate may require some additional force during removal. If necessary, a thin-bladed screwdriver can be used to start removal.

- Slowly remove your thumb thereby releasing the spring tension on the internal parts.

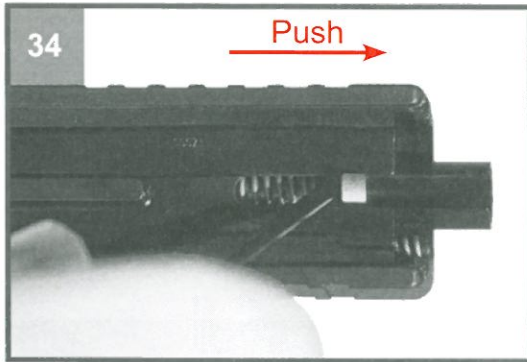

- Remove the firing pin assembly by lifting upwards on the spacer sleeve or firing pin lug. (Fig. 34 / 35)

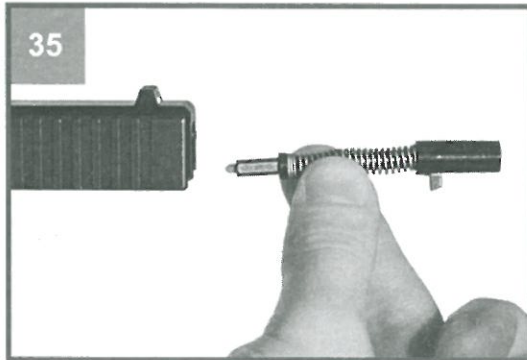

Extractor Depressor Plunger Assembly Removal



- Remove the extractor depressor plunger assembly by lifting it upwards. This assembly is made up of three parts: the extractor depressor plunger, extractor depressor spring and spring loaded bearing. (Fig. 36 / 37)

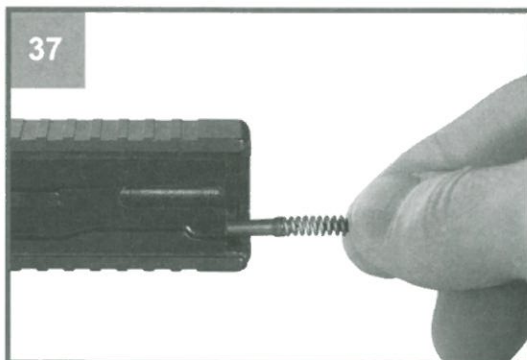

The EDP (extractor depressor plunger) assembly serves to put the proper amount of tension on the extractor. There are three color-coded bearings: **Black** for 9mm & .380, **White** for .40, .357 auto & .45 GAP and **Olive** for 10mm & .45 ACP (see Fig. 43).

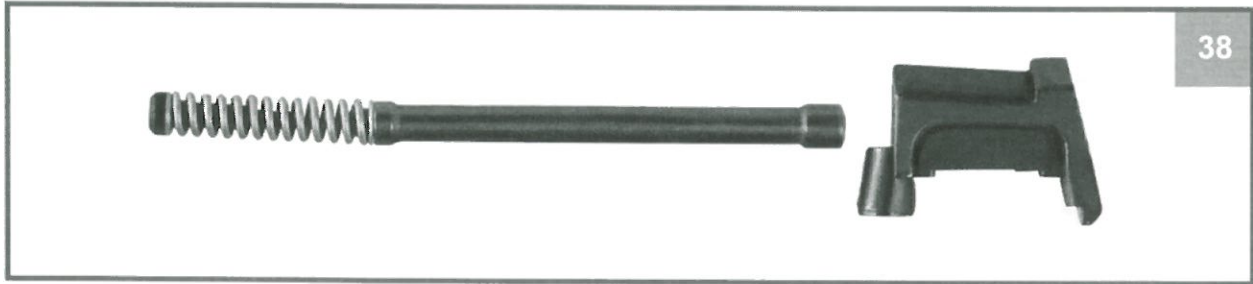

Please consider chapter XXIII "Parts overview" for original parts.

Extractor Removal

- Orient the slide so the extractor is facing downwards. Then, pressing inwards on the firing pin safety with your finger or punch should release the extractor. You may need to push on the extractor if it doesn't fall freely. (Fig. 39)

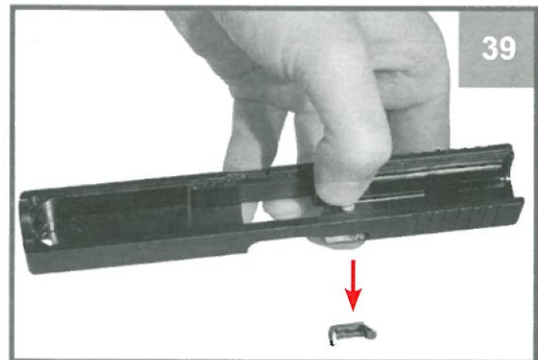

Firing Pin Safety Removal

- Using your fingers, lift upwards on the firing pin safety and remove it from the slide. If the safety is dirty or does not come out easily, pry upwards with a pin punch. You can also carefully use a pair of pliers to pull it from its recess. When the firing pin safety is removed, the spring should be attached. (Fig. 40)

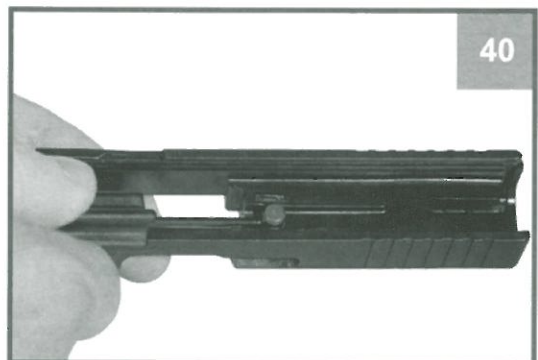

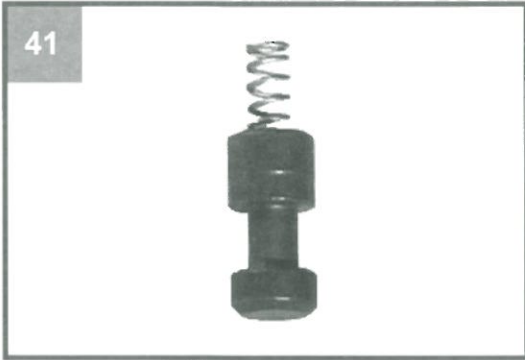

If the spring should become separated from the safety, merely press either end back into its receptacle in the bottom of the safety. Compress the spring fully and turn it ¼ turn clockwise. When the spring is released, it should be reattached to the safety. If the spring is not firmly attached, it may fall into the recess, turn sideways and not provide proper spring tension to the safety.

Please consider chapter XXIII "Parts overview" for original parts.



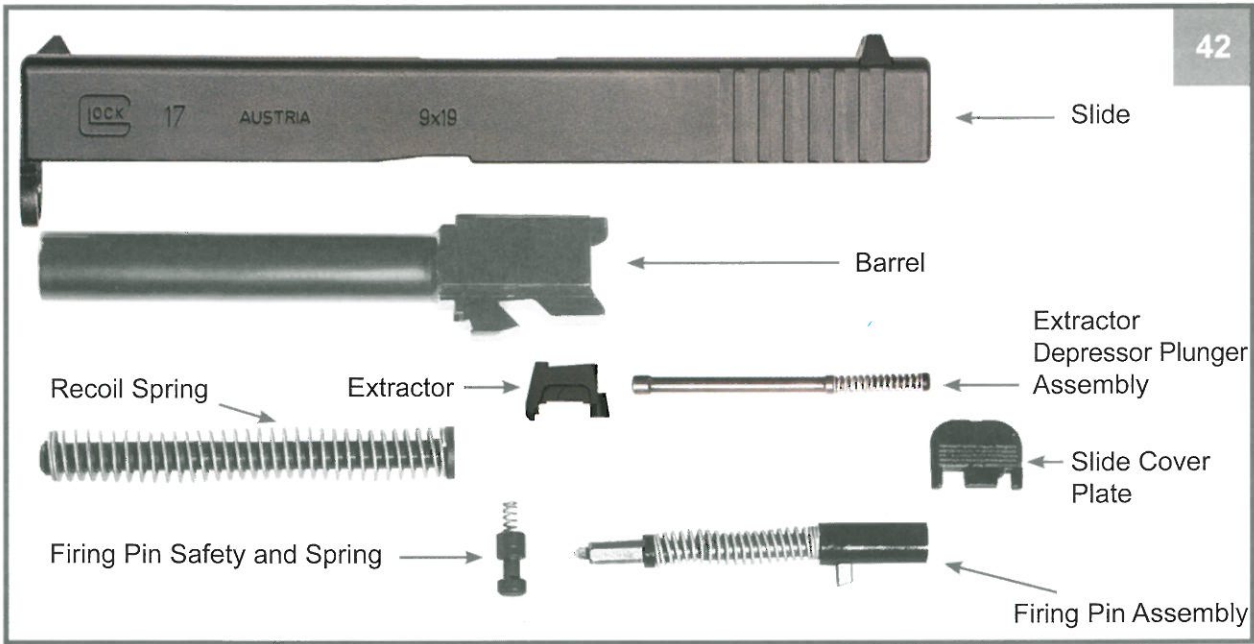



Slide Detail Stripped



Further Slide Disassembly

Extractor Depressor Plunger Assembly (EDP)

- Grasp the rod with one hand and the spring with the other and pull them apart. While holding the spring, pull the spring loaded bearing away. The EDP assembly has three parts (rod, spring and bearing). There is a separate rod for each of the two frames offered (standard frame and large frame). The extractor depressor assembly provides proper tension to the extractor during chambering and extraction. (Fig. 43)

<p>Large Frame</p> 		<p>10mm /.45 ACP olive</p> 	43
<p>Standard Frame</p> 		<p>.40/.357/.45 GAP white</p> 	
		<p>380/9mm black</p> 	

Please consider chapter XXIII "Parts overview" for original parts.

Notes:

Firing Pin Disassembly

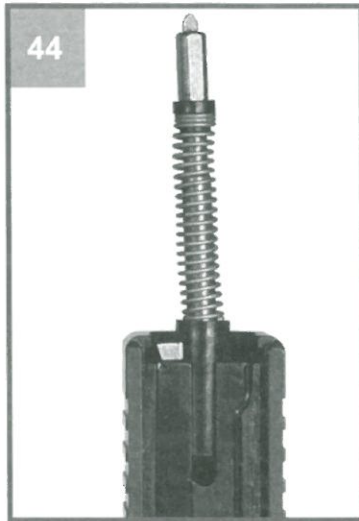

Use the slide to assist you in disassembling the firing pin assembly. Install the firing pin assembly upside down into the firing pin channel cut and turn the lug to one side. This will secure the assembly and assist you in removing the spring cups and firing pin spring. (Fig. 44)

Caution
Always wear safety glasses.

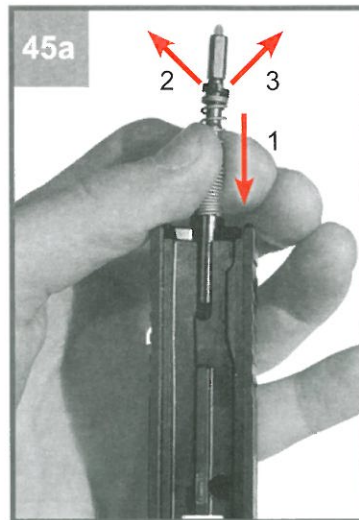

- With the firing pin assembly reversed and installed in the firing pin channel cut and with the lug turned to one side, grasp the firing pin spring just below the spring cups. Using your thumb and forefinger, pull downwards on the spring about 3/8 in. (9 mm) to allow the spring cups to fall clear. If they do not release, pull them away with your other hand. (Fig. 45a)

Caution
Be sure to keep control of the firing pin spring. Do not allow it to release prematurely as that can cause the spring and/or spring cups to fly off causing injury or loss of parts.

- Gradually release tension on the firing pin spring (Fig. 45b).
- Take the spring off the firing pin (Fig. 45b).
- Remove the firing pin spacer sleeve.

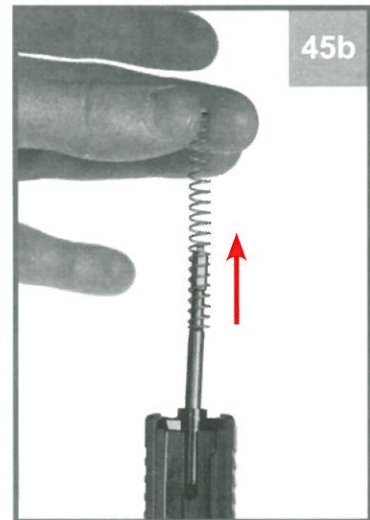

Components of the firing pin assembly. (Fig. 46)

Reassembly of the firing pin in reverse order of disassembly.

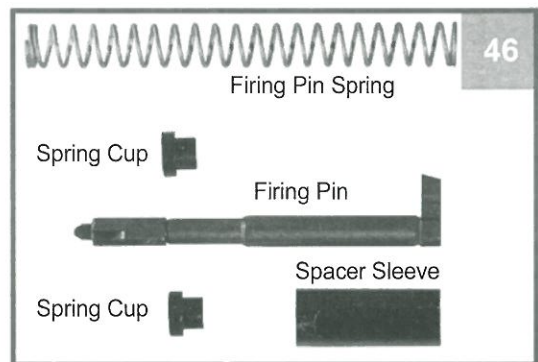

Please consider chapter XXIII "Parts overview" for optional parts.

Notes:

XI Slide Reassembly

Firing Pin Safety

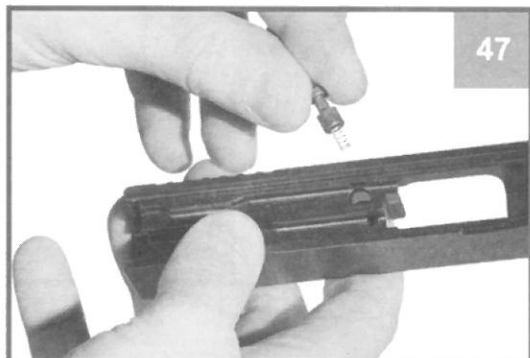

- Ensure the firing pin safety and spring are connected and replace the safety (spring down) into its receptacle. Press down on the safety to check proper spring function. (Fig. 47)

Extractor



- Insert the extractor into the extractor cut and simultaneously press down on the firing pin safety. This will allow both parts to fit together properly. When released, both parts should remain in the slide. (Fig. 48a /48b)

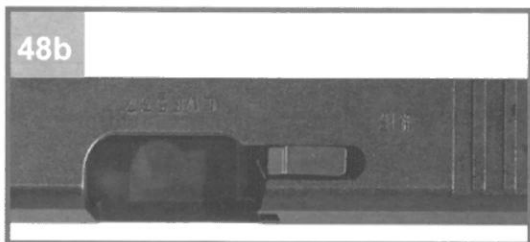

Different Extractors For Different Calibers

Be sure to match the extractor by caliber. (Figs. 48c)

Please consider chapter XXIII "Parts overview" for original parts.

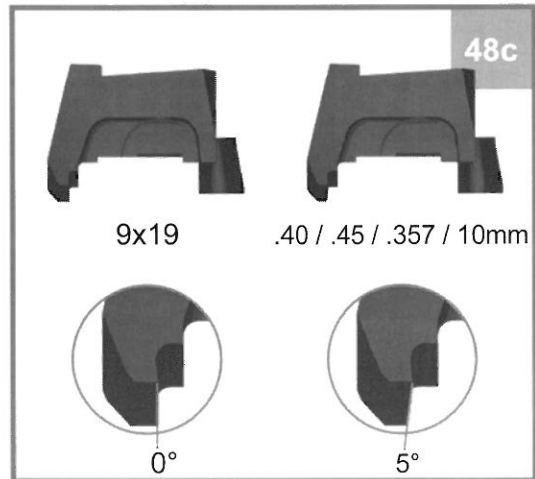

Extractor Depressor Plunger

- Insert the extractor depressor plunger (EDP) assembly into the slide. The metal rod end always goes in first to mate with the metal extractor. This leaves the polymer spring loaded bearing to mate with the polymer slide cover plate. (Fig. 49)

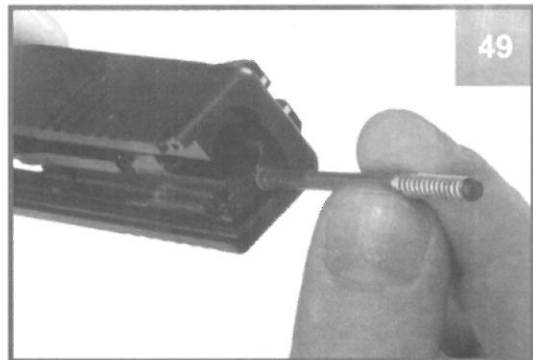

Notes:

Firing Pin Assembly

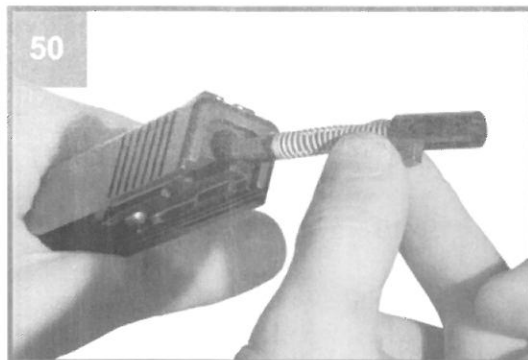

- Insert the firing pin assembly into the firing pin channel. (Fig. 50)

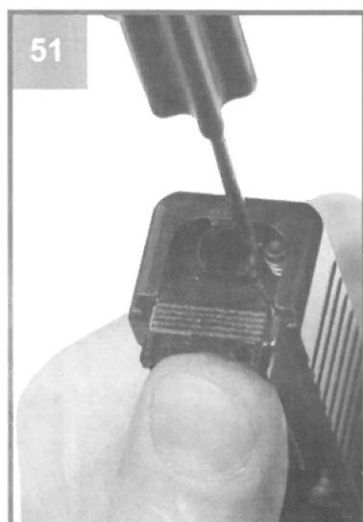

- When replacing slide cover plate, hold it partially in its place and press down on the spacer sleeve with a finger or pin punch. This will allow the cover plate to move inwards. Then press down on the spring loaded bearing while continuing to press the cover plate inwards. This will let the slide cover plate move all the way up and snap into position. (Fig. 51)

Note:

The slide cover plate will not go on properly unless the firing pin spacer sleeve and spring loaded bearing are depressed while keeping tension on the cover plate.

Caution

Prematurely releasing tension on the firing pin and/or spring loaded bearing before the slide cover plate is fully seated may cause either part to be launched from the slide.

52



Notes:

Locking Block Pin Removal



All current production models contain three pins. Earlier 9 mm models may only have two pins (no locking block pin in those models).

It is suggested that all pins be removed from left to right (with the pistol seen from the safe shooter's perspective) and reinstalled from right to left.

- Using the pin punch, press on the left side of the locking block pin and remove it from the right side of the receiver. (Fig. 53).

Note:

This pin is steel and supports the steel locking block.

THE LOCKING BLOCK PIN MUST BE THE FIRST PIN REINSTALLED DURING REASSEMBLY.

Trigger Mechanism Housing Pin Removal

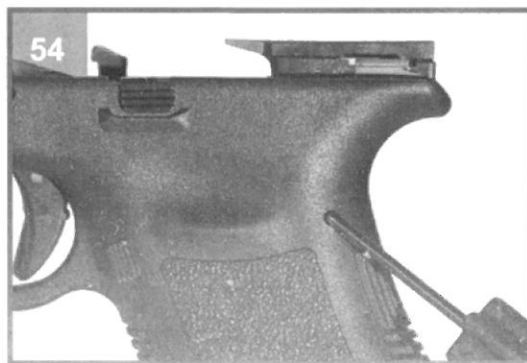

- Using the punch, press on the left side of the trigger mechanism housing pin and remove it from the right side of the receiver. (Fig. 54)

Note:

This pin is the same diameter as the locking block pin, but is shorter, made of polymer and contacts polymer parts.

Caution

Take care to reinstall the proper pin in each location.

Trigger Pin Removal

- Using the punch, press on the left side of the trigger pin. This pin will not be removed as easily as the other pins.
- To facilitate trigger pin removal, move the slide stop lever forwards and backwards while applying pressure on the trigger pin. In order to get the trigger pin out, you must move the slide stop lever out of the trigger pin groove. (Figs. 55a / 55b / 55c)



IT IS NOT NECESSARY TO USE EXCESSIVE FORCE TO REMOVE THIS PIN!
NEW WEAPONS NEED MORE PRESSURE!

When the slide stop lever is moved forward and backwards, it can be “unhooked” from the trigger pin groove and the pin may be removed from the right side of the receiver.

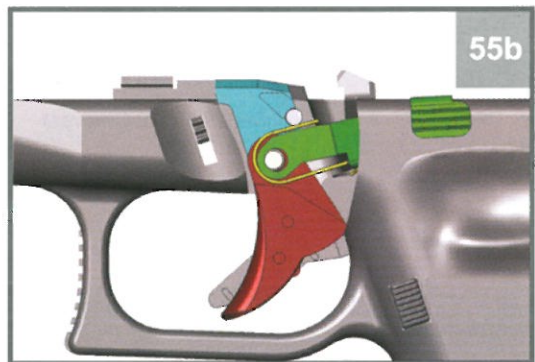

Caution

If you try to push the trigger pin out from right to left, when you “unhook” it from the trigger pin groove, be aware that it will then move into the second trigger pin groove and you will still be unable to remove the pin. In this case continue the rocking movement to unhook.

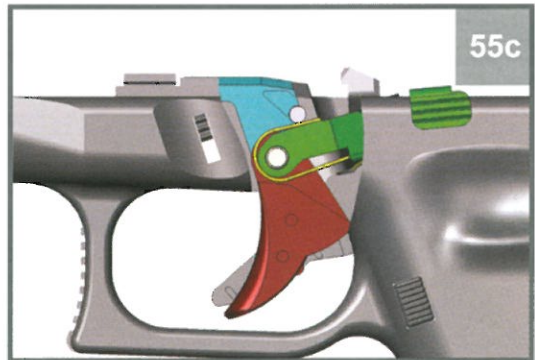

If unable to remove the trigger pin as outlined above, you may be able to put light pressure on the right side of the pin first, then move back to the left side and try the above procedure again.

Comparison of the Three Pins

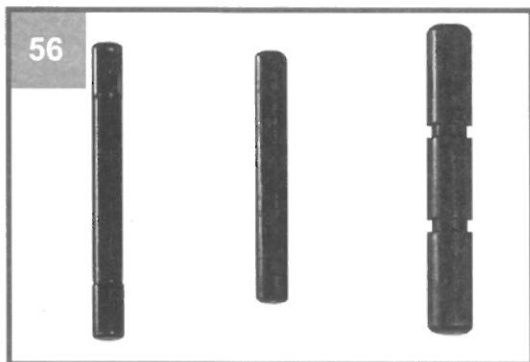

Locking Block Pin (Steel) "First Pin"	Trigger Mechanism Housing Pin (Polymer)	Trigger Pin (Steel) (Large with 2 Grooves)
--	--	---

"First" Pin – Locking Block Pin
(1st Pin Removed and 1st Pin Reinstalled)

Trigger Mechanism Housing Pin

Trigger Pin
(move slide stop lever to remove)

Remove pins from left to right and reinsert pins from right to left (locking block pin first).

Slide Stop Lever Removal



- With the trigger pin removed, simply lift the slide stop lever out of the receiver. (Fig. 57)

Please consider chapter XXIII "Parts overview" for optional parts.

Locking Block Removal

- Lay the shaft of the pin punch across the left or right side of the magazine well with the tip under the locking block. By pressing downward on the punch handle, the tip will pry up the back end of the locking block. (Fig. 58)

Do not support tool on the vertical extension of the trigger bar.



Use fingers to remove the block. (Fig. 59)



Please consider chapter XXIII "Parts overview" for original parts.

Trigger Assembly Removal

- Using the pin punch, apply upward pressure under the ejector to raise the trigger mechanism housing assembly. You can also merely grasp the ejector and pull the assembly upwards. When the housing is withdrawn, the trigger assembly will be connected to the housing and the entire unit will come out together. (Fig. 60a / 60b)

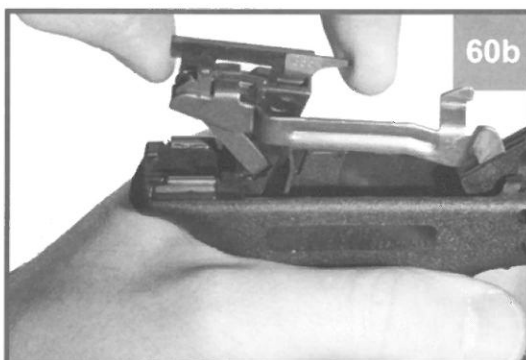
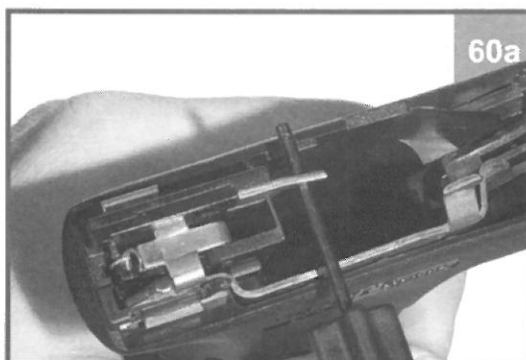

Trigger Assembly Disassembly

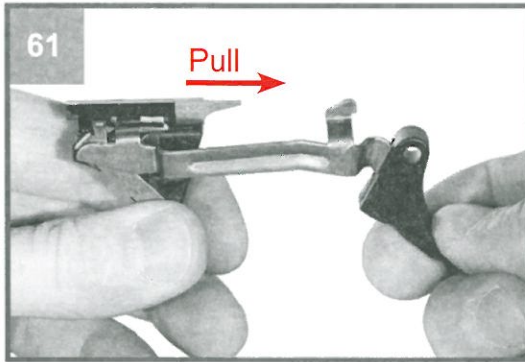

- Grasp the trigger mechanism housing with your left hand and the trigger pad with your right. Ensure that the ejector is pointing to your right. (Fig. 61)

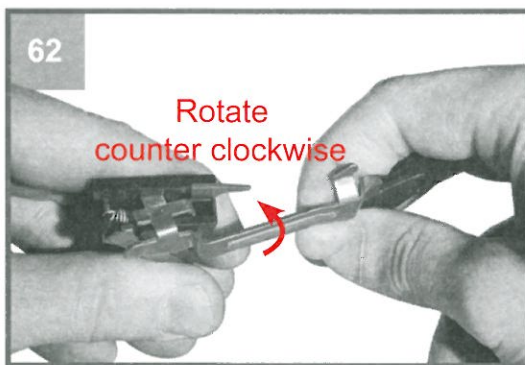

- Carefully pull your hands apart about 1/4 in. (6 mm). Push the trigger pad straight away from yourself. This will move the left arm of the cruciform out from its position on top of the drop safety and allow you to lift the trigger bar away from the housing. (Fig. 62)

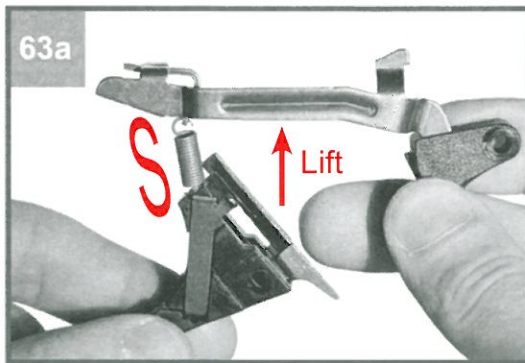

Note:

After the trigger bar has been lifted away from the housing, you will see the coil trigger spring is connected to the housing and trigger bar. Viewed from the right, the coil spring has an “S” configuration. When reinstalling this spring, take care to retain the “S” shape when this assembly is viewed from the right. (Fig. 63a / 63b)

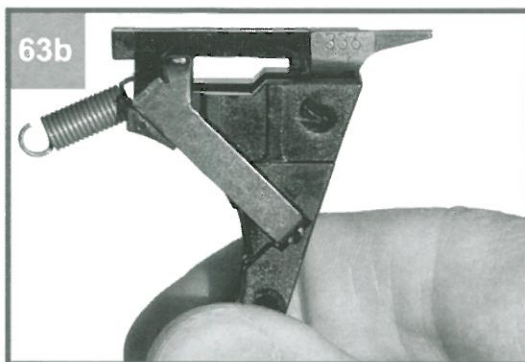

Separate the trigger with trigger bar from the coiled trigger spring by working the hooked end of the trigger spring off the trigger bar.

Separate the trigger mechanism housing from the trigger spring by “unhooking” the end of the “S” shaped coil trigger spring

Trigger Spring Inspection

Notice: During Annual Inspection of the Trigger Spring it is important to note any conditions that might warrant the need for the spring's replacement.

This spring should be replaced if:

1. The Trigger Spring is broken or missing
2. The coils are bent, crimped or stretched
3. The hooks of the spring show any stress marks
4. The Trigger Spring is not the current version (Grey Finish)

Note: If necessary to replace the coil trigger spring, please refer to the information in "Coiled Trigger Spring Replacement" page 53.

Remove the connector by pushing the pin punch through the hole provided on the opposite side of the trigger mechanism housing. (Fig. 64)



Note:

Older trigger mechanism housings do not have the hole mentioned above. Remove the connector by inserting a small screwdriver blade along the long axis of the connector. Exercise caution by getting as close as possible to the bend of the connector before prying the connector upwards. Otherwise, it is possible to cause some damage. (Fig. 65)

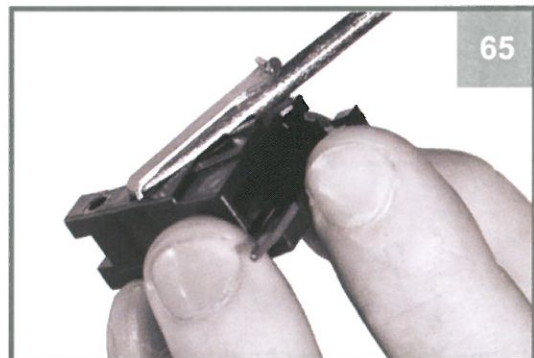

Exercise caution when removing and installing the connector. Excessive disassembly may cause wear on the housing. When re-inserting the connector, make sure it is completely seated and fits snugly into place.

The trigger assembly contains the trigger mechanism housing, the ejector, connector, trigger spring and the drop safety ledge. (Figs. 66).

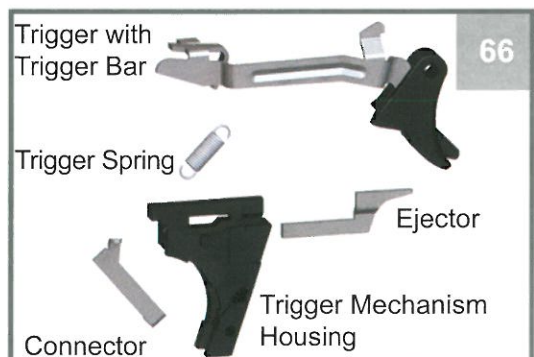

Connector Options

In addition to the standard 5.5 lb. (2.5 kg) connector, 4.5 lb. (2.0 kg) and 8.5 lb. (3.5 kg) connectors are available. To change the trigger pull weight, merely change the connector and/or the trigger spring.

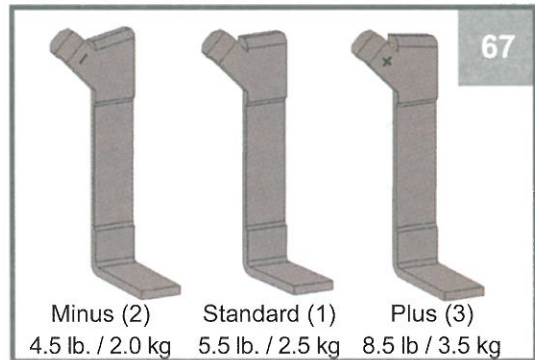

Trigger Springs

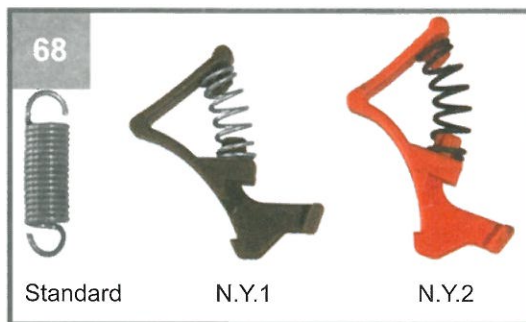

Along with the standard coil trigger spring, GLOCK offers two versions of the New York trigger springs.

New York Trigger Springs

The New York trigger springs are alternatives to the standard coil trigger spring and give a more “revolver-type” feel to the trigger pull. There are currently two versions of New York springs and they are produced in two different colors with two different colored springs. New York springs should only be installed with the 4.5 lbs. (2 kg) or 5.5 lbs. (2.5 kg) connectors.

A New York spring should never be installed with the 8 lb. (3.5 kg) (+ marked) connector.











The **NY1** trigger spring is olive green colored with a silver spring attached. Use of this part will increase the trigger pull weight approximately 3 lbs. (~1.5 kg) over the normal weight associated with that connector.

The **NY2** trigger spring is orange colored with a black spring attached. Use of this part will increase the trigger pull weight approximately 5 lbs. (~2.5 kg) over the normal weight associated with that connector.

Note:

When installing New York trigger springs, make sure the connector fits tightly in the trigger mechanism housing. If it does not fit tightly, replace the housing and/or the connector to ensure a secure fit.

Trigger Pull Weight Chart

Firing pin spring 24N (silver) 		→		~4.5 lbs. (~2.0 kg)	69
		→		~7.5 lbs. (~3.5 kg)	
		→		~5.5 lbs. (~2.5 kg)	
		→		~9 lbs. (~4.0 kg)	
		→		~11 lbs. (~5.0 kg)	
		→		~8 lbs. (~3.5 kg)	

Notes:

Slide Lock Removal

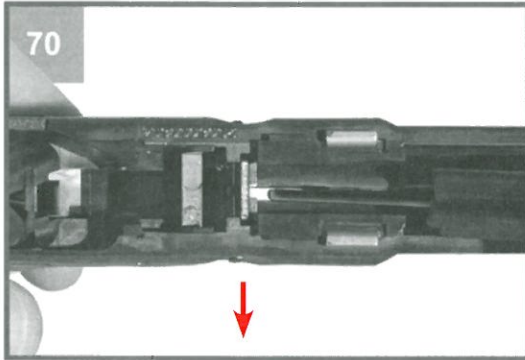

- To remove the slide lock, first hold the receiver on its side. Use the pin punch to press downwards on the flat slide lock spring just forward of and under the slide lock. When this spring is depressed, the slide lock should fall free from the receiver. (Fig. 70)

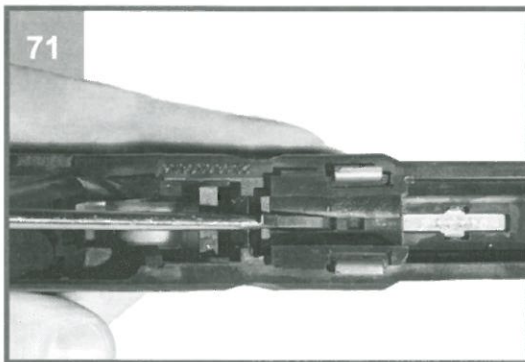

- Remove the slide lock spring by raising it from its recess in the receiver. (Fig. 71)

Caution

Place a pin punch, small bladed screwdriver or needle nose pliers as far forward under the spring as possible before attempting to raise the spring.

Notes:

Magazine Catch Removal

- Hold the receiver so that you can see into the magazine well.
- Prevent movement by pressing on both sides of the catch. (Fig. 72)

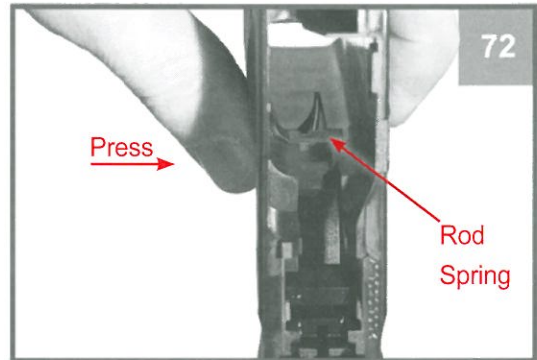

- Use a small screwdriver to push the magazine spring (rod shaped) up and toward the “U” shaped cut in the catch. This will release the tension from the magazine catch. (Fig. 73)

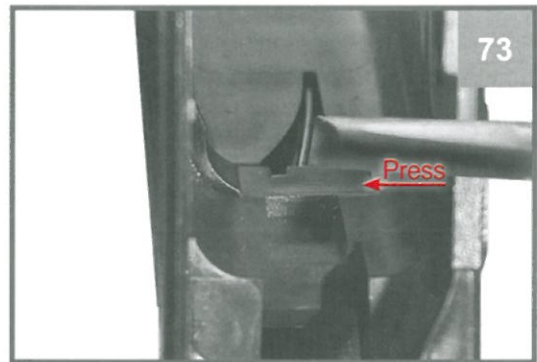

- Remove the magazine catch from the large side. (Fig. 74)

Magazine Catch Spring Removal

- Grasp the top of the rod magazine catch spring with a pair of pliers and pull the spring straight up out of its recess in the receiver.

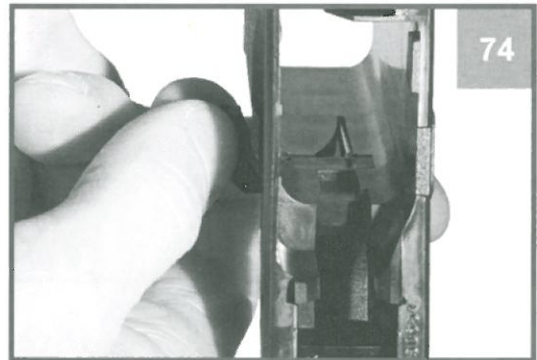

Please consider chapter XXIII “Parts overview” for optional parts.

Ambidextrous Magazine Release Removal



In 2007, GLOCK introduced the GLOCK 21SF model with an ambidextrous magazine release for the U.S. market. The ambidextrous magazine release on the GLOCK 21SF model requires the new version magazine body to operate properly. The magazine body has an additional recess cut into its front side to accept the new latch.

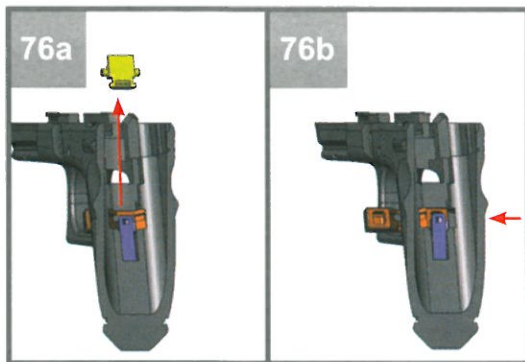

Using the pin punch or screwdriver, reach down into the front of the magazine well and press the magazine catch forward and flush against the front strap. This will release the tension on the magazine catch from the magazine release spring (Fig. 75). Slide the magazine catch out of the receiver (Fig. 76a). Then use disassembly tool to push the magazine release out of the receiver from either side (Fig. 76b). You can now remove the magazine catch spring.

Attention, when removing the magazine release magazine catch spring may become dislodged.

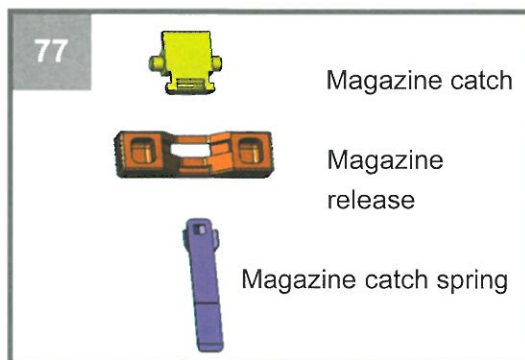
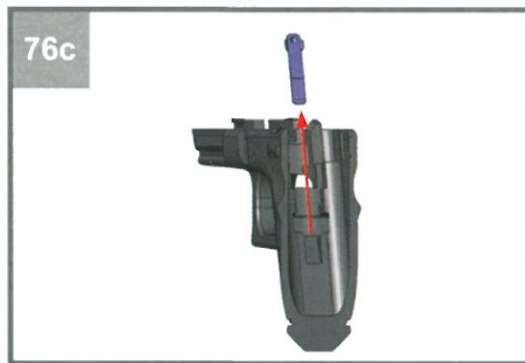

Components of ambidextrous magazine catch. (Fig. 77)

Standard Magazine Catch Replacement

- Using the pliers, insert the rod spring into the recess and make sure to seat it completely.
- Insert magazine catch. When the catch meets the rod spring, you will have to carefully push up the spring end to allow the catch to slip under the spring. (Fig. 78)
- Using the small bladed screwdriver, push the end of the spring back into the “U” shaped cut in the magazine catch.
- Check for proper tension and function (use an empty magazine).

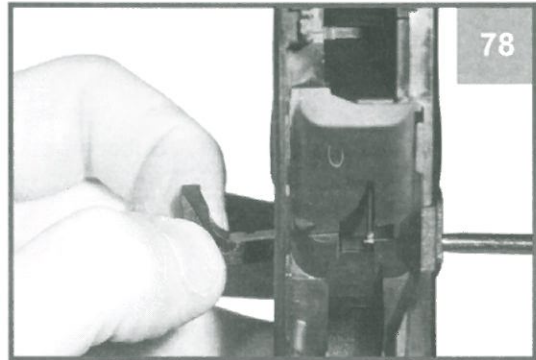

Ambidextrous Magazine Release Replacement

- Slide the magazine release in from either side (ensure that the thinnest portion of the body is at the top).
- Insert the magazine catch properly. (Fig. 79)
- Push the magazine catch spring back into the recess use punch to seat it completely.
- Check for proper tension and function (use a magazine).



Different Slide Lock Springs

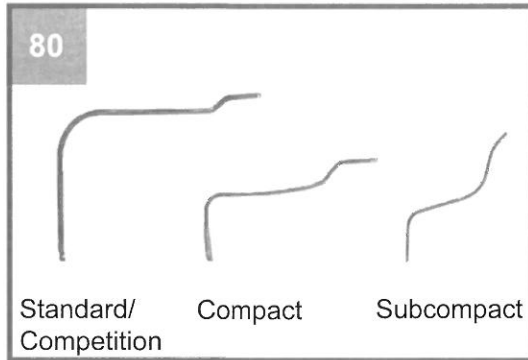

The slide lock spring has one straight end and the other end has a "hump." The straight end is inserted vertically into a recess in the receiver and the "hump" faces toward the rear. (Fig. 80 shows the shape and sizes of springs)

Make sure to fit the slide lock springs by size.

Slide Lock Spring Replacement



- Insert the straight end of the slide lock spring down into its recess in the receiver (located just behind the front rails). (Figs. 81a / 81b)

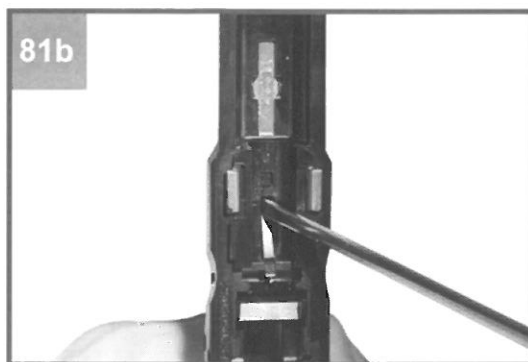

Caution

- Insert the slide lock and make sure it goes over the spring (press down the tip of the spring and allow the lock to go on top).

Slide Lock Replacement

Caution

The slide lock lever must always be installed so the groove is facing up and towards the rear. Improper installation may allow the slide to disengage from the receiver when the trigger is pressed rearwards.

(Figs. 82a / 82b)

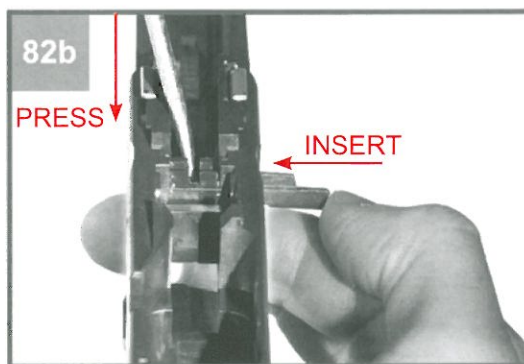
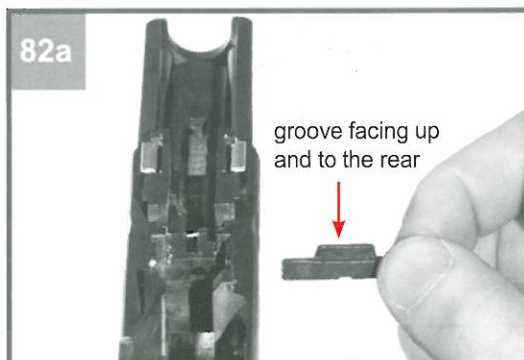

Different Trigger Mechanism Housings with Ejector

83a



Standard size Trigger mechanism housing with ejector.

83b

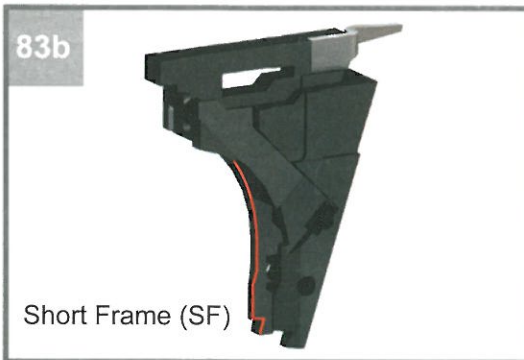

Trigger mechanism housing for Short Frame models.

Be sure to match the Trigger mechanism housing by frame size. (Fig. 83a/ 83b)

Different Ejectors

84

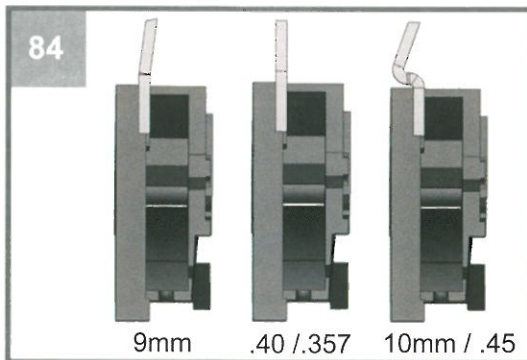

Trigger Mechanism Housing with Ejector. Be sure to match the ejector by caliber. (Fig. 84)

Connector Replacement

The connector is a “L” shaped part with one long leg and one short leg. At the end of the long leg there is a raised, angled section and a hook. The connector, along with the trigger spring, determines the trigger pull weight. Three different connectors are offered and they are marked as in Figs. 67 and 69.

- Insert the short leg of the connector into its recess in the trigger mechanism housing. Always seat the connector fully and ensure that it's firmly in place. Press your pin punch (or your screwdriver) against the connector to push it in. While doing this operation, be careful to locate your tool as near as possible to where the connector is inserted in the trigger mechanism housing. Otherwise you could damage the connector. This should be a snug fit. (Figs. 85a / 85b)

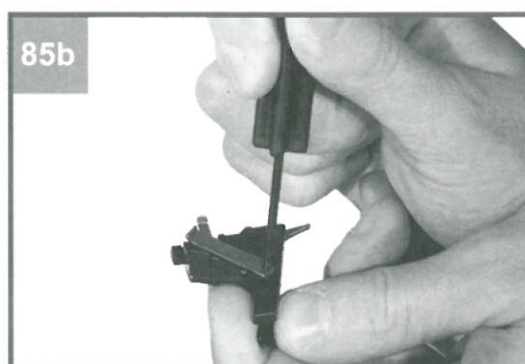
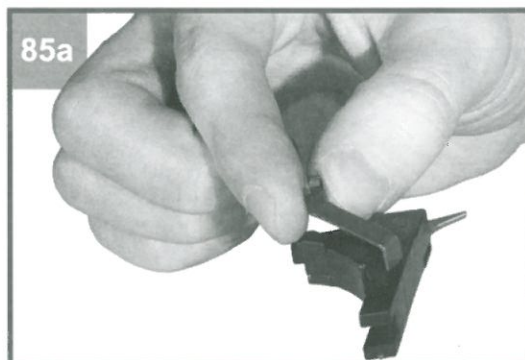

Coiled Trigger Spring Replacement

- If using the standard “S” shaped coiled trigger spring, hook one end through the hole in the top of the trigger mechanism housing and the other end through the hole on the bottom leg of the trigger bar. If viewed from the right and oriented correctly, the coiled trigger spring should resemble an “S.” (Fig. 86)

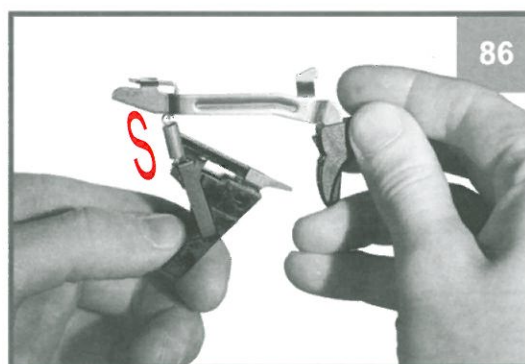

OR:

New York Trigger Spring

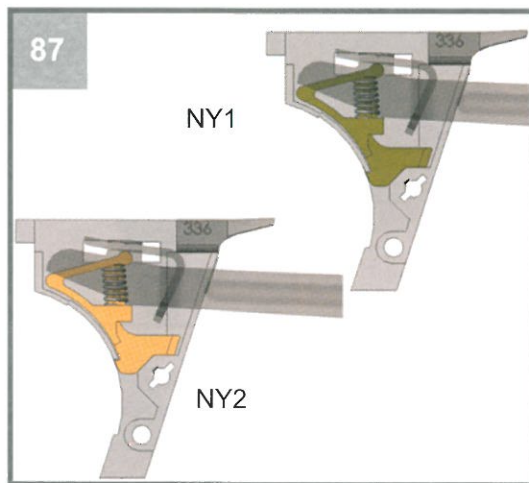

- If using the NY1 (olive green) or NY2 (orange) trigger spring; insert the spring down inside the trigger mechanism housing and ensure that it is oriented correctly. Ensure the catch on the lower end of the NY Trigger Spring snaps into the slot at the rear of the trigger housing. (Fig. 87)

Trigger Bar Replacement

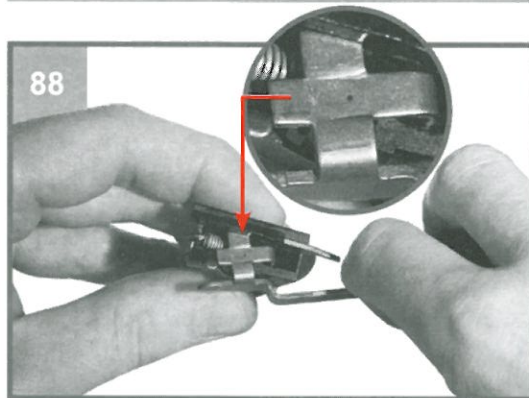

- Reinstall the trigger bar and ensure the left arm of the cruciform goes on top of the drop safety ledge of the trigger mechanism housing. (Fig. 88)

Caution

When replacing the trigger bar make sure to use identical marking. Marking is visible on top of the cruciform part of the trigger bar.

Trigger Assembly Replacement

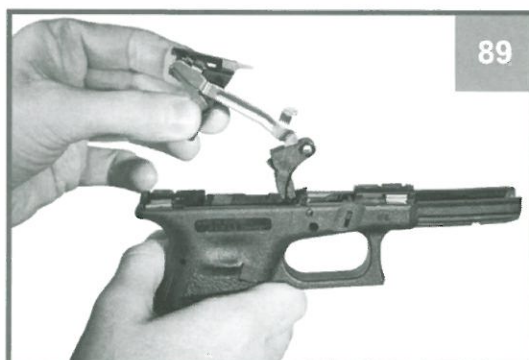

- Now that the trigger bar with trigger is reconnected to the trigger mechanism housing, place it back into the receiver by allowing the trigger pad to enter the trigger guard area and pushing down on the housing until it seats properly in the receiver. (Fig. 89)

Trigger Pin Replacement

- While holding the slide stop lever in position, insert the trigger pin from the right. When centered, the left groove on this pin will help keep the slide stop lever in its proper position. (Fig. 95a)



- Center two pins by pressing on the right side of the pin with the pin punch.**
(Fig. 95b)

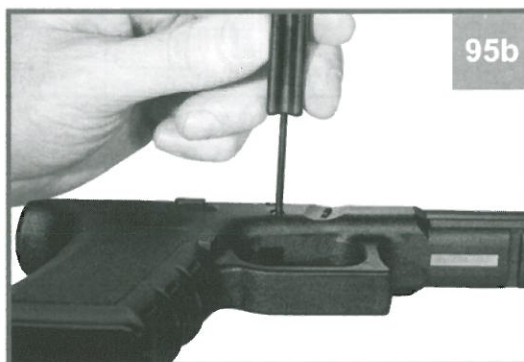

- Complete the reassembly by installing the fully assembled slide on the fully assembled receiver.** (Fig. 96)



XIV Magazines

		Magazine Capacity										
		33	19	17	15	13	12	11	10	9	8	6
GLOCK 17	9x19			■								
GLOCK 19	9x19			■	■							
GLOCK 26	9x19			■			■		■			
GLOCK 34	9x19			■								
GLOCK 22	.40			■	■							
GLOCK 23	.40			■	■	■						
GLOCK 27	.40			■	■	■		■		■		
GLOCK 35	.40			■	■							
GLOCK 20	10 mm AUTO			■	■							
GLOCK 29	10 mm AUTO			■					■			
GLOCK 21	.45 AUTO					■						
GLOCK 30	.45 AUTO					■			■	■		
GLOCK 36	.45 AUTO											■
GLOCK 37	.45 G.A.P.								■			
GLOCK 38	.45 G.A.P.								■		■	
GLOCK 39	.45 G.A.P.								■		■	■
GLOCK 25	.380 AUTO		■		■							
GLOCK 28	.380 AUTO		■		■		■		■			
GLOCK 31	.357			■	■							
GLOCK 32	.357			■	■	■						
GLOCK 33	.357			■	■	■		■		■		

GLOCK 17T	9 mm FX®			■								
GLOCK 19T	9 mm FX®			■	■							
GLOCK 26T	9 mm FX®			■	■				■			
GLOCK 17T	9 mm UTM			■								
GLOCK 19T	9 mm UTM			■	■							
GLOCK 17P	NO Live Fire			■								
GLOCK 19P	NO Live Fire			■	■							
GLOCK 26P	NO Live Fire			■					■			
GLOCK 22P	NO Live Fire			■	■							
GLOCK 23P	NO Live Fire			■	■	■						
GLOCK 17R	NO Live Fire			■								
GLOCK 19R	NO Live Fire			■	■							

standard

optional

New style magazines fit all frames
Pistols configured with the ambidextrous magazine release
require a new style magazine to operate properly.
Old style magazines will not work with pistols configured
with the ambidextrous magazine release.

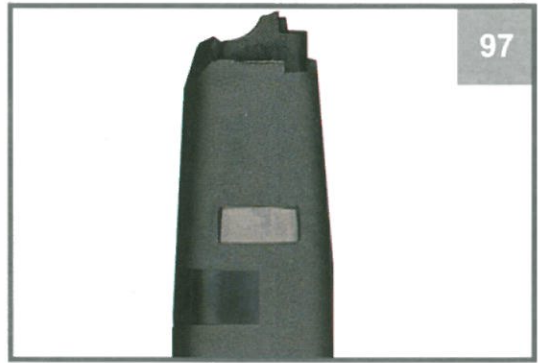

Interchangeability of magazines within the same caliber
from standard to compact and subcompact frames (not
applicable for GLOCK 36).

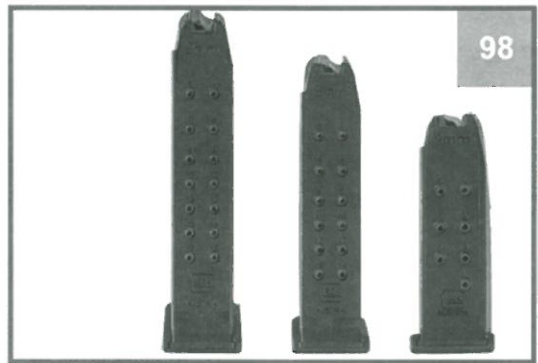

Magazine 33 rounds in caliber 9x19.
Fits all GLOCK pistol models in caliber 9x19.

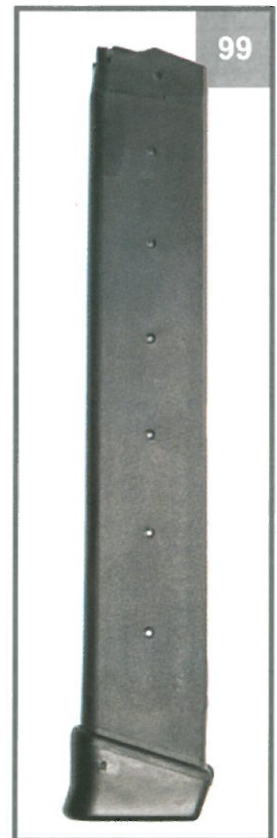

Magazine Disassembly

Caution

When disassembling the magazines only use 100% identical GLOCK magazine parts for reassembly.

In general, disassembly of GLOCK magazines is not recommended.

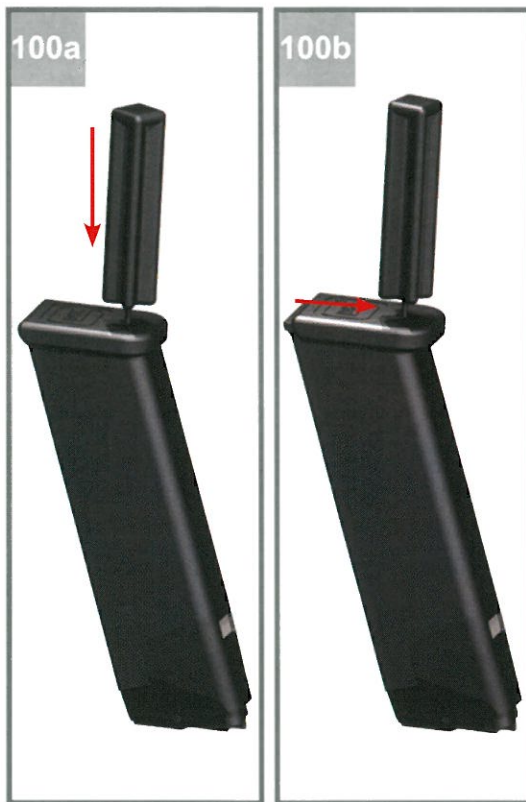

All standard current production magazines have removable floor plates and magazine inserts. To disassemble these magazines, you must depress the magazine insert before you can remove the floor plate, magazine spring and follower.

- Inserting the pin punch as far as possible through the hole in the floor plate will fully depress the insert and “unlock” the floor plate. Leaving the pin punch in place, pull forward on the punch handle moving the floor plate forward slightly. (Fig. 100a)
- Put your thumb over the floor plate to control the compressed magazine spring. Failure to do so may cause injury.
- Withdraw the pin punch and remove the floor plate. Slowly release the spring tension and then you can remove the insert, spring and follower. (Fig. 100b)

Earlier magazines do not use an insert to assist in retaining the floor plate. Tabs on the magazine body and recesses in the sides of the floor plate combine to keep the magazine together.

- Use your thumb and forefinger to compress the sides of the magazine body near the floor plate, or press a corner of the floor plate against a hard surface to “unlock” the floor plate.)

To disassemble full-size 10 round magazines, an alternate technique is necessary to unlock the floor plate. Use a thin bladed screwdriver to slightly depress the insert and pull the floor plate forward.

Caution

When disassembling the magazines only use 100% identical GLOCK magazine parts for reassembly. In general disassembly of GLOCK magazines is not recommended.

Components of the magazine. (Fig. 101)

Magazine Tubes and Liners

Current magazine tubes have a four-sided metal liner that usually falls free from the receiver when the magazine catch is depressed.

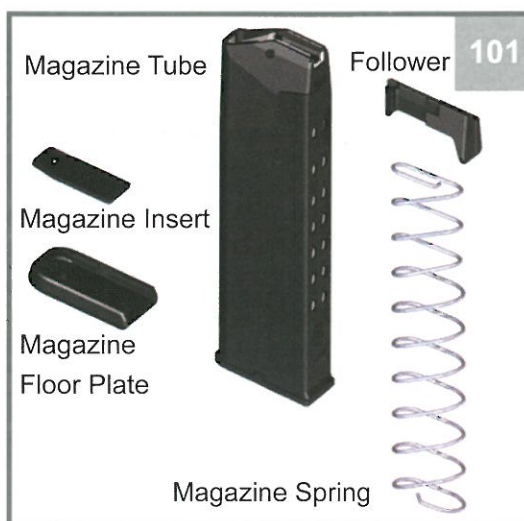

Followers

When exchanging followers, make sure to use the identical index number. Index number is visible on top of the follower. (Fig. 102)

Earlier followers had a hole in the body through which the magazine spring was hooked. Current followers snap on top of the magazine spring.

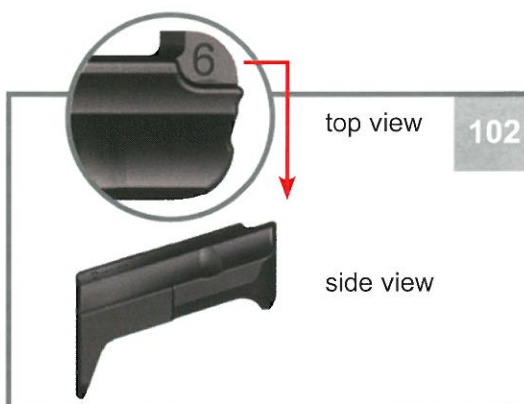

Magazine Springs

The magazine spring is extremely important to the proper functioning of any pistol. It must present the cartridge at the proper time in the cycle of operation and at the correct angle to be fed into the chamber. Proper spring tension must be maintained. The length of the magazine body, the weight and number of the cartridges to be lifted and the spring construction must all be considered for satisfactory magazine operation. (Fig. 103)

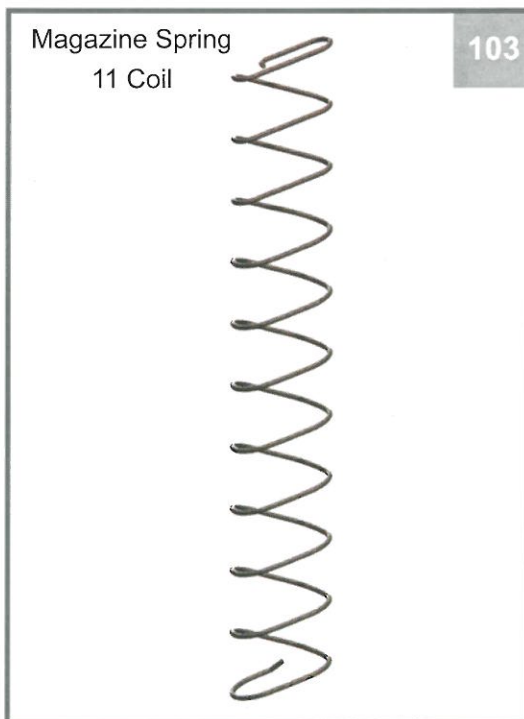

104

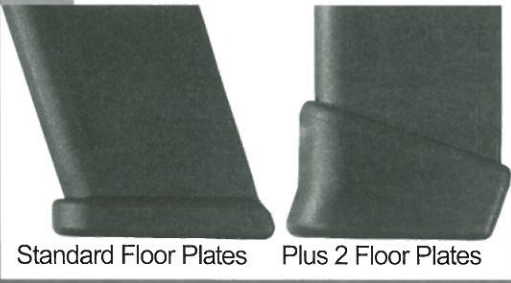

Magazine Floor Plates

Standard Floor Plates

Plus 2 Floor Plates

Magazines with extended floor plate (plus 2 rounds) are available for standard frame models (calibers 9x19, .40, .380, .357) and increase magazine ammo capacity while also assisting with seating and removal of the magazine.

Magazine Inserts

The magazine insert serves to lock the floor plate to the magazine body.

105

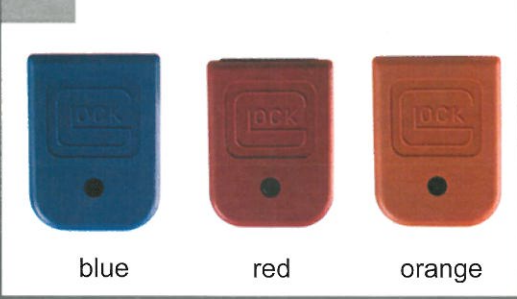

Blue floor plate magazines for training pistol models.

Red floor plate magazines for reset and practice pistol models.

Orange floor plate magazines for identifying training magazines.

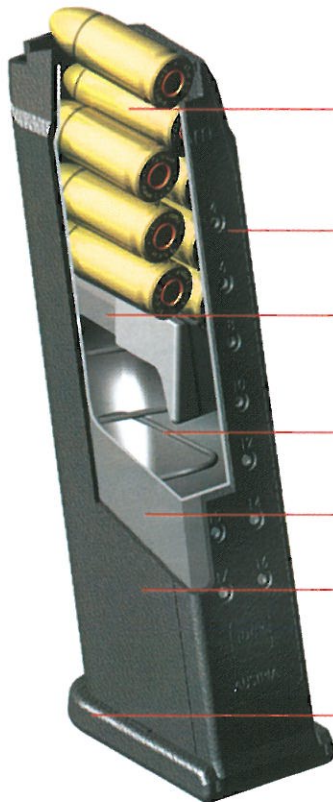

Cartridges arranged in double rows

Window for each cartridge

Follower

Magazine spring

Hardened steel tube

Polymer jacket

Floor plate

Caution

Prior to performing any of these inspections unload pistol and do safety check as per procedure in chapter VIII.

Fully Assembled Pistol**1. Slide Lock** (3 steps to this inspection)

- a. With thumb and forefinger, try to pull down on both sides of the slide lock lever. It should not move downwards if the slide is forward and locked in battery. **This lets you know the slide lock is present and “locked” properly.**
- b. Using the disassembly grip, move the slide rearward approximately 3 mm / 1/8" and pull down on both sides of the slide lock and release. **This verifies the slide lock will “unlock” and the spring is operational.**
- c. With the slide lock lever fully engaged, point the pistol in a safe direction and pull the trigger while pushing the slide forward. **The slide should remain “locked” and not move forward off the receiver.**

2. Trigger Safety (2 steps to this inspection)

- a. With the slide forward, action set and the trigger forward (ready to shoot), press on both **sides** of the trigger and try to move the trigger backwards. The trigger should only move slightly rearward (not releasing the firing pin). Be careful not to press on the **center portion** (trigger lever safety) of the trigger pad. **This verifies the trigger lever safety is present, operational and would prevent any unwanted rearward movement of the trigger bar.**
- b. After making sure the pistol is unloaded, point it in a safe direction and pull the trigger. **When the finger depresses the trigger lever safety, it should allow the trigger lever safety and trigger to move rearwards and release the firing pin.**

3. Recoil Spring/Guide Rod Assembly

The recoil spring should be strong enough to move the slide forward reliably to chamber cartridges even if the pistol is somewhat dirty, dry or the ammunition is not perfect. With an unloaded pistol, point it 45° upwards and pull the trigger. While holding the trigger back, pull the slide to the rear and release it very slowly. The recoil spring should be able to push the slide completely forward and fully into battery. **This test verifies that the recoil spring is strong enough to chamber ammunition despite less than ideal circumstances.**

4. Magazine Spring

The magazine spring must be strong enough to feed all ammunition reliably and be able to push the magazine follower up with sufficient strength to move the slide stop lever up to lock the slide to the rear when no ammunition remains. Insert an empty magazine and pull the slide completely rearwards forcefully. The slide should lock back every time without any assistance. **This test ensures that the magazine spring is strong enough to lock the slide back when no ammunition remains in the magazine. It also checks for proper operation of the follower and slide stop lever.**

5. Firing Pin Safety Release (free movement)

When the trigger is pulled, the firing pin safety moves upwards and clears the firing pin channel to allow the firing pin to move freely to strike the primer with sufficient force. With an unloaded pistol, point it in a safe direction and pull the trigger. Hold the trigger rearward and shake the entire pistol. You should hear the firing pin moving forwards and backwards. **This ensures the firing pin channel is unobstructed and the firing pin safety has been moved enough to allow the firing pin to move freely.**

Engagement

“Engagement” is a term to describe the relationship between the raised back portion of the trigger bar and its contact with the firing pin lug. In addition to all the previous safety features, this area should be inspected periodically to insure adequate surface contact is maintained. A minimum of 2/3rds of the surface area of the back leg of the trigger bar should be in contact with the firing pin lug when the action is set and the slide is fully forward.

(Figs 106 - 109)

Minimum engagement of 2/3rds.

Unacceptable engagement.

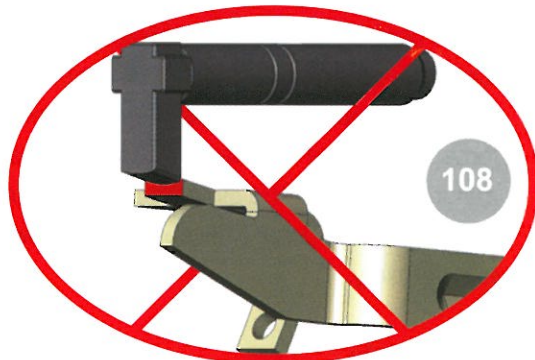
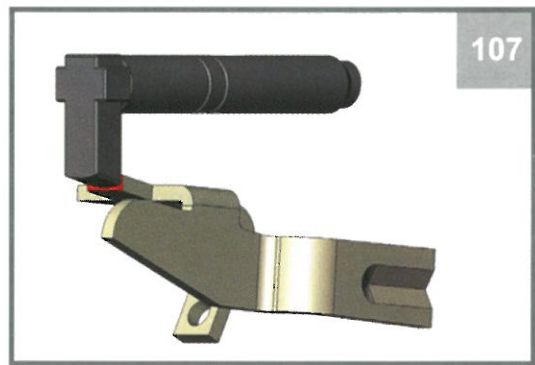
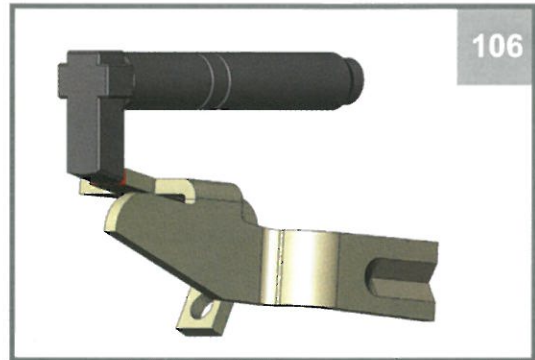

Replace the standard slide cover plate with the orange half slide cover plate. Determine how much engagement you can see. 2/3rds or more of the back of the trigger bar should contact the firing pin lug.

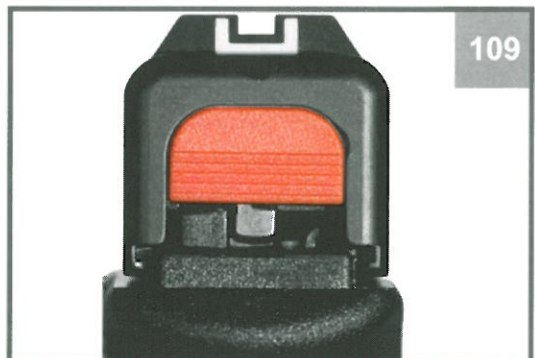

Field Inspections While Field Stripped

Slide

1. Firing Pin/Firing Pin Safety Engagement (push by)

With the slide off the receiver, use your finger to pull back on the firing pin lug. Ease the lug forward again and it will rest against the firing pin safety. The firing pin safety should block any forward movement of the firing pin. Press forward on the back of the firing pin lug and attempt to force the firing pin forward. There should be no forward movement of the firing pin unless the safety is depressed. If there was no forward movement with the safety engaged, then press in on the firing pin safety and the firing pin should now move freely forwards. **This inspection verifies that the firing pin safety does block the firing pin and prevents any forward movement unless the safety is depressed.**

2. Firing Pin Free Movement (no obstructions)

With the firing pin safety depressed, shake the slide forwards and backwards. You should be able to hear the firing pin moving freely. **This check verifies that the firing pin channel is unobstructed and the firing pin may move forwards freely when the safety is depressed.**

Receiver

1. Slide Stop Lever Tension

When properly assembled, the slide stop lever should be under spring tension and slight backwards and forwards movements should be possible. The slide stop lever should be held down until the follower forces it up. With your fingers, pull the rear of the slide stop lever upwards and release. It should snap down with force. If the slide stop lever does not have sufficient downward force, it may engage the slide notch prematurely and lock the slide back even if ammunition remains in the magazine. **This check ensures that the slide stop lever has sufficient downward spring pressure and should not lock the slide back prematurely.**

2. Drop Safety

Using your fingers, pull the trigger forward (or push forward on the vertical extension of the trigger bar). On the top of the back of the trigger bar, you will find the cruciform. The arms of the cruciform rests on the drop safety ledge when the trigger is in the forward position. The drop safety ensures the back of the trigger bar does not move downwards and release the trigger bar unless the trigger is pulled fully to the rear. With your pin punch centered on top of the cruciform, press down firmly and see if the back of the trigger bar will move downwards. It should not move down unless the trigger is pulled. After seeing that the drop safety is operational, press forward on the vertical extension of the trigger bar and pull the trigger. The back of the trigger bar should move backwards and then downwards. **This shows that the drop safety would prevent any premature separation of the trigger bar and firing pin.**

These "Field Inspections" should be performed anytime the pistol has been disassembled and reassembled to ensure proper operation.

Other appropriate times would be whenever a pistols are returned to service, bought, sold or traded.

Caution

Before installing or adjusting sights, be certain that the pistol is unloaded by removing the magazine and clearing the chamber. **Physically and visually check chamber and magazine well!**

Sight Mounting Tools

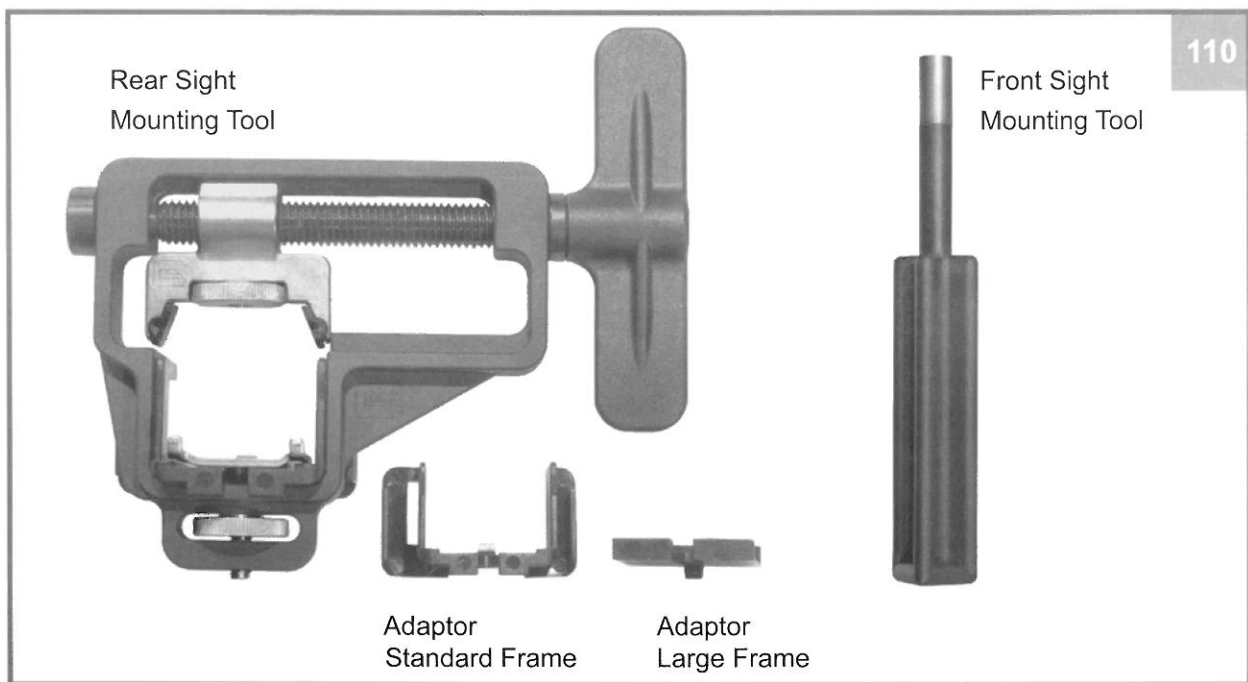

Rear Sights

Point of Impact

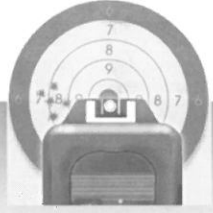

TOO FAR LEFT
Slide the rear sight to the right with the rear sight mounting tool. Turn the handle clockwise for this purpose.



TOO FAR RIGHT
Slide the rear sight to the left with the rear sight mounting tool. Turn the handle counter-clockwise.

Point of Impact



TOO HIGH
Insert a lower rear sight with the rear sight mounting tool.



TOO LOW
Insert a higher rear sight with the rear sight mounting tool.

Note:

Rear sights may be adjusted, installed or removed with the slide off the receiver or with the slide merely locked to the rear.

All sight adjustments are made to the rear sight.

When adjusting rear sights, always move the rear sight in the direction you want the group to move.

- Windage adjustments are made by moving the rear sight to the left or right in the dovetail cut of the slide.
- Elevation adjustments are made by raising or lowering the height of the rear sight.

Please consider chapter XXIII “Parts Overview” for optional parts.

Rear Sight Markings on the Right Side of the Rear Sight



6.1 mm



6.5 mm



6.9 mm



7.3 mm

Each rear sight height change represents approx. 2.4 in. (~61 mm) difference in bullet impact at 27 yards (25 m) for the GLOCK 17. For standard rear sight heights please consult rear sight height chart.

Rear Sight Mounting Tools

Current Rear Sight Mounting Tool

Has adaptors to fit both frame sizes.

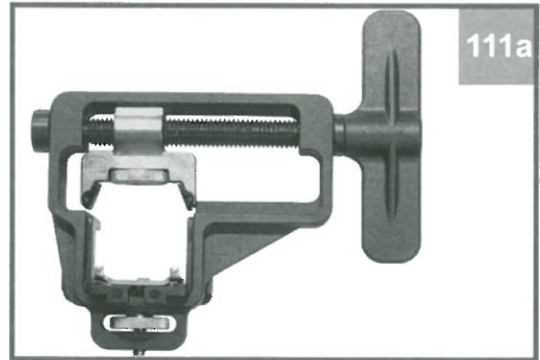

Adaptors:

Standard frames (plus GLOCK 36)

Large frames (except GLOCK 36)

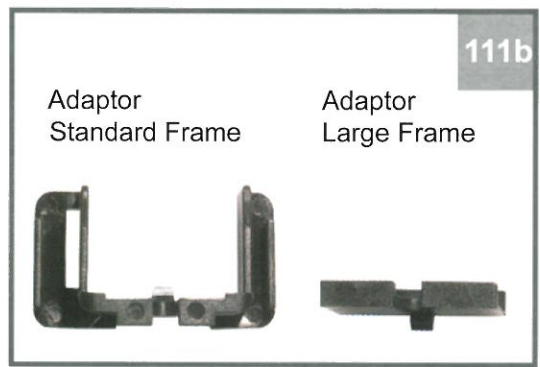

Previous version. (No longer offered)



Original Rear Sight Mounting Tool

Standard and Large Frames (Two Versions)
(No longer offered)

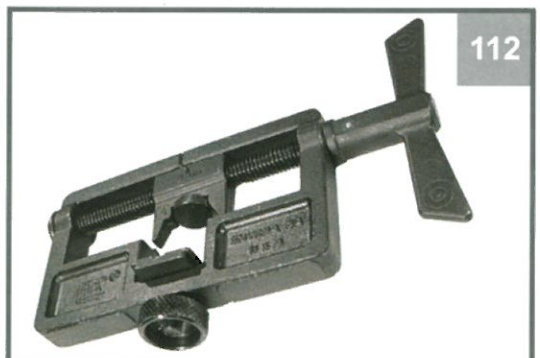

Caution

Be certain the pistol is not loaded. Remove the slide from the receiver (or lock the slide to the rear).
Select the proper size tool or rail plate insert — standard or large frame.

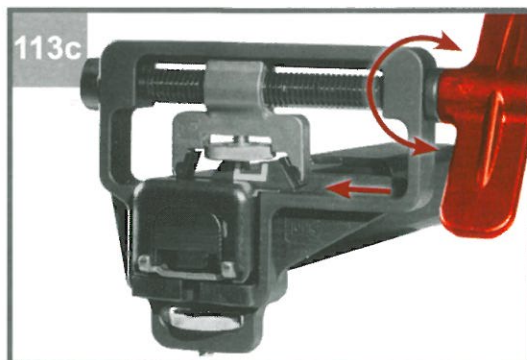
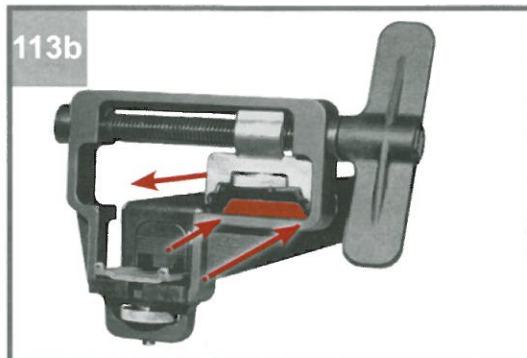
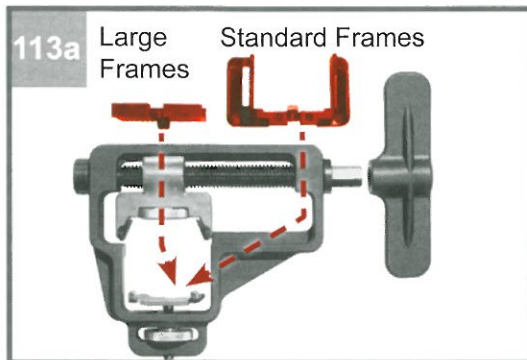

To Replace Rear Sight

Move the sight carrier to the right. After elevating the slide rail plate assembly by turning the thumb nut, insert the corresponding adaptor depending on your slide width (Fig. 113a).

Place the slide in the slide rail plate assembly by aligning the slide rail cuts with the slide rail plate. Push the slide to the rear until the slide contacts the ramp protruding from the slide rail plate assembly, tighten thumb nut.

Insert a new GLOCK sight in the carrier (still at the right side), making sure the white outline of the sight is facing toward the rear. Turn downward pressure screw to apply slight pressure to the top of the new sight (Fig. 113b).

Turn handle to adjust the new rear sight. (Fig. 113c).

To Adjust the Rear Sight for Windage Corrections

































- Loosen the thumb nut screw and slide the slide rail plate assembly into the slide rail cuts.
- Tighten the thumb nut screw.
- Turning the drive screw handle to the right or left will move the sight accordingly.
- Loosen thumb nut screw and remove slide from the tool.

Note:

Ensure the sight carrier is centered with respect to the dovetail on the slide.

Otherwise, there may be damage to the sight mounting tool, slide or both.

Rear Sight Height Chart

Caliber	GLOCK Pistol Model		Standard Rear Sight Height	Markings on Side of Rear Sight
9x19	GLOCK 17	full-size	6.5 mm	
	GLOCK 17C	full-size	6.5 mm	
	GLOCK 17L	full-size long-slide	6.1 mm	
	GLOCK 19	compact mid-size	6.5 mm	
	GLOCK 19C	compact mid-size	6.5 mm	
	GLOCK 26	sub-compact	6.5 mm	
	GLOCK 34	tactical long-slide	6.5 mm	
.40	GLOCK 22	full-size	6.5 mm	
	GLOCK 22C	full-size	6.5 mm	
	GLOCK 23	compact mid-size	6.5 mm	
	GLOCK 23C	compact mid-size	6.5 mm	
	GLOCK 24	full-size long-slide	6.5 mm	
	GLOCK 24C	full-size long-slide	6.5 mm	
	GLOCK 27	sub-compact	6.5 mm	
	GLOCK 35	tactical long-slide	6.5 mm	
10mm	GLOCK 20	full-size	6.9 mm	
	GLOCK 20C	full-size	6.9 mm	
	GLOCK 29	sub-compact	6.9 mm	
.45 AUTO	GLOCK 21	full-size	6.9 mm	
	GLOCK 21C	full-size	6.9 mm	
	GLOCK 30	sub-compact	6.9 mm	
	GLOCK 36	slim-line	6.9 mm	
.45 GAP	GLOCK 37	full-size	6.5 mm	
	GLOCK 38	compact mid-size	6.5 mm	
	GLOCK 39	sub-compact	6.5 mm	
.357	GLOCK 31	full-size	6.9 mm	
	GLOCK 31C	full-size	6.9 mm	
	GLOCK 32	compact mid-size	6.9 mm	
	GLOCK 32C	compact mid-size	6.9 mm	
	GLOCK 33	sub-compact	6.5 mm	
.380 AUTO	GLOCK 25	compact mid-size	6.9 mm	
	GLOCK 28	sub-compact	6.9 mm	

Note: The front sight height is the same for all models. However, do not mix brands of front and rear night-sights.

Note: A one-step change in rear sight height change represents approx. 2.4 in. (~61 mm) difference in bullet impact at 27 yards (25 m) for GLOCK 17.

Note: Rear sight height may vary due to factory test-firing.

Front Sight Mounting Tools

114a

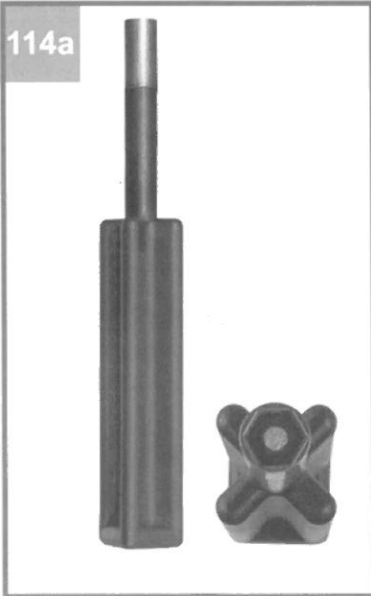

Current Front Sight Mounting Tool

For:
GLOCK Polymer screw-on front sights
GLOCK Steel screw-on front sights.

114b

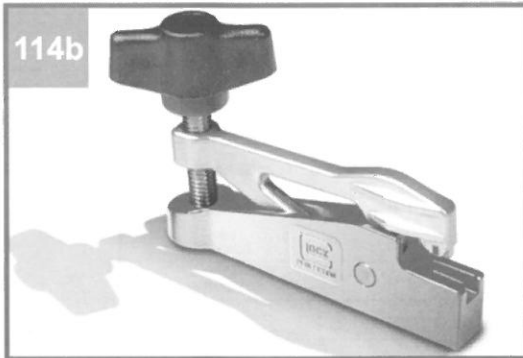

Front Sight Mounting Tool

For:
GLOCK Steel stake-on front sights.

Front Sight Removal and Installation

Caution

Be certain the pistol is not loaded. Remove the slide from the receiver.
Select the proper tool according to the type of front sight.

Please consider chapter XXIII “Parts Overview” for different front sights.

Front Sight Removal

Screw-on Front Sights

Remove screw-on front sights by turning the hex-head tool counter-clockwise.

Stake-on Front Sights

To remove the front sight from the slide, position the front of the slide in an upside-down position over the edge of a table or workbench. Using a straight-shafted pin punch and a small hammer, tap the sight from the slide. If removing a staked-on metal sight, use a strong steel punch. If necessary or desired, use projected jaw covers and lock the slide into a vise to perform this procedure.

Front Sight Installation

Polymer Sights (screw-on)

Position the screw-on polymer front sight in the slot of the slide.

Insert the fixing screw in the slot in the base of the front sight mounting tool. (Fig. 115, 116)

Tighten screw/nut until it is snug (do not overtighten and break screw).

Adjust front sight if necessary.

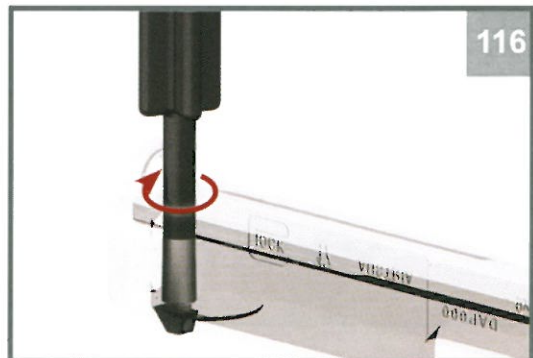
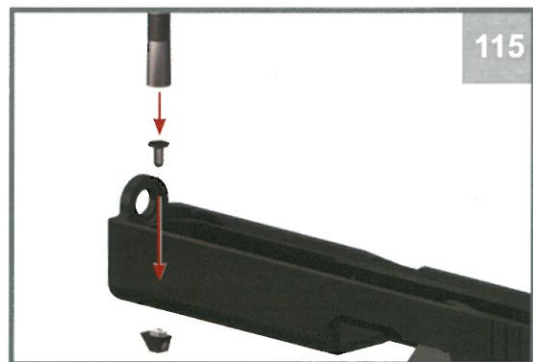

Steel or Night Sights (screw-on)

- Degrease the slide, sight and screw to remove any oil or solvents.
- Apply threadlocking type adhesive to the thread of the front sight. Remove excessive amount of adhesive.
- Position the steel front sight in the slot of the slide.
- Insert the fixing screw in the slot in the base of the front sight mounting tool.
- Tighten screw/nut until it is snug (do not overtighten and break screw).
- Adjust front sight if necessary.

Polymer Sights (stake-on)

- Insert a new front sight into the front sight slot and press it down flush with the top surface of the slide.
- Place the slide upside down with the top of the front sight on a smooth wood or plastic surface so the sight will not be pushed out of the slide when inserting the wedge pin.
- Using your fingers, needle nose pliers or tweezers, insert a front sight wedge pin into the slot at the base of the front sight.
- With a pin punch, push the wedge pin in just below the base of the front sight.

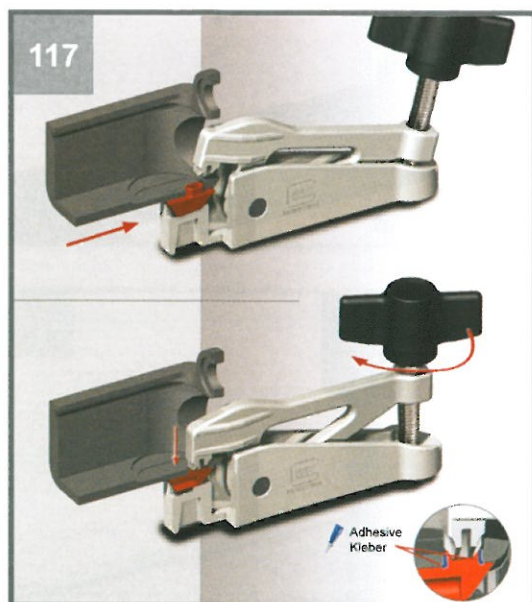

Steel or Night Sights (stake-on) (Fig. 117)

- Degrease the slide and sight to remove any oil or solvents.
- Apply threadlocking type adhesive to the base of the sight.
- Install the sight into the slide hole.
- Position sight down on a smooth wood or plastic surface.
- Properly position GLOCK front sight staking tool.
- Press down firmly on the slide while turning the handle clockwise as far as possible.
- Turn the staking tool handle counter-clockwise until the tool can be removed from the slide.
- Inspect to ensure the front sight base is flush with the slide and is firmly attached and straight.

The standard GLOCK pistol does not have any left hand specific features or ambidextrous controls because none is needed.

All the following functions can be easily achieved by both right and left handed users with the proper technique:

- Pulling the trigger.
- Loading, unloading and reloading.
- Clearing any type of stoppage.
- Locking open and releasing the slide.
- Disassembly and reassembly.

*** Note:**

In 2007 GLOCK introduced the ambidextrous magazine catch as an optional feature for GLOCK pistols. It allows anyone to choose between using the thumb or forefinger to operate the magazine catch from either side.

For the U.S. only the model G21SF is available with ambidextrous magazine release.

Notes:

XVIII Maintenance

Caution

Unload pistol. Physically and visually check the chamber area and magazine well to insure all ammunition has been removed. Prior to any maintenance and field stripping: always perform unloading procedure and safety check (Chapter VIII).

Field Stripping

Using the disassembly grip, retract the slide approximately 1/8 in. (3 mm) while pulling down on both sides of the slide lock. While holding the slide lock in the downward position, move the slide forward. Remove the recoil spring/guide rod assembly by grasping the end nearest the barrel lug and pulling it straight up. Lift up on the barrel lug and remove the barrel. You should have the following: slide, barrel, recoil spring assembly, receiver and magazine(s). (See also Chapter IX)

Cleaning Supplies

Use only solvents and lubricants designed for use on firearms. Any product that is advertised and/or marketed for use on guns may be used on GLOCK pistols. When using solvents, make sure all solvent is removed before lubrication, use or storage of the firearm. Under some circumstances, a “dry” (no solvent) cleaning may be appropriate. After cleaning, GLOCK pistols require a minimum of lubrication.

Barrel

Inspect the barrel to ensure that the bore is clear. Using a proper size bore brush or cloth patch, push it all the way through from the chamber and out the muzzle end of the barrel. Heavy fouling may require multiple passes. With a small brush (toothbrush), clean the lug areas, feed ramp and outside surfaces of the barrel. When satisfied all residue and solvent has been removed and all surfaces are dry, move to the slide.

Slide

Inspect the slide for any obvious fouling. Holding the slide with the firing pin channel up to prevent solvents from entering, clean the breech face and extractor area with the toothbrush. Take care to scrub under the extractor hook. Brush down the slide grooves, the ejection port area and all other surfaces.

For cleaning the openings of the slide use GLOCK channel maintenance kit. (Fig. 118)

When satisfied all residue and solvent has been removed, move on to the recoil spring assembly.

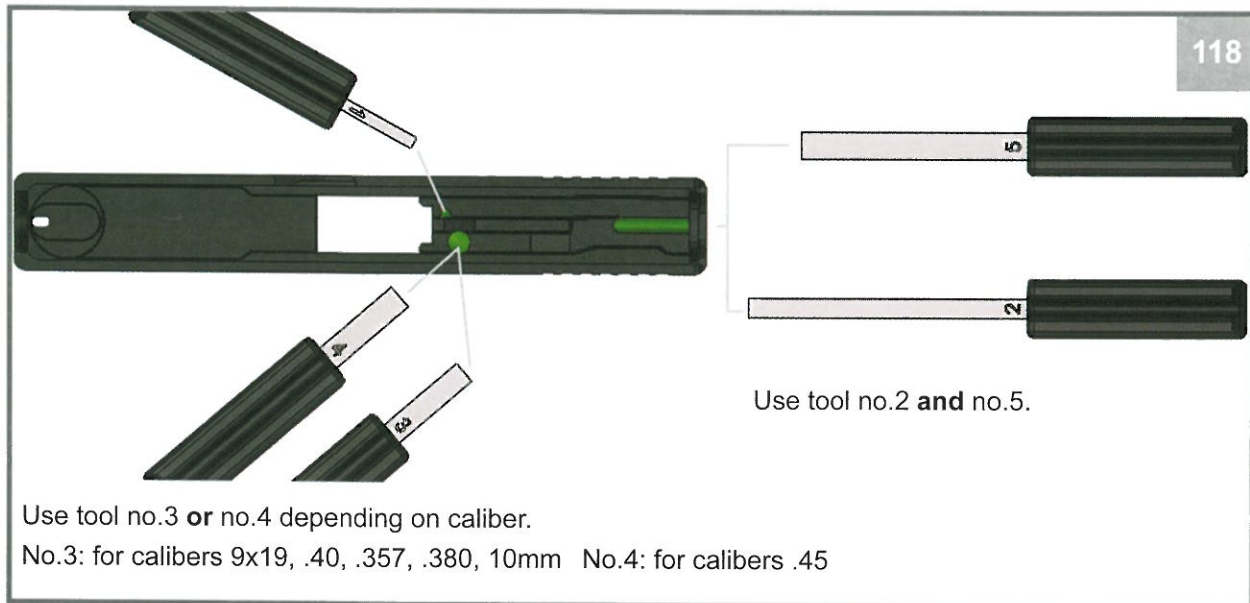

Recoil Spring

Inspect the recoil spring/guide rod assembly for wear and obvious fouling. Using a cloth or brush, clean all surfaces. When satisfied all residue and solvent has been removed, move on to the receiver.

Receiver

Use the brush to clean the rails and brush down all other surfaces as necessary. Be certain all solvent and residue has been removed before you attempt to reassemble the pistol.

Magazine

Don't disassemble. Use a brush or cloth to clean down all surfaces as necessary.

Lubrication

After a thorough cleaning, remove any remaining solvent from the pistol. Using a quality gun oil or grease product, lightly lubricate the barrel, barrel hood, barrel lug and the inside of the slide where the barrel hood contacts the slide (Fig. 116 - 118). Apply a small amount of lubricant on either the frame rails or inside the slide grooves. Once the slide is replaced on the receiver and the action worked several times, the lubricant will be distributed equally along the slide grooves and frame rails.

Most important is one drop of oil placed just under the connector hook (located just above the right rear receiver rail). Any lubricant placed here will move down where the connector and trigger bar meet. If this area is not properly lubricated, the result may be a "hard" trigger pull that can lead to connector and/or trigger bar damage.

GLOCK pistols are designed to operate properly with minimal lubrication.

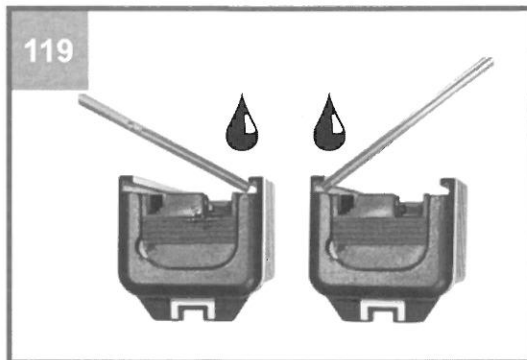

Caution

Large quantities of oil or grease may collect unburned powder, grit, dust or other residue that could interfere with proper functioning of any firearm. Extreme climate (cold or hot weather) could affect large amounts of lubricant.

(Figs. 119-122)

Caution

Never leave any solvent or put any lubricant inside the firing pin channel or magazine tube. Along with the breech face and barrel chamber, these areas should be wiped dry before reassembly or use. Leaving solvent or lubricant in any of these areas may cause contamination of primers or powder and possible failure to fire.

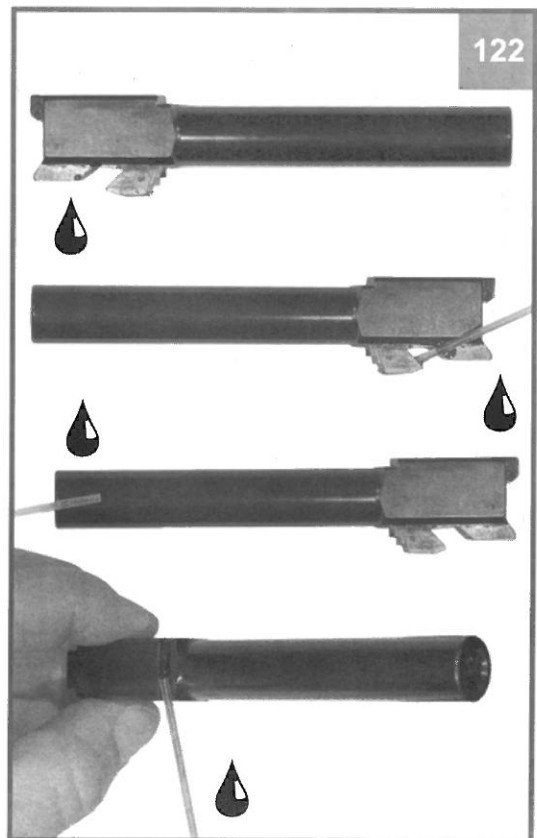
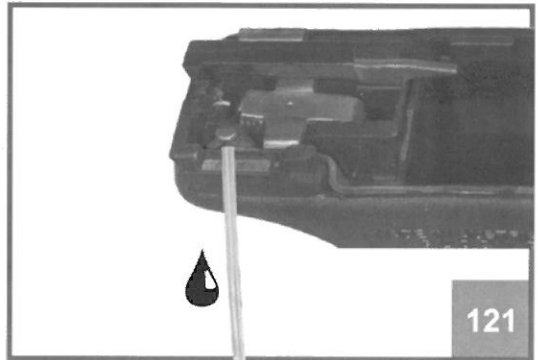
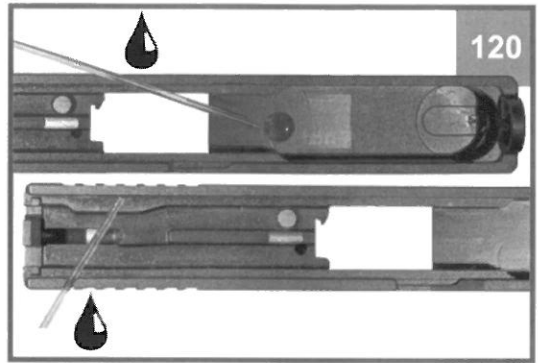

Note:

The copper colored substance on the cam area of the interior of the slide is a high-temperature, factory applied lubricant for new pistols. It should be allowed to remain until it naturally wears away to assure long-term lubrication of this area.

XIX Scheduled Replacement Parts

As with every type of machine and all firearms, GLOCK pistols do have some parts that may occasionally require maintenance, adjustment and/or replacement. "Wearable" parts are those that by their very nature will not maintain absolute factory specifications forever and will need to be monitored periodically for satisfactory function.

Generally it is recommended that all GLOCK Pistols be detail disassembled and inspected by a certified GLOCK armorer at least annually. All field inspections listed previously will assist in identifying any possible areas of concern.

Springs

Springs are very important to the proper operation of all semi-automatic pistols and as they age or "tire" they can affect the "cycle of operation," leading to unsatisfactory performance. Any spring can be damaged, weakened, worn or broken and should be evaluated often.

Springs in the GLOCK pistol that may require attention at some point are:

1. Recoil spring assembly
2. Firing pin spring
3. Firing pin safety spring
4. Extractor depressor plunger spring
5. Magazine catch spring
6. Slide lock spring
7. Trigger spring
8. Magazine spring
9. Slide stop lever spring (not a separate part—attached to the slide stop lever).

Extractors

Extractors should have the proper tension and that area should be relatively clean. The tip should not be "chipped" or damaged. Feeding and extraction problems can be caused by "worn" and/or damaged extractors.

Firing Pin/Firing Pin Safety

The front area of the firing pin engages the firing pin safety and it is possible to detect some wear in this area. Periodic field inspections and proper armorer handling techniques will minimize any potential problems in this area.

Magazine Followers

Followers help hold the cartridges at the proper angle for feeding and signal the slide stop lever to lock the slide to the rear. Check occasionally and monitor their condition.

Magazine Bodies

The side or front cut on the magazine body allows the magazine catch to operate properly. The “lips” of the magazine assist with proper feeding and can be damaged by improper cleaning and/or assembly and disassembly. Check these areas often.

Loading XX

Caution

Do not use live ammunition in the classroom!

Before loading a GLOCK pistol, always make sure you have the correct ammunition. Use only the proper caliber and ensure that the ammunition is in good condition. GLOCK pistols should only be fired with factory loaded, jacketed ammunition in accordance with CIP/SAAMI and/or NATO pressure standards.”

- Insert the correct ammunition into the magazine properly.
- The slide can be either forward in battery, or locked to the rear.
- Insert the magazine into the magazine well, seat it firmly and ensure it locks into place.
- Using the overhand method, pull the slide fully rearward and release.

You should now have a cartridge in the chamber. You can remove the magazine and replace the chambered round, if desired.

Before loading the GLOCK pistol, always make sure that you have the correct ammunition. Use only the correct caliber and be sure the ammo is in good condition. GLOCK pistols should only be used with quality factory ammunition that contains jacketed projectiles and is loaded to CIP/SAAMI/NATO standard pressures.

DO NOT USE HANDLOADS OR RELOADED AMMUNITION!

Use of non-factory loaded ammunition or ammunition loaded with non-jacketed (lead) bullets will void the warranty.

GLOCK currently offers models chambered for conventional ammunition in seven different calibers—9mm, .357 Auto, .380 Auto, .40 Auto, 10mm, .45ACP and .45GAP

Note:

In the United States, models chambered for the .380 Auto are only available to Law Enforcement agencies.

ANY AMMUNITION THAT APPEARS TO BE IN POOR CONDITION, DAMAGED, KNOWN TO HAVE BEEN STORED IMPROPERLY OR OBVIOUSLY SHORTER IN OVERALL LENGTH THAN USUAL SHOULD NOT BE FIRED IN ANY FIREARM.

“Set Back”

Cartridges sometimes may be damaged or altered in some way and this can cause an unsafe condition. An example is a cartridge that has had the projectile (bullet) pushed back deeper than normal into the casing. This can change the combustion space characteristics and powder burn rate boosting pressures to unacceptable levels. Repeated loading and unloading of the same cartridge can cause a condition known as “set back.” The projectile has been pushed deeper into the case and the overall length of the round is noticeably shorter than others of the same bullet weight, make or style.

DO NOT CHAMBER AND EJECT THE SAME ROUND REPEATEDLY!

Caution

Cartridges with the projectiles “pushed back” or seated deeper than normal may have significantly increased pressures. This can possibly damage the firearm and cause personal injury.

OBSERVED PROBLEM	PROBABLE CAUSES	CORRECTION
FAILURE TO EXTRACT	Extractor worn/broken/missing	Replace
	Defective ammunition	Change ammunition
	Dirt under extraction claw	Clean extractor and check function
	Dirty chamber	Clean chamber
	Shooting with an unlocked wrist	Lock shooting hand wrist
FAILURE TO EJECT OR ERRATIC EJECTION (INCLUDING STOVE PIPES)	Broken or damaged ejector	Replace trigger mechanism housing with ejector
	Underpowered ammunition	Change ammunition
	Dirty chamber	Clean chamber
	Shooting with an unlocked wrist	Lock shooting hand wrist
	Lack of lubrication	Lubricate
FAILURE TO FEED	Dirty gun	Clean
	Magazine not properly inserted	Reinsert magazine
	Underpowered ammunition	Change ammunition
	Dirty magazine	Clean and inspect magazine
	Weak magazine spring	Replace magazine
	Dirty chamber	Clean chamber
	Tight extractor	Replace or clean as needed
	Shooting with an unlocked wrist	Lock wrist
	Deformed magazine (Magazine sides or lips deformed)	Replace magazine
Weak recoil spring	Replace	
SLIDE FAILS TO LOCK OPEN ON LAST ROUND	Magazine follower broken	Replace magazine
	Dirty magazine	Clean and inspect magazine
	Weak magazine spring	Replace magazine
	Worn slide stop lever notch	Contact Warranty Department if replacement of the magazine and slide stop lever did not correct the issue.
	Dirty gun	Clean
	Needs lubrication	Lubricate
	Deformed magazine	Replace magazine
	Trigger pin inserted too far (left or right) Slide stop lever worn	This can cause the spring on the slide stop lever to bind. Check to see if the slide stop lever moves freely. if not, press the trigger pin slightly to the right until the slide stop lever moves freely.
	Slide stop lever damaged	Inspect and replace if necessary.
	Underpowered ammunition	Change ammunition
	Shooting with an unlocked wrist	Lock wrist
Improper grip	Tighten grip	

* The above listed are intended as aids in diagnosing the cause and correction of problems observed when shooting. They are not intended to be exclusive or "catch-all" remedies. The actual remedy may consist of one or more of the above listed factors.

OBSERVED PROBLEM	PROBABLE CAUSES	CORRECTION
FAILURE TO FIRE	Slide out of battery (DO NOT FORCE INTO BATTERY) due to:	
	Deformed/defective round	Inspect and replace round
	Under-powered ammunition	Change ammunition
	Damaged/weak recoil spring	Replace recoil spring assembly
	Damaged recoil spring tube	Replace recoil spring assembly
	Mating surfaces of barrel, slide and receiver excessively dirty.	Field strip and clean
	Gun dirty/obstructed chamber	Clean chamber
NO PRIMER STRIKE	Shooting with an unlocked wrist	Lock shooting hand wrist
	Worn or broken firing pin tip	Replace
	Obstructed channel	Clear
LIGHT, CENTERED STRIKE	Spring cups inverted	Assemble properly
	Hard primer (SMG ammunition)	Change ammunition
LIGHT OFF-CENTER STRIKE	Obstructed firing pin channel	Remove, inspect and clean firing pin and firing pin spring Clean firing pin channel
	Tight extractor	Replace
	Dirty gun	Clean
	Slide lock reversed or not beveled	Replace
INCONSISTENT TRIGGER PULL OR WILL NOT RELEASE	Weak recoil spring	Replace
	Connector loose in housing	Replace housing
	Pistol is excessively dirty	Field strip and clean
	Wrong trigger bar	Replace
	Connector needs lubrication	Lubricate
TRIGGER SAFETY FAILS TO RETURN TO ENGAGED (FORWARD) POSITION	Trigger bar is bent/damaged	Replace trigger bar
	Improperly stored in original box with trigger in full forward position (trigger safety fully depressed)	Replace trigger bar. When stored in original box, pistol must be unloaded, trigger in back position.
FIRING PIN SAFETY FAILS AS DESCRIBED IN THE MANUAL	Damaged, worn or defective firing pin safety	Replace
LOCKS OPEN EARLY	Improper hand position	Change grip
	Reverse tension on slide stop lever	Install lever correctly and perform field inspection for proper tension.
	Damaged slide stop lever	Replace

* The above listed are intended as aids in diagnosing the cause and correction of problems observed when shooting. They are not intended to be exclusive or "catch-all" remedies. The actual remedy may consist of one or more of the above listed factors.

Gauges

No gauges are available in the U.S. market.

Caution

Before testing, conduct the safety check first. The pistol has to be completely clean before using the gauges.

Pull the slide back and lock it by pushing the slide stop lever upwards. Insert the gauge into the chamber with the smaller end facing the breech face. Then bring the slide carefully into forward position.

"GO" Barrel and slide must lock completely. (Fig. 123a)

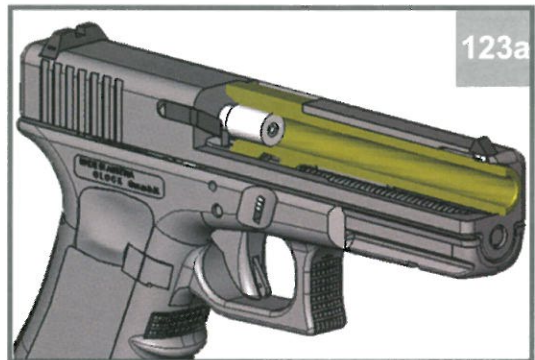

"NO GO" Barrel and slide will not lock completely. (Fig. 123b)



Pull the slide back and lock it by pushing the slide stop lever upwards. Insert the gauge into the barrel through the muzzle.

"GO" The gauge can be passed completely through the barrel. (Fig. 124a)



"NO GO" The gauge will not pass completely through the barrel. (Fig. 124b)

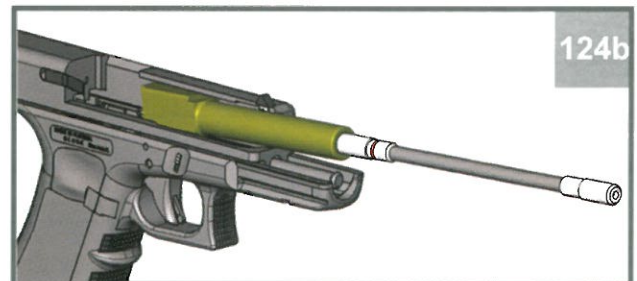

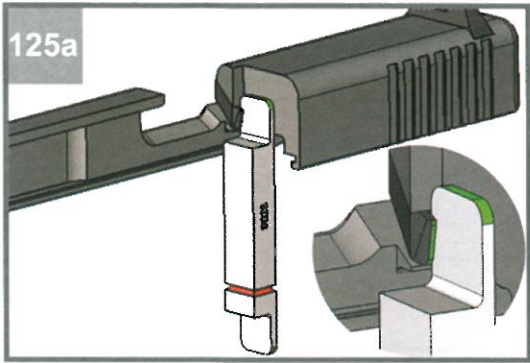

Remove the slide from the receiver. Remove the recoil spring assembly and the barrel. Place the gauge between the breech face and the extractor claw.



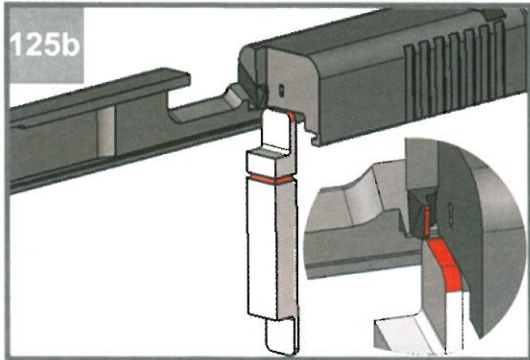



"GO" The gauge passes behind the extractor claw. (Fig. 125a)



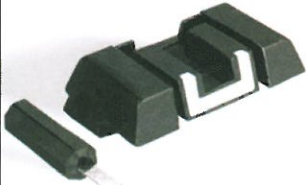
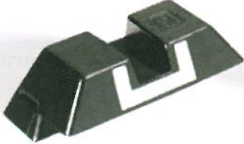
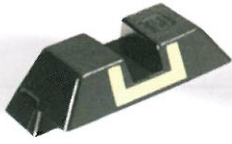
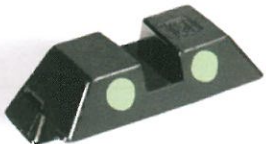



"NO GO" The gauge will not pass behind the extractor claw. (Fig. 125b)



Notes:



Optional Parts

Rear Sights			
<p>Polymer Sight</p>  <p>Standard</p>  <p>Adj. Rear Sight</p>	<p>Steel Sight</p> 	<p>Luminescent Steel Sight</p> 	<p>Self-Luminescent Steel Sight</p> 
Screw-On Front Sights			
<p>Polymer Sight</p> 	<p>Steel Sight</p> 	<p>Luminescent Steel Sight</p> 	<p>Self-Luminescent Steel Sight</p> 
			

Magazine Catch			
Standard	Extended	Oval	Ambidextrous Magazine Release
			
		not available for the US market	

Firing Pin Spring		
Standard	28 Newton	31 Newton
		
	not available for the US market	not available for the US market

Connector		
2,0Kg/4.5Lbs.	2,5Kg/5.5Lbs.	3,5Kg/8.0Lbs.
		

Trigger Spring		
Standard	N.Y.1	N.Y.2
		

Spring Cups

Standard



Maritime

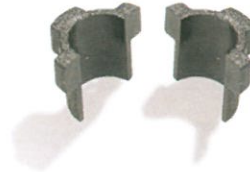

Slide Stop Lever



Standard







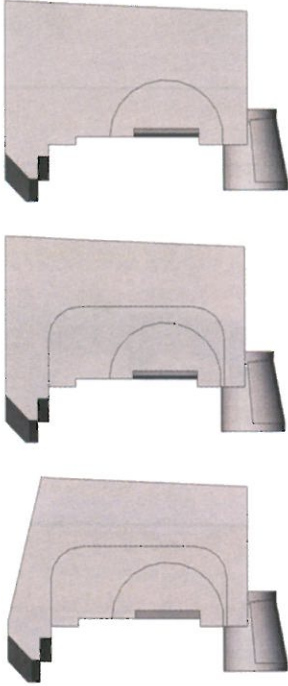
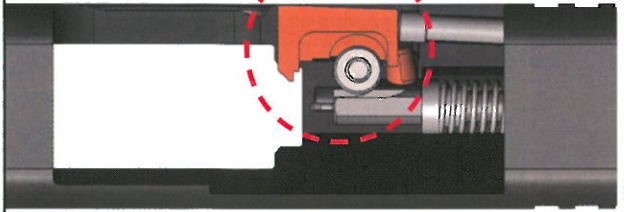
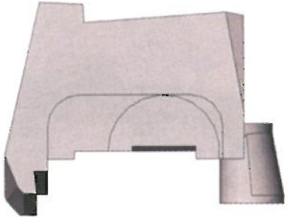
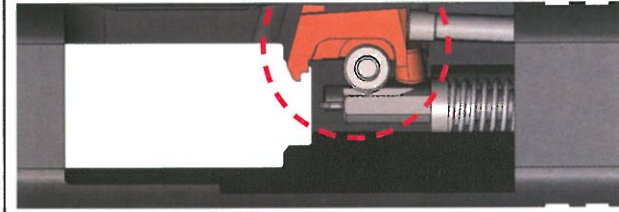



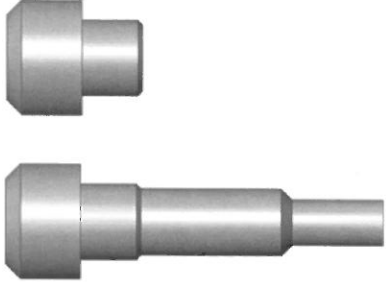

Extended

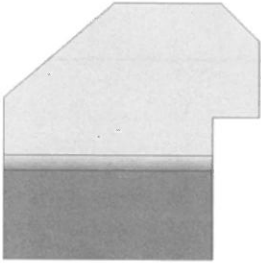
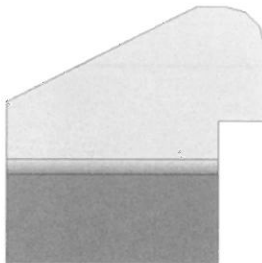

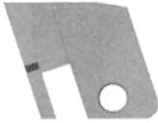
Original vs. New Parts

Original	New
Extractor	
 <p data-bbox="370 1213 607 1289">90° Breach Face 90° Cut</p> 	 <p data-bbox="984 1213 1221 1289">15° Breach Face 15° Cut</p> 
Firing Pin	
	

Original	New
Firing Pin Safety	
	
Spring Loaded Bearing	
	
Trigger Bar Vertical Extension	
	

Original	New
Locking Blocks	
<p style="text-align: center;">G17</p>  <p style="text-align: center;">G22</p>  <p style="text-align: center;">G20/G21</p> 	<p style="text-align: center;">V 01</p> 
<p style="text-align: center;">G19</p> 	<p style="text-align: center;">G23/G19</p> 

Three Generations of GLOCK Magazines

Non Full Metal Lined



Full Metal Lined



Full Metal Lined



GLOCK "Safe Action" Firing Pin Markings

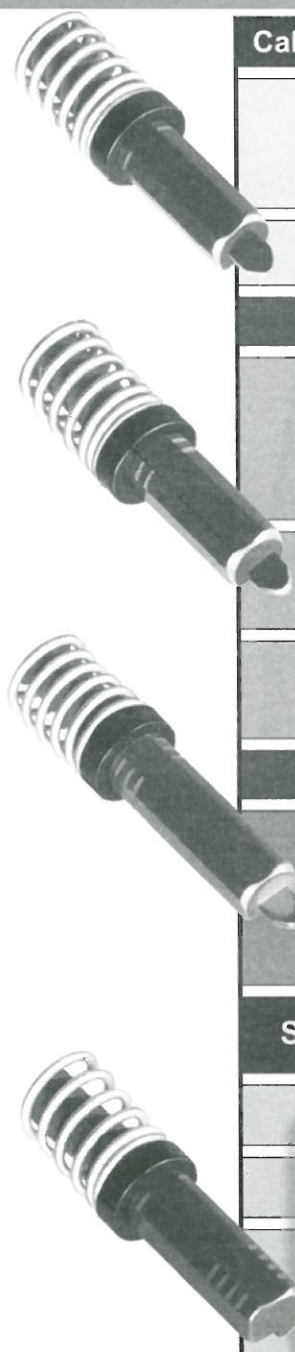

Caliber Code	Configuration	Pistol*	Caliber
I	no marking for standard configuration	GLOCK 17 / 17L	9x19 mm
		GLOCK 19	
		GLOCK 26	
		GLOCK 34	
I	no marking for standard configuration	GLOCK 25	.380 AUTO
		GLOCK 28	
II	no marking for standard configuration	GLOCK 22	.40
		GLOCK 23	
		GLOCK 24	
		GLOCK 27	
		GLOCK 35	
II	no marking for standard configuration	GLOCK 31	.357
		GLOCK 32	
		GLOCK 33	
II	no marking for standard configuration	GLOCK 37	.45 G.A.P.
		GLOCK 38	
		GLOCK 39	
III	no marking for standard configuration	GLOCK 20	10 mm
		GLOCK 29	
III	no marking for standard configuration	GLOCK 21	.45 AUTO
		GLOCK 30	
		GLOCK 36	
Special Configurations (for official Authorities only)			
see caliber codes above	I	T Models	
	II	P Models	
	III	Demo Models	
	IIII	R Models	

New Firing Pin Marking System since beginning of 2007	Firing Pin Marking System prior to 2007
<p>Example for GLOCK 17R / 19R</p> <p>Configuration (front)</p> <p>Caliber (rear)</p>	<p>Example for GLOCK 22</p> <p>Caliber (firing pin lug)</p>

When changing the Firing Pin, make sure to check the caliber marking!