



Model 9C1 Gen 2

Instruction Manual and Safety Features
Read the manual completely before using this handgun.



“You know why there’s a second Amendment? In case the government fails to follow the first one.

— Rush Limbaugh

Model 9C1 Gen2

Proudly American

Instruction Manual and Safety Features

Read this manual completely before using the handgun.

100% American Made



Introduction

American *exceptionalism* is that quality, Americans possess and embrace, which defines our culture and differentiates us from cultures throughout the world. Americans believe we can accomplish anything and that we can make these accomplishments without government aid. Furthermore, Americans believe it is foundational to our culture that government shall not interfere with these just aspirations and that American individualism and aspiration are God given, where government's only role can be to protect this freedom.

Any opposition to this concept is opposition to the ideologies the American Founder's fought for, and in fact—anti-American.

After spending my whole working life in the plastics industry, plying my trade and honing my skill, it was my can-do spirit engrained in my "American" upbringing that made me think I might build a product that fellow Americans would find appealing. Watching California gun manufacturers claim bankruptcy, one after another, my pugnacious character provoked me to consider manufacturing a handgun in this most hostile environment; not to spite California politicians, but because it just seemed the "American" thing to do.

In an industry where manufacturers and dealers are continually under assault by politicians and activists, and forced to spend large amounts of money in legal defense, I found it understandable that they tend to keep a low profile, advertising primarily in trade journals and industry publications, avoiding provocative attention. While understandable, this strategy would not be one that would define the FMK Firearms Company.

Visiting with gun dealers, it became evident early on that I was not alone in my passion and love for American virtues and American freedoms. The FMK Firearms Company is proud to brag about these virtues and has a unique opportunity to promulgate these ideas being so fortunate to address a clientele also committed to these principles. We are proud to be a boisterous advocate for American freedoms and a pugnacious opponent to any policies which threaten them.

In my serendipitous journey I have spoken with gun enthusiasts and patriots across the nation and found a community starved for the reaffirming pride in country, passion for freedom and reverence to God, often subjugated in popular culture. Additionally, I have been humbled to find a group more knowledgeable of American history and our Constitution than average citizens; so much so, I endeavored to learn more about our history and that document so meticulously constructed by the brightest minds among America's Founding generation.

It is this evolution that inspired me to engrave the Bill of Rights on the 9C1 handgun, not as some gimmick, but hopefully to inspire others as I have been inspired.

Sincerely,
James V. Pontillo II
Founder, FMK Firearms



Rules for safe gun handling:

1. Always keep muzzle pointed in a safe direction.
2. Always keep finger off trigger until ready to shoot.
3. Always keep firearm unloaded unless ready for use.
4. Only point weapon at targets you intend to shoot.
5. Know your target and what is beyond. Your projectile can be deadly at over one mile!

Table of Contents:

- 4) Introduction
- 5) Rules For Safe Gun Handling
- 6) Table of Contents
- 7) Technical Specifications
- 8) Operation and Safety Devices
- 9) Loaded Chamber Indicator
- 10) Mag-Out Safety (Trigger Bar Disconnect)
- 11) Firing Pin Block
- 12) Loading and Firing - Loading Magazine
- 13) Loading Pistol
- 14) Firing Pistol
- 15) Reloading
- 16) Assembly and Cleaning - Disassembly
- 18) Assembly
- 19) Cleaning
- 20) Sights
- 21) Contents Complete Set
- 22) Exploded View

24) Testing and Safety

26) Warranty

The FMK 9C1 Story

28) The Engravings

31) No Tragedies...Please!

32) The Bill of Rights

34) In God We Trust

36) Liberty, Freedom, America

38) Thank you; U.S. Soldiers

40) E Pluribus Unum

42) Build a Stronger America; Support the Flat Tax

44) Why the Left Hates Guns

46) For My Kountry



Technical Specifications

Caliber	9 X 19
Length	6.85"
Height	5.09"
Width	1.14"
Weight (with empty magazine)	23.45 oz.
Barrel Length	4.0"
Rifling	6 grooves left hand twist

Operation and Safety Devices

To fire this gun:

Depress trigger safety and pull trigger.

Note: Pistols depend on the recoil action of the slide moving rearward to discharge the spent cartridge and load a new one into the chamber. If the pistol is not held firmly (with elbows locked) it can fail to properly eject the spent cartridge or load a new one.

Trigger Safety: The trigger safety prevents the trigger from moving rearward unless depressed. Its red color is to remind operator of danger.

Trigger Guard: The trigger guard is designed to protect the trigger from accidental depression and discharge.

Always keep finger outside of trigger guard and off trigger until target is acquired and you are ready to fire.



WARNING: Any safety device can be damaged or fail. No safety device can avert tragedy if safe gun handling rules are not followed. Always follow rules for safe gun handling.

Loaded Chamber Indicator

When Chamber Loaded:

A red pin will protrude out the back of the slide when a round is in the chamber. Text "**LOADED IF OUT**" warns the user of the condition. The loaded condition is visually apparent in light and readily apparent in dark by feel.



When Chamber Unloaded:

The red pin will not protrude out the back of the slide if no round is in the chamber. The unloaded condition is visually apparent in light and readily apparent in dark by feel.



Mag-Out Safety (Trigger Bar disconnect)

When the magazine is removed from the pistol, the cam, which guides the trigger bar, rotates forward to move the trigger bar out of the path that would allow its abutment to engage the striker. When the trigger is pulled back, the trigger bar will not engage the striker at its abutment, and the gun will not fire.

Replacing the magazine will move the cam allowing the trigger bar to once again engage the striker at its abutment and fire the weapon when the trigger is pulled.

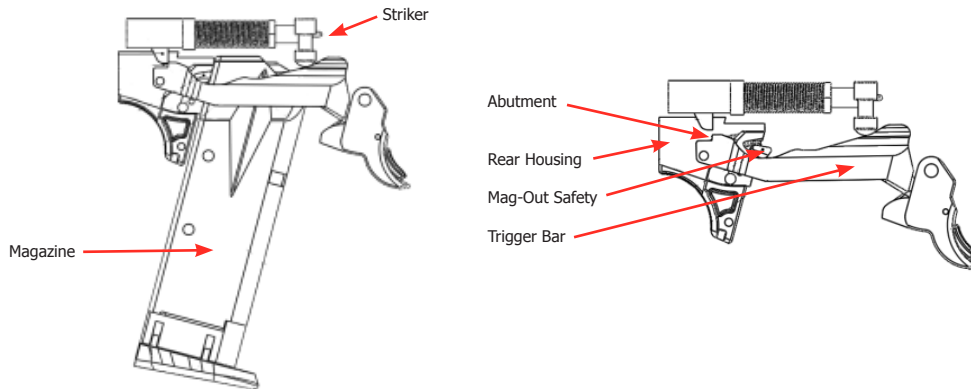

WARNING: Removing the magazine will not unload the chamber and an empty magazine placed into the pistol will allow it to fire.

WARNING: Any safety device can be damaged or fail. No safety device can avert tragedy if safe gun handling rules are not followed. Always follow rules for safe gun handling. Do not assume removing the magazine will make the weapon impossible to fire.

Firing Pin Block

The block prevents the striker from moving forward.

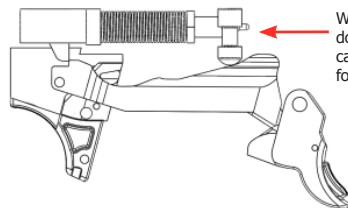

When block is down striker cannot move forward

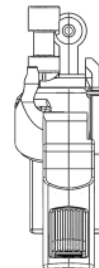

When the trigger is pulled, the trigger bar lobe moves the block upward allowing the striker to move forward after release and protrude through the breach face to strike the cartridge primer discharging the pistol.

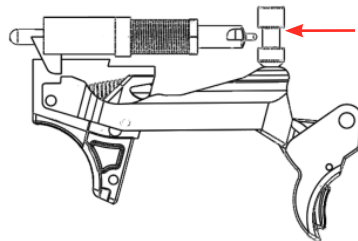

When block up, striker can move forward to contact cartridge primer

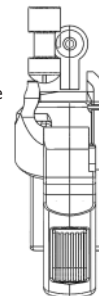

WARNING: This feature is designed to prevent the pistol's discharge if it is dropped; however, any mechanical device can fail or become overruled with careless handling. Care must be taken to insure the pistol is not dropped and that the trigger only be activated in accordance with all safe operating protocols.

Loading and Firing

Loading Magazine

To remove the magazine from the pistol, depress the magazine release and remove the magazine.



depress the magazine release



remove magazine

To load a cartridge into the magazine:

With the rear end of a cartridge, depress the follower just in front of the feed rails and slide the cartridge back. Repeat with successive rounds. The magazine will hold ten rounds. The magazine base can also be used to depress the follower and successive rounds to make loading easier.

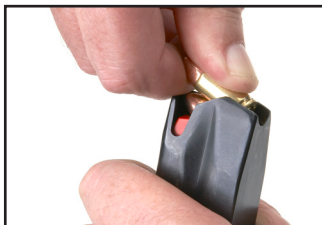

depress the follower



magazine base

Loading Pistol

Insert magazine securely into place. The magazine release button will drop and pop back up after complete insertion. Pressing down on the slide hold lever will release the slide and chamber one round, **READY TO FIRE**.

Insert magazine securely



WARNING: Do not assist the slide in moving forward. Allow it to move forward under full spring pressure to properly load the pistol otherwise a jam may occur. Keep hands clear of slide and barrel; injury can occur if pinched by pistol slide closing with **GREAT FORCE**.

If magazine was inserted with slide in forward position, slide must be pulled back fully and released without assistance to chamber first round, **READY TO FIRE**.

WARNING: The 9C1 handgun is designed to use only standard 9mm ammunition designated 9x19mm, sometimes called 9mm Luger or Parabellum or Para. This handgun is **NOT** designed to use +P ammunition or low quality reloaded ammunition, and under no circumstances should be used with any ammunition generating pressures in excess of standard factory loads.

Firing Pistol

Grip the pistol firmly with finger outside of trigger guard (not on trigger). Acquire target. Maintain a steady stance with elbows locked to insure pistol reloads correctly after firing. Place finger on trigger and pull steadily through full travel; pistol will fire.

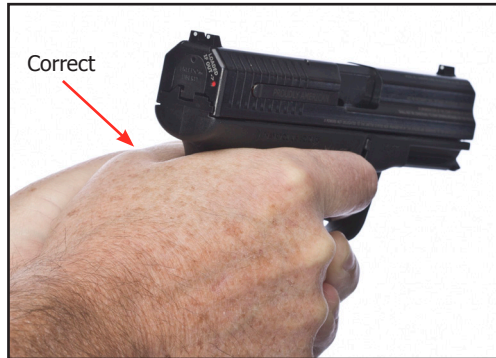

WARNING: If firing with two hands, do NOT allow thumb from supporting hand to cross over pistol behind slide. When pistol is fired, slide will move rearward and WILL cause SEVERE INJURY to thumb blocking slide path.

Reloading

Before the last round has been expended from the pistol it is possible to replace the partially or fully exhausted magazine, with a full one, and continue firing without manually retracting the slide (SINCE ONE ROUND REMAINS IN THE CHAMBER ENABLING THE PISTOL TO FIRE).

WARNING: Removing the magazine from the pistol will not completely unload the pistol.

To fully unload pistol:

Depress magazine release and remove magazine. Keep pistol aimed in a safe direction and manually retract slide, carefully angling ejection port to a soft pad on a table or rest where the live cartridge will be ejected.

WARNING: Allowing a live round to fall onto a hard surface, sharp edge, or pointed object could cause gun to discharge.

Assembly and Cleaning

Disassembly

WARNING: Always completely unload the pistol prior to disassembly. It is possible to disassemble the 9C1 handgun with a round in the chamber. EVEN WITH THE SLIDE AND BARREL REMOVED FROM THE FRAME, IT IS STILL POSSIBLE TO FIRE A ROUND, IF A LIVE CARTRIDGE IS LEFT IN THE CHAMBER. THIS COULD CAUSE INJURY OR DEATH.

To remove the slide:



1. Insure the pistol is unloaded and the magazine is removed.



2. Hold the 9C1 Handgun as shown and slightly retract the slide so the barrel release latch can be moved downward.



3. Move the barrel release latch downward with your other hand and allow the slide to move forward under spring pressure.



4. The slide barrel assembly can now be removed from the frame.



5. Holding the slide assembly upside down push the recoil spring slightly forward and lift for removal.



6. The barrel can now be removed from the slide.

To remove the striker assembly:



1. Insert a 1/16" punch into the small hole in the slide end cap and depress slightly. This will allow the end cap to be removed.



2. Slide the slide end cap downward. The striker assembly can now be removed.

No further disassembly of the pistol is required for normal cleaning or maintenance. If further disassembly is required it should be performed by a certified gunsmith.

Assembly

WARNING: Always insure there are no live cartridges in the chamber when assembling.

To replace the striker unit:

1. Slide the striker unit into its hole in the rear of the slide.
2. Depress the rear striker spring retainer with the edge of the slide end cap and slide the end cap up until you feel or hear a click.

To replace the slide assembly:

1. Place the barrel into the slide, into its lock up position.
2. The recoil spring retainer has one large diameter end and one small diameter end. Place the small diameter end into the slide and depress the assembly until it rests on the barrel lug designed to accept the recoil spring assembly.
3. Line up the slide rail grooves with the frame rails and move the slide rearward until the barrel release clicks into place.
4. Move the slide back and forth to ensure smooth operation and assure completed assembly is correct.



Cleaning

Disassemble in accordance with disassembly instructions.
(See page 16)

1. Apply gun solvent with a soft cloth or cleaning patch to all areas fouled by gunshot residue on the slide, frame, barrel, and recoil spring. A small brush works well to apply fluid to small areas inside the frame around the trigger and rear housing.
2. With a barrel brush designed for 9mm pistols, brush the barrel and chamber with cleaning fluid.
3. Wipe all components dry to remove all cleaning fluid.
4. Use light gun oil sparingly on all metal parts to prevent rust and ensure reliable operation. Oil should be applied to all moving surfaces with special attention to the frame rails, trigger bar, and barrel/slide lock up. Also, add a few drops between the extractor and slide, inside the striker tunnel, and around the block. Acid in skin from finger prints can cause rust, so wipe with clean cloth or oil before storage.



WARNING: Ensure the pistol is unloaded before cleaning. Many gun accidents and DEATHS occur by attempting to clean a loaded weapon.

Sights

The 9C1B handgun is a compact pistol, designed to have a minimum number of protrusions, allowing it to be stowed easily in a purse or upon the person. This design reduces the chance of snag when removing quickly for operation. The 9C1B low profile sights were considered with this design intent in mind.

Elevation

Three front sights are included for elevation 1 blank (center), U2.0, and D2.0. These numbers that indicate how much the bullet impact will move (in inches) on a target set at 50'. To change the front sight, loosen the Phillips screw and tap it (the screw) to unseat the sight before completely removing the screw and replacing the sight with another.



The rear sight can be removed by tapping on it rearward with a small punch.

Windage

Six windage sights are included. 2 blank (center) L1.0, L2.0, R1.0, and R2.0. The sights are labeled with numbers that indicate how much the bullet impact will move (in inches) on a target set at 50'. The rear sight can be removed by tapping on it rearward (picture) with a small punch. A new sight can be pressed into place and tapped home with soft mallet until seated.



Model 9C1 Gen2 Complete Set:

- (1) Model 9C1 Gen2 9mm Pistol
- (2) Magazines
- (1) Lockable Case
- (1) Instruction Manual
- (1) Red State Coalition (Vermont not to be excluded) Book

Exploded View

- | | | |
|-------------------------------------|--------------------------------|-------------------------------------|
| (1) Frame | (16) Barrel Release | (31) Trigger Return Spring |
| (2) Back Strap | (17) Trigger Pin | (32) Trigger Bar Cushion (optional) |
| (3) Magazine Assembly | (18) Rear Housing Pin | |
| (4) Striker Assembly | (19) Magazine Release Spring | |
| (5) Chamber Loaded Indicator Spring | (20) Magazine Release | |
| (6) Chamber Loaded Indicator | (21) Rear Housing/MOS Assembly | |
| (7) Rear Sight | (22) Ejector | |
| (8) Extractor Spring | (23) Slide End Cap | |
| (9) Extractor | (24) Block Spring | |
| (10) Extractor Pin | (25) Block | |
| (11) Front Sight | (26) Barrel Guide | |
| (12) Front Sight Screw | (27) Trigger Bar Assembly | |
| (13) Slide | (28) Barrel Release Spring | |
| (14) Barrel | (29) Slide Hold Spring | |
| (15) Recoil Spring Assembly | (30) Slide Hold | |

Warning: Broken or worn components should be replaced by a certified gunsmith. Modification to any part could cause this handgun to fire unreliably, causing injury or death.

Do not modify any components!

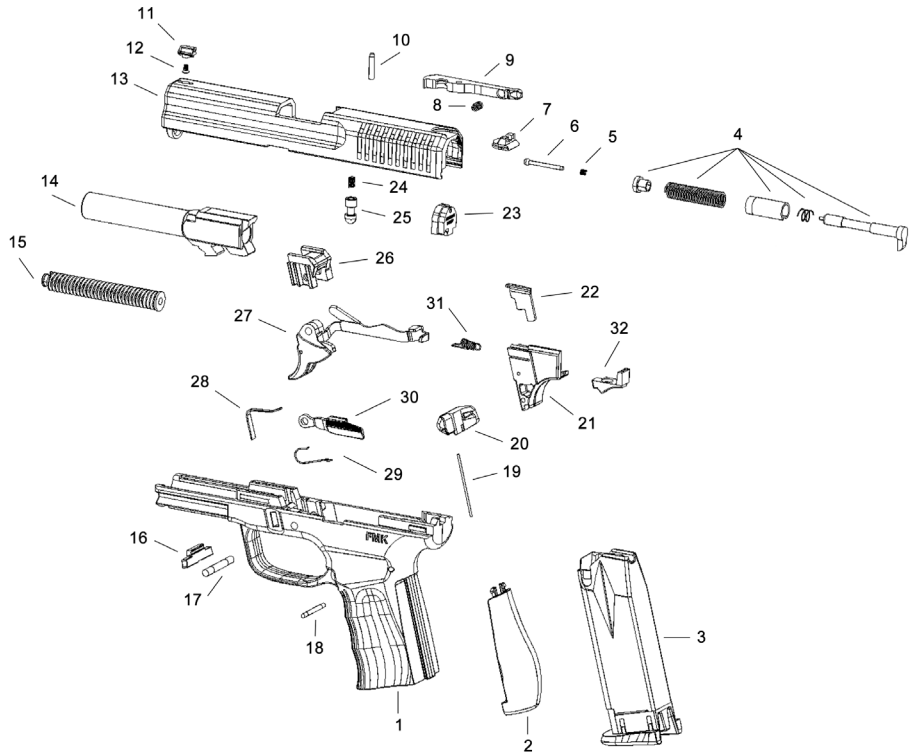

Testing and Safety

"The manufacturer/importer certifies that this model of handgun has been tested and has been determined not to be an unsafe handgun as defined in California Penal Code Section 12126."

To be sold or manufactured in California, the 9C1 Handgun has been subjected to and passed a battery of tests (most rigorous in the nation) required by the State.

Per California requirements, the pistol is first inspected to ensure it has incorporated a magazine trigger disconnect and a loaded chamber indicator labeled as such.

Three handguns and ten magazines must be submitted for testing, and each pistol must shoot 600 rounds with no more than 6 malfunctions. A malfunction is defined as a failure to feed, fire, extract, eject, to hold the slide open (if pistol designed to do so) after the last cartridge has been expended, or to prematurely lock the slide open before the last cartridge has been fired.

Additionally, if any pistol experiences a single failure within the first twenty rounds, the model fails the test.

To complete the 600 round test, 50 rounds are fired through a pistol and it is then allowed to cool before 50 more rounds are fired. After 100 rounds have been expended, the pistol is disassembled and cleaned in accordance with the instructions in this manual; this process is repeated until 600 rounds have been expended.

If all three samples pass these tests, each is submitted to a drop test where the pistols are loaded with a cartridge containing a live primer, but without projectile, and dropped from a height of 1 meter onto a concrete foundation. The drop is performed in six configurations, on left side, right side, butt, upsidedown, muzzle down, and muzzle up. After each drop, the cartridge is removed and its primer is inspected for indentations. If all three samples pass all six drop tests, one sample is sent to Sacramento, and the firearm will be placed on the DOJ's centralized list; allowing it to be manufactured and sold in the State.

FMK Firearms Inc., has used novel designs and innovative materials in the manufacture of this handgun. To ensure high quality and to guarantee customer satisfaction we have subjected many samples to abusive conditions, firing pistols more than 1000 rounds without stopping to clean or allow cooling.

While plastic materials have been used to replace many steel components, our testing has demonstrated that with normal use, proper care and maintenance, the 9C1 handgun will shoot many thousands of rounds reliably without malfunction.

If any malfunction described occurs chronically, your dealer should be consulted immediately to insure no damage has been sustained to the pistol, and that it is being operated properly and with correct ammunition.

Warranty

FMK Firearms warrants to you, the original purchaser of a new firearm, that for two years from the date of purchase in the United States, your FMK firearm will be free from defects in material and workmanship.

If you make a claim within the warranty period following the instructions given in this warranty, we will, at our option, repair the defect(s), or replace the firearm at no cost to you. If we send you a new firearm, we will keep the defective one.

First, when you purchase your firearm, you must complete in full either the online registration form or mail the warranty registration card to us within 30 days of date of purchase. Then, if you discover a defect, you must notify us or an authorized FMK warranty repair center before the end of the two-year period. You may either email support@fmkfirearms.com or write to FMK at: FMK Firearms, Inc. Consumer Service Department: P.O. Box 1358, Placentia, CA 92871

PLEASE DO NOT RETURN FIREARMS TO THE ABOVE ADDRESS. If we decide that it is necessary for you to return the firearm to the factory or an authorized warranty repair center, the sender must prepay freight. We will not accept C.O.D. shipments. We will not cover damage of your firearm caused by:

- Failure to provide proper care and maintenance
- Accidents, abuse or misuse
- Barrel obstruction
- Hand loaded, reloaded or improper ammunition
- Unauthorized adjustments, repairs or modifications
- Normal wear and tear

FMK Firearms excludes and will not pay incidental or consequential damages under this warranty. By this we mean any loss, expense or damages other than to repair the defects in the firearm or replace the firearm. No implied warranties extend beyond the term of this written warranty. PLEASE NOTE: Some jurisdictions do not allow exclusion of incidental or consequential damages, or limitation on how long an implied warranty lasts, so the above exclusion and limitations may not apply to you. This warranty gives you specific legal rights and you may also have other rights.

NOTICE: It is illegal to ship a firearm with ammunition in the firearm or in the same packaging. Firearms and ammunition must be shipped separately.

The FMK 9C1 Story

The Engravings

My work experience began in a machine shop when I was fifteen years old. My grandfather was a toolmaker and I was the one of seventeen grandchildren who would follow in the trade in which he made his living.

Working in the plastics trade a bit over a year, my grandfather visited me at my job. He was notably proud of my work and proclaimed, "Jimmy, if you learn this trade well you will never have to worry about finding a job for the rest of your life."

Little did he know, the trade which earned him a respectful living would be reduced in stature and become a second class career, decimated by foreign competition; hastened by large corporations moving to procure services overseas where that promise to his eldest grandson, "...never have to worry about finding a job..." would not be true.

Regardless, any hardship I've endured I have always embraced the idea that excellence would sustain my efforts and guarantee my success.

I was raised to believe anyone could succeed in America, and "anyone" included even me.

Unfortunately, this can do attitude is not one that is embraced nor encouraged by all Americans and many of our politicians.

Today, excellence is shamefully not the only quality required to succeed in business. A keen understanding of political policy and the social upheavals, encouraged by politicians, is necessary to navigate the bureaucratic malaise which is wholly uninterested in private sector success, despite its dependence on it for its continued existence.

Study of many Fortune 500 companies reveals a movement to publicly embrace Green technology and Green business practices; whether or not they actually follow the protocols. These corporate proclamations are politically induced, but quite beneficial to the large corporations with vast resources able to meet any and all bureaucratic demands.

While small businessmen struggle to survive in an environment that is seeking to mandate employer paid health care, higher wages without an increase in compensation for services and continued and expansive bureaucratic demands, the Fortune 500 comfortably employs overseas workers and seems to acquiesce to any government demand.

So much for looking out after the little guy. The American small businessman provides 75% (according to SBA) of all new jobs in America, and he does not enjoy the luxury of influence garnered by playing golf with U.S. Senators.

My youngest recollection of American opportunity is that it was available to all, guaranteed by government, and awarded for excellence.

My study of American history, the United States Constitution, and my acquaintance with the lively and independent lot of gun enthusiasts I have met in my quest to become an American gun manufacturer has reinforced this view; that it is the essence of American culture to place excellence above all else. Unfortunately, some of this sturdy self-reliant culture has withered by corrosive government policy.

The engravings on the 9C1 handgun have been selected to remind us of the culture America's Founders intended to leave posterity.

I still believe a system that rewards excellence above all else is worth encouraging and protecting, regardless of political upheavals and ignoble efforts by man's ambition that venture to subjugate those lofty ideals.

Naive me.



The Engravings

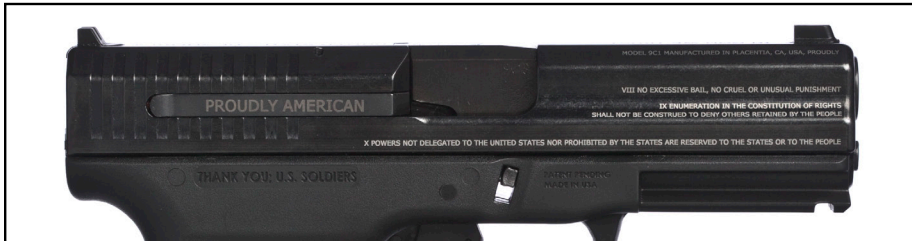
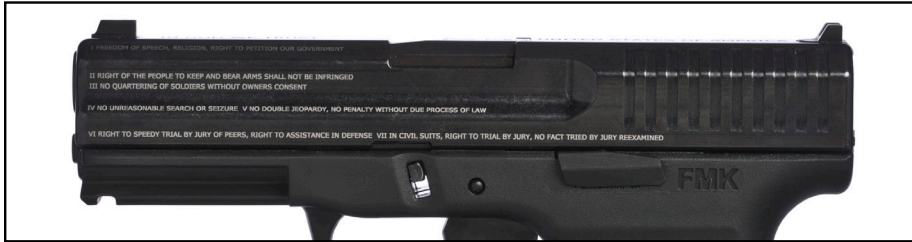

No Tragedies...Please!

Handgun ownership is a terrific and special American luxury. It does, however, carry extraordinary responsibilities. About 15,000 people are killed by firearms each year, most are the result of homicides. About 1,000 accidental deaths occur each year due to firearms, often involving children.

Well over 200,000 people die each year due to mistakes made by medical doctors. Approximately 50,000 people die each year in automobile accidents. When looking at cause of death in the United States, firearms don't make it into the top ten or even top twenty. We could go on for hours quoting statistics, but it is futile. Liberal ideology will always encourage transfer of power from citizens to government. Your right to own firearms is offensive to their values whether or not the death statistic was one per year or one million per year.

Our leftist friends would like you to believe firearms are a leading cause of death in the U. S.

As responsible handgun owners we must always protect the possession of our firearms. Children must handle firearms only with close adult supervision, and we must be exceedingly familiar with the operation and capabilities of our firearms. We must be competent marksmen and we must be thoroughly knowledgeable of our laws concerning firearms.

Firearms can be an excellent tool for self-protection; however, they are tools only to be used in the direst of circumstances. Our laws are generally written to allow lethal force only in situations where imminent or immediate danger is at hand. While the spirit of our law is "innocent until proven guilty", you can be sure if you use a handgun in self defense, you will be assumed guilty until you can prove your life or the life of someone you were protecting was in imminent danger.

A handgun should not be displayed in public. If you wish to carry a handgun, you should take the concealed carry courses and obtain your concealed carry permit. If more Americans did, we would be more secure.

The Bill of Rights



Amendment I Congress shall make no law respecting an establishment of religion, or prohibiting the free exercise thereof; or abridging the freedom of speech, or of the press; or the right of the people peaceably to assemble, and to petition the government for a redress of grievances.

Amendment II A well regulated militia, being necessary to the security of a free state, the right of the people to keep and bear arms, shall not be infringed.

Amendment III No soldier shall, in time of peace be quartered in any house, without the consent of the owner, nor in time of war, but in a manner to be prescribed by law.

Amendment IV The right of the people to be secure in their persons, houses, papers, and effects, against unreasonable searches and seizures, shall not be violated, and no warrants shall issue, but upon probable cause, supported by oath or affirmation, and particularly describing the place to be searched, and the persons or things to be seized.

Amendment V No person shall be held to answer for a capital, or otherwise infamous crime, unless on a presentment or indictment of a grand jury, except in cases arising in the land or naval forces, or in the militia, when in actual service in time of war or public danger; nor shall any person be subject for the same offense to be twice put in jeopardy of life or limb; nor shall be compelled in any criminal case to be a witness against himself, nor be deprived of life, liberty, or property, without due process of law; nor shall private property be taken for public use, without just compensation.

Amendment VI In all criminal prosecutions, the accused shall enjoy the right to a speedy and public trial, by an impartial jury of the state and district wherein the crime shall have been committed, which district shall have been previously

ascertained by law, and to be informed of the nature and cause of the accusation; to be confronted with the witnesses against him; to have compulsory process for obtaining witnesses in his favor, and to have the assistance of counsel for his defense.

Amendment VII In suits at common law, where the value in controversy shall exceed twenty dollars, the right of trial by jury shall be preserved, and no fact tried by a jury, shall be otherwise reexamined in any court of the United States, than according to the rules of the common law.

Amendment VIII Excessive bail shall not be required, nor excessive fines imposed, nor cruel and unusual punishments inflicted.

Amendment IX The enumeration in the Constitution, of certain rights, shall not be construed to deny or disparage others retained by the people.

Amendment X The powers not delegated to the United States by the Constitution, nor prohibited by it to the states, are reserved to the states respectively, or to the people.

In God We Trust

Our Nation was founded on the principles that specific inalienable rights are guaranteed to all living people that no man or government can take away. How is it that "In God We Trust" is even questioned in contemporary society?

Would Americans prefer their motto:

- In communism we trust.
- In atheists we trust.
- In man we trust.
- In government we trust.
- In the United States we trust.
- In Democrats we trust.
- In Republicans we trust.
- In Europe we trust.
- In China we trust.



Which motto do you like better?

Despite a secular upbringing, I never felt "In God We Trust" was some sort of offensive gesture thrust upon me by the religious right. Intuitively, I knew this motto suggested our humility as human beings and possessed the recognition that we as individuals, while free, shall not try to dominate over fellow citizens and that we all are answerable to a higher power.

If it is not "In God We Trust" that we place our highest reverence and respect, but some other entity, is it not within the purview of that authority or entity to dispense or withhold our rights?

If rights are guaranteed by man, can man take them away?

If rights are guaranteed by government, can government take them away?

Inalienable rights are unarguable, they are undeniable and they cannot be taken away. Under what authority can such rights be guaranteed? Only God has the authority to grant such rights. Only under God, can a government of the people, by the people and for the people operate morally and fairly.

A recent trend among our liberal Supreme Court Justices is to defer to European law and to International law when their activist views cannot be reconciled, with current precedent, in United States Law. The main reason these views cannot be reconciled is because our law is grounded to an ultimate and all powerful authority, and not driven by humanistic whim. If we do concede that United States Law is inadequate to rule our country, then we also must concede that we do in fact have no inalienable rights and that government does have authority to take and award rights at will.

It is always instructive to study governments which are antithesis of our government, to prognosticate what our nation would be like if we were to move away from our core values and our "inalienable rights". Communist countries give us the best glimpse of what this life would look like when authority does not come from God, but when it comes from government. In communist countries, individuals are properties of the state. The state is all powerful and individual liberties are inconsequential. In communist nations God and religion are subjugated in the most offensive and prejudicial methods possible. It is common for communist nations to jail or kill individuals for religious speech and opinion. How can a state demand allegiance from its people if it is competing with God for authority? Obviously, it cannot.

If a Nation is to have a motto I can think of none better than, "In God We Trust".

And if a Nation is to have no motto, are we not saying, "Anything Goes" and inviting despotism upon our people when some charismatic politician convinces a narrow majority that God's inalienable rights ought to be reconsidered?



Liberty, Freedom, America

When the Founding Fathers endeavored to write the Constitution, they studied all governments of the world and were knowledgeable about failed governments throughout history. A government of the people, by the people and for the people was a radical concept for the time, and it was not without experiment (Articles of Confederation) that our Founders came up with a workable system for our Republic.

The concept of democracy is often admired by our people and our politicians; it is however important to understand our government is not a true democracy, and very well it is not. Mob tyranny was a great fear for our Founders and to insure basic rights were guaranteed to all American citizens a paper was drafted to be the ultimate law of our land, the United States Constitution.

Our government system and our economic system are based upon the capitalist idea that any individual should be able to travel as far as his "virtue, accomplishment, and character" should take him. In business and in government it is excellence which must reign supreme to realize success.

There is often heated and obstreperous debate over "fairness" in America. That some have so much, while others have so little, is cause for legal wrangling, political posturing and epithets flung from every direction. If government is obliged to be arbiter of outcomes, deciding who should have what, can government also be arbiter of inputs? And what happens when inputs decrease because government has arbitrarily decided those with the greatest inputs have acquired too much? Whose job does government eliminate when its policies convince those with high inputs to do less?

There are individuals in society who desire to accomplish little, and so have little to show for their existence. These darlings of the left are paraded out for all of us to see, evidence of our systems prejudice and inherent "unfairness".

Schemes and strategies devised by the left to ostensibly help these hapless and lazy soles do nothing to improve their position.

Most often, however, these “programs” do not help the poor, but penalize the wealthy (who those in need of jobs depend on for opportunity).

Additionally, these “programs” take valuable resources away from those wealth producing, value inspired entities and invest them in bureaucratic government, whose sole purpose is self-promotion; the American citizen be damned.

Freedom isn't easy, it has a cost, and that cost is the chance of failure. With our failures we earn education and wisdom. By removing the cost of failure, we take from our people the opportunity to gain education and wisdom.

To succeed in America's capitalist system, there are no special requirements and there are no prescriptions to follow “party line”. Rewards go to those who attain excellence, and excellence benefits all Americans. Any system of reward our politicians devise to shift efforts from the attainment of excellence will encourage the sort of corruption and waste of resources that hastened the Soviet Union's collapse.

History shows that when government policies shift citizen efforts from attaining excellence, the free-enterprise system which allows any to succeed regardless of age, race, or gender, is subjugated to favor a system where the privileged political class holds power over reward. Excellence yields to party loyalty.

Our evolution toward such a system is offensive to Liberty, to Freedom, and to the system America's Founders set; to make the United States a land to which all others would aspire.

Thank you; U.S. Soldiers

FEBRUARY 27, 1968

Tonight, back in more familiar surroundings in New York, we'd like to sum up our findings in Vietnam, an analysis that must be speculative, personal, subjective. Who won and who lost in the great Tet offensive against the cities? I'm not sure. The Vietcong did not win by a knockout, but neither did we. The referees of history may make it a draw. Another standoff may be coming in the big battles expected south of the Demilitarized Zone. Khesanh could well fall, with a terrible loss in American lives, prestige and morale, and this is a tragedy of our stubbornness there; but the bastion no longer is a key to the rest of the northern regions, and it is doubtful that the American forces can be defeated across the breadth of the DMZ with any substantial loss of ground. Another standoff. On the political front, past performance gives no confidence that the Vietnamese government can cope with its problems, now compounded by the attack on the cities. It may not fall, it may hold on, but it probably won't show the dynamic qualities demanded of this young nation. Another standoff.

We have been too often disappointed by the optimism of the American leaders, both in Vietnam and Washington, to have faith any longer in the silver linings they find in the darkest clouds. They may be right, that Hanoi's winter-spring offensive has been forced by the Communist realization that they could not win the longer war of attrition, and that the Communists hope that any success in the offensive will improve their position for eventual negotiations. It would improve their position, and it would also require our realization, that we should have had all along, that any negotiations must be that -- negotiations, not the dictation of peace terms. For it seems now more certain than ever that the bloody experience of Vietnam is to end in a stalemate. This summer's almost certain standoff will either end in real give-and-take negotiations or terrible escalation; and for every means we have to escalate, the enemy can match us, and that applies to invasion of the North, the use of nuclear weapons, or the mere commitment of one hundred, or two hundred, or three hundred thousand more American troops to the battle. And with each escalation, the world comes closer to the brink of cosmic disaster.

To say that we are closer to victory today is to believe, in the face of the evidence, the optimists who have been wrong in the past. To suggest we are on the edge of defeat is to yield to unreasonable pessimism. To say that we are mired in stalemate seems the only realistic, yet unsatisfactory, conclusion. On the off chance that military and political analysts are right, in the next few months we must test the enemy's intentions, in case this is indeed his last big gasp before negotiations. But it is increasingly clear to this reporter that the only rational way out then will be to negotiate, not as victors, but as an honorable people who lived up to their pledge to defend democracy, and did the best they could.

This is Walter Cronkite. Good night.



Facts on the Tet Offensive: The North Vietnamese lost between 45,000 and 70,000 fighters in the assault. The United States, Korea, and Australia had combined losses of 1,536 soldiers.

This is what Walter Cronkite says, "The referees of history may make it a draw". The Tet Offensive was such a huge failure for the North Vietnamese that they were ready to come to the peace table until Walter Cronkite got on TV and told the American people how badly we were trounced.

By not committing to win in 1968, when the enemy was on its knees, we caused additional American deaths in the tens of thousands and endured five more years of war, culminating in the sacrifice of our ally South Vietnam to communism.

In the first Iraq war the United States encouraged southern Shiites to oppose Sadaam Hussein, and we promised to support them only to leave them to suffer Hussein's wrath. And we wonder why the rest of the world hates us; we have no integrity. Two things we are very good at, us Americans, we don't support our troops, and we don't support our allies.

American soldiers are the best equipped and best trained in the world. Since World War II, the United States military has dominated all others on earth. Knowing this, why would any military challenge us? Because, they know we don't have the mettle to follow through.

With the tepid support you receive at home I do not know how you do the job you do, but I do wish to thank all American soldiers for your sacrifices. Without you I could not do what I do; I could not venture for excellence, and I could not attempt to attain those childish aspirations that are promised to me in America's Constitution, but guaranteed only by your efforts.

E Pluribus Unum



From many, one.

America's motto was selected by the first Great Seal committee in 1776 at the beginning of the American Revolution. The thirteen original colonies adopted this motto and though spiritual and geographical differences separated our people, our young nation knew in order to survive we must adopt, preserve, and protect one common culture. With freedom and liberty threatened under England's rule, it was vital we come together as one people for our health and welfare.

American culture became an appreciation for liberty and freedom, it became a culture dependent on one's own will and initiative, and it became a culture fearful and suspicious of government authority. These were foundational ideas that all our people held dear. It bound us as one, regardless of our spiritual

or geographical differences. With these values, our small little "upstart" defeated the most powerful army on earth, and we subsequently forged the Constitution of the United States from these values.

Not only did we create a new Nation; over the next two hundred years we would become the greatest economic power, and the greatest military power. With thousands of years of culture and history behind them, European nations could not compete with the industrial might of the United States, precisely because our culture stimulated and motivated individual initiative and productivity like no other.

While we were fighting for our very lives during the Revolution, E Pluribus Unum, might just be a more important concept today than it was then. The fight for freedom bound us together and it was our “oneness” that kept us fighting for a common goal. Today that “oneness” has virtually left our culture. We have become a nation where individual failures should somehow be placated by government. We are spoiled and believe success and an easy life is some sort of American birth right. When we talk of freedom we seem to think we have unfettered license to indulge in any hedonistic activity regardless of its effects on our neighbors and ultimately our culture. It is impossible to attain the lofty ideal of “From many, one” when our own selfish pursuits are put in front of any measured and responsible respect we must have for our fellow citizens.

If we do not make it the central theme of our culture to value the concepts our Founders so diligently fought for, the great wealth and good fortune our nation enjoys will be squandered. Ultimately, the left will get what it wants, a society that can no longer provide for its own, spreading desperation among the least successful in our society and empowering a very small number of people at the highest levels of government to establish policy where freedoms are curtailed and individual excellence is no longer the most important quality required to succeed in our nation.

E Pluribus Unum will no longer be.

From many, one, shall become...From many, many suffer.

Build a Stronger America; Support the Flat Tax

Every time I get into an argument about taxes (which is plenty) the rationale for my opponents position is consistently, "the rich can afford it" or some variation including the word "fair" or "the rich got their money by screwing the little guy".

Invariably, my reply to these "arguments" entails explanation that shows how confiscatory taxation actually decreases revenue flow into government. Better and equitable systems of taxation have been proven to bolster those economies that have embraced them. Steve Forbes has written a fine little book, *The Flat Tax Revolution*, which provides excellent explanation and examples supporting this system.

Even after showing that government tax receipts proportionally shifted further to the richest Americans after George W. Bush's tax cuts (39% of all income taxes paid by the richest 1% of wage earners under Bush after tax cuts, only 37% of all income taxes paid by the richest 1% of wage earners in 2000, and only 19% was paid by the richest Americans when our top rate was set at a criminal 91%. Source: IRS.), my opponents insist it doesn't matter, and they insist it without explanation.

America's tax model is not about helping the poor, reducing poverty, making education better, providing jobs, or for any other altruistic motive.

The tax code is designed specifically to engage America's entrepreneurs and businessmen and encourage them to produce; all the while giving them just enough line to create wealth, without so much freedom as to expand their influence over American culture. This venue, bureaucrats attempt to reserve for themselves.

It is not by accident that America's government agencies are overwhelmingly staffed by people embracing a political ideology which leans left. Bureaucracy is an institution which awards advancement, not for achievement or excellence as does the private sector; it is an institution which awards advancement for loyalty and dedication to party principles.

Notably, it is those personalities which cannot compete in the arena, where excellence is supreme arbiter of reward, which

inhabit America's bureaucracies. Regrettably, it is this contingent which makes our laws, manages our rules, and chains our businesses, and ultimately our people.

Taxes are the power which allows bureaucratic authority to manipulate our free-enterprise actions.

A flat tax would give government all the revenue it requires, and it would eliminate bureaucratic control over a creative and imaginative population that should be motivated by excellence and achievement, not bureaucratic prerogative.

Additionally, a flat tax would not pit classes against each other, it would provide an environment where we are all truly, "In this together".

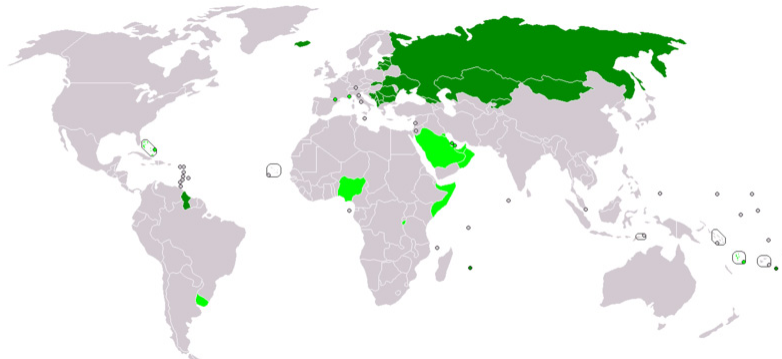

Countries that have flat tax systems

These are countries, as well as minor jurisdictions with the autonomous power to tax, that have adopted tax systems that are commonly described in the media and the professional economics literature as a flat tax.

Why the Left Hates Guns?

Why don't communist nations allow their populations to possess guns?

Well, I suppose, they might rebel. It is difficult to oppress if those under oppression have the ability to fight that oppression. At its core, communism is an oppressive ideology. It can only promulgate by subjugating its citizens. If communism were a government of the people, by the people and for the people, there would be no reason to disarm the people.

That "the people" are not allowed to possess firearms is all the evidence we need to understand that these governments do not have its citizen's best interests in mind. Guaranteed / Empowered by government, why would a people undermine the source of that Freedom and Liberty?

In the United States we don't fear possession of firearms by our citizenry because American culture does not endeavor to subjugate its people. When politicians suggest that we citizens should not be allowed to possess firearms, we really need to examine their motivations.

Politicians whom suggest citizens should not possess firearms, do not wish to see boundless Freedom or Liberty among the citizenry. As in communist nations, these politicians believe that "We the People" are not smart enough to enjoy such unfettered liberty. Dumb citizens like us need a superior in government to "properly" guide us. Additionally, if we are not dependent on these "superiors" in government, what need are they?

Guns give people a sense of independence and a sense of power over their own destiny. This independence is despised on the left. As long as people feel empowered and independent there is no value in liberal policies, and there is no need to grow government. For government to grow, people must feel dependent and desperate. They must feel they could not survive without government. They must feel that less government threatens their livelihood, ergo, more government would enhance it. Gun ownership directly affects the psyche of the gun owner and directly challenges the "dependence" on government liberals are so driven to instill into "the people". Every time a man or woman buys a gun, psychologically, it is a triumph for Liberty, and a nail in the coffin of liberalism.

There is an intimate connection between capitalist government, Freedom, Liberty, and gun ownership among the citizenry. It is a natural progression that as government grows, it oppresses. Because free people in a healthy society only need sparing support by government; expanding bureaucracy dependent upon the people's support will always embrace policy which undermines the health of that society.

It ought to be apparent, by casual observation, that it is within only the last 30 or 40 years that our government's politicians have embraced the idea that our people should not possess arms.

For over 200 years the United States grew wealthy and strong by supporting its people. Today, many facets of government, controlled by bureaucracy, have ventured to hold us down; subjugating free speech, confiscating private property and attempting to deny us self-protection.

A faction in government today is not interested in serving the people and is only interested in increasing its despotic power.

The arrogance of our politicians supporting these philosophies is mind boggling. This is not their government; it is ours, the people. Their role is to serve us; these politicians believe however, it is we who should serve them.

As American citizens, we must be vigilant in controlling our government and protecting our rights. Gun ownership is vilified by liberalism's establishment, and they have made it their mission to attach some sort of negative stigma to guns and gun owners.

Many believe the 2nd Amendment is that one Right which holds together and protects the complete precarious system glorified by our Bill of Rights.

We must purchase and possess more firearms. Only by doing so, can we ensure the preservation of such rights. If the 2nd Amendment falls, how long till Amendment I goes, then IV, V, VI, etc?

For My Kountry

For many American citizens, who embrace a political philosophy which swings left; collectivism, socialism, and ultimately communism is the idealist utopia they aspire to capture and promulgate across America. For these people, For My Kountry, means to ridicule excellence, to fear prosperity, and to blame others for individual failures.

It is an ideology which springs from mankind's weakest tenets...jealousy and envy. It is an ideology which attempts to tear all down to one low and "equal" or "fair" level. It is an ideology incapable of raising anyone or anything upward. Most of all, it is an ideology without any understanding of American culture or our American Founders' dream of creating a country free from government tyranny, open to individual initiative and most important, insuring to all citizens those inalienable rights guaranteed to mankind by God.

It might seem a little bit ridiculous, an inconsequential little guy, running an inconsequential little plastics company, with his inconsequential little handgun, might take on the audacious task of encouraging his fellow Americans to stand on their own, believe in themselves, appreciate our wonderful uniquely American freedoms, remind them of those simple but succinct liberties called the Bill of Rights, and expect he might have any effect on this vast and diverse land.

In my rumination, I realize it is no more ridiculous than hoping for dread, encouraging distrust against those wealthier than myself, blaming others for my failures, or expecting that a communist form of government would make life better for more people in America than our free-enterprise form of government does. No, it's not ridiculous as that, and while inconsequential, it does make me feel I'm doing something positive...**For My Kountry.**

“ Freedom is never more than one generation away from extinction. We didn't pass it to our children in the bloodstream. It must be fought for, protected, and handed on for them to do the same.

— Ronald Reagan

Congress of THE United States

begun and held at the City of New York, on
Wednesday the fourth of March, one thousand seven hundred and eighty nine.

Proudly American

RESOLVED

ARTICLES



FMK Firearms, Inc.

P.O. Box 1358, Placentia, CA 92871

Tel: 1-714-630-0658 Fax: 1-714-630-0664

www.fmkfirearms.com