

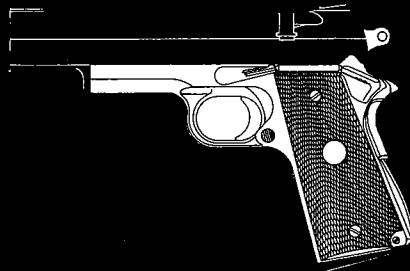

**CROSMAN/BLASER Model 455™ Conversion for Colt\* 45 OWNER'S MANUAL**  
.**177 Caliber Pellet Gun Conversion for Colt 45 Series 70 and earlier, 9mm,**  
**38 Super and 45**



**READ ALL INSTRUCTIONS AND WARNINGS IN  
THIS MANUAL BEFORE USING THIS AIRGUN.**

\*Colt is a trademark of Colt Industries Operating Corp.

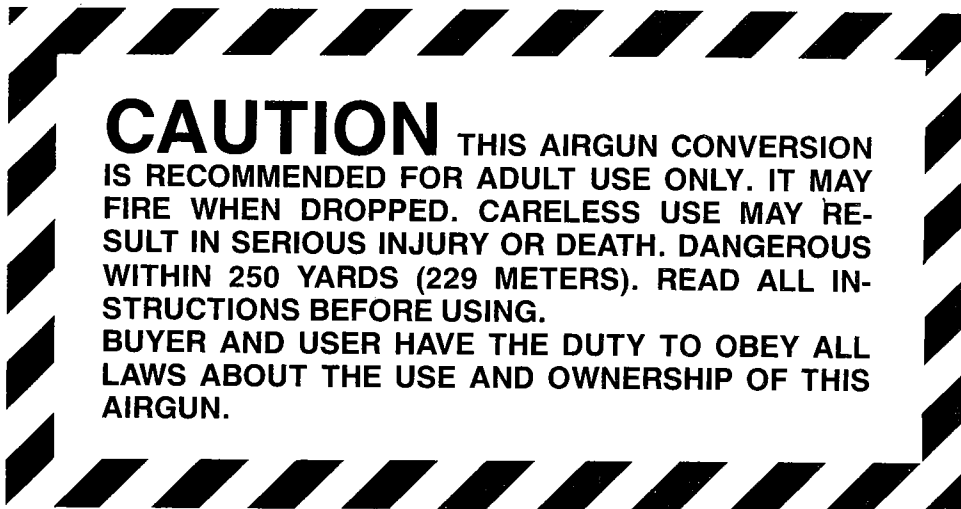

## **STEPS FOR SAFE SHOOTING**

	<b>Page</b>
Step 1. Your Crosman/Blaser Conversion.....	4
Step 2. Assembly Instructions.....	5
Step 3. Removing and Installing CO <sub>2</sub> Cylinder.....	6,7
Step 4. Loading and Unloading.....	8
Step 5. Aiming and Firing Safely.....	9
Step 6. Removing a Jammed Pellet.....	10
Step 7. Choosing Targets.....	11
Step 8. Reviewing Safety.....	12

## Step 1. Your Crosman/Blaser Conversion

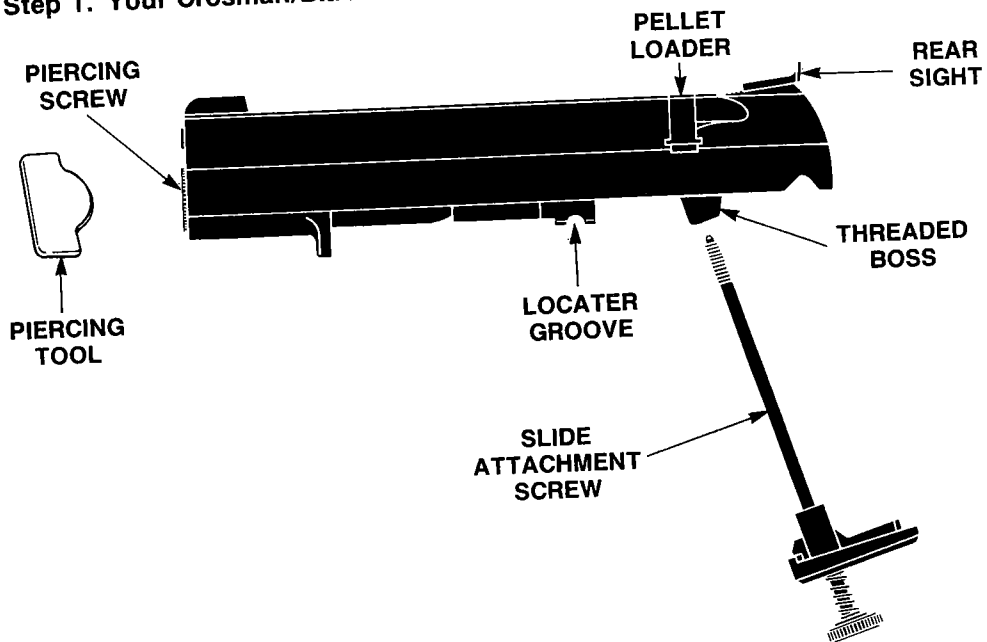

4

## Step 2. Assembly Instructions

- Remove magazine from your 45.
- Check breech to assure pistol is unloaded.
- Remove slide as shown in your 45 instruction manual.
- Replace slide stop - the slide stop pin is used to properly locate the conversion unit.
- With hammer fully cocked, place safety in on safe position as shown in your 45 instruction manual.
- Place conversion unit on 45 frame as shown in Fig. 1. Place the locater groove over the slide stop pin.
- Holding the conversion unit and the frame together with one hand, insert the slide attachment screw through the grip.
- Turn the slide attachment screw clockwise into the threaded boss located on the bottom of the slide. (Fig. 2)

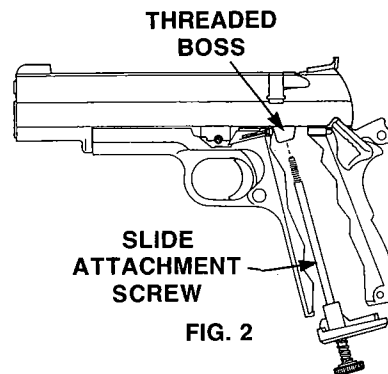
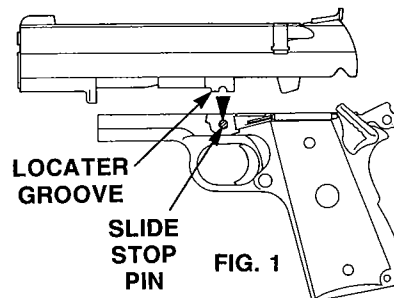

5

### Step 3. Removing and Installing CO<sub>2</sub> Cylinder

#### A. Removing CO<sub>2</sub> Cylinder

- Put pistol on safe.
- Push pellet loader open by pushing it from right to left. Check to be sure it does not have a pellet in it. (Fig. 3)

**CAUTION: WHEN REMOVING OR INSTALLING A CO<sub>2</sub> CYLINDER, ALWAYS KEEP PELLET LOADER IN OPEN POSITION. THIS BLOCKS CO<sub>2</sub> FROM THE BARREL AND PREVENTS ACCIDENTAL DISCHARGE OF A PELLET WHILE REMOVING AND INSTALLING A CYLINDER.**

- Pointing the pistol in a safe direction, hold on to slide with one hand. (Fig. 4) With the other hand insert the tool provided or a coin into the piercing screw and turn it counterclockwise. (Fig. 4) Never use any other type of tool on the piercing screw. It could result in damage to the screw.

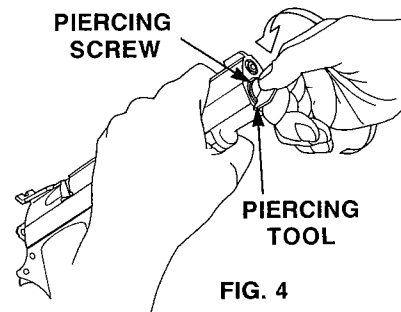
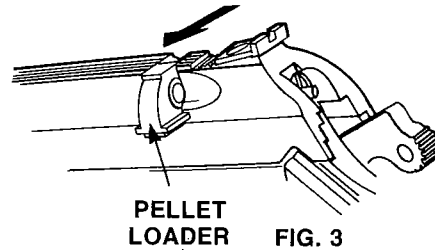

6

**CAUTION: KEEP HANDS AWAY FROM ESCAPING CO<sub>2</sub> GAS. IT CAN CAUSE FROSTBITE IF ALLOWED TO COME IN CONTACT WITH SKIN.**

- After removing piercing screw, slide CO<sub>2</sub> cylinder out of conversion unit.
- #### B. Installing New CO<sub>2</sub> Cylinder
- Insert the new CO<sub>2</sub> cylinder into the conversion unit with the neck of the cylinder pointing toward the rear of the pistol. (Fig. 5)
  - Place the piercing screw back into the unit by turning it clockwise until CO<sub>2</sub> cylinder is pierced. Do not overtighten. Overtightening can cause damage to your conversion unit.

**NOTE:** We recommend the use of Crosman Copperhead® CO<sub>2</sub> Powerlets®. They are made to fit the conversion unit. Other brands of CO<sub>2</sub> cylinders may not fit properly and if you force them into place it may result in injury to you or damage to your conversion unit. Never try to force any CO<sub>2</sub> cylinder into place.

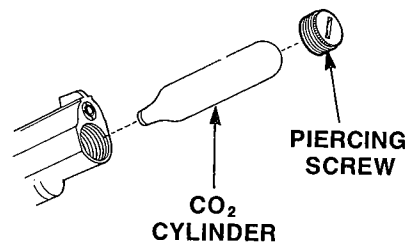

FIG. 5

#### Step 4. Loading and Unloading

##### A. Loading Pellets

- Put pistol on safe.
- Push pellet loader open as shown in Fig. 3.
- Place pellet, nose first, into pellet loader. (Fig. 6) To avoid jams, make sure pellet skirt is flush with the back of the loader.
- Close pellet loader. Make sure you have pushed it all the way over so the pellet is properly aligned with the barrel.

Note: Pellet loader can be reversed for left-handed loading.

##### B. Unloading Pellets

- Aim the pistol in a safe direction, take it off safe and fire.

**CAUTION: USE .177 CALIBER PELLETS ONLY, NEVER REUSE PELLETS. USE OF ANY PELLET OTHER THAN .177 CALIBER CAN CAUSE INJURY TO YOU OR DAMAGE TO THE PISTOL.**

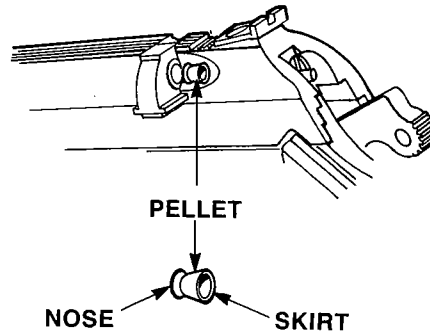

FIG. 6

8

#### Step 5. Aiming and Firing Safely

##### A. Aiming and Firing Safely

- Always follow all instructions and cautions in your Colt 45 Instruction Manual as well as this Conversion Manual.
- Always aim your pistol in a SAFE DIRECTION. When you are sure of your target and backstop, and the area around the target is clear, take the pistol Off Safe and squeeze the trigger to fire.
- Don't shoot at hard surfaces or at the surface of water. The pellet may bounce off and hit someone or something you had not intended to hit.

##### B. Sight Adjustment

- The rear sight may be adjusted for windage and elevation by loosening the screw and moving the sight up or down, or to the right or left as needed.

9

### Step 6. Removing a Jammed Pellet

- Put pistol on safe.
- Remove CO<sub>2</sub> cylinder from conversion unit to avoid accidental discharge when removing conversion unit from pistol frame.
- Remove conversion unit from pistol frame.
- Push pellet loader open and turn conversion unit upside down.
- Remove screw from pellet loader.
- Remove spacer that rests between screw and loader. (Fig. 7) Be sure to note orientation of spacer when removing. It must be replaced in exactly the same position.
- Remove the loader from the unit.
- A ramrod can now be inserted into the barrel and the jammed projectile can be pushed into the breech and be removed.
- Replace pellet loader, spacer and screw. Do not overtighten screw, you may strip it.

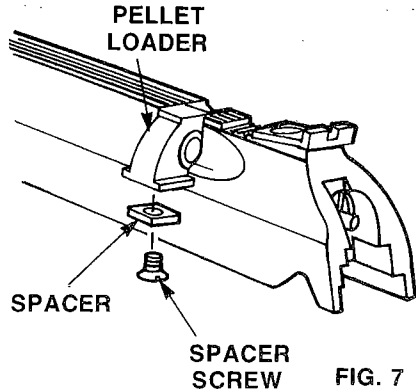

10

**CAUTION: KEEP HANDS AWAY FROM ESCAPING CO<sub>2</sub> GAS. IT CAN CAUSE FROSTBITE IF ALLOWED TO COME IN CONTACT WITH SKIN.**

- After removing piercing screw, slide CO<sub>2</sub> cylinder out of conversion unit.
- B. Installing New CO<sub>2</sub> Cylinder
- Insert the new CO<sub>2</sub> cylinder into the conversion unit with the neck of the cylinder pointing toward the rear of the pistol. (Fig. 5)
  - Place the piercing screw back into the unit by turning it clockwise until CO<sub>2</sub> cylinder is pierced. Do not overtighten. Overtightening can cause damage to your conversion unit.

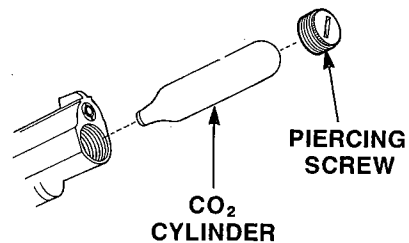

**NOTE:** We recommend the use of Crosman Copperhead® CO<sub>2</sub> Powerlets®. They are made to fit the conversion unit. Other brands of CO<sub>2</sub> cylinders may not fit properly and if you force them into place it may result in injury to you or damage to your conversion unit. Never try to force any CO<sub>2</sub> cylinder into place.

### **Step 7. Choosing Targets**

- Always choose your targets carefully. It is best to shoot at paper bullseye targets which are attached to a safe backstop such as the Crosman Target Trap. A heavy blanket should be hung behind the target trap to prevent ricochet or pellets bouncing off should you miss the backstop. We recommend that you wear shooting glasses to protect your eyes.
- Don't shoot at hard surfaces or at the surface of water. The pellet may bounce off and hit someone or something you had not intended to hit.

**CAUTION: YOUR BACKSTOP SHOULD BE INSPECTED FOR WEAR BEFORE AND AFTER EACH USE. DISCONTINUE USE IF THE BACKSTOP SURFACE SHOWS SIGNS OF FAILURE. SINCE BACKSTOP SURFACES EVENTUALLY FAIL, ALWAYS PLACE THE BACKSTOP IN A LOCATION THAT WILL BE SAFE SHOULD THE BACKSTOP FAIL. DISCONTINUE THE USE OF A BACKSTOP IF THE PELLET REBOUNDS OR RICOCHETS.**

- Your conversion unit is designed for target shooting and is suited for both indoor and outdoor use. Always remember to place your target carefully. THINK what you will hit if you miss the target!

11

### **Step 8. Reviewing Safety**

- Always follow all instructions, cautions and warnings in your Colt 45 Instruction Manual as well as this Instruction Manual.
- ALWAYS HANDLE YOUR PISTOL AS THOUGH IT WERE LOADED.
- Don't point at anything you don't intend to shoot. Always aim in a SAFE DIRECTION.
- Always keep pistol on safe until you are ready to shoot.
- Use .177 caliber pellets only. Never reuse ammunition.
- Don't shoot at hard surfaces or at the surface of water. The pellet may bounce off and hit someone or something you had not intended to hit.
- Stop using a backstop if it becomes worn. Place backstop in a location that will be safe should the backstop fail.
- Always check to see if the pistol is "On Safe" and unloaded when getting it from another person or from storage.
- Don't put the pistol away loaded. Make sure the pellet is unloaded.
- Keep hands away from escaping CO<sub>2</sub> gas. It can cause frostbite if allowed to come in contact with skin.
- Use of shooting glasses is recommended to protect your eyes.

## SPECIFICATIONS

Caliber: .177  
Ammunition: Copperhead® .177 Cal. Pellets  
Challenger® .177 Cal. Pellets  
Sights: Fixed front blade  
Rear - Adjustable for elevation  
& windage  
Barrel: Steel, rifled  
Power Source: CO<sub>2</sub> Powerlet®

## REPAIR SERVICE

If your conversion unit needs repair, we recommend you send it to Crosman Airguns, Rts. 5 & 20, East Bloomfield, N.Y. 14443, Attn: Service Department. If you take the unit apart, you probably will not be able to reassemble it correctly. Crosman assumes no warranty responsibility in this case.

## PERFORMANCE

Muzzle Velocity	Projectile	Weight
Up to 380 fps	.177 pellet	8.2 gr.

Average 60 shots per CO<sub>2</sub> Powerlet®

**NOTE:** Operating gun at below 70°F will decrease the number of effective shots. The reverse is true for operation above 70°F.

13

## LIMITED 90 DAY WARRANTY

This product is warranted to the retail consumer for 90 days from date of retail purchase against defects in material and workmanship and is transferable. To register the serial number of your conversion unit, please return the Airgun registration form. The warranty is not conditioned on the return of the card.

### WHAT IS COVERED

Replacement parts and labor. Transportation charges to consumer for repaired product.

### WHAT IS NOT COVERED

Transportation charges to Crosman for defective product. Damages caused by abuse or failure to perform normal maintenance. Sales outside of the United States. Any other expense. CONSEQUENTIAL DAMAGES, INCIDENTAL DAMAGES, OR INCIDENTAL EXPENSES, INCLUDING DAMAGE TO PROPERTY. SOME STATES DO NOT ALLOW THE EXCLUSION OR LIMITATION OF INCIDENTAL OR CONSEQUENTIAL DAMAGES, SO THE ABOVE LIMITATION OR EXCLUSION MAY NOT APPLY TO YOU.

### HOW TO OBTAIN WARRANTY PERFORMANCE

Attach to Product your name, address, description of problem, phone number and proof of date of retail purchase (sales slip). Package and return Product to Crosman Airguns, Rts. 5 & 20, East Bloomfield, NY 14443, transportation charges prepaid.

### IMPLIED WARRANTIES

ANY IMPLIED WARRANTIES, INCLUDING THE IMPLIED WARRANTIES OF MERCHANTABILITY AND FITNESS FOR A PARTICULAR PURPOSE, ARE LIMITED IN DURATION TO ONE YEAR FROM DATE OF RETAIL PURCHASE. SOME STATES DO NOT ALLOW LIMITATIONS ON HOW LONG AN IMPLIED WARRANTY LASTS, SO THE ABOVE LIMITATIONS MAY NOT APPLY TO YOU.

To the extent any provision of this warranty is prohibited by federal, state, or municipal law which cannot be preempted, it shall not be applicable. This warranty gives you specific legal rights, and you may also have other rights which vary from state to state.