

UZI SMG

OPERATION MANUAL

Cal. 9 mm PARABELLUM

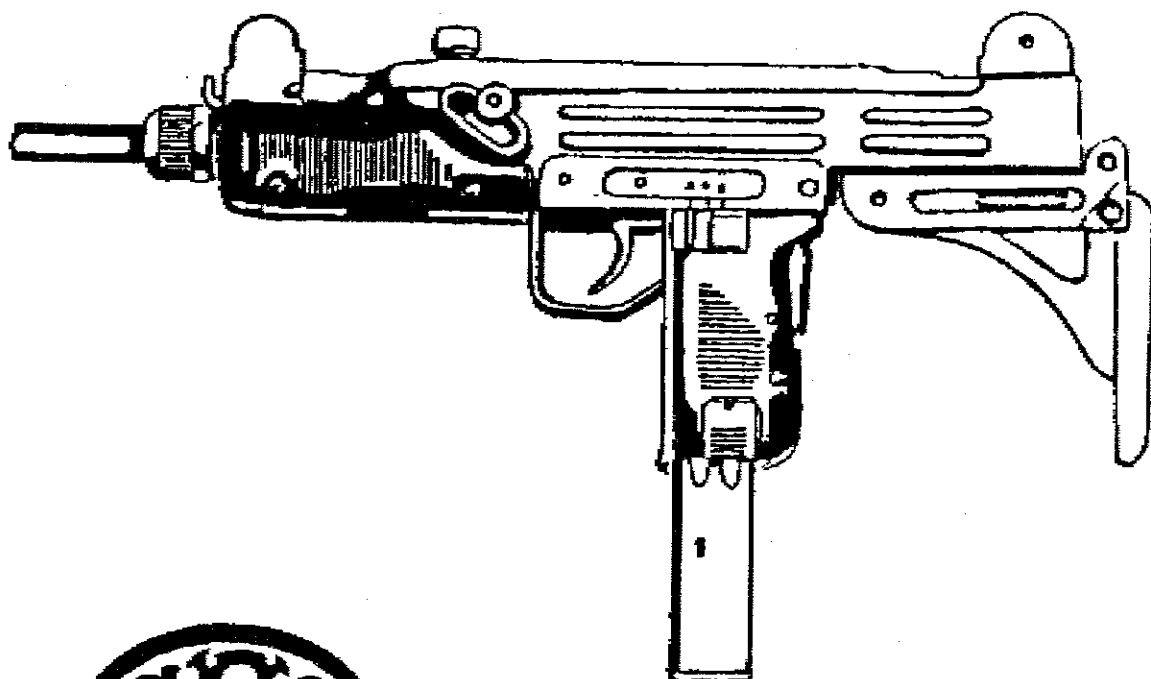

FABRIQUE NATIONALE D'ARMES DE GUERRE, S. A., HERSTAL-LIÈGE (BELGIUM)

TABLE OF CONTENTS

Historical Background	1
General Characteristics	5
Functioning	10
Handling	17
Exploded View	22-23
Zeroing	25
Immediate Action And Stoppages	26
Cleaning And Maintenance	28
Stripping And Assembling	30
Accessories	43
List Of Components	46

Historical Background

Although automatic weapons in the form of the early Maxim, Hotchkiss and Lewis designs first appeared in the late 1800's, and one form of early machine gun was actually used by the Confederacy during the Civil War, the submachine gun is uniquely a 20th Century weapon, like the guided missile and the submarine. The first true submachine gun, the Italian Villar Perosa, appeared in 1915. Originally designed for use in aircraft, it was quickly adapted to use by ground troops. While it doesn't fit today's image of an SMG, it did nevertheless presage better things to come.

World War I had ground to a standstill in the trenches and probably would have ended in a negotiated settlement between the Allies and the Central Powers had the U.S. not entered the war on the Allied side in the spring of 1917. The British SMLE and German M98 Mauser rifles which dominated the conflict were superb weapons for long range, deliberate fire, but they were hardly suited to the quick, close in work that resulted when one side decided to go "over the top" and assault the enemy's trenches. While the U.S. relied heavily on the Winchester M97 shotgun, the Germans went to work on designing a compact, lightweight automatic weapon that could be used to achieve the same results. Even while protesting the "inhumane" shotgun the Americans were using, the Germans were developing the MP-18 (*Machinen Pistole* 1918). The machine pistol handle was actually a misnomer, since the MP-18 looked very much like a conventional semi-automatic rifle. However, it was chambered for the 9mm Parabellum pistol cartridge, and it *was* capable of automatic fire, so the term machine pistol can be justified by only a little misguided logic. Also, it has been reported that the Germans

who were developing the first true assault rifle during World War II also referred to that arm as a machine pistol since Hitler had specifically forbidden development work on what he considered a frivolous weapon. A little of the same rationale may have been applied 25 years earlier, although true machine pistols were themselves just barely off the drawing board at the time.

The MP-18's designers were well aware that a cartridge more powerful than the 9mm Parabellum was needed to make their weapon more effective, but the demands of war were hardly conducive to spending a lot of time and money on R&D for a new cartridge. As a practical compromise, the already proven 9mm was selected. In the United States, Brig. Gen. John Thompson was also working on a submachine gun (which he labeled a "trench broom") chambered for the .45 ACP cartridge. Despite the technological advances in armament produced by two global conflicts and numerous smaller wars, to say nothing of the luxury of plenty of time between wars for R&D, the 9mm Parabellum and .45 ACP remain the principal cartridges for use in subguns throughout the Free World, with the former being by far the most prolific.

Although World War I ended before the MP-18 could really be given a fair trial under actual combat conditions, the little evidence that was available indicated that the concept of the submachine gun was well worth exploring. Of particular interest is the fact that the Treaty of Versailles specifically prohibited Germany from developing and manufacturing submachine guns and equipping her token army that the treaty permitted with them. History was even more unkind in the case of field trials for the Thompson. According to an interesting but doubtful legend, a crate of Thompsons bound for the front lines in France arrived at New York Harbor on November 11, 1918 — the very day the armistice was signed.

Although General Thompson continued working on his dream which would eventually be known worldwide as the "Tommy Gun", SMG development was, for all intents and purposes, a dead issue in the United States and Britain. Such was not the case in Europe, however, and numerous con-

tinental arms firms were experimenting with different designs, all of which bore a stronger resemblance to semi-auto rifles than to the submachine gun as we know it today. These guns received their first real tests during the Spanish Civil War, along with a lot of German and Soviet aircraft which would be the mainstays during the opening battles of World War II. Subguns proved to be especially well suited to house to house fighting and firefights in forested areas. As war clouds loomed over Europe in the closing days of the 1930's and everyone became painfully aware of the fact that German rearmament was hardly of a strictly defensive nature, the United States and Britain continued to ignore the need for submachine gun development.

On the morning of September 1, 1939, the world awakened to war borne by the screaming cry of Stukas diving toward Polish cities below. That war would officially end six years and one day later on the deck of an American battleship anchored in Tokyo Bay. During those six years, the submachine gun proved its value in war from the steaming, malaria-infested jungles of New Guinea to the icy streets of Stalingrad. Successive SMG designs began to evolve into the classic profile we know today — a large, detachable box magazine, a short barrel and collapsible buttstock. The American M3 "Grease Gun" is a perfect example of the type of weapons that emerged from the conflict.

The Israeli Uzi is what is known as a "second generation" SMG, being somewhat shorter and lighter than its predecessors. It was designed by Israel Galili, who borrowed heavily from several of the better Czechoslovakian designs, especially in his use of the telescoping bolt. Galili can hardly be condemned for copying the Czechs so closely. After all, it makes far more sense to copy what works than to waste time on originality which may or may not produce the desired result. Galili added a few refinements of his own and came up with the Uzi, which is believed by many to be the finest submachine gun in the world. First adopted for service in 1950, it has been the standard SMG in the numerous Arab-Israeli conflicts ever since. Originally equipped with a wooden buttstock, it is now normally equipped with a collapsible metal

UZI SMG OPERATION MANUAL

stock, although the wooden one is available as an accessory item. Due to the constant demand for Uzi's, they are made under license by the FN plant in Belgium as well as by Israeli Military Industries. The Uzi is a favorite of the American Secret Service and has been adopted by the military of a number of Free World nations. Indeed, the Uzi and Gordon Ingram's MAC 10 are the SMG's by which all others are judged.

Since the infamous Gun Control Act of 1968 prohibits American civilians from owning foreign-made, fully automatic Uzi's, a semi-auto version was introduced in this country in 1980. Within months, several enterprising firms were manufacturing parts which could be used to convert the semi-auto guns to full auto (legal with prior BATF approval). At least three books have also been written on the subject. Other than the obvious differences in the select lever, etc., the weapons are essentially the same whether semi- or full auto and are handled and field stripped in the same manner.

Although some ordnance experts are heralding the shotgun as the up and coming individual military weapon, it is doubtful if the submachine gun will ever totally disappear from the action spots of the world, even should hand held laser guns become a reality in the near future. Whether in its original "home grown" IMI version or of F.N. parentage, you can expect to see the Uzi in action for a long time to come.

The material that follows has been adapted from the original factory manual published by FN. Since its publication, the cocking knob has been enlarged and the selector modified. The latter was necessary since the original selector would permit an occasional, random burst of full auto fire when it was set on semi-auto.

I. GENERAL CHARACTERISTICS

1. **Calibre.** — The F. N. submachine gun is designed to fire the Luger 9 mm Parabellum round. Many armies have used this cartridge for a long time and it is now becoming universally standardised.

2. **Functioning principle.** — The blowback principle has been adopted for this weapon*. In this type, the breech is not mechanically locked but the breech block is relatively heavy and its

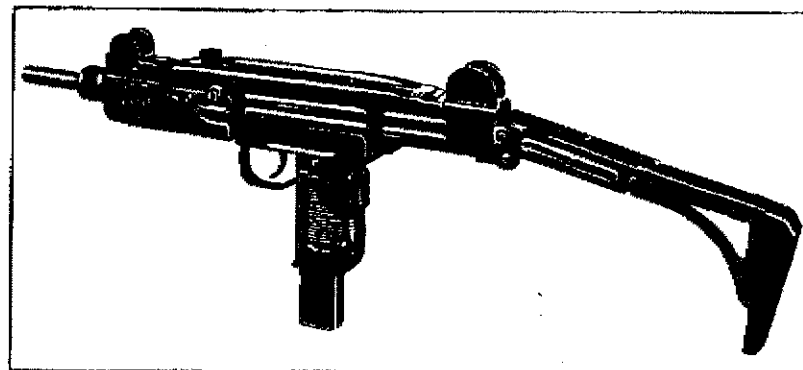

Fig. 1.

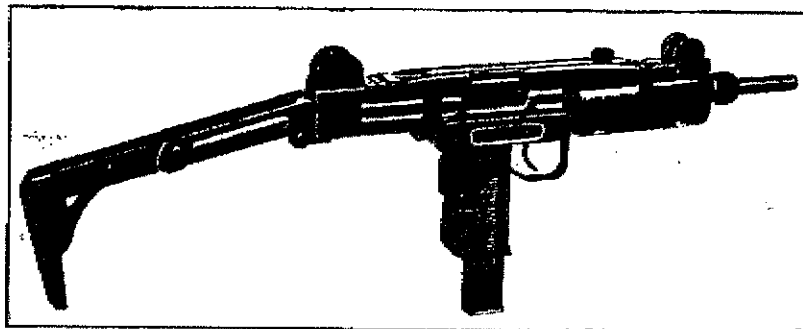

Fig. 2.

* This is an application of the principle of equality of momentum.

UZI SMG OPERATION MANUAL

mass prevents the breech from opening effectively until gas pressure in the barrel has fallen considerably.

3. **Firing.** — The weapon can be fired in two ways : either semi-automatic (single shot) or fully automatic.

The change lever is on the left side of the pistol grip. It can be set with the thumb of the right hand when this hand is holding the weapon.

4. **Stability and handiness.** — Careful calculation of its centre of gravity and weight has made the weapon very steady when firing, which, in turn, practically eliminates any upward jerk and reduces recoil considerably.

The F. N. submachine gun is so designed that the soldier can advance with his weapon ready to fire held in one hand, leaving his other hand free for any contingency.

5. **Feed.** — Location of the magazine in the pistol grip makes changing a magazine both simple and speedy.

6. **Sights.** — These consist of :—

A diopter rearsight, which can be tilted for settings corresponding to distances of 100 and 200 metres respectively.

A blade foresight, simultaneously adjustable for height and direction.

Both sights are provided with protectors.

The level of sight line above ground is very low, which allows the soldier to keep well under cover when firing.

7. **Safety.** — The F. N. submachine gun has a double safety device :—

a) The automatic safety in the pistol grip, located at the rear ; this contact safety prevents both cocking the action and firing so long as the firer does not tighten his clasp on the pistol grip and thus press the safety. This device prevents release of the sear and thus any movement of the breech-block.

UZI SMG OPERATION MANUAL

b) The ordinary safety acts directly on the trigger and is operated by the knob of the changeover lever, located on the left hand side, above the pistol grip.

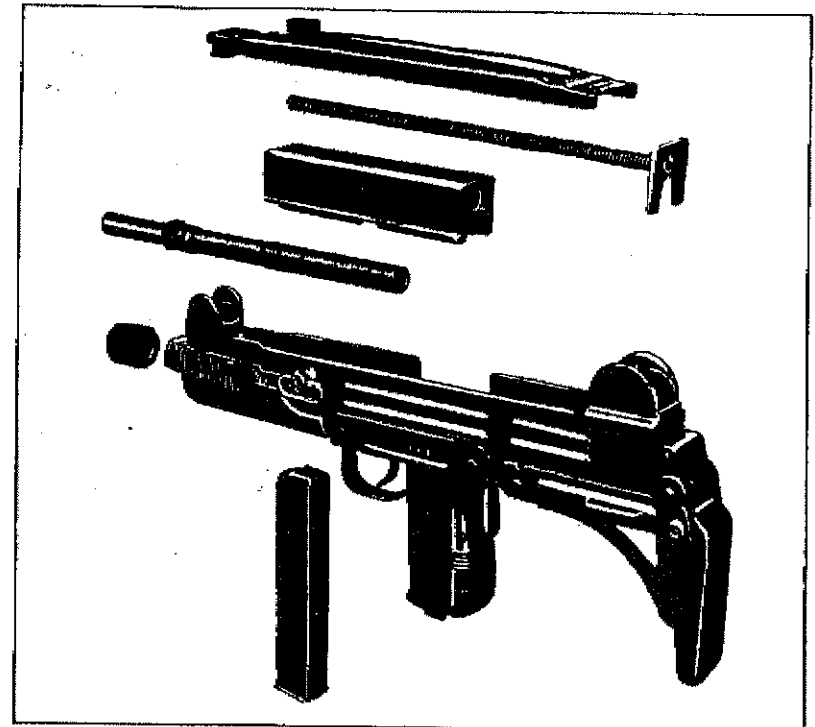

Fig. 3.

8. **Protection against foreign bodies in the mechanism, etc.** — The weapon is practically weatherproof. The breech-block unit envelops the rear part of the barrel and prevents anything penetrating into the chamber.

The method of cocking the gun closes the cover slide and keeps foreign bodies out of the mechanism.

The decreased span of the breech-block bearings ensures that any particles of dust, sand or mud, that may have accumulated, do not affect functioning of the weapon.

UZI SMG OPERATION MANUAL

9. **Stripping and assembly.** — Stripping for normal cleaning and maintenance and reassembly can be done without using tools.

Stripping is simple and quick. Barrel, cover, breech-block unit and main spring can be dismantled in a few seconds.

10. **Butt.** — The F. N. submachine gun is usually fitted with a metal butt, which can be extended, or folded into an inoperative position, as required (see fig. 1 & 2).

A wooden butt can be supplied, if preferred (see fig. 4).

11. **Bayonet.** — A small bayonet can be fixed; this is engaged by a stud.

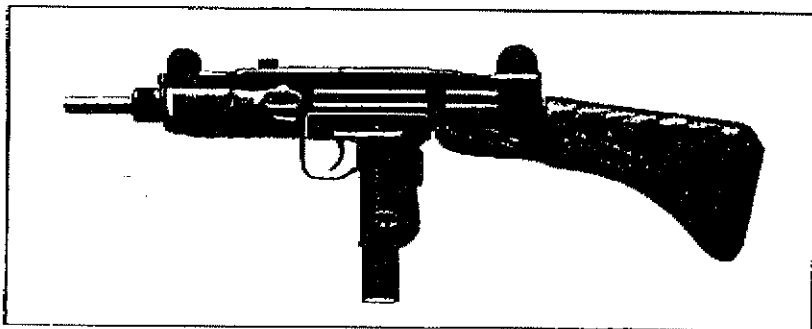

Fig. 4.

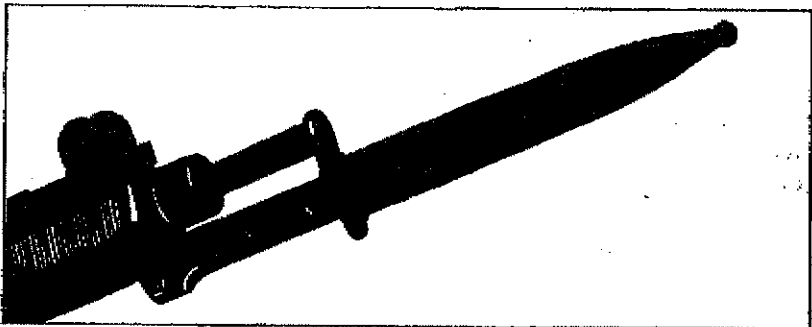

Fig. 5.

UZI SMG OPERATION MANUAL

12. Statistical data.

Weight.

Gun, without magazine:—

- a) with metal butt : 3.570 kg (7.8 lbs.)
- b) with wooden butt : 3.500 kg (7.7 lbs.)

"Standard" magazine, empty : 0.180 kg (6 ozs.)

"Standard" magazine with 25 rounds : 0.500 kg (1.1 lbs.)

Overall length of gun.

- a) With metal butt extended : approx. 650 mm (25.5")
- b) With metal butt folded : approx. 470 mm (18.5")
- c) With wooden butt : approx. 635 mm (25")

Barrel.

Length : 260 mm (10.2")

Rifling, N° of grooves : 4

Sight radius :

309 mm (12.2").

Cyclic rate of fire : 650 r. p. m.

Magazine.

There are two types:—

- "Standard" Magazine, capacity 25 rds ;
- 32-rd Magazine.

Cartridge.

9 mm Parabellum Luger.

a) Statistics:—

Length : 29.70 mm (1.16").

Weight : 12.10 grams (.43 ozs.).

Length of bullet : 15.70 mm (.62").

Weight of bullet : 8.00 grams (.28 oz.).

Weight of powder charge : .40 grams (.014 oz.).

b) Ballistical characteristics :

	8-gram Bullet	7.5 gram Bullet
Initial Velocity (Vo)	400 m/s. (1312 ft./sec.)	425 m/s. (1394 ft./sec.)
Velocity at 12.5 m (V. 12.5)	390 m/s. (1279 ft./sec.)	415 m/s. (1361 ft./sec.)
Muzzle Energy (Eo)	65 kgm. (470 ft.-lbs.)	69 kgm. (499 ft.-lbs.)
Maximum Pressure	2500 kg/cm ² (35,558 lbs./sq.in.)	
Effective range	up to 200 metres (218 yds.)	

II. FUNCTIONING

Firing Cycle.

The gun is loaded and cocked, i. e. the breech-block is held in the rear position by the sear.

1. Forward movement of the breech-block.

The action of pressing the trigger causes the sear to release the breech-block, which is pushed forward by the return spring.

a) Feed.

After moving forward about 25 mm, the underside (C 1) of the breech-block (C) contacts the base of the uppermost cartridge in the magazine (fig. 6) and pushes the round forward.

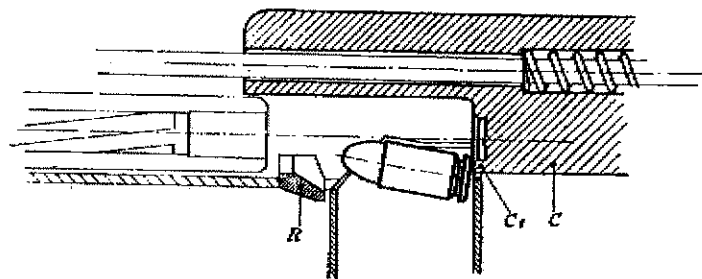

Fig. 6.

As it moves, the cone of the bullet meets the feed ramp (R), which guides it towards the chamber, thus disengaging the round from the mouth of the magazine.

b) Chambering.

The breech-block (C) continues its thrust on the base of the round and chambers it (fig. 7).

The neck of the cartridge case contacts the shoulder (F) of the chamber, which positions the round correctly in the chamber.

c) Firing.

When the breech-block has completed its forward movement, it forces the extractors to rise and the base of the cartridge is positioned in the recess in the breech-block.

UZI SMG OPERATION MANUAL

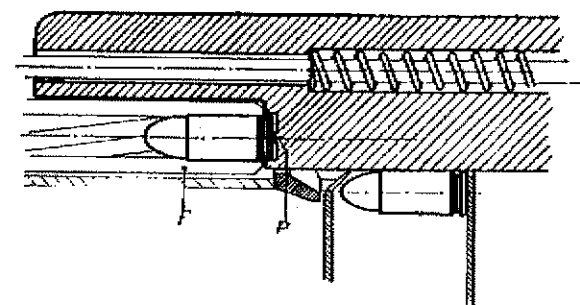

Fig. 7.

At this moment, the firing pin (P), which projects into the breech-block recess (C), strikes the percussion cap and fires the charge.

2. Backward movement of the breech-block.

The pressure developed by combustion of the powder charge forces the bullet forwards and starts the rearward course of the breech-block.

The initial recoil is slowed down due to the mass of the breech-block and only becomes effective after the bullet has left the barrel.

a) Extraction.

During recoil, the extractor claw holds the cartridge case in the breech-block recess until the case contacts the ejector.

b) Ejection.

When the recess in the breech-block arrives at the level of the rear face of the ejection opening, the case contacts the ejector (E), which projects into the recess and pivots the case round the extractor and ejects it. (fig. 8).

After this operation, the breech-block recoils until it strikes the rear of the body.

The cartridges in the magazine are thus released from the hold of the breech-block and rise under action of the magazine spring, until the uppermost round is in contact with the mouthpiece of the magazine.

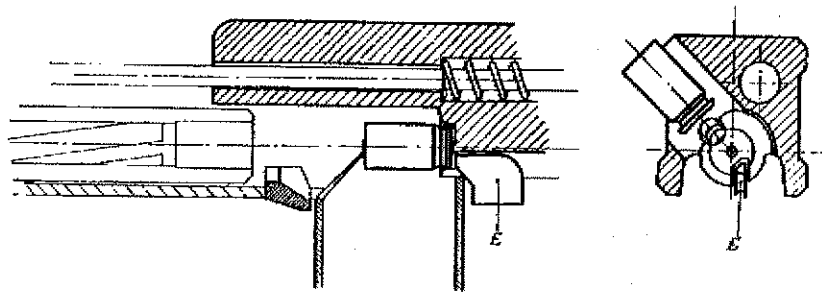

Fig. 8.

During the whole of the recoil movement the return spring is being compressed.

After completion of its backward movement, the breech-block is pushed forward again under action of the return spring, but its movement is halted by the sear, if the change lever is set at repetition (R), or the firing cycle recommences if the lever is set at automatic fire (A).

3. Trigger Mechanism.

a) *Automatic safety, pistol grip.* — The safety sear fulfils two functions (fig. 9).

If the mechanism is closed, the two pinions (G) of the sear are engaged in the two mid-way bents (C 1) in the breech-block and the right-angled front arm (S) of the automatic safety prevents their release. The breech-block (C) cannot then move towards the rear, which guards against the accidental firing of a shot on the rebound, in the event of a fall or similar shock. When this safety is compressed, its front arm moves beyond the two pinions and the sear is tripped; the breech-block will then travel to the rear and cocking can take place.

If the mechanism is open, the two pinions (G) of the sear are engaged in the two front bents (C 2) in the breech-block and the front arm (S) of the safety again prevents their release. The breech-block (C) cannot then move forwards and any accidental firing of a shot, through shock, fall or inadvertent action on the trigger, is thus prevented.

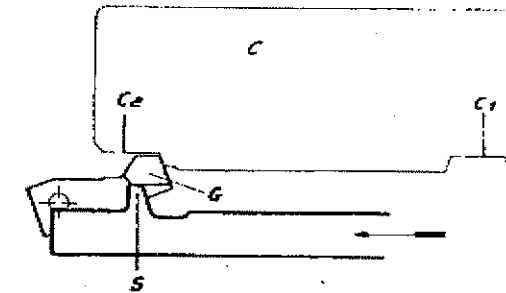
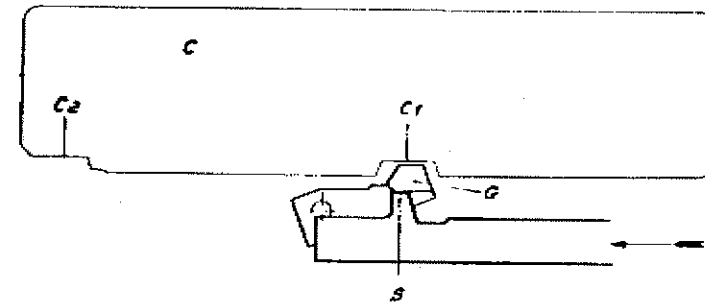

Fig. 9.

By compressing the safety, its fore arm moves beyond the two sear pinions, releasing the sear when the trigger is pulled to fire a shot.

Ordinary Safety (Change Lever).

The knob of the change lever is set in the rear position, i. e. at safety ("S").

The fore arm of the change lever (S) is then positioned below the trigger (D) (fig. 10).

In this position, the trigger cannot move downwards, the intermediate lever (L) is thus immobilised and consequently the sear (G).

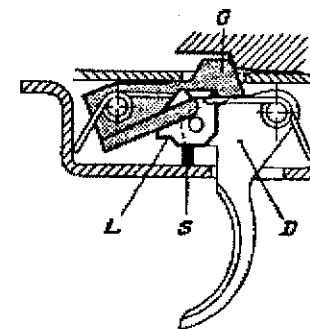

Fig. 10.

UZI SMG OPERATION MANUAL

b) Semi-automatic fire.

The change lever is set in the mid-way position "R" for single shot firing.

The fore arm of the change lever (S) is then positioned below the front shoulder (L 2) of the intermediate lever (fig. 11).

When the automatic safety has been compressed, finger pressure on the trigger pivots the upper arm (D 1) of the trigger downwards (fig. 12).

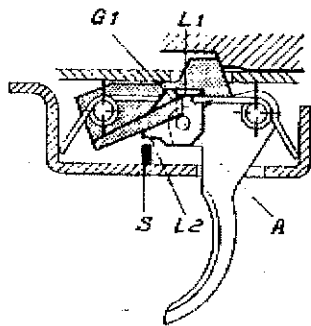

Fig. 11.

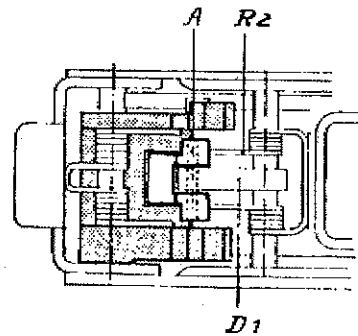

Fig. 12.

This in turn brings the intermediate lever downwards, as it is joined to the upper arm by a pin (A).

At the same time, the intermediate lever depresses the sear by the action of the lever ramps (L 1) on the shoulders (G 1) of the sear (fig. 11).

The shoulder (L 2) of the intermediate sear lever strikes against the change lever (S) (fig. 13). The firer feels the initial check.

Continued pressure on the trigger forces the intermediate lever to pivot round the joint pin (A) to the rear and the ramps (L 1) of this lever depress the sear (fig. 13) slightly. The breech-block, pushed forward by the return spring then trips the sear.

Towards the end of the front to rear rotation of the intermediate lever its ramps (L 1) pass behind the shoulders (G 1) of the sear, freeing it from the intermediate lever (fig. 14).

UZI SMG OPERATION MANUAL

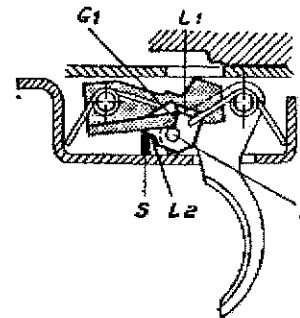

Fig. 13.

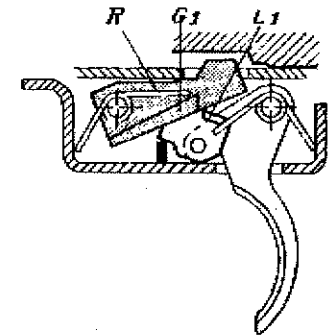

Fig. 14.

The sear, pushed upwards by its spring (R) is then in position, after the shot has been fired, to stop the breech-block's forward movement and the next shot cannot be fired if there is continuous pressure on the trigger.

This ensures single shot firing and it will be necessary to release the trigger before another shot can be fired.

When the trigger is released, its upper arm (D 1) pivots upwards and through the joint pin (A) takes the intermediate lever with it. (fig. 12).

This lever then pivots forward, under pressure of the two front spires (R 2) of the trigger spring and the lever ramps (L 1) pass over the shoulders (G 1) of the sear, which again makes the sear part of the trigger-intermediate lever unit and prevents the following shot from being fired until the trigger is pulled again.

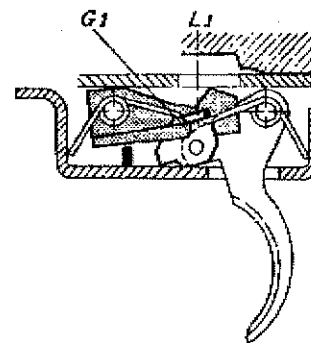

Fig. 15.

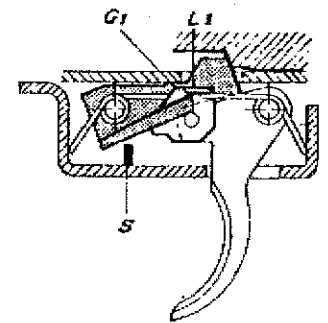

Fig. 16.

UZI SMG OPERATION MANUAL

c) *Automatic Fire.*

The change lever is set in the fore position at "A" for automatic fire.

The fore arm of the change lever (S) is then in front of the intermediate lever circuit (fig. 15).

After pressing the automatic safety, pressure on the trigger depresses the intermediate sear lever and the ramps (L 1) contact the shoulders (G 1) of the sear.

The firer again feels the initial check.

Continued pull on the trigger causes the intermediate lever to bring the sear to its depressed position (fig. 16); the breech-block is thus freed from the sear.

As the fore arm of the change lever (S) is out of action, the intermediate lever cannot pivot to the rear and the sear remains in its depressed position and is held there by the ramps of the intermediate lever resting on the shoulders (G 1) of the sear; the breech block continues its firing cycle so long as pressure is kept on the trigger (fig. 16).

When the trigger is released, trigger and sear revert to their original position under the action of the sear and trigger springs.

The sear is therefore in position to stop the breech-block in its course rear-forward.

III. HANDLING

1. **Filling a magazine.**

Hold the magazine in one hand; insert the cartridges one by one through the mouth of the magazine, with the base towards the flanged end of the magazine.

Use slight pressure to push each round fully home.

2. **Loading and cocking.**

Set the knob of the change lever at Safety "S".

Hold the weapon by the pistol grip, in the right hand, exerting pressure on the automatic safety.

As a precaution, keep the index finger outside the trigger guard.

Tilt the gun towards the right and insert a filled magazine, push fully home in its housing in the pistol grip until the magazine catch engages in its notch in the magazine.

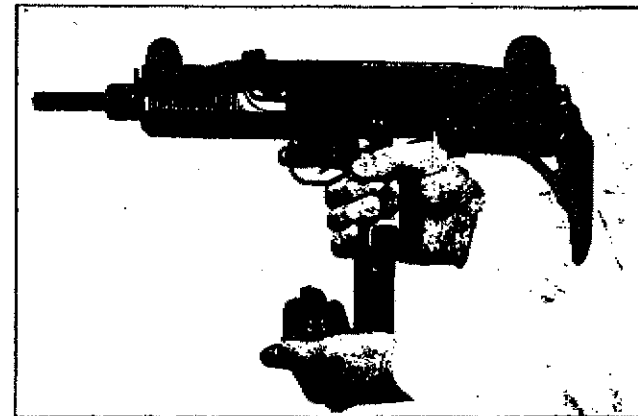

Fig. 17.

When the magazine is engaged, use the left hand to pull the cocking lever fully to the rear. This causes the mechanism to recoil, compresses the recoil spring and ensures action of the sear on the breech-block.

UZI SMG OPERATION MANUAL

Release the cocking lever which then returns to its original position under action of its spring.

Set the knob of the change lever at "A" or "R", as required.

The gun is then ready to fire.

3. Removal of magazine.

Turn the weapon as for loading; with the left hand thumb, press on the knurled button of the magazine catch and withdraw the magazine from the pistol grip (fig. 18).

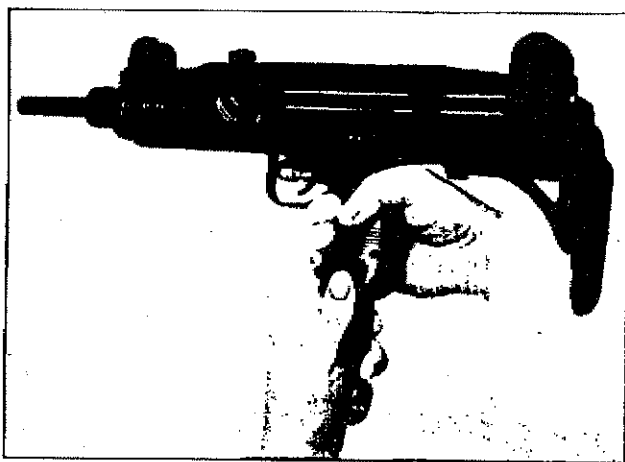

Fig. 18.

4. Re-loading.

Remove the empty magazine as described in Para. 3 above. Engage another loaded magazine and re-cock the gun as in Para. 2.

N. B. — Note that in certain cases the mechanism remains in the rear position after firing the last round in a magazine (when firing single shot or after release of the trigger in automatic fire, when it coincides with the firing of the last round). In such cases there is no need to re-cock but we advise that the cocking drill be carried out systematically.

5. Unloading the gun.

Place the knob of the change lever at safe-"S".

UZI SMG OPERATION MANUAL

Remove the magazine (see Para. 3).

Inspect the chamber to make sure it is empty, cocking the gun, if necessary.

Position the change lever at "A" or "R".

Press the trigger to free the breech-block.

6. Change Lever.



Fig. 19.

The change lever is on the left side of the pistol grip and its knob can be pushed directly to the required position. It can occupy three positions: "S" Safety (rear position). "R" Repetition, or single shot (mid-way position). "A" Automatic, or bursts of fire (front position).

7. Backsight.

The rear peepsight can be set in two positions, i. e. for 100 or 200 metres, and can be tipped over for the required setting.

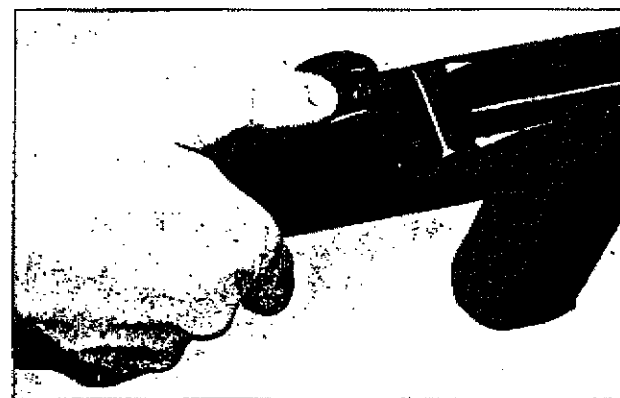

Fig. 20.

UZI SMG OPERATION MANUAL

8. Butt.

a) Engagement of the metal butt.

Use the palm of the hand to give a sharp impact to the tip of the butt plate (fig. 21); this will unlock the butt and disengage it from its catch.



Fig. 21.

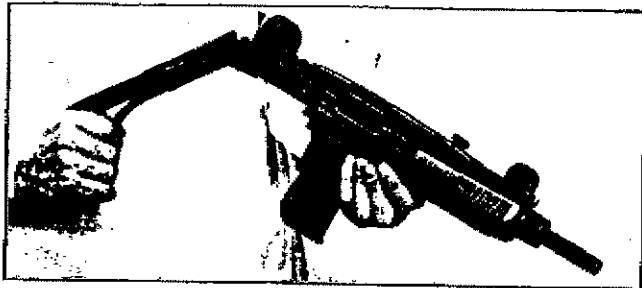

Fig. 22.

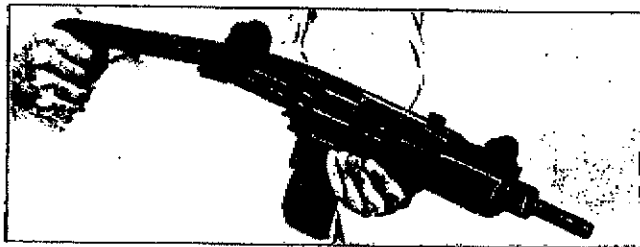

Fig. 23.

UZI SMG OPERATION MANUAL

Take hold of the butt plate and draw the butt assembly to the rear (fig. 22), until the two parts of the butt snap into location and lock.

Bring the locked butt down against the body (fig. 23).

b) Folding the metal butt into its inoperative position.

Press the locking stud to release and pivot the butt downwards (fig. 24).

Compress the rear lateral plate on the right and swing it upwards (fig. 25).

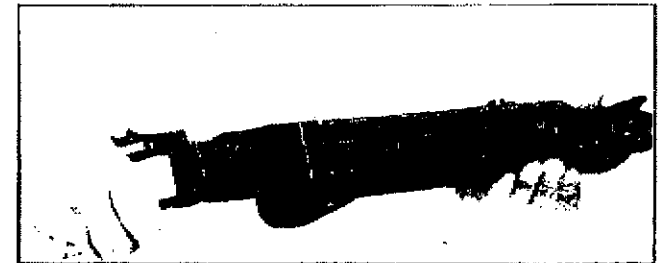

Fig. 24.

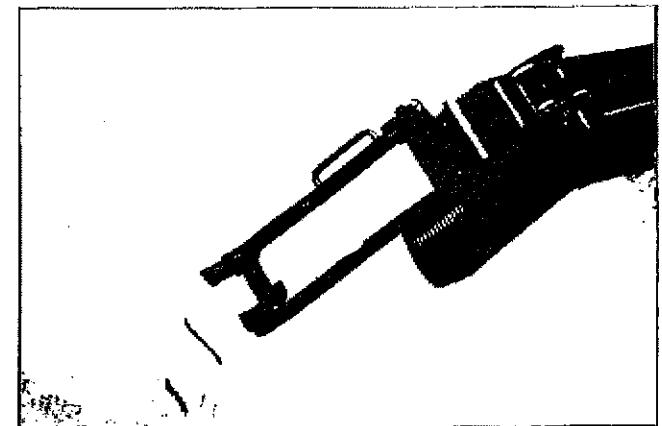

Fig. 25.

UZI SMG OPERATION MANUAL

Take hold of the butt plate and bring the front part of the butt into contact with the underside of the body.

Keeping this contact, swing the butt plate upwards, using pressure or a sharp impact, until it locks in the inoperative position.



Fig. 26.

IV. ZEROING

The gun is zeroed before issue to the firer, but may require adjustment in elevation and direction to suit the individual, or when the gun has been brought in for repair. Adjustments must be carried out by a qualified armorer only, who uses a special combined tool to loosen and tighten the foresight screw and make corrections for elevation and direction simultaneously.

A half turn of the foresight will move the M. P. I. as follows:—

- vertically, approximately 4 cm at 50 metres ;
- horizontally, approximately 64 cm at 50 metres, in the event of the foresight being moved laterally to the extreme limit.

Corrections for elevation and direction are carried out with regard to the above figures and the amount of adjustment needed:

- Loosen or screw down the foresight according to whether the M. P. I. is too high or too low ;
- Move it laterally to the right or left, according to whether the M. P. I. is too far to the right or too far to the left.

V. IMMEDIATE ACTION AND STOPPAGES

1. Immediate action.

If the gun ceases to fire when correctly operated, there is a stoppage.

This stoppage (except in the case of an empty magazine) can often be cleared by taking quick action, without investigating the cause of the incident.

2. Immediate action to be taken.

First action.

Operation 1. — Cock the gun.

Operation 2. — Withdraw the magazine.

Operation 3. — Replace another magazine.

Operation 4. — Fire again.

If there is still a stoppage, proceed as follows:—

Second action.

Operation 1. — Cock the gun.

Operation 2. — Remove the magazine.

Operation 3. — Check that the cartridges are correctly positioned in the magazine.

Operation 4. — Check that there is neither a trapped case nor cartridge in the mechanism or chamber; if this is the cause, clear the obstruction.

Operation 5. — Replace the magazine, pushing it fully home.

Operation 6. — Fire again.

3. Stoppages.

If the incident recurs systematically, check the points listed below, after repeating the first 4 operations under "Second action".

Tightness of barrel.

- a) Barrel locking nut loosened : screw up tightly, locating the barrel correctly.
- b) Barrel locking catch damaged : if it is not possible to repair immediately, tighten the barrel locking nut periodically.

Extractor.

- a) broken : fit a new extractor.
- b) deformed : fit a new extractor.
- c) fouled : strip and clean.

Breech-block and body :

carry out field stripping procedure and clean the gun; after cleaning, the breech-block should slide easily in the body.

Extractor housing, breech-block :

clean the hollowed part carefully, also underneath the extractor claw.

Return spring :

the guide-rod must be straight : the spring must slide on the rod without catching.

Magazine catch :

check that it is engaging the magazine securely and is clean.

Trigger assembly :

fouling; if there is any stoppage caused by the trigger mechanism, if possible, fire automatically; inspect, strip and clean thoroughly, as soon as circumstances permit.

VI. CLEANING AND MAINTENANCE

1. General observations.

It must be emphasized that all automatic weapons need careful maintenance and that the majority of stoppages mentioned only occur as a result of the user's negligence, or lack of knowledge of his gun. Any weapon, whether fully automatic or self-loading, must always be cleaned at the end of a day's firing, particularly after using blank cartridges.

2. Servicing the gun.

a) Care and cleaning by the soldier.

The F. N. 9 mm submachine gun need only be partially stripped (field stripping) for this maintenance, which consists of :—

- passing a pullthrough, soaked in special oil, through the bore of the barrel and repeating this several times ;
- pulling two or three dry rags through until bore is clean ;
- cleaning the chamber with its cleaning brush ;
- cleaning the breech-block and the inside of the receiver ;
- cleaning underneath the extractor claw, without stripping it ;
- lubricating the barrel with a lightly oiled rag ;
- slightly oiling the moving parts.

b) Servicing by the Unit Armourer.

On the other hand, it is essential that the gun be periodically checked by the armourer, who will ensure that it is receiving proper care from the user.

This inspection must cover all the components of the weapon to ensure that everything is in good working order. The armourer's servicing will include :—

- stripping and cleaning the extractor ;
- checking and adjusting sights, if necessary.

3. Barrel Inspection.

Firstly, the barrel must be regularly cleaned, in the manner described above, so that it is never neglected to the point where the use of harmful abrasives, such as emery, sand or powdered brick, becomes necessary.

When the gun is called in for its periodical servicing, the armourer must pay special attention to the condition of the barrel. Where this is not satisfactory (powder deposit, burning, etc.) he should carry out the operations listed under 1. above, i. e. the soldier's maintenance. Before oiling, the bore must be so clean that a piece of white flannelette comes through the barrel unsoiled. Follow this by lightly oiling the bore and chamber.

Dry the outside of the barrel and then rub with a greasy rag. If the gun is to be laid up for a certain time, lubricate the inside of the barrel, using a suitable barrel grease.

VII. STRIPPING AND ASSEMBLING

The F. N. submachine gun is designed for easy stripping and assembly; there is no difficulty, if the correct procedure is followed.

When stripping the weapon, take care to place the components on a flat clean surface, arranged in the order in which they have been stripped; this will facilitate re-assembling, which is done in the opposite order to stripping.

A. STRIPPING.

Make sure that no cartridge is left in the weapon. Check as follows:—

- remove the magazine,
- act on the automatic safety, pistol grip,
- pull the cocking lever a few centimetres to the rear so that it clears the ejection opening,
- check through the ejection opening that there is no cartridge in the barrel,
- let the cocking lever go forward,
- set the gun at "S" (Safe).

1. Field Stripping.

This consists of:

a) Removing the cover.

Press the cover catch to the rear (located in the fore part of the backsight seating), raise the rear part of the cover and remove to the rear and upwards. This frees it from the body of the gun.

b) Removal of breech-block and return spring assembly.

Raise the front of the breech-block until clear of the body; remove it forwards with the return spring assembly.

Separate this assembly from the breech-block by pulling it to the rear.



Fig. 27 (a)

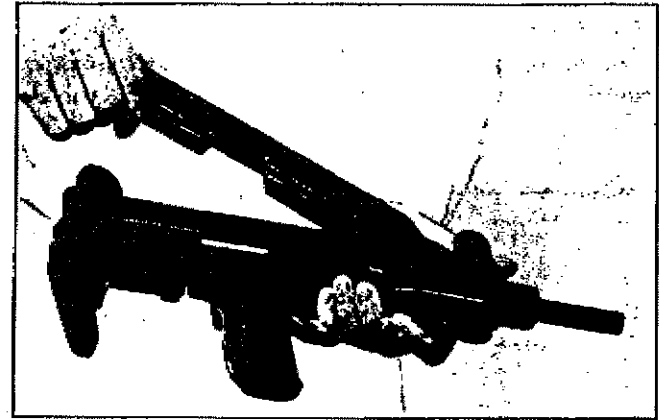

Fig. 27 (b)

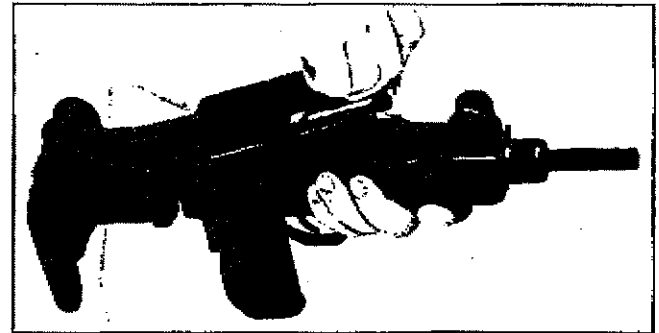

Fig. 28.

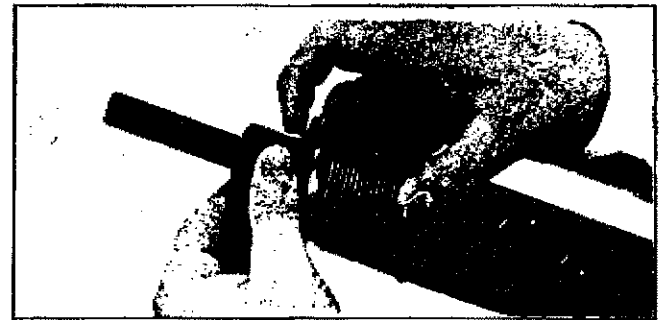

Fig. 29.

c) *Removal of barrel.*

Press the barrel catch to the rear (located in front part of foresight housing). Unscrew the barrel nut. Remove the barrel forwards.

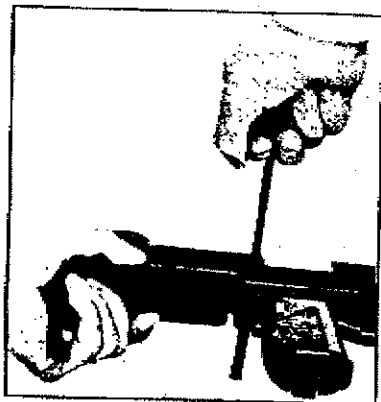

Fig. 30 (a)

assembly from the body by swinging the pistol grip slightly downwards and forwards.



Fig. 30 (b).

2. **Extractor.**

Remove the extractor retaining pin.

Push the extractor from back to front to separate it from the breech-block.

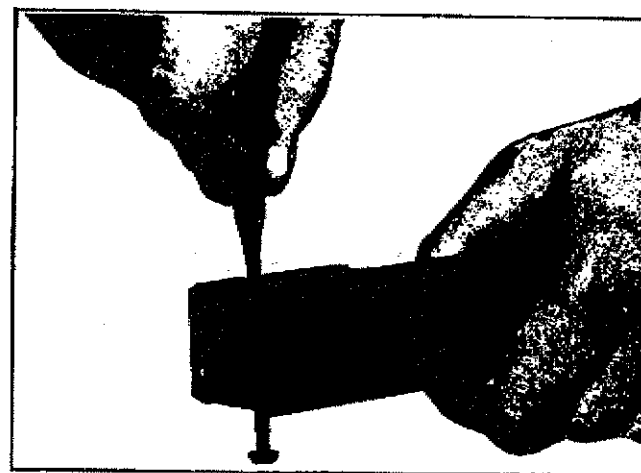

Fig. 31.

3. **Handguard.**

Unscrew the lock-nuts retaining the two handguard screws; loosen the screws and separate the right and left sections of the handguard.

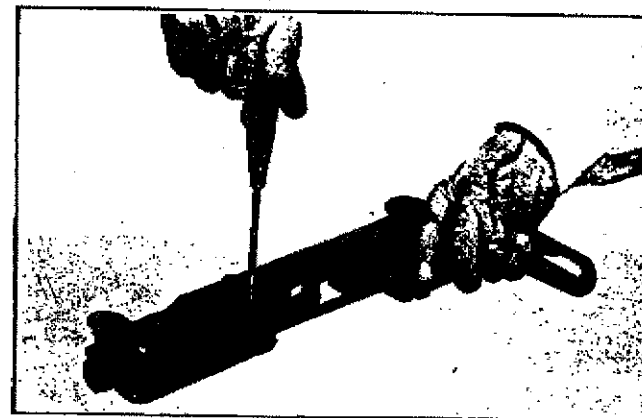

Fig. 32.

4. **Cover.**

Unhook the rear spiral of the cocking lever spring. Undo the stud screw (located by two centre punchings), remove it with its

UZI SMG OPERATION MANUAL

spring washer. Remove the cocking lever and the cocking handle.

Normally, there is no need to strip the cover spring.

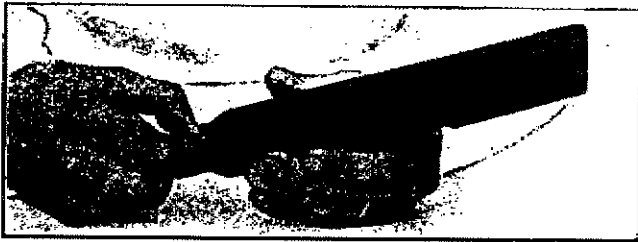

Fig. 33.

5. Trigger mechanism.

Undo the two screws securing the pistol grip sections, then separate the two halves of the pistol grip. Set the knob of the change lever at "R". Pull the trigger and press the safety to release the sear. Use a pin drift to push the sear pin from left to right and remove it from its housing in the trigger frame. Remove the sear and its spring. Separate the spring from the sear by disengaging the two rear ends of the spring.

Free the two front ends of the trigger spring by pressing them downwards, bringing them away from the sear intermediate lever; in this position, the lever is freed from the pressure of the trigger spring.

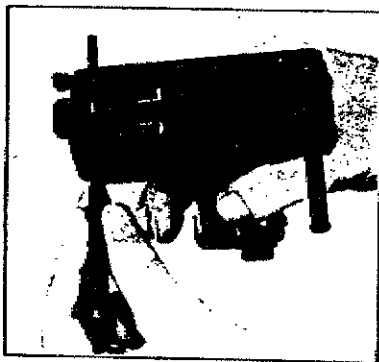

Fig. 34.

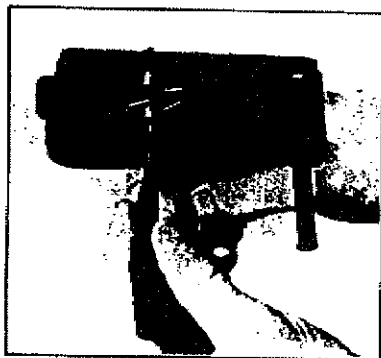

Fig. 35.

UZI SMG OPERATION MANUAL

Use a pin drift to push the trigger pin from left to right and remove it from its housing. Remove the assembly of trigger, sear intermediate lever and trigger spring from the trigger frame.

Compress the safety spring slightly and remove from the pistol grip. Remove the assembly of safety and plunger upwards.

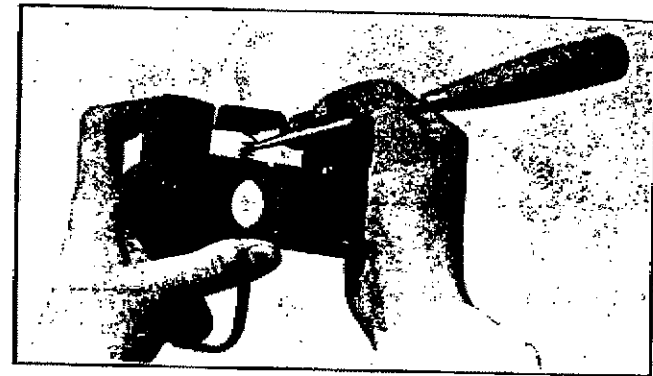

Fig. 36.

Move the change lever knob forward to position "A". Insert the blade of a screwdriver, or similar blade, underneath the change lever knob, into the interior groove; push upwards until knob and lever are freed. Remove the knob and change lever. Use a screwdriver to release the spring plunger of the lever; this disengages it from its slots; push upwards.

Use a pin drift to remove the magazine catch pin; remove the magazine catch and its spring.

6. Butt.

a) Folding metal butt.

Undo the hexagonal screw which secures the butt to the rear face of the body. Remove the butt catch forwards. Separate the butt from the body.



Fig. 37.

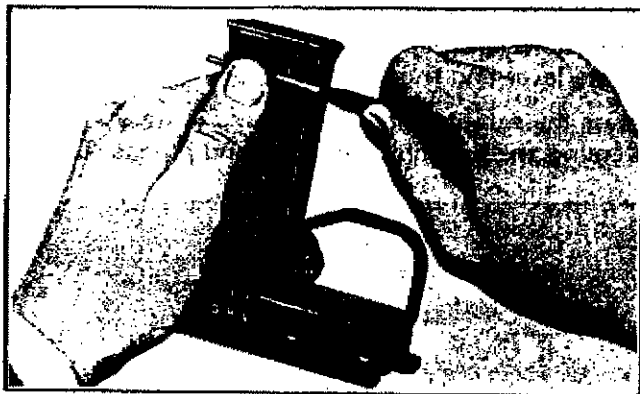

Fig. 38.



Fig. 39.



Fig. 40.

b) **Wooden butt.**

Press the catch stud and remove the butt rearward.

7. **Backsight and foresight.**

Unscrew the nut of the backsight screw, then the screw ; remove the backsight and secure the nut to the screw, otherwise it may be mislaid. Unscrew the nut securing the foresight ; unscrew the foresight and remove its spring washer.

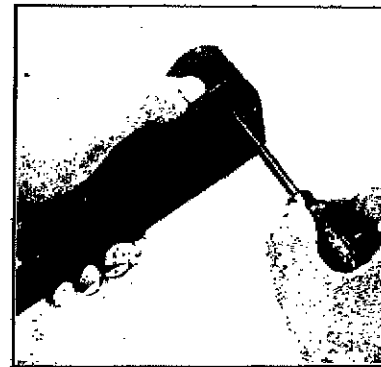

Fig. 41 (a)



Fig. 41 (b)

8. **Barrel catch.**

Compress and push forward on the rear tip of the barrel catch. Remove the barrel catch and its spring forward. Remove the spring from its housing in the catch.



Fig. 42.

9. **Cover catch.**

Take care that the coiled spring of the cover catch is not released from its housing. To avoid this, strip as follows : after removal of the backsight, press the blade of a screwdriver against the front rim of the curved spring of the backsight, exert slight pressure to the rear so that the spring is raised slightly, but hold it securely with the thumb. Gradually lessen pressure on the

screwdriver, so that the cover catch disengages slowly forwards. Remove the cover catch, its coiled spring and the curved backsight spring from their housings.

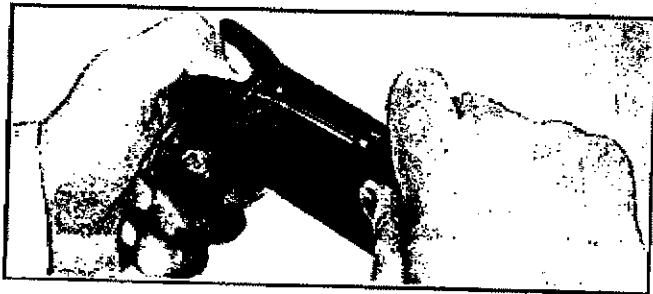

Fig. 43.



Fig. 44.

10. Magazine.

Insert the tip of a cartridge in the central opening of the magazine base, pushing without undue pressure until the magazine base plate slides forward and can be removed.

B. REASSEMBLY.

Components of the F. N. submachine gun are reassembled in the opposite order to stripping procedure. To assist in reassembly, it is advisable to look at the illustrations for the corresponding stripping operations.

There are no special difficulties, if the following precautions are taken:—

1. Magazine.

The magazine platform spring must be positioned so that the uppermost spire is approximately parallel to the lower face of the platform.

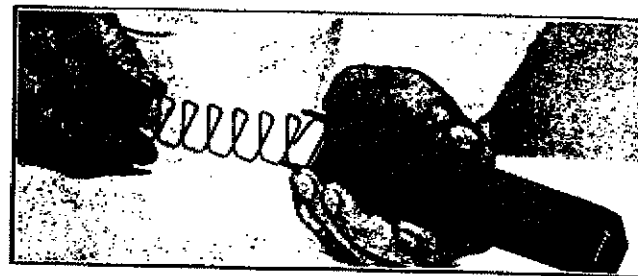

Fig. 45.



Fig. 46.

2. Cover catch.

Locate the curved backsight spring, placing the right-angled side to the rear, then position the coiled spring horizontally underneath the curved spring. Insert the cover catch beneath the curved spring. Using the right hand thumb, push the cover catch to the rear so that the coiled spring is fully compressed and, when this has been done, press hard on the curved spring with the left hand thumb until it engages with the cover catch.

3. Backsight.

When reassembling, take care that the flap marked "100" is located to the rear.

4. Trigger mechanism.

To reassemble the magazine catch, locate the two spires of the catch spring inside the catch; insert the two parts in their housing by pressing the coiled part of the spring against the grip. Compress fully and secure with a pin drift. Replace the magazine catch pin gradually, withdrawing the pin drift as the pin is inserted.

First replace the spring plunger; to ensure that the change lever and its knob form an integral part, insert the lever in the trigger frame from the top until it comes up against the spring; the



Fig. 47.

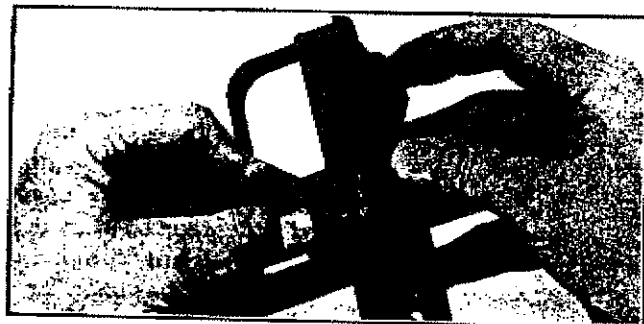

Fig. 48.

small lower arm comes opposite the letter "A" ; slide the knob upwards on this arm ; still exerting pressure from above, push the change lever fully home in the trigger frame, compressing the spring with a screwdriver, or any handy substitute.

Re-assemble the automatic safety and its spring. Replace the trigger and intermediate lever assembly in the trigger frame and position the trigger spring on either side of the trigger, with the straight arm of the spring against the rear part of the trigger guard. Pass the trigger pin from right to left through the coils of the spring and into the hole on the left side, locating the split, righthand end of the pin vertically, with the cross-wise grooves downwards. Secure the two free ends of the trigger spring in the two locating grooves in the intermediate sear lever.



Fig. 49.



Fig. 50.

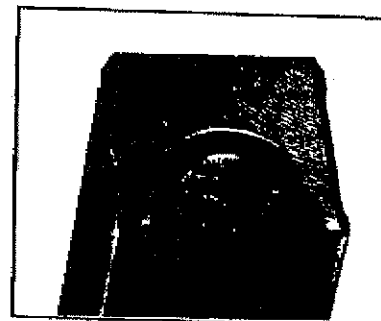

Fig. 51.

Position the sear in the trigger frame, then the sear spring, pressing the rounded part against the front plate of the trigger frame. Insert the sear pin from right to left in the sear holes and through the spirals of the spring, locating the split, righthand end of the pin vertically, with the cross-wise groove downwards. Insert the two free ends of the spring in the small holes in

the sear. Check for correct functioning of the trigger.

5. Extractor.

When assembling the extractor, the slot in its rear face must be parallel to the arrow on the rear face of the breech-block.

6. Trigger frame assembly.

Hold the assembly firmly against the body of the gun so that the trigger frame retaining pin can be replaced.

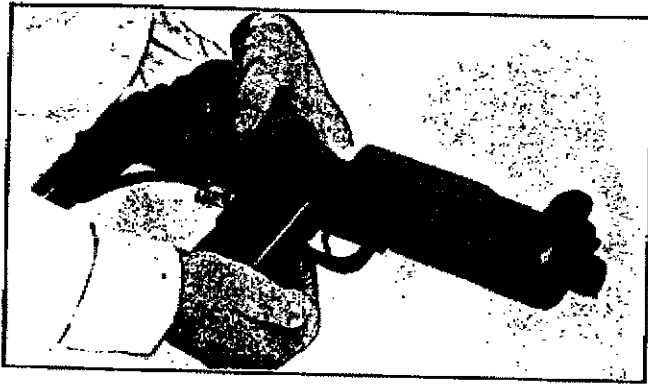

Fig. 52.



Fig. 53.

7. Barrel.

Take care that the barrel retaining nut is screwed fully home.

8. Spring, cocking lever.

If this spring has to be replaced, engage the end of the spring on the cover, drawing aside the last coil, then pull and twist the spring (as shown in figure 53).

VIII. ACCESSORIES

(supplied, if required, at extra charge)

1. Bayonet.

The Bayonet has been specially designed so that it does not upset the balance of the gun and can be easily mounted and removed.

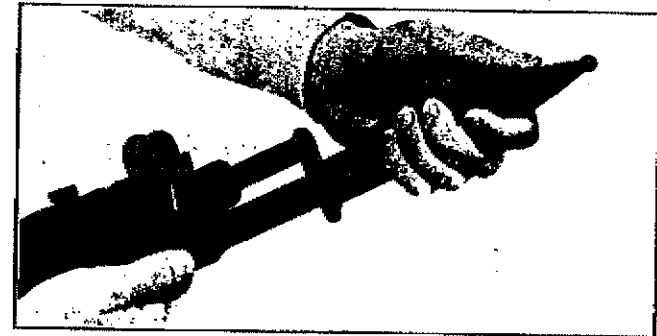

Fig. 54.

2. Blank firing attachment.

A blank firing attachment can also be fitted; this can be done very easily as it takes the place of the barrel retaining nut.

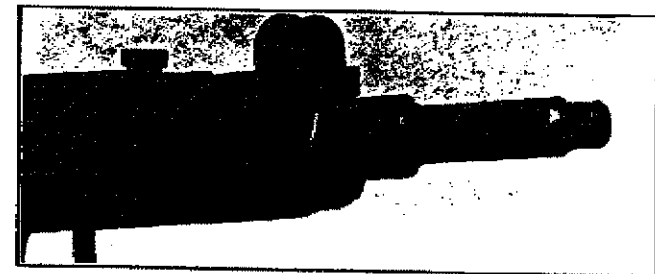

Fig. 55.

UZI SMG OPERATION MANUAL

3. Magazine filler.

This device is fitted to the magazine and enables magazines to be filled rapidly and effortlessly.

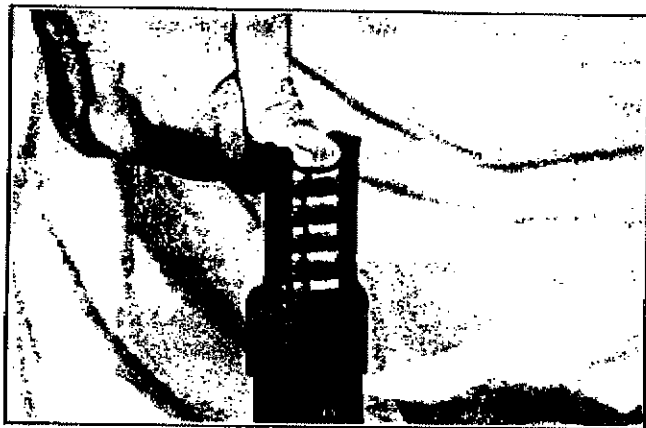

Fig. 56.

4. Cleaning kit.

This little hold-all has three compartments to take cleaning

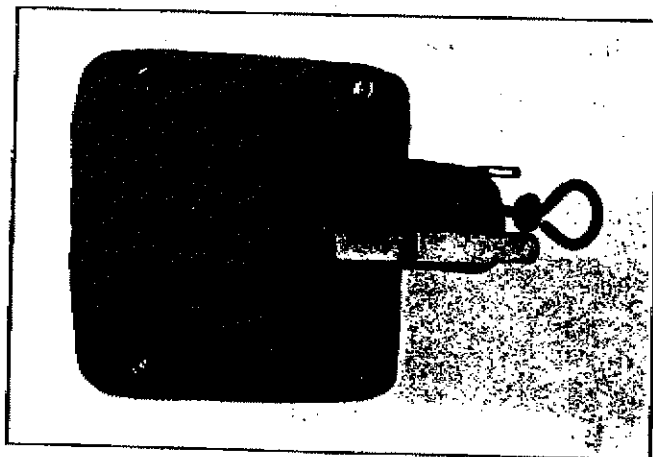

Fig. 57.

UZI SMG OPERATION MANUAL

necessities: the cleaning rod in two parts and the plastic tube takes both the cleaning brush and the oil infuser.

5. Sling.

The submachine gun can be supplied with an adjustable sling.

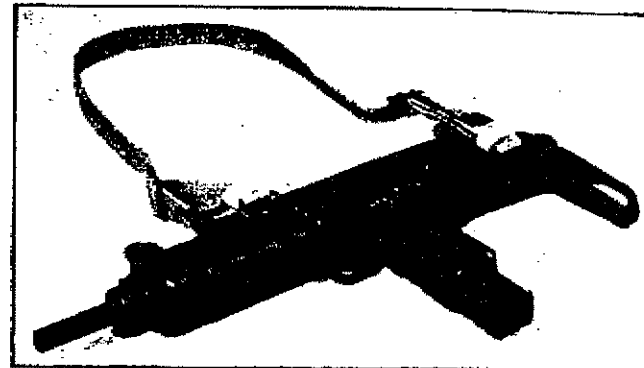

Fig. 58.

IX. LIST OF COMPONENTS

(See Exploded View on pages 22-23.)

Part No.	Description	Number
101	Barrel	1
102	Barrel retaining nut	1
111	Breech block	1
115	Extractor	1
116	Pin extractor	1
120	Return spring assembly	1
200	Body assembly	1
251	Barrel catch	1
255	Spring control barrel catch	1
261	Foresight	1
262	Nut, foresight	1
263	Spring washer, foresight	1
271	Backsight	1
272	Screw, backsight	1
273	Spring, backsight	1
274	Catch, cover	1
275	Spring, catch cover	1
281	Handguard, right	1
282	Handguard, left	1
285	Screw, handguard	1
286	Locknut, screw handguard	2
288	Nut, screw backsight	2
301	Cover assembly	1
311	Cocking lever	1
312	Spring, cocking lever	1
313	Stud, cocking lever handle	1
314	Screw, stud cocking lever	1
315	Cocking handle	1
316	Spring washer	1
400	Trigger frame	1
411	Sear	1
412	Pin, sear	1
413	Spring, trigger frame	1
421	Trigger	1
422	Pin, trigger	1
423	Spring, trigger	1
424	Lever, intermediate, sear	1
425	Pin, intermediate sear lever	1
431	Change lever	1
432	Knob, operating change lever	1
433	Spring, plunger safety	1
440	Automatic safety, pistol grip	1
445	Spring, safety	1
451	Catch, magazine	1
452	Pin, catch magazine	1
453	Spring, catch magazine	1
461	Pistol grip, right half	1
462	Pistol grip, left half	1

UZI SMG OPERATION MANUAL

Part No.	Description	Number
465	Screw, pistol grip	2
471	Pin securing trigger frame	1
15	Metal butt assembly (folding)	1
1551	Screw, butt assembly catch	1
1552	Catch, butt	1

b) BAYONET

STA 151	Blade, bayonet	1
STA 152	Grip, left, bayonet	1
STA 153	Grip, right, bayonet	1
STA 154	Screw, assembly bayonet	2
STA 155	Nut, screw assembly bayonet	2
STA 156	Plunger, bayonet	1
STA 157	Spring, plunger bayonet	1
STA 158	Nut, plunger bayonet	1
STA 161 A	Scabbard, bayonet	1
STA 161 B	Spring, scabbard bayonet	1
STA 61	Screw, spring scabbard, bayonet	1

This Manual Was Provided To You By:



**CENTURY
INTERNATIONAL
ARMS INC.**

www.centuryarms.com