



**JIAN WEI**

ZONGZE ZHONG

**OPERATION MANUAL  
FOR JW-87(83) SHOTGUN**

# Operation Manual for JW-87(83) Shotgun



Figure1,full shotgun view

## 1.USAGE

The shotgun is mainly used for hunting upland birds and small game. Do not use steel shot in this gun.

## 2.FEATURES

The JW-87 shotgun is constructed using high quality steel and fine Asian woods.

The metal is heat treated to exact specifications,highly polished and blued to a deep blue/black finish.

If properly maintained,your shotgun will give you a lifetime of service.

## 3.PRINCIPAL TECHNICAL DATA

Caliber:12 GA or 16 GA(depending on the model purchased)

Overall length: 44"

Barrel length: 28"

Chamber: 3"

Single shot

Trigger pull: 10-15 lbs.

Overall weight: 7.05 lbs.

Firing concentration: when the target is 115 feet away, no less than 65% of the pellets are within the circle of 2.46 feet.

Cartridge: 12 GA(16 GA)standard shotgun shell

Effective range: 75 yards

Figure 2, action opened



#### 4. OPERATION PROCEDURE

##### Opening:

Depress the locking lever and push downward on the barrel to open the action.

##### Loading:

Depending on the caliber of the gun 12 GA(16 GA), place your shell into the chamber.

### Locking:

Grasp the gun with one hand on the stock wrist and the other hand on the barrel then snap the barrel upward in a quick motion. This will lock the barrel into place.

Figure 3, barrel locked in place



### Firing:

Pull the hammer fully to the rear and push the safety button to the left; the gun is now ready to fire.

### Trigger Safety:

When the safety lever is pushed to the left, the red indicator hoop will come into view. In this case the shotgun cannot fire even if you pull the trigger. The use of any mechanical safety on any firearm does not eliminate the need for safe gun handling practices. Always keep a firearm pointed in a safe direction with your finger off the trigger until you are ready to fire.

## 5. DISASSEMBLING AND ASSEMBLING

The shotgun should be cleaned after each use.

**Safety Examination:**

Depress the locking lever and push downward on the barrel to open the action.

Inspect the chamber to ensure there is no cartridge in the chamber.

Figure 4, disassembly motions

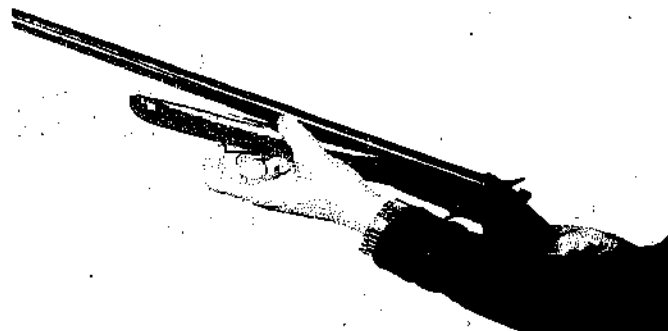

**Disassembly:**

Remove the forearm by pulling down on the lock and rotating the forearm toward the action. Depress the locking lever and push downward on the barrel to open the action. The barrel will rotate down and come off the receiver.

**Assembling:**

Reverse the order of disassembly.

## 6. CAUTIONS

Firearms can be dangerous and can cause serious injury or death. Proper and safe firearms handling is the responsibility of anyone who touches or uses a firearm.

When purchasing a firearm, you assume responsibility for its safe use, storage and transportation. It is particularly critical that firearms be kept from unauthorized use, especially children. Your responsibility also includes but is not limited to, the need to protect yourself and others from injury resulting from the misuse or abuse of a firearm.

At all times treat firearms as though they are loaded.

Always be aware of where the muzzle is pointed.

At all times, carry your firearm in a way that will preclude accidental injury to yourself or others in the event you should stumble, fall or drop the firearm. Before shooting, make certain the barrel has no obstructions.

Do not allow a firearm or ammunition to be left unattended. Secure both the firearm and ammunition from access by unauthorized people, especially children.

When shooting, always be certain that the area beyond the target including the backstop is clear and safe. Also make certain that shots fired present no safety hazards to yourself or others.

Always use both ear and eye protection when shooting.

Always use factory-loaded ammunition designed for and intended

for use in the firearm you are shooting. It must be the proper caliber and type for your firearm.

Always understand the proper operation of your firearm and never allow the firearm to be used by anyone who does not understand how to use the firearm properly and safely.

Never pass a firearm to another person unless the action is open and the firearm is in an unloaded and safe condition. Never put your finger into the trigger guard until you are ready to shoot.

When not using the firearm, ensure that it is unloaded.

Store your firearm unloaded and in an area which is secure from unauthorized access. Further, store ammunition separately and in an area secure from unauthorized access.



Figure5,(shows parts,guard wood,barrel,receiver & stock)

Table 1: Unit Name and Number

Number	Code Name	Name	Part Number
1	01	Barrel unit	1, 2, 3, 4, 5, 6
2	02	Guard wood unit	7, 8, 9, 10, 15
3	02-01	Locking unit	11, 12, 13, 14, 16
4	03	Receiver unit	21, 27, 28, 30, 32 ,33
5	04	Firing base unit	17, 20, 21, 22, 23
6	05	Wood butt unit	43, 46, 47, 48
7	06	Trigger unit	24, 26
8	07	Hammer unit	40, 42
9	08	Firing pin safety unit	35, 36, 37

**WARNING:**The numbers of the units mentioned above are not to disassemble.



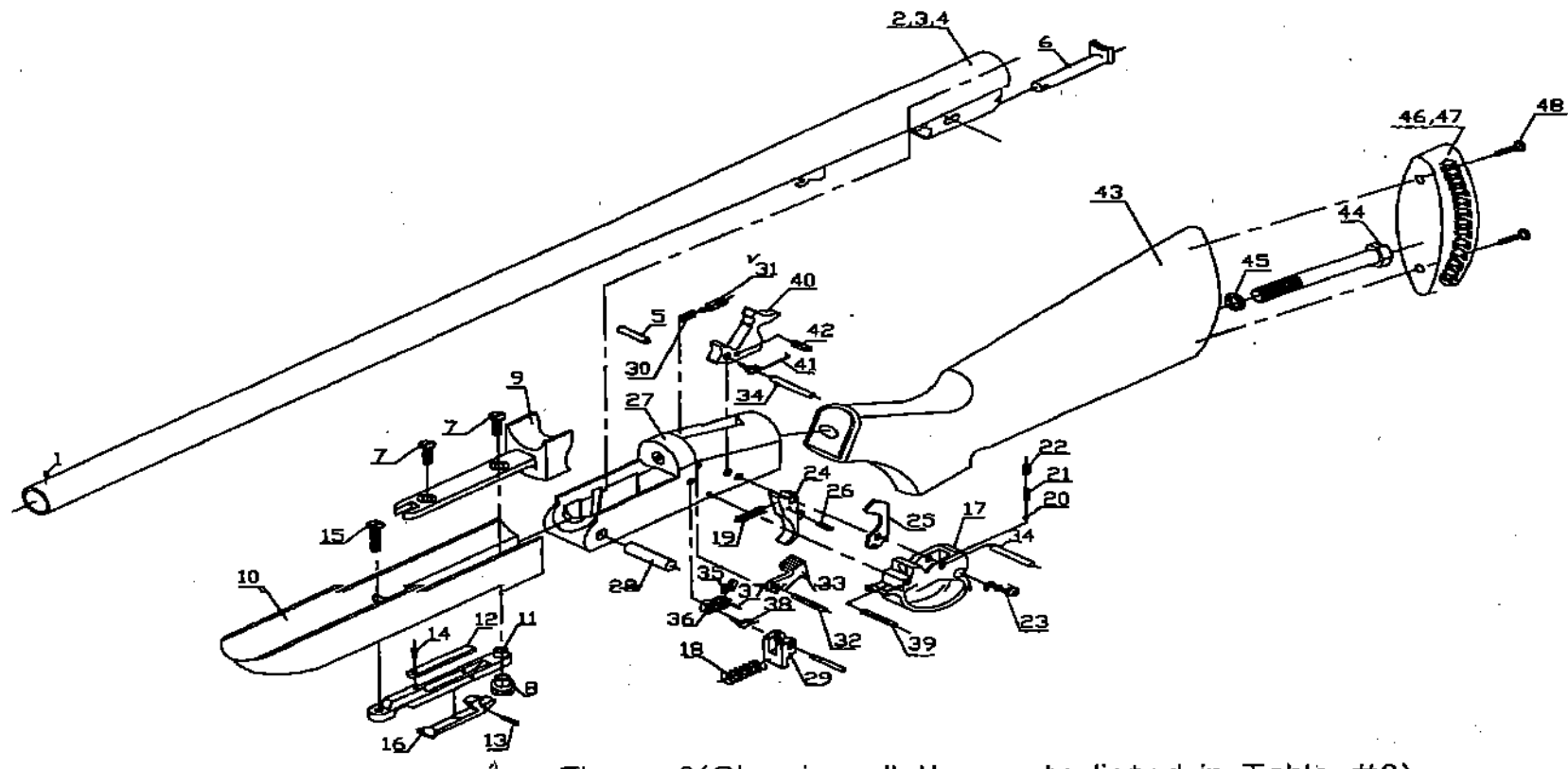

Figure 6(Showing all the parts listed in Table #2)

Table 2: Part Name and Number

Number	Code Name	Name	Quantity
1	01-8	Front sight	1
2	01-5	Barrel	1
3(※)	01-4	Guard lock	1
4(※)	01-3	Barrel stand	1
5	01-2	Ejection tappet bin	1
6	01-1	Ejection tappet	1
7	02-3	Connecting screw	2
8	02-8	Guard wood nut	1
9	02-4	Iron liner	1
10	02-1	Guard wood	1
11	02-7	Lock base	1
12	03 · 17/JW81	Lock spring	1
13	02-6	Lock pin	1
14	GB67 · 85M3 × 5	Screw	1

Table 2: Part Name and Number

Number	Code Name	Name	Quantity
15	02-2	Guard wood screw	1
16	02-5	Lock buckle	1
17	04-1	Firing base	1
18	00-1	Lock fixture spring	1
19	00-2	Trigger spring	1
20	3000GB308 · 89	Steel ball	1
21	04-3	Safety spring	1
22	GB73 · 85M4 × 6	Screw	1
23	04-2	Safety lever	1
24	06-1	Trigger	1
25	00-3	Safety stand	1
26	06-2	Safety stand pin	1
27	03-4	Receiver	1
28	03-5	Receiver pin	1

Table 2: Part Name and Number

Number	Code Name	Name	Quantity
29	00-9	Lock catch	1
30	03-1	Firing pin spring	1
31	03-2	Firing pin	1
32	03-6	Firing strike pin	1
33	03-3	Pressing board	1
34	00-4	Pin	1
35	08-2	Firing pin safety	1
36	08-1	Safety rod	1
37	08-3	Rod pin	1
38	00-8	Safety rod spring	1
39	00-7	Firing base pin	1
40	07-1	Hammer	1
41	00-5	Hammer pin spring	1
42	07-2	Hammer spring pin	1

Table 2: Part Name and Number

Number	Code Name	Name	Quantity
43	05-1	Wood stock	1
44	00-6	Bolt	1
45	GB848 · 8510	Washer	2
46(※)	05-3	Skeleton	1
47	05-1	Butt plate	1
48	GB845·85·ST4.8×25	Screw mail	2



MADE IN ZHONGZHOU MACHINERY PLANT  
CHINA NORTHINDUSTRIAL CORPORATION

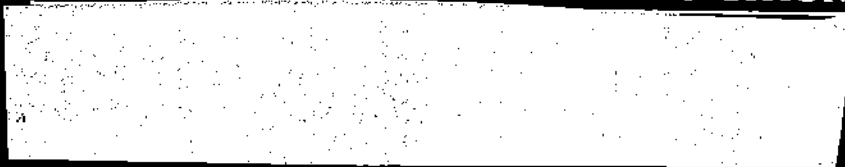

This Manual Was Provided To You By:



**CENTURY  
INTERNATIONAL  
ARMS INC.**

**[www.centuryarms.com](http://www.centuryarms.com)**