

12 Gauge Pump Shotgun Instructional Manual

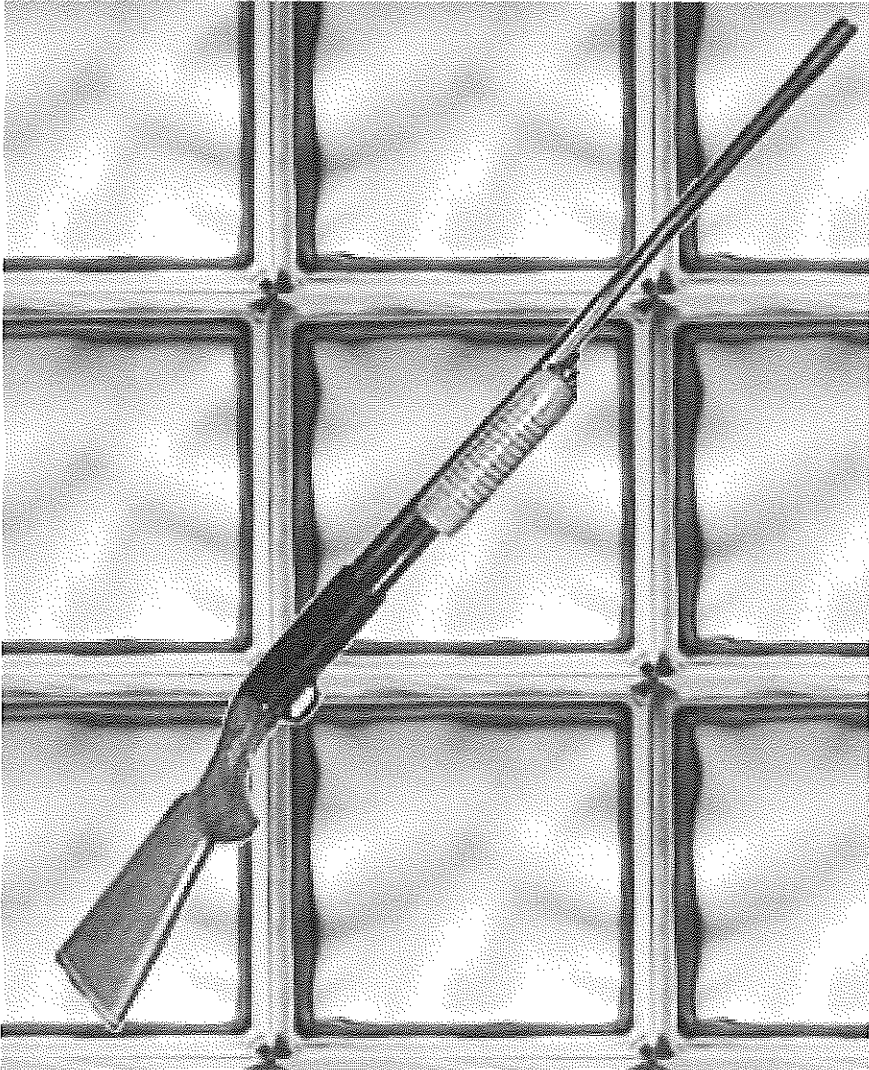

12 Gauge pump-action shotgun HL12-102 has the capability of using standard 12-gauge shells and also has advantages of elegant shape, long service and reliability. It is applicable to hunting or sport shooting. All parts of the pump shotgun are composed of high-quality material, among which the barrel, trigger actuator, and actuator frame made of alloy steel. **NOTE: Do not use steel shot in this gun. The use of steel shot will damage the barrel and will void the warranty.**

The pump shotgun mainly consists of the following:

- (1) barrel
- (2) forend
- (3) receiver
- (4) bolt
- (5) follower
- (6) stock
- (7) stock bolt
- (8) washer
- (9) screws
- (10) butt plate
- (11) firing gear
- (12) bolt frame

For the purpose of giving aid to user to learn how to use and maintain the gun now we shall herein introduce the principal data, structural feature, method of firing, assembling, disassembling and some cautions:

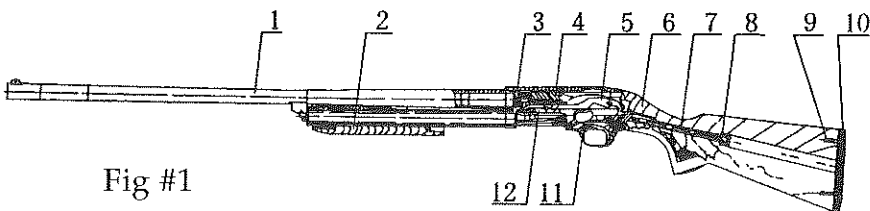

Fig #1

PRINCIPAL DATA

Gauge	12
Chamber Length	2 ¾
Barrel Length (in)	29½
Chokes Available	F(1/1), IM(3/4), M(1/2), IC(1/4)
Length of Pull (in)	14
Drop at Heel (in)	2½
Drop at Comb (in)	1½
Weight (lb)	7¼
Magazine Capacity (round)	5(One round in chamber)
Overall Length (in)	49

OPERATION

This HL-12-102 shotgun is a pump action firearm. The forend slides along the magazine tube forwards and backwards and is connected to the bolt by the action bar. After firing, movement of the forend backwards, release the bolt, extracting and ejecting the shell and cocks the hammer. Forward movement of the forend thrusts a shell into the chamber and locks the breech. The gun is again ready to be fired.

Loading and ejection of the cartridges takes place through the bottom of the receiver making this shotgun user friendly for both left and right handed shooters.

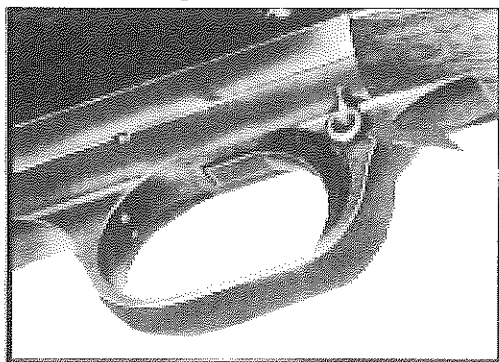

Figure #2a

The safety is located behind the trigger for easy access. Pushing the safety from the left to the right blocks the trigger, pushing the safety from right to the left (red ring exposed) the gun is in the fire position. See figure #2a.

NOTE:

The shotgun must be cocked in order to apply the safety. Never place the shotgun safety in the fire position until you are sure of your target and are ready to fire.

A bolt release lever is located on the forward right side of the triggerguard. By depressing this lever down the bolt is released.

This shotgun is equipped with interchangeable chokes. (Not available HL12-102S Security Model). There are four chokes supplied with this shotgun. The full choke tube has been installed at the factory. A grooved marking system can be found on the front of each tube which indicates the choke.

Full	=	1 groove
Improved Modified	=	2 grooves
Modified	=	3 grooves
Improved Cylinder	=	4 grooves

This system allows the shooter to readily see which choke is installed with out removing it from the barrel. To change chokes:

- 1) Ensure the firearm is empty and the forend is in it's rear most position.
- 2) Using the wrench supplied, turn out the choke counter clockwise and remove the tube.
- 3) Inspect the choke tube you are about to insert in the barrel to ensure the threads are clean and free of burrs (a light coating of oil should be applied).

- 4) Insert the tube into the barrel and screw it clock wise using only finger action (DO NOT CROSSTHREAD).
- 5) Once the choke tube is seated as far as possible using finger pressure use the wrench to snug it up -

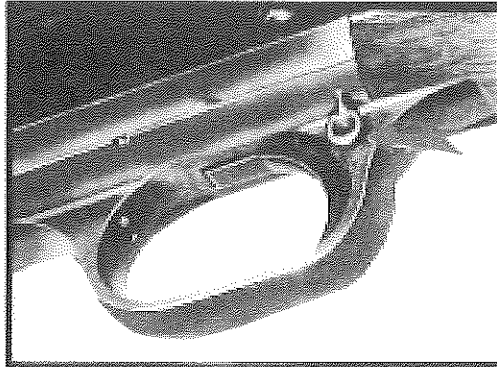

Figure #2b

DO NOT OVERTIGHTEN!

NOTE: Periodic lubrication of the choke tube threads is recommended.

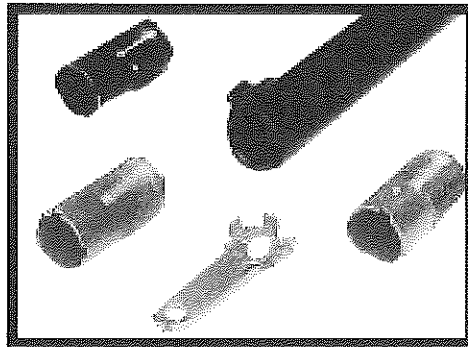

Figure #3

Do not fire this shotgun without a choke installed.

HOW TO FIRE

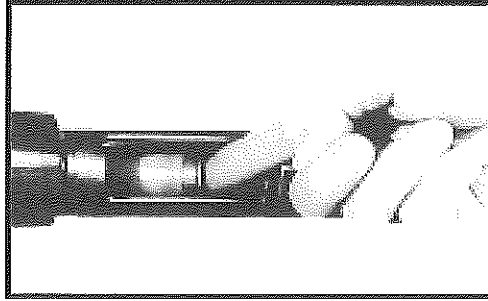

Fig #4

Loading: Push the safety button into the safe position. Insert a cartridge into the magazine. Move the forend briskly backwards and forwards chambering the cartridge. Load four cartridges into the magazine tube. The unit is fully loaded and now ready to fire. Note: Use lead shot only.

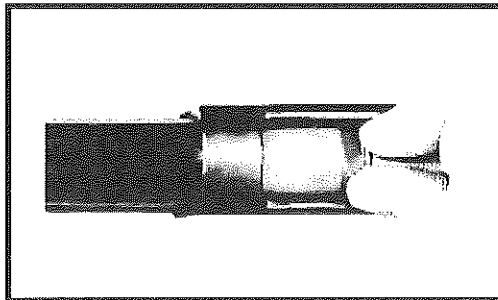

Fig #5

Firing: Push the safety button to the left-hand side (red mark appears) then aim at the target and pull the trigger.

Ejection: After the gun fires. Pull the forend back smartly. This will eject the shell and recock the shotgun.

Chambering the Round: Sliding the forend forward will cause a shell to be taken from the mag tube, inserted into the chamber. The shotgun is now ready for another shot. Push safety to the safe position if you do not intend to fire again.

ASSEMBLING AND DISASSEMBLING

The gun can be disassembled into 63 parts, the names of them listed in table (2) and the assembling and disassembling procedures shown in fig 6 (the dotted line indicates the flow).

Disassembling:

(1) Move the forend back so the bolt retracts fully. Screw out the locking nut (clockwise) so that the lug withdraws from the hole which is situated in the upper barrel retainer. Turn the barrel 90° (ccw) and pull forward. (2) With a screwdriver, loosen two screws on the butt plate and screw out the stock bolt, remove the stock. (3) Unscrew the screws on both sides of the receiver and pull inwards on the connection shaft mounted on the receiver, then the firing gear, follower, bolt frame, bolt etc can be withdrawn from the rear side of the receiver. Remove the right and left sears and springs. The gun is now completely disassembled.

Assembling: (1) First, fit the rear sear and its spring and left sears. Put the bolt (assy) and bolt frame (assy) together then thrust them into the receiver from the rear. Insert the connection shaft into the relative hole of the cylinder, mount the follower from the rear side of the receiver then tighten the lock screw. Put the firing gear (assy) into the receiver and screw it in. (2) Install the stock bolt with disk springs and washers through the stock and screw in the end of the firing gear, so as to bind the stock and receiver together screw the butt plate on the stock. (3) Insert the end of the

barrel into the receiver then turn it 90°. Tighten the lock nut (ccw) and the front convex part enters the hole of the upper restrictor, make the upper restrictor tight in this condition. All assembling work has been done.

SAFETY FIRST

Firearms can be dangerous and can cause serious injury or death. Proper and safe firearms handling is the responsibility of anyone who touches or uses a firearm. Safety has to be the primary consideration of anyone using a firearm.

When purchasing a firearm, you assume responsibility for its safe use, storage, and transportation. Particularly, it is critical that firearms be kept from unauthorized use, and this includes children. Your responsibility also includes, but is not limited to, the need to protect yourself and others from injury resulting from the misuse or abuse of a firearm.

Treat firearms as though they are loaded.

Always be aware of where the muzzle is pointed.

Carry your firearm in a way that will preclude accidental injury to yourself or others in the event you should stumble, fall, or drop the firearm.

Before shooting, make certain the barrel has no obstructions.

Do not allow a firearm or ammunition to be left unattended. Secure both the firearm and ammunition from access by unauthorized people, including children.

When shooting, always be certain that the area beyond the target, including the backstop, is clear and safe. Also make certain that shots fired present no safety hazards for yourself, or others.

Always use both ear and eye protection when shooting.

Always use factory loaded ammunition designed for and intended to be used in the firearm you are shooting. It must be the proper caliber (gauge) and type for your firearm.

Always understand the proper operation of your firearm, and never allow the firearm to be used by anyone who does not understand how to use the firearm properly and safely.

Never pass a firearm to another person unless the action is open and the firearm is in an unloaded and safe condition. Never put your finger into the trigger guard until you are ready to shoot.

When not using the firearm, ensure that it is unloaded.

SAFETY WARNING: Discharging firearms in poorly ventilated areas, cleaning firearms or handling ammunition may result in exposure to lead and other substances known to cause birth defects, reproductive harm and other serious physical injury. Have adequate ventilation at all times. Wash hand thoroughly after exposure.

Store your firearm unloaded and in an area which is secure from unauthorized access. Furthermore, store ammunition separately, and in an area secure from unauthorized access.

PARTS LIST OF THE PUMP SHOTGUN HL12-102 GAUGE 12

<u>NO</u>	<u>NAMES</u>	<u>AMOUNT</u>
1	Firing Pin	1
2	Firing Pin Spring	1
3	Trigger Actuator	1
4	Upper Extractor Spring	1
5	Spring Pin	1
6	Upper Extractor	1

<u>NO</u>	<u>NAMES</u>	<u>AMOUNT</u>
7	Lower Extractor Spring	1
8	Spring Pin	1
9	Lower Extractor	1
10	D2.5x14 Pin	1
11	Bolt Frame	1
12	Connecting Shaft	1
13	Return Spring	1
14	D2.5x18 Pin	1
15	D2x8 Pin	1
16	Stock Bolt	1
17	Disk Springs	4
18	Washer	1
19	Screws	2
20	Buttplate	1
21	Stock Shim	1
22	Stock	1
23	Screw	4
24	Follower Screws	2
25	Set Screws	2
26	Receiver	1
27	Forend	1
28	Hoop	1
29	Collar	1
30	Locking Nut	1
31	Screw	1
32	Locating Pin	1
33	Locating Spring	1
34	Screw	1
35	Barrel	1
36	Choke Tube	1
37	Magazine Spring	1
38	Cap Magazine Spring	1
39	Magazine Tube	1
40	Slider Sleeve	1
41	Trigger	1

<u>NO</u>	<u>NAMES</u>	<u>AMOUNT</u>
42	Trigger Spring	1
43	Hammer Spring Rod	1
44	D2x8 Pin	1
45	Hammer	1
46	Slider-Locking Spring	1
47	Firing Gear Support	1
48	D4x24 Pin	1
49	Slider Lock	1
50	Torsion Spring	1
51	D2.5x24 Pin	1
52	Safety Button	1
53	D2.5 x 12 Pin	1
54	Bar Post Spring, Safety Button	1
55	Bar Post	1
56	Hammer Spring Sleeve	1
57	Hammer Spring	1
58	Spring Seat	1
59	Left Sear Spring	1
60	Left Sear	1
61	Pin	1
62	Follower	1
63	Right sear	1

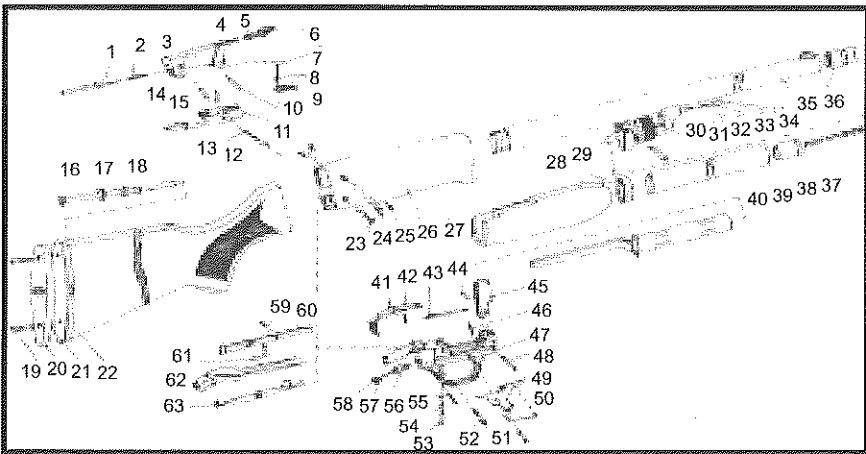

Fig #6

Distributed by:

Century International Arms, Inc.

P.O. Box 714

St. Albans, Vermont 05478

Tel: 1-800-527-1252

WWW.CENTURYARMS.COM