

WARNING

BEFORE USING THIS FIREARM READ
AND FOLLOW THESE INSTRUCTIONS

 **CALICO®**

M. 110

.22 Lr. Semi-Automatic Pistol

SAFETY AND INSTRUCTION MANUAL

**THIS MANUAL SHOULD ALWAYS ACCOMPANY THIS FIREARM
AND BE TRANSFERRED WITH IT UPON CHANGE OF OWNERSHIP.**

FOR PARTS OR SERVICE CONTACT:



**5405 SE Alexander St., Unit P
Hillsboro, OR 97123**

United States of America

Tel: (503)649-3010 Fax:(503)649-3831

Email: help@calicolightweaponsystems.com

www.calicolightweaponsystems.com

WARNING: If this firearm is carelessly or improperly handled, unintentional discharge could result and could cause injury, death, or damage to property.

CAUTION: Carefully read this instruction manual which gives basic advice on the proper handling and functioning of this CALICO firearm prior to loading and firing. However, your safety and the safety of others (including your family) depends on your mature compliance with that advice, and your adoption, development and constant employment of safe practices. If unfamiliar with firearms, seek further advice through safe handling courses run by your local gun clubs, NRA approved instructor, or similar qualified organizations.

2.

NOTICE - DISCLAIMER OF LIABILITY

CALICO shall not be responsible for injury, death, or damage to property resulting from either intentional or accidental discharge of this firearm, or from its function when used for purposes or subjected to treatment for which it was not designed. CALICO will not honor claims involving this firearm which result from careless or improper handling, unauthorized adjustment or parts replacement, corrosion, neglect, or the use of wrong caliber ammunition, or the use of ammunition other than original high quality commercially manufactured ammunition in good condition, or any combination thereof. CALICO will not honor claims involving this firearm for any reason or cause when such claims are made by the second or subsequent owner.

IMPORTANT

Before it left the factory this firearm was tested, carefully inspected, and packaged. CALICO cannot control product handling after it leaves the factory; therefore, please examine this firearm carefully at the time of purchase to insure that it is unloaded and undamaged. The dealer will be pleased to assist you in making this examination and endeavor to answer your further questions. This instruction manual should always accompany this firearm and be transferred with it upon change of ownership.

4.

Welcome to the proud family of CALICO Pistol owners. In acquiring your new CALICO carbine, you have chosen a firearm ahead of all others in innovative design and capacity.

To get the most out of your CALICO pistol, please read this manual from cover to cover before handling and operating the Pistol for the first time.

WARNING

It is dangerous to alter or modify this firearm in any way. Any alteration or modification of the firing mechanism may result in this firearm becoming unsafe. Any attempt to alter or modify this firearm is illegal and will nullify all warranties and will be subject to immediate notification of appropriate federal law enforcement agencies.

TABLE OF CONTENTS

- I. SAFETY**
 - A. Safety Instructions
 - B. Cautions
 - C. Safety Features
 - 1. Trigger Block
 - 2. Hammer Block
- II. DESCRIPTION AND FEATURES**
 - A. Diagram of Features
 - B. Specifications
 - C. Magazine
 - 1. Function
 - 2. Disassembly
 - 3. Assembly
- II. D. PISTOL**
 - 1. Disassembling Receiver
 - 2.. Reassembling Receiver
- III. OPERATING**
 - A. Loading, Unloading, & Attaching Magazine
 - B. Cocking, Sighting & Firing
 - C. Adjusting Sights
 - D. Care & Cleaning
 - E. Trouble Shooting

6.

SECTION I. SAFETY

SAFETY INSTRUCTIONS

We want you to enjoy shooting your CALICO M-100P, and we want you to enjoy it safely. You may be an experienced safe shooter already familiar with the procedures in this instruction manual, or you may never have handled a gun before. Either way we urge you to **READ THIS ENTIRE INSTRUCTION MANUAL CAREFULLY. YOU MUST FOLLOW THE SAFETY INSTRUCTIONS FOR YOUR SAFETY AND THE SAFETY OF OTHERS.**

WARNING: When you **SQUEEZE** the trigger, you must expect the gun to fire, and you must take full responsibility for firing it. Your care can avoid accidental discharge and you will thereby avoid accidental injury and death.

CAUTIONS:

GENERAL HANDLING CAUTIONS

1. Always handle your pistol as if it were loaded so that you never fire it accidentally when you think it is unloaded.
2. Never point your pistol at anything you do not intend to shoot so that if it fires accidentally, injury, death, or damage to property will be prevented.
3. Never take anyone's word that a gun is unloaded: check for yourself with fingers off the trigger and gun pointed in a safe direction, so that you never fire the gun accidentally when you think it is unloaded.

8.

4. Always make sure your pistol is not loaded and the bolt is latched open before laying it down, or handing it to another person, so that it cannot be fired when it is unsafe to do so.

5. Always keep and carry your pistol empty, with the hammer forward except when you intend to shoot, so that your pistol cannot be fired when you do not mean to fire it.

6. Always be aware of possible risk from dropping your pistol. Some parts of the mechanism could be damaged. You may not see the damage but if it is severe, the pistol may discharge and cause injury, death or damage to property. If your pistol has been dropped, have it examined by a competent gunsmith before using it again.

7. Never leave your pistol cocked ready to fire as this condition is extremely dangerous, and the pistol could easily be accidentally discharged, causing injury, death, or damage to property.

8. Never leave a loaded pistol unattended; someone, especially a child, may fire it and cause injury, death, or damage to property.

9. Always instruct children to respect firearms. If you teach your children to shoot, teach them or get them trained by a qualified instructor to treat and use the pistol properly, and always supervise them closely. Always stress safety so that your children will not fire the pistol when it is unsafe to do so.

RANGE CAUTIONS:

10. Always be sure your backstop is adequate to stop and contain bullets before beginning target practice so that you do not hit anything outside the range shooting area.

11. Always put a knowledgeable and responsible person in charge to maintain safety control when a group is firing on a range. Obey his commands so that discipline is maintained to reduce the likelihood of accidents.

12. Always carry your pistol empty with bolt latched open while on a range until preparing to fire, keep it pointing towards the backstop when loading, firing and unloading, to eliminate the risk of injury, death, or damage to property.

10.

LOADING CAUTIONS:

13. Always be sure barrel bore, chamber and action are clean and clear of obstructions. Clean a fouled pistol immediately so that it will function correctly and safely.

14. Always use only clean, dry, original high quality commercially manufactured ammunition in good condition which is appropriate to the caliber of your pistol. Gun and ammunition manufacturers design their products within exacting engineering safety limits. However, improperly stored or handled ammunition and excessively dirty or greasy ammunition may not function properly in this firearm possibly causing subsequent injury, death, or property damage.

SHOOTING CAUTIONS:

15. Never drink alcoholic beverages or take drugs before or during shooting, as your vision and judgment could be seriously impaired making your gun handling unsafe.

16. Always seek a doctor's advice if you are taking medication, to be sure you are fit to shoot and handle your pistol safely.

17. Always wear and encourage others near you to wear ear protection when shooting, especially on a range. Without protection, the noise from your pistol and other guns close to you, could leave a “ringing” in the ears for some time after firing, while the cumulative long term effect could be permanent hearing loss.

18. Always wear and encourage others to wear protective shooting glasses. Flying particles could damage eyes and cause blindness; but protective shooting glasses should prevent such injury.

19. Always keep the safety on when the pistol is loaded and cocked until you are ready to fire. This will minimize risk of an accidental discharge.

20. Always keep clear and keep others clear of the ejection port. Spent cartridges are ejected with enough force to cause injury and the ejection port must be unobstructed by your hand to insure safe ejection of live rounds. Never place fingers in ejection port; they could be burned by hot metal or injured by the bolt moving forward.

12.

21. Never squeeze the trigger or put your finger in the trigger guard until you are aiming at a target and ready to shoot. This will prevent you from firing the pistol when it is pointing in an unsafe direction.

22. Always be absolutely sure of your target and the area behind it before you squeeze the trigger. A bullet could travel through or past your target up to 1½ miles. . . if in doubt, don't shoot.

23. Never shoot at a hard surface such as rock, or a liquid surface such as water. A bullet may ricochet and travel in any direction to strike you, or an object you cannot see, causing injury, death, or damage to property.

24. Never fire your pistol near an animal unless it is trained to accept the noise; an animal's startled reaction could injure it or cause an accident.

25. Never indulge in "horseplay" while holding your pistol, as it may be accidentally discharged.

26. Never walk, climb or follow a companion with your pistol cocked ready to fire, or with the hammer in any position other than forward on an empty chamber, to eliminate risk of accidental discharge. When hunting, hold your pistol so that you can always control the direction of the muzzle.

MALFUNCTION CAUTIONS:

27. Failure to fire: Always hold pistol, keeping it pointed towards the target or a safe open area and wait 30 seconds when pistol fails to fire. If a hangfire (slow ignition) has occurred, round will fire within 30 seconds. If round does not fire, remove magazine, eject round and examine the rim; if firing pin indent on rim is light, off center, or non-existent, have pistol examined by a competent gunsmith. If firing pin indent on rim appears normal (in comparison with similar previously fired rounds) assume faulty ammunition; segregate misfired rounds from other live ammunition and empty cases, reload and carry on firing.

28. Never use your pistol if it fails to function properly, and never force a jammed action, as a round may explode causing serious injury, possible death, or severe damage to your pistol.

14.

CLEANING AND STORAGE CAUTIONS:

29. Always make sure your pistol is not loaded before cleaning and storing so that it cannot be fired when it is unsafe to do so.

30. Always keep and store your pistol and ammunition in separate locked receptacles out of reach and sight of children and untrained people, to minimize the risk of pistol and ammunition being easily available for loading and firing.

GUN ABUSE CAUTIONS:

31. Never abuse your pistol by using it for any purpose other than shooting.

32. Never dry fire the pistol when the lower receiver is removed from the upper receiver, and do not alter parts as the level of safety could be reduced.

Note: Please note that we have chosen to use the word “squeeze” in this instruction manual instead of “pull” or “press” when trigger movement is described; this is simply to remind you of the need for a gentle squeezing action to achieve accuracy.

SECTION I - (Cont'd)

M-100P SAFETY - TRIGGER AND HAMMER BLOCK

The M-100 Pistol is equipped with an ambidextrous, double acting safety. To activate the safety, the hammer must first be cocked by pulling back on the bolt handle. The bolt may be held back by pushing up on the bolt catch, or it may be released to seat against the barrel. After the hammer is cocked, the safety lever on either side of the receiver may be rotated up, parallel to the barrel and exposing the "S" on the receiver, indicating "SAFE". Rotating the safety lever causes the safety cam to rotate inside the receiver. One lobe of the cam interferes with the action of the trigger so that it cannot be pulled, making the gun safe. The other lobe of the cam rotates into the path of the hammer to prevent it from striking the firing pin in the extremely unlikely event of the hammer being accidentally released. This combined trigger and hammer block safety should be used at all times, except when actually firing the Pistol.

REMEMBER - SAFETY DEPENDS ON YOU

16.

CALICO M.100P

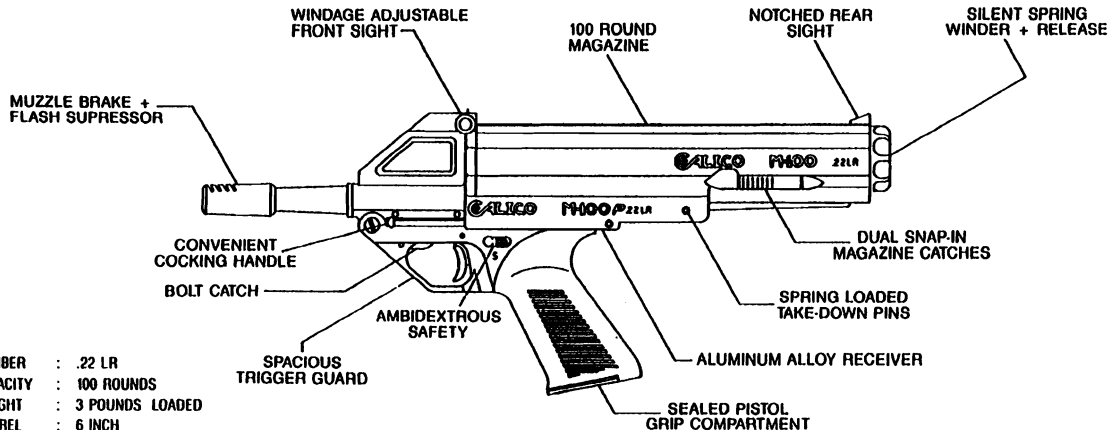

CALIBER : .22 LR
CAPACITY : 100 ROUNDS
WEIGHT : 3 POUNDS LOADED
BARREL : 6 INCH
OVERALL : 17.9 INCH

SECTION II - DESCRIPTION AND FEATURES

M-100P SPECIFICATIONS

| | | | |
|--------------------------|-------------|--------------------------------------|-----------------|
| WEIGHT | | BARREL RIFLING, RH 6 GROVES | 12" lead |
| Pistol, w/o magazine | 2.21 lb. | | |
| Pistol, fully loaded | 3.75 lb. | | |
| Magazine, empty | 14 oz. | | |
| Magazine, w/100 rounds | 24 oz. | Sight radius | 10.4 in. |
| LENGTH | | FRONT SIGHT | |
| | 17.9 in. | Post, Adjustable for Windage | |
| | | REAR SIGHT | |
| HEIGHT (MAX) | 7.3 in. | Notch | |
| WIDTH (MAX) | 2.2 in. | SAFETY | |
| AMMUNITION | .22 LR only | Ambidextrous, Trigger & Hammer Block | |
| MAGAZINE CAPACITY | 100 rounds | OPERATION | |
| BARREL LENGTH | 6 in. | Blowback Semi-Automatic | |

18.

II - DESCRIPTION AND FEATURES CONTINUED

A. MAGAZINE

The magazine for the M-100 Pistol is unique in its design and function, and offers advantages of increased capacity, compactness, streamlining and balance. As shown in the diagram, the 'helical feed' magazine necessarily has more parts than a conventional column-type magazine, and must be properly handled and serviced to assure safe and consistent shooting.

HOW IT WORKS

The M-100P magazine contains 100 rounds laying end-to-end in fourteen grooves in the cartridge carrier (#1). The rounds are separated by a helical rib which is molded into the OUTER SHELL (#2). The TORQUE SPRING (#3) rotates the driver, which propels the rounds along the helical 'path' in the outer shell. The energy stored by the torque spring is controlled by the CLUTCH ASSEMBLY (#4). The FOLLOWER (#5) pushes the last round into the FEED LIPS (#6), and completes 7½ revolutions along the length of the magazine when a fully loaded magazine is emptied.

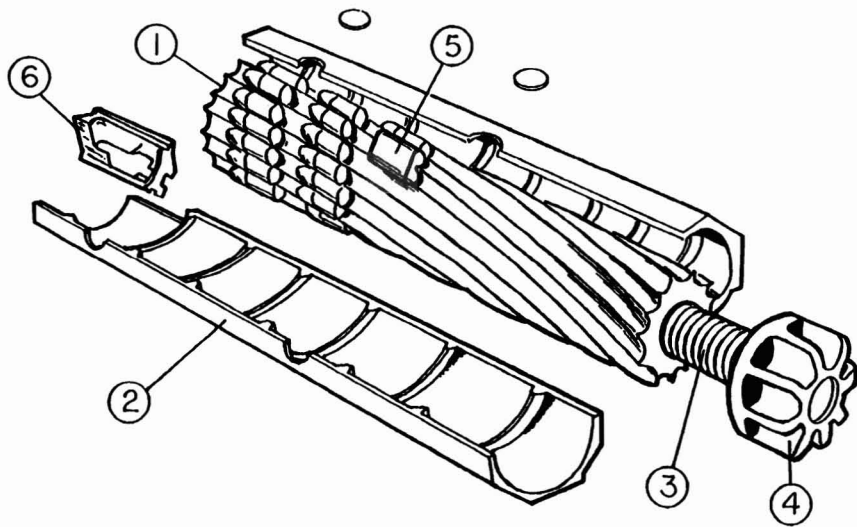

HOW TO DISASSEMBLE THE MAGAZINE

The M-100P magazine is durable and reliable, but like all magazines it can become fouled by accumulations of dirt or wax from excessively lubricated ammunition, and it must occasionally be disassembled for cleaning. **BEFORE DISASSEMBLING THE MAGAZINE MAKE SURE IT IS EMPTY.** See that the follower is visible in the feed lips, then release any energy stored in the torque spring by pushing the spring release button in the center of the winder at the back of the magazine. **WEAR PROTECTIVE GLASSES WHILE DISASSEMBLING THE MAGAZINE TO PREVENT INJURY FROM SUDDENLY RELEASED SPRING LOADED PARTS.**

To remove rear sight grasp magazine in one hand while sliding sight to the rear and free of ribbon clamp with the other. Using a small blunt screwdriver, fingernail file or similar tool, gently pry off the **Lower Ribbon Clamp**, in the same manner that you would pry open a paint can lid. **CAUTION: DO NOT GRASP THE RIBBON CLAMP WITH YOUR BARE HAND. USE A TOOL, OR WEAR GLOVES. OTHERWISE, SERIOUS INJURY MAY RESULT.**

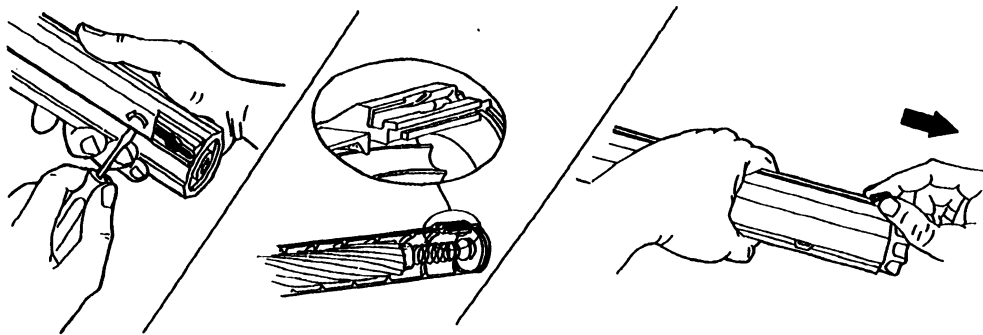

22.

HOW TO DISASSEMBLE THE MAGAZINE (Cont'd)

Gently pry the Magazine open like a clamshell, and separate the two halves. Do this on a flat surface so the loose parts, including the Front End Cap, Feed Lips, Compression Spring, Follower, and Lenses will not be lost. Pull the Winder Assembly free from the Cartridge Carrier, exposing an inch or two of the Torque Spring. Using a small tool, lift the end of the Torque Spring out of its hole in the Winder Assembly. Remove the Torque Spring, with the Splined Driver attached, through the front of the Cartridge Carrier. Do not disassemble the Winder Assembly. If it is not functioning properly, send it to CALICO and it will be serviced or replaced and returned to you. We urge this caution because the Winder/Clutch Assembly requires special tools for disassembly, and the small Clutch Rollers inside are easily lost.

NOTE: The Lenses on top of the Magazine indicate the number of rounds left in the Magazine. If brass is visible in the rear window, at least 93 rounds are left; in the center window at least 49 rounds, and in the front window at least 7 rounds are remaining.

RE-ASSEMBLING THE MAGAZINE

Note that the two halves of the magazine's outer shell have matching pins and sockets for alignment. Place the 'pin' half on a flat surface, concave side up. Place the follower between two segments of the helical rib, flat side down. Insert the torque spring through the front of the cartridge carrier, making sure the splined driver is properly aligned and free to move in its track. Pull an inch or two of the torque spring out the end of the cartridge carrier, and re-insert the hooked end of the torque spring into the small hole in winder assembly. Fit the winder assembly into the end of the cartridge carrier and place them together into the pin half of the outer shell. **MAKE SURE THE WINDER ASSEMBLY IS NESTED PROPERLY, AT THE REAR OF THE MAGAZINE (OPPOSITE THE LARGE OPENING FOR THE FEED LIPS)**. Now, place the feed lips into position, noting that the angle at the rear of the feed lips matches the angle in the outer shell. Insert the compression spring into the cartridge carrier so it pushes against the splined driver. Place the front end cap in position, so that its pin fits into the socket in the feed lips, and it is nested properly in the outer shell half. Now place the 'socket' outer shell half in place, making sure it fits snugly

24.

RE-ASSEMBLING THE MAGAZINE (Cont'd)

over the front end cap and winder assembly, and that the feed lips are locked into position. Holding the magazine together in one hand, hook one edge of the lower Ribbon Clamp into the Dovetail and snap the Clamp into place along it's full length. **CAUTION: DO NOT GRASP AND PUSH ON THE RIBBON CLAMP WITH BARE HANDS, AS INJURY MAY RESULT. HOLD THE RIBBON CLAMP WITH A RAG, OR WEAR GLOVES.**

Still holding the Magazine together, turn it over and place the clear plastic Lenses in their sockets. Finally, position the Upper Ribbon Clamp with the holes over the Lenses and snap it into place along its full length. Check if the magazine is functioning properly by holding it upside down (Feed Lips up) and turning the Winder clockwise until the Follower stops in the Feed Lips. Wind the Magazine an additional 10 full turns, then release the Spring by pushing the Release Button in the center of the Winder.

You should hear the Spring 'burb' as it unwinds.

RE-ASSEMBLING THE MAGAZINE (Cont'd)

If you don't, refer to the trouble shooting section of the manual. Now, wind the magazine again until the follower stops in the feed lips. The magazine is ready to load.

II SECTION - DESCRIPTION AND FEATURES

The M100 Pistol was designed to maximize the potential advantages of the Helical Feed Magazine. With 100 rounds capacity, it is in a class unto itself. The M-100P is constructed of high quality materials, including an aluminum alloy receiver, stainless steel bolt, and glass-fiber reinforced thermoplastic magazine and pistol grip.

Designed with ease of maintenance in mind, the M-100P should give years of use when properly cared for. - ENJOY -

26.

DISASSEMBLING THE RECEIVER

CAUTION: MAKE SURE THE MAGAZINE IS REMOVED AND THE CHAMBER IS CLEAR BEFORE DISASSEMBLING THE RECEIVER. OTHERWISE, SERIOUS INJURY MAY RESULT.

The Upper and Lower Receivers are held together by two hollow spring pins, located as shown. Cock the empty pistol and put the Safety on, then push the spring pins out. If they are too tight to remove by hand, a small twig or other safe object may be used to push the pins out. **CAUTION: NEVER USE LIVE AMMUNITION TO PUSH THE PINS. DOING SO MAY CAUSE THE ROUND TO ACCIDENTALLY DISCHARGE AND MAY RESULT IN SERIOUS INJURY OR DEATH.**

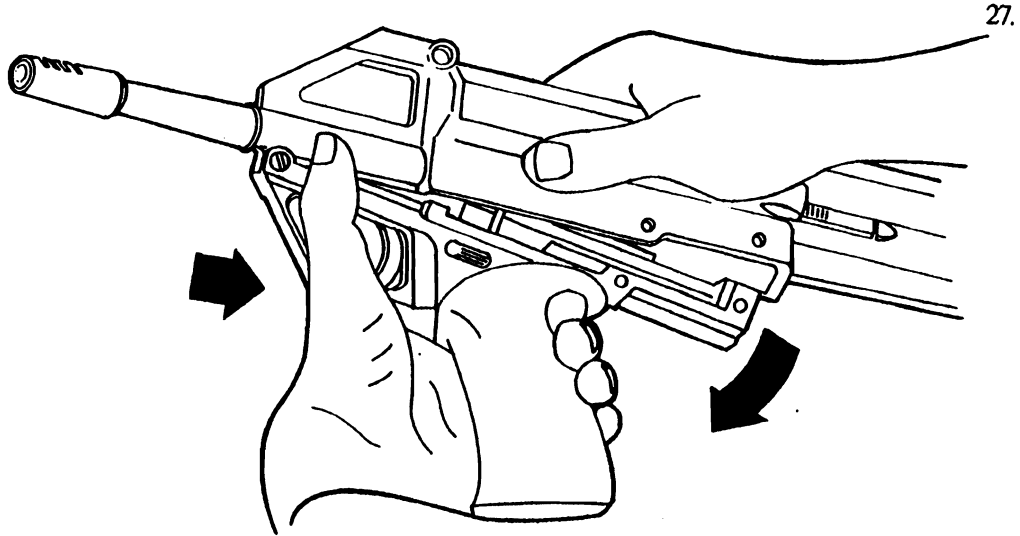

28.

DISASSEMBLING THE RECEIVER (Cont'd)

After the pins are removed hold the Bolt back one-quarter inch or so with your thumb as shown and carefully open the Upper and Lower Receivers, exposing the Bolt. Lift the Bolt off the Lower Receiver, being careful not to lose the Ejector Rod or Buffer. **CAUTION: DO NOT DRY FIRE WHILE THE RECEIVER IS DISASSEMBLED; OTHERWISE THE EXPOSED HAMMER MAY CAUSE ACCIDENTAL INJURY.**

Do not disassemble the Lower Receiver further. If the action is malfunctioning, take it to a qualified gunsmith or send it to CALICO for repair. **ANY ALTERATION OF THE FIRING MECHANISM MAY RESULT IN THIS FIREARM BECOMING UNSAFE AND ILLEGAL, AND WILL NULLIFY ALL WARRANTIES AND MAY REQUIRE THE IMMEDIATE NOTIFICATION OF APPROPRIATE FEDERAL LAW ENFORCEMENT AGENCIES.**

NOTE: THE PISTOL-GRIP COMPARTMENT OPENS EASILY BY INSERTING A SMALL BLUNT TOOL INTO THE HOLE IN THE FRONT, AND SLIDING THE DOOR FORWARD. TO CLOSE, JUST PUSH IT BACK UNTIL IT 'CLICKS' INTO PLACE.

RE-ASSEMBLING THE RECEIVER

While holding the Receiver open, place the Neoprene Buffer against the back of the Lower Receiver as shown. Place the end of the Recoil Spring Rod into the socket in the Buffer, and, compressing the Spring $\frac{1}{4}$ inch, lower the Bolt in place. Lay the Ejector Rod in the slots in the top of the Bolt and Lower Receiver, making sure the 'L' part of the Ejector is to the rear and down. Close the Receiver halves together, carefully fitting the Bolt into the Upper Receiver. The Bolt Handle must be held $\frac{1}{4}$ inch to the rear so the Extractor will clear the Barrel and the Receivers will mate properly. Finally, insert the two Spring Pins into the $\frac{3}{16}$ holes in the Receiver. Work the action to make sure it is functioning properly.

Do not disassemble the Bolt any further than removing the Recoil Spring. If it is not functioning properly, take it to a qualified gunsmith or send it to CALICO for repair. The Bolt may easily be cleaned without disassembly.

30.

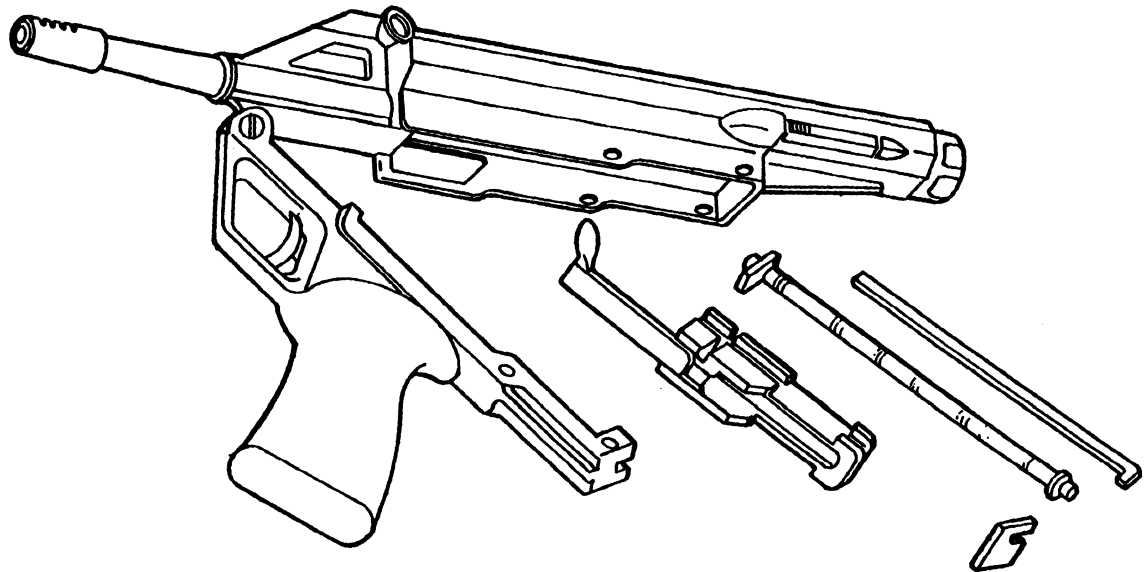

III SECTION - OPERATION AND MAINTENANCE

LOADING, UNLOADING, AND ATTACHING THE MAGAZINE

The Helical-Feed Magazine must be loaded through the Feed Lips, one round at a time like every other .22 Magazine. Loading 100 rounds may sound tedious, but is less so than loading ten rounds ten times. Also the M-100P Magazine is equipped with a Spring Release, so the rounds may be inserted into the Magazine with **NO SPRING RESISTANCE**.

To load the Magazine, first release any spring tension by pushing the Spring Release Button in the center of the Winder. Then turn the Winder just enough to make the Follower visible in the Feed Lips. Load one round by pushing the Rim down against the Follower until the Rim can slide back under the Feed Lips. Repeat the procedure until the Magazine is fully loaded. It will be helpful to push the Spring Release Button 2 or 3 times while loading, as the tension buildup will somewhat hamper the loading process. After loading 100 rounds into the Magazine, turn the Winder through fifteen (15) complete turns. There is a raised line on the back of the Winder to

32.

LOADING, UNLOADING, AND ATTACHING THE MAGAZINE (Cont'd)

help you count the turns. **CAUTION: DO NOT OVERWIND THE MAGAZINE.** Although the Torque Spring is designed to survive 100% overwind, overwinding may damage the Spring and will significantly increase the force necessary to strip a round from the Feed Lips. If the rotation of the Cartridge Carrier seems sluggish, or if the rounds fail to feed properly, it is most likely due to excessively lubricated or dirty ammunition. Use only **CLEAN** ammunition for good results. Refer to the Trouble-Shooting Section for further information.

To unload the magazine each round must be individually pushed forward out of the Feed Lips. Use your thumbnail, a small stick or other safe blunt tool to push the rounds out. **CAUTION: DO NOT USE ANY SHARP METAL TOOL TO UNLOAD THE MAGAZINE. OTHERWISE, A ROUND MAY DISCHARGE ACCIDENTALLY AND POSSIBLY CAUSE INJURY.**

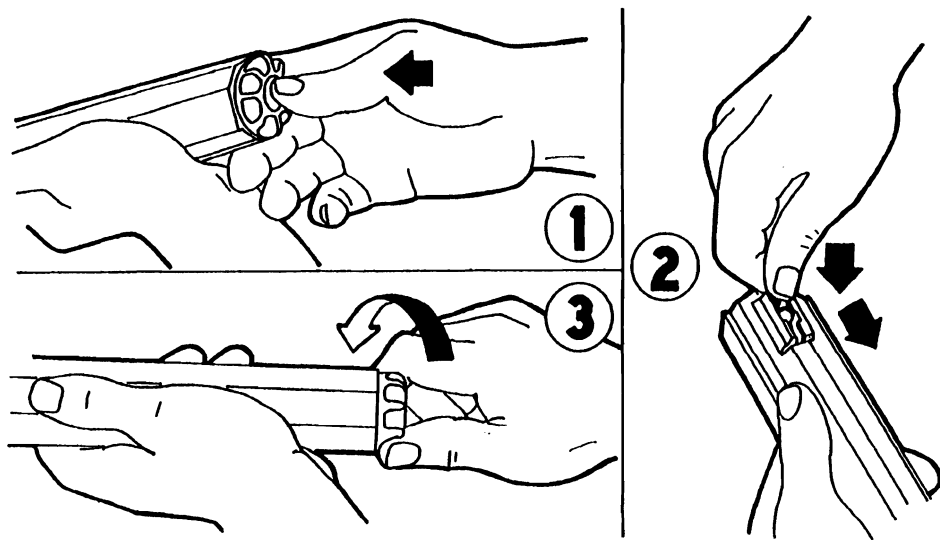

34.

REMOVING/ATTACHING THE MAGAZINE

The M-100P Magazine is quite simple to attach to the Receiver, and with a little practice the M-100P Magazine can be changed as rapidly as any magazine-fed weapon. To remove the Magazine simply place the palm of your hand over the rear portion of the Magazine squeeze the two Magazine Latches together, as shown, and lift up on the Magazine at the same time.

To attach the Magazine, simply place it in the Cradle of the Receiver, firmly forward so that the Pin on the Bulkhead fits into the Socket in the front of the Magazine. Press firmly down on the rear of the Magazine until the Latches snap in place. The Magazine will remain firmly fixed to the Receiver even if only one Latch is engaged, but check to make certain that both Latches are engaged in the Magazine. **NOTE:** The Magazine can be attached with the Bolt forward or back.

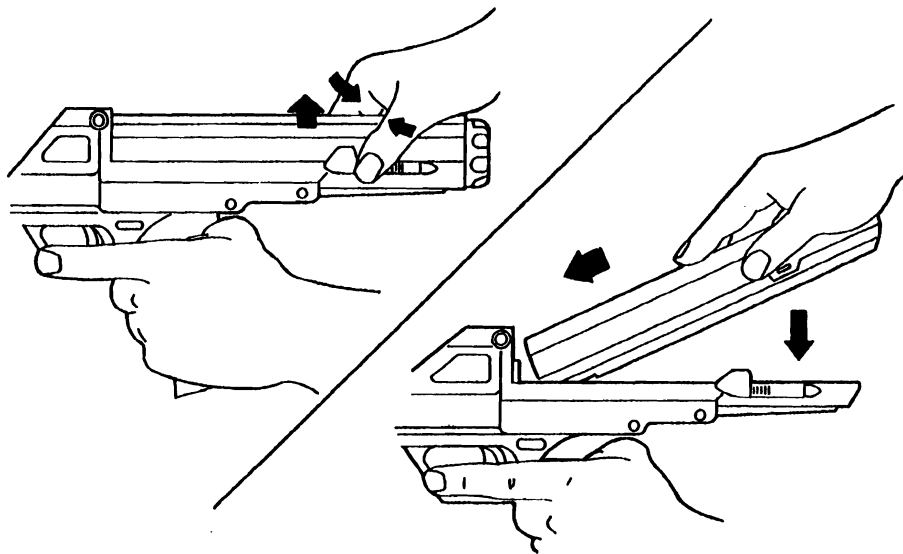

36.

COCKING, SIGHTING & FIRING

With the Magazine attached, the M-100 Pistol is made ready to fire by simply pulling sharply back on the Bolt Handle until it stops, and then releasing it. As the Bolt Springs forward it strips a round out of the Feed Lips and puts it in the Chamber. **CAUTION: ALWAYS MAKE SURE YOUR PISTOL'S SAFETY IS IN THE 'SAFE' POSITION WHEN ATTACHING A LOADED MAGAZINE AND CHAMBERING A LIVE ROUND.**

If a round jams while loading, pull the Bolt Handle back, and push up on the bolt Stop to lock it back. Hold the Pistol with the Ejection Port down and shake the round out. If the round is damaged in any way, discard it in a safe place.

TO FIRE:

1. Be sure you are familiar with all the safety instructions in this manual.
2. Load Magazine, attach to Pistol, and chamber a round as previously described.
3. Grasp Pistol by Pistol Grip and with index finger along the outside of Trigger Guard, take aim. Aim by aligning Front and Rear Sights.
4. Press Safety down, out of engagement.
5. Place index finger on trigger and squeeze gently until the Hammer falls. Don't jerk the Trigger as you will disturb your aim. To fire the second and subsequent rounds, all that is necessary is to release the Trigger and squeeze it again after every shot until you have completed firing.

38.

TO FIRE (Cont'd)

6. CAUTION: THIS IS A SEMI-AUTOMATIC PISTOL AND IS IMMEDIATELY LOADED AND COCKED, READY TO FIRE AGAIN AFTER EACH SHOT UNTIL THE MAGAZINE IS EMPTY.

7. Release Trigger, place index finger outside of Trigger Guard, and apply Safety by pushing it up. **CAUTION: IF PISTOL FAILS TO FIRE, HOLD IT, KEEP IT POINTED TOWARD THE TARGET OR SAFE OPEN AREA, AND WAIT 30 SECONDS.** If a hangfire (slow ignition) has occurred, round will fire within 30 seconds. If round does not fire, remove Magazine, eject round, and examine Rim. If Firing Pin indent on Rim is light or non-existent, have Pistol examined by a competent gunsmith. If Firing Pin indent on Rim appears normal assume faulty ammunition. Segregate misfired rounds from other live ammunition. Reload and resume firing.

8. Keep Pistol pointed in a safe direction and unload as previously described. If you cock

TO FIRE (Cont'd)

your Pistol but do not fire, apply Safety until ready to fire. Remember, if there is a round in the Chamber, there is a risk of accidental discharge.

CAUTION: NEVER LEAVE YOUR PISTOL COCKED READY TO FIRE. TO DO SO IS EXTREMELY DANGEROUS AND THE PISTOL COULD EASILY BE ACCIDENTALLY DISCHARGED CAUSING INJURY OR DEATH. SAFETY DEPENDS ON YOU.

SIGHTS

Your CALICO M-100P is equipped with a windage adjustable front sight and a fixed notched rear sight. A spring loaded detent keeps the front sight firmly in place until it is turned by hand. Each click of the front sight changes the impact point of the bullet approximately one-quarter inch at 50 yards. Turning the front sight clockwise (while facing the knob) moves the impact point to the right. **CAUTION:** Do not overtighten sight against it's stops as damage and loss of parts may result.

40.

CARE AND CLEANING

GENERAL

Comprehensive knowledge of how to service and handle your Pistol is of great importance. Experience has shown that most failures which occur while operating the Pistol are due to negligence in maintenance. Special attention must be paid to cleaning, lubricating and inspecting the Pistol; this will determine whether or not the Pistol will function properly when you need it. In order to maintain accuracy, the Barrel must be serviced thoroughly. The Receiver, the Bolt Assembly and other moving parts of the Pistol must be kept clean and lightly lubricated to ensure proper operation. Care and cleaning includes the Magazine, which must be kept free from wax, grit, etc., in order to function properly.

INITIAL CLEANING

1. Upon receipt of Pistol, disassemble (see page 26) and inspect.
2. Clean Pistol as per Periodic Maintenance Procedure.
3. Any heavy or gummy deposits may be removed using very light rust preventive oils such as Breakfree, c.b.c., or W.D. 40. After cleaning, wipe dry and lightly coat with gun oil.
4. Never use abrasive or metallic objects, synthetic cloth, dry cleaning fluids, detergents, acids, lyes, water or steam.
5. Reassemble and make sure of proper functioning of Pistol including Safeties. (see page 29).
6. Observe all safety precautions (see page 6).

PERIODIC MAINTENANCE

1. Disassemble the Pistol. (see page 26). Clean all disassembled parts as explained below. Remove all foreign matter or dirt using any widely distributed gun oil and gun cleaning equipment made for sporting and hunting firearms.

CAUTION: MAKE SURE YOUR PISTOL IS EMPTY BEFORE CLEANING. SAFETY DEPENDS ON YOU.

42.

PERIODIC MAINTENANCE (Cont'd)

2. Clean the Barrel Bore and Chamber: use cleaning rod or pull through with a patch. Continue until patches come out clean. After cleaning, lightly lubricate the Bore and Chamber with a patch dipped in lubricant to prevent corrosion and pitting.

3. Clean exterior and interior surfaces of all subassemblies to remove dampness, dirt and perspiration. Then wipe all metal surfaces with a lightly oiled patch or rag. Pay particular attention to all parts of the firing mechanism.

4. While cleaning, the following inspection must be carried out:

- a. Examine the Bore and Chamber visually and make sure it is free of rust, pitting and metal fouling, and that the Barrel has not been damaged.
- b. Check that all disassembled parts are serviceable and none are missing.
- c. Check the action mechanism in the Lower Receiver for dirt or grit, loose parts or excessive wear.
- d. Inspect the firing pin visually to make sure that it is undamaged. It is normal for the Firing Pin to be loose in the Bolt.

CAUTION: MAKE SURE YOUR PISTOL IS EMPTY BEFORE CLEANING. SAFETY DEPENDS ON YOU.

PERIODIC MAINTENANCE (Cont'd)

4. e. Inspect Extractor visually and make sure it is clean and undamaged.
5. Assemble the Pistol. (See page 29).
6. After assembly, check the following:
 - a. Make sure the Chamber is empty.
 - b. With fire selector "F" showing (exposed for fire), cock and dry fire at least twice to make sure that the mechanism is working smoothly and properly.
 - c. Cock the Pistol, move fire selector to Safety position, ("S" exposed for Safety), point Barrel in safe direction, squeeze trigger to make sure Safety Catch is working properly. Return fire selector to fire position ("F" exposed), and dry fire. Set fire selector to Safety position ("S" exposed for Safety).
 - d. Check sights and all exterior parts of the Pistol to make sure that they are undamaged and serviceable.

CAUTION: MAKE SURE YOUR PISTOL IS EMPTY BEFORE CLEANING. SAFETY DEPENDS ON YOU.

44.

PERIODIC MAINTENANCE (Cont'd)

7. It is imperative that Magazines be given the best care and kept in perfect condition. They should be disassembled and cleaned with mineral oil or other mild cleaning agent. Make sure all build-up of cartridge lube is removed. (See page 20). Check Magazine Lips. They should not be deformed or nicked.

CLEANING BEFORE FIRING

1. Disassemble the Pistol. (See page 26).
2. Run clean patches through Bore and Chamber to remove all dust and oil. There should be no oil in Bore and Chamber before firing as this may cause dangerous pressures to develop.
3. Remove excess oil from interior of Bolt and Bolt Face.
4. Check that all moving parts are lightly oiled.
5. Assemble the Pistol and check functioning. (See page 29).

CAUTION: MAKE SURE YOUR PISTOL IS EMPTY BEFORE CLEANING. SAFETY DEPENDS ON YOU.

CLEANING AFTER FIRING

- 1. The Pistol should be cleaned not later than the evening of the day on which it was fired to prevent corrosion and caking of deposits.**
- 2. Follow procedures of periodic maintenance and pay particular attention to all parts which have been in contact with powder gases.**
 - a. Barrel - In order to remove heavy deposits, use cleaning brush. Make sure the brush goes all the way through the Bore before reversing the direction. Deposits that cannot be readily removed with the brush may be treated by coating Bore and Chamber with good quality bore cleaning fluid and repeat above procedure. The Barrel should be cleaned and reoiled, at least once on the day after firing.**
 - b. Firing Mechanism - Remove all powder residues from Bolt Face and interior surfaces of Bolt. If necessary, use stiff nylon brush or tooth brush. Clean and lightly oil all parts of Bolt Mechanism.**

CAUTION: MAKE SURE YOUR PISTOL IS EMPTY BEFORE CLEANING. SAFETY DEPENDS ON YOU.

46.

CLEANING AFTER FIRING (Cont'd)

- c. Receiver - Wipe off any heavy deposits in interior and oil lightly.
- d. Magazine - Make sure Magazines are clean and Follower moves freely.

IMMEDIATE ACTION AND TROUBLE SHOOTING

A failure to fire including one caused by an empty Magazine, may often be corrected by taking immediate action.

IMMEDIATE ACTION

Remove Magazine and wait 3 seconds with Barrel pointing in a safe direction, then inspect Magazine.

1. MAGAZINE EMPTY

- a. Cock to remove possible last round. Inspect Chamber and if empty, attach full Magazine, recock and continue firing.

IMMEDIATE ACTION (Cont'd)**2. MAGAZINE NOT EMPTY (MALFUNCTION)**

- a. **Recock to clear possible defective or wrongly positioned round. If a round or case ejects, inspect Chamber and if empty, reload and continue firing.**
- b. **If nothing ejects, fully draw back Bolt and check if a cartridge or case is in Chamber. If empty, reload and continue firing.**
- c. **If base of cartridge is visible, allow Bolt to snap home and fire in a safe direction. If Pistol fires and ejects, reload and continue.**
- d. **If Pistol does not fire, set fire selector on Safety and follow trouble shooting procedure for “spent case or round stuck in Chamber”. (See page 51).**

48.

**FAILURE TO FEED -
CAUSE**

- A. Incorrect Cocking
- B. Magazine Improperly Seated
- C. Magazine Improperly Loaded
- D. Dirty Magazine
- E. Damaged Magazine
- F. Short Recoil

TROUBLE SHOOTING

PISTOL JAMS OR CLOSES ON EMPTY CHAMBER.

REMEDY

- Clear jam if necessary and recock.
Pull Bolt all the way back and let it snap home by itself: don't ride the Bolt Handle.
Push Magazine home until Latch catches.
1. Seat top Cartridge properly
 2. Check that the Magazine is fully wound - 15 turns
 3. Make sure the rounds in the Magazine are clean - not excessively 'waxy'.
- Disassemble and Clean.
Replace
Clear jam. Check Chamber for cleanliness. Check type of ammunition (may be underpowered). Try other currently commercially manufactured .22LR ammunition.

TROUBLE SHOOTING (Cont'd)**FAILURE TO FEED (Cont'd)**

G. Double Feed

1. Inspect for stuck case or cartridge. (See page 51).
2. Check Extractor and Ejector.

FAILURE TO CHAMBER**BOLT DOES NOT FULLY CLOSE AND PISTOL DOES NOT FIRE.****CAUSE**

- A. Incorrect Cocking
- B. Dirty Chamber
- C. Defective Ammunition
- D. Very Dirty Pistol

- E. Defective Return Spring

REMEDY

- Remove Magazine. Recock and reload.
- Clean
- Check for damaged cartridges.
- Check for sluggishness in Bolt and Firing Mechanism.
Clean and oil as necessary.
- Check for recurrent sluggishness in operation.
Check spring assembly for damage. Replace if necessary.

50.

TROUBLE SHOOTING (Cont'd)

FAILURE TO FIRE

HAMMER SNAPS HOME BUT PISTOL WILL NOT FIRE.

CAUSE

A. Bolt not Fully Closed

B. Defective Cartridge

C. Dirty Firing Mechanism

D. Defective Firing Pin

REMEDY

Follow procedure for incorrect cocking or short recoil. (See page 48).

Inspect Rim. If fully indented discard safely. If not fully indented, check Firing Mechanism.

Check for sluggishness of operation

Clean and replace as necessary.

FAILURE TO EXTRACT OR EJECT

THE BOLT MAY NOT FULLY RECOIL, THE FIRED CASE MAY NOT EJECT, OR THE PISTOL MAY JAM (SPENT CASE LEFT IN CHAMBER).

CAUSE

A. Underpowered Ammunition (Short Recoil)

REMEDY

Check ammunition and change to a different brand of currently commercial manufactured .22LR if problem persists.

TROUBLE SHOOTING (Cont'd)**FAILURE TO EXTRACT OR EJECT (Cont'd)**

- | | |
|-----------------------------------|---|
| B. Dirty or Damaged Chamber | Inspect, clean, replace Barrel if necessary. |
| C. Defective Ammunition | Check ammunition for damage. Replace if problems persist. |
| D. Fouled Extractor | Clean Extractor. |
| E. Extractor Defective or Missing | Replace |
| F. Damaged Ejector | Replace if necessary. |

SPENT CASE OR ROUND STUCK IN CHAMBER

CAUTION: THE FOLLOWING PROCEDURE SHOULD BE CARRIED OUT ONLY AFTER FOLLOWING THE STEPS IN 'IMMEDIATE ACTION' (See page 46).

1. Remove Bolt Assembly.
2. With Barrel in place, insert cleaning rod through front of Barrel. Push or tap gently to remove obstruction.
3. Check Chamber and Bore. Clean before reassembly.
4. If obstruction cannot be removed, disassemble Barrel and contact a competent gunsmith or CALICO.

52.

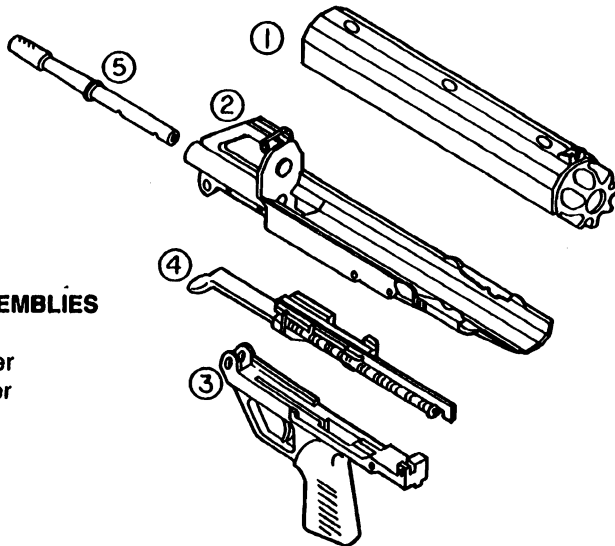

M-100P SUB-ASSEMBLIES

1. Magazine
2. Upper Receiver
3. Lower Receiver
4. Bolt
5. Barrel

54.

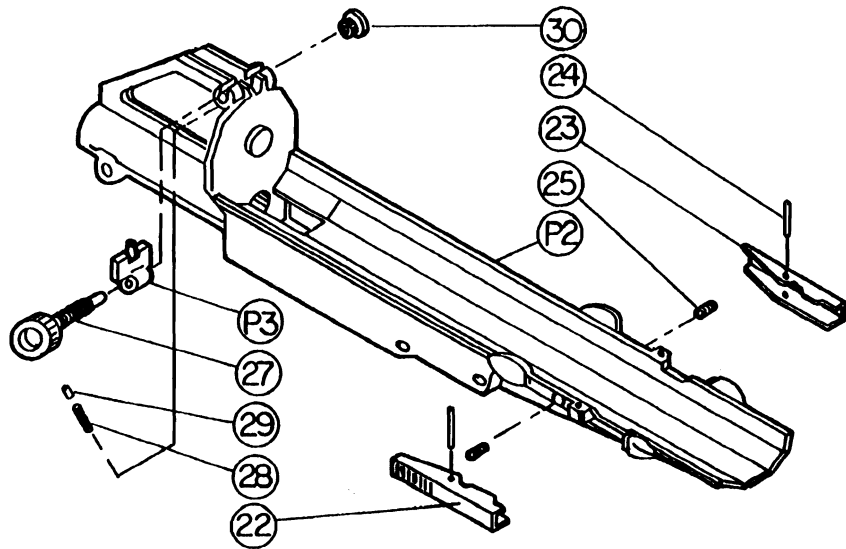

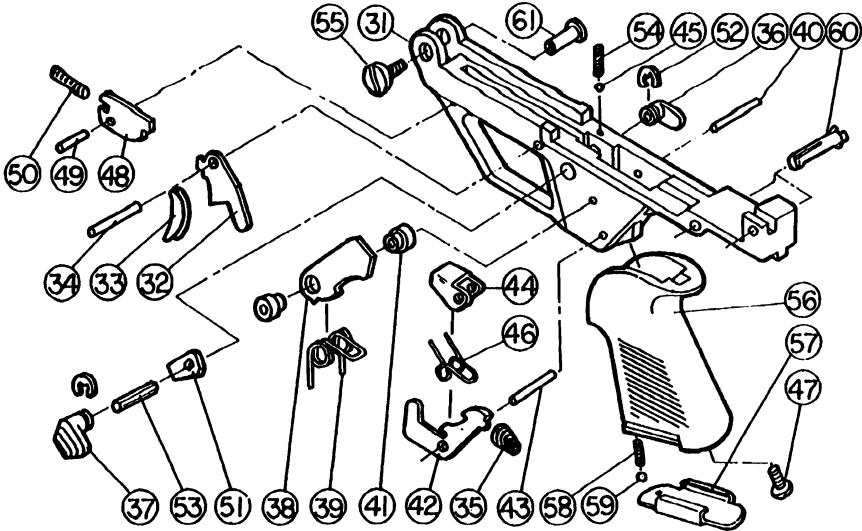

56.

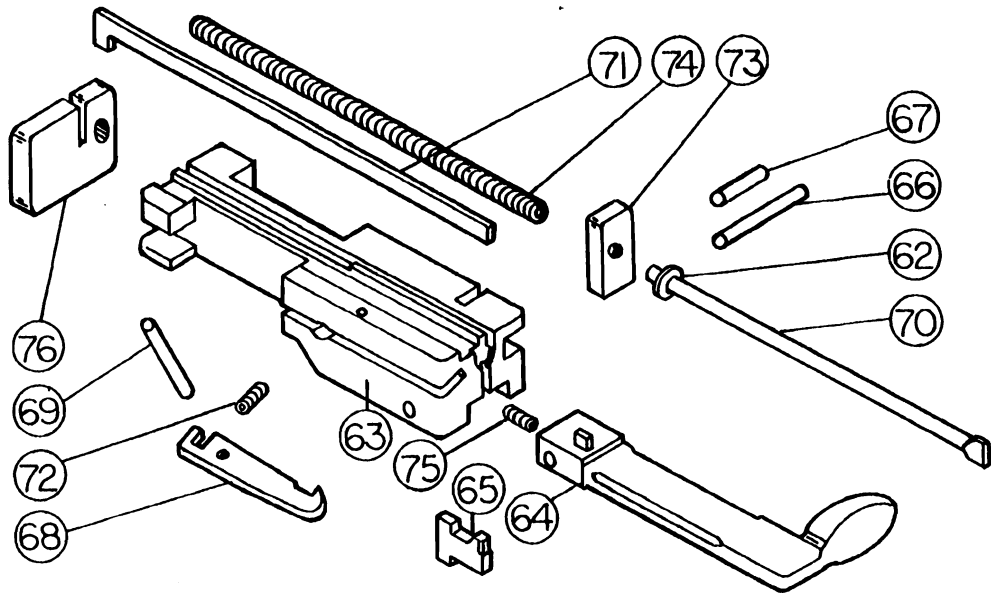

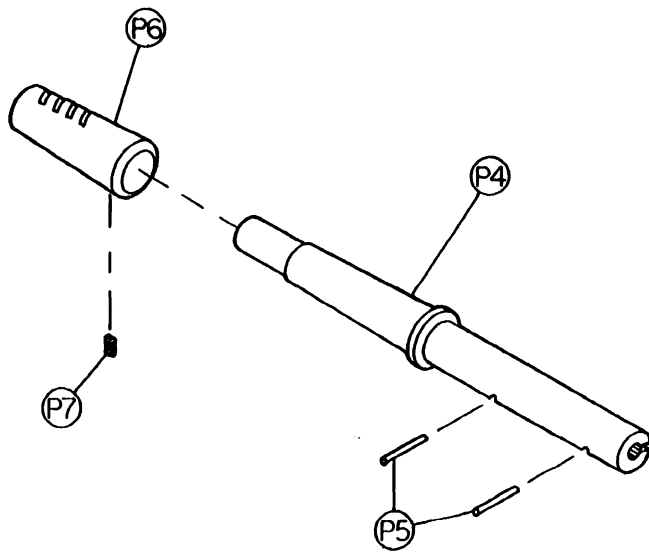

CALICO M-100P PARTS LIST

| MAGAZINE ASSEMBLY | | | LOWER RECEIVER ASSEMBLY | | | BOLT ASSEMBLY | | | BARREL ASSEMBLY | | |
|-------------------|-----------------------------|--------------|-------------------------|-----------------------------|-------------|---------------|--------------------|----------|-----------------|------------------|----------|
| NO. | PART DESCRIPTION | PART NO. | NO. | PART DESCRIPTION | PART NO. | NO. | PART DESCRIPTION | PART NO. | NO. | PART DESCRIPTION | PART NO. |
| 1 | FLUID CARTRIDGE CARRIER | C-22-201 | 40 | PH, HAMMER | C-22-403-3 | P4 | BARREL | | | | |
| 2 | CAP, REAR END | C-22-202-1 | 41 | BUSHING, HAMMER (1) | C-22-403-5 | P5 | PHS, BARREL (1) | | | P-22-501-1 | |
| 3 | BUTTON, SPRING RELEASE | C-22-202-2 | 42 | SEAR | C-22-404-1 | P6 | COMPENSATOR | | | P-22-404 | |
| 4 | CLUTCH PLATE | C-22-202-3 | 43 | PIVOT PH, SEAR | C-22-402-3 | P7 | SCREW, COMPENSATOR | | | P-22-404-1 | |
| 5 | RETAINER, DRIVE SPRING | C-22-202-4 | 44 | DISCONNECT | C-22-405-1 | | | | | | |
| 6 | MAGAZINE OUTER SHELL, RIGHT | C-22-202-7 | 45 | BALL, SAFETY | C-22-303-4 | | | | | | |
| 7 | MAGAZINE OUTER SHELL, LEFT | C-22-203-1 | 46 | SPRING, DISCONNECT | C-22-423-3 | | | | | | |
| 8 | CAP, FRONT END | C-22-204-1 | 47 | MOUNTING SCREW, PISTOL GRIP | C-22-405-4 | | | | | | |
| 9 | LENS, MAGAZINE (1) | C-22-204-2 | 48 | BOLT CATCH | CC-22-406-1 | | | | | | |
| 10 | SPLINED DRIVER | C-22-205-3 | 49 | PH, BOLT CATCH | C-22-406-2 | | | | | | |
| 11 | ROLLER BEARING, CLUTCH (1) | C-22-204-4 | 50 | SPRING, BOLT CATCH | C-22-411 | | | | | | |
| 12 | FEED LIPS | C-22-205 | 51 | SAFETY | C-22-407-2 | | | | | | |
| 13 | SPRING DRIVE | C-22-204-5 | 52 | C.R.U.D, SAFETY (1) | C-22-407-3 | | | | | | |
| 14 | SPRING, CLUTCH | C-22-206-1 | 53 | SHAFT, SAFETY | C-22-407-4 | | | | | | |
| 15 | SNAP RING, LARGE | C-22-208-2 | 54 | SPRING, SAFETY | C-22-303-3 | | | | | | |
| 16 | SNAP RING, SMALL | C-22-208-3 | 55 | HINGE SCREW | C-22-410-3 | | | | | | |
| 17 | MAGAZINE COMPRESSION SPRING | C-22-204-7 | 56 | PISTOL GRIP | C-22-408 | | | | | | |
| 18 | FOLLOWER, MAGAZINE | C-22-204-6 | 57 | COVER PISTOL GRIP | C-22-409 | | | | | | |
| 19 | RIBBON CLAMP, UPPER | C-22-207-1 | 58 | SPRING, PISTOL GRIP COVER | C-22-303-3 | | | | | | |
| 20 | RIBBON CLAMP, LOWER | C-22-207-2 | 59 | BALL, PISTOL GRIP COVER | C-22-302-4 | | | | | | |
| 21 | REAR SIGHT | P-22-301 | 60 | PH, TAKE-DOWN (1) | C-22-410-1 | | | | | | |
| P2 | UPPER RECEIVER | P-22-301 | 61 | HINGE INU | C-22-410-2 | | | | | | |
| 22 | MAGAZINE CATCH, LEFT | C-22-302-1 | 62 | WASHER RETURN SPRING | C-22-403-2 | | | | | | |
| 23 | MAGAZINE CATCH, RIGHT | C-22-302-2 | 63 | BOLT | C-22-501 | | | | | | |
| 24 | PH, MAGAZINE CATCH (1) | C-22-302-3 | 64 | BOLT HANDLE | C-22-102-1 | | | | | | |
| 25 | SPRING MAGAZINE CATCH (1) | C-22-302-4 | 65 | FIRING PIN | C-22-502-2 | | | | | | |
| P3 | FRONT SIGHT | P-22-303-1 | 66 | PH, BOLT HANDLE | C-22-503-3 | | | | | | |
| 27 | SCREW, FRONT SIGHT | C-22-303-2 | 67 | PH, FIRING PIN STOP | C-22-502-5 | | | | | | |
| 28 | SPRING, FRONT SIGHT | C-22-303-5 | 68 | EXTRACTOR | C-22-503-1 | | | | | | |
| 29 | PH, FRONT SIGHT | C-22-606 | 69 | PH, EXTRACTOR | C-22-522-1 | | | | | | |
| 30 | BUSHING, FRONT SIGHT | C-22-303-5 | 70 | ROD, RETURN SPRING | C-22-503-3 | | | | | | |
| 31 | LOWER RECEIVER | C-22-401 | 71 | EJECTOR | C-22-503-4 | | | | | | |
| 32 | TRIGGER | C-22-402-1 | 72 | SPRING, EJECTOR | C-22-504-1 | | | | | | |
| 33 | TRIGGER PAD | C-22-402-2 | 73 | RETAINER, RETURN SPRING | C-22-504-2 | | | | | | |
| 34 | PH, TRIGGER | C-22-402-3 | 74 | SPRING, BOLT RETURN | C-22-504-3 | | | | | | |
| 35 | SPRING, TRIGGER | C-22-402-4 | 75 | SPRING, FIRING PIN | C-22-504-4 | | | | | | |
| 36 | SAFETY LEVER, RIGHT | C-22-407-1-2 | 76 | BUFFER | C-22-504-5 | | | | | | |
| 37 | SAFETY LEVER, LEFT | C-22-407-1-1 | | | | | | | | | |
| 38 | HAMMER | C-22-403-1 | | | | | | | | | |
| 39 | SPRING, HAMMER | C-22-403-2 | | | | | | | | | |

FOR REPLACEMENT PARTS, CONTACT:



5405 SE Alexander St., Unit P
 Hillsboro, OR 97123
 Tel: (503) 649-3010 Fax: (503) 649-3831
www.calicolightweaponsystems.com

LIMITED WARRANTY

CALICO warrants this product only to the original purchaser at retail to be free from defective materials and workmanship from the date of original retail purchase for the period as shown below.

| MODEL NO. | SERIAL NO. | PARTS | LABOR |
|---------------|------------|---------|---------|
| Calico M-100P | | 90 Days | 90 Days |

WHAT IS COVERED

All parts which are defective in materials or workmanship, subject to the following:

WHAT IS NOT COVERED

- (1) Products which have been subjected to abuse, accident, alteration, modification tampering, negligence, misuse, or if repaired or serviced by anyone other than a service facility authorized by Calico to render such service, or if the model or serial number has been altered, tampered with, defaced, or removed.
- (2) Operational adjustments or procedures covered in the Owner's Manual, if any.
- (3) Actual or alleged labor, transportation, or other incidental charges.
- (4) Actual or alleged consequential damages incurred by us of this product.

WHO IS COVERED:

The original purchaser, at retail.

WHAT WE WILL DO:

CALICO, at its election, will repair or replace all defective parts free of charge that are covered by this limited warranty.

60.

**WHAT YOU MUST DO FOR
WARRANTY SERVICE:**

Box this product carefully, preferably in the original carton, and ship, insured, with a copy of your bill of sale or credit-card charge receipt plus a letter of explanation of the problem to:



Attention: Repairs
5405 SE Alexander St., Unit P
Hillsboro, OR 97123
Tel: (503) 649-3010 Fax: (503) 649-3831
www.calicolightweaponsystems.com

A copy of your dated bill of sale or credit-card charge receipt is necessary to prove warranty coverage.

No other express warranty is applicable to this product. THE DURATION OF ANY IMPLIED WARRANTIES, INCLUDING THE IMPLIED WARRANTY OF MERCHANTABILITY, IS LIMITED TO THE DURATION OF THE EXPRESS WARRANTY HEREIN. CALICO SHALL NOT BE LIABLE FOR THE LOSS OF USE OF THE PRODUCT, INCONVENIENCE, LOSS OR ANY OTHER DAMAGES, DIRECT OR CONSEQUENTIAL, ARISING OUT OF THE USE OF, OR INABILITY TO USE, THIS PRODUCT OR FOR ANY BREACH OF ANY EXPRESS OR IMPLIED WARRANTY, INCLUDING THE IMPLIED WARRANTY OF MERCHANTABILITY APPLICABLE TO THIS PRODUCT.

Some states do not allow the exclusion or limitation of incidental or consequential damages or limitations on how long an implied warranty lasts, so these limitations or exclusions may not apply to you. This warranty gives you specific legal rights, and you may also have other rights which vary from state to state.

RETAIN THIS PART OF YOUR WARRANTY

M-110

- PAPER WORK
- REAR SIGHT
- COMPENSATOR

**CALICO IS DEDICATED TO THE SAFE ENJOYMENT OF THE SHOOTING SPORTS.
WE ENCOURAGE ALL FIREARM OWNERS TO BE SAFE AND RESPONSIBLE,
AND TO OBSERVE ALL THE LAWS AND REGULATIONS RELATING TO
FIREARMS AND SHOOTING.**

- R E M E M B E R -

SAFETY DEPENDS ON YOU.