

# **BUSHMASTER**

## **MI7S Bullpup**



# **OPERATION AND SAFETY INSTRUCTIONS**



**Bushmaster Firearms, Inc.**  
**Quality Parts Co.**  
**P.O. Box 1479**  
**999 Roosevelt Trail**  
**Windham, Maine 04062**  
**Customer Service: 1 800 883 6229**  
**Orders: 1 800 998 SWAT • 1 207 892 3594**



**WARNING!**  
**DANGEROUS WEAPONS**

---

Semi-automatic rifles are classified as **FIREARMS** or **DANGEROUS WEAPONS** and are sold by Bushmaster Firearms, Inc. with the specific understanding that we are not responsible in any manner whatsoever for their improper or negligent handling or resale under local laws and regulations. Bushmaster Firearms, Inc. shall not be responsible in any manner whatsoever for malfunctioning of the firearm or for physical injury or property damage resulting in whole or in part from:

1. Criminal or negligent discharge
2. Improper or careless handling
3. Unauthorized modifications
4. Defective, improperly loaded or reloaded ammunition
5. Corrosion
6. Neglect
7. Other influences beyond our immediate control.

This limitation applies regardless of whether liability is asserted on the basis of contract, negligence or strict liability (including any failure to warn.) Under no circumstances shall Bushmaster Firearms, Inc. be liable for incidental or consequential damages such as loss of use of property, commercial loss, and loss of earnings or profits.

---



**WARNING!**  
**EYE AND EAR PROTECTION**

Always wear adequate shooting glasses, ear plugs or earmuff type protection when discharging firearms. Ensure that persons close to you are similarly protected.

Unprotected eyes may be injured by powder gas, carbon residue, lubricant, metallic particles or similar debris which may emanate occasionally from any firearm in normal use.

Without ear protection, repeated exposure to shooting noise may lead to cumulative permanent hearing loss.

## **LIMITED WARRANTY...**

---

It is our intention under normal conditions to warrant any and all defects in parts, material or workmanship which affect the satisfactory operation of the rifle. Our warranty obligation is limited to the repair or replacement of any part(s) which is returned to us and is determined by us to be defective. We assume no liability for any incidental or consequential damage. Our warranty is made to the original owner and is not transferable. The following items are specifically excluded from coverage under this warranty.

- (A) Normal wear of the protective finishes, and of all metal or plastic parts;
  - (B) Damage or malfunction resulting from accident, negligence, misuse or unauthorized repair or alteration;
  - (C) Damage or malfunction resulting from barrel obstructions;
  - (D) Damage or malfunction resulting from use of other than factory ammunition.
- 



## **FIREARM SAFETY IS UP TO YOU!**

1. ALWAYS KEEP MUZZLE POINTED IN SAFE DIRECTION
2. UNLOAD FIREARM WHEN NOT IN USE
3. DON'T RELY ON YOUR GUN'S "SAFETY"
4. BE SURE OF YOUR TARGET AND WHAT IS BEYOND IT
5. USE CORRECT AMMUNITION
6. IF RIFLE FAILS TO FIRE, HANDLE WITH CARE
7. WEAR EYE AND EAR PROTECTION
8. ENSURE BARREL IS CLEAR OF OBSTRUCTIONS
9. DON'T ALTER OR MODIFY YOUR GUN
10. LEARN ITS MECHANICAL AND HANDLING CHARACTERISTICS
11. SERVICE OFTEN



## **SAFETY WARNINGS !**

**THESE ARE ALL IMPORTANT SAFETY WARNINGS.  
PLEASE NOTE WARNING SYMBOLS FOUND  
THROUGHOUT THIS MANUAL.**

---



**These safety warnings are for your protection as well as the safety of others.  
Disregarding information in this manual may result in serious injury or death.**

---



**Do not attempt to load or use any firearm until you have read and understand the information contained in this manual. Before handling this firearm, learn how it operates - and how to maintain it. This includes knowing its basic parts, how the safety features operate, how to safely open and close the action and how to safely load and unload ammunition.**

---



**Improper use and handling could cause severe injury or death to you or those around you.**

---



**Be certain this owner's manual is available for reference and is kept with this firearm if transferred to another party. If the manual is lost or misplaced, write or call for a replacement copy to:**

**Bushmaster Firearms, Inc.  
999 Roosevelt Trail, Windham, Maine 04062  
Customer Service Tel.: 1 800 883 6229**

---



**As the owner of this firearm, you must undertake the full time responsibility of safe firearms handling for your own safety and the safety of others.**

**Bushmaster Bullpup Operation & Safety Instructions**  
**Downloadable version - July 1999**



- Keep all firearms and ammunition out of reach of children.
  - Store firearms and ammunition separately.
  - Never store a loaded gun and always separate Upper and Lower Receiver and remove Bolt Carrier.
  - Never leave a loaded firearm unattended.
  - Never carry a loaded firearm in a vehicle.
- 



A firearm's safety button is a mechanical device which can never replace safe gun handling.

---



Always point the muzzle of your firearm in a safe direction, regardless of whether the firearm is loaded or unloaded.

---



It's your responsibility to obtain proper training to use and maintain your firearm. Certified and reputable safety courses and instructions are offered by the National Rifle Association and state and local organizations. You also have a responsibility to know and obey all local, state and federal laws governing the use, possession and transportation of firearms.

---



**TREAT EVERY FIREARM AS IF IT WERE LOADED.**  
Give your firearm to someone with the action open and in the "safe" position, after you verify that the firearm is unloaded. Insist on the same procedure when receiving a firearm. Learn the location and operation of all safety features.

---

**SAFE GUN HANDLING DEPENDS ON YOU!**

## **CONTENTS:**

---

**A. GENERAL DESCRIPTION - Page 7**

1. Type of Weapon
2. Technical Data
3. Ammunition
4. Main Groups

**B. SAFETY MODE SELECTION - Page 8**

**C. STRIPPING AND ASSEMBLING - Page 8**

1. Stripping
2. Assembling
3. Check Function
4. Cleaning

**D. LOADING, FIRING AND  
UNLOADING WEAPON - Page 11**

1. Loading
2. Firing
3. Loading after last round fired
4. Unloading

**E. PARTS LIST AND EXPLODED DRAWING - Page 14**

**F. SERVICE INFORMATION/INSTRUCTIONS - Page 16**

---



**Bushmaster Bullpup Operation & Safety Instructions**  
**Downloadable version - July 1999**

---

**B. SAFETY MODE SELECTION**

---

When the safety catch is pushed flush with the left side of the Lower Receiver, a **WHITE** line can be seen on the **right** side of the Lower Receiver.

The rifle is now in **SAFE** mode.

When the safety catch is pushed flush with the right side of the Lower Receiver, a **RED** line can be seen on the **left** side of the Lower Receiver.

The rifle is now in **FIRE** mode.

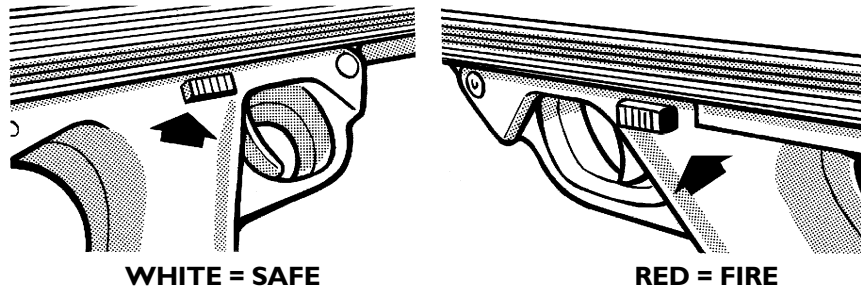

**BEFORE STRIPPING**, the rifle must be unloaded and placed in **SAFE** mode.

The Safety is located on the left side of the Lower Receiver. Push safety in. A **WHITE** line will be visible on the **RIGHT** side of the lower receiver.

---

**C. STRIPPING AND ASSEMBLING (for cleaning purposes)**

---

**C1. Stripping...**

**Step 1.** Unload rifle. Remove the Magazine. Check to ensure no round remains in chamber.

**Step 2.** Open the Rifle.

Place right hand on the pistol grip, fingers **away** from trigger. Cock the rifle with the left hand. Press in the heads of the two pins on the left hand side of the Lower Receiver.

The upper receiver group can now be swung open - exposing internal mechanisms.

**Note:** Do not over pressure the hinge pivot pin by forcing the upper receiver to its maximum swing position. Damage may occur to hinge or pin.



**Bushmaster Bullpup Operation & Safety Instructions**  
**Downloadable version - July 1999**

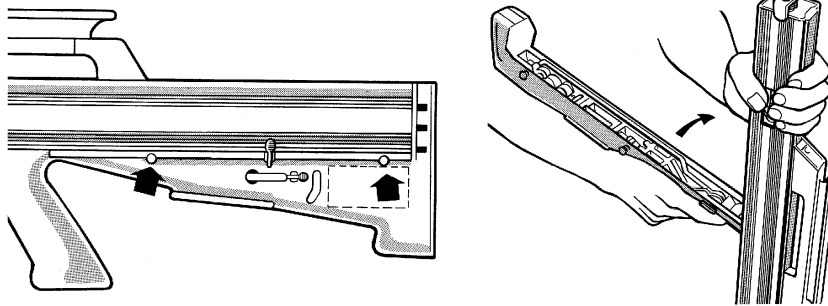

**Step 3. Removing the Bolt Carrier Group.**

Holding the pistol grip, use the thumb and two fingers of the left hand to grip the exposed action plate. Withdraw bolt carrier by pulling up and out.

**Do not strip Bolt Carrier any further.**

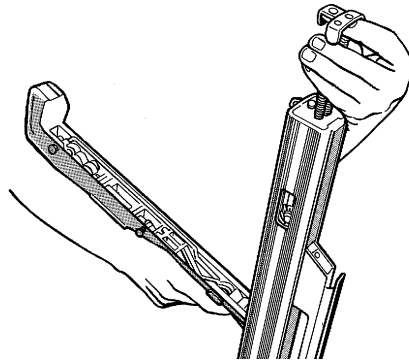

**Removing the Ignition Pocket is a complex operation.**

**It is recommended that it be carried out only by a qualified gunsmith.**

**C2. Assembling Bolt Carrier Group to Upper Receiver...**

**Step 1.** With the right hand on the pistol grip and the Upper Receiver in the open position, hold the bolt carrier by the action plate with the thumb and the two fingers of the left hand.

Lower the bolt carrier into the Upper Receiver with the cam pin head located in the cam track of the Upper Receiver. Ensure breech bolt enters the slots of the barrel assembly. Align the three legs of the action plate inside the Upper Receiver.

Assembly is now complete.

## **Bushmaster Bullpup Operation & Safety Instructions**

### **Downloadable version - July 1999**

---

#### **Step 2. Closing the Rifle**

Cock the hammer onto the sear with the left hand. Hold the end of the upper receiver with the left hand with the thumb pressing on the action plate to keep it level with the end of the receiver.

Swing the upper receiver down until the action plate is retained by the face of the lower receiver. Remove thumb and fully close the rifle.

Press in the two headed pins on the right side of the Lower Receiver until the heads are against the Lower Receiver. Rifle is now closed.

---



#### **WARNING!**

**Do not insert full magazine until the next function is completed.**

---

#### **C3. Check Function...**

**ENSURE RIFLE IS POINTED IN A SAFE DIRECTION.** Push the safety to **FIRE** position and pull the trigger. You must hear a click (hammer hitting the firing pin). Push the safety to **SAFE** position. Now try to pull the trigger - it must not move.

#### **Magazine Check...**

With the right hand on the pistol grip push in the magazine with the left hand. Push it upward until a click is heard. Check by pulling down on the magazine. It should not be able to be removed.

#### **C4. Cleaning...**

##### **I. Barrel**

Open rifle and remove bolt carrier. Using a standard type cleaning kit, pull the patch through the barrel using cleaning fluid. Repeat until barrel is clean. Use a dry patch to clean the dirty fluid from barrel.

Note: Clean the barrel from the chamber towards muzzle.

---



**After cleaning, make sure barrel is free of obstructions and excessive lubricant.**

---

## **Bushmaster Bullpup Operation & Safety Instructions**

### **Downloadable version - July 1999**

---

#### **2. Plastic Parts and Metal Parts**

Plastic parts and the upper receiver are cleaned with a soft rag. If necessary, use water for cleaning. The bolt carrier and ignition pocket are cleaned with a soft brush.

To increase the life of the rifle and ensure proper functioning, some metal parts have to be oiled slightly after cleaning. Use only lubricants specially designed for firearms. Avoid abrasives. Oil outside metal surfaces very lightly. Oil bolt carrier as follows:

- 2 drops of oil per guide rod.
- 2 drops of oil into cam slot.



**After any cleaning, disassembly or accessory installation, the rifle should be re-checked for proper functioning before firing.**

---

Clean and inspect rifle periodically to ensure it remains in good condition. Clean after use, especially if it has been exposed to moisture.



**Before loading, slide safety to SAFE position.**

**During loading, never allow fingers or any objects to contact the trigger. Keep the muzzle pointed in a safe direction at all times.**

**Inspect the chamber - the rear portion of barrel which contains the bullet - and bore of the barrel for any obstruction, excessive oil or grease. Failure to do so may result in gun damage and, or personal injury when rifle is fired. Do not load until ready for use. Unload firearm when shooting has been completed. The safety slide should always be in the SAFE position whether the firearm is loaded or not.**

---

#### **D. LOADING, FIRING AND UNLOADING...**

---

##### **DI. Loading...**

Insert a loaded magazine into magazine well. The magazine is home once an audible click is heard and when pulling downward, the magazine cannot be removed.

See illustration on next page.

**Bushmaster Bullpup Operation & Safety Instructions**  
**Downloadable version - July 1999**

**Inserting Magazine...**

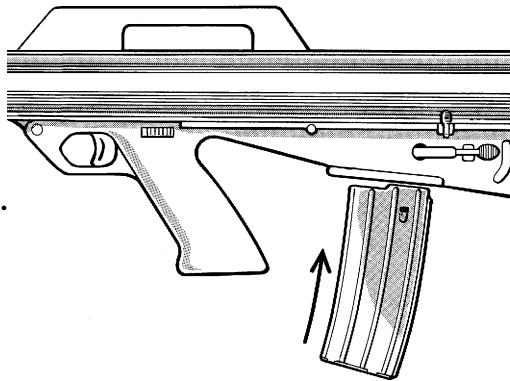

**Cocking...**

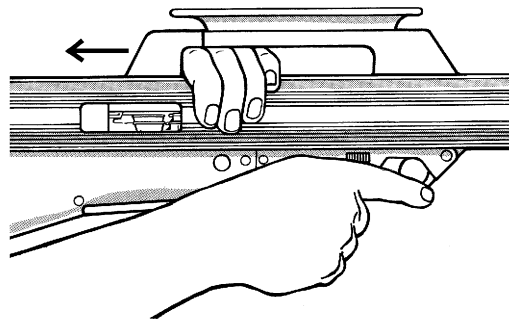

Place left hand in the space between the carry handle and slide rearward as far as possible. When the furthest point of this motion is reached, remove hand to allow the cocking handle to slide forward. The cocking handle will automatically return to its previous position to form part of the carry handle.

This cocks the action and makes the gun **READY TO FIRE**.

**NOTE:** This action is non-reciprocating. A once-only cocking action is all that is required. Cocking handle stays in place when firing.

**D2. Firing...**

To fire the rifle, slide the safety to **FIRE** position.

Aim at intended target and pull the trigger through its full travel towards you.



**Aim rifle only at your intended target.**  
**SAFE GUN HANDLING DEPENDS ON YOU!**

## **Bushmaster Bullpup Operation & Safety Instructions**

### **Downloadable version - July 1999**



Should the ammunition fail to fire, keep the rifle pointed in a safe direction. Slide safety to **SAFE** position. Do not refire shell. Slide cocking handle rearwards. The problem round will be ejected and a new round automatically selected.

NOTE: Spent cartridges are ejected from the right of the rifle through the ejection port. Be sure that all observers are clear of the path of ejection as empty cartridges are thrown out with considerable force and are very hot.



If a noticeable difference in sound or recoil is experienced, **STOP FIRING!** Move safety slide to **SAFE**. Remove the magazine from the body and cock the action to remove any live rounds. Inspect the rifle for damage or obstruction in the barrel or bore. If you have recurring misfires, have the rifle inspected by a qualified gunsmith.

#### **D3. Loading after Having Fired the Last Round...**

After having fired the last round of a magazine, the bolt carrier will be held in its rear position by the bolt catch. You can now see that you have an empty magazine and that the chamber is clear.

With the pistol grip in the right hand, select **SAFE** mode. Remove the magazine and replace with a fully loaded one. Press the bolt release button. The bolt carrier will automatically travel forward to the locked bolt position, loading a round into the chamber.

#### **D4. Unloading...**

Move safety slide to **SAFE**. Locate the magazine release button on the side of the rifle. Press button, at the same time removing magazine in a downward motion.

Keep fingers away from trigger when removing the magazine.

Turn rifle over and cock the action several times to see if any live ammunition is remaining in the chamber.

**Note:** The Bushmaster M17S is designed for use with either a telescopic sight or the rifle's open iron "field sights". A simulated "shooter's view" of sighting with the field sights is shown at right. If you depend on telescopic sights, it may be advisable to carry a spare scope due to their inherent delicacy.

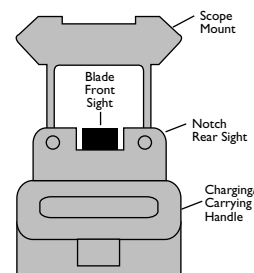

**Bushmaster Bullpup Operation & Safety Instructions**  
**Downloadable version - July 1999**

**Bushmaster M 17 S Parts List:**

30-103 - 1/4 High Collar Lock Washer	1.00	30-216 - Trigger Roll Pin	1.00	30-408 (MS19060-4808) - A-2 Ball Bearing	0.50
30-104 - Thrust Washer	1.95	30-217 - Safety	11.95	30-409 - Hinge Pin Spring	0.95
30-105 - Barrel Extension Retaining Screw	2.50	30-218 - Trigger Cam	5.95	30-400a - Hinge Pin Assembly (400+408+409)	6.95
30-106 - Gas Housing	18.95	30-219 - Trigger Cam Roll Pin	1.00	30-410 (8448585) - Tkdwn Pin Detent (2 per gun)	0.50
30-107 (9349054btp) - Taper Pin (2 per gun)	0.95	30-221 - Trigger Bar	9.00	30-411 (8448586) - Tkdwn Pin Det. Spring (2)	0.50
30-108 - Piston	14.95	30-222 - Cover Plate	7.95	30-413 - Hammer	19.95
30-109 - Gas Cylinder	15.95	30-224 - Cocking Spring	3.00	30-414 - Hammer Spring	3.50
30-110 - Link Rod	9.95	30-230 - Scope Mount	19.95	30-415 - Pivot Pin (2 per gun)	4.95
30-111 - Operating Rod	9.95	30-231 - Rail	19.95	30-417 - Seal	14.95
30-112 - Operating Rod Spring	3.00	30-232 - Rail Retaining Screw (4 per gun)	2.00	30-418 - Disconnecter	11.95
30-113 - Sleeve Piston	6.95	30-301 - Breech Bolt	64.95	30-419 - Disconnecter Spring	0.50
30-114 - Handguard Cap	20.00	30-302 (MS16562-98) - Ejector Roll Pin	0.50	30-420 - Ignition Pocket	10.95
30-115 - Lock Nut (2 per gun)	5.00	30-303 (8448512) - Extractor Cartridge	6.95	30-430 (8448571) - Sling Swivel (2 per gun)	2.50
30-116 (8448577) - Lock Washer	2.00	30-304 (8448513) - Extractor Pin	0.80	30-434 - Rear Sling Swivel Roll Pin	0.95
30-118 - Sight Base Screw	2.50	30-305 (8448755sp) - Extractor Spring	10.95	30-440 - Ignition Pocket Retaining Clip	0.95
30-201 - Upper Receiver - Stripped	119.95	30-306 - Firing Pin	0.95	30-441 - Bolt Catch	6.00
30-202-L - Barrel Extension Tube	8.00	30-307 - Firing Pin Spring (deleted 1998)	4.95	30-442 - Ambi. Magazine Release	6.00
30-204 - Sight Base	29.95	30-308 - Cam Pin	75.00	30-443 (8448633) - Bolt Catch Spring	0.50
30-205 - Sight Base/Cocking Handle Screw (3)	2.00	30-309 - Bolt Carrier	1.95	30-444 (8448634) - Bolt Catch Plunger	0.50
30-206 - Spring Washer (4 per gun)	2.00	30-310 (8448515) - Ejector Cartridge	1.95	30-445 (MS16562-119) - Spring Pin (2 per gun)	0.50
30-207 - Sight Base Screw	2.00	30-311 - Firing Pin Retaining Pin	0.50	30-447 (8448638) - Magazine catch	2.95
30-208 - Spring Retainer	5.00	30-312 (8448516) - Ejector Detent Spring	0.80	30-448 - Magazine Button	1.95
30-209 - Cocking Handle	15.95	30-313 - Action Plate	12.95	30-449 (8448637) - Magazine Catch Spring	0.50
30-210 - Cocking Plate	9.95	30-314 - Action Rod (2 per gun)	14.95	30-451 - Takedown Pin (2 per gun)	4.95
30-211 - Trigger Spring	2.00	30-315 - Action Spring (2 per gun)	5.00	30-452 - Front Sling Swivel Rivet	0.95
30-212 (8448583) - Safety Detent Spring	2.00	30-316 - Retainer - Action Rod (2 per gun)	1.95	30-962 - Operator's Manual	.50
30-213 - Safety Detent	2.00	30-317 - Bolt Carrier Cap Screw	2.00	<b>Major Assemblies:</b>	
30-215 - Trigger	19.95	30-318 - Buffer	4.95	30-905 - Barrel/Gas Housing Sub-Assembly	195.00
		30-321 (8448754) - Extractor Spring Insert	0.50	30-925 - Stripped Lwr. Rec./Pistol Grip Asmbly.	89.95
			4.95	<b>*30-965 - Field Repair Kit (described below)</b>	<b>29.95</b>

**Note:** In later model Bullpups, the Bolt Carrier was redesigned to eliminate the Firing Pin Spring (Part # 30-307).

# Bushmaster Bullpup Operation & Safety Instructions

## Downloadable version - July 1999

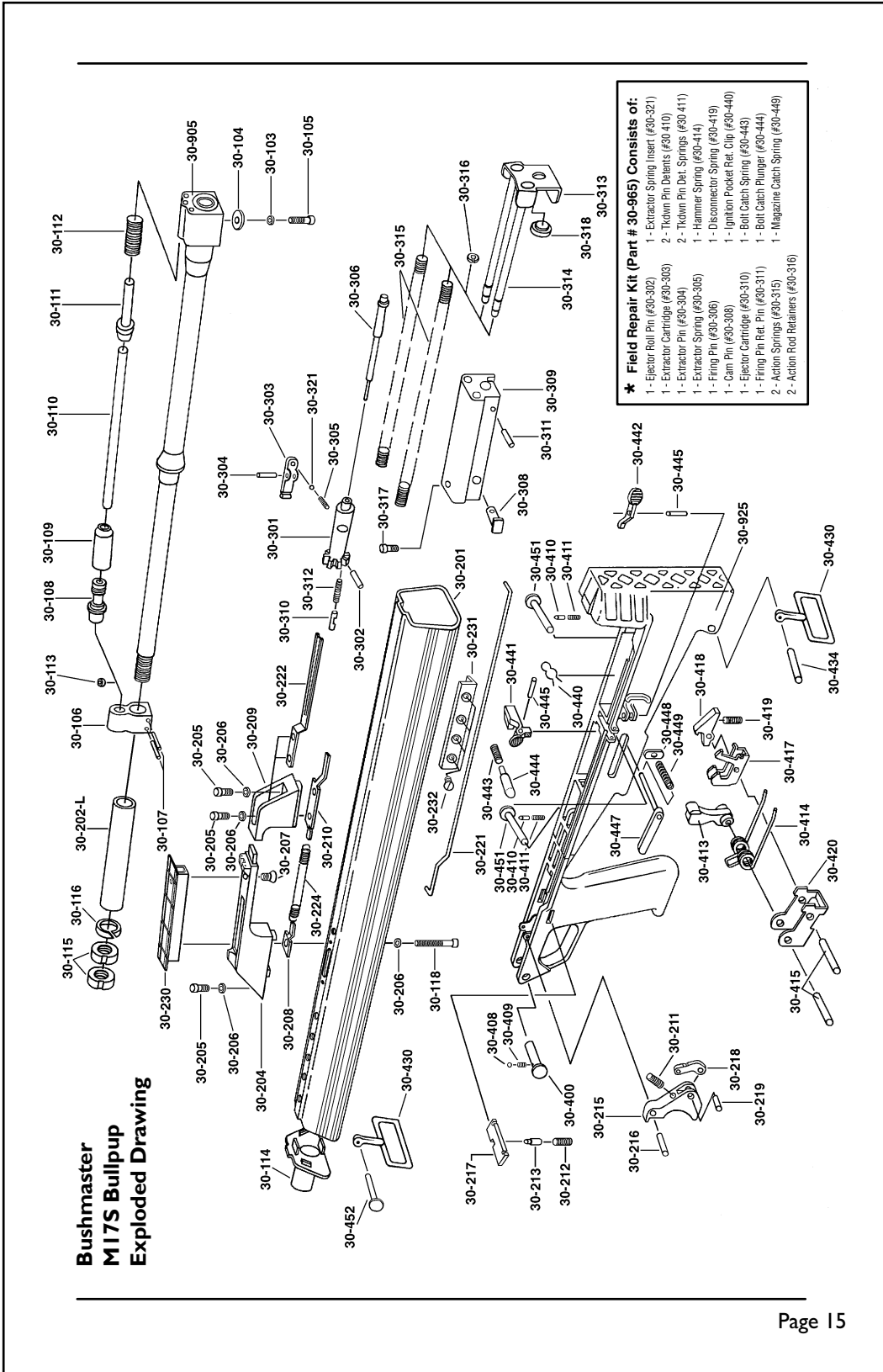

**Bushmaster Bullpup Operation & Safety Instructions**  
**Downloadable version - July 1999**

---

**SERVICE INSTRUCTIONS**

---

Should your firearm require service that necessitates shipping to an authorized service center, please follow these instructions.

---



**BE ABSOLUTELY SURE THAT  
THE FIREARM IS NOT LOADED!**

---

Ship the firearm in a sturdy gun case or appropriate padded container. Do not send accessories, scopes or optics with the firearm. Wrap all pieces, if disassembled, in protective wrapping (foam or bubblepak). The Service Center will not be responsible for damage to firearms that may occur during shipping. Insure your rifle with the shipper.

Please include a letter stating the reason you are returning the firearm. Ship to our Central Factory Service Center:

**BUSHMASTER FIREARMS, INC.**  
**999 ROOSEVELT TRAIL**  
**WINDHAM, MAINE 04062**  
Customer Service Telephone: 1 800 883 6229

---

**PARTS ORDERS:**

When ordering replacement parts, please provide the Model Number of Rifle (M17S for the Bullpup), the Serial Number of Rifle, the Part Name and Part Reference Number as indicated on the exploded view drawing (Pg. 15 of this manual) - or you may order by phone. Call 1-800-998 SWAT. Our phone lines are open seven days a week / 24 hours a day.

If ordering by mail, please include your complete return address (not a Post Office Box number) and phone number where you can be reached during normal business hours.

---



**Bushmaster Firearms, Inc. / Quality Parts Co.**  
**999 Roosevelt Trail • P.O. Box 1479**  
**Windham, Maine 04062 U.S.A.**  
Customer Service Tel: 1 800 883 6229  
Orders: 1 800 998 SWAT • 1 207 892 3594

