

BUSHMASTER FIREARMS, INC.

Bushmaster – .308

Operating and Safety Instruction Manual



BFIMAN3080P

Please Practice Safe Firearms Handling

Our mission is to manufacture quality firearms, **Made With Pride In The USA**, and using the best **American Made** parts. We value our customers, and do our best to assure quality and friendly service. Bushmaster Firearms, Inc. is always striving to make great firearms even better.

Thank you for buying Bushmaster!

This Operation Manual should always accompany this firearm. When you lend, give, or sell this firearm, be sure this manual goes with it. To obtain a replacement manual, write to:
Bushmaster Firearms, Inc.

999 Roosevelt Trail • Windham, Maine • 04062

Include the serial number, or have it available when making a phone request at 800 883 6229

Note: For any information or details not covered in this Operating Manual, contact our Tech Support Staff at: techsupport@bushmaster.com • 800 883 6229

Model: _____

Serial Number: _____

Purchased From: _____

Date Purchased: _____

**Before disassembling, loading, or using this firearm, please
READ, UNDERSTAND, AND FOLLOW ALL THE INSTRUCTIONS
in this manual, regarding proper handling and safe use!**



Caution: If unfamiliar with firearms, seek further advice through **Gun Safety Organizations, Local Gun Clubs, NRA Approved Instructors**, or similar qualified organizations.



Warning: **If this firearm is carelessly or improperly handled**, unintentional discharge could result and could cause **injury, death, or damage to property.**



Warning: **This firearm could chamber a round if it is dropped or jarred with a loaded magazine in place** – with the bolt carrier assembly locked to the rear, or in its forward position.



Caution: **Use only clean, dry, high quality commercially manufactured ammunition.** Use only ammunition that is appropriate for the 7.62x51NATO/.308 Winchester caliber of your firearm.

1

WARNING: Before Using This Rifle, Read And Follow These Instructions!

If there is anything you do not understand,
get help from someone qualified in the safe handling of firearms.

- Be sure cam pin is installed in the bolt group. If it isn't, **your rifle can still fire and will explode.**
- If you are using a blank firing attachment, never fire anything except blank rounds (for safety, we recommend the visible military style blank firing attachment).
- If your rifle stops firing with a live round in the chamber of a hot barrel (a misfire), remove the round fast. However, if you cannot remove it within 10 seconds, remove magazine and wait 15 minutes with the rifle pointing in a safe direction. This way you won't get hurt by a possible round "cooking-off" (i.e. the round detonating just from the heat of the barrel). In any event, keep your face away from the ejection port while clearing a hot chamber.
- If your bolt fails to unlock, try to free it by banging the buttstock on the ground while pulling back on charging handle. **Always keep yourself clear of the muzzle.**
- If there's water in the barrel, do not fire the rifle. **It could explode.**
- If a noticeable difference in sound or recoil is experienced, **STOP FIRING.** Either condition could indicate an incomplete powder burn and/or a bullet stuck in the bore.

**WARNING: Beware of Dangerous Procedures.
Always Practice Safe Firearms Handling!**

2

Facts about your Bushmaster .308 rifle...

The **Bushmaster .308 rifle** consists of a rifle and a magazine. It is a gas operated, air-cooled, magazine-fed, shoulder-fired weapon that can be fired in a semi-automatic mode – i.e., a single shot each time the trigger is pulled.

- The upper receiver and barrel assembly have a fully adjustable rear sight. (flat-top version does not).
- The upper and lower receivers are easily opened for cleaning and inspection.
- The bolt group and barrel extension are designed with locking lugs that lock the bolt group to the barrel extension.
- The forged aluminum upper and lower receivers reduce the weight of the rifle.
- Caliber: .308 Winchester / 7.62 mm NATO.
- Weight: (depends upon model) 20" Bbl. Rifle = 9.57 lbs. / 4.35 kg.
- Length: (depends upon model) 20" Bbl. Rifle = 42.75" / 108.5cm.
- Barrel Rifling: R.H. twist; 1 turn in 10"; 4 lands & grooves.
- Firing characteristics: muzzle velocity approx. 2,700 fps; chamber pressure 62,000 psi.
- Maximum effective rate of fire: 45 rounds per min. / semi-automatic.
- Max effective range: 1000 meters (individual / point targets).
- Maximum range: 3754 meters.

3

Table of Contents

Owners Information		Safety Function Checks	29
Before Using This Firearm	1	Loading a Magazine • Forward Assist	30
Warnings	2	Adjustable Front Sight Post	31
Facts About Your Bushmaster .308	3	Zeroing Your Sights	32
Rifle Parts and Where To Find Them	5	Zeroing Adjustments	33
Clearing Your Rifle	7	25 Meter Zeroing Procedure	34
Disassembling Your Rifle	9	Operation of Your Rifle	35
Cleaning • Inspection • Lubrication	14	Operation • Inserting a Magazine	36
Detailed Cleaning Techniques	15	Operation • Chambering a Round	37
Cleaning the Upper Lower Receivers	17	Immediate Action in Case of Trouble	39
Cleaning the Ejector	18	Remedial Action	41
Inspection before Lubrication	19	Bullet Stuck in the Bore	42
Lubrication of Upper & Lower Receivers	20	Troubleshooting	43
Lubrication of Bolt Carrier Group	21	Disassembly Views	51
Lubrication of Adjustable Rear Sight	22	Limited Warranty	
Reassembly	23		

BEFORE USING THIS FIREARM, READ AND FOLLOW THESE INSTRUCTIONS.

**If there is anything you do not understand, get help
from someone qualified in the safe handling of firearms.**

4

Rifle parts and where to find them...

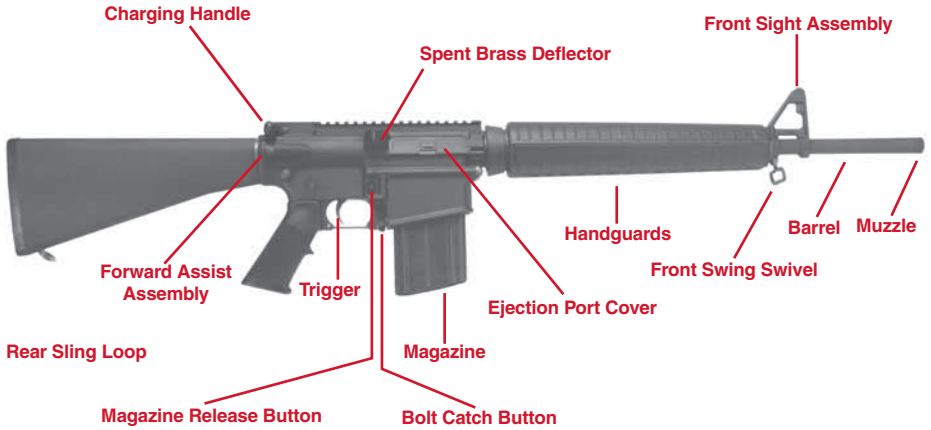

Pictured here is a 20" Bbl. flat top rifle

5

Rifle parts and where to find them (left side)...

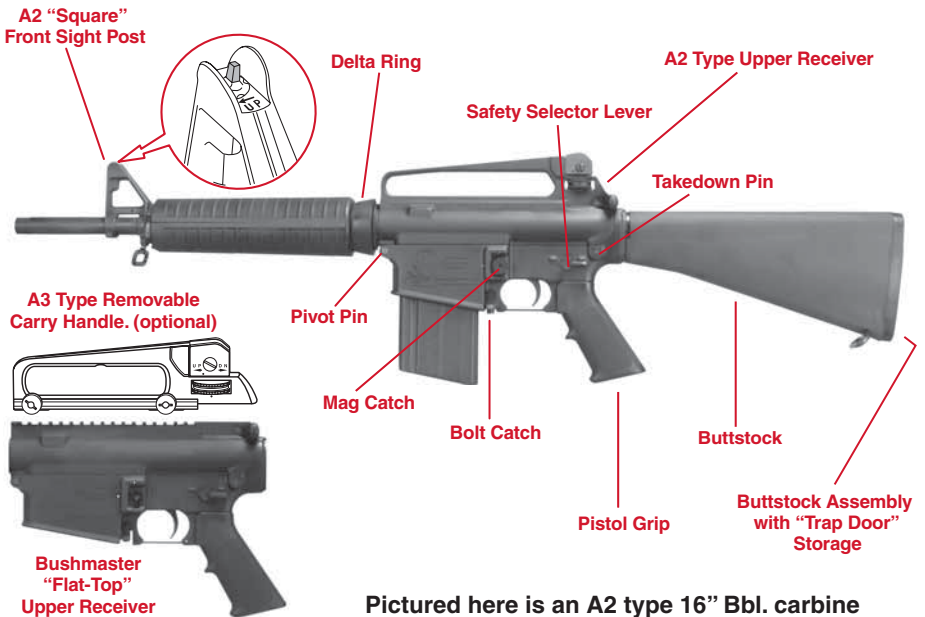

Pictured here is an A2 type 16" Bbl. carbine

6

Clearing Your Rifle...



1.) POINT RIFLE IN A SAFE DIRECTION!

Place safety selector lever on **SAFE**. (If the rifle is not cocked, the selector lever cannot be pointed toward **SAFE**.)



2.) Press **magazine catch button**, and pull **magazine** down to remove.

7

Clearing your rifle (continued)...

3.) To lock bolt open, pull **charging handle** rearward. Press up on **bolt catch**, and allow bolt to move forward. If you haven't before, **place safety selector lever on SAFE**.



4.) Check **receiver** and **chamber** to ensure there is no ammunition in the rifle.



5.) With **selector lever** pointing toward **SAFE**, allow **bolt** to go forward by pressing down on **bolt catch button**.

8

Disassembling your rifle...

- 1.) Clear your rifle and disconnect the sling.
- 2.) Push in **takedown pin** as far as it will go.
Pivot upper receiver away from lower.



- 3.) Push in front **pivot pin**.



- 4.) Separate upper and lower receivers.
- 5.) Pull back **charging handle** and **bolt carrier**.

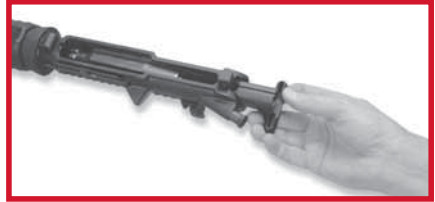

9

Disassembling your rifle (continued)...



- 6.) Remove **bolt carrier** and **bolt**.



- 7.) Remove **charging handle** by pulling back and up.



- 8.) Remove **firing pin retaining pin**.

**DO NOT OPEN OR CLOSE
Split End of Firing Pin
Retaining pin!**



10

Disassembling your rifle...



9.) Push **bolt** in to locked position.



10.) Drop **firing pin** out from rear of **bolt carrier**.



11.) Remove **bolt cam pin**.



12.) Remove **bolt assembly** from carrier.

11

Disassembling your rifle (continued)...

Disassemble using steps 13 through 16, only when dirty or damaged!



13.) Remove **extractor pin** by pushing out with a drift punch. You may need to use a small hammer to drive the pin out.

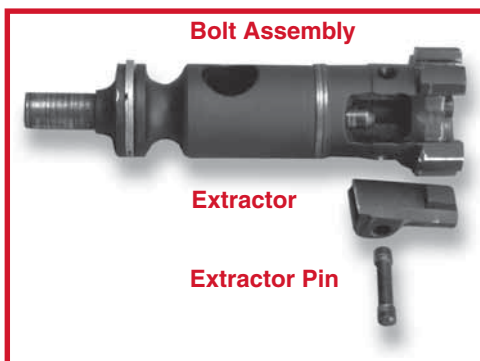

14.) Remove **extractor plunger**, and **spring**.

CAUTION: Extractor spring may pop out and get lost!

12

Disassembling your rifle (continued)...

15.) Press in **buffer**, depress **retainer**, and release **buffer**.



16.) Remove **buffer** and **buffer spring**.

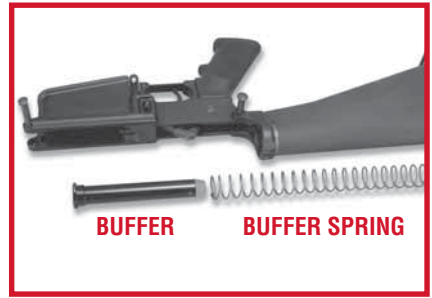

The **handguards** may be disassembled at any point in your cleaning procedures as necessary (see page 28 - "Buddy System" instructions). If your rifle is equipped with the A3 Type removable carry handle, that may be removed for cleaning by loosening the 2 thumb nuts. Clean as per instructions for aluminum upper and lower receivers (see page 17). Lightly lubricate the thumb nut threads and the rear sight mechanism (as described on page. 22 - Lubrication - Adjustable Rear Sight).



Bushmaster does not recommend any further disassembly!

13

Cleaning • Inspection • Lubrication...

- **After firing**, clean your rifle as soon as possible to make the job easier and to avoid allowing the development of any corrosion.
- **When your firearm has not been fired**, you should clean it at least once or twice a year if you live in a temperate climate, or as often as once a week in a tropical climate.
- **If you get your firearm wet**, clean it as soon as possible.



Use a high quality rifle cleaning kit that includes a cleaning rod; swab holder; cotton flannel bore patches; pipe cleaners; a small toothbrush; brass wire bristle bore and chamber brushes and a Cleaner/Lubricant/Preservative (CLP in Army terminology).

After you have disassembled the rifle, thoroughly clean, inspect and lubricate all parts according to the techniques described on following pages.

14

Detailed cleaning techniques...

NOTE: The procedures below describe cleaning with a **standard multi-piece rod cleaning kit**. Other commercial cleaning kits may include alternate cleaning instructions which may be just as effective.

CLEANING THE BORE: The **bore** of your **Bushmaster** rifle has lands and grooves called rifling. Rifling makes the bullet spin very fast as it moves down the bore and down range. It is difficult to push a new, stiff bore brush through the bore. You will find it much easier, and more effective, to pull your bore brush through the bore. Also, because the brush will clean better if the bristles follow the grooves (this is called tracking), you want the bore brush to be able to turn as you pull it through. **Always clean from from chamber toward the muzzle.** This is how it's done:

- 1.) Swab out the **bore** with a **patch** moistened with "CLP".
- 2.) Attach three **rod sections together** but leave each one about two turns short of being tight.
- 3.) Attach the **bore brush** but leave it two turns short also.
- 4.) Point muzzle down. Hold the **upper receiver** in one hand while inserting the end of the rod without the brush into the chamber. Guide the rod carefully through the bore. **CAUTION: do not let the rod or its threaded end scratch the Bore or Firing Chamber.** About 2 - 3 inches of the rod should protrude out of the muzzle.



15

Detailed cleaning techniques (continued)...

- 5.) Attach the **handle section of the cleaning rod** to the end of the rod sticking out of the muzzle.
- 6.) **Pull the brush** through the **bore** and out the muzzle. You should be able to see the rod twisting as you pull it - this is the brush "tracking" in the rifling.
- 7.) After one pull, take off the handle section and repeat the process. After three or four pulls, the three rod sections and the bore brush may become screwed tightly together. Loosen them up and repeat the process.
- 8.) **Send a patch through the bore occasionally** to clean out any debris that the brush is getting loose. Just replace the bore brush with the rod tip (patch holder) and a wet patch. Pull it through. If you leave the rods loose, the patch will also "track" in the rifling. Always have the bore wet with cleaner before pulling a brush through.

Cleaning the upper receiver...

NOTE: Check to ensure that there is no looseness between the barrel and the upper receiver - if you detect any movement by twisting with your hands, the barrel nut must be re-torqued. Bring the rifle to a qualified gunsmith.



Never reverse the direction of the bore brush while it is in the bore.

- 1.) Using a "CLP" product, clean all areas of **powder, corrosion, dirt and rust.** **Never use a wire brush or any type of abrasive to clean the aluminum upper receiver - you'll scratch and damage the finish.**

16

Cleaning the upper receiver (continued)...

- 2.) Clean the firing chamber - dip the chamber cleaning brush in CLP and use at least five plunge strokes and three 360 clockwise rotations. Then swab out the bore as described previously to remove any contaminated solution or loosened debris.
- 3.) Use the bore cleaning brush, still wet with CLP, and clean carbon and powder residue from around the gas tube, run a pipe cleaner into the gas tube, clean the bolt locking lugs, bolt rings, firing pin, bolt cam pin, lip of the extractor, and inside the bolt carrier from both front and rear.
- 4.) Wipe all components clean and dry, and inspect for excessive wear, corrosion or mechanical damage. Replace any defective parts before firing (order new parts at 1-800-998-7928).



Cleaning the lower receiver...

- 1.) Clean all areas of powder fouling, corrosion, dirt and rust. Again, never use a wire brush or any type of abrasive to clean the aluminum lower receiver.
- 2.) Wipe any dirt from the trigger mechanism. Clean the buffer, action spring, and inside the lower receiver extension (the buffer tube).



**CLEAN THE DRAIN HOLE
IN THE BUTTPLATE SCREW**

17

Cleaning the ejector...

The design of the ejector makes its disassembly for cleaning somewhat impractical (i.e. we don't recommend it). Make sure your Bushmaster ejects empty cases efficiently by following these steps on a monthly basis (more frequently if firing blanks).

- 1.) Remove the bolt from the carrier (as described on previous pages). Hold it as shown with the ejector down and the extractor up.
- 2.) Dribble a few drops of CLP around the ejector to form a puddle.
- 3.) Take a fired or dummy case and place it under the lip of the extractor. With a rocking motion, press the case down against the ejector. Since the ejector is spring loaded, some resistance will be felt. Press on the case until it stops against the bolt face. Ease off with your thumb slightly and press down again. Repeat several times.

Replace the CLP frequently. Once the spring action of the ejector is smooth and strong, dry off any excess.



EJECTOR



**ROCK EMPTY
CASE AGAINST
EJECTOR TO
LUBRICATE**

18

Inspection before lubricating...



- 1.) Check the **bolt**: Look for cracks or fractures, especially in the **cam pin hole area**. Bolts with any pitting extending into the firing pin hole should be replaced.



- 2.) Check the **firing pin**; if it is bent, cracked, too bunted or too sharp, it should be replaced.

**WARNING: If cam pin is missing,
DO NOT FIRE THE RIFLE!
It will explode!**

- 3.) Check the **firing pin retaining pin**: If it is bent, or badly worn, it should be replaced. **Never use a "cotter pin" as a substitute for a real firing pin retaining pin**. Cotter pins are not made of heat treated spring steel and their round head shape will cause damage.



- 4.) Check the **cam pin**: If it is cracked, or chipped, it should be replaced.



- 5.) Check the **extractor and extractor spring**: If the extractor is chipped, or has broken edges in the area of the lip that engages the cartridge rim, it should be replaced.



19

Lubrication – upper receiver...

Lightly lubricate:

- The inside of the **upper receiver**, the **bore** and **chamber** (using the cleaning rod and a patch), the outer surfaces of **barrel**, **front sight**, and **surfaces under the handguard**.
- Be sure you lube in and around all the **locking lugs** (see illustration at right). Depress the **front sight detent** and apply 2-3 drops of **CLP** to it. Depress the **detent** several times to work the lubricant into the spring.
- The **firing pin** and the firing pin recess in the bolt with **CLP**.
- The **charging handle**, the inner and outer surfaces of the **bolt carrier**, the **extractor** and its pin. The inside of the **carrier key** should be dried with a pipe cleaner – then place one drop of **CLP** inside.



Generously lubricate:

- The **slide** and **cam pin** area of the **bolt carrier**, the **bolt**, and the **bolt gas rings**.

Lubrication – lower receiver...

Lightly lubricate:

- Inside the **lower receiver extension** (buffer tube), **buffer** and the **action spring**.

Generously lubricate:

- All moving lower receiver parts **trigger**, **hammer**, **safety**, **bolt catch**, **forward assist**, etc), and their various **pins** and **detents**. Don't forget the **takedown** and **pivot pins** and **detents**. Clean fingerprints (they can start the corrosion process) off the exterior surfaces with a oiled black rag (black rags leave no visible lint).

20

Lubrication – bolt carrier group...

- **Lightly lubricate** the **firing pin** with CLP - also the firing pin recess in the bolt.
- **Generously lubricate** the **bolt**, its cam pin area, the bolt gas rings. A lighter application is good on the extractor and its pin.
- **Lightly lubricate** the **charging handle** and the inner and outer surfaces of the bolt carrier.
- **Generously lubricate** the **slide and cam pin area** of the bolt carrier.



- The inside of the **carrier key** on the bolt carrier should be dried with a pipe cleaner or cotton swap - then place one drop of CLP inside.

21

Lubrication – adjustable rear sight...

Note: Record how far you move the rear sight so it can be returned to its original position upon the completion of this task.

Rear Sight Moving Parts: Use 1 or 2 drops of **CLP**. Rotate these parts to ensure that the lubricant is spread evenly above, below and around the threads of the:

- **Elevation knob**
- **Elevation screw shaft**
- **Windage knob**
- **Windage screw**
- **Detent holes**

Elevation Screw Shaft:

Also lube from inside the upper receiver as follows:

- Turn **upper receiver** upside down
- Remove **charging handle**
- Put 2 or 3 drops on bottom of **elevation screw shaft** and in **elevation detent spring hole**
- Rotate the **elevation dial** back and forth a few times while keeping **upper receiver** upside down

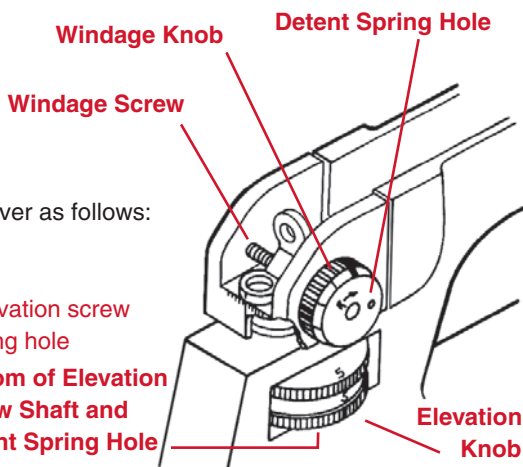

22

Reassembly...

- 1.) Insert **action spring** and **buffer**. Depress **buffer detent** and push **buffer** in past the **detent**, then release.

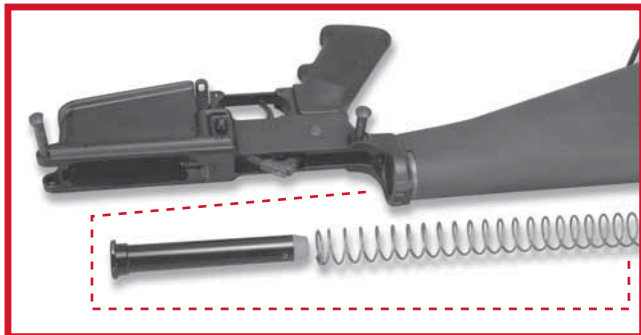

- 2.) Insert **extractor**, **plunger**, and **spring**.

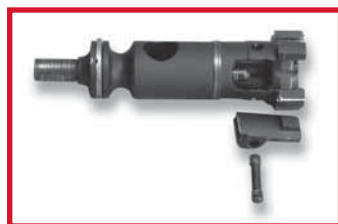

23

Reassembly (continued)...



- 3.) Push in **extractor pin**.

STAGGER THE GAS RING GAPS TO REDUCE GAS LOSS. Position the three ring gaps 120 apart around the bolt.

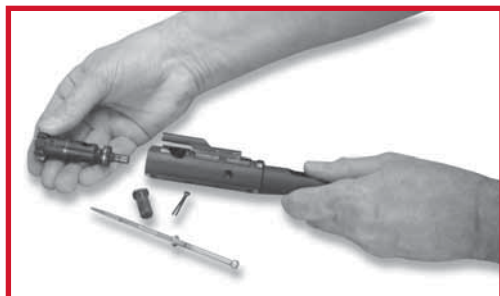

- 4.) Slide **bolt** into carrier.

24

Reassembly (continued)...

WARNING: If cam pin is missing, DO NOT FIRE THE RIFLE! It will explode!

NOTE: The **bolt** is machined so as to allow insertion of the **cam pin** from one side only. This provision aligns the **extractor** and **ejector** properly within the **upper receiver**.



5.) Replace **bolt cam pin**.

6.) Drop in and seat the **firing pin**.



7.) Pull **bolt** out.

25

Reassembly (continued)...

NOTE: **Firing pin** should not fall out when bolt carrier group is turned upside down.



8.) Replace **firing pin retaining pin**

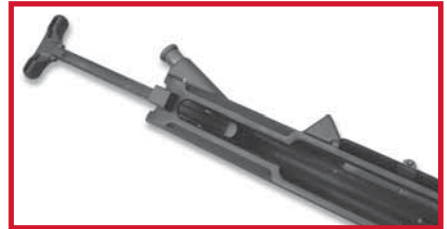

9.) Engage, then push **charging handle** part way



10.) Position **carrier key** in slotted bottom of charging handle. Slide in **bolt carrier group**.

CAUTION: Bushmaster does not recommend the practice of swapping bolts between different rifles. Doing so could result in damage, personal injury, or death.

26

Reassembly (continued)...



- 11.) Push **charging handle** and **bolt carrier group** into receiver together.



- 12.) Join **Upper and Lower Receivers**.
13.) Engage Receiver **Pivot Pin**.

CAUTION: Selector lever should be on **SAFE** before closing Upper Receiver.



27

Reassembly (continued)...

- 14.) Close the **upper and lower receiver groups** and push in the **takedown pin**.

When removing or reattaching the handguards, use a handguard removal tool (part #HGD-Tool) or use the "Buddy System" as describe below.

- 15.) Place the rifle on the **buttstock** and press down on the **slip ring** with both hands. **Note:** The "Half-Round" Handguards are identical and can be used on top or bottom.



- 16.) Have your buddy install one handguard on top and the other on the bottom.

- 17.) Reattach the **sling**.

28

Safety function check...

UNLOAD RIFLE → REMOVE MAGAZINE → CHECK CHAMBER

- 1.) Remove **magazine** if installed. Pull **charging handle** assembly to rear. Check that the chamber is clear. Let **bolt** and **bolt carrier** close. **DO NOT PULL TRIGGER.** Leave **hammer** in cocked position.

WARNING: If rifle fails any of the following tests, continued use of the Rifle could result in injury to, or death of, personnel.

- 2.) Place Selector Lever in **SAFE** position and pull trigger. The **hammer** should not fall.
- 3.) Place Selector Lever in **FIRE** position. Pull trigger. The **hammer** should fall.

NOTE: For the purpose of the following check, "SLOW" is defined as one fourth to one half the normal rate of trigger release.

- 4.) Hold **trigger** to the rear, pull **charging handle** to the rear and release **charging handle**. Let off pressure on the **trigger** with a slow, smooth motion, without hesitations or stops, until the **trigger** is fully forward. An audible click should be heard – the **hammer** should not fall.
- 5.) Repeat the **FIRE** position test five times. The rifle must not malfunction during any of these five tests. If the rifle malfunctions during any of these five tests, have the rifle checked by a qualified gunsmith.

29

Loading a magazine...

- Use only quality ammunition suitable for your firearm. Examine each cartridge – particularly around the primer.
- Look for dents, scratches, and other signs of damage.
Do not load damaged ammunition.
- With the **magazine** facing forward as shown in the illustration, place a round between the lips of the magazine with the bullet tip forward. Push the round down until it is held by the magazine lips.
- If necessary, give the round a slight push backward to seat it against the back edge of the magazine lips. Place next round on top of previous round and repeat steps until desired number of rounds are loaded.



The forward assist...

CAUTION: Safe firearms handling dictates that you load live ammunition into your rifle only when you are ready to shoot.

The **forward assist** helps lock the bolt into the barrel, but it will only be useful on rare occasions when the bolt fails to lock automatically. If you find that you need to use the forward assist it is probably time you cleaned your rifle – pay particular attention to the locking lug areas in the chamber and on the bolt.

CAUTION: Before using the forward assist, make sure your ammunition is clean and undamaged. Forcing dirty or damaged ammunition into the chamber could damage your rifle and could result in injury, death or property damage.

30

Adjustable front sight post...

The **front sight post** is threaded - allowing it to be moved up or down when "Zeroing" the **rear sight** (see "Zeroing Your Sights" on next page)

Front Sight Post

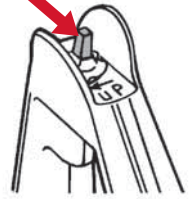

A2 dual aperture rear sight...

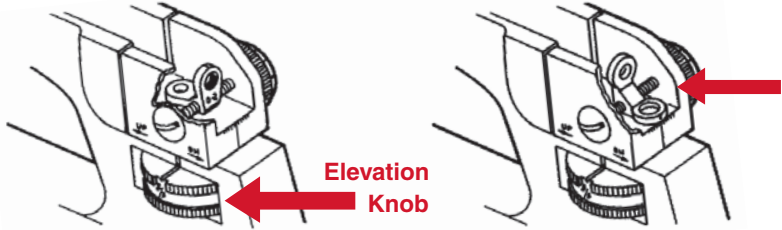

NORMAL RANGE - The **smaller aperture** is unmarked and is used for most firing situations. It is used in conjunction with the **elevation knob** for 300, 400, 500, 600, 700, 800, and 1000 meter targets.

31

Zeroing your sights...

This is the procedure to follow in order to "Zero" your mechanical sights.

- 1.) In this procedure, the **front sight post** and **rear sight windage knob** are adjusted so that you can hit your point of aim at 300 meters:
- 2.) Flip the unmarked (**smaller**) **aperture** to the up position (as shown).
- 3.) Set the **rear sight** so that the 300-meter mark is aligned with the mark on the left side of the receiver.

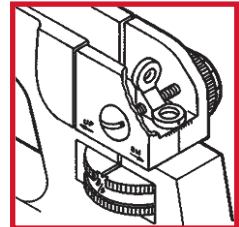

Zeroing adjustments...

- 1.) During zeroing procedures, only the **front sight post** and **windage knob** are adjusted to move the strike of the bullet on the target.
- 2.) Also see the detailed zeroing procedures on the following pages.

FRONT SIGHT: To adjust elevation, depress **detent** and rotate **post**. To raise strike of bullet, rotate **post** in the direction of arrow marked UP. Reverse the direction of rotation to lower strike of bullet. Each graduation (notch) moves the point of impact of bullet as indicated.

Impact	Distance
0.9 cm (3/8 in.)	25 meters
3.5 cm (1 3/8 in.)	100 meters
7.0 cm (2 3/4 in.)	200 meters

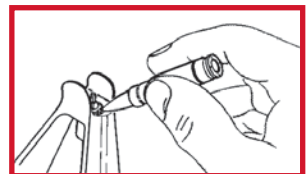

32

Zeroing adjustments (continued)...

For windage knob (per click)*...

Impact	Distance	Impact	Distance
0.3 cm	(1/8 in.)	6.3 cm	(21/2 in.)
1.25 cm	(1/2 in.)	7.6 cm	(3 in.)
2.50 cm	(1 in.)	8.8 cm	(3 1/2 in.)
3.8 cm	(1 1/2 in.)	10.0 cm	(4 in.)
5.0 cm	(2 in.)		

*All of the above values have been rounded off.

Note: To remember your correct zero windage, note location of windage scale and **windage knob** pointer (heavy mark on outside of knob). Once you have established your correct zero windage leave your windage Scale and **windage knob** pointer on these settings at all times.

25 meter zeroing procedures...

Place an appropriate 25 meter paper sighting target 25 meters down range and follow the steps below to establish a "battlesight" zero.

- 1.) Do not move the **front sight** post on your rifle at this time. It was set at the factory and should be very close to zero.
- 2.) Center the **rear sight aperture** by turning the **windage knob** left or right. This is called "Mechanical Zero Windage".
- 3.) The unmarked (**smaller**) **aperture** should be up.

33

25 meter zeroing procedures (continued)...

- 4.) Now rotate the **elevation knob** "up" one click past the 300 - meter mark. From this point on, the **elevation knob** should not be moved. Any changes in elevation required in the following zeroing steps are made to the **front sight post** only.
- 5.) Carefully aim and fire at the center of the target bull's-eye.
- 6.) If your shot group is not in the center of the bull's-eye, use the squares on the target sheet to calculate the required "clicks" necessary to move your next shot group into the bull's-eye.

Remember - any changes in elevation are made by moving front sight post only!

- 7.) In order to raise your next shot group, rotate the front sight post clockwise. To lower shot group, rotate front sight post counterclockwise.

Changes in windage are made with the windage knob. In order to move the shot group to the left, turn the windage knob counterclockwise. In order to move the shot group to the right, turn the windage knob clockwise.

- 8.) Carefully aim and fire another group at the center of the target bull's-eye.
- 9.) Repeat Steps 7 through 9, if required.
- 10.) If your group is on target, your sight is now "calibrated." To place your actual 300 - meter zero on the rifle, you must rotate the elevation knob one click "down." (The range scale's 300-meter mark should now be aligned with the mark on the rifle's receiver).

34

Operating your rifle...

WARNING: If a noticeable difference in sound or recoil is experienced, **STOP FIRING**. Either condition could indicate an incomplete powder burn and/or a bullet stuck in the bore (also see page 42). Retract the bolt slowly and remove the fired cartridge case. Clear the weapon and check for unburned powder grains in the receiver or bore, and for a bullet stuck in the bore. Clean out any unburned powder before resuming firing. If a bullet is stuck in the bore, do not attempt to remove it. Take the rifle to a qualified gunsmith.

Loading...

CAUTION: Always point the muzzle in a safe direction!



1.) With **hammer** cocked, place **selector lever** on **SAFE**.



2.) Open **bolt** and check **chamber**. Make sure it is clear.

35

Operation of your rifle... Inserting a magazine...



3.) Push **magazine** up into magazine well until **magazine catch** engages and holds the **magazine**.

4.) Tap upward on **magazine bottom** to make sure it's seated correctly.

36

Operation of your rifle...

Chambering a round with bolt assembly open...

NOTE: The magazine may be inserted into the rifle with bolt assembly open or closed.

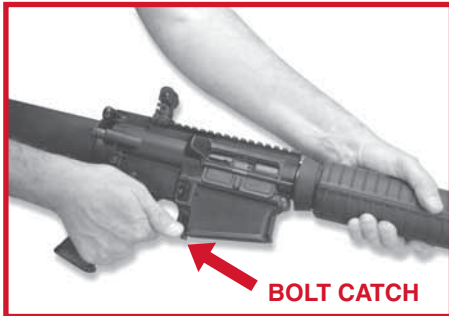

- 1.) Depress upper portion of **bolt catch**. Bolt should spring forward.



- 2.) TAP the **forward assist** to ensure bolt is fully forward and locked.

37

Operation of your rifle...

Chambering a round with bolt assembly closed...



- 1.) Pull **charging handle** fully to rear.
- 2.) Release the **charging handle**.



- 3.) TAP the **forward assist** to ensure bolt is fully forward and locked.

NEVER "Ride" the charging handle.
Let it move forward on its own.

Note: If the rifle is not going to be fired immediately, make sure the selector lever is still on safe, and close the ejection port cover to keep out dirt.

Always keep muzzle pointed in safe direction.

38

Immediate action in case of trouble...

IF YOUR RIFLE STOPS FIRING: Perform the following immediate actions...



- 1.) **SLAP** upward on **magazine** to make sure it's seated properly.



- 2.) **PULL** **charging handle** all the way back observe ejection of case or cartridge. **Check Chamber for any obstruction.**

WARNING: DO NOT LOAD WITH A HOT CHAMBER. A ROUND MAY "COOK OFF"
(meaning it may fire from the heat of the chamber).

39

Immediate action in case of trouble (continued)...

- 3.) If **cartridge or case** is ejected or chamber is clear, **RELEASE** **Charging Handle** to feed a new round.

- 4.) **TAP** Forward Assist.



- 5.) Now **FIRE..**
If the Rifle won't fire, look for trouble and apply remedial action. (See next page).

40

Remedial action...

WARNING: If your rifle stops firing with a live round in the chamber of a hot barrel, remove the round fast. However, if you cannot remove it 10 seconds, remove the magazine and wait 15 minutes with the rifle pointing in a safe direction (always check that the “SAFE” direction remains safe during that time) This way you won't get hurt by a round cooking off.

Regardless, keep your face away from the ejection port while clearing the hot chamber.



If your rifle still fails to fire, check the troubleshooting section in this manual, or take the rifle to a qualified gunsmith.

If your rifle still fails to fire after performing steps 1 through 5 on a previous page, check again for a jammed cartridge case.

41

Bullet stuck in bore...

WARNING: If an audible “POP” or reduced RECOIL is experienced during firing, IMMEDIATELY CEASE FIRE! Then...



1.) Remove the **magazine**.



2.) Lock the **bolt** to the rear.



4.) Check for a **bullet** in the bore with a cleaning rod.



3.) Put **selector lever** on the **SAFE** position.

Do not apply the IMMEDIATE ACTIONS described on previous pages. If a bullet is stuck in the barrel of the weapon, do not try to remove it! Take the rifle to a qualified gunsmith.

42

Troubleshooting (continued)...

Problem... Won't Fire

Check For...

Selector lever on **SAFE**.

Improper assembly of firing pin.

Too much oil in firing pin recess.

Defective ammunition.

Too much carbon on firing pin or in firing pin recess.

What To Do...

Put it on **FIRE**.

Assemble correctly.
Retaining pin goes in back of large shoulder on firing pin.

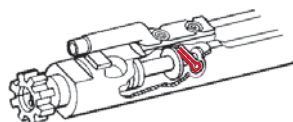

Wipe out with pipe cleaner.



Remove and discard.



43

Troubleshooting (continued)...

Problem...

Bolt Won't Unlock

Won't Extract

Check For...

Dirty or burred bolt.

Broken extractor spring.

Carbon in chamber.

Fouling or carbon in extractor recess or lip.

What To Do...

Clean or see a qualified gunsmith.

See a qualified gunsmith.

Clean chamber.

Clean extractor.



44

Troubleshooting (continued)...

Problem... Won't Feed

Check For...

Dirty or corroded ammo.

Dirty magazine.

Defective magazine.

Too many rounds in magazine

Action of buffer assembly is restricted.

Magazine not fully seated.

What To Do...

Clean.

Clean.

Replace.

Take out excess.

Take out buffer and spring;
clean them.

Adjust magazine catch.

**PRESS MAGAZINE
CATCH BUTTON
ON RIGHT OR
LEFT SIDE**



45

Troubleshooting (continued)...

Problem...

Double Feed

Check For...

Defective magazine.

What To Do...

Replace.

Won't Chamber

Dirty or corroded ammo.

Clean.

Damaged ammo.

Replace.

Carbon in chamber
or on gas tube.

Clean.

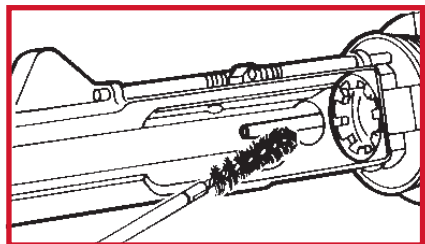

46

Troubleshooting (continued)...

Problem...

Won't Lock

Check For...

Dirt, corrosion, or carbon buildup in barrel locking lugs.

What To Do...

Clean lugs.



Won't Extract

Frozen extractor.

Remove and clean.

Restricted buffer assembly.

Remove and clean.

Restricted movement of bolt carrier group.

Remove, clean, and lube. (Make sure gas tube fits into carrier key and that the carrier moves freely before replacing).



47

Troubleshooting (continued)...

Problem...

Short Recoil

Check For...

Correct alignment of gaps in bolt rings.

What To Do...

"Gaps" in the gas rings should be staggered 120 around the bolt body for maximum effectiveness.

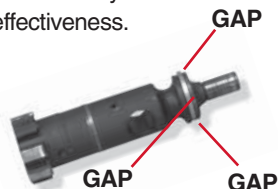

Carbon or dirt in carrier key, or on outside of gas tube.

Clean carrier key, or around area of gas tube.

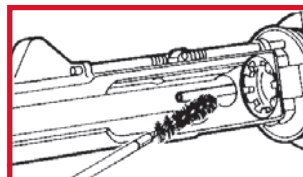

48

Troubleshooting (continued)...

Problem...
Short Recoil

Check For...
Q-tip or pipe cleaner pieces
stuck inside carrier key.

What To Do...
Clean out if possible
or have rifle checked
by a qualified gunsmith.

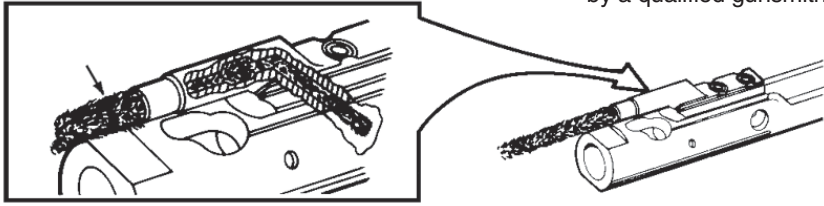

**Bolt Fails to
Lock After
Last Round**

Dirty or corroded bolt latch.

Clean out if possible
or have rifle checked
by a qualified gunsmith.

Faulty magazine.

Replace.

**Selector
Lever Binds**

Needs oil.

Lubricate with CLP.

Dirt or sand under trigger.

Clean.

49

Troubleshooting (continued)...

Problem...
Bolt Carrier
“Hung Up”

Check For...
Round jammed between
bolt and charging handle
and/or double feed.

WARNING:
Keep clear of muzzle!

CAUTION:
After round is removed,
bolt is under tension!

What To Do...

- 1.) Remove magazine.
- 2.) Point muzzle in safe direction. Engage safety if possible by pushing out takedown pin and manually cocking hammer. Close receivers.
- 3.) While pulling down on the charging handle, bang the rifle butt on the ground. Round should eject.



Disassembly Views...

Bushmaster .308 Rifle

Upper Receiver • Barrel • Bolt • Sight Groups

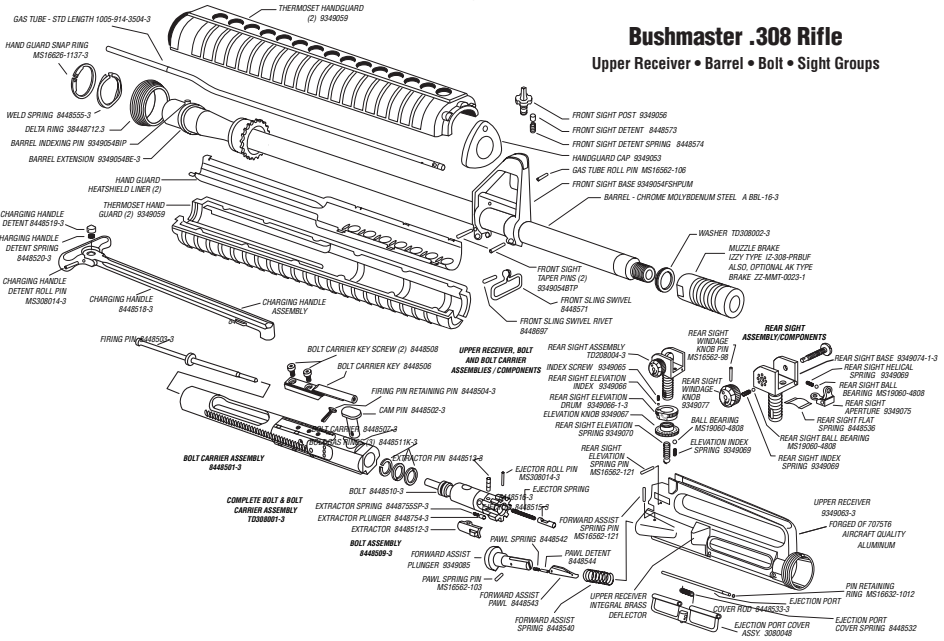

Disassembly Views...

Bushmaster .308 Rifle

Lower Receiver • Magazine Groups

Note:
This rifle is also available with the "Flat-top" A3 type upper receiver.

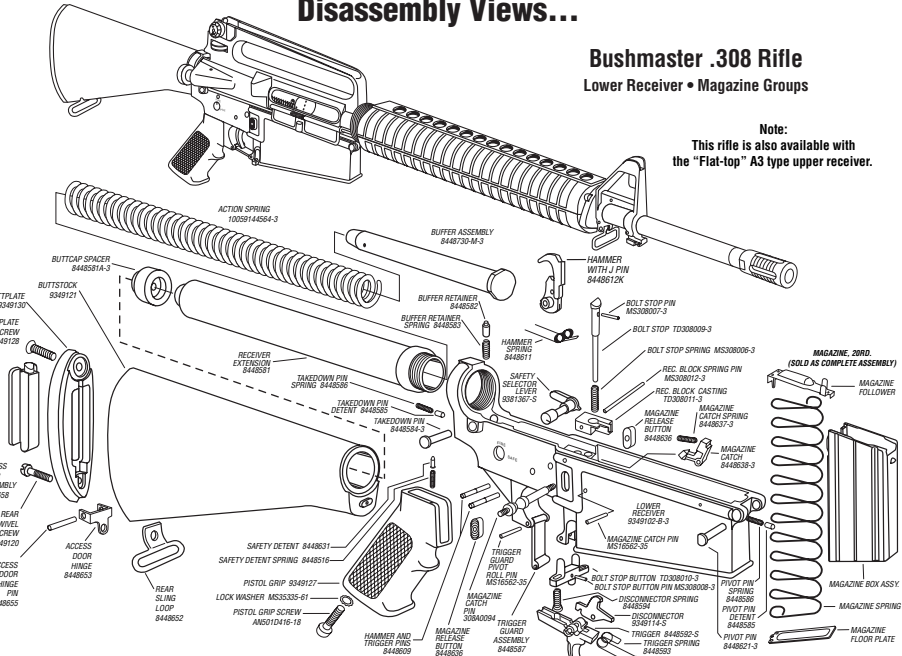

Limited One Year Warranty

Bushmaster Firearms, Inc. products are warranted to be free from defects in material and workmanship. Warranty cards are included with all firearms and should be completely filled out and sent to Bushmaster Firearms, Inc. to activate the terms of the warranty. Any such defect of which Bushmaster Firearms, Inc. is given written notice, as provided below, within one year and ten days from the date of first purchase by a customer will be remedied by Bushmaster Firearms, Inc. This warranty is granted by Bushmaster Firearms, Inc., 999 Roosevelt Trail, Windham, Maine 04062.

To initiate a warranty claim call Bushmaster Firearms, Inc. at 1-800-883-6229, between 8:30 am and 6:00 pm E.S.T., Monday through Friday to get a **“Return Merchandise Authorization”** number. Warranty claims (transportation charges prepaid), should state the model and serial number of the gun concerned, a description of the difficulty experienced, and the date of purchase. It is recommended that shipment be insured by the owner, since Bushmaster Firearms, Inc. will accept no responsibility for loss or damage in transit. Transportation and insurance charges for return to owner will be paid by Bushmaster Firearms, Inc., if the related claim is a proper claim for warranty work. The firearm should then be sent to the Warranty Service Department, Bushmaster Firearms, Inc., 999 Roosevelt Trail, Windham, Maine 04062.

53

Please Practice Safe Firearms Handling!

***This Manual Should Always Accompany
Your Bushmaster – 308 Firearm!***



Bushmaster Firearms, Inc.

999 Roosevelt Trail • Windham, ME. 04062

Orders: 800 998 7928 • Customer Service: 800 883 6229 • FAX: 207 892 8068

www.bushmaster.com • info@bushmaster.com



***Made With Pride
In The USA***