

# **Responsibility**

This manual provides instructions on the operation and maintenance of the Barrett model M468 rifle. **Read and understand it carefully before you try to use your rifle.** Your safety, and that of those around you, depends on your knowledge of your rifle and on your knowledge of safety rules common to all firearms. Please study the common-sense safety rules noted in this manual. Your first concern as a gun owner should always be safety.

As a gun owner the security of your rifle is your responsibility. Make sure that your rifle remains in responsible hands...**yours!** Don't become involuntarily associated with it in a crime or tragedy: make sure your rifle is properly secured. Lock it in a secure storage container, or if none is available, remove the bolt carrier assembly and store it separately.

## **WARNING**

When not actually shooting your rifle, to avoid accidental firing, **be sure the ammunition in the rifle is unloaded.** Failure to do so could result in serious injury or death.

Be sure the cam pin is installed in the bolt group. If it isn't, your rifle can still fire and will explode causing injury.

**Do not** exchange or switch bolt assemblies from one rifle into another. It could cause damage to both you and your rifle.

**Don't overheat your barrel.** Sustained firing of the M468 will rapidly raise the temperature of the barrel to a critical point.

Firing 140 rounds, rapidly and continuously, will raise the temperature of the barrel to **cookoff point.** At this temperature, any live round remaining in the chamber for any reason may detonate (cookoff) in as short a period as 10 seconds.

If the cookoff point is felt to be possible clear your rifle and allow it to cool.

Sustained rate of fire for the M468 rifle is 12-15 rounds per minute. This is the actual rate of fire this rifle can continue to deliver for an indefinite length of time without overheating.

Sustained rate of fire should never be exceeded except under circumstances of extreme urgency.

If there is water or any obstruction in the barrel, do not fire the rifle. It could explode.

If you experience a noticeable difference in sound or recoil, **stop firing.** Either condition could indicate an incomplete propellant burn, and a bullet still in the bore. Retract bolt slowly and remove fired cartridge case. Clear rifle and check for unburned powder grains in the receiver or bore and for a bullet in the bore. Remove unburned propellant or bullet from the bore before resuming firing or barrel could explode. If bullet is lodged in bore, take your rifle to a qualified gunsmith.

Use only authorized ammunition manufactured to U.S. specifications.



**Do not mistake** the 6.8 round with the .223/5.56 round. Firing the wrong caliber ammunition could result in the rifle exploding, possibly causing injury to yourself. **Do not use** or confuse yourself with any 5.56 components. **Do not mix** 5.56 magazines, muzzle brakes, flash hiders, sound suppressors, or blank firing attachments. **Be aware** that a simple mixing of components can result in rifle damage and personal injury.

Use of improper ammunition will invalidate your warranty.

### **Fundamental Rules For Safe Rifle Handling**

**Always keep the rifle pointed in a safe direction.**

**Never load the gun until ready to use.**

**Keep your finger off the trigger until ready to shoot.**

## **Notice**

Barrett Firearms Manufacturing, Inc. (B.F.M.I.) has no control over the use of your rifle, and shall not be responsible for injury, death, or damage to property resulting from either intentional or accidental discharge of this firearm, or for its function when used for purposes or subjected to treatment for which it was not intended. B.F.M.I. will not honor claims under the warranty which result from careless or improper handling, unauthorized adjustments or part replacement, corrosion, neglect, use of the wrong type caliber of ammunition, or the use of ammunition that is not original, high quality commercially manufactured and in good condition, or any combination thereof. B.F.M.I. will not honor claims under the warranty for any reason or cause when second or subsequent owners make such claims.

## **ABOUT YOUR M468 RIFLE**

**Caliber:** 6.8 mm SPC – 6.8 x 43 mm

**Weight:** W/30 round mag 4.37 Kg (9.62 lb) approx

**Length:** Rifle w/muzzle brake 35 3/8 inches

**Mechanical features:** Rifling (RH 1/10 twist)

**Firing Characteristics:** Muzzle velocity (approx) 2,650 fps

Cyclic rate of fire (approx) 750 rounds per min

**Max effective rates of fire:** Semi: 45 rounds per min  
Auto: 90 rounds per min

**Sustained rate of fire:** 12/15 rounds per min

**Max effective range:** 600 meters (individual/point targets)  
800 meters (area targets)



# **OPERATING INSTRUCTIONS**

## **Description and Use of Operator's Controls and Indicators**

### **MECHANICAL CONTROLS**

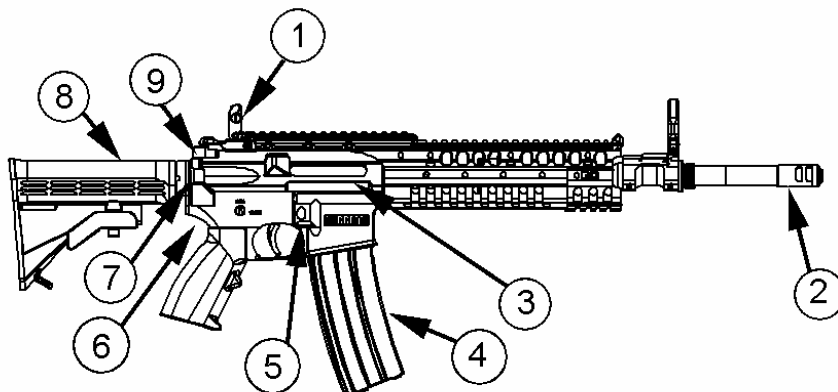

- REAR SIGHT (1) – zeroes rifle and engages targets to 460 meters.  
MUZZLE BRAKE (2) – reduces amount of recoil when rifle is fired.  
EJECTION PORT COVER (3) – protects upper receiver from foreign matter when rifle is not in use. Keep port cover closed when not in use.  
CARTRIDGE MAGAZINE (4) – supplies ammunition to the rifle.  
MAGAZINE CATCH BUTTON (5) – releases cartridge magazine (4) from rifle when it is depressed.  
LOWER RECEIVER AND EXTENSION ASSEMBLY (6) – provides firing control for the rifle.  
FORWARD ASSIST ASSEMBLY (7) – ensures that bolt is fully forward and locked.  
SHOULDER GUN STOCK ASSEMBLY (8) – stabilizes rifle and with the standard buttstock, provides storage for basic cleaning materials.  
CHARGING HANDLE ASSEMBLY (9) – cocks rifle when preparing to fire or when clearing rifle.

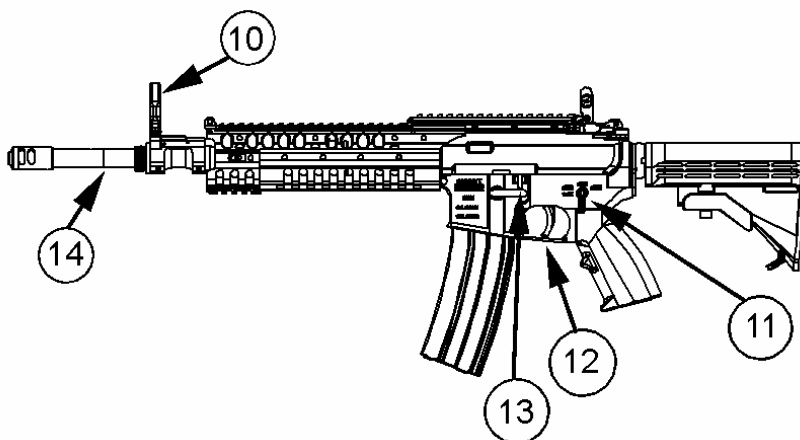

- FRONT SIGHT (10) – adjustable for elevation.  
SELECTOR SWITCH (11) – arms the rifle (in semi or auto) or safes the rifle.  
TRIGGER (12) – controls the firing of the rifle.  
BOLT CATCH (13) – automatically retains carrier assembly to rear after firing last shot. Can also be manually engaged.  
BARREL ASSEMBLY (14) – directs the projectile upon firing.

# **OPERATING PROCEDURES**

## **1. LOADING**

### **WARNING**

*Point muzzle in a safe direction.*

### **Note:**

*The hammer must be cocked in order for the selector switch to be placed on "SAFE".*

*To cock hammer and hold bolt open;*

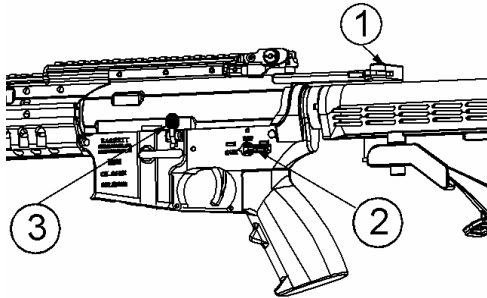

1. Pull charging handle assembly (1) rearward, depress bottom of bolt catch (3), and manually return charging handle. Place selector switch (2) on SAFE.

*To cock and allow bolt to close;*

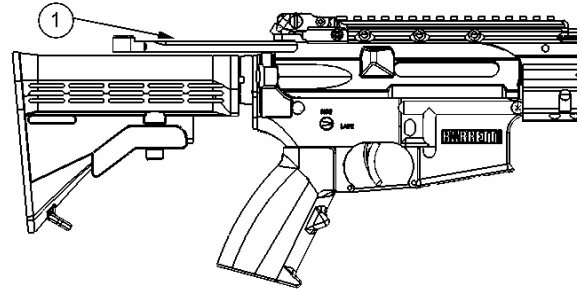

2. Pull charging handle assembly (1) rearward and check to see that chamber is clear. Release charging handle assembly. Place selector switch (2) on SAFE.

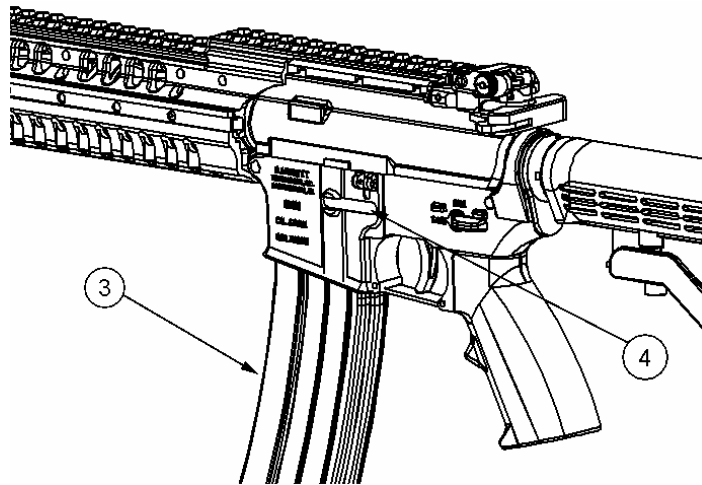

Insert loaded magazine (3) into rifle's magazine well until magazine catch (4) engages and holds cartridge magazine. Tap upward to make sure cartridge magazine is seated correctly.

### **Note:**

*Magazine may be inserted with bolt assembly open or closed*

## 2. CHAMBERING AND FIRING A ROUND

### 2.A. BOLT ASSEMBLY OPEN METHOD

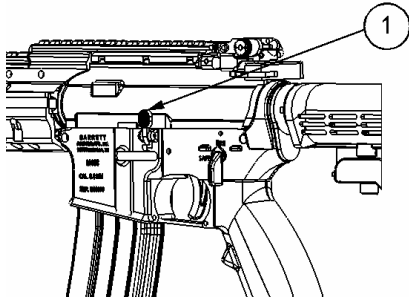

1. Depress upper portion of bolt catch (1) to release the bolt.

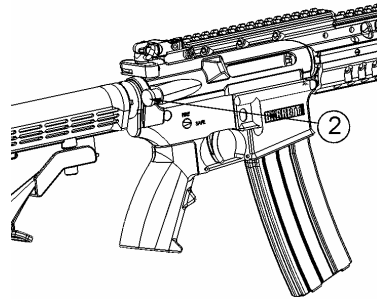

2. Tap forward assist assembly (2) to ensure bolt is fully forward and locked.

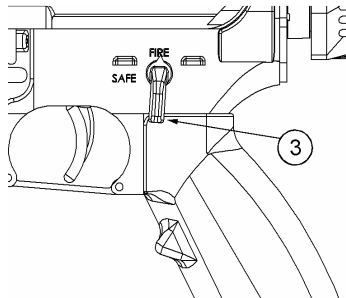

3. Move selector switch (3) to FIRE.

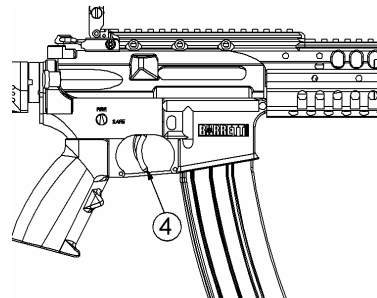

4. Squeeze the trigger (4) and fire.

### 2.B. BOLT ASSEMBLY CLOSED METHOD

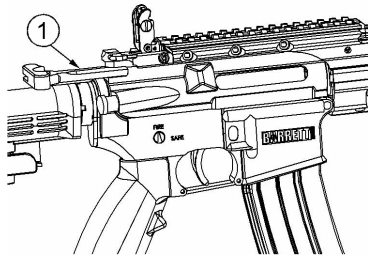

1. Pull the charging handle assembly (1) to the rear, until it stops.



2. Release the charging handle assembly.

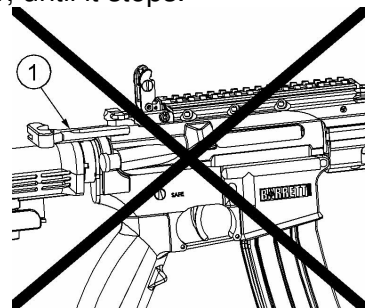

3. Never “ride” the charging handle assembly (1). Let it go on its own.

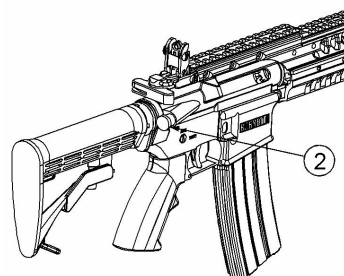

4. Tap forward assist assembly (2) to ensure bolt is fully forward and locked.

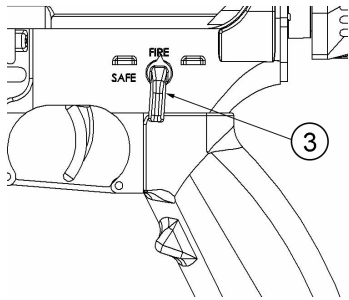

5. Place the selector switch (3) on FIRE.

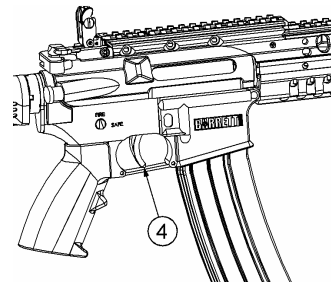

6. Squeeze the trigger (4) and fire.

### 3. CLEARING YOUR RIFLE

#### WARNING

*To avoid accidental firing, always look into chamber after clearing rifle to make sure it does not contain a round.*

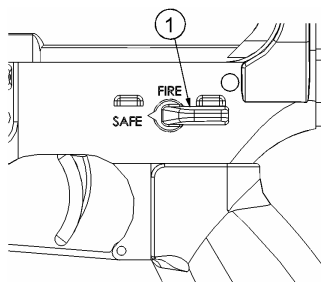

1. Place selector switch (1) on SAFE.

#### Note:

*If rifle is not cocked, lever cannot be pointed toward SAFE.*

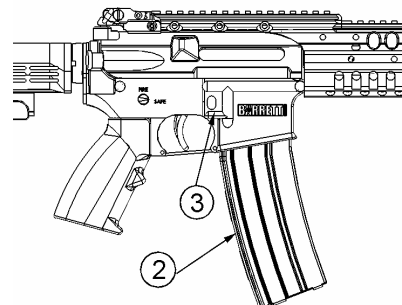

2. Remove cartridge magazine (2) by depressing magazine catch button (3) and pulling cartridge magazine (2) down.

**Note: Ensure that the selector switch (1) is on SAFE.**

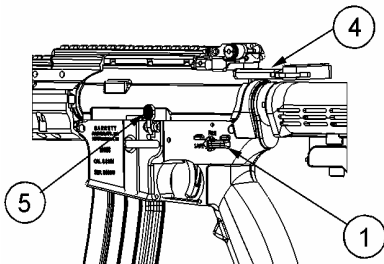

3. To lock bolt open, pull charging handle assembly (4) rearward, press bottom of bolt catch and allow bolt to move forward until it engages bolt catch (5). Return charging handle assembly (4) forward.

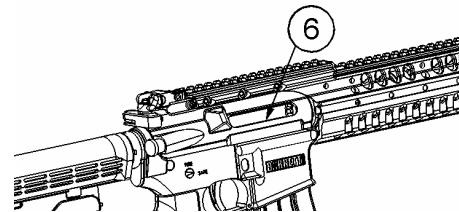

4. Check receiver and chamber (6) to ensure these areas contain no ammunition

**Note:**

*If rifle is to be stored, it should be dry fired to release tension on hammer spring.*

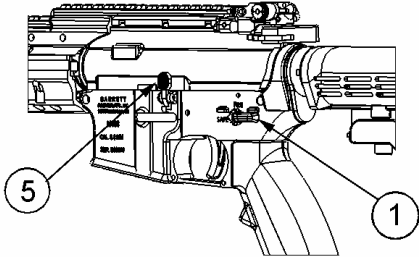

5. With selector switch (1) pointing toward SAFE, allow bolt to go forward by pressing upper portion of bolt catch (5).

**WARNING**

*Be sure to clear rifle before dry fire.*

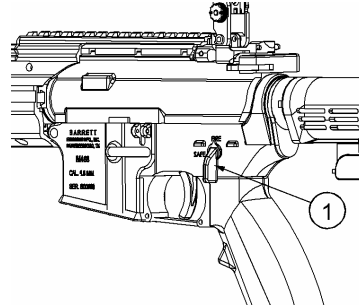

6. Place selector switch (1) on FIRE and squeeze trigger to release tension on hammer spring.

## **OPERATION UNDER UNUSUAL CONDITIONS**

**Note:**

*Unusual conditions are defined as any climatic conditions requiring special maintenance of the rifle. Perform the maintenance of the rifle for the climate that most applies to your operational area.*

### **HOT, DRY CLIMATES**

- A. Dust and sand will get into rifle and will cause malfunctions and excessive wear on component working surfaces through abrasive action during the firing operations.
- B. Lubricate internal working surfaces with a small amount of CLP (Cleaner, Lubricant and Preservative). Do not overly lubricate external parts of the rifle. Doing so will only collect dust and sand, making it difficult to keep the rifle clean. Do not lubricate internal components of the magazine.
- C. The use of additional equipment, such as protective end cap and spare magazine protective bags and overall rifle protective cover is recommended and will help keep dust and sand from getting into the rifle.

### **EXTREME COLD CLIMATES**

- A. To prevent condensation of moisture and freezing, keep rifle covered when moving from a warm to a cold area to allow gradual cooling. Do not lay a warm rifle directly in snow or ice. Always attempt to keep the rifle dry. Unload and hand function the rifle every 30 minutes to help prevent freezing of the functional parts.
- B. When moving a cold rifle into to a warm place, moisture (condensation) will form in and on your rifle. If possible, leave your rifle in a protected but cold area outside. When the rifle is brought inside a warm place, it should be disassembled and wiped dry several times as it reaches room temperature.
- C. Keep the insides of magazines and your ammunition wiped dry. Moisture will freeze and cause malfunctions. Do not lubricate the ammunition. The use of the muzzle cap, protective magazine bags, and overall rifle cover will help protect your rifle. Use them whenever the situation permits

## HEAVY RAIN CLIMATES

- A. Clean and lubricate rifle more frequently. Inspect hidden surfaces of the bolt and carrier assembly, upper receiver and chamber/barrel extension, and the lower receiver and buffer tube for corrosion. Also, pay close attention to spring-loaded detents on rifle.
- B. To help prevent corrosion, remove handprints with a dry rag and lubricate lightly with CLP. Unload and check the inside of the magazines frequently for moisture and corrosion. Wipe ammunition dry before reloading.
- C. Always keep the rifle dry.
- D. Always drain any water from barrel before firing. Using the protective cap will help keep water out of the barrel. Perform maintenance according to the appropriate climatic condition as the situation warrants.

## MAINTENANCE PROCEDURES

### FIELD-STRIPPING YOUR M468

#### CLEARING RIFLE

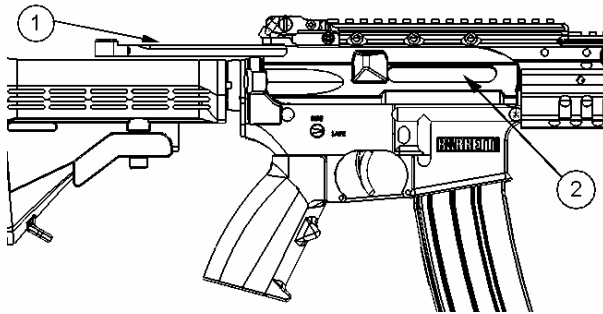

#### WARNING

*To avoid accidental firing, be sure rifle is clear. Place selector switch on SAFE. Pull back charging handle (1) and check chamber (2). Remove magazine.*

#### HAND GUARDS

1. Only remove and clean hand guards if dirt and corrosion can be seen through hand guard vent holes.
2. To release hand guard, push in on spring-loaded buttons and turn it so the slot with the scallop is facing the opened padlock emblem.
3. The locking buttons will pop out for releasing the hand guards.
4. After cleaning, space interlocking lugs between one another and lock into upper receiver rail track (1) on one side.
5. Re-attach by slapping lower hand guard (2) into track and pulling rearward to locking position.
6. To lock lower hand guard, push in spring loaded button so that two scallops on each side of slot are in a vertical position. For additional information, see Selective Integrated Rail installation guide.

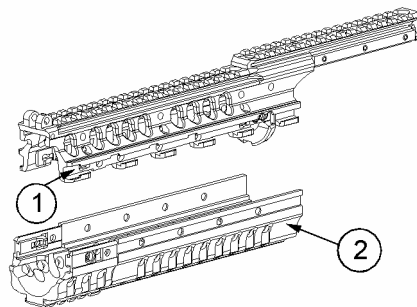



## SEPARATING THE UPPER AND LOWER RECEIVERS

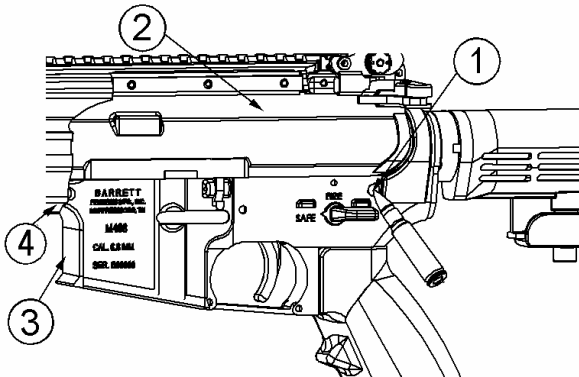

With safety on and bolt carrier closed, push takedown pin (1) as far in as it will go (takedown pins remain captured to lower receiver and are not intended to be removed from hole). Pivot upper receiver (2) from lower receiver (3). Push receiver pivot pin (4). Separate upper (2) and lower (3) receivers.

## DISASSEMBLY OF UPPER RECEIVER COMPONENTS

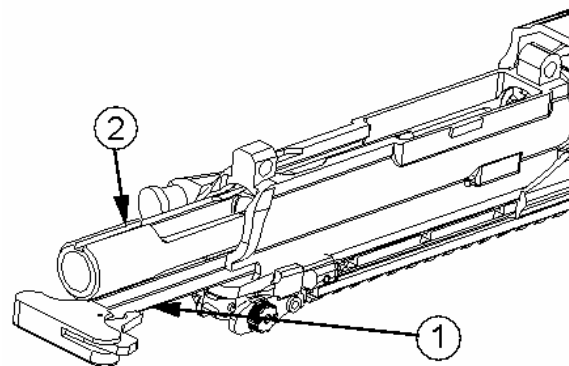

1. Pull back charging handle assembly (1) and withdraw the bolt carrier assembly (2) from the upper receiver.

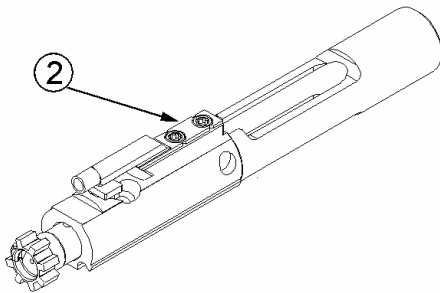

2. Remove bolt carrier assembly (2).

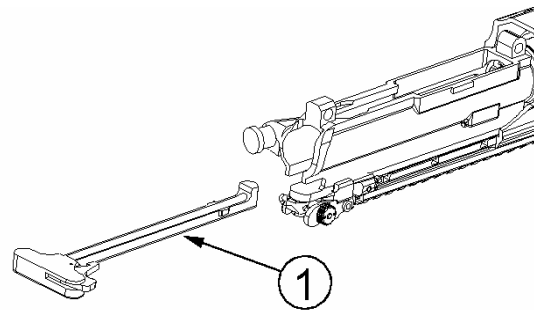

3. Pull and lift charging handle assembly (1) back out of its track and remove it.

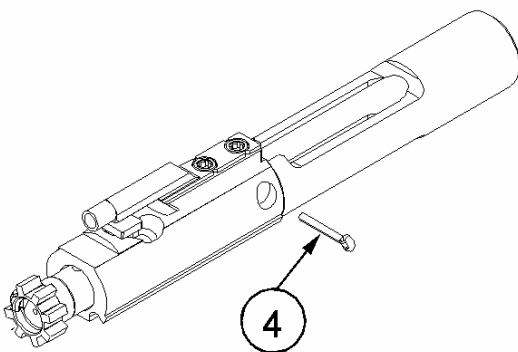

4. Remove firing pin retaining pin (4). Do not open or close split end of firing pin retaining pin (4).

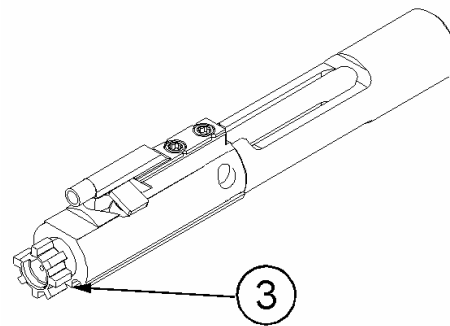

5. Push bolt (3) into locked position.

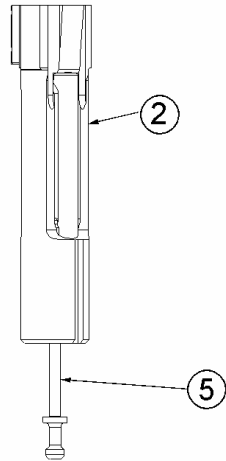

6. Remove firing pin (5) out of rear of bolt carrier assembly (2).

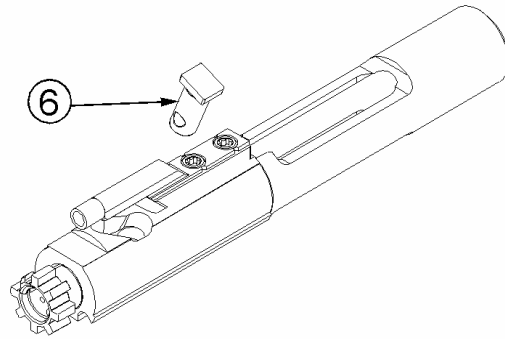

7. Rotate bolt cam pin (6) a ¼ turn and lift it out.

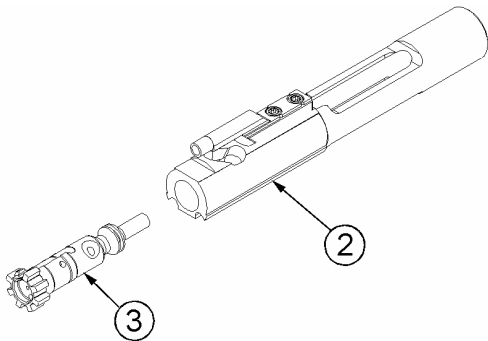

8. Remove bolt assembly (3) from bolt carrier (2).

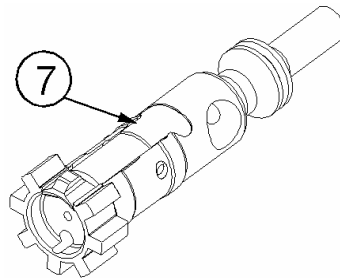

9. Press top of extractor (7) to check that spring works.

**Note:**

*Disassemble extractor and spring assembly only when dirty or damaged.*

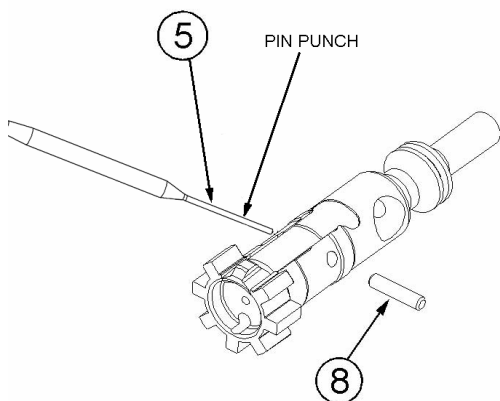

10. Use pin punch (5) to remove extractor pin (8).

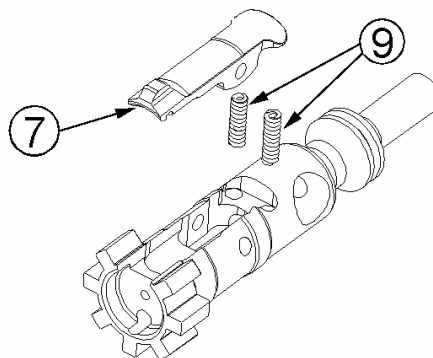

11. Remove extractor (7) and springs (9).

## DISASSEMBLY OF THE LOWER RECEIVER

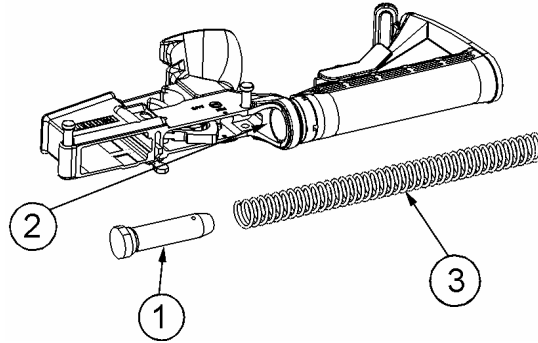

Press in and hold buffer (1), then depress retainer (2) to release buffer. Carefully remove buffer (1) with main spring (3). No further disassembly is recommended.

### CAUTION

*The buffer can be launched from its tube and cause injury.*

**REASSEMBLY** is the reverse of all procedures.

## UPPER RECEIVER AND BARREL ASSEMBLY CLEANING

Use quality commercial lubricant on the following areas:

- A. All areas of powder fouling, dirt, rust, and corrosion.
- B. Bore and chamber.
- C. Upper receiver and barrel assembly locking lugs.
- D. Gas tube.

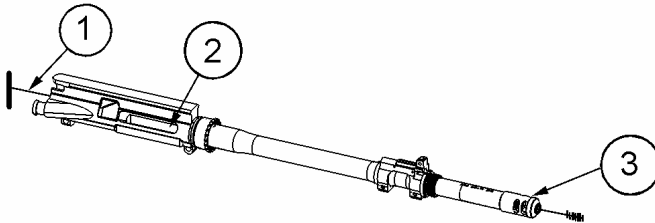

1. Use cleaning rod, bore brush, and quality commercial lubricant. Lightly lubricate bore and chamber, locking lugs, outer surfaces of barrel and front sight, and surfaces under hand guards. Run rod through chamber and muzzle brake (3).

### Note:

*Do not reverse direction of bore brush while it is in the bore.*

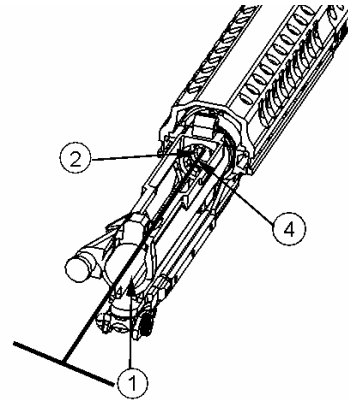

2. Install chamber brush on cleaning rod (1), dip in quality commercial lubricant, and insert in chamber (2) and locking lugs (4). Clean by pushing and twisting cleaning rod.

## CHARGING HANDLE ASSEMBLY AND BOLT CARRIER ASSEMBLY CLEANING

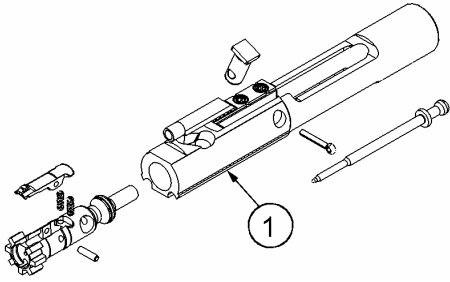

1. Clean all parts and outer surfaces of the bolt carrier assembly (1) with a swab saturated with quality commercial lubricant.

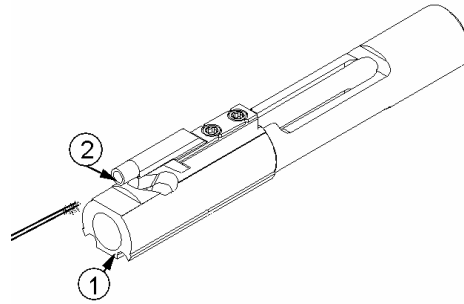

2. Clean the bolt carrier key (2) with a worn bore brush dipped in lubricant. Dry with a pipe cleaner. Use a pipe cleaner to apply a light coating of lubricant to carrier key (2).

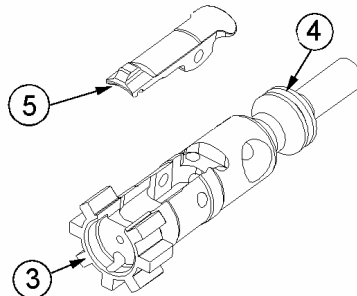

3. Remove carbon deposits and dirt from locking lugs (3) with bore brush dipped in quality commercial lubricant.

4. Clean areas behind bolt rings (4) and under lip of extractor (5).

### CAUTION

*Do not use firing pin to clean inner surfaces of bolt or bolt carrier assembly.*

## CHARGING HANDLE ASSEMBLY AND BOLT CARRIER ASSEMBLY INSPECTION

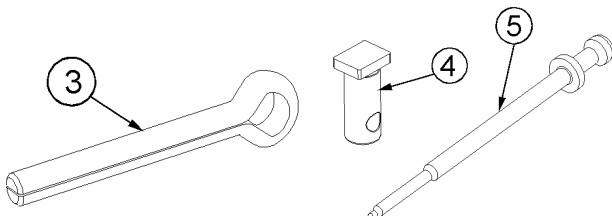
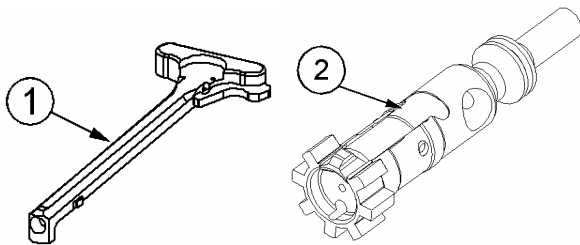

### WARNING

**DO NOT interchange bolt assemblies between rifles.**

1. Inspect charging handle assembly (1) for cracks, bends, or breaks.
2. Inspect bolt assembly (2) for cracks and fractures, especially in the cam pin hole area.
3. Inspect firing pin retaining pin (3) for bends, dents, or breaks.
4. Inspect bolt cam pin (4) for cracks or chips.
5. Inspect firing pin (5) for bends, cracks, or blunted tip.

# CHARGING HANDLE ASSEMBLY AND BOLT CARRIER ASSEMBLY LUBRICATION

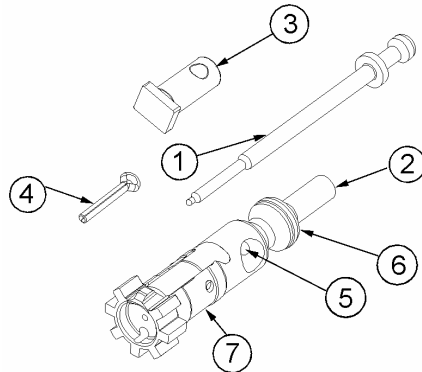

1. Lightly lubricate firing pin (1) and firing pin recess (2) in bolt assembly.
2. Generously lubricate outside of bolt cam pin (3) and firing pin retaining pin (4) with quality commercial lubricant. Make certain to lubricate bolt assembly cam pin hole (5), bolt rings (6), and outside of the bolt assembly (7).

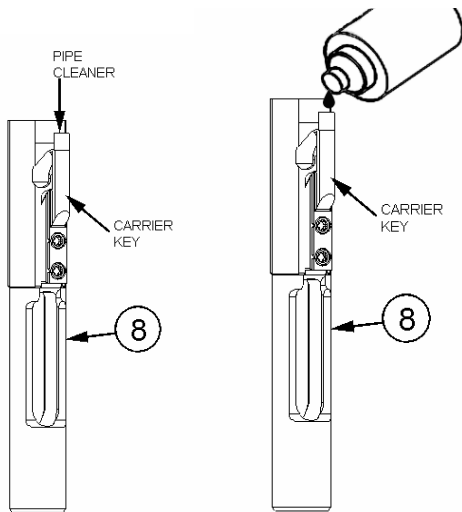

3. Dry inside key of bolt carrier assembly (8). Place drop of lubricant inside key.

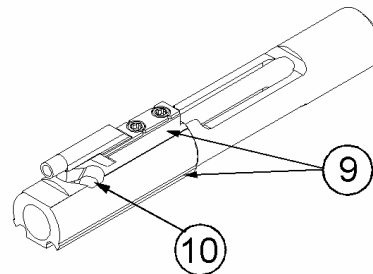

4. Lightly lubricate inner and outer surfaces of bolt carrier assembly (8) with quality commercial lubricant. Generously lubricate slide (9) and cam pin area (10) of bolt carrier assembly.

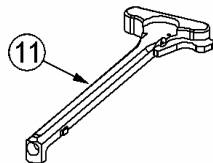

5. Lightly lubricate charging handle assembly (11).

## LOWER RECEIVER CLEANING

### CAUTION

*Do not use steel wire brush or abrasive materials to clean aluminum surfaces.*

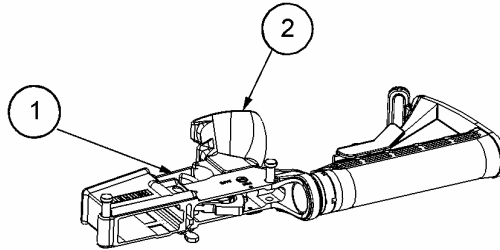

1. Wipe dirt from trigger (1) with a swab.
2. Use a swab dipped in quality commercial lubricant and cleaning brush to clean powder fouling, corrosion, and dirt from outside parts of lower receiver and extension assembly (2).

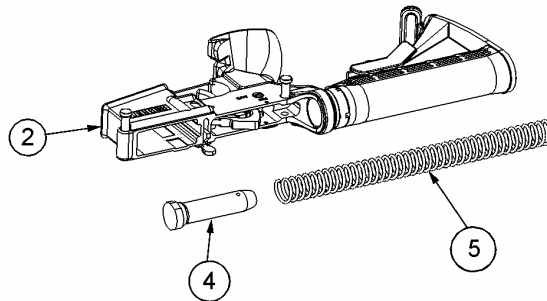

3. Clean buffer assembly (4), spring (5), and inside lower receiver and extension assembly (2) with swab dipped in quality commercial lubricant. Wipe dry.

## LUBRICATION LOWER RECEIVER AND EXTENSION ASSEMBLY

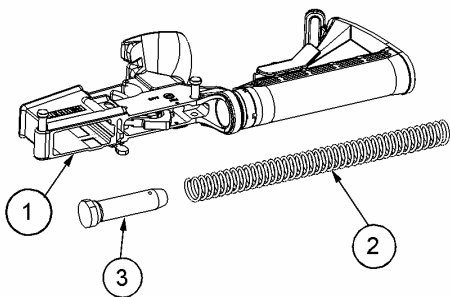

1. Lightly lubricate inside of lower receiver and extension assembly (1), spring (2), and buffer assembly (3) with quality commercial lubricant.

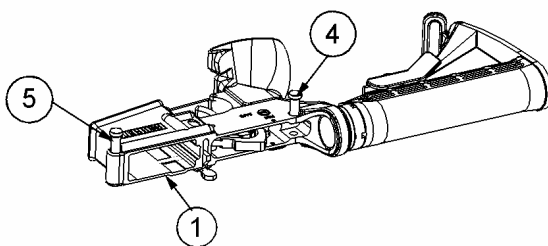

2. Generously lubricate takedown (4) and pivot pins (5) and inside parts of lower receiver and extension assembly (1) with quality commercial lubricant.

# **FUNCTIONAL CHECK**

## **WARNING**

*To avoid accidental firing, be sure that the cartridge magazine is removed and the chamber is clear.*

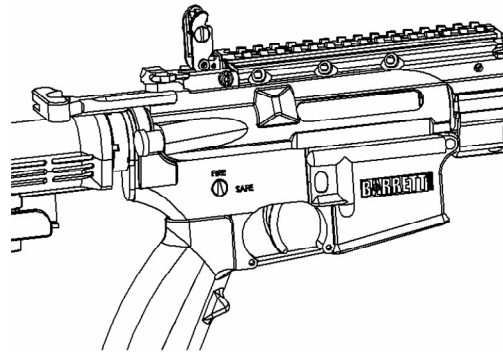
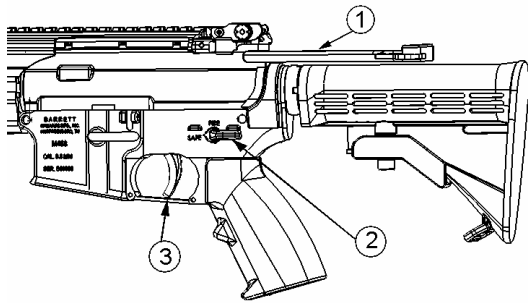

1. Pull charging handle assembly (1) to rear and release. Place selector switch (2) on SAFE. Squeeze trigger (3). Hammer should not fall.

2. Place selector switch (2) on FIRE. Squeeze trigger; hammer should fall. Hold trigger to the rear. Pull charging handle assembly (1) to rear and release. Release trigger (3). You should hear a click as you release the trigger. Squeeze again; hammer should fall.

# **SIGHT ADJUSTMENTS – M468 RIFLE**

## **RIFLE SIGHTS (ZERO ADJUSTMENT)**

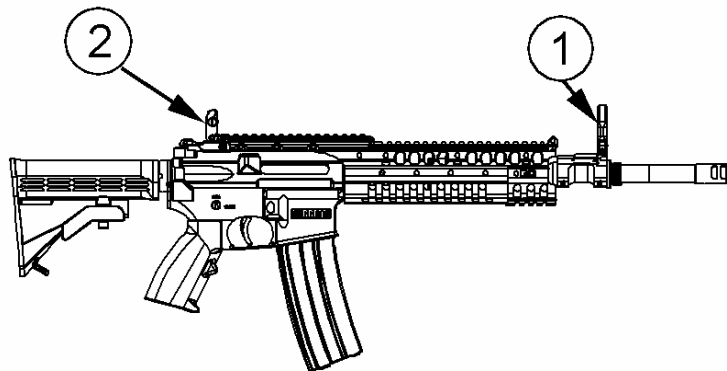

Move front (1) and rear (2) sights to make sure they can be adjusted. Return sights to zero setting of your rifle. The elevation adjustments of the rifle are adjusted with the front sight. The windage adjustments of the rifle are made with the rear sight.

## FRONT SIGHT

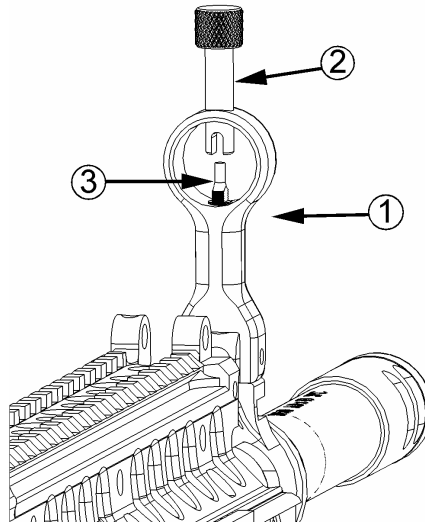

1. The front sight (1) can be moved up or down when zeroing rear sight.
2. To increase front sight post elevation (raise point of impact of bullet), insert key (2) and turn clockwise.
3. To decrease elevation (lower point of impact of bullet), insert key and turn counterclockwise. Once rear sight is zeroed, front sight post (3) should not be moved.

## REAR SIGHT

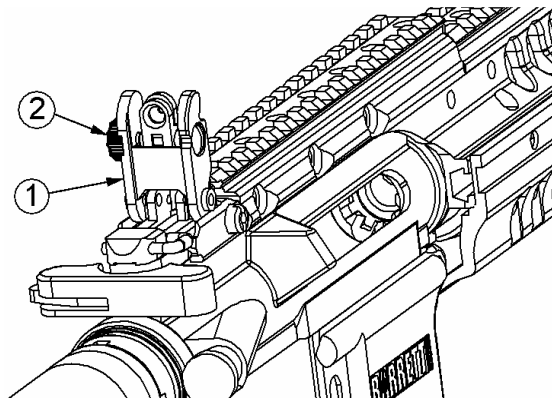

1. The low-profile rear sight (1) can be engaged by depressing the spring-loaded flip-up lever.
2. To change horizontal point of impact of the bullet, rotate windage knob (2) located on the side of rear sight. This will move rear sight to left or right when zeroing.
3. Rotate windage knob (2) clockwise to move point of impact of bullet to the right. Rotate knob counterclockwise to move point of impact of bullet to the left.



# **SUPPRESSOR – M468 RIFLE**

## **WARNING:**

The ownership of a sound suppressor must be approved by the BATFE. Go to [www.atf.gov/forms](http://www.atf.gov/forms) ATF F 5320.4 (Form 4) to obtain approval information.

## **SUPPRESSOR ATTACHMENT**

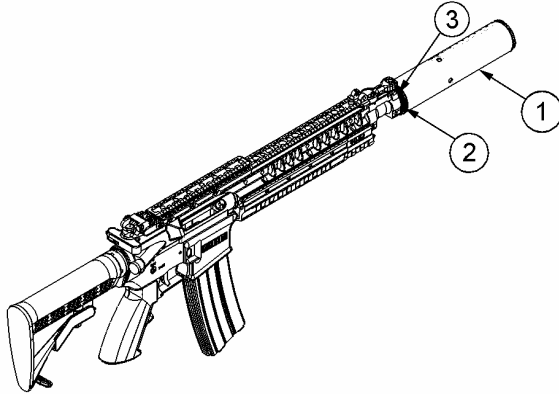

To attach suppressor (1) to the rifle barrel (2), slide sound suppressor over muzzle and rotate clockwise until it locks in place.

### **CAUTION:**

***The temperature of the suppressor will rapidly increase during use. Do not burn hands or clothes.***

## **SUPPRESSOR DETACHMENT**

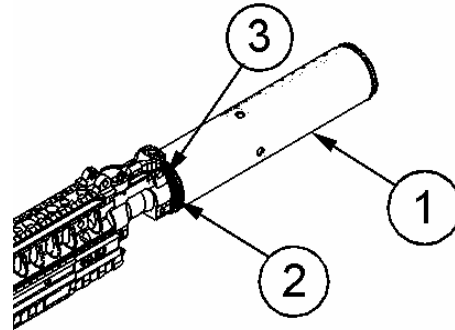

To detach suppressor (1) from end of M468 rifle barrel (2), depress suppressor ratchet pawl button (3) and rotate sound suppressor counterclockwise. Once suppressor is off its threads, it can be removed from the rifle.

### **NOTE:**

***Use only BMFI sound suppressors in conjunction with the M468 rifle system!***

***USE OF NON-BMFI SOUND SUPPRESSOR VOIDS ALL WARRANTIES!***