

FIELD MANUAL

**40-MM GRENADE LAUNCHERS  
M203 AND M79**

FOR REFERENCE

Not to be taken from this room

DEPARTMENT OF THE ARMY  
ARMY NATIONAL GUARD OF SOUTH CAROLINA  
BATTERY D 2d BN (AW) (SP) 263d ADA  
P. O. BOX 713 ANDERSON, SC 29622

FIELD MANUAL

No. 23-31

HEADQUARTERS  
DEPARTMENT OF THE ARMY  
WASHINGTON, D.C., 1 May 1972

## 40-MM GRENADE LAUNCHERS M203 and M79

	Paragraph	Page
<b>CHAPTER 1. INTRODUCTION</b> -----	1-1 — 1-3	1-1
<b>2. CHARACTERISTICS, LAUNCHER CONTROLS, AND SIGHTING EQUIPMENT OF 40-MM GRENADE LAUNCHER, M203</b>		
Section I. Characteristics -----	2-1 — 2-3	2-1
II. Controls -----	2-4 — 2-6	2-2
III. Sighting equipment -----	2-7, 2-8	2-4, 2-5
<b>CHAPTER 3. MECHANICAL TRAINING, OPERATION AND FUNCTIONING</b>		
Section I. Disassembly and assembly -----	3-1 — 3-3	3-1
II. Operation and functioning -----	3-4, 3-5	3-2
III. Stoppages and immediate action -----	3-6 — 3-8	3-6, 3-7
<b>CHAPTER 4. AMMUNITION</b> -----	4-1 — 4-9	4-1 — 4-3
<b>5. MAINTENANCE</b> -----	5-1 — 5-6	5-1 — 5-3
<b>6. MARKSMANSHIP TRAINING (M203)</b>		
Section I. Introduction -----	6-1, 6-2	6-1
II. Sight, aiming and sight manipulation -----	6-3 — 6-5	6-1, 6-2
III. Positions and rapid fire -----	6-6 — 6-14	6-2 — 6-9
IV. Sensing and adjustment of fire -----	6-15 — 6-17	6-11, 6-12
V. Zeroing procedure and range determination -----	6-18 — 6-21	6-12, 6-13
<b>CHAPTER 7. RANGE CONSTRUCTION</b> -----	7-1, 7-3	7-1
<b>8. RANGE FIRING</b> -----	8-1 — 8-4	8-1 — 8-4
<b>9. CHARACTERISTICS, LAUNCHER CONTROLS, AND SIGHTING EQUIPMENT OF 40-MM GRENADE LAUNCHER, M79</b>		
Section I. Characteristics -----	9-1 — 9-3	9-1
II. Controls -----	9-4 — 9-6	9-2, 9-3
III. Sighting equipment -----	9-7, 9-8	9-5 — 9-7
<b>CHAPTER 10. MECHANICAL TRAINING: OPERATION AND FUNCTIONING: AND MAINTENANCE</b>		
Section I. Disassembly and assembly -----	10-1 — 10-3	10-1
II. Operation, functioning, and troubleshooting -----	10-4 — 10-5	10-3, 10-4
III. Maintenance -----	10-7, 10-8	10-7
<b>CHAPTER 11. MARKSMANSHIP TRAINING (M79)</b> -----	11-1 — 11-4	11-1 — 11-4
<b>12. INDIRECT FIRE ROLE, M79</b> -----	12-1 — 12-5	12-1 — 12-5
<b>APPENDIX A. REFERENCES</b> -----		A-1
<b>B. AMMUNITION</b> -----		B-1
<b>C. LESSON OUTLINE—40-MM GRENADE LAUNCHERS, M203/M79</b> -----		C-1
<b>D. TRAINING AIDS</b> -----		D-1
<b>INDEX</b> -----		Index-1

## CHAPTER 1

### INTRODUCTION

---

#### 1-1. Purpose

Chapters 1 through 8 of this manual provide guidance for training with the 40-mm grenade launcher, M203 and Chapters 9 through 12 provide guidance for training with the 40-mm grenade launcher, M79.

#### 1-2. Scope

This manual contains a discussion of the launchers and their characteristics, disassembly/assembly procedures, launcher controls and sighting equipment, operation and functioning, types and functioning of standard ammunition, safety precautions, and marksmanship training.

#### 1-3. Recommended Changes

Users of this manual are encouraged to submit recommended changes or comments to improve it. Comments should be keyed to the specific page, paragraph, and line of text in which the change is recommended. Reasons will be provided for each comment to insure understanding and complete evaluation. Comments should be prepared using DA Form 2028 (Recommended Changes to Publications) and forwarded to the Commandant, US Army Infantry School, Fort Benning, Georgia 31905.

CHAPTER 2

CHARACTERISTICS, LAUNCHER CONTROLS, AND SIGHTING EQUIPMENT OF 40-MM GRENADE LAUNCHER, M203

Section I. CHARACTERISTICS

2-1. Description

The 40-mm grenade launcher, M203, is a light-weight, single-shot, breech loaded, pump action (sliding barrel), shoulder-fired weapon attached to the M16/M16A1 rifle (fig 2-1). It consists of a handguard and sight assembly group, receiver assembly, quadrant sight assembly, and barrel assembly.

2-2. Ammunition

a. The grenade launcher uses fixed type ammunition. The two major assemblies of a round are the cartridge case and the projectile. There are varieties of high explosive, training, multiple projectile (buck shot), illuminating, and signaling rounds (both standard and developmental types) available for use in the M203.

b. For detailed information on ammunition, see chapter 4.

2-3. Data

a. Weapon.

Length of launcher	-----	15 1/4 in.
Length of barrel	-----	12 in.
Weight (unloaded)	-----	3 lb (approx)
Weight (loaded)	-----	3.5 lb (approx)
Weight (loaded) (M16A1 and M203)	-----	11 lb (approx)
Trigger pull	-----	5 lb

b. Ammunition.

Caliber	-----	40-mm
Weight	-----	8 oz (approx)

c. Operational Characteristics.

Action	-----	Pump
Maximum range	-----	400 m (approx)
Maximum effective range (area targets)	-----	350 m
Maximum effective range (point target)	-----	150 m
Minimum safe firing ranges (HE and TP):		
Training	-----	80 m
Combat	-----	31 m

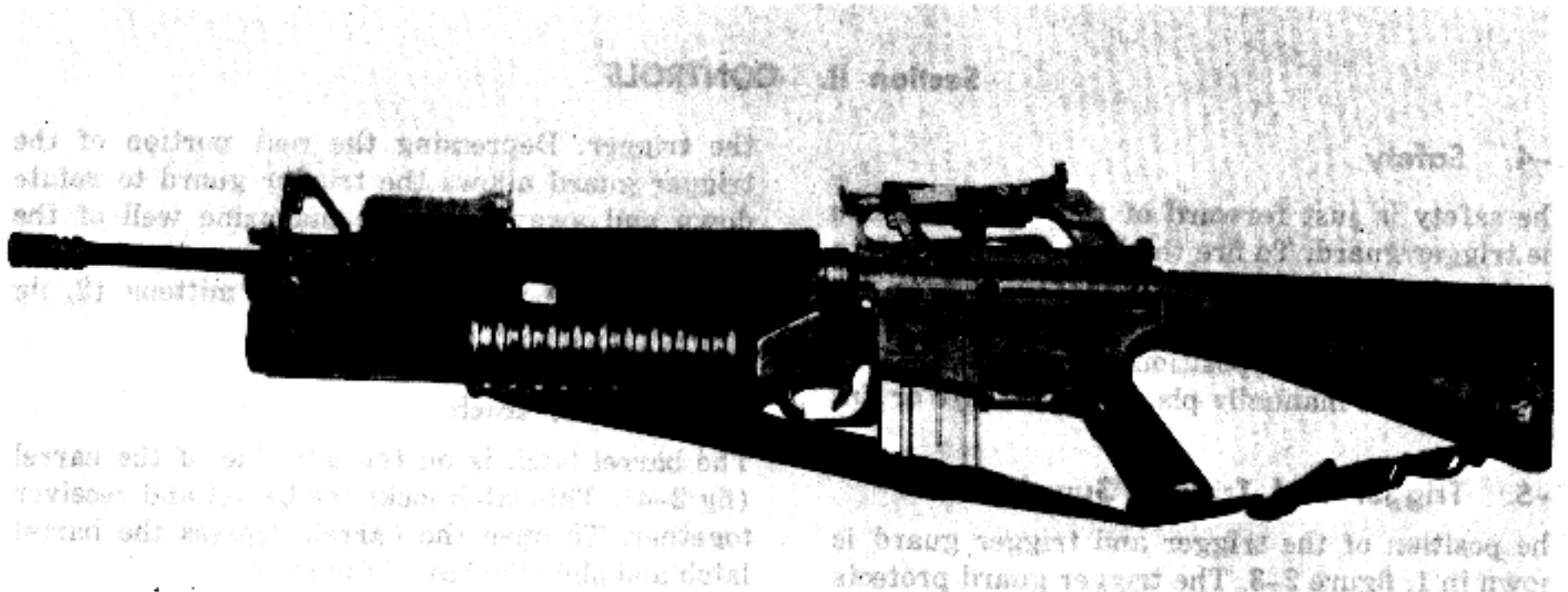

(1) Left side view.

Figure 2-1. The 40-mm grenade launcher, M203 attached to the M16A1 rifle.



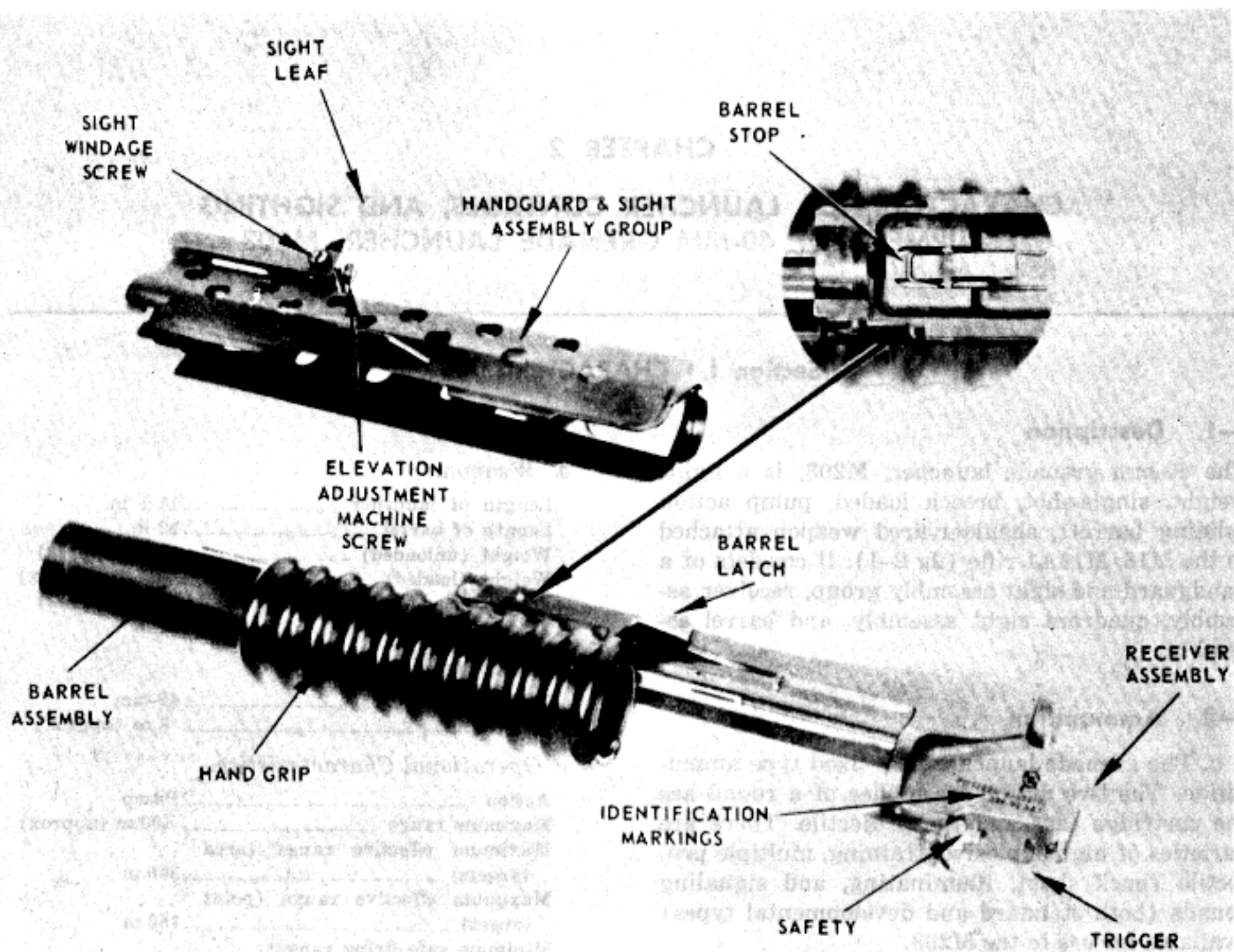

(2) Controls and identifications.  
Figure 2-1.—Continued.

## Section II. CONTROLS

### 2-4. Safety

The safety is just forward of the trigger, inside the trigger guard. To fire the launcher, the safety must be in the forward position (1, fig 2-2). To place the launcher on *safe* the safety must be in the most rearward position (2, fig 2-2). The safety must be manually placed on the *safe* or *fire* position.

### 2-5. Trigger and Trigger Guard

The position of the trigger and trigger guard is shown in 1, figure 2-3. The trigger guard protects

the trigger. Depressing the rear portion of the trigger guard allows the trigger guard to rotate down and away from the magazine well of the rifle thus allowing the grenadier to fire the weapon while wearing gloves or mittens (2, fig 2-3).

### 2-6. Barrel Latch

The barrel latch is on the left side of the barrel (fig 2-4). This latch locks the barrel and receiver together. To open the barrel, depress the barrel latch and slide the barrel forward.

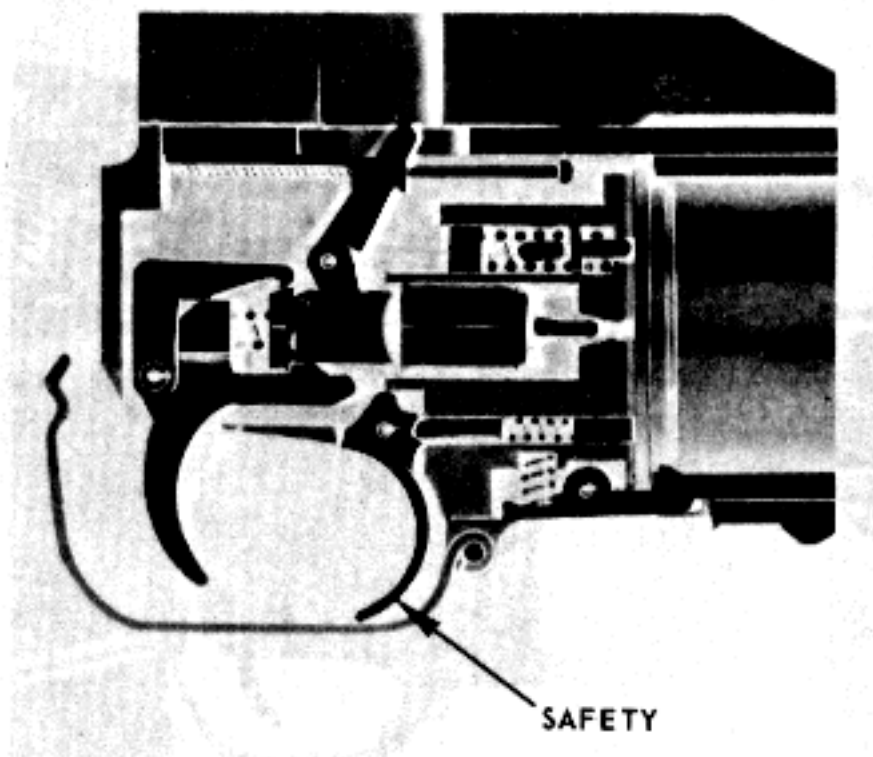

(1) In the firing position.  
*Figure 2-2. Location of the safety.*

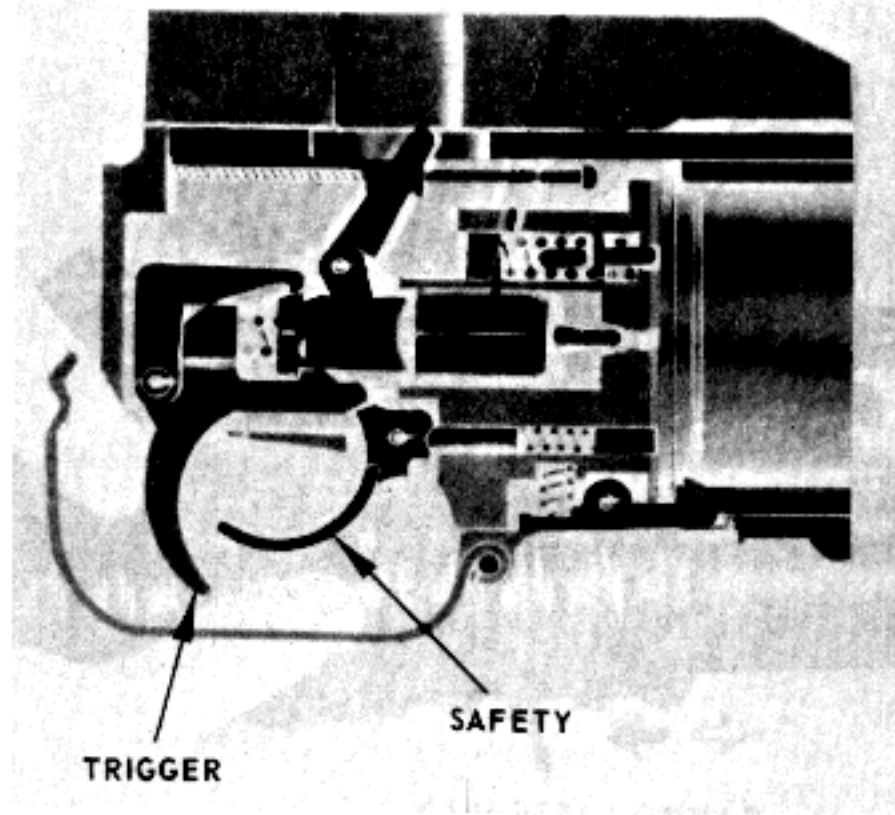

(2) In the safe position.  
*Figure 2-2.—Continued.*

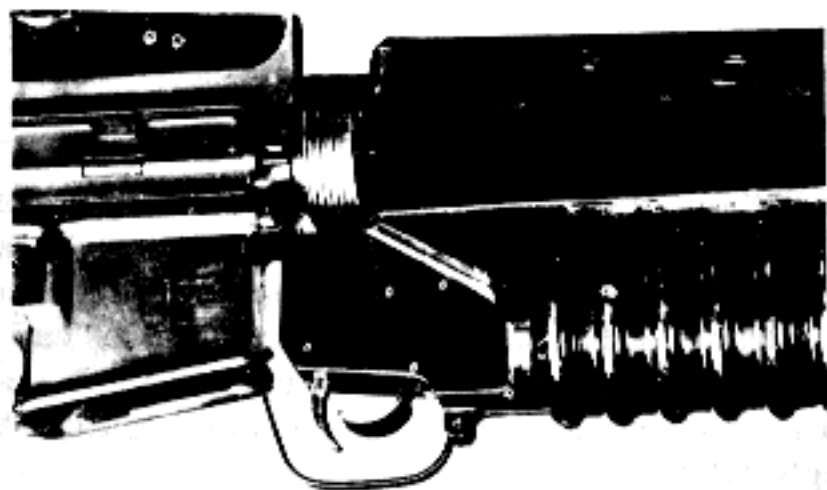

(1) Trigger guard.  
*Figure 2-3. Trigger and trigger guard.*

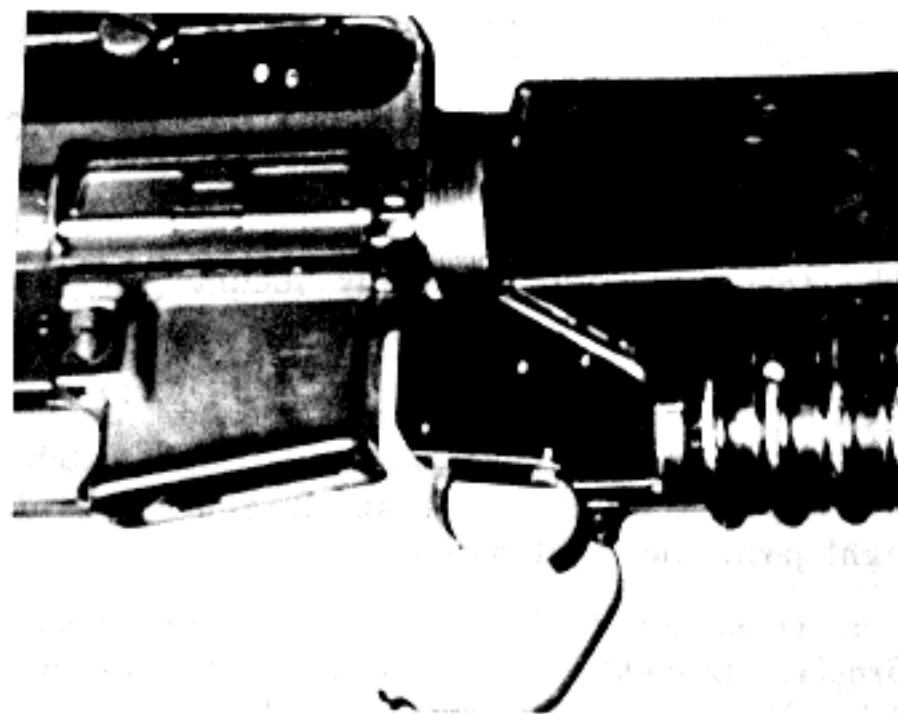

(2) Trigger guard rotated down.  
*Figure 2-3.—Continued.*

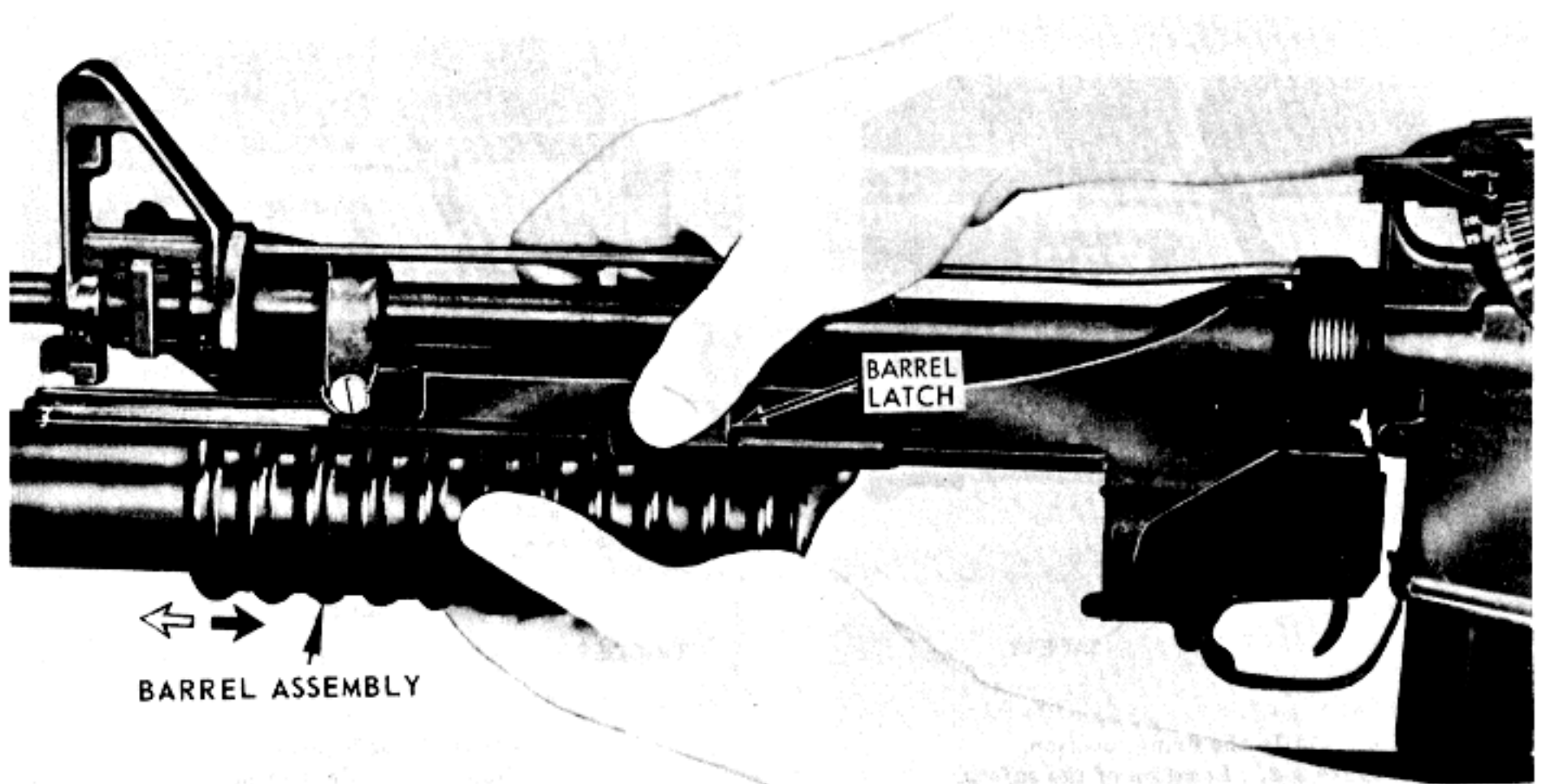

Figure 2-4. Operating the barrel latch.

### Section III. SIGHTING EQUIPMENT

#### 2-7. Quadrant Sight

The Quadrant sight assembly mounts on the left side of the carrying handle of the M16/M16A1 rifle. The quadrant sight assembly consists of a mounting screw, quadrant sight assembly clamp, sight bracket assembly, sight latch, rear sight aperture, sight aperture arm, front sight post, and sight post arm.

*a. Quadrant Sight Assembly Clamp, Sight Bracket Assembly and Mounting Screw* (1, fig 2-5). The quadrant sight assembly clamp and sight bracket assembly hold the quadrant sight assembly to the carrying handle of the M16/M16A1 rifle and are secured by a mounting screw inserted through the right side of the quadrant sight assembly clamp, into the sight bracket assembly.

*b. Quadrant Sight Arm and Range Quadrant* (2, fig 2-5). The quadrant sight arm serves a dual purpose. It mounts the sight aperture arm (which holds the sight aperture) and the sight post arm (which holds the front sight post). This permits the sight to pivot on the range quadrant to the desired range setting. The range quadrant is graduated in 25-meter increments from 50 to 400 meters. To move the quadrant sight arm along the

range quadrant, move the sight latch rearward. This rearward pressure unlocks the quadrant sight arm allowing it to move along the range quadrant so that the desired range number can be centered in the window on the quadrant sight arm. To lock the sight in position, release the sight latch.

*c. Front Sight Post* (2, fig 2-5). The front sight post mounts on the quadrant sight arm by means of a pivot bracket that can be opened when the sights are in use or closed when not in use, to prevent damage to the sights. The sight post can be used to make minor adjustments in elevation when zeroing the launcher. For elevation adjustments, turn the elevation adjustment screw on the sight post to the right to decrease elevation and to the left to increase elevation. One full turn on the elevation adjustment screw will move the impact of the projectile 5 meters at a range of 200 meters.

*d. Rear Sight Aperture* (2, fig 2-5). The rear sight aperture connects to the sight aperture arm, which is attached to the rear portion of the quadrant sight arm. The sight aperture arm serves the same purpose as the sight post arm. The rear sight aperture can be adjusted for minor changes



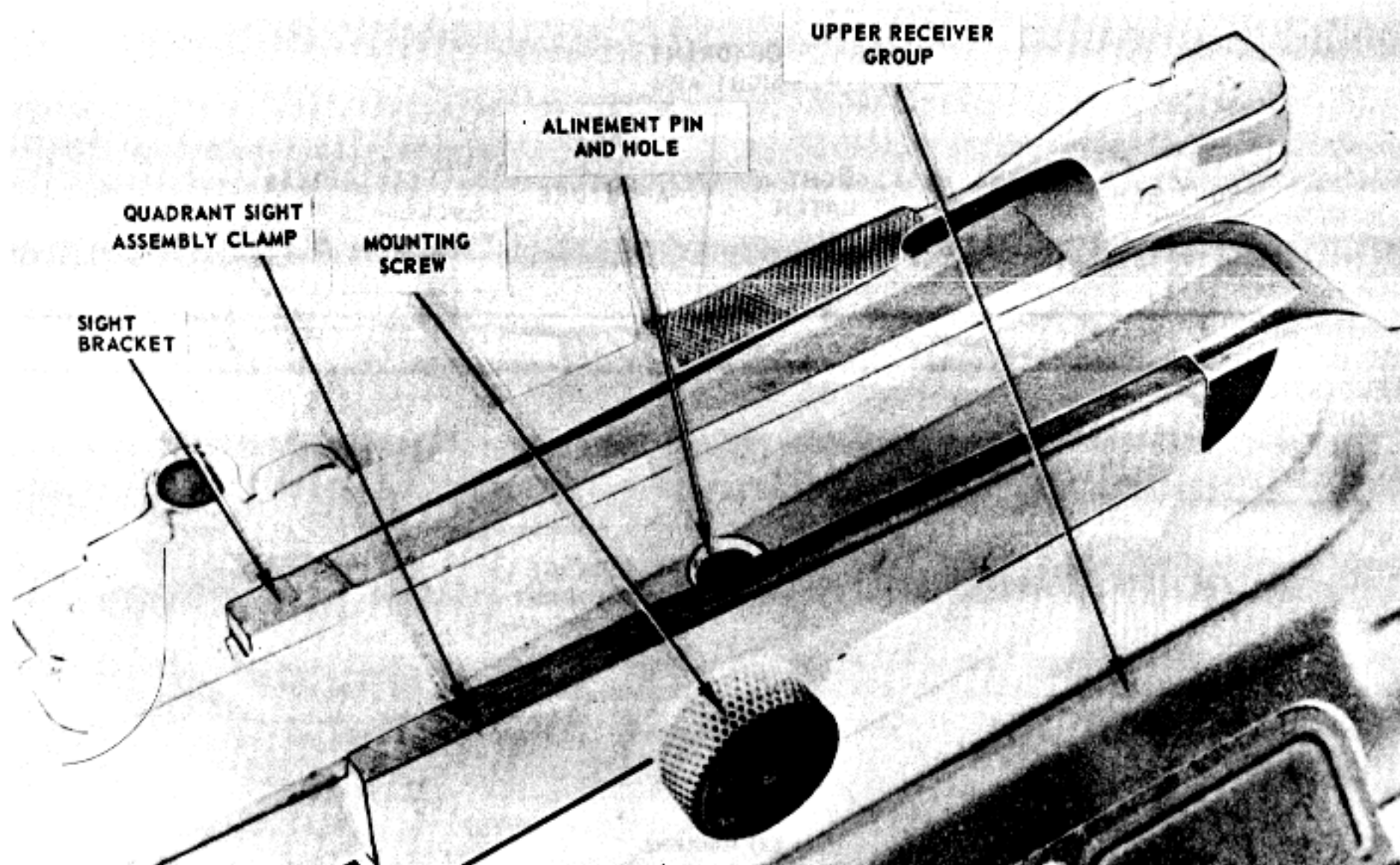

(1) Quadrant sight assembly clamp, sight bracket assembly, and mounting screw.

Figure 2-5. Quadrant sight assembly.

in deflection when zeroing the launcher. For windage adjustment, press the rear sight retainer and move the aperture away from the barrel to move impact to the left. One notch on the rear sight aperture will move the impact of the projectile  $1\frac{1}{2}$  meters at a range of 200 meters.

## 2-8. Sight Leaf Assembly (fig. 2-6)

The sight leaf base is part of the handguard and sight assembly group. It is located on top of the handguard and consists of a sight leaf, sight leaf base, sight leaf mount, elevation adjustment machine screw, and a sight windage screw. The elevation and windage scales are marked on the sight leaf mount. The sight leaf is a folding, adjustable open ladder design that permits rapid firing without sight manipulation. The sight leaf uses the front sight post of the M16/M16A1 rifle as the front aiming post.

*a. Sight Leaf Base (fig 2-6).* The sight leaf base is permanently attached to the rifle handguard by two mounting screws. The sight leaf base serves to protect the sight leaf from damage when the leaf is not being used and in the *down* position.

*b. Sight Leaf Mount and Sight Leaf (fig 2-6).* The mount is attached to the sight base and is used to raise or lower the sight leaf blade. The sight leaf is graduated in 50 meter increments from 50 to 250 meters and numbered at 100 and 200 meters.

*c. Elevation Adjustment Screw and Elevation Scale (fig 2-6).* The screw attaches the sight leaf to the sight mount. To make minor adjustments in elevation when zeroing the launcher, the sight leaf can be moved up or down by loosening the screw. The rim of a 40-mm cartridge case may be used to turn the elevation adjustment screw. Raising the sight leaf increases the range and lowering it decreases the range. The elevation scale consists of five lines spaced equally apart on the sight leaf. The index line is on the left of the sight leaf. One increment will move the impact of the projectile 10 meters in elevation at a range of 200 meters.

*d. Windage Screw and Windage Scale (fig 2-6).* The left end of the screw consists of a knob which is used to turn the sight windage screw to adjust for deflection. The windage scale consists of a

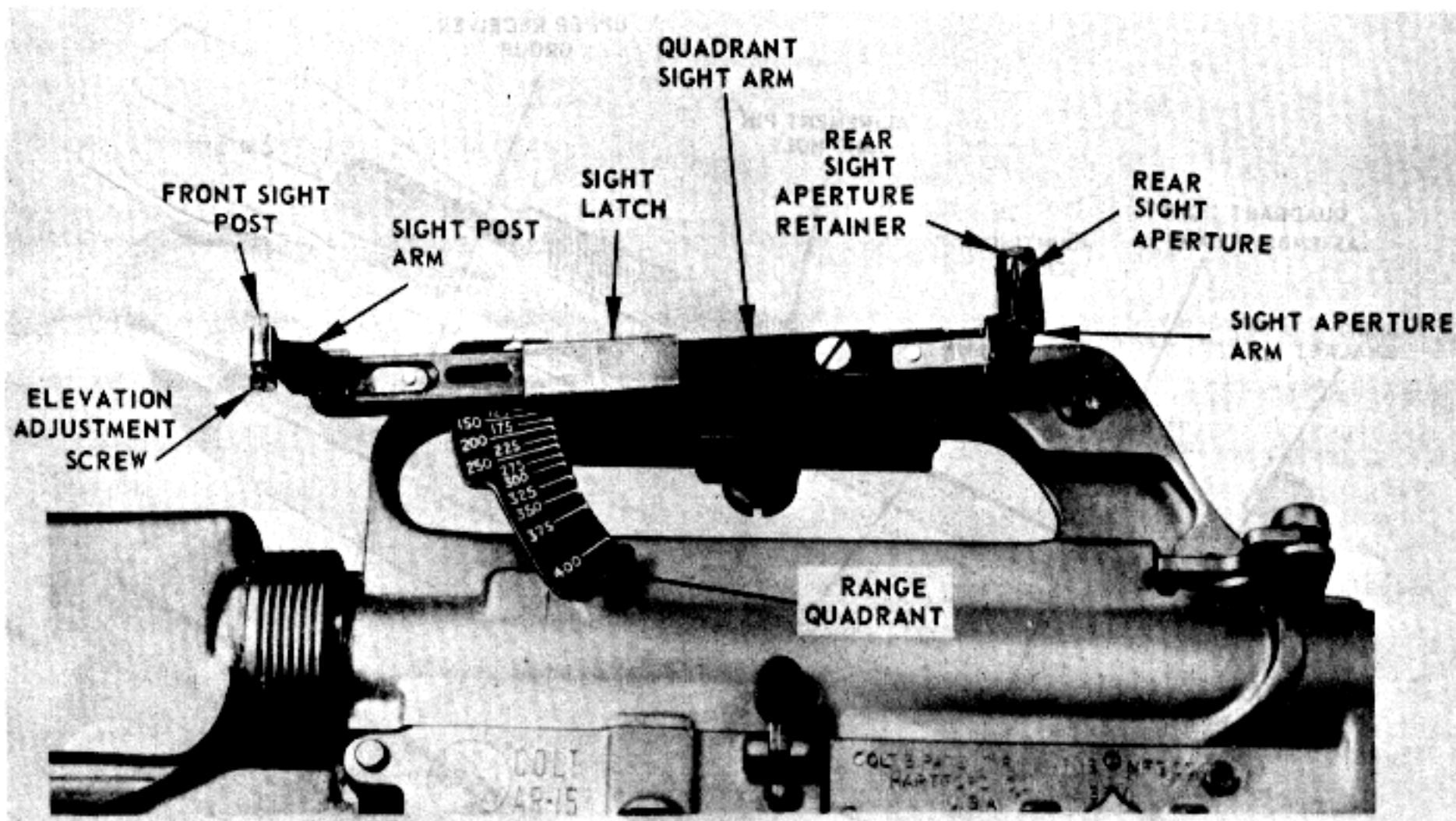

(2) Controls.  
 Figure 2-5.—Continued.

zero line in the center of the scale and two lines spaced equally on each side of the zero line. When making minor adjustments in deflection while

zeroing the launcher, one increment on the windage scale will move the impact of the projectile  $1\frac{1}{2}$  meters at a range of 200 meters.



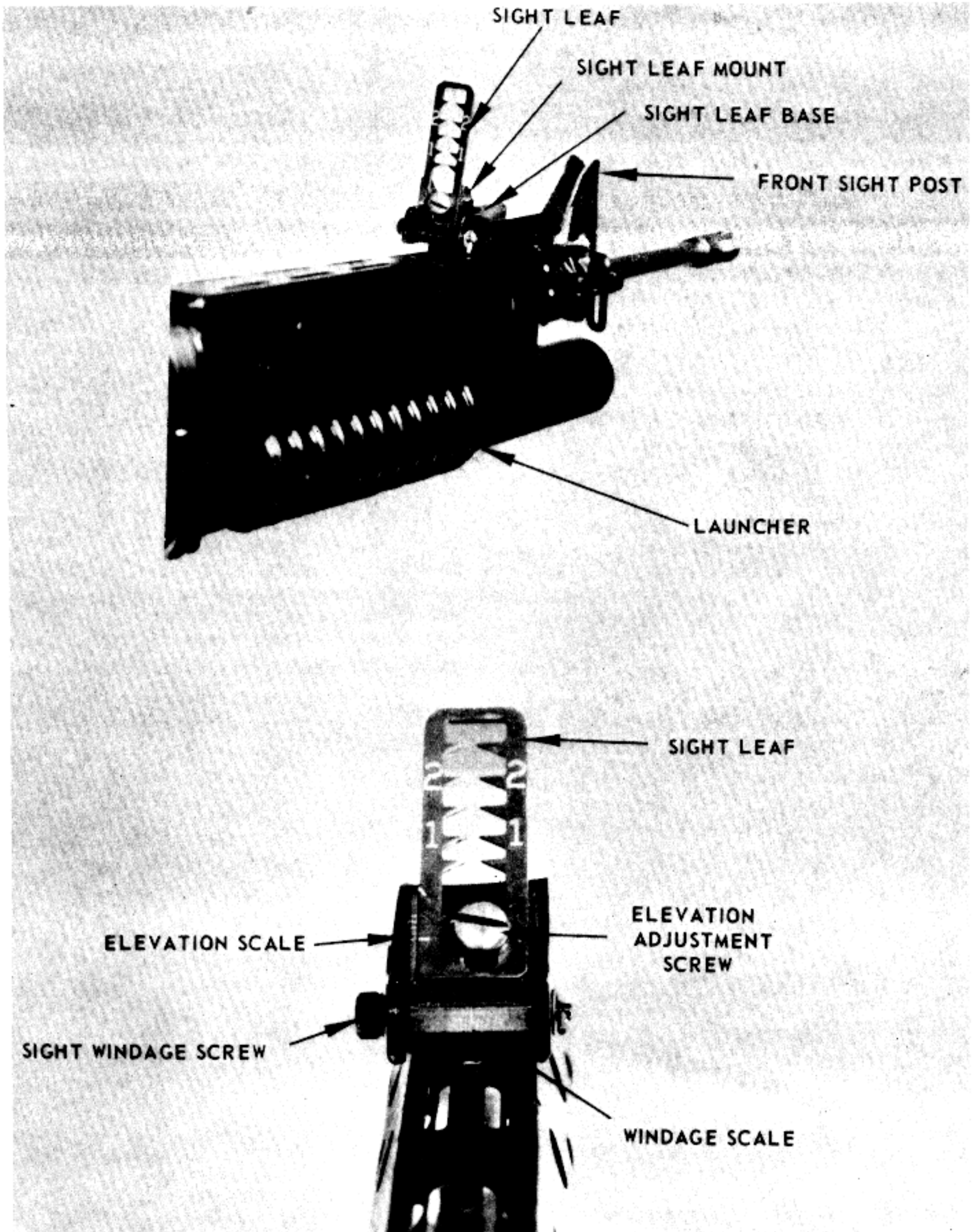

Figure 2-6. Grenade launcher, sight leaf, and front sight post of the M16A1 rifle.

## CHAPTER 3

## MECHANICAL TRAINING, OPERATION AND FUNCTIONING

## Section I. Disassembly and Assembly

## 3-1.

This chapter contains instructions for mechanical training, operation and functioning of the 40-mm grenade launcher, M203.

## 3-2. General Disassembly

Grenadiers are authorized to disassemble the launcher as follows:

*a.* Clear the weapon by depressing barrel latch and sliding the barrel assembly forward (fig 2-4). Inspect the breech to insure that no round is present.

*b.* Loosen the mounting screw and remove the quadrant sight assembly from carrying handle of the M16/M16A1 rifle (1, fig 2-5).

*c.* There are two methods for removing the barrel assembly:

(1) Depress the barrel latch and slide the barrel assembly forward. From the muzzle of the M16A1, count back to the fourth hole on the left side of the handguard. Insert one end of a section of cleaning rod into the fourth hole, depress the barrel stop, and slide the barrel assembly off the receiver track (1, fig 3-1).

(2) Remove the handguard and sight assembly, push down on the slip ring of the M16A1, pulling down and out on the base. Depress the barrel latch and slide the barrel assembly forward. Then depress the barrel stop and slide the barrel assembly from the receiver track (2, fig 3-1).

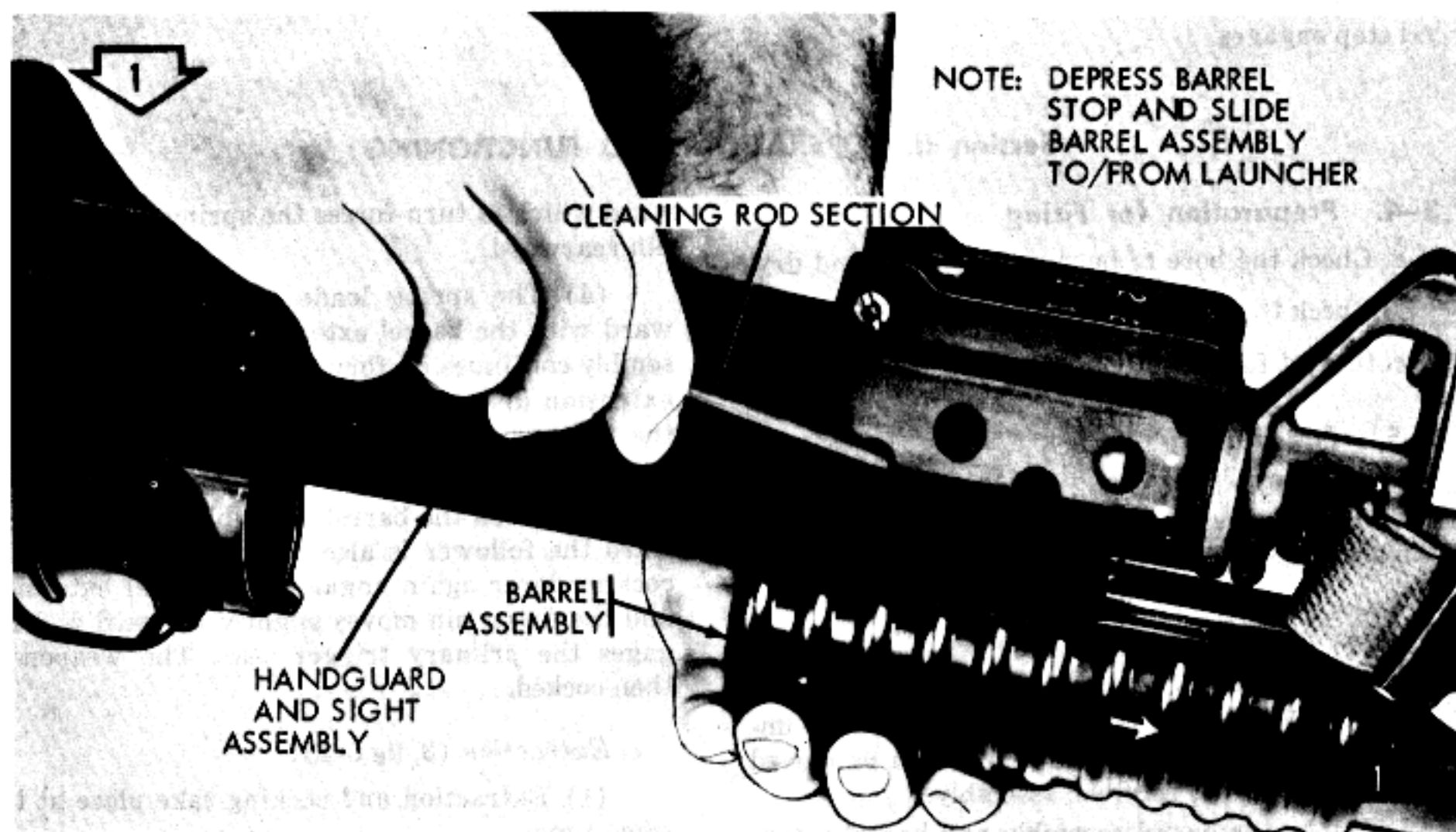

(1) First Method

Figure 3-1. Removal of barrel assembly.

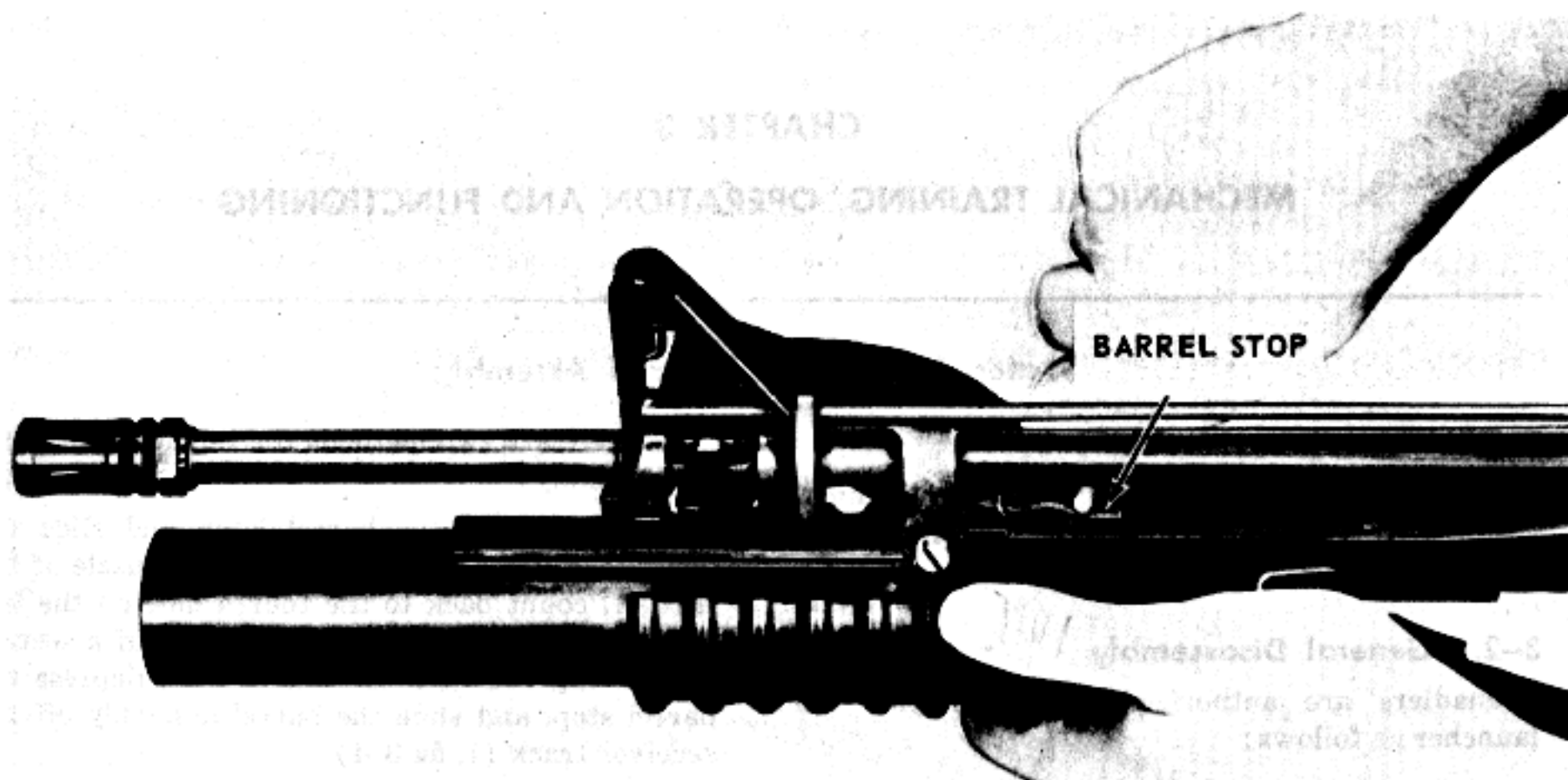

(2) Second Method  
 Figure 3-1. Removal of barrel assembly.

### 3-3. Assembly

Assembly of the grenade launcher is the reverse of disassembly.

a. Slide barrel assembly onto receiver until barrel stop engages.

b. Install quadrant sight bracket assembly and quadrant sight assembly clamp to carrying handle of the M16/M16A1 rifle, then tighten mounting screw.

## Section II. OPERATION AND FUNCTIONING

### 3-4. Preparation for Firing

- Check the bore to be sure it is clear and dry.
- Check the launcher to be sure it is clean.
- Inspect for defective parts.

### 3-5. Functioning

a. *Unlocking* (1, fig 3-2). Unlocking is accomplished by depressing the barrel latch and sliding the barrel assembly forward.

b. *Cocking* (2, fig 3-2).

(1) The weapon is cocked when the barrel assembly is opened.

(2) The barrel latch, when depressed, unlocks the barrel assembly so that it can be moved forward along the receiver assembly.

(3) As the barrel assembly and barrel extension, which are interlocked with the cocking lever, move forward, the cocking lever is forced down-

ward which in turn forces the spring loaded firing pin rearward.

(4) The spring loaded follower moves forward with the barrel extension. As the barrel assembly continues its forward movement the barrel extension disengages from the cocking lever, and the follower holds the cocking lever in the *down* position.

(5) When the barrel assembly is moved rearward the follower is also forced to the rear. The cocking lever again engages the barrel extension and the firing pin moves slightly forward and engages the primary trigger sear. The weapon is then cocked.

c. *Extraction* (3, fig 3-2).

(1) Extraction and cocking take place at the same time.

(2) As the barrel assembly is opened, a spring loaded extractor keeps the spent cartridge





(1) Unlocking the barrel.

Figure 3-2. Functioning of the launcher.

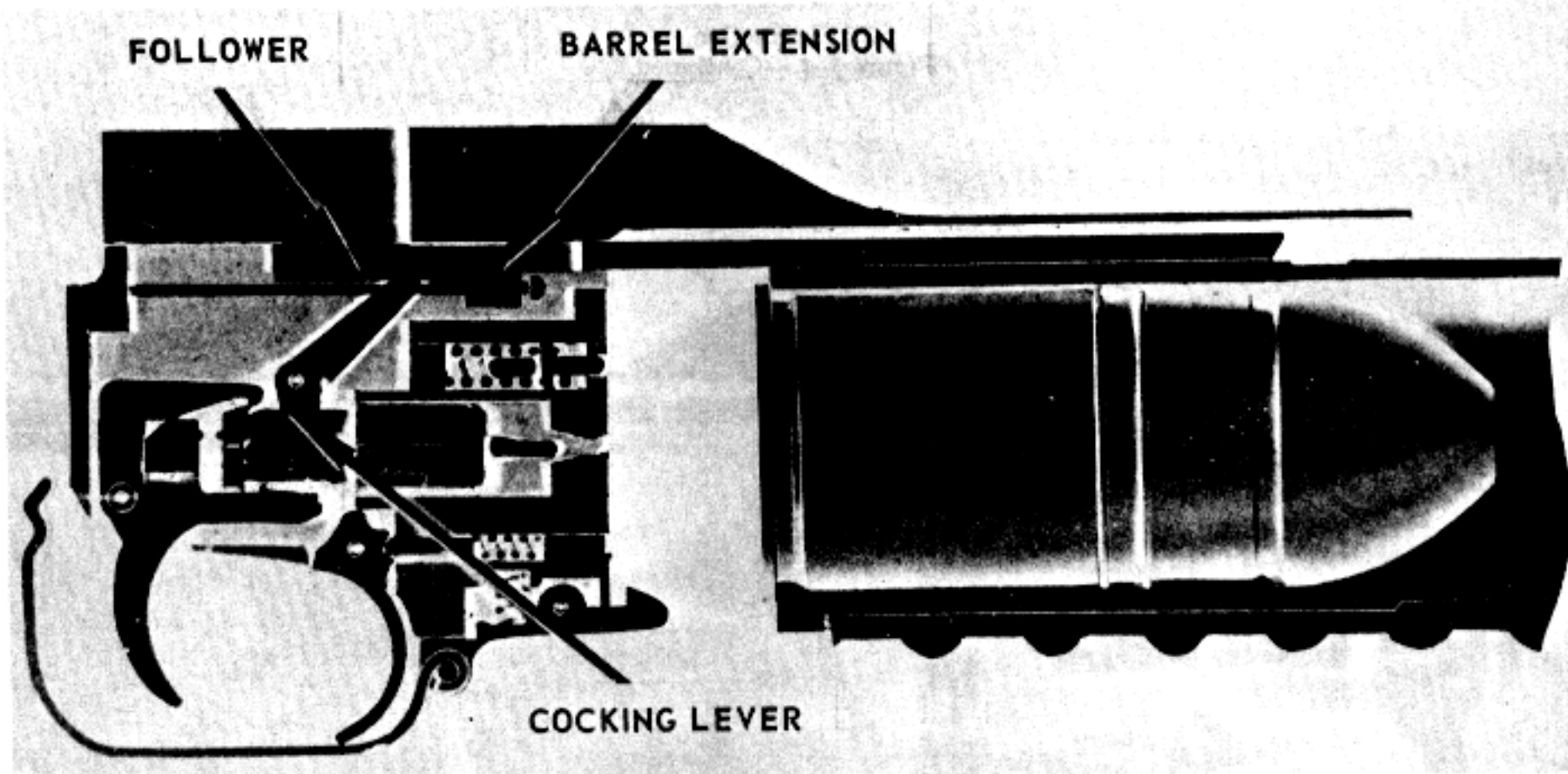

(2) Cocking the launcher.

Figure 3-2.—Continued.

seated against the receiver until the barrel is clear of the cartridge case.

*d. Ejection* (4, fig 3-2). Ejection is accomplished by a spring loaded ejector pushing the expended cartridge case or live round from the barrel assembly.

*e. Loading* (1, fig 3-3). When the barrel assembly is in the open position the cartridge is inserted into the breech end of the barrel.

*f. Chambering* (2, fig 3-3).

(1) Chambering takes place during the closing of the barrel assembly.

(2) As the breech end of the barrel assembly closes the extractor contacts the rim of the cartridge and the round is firmly seated.

*g. Locking* (3, fig 3-3). As the barrel assembly closes, the barrel latch becomes engaged to the

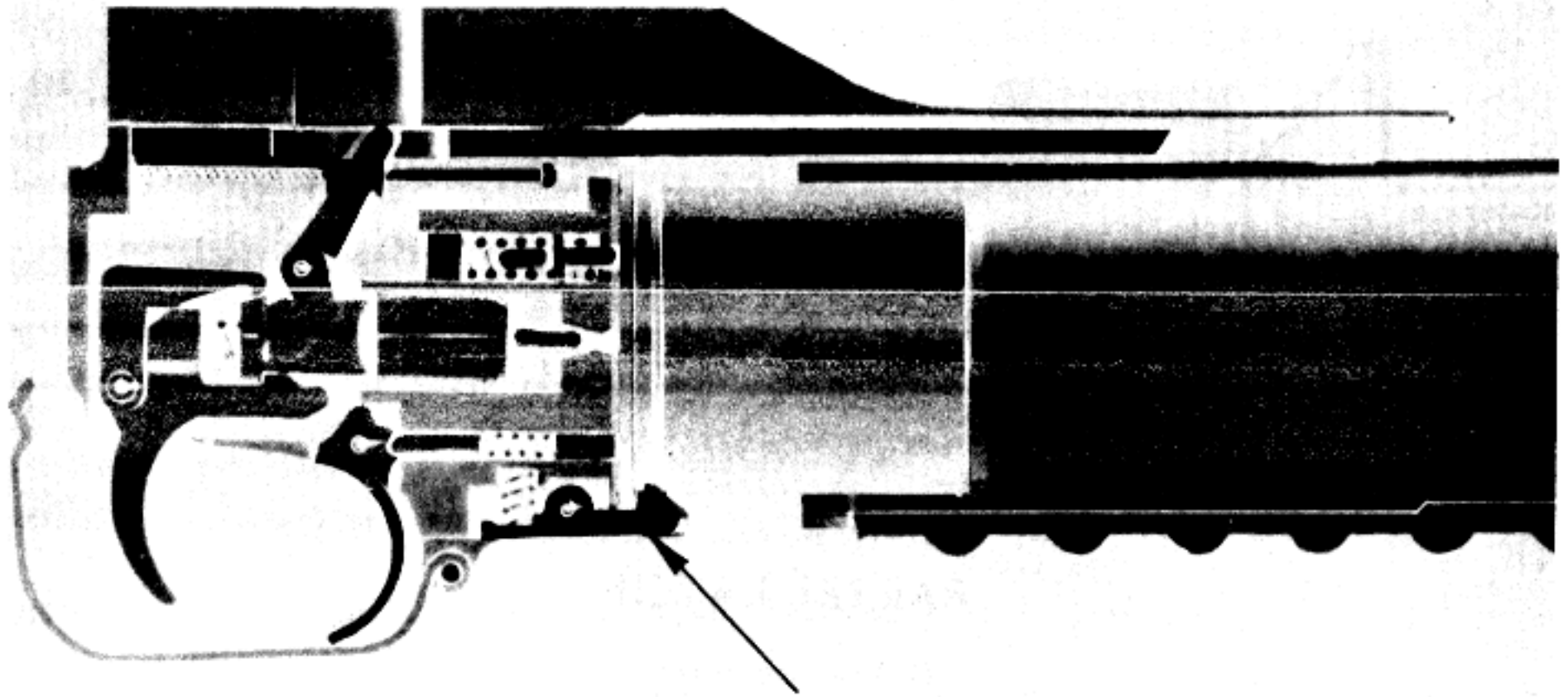

EXTRACTOR

(3) Extraction.  
*Figure 3-2.—Continued.*

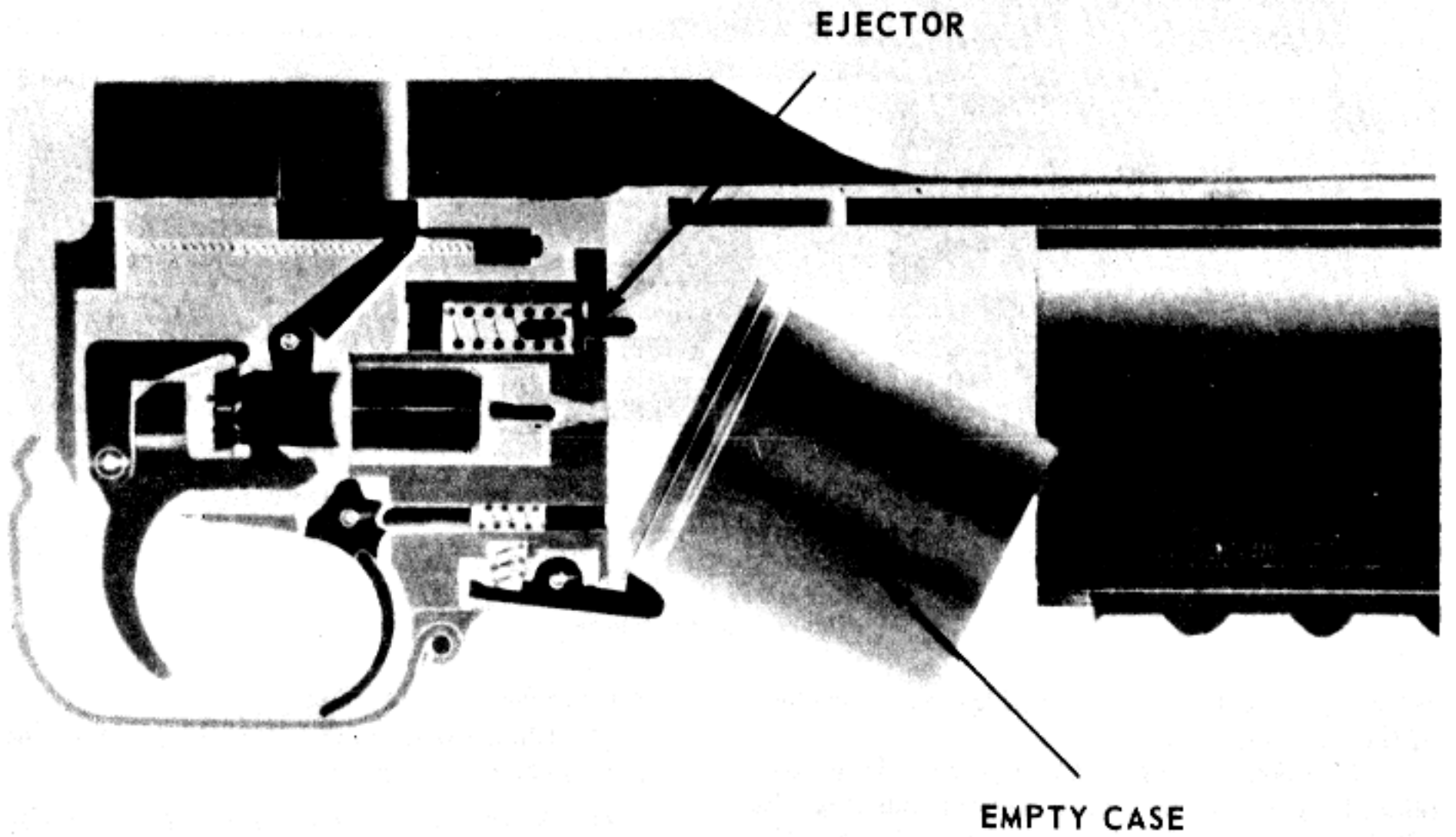

EJECTOR

EMPTY CASE

(4) Ejection.  
*Figure 3-2.—Continued.*

barrel assembly and the cocking lever engages the barrel extension so that it cannot be moved forward along the receiver assembly.

*h. Firing* (4, fig 3-3). As the trigger is pulled

rearward, the primary trigger sear is disengaged from the bottom sear surface of the firing pin, releasing the spring driven firing pin and causing it to be forced forward against the primer of the cartridge.

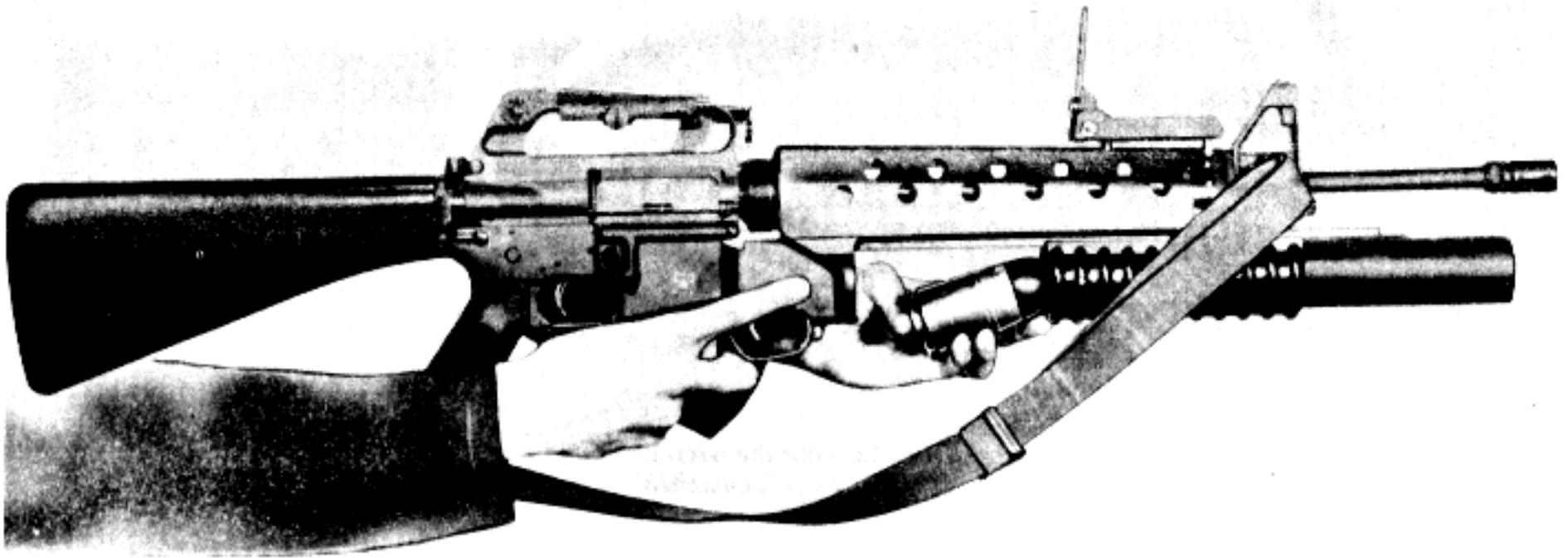

(1) Loading the launcher.  
*Figure 3-3. Operating the launcher.*

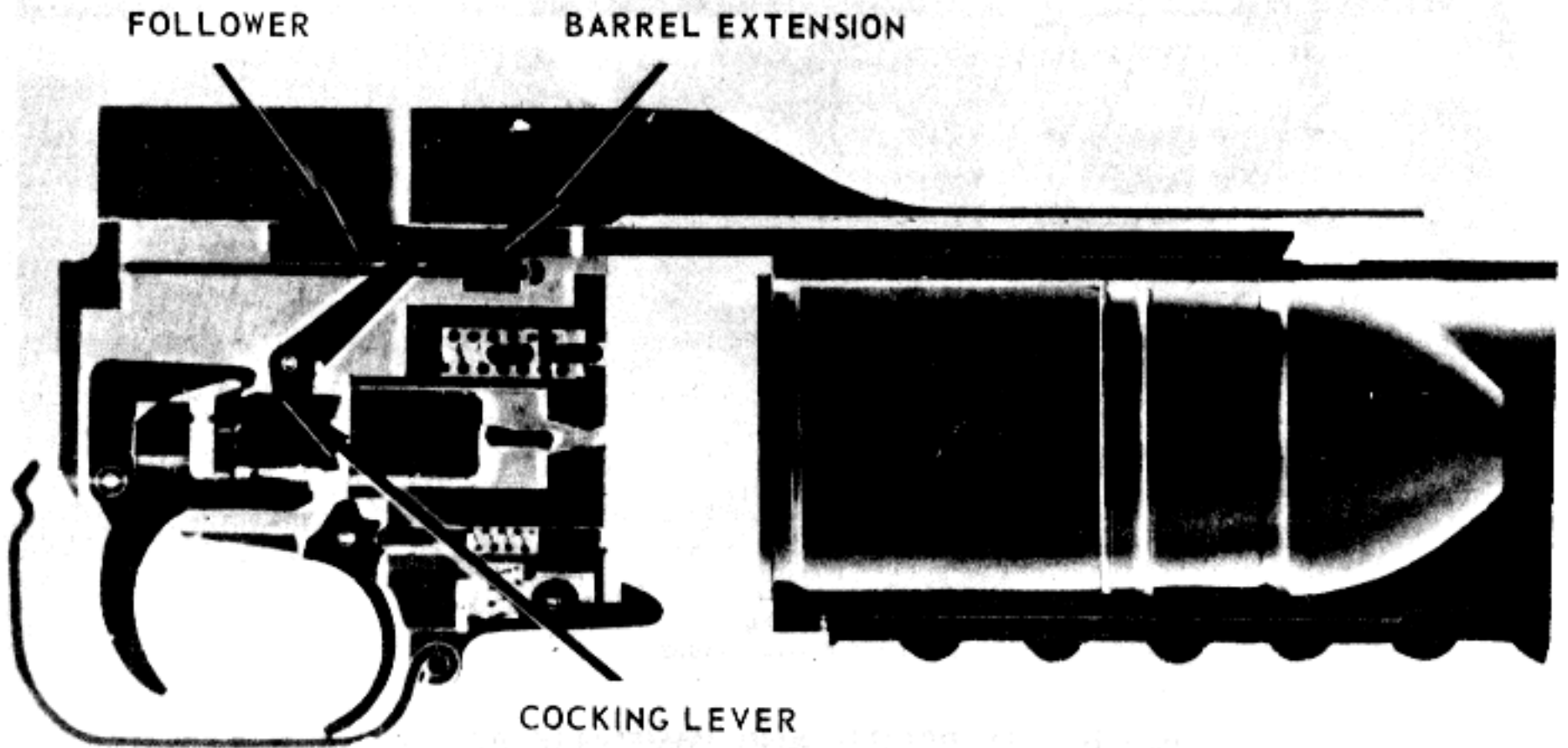

(2) Chambering.  
*Figure 3-3.—Continued.*

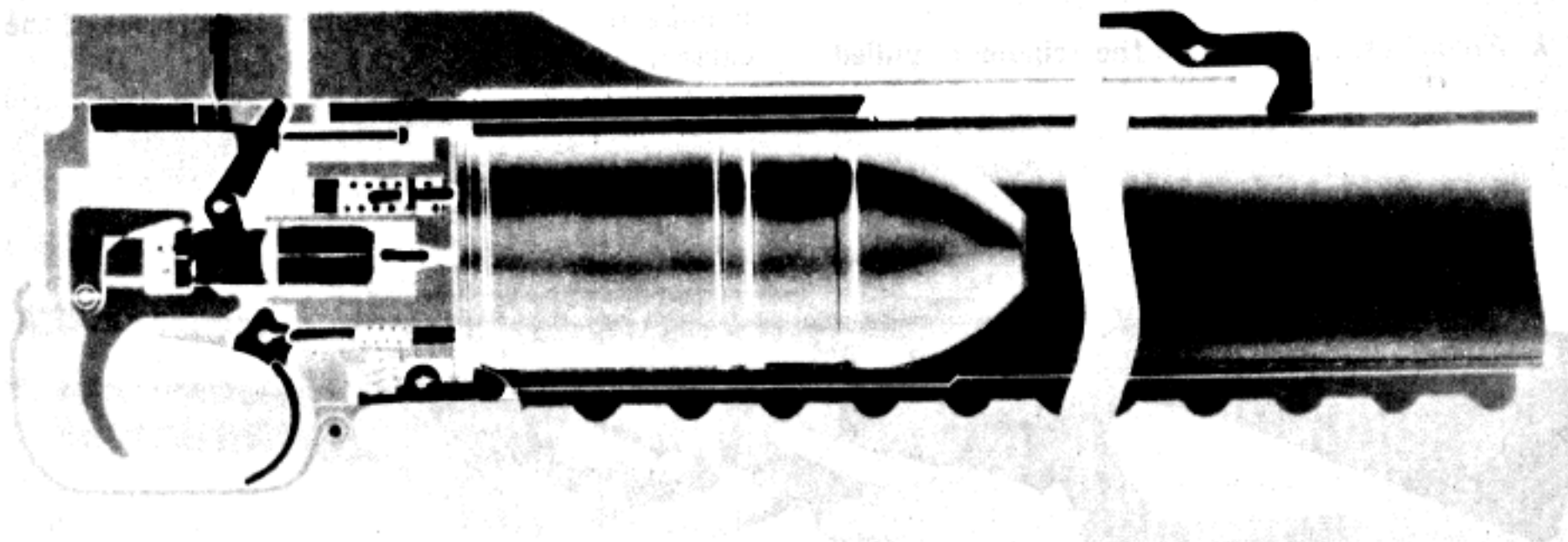

(3) Locking the barrel.  
 Figure 3-3.—Continued.

FIRING PIN

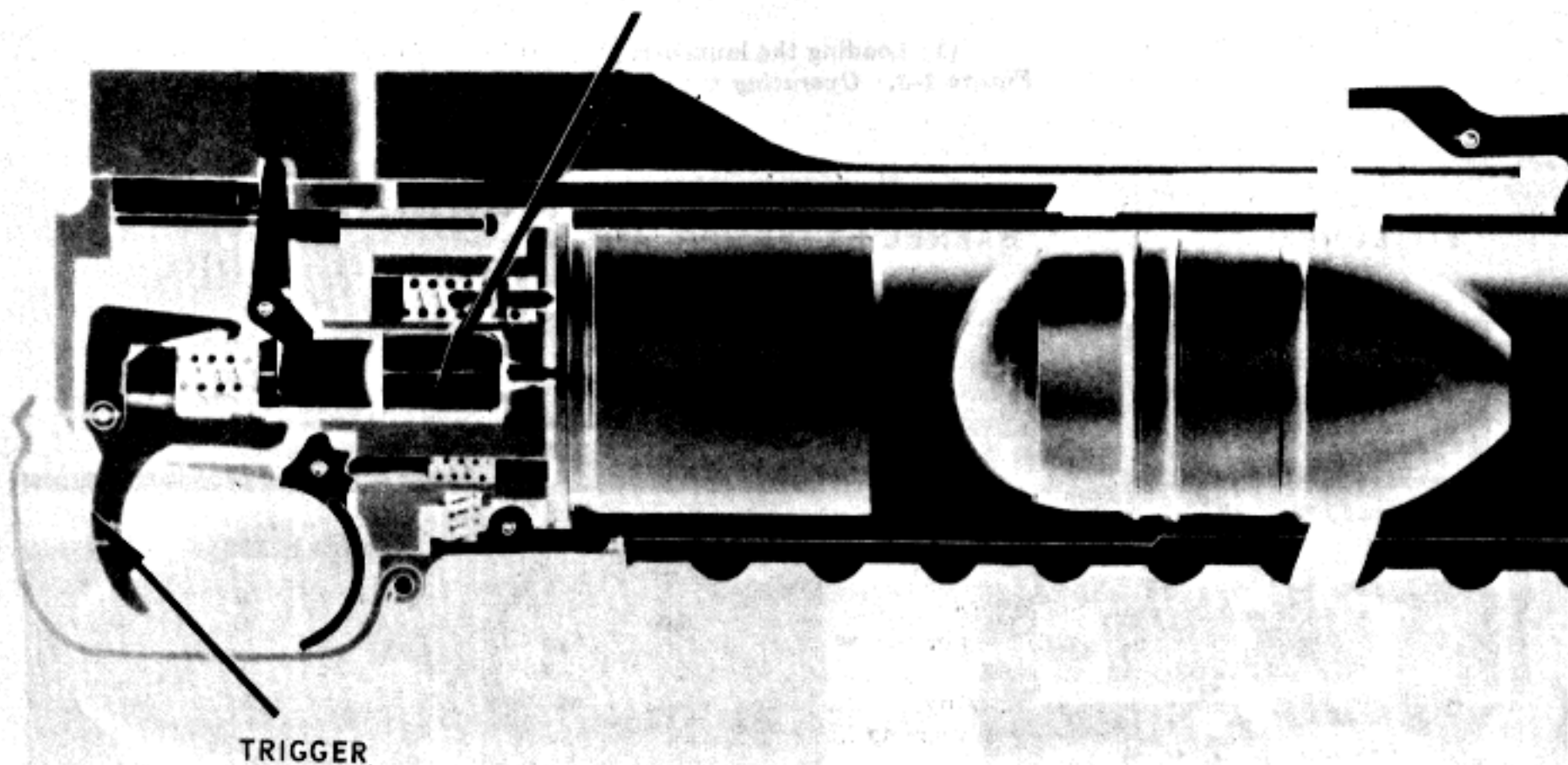

TRIGGER

(4) Firing.  
 Figure 3-3.—Continued.

### Section III. STOPPAGES AND IMMEDIATE ACTION

#### 3-6. Stoppage

a. A stoppage is any unintentional interruption in the functioning of the weapon. Some common stoppages are: a failure to fire, a failure to chamber, a failure to extract, a failure to cock.

b. Immediate action is the unhesitating application of a probable remedy without considering the cause of the stoppage. To apply immediate action, follow the same procedure prescribed for a failure to fire in paragraph 3-8.



c. Troubleshooting is the systematic study of trouble signs, testing to determine the defective part, and applying corrective action (chart 3-1).

### 3-7. Hangfire and Misfire

a. *Hangfire.* A *hangfire* is a delay in the functioning of a propelling-charge-explosive-train at the time of firing. The amount of delay is unpredictable, but in most cases it falls in the range of a split second to 30 seconds. Any failure to fire *must* be considered to be a hangfire until that possibility has been eliminated.

b. *Misfire.* A *misfire* is a complete failure to fire. A misfire in itself is not dangerous, but since it cannot be immediately distinguished from a delay in the functioning of the firing mechanism or a hangfire, it *must* be considered to be a hangfire until proven otherwise. A delay in the functioning of the firing mechanism could result from the presence of grit, sand, frost, ice, or excess oil or grease.

### 3-8. Failure to Fire

After a failure to fire, due to the possibility of a misfire or hangfire, the following precautions must be observed until the round has been removed from the weapon and cause of failure determined:

a. Shout "MISFIRE," keep the weapon trained on the target, and all troops clear of the muzzle.

*Warning:* Before attempting to remove the round from the grenade launcher, men not required for the operation must be cleared from the vicinity.

b. Wait 30 seconds from the time of failure to fire before opening the breech for unloading procedures.

c. Exercise extreme caution during unloading procedures; where circumstances permit, either catch the ejected round or reduce the distance of free fall to ground.

d. After the round has been removed from the receiver, determine whether the round or the firing mechanism is defective. Examine the primer to see if it has been dented. If the primer has not been dented, the firing mechanism is at fault. The round may be reloaded and fired after the cause of the failure to fire has been corrected.

e. If the primer has been dented, keep the round separate from other ammunition until it can be properly disposed of.

f. Shouting "MISFIRE" should apply only to training situations.

Chart 3-1. Troubleshooting

Malfunction	Probable cause	Corrective action
Failure to fire	Safety on	Place in fire position.
	Empty chamber	Load Weapon.
	Faulty ammunition	Reload.
	Water or excess lubricant in firing pin well	Hand cycle wpn several times to include pulling the trigger.
	Worn or broken firing pin	Replace.*
	Dirt or residue in firing pin recess	Clean.
	Burred sear or firing pin	Replace.*
Failure to cock	Dirty firing pin well opening	Clean firing pin well opening.*
	Weak or broken firing pin spring	Replace.*
	Broken sear	Replace.*
Failure to lock	Improper assembly of cocking lever	Reassemble.*
	Loose, broken, or missing cocking lever spring pin	Replace.*
Failure to chamber.	Excess plastic on breech end of barrel assembly	Trim excess plastic until barrel assembly will lock.*
	Dirty follower assembly or receiver cavity	Clean.
Failure to extract.	Faulty ammunition	Reload.
	Dirty chamber	Clean bore and chamber.
Failure to extract.	Defective extractor on spring or spring pin	Replace.*
	Ruptured cartridge case	Remove from barrel.

\*Procedures to be accomplished by DS/GS Maintenance.

Chart 3-1. Troubleshooting—Continued

Malfunction	Probable cause	Corrective action
Failure to eject	Worn, broken, or missing ejector spring or retainer.	Replace.*
Safety fails to stay in position.	Broken or worn safety or missing spring pin	Replace.*
Sight will not stay in selected position.	Sight mounting machine screw loose	Tighten screw or replace if dented or broken.

\*Procedures to be accomplished by DS/GS Maintenance.

*[The following text is extremely faint and largely illegible due to the quality of the scan. It appears to be a detailed troubleshooting procedure or maintenance manual section.]*

## CHAPTER 4

### AMMUNITION

#### 4-1. General

The 40-mm cartridge is a fixed-type munition which consists of two major assemblies (fig 4-1): the cartridge case and the projectile.

#### 4-2. Cartridge Case

The aluminum cartridge case is made with an integral propellant retainer. Into this retainer is inserted a thin-walled brass cup containing the propellant. An aluminum base plug which seals the base of the cartridge case is then pressed into the propellant retainer.

#### 4-3. Types

a. There are five standard "A" types of 40-mm ammunition for use with the launcher: HIGH EXPLOSIVE (HE), HIGH EXPLOSIVE AIRBURST (HE AIRBURST), HIGH EXPLOSIVE SMOKELESS AND FLASHLESS, AND HIGH EXPLOSIVE DUAL PURPOSE (HEDP), and TRAINING PRACTICE (TP) (fig 4-2).

(1) The HIGH EXPLOSIVE ROUNDS contain a grenade 1.5 inches in diameter with about 1.25 ounces of explosive (fig 4-1). The grenade is formed of rectangular-wrapped steel wire. The wire is notched at intervals to allow for fragmentation upon detonation of the grenade.

(2) The PRACTICE ROUND is ballistically matched to the high explosive (HE) round and is filled with a yellow dye powder. Upon impact, the fuze booster breaks open the grenade and disperses the powder as a puff of yellow smoke which is visible out to the maximum range of the launcher.

b. Both standard and developmental ammunition (app B) designed for the 40-mm grenade launcher, M79, is normally adaptable to the M203 grenade launcher.

**Warning:** MAKE NO ATTEMPT UNDER ANY CONDITIONS TO FIRE 40-MM HIGH VELOCITY AMMUNITION IN THE M203 GRENADE LAUNCHER. (This ammunition is for

use in automatic grenade launchers. Those rounds are longer and more powerful than the ammunition made for the M203/M79 weapons.)

#### 4-4. Identification (fig 4-2)

The HE (406), HE (463), and TP (M407A1) are identical in size and shape. However, the weight of the M463 is slightly greater than the M406 or the M407A1. There are two notches on the rim of the M463 to identify it during the hours of limited visibility. The appearance of the HE airburst round differs from the M406, M463, and M407A1, in that the skirt is longer and the ogive is smaller. However, the size and weight of the HE airburst and the HE (M433) dual purpose round are almost identical. The M406, M433, and M397 have gold colored ogives, while the M407A1 has a silver colored ogive and the M463 has a black colored ogive.

#### 4-5. Fuzes

The M552 and M551 impact detonating fuzes are used with the HE and the TP rounds. The M552 fuze arms by a spin action and is armed about 8 meters from the muzzle. The M551 fuze arms by a spin and setback action and must travel between 14 and 28 meters before being armed (fig 4-1). The HE airburst round is equipped with the M586 fuze that incorporates the same spin and setback action as well as the same arming distance as the M551 fuze. Upon impact the fuze ignites a separation charge assembly which ejects a grenade into the air. At a height of about 5 feet the grenade explodes into fragments.

#### 4-6. High-Low Propulsion System (fig 4-3)

To propel a 40-mm projectile from a shoulder fired weapon requires a high-low propulsion system. This system functions as follows: when the firing pin strikes the primer, the primer flash ignites the propellant which is contained within the brass powder-charge cup inside the high pressure chamber. The burning propellant creates a pres-

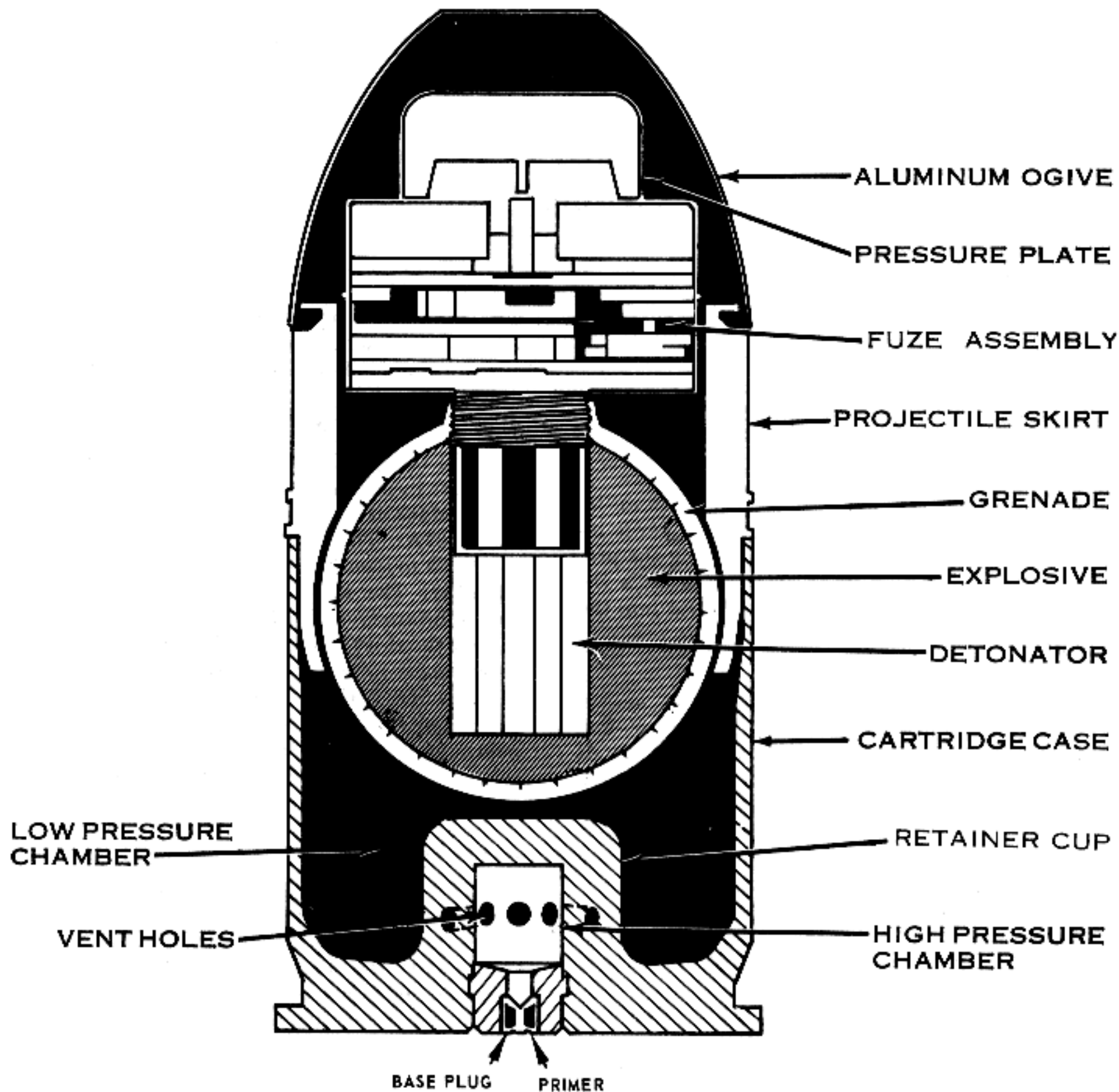
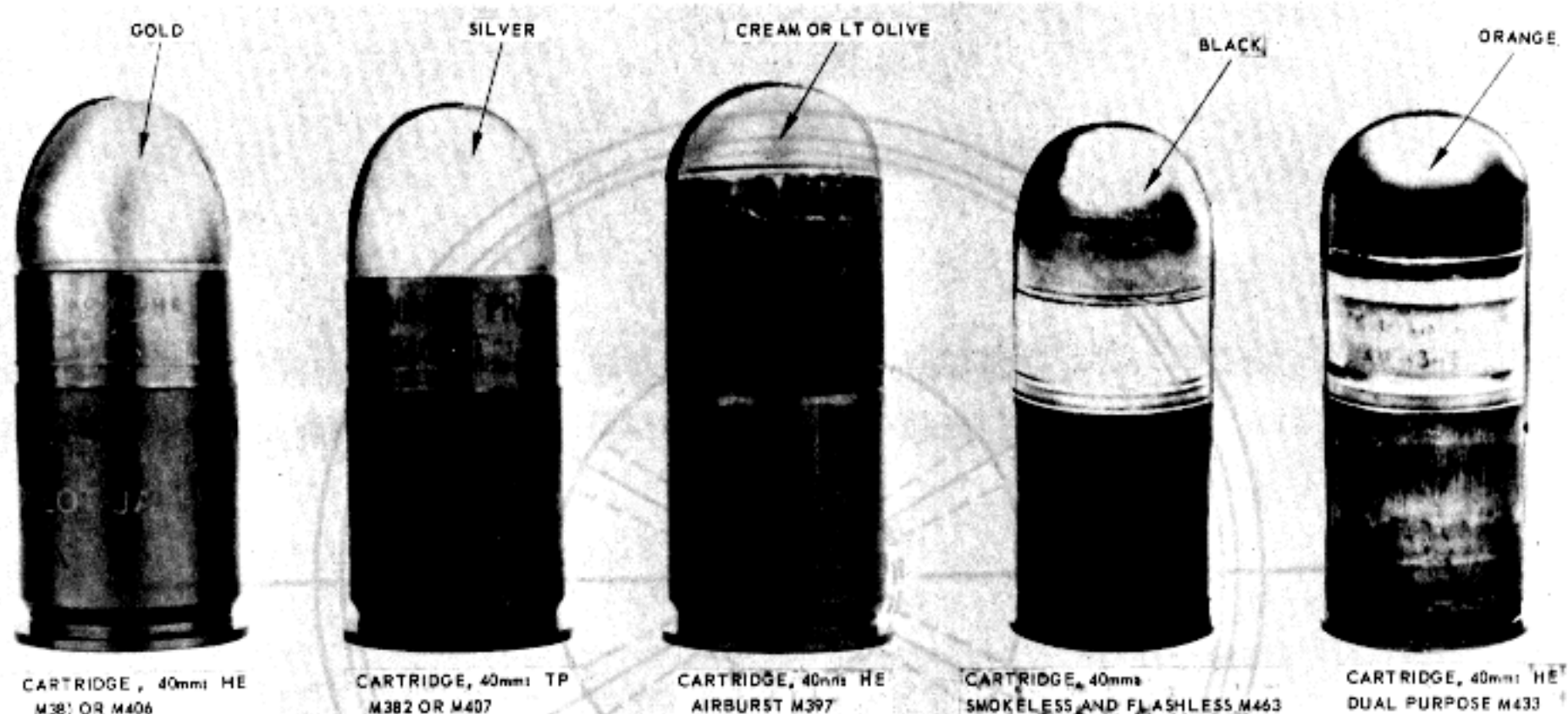

Figure 4-1. Cross section of the 40-mm cartridge, HE round.

sure of 35,000 pounds per square inch within the high pressure chamber, causing the brass powder-charge cup to rupture at the vent holes. As the vent holes rupture, the gases flow into the low pressure chamber (interior portion of the cartridge case). As the gases enter the larger area, the pressure is reduced to 3,000 pounds per square

inch which is sufficient to propel the projectile through the barrel and to the target. The grenade leaves the barrel of the launcher with a muzzle velocity of 250 feet per second and a right-hand spin of 37,000 revolutions per minute. The spin stabilizes the grenade during flight and provides rotational forces necessary to arm the fuze.





*Figure 4-2. Some standard 40-mm cartridges available for use with the grenade launcher, M208.*

#### 4-7. Effective Casualty Radius

The high explosive grenade has an effective casualty radius of 5 meters. The effective casualty radius is defined as the radius of a circle about the point of detonation in which it may be expected that 50 percent of exposed troops will become casualties.

#### 4-8. Combat Load

The recommended minimum combat load is 36 rounds of HE 40-mm ammunition.

#### 4-9. Packing (fig 4-4)

All HE and TP ammunition is packed in wooden boxes containing 12 bandoleers of 6 rounds each for a total of 72 rounds.

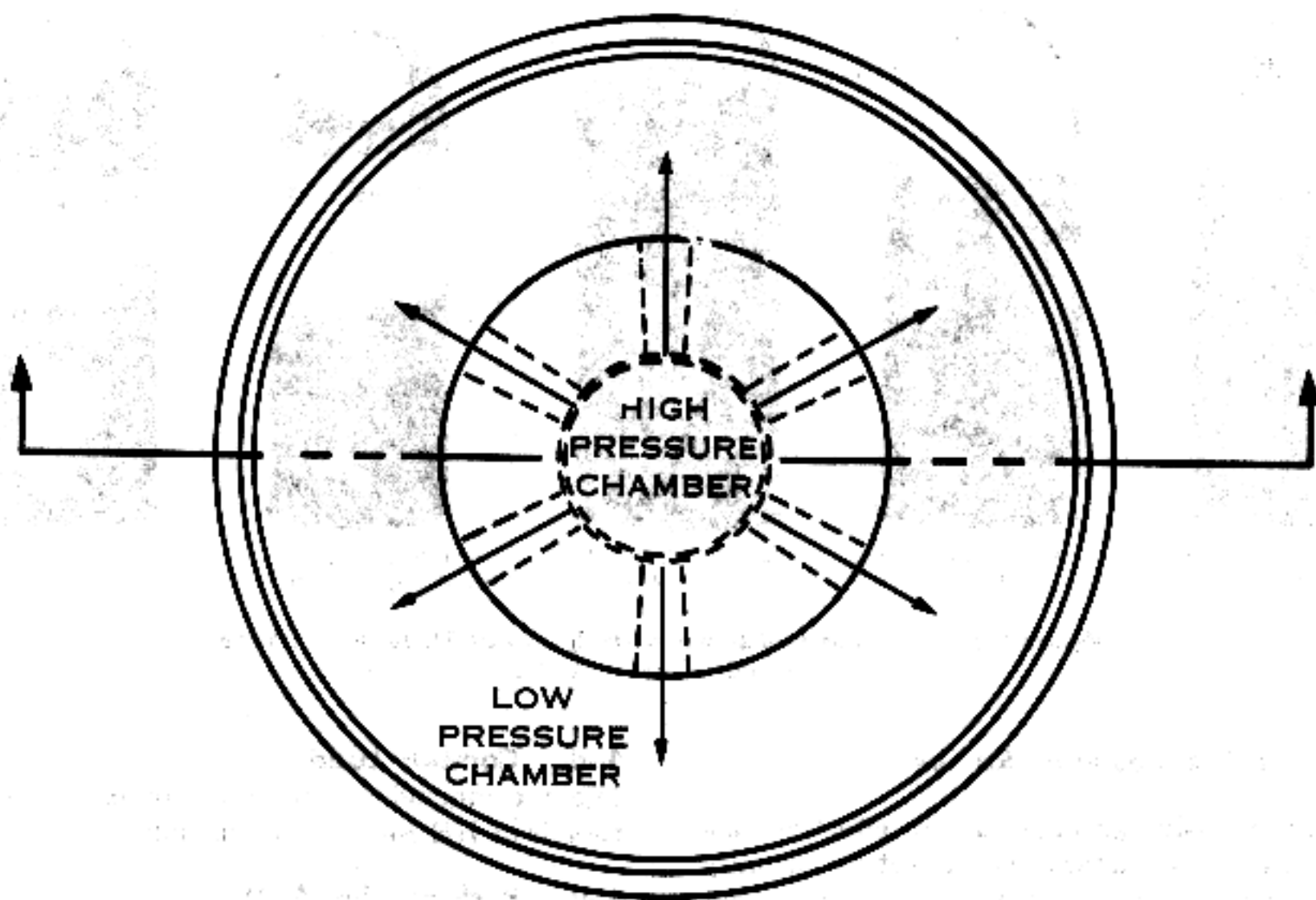

WHEN IGNITED BY THE PRIMER, THE PROPELLANT ENCLOSED IN THE BRASS POWDER CHARGE CUP (HIGH PRESSURE CHAMBER) RUPTURES THE CUP AT THE VENT HOLES AND IS VENTED INTO THE REMAINDER OF THE CARTRIDGE CASE (LOW PRESSURE CHAMBER)

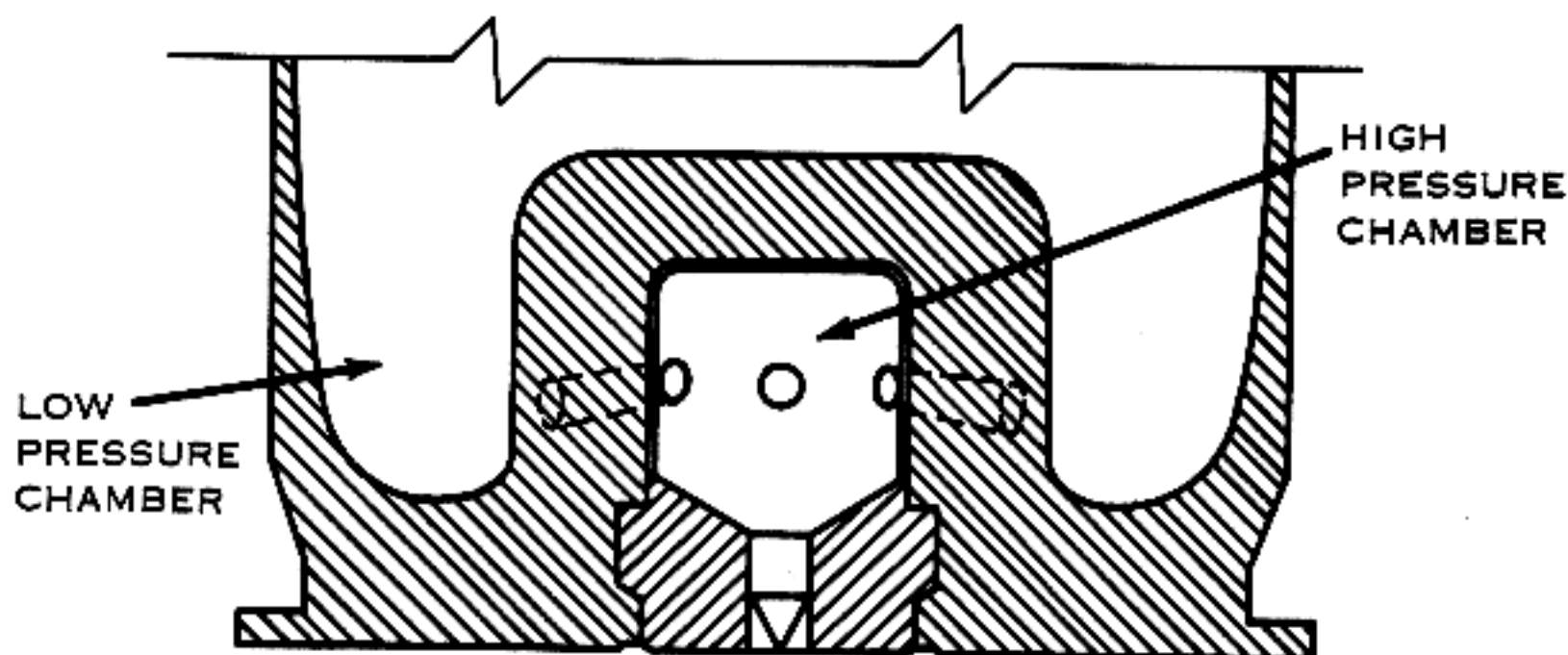

Figure 4-3. High-low propulsion system.

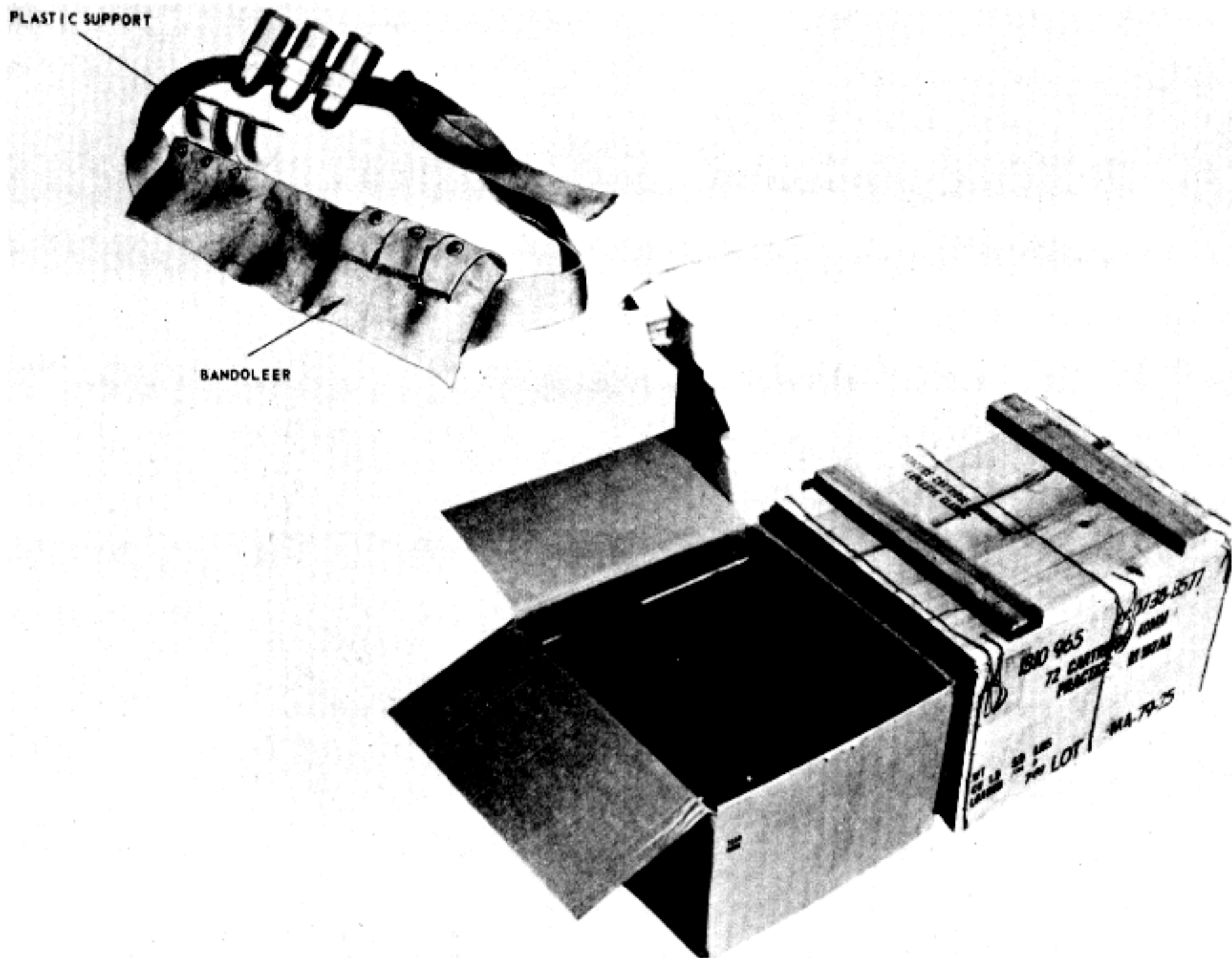

Figure 4-4. 40-mm ammunition bandoleer and packaging.

## CHAPTER 5

### MAINTENANCE

#### 5-1. General

Maintenance includes all measures taken to keep the launcher in operating condition. This includes cleaning, inspection for defective parts, lubrication, and repair.

#### 5-2. Cleaning Material, Lubricants, and Equipment

##### a. Cleaning Materials.

(1) Rifle bore cleaner (RBC) is used for cleaning the bore of the launcher and provides temporary protection from corrosion.

(2) Any dry cleaning solvent that does not contain acid can be used for cleaning the launcher of grease, oil, or corrosion-preventive compounds.

##### b. Lubricants.

(1) Military lubricant, MIL-L-46000A (LSA) is used for lubricating the launcher at temperatures of  $-85^{\circ}$  Farenheit and above.

(2) Weapons lubricating oil MIL-L-141078 is used at temperatures below  $0^{\circ}$  F.

##### c. Equipment.

(1) A set of maintenance equipment is shown in figure 5-1.

(2) Maintenance equipment is carried in a canvas case that can be attached to the universal small arms ammunition pouch or to the front of the universal load carrying equipment harness (fig 5-2).

#### 5-3. Cleaning and Launcher

a. The launcher must be cleaned after it has been fired because firing produces deposits of primer fouling, powder ashes, carbon, and metal fouling. These deposits may collect moisture and promote rust if not removed. The cleaning procedure described below will remove all deposits except metal fouling which should be removed by the unit armorer.

b. After firing, field strip the launcher and clean it as follows:

(1) *Bore.* Attach a clean, dry rag (the size of a handkerchief) to the thong and thoroughly moisten the rag with rifle bore cleaner. Pull the rag through the bore several times. Attach the bore brush to the thong, pull it through the bore several times, and follow this with more damp rags (fig 5-3). Pull dry rags through the bore and inspect each rag as it is removed. The bore is clean when a dry rag is removed which shows no evidence of fouling. Finally, pull a lightly oiled

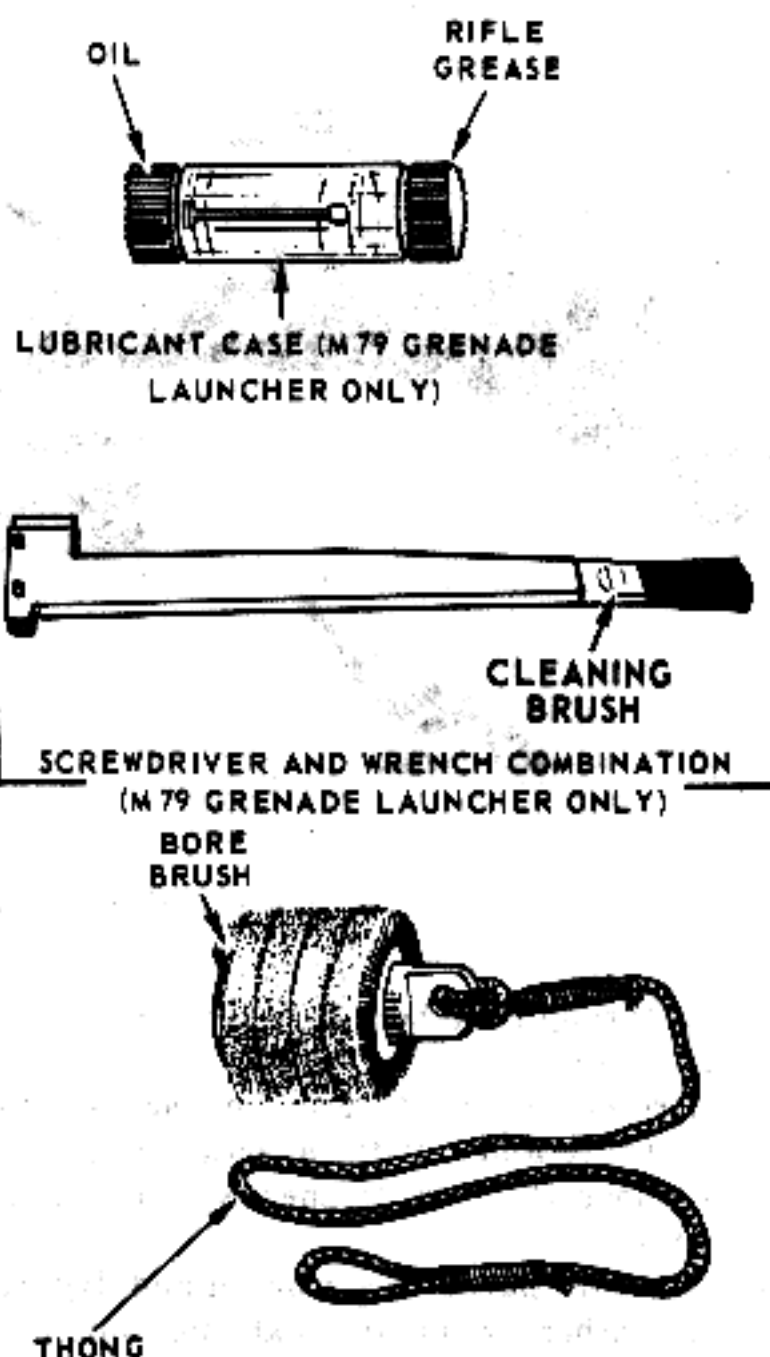

Figure 5-1. Maintenance equipment.

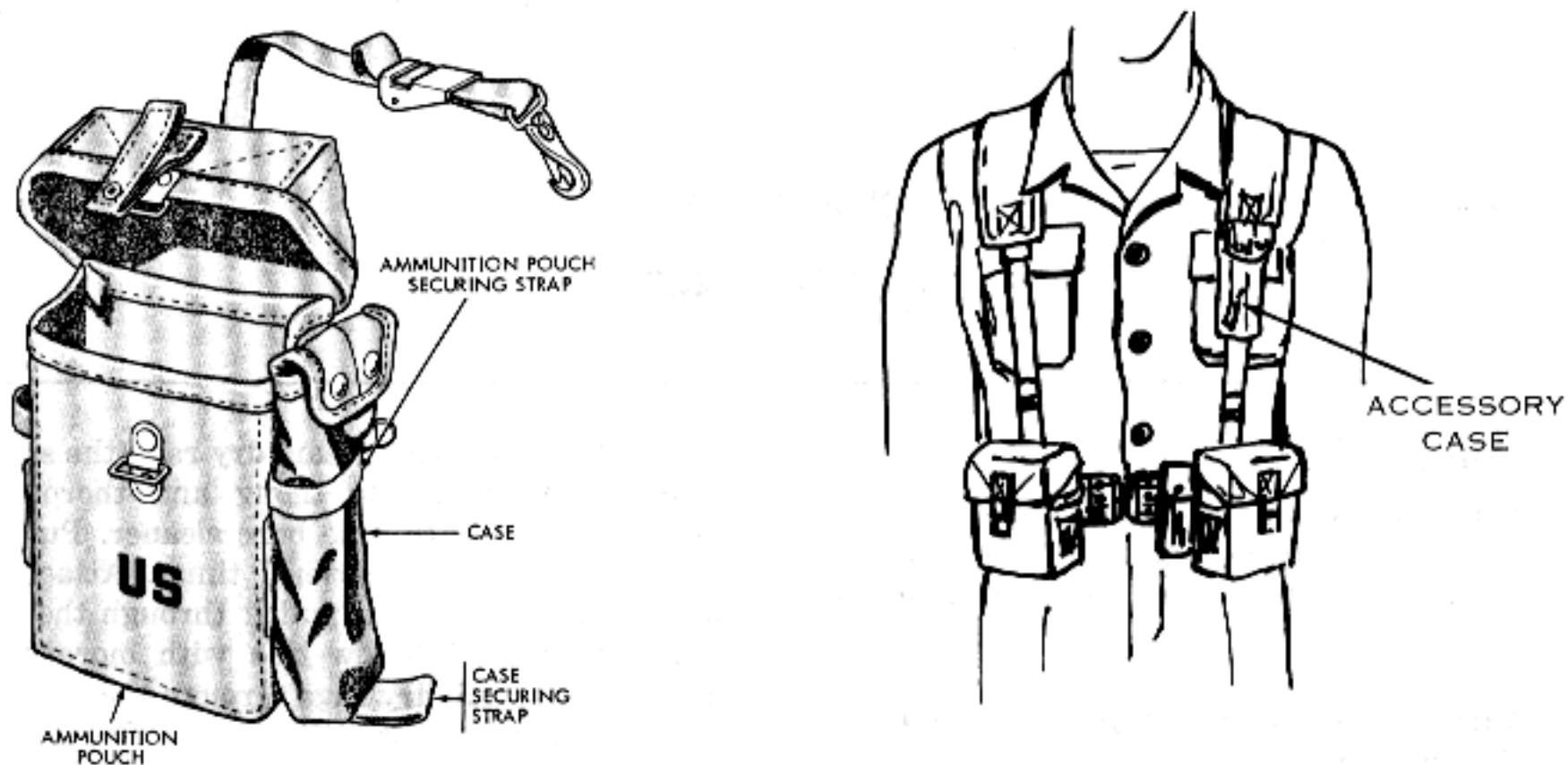

Figure 5-2. Small arms accessories case attached to the universal ammunition pouch or harness.

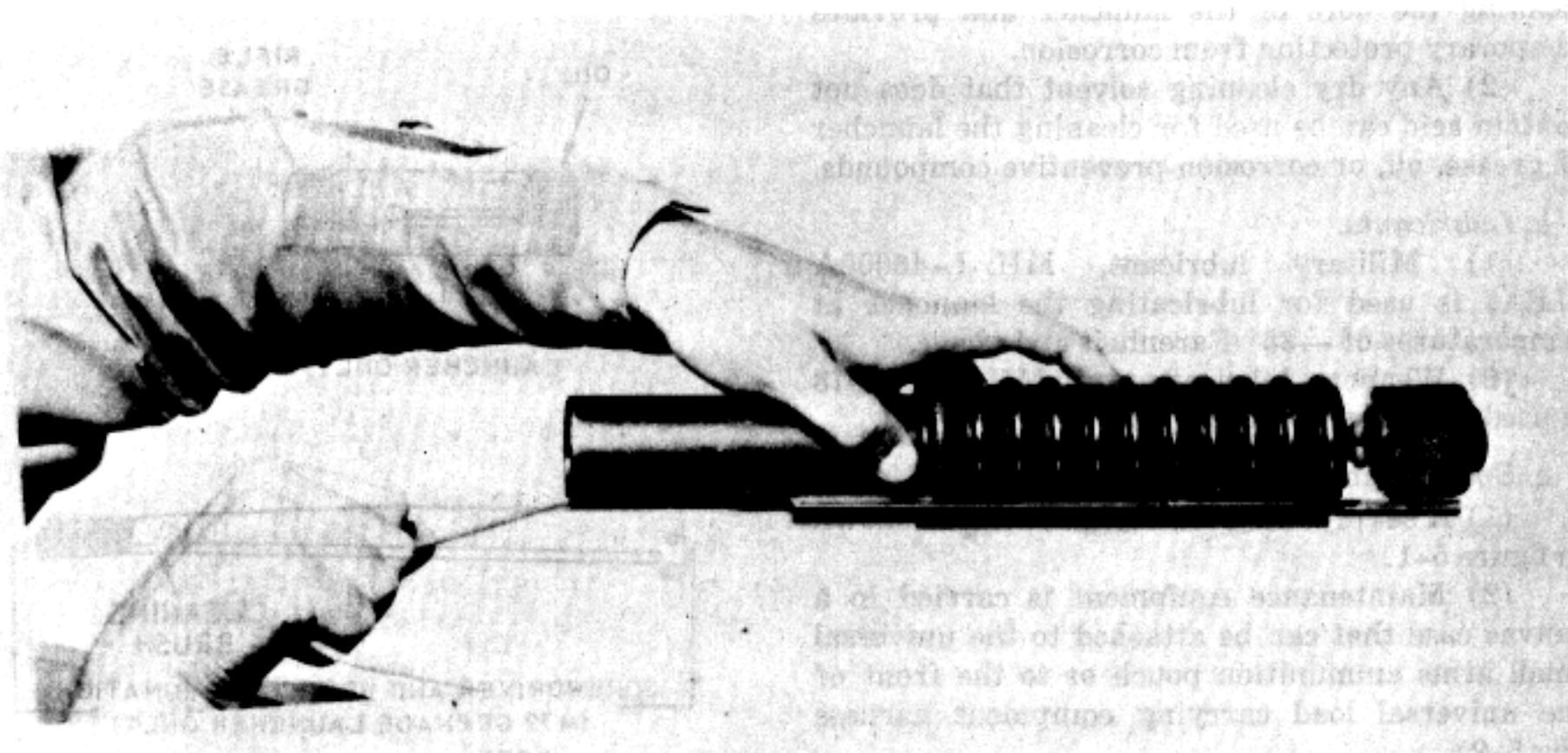

Figure 5-3. Cleaning the bore with thong and bore brush.

(LSA) rag through the bore to leave a light coat of oil inside the barrel.

(2) *Breech insert.* Clean the face of the breech insert retainer with a patch and bore cleaner. Remove the bore cleaner with dry rags, and oil lightly.

(3) *All other parts.* Use a brush and dry rag to clean all other parts and exterior surfaces. Apply a light coat of LSA to the exterior of the launcher after cleaning.

#### 5-4. Normal Maintenance

Inspect the launcher daily for evidence of rust, burred, worn, or cracked parts. Report defects to the armorer for correction. Authorized organizational maintenance for the M203 is shown in chart 5-1.

#### 5-5. Special Maintenance

a. Where the temperature falls below freezing



Chart 5-1. Authorized Organizational Maintenance (AOM)

	Grenadier	Armorer
<b>Grenade launcher:</b>		
Installation/removal on rifle -----	--	X
Cleaning and lubrication -----	X	--
<b>Handguard and sight assembly group:</b>		
Removal/installation -----	X	X
Replace machine screw (sight leaf and sight leaf base) -----	--	X
Replace key washer -----	--	--
Replace sight leaf -----	--	X
Replace handguard -----	--	X
Cleaning and lubrication -----	X	X
<b>Quadrant sight assembly:</b>		
Removal/installation -----	X	X
Replace mounting screw -----	--	X
Replace sight clamp -----	--	X
Replace sight post -----	--	X
Cleaning and lubrication -----	X	X
<b>Barrel assembly:</b>		
Removal/installation -----	X	X
Cleaning and lubrication -----	X	X
<b>Receiver assembly:</b>		
Replace back plate -----	--	X
Replace barrel extension follower -----	--	X

the launcher must be kept free of moisture and excess oil by wiping all metal parts with a clean dry rag after performing normal maintenance. Moisture and excess oil on the working parts cause them to operate sluggishly or fail completely. The launcher must be disassembled and wiped with a clean dry cloth. It is best to keep the launcher as close as possible to outside temperatures at all times to prevent the collection of moisture which occurs when cold metal comes in contact with warm air. If the launcher is brought into a warm room it should be allowed to reach room temperature and be cleaned.

b. In hot, humid climates, or when exposed to a salt water atmosphere, inspect the launcher thoroughly each day for signs of moisture and rust.

c. In hot, dry climates the launcher must be cleaned daily or more often to remove sand or

dust from the bore and working parts. In sandy areas the launcher must be kept dry to prevent the collection of sand. The muzzle and receiver should be kept covered during sand and dust storms. The launcher should be lubricated when sandy or dusty conditions decrease or when it begins to show rust or corrosion.

d. Instruction on caring for the launcher when it is subjected to nuclear, biological, or chemical contamination is in FM 21-40.

### 5-6. Storage

Thoroughly clean and dry the bore, the firing mechanism, and the exterior of the weapon. After the launcher has been dried, be careful not to touch it with bare hands. Coat the launcher with LSA. Never store a launcher in a cloth or similar cover and never plug the bore. This will cause the launcher to collect moisture and rust.

## CHAPTER 6

### MARKSMANSHIP TRAINING (M203)

#### Section I. INTRODUCTION

##### 6-1. General

Marksmanship training is to teach the grenadier how to fire the grenade launcher and to prepare him mentally and physically to employ it in combat. His previous rifle marksmanship training provides a sound basis for training with the grenade launcher.

##### 6-2. Elements of Marksmanship

a. Marksmanship training with the grenade launcher develops skill in—

(1) Sighting, aiming, and sight manipulation.

- (2) Position and rapid fire.  
 (3) Sensing and adjusting fire.  
 (4) Zeroing procedure.  
 (5) Range determination.

b. The skills learned from previous marksmanship training with other weapons are similar to those skills required for firing the grenade launcher. Proficiency in all skills listed above is essential and can only be attained by proper training.

**Warning:** Be sure the sling is clear of the weapon muzzle prior to firing.

#### Section II. SIGHT, AIMING AND SIGHT MANIPULATION

##### 6-3. Sighting

a. Sighting consists of sight alinement and getting a sight picture.

(1) Sight alinement is the relationship between the front sight post and the rear sight aperture/sight leaf.

(a) *Sight leaf* (1, fig 6-1). If an imaginary horizontal line is drawn through the center of the rear sight leaf, the top of the front sight post of the rifle will touch this line. If an imaginary ver-

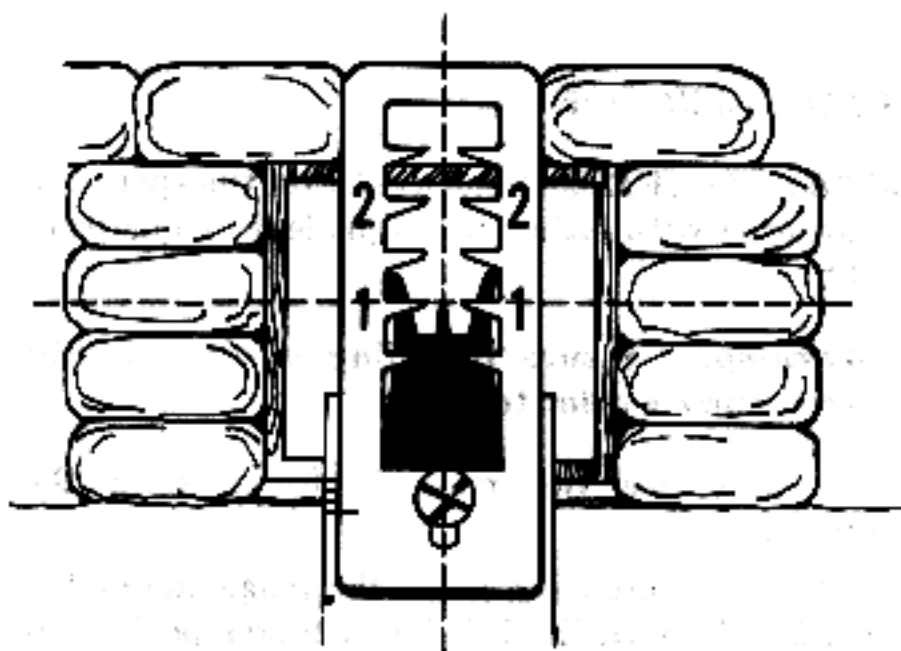

(1) With sight leaf.  
 Figure 6-1. Correct sight alignment.

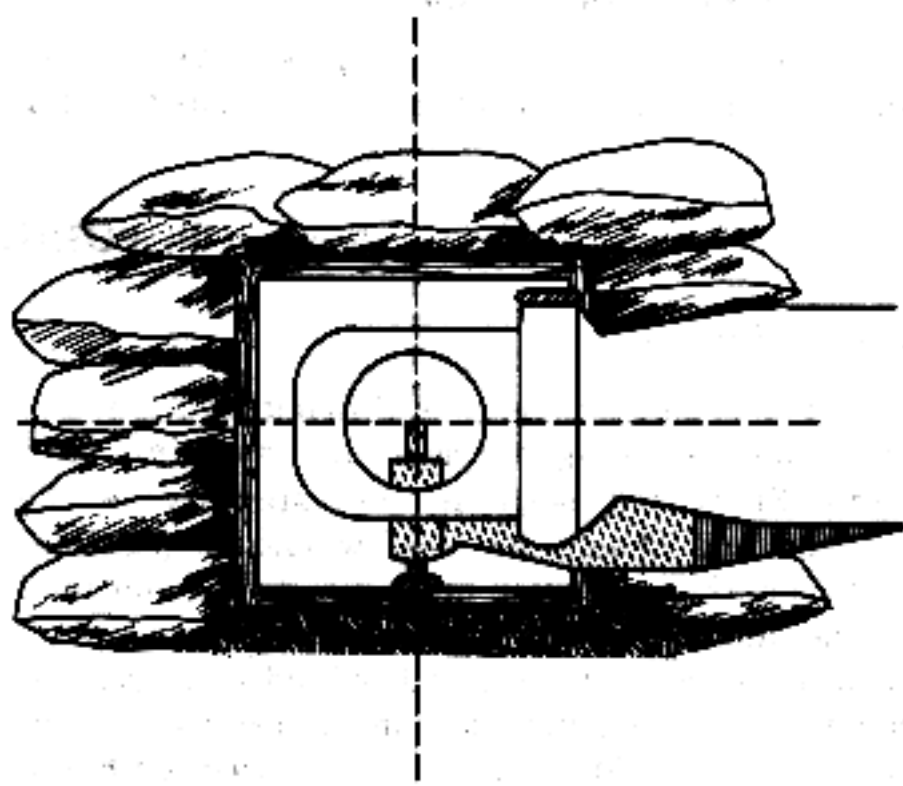

(2) With quadrant sight.  
 Figure 6-1.—Continued.

tical line is drawn through the center of the rear sight, the line will cut the front sight post in half.

(b) *Quadrant sight* (2, fig 6-1). If an imaginary horizontal line is drawn through the center of the rear sight aperture, the top of the front sight post will touch this line. If an imaginary vertical line is drawn through the center of the rear sight aperture, the line will cut the front sight post in half.

(2) Getting the sight picture includes sight alinement and placement of the aiming point. To get a correct sight picture, aline the sights as described above, and position the top edge of the front sight post on the center of the target.

b. Sight alinement is more important than sight picture. An error in sight alinement results in a miss that becomes proportionately greater as the range to the target increases, whereas an error in sight picture will remain constant at all ranges.

#### 6-4. Aiming

a. Initially, the firer should get correct sight alinement and then shift his focus to the target and get a correct sight picture. As he presses the trigger the firer continues this shifting of the focus of his eye. With practice these steps become a continuous automatic process.

b. Controlled breathing is an essential element of marksmanship. When firing the grenade launcher the grenadier must practice controlled breathing just as he would when firing the rifle.

#### 6-5. Sight Manipulation

a. Sight manipulation is the procedure of placing the quadrant sight in the proper position for

firing and placing the proper range setting on the sight to engage the target. Since the sight leaf is a fixed ladder-type sight, sight manipulation is done only during zeroing procedures.

b. The purpose of a sight manipulation exercise with the quadrant sight is to teach the grenadier to place the rear sight at the proper index mark on the elevation scale accurately and quickly. The sight manipulation exercise is conducted as follows:

(1) The exercise is performed first from the prone position but should be repeated in all other positions as proficiency increases. The exercise may be performed on a range or any other suitable training area.

(2) The rear sight is set initially at 200 meters elevation. This allows maximum sight adjustments either up or down. For this exercise, use three elements of a standard fire command. The instructor gives the direction to the target—identifies the target—and gives a range (e.g. right front—troops—300). The range element is the command of execution. On the command of execution:

(a) The firer moves the sight arm along the range quadrant until it is alined with the proper index mark (300), takes the firing position, aims at the target, and calls "UP."

(b) The assistant instructor checks to see that the proper setting is on the sight. If an error exists, the firer is required to make corrections.

(c) The assistant instructor then resets the quadrant sight arm at 200 meters elevation. He raises his hand to signify that the grenadier is ready for another command from the instructor.

### Section III. POSITIONS AND RAPID FIRE

#### 6-6. General

a. The most commonly used firing positions are the prone, kneeling, foxhole, and standing positions. Supported positions add stability to the weapon and should be used whenever possible; however, the grenadier must insure that no part of the launcher touches the support. The employment considerations, methods of indirect fire, and modifications to firing positions described in chapter 12 for the M79 may also be used with the M208. The grenadier takes the various firing positions with the M208 in the same way as with the

M16A1 rifle (FM 23-9), except that the spot weld is not used with either the sight leaf or quadrant sight.

**Warning:** Be sure the sling is clear of the weapon muzzle prior to firing.

b. There are two methods for holding the weapon:

(1) The left hand grips the magazine of the M16A1 rifle with the left index finger positioned in the trigger guard of the M203 while the right hand grips the pistol grip of the M16A1 rifle.



(2) The right hand grips the magazine of the M16A1 rifle with the right index finger positioned in the trigger guard of the M208 while the left hand grasps the hand grip of the barrel assembly.

c. At ranges up to 150 meters, the grenadier can fire from the shoulder in the normal manner from all positions using the sight leaf or the quadrant sight. However, in order to maintain sight alignment at ranges greater than 150 meters he must make the following adjustments:

(1) Use the quadrant sight at ranges in excess of 250 meters.

(2) In the modified prone position, the position of the butt of the rifle stock depends on the configuration of the grenadier's body, and position of the grenadier's hands on the weapon, and the range to the target.

(3) In other firing positions, lower the stock to an underarm position in order to maintain sight alignment.

#### 6-7. Prone Position and Modified Prone Position

a. The prone position is a steady position, easy to take and excellent for initial training. It presents a low silhouette and is comfortable for long periods (fig 6-2).

b. To take the prone position, stand facing the target with the butt of the rifle resting against the right hip, the right hand grasping the rifle pistol grip and the left hand on the hand grip. Spread the feet a comfortable distance apart, shift the weight slightly to the rear, and drop to the knees. Remove the right hand from the weapon, fall forward breaking the fall with the right hand well forward and on line with the right knee and the target. Using the left hand to support the weapon, roll over on the left side and

elbow. Place the butt of the rifle into the pocket of the right shoulder. Grasp the rifle's pistol grip with the right hand and lower the right elbow to the ground so that the shoulders are level. This insures that the weight of the body is behind the weapon so that the firer can recover quickly after each round is fired. Grasp the magazine of the rifle with the left hand. The upper body is straight, and the legs are spread a comfortable distance apart. The toes are pointing outward and the ankles are relaxed so that the heels will rest on the ground if possible. The weight of the upper body is relaxed forward onto the left arm.

c. In the modified prone position, the placement of the butt of the rifle stock depends on the configuration of the grenadier's body, and the position of the grenadier's hands on the weapon for ranges greater than 150 meters.

d. Use the quadrant sight at ranges in excess of 200 meters.

#### 6-8. Kneeling Position

a. The kneeling position is particularly good on level ground or ground that slopes upward towards the target (fig 6-3).

b. For the kneeling position, stand facing the target with the left hand on the handgrip and the right hand grasping the rifle pistol grip. Face right and place the left foot about 18 inches to the left front with toe pointing in the general direction of the target. Kneel on the right knee keeping the right toe in place. Sit with the right buttock on the right heel. Place the left elbow forward of the left knee, resting the flat portion of the upper arm on the knee. Move the rifle butt into the pocket of the right shoulder keeping the right hand on the rifle pistol grip. Place the left hand on the rifle magazine with left forefinger in



Figure 6-2. Prone position.



Figure 6-3. Kneeling position.

launcher trigger guard. Pull the rifle well into the shoulder. The right elbow is pulled in close to the body so as to apply rearward pressure to the weapon. The leg completes a solid, three-point base for the position.

#### 6-9. Sitting Position

The sitting position is especially suitable for use on ground which slopes downward to the target. It may be used when the firer's view of the target is obscured. Three variations of the sitting position are described below. Use the variation which best suits you.

a. To take the open-legged sitting position, face the target, face half right and spread the feet wide apart (fig 6-4). Sit down breaking the fall with the right hand, and slide the buttocks well to

the rear. Grasp the rifle magazine with the left hand. Bend forward from the hips and rest the left upper arm against the inside portion of the left knee. Move the butt of the rifle into the pocket of the right shoulder keeping the right hand on the rifle pistol grip. Rest the right elbow on the inside of the right knee. Pull down slightly with the left hand and pull to the rear firmly with the right hand.

b. To take the cross-ankled sitting position, face the target, face half-right, and sit down. With legs extended from the body, cross the left ankle over the right ankle. Keep both ankles straight. Grasp the rifle magazine with the left hand. Place the left upper arm across the left knee. Move the butt of the rifle into the pocket of the right shoulder. Lower the right elbow so that the upper right arm

is in contact with the right knee. This position can be adjusted by varying the distance the legs are extended (fig 6-5).

c. To take the cross-legged position, face the target, face half-right, and sit down. Cross the left leg over the right leg and draw both feet close to the body. Grasp the rifle magazine with the left hand. Place the left upper arm against the left knee. Move the butt of the stock into the pocket of the right shoulder and take the proper grip on the pistol grip. Lower the right elbow so that the right upper arm is against the right knee (fig 6-6).

## 6-10. Squatting Position

a. The squatting position is good when firing from mud, shallow water, or contaminated areas because only the feet are in contact with the ground. It is best used on level ground or on ground which slopes downward (fig 6-7).

b. To take the squatting position, face the target and face half right. Spread the feet a comfortable distance apart and squat as low as possible, keeping both feet flat on the ground. Grasp the rifle magazine with the left hand. Place the left upper arm inside the left knee, the butt of the



Figure 6-4. Open-legged sitting position.





*Figure 6-5. Cross-ankled sitting position.*

stock into the pocket of the right shoulder, and take a proper grip on the pistol grip. Lower the right elbow so that it is against the inside of the right knee.

### **6-11. Foxhole Position**

*a.* Use the foxhole position when prepared positions are available.

*b.* For the foxhole position, place the right foot against the rear of the foxhole and lean forward until the chest is against the forward edge of the foxhole (fig 6-8). Grasp the rifle magazine with the left hand. Place the left elbow on or against solid support. With the right hand position the butt of the stock in the pocket of the shoulder and take a proper grip on the pistol grip. Place the right elbow on or against a solid support and

relax into a comfortable firing position. Do not permit the weapon to touch the support.

### **6-12. Standing Position**

*a.* The standing position is normally used when engaging targets at ranges of less than 100 meters. It is the position for engaging surprise targets while moving.

*b.* To take the standing position, face the target, face half right, and spread the feet a comfortable distance apart (fig 6-9). With the right hand on the pistol grip of the rifle and the left hand on the rifle magazine, place the butt of the stock into the pocket of the shoulder so that the sight is level with the eyes. Hold the right elbow high to form a good pocket for the butt of the stock and to permit a strong rearward pressure with the right



*Figure 6-6. Cross-legged sitting position.*

hand. Hold most of the weight of the weapon with the left hand. Shift the feet until a natural aiming stance is attained.

### **6-13. Rapid Fire**

*a.* Rapid fire is a series of aimed rounds launched as fast as the grenadier can get a sight picture, control the trigger, and reload the weapon. Accuracy in rapid fire, as in slow fire, requires a steady aim, a good position, and proper trigger control.

*b.* In rapid fire training the firer is required to take positions and reload rapidly. The actions are included in two exercises which are described below for the prone position.

(1) *Rapid fire position exercise.* This exercise consists of taking the prone position and launching the first grenade in 10 seconds at a preselected target at a known range. The grenadier first takes

the prone position. He checks to see that he is aiming naturally at his target. The assistant instructor checks the position to see that it is correct. The grenadier marks the location of his elbows on the ground, rises, keeping his feet in place, and stands ready with the butt of the rifle resting against the right hip, the right hand grasping the rifle pistol grip and the left hand on the handgrip. On command the firer again takes the prone position, breaking his fall with his right hand. He quickly but carefully places his elbow on their marks. He then completes the position, aims at his target, and simulates launching the first round.

#### *(2) Rapid fire reloading exercise.*

(*a*) This exercise consists of reloading quickly and smoothly. In 10 seconds the grenadier is required to remove a cartridge case from the launcher, take a dummy round or cartridge case,



Figure 6-7. Squatting position.

load it into the launcher, reassume his position, and simulate launching one round.

(b) Before starting the exercise, the grenadier loads a dummy round or empty cartridge case into the launcher. The bandoleer should be so located that the grenadier has easy access to his ammunition. He then takes the prone position and takes natural aim at the target. The assistant instructor also checks to see that the position is correct.

(c) The exercise is executed on the following commands:

1. GRENADIER IN POSITION.
2. AIM AT YOUR TARGET.
3. RELOADING EXERCISE.
4. YOU HAVE 10 SECONDS.

5. FIRE.

6. CEASE FIRING.

At the command FIRE the grenadier simulates launching the first grenade by pulling the trigger, opens the breech, reloads, and simulates launching the second grenade. The command CEASE FIRING is given 13 seconds after the command FIRE.

c. These exercises are repeated in the same way from all positions until proficiency is attained.

*Note.* Either dummy rounds or empty cartridge cases may be used for this exercise. Live practice or high explosive ammunition is never used for rapid fire training except on the grenade range during range firing. A recommended method for constructing dummy rounds is to use expended cartridge cases and wooden plug inserts shaped to the configuration of the projectile. This provides a





*Figure 6-8. Foxhole position.*

satisfactory training aid for marksmanship exercises. If expended cartridge cases are not available, the dummy round may be fashioned from wood or some other suitable material.

#### **6-14. Pointing Techniques**

*a.* Use the pointing technique to deliver a high rate of HE fire when pinpoint accuracy is not required. Although the sights are not used in the pointing technique, the grenadier must first be proficient in sighting and aiming using the sight leaf and quadrant sight. He uses a modified underarm firing position (FM 23-9), enabling him to use his left hand for rapid reloading. Although

the pointing technique can be used by modifying any standard firing position, it is to be used during the assault.

*b.* To use the pointing technique, bring the weapon to a modified underarm firing position (fig 6-10). With both eyes open, concentrate your vision on the target keeping the flash suppressor of the RIFLE in the lower part of the field of view. Point the flash suppressor of the RIFLE at the target and sense the elevation of the weapon system with respect to the range to the target. To make corrections in elevation and deflection sense the impact of the round and make appropriate changes in the attitude of the weapon system.



Figure 6-9. Standing position.



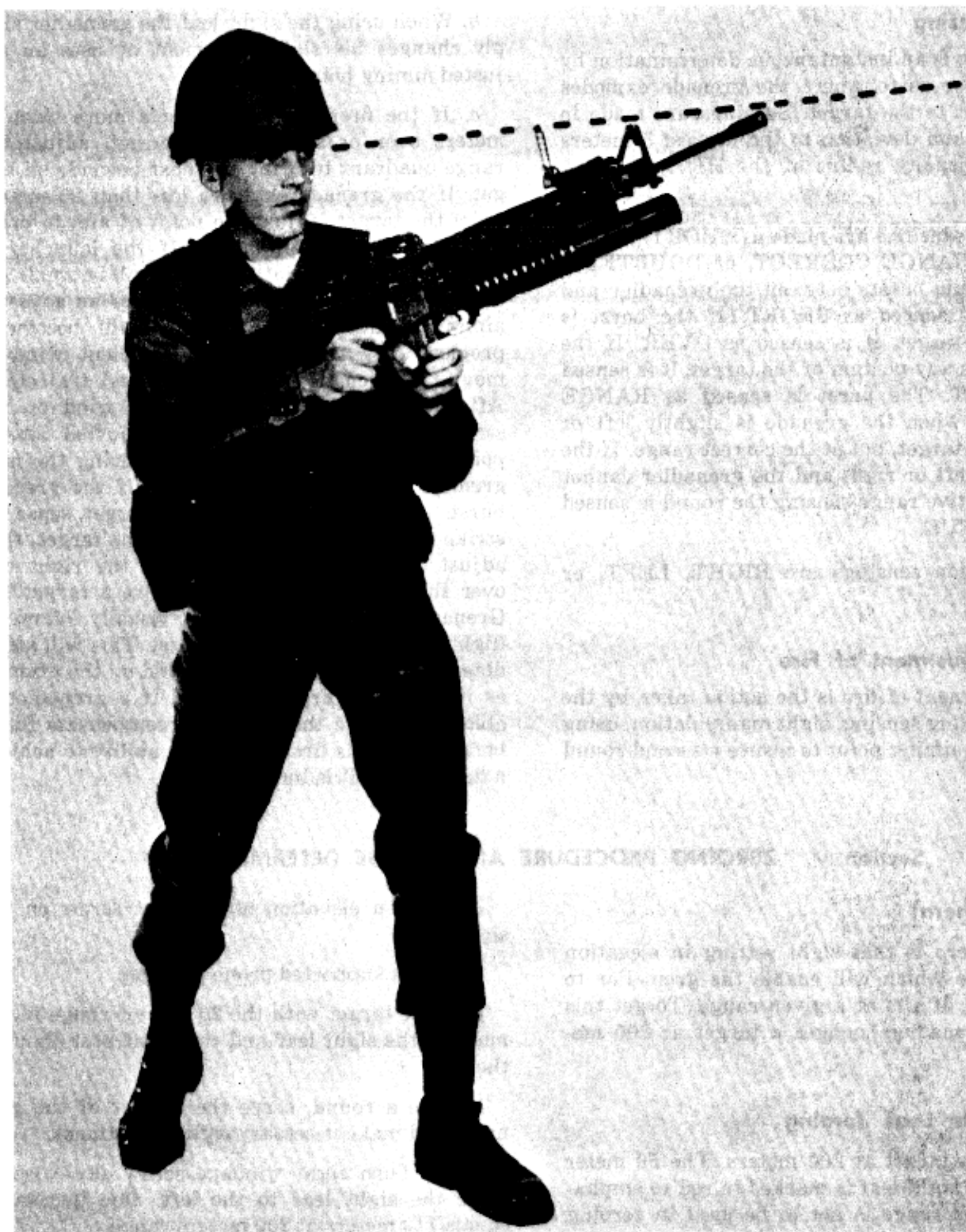

*Figure 6-10. Modified underarm firing position.*

#### **Section IV. SENSING AND ADJUSTMENT OF FIRE**

##### **6-15. General**

If a first round hit is not made, determine where the grenade landed in relation to the target (sen-

sing) and make the required adjustments in elevation and deflection to bring the next grenade on target (adjustment of fire).

**6-16. Sensing**

a. Sensing is an instantaneous determination by the grenadier as to where the grenade explodes with respect to the target. Sensings are made in both range and deviation to the nearest 5 meters since the casualty radius of the HE round is 5 meters.

b. Range sensings are made as **SHORT**, **OVER**, **TARGET**, **RANGE CORRECT**, or **DOUBTFUL**. If the grenade bursts between the grenadier and target, it is sensed as **SHORT**. If the burst is beyond the target, it is sensed as **OVER**. If the grenade hits any portion of the target, it is sensed as **TARGET**. The burst is sensed as **RANGE CORRECT** when the grenade is slightly left or right of the target, but at the correct range. If the grenade is left or right and the grenadier cannot make a positive range sensing the round is sensed as **DOUBTFUL**.

c. Deviation sensings are **RIGHT**, **LEFT**, or **LINE**.

**6-17. Adjustment of Fire**

a. Adjustment of fire is the action taken by the grenadier using sensing, sight manipulation, using an adjusted aiming point to insure a second round hit.

b. When using the sight leaf the grenadier simply changes his sight alinement or uses an adjusted aiming point.

c. If the first grenade impacts more than 25 meters over or short of the target, adjust the range quadrant to bring the next grenade on target. If the grenade explodes less than 25 meters from the target, adjust the point of aim to bring the next grenade on target. If the launcher is properly zeroed, deviation errors will be small and can easily be corrected by the use of an adjusted aiming point. Deviation errors will become a problem only when there is sufficient wind to move the grenade out of its normal trajectory. After observing the effect of the wind on the strike of the grenade, use an adjusted aiming point by aiming into the wind to bring the next grenade on target. For example, if the grenade bursts to the left and short of the target, sense the strike of the round in relation to the target, then adjust an equivalent distance to the right and over the target in order to achieve a target hit. Grenadiers should be taught to visually follow the flight of the grenade to the target. This will aid in determining the effect of the wind on the grenade as it moves toward the target. If a grenadier is able to evaluate the wind and compensate for it before firing his first round, his ability to achieve a first round hit is increased.

**Section V. ZEROING PROCEDURE AND RANGE DETERMINATION****6-18. General**

A correct zero is that sight setting in elevation and windage which will enable the grenadier to hit his point of aim at a given range. To get this zero, the grenadier engages a target at 200 meters.

**6-19. Sight Leaf Zeroing**

a. Select a target at 200 meters. The 50 meter mark on the sight leaf is marked in red to emphasize that this range is not to be used in zeroing procedures.

b. Place the sight leaf in upright position.

c. Place the center mark of the windage scale on the index line on the rear of the sight base.

d. Loosen the elevation adjustment screw on the sight leaf and place the index line of the sight leaf on the center elevation mark on the sight mount.

e. Tighten elevation adjustment screw on the sight leaf.

f. Take a supported prone position.

g. Aline target with the 200 meter range increment of the sight leaf and the front post sight of the rifle.

h. Fire a round, sense the impact of the grenade, and make necessary sight adjustment.

(1) Turn sight windage screw clockwise to move the sight leaf to the left. One increment equals  $1\frac{1}{2}$  meters at 200 meters range.

(2) Raising sight leaf increases range and lowering decreases range. One increment equals 10 meters at 200 meters range.

(3) The rim of a 40-mm cartridge case may be used to turn the elevation adjustment machine screw.

i. Fire two more cartridges and make necessary

adjustments after each round. If the last round has landed within 5 meters of the target the weapon is zeroed.

#### 6-20. Quadrant Sight Zeroing

a. Select a target at 200 meters.

b. Insure that the sight is correctly mounted on the carrying handle of the rifle.

c. Move the front sight post and rear sight aperture from the *closed* to *open* position.

(1) Depress the rear sight retainer, slide the rear sight aperture to the left until the white index line of the rear sight aperture is aligned with the edge of the sight aperture arm.

(2) Move the front sight post to its highest position and then back off  $2\frac{1}{2}$  turns.

d. Move sight latch rearward and reposition quadrant sight arm to zeroing range (200 meters).

e. Take a supported prone position.

f. Aline target with the front and rear sights using correct sighting and aiming procedure.

g. Fire round, sense the impact of the grenade, and make sight adjustment.

(1) For elevation adjustment, turn front sight post to the right to decrease elevation and to the left to increase elevation. One full turn equals 5 meters at 200 meters.

(2) For windage adjustment, press sight aperture retainer and move rear sight aperture away from barrel to move trajectory of the projectile to the left. Move rear sight aperture toward barrel to move trajectory to the right. One notch on the rear sight aperture equals  $1\frac{1}{2}$  meters at 200 meters.

h. Fire two more cartridges and make necessary adjustments after each round. If the last

round has landed within 5 meters of the target the weapon is zeroed.

#### 6-21. Range Determination

a. The ability of the grenadier to successfully engage targets with first round hits and to adjust and shift fire, depends upon his ability to determine ranges. Since the grenadier cannot usually see all of the terrain between himself and the target he uses the appearance of objects method to determine range.

b. When using the appearance of objects method for range determination, remember to make allowances for the following effects:

(1) Objects seem nearer when—

(a) They are in bright light.

(b) Their color contrasts sharply with the background.

(c) Looking over water, snow, desert, or a uniform surface like a wheat field.

(d) Looking from high ground to lower ground.

(e) In the clear atmosphere of high altitudes.

(f) Looking over a depression, most of which is hidden.

(g) Looking down a straight road or railroad track.

(2) Objects seem more distant when—

(a) Looking over a depression, most of which is visible.

(b) In poor light or fog.

(c) Only a small part of the object can be seen.

(d) Looking from low ground toward higher ground.

c. For a detailed coverage of range determination training see FM 28-71 and FM 23-12.



## CHAPTER 7

### RANGE CONSTRUCTION

#### 7-1. General

Figure 7-1 is a schematic illustration of one lane of the grenade launcher range. Any number of parallel lanes may be established depending on the terrain available for constructing this range. This range is to be used when firing the courses of fire outlined in chapter 8. Consult Army Regulation 885-68 and local range and safety regulations to determine safety requirements.

#### 7-2. Description of Area

a. The range consists of one or more lanes, with each lane complete within itself. Allow a minimum width of 30 meters and a depth of 500 meters for each lane. Targets within the lane are grouped and spaced so that the grenadier may fire at close range, midrange, and long range targets in that order.

b. Divide each lane into four stations:

(1) Station 1 consists of a prone firing position with a log or sandbag support and a zeroing target at 200 meters range. The target may be made of logs or other suitable material. It must have a surface at least 6 feet high and 6 feet wide. The zeroing target should be clearly marked by painting a large Z with color that will contrast with the surrounding background.

(2) Station 2 consists of an upright log or log wall firing point about 4 feet high and two point-type targets. The targets are a simulated window or door of a building and a simulated small

bunker or covered firing position. The range to the two targets is shown in table 8-1. The targets may be constructed of logs, sandbags, or other suitable material.

(3) Station 3 consists of a foxhole firing point and two targets. The targets consist of a simulated two-man bunker and an uncovered weapon position. The ranges to the two targets are shown in table 8-1, chapter 8. The bunker represents a point target and the weapon position represents a target which can be engaged using area-type fire.

(4) Station 4 consists of a prone firing point with a log or sandbag support and two area targets. The log or sandbags on the firing point are used for support and cover. The area targets are to simulate troops in the open. The range to the two targets is shown in table 8-1.

c. The impact area must be kept free of vegetation other than short grass. This is to facilitate the location and destruction of duds. Ideally, the terrain should slope downward for the first 100 to 200 meters and then slope gently upward out to a range of about 500 meters.

d. After considerable use, the impact area will probably have many duds in it. Therefore, targets should be constructed of a long-lasting, durable material that will withstand constant use and need little maintenance. Targets should be constructed of salvaged oil drums filled with sand or from other durable salvaged material.

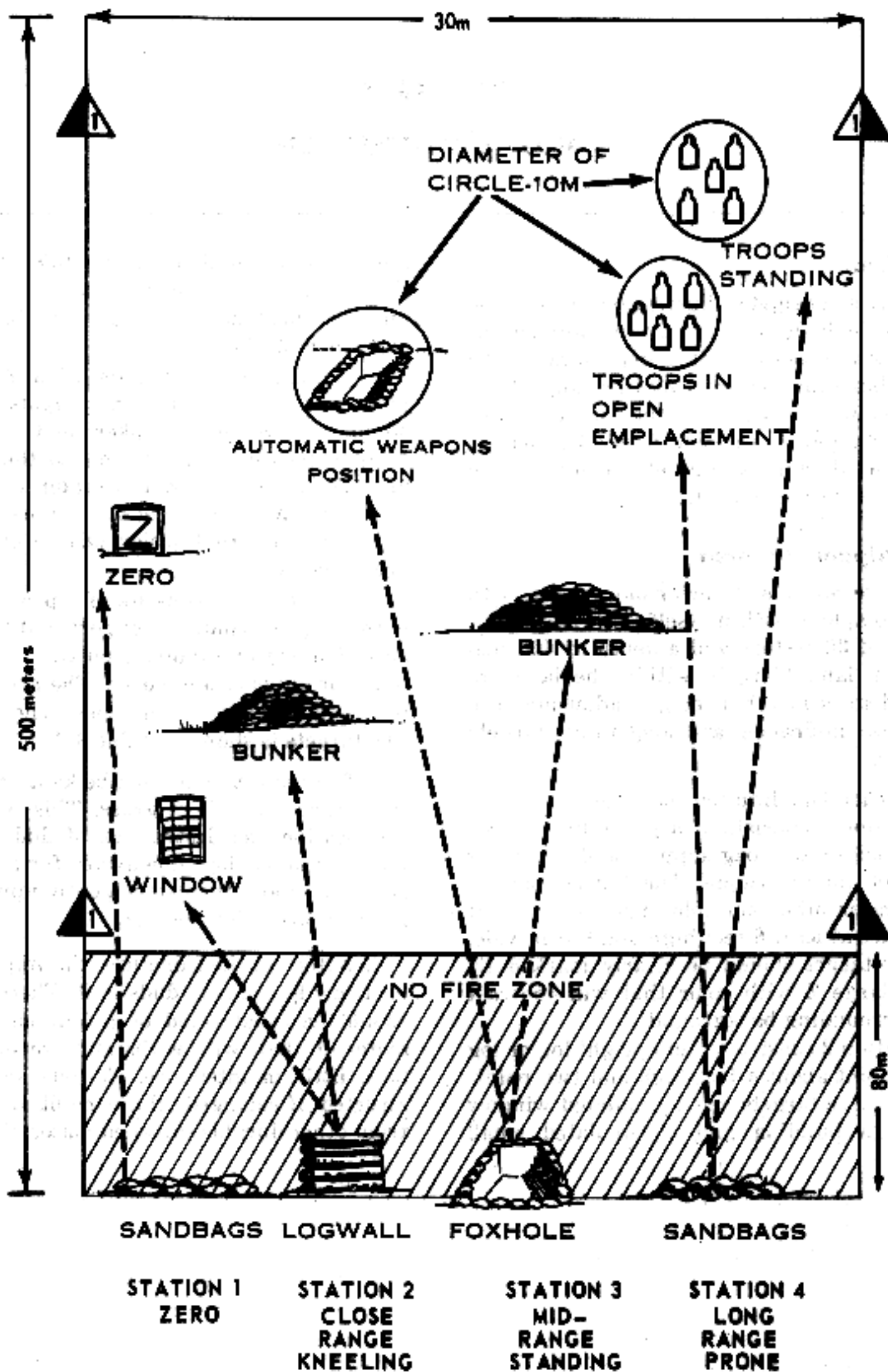

Figure 7-1. Lane of Live firing range.



## CHAPTER 8

### RANGE FIRING

#### 8-1. General

a. Schedule range firing only after the soldier has demonstrated his ability to apply the steps of marksmanship training. The three courses of fire for the grenade launcher are: Instructional firing, qualification firing, and instruction course (modified).

b. Observe safety precautions during all range firing. The surface danger area and range safety requirements vary with the type of ammunition being used. Consult Army Regulation 385-63 and

local range and safety regulations to determine current safety requirements.

#### 8-2. Instructional Firing

a. Conduct instructional firing prior to qualification firing to provide the grenadier with additional training in sighting, aiming, sight manipulation, positions, rapid loading, sensing, and adjustment of fire while engaging targets.

b. Instructional firing consists of firing table 8-1 one time on the grenade launcher range described in chapter 7.

Table 8-1. Instructional Firing (Total Rounds—12)

Station*	Position	Target(s)**	Range	Rounds	Time limit
1	Prone supported	Zeroing panel	200m	8	2 minutes
2	Kneeling supported	2 point targets: Window Bunker	90-100m 105-115m	8	2 minutes
3	Foxhole	1 point target: Bunker 1 area target: Automatic weapon position	185-150m 200-250m	8	2 minutes
4	Prone supported	2 area targets: Troops in open emplacement Troops in open	275-300m 325-350m	8	2 minutes

\*See figure 7-1.

\*\*Targets may be simulated.

(1) Station 1 is to permit the grenadier to zero the grenade launcher. After the completion of firing, the launcher will be cleared. It is cleared when the breech end of the barrel assembly is open, the cartridge or cartridge case removed, and a visual check has been made of the barrel assembly. Always carry the launcher with the breech open on the range.

(2) Station 2 is to instruct and test the grenadier in the kneeling supported position, range determination, sight setting, firing, sensing, and adjustment of fire at close-in point targets. The grenadier may engage either of the two targets in

the station, but once he fires at one target, he must not engage the other target until he has hit the first target.

(3) Station 3 is to instruct and test the grenadier in firing from the foxhole position at point and area targets. The sequence of fire and engagement of targets is as prescribed in (2) above.

(4) Station 4 is to instruct and test the grenadier in firing from the prone supported position at area targets. The sequence of fire and engagement of targets is as in (2) above.

(5) Each station within the lane will be supervised by an assistant instructor who is also

responsible for scoring. The assistant instructor will also observe the impact of all grenades, keep a record of the number and location of all duds within the station, and report these when required. An ammunition point will be established on each lane and supervised by the safety non-commissioned officer. Ammunition will be drawn and issued by the assistant instructors at each station. Grenadiers are organized into orders. Ro-

tate in a clockwise direction. Order one will complete firing on station 1 and move to stations 2, 3, and 4 in that order. Order two follows order one through the stations. When the first order has reached station 4, all stations should be occupied or all orders should be on the line.

(6) Fire commands are given as follows:

(a) On command from the officer in charge of firing, the grenadier moves to his station and

		QUALIFICATION SCORE	SCORER (Initial)
<b>STATION 2</b>			
TARGET	VALUE		
1	5	5	DES
2	5	5	DES
BONUS	5	0	DES
<b>SUBTOTAL</b>		<b>10</b>	
<b>STATION 3</b>			
TARGET	VALUE		
1	5	5	DES
2	5	5	DES
BONUS	5	5	DES
<b>SUBTOTAL</b>		<b>15</b>	
<b>STATION 4</b>			
TARGET	VALUE		
1	5	5	DES
2	5	5	DES
BONUS	5	5	DES
<b>SUBTOTAL</b>		<b>15</b>	
<b>TOTAL SCORE</b>		<b>40</b>	
<b>QUALIFICATION</b>			
<b>EXPERT</b>			
Expert - 40 or 45 First Class - 30 or 35 Second Class - 20 or 25 Unqualified - 0 to 15			
<b>SIGNATURE OF FIRER</b>			
<i>Michael D. Hayes</i>			
<b>SIGNATURE OF OFFICER</b>			
<i>David E. Sullivan</i>			

SCORECARD FOR 40mm GRENADE LAUNCHER FOR USE OF THIS FORM, SEE FM 23-31; THE PROPER AGENCY IS USCONARC.			
NAME (First Name - Middle Initial - Last Name)			
<b>MICHAEL D. HAYES</b>			
SERIAL		GRADE	
<b>241-09-9417</b>		<b>SP/4</b>	
ORGANIZATION			
<b>CO. A, 1st BN, 66th INF.</b>			
DATE			
<b>13 MAY 70</b>			
ZERO:			
DEF <b>0</b>		ELEV <b>4 METERS</b>	
		INSTRUCTION SCORE	SCORER (Initial)
<b>STATION 2</b>			
TARGET	VALUE		
1	5	5	DES
2	5	5	DES
BONUS	5	5	DES
<b>SUBTOTAL</b>		<b>15</b>	
<b>STATION 3</b>			
TARGET	VALUE		
1	5	5	DES
2	5	5	DES
BONUS	5	5	DES
<b>SUBTOTAL</b>		<b>15</b>	
<b>STATION 4</b>			
TARGET	VALUE		
1	5	5	DES
2	5	5	DES
BONUS	5	5	DES
<b>SUBTOTAL</b>		<b>15</b>	
(See Reverse Side)			

DA FORM 2946, 1 MAR 65

Figure 8-1. Scorecard.

takes the firing position specified by the range officer.

(b) The officer in charge of firing will then announce: **THE FIRING LINE IS NO LONGER CLEAR. GRENADIERS DESIGNATE THE TARGET; DETERMINE THE RANGE TO THE TARGET; PLACE THE PROPER SETTING ON THE REAR SIGHT. ASSISTANT INSTRUCTORS DRAW THREE ROUNDS OF TRAINING PRACTICE (HIGH EXPLOSIVE) AMMUNITION AND ISSUE THEM TO THE GRENADIERS.**

(c) At the command **DESIGNATE THE TARGET**, the grenadier will identify the target he intends to engage by announcing: **WINDOW, BUNKER, AUTOMATIC WEAPON, TROOP EMPLACEMENT; or TROOPS IN THE OPEN**, as appropriate for his station. At the command **DETERMINE THE RANGE**, the grenadier will announce the range to the target. At the command **ASSISTANT INSTRUCTORS DRAW THREE ROUNDS OF TRAINING PRACTICE (HIGH EXPLOSIVE) AMMUNITION AND ISSUE THEM TO THE GRENADIER**, the assistant instructor will pick up the ammunition at the ammunition point and issue it to the grenadier.

(d) When the grenadier has made his sight setting and the ammunition has been issued, the assistant instructor on each lane will signal that his lane is ready.

(e) When all lanes are ready, the officer in charge will command: **YOU HAVE TWO MINUTES TO COMPLETE THIS EXERCISE. ON THE FIRING LINE, ONE ROUND OF (TP) (HE) AMMUNITION—LOAD. READY ON**

**THE RIGHT? READY ON THE LEFT? READY ON THE FIRING LINE. COMMENCE FIRING.**

(f) After each grenade is fired the assistant instructor will call out **HIT** or **MISS**, whichever is correct. The grenadier is not permitted to engage the second target until the first target has been hit.

(g) After 2 minutes have elapsed the officer in charge of firing commands: **CEASE FIRING—CLEAR ALL WEAPONS. ASSISTANT INSTRUCTORS TURN IN ALL UNEXPENDED ROUNDS AND REPORT ALL DUDS. GRENADIERS ROTATE.**

(h) After completing firing on station 4, the grenadier will have his weapon cleared and move off the firing line.

### 8-3. Qualification Firing

a. Qualification firing is conducted to test the grenadier's ability to apply the techniques of marksmanship.

b. Instructional firing and qualification firing should be conducted on the same day. When this is not possible, station 1, the zeroing station, must be fired as an unscored part of the qualification course in order to let each grenadier get or confirm his zero of the launcher he will fire for qualification.

c. Qualification firing consists of firing table 8-2 one time on station 2, 3, and 4 of the grenade launcher range, described in chapter 7. The firing commands and procedures are as outlined for instructional firing (para 8-2).

Table 8-2. Qualification Firing (Total Rounds—9)

Station*	Position	Target(s)**	Range	Rounds	Time limit
2	Kneeling supported	2 point targets:		3	2 minutes
		Window	90-100m		
		Bunker	105-115m		
3	Foxhole	1 point target:		3	2 minutes
		Bunker	185-150m		
		1 area target:			
		Automatic weapon position	200-250m		
4	Prone supported	2 area targets:		3	2 minutes
		Troops in open emplacement	275-300m		
		Troops in open	325-350m		

\*See figure 7-1.

\*\*Targets may be simulated.

d. Qualification scores are rated for the qualification firing course (table 8-2) as follows:

(1) *Qualification scores.*

EXPERT GRENADIER	-----	40 to 45
FIRST CLASS GRENADIER		
(SHARPSHOOTER)	-----	30 to 35
SECOND CLASS GRENADIER		
(MARKSMAN)	-----	20 to 25
UNQUALIFIED	-----	0 to 15

(2) *Scorecard.* DA Form 2496 (Scorecard for 40-mm grenade launcher) for use on the qualification course is shown in figure 8-1. Each time the grenadier moves from one station to another he must carry his scorecard with him. All scoring entries on the card are made and initialed by the assistant instructor at the station being fired. After completion of qualification firing, the grenadier must sign the scorecard.

(3) *Target scoring.* When scoring, the assistant instructor will evaluate each grenade fired as outlined below:

(a) *Window or door.* The grenade must go through the opening in the center of the target.

(b) *Bunker.* Credit will be given for a hit if the grenade impacts anywhere on the face of the bunker.

(c) *Automatic weapon.* Credit will be given for a hit only if the grenade impacts within a 10 meter (diameter) circle surrounding the target.

(d) *Troops.* Credit will be given for a hit

only if the grenade impacts within a 10 meter (diameter) circle surrounding the targets.

(4) *Scoring.* Issue each grenadier three grenades for each of the qualification firing stations. Each hit is worth five points. The grenadier gets a five-point bonus score if he achieves first round hits on both targets at a station. So, each station is worth 15 points. For example, station 3 has two targets, a point target and an area target. The grenadier may select either target to engage first. If he scores a hit on the first target selected, he receives a score of five points. He is then permitted to engage the second target on the station. If he hits the second target, he earns another five points. If he scores a hit on both targets on the station with first round hits, he is given a five-point bonus for a total of 15 points. He then gives the unexpended round to the assistant instructor. Do not allow the grenadier to change from one target to the other within the station until the first target he selected has been hit. Scoring for station 2 and 4 is the same as for station 3.

**8-4. Familiarization Course**

This course may be conducted on station 1 and 3 of the grenade launcher range described in chapter 7. It consists of firing table 8-3 one time with no time limit and is not scored. The firing commands and procedures are as outlined for instructional firing (para 8-2) except that the grenadier is given the range to each target he engages.

Table 8-3 . Familiarization Course (Total Rounds—8)

Station*	Position	Target(s)**	Range	Rounds	Time Limit
1	Prone supported	Zeroing panel	200m	8	None
3	Foxhole	1 point target: Bunker	185-150m	2	None
		1 area target: Automatic weapon position	200-250m		

\*See figure 7-1.

\*\*Targets may be simulated.

32  
32



## CHAPTER 9

CHARACTERISTICS, LAUNCHER CONTROLS, AND SIGHTING  
EQUIPMENT OF 40-MM GRENADE LAUNCHER, M79

## Section I. CHARACTERISTICS

## 9-1. Description

The 40-mm grenade launcher, M79, is a single shot, breakopen, breech-loading, shoulder-fired weapon (fig 9-1). It consists of a receiver group, fore-end assembly, barrel group, sight assembly, and stock assembly (fig 9-2). A rubber recoil pad is attached to the butt of the stock to partially absorb the recoil. A sling is provided to carry the weapon.

## 9-2. Ammunition

Standard and developmental ammunition designed for use with the 40-mm grenade launcher, M203 (fig 4-2), is used with the M79 grenade launcher. The grenadier carries part of his ammunition in two universal ammunition pouches, each of which can hold three rounds (fig 5-2). Ammunition is also carried in the two-pocket bandoleer in which the ammunition is packed. Each pocket contains a plastic support which holds three rounds.

## 9-3. Data

## a. Weapons.

Length of launcher  
(overall) ----- 29 in (approx)

Length of barrel group ----- 15 in (approx)

Length of barrel only ----- 14 in

Weight of launcher

loaded ----- 6.5 lbs (approx)

Weight of launcher

unloaded ----- 6 lbs (approx)

## b. Ammunition.

Caliber ----- 40-mm

Weight ----- 8 oz (approx)

## c. Operational Characteristics.

Action ----- Breakopen,  
single shot

Sights:

Front ----- Blade

Rear ----- Folding leaf, adjustable

Chamber pressure ----- 3,000 lbs per square in.

Muzzle velocity ----- 250 ft per second.  
76 meters per second

Maximum range ----- 400 m (approx)

Maximum effective range  
(area targets) ----- 350 m

Maximum effective range  
(point targets) ----- 150 m

Minimum safe firing range:

Training ----- 80 m

Combat ----- 31 m



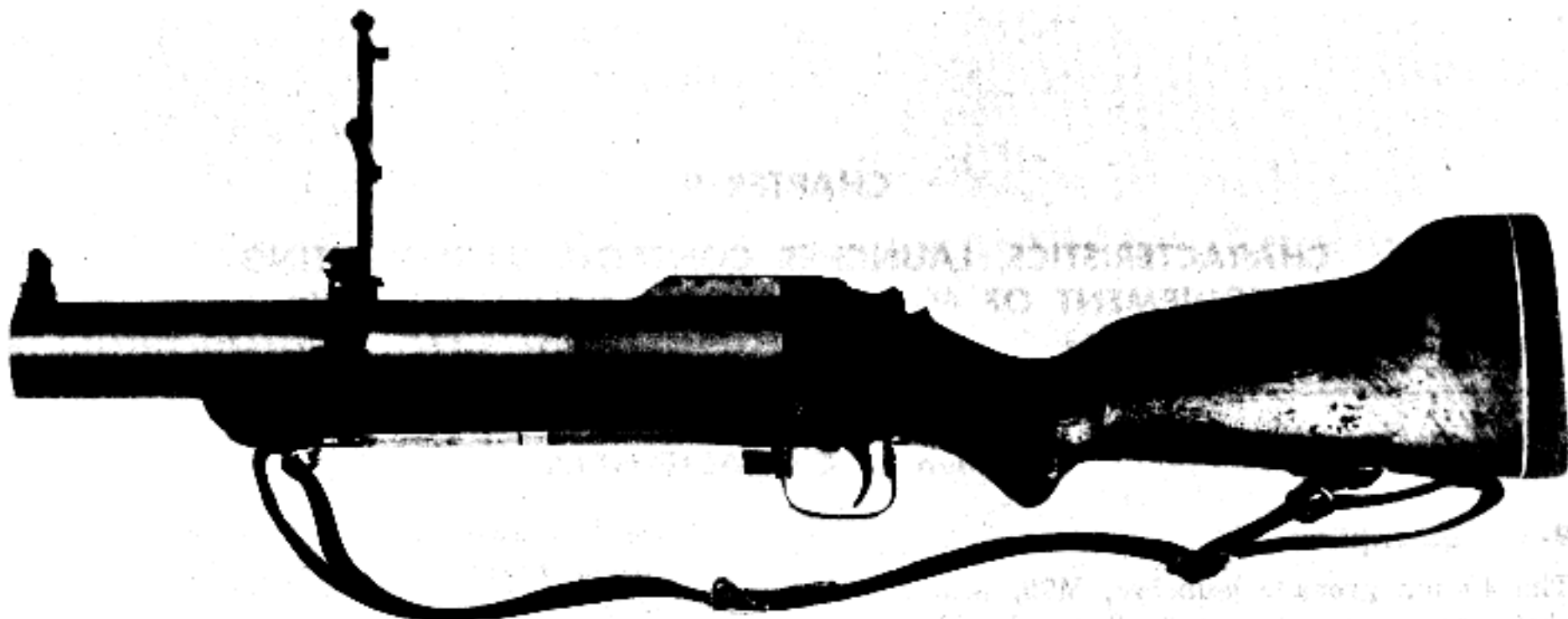

Figure 9-1. The 40-mm grenade launcher, M79, left side view, with rear sight in UP position.

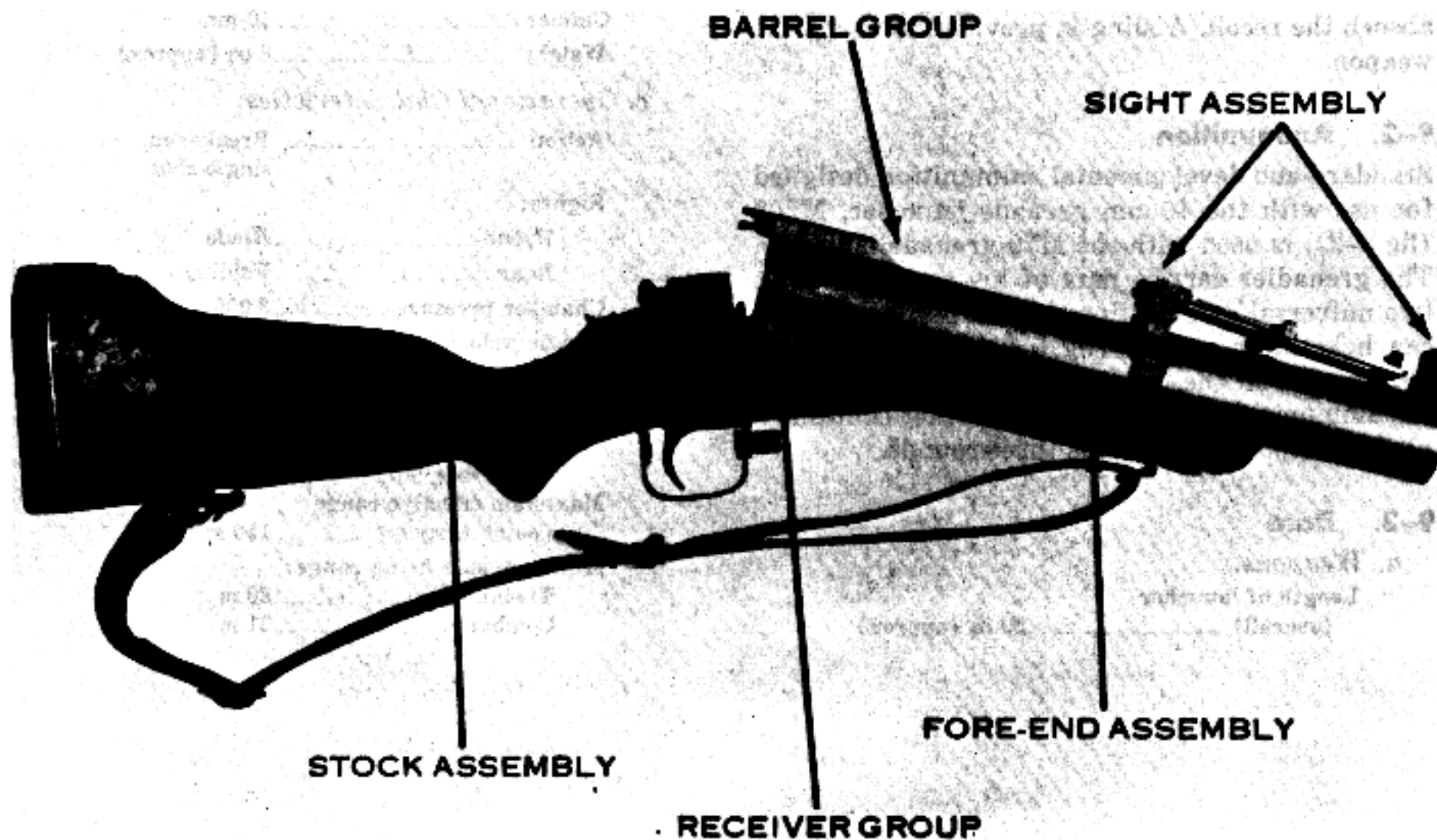

Figure 9-2. Five major subassemblies and groups of M79.

## Section II. CONTROLS

### 9-4. Safety

The location of the safety is shown in figure 9-3. To fire the launcher the safety must be in the forward position (fig 9-4). In this position the

letter F is visible near the rear end of the safety. When the letter S is visible just forward of the safety, the launcher will not fire. The safety is automatically engaged when the barrel locking latch is operated to open the breech.

### 9-5. Trigger and Trigger Guard Detent Assembly

The position of the trigger and trigger guard is shown in figure 9-5. The trigger guard protects the trigger. Depressing the detent assembly per-



Figure 9-3. Location of the safety in the safe position.

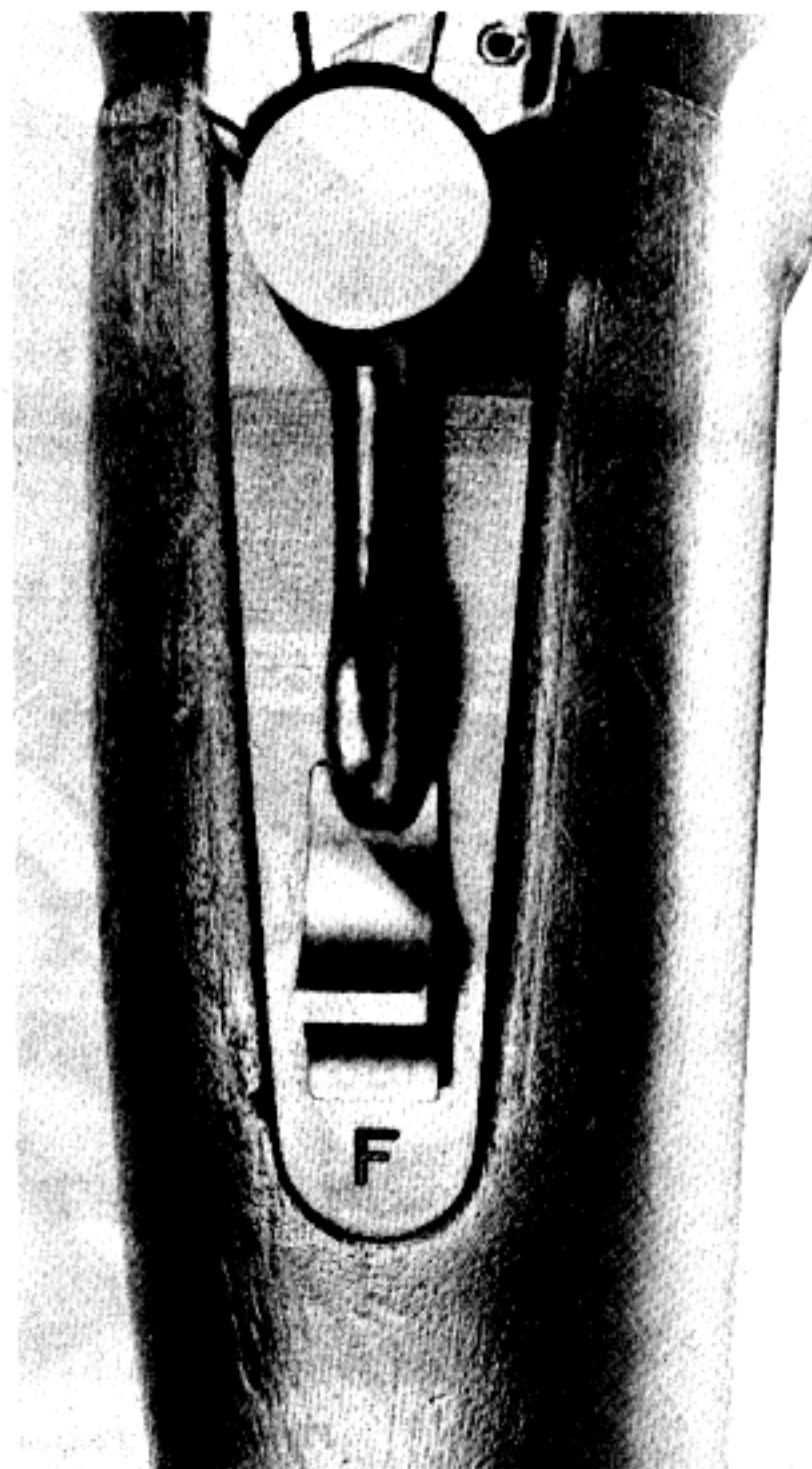
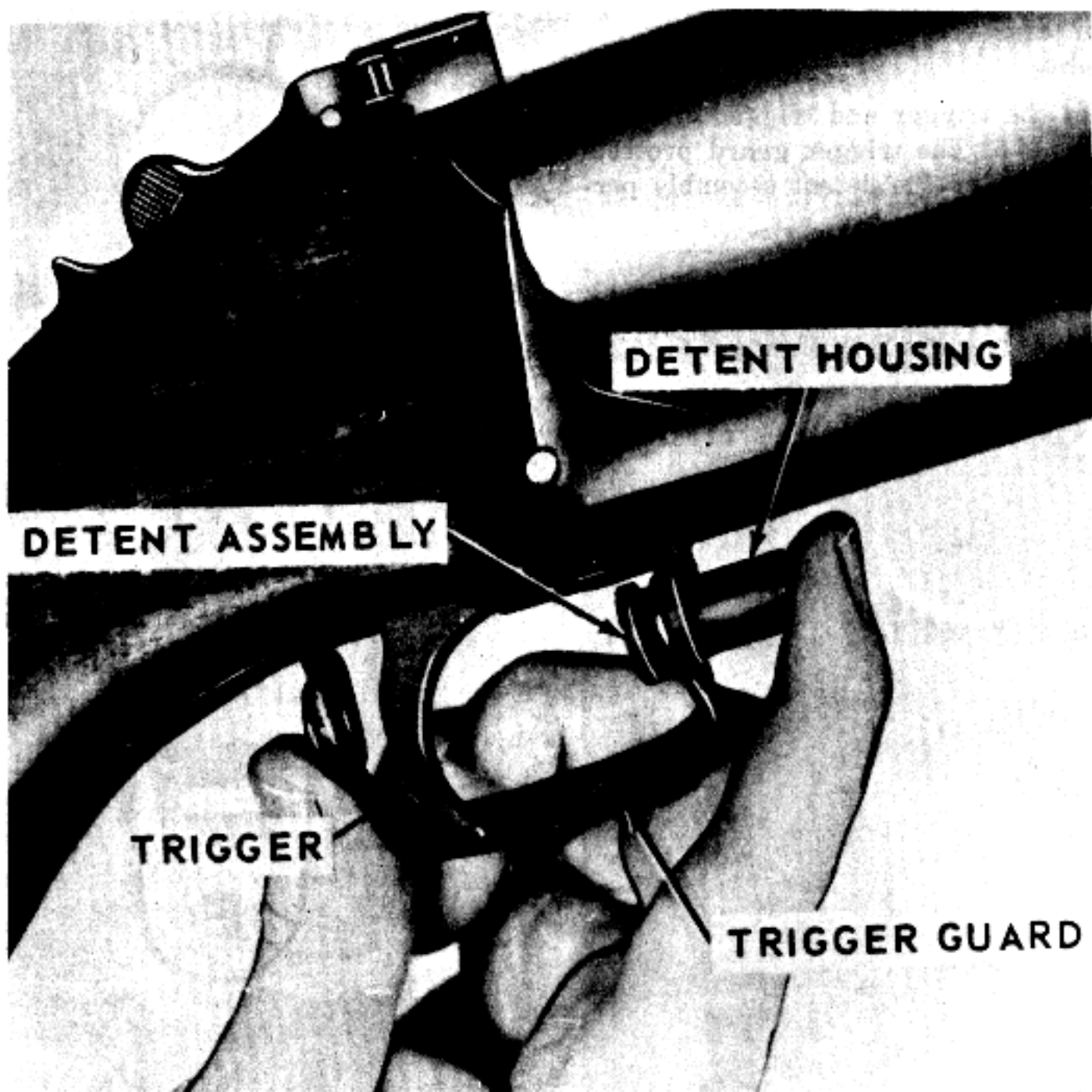

Figure 9-4. Location of the safety in the firing position.

mits the movement of the trigger guard to the right or left and allows the grenadier to fire the weapon while wearing gloves or mittens.

### 9-6. Barrel Locking Latch and Lever

The barrel locking latch is on top of the receiver (fig 9-6). This latch locks the receiver and barrel together. To open (or break) the breech end of the barrel, press the barrel locking latch lever its full travel to the right.



*Figure 9-5. Position of trigger and trigger guard.*

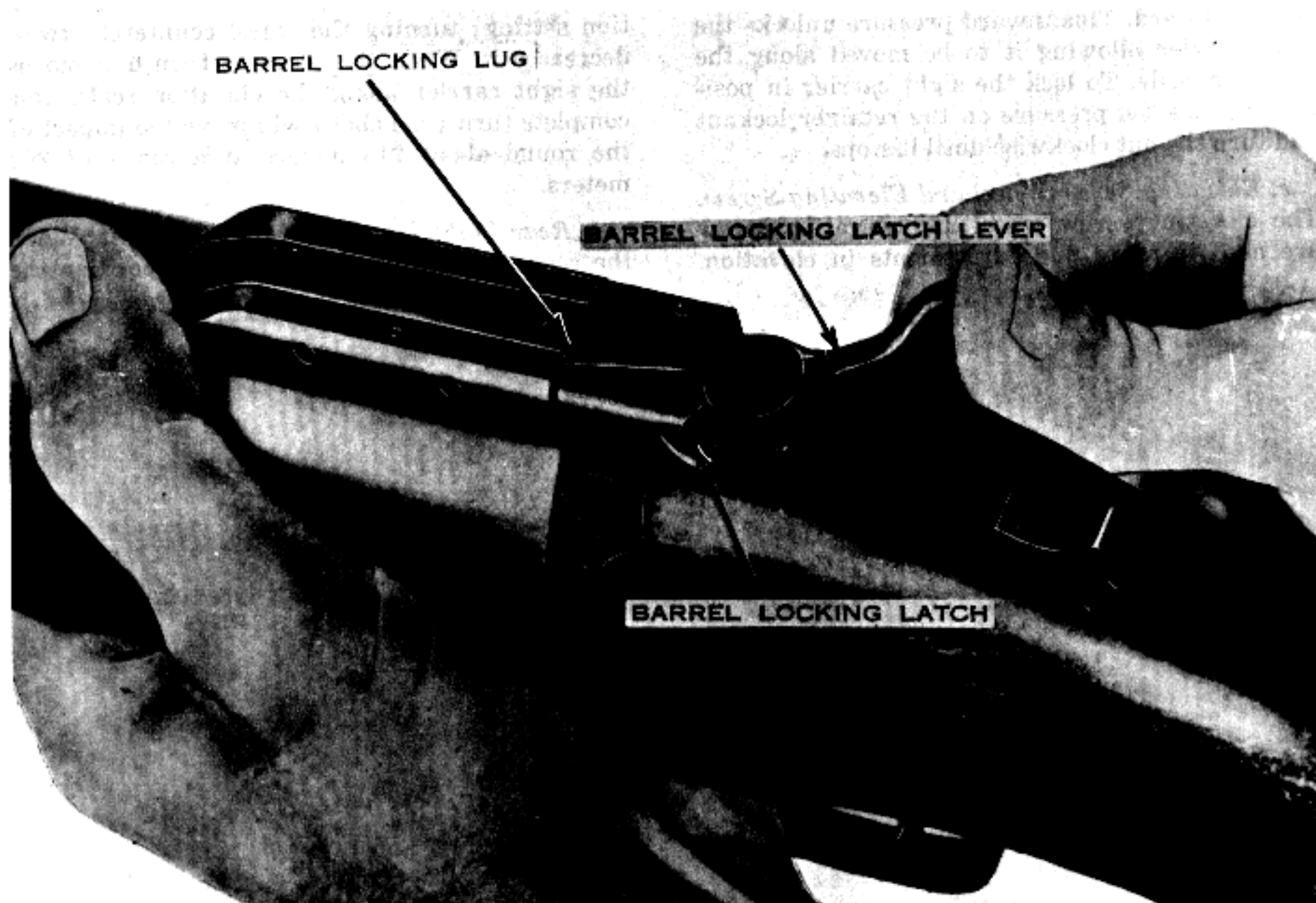

Figure 9-6. Operating the barrel locking latch.

### Section III. SIGHTING EQUIPMENT

#### 9-7. Rear Sight Assembly

The adjustable rear sight assembly consists of a rear sight lock, a windage screw and windage scale, and elevation scale and lock screw, a sight carrier and retainer locknut, and elevating screw wheel and elevating screw, and a rear sight frame and fixed sight (fig 9-7).

*a. Rear Sight Lock.* The lock is spring loaded and permits the rear sight frame assembly to be locked in either the *up* or *down* position. To unlock the sight frame push down on the flat surface of the rear sight lock. By releasing the pressure the frame is locked in the desired position.

*b. Windage Screw and Windage Scale.* The right end of the screw is a knob which turns the windage screw to adjust the rear sight for deflection. One click of the windage screw will move the impact of the grenade about 28 centimeters or 11 inches at a range of 200 meters. For right wind-

age turn the screw clockwise; for left windage turn it counterclockwise. The windage scale consists of a zero line in the center of the scale and 10 lines spaced equally on each side of the zero line. The rear sight assembly can be moved 42 clicks right or left of center.

*c. Elevation Scale and Lock Screw.* The scale is graduated from 75 to 375 meters in 25-meter increments and numbered at 100, 200, 300, and 375 meters. As the rear sight carrier is moved up the adjustable elevation scale, the rear sight is cammed to the left compensating for the normal right-hand drift of the projectile. The lock screw holds the elevation scale in position.

*d. Sight Carrier Retainer Locknut.* The retainer locknut permits the sight carrier to be moved along the elevation scale and clamps the carrier to the sight frame in the desired position. To move the sight carrier along the elevation scale turn the



retainer locknut counterclockwise until it can be pushed inward. This inward pressure unlocks the sight carrier allowing it to be moved along the elevation scale. To lock the sight carrier in position, release the pressure on the retainer locknut and turn the nut clockwise until it stops.

*e. Elevating Screw Wheel and Elevating Screw.* The elevating screw wheel and elevating screw are used to make fine adjustments in elevation.

Turning the wheel clockwise increases the elevation setting; turning the wheel counterclockwise decreases it. When the screw is turned it moves the sight carrier along the elevation scale. One complete turn (one click) will move the impact of the round about  $2\frac{1}{2}$  meters at a range of 200 meters.

*f. Rear Sight Frame With Fixed Sight.* When the rear sight frame is in the down position the

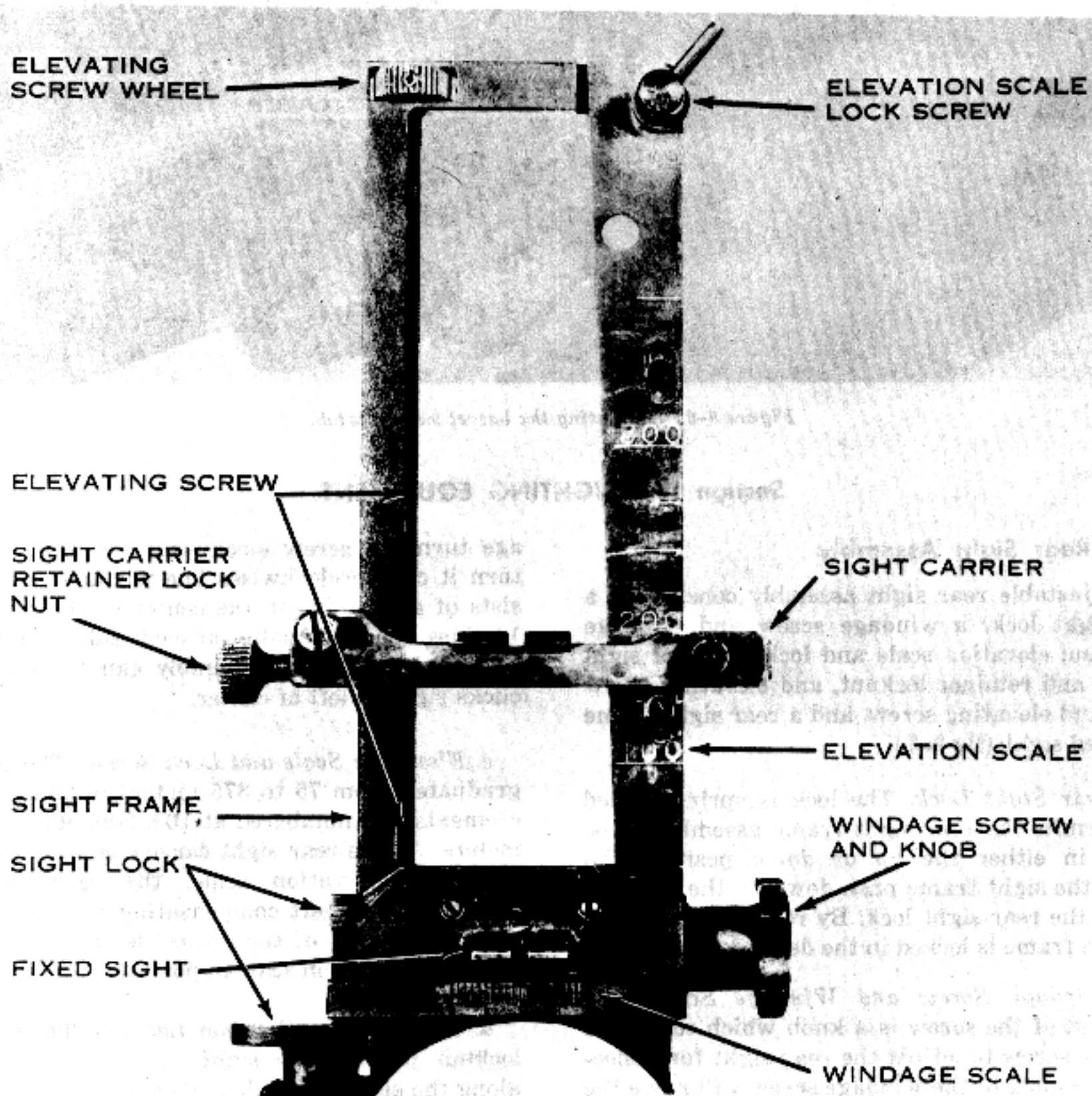
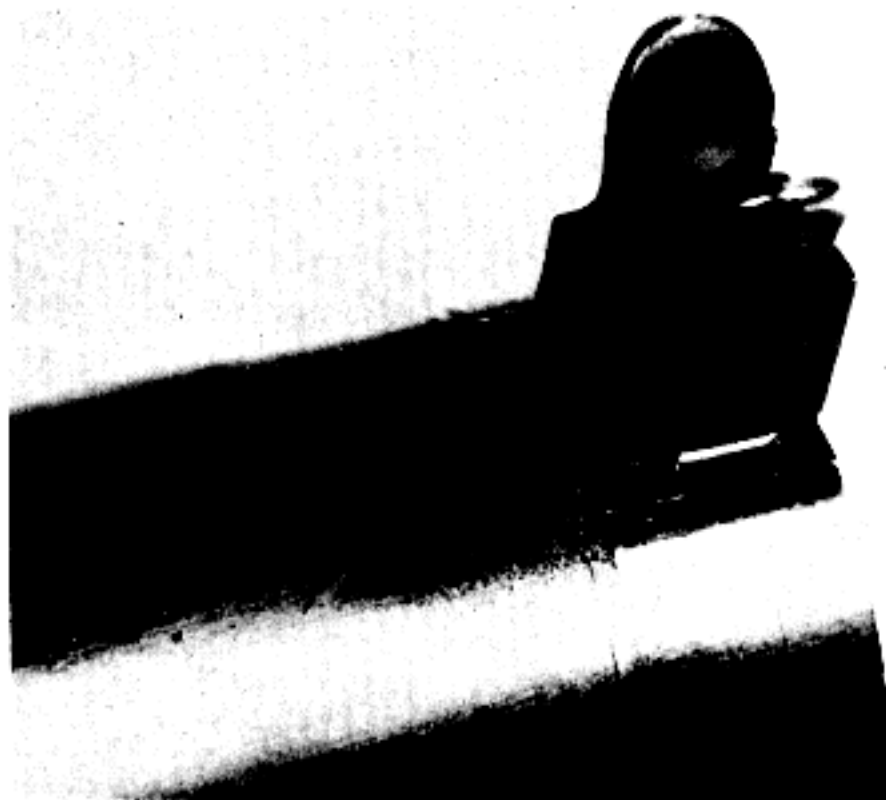

Figure 9-7. Rear sight assembly.

fixed sight may be used to engage targets, at ranges up to 100 meters.

### **9-8. Front Sight**

The front sight consists of a tapered front sight blade and two front sight blade guards (fig 9-8).



*Figure 9-8. Front sight.*

## CHAPTER 10

### MECHANICAL TRAINING; OPERATION AND FUNCTIONING; AND MAINTENANCE

#### Section I. DISASSEMBLY AND ASSEMBLY

##### 10-1. General

This chapter contains instruction for mechanical training, operation and functioning of the 40-mm grenade launcher, M79.

##### 10-2. General Disassembly

Grenadiers are authorized to disassemble the launcher as follows:

- a. Clear the weapon by rotating the barrel lock-

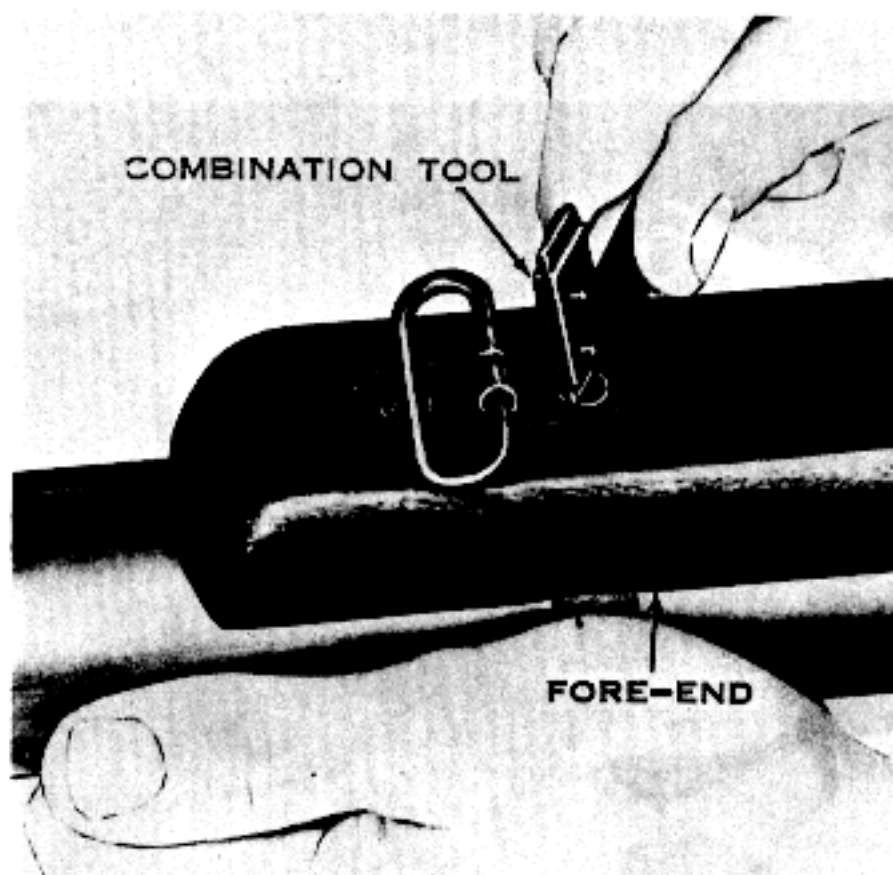

*Figure 10-1. Removing or installing the retaining band screw.*

ing latch lever its full travel to the right and opening the barrel. Inspect the breech to insure that no round is present.

- b. Remove the sling from the stock.

- c. Remove the retaining band screw, which passes through the rear mounting of the front sling swivel, and pull the fore-end assembly away from the barrel (fig 10-1 and 10-2).

- d. Press the barrel locking latch lever to the right; pivot the barrel down until it stops; slide the barrel off the fulcrum pin and remove it from the receiver (fig 10-3). Do not remove the rear sight from the barrel.

- e. Remove the stock screw and washers and pull the stock rearward from the receiver (fig 10-4).

##### 10-3. Assembly

Assembly of the grenade launcher is the reverse of disassembly.

- a. Place the stock on the receiver and replace the stock screw and washers. Place the lock-washer on the stock screw first.

- b. Place the barrel on the fulcrum pin (fig 10-5). Hold the cocking lever up, lower the barrel, and insure that the cocking arm slides under the cocking lever. Close the barrel.

- c. Place the fore-end assembly on the barrel and secure it by replacing the retaining band screw.

- d. Replace the sling.

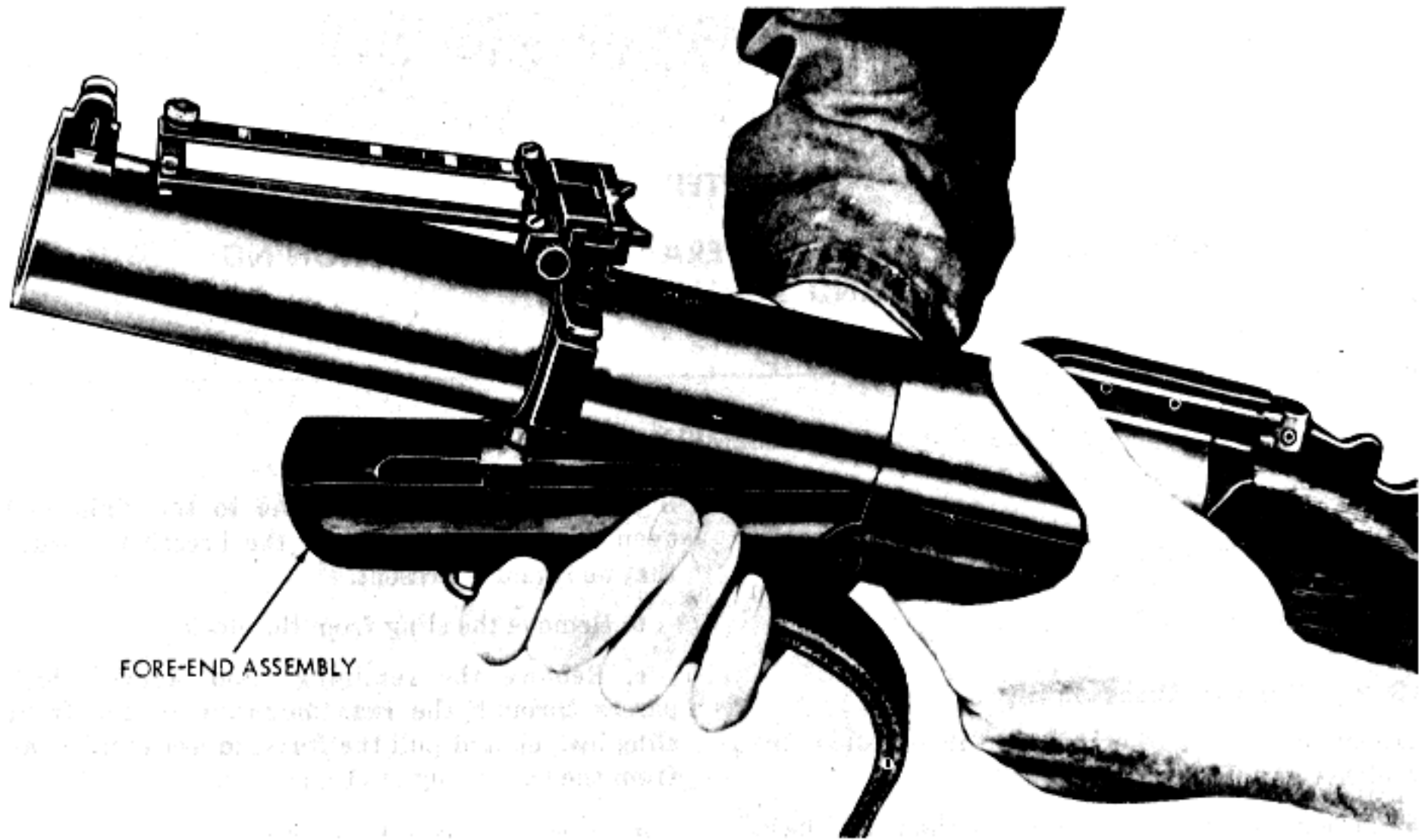

Figure 10-2. Removing or installing fore-end assembly.



Figure 10-3. Removing or installing the barrel group.



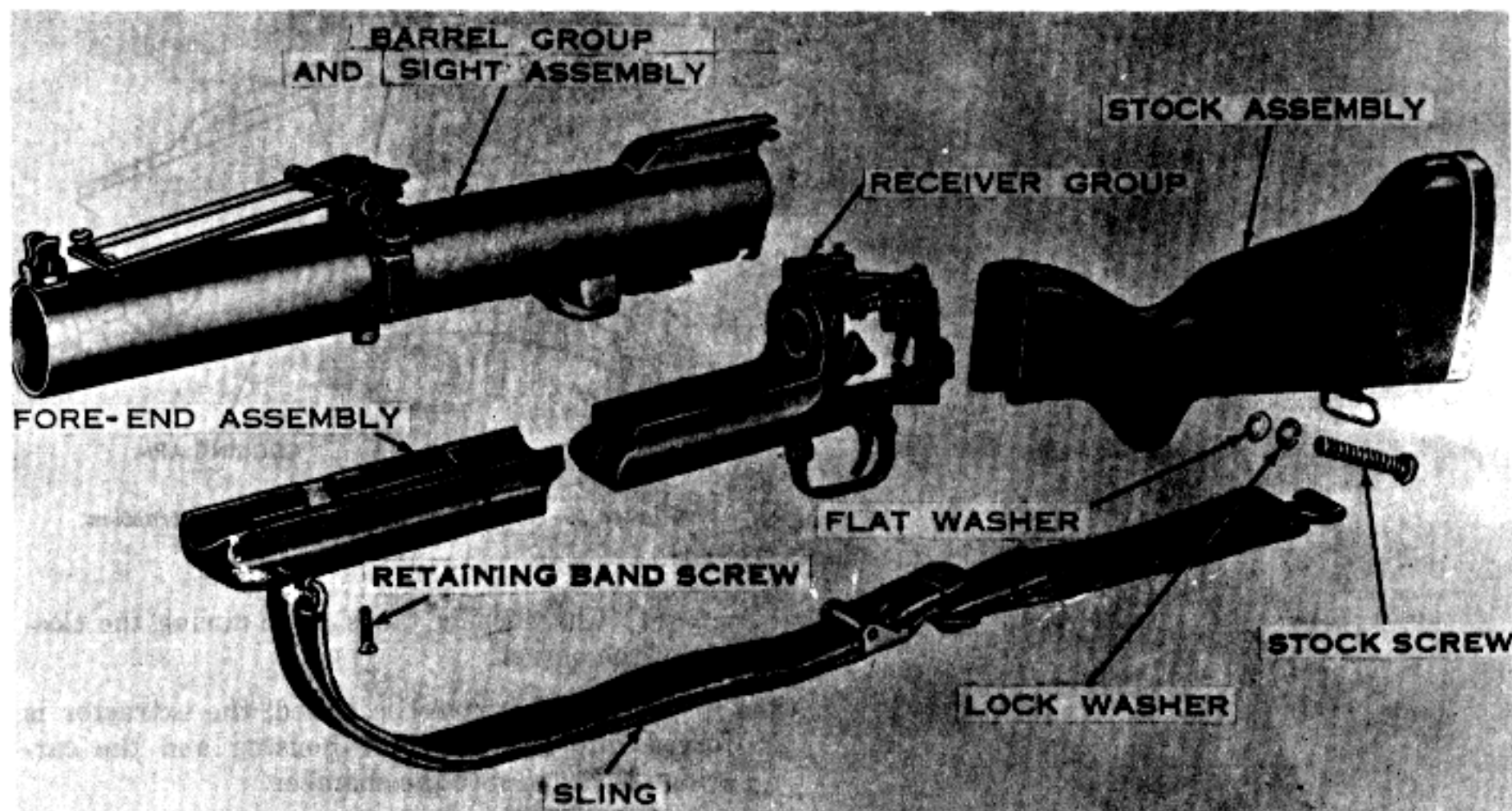

Figure 10-4. Grenade launcher, general disassembly.

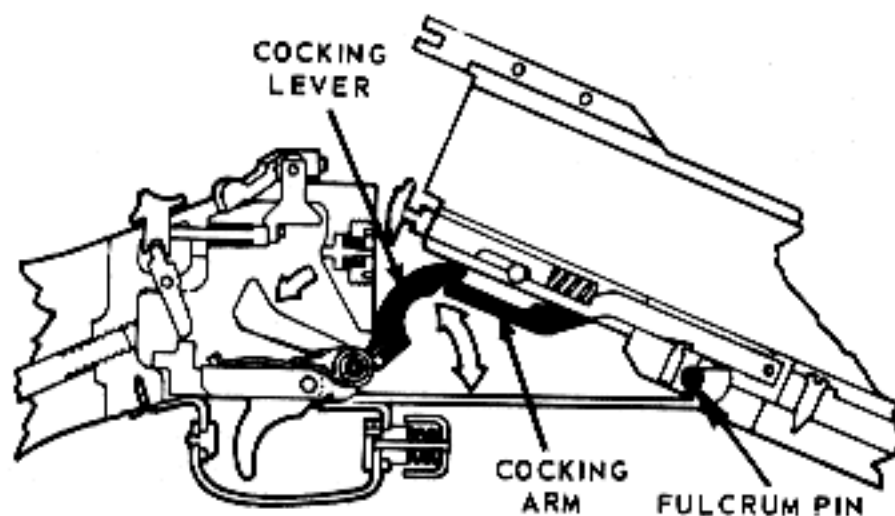

Figure 10-5. Assembling barrel group and receiver group.

## Section II. OPERATION, FUNCTIONING, AND TROUBLESHOOTING

### 10-4. Preparation for Firing

- a. Check the bore to be sure it is clear and dry.
- b. Check the launcher to be sure it is clean.
- c. Inspect for defective parts.
- d. Insure that the firing pin retainer is tight (fig 10-6). Turn it clockwise with the combination tool. A loose firing pin retainer is the most probable cause for a failure to fire.

### 10-5. Functioning

- a. *Unlocking* (fig 10-7).

- (1) Unlocking is done by pressing the barrel locking latch lever its full travel to the right. This unlocks the barrel from the receiver and moves the safety to the *safe* position.

- (2) The barrel locking latch is held in the open position by a spring-loaded latch lock (fig 10-10).

- b. *Cocking* (fig 10-7).

- (1) The weapon is cocked when the barrel is opened.

- (2) As the barrel is opened the cocking arm lifts the cocking lever and causes it to rotate

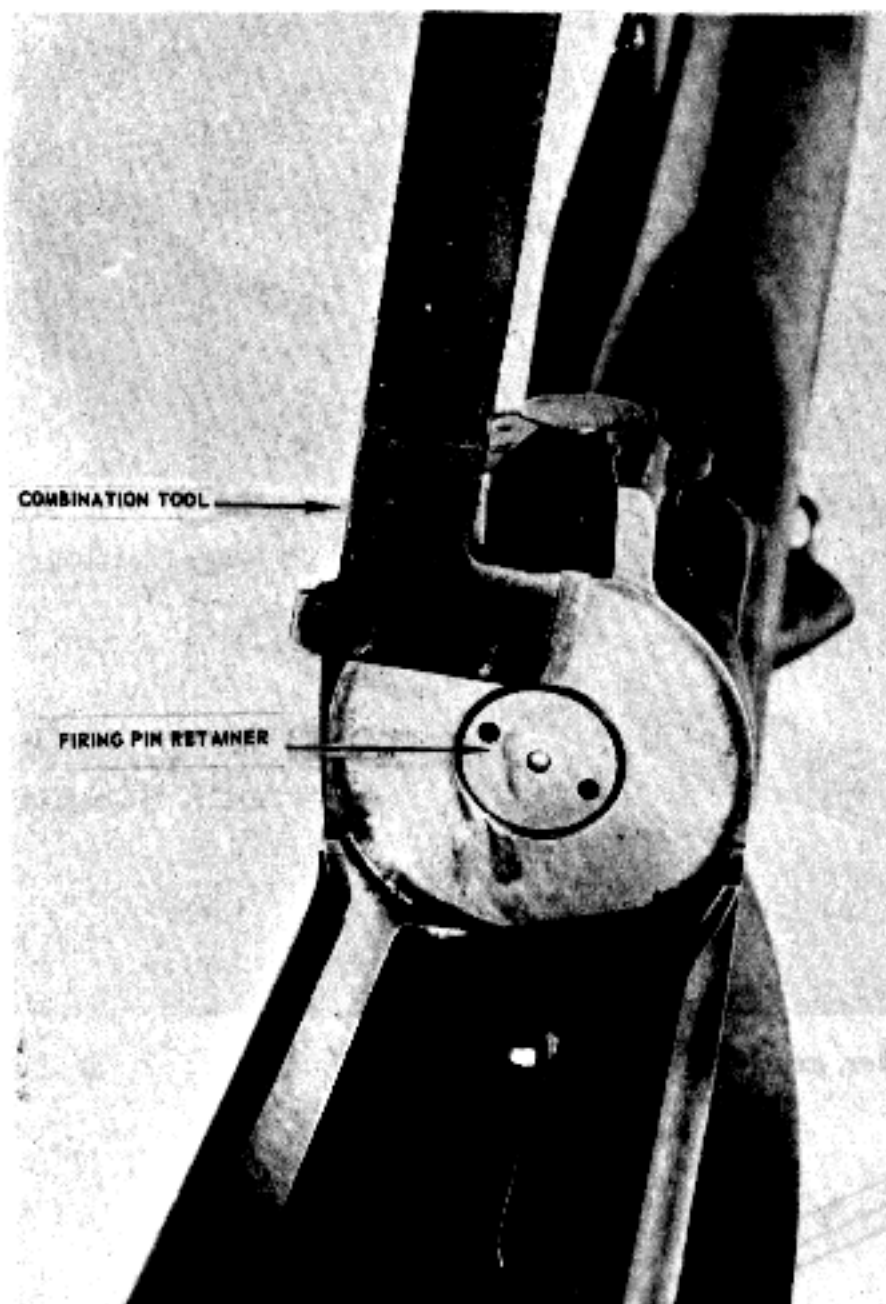

Figure 10-6. Position of firing pin retainer.

around the hammer pin contacting a stud on the hammer.

(3) The cocking lever rotates upward with the hammer until the sear notch is engaged by the sear.

*c. Extraction (fig 10-7).*

(1) Extraction and cocking take place at the same time.

(2) As the barrel is opened, the spring-loaded extractor withdraws the spent cartridge case about  $\frac{1}{2}$  inch from the breech end of the barrel.

*d. Ejection (fig 10-8).*

(1) The launcher is not equipped with an automatic ejector.

(2) To eject, manually remove the expended cartridge case or live round from the barrel.

*e. Loading (fig 10-8).* With the barrel in the open position the cartridge is inserted into the breech end of the barrel.

*f. Chambering.*

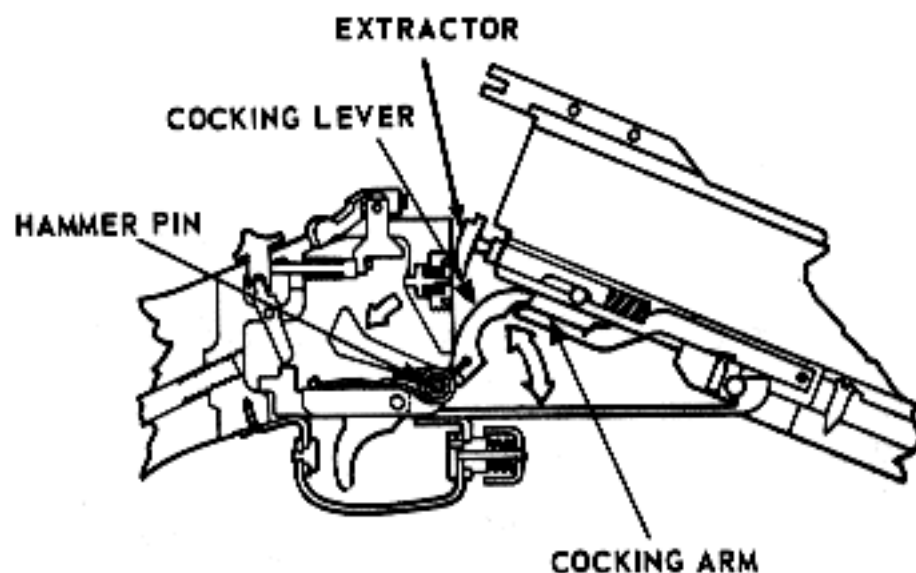

Figure 10-7. Unlocking, cocking, and extraction.

(1) Chambering takes place during the closing of the barrel.

(2) As the barrel is closed, the extractor is forced into the extractor housing and the cartridge is seated into the chamber.

*g. Locking (fig 9-6).*

(1) As the barrel closes and the latch lock is depressed, the barrel locking latch rotates until it is engaged with the barrel locking lug.

(2) The barrel is now locked to the receiver and the launcher can be fired after the safety is pushed forward exposing the letter F.

*h. Firing (fig 10-9).*

(1) As the trigger is pulled rearward it rotates about the trigger pin and the rear of the trigger lifts the rear of the sear causing the nose of the sear to become disengaged from the sear notch in the hammer. This releases the spring driven hammer to strike the firing pin and drive it forward to strike the primer of the cartridge.

(2) As the trigger is released the hammer settles back slightly, allowing the firing pin to be withdrawn from the face of the retainer through the action of the firing pin spring.

## 10-6. Troubleshooting

*a.* Stoppages and immediate action are as outlined in paragraph 3-6, 3-7, and 3-8.

*b.* Troubleshooting is the systematic study of trouble signs, testing to determine the defective components, and applying corrective action (chart 10-1).

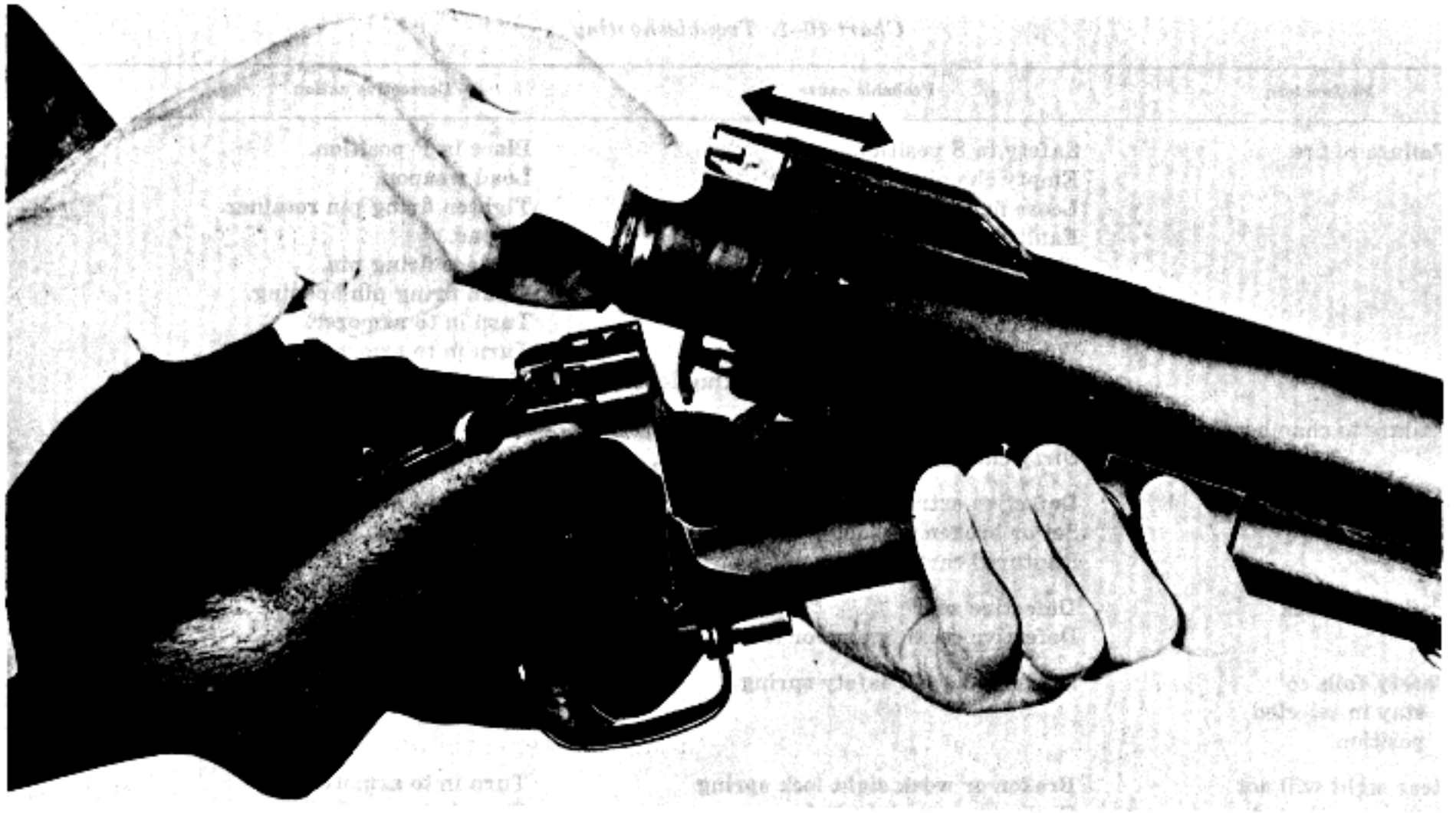

Figure 10-8. Loading or ejecting.

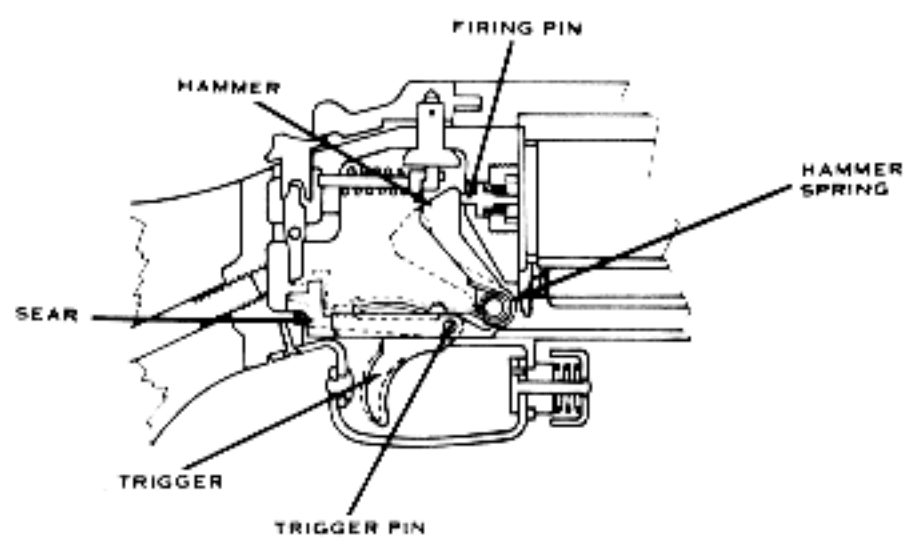
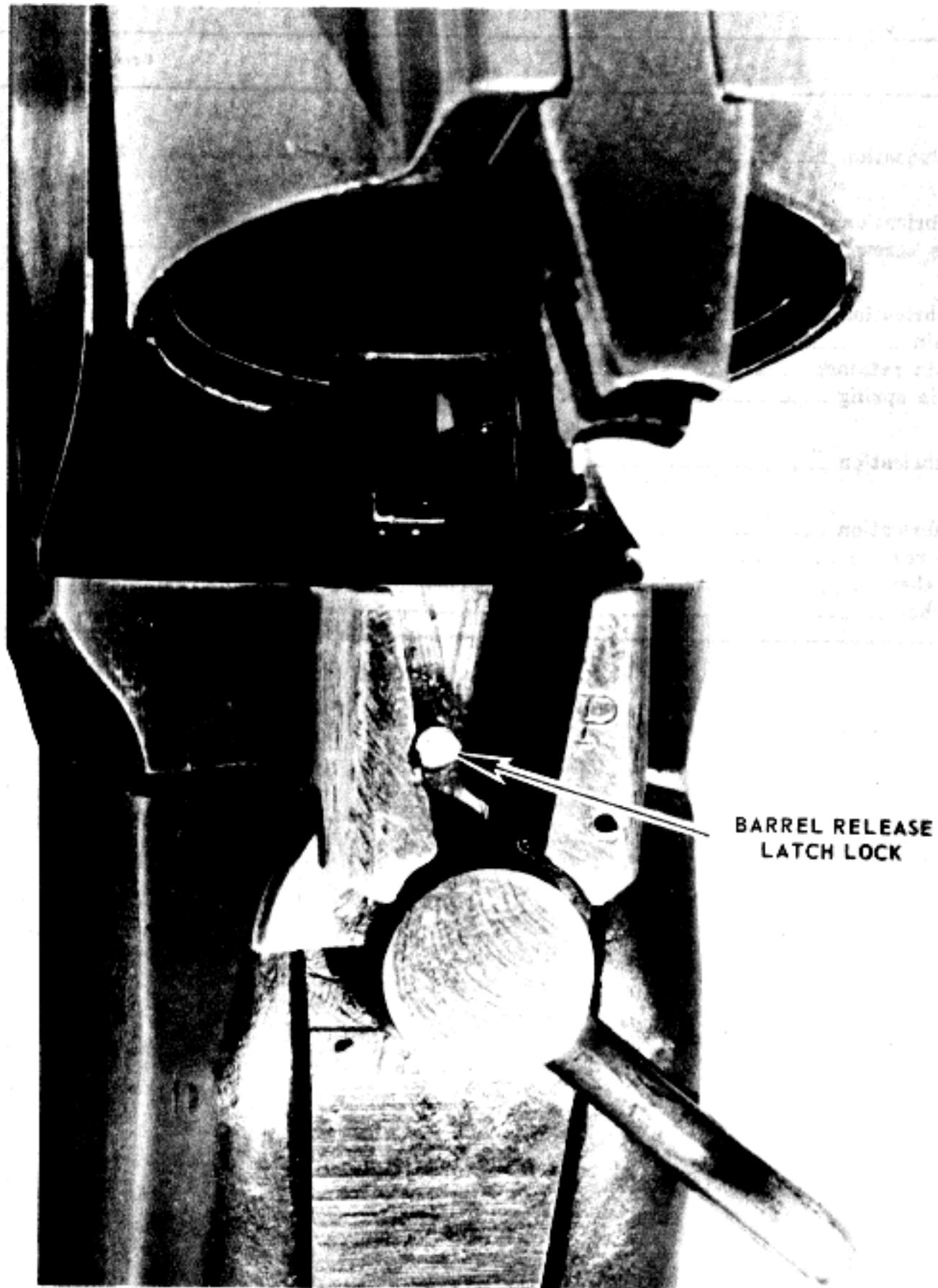

Figure 10-9. Firing.

Chart 10-1. Troubleshooting

Malfunction	Probable cause	Corrective action
Failure to fire	Safety in S position Empty chamber Loose firing pin retainer Faulty ammunition Short, worn, or broken firing pin. Dirty firing pin opening Broken hammer Weak or broken hammer spring Broken sear, cocking arm, cocking lever	Place in F position. Load weapon. Tighten firing pin retainer. Reload. Replace firing pin. Clean firing pin opening. Turn in to armorer. Turn in to armorer. Turn in to armorer.
Failure to chamber	Faulty ammunition Dirty chamber	Reload. Clean bore.
Failure to extract	Defective extractor Set or broken extractor spring Ruptured cartridge case	Turn in to armorer. Turn in to armorer. Remove from barrel.
Failure to cock	Defective sear Defective cocking arm or lever	Turn in to armorer. Turn in to armorer.
Safety fails to stay in selected position.	Broken or weak safety spring	Turn in to armorer.
Rear sight will not stay in selected position	Broken or weak sight lock spring Broken lug on sight lock	Turn in to armorer. Turn in to armorer.





*Figure 10-10. Barrel release latch lock.*

### Section III. MAINTENANCE

#### 10-7.

Maintenance of the M79 is the same as that for the M203 in chapter 5.

#### 10-8.

Authorized organizational maintenance is shown in chart 10-2.

Chart 10-2. Authorized Organizational Maintenance (M78)

	Grenadier	Armorer
<b>Barrel group:</b>		
Cleaning and lubrication -----	X	X
<b>Fore-end assembly:</b>		
Cleaning and lubrication -----	X	X
Replace machine screw -----		X
<b>Receiver group:</b>		
Cleaning and lubrication -----	X	X
Replace firing pin -----		X
Replace firing pin retainer -----		X
Replace firing pin spring -----		X
<b>Sight assembly:</b>		
Cleaning and lubrication -----	X	X
<b>Stock assembly:</b>		
Cleaning and lubrication -----	X	X
Replace stock screw -----		X
Replace flat washer -----		X
Replace lockwasher -----		X

## CHAPTER 11

## MARKSMANSHIP TRAINING (M79)

## 11-1. General

Marksmanship training is to teach the grenadier to fire the grenade launcher and to prepare him to employ it in combat. Except as discussed below, the marksmanship training, range construction, and range firing for the M79 are identical with that for the M208 (chap 1-8).

## 11-2. Sight Alignment, Sight Picture, and Sight Manipulation

a. Sight alignment is the relationship between the front sight blade and the rear sight notch. To have correct sight alignment the sights should be aligned as shown in figure 11-1. If an imaginary horizontal line were drawn across the top of the rear sight notch, the top of the front sight blade would touch this line. If an imaginary vertical line were drawn through the center of the notch, the line would cut the front sight blade in half.

b. Sight picture includes sight alignment and the placement of the aiming point as shown in figure 11-2.

c. Sight manipulation is the procedure of placing the rear sight carrier at the proper setting on the elevation scale to correspond with the range to the target.

## 11-3. Positions

a. Fire the M79 grenade launcher from the same positions as the M208 grenade launcher. The

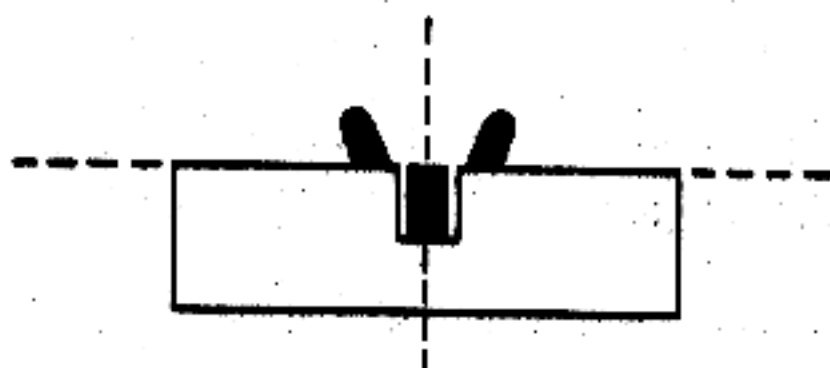

Figure 11-1. Correct sight alignment.

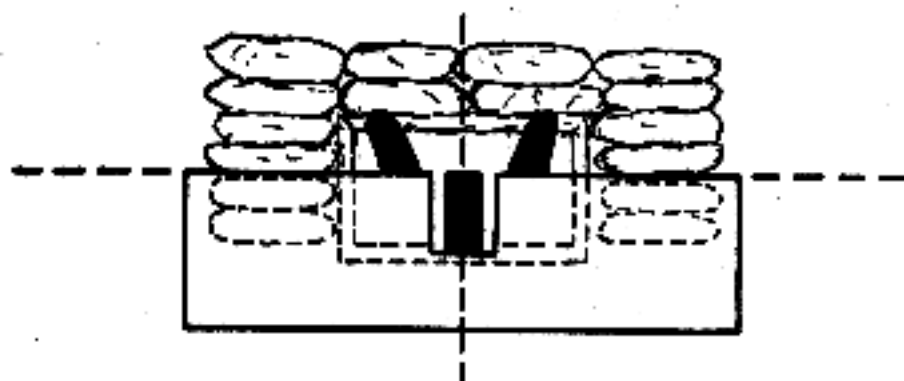

Figure 11-2. Correct sight picture.

most commonly used firing positions are the prone, kneeling, foxhole, and standing positions. Supported positions add stability to the weapon and should be used when possible. The grenadier takes the various firing positions in the same way as with the service rifle (FM 23-9), with the following exceptions:

(1) Hold the thumb of the right hand against the right side of the stock. The safety may injure the thumb when the launcher recoils if the thumb is placed over the top of the small of the stock.

(2) The spot weld is not attained.

b. The following points are common to all positions. Check for them when training the grenadier.

(1) The launcher should rest in the V formed by the thumb and forefinger of the left hand across the heel of the hand.

(2) The fingers of the left hand are relaxed. The hand is placed so that it will not be pinched by the upper-sling swivel.

(3) The left wrist is straight with the left thumb resting against the fore-end assembly and not on the rear sight base. If the thumb is placed near the rear sight base, injury to the thumb may result.

(4) The left elbow is under the launcher.

(5) The right elbow is positioned far enough to the right to level the shoulders and far enough forward to form a good pocket for the butt of the launcher.

(6) The thumb of the right hand rests along the side of the stock. Do not place the thumb over the top of the small of the stock as the safety may injure it when the launcher recoils.

(7) The trigger finger is placed on the trigger so that there is no contact between the finger and the side of the stock.

(8) The grenadier must be relaxed in all firing positions.

c. At ranges less than 150 meters, the grenadier is able to fire from the shoulder in the normal manner from all positions. However, in order to maintain sight alinement as range to the target increases, he must adjust as follows:

(1) Lower the position of the stock on the shoulder or drop the butt from the shoulder to maintain sight alinement. At near maximum ranges the stock will be positioned between the waist and the armpit and held firmly into the body by the upper arm. In the prone position the butt of the launcher will rest on the ground once the stock is no longer against the shoulder.

(2) As contact between the cheek and the stock is broken, care must be taken to keep the

head level. Figure 11-3 illustrates the changes which take place as the range-to-target increases.

d. Use the pointing technique to deliver a high rate of HE fire when pinpoint accuracy is not required (fig 11-4). Although the sights are not used in the pointing technique, the grenadier must first become proficient in sighting and aiming. The grenadier uses a modified underarm firing position, enabling him to use his left hand for rapid reloading. Although the pointing technique can be used by modifying any of the standard firing positions, it is most frequently used during the assault.

e. To employ the pointing technique use a modified underarm firing position. With both eyes open, concentrate your vision on the target keeping the muzzle of the launcher in the lower part of the field of view. Point the muzzle at the target and sense the elevation of the launcher with respect to the range to the target. To make corrections in elevation and deflection sense the impact of the round and make proper changes in the attitude of the launcher.

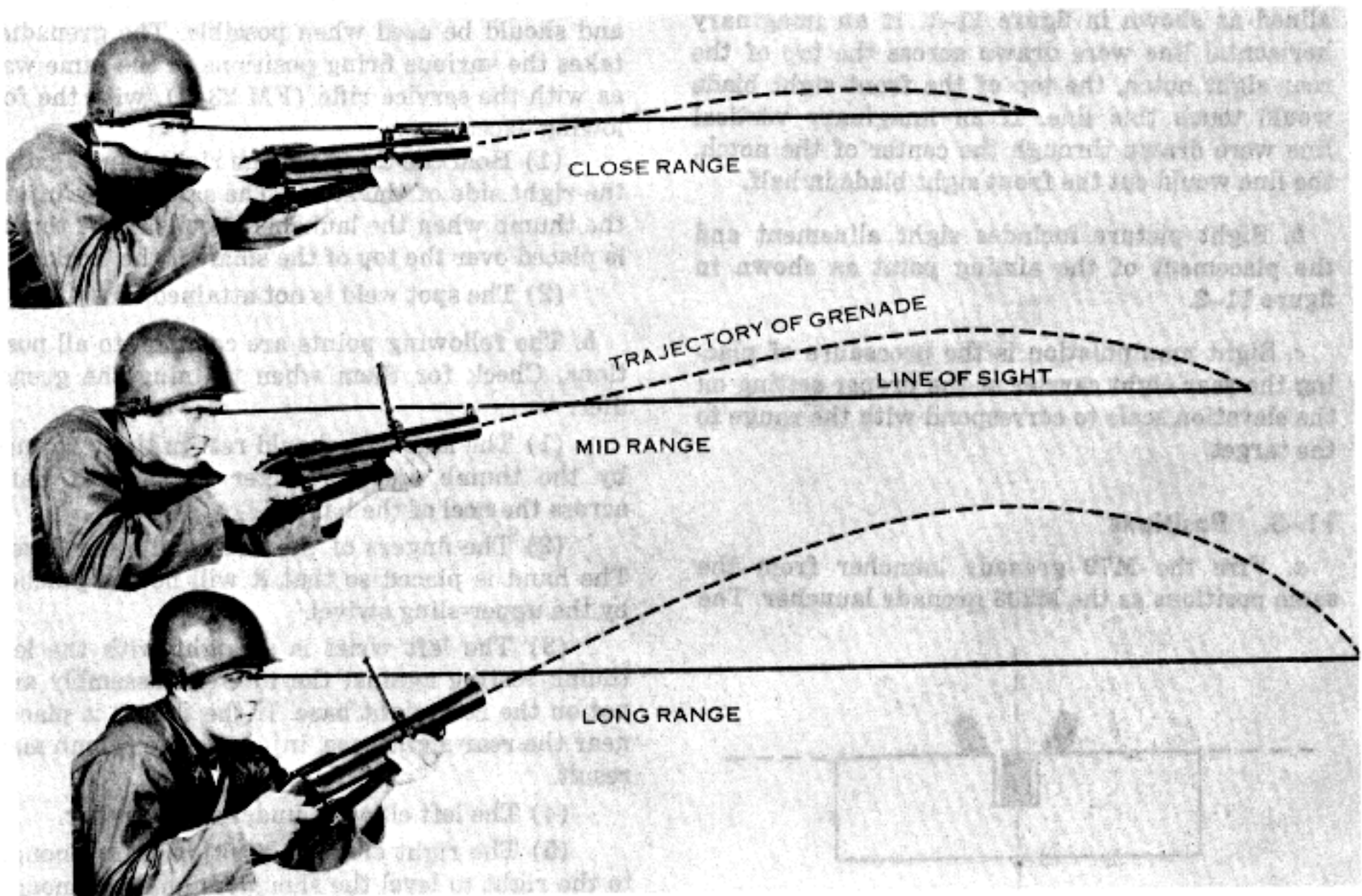

Figure 11-3. The effect of increasing range.





Figure 11-4. Pointing technique.

#### 11-4. Zeroing Procedure

The correct zero of the grenade launcher is that sight setting of elevation and windage which will enable the firer to hit his point of aim at a given range. To get a zero, the grenadier engages a target 200 meters from the weapon position. Use a 200 meter range because this is the mid-range capability of the weapon and allows for maximum changes in elevation. Zero the M79 in the following sequence (fig 9-7):

a. Place the center index line of the rear sight on the center mark of the windage scale.

b. Unlock the elevation scale by turning the elevation scale lock screw counterclockwise. Position the top of the elevation scale flush with the top of the sight frame. Lock the elevation scale.

c. Unlock the rear sight carrier by turning the rear sight carrier retainer locknut, push it in, and slide the sight carrier along the elevation scale until the 200 meter index mark on the elevation scale is aligned with the top edge of the sight carrier. Lock the rear sight carrier in position.

d. Take a prone supported position and align the target with the front and rear sights using correct sighting and aiming procedure.

e. Fire a round, sense the impact of the grenade, and make sight adjustment.

(1) For elevation adjustment, turn the elevation screw wheel clockwise to increase (or counterclockwise to decrease) the range. One click on the elevation screw wheel moves the impact of the grenade  $2\frac{1}{2}$  meters at a range of 200 meters.

(2) For windage adjustment, turn the windage knob clockwise to move the impact of the grenade to the right. One click of the windage knob moves the impact of the grenade about 11 inches at a range of 200 meters.

f. Fire two more rounds and make necessary adjustments after each round. If the last round has landed within 5 meters of the target, the weapon is zeroed.

g. After the zero has been confirmed, insure that the elevation scale is moved so that the 200 meter index line is flush with the top of the sight carrier.

## CHAPTER 12

### INDIRECT-FIRE ROLE, M79

#### 12-1. General

a. This chapter describes the use of the 40-mm grenade launcher, M79, in the indirect-fire role. Although the M79 is designed for direct fire, it can fire indirect-fire as an expedient means of placing high explosive fragmentation fire on area targets which cannot be observed.

b. By massing the indirect fire of several M79s, the small unit leader has organic firepower with which to suppress fire when the enemy's position is screened by vegetation, in defilade, or located on a steep slope above the friendly unit. During periods of limited visibility this fire can supplement the indirect fires of other weapons supporting the unit.

#### 12-2. Employment Considerations

a. *Employment.* When using the M79 for indirect-fire, its accuracy is limited. Range adjustment can be made in 25-meter increments to the maximum range of about 400 meters.

b. *Sighting System.* The sighting system for the M79 is graduated up to 375 meters which corresponds to a 32° quadrant elevation. However, the rear sight carrier can be raised higher so that a maximum quadrant elevation of 40° is possible. At elevations greater than 40°, where the rear sight cannot be used, the range will decrease as the angle of elevation is increased.

#### c. Adjustments for Elevation and Deflection.

(1) Indirect fires with the M79 are adjusted by moving the barrel slightly for elevation or deflection to bring succeeding rounds nearer the target.

(2) Deflection is attained by sighting over or along the side of the barrel at an aiming point. When opportune, an aiming stake should be used. If time permits, greater accuracy can be attained by placing a string or straight stick on the ground in the direction of an aiming point or stake.

(3) The correct elevation is achieved by estimating the range to the target and moving the barrel either up or down. Table 12-1 (Range Estimate/Elevation) is a guide for setting the proper elevation on the weapon:

*Table 12-1. Range Estimate/Elevation*

Range	Elevation	Distance from front sling swivel to ground
200 meters	69°	21 ¼ inches
300 meters	58°	19 ¾ inches
400 meters	41°	18 ¼ inches



*Figure 12-1. Kneeling position using marked sling method.*



*d. Ammunition.*

(1) If available, use the cartridge, 40-mm practice, M407, for training and zeroing. On impact, it emits a puff of yellow smoke which aids the grenadier in adjusting his fire. The possibility of a training injury is greatly reduced by using this round, as there is very little fragmentation.

(2) Ammunition should be conserved in both training and combat.

(3) The projectile takes nearly twice as much time to reach its target when fired indirect. Therefore, wind, snow, or rain may cause the projectile to deviate from its normal trajectory.

(a) Before firing, the grenadier should evaluate the wind and compensate for it, whether it is a crosswind or blowing on the same axis as

the grenade. This evaluation (Kentucky windage) will increase his chances of getting a first round hit and reduce the chances of a round impacting closer than desired.

(b) Use caution when a wind 5 miles per hour or greater is coming from the direction of the target. This wind condition must be considered when firing at all ranges and especially when firing at the *minimum* range of 200 meters.

*e. Fire Control.*

(1) The responsibility for the use of indirect fire with the M79 should be delegated to the squad leader. The methods of fire control used should be prescribed in the squad SOP. This SOP should state that the grenadiers will not fire indirect fire without specific command.



Figure 12-2. Sitting position for indirect fire.



(2) The fire commands used with indirect fire are the same as direct fire except for the method of fire. The squad leader must designate the target, range, and method of employment. An example of a fire command to use when employing indirect fire is—

SQUAD  
FRONT  
LINE OF RIFLEMEN  
THREE HUNDRED  
GRENADIERS, INDIRECT FIRE  
THREE ROUNDS

(3) An observer may be used when using the M79 for indirect-fire if the grenadier cannot observe the target.

(4) Fire for effect with the M79 should always be three to five rounds depending on the nature of the target.

### 12-3. Firing Positions

The positions for indirect-fire with the M79 are kneeling, sitting, or squatting.

*a. Kneeling* (fig 12-1). The kneeling position can be used with any of the three methods of fire described in paragraph 12-4. A modified kneeling position is the most comfortable. Face the target and kneel on the right knee (if firing right-handed), keeping the left foot pointed in the direction of the target. Sit on the right heel and place the left elbow outside the left knee. Place the butt of the stock on the ground against or along the side of the right knee. Grasp the launcher near the upper sling swivel with the left hand and by the small of the stock with the right hand. The right thumb should be against the right side of the stock, parallel to the trigger finger. The weight of the body should rest on the right heel.

*b. Sitting* (fig 12-2). The sitting position is identical to the direct fire sitting position except for the following variations: keep the right leg flat on the ground and pointed at the target, cross the left leg over the knee so that the left knee will support the left elbow, and place the butt of the stock along-side the right hip. The weapon is held as described in *a* above. The sitting position can be used with the aiming stakes or M15 sight methods.

*c. Squatting* (fig 12-3). The squatting position is identical to the direct fire modified squatting position except for one variation; the M79 is



Figure 12-3. Squatting position for indirect fire.

placed between the knees with the butt of the stock on the ground. The launcher is held as described in *a* above. The squatting position can be used with the aiming stakes or M15 sight methods, although it is the least comfortable of the positions when held for any length of time.

### 12-4. Methods of Indirect Fire (fig 12-1)

*a.* The marked-sling method is the best field expedient to use with the M79. To use this method, loosen the sling, take a kneeling position, and place the forward foot in the sling. Before firing, insure that the sling, between the front sling swivel and the boot, is taut and vertical. If not, the rounds will impact at a greater range than desired. An easy way to check is by tying a string or thread to a weight, such as a cartridge case, and letting it hang from the front sling swivel. Then aline the edge of the sling with the string or thread to insure that the sling is vertical. Fire several rounds to determine the desired

range. Then mark the sling, where it is held to the ground by the foot, with tape, paint, ink, or a similar material. The position of the sling keeper and buckle must also be marked so if either is moved the grenadier can return them to their original positions and be assured of constant range accuracy. Remember that the sling may stretch or shrink if it gets wet, indirectly causing the rounds to impact closer or farther than desired.

b. Preplanned indirect fire can be delivered with the M79 using aiming stakes (fig 12-4). The aiming stakes must be placed and their alignment verified during daylight. Preplanned fires should be recorded on a range card or sector sketch. The fore-end assembly of the weapon is placed on top of an elevation support. A slight depression is scooped out of the ground for the toe of the weapon's stock. Adjust the weapon for the range desired and then drive a stake into the ground behind the toe of the weapon's stock to absorb and prevent the weapon from digging into the ground. Place two deflection stakes behind the front elevation support to control lateral movement of the barrel. Place another elevation support beneath the stock of the weapon and two additional deflection stakes behind this support, but closer to-

gether than the two front stakes, to control lateral movement of the stock.

c. The most accurate way to fire the M79 for indirect fire is with an M15 rifle grenade sight fitted to the weapon's stock (fig 12-5). The M15 rifle grenade sight consists of a mounting scale plate and a sight bar assembly. The mounting plate is attached to the side of the stock of the launcher by two short wood screws. (Insure that the screws do not protrude through the stock or disassembly of the weapon will be a problem.) When the weapon is in a horizontal position, the mounting plate should be positioned so that the two screw holes are vertical. The holes in the stock should be predrilled if possible, to prevent cracking the wood. When the M15 sight is attached to the M79, the degree scale on the mounting plate is not used. A short piece of masking tape can be placed on the stock above the mounting plate. The grenadier adjusts his fires until the rounds impact at the desired range. After the sight setting has been determined, the grenadier can draw a line along the top of the sight bar on the tape. Each line should be labeled for the appropriate range. Indirect-fire sighting and aiming with the M15 sight consists of the following three

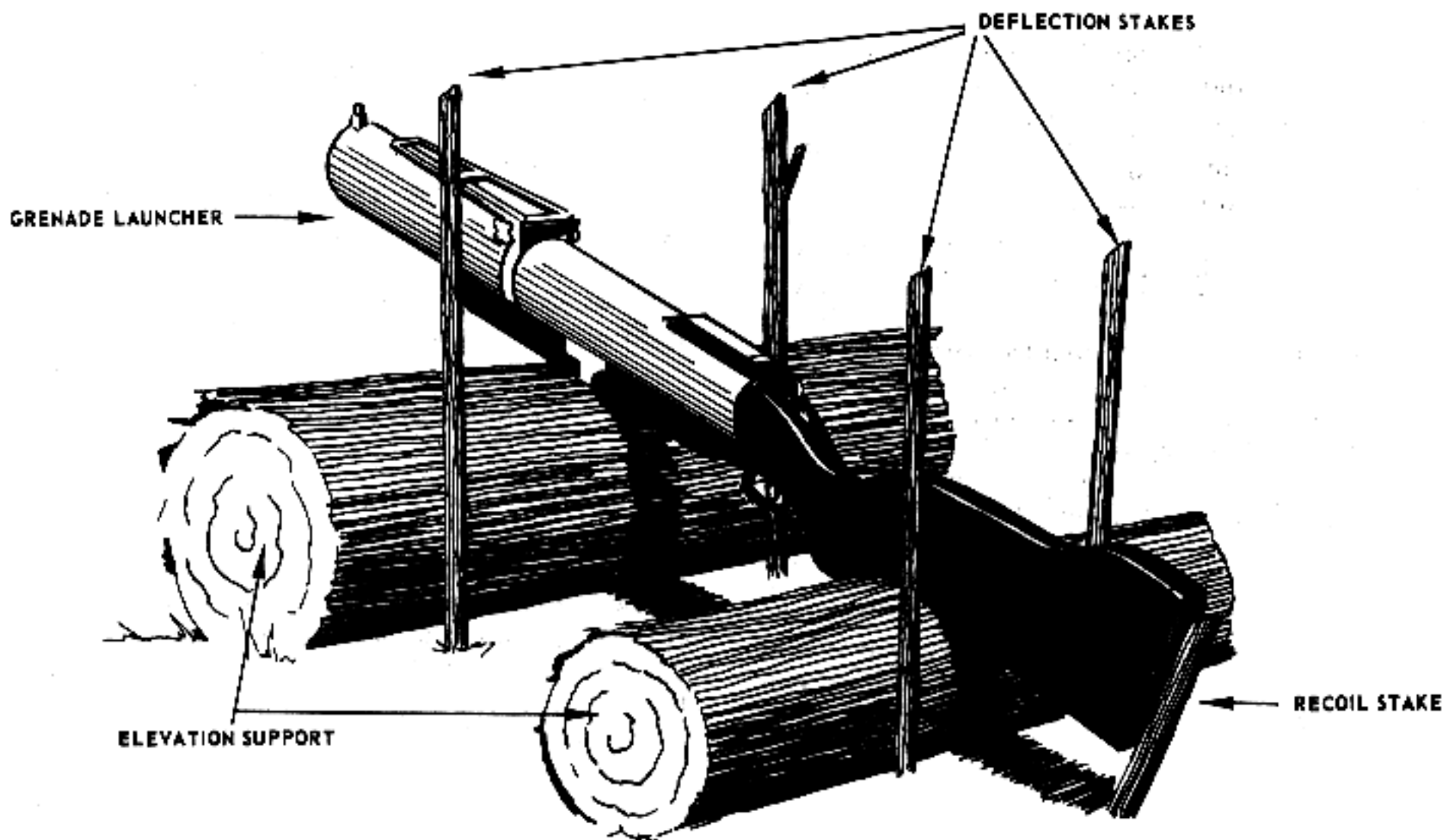

Figure 12-4. Preplanned fires using aiming stakes.



Figure 12-5. M79 with M15 rifle grenade sight.

steps: adjusting the sight, aligning the launcher for deflection, and centering the leveling bubble.

(1) *Adjusting the sight.* By firing several rounds during zeroing, the grenadier can determine what elevation graduation is required on the M15 sight to cause the round to impact at a given range. This graduation can be marked on the stock for quick reference.

(2) *Aligning the launcher for deflection.* Take a correct firing position and sight over or along the barrel. Move the launcher so that the barrel is aligned toward the target.

(3) *Centering the leveling bubble.* Raise or lower the muzzle of the launcher until the leveling bubble is centered in its vial. Insure that the weapon is not canted; this can cause the grenadier to miss his area target.

(4) *Determining the angle of elevation.* If enough light is available, the M15 sight will provide a quick easy method for determining the proper angle of elevation.

## 12-5. Safety Precautions

a. The grenadier must keep his head behind and below the muzzle of the launcher when firing.

b. Be cautious, and insure overhead clearance when firing indirect fire. Remember that the M406 40-mm cartridge arms itself 14 to 28 meters from the muzzle of the launcher.

c. Absolutely no rounds should be fired at less than 200 meters.

d. These safety precautions are in addition to those in AR 885-63, and local range regulations.

## APPENDIX A

## REFERENCES

---

AR 385-63	Regulations for Firing Ammunition for Training, Target Practice, and Combat.
ASubjScd 7-2	Rifle Squad Tactical Training.
ASubjScd 7-11B(C)(H)10	MOS Technical Training of Light Weapons Infantryman, Infantry Indirect Fire Crewman, and Infantry Direct Fire Crewman.
ATP 7-16	Headquarters and Headquarters Company, Infantry, Airborne Infantry, and Mechanized Infantry Battalions.
ATP 7-18	Rifle Company, Infantry, Airborne, Airmobile and Light Infantry Battalions.
CTA 23-100-1	Ammunition, Rockets, and Missiles for Basic and Advanced Individual Training (by MOS).
DA Form 2946	Scorecard for 40-mm Grenade Launcher, M79.
DA Pam 108-1	Index of Army Films, Transparencies, GTA Charts and Recordings.
FM 5-25	Explosives and Demolitions.
FM 21-75	Combat Training of the Individual Soldier and Patrolling.
FM 23-8	US Rifle 7.62-mm, M14 and M14A1.
FM 23-9	US Rifle 5.56-mm, M16A1.
FM 23-12	Technique of Fire of the Rifle Squad and Tactical Application.
FM 23-30	Grenades and Pyrotechnic Signals.
FM 23-71	Rifle Marksmanship.
TF 9-3292	Grenade Launcher, M79, Operation, Disassembly and Assembly (15 min).
TM 9-1010-205-12	Operator and Organizational Maintenance Manual: 40-mm Grenade Launcher, M79.
TM 9-1010-205-24P	Combined Organizational, DS, GS, and Repair Parts and Special Tools List for Launcher, Grenade, 40-mm: M79.
TM 9-1010-221-14	Operator's, Organizational DS and GS Maintenance Manual: 40-mm Grenade Launcher, M203.
TM 9-1300-206	Care, Handling, Preservation and Destruction of Ammunition.
TM 9-1300-200	Ammunition, General.
TM 9-6920-210-14	Operator, Organizational, Direct Support and General Support Maintenance Manual Including Basic Issue Items List and Repair Parts List: Small Arms Targets and Target Material.
TV Tape—FP 175	Review of M79 Grenade Launcher.



## APPENDIX B

### AMMUNITION

This appendix lists in table B-1 the standard and developmental ammunition used with 40-mm grenade launchers M203/M79. The letters XM preceding a numerical designation indicates that the round is developmental (Example: XM583). Figures B-1 through B-10 illustrate the more common types of ammunition used with the M203/M79.

*Table B-1. 40-mm Cartridge Identification*

Cartridge	Body	Color Identification Ogive*	Lettering
40-mm, HE M381 and M406	Green	Gold	Yellow
40-mm, HE, M386 and M441	Green	Gold	Yellow
40-mm, HE, M468 (smokeless, flashless)	Green	Black	Yellow
40-mm, HE, M397 (airburst)	Green	Gold	Yellow
40-mm, HE, M488 (dual purpose)	Green	Gold	Yellow
40-mm, practice, M382 and M407A1	Green	Silver	Yellow
40-mm, multiple projectile, XM576E1	Green	Black (SABOT)	White
40-mm, multiple projectile, XM576E2	Green	None	White
40-mm, green smoke parachute, XM658	Green	Green	Black
40-mm, white star parachute, XM588	White	White	Black
40-mm, red smoke parachute, XM659	Green	Red	Black
40-mm, white star cluster, XM585	White	White	Black
40-mm, yellow smoke parachute, XM660	Green	Yellow	Black
40-mm, violet smoke parachute, XM669	Green	Violet	Black
40-mm, tactical CS, XM651E1	Green	Gray	Black
40-mm, yellow smoke streamer, XM696	Green	Yellow	Black
40-mm, green star parachute, XM661	White	Green	Black
40-mm, green smoke streamer, XM697	Green	Green	Black
40-mm, red star parachute, XM662	White	Red	Black
40-mm, orange smoke streamer, XM698	Green	Orange	Black
40-mm, green star cluster, XM668	White	Green	Black
40-mm, red smoke streamer, XM699	Green	Red	Black
40-mm, red star cluster, XM664	White	Red	Black
40-mm, brown smoke streamer, XM700	Green	Brown	Black
40-mm, yellow smoke canopy, XM676	Green	Yellow	Black
40-mm, violet smoke streamer, XM701	Green	Violet	Black
40-mm, green smoke canopy, XM679	Green	Green	Black
40-mm, white smoke canopy, XM680	Green	White	Black
40-mm, violet smoke canopy, XM681	Green	Violet	Black
40-mm, red smoke canopy, XM682	Green	Red	Black
40-mm, riot control CS, XM674 (E24)**	Gray	N/A	Black
40-mm, riot control CS, XM675 (E25 RS)**	Light Green	N/A	Black
40-mm, orange star parachute, XM695	White	Orange	Black

\*The ogive is the nose end of the cartridge.

\*\*Not authorized for use with M203 grenade launcher.

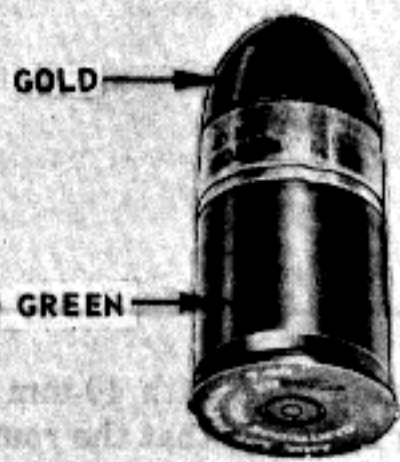

CARTRIDGE 40-mm HE  
M 381 OR M 406

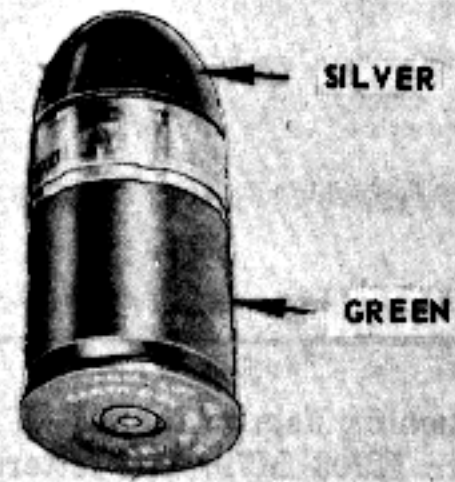

CARTRIDGE 40-mm TP  
M 382 OR M 407A1

M406	
TYPE OF FILLING	HE
MAXIMUM RANGE	400 METERS
EFFECTIVE CASUALTY RADIUS	5 METERS
ARMING DISTANCE	14 TO 28 METERS
M381	
ARMING DISTANCE	2 TO 3 METERS

M407A1	
TYPE OF FILLING	YELLOW SMOKE
MAXIMUM RANGE	400 METERS
ARMING DISTANCE	14 TO 28 METERS
M382	
ARMING DISTANCE	2 TO 3 METERS



CARTRIDGE, 40mm: HE, SF M463

TYPE OF FILLING	COMP B
MAXIMUM RANGE	400 METERS
EFFECTIVE CASUALTY RADIUS	5 METERS
ARMING DISTANCE	14 - 28 METERS



CARTRIDGE, 40mm: HEDP M433

TYPE OF FILLING	RDX
MAXIMUM RANGE	400 METERS
EFFECTIVE CASUALTY RADIUS	COMPARABLE TO THE M406
ARMING DISTANCE	14 TO 28 METERS
PENETRATION	2 INCHES OF STEEL ARMOR AT 0

Figure B-1. 40-mm HE cartridge, M381, M406, M382, M433 and M463.

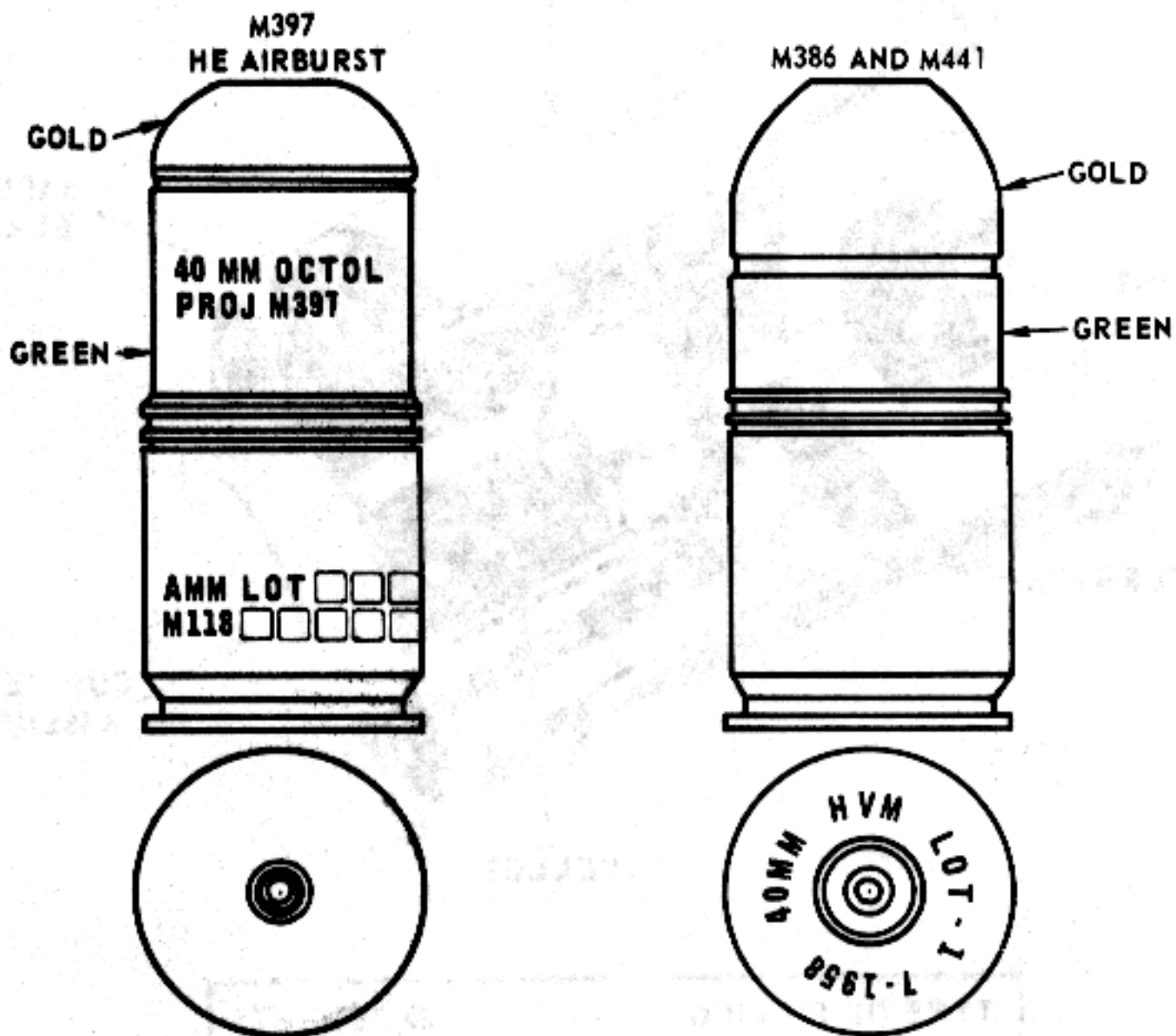

M397	
TYPE OF FILLING . . . . .	HE
MAXIMUM RANGE . . . . .	400 METERS
AIRBURST . . . . .	2 METERS
EFFECTIVE CASUALTY RADIUS . . . . .	5 METERS

M386	
TYPE OF FILLING . . . . .	HE
MAXIMUM RANGE . . . . .	400 METERS
EFFECTIVE CASUALTY RADIUS . . . . .	5 METERS
ARMING DISTANCE . . . . .	14 TO 28 METERS
M441	
ARMING DISTANCE . . . . .	2 TO 3 METERS

Figure B-2. 40-mm HE cartridge M397, M386, and M441.



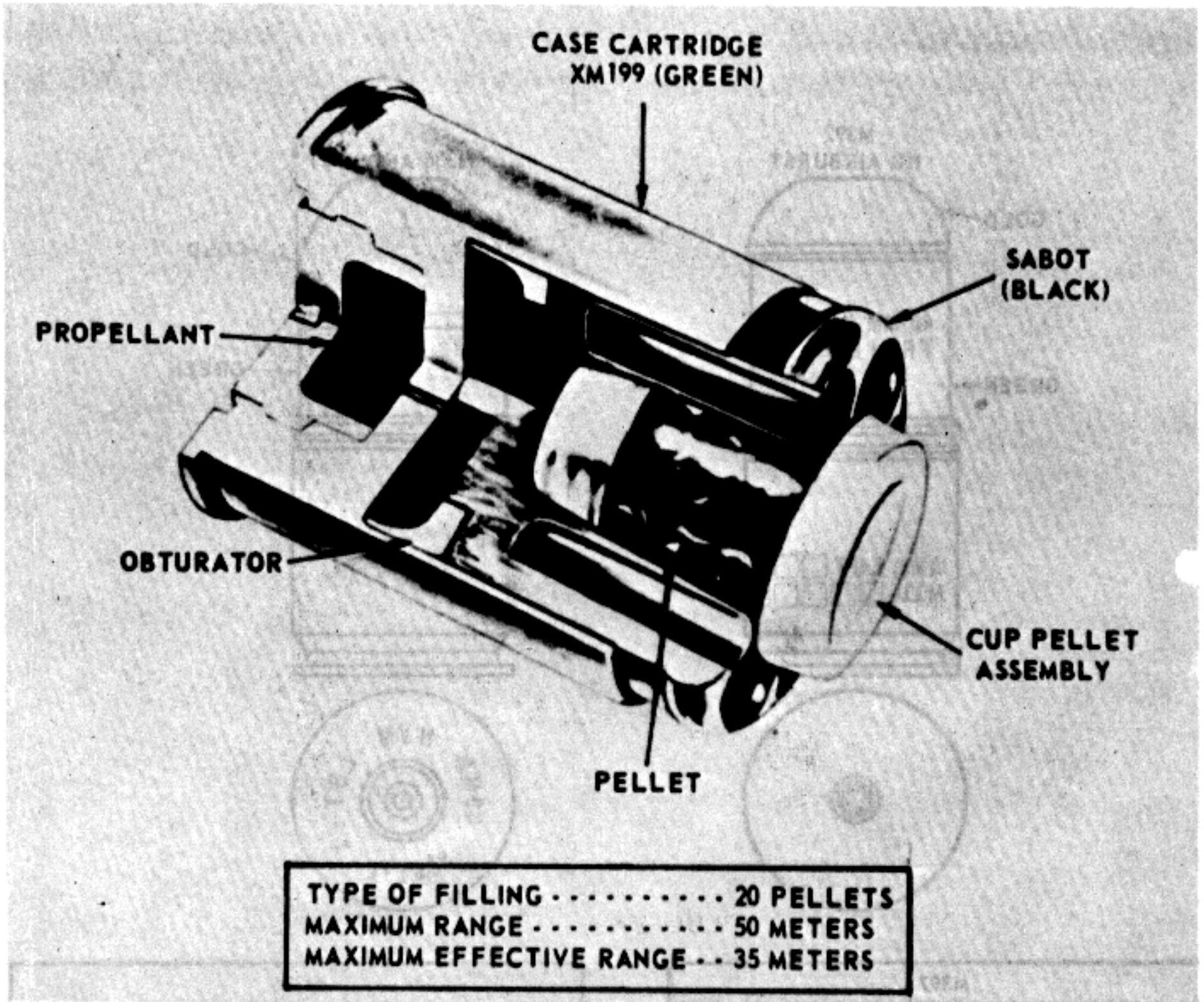

Figure B-3. 40-mm MP cartridge XM576E1—cutaway view.



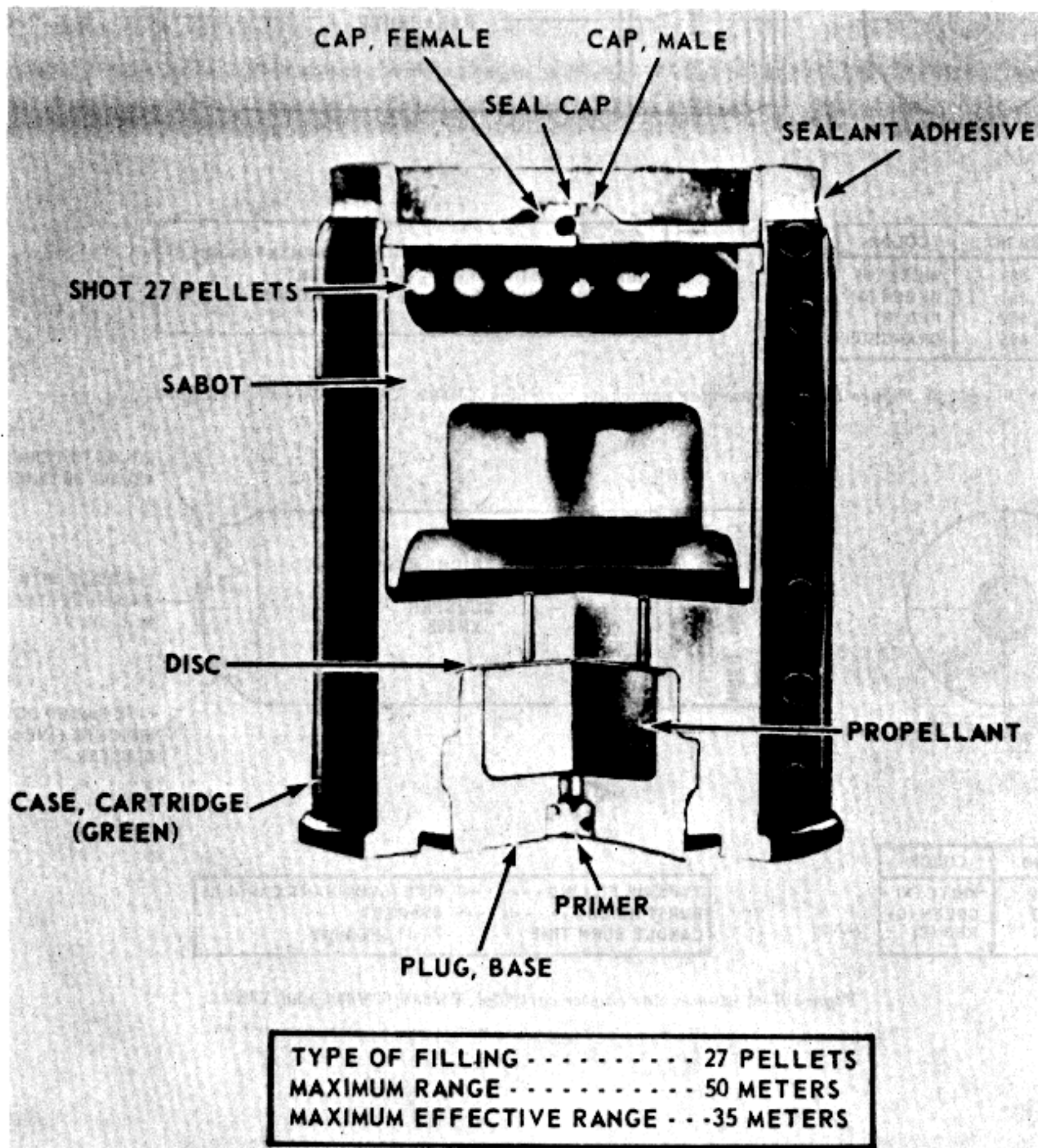
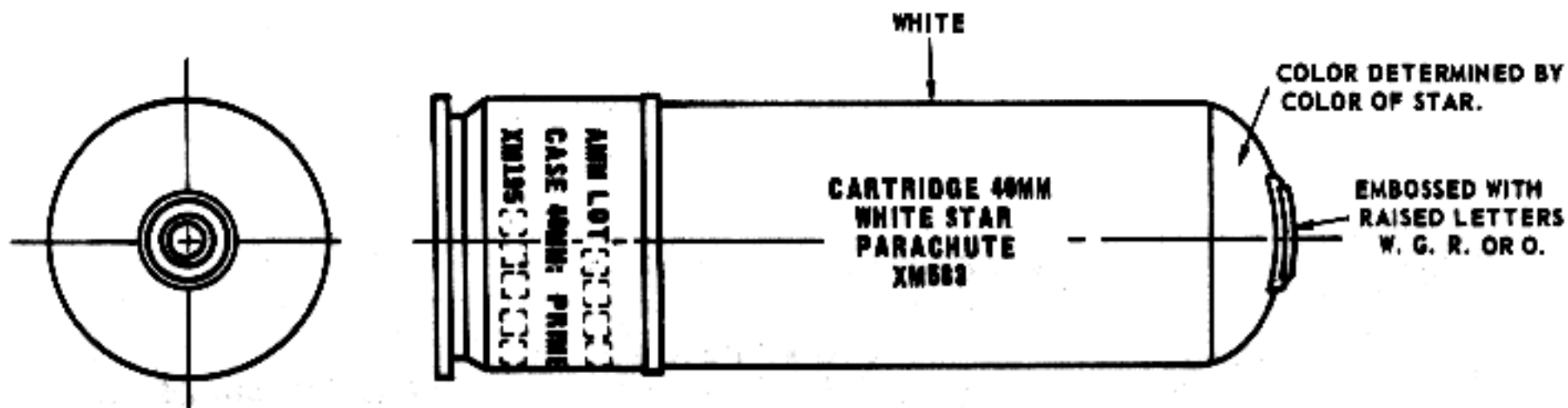

Figure B-4. 40-mm MP cartridge XM576E2—cutaway view.



XM NO.	COLOR
583	WHITE (W)
661	GREEN (G)
662	RED (R)
695	ORANGE (O)

TYPE OF FILLING	ILLUMINANT CANDLE
BURST HEIGHT	550 FEET
CANDLE BURN TIME	40 SECONDS

Figure B-5. 40-mm star parachute cartridge XM588, XM661, XM662, and XM695.

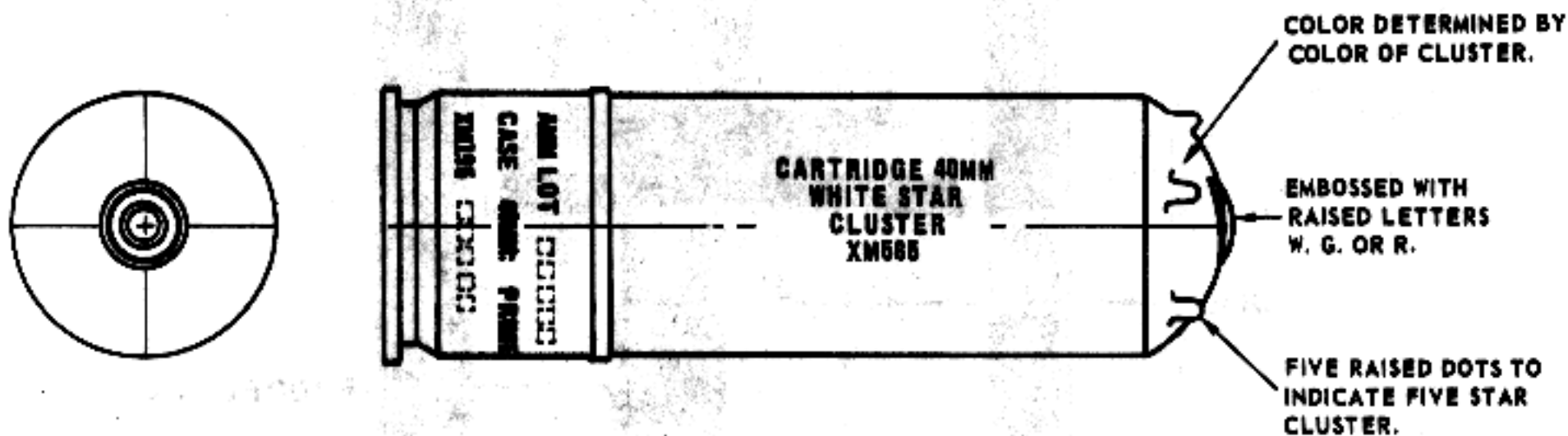

XM NO.	COLOR
585	WHITE (W)
663	GREEN (G)
664	RED (R)

TYPE OF FILLING	FIVE ILLUMINANT CANDLES
BURST HEIGHT	550 FEET
CANDLE BURN TIME	7.11 SECONDS

Figure B-6. 40-mm star cluster cartridge XM585, XM663, and XM664.

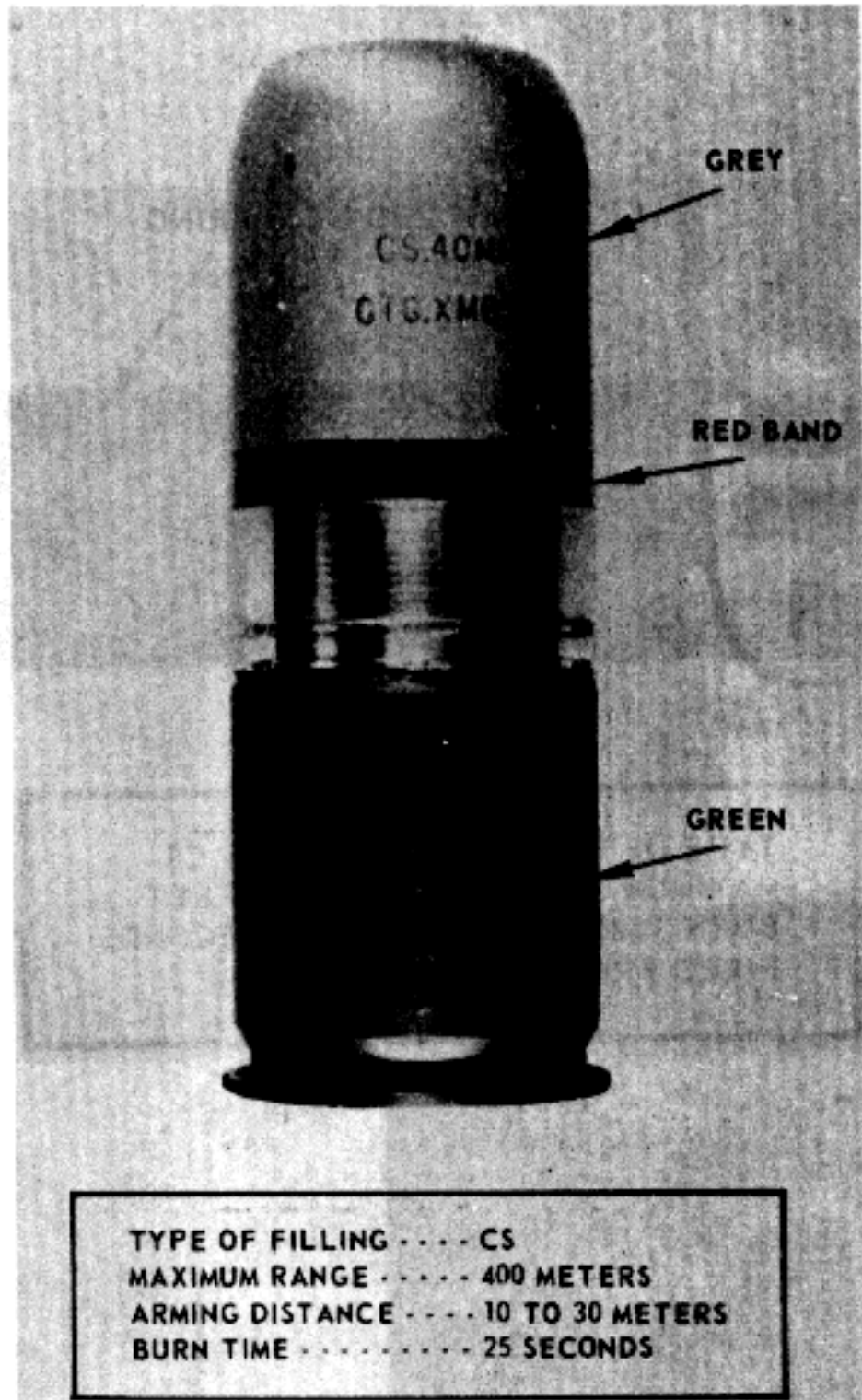

Figure B-7. 40-mm CS, tactical cartridge XM651E1.

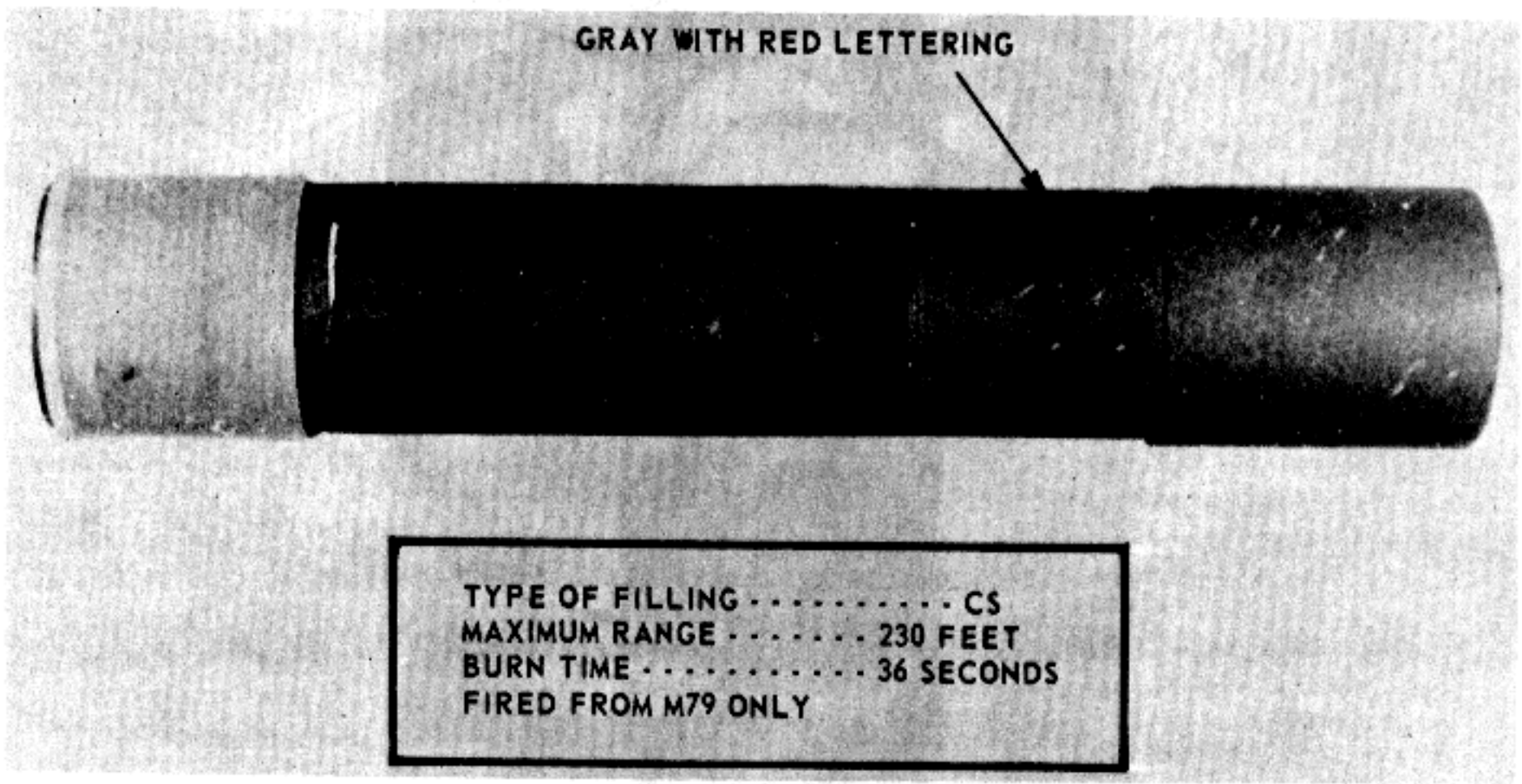
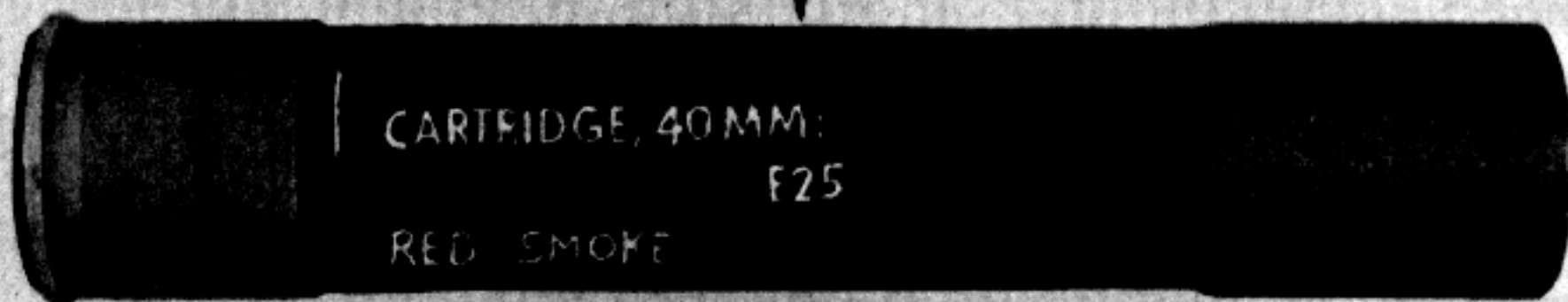

Figure B-8. 40-mm CS, riot-control cartridge XM874.



LIGHT GREEN WITH WHITE LETTERING



TYPE OF FILLING . . . . . RED SMOKE  
 MAXIMUM RANGE . . . . . 230 FEET  
 BURN TIME . . . . . 36 SECONDS  
 TO BE FIRED IN M79 ONLY

Figure B-9. 40-mm, red smoke cartridge XM675.

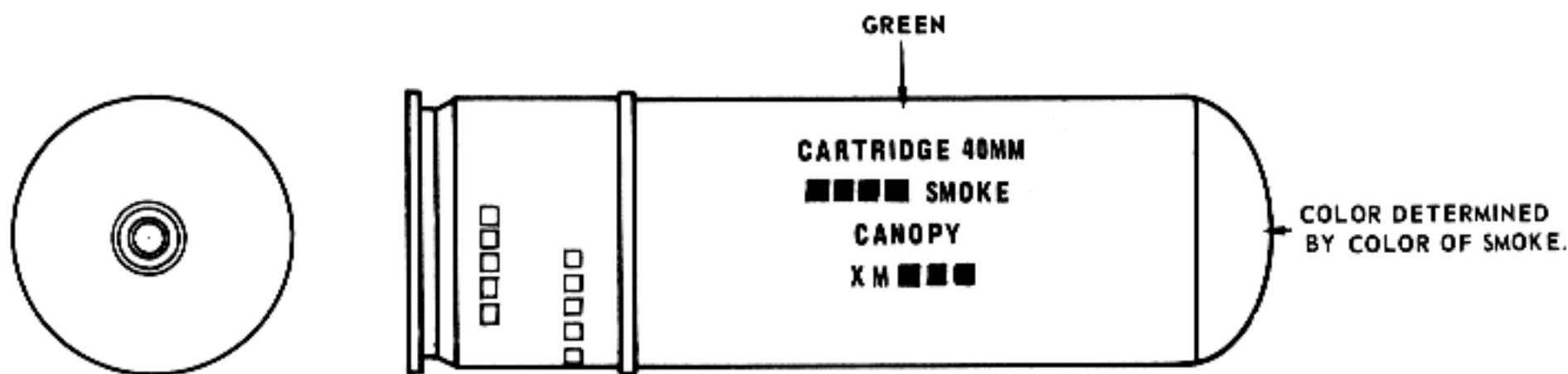

MODEL NO.	SMOKE COLOR
XM676	YELLOW
XM679	GREEN
XM680	WHITE
XM681	VIOLET
XM682	RED

TYPE OF FILLING . . . . . SMOKE  
 BURST HEIGHT . . . . . 350 FEET  
 BURN TIME . . . . . 60 - 90 SECONDS

Figure B-10. 40-mm smoke canopy cartridge XM676, XM679, XM680, XM681, and XM682.

## APPENDIX C

## LESSON OUTLINE

## 40-MM GRENADE LAUNCHERS, M203/M79

This appendix is a guide for instructors. This lesson outline is for training, from 1 to 5 hours, on the M203 or M79. The scope depends on the availability of time, equipment, and ammunition. Instruction can be given in unit areas during non-scheduled periods in subjects such as firing positions, sighting and aiming, and range determination.

**C-1. Period I. Functioning of M203/M79***a. Learning Objective.* The soldier can—

- (1) Apply the characteristics, capabilities, and functioning of the grenade launcher.
- (2) Identify the types and capabilities of standard 40-mm ammunition.

*b. Lesson Outline.*(1) *Characteristics of M203.*

- (a) Designed to be attached and used with the M16A1 rifle.
- (b) Weight.
- (c) Size.
- (d) Singleshot.
- (e) Breechloaded.
- (f) Pump action.
- (g) Adjustable sights.
- (h) Maximum range.

(i) Maximum effective range for point targets.

(j) Maximum effective range for area targets.

(k) Rate of fire.

(2) *Characteristics of M79.*

- (a) Weight.
- (b) Size.
- (c) Singleshot.
- (d) Breechloaded.
- (e) Break open.
- (f) Adjustable sights.
- (g) Maximum range.

(h) Maximum effective range for point targets.

(i) Maximum effective range for area targets.

(j) Rate of fire.

(8) *Functioning of M203.*

- (a) Locking.
- (b) Cocking (extraction and ejection).
- (c) Firing.

(4) *Functioning of M79.*

- (a) Locking.
- (b) Cocking (extraction and ejection).
- (c) Firing.

(5) *Ammunition.*

(a) Authorized standard A and developmental ammunition.

(b) Effective casualty radius.

(c) Identification by color and form.

(d) Weight.

(e) Functioning of high explosive rounds.

(6) *Summarize.***C-2. Period II. Preparatory Marksmanship**

*a. Learning Objective.* The soldier can apply the steps of preparatory marksmanship with the M203/M79.

*b. Lesson Outline.*(1) *Sighting and aiming with M203.*

- (a) Sight picture.
- (b) Sight alinement.
- (c) Pointing technique.

(2) *Sighting and aiming with M79.*

- (a) Sight picture.
- (b) Sight alinement.
- (c) Pointing technique.

(3) *Sensing.*

(a) Determine impact of grenade in relation to target.

(b) Sense first for range and then for deviation.

(c) Sensing made to nearest 5 meters.

(4) *Adjustment of fire.*

(a) When using sight leaf of M203, use an adjusted aiming point if impact of round is less than 50 meters from target. Sight change must be made if the impact of the round is more than 50 meters from target.

(b) When using quadrant sights of M203 or M79 sights, use an adjusted aiming point if impact of round is less than 25 meters from target. Sight changes must be made if the impact of the round is more than 25 meters from the target.

(5) *Zeroing procedures for M203.*

(a) *Quadrant sight.*

1. Select target at 200 meters.

2. Position front and rear sight perpendicular to barrel.

3. Move range selector latch rearward and reposition quadrant sight arm to 200 meters.

4. Choose firing position (prone).

5. Aline target with front and rear sights.

6. Fire round; sense; and adjust.

(a) Turn elevation adjustment screw clockwise to decrease range.

(b) Turn elevation adjustment screw counterclockwise to increase range.

(c) Depress sight aperture retainer.

(d) Move rear sight aperture away from barrel to move impact of round to the left.

(e) Move rear sight aperture toward barrel to move impact of round to the right.

(f) Fire additional rounds as necessary to make adjustments and confirm zero.

(b) *Sight leaf.*

1. Select a target at 200 meters.

2. Raise the sight leaf.

3. Place the center mark of the windage scale on the index line on the rear of the sight base.

4. Loosen the elevation adjustment screw on the sight leaf.

5. Place the index line on the sight leaf on the center elevation mark on the sight mount.

6. Tighten elevation adjustment screw on the sight leaf.

7. Select firing position (prone).

8. Aline the target with the front sight post of the M16A1 rifle and the 200 meter mark on the sight leaf, using correct sighting and aiming procedures.

9. Fire round. Sense the impact of the grenade and make sight adjustment, if necessary,

by loosening the elevation adjustment screw and moving the sight leaf up or down.

(a) Move sight leaf up to increase range.

(b) Move sight leaf down to decrease range.

(c) Move sight leaf to the left to move the impact of the round to the left.

(d) Move sight leaf to the right to move the impact of the round to the right.

(e) Fire additional rounds as necessary to make adjustments and confirm zero.

(6) *Zeroing procedures with M79.*

(a) Select target at 200 meters.

(b) Set windage scale at zero.

(c) Move adjustable elevation scale until flush with top of rear sight frame.

(d) Set sight carrier on 200 meters.

(e) Choose firing position (prone).

(f) Aline target with front and rear sight.

(g) Fire round; sense; and adjust.

1. Turn elevation screw-wheel clockwise to increase range.

2. Turn elevation screw-wheel counterclockwise to decrease range.

3. Turning windage knob clockwise moves impact of the round to the right.

4. Turning windage knob counterclockwise moves impact of the round to the left.

5. Fire additional rounds as necessary to mark adjustments and confirm zero.

(7) *Range determination.*

(a) 100 meter units of measure method.

(b) Appearance of objects method.

(8) *Firing positions with M203.*

(a) Positions are basically the same as those of the standard service rifle.

(b) Left hand grasps the magazine of M16A1 rifle.

(c) Right hand grasps pistol grip of rifle.

(d) Right hand grasps the magazine of M16A1 rifle.

(e) Left hand grasps handgrips.

(f) As range to the target increases in excess of 250 meters, the grenadier must modify his position.

(g) Grenadier must maintain direct line of sight when sighting.

(h) Standing.

(i) Prone.

(j) Pointing.

(9) *Firing positions with M79.*

(a) Left hand grasps the fore-end assembly of the M79.

- (b) Right hand grasps small of the stock with finger inserted into trigger guard.
- (c) Standing.
- (d) Kneeling.
- (e) Prone.
- (f) Pointing.

### C-3. Period III. Mechanical Training and Maintenance

- a. *Learning Objective.* The soldier can—
  - (1) Disassemble and assemble the grenade launcher.
  - (2) Maintain the grenade launcher.
- b. *Lesson Outline.*
  - (1) *Disassembly of M203.*
    - (a) Clear weapon.
    - (b) Depress barrel latch and slide barrel assembly forward.
    - (c) Into fourth hole on left side of handguard insert cleaning rod section and depress barrel stop. Slide barrel assembly from receiver assembly.
    - (d) Remove handguard and sight assembly.
    - (e) Depress barrel stop and slide barrel assembly from receiver assembly.
    - (f) To remove quadrant sight assembly, loosen mounting screw.
  - (2) *Assembly of M203.* Reverse above procedure.
  - (3) *Disassembly of M79 into four groups.*
    - (a) Clear weapon.
    - (b) Remove sling.
    - (c) Unscrew retaining band screw.
    - (d) Remove fore-end assembly.
    - (e) Break weapon open and remove barrel from receiver.
    - (f) Unscrew stock assembly screw.
    - (g) Separate stock from receiver group.
  - (4) *Assembly of M79.* Reverse above procedure.

### (5) Maintenance of M203/M79.

- (a) Run bore brush through barrel until clean.
- (b) Clean firing pin retainer well (M79).
- (6) *Summarize.*

### C-4. Period IV. Instruction Course Modified

- a. *Learning Objective.* The soldier can successfully engage targets.
- b. *Lesson Outline.*
  - (1) *Safety precautions.*
    - (a) Keep head behind and below muzzle.
    - (b) Insure overhead clearance.
    - (c) Be cautious when head wind is 5 miles per hour or greater.
    - (d) Insure sling of M203 is clear of muzzle prior to firing.
  - (2) *Immediate action.*
    - (a) Keep weapon trained on target.
    - (b) Wait 30 seconds before opening breech.
    - (c) Check to see if primer has been dented (M79).
    - (d) Catch the ejected round and check to see if primer has been dented (M203).
    - (e) Load and attempt to fire.
    - (f) Call for safety officer.
  - (3) *Conduct firing.*
  - (4) *Critique.*

*Note.* Establish remedial training station on one end of the firing line. Inept soldiers should be identified early in the firing and given individual instruction.

### C-5. Period V. Qualification Firing Course

- a. *Learning Objective.* The soldier will qualify with the 40-mm grenade launcher, M203 during the conduct of the qualification firing course.
- b. *Lesson Outline.*
  - (1) Orientation on the qualification firing course and safety review.
  - (2) Conduct of the qualification firing course.
  - (3) Critique.



## APPENDIX D

### TRAINING AIDS

Figure D-1 illustrates a type of chart that may be used as a training aid. Similar charts may be made of any other illustrations that instructors need. Those recommended include 2-1, 2-5, 4-1, 9-2, 9-7, and 10-4.

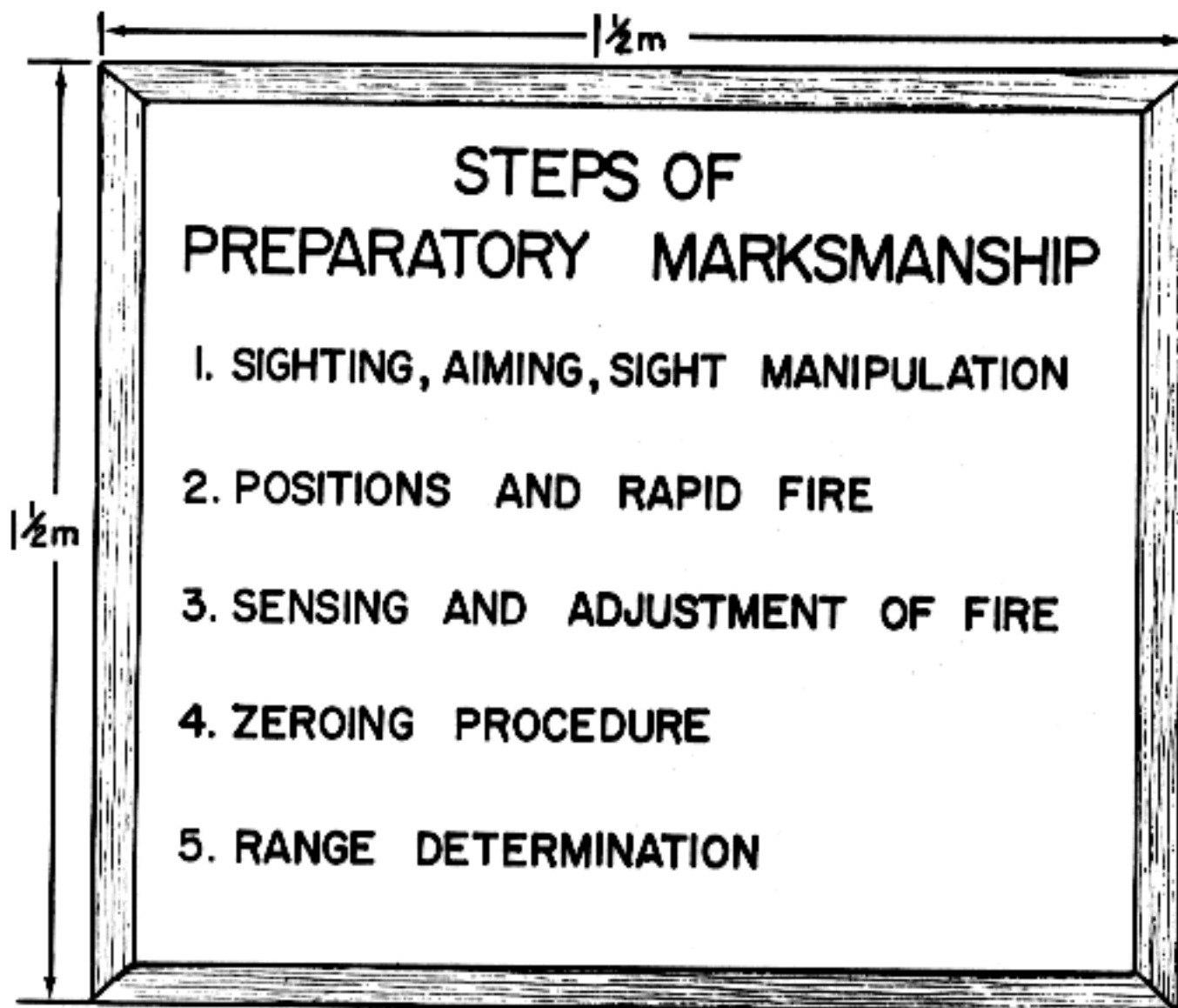

*Figure D-1. Chart of steps of preparatory marksmanship.*

Index

	Paragraph	Page		Paragraph	Page
Adjustment of fire	6-17	6-18	Hangfire and misfire	8-7	8-7
Aiming	6-4	6-8	Lesson outline	App C	C-1
Ammunition:			Methods of indirect fire	12-4	12-8
M203/M79	App B	B-1	Pointing technique	6-14	6-9
M79	2-2	2-1	Positions, M203/M79:		
M203:			Foxhole	6-11	6-9
Fuses	4-5	4-1	Kneeling	6-8	6-8
High-low propulsion system	4-6	4-1	Prone	6-7	6-8
Identification	4-4	4-1	Sitting	6-9	6-1
Types	4-3	4-1	Squatting	6-10	6-6
Characteristics	2-1	2-1	Standing	6-12	6-8
Cleaning material, lubricants and equipment	5-9	5-1	M79	11-3, 12-3	11-1, 12-9
Controls:			Preparation for firing, M79	10-4	10-3
M79:			Quadrant sight, M203	2-7	2-4
Barrel locking latch and lever	9-8	9-3	Range construction	7-1	7-1
Safety	9-4	9-2	Range determination	6-21	6-18
Trigger and trigger guard detent assembly	9-5	9-3	Rapid fire	6-18	6-7
M203:			References	App A	A-1
Barrel latch	2-3	2-2	Scoring, qualification	8-3	8-3
Safety	2-4	2-2	Sensing	6-15	6-11
Trigger and trigger guard assembly	2-5	2-2	Sight alignment, sight picture, and sight manipulation, M79	11-3	11-1
Data:			Sighting, M203:		
M203	2-3	2-1	Sight leaf	6-3	6-1
M79	9-3	9-1	Quadrant sight	6-3	6-1
Disassembly/assembly:			Sighting equipment, M79	9-7	9-5
M203:			Special maintenance, M203	5-6	5-2
Assembly	2-3	2-2	Stoppages	2-6	2-6
Disassembly	2-2	2-1	Storage, M203	5-3	5-3
M79	10-1	10-1	Training aids	App D	D-1
Employment considerations (indirect fire role)	12-2	12-1	Troubleshooting, M79	10-5	10-4
Firing:			Zeroing:		
Instructional	8-2	8-1	Sight leaf zeroing	6-19	6-12
Qualification	8-3	8-3	M79	11-4	11-4
Functioning:			Quadrant sight zeroing	6-20	6-13
M203	3-5	3-2			
M79	10-5	10-3			