

TM 9-1005-222-35

DEPARTMENT OF THE ARMY TECHNICAL MANUAL

DS, GS, AND DEPOT MAINTENANCE
MANUAL INCLUDING REPAIR PARTS AND
SPECIAL TOOL LISTS

RIFLE, CALIBER .30, M1,
M1C (SNIPER'S) AND M1D
(SNIPER'S)

This copy is a reprint which includes current
pages from Change 1.



HEADQUARTERS, DEPARTMENT OF THE ARMY
FEBRUARY 1966

RIFLE, CALIBER .30, M1, M1C (SNIPER'S) AND M1D (SNIPER'S)

		Paragraphs	Pages
CHAPTER	1. INTRODUCTION		
Section	I. General	1-1-1-3	1
	II. Description and data	1-4, 1-5	1
CHAPTER	2. PARTS, SPECIAL TOOLS, AND EQUIPMENT	2-1-2-3	8
CHAPTER	3. INSPECTIONS	3-1, 3-2	9
CHAPTER	4. TROUBLESHOOTING AND GENERAL MAINTENANCE	4-1-4-3	10, 11
CHAPTER	5. MAINTENANCE OF RIFLES		
Section	I. Maintenance	5-1	12
	II. Gaging headspace	5-2	55
	III. Timing rifle	5-3	55
CHAPTER	6. FINAL INSPECTION	6-1, 6-2	56
CHAPTER	7. REPAIR STANDARDS	7-1, 7-2	57
CHAPTER	8. OVERHAUL PROCEDURES	8-1	58
APPENDIX	I. REFERENCES		59
	II. REPAIR PARTS AND SPECIAL TOOL LISTS		60

*This manual supersedes TM 9-1005-222-35P, 20 September 1961.

CHAPTER 1

INTRODUCTION

Section I. GENERAL

1-1. Scope

a. This manual is published for the information and guidance of personnel responsible for direct support, general support, and depot maintenance of the caliber .30 rifles M1, M1C (Sniper's) and M1D (Sniper's).

b. TM 9-1005-222-12P/2 contains a list of repair parts and special tools allocated to using organizations. FM 23-5 contains operating and lubricating instructions for the materiel.

c. Use DA Form 2028 for reporting errors, omissions and recommendations for improvement and forward direct to:

Commanding General
Headquarters
U.S. Army Weapons Command
ATTN: AMSWE-SMM-P

Rock Island Arsenal
Rock Island, Illinois 61201

1-2. Maintenance Allocation

See TM 9-1005-222-12P/2.

1-3. Forms, Records, and Reports

a. *Authorized Forms.* Refer to DA Pam 310-2 and TM 38-750.

b. *Reports of Accidents.*

(1) *Injury to personnel or damage to materiel.* Refer to AR 385-40.

(2) *Ammunition, accidents and malfunctions.* Refer to AR 700-1300-8.

c. *Report of Unsatisfactory Equipment or Materials.* Refer to TM 38-750.

Section II. DESCRIPTION AND DATA

1-4. Description

The rifles M1, M1C (Sniper's) and M1D (Sniper's) (figs. 1-1, 1-3 and 1-5) are gas-operated, clip-fed, air-cooled, semiautomatic shoulder weapons. The rifles are designed to accommodate either bayonet-knife M5 or M5A1, the grenade launcher M7A3 and grenade launcher sight M15 and winter trigger kit (fig. 1-7). For convenience of maintenance and repair, the rifles are divided into groups and assemblies as indicated in figures 1-2, 1-4 and 1-6.

1-5. Tabulated Data

Data necessary for direct, general support, and depot maintenance are listed below.

a. *Rifle M1.*

Trigger pull, maximum ----- 7.5 lb

Trigger pull, minimum ----- 5.5 lb

b. *Rifle M1C (Sniper's) and M1D (Sniper's).*

Trigger pull, maximum ----- 6.5 lb

Trigger pull, minimum ----- 4.5 lb

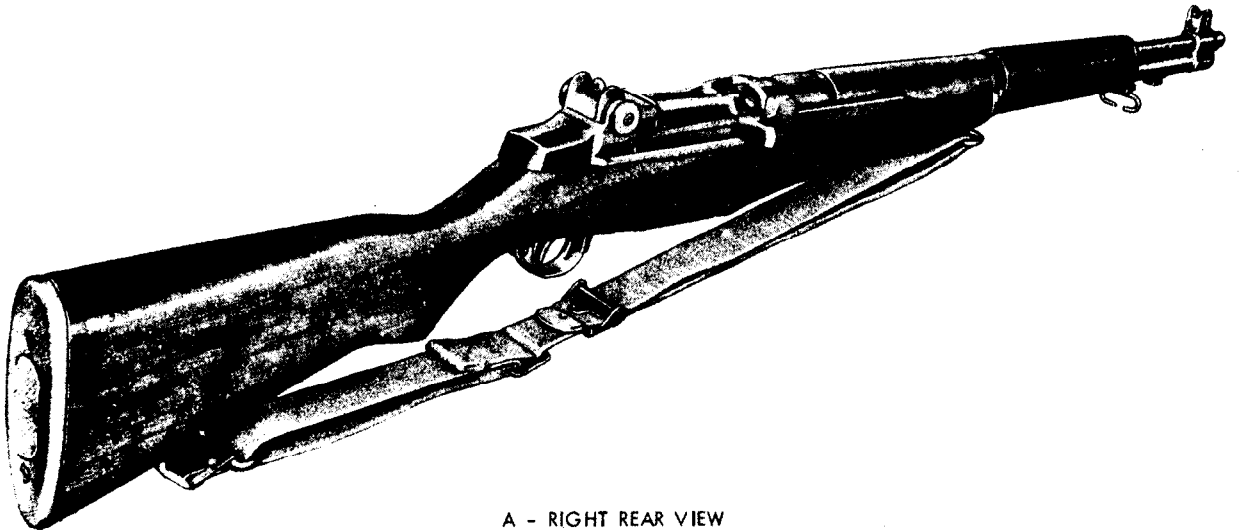

A - RIGHT REAR VIEW

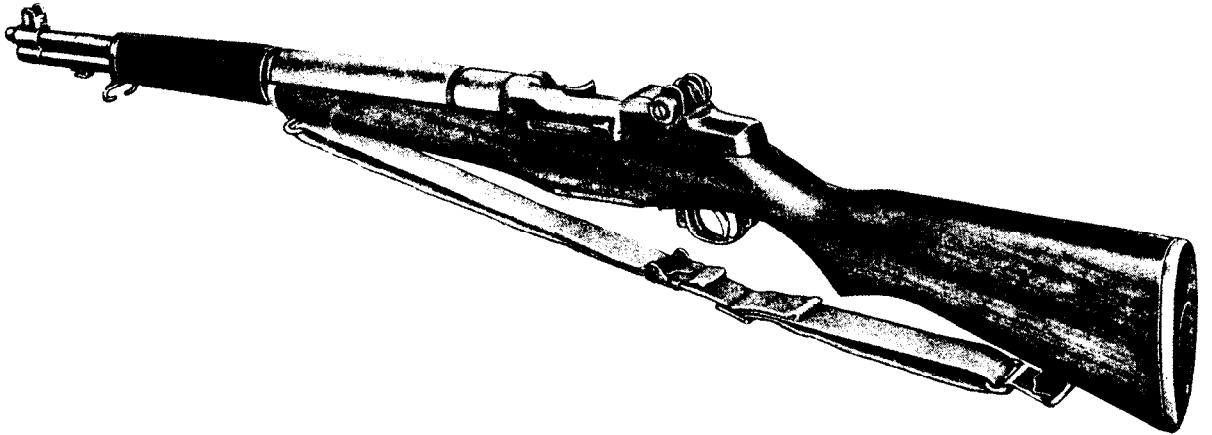

B - LEFT REAR VIEW

WE 10435

Figure 1-1. Caliber .30 rifle M1 - left and right rear views.

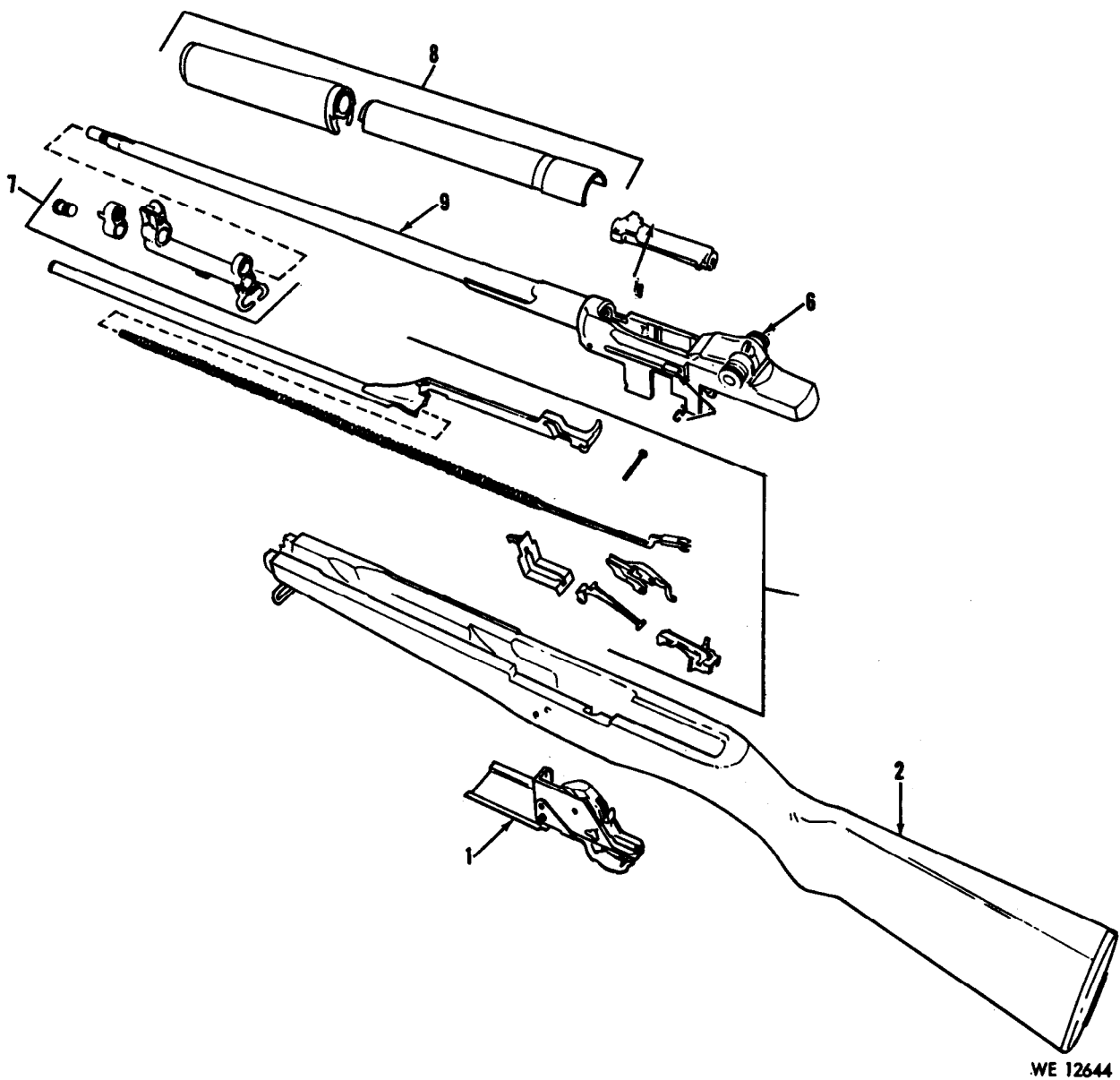
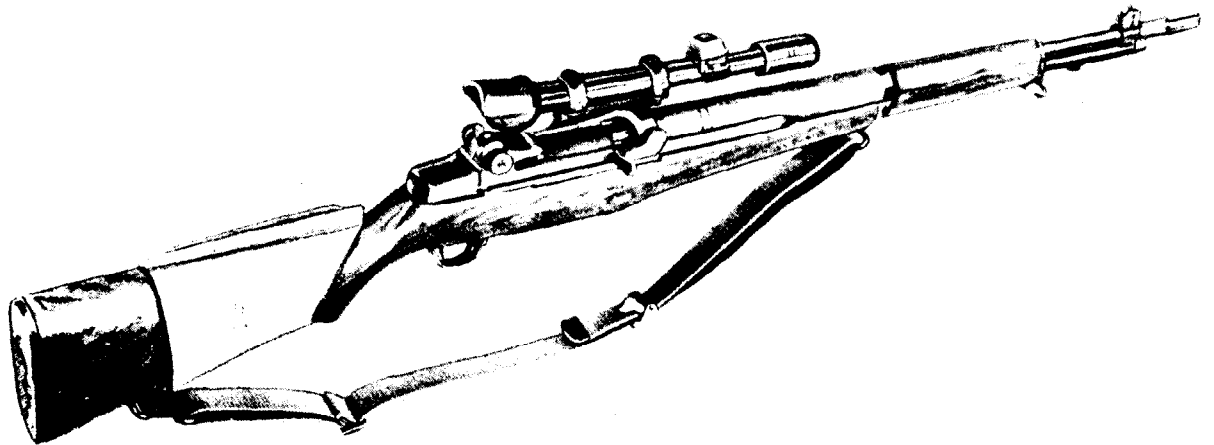
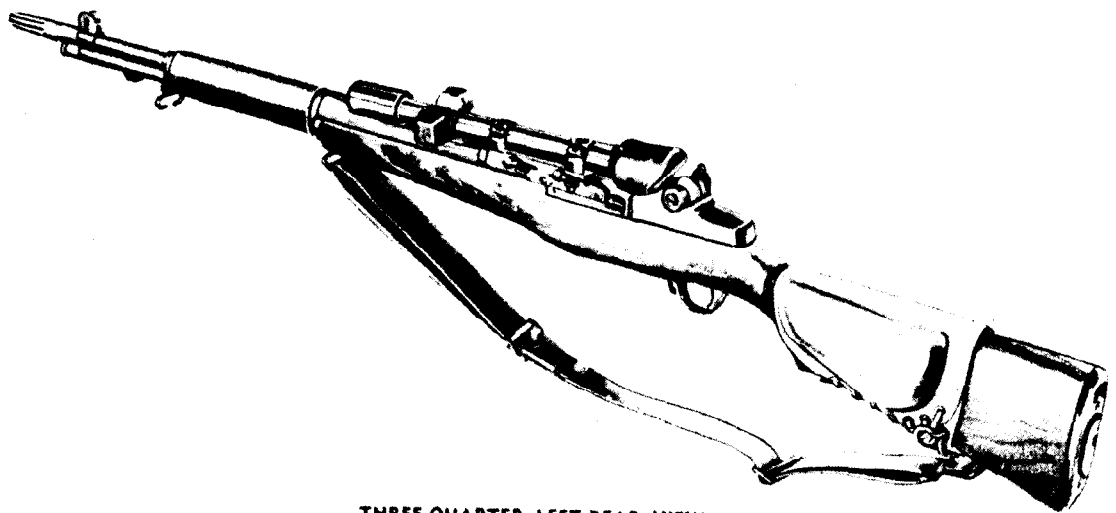

Figure 1-2. Caliber .30 rifle M1, M1C (Sniper's) and M1D (Sniper's) - major groups and assemblies.



THREE-QUARTER RIGHT-REAR VIEW



THREE-QUARTER LEFT-REAR VIEW

RA PD 134666

Figure 1-3. Caliber .30 rifle M1C (Sniper's) - left and right rear views.

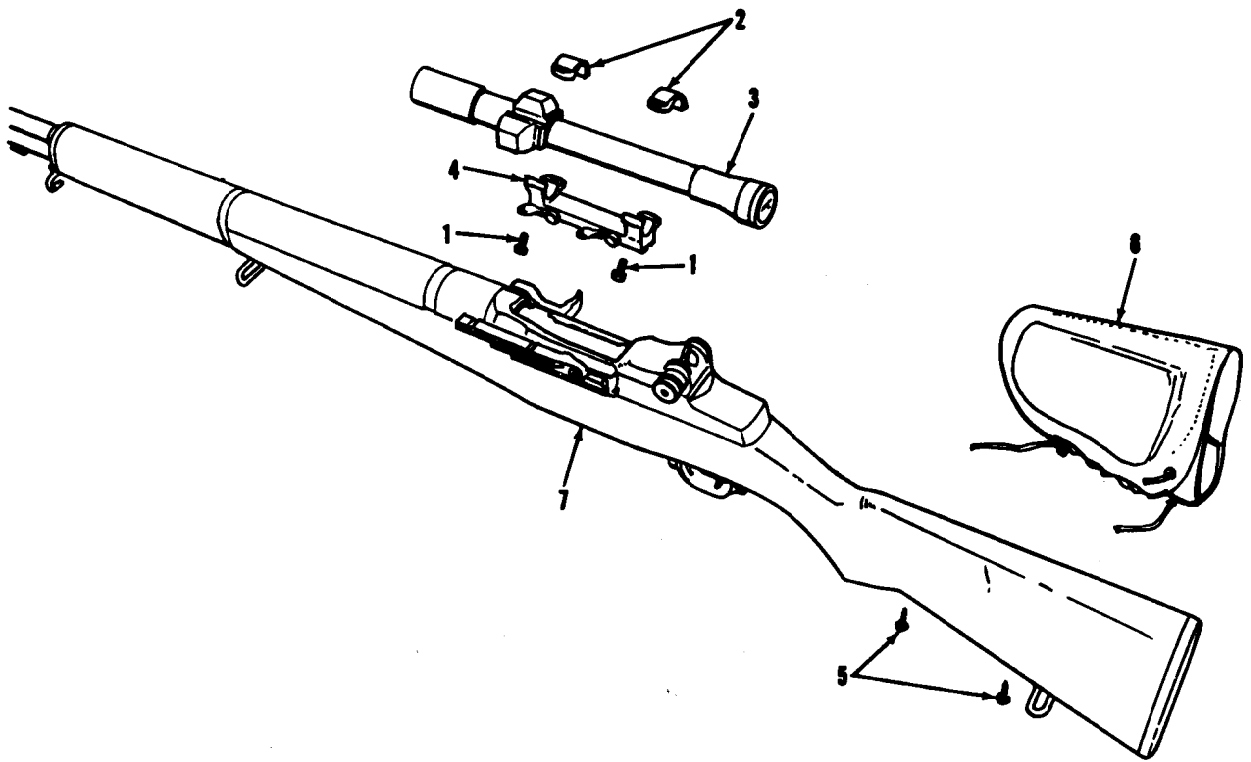

WE 12645

Figure 1-4. Caliber .30 rifle M1C (Sniper's) - major groups and assemblies.

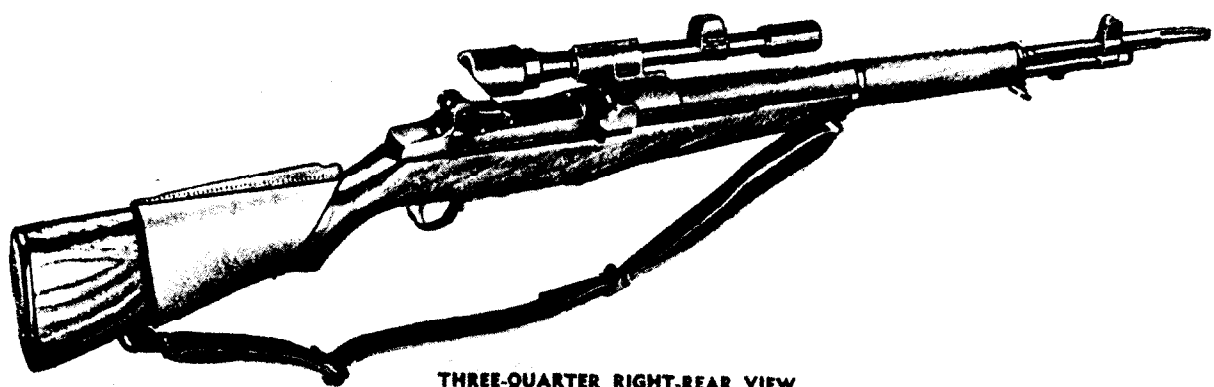

THREE-QUARTER RIGHT-REAR VIEW

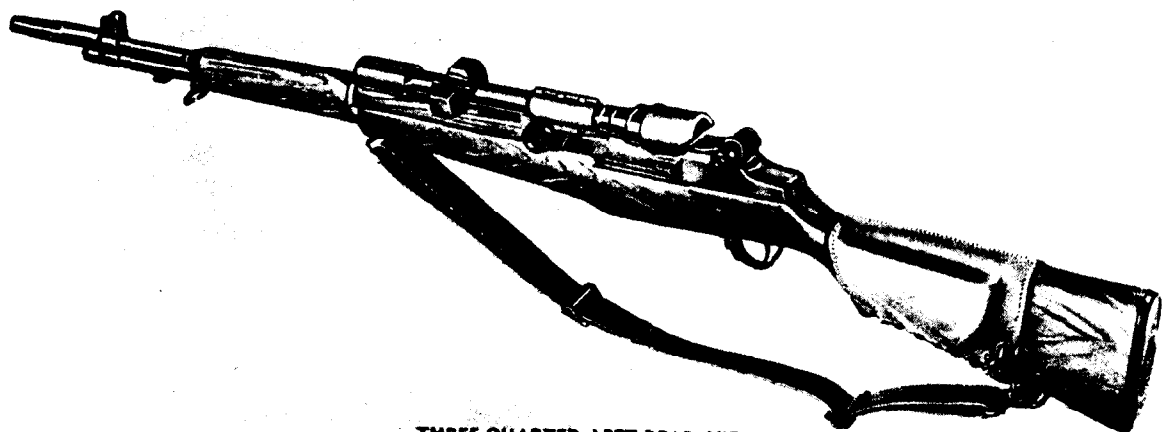

THREE-QUARTER LEFT-REAR VIEW

RA PD 134667

Figure 1-5. Caliber .30 rifle M1D (Sniper's) - left and right rear views.

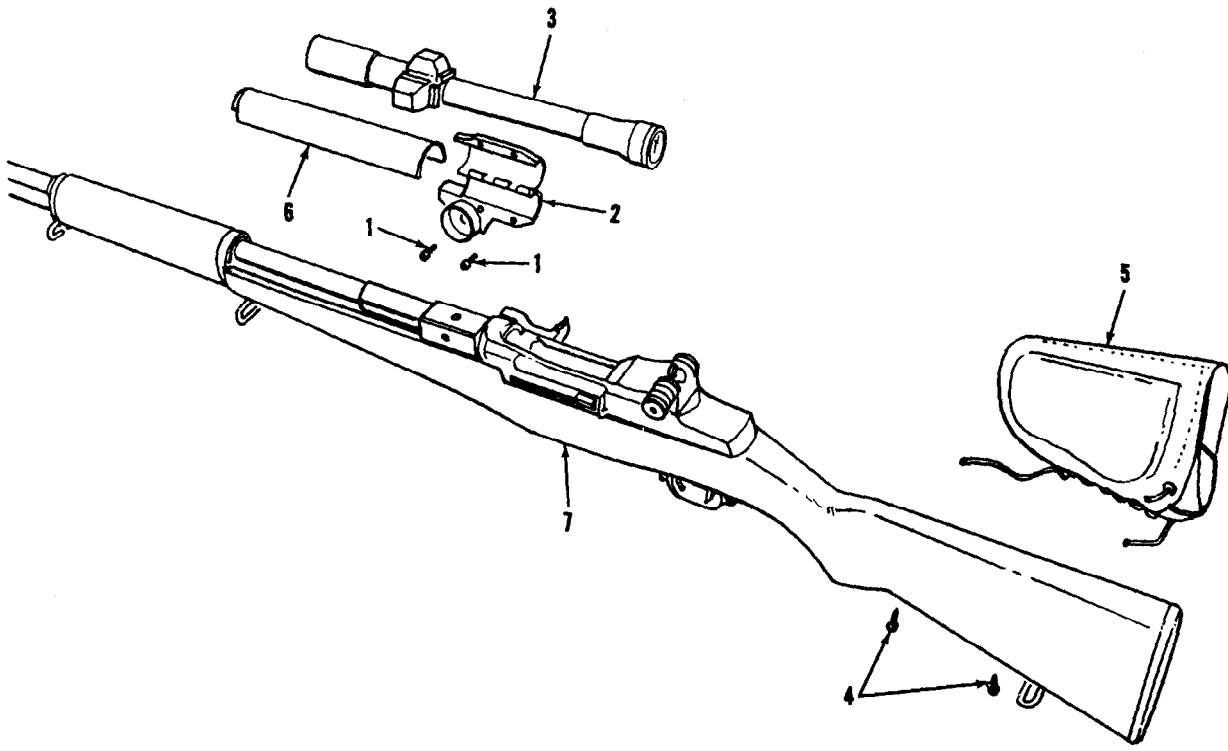

WE 12646

Figure 1-6. Caliber .30 rifle M1D (Sniper's) - major groups and assemblies.

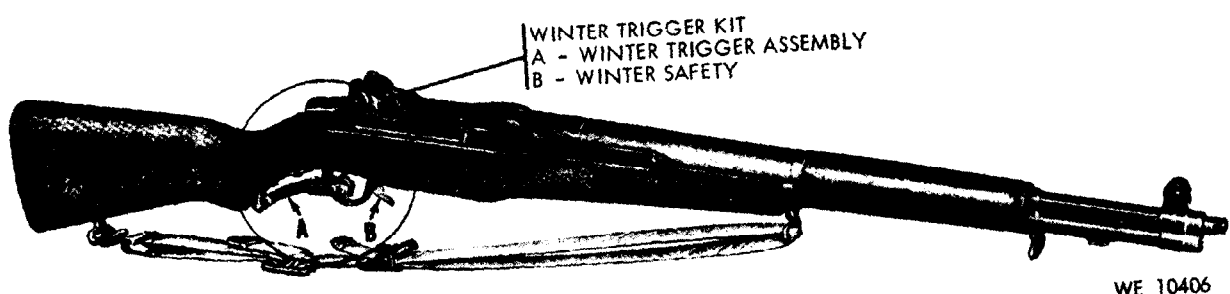

WE 10406

Figure 1-7. Caliber .30 rifle M1 with winter trigger kit installed - right front view.

CHAPTER 2

PARTS, SPECIAL TOOLS, AND EQUIPMENT

2-1. Repair Parts

Refer to appendix II.

2-2. Common Tools

Standard and common tools are author-

ized by tables of allowances and tables of organization and equipment.

2-3. Special Tools and Equipment

Refer to appendix II.

CHAPTER 3 INSPECTIONS

3-1. General

Warning: Before inspection, determine that the weapon is pointed in a safe direction, that live rounds or obstructions are NOT present in the bore or chamber, and that the ammunition is not in position to be loaded. Do not pull the trigger until the weapon has been cleared.

Make an overall inspection of the weapons for appearance, condition, and operation. Manually function, using dummy cartridges.

3.2. Inspection of Materiel in the Hands of Troops in the Field

a. *General.* Refer to AR 750-8.

b. *Specific.*

- (1) Inspect parts for wear that would impair functioning of weapons.

- (2) Check to be certain that all cleaning and preservative materials, authorized by pertinent manuals, are available.

3-3. Inspection of Materiel to Accompany Troops Overseas

a. *General.* This inspection is conducted on materiel in alerted units scheduled for oversea duty to insure that such materiel will not become unserviceable or worn out in a relatively short time. It prescribes a higher percentage of remaining usable life in serviceable materiel to meet a specific need beyond minimum serviceability.

b. *Specific.* Refer to table 3-1 for serviceability standards.

Table 3-1. Serviceability Standards for Rifle, Caliber .30, M1, M1C (Sniper's) and M1D (Sniper's)

Item	In the hands of troops	To accompany troops overseas
Headspace (fig. 5-35)	GAGE, HEADSPACE 7319954 Maximum 1.950	GAGE, HEADSPACE 7319954 Maximum 1.950
Breech bore (fig. 5-31)	BOLT, FIELD TEST 6046302 GAGE, BREECH BORE 5564343 Maximum 0.310	BOLT, FIELD TEST 6046302. GAGE, BREECH BORE 5564343. Maximum 0.306
Gas cylinder diameter (fig. 5-23).	GAGE, PLUG, GAS CYLINDER DIAMETER 7319919. Shoulder of gage must be flush or above	GAGE, PLUG, GAS CYLINDER DIAMETER 7319919. Shoulder of gage must be flush or above.
Barrel diameter (fig. 5-32)	GAGE, RING, PLAIN, No-go 7319918 Minimum 0.5991	GAGE, RING, PLAIN, No-go 7319918. Minimum 0.5991
Piston diameter (fig. 5-14)	GAGE, SNAP, PLAIN, ADJUSTABLE 7319911. Minimum 0.525	GAGE, SNAP, PLAIN, ADJUSTABLE 7319911. Minimum 0.525
Firing pin protrusion (fig. 5-17).	GAGE, FIRING PIN PROTRUSION 7274736. Minimum 0.044 Maximum 0.060	GAGE, FIRING PIN PROTRUSION 7274736. Minimum 0.044 Maximum 0.060
Timing (fig. 5-36)	GAGE, TIMING 7319920 Bolt must release when bottom notch in gage is flush or below.	GAGE, TIMING 7319920. Bolt must release when bottom notch in gage is flush or below.
Trigger pull (fig. 5-5)	FIXTURE, MEASURING, TRIGGER PULL 7274758. <i>M1</i> Minimum 5.5 lbs Maximum 7.5 lbs <i>M1C—M1D</i> Minimum 4.5 lbs Maximum 6.5 lbs	FIXTURE, MEASURING, TRIGGER PULL 7274758. <i>M1</i> Minimum 5.5 lbs. Maximum 7.5 lbs. <i>M1C—M1D</i> Minimum 4.5 lbs. Maximum 6.5 lbs.
Firing pin cam location (fig. 5-34).	GAGE, RECEIVER 7799709 Plug positioned flush or below	GAGE, RECEIVER 7799709. Plug positioned flush or below.

CHAPTER 4 TROUBLESHOOTING AND GENERAL MAINTENANCE

4-1. Troubleshooting

Refer to table 4-1.

Table 4-1. Troubleshooting

Malfunction	Probable cause	Corrective action	
	RIFLE M1, M1C (Sniper's) AND M1D (Sniper's)		
Cartridge clip inserts with difficulty.	Deformed clip.....	Replace.	
	Broken ejector.....	Replace.	
Short recoil.....	Interference between bullet guide and follower arm.	Replace bullet guide.	
	Undersized or out of round operating rod piston.	Replace operating rod assembly.	
	Oversized gas cylinder.....	Replace.	
	Undersized barrel at gas port.....	Turn-in weapon for replacement.	
	Carbon in gas cylinder.....	Clean.	
	Carbon or foreign matter in gas port of barrel.	Clean.	
	Operating rod assembly binding.....	Replace operating rod assembly if damaged, or relieve wood from gun stock assembly, where operating rod binds on wood.	
Bolt fails to close tightly...	Leak in gas cylinder lock screw with valve.	Replace gas cylinder lock screw with valve.	
	Defective helical spring (operating rod).....	Replace helical spring (operating rod).	
	Bolt binding.....	Remove burs from bolt.	
	Distorted or damaged receiver.....	Repair or turn in for replacement.	
	Extractor does not open enough to pass over rim of cartridge.	Clean bolt assembly.	
	Operating rod assembly binding.....	Replace operating rod or relieve wood from stock assembly where operating rod binds on wood.	
Bolt does not release when clip is latched.	Weak or broken helical spring (operating rod).	Replace helical spring (operating rod).	
	Rust or dirt in chamber.....	Clean barrel chamber.	
	Damaged cartridge, or frozen ejector.....	Repair or replace ejector.	
	Damaged or deformed bolt and/or receiver.	Replace bolt or turn in weapon for replacement.	
	Insufficient headspace.....	Replace bolt assembly by selective fit or turn in weapon for replacement.	
	Insufficient radii on operating rod catch or operating rod hooks.	Repair or replace operating rod catch or operating rod assembly.	
	Bullet guide low at accelerator bearing point.	Replace.	
	Worn or broken clip latch.....	Replace.	
	Bolt released before clip is latched.	Worn or broken helical spring (latch).....	Replace helical spring (latch).

Table 4-1. Troubleshooting—Continued

Malfunction	Probable cause	Corrective action
Bolt fails to be held rearward after firing last round of clip and clip held inside of rifle jammed by bolt.	Excessive radii on operating rod catch or operating rod assembly.	Replace operating rod catch or operating rod assembly.
	Bullet guide high at accelerator bearing point.	Replace.
Failure to eject cartridge case ---	Bolt does not move sufficiently rearward.	See short recoil.
	Binding latch -----	Replace latch.
Failure to eject cartridge clip ---	Arm or operating rod catch bent or deformed.	Replace operating rod assembly.
	Low power, causing short recoil	Correct short recoil malfunctions.
Failure of bolt to open after firing	Weak, missing, or frozen helical spring (ejector).	Replace helical spring (ejector).
	Ejector binds-----	Clean bolt ejector opening or remove burs from ejector.
Failure to fire-----	Short recoil-----	Clean gas port. Replace operating rod assembly or helical spring.
	Clip ejector worn, weak, or broken.	Replace.
Pressure on trigger does not release hammer.	Operating rod catch deformed or broken.	Replace catch.
	Plugged gas port -----	Clean.
One or more live cartridges ejected with clip.	Loose gas cylinder-----	Replace gas cylinder.
	Barrel undersize at gas port area	Turn in weapon for replacement.
Operating rod assembly disengages from bolt while firing.	Gas cylinder lock screw with valve fails to close.	Replace.
	Light indent on primer -----	Replace helical spring (hammer).
	Inadequate firing pin protrusion	Replace.
	Hammer spring housing damaged	Replace.
	Deformed trigger, pin, or hammer.	Replace defective trigger, pin or hammer.
	Operating rod assembly releases too soon when clip is inserted.	Replace operating rod catch and bullet guide.
	Worn operating rod lug or kinked helical spring (operating rod assembly).	Replace operating rod assembly or helical spring.

4-2. Special Repair Methods

a. Parts or assemblies that cannot be repaired or reclaimed will be replaced. Non-repairable assemblies may be disassembled and the serviceable parts returned to stock.

b. If a required new part is not available, a reconditioned used part may be substi-

tuted. Such reconditioned used parts should be examined carefully to determine their suitability.

4-3. Cleaning

Refer to TM 9-247, TM 9-208-1 and TM 9-208-2.

CHAPTER 5

MAINTENANCE OF RIFLES

Section I. MAINTENANCE

Note. White arrows shown on illustrations indicate removal, black arrows indicate installation.

5-1. Maintenance Procedures

Refer to table 5-1.

Table 5-1. Maintenance of Rifles

Major Item, Groups and Assemblies	Removal/ Installation	Disassembly/ Assembly	Inspect	Replace	Repair
Rifle, cal. .30 M1		Fig. 1-2.	Figs. 5-5, 5-35, 5-36.		Fig. 5-30.
Rifle, cal. .30 M1C(Sniper's)		Fig. 1-4.	Figs. 5-5, 5-35, 5-36.	Fig. 1-4 except items 1, 2, 4 and 7.	Fig. 5-30.
Rifle, cal. .30 M1D(Sniper's)		Fig. 1-6.	Figs. 5-5, 5-35, 5-36.	Fig. 1-6 except item 7.	Fig. 5-30.
Trigger housing assembly		Figs. 5-1 and 5-2.	Fig. 5-3.	Fig. 5-48 except item 11.	Fig. 5-4.
Stock assembly		Fig. 5-6.	Fig. 5-7.	Fig. 5-49 except items 1, 1D (1, thru 5) and 1E(4).	Figs. 5-9, 5-10, 5-42 and TB ORD 507.
Follower group		Fig. 5-11 and 5-12.	Figs. 5-13 and 5-14.	Fig. 5-50 except items 7, 9, and 10.	
Bolt assembly		Fig. 5-15	Figs. 5-16 and 5-17.	Fig. 5-51.	
Latch group		Fig. 5-18.		Fig. 5-52.	
Rear sight group		Fig. 5-19.	Fig. 5-16.	Fig. 5-53.	
Gas cylinder group		Figs. 5-20 and 5-21.	Figs. 5-22 and 5-23.	Fig. 5-54.	
Gun hand guard group		Figs. 5-24 and 5-25.	Fig. 5-26.	Fig. 5-49.	Fig. 5-27.
Barrel and receiver groups		Fig. 5-28.	Figs. 5-29, 5-31, 5-32, 5-33, 5-34, and TB 9- 4933-202-30.		
Telescope mount assembly for rifle M1C (Sniper's)		Fig. 5-37.		Fig. 5-55 except items 2, 2A thru 2E, 3 and 4.	
Mounting bracket assembly for rifle M1D (Snipers)		Fig. 5-38.		Fig. 5-56.	
Cheek pad for rifles M1C, M1D(Sniper's)		Fig. 5-39.		Fig. 5-57.	
Grenade launcher M7A3		Fig. 5-40.		Retaining spring (fig. 5-40).	<i>Note.</i> Refer to TM 9-1005-234-14P for repair parts of

Table 5-1. Maintenance of Rifles—Continued

Major Item, Groups and Assemblies	Removal/Installation	Disassembly/Assembly	Inspect	Replace	Repair
Grenade launcher sight, M15 Bayonet-knife M5	Figs. 5-41.	Fig. 5-43. Fig. 5-44.		Fig. 5-43 except items 4, 7. Fig. 5-44 except Blade Assembly. (7266555).	M7A3 launcher and M15 sight. <i>Note.</i> Refer to TM 9-1005-237-15P for repair parts of M5, M5A1 bayonet-knives.
Bayonet-knife M5A1		Fig. 5-45.		Fig. 5-45 except Blade Assembly.	
Winter trigger kit	Fig. 5-8.	Fig. B-1.		Fig. B-1 except item 1C.	
Scabbard-bayonet knife M8A1			Fig. 5-46.		
Sling M1			Fig. 5-47.		

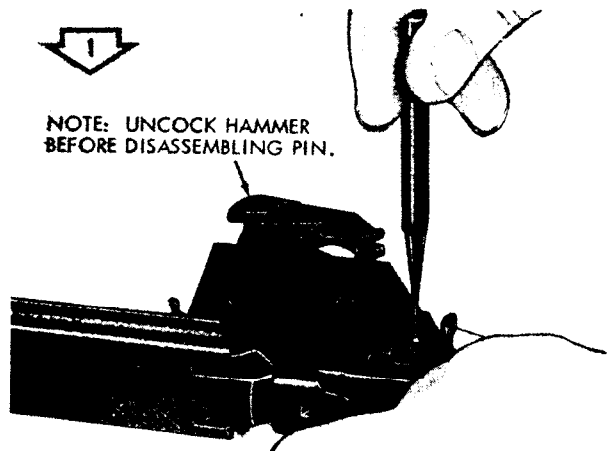

NOTE: UNCOCK HAMMER BEFORE DISASSEMBLING PIN.

UNSEAT TRIGGER PIN.

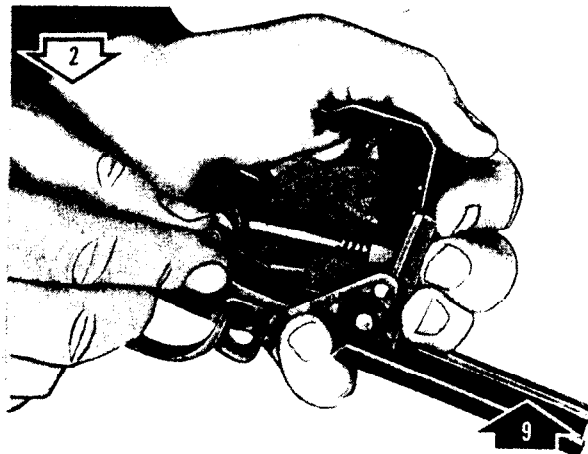

DISASSEMBLE/ASSEMBLE TRIGGER PIN.

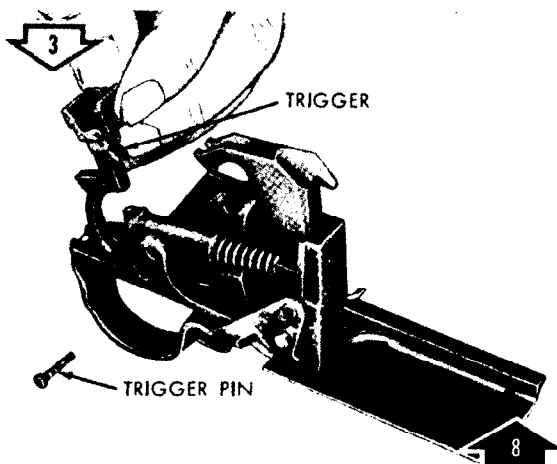

DISASSEMBLE/ASSEMBLE TRIGGER

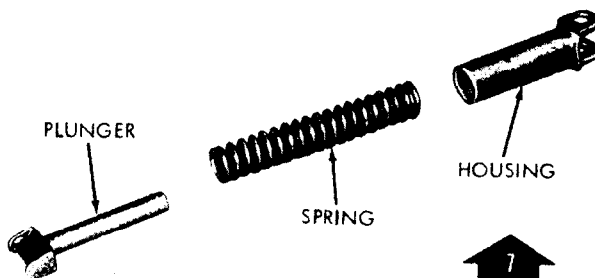
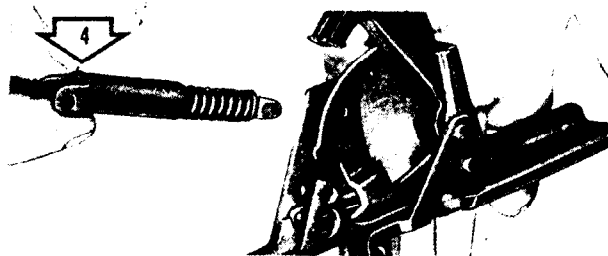

DISASSEMBLE/ASSEMBLE HAMMER SPRING HOUSING, HAMMER HELICAL COMPRESSION SPRING AND HAMMER SPRING PLUNGER.

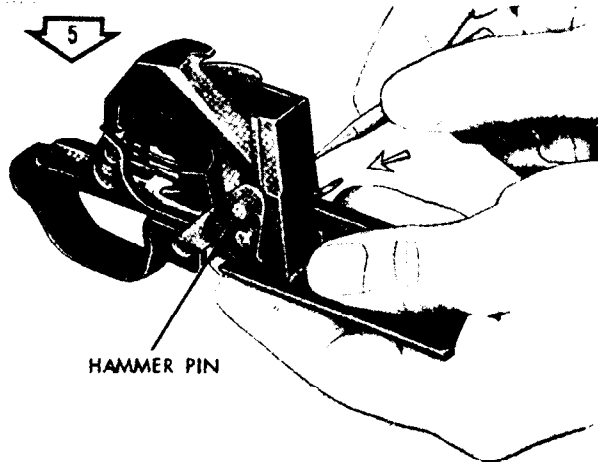

DISASSEMBLE STRAIGHT HEADED HAMMER PIN.



ASSEMBLE STRAIGHT HEADED HAMMER PIN.

WE 10525

Figure 6-1. Disassembly/assembly of trigger housing assembly. (1 of 2)

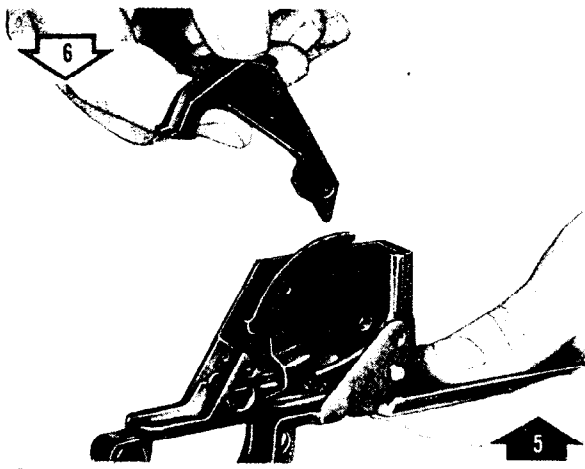

DISASSEMBLE/ASSEMBLE HAMMER.

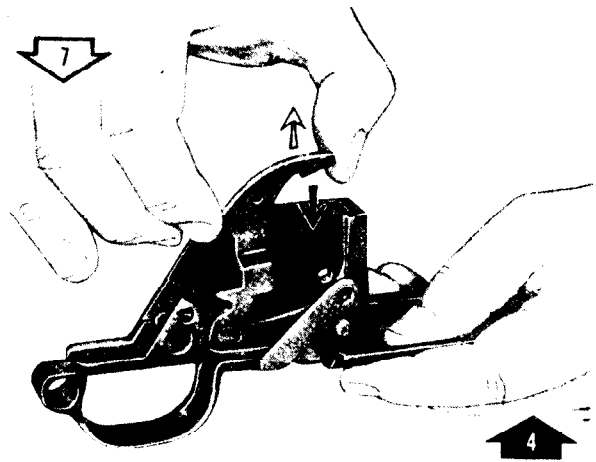

DISASSEMBLE/ASSEMBLE SAFETY.

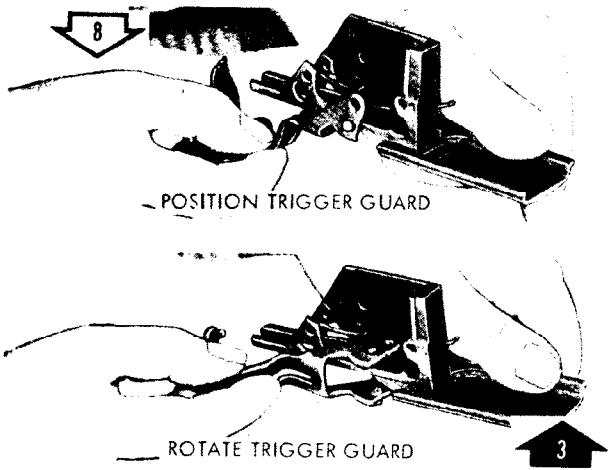

POSITION TRIGGER GUARD

ROTATE TRIGGER GUARD

DISASSEMBLE/ASSEMBLE TRIGGER GUARD.

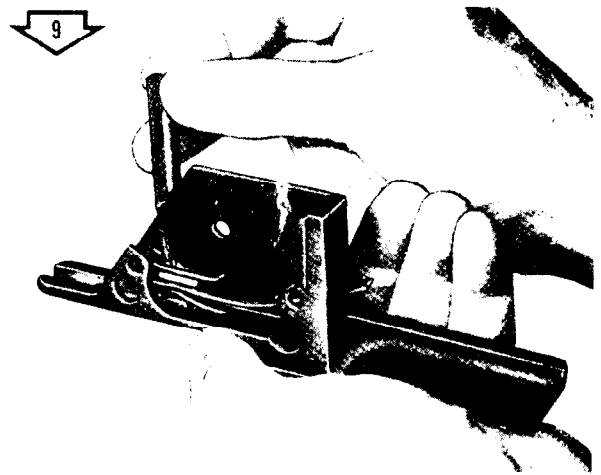

UNSEATING EJECTOR.

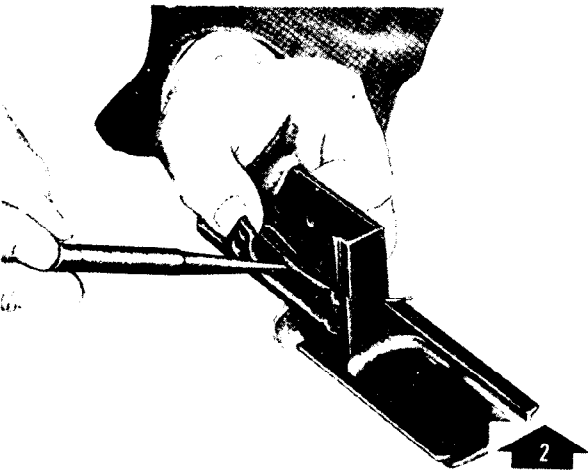

SEATING EJECTOR ON EJECTOR STUD.

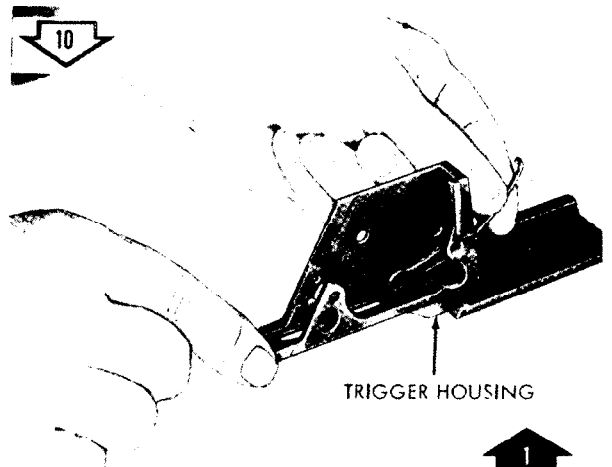

DISASSEMBLE/ASSEMBLE EJECTOR.

TRIGGER HOUSING

WE 10526

Figure 5-2. Disassembly/assembly of trigger housing assembly. (2 of 2)

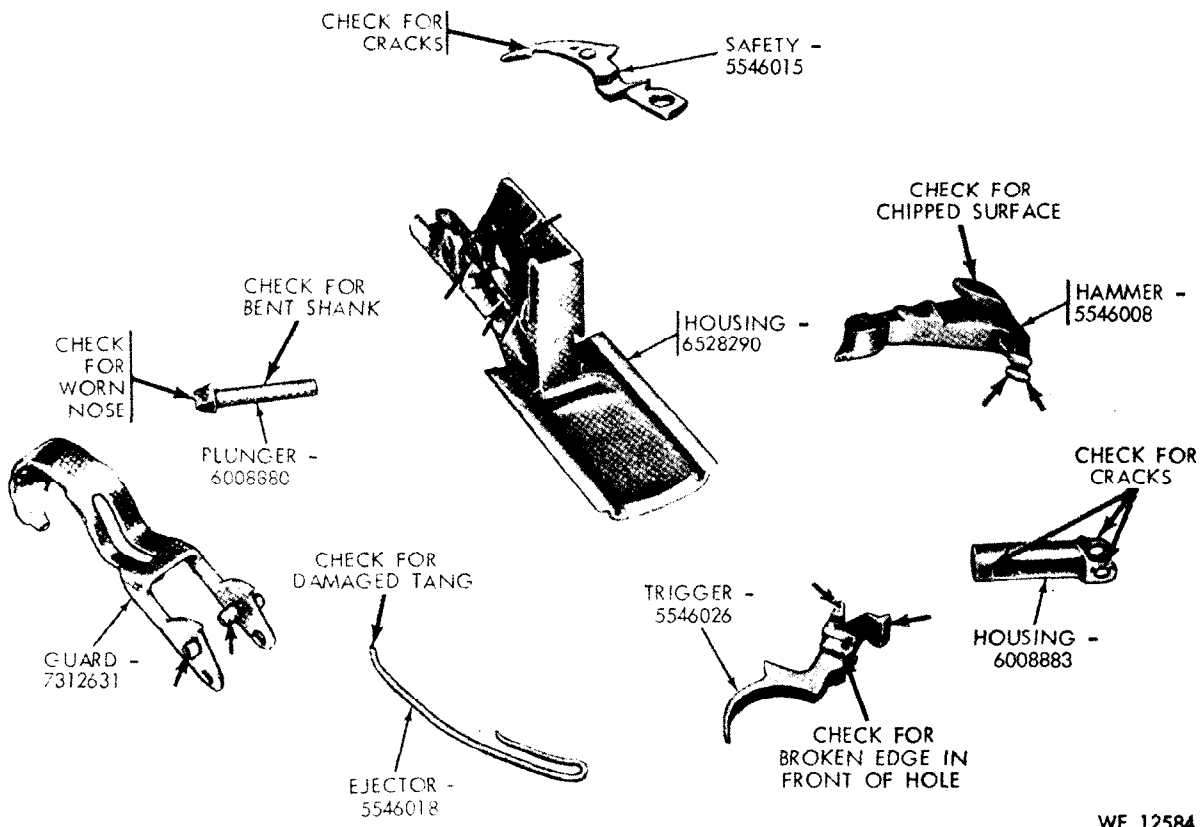

WE 12584

Figure 5-3. Inspection points of component parts of trigger housing assembly.

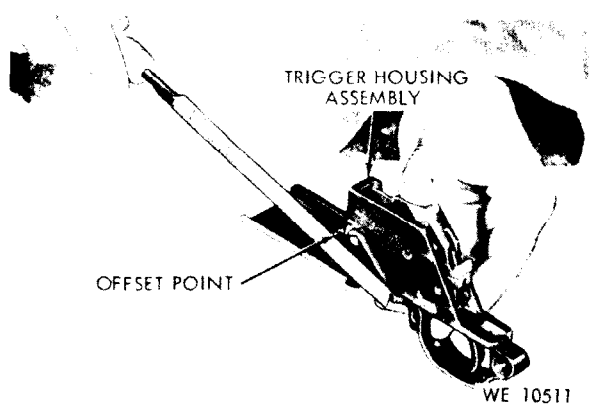

Figure 5-4. Filing offset point of ejector.

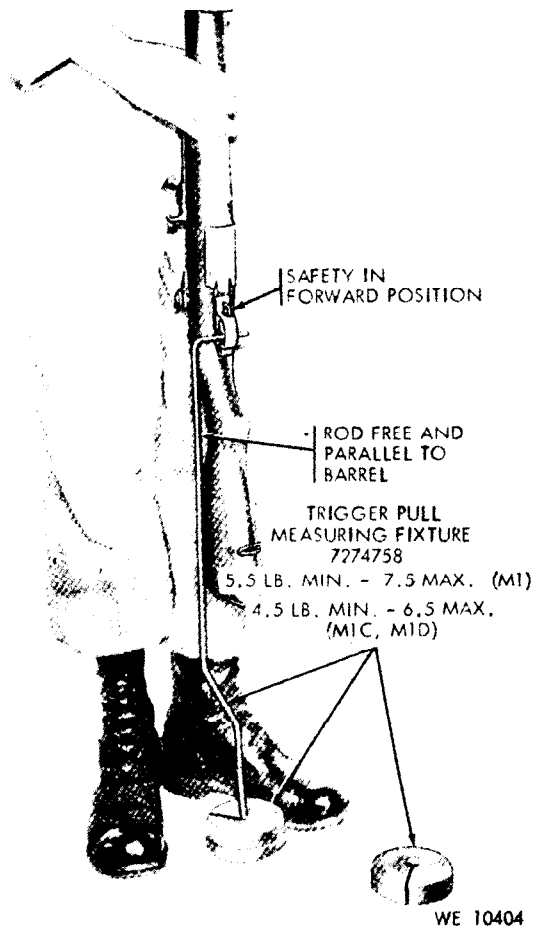
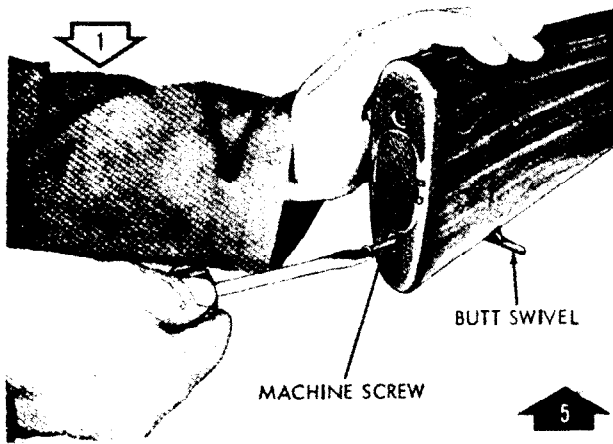
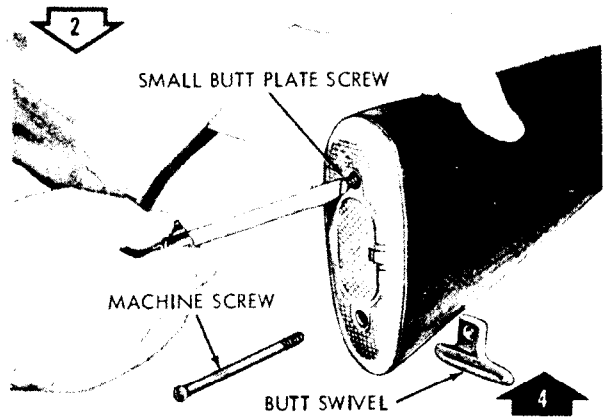

Figure 5-5. Trigger pull test.



DISASSEMBLE/ASSEMBLE MACHINE SCREW AND BUTT SWIVEL.



DISASSEMBLE/ASSEMBLE SMALL BUTT PLATE SCREW.

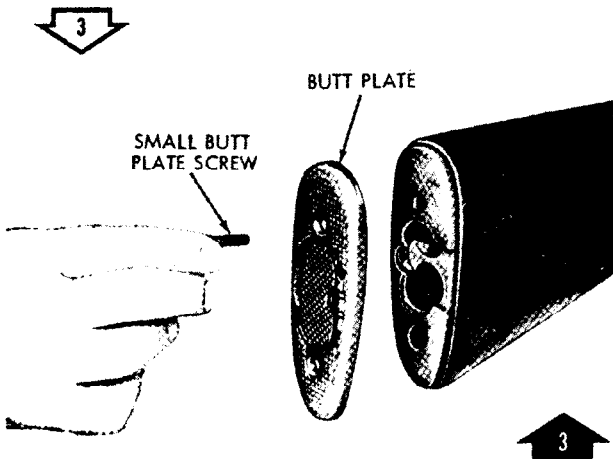

DISASSEMBLE/ASSEMBLE BUTT PLATE.

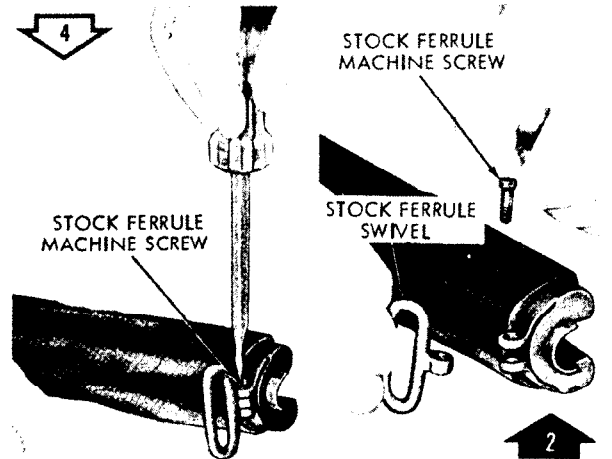

DISASSEMBLE/ASSEMBLE STOCK FERRULE MACHINE SCREW AND STOCK FERRULE SWIVEL.

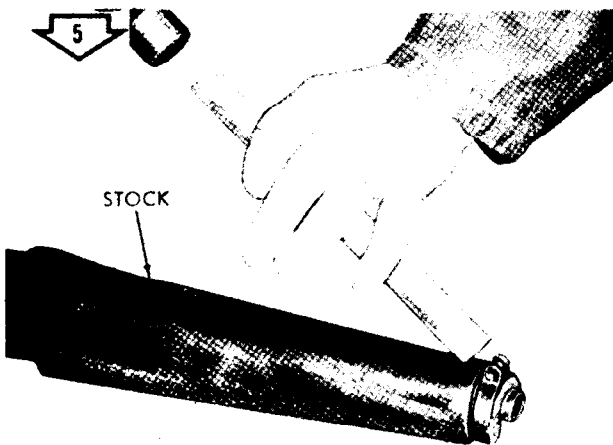

DISASSEMBLE STOCK FERRULE.

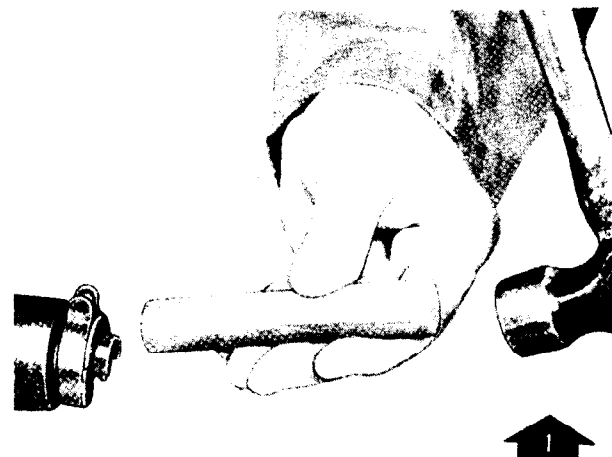

ASSEMBLE STOCK FERRULE.

WE 10434

Figure 5-6. Disassembly/assembly of stock assembly.

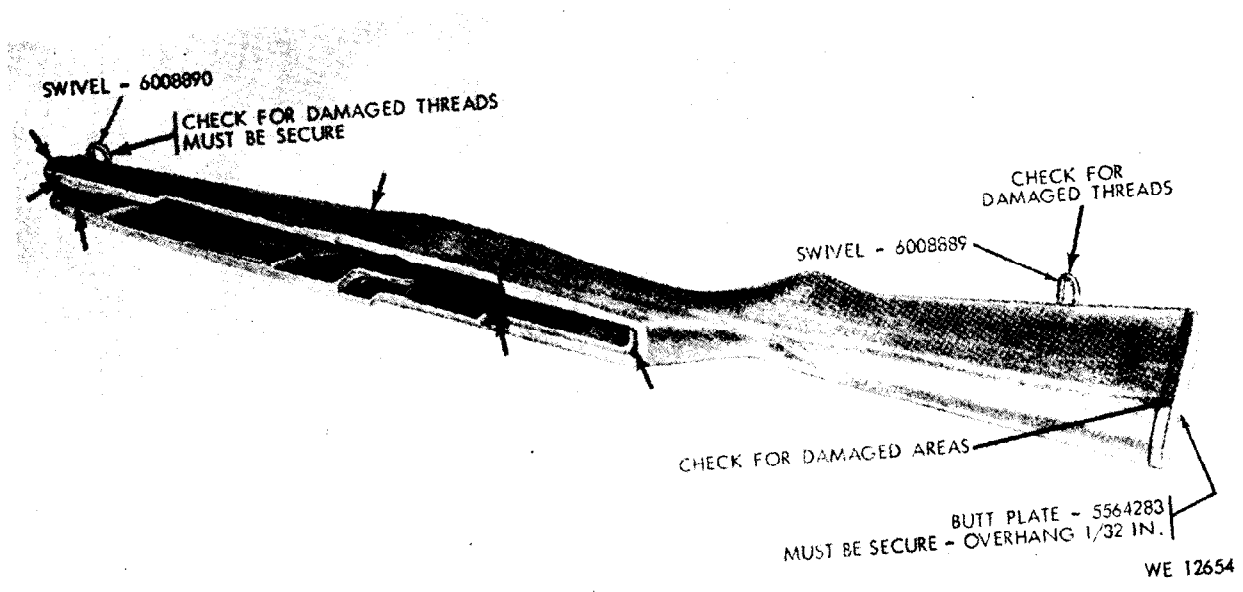
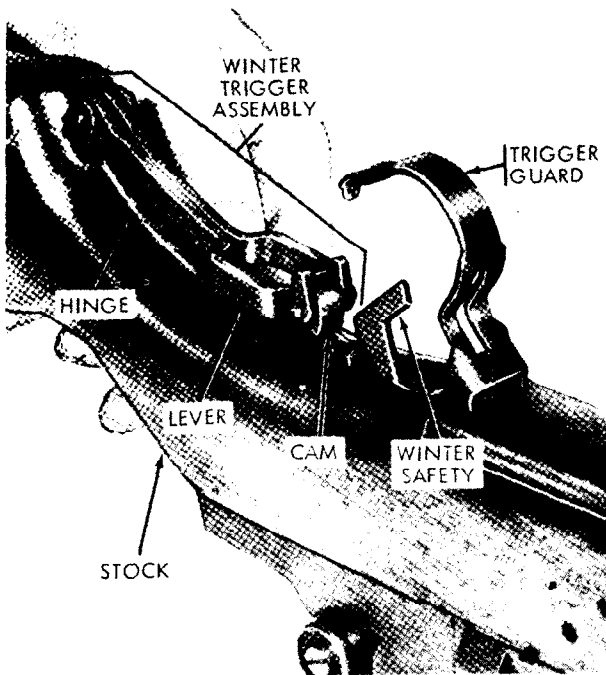
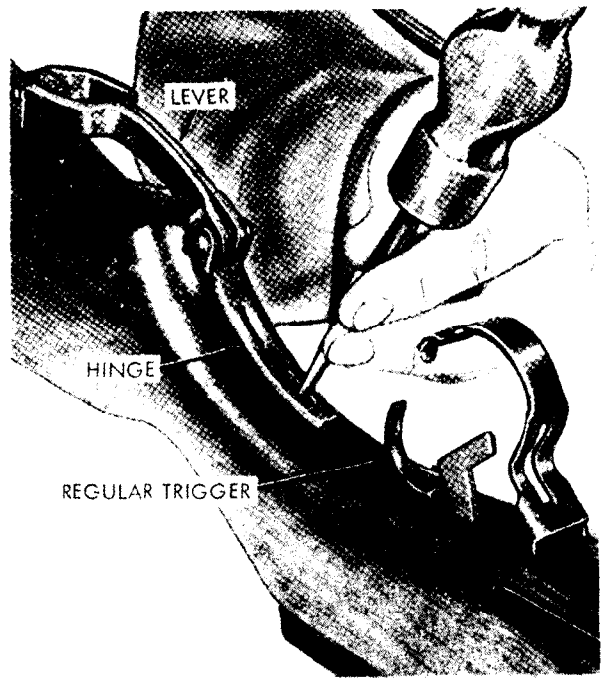

Figure 5-7. Inspection points of component parts of stock assembly.



A - POSITIONING WINTER TRIGGER ASSEMBLY ON STOCK ASSEMBLY.



B - MARKING LOCATION FOR DRILLING HOLES.

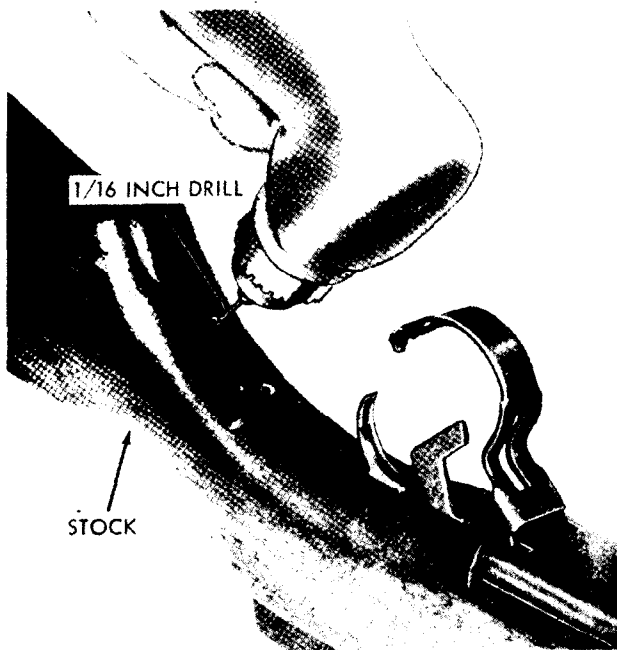

C - DRILLING HOLES IN STOCK ASSEMBLY.

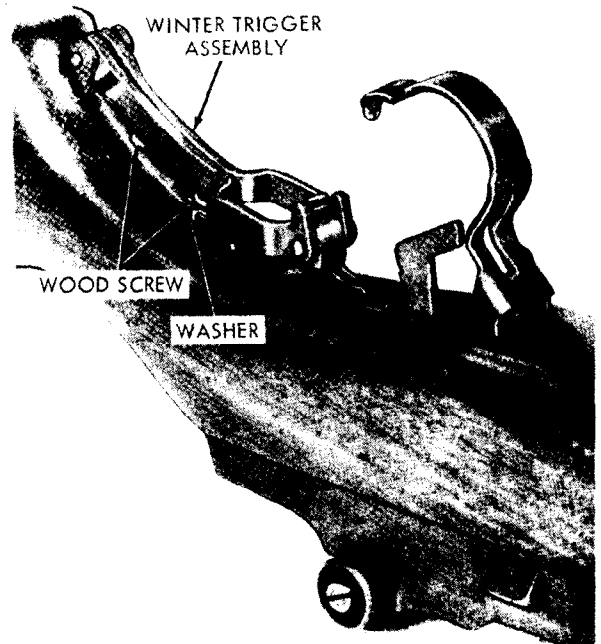

D - WINTER TRIGGER ASSEMBLY INSTALLED.

WE 10433

Figure 5-8. Procedures for installing winter trigger kit on stock assembly.

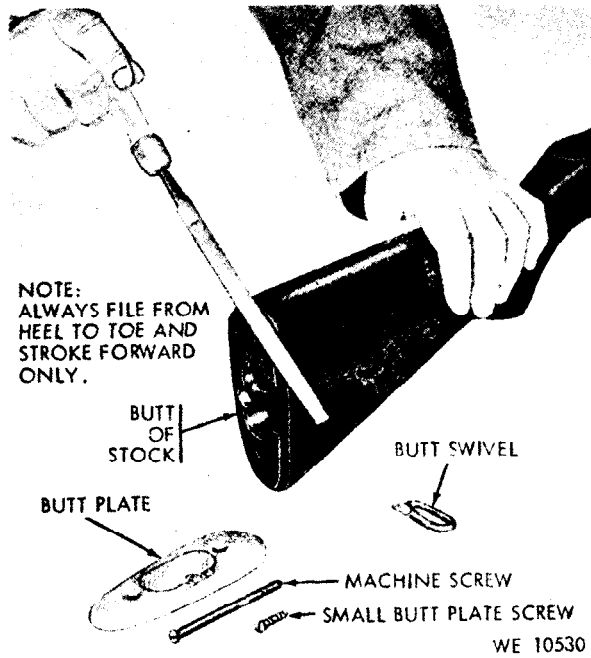

Figure 5-9. Fitting butt plate on stock assembly.

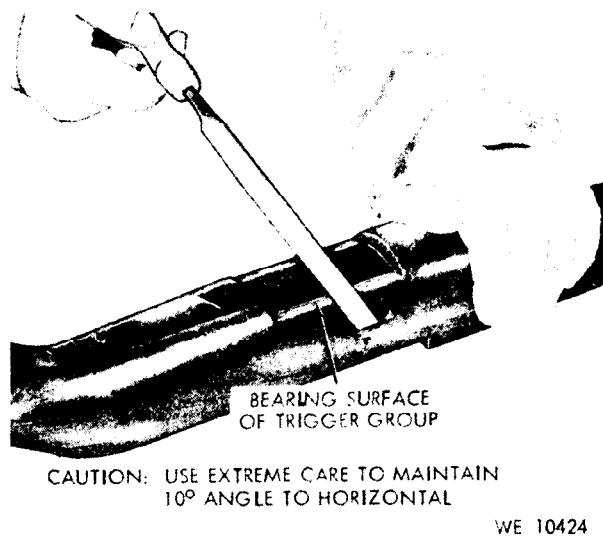
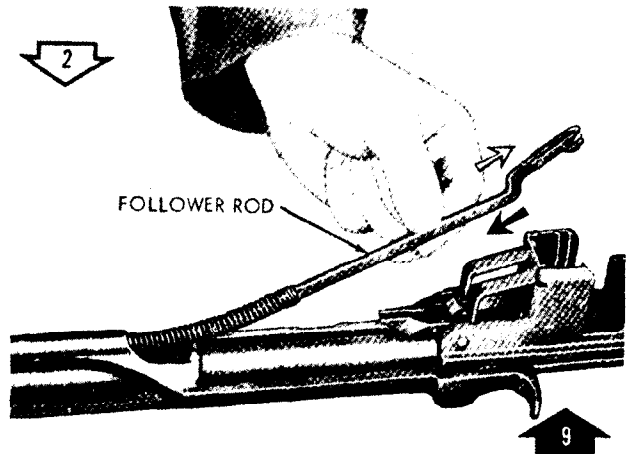
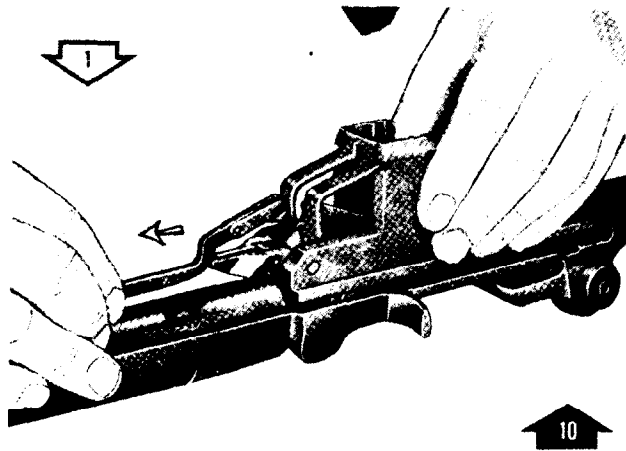
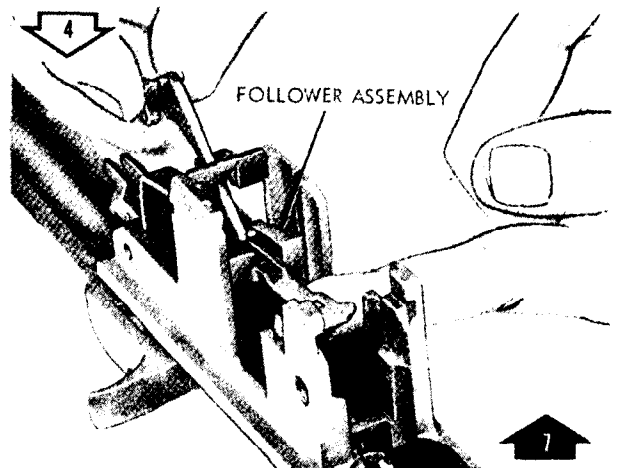
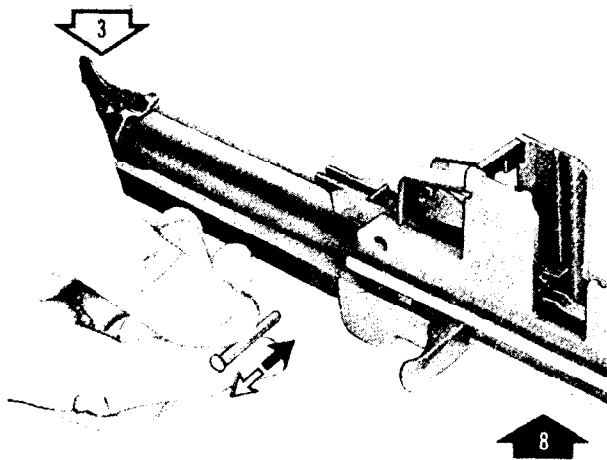

Figure 5-10. Correcting swelling in stock assembly.



DISASSEMBLE/ASSEMBLE FOLLOWER ROD AND OPERATING ROD SPRING.



DISASSEMBLE/ASSEMBLE SHOULDER HEADED PIN.

DISASSEMBLE/ASSEMBLE FOLLOWER ARM.

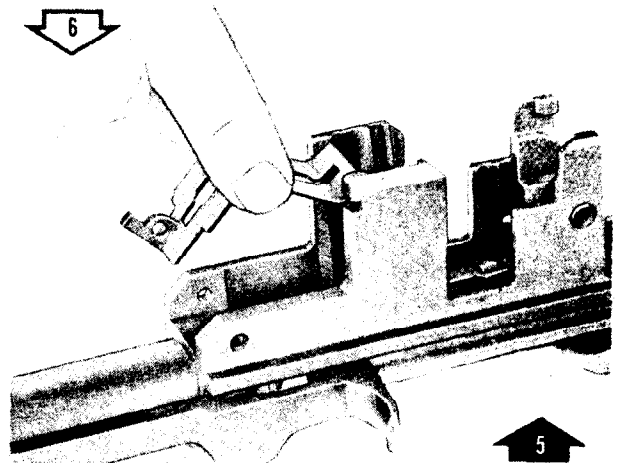
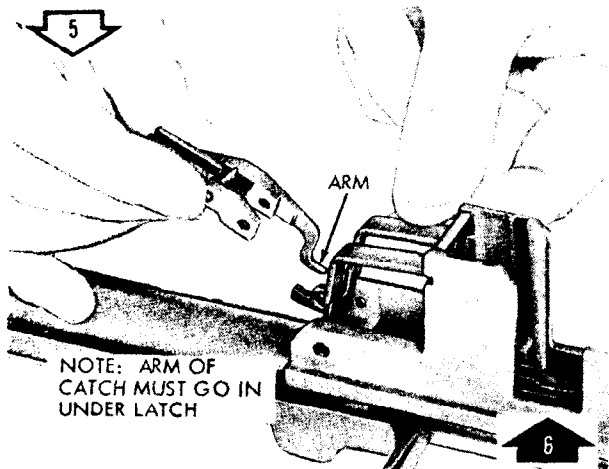

DISASSEMBLE/ASSEMBLE OPERATING ROD CATCH.

DISASSEMBLE/ASSEMBLE BULLET GUIDE.

WE 10524

Figure 5-11. Disassembly/assembly of follower group. (1 of 2)

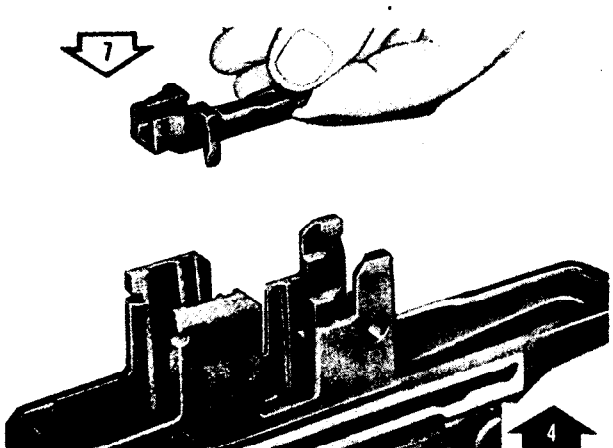

REMOVE/INSTALL FOLLOWER ASSEMBLY.

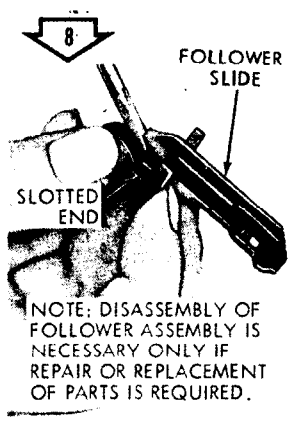

NOTE: DISASSEMBLY OF FOLLOWER ASSEMBLY IS NECESSARY ONLY IF REPAIR OR REPLACEMENT OF PARTS IS REQUIRED.

DISASSEMBLE FOLLOWER SLIDE FROM FOLLOWER.

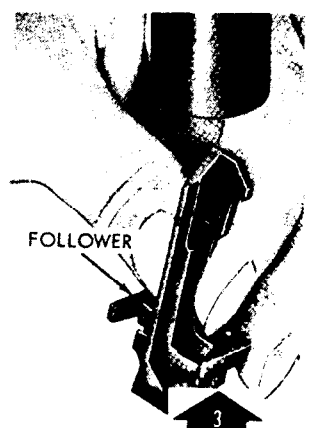

ASSEMBLE FOLLOWER SLIDE ON FOLLOWER.

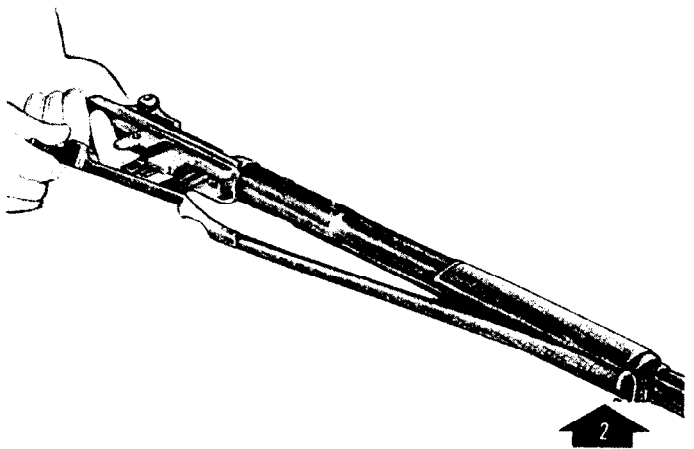
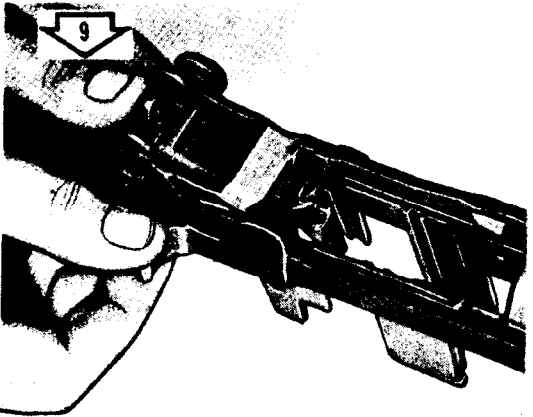

DISASSEMBLE/ASSEMBLE OPERATING ROD ASSEMBLY.

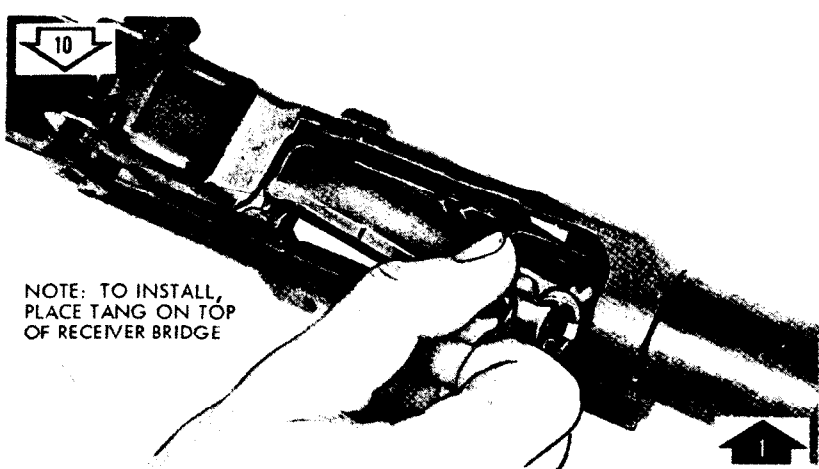

NOTE: TO INSTALL, PLACE TANG ON TOP OF RECEIVER BRIDGE

REMOVE/INSTALL BOLT ASSEMBLY.

WE 10446

Figure 5-12. Disassembly/assembly of follower group. (2 of 2)

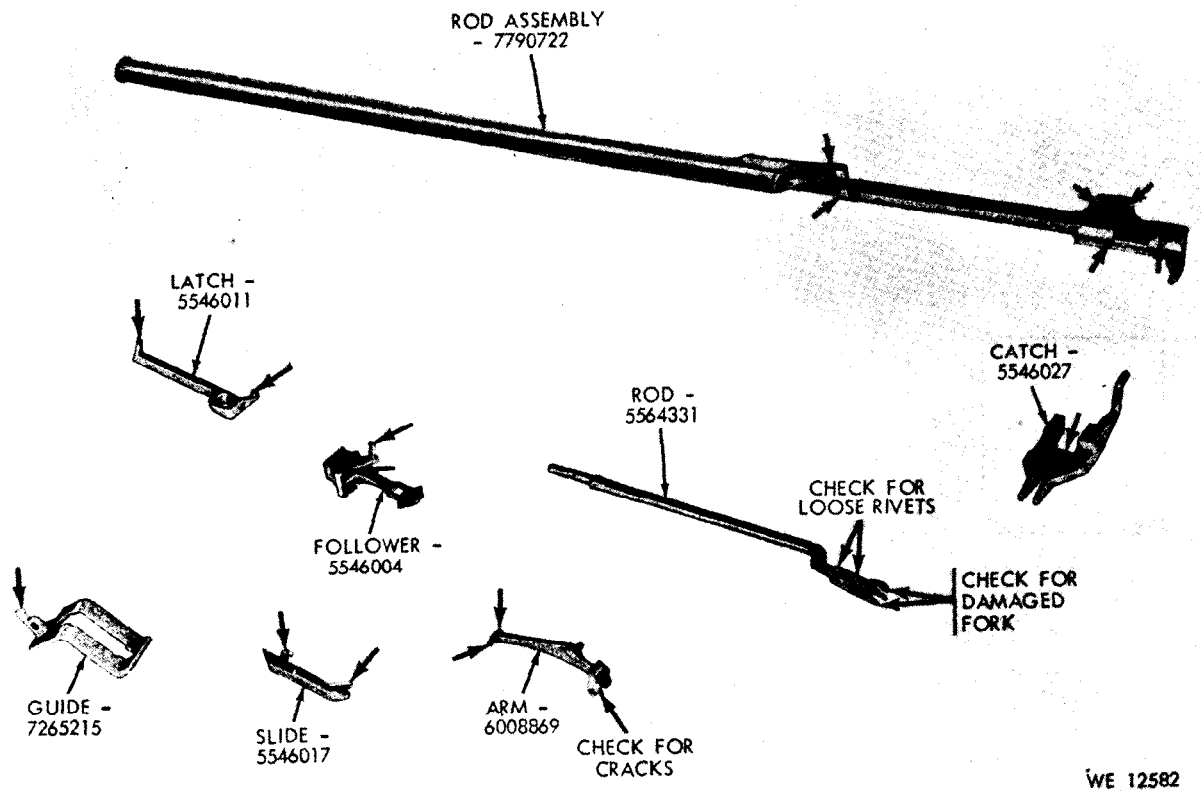

Figure 5-13. Inspection points of component parts of follower group.

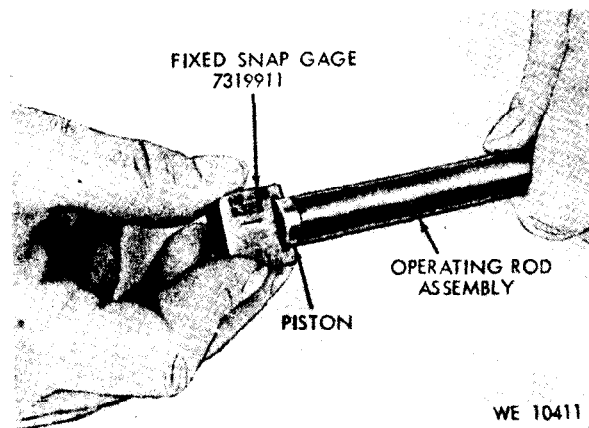
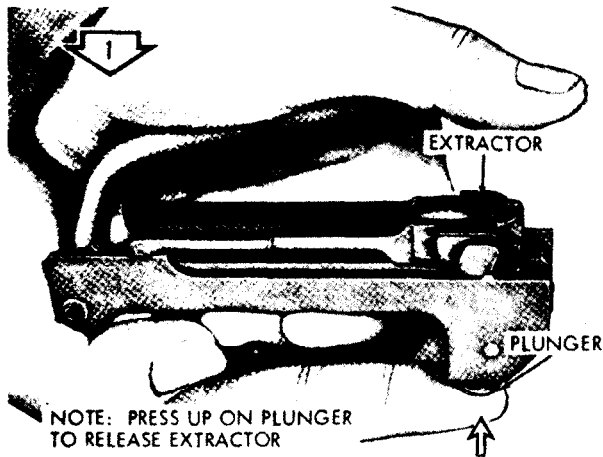
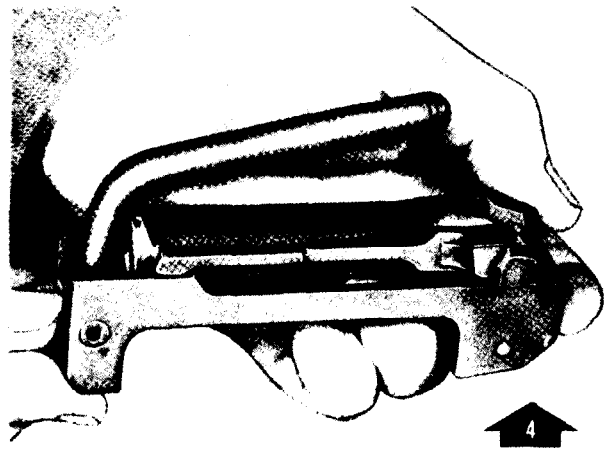

Figure 5-14. Gaging diameter of gas piston.



DISASSEMBLING EXTRACTOR WITH ASSEMBLING AND DISASSEMBLING FIXTURE.



ASSEMBLING EXTRACTOR WITH ASSEMBLING AND DISASSEMBLING FIXTURE.

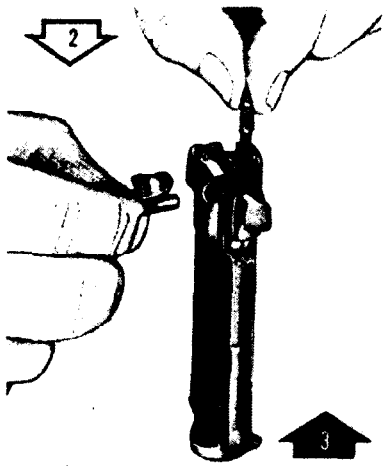

DISASSEMBLE/ASSEMBLE EXTRACTOR AND CARTRIDGE EJECTOR.

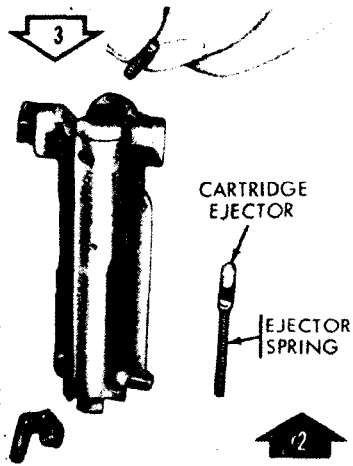

DISASSEMBLE/ASSEMBLE EXTRACTOR SPRING PLUNGER.

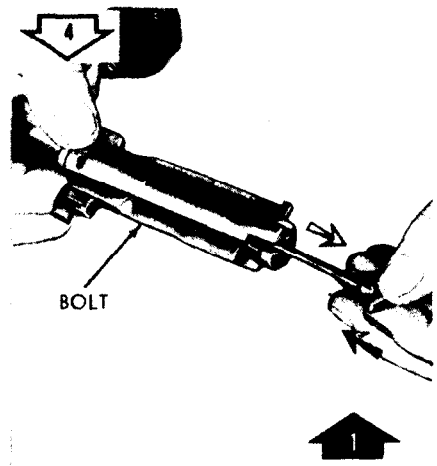

DISASSEMBLE/ASSEMBLE FIRING PIN.

WE 10441

Figure 5-16. Disassembly/assembly of bolt assembly.

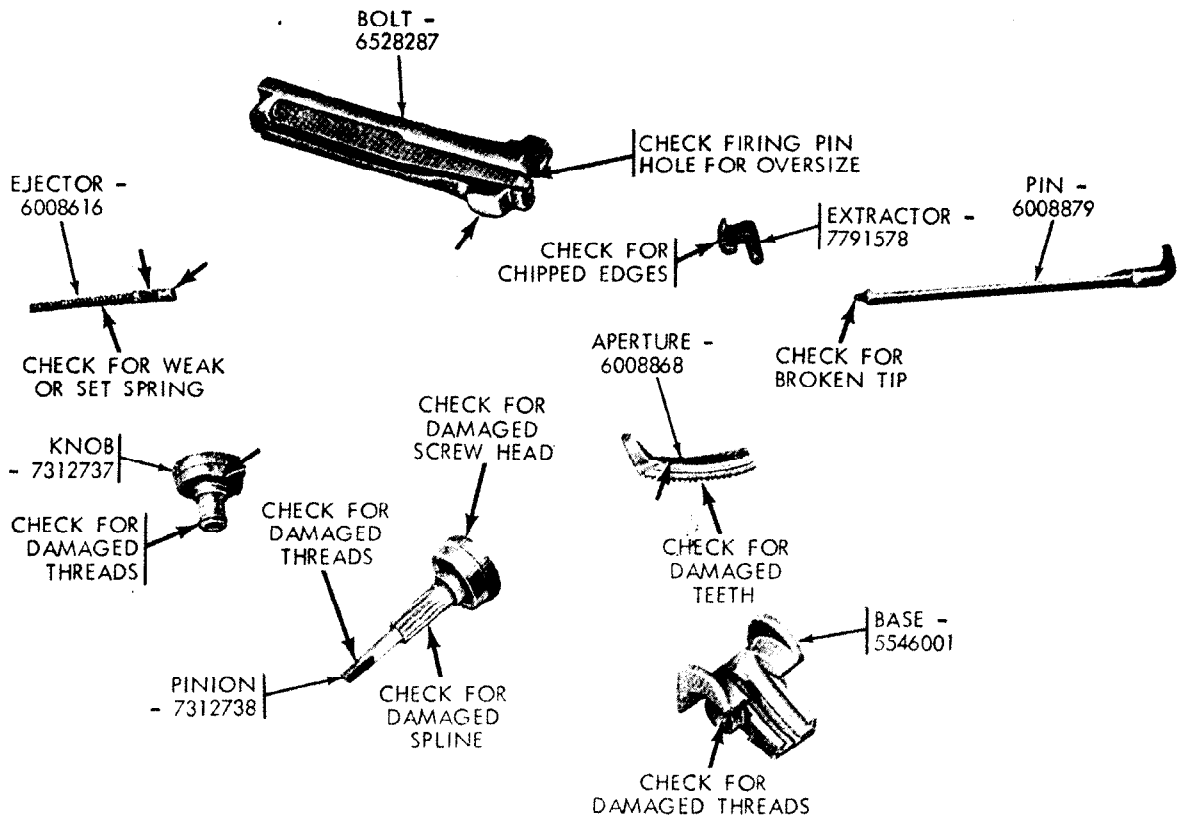

WE 12581

Figure 5-16. Inspection points of component parts of bolt assembly and rear sight group.

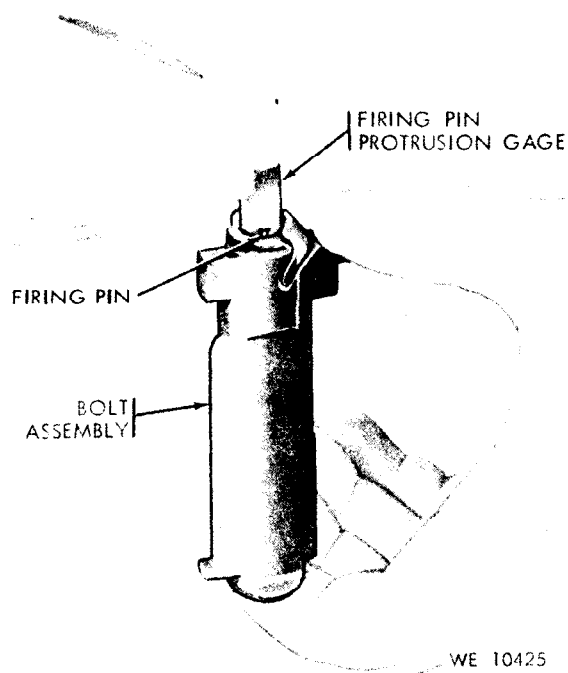

WE 10425

Figure 5-17. Gaging firing pin protrusion.

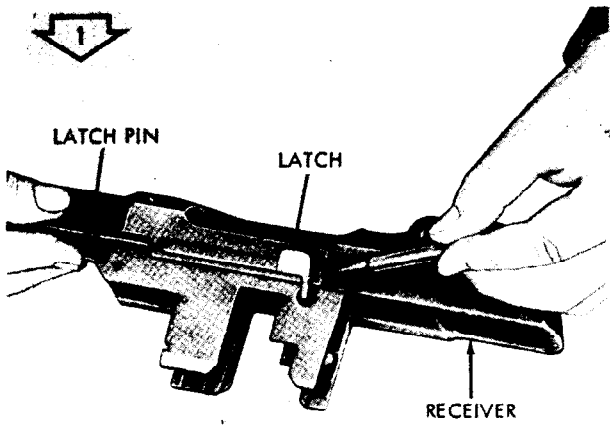

UNSEAT STRAIGHT HEADED LATCH PIN.

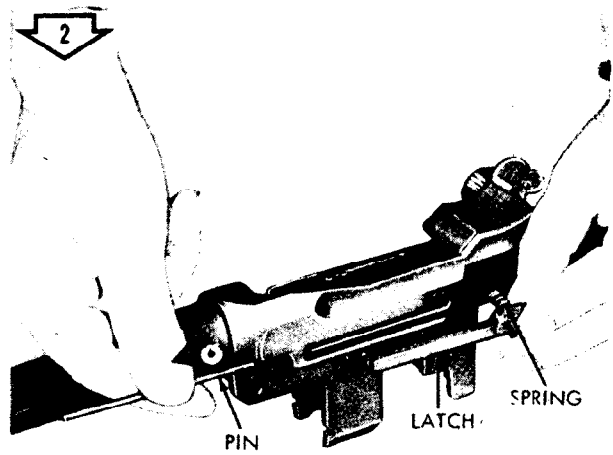

REMOVE LATCH PIN, LATCH AND HELICAL COMPRESSION SPRING.

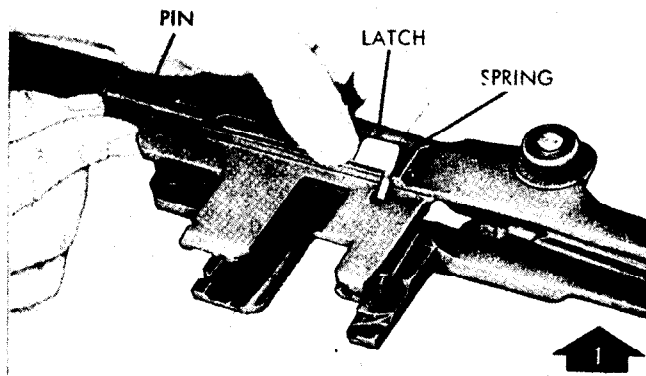

INSTALL LATCH PIN, LATCH AND SPRING.

WE 10445

Figure 6-18. Disassembly/assembly of latch group.

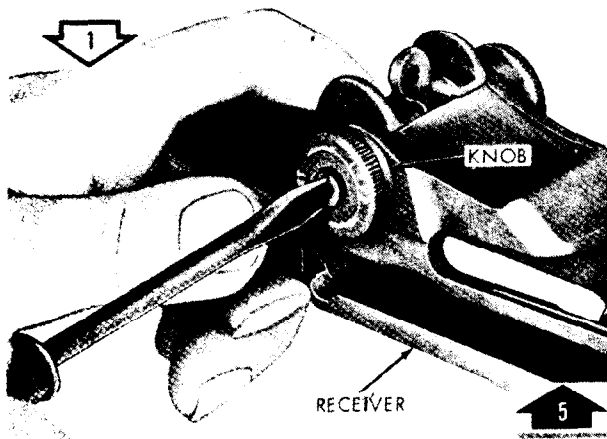

1
LOOSEN/TIGHTEN NUT.
5

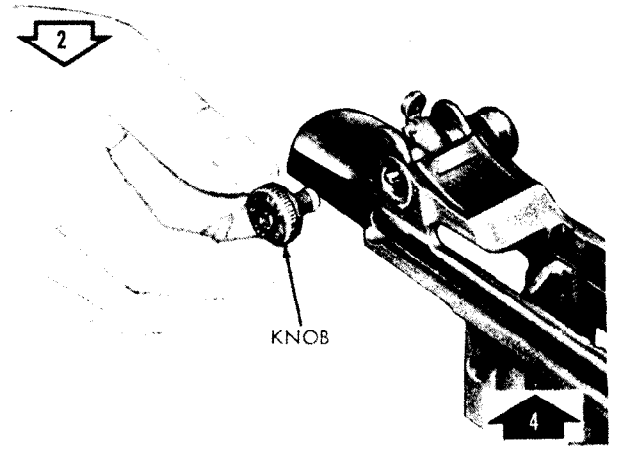

2
DISASSEMBLE/ASSEMBLE WINDAGE KNOB.
4

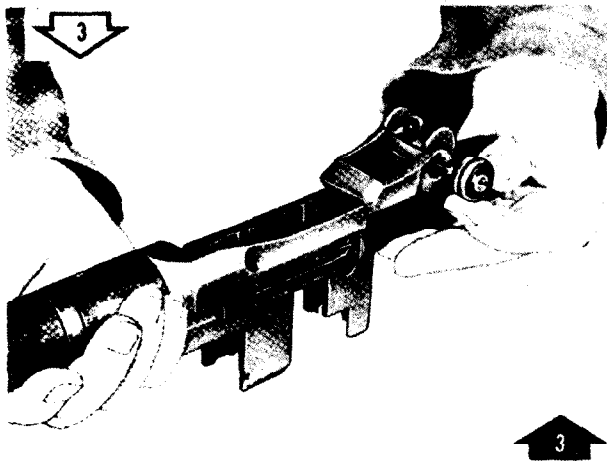

3
DISASSEMBLE/ASSEMBLE ELEVATING PINION.
3

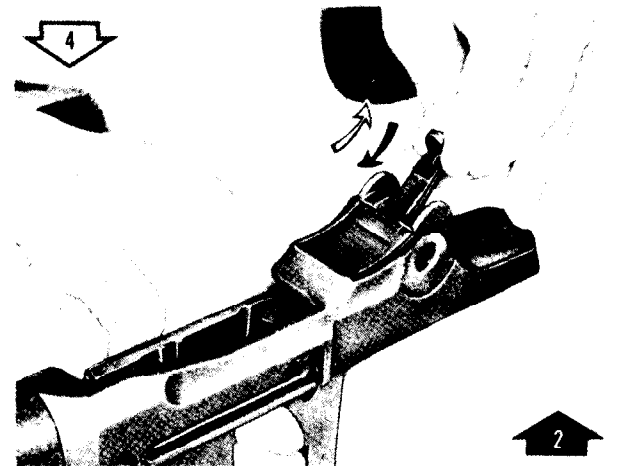

4
DISASSEMBLE/ASSEMBLE APERTURE.
2

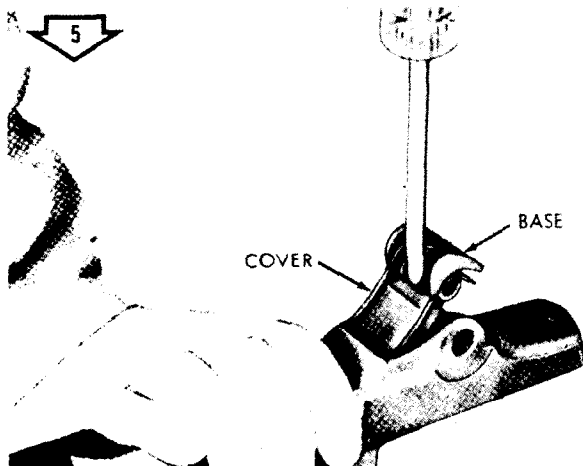

5
SEPARATE REAR SIGHT COVER FROM BASE.
COVER
BASE

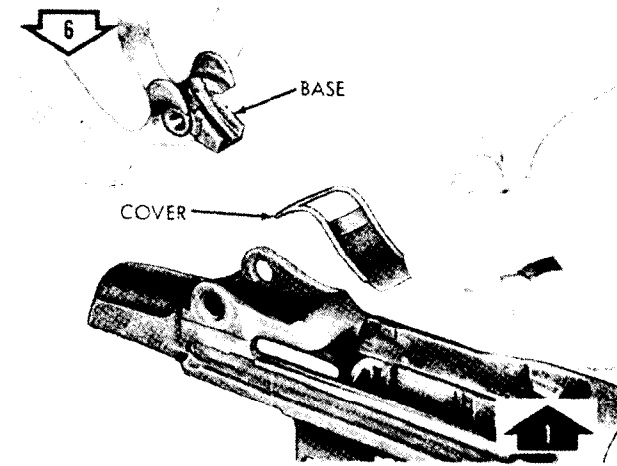

6
DISASSEMBLE/ASSEMBLE REAR SIGHT COVER AND BASE.
COVER
BASE
1

WE 10519

Figure 5-19. Disassembly/assembly of rear sight group.

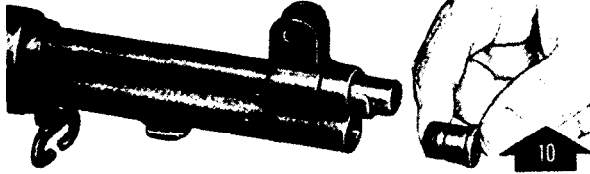

DISASSEMBLE/ASSEMBLE GAS CYLINDER LOCK SCREW.

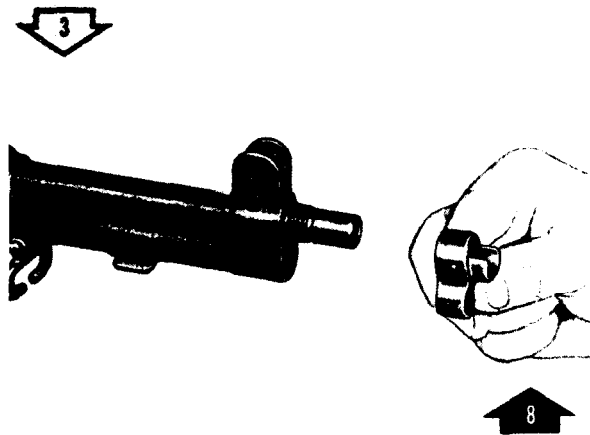

DISASSEMBLE/ASSEMBLE GAS CYLINDER LOCK.

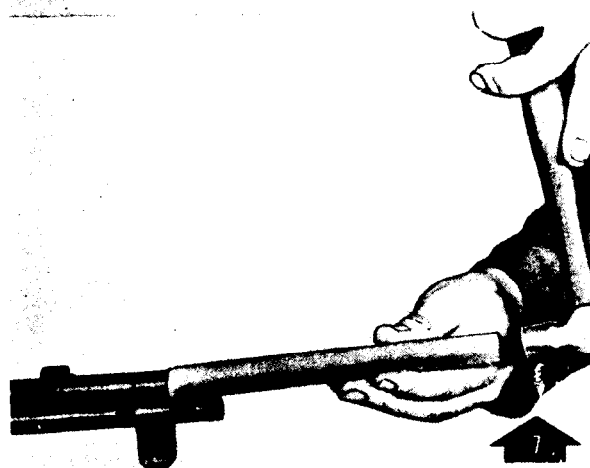

SECURE GAS CYLINDER ASSEMBLY TO BARREL.

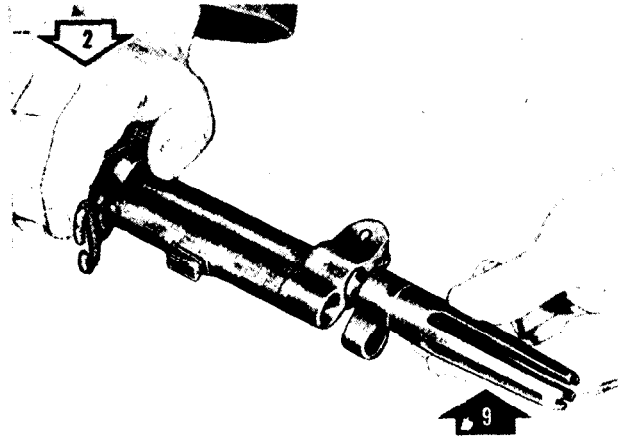

DISASSEMBLE/ASSEMBLE FLASH HIDER T37 FROM RIFLE MIC, MID.

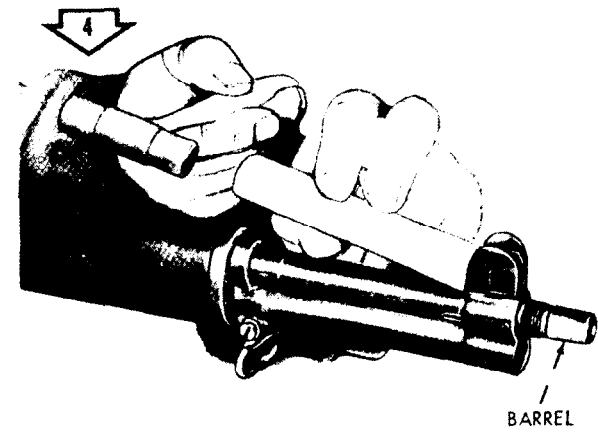

LOOSEN GAS CYLINDER ASSEMBLY FROM BARREL.



REMOVE/INSTALL GAS CYLINDER ASSEMBLY.

WE 10444

Figure 5-20. Disassembly/assembly of gas cylinder group. (1 of 2)

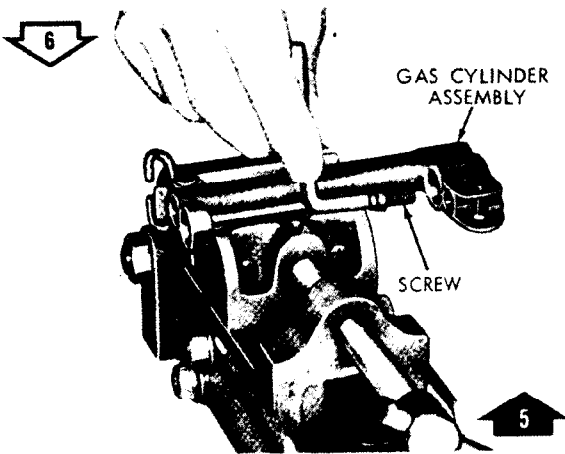

DISASSEMBLE/ASSEMBLE SOCKET HEAD SCREW.

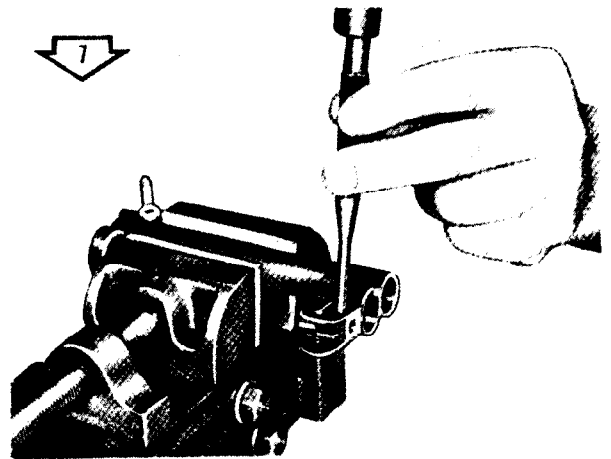

DISASSEMBLE FRONT SIGHT.

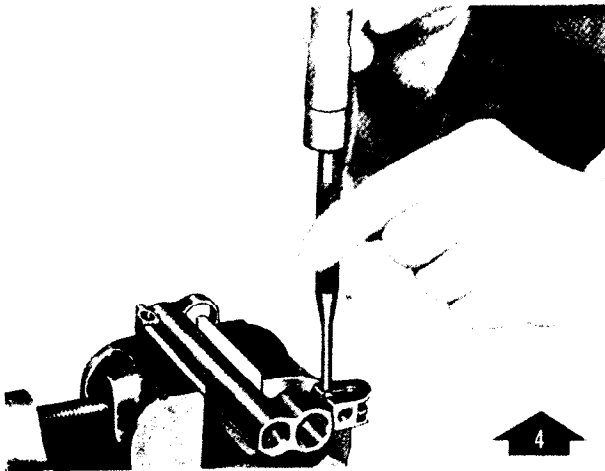

ASSEMBLE FRONT SIGHT.

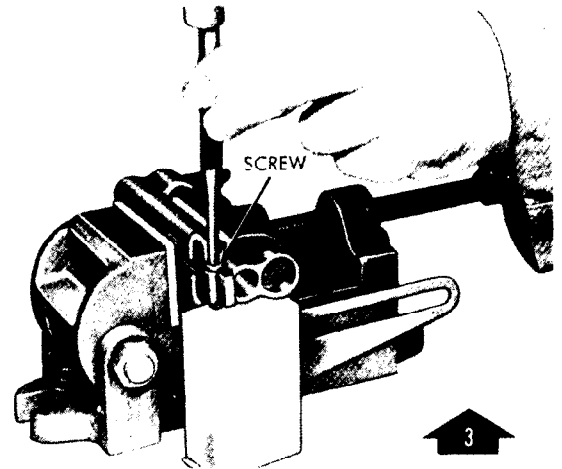

STAKE STACKING SWIVEL SCREW.

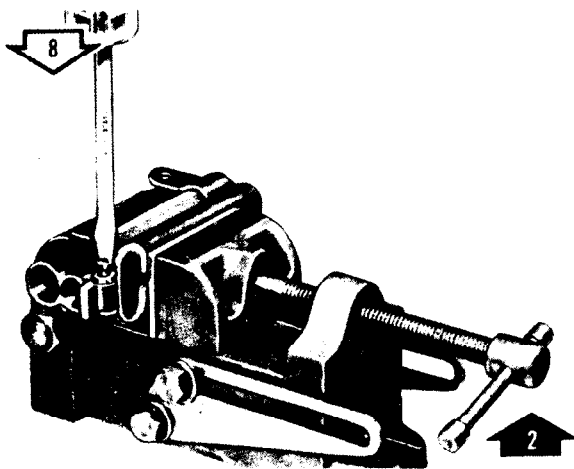

DISASSEMBLE/ASSEMBLE STACKING SWIVEL SCREW.

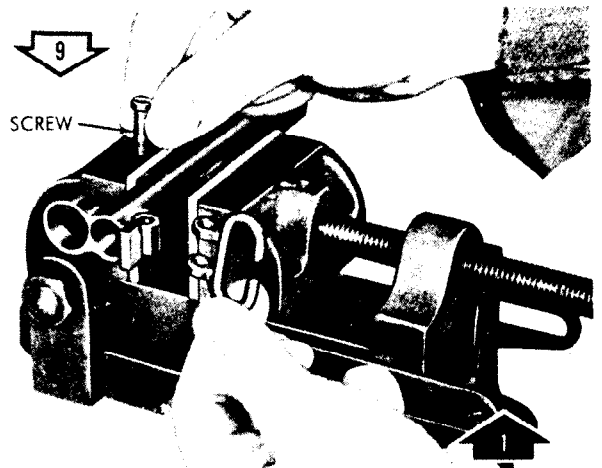

DISASSEMBLE/ASSEMBLE STACKING SWIVEL.

WE 10443

Figure 5-21. Disassembly/assembly of gas cylinder group. (2 of 2)

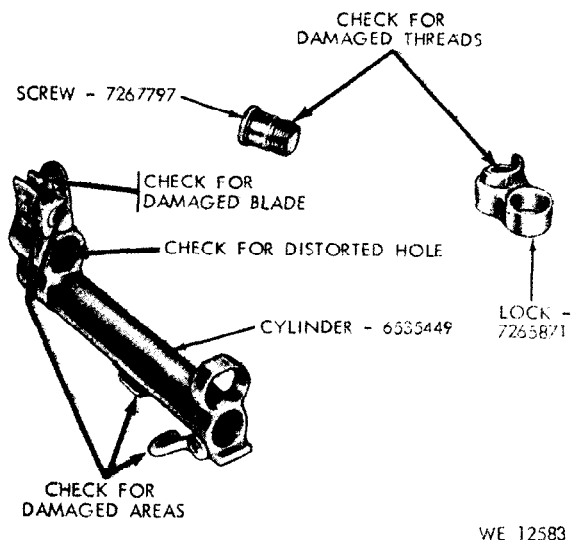

Figure 5-22. Inspection points of component parts of gas cylinder group.

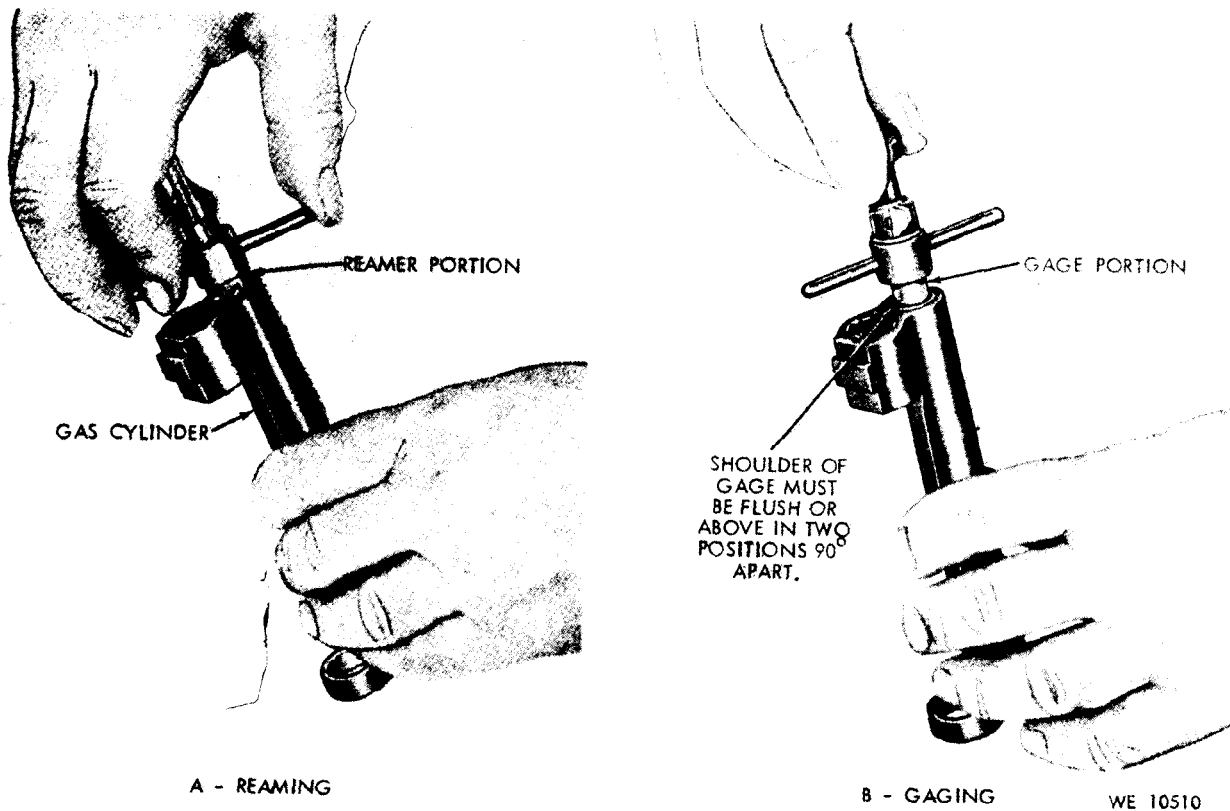

Figure 5-23. Use of gas cylinder diameter plug gage 7319919.

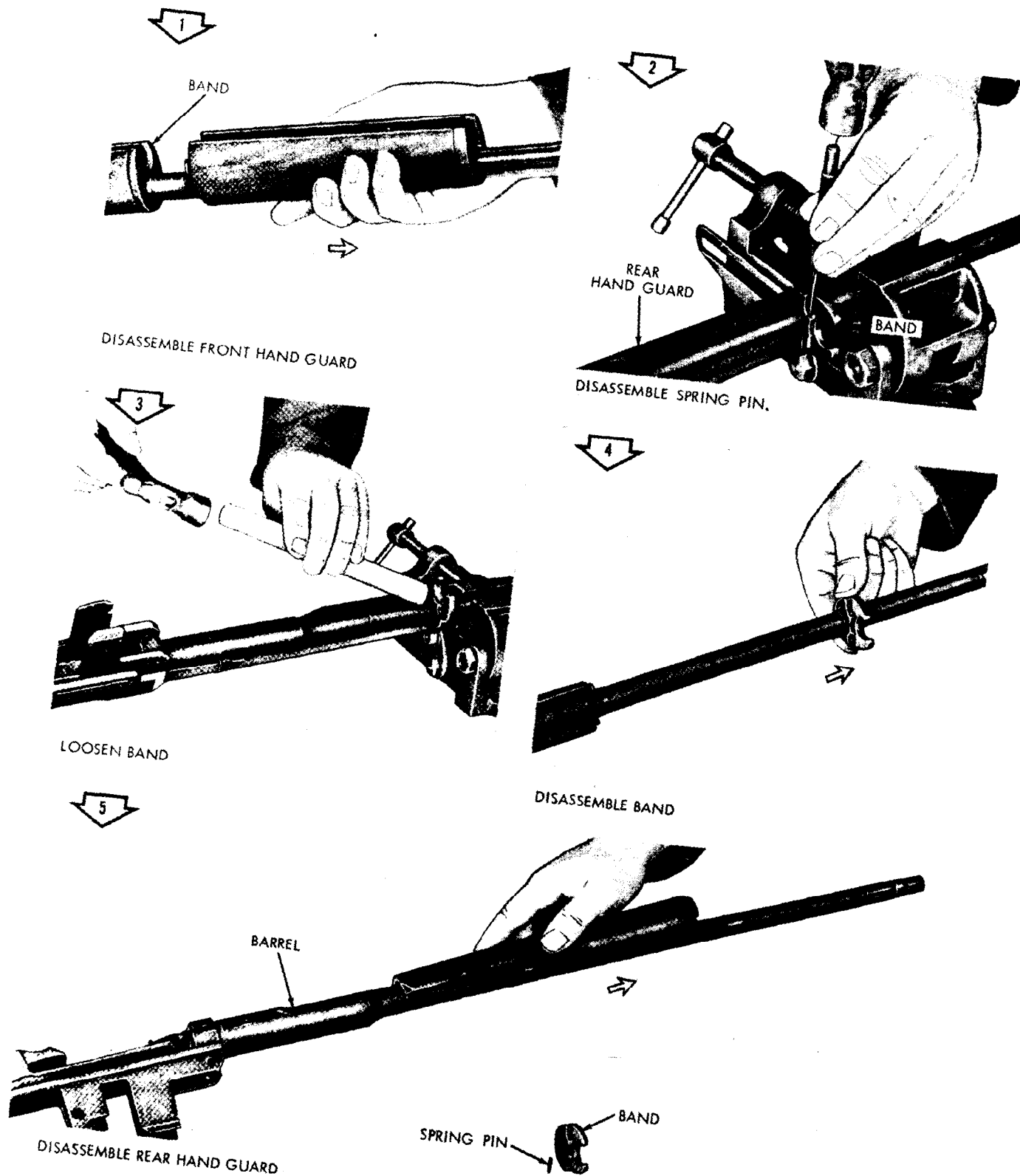
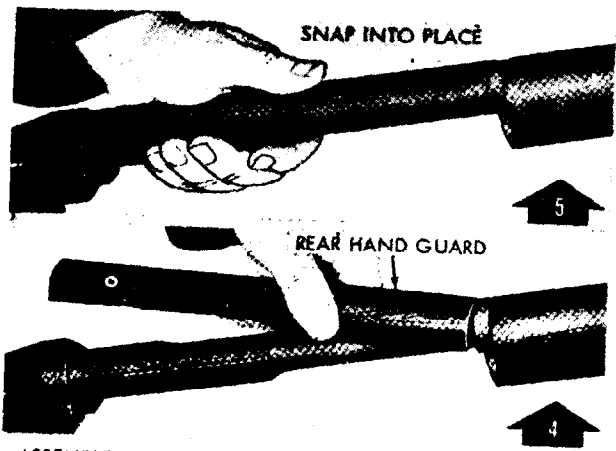
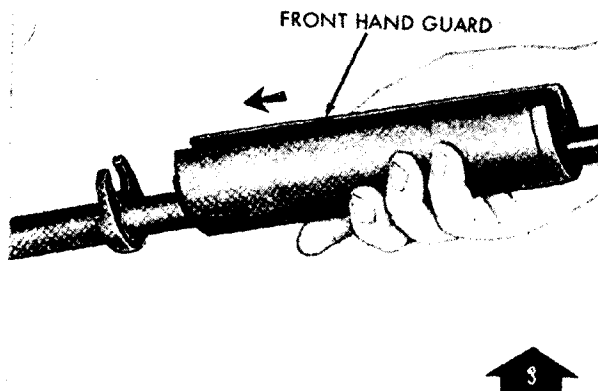

Figure 5-24. Disassembly of gun hand guard group.



ASSEMBLE REAR HAND GUARD.



ASSEMBLE FRONT HAND GUARD.

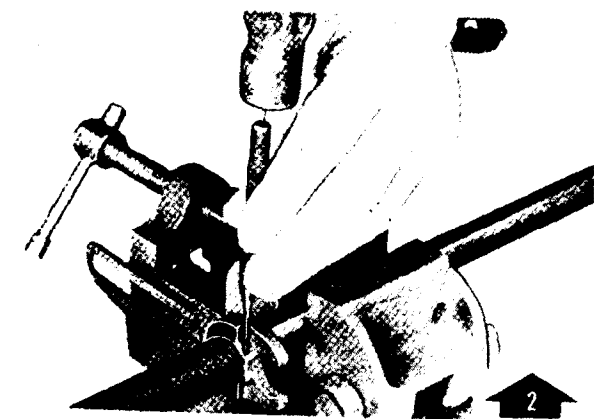

ASSEMBLE SPRING PIN.

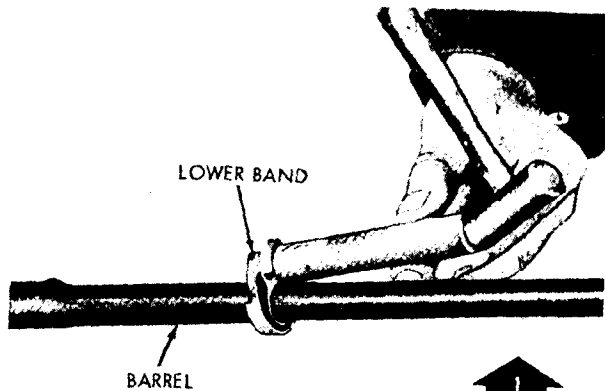

ASSEMBLE BAND ON M1, M1C RIFLE.

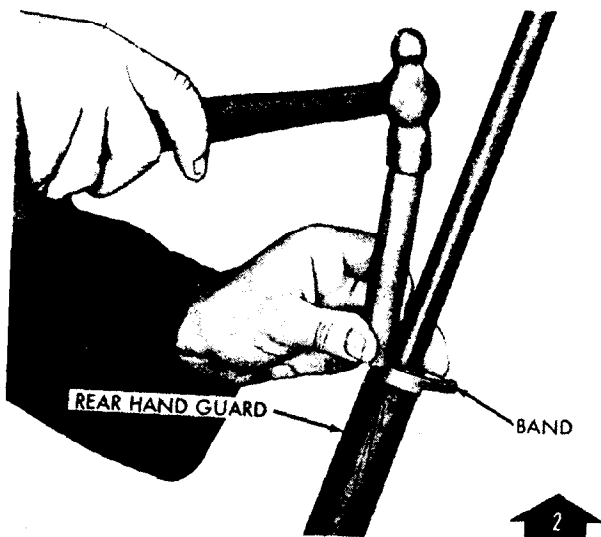

ASSEMBLE BAND ON MID RIFLE.

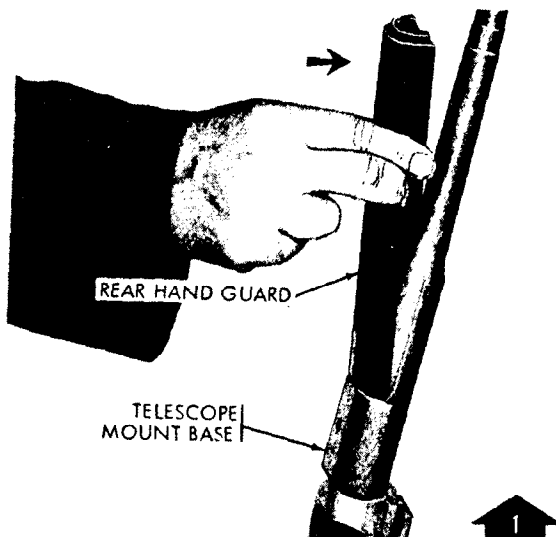

ASSEMBLE REAR HAND GUARD ON MID RIFLE.

NOTE: ON THE MID RIFLE, THE REAR HAND GUARD MUST BE ASSEMBLED FIRST. THEN ASSEMBLE THE BAND, SPRING PIN AND FRONT HAND GUARD.

WE 10520

Figure 5-25. Assembly of gun hand guard group.

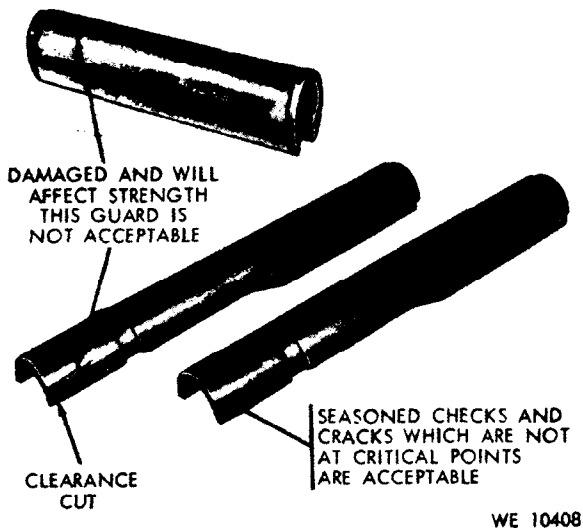

Figure 5-26. Gun hand guard defects and clearance cut for rifles.

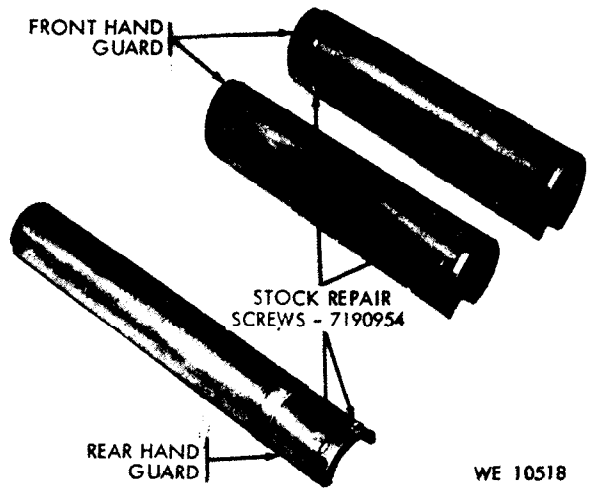

Figure 5-27. Repaired front and rear gun hand guards.

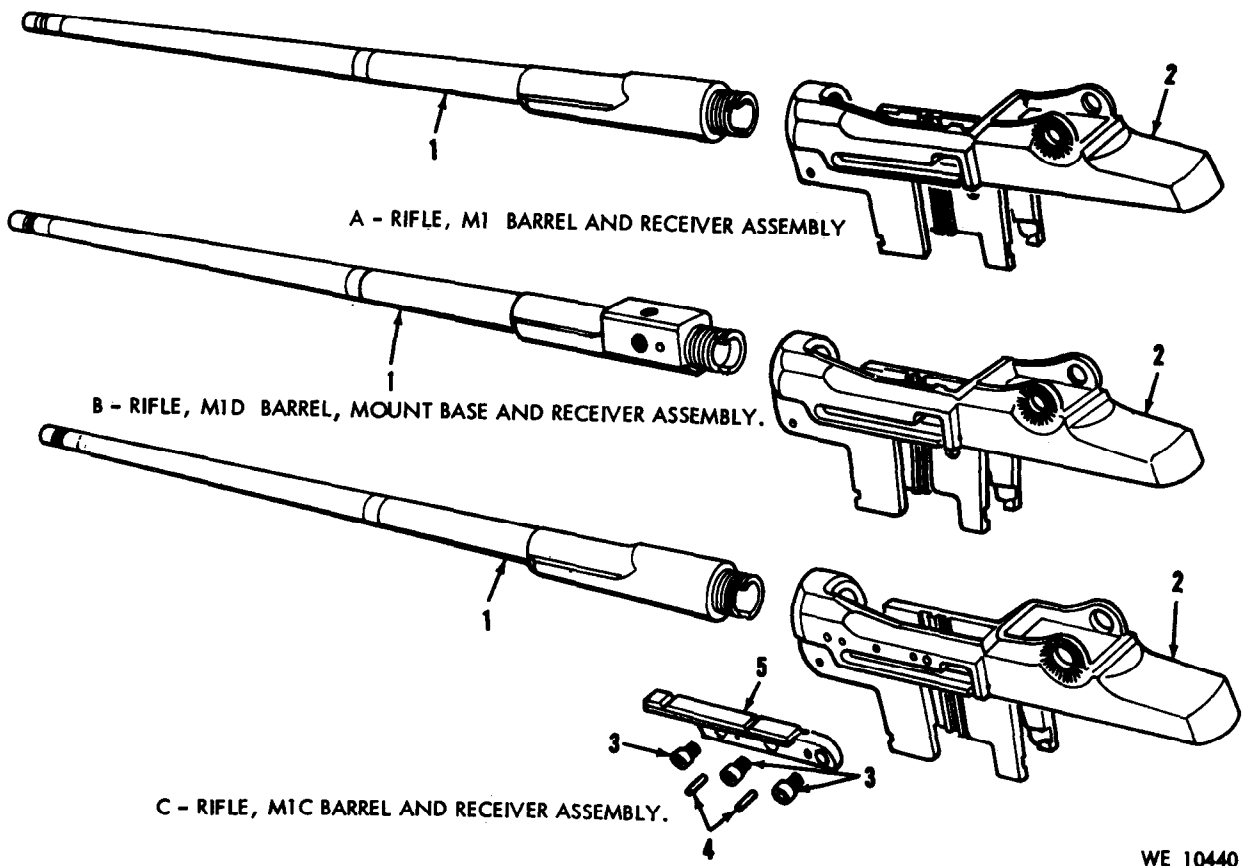
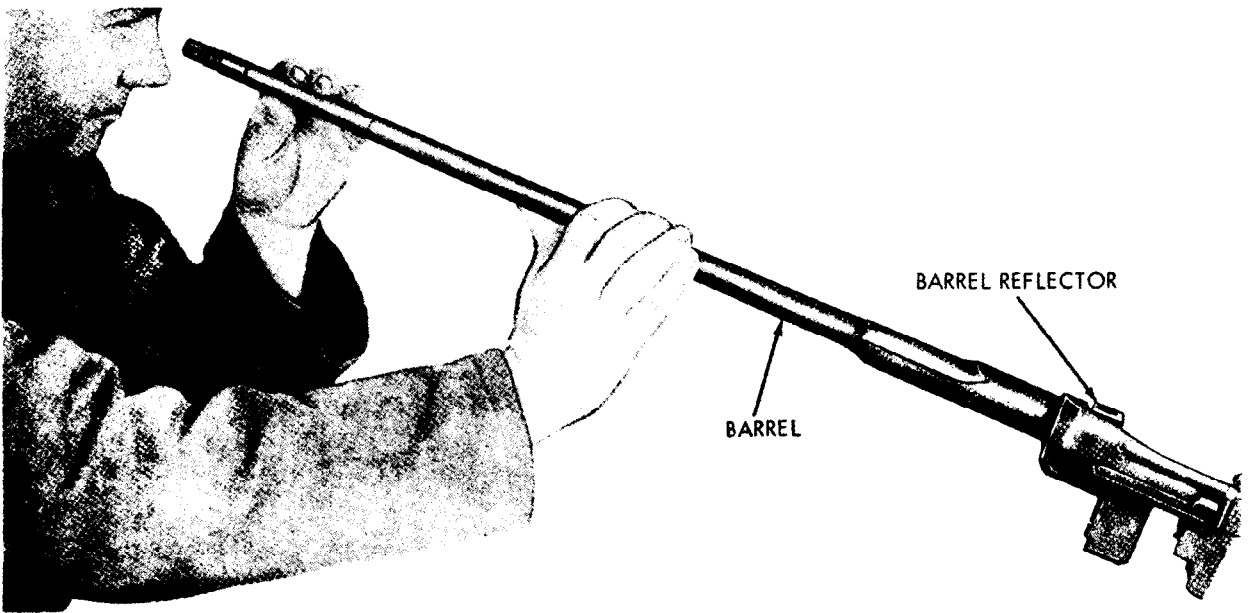
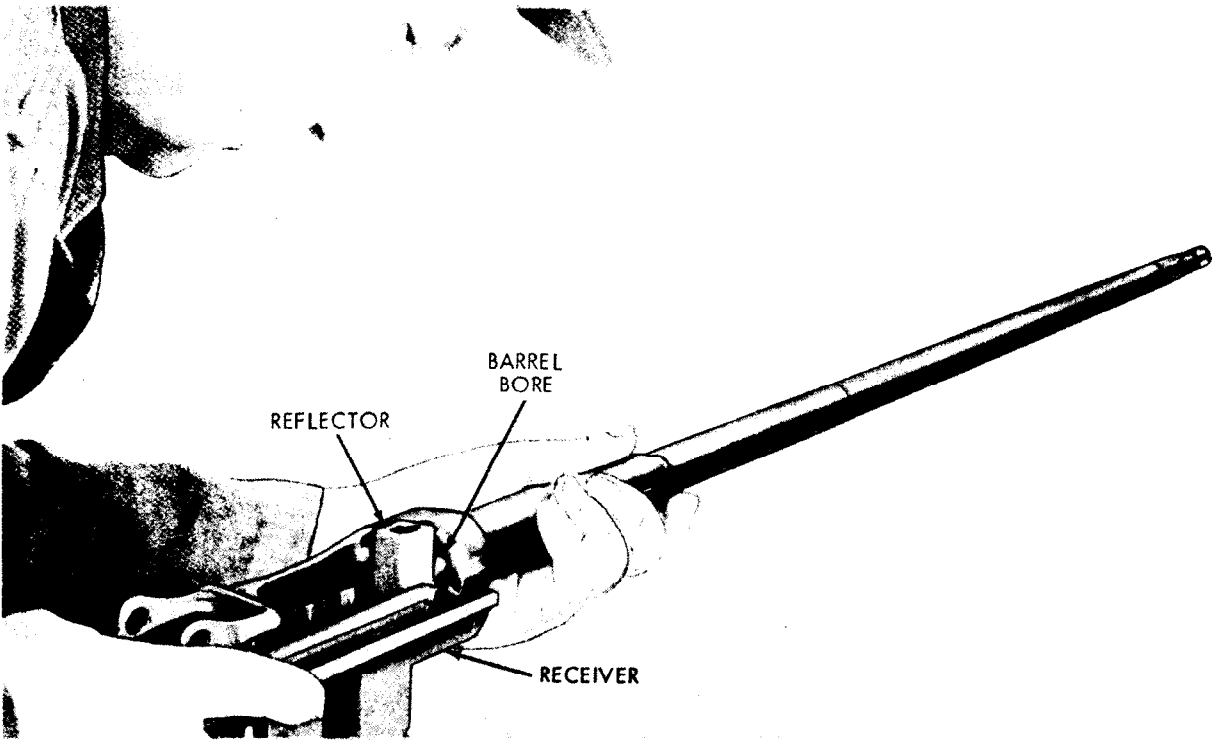

Figure 5-28. Barrel and receiver groups - exploded view.



A - VIEWING BARREL FROM MUZZLE END



B - VIEWING BARREL FROM CHAMBER END

WE 10521

Figure 5-29. Inspection of barrel using barrel reflector.

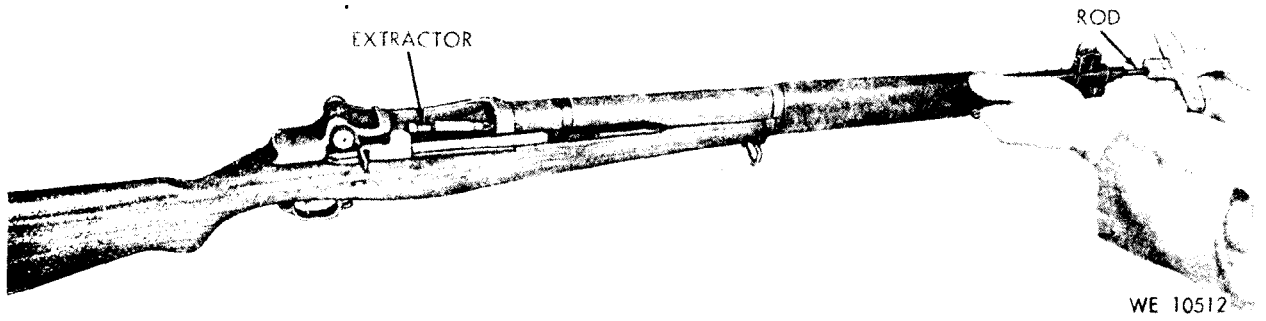

Figure 5-30. Removing ruptured cartridge case.

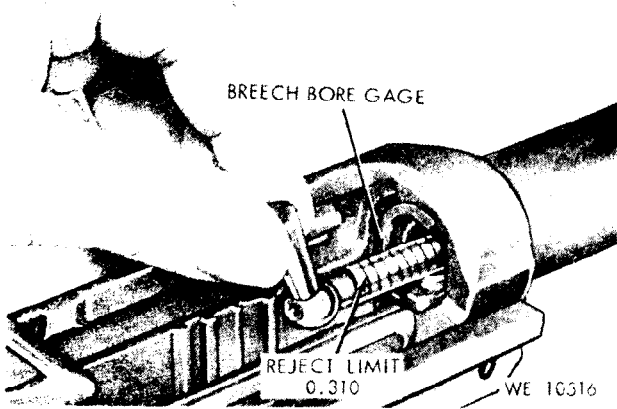

Figure 5-31. Gaging breech bore.

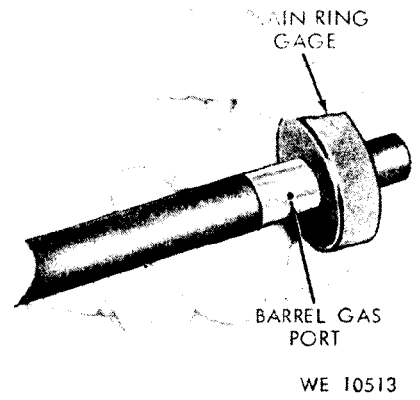

Figure 5-32. Gaging diameter of barrel at gas port.

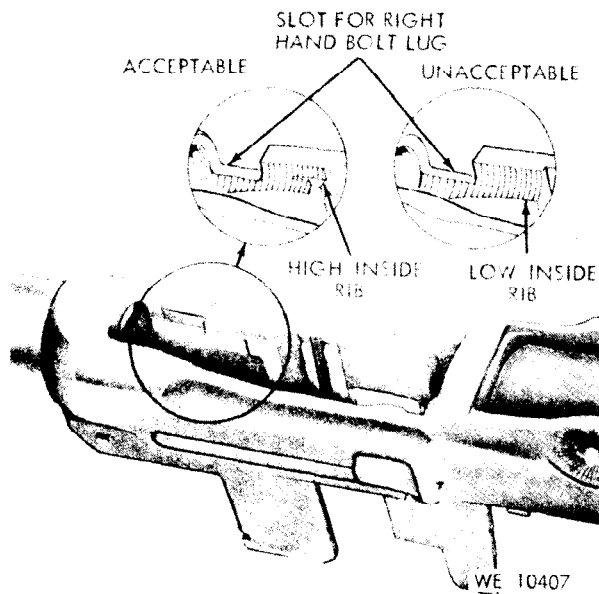
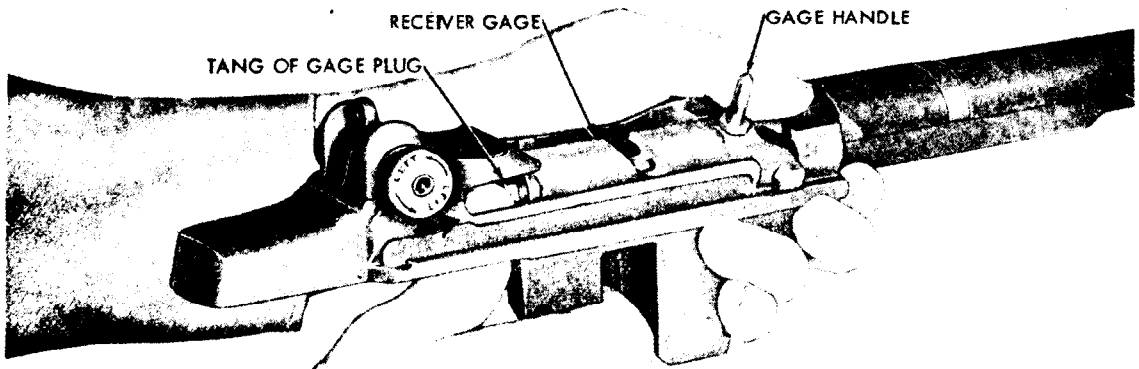
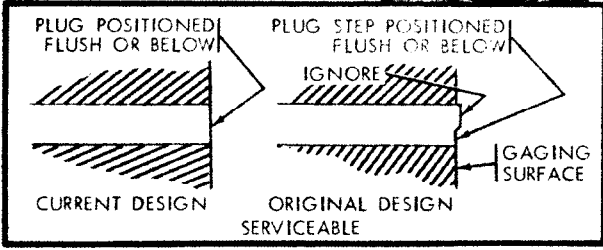
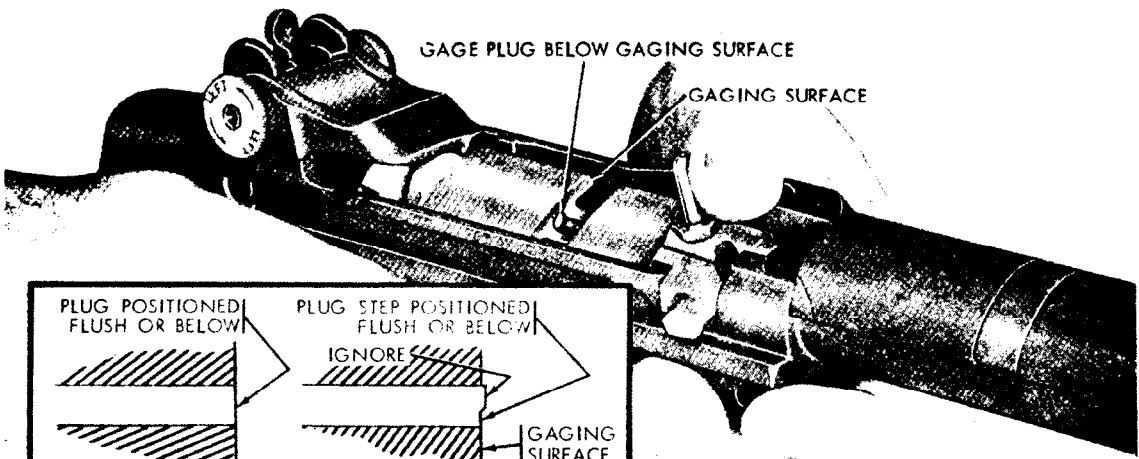

Figure 5-33. Checking contour of receiver rib.



GAGE PROPERLY POSITIONED IN RECEIVER



CHECKING GAGE - RECEIVER SERVICEABLE

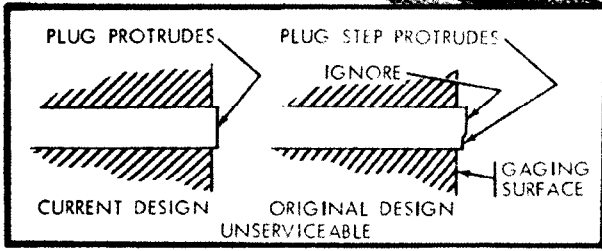
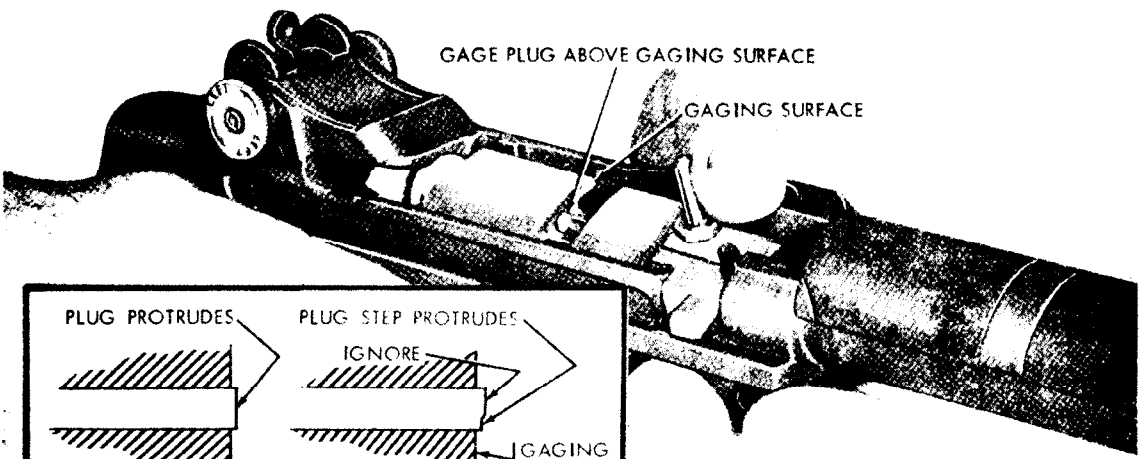

CHECKING GAGE - RECEIVER UNSERVICEABLE

WE 10442

Figure 5-34. Procedures for gaging receiver, using gage 7799709.

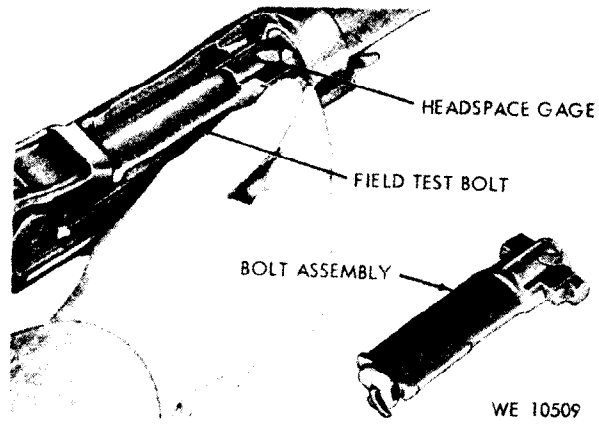

Figure 5-35. Gaging headspace of rifle.

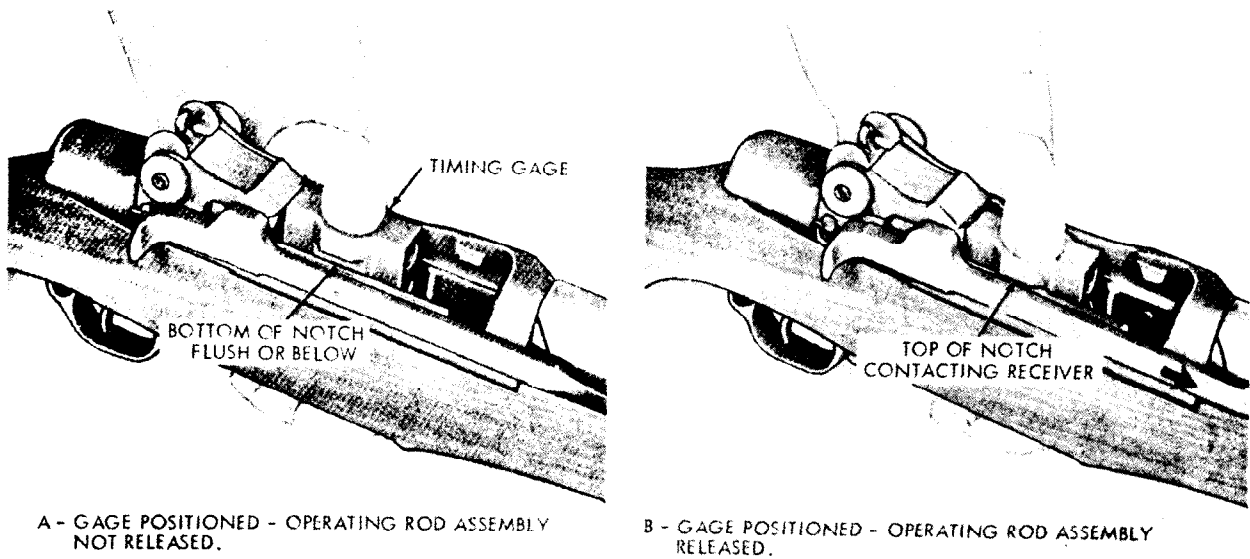
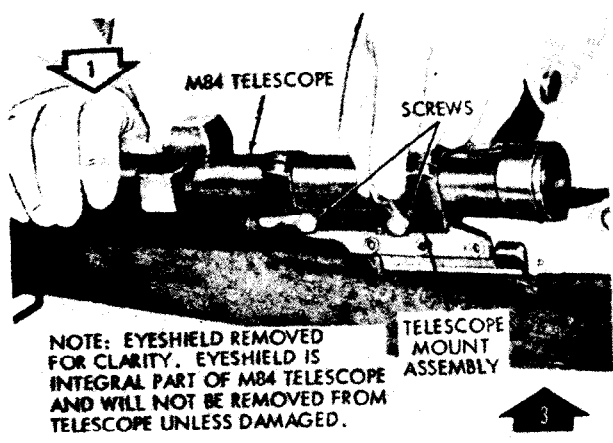
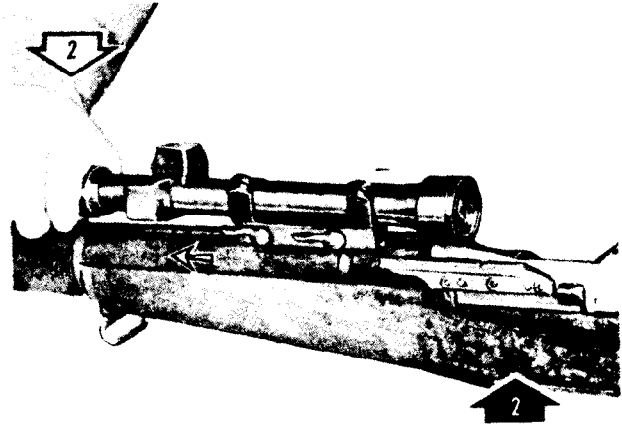

Figure 5-36. Timing the rifle.



LOOSEN/TIGHTEN MACHINE SCREWS.



REMOVE/INSTALL M84 TELESCOPE AND MOUNT ASSEMBLY.

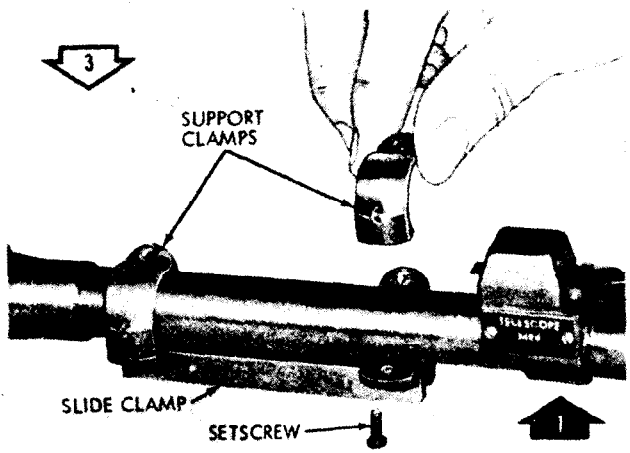

DISASSEMBLE/ASSEMBLE CLAMPS FROM TELESCOPE M84.

WE 10523

Figure 5-37. Disassembly/assembly telescope mount assembly for rifle M1C (Sniper's).

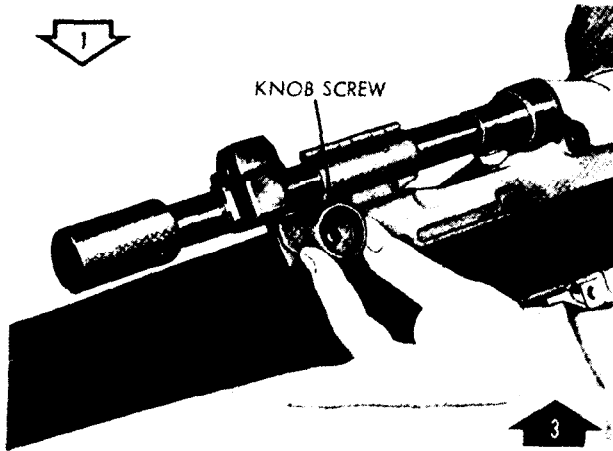

LOOSEN/TIGHTEN KNOB SCREW.

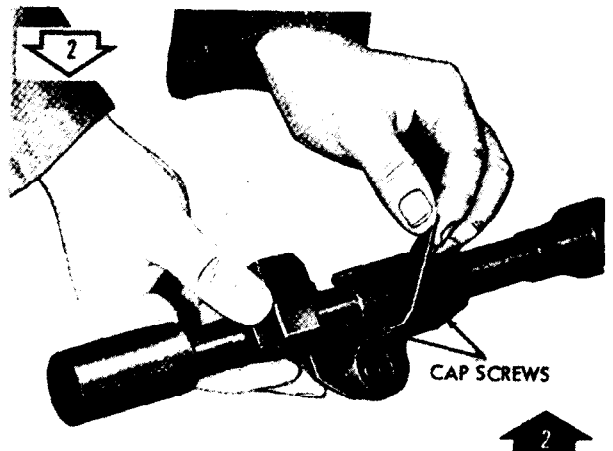

DISASSEMBLE/ASSEMBLE CAP SCREWS.

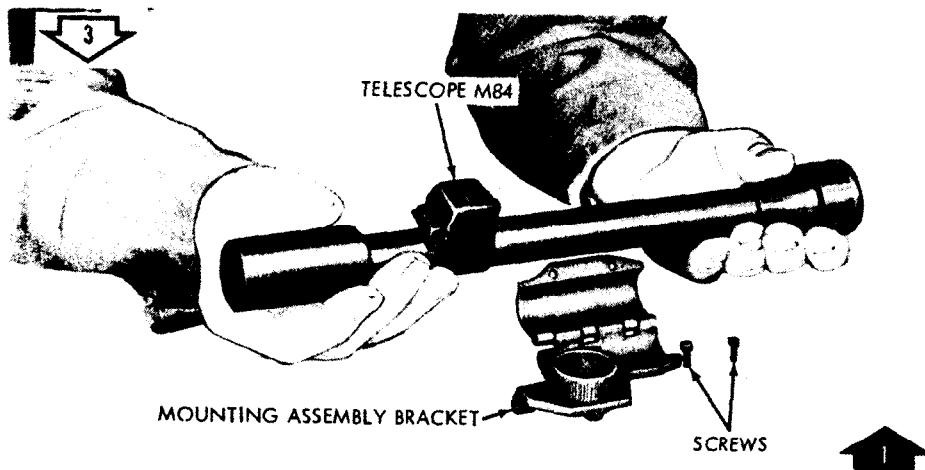

DISASSEMBLE/ASSEMBLE M84 TELESCOPE FROM BRACKET ASSEMBLY.

WE 10437

Figure 6-38. Disassembly/assembly of mounting bracket assembly for rifle M1D (Sniper's).

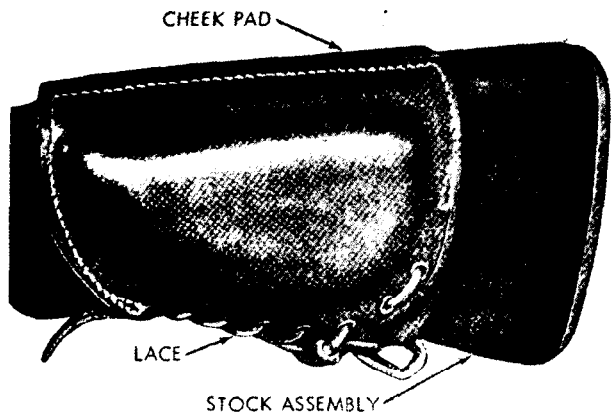

CHEEK PAD WITH LACE INSTALLED ON RIFLE, MIC OR MID.

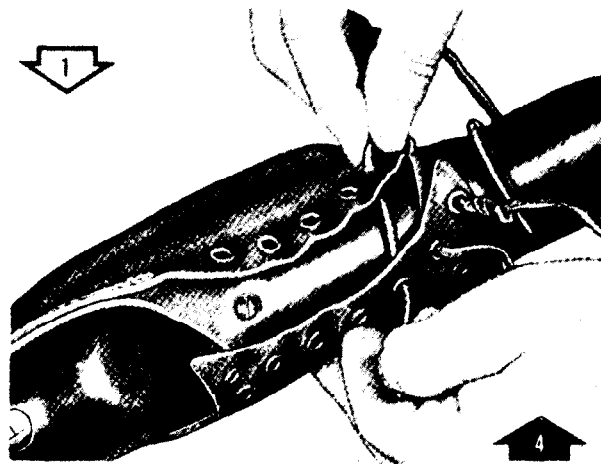

DISASSEMBLE/ASSEMBLE LACE.

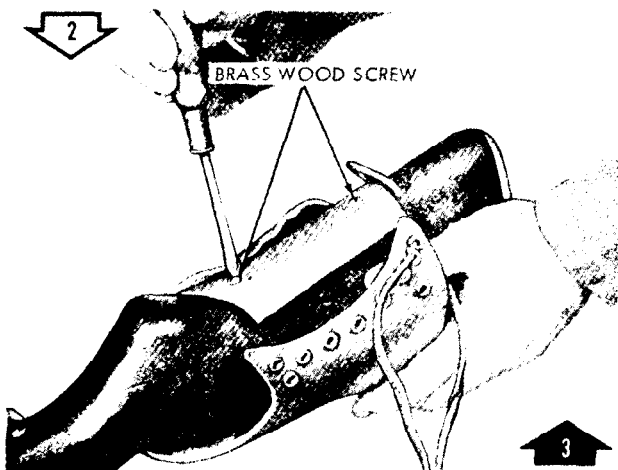

DISASSEMBLE/ASSEMBLE WOOD SCREW.

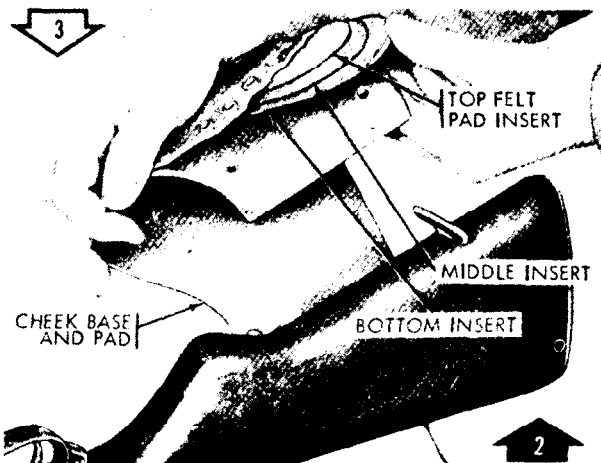

REMOVE/INSTALL CHEEK PAD.

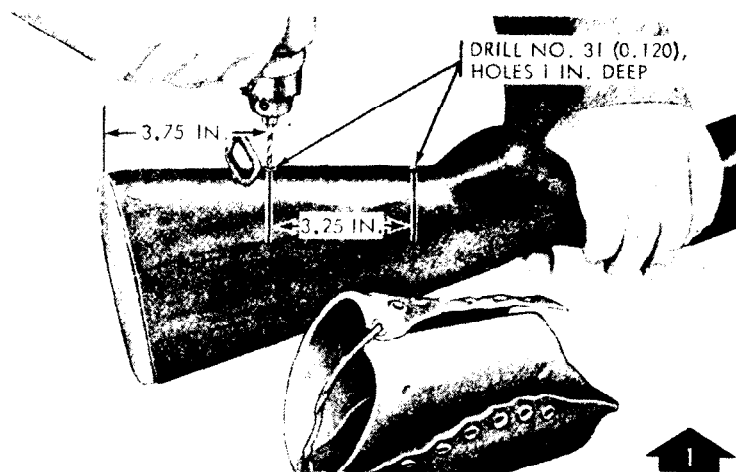

DRILLING HOLES IN STOCK ASSEMBLY FOR ASSEMBLING WOOD SCREWS.

WE 10438

Figure 5-39. Disassembly of cheek pad for rifles MIC and MID (Sniper's).

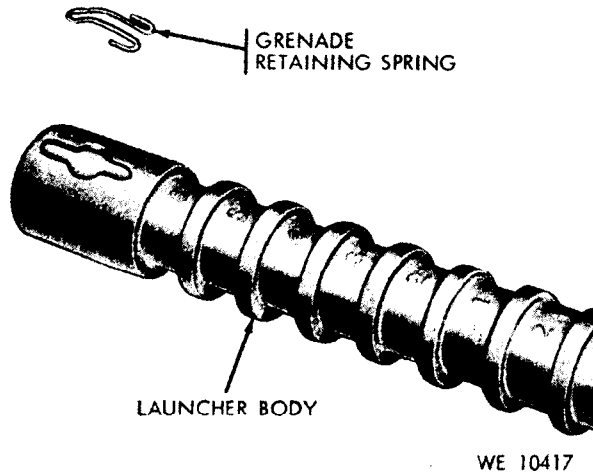
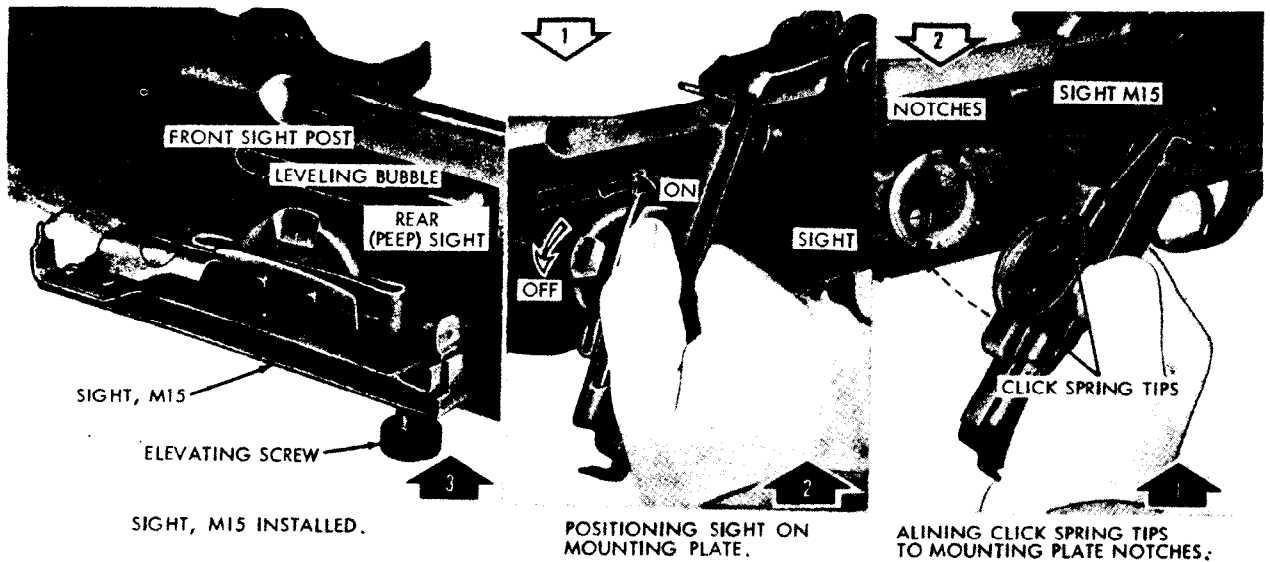

Figure 5-40. Disassembly/assembly of grenade launcher M7A3.



WE 10430

Figure 5-41. Remove/install grenade launcher sight M15.

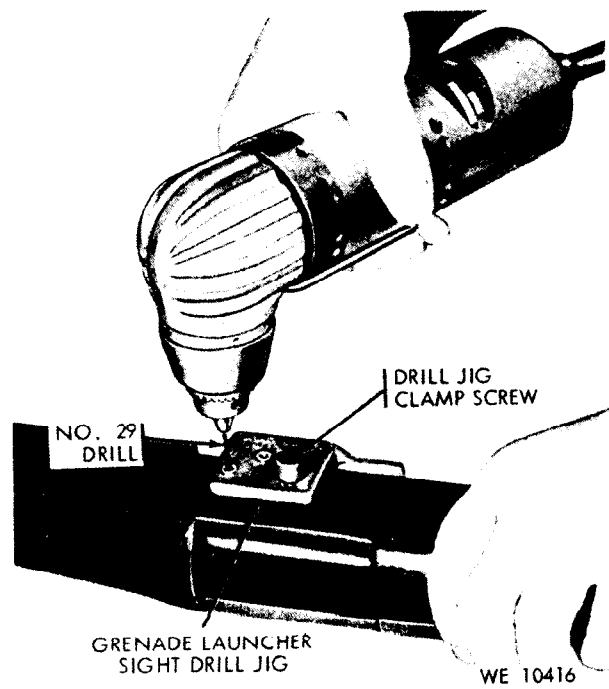
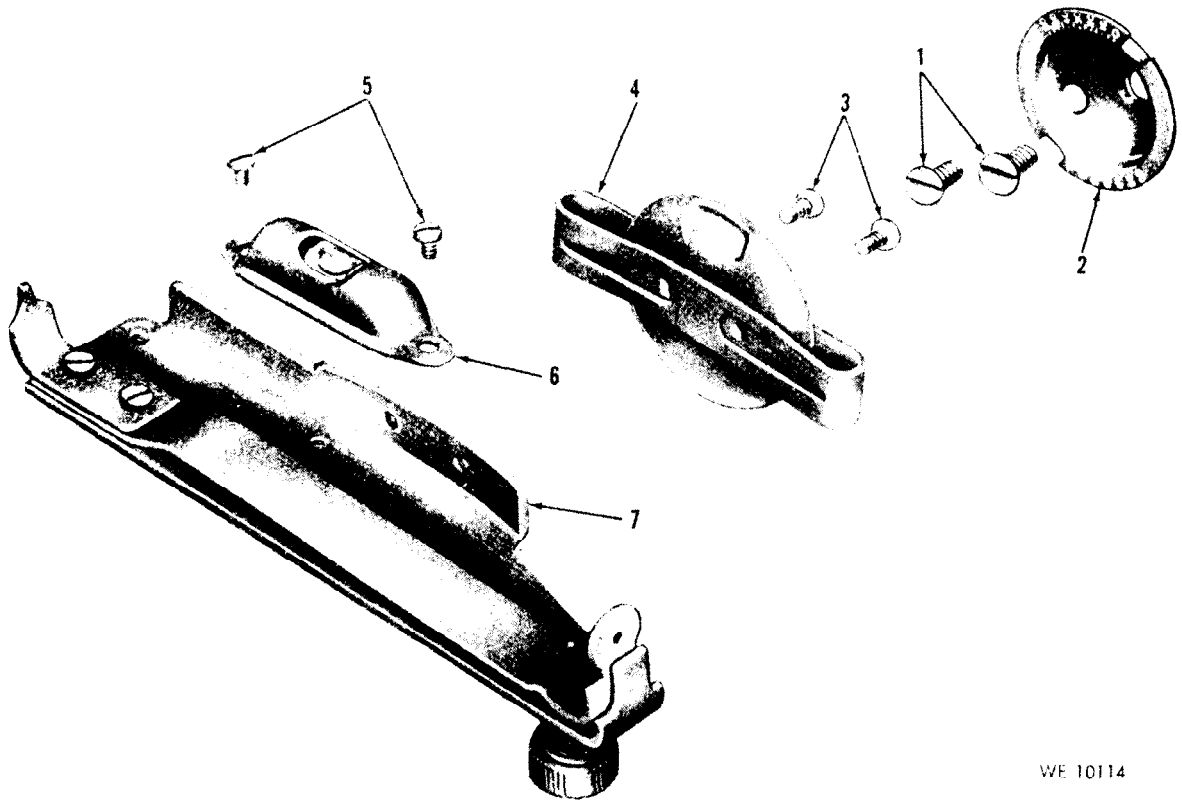

Figure 5-42. Drilling stock assembly using grenade launcher sight jig.



WE 10114

- | | |
|------------------------|----------------------------|
| 1 - Screw 7310009 | 5 - Screw 7310093 |
| 2 - Plate 7311859 | 6 - Level Assembly 7310097 |
| 3 - Screw 7310095 | 7 - Body 7310096 |
| 4 - Bracket and Spring | |

Figure 5-43. Grenade launcher sight M15 - exploded view.

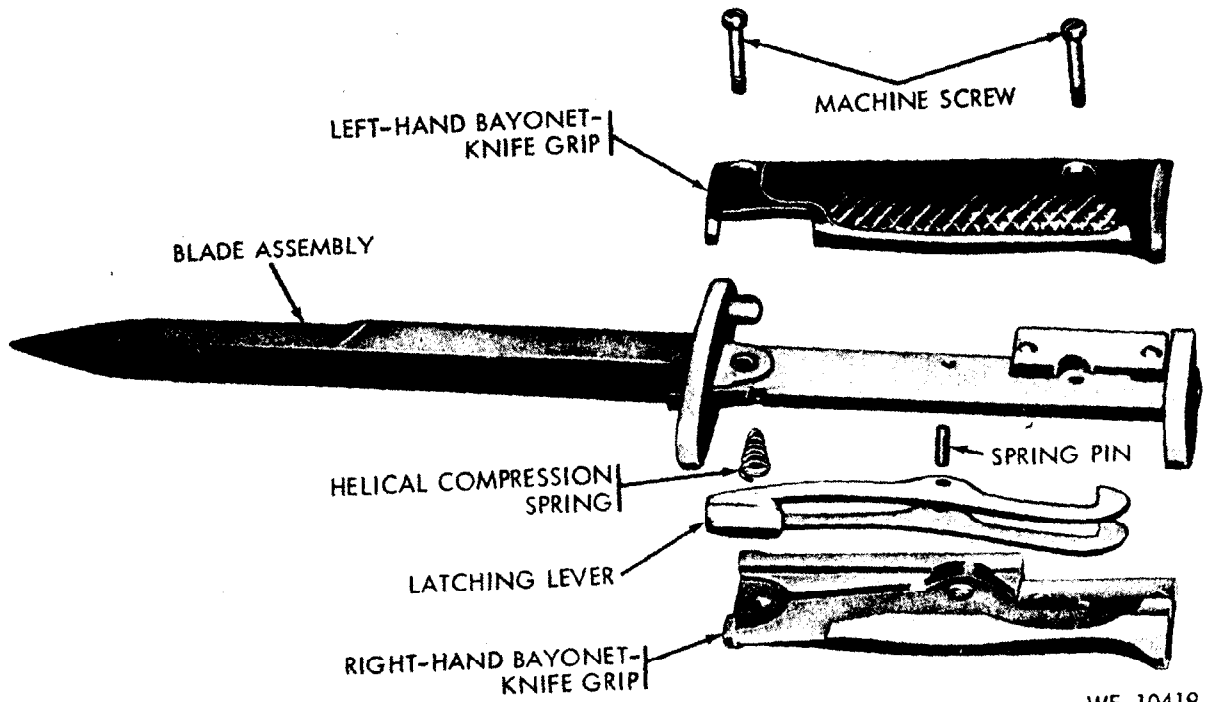

WE 10419

Figure 5-44. Disassembly/assembly of bayonet-knife M5.

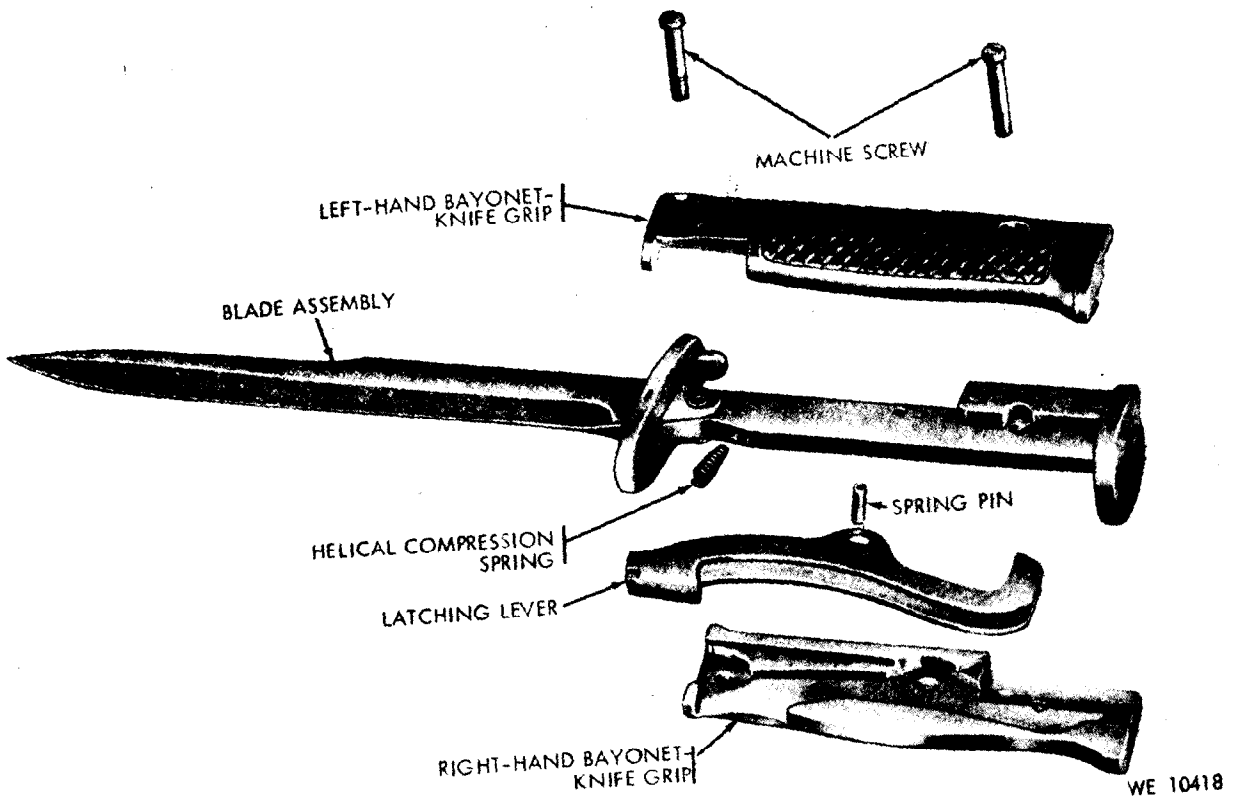
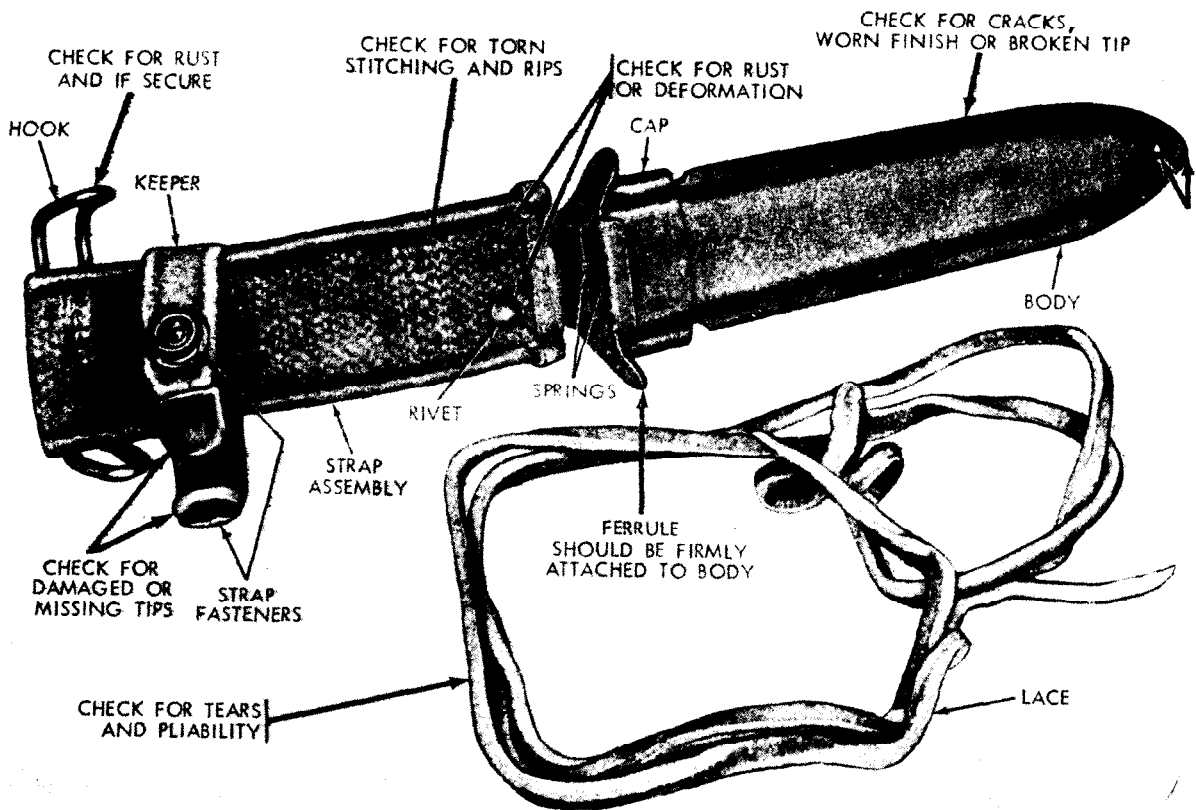
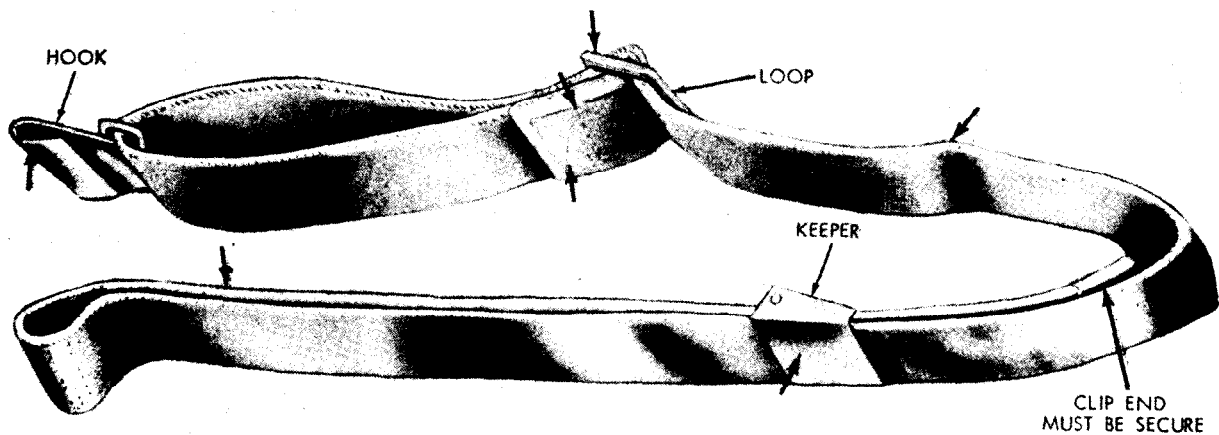

Figure 5-45. Disassembly/assembly of bayonet-knife M5A1.



WE 12706

Figure 5-46. Inspection points for scabbard-bayonet knife M8A1.



WE 12647

Figure 5-47. Inspection points for sling M1.

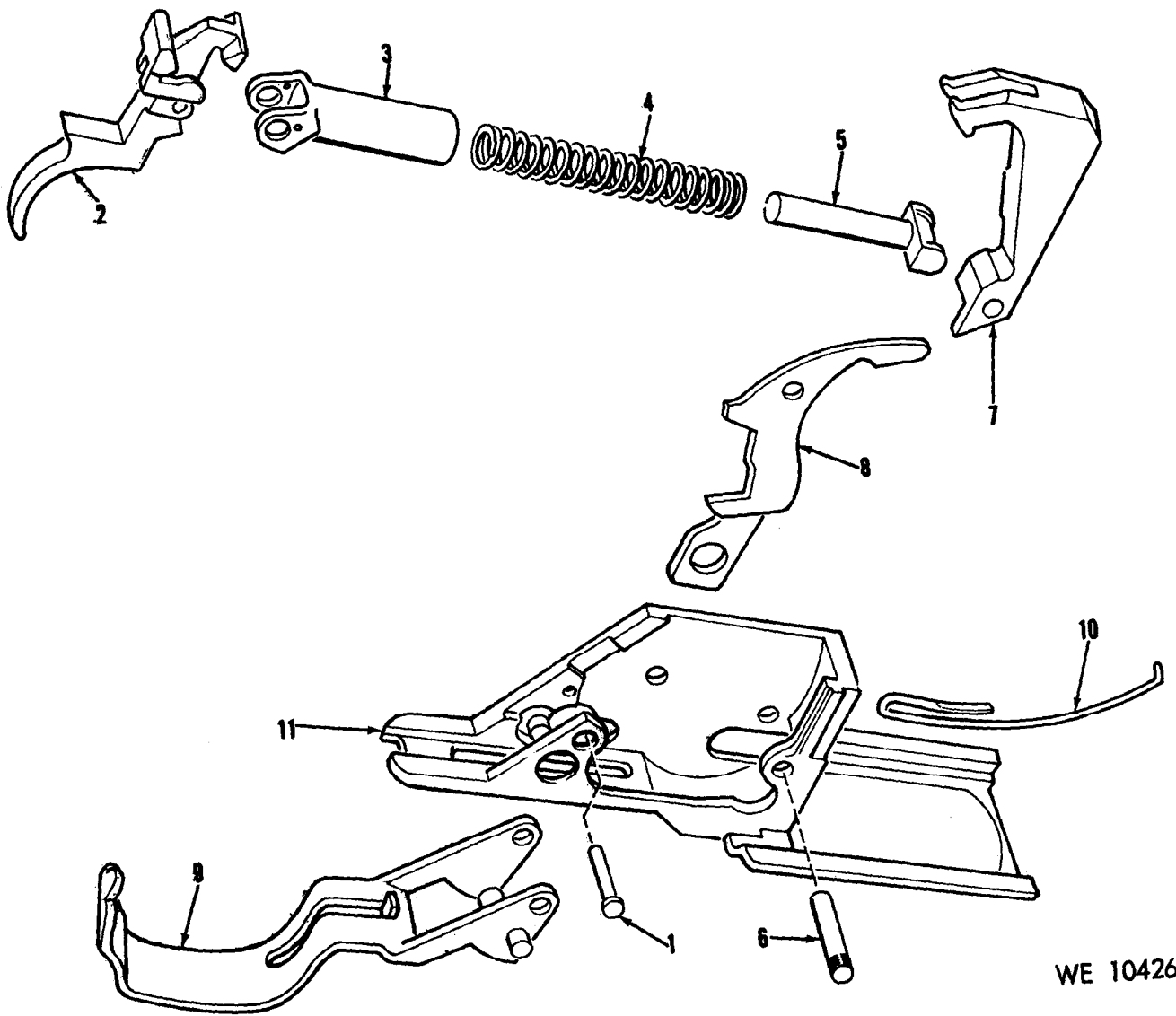

WE 10426

Figure 5-48. Trigger housing assembly 6528297 - exploded view.

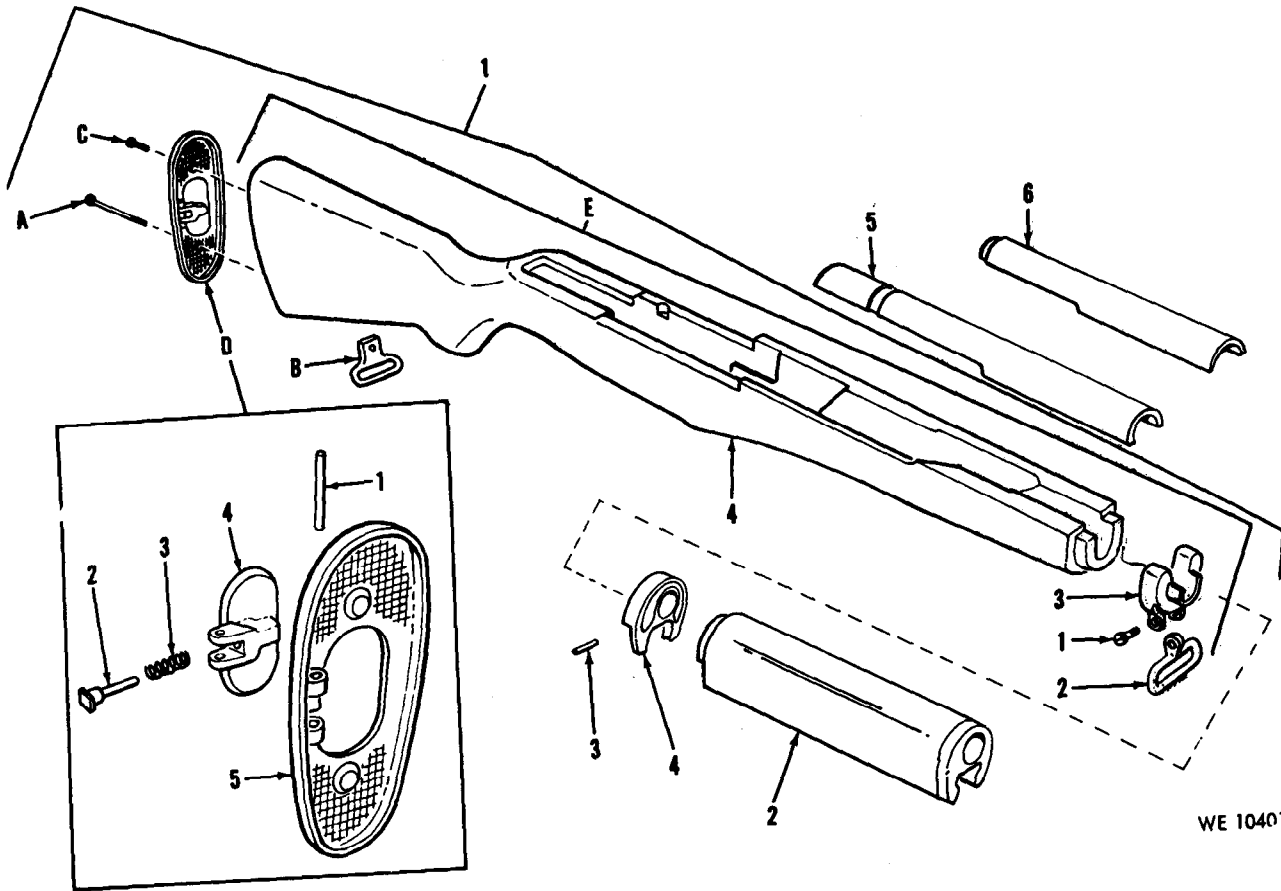
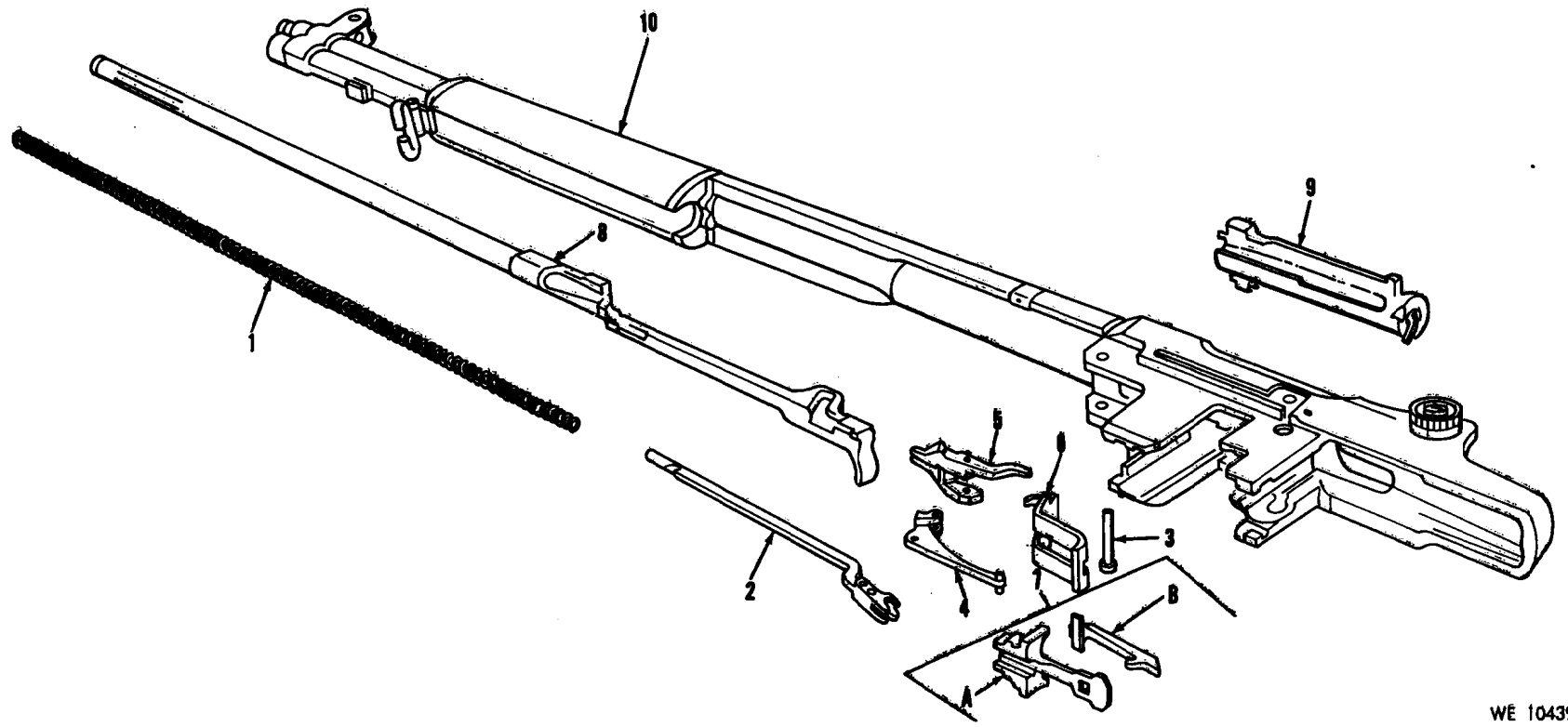

Figure 5-49. Stock assembly and gun hand guard group - exploded view.



WE 10439

Figure 5-50. Follower group - exploded view.

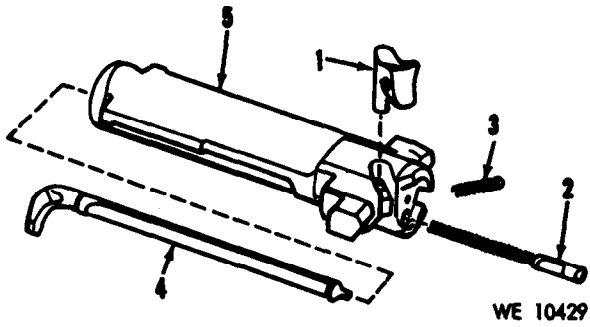

Figure 5-51. Bolt assembly 5646023 - exploded view

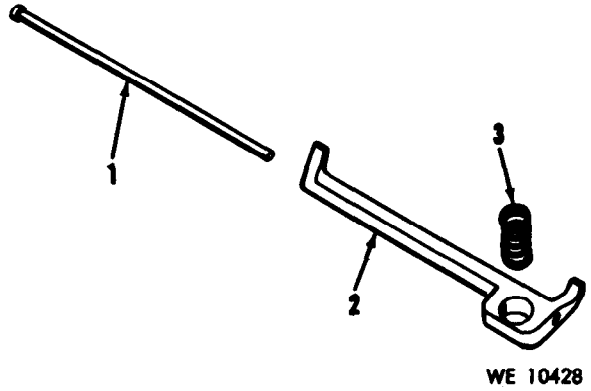

Figure 5-52. Latch group - exploded view.

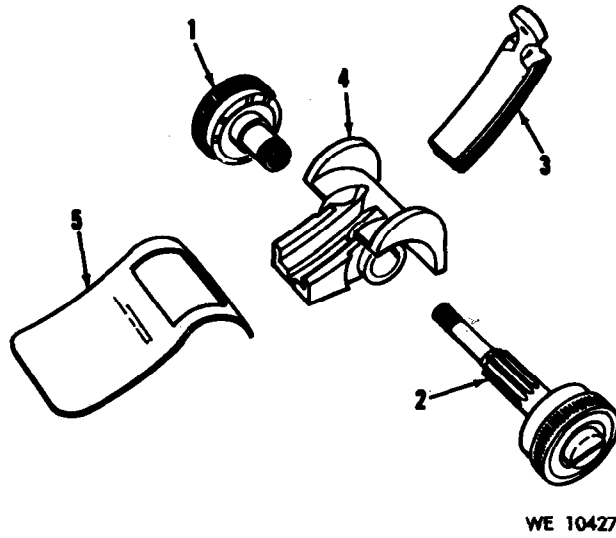
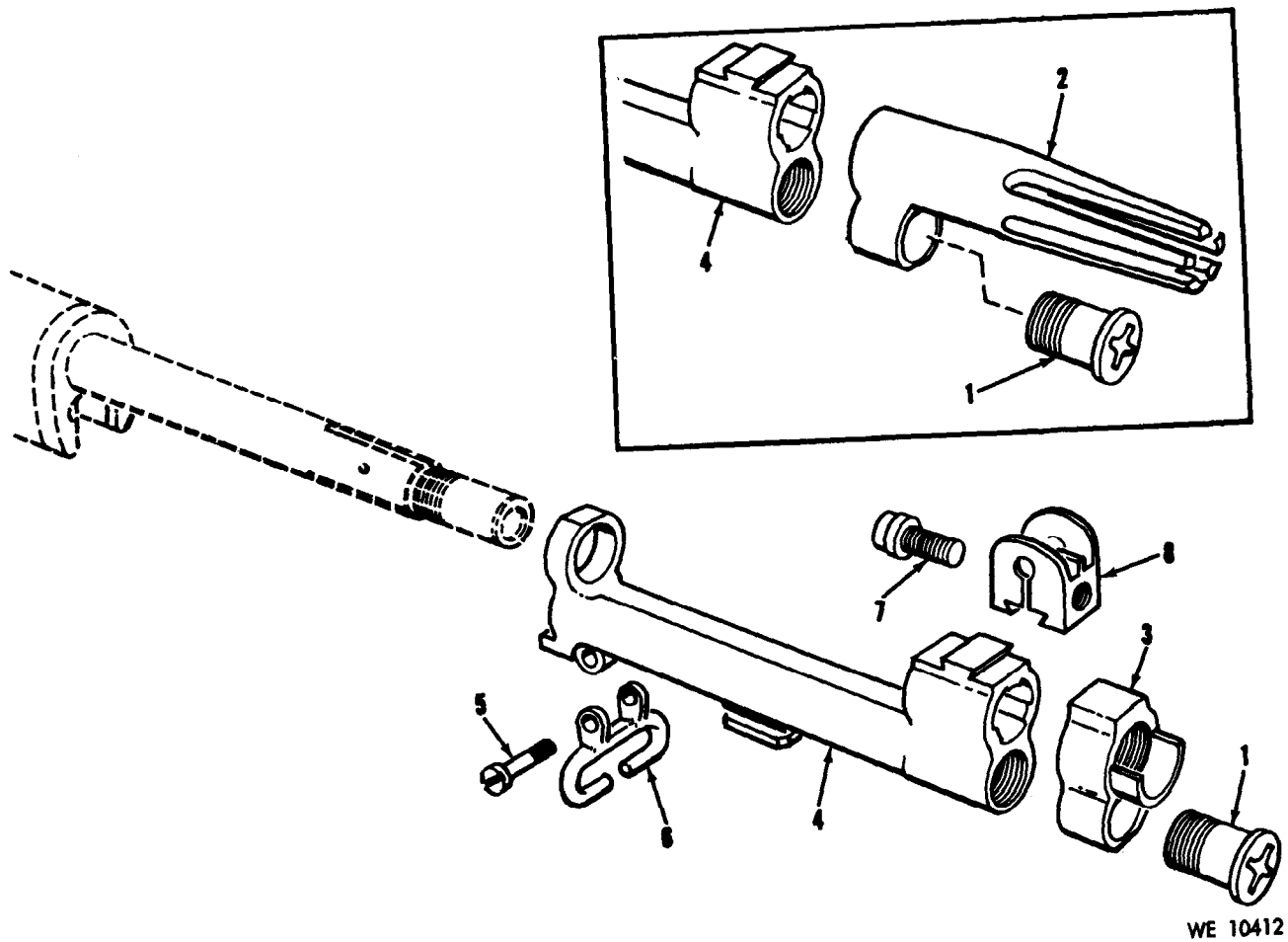
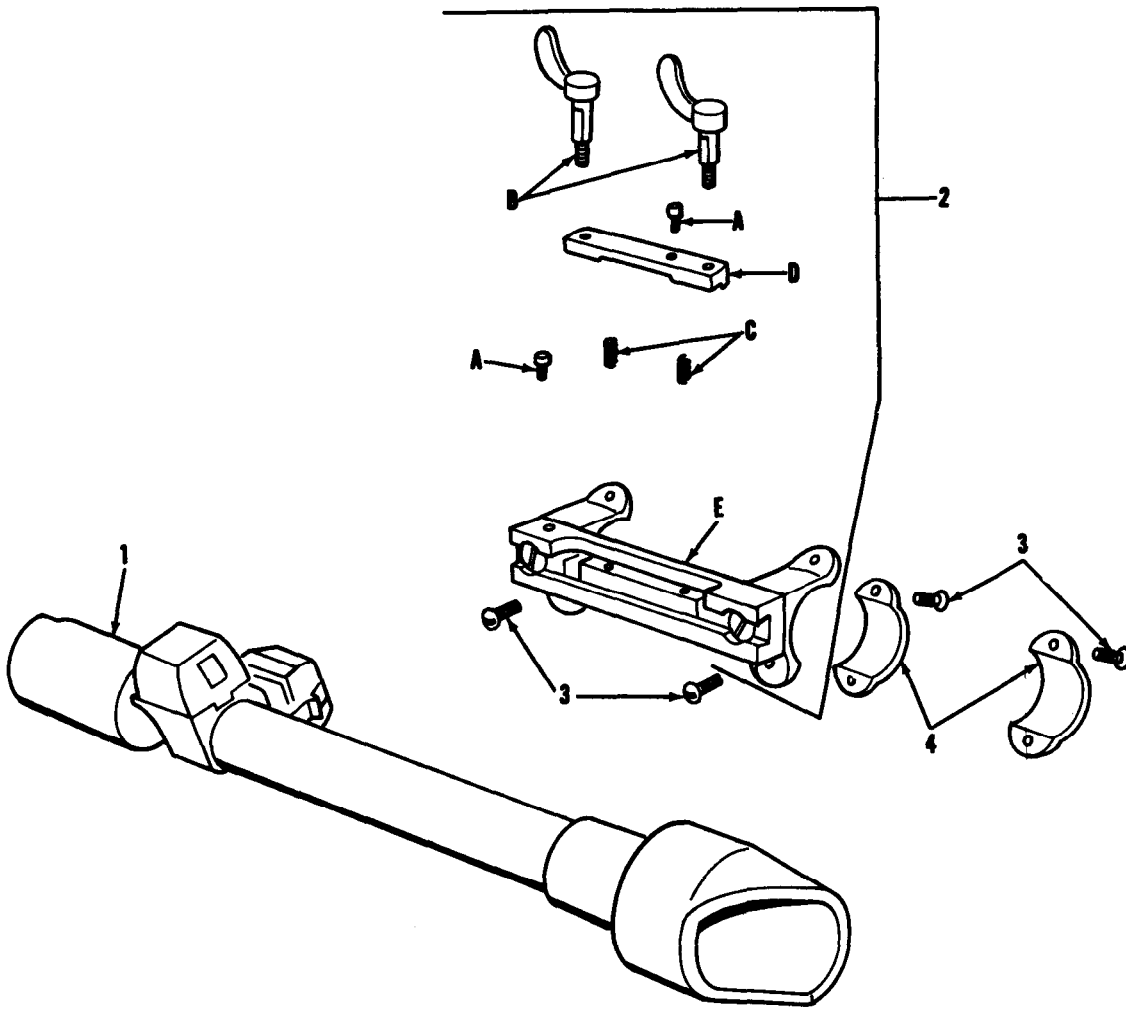

Figure 5-53. Rear sight group - exploded view.



WE 10412

Figure 5-54. Gas cylinder group - exploded view.



WE 10527

Figure 5-55. Telescope mount assembly for rifle M1C (Sniper's) - exploded view.

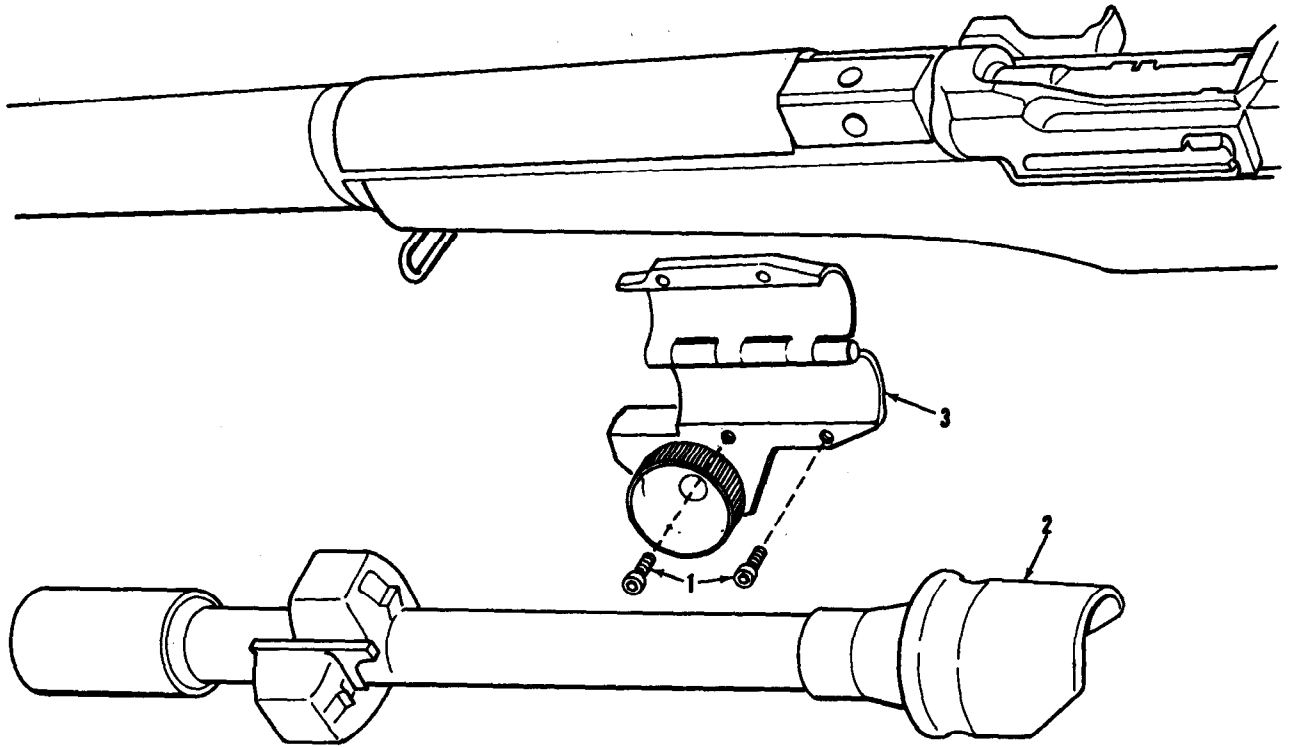

WE 12643

Figure 5-56. Telescope mounting bracket assembly for rifle M1D (Sniper's) - exploded view.

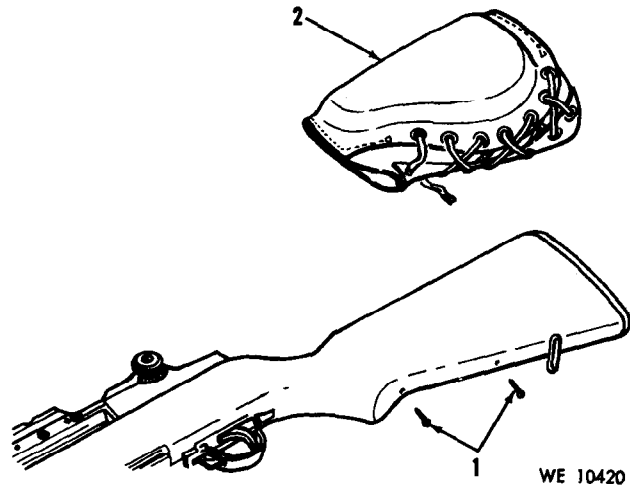

WE 10420

Figure 5-57. Cheek pad for rifles M1C and M1D (Sniper's) - exploded view.

Section II. GAGING HEADSPACE

5-2. Gaging Headspace

See figure 5-35.

Section III. TIMING RIFLE

5-3. Timing Rifle

See figure 5-36.

CHAPTER 6

FINAL INSPECTION

6-1. General

The rifles must meet the limits of serviceability as indicated by the repair standards in chapter 7. Gaging is limited to those dimensions that are critical or that may be more advantageously measured than repaired.

6-2. Visual Inspection

Overall appearance will be approx-

imately that of a new weapon. All exposed metal surfaces are to have a dull, rust resistant finish with no burs or deep scratches. Barrels must be straight, clean, free of rust, powder fouling, bulges, cracks and rings. All applicable modifications must be applied. The serial numbers must be legible.

CHAPTER 7

REPAIR STANDARDS

7-1. General

The repair standards included here in give the minimum and maximum measure-

ments of repaired parts; those beyond the limits will be replaced by new parts.

7-2. Specific

a. Bolt Assembly.

<i>Fig. No.</i>	<i>Point of Measurement</i>	<i>Repair Standards</i>	
		<i>Minimum</i>	<i>Maximum</i>
5-17.	Firing pin protrusion	0.044 in.	0.060 in. (overseas)

b. Gas Cylinder Group.

<i>Fig. No.</i>	<i>Point of Measurement</i>	<i>Repair Standards</i>	
		<i>Minimum</i>	<i>Maximum</i>
5-23.	Gas cylinder bore	0.5320 in.	—

c. Follower Group.

<i>Fig. No.</i>	<i>Point of Measurement</i>	<i>Repair Standards</i>	
		<i>Minimum</i>	<i>Maximum</i>
5-14.	Operating rod gas piston diameter	0.525 in.	—

d. Trigger Housing Assembly.

<i>Fig. No.</i>	<i>Point of Measurement</i>	<i>Repair Standards</i>	
		<i>Minimum</i>	<i>Maximum</i>
5-5.	Trigger-trigger pull	<i>M1</i>	
		5.5 lb	7.5 lb
		<i>M1C and M1D (Sniper's)</i>	
		4.5 lb	6.5 lb

e. Barrel and Receiver Group.

<i>Fig. No.</i>	<i>Point of Measurement</i>	<i>Repair Standards</i>	
		<i>Minimum</i>	<i>Maximum</i>
5-31.	Throat of chamber	0.306 in. (overseas)	0.310 in. (hands of troops)
5-32.	Barrel gas port	0.5991 in. outer (over- seas)	

CHAPTER 8

OVERHAUL PROCEDURES

8-1. General

Overhaul procedures are similar to those contained in chapter 5. Repairparts are listed in appendix II. For further details on overhaul, contact Command Gen-

eral, Headquarters, U.S. Army Weapons Command, Attn: AMSWE-SMM-SA, Rock Island Arsenal, Rock Island, Illinois 61201.

APPENDIX I

REFERENCES

A-1. Publication Indexes

Military Publications:

Index of Doctrinal, Training, and Organizational Publications.

DA Pam 310-3

Index of Supply Catalogs and Supply Manuals

DA Pam 310-6

Index of Technical Manuals, Technical Bulletins, Supply Manuals
(types 7, 8, and 9), Supply Bulletins, Lubrication Orders, and
Modification Work Orders.

DA Pam 310-4

A-2. Form

DD Form 6, Report of Damaged or Improper Shipment (cut sheet)

APPENDIX II

REPAIR PARTS AND SPECIAL TOOL LISTS

Section I. PREFACE

B-1. General

This appendix is a list of:

- a. Items authorized for initial stockage at direct and general support maintenance and supply support activities.
- b. Repair parts recommended for the overhaul of one hundred components or end items of equipment.

B-2. Explanation of Columns

a. *Source, Maintenance and Recoverability Code (Col. 1).*

- (1) *Source (col. 1a).* Source codes used in this list are:

<i>Code</i>	<i>Explanation</i>
C	Obtain through local procurement. If not obtainable from local procurement, requisition through normal supply channels with a supporting statement of nonavailability from local procurement.
P	Applies to high mortality parts.
P1	Applies to low mortality parts.
X1	Requisition next higher assembly or component.

- (2) *Maintenance level (col. 1b).* Maintenance level codes used in this list are:

<i>Code</i>	<i>Explanation</i>
O	Organizational maintenance.
F	Direct support maintenance.
H	General support maintenance.
D	Depot maintenance.

- (3) *Recoverability (col. 1c).* Recoverability codes used in this list are:

<i>Code</i>	<i>Explanation</i>
R	Items which are economically repairable at direct and general support maintenance activities are normally furnished by supply on an exchange basis. Gages will be forwarded to Gage Laboratory in accordance with SB 9-75.

<i>Code</i>	<i>Explanation</i>
T	High dollar value recoverable items which are subject to special handling and are issued on an exchange basis. Such repair parts are normally repaired or overhauled at depot maintenance activities.

- b. *15-Day Maintenance Allowance (Col. 6).*

- (1) These factors represent the estimated average quantities required to provide maintenance and supply support for 100 equipments for a 15-day period under combat conditions.
- (2) Allowance factors inclosed in parentheses are "combat essential items" and must be stocked at all times regardless of demand.
- (3) Items indicated by an asterisk (*) will not be stocked. These items are to be requisitioned as required.

c. *Depot Maintenance Guide per 100 Equipments (Col. 7).* These factors represent the estimated quantities required to overhaul 100 components or end items of equipment.

B-3. Abbreviations and Symbols

a. Abbreviations.

<i>Abbreviations</i>	<i>Explanation</i>
bbl -----	barrel
br -----	bronze
cal. -----	caliber
cone-pt -----	cone point
dia -----	diameter(s)
fil-ck-hd -----	fillister countersunk head
fil-hd -----	fillister head
fl-fil-hd -----	flat fillister head
ft -----	feet (foot)
h -----	height (high)
hd -----	head
hex -----	hexagon(al)
id -----	inside diameter
in. -----	inch(es)
lg -----	length (long)
max -----	maximum
min -----	minimum

<i>Abbreviations</i>	<i>Explanation</i>
NC -----	American National Coarse Thread
NF -----	American National Fine Thread
no. -----	number(s)
nom -----	nominal
o/a -----	over-all
phos-ctd -----	phosphate coated
phos-fin. -----	phosphate finish
rd-hd -----	round head
S -----	steel
slot-dr-----	slot drive
sq -----	square
thd -----	thread(s)(ed)
thk -----	thick(ness)
UNF -----	Unified Fine Thread
VCI -----	volatile corrosion inhibitor
w -----	wide (width)
w/ -----	with
x -----	by (used between dimensions)

b. Symbols.

<i>Symbol</i>	<i>Explanation</i>
*	Indicates repair parts which may be required to perform authorized maintenance but not authorized for stockage in the prescribed load. These parts are to be requisitioned, as required for immediate use only.
()	Allowances inclosed in parentheses are "combat essential items." These items are of a critical nature and <i>must</i> be stocked at all times.

B-4. Suggestions and Recommendations

See chapter 1, paragraph 1-1

SECTION II. REPAIR PARTS AND SPECIAL TOOL LISTS

(1) Source, maintenance, and recoverability code			(2) Federal stock No.	(3) Description	(4) Unit of issue	(5) Quantity incorporated in unit	(6) 15-Day maintenance allowance per 100 equipments		(7) Depot maintenance guide per 100 equipments	(8) Illustration	
(a) Source	(b) Maintenance level	(c) Recoverability					(a) Direct support	(b) General support		(a) Figure No.	(b) Item No.
REPAIR PARTS FOR:											
RIFLE, CALIBER .30, M1 M1C (SNIPERS) and M1D (SNIPERS)											
P1	O	---	1005-600-8868	APERTURE, SIGHT: (6008868)	20	1	(0.8)	(0.2)	10	5-53	3
P1	F	---	1005-600-8869	ARM, FOLLOWER: (6008869)	20	1	(0.4)	(0.1)	10	5-50	4
P1	F	---	1005-554-6000	BAND: lower front hand guard (5546000).	10	1	(0.2)	(0.1)	13	5-49	4
X1	---	---	-----	BARREL, MOUNT BASE AND RECEIVER ASSEMBLY: (7312563) (M1D only).	---	1	---	---	---	5-28	B
P1	D	---	1005-653-5448	BARREL, RIFLE: (6535448) (M1 and M1C only).	20	1	---	---	59	5-28	A1, C1
P1	D	---	1005-731-2553	BARREL AND MOUNT BASE ASSEMBLY: (7312553) (M1D only).	1	1	---	---	50	5-28	B1
X1	---	---	-----	BARREL AND RECEIVER ASSEMBLY: (6535464) (M1 only).	---	1	---	---	---	5-28	A
X1	---	---	-----	BARREL AND RECEIVER ASSEMBLY: (7312617) (M1C only).	---	1	---	---	---	5-28	C
				BARREL AND RECEIVER GROUP (M1).	---	---	---	---	---	1-2	9
P1	F	---	1005-554-6001	BASE: (5546001) -----	10	1	(0.4)	(0.1)	10	5-53	10
P1	F	---	1005-652-8287	BOLT, BREECH: (6528287) ---	5	1	(0.2)	(0.1)	19	5-51	4
X1	---	---	-----	BOLT ASSEMBLY: (5546023) --	---	1	---	---	---	1-2	4
										5-50	9
X1	---	---	-----	BRACKET: mount (7312600) (M1C only).	---	1	---	---	---	5-28	C5
P	F	---	1005-731-2554	BRACKET ASSEMBLY, MOUNTING: telescope mount (7312554) (M1D only).	1	1	(1.5)	(0.5)	3	1-6	2
										5-56	3
P1	D	---	1005-614-7465	CAP: (6147465) -----	20	1	---	---	5	5-49	1D4
P1	F	---	1005-554-6027	CATCH: operating rod (5546027).	20	1	(0.2)	(0.1)	10	5-50	5
X1	---	---	-----	CLAMP: (7312601) (M1C only)	---	1	---	---	---	5-55	2D
X1	---	---	-----	CLAMP: telescope support (7312602) (M1C only).	---	2	---	---	---	1-4	2
										5-55	4
P1	F	---	1005-600-8872	COVER, REAR SIGHT: (6008872).	20	1	(0.8)	(0.2)	12	5-53	5
P1	F	T	1005-653-5449	CYLINDER: (6535449) -----	10	1	(0.4)	(0.1)	25	5-54	4
P1	O	---	1005-554-6018	EJECTOR: trigger housing clip (5546018).	20	1	(0.2)	(0.1)	9	5-48	10
P1	O	---	1005-600-8616	EJECTOR, CARTRIDGE: (6008616).	20	1	(0.5)	(0.2)	13	5-51	2
P1	O	---	1005-953-9504	EXTRACTOR, CARTRIDGE: (7791578).	20	1	(0.8)	(0.2)	50	5-51	1
P1	F	---	1005-554-6013	FERRULE: (5546013) -----	20	1	0.2	0.1	8	5-49	1E3

(1) Source, maintenance, and recoverability code			(2) Federal stock No.	(3) Description	(4) Unit of issue	(5) Quantity incorporated in unit	(6) 15-Day maintenance allowance per 100 equipments		(7) Depot maintenance guide per 100 equipments	(8) Illustration	
(a) Source	(b) Maintenance level	(c) Recoverability					(a) Direct support	(b) General support		(a) Figure No.	(b) Item No.
P1	F	---	1005-554-6004	FOLLOWER: (5546004) -----	20	1	(0.2)	(0.1)	12	5-50	7A
XI	---	---	-----	FOLLOWER ASSEMBLY: (5546034).	---	1	---	---	---	5-50	7
				FOLLOWER GROUP	---	---	---	---	---	1-2	3
				GAS CYLINDER GROUP (M1 only).	---	---	---	---	---	1-2	7
P	O	---	1005-556-4245	GUARD, HAND, GUN: front (5564245).	20	1	(0.8)	(0.2)	48	5-49	2
P1	O	---	1005-554-6024	GUARD, HAND, GUN: rear (5546024) (M1 and M1C only).	20	1	(0.5)	(0.2)	55	5-49	5
P1	O	---	1005-731-2556	GUARD, HAND, GUN: rear (7312556) (M1D only).	20	1	(0.8)	(0.2)	55	1-6	6
										5-49	6
P1	F	---	1005-731-2631	GUARD, TRIGGER: trigger housing (7312631).	10	1	(0.1)	(0.1)	8	5-48	9
P1	F	---	1005-726-5215	GUIDE, BULLET: (7265215)---	10	1	(0.4)	(0.1)	27	5-50	6
				GUN HAND GUARD GROUP	---	---	---	---	---	1-2	8
P1	F	---	1005-554-6008	HAMMER: trigger housing (5546008).	10	1	(0.8)	(0.2)	12	5-48	7
P	F	---	1005-726-6434	HIDER, FLASH T37: (7266434) (M1C and M1D only).	1	1	0.8	0.2	20	5-54	2
P1	D	---	1005-652-8290	HOUSING: (6528290)-----	2	1	---	---	9	5-48	11
P1	F	---	1005-600-8883	HOUSING, HAMMER SPRING: (6008883).	20	1	(0.4)	(0.1)	10	5-48	3
XI	---	---	-----	HOUSING ASSEMBLY, TRIGGER: (6528297).	---	1	---	---	---	1-2	1
P	O	---	1005-731-2737	KNOB: windage (7312737) -----	20	1	(1.5)	(0.5)	24	5-53	1
P1	F	---	1005-554-6011	LATCH: (5546011)-----	20	1	(0.2)	(0.1)	5	5-52	2
				LATCH GROUP	---	---	---	---	---	1-2	5
P1	F	---	1005-726-5871	LOCK, GAS CYLINDER: (7265871) (M1 only).	20	1	(0.2)	(0.1)	5	5-54	3
XI	---	---	-----	MOUNT ASSEMBLY, TELESCOPE: (7312619).	---	1	---	---	---	1-4	4
P	F	---	1005-731-2621	PAD: cheek (7312621) (M1C and M1D only).	1	1	1.5	0.5	83	1-4	6
										1-6	5
										5-57	2
P1	O	---	1005-600-8879	PIN, FIRING: bolt assy (6008879).	20	1	(0.4)	(0.1)	10	5-51	4
P1	O	---	1005-501-3667	PIN, SHOULDER, HEADED: follower arm (5013667).	1	1	(0.8)	(0.2)	11	5-50	3
P	F	---	5315-058-6079	PIN, SPRING: S, phos-ctd, 1/8 dia, 1/2 lg, 0.028 thk (586079).	100	1	(2.0)	(1.0)	100	5-49	3
P	O	---	5315-501-3668	PIN, STRAIGHT, HEADED: S, fl-fil-hd, 0.187 max dia shank, 3/4 nom lg under hd (hammer) (5013668).	20	1	(1.3)	(0.4)	8	5-48	6
P1	F	---	5315-600-8878	PIN, STRAIGHT, HEADED: S, fil-hd, cone-pt end, 0.152 dia x 3.300 lg (clip latch) (6008878).	20	1	(0.2)	(0.1)	10	5-52	1

(1) Source, maintenance, and recoverability code			(2) Federal stock No.	(3) Description	(4) Unit of issue	(5) Quantity incorporated in unit	(6) 15-Day maintenance allowance per 100 equipments		(7) Depot maintenance guide per 100 equipments	(8) Illustration	
(a) Source	(b) Maintenance level	(c) Recoverability					(a) Direct support	(b) General support		(a) Figure No.	(b) Item No.
P1	D	---	5315-515-2865	PIN, STRAIGHT, HEADLESS: dowel, S, 0.126 x 100 (butt plate) (5152865).	20	1	---	---	3	5-49	1D1
P1	D	---	5315-731-2603	PIN, TAPERED, PLAIN: S, 0.149 dia, 7/16 lg, (mount bracket) (7312603) (M1C only).	10	2	---	---	200	5-28	C4
P	O	---	1005-819-4501	PIN, TRIGGER: (7791367) ----	20	1	(1.5)	(0.5)	24	5-48	1
P	O	---	1005-731-2738	PINION: elevating (7312738) ----	20	1	(1.5)	(0.5)	75	5-53	2
XI	---	---	-----	PLATE: butt (5564277) ----	---	1	---	---	---	5-49	1D5
P1	H	---	1005-556-4283	PLATE, BUTT, SHOULDER GUN STOCK: (5564283).	10	1	---	0.5	5	5-49	1D
P1	D	---	1005-515-2864	PLUNGER, BUTT PLATE: (5152864).	20	1	---	---	5	5-49	1D2
P1	O	---	1005-600-8618	PLUNGER, EXTRACTOR SPRING: (6008618).	20	1	(0.8)	(0.2)	12	5-51	3
P1	F	---	1005-600-8880	PLUNGER, HAMMER SPRING: (6008880).	20	1	(0.2)	(0.1)	4	5-48	5
XI	---	---	-----	REAR SIGHT GROUP-----	---	---	---	---	---	1-2	6
XI	---	---	-----	RECEIVER: (6528291) (M1 and M1D only).	---	1	---	---	---	5-28	A2, B2
XI	---	---	-----	RECEIVER: (7312604) (M1C only).	---	1	---	---	---	5-28	C2
XI	---	---	-----	RIFLE -----	---	---	---	---	---	1-4	7
P1	F	---	1005-556-4331	ROD: (5564331) -----	20	1	(0.4)	(0.1)	25	5-50	2
P1	F	T	1005-711-6203	ROD ASSEMBLY, OPERATING: (7790722).	25	1	(0.5)	(0.2)	7	5-50	8
P1	F	---	1005-554-6015	SAFETY, SMALL ARMS: trigger housing (5546015).	20	1	(0.4)	(0.1)	10	5-48	8
P1	O	---	1005-313-9441	SCREW: gas cylinder lock (7267797).	20	1	(0.8)	(0.2)	62	5-54	1
XI	---	---	-----	SCREW: locking, clamp (7312606) (M1C only).	---	2	---	---	---	5-55	2A
P1	F	---	1005-614-6873	SCREW, BUTT PLATE, SMALL: (6146873).	20	1	0.8	0.2	5	5-49	1C
P1	D	---	5305-731-2607	SCREW, CAP, SOCKET HEAD: S, phos-fin., fl-fil-hd, no. 10 (0.190)-32NF-3 x 9/32 lg (mount bracket) (7312607) (M1C only)	10	3	---	---	50	5-28	C3
C	F	---	5305-983-6649	SCREW, CAP, SOCKET HEAD: S, phos-fin., no. 6 (0.138)-40NF-3A full thd, fl-fil-hd, 0.138 max h x 0.226 max dia, 3/8 lg under hd, 3/32 hex socket (hinge locking) (96906-35460-2) (M1D only).	10	2	0.8	0.2	10	1-6 5-56	1 1

(1) Source, maintenance, and recoverability code			(2) Federal stock No.	(3) Description	(4) Unit of issue	(5) Quantity incorporated in unit	(6) 15-Day maintenance allowance per 100 equipments		(7) Depot maintenance guide per 100 equipments	(8) Illustration	
(a) Source	(b) Maintenance level	(c) Recoverability					(a) Direct support	(b) General support		(a) Figure No.	(b) Item No.
P1	F	---	5305-269-6419	SCREW, CAP, SOCKET HEAD: S, phos-ctd, fl-fil-hd, hex socket, 1/4-28UNF-3A x 1/2 (front sight) (96906-35460-21).	100	1	(0.4)	(0.1)	15	5-54	7
P1	O	---	5305-501-3678	SCREW, MACHINE: S, fil-hd, no. 10 (0.190)-32NF-2 x 0.700 max lg (stacking swivel) (5013678).	20	1	0.4	0.1	45	5-54	5
P1	F	---	5305-501-3677	SCREW, MACHINE: S, fil-hd, no. 10 (0.190)-32NF-2 x 0.520 max lg (stock ferrule) (5013677).	20	1	0.2	0.1	18	5-49	1E1
P1	F	---	5305-600-8881	SCREW, MACHINE: S, phos-ctd, fil-ck-hd, slot drive, no. 12 (0.216)-28NF-2A, 3.171 lg (butt swivel) (6008881).	20	1	0.5	0.2	12	5-49	1A
P1	D	---	5305-731-2615	SCREW, MACHINE: S, phos-fin., fl-fil-hd, no. 2 (0.086)-56NC-3 (7312615) (M1C only).	10	2	---	---	2	5-55	2B
P1	F	---	5305-013-0611	SCREW, WOOD: rd-hd, br, slot dr, no. 7 (0.151) nom dia, 1/2 lg (130611) (M1C and M1D only).	100	2	0.4	0.1	10	1-4 1-6 5-57	5 4 1
P1	D	---	5305-731-2623	SETSCREW: S, phos-fin., fil-hd, no. 6 (0.138)-40NF-3 x 13/32 lg (support clamp) (7312623) (M1C only).	10	4	---	---	6	1-4 5-55	1 3
P1	F	---	1005-614-7427	SIGHT, FRONT: (6147427) ----	20	1	(0.2)	(0.1)	12	5-54	8
P1	F	---	1005-554-6017	SLIDE: (5546017)-----	20	1	(0.2)	(0.1)	10	5-50	7B
				SLIDE CLAMP GROUP (M1C only).	---	---	---	---	---	5-55	2E
X1	---	---	-----	SLIDE ASSEMBLY: mount bracket (7312618) (M1C only).	---	1	---	---	---	5-55	2
P1	D	---	1005-731-2614	SPRING, HELICAL, COMPRESSION: 6 coils, slide clamp (7312614) (M1C only).	10	2	---	---	4	5-55	2C
P1	O	---	1005-600-8885	SPRING, HELICAL, COMPRESSION: 6-7/8 coils, clip latch (6008885).	20	1	(0.4)	(0.1)	15	5-52	3
P1	D	---	1005-515-2863	SPRING, HELICAL, COMPRESSION: 8 coils, butt plate plunger (5152863).	20	1	---	---	57	5-49	1D3
P	O	---	1005-600-8887	SPRING, HELICAL, COMPRESSION: 20 coils, hammer (6008887).	20	1	(1.0)	(0.3)	12	5-48	4
P1	O	---	1005-614-7568	SPRING, HELICAL, COMPRESSION: 200 total coils, operating rod (6147568).	20	1	(0.4)	(0.1)	46	5-50	1
X1	---	---	-----	STOCK: (6535466)-----	---	1	---	---	---	5-49	1E4

(1) Source, maintenance, and recoverability code			(2) Federal stock No.	(3) Description	(4) Unit of issue	(5) Quantity incorporated in unit	(6) 15-Day maintenance allowance per 100 equipments		(7) Depot maintenance guide per 100 equipments	(8) Illustration	
(a) Source	(b) Maintenance level	(c) Recoverability					(a) Direct support	(b) General support		(a) Figure No.	(b) Item No.
P1	F	---	1005-653-5467	STOCK, GUN SHOULDER: (6535467).	20	1	(0.4)	(0.1)	35	5-49	1E
XI	---	---	-----	STOCK ASSEMBLY (6535468) --	---	1	---	---	---	1-2	2
P1	F	---	1005-600-8889	SWIVEL: stock (6008889)-----	10	1	0.4	0.1	10	5-49	1B
P1	O	---	1005-600-8891	SWIVEL, STACKING: gas cylinder (6008891).	20	1	0.8	0.2	20	5-54	6
P1	F	---	1005-600-8890	SWIVEL, STOCK: (6008890)---	20	1	0.4	0.1	3	5-49	1E2
P1	H	R	1240-759-7774	TELESCOPE: M84 (7597774) (M1C and M1D only).	1	1	---	(1.0)	4	1-4	3
										1-6	3
										5-55	1
										5-56	2
P1	O	---	1005-554-6026	TRIGGER: trigger housing (5546026).	20	1	(0.2)	(0.1)	10	5-48	2
				KIT, WINTER TRIGGER:							
XI	---	---	-----	LEVER: (7791211) -----	---	---	---	---	---	B-1	1C
P1	O	---	1005-778-0580	SAFETY, WINTER: (7790903)	1	---	(0.4)	---	---	B-1	2
P1	O	---	5305-990-6435	SCREW, TAPPING, THREAD FORMING: (7791415)	2	2	(0.8)	---	---	B-1	1A
P1	O	---	1005-775-0364	TRIGGER ASSEMBLY, WINTER: M5 (7790808)	1	1	(0.4)	---	---	B-1	1
P1	O	---	1005-010-5022	WASHER, HINGE RETAINING: trigger assembly (7791237)	10	1	(0.1)	---	---	B-1	1B
				MATERIAL FOR REPAIR OF WOODEN COMPONENTS							
P	H	---	1005-523-3523	SCREW: (5233523) -----	20	---	---	*	*	-	-
P1	H	---	1005-719-0954	SCREW, STOCK REPAIR, SMALL: br (7190954)	10	---	---	*	*	-	-
				SPECIAL PACKAGING MATERIAL							
				The volatile corrosion in- hibitor listed below is required when the Major Item is packaged for storage purposes.							
			1005-336-0211	BAG, BARRIER, VCI TREATED: (7265933)	50	---	---	---	100	-	-
			1005-018-3254	CAP, REAR SIGHT ELEVATING KNOB: (7791345)	10	---	---	---	100	-	-
			1005-875-9765	PROTECTOR, HANDLE: (7790231)	100	---	---	---	100	-	-
			1005-875-9767	PROTECTOR, MUZZLE: plastic (7791037)	100	---	---	---	100	-	-
			1005-336-0212	TUBE, BORE, VCI TREATED: (7266316)	500	---	---	---	100	-	-

(1) Source, maintenance, and recoverability code			(2) Federal stock No.	(3) Description	(4) Unit of issue	(5) Quantity incorporated in unit	(6) 15-Day maintenance allowance per 100 equipments		(7) Depot maintenance guide per 100 equipments	(8) Illustration	
(a) Source	(b) Maintenance level	(c) Recoverability					(a) Direct support	(b) General support		(a) Figure No.	(b) Item No.
				TOOLS AND EQUIPMENT AUTHORIZED FOR UNIT REPLACEMENT							
				RIFLE, CALIBER .30, M1, M1C (SNIPERS) and M1D (SNIPERS)							
			1005-556-4174	BRUSH, CLEANING, SMALL ARMS: bore (5564174)	10	---	-	---	---	-	-
			1005-691-1381	BRUSH, CLEANING, SMALL ARMS: chamber (7790582)	10	---	-	---	---	-	-
			1005-694-1662	BUFFER, CLEANING ROD: (7268275)	100	---	-	---	---	-	-
			1240-763-1596	CASE, TELESCOPE: M84 (7631596) (M1C and M1D only)	10	---	-	---	---	-	-
			1005-791-3377	CASE, LUBRICANT: (7790995)	72	---	-	---	---	-	-
			1005-650-4510	CASE, SMALL ARMS CLEANING ROD: (7267754)	10	---	-	---	---	-	-
			1005-722-8907	ENVELOPE: fabric, 2-button, 3 h x 4-7/8 w (7228907)	10	---	-	---	---	-	-
			4933-652-9950	EXTRACTOR, RUPTURED CARTRIDGE CASE: (7790352)	1	---	-	---	---	-	-
			1005-793-8761	HANDLE ASSEMBLY: cleaning rod (7266115)	1	---	-	---	---	-	-
			4933-628-9700	REFLECTOR, GUN BARREL: (7790138)	1	---	-	---	---	-	-
			1005-726-8109	ROD SECTION, CLEANING, SMALL ARMS: (7266109)	10	---	-	---	---	-	-
			1005-654-4058	SLING, SMALL ARMS: M1 webbing (6544058)	10	---	-	---	---	-	-
			1005-288-3565	SWAB, SMALL ARMS CLEANING: cotton, 2-1/2 sq (1000 in pkg) (5019316)	1	---	-	---	---	-	-
			1005-726-8110	SWAB HOLDER SECTION, SMALL ARMS CLEANING ROD: (7266110)	10	---	-	---	---	-	-
				SPECIAL TOOLS AND EQUIPMENT							
				The 15-day level is not applicable.							
				The following items are requisitioned and issued, if not otherwise authorized, to Maintenance units performing direct and general support maintenance of the major items. Items may be requisitioned as required for replacement under their individual stock numbers.							

(1) Source, maintenance, and recoverability code			(2) Federal stock No.	(3) Description	(4) Unit of issue	(5) Quantity incorporated in unit	(6) 15-Day maintenance allowance per 100 equipments		(7) Depot maintenance guide per 100 equipments	(8) Illustration	
(a) Source	(b) Maintenance level	(c) Recoverability					(a) Direct support	(b) General support		(a) Figure No.	(b) Item No.
		R	4933-726-5849	TOOL SET, DIRECT AND GENERAL SUPPORT MAINTENANCE: (7265849) (for cal. .30 rifle M1 Series) CONSISTING OF:	1	---	*	*			
		R	4933-604-6302	1-BOLT, FIELD TEST: (6046302)	1	---	---	---		B-3	3
		R	4933-556-4343	1-GAGE, BREECH BORE: (5564343)	1	---	---	---		B-4	2
		R	4933-345-6122	3-GAGE, FIRING PIN PROTRUSION: min 0.044, max 0.059 (7274736)	1	---	---	---		B-3	5
		R	4933-398-4108	1-GAGE, HEADSPACE: (1.950) (7319954)	1	---	---	---		B-4	3
		R	4933-731-9919	1-GAGE, PLUG, GAS CYLINDER, DIAMETER: (7319919)	1	---	---	---		B-3	4
		R	4933-897-6706	1-GAGE, RECEIVER: (7799709)	1	---	---	---		B-4	1
		R	5220-731-9918	1-GAGE, RING, PLAIN: no-go, 0.5991 id (7319918)	1	---	---	---		B-3	6
		R	5220-731-9911	1-GAGE, SNAP, PLAIN ADJUSTABLE: no-go 0.525 id (7319911)	1	---	---	---		B-3	7
		R	4933-731-9920	1-GAGE, TIMING: (7319920)---	1	---	---	---		B-3	1
			5140-652-8243	1-TOOL BOX, PORTABLE: w/tray, 7 h, 7w, 16 lg (41-C-853) The following Basic Small Arms Direct and General Support Maintenance Tool Set is authorized, as required, to all Maintenance Support Units with a Small Arms Repair Mission.	1	---	---	---		B-2	-
		R	4933-775-0366	TOOL SET, DIRECT AND GENERAL SUPPORT MAINTENANCE, BASIC SMALL ARMS: (8426358) NOTE: See SC 4933-95-CL-E04 components.	1						
		R	4933-726-5848	TOOL SET, DEPOT MAINTENANCE: (7265848) (for cal. .30 rifle M1 Series) CONSISTING OF:	1	---	---	---	*		
		R	4933-604-6302	1-BOLT, FIELD TEST: (6046302)	1	---	---	---		B-3	3

(1) Source, maintenance, and recoverability code			(2)	(3)	(4)	(5)	(6) 15-Day maintenance allowance per 100 equipments		(7)	(8) Illustration	
(a) Source	(b) Maintenance level	(c) Recoverability	Federal stock No.	Description	Unit of issue	Quantity incorporated in unit	(a) Direct support	(b) General support	Depot maintenance guide per 100 equipments	(a) Figure No.	(b) Item No.
		R	4933-659-5353	1-FIXTURE, ASSEMBLING, BARREL AND RECEIVER: (6595353)	1	---	---	---	---	B-5	1
		R	4933-666-1055	3-FIXTURE, ASSEMBLING, EJECTOR: (6661055)	1	---	---	---	---	B-6	4
		R	4933-713-7938	1-FIXTURE, BARREL AND RECEIVER: (7137938)	1	---	---	---	---	B-5	3
		R	4933-556-4343	1-GAGE, BREECHBORE: (5564343)	1	---	---	---	---	B-4	2
		R	4933-345-6122	3-GAGE, FIRING PIN PROTRUSION: min 0.044, max 0.059 (7274736)	1	---	---	---	---	B-3	5
		R	4933-731-9904	1-GAGE, GAS CYLINDER CHECK: cal. .30 (7319904)	1	---	---	---	---	B-6	3
		R	4933-398-4106	2-GAGE, HEADSPACE: 1.940 (7319944)	1	---	---	---	---	B-3	2
		R	4933-398-4107	2-GAGE, HEADSPACE: 1.946 (7319950)	1	---	---	---	---	B-6	5
		R	4933-731-9933	3-GAGE, LOCATING, LOCKING LUGS: (7319933)	1	---	---	---	---	B-7	2
		R	4933-731-9919	3-GAGE, PLUG, GAS CYLINDER DIAMETER: (7319919)	1	---	---	---	---	B-3	4
		R	4933-731-8620	3-GAGE, PLUG, THREAD, RECEIVER: (7318620)	1	---	---	---	---	B-6	1
		R	4933-015-6689	1-GAGE, RECEIVER: bridge location (7799737)	1	---	---	---	---	-	-
		R	4933-966-9316	3-GAGE, RING, PLAIN: no go, 0.5993 id (7799727)	1	---	---	---	---	B-3	6
		R	5220-731-9911	3-GAGE, SNAP, PLAIN ADJUSTABLE: no-go, 0.525 id (7319911)	1	---	---	---	---	B-3	7
		R	4933-731-9920	3-GAGE, TIMING: (7319920)---	1	---	---	---	---	B-3	1
		R	4933-604-5949	3-GAGE ASSEMBLY: aligning bbl, w/pin (6045949)	1	---	---	---	---	B-6	2
			4933-714-2269	1-JAW, REAMER ASSEMBLY, HEADSPACE: (7142269)	1	---	---	---	---	B-7	1A
		R	4933-714-2262	3-REAMER, HEADSPACE: (7142262)	1	---	---	---	---	B-7	1
			4933-714-2263	1-REAMER, REAMER ASSEMBLY HEADSPACE: 0.441 dia of flutes, 2-11/16 o/a lg (7142263)	1	---	---	---	---	B-7	1B
		R	4933-713-7939	1-WRENCH, BARREL AND RECEIVER: (7137939)	1	---	---	---	---	B-5	4
			4933-631-6048	3-WRENCH ASSEMBLY, GAS CYLINDER LOCK: (6316048)	1	---	---	---	---	B-5	2

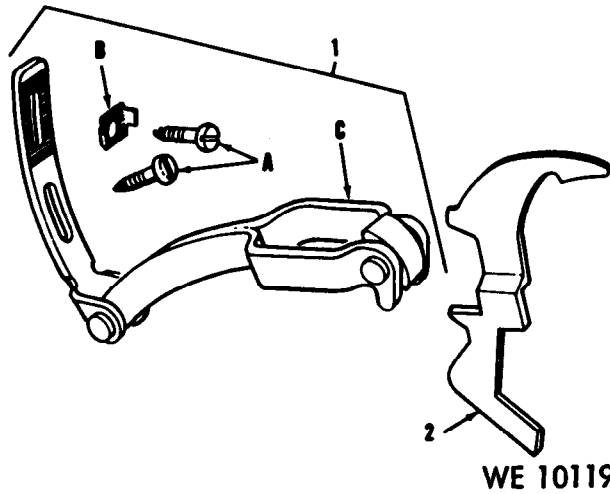

WE 10119

*Figure B-1. Winter trigger kit 5910520-
exploded view.*

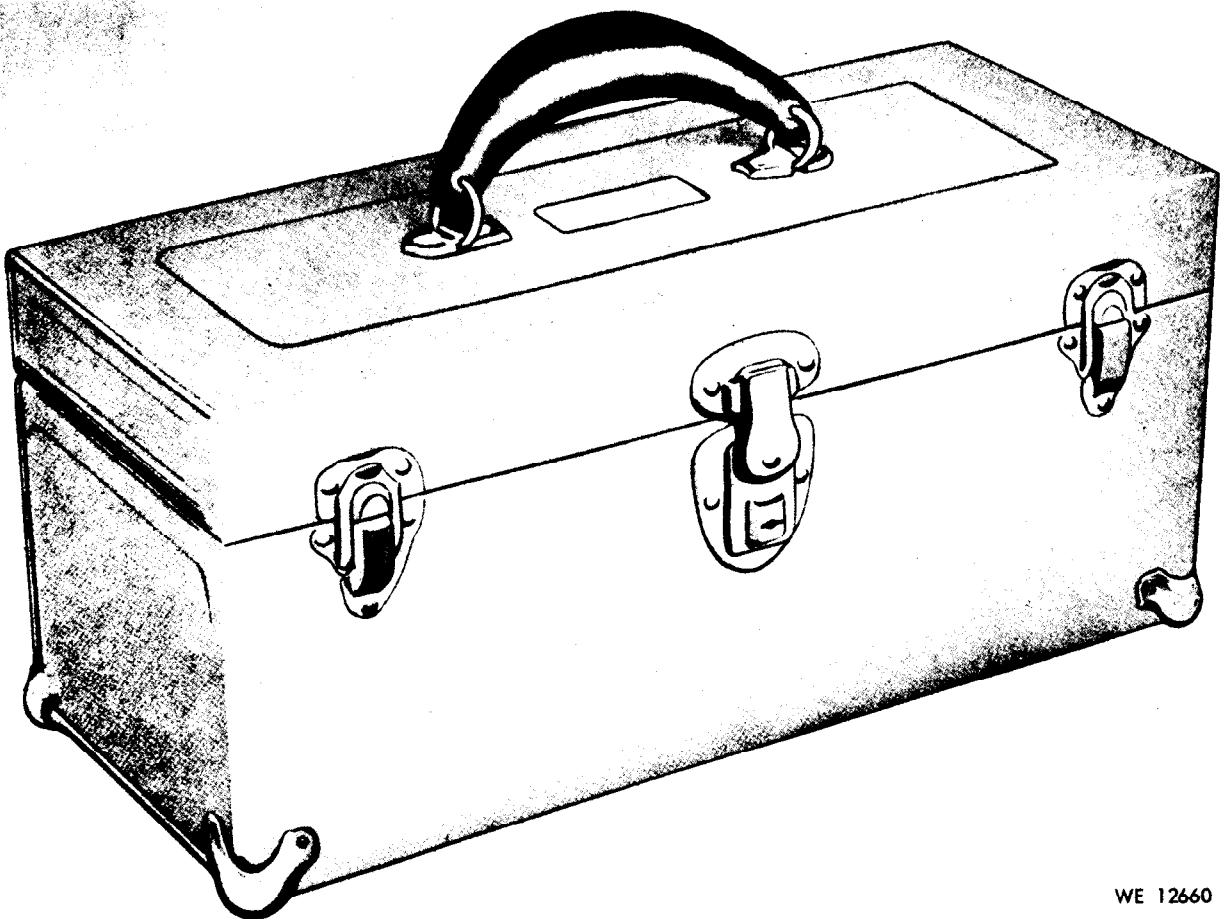

WE 12660

Figure B-2. Tool box 41-C-863.

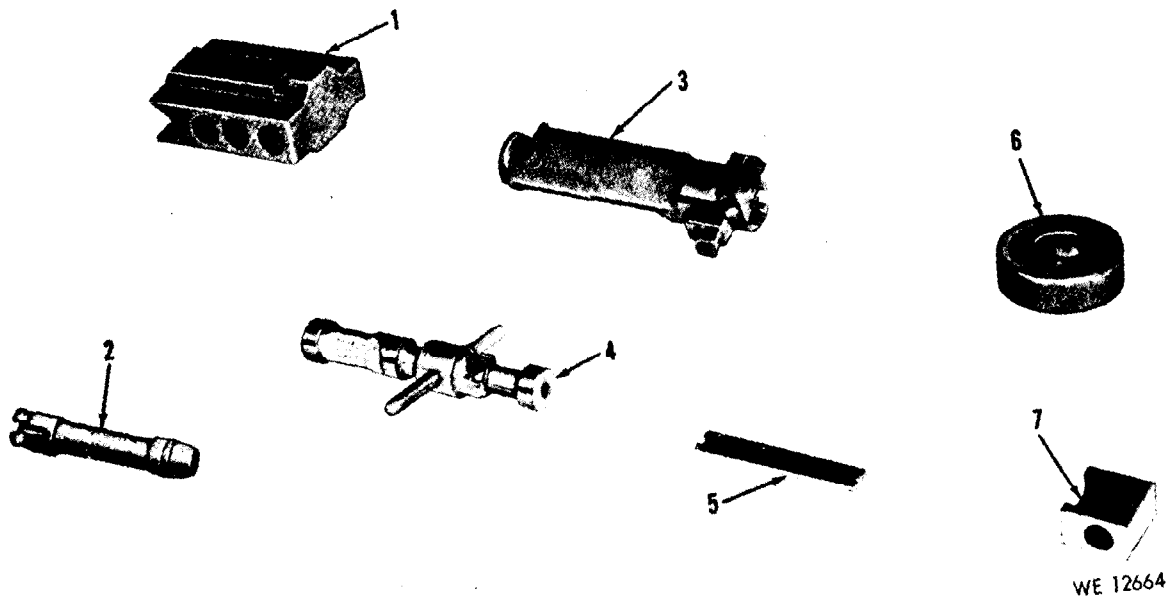

Figure B-3. Special tools and equipment.

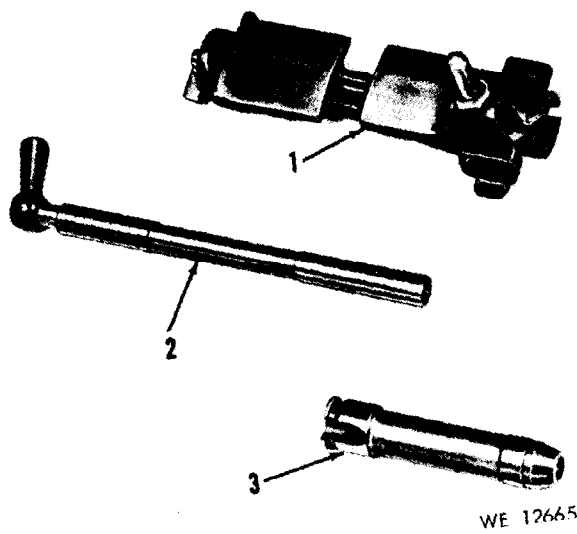
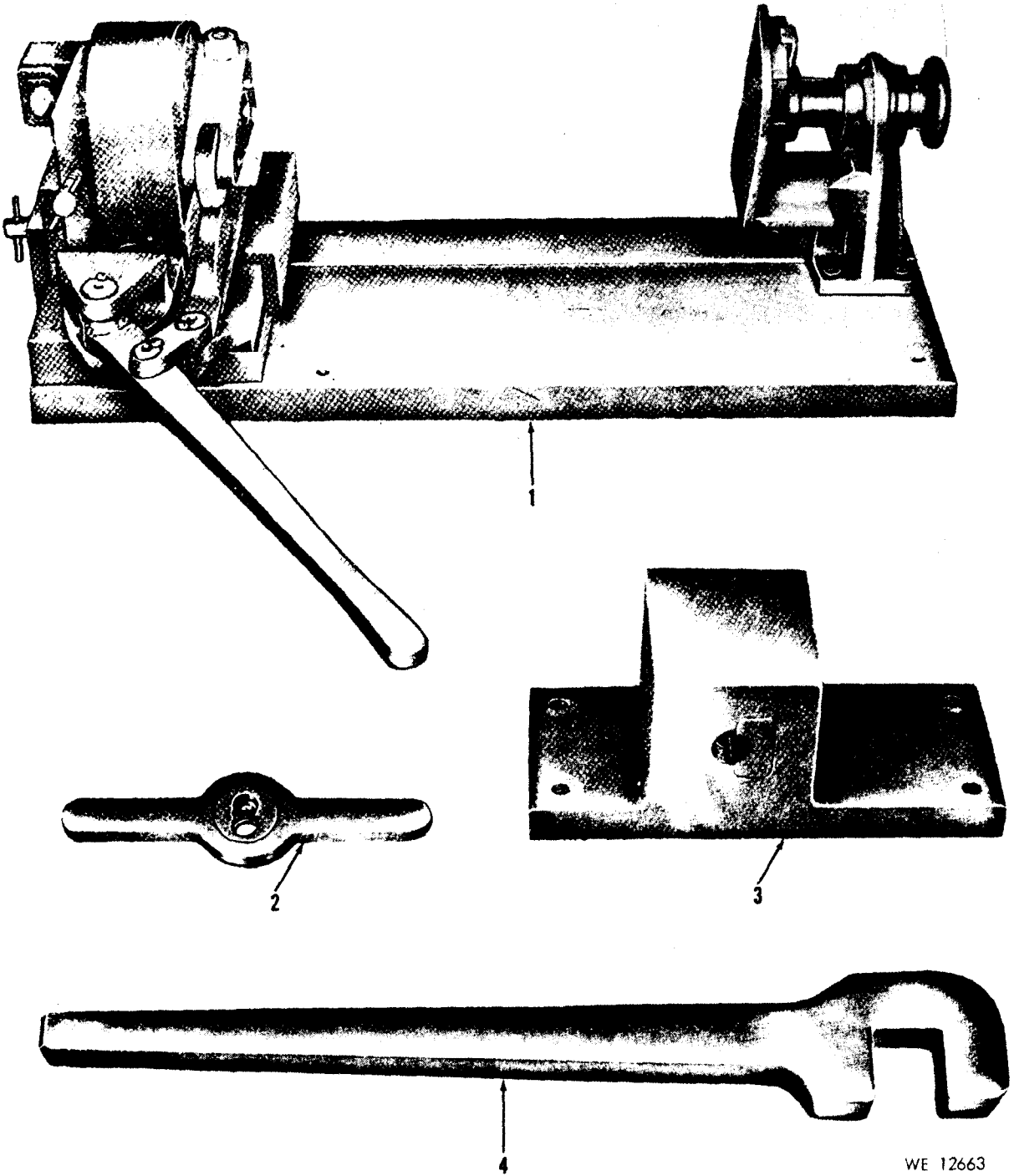
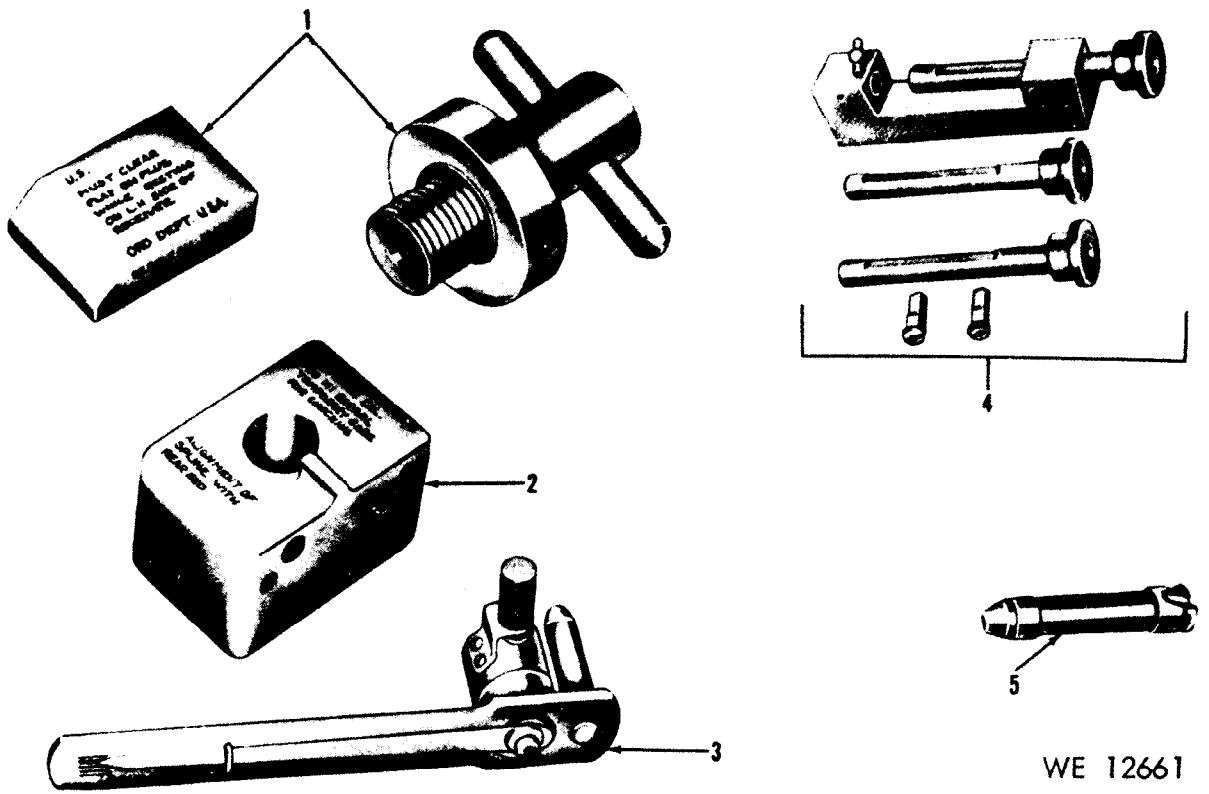

Figure B-4. Special tools and equipment.



WE 12663

Figure B-5. Special tools and equipment.



WE 12661

Figure B-6. Special tools and equipment.

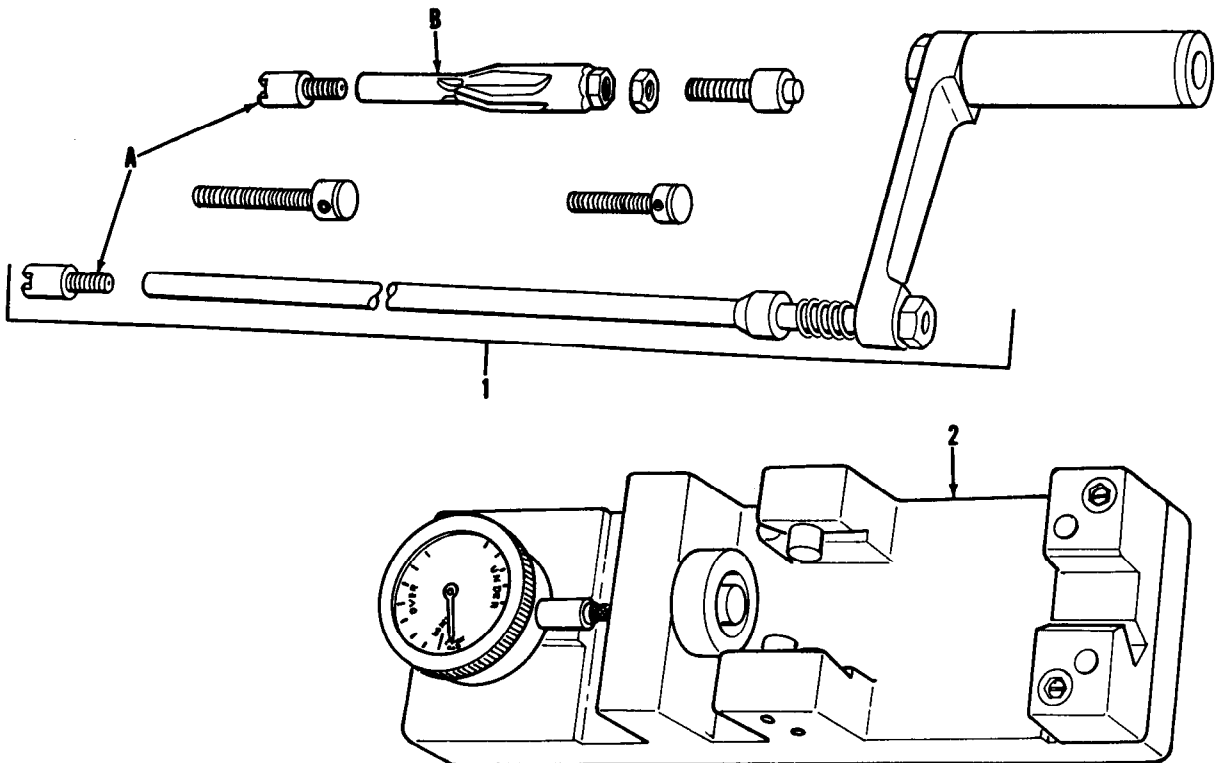

WE 12662

Figure B-7. Special tools and equipment.

By Order of the Secretary of the Army:

HAROLD K. JOHNSON,
General, United States Army,
Chief of Staff.

Official:

J. C. LAMBERT,
Major General, United States Army,
The Adjutant General.

Distribution:

To be distributed in accordance with DA Form 12-40 requirements for Direct and General Support Maintenance for Rifles, Caliber .30, M1, M1C and M1D.