

# FM 44-62

DEPARTMENT OF THE ARMY FIELD MANUAL

---

## AIR DEFENSE ARTILLERY AUTOMATIC WEAPON GUNNERY



HEADQUARTERS, DEPARTMENT OF THE ARMY  
AUGUST 1969

**AIR DEFENSE ARTILLERY AUTOMATIC WEAPON GUNNERY**

		Paragraph	Page
Chapter	<b>1. INTRODUCTION</b>		
	Purpose and scope .....	1-1	1-1
	Recommended changes and comments .....	1-2	1-1
	References, symbols, and terms .....	1-3	1-1
	<b>2. AUTOMATIC WEAPON GUNNERY PROBLEM</b>		
Section	<b>I. INTRODUCTION</b>		
	General .....	2-1	2-1
	Slant plane concept .....	2-2	2-1
	<b>II. Elements of data</b>		
	General .....	2-3	2-2
	Planes .....	2-4	2-2
	Points .....	2-5	2-2
	Lines .....	2-6	2-3
	Angles .....	2-7	2-4
	<b>III. Solution of the problem</b>		
	General .....	2-8	2-4
	Gunnery chain .....	2-9	2-4
	Requirements for a hit .....	2-10	2-5
	<b>IV. General application of problem</b>		
	General .....	2-11	2-10
	The four links of the gunnery chain .....	2-12	2-10
Chapter	<b>3. TRACER OBSERVATION</b>		
	General .....	3-1	3-1
	Basic principles .....	3-2	3-2
	Observation at the gun, crossing course .....	3-3	3-3
	Observation at the gun, incoming course .....	3-4	3-4
	Observation at the gun, outgoing course .....	3-5	3-4
	Observation at the gun, nonlevel crossing course .....	3-6	3-5
	Observation at the gun, directly-at-the-gun course .....	3-7	3-5
	Downcourse observation .....	3-8	3-7
Chapter	<b>4. AUTOMATIC WEAPON SIGHTING SYSTEMS</b>		
Section	<b>I. Speed ring sights</b>		
	Basic principles .....	4-1	4-1
	Speed ring sight used with 40-mm gun M2A1 .....	4-2	4-1
	Reflex sight M18 .....	4-3	4-2
	Gunnery chain, speed ring sights .....	4-4	4-2
	Adjustments for a hit .....	4-5	4-5
	Speed ring sight engagement technique .....	4-6	4-6
	<b>II. Computing sight M38</b>		
	General .....	4-7	4-9
	Operation and functioning .....	4-8	4-9
	Establishing the gunnery chain with computing sight M38 .....	4-9	4-12
	<b>III. Computing sight XM61</b>		
	General .....	4-10	4-15
	Operation and functioning .....	4-11	4-15
	Establishing the gunnery chain .....	4-12	4-18

\*This manual supersedes FM 44-62, 26 September 1964.

		Paragraph	Page
<b>Chapter</b>	<b>5. SURFACE FIRING</b>		
<b>Section</b>	<b>I. Introduction</b>		
	General .....	5-1	5-1
	Basic elements of data .....	5-2	5-1
<b>Section</b>	<b>II. Direct fire</b>		
	General procedure .....	5-3	5-1
	Specific direct fire methods .....	5-4	5-1
	<b>III. Indirect fire</b>		
	General .....	5-5	5-3
	Indirect fire positions .....	5-6	5-3
	Orientation .....	5-7	5-5
	Adjusting the sheaf .....	5-8	5-5
	Direct command procedure .....	5-9	5-6
	Target grid procedure .....	5-10	5-7
	<b>IV. Miscellaneous</b>		
	Harassing and interdiction fire .....	5-11	5-9
	Ballistics .....	5-12	5-10
	Registration .....	5-13	5-10
	Range cards .....	5-14	5-10
<b>Appendix</b>	<b>A. REFERENCES</b> .....		A-1
	<b>B. GLOSSARY OF AIR DEFENSE ARTILLERY AUTOMATIC WEAPON SYMBOLS AND TERMS</b> .....		B-1
	<b>C. PREPARATION OF M55 FOR INDIRECT FIRE</b> .....		C-1

## CHAPTER 1

### INTRODUCTION

---

#### 1-1. Purpose and Scope

a. This manual is a guide to the gunnery techniques used by air defense artillery automatic weapon units. Written primarily for air defense artillery automatic weapon commanders and leaders, its content is applicable to all persons concerned with air defense artillery (ADA) automatic weapon (AW) gunnery.

b. This manual contains discussions of the ADA AW gunnery problem and its solution, tracer observation, sighting systems used with the weapons, and procedures for firing against surface targets.

c. The material contained herein is applicable to both nuclear and nonnuclear warfare.

d. The term, ADA AW, as used in this manual, refers to the twin 40-mm, self-propelled gun M42; the multiple caliber .50 machinegun trailer mount M55; and the self-propelled and towed Vulcan weapon systems. These weapons are re-

ferred to in the manual as the M42, M55, and Vulcan.

#### 1-2. Recommended Changes and Comments

Users are encouraged to submit recommended changes and comments to improve this manual. Comments should be keyed to the specific page, paragraph, and line of the text in which the change is recommended. Reasons will be provided for each comment to insure understanding and complete evaluation. Comments should be prepared using DA Form 2028 (Recommended Changes to DA Publications) and forwarded direct to Commandant, U.S. Army Air Defense School, ATTN: AKBAA-S-DL, Fort Bliss, Texas 79916.

#### 1-3. References, Symbols, and Terms

Appendix A lists reference material that supplements this manual. Symbols and terms peculiar to ADA AW are listed in appendix B.

## CHAPTER 2

## AUTOMATIC WEAPON GUNNERY PROBLEM

## 2-1. General

Basically, the ADA AW gunnery problem is one of predicting the future position of the target and firing so that projectile and target arrive at that position simultaneously. The sights of AW systems are designed to aid gunners in solving this problem. The solution of the ADA AW gunnery problem is based on certain assumptions. It is assumed that the target will fly a straight course during engagement, that it will maintain its present speed during engagement, and that the closest it will come to the gun during its flight is a distance (midpoint slant range) fixed by the target's present course.

## 2-2. Slant Plane Concept

To facilitate understanding of the ADA AW gunnery problem and the sighting devices used in its solution, a geometric approach known as the

slant plane concept has been developed. The future position of the target is located in an imaginary tilted surface, or slant plane, containing the gun, the present position of the target, and the future position of the target (fig. 2-1). To hit the target, the projectile must be fired at a point in space ahead of the present position of the target. The elevation and azimuth angles of that point are different from those of the present position. The differences between present target position elevation and azimuth and the elevation and azimuth at which the gun must be fired to get a hit are the elevation and azimuth lead angles, and they lie in the vertical and horizontal planes, respectively. The slant plane concept is a simplified approach that resolves these two lead angles into a single lead angle in an imaginary slant plane. The only other requirement to obtain a hit is to add superelevation to allow for the effect of gravity.

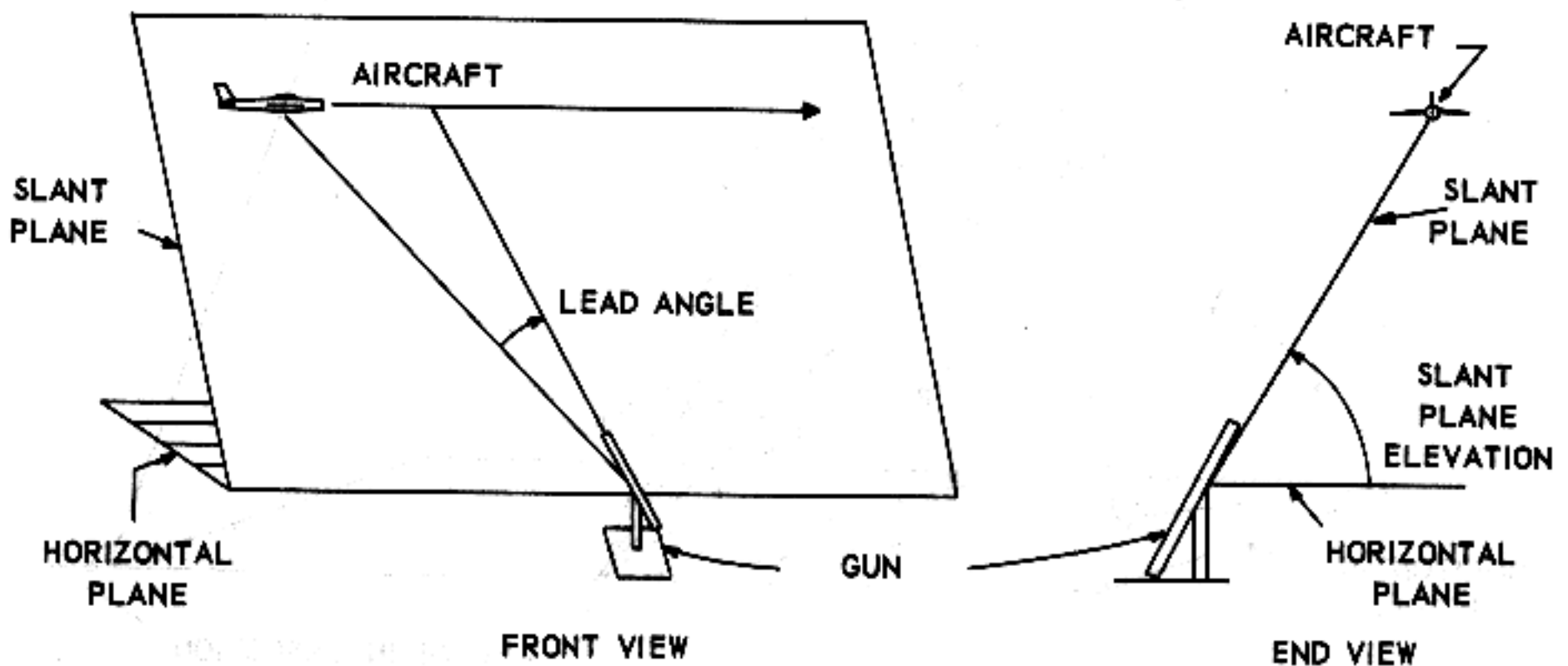

Figure 2-1. Slant and horizontal planes.

## Section II. ELEMENTS OF DATA

## 2-3. General

To present the AW gunnery problem, certain geometric plane surfaces, points, lines, and angles used in its discussion must be named and defined.

## 2-4. Planes

a. *General.* By definition, a geometric plane is an imaginary flat surface of infinite dimensions which can be established by a straight line and a point not on that line or by three points not on a straight line.

b. *Slant Plane.* The slant plane is the geometric plane established by the target course line and the pintle center of the gun. The target course line is a straight line established by extending the longitudinal axis of the target. The pintle center of the gun is the point around which the gun bore moves laterally and vertically. As long as the target course line does not pass through the pintle center of the gun, a slant plane is established (fig. 2-1).

c. *Horizontal Plane.* The horizontal plane is established by the pintle center of the gun and all points at that elevation, disregarding curvature of the earth's surface (fig. 2-1).

2-5. Points  
(fig. 2-2)

a. *G.* Point  $G$  is the pintle center of the gun.

b.  $T_o$ . Point  $T_o$  is the present position (observed position) of the target and is defined as the location of center of mass of the target at the moment a round is fired.

c.  $T_p$ . Point  $T_p$  is the future position (predicted position) of the target and is defined as the point on the course line where the round, if correctly aimed, will intersect the center of mass of the target.

d.  $T_m$ . Point  $T_m$  is midpoint and is defined as the point on the course line that is at minimum slant range from the gun.

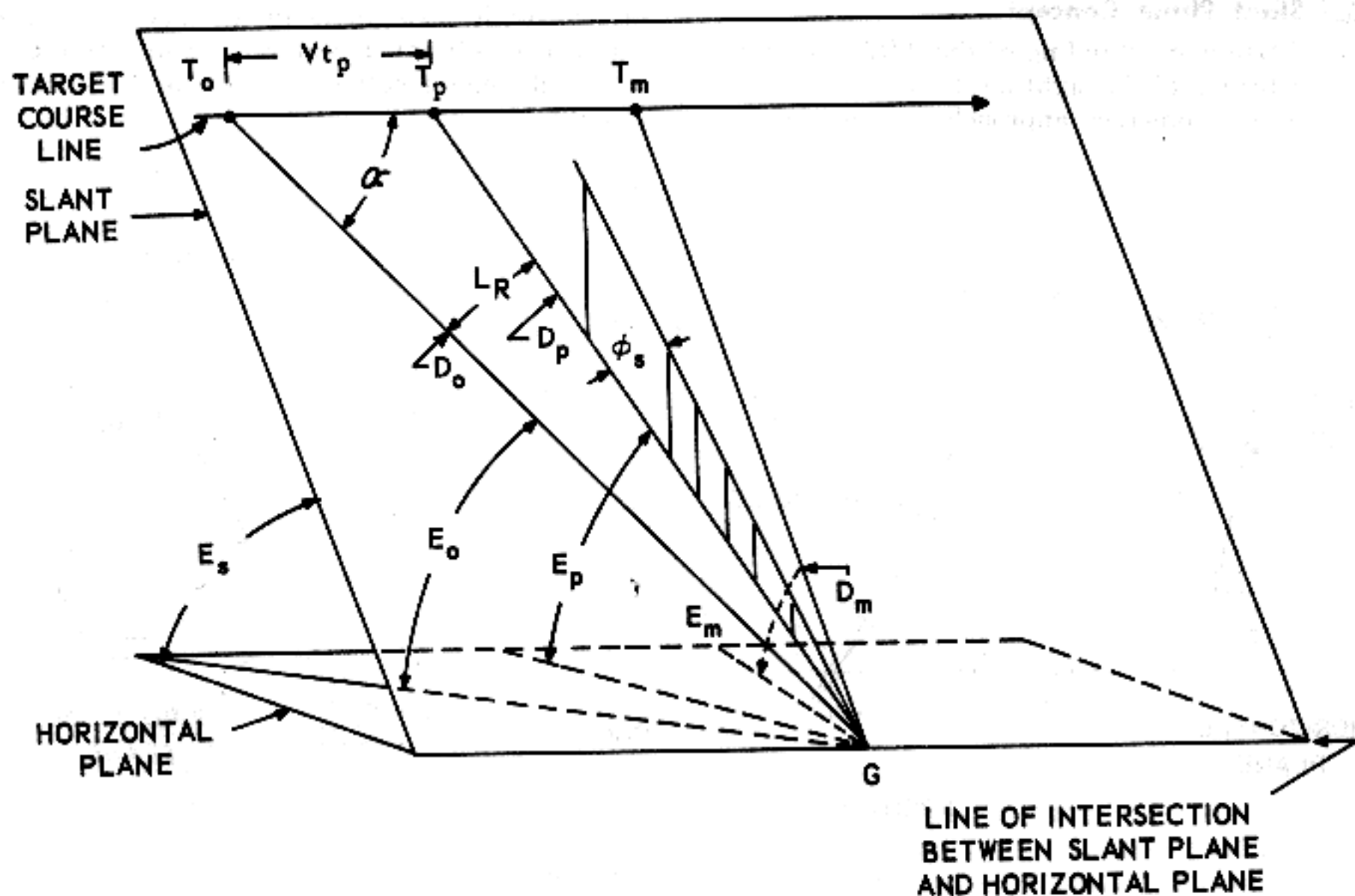

Figure 2-2. Points, lines, and angles.



## 2-6. Lines

(fig. 2-2)

a.  $D_o$ . The line  $D_o$  is present slant range and is defined as the straight line distance between the gun pintle center and the present position of the target.

b.  $D_f$ . The line  $D_f$  is future slant range and is defined as the straight line distance between the gun pintle center and the future position of the target.

c.  $D_m$ . The line  $D_m$  is midpoint slant range and is defined as the straight line distance between the gun pintle center and midpoint of the target course.

d. *Target Course Lines* (fig. 2-3). In any discussion of ADA AW gunnery, the attitude of the target course line in space is of prime importance. To describe different attitudes, target courses are named according to the altitude from the horizontal plane and the direction of flight in respect to the gun. Every target course will be described by two words, one describing altitude, the other describing direction.

(1) *Level*. A level course is formed by a target flying at constant altitude.

(2) *Climbing*. A climbing course is formed by a target flying at increasing altitude.

(3) *Diving*. A diving course is formed by a target flying at decreasing altitude.

(4) *Incoming*. An incoming course is formed

by the target flying toward a vertical line extended through the pintle center of the gun.

(5) *Outgoing*. An outgoing course is formed by a target flying directly away from a vertical line extended through the pintle center of the gun.

(6) *Crossing*. A crossing course is any course where the target course line does not pass directly over the gun.

(7) *Directly-at-the-gun*. A directly-at-the-gun course is formed when the target is flying directly toward the pintle center of the gun.

e. *Course Descriptions*. By combining the above words, any course can be described; for example, *incoming diving*, *crossing level*, *climbing outgoing*, or *diving directly-at-the-gun*.

f. *Legs*. Target course lines can be divided, for gunnery purposes, into two portions called legs. The *approaching leg* is that portion of the target course line along which the target is flying toward midpoint. The *receding leg* is that portion of the target course line along which the target is flying away from midpoint.

g.  $Vt_p$ . The line  $Vt_p$  (fig. 2-2) is the straight line distance from the present position of the target to its future position. The letter  $V$  is the target speed (velocity) along the course line. The letter  $t$  is the time of flight of the projectile (in seconds). The subscript  $p$  designates future posi-

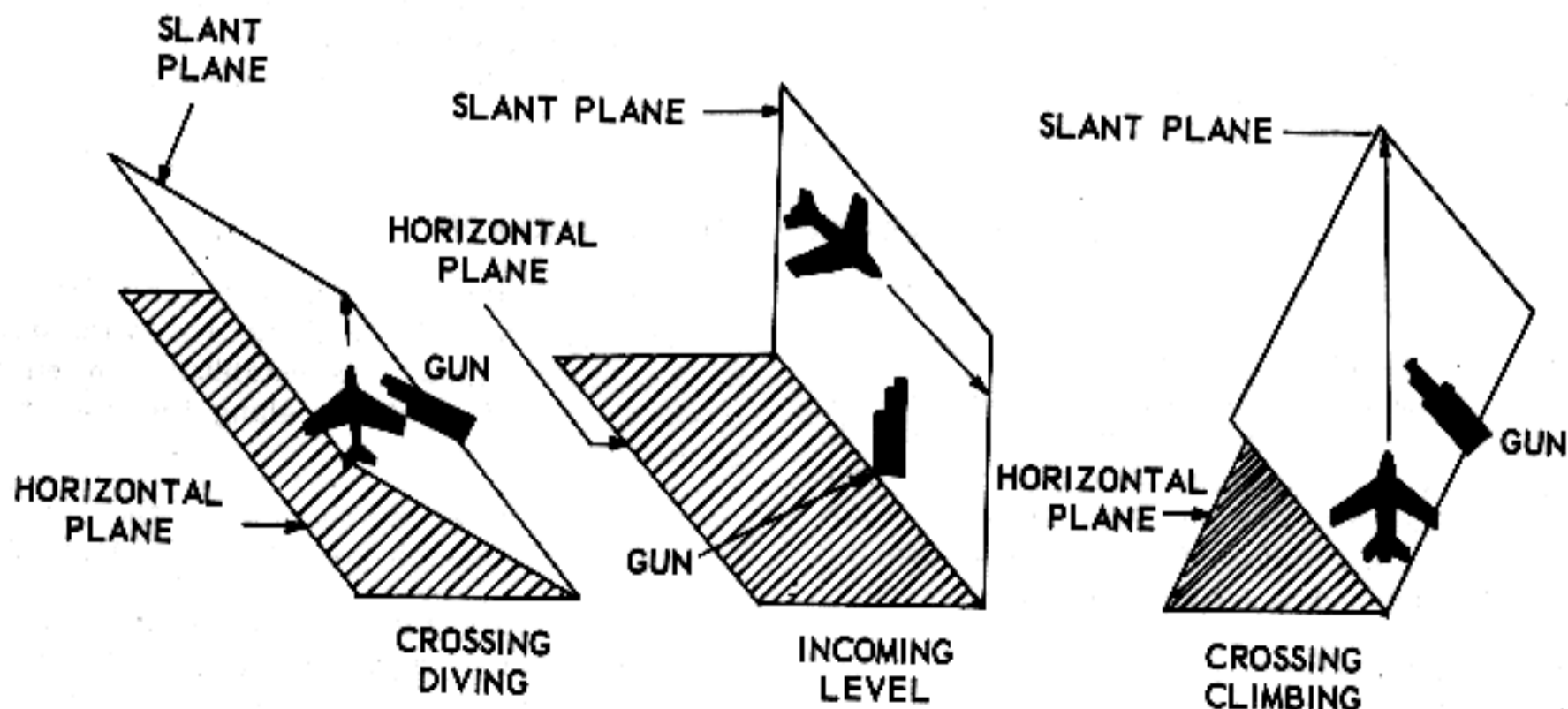

Figure 2-3. Target courses.

tion.  $Vt_p$ , then, has the value of the speed of the target multiplied by the time of flight of the projectile.

## 2-7. Angles

(fig. 2-2)

a.  $E_o$ . The angle  $E_o$  is present angular height of the target and is defined as the vertical angle between the line of present slant range and the horizontal plane.

b.  $E_p$ . The angle  $E_p$  is future angular height of the target and is defined as the vertical angle between the line of future slant range and the horizontal plane.

c.  $E_m$ . The angle  $E_m$  is midpoint angular height and is defined as the vertical angle between the line of midpoint slant range and the horizontal plane.

d.  $E_s$ . The angle  $E_s$  is slant plane angular height and is defined as the vertical angle between the slant plane and the horizontal plane measured perpendicular to their line of intersection.

### e. Angular Height Variations.

(1)  $E_s$ , the slant plane angular height, cannot vary with any single target course line because the position of the course line is fixed in space.

(2)  $E_o$  and  $E_p$ , present angular height and future angular height, respectively, will both change in value as the target progresses along a target course line provided the target course line does not lie in the horizontal plane. On level courses,  $E_o$  and  $E_p$  increase to midpoint and decrease thereafter. On climbing and diving courses they increase to a point other than midpoint where angular height to that point is equal to slant plane

angular height and decrease thereafter. This point is located on the approaching leg of a diving course and on the receding leg of a climbing course.

f.  $\phi$  (Phi). The angle  $\phi$  (phi) (not shown in fig. 2-2) is quadrant elevation and is defined as the vertical angle between the axis of the gun bore and the horizontal plane.

g.  $\phi_s$ . The angle  $\phi_s$  is superelevation and is defined as the vertical angle required to elevate the gun bore above the line of future slant range to overcome the effect of curvature of trajectory caused by gravity. This angle varies inversely with the elevation of the gun bore and directly with range to the target (future slant range).

h.  $\alpha$  (Alpha). The angle  $\alpha$  (alpha) is the angle of approach and is defined as the angle  $GT_oT_p$ , with the apex at  $T_o$ . This angle, which increases as the target progresses along a course line, varies from  $0^\circ$  to  $180^\circ$ . It always lies in the slant plane.

i.  $L_R$ . The angle  $L_R$  is the required lead angle and is defined as the angle between the lines of present slant range and future slant range. This is a slant plane angle.

j.  $L_G$ . The angle  $L_G$  (not shown in fig. 2-2) is the generated lead angle and is defined as the angle between the tracker's line of sight and the axis of the gun bore (disregarding superelevation). The tracker's line of sight is a line projected from the tracker's eye through the target. The axis of the gun bore (disregarding superelevation) is an imaginary line along which the axis of the gun bore would lie if the angle of superelevation were not set in. The generated lead is the lead that actually exists. The problem is to make the generated lead coincide with the required lead.

## Section III. SOLUTION OF THE PROBLEM

### 2-8. General

With certain points, lines, and angles established in and between the slant and horizontal planes, the ADA AW gunnery problem can be solved. The problem of obtaining a hit is reduced to two basic requirements, line and lead. A set of four conditions, called links of the gunnery chain, must be established to satisfy these requirements.

### 2-9. Gunnery Chain

a. *Link I.* Establish and maintain the tracker's line of sight on the center of mass of the target.

The tracker's line of sight is a line from the tracker's eye through, or along, a sighting device to the target. Link I is established when the tracker's line of sight lies along the line of  $D_o$ , present slant range.

b. *Link II.* Establish the axis of the gun bore (disregarding superelevation) in the slant plane.

c. *Link III.* Establish the correct lead. Having established links I and II, make the axis of the gun bore (disregarding superelevation) lie along the line of future slant range,  $D_p$ .



d. *Link IV.* Establish the correct superelevation. With the axis of the gun bore (disregarding superelevation) lying along  $D_p$ , the last step to obtain a hit is to elevate the gun bore a small amount (superelevator) necessary to overcome curvature of trajectory caused by gravity.

**2-10. Requirements for a Hit**

The problem is reduced to two requirements for a hit; i.e., line and lead.

a. *Line.* This requirement is satisfied if the projectile is made to intersect the target course line within tolerance. In the *line tolerance*, a margin for error exists. The projectile need not intersect the narrow line of the projected longitudinal axis of the target fuselage to be effective. Intersecting the bottom or top of the fuselage is a hit. By definition, the line tolerance is one-half the angle at the gun subtended by the diameter, from top to bottom, of the target fuselage. The

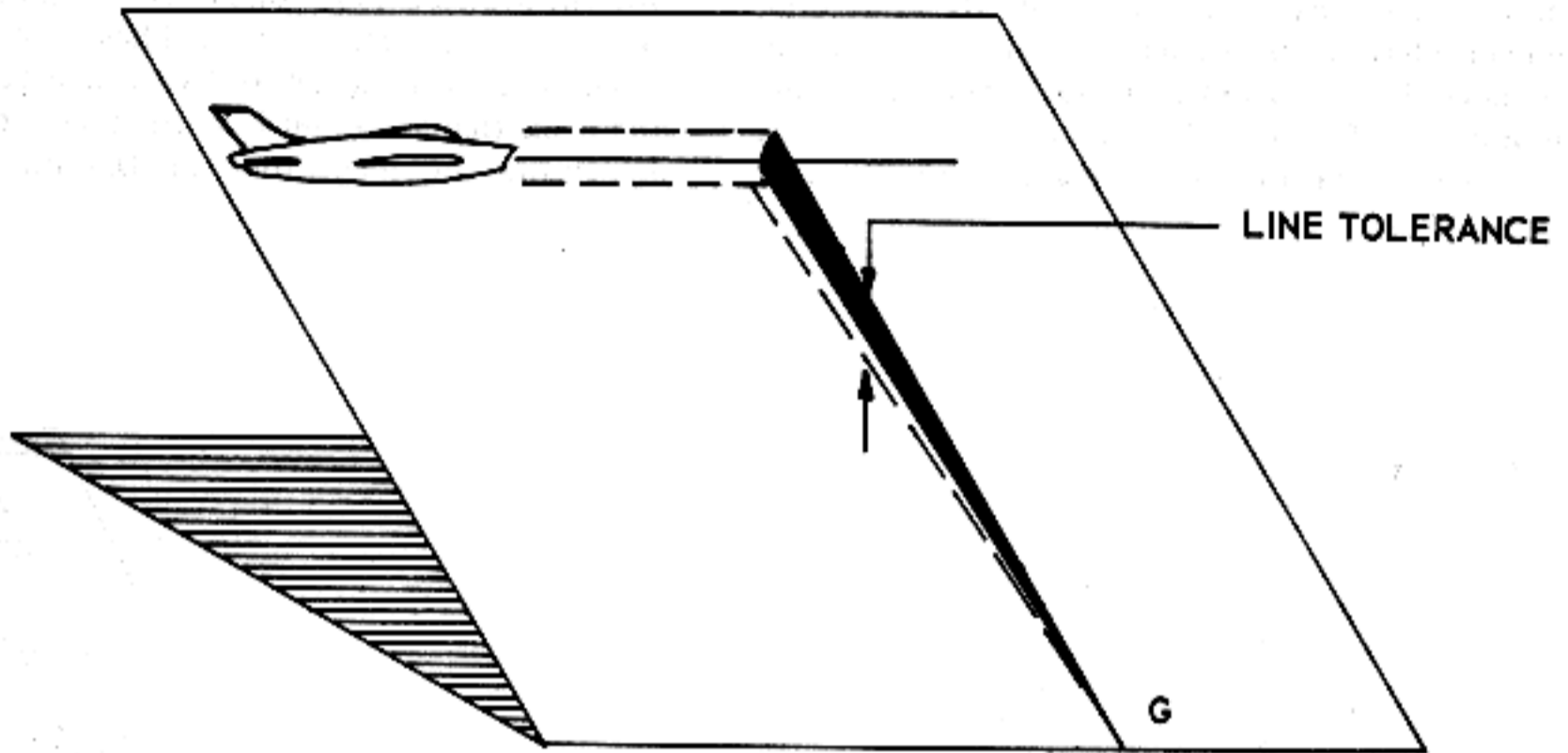

1. SLANT-PLANE VIEW, CROSSING COURSE.

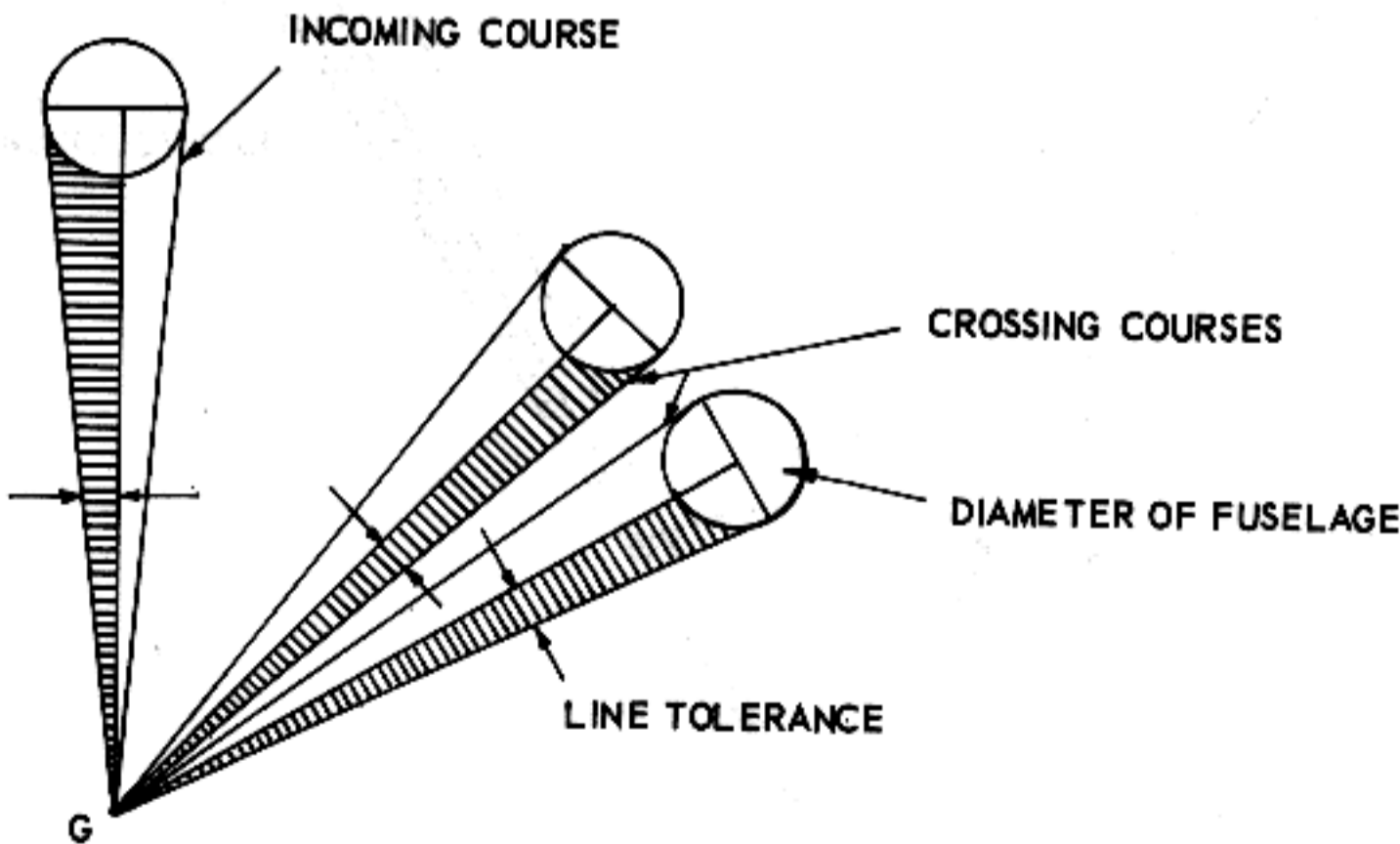

2. CROSS-SECTIONAL VIEW.

Figure 2-4. Line tolerances.

amount of this line tolerance increases with the diameter of the target fuselage and decreases with increasing range ( $D_p$ ) to the target (fig. 2-4).

b. *Lead*. This requirement is satisfied, after line is obtained, when the projectile is made to intersect the target.

(1) *Lead tolerance*. Here again a margin for error exists. The projectile need not hit the center of mass of the target to be effective. An intersection with the nose or tail is a hit. By definition, the lead tolerance is one-half the angle at the gun subtended by the length of the target fuselage. The amount of this lead tolerance increases with the length of the target fuselage, decreases with

greater range ( $D_p$ ) to the target, and increases with the angle of approach to minimum slant range but decreases thereafter (fig. 2-5). In figure 2-5,  $L_{Rt}$  indicates the required lead angle to intersect the tail of the target and  $L_{Rn}$  indicates the required lead angle to intersect the nose of the target.

(2) *Mathematical solution of lead angles*.

(a) In figure 2-2, the triangles in the slant plane are formed by the gun ( $G$ ), target present position ( $T_p$ ), target future position ( $T_f$ ), and target midpoint ( $T_m$ ). These points are located when the target is flying a certain course and a particular round is fired. The problem is to determine the magnitude of the angle  $L_R$ , the

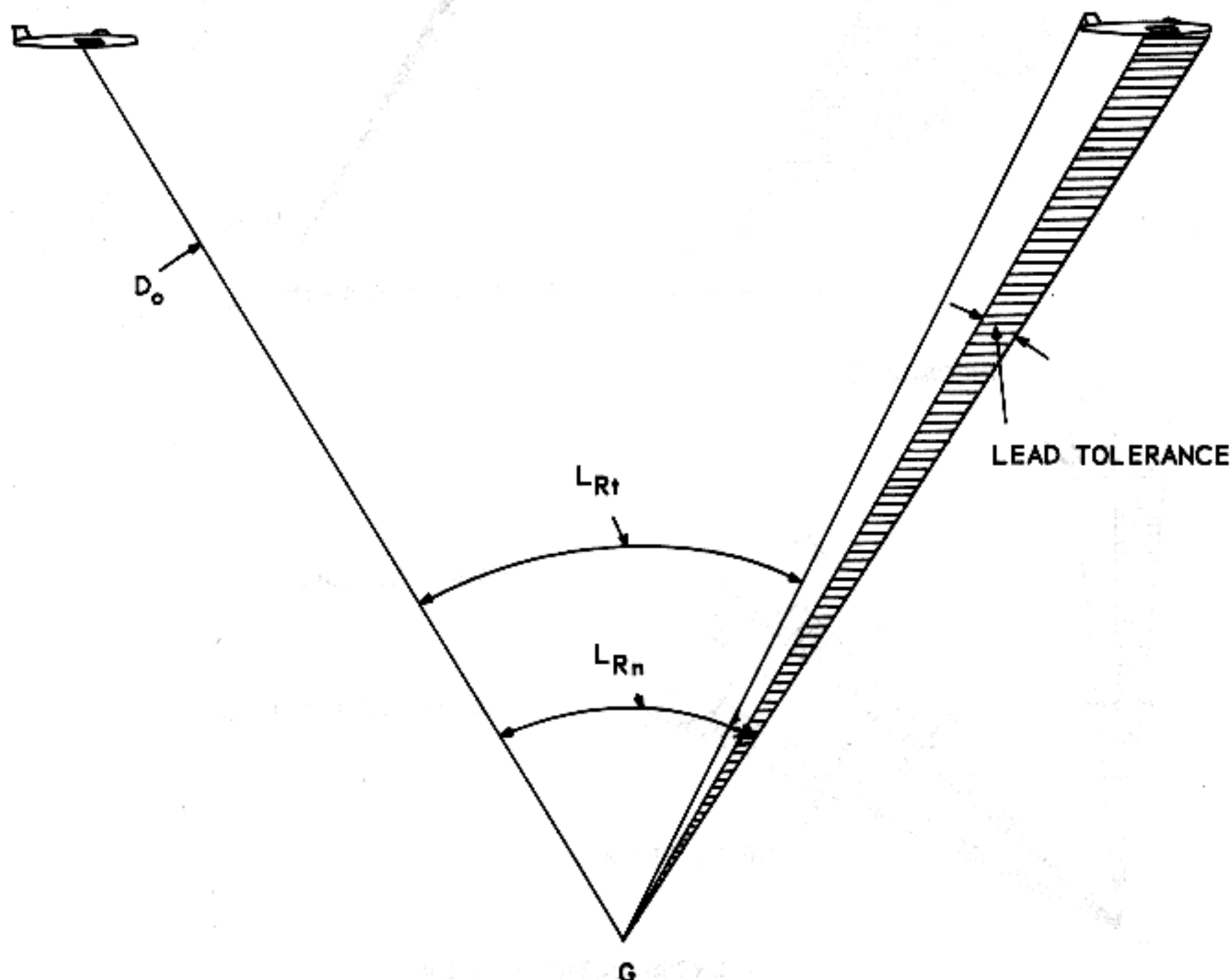

Figure 2-5. Lead tolerance.

lead angle required to hit the target. By applying the law of sines to the triangle  $GT_pT_o$ , the following proportion is found:

$$\frac{\sin L_R}{V t_p} = \frac{\sin \alpha}{D_p}$$

Solving for  $\sin L_R$ ,

$$\sin L_R = \frac{V t_p \times \sin \alpha}{D_p}$$

Since  $D_p$  equals the velocity of the projectile times the time of flight,  $D_p = V_{proj} \times t_p$ . By substituting:

$$\sin L_R = \frac{V \times t_p}{V_{proj} \times t_p} \sin \alpha$$

$$\sin L_R = \frac{V}{V_{proj}} \sin \alpha$$

(b) The foregoing trigonometric equation can be interpreted to show that the sine of the lead angle is directly proportional to the sine of the angle of approach and is inversely proportional to the velocity of

the projectile. As the velocity of the projectile is nearly constant for a given weapon at short ranges, the size of the lead angle, required for hits on a target of constant speed on a straight course, will increase as the target approaches and will decrease after it passes midpoint. This can be shown in a practical way by using ranges and times of flight listed in firing tables (FT .50AA-T-1) and computing the lead angles necessary to get hits at specific slant ranges. For convenience and ease of computing, the problems illustrated here (figs. 2-6—2-9) start at a  $T_p$  at midpoint and work back on the approaching leg of the target course. The example problems have the following data given:

Target speed .....	200 meters/second
Course .....	level crossing
Midpoint slant range .....	400 meters
Altitude .....	not considered

1. *Problem* (fig. 2-6). Determine the lead angle ( $L_R$ ) required to hit the target at a slant range ( $D_p$ ) of 400 meters, and determine

#### TARGET COURSE

$V = 200 \text{ m/sec}$

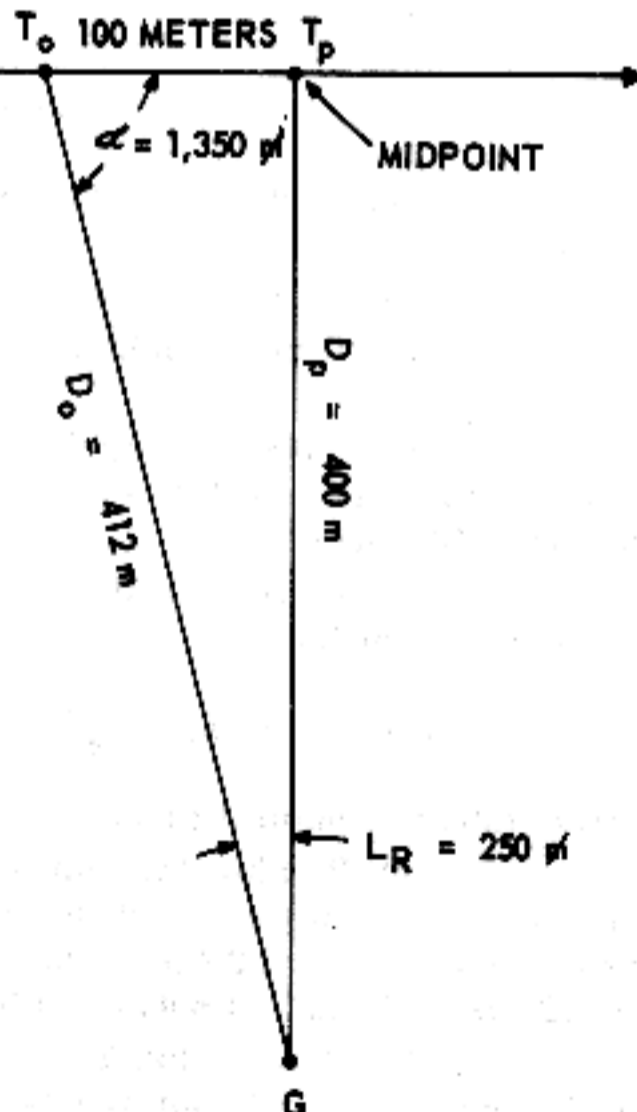

Figure 2-6 Computation of lead angle, problem 1.

TARGET COURSE

V = 200 m/sec

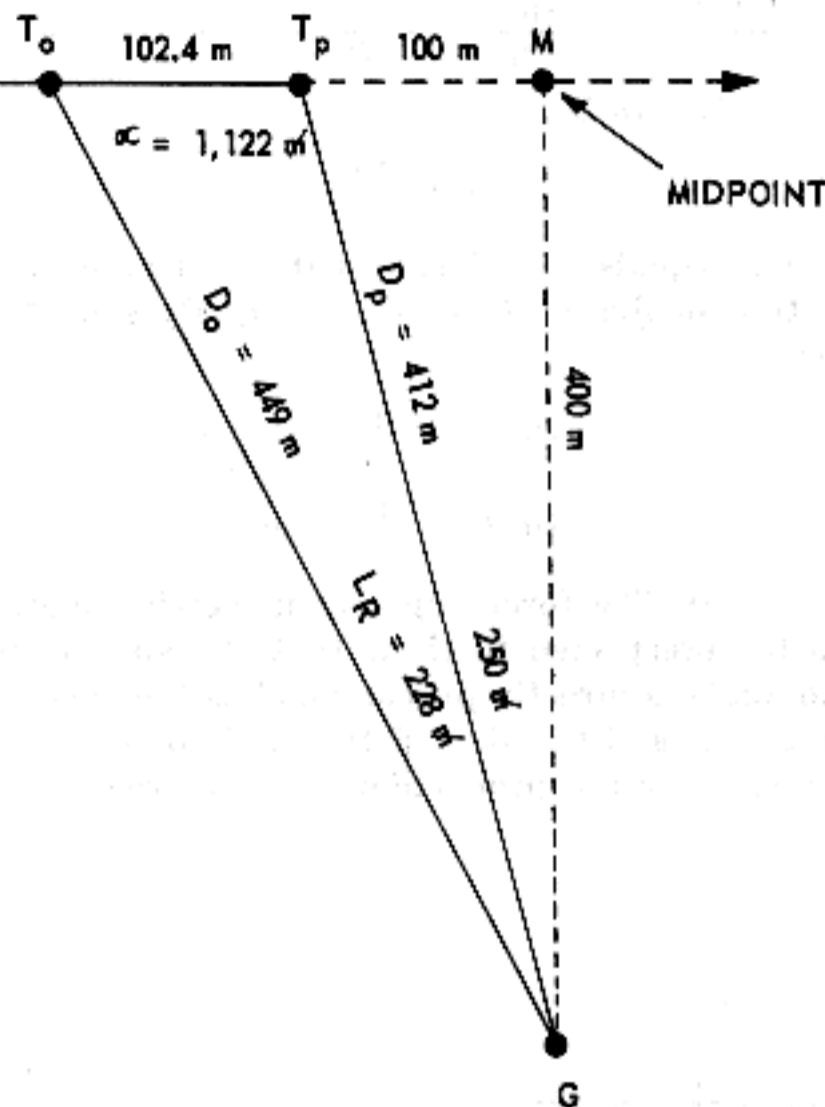

Figure 2-7. Computation of lead angle, problem 2.

the angle of approach ( $\alpha$ ) at the time the weapon is fired.

(a)  $D_p = 400$  meters.

(b) Time of flight (from firing tables) = 0.5 second.

(c) Distance target will fly during time of flight ( $T_o$  to  $T_p$ ) = 200 meters  $\times$  0.5 second = 100 meters.

(d) Present slant range  $D_o = \sqrt{100^2 + 400^2} = 412$  meters.

(e) Sine of  $L_R = \frac{100}{412} = 0.2427$ .  $L_R$

(from tables of natural functions) = 250m.

(f) Because the sum of the internal angles of any triangle =  $3,200\pi$ , the angle of approach ( $GT_oT_p$ ) =  $3,200\pi - L_R - \text{angle } GT_pT_o = 3,200\pi - 250\pi - 1,600\pi = 1,350\pi$ .

2. Problem 2 (fig. 2-7). Determine the lead angle required to hit the target at a slant range ( $D_p$ ) of 412 meters (incoming leg). Determine the angle of approach ( $\alpha$ ) (fig. 2-7).

(a)  $D_p = 412$  meters.

(b) Time of flight (from firing tables) for 412 meters = 0.512 second.

(c) Distance target will fly during time of flight ( $T_o$  to  $T_p$ ) = 200m/sec  $\times$  0.512 second = 102.4 meters.

(d) Distance to M = 102.4 m + 100 m = 202.4 m.

(e)  $D_o = \sqrt{202.4^2 + 400^2} = 449$  m.

(f) The sine of angle  $T_oGM = \frac{202.4}{449}$

= 0.4508 and (from tables of natural functions) angle  $T_oGM = 478\pi$ . The required lead angle ( $L_R$ ) =  $478\pi - 250\pi = 228\pi$ .

(g) The angle of approach ( $\alpha$ ) =  $1,600\pi - 478\pi = 1,122\pi$ .

3. Problem 3 (fig. 2-8). Determine the lead angle required to hit the target at a slant range ( $D_p$ ) of 449 meters (incoming leg). Determine the angle of approach ( $\alpha$ ).

(a)  $D_p = 449$  meters.

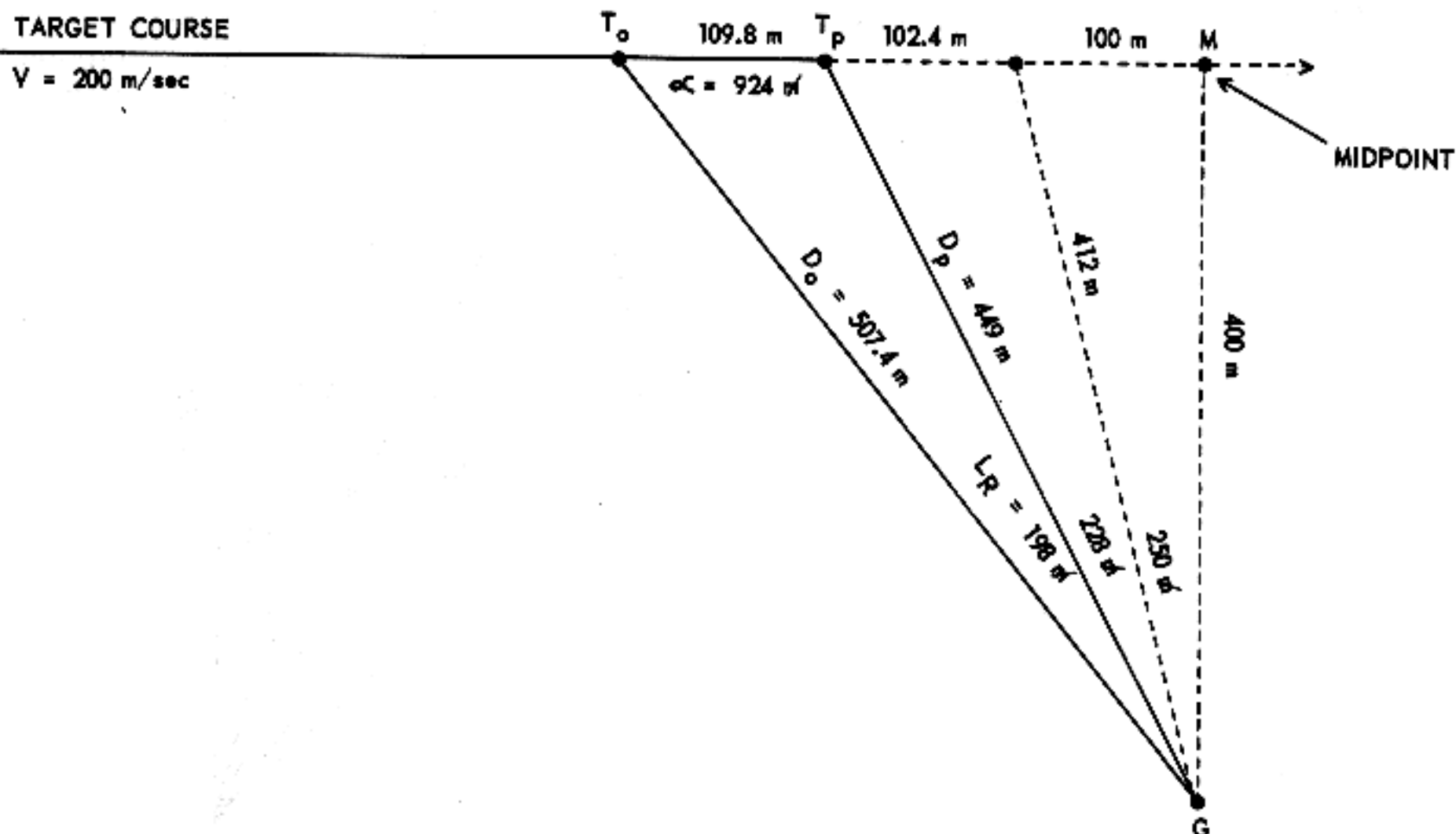

Figure 2-8. Computation of lead angle, problem 3.

(b) Time of flight (from firing tables) for 449 meters = 0.549 second.

(c) Distance target will fly during time of flight (from  $T_o$  to  $T_p$ ) =  $200 \text{ m/sec} \times 0.549 \text{ second} = 109.8 \text{ meters}$ .

(d) Distance from  $T_o$  to  $M$  =  $109.8 \text{ m} + 102.4 \text{ m} + 100 \text{ m} = 312.2 \text{ meters}$ .

(e)  $D_o = \sqrt{312.2^2 + 400^2} = 507.4 \text{ meters}$ .

(f) The sine of angle  $T_oGM = \frac{312.2}{507.4} = 0.6158$ , and (from tables of natural functions) angle  $T_oGM = 676\text{m}$ . The required lead angle ( $L_R$ ) =  $676\text{m} - 228\text{m} - 250\text{m} = 198\text{m}$ .

(g) The angle of approach ( $\alpha$ ) =  $1,600\text{m} - 676\text{m} = 924\text{m}$ .

4. *Problem 4* (fig. 2-9). Determine the lead angle required to hit the target at a slant range ( $D_p$ ) of 507.4 m (incoming leg). Determine the angle of approach ( $\alpha$ ).

(a)  $D_p = 507.4 \text{ meters}$ .

(b) Time of flight (from firing table) for 507.4 meters = 0.6074 second.

(c) Distance target will fly during time of flight (from  $T_o$  to  $T_p$ ) =  $200 \text{ m/sec} \times 0.6074 \text{ second} = 121.5 \text{ meters}$ .

(d) Distance from  $T_o$  to  $M$  =  $121.5 \text{ m} + 109.8 \text{ m} + 102.4 \text{ m} + 100 \text{ m} = 433.7 \text{ meters}$ .

(e)  $D_o = \sqrt{433.7^2 + 400^2} = 590 \text{ meters}$ .

(f) The sine of angle  $T_oGM = \frac{433.7}{590} = 0.7351$ , and (from tables of natural functions) angle  $T_oGM = 842\text{m}$ . The required lead angle ( $L_R$ ) =  $842\text{m} - 198\text{m} - 228\text{m} - 250\text{m} = 166\text{m}$ .

(g) The angle of approach ( $\alpha$ ) =  $1,600\text{m} - 842\text{m} = 758\text{m}$ .

5. *Summary*. The foregoing problems illustrate that both the lead angle required for hits and the angle of approach increase as the target approaches midpoint. If the problems were continued past midpoint, it would be seen that the required lead angle decreases but the angle of approach continues to increase on the receding leg of the course.





proper setting of sight components. Establishing link II insures that an extension of the gun bore axis will intercept the target course line and (disregarding superelevation) will insure that line shots will be obtained.

*c. Link III—Establish the Required Lead.* The required lead angle is established by tracking the target on the correct ring of a speed ring sight and by estimating and setting in the correct target speed on computing sight M88. The XM61 sight, used on the Vulcan, is an exception in that

it uses range, range rate, target speed, angular velocity, ammunition ballistics, and air density inputs in computing the required lead angle.

*d. Link IV—Establish Required Superelevation.* Superelevation is a small amount of elevation that causes the gun to point above the target course line enough to allow for the drop of the projectile caused by gravity. A fixed superelevation is set into speed ring sighting systems during alinement and boresighting procedures. A variable superelevation is computed by the lead-computing sight XM61.

## CHAPTER 3

## TRACER OBSERVATION

## 3-1. General

Proper observation and sensing of tracers provide the gunner and observers with information on the trajectories of rounds fired in relation to the target. Corrections can be made while firing the M42 or M55 to bring successive rounds on target. In the case of Vulcan firing, the rate of fire is too

great to allow corrections to be made while firing. However, tracers can be observed and corrective adjustments can be made to range and speed inputs to the sighting system between bursts or between target engagements. Tracer observation in Vulcan firing can also show up malfunctioning of fire control system components that could not otherwise be noticed.

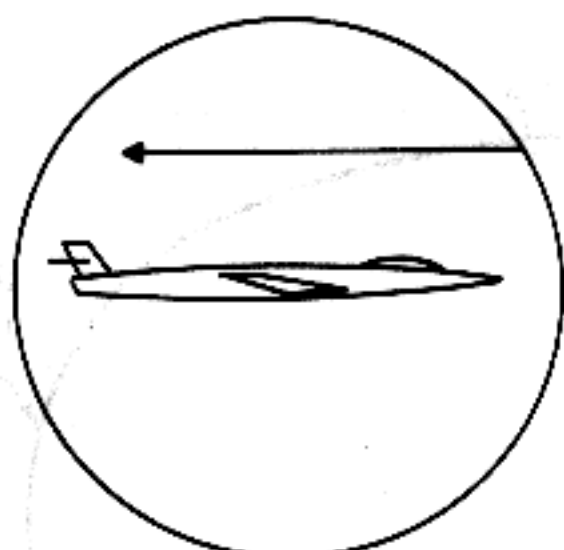

(1) HIGH

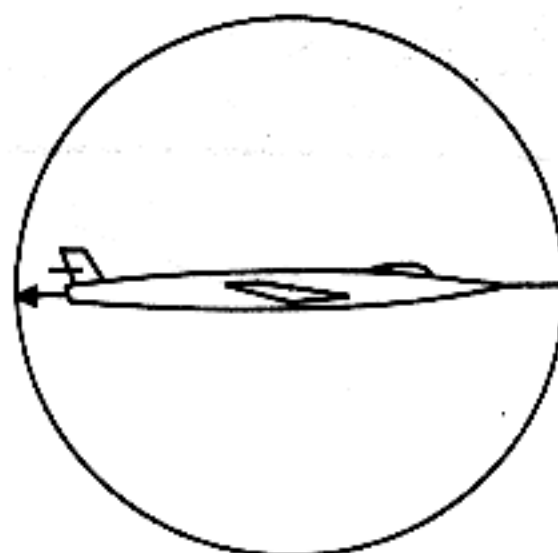
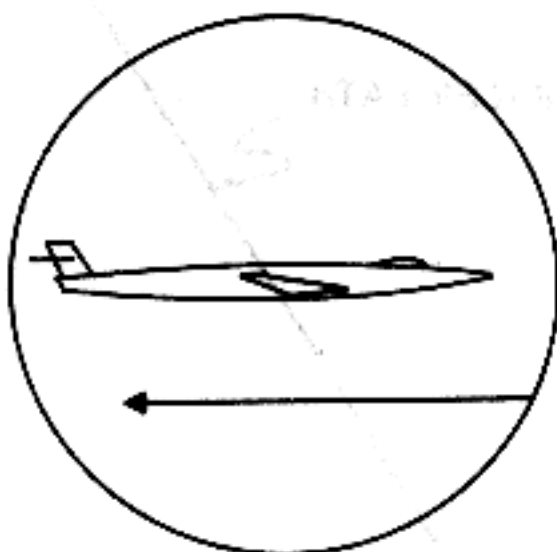
ON  
(2) (LINE, ECLIPSE, AHEAD)

(3) LOW

ON  
(4) (LINE, SILHOUETTE, ASTERN)

Figure 3-1. Line and lead senseings, crossing course.

### 3-2. Basic Principles

Three basic principles govern effective observation of tracers. These three principles are to *superimpose tracer and target*, *localize vision*, and *read tracer passing from nose to tail of target*.

*a. Superimpose Tracer and Target.* Because the target is moving across the tracer path and the observer is moving his line of sight with the target, the tracer path appears to curve and pass the target from nose to tail and the target appears to be stationary. If the tracer path is above or below the target, an observer cannot judge whether the target or the tracer is at greater range ((1) and (3) fig. 3-1). With a line shot, the tracer will appear to pass between the target and the gun (called a silhouette) ((4), fig. 3-1), will appear

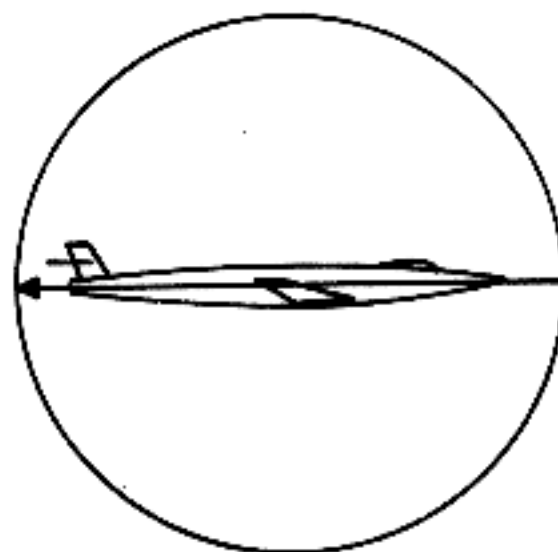
to pass beyond the target (called an eclipse ((2), fig. 3-1), or will disappear into the target if it is a hit. To judge for lead the observer must see a silhouette, an eclipse, or a hit. To sense a silhouette or an eclipse, the tracer and target must appear one in front of the other (superimposed).

*b. Localize Vision.* In figure 3-2, a large part of the tracer path is depicted as it is viewed from the gun. The part of the tracer path where maximum curvature appears is called *tracer hump*. To obtain proper sensings, an observer at the gun must ignore the tracer path except for that part in the immediate vicinity of the target (fig. 3-3). Although the observer will see the curve and the tracer hump in his field of vision, he must ignore

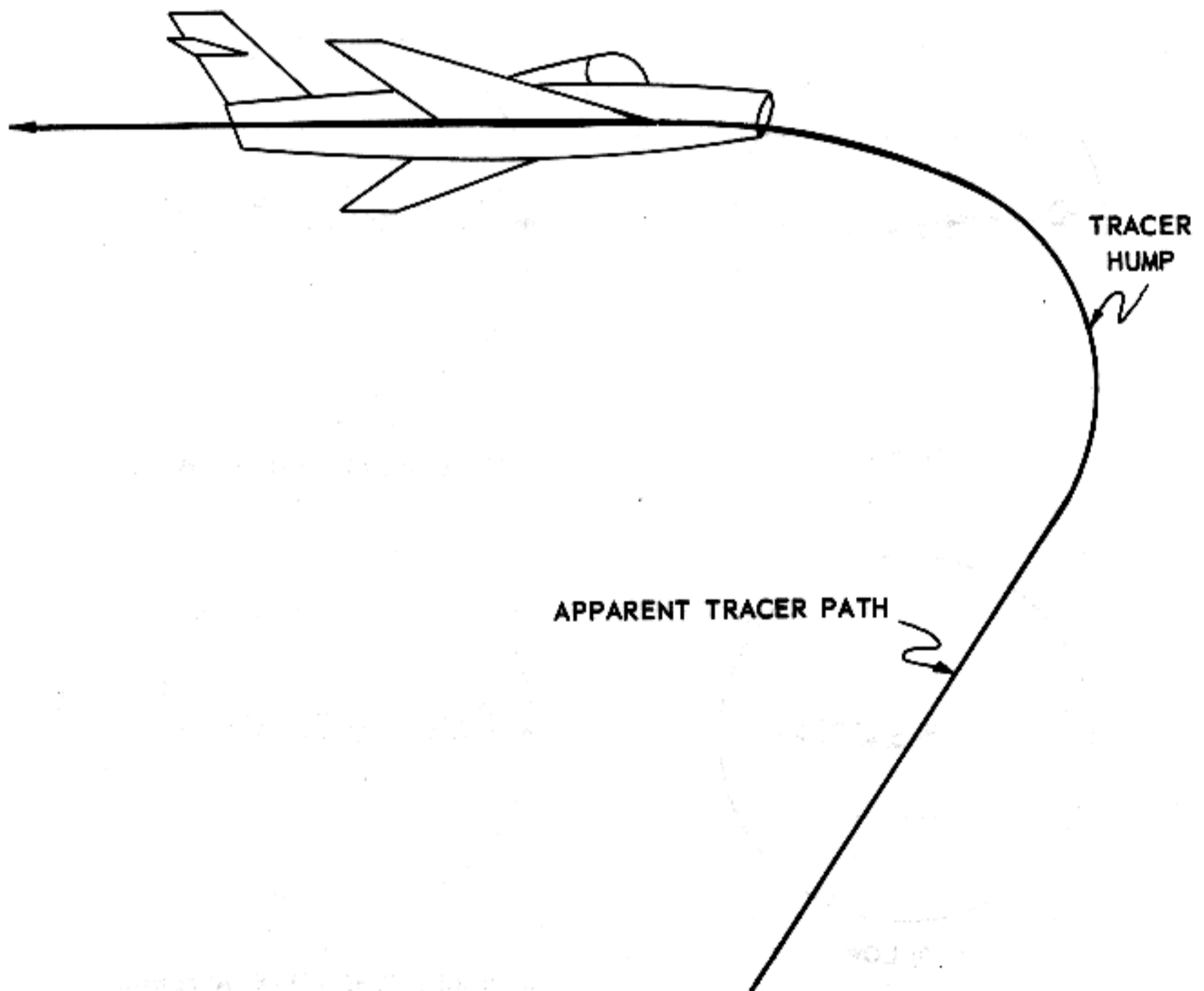
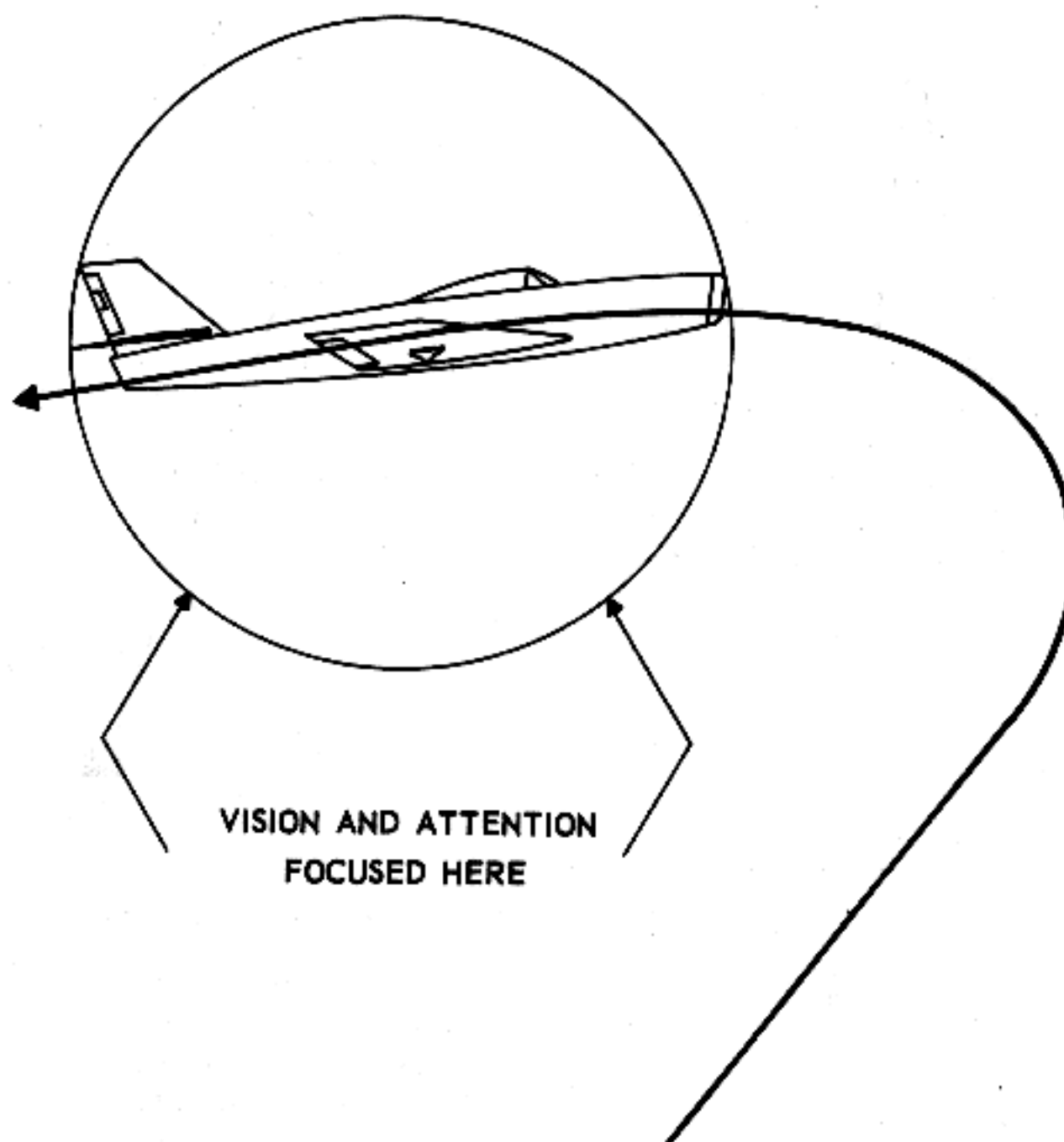

Figure 3-2. Complete apparent tracer path.



3-3. Localize vision.

them completely and focus his vision and attention on the target and the tracer as they pass each other.

*c. Read Tracer Passing Target From Nose to Tail.* The target actually crosses the tracer path only once; it enters the path nose first and leaves the path tail last. Because of the illusion of curvature, the observer at the gun will see this passage when the tracer appears to pass by the target in a nose-to-tail direction. Under certain circumstances, the tracer will appear to pass by the target in a tail-to-nose direction ((1) fig. 3-4). For example, on incoming courses the observer at the gun will sometimes see the tracer pass by the target twice; first in a tail-to-nose direction, then in a nose-to-tail direction. Many observers make a tracer sensing in the first instance. This is wrong, because the tracer is not actually in the immediate vicinity of the target, but is somewhere short

of the target ((2), fig. 3-4). The third basic principle of tracer observation is: *read the tracer only when it is passing the target in a nose-to-tail direction.*

### 3-3. Observation at the Gun, Crossing Course

*a. Line Information.* The following are sensings for line information used by observers:

(1) *High.* The tracer sensing *High* is shown in (1), figure 3-1. Lead information cannot be obtained.

(2) *Low.* The tracer sensing *Low* is shown in (3), figure 3-1. As in the case with the *High* tracer sensing, this *Low* tracer sensing cannot provide lead information to the observer at the gun.

(3) *On.* The tracer sensing called *On*, as shown in (2) and (4), figure 3-1, is made when a line shot occurs. A line shot occurs when the tra-



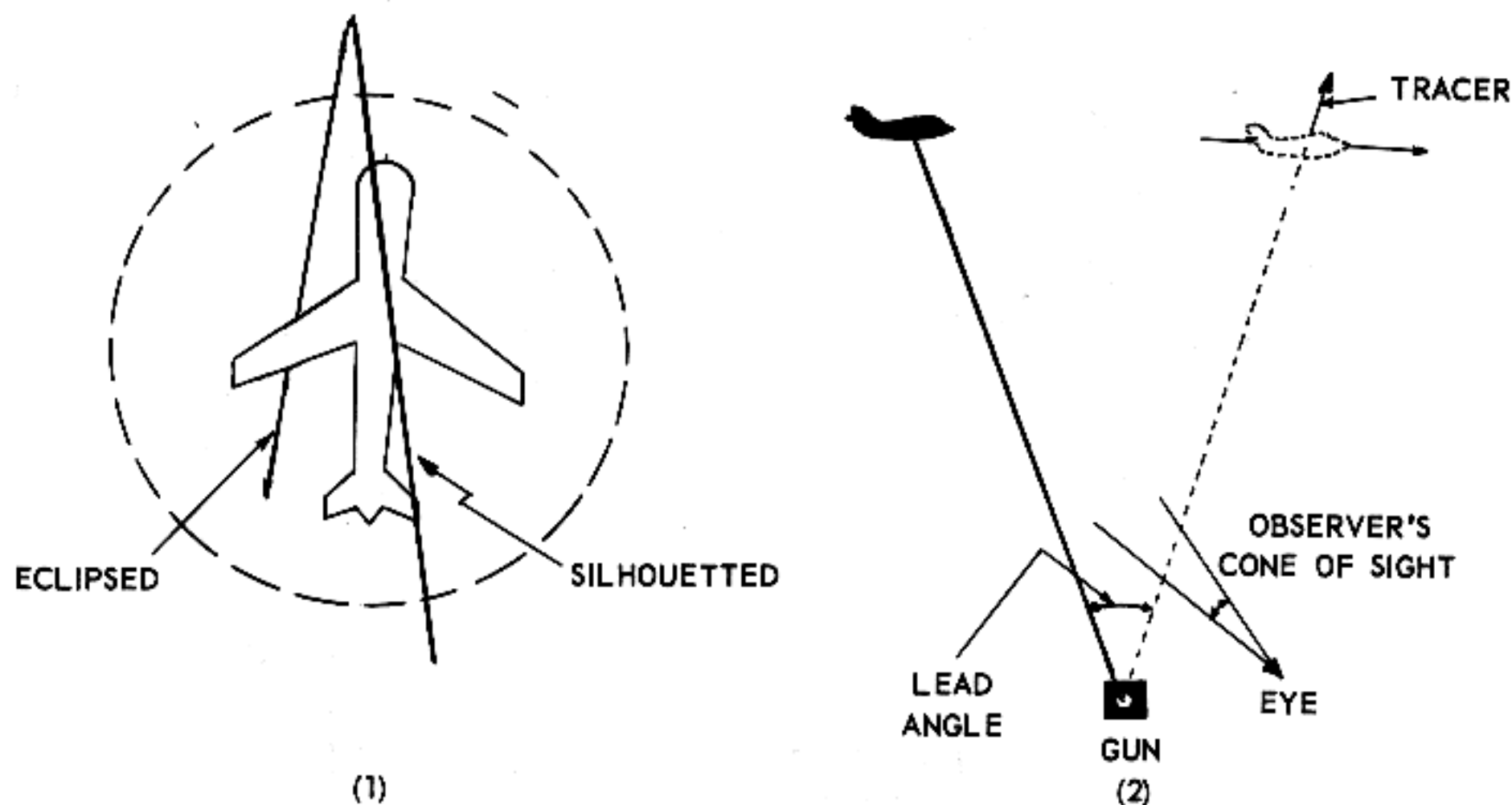

Figure 3-4. False picture on incoming course.

cer intersects the target course line within line tolerance.

b. *Lead Information.* The following are sensings for lead information used by observers:

(1) *Ahead* ((2), fig. 3-1). Line shots will provide lead information at the gun because of the principle of superimposition. When the tracer passes the target at a greater range than that of the target, the tracer is eclipsed by the target. The tracer reaches the target course line in front of the nose of the target and, therefore, is *Ahead*.

(2) *Astern* ((4), fig. 3-1). When the tracer passes the target at a range less than that of the target, the tracer is silhouetted against the target. The target crosses the point of intersection of the tracer path and target course line in advance of the projectile. When the nose of the target arrives at that point, the tracer will be silhouetted against the target until the tail or rear edge of the target clears that point. The tracer will then reach the point of intersection, passing to the rear of the target and, therefore, is *Astern*.

### 3-4. Observation at the Gun, Incoming Course

a. *Line Information.* The following are sensings for line information:

(1) *Left.* In (1), figure 3-5, the observer knows that the tracer has passed to his left of the target and that no lead sensing can be made. It is, therefore, sensed as *Left*.

(2) *Right.* In (2), figure 3-5, the observer knows that the tracer has passed to his right of the target and that no lead sensing can be made. It is, therefore, sensed as *Right*.

b. *Lead Information.* The following are sensings for lead information:

(1) *Ahead.* In (3), figure 3-5, the observer knows that the tracer has intercepted the target course line ahead of the target because the tracer is eclipsed by the target. When the projectile crossed the target course line, it was in front of the nose of the target. It, therefore, had too much lead and is sensed as *Ahead*.

(2) *Astern.* In (4), figure 3-5, the tracer is silhouetted against the target; therefore, the shot passed astern and had too little lead. Thus, it is sensed as *Astern*.

### 3-5. Observation at the Gun, Outgoing Course

Figure 3-6 shows tracer pictures for sensings of *Left*, *Right*, *Ahead*, and *Astern* for an outgoing

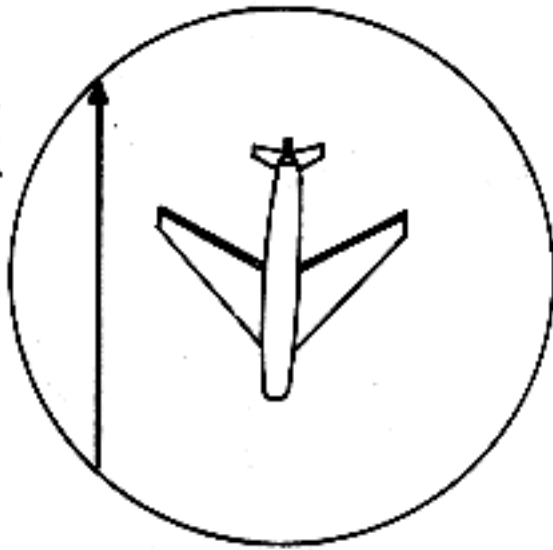

(1) LEFT

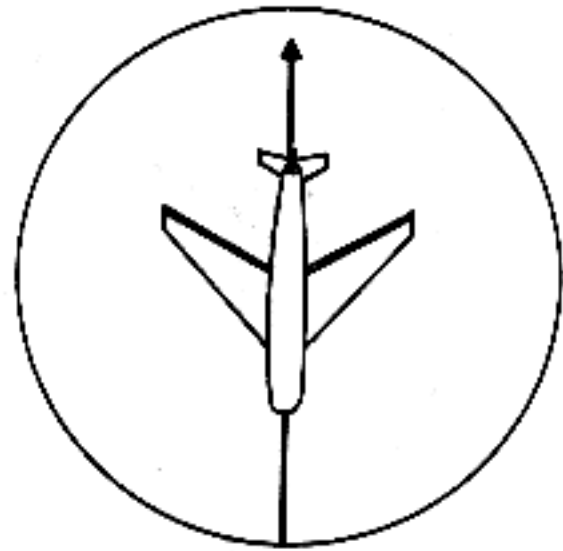

(3) AHEAD

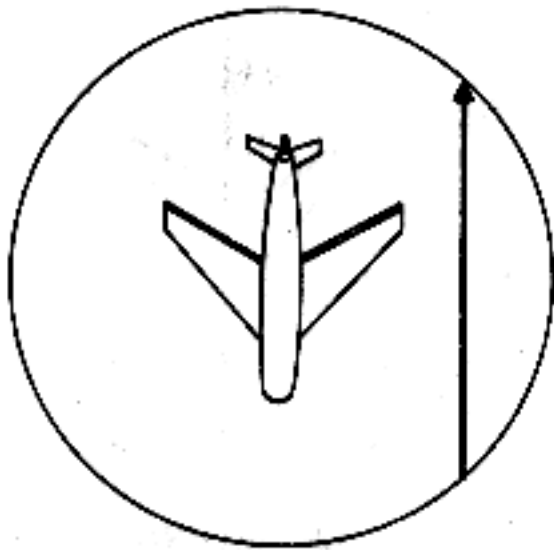

(2) RIGHT

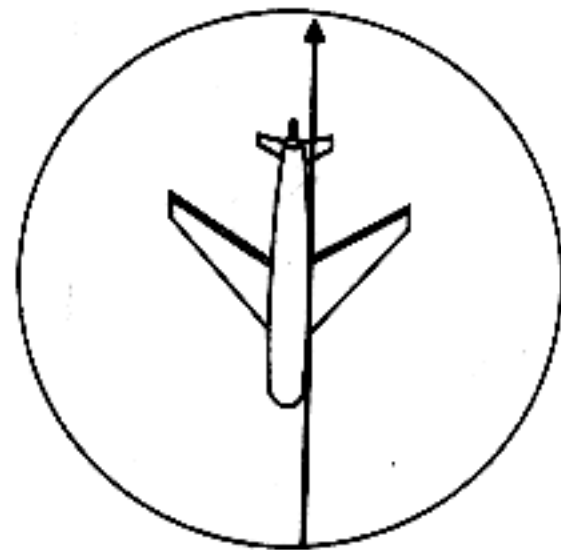

(4) ASTERN

Figure 3-5 Line and lead sensings, incoming course.

course. Notice that the tracer is always read in a nose-to-tail direction.

### 3-6. Observation at the Gun, Nonlevel Crossing Course

Tracers of shots fired at crossing targets that are climbing or diving will produce the same picture to the observer as those fired at level course targets (fig. 3-7). Merely tilt figure 3-1 to the desired angle of dive or climb of the target and the tracer still follows the target course line in a nose-to-tail direction. However, if the climb or dive becomes very steep, the sensings for line change from *High* or *Low* to *Left* or *Right*, respectively (fig. 3-8).

### 3-7. Observation at the Gun, Directly-at-the-Gun Course

Line sensings only are required for a directly-at-the-gun course because the required lead to hit the target is zero. There is no lateral or vertical movement of the target in respect to the gun. Therefore, the tracers are sensed as either *High*, *Low*, *Right*, *Left*, or appropriate combinations of these. Figure 3-9 shows three different tracer pictures for a directly-at-the-gun course. The tracer appears to climb from the bottom to the top of the picture, passing through the cone of sight, and then appears to drop from top to bottom of the picture. This drop, or curve, of the tracer is caused by the actual curvature of the trajectory and is not an illusion. Whenever possible, the tracer should be read as it appears to drop from top

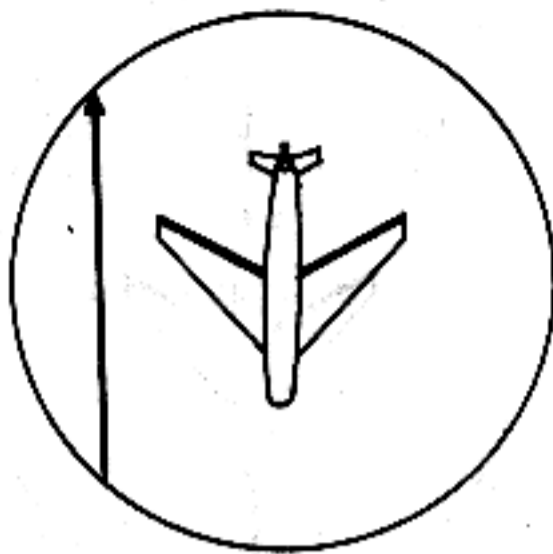

(1) LEFT

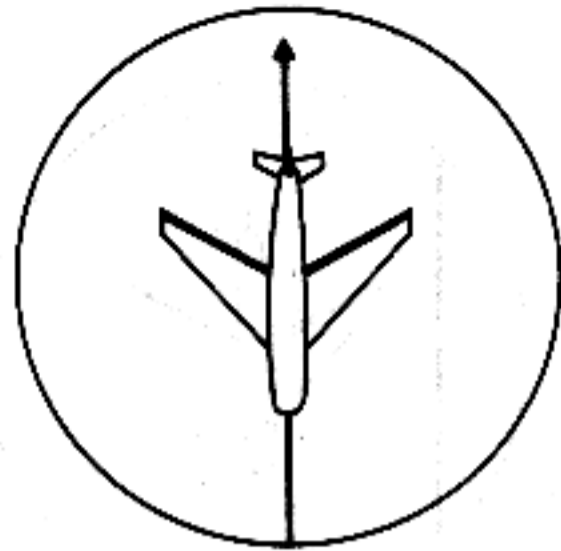

(3) AHEAD

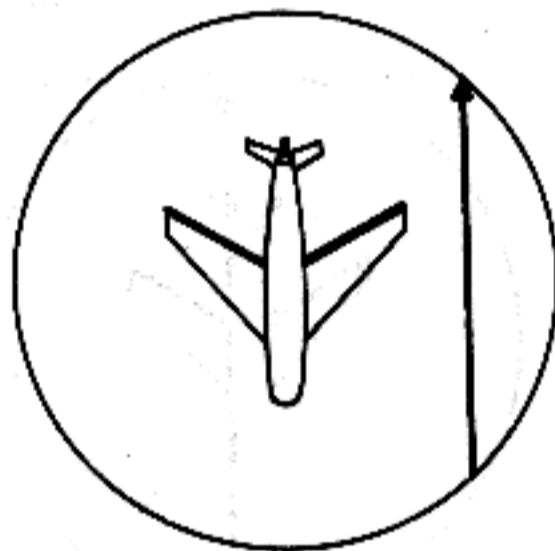

(2) RIGHT

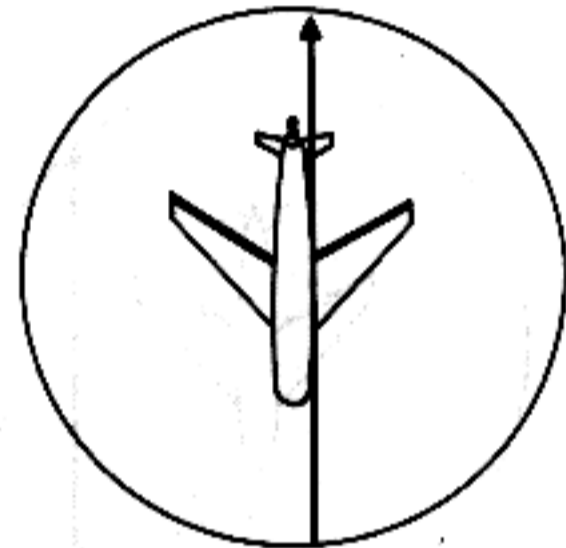

(4) ASTERN

Figure 3-6. Line and lead sensing, outgoing courses.

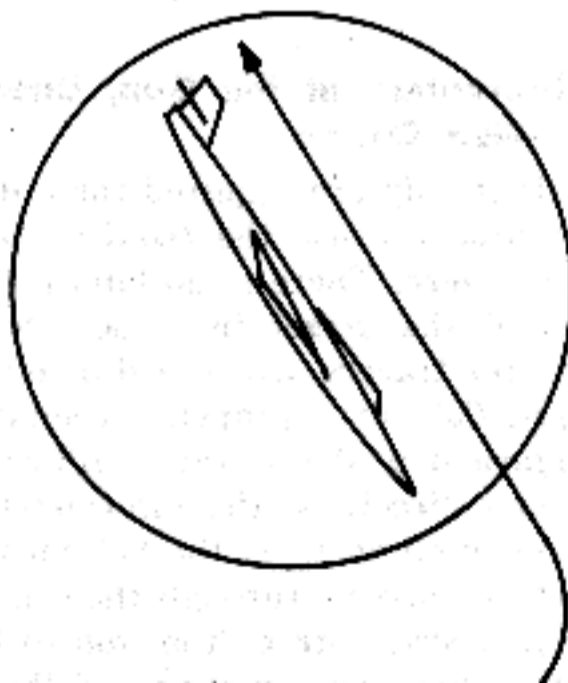

(1) HIGH

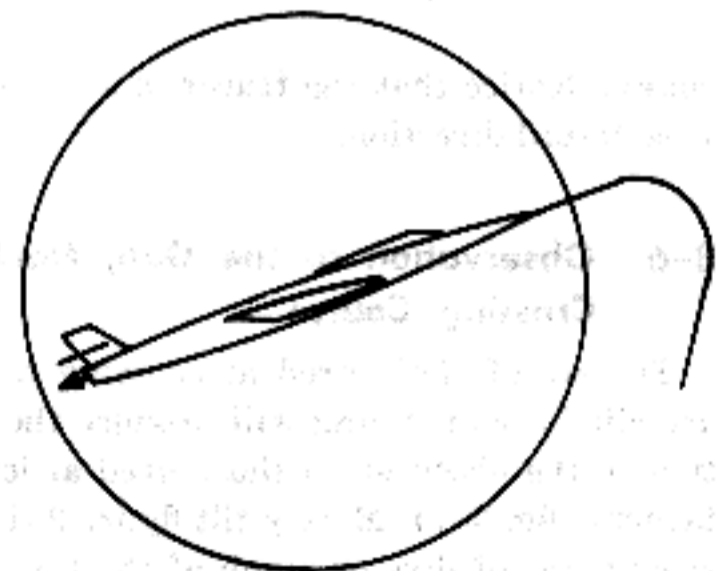

(2) AHEAD

Figure 3-7. Line and lead sensing, nonlevel crossing courses.

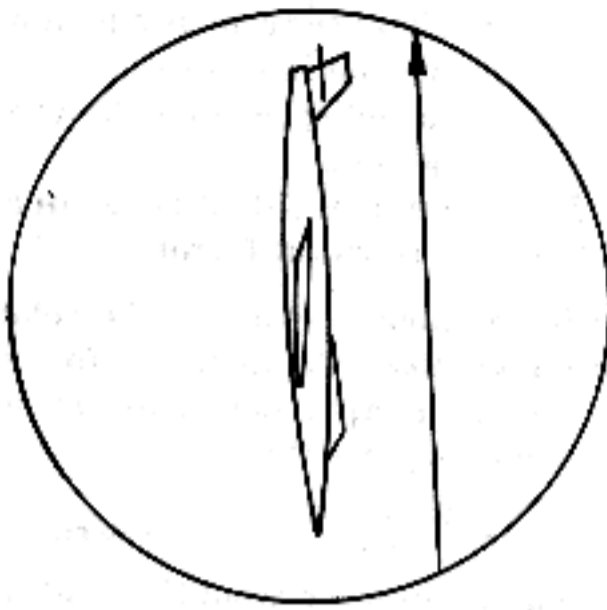

RIGHT

Figure 3-8. Line sensing, steep diving course.

to bottom of the picture because this drop normally starts at a range slightly less than the range to the target. Reading the tracer from top to bottom satisfies the basic principle of reading from nose to tail in the immediate vicinity of the target.

**3-8. Downcourse Observation**

*a. How to Observe.*

(1) As long as an observer at the gun can see both target and tracer, sensings for line can be made. In combat, tracer observations for both line and lead usually will be made by observers at the gun. However, during training, a gun crew can profit from lead information obtained from nonlinear shots. Observers at the gun cannot provide lead information on nonlinear shots, but it can be provided by an observer at a downcourse observation station. The downcourse observer is placed in the slant plane, a computed distance (*b* below) from the gun in the direction of target

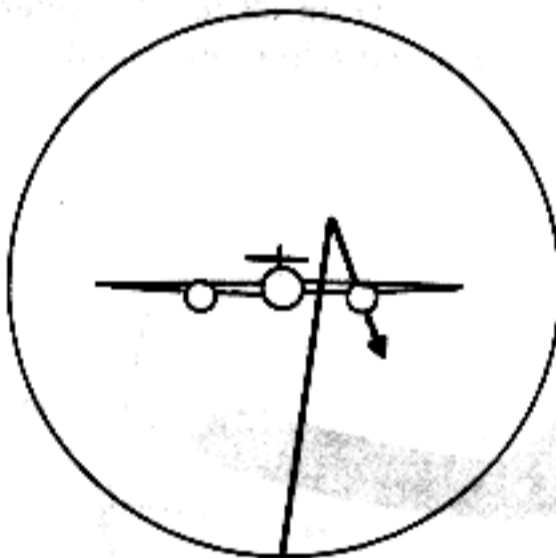

(1) RIGHT AND HIGH

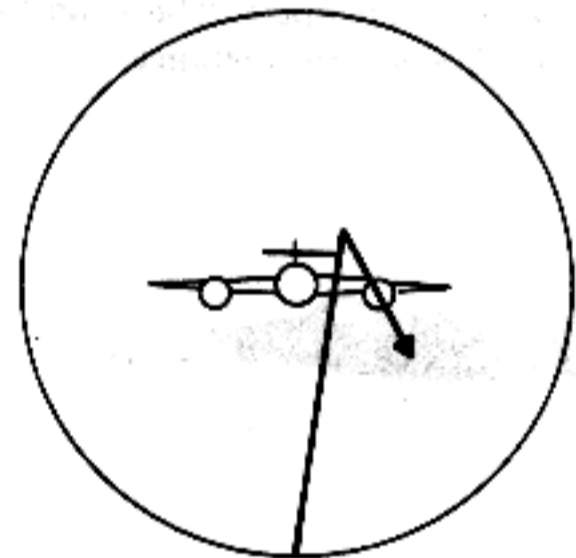

(2) RIGHT AND LOW

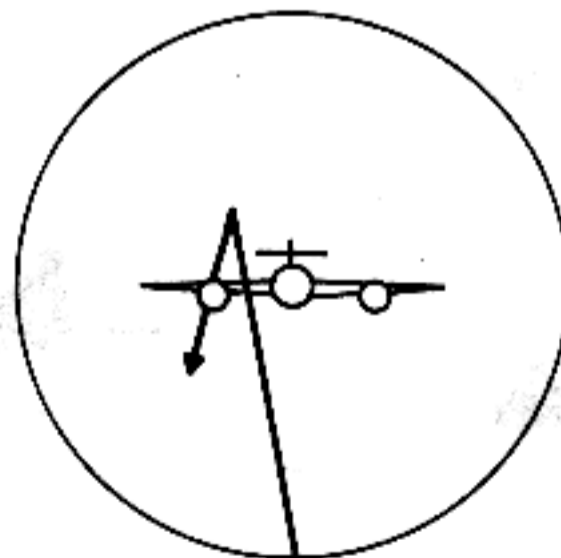

(3) LEFT AND HIGH

Figure 3-9. Sensings, directly-at-the-gun course.

flight. The observation station is located left of the gun for a right-to-left course, right of the gun for a left-to-right course, and to the rear of the gun for an incoming course. The position of the downcourse observer, who is placed in the slant plane the computed distance  $b$  to the right of the gun for a left-to-right course is shown in (1), figure 3-10.

(2) From a downcourse station, the observer sees a view of the tracer hump different from that seen by an observer at the gun. A target on the approaching leg and the appearance of the tracer hump is shown in (2), figure 3-10. The observer determines a lead sensing by noting the position of the hump in relation to the target. An imaginary line is projected from the hump perpendicular to the target course line. If the intersection of this perpendicular line with the course line is anywhere on the target, the lead is correct and the sensing is *On* ((4), fig. 3-10). If the perpendicular line intersects the course line in front of or behind the target, the sensings are *Ahead* or *Astern*, respectively ((2) and (3), fig. 3-10).

*b. Downcourse Distance.* The equation used to solve for the downcourse distance  $b$  is:

$$b = \frac{V \times D_m}{450}$$

Where  $b$  = distance from gun to downcourse station in meters.

$V$  = target speed in meters per second.

$D_m$  = midpoint slant range in meters.

450 = a constant factor.

To illustrate the above equation, the solution for the downcourse observer distance for a target traveling 300 kilometers per hour, at midpoint range of 600 meters, is as follows:

$$b = \frac{83 \times 600}{450} = 110 \text{ meters.}$$

The downcourse observer would be stationed 110 meters from the gun.

*c. Tolerance.* The downcourse observer, as shown in  $b$  above, need not be stationed exactly 110 meters from the gun for sufficient accuracy of observation. A tolerance in this distance makes observing for several guns possible. This tolerance is  $\pm \frac{1}{4} b$ , or in the case above,  $\pm 28$  meters. This means that the downcourse observer can be placed anywhere from 82 to 138 meters from the firing gun. If a firing line contained 5 guns 14 me-

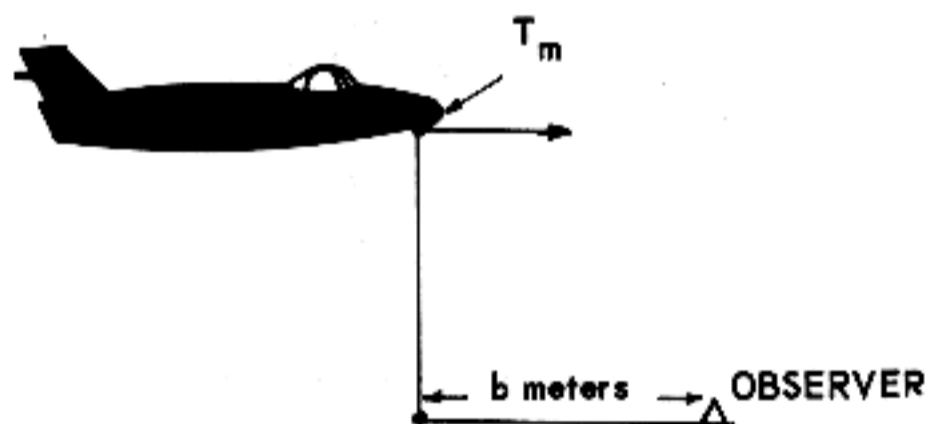

(1) DOWNCOURSE STATION

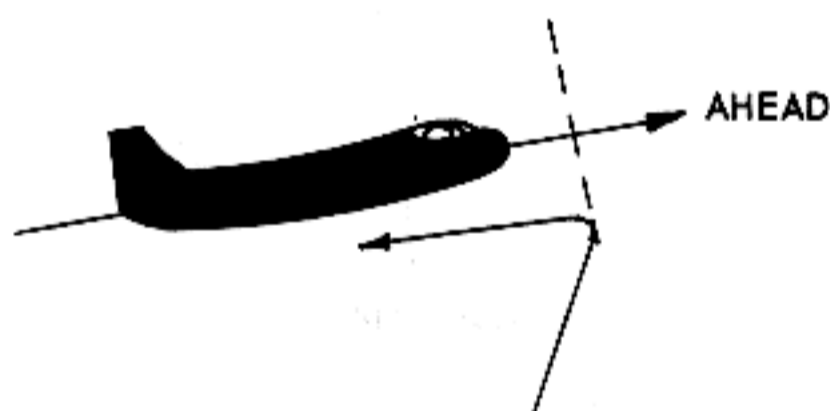

(2) LEAD TOO GREAT

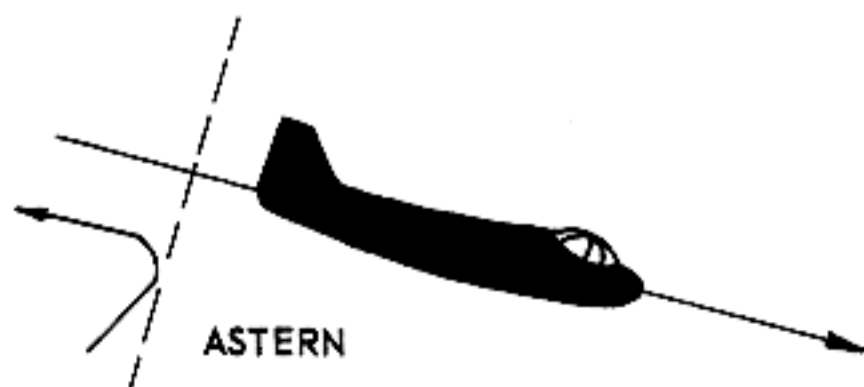

(3) LEAD TOO SMALL

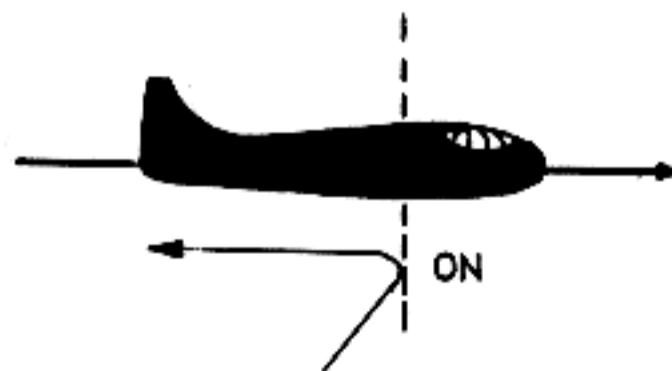

(4) LEAD CORRECT

Figure 3-10. Downcourse sensings.



ters apart, a single downcourse observer stationed 110 meters from the center gun could observe for all 5 guns with acceptable accuracy (fig. 3-11). Because of the large tolerance, it is not necessary to compute and measure exact dis-

tances. In the above example, the observer could be stationed 100 meters from the left flank gun and move in 14 meters as each gun fires. Any convenient arrangement can be used as long as the tolerance is not exceeded.

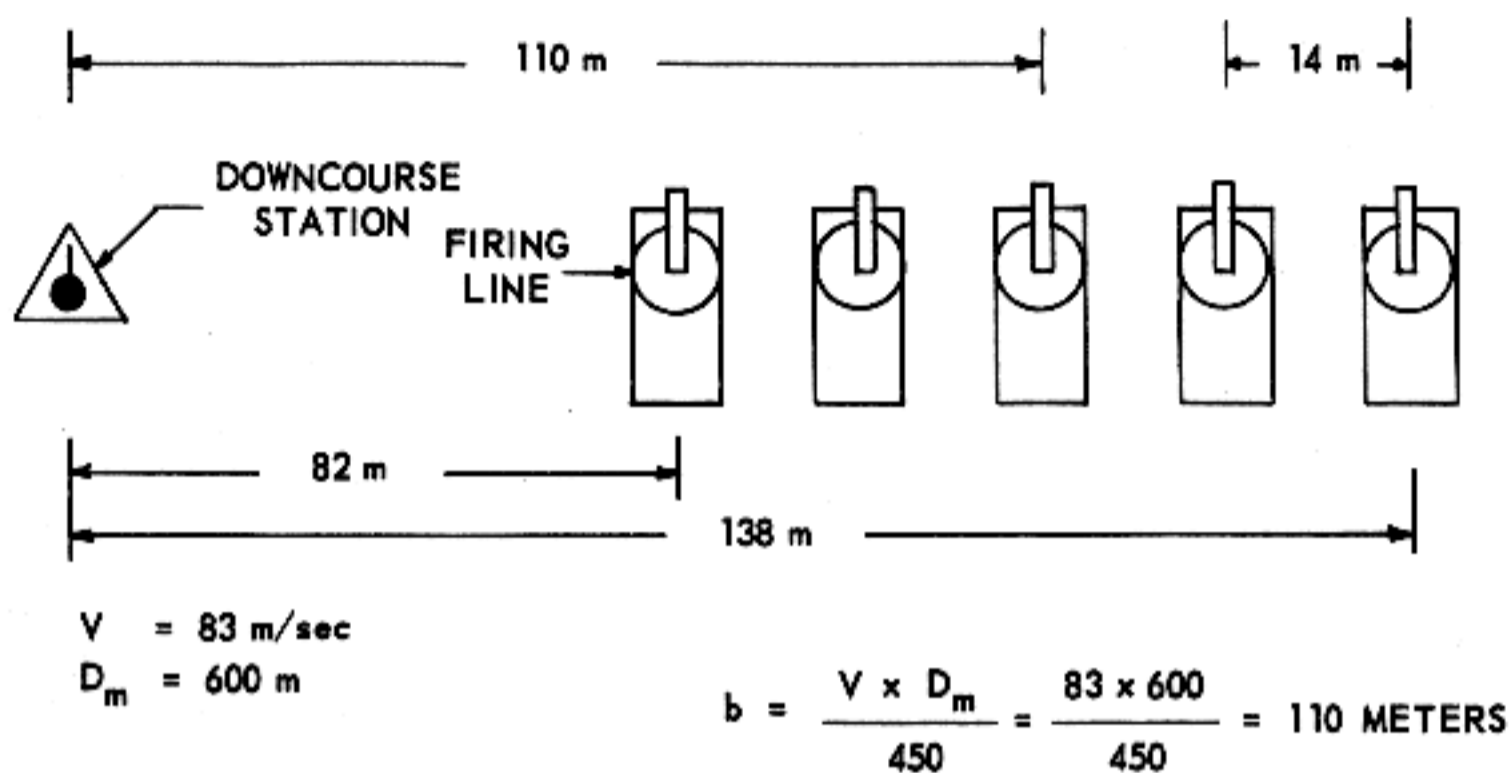

Figure 3-11. Downcourse observer location.

## CHAPTER 4

### AUTOMATIC WEAPON SIGHTING SYSTEMS

#### Section I. SPEED RING SIGHTS

##### 4-1. Basic Principles

a. Speed ring sights are the simplest but least accurate of ADA AW fire control devices. They are designed on the principle of similar triangles. A small triangle formed by the rings and the gunner's eye (peep sight) is similar to the slant plane triangle in space,  $GT_oT_p$  (fig. 4-1). The basic speed ring sight has a rear peep element represented by the point  $G$  and a series of concentric circles as a front element, the center or hub of which represents the point  $T'_p$ . The point  $T'_o$  is represented at a point on one of the outer concentric circles where the center of mass of the target is carried while tracking. The concentric circles are called speed rings, and the points similar to the slant plane points  $G$ ,  $T_o$ , and  $T_p$  are given the symbols  $G$ ,  $T'_o$ , and  $T'_p$ .

b. The radius of the individual speed rings depends on the range ( $D_p$ ) for which the sight was designed, the distance the rings are placed from the rear peep sight, and the target speeds they represent.

c. Most speed rings represent multiples of 100 miles per hour; one ring representing 100 miles per hour, the next representing 200 miles per hour, etc. For this reason, the English measuring system (miles, yards, etc.) will be used in this chapter.

##### 4-2. Speed Ring Sight Used with 40-mm Gun M2A1

(fig. 4-2)

a. *Front Sight.* The speed ring sight used with the 40-mm guns M2A1 has eight speed rings. The eight speed rings represent the required lead, at a midpoint range of 1,000 yards (914.4 meters), for targets traveling 25 (40.2), 100 (160.9), 200 (321.8), 300 (488.7), 400 (643.6), 500 (804.5), 600 (965.4), or 700 (1,126.3) miles (kilometers) per hour, respectively. This sight has eight radial wires which serve to hold the sight together and

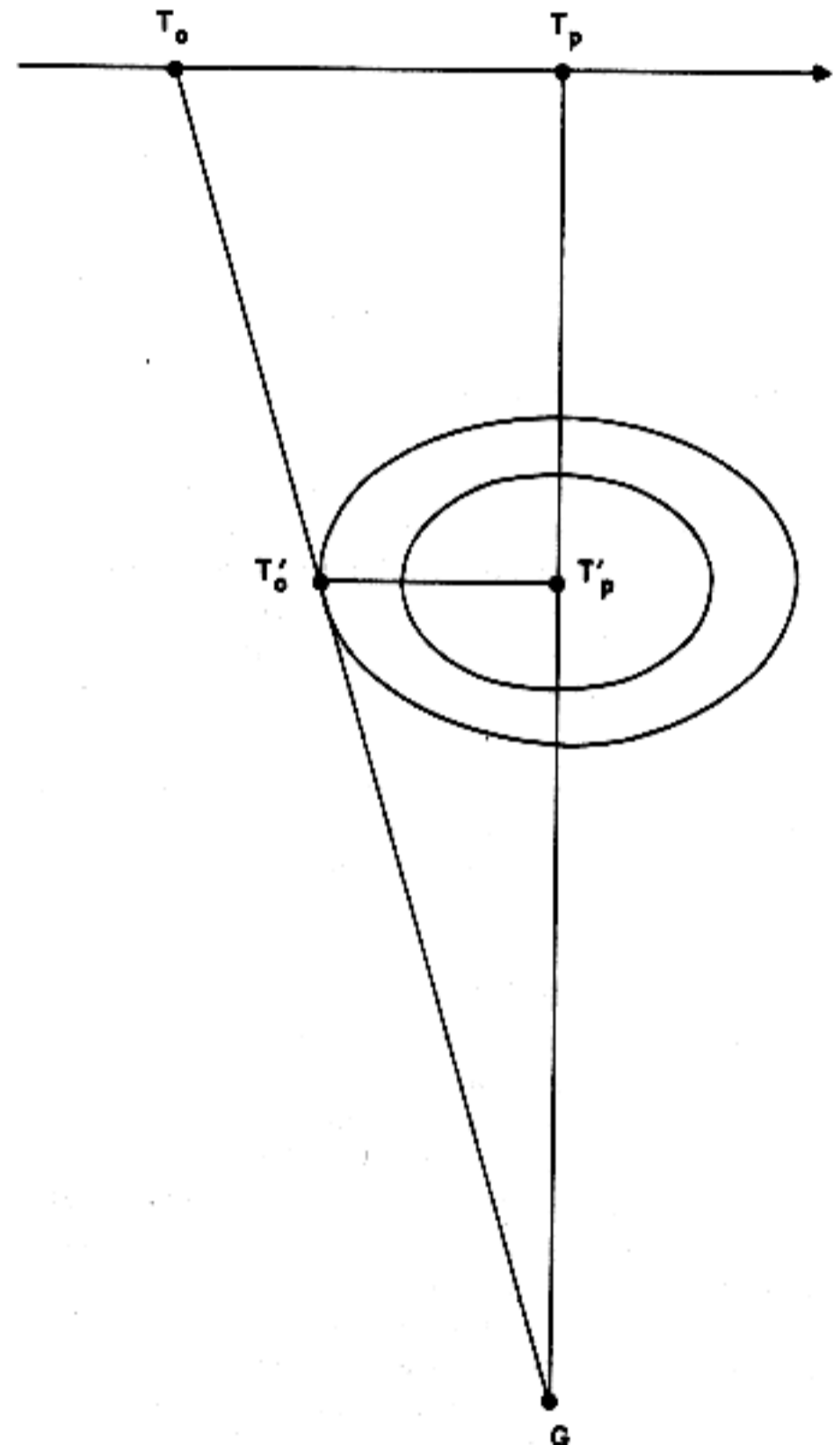

Figure 4-1. Similar triangles, speed ring sight.

aid the tracker in keeping the target nose pointed toward the center of the sight.

b. *Rear Sights.* Both rear sights are peep

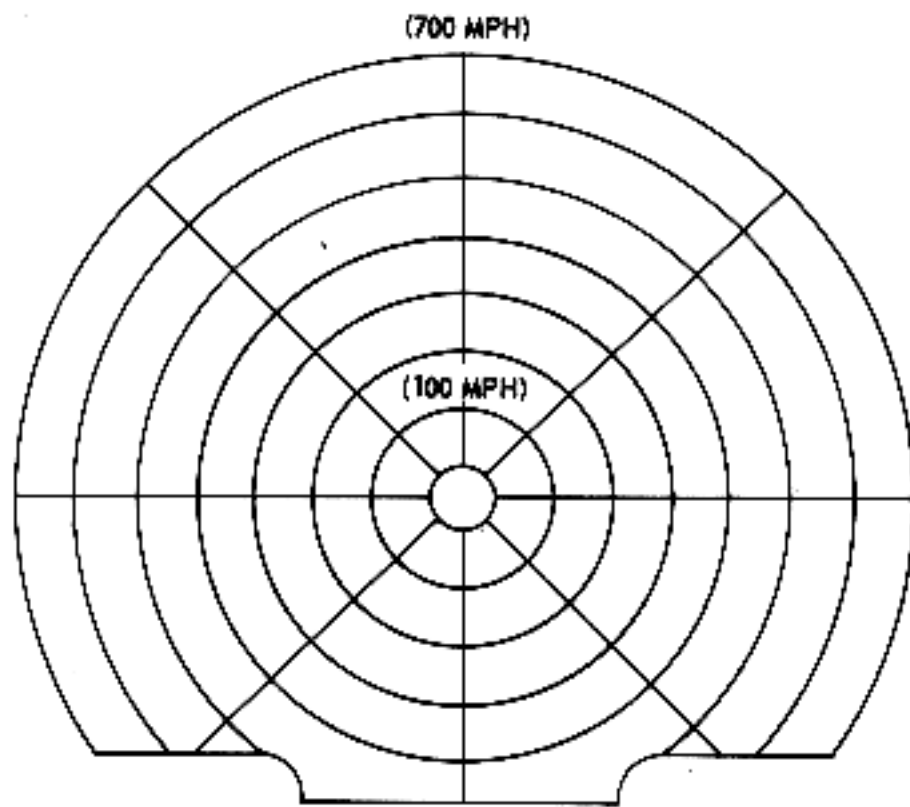

Figure 4-2. Speed ring sight used on M42.

sights, but are mounted differently and adjusted differently for alinement.

(1) To adjust the left peep sight in elevation, loosen the safety nut holding the peep sight bracket to the bracket stud and swing the bracket up or down. To adjust the left peep sight in azimuth, loosen the cap screw holding the sight in the bracket and move the peep sight in or out of the bracket.

(2) To adjust the right peep sight in azimuth, loosen the wing nut on the bottom of the sight and slide the sight right or left. The right peep sight cannot be adjusted in elevation.

### 4-3. Reflex Sight M18

*a. Description.* The reflex sight M18 (fig. 43) used on the multiple caliber .50 machinegun mount consists of a mounting bracket, sight assembly, and housing assembly. The sight assembly contains the optical system of the reflex sight, while the housing assembly provides for artificial illumination when desired. The housing assembly can be raised by pulling out on the housing knob and rotating it 90°. In the up position, the housing assembly will allow daylight to enter the optical system of the sight assembly. The light rays, either from a natural or artificial source, pass through the sight assembly window. The diffused light passes through the reticle, is reflected 90° by a mirror, and is focused at infinity by a double-lens objective in the objective assembly. The reticle image from the objective assem-

bly strikes the reflector which is held at an angle of 45°. This reflector is a chemically-treated glass plate that acts as both a mirror and a window. To the tracker, the image appears in space at the same range as the target. This image has four speed rings and three dots. The speed rings represent the required lead, at a midpoint range of 1,000 yards (914.4 meters), for targets traveling 100 (160.9), 200 (321.8), 300 (482.7), and 400 (648.6) miles (kilometers per hour, respectively). The lower dot is the hub or center of the speed ring reticle. The upper dot is used during boresighting to establish superelevation and is approximately 10 mils from the dot at the hub. The dot located midway between the hub and the upper dot is used to vary superelevation in surface firing and represents approximately 5 mils of superelevation. For alinement, the sight is adjusted vertically by loosening the elevation clamp nut and turning the elevation adjusting screw, moving the reticle image up or down. For lateral adjustments, the azimuth clamp nut is loosened and the azimuth adjusting screw is turned, moving the reticle image left or right as desired.

*b. Operation.* The tracker sights at the target through the reflector. He moves the mount in azimuth and elevation until the reticle image is properly superimposed on the target. The speed ring image always subtends the same lead angle regardless of range to the target. The point  $T$ , (fig. 4-1) is the point on the reticle image corresponding to the tracking point.  $T_0'$  is the geometric center of the reticle image. Point  $G$  is the point of convergence of the reticle image. The position of the tracker's eye does not affect the image position. The only requirement is that the tracker look into the reflector in such a manner that the reticle image is reflected back to his eye and, at the same time, the target is visible through the reflector.

### 4-4. Gunnery Chain, Speed Ring Sights

*a. Link I.* The tracker's line of sight is established when the target appears within the sight pattern (fig. 44). This requirement is not exacting since the other links of the gunnery chain will position the target at one specific spot in the sights.

*b. Link II.* The tracker keeps the nose of the target pointing toward the center of the sight. This will establish the axis of the gun bore (disregarding superelevation) in the slant plane. The tracker visualizes the target course line by ex-

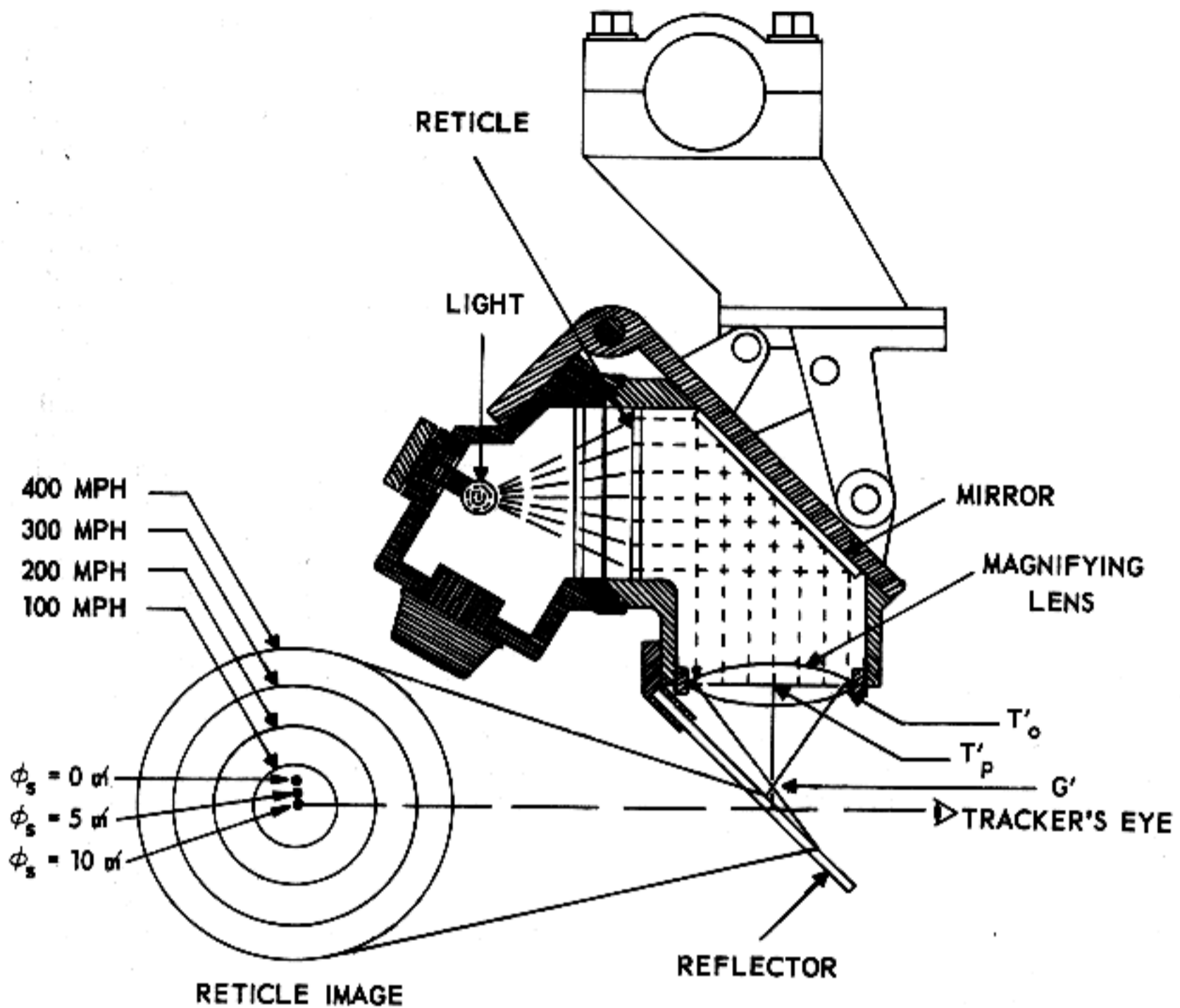

Figure 4-5. Reflex sight M18, cross section.

tending the center line of the fuselage of the target. Then he positions the target in the sight so that the target course line passes through the center of the sight. In figure 4-4, the target course line is above the hub of the sight. The axis of the gun bore is represented by the center of the sight. Therefore, the axis of the gun bore (disregarding superelevation) is not in the slant plane, and the sight must be elevated until the center lies on the target course line (fig. 4-5). When a target is being tracked properly, on a level crossing course, it will appear to be climbing toward the center of the sight on the approaching leg, will appear to level off at midpoint, and will appear to be diving toward the center on the receding leg. This appearance of the target rotating about the hub of a sight is called *image spin* and makes the maintenance of link II a continuous operation.

c. *Link III.* The tracker establishes the correct amount of lead (fig. 4-6). The required lead angle is constantly changing because the angle of approach and range are constantly changing. When the tracker carries the target on one speed ring the entire length of the course, the generated lead is constant. Assuming the speed ring on which the target is tracked represents the correct speed of the target, the generated lead will equal the required lead only when  $D_p$  equals the range for which the sight was designed. To establish link III, the tracker must be able to estimate the speed of the target correctly. If the tracker should overestimate the speed of the target, the result would be the firing of an entire course with all rounds ahead of the target. To eliminate this possibility, the tracker must adjust the sight picture so that the center of the target will lie under a speed ring representing three-fourths of

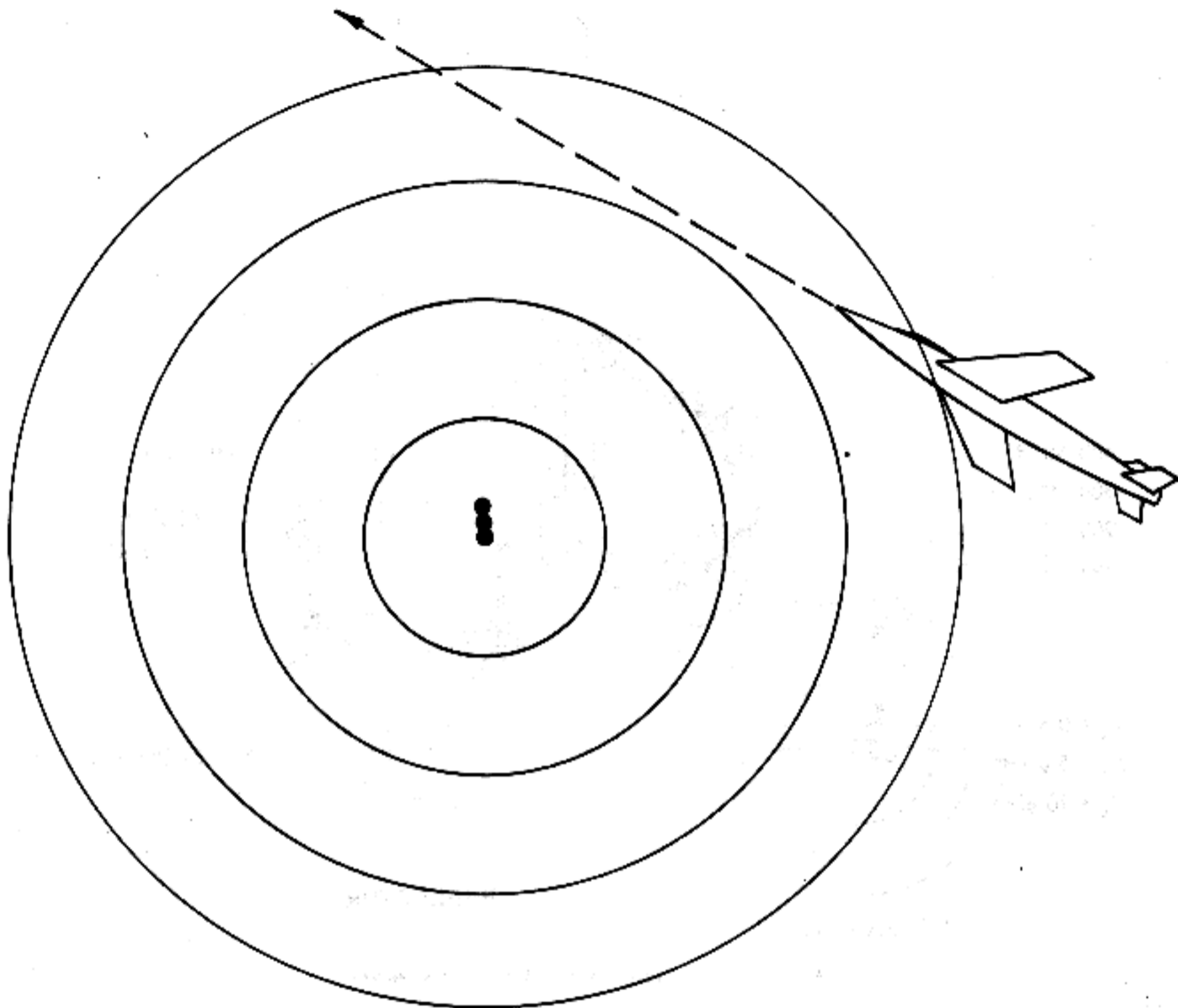

Figure 4-4. Link I established.

the estimated target speed (fig. 4-6). Using this rule, the tracker is given a leeway in target speed estimation and will be assured of an effective flythrough. The factor of three-fourths speed gives the greatest assurance of at least one effective flythrough. Figure 4-7 illustrates a flythrough. As explained in paragraph 2-10, the required lead angle increases as the target approaches midpoint and decreases after midpoint. Using a fixed lead generated by a speed ring, representing three-fourths of estimated target speed, will cause the generated lead angle to be too great at the beginning of the course and too small at midpoint. After midpoint the generated lead will change from too small to too great again as the target moves out on the receding leg of the

course. At one point on the incoming leg and one point on the receding leg, the generated lead angle will be correct and the target will fly through these hit zones.

d. *Link IV.* Superelevation is set into speed ring sights during alinement and is a fixed value. In every case, the aiming point will be alined with a point above the center of the sight. The sight pictures, when the sights are properly alined on the aiming point, are depicted in figure 4-8. The first step in alining any speed ring sight is to boresight the gun on the aiming point.

(1) *Reflex sight M18.* The top dot is alined with the aiming point; then, when the bottom (center of sight) dot is used for tracking, 10 mils



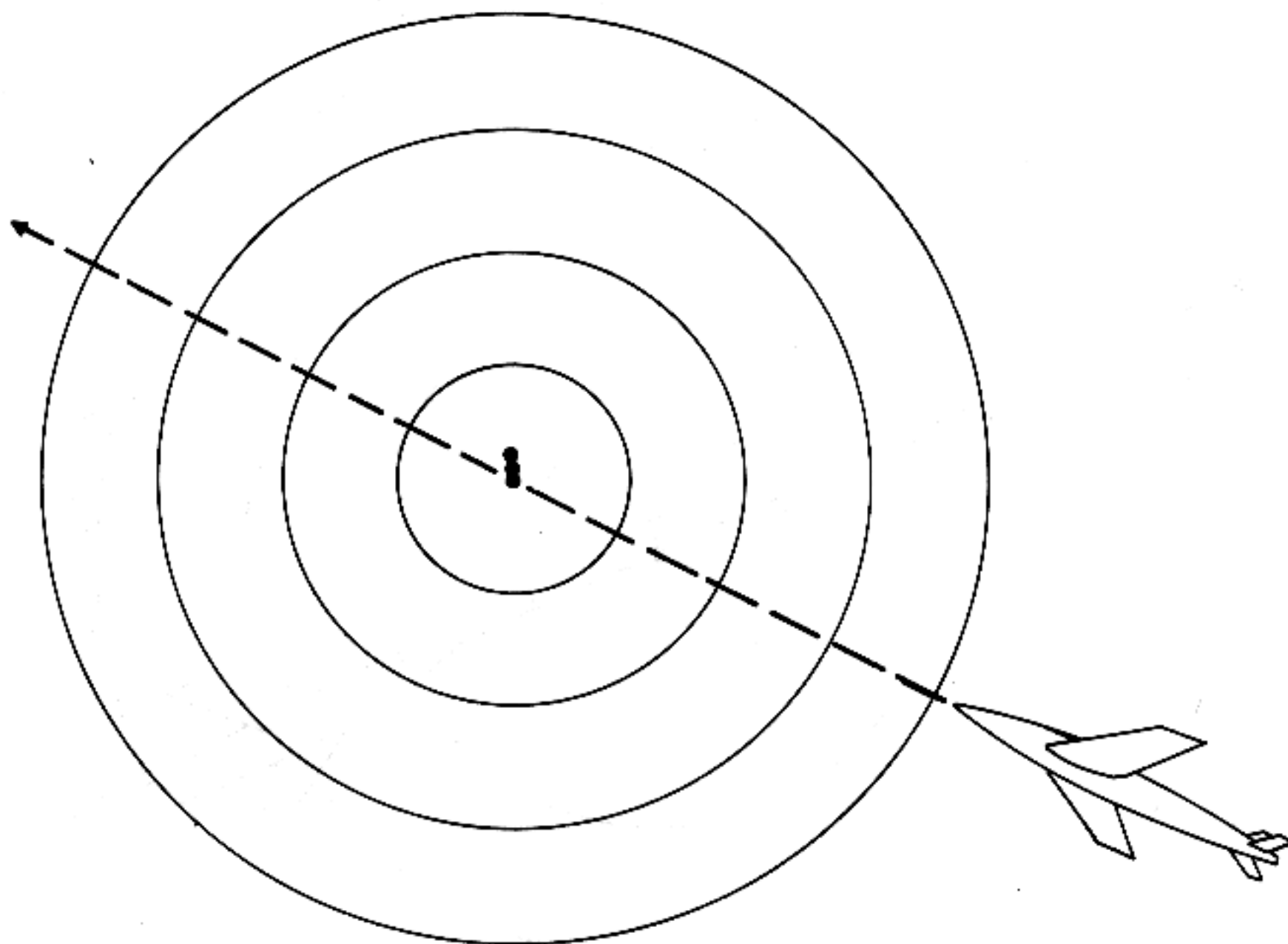

Figure 4-5. Link II established.

of superelevation are set in. The middle dot, representing 5 mils of superelevation, is used in surface firing.

(2) *Speed ring auxiliary sight for M42 gun.* The peep sight is adjusted so that the aiming point appears two-thirds of the distance from the center of the sight to the top of the innermost ring. This alinement will set in 10 mils of superelevation.

#### 4-5. Adjustments for a Hit

*a. General.* Speed ring gunnery does not necessarily depend on tracer observation. If the tracker establishes the four links of the gunnery chain as prescribed, flythroughs will be obtained. If, however, the tracker is able to make a positive tracer sensing, a correction should be made under certain circumstances.

*b. Line.* If the tracers appear high, low, left, or right, depending on the type of course, the tracker should adjust the fire. For line adjust-

ment on crossing courses, he moves the center of the sight up or down depending on the correction needed. The basic rule is: *move the center of the sight in the direction you desire the rounds to go.*

*c. Lead.* Because of smoke, dust, and vibration of the gun, the tracker will rarely be able to obtain accurate lead sensings and, therefore, should concentrate on tracking the center of mass of the target on the proper speed ring to obtain two flythroughs. If the tracker does make a lead sensing, an adjustment should be made only if the sensing indicates a hopeless case. A hopeless case is an *Astern* far out on the approaching leg, an *Ahead* in the immediate vicinity of midpoint, and an *Ahead* anywhere on the receding leg of a course. These are hopeless cases because, if the firing is continued in that manner, no flythroughs can occur. For a properly tracked course, tracers should appear *Ahead* far out on the approaching leg, *Astern* in the vicinity of midpoint, and *Ahead* far out on the receding leg. Thus, even a properly tracked course has a hopeless case on

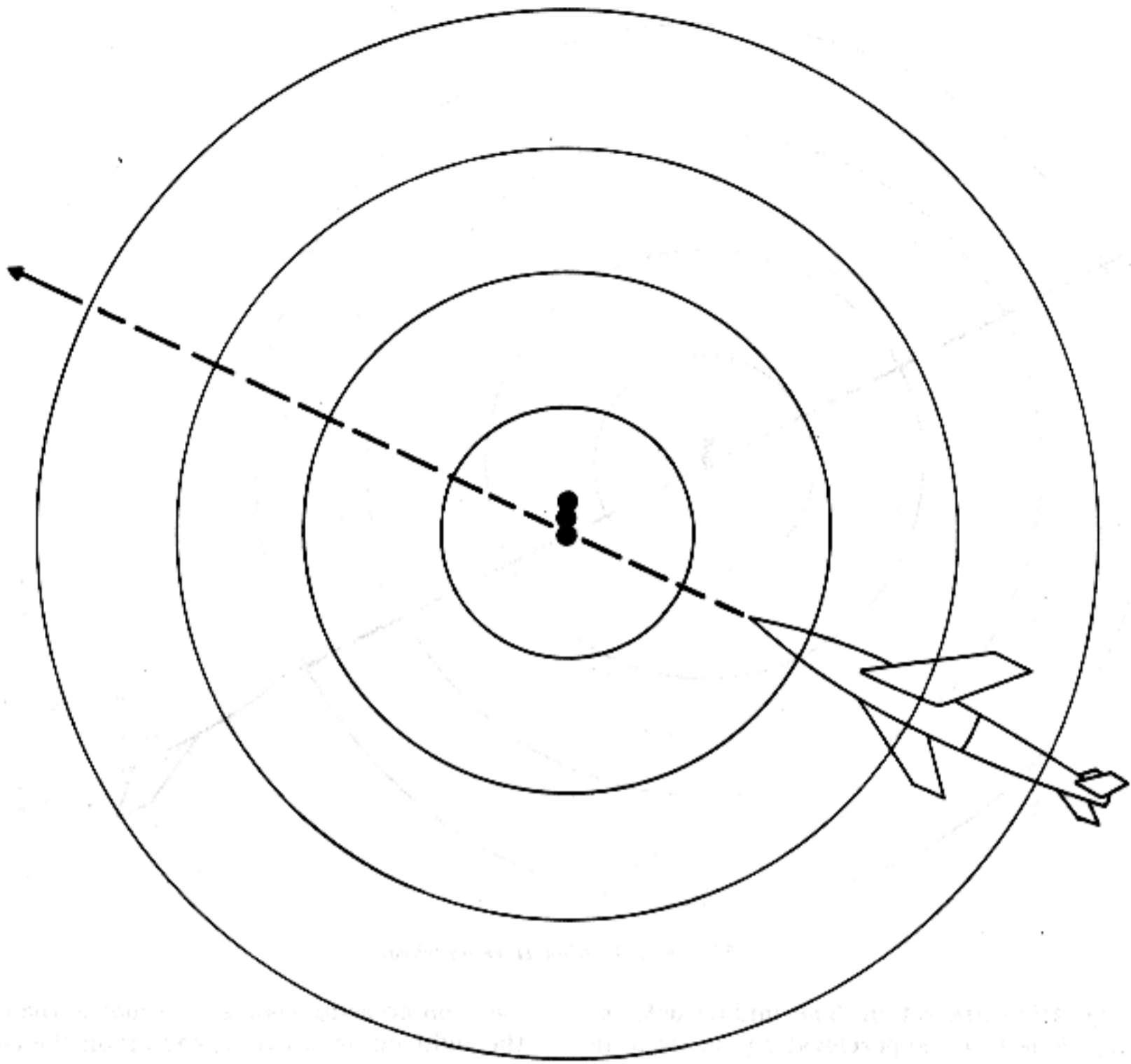

Figure 4-6. Link III established.

the receding leg. To correct for a hopeless case, select a larger or smaller speed ring (at least 100 mph (160.9 km) difference).

**4-6. Speed Ring Sight Engagement Technique**

a. The following technique will bring hits on all types of courses except one:

(1) Point the nose of the target toward the center of the sight at all times.

(2) Track the center of mass of the target on the speed ring representing three-quarters estimated target speed.

(3) Keep firing.

b. The one exception to the above is made during a directly-at-the-gun course. In that course, the rule is to *hold the center of the sight on the nose of the target and keep firing.*

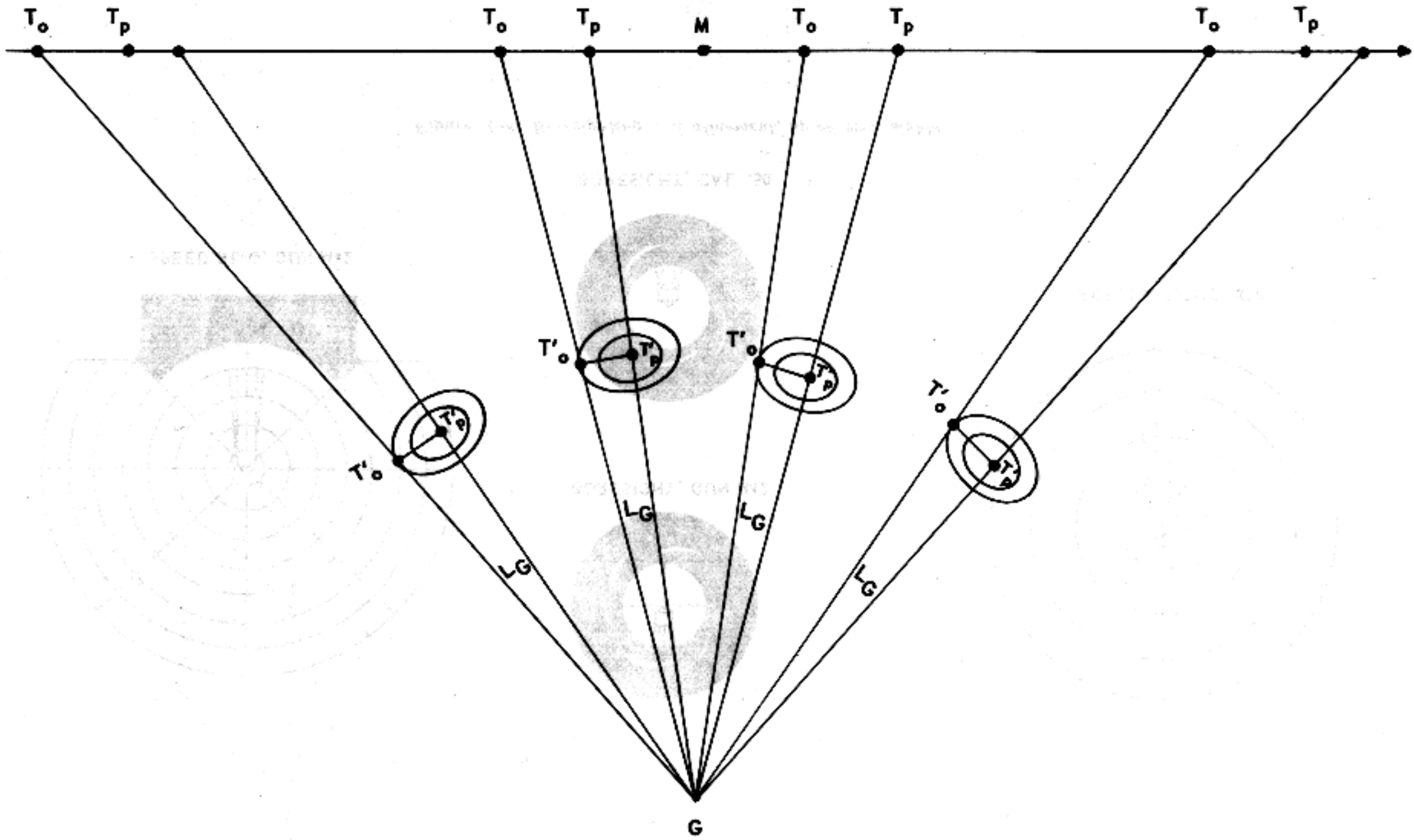
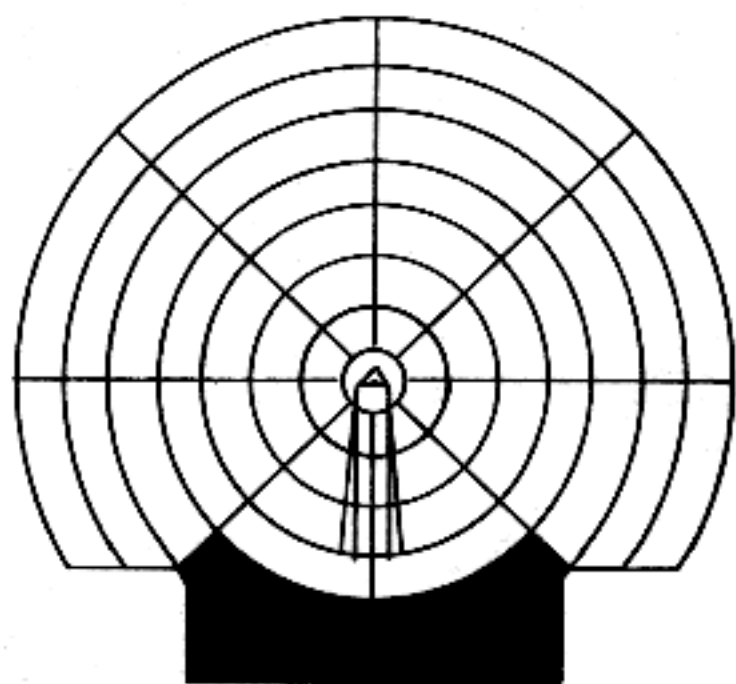

Figure 4-7. Flythrough with constant generated lead angle ( $L_g$ ).



SPEED RING, GUN M42



BORESIGHT, GUN M42



BORESIGHT, CAL .50

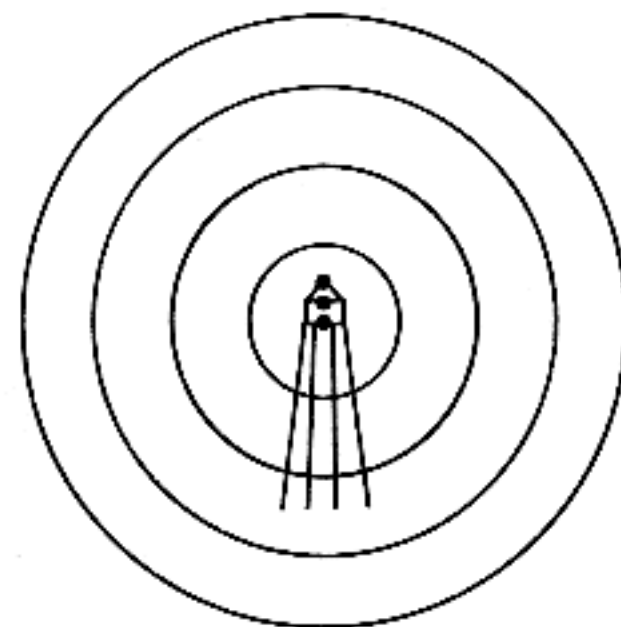

REFLEX SIGHT, M18

Figure 4-8. Boresighting and alinement, speed ring sights.

## Section II. COMPUTING SIGHT M38

## 4-7. General

Computing sight M38 (fig. 4-9) includes reflex sight M24C, a mechanical computer, and the linkage necessary to couple the outputs of the computer to the sight. Computing sight M38 is used with the twin 40-mm gun M42 for controlling fire against rapidly moving aerial and surface targets and against stationary surface targets. Inputs to the sight are target speed and target flight direction. The computer is constructed for accuracy at a range of 914.4 meters (1,000 yd) and computes the required lead angle based on this range constant, target speed, flight direction, and continuously changing angle of approach. Superelevation is generated by a mechanical linkage that causes 9 mils superelevation at 0 mils elevation of the gun and gradually diminishes superelevation to zero as the gun is elevated.

## 4-8. Operation and Functioning

*a. Basic Principles.* Computing sight M38 addresses the solution of the AW gunnery problem through the slant plane concept and the principles of similar triangles.

*b. Operation.* Two men are required to operate the sight. A tracker controls the gun and mount while tracking the center of mass of the target in the center of reflex sight M24C. A computer operator observes the target and enters target course (angle of approach), target inclination (angle of climb or dive), and target speed into the computer, using the following procedure.

(1) Turn computer positioning handwheel (fig. 4-9) to position flight direction indicator (fig. 4-10) so that it points in the same direction that the target is flying.

(2) Turn inclination slide adjusting knob (or position bail directly) (fig. 4-10) to position the flight direction indicator at the same dive or climb angle as that of the target.

(3) Estimate target speed and set it on the speed knob scale (fig. 4-10).

*c. Function Principles.* Figure 4-11 illustrates the basic principles on which the computer functions. The distance traveled by the target during time of flight of the projectile ( $T_o$  to  $T_p$ ), present slant range ( $G$  to  $T_o$ ), and predicted slant range ( $G$  to  $T_p$ ) form a large triangle in the slant plane. To mechanically generate the required lead angle within the computer, a small similar triangle must

be set up within the computer. The computer is so constructed that the speed input determines the length of side  $T_p'$  to  $T_o'$ , represented in figure 4-11 by the inclination slide rack. Side  $T_p'$  to  $T_o'$  is measured from the center of the spur gear at  $T_p'$  to the center of the stud at  $T_o'$ . The inclination slide is made parallel to the target course line by positioning the flight direction indicator in azimuth and dive or climb angle. The stud at  $T_o'$  is mechanically connected to sight M24C, causing the sight to be offset from the axis of the gun tube by the angle  $L_o$  in the slant plane. The flight direction indicator and the inclination slide (and slide rack) are always parallel to each other.

*d. Function Mechanics.* Figure 4-10 shows the position of the computer parts with zero speed and level flight set in. The vertical axis of the computer is the vertical center line of the slide joint stem under these conditions. It can be seen that the stud and the spur gear are centered on each other, and that setting in a dive or climb angle or positioning the computer in azimuth will not cause lateral or vertical movement of the slide joint stem. Consequently, reflex sight M24C will remain lined on the gun tube axis (disregarding superelevation).

(1) *Speed setting.* If a speed of 400 miles per hour is set in by positioning the speed knob (fig. 4-12), the inclination slide is moved back (opposite to the direction of flight) and the stud, vertical and horizontal slides, and slide joint stem move with it. This action will move the tracker's line of sight back along the target course line and cause him to traverse and elevate or depress the gun ahead of the target to again line the sight on target.

(2) *Target course setting.* In figure 4-12, the flight direction indicator shows a level course. Figure 4-13 shows the position of the computer parts for a target speed of 400 miles per hour and a climb angle of  $35^\circ$ . Note that moving the bail and flight direction indicator to the proper climb angle rotated the speed knob, spur gear, and inclination slide together, causing the stud, vertical slide, and slide joint stem to move down. This action will move the sight down (opposite to target flight direction), and the tracker will have to move the gun ahead along the target course line to bring the sight back on target.

(3) *Sight movement.* Figures 4-12 and 4-13 show lateral and vertical movement of the slide



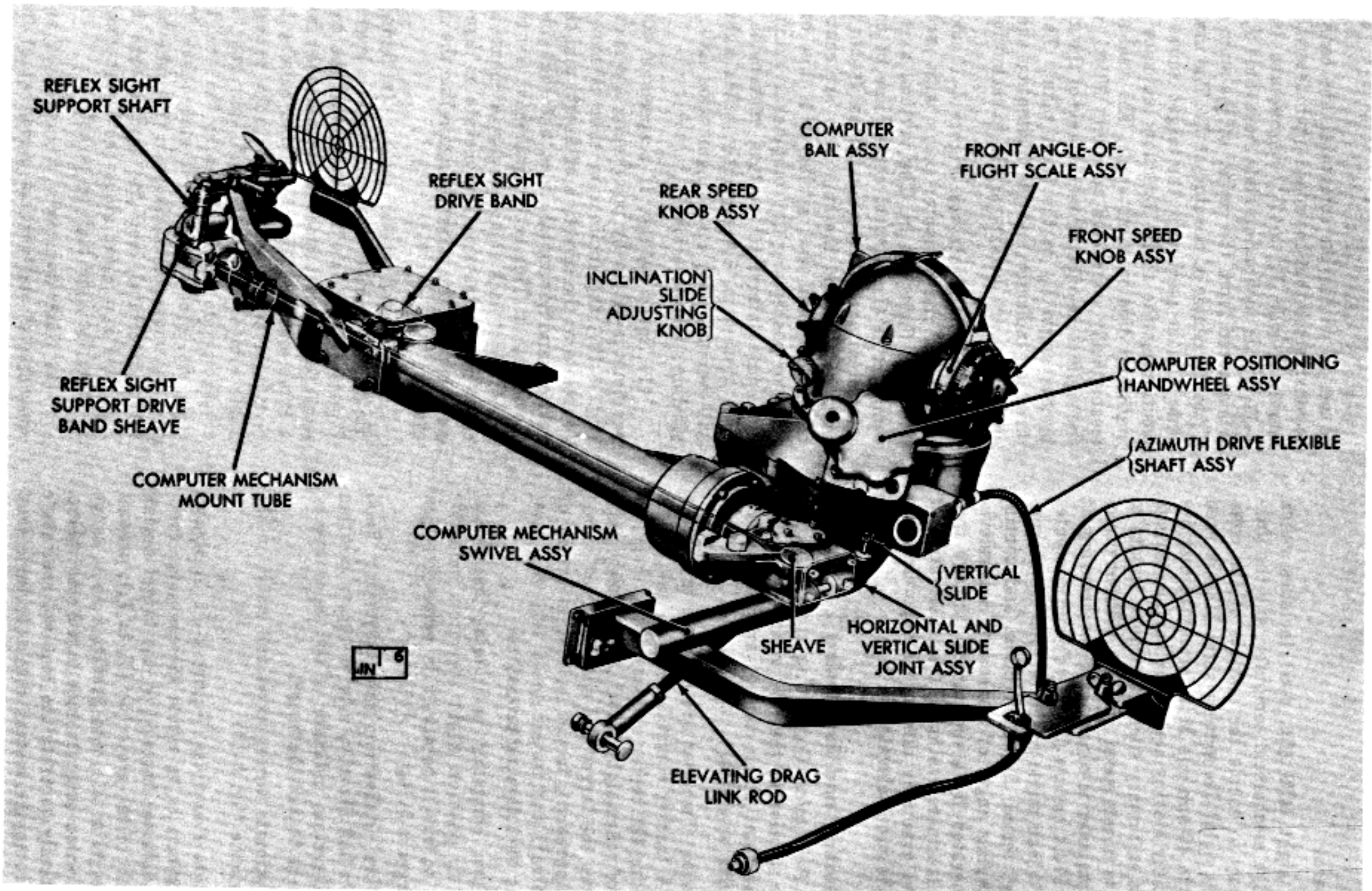

Figure 4-9. Computing sight M58 and auxiliary speed ring sights.



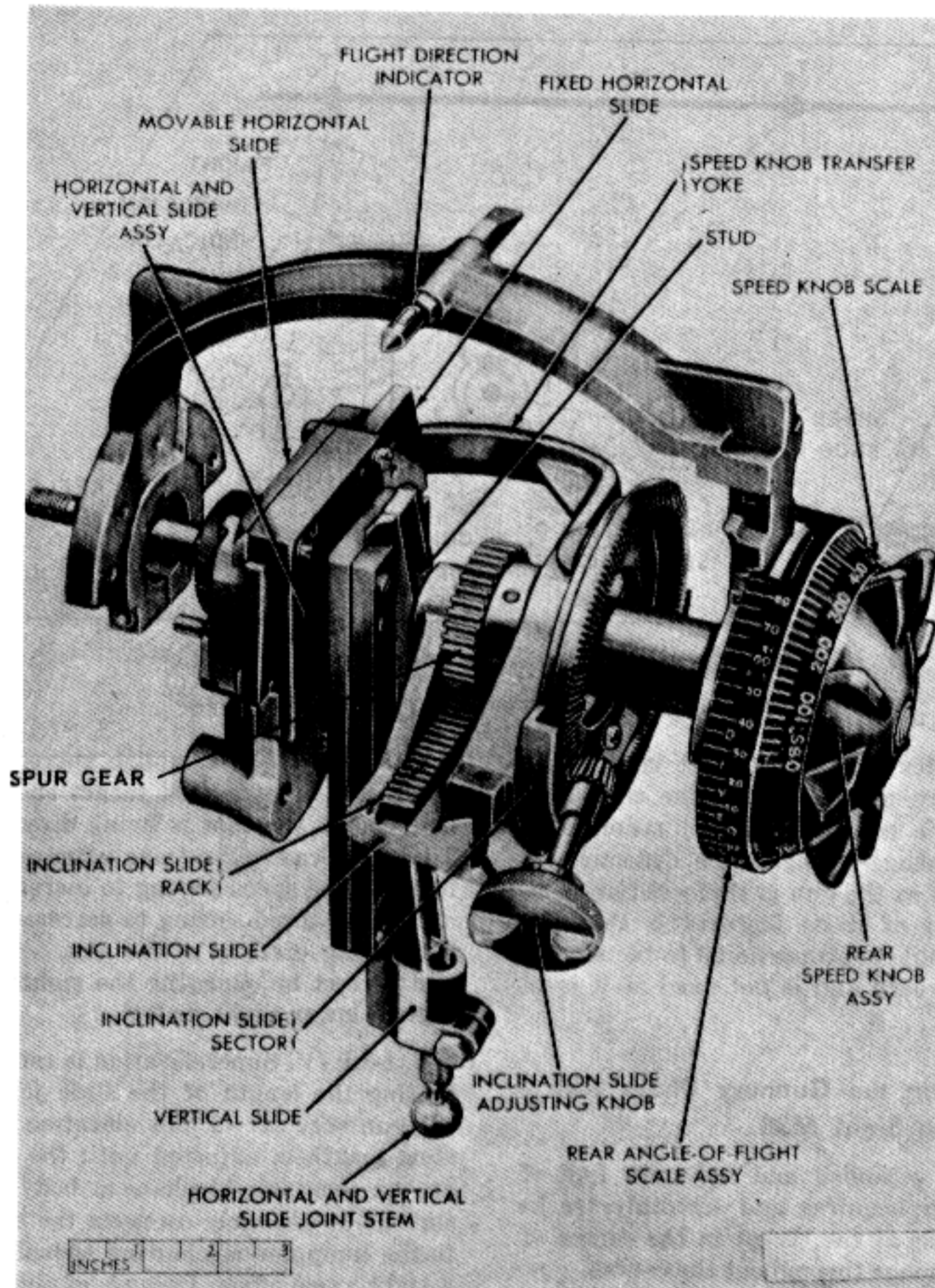

Figure 4-10. Position of slides (zero speed, level flight).

joint stem, respectively. The actual movement of the sight in elevation and azimuth depends on the target course direction as well as on the movement of the slide joint stem. For example, with a directly-at-the-gun course, speed and target course settings will cause a movement of the slide joint stem, but they will cause no movement of the sight even though the stem ball moves vertically and laterally as the speed knob is turned.

(4) *Course memory feature.* The computer

is positioned in azimuth by both the computer positioning handwheel and by the azimuth drive flexible shaft (fig. 4-9) working through a differential. As the gun is traversed, the computer, including the flight direction indicator and inclination slide, will remain parallel to the target course line because the flexible shaft turns it an equal amount and in the opposite direction to the gun movement. As the gun is elevated or depressed, the elevating drag link rod (fig. 4-9)

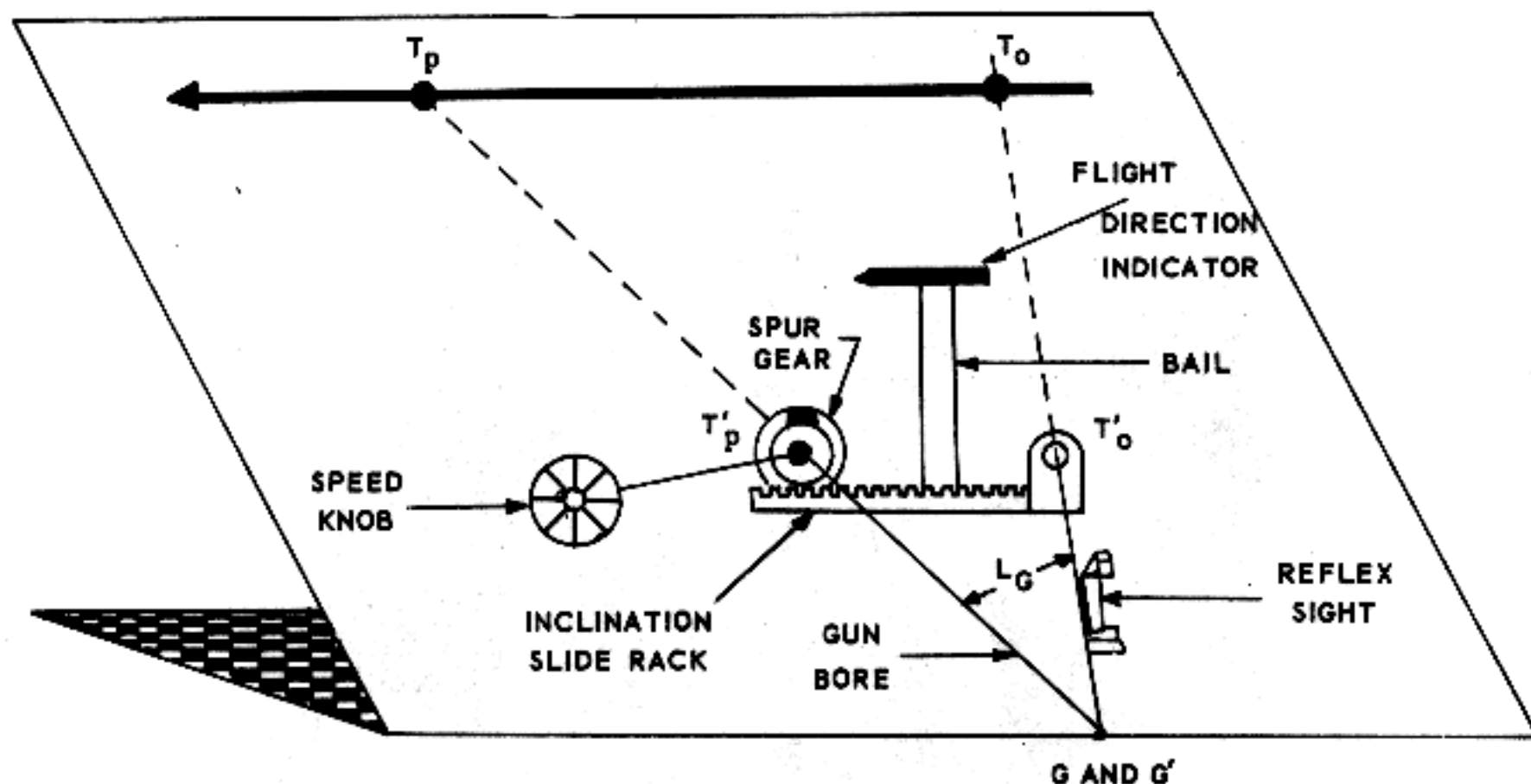

Figure 4-11. Basic principles of computing sight M38.

keeps the computer level. The effect is that the gun and sight are moved around the computer. Because the angle between the inclination slide and the sight linkage changes, the deflection of the sight changes as the gun is traversed and elevated. The result of these features is that the generated lead angle is proportional to the sine of the angle of approach and is not fixed as it is in speed ring sights.

#### 4-9. Establishing the Gunnery Chain with Computing Sight M38

*a. Link I.* To establish and maintain line of sight, the gunner acquires and smoothly tracks the center of mass of the target in the center of the sight reticle image throughout the course.

*b. Link II.* To place the axis of the gun bore (disregarding superelevation) in the slant plane, position the computer and the inclination slide so that the flight direction indicator is parallel to the target course line. To raise shots to the target course line, adjust the inclination slide to bring the point of the flight direction indicator up. To bring shots down to the target course line, adjust the inclination slide to bring the point of the flight direction indicator down. An exception is made in the case of a target flying directly at the gun; in this case, ignore the flight direction indicator and set speed at zero.

*c. Link III.* To establish correct lead, set the speed to full estimated target speed for all targets except one that is flying directly at the gun. To make lead corrections after sensing tracers, increase the speed setting to increase lead and decrease the speed setting to decrease lead. For targets flying directly at the gun, set in zero speed and correct by changing the sight picture to aim higher, lower, right, or left.

*d. Link IV.* Superelevation is established by adjusting the length of the slide joint stem. With the gun bore at  $-9$  mils elevation, the slide joint stem length is adjusted until the quadrant seats on the computer mechanism body are level. The slide joint assembly connects the slide joint stem to the computer mechanism swivel assembly with a right-angle offset. Because of this offset, the superelevation will decrease from 9 mils at 0 mils elevation to 0 mils at 1,600 mils elevation. (For details on making the superelevation adjustment, see TM 9-7218.)

*e. Computer Synchronization (Leveling).* To perform properly, the computer must be level with the gun mount at all elevations of the gun. Adjustment of synchronization is accomplished by adjusting the length of the elevating drag link rod (fig. 4-9). (For details on making synchronization adjustments, see TM 9-7218.)

*f. Sight Alinement.* To aline reflex sight M24C

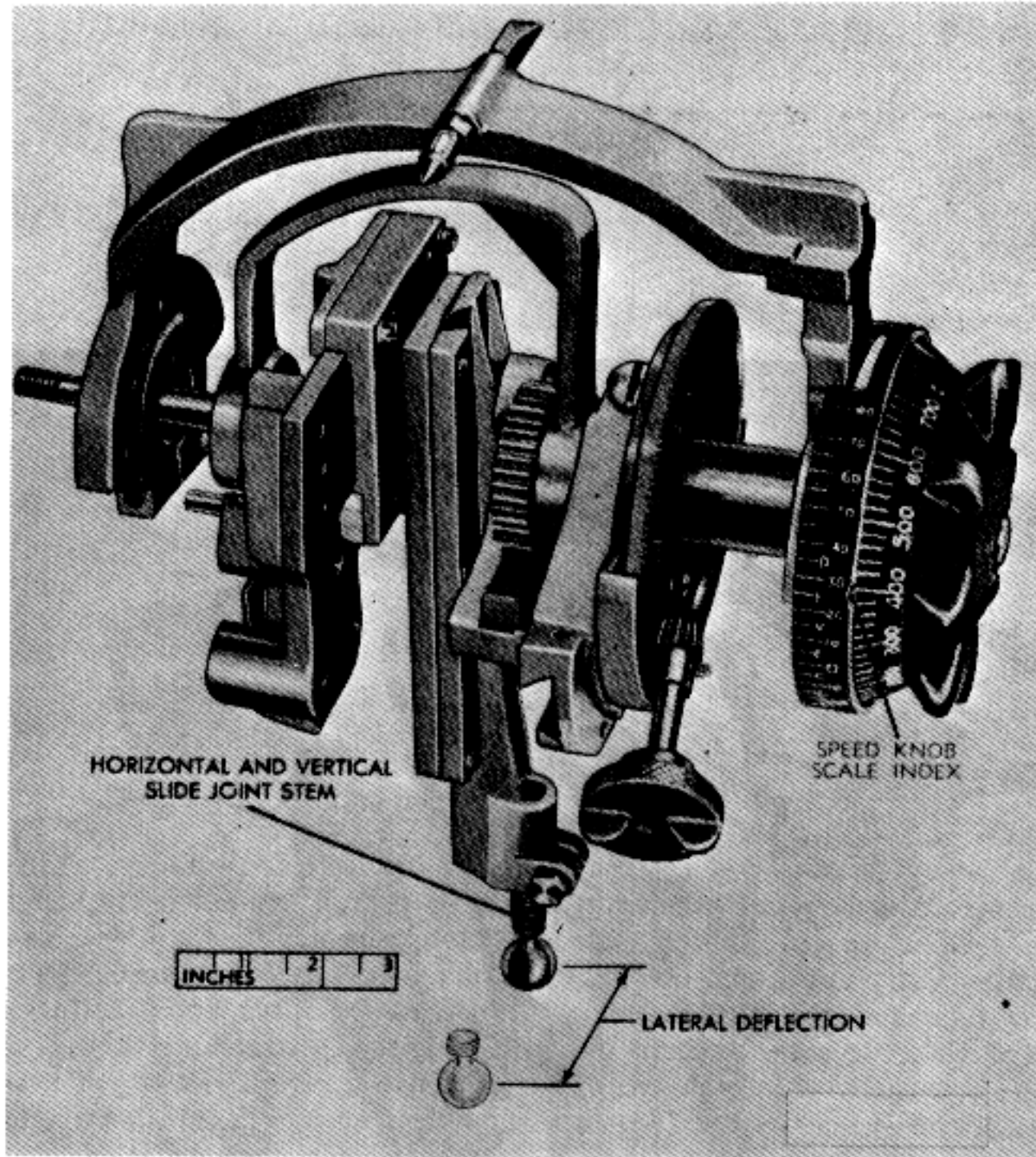

Figure 4-12. Computer slide positions (speed 400 mph, level course).

(fig. 4-14), the gun must be boresighted on an aiming point (fig. 4-8); the computer, flight direction indicator, and speed knobs positioned as

prescribed in FM 44-61 to eliminate superelevation; and the reflex sight adjusted to align the center of the reticle image on the aiming point.



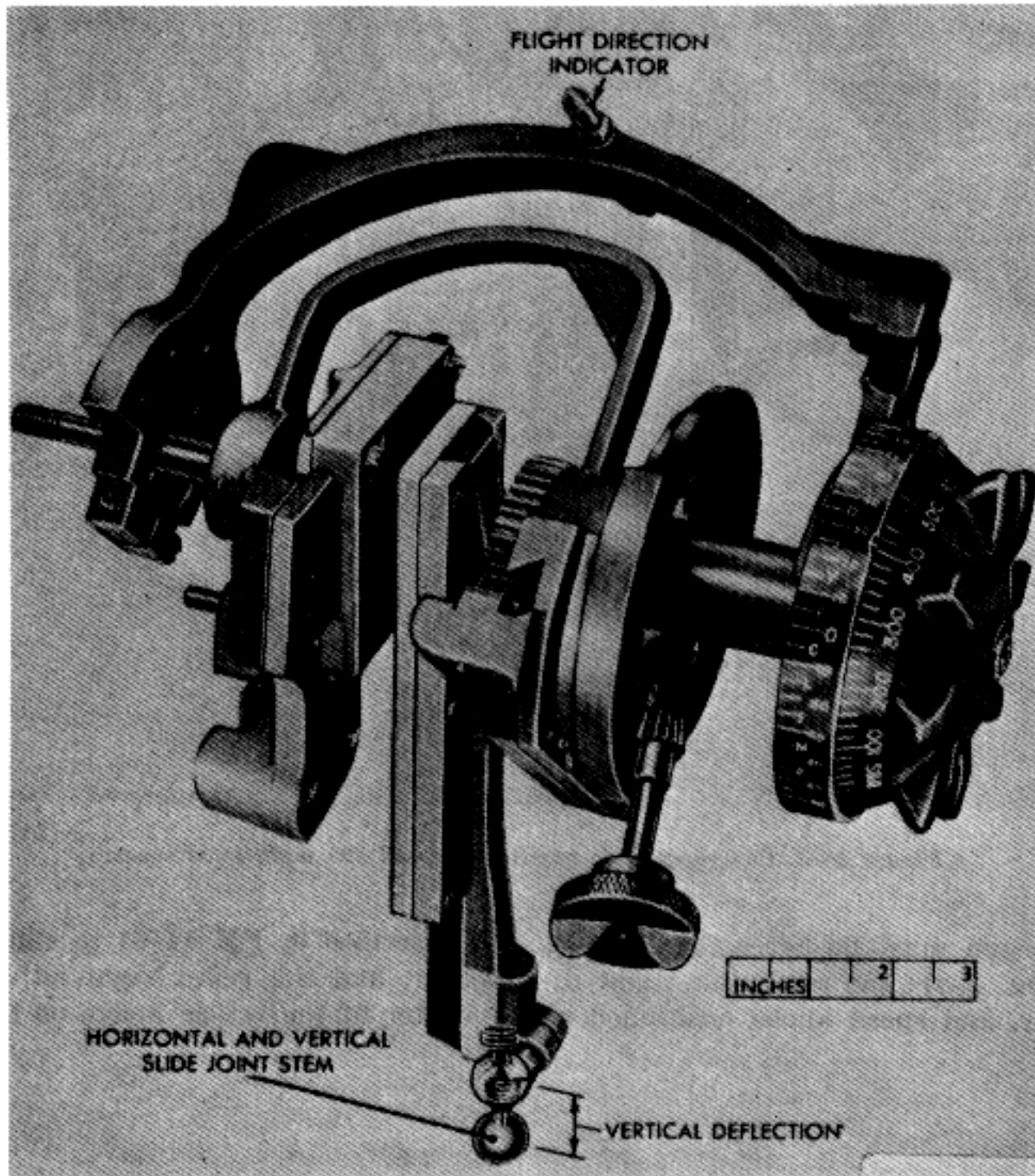

Figure 4-13. Computer slide positions (speed 400 mph, climbing course).

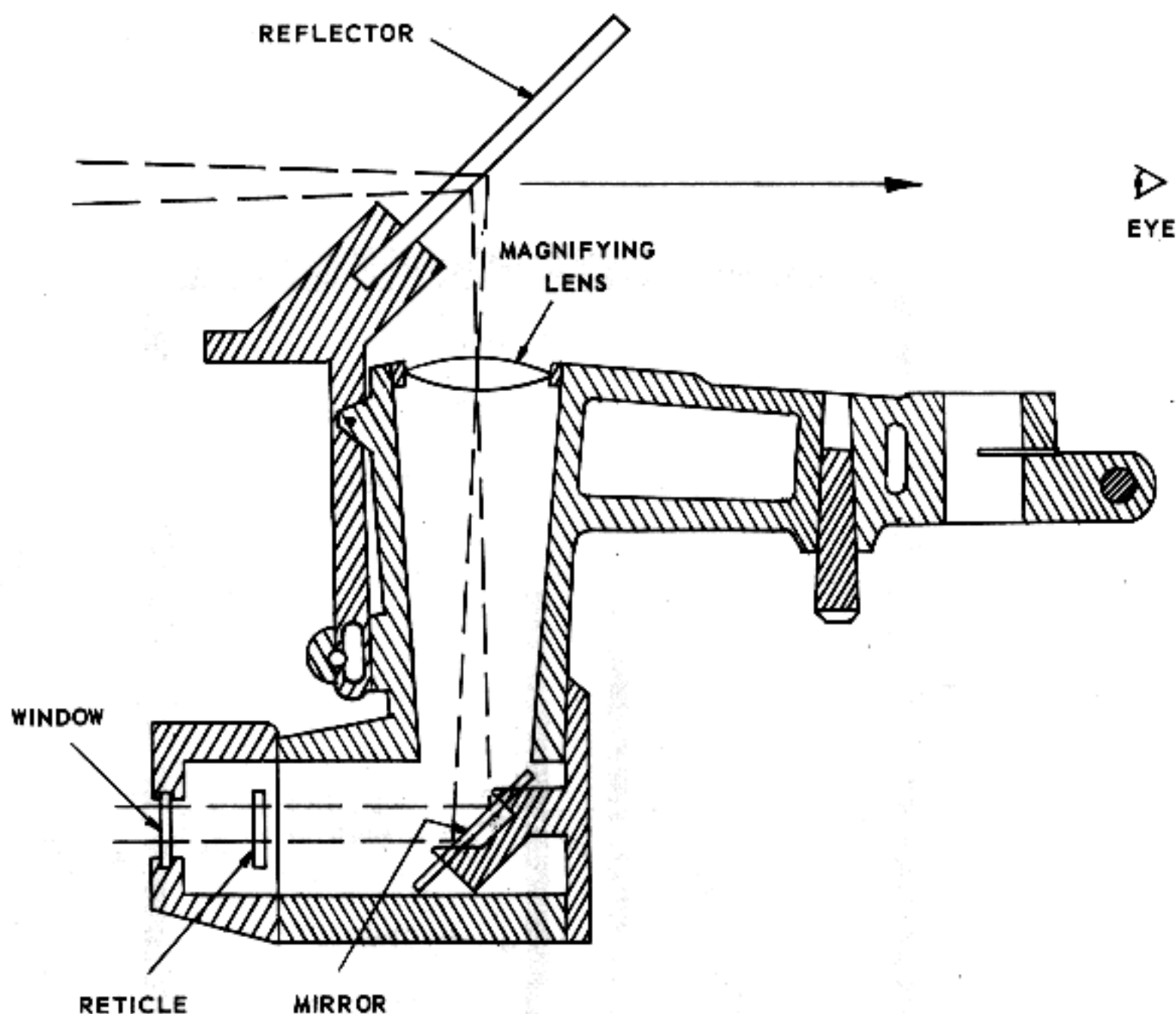

Figure 4-14. Reflex sight M24C.

### Section III. COMPUTING SIGHT XM61

#### 4-10. General

Computing sight XM61 is used on the towed and self-propelled Vulcan weapon systems. This sight is part of a fire control system that includes a range-only radar and a sight current generator. It uses electric current inputs from the sight current generator and the angular rate of traverse and elevation to position the vertical and horizontal axes of a gyroscope. The positions of the gyroscope axes are transmitted mechanically to position the sight reticle image up or down and left or right in accordance with the computed lead angles. Superelevation is computed in the sight current generator and is received by the torque motor in the sight. The torque motor current effects movement of the gyro vertical axis and causes the sight reticle image to be moved down

an amount equal to the required superelevation. The sight contains a reticle illuminating lamp and a ready-to-fire indicator lamp. The sight case is a sealed unit, filled with dry nitrogen at a pressure of 5 pounds per square inch.

#### 4-11. Operation and Functioning

*a. Basic Principles* (fig. 4-15). The computing sight XM61 solves the AW gunnery problem in the slant plane, but, unlike the M38 sight, it solves for the required lead angle by generating an angular rate of target movement and multiplying that rate by the time of flight of the projectile. Range, range rate, muzzle velocity, air density, external ballistics, and angular rate are combined by the sight current generator to determine magnet current and torque motor current

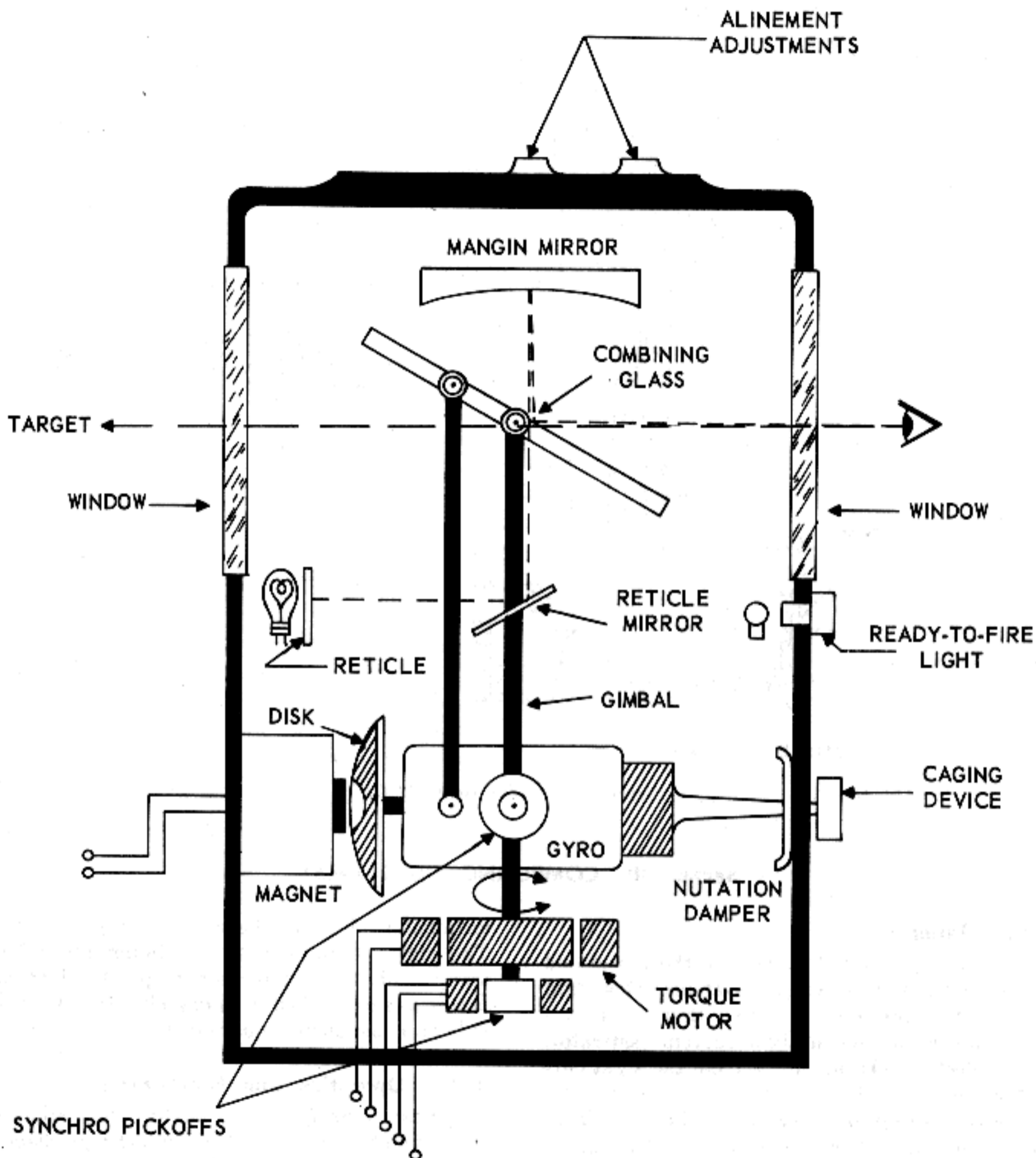

Figure 4-15. Sight XM61, schematic.

inputs to the sight. The magnitude of the magnet current is a factor in the size of the generated lead angle and the magnitude of the torque motor current is a factor in the size of the generated superelevation angle.

b. *Operation.* Using computing sight XM61, the Vulcan system can be operated in either the radar, manual, external, or ground mode. Selection of the mode of operation desired is made by



turning the MODE switch on the weapon control panel to RADAR, MAN, EXT, or GRD.

(1) *Radar mode.* When the MODE switch is turned to RADAR, the radar is put in a standby condition, ready for use after a 2-minute warm-up. To operate in the radar mode, the following procedure is followed:

(a) Turn MODE switch to RADAR, and wait until the READY WHEN LIT indicator lamp on the control panel lights.

(b) Manually uncage sight.

(c) Slew mount to bring sight reticle center on target. If possible, bring sight on target from the rear of target.

(d) Press foot switch and continue to track target.

(e) When radar locks on target, sight reticle will move quickly to a position behind the target. Smoothly bring sight back on target and keep it there for at least 2 seconds before firing the gun. Ready-to-fire lamp must light before gun is fired.

(f) Continue to track target smoothly while firing.

(g) If sight is slightly off target at end of burst, move it back on and wait at least 2 seconds before firing again. If sight gets off target, the radar may break lock; check the ready-to-fire lamp.

(2) *Manual mode.* The radar is not used in the manual mode of operation. Range and target speed must be set on the RANGE and TARGET SPEED controls on the control panel. Electrical caging must be accomplished by the gunner pressing the sight cage switch on the left control handle. To engage a target in the manual mode, proceed as follows:

(a) Turn MODE switch to MAN.

(b) Set TARGET SPEED control to estimated speed of target.

(c) Set RANGE control to estimated range at which the target will be when fire will commence.

(d) Manually uncage sight.

(e) Press sight cage switch and acquire target in sight reticle image by moving sight reticle image up from behind the target.

(f) Release sight cage switch when center of reticle image is on the tail of the target and bring center of reticle image on center of target.

(g) Track center of target smoothly for at least 2 seconds, then fire.

(h) Continue to track smoothly while firing and between bursts.

(3) *External mode.* In the external mode, operation must be accomplished by two persons; i.e., the senior gunner and the operator of the external range unit. To operate in the external mode, proceed as follows:

(a) Turn MODE switch to EXT.

(b) Manually uncage sight.

(c) Press sight cage switch and acquire target in sight reticle image by approaching it from the rear.

(d) Release sight cage switch when center of reticle image is on tail of target and bring center of reticle image on target.

(e) External range unit operator sets range, at which he desires to open fire, on external range unit. When estimated range reaches set range, he pushes ready-to-fire switch on external range unit, then continuously adjusts range setting as target range changes.

(f) When ready-to-fire indicator lamp on sight lights, gunner fires and continues to track target.

(4) *Ground mode.* In the ground mode the computing features of the sight are not used. The sight is caged mechanically, automatically setting in a fixed superelevation of 7 mils.

*c. Function Principles.* The sight measures the angular rate of movement of the target and multiplies this rate by the time of flight to the target future position. For example, if the gunner is tracking the target at a rate of  $10^\circ$  per second and the time of flight of the projectile is 2 seconds, the generated lead angle is  $20^\circ$ .

*d. Function Mechanics* (fig. 4-16). Lead angle is generated by the gyro lagging behind the movement of the sight case as the target is tracked. The amount that it lags depends on the rate of tracking and other forces exerted upon it.

(1) *Magnet current.* The main force exerted on the gyro is applied by the range magnet, mounted inside the sight case just in front of the eddy current disk. The eddy current disk is mounted on the left (forward) end of the gyro shaft and spins in the magnetic field of the range magnet. The result is that the magnet tends to pull the gyro around with it as the sight case moves. The strength of the range magnet and, consequently, the amount of gyro lag behind the magnet movement depend on the magnitude of the magnet current and the rate of tracking.

(2) *Torque motor current.* The second force exerted on the gyro is applied by the torque motor. Current supplied to the torque motor exerts a force on the gyro, tending to turn it on its vertical axis. The gyro reacts to this force by moving down on the left (forward) end and causing the reticle image to be depressed an amount equal to superelevation.

(3) *Caging.*

(a) Mechanical caging locks the sight gyro and reticle image in a zero-lead and 7-mil superelevation position. Mechanical caging prevents damage to the sight during rapid movement of the mount. It is also used in ground target fire. To mechanically cage the sight, turn the caging knob on the rear of the sight until the white stripe on the knob is vertical and aligned with the white stripe on the sight case.

(b) Electrical caging applies maximum current to the sight magnet and, in effect, locks the gyro so that the line of sight is parallel to the gun. Electrical caging prevents damage to the sight and keeps the sight, gun, and radar aligned while the mount is slewed to acquire a target. Electrical caging is accomplished manually by pressing the cage switch on the left control handle when operating in the manual and external modes. In the radar mode, the sight is automatically caged when the system has warmed up and remains caged until the radar lock-on signal releases it. It is automatically caged again when the foot switch is released and the radar breaks lock. The lock-on signal removes all magnet current and most of the elevation and azimuth tachometer feedback for a very short acquisition delay. Removal of the magnet current allows the sight to generate a lead angle quickly, and removal of the tachometer feedbacks causes the cannon to accumulate the lead angle at a fast rate. As a result, the mount will jump ahead at lock-on. After this short delay, normal magnet current is applied to the sight, and tachometer feedbacks are

restored. Gunners must be trained to expect this and to bring the reticle image back on target smoothly, with a minimum of correction.

#### 4-12. Establishing the Gunnery Chain

a. *Link I.* To establish and maintain line of sight, the gunner acquires the target by bringing the sight reticle image onto the center of the target from the rear (moving the sight and mount in the same direction that the target is moving) and holding the center of the reticle image on the center of the target. Smooth tracking is a major factor in effective operation of the sight XM61. The slightest jerk or hesitation in movement of the mount will cause extreme changes in the tracking rate, which is a major factor in computation of lead angle.

b. *Link II.* The axes of the gun bores (disregarding superelevation and deliberate dispersion) will be in the slant plane if tracking is accurate. The total displacement of the gun axis from the line of sight is the vector sum of the elevation and traverse angles developed by displacement of the sight gyro and, consequently, the sight reticle image.

c. *Link III.* Correct lead is established by the tracking rate and the magnitude of the magnet current. In the radar mode, the magnet current will be correct if tracking is smooth and accurate, the radar is locked on and functioning properly, the sight current generator is functioning properly, and the muzzle velocity and air density inputs to the sight current generator are correct. Faulty lead would indicate malfunctioning of fire control equipment or faulty tracking. In the manual mode, faulty lead can result from incorrect estimation or setting of target speed and range. An increase in range and speed settings will cause an increased lead angle.

d. *Link IV.* Superelevation is computed by the sight current generator and applied through the torque motor to the gyro.

## CHAPTER 5

### SURFACE FIRING

#### Section I. INTRODUCTION

##### 5-1. General

Air defense automatic weapons can be fired against surface targets by either direct or indirect fire methods. Direct fire is used against targets that are visible to the trackers at the weapon. Indirect fire is used against targets that cannot be seen through the weapon sights.

##### 5-12. Basic Elements of Data

Regardless of the method used in surface fire, certain elements of data are always present in the gunnery problem.

*a. Direction, Gun to Target.* The horizontal

angle in mils measured in a clockwise direction from a fixed reference (usually grid north) to the target is called direction to target.

*b. Angle of Site.* The vertical angle between the horizontal plane and the gun-target line is called the angle of site.

*c. Range.* Range is the horizontal distance from gun to target.

*d. Target Description.* The type of target is an important factor in determining the type of ammunition to be used. Dimensions of the target will aid in determining range when using binoculars and applying the mil relation formula.

#### Section II. DIRECT FIRE

##### 5-3. General Procedure

Direct fire is aimed fire in which the gun is laid by sighting directly at the target. Corrections are made by sighting above or below, and left or right, of the target. The gun is laid by the gunner (or trackers) visually lining the sight on the target.

*a. Azimuth.* The vertical center line of the sight is positioned on the center of mass of a stationary target, or ahead of a moving target.

*b. Elevation* (fig. 5-1). The horizontal center line of the sight is positioned on the center of mass of the target, or above or below the target, depending on range. To determine how much above or below the target to position the line of sight, the required superelevation for that range and the superelevation already set into the sight must be considered. Angle of site will automatically be included in the gun elevation (quadrant elevation) when the sight is on target.

(1) Quadrant elevation is the vertical angle of the gun bore axis above or below horizontal. It is the algebraic sum of the angle of site and superelevation.

(2) Superelevation for a given range to the target will vary with the height of the target above or below the horizontal plane at the gun. Firing tables for ADA AW contain superelevation data for targets at altitudes above the gun.

(8) Some superelevation is set into the sighting systems of all air defense artillery automatic weapons. This preset superelevation will be the correct amount for firing at surface targets at specific ranges. If the target is at less or more than these ranges, the sight should be positioned an estimated amount below or above, respectively, the center of the target. Weapons, sights, ranges, and preset superelevations for current automatic weapons are as follows:

(a) M42—M38 sight—1,060 meters—9

(b) M55—M18 sight—990 meters—10  
mils.

(c) Vulcan—XM61 sight (mechanically caged)—500 meters—7 mils.

##### 5-4. Specific Direct Fire Methods

*a. Stationary Targets.*

(1) *Computing sight M38.* Manual control



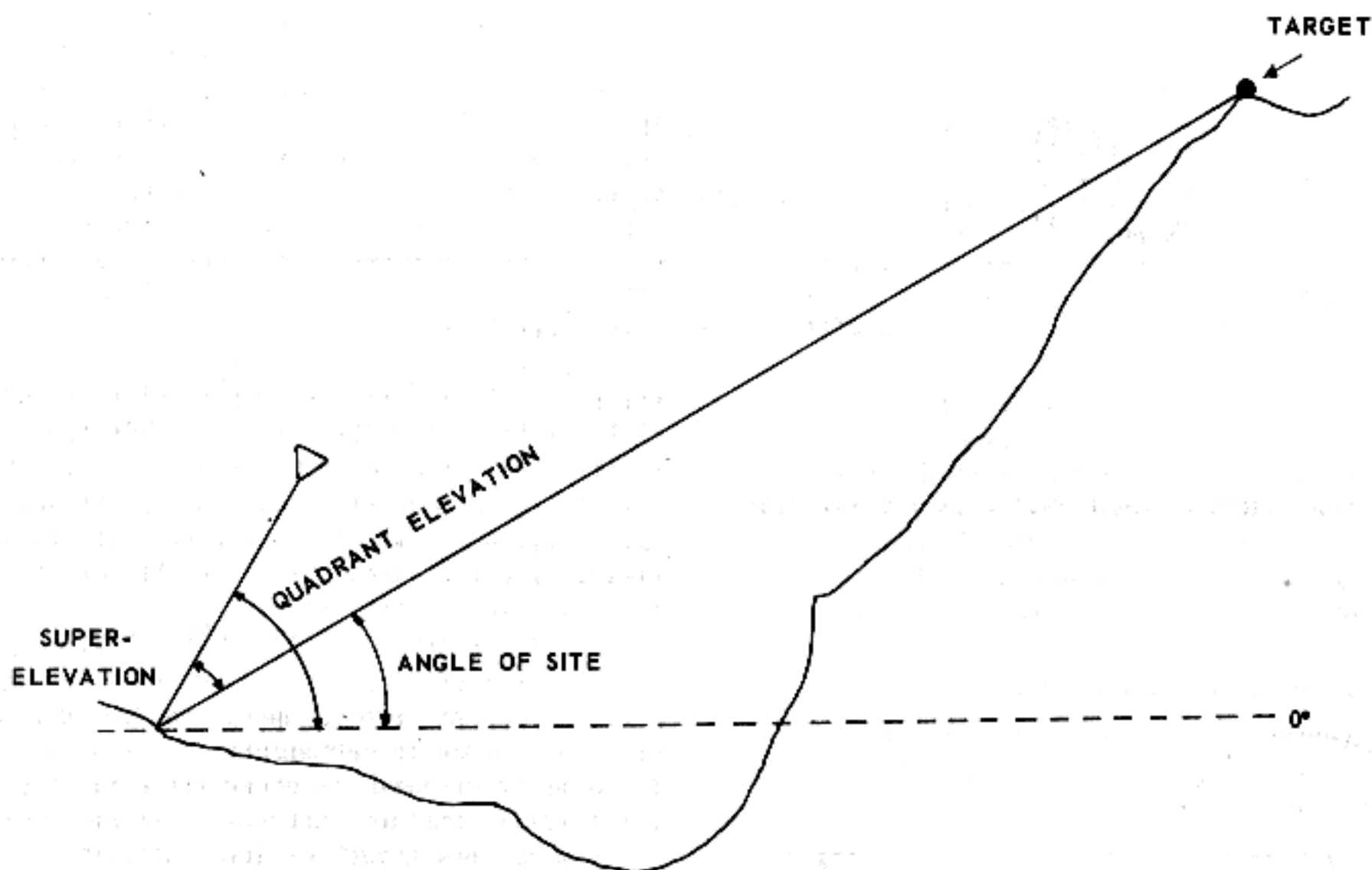

Figure 5-1. Angle of site, super-elevation, and quadrant elevation.

usually is used for stationary surface targets. The azimuth tracker uses the speed ring sight, and manually aligns the vertical sight reference line on the center of mass of the target. Adjustments for deviations in azimuth are made by using the splash or burst of the projectile as a reference for moving the gun according to deviations observed by the azimuth tracker. For example, the azimuth tracker tracks off, moving the point of burst position in the sight (with reference to the vertical sight reference line) onto the target (fig. 5-2). Adjustments are continued until fire is brought on target. The elevation tracker should use the reflex sight M24C instead of the speed ring sight. Zero speed must be set on the computer. The angle of site and super-elevation are applied by tracking the center of mass of the target with the horizontal sight reference line, then modifying this setting according to target range by tracking higher or lower. Range deviations are corrected by the splash-on-target method of adjustment; i.e., the elevation tracker tracks off, moving the point of burst position in the sight (with reference to the horizontal sight reference line) onto the target (fig. 5-2). Adjust-

ments are continued until correct, then fire for effect is employed.

(2) *Computing sight XM61.* Ground mode is used for stationary targets. The senior gunner aligns the vertical center line (imaginary line) of the sight reticle image on target and, according to the range, aligns the horizontal center line (imaginary line) or the open sector at the bottom of the inner reticle image ring on target. Corrections are made by the splash-on-target method. To prevent movement of the mount during bursts, it may be desirable to set the NORM/STATIC/TEST switch on the distribution box at STATIC before firing for effect.

(3) *Speed ring sights.* For speed ring sights, except the M18, the tracker aligns the vertical sight reference line on the center of the target and the horizontal sight reference line on, above, or below the target, depending on range. For the M18 sight, the bottom dot, center dot, or top dot in the reticle pattern is aligned on the center of the target, depending on range. Adjustments are made by the splash-on-target method with all speed ring sights.

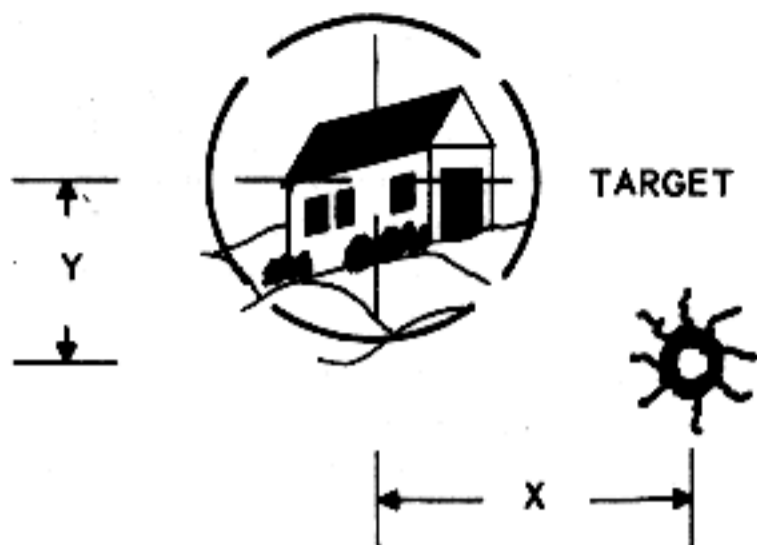

(1) SIGHT PICTURE WHEN FIRST SPLASH IS OBSERVED

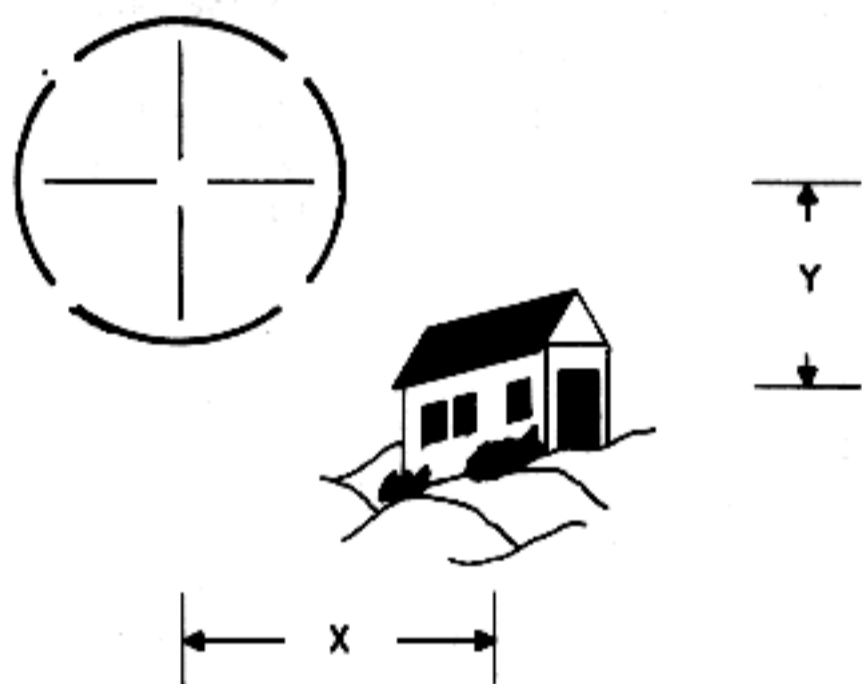

(2) SIGHT PICTURE AFTER PROPER ADJUSTMENT

Figure 5-2. Splash-on-target adjustment.

### b. Moving Targets.

(1) *Computing sight M38.* If a rapidly moving surface target can reasonably be expected to maintain its speed and course, the computing sight M38 can be used to compute and set in lead. In this case, it is operated by setting the flight direction indicator parallel to the target course, setting estimated target speed on the speed knob, and tracking the target in the center of the M24C sight. In most cases, the speed knob should be set at zero speed and the trackers lead the target by tracking ahead of it by one apparent target length. Tracking may be manual with the azimuth tracker using the speed ring sight, or it may be power tracking with the gunner tracking in elevation and azimuth and using the M24C sight only. Adjustments of fire can be accomplished by tracer observation and the splash-on-target method of correction.

(2) *Computing sight XM61.* The Vulcan can be fired at moving surface targets in either the ground mode or manual mode. In the ground mode, the senior gunner sights on the target in the same manner that he would for a stationary target, except that he must lead it by one target length and then adjust by the splash-on-target method. In the manual mode, target speed and range are estimated and set on the respective controls. The gunner then tracks the center of target in the center of the sight and adjusts by the splash-on-target method, adding or subtracting from the sight-computed lead as required to obtain hits.

(3) *Speed ring sights.* In utilizing speed ring sights (except the M18 sight) on moving surface targets, manual or aided tracking may be used. The trackers track off in both azimuth and elevation, depending on range and speed of the target. The M55 machinegunner tracks the target with the lower dot of the sight reticle pattern ahead and above or below the target, depending on target speed and range. Adjustments are made by tracer observation or splash-on-target method.

## Section III. INDIRECT FIRE

### 5-5. General

Automatic weapons may be required to deliver indirect fire in a direct support role or to deliver harassing and interdicting fire. Indirect fire can be conducted by either the *direct command* or *target grid* procedure.

### 5-6. Indirect Fire Positions

a. *Positioning Weapon.* Although indirect fire can be delivered from air defense or direct fire positions, situations may arise when indirect fire positions must be used. Gun positions must be selected to provide defilade and still provide the de-

sired target area coverage. It is desirable that guns be emplaced 20 to 30 meters apart to provide working space and still get adequate density of fire with a parallel sheaf. However, the tactical situation may require that weapons be emplaced at other intervals. If this results in a front greatly in excess of target width, corrections are applied to reduce the width of the sheaf (para 5-8).

*b. Numbering Weapons.* No matter how the weapons are positioned, guns in a surface firing position are normally numbered from right to left, facing the direction of fire.

*c. Leveling.* Gun carriages should be cross-leveled to eliminate errors produced by cant. The level may be checked by using the gunner's quadrant.

*d. Minimum Quadrant Elevation.* To insure safety of friendly troops, the minimum quadrant elevation required to clear the crest (visible from the *battery* position), minimum range lines, no-fire lines, and intermediate crests must be determined and recorded. Minimum quadrant elevation for ADA AW indirect fire positions can be determined as follows:

(1) Determine the angle of site from each

weapon to the highest point on the visible crest by boresighting and measuring quadrant elevation. The greatest angle measured is the angle of site for the *battery*.

(2) Determine the range to the highest point on the crest by map measurement, estimation, or by triangulation. To compute the range to a point on the visible crest, using triangulation, proceed as follows (fig. 5-3).

(a) Boresight the two flank pieces on each other. Set the azimuth indicator on the left piece to 3,200 mils and the azimuth indicator on the right piece to 0 mils.

(b) Traverse the flank pieces and boresight them both on the same point on the crest.

(c) Measure the distance between the two flank pieces. This distance is the width of the *battery*.

(d) Enter the azimuth readings to the point on the crest and the *battery* width into the mil relation formula and solve for the range to the crest as in the following example.

*Example:* The *battery* width is 100 meters, azimuth from left flank piece to crest point is 1,700 mils, and azimuth from right flank piece to crest point is 1,500 mils.

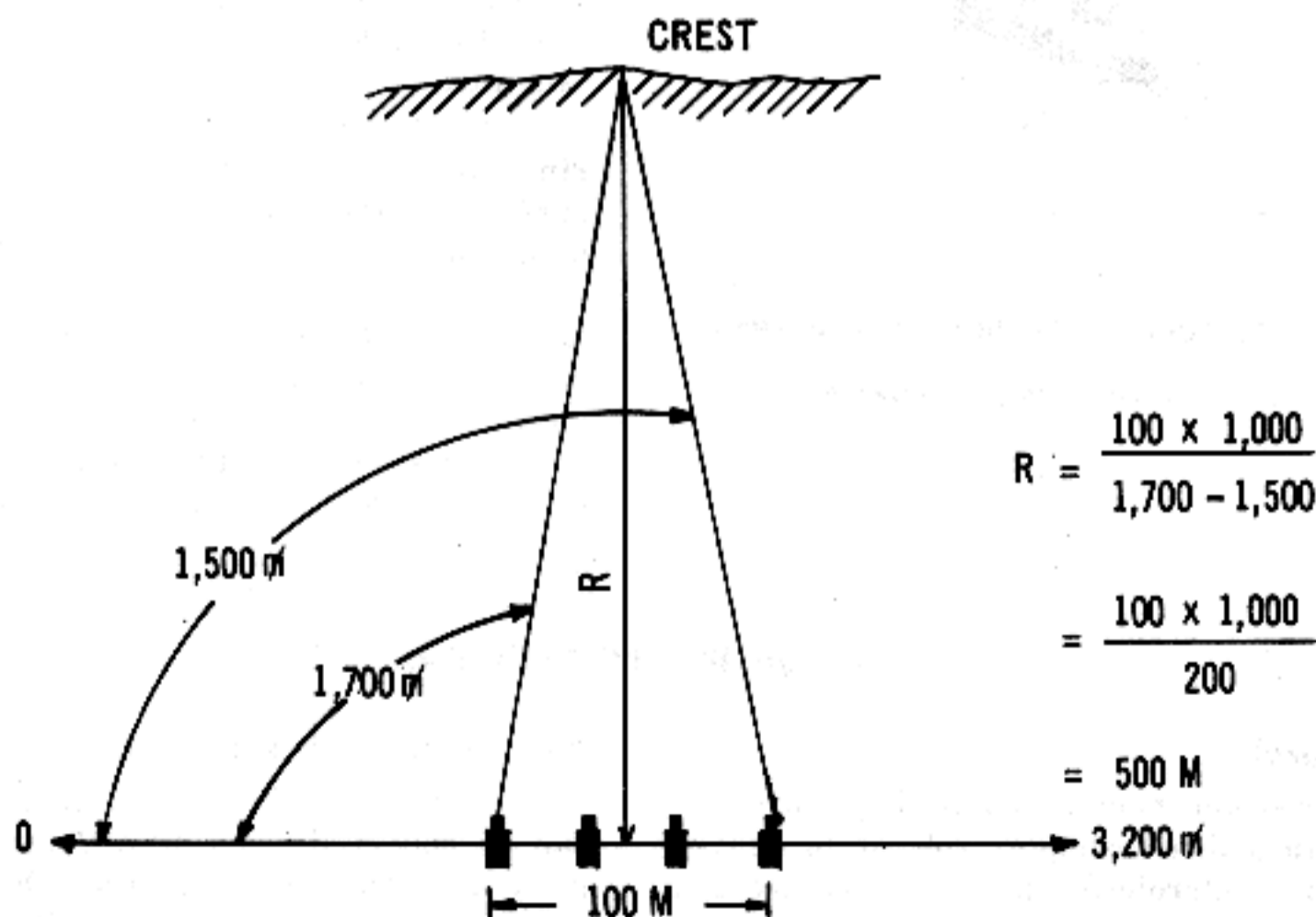

Figure 5-3. Computing range to crest.



$$\begin{aligned} \text{Range to crest (meters)} &= \frac{\text{width of battery (meters)} \times 1000}{(\text{left flank azimuth}) - (\text{right flank azimuth})} \\ &= \frac{100 \times 1000}{1700 - 1500} = \frac{100 \times 1000}{200} \\ &= 500 \text{ meters.} \end{aligned}$$

(3) Elements of the minimum quadrant elevation consist of:

(a) Angle of site to highest point on crest.

(b) Vertical angle corresponding to a 5-meter vertical clearance of the crest. This angle is computed by using the mil relation formula (5 meters divided by the range to the crest in thousands of meters). Unless otherwise informed, the ADA commander will assume the crest is occupied by friendly troops.

(c) Superelevation corresponding to range to crest.

(d) Two *C* factors (elevation change required to increase range 200 meters) at the range to crest. The sum of elements (a) through (d) is the minimum quadrant elevation at which the guns may be fired to clear the crest safely. Minimum quadrant elevations for other crests, friendly troops, no-fire lines, and minimum range lines are computed in a similar manner. An example of computing minimum quadrant elevation for an M42 platoon follows:

*Example:* 40-mm gun M42, cartridge HE-T-SD, range to crest 500 meters, greatest angle of site to crest 10 mils.

*Solution:*

- |  |                  |
|--|------------------|
| 1. Greatest angle of site report   | 10 mils          |
| 2. Vertical angle corresponding to 5-meter vertical clearance of crest (5 ÷ 0.5) | 10 mils          |
| 3. Superelevation for crest range (from firing tables)                           | 3.8 mils         |
| 4. Two <i>C</i> factors (from firing tables)                                     | 1.6 mils         |
| <b>Total</b>   | <b>25.4 mils</b> |
- Minimum quadrant elevation is 26 mils.

(4) Minimum quadrant elevation for the M55 can be computed in the same manner. Some firing tables for caliber .50 machineguns contain a table from which minimum quadrant elevation can be read direct. To compute minimum quadrant elevation for Vulcan, proceed as explained in (3) above except that 3 mils must be added to compensate for vertical dispersion caused by the muzzle clamp.

**5-7. Orientation**

The M42 and Vulcan are oriented by boresighting and setting azimuth on their azimuth indicators. Improvised azimuth indicators for the M55 are

described in appendix C. There are two methods of orienting; i.e., known datum point method and backsighting method.

*a. Known Datum Point Method.* Boresight the weapon on the known datum point (aiming point to which the azimuth is known). Set the azimuth indicator to read the azimuth of the datum point.

*b. Backsighting Method.* Set up an aiming circle at least 60 meters from the closest gun. Orient the aiming circle on grid north, using the compass needle of the aiming circle or a surveyed orienting line (FM 6-40). Boresight a gun on the optical center of the aiming circle. Sight the aiming circle on the gun bore. When the axis of the gun bore and the line of sight of the aiming circle are aligned, read the angle on the aiming circle. Set the back azimuth of this angle on the gun azimuth indicator. Boresight and set azimuth indicators on the remainder of the guns in the same manner.

*c. Distances to Metallic Objects.* When the aiming circle or magnetic compass is used, all objects (barbed wire, small arms, etc.) that may attract the needle must be kept away from the instrument. The instrument should be set up no closer to the following objects than the distances listed:

Objects	Distances in meters
High-tension powerlines	150
Railroad tracks	75
Medium and heavy towed artillery pieces and all self-propelled artillery pieces	60
Telephone wire or vehicles	40
Barbed wire and small metallic objects	10

**5-8. Adjusting the Sheaf**

Usually several weapons are employed as a *battery* in delivering indirect fire. The width of the parallel sheaf of the *battery* may be too small or too large to produce the desired density of fire on the target. An azimuth difference is applied to individual weapons to achieve a width of sheaf different from the width of the *battery* front. The sheaf is opened or closed on any desired piece (normally the base piece) a computed number of mils. The sheaf is opened when the width of the desired sheaf is greater than the width of the *battery* front and closed when the width of the desired sheaf is less than the width of the *battery* front. No corrections are applied to make the lateral interval between bursts equal.

*a.* The adjustment to open or close the sheaf is determined in the following manner.

- (1) Determine the difference between the

width of the desired sheaf and the *battery* front (with respect to the direction of fire).

(2) Divide the value determined in (1) above by one less than the number of pieces in the *battery*.

(3) Divide the value obtained in (2) above by the range in thousands of meters.

*Example:* An M42 platoon is in position with a *battery* front of 210 meters. Fire commands are received that include BATTERY ADJUST, SHEAF 70 METERS AT 4,000, etc. The platoon leader determines the difference (140 meters) between the width of the desired sheaf (70 meters) and the width of the *battery* front (210 meters). He divides 140 meters by 7 intervals (8 pieces in the *battery*). The result (20) is divided by the range in thousands of meters (4). The amount to be closed is 5 mils. The fire commands to the M42's will include, AZIMUTH 1,800, ON NUMBER 4, CLOSE 5 (number 4 gun being the base piece).

b. The squad leader at each automatic weapon except No. 4 will multiply the amount to be closed (5 mils) by the number of pieces his piece is removed from No. 4 and apply the result to the announced azimuth. The application of azimuth correction to close on No. 4, as required in a above, would be subtracted for pieces to the right of No. 4 and added for pieces to the left of No. 4. For example, the squad leader of No. 2 would command, AZIMUTH 1792 (azimuth difference multiplied by number of pieces removed =  $4 \times 2 = 8$ ; therefore, LEFT 8); the squad leader of No. 7 would command AZIMUTH 1812 (azimuth difference multiplied by number of pieces removed =  $4 \times 3 = 12$ ; therefore, RIGHT 12). Other pieces would lay on new azimuths in a like manner. The gunner's aid dial of the azimuth indicator M27 on the M42 and Vulcan is set at zero on the announced azimuth, and corrections LEFT or RIGHT are made, using this dial. Corrections on the M55 must be made by laying on a new azimuth as indicated on the improvised azimuth scale (app C). At the end of the fire mission, azimuth differences must be removed and the weapons returned to lay parallel on the same azimuth.

## 5-9. Direct Command Procedure

a. *General.* This procedure provides a rapid accurate method of placing fire on targets when

they are beyond the effective vision of on-carriage sights or when visibility from the guns is reduced by dust, smoke, defilade, or other causes. It is used primarily with single weapons where a fire direction center is not available. However, with proper coordination, it may be used to fire a platoon.

b. *Limitation.* Direct command procedure can be used only when the displacement of the observer, normally the squad leader, from the gun position in any direction is not more than one-tenth of the gun-target range. The observer transmits his commands direct to the gun without resorting to the use of a fire direction center. If it is apparent that more than one target is to be engaged from any one position, the observer should select an observation point so that his lateral location from the gun is not more than one-tenth of the gun-target range to the most critical target.

c. *Initial Firing Data.* Upon entering an indirect fire position, the observer determines certain initial data necessary to orient the weapon and to place initial rounds on or near the target.

(1) *Orientation.* The observer selects a terrain feature that is visible from the gun as a reference point. He determines the approximate azimuth from the gun to the reference point by means of a map or compass, or he may assume an arbitrary azimuth for this direction line. The weapon is oriented in azimuth by sighting on the reference point and setting the azimuth to that point on the azimuth indicator.

(2) *Target azimuth.* The observer determines the azimuth to the target by use of a compass, or by measuring the angle between the reference point and the target with binoculars. The initial azimuth is announced to the guns as AZIMUTH, \_\_\_\_\_ MILS.

(3) *Site.* The difference in altitude between the gun and target usually is estimated or scaled from a map. This difference in altitude, in meters, is converted to a vertical angle in mils by use of the mil relation formula. If an aiming circle is available, the angle of site may be measured directly; this is announced to the gun as SITE, PLUS (MINUS) \_\_\_\_\_ Mils.

d. *Sequence of Fire Command Elements.* The elements of initial fire commands are transmitted in the following sequence:

<i>Element</i>	<i>Example</i>
(1) <i>Pieces to follow command</i> ..	BATTERY, ADJUST. (If only one weapon is present, the command is ADJUST.)
(2) <i>Projectile</i> .....	SHELL HE (AP, etc.).
(3) <i>Pieces to fire</i> .....	BASE PIECE.
(Omit if only one piece is present.)	(Any or all pieces alerted by first command may be designated to fire.)
(4) <i>Method of fire</i> .....	1 ROUND, BATTERY 4 ROUNDS IN EFFECT.
(5) <i>Azimuth</i> .....	AZIMUTH, 1,800.
(6) <i>Height of target above or below gun.</i>	SITE PLUS (MINUS) 10.
(7) <i>Range from gun to target in meters.</i>	RANGE 3,000.

*e. Application of Initial Fire Command.* In direct command procedure, the gun crew acts as its own fire direction center in computing quadrant elevation from the range and site information announced by the observer. The initial fire command is applied to the weapons in the following manner:

(1) The first four elements of the command serve to alert the crew, designate the type of projectile to be used, and specify the method of fire.

(2) The azimuth element is transmitted to the azimuth tracker or gunner who traverses the weapon to the announced azimuth.

(3) The commands for site and range are transmitted to the quadrant setter. From appropriate firing tables, the quadrant setter determines the superelevation corresponding to the announced range. He adds the angle of site algebraically to the superelevation to get the quadrant elevation. He then sets quadrant elevation on the gunner's quadrant and places the quadrant on the weapon. When the gun has been elevated or depressed so that the quadrant is level, he removes the quadrant and commands, FIRE.

*f. Subsequent Corrections.* The observer adjusts fire by sensing the impact of the rounds and sending corrections directly to the gun. Shots that are off the observer-target line are corrected by commanding a shift in the appropriate direction in mils, e.g., RIGHT (LEFT) 5. The target is bracketed for range by commanding changes in range in meters, e.g., ADD (DROP) 400. The initial range change should be large enough to in-

sure bracketing the target. This bracket is successively split until the target is within a bracket of suitable size, depending on the nature of the target and the characteristics of the weapon and ammunition used. Fire for effect is begun at the center of that bracket. Corrections are announced in the following sequence:

<i>Element</i>	<i>Example</i>
(1) Change in ammunition ..	SHELL AP.
(2) Change in method of fire: for example, to change the number of rounds upon entering fire for effect.	10 ROUNDS.
(3) Azimuth correction .....	RIGHT 10.
(4) Range correction .....	DROP 50.

*Note.* Subsequent corrections are always terminated with a correction for range. Any element that is not being changed may be omitted. If no change is desired, the observer sends, REPEAT.

*g. Application of Subsequent Corrections at Gun.*

(1) When a change in azimuth is announced by the observer, the azimuth tracker, or gunner, traverses the gun until the new azimuth is set on the azimuth indicator. The azimuth tracker, or gunner, must bear in mind that azimuth decreases when moving to the left and increases when moving to the right. For example, a shift of RIGHT 60 from an azimuth setting of 1,367 would result in a new setting of  $1,367 + 60$ , or 1,427. A subsequent command of LEFT 35 would change the setting to  $1,427 - 35$ , or 1,392.

*Note.* The gunner's aid dial on azimuth indicator M27 (on M42 and Vulcan) is used as an aid in the application of azimuth changes. (For complete instructions on the use of the azimuth indicator and gunner's aid dial, see FM 44-61.)

(2) In handling subsequent corrections in range, the quadrant setter uses the *C* factor (number of mils elevation equivalent to a 100-meter change in range) corresponding to the initial range command. The value of *C* in mils is taken from the tabular firing tables. The quadrant setter multiplies *C* by the range correction expressed in hundreds of meters. He adds the resulting value in mils algebraically to the last quadrant setting fired. For example, assume a round was fired at a quadrant of 70 mils and that  $C = 3$  mils. If a range change of ADD 400 were ordered, the quadrant setter would set his quadrant at  $70 + (3 \times 4)$ , or 82 mils. A subsequent correction of DROP 200 would result in a quadrant setting of  $82 - (3 \times 2)$ , or 76 mils.

## 5-10. Target Grid Procedure

Target grid procedure for indirect fire involves the employment of a fire direction center (FDC).



The FDC receives information from an observer, computes fire commands, and transmits fire commands to the guns. The observer is seldom within the short distance from the guns required for direct command procedure; therefore, location of guns and observer orientation are desirable for accurate firing:

*a. Platoon Fire Direction Center.*

(1) *General.* When necessary, an improvised fire direction center may be established within the automatic weapons platoon headquarters. Its purpose is to process target information from an observer into fire commands used by AW squads.

(2) *Personnel.* The personnel required to operate a platoon FDC include:

- (a) Fire direction officer (FDO).
- (b) Chart operator.
- (c) Computer.

*Note.* The FDO usually is the ADA AW platoon leader or platoon sergeant. Others listed above are obtained from selected members of the platoon headquarters. Duties of the personnel are outlined in FM 6-40. (The chart operator performs the combined duties of the horizontal control operator (HCO) and vertical control operator (VCO).)

(3) *Equipment.* As the normal fire direction equipment provided a field artillery unit is not authorized for the ADA AW unit, necessary equipment must be improvised. At a minimum, the following items are needed:

(a) *Firing chart.* The firing chart may be a map of the area or a grid sheet.

(b) *Scale.* A scale is needed to measure range. A scale cut from a map may be used. The scale should be the same as that of the firing chart.

(c) *Protractor.* A protractor is used to measure azimuth. The protractor should be graduated in mils.

(d) *Firing tables.* Firing tables for the weapons and ammunition used are required.

(e) *M17 plotting board.* This device may be used to convert the observer's corrections to corrections with respect to the gun-target line when a firing chart and target grid are not available. An M17 plotting board can be improvised if one is not available. (For a description of the plotting board, see FM 23-85. Operation of the board is the same as that of the M10 plotting board which is described in FM 6-40.)

(f) *Target grid.* The target plotting grid (DA Form 6-53) is issued in pads of 50 and may

be requisitioned through normal publications channels. (For details of the use of the target grid, see FM 6-40.)

(g) *Coordinate scale.* The coordinate scale is used to plot target locations when they are given by grid coordinates. Coordinate scales should be graduated in meters and of the same scale as the firing chart.

(h) *Miscellaneous.* In addition, map tacks or plotting needles, straightedges, and hard lead pencils are needed.

*b. Observer Procedure.*

(1) *Call for fire.* When an observer desires fire on a target, he transmits a *call for fire*. This is a concise message containing the information needed at the FDC for preparation of fire commands. The call for fire, as developed by the field artillery, contains six elements arranged in a prescribed sequence as follows:

- (a) Identification of observer.
- (b) Warning order.
- (c) Location of target.
- (d) Description of target.
- (e) Method of engagement.
- (f) Method of fire and control.

(2) *Identification of observer.* The element identifying the observer consists of the call signs or codes necessary to establish contact between the observer and the FDC. For example, the observer transmits VOODOO ALPHA 2 (call sign of platoon FDC), THIS IS VOODOO ALPHA 20 (observer's call sign).

(3) *Warning order.* The warning order element is sent by the observer to achieve communication priority and to alert the FDC. The warning order is announced as, FIRE MISSION.

(4) *Location of target.*

(a) The location-of-target element must always contain two or more subelements, one of which will be the reference line (direction). The following are examples of reporting the direction of the spotting line:

- 1. Grid azimuth from observer to target; e.g., DIRECTION 4310.
- 2. Magnetic azimuth from observer to target; e.g., MAGNETIC DIRECTION 2450.
- 3. Gun-target line; e.g., DIRECTION GUN TARGET.

(b) When a target is located by grid coordinates, the subelements of target location are transmitted in the following manner.

1. Grid coordinates; e.g., GRID 576431.
2. Grid azimuth from observer to target; e.g., DIRECTION 3410.

(c) When a target is located by a shift from a known point, the subelements of the target location are transmitted in the following manner and sequence:

1. Known point; e.g., FROM TARGET AF 2011.
2. Observer target azimuth; e.g., DIRECTION 1230.
3. Lateral shift; e.g., RIGHT (LEFT) 200.
4. Range shift; e.g., ADD (DROP) 400.
5. Vertical shift; e.g., UP (DOWN) 20.

*Note.* If there is no shift in a particular direction, that subelement is omitted.

(d) When the target location is reported by polar coordinates, the subelements of the target location are transmitted in the following manner:

1. Observer-target azimuth; e.g., DIRECTION 1620.
2. Observer-target distance; e.g., DISTANCE 2500.
3. Vertical shift; e.g., UP 50.

(5) *Description of target.* The element indicating the nature of the target includes a brief description of the installation, personnel, equipment, or activity at which the observer desires to fire. This description should be sufficiently informative to enable the fire direction officer (FDO) to determine the relative importance of the target and the best manner of attack. The observer should state the approximate number of persons or units of materiel comprising the target; e.g., 50 INFANTRY AND 3 TANKS IN THE OPEN. He should give a clear description of the target to include the shape when significant; e.g., 60 INFANTRY DIGGING IN ALONG RIDGE LINE. He should indicate the approximate size of a target that covers a large area; e.g., TRUCK PARK IN WOODS, 300 BY 300.

(6) *Method of engagement.* If no specific type of adjustment is designated, area fire will be

used. In area fire, the adjustment normally is conducted by firing the two center pieces of the battery (platoon). The term, DANGER CLOSE, may be included in the method of engagement when the target is within 600 meters of friendly troops, and the observer may request certain types of ammunition and the volume of fire desired in fire for effect. The type sheaf desired (e.g., CONVERGE or SHEAF 100 METERS) may also be included in this element.

#### (7) *Method of fire and control.*

(a) Adjustment normally is conducted by firing the two center pieces simultaneously. If, for any reason, the observer determines that PLATOON RIGHT (LEFT) will be better, he may request it. If he wants the fire at other than 5-second intervals, he may so specify.

(b) Method of control is indicated by the observer by use of the terms below.

1. AT MY COMMAND indicates that the observer desires to control the time of delivery of fire. This announcement immediately precedes ADJUST FIRE or FIRE FOR EFFECT; e.g., AT MY COMMAND, ADJUST FIRE. When the pieces are ready to fire, FDC announces to the observer, PLATOON IS READY. AT MY COMMAND remains in effect until the observer announces, CANCEL AT MY COMMAND.

2. ADJUST FIRE indicates that adjustment is necessary and the observer can see to adjust fire. Unless AT MY COMMAND has been included, ADJUST FIRE indicates that the unit may begin firing when ready.

3. FIRE FOR EFFECT may be announced instead of ADJUST FIRE, indicating that no adjustment is necessary. It may be announced after fire has been adjusted onto the target. Except when preceded by AT MY COMMAND, fire for effect may begin when the unit is ready.

4. If the observer announces, CANNOT OBSERVE, he is unable to adjust fire but requests fire on the target without adjustment.

(8) *ADJUSTMENT PROCEDURE.* Technique of spotting shots and announcing corrections is explained in detail in FM 6-40.

## Section IV. MISCELLANEOUS

### 5-11. Harassing and Interdiction Fire

Current air defense automatic weapons are suited for firing indirect fire to harass the enemy or to deny his unrestricted use of areas. Harassing or

interdiction fire is prearranged, and target locations and the gun-laying data required to hit them are recorded. Weapons are laid to the required azimuth and quadrant elevation and fired

in a static condition; that is, with tracking power off (Vulcan will have the NORM/STATIC/TEST switch on the distribution box set at STATIC). If the fire is observed, corrections, will be made through the procedures outlined in paragraphs 5-3 and 5-4 or 5-5 through 5-10, as applicable.

### 5-12. Ballistics

Interior and exterior ballistics of projectiles are affected by many factors, among which are powder temperature, tube wear, characteristics peculiar to a particular lot of ammunition, and atmospheric conditions. Firing tables list data on projectile trajectories for a standard muzzle velocity and for standard atmospheric conditions. Insofar as changes from standard can be determined and data on the effects cause by these changes are available, correction can be made to firing data to compensate for nonstandard conditions. Firing tables for ADA AW lack the necessary data to compute some desirable corrections; therefore, registration becomes necessary to improve accuracy of first rounds in indirect fire.

### 5-13. Registration

Registration is conducted to determine firing data that will place the mean point of impact on the

target. Registration data are used to determine corrections that must be applied to compensate for the effects of nonstandard conditions. Correction factors obtained from a registration are valid until atmospheric conditions change significantly or a new ammunition lot is used. Registrations should be conducted as described in FM 6-40, modified as required by availability of FDC equipment and as authorized by the commander concerned.

### 5-14. Range Cards

A range card should be made for all automatic weapons upon occupation of position. It should be a sketch of the position and surrounding area showing pertinent objects within the ground range of the weapon and the ranges to each object. Likely targets for harassing or interdiction fire and for fire in ground defense of the position should have their range and the firing data required to hit them recorded on the range cards. If time and tactical situation permit, ranges should be accurately determined and the gun registered on several key targets.



## APPENDIX A

### REFERENCES

Department of the Army pamphlets (310-series) should be consulted for the latest changes or revisions of references listed in this appendix

and for new publications relating to material covered in this manual.

AR 310-25	Dictionary of United States Army Terms.
AR 310-50	Authorized Abbreviations and Brevity Codes.
AR 385-63	Regulations for Firing Ammunition for Training, Target Practice, and Combat.
DA Pam 310-series	Indexes of military publications.
DA Pam 350-15-series	Operations—Lessons Learned.
FM 6-40	Field Artillery Cannon Gunnery.
FM 23-85	60-mm Mortar, M19.
FM 31-36 (Test)	Night Operations.
FM 44-2	Air Defense Artillery Employment, Automatic Weapons, M42/M55.
FM 44-3	Air Defense Artillery Employment, Chaparral/Vulcan.
FM 44-5	Procedures and Drills for Vulcan Self-Propelled Weapon System.
FM 44-57	Procedures and Drills: Multiple Caliber .50 Machinegun Trailer Mount M55.
FM 44-61	Procedures and Drills for Twin 40-mm Self-Propelled Gun M42 and M42A1.
TM 9-2010	Organizational Maintenance: Mount, Machinegun, Caliber .50, M55 (Composed of Mount, Machinegun, Multiple, Caliber .50, M45C and Trailer, 1-Ton, 2-Wheel, Machinegun Mount, M20).
TM 9-2350-300-10	Operator's Manual for Gun, Antiaircraft Artillery, Self-Propelled: 20-mm, XM163.
TM 9-7218	Operator and Organizational Maintenance Manual: Gun, Antiaircraft Artillery, Self-Propelled; Twin 40-mm, M42 and M42A1.
FT .50AA-T-1	Firing Tables for Gun, Machine, Cal. 0.50, Browning, M2; Firing Cartridge, Armor-Piercing-Incendiary, Cal. 0.50, M8.
FT 40AA-A-3	Gun, Automatic, 40-mm, M1, and Gun, Dual, Automatic, 40-mm, M2; Firing Cartridge HE-T, SD, Mk 2; With Fuzes, PD, Mk 27, M64A1, M71 or No. 251 Mk 1; and Cartridge AP-T, M81 and M81A1.

## APPENDIX B

## GLOSSARY OF AIR DEFENSE ARTILLERY AUTOMATIC WEAPON SYMBOLS AND TERMS

## Section I. SYMBOLS

Symbol	Definition
$d$ .....	Angle of approach.
$L$ .....	Lead angle.
$L_0$ .....	Generated lead angle.
$L_s$ .....	Required lead angle.
$L_{s1}$ .....	Required lead angle to intersect tail of target.
$L_{s2}$ .....	Required lead angle to intersect nose of target.
$D$ .....	Slant range.
$D_m$ .....	Slant range to midpoint.
$D_o$ .....	Slant range to present (observed) position.
$D_f$ .....	Slant range to future (predicted) position.
$E$ .....	Angular height.
$E_m$ .....	Midpoint angular height.

Symbol	Definition
$E_o$ .....	Present (observed) angular height.
$E_f$ .....	Future (predicted) angular height.
$E_s$ .....	Slant plane angular height.
$G$ .....	Pintle center of the gun.
$M$ .....	Midpoint.
$\phi$ .....	Quadrant elevation (phi).
$\phi_s$ .....	Superelevation.
$t_0$ .....	Time of flight.
$V$ .....	Speed of target.
$V_{proj}$ .....	Velocity of projectile.
$T$ .....	Target position.
$T_m$ .....	Target at midpoint.
$T_o$ .....	Present (observed) position.
$T_f$ .....	Future (predicted) position.

## Section II. TERMS

**Ahead**—In tracer observation, a sensing on a tracer that passes in front of the target.

**Angle of approach**—The angle formed by  $G$ ,  $T_o$ , and  $T_f$  with the apex at  $T_o$ .

**Angle of site**—In surface gunnery, the vertical angle between the gun-target line and the horizontal plane.

**Approaching leg**—That portion of the target course line where the target is flying toward midpoint.

**Astern**—In tracer observation, a sensing of a tracer that passes to the rear of the target.

**Base machinegun**—Right inboard machinegun of the mount M55.

**Base piece**—A weapon, at or near the center of the battery, normally used for registrations.

**Center of mass**—That point representing the mean portion of matter in a given target.

**Climbing course**—A target course with increasing altitude.

**Cone of sight**—In tracer observation, a general cone with the apex at the observer's eye, having a cross section shaped like the outline of the target, and extending to infinity.

**Crossing course**—Any target course that does not pass directly over the gun.

**Directly-at-the-gun course**—A target course that passes through the pintle center of the gun.

**Diving course**—A target course with decreasing altitude.

**Downcourse observer**—In tracer observation, a person stationed a specified distance from a gun opposite the receding leg of a target course for the purpose of obtaining lead sensings.

**Eclipse**—In tracer observation, a tracer being momentarily blotted out by the target as the target passes between the tracer and the observer.

**Flythrough**—A condition in firing where the lead angle generated by the sighting device is temporarily equal to the correct lead angle required to hit the target.

**Flythrough time interval**—The length of time during which a flythrough occurs.

**Gunnery chain**—A set of four conditions, known as links I, II, III, and IV, which must be established to meet the two requirements for a hit.

**High**—In tracer observation, a sensing of a tracer observed to pass above the target.

**Horizontal plane**—A geometric plane established by the point at the pintle center of the gun and all other points at that same altitude, disregarding curvature of the earth.

**Image spin**—The apparent climbing, level flight, and diving attitude of a target while flying a crossing course.

**Incoming course**—The course of a target flying toward an imaginary line erected perpendicularly through the pintle center of the gun.

**Lead tolerance**—Half the angle subtended at the gun by the length of the target.

**Level course**—The course of a target flying at constant altitude.

**Line**—In tracer observation, a tracer that produces an eclipse or a silhouette.

**Line tolerance**—Half the angle subtended at the gun by the vertical diameter of the target fuselage.

**Low**—In tracer observation, a sensing on a tracer passing below the target.

**ON**—In tracer observation, a sensing on a tracer correct for line or lead.

**Outgoing course**—The course of a target flying

away from an imaginary line erected perpendicularly through the pintle center of the gun.

**Receding leg**—The portion of the target course where the target is flying away from midpoint.

**Silhouette**—In tracer observation, the tracer is superimposed on the target as the tracer passes between the gun and the target.

**Target course line**—A straight line of infinite length formed by an extension of the longitudinal axis of a target fuselage.

**Target path**—The course a target actually takes in flight; not necessarily a straight line.

**Tracer control**—The art of adjusting fire based on information from tracer observation.

**Tracer hump**—The point of maximum apparent tracer path curvature.

**Tracer observation**—The technique of visually determining the location of tracers in relation to a target.

**Tracer sensing**—A decision made by observation as to the relative position of a tracer to a target.

**Tracker's line of sight**—A line from a tracker's eye through or along a sighting device.

## APPENDIX C

## PREPARATION OF M55 FOR INDIRECT FIRE

**C-1. General**

The M55 has proved to be an effective weapon in indirect fire. However, to realize maximum effectiveness, a quick and accurate means for laying it in azimuth and elevation must be improvised. A gunner's quadrant is used to level the mount and to set required quadrant elevation for firing. The gunner's quadrant must be placed on the receiver of the base machinegun (top right machinegun) when checking mount level and when laying the guns in elevation. For laying in azimuth, either of two improvised azimuth scales may be used; i.e., a tape scale or a painted scale.

**C-2. Leveling**

Leveling the mount within tolerance is important to the proper operation of the mount and the weapon. However, using a gunner's quadrant to measure elevation will eliminate elevation error that would otherwise be caused by cant. The M55 must be emplaced on level ground or the carrier vehicle must be leveled. Level can be checked with a gunner's quadrant on the receiver of the base machinegun while the mount is traversed.

**C-3. Laying in Elevation**

*a. Elevation Scale.* An elevation scale is not a necessity for laying the M55 in elevation, but it is an aid to quickly setting the elevation close to that desired. Fine laying can then be done with the gunner's quadrant. To construct an elevation scale, proceed as follows:

(1) Level the mount as closely as possible by leveling the ground on which it is emplaced.

(2) Place the gunner's quadrant on the receiver of base machinegun and elevate or depress the guns until they are level.

(3) Place an adhesive (removable) index mark on the outside of the moving portion of the left trunnion. It should be placed near the top of the trunnion and as close as possible to the stationary portion of the trunnion.

(4) Mark the stationary trunnion exactly opposite the index mark. This is the zero elevation mark on the elevation scale (fig. C-1).

(5) Set 800 mils on the gunner's quadrant, set the quadrant on the base machinegun receiver, and elevate the weapon until the gunner's quadrant bubble is centered.

(6) Place a mark on the stationary trunnion opposite the index mark. This is the 800-mil mark on the elevation scale.

(7) The space between these two marks should be divided into 8 equal spaces, and all 100-mil points marked and labeled; i.e., 0 through 8. This can be done by setting multiples of 100 mils on the quadrant and marking the stationary trunnion at each point opposite the index.

*b. Calibrating Elevation Scale.* Because the mount will settle and the degree of level will change, and because the degree of level will vary at different emplacements, calibration of the elevation scale should be checked and adjusted frequently. Adjustment can be accomplished in the following manner.

(1) Level the machineguns, using a gunner's quadrant on the base machinegun to check level.

(2) Check the position of the elevation index. If necessary, move the index to a point exactly opposite the 0-mil point on the scale.

**C-4. Laying in Azimuth**

Either a movable tape or a painted azimuth scale can be used in conjunction with a vernier index to allow laying in azimuth with an accuracy of a few mils. Accuracy in reading the scale depends on accurate construction and fine markings.

*a. Tape Scale.* Any durable tape can be used for constructing the scale, but the procedures outlined are for use of embossing tape, which is recommended.

(1) Cut tape to a length exactly equal to the circumference of the mount base.

(2) Fold the tape into two equal parts and crease the fold. A white mark will appear at the crease. This mark will be the 8,200-mil mark.

(3) Fold each part of the tape into two equal parts and continue to fold and crease until the tape is creased into 64 equal parts.



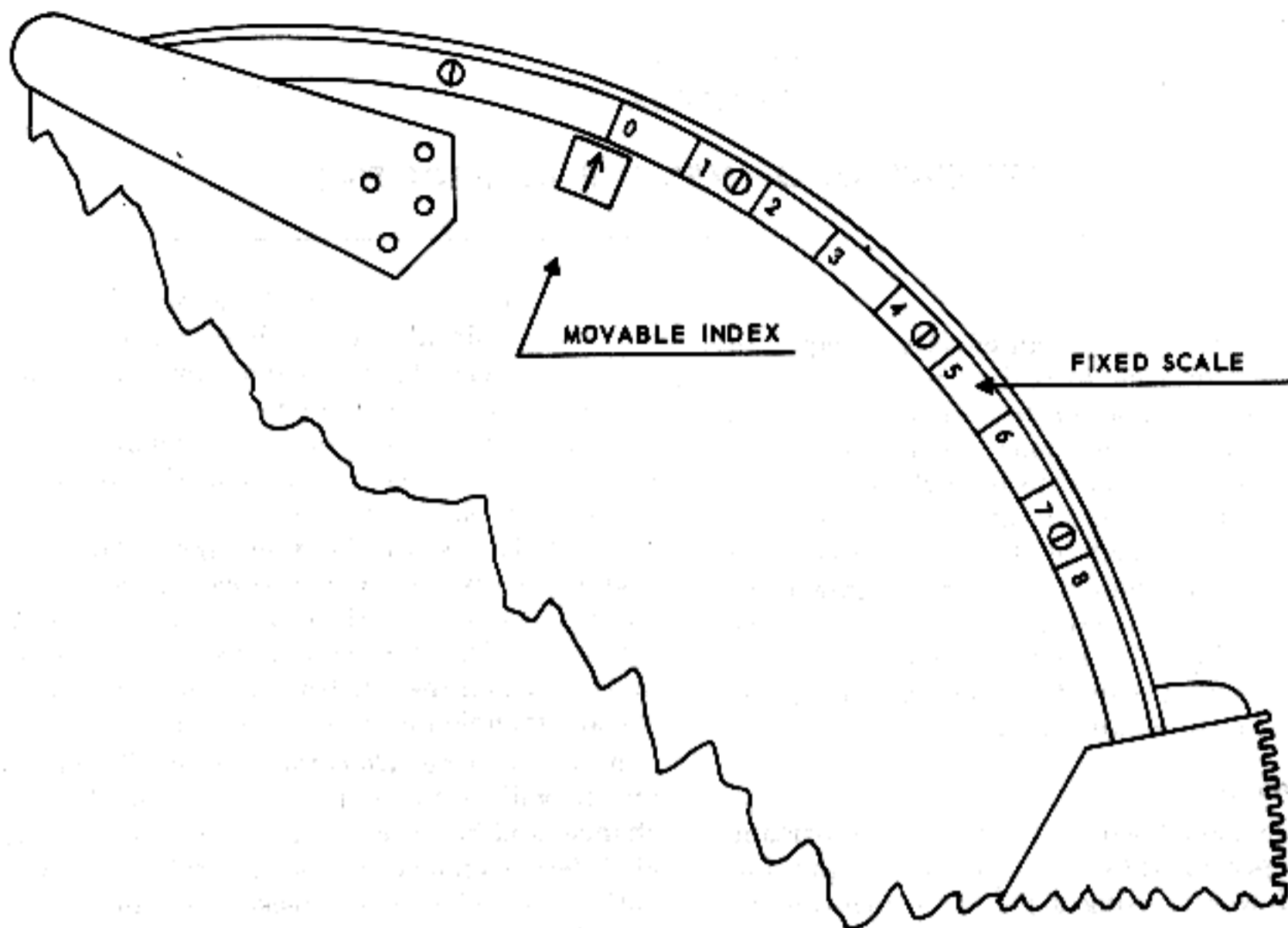

Figure C-1. Elevation scale on M55.

(4) Using an embossing machine, number the crease marks from 1 to 63. The ends of the tape will represent 0 and 6,400 mils and the numbered marks will represent 100 through 6,300 mils.

(5) With the mount sighted on an orienting point, position the tape around the base of the mount so that the vernier index (*c* below) indicates the azimuth of the orienting point (fig. C-2). Do not remove the tape backing.

(6) Fasten scale to mount base with scotch or masking tape so that it can be moved when necessary for orientation.

*b. Painted Scale.* In lieu of an embossing tape scale, a scale can be painted on top of the mount base. If this is done, a movable index must be used to effect accurate orientation. A painted scale can be prepared as follows:

(1) Using a nonadhesive tape or similar aid marked in 64 equal parts, mark and paint a scale on the top surface of the mount base as close to the turret as possible. Do not number the 100-mil marks but paint 10-mil marks (smaller than the others) between the 100-mil marks.

(2) Sight the weapon on an orienting point.

(3) Using chalk or other temporary marker, label the 100-mil mark closest to the cutout plug with the orienting point azimuth in hundreds of mils. For example, if the orienting point azimuth is 3,760 mils, label the 100-mil mark closest to the cutout plug 37.

(4) Place a temporary index mark on the turret so that the mark indicates 3,760 (six 10-mil marks clockwise from the mark labeled 37).

(5) Label all 100-mil marks for the complete azimuth scale.

*c. Azimuth Vernier Index* (fig. C-2). A vernier index can be made for reading azimuth on a tape scale. One end of the index plate is inserted under the warning plate next to the cutout plug on the turret. Care must be taken by the crew to insure that the index is not bent, loosened, or otherwise disturbed after the weapon has been oriented. To construct and install the index, proceed as follows:

(1) Procure a flat piece of sheet metal approximately 8 by 5 inches in size.



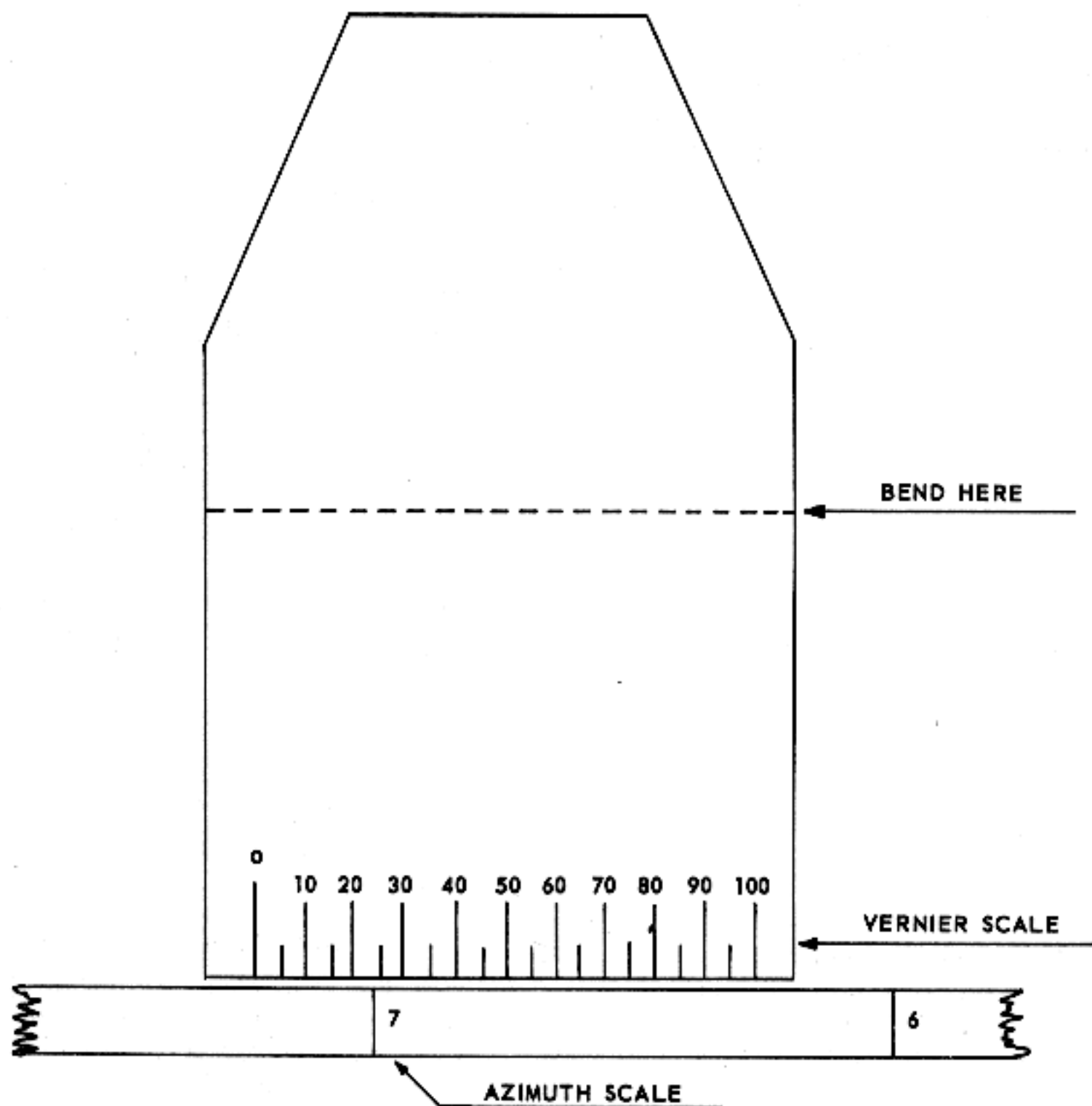

Figure C-2. Azimuth index

(2) Measure the length of a 100-mil segment of the azimuth scale.

(3) Scribe a 100-mil scale on one of the 3 inch edges of the sheet metal. Mark every 5-mil point. The 0 mark and multiples of 10-mil marks should be longer than the 5-mil marks and should be labeled 0, 10, 20, etc. (fig. C-2).

(4) Taper the end opposite the scale end and bend the index plate as indicated in figure C-2.

(5) Push the tapered end under the cutout plug warning plate so that the scale on the vernier is located just free of the mount base and about  $\frac{1}{8}$  inch from the azimuth scale.

(6) To read the indicated azimuth, took the 100-mil indication at, or just to the right of, the 0-mark on the vernier and add the reading on the vernier that is closest to the 100-mil mark taken. For example, the azimuth indicated in figure C-2 is 700 mils + 23 mils, or 723 Mils.